

## **SECTION 04 : EXHAUST SYSTEM**

---

### **CONTENTS**

<b>1. MAINTENANCE.....</b>	<b>04-2</b>
<b>2. MUFFLER REMOVAL / INSTALLATION .....</b>	<b>04-3</b>
<b>3. FLEXIBLE TUBE INSTALLATION .....</b>	<b>04-3</b>

### **ILLUSTRATIONS**

<b>FIGURE 1: EXHAUST SYSTEM .....</b>	<b>04-2</b>
<b>FIGURE 2: FLEXIBLE TUBE INSTALLATION .....</b>	<b>04-3</b>

## Section 04: EXHAUST SYSTEM

### 1. MAINTENANCE

Inspect the exhaust system periodically for restrictions and leaks. Figure 1 presents the major components of the exhaust system. Restrictions such as kinked or crimped pipes result in excessive back pressure which can lead to increased fuel consumption, power loss and possible damage to engine combustion chamber components. Exhaust leaks are commonly the result of loose clamp bolts, corroded pipes or a punctured muffler. In addition to excessive noise, a leaking exhaust system could allow

toxic gases to enter the vehicle. Damage to surrounding components from hot gases could result as well. Replace damaged or corroded exhaust components immediately.

Inspect the exhaust system as follows:

- At vehicle inspection intervals;
- Whenever a change is noticed to the sound the exhaust system makes;
- When components close to the exhaust system get unnaturally dirty.

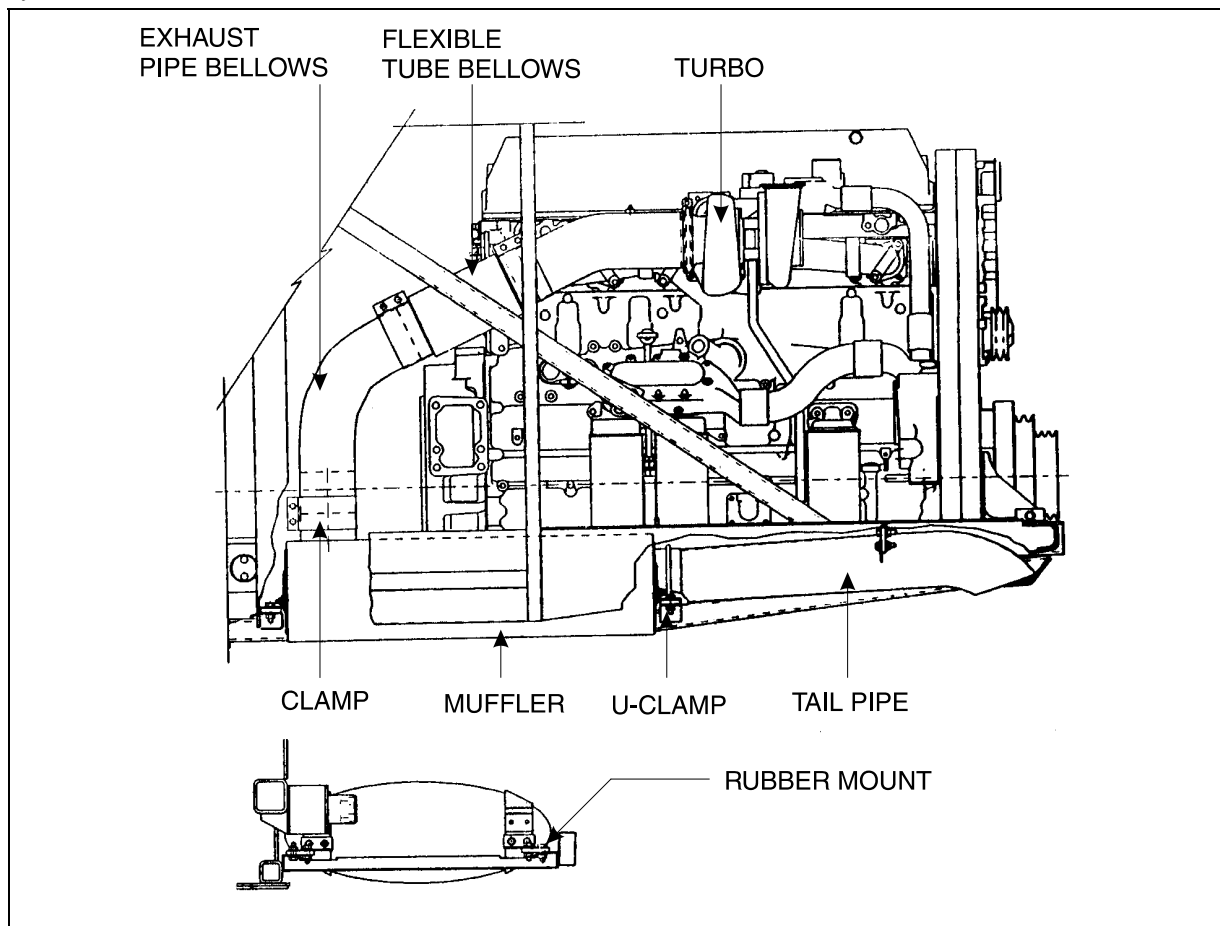

FIGURE 1: EXHAUST SYSTEM

04001

## Section 04: EXHAUST SYSTEM

When operating the engine in a closed area such as a service garage, vent exhaust gases to the outside by means of a shop vent hose placed over the exhaust outlet pipe.

**Warning:** Avoid breathing exhaust gases. Exhaust gases are poisonous and contain carbon monoxide, an odorless and colorless gas that can cause unconsciousness or death. If exhaust gases are suspected of entering the vehicle, the cause(s) must be located and corrected immediately.

### 2. MUFFLER REMOVAL / INSTALLATION

**Warning:** Be sure muffler and components are cold before handling.

1. Remove bolts and clamps securing exhaust pipe bellows to muffler;
2. Support muffler from under vehicle;
3. Remove U-clamp retaining the tail pipe to the frame bracket;
4. Remove tail pipe;
5. Remove the fasteners holding the four rubber mounts to the frame brackets and the fasteners securing the rubber mounts to the muffler brackets;
6. Note: The front retaining bolts are accessible from the L.H. side axle wheel housing;

7. Remove rubber mounts. Lower muffler from under vehicle;
8. Remove attached parts from muffler such as brackets and collar. Inspect and replace if necessary.

Installation is the same as removal.

### 3. FLEXIBLE TUBE INSTALLATION

The flexible exhaust tube contains a rigid interior pipe (Fig. 1). To allow appropriate flexibility for assembly, be sure interior pipe is concentric to flexible part. To maintain the pipe centered at time of installation, insert cardboard spacers as shown (Fig. 2). These spacers may be left in place for they will deteriorate over time.

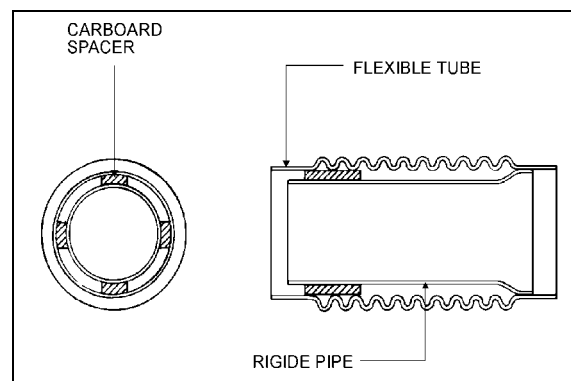

FIGURE 2: FLEXIBLE TUBE INSTALLATION

04003