

CONTENTS

1. TORQUE TABLES	4
Constant-Torque hose clamps - charge air cooler (CAC)	4
Fan bolts	6
Right angle gearbox - Oil level plug	7
Water pump - Body to back cover	8
2. DESCRIPTION	9
3. MAINTENANCE	10
3.1 GENERAL RECOMMENDATIONS	10
4. HOSES	10
4.1 CONSTANT-TORQUE HOSE CLAMPS ON COOLANT LINES –VOLVO D13	10
4.1.1 <i>Installation</i>	11
4.1.2 <i>Maintenance</i>	11
4.2 CONSTANT-TORQUE HOSE CLAMPS ON CHARGE AIR COOLER (CAC).....	11
4.2.1 <i>Maintenance</i>	11
5. THERMOSTAT OPERATION	12
5.1 THERMOSTAT REPLACEMENT	12
5.2 CHECKING THERMOSTAT	12
6. COOLANT	12
6.1 COOLANT LEVEL VERIFICATION	12
6.2 COOLANT LEVEL SENSOR	12
6.3 THAWING COOLING SYSTEM	12
6.4 COOLING SYSTEM RECOMMENDATIONS.....	13
6.5 COOLANT RECOMMENDATIONS FOR VOLVO D13 ENGINE	13
6.6 COOLANT SAMPLING	14
7. DRAINING COOLING SYSTEM	15
8. FILLING COOLING SYSTEM	16
9. FLUSHING	17
9.1 COOLING SYSTEM DESCALERS	17
9.2 REVERSE FLUSHING.....	17
10. SPIN-ON COOLANT FILTER	18
11. RADIATOR	18
11.1 MAINTENANCE.....	19
11.2 RADIATOR REMOVAL & INSTALLATION	19
12. CHARGE AIR COOLER LEAKAGE	21
13. COOLING FAN DRIVE MECHANISM	22
13.1 DRIVE PULLEY AND UNIVERSAL JOINT SHAFT	22
13.2 IDLER REPLACEMENT	22
14. VARIABLE SPEED COOLING FAN	23

- 14.1 LOCKING RADIATOR FAN CLUTCH FOR EMERGENCY OPERATION 23
 - 14.1.1 *Electrical Locking* 23
 - 14.1.2 *Mechanical Locking In Case Of Power Failure* 23
- 14.2 MAINTENANCE..... 24
- 14.3 INSPECTION..... 24
- 14.4 FAN REMOVAL / INSTALLATION..... 24
- 15. FAN RIGHT ANGLE GEARBOX 24**
 - 15.1 MAINTENANCE..... 25
 - 15.2 OIL CHANGE 25
 - 15.3 REMOVAL / INSTALLATION 25
- 16. COOLING FAN DRIVE BELT 26**
 - 16.1 MAINTENANCE..... 26
 - 16.2 MOUNTING THE DRIVE BELT..... 26
- 17. SPECIFICATIONS..... 27**

ILLUSTRATIONS

FIGURE 1: COOLANT SURGE TANK9

FIGURE 2: COOLANT FLOW TO RADIATOR (VOLVO D13)11

FIGURE 3: CONSTANT-TORQUE CLAMP11

FIGURE 4: CHARGE AIR COOLER HOSE CLAMPS11

FIGURE 5: VOLVO D13 THERMOSTAT HOUSING12

FIGURE 6: LOCATION OF HEATER LINE SHUT-OFF VALVES IN ENGINE COMPARTMENT14

FIGURE 7: EXTRACTING COOLANT16

FIGURE 8: COOLANT FILTER (VOLVO D13)18

FIGURE 9: RADIATOR DRAIN PLUG19

FIGURE 10: ACCESS PANEL (TYPICAL)19

FIGURE 11: RADIATOR SEALING FRAME19

FIGURE 12: RADIATOR HOSE CLAMPS20

FIGURE 13: CHARGE AIR COOLER HOSE CLAMPS20

FIGURE 14: UPPER SUPPORT BRACKET & TUBE PROTECTOR20

FIGURE 15: RADIATOR ASSEMBLY LOWER MOUNTING FASTENERS20

FIGURE 16: DISCONNECTING FAN DRIVE SHAFT21

FIGURE 17: POSITIONING FORKLIFT21

FIGURE 18: REMOVING FASTENERS21

FIGURE 19: REMOVING UPPER FAN DRIVE SUPPORT BRACKET21

FIGURE 20: REMOVING FAN SHROUD FROM RADIATOR21

FIGURE 21: COOLING FAN DRIVE MECHANISM22

FIGURE 22: PULLEY AND SHAFT22

FIGURE 23: IDLER MOUNTED ON THE CAST ALUMINUM SUPPORT22

FIGURE 24: MECHANICAL LOCKING24

FIGURE 25: RADIATOR FAN MOUNTING BOLTS24

FIGURE 26: RIGHT ANGLE GEARBOX25

FIGURE 27: RIGHT ANGLE GEARBOX25

FIGURE 28: RIGHT ANGLE GEARBOX25

FIGURE 29: DRIVE BELT ROUTING (VOLVO D13 ENGINE)26

1. TORQUE TABLES

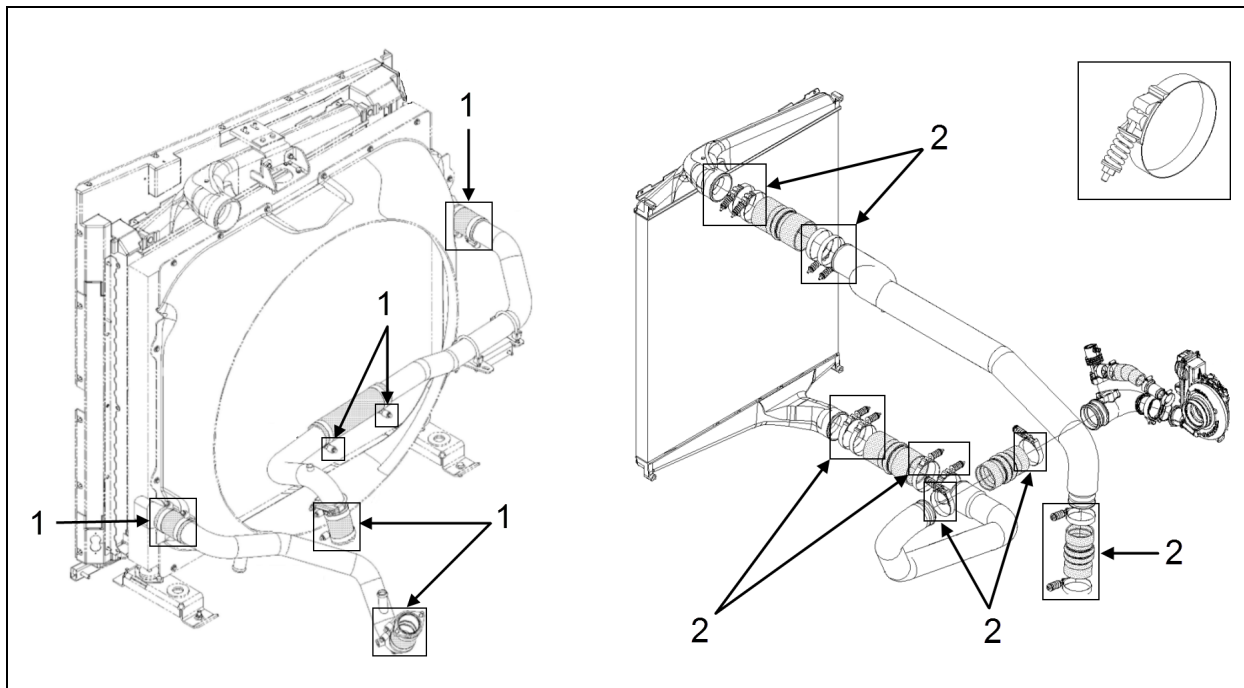

HOSE CLAMPS

No	DESCRIPTION	TORQUE
1	Constant-Torque hose clamps - coolant lines (2.5in O.D)	90-100 lb-in (10-11 Nm)
2	Constant-Torque hose clamps - charge air cooler (CAC)	4.5-5.5 lb-ft (6.1-7.46 Nm)

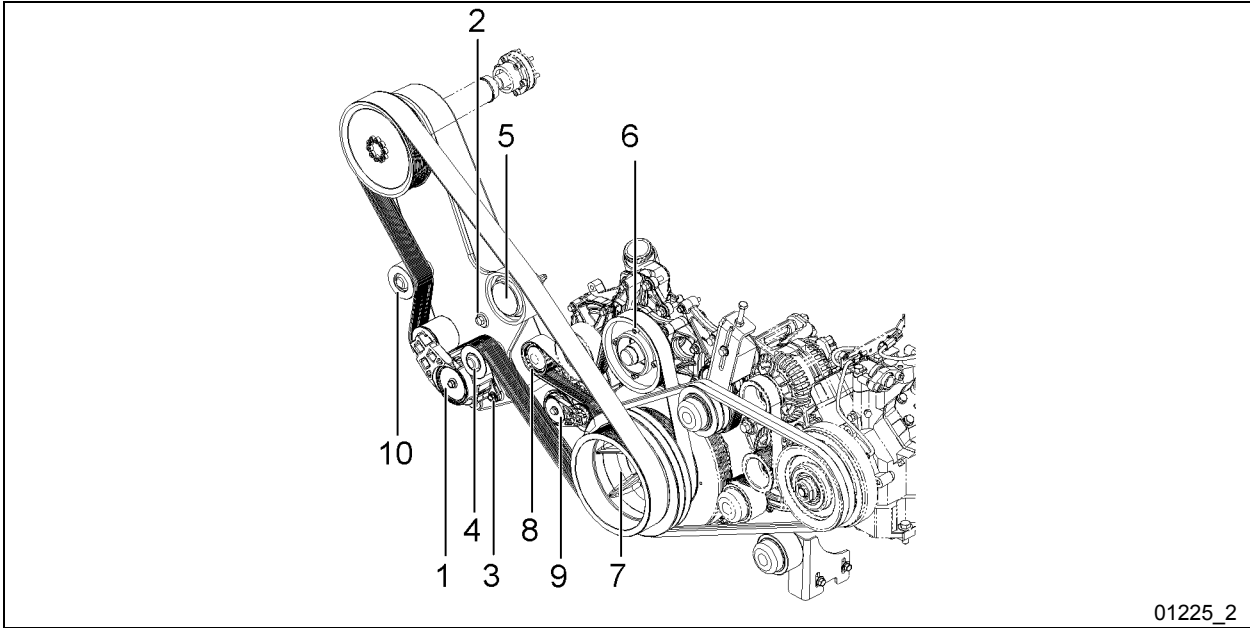

01225_2

PULLEY, IDLERS & TENSIONERS

No	DESCRIPTION	TORQUE
1	Automatic belt tensioner bolt – cooling fan	32 lb-ft (43 Nm)
2	Fan drive support (casting)	60 lb-ft (81 Nm)
3	Automatic belt tensioner 2 nd bolt	32 lb-ft (43 Nm)
4	Lower idler bolt – fan belt	32 lb-ft (42 Nm)
5	Upper idler bolt – fan belt	32 lb-ft (43 Nm)
6	Water pump idler pulley bolts	16 lb-ft (22 Nm)
7	Crank pulley bolts – cooling fan	22 lb-ft (30 Nm)
8	Idler bolt – water pump	43 lb-ft (58 Nm)
9	Automatic belt tensioner bolt – water pump	48 lb-ft (65 Nm)
10	idler bolt – fan belt	32 lb-ft (43 Nm)

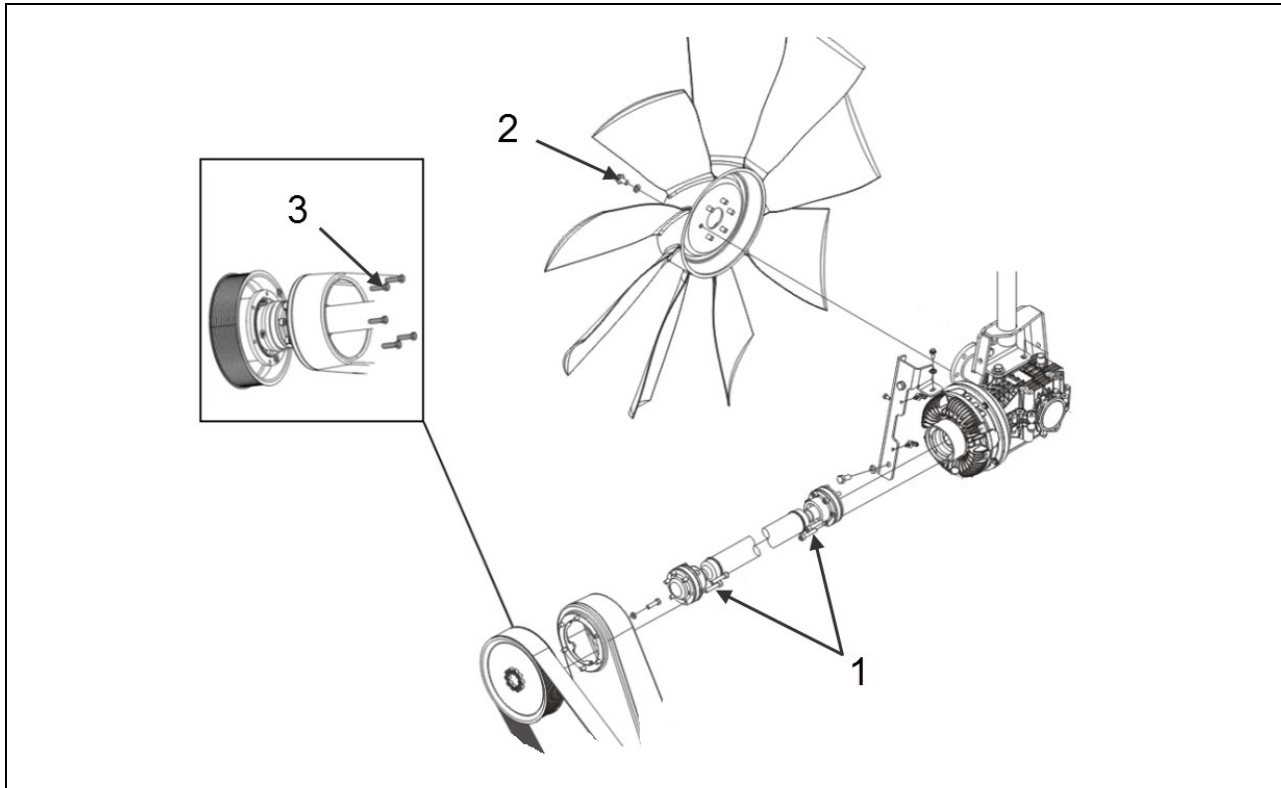

COOLING FAN DRIVE MECHANISM

No	DESCRIPTION	TORQUE
1	Shaft – universal joint bolts	16-18 lb-ft (22-24 Nm)
2	Fan bolts	32 lb-ft (43 Nm)
3	Fan pulley hub to bracket	16 lb-ft (22 Nm)

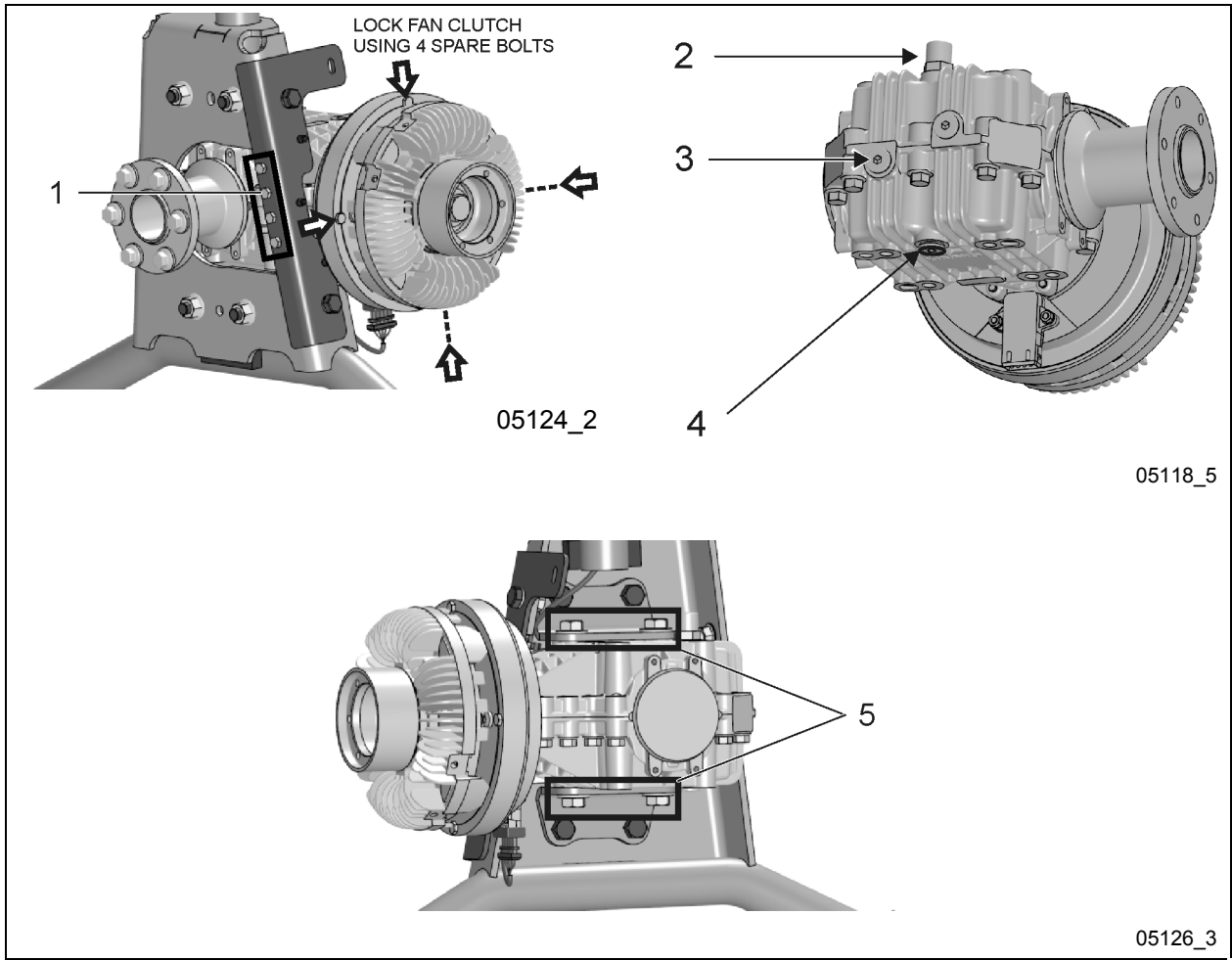

RIGHT ANGLE GEARBOX

No	DESCRIPTION	TORQUE
1	Spare bolts (when used to lock fan clutch)	7.5 lb-ft (10 Nm)
2	Right angle gearbox - Oil fill plug	5.4-6.6 lb-ft (7.32-8.95 Nm)
3	Right angle gearbox - Oil level plug	24-28 lb-ft (33-38 Nm)
4	Right angle gearbox - Oil drain plug	24-28 lb-ft (33-38 Nm)
5	Right angle gearbox mounting bolts	53-65 lb-ft (72-88 Nm)

SECTION 05b: X3 SERIES COOLING SYSTEM

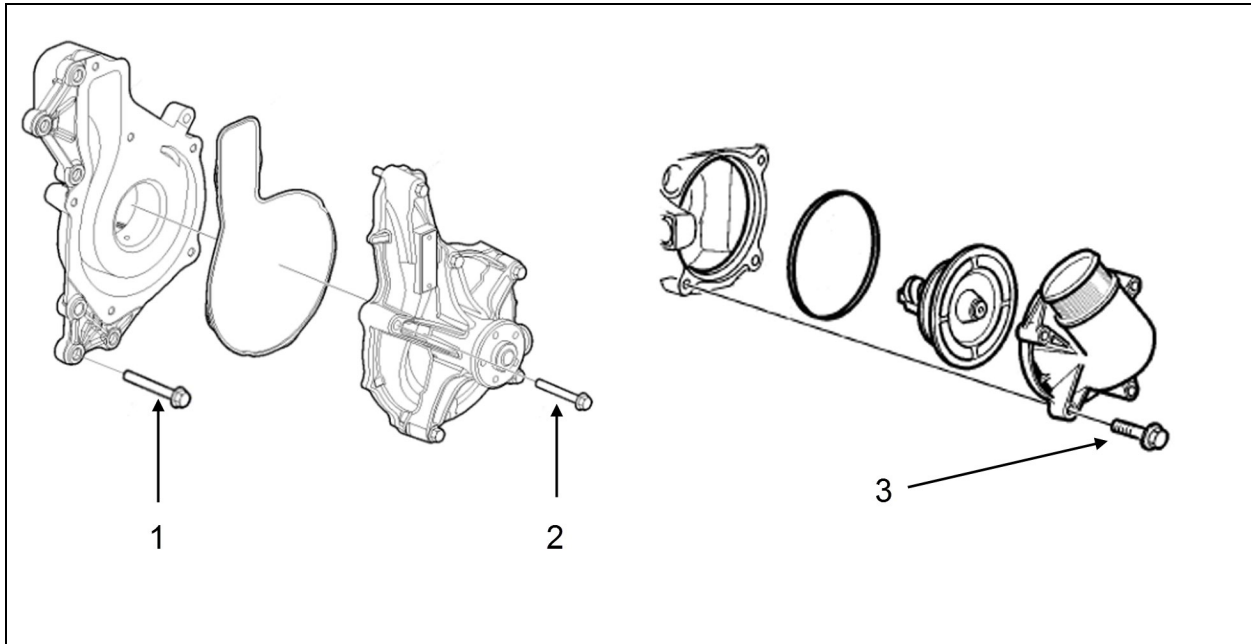

MISCELLANEOUS

No	DESCRIPTION	TORQUE
1	Water pump - Back cover to engine	29-41 lb-ft (39-56 Nm)
2	Water pump - Body to back cover	15-21 lb-ft (20-28 Nm)
3	Thermostat housing bolts	15-21 lb-ft (20-28 Nm)

2. DESCRIPTION

A radiator and thermo-modulated fan are used to effectively dissipate the heat generated by the engine. A centrifugal-type water pump is used to circulate the engine coolant.

One full blocking-type thermostat is used in the water outlet passage to control the flow of coolant, providing fast engine warm-up and regulating coolant temperature.

The engine coolant is drawn from the lower portion of the radiator by the water pump and is forced through the transmission cooler before going through the oil cooler and into the cylinder block.

From the cylinder block, the coolant passes up through the cylinder head and, when the engine is at normal operating temperature, it goes through the thermostat housing and into the upper portion of the radiator. The coolant then passes through a series of tubes where its heat is dissipated by air streams created by the revolving fan and the motion of the vehicle.

Upon starting a cold engine or when the coolant is below normal operating temperature, the closed thermostat directs coolant flow from the thermostat housing through the by-pass tube to the water pump. Coolant is recirculated through the engine to aid engine warm up.

When the thermostat opening temperature is reached, coolant flow is divided between the radiator inlet and the by-pass tube. When the thermostat is completely open, all of the coolant flow is to the radiator inlet.

The cooling system is filled with a funnel through a pressure & filler cap on the surge tank (Figure 1), the cap is also used to maintain pressure within the system. When system exceeds normal pressure rating (14 psi - 96.53 kPa), the cap releases air and if necessary, coolant through the overflow tube (Figure 1). The thermostat is located in the housing bolted to the engine on the L.H. side.

The engine cooling system also provides hot coolant fluid for the vehicle heating system. Refer to section 22, "HEATING AND AIR CONDITIONING" in this manual for information relating to heating system water circulation.

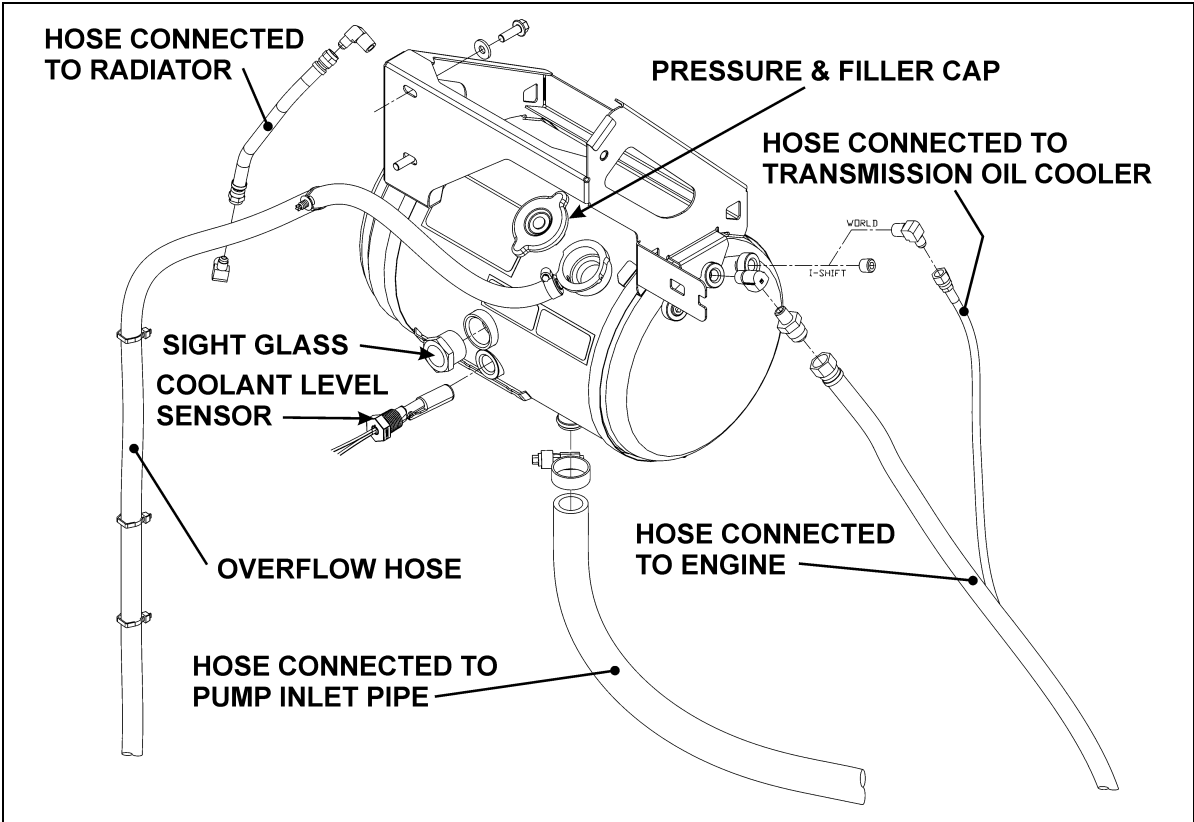

FIGURE 1: COOLANT SURGE TANK

05132

3. MAINTENANCE

3.1 GENERAL RECOMMENDATIONS

A systematic routine inspection of cooling system components is essential to ensure maximum engine and heating system efficiency.

- Check coolant level in the surge tank daily, and correct if required. Test antifreeze strength.
- Check belts for proper tension; adjust as necessary and replace any frayed or badly worn belts.
- Check radiator cores for leaks and make sure the cores are not clogged with dirt or insects. To avoid damaging the fins, clean cores with a low-pressure air hose. Steam clean if required.
- Inspect the water pump operation. A leaky pump sucks in air, increasing corrosion.
- Repair all leaks promptly. Unrepaired leaks can lead to trouble. Inspect and tighten radiator mounts periodically. Test and replace thermostat regularly.

NOTE

In order to ensure the integrity of the system, it is recommended that a periodic cooling system pressure check be made. Pressurize the cooling system to 103-138 kPa (15-20 psi) using Radiator and Cooling System Tester, J24460-1. Do not exceed 138 kPa (20 psi).

Any measurable drop in pressure may indicate a leak. Whenever the oil pan is removed, the cooling system should be pressure checked as a means of identifying any incipient coolant leaks. Make sure the cause of the internal leak has been corrected before flushing the contaminated system.

Leaks at the thermostat housing hose connections may be caused by deformation of connections or by rough surfaces on the castings of the hose mounting surfaces. It is recommended that "Dow Corning RTV-102 Compound" or any equivalent product be applied on cast surfaces prior to hose installation.



CAUTION

Castings should be clean and free of oil and grease before applying compound. No other sealer should be used with RTV-102 compound.

NOTE

For additional information concerning Volvo D13 engine components or engine-related components, consult Volvo Trucks Canada or Volvo Trucks North America Web Site under: Parts & Service. On Volvo web site, you will find detailed service procedures for parts replacement, repair and maintenance.

4. HOSES

Rotten, swollen, and worn out hoses or loose connections are frequent causes of cooling system problems.

Serious overheating is often caused by an old hose collapsing or from rotten rubber shedding from hoses and clogging the coolant passages.

Connections should be inspected periodically and hose clamps tightened. Replace any hose found to be cracked or swollen.

When installing a new hose, clean pipe connections and apply a thin layer of a non-hardening sealing compound. Replace worn out clamps or clamps that pinch hoses.

4.1 CONSTANT-TORQUE HOSE CLAMPS ON COOLANT LINES –VOLVO D13

All hose clamps of 1 3/8" ID and over, used on the heating and cooling systems, are of the "Constant-torque" type. These clamps are worm-driven, made of stainless steel, and supplied with a series of Belleville spring washers. They also feature an extended integral liner that covers the band slots to protect soft/silicone hoses from damage, and help maintain consistent sealing pressure.

This type of clamp is designed to automatically adjust its diameter to compensate for the normal expansion/contraction of a hose and metal connection that occurs during vehicle operation and shutdown. The constant-torque clamp virtually eliminates coolant losses due to "Cold flow" leakage and greatly minimizes clamp maintenance.

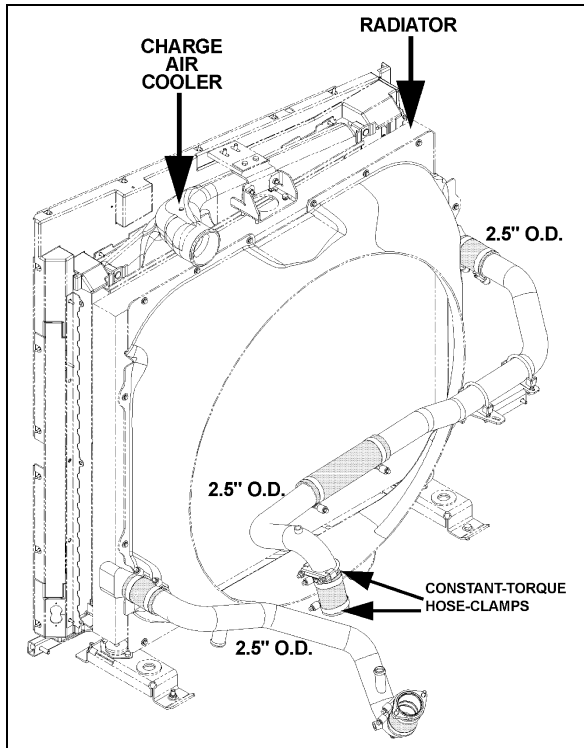

FIGURE 2: COOLANT FLOW TO RADIATOR (VOLVO D13)

4.1.1 Installation

A torque wrench should be used for proper installation. The Belleville spring washer stacks should be nearly collapsed flat and the screw tip should extend 1/4" (6 mm) beyond the housing (FIGURE 3).

TORQUE: 90-100 lb-in (10-11 Nm)

CAUTION

The hose clamps will break if over-torqued. Do not over-tighten, especially during cold weather when hose has contracted.

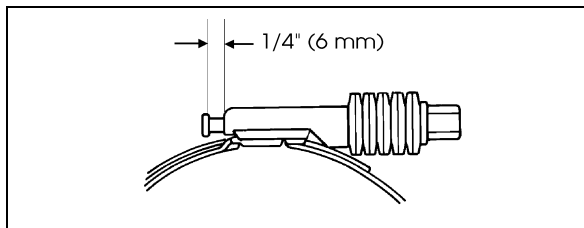

FIGURE 3: CONSTANT-TORQUE CLAMP 05037

4.1.2 Maintenance

The constant-torque clamps contain a "Visual torque check" feature. When the tip of the screw

is extending 1/4" (6 mm) out of the housing, the clamp is properly installed and maintains a leak-proof connection. Since the constant-torque clamp automatically adjusts to keep a consistent sealing pressure, there is no need to re-torque hose clamps on a regular basis. During vehicle operation and shutdown, the screw tip will adjust according to the temperature and pressure changes.

Checking for proper torque should be done at room temperature.

4.2 CONSTANT-TORQUE HOSE CLAMPS ON CHARGE AIR COOLER (CAC)

If for any reason hose clamps need to be replaced; install and tighten hose clamps to specified torque (dry) (Figure 4).

TORQUE: 4.5-5.5 lb-ft (6.1-7.46 Nm)

CAUTION

The hose clamps will break if over-tighten. Do not over-tighten, especially during cold weather when hose has contracted.

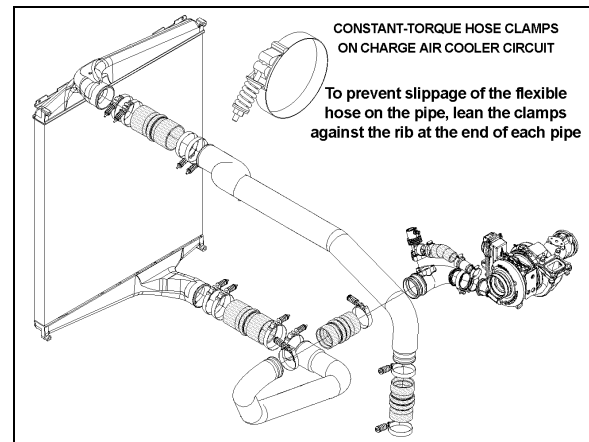

FIGURE 4: CHARGE AIR COOLER HOSE CLAMPS

4.2.1 Maintenance

Since the constant-torque clamp automatically adjusts to keep a consistent sealing pressure, there is no need to torque hose clamps on a regular basis. During vehicle operation and shutdown, the screw tip will adjust according to the temperature and pressure changes.

Checking for proper torque should be done at room temperature.

5. THERMOSTAT OPERATION

5.1 THERMOSTAT REPLACEMENT

1. Drain the cooling system.
2. Remove the bolts, the thermostat housing and the thermostat. Carefully clean the thermostat seat and all cylinder head-to-thermostat housing mating surfaces.

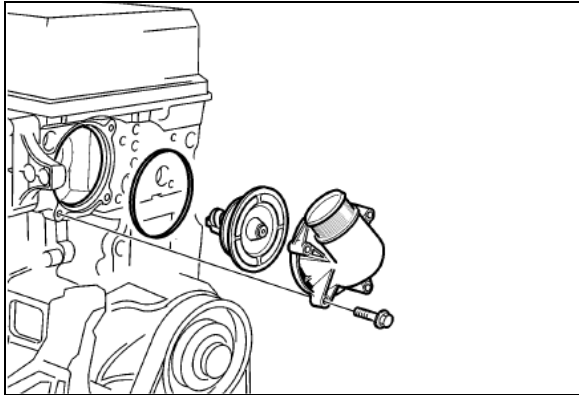

FIGURE 5: VOLVO D13 THERMOSTAT HOUSING

3. Install the new thermostat. Make sure that the rubber seal remains properly seated.
4. Position the thermostat housing to the cylinder head, install the bolts and tighten.

TORQUE: 15-21 lb-ft (20-28 Nm)

5. Install the rubber radiator hose to the thermostat housing. Position the clamp and tighten to secure.
6. Fill the system with the recommended coolant.
7. Start the engine, check for leaks and proper operation. After shutdown, replenish fluids as necessary.

5.2 CHECKING THERMOSTAT

A function check must be carried out before installing a new thermostat.

NOTE

Check to be sure that the thermostat closes fully. This can be done by holding it up to the light to check that there is no visible gap at the opening point. If the thermostat does not close properly, replace it.

1. Warm up water in a receptacle to 75°C (167°F) and immerse the thermostat in the water. Use a piece of wire attached to the thermostat.

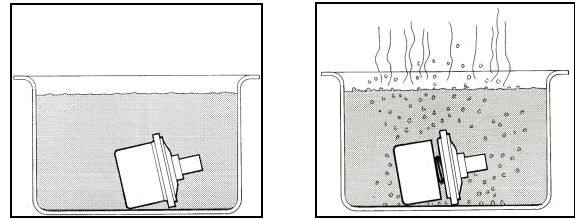

2. After at least 30 seconds, check that the thermostat is still closed.
3. Now warm the water to 100°C (212°F). After at least 30 seconds at the boiling point, check that the thermostat has opened at least 7mm (9/32in). If the thermostat has not opened, it must be replaced. A good thermostat starts to close at 95°C (203°F) and is fully closed at approximately 85°C (185°F).

6. COOLANT

6.1 COOLANT LEVEL VERIFICATION

Coolant level is correct when cold coolant is visible through the surge tank sight glass (Figure 1). If coolant level is low, fill cooling system.

6.2 COOLANT LEVEL SENSOR

This warning device consists of a fluid level probe mounted on the surge tank. The probe sends a signal to the engine control module to indicate coolant level. If the coolant level drops below the probe, the "Check Engine" light flashes and a diagnostic code is registered (see section 01 "ENGINE").



CAUTION

Do not run engine with the "Check Engine" light flashing.

The level probe is mounted on the front of the surge tank.

6.3 THAWING COOLING SYSTEM

If the cooling system becomes frozen solid, place the coach in a warm area until the ice is completely thawed.



CAUTION

Under no circumstances should the engine be operated when the cooling system is frozen, as it will result in engine overheating due to insufficient coolant.

Once thawed, check engine, radiator and related components for damage caused by expansion of frozen coolant fluid.

6.4 COOLING SYSTEM RECOMMENDATIONS

Always maintain cooling system at the proper coolant level. Check daily.

The cooling system must be pressurized to prevent localized boiling of coolant. The system must be kept clean and leak-free. The filler and pressure caps must be checked periodically for proper operation.

The coolant provides a medium for heat transfer and controls the internal temperature of the engine during operation. In an engine having proper coolant flow, some of the combustion heat is conveyed through the cylinder walls and the cylinder head into the coolant. Without adequate coolant, normal heat transfer cannot take place within the engine, and engine temperature rapidly rises. Coolant must therefore be carefully selected and properly maintained.

Select and maintain coolant in order to meet the following basic requirements:

- Provide for adequate heat transfer.
- Provide protection from cavitation damage.
- Provide a corrosion and erosion resistant environment within the cooling system.
- Prevent formation of scale or sludge deposits in the cooling system.
- Be compatible with the cooling system hose and seal materials.
- Provide adequate freeze protection during cold weather operation.

When freeze protection is required, a mixture of suitable water and antifreeze containing adequate inhibitors will provide a satisfactory coolant fluid.

Freeze protection down to:	percentage of antifreeze in mixture
-13°F (-25°C)	40%
-22°F (-30°C)	46%
-36°F (-38°C)	54%
-51°F (-46°C)	60%

6.5 COOLANT RECOMMENDATIONS FOR VOLVO D13 ENGINE

Coolant mixture consisting of 50/50 antifreeze and deionized water solution should be used year-round to provide freeze and boil-over protection as well as providing a stable environment for seals and hoses.

When topping up coolant, use the same coolant mixture type as the mixture already in the cooling system. Do not mix two different types of coolant.

Do not use antifreeze formulated for automobile gasoline engines, these have a very high silicate content that will clog the radiator and leave unwanted deposits in the engine.

A decal (053487) located on the surge tank provides information on recommended coolants.

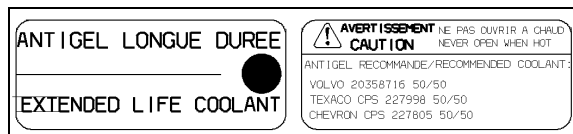

Recommended coolants for Volvo D13 engine:

- Prevost #685241 (pre-diluted 50/50 mixture);
- Texaco CPS#227998 (pre-diluted 50/50 mixture);
- Chevron CPS#227805 (pre-diluted 50/50 mixture);
- Volvo 20358716 (pre-diluted 50/50 mixture);



CAUTION

On Volvo D13 engine, use **only** Extended Life Coolant (ELC). **Do not** add supplemental coolant additives (SCA) to extended life coolant. **Do not** use a coolant filter containing Supplemental Coolant Additives (SCA).



CAUTION

Extended Life Coolant (ELC) will test as out of additives (SCA), but SCA should not be added. Shortened engine life may be the result of adding SCA.

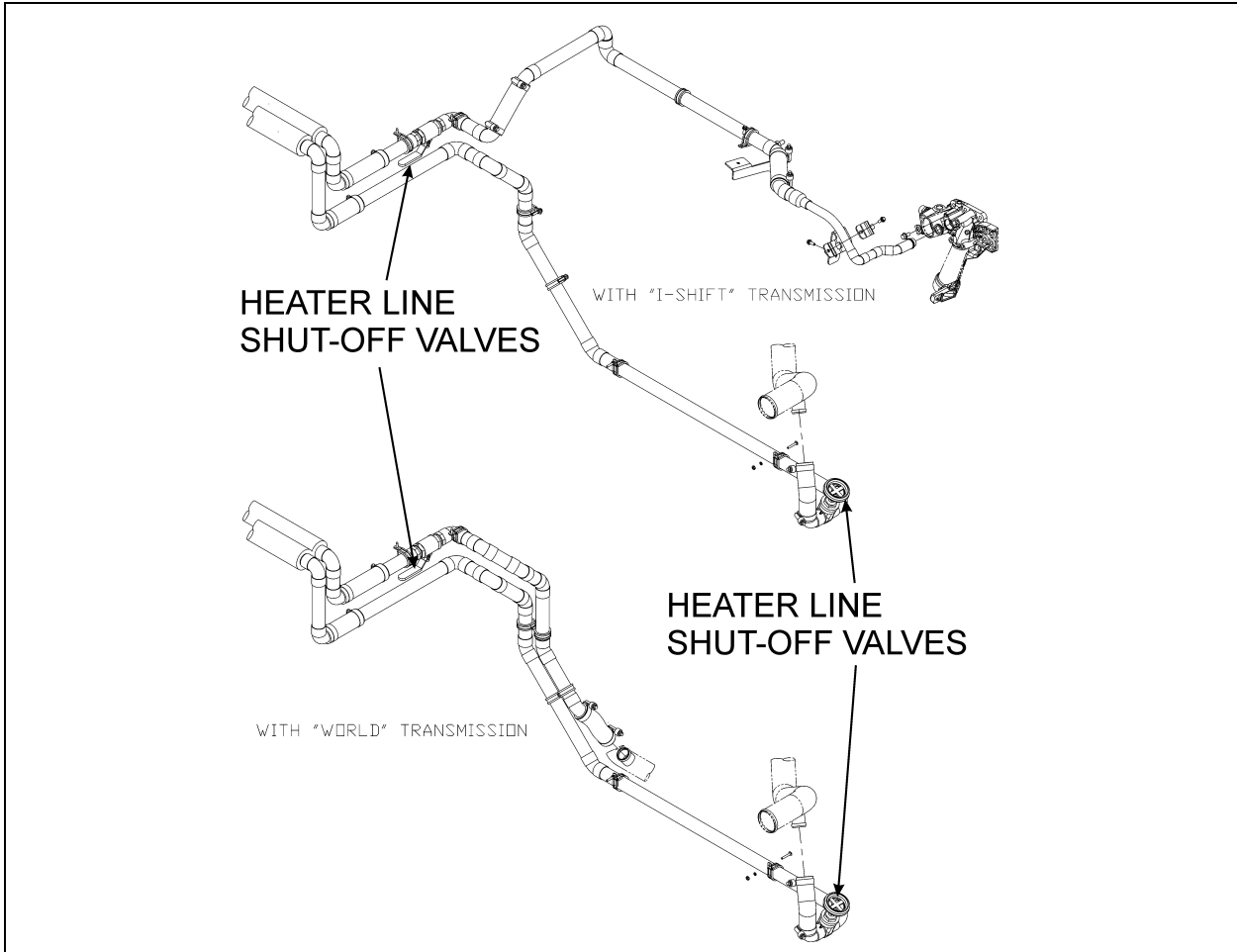

FIGURE 6: LOCATION OF HEATER LINE SHUT-OFF VALVES IN ENGINE COMPARTMENT

05105

6.6 COOLANT SAMPLING

Providing a sample of coolant for lab analysis may be required at some point in the life of the vehicle.

NOTE

The following procedure is provided for reference only.

Instructions coming with the laboratory test kit take precedence over this procedure.



WARNING

Before proceeding with the following steps, make sure the coolant has cooled down. The sudden release of pressure from a heated cooling system can result in loss of coolant and possible personal injury (scalding) from the hot liquid.

Sampling should be performed on a *cold engine*.

Typical material required:

- Hand Vacuum Pump w/ bottle provision

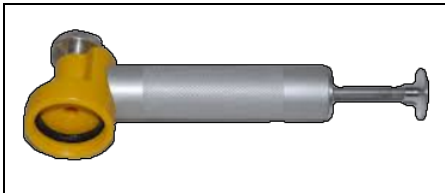

- Sample bottle
- Plastic tube (1/4 "refrigerator" tube)
- Nitrile gloves
- Security glasses
- Shop Towels

NOTE

Watch out for accidental contamination!

Hand vacuum pump should be used for coolant sampling only to prevent cross-contamination.

Also, ensure cleanliness throughout this procedure to make sure the coolant sample is not contaminated accidentally.

Sampling should be performed on the surge tank, on a cold engine.

If the vehicle has been standing still for a significant period, drive it around 30 min up to normal operating temperature. Then let it cool down.

1. Pull the pressure cap off the surge tank. Refer to Figure 1 for location of cap.
2. Thread the sample bottle to the pump. Hand tighten.
3. Slide the plastic tubing in the fitting on the pump until it exceeds about 1/2 inch into pump cavity.
4. Insert tube in the surge tank about half way to the bottom. (Do not draw sample in the bottom of the surge tank.)
5. Pump until sample bottle is about 2/3 full. Do not overfill.
6. Loosen pump fitting to remove tube from pump. Allow any coolant in the tube to flow in the bottle.
7. Remove sample bottle and install cap.

8. Throw plastic tube away. (Not to be re-used)
9. Complete any forms required by the laboratory.

7. DRAINING COOLING SYSTEM

Use the following procedures to drain the cooling system partially or completely.

To drain engine and related components:

1. Stop engine and allow engine to cool. Close both heater line shutoff valves.

On X3- 45 coaches & VIP, and also on XLII Entertainer Bus Shells, the valves are located in the engine compartment. One is located under the radiator fan drive mechanism support; another valve is on the L.H. side of the engine compartment in front of the radiator (Figure 6).

NOTE

Refer to section 22 under "Preheating System" for information about preheater access and heater line shutoff valve.

MAINTENANCE

Cooling system

Drain, flush, thoroughly clean and refill the system at the intervals specified by the Lubrication And Servicing Schedule in Section 24: LUBRICATION & SERVICING.

When using ELC, **do not** use a filter that contains Supplemental Coolant Additives (SCA).

WARNING

Before proceeding with the following steps, make sure the coolant has cooled down. The sudden release of pressure from a heated cooling system can result in loss of coolant and possible personal injury (scalding) from the hot liquid.

2. Close the shut-off valve on the coolant filter mounting head and remove filter (perform only if filter as to be replaced).
3. Open the shut-off valve on the coolant filter mounting head and drain the coolant into a suitable container. Close the shut-off valve.

4. Unscrew the surge tank pressure cap counterclockwise, $\frac{1}{4}$ turn to let air enter the system and permit the coolant to drain completely from system.
5. Connect coolant extractor (Figure 7). Use coolant extractor to drain the coolant from the engine. An alternate method is to drain the coolant into a suitable container using the drain hose.

**DANGER**

Coolant is toxic; risk of poisoning. Do not drink coolant. Use proper hand protection when handling. Keep coolant out of reach of children and animals. Failure to follow these precautions can cause serious illness or death.

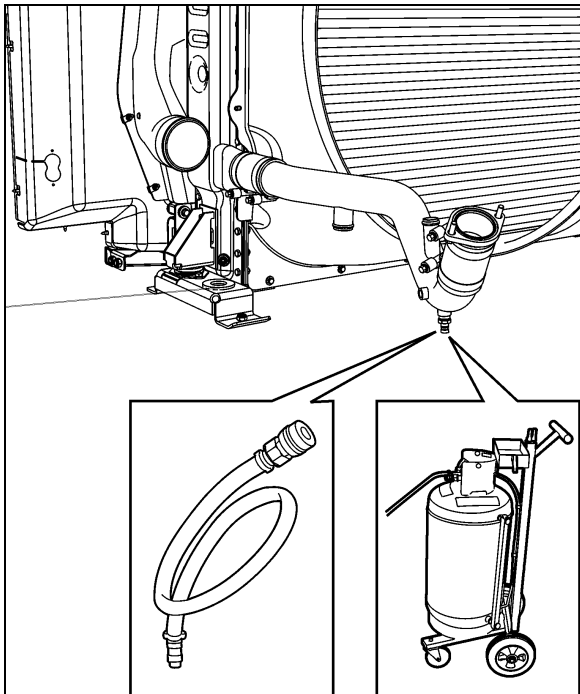

FIGURE 7: EXTRACTING COOLANT

05093

6. Open the radiator drain cock.
7. Remove the transmission oil cooler. Drain, flush and inspect. Refer to Section 7, "TRANSMISSION" for oil cooler maintenance or preventive replacement.

**CAUTION**

Drain water pump completely before extended storage to avoid possible water pump damage.

If freezing weather is anticipated and the engine is not protected with antifreeze, drain the cooling system completely when vehicle is not in use. Trapped water in the cylinder block, radiator or other components may freeze and expand resulting in damages. Leave the drain plugs open until the cooling system can be filled with coolant fluid. Do not run engine with cooling system empty.

To drain the entire system, do the previous steps while maintaining the shutoff valves in the open position; then follow the procedure under "Draining Heating System" in Section 22.

8. FILLING COOLING SYSTEM

If only the engine and related components were drained, maintain the two heater line shutoff valves in their closed position, then proceed as follows:

1. Close radiator drain cock.
2. Open the shut-off valve on the coolant filter mounting head.
3. Refill cooling system from the surge tank filler cap inlet with the recommended ethylene glycol-based antifreeze and water solution of the required concentration using the coolant extractor.

NOTE

Make sure the purge lines are properly connected and not obstructed. The purge lines (thermostat housing dome, radiator top tank, transmission oil cooler or delivery line) are required to ensure complete engine fill and proper purging of air in the system.

NOTE

The coolant level should remain within two inches of the surge tank filler neck.

4. Install the filler and pressure cap, then start the engine and run it at fast idle until reaching normal operating temperature. Check for leaks.

NOTE
 If for any reason, the coolant level drops below the surge tank level probe, the Check Engine warning light will illuminate.

5. Stop engine and allow cooling.
6. Open the two heater line shutoff valves, check the coolant level in the surge tank, and then add as required.

 **CAUTION**
 Never pour cold coolant into a hot engine. The sudden change in temperature may crack the cylinder head or block.

If the entire system has been drained, redo the previous steps while maintaining the two heater line shutoff valves in the "Open" position. With engine running, activate the driver's and central heating systems to permit coolant circulation. Complete the procedure by bleeding the heater cores as explained in Section 22, under "Bleeding Heating System".

9. FLUSHING

If the cooling system is contaminated, flush the cooling system as follows:

1. Drain the coolant from the engine.
2. Refill with clean water.

 **CAUTION**
 If the engine is hot, fill slowly to prevent rapid cooling and distortion of the engine castings.

3. To thoroughly circulate the water, start and run the engine for 15 minutes after the thermostats have opened.
4. Fully drain system.
5. Refill with clean water and operate for 15 minutes after the thermostats have opened.
6. Stop engine and allow cooling.
7. Fully drain system.

Vehicles without coolant filters:

Fill with a 50/50-antifreeze/water solution and add required inhibitors.

Vehicles with coolant filters:

Fill with a 50/50-antifreeze/water solution. Replace coolant filter as per the Lubrication and Servicing Schedule in section 24 if required.

Dispose of spent fluids in an environmentally responsible manner according to regulations in effect in your area.

COOLING SYSTEM (approximation)	SYSTEM	CAPACITY
Includes heating system: 24 US gal (91 liters)		

9.1 COOLING SYSTEM DESCALERS

If the engine overheats and the fan belt tension, coolant level and thermostat operation have been found to be satisfactory, it may be necessary to de-scale and flush the entire cooling system.

Remove scale formation by using a reputable and safe de-scaling solvent. Immediately after using the de-scaling solvent, neutralize with a neutralizing agent. It is important that product directions be thoroughly read and followed.

After using the solvent and neutralizer, fully drain the system, and then reverse flush the engine and radiator (see "Reverse Flushing" in this section) before filling the system with coolant solution.

9.2 REVERSE FLUSHING

After the engine and radiator have been thoroughly de-scaled, they should be reverse-flushed. The water pump should be removed and the radiator and engine reverse-flushed separately to prevent dirt and scale deposits from clogging the radiator tubes or being forced through the pump. Reverse flushing is accomplished by hot water, under pressure, being forced through the cooling system in a direction opposite to the normal flow of coolant, loosening and forcing deposits out.

The radiator is reverse flushed as follows:

1. Remove the radiator inlet and outlet hoses and replace existing radiator cap with a new one.
2. Attach a hose to the top of the radiator to lead water away from the engine.
3. Attach a hose at the bottom of the radiator and insert a flushing gun in the hose.

- Connect the water hose of the gun to the water outlet and the air hose to the compressed air outlet.
- Turn on the water and when the radiator is full, turn on the air in short blasts, allowing the radiator to fill between blasts.

NOTE

Apply air gradually. Do not exert more than 138 kPa (20 psi) air pressure. Too great a pressure may rupture a radiator tube.

- Continue flushing until only clean water is expelled from the radiator.

The cylinder block and cylinder head water passages are reverse flushed as follows:

- Remove the thermostats and the water pump.
- Attach a hose to the water inlet of oil cooler housing to drain water away from engine.
- Attach a hose to the water outlet at the top of the cylinder head (thermostat housing) and insert the flushing gun in the hose.
- Turn on the water until the jackets are filled, and then turn on the air in short blasts. Allow jackets to fill with water between air blasts.
- Continue flushing until the water from the engine runs clean.

If scale deposits in the radiator cannot be removed by chemical cleaners or reverse flushing as outlined above, it may be necessary to remove the upper tank and rod out the individual radiator tubes with flat steel rods. Circulate the water through the radiator core from the bottom to the top during this operation.

10. SPIN-ON COOLANT FILTER

The optional engine cooling system filter is used to filter out impurities such as scale or sand from the coolant and it also eliminates the process of adding inhibitors to the antifreeze/water solution. The filter is mounted onto the cooling fan drive mechanism aluminum casting (Figure 8).

To replace a filter:

- Close the filter shutoff cock on the filter mounting head and unscrew the old filter from mounting.

**WARNING**

Failure to relieve cooling system pressure may result in personal injury.

- Remove and discard the filter. Recover the coolant remaining in the filter with a suitable container.
- Clean the filter adapter with a clean, lint-free cloth.
- Coat surface of gasket with clean antifreeze, tighten 2/3 to 1 turn after gasket makes contact with head.
- Open the filter shutoff cock.
- Start engine and check for leaks.

**CAUTION**

Do not exceed recommended service intervals.

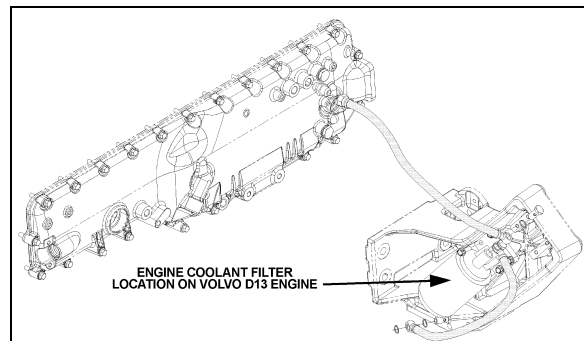

FIGURE 8: COOLANT FILTER (VOLVO D13)

05145

**MAINTENANCE****Coolant filter**

Replace the coolant filter cartridge at the intervals specified by the Lubrication And Servicing Schedule in Section 24: LUBRICATION & SERVICING.

11. RADIATOR

The radiator is mounted on the L.H. side of engine compartment. It is designed to reduce the temperature of the coolant under all operating conditions. It is essential that the radiator core be kept clean and free from corrosion and scale at all times.

11.1 MAINTENANCE



MAINTENANCE

Inspect the exterior of the radiator core at the intervals specified by the Lubrication And Servicing Schedule in Section 24: LUBRICATION & SERVICING. Clean with a quality grease solvent, such as a mineral spirits and dry with compressed air. Do not use fuel oil, kerosene, gasoline, or any caustic material. It may be necessary to clean the radiator more frequently if the vehicle is operated in extremely dusty or dirty areas. Refer to coolant system flushing and reverse flushing in this section for maintenance of radiator interior.

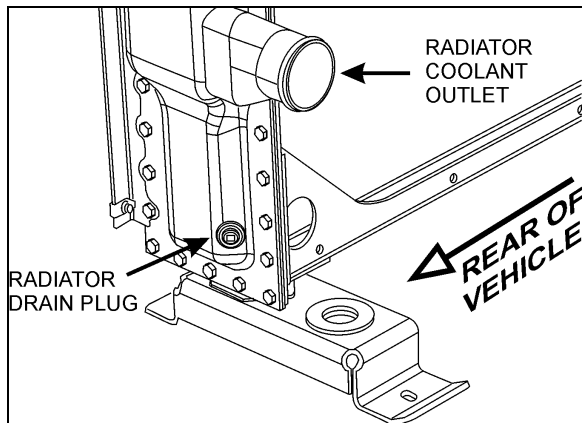

FIGURE 9: RADIATOR DRAIN PLUG

05139

11.2 RADIATOR REMOVAL & INSTALLATION

1. Apply the parking brake and shift the transmission to neutral. Shut off all electrical loads. Turn the ignition key to the OFF position.
2. Open engine compartment doors.
3. Set starter selector switch to the OFF position.
4. Connect coolant extractor (Figure 7). Use coolant extractor to drain the coolant from the engine. An alternate method is to drain the coolant into a suitable container using the drain hose.
5. Raise L.H. side hinged rear fender.
6. Remove tag axle L.H. side wheel.

**DANGER**

Coolant is toxic; risk of poisoning. Do not drink coolant. Use proper hand protection when handling. Keep coolant out of reach of children and animals. Failure to follow these precautions can cause serious illness or death.

7. Unfasten 4 cap screws and remove access panel located behind tag axle L.H. side wheel (refer to figure 10).

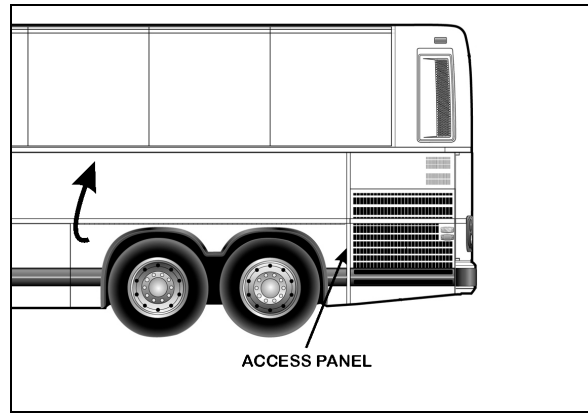

FIGURE 10: ACCESS PANEL (TYPICAL)

8. Open radiator door to access radiator assembly. Unfasten upper arm assembly.
9. Remove radiator sealing frame.

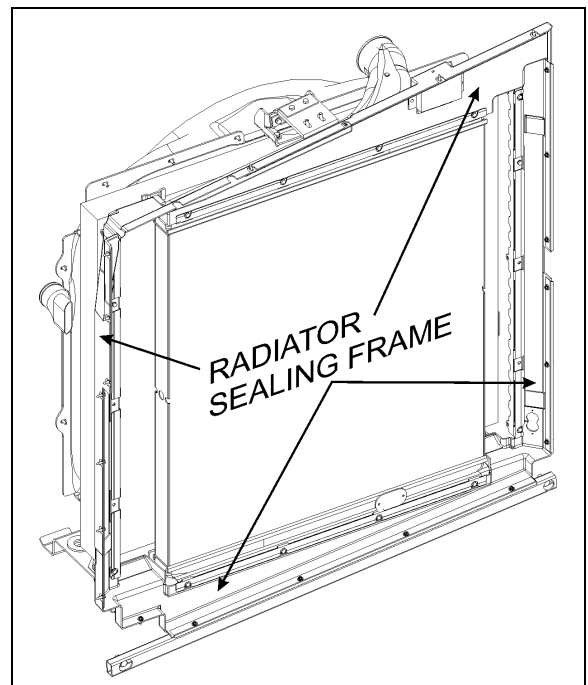

FIGURE 11: RADIATOR SEALING FRAME

10. Remove clamps and then break hoses from the front coolant and charge air pipes (Figure 12 & Figure 13).

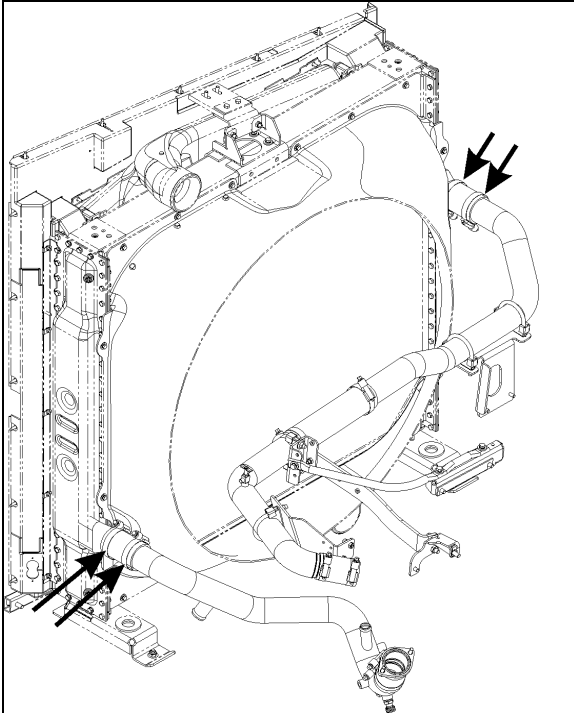

FIGURE 12: RADIATOR HOSE CLAMPS

11. Remove rear coolant and charge air hose clamps then break hoses loose (Figure 12 & Figure 13).

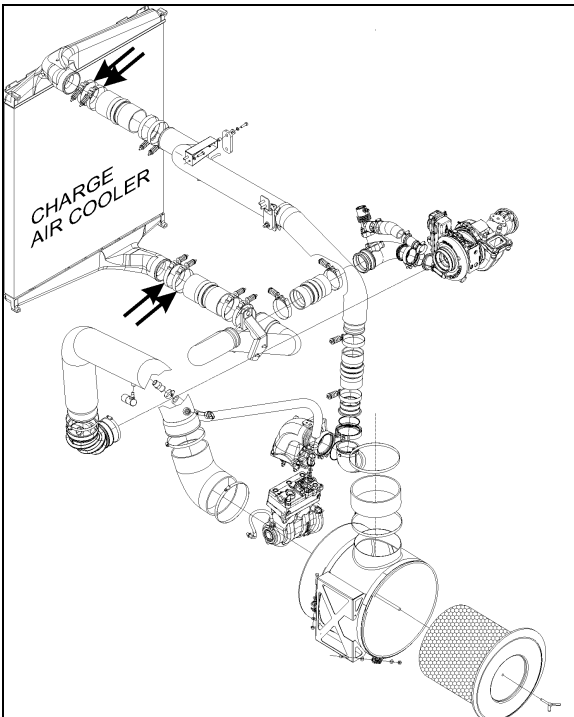

FIGURE 13: CHARGE AIR COOLER HOSE CLAMPS

12. Remove the upper radiator assembly support bracket (Figure 14).

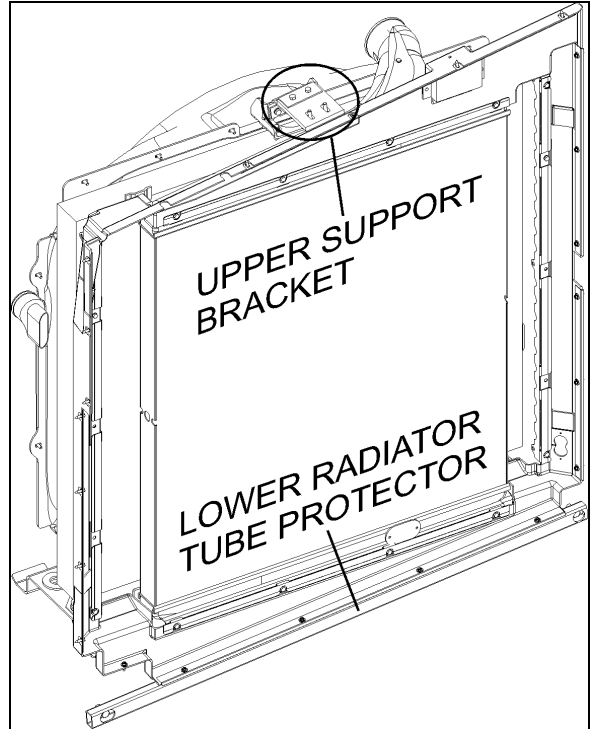

FIGURE 14: UPPER SUPPORT BRACKET & TUBE PROTECTOR

13. Remove the lower radiator assembly tube protector from the lower section (Figure 14).

14. Remove all lower radiator assembly mounting fasteners.

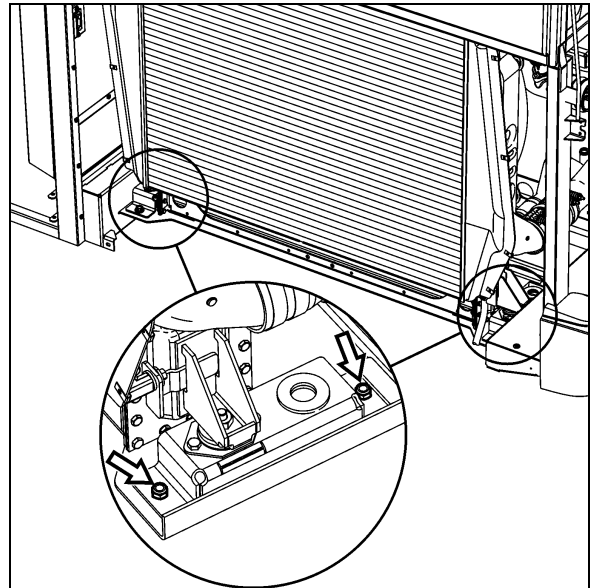

FIGURE 15: RADIATOR ASSEMBLY LOWER MOUNTING FASTENERS

15. Cut cable tie and disconnect electrical connector from fan clutch. Remove fan drive shaft fasteners at the gear box.

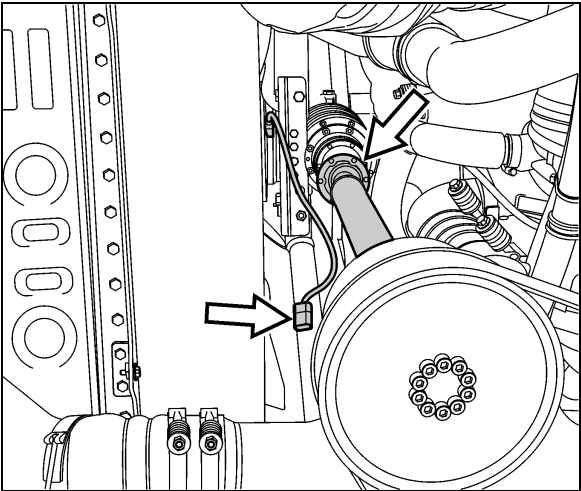

FIGURE 16: DISCONNECTING FAN DRIVE SHAFT

16. Position a forklift under the radiator assembly that is capable of safely lifting the radiator.

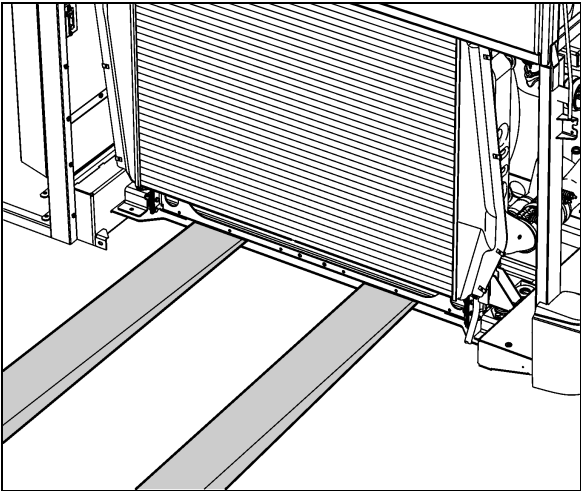

FIGURE 17: POSITIONING FORKLIFT

17. With assistance, slide radiator assembly out and onto the forklift. Transfer radiator assembly to a secure location.

18. Separate charge air cooler from radiator.

19. Lay radiator face down. Remove the fasteners that connect lower radiator mounts to radiator.

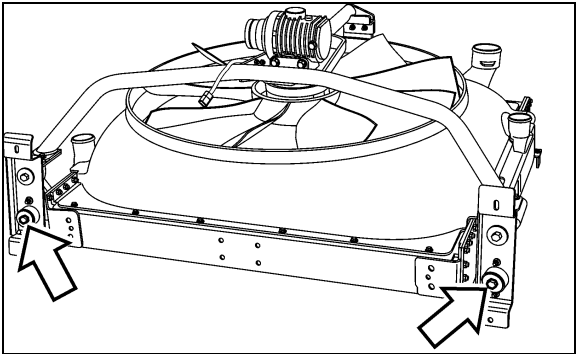

FIGURE 18: REMOVING FASTENERS

20. Remove upper fan drive support bracket from the upper section of the radiator.

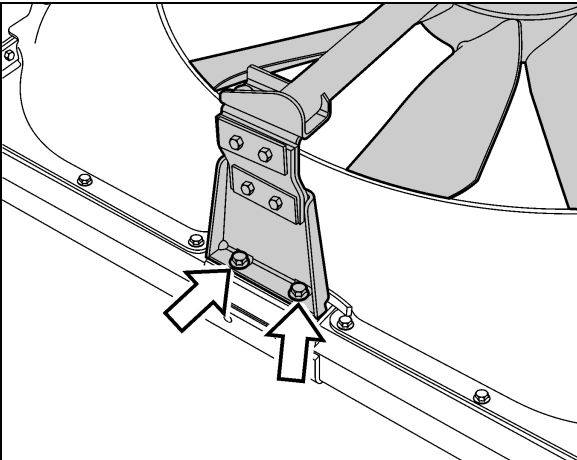

FIGURE 19: REMOVING UPPER FAN DRIVE SUPPORT BRACKET

21. With assistance, remove fan drive and drive frame from radiator.

22. Remove fan shroud from radiator.

FIGURE 20: REMOVING FAN SHROUD FROM RADIATOR

23. Reverse removal procedure to reinstall radiator assembly.

12. CHARGE AIR COOLER LEAKAGE

Spec for CAC acceptable leakage:

“The CAC is considered acceptable if it can hold 30 psi (206 kPa) gauge pressure with less than 5 psi (34.5 kPa) loss in 15 seconds after turning off the hand valve.”

NOTE
 This spec does not apply if there is any evidence that the leak was caused by a foreign object impact.

13. COOLING FAN DRIVE MECHANISM

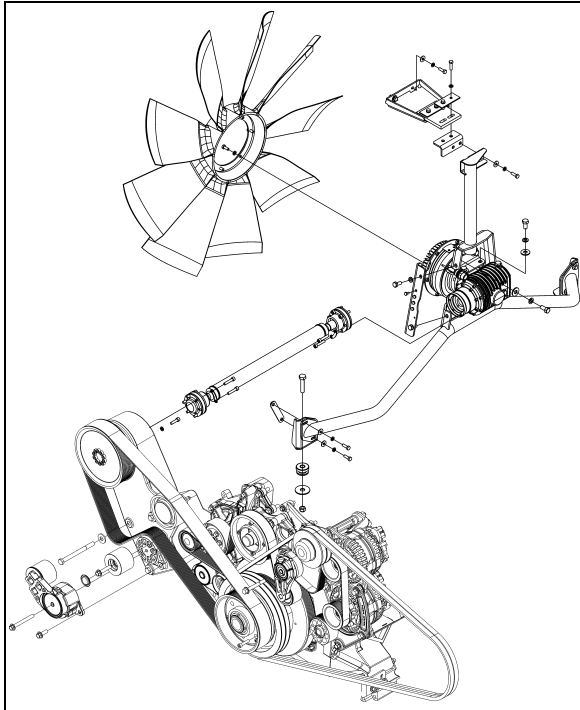

FIGURE 21: COOLING FAN DRIVE MECHANISM

13.1 DRIVE PULLEY AND UNIVERSAL JOINT SHAFT

To disconnect the universal shaft, proceed as follow:



WARNING

Set the ignition to the OFF position and remove the key from the contact switch to prevent accidental starting of the engine.

1. Unwrap the drive belt from around the pulley (see paragraph MOUNTING THE DRIVE BELT).
2. Dismount the drive pulley. Gain access to the 6 mounting bolts from behind the pulley, through the opening in the cast aluminum support (Figure 22).
3. Unscrew and remove the universal joint shaft mounting bolts (6) at the right angle gearbox.
4. Slowly, move the shaft toward the rear of the vehicle.
5. Finally, dismount the universal joint shaft from the drive pulley (6 bolts).

Installation of the universal joint shaft is the same as removal, but in reverse order.

TORQUE: 16 lb-ft (22 Nm)

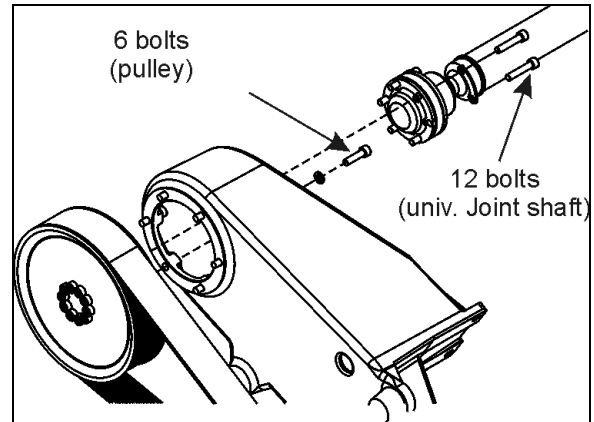

FIGURE 22: PULLEY AND SHAFT

05123B

13.2 IDLER REPLACEMENT

If an idler is defective, replace as follow:



WARNING

Set the ignition to the OFF position and remove the key from the contact switch to prevent accidental starting of the engine.

1. Remove the protective cap (replace with a new one).
2. Unscrew the idler mounting bolt.
3. Replace idler with a new one.



CAUTION

When installing the idler, make sure it rests perfectly against the bearing surface on the cast aluminum support. If not, the drive belt may slip of the idler. See following figure.

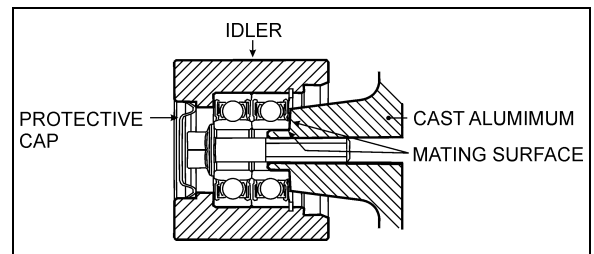

FIGURE 23: IDLER MOUNTED ON THE CAST ALUMINUM SUPPORT

4. Bolt the new idler on the cast aluminum support.



TORQUE: 32 lb-ft (43 Nm)



5. Place a new protective cap.

14. VARIABLE SPEED COOLING FAN

The cooling fan clutch has two thermostatically controlled speeds, plus a neutral (clutch disengaged). The engine control module controls the speed by comparing data from engine coolant temperature, charge air temperature, Allison transmission oil temperature and small A/C high side pressure to a set of calibration data. The fan drive clutch is electromagnetic; the engine control module sends an electric current to regulate speed by activating one magnetic coil for the first speed and two magnetic coils for the second speed.

The settings are:

	Engine coolant temp.	Air intake temp.	Allison trans. oil temp.
temperature rising 	208°F: fan engages in HIGH SPEED	194°F: fan engages in HIGH SPEED	230°F: fan engages in HIGH SPEED
	203°F: fan engages in LOW SPEED	176°F: fan engages in LOW SPEED	216°F: fan engages in LOW SPEED
temperature dropping 	203°F: fan HIGH SPEED disengages	189°F: fan HIGH SPEED disengages	225°F: fan HIGH SPEED disengages
	198°F: fan LOW SPEED disengages	170°F: fan LOW SPEED disengages	210°F: fan LOW SPEED disengages

	Small A/C high side pressure
pressure rising 	170 psi: fan engages in HIGH SPEED
	120 psi: fan engages in LOW SPEED
pressure dropping 	130 psi: fan HIGH SPEED disengages
	90 psi: fan LOW SPEED disengages



WARNING

DO NOT work near the fan with the engine running or the ignition in the ON position. The engine fan can engage at any time without warning. Anyone near the fan when it turns on could be seriously injured.

14.1 LOCKING RADIATOR FAN CLUTCH FOR EMERGENCY OPERATION

14.1.1 Electrical Locking

If the radiator fan clutch does not function due to an electrical control system malfunction and the engine is overheating, you can activate the fan clutch through one of the Driver Information Display menus. For more detail, refer to “Forced Activation of the Radiator Fan Clutch” paragraph in Section 06: ELECTRICAL.

NOTE

If the fan clutch does not engage using this procedure then the clutch is faulty or the wiring between the multiplex module and the clutch is faulty. Mechanically lock the fan as described in section 13.1.2.

14.1.2 Mechanical Locking In Case Of Power Failure

Once mechanically locked, the fan clutch is rigidly connected to the drive mechanism and will rotate continuously, with no considerations for the cooling needs. This is an emergency situation and the vehicle shall not be operated in that situation for an extended period.

In case of a magnetic clutch malfunction:

1. Set the ignition to the OFF position and remove the key from the contact switch to prevent accidental starting of the engine.
2. Disconnect the fan clutch electrical connector.
3. Unscrew and remove the 4 spare M6x12 hex bolts screwed to the angle on the fan gearbox mounting support (FIGURE 24).
4. Screw in 4 hex bolts through the clutch anchor plate into the rotor. Using the automatic belt tensioner, release tension on the drive belt in order to be able to rotate the fan clutch drive mechanism by hand.

TORQUE: 7.5 lb-ft (10 Nm)

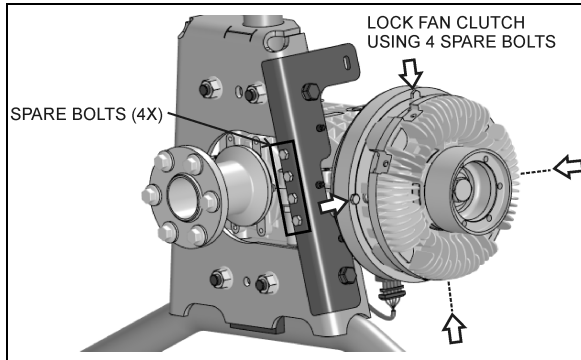

FIGURE 24: MECHANICAL LOCKING

05124

14.2 MAINTENANCE

1. Clean the fan and related parts with clean fuel oil and dry them with compressed air. Do not clean with steam or high-pressure jet.
2. Check the fan blades for cracks or other damage. Replace the fan if the blades are cracked or deformed.
3. Remove any rust or rough spots in the grooves of the fan drive mechanism pulley. If the grooves are damaged or severely worn, replace the pulley.
4. Do not restrict fan rotation during engine operation for any reason.
5. Do not operate fan driving mechanism with a damaged fan assembly. Replace a damaged fan as soon as the fault is noted.
6. Immediately investigate and correct any operator complaint involving driving mechanism or cooling system performance.
7. When questions arise, obtain answers before proceeding. Assistance is available through the Prevost After-Sales Service support serving your area.

14.3 INSPECTION



WARNING

Set the starter selector switch in engine compartment to the "OFF" position to prevent accidental starting of the engine.

- Check security of fasteners securing fan blade assembly to right angle gearbox.
- Visually inspect fan driving mechanism, fan blade assembly, shroud, radiator, and surrounding area for evidence of contact between rotating and non-rotating parts.

- Check drive belt for fraying, cracking, and proper tension.
- Turn fan through at least 360° of rotation. It should turn smoothly with no resistance.

14.4 FAN REMOVAL / INSTALLATION

The fan is bolted to the right angle gearbox shaft flange. To remove the fan:

- Unscrew and remove the mounting bolts and washers.

To reinstall the fan:

- If the fan is still in the radiator fan shroud, place 2 of the mounting bolts on the opposite side of the flange, in reverse direction, in order to use them as guide pins to position the fan.
- Once properly positioned, screw the 4 remaining bolts back in (finger tight).
- Finally, take the 2 bolts that were used as guide pins and screw them back in on the proper side of the fan. Tighten in a star pattern.

TORQUE: 32 lb-ft (43 Nm)

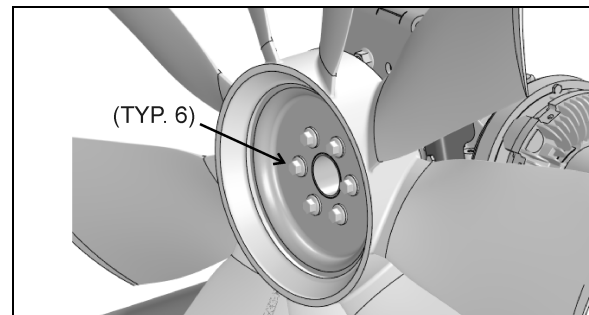

FIGURE 25: RADIATOR FAN MOUNTING BOLTS

05125_2

15. FAN RIGHT ANGLE GEARBOX

The radiator fan is belt driven from the engine crankshaft pulley through a drive belt, a universal joint shaft, a clutch and right angle gearbox assembly.

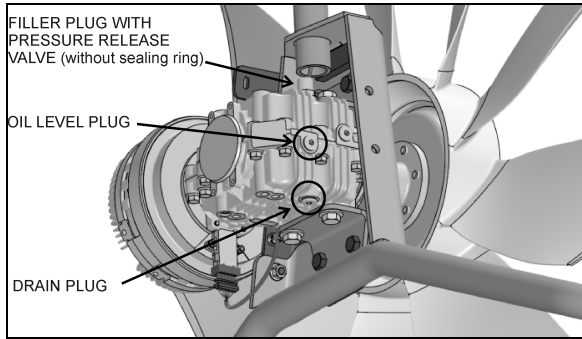

FIGURE 26: RIGHT ANGLE GEARBOX 05118_4

15.1 MAINTENANCE

MAINTENANCE

Change the right angle gearbox oil only at operating temperature at the intervals specified by the Lubrication And Servicing Schedule in Section 24: LUBRICATION & SERVICING. Replace sealing rings at every oil change.

15.2 OIL CHANGE

1. Stop engine and make sure that all engine safety precautions have been observed.
2. Set the ignition to the OFF position and remove the key from the contact switch to prevent accidental starting of the engine or set the rear start panel selector switch to the OFF position.
3. Clean gear case carefully.
4. Remove the drain plug and allow the oil to drain into a suitable container.
5. Replace the sealing ring and screw the drain plug back in.
6. Unscrew and remove the oil level plug and the top filler plug/vent.
7. Add gear lubricant. The oil level is correct once the top of the oil has reached the bottom of the oil level plug.

WARNING

Note that warranty may be voided if proper maintenance at oil change intervals is not respected.

8. Replace the sealing rings and screw oil level plug and top filler plug back in.

9. Start the engine and allow running a few minutes. Stop the engine and check for leaks.

15.3 REMOVAL / INSTALLATION

To remove the right angle gearbox, proceed as follow:

1. Set the ignition to the OFF position and remove the key from the contact switch to prevent accidental starting of the engine.
2. Disconnect the fan clutch electrical connector.
3. Dismount the fan and lean it against the radiator (refer to previous paragraph).
4. Disconnect the universal joint shaft.
5. Dismount the angle.
6. Loosen the gearbox upper support bracket top bolts.
7. Unscrew and remove 4 gearbox mounting bolts.
8. Slide the gearbox out of the support assembly.

Installation procedure is the same as removal but in reverse order. Tighten the 4 mounting bolts as specified.

TORQUE: 53-65 lb-ft (72-88 Nm)

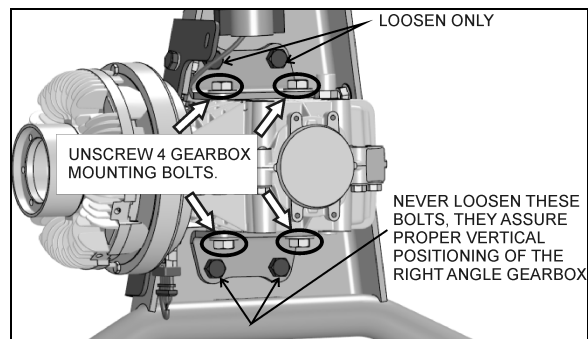

FIGURE 27: RIGHT ANGLE GEARBOX 05126

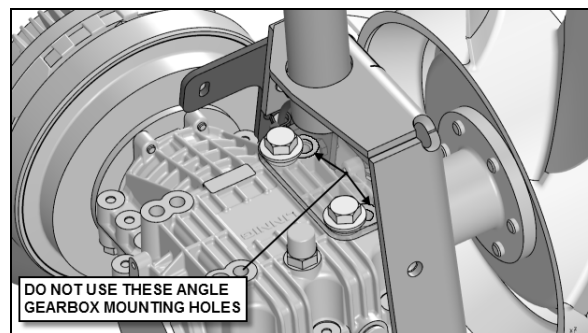

FIGURE 28: RIGHT ANGLE GEARBOX

16. COOLING FAN DRIVE BELT**16.1 MAINTENANCE****MAINTENANCE**

Inspect the cooling fan drive belt for cracks or frayed material at the intervals specified by the Lubrication And Servicing Schedule in Section 24: LUBRICATION & SERVICING.

16.2 MOUNTING THE DRIVE BELT

To install the cooling fan drive belt, proceed as follow:

**WARNING**

Set the ignition to the OFF position and remove the key from the contact switch to prevent accidental starting of the engine.

**WARNING**

Potential Accident Risk. Always use extreme caution when working in the vicinity of hot, rotating or moving parts.

1. Wrap the new drive belt around the fan drive mechanism pulley, the idlers and the automatic tensioner idler as shown on figure 30.
2. Using the special tool included with your vehicle (see inside the Warning Reflectors box located in the first curb-side baggage bay), rotate the automatic tensioner in clockwise direction to relieve tension on the belt and hold the tensioner in that position (Figure 29).
3. Finally, place the drive belt around the engine crankshaft pulley.

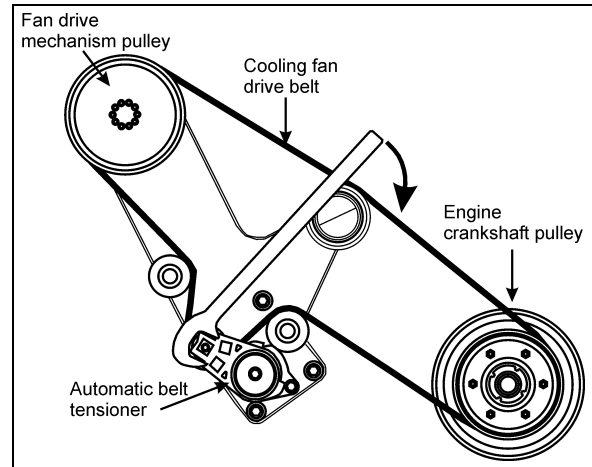

FIGURE 29: DRIVE BELT ROUTING (VOLVO D13 ENGINE)

4. Release the tensioner slowly and let it return to its natural position.

COOLING FAN DRIVE BELT**With Volvo D13 engine**

Type: 14PK2526

Prevost number: 5060097

17. SPECIFICATIONS

Cooling System Capacity (Approximation)

Includes heating system24 US gal (91 liters)

Thermostat - Volvo D13 Engine

Number used 1
Start to close203°F (95°C)
Fully closed185°F (85°C)

Cooling Fan Drive Belt – Volvo D13 Engine

Type Poly-Rib 14PK2526
Qty 1
Prevost number 5060097

Coolant - Volvo D13 Engine

Prevost Number685241
Texaco CPS227998
Chevron CPS 2227805

Coolant Filter Cartridge – Volvo D13 Engine

Number used 1
Type Spin-on
Prevost number 20458771