

G2270 OPERATION / INSTALLATION / MAINTENANCE OF LEVEL CONTROL VALVE (LCV)

Operation

The Level Control Valve (LCV) provides the intelligence to the Posi/Lock system.

Note: Each fuel tank design requires a specific LCV setting to ensure fueling levels comply with DOT regulations (49 CFR Ch.III ss 393.67). During fueling, the LCV will close when the fuel reaches the level in the tank corresponding to 95% of the tank volume, permitting a small build-up of pressure in the tank. When the back pressure reaches 1.1 – 1.5 psig it forces the nozzle to close automatically.

The valve body is aluminum with an internal Viton™ seal. A 1" female NPT outlet accepts the G2257 Whistle or pipe off elbows. The pipe off configuration is recommended to direct fuel which is condensed from the vapors into the fuel tank. (Figure 2)

Installation

There are two types of LCV's available. One uses a tapered mounting area for installation on filler necks. The second type uses a flat bottom for remote mounting. (Flat bottom version shown in Figure 1, tapered bottom version shown in Figure 2)

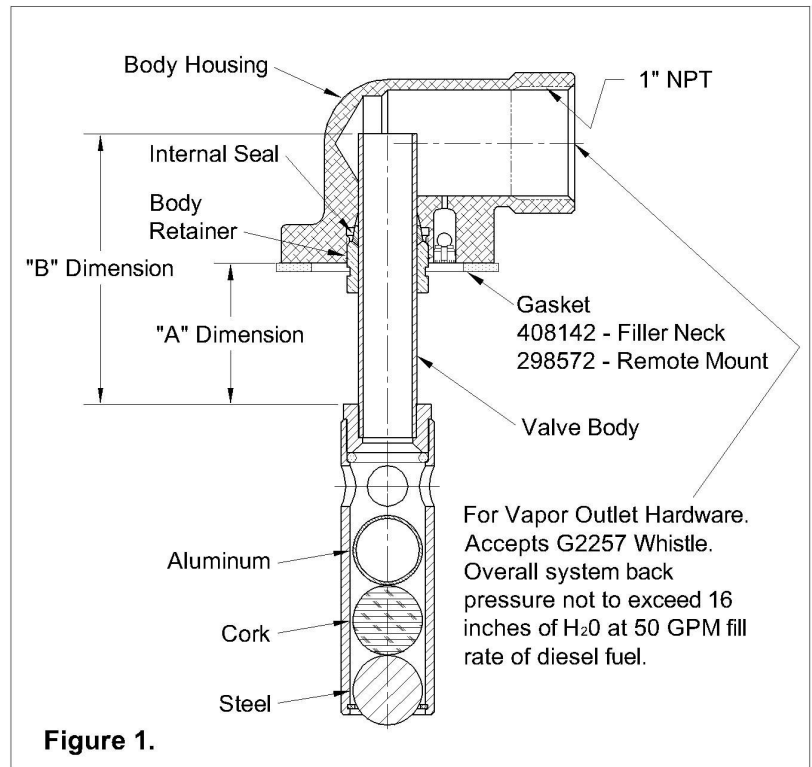

Figure 1.

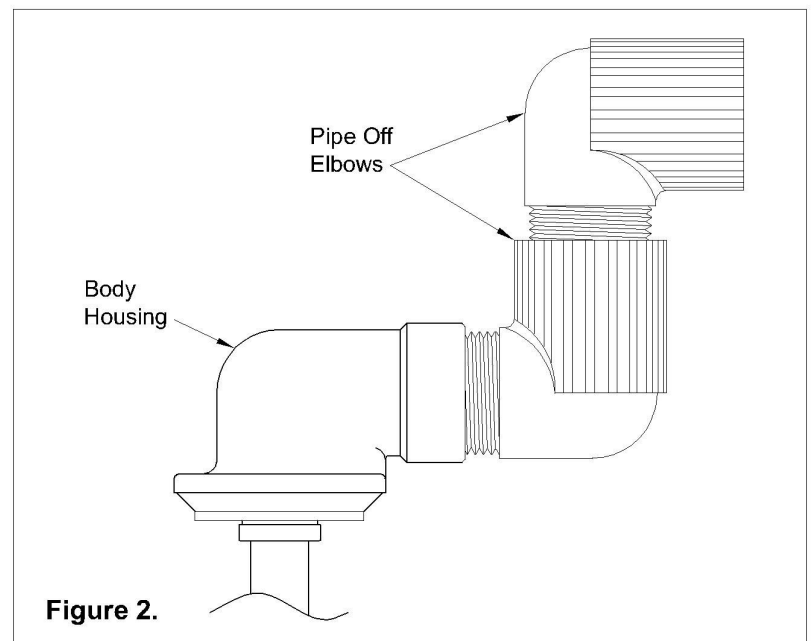
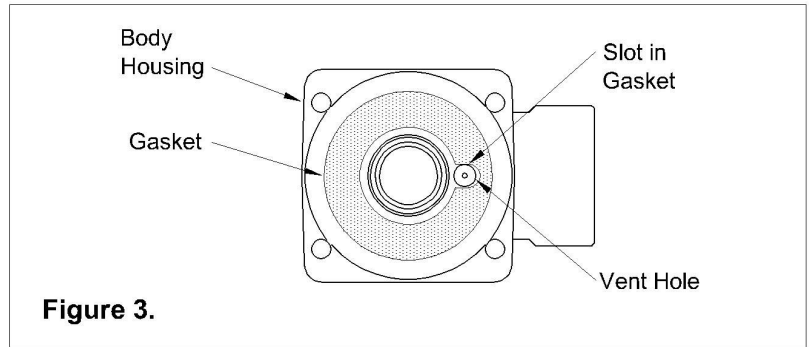

Figure 2.

When installing the LCV on a filler neck, use gasket 408142. When installing a remotely mounted LCV use gasket 298572. In each case, glue the gasket to the bottom of the LCV housing with a drop of cyanoacrylate based glue (eg: Superglue, Krazy Glue). Ensure the slot in the gasket is in line with the vent (Figure 3).



Line up the valve body with the through hole in the flange and place the housing on the flange. Install the four screws with lock washers and tighten with 10 -15 lb-in torque.

Maintenance

Proper functioning of the level control valve is critical. A malfunctioning valve can cause the system to under or overfill. A visual inspection for cracks in the housing, leaks around the flange gasket, obstructions in the body housing, or leakage past the internal seal should be completed regularly. Remove any obstructions and replace gaskets as necessary. If the housing is cracked or the internal seal leaks, the unit should be replaced.

Recommended Spare Parts

Emco Wheaton recommends keeping inventories of various types of Level Control Valves for each different type of bus in your fleet. A ratio of one LCV for every 50 of each type of bus should be sufficient.