



Maintenance Manual Update

Applying Loctite® Ultra Grey Flange Sealant 5699/Meritor Part Number 2297-Z-7098

Hazard Alert Messages

Read and observe all Warning and Caution hazard alert messages in this publication. They provide information that can help prevent serious personal injury, damage to components, or both.

⚠ WARNING

To prevent serious eye injury, always wear safe eye protection when you perform vehicle maintenance or service.

When you apply some silicone gasket materials, a small amount of acid vapor is present. To prevent serious personal injury, ensure that the work area is well-ventilated. Read the manufacturer's instructions before using a silicone gasket material, then carefully follow the instructions. If a silicone gasket material gets into your eyes, follow the manufacturer's emergency procedures. Have your eyes checked by a physician as soon as possible.

Procedures

1. Remove all old gasket material from both the axle and the carrier surfaces. Figure 1.

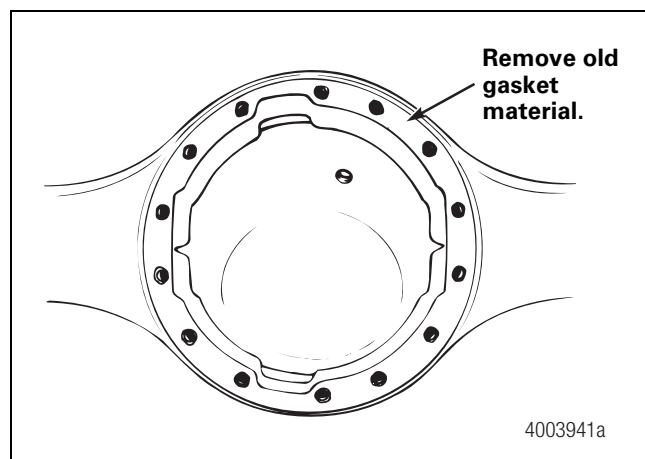

Figure 1

2. Clean the surfaces where you will apply the silicone gasket material. Remove all oil, grease, dirt and moisture. Figure 1.
3. Dry both surfaces.

⚠ CAUTION

The amount of silicone gasket material applied must not exceed a 0.125-inch (3 mm) diameter bead. Too much gasket material can block lubrication passages and result in damage to the carrier or axle components.

4. Apply a 0.125-inch (3 mm) diameter continuous bead of Loctite® Ultra Grey Flange Sealant 5699, Meritor part number 2297-Z-7098, around one surface. Also apply the gasket material around the edge of all fastener holes on that surface. Figure 2.

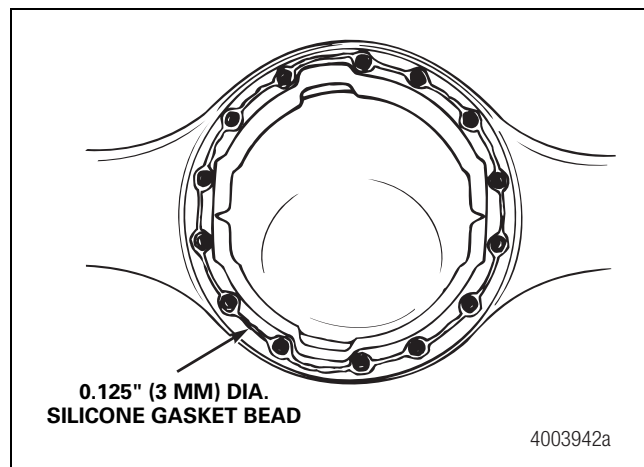

Figure 2

5. Assemble the components immediately to permit the silicone gasket material to compress evenly between the parts. Tighten the fasteners to the required torque value for that size fastener.
6. Wait 20 minutes before filling the assembly with lubricant.

Maintenance Manuals

The information in this Technical Bulletin updates the following Maintenance Manuals.

| MM | Title | Date |
|-----------|--|-------------|
| 5B | Tandem Axle Forward Rear Drive Units | 09-88 |
| 5J | Single-Reduction Hypoid Drive Unit | 08-79 |
| 5P | Tandem Axle Forward Rear Drive Units | 03-91 |
| 6C | Double-Reduction Differential Carriers | 08-84 |
| 7A | Hypoid Planetary Two-Speed Differential Carriers | 08-90 |
| 12 | Heavy-Duty Front Drive Steer Axles | 11-98 |

ArvinMeritor™

Meritor Heavy Vehicle Systems, LLC
2135 West Maple Road
Troy, MI 48084 USA
800-535-5560
arvinmeritor.com



Information contained in this publication was in effect at the time the publication was approved for printing and is subject to change without notice or liability. Meritor Heavy Vehicle Systems, LLC, reserves the right to revise the information presented or discontinue the production of parts described at any time.

Copyright 2003
ArvinMeritor, Inc.
All Rights Reserved

Printed in the USA

TP-96105
Revised 07-03
(16579/24240)