

SECTION 2

EXTERIOR VIEW	2
ENGINE COMPARTMENT COMPONENTS	4
ENGINE COMPARTMENT CURBSIDE DOOR	6
ENGINE COMPARTMENT REAR DOOR	6
EXHAUST AFTERTREATMENT SYSTEM ACCESS DOOR	7
MAIN POWER COMPARTMENT	7
ENGINE RADIATOR DOOR	9
SCR CATALYTIC CONVERTER ACCESS HATCH	9
CONDENSER COMPARTMENT (A/C)	10
EVAPORATOR COMPARTMENT	10
COOLANT HEATER	11
FRONT ELECTRICAL AND SERVICE COMPARTMENT	11
BAGGAGE COMPARTMENTS	12
SPARE WHEEL COMPARTMENT	13
FUEL AND DIESEL EXHAUST FLUID (DEF) FILLER DOOR	13
ENTRANCE DOOR	14
LOCK OPERATION	14
OPENING THE ENTRANCE DOOR FROM OUTSIDE	14
OPENING THE ENTRANCE DOOR FROM INSIDE	15
DOOR OPERATION LOGIC	15
EMERGENCY DOOR OPENING	15
WHEELCHAIR LIFT ACCESS DOORS	15
REAR-VIEW MIRRORS	15
120-VOLT CONNECTORS	16
ENGINE BLOCK HEATER	16
BATTERY CHARGER	16
HUBODOMETER	16
TRAILER HITCH	17

Coach Exterior 2-2

EXTERIOR VIEW

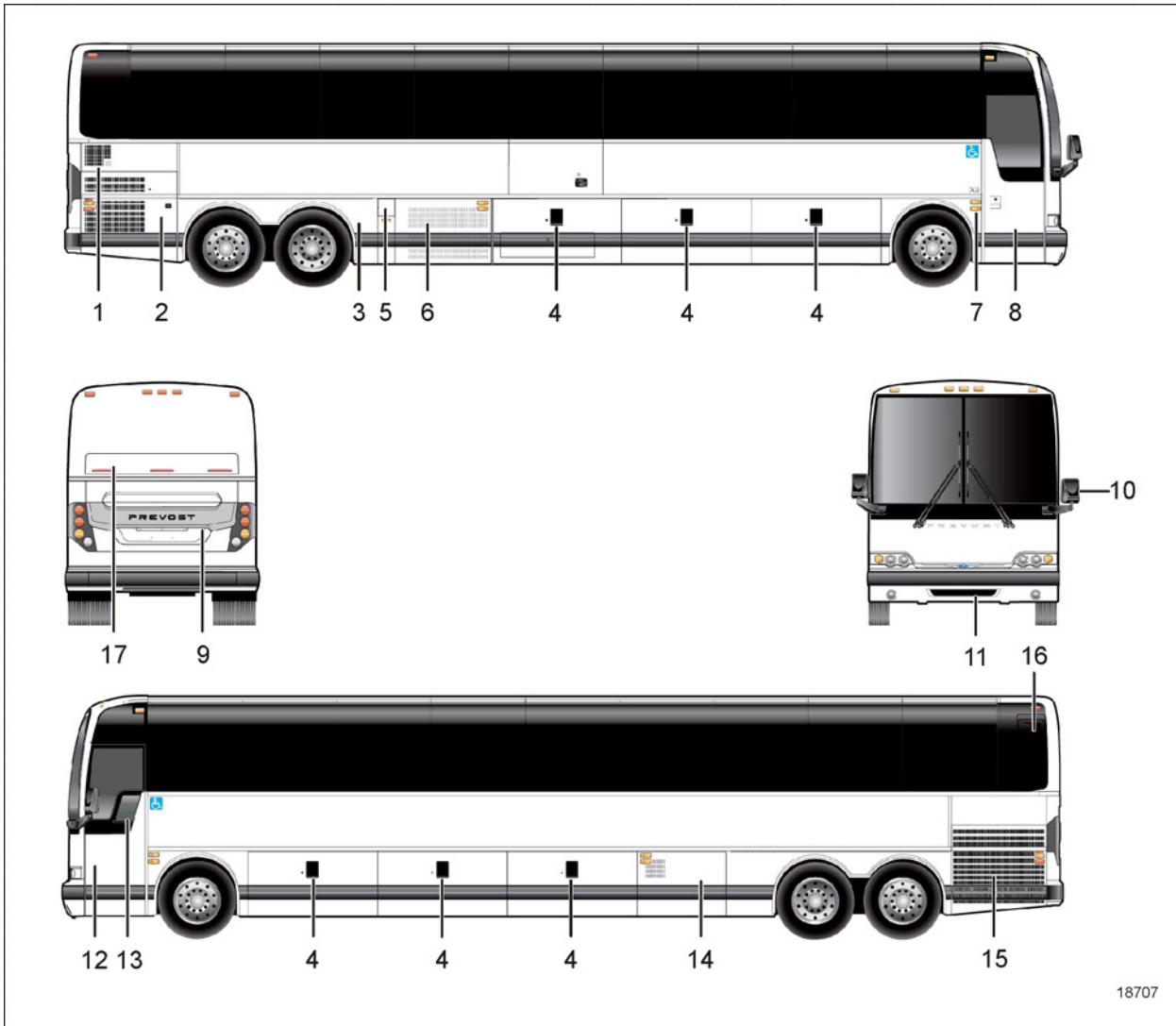

X3-45 EXTERIOR VIEW (TYPICAL)

1. Engine air filter intake grill
2. Engine compartment curbside door
3. Hinged rear fender
4. Baggage compartment
5. Fuel & DEF filler door
6. Condenser compartment
7. Entrance door control switch
8. Entrance door
9. Engine compartment rear door
10. Rear-view mirrors
11. Spare wheel compartment
12. Front electrical and service compartment
13. Driver's power window
14. Evaporator compartment and coolant heater compartment
15. Radiator door
16. Catalytic converter access door
17. Exhaust aftertreatment system access door

ENGINE COMPARTMENT COMPONENTS

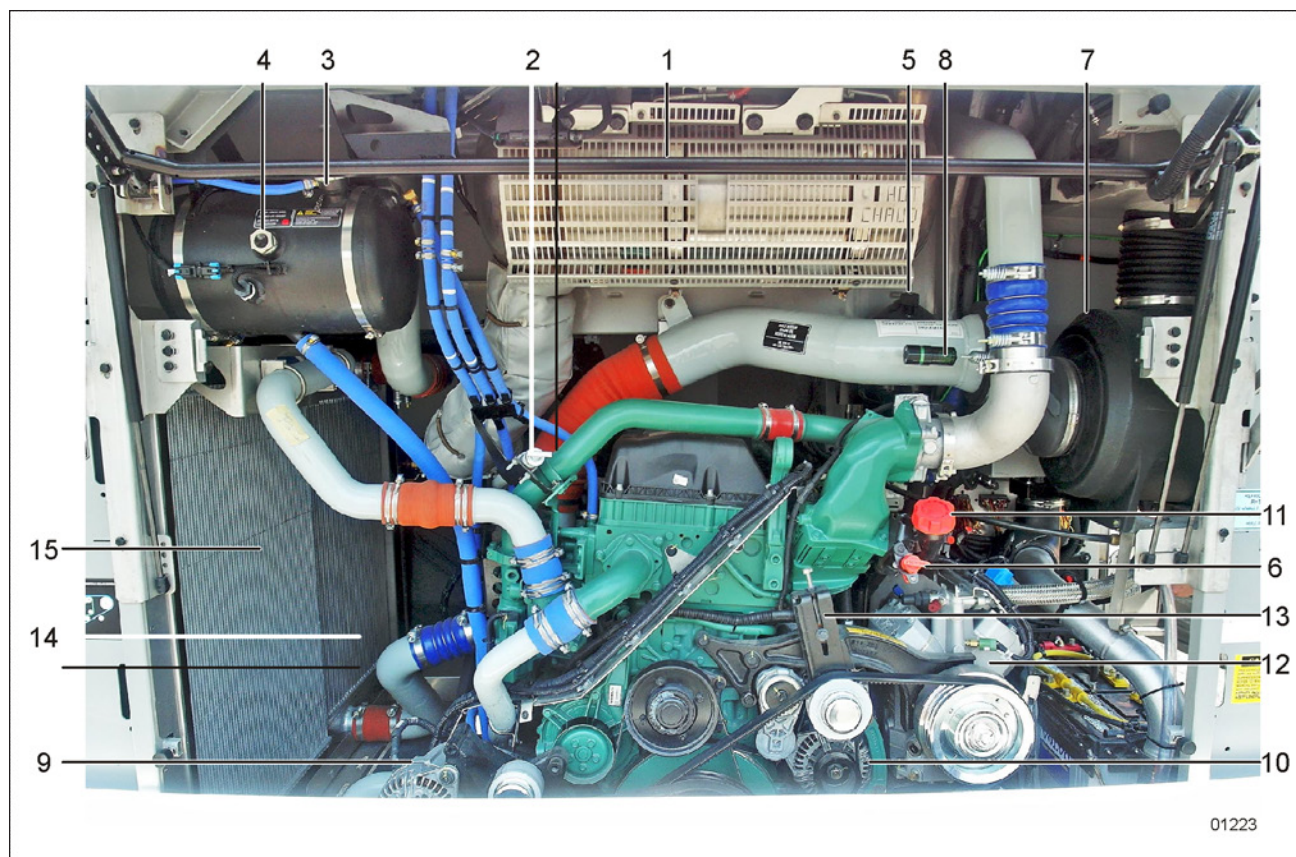

ENGINE COMPARTMENT FEATURING VOLVO D13 ENGINE

1. Diesel Oxidation Catalyst (DOC) & Diesel Particulate Filter (DPF) Assembly;
2. Transmission fluid dipstick (if equipped with Allison transmission);
3. Coolant fluid surge tank filler cap;
4. Coolant fluid surge tank sight glass;
5. Power steering fluid reservoir;
6. Engine oil dipstick;
7. Air filter;
8. Air filter restriction indicator;
9. Alternators, Road side
10. Alternator, Curb side;
11. Engine oil filler tube;
12. Central A/C compressor;
13. Compressor belt tensioner;
14. Charge air cooler;
15. Radiator;

Coach Exterior 2-6

ENGINE COMPARTMENT CURBSIDE DOOR

The engine compartment curbside door provides access to the following (if equipped):

- Engine compartment rear door release handle;
- Booster terminals;
- Rear electrical panel;
- Rear junction panel;
- Battery compartment;
- Fuel filter/water separator (optional);
- Emergency air system fill valve;
- Sump tank access cap;
- 110 - 120 volt connector;
- Lavatory maintenance valve and connectors;
- Fresh water reservoir fill connector;

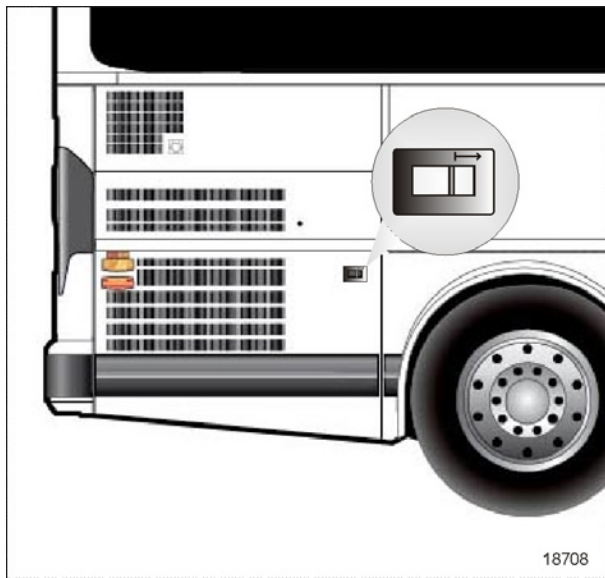

ENGINE COMPARTMENT CURBSIDE DOOR

This door can be locked or unlocked using the exterior compartment key. To open, pull towards the front on the rod located in the recess to the right of the door.

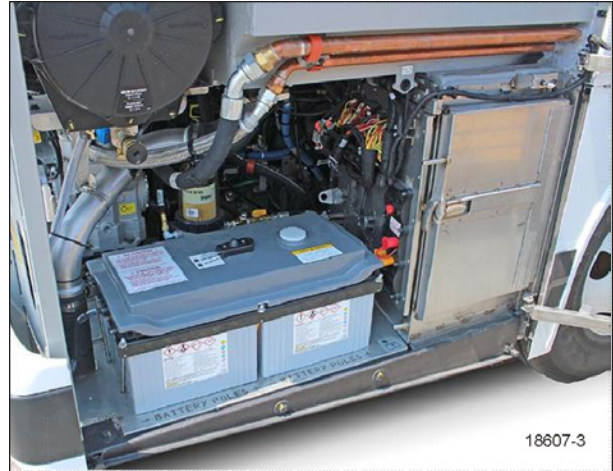

ENGINE COMPARTMENT R.H. SIDE

A telltale light illuminates when one or more compartments are unlocked.

ENGINE COMPARTMENT REAR DOOR

To open the engine compartment rear door, open the engine compartment curb side door and pull the yellow handle located on the rear door, grab the side of the door in the middle, pull and lift the door.



OPENING ENGINE COMPARTMENT REAR DOOR



WARNING

Unless otherwise stated, do not run the engine when the engine compartment is open.

The door swings out to provide access to the following:

- Engine;
- Alternators;
- Compressor(s);
- Belt tension control valve (refer to "[A/C COMPRESSOR BELTS](#)" on page 11 in Care and Maintenance);
- Engine starting selector (refer to "[STARTING FROM THE ENGINE COMPARTMENT](#)" on page 4 in Starting and Stopping Procedures);
- Coolant line shutoff valves;
- Certification plates;
- Engine coolant surge tank and filler cap;
- Air filter restriction indicator;
- Engine oil dipstick;
- Power steering fluid reserve tank;
- Allison automatic transmission fluid dipstick;

NOTE

The engine compartment lights will turn on automatically when the engine door is opened

A catch engages to maintain the door in the full open position. To close the door, slightly lift up the door and release the catch before firmly shutting down the door.

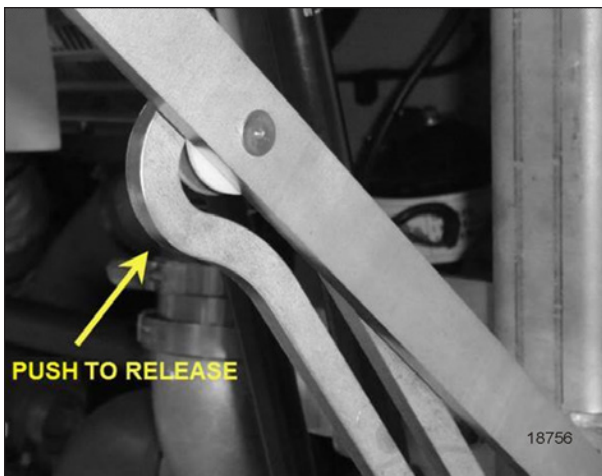

REAR DOOR SAFETY CATCH



WARNING

Unless otherwise specified, do not run the engine when the engine compartment rear door is open. Close the engine compartment rear door before starting the engine.

EXHAUST AFTERTREATMENT SYSTEM ACCESS DOOR



The engine door must be open before opening the exhaust aftertreatment system access door. To open the access door, lower the latch release lever, using a flat tip screwdriver.



AFTERTREATMENT ACCESS DOOR LATCH

To close the door, lower the door and push against the release lever spring to latch the door shut.

MAIN POWER COMPARTMENT

The main power compartment (a.k.a. rear junction box) and battery installation are accessible from the engine compartment curbside door.

Coach Exterior 2-8

The batteries are housed and secured on the engine R.H. side deck. The battery posts and connections are protected by a watertight cover. The cover is fitted with a built-in vent. The cover can be unlocked and then removed with the use of the same type of hardware that allows opening and closing of the rear fender.

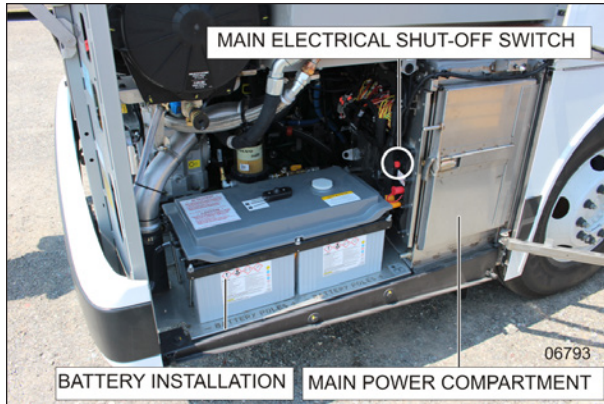

ENGINE R.H. SIDE COMPARTMENT

The main power compartment panel provides access to the following:

- Rear 12VD, 24VD junction blocks
- Main circuit breakers
- AE49, AE50, AE51, AE52 I/O-EB Multiplex modules
- Vehicle Electrical Center Rear (VECR)
- Master relay R1
- 12V ignition relay R3
- Starter relay
- Relays and fuses
- Battery equalizer
- 12VD & 24 VD current sensors



MAIN POWER COMPARTMENT

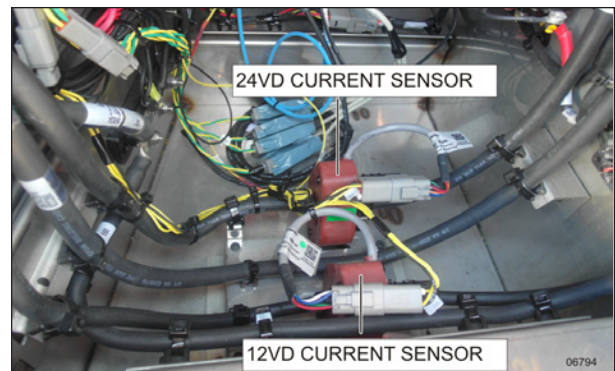

12VD / 24VD CURRENT SENSORS IN MPC

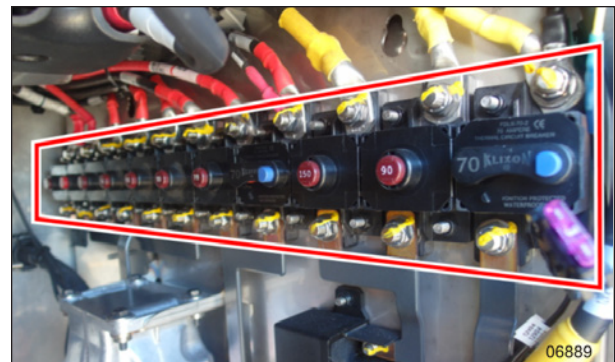

MAIN CIRCUIT BREAKERS IN MPC

ENGINE RADIATOR DOOR

The engine radiator door gives access to the radiator electrical fans and power distribution box.



RADIATOR DOOR

Open the engine compartment rear door to access the engine radiator door release handle. Radiator door release handle is located inside the left pillar (Arrow).



RADIATOR DOOR HANDLE LOCATION

Pull handle towards you to release the radiator door.



RADIATOR DOOR RELEASE HANDLE

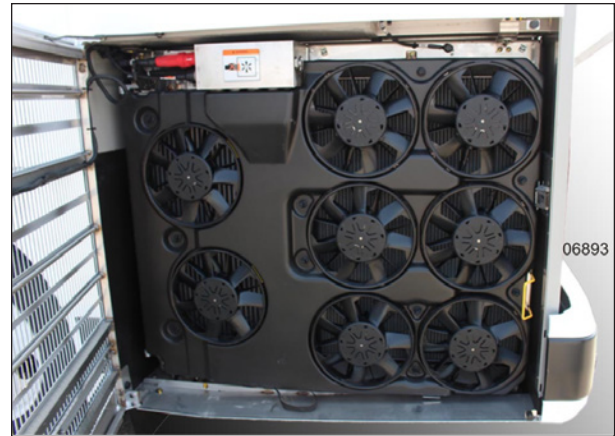

RADIATOR DOOR OPENED



WARNING

WHEN THE ENGINE IS RUNNING...

Cooling fans may activate at any moment.

Keep hands away from cooling fans or keep the radiator door closed



WARNING

Cooling fans may be running when the engine is shut down in the following conditions:

If a High Exhaust Temperature condition exists (e.g. following regeneration). The CAC fans will keep running for a maximum of 15 minutes.

During the electric Motor Test Sequence, the cooling fans will start running briefly.

SCR CATALYTIC CONVERTER ACCESS HATCH

The hatch is located on the road side (left side) above the radiator door.

To gain access to the SCR catalytic converter:

1. Open the radiator door first;
2. Pull the catch connecting rod to unlock the access hatch;
3. Lift the hatch open;
4. Hold the door open by inserting the support rod free end into the receptacle.

Coach Exterior 2-10

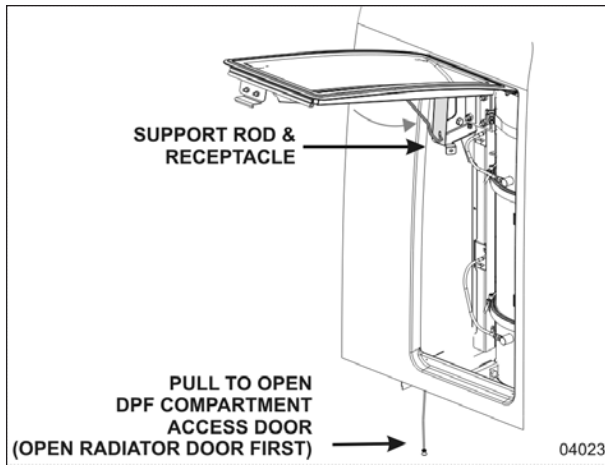

ACCESS TO THE SCR



WARNING

After inserting the support rod into the receptacle, make sure the rod supports the door securely from falling down on to your head or body.



WARNING

External and internal temperatures remain hot long after the engine has been shut down. Allow the Exhaust Aftertreatment System to cool before handling. Wear protective clothing and gloves while servicing.

CONDENSER COMPARTMENT (A/C)

Pull the release latch located inside the adjacent baggage compartment to open the condenser door.

The condenser compartment provides access to the following:

- Diesel Exhaust Fluid (DEF) Tank
- Condenser;
- Condenser fans and motors;
- Filter dryer and moisture indicator;
- Receiver tank;

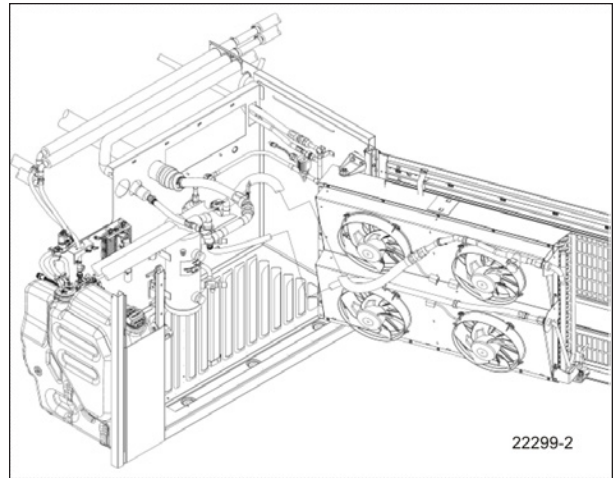

CONDENSER COMPARTMENT (A/C)

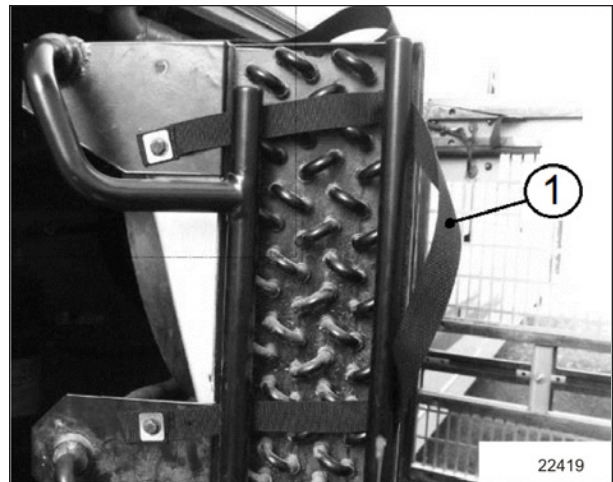

CONDENSER COMPARTMENT STRAP



CAUTION

Only the strap should be used to pull the condenser- fan assembly open. Damage to condenser could result if pulling by other means

EVAPORATOR COMPARTMENT

The HVAC (Heating, Ventilating and Air-Conditioning) evaporator and heater coils are located in this compartment along with the blowers.

The evaporator compartment door release latch is located on the right wall of the baggage compartment, left of the door. Pull the release latch then slide your hand in the opening to depress the secondary lock and swing open.

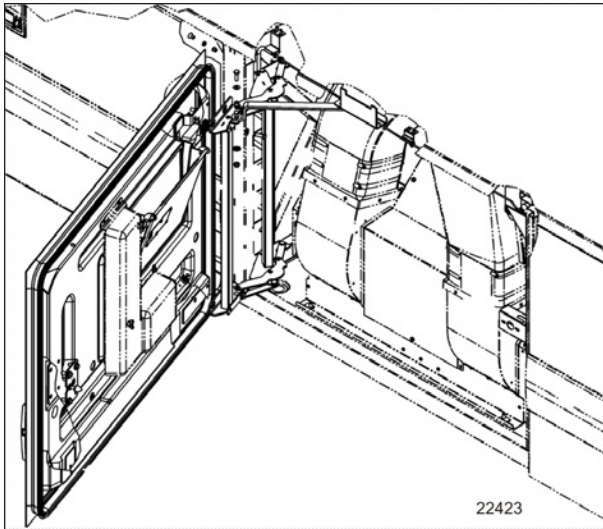

EVAPORATOR COMPARTMENT

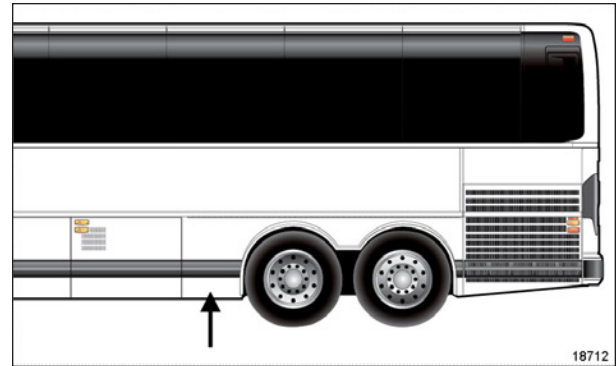

LOCATION OF PREHEATER

The water recirculating pump is also located in this location.



SECONDARY LOCK LEVER

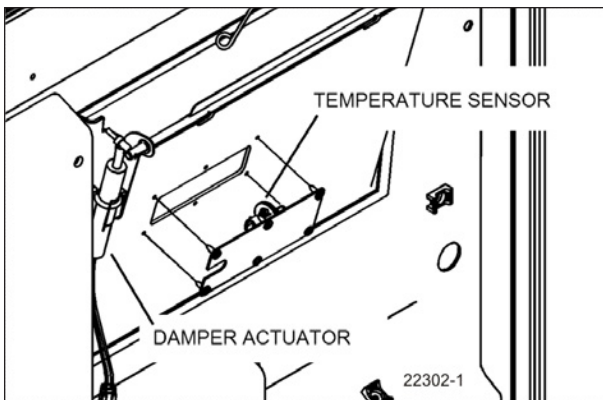

FRESH AIR DAMPER

COOLANT HEATER

The vehicle may be equipped with the optional preheater located aft of the evaporator compartment, and accessible under left rear fender.

FRONT ELECTRICAL AND SERVICE COMPARTMENT

- To open the front electrical and service compartment door, pull the rod inside the vehicle, next to the driver's power window or use the key to open from outside the coach.
- The electrical section of the front compartment provides access to the following:
 - Vehicle Electrical Center Front (VECF)
 - Relays and diodes
 - MCM
 - Front terminal block
 - IOE-B Multiplex Modules
 - VECU
 - ABS Electronic Control Unit (ECU)
 - IOE-A Multiplex Modules

The lower section of the front service compartment provides access to the following

- Emergency door opening unlatch valve
- Windshield washer reservoir & headlights washer reservoir (optional)
- Accessories air tank fill valve
- Accessories air tank drain valve
- Jack and tools

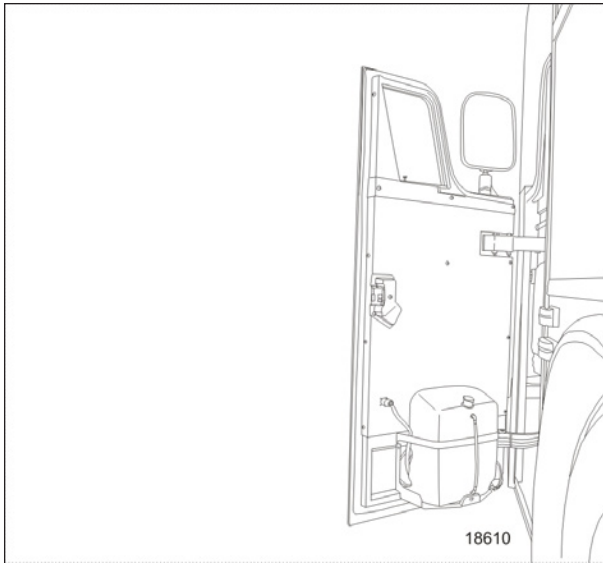

FRONT SERVICE COMPARTMENT DOOR

This compartment door can be locked/unlocked using the exterior compartment key.

The light in the front electrical and service compartment turns on automatically when the door is opened.

NOTE

Jack and tools are located inside the front electrical and service compartment

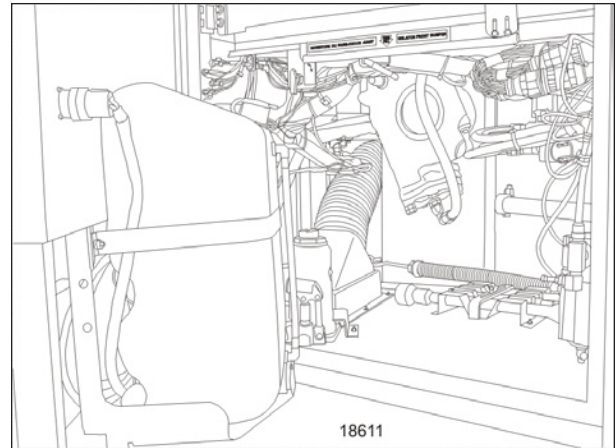

FRONT SERVICE COMPARTMENT

BAGGAGE COMPARTMENTS

The baggage compartments of the X3-45 provide 406 ft³ (11.5 m³) of storage capacity. The compartments can be locked or unlocked by using the exterior compartment key. Pull up operating handle to release the latch, and then pull the door open. Pressurized cylinders assist the opening and closing of the baggage compartment doors and hold the doors open.

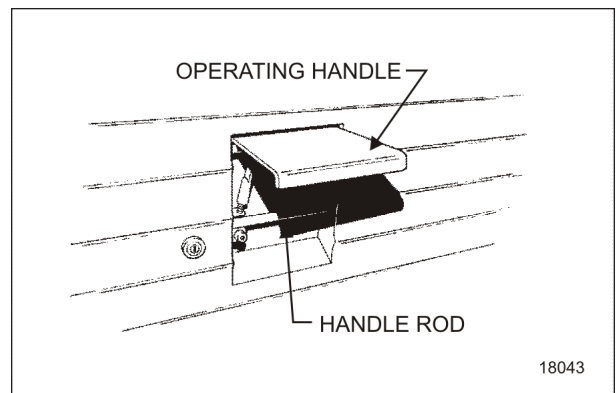

BAGGAGE DOOR LOCK AND LEVER

To close, pull the door down by the handle rod. Complete the closing of the door by returning the operating handle to its initial position.



CAUTION

Do not slam shut the baggage compartment doors. Damage to the door weather-stripping or locking mechanism could result.

Lights in the baggage compartments turn on automatically when the door is opened.

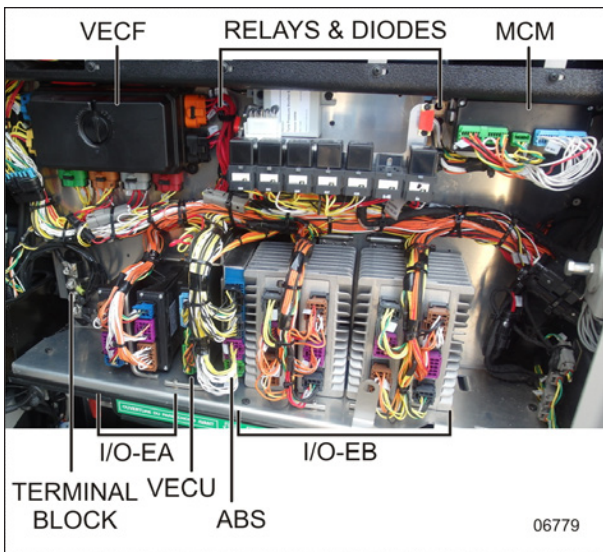

FRONT ELECTRICAL COMPARTMENT



BAGGAGE DOOR LOCK AND LEVER

NOTE

The baggage compartment doors can be locked/unlocked from the driver's position by the optional central locking system. The switch is on the L.H. control panel. Refer to "Controls & Instruments" chapter.

NOTE

For added safety, open the door until the catch assist in holding the door in the open position. Lift lever to release the door



WARNING

To avoid injury, keep hands clear of baggage compartment door edge and door frame when closing.

NOTE

To prevent theft and vandalism, always lock the baggage compartment doors before leaving the vehicle unattended.

SPARE WHEEL COMPARTMENT

The front bumper can be tilted downward to give access to the spare wheel.



WARNING

The compartment behind the bumper is not designed for miscellaneous storage. Never store loose objects in this compartment since they can interfere with the steering linkage mechanism.

Pull the release handle located inside front service compartment to tilt down the entire bumper assembly.

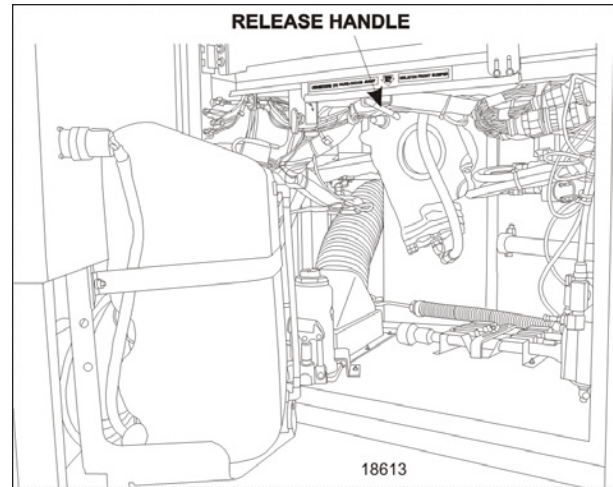

RELEASE HANDLE

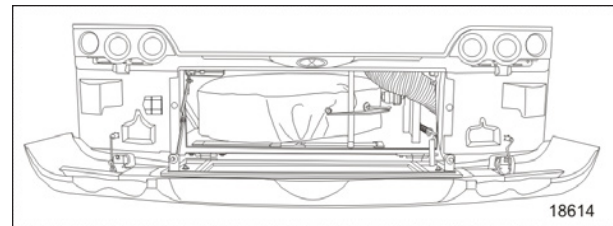

SPARE WHEEL IN FRONT BUMPER COMPARTMENT



WARNING

Although a powerful spring assists in reclining the bumper, it remains heavy and rests low when open. Caution should be used when reclining.

Check that bumper is securely closed shut before driving.

FUEL AND DIESEL EXHAUST FLUID (DEF) FILLER DOOR

The fuel and Diesel Exhaust Fluid (DEF) filler door is located on the R.H. side of the coach providing easy filling. A spring keeps the door either open or shut. A key is provided for unlocking the door if the option was chosen.

Coach Exterior 2-14

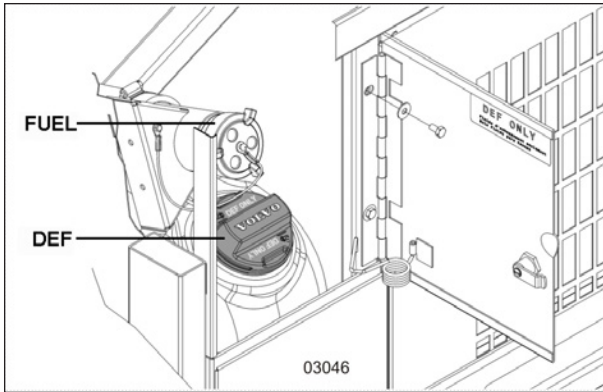

FUEL & DEF FILLER DOOR

NOTE

Provided the vehicle is parked on level ground, an automatic nozzle will automatically shut off when the fuel tank is approximately 95% full.

NOTE

The fuel & DEF filler door must be in the unlocked position before closing



WARNING

Diesel exhaust fluid DEF will begin to crystallize and freeze at 12°F (-11°C) and expand by 7% when frozen. To allow expansion without damaging the DEF tank, do not fill the tank with more than 15.9 gallons (60 liters).



WARNING

Do not fill to more than 95% of the fuel tank capacity. Do not "top off" the tank, doing so may result in fuel spillage when the fuel expands.

ENTRANCE DOOR

Entrance door operation from the inside or outside and in case of emergency.

LOCK OPERATION

Lock or unlock the entrance door from outside the vehicle by turning the key in the door lock (counterclockwise to lock, clockwise to unlock).

The only way to unlock the entrance door from the inside is by sliding its lock lever to the left.

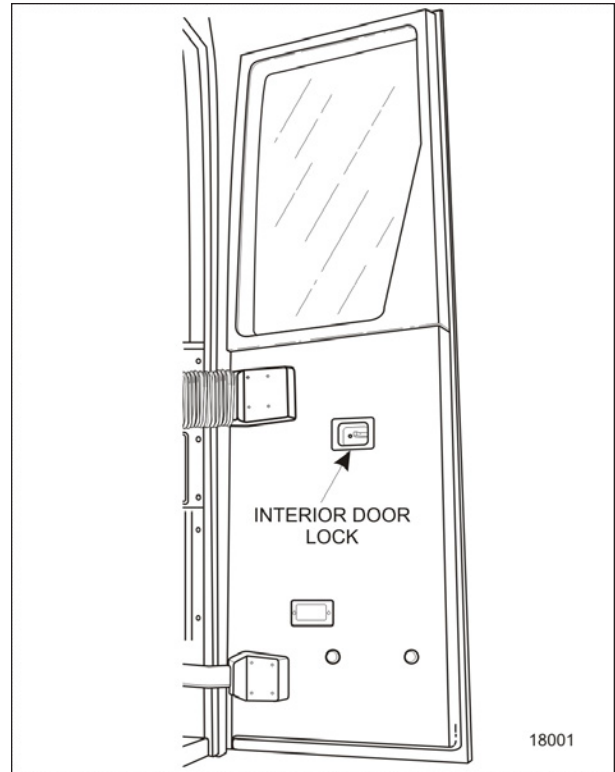

ENTRANCE DOOR - X3

OPENING THE ENTRANCE DOOR FROM OUTSIDE

The opening and closing of the door may be pneumatically controlled from the outside using the 3-position switch located on the door L.H. side. Open the door by pushing the switch forward, close by pushing the switch rearward.

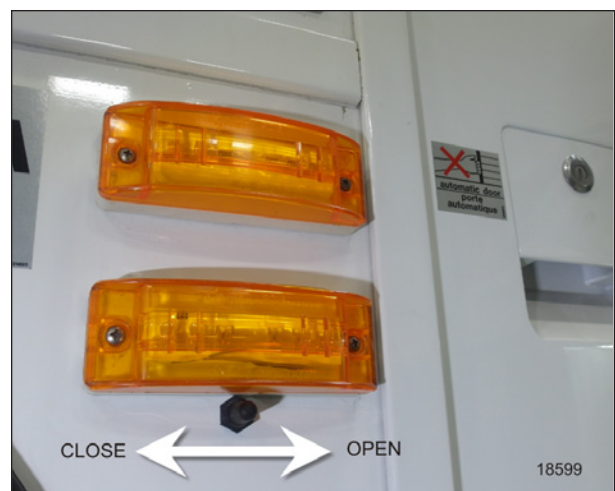

ENTRANCE DOOR EXTERIOR SWITCH - X3

OPENING THE ENTRANCE DOOR FROM INSIDE

From the inside, open the door by pressing the door opening switch (L.H. button) on the R.H. dashboard panel. Close by pressing the door closing switch (R.H. button) on the dashboard. Refer to “Controls and Instruments” chapter for more information.

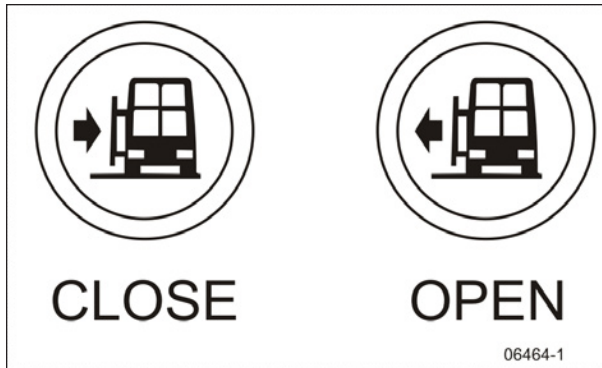

DASHBOARD SWITCHES

NOTE

If the interior lever is used to exit the coach and the key is not used to unlock the door, it will lock again upon closing. Remember to remove the keys upon exiting.

DOOR OPERATION LOGIC

If the switch is held in position until the door is fully open or closed, the system holds pressure in the door cylinder, locking the door in that position. The door can be open to any position by releasing the switch (or button if inside) when the desired position is attained. However, the door is not locked in any position other than fully open or fully closed. The door can then be open or closed further by pushing or pulling on the door.

When the door is almost shut, a mechanism will finish the closing of the door. This works even when the door is shut manually.

EMERGENCY DOOR OPENING

Refer to ["EMERGENCY ENTRANCE DOOR OPENING" on page 3](#) in Section 7, Safety Features and Equipment.

WHEELCHAIR LIFT ACCESS DOORS

To open the optional wheelchair lift access doors, the coach must be parked on a flat and level surface with the parking brake on. Using the exterior compartment doors key, unlock and carefully lower the lift mechanism access door which is part of the baggage compartment door. The lift mechanism access door is located directly below the wheelchair access door. A handle at the left of the lift mechanism unlocks and enables opening of the wheelchair access door. If the parking brake is not activated, a switch in the door will activate the parking brake when it detects the door is open.

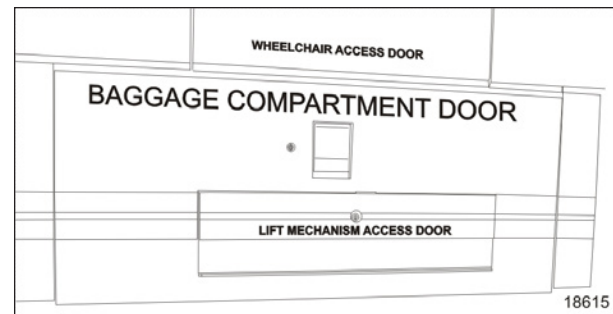

WHEELCHAIR LIFT ACCESS DOORS

Open the wheelchair access door completely until it locks in the open position. To close the door, pull on the tab located on the inside of the door and slam the door shut. Refer to “Other Features” for more information on operating the optional wheelchair lift.

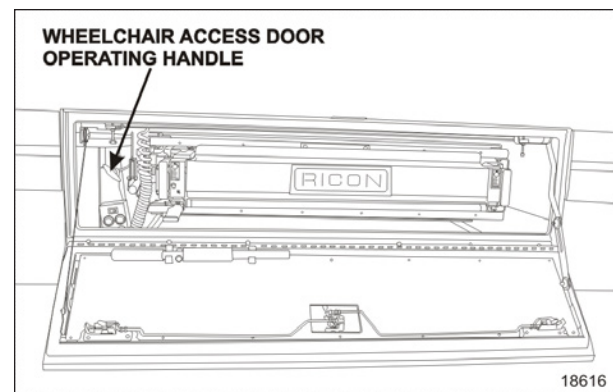

WHEELCHAIR ACCESS DOOR OPERATING HANDLE

REAR-VIEW MIRRORS

The vehicle is equipped with flat-type and convex-type rear-view mirrors. Convex mirrors give a wide-angle view. Objects viewed in convex-type rear-view mirrors appear smaller and are actually closer than they appear.

Coach Exterior 2-16

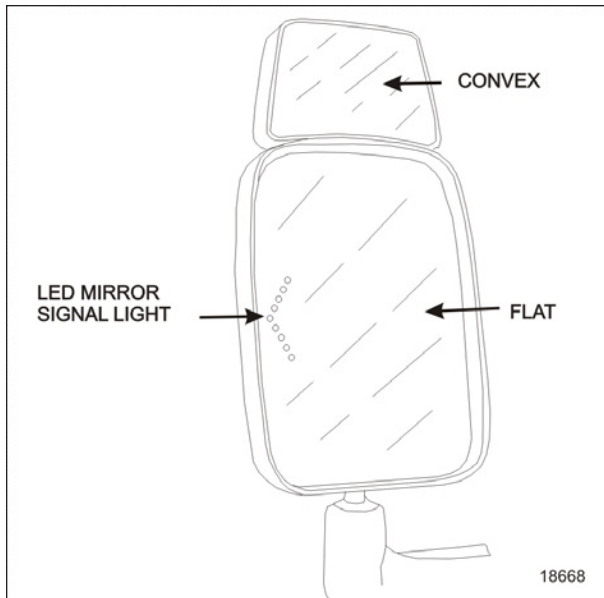

REAR-VIEW MIRRORS

To provide good visibility in cold weather, the mirrors can be equipped with heating elements. The elements are activated by a rocker switch located on the dashboard. Refer to "Controls & Instruments" chapter. Thermostats are used to prevent continuous operation of the heating elements.



CAUTION

Do not attach stick-on type convex mirror accessories to the heated mirror glass. This could impede uniform heat distribution on the mirror surface and could break the mirror glass.

As an option, the mirrors may be equipped with LED turning signal lights to give an additional signal light when turning or changing lane for extra safety or for other divers to see your signal when driving too close, in rain, fog or when in blind spot.

The mirrors are adjusted using the controls located on the L.H. control panel. Refer to "Controls & Instruments" chapter. Manual adjustment is also possible.

Adjust the side-view mirrors until the side of the vehicle is visible. Adjust the flat-type mirror until the road behind is in full view.

120-VOLT CONNECTORS

ENGINE BLOCK HEATER

One connector is provided for the electric block heater to connect to a 120 VAC power source. It is

located near the engine compartment rear door release handle. (Refer to chapter "Starting and Stopping Procedures").

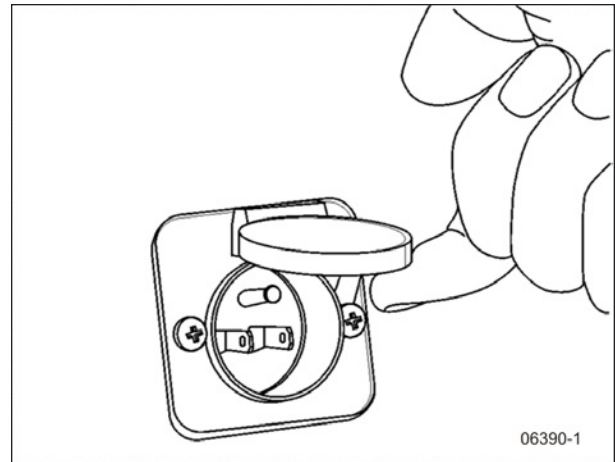

BLOCK HEATER 120-VOLT CONNECTOR

BATTERY CHARGER

Another connector is used to connect the battery charger to a 120 VAC power source. It is located above the engine compartment curbside door next to the air filter intake grill.



BATTERY CHARGER 120-VOLT CONNECTOR - X3

HUBODOMETER

An odometer is installed on the curbside drive axle wheel hub. The odometer calculates the total distance in miles or kilometers (depending on the model installed) traveled by the coach since manufacture, including factory road testing.

NOTE

It is normal for the hubodometer, the engine ECM and the vehicle odometer to disagree on the total mileage.

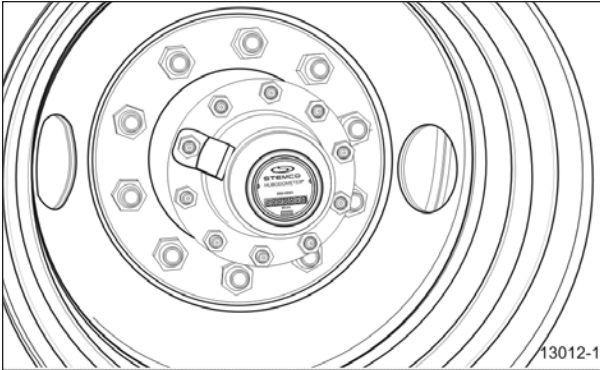

HUBODOMETER

**WARNING**

Pulling a trailer weighing more than the recommended *maximum gross weight* may cause engine and transmission overheating, and a possible hitch failure.

NOTE

Pulling a trailer over long distances is considered as a "severe operating condition" for the vehicle. The engine will require more frequent servicing.

TRAILER HITCH

Your vehicle may be equipped with a factory-installed trailer hitch which has been designed to meet the following rating:

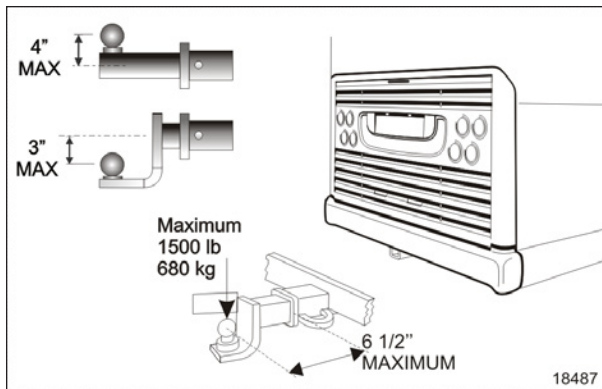

TRAILER HITCH

Maximum gross trailer weight:

20,000 lbs. (9072 kg)

Maximum tongue weight at 6 1/2 inches (165 mm) or less from coupling receiver:

1,500 lbs. (680 kg)

**DANGER**

The draw bar and the ball used for towing the trailer should be rated for 20,000 lbs. capacity or more.

Coach Exterior 2-18

NOTE

The minimum requirement for a trailer weighing up to 20,000 lbs. when coupled to a 20,000 lbs. Prevost Trailer Hitch is as per the following:

Trailer must comply with **Federal Motor Carrier Safety Regulations 393.52** regarding trailer braking capability.

The trailer coupling attachments must meet the following minimum static test load requirements. Use the indicated Gross Trailer Weight Rating (GTWR) of your trailer and multiply by the indicated value below.

Longitudinal tension and compression:

(1.5 x GTWR)

Transverse thrust:

(0.5 x GTWR)

Vertical tension and compression:

(0.5 x GTWR)

Loads indicated must be applied without incurring loss of attachments or distortion or failure which could affect the safe towing of trailer.

The ball and trailer coupling must meet the following minimum test load requirements without incurring failure. Use the indicated Gross Weight Rating (GTWR) of your trailer and multiply by the indicated value below.

Longitudinal tension and compression:

(GTWR x 3)

Transverse thrust:

(GTWR x 1)

Vertical tension and compression:

(GTWR x 1.3)

In this case, failure is identified as the point at which the coupling or ball will accept no additional test load without separation of the ball from the coupling ball socket, or the occurrence of a metal fracture of either coupling ball or coupling assembly, which results in separation of the ball from the coupling ball socket.

Two lengths of safety chain shall be used. The strength rating (minimum breaking force) of each individual chain and its connecting means shall be equal to, or exceed the trailer's Gross Weight Rating (GTWR).

NOTE

Towing vehicle must be equipped with engine or transmission retarder. The engine or the transmission retarder on the vehicle must be functional at all time (to be inspected frequently).