

# SECTION 3

<b>DRIVER'S "DELIVERY" SEAT</b> .....	2
<b>DRIVER AND CO-PILOT SEAT-ISRI</b> .....	2
PNEUMATIC ISRI SEAT .....	2
ELECTRICAL ISRI SEAT .....	2
<b>DRIVER SEAT BELT</b> .....	3
<b>STEERING WHEEL ADJUSTMENT</b> .....	4
<b>DRIVER'S WINDOW SHADES</b> .....	4
<b>INSIDE MIRROR</b> .....	4
<b>ADJUSTABLE HVAC REGISTERS</b> .....	4
<b>WINDOWS</b> .....	5
DRIVER'S POWER WINDOW .....	5
FIXED WINDOWS .....	5
AWNING WINDOWS .....	5
SLIDING WINDOWS .....	5

## 3-2 Coach interior

### DRIVER'S "DELIVERY" SEAT

The driver's "delivery" seat is standard and legal only for driving the vehicle on its initial delivery. It is a conventional van seat equipped with tracks for fore and aft adjustments.



DRIVER'S DELIVERY SEAT

### DRIVER AND CO-PILOT SEAT-ISRI

Two distinct ISRI model driver's and co-pilot's seats may be supplied with your vehicle: both with a sophisticated air suspension system, one being pneumatically operated, while the other is electrically operated. Both seats may be equipped with lumbar supports, heated cushions and adjustable armrests. Seats can be adjusted to the desired driving position by following the instructions listed below:

#### PNEUMATIC ISRI SEAT

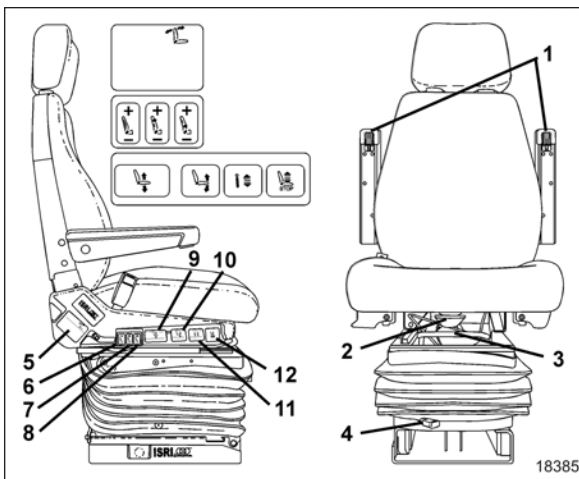

PNEUMATIC DRIVER'S SEAT

#### (1) Armrest

Rotate control knob to select desired arm-resting angle. When not in use, raise armrest parallel with backrest.

#### (2) Seat Cushion

Provides optimum comfort and support for any driver size. Adjustable to 50 mm (2 inch) length.

#### (3) Fore-and-aft

Pull handle up and slide seat forwards or backwards to adjust distance between seat and dashboard.

#### (4) Isolator

Reduces horizontal vibration, ensuring smooth ride.

#### (5) Backrest

Lift lever to select proper angle of backrest.

#### (6) Air Side Bolster

Offers desired side support to avoid body side-way.

#### (7) (8) Air Lumbar

Provides back support with upper and lower settings, ensuring comfort during lengthy sitting.

#### (9) Air Height Adjustment

Moves seat up or down independently of other seat settings. 100 mm (4 inch) total travel.

#### (10) Adjustable Seat Recline

Allows easy adjustment of four-setting inclination.

#### (11) Adjustable Shock Absorber

Choose stiff or soft ride infinitely.

#### (12) Quick Air Release

Exhausts all air from suspension, allowing for easy entry/exit. Returns seat to previous position.

#### ELECTRICAL ISRI SEAT

Adjust electric seats as follows:

##### Tilt (rear) (1)

Pull switch up to raise rear section of seat. Push switch down to lower rear section of seat.

##### Fore-and-aft/Up-Down (2)

Push switch towards dashboard to move seat forwards or back to move seat backwards. Pull

switch up to raise seat or push switch down to lower seat

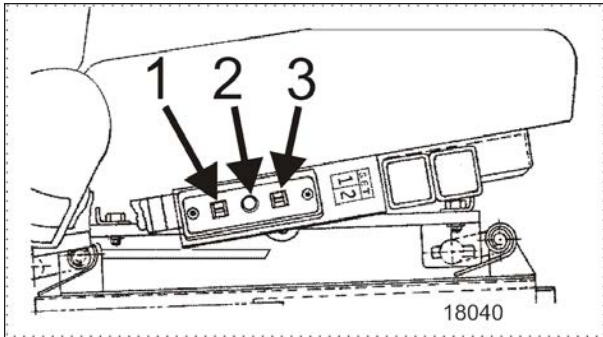

#### SEAT CONTROLS

##### Tilt (front) (3)

Pull switch up to raise front section of seat. Push switch down to lower front section of seat.

#### DRIVER SEAT BELT

The driver's seat is equipped with a retractable safety belt as required by State, Provincial and Federal regulations.



#### WARNING

A snug fit with the lap belt positioned low on the hips is necessary to maximize driver safety. The belt should not be worn twisted. Avoid pinching belt and/or belt hardware in seat mechanism. Do not wear belt over rigid or breakable objects, such as eyeglasses, pens or keys as these may cause injuries.



#### CAUTION

Never bleach or dry clean safety belt.

To fasten, pull seat belt out of the retractor and insert the latch plate into the buckle until it clicks. No special adjustment is required since the reel device is self-adjusting. If seat belt operation becomes defective, report to a Prevost Car service center immediately.

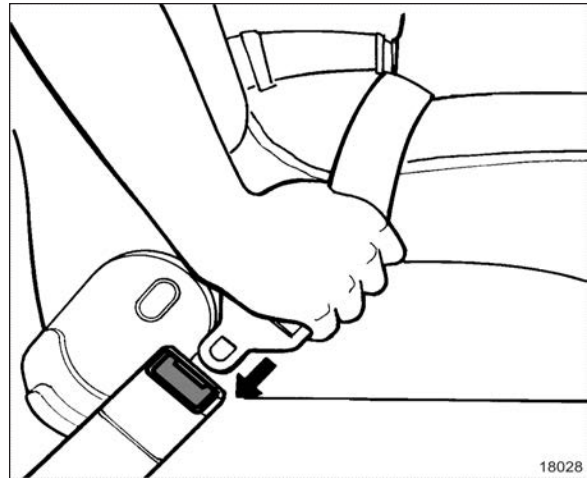

#### TO FASTEN SEATBELT

To unfasten belt, press the red button in center of buckle and allow belt to retract. If the belt does not fully retract, pull it out and check for kinks or twists. Make sure that it remains untwisted as it retracts.

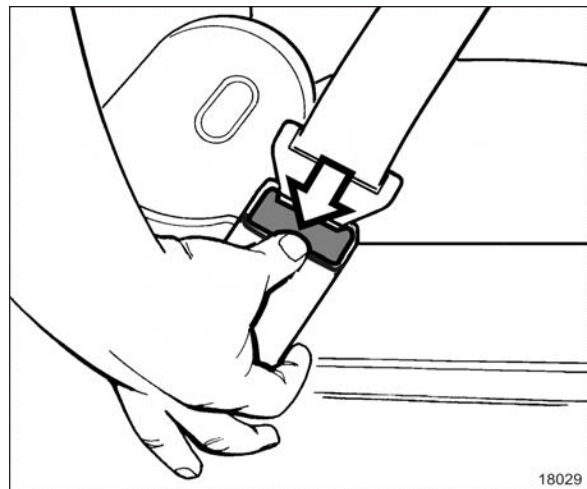

#### TO UNFASTEN SEATBELT



#### WARNING

Most State and Provincial laws require that safety belts be worn when they are supplied with the seat.

#### NOTE

*The safety belt must be pulled out slowly and continuously, otherwise it will lock the reel before the latch plate reaches the buckle. If this happens, allow the belt to retract completely and repeat the procedure correctly.*

## 3-4 Coach interior

### STEERING WHEEL ADJUSTMENT

Push on the valve button located in the foot-operated control housing to unlock the steering wheel for tilt and telescopic adjustment (refer to "[FOOT-OPERATED CONTROLS](#)" on page 7 in Controls and Instruments chapter).

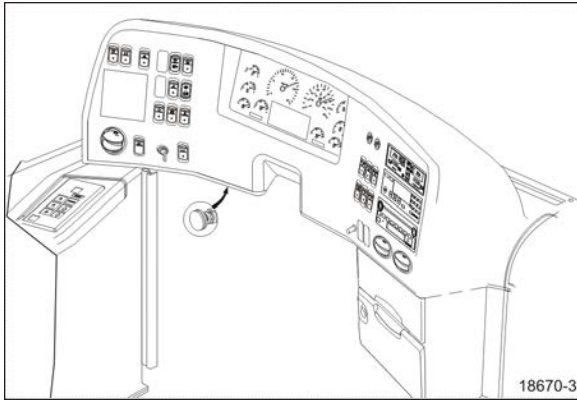

TILT AND TELESCOPIC ADJUSTMENT



#### DANGER

Do not adjust the steering wheel while driving. Loss of control could result. Park the vehicle safely and apply parking brakes before adjusting the steering wheel.

### DRIVER'S WINDOW SHADES

This vehicle is provided with a sun shade on the driver's left side window. To operate, pull down the shade by its knob to the appropriate position and release. It will remain in position. To raise, pull up the shade by its knob.

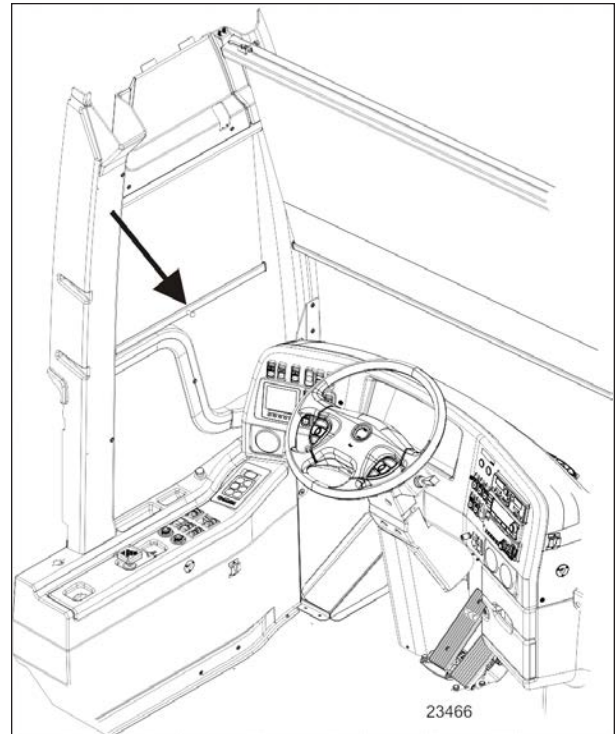

DRIVER'S WINDOW SUNSHADE

Two electrically-operated shades are installed behind the windshields. Two rocker switches on the dashboard operate each shade individually. Refer to "Controls and Instruments" chapter for more information.



#### CAUTION

The electric shades should only be operated electrically. Pulling down manually may damage the mechanism.

### INSIDE MIRROR

One (optional) mirror is located in the driver's area. The central mirror allows the driver to see in the central cabin aisle.

### ADJUSTABLE HVAC REGISTERS

The HVAC system has adjustable registers to control air flow around the driver's area. Three are located on the dashboard; two on the R.H. side and one on the L.H. Another one is located close to the door, below the modesty panel wall for step de-icing. The direction and volume of air flow are adjustable manually.

Use the HVAC control panel to set air temperature (refer to "[HVAC CONTROL UNIT](#)" on page 21 in Controls & Instruments chapter).

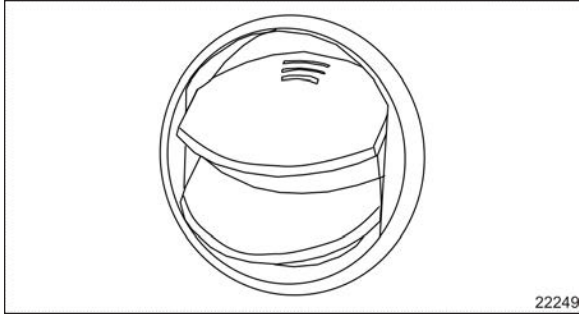

DASHBOARD AIR REGISTER

## WINDOWS

The vehicle is equipped with single pane or double pane (thermos) windows. There is either one or two power windows and a possible combination of three types of side windows, all of them flush-mounted to the structure: fixed, awning and sliding windows. Following is a description and operating instructions for these types of windows:

### DRIVER'S POWER WINDOW

The driver has a power window on the left side of the vehicle. The windows are controlled by a rocker switch located on the driver's control panel. Refer to "Controls and Instruments".

### FIXED WINDOWS

These windows are glued to the structure and form an integral part of the body of the vehicle, helping reduce vibration and noise. Fixed windows cannot be opened.

### AWNING WINDOWS

To open or close an electrically-operated awning window, use the rocker switch button located on the wall, next to the window. After closing the window, maintain the rocker switch button depressed to latch the window.



### CAUTION

Avoid holding the rocker switch button depressed after the window has reached its full opened position or after the window has been latched.



### CAUTION

Never try to open or close the awning window by pulling or pushing directly on the window; this could damage the opening mechanism gearbox.

A telltale light on the dashboard illuminates when an awning window is opened. Refer to Controls and instruments chapter for more information.

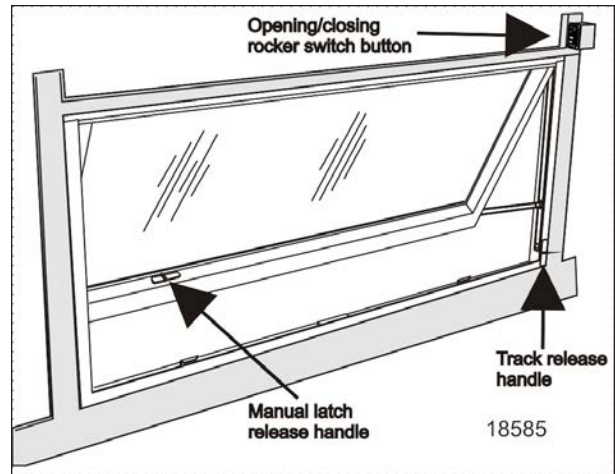

ELECTRIC AWNING WINDOW

### NOTE

*The awning window electrical circuit is equipped with a thermistor protecting the components from overheating. If the awning window is opened and closed repeatedly, causing overheating of the components, the thermal protection will interrupt the operation of the window for a short while to permit cooling down of the components. This feature also prevents personal injuries and damages to the components if something obstructs the window movement.*

### SLIDING WINDOWS

To open or close an electrically-operated sliding window, use the rocker switch button located on the wall, next to the window.



### CAUTION

Never try to open or close the sliding window by pulling or pushing directly on the window; this could damage the opening mechanism gearbox.

### 3-6 Coach interior

---

#### **NOTE**

*If the sliding window electrical circuit is inoperative, the power sliding window can be manually closed by removing the lateral plastic trim located on the R. H. side of the window to access the drive belt. Manually move the drive belt to close the window.*

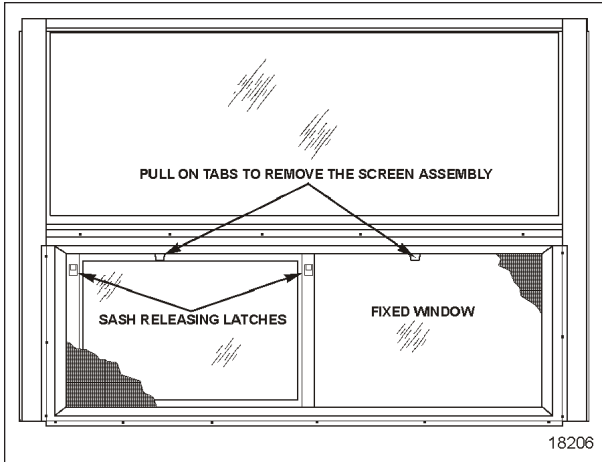

#### **SLIDING WINDOW**

#### **NOTE**

*The sliding window electrical circuit is equipped with a thermistor protecting the components from overheating. If the sliding window is opened and closed repeatedly, causing overheating of the components, the thermal protection will interrupt the operation of the window for a short while to permit cooling down of the components. This feature also prevents personal injuries and damages to the components if something obstructs the window movement.*