

SECTION 22: HEATING AND AIR CONDITIONING

CONTENTS

1. HEATING AND AIR CONDITIONING	5
2. AIR CIRCULATION WITH CENTRAL HVAC SYSTEM	5
2.1 DRIVER'S AREA	5
2.1.1 <i>Coaches only</i>	5
2.1.2 <i>VIP only</i>	5
2.2 PASSENGER'S (CABIN) AREA	5
3. AIR CIRCULATION WITH SMALL HVAC SYSTEM	7
3.1 AUXILIARY UNIT.....	7
4. SMALL HVAC SYSTEM OPERATION	7
4.1 DRIVER'S UNIT OPERATION.....	7
4.2 AUXILIARY UNIT OPERATION.....	7
5. CENTRAL HVAC SYSTEM OPERATION	7
5.1 DRIVER'S UNIT.....	7
5.2 PASSENGER'S UNIT	8
5.3 OVERHEAD COMPARTMENT UNIT (H3 COACHES).....	9
6. HVAC UNIT MAINTENANCE	9
6.1 COIL CLEANING	10
6.2 DRIVER'S HVAC UNIT AIR FILTERS	10
6.3 PASSENGER'S UNIT AIR FILTER.....	11
6.4 OVERHEAD COMPARTMENTS FAN AIR FILTER.....	11
7. HVAC SYSTEM PARTICULARITIES, TESTING AND TROUBLESHOOTING	11
7.1 HVAC SYSTEM AND TEST MODE FOR SWITCHES AND SENSORS	12
7.2 HVAC SYSTEM AND TEST MODE FOR ELECTRIC MOTORS	12
7.3 PARTICULARITIES.....	12
7.4 HVAC SYSTEM TROUBLESHOOTING.....	13
8. CENTRAL HVAC SYSTEM - AIR CONDITIONING	14
8.1 A/C CYCLE	14
8.2 REFRIGERANT	15
8.2.1 <i>Procurement</i>	15
8.2.2 <i>Precautions in Handling Refrigerant</i>	15
8.2.3 <i>Treatment in Case of Injury</i>	16
8.2.4 <i>Precautions in Handling Refrigerant Lines</i>	16
8.3 REFRIGERANT SYSTEM CLEAN-OUT AFTER COMPRESSOR FAILURE.....	16
8.3.1 <i>Determining Severity of Failure</i>	17
8.3.2 <i>Clean-out after Minor Compressor Failure</i>	17
8.3.3 <i>Clean-out After Major Compressor Failure</i>	17
8.4 PUMPING DOWN.....	17
8.5 ADDING REFRIGERANT (VAPOR STATE).....	19
8.6 EVACUATING SYSTEM.....	20
8.6.1 <i>Double Sweep Evacuation Procedure</i>	20
8.7 CHARGING SYSTEM.....	21
9. CENTRAL HVAC SYSTEM – AIR CONDITIONING COMPONENTS	22
9.1 COMPRESSOR.....	22
9.1.1 <i>Belt Replacement</i>	22
9.1.2 <i>Belt Play</i>	23
9.1.3 <i>Pulley Alignment</i>	23

Section 22: HEATING AND AIR CONDITIONING

9.1.4	Longitudinal Compressor Alignment	23
9.1.5	Horizontal Compressor Alignment	23
9.1.6	Vertical Compressor Alignment.....	23
9.1.7	Compressor Maintenance	23
9.1.8	Troubleshooting Guide.....	24
9.2	MAGNETIC CLUTCH	25
9.2.1	HVAC Control Unit and Clutch Operation	25
9.3	EVAPORATOR MOTOR	25
9.3.1	Removal	25
9.3.2	Installation	26
9.3.3	Checking Operation of Brush in Holder	26
9.3.4	Brush Wear Inspection and Replacement	26
9.3.5	Seating Brushes	26
9.3.6	Brush Holder Adjustment	27
9.3.7	Checking Commutator.....	28
9.4	CONDENSER.....	28
9.4.1	Condenser Fan Motors.....	28
9.4.2	Condenser Fan Motor Removal.....	28
9.4.3	Brush Wear Inspection / Replacement.....	29
9.5	RECEIVER TANK.....	29
9.6	FILTER DRYER	29
9.6.1	Replacement	30
9.6.2	Moisture Indicator.....	30
9.7	LIQUID REFRIGERANT SOLENOID VALVE	30
9.7.1	Manual Bypass.....	30
9.7.2	Coil Replacement.....	30
9.7.3	Valve Disassembly.....	31
9.7.4	Valve Reassembly.....	31
9.8	EXPANSION VALVE	31
9.8.1	Central system	31
9.8.2	Driver's System	34
9.9	TORCH BRAZING	34
9.10	TROUBLESHOOTING	35
9.10.1	Expansion Valve.....	35
9.10.2	A/C.....	36
9.11	TEMPERATURES & PRESSURES.....	38
9.12	LEAK TESTING	38
10.	SMALL HVAC SYSTEM – AIR CONDITIONING COMPONENTS.....	39
10.1	COMPRESSOR.....	39
10.2	MAGNETIC CLUTCH	39
10.3	MAINTENANCE PRECAUTIONS	39
10.3.1	Work Area.....	39
10.3.2	Refrigerant Handling	40
10.3.3	PAG Oil Handling	40
10.3.4	Refrigerant Recovery	40
10.3.5	Compressor Handling.....	40
10.4	COMPRESSOR REMOVAL	40
10.4.1	When the compressor is operational.....	40
10.4.2	When the compressor is inoperable.....	40
10.5	INSTALLATION PRECAUTIONS	41
10.6	COMPRESSOR OIL CHANGE	41
10.6.1	Evacuating System Before Adding Refrigerant (Driver's or Auxiliary System).....	42
10.7	OIL ADDITION.....	42
10.8	COMPRESSOR OIL CONTAMINATION.....	42
10.9	OIL RETURN OPERATION.....	42
10.10	OIL CHECK INTERVAL	43

10.11	LEAK TEST PROCEDURE WITH COMPRESSOR REMOVED.....	43
10.12	TIGHTENING TORQUES.....	44
11.	HEATING SYSTEM	47
11.1	SMALL HVAC SYSTEM	48
11.2	CENTRAL HVAC SYSTEM	48
11.3	DRAINING HEATING SYSTEM.....	48
11.3.1	<i>Draining Driver's Unit Heater Core.....</i>	<i>48</i>
11.3.2	<i>Draining Passenger's Unit Heater Core.....</i>	<i>48</i>
11.4	FILLING HEATING SYSTEM.....	49
11.5	BLEEDING HEATING SYSTEM	49
11.6	SOLDERING.....	50
11.7	DRIVER'S UNIT HOT WATER PNEUMATIC VALVE.....	50
11.8	PASSENGER'S UNIT HOT WATER PNEUMATIC VALVE ASSEMBLY	50
11.8.1	<i>Description</i>	<i>50</i>
11.8.2	<i>Hot Water Pneumatic Valve Disassembly.....</i>	<i>50</i>
11.8.3	<i>Hot Water Pneumatic Valve Reassembly</i>	<i>51</i>
11.8.4	<i>Pilot Solenoid Valve</i>	<i>51</i>
11.8.5	<i>Valve Troubleshooting.....</i>	<i>51</i>
11.9	HOT WATER RECIRCULATING PUMP.....	51
11.9.1	<i>Removal</i>	<i>52</i>
11.9.2	<i>Disassembly.....</i>	<i>52</i>
11.9.3	<i>Brushes</i>	<i>52</i>
11.9.4	<i>Assembly.....</i>	<i>53</i>
11.9.5	<i>Installation</i>	<i>53</i>
11.10	WATER FILTER	53
11.10.1	<i>Maintenance</i>	<i>53</i>
11.10.2	<i>Filter Servicing.....</i>	<i>53</i>
11.11	BYPASS SOLENOID WATER VALVE (OPTIONAL)	54
11.11.1	<i>Improper Operation.....</i>	<i>54</i>
11.11.2	<i>To Remove or Change the Coil.....</i>	<i>54</i>
11.11.3	<i>Valve disassembly and Reassembly.....</i>	<i>54</i>
12.	PREHEATING SYSTEM (OPTIONAL ON COACHES ONLY).....	55
12.1	OPERATION.....	56
12.2	PREHEATING SYSTEM TIMER.....	56
12.2.1	<i>Timer operating instructions (Webasto).....</i>	<i>56</i>
12.3	TROUBLESHOOTING AND MAINTENANCE.....	58
13.	SPECIFICATIONS	59

ILLUSTRATIONS

FIGURE 1:	DRIVER'S UNIT AIR CIRCULATION (COACHES & VIP).....	5
FIGURE 2:	CENTRAL HVAC SYSTEM – PASSENGER'S UNIT AIR CIRCULATION (COACH)	6
FIGURE 3:	OVERHEAD COMPARTMENT VENTILATION SYSTEM.....	7
FIGURE 4:	CONTROL UNIT - SMALL HVAC SYST.....	7
FIGURE 5:	CONTROL UNIT - CENTRAL HVAC SYST	7
FIGURE 6:	MAIN BREAKERS.....	9
FIGURE 7:	HVAC CONTROL PANEL	9
FIGURE 8:	PASSENGER OVERHEAD COMPARTMENT UNIT.....	9
FIGURE 9:	PASSENGER'S UNIT EVAPORATOR COIL	10

Section 22: HEATING AND AIR CONDITIONING

FIGURE 10: PASSENGER'S UNIT EVAPORATOR COIL (VIP WITH CENTRAL HVAC SYSTEM ONLY)	10
FIGURE 11: PASSENGER'S UNIT CONDENSER COIL	10
FIGURE 12: R.H CONSOLE AIR FILTER ACCESS GRILL (COACHES)	11
FIGURE 13: R.H. CONSOLE AIR FILTER ACCESS GRILL (VIP)	11
FIGURE 14: DRIVER'S UNIT AIR FILTERS.....	11
FIGURE 15: PASSENGER'S UNIT AIR FILTER	11
FIGURE 16: PARCEL RACK FAN AIR FILTER	11
FIGURE 17: CENTRAL HVAC SYSTEM – AIR CONDITIONING.....	19
FIGURE 18: DOUBLE SWEEP EVACUATION SET-UP	21
FIGURE 19: TENSIONING VALVE	22
FIGURE 20: DRIVE BELT TENSIONING AIR BELLOWS.....	23
FIGURE 21: BELT PLAY	23
FIGURE 22: COMPRESSOR ALIGNMENT	24
FIGURE 23: COMPRESSOR ALIGNMENT	24
FIGURE 24: EVAPORATOR COMPARTMENT	25
FIGURE 25: EVAPORATOR MOTOR ASSEMBLY.....	26
FIGURE 26: PROPER GRINDING TECHNIQUE	26
FIGURE 27: IMPROPER GRINDING TECHNIQUE	27
FIGURE 28: GRINDING WITH THE BRUSH SEATER STONE	27
FIGURE 29: SEATING SURFACE OF THE BRUSH.....	27
FIGURE 30: EVAPORATOR MOTOR	28
FIGURE 31: CONDENSER FAN SPEED IN RELATION WITH HIGH SIDE PRESSURE	28
FIGURE 32: CONDENSER FAN MOTOR	29
FIGURE 33: A/C CONDENSER COMPARTMENT	29
FIGURE 34: REFRIGERANT SOLENOID VALVE	31
FIGURE 35: EXPANSION VALVE	32
FIGURE 36: SUPERHEAT ADJUST. INSTALLATION	33
FIGURE 37: HIGH & LOW SWING TEMPERATURE AT REMOTE BULB.....	33
FIGURE 38: SELTEC TM-16HD COMPRESSOR	39
FIGURE 39: COMPRESSOR REMOVAL OR INSTALLATION.....	40
FIGURE 40: LOOSENING THE DISCHARGE SIDE CONNECTOR'S CAP.....	41
FIGURE 41: ROTATING MAGNETIC CLUTCH	41
FIGURE 42: COMPRESSOR OIL LABEL.....	41
FIGURE 43: DRAINING THE OIL	41
FIGURE 44: ADDING NEW COMPRESSOR OIL.....	41
FIGURE 45: ADDING OIL AFTER REPLACING A COMPONENT	42
FIGURE 46: DISCHARGE AND SUCTION CAPS	43
FIGURE 47: TIGHTENING TORQUES	44
FIGURE 48: SMALL HVAC SYSTEM - AIR CONDITIONING.....	45
FIGURE 49: SMALL HVAC SYSTEM - DRIVER'S AND AUXILIARY UNIT	45
FIGURE 50: SMALL HVAC SYSTEM	46
FIGURE 51: CENTRAL HVAC SYSTEM – HEATING	47
FIGURE 52: DRIVER'S UNIT AIR MIXING BOX	48
FIGURE 53: PASSENGER'S UNIT HEATER CORE (H3 COACHES).....	49
FIGURE 54: HEATER CORE INSIDE EVAPORATOR COMPARTMENT (H3 COACHES)	49
FIGURE 55: HEATER LINE SHUTOFF VALVES (CENTRAL HVAC SYSTEM)	49
FIGURE 56: HEATER LINE SHUTOFF VALVES (SMALL HVAC SYSTEM)	49
FIGURE 57: PASSENGER'S UNIT HOT WATER PNEUMATIC VALVE ASSEMBLY	50
FIGURE 58: PASSENGER'S UNIT HOT WATER PNEUMATIC VALVE	51
FIGURE 59: HOT WATER RECIRCULATING PUMP INSTALLATION (CENTRAL HVAC SYSTEM)	52
FIGURE 60: HOT WATER RECIRCULATING PUMP INSTALLATION (SMALL HVAC SYSTEM)	52
FIGURE 61: HOT WATER RECIRCULATING PUMP	53
FIGURE 62: WATER FILTER	54
FIGURE 63: BYPASS HOT WATER SOLENOID VALVE.....	55
FIGURE 64: WEBASTO PREHEATER (104,000 BTU)	55
FIGURE 65: WEBASTO	56

1. HEATING AND AIR CONDITIONING

The coach's interior is pressurized by its Heating, Ventilation, Air Conditioning (HVAC) system. Air flow and controls divide the vehicle in two areas: driver's area and passenger's (cabin) area. The interior of vehicle should always be slightly pressurized to prevent dust and moisture from entering vehicle. Each section has its own fresh air, returning air and discharge air ducting. The exhaust is mainly done through the lavatory ventilator and through normal air-tightness losses.

2. AIR CIRCULATION WITH CENTRAL HVAC SYSTEM

2.1 DRIVER'S AREA

Fresh air is taken from a plenum behind the front bumper and enters the mixing box through an ON/OFF damper. Return air is taken through the right console into the mixing box. Mixed air goes through cooling and heating coils, fans and discharge ducts.

Both right and left discharge ducts defrost one half of the windshield. The driver can also divert his air flow to the dashboard, from which he can direct vent to his upper body with adjustable HVAC register and to his feet with the appropriate button (see Figure 1 and Operator's manual or Owner's manual).

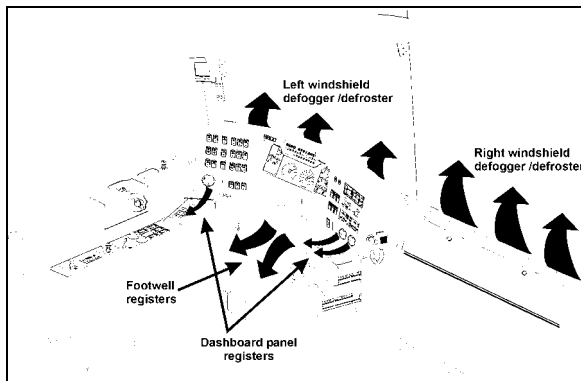

FIGURE 1: DRIVER'S UNIT AIR CIRCULATION (COACHES & VIP)

22291

2.1.1 Coaches only

Two additional air outlets are located in the driver's area but supplied by the passenger's (cabin) unit ducting system. One is located in the stepwell for step de-icing (Figure 2). The air flow outlet comes from the left side and is drawn from the first step riser. The other air outlet is located behind the driver, on his L.H. side. The air outlets can be rotated to direct Air flow. Optionally, the coach may be equipped with a

defogger/defroster system in the windshield upper-section, refer to paragraph: "Central Heating System" for more information.

2.1.2 VIP only

VIP vehicles equipped with the Central HVAC System have two additional registers called Navigator's registers located near the entrance door, at bottom of first lateral window.

2.2 PASSENGER'S (CABIN) AREA

Fresh air is taken from the left side of vehicle through a two-position damper located at the left of the evaporator compartment. The thermal control damper can be fully opened for normal operation or partially closed for extreme weather or highly polluted areas. The recirculation REC button is located on the HVAC control unit. Press down the button to partially close the fresh air damper.

NOTE

Opening the entrance door also partially closes the fresh air damper.

Return air is drawn through the first entrance step riser (coaches only), last entrance step riser and from the lower section of the floor ducts in two locations: one in the rear section of vehicle and the other in the front section of vehicle on the L.H. side (Figure 2).

A double blower fan unit, which is activated by the evaporator motor, draws mixed air through an air filter, cooling and heating coils, then forces this air in the ventilation ducts (upper section) along the walls, and finally exhausts it at the bottom of the windows.

On coaches, the Central HVAC system includes an overhead compartment ventilation system equipped with adjustable registers in the passenger's overhead console to control air flow for the passenger seats. One register per seat direct air flow by pointing or rotating register. Open or close register to adjust air flow (Figure 3). Also on coaches, the lavatory ventilator acts as the main exhaust for the whole vehicle, eliminates odors, and finally heats or cools the lavatory with the vehicle's ambient air.

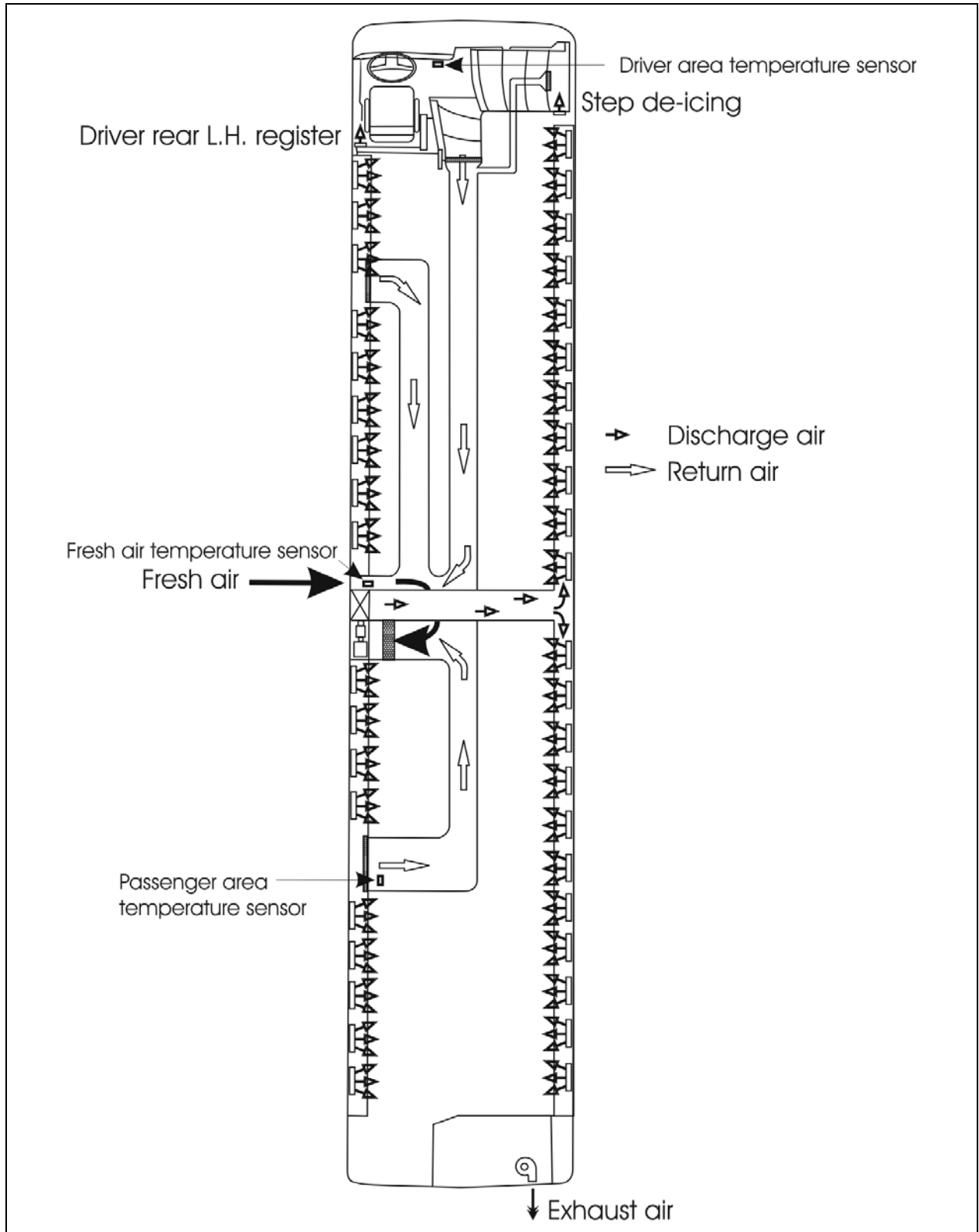

FIGURE 2: CENTRAL HVAC SYSTEM – PASSENGER'S UNIT AIR CIRCULATION (COACH)

22264

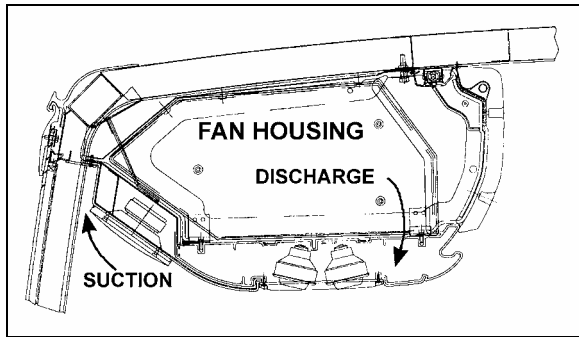

FIGURE 3: OVERHEAD COMPARTMENT VENTILATION SYSTEM 22211

3. AIR CIRCULATION WITH SMALL HVAC SYSTEM

Fresh air is taken from a plenum behind the front bumper and enters the mixing box through an adjustable damper. Returning air is taken through the right console into the mixing box. The recirculation REC button is located on the HVAC control unit (Figure 4). Mixed air goes through cooling and heating coils, fans and discharge ducts.

Both right and left discharge ducts defrost/defog one half of the windshield. The driver can divert his air flow to the dashboard, from which he can direct vent to his upper body with adjustable HVAC register and to his feet with the appropriate button (see Figure 1 and Owner's manual).

3.1 AUXILIARY UNIT

VIP vehicles with small HVAC system are equipped with an auxiliary system that provides five additional registers. Three are located behind the driver's seat and the other two are located near the entrance door, at bottom of first lateral window. The auxiliary unit comes with cooling and heating coils, fan and discharge ducts.

4. SMALL HVAC SYSTEM OPERATION

4.1 DRIVER'S UNIT OPERATION

The temperature control in the driver's area is provided directly by the HVAC control unit mounted on the dashboard R.H. side.

Using the Up/Down type switch sets the fan speed and the speed chosen is displayed on the HVAC control unit.

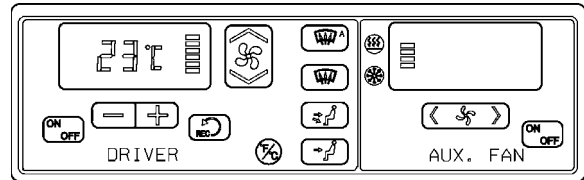

FIGURE 4: CONTROL UNIT - SMALL HVAC SYST. 22286

4.2 AUXILIARY UNIT OPERATION

The temperature control is provided by the small system HVAC control unit. The R.H. portion of the HVAC control unit enables to actuate the Auxiliary Unit and to regulate the fan speed. Using the < > type switch sets the fan speed and the speed chosen is illustrated on the window display.

5. CENTRAL HVAC SYSTEM OPERATION

To operate the air conditioning system when coach is stationary, engine should run at fast idle. During operation of the air conditioning system, windows should be kept closed and door not left open longer than necessary. In order to prevent battery discharge, HVAC system will not operate if vehicle charging system is not working properly.

5.1 DRIVER'S UNIT

The temperature control in the driver's area is provided directly by the L.H. portion of the HVAC control unit.

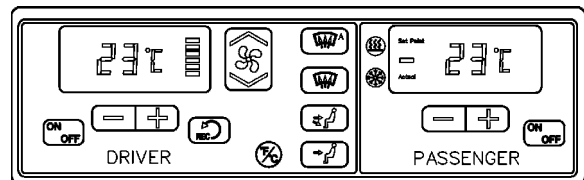

FIGURE 5: CONTROL UNIT - CENTRAL HVAC SYST 22276

The driver's unit piping is paralleled with the passenger's unit piping. Both units use the same refrigerant and coolant, and are linked to the same condenser and compressor, even if they are individually controlled. It requires the passenger's unit to engage the A/C compressor magnetic clutch; consequently, the driver's unit cannot be operated alone in the air conditioning mode.

NOTE

The driver's HVAC section turns on automatically at starting of the engine and uses the settings that were kept in memory before turning off of the system.

The A/C compressor starts automatically when the two following conditions are satisfied:

Section 22: HEATING AND AIR CONDITIONING

1. The outside temperature is above 32°F (0°C).
2. The passenger's area temperature has reached 7°F (4°C) under the set point.

NOTE

Upon starting, if the outside temperature is above 32°F (0°C) and then drops below 32°F (0°C), the compressor will keep running up to a temperature of 15°F (-9°C) to prevent condensation from forming on the windows.

NOTE

To perform a test of the driver's section windshield defroster, it is possible to run the system without running the engine.

The following table and 2% error chart can be used to troubleshoot the driver's area air temperature sensor and the two other temperature sensors (passenger's area and fresh air).

NOTE

VIP vehicles equipped with Small HVAC System have two air temperature sensors; the driver's area temperature sensor (same place as coaches) and the exterior temperature sensor located behind the reclining bumper.

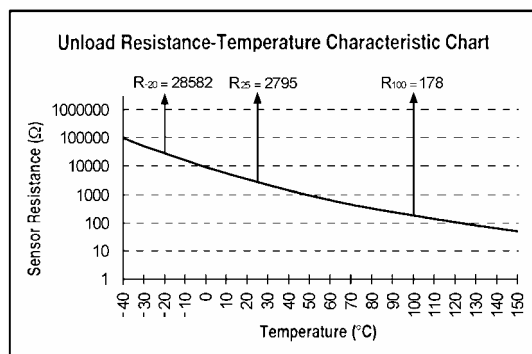

TEMPERATURE SENSOR		
Temp °C	Temp °F	Resistance Ohms
-40	-40	100865
-35	-31	72437
-30	-22	52594
-25	-13	38583
-20	-4	28582

-15	5	21371
-10	14	16120
-5	23	12261
0	32	9399
5	41	7263
10	50	5658
15	59	4441
20	68	3511
25	77	2795
30	86	2240
35	95	1806
40	104	1465
45	113	1195
50	122	980
55	131	808
60	140	670
65	149	559
70	158	468
75	167	394
80	176	333
85	185	283
90	194	241
95	203	207
100	212	178
105	221	153
110	230	133
115	239	115
120	248	100
125	257	88
130	266	77
135	275	68
140	284	60
145	293	53
150	302	47

Using the Up/Down type switch sets the fan speed and the speed chosen is illustrated on the window display.

5.2 PASSENGER'S UNIT

The passenger section of the HVAC control unit enables the selection of the temperature in the passenger's section (Refer to the VIP Owner's manual or H3 Operator's Manual for details).

Temperature control is provided in conjunction with a thermistor sensor located inside return duct, on L.H. side of vehicle (Figure 2).

The flow of water to the passenger's unit heater core is controlled by a pneumatic water valve which varies the cycling rate depending on selected temperature. A red LED indicator, located on the HVAC control unit, illuminates when the heating mode is one. A green LED indicator illuminates when compressor clutch is in operation.

The evaporator motor is located in the evaporator compartment on the L.H. side of vehicle is protected by a 90 amp, manually-resettable (CB3) circuit breaker mounted in the

main power compartment (refer to Section 06, "Electrical System" in this manual for details).

The condenser coil mounted on the opposite side of the evaporator is ventilated by two axial fans. The fan motors are protected by a manually-resettable 40 amp circuit breaker (CB 12) and a 70 amp circuit breaker (CB 7) mounted in the main power compartment on rear R.H. side of vehicle (Figure 6). Furthermore, the following relays, diodes and multiplex modules are located in the evaporator compartment (Figure 7). They are mounted on the HVAC components panel located on the R.H. side wall when facing the compartment.

Multiplex Module (evaporator compartment)	
A54	I/O-B
Relays (evaporator compartment)	
R9	24V Condenser fan R.H.
R10	24V Condenser fan L.H.
R12	24V Evaporator fan
R20	Water pump
R26	Pre-heating
Diodes (evaporator compartment)	
D9	Pre-heating
D10	Pre-heating
D16	Baggage compartment -3
D17	Baggage compartment -5
D19	Baggage compartment -2
D20	Baggage compartment -1
DXX	Not used

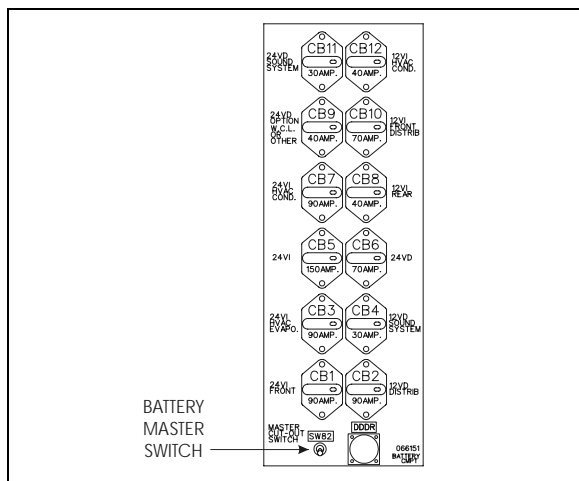

FIGURE 6: MAIN BREAKERS

06582

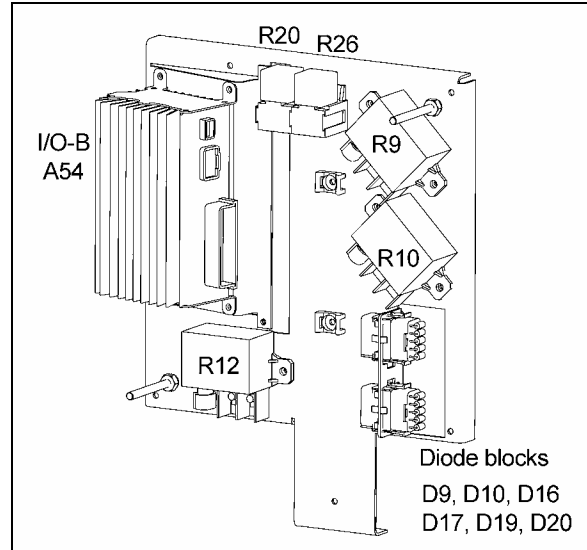

FIGURE 7: HVAC CONTROL PANEL

06596

5.3 OVERHEAD COMPARTMENT UNIT (H3 COACHES)

Optional evaporator coils may be added to both overhead compartment air systems. This air conditioning unit permits a wider temperature range in the passenger's area.

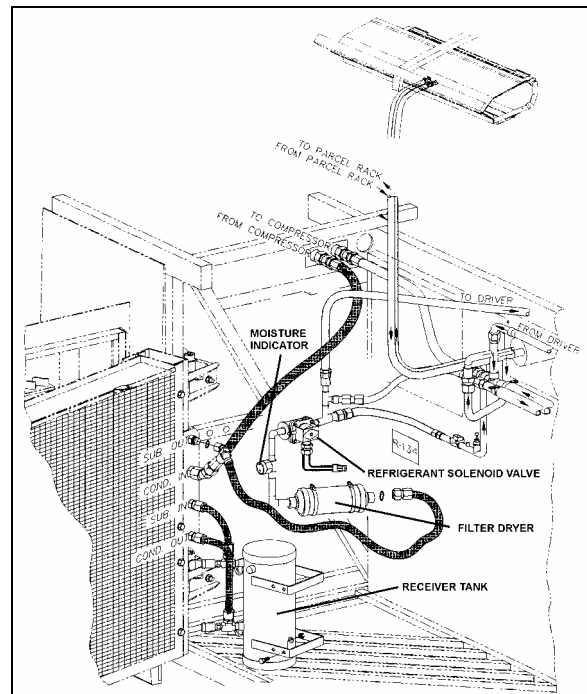

FIGURE 8: PASSENGER OVERHEAD COMPARTMENT UNIT

22221

6. HVAC UNIT MAINTENANCE

No special maintenance is required on the passenger's and driver's units, with the

Section 22: HEATING AND AIR CONDITIONING

exception of cleaning their respective coil air filters.

NOTE

Squeeze rubber hose located under the concerned compartment, to eliminate water and dirt when you make routine maintenance.

6.1 COIL CLEANING

Check the external surface of the coil at regular intervals for dirt or any foreign matter.

For the driver's HVAC unit, remove the grill and the access panels and back flush the evaporator coil from inside (Figure 14).

For the optional windshield upper section defogger/defroster, remove the bottom access panel, remove the six bolts fixing the blower motor assembly. Use low air pressure to clean the coil.

For the passenger's unit evaporator coil, back flush the coil (Figure 9) every 12,500 miles (20 000 km) or once a year whichever comes first and for the condenser, back flush the coil (Figure 11) every 6,250 miles (10 000 km) or twice a year, whichever comes first.

Use a water jet or water mixed with low air pressure to clean the coil.

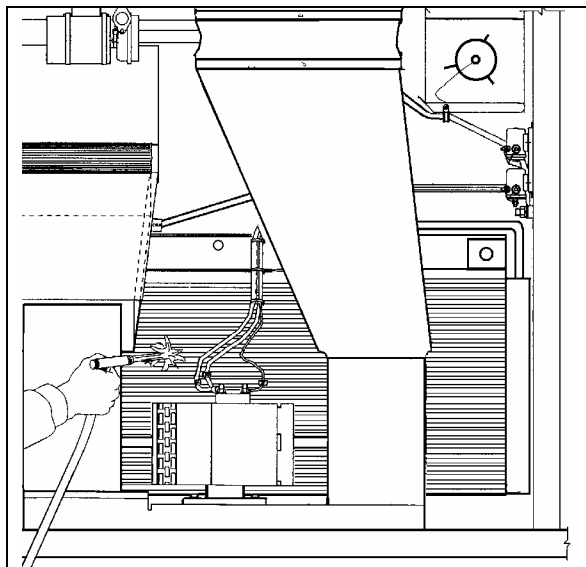

FIGURE 9: PASSENGER'S UNIT EVAPORATOR COIL 22226

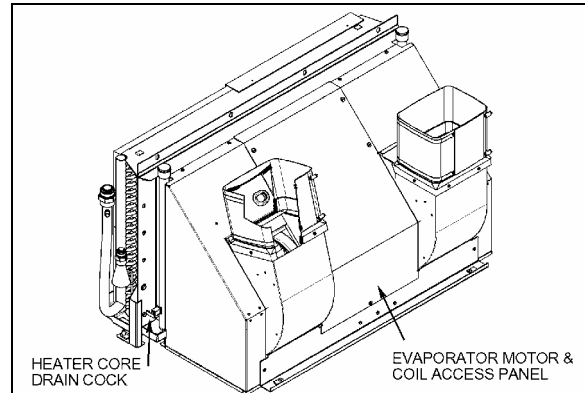

FIGURE 10: PASSENGER'S UNIT EVAPORATOR COIL (VIP WITH CENTRAL HVAC SYSTEM ONLY)

22332

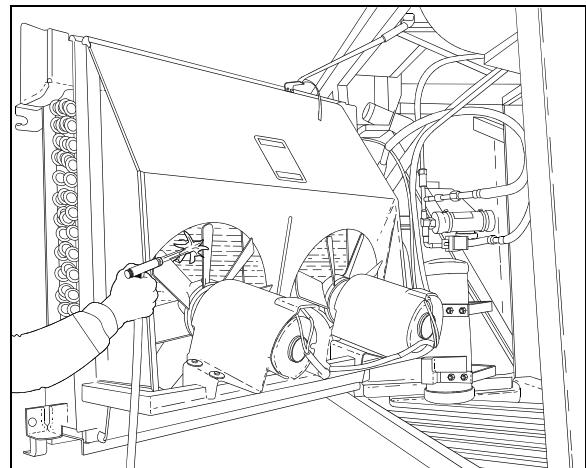

FIGURE 11: PASSENGER'S UNIT CONDENSER COIL 22170

CAUTION

Direct the pressure straight through the coil to prevent bending of fins and do not use extremely high pressure. Do not use hot water, steam or caustic soap.

6.2 DRIVER'S HVAC UNIT AIR FILTERS

The driver's unit is located behind the R.H. console panel. To gain access to the air filters, unscrew the R.H. console's grill located in the entrance stepwell. Slide out the "recirculating air filter" and "fresh air filter". To clean filter back flush with water, then dry with air, every 12,500 miles (20 000 km) or once a year, whichever comes first (Figure 12 to Figure 14).

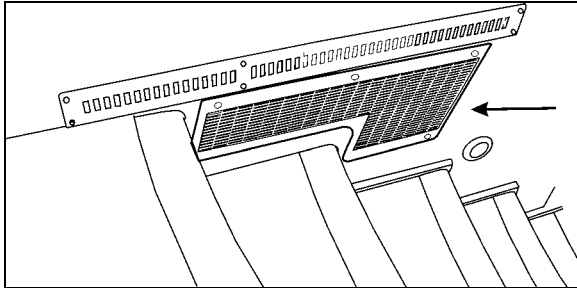

FIGURE 12: R.H. CONSOLE AIR FILTER ACCESS GRILL (COACHES) 18505

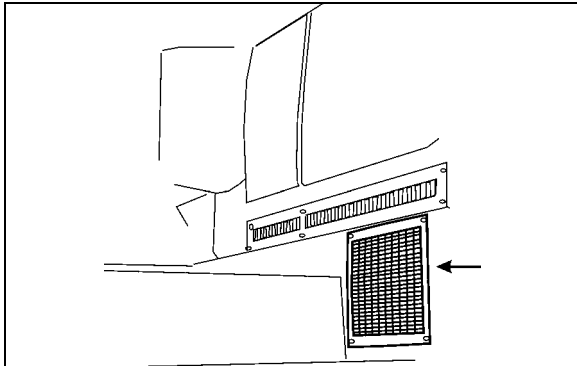

FIGURE 13: R.H. CONSOLE AIR FILTER ACCESS GRILL (VIP) 22232

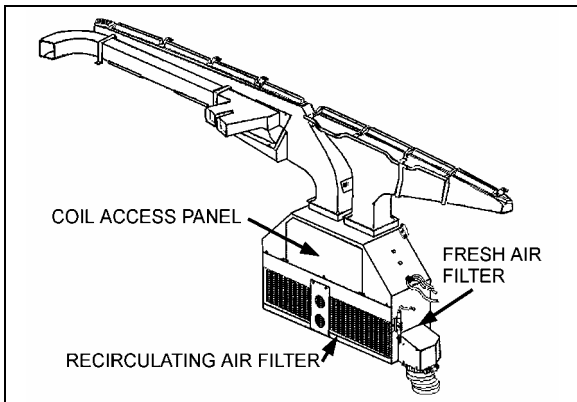

FIGURE 14: DRIVER'S UNIT AIR FILTERS 22171

6.3 PASSENGER'S UNIT AIR FILTER

The passenger's unit air filter is located in the evaporator compartment (Figure 15). To access the filter, locate access panels in one of the baggage compartments adjacent to the evaporator compartment. Open panels by turning the three screws of either panel ¼ of a turn, unsnap both fasteners on top of filter, and slide out filter. To clean filter, back flush with water or soapy water, then dry with air every 12,500 miles (20 000 km) or once a year, whichever comes first.

⚠ CAUTION ⚠

Do not use high pressure water jet to

avoid damaging filter.

⚠ CAUTION ⚠

Be sure not to reverse filter upon installation.

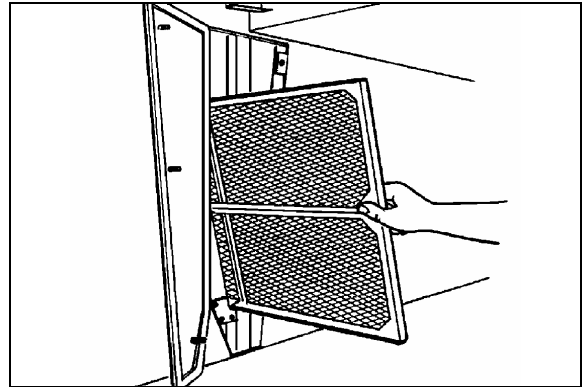

FIGURE 15: PASSENGER'S UNIT AIR FILTER 22100

6.4 OVERHEAD COMPARTMENTS FAN AIR FILTER

Air conditioning evaporator coils may be installed in both overhead compartment air systems. Only the air filters are serviceable. The air filters are accessible from inside the overhead compartments (Figure 16). Slide out the filters, then back flush with water, dry with air and replace. This procedure should be done every 12,500 miles (20,000 km) or once a year, whichever come first.

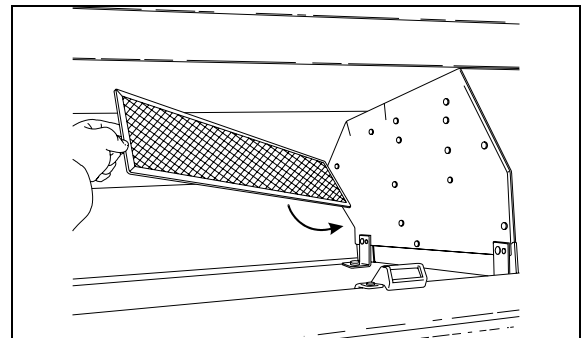

FIGURE 16: PARCEL RACK FAN AIR FILTER 22201

For air conditioning unit, ball valves are added on supply and return lines in the condenser compartment. They have service port to evacuate the A/C parcel rack circuit. When work has to be done on an evaporator coil unit, it will be easier to remove it and repair it on a bench.

7. HVAC SYSTEM PARTICULARITIES, TESTING AND TROUBLESHOOTING

Before undertaking any troubleshooting on the HVAC system, study the appropriate wiring

Section 22: HEATING AND AIR CONDITIONING

diagrams to get a complete understanding of the HVAC components circuitry, read and understand section 06:ELECTRICAL of this manual under "Troubleshooting And Testing The Multiplex Vehicles" and "Test Mode For Switches And Sensors". The information included in these paragraphs is necessary for troubleshooting the HVAC system on Multiplex vehicles.

7.1 HVAC SYSTEM AND TEST MODE FOR SWITCHES AND SENSORS

When in switch/sensor test mode (see Section 06: ELECTRICAL for complete information), the A/C compressor HI and LO pressure values are displayed one after the other instead of the outside temperature in the telltale panel LCD display. This feature can be used when the vehicle is traveling to check the A/C compressor pressure values.

NOTE

When starting the A/C compressor wait 5 seconds before checking pressures in order to give the system a chance to build its pressure. During the first 5 seconds after startup, the compressor is active on 6 cylinders and the A/C valve is open regardless of the pressure readings.

In test mode, with the parking brake applied and the passenger set point set to a value higher than 64°F (18°C), the hot water circulating pump is not set to OFF as it would normally do when the outside temperature gets above 50°F

Conditions for engaging the 2 nd speed on the evaporator motor (cooling demand).	The 2 nd speed engages if the passenger's area temperature is 1 degree above the set point and it revert to speed 1 if the temperature gets equal or below the set point.
Conditions for hot water recirculating pump activation (heating demand).	The pump turns to OFF if the outside temperature is above 50°F (10°C), when there is less demand for heating. Note: To test a working pump, it is possible to keep it active even if the outside temperature is above 50°F (10°C). See paragraph 5.2 HVAC SYSTEM AND TEST MODE FOR SWITCHES AND SENSORS.
The compressor unloaders are working based on pressure and also on the difference between the passenger's area temperature and the set point.	2 left compressor cylinders: Stop if: Passenger's area temperature is at less than 0.4°C degree above the set point or if the compressor output is above 280 psi, or if the compressor input is below 26 psi. Restart if: Passenger's area temperature is 0.9°C or more above the set point and the compressor pressure output is less than 220 psi and

(10°C). This feature allows verification of the pump when inside a garage. This is also useful when working on the heating system to remove air pockets trapped in the system.

When performing an A/C cooling test and having the water pump shut off in switch/sensor test mode is required, just set the passenger set point temperature to the minimum 64°F (18°C) to shut off the pump.

7.2 HVAC SYSTEM AND TEST MODE FOR ELECTRIC MOTORS

The test mode allows testing the motors and electric contactors without the need to have the engine running (see Section 06: ELECTRICAL under "TEST MODE FOR ELECTRICAL MOTORS" for complete information).

Use this test mode for testing of the condenser motors, the A/C compressor clutch activation, left and right unloaders, evaporator motor, water pump, hot water solenoid valve and overhead compartment air register fans.

7.3 PARTICULARITIES

	<p>the compressor pressure input is above 34 psi.</p> <p>2 right compressor cylinders:</p> <p>Stop if: Passenger's area temperature is at less than 0.2°C above the set point or if the compressor input falls below 23 psi.</p> <p>Restart if: Passenger's area temperature is 0.7°C or more above the set point and the compressor input pressure is above 32 psi.</p>
The A/C deactivation pressure is 320 psi.	<p>In case of high pressure, the analog pressure sensor connected to the Multiplex module deactivates the compressor.</p> <p>There is also a « Pressure switch » adjusted to 350 PSI that acts to stop the compressor in the instance that the Multiplex module fails.</p>

7.4 HVAC SYSTEM TROUBLESHOOTING

Problem/Symptom	Probable Causes	Actions
<p>No temperature control in the passenger area</p> <p>Passenger temperature display indicates two dashes "--"</p>	<p>Problem with the temperature sensor located in the passenger's area return air duct or the sensor wiring</p>	<p>1. Instruct the driver to manually control the temperature by playing with the passenger set point. Set above 22°C (72°F) to heat and below 22° C (72°F) to cool</p>
<p>Defroster fan not functioning</p>	<p>Module A47 is not powered or is faulty</p>	<p>1. Check the SYSTEM DIAGNOSTIC menu of the message center display (MCD). Select FAULT DIAGNOSTIC and ELECTRICAL SYSTEM. The message "Voltage Module A47, Value too Low, Active" confirms a power problem on the module</p> <p>2. Check / reset circuit breaker CB6</p> <p>3. Check / replace fuse F5</p> <p>4. Use the air release valves near the entrance door and in the front service compartment to lock / unlock the door</p>
<p>HVAC condenser fans not functioning in speed 1</p>	<p>Circuit breaker CB12 was manually tripped and not reset</p> <p>Seized bearing</p> <p>Brush problem</p> <p>Bad wiring</p>	<p>1. Check / reset circuit breaker CB12</p>
<p>HVAC condenser fans not functioning in speed 1</p>	<p>Module A54 is not powered or is faulty</p>	<p>1. Check the SYSTEM DIAGNOSTIC menu of the message center display (MCD). Select FAULT DIAGNOSTIC and ELECTRICAL SYSTEM. The message "Voltage Module A54, Value too Low, Active" confirms a power problem on the module</p> <p>2. Check / reset circuit breaker CB5</p> <p>3. Check / replace fuse F67 , F68</p>

Section 22: HEATING AND AIR CONDITIONING

Problem/Symptom	Probable Causes	Actions
HVAC condenser fans not functioning in speed 2	Circuit breaker CB7 was manually tripped and not reset Seized bearing Brush problem Bad wiring	1. Check / reset circuit breaker CB7
Defroster fan is functioning but no heat or cooling available in the driver area	Module A46 is not powered or is faulty Faulty speed control Bad wiring	1. Check the SYSTEM DIAGNOSTIC menu of the message center display (MCD). Select FAULT DIAGNOSTIC and ELECTRICAL SYSTEM. The message "Voltage Module A46, Value too Low, Active" confirms a power problem on the module 2. Check / reset circuit breaker CB1 3. Check / replace fuse F12
The A/C compressor clutch does not engage	Module A52 is not powered or is faulty	1. Check the SYSTEM DIAGNOSTIC menu of the message center display (MCD). Select FAULT DIAGNOSTIC and ELECTRICAL SYSTEM. The message "Voltage Module A52, Value too Low, Active" confirms a power problem on the module 2. Check / reset circuit breaker CB5 3. Check / replace fuse F65
Evaporator fan not functioning	Circuit breaker CB3 tripped Module A54 is not powered or is faulty Brush problem	1. Check / reset circuit breaker CB3 2. Check the SYSTEM DIAGNOSTIC menu of the message center display (MCD). Select FAULT DIAGNOSTIC and ELECTRICAL SYSTEM. The message "Voltage Module A54, Value too Low, Active" confirms a power problem on the module 3. Check / reset circuit breaker CB5 4. Check / replace fuse F67 , F68

8. CENTRAL HVAC SYSTEM - AIR CONDITIONING

The schematic of Figure 17 shows the central A/C system and its components. The central system is equipped with a 6 cylinder, 05G Twin Port-134A Carrier compressor with an air conditioning capacity of 9 tons. The receiver tank and filter dryer are mounted inside the condenser compartment.

NOTE

For opening of the A/C condenser door, open the baggage compartment door at the right of the A/C condenser compartment door. The condenser compartment door must be unbolted to fully swing open.

8.1 A/C CYCLE

Refrigeration may be defined as "the transfer of heat from a place where it is not wanted to a place where it is unobjectionable". Components required for a closed circuit refrigeration system are shown in Figure 17.

The air conditioning system used in the H3 series vehicle is the "Closed" type using R134a refrigerant.

1. The refrigerant flowing to the compressor is compressed to high pressure and reaches a temperature higher than the surrounding air. It is passed through the air-cooled fins and tubes of the condenser causing the hot, high pressure gas to be condensed into a liquid form.
2. The liquid refrigerant flows to the receiver tank, then back to the condenser sub-cooler. It leaves the condenser and passes through a filter dryer where moisture, acids and dirt are removed and then through a moisture indicator which indicates if any moisture is present in the system.
3. By its own pressure, the liquid refrigerant flows through a thermal expansion valve where the pressure drop causes the refrigerant to vaporize in a vapor-liquid state at a low temperature pressure.
4. The cold low pressure refrigerant passes through the passenger's and driver's unit evaporator coils which absorb heat from the air passing over the fins and tubes, and changes into gas. In this form, the refrigerant is drawn into the compressor to repeat the air conditioning cycle.
5. The success of the air conditioning system depends on retaining the conditioned air within the vehicle. All windows and intake vents should be closed. An opening of approximately 8 in² (5162 mm²) could easily neutralize the total capacity of the system.
6. Other causes of inadequate cooling are dirty coils or filter. Dirt acts as insulation and is also serves as a restriction to the air flow.
7. The refrigeration load is not constant and varies. It is also affected by outside temperature, relative humidity, passenger load, compressor speed, the number of stops, etc.
8. The compressor will load depending on operating conditions.

8.2 REFRIGERANT

The A/C system of this vehicle has been designed to use Refrigerant 134a as a medium. Regardless of the brand, only R-134a must be used in this system. The chemical name for this refrigerant is Ethane, 1, 1, 1, 2-Tetrafluoro.

⚠ WARNING ⚠

Refrigerant in itself is nonflammable, but if it comes in contact with an open flame, it will decompose.

8.2.1 Procurement

Refrigerant is shipped and stored in metal cylinders. It is serviced in 30 and 100 pound (13,6 and 45 kg) cylinders. Approximately 25 pounds (11,4 kg) are used in the central system.

It will be impossible to draw the entire refrigerant out of the cylinder. However, the use of warm water when charging the system will assure the extraction of a maximum amount of refrigerant from the cylinder.

8.2.2 Precautions in Handling Refrigerant

1. Do not leave refrigerant cylinder uncapped.
2. Do not subject cylinder to high temperatures, do not weld or steam clean near system or cylinder.
3. Do not fill cylinder completely.
4. Do not discharge vapor into an area where a flame is exposed.
5. Do not expose the eyes to liquid refrigerant.

All refrigerant cylinders are shipped with a heavy metal screw cap. The purpose of the cap is to protect the valve and safety plug from damage. It is a good practice to replace the cap after each use of the cylinder for the same reason. If the cylinder is exposed to the sun's radiant heat pressure increase resulting may cause release of the safety plug or the cylinder may burst.

For the same reason, the refrigerant cylinder should never be subjected to excessive temperature when charging a system. The refrigerant cylinder should be heated for charging purposes by placing it in 125°F (52°C) water. Never heat above 125°F (52°C) or use a blowtorch, radiator, or stove to heat the cylinder.

Welding or steam cleaning on or near any refrigerant line or components of the A/C system could build up dangerous and damaging pressures in the system.

If a small cylinder is ever filled from a large one, never fill the cylinder completely. Space should always be allowed above the liquid for expansion. Weighing cylinders before and

during the transfer will determine the fullness of the cylinders.

⚠ WARNING ⚠

One of the most important precautions when handling refrigerant consists in protecting the eyes. Any liquid refrigerant which may accidentally escape is approximately -40°F (-40°C). If refrigerant comes in contact with the eyes, serious injury could result. Always wear goggles to protect the eyes when opening refrigerant connections.

8.2.3 Treatment in Case of Injury

If liquid refrigerant comes in contact with the skin, treat the injury as if the skin was frost-bitten or frozen. If liquid refrigerant comes in contact with the eyes, consult an eye specialist or doctor immediately. Give the following first aid treatment:

1. Do not rub the eyes. Splash eyes with cold water to gradually bring the temperature above the freezing point.
2. Apply drops of sterile mineral oil (obtainable at any drugstore) in the eyes to reduce the possibility of infection. The mineral oil will also help in absorbing the refrigerant.

8.2.4 Precautions in Handling Refrigerant Lines

1. All metal tubing lines should be free of kinks, because of the resulting restrictions on the flow of refrigerant. A single kink can greatly reduced the refrigeration capacity of the entire system.
2. The flexible hose lines should never be allowed to come within a distance of 2-½" (6,3 cm) from the exhaust manifold.
3. Use only sealed lines from parts stock.
4. When disconnecting any fitting in the refrigeration system, the system must first be discharged of all refrigerant. However, proceed very cautiously, regardless of gauge readings. If there happens to be liquid refrigerant in the line, disconnect fittings very slowly, keeping face and hands away so that no injury can occur. If pressure is noticed when fitting is loosened, allow it to bleed off very slowly.

⚠ WARNING ⚠

Always wear safety goggles when opening refrigerant lines.

5. In the event that any line is opened to the atmosphere, it should be immediately capped to prevent entrance of moisture and dirt.
6. The use of the proper wrenches when making connections on O-ring fittings is important. The use of improper wrenches may damage the connection. The opposing fitting should always be backed up with a wrench to prevent distortion of connection lines or components. When connecting the flexible hose connections, it is important that the swaged fitting and the flare nut, as well as the coupling to which it is attached, be held at the same time using three different wrenches to prevent turning the fitting and damaging the ground seat.
7. The O-rings and seats must be in perfect condition. The slightest burr or piece of dirt may cause a leak.
8. O-rings should be coated with refrigeration oil and installed on the line before the line is inserted into the fitting to prevent damaging the O-ring. If leaks are encountered at the couplings or connectors, no attempt should be made to correct the leaks by tightening the connections beyond the recommended torque. The O-rings are designed to seal at the specified torque and overtightening the connection does not result in a satisfactory and permanently sealed connection. The connection must be disassembled and the cause of the leak (damaged O-ring, defective lines, etc.) corrected. Use new O-ring.

8.3 REFRIGERANT SYSTEM CLEAN-OUT AFTER COMPRESSOR FAILURE

Although the vast majority of reciprocating refrigerant compressors manufactured today are extremely reliable, a small percentage do fail. These failures usually result in minor or extensive system contamination depending on the severity of the failure. When an open type compressor becomes damaged internally, this provokes small particles of bearings, steel, brass, copper, and aluminum and, in severe cases, carbonized oil, which could contaminate the system. To prevent repeated failures, the problem which caused the failure should be

corrected, and depending upon the severity of the failure, the system should be thoroughly cleaned out using one of the cleanout procedures mentioned.

8.3.1 Determining Severity of Failure

The severity of compressor failure can be categorized as minor or major. A failure is considered minor when the contamination is limited to the compressor with little or no system contamination. A major failure, or burnout, results in extensive system contamination as well as compressor damage. Extensive system contamination can be determined by withdrawing a small sample of compressor oil and checking its color, odor and acidity. A Virginia Chemical "TKO" one step acid test kit is one of several compressor oil test kits that may be used. A high acid content would indicate a major failure or burnout. A small amount of refrigerant gas may be discharged. A characteristic burned odor would also indicate severe system contamination.

8.3.2 Clean-out after Minor Compressor Failure

1. Be sure to correct the problem which caused the failure.
2. Change liquid line filter dryer.
3. Run the unit for 2 hours on high speed cool only.
4. Check compressor oil level to ensure compressor is not overcharged with oil. Sometimes a significant amount of oil is pumped out of the compressor to other parts of the system when a compressor fails. This oil will return to the replacement compressor when it is started, causing an overcharge of oil in the sump of the replacement compressor. In this case, it is important that the oil level be adjusted to the proper level.
5. Withdraw a sample of the compressor oil and check its color, odor, and acidity, using instructions supplied above. If the oil is contaminated, change the oil and filter dryer, and repeat the procedure until the system is clean.

8.3.3 Clean-out After Major Compressor Failure

1. Reclaim the refrigerant into a refrigerant bottle through a filter dryer to filter out contaminants.
2. Remove the failed compressor and repair it if possible.
3. Install new or repaired compressor.
4. Change the filter dryer.
5. Circulate clean R-134a with the reclaimer to clean out many of the contaminants collected in the coil valves, TXV (Thermal Expansion Valve), solenoid valves, check valves, and any other mechanical component that may have collected contaminants.
6. Evacuate and charge the system normally.
7. Run the unit for 8 hours and monitor the pressure drop across the filter dryer. Also check the liquid line dryer for signs of restriction. If the pressure drop across the filter dryer exceeds 12 to 14 psig (82,75 to 96,5 kPa) with a 40°F (5°C) evaporator coil temperature, stop the unit and change the liquid line and suction line filter dryer. After 4 or 5 hours of operation, stop the unit and replace the filter dryer.
8. After 8 hours of operation, stop the unit and remove a sample of the compressor oil and check its color, odor, and acidity, using instructions supplied above. If the oil is contaminated, replace the oil and repeat step 7. If the oil is not contaminated, change the filter dryer again and replace the moisture-liquid indicator.
9. After approximately 7 days of operation, recheck the compressor oil for cleanliness and acidity.

8.4 PUMPING DOWN

This procedure is intended to reduce refrigerant loss by isolating it in the compressor and the receiver tank, as well as in their connecting line, in order to carry out repairs on other sections of the air conditioning system (lines and components).

NOTE

Before attempting any repair between compressor and receiver tank, use a recovery unit to remove refrigerant from the system.



When air conditioning system must be opened, refer to previous paragraph “Precautions In Handling Refrigerant” to prevent any injury.

NOTE

To ease purging and refilling of refrigerant, it is possible to open the passenger's and overhead compartment system liquid solenoid valves. To do so, connect both male and female connector housing of C24 together for the passenger's area (located in evaporator compartment). During normal use, both male and female housings of connector C24 are kept unplugged. They are connected only for refrigerant refilling and pumping down procedure.

Procedure

1. Open the solenoid valves by connecting both male and female connector housing of C24 together.
2. Run the system for 10 minutes, shut it OFF, then close the receiver tank outlet valve by turning it clockwise, backseat the suction service valve on the compressor, install an appropriate pressure gauge set, and turn the valve forward ¼ turn to enable a visual check of the suction pressure.
3. Disconnect the “Low Pressure Switch” connector (mounted near the A/C compressor).
4. Start the engine, press the “Passenger ON/OFF” switch then the A/C switch, adjust “A/C Temperature” control to maximum A/C.
5. Run the compressor until pressure reaches 1-2 psi (7-14 kPa).

NOTE

During this operation, care must be taken not to fill the receiver tank over the upper sight glass. If so, stop process immediately. Always allow refrigerant piping and units to warm up to the ambient air temperature before opening system or sweating will take place inside the lines.

5. Stop engine, and close compressor outlet valve by turning it clockwise until valve is properly seated.
6. Close compressor suction valve by turning it clockwise until it is properly seated.

7. Wait until pressure gauge reaches 1 to 2 psi (7 to 14 kPa). To accelerate procedure, lightly open compressor suction valve until pressure reaches this value.
8. Connect the “Low Pressure Switch” connector and disconnect C24.

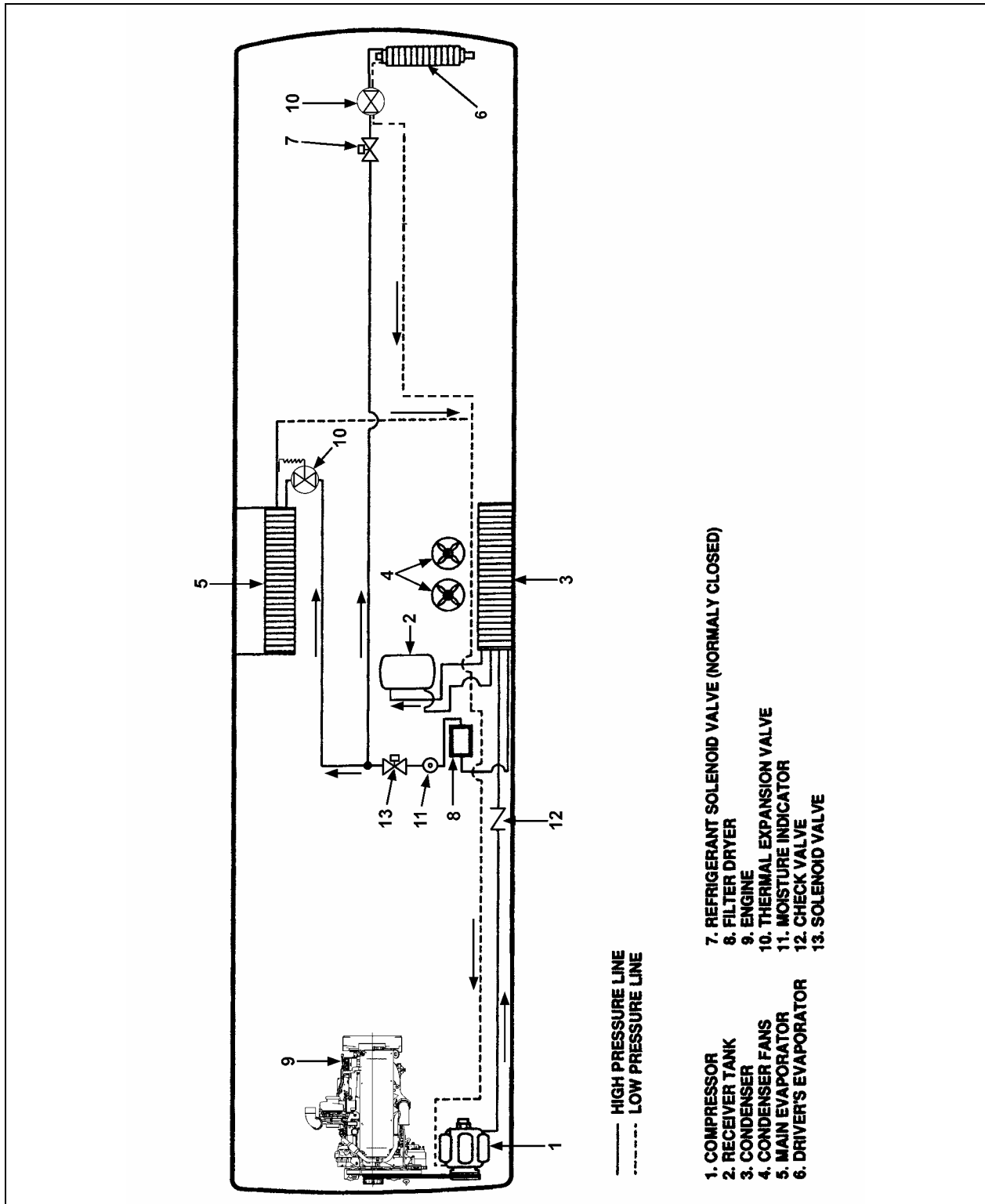

FIGURE 17: CENTRAL HVAC SYSTEM – AIR CONDITIONING

22220

8.5 ADDING REFRIGERANT (VAPOR STATE)

Use the suction service valve on the compressor to add a small quantity of refrigerant to the

system. Backseat the valve and connect a charging line from the refrigerant cylinder to the valve. Tighten connection at level of refrigerant cylinder and open tank end slightly to purge air from the charging line. Tighten the charging line

at the compressor. Screw in the stem of suction valve approximately two turns. Start the engine and run at fast idle. Add sufficient refrigerant to bring the level in lower sight glass of receiver tank to mid-point. Always charge the system with the cylinder upright and the valve on top to avoid drawing liquid out of the cylinder. Fill liquid refrigerant at the receiver tank and completely charge, if necessary, using previous procedure.

8.6 EVACUATING SYSTEM

1. Open both receiver valves by turning "out" (normal position).
2. Remove the caps from the two 90° adapters on the suction, discharge valves and connect two hoses to the vacuum.
3. Place the two compressor valves, suction and discharge, in neutral position by turning each one 3 to 4 turns "in" from the "out" position.
4. Open the solenoid valves by connecting together both male and female connector housing of C24 (located in evaporator compartment) and C44 (located on the ceiling of the spare wheel compartment).
5. Start the vacuum pump. Open the large (suction) shutoff valve and close the small vacuum gauge valve.
6. The pressure will drop to approximately 29 inches vacuum (14.2 psi or 97,9 kPa) (the dial gauge only gives a general idea of the absolute system pressure).
7. Backseat the compressor valves by turning "out" all the way.
8. Shut down the vacuum pump.
9. Remove the hoses.
10. Reinstall the caps at the suction valve take-off points.
2. Connect the evacuation manifold, vacuum pump, hoses and micron gauge to the unit.
3. With the unit service valves closed (back seated) and the vacuum pump and the thermistor valves open, start the pump and draw the manifold and hoses into a very deep vacuum. Shut the vacuum pump off and see if the vacuum holds. This is to check the setup for leaks.
4. Midseat the system service valves.
5. Open the vacuum pump and the thermistor valves. Start the pump and evacuate to a system pressure of 2000 microns.
6. Close the vacuum pump and the thermistor valves, turn off the vacuum pump (closing the thermistor valve protect the valve from damage).
7. Break the vacuum with clean refrigerant (or dry nitrogen) and raise the pressure to approximately 2 PSIG. Monitor the pressure with the compound gauge.
8. Remove the refrigerant with the recovery machine.
9. Repeat steps #5 – 8 one time.
10. After the second "sweep", change the filter drier (if you have not done so) and evacuate to 500 microns.
11. Evacuating the system below 500 microns on systems using the Carrier 05G Twin Port compressor may risk drawing air into the system past the carbon shaft seal.
12. Check to insure that vacuum holds. (If the pressure continues to rise, it indicates a leak or moisture in the system).
13. Charge the system with the proper amount of refrigerant using recommended charging procedures.

8.6.1 Double Sweep Evacuation Procedure

1. Remove any remaining refrigerant from the system using a refrigerant recovery machine.

NOTE

This method will aid in preventing unnecessary system failures by ensuring that the refrigeration system is free of contaminants.

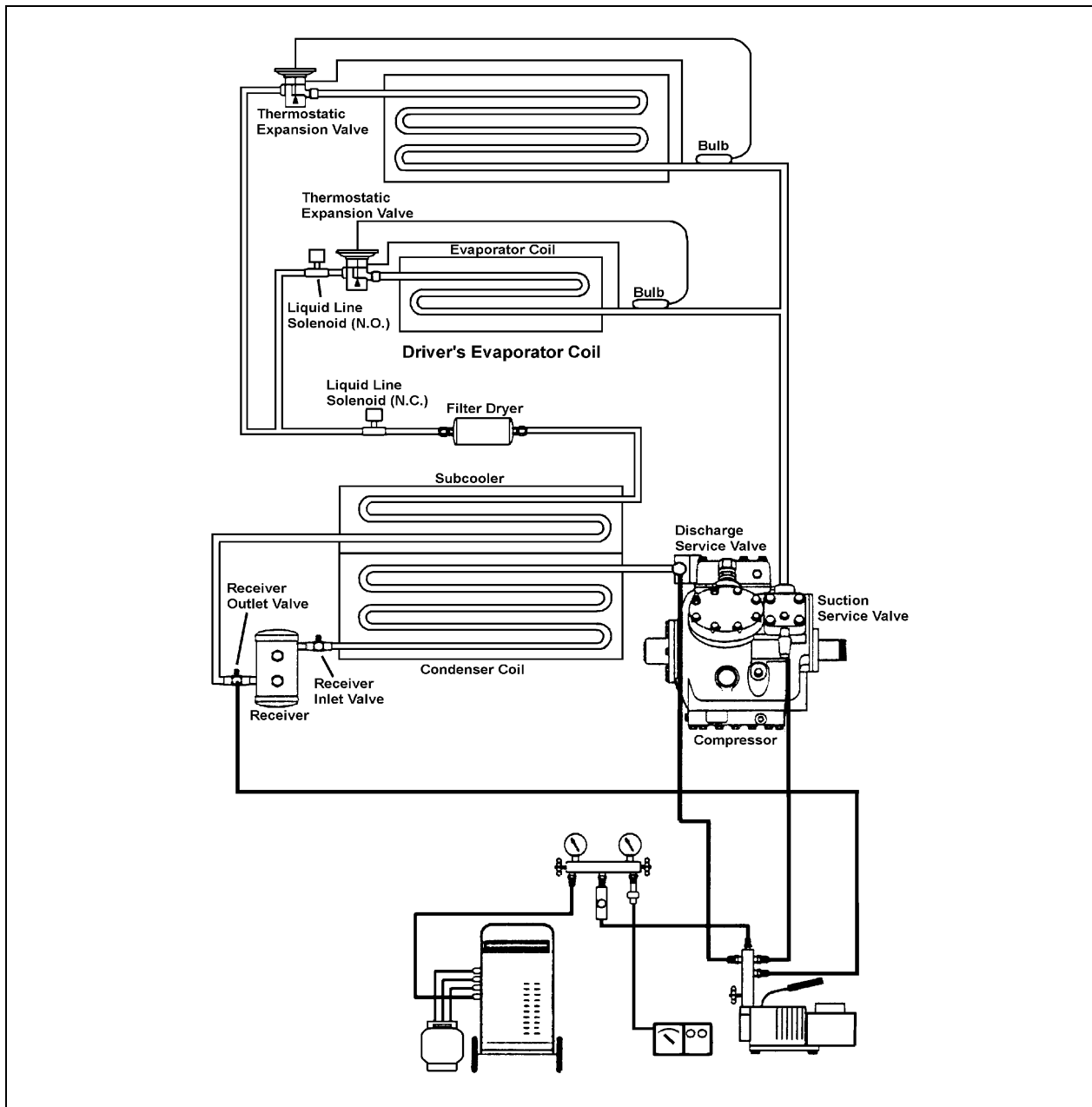

FIGURE 18: DOUBLE SWEEP EVACUATION SET-UP

8.7 CHARGING SYSTEM

When a system has been opened or if there are any questions about the air or moisture in the system, evacuate the system. Charging of an evacuated system may be accomplished by forcing liquid R-134a directly into the receiver tank.

When charging an empty system, weigh the amount of refrigerant put into the system.

This will eliminate any possibility of overfilling. A nominal charge requires 24 pounds (10,9 kg).

1. Backseat the two compressor shutoff valves ("out").
2. Install the test gauges at the shutoff valves noting that the 400 psi (2758 kPa) gauge is connected to the discharge.
3. Turn in the two shutoff valves 3 to 4 turns.
4. Open the lower receiver valve by turning "out" all the way.
5. Backseat the upper receiver valve by turning out all the way.

Section 22: HEATING AND AIR CONDITIONING

6. Remove the cover cap from the service fitting in the top receiver valve.
7. Attach a charging hose to the R-134a tank. Open the tank valve slightly permitting R-134a to escape thus purging the hose of air.
8. Connect the charging hose to the service fitting.
9. Open the R-134a tank valve.
10. To build up pressure in the receiver tank, heat the receiver tank with a heating blanket.
11. Turn in the upper receiver valve several turns. The R-134a will now enter the system.
12. The proper charge of R-134a is 24 lbs (10.89 kg). When the scale indicates this amount of charge, backseat the receiver valve and close the R-134a tank valve.
13. Disconnect the charging hose. Replace the cover caps.
14. The system is now ready for operation.

⚠ CAUTION ⚠

The evacuation of the system must be made by authorized and qualified personnel only. Refer to local laws for R-134a recuperation.

9. CENTRAL HVAC SYSTEM – AIR CONDITIONING COMPONENTS

9.1 COMPRESSOR

9.1.1 Belt Replacement

⚠ WARNING ⚠

Set the main battery disconnect switch to the “Off” position. For greater safety, set the engine starter selector switch in engine compartment to the “Off” position.

1. Open engine compartment rear doors and locate the belt tensioner two-way control valve (Figure 19), mounted above the engine R.H. side door next to the pressure

regulating valve, then turn handle counterclockwise in order to release pressure and tension on belts.

2. Slip the old belts off and the new ones on.
3. Reset belt tensioning pressure control valve (Figure 19). Pressure is factory set to 45 psi (310 kPa), periodically check proper pressure.

NOTE

Both belts must always be replaced simultaneously to ensure an equal distribution of load on each of them.

NOTE

For proper operation of the air bellows, adjust upper tensioning bracket to provide a $\frac{1}{4}$ " (7 mm) gap between stopper and bracket under normal pressure of 45 psi - 310 kPa. (Figure 20).

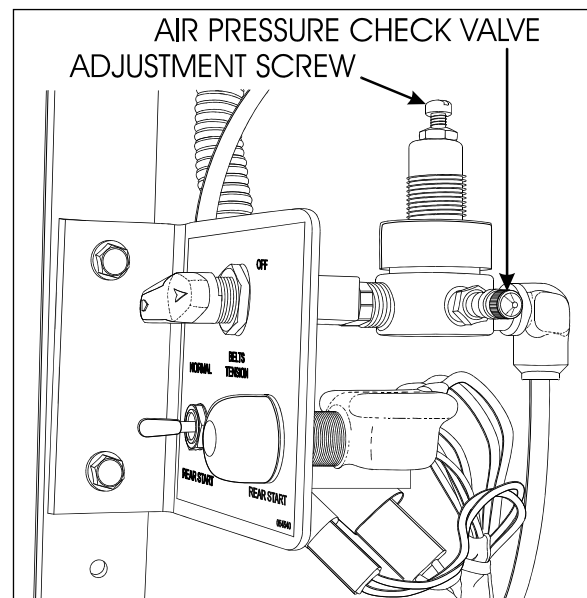

FIGURE 19: TENSIONING VALVE

01058

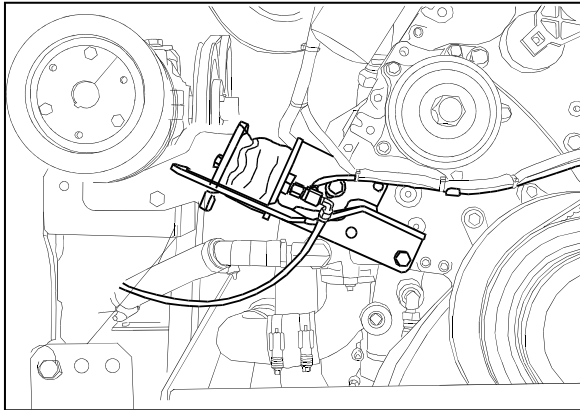

FIGURE 20: DRIVE BELT TENSIONING AIR BELLOWS⁰¹⁰⁵⁹

9.1.2 Belt Play

After belt replacement or during normal maintenance, belt play between pulleys and belt must be checked to ensure proper operation. Refer to Figure 22 for proper plays.

9.1.3 Pulley Alignment

In order to avoid skipping, disengagement and a premature wear of compressor belt, it is necessary to align compressor pulley with the crankshaft pulley. Before performing the following procedure, release air from belt tensioners by means of the two-way control valve. After completing these procedures reset belt tensioning pressure control valve to 45 psi (310 kPa).

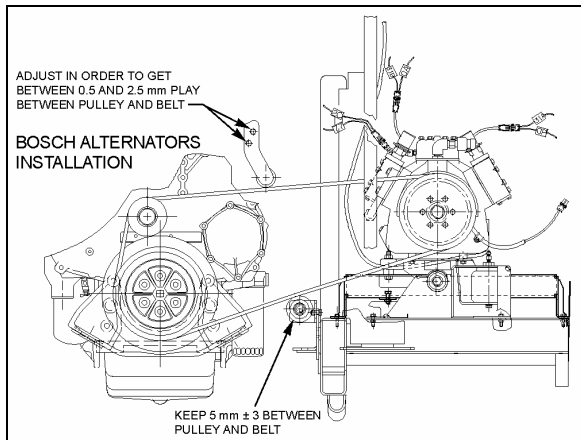

FIGURE 21: BELT PLAY

9.1.4 Longitudinal Compressor Alignment

1. Rest an extremity of a straight edge of approximately 46 inches (117 cm) against the upper part of the outer face of crankshaft pulley, positioning the other end close to the

compressor clutch pulley (Figure 22 & Figure 23).

2. Check the distance between each extremity of straight edge (1, Figure 22) and the first drive belt. If they are different, loosen the compressor support bolts and with a hammer, knock support to slide it in order to obtain the same distance; then tighten bolts.

9.1.5 Horizontal Compressor Alignment

1. Rest an extremity of the straight edge against the upper part of the outer face of compressor pulley, positioning the other end close to the crankshaft pulley.
2. Check the distance between each extremity of straight edge (1, Figure 22) and drive belt. If they are different, loosen the pillow block compressor bolts and with a hammer, knock compressor pillow block to slide it, in order to obtain the same distance; then tighten bolts.

9.1.6 Vertical Compressor Alignment

Rest a short "angle and level indicator" on the outer side face of the crankshaft pulley, adjust the level indicator inclination at 0° and check if the compressor pulley is at same angle (Figure 22 & Figure 23). If it is not the same, shim under the appropriate pillow block in order to obtain the correct angle.

9.1.7 Compressor Maintenance

For the maintenance of the A/C compressor, see the "Carrier Compressor Operation and Service Manual" included at the end of this section.

<p>⚠ CAUTION ⚠</p>
<p>Use only Castrol SW 68 (POE) oils with refrigerant 134a.</p>

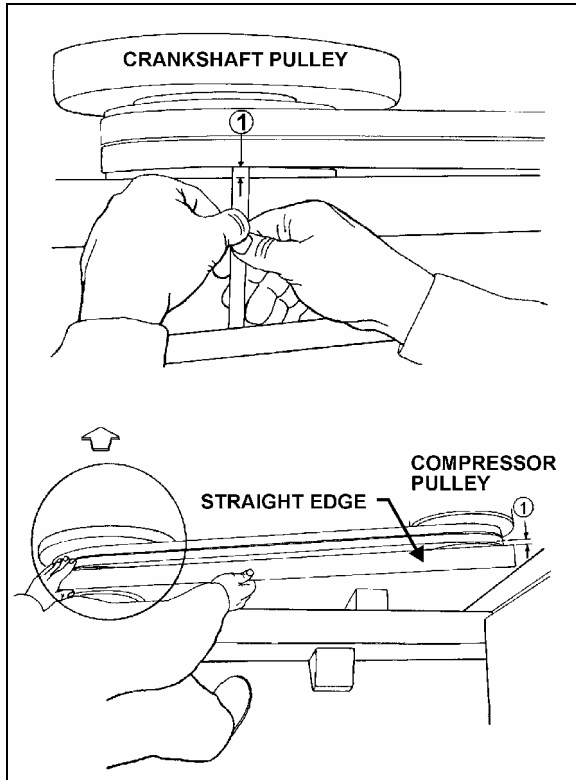

FIGURE 22: COMPRESSOR ALIGNMENT 22040

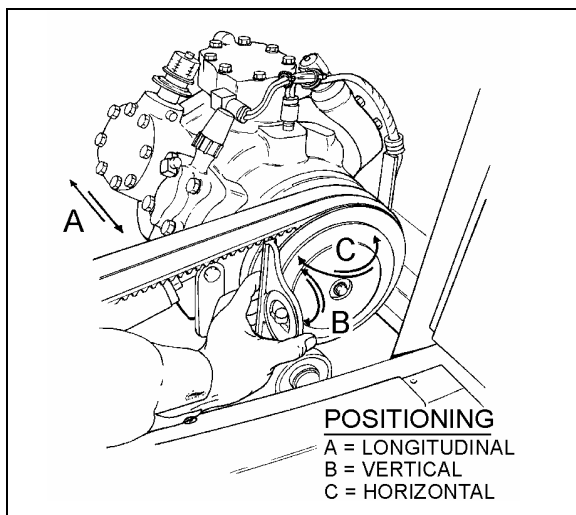

FIGURE 23: COMPRESSOR ALIGNMENT 22072

9.1.8 Troubleshooting Guide

A preliminary check may be made by simply feeling the cylinder heads with the unit in operation at ambient temperatures of 35 °F (2°C) and over. The cylinder heads are internally divided into suction and discharge valves. The lower half of the cylinder head is the suction side, and it should be relatively cool to the touch, as opposed to the hot upper discharge side. If a valve plate or head gasket is blown, or a compressor unloader is stuck open, partially

compressed refrigerant vapor will be circulated between the suction and discharge sides of the head. The affected cylinder head will then have a relatively even temperature across its surface and be neither as hot as the normal discharge temperature nor as cool as the normal suction temperature.

Blown Head Gaskets

Symptom:

- Loss of unit capacity at low temperature.
- Even cylinder head temperature.

Cause:

- Improperly torqued cylinder head bolts.
- Improperly positioned gasket at assembly.
- Warped cylinder head.
- Severe liquid refrigerant floodback.

Blown Valve Plate Gaskets

Symptom:

- Loss of unit capacity at medium and low temperatures.
- Very hot cylinder head surface.
- Higher than normal suction pressure.

Cause:

- Improperly torqued cylinder head bolts.
- Severe liquid refrigerant floodback.
- Oil slugging caused by an overcharge of oil or flood starts.
- Discharge valves not seated properly (liquid drainback during shutdown).

Broken Suction Valves

Symptom:

- Loss of unit capacity at all temperatures.
- Compressor unable to pull extremely low vacuum with suction service valve frontseated.

Cause:

- Repeated liquid refrigerant floodback.
- Flooded starts.
- Overcharge of oil.

- Discharge valves not seated properly (liquid drainback during shutdown).
- Expansion valve not controlling properly.

Unloader Valve Stuck Open

Symptom:

- Loss of unit capacity at all temperatures.
- Higher than normal suction pressure.
- Even cylinder head temperature.

Cause:

- Unloader body stem bent.
- Foreign material binding unloader piston or plunger.

9.2 MAGNETIC CLUTCH

Refer to Carrier service information entitled “Housing-Mounted Electric Clutch” at the end of this section for the description and maintenance of the magnetic clutch.

9.2.1 HVAC Control Unit and Clutch Operation

The A/C compressor starts automatically when the two following conditions are satisfied:

3. The outside temperature is above 30°F (-1°C).
4. The passenger's area temperature has reached 7°F (4°C) under the set point.

NOTE
<p><i>Upon starting, if the outside temperature is above 30°F (-1°C) and then drops below 30°F (-1°C), the compressor will keep running up to a temperature of 15°F (-9°C) to prevent condensation from forming on the windows.</i></p>

When A/C compressor clutch engages, the corresponding A/C ON indicator LED  turns on.

The A/C ON indicator LED  will also turn off and the clutch will disengage if a low pressure (5 psi cut-out, 30 psi cut-in) or a high pressure (350 psi cut-out, 245 psi cut-in) condition is present.

9.3 EVAPORATOR MOTOR

The evaporator motor is installed in the evaporator compartment (L.H. side of vehicle) (Figure 24). It is a 27.5 volt, 2HP (1,5 kW) motor which activates a double blower fan unit.

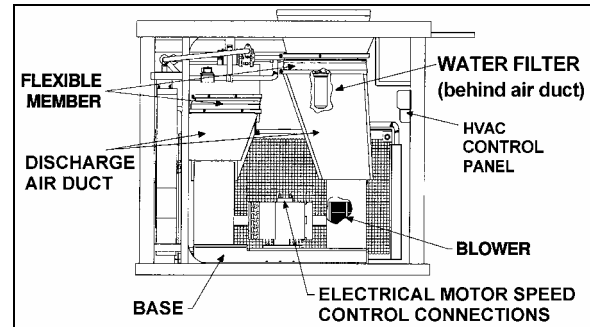



FIGURE 24: EVAPORATOR COMPARTMENT 22275

9.3.1 Removal

1. Set the battery safety switch to the “OFF” position.
2. Open the last L.H. side baggage compartment door. Pull the black release button located on the L.H. side in order to unlock and open the evaporator compartment door.
3. Identify the L.H. side discharge duct inside compartment and remove the Phillips head screws fixing the air duct to blower fan.
4. Repeat step 3 for the R.H. side return air duct.
5. Disconnect electrical motor speed control connections on the motor plate.
6. From under the vehicle, remove the eight bolts fixing the double blower fan unit base. Remove the complete unit from the evaporator compartment (Figure 25).

 CAUTION 
<p>Never support evaporator motor assembly by its output shafts while moving it. Always use double blower fan unit base.</p>

7. Install the complete unit on a work bench, unfasten the fan square head set screws, the Phillips head screws retaining cages to base and slide out the assemblies from the evaporator motor output shaft.
8. Remove motor from double blower fan unit base.

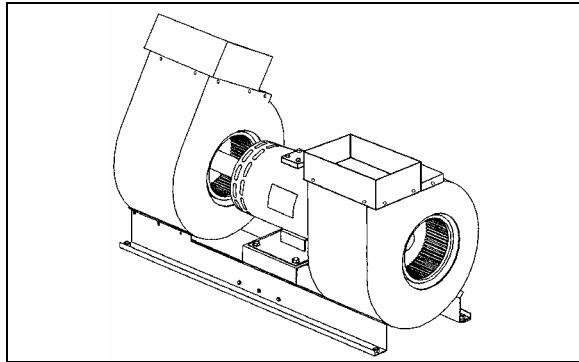

FIGURE 25: EVAPORATOR MOTOR ASSEMBLY 22228

9.3.2 Installation

To reinstall the evaporator motor, reverse "Evaporator Motor Removal" procedure.

9.3.3 Checking Operation of Brush in Holder

Lift brush slightly 1/8 inch (3 mm) and release it. Brush must produce a dry noise.

9.3.4 Brush Wear Inspection and Replacement

⚠ CAUTION ⚠

Only use replacement brushes recommended by the manufacturer. Not doing so will void warranty.

Replace the brushes if less than 3/4 inch (19 mm). New brush length is 1-1/4 inch. Clean brushes with a clean cloth impregnated with gasoline or alcohol.

⚠ WARNING ⚠

Cleaning products are flammable and may explode under certain conditions. Always handle in a well ventilated area.

To replace brushes, proceed as follows:

1. Set battery safety switch to the "OFF" position.
2. Remove the protective screen band from the motor housing by pulling down the spring loaded fastener.
3. Lift the spring, remove and replace brushes as per the following procedure: "SEATING BRUSHES".
4. For the installation, reverse procedure.

9.3.5 Seating Brushes

Grinding consists in giving to the seating face of a new brush the exact curve of the commutator or ring so that good mechanical and electric contact of the brush is ensured upon startup.

For best results, remove oil and grease from commutator before applying brush seater.

NOTE

The new motor brushes are provided with preformed seating face, i.e. with curved face machined with the required radius. This curve is only approximate and does not exempt further grinding. The advantage of preforming is to appreciably shorten the time required for grinding.

Grinding is generally done on the machine itself, in accordance with various processes' and conformably to the importance and the type of machines:

- a) Grinding with abrasive cloth medium grit (sandpaper) (grit 60) applied to a part of the commutator by hand. The new brushes installed in their brush holder and pressing against the cloth, one makes oscillate the rotor until complete grinding of the seating faces (Refer to Figure 26). It is necessary to avoid raising the cloth under the brushes otherwise it would result, after grinding, to reduce and badly definite surfaces (Refer to Figure 27).

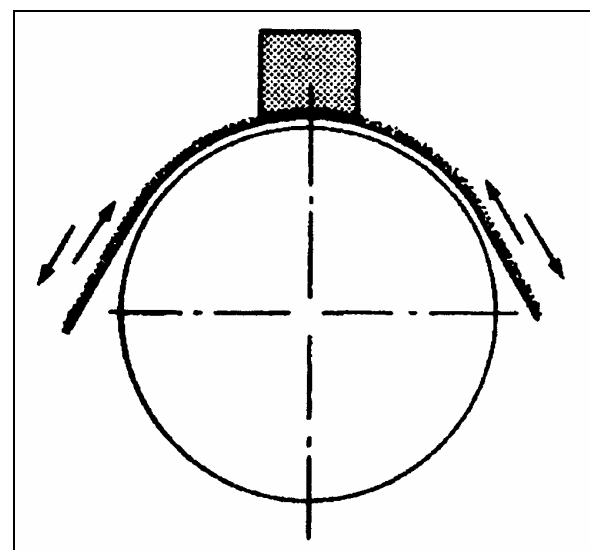

FIGURE 26: PROPER GRINDING TECHNIQUE

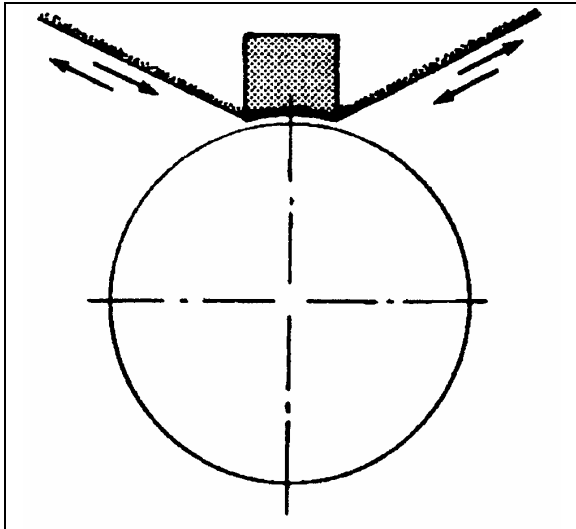

FIGURE 27: IMPROPER GRINDING TECHNIQUE

⚠ CAUTION ⚠

If grinding with a brush seater, you must disconnect the time delay in order to keep the motor in 1st speed. If you prefer, you may also install a jumper on the evaporator motor between terminal E2 and A1 to bypass relay R60 and keep the motor in 1st speed as well.

- b) Grinding with the brush seater stone is always done under no or much reduced voltage. Dust particles act like abrasive and wear down the brushes exactly with the profile of the commutator. **Do not misuse this method because grinding removes some metal from the commutator. It is applicable only to grinding requiring only reduced wear of the brushes.**

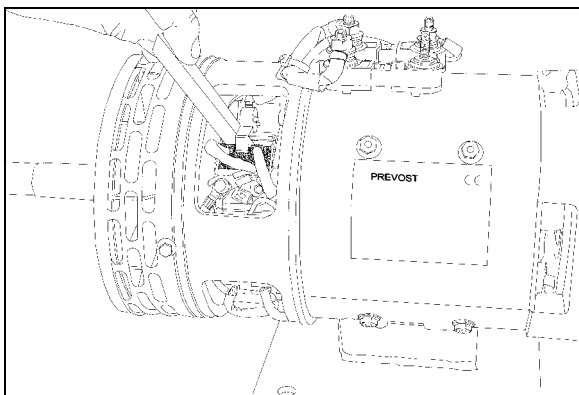

FIGURE 28: GRINDING WITH THE BRUSH SEATER STONE

Repeat method a or b until brushes are fully seated. **Seating surface of the brush must be no less than 80% of the face** (Refer to Figure 29).

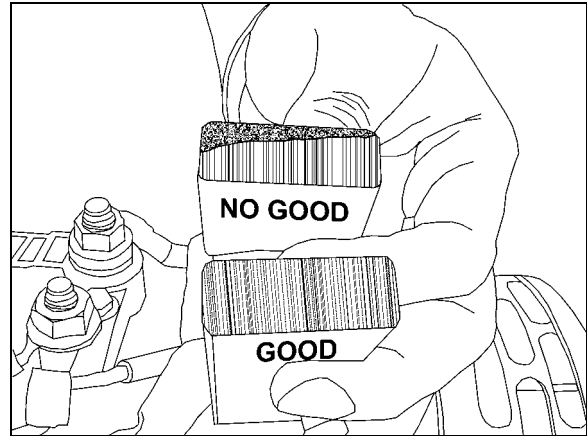

FIGURE 29: SEATING SURFACE OF THE BRUSH

⚠ CAUTION ⚠

After grinding with the sandpaper or the seater stone, it is necessary to remove the brushes from the brush holders and vigorously clean with an air gun the commutator and the seating faces of the brushes to eliminate abrasive dust and dust from brushes.

⚠ WARNING ⚠

Use a dust mask to prevent inhalation of dust particles. Protect against electrical shock when working on energized equipment. Protect against falling or slipping when working on rotating equipment.

⚠ CAUTION ⚠

If grinding is not carried out or is carried out in an incorrect way, the brush may seat against a restricted zone only, which will support the entire load. The consequences risk to be serious for the commutator as for the brush and to seriously damage the motor.

After grinding is completed, it is necessary to check the evaporator motor amperage in 1st speed and in 2nd speed. **Make sure that the evaporator compartment door is closed and that the reading is 30 A ± 3 in 1st speed. Confirm that the reading is 64 A ± 4 (MAX 68 A) in 2nd speed.**

9.3.6 Brush Holder Adjustment

NOTE

The brush holders are mounted on a support that can rotate. Rotating that rocker ring will

move all the brush holders at the same time.

1. Remove the screws securing the grid and remove the grid. Locate the 2 bolts fixing the mechanism permitting the rotation of the brush rocker ring.
2. Loosen (do not remove) the bolts just enough to release the mechanism.
3. Move gently the exposed brush holder in order to have **30 A ± 3 in 1st speed and 64 A ± 4 in 2nd speed when the door is closed** and a maximum distance of 10 mm (3/8 inch) between the brush face and a reference line passing through the center of the 2 bolts on the motor housing.

⚠ CAUTION ⚠

If rotating the rocker ring is necessary, it is preferable to mark off the angular position of the rocker ring before unfastening the bolts fixing the mechanism in order to get back to the factory setting at the end of the operation.

NOTE

Take a final reading in 1st and in 2nd speed after tightening the brush holder bolts. The amperage may have changed.

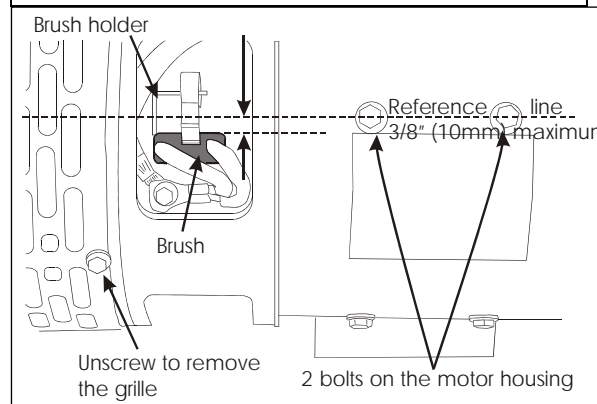

FIGURE 30: EVAPORATOR MOTOR

9.3.7 Checking Commutator

The surface must be polished. A brown-black colored surface is normal and indicates a good switching. Ensure there is no evidence of arcing or metal chips.

9.4 CONDENSER

The central A/C system condenser coil is hinge mounted on the R.H. side of the vehicle on the condenser compartment door. Since

condenser's purpose is to dissipate heat from the hot refrigerant, it is important to keep the cooling coils and fins clean. A clogged coil will cause high discharge pressure and insufficient cooling.

9.4.1 Condenser Fan Motors

Two axial fan motors are installed in condenser compartment on R.H. side of vehicle in order to ventilate the condenser coil. The fans pull outside air through the condenser coil and discharge it through an opening at bottom of compartment. Depending on pressure in receiver tank (Figure 33), the fan motors may be operated at full rpm, half rpm or not operated at all. With low pressure in receiver tank, both fan motors are connected in series and then operate at half rpm and, with a high pressure in receiver tank, both fan motors are connected in parallel and operate at full rpm. For details about electrical wiring, refer to "A/C and Heat system" in the master wiring diagram.

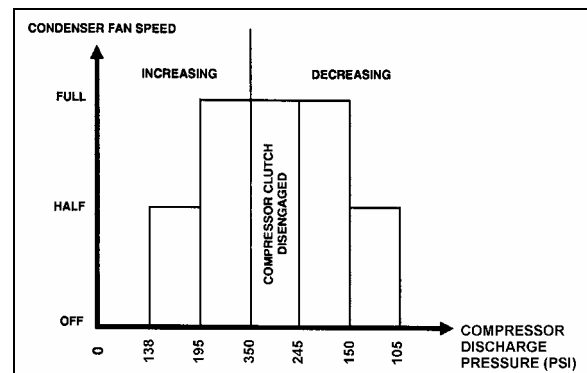

FIGURE 31: CONDENSER FAN SPEED IN RELATION WITH HIGH SIDE PRESSURE

22041

9.4.2 Condenser Fan Motor Removal

1. Set the main battery disconnect switch to the "Off" position.
2. Remove the two "Phillips" head screws retaining the fan motor protective cover to the square tubing.

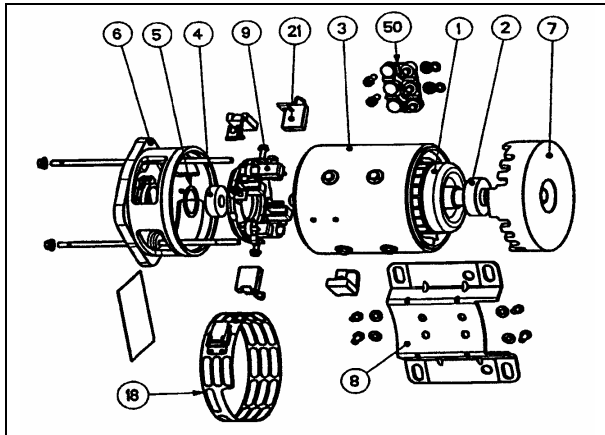

FIGURE 32: CONDENSER FAN MOTOR 22234

1	Winded armature	7	Cover
2	Bearing	8	Support
3	Winded stator	18	Screen band
4	Bearing	21	Brush
5	Spring washer	50	Terminal block
6	End cover		

3. Disconnect wiring from terminals on motor. Tag each wire to aid in identification at time of reconnection.
4. Support motor, and remove bolts which attach motor to support plate. Remove the motor.

9.4.3 Brush Wear Inspection / Replacement

Replace the brushes (21) if worn up to the wear mark. Clean brushes with a clean cloth impregnated with gasoline or alcohol.

<p>⚠ WARNING ⚠</p> <p>Cleaning products are flammable and may explode under certain conditions. Always handle in a well ventilated area.</p>
--

To replace brushes, proceed as follows:

1. Set battery safety switch to the "OFF" position.
2. Remove the protective screen band (18) from the motor housing.
3. Unscrew the wire terminal, lift the torsion spring, remove and replace brushes.
4. For installation, reverse procedure.

9.5 RECEIVER TANK

The receiver tank is located in the condenser compartment (Figure 33). The function of the receiver tank is to store the liquid refrigerant. During normal operation, the level of the refrigerant should be approximately at the midpoint of the lower sight glass.

In case of extreme pressure there will be a rise in the liquid receiver tank. A pressure relief valve will break at 450 psi (3103 kPa) and relieve the receiver tank pressure.

The receiver tank incorporates an inlet valve on the inlet side (upper section) which allows the tank to be isolated or serviced. An outlet valve on the outlet side (lower section) permits complete isolation from the rest of the system.

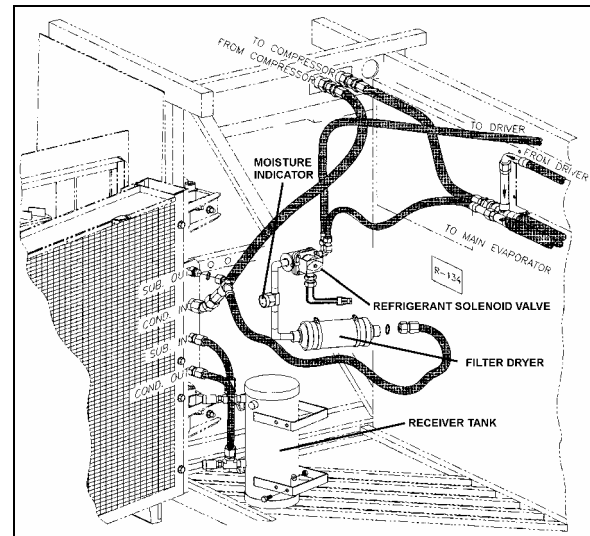

FIGURE 33: A/C CONDENSER COMPARTMENT 22219

9.6 FILTER DRYER

A filter dryer, also located in the A/C condenser compartment, is installed on the liquid refrigerant line (near the receiver tank). It is used to absorb moisture and foreign matter from refrigerant before it reaches the expansion valves.

The filter should be replaced if the system has been opened to prolonged exposure as shown by the moisture indicator sight glass.



A filter dryer, located in the engine compartment near the radiator is installed on vehicles equipped with a driver's system only. Its function is similar to that of filter used on main systems. Replace only when system is opened or a problem occurs.

Section 22: HEATING AND AIR CONDITIONING

9.6.1 Replacement

The filter is of the disposable type. When replacement is required, remove and discard the complete unit and replace with a new unit of the same type according to this procedure:

1. Isolate the refrigerant in the receiver tank by following the "Pumping Down" procedure explained in this section
2. Change the filter dryer as a unit.
3. Add a small quantity of refrigerant R-134a to the low side of the system. Check for leaks. Return the system to normal operation.

 CAUTION 
Do not use carbon tetrachloride or similar solvents to clean parts. Do not use steam guns. Use mineral spirits or naphtha. All parts should be thoroughly cleaned. Use a stiff brush to wash dirt from grooves, holes, etc.

 WARNING 
Cleaning products are flammable and may explode under certain conditions. Always handle in a well ventilated area.

9.6.2 Moisture Indicator

The moisture sensitive element consists of a color changing ring which is reversible from yellow to green and vice versa as the moisture content in the refrigerant changes. Yellow indicates a wet refrigerant, yellow green (caution) and green indicates a dry refrigerant.

Since temperature changes affect the solubility, color change will also vary with the refrigerant temperature. The following table shows the color change for R-134a at various moisture levels and liquid line refrigerant temperatures.

COLOR INDICATOR			
Temperature	BLUE (ppm)	LIGHT VIOLET (ppm)	PINK (ppm)
75°F (24°C)	Below 5	5-15	Above 15
100°F (38°C)	Below 10	10-30	Above 30
125°F (52°C)	Below 15	15-45	Above 45
p.p.m.= parts per million (moisture content)			

A moisture level of less than 15 p.p.m. for R-134a indicated in the blue color range of the above table is generally considered dry and safe. A color indication of light blue to light violet indicates the caution range of moisture level. For positive protection, the drying of the system should be continued until the color of the element turns to deep blue.

The liquid refrigerant is readily visible through the center opening of the moisture element where the presence of bubbles indicates a shortage of refrigerant or restriction in line.

Moisture is one of the main causes of chemical instability or contamination in air conditioning systems. If moisture is present, it can corrode the valves, condenser and evaporator coils, compressor and other components causing a malfunction and eventually failure of the system. Uncontrolled moisture in the system can result in expensive multiple component replacements if not corrected at an early stage. The moisture indicator permits an early detection of moisture in the system and when corrected by a desiccant charge, system contamination is greatly minimized.

9.7 LIQUID REFRIGERANT SOLENOID VALVE

The flow of liquid refrigerant to both driver's and passenger's evaporators is controlled by a normally-closed solenoid valve. The driver's solenoid valve is located on the ceiling of the spare wheel compartment and is accessible through the reclining bumper while the central HVAC system solenoid valve is located in the condenser compartment.

9.7.1 Manual Bypass

To ease purging, pumping down and refilling of refrigerant, it is possible to open the driver's, passenger's and overhead compartment system liquid solenoid valves. To do so, connect either male and female connector housing of C24 together for the passenger's area (located in evaporator compartment) or C44 for the driver's area (located on the ceiling of the spare wheel compartment). During normal use, both male and female housings of connector C24 & C44 are kept unplugged.

9.7.2 Coil Replacement

1. Disconnect connector from the coil connector.

2. Take out the retaining screw at the top of the coil housing. The entire coil assembly can then be lifted off the enclosing tube.
3. Place the new coil and yoke assembly on the enclosing tube. Lay data identification plate in place.
4. Insert the coil retaining screw, rotate housing to proper position and tighten screw securely.
5. Connect connector from coil connector.

9.7.3 Valve Disassembly

1. Remove the coil as stated previously.
2. Pump down the system as stated earlier in this section.
3. Remove the four socket head screws which hold the body and bonnet together (Figure 34).
4. Carefully lift off the bonnet assembly (upper part of the valve) so that plunger will not fall out. The diaphragm can now be lifted out.

Be careful not to damage the machined faces while the valve is apart.

9.7.4 Valve Reassembly

1. Place the diaphragm in the body with the pilot port extension up.
2. Hold the plunger with the synthetic seat against the pilot port.
3. Make sure the bonnet O-rings are in place. Lower the bonnet assembly over the plunger, making sure that the locating sleeve in the bonnet enters the mating hole in the body.
4. Insert the four socket head screws and tighten evenly.
5. Replace the coil as stated previously.
6. Add a small quantity of refrigerant R-134a to the low side of the system. Check for leaks. Return the system to normal operation.

9.8 EXPANSION VALVE

9.8.1 Central system

The expansion valve for the main system is a thermo-sensitive valve with a remote control bulb head attached to the evaporator outlet line and is accessible by the evaporator filter access door (Figure 17 & Figure 35). The valve regulates the flow of refrigerant liquid into the evaporator coils and is controlled by the suction gas temperature leaving the evaporator. The bulb head senses the refrigerant gas temperature as it leaves the evaporator. High temperature will cause expansion and pressure on the power head and spring. Such action causes the assembly valve to open, allowing a flow of refrigerant liquid into the evaporator.

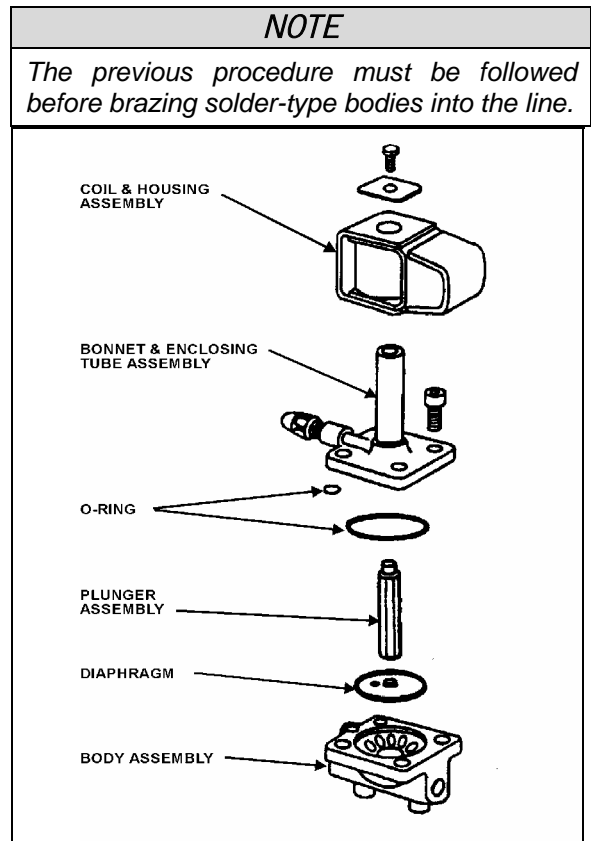

FIGURE 34: REFRIGERANT SOLENOID VALVE 22044

CAUTION

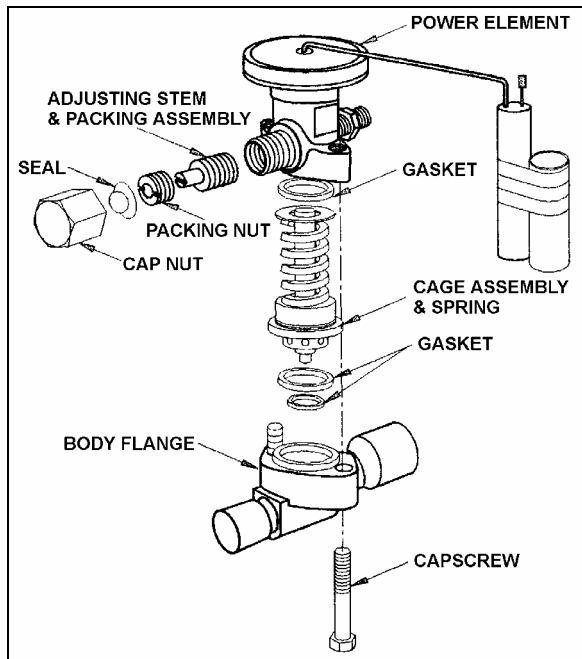

FIGURE 35: EXPANSION VALVE 22215

The remote bulb and power assembly is a closed system. The pressure within the remote bulb and power assembly corresponds to the saturation pressure of the refrigerant temperature leaving the evaporator and moves the valve pin in the opening direction. Opposed to this force, on the under side of the diaphragm and acting in the closing direction, is the force exerted by the superheat spring. As the temperature of the refrigerant gas at the evaporator outlet increases above the saturation temperature corresponding to the evaporator pressure, it becomes superheated. The pressure thus generated in the remote bulb and power assembly surpasses the combined pressures of the evaporator pressure and the superheat spring, causing the valve pin to move in the opening direction. Conversely, as the temperature of the **refrigerant** gas leaving the evaporator decreases, the pressure in the remote bulb and power assembly also decreases and the combined evaporator and spring pressures cause the valve pin to move in the closing position.

As the operating superheat is raised, the evaporator capacity decreases, since more of the evaporator surface is required to produce the superheat necessary to open the valve. It is obvious, then, that it is most important to adjust the operating superheat correctly and that a minimum change in superheat to move the valve pin to full open position, is of vital importance because it provides savings in both initial

evaporator cost of operation. Accurate and sensitive control of the refrigerant liquid flowing to the evaporator is necessary to provide maximum evaporator capacity under load conditions. The spring is adjusted to give 12 to 16° F (-11.1 to -8.8 ° C) of superheat at the evaporator outlet. This ensures that the refrigerant leaving the evaporator is in a completely gaseous state when drawn into the suction side of the compressor. Liquid would damage the compressor valve, piston and heads if allowed to return in the suction line.

A vapor is said to be superheated when its temperature is higher than the saturation temperature corresponding to its pressure. The amount of the superheat is, of course, the temperature increase above the saturation temperature at the existing pressure.

As the refrigerant moves along in the evaporator, the liquid boils off into a vapor and the amount of liquid decreases until all the liquid has evaporated due to the absorption of a quantity of heat from the surrounding atmosphere equal to the latent heat of vaporization of the refrigerant. The gas continues along in the evaporator and remains at the same pressure. However, its temperature increases due to the continued absorption of heat from the surrounding atmosphere. The degree to which the gas refrigerant is superheated is related to the amount of refrigerant being fed to the evaporator and the load to which the evaporator is exposed.

Superheat Adjustment

The easiest method of adjusting the superheat is to unscrew completely the main evaporator expansion valve adjusting screw, and screw in 13 turns clockwise for 134A (Figure 36). If this method does not provide an accurate superheat, the following procedure should be followed:

1. Operate coach for at least one-half hour at fast idle with temperature control set at 82°F (27,7°C), Then set temperature to minimum to keep the compressor on 6 cylinders.

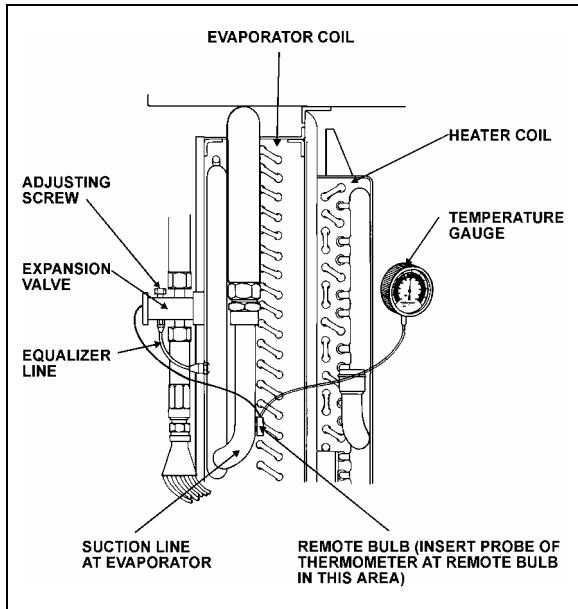

FIGURE 36: SUPERHEAT ADJUST. INSTALLATION 22046

2. Install pressure gauge at the evaporator suction header. You may install the pressure gauge at compressor suction, but then add 3 psi to reading.
3. Install a remote reading thermometer to the evaporator outlet line near the existing remote bulb (Figure 36).
4. Apply thermostatic tape around the bulb and evaporator outlet line to get a true reading of the line temperature.
5. Block condenser if necessary to keep pressure over 150 psi.
6. Check approximately 5 readings of pressure at 2-minute intervals and convert to temperature using the vapor-pressure table (page 36). Likewise check the temperature reading at the remote bulb at the same 2-minute intervals and record the low and high swing readings of the needle (refer to Figure 37).

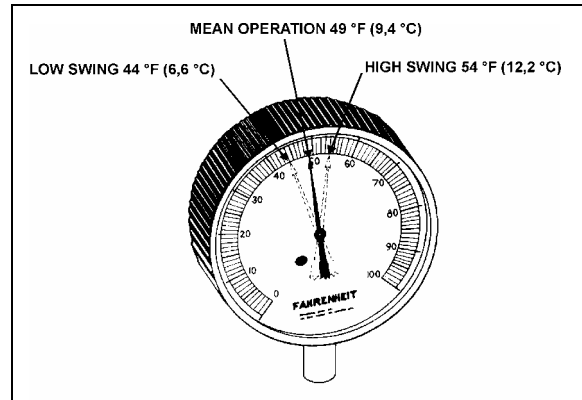

FIGURE 37: HIGH & LOW SWING TEMPERATURE AT REMOTE BULB 22047

Example of readings taken at Figure 37:

A/C pressure gauge converted to temperature at expansion valve fitting	Temperature on remote bulb	
40°F(4,4°C)	Low-swing 44°F (6,6°C)	High swing 54°F (12,2°C)
Formula for superheat 49°F-40°F=9°F (9,4°C-4,4°C = 5°C)	Average of low and high swing is 49°F (9,4°C)	

NOTE

The low swing of the superheat should be a minimum of 4°F (2,2°C) higher at the remote bulb and have an average of 12 to 16°F (4 to 6°C) higher range at the bulb than the fitting at the expansion valve.

NOTE

To reduce the superheat, flow of refrigerant is increased by turning adjusting screw of expansion valve lower evaporator temperature counterclockwise. To increase temperature or increase superheat, flow of refrigerant is reduced by turning adjustment screw of expansion valve clockwise.

7. Regulate suction pressure to temperature reading according to temperature chart or to the R-134a temperature scale on the pressure gauge.

Example: Suction pressure 30 psi (207 kPa) converted to 32°F (0°C) on chart. If temperature

Section 22: HEATING AND AIR CONDITIONING

reading is 40°F (4,4°C), subtract 32°F (0°C) and the result will be 8°F (4,4°C) of superheat.

CAUTION

Before proceeding with the expansion valve adjustment, check for restriction on suction side for plugged filter dryer and partially open valves. These conditions will give a high superheat.

Maintenance

1. Pump down the system as previously indicated in this section.
2. Disconnect the external equalizer line from the under side of the power head, and unclamp the remote control bulb from the evaporator coil outlet line.
3. Remove the two cap screws holding the power assembly to the valve body flange. Lift off the power assembly and remove the cage assembly.
4. When reassembling, replace with the new gaskets in proper location. Make sure the two lugs on the cage assembly fit into grooves provided in the power assembly. Do not force the valves together. The cage must fit properly before tightening the body flange. Tighten bolts evenly.
5. Check for leaks.

Safety Instructions

1. Make sure the valve is installed with the flow arrow on the valve body corresponding to the flow direction through the piping system.
2. Before opening any system, make sure the pressure in the system is brought to and remains at the atmospheric pressure. Failure to comply may result in system damage and/or personal injury.

9.8.2 Driver's System

The function and operation of the expansion valve for the driver" system are similar to the central system, but no superheat adjustment is required (see Figure 35).

9.9 TORCH BRAZING

Use an electrode containing 35% silver.

NOTE

A 3.5% silver low temperature brazing electrode can be used on low side pressure and liquid high side.

CAUTION

When using heat near a valve, wrap with a water saturated rag to prevent overheating of vital parts.

WARNING

Before welding any part of refrigeration system, make sure the area is well ventilated.

9.10 TROUBLESHOOTING

9.10.1 Expansion Valve

PROBABLE CAUSE	PROBABLE REMEDY
LOW SUCTION PRESSURE-HIGH SUPERHEAT	
EXPANSION VALVE LIMITING FLOW:	
Gas in liquid line due to pressure drop in the line or insufficient refrigerant charge.	Locate cause of line flash and correct by use of any of the following methods. Add R-134a. Replace or clean filter dryer.
Inlet pressure too low from excessive low condensing temperature. Resulting pressure difference across valve too small.	Increase head pressure. Verify pressure switch for fan speed control.
Superheat adjustment too high.	Adjust superheat as outlined under "Superheat Adjustment".
Power assembly failure or partial loss of charge.	Replace power assembly or replace valve.
Air filter screen clogged.	Clean or replace air filter screen.
Plugged lines.	Clean, repair or replace lines.
LOW SUCTION PRESSURE-LOW SUPERHEAT	
Uneven or inadequate evaporator loading due to poor air distribution or liquid flow.	Balance evaporator load distribution by providing correct air or liquid distribution.
HIGH SUCTION PRESSURE-HIGH SUPERHEAT	
Compressor discharge valve leaking.	Replace or repair valve.
HIGH SUCTION PRESSURE-LOW SUPERHEAT (DEFECTIVE UNLOADER)	
Valve superheat setting too low.	Adjust superheat as outlined under "Superheat Adjustment".
Compressor discharge valves leaking.	Replace or repair discharge valve.
Incorrect superheat adjustment.	Superheat adjustment 12 to 16°F.
FLUCTUATING DISCHARGE PRESSURE	
Insufficient charge.	Add R-134a to system.
HIGH DISCHARGE PRESSURE	
Air or non-condensable gases in condenser.	Purge and recharge system.
Overcharge or refrigerant.	Bleed to proper charge.

Section 22: HEATING AND AIR CONDITIONING

PROBABLE CAUSE	PROBABLE REMEDY
Condenser dirty.	Clean condenser.

9.10.2 A/C

TROUBLE	CAUSE
Low suction pressure and frosting at dryer outlet.	Clogged filter.
Low Oil Level.	Check for oil leaks and for leaking oil seal. Do not attempt to check oil level unless system has been stabilized at least 20 minutes. See oil level verification.
Excessively cold suction line.	Loss of contact between the expansion valve bulb and the suction line or sticking of the expansion valve. Check for foreign matter and clean, repair or replace the valve.
Excessively cold suction line and noisy compressor.	Check superheat adjustment. Check remote bulb contact. Check expansion valve for sticking.
Compressor squeaks or squeals when running.	Check oil level. Replace oil seal.
Noisy or knocking compressor.	Check for broken internal parts. Overhaul if required.
Compressor vibrates.	Check and tighten compressor mounting bolts and belt tension.
Low refrigerant level	Check for refrigerant leaks and add refrigerant if required.
Suction pressure rises faster than 5 pounds per minute after shutdown.	Check compressor valve for breakage or damage.
Insufficient cooling.	Check for refrigerant leaks. Check condition of air filter and motors.
Insufficient air flow.	Dirty or iced evaporator. Dirty air filter. Blowers inactive. Clogged ducts.
No flow of refrigerant through expansion valve.	Filter dryer is clogged. Remote bulb has lost charge or expansion valve is defective.
Expansion valve hisses. Bubbles in moisture and liquid indicator.	Gas in liquid line. Add refrigerant.
Loss of capacity Superheat too high.	Clogged filter. Obstructed or defective expansion valve. Reset superheat adjustment. Check for clogged external equalizer line, or filter dryer.
Reduced air flow: a. Dirty or clogged air filter; b. Evaporator motor inoperative; or c. Plugged return air ducts.	Dirty or iced evaporator coil. Clean air filter screen. Check return ducts for obstructions. Check blower motor.
Frequent startings and stoppings on low pressure control switch.	Lack of refrigerant. Check for leaks. Recharge.
Compressor intermittently starts and stops.	Intermittent contact in electrical control circuit. Compressor valves not in operating position.
Non-condensable in the refrigeration system.	Leak on system, system in vacuum in low temp. Specific symptom, pressure in system will not correspond to ambient temperature on shutdown. Only non-condensable will cause this.

TROUBLE	CAUSE
	<p>(Example: Pressure of idle R-134a system in 80°F (26.6°C) room should be 86.4 psi (595.7 kPa). See temperature chart in this section.)</p> <p>An evaporator just does a proper cooling job without sufficient air. Shortage of air can be caused by the following:</p> <ul style="list-style-type: none"> ○ Dirty filters; or ○ Dirty coils.
<p>Testing condenser pressure.</p> <p>Note: R-134A pressure is function of the temperature variation.</p> <p>Example, for an exterior temperature of 100°F. Exterior temperature (100°F) + 40°F = 140°F. Refer to paragraph "9.11 Temperatures & Pressures". Note the corresponding pressure for a temperature of 140°F., 230.5 psi. Read the condenser pressure, example 171.9 psi. 171.9 psi 199.8 psi, the pressure in the condenser is inferior to the pressure corresponding to the exterior temperature, then condenser pressure may be too low. Check for refrigerant leaks and add refrigerant if necessary. If the pressure corresponding to the condenser temperature is superior to the pressure corresponding to the exterior temperature, then air cooled condenser pressure may be too high. Most frequent causes are:</p> <p>Reduced air quantity. This may be due to:</p> <ul style="list-style-type: none"> ○ Non-condensable in system; ○ Dirt on the coil; ○ Restricted air inlet or outlet; ○ Dirty fan blades; ○ Incorrect rotation of fan; ○ Fan speed too low; ○ Fan motor going out on overload; or ○ Prevailing winds. ○ Too much refrigerant in system. Remove refrigerant if necessary. 	

Section 22: HEATING AND AIR CONDITIONING

9.11 TEMPERATURES & PRESSURES

VAPOR-PRESSURE			
TEMPERATURE		PRESSURE	
°F	°C	psi	kPa
-100	-73.3	27.8	191.7
-90	-67.8	26.9	185.5
-80	-62.2	25.6	176.5
-70	-56.7	23.8	164.1
-60	-51.1	21.5	148.2
-50	-45.6	18.5	127.6
-40	-40.0	14.7	101.4
-30	-34.4	9.8	67.6
-20	-29	3.8	26.2
-10	-23	1.8	12.4
0	-18	6.3	43.4
10	-12	11.6	80
20	-7	18.0	124.1
30	-1	25.6	176.5
40	4	34.5	237.9
50	10	44.9	309.6
60	16	56.9	392.3
70	21.1	70.7	487.5
80	27	86.4	595.7
90	32.2	104.2	718.5
100	38	124.3	857.0
110	43.3	146.8	1012.2
120	49	171.9	1185.3
130	54.4	199.8	1377.6
140	60	230.5	1589.3
150	65.6	264.4	1823.0
160	71	301.5	2078.8
170	76.7	342.0	2358.1
180	82.2	385.9	2660.8
190	87.8	433.6	2989.7
200	93.3	485.0	3344.1
210	98.9	540.3	3725.4

9.12 LEAK TESTING

Some methods such as nitrogen pressure and soap, and electronic sniffer can be used for leak

testing. However, the most common method used is a "Halide" torch consisting of an acetylene tank, a burner and a suction test hose. Proceed as follows:

⚠ WARNING ⚠

Do not inhale fumes from leak detector.

The flow of acetylene to the burner causes a depression in the test line. Any gas refrigerant present will be drawn through the hose and into the burner where it decomposes into free acids.

These acids come in contact with the hot copper reaction plate in the burner, causing color reaction in the flame. A small concentration is indicated by a green tint and a large concentration by an intense blue. Do not confuse this change in color with the change caused by shutting off the air supply through the hose by holding the end too close to an object.

The procedure for testing is:

1. Adjust flame so that the top of the cone is approximately level or within one-half inch above the plate.
2. Probe end of suction test tube around all joints, valves, etc. When a leak has been found at a soldered joint, this specific section of the system must be pumped down. Do not solder as pressure will force hot solder out. If the system is empty, it is more economical to put in just enough R-134a to produce about 15 psi (103 kPa). The pressure can be raised to about 150 psi (1034 kPa) with dry nitrogen.

NOTE

This gas is put into the suction and discharge shutoff valves at the compressor. The receiver valves must be opened. If no leaks are found, dump this mixture, evacuate the system and fill with refrigerant.

10. SMALL HVAC SYSTEM – AIR CONDITIONING COMPONENTS

10.1 COMPRESSOR

MODEL	TM-16HD
TYPE	Swash-plate type
Number of cylinders	6
Bore	36 mm (1.42")
Stroke	26.7 mm (1.05")
Displacement	163 cm ³ (10cu.in)
Permissible speed	700-6000 rpm
Refrigerant	HFC-134a
Lubricant	ZXL100PG

	180 cm ³
Mass	4.9 kg (10.9 lbs)

10.2 MAGNETIC CLUTCH

TYPE	Electromagnetic single-plate dry clutch
Rated Voltage	24/12 volts DC
Current consumption	3.75 amperes (max)
Stalling torque	49 Nm (36.1 Lbf-ft) min
Rotation	CW/CCW
Mass	2.2 kg (4.9 lbs)

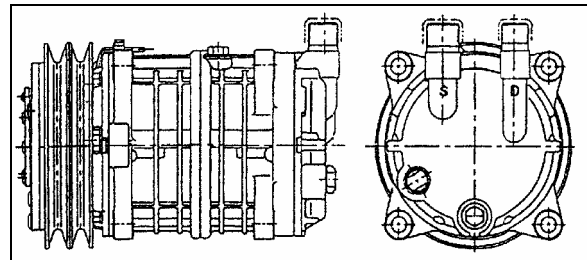

FIGURE 38: SELTEC TM-16HD COMPRESSOR

10.3 MAINTENANCE PRECAUTIONS

10.3.1 Work Area

Because the components of air conditioning systems are especially sensitive to moisture, dirt and dust, always observe the following procedures:

- Work indoors whenever possible.
- Select a level work area.
- Keep work area clean.
- Select a work area with adequate ventilation.

⚠ WARNING ⚠

Refrigerant itself is not harmful, but excessive accumulation in a closed area can cause oxygen deficiency.

- Keep open flame and flammables away from the vehicle in which the air conditioning system is being serviced. **Open flame is especially dangerous during Freon leak testing.**

⚠ WARNING ⚠

Contact with flame and high temperatures can generate toxic gases.

10.3.2 Refrigerant Handling

Never directly heat refrigerant cylinder or put in hot water heated above 40°C (104°F) since it may cause release of the safety plug or the cylinder may burst. When it is necessary to heat refrigerant cylinder for charging in cold weather, use warm water at a temperature below 40°C (104°F).



WARNING

Do not put the charge valve in warm water.

- Never store refrigerant cylinder in direct sunlight, near flame, or where the temperature exceeds 40°C (104°F). Always store refrigerant cylinder in a cool dry place.
- Never throw or strike refrigerant cylinder and never handle roughly.

10.3.3 PAG Oil Handling

Whenever a part replacement has to be done on the system, additional task about PAG oil will have to be performed.

The compressor has little reserve and is lubricated by the oil refrigerant mixture. To perform correctly, the compressor needs the mixture to be from 3% to 6% of Poly Alkaline Glycol (PAG) oil.

When a compressor has to be top off due to a severe lost, the amount of oil to be added should be evaluated with the refrigerant charge or a compressor oil change should be performed to rise up the compressor oil charge to 180 ml or the written charge on the nameplate.

- The oil should be free from moisture, dust, metal shavings, etc.
- Do not mix with other oils.
- The moisture content of the oil increases when exposed to the air for prolonged period. Therefore, after use, seal the container immediately.

DO NOT MIX PAG AND POE OR MINERAL OILS!

10.3.4 Refrigerant Recovery

Some air conditioning system refrigerant compounds are chlorofluorocarbons, and therefore may be damaging the earth's ozone layer. Consequently, the release of refrigerant into the atmosphere must be avoided. Whenever refrigerant is to be released from the

air conditioning system, a refrigerant recovery unit must be used to recover the refrigerant. This refrigerant can then be recycled and reused, which is both environmentally safe and economical.

For complete system recovery, any of the High and Low service ports can be used (Refer to Figure 17 & Figure 18). Energize liquid solenoid valve and measure the quantity of oil recovered. For the compressor only, use the service valve port and close the valves. The service valves open permits full flow of refrigerant to service port. Service valve closed permits flow of refrigerant from compressor to service port.

10.3.5 Compressor Handling

Do not strike, drop or turn the compressor upside down. If the compressor is knocked over or turned upside down, rotate the compressor's magnetic clutch 5 to 6 times by hand to circulate the oil which has settled in the cylinder. Sudden rotation with oil in the cylinder can cause valve damage and adversely affect durability.

10.4 COMPRESSOR REMOVAL

10.4.1 When the compressor is operational

- Perform the "OIL RETURN OPERATION" (Refer to paragraph 10.9).

10.4.2 When the compressor is inoperable

- Perform the "Refrigerant Recovery" operation (Refer to paragraph 10.3.4).
- Slacken bolts A (Figure 39).
- Remove bolts B & C.
- Remove the compressor.

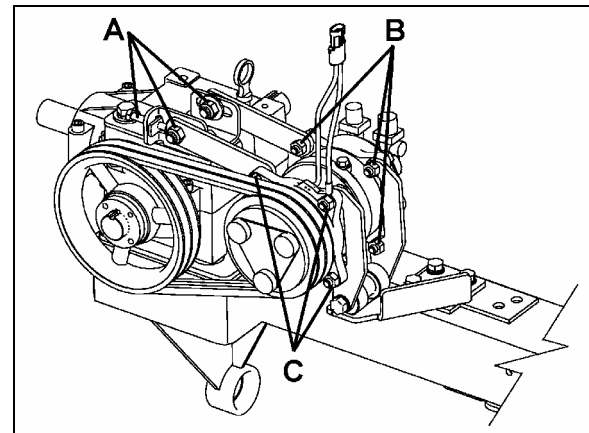

FIGURE 39: COMPRESSOR REMOVAL OR INSTALLATION

22285

10.5 INSTALLATION PRECAUTIONS

The new compressor is filled with the specified quantity of compressor oil and nitrogen gas (N²). When mounting the compressor on the vehicle, take the following steps:

Loosen the discharge side connector's cap and gently release N² from compressor (Refer to Figure 40).

Note: Take care not to let the oil escape.

- Slowly rotate the compressor's magnetic clutch several times by hand to distribute the oil which has settled in the cylinders (Figure 41).
- When using the old compressor in the system, the compressor should be installed after changing the oil.

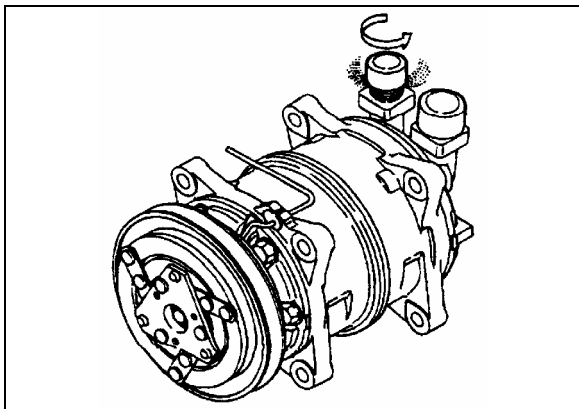

FIGURE 40: LOOSENING THE DISCHARGE SIDE CONNECTOR'S CAP

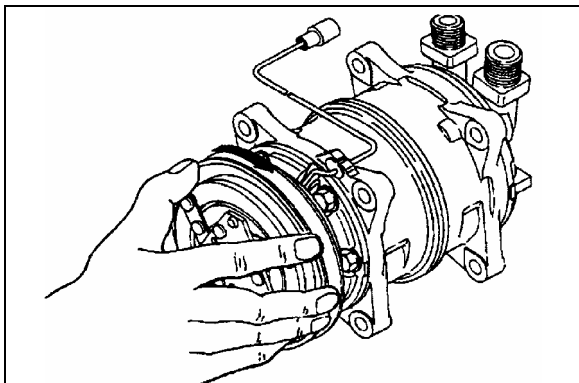

FIGURE 41: ROTATING MAGNETIC CLUTCH

10.6 COMPRESSOR OIL CHANGE

Each compressor is delivered filled with the specified quantity of compressor oil, depending on the type of air conditioning system. A label describing the amount/type of compressor oil is attached to the compressor.

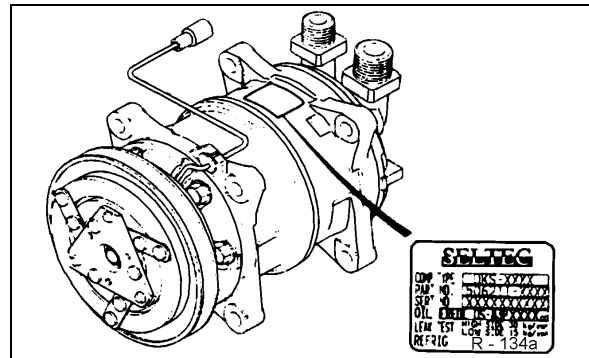

FIGURE 42: COMPRESSOR OIL LABEL

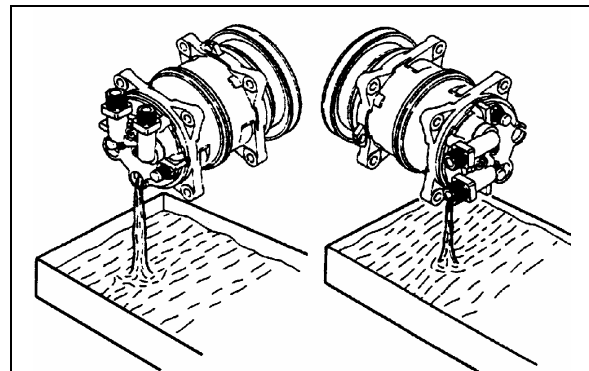

FIGURE 43: DRAINING THE OIL

- Check oil for contamination. Refer to PARAGRAPH 9.8: "COMPRESSOR OIL CONTAMINATION".

Tighten the oil drain plug with a new o'ring lightly coated with clean compressor oil to specified torque.

Torque: 13-15 Nm (9.4-10.8 Lbf-ft)

- Add new compressor oil through the suction-side connector with the amount specified on the label (180 ml).

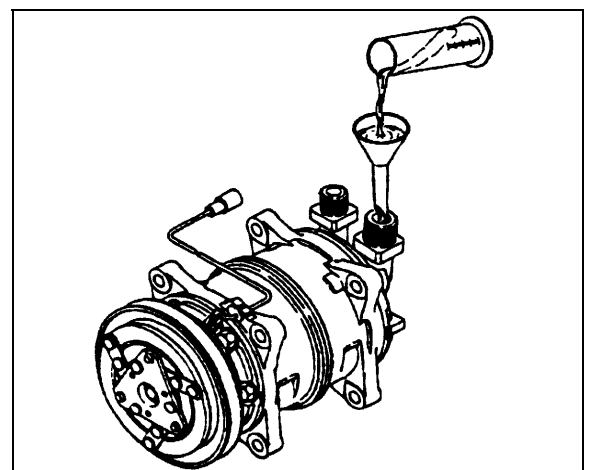

FIGURE 44: ADDING NEW COMPRESSOR OIL

Section 22: HEATING AND AIR CONDITIONING

10.6.1 Evacuating System Before Adding Refrigerant (Driver's or Auxiliary System)

When a system has been opened for repairs, change the filter dryer and evacuate the system. VIPs equipped with a driver's system must use high-pressure service port located on the other side of check valve and low-pressure port located alongside rear truss. (Figure 17 and Figure 18). It would be good practice to open the solenoid valve.

1. Connect two hoses equipped with a micron gauge between the high-pressure service port, the low-pressure service port and the vacuum pump.
2. With the unit service valves open and the vacuum pump valves open, start the pump and draw the manifold and hoses into a very deep vacuum (700 microns).
3. Close manifold valve
4. Shut down the vacuum pump.
5. Check to insure that vacuum holds. (If the pressure continues to rise, it indicates a leak or moisture in the system).
6. Charge the system with the proper amount of refrigerant through the service port near the check valve using recommended charging procedures.
7. Remove the hoses.

10.7 OIL ADDITION

The chart below shows the approximate amount of oil to be added to the system when replacing a component.

Component replaced	Typical amount of oil
Evaporator	50 cm ³ (1.7 ozs)
Condenser	30 cm ³ (1.0 ozs)
Filter-Dryer	10 cm ³ (0.3 ozs)

The amount of oil recovered with the refrigerant recovery should be added at the same time.

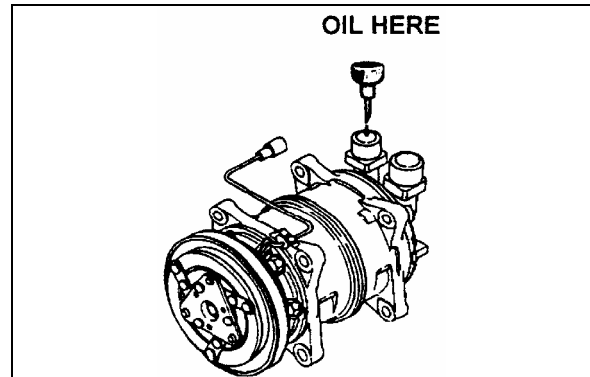

FIGURE 45: ADDING OIL AFTER REPLACING A COMPONENT

10.8 COMPRESSOR OIL CONTAMINATION

Unlike engine oil, no cleaning agent is added to the compressor oil. Even if the compressor is run for a long time, the oil never becomes turbid as long as there is nothing wrong with the compressor or its method of use. Inspect the extracted oil for any of the following conditions:

- Dirt in the oil.
- Change to a varnish color.
- Presence of foreign substance, metal shavings, etc. in the oil. When the oil extracted from the compressor is as described above, replace the oil as follows:
 1. Clean the interior of the system with approved method.
 2. Replace the filter-dryer.
 3. Supply with new oil as specified in paragraph 11.6: "COMPRESSOR OIL CHANGE".

10.9 OIL RETURN OPERATION

There is a close affinity between oil and refrigerant. During normal operation, part of the oil recirculates with the refrigerant in the system. Therefore, when checking the amount of oil in the system or replacing any system component, the compressor must be run in advance to ensure return. This procedure is as follows:

- If the amount of refrigerant in the system has decreased, charge to the proper amount.
- Start the engine and select fast idle.
- Set the fan speed to full air/full A/C and let run for 20 minutes.

10.10 OIL CHECK INTERVAL

Unlike engine oil, it is not necessary to frequently check or change the compressor oil. However, it is necessary to check and replenish or replace the compressor oil in the following cases:

- Whenever the compressor, evaporator, condenser or filter-dryer is replaced.
- Whenever refrigerant has leaked from the system, evaluate the amount of oily spot.
- Whenever refrigerant is suddenly released from the cooling cycle, replenish the compressor (180 ml) plus 150 ml.
- Whenever any oil-related problems occur in the cooling cycle.

10.11 LEAK TEST PROCEDURE WITH COMPRESSOR REMOVED

When a compressor is repaired, it must be checked prior to installation.

- Install the discharge and suction caps to the connector.

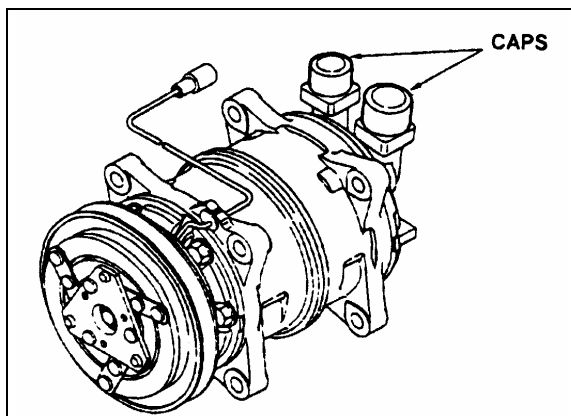

FIGURE 46: DISCHARGE AND SUCTION CAPS

- Fill the compressor with refrigerant through connector's suction port raising the pressure to at least 0.5 Mpa (70 psi).
- Check the compressor for leaks using a leak detector.

NOTE

Never leave the compressor upside down for longer than 30 seconds. This is because the oil inside the compressor will enter the cylinders, causing liquid compression which will damage the compressor's suction and delivery valves.

10.12 TIGHTENING TORQUES

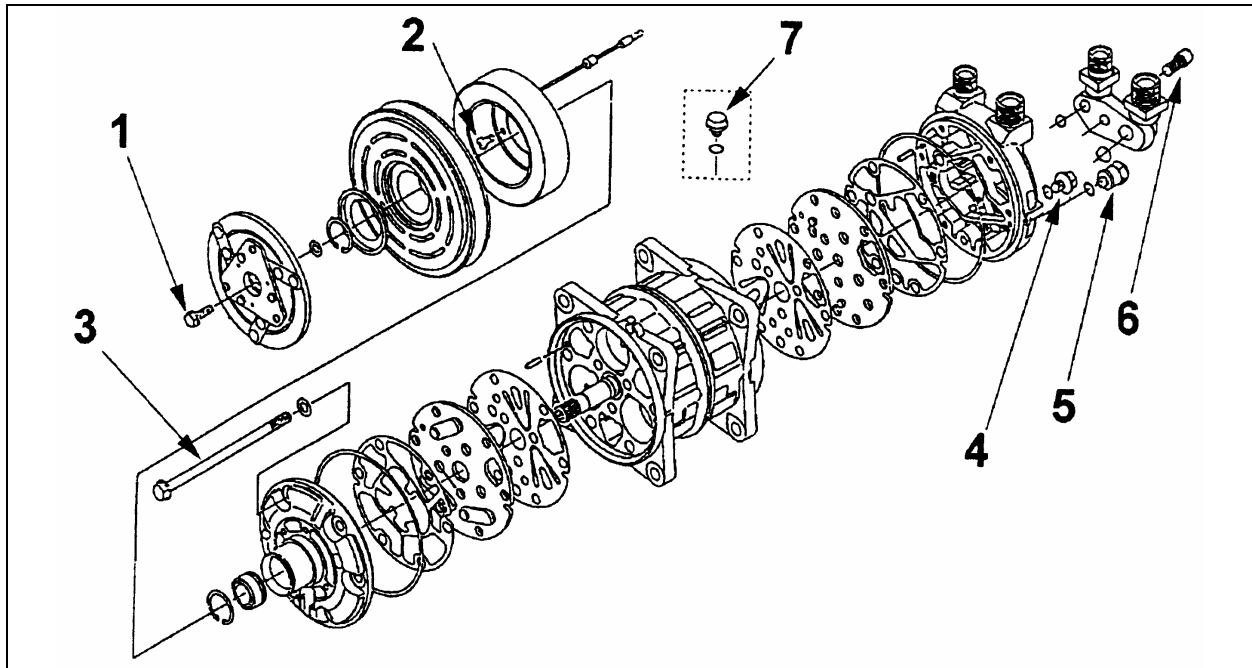

FIGURE 47: TIGHTENING TORQUES

PART	THREAD SIZE	TIGHTENING TORQUE
1. Bolt Armature	M6 x 1.0	12 - 14 Nm (8.7 - 10.1 Lbf-ft)
2. Field Coil Screw	M5 x 0.8	4 - 6 Nm (2.9 - 4.3 Lbf-ft)
3. Body Bolt	M8 x 1.25	20 - 24 Nm (14.5 - 17.3 Lbf-ft)
4. Oil Drain Plug	M8 x 1.25	13 - 15 Nm (9.4 - 10.8 Lbf-ft)
5. Pressure Relief Valve	3/8 - 24UNF	13 - 15 Nm (9.4 - 10.8 Lbf-ft)
6. Connector Bolt	M8 x 1.25	20 - 24 Nm (14.5 - 17.3 Lbf-ft)
7. Oil Filler Plug	M8 x 1.25	13 - 15 Nm (9.4 - 10.8 Lbf-ft)

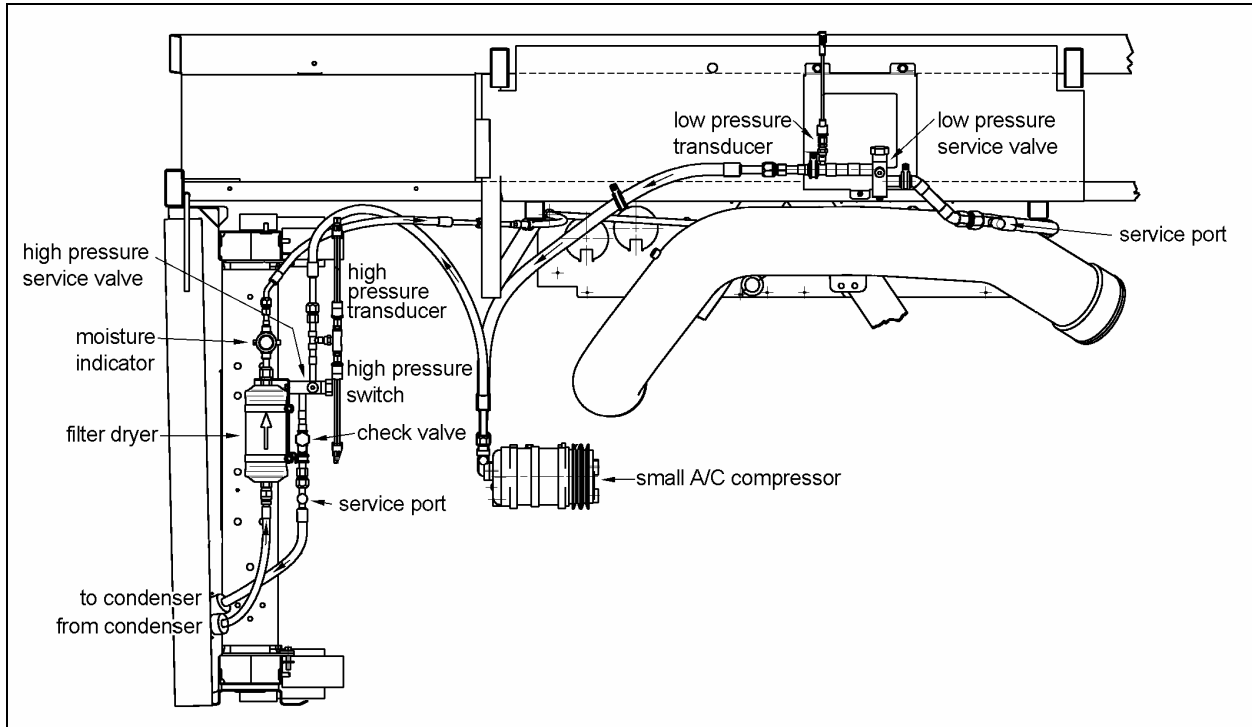

FIGURE 48: SMALL HVAC SYSTEM - AIR CONDITIONING

22293

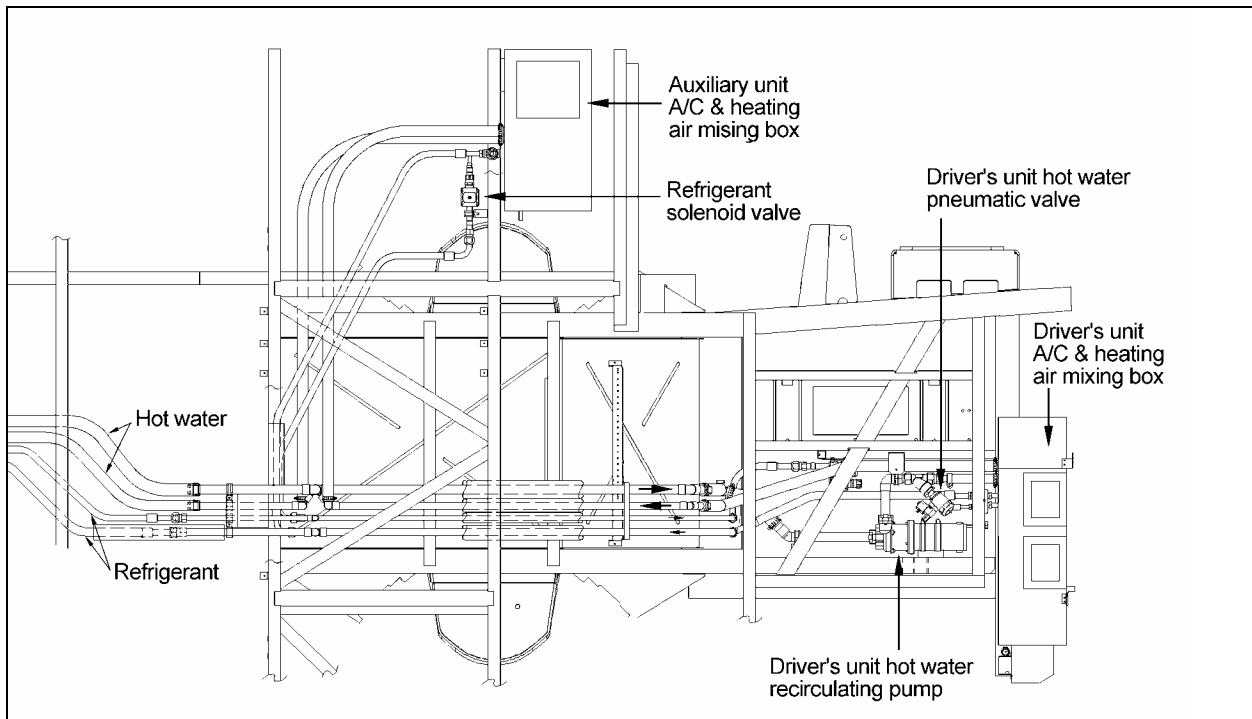

FIGURE 49: SMALL HVAC SYSTEM - DRIVER'S AND AUXILIARY UNIT

22290

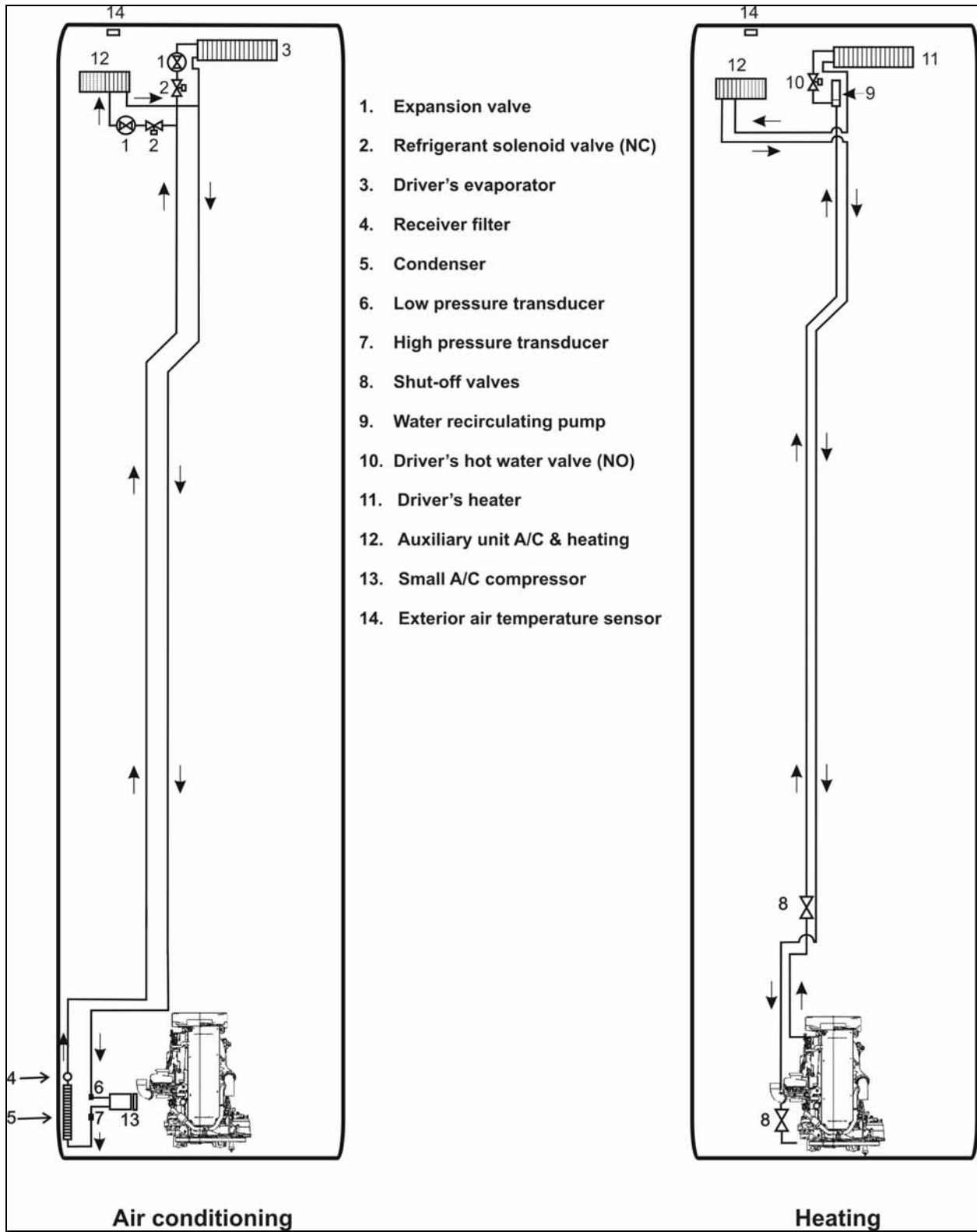

FIGURE 50: SMALL HVAC SYSTEM

22290

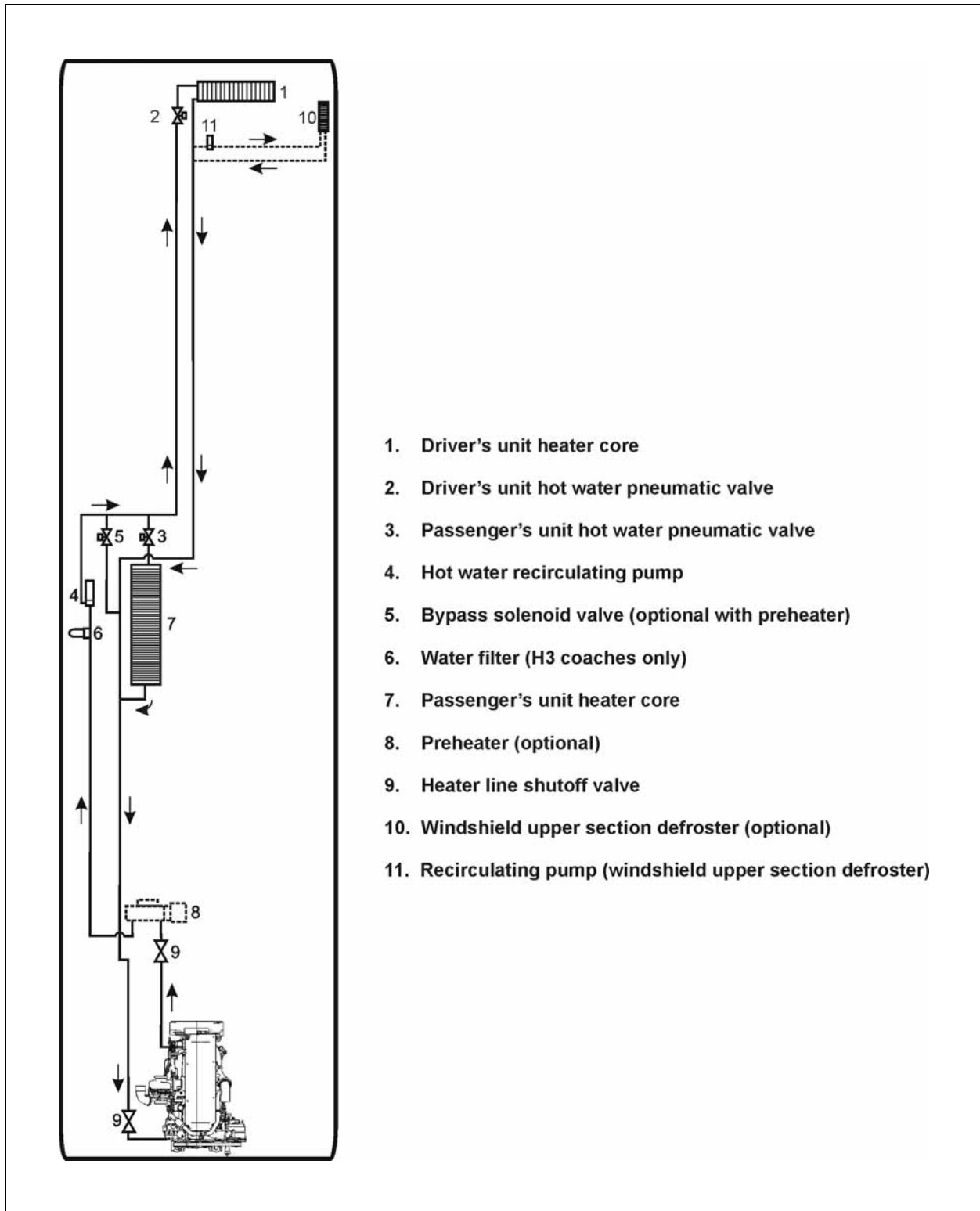

FIGURE 51: CENTRAL HVAC SYSTEM – HEATING

22262

11. HEATING SYSTEM

The schematics of Figure 50 and FIGURE 51 show respectively, the small HVAC system heating and air conditioning arrangement and the central HVAC system heating arrangement.

In addition to the normal heating provided by the engine, a preheating system (104,000 Btu/hr) (optional on coaches only) may have been installed in the vehicle.

Section 22: HEATING AND AIR CONDITIONING

11.1 SMALL HVAC SYSTEM

The small HVAC system driver's unit is similar to the driver's unit of the central HVAC system, except that the recirculating pump is located on the ceiling of the spare wheel compartment (Figure 60). For more information on components, refer to paragraph 11.2: CENTRAL HVAC SYSTEM.

Furthermore, an auxiliary unit is added in series on the return line of the small system, it increases the whole system heating capacity and gives the driver more options.

11.2 CENTRAL HVAC SYSTEM

The schematic of FIGURE 51 shows the central HVAC system heating arrangement.

On coaches only, in addition to the normal heating provided by the engine, an optional preheating system (104,000 Btu/hr) may have been installed above the rear wheelhousing on the L.H. side.

11.3 DRAINING HEATING SYSTEM

To drain the entire system, refer to Section 05, "Cooling". If only the driver's unit heater core or passenger's unit heater core must be drained, refer to the following instructions.

11.3.1 Draining Driver's Unit Heater Core

1. Stop engine and allow engine coolant to cool.
2. Locate the normally open hot water pneumatic valve on the ceiling of the spare wheel compartment (Figure 49), disconnect its wiring connector, then connect a 24-volt external power source, using jumper cables, to close valve.

⚠ WARNING ⚠
Before proceeding with the following steps, check that coolant has cooled down.

3. Loosen hose clamp, install an appropriate container to recover coolant, and disconnect silicone hose from hot water pneumatic valve.
4. From inside of vehicle, remove the grill and the access panels. Open the purge valve located inside the driver's unit (Figure 52) to ensure an efficient draining.

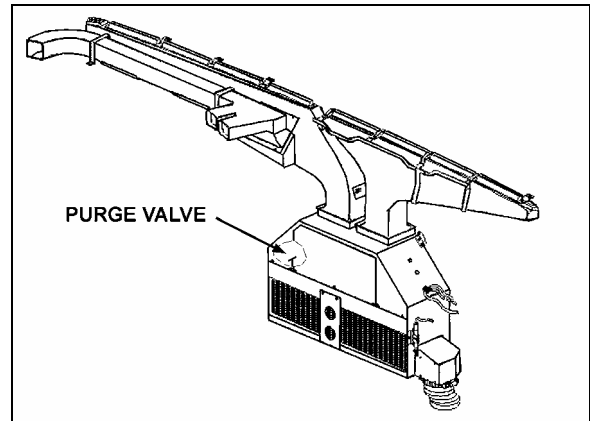

FIGURE 52: DRIVER'S UNIT AIR MIXING BOX 22171PV

11.3.2 Draining Passenger's Unit Heater Core

1. Stop engine and allow engine coolant to cool.
2. Close both heater line shutoff valves (Figure 55 & Figure 56). One is located in the engine compartment under the radiator fan gearbox, while the other one is located behind the L.H. hinged rear fender near the preheater. Refer to "Preheater System" in this section to gain access to the heater line shutoff valve.
3. Open the last L.H. side baggage compartment door and then pull the black release button located on the L.H. side in order to unlock and open the evaporator compartment door.

⚠ WARNING ⚠
Before proceeding with the following step, check that coolant has cooled down.

4. Open drain cock in bottom of heater core, then open purge valve located on top of heater core (Figure 53) in order to allow air to enter while draining.

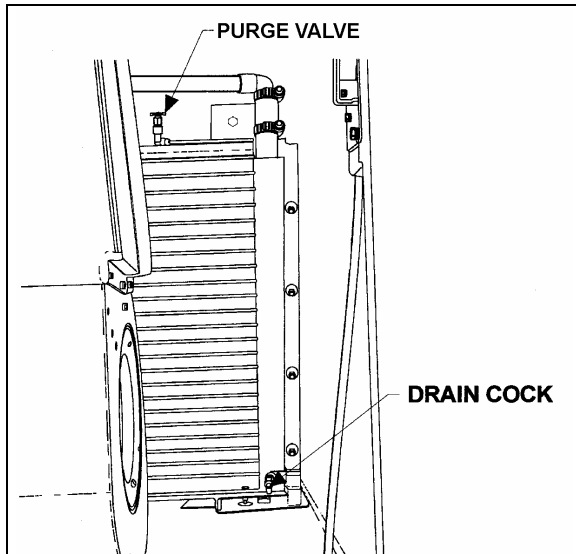

FIGURE 53: PASSENGER'S UNIT HEATER CORE (H3 COACHES) 22229

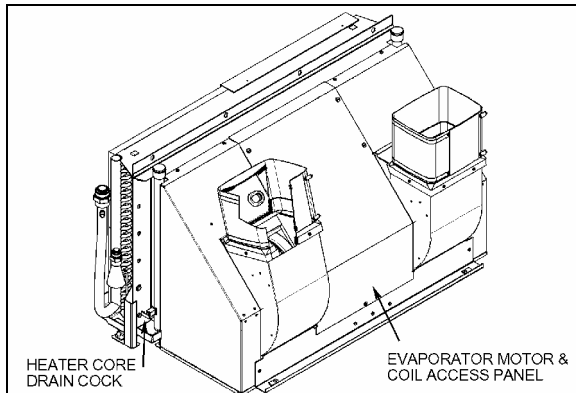

FIGURE 54: HEATER CORE INSIDE EVAPORATOR COMPARTMENT (H3 COACHES) 22332

11.4 FILLING HEATING SYSTEM

1. Ensure that the drain hose is reconnected and the purge valves and drain cock are closed.
2. Open the surge tank filler cap and slowly fill the system to level of filler neck.
3. After initial filling, the water valves should be open and the water recirculating pump should be energized to assist in circulating coolant through the heating system. To perform this operation, start the engine, switch on the HVAC control unit, both driver and passenger sections, and set temperature to their maximum positions in order to request the heating mode in each of these sections.

4. When coolant level drops below the surge tank filler neck, slowly fill the system to level of filler neck.
5. If vehicle is equipped with a windshield upper section defroster, open front baggage compartment R.H. side door. Locate recirculating pump on top of front wheelhousing, momentarily pinch the hose located between the recirculating pump suction and the defroster outlet connector to ensure windshield upper section defroster complete filling.
6. Once the level has been stabilized, replace cap.

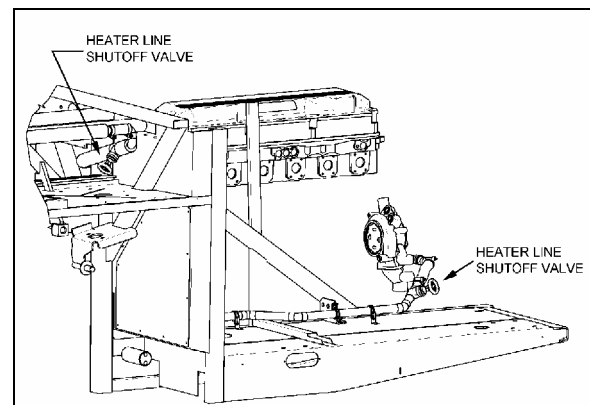

FIGURE 55: HEATER LINE SHUTOFF VALVES (CENTRAL HVAC SYSTEM)

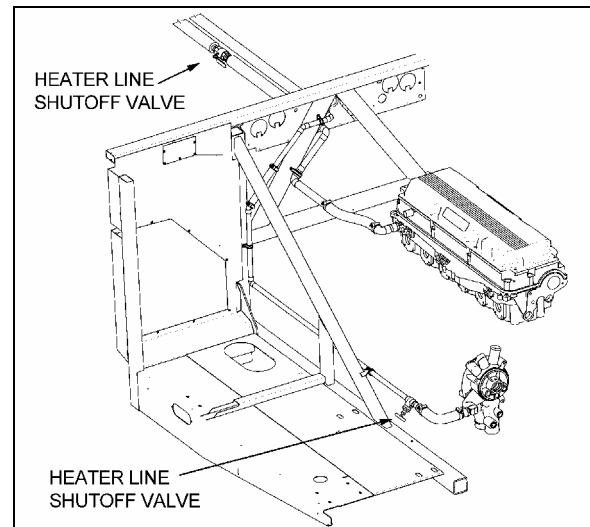

FIGURE 56: HEATER LINE SHUTOFF VALVES (SMALL HVAC SYSTEM)

11.5 BLEEDING HEATING SYSTEM

Whenever the heating system has been drained and refilled, or the system has run low on coolant and coolant has been added, it is necessary to bleed air from heating system. Locate the purge valve illustrated in Figure 52

and Figure 53, and open them momentarily until no air escapes from the lines.

NOTE

In test mode (see paragraph 7.1 HVAC SYSTEM AND TEST MODE FOR SWITCHES AND SENSORS), with the parking brake applied and the passenger set point set to a value higher than 64°F (18°C), the hot water circulating pump is not set to OFF as it would normally do when the outside temperature gets above 50°F (10°C). This feature is useful when working on the heating system to remove air pockets trapped in the system.

11.6 SOLDERING

Before soldering any part of the system, make sure the area is well ventilated. Use (stay clean) flux sparingly and apply solder (95-5 round wire 1/8 inch [3,1 mm]). After completing repairs, test for leaks.

When using heat at or near a valve, wrap with a rag saturated of water to prevent overheating of vital parts.

11.7 DRIVER'S UNIT HOT WATER PNEUMATIC VALVE

The flow of hot water to the driver's unit heater core is controlled by a pneumatic valve like the passenger's unit hot water pneumatic valve. It is mounted on the coolant inlet line of the driver's heater core, and is accessible through the spare wheel compartment (see Figure 50, FIGURE 51 & Figure 60). For more information, refer to paragraph 11.8.

11.8 PASSENGER'S UNIT HOT WATER PNEUMATIC VALVE ASSEMBLY

11.8.1 Description

The flow of hot water to the vehicle's central heater core is controlled by a NO pneumatic water valve assembly (Figure 57). The valve, located in the evaporator compartment, is designed so that the pilot solenoid valve, which is part of the assembly, opens and closes a port which directs air pressure to the actuator casing, thereby opening or closing the valve.

When the vehicle is operating with no current to the pilot solenoid valve, no air pressure is admitted to the actuator casing, the cylinder spring pushes up against the cylinder, thereby keeping the water valve open.

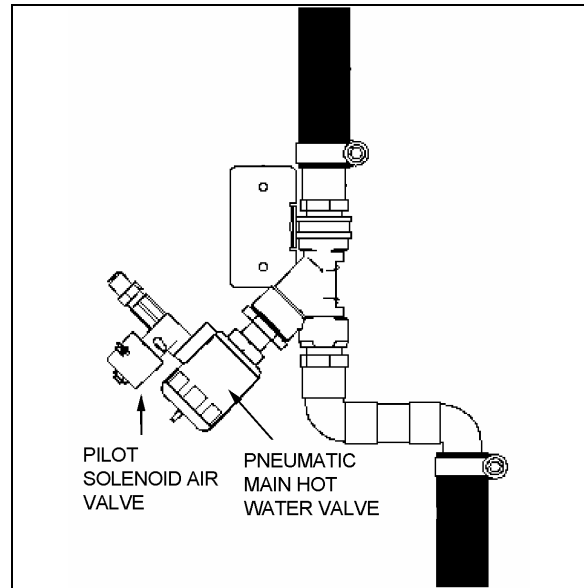

FIGURE 57: PASSENGER'S UNIT HOT WATER PNEUMATIC VALVE ASSEMBLY

22240

The passenger's unit heater water valve requires a minimum amount of maintenance. The valve should be free of dirt sediment that might interfere with its operation. No other maintenance is needed unless a malfunction occurs.

11.8.2 Hot Water Pneumatic Valve Disassembly

1. Shut off air supply pressure and electrical current to the pilot solenoid valve. Disconnect wires.
2. The water valve need not be removed from the line. Unscrew nipple, the actuator casing, tube, spindle and closure member can be removed (Figure 58).

3. Remove the snap ring using a pair of pliers.
1. You can now access all seals for replacement

Pneumatic water valve replacement seal kits:

- o Water Side: 871311
- o Actuator Side: 871312

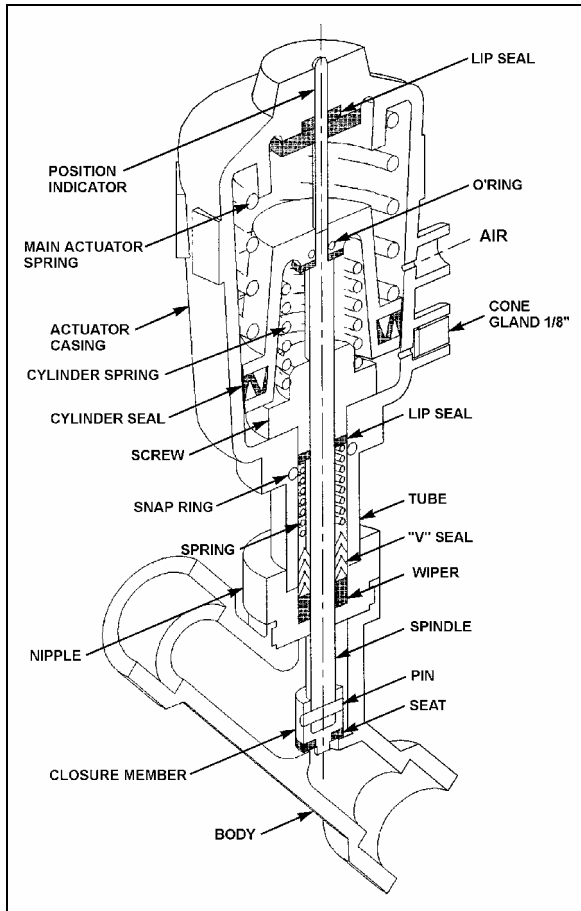

FIGURE 58: PASSENGER'S UNIT HOT WATER PNEUMATIC VALVE

22241

11.8.3 Hot Water Pneumatic Valve Reassembly

1. Assemble the actuator casing, tube, nipple, spindle and closure member.
2. Tighten the nipple in place in the body cavity as per Figure 58. Fasten pilot solenoid valve to the pneumatic water valve. Reconnect air supply pressure and electrical current to the pilot solenoid valve.
3. Check for proper operation.

11.8.4 Pilot Solenoid Valve

1. No maintenance is needed unless a malfunction occurs.
2. A pilot solenoid valve replacement seal kit is available: 871311.

11.8.5 Valve Troubleshooting

PROBLEM	PROCEDURE
Valve fails to close	1. Check electrical

	<p>supply with a voltmeter. It should agree with nameplate rating.</p> <ol style="list-style-type: none"> 2. Check pressure at pilot solenoid valve inlet. It must be at least equal to the minimum pressure stamped on the nameplate. It should not go below minimum while valve is operating.
Valve fails to open	<ol style="list-style-type: none"> 1. Check that the closure member assembly, and that main actuator and cylinder springs are free to travel. 2. Check that there is no restriction to the air escaping from the actuator casing. 3. Make sure that pilot solenoid valve operates properly.

11.9 HOT WATER RECIRCULATING PUMP

This vehicle is provided with a water recirculating pump which is located in the evaporator compartment (Figure 59) or on the ceiling of the spare wheel compartment for vehicles equipped with a small HVAC (Figure 60). The water recirculating pump consists of a centrifugal pump and an electric motor which are mounted in a compact assembly.

The motor is equipped with pre-lubricated sealed ball bearings which require no maintenance. The pump requires no periodic maintenance other than replacement of motor brushes. Replacement of motor brushes can be performed without removing the pump assembly.

Inspection of the pump, to determine to determine if the pump is working properly, should be made while the pump is in operation. If there is evidence that the pump is not operating as per specifications, the unit must be disassembled for corrective measures. Disassembly of the pump will be necessary only in the case of impellor failure or motor failure.

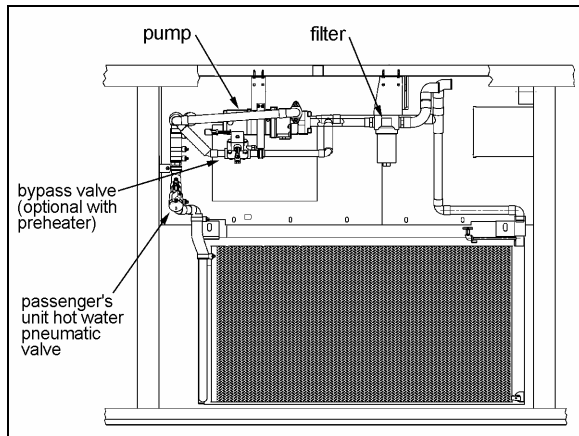

FIGURE 59: HOT WATER RECIRCULATING PUMP INSTALLATION (CENTRAL HVAC SYSTEM) 22280

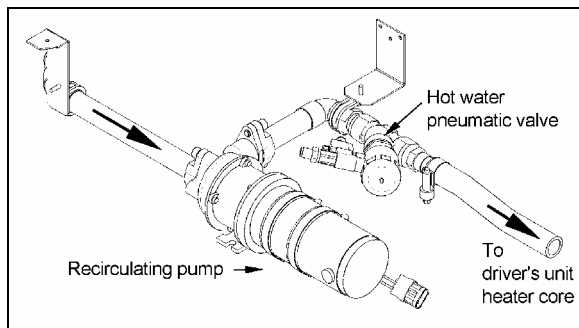
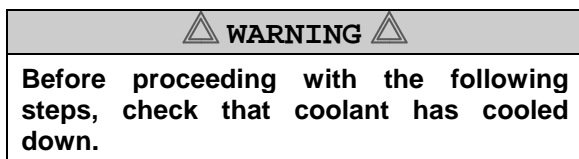

FIGURE 60: HOT WATER RECIRCULATING PUMP INSTALLATION (SMALL HVAC SYSTEM) 22292

11.9.1 Removal

1. Stop engine and allow engine coolant to cool.
2. Close shutoff valves on the heater line. Refer to "Preheater System" in this section to gain access to the heater line shutoff valve.
3. Disconnect the electrical wiring from the motor.



4. Disconnect water lines from the pump at the flange connections.
5. Remove the two clamps holding the pump motor to its mounting bracket. Remove the pump with the motor as an assembly.

11.9.2 Disassembly

Refer to Figure 61.

1. Separate the housing from the adapter by first removing the 4 capscrews. Remove housing carefully to prevent damaging the O-ring.
2. Remove rotor assembly, washers and shaft from the adapter.

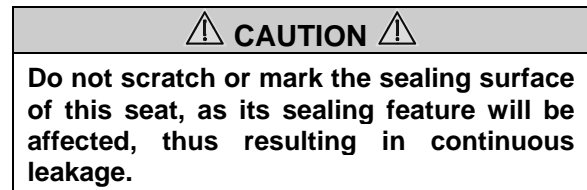

Inspection

Components removed from the recirculating pump and motor assembly should be compared with new parts to determine the degree of wear.

11.9.3 Brushes

- 1) When removing brushes, note the position of the brush in the tube. Brush life is shortened if the brushes are not replaced properly.
- 2) Examine brushes for the following:
 - a) Wear
Replace the brushes if less than 25% of the usable brush is left (less than 0.300 inch (8 mm)).
 - b) Chipped edges
Chips can be caused by improper handling or installation. Badly chipped brushes should be replaced regardless of their length.
 - c) Annealed brush spring

This can be detected by noting the resiliency of the spring. Annealing is caused by failing to tighten the brush caps properly, thus not providing a good low resistance contact between the terminal and the brush tube. Replace brushes showing evidence of annealed springs.

- d) Frayed or broken pigtail

An improperly installed brush may have the pigtail (shunt) pinched under the terminal or between the coils of the spring. If the pigtail is badly frayed or broken, replace the brush.

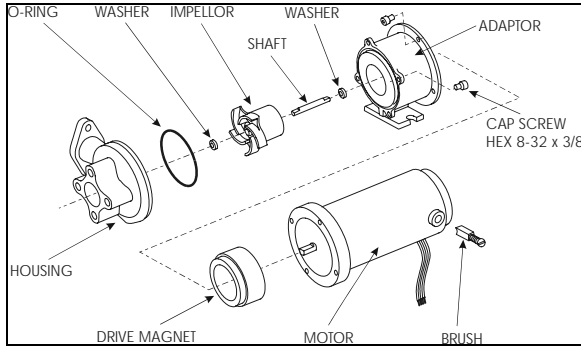

FIGURE 61: HOT WATER RECIRCULATING PUMP

- 3) Observe the following factors when replacing brushes
 - a. The face of a new brush is carefully cut to cause proper seating during the "wear-in" period.
 - b. Improper installation can harm both the brush and the commutator.
 - c. Replacement brushes should be of the proper grade.
 - d. Brush performance will be affected if the spring and terminal are not properly placed in the brush tube. The spring should be free over its entire length and the terminal should make good contact with the metal brush tube insert.

11.9.4 Assembly

Refer to Figure 61.

1. Install washer, shaft and rotor assembly into adapter.
2. Install O-ring into housing and assemble housing to the adapter.
3. Secure housing to adapter using 4 capscrews.

11.9.5 Installation

1. Apply gasket cement to the pump body line adapter and to the line flanges, put the two gaskets in place, and connect water lines from the pump at the flange connections. Position the pump and motor assembly on the mounting bracket. Position the mounting clamps over the motor and secure with mounting bolts.
2. Connect electrical wiring to the pump motor.
3. Open both shutoff valves. Refer to "Preheater System" in this section to gain access to the heater line shutoff valves.

4. Fill the cooling system as previously instructed in this section under "Filling Heating System" and then bleed the system as previously instructed in this section under "Bleeding Heating System".

11.10 WATER FILTER

This vehicle is provided with a cleanable water filter (Figure 62), which is located in the evaporator compartment behind the right air duct (Figure 24).

22277

11.10.1 Maintenance

Filter maintenance consists in changing the element at break-in 3000 miles (4 800 km), and subsequently every 50,000 miles (80 000 km) or once a year, whichever comes first.

NOTE

Each time soldering is performed on any water pipe of the heating system, operate heating system a few minutes so that any foreign matter will be routed to the filters. Clean filters.

11.10.2 Filter Servicing

1. Stop engine and allow engine coolant to cool.
2. Close the shutoff valves (Figure 55). Refer to "Preheater System" in this section to gain access to the heater line shutoff valve near the preheater.

WARNING

Before proceeding with the following steps, check that coolant has cooled down.

3. Rotate bowl counterclockwise and remove.
4. Remove filter element from housing.
5. Clean the filter element or use a new one. Place new/clean element in housing, centering it on location in the head.
6. Inspect bowl seal and replace if necessary.
7. Replace bowl. Rotate clockwise and hand-tighten.
8. Correct coolant level in surge tank as instructed previously in this section under "Filling Heating System".

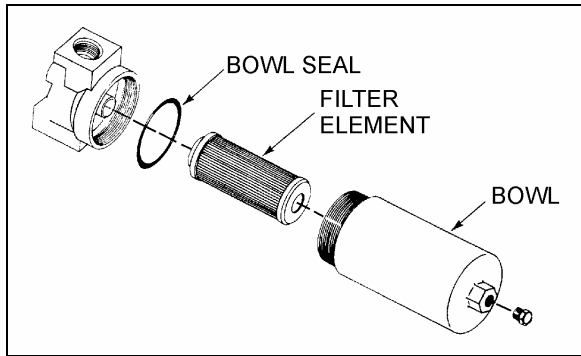

FIGURE 62: WATER FILTER

22057

11.11 BYPASS SOLENOID WATER VALVE (OPTIONAL)

This valve is optional and is installed on the vehicle equipped with a preheater. The valve is located in the evaporator compartment (Figure 59). Refer to Figure 63 for part names.

11.11.1 Improper Operation

1. **Faulty control circuit:** Check the electric system by energizing the solenoid. A metallic clicking noise indicates that the solenoid is operating. Absence of clicking indicates a loss of power or a defective solenoid. Check for open breaker, open-circuited or grounded coil, broken lead wires.
2. **Burned-out coil:** Check for open-circuited coil. Replace coil if necessary.
3. **Low voltage:** Check voltage across the coil leads. Voltage must be at least 85% of nameplate rating.
4. **Excessive leakage:** Disassemble valve and clean all parts. Replace worn or damaged parts with a complete repair kit for best results.

11.11.2 To Remove or Change the Coil

- o Stop engine and allow engine coolant to cool.
- o Close shutoff valve on the line located in the rear electric compartment. Refer to "Preheater System" in this section to gain access to the heater line shutoff valve.

To remove the solenoid coil:

First take out the retaining screw at the top of the coil housing. The entire coil assembly can be lifted off the enclosing tube.

To reassemble:

Make sure that the parts are placed on the enclosing tube in the following order:

Be sure to change electrical data plate according to coil specifications change.

1. Place coil and yoke assembly on the enclosing tube. Lay data identification plate in place.
2. Insert the coil retaining screw, rotate housing to proper position and tighten screw securely.

11.11.3 Valve disassembly and Reassembly

Disassembly:

This valve may be taken apart by removing the socket head screws which hold the body and bonnet together. After removing the screws, carefully lift off the bonnet assembly (upper part of the valve). Don't drop the plunger. The diaphragm can now be lifted out. Be careful not to damage the machined faces while the valve is apart.

NOTE

The above procedure must be followed before brazing solder type bodies into the line.

Reassembly:

Place the diaphragm in the body with the pilot port extension up. Hold the plunger with the synthetic seat against the pilot port. Make sure the bonnet O-rings are in place, the bonnet assembly over the plunger, and that the locating sleeve in the bonnet enters the mating hole in the body. Insert body screws and tighten uniformly.

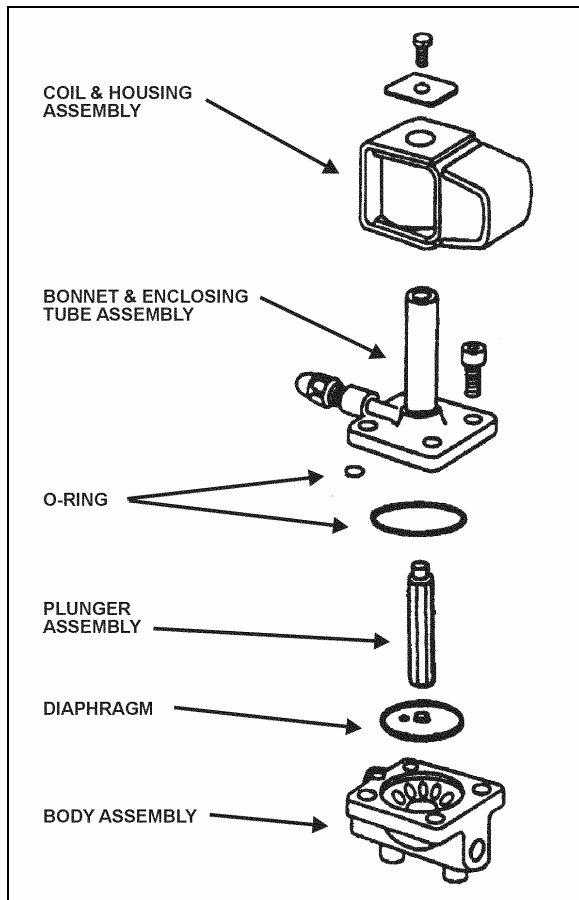

FIGURE 63: BYPASS HOT WATER SOLENOID VALVE
22044

12. PREHEATING SYSTEM (OPTIONAL ON COACHES ONLY)

The preheater is located over the rear wheelhousing, behind the vehicle's L.H. side rear fender.

To gain access to the preheater and the heater line shutoff valve next to it (Figure 55), remove the L.H side rear fender.

This Auxiliary Preheating System is used for preheating and retaining the heat of water-cooled engines. It can be used before starting the engine to ease its starting and to provide immediate inside heat upon operation of the heating system. It can also be used with engine running to maintain coolant heat and maintain the set temperature inside vehicle.

The heater operates independently from the vehicle engine. It is connected to the cooling and heating circuits, the fuel system and the electrical system of the vehicle.

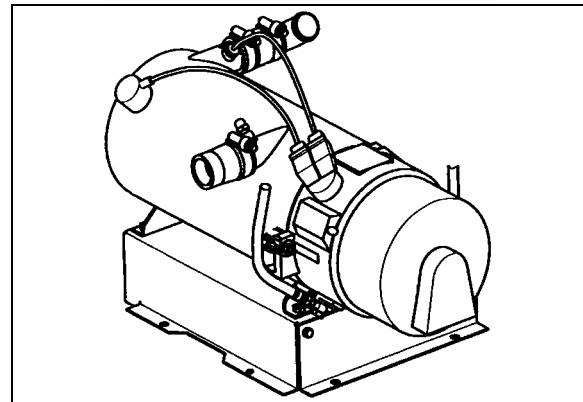

FIGURE 64: WEBASTO PREHEATER (104,000 BTU) 22224

The pilot lamp turns on when the heater is switched on. Combustion air flows in to flush out the combustion chamber and the water circulation pump is put into operation. The fuel metering pump conveys fuel in precise doses to the combustion chamber where fuel and combustion air form a combustible mixture which is ignited by the glow plug.

Once the flame sensor has signaled to the control unit that combustion has taken place correctly, the glow spark plug and ignition coil are switched off.

The hot combustion gases are diverted at the end of the flame pipe, then pass through the indirect heating surfaces of the heat exchanger and transmit their heat to the water passing through the heat exchanger.

The heat is thermostatically controlled and operates intermittently, i.e. the switched-on times of the burner vary depending on the heat requirement. The water temperature depends on the setting of the built-in water thermostat.

The water circulation pump remains in operation as long as the heater is operating, even in the regulation intervals and during the delayed cutout of the switched-off heater. The pump can also be operated independently from the heater by means of an appropriate circuit. The heater can be switched on at any time, even during the delayed cutout period. Ignition takes place once this delay time is over.

When the heater is switched off, the fuel supply is interrupted. The flame goes out, and at the same time a delayed cutout of some 2.5 minutes begins. The combustion air still flowing flushes the remaining combustion gases out of the chamber and cools off the hot parts on the exhaust side of the heat exchanger, while the water circulation pump, still running, transmits the heat present in the heat exchanger, thus

preventing local overheats. Once the delayed cutout time is over, both the combustion air blower and the water circulation pump switch off automatically.

A cutout will take place in case of any failure of the preheater.

12.1 OPERATION

Switch on the heater. The operation indicator lamp comes on and the heater motor and circulating pump begin to run. After about 10-25 seconds the solenoid valve opens and fuel is sprayed into the combustion chamber. At the same time, the electronic ignition unit produces high voltage (8000 V) and the mixture of fuel and air in the combustion chamber is ignited by the spark on the ignition electrodes. The flame is indicated by the flame detector, then the electronic ignition unit stops producing high voltage and combustion continues by itself (spark on electrodes is required only to ignite the flame). At this moment, the heater is working and producing heat.

If the heater is switched off by the on/off switch, the solenoid valve interrupts fuel supply, combustion stops and indicator lamp turns off. Combustion air fan still blows air, cleaning the combustion chamber of any fumes and cooling down the combustion chamber. Coolant circulation pumps coolant, making a purge cycle for approximately 2-3 minutes, thus protecting the heater against overheating.

If the heater is not switched off by the on/off switch, the control thermostat will switch off the heater when coolant temperature reaches $165^{\circ} \pm 6^{\circ}\text{F}$ ($75^{\circ} \pm 3^{\circ}\text{C}$) and turns it on at $154^{\circ} \pm 9^{\circ}\text{F}$ ($68^{\circ} \pm 5^{\circ}\text{C}$). During this time, the heater (combustion) is off and the indication lamp and coolant pump are on. Combustion air fan blows air for 2-3 minutes and then turns off.

12.2 PREHEATING SYSTEM TIMER

The timer, located on L.H. lateral console is used to program the starting and stopping time of the preheating system. The system indicator light, located on the timer, illuminates when the system is functional.



The preheating system should not operate for more than one hour before starting engine as this could discharge batteries.



Preheating system must not operate when vehicle is parked inside or during fuel fill stops.

NOTE

Preheating system uses the same fuel as the engine.

In case of failure:

1. Shut off and turn on again.
2. Check main circuit breaker and overheating fuse.
3. Have system repaired in a specialized shop.

12.2.1 Timer operating instructions (Webasto)

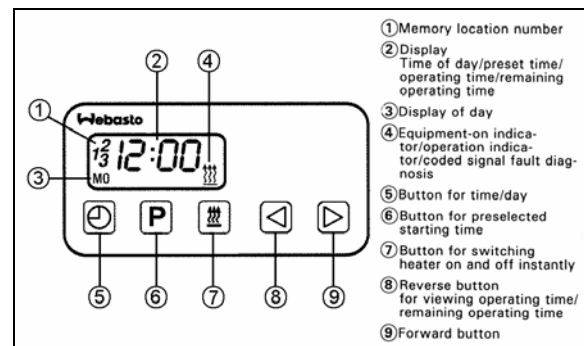

FIGURE 65: WEBASTO

22223

These instructions refer to the timer illustrated in Figure 65. They are the same instructions provided in the Webasto instruction booklet, provided with your vehicle.

Remaining Operating Time

The remaining operating time refers to the period of time the heater still continues to remain in operation. It may be changed while the heater is in operation.

Setting the Digital Timer

After the power has been connected, all symbols on the digital display are flashing. The time of the day and the day of the week must be set.

All flashing symbols of the timer can be set by means of the Forward (9) or Reverse (8) buttons.

When buttons (8) and (9) are pressed for more than 2 seconds, the quick digit advance mode is activated.

Setting the Time and Day of the Week

1. Press button (5) for more than 2 seconds (time display flashes).
2. Press (8) or (9) button to set the time of day.
3. Wait 5 seconds. The time of day is stored (time of week flashes).
4. Press (8) or (9) button to set the correct day of week.
5. Wait 5 seconds. The day of week is stored.

Viewing the Time (Ignition ON)

Continuous display of current time and day of the week.

Viewing the Time (Ignition OFF)

Briefly press button (5) to display current time and day for 5 seconds.

Switching Heater ON (Instant Heating)

With Ignition ON:

Press button (7). Heater is switched on (continuous operation) and continues to operate until button (7) is pressed again or ignition is switched off.

NOTE

If the ignition is switched off while heater is in operation, the remaining operating time of 5 minutes flashes on the display and the heater will continue to operate for this period of time.

With Ignition OFF:

Press button (7). Heater is switched on for preset operating time (the factory-set heater operating duration is 60 minutes).

Switching Heater OFF

Press button (7). The heater starts its after-run cycle and switches off thereafter.

Presetting Operating Duration

1. Press button (6). Memory location number flashes.

NOTE

By repeatedly pressing button (6), starting time 2 or 3 can be preset.

2. Press button (8) or (9) until correct startup time is set.

3. Wait 5 seconds. Preset starting time is stored and day of week flashes.
4. Press button (8) or (9) to select the correct startup day of week.
5. Wait 5 seconds. The startup day of week is stored.

The number of memory location remains on the display. The timer is now in the programmed mode and will switch the heater in a the preset time.

NOTE

We recommend that memory locations 1 and 2 be used for presetting times within 24 hours of setting the timer. Memory location 3 can be used for a starting time within the next 7 days of setting the timer.

Recalling Preset Times

Press (6) repeatedly until the desired memory location number and preset time are displayed.

Canceling Preset Time

Press button (6) repeatedly until no more memory location number is visible on the display.

Setting Operating Time

1. With heater off, press button (8). Operating time flashes.
2. Press button (8) or (9) to set the operating time (between 1 and 120 minutes).
3. Wait 5 seconds. Operating time is stored.

The heater remains in operation for the preset time (except for continuous operation).

Setting the Remaining Operating Time

1. With heater in operation, press button (8). Remaining operating time flashes.
2. Set remaining time with button (8) or (9).
3. Wait 5 seconds. Remaining operating time is stored.

Operational Failure Symptoms via Fault/Flash code

On heaters equipped with a fault diagnosis system using coded light signals, the equipment-on indicator/operation indicator flashes. Refer to the following table.

Section 22: HEATING AND AIR CONDITIONING

12.3 TROUBLESHOOTING AND MAINTENANCE

Refer to the Webasto manual for more information.

NOTE

If there are no heater faults, the heater will go through a normal start cycle and regulate based on thermostat setting.

NOTE

Switch on the preheating system briefly about once a month, even during the warm season.

⚠ CAUTION ⚠

When welding on the vehicle, disconnect the preheater module connector in order to protect this system from voltage surges.

⚠ CAUTION ⚠

To avoid running down the batteries, do not turn on the preheating system for more than one hour before starting the engine.

⚠ WARNING ⚠

The preheating system uses the same fuel as the engine. Do not operate in a building or while refueling. Operate only in a well-ventilated area.

Failure Symptom	Probable Cause	Check and Correct
1X Flash (F 01) No combustion after completion of start up sequence.	- Fuel system - Combustion air - Electronic ignition	- Fuel level - Type of fuel being used - Fuel filter - Fuel line connections (air bubbles in fuel lines) - Fuel nozzle plugged - Air intake or exhaust, restricted or plugged - Incorrect electrode gap
2X Flashes (F 02) Flame out during burner operation no restart possible	- Fuel supply (shortage of fuel)	- Restriction in the fuel system - Fuel filter - Fuel line connections (air bubbles in fuel lines) - Type of fuel being used
3X Flashes (F 03) Low voltage for more than 20 seconds	- Electrical system	- Load test batteries - Corrosion at connections - Loose connections
4X Flashes (F 04) Flame detector recognizes false flame signal during pre-start or shut-down cycle	- Defective flame detector	- Replace flame detector
5X Flashes (F 05) Flame detector	- Wiring - Defective flame detector	- Damaged wiring, open or short circuit - Replace flame detector
6X Flashes (F 06) Temperature sensor	- Wiring - Defective temperature sensor	- Damaged wiring, open or short circuit - Replace temperature sensor
7X Flashes (F 07) Fuel solenoid valve	- Wiring - Defective solenoid valve	- Damaged or corroded wiring, open or short circuit

Section 22: HEATING AND AIR CONDITIONING

		- Replace solenoid valve
8X Flashes (F 08) Combustion air fan motor	- Wiring - Wrong RPM - Defective combustion air fan motor	- Damaged wiring, open or short circuit - Replace combustion air fan - Replace combustion air fan
9X Flashes (F 09) Circulation pump motor	- Wiring - Defective circulation pump motor	- Damaged wiring, open or short circuit - Replace circulation pump motor
10X Flashes (F 10) Temperature limiter	- Overheat condition - Coolant flow - Wiring - Defective temperature limiter	- Reset temperature limiter - Coolant level or flow restriction - Air trapped in coolant circuit - Damaged or corroded wiring, open or short circuit - Replace temperature limiter
11X Flashes (F 11) Electronic ignition coil	- Wiring - Defective electronic ignition coil	- Damaged wiring, open or short circuit - Replace electronic ignition coil
12X Flashes (F 12) Heater lock out	- 3 repeated faults/flame-outs or 5 repeated start attempts	- Reinitialize control unit by switching heater on and disconnecting power.

13. SPECIFICATIONS

Passenger's unit evaporator motor

Make.....US MOTOR
 TypeT-17
 Voltage 27.5 V DC
 Current draw 68 amps
 Horsepower..... 2
 Revolution 1400 & 1800 rpm
 InsulationClass F
 Motor Life20 000 hours
 Brush life 10 000 hours
 Motor Prevost number..... 563008
 Brush Prevost number 562951

Passenger's unit condenser fan motors

Section 22: HEATING AND AIR CONDITIONING

Make.....US MOTOR
Type T11G
Voltage 28.5 V DC
Current draw 25 amps
Horsepower..... 0.57
Revolution 1950 rpm
Insulation Class F
Motor 20 000 hours
Brush life 10 000 hours
Qty..... 2
Prevost number 563051
Brush Prevost number 561914

Passenger's unit evaporator air filter

Make..... Permatron Corp.
Type Washable 1" X 23 3/8" X 43 1/2" Polypropylene filter
Prevost number 871051

Driver's unit evaporator motors

Make..... MCC
Voltage 24 V DC
Quantity 2
Prevost number 871135

Driver's unit evaporator air filter

Make..... MCC
TYPE Recirculating air 6-1/4" x 28" Washable
Prevost number 871147

Make..... MCC
TYPE Fresh air 3-5/8" X 5-1/4" Washable
Prevost number 871144

Refrigerant

Type R-134a
Quantity (standard) 24 lbs (10.89 Kg)
Quantity (with A/C unities Parcel Rack) 26 lbs (11.82 Kg)

Compressor (Central HVAC system)

Make..... Carrier Transicold
 Capacity 41 CFM
 Model..... 05G Twin Port-134A
 No. of cylinders 6
 Bore..... 2" (50,8 mm)
 Operating speed.....400 to 2200 rpm (1750 rpm. Nominal)
 Minimum speed (for lubrication)..... 400 rpm
 Nominal horsepower 15
 Oil pressure at 1750 rpm 15 to 30 psi (103-207 kPa)
 Oil capacity..... 1.13 U.S. gal (4,3 liters)
 Weight 142 lbs (64,5 kg)
 Approved oils
 -Castrol..... SW 68 (POE)

A/C Compressor (Small HVAC system)

Make.....Seltec
 Model.....TM-16HD
 Weight 10.9 lbs (4,9 kg)
 Prevost number 950372
Approved oil ZXL100PG (PAG)
 Prevost number 950382

Compressor unloader valve

Make..... Carrier Transicold
 Type Electric (AMC)
 Voltage 24 V DC
 Watts 15
 Prevost number (without coil) 950095
 Coil Prevost number..... 950096

Magnetic clutch

Make..... Carrier Transicold
 Type Housing mounted 9" dia., 2-B grooves
 Voltage 24 V DC
 Coil resistance at 68 °F (20 °C)..... 5.15 – 5.69 ohms
 Prevost number 950204

Section 22: HEATING AND AIR CONDITIONING

Compressor V belts

Make..... Dayco
Model (matching set of 2) BX97
Prevost number (with Delco 270/300 Amp Alternator) 506664

Compressor V belt

Make..... Dayco
Model..... BX100
Prevost number (with two BOSH Alternators) 506681

Condenser coil

Make..... Carrier Transicold

Aluminium

Prevost number 452968

Copper

Prevost number 453013

Receiver tank (with sight glasses)

Make..... HENRY or PARKER

Maximum pressure..... 450 psig

Prevost number 950261

Filter Dryer assembly

Make..... ALCO

Prevost number 950332

Moisture indicator

Make..... ALCO

Prevost number 950333

Driver's refrigerant liquid solenoid valve

Make..... Parker

Type Normally closed with manual bypass

Voltage 24 V DC

Amperage draw 0.67 amps

Watts 16

Prevost number (without coil) 95-0054
 Coil Prevost number..... 950055
 Repair kit Prevost number 950056

Driver’s & passenger’s hot water pneumatic valve

Make.....BURKERT
 Type Normally open
 Voltage 24 V DC
 Pressure range..... 0 to 230 psi
 Max. temperature356°F
 Prevost number 871252

Hot Water recirculating pump

Make.....M.P. pumps
 Voltage 24 V DC
 Prevost number 871342

Water filter (standard system)

Make..... Parker
 Prevost number (with element) 871028
 Element Prevost number 871029

Driver’s expansion valve

Prevost number 950221

Main expansion valve

Make.....CARRIER
 Prevost number 950316

Bypass solenoid water valve

Make..... Parker Hanninfin
 Bypass Prevost number 870886
 Coil Prevost number..... 870886
 Repair kit Prevost number 870980

Preheating system

Make..... WEBASTO
 Model..... THERMO 300
 Capacity 104 000 Btu/h (30 kW)
 Heating medium Coolant

Section 22: HEATING AND AIR CONDITIONING

Rated voltage	24 V DC
Operating voltage	20-28 V DC
Electric power consumption (without coolant recirc. pump)	110 watts
Fuel consumption	1,2 US gallons/hr (4,5 liters/hr)
Prevost number	871202