

# **DHOLLANDIA**

## **DH-CH103**

### **DOT-Public Use Lift**

# **MAINTENANCE & REPAIR MANUAL**

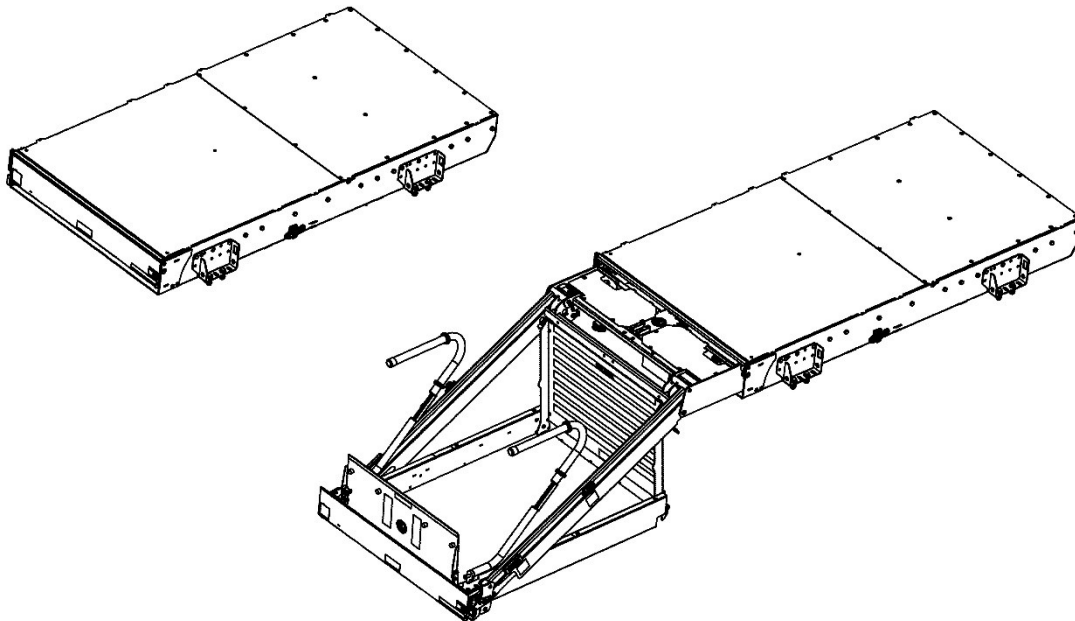

**Manufacturer:**  
**DHOLLANDIA US, L.L.C.**  
**E-mail : [us.info@dhollandia.com](mailto:us.info@dhollandia.com)**  
**270 Southridge Parkway**  
**Bessemer City North Carolina, 28016**  
**website : [www.dhollandia.com](http://www.dhollandia.com)**



**Read the manual in its entirety before operating the wheelchair lift**  
**Keep this manual in the vehicle cab, as reference for the driver and wheelchair lift operator**

**“DOT-Public Use Lift’ verifies that this platform lift meets the “public use lift” requirements of FMVSS No. 403. This lift may be installed on all vehicles appropriate for the size and weight of the lift, but must be installed on buses, school buses, and multi-purpose passenger vehicles other than motor homes with a gross vehicle weight rating (GVWR) that exceeds 4,536 kg (10,000 lb).**

# TABLE OF CONTENTS

|     |   |    |
|-----|---|----|
| 1   | INTRODUCTION .....  | 4  |
| 1.1 | General introduction.....   | 4  |
| 1.2 | Public use lift.....  | 4  |
| 1.3 | Understanding safety and warning signs .....  | 5  |
| 1.4 | Contact information and disclaimers .....   | 6  |
| 1.5 | Safety instructions for maintenance and repair.....                                 | 7  |
| 1.6 | Identification.....   | 8  |
| 2   | DESCRIPTION AND LIFT TERMINOLOGY.....   | 9  |
| 2.1 | General .....   | 9  |
| 2.2 | Safety measures.....  | 13 |
| 3   | IMPORTANCE OF PREVENTATIVE MAINTENANCE .....  | 17 |
| 3.1 | Checklist for preventative maintenance and inspection .....                         | 17 |
| 4   | TROUBLESHOOTING AND REPAIR.....   | 22 |
| 4.1 | Introduction .....  | 22 |
| 4.2 | General troubleshooting diagram.....  | 22 |
| 4.3 | PCB - Functions test.....   | 22 |
| 4.4 | PCB - Positions test.....   | 23 |
| 5   | SPARE PARTS .....   | 23 |
| 6   | DIAGRAMS .....  | 24 |
| 6.1 | General .....   | 24 |
| 6.2 | Hydraulic overview.....   | 25 |
| 6.3 | Wheelchair lift power pack terminology .....  | 26 |
| 7   | EMERGENCY OPERATION .....   | 28 |
| 8   | IMPORTANT PROCEDURES .....  | 31 |
| 8.1 | Procedure I-SERV-G-001: manual operation of the SINGLE ACTING valves.....           | 31 |
| 8.2 | Procedure I-SERV-G-002: manual operation of the DOUBLE ACTING valves (2 types)..... | 32 |
| 8.3 | Procedure I-SERV-G-003: hydraulic pressure reading and adjustment.....              | 33 |
| 8.4 | Procedure I-SERV-G-004: flushing of pressure relief valve.....                      | 34 |
| 8.5 | Procedure I-SERV-G-005: check on valve and solenoid function.....                   | 36 |
| 8.6 | Procedure I-SERV-G-006: Flushing and cleaning of valve cartridge .....              | 37 |
| 8.7 | Procedure I-SERV-G-007: Testing internal cylinder leaks .....                       | 38 |
| 8.8 | Procedure I-SERV-G-008: Oil replacement, filling and bleeding .....                 | 39 |
| 8.9 | Resolving malfunctioning Hand pump .....  | 40 |
| 9   | DECALS .....  | 42 |
| 9.1 | Decals on inside of bus.....  | 44 |
| 10  | MEANING OF SAFETY AND WARNING SIGNS.....  | 46 |
| 11  | PRESCRIBED TORQUE VALUES.....   | 48 |

|      |                                      |    |
|------|--------------------------------------|----|
| 12   | END NOTE .....                       | 49 |
| 13   | APPENDIX .....                       | 50 |
| 13.1 | General troubleshooting diagram..... | 50 |
| 13.2 | Toubleshooting: Functions test.....  | 51 |
| 13.3 | Troubleshooting: Positions test..... | 53 |
| 13.4 | Datasheets grease and oil .....      | 55 |



# 1 INTRODUCTION

## 1.1 GENERAL INTRODUCTION

- The MAINTENANCE AND REPAIR MANUAL explains how to maintain and service the wheelchair lift in the appropriate manner, maximizing the safety of the operator and any bystanders and ensuring the reliability of the wheelchair lift over the intended lifetime.
- The manuals must be kept with the wheelchair lift at all times, as a reference book for the operators and technical service.



### WARNING

- Improper use of the wheelchair lift will put the operator and other parties at great risk of serious bodily injury and death. Therefore, the use of the wheelchair lift is restricted to skilled operators only; who have been properly trained, and who know and understand the full contents of this manual.
- Unauthorized modifications to the wheelchair lift can put the operator and other parties at great risk of serious bodily injury and death. Therefore, it is strictly forbidden to modify the wheelchair lift and its safety devices in any way.
- The use of aftermarket or non-OEM replacement parts to repair the wheelchair lift is strictly prohibited and may result in serious bodily injury or death of the operator or any bystanders.

## 1.2 PUBLIC USE LIFT

- **DHOLLANDIA public use lifts** [DH-CH...series used for commercial purposes] are designed to be fitted to vehicles with a gross vehicle weight rating (GVWR) that exceeds 4,536 kg (10,000 lb) (buses, school buses, and multi-purpose passenger vehicles other than motor homes), and shall be used exclusively to assist wheelchair passengers to embark and disembark the vehicle.
- The lift shall be used with obedience of the loading diagram, and the user's- and safety instructions contained in this manual.



### WARNING

- Improper use of the lift will put the operator and bystanders at great risk of serious bodily injury and death. Therefore, it is strictly forbidden to use the lift in a different way, or for different purposes than described in the operation manual.
- The lift shall NEVER be used as an elevated work platform, to push loads, to move snow or other debris.
- DHOLLANDIA disclaims liability for any personal injury and / or property damage that results from improper use.

### 1.3 UNDERSTANDING SAFETY AND WARNING SIGNS

Many safety signs and symbols used in this manual are based on international standards, others refer to specific situations or actions.

Consult section 10 for an overview of signs and symbols used in DHOLLANDIA manuals and their meanings. Make sure you understand these signs and symbols prior to starting the installation.

|   |   |   |  |   |
|---|---|---|--|---|
| Examples of standard ANSI signs           |  |  |  |  |
| Examples of DHOLLANDIA purpose made signs |  |  |  |  |

Please take special notice of the following signs used in the manual. They indicate the likelihood and severity of a potential injury if a person fails to follow the instructions presented on the safety sign.



**DANGER**: indicates an imminently hazardous situation which, if not avoided, will result in death or serious injury. [white letters on red background]



**WARNING**: indicates a potentially hazardous situation which, if not avoided, could result in death or serious injury. [black letters on orange background]



**CAUTION**: indicates a potentially hazardous situation which, if not avoided, could result in minor or moderate injury. [black letters on yellow background]



**NOTICE**: is used to address practices not related to physical injury. [white letters on blue background]



**SAFETY INSTRUCTIONS**: indicate general instructions relative to safe work practices, reminders of proper safety procedures, or the location of safety equipment. [white letters on green background]



**SAFETY ALERT SYMBOL**: is used to alert the user to potential hazards. All safety messages that accompany this sign shall be obeyed to avoid possible harm. [free-standing, or on background colours red, orange, yellow or black]



|   |
|---|
|  <b>WARNING</b>  |
| <ul style="list-style-type: none"> <li>• Failure to understand and follow the instructions in this manual can put the operator and any bystanders at great risk of serious bodily injury and death.</li> <li>• Prior to operating the wheelchair lift, make sure you understand the safety and warning signs used, and read them in conjunction with the instructions in this manual.</li> <li>• If in doubt, DO NOT operate the wheelchair lift. Contact your national DHOLLANDIA distributor. See page 4 for contact info.</li> </ul> |

## 1.4 CONTACT INFORMATION AND DISCLAIMERS

DHOLLANDIA wheelchair lifts are regularly being adapted to new vehicle and chassis developments and specialized customer requirements. Therefore, DHOLLANDIA reserves the right to alter product specifications without prior notice and potentially modifications or new developments might not have been taken into account at the time of printing

### **NOTICE**

Please confirm you have reviewed the most up-to-date version of this manual prior to operation of the associated DHOLLANDIA wheelchair lift. See below for instructions to download the latest version of the manual.

Contact your national DHOLLANDIA distributor if you have any questions regarding the installation, operation, repair and maintenance of DHOLLANDIA wheelchair lifts, to obtain replacement copies of manuals or decals, or to learn about available equipment options for DHOLLANDIA wheelchair lifts.

#### **DHOLLANDIA US, LLC United States - West**

12968 Santa Ana Avenue  
Fontana CA 92337  
Tel: 855-856-8225

[Sales.USA@dhollandia.com](mailto:Sales.USA@dhollandia.com)

#### **DHOLLANDIA US, LLC United States - East**

200 Hilton Street West  
Easton PA 18042  
Tel: 855-894-1188

[Sales.USA@dhollandia.com](mailto:Sales.USA@dhollandia.com)

#### **DHOLLANDIA CANADA, Inc. Canada**

2105 Boulevard des Entreprises  
Terrebonne Quebec J6Y1W9  
Tel: 888-750-5438

[Sales.CANADA@dhollandia.com](mailto:Sales.CANADA@dhollandia.com)

#### **DHOLLANDIA MEXICO, Inc. Mexico**

Fraccionamiento Industrial  
Dinamo del Norte,  
Calle Tierra 103-105  
C.P. 65500, Salinas Victoria,  
Monterrey- Nuevo Leon  
Tel: +52 81 13340968

[Sales.MEXICO@dhollandia.com](mailto:Sales.MEXICO@dhollandia.com)



The latest version of all manuals can also be downloaded from the DHOLLANDIA website

[www.dhollandia.com](http://www.dhollandia.com) → **Downloads** → **User's manuals** → ... **select required manual**

- Take notice of following important disclaimers:

### **DISCLAIMERS**

- DHOLLANDIA disclaims liability for any personal injury, death, or property damage that results from **operating a wheelchair lift that has been modified from the original design**, without explicit written approval from the manufacturer.
- DHOLLANDIA disclaims liability for any personal injury, death, or property damage that results from **use of aftermarket or non-OEM replacement parts for service or repair of the wheelchair lift**.
- DHOLLANDIA disclaims liability for any personal injury, death, or property damage that results from **improper use of the wheelchair lift**.
- DHOLLANDIA disclaims liability for any personal injury, death, or property damage that results from **overloading or improperly loading the platform**, disregard of the maximum rated lift capacity and the applicable load charts.
- There are no warranties, express or implied, including the warranty of merchantability or a warranty of fitness for a particular purpose extending beyond that set forth in this manual.

## 1.5 SAFETY INSTRUCTIONS FOR MAINTENANCE AND REPAIR



- It is essential that the personnel involved in installing, servicing and repairing wheelchair lifts, know, understand and apply the safety instructions and precautions contained in the GENERAL SAFETY INSTRUCTIONS FOR INSTALLATION, MAINTENANCE AND REPAIR manual.
- Therefore, make sure you consult the GENERAL SAFETY INSTRUCTIONS FOR INSTALLATION, MAINTENANCE AND REPAIR manual prior to performing maintenance to the wheelchair lift.
- These instructions are supplied as a separate manual with your wheelchair lift.
- You can also contact your national DHOLLANDIA distributor for the latest edition of this manual. See page 6 for contact info. Or download the latest edition from the website:

[www.dhollandia.com](http://www.dhollandia.com) → your language → Downloads → User's manuals → General information

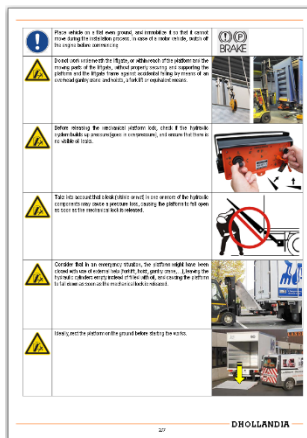

### WARNING

- In order to ensure the safety of the technicians performing the installation, repair- or maintenance work on wheelchair lifts, it is essential that they follow the instructions and precautions of the GENERAL SAFETY INSTRUCTIONS FOR REPAIR AND MAINTENANCE at all times.
- Make sure you wear safe work clothes, and take safety precautions as described in these instructions at all times.
- Additionally, when dismantling parts of the hydraulic circuit, make sure you take maximum precautions to avoid oil spillage and protect the environment, as described in these instructions.



### WARNING

- In order to ensure the safety of the technical personnel, of the wheelchair lift operators and of any bystanders, installation, maintenance and repair work should only be performed by skilled and authorised technicians. These technicians must be duly and professionally trained; must know and understand the content of the operation manual and the relevant installation, repair and maintenance manuals and must master the safety aspects involved in their job.
- Negligence can put the technical personnel, the operator and third parties at great risk and could result in severe personal injury or death. Negligence can also cause premature wear or damage to the wheelchair lift.



- In case of doubt, contact your national DHOLLANDIA distributor for further help and instructions.

## 1.6 IDENTIFICATION

- Every DHOLLANDIA wheelchair lift is identified by and labelled with a **unique 8-digit serial number** (with or without a space between the first and last 4 digits). Use this number for any inquiry on a particular wheelchair lift or when ordering replacement parts.
- In addition to the wheelchair lift type and serial number, the various serial number labels provide additional information, such as: the maximum rated lift capacity and load chart, the date of manufacture, etc...
- These labels are usually affixed to various wheelchair lift components and can be found in following locations (the yellow arrows point to the serial numbers):

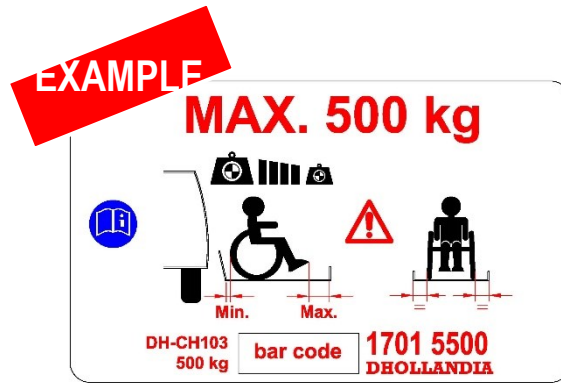

Affixed to the side of the vehicle body or on the platform

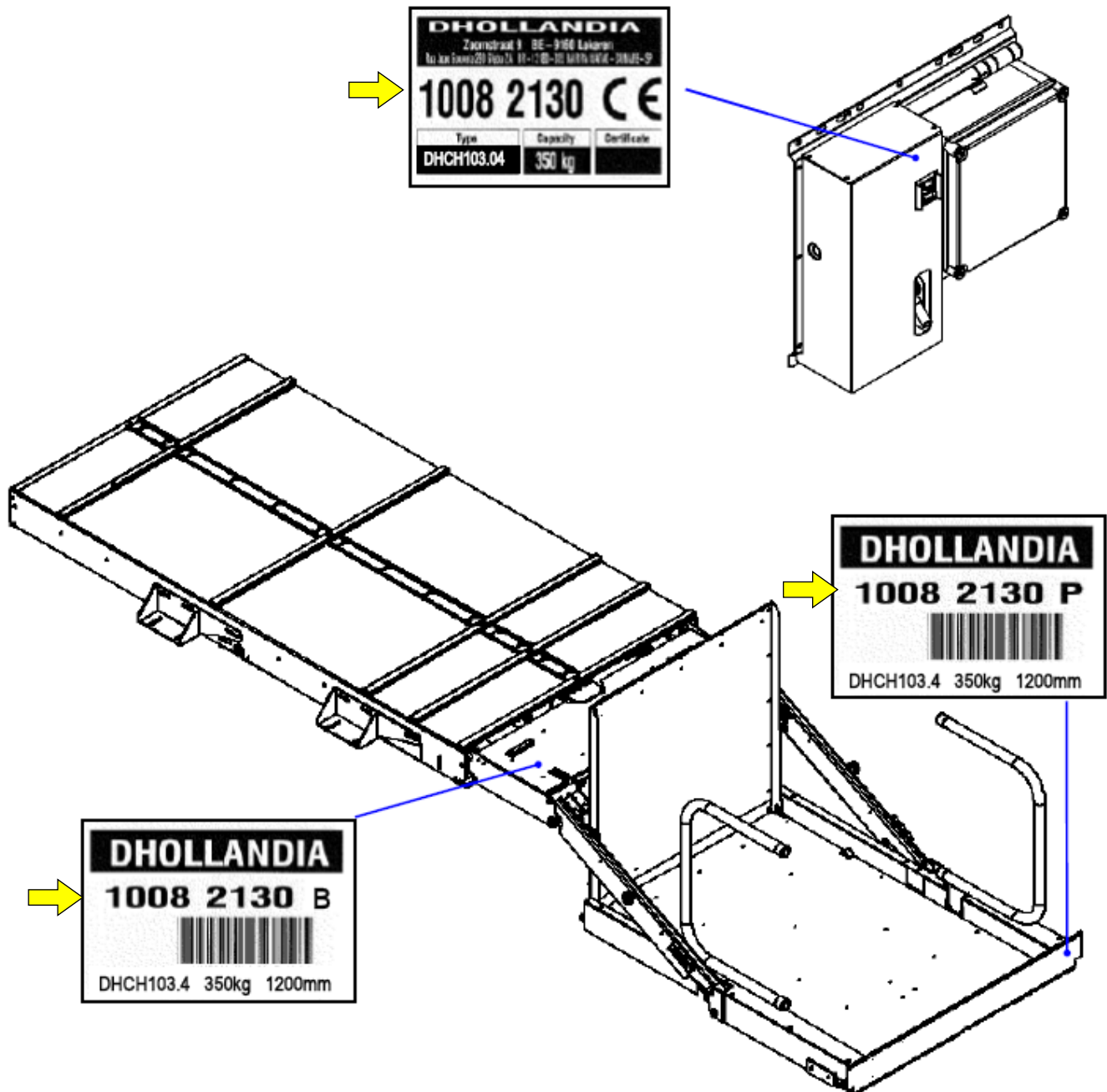

## 2 DESCRIPTION AND LIFT TERMINOLOGY

### 2.1 GENERAL

- DHOLLANDIA lifts are developed and manufactured using state-of-the-art technology, high quality materials and components, and comply with the European CE safety regulations mentioned in the Declaration of Conformity (unless agreed otherwise upon ordering - export outside CE region) and the FMVSS 403-404 for US.
- The **DH-CH... series passenger lifts** are retractable lifts, whose lift mechanism and platform are stowed in a closed cassette box in travel position. This cassette can be mounted to the chassis of the vehicle, in a luggage compartment or integrated in one of the steps of the stairs at the access door.
- Main details and terminology: see below

| DH-CH103* • TERMINOLOGY   |   |
|---|---|
| See figure below for parts corresponding to numbers in this table |   |
| #   | Description   |
| 1   | <b>Cassette:</b> sealed box housing the lift frame and platform when stowed in travel position, and protecting the mechanism against adverse weather conditions.<br>The cassette is equipped with slide rails and a retraction system to slide the lift frame and the platform from a travel position deep inside the cassette to a work position at the outboard edge of the cassette, and vice versa.   |
| 2   | <b>Mounting brackets:</b> brackets used to mount the cassette to the vehicle.   |
| 3   | <b>Lift frame:</b> steel assembly incorporating the lift arms and lift cylinders, who together carry the platform. The lift frame is moved in and out of the cassette by means of an electric motor and gearwheel system.   |
| 4   | <b>Lift arms + lift cylinders:</b> 2 lift arms L+R actuated by the lift cylinders, used to lift / lower the platform and its load (= functions UP / DOWN).  |
| 5   | <b>Platform:</b> carries the load during lifting / lowering. The platform is covered with an aluminium top plate with a non-slip surface. It is further equipped with a bridge plate, handrails and a roll stop flap.   |
| 6   | <b>Flashing platform lights:</b> used to make the platform visible to other parties in traffic.   |
| 7   | <b>Bridge plate:</b> plate mounted at the inboard platform edge, used to bridge any gap between the platform and the vehicle floor when the platform is raised to its maximum height.   |
| 8   | <b>Handrails:</b> Rails mounted at both sides of the platform. Lift occupants should hold on to these handrails to prevent them from falling off the platform. Handrails must be deployed manually and secured in vertical position prior to using the lift, they must be stowed manually before retracting the lift back into its travel position.   |
| 9   | <b>Roll stop:</b> roll stop mounted at the outboard platform edge. The roll stop is tilted up automatically when the platform leaves the ground, it is tilted down automatically when the platform touches the ground.<br>The roll stop prevents the wheelchair from slowly and unexpectedly rolling off the platform during lifting and lowering. It is not designed to stop fast and powered movements. |
| 10  | <b>Automatic cassette lock:</b> in regular conditions, the lift frame and platform are automatically locked inside the cassette by means of a lock mounted at the inboard edge of the cassette.   |
| 11  | <b>Emergency cassette lock:</b> in emergency conditions (in case of an electrical power failure) the automatic cassette lock can be disengaged, and the platform and lift frame can be pulled out by hand.  |
| 12  | <b>Wander lead with spiral cable:</b> control box to execute all functions DEPLOY – UP – DOWN - STOW. In standard configuration, the wander lead features 4 buttons for 4 functions.<br>The wander lead is equipped with an emergency button that immediately stops all electrical functions when activated.  |
| 13  | <b>Hydraulic power pack:</b> contains the electric motor driving the hydraulic pump, the oil tank, and the control valves.  |
| 14  | <b>Threshold module:</b> Guarantees a safe departure from the vehicle floor. It also makes sure the wheelchair lift will only initiate and continue the lift action when the threshold area is clear, in conformity with FMVSS requirements.  |



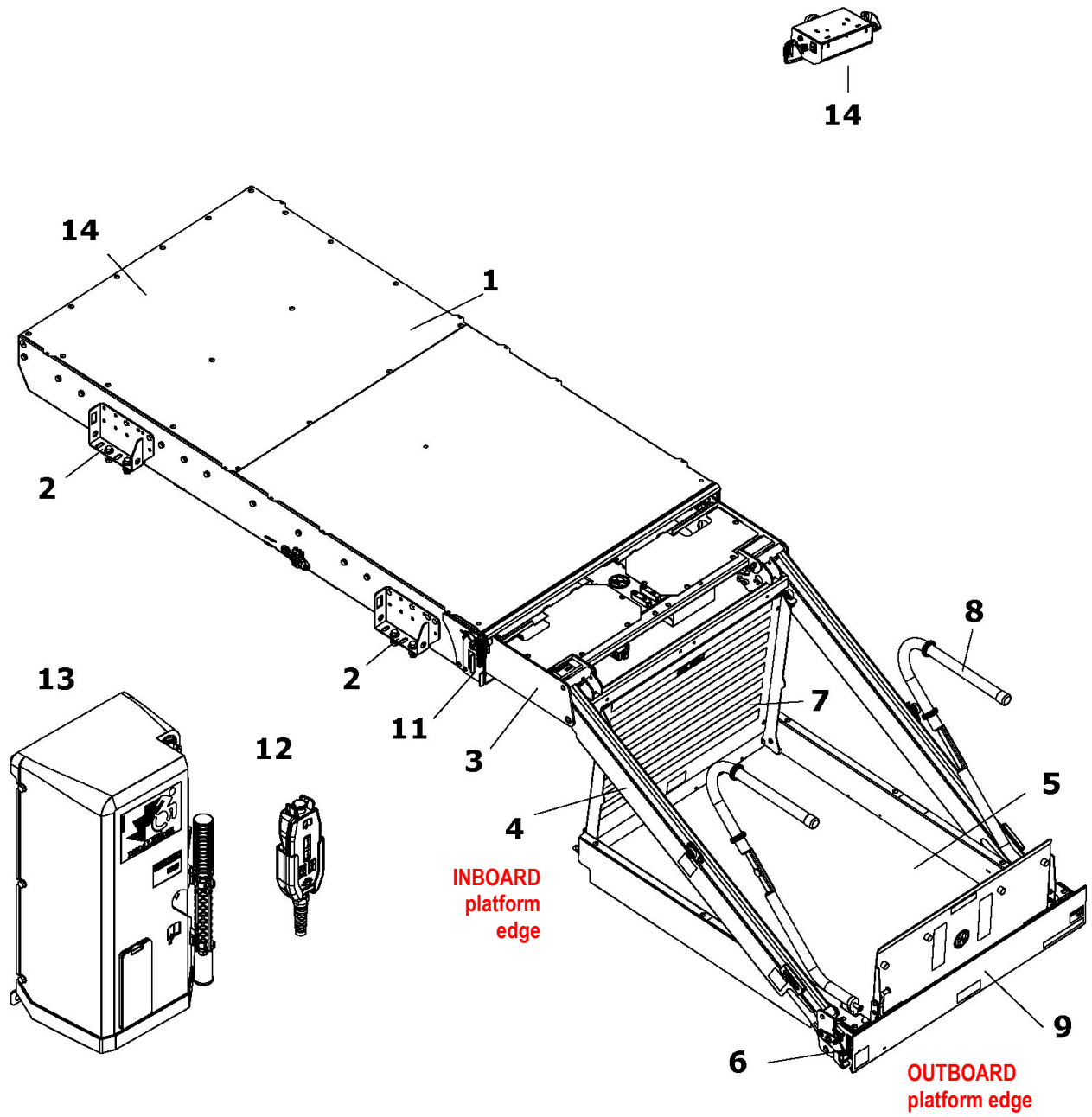

## POWER PACK • TERMINOLOGY

See figure below for parts corresponding to numbers in this table

| # | Description  |
|---|--|
| 1 | <b>Power pack:</b> sealed box containing the electric motor and hydraulic pump, the oil tank, control valves, electronic control unit and various emergency controls that can be operated in case of an electrical power failure.  |
| 2 | <b>Removable cover:</b> can be removed to get access to the electric motor and hydraulic pump, the oil tank, control valves and electronic control unit.   |
| 3 | <b>Hydraulic hand pump:</b> manual back-up pump to lift the platform in case of an electrical power failure (= function UP). The lever [# 3a] for the hand pump is stored at the front face of the cover of the power pack.  |
| 4 | <b>Emergency Descent button:</b> manual back-up button to lower the platform in case of an electrical power failure (=function DOWN).  |
| 5 | <b>EMR = Emergency Motor Release:</b> in regular mode, the lift frame and platform are blocked inside the cassette, and cannot be pulled out by hand easily. When turning the EMR button, the lift frame and platform are unlocked inside the cassette, and they can be pulled out by hand much more easily. After emergency use, the EMR button <b>MUST</b> be reset in its initial position. |
| 6 | <b>Electric connection:</b> plug for the connection of the wander lead with spiral cable.  |

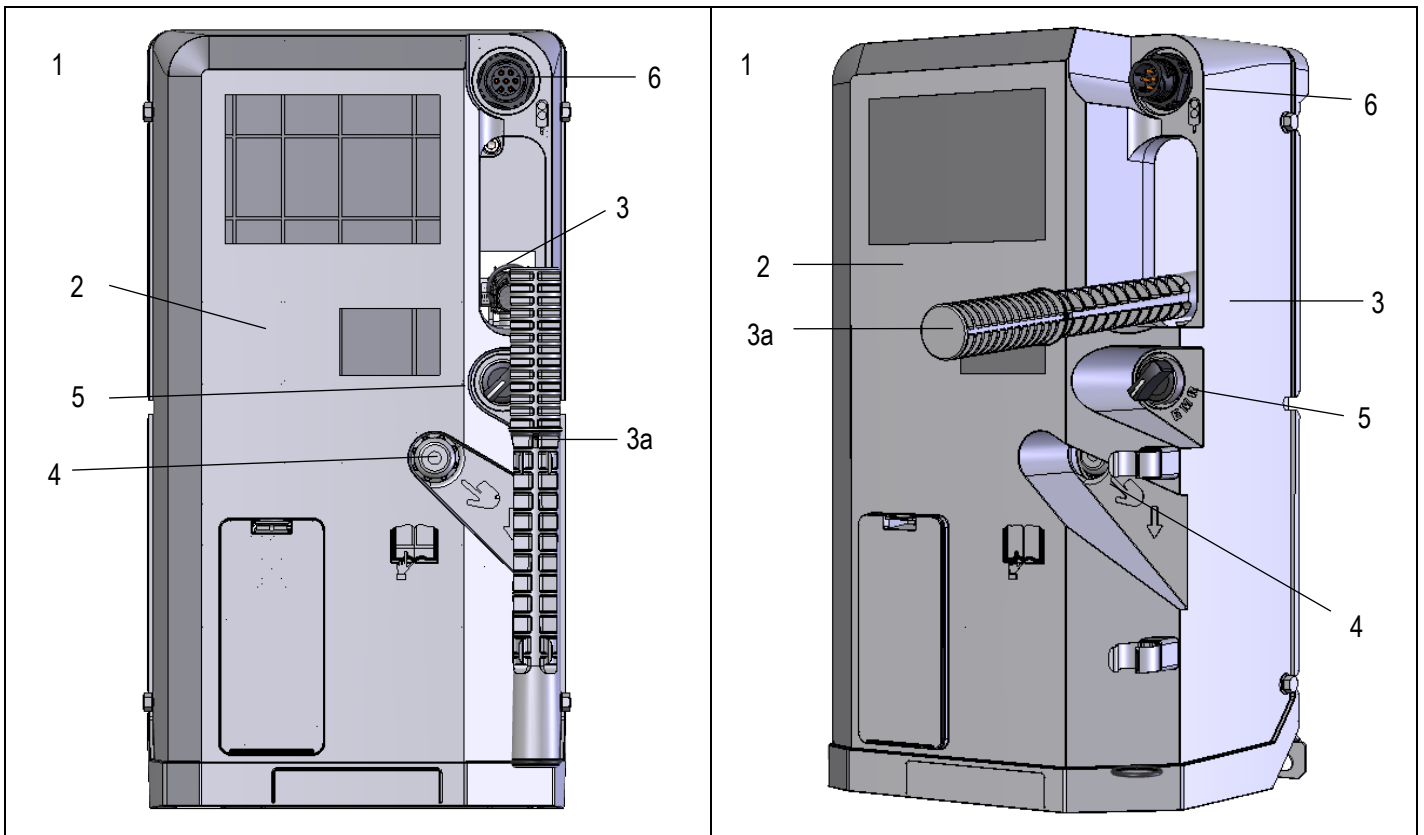



- Note: depending on the lift type and the installation environment, other types of power packs can be used. Despite different appearances, the main devices and components are identical. For example:

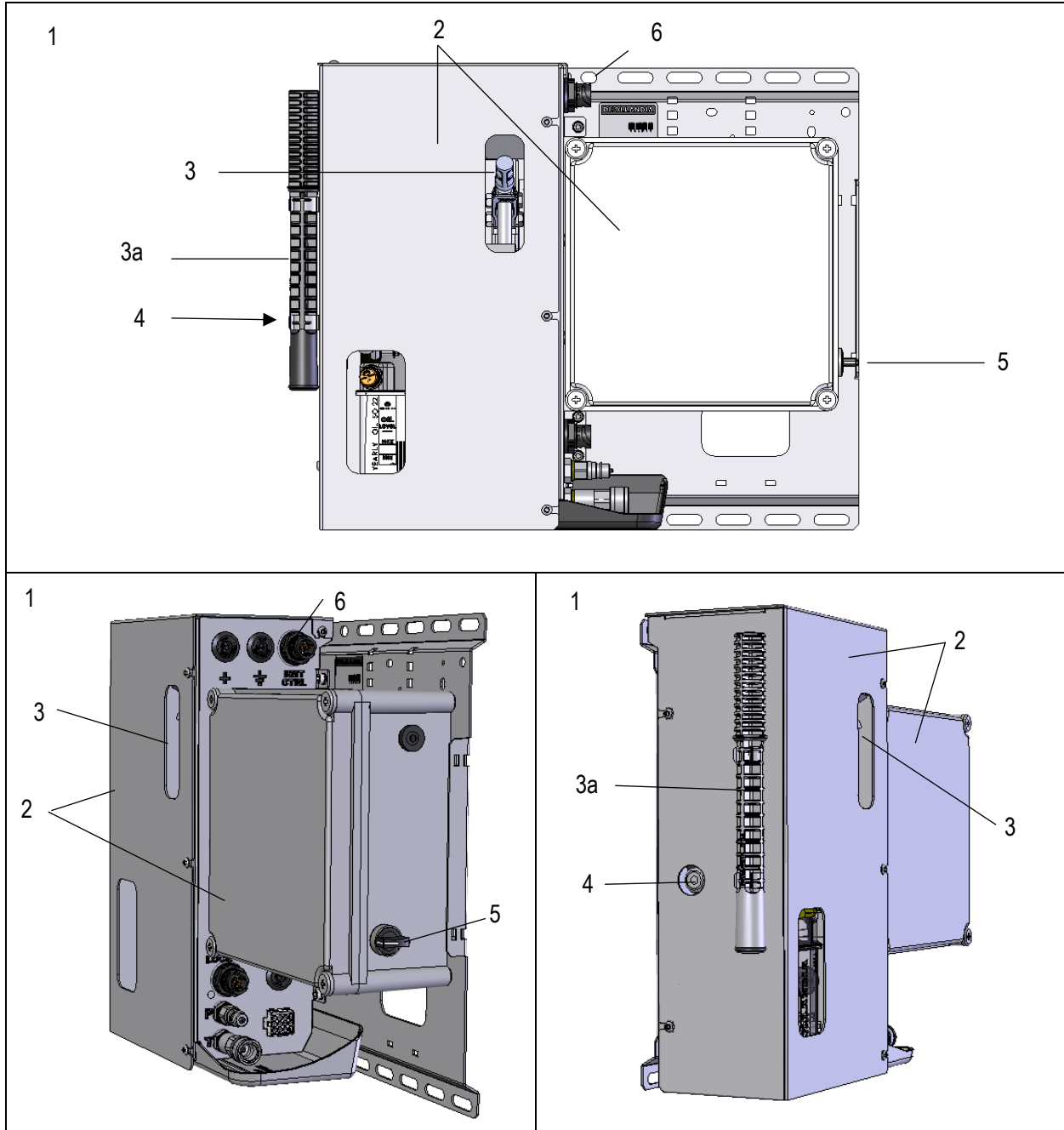





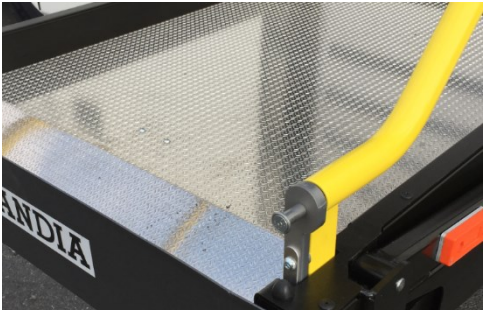

## NOTICE

- To ensure the reliability of the lift over many years, it is extremely important that the batteries, their charging system, the battery- and earth cables, and fuses are dimensioned sufficiently strong, and fitted with care following below mentioned instructions. Insufficient battery voltage will cause harm and irreparable damage to the electric components of the lift (starter solenoid, electric motor, electric switches, etc...).
- Vehicle manufacturers often impose prescribed connections for the battery and earth connections of the lift, which should be observed to avoid damage to the vehicle electrics. Where such prescriptions conflict with the fitting instructions of **DHOLLANDIA**, contact the vehicle importer or **DHOLLANDIA** for further advice.

## 2.2 SAFETY MEASURES

- DHOLLANDIA lifts are equipped with a wide range of safety measures, to enable its intended use with a maximum degree of safety for the operator, the wheelchair passenger on the platform and bystanders. The following safety devices are incorporated on the DH-CH... Series:

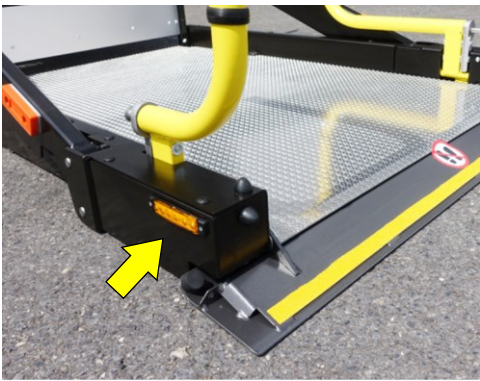
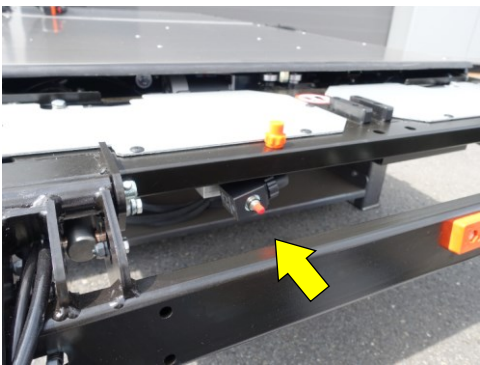
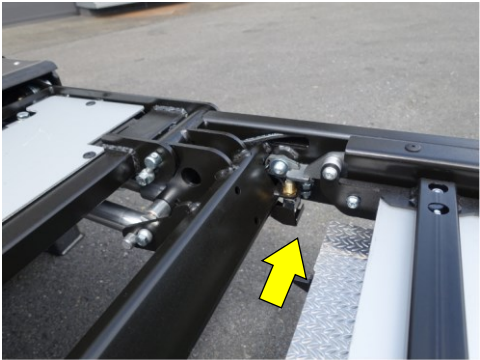
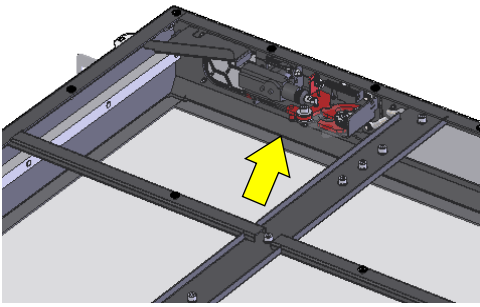
| N° | Description   | Image   |
|----|---|---|
| 1  | <p><b>Non-slip surface:</b> the platform surface incorporates an non-slip profiling to prevent the operator and platform occupants from slipping and falling.</p>   |    |
| 2  | <p><b>Roll stop:</b> roll stop mounted at the outboard platform edge. The roll stop is tilted up automatically when the platform leaves the ground, it is tilted down automatically when the platform touches the ground. The roll stop prevents the wheelchair from slowly and unexpectedly rolling off the platform during lifting and lowering. It is not designed to stop fast and powered movements.</p>   |    |
| 3  | <p><b>Handrails:</b> Rails mounted at both sides of the platform. Lift occupants should hold on to these handrails to prevent them from falling off the platform. Handrails must be deployed manually and secured in vertical position prior to using the lift, they must be stowed manually before retracting the lift back into its travel position.</p>  |  |
| 4  | <p><b>Bridge plate:</b> plate mounted at the inboard platform edge, used to bridge any gap between the platform and the vehicle floor when the platform is raised to its maximum height. The bridge plate tilts down automatically as the platform approaches the vehicle floor. It tilts up automatically as the platform lowers to the ground. It also forms a toe-guard for the operator and the wheelchair occupant while travelling up / down on the platform.</p> |  |

|   |   |   |
|---|---|---|
| 5 | <p><b>Flashing platform lights:</b> used to make the platform visible to other parties in traffic.</p>  |    |
| 6 | <p><b>Safety valve on the roll stop cylinder:</b> the valve keeps the roll stop secured in the upright position as long as the platform has not reached the ground.</p>   |    |
| 7 | <p><b>End stop for STOW:</b> combination of a cam and a switch to automatically stop the platform at the correct height to slide in and STOW the platform in its travel position.</p>   |   |
| 8 | <p><b>Automatic cassette lock:</b> in regular conditions, the lift frame and platform are automatically locked inside the cassette by means of a lock mounted at the inboard edge of the cassette.</p>                                |  |
| 9 | <p><b>Emergency cassette lock:</b> in emergency conditions (in case of an electrical power failure) the automatic cassette lock can be disengaged, and the platform and lift frame can be pulled out by hand (= function DEPLOY).</p> |  |

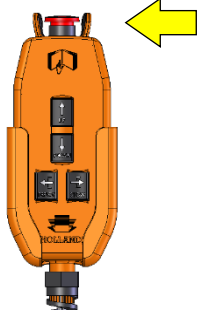
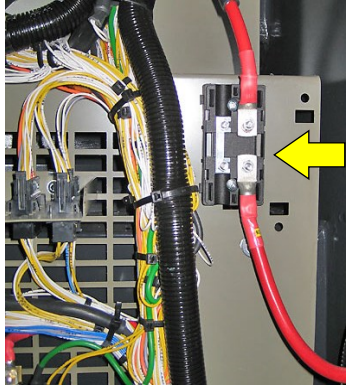
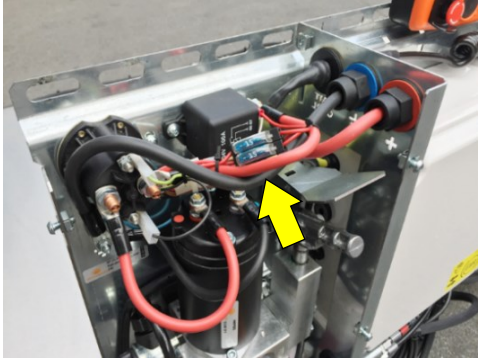
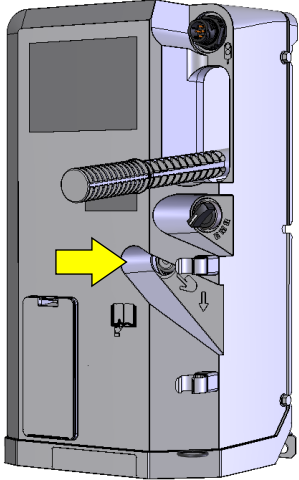
|    |  |   |
|----|--|---|
| 10 | <p><b>Electric emergency stop:</b> enables the operator to switch-off the electric power to the control unit and to cause an immediate stop of all electrically actuated lift movements. This switch is usually incorporated in the wander lead with spiral cable.</p> |    |
| 11 | <p><b>Main battery fuse:</b> a main fuse 100 – 150A is supplied by the vehicle manufacturer or by DHOLLANDIA. It protects the main battery cable from the batteries to the power pack of the lift against short circuits and amperage peaks.</p>                       |    |
| 12 | <p><b>15A fuse:</b> lighter fuses are used to protect the control unit, associated wires and the printed circuit against short circuits and amperage peaks.</p>  |   |
| 13 | <p><b>Emergency descent button:</b> manual back-up button to lower the platform in case of an electrical power failure (= function DOWN).</p>  |  |

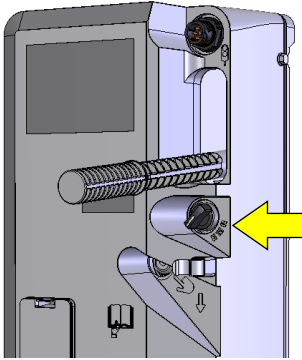
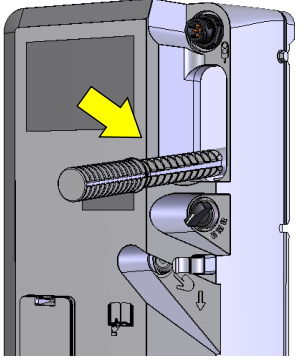
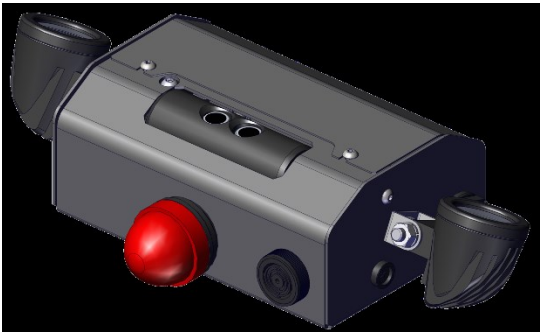

|    |  |  |
|----|--|--|
| 14 | <p><b>EMR = Emergency motor release:</b> in regular mode, the lift frame and platform are blocked inside the cassette, and cannot be pulled out by hand easily. When turning the EMR button, the lift frame and platform are unlocked inside the cassette, and they can be pulled out by hand much more easily. After emergency use, the EMR button <b>MUST</b> be reset in its initial position.</p>                  |   |
| 15 | <p><b>Hydraulic hand pump:</b> manual back-up pump to lift the platform in case of an electrical power failure (= function UP).</p>  |   |
| 16 | <p><b>Pressure relief valve:</b> safety device integrated in the power pack, enabling the manufacturer and the installer of the lift to limit the real lift capacity to the maximum rated capacity of the lift sold, and protect it against overload while lifting (= function UP).</p>  |  |
| 17 | <p><b>Pressure compensated flow valves:</b> flow valves are integrated in the hydraulic circuits to ensure the platform lowers at a safe speed, both empty and when fully loaded.</p>  |  |
| 18 | <p><b>Decals:</b> the lifts are supplied with a number of operation decals, load diagrams and safety decals. Some of these decals are pre-mounted by DHOLLANDIA on the lift. Some of these decals are supplied loose and shall be affixed by the installer near to the lift at a location clearly visible to the operator. The decals must be kept clean and legible at all times, and replaced whenever required.</p> |  |
| 19 | <p><b>Bridge plate load detection:</b> Prevents the wheelchair lift from departing from the vehicle floor when a load is still applied on the bridge plate.</p>  |  |
| 20 | <p><b>Roll-stop load detection:</b> Prevents the wheelchair lift from initiating the LIFT-action when a load is still applied on the roll-stop at floor level.</p>   |  |
| 21 | <p><b>Threshold warning sensor:</b> it guarantees a safe departure from the vehicle floor. It also makes sure the wheelchair lift will only initiate and continue the lift-action when the threshold area is clear.</p>  |  |

### 3 IMPORTANCE OF PREVENTATIVE MAINTENANCE

#### **NOTICE**

- Competent and regular preventative maintenance is essential to the operational reliability of the wheelchair lift as well as the safety of the operator and all bystanders.
- All maintenance and repair work must be performed by authorized DHOLLANDIA service agents and using original DHOLLANDIA replacement parts only.

- When checking the correct fastening of bolts and nuts, use a calibrated torque wrench to do so. The prescribed values are mentioned in the annex of this manual.
- The life cycle of a product will be determined by different factors, such as: climate, frequency of use, frequency of preventative maintenance, ... To ensure operational reliability and to extend the life cycle of a wheelchair lift, frequent maintenance is required.
- Above mentioned factors will determine the regularity of lift maintenance.
- If a wheelchair lift cannot be repaired immediately in case of breakdown, it must be put out of operation and secured against unauthorized use.



#### **WARNING**

To reduce the risk of injury in case of a malfunctioning or damaged wheelchair lift:

- Attach a warning sign or note to warn other people that the lift is out of service and should not be used.

- One of the most effective ways to prevent damage or malfunction of the wheelchair lift is to keep the platform and lift housing clean. Bad weather conditions (snow, mud etc.) together with dirt or other debris entering the wheelchair lift housing can cause problems if not kept clean properly.
- A maintenance and lubrication schedule is incorporated in the checklist for preventative maintenance and inspection in section 3.1. This schedule will function as a guide but remember that the maintenance frequency depends on the frequency- and conditions of use.
- The datasheets for the correct grease and oil can be found in appendix 13.4.

#### 3.1 CHECKLIST FOR PREVENTATIVE MAINTENANCE AND INSPECTION

- All maintenance and repair work must be performed by authorized DHOLLANDIA service agents and using original DHOLLANDIA replacements parts only.
- **This checklist will be the only part that can be performed by lift-operators or non-authorized service agents.** When a problem occurs, make sure to contact your national DHOLLANDIA distributor.
- The maintenance frequency depends on the frequency and conditions of use.



#### **WARNING**

- Besides the regular maintenance performed by skilled technicians, DHOLLANDIA strongly recommends that operators **perform daily pre-trip inspections** as detailed in the operation manual.
- Some steps in the maintenance check list require special skills and specific knowledge, that can be acquired through the DHOLLANDIA training programs for maintenance and repair. In case of doubt, DON'T go any further, but ask your local DHOLLANDIA distributor for professional advice.

|  |  |                 |              |  |
|--|--|-----------------|--------------|--|
| <br><b>DHOLLANDIA</b> | <b>Checklist for preventive maintenance and inspection</b>                   |                 | Work order # |  |
|  |  |                 | Client PO #  |  |
| Client :   |  | Plate :         | Mileage :    |  |
| Address :  |  | Model + S/N :   |              |  |
|  |  | Contact phone : |              |  |
| City :   | ST :   | Zip :           | Date :       |  |
| <b>PASSENGER LIFT</b>  | <b>When "NOT OK", lift must be serviced or repaired prior to further use</b> |                 |              |  |

| 1. Before getting started...  | Frequency | OK ? | Corrected |
|---|-----------|------|-----------|
| Lift cleaning<br><i>Clean lift thoroughly to make it ready for inspection</i> | As needed |      |           |

| 2. Documentation, safety markings and decals  | Frequency              | OK ? | Corrected |
|---|------------------------|------|-----------|
| Operation manual<br><i>Present in vehicle cab, complete</i>   | 90 days<br>1750 cycles |      |           |
| Model ID decal, serial number decal, maximum rated capacity decal<br><i>Present, well legible and in good condition</i> | 90 days<br>1750 cycles |      |           |
| Safety and operation decals<br><i>Present, complete, well legible and in good condition</i>                             | 90 days<br>1750 cycles |      |           |

| 3. Controls and electrical wiring   | Frequency               | OK ? | Corrected |
|---|-------------------------|------|-----------|
| Main battery disconnect switch in control box, dashboard switch in cabin (when applicable)<br><i>Condition, operation</i> | 180 days<br>3500 cycles |      |           |
| Switches and buttons, protective rubber covers<br><i>Condition, operation, automatic return to neutral position</i>       | 180 days<br>3500 cycles |      |           |
| Wiring harnesses<br><i>Condition, secured with clamps and/or cable ties, undamaged</i>                                    | 180 days<br>3500 cycles |      |           |
| Remote control<br><i>Condition, operation, condition of holder or magnetic catch, spiral cable and plugs</i>              | 90 days<br>1750 cycles  |      |           |

| 4. Electrical installation  | Frequency               | OK ? | Corrected |
|---|-------------------------|------|-----------|
| Batteries and battery connections<br><i>Condition, charging system output is sufficient, connections are secure. Apply dielectric grease to all exposed connections</i>                                   | Yearly                  |      |           |
| Main fuse or circuit breaker in battery box<br><i>Battery connectors are tight, corrosion free, no signs of overheating</i>   | 90 days<br>1750 cycles  |      |           |
| (+) Battery and cables, plugs, terminal connections, protective looms<br><i>Condition, undamaged, secured with clamps and/or cable ties, inspect full length and connection at both ends of the cable</i> | 180 days<br>3500 cycles |      |           |
| (-) Ground cables, plugs, terminal connections, protective looms<br><i>Condition, undamaged, secured with clamps and/or cable ties, inspect full length and connection at both ends of the cable</i>      | 180 days<br>3500 cycles |      |           |
| Wiring harness between remote control and power pack<br><i>Condition, secured with clamps and/or cable ties, undamaged</i>  | 180 days<br>3500 cycles |      |           |

|   |                         |  |  |
|---|-------------------------|--|--|
| Harness(es) from platform to control or power pack (buzzer, platform lights, etc.)<br><i>Condition, routing, secured with cable ties, undamaged</i> | 90 days<br>1750 cycles  |  |  |
| Harnesses for other auxiliary controls<br><i>Condition, routing, secured with cable ties, undamaged</i>   | 90 days<br>1750 cycles  |  |  |
| Connections in power pack, electric connection board<br><i>Condition, all connections tight, dry and corrosion free</i>                             | 180 days<br>3500 cycles |  |  |
| Limit switches, pressure switches<br><i>Condition, operation, automatic return to the neutral position</i>  | 90 days<br>1750 cycles  |  |  |

| 5. Hydraulic pipes and connections  | Frequency              | OK ? | Corrected |
|---|------------------------|------|-----------|
| Hydraulic pipes, flexible and rigid<br><i>Condition, routing, no damage, leaks or chafing</i> | 90 days<br>1750 cycles |      |           |
| Hydraulic fittings, O-ring seals<br><i>Condition, no leaks</i>                                | 90 days<br>1750 cycles |      |           |
| Hydraulic circuit general<br><i>No visible oil leaks during operation and at rest</i>         | 90 days<br>1750 cycles |      |           |

| 6. Hydraulic power pack   | Frequency               | OK ? | Corrected |
|---|-------------------------|------|-----------|
| Power pack box + cover, outside & inside<br><i>Condition, undamaged, sealed, dry and corrosion free</i>   | 90 days<br>1750 cycles  |      |           |
| Mounting of power pack to lift frame or vehicle chassis<br><i>Condition, undamaged (no deformation, cracks in material or welds)</i>                  | 180 days<br>3500 cycles |      |           |
| Oil reservoir, oil filter<br><i>Check oil level, clean filter yearly, replace hydraulic oil yearly</i>  | Yearly<br>As needed     |      |           |
| Bleed hydraulic circuits<br><i>After replacing oil or hoses, or after cylinder reconditioning</i>   | As needed               |      |           |
| Motor, starter solenoid, connection between both<br><i>Condition inside power pack, operation, all connections are tight, no signs of overheating</i> | 180 days<br>3500 cycles |      |           |
| Valve block, control valves and hydraulic circuit<br><i>No visible oil leaks during operation and at rest</i>   | 90 days<br>1750 cycles  |      |           |

| 7. Hydraulic cylinders   | Frequency               | OK ? | Corrected |
|--|-------------------------|------|-----------|
| All hydraulic cylinders<br><i>Condition, operation, fastening of articulation pins, locking bolts / nuts</i>     | 180 days<br>3500 cycles |      |           |
| Piston rods, rubber protection boots<br><i>Condition, rod surface free of paint, dirt, scratches and pitting</i> | Yearly                  |      |           |
| Cylinder safety valves<br><i>Condition, undamaged</i>  | 180 days<br>3500 cycles |      |           |
| Hydraulic circuits of cylinders, valves and couplings<br><i>No visible oil leaks in operation and at rest</i>    | 90 days<br>1750 cycles  |      |           |

| 8. Lift frame and cassette box (DH-C)   | Frequency               | OK ? | Corrected |
|---|-------------------------|------|-----------|
| Lift frame, lift arms<br><i>Condition, undamaged (no deformation, cracks in material or welds), no corrosion</i>  | 180 days<br>3500 cycles |      |           |
| Articulation points, articulation pins and bearings<br><i>Condition, no damage or wear, fastening of articulation pins, locking bolts / nuts<br/>Presence, condition, operation of grease nipples</i> | 180 days<br>3500 cycles |      |           |
| Articulation points, articulation pins and bearings<br><i>Pump grease in all grease nipples (when applicable)</i>   | 90 days<br>1750 cycles  |      |           |





|   |                         |             |                  |
|---|-------------------------|-------------|------------------|
| Mounting plates<br><i>Condition, undamaged (no deformation, cracks in material or welds), sufficient bolts as per installation instructions, fastened with required torque, correct alignment</i>           | 180 days<br>3500 cycles |             |                  |
| Rubber cassette sealing (DH-C)<br><i>Condition, undamaged, firmly attached to the cassette</i>  | 90 days<br>1750 cycles  |             |                  |
| Cassette box (when mounted underneath the vehicle)<br><i>Condition, undamaged, no corrosion, no gaps or holes</i>   | 90 days<br>1750 cycles  |             |                  |
| Cassette box<br><i>Clear the inside of the cassette box of any debris or dirt</i>   | 90 days<br>1750 cycles  |             |                  |
| <b>9. Platform</b>  | <b>Frequency</b>        | <b>OK ?</b> | <b>Corrected</b> |
| Platform<br><i>Condition, undamaged (no deformation, cracks in material or welds), no corrosion</i>   | 180 days<br>3500 cycles |             |                  |
| Articulation points, articulation pins and bearings<br><i>Condition, no damage or wear, fastening of articulation pins, locking bolts / nuts<br/>Presence, condition, operation of lubrication fittings</i> | 180 days<br>3500 cycles |             |                  |
| Articulation points, articulation pins and bearings<br><i>Pump grease in all grease nipples</i>   | 90 days<br>1750 cycles  |             |                  |
| Platform at loading floor<br><i>Alignment of platform with vehicle floor; correct position of bridge plate</i>  | Yearly                  |             |                  |
| Roll stop, bridge plate<br><i>Condition, operation, no debris underneath</i>  | 90 days<br>1750 cycles  |             |                  |
| Flashing platform lights<br><i>Condition, operation of the device. Condition, routing and securement of the harness(es) leading to the control box or power pack</i>  | 90 days<br>1750 cycles  |             |                  |
| Mechanical platform lock (optional), platform fold lock on foldable platforms, safety hooks<br><i>Condition, operation, lubricate mechanism</i>   | 180 days<br>3500 cycles |             |                  |
| Automatic cassette lock and emergency release handle<br><i>Condition, operation</i>   | 180 days<br>3500 cycles |             |                  |
| Hand rails<br><i>Condition, operation, secure lock in work position, secure stowage in travel position<br/>Condition and operation of auxiliary control on the hand rail (when applicable)</i>              | 180 days<br>3500 cycles |             |                  |

|  |                        |             |                  |
|--|------------------------|-------------|------------------|
| <b>10. Practical tests</b>   | <b>Frequency</b>       | <b>OK ?</b> | <b>Corrected</b> |
| General operation test with empty platform<br><ul style="list-style-type: none"> <li>Execute all movements minimum 3 times with all available control units.</li> <li>Lift should operate smoothly and quietly through its full range of motion.</li> <li>Check the correct alignment of the platform and bridge plate with the vehicle floor.</li> <li>Check condition of articulation points (no excessive play).</li> </ul>   | 90 days<br>1750 cycles |             |                  |
| Dynamic weight test at 100% of the maximum rated lift capacity<br><ul style="list-style-type: none"> <li>Place the platform at rest on the ground.</li> <li>Put a load equal to 100% of the maximum rated lift capacity at the center point of maximum load.</li> <li>Lift the platform. Check if the lift capacity is sufficient. Check general operation and stability.</li> <li>Check the correct alignment of the platform and bridge plate with the vehicle floor.</li> <li>Check safe working speeds: <ul style="list-style-type: none"> <li>→ Lift &amp; lower: max. 150 mm / sec (5.9 inches / sec)</li> <li>→ Hydraulic open and close: max. 10° / sec</li> </ul> </li> </ul> | Yearly                 |             |                  |
| Overload test, adjustment of pressure relief valve   | Yearly                 |             |                  |

|  |                         |  |  |
|--|-------------------------|--|--|
| <ul style="list-style-type: none"> <li>Place the platform at rest on the ground.</li> <li>Put a load of 100% of the maximum rated lift capacity at the center point of maximum load. Adjust the hydraulic pressure at the pressure relief valve so that the maximum rated lift capacity is just reached.</li> <li>Add max. 10% overload at the center point of maximum load. Adjust the hydraulic pressure so that the platform cannot lift the maximum rated lift capacity + the overload.</li> <li>Refer to procedure I-SERV-G-003 in the Maintenance and Repair Manual.</li> <li>(Note: pressure should never exceed 220 bar / 3190 psi)</li> </ul> |                         |  |  |
| DH-C cassette lifts: slide-in / out test <ul style="list-style-type: none"> <li>Slide lift in / out 3 times</li> <li>Ensure sliding movement goes smoothly, without juddering</li> </ul>   | 180 days<br>3500 cycles |  |  |
| Emergency operation test with empty platform <ul style="list-style-type: none"> <li>Follow the steps for emergency operation as mentioned in the operation manual.</li> <li>Hand pump, manual descent button and EMR (DH-C) function properly.</li> <li>Lift should operate smoothly and quietly through its full range of motion.</li> </ul>  |                         |  |  |

| 11. Test and inspection results  | Frequency | OK ? | Corrected |
|--|-----------|------|-----------|
| Lift has been: <input type="checkbox"/> serviced <input type="checkbox"/> repaired <input type="checkbox"/> inspected<br><input type="checkbox"/> The lift is safe and suitable for further use<br><input type="checkbox"/> The lift requires further testing<br><input type="checkbox"/> The lift requires immediate maintenance or repair prior to further use |           |      |           |
| <b>Observations / Partial works or inspections to follow:</b>  |           |      |           |
|  |           |      |           |
|  |           |      |           |
|  |           |      |           |

|   |                                       |
|---|---------------------------------------|
| Maintenance or inspection performed by  | Name of technician                    |
| Service centre  | Date of next maintenance / inspection |
|  <b>Safety first!</b> ALWAYS follow the instructions and precautions of: <ul style="list-style-type: none"> <li>→ the Operation Manual</li> <li>→ the Safety Instructions for Installation, Maintenance and Repair</li> <li>→ the Maintenance and Repair Manual</li> </ul> |                                       |
|  In order to guarantee the safety of the operators and bystanders in between service and inspection intervals, ALWAYS insist that operators conduct the daily pre-trip inspection in accordance with the Operation manual  |                                       |

## 4 TROUBLESHOOTING AND REPAIR

### 4.1 INTRODUCTION

- Troubleshooting chart can be used in two occasions:
  - For the operator to explain the severity and scope of the problem when contacting a DHOLLANDIA service agent.
  - For the DHOLLANDIA service agent to find and resolve the problem more quickly.
- It is very important that the troubleshooting is performed in a logical and systematic way. Too often components are replaced at random until the malfunction disappears. However, such methods can be very expensive for labor hours and the replacement parts costs.
- Therefore, it is very important to **identify quickly and precisely if a malfunction has an electric, a hydraulic or a mechanical cause.**
- The tables below can be used to guide you through the troubleshooting. Contact your national DHOLLANDIA distributor if further advice is needed.



## WARNING

Some steps in the troubleshooting instructions require special skills and specific knowledge, that can be acquired through the DHOLLANDIA training programs for maintenance and repair. In case of doubt, DON'T go any further, but ask your local DHOLLANDIA distributor for professional advice.

### 4.2 GENERAL TROUBLESHOOTING DIAGRAM

- A general troubleshooting diagram is provided in appendix 13.1 of this manual.
- **Use this to locate and solve problems but keep in mind that repair or maintenance should always be done by certified DHOLLANDIA service agents.**

### 4.3 PCB - FUNCTIONS TEST

- Check the lights on the PCB while operating the various lift functions to locate the problem.
- Check appendix 13.2 for the complete table.
- Mention the results from this functions test when contacting your DHOLLANDIA distributor or service point.

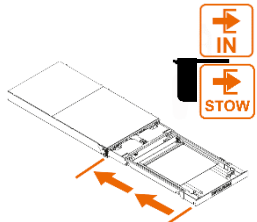
| EXAMPLE   | FUNCTIONS TEST / SELF-DIAGNOSIS  |             |  |
|---|--|-------------|--|
|   | Condition  | PCB lay-out | Check items  |
| STOW/ IN<br><br> | <ul style="list-style-type: none"> <li>• SWpower: ON</li> <li>• Emergency stop: OFF</li> <li>• Emergency Motor Release (S0): OFF</li> <li>• Battery voltage: 11-14 / 22-28V</li> </ul> |             | <ul style="list-style-type: none"> <li>• SWdown</li> <li>• SWin (4 button ctrl)</li> <li>• R2 IN</li> <li>• COIL R2</li> <li>• D</li> <li>• +BAT 12/24V</li> <li>• UNSTOW</li> <li>• +Rbat</li> <li>• LIFT ON</li> <li>• WORKING</li> <li>• +12/24V DC</li> <li>• SW0</li> <li>• PARKING BRAKE</li> <li>• DOOR OPEN</li> <li>• INTERLOCK</li> <li>• Me power (5A)</li> <li>• Light</li> <li>• Buzzer</li> <li>• Rbat</li> <li>• EMG stop</li> <li>• SWpower</li> </ul> |

## 4.4 PCB - POSITIONS TEST

- Check the lights on the PCB in the various lift positions to locate the problem.
- Check appendix 13.3 for the complete table.
- Mention the results from this positions test when contacting your DHOLLANDIA distributor or service point.

| EXAMPLE            |  |   |             | POSITIONS TEST / SELF-DIAGNOSIS   |  |  |  |
|--------------------|--|---|-------------|---|--|--|--|
|                    |  | Condition   | PCB lay-out | Check items   |  |  |  |
| IN – STOW position |  | <ul style="list-style-type: none"> <li>• SWpower: OFF</li> <li>• Emergency stop: OFF</li> <li>• Emergency Motor Release (S0): OFF</li> <li>• Battery voltage: 11-14 / 22-28V</li> </ul> |             | <ul style="list-style-type: none"> <li>• +BAT 12/24V</li> <li>• STOW</li> </ul> |  |  |  |

## 5 SPARE PARTS

Only original DHOLLANDIA parts should be used as replacements in case of repair. Part lists for the wheelchair lift can be found as an appendix and can be downloaded from the DHOLLANDIA website.



The latest version of all spare parts lists can also be downloaded from the DHOLLANDIA website

[www.dhollandia.com](http://www.dhollandia.com) → Downloads → Spare parts lists → Passenger wheelchair lifts

| EXAMPLE        |               | CH103.03.06-01                 |     |      |               |                |     |
|----------------|---------------|--------------------------------|-----|------|---------------|----------------|-----|
|                |               | Frame compl. CH103.03.06 + Snr |     |      |               |                |     |
| Taillift types |               | Subgroup: Passenger lifts      |     |      |               |                |     |
|                |               |                                |     |      |               |                |     |
| Pos.           | Code          | Description                    | Qty | Pos. | Code          | Description    | Qty |
| 1              | 0103.03.06.01 | CH103.03.06-01                 | 1   | 16   | 0103.03.06.01 | CH103.03.06-01 | 1   |
| 2              | 0103.03.06.01 | CH103.03.06-01                 | 1   | 17   | 0103.03.06.01 | CH103.03.06-01 | 1   |
| 3              | 0103.03.06.01 | CH103.03.06-01                 | 1   | 18   | 0103.03.06.01 | CH103.03.06-01 | 1   |
| 4              | 0103.03.06.01 | CH103.03.06-01                 | 1   | 19   | 0103.03.06.01 | CH103.03.06-01 | 1   |
| 5              | 0103.03.06.01 | CH103.03.06-01                 | 1   | 20   | 0103.03.06.01 | CH103.03.06-01 | 1   |
| 6              | 0103.03.06.01 | CH103.03.06-01                 | 1   | 21   | 0103.03.06.01 | CH103.03.06-01 | 1   |
| 7              | 0103.03.06.01 | CH103.03.06-01                 | 1   | 22   | 0103.03.06.01 | CH103.03.06-01 | 1   |
| 8              | 0103.03.06.01 | CH103.03.06-01                 | 1   | 23   | 0103.03.06.01 | CH103.03.06-01 | 1   |
| 9              | 0103.03.06.01 | CH103.03.06-01                 | 1   | 24   | 0103.03.06.01 | CH103.03.06-01 | 1   |
| 10             | 0103.03.06.01 | CH103.03.06-01                 | 1   | 25   | 0103.03.06.01 | CH103.03.06-01 | 1   |
| 11             | 0103.03.06.01 | CH103.03.06-01                 | 1   | 26   | 0103.03.06.01 | CH103.03.06-01 | 1   |
| 12             | 0103.03.06.01 | CH103.03.06-01                 | 1   | 27   | 0103.03.06.01 | CH103.03.06-01 | 1   |
| 13             | 0103.03.06.01 | CH103.03.06-01                 | 1   | 28   | 0103.03.06.01 | CH103.03.06-01 | 1   |
| 14             | 0103.03.06.01 | CH103.03.06-01                 | 1   | 29   | 0103.03.06.01 | CH103.03.06-01 | 1   |
| 15             | 0103.03.06.01 | CH103.03.06-01                 | 1   | 30   | 0103.03.06.01 | CH103.03.06-01 | 1   |
| 31             | 0103.03.06.01 | CH103.03.06-01                 | 1   | 31   | 0103.03.06.01 | CH103.03.06-01 | 1   |
| 32             | 0103.03.06.01 | CH103.03.06-01                 | 1   | 32   | 0103.03.06.01 | CH103.03.06-01 | 1   |
| 33             | 0103.03.06.01 | CH103.03.06-01                 | 1   | 33   | 0103.03.06.01 | CH103.03.06-01 | 1   |
| 34             | 0103.03.06.01 | CH103.03.06-01                 | 1   | 34   | 0103.03.06.01 | CH103.03.06-01 | 1   |
| 35             | 0103.03.06.01 | CH103.03.06-01                 | 1   | 35   | 0103.03.06.01 | CH103.03.06-01 | 1   |
| 36             | 0103.03.06.01 | CH103.03.06-01                 | 1   | 36   | 0103.03.06.01 | CH103.03.06-01 | 1   |
| 37             | 0103.03.06.01 | CH103.03.06-01                 | 1   | 37   | 0103.03.06.01 | CH103.03.06-01 | 1   |
| 38             | 0103.03.06.01 | CH103.03.06-01                 | 1   | 38   | 0103.03.06.01 | CH103.03.06-01 | 1   |
| 39             | 0103.03.06.01 | CH103.03.06-01                 | 1   | 39   | 0103.03.06.01 | CH103.03.06-01 | 1   |
| 40             | 0103.03.06.01 | CH103.03.06-01                 | 1   | 40   | 0103.03.06.01 | CH103.03.06-01 | 1   |
| 41             | 0103.03.06.01 | CH103.03.06-01                 | 1   | 41   | 0103.03.06.01 | CH103.03.06-01 | 1   |
| 42             | 0103.03.06.01 | CH103.03.06-01                 | 1   | 42   | 0103.03.06.01 | CH103.03.06-01 | 1   |
| 43             | 0103.03.06.01 | CH103.03.06-01                 | 1   | 43   | 0103.03.06.01 | CH103.03.06-01 | 1   |
| 44             | 0103.03.06.01 | CH103.03.06-01                 | 1   | 44   | 0103.03.06.01 | CH103.03.06-01 | 1   |
| 45             | 0103.03.06.01 | CH103.03.06-01                 | 1   | 45   | 0103.03.06.01 | CH103.03.06-01 | 1   |
| 46             | 0103.03.06.01 | CH103.03.06-01                 | 1   | 46   | 0103.03.06.01 | CH103.03.06-01 | 1   |
| 47             | 0103.03.06.01 | CH103.03.06-01                 | 1   | 47   | 0103.03.06.01 | CH103.03.06-01 | 1   |
| 48             | 0103.03.06.01 | CH103.03.06-01                 | 1   | 48   | 0103.03.06.01 | CH103.03.06-01 | 1   |
| 49             | 0103.03.06.01 | CH103.03.06-01                 | 1   | 49   | 0103.03.06.01 | CH103.03.06-01 | 1   |

## 6 DIAGRAMS

### 6.1 GENERAL

- DHOLLANDIA wheelchair lifts are regularly being adapted to new vehicle and chassis developments and specialized customer requirements. Therefore, the electric and hydraulic diagrams applicable to your wheelchair lift might deviate from the generic diagrams contained in this manual.
- The specific diagrams can usually be found inside the main control box or inside the pump unit. They can also be obtained from your national DHOLLANDIA distributor or can be downloaded from:



[www.dhollandia.com](http://www.dhollandia.com) → your language → Downloads → Electric & hydraulic diagrams (2014-...) → ...

- Besides regular electric and hydraulic schematics, all diagrams also explain which solenoids and valves are operated for each function.
- The figure below shows an example of a diagram that is provided with the lift.

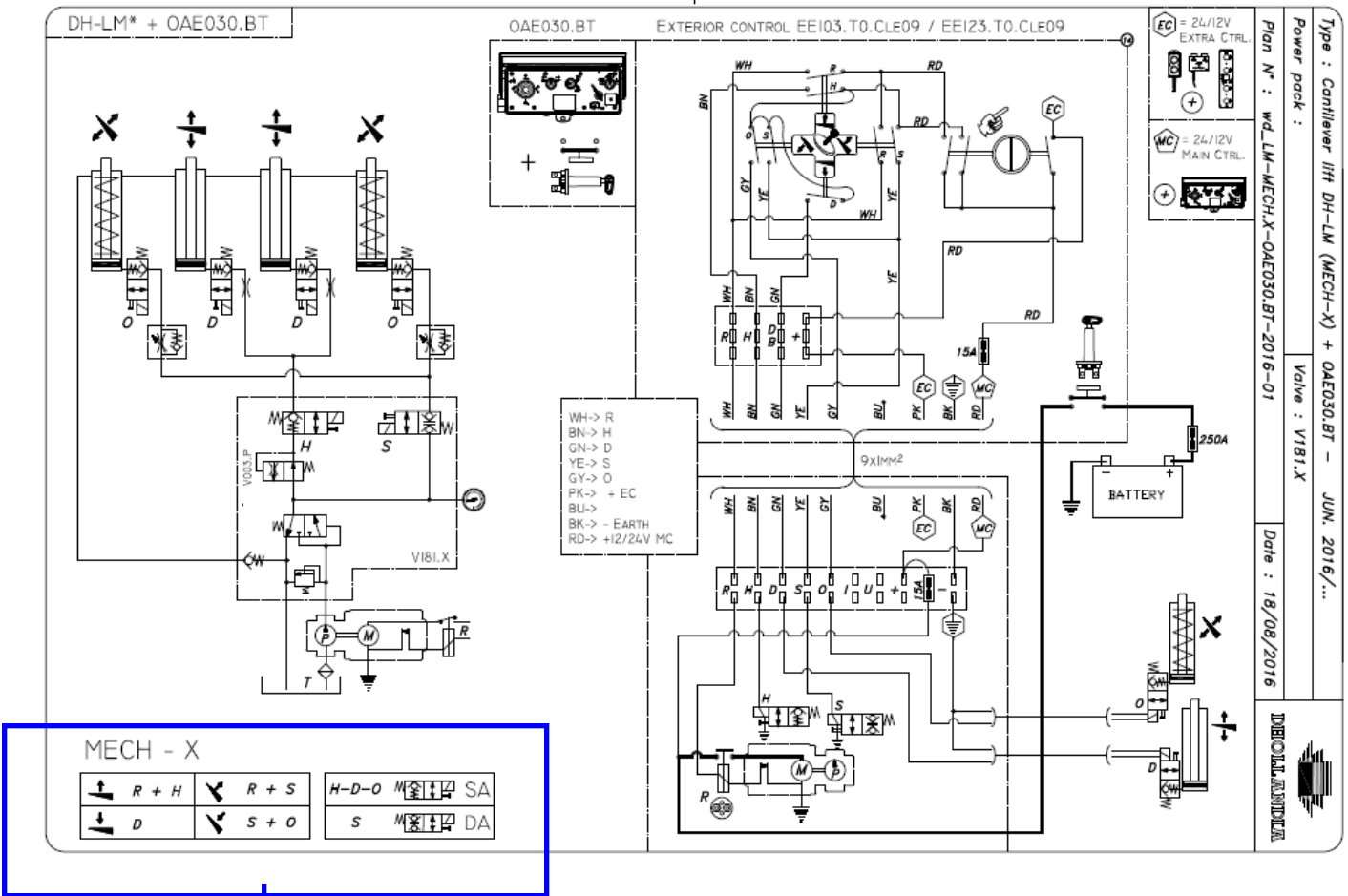

MECH - X

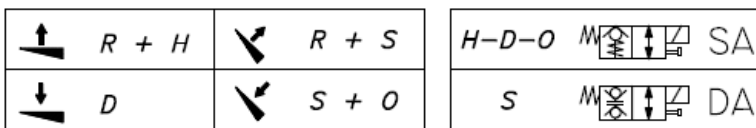

- R** = Starter solenoid of DC motor in pump unit
- H** = Control valve LIFT in pump unit
- D** = Electric lock valve on LIFT cylinders
- S** = Control valve TILT (OPEN + CLOSE) in pump unit
- O** = Electric lock valve on TILT cylinders
- US** = Control valve LEGS OUT on stabilising legs (\*)
- IS** = Control valve LEGS IN on stabilising legs (\*)
- (\*) if so equipped

## 6.2 HYDRAULIC OVERVIEW

- The hydraulic overview shown below and the parts needed can be found in the spare parts list in the appendix and on the DHOLLANDIA website.

### EXAMPLE

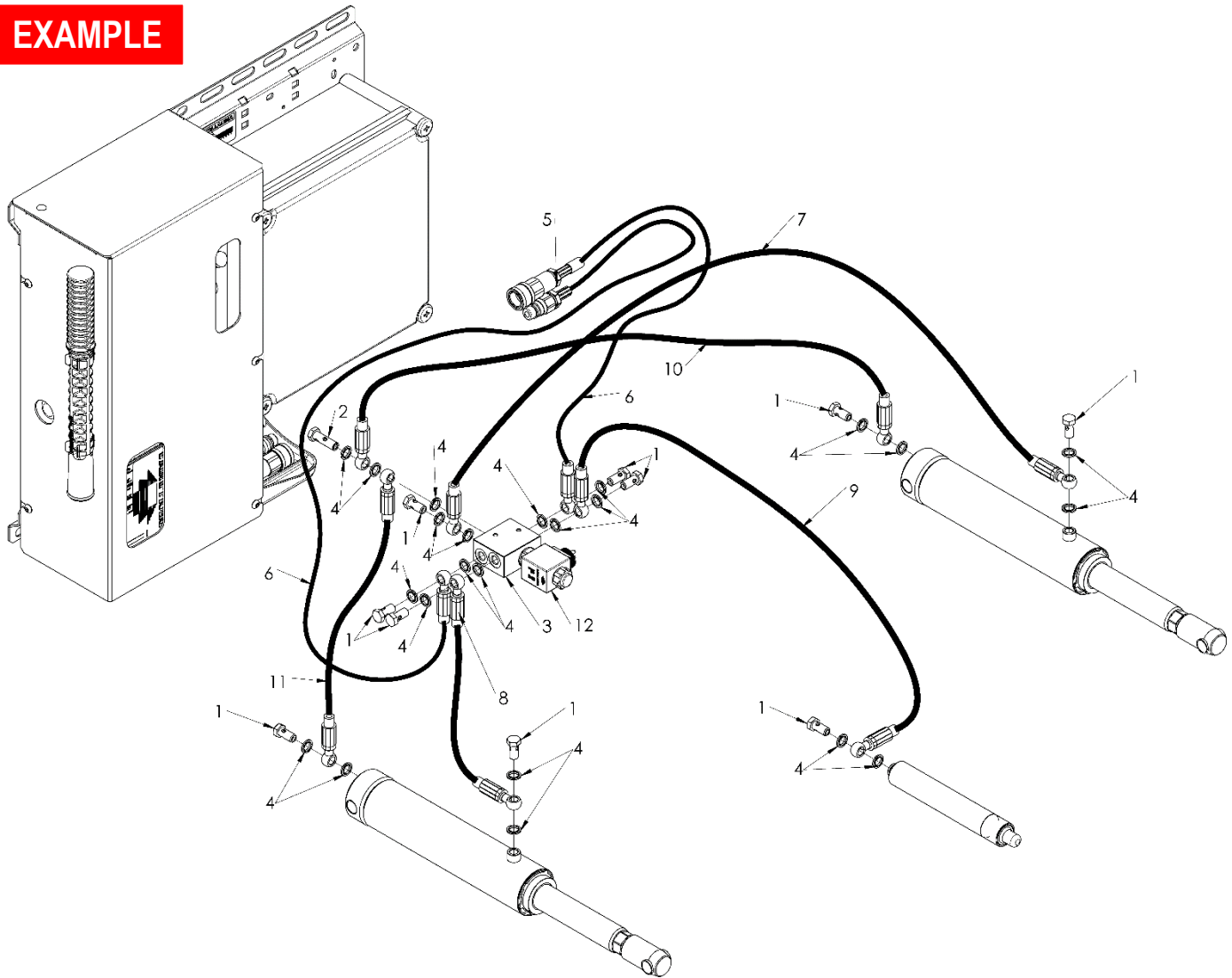



### 6.3 WHEELCHAIR LIFT POWER PACK TERMINOLOGY

All parts included in this power pack can be found in the part lists in the appendix. Depending on the date of manufacture and lift type, different types of power packs are used. Images could differ from your installation case but the same components and principles are used.

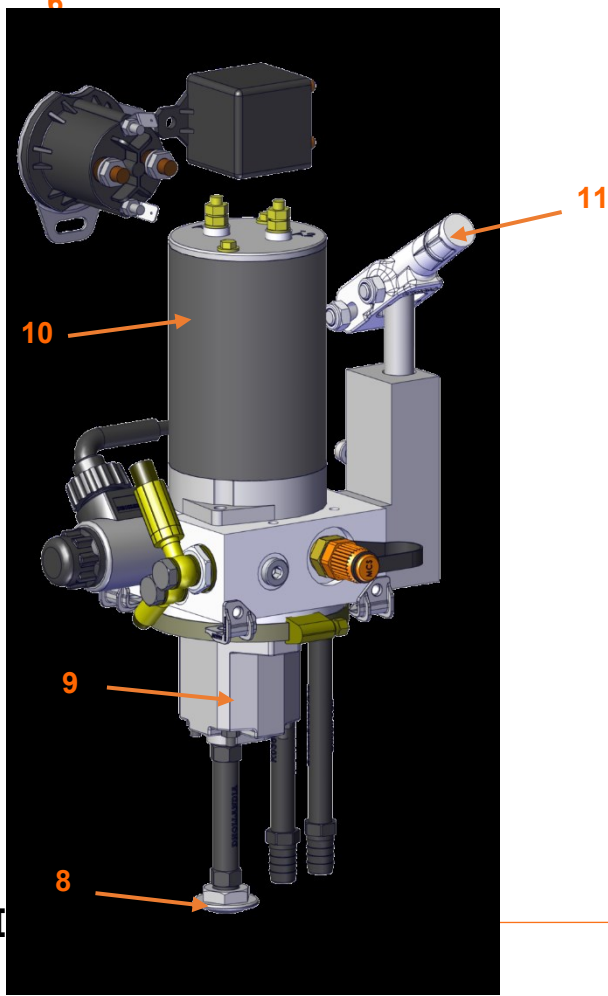
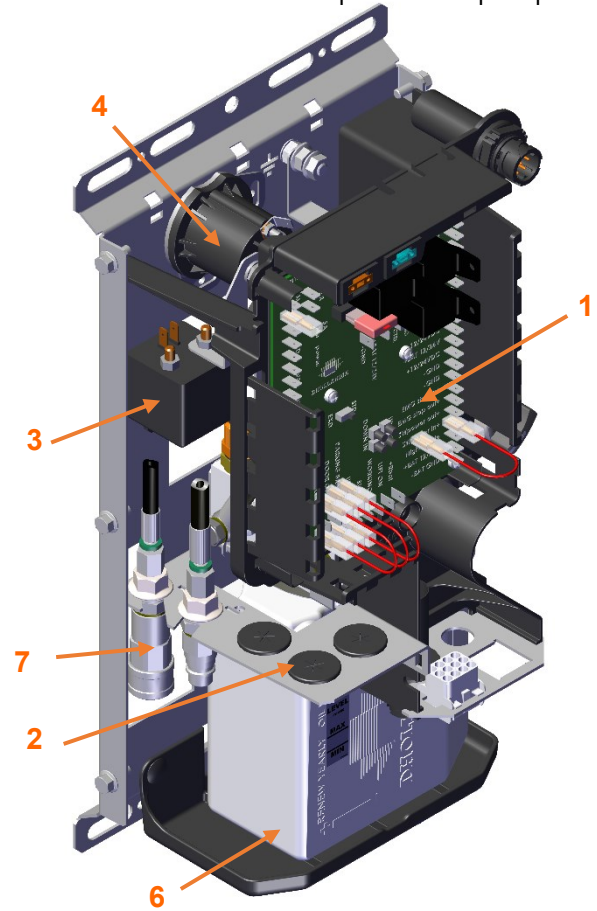
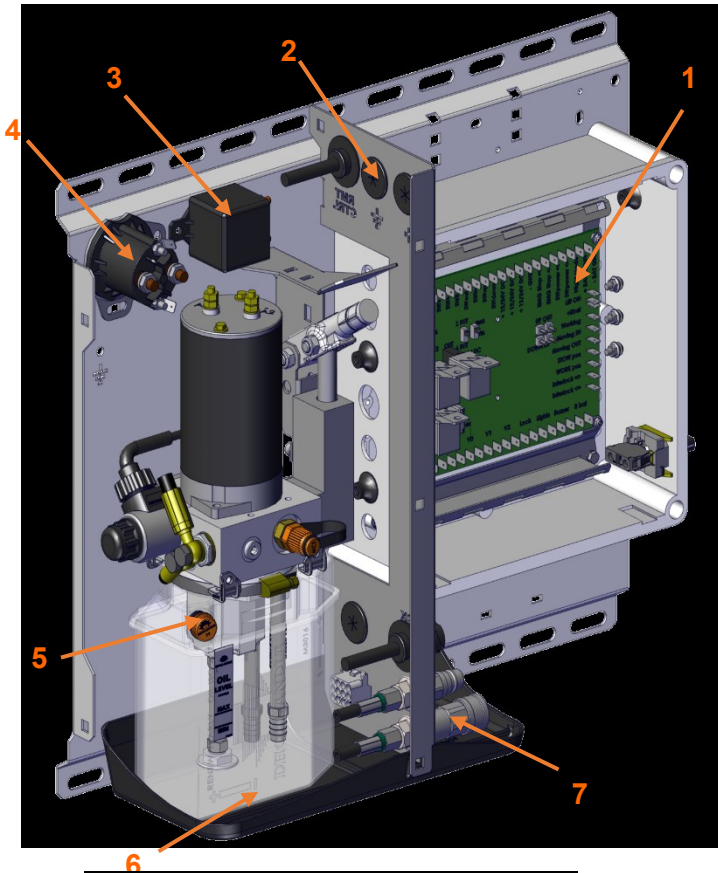

| N° | Description                  |
|----|------------------------------|
| 1  | Electric connection board    |
| 2  | Battery cables inlet         |
| 3  | Micro relay                  |
| 4  | Starter solenoid             |
| 5  | Oil tank cap                 |
| 6  | Oil tank                     |
| 7  | Hydraulic connections: P - T |
| 8  | Filter                       |
| 9  | Hydraulic pump               |
| 10 | Electric DC motor            |
| 11 | Hand pump                    |

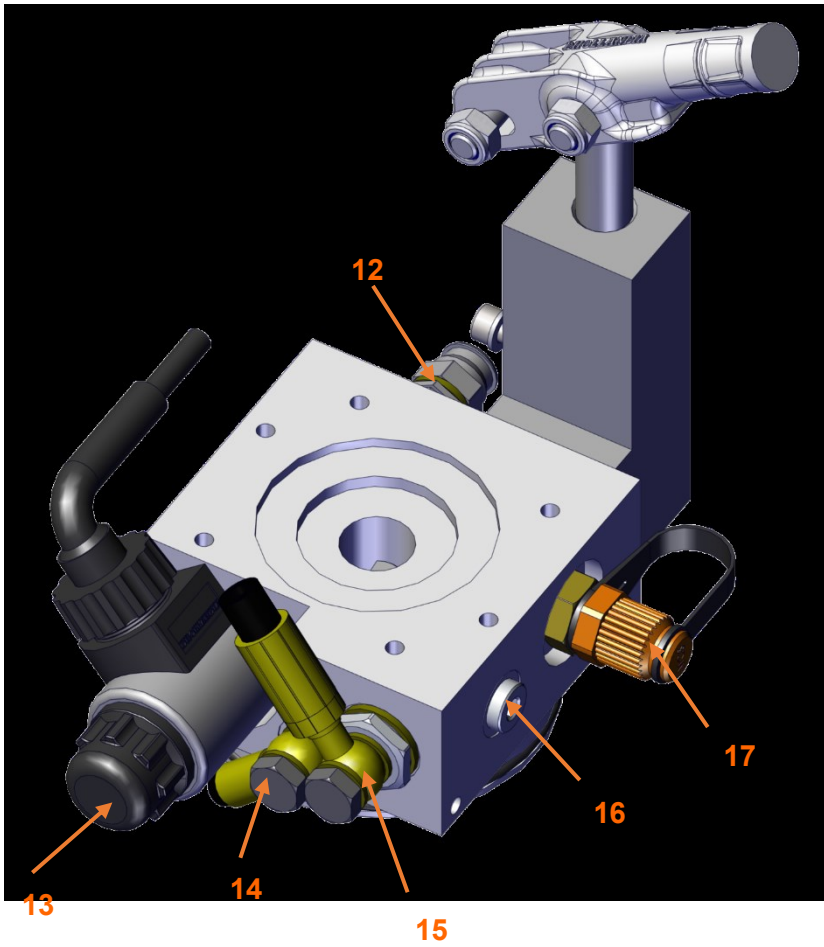

| N° | Description                        |
|----|------------------------------------|
| 12 | Pressure relief valve              |
| 13 | Safety valve                       |
| 14 | LP (Low pressure outlet to tank    |
| 15 | HP (high pressure) inlet from pump |
| 16 | Closing cap                        |
| 17 | Coupling pressure gauge            |



## 7 EMERGENCY OPERATION

- In case of a failure in the electrical power supply to the wheelchair lift (insufficient battery power, damaged fuse, damaged electrical controls,...), the various functions of the lift can be operated manually as explained below.



### WARNING

- Negligence or ignorance during the emergency operation can put the operator and third parties at great risk of serious bodily injury or death.
- Therefore, the emergency operation of the wheelchair lift is restricted to skilled operators, who have been properly trained, and who know and understand the full contents of this manual.
- Prior to operating the manual emergency controls of the lift, ALWAYS make sure you follow all applicable instructions.
- In case of doubt, DO NOT CONTINUE, but contact the national **DHOLLANDIA** distributor for further help and instructions. See contact info on page 6.



### WARNING



- To avoid unexpected movements, the electric power to lift must be switched off before starting the emergency operation.
- Always stand clear of the platform area.
- Keep head, hands and feet clear of pinch points and moving parts.

#### Emergency operation

| STEP | Initiating manual operation   |
|------|---|
| 1    | <p>In regular mode, the lift frame and platform are blocked inside the cassette by an automatic cassette lock.</p> <p>Locate the Emergency Motor Release or EMR button at the side of the hydraulic power pack. Turn the switch to put the electric motor in idle mode.</p> |

STEP 1

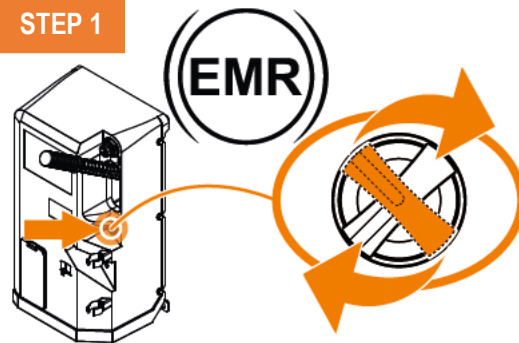

### Emergency operation: DEPLOY platform

| STEP | Manual operation: DEPLOY  |
|------|---|
| 2    | Locate the red emergency release handle at the front of the cassette. Pull the handle to disengage the automatic cassette lock.   |
| 3    | PULL the platform out by hand, until it comes to a complete stop at the dedicated work position. DO NOT apply brutal force as this may cause mechanical damage to the lift. |

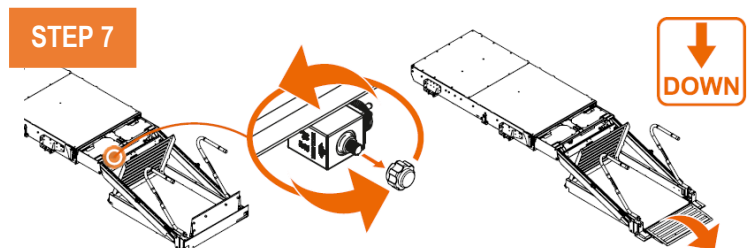
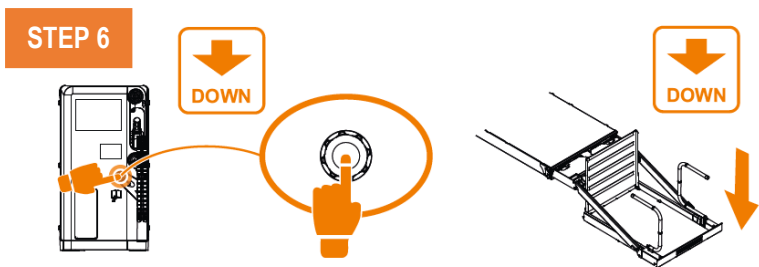
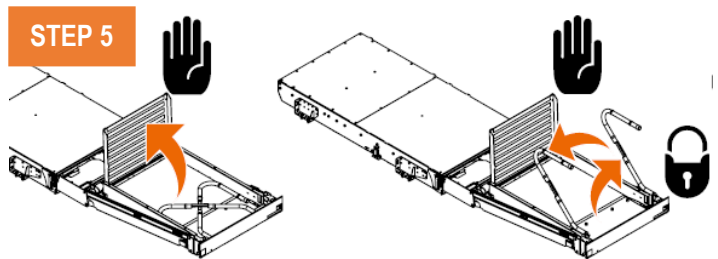
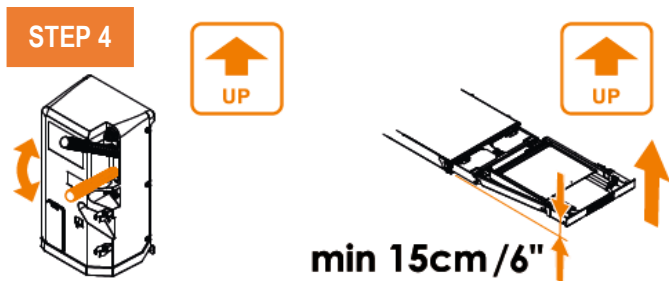
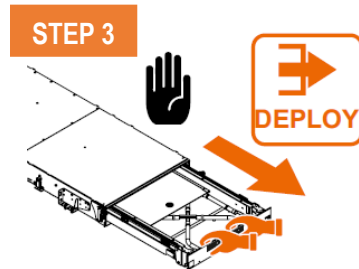

### Emergency operation: LIFT platform

| STEP | Manual operation: LIFT  |
|------|---|
| -    | Locate the handle of the hand pump on the cover of the power pack. Fit it over the lever arm of the hand pump.  |
| 4    | Move the lever of the hand pump up and down slowly to lift the platform (= UP). Stop at approx. 15 cm – 6" above cassette height. The platform stops as soon as you stop pumping. |
| 5    | Manually open the bridge plate at the inboard platform edge.<br>Raise the handrails at the left and right side of the platform and ALWAYS secure them in the upright position.    |
| -    | Operate the hand pump to raise the platform until the desired position has been reached.  |

### Emergency operation: LOWER platform

| STEP | Manual operation: DOWN  |
|------|---|
| 6    | To lower the platform (= DOWN), press the Emergency Descent button on the power pack. Depending on executions, this button can be positioned at the side or at the front of the cover.  |
| 7    | To LOWER the outer roll-stop, locate the electro valve between the lift arms. A screw is located underneath the nut. Remove the nut and turn the screw counter-clockwise to open the valve.<br><br>Press the button on the side of the power pack to LOWER the roll-stop of the platform. |

**Emergency operation: STOW platform**

| STEP | Manual operation: STOW   |
|------|--|
| 8    | Locate the electro valve between the lift arms. A screw is located underneath the nut. Remove the nut and turn the screw clockwise to close the valve.   |
| 9    | Operate the hand pump to LIFT the platform and to close the roll stop. Lift the platform 15cm – 6 inches above the cassette-height. The platform stops as soon as the pump action has ended.                           |
| 10   | Release the lock on the roll stop and place it back on to the platform. Close the safety handrails manually by lifting them up to unlock. Place the bridge plate on the platform.                                      |
| 11   | Press the Emergency Descent button on the power pack to lower the platform (= DOWN) until it comes to a stop.<br><br>Cams on the lift arms will stop the platform at the correct height to initiate the STOW function. |
| 12   | Manually push the platform in the cassette (= STOW) until the platform comes to a complete stop.<br><br>Make sure the platform is fully retracted inside the cassette and properly locked.                             |

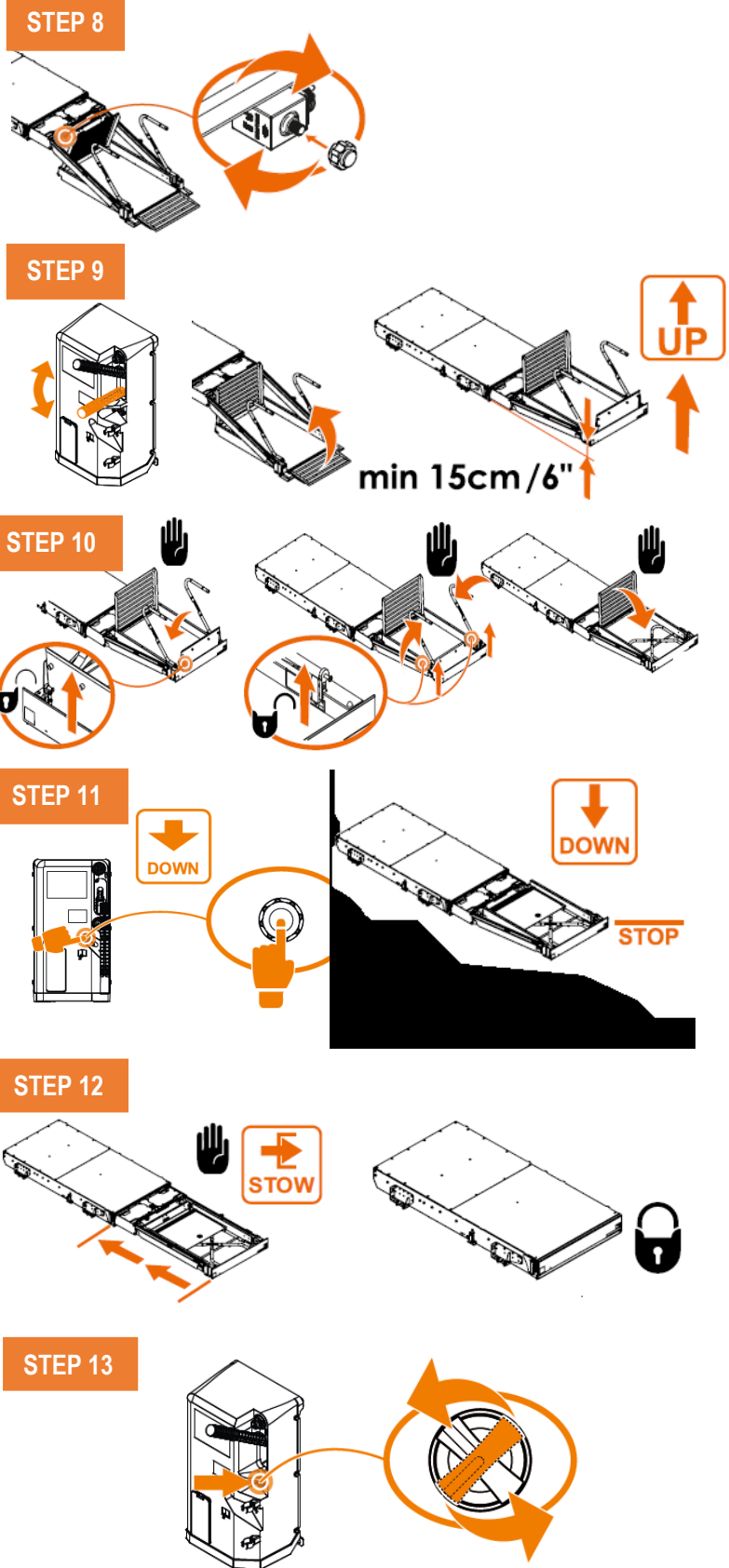

**Emergency operation**

| STEP | Restoring automatic mode  |
|------|---|
| 13   | Turn the EMR button back in its normal operative mode.<br><br>Upon release of the emergency cassette lock, it should no longer be possible to pull out the platform manually. |

- In order to put any of the emergency systems out of service again, proceed in opposite order.

## 8 IMPORTANT PROCEDURES

### **WARNING**

- Make sure you stand next to the main valve block and the pump unit, not directly behind the pressure relief valve.
  - Wear appropriate work clothes, including a wrap-around face shield, protective gloves and fire resistant overalls.
  - Follow the safety instructions for repair and maintenance carefully. Pay attention to your personal safety and environmental protection.
  - Turning out the centre pressure screw too far (CCW) while the pump is trying to build up pressure, can expel the bolt forcefully and disperse oil at high pressure. Failure to follow instructions can cause serious bodily injury.
- Detach the power pack from its mounting position when certain parts can't easily be reached.

### 8.1 PROCEDURE I-SERV-G-001: MANUAL OPERATION OF THE SINGLE ACTING VALVES

| Manual operation of SINGLE ACTING valves<br>V036 / V037 / V133.24 / V133.12 and their H variants |  |
|--|--|
| Step   | Opening the valve manually   |
| 1  | Remove the plastic cap from the top of the cartridge.  |
| 2  | Turn emergency knob CCW (counter-clockwise) to OPEN the valve manually.  |
| 3  | The flow of oil through the valve and the speed of the down movement can be regulated by opening the valve more (= faster) or less (= slower). |
| Step   | Closing the valve manually   |
| 4  | Turn emergency knob CW (clockwise) to CLOSE the valve manually. Fasten it hand-tight in the closed position. (use no tools!)                   |
| 5  | Mount the plastic cap back on top of the cartridge.  |

V036 / V037  
V133.12 /  
V133.24



V036.H / V037.H  
V133.12.H / V133.24.H

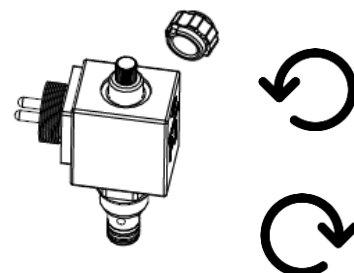

## 8.2 PROCEDURE I-SERV-G-002: MANUAL OPERATION OF THE DOUBLE ACTING VALVES (2 TYPES)

| Manual operation of DOUBLE ACTING valves V177.12.H / V177.24.H |   |
|--|---|
| <b>Step</b>  | <b>Opening the valve manually</b>   |
| 1  | The plastic cap has an elastic skin, covering an emergency button that can be pushed in by a finger. These valves can be operated manually without removing anything. |
| 2  | Push the button IN to OPEN the valve manually.  |
| <b>Step</b>  | <b>Closing the valve manually</b>   |
| 3  | Release the button to CLOSE the valve manually.   |

V177.12H /  
V177.24.H

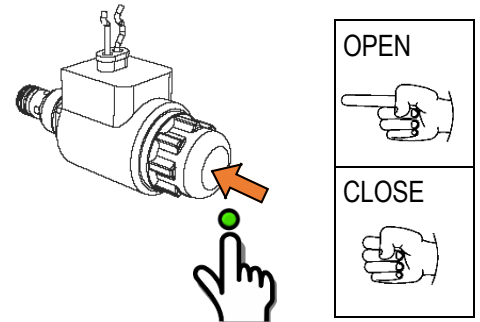

| Manual operation of DOUBLE ACTING valves V177.12 / V177.24 |   |
|--|---|
| <b>Step</b>  | <b>Opening the valve manually</b>   |
| 1  | Remove the metal cap from the top of the cartridge (turn CCW). The push button below the nut must be pushed IN to OPEN the valve manually.  |
| 2  | Push the button IN to OPEN the valve manually.  |
| 3  | If the button is difficult to push, remove the solenoid. Put the metal nut back on the cartridge without solenoid, and turn the metal cap CW (clockwise) as far as possible to OPEN the valve manually. |
| <b>Step</b>  | <b>Closing the valve manually</b>   |
| 4  | Release the button, or turn the nut CCW (= counter-clockwise) to CLOSE the valve manually.  |
| 5  | Reinstall the solenoid back in its original position on the cartridge.  |
| 6  | Reinstall the metal cap back in its original position and fasten it hand-tight.   |

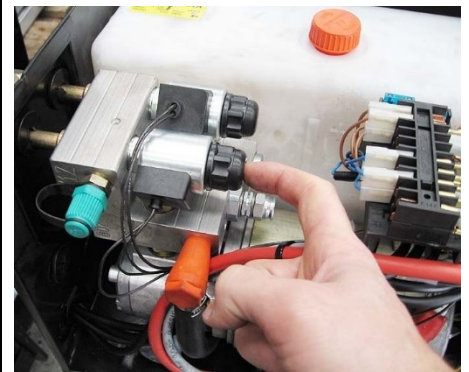

V177.12 / V177.24

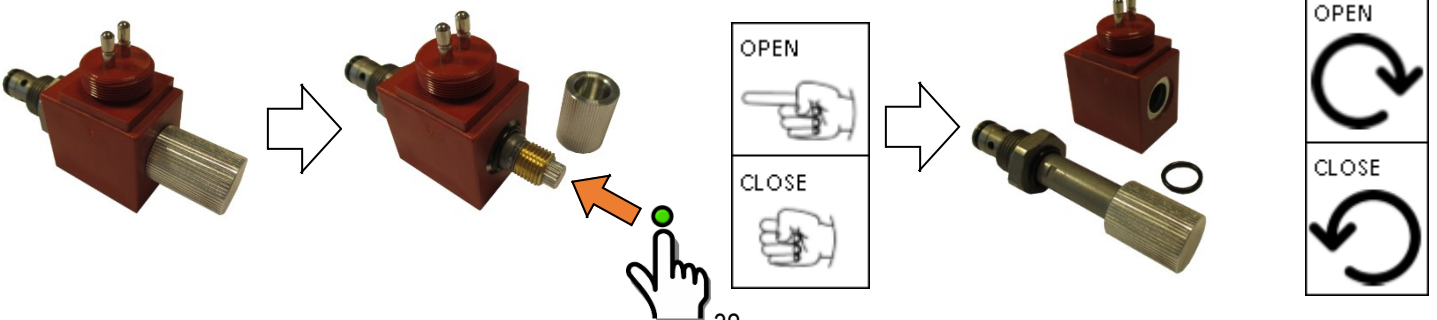
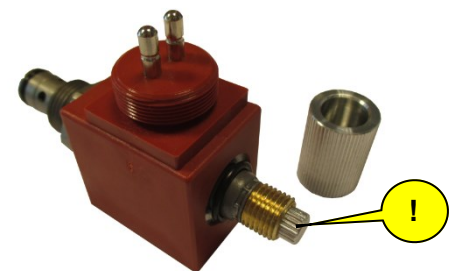



### 8.3 PROCEDURE I-SERV-G-003: HYDRAULIC PRESSURE READING AND ADJUSTMENT

- The lift capacity of the wheelchair lift is determined by the maximum pressure generated by the pump, before the pressure relief valve (on the main valve block in the pump unit) opens, returning the oil back to the oil tank.
- The correct pressure is set via an overload test:

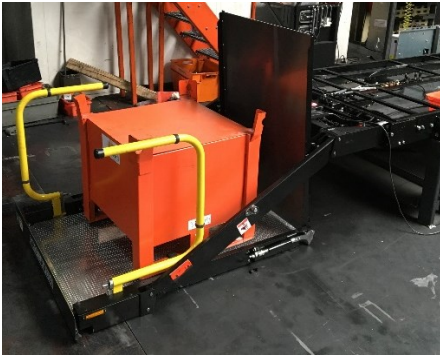

Place a load corresponding with the max. rated capacity at the correct centre point of max. load on the platform.

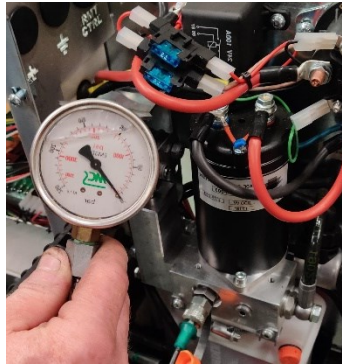

Attach a pressure gauge K0106 (or equivalent) on the pressure gauge coupling.

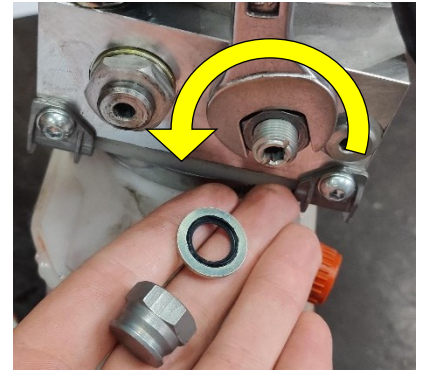

Remove the cap of the pressure relief valve, loosen the jam nut (CCW).



Use an Allen key or screwdriver to adjust the centre pressure screw. Press LIFT. Adjust the pressure screw so the wheelchair lift is able to just lift the max. rated capacity.

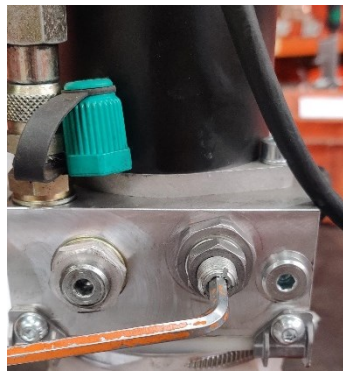

Turn CCW = lower pressure and lift capacity

Turn CW = raise pressure and lift capacity



Increase the load on the platform by 10%. Adjust the pressure so that the wheelchair lift can NOT lift the max. rated capacity + 10%.

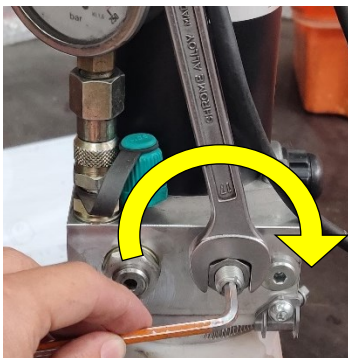

Counter-hold the centre pressure bolt and tighten the jam nut (CW). Reinstall the sealing ring and cap back in original place.

|  |               |
|--|---------------|
| <b>! WARNING</b>   | <b>NOTICE</b> |
| <ul style="list-style-type: none"> <li>• Never adjust the pressure relief valve without using a pressure gauge to verify the changes.</li> <li>• Never raise the hydraulic pressure above 3190 psi / 220 bar, without asking advice from your national DHOLLANDIA distributor.</li> <li>• Excessive pressure can cause damage to the wheelchair lift, and serious bodily injury in case of a pressure induced burst in the hydraulic circuit.</li> </ul> |               |

## 8.4 PROCEDURE I-SERV-G-004: FLUSHING OF PRESSURE RELIEF VALVE

- If the wheelchair lift doesn't reach its max. rated lift capacity, one reason might be that the pressure relief valve is stuck open by debris, and the pump cannot build up pressure.
- To flush and clean the pressure relief valve:

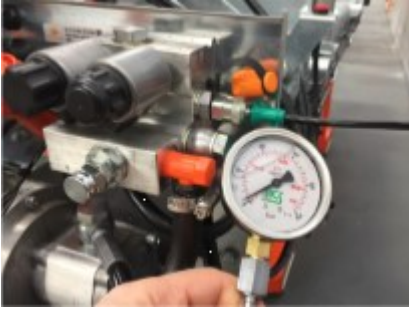

Attach a pressure gauge K0106 (or equivalent) on the pressure gauge coupling



Remove the cap of the pressure relief valve, loosen the jam nut (CCW).



This procedure will require that you unscrew the centre pressure screw while the pump is running and building up pressure. Hence you must be sure of the bolt's length to keep it inside the base of the cartridge with sufficient safety margin, before proceeding to the next step.



Rest the platform at the ground to dump all hydraulic pressure in the system. Use an Allen key or screwdriver to unscrew the centre pressure screw and measure its length. Then assemble the centre pressure bolt back in its original position.

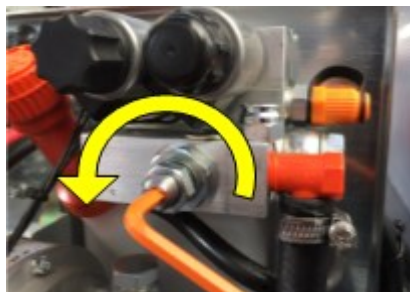

Press LIFT to make the pump run.

Use Allen key or screwdriver to turn the centre pressure bolt CCW. Make sure you stand on the side of the valve block, not directly behind (see warning box on next page).

Turn CCW = lower pressure and lift capacity

Turn CW = raise pressure and lift capacity



While unscrewing the centre pressure screw, measure and make sure you always keep the bottom end min. 4 mm or 5/32" inside the base of the cartridge. Press LIFT for 30 sec.

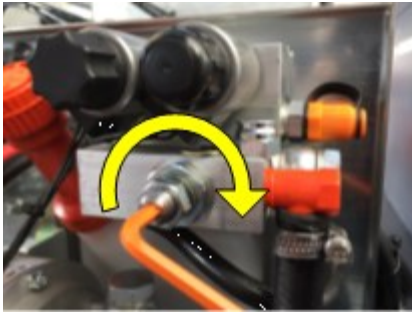

Press LIFT to make the pump run.

■ Turn the centre pressure screw CW to try and raise the pressure again, beyond the original pressure screw position.

If pressure is rising, follow procedure I-SERV-G-003 to set the correct pressure.

If pressure is NOT rising:

- Rest platform on the ground, and try replacing the pressure relief valve assembly.
- Clean or replace the oil filter (remove debris or ice).
- Replace worn-out pump (if pump body heats up fast).



## 8.5 PROCEDURE I-SERV-G-005: CHECK ON VALVE AND SOLENOID FUNCTION

- The solenoids on the control valves on the main valve block in the pump unit can be checked in various ways. 2 popular ways are as follows.
- Test with magnet tester E0247: the light bulb at the back of the tester shines when a magnetic field is detected.



Electric function of valve is OK. (+) and (-) wire and solenoid are functional.



Electric function of valve is NOT OK. Defect in (+) or (-) wire, or solenoid itself.

Test of solenoid on control valve in pump unit

- Test by means of the manual emergency operation of the cartridge: electric function of valve can be replaced by manual actuation. See section 8, Procedures I-SERV-G-001 and -002 on emergency operation. If a non-working movement can be brought alive by manually opening the valve(s), the related solenoid is not functional: defect in (+) or (-) wire, or solenoid itself.

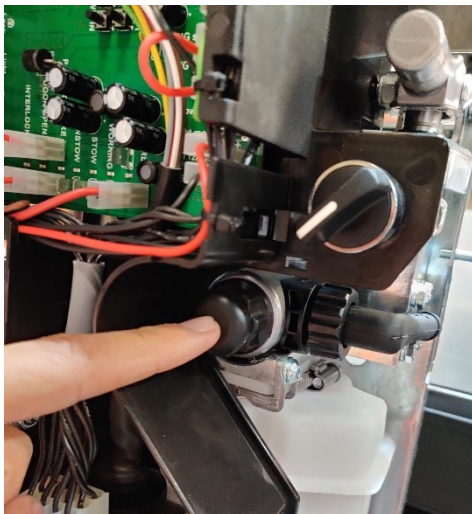

Manual operation of double acting control valve D (LOWER) in pump unit

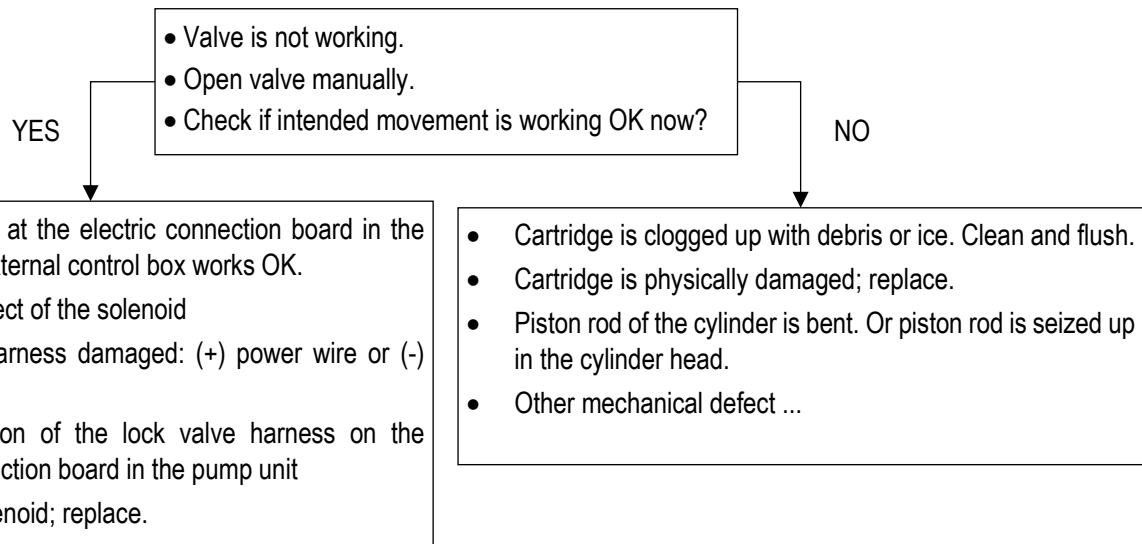

- To end, close the valve manually hand-tight, orient the solenoid in a position that will not damage the valve harness and plug during any of the tail lift functions, replace the nut back on the solenoid and tighten firmly.

## 8.6 PROCEDURE I-SERV-G-006: FLUSHING AND CLEANING OF VALVE CARTRIDGE

- If a valve cartridge is leaking, is held partially open by debris in the oil, you can try to flush the debris and clean the valve as follows.
- Open the valve manually by means of the manual emergency operation of the cartridge. Press LIFT for 30 sec. to flush a valve on the LIFT / LOWER circuit.

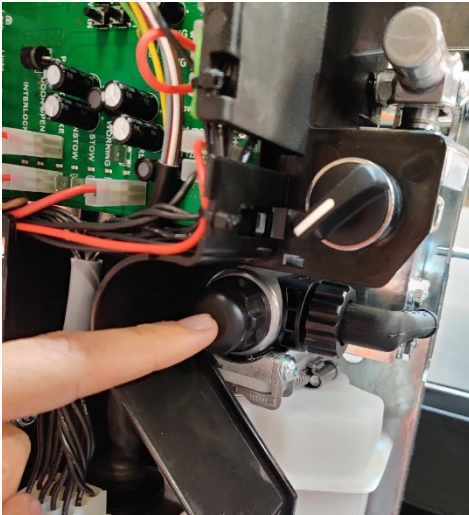

Manual operation of double acting control valve D (LOWER) in pump unit

- If not successful, rest the platform on the ground. Dismount the leaking valve, and try to clean dismantled valve with air gun.
- If not successful, replace the leaking valve.
- To end, close the valve manually hand-tight, orient the solenoid in a position that will not damage the valve harness and plug during any of the wheelchair lift functions, replace the nut back on the solenoid and tighten firmly.

## 8.7 PROCEDURE I-SERV-G-007: TESTING INTERNAL CYLINDER LEAKS

- DHOLLANDIA hydraulic cylinders usually consist out of the parts shown below:  
→ “Piston” cylinder with a piston rod that is substantially narrower than the barrel, plus a piston with seals.

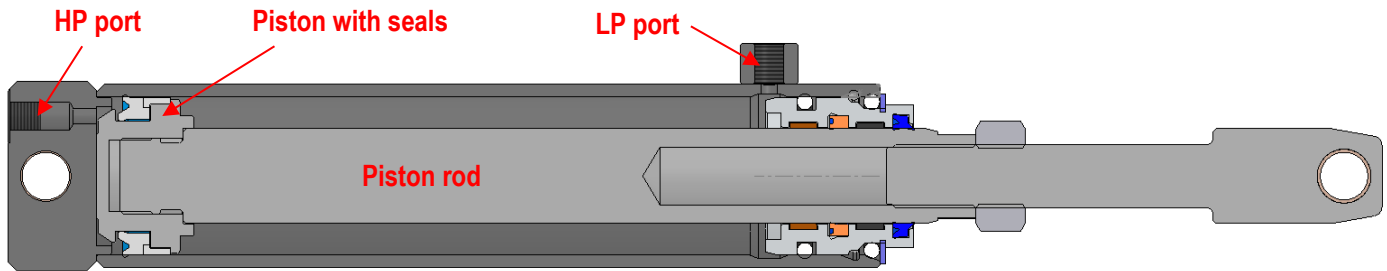

- “Piston” cylinders can be tested for internal leakage past the pistons seals as follows.
- To test cylinder(s):

1. Rest the platform on the ground
2. Disconnect the LP (low pressure) pipes from the cylinder, and guide them into a clean oil pan to avoid oil spilling on the ground.
3. Perform 2-3 complete LIFT cycles from ground to vehicle floor and back, to evacuate any remaining oil from the LP side of the lift cylinder. A small amount of oil is normal.
4. After 4-5 complete cycles, the LP port of the lift cylinder should lose no more oil. If OK, the cylinder is good. If not OK, recondition or replace the cylinder.

HP = high pressure

LP = low pressure

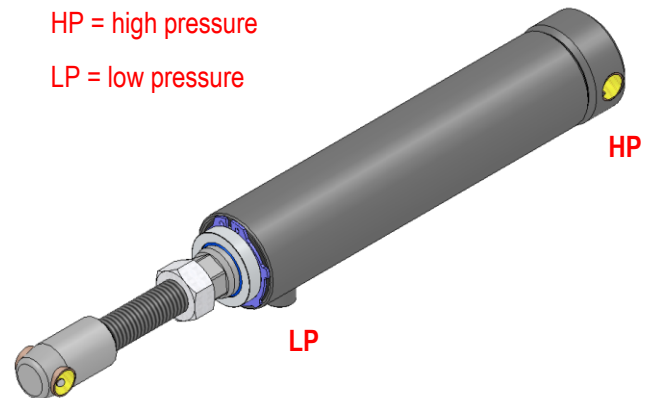

- Contact your national DHOLLANDIA distributor, or consult the website to view the “GUIDELINES FOR THE REVISION OF HYDRAULIC CYLINDERS ” and the applicable safety precautions. Confirm that you have reviewed the most up-to-date version of this manual prior to working on hydraulic cylinders.

[www.dhollandia.com](http://www.dhollandia.com) → Downloads → Education Training → I-SERV-BE 2012-02-EN-cylinder revisions GEN 2

## 8.8 PROCEDURE I-SERV-G-008: OIL REPLACEMENT, FILL REPLACEMENT OF HYDRAULIC OIL

- Oil is usually drained from the pump unit of the wheelchair lift by means of a vacuum extractor like [1].
- To remove a maximum possible quantity of oil, lower down the platform so that it rests on the ground [2]. This slides the cylinders in to their minimum stroke, and push a maximum volume of oil back to the tank.
- Replace the oil yearly.

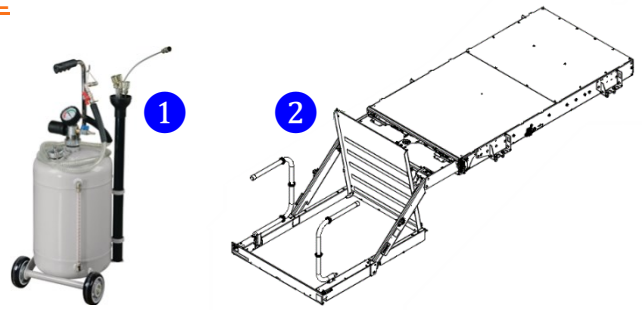

### OIL LEVELS

- The oil tanks are marked with minimum and maximum oil levels.
- To fill up the oil, rest the platform in horizontal position, and fill up between the MAX and MIN mark.
- LOWER the platform to the ground. Check if the movement can be performed fully without oil aspiration problems at filter. Check if the oil level is below the filling cap.
- If the platform cannot be raised fully without oil aspiration problems, top up more oil but not above the (+) mark on the oil tank.

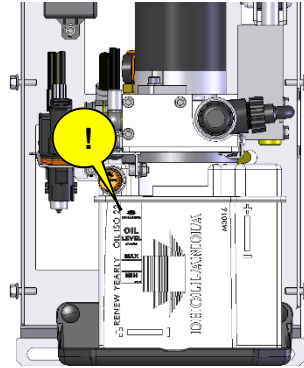

### BLEEDING OF HYDRAULIC CIRCUITS

- The hydraulic circuits must be bled after following work:
  - Reconditioning or replacement of hydraulic cylinders
  - Replacement of hydraulic pipes
  - Full replacement of oil
- LOWER the platform to the ground to bring the cylinders to th minimum stroke, as shown in [3]. Continue to press DOWN for seconds.
- Repeat this action, until you hear no further oil bubbling back to the tank.

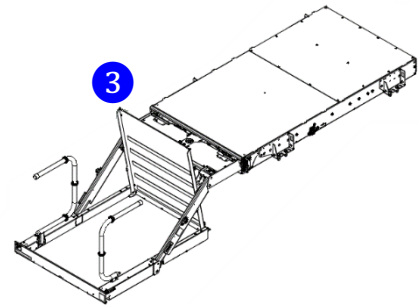

### TYPES OF OIL

- For various climate conditions, DHOLLANDIA uses 3 types of oil. See table.
- When filling up oil, make sure that you use the same, or a compatible type of oil.
- Detailed oil characteristics can be obtained from your national DHOLLANDIA distributor [doc. I-SERV-H-001 in latest version].

| Option code          | Temperature  | Type of oil, examples                        |
|----------------------|--|--|
| Standard             | Mild to hot  | ISO VG 22                                    |
| OAH001<br>winter oil | Down to $-30^{\circ}\text{C}$<br>= $-22^{\circ}\text{F}$ | ISO VG15                                     |
| OAH002<br>Arctic oil | Down to $-52^{\circ}\text{C}$<br>= $-60^{\circ}\text{F}$ | Hydr. fluid such as<br>Castrol Aero HF 585 B |

## 8.9 RESOLVING MALFUNCTIONING HAND PUMP

If the problem is not resolved after performing the guidelines below, contact your DHOLLANDIA distributor for guidance or spare parts.

### 1. Perform a second priming of the hand pump to remove air from the hydraulic circuit.

Attach the lever to the hand pump.

Press the descent button on the remote control while performing the pump-action with the hand pump.

If the lever of the hand pump raises on its own while pressing the descent button, this means that there is a problem with one of the valves and a cleaning of the hand pump is required.

### 2. Cleaning the hand pump

Remove the cover of the power pack

Detach the hand pump from the valve block by removing the hexagon bolts.

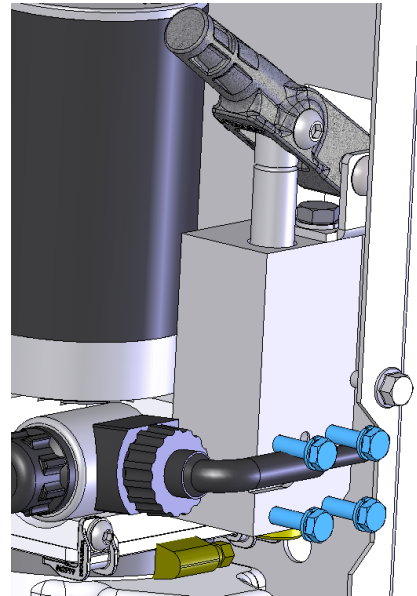

Take out the non-return valve by unscrewing it with a Torx wrench.



Take out the second non-return valve and make sure to keep all the parts that you have removed from the hand pump.





Remove the rod of the hand pump by detaching it from the pump handle.



Remove the blue seals



Use an air pistol to blow out any debris



Proceed in the opposite order to place all the removed parts back in their original position.



## 9 DECALS

- The following decals are supplied with each new wheelchair lift and should be affixed to the vehicle body during installation in the manner set forth in the adjacent drawings.
- NEVER remove or paint over any decal. Missing, worn or illegible warning decals must be immediately replaced. Get free replacement decals from DHOLLANDIA. Contact your national DHOLLANDIA distributor. See page 6 for contact info.
- The operator should comply with all affixed safety and operation decals. Be aware that the decals merely summarize the main points, and that the operator must know, understand, and comply with the full contents of the operation manual.
- Note: the decals marked as "EXAMPLE" can vary in function of the maximum rated capacity of the wheelchair lift or the chosen type of external control box.

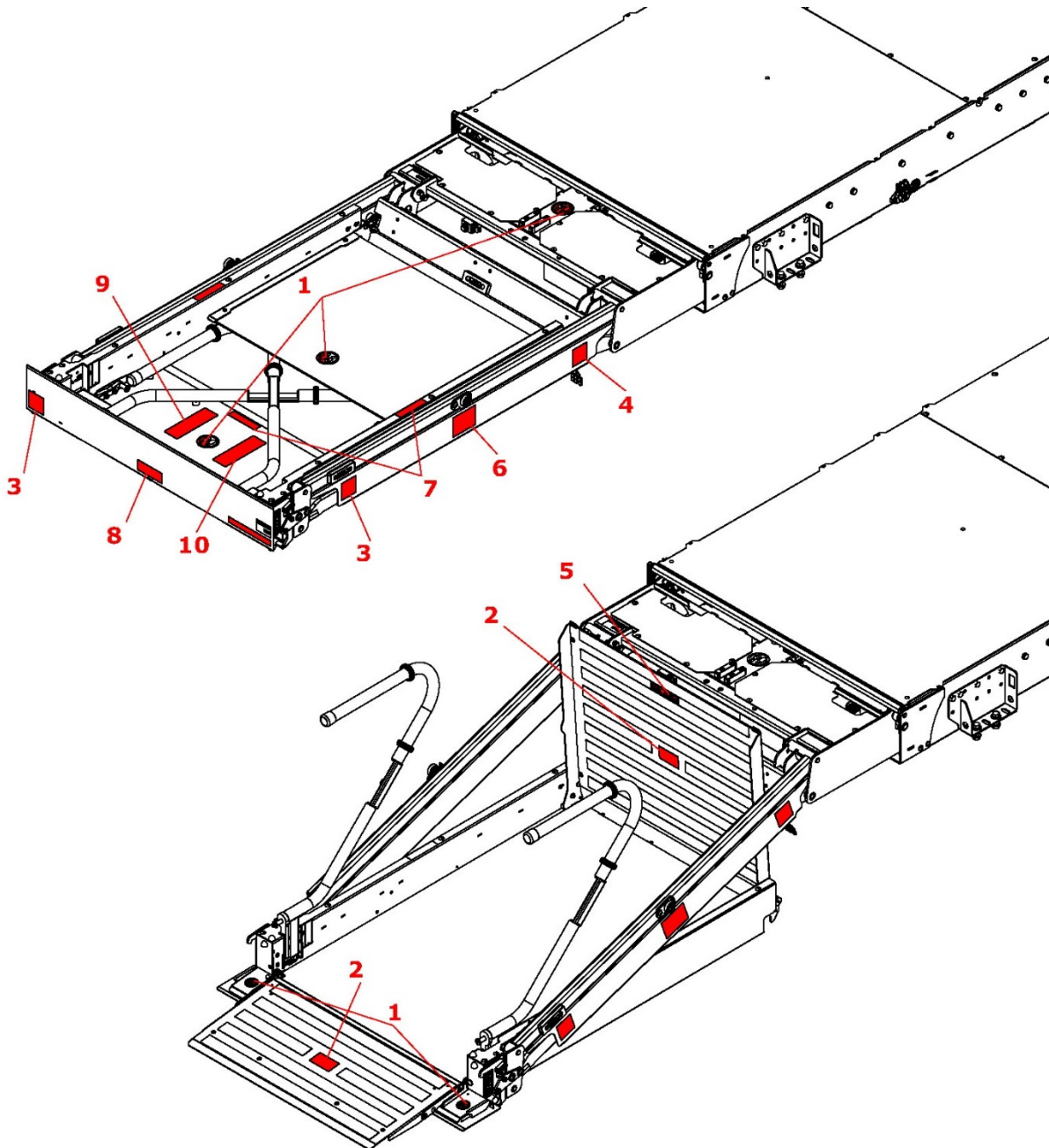

1

EF0505



2

EF0505.B



3

EF0506



4

EF0503



5

EF0570.CAP



6

EF0562.B

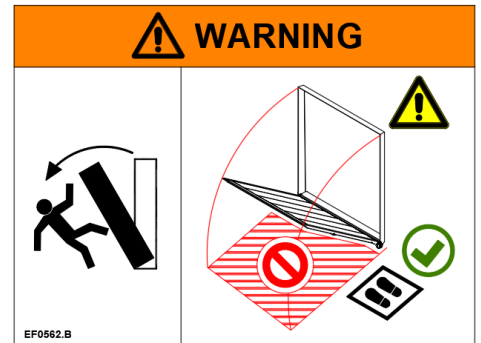

7

EF0593.EN



8

EF0562.EN



9

EF0507.170.05

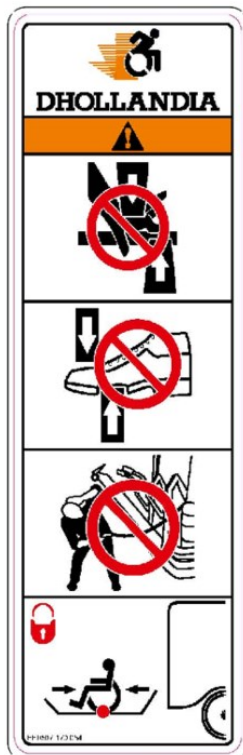

10

EF0504.170.05

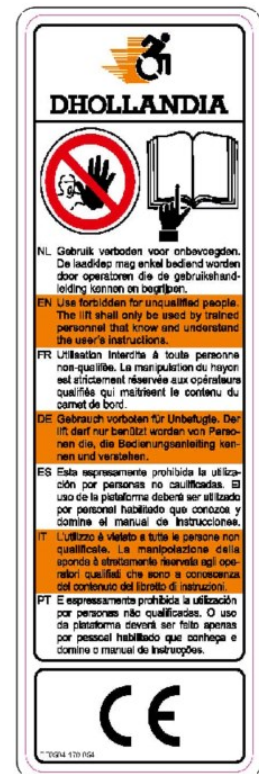

## 9.1 DECALS ON INSIDE OF BUS

- The following decals are supplied loose with the wheelchair lift and shall be affixed by the installer near to the lift at a location clearly visible to the operator, preferably inside the bus to maximize longevity.

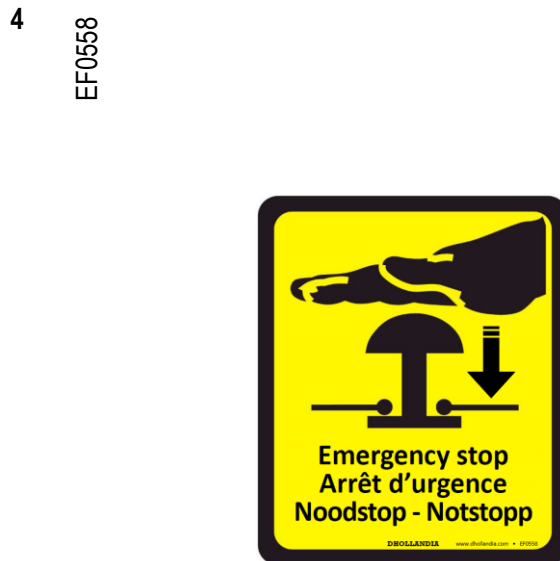
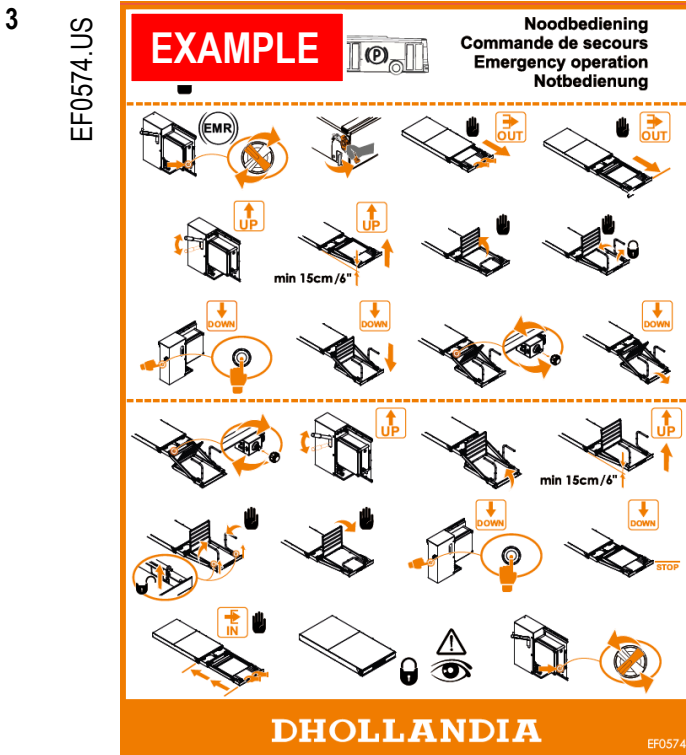
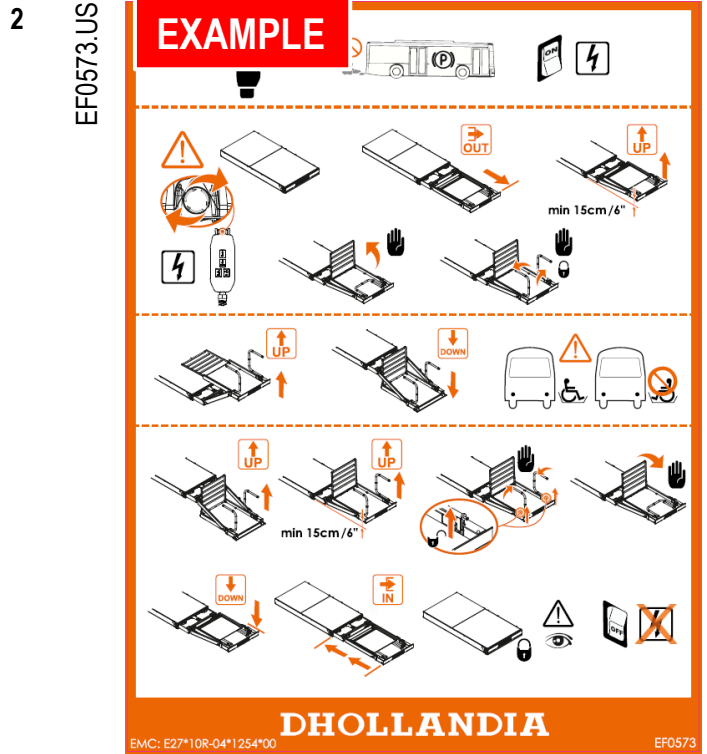
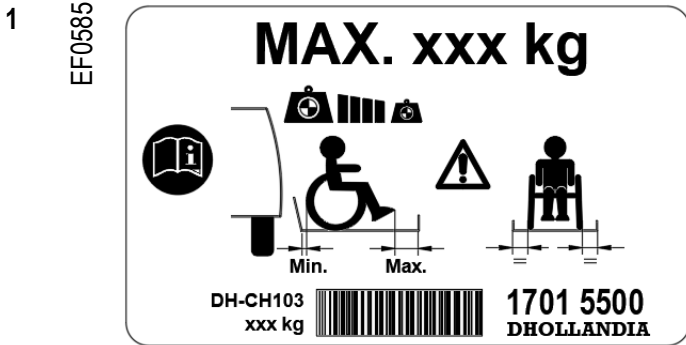

5

EF0504

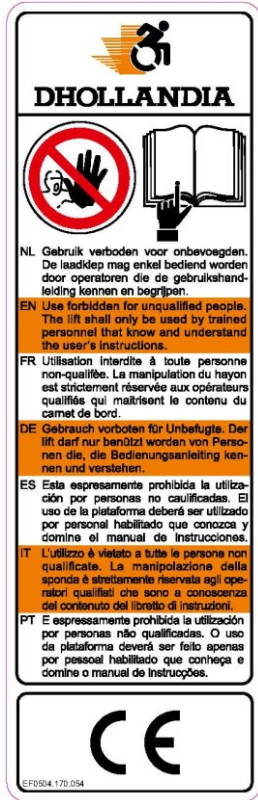

6

EF0507

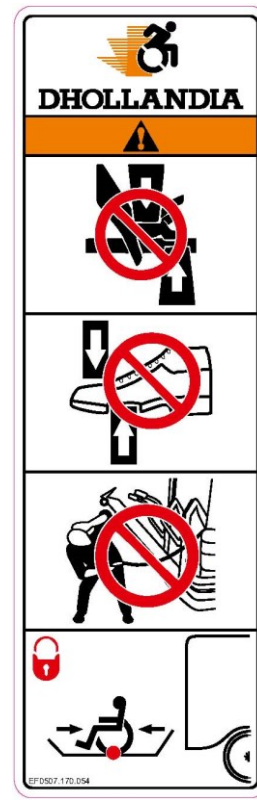

7

EF0563.EN







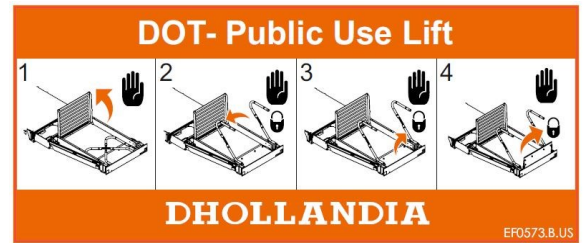













8

EF0573.B.US



















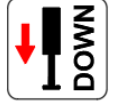

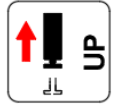

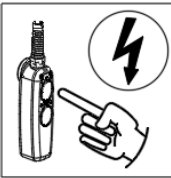

## 10 MEANING OF SAFETY AND WARNING SIGNS

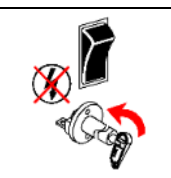
| WARNING signs   |  | MANDATORY ACTION signs  |   |
|---|--|---|---|
|    | Overview and keep visual control over the working area of the lift at all times.   |    | Contact your regional DHOLLANDIA distributor.   |
|    | General warning sign used to alert the user to potential hazards. All messages that follow this sign shall be obeyed to avoid possible harm. |    | Consult the DHOLLANDIA website.<br>Download from DHOLLANDIA website.  |
|    | Entrapment hazard. Keep hands, limbs, loose clothes and long hair away from moving parts.  |    | Read the manual or instructions.  |
|    | Crushing & shearing hazard. Keep hands away from moving parts.   |    | Hold onto handrail. Protect yourself from falling off the platform, or vehicle floor.                             |
|    | Crushing & shearing hazard. Keep feet away from moving parts.  |    | Wear safety gloves.   |
|    | Slipping hazard.   |    | Wear safety-toe shoes.  |
|   | Tripping hazard.   |   | Wear appropriate work clothes, avoid loose-fitting clothes that might be trapped in the moving parts of the lift. |
|  | Hazard caused by tilting objects.  |  | Wear safety protection, eye protection and a safety hard hat.   |
|  | Hazard of falling from heights.  |   |   |
|  | Crushing & entrapment hazard. Keep head, upper body and limbs away from moving parts.  |   |   |

| PROHIBITION signs   |                                 |   |   |
|---|---------------------------------|---|---|
|  | General prohibition. DO NOT do! |  | DO NOT use machine by more than 1 operator! |
|  | General prohibition. DO NOT do! |  | DO NOT step or stand here!                  |

| Other frequently used signs   |  | Signs for electro/hydraulic functions   |   |
|---|--|---|---|
|    | Yes, do this way. Correct work procedure.  |    | Deploy the platform from its travel position to its work position.  |
|    | No, DO NOT do this way. -Incorrect work procedure.   |    | Lower the platform.   |
|    | Position the load at the applicable center of gravity or load center. - Follow the load instructions.                                |    | Lift the platform   |
|    | Emergency stop.<br>Will cause an immediate stop of the lift.   |    | Stow the platform from its work position to its travel position.  |
|    | Emergency exit.<br>Provision (lever, valve) creating an emergency exit.  |    | LEG(S) DOWN: lower down the stabilizing legs  |
|   | Unlock.<br>Disengage the mechanical locking system.  |   | LEG(S) UP: raise the stabilizing legs   |
|  | Lock.<br>Engage the mechanical locking system.   |  | SWITCH between internal and external controls   |
|  | Switch ON the electrical power.  |  | Normal operation by means of the electric controls  |
|  | Switch ON the electrical power to the lift via the main battery disconnect switch and / or cabin switch.                             |  | Switch OFF the electrical power to the lift via the main battery disconnect switch and / or cabin switch. |
|  | Switch OFF the electrical power.   |  | Manual emergency operation  |
|  | This is an operation to be executed manually (as opposed to an electrical function controlled by means of one of the control units). |   |   |



## 11 PRESCRIBED TORQUE VALUES





- The installer **MUST** verify that all bolted connections are fastened with required torque in accordance with the table below.
- After weight testing, the installer **MUST** verify that all bolted connections between lift frame and mounting plates, and between mounting plates and vehicle chassis are still tightened in accordance with required torque. Retighten if required.
- Use a calibrated torque wrench to tighten bolts and nuts to the prescribed torque value.



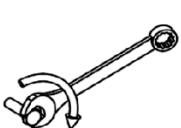

### NOTICE

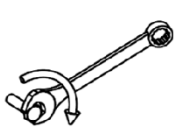

### WARNING

- Incorrect, too soft or too hard tightening of bolts can lead to accidental fall of the tail lift off the vehicle chassis.
- A fall of the tail lift off the chassis can damage the tail lift and / or vehicle chassis and can cause serious bodily injury or death to the operator and any bystanders.
- Therefore, it is essential that the mounting plates are installed following the instructions of this manual.

| Prescribed torque values  |   |   |   |   |
|---|---|---|---|---|
| Nm<br> | Type of stress  |   |   |   |
|   | Pull  |   | Shear   |   |
|   | Class   |   | Class   |   |
|   | 8.8   | 10.9  | 8.8   | 10.9  |
| Metric Value  |  |  |  |  |
| M08 x 1.25  | 8   | 11  | 23  | 34  |
| M10 x 1.50  | 15  | 22  | 46  | 68  |
| M12 x 1.75  | 26  | 44  | 79  | 116   |
| M14F x 1.50   | 45  | 65  | 135   | 195   |
| M14 x 2.00  | 45  | 65  | 125   | 184   |
| M16F x 1.50   | 100   | 150   | 208   | 300   |
| M16 x 2.00  | 100   | 150   | 195   | 287   |
| M20F x 1.50   | 215   | 310   | 425   | 605   |
| M20 x 2.50  | 191   | 275   | 382   | 550   |
| M24F x 2.00   | 360   | 490   | 715   | 975   |
| M24 x 3.00  | 330   | 472   | 660   | 945   |

| Prescribed torque values   |   |   |   |   |
|--|---|---|---|---|
| LbsFt<br> | Type of stress  |   |   |   |
|  | Pull  |   | Shear   |   |
|  | Class   |   | Class   |   |
|  | 8.8   | 10.9  | 8.8   | 10.9  |
| Imperial Value   |  |  |  |  |
| M08 x 1.25   | 6   | 8   | 18  | 24  |
| M10 x 1.50   | 11  | 16.5  | 34.5  | 50  |
| M12 x 1.75   | 17.5  | 32.5  | 60.5  | 85  |
| M14F x 1.50  | 33  | 48  | 99.5  | 144   |
| M14 x 2.00   | 33  | 48  | 95  | 136.5   |
| M16F x 1.50  | 74  | 110.5   | 153.5   | 221.5   |
| M16 x 2.00   | 74  | 110.5   | 144   | 210   |
| M20F x 1.50  | 158.5   | 228.5   | 313.5   | 446.5   |
| M20 x 2.50   | 141   | 203   | 282   | 405.5   |
| M24F x 2.00  | 265.5   | 361.5   | 527.5   | 719   |
| M24 x 3.00   | 243.5   | 348   | 487   | 697   |

| Banjo Bolt Torque Specifications |                   |                              |                        |                   |                              |
|----------------------------------|-------------------|------------------------------|------------------------|-------------------|------------------------------|
| BSPP Banjo Bolt Size             | Newton Metre (Nm) | Pounds Force - Feet (lbf-ft) | Metric Banjo Bolt Size | Newton Metre (Nm) | Pounds Force - Feet (lbf-ft) |
| 1/8                              | 17                | 12                           | M10                    | 10.5              | 13                           |
| 1/4                              | 34                | 25                           | M12                    | 24.5              | 15                           |
| 3/8                              | 47                | 35                           | M14                    | 48                | 19                           |
| 1/2                              | 102               | 75                           | M16                    | 85                | 33                           |
| 5/8                              | 122               | 90                           | M18                    | 136.5             | 37                           |
| 3/4                              | 149               | 110                          | M20                    | 195               | 52                           |
|                                  |                   |                              | M22                    | 136               | 55                           |
|                                  |                   |                              | M26                    | 195               | 81                           |

## 12 END NOTE

- DHOLLANDIA would like to thank you for using our products and leave you with this final notice and warning.
- Additional information about this wheelchair lift and many other DHOLLANDIA products is available at the following link: <http://www.dhollandia.com/>

### **NOTICE**

- Competent and regular preventative maintenance is essential to the operational reliability and safety of the operator or bystanders.
- All maintenance and repair work should be performed by authorized DHOLLANDIA service agents.
- Only authorized OEM DHOLLANDIA replacement parts should be used for all repairs.



### **WARNING**

- Improper use of the wheelchair lift may result in damage, premature wear or failure of the wheelchair lift, and will increase the risk of serious injury or death to the operator or bystanders.
- To maximize the durability, ensure long-term reliability of the wheelchair lift, and protect operators and bystanders from serious bodily injury or death, the operator **MUST** comply with the proper loading instructions and safe working procedures in the OPERATIONS MANUAL.

# 13 APPENDIX

## 13.1 GENERAL TROUBLESHOOTING DIAGRAM

| GENERAL TROUBLESHOOTING DIAGRAM                          |  |   |   |   |
|--|--|---|---|---|
| Symptom / Failure  | Possible Cause / Malfunctioning parts                                      | Check item  | LED check on PCB                                      | Solution  |
| No operation   | • Low battery voltage  | • Battery voltage: 11-14V/22-28V<br>• Check main fuse   | • +BAT12/24V • +Rbat                                  | • Charge battery<br>• Replace broken fuse   |
|  | • Fuse   | • Check Fuses 15A   | • +BAT12/24V • +Rbat                                  | • Replace broken fuse   |
|  | • Lift is not powered ON   | • SWpower: ON (power switch)  | • SWpower   | • Switch on the electrical power to the lift  |
|  | • Battery relay  | • Output +Rbat  | • +Rbat   | • Check wiring  |
|  | • Start-up conditions are not met  | • Parking Brake signal<br>• Door open signal<br>• Interlock signal  | • PARKING BRAKE<br>• DOOR OPEN<br>• INTERLOCK         | • Check condition of the vehicle<br>• Check condition of the vehicle<br>• Check condition of the vehicle  |
|  | • Emergency stop: ON   | • Platform lights flashing rapidly  |   | • Disengage emergency stop (rotate clockwise)   |
|  | • Remote control failure   | • Remote control correctly plugged in<br>• All button lights are active<br>• Button check   | • SWup • SWdown<br>• SWout • SWin                     | • Plug in remote control<br>• Check wiring and connector, replace remote control<br>• Check wiring and connector, replace remote control                            |
| • Check connectors                                       | • Check connections between lift and power pack                            |   | • Check pins and plug of connectors<br>• Check wiring |   |
| Lift will not slide OUT                                  | • Emergency Motor Release (SD): ON   | • EMR switch on side of the electric box  |   | • Disengage EMR switch (rotate counterclockwise)  |
|  | • Automatic lock release malfunction                                       | • Output 'LOCK'   | • Lock  | • Release lock manually by pulling the red handle<br>• Check wiring and connector<br>• Replace lock actuator  |
|  | • Automatic Fuse 5A  | • Automatic Fuse 5A   | • 5A Me Power   | • Wait 10 sec or replace damaged fuse   |
|  | • Relay failure R1   | • Relay R1  | • R1 • COIL R1  | • Replace R1  |
|  | • Lift is stuck inside cassette box  | • Resistance while opening the lift manually after engaging the EMR switch<br>• Input SW0   | • SW0   | • Disengage the EMR switch. Push the DOWN button (2-button controller) or the DEPLOY button (4-button controller) of the remote control for 5 sec<br>• Check wiring |
| • Motor drive failure                                    | • Resistance while opening the lift manually after engaging the EMR switch |   | • Replace motor<br>• Fix gear rack wheel              |   |
| Lift will not slide IN                                   | • Emergency Motor Release (SD): ON   | • EMR switch on side of the electric box  |   | • Disengage EMR switch (rotate counterclockwise)  |
|  | • Switch SW0   | • Hand rails and bridge plate position<br>• SW0 function<br>• Movement of mechanical swing on right side of lift arm that actuates switch SW0                   | • SW0   | • Fold hand rails and bridge plate<br>• Check wiring and connector<br>• Make swing free for rotating, lubricate   |
|  | • Automatic Fuse 5A  | • Automatic Fuse 5A   | • 5A Me Power   | • Wait 10 sec or replace damaged fuse   |
|  | • Relay failure R2   | • Relay R2  | • R2 • COIL R2  | • Replace R2  |
|  | • Motor drive failure  | • Resistance while opening the lift manually after engaging the EMR switch  |   | • Replace motor<br>• Fix gear rack wheel  |
|  | • Lock is closed   | • Check automatic lock  | • STOW  | • Release lock manually by pulling the red handle   |
| Lift will not go UP                                      | • Switch SW1   | • SW1 function<br>• SW1 set-up  | • SW1<br>• SW1  | • Check wiring and connector<br>• Adjust SW1 position closer towards the platform   |
|  | • Pump relay   | • Output R  | • R   | • Check wiring  |
|  | • Oil pressure too low   | • Pressure relief valve setting<br>• Descent electrovalve function<br>• Descent electrovalve blocked/open   | • D   | • Reset pressure relief valve<br>• Check wiring<br>• Remove valve and check for debris, replace valve   |
|  | • Low oil level  | • Check oil level   |   | • Re-fill oil tank to correct level   |
|  | • Hose   | • Oil leak, hose burst<br>• Quick couplings on power pack   |   | • Change damaged hoses<br>• Plug in quick connector couplings   |
| Lift will not go DOWN                                    | • Descent electrovalve D   | • Descent electrovalve output D<br>• Descent electrovalve blocked   | • D   | • Check wiring, operate manually<br>• Remove valve and check for debris, replace valve  |
|  | • Lift is blocked  | • Check obstacles<br>• Bridge plate blocked   |   | • Remove obstacles<br>• Release bridge plate  |
| Lift goes UP and OUT simultaneously when pressing UP     | • Switch SW1   | • Lift is pushed back inside the cassette box   |   | • Raise the lift while empty and lower back to the ground   |
| Roll stop doesn't lower down upon arriving at the ground | • Roll stop electrovalve V0  | • Oil return<br>• Roll stop electrovalve output V0<br>• Roll stop electrovalve blocked  | • V0  | • Push DOWN button for minimum 5 sec<br>• Check wiring, operate manually<br>• Remove valve and check for debris, replace valve                                      |
|  | • Roll stop is blocked   | • Check working mechanical lock on right side of platform<br>• Movement of the roll stop cylinder<br>• Check obstacles on ground<br>• Movement of the roll stop |   | • Check movement, operate manually<br>• Adjust roll stop cylinder shims<br>• Remove obstacles<br>• Check movement of the roll stop, operate manually, lubricate     |
| Roll stop will not go up                                 | • Roll stop electrovalve V0  | • Roll stop electrovalve blocked  |   | • Remove valve and check for debris, replace valve  |
|  | • Roll stop is blocked   | • Movement of the roll stop cylinder<br>• Movement of the roll stop   |   | • Adjust roll stop cylinder shims<br>• Check movement of the roll stop, operate manually, lubricate   |
| Bridge plate doesn't align with the vehicle floor        | • Maximum elevation setting of the lift                                    | • Alignment of bridge plate at maximum elevation  |   | • Reset maximum height of the lift  |
|  | • Cam system   | • Setting of the cam and rod<br>• Cam system failure  |   | • Reset cam system according to the maximum lift height<br>• Replace damaged parts  |
| Bridge plate is not returning to vertical pos.           | • Cam system   | • Setting of the cam system<br>• Cam system failure   |   | • Reset cam system according to the maximum lift height<br>• Replace damaged parts  |
|  | • Bridge plate blocked   | • Check obstacles   |   | • Remove obstacles  |
| Hand rails falling down                                  | • Hand rail lock malfunction   | • Firm locking of the hand rails  |   | • Remove lock and check for debris, lubricate   |

Disclaimer: Check the OPERATION- and MAINTENANCE & REPAIR manual prior to performing any actions. When in doubt, contact your national DHOLLANDIA distributor.

## 13.2 TROUBLESHOOTING: FUNCTIONS TEST

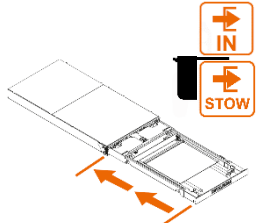
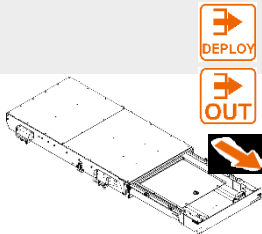
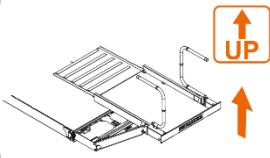
| FUNCTIONS TEST / SELF-DIAGNOSIS   |  |             |   |
|---|--|-------------|---|
| Lift function   | Condition  | PCB lay-out | Check items   |
| <b>STOW/ IN</b><br><br>      | <ul style="list-style-type: none"> <li>• SWpower: ON</li> <li>• Emergency stop: OFF</li> <li>• Emergency Motor Release (S0): OFF</li> <li>• Battery voltage: 11-14 / 22-28V</li> </ul> |             | <ul style="list-style-type: none"> <li>• SWdown</li> <li>• SWin (4 button ctrl)</li> <li>• R2 IN</li> <li>• COIL R2</li> <li>• D</li> <li>• +BAT 12/24V</li> <li>• UNSTOW</li> <li>• +Rbat</li> <li>• LIFT ON</li> <li>• WORKING</li> <li>• +12/24V DC</li> <li>• SW0</li> <li>• PARKING BRAKE</li> <li>• DOOR OPEN</li> <li>• INTERLOCK</li> <li>• Me power (5A)</li> <li>• Light</li> <li>• Buzzer</li> <li>• Rbat</li> <li>• EMG stop</li> <li>• SWpower</li> </ul>    |
| <b>DEPLOY/ OUT</b><br><br> | <ul style="list-style-type: none"> <li>• SWpower: ON</li> <li>• Emergency stop: OFF</li> <li>• Emergency Motor Release (S0): OFF</li> <li>• Battery voltage: 11-14 / 22-28V</li> </ul> |             | <ul style="list-style-type: none"> <li>• SWup</li> <li>• SWout (4 button ctrl)</li> <li>• R1 OUT</li> <li>• COIL R1</li> <li>• +BAT 12/24V</li> <li>• UNSTOW</li> <li>• +Rbat</li> <li>• LIFT ON</li> <li>• WORKING</li> <li>• +12/24V DC</li> <li>• SW0</li> <li>• PARKING BRAKE</li> <li>• DOOR OPEN</li> <li>• INTERLOCK</li> <li>• Me power (5A)</li> <li>• Light</li> <li>• Buzzer</li> <li>• Rbat</li> <li>• Lock</li> <li>• EMG stop</li> <li>• SWpower</li> </ul> |
| <b>Going UP</b><br><br>     | <ul style="list-style-type: none"> <li>• SWpower: ON</li> <li>• Emergency stop: OFF</li> <li>• Emergency Motor Release (S0): OFF</li> <li>• Battery voltage: 11-14 / 22-28V</li> </ul> |             | <ul style="list-style-type: none"> <li>• SWup</li> <li>• R</li> <li>• +BAT 12/24V</li> <li>• UNSTOW</li> <li>• +Rbat</li> <li>• LIFT ON</li> <li>• WORKING</li> <li>• +12/24V DC</li> <li>• SW1</li> <li>• PARKING BRAKE</li> <li>• DOOR OPEN</li> <li>• INTERLOCK</li> <li>• Me power (5A)</li> <li>• Light</li> <li>• Buzzer</li> <li>• Rbat</li> <li>• EMG stop</li> <li>• SWpower</li> </ul>  |

Going DOWN

- SWpower: ON
- Emergency stop: OFF
- Emergency Motor Release (S0): OFF
- Battery voltage: 11-14 / 22-28V

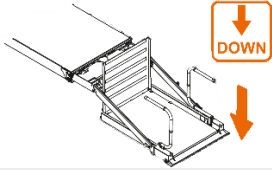

- SWdown
- D
- V0
- +BAT 12/24V
- UNSTOW
- +Rbat
- LIFT ON
- WORKING
- +12/24V DC
- SW1
- PARKING BRAKE
- DOOR OPEN
- INTERLOCK
- Me power (5A)
- Light
- Buzzer
- WORKING
- Rbat
- EMG stop
- SW power

### 13.3 TROUBLESHOOTING: POSITIONS TEST

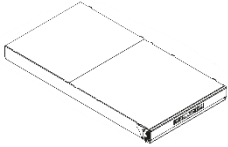
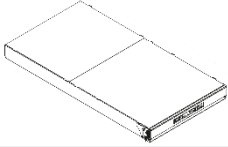
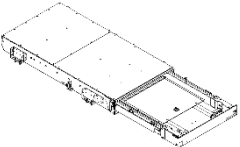
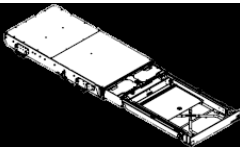
| POSITIONS TEST / SELF-DIAGNOSIS   |   |             |  |
|---|---|-------------|--|
| Lift position   | Condition   | PCB lay-out | Check items  |
| IN – STOW position<br><br>   | <ul style="list-style-type: none"> <li>• SWpower: OFF</li> <li>• Emergency stop: OFF</li> <li>• Emergency Motor Release (S0): OFF</li> <li>• Battery voltage: 11-14 / 22-28V</li> </ul> |             | <ul style="list-style-type: none"> <li>• +BAT 12/24V</li> <li>• STOW</li> </ul>  |
| IN – STOW position<br><br>   | <ul style="list-style-type: none"> <li>• SWpower: ON</li> <li>• Emergency stop: OFF</li> <li>• Emergency Motor Release (S0): OFF</li> <li>• Battery voltage: 11-14 / 22-28V</li> </ul>  |             | <ul style="list-style-type: none"> <li>• +BAT 12/24V</li> <li>• STOW</li> <li>• +Rbat</li> <li>• LIFT ON</li> <li>• +12/24V DC</li> <li>• SW0</li> <li>• SW5</li> <li>• PARKING BRAKE</li> <li>• DOOR OPEN</li> <li>• INTERLOCK</li> <li>• Me power (5A)</li> <li>• EMG stop</li> <li>• SWpower</li> <li>• Rbat</li> </ul> |
| OUT/DEPLOY–<br>UNSTOW position<br>(between STOW and<br>WORK position)<br><br><br><br>OUT/ DEPLOY – WORK<br>position<br><br> | <ul style="list-style-type: none"> <li>• SWpower: OFF</li> <li>• Emergency stop: OFF</li> <li>• Emergency Motor Release (S0): OFF</li> <li>• Battery voltage: 11-14 / 22-28V</li> </ul> |             | <ul style="list-style-type: none"> <li>• +BAT 12/24V</li> <li>• UNSTOW</li> </ul>  |

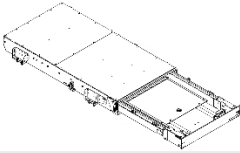
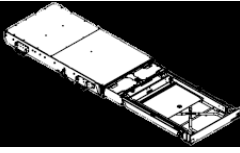
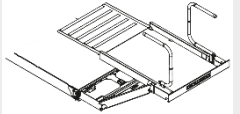
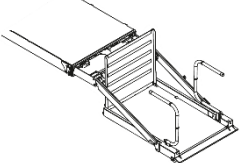

|   |  |  |   |
|---|--|--|---|
| <p>OUT/DEPLOY – UNSTOW position</p>   | <ul style="list-style-type: none"> <li>• SWpower: ON</li> <li>• Emergency stop: OFF</li> <li>• Emergency Motor Release (S0): OFF</li> <li>• Battery voltage: 11-14 / 22-28V</li> </ul> |  | <ul style="list-style-type: none"> <li>• +BAT 12/24V</li> <li>• UNSTOW</li> <li>• +Rbat</li> <li>• LIFT ON</li> <li>• +12/24V DC</li> <li>• SW0</li> <li>• PARKING BRAKE</li> <li>• DOOR OPEN</li> <li>• INTERLOCK</li> <li>• Me power (5A)</li> <li>• EMG stop</li> <li>• SWpower</li> <li>• Light</li> <li>• Rbat</li> </ul>                |
| <p>OUT/DEPLOY – WORK position</p>    | <ul style="list-style-type: none"> <li>• SWpower: ON</li> <li>• Emergency stop: OFF</li> <li>• Emergency Motor Release (S0): OFF</li> <li>• Battery voltage: 11-14 / 22-28V</li> </ul> |  | <ul style="list-style-type: none"> <li>• +BAT 12/24V</li> <li>• UNSTOW</li> <li>• +Rbat</li> <li>• LIFT ON</li> <li>• +12/24V DC</li> <li>• SW0</li> <li>• SW1</li> <li>• PARKING BRAKE</li> <li>• DOOR OPEN</li> <li>• INTERLOCK</li> <li>• Me power (5A)</li> <li>• EMG stop</li> <li>• SWpower</li> <li>• Light</li> <li>• Rbat</li> </ul> |
| <p>LIFT UP – WORK position</p>  <p>LIFT DOWN – WORK position</p>  | <ul style="list-style-type: none"> <li>• SWpower: ON</li> <li>• Emergency stop: OFF</li> <li>• Emergency Motor Release (S0): OFF</li> <li>• Battery voltage: 11-14 / 22-28V</li> </ul> |  | <ul style="list-style-type: none"> <li>• +BAT 12/24V</li> <li>• UNSTOW</li> <li>• +Rbat</li> <li>• LIFT ON</li> <li>• +12/24V DC</li> <li>• SW1</li> <li>• PARKING BRAKE</li> <li>• DOOR OPEN</li> <li>• INTERLOCK</li> <li>• Me power (5A)</li> <li>• EMG stop</li> <li>• SWpower</li> <li>• Light</li> <li>• Rbat</li> </ul>                |

## 13.4 DATASHEETS GREASE AND OIL

- Grease:
  - Sales code: K0505

| CHARACTERISTICS              | UNITS              | METHODS     | TYPICAL DATA         |
|------------------------------|--------------------|-------------|----------------------|
| Soap                         | -                  | -           | Lithium              |
| Basic oil                    | -                  | -           | Mineral oil          |
| Texture                      | -                  | -           | Smooth               |
| Colour                       | -                  | Visual      | Light yellow         |
| NLGI Grade                   | -                  | ASTM D 217  | 2                    |
| Drop point                   | °C                 | IP 396      | > 190                |
| Kinematic viscosity at 40°C  | mm <sup>2</sup> /s | ASTM D 7152 | 110                  |
| Kinematic viscosity at 100°C | mm <sup>2</sup> /s | ASTM D 7152 | 12                   |
| Penetration 60 strokes       | 1/10 mm            | ISO 2137    | 265-295              |
| 4 ball welding               | Kg                 | ASTM D 2596 | 200                  |
| Water jet resistance at 79°C | %                  | ISO 11009   | < 10                 |
| Temperature range            | °C                 | -           | -20 / +120 (max 130) |

*The above data are provided on an indicative basis only.*

- Oil
  - Sales code: UOV005

### **PROPERTIES**

| CHARACTERISTICS             | UNITS                    | METHODS   | TYPICAL DATA |
|-----------------------------|--------------------------|-----------|--------------|
| Specific gravity at 20°C    | kg/m <sup>3</sup>        | NFT 60101 | 807          |
| Kinematic viscosity at 20°C | mm <sup>2</sup> /s (cSt) | NFT 60100 | 1            |
| Flash point                 | °C                       | NFT 60118 | -20          |
| Pour point                  | °C                       | NFT 60105 | -140         |

*The average values are given for information only and ...*