



## M-SERIES DIAPHRAGM COMPRESSOR REBUILD KIT Part# 200690K

### Disassembly Instructions

#### NOTICE

DO NOT discard any component unless directed to do so. All mounting hardware will be re-used during the installation of the compressor kit.

#### WARNING

To avoid the risk of shock, ensure to disconnect power to the heater unit during disassembly/reassembly.

1. Disconnect all harnesses at the PCM.
2. Disconnect the fuel supply line.
3. Referring to figure A, loosen and back out the burner head mounting bolts (item 1) allowing enough room to rotate the burner head 15° counter-clockwise and remove.
4. Remove the blower housing (item 3) by removing the two M6 screws (item 2). Item 3a may vary in appearance depending on the type of heater model. Note initial orientation of blower housing.
5. Remove the combustion air blower (item 5) by removing the retaining ring (item 4).
6. Disconnect the motor (item 6), fuel solenoid (item 7), and ignition module (item 8) at the PCM (item 9), then carefully slide off the PCM (item 10) to avoid damaging the motor wires.

Figure A.

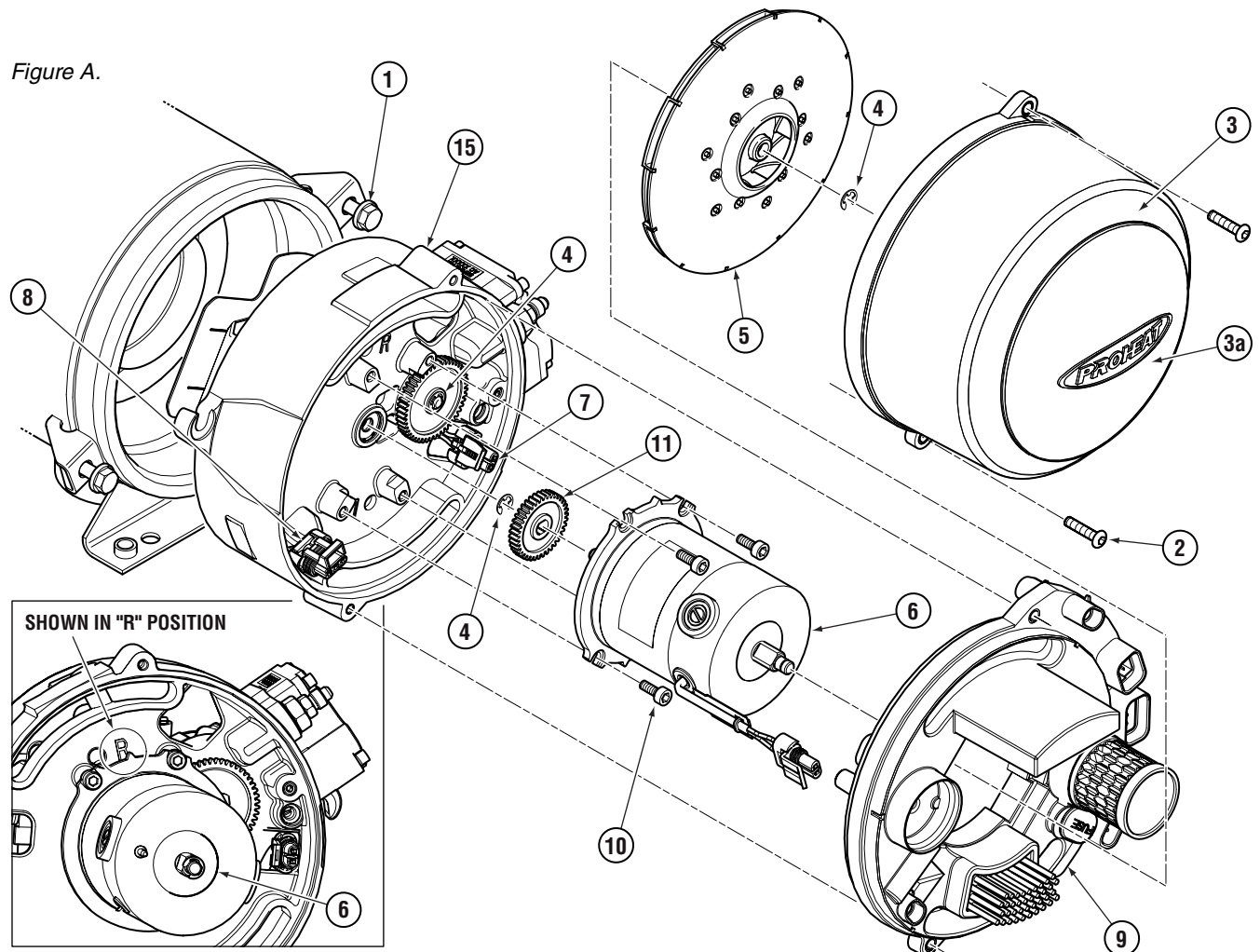



7. Remove the motor (item 6) by removing the four M6 screws (item 10). Note initial orientation of motor for reassembly (refer to figure A inset).
8. Remove and discard the Motor Gear (item 11) by removing the retaining ring (item 4). **Ensure Motor Shaft and retaining ring groove are thoroughly cleaned and free from all green Loctite® adhesive before reassembly.**
9. Turn the Burner head over as shown in figure B. Remove the ignition electrode (item 28) then the flame shield (item 29).
10. Remove the valve cover (item 18) by removing the four M5 screws (item 16) and lock washers (item 17).
11. Remove and discard the two O-rings (item 19 & 20) and cylinder head assembly (item 21).
12. Remove the #8 screw (item 22) from the connecting rod assembly (item 23), then remove the intake disk (item 24), diaphragm (item 25) and compression disk (item 26).
13. Remove and discard the two O-rings (item 27) from the burner head flange (item 15).

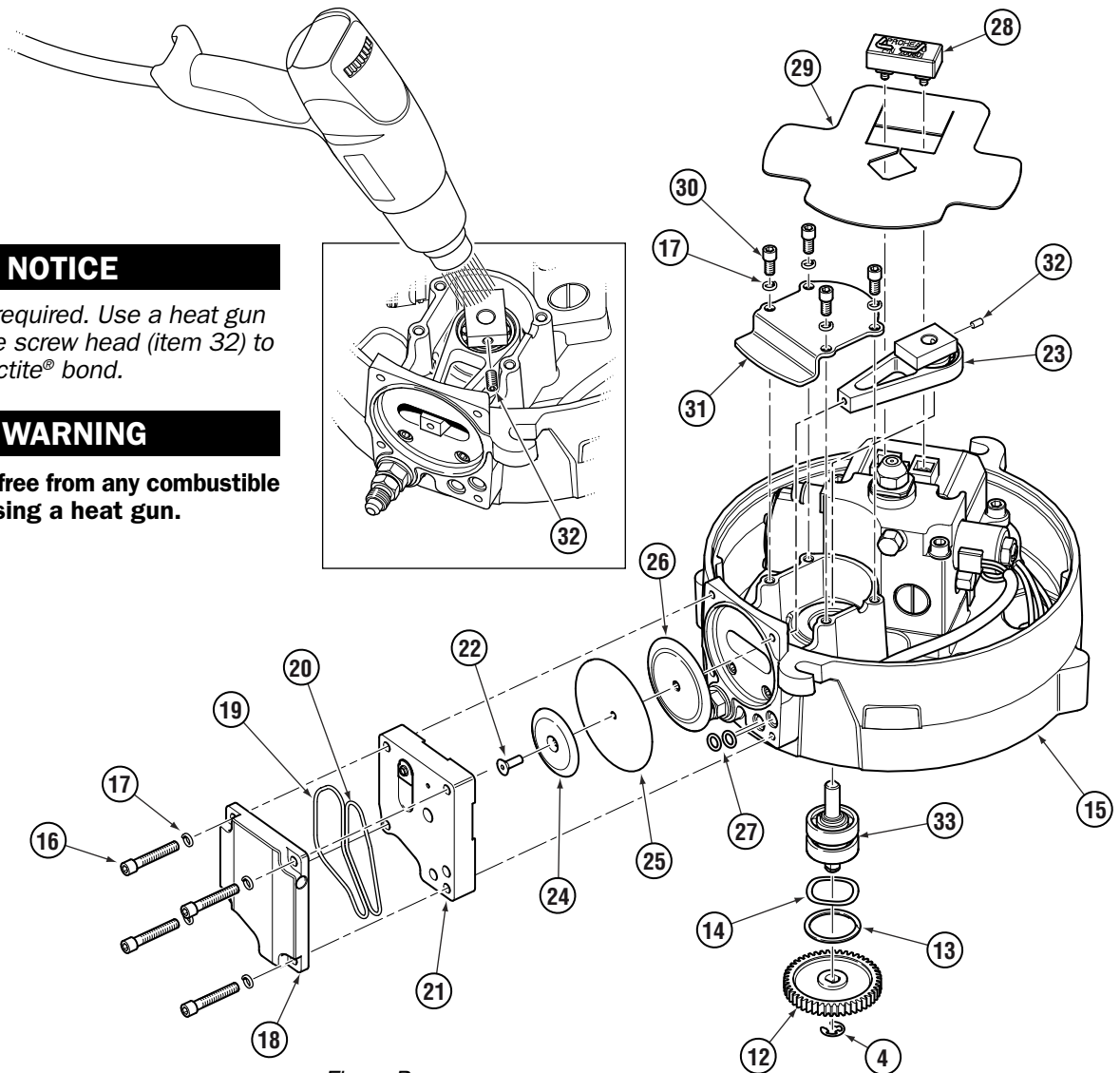

Figure B.

## NOTICE

Heat may be required. Use a heat gun directed at the screw head (item 32) to loosen the Loctite® bond.

## ⚠ WARNING

Area must be free from any combustible fuels when using a heat gun.



Figure C.

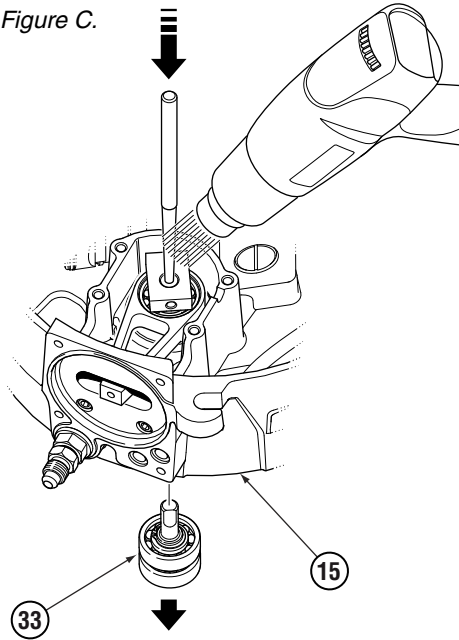

14. Remove the compressor cover (item 31) by removing the four M5 screws (item 30) and lock washers (item 17).
15. Remove and discard the compressor gear (item 12) by removing the retaining ring (item 4). **Ensure the Compressor Shaft and retaining ring groove are thoroughly cleaned and free from all green Loctite® adhesive before reassembly.**
16. Remove the internal retaining ring (item 13) and spring washer (item 14) from the burner head flange (item 15).
17. Remove the #10 set screw (item 32) from the connecting rod assembly. **NOTE:** heat may be required. Use a heat gun directed at the screw head to loosen the Loctite® bond (See figure B inset).
18. Referring to figure C, remove the compressor shaft assembly (item 33). **NOTE:** heat may be required. Use a heat gun directed at bearings to loosen the Loctite® bond, then tap out with a hammer being careful not to damage the burner head flange (item 15).
19. Slide the connecting rod assembly (item 23) out from the compressor crankcase.
20. Discard all of the remaining components as per the disassembly parts checklist.

## Disassembly Parts Checklist

ITEM	RE-USE	DISCARD	DESCRIPTION	QTY	UOM
1	X		Screw, M8 x 1.25 x 30, HWHCS	2	ea
2	X		Screw, M6 x 1 x 1.25, BHSCS SS	2	ea
3	X		Blower Housing	1	ea
4		X	Retaining Ring	3	ea
5	X		Combustion Air Blower	1	ea
6	X		Motor	1	ea
7	X		Fuel Solenoid	1	ea
8	X		Ignition Module	1	ea
9	X		Proheat Control Module (PCM)	1	ea
10	X		Screw, M6 x 1 x 16, SHCS SS	4	ea
11		X	Motor Gear	1	ea
12		X	Compressor Gear	1	ea
13		X	Snap Ring	1	ea
14		X	Spring Washer	1	ea
15	X		Burner Head Flange	1	ea
16	X		Screw, M5 x 0.8 x 30 SHCS ZP	4	ea
17	X		Lockwasher, #10 SS	8	ea
18	X		Valve Cover	1	ea
19		X	O-Ring, 2-035	1	ea
20		X	O-Ring, 2-031	1	ea
21		X	Cylinder Head	1	ea
22		X	Screw, #8-32 x 1/2, FHSCS SS	1	ea
23		X	Connecting Rod Assembly	1	ea
24		X	Intake Disk	1	ea
25		X	Diaphragm	1	ea
26		X	Compression Disk	1	ea
27		X	O-Ring, 2-010	2	ea
28	X		Ignition Electrodes	1	ea
29	X		Flame Shield	1	ea
30	X		Screw, M5 x 0.8 x 10, SHCS SS	4	ea
31	X		Compressor Cover	1	ea
32		X	Set Screw, #10-32 x 3/8, SHSS	1	ea
33		X	Compressor Shaft Assembly	1	ea



## Reassembly Instructions

1. Prep drive hub to ensure it is clean and free from any debris and/or contaminants. Use of a Scotch Bright pad is permitted.
2. Apply Loctite® 620 (item 50) to the outer race of the bearings in item 34. Ensure no Loctite® contacts the sealing surfaces.
3. Place the connecting rod assembly (item 37) in position as shown in figure E FIRST. Insert the compressor shaft assembly (item 34) into the drive hub SECOND. **NOTE:** the order of this operation is important.
4. Install the spring washer (item 35) and snap ring (item 36). Ensure the spring washer sits evenly against the bearing surface, and the snap ring is properly seated in the groove in the drive hub.

Figure D.

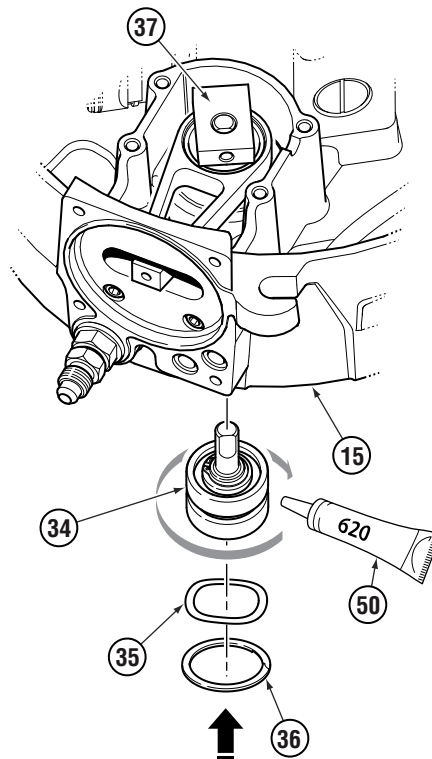
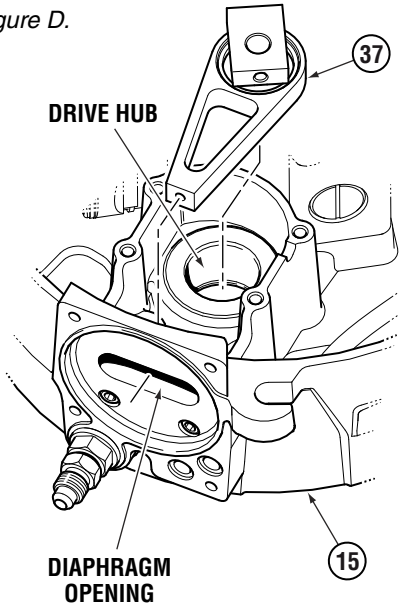
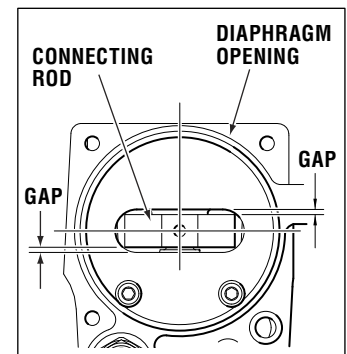
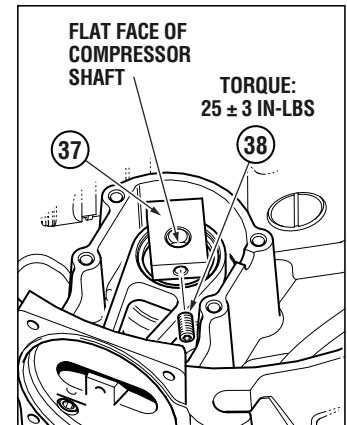

figure E.



5. Install set screw into the connecting rod assembly ensuring that it mates flush to flat face of compressor shaft after tightening. If positioned correctly, the areas marked "gap" will be equal in size (see figure E insets).



- Orient the compressor gear (item 47) as noted in figure F. with appropriate side facing compressor as per gear text. Install by hand and secure to the compressor shaft with a new retaining ring (item 48). If gear cannot be installed by hand, remove the four screws securing the compressor cover in place and support the compressor shaft as shown in figure C. A 13 mm deep socket and soft hammer can then be used to lightly tap gear onto shaft.

## NOTICE

DO NOT apply lubricants or Loctite® to compressor shaft or gear during installation.

Compressor Gear.

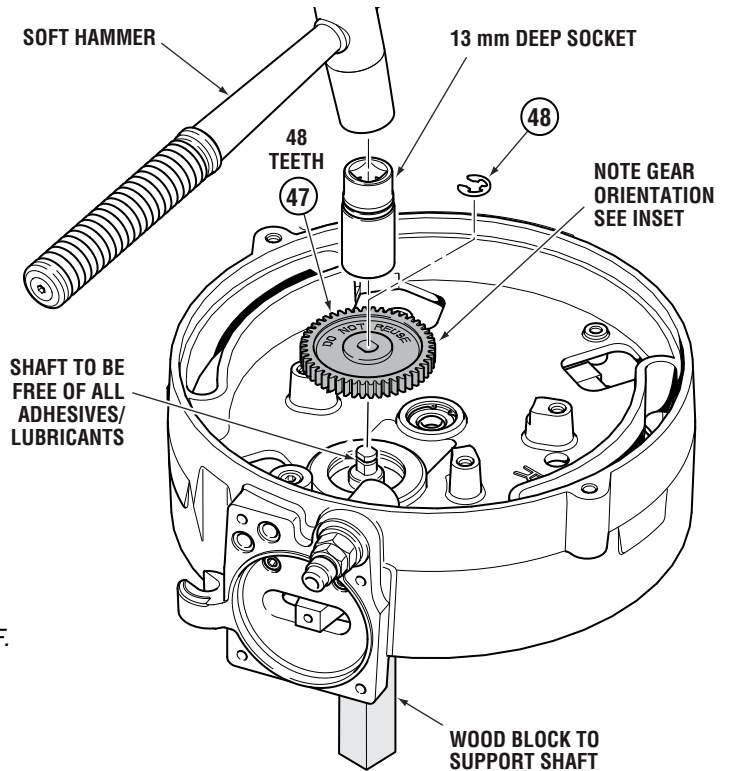
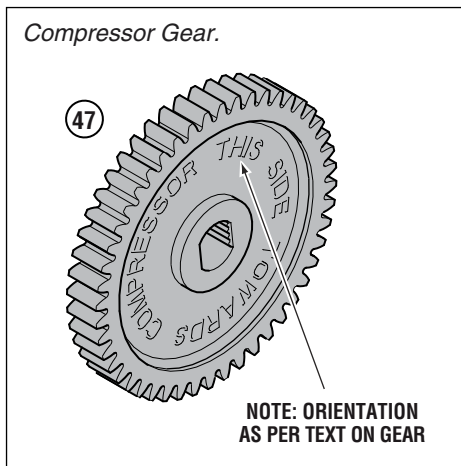

Figure F.

- Install the diaphragm assembly (items 39–42) onto the connecting rod as shown in figure G. **NOTE:** orient the intake disk (item 40) and compression disk (item 42) with the beveled side pointing away from burner head flange (see figure G inset).

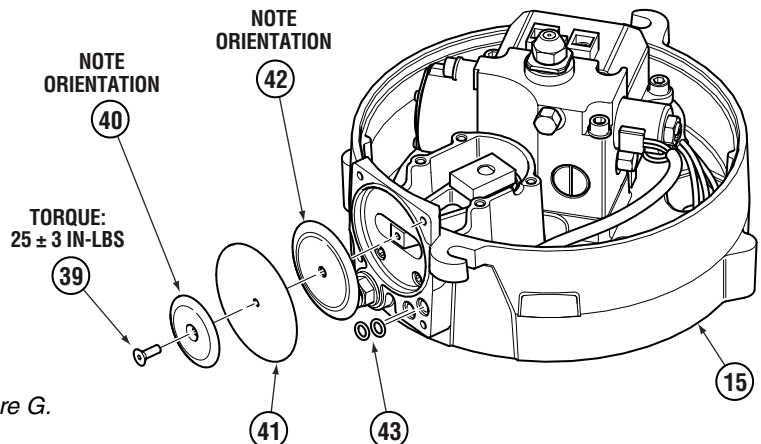
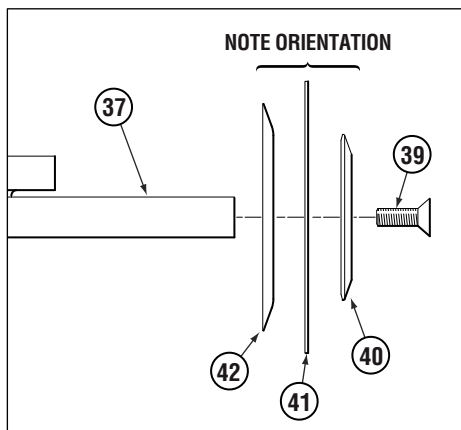
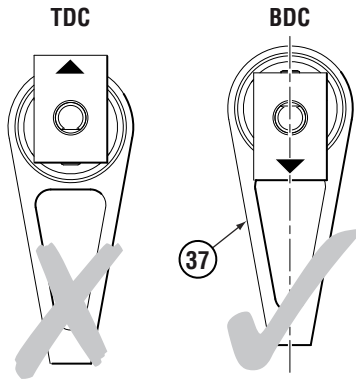

Figure G.

- Install two O-rings (item 43) into the burner head flange (item 15).
- Install two O-rings (items 44 and 45) into the valve cover (item 18).



Figure H.



ENSURE COUNTER-WEIGHT IS ALIGNED BOTTOM DEAD CENTER (BDC) BEFORE INSTALLATION

- 10.** Position the connecting rod assembly (item 37) so that it is in BDC (see figure H), and ensure the diaphragm (item 41) is concentric to the “diaphragm opening”.

**NOTE:** this operation is CRITICAL prior to proceeding onto step 11.

- 11.** Install the cylinder head assembly (item 46) and valve cover (item 18) and secure with four M5 screws (item 16) and lock washers (item 17). Torque the screws according to the torque sequence shown in figure I inset.
- 12.** Install the compressor cover (item 31) and secure with four screws (item 30) and lock washers (item 17).

Figure I.

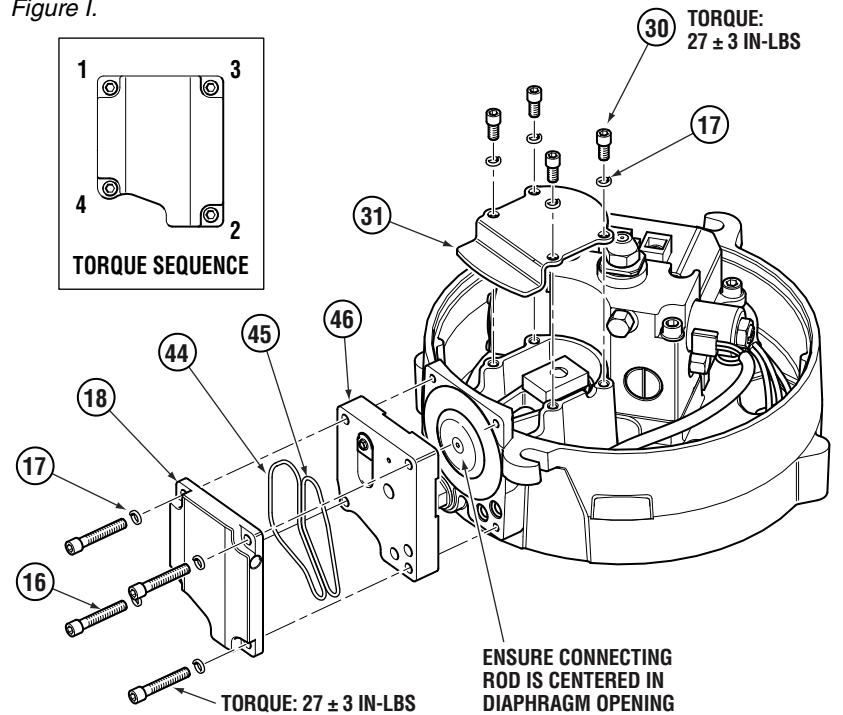
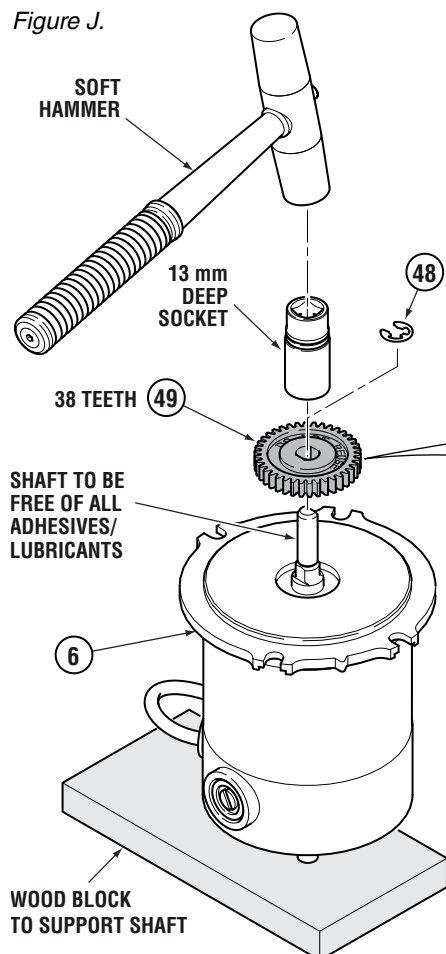
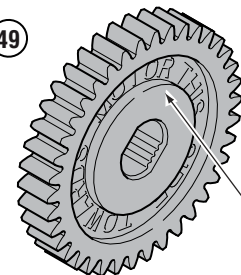

Figure J.



Black Motor Gear  
with 38 Teeth.

49



NOTE: ORIENTATION  
AS PER TEXT ON GEAR

- 13.** Orient the Motor Gear (item 49) as noted in figure J. (Inset) with appropriate side facing Motor flange as per gear text. Install by hand and secure to the Motor Shaft with a new retaining ring (item 48). If gear cannot be installed by hand, a 13 mm deep socket and soft hammer can be used to lightly tap gear onto shaft. Support Motor shaft from combustion air blower side as shown in figure J.



# INSTALLATION INSTRUCTIONS

Copy Part# 206000, Rev. E  
Date: 05/2017



Page 7 of 9

- Referring to figure K, install the motor (item 6) onto the burner head flange and secure with four M6 screws (item 10). Ensure to apply Loctite® 242 (item 51) to the screw threads prior to installation. **NOTE:** Motor (item 6) must be re-installed according to its original position (see orientation marks item figure K inset).
- Install the PCM (item 9), then reconnect the motor (item 6), fuel solenoid (item 7) and ignition module (item 8) to their respective terminals. **NOTE:** Ensure the PCM is reinstalled in its original orientation.

Figure K.

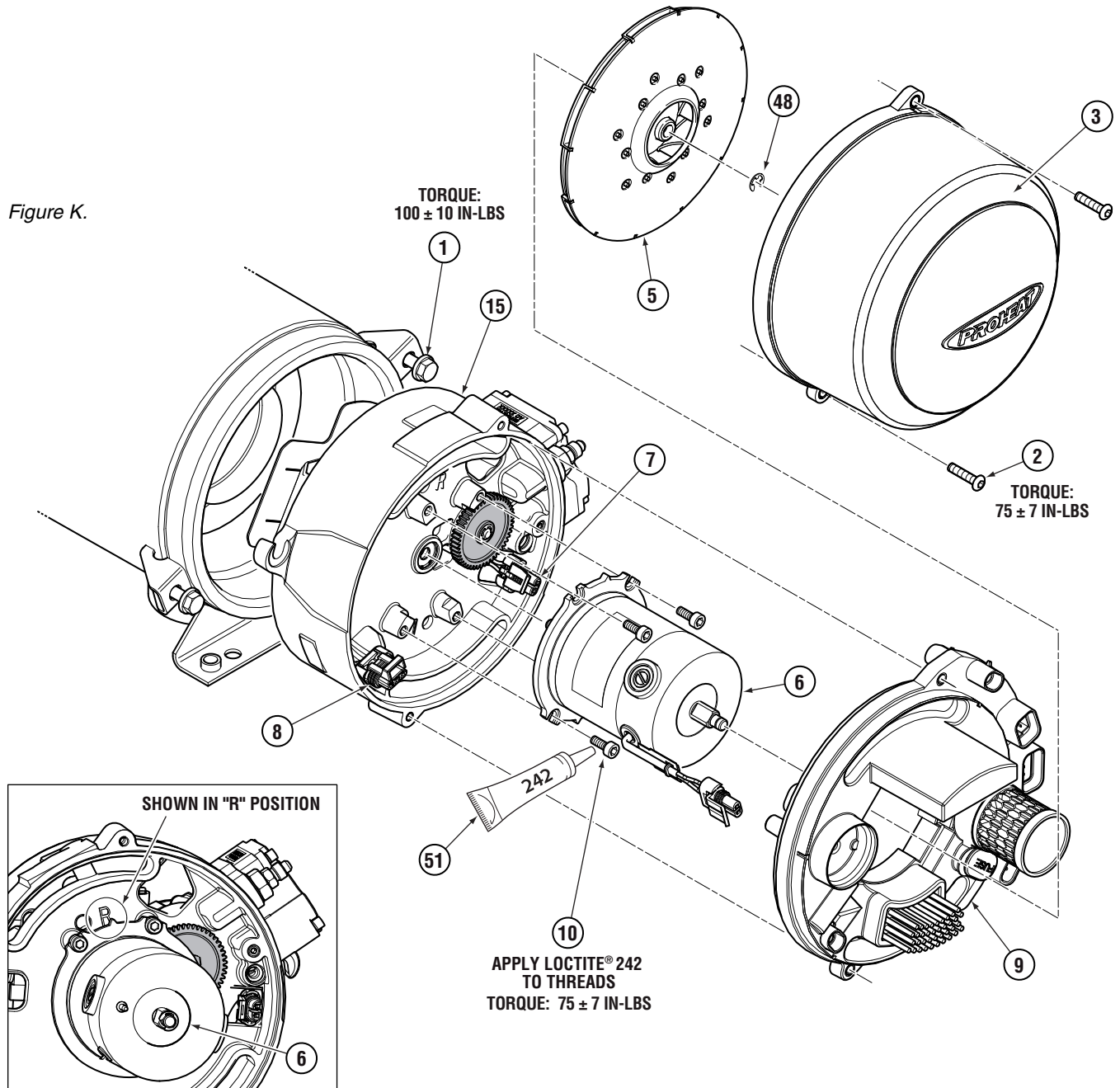



# INSTALLATION INSTRUCTIONS

Copy Part# 206000, Rev. E  
Date: 05/2017



Page 8 of 9

## NOTICE

Ensure to rotate combustion air blower (item 5) by hand until it spins freely. This seats the fuel pump gear pack and avoids a Code 12 on startup. For more information, refer to the manual at [www.proheat.com](http://www.proheat.com)

## NOTICE

PK0036 Digital Manometer or PK0067 Pressure Test Gauge (not shown) is required to complete the rebuild. It is NOT supplied in the rebuild kit. Go to [www.proheat.com](http://www.proheat.com) for more information.

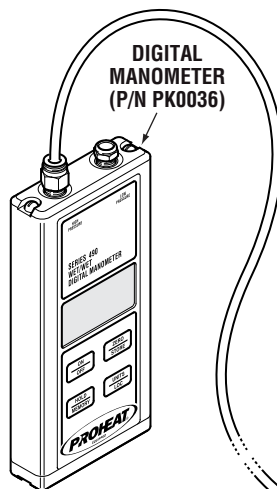

PRESSURE ADJUSTMENT SCREW

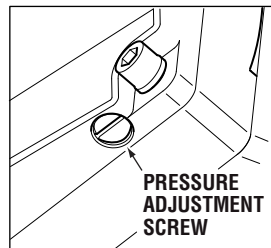

16. Install the combustion air blower (item 5) and secure with a new retaining ring (item 48). Spin the combustion air blower by hand after installation to ensure it spins freely.
17. Install the blower housing (item 3) ensuring correct orientation, and secure with two screws (item 2).
18. Set Compressor Pressure (refer to figure L).  
Refer to M-Series Service Manual at [www.proheat.com](http://www.proheat.com) for detailed instructions. Air filter and nozzle must be clean for compressor setting. Inspect air passages of fuel block and clean as required.

MODEL	AIR PRESSURE (DIAPHRAGM COMPRESSOR)
-------	-------------------------------------

M50	6.0 ± 0.1 PSI (41.4 ± 0.7 kPa)
-----	--------------------------------

M80/M90	2.9 ± 0.1 PSI (20.0 ± 0.7 kPa)
---------	--------------------------------

M105/M125	3.65 ± 0.1 PSI (25.1 ± 0.7 kPa)
-----------	---------------------------------

19. Install the heat shield (item 29) and ignition electrodes (item 28).

### 20. Inspect and Clean Heat Exchanger and Combustion Tube.

Remove combustion tube to access the inside of the heat exchanger. Clean any combustion deposits that may have accumulated on the heat exchanger fins with a wire brush. Use a vacuum to suck the combustion deposits out. Ensure that the exhaust pipe is clean and free from restriction.

Clean the combustion tube with a wire brush. Reinstall combustion tube into the heat exchanger ensuring that the orientation boss is at the 12 o'clock position as shown in figure M.

Figure L.

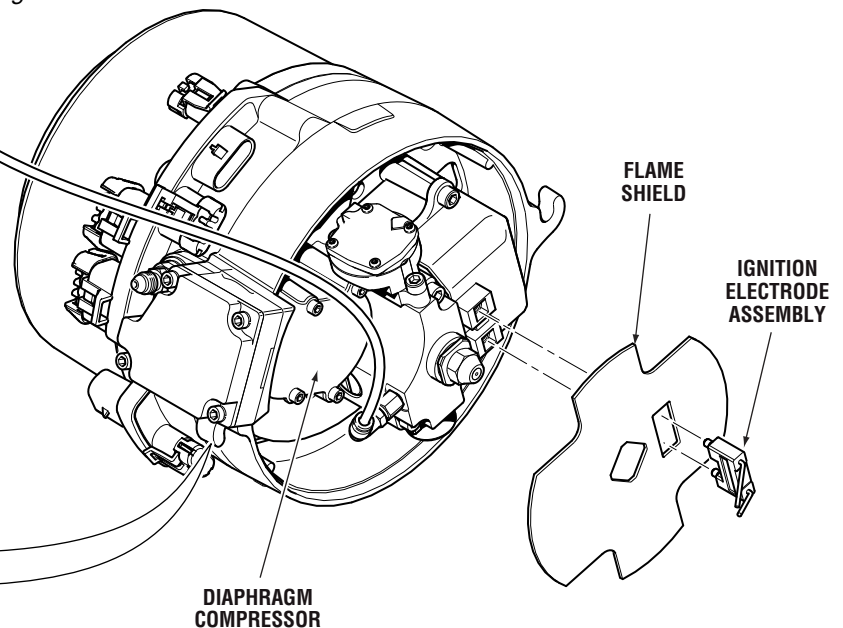

## ⚠ WARNING

Flammable. Point Nozzle away from face, open sparks and flames.





# INSTALLATION INSTRUCTIONS

Copy Part# 206000, Rev. E  
Date: 05/2017



Page 9 of 9

Figure M.

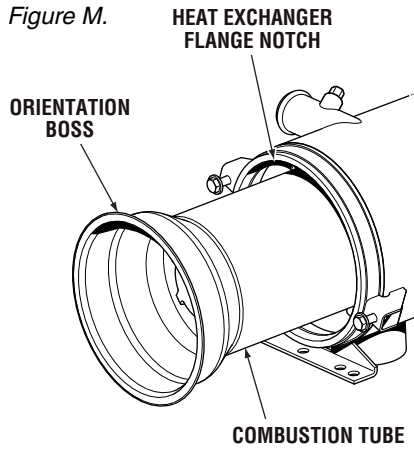

21. Install the burner head back onto the heat exchanger and secure with two screws (item 1).
22. Operate heater for a minimum of two cycles to ensure functionality. Inspect for fuel leaks around the exterior of the burner head and heat exchanger.

## Reassembly Parts Checklist

ITEM	DESCRIPTION	QTY	UOM
34	Compressor Shaft Assembly	1	ea
35	Spring Washer	1	ea
36	Snap Ring	1	ea
37	Connecting Rod Assembly	1	ea
38	Set Screw, #10-32 x 3/8, SHSS	1	ea
39	Screw, #8-32 x 1/2, FHSCS SS	1	ea
40	Intake Disk	1	ea
41	Diaphragm	1	ea
42	Compression Disk	1	ea
43	O-Ring, 2-010	2	ea
44	O-Ring, 2-035	1	ea
45	O-Ring, 2-031	1	ea
46	Cylinder Head	1	ea
47	Gear, Compressor, 48 Teeth, Black	1	ea
48	Retaining Ring	3	ea
49	Gear, Motor, 38 Teeth, Black	1	ea
50	Loctite® 620 (.5 ml Tube)	1	ea
51	Loctite® 242 (.5 ml Tube)	1	ea