

Maintenance Manual MM-0467

EX+™ Air Disc Brake

L and H Models

Revised 05-20

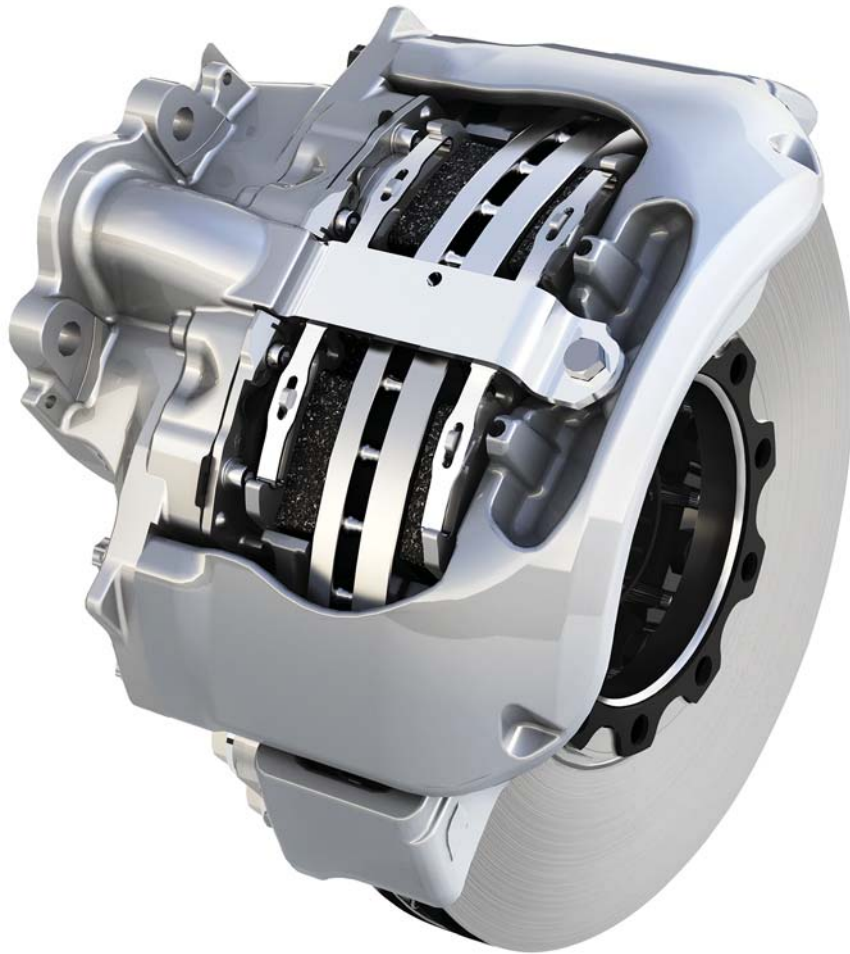

Service Notes

About This Manual

This manual provides installation and maintenance procedures for the EX+™ air disc brake models L and H. Refer to Section 1 to identify the brake model for service.

Before You Begin

1. Read and understand all instructions and procedures before you begin to service components.
2. Read and observe all Warning and Caution hazard alert messages in this publication. They provide information that can help prevent serious personal injury, damage to components, or both.
3. Follow your company's maintenance and service, installation, and diagnostics guidelines.
4. Use special tools when required to help avoid serious personal injury and damage to components.

Hazard Alert Messages and Torque Symbols

WARNING

A Warning alerts you to an instruction or procedure that you must follow exactly to avoid serious personal injury and damage to components.

CAUTION

A Caution alerts you to an instruction or procedure that you must follow exactly to avoid damage to components.

 This symbol alerts you to tighten fasteners to a specified torque value.

How to Obtain Additional Maintenance and Service Information

Visit Literature on Demand on meritor.com to access and order additional information. Additional information is also available at meritorbullpen.com.

Contact the OnTrac Customer Service Center at 866-668-7221 (United States and Canada); 001-800-889-1834 (Mexico); or email OnTrac@meritor.com.

If Parts, Tools and Supplies are Specified in This Manual

Contact Meritor's Commercial Vehicle Aftermarket 888-725-9355.

For assistance with parts, you may also contact the Meritor Parts Center in Florence, KY at 859-525-3500 or CustCareCntr.Florence@Meritor.com.

Information contained in this publication was in effect at the time the publication was approved for printing and is subject to change without notice or liability. Meritor Heavy Vehicle Systems, LLC, reserves the right to revise the information presented or to discontinue the production of parts described at any time.

pg. i	Asbestos and Non-Asbestos Fibers	pg. 37	Remove the Slide Pin Boots
1	Section 1: Brake Identification	38	Remove the Slide Pin Bushings
	Identifying EX+ Brake Models	39	Install the Slide Pin Bushings
5	Section 2: Exploded Views	43	Replace the Slide Pins
	EX+ Air Disc Brake Models		Install the Slide Pin Boots
15	Caliper Sectional View		Install the Caliper Housing Assembly
16	Section 3: Introduction	45	Install the Caliper Bridge
	Description	47	Section 7: Rotor
	Operation		Inspection
	Automatic Adjustment		Cracks
17	Operation Without Adjustment		Heat Checking
	Operation with Adjustment	48	Light Heat Checking
	Manual Adjustment and Deadadjustment During a Pad Change		Heavy Heat Checking
18	Section 4: Preventive Maintenance Inspection		Deep Grooves or Scores
	Intervals		Blue Marks or Bands
	Before You Begin Inspection	49	Measure the Rotor Thickness
	Wheels-On Inspections		Measure the Rotor Runout
	Visual Wear Indicator		Removal and Installation
19	Rotor		Replace the Rotor
	Air Chamber	51	Section 8: Air Chamber
20	Section 5: Caliper Assembly and Brake Pad		Introduction
	Caliper Operation Overview		Removal and Inspection
	Operation with Adjustment		Spring or Service Brake Chamber
	Manual Adjustment and Deadadjustment During a Pad Change	52	Installation
	Procedures		Spring or Service Brake Chamber
	Caliper Inspection	54	Section 9: Pad Wear Warning Indicator (PWWI) System
21	Brake Deadadjustment Procedure		Pad Wear Warning Indicator (PWWI) System
23	Check Brake Adjuster Operation		PWWI Overview
	Brake Pad Removal and Inspection	57	Section 10: Specifications
27	Check Slide Pin Bushing Wear		Lining Wear Limits
28	Brake Pad Installation	60	Section 11: Diagnostics
29	New Pad Shield Installation		Troubleshooting
	Set the Initial Brake Pad-to-Rotor Running Clearance	62	Section 12: Special Tools
30	Section 6: Caliper Components Replacement		MST1000, Bushing Service Tool
	Introduction		MST225 5001, ADB225 Wrench (Extension Adapter)
	Remove the Caliper Assembly		Vacuum Gauge Test Kit
31	Install the Caliper Assembly		
33	Replace the Adjuster Cover		
	Replace the Piston Boots		
36	Remove the Caliper Bridge		
37	Remove the Caliper Housing Assembly		

ASBESTOS FIBERS WARNING

The following procedures for servicing brakes are recommended to reduce exposure to asbestos fiber dust, a cancer and lung disease hazard. Material Safety Data Sheets are available from Meritor.

Hazard Summary

Because some brake linings contain asbestos, workers who service brakes must understand the potential hazards of asbestos and precautions for reducing risks. Exposure to airborne asbestos dust can cause serious and possibly fatal diseases, including asbestosis (a chronic lung disease) and cancer, principally lung cancer and mesothelioma (a cancer of the lining of the chest or abdominal cavities). Some studies show that the risk of lung cancer among persons who smoke and who are exposed to asbestos is much greater than the risk for non-smokers. Symptoms of these diseases may not become apparent for 15, 20 or more years after the first exposure to asbestos.

Accordingly, workers must use caution to avoid creating and breathing dust when servicing brakes. Specific recommended work practices for reducing exposure to asbestos dust follow. Consult your employer for more details.

Recommended Work Practices

1. **Separate Work Areas.** Whenever feasible, service brakes in a separate area away from other operations to reduce risks to unprotected persons. OSHA has set a maximum allowable level of exposure for asbestos of 0.1 f/cc as an 8-hour time-weighted average and 1.0 f/cc averaged over a 30-minute period. Scientists disagree, however, to what extent adherence to the maximum allowable exposure levels will eliminate the risk of disease that can result from inhaling asbestos dust. OSHA requires that the following sign be posted at the entrance to areas where exposures exceed either of the maximum allowable levels:

**DANGER: ASBESTOS
CANCER AND LUNG DISEASE HAZARD
AUTHORIZED PERSONNEL ONLY
RESPIRATORS AND PROTECTIVE CLOTHING
ARE REQUIRED IN THIS AREA.**

2. **Respiratory Protection.** Wear a respirator equipped with a high-efficiency (HEPA) filter approved by NIOSH or MSHA for use with asbestos at all times when servicing brakes, beginning with the removal of the wheels.
3. **Procedures for Servicing Brakes.**
 - a. Enclose the brake assembly within a negative pressure enclosure. The enclosure should be equipped with a HEPA vacuum and worker arm sleeves. With the enclosure in place, use the HEPA vacuum to loosen and vacuum residue from the brake parts.
 - b. As an alternative procedure, use a catch basin with water and a biodegradable, non-phosphate, water-based detergent to wash the brake drum or rotor and other brake parts. The solution should be applied with low pressure to prevent dust from becoming airborne. Allow the solution to flow between the brake drum and the brake support or the brake rotor and caliper. The wheel hub and brake assembly components should be thoroughly wetted to suppress dust before the brake shoes or brake pads are removed. Wipe the brake parts clean with a cloth.
 - c. If an enclosed vacuum system or brake washing equipment is not available, employers may adopt their own written procedures for servicing brakes, provided that the exposure levels associated with the employer's procedures do not exceed the levels associated with the enclosed vacuum system or brake washing equipment. Consult OSHA regulations for more details.
 - d. Wear a respirator equipped with a HEPA filter approved by NIOSH or MSHA for use with asbestos when grinding or machining brake linings. In addition, do such work in an area with a local exhaust ventilation system equipped with a HEPA filter.
 - e. **NEVER** use compressed air by itself, dry brushing, or a vacuum not equipped with a HEPA filter when cleaning brake parts or assemblies. **NEVER** use carcinogenic solvents, flammable solvents, or solvents that can damage brake components as wetting agents.
4. **Cleaning Work Areas.** Clean work areas with a vacuum equipped with a HEPA filter or by wet wiping. **NEVER** use compressed air or dry sweeping to clean work areas. When you empty vacuum cleaners and handle used rags, wear a respirator equipped with a HEPA filter approved by NIOSH or MSHA for use with asbestos. When you replace a HEPA filter, wet the filter with a fine mist of water and dispose of the used filter with care.
5. **Worker Clean-Up.** After servicing brakes, wash your hands before you eat, drink or smoke. Shower after work. Do not wear work clothes home. Use a vacuum equipped with a HEPA filter to vacuum work clothes after they are worn. Launder them separately. Do not shake or use compressed air to remove dust from work clothes.
6. **Waste Disposal.** Dispose of discarded linings, used rags, cloths and HEPA filters with care, such as in sealed plastic bags. Consult applicable EPA, state and local regulations on waste disposal.

Regulatory Guidance

References to OSHA, NIOSH, MSHA, and EPA, which are regulatory agencies in the United States, are made to provide further guidance to employers and workers employed within the United States. Employers and workers employed outside of the United States should consult the regulations that apply to them for further guidance.

NON-ASBESTOS FIBERS WARNING

The following procedures for servicing brakes are recommended to reduce exposure to non-asbestos fiber dust, a cancer and lung disease hazard. Material Safety Data Sheets are available from Meritor.

Hazard Summary

Most recently manufactured brake linings do not contain asbestos fibers. These brake linings may contain one or more of a variety of ingredients, including glass fibers, mineral wool, aramid fibers, ceramic fibers and silica that can present health risks if inhaled. Scientists disagree on the extent of the risks from exposure to these substances. Nonetheless, exposure to silica dust can cause silicosis, a non-cancerous lung disease. Silicosis gradually reduces lung capacity and efficiency and can result in serious breathing difficulty. Some scientists believe other types of non-asbestos fibers, when inhaled, can cause similar diseases of the lung. In addition, silica dust and ceramic fiber dust are known to the State of California to cause lung cancer. U.S. and international agencies have also determined that dust from mineral wool, ceramic fibers and silica are potential causes of cancer.

Accordingly, workers must use caution to avoid creating and breathing dust when servicing brakes. Specific recommended work practices for reducing exposure to non-asbestos dust follow. Consult your employer for more details.

Recommended Work Practices

1. **Separate Work Areas.** Whenever feasible, service brakes in a separate area away from other operations to reduce risks to unprotected persons.
2. **Respiratory Protection.** OSHA has set a maximum allowable level of exposure for silica of 0.1 mg/m³ as an 8-hour time-weighted average. Some manufacturers of non-asbestos brake linings recommend that exposures to other ingredients found in non-asbestos brake linings be kept below 1.0 f/cc as an 8-hour time-weighted average. Scientists disagree, however, to what extent adherence to these maximum allowable exposure levels will eliminate the risk of disease that can result from inhaling non-asbestos dust.

Therefore, wear respiratory protection at all times during brake servicing, beginning with the removal of the wheels. Wear a respirator equipped with a high-efficiency (HEPA) filter approved by NIOSH or MSHA, if the exposure levels may exceed OSHA or manufacturers' recommended maximum levels. Even when exposures are expected to be within the maximum allowable levels, wearing such a respirator at all times during brake servicing will help minimize exposure.
3. **Procedures for Servicing Brakes.**
 - a. Enclose the brake assembly within a negative pressure enclosure. The enclosure should be equipped with a HEPA vacuum and worker arm sleeves. With the enclosure in place, use the HEPA vacuum to loosen and vacuum residue from the brake parts.
 - b. As an alternative procedure, use a catch basin with water and a biodegradable, non-phosphate, water-based detergent to wash the brake drum or rotor and other brake parts. The solution should be applied with low pressure to prevent dust from becoming airborne. Allow the solution to flow between the brake drum and the brake support or the brake rotor and caliper. The wheel hub and brake assembly components should be thoroughly wetted to suppress dust before the brake shoes or brake pads are removed. Wipe the brake parts clean with a cloth.
 - c. If an enclosed vacuum system or brake washing equipment is not available, carefully clean the brake parts in the open air. Wet the parts with a solution applied with a pump-spray bottle that creates a fine mist. Use a solution containing water, and, if available, a biodegradable, non-phosphate, water-based detergent. The wheel hub and brake assembly components should be thoroughly wetted to suppress dust before the brake shoes or brake pads are removed. Wipe the brake parts clean with a cloth.
 - d. Wear a respirator equipped with a HEPA filter approved by NIOSH or MSHA when grinding or machining brake linings. In addition, do such work in an area with a local exhaust ventilation system equipped with a HEPA filter.
 - e. **NEVER** use compressed air by itself, dry brushing, or a vacuum not equipped with a HEPA filter when cleaning brake parts or assemblies. **NEVER** use carcinogenic solvents, flammable solvents, or solvents that can damage brake components as wetting agents.
4. **Cleaning Work Areas.** Clean work areas with a vacuum equipped with a HEPA filter or by wet wiping. **NEVER** use compressed air or dry sweeping to clean work areas. When you empty vacuum cleaners and handle used rags, wear a respirator equipped with a HEPA filter approved by NIOSH or MSHA, to minimize exposure. When you replace a HEPA filter, wet the filter with a fine mist of water and dispose of the used filter with care.
5. **Worker Clean-Up.** After servicing brakes, wash your hands before you eat, drink or smoke. Shower after work. Do not wear work clothes home. Use a vacuum equipped with a HEPA filter to vacuum work clothes after they are worn. Launder them separately. Do not shake or use compressed air to remove dust from work clothes.
6. **Waste Disposal.** Dispose of discarded linings, used rags, cloths and HEPA filters with care, such as in sealed plastic bags. Consult applicable EPA, state and local regulations on waste disposal.

Regulatory Guidance

References to OSHA, NIOSH, MSHA, and EPA, which are regulatory agencies in the United States, are made to provide further guidance to employers and workers employed within the United States. Employers and workers employed outside of the United States should consult the regulations that apply to them for further guidance.

Identifying EX+ Brake Models

Meritor offers several different EX+ air disc brake models including L, L optimized and H. The model can be identified using the information on the label or caliper tag. If necessary, you may also use the distinguishing characteristics shown in this section to identify the brake model for service.

Brake Model Number

The brake model number may be located on a metal tag below the adjuster cover on the caliper or on a mylar label on top of the caliper. Figure 1.1. Use the model number to identify the type of brake for service. Figure 1.2.

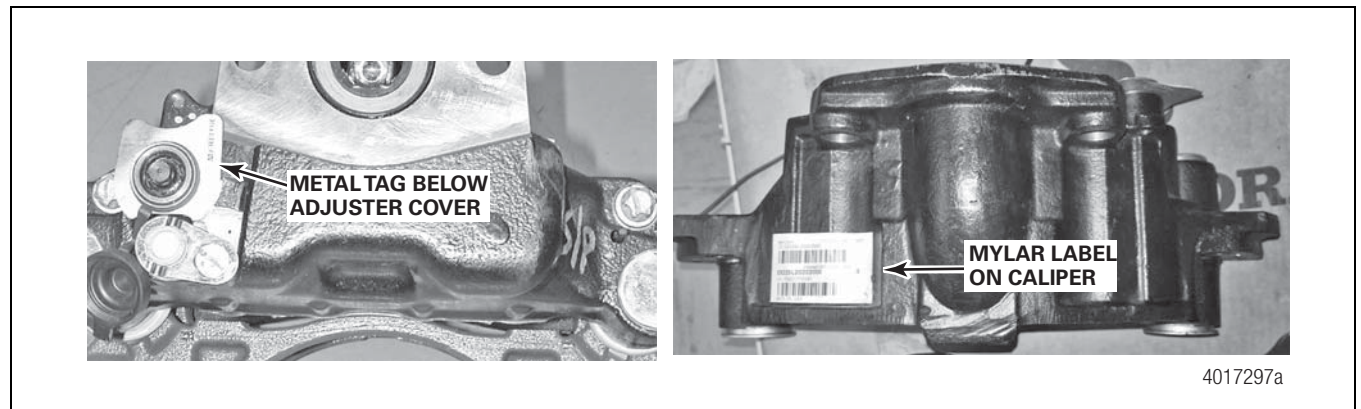

Figure 1.1

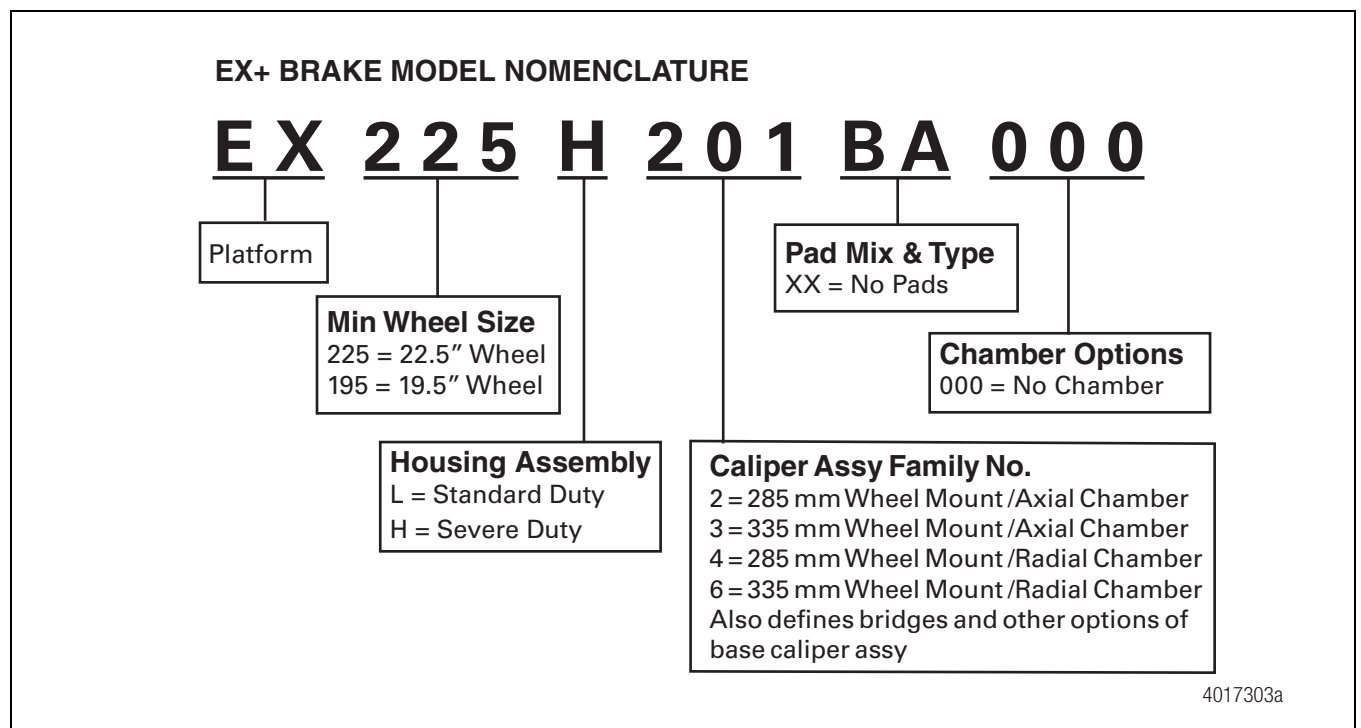

Figure 1.2

1 Brake Identification

Pad Strap Differences

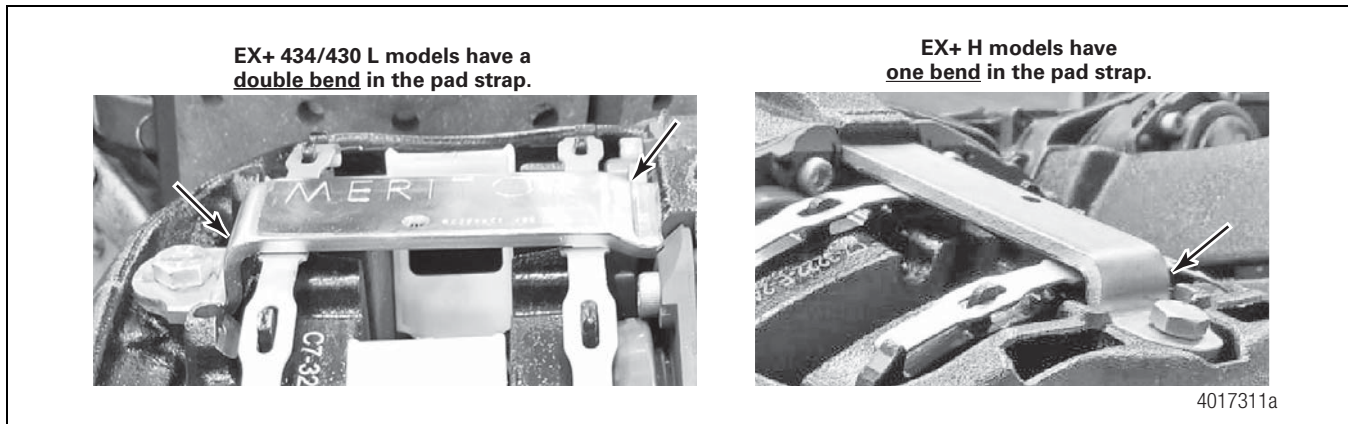

Figure 1.3

Bridge Bolt Differences

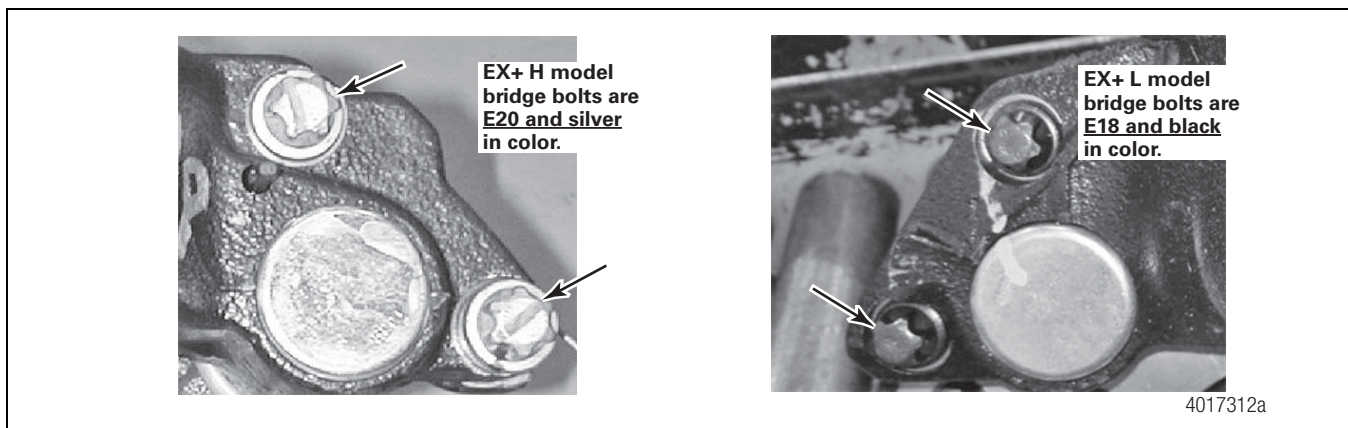

Figure 1.4

Adjuster Cover Differences

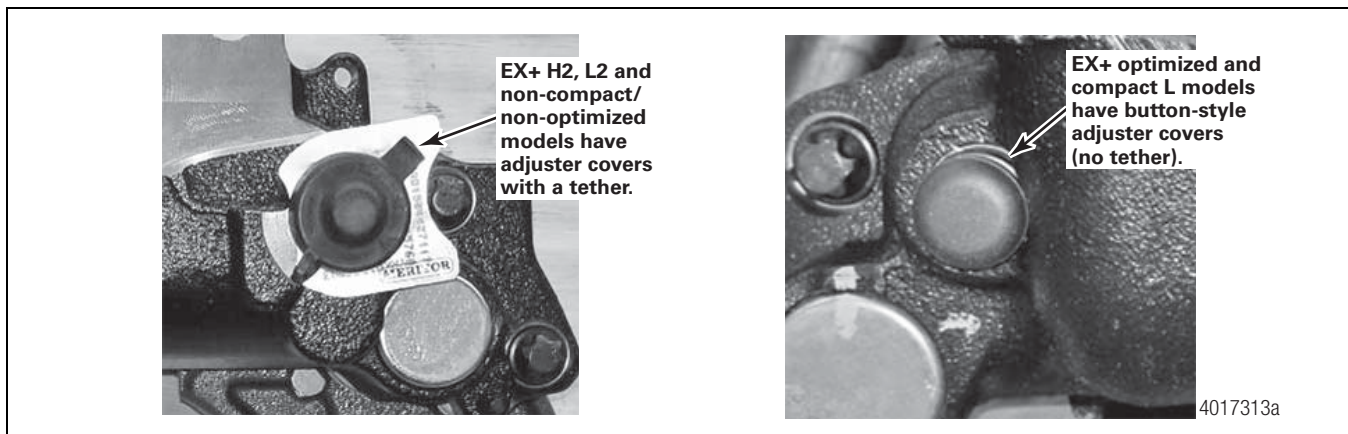

Figure 1.5

Housing Casting Differences

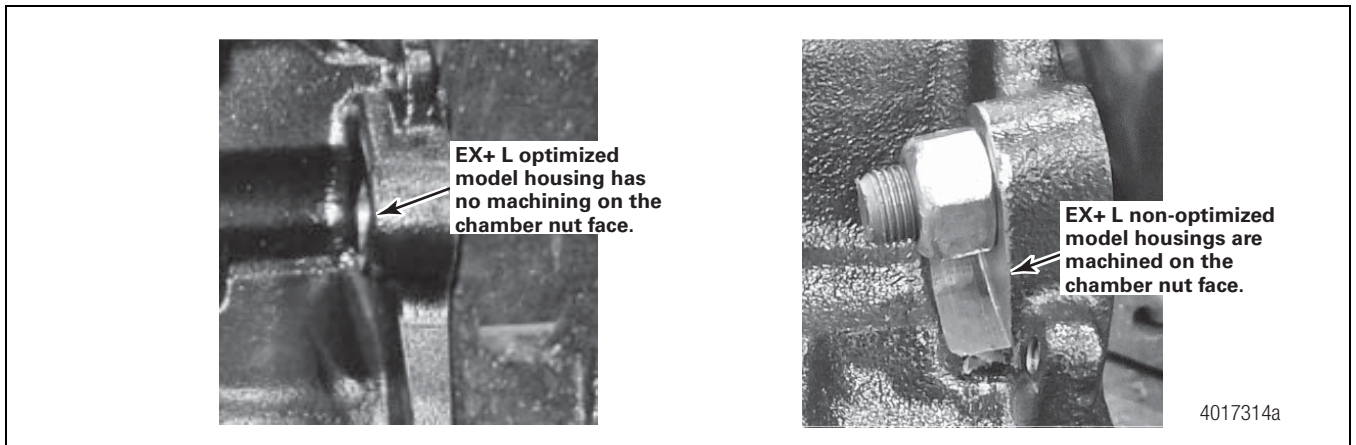

Figure 1.6

Housing Interface Differences

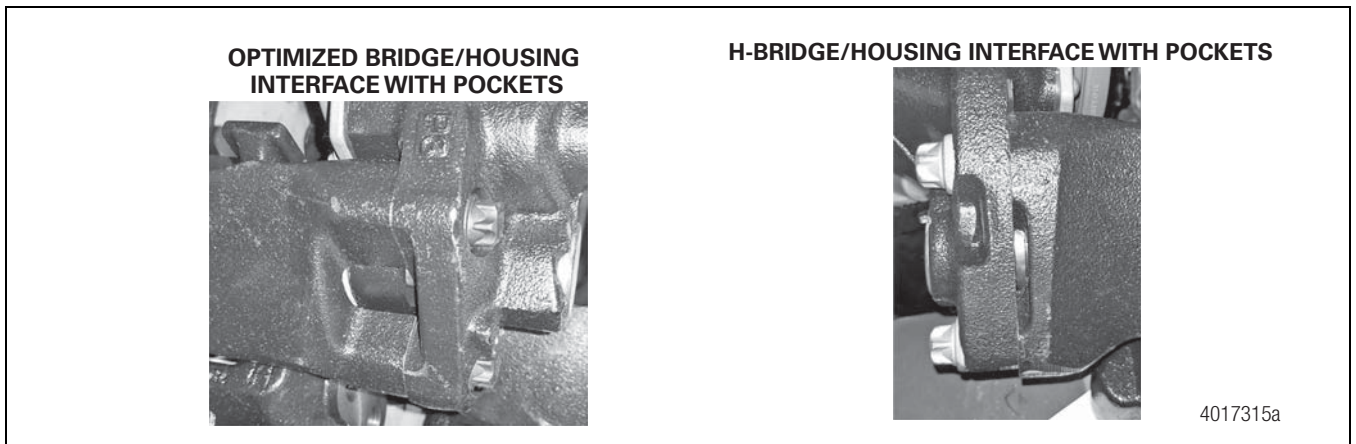
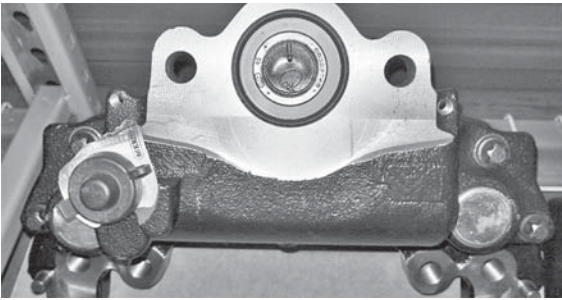

Figure 1.7

1 Brake Identification

Housing Design Differences

EX+ L (NON-OPTIMIZED, NON-COMPACT) BACK



EX+ L COMPACT/OPTIMIZED BACK

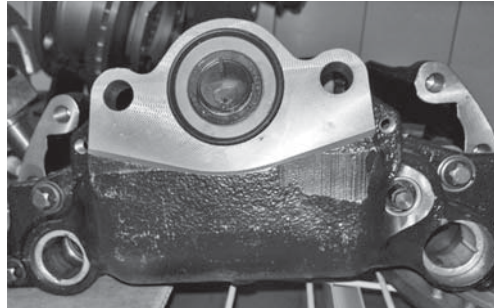

EX+ L2 (NON-VOLVO, NON-COMPACT, NON-OPTIMIZED)

BACK

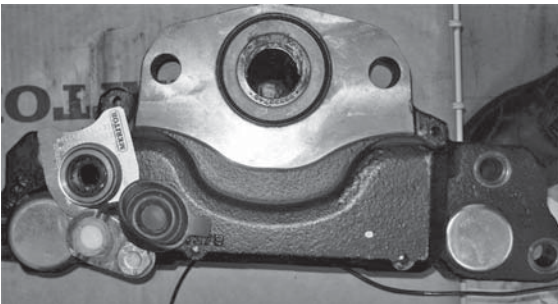

TOP



EX+ H MODEL (NON-VOLVO)

BACK

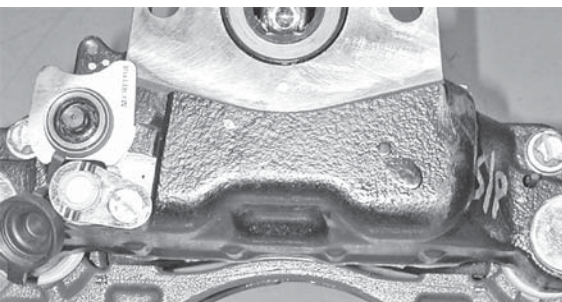

TOP, BACK OF HOUSING WITH LOOSE SADDLES

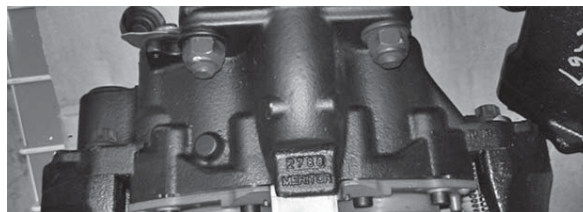

4017316a

Figure 1.8

EX+ Air Disc Brake Models

EX+ 225L2A Axial Mount

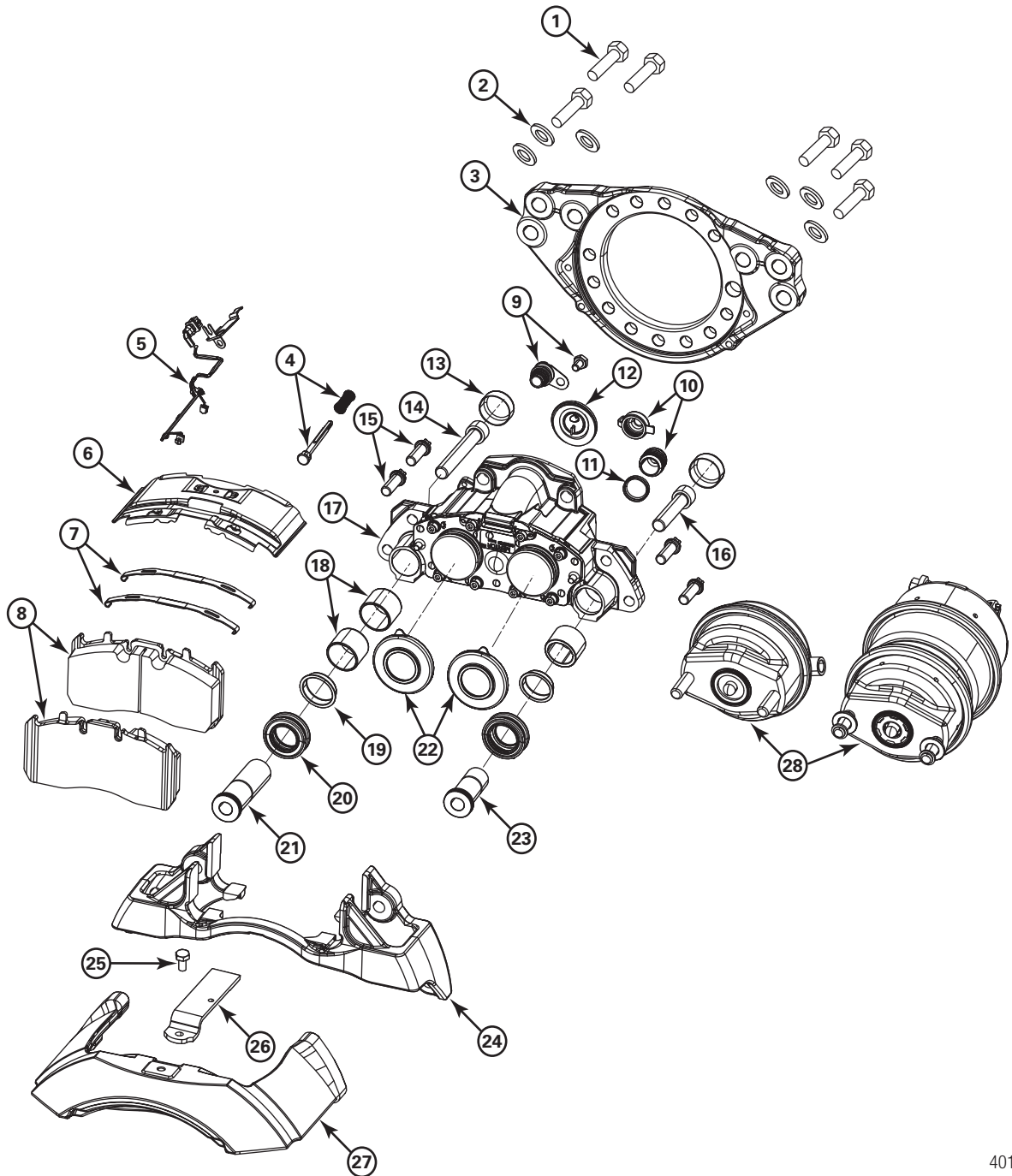

4017246a

2 Exploded Views

Item	Description
1	Torque Plate Bolt
2	Torque Plate Washer
3	Torque Plate
4	Visual Wear Indicator
5	Pad Wear Warning Indicator (PWWI), If Equipped
6	Pad Shield
7	Pad Springs
8	Brake Pads
9	Continuous Wear Indicator Plug
10	Adjuster Cover (Old and New Style)
11	Adjuster Cover Retainer (for New Cover Only)
12	Brake Caliper Plug
13	Slide Pin Cap
14	Long Slide Pin Bolt
15	Bridge Bolts
16	Short Slide Pin Bolt
17	Caliper Assembly
18	Slide Pin Bushing
19	Slide Pin Boot Retainer
20	Slide Pin Boot
21	Long Slide Pin
22	Piston Boot
23	Short Slide Pin
24	Carrier
25	Pad Strap Bolt
26	Pad Strap
27	Bridge
28	Air Brake Chamber

EX+ 225L2R Radial Mount

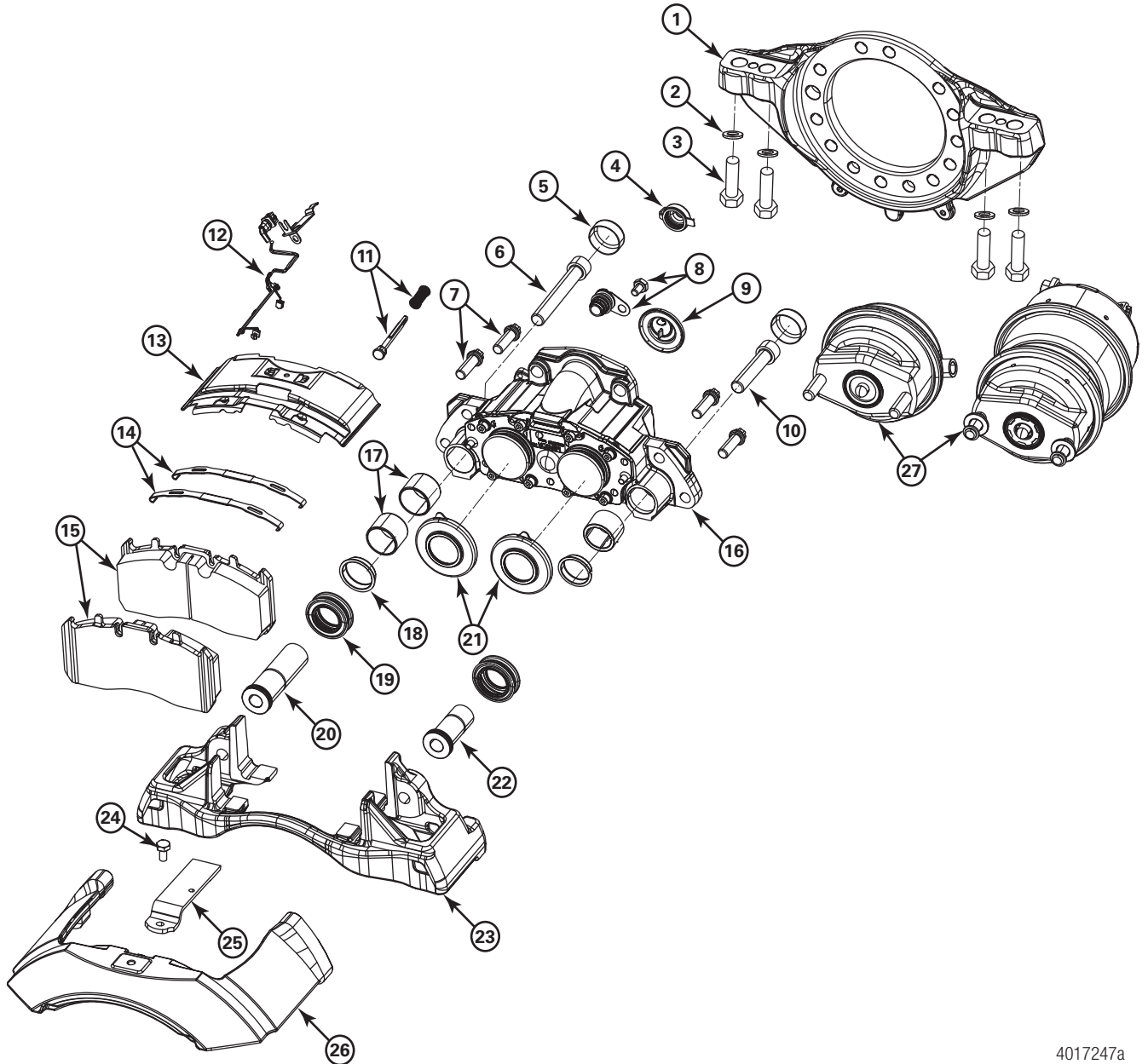

4017247a

Item	Description
1	Torque Plate
2	Torque Plate Washer
3	Torque Plate Bolt
4	Adjuster Cover

Item	Description
5	Slide Pin Cap
6	Long Slide Pin Bolt
7	Bridge Bolts
8	Continuous Wear Sensor Plug

2 Exploded Views

Item	Description
9	Brake Chamber Plug
10	Short Slide Pin Bolt
11	Visual Wear Indicator
12	Pad Wear Warning Indicator (PWWI)
13	Pad Shield
14	Pad Springs
15	Brake Pads
16	Caliper Assembly
17	Slide Pin Bushings
18	Slide Pin Boot Retainer
19	Slide Pin Boot
20	Long Slide Pin
21	Piston Boots
22	Short Slide Pin
23	Carrier
24	Pad Strap Bolt
25	Pad Strap
26	Bridge
27	Air Brake Chamber

EX+ 225H3A Axial Mount

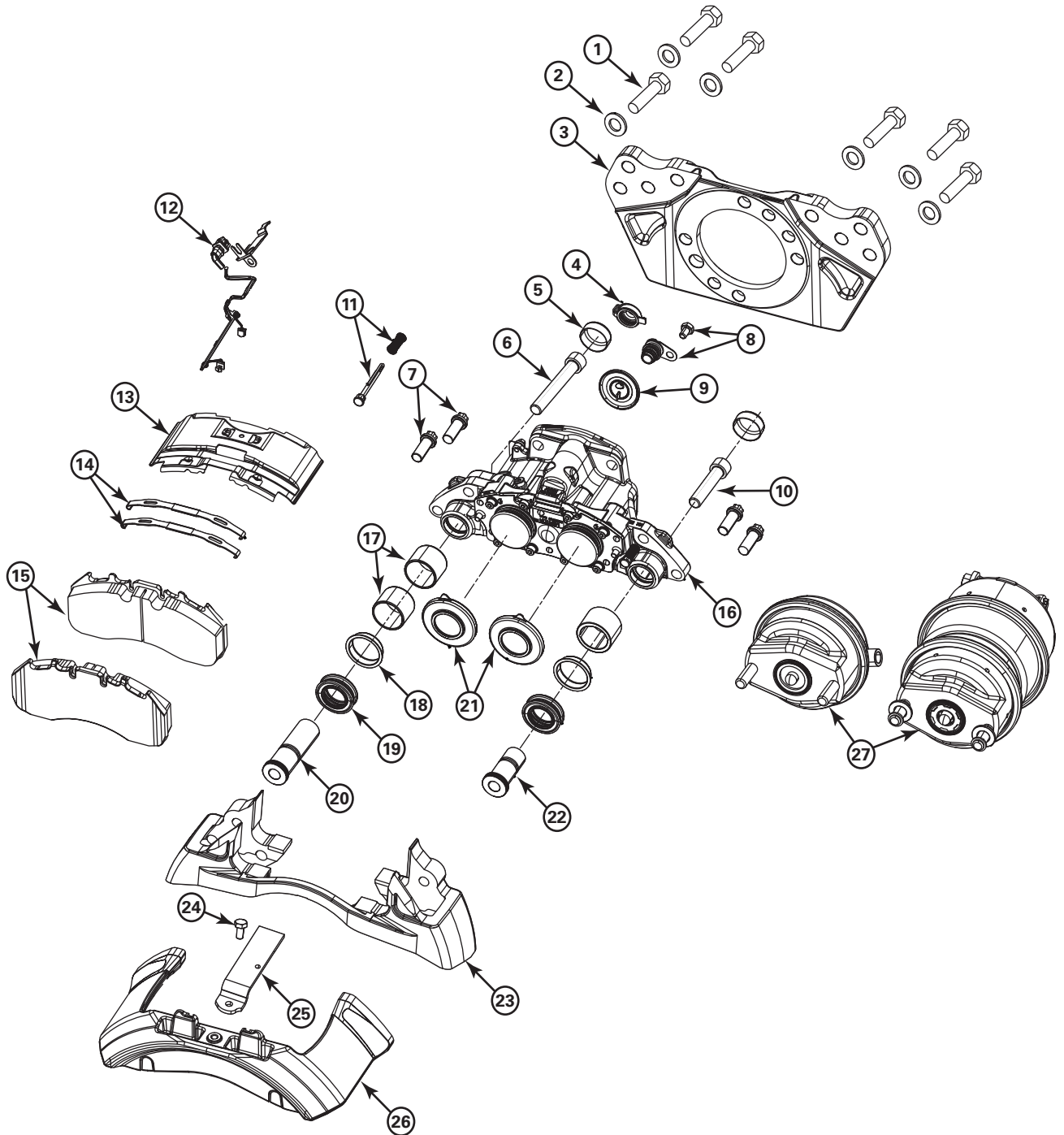

4017248a

2 Exploded Views

Item	Description
1	Torque Plate Bolt
2	Torque Plate Washer
3	Torque Plate
4	Adjuster Cover
5	Slide Pin Cap
6	Long Slide Pin Bolt
7	Bridge Bolts
8	Continuous Wear Sensor Plug
9	Brake Chamber Plug
10	Short Slide Pin Bolt
11	Visual Wear Indicator
12	Pad Wear Warning Indicator (PWWI)
13	Pad Shield
14	Pad Springs
15	Brake Pads
16	Caliper Assembly
17	Slide Pin Bushings
18	Slide Pin Boot Retainer
19	Slide Pin Boot
20	Long Slide Pin
21	Piston Boots
22	Short Slide Pin
23	Carrier
24	Pad Strap Bolt
25	Pad Strap
26	Bridge
27	Air Brake Chamber

EX+ 225H4 6A Axial Mount

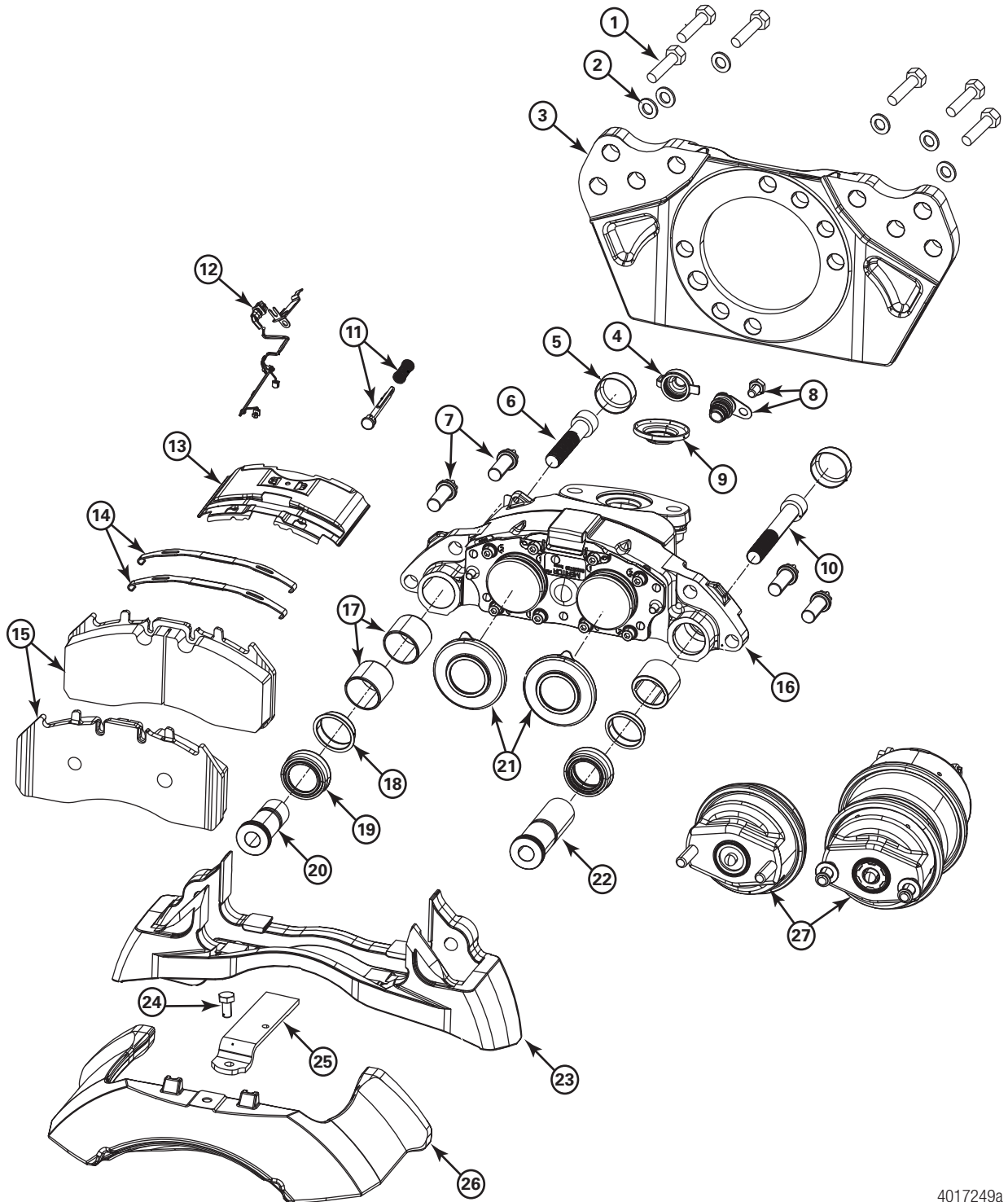

4017249a

2 Exploded Views

Item	Description
1	Torque Plate Bolt
2	Torque Plate Washer
3	Torque Plate
4	Adjuster Cover
5	Slide Pin Cap
6	Short Slide Pin Bolt
7	Bridge Bolts
8	Continuous Wear Sensor Plug
9	Brake Chamber Plug
10	Long Slide Pin Bolt
11	Visual Wear Indicator
12	Pad Wear Warning Indicator (PWWI)
13	Pad Shield
14	Pad Springs
15	Brake Pads
16	Caliper Assembly
17	Slide Pin Bushings
18	Slide Pin Boot Retainer
19	Slide Pin Boot
20	Short Slide Pin
21	Piston Boots
22	Long Slide Pin
23	Carrier
24	Pad Strap Bolt
25	Pad Strap
26	Bridge
27	Air Brake Chamber

EX+ 225H4 6R Radial Mount

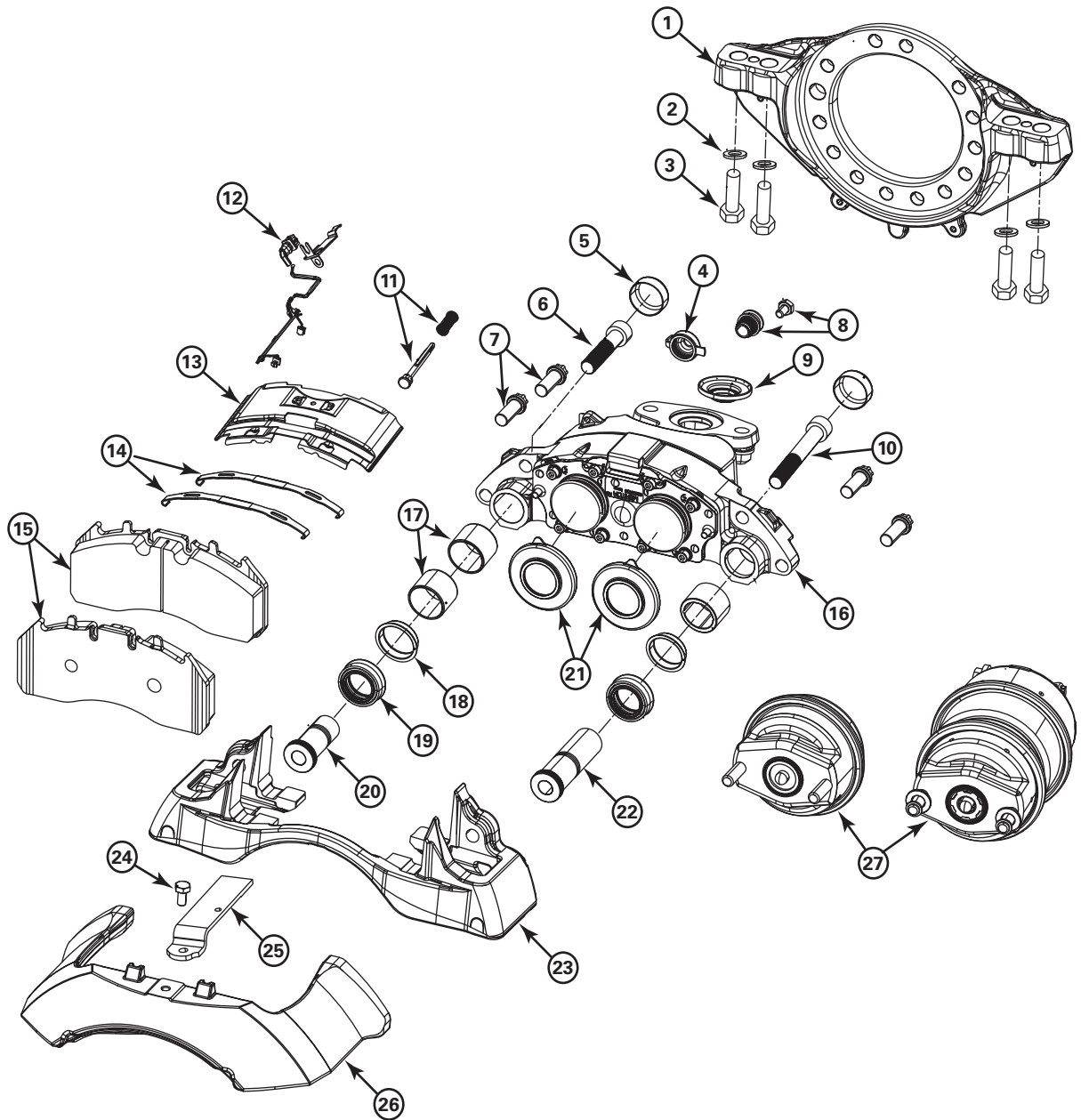

4017250a

2 Exploded Views

Item	Description
1	Torque Plate
2	Torque Plate Washer
3	Torque Plate Bolt
4	Adjuster Cover
5	Slide Pin Cap
6	Short Slide Pin Bolt
7	Bridge Bolts
8	Continuous Wear Sensor Plug
9	Brake Chamber Plug
10	Long Slide Pin Bolt
11	Visual Wear Indicator
12	Pad Wear Warning Indicator (PWWI)
13	Pad Shield
14	Pad Springs
15	Brake Pads
16	Caliper Assembly
17	Slide Pin Bushings
18	Slide Pin Boot Retainer
19	Slide Pin Boot
20	Short Slide Pin
21	Piston Boots
22	Long Slide Pin
23	Carrier
24	Pad Strap Bolt
25	Pad Strap
26	Bridge
27	Air Brake Chamber

Caliper Sectional View

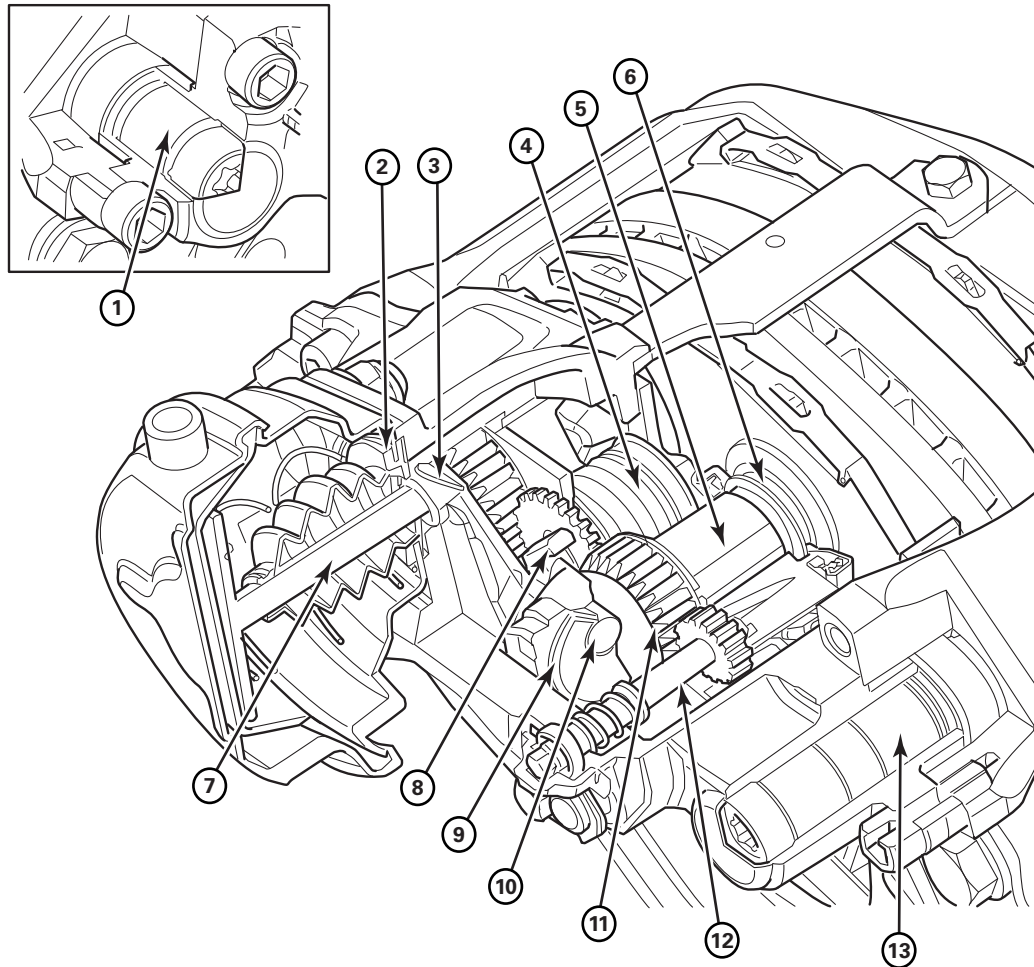

4005032a

Item	Description
1	Short Slide Pin Oval Bushing
2	Housing Seal
3	Operating Shaft
4	Return Spring
5	Piston
6	Piston Head
7	Chamber Piston
8	Adjuster Shaft
9	Half Bearing
10	Roller
11	Tappet

Item	Description
12	Adjuster Stem
13	Long Slide Pin Bushing

3 Introduction

Description

The EX+ air-actuated disc brake has a direct-mounted air chamber. Figure 3.1. The brake can be installed onto any axle and can be used for vehicle parking when it is equipped with a service/spring brake chamber. The basic operation of the brake is simple, but it is important that the features of the load insensitive automatic adjuster are clearly understood. It is essential that the correct service procedures be observed to ensure that the brake gives satisfactory service throughout its working life.

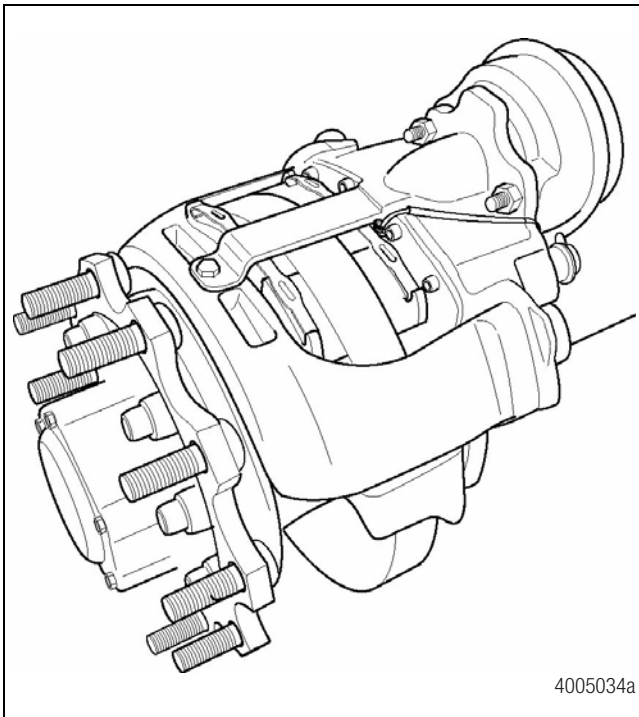

Figure 3.1

Operation

The air chamber is attached to the caliper housing and operates directly onto the internal operating shaft assembly. Seals in the housing and chamber assemblies provide sealing between the air chamber and housing. The carrier is mounted to the vehicle. It straddles the rotor and supports the brake pads. The housing assembly slides on two fully sealed slide pins which are bolted to the brake carrier. As the pads wear, adjustment takes place automatically and independently of load. Load independent means adjustment takes place under very small clamping forces only, therefore preventing over adjustment and minimizing air consumption.

Two slide pins are attached to the brake carrier by slide pin bolts. The brake carrier is connected to the axle through the use of the torque plate. The torque plate may be a separate part bolted onto the axle, such as a drive axle brake mounting flange, or may be incorporated into the casting of another component, such as a steer axle knuckle. The caliper housing assembly is mounted so that it floats on the slide pins. A bridge is attached to the caliper housing assembly to provide the reaction force on the outboard pad.

The caliper housing and bridge slide on bushings that are pressed into the caliper housing assembly. On the short slide pin side, the bushing is oval to accommodate brake deflection during braking. On the long slide pin side, the bushings are round and provide a more positive location for the housing. The slide pins are sealed externally by slide pin boots and slide pin caps.

The force introduced from the air chamber is amplified by the geometry of the operating shaft. This clamping force is transferred to the inboard pad through the half-bearings, rollers, tappets, pistons and piston heads. Once the inboard pad has been applied, the force of reaction acting through the floating caliper housing assembly and bridge pulls the outboard pad onto the brake rotor. The forces created by the friction of the brake pads on the brake rotor are transferred at the ends of the pads onto the carrier, which is rigidly mounted to the axle.

The brakes are released by reducing the input force on the operating shaft, thus reducing the clamp force of the brake. The return spring then returns the clamping mechanism and the operating shaft back to their starting position, leaving the pads with a defined running clearance to the rotor. The small runout of the brake rotor and hub-bearing clearances will then generate a small clearance for the outboard pad through only a few revolutions of the rotor.

Automatic Adjustment

The automatic adjuster adjusts the brake pad clearance to compensate for pad wear. Every time the brake is applied, the system senses whether adjustment is required or whether the running clearance of the brake pads to the brake rotor is still within the built-in tolerance and does not need to be adjusted. The built-in tolerance is determined in the design by the clearance between the ball-ended drive pin that is rigidly fixed to the operating shaft and the fork on the end of the adjuster shaft.

Operation Without Adjustment

From the rest position, the air chamber push rod moves FORWARD, rotating the operating shaft. When the pistons move FORWARD through the built-in running clearance, the ball-ended drive pin starts to contact the driving side of the fork on the end of the adjuster shaft. Further movement of the air chamber push rod rotates the operating shaft, causing the adjuster shaft to rotate because the built-in clearance has been taken up. The outer drive sleeve is fixed to the adjuster shaft and rotates the inner drive sleeve through the clutch pack. The inner drive sleeve is linked to the intermediate gear by a unidirectional friction spring and this tries to rotate the tappets. However, the friction in the threads of the tappets and pistons increases due to the clamping force on the pads. This prevents the pistons and tappets from rotating relative to one another. The pistons cannot rotate in the adjuster housing, and due to the high torque to turn the tappets, the clutch pack slips, preventing adjustment of the mechanism below the correct running clearance.

Operation with Adjustment

When the running clearance is greater than the built-in tolerance as a result of pad or rotor wear, adjustment is required. From the rest position, the push rod of the air chamber moves FORWARD, rotating the operating shaft. As the pistons move FORWARD beyond the built-in running clearance, the ball-ended drive pin starts to contact the driving side of the fork on the end of the adjuster shaft. Further operating shaft movement causes rotation of the adjuster shaft through the ball-ended drive pin.

Driving through the clutch plates and the unidirectional friction spring, the intermediate gear rotates. Due to the excessive running clearance, the tappets now rotate in the pistons. The pistons cannot rotate and are wound out from their housing. When the pads contact the rotor, the clamping force increases the thread friction in the tappets and pistons. The torque to turn the tappets increases and the clutch pack driving the intermediate gear starts to slip, preventing further adjustment. The adjustment is not wound back during the return of the actuation mechanism. As the operating shaft returns to the brake's off position, the ball-ended drive pin travels back through the clearance in the fork on the end of the adjuster shaft. Once this clearance is taken up, the adjuster shaft rotates in the reverse direction, rotating the inner drive sleeve through the clutch pack. However, in this direction, the unidirectional friction spring cannot drive the intermediate gear, leaving the tappets and intermediate gear in the adjusted state. The system is in its starting position.

Manual Adjustment and Deadadjustment During a Pad Change

Manual adjustment of the brake must only be made at a pad change. No manual intervention is required between pad changes.

A manual adjuster stem runs in constant mesh with the gear form on the outside of the tappets. The end of this stem comes out from the brake housing through a seal and is protected by an adjuster cover.

The automatic adjuster maintains a nominal pad-to-rotor clearance of 0.030-inch (0.75 mm).

Refer to Section 5 for adjustment and deadadjustment procedures.

4 Preventive Maintenance Inspection

Intervals

For military on/off highway and military severe duty applications, refer to TP-10109. For a copy of this technical bulletin, contact the Meritor OnTrac™ Customer Call Center at 866-OnTrac1 (688-7221).

Use the schedule below that gives the most frequent inspection of the brakes. Check the caliper, torque plate, pads and rotor for signs of wear and damage. Also check for any loose or missing screws. For additional roadside inspection information, contact the Meritor OnTrac™ Customer Call Center at 866-OnTrac1 (688-7221).

- Fleet chassis lubrication schedule
- Chassis manufacturer lubrication schedule
- At least four times during lining life
- At tire replacement

Before You Begin Inspection

Before performing any maintenance or service, put on safe eye protection. Park the vehicle on a level surface and block the wheels to prevent the vehicle from moving.

⚠ WARNING

To prevent serious eye injury, always wear safe eye protection when you perform vehicle maintenance or service.

Park the vehicle on a level surface. Block the wheels to prevent the vehicle from moving. Support the vehicle with safety stands. Do not work under a vehicle supported only by jacks. Jacks can slip and fall over. Serious personal injury and damage to components can result.

Wheels-On Inspections

Visual Wear Indicator

NOTE: If the brake is equipped with a pad wear warning indicator (PWWI) system, refer to Section 9 for service information.

The visual wear indicator (VWI) alerts you as to when the braking system needs to be inspected for wear on the pads and rotor. Figure 4.1.

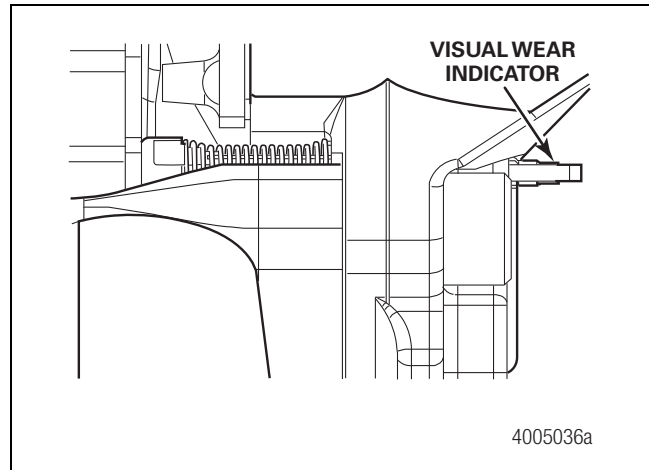

Figure 4.1

When the pads are new, the end of the visual wear indicator stem will protrude past the edge of the housing casting. Figure 4.2. As the pads wear, less and less of the indicator will be visible past the edge of the casting. The increments of the indicator equate to a level of pad wear. Figure 4.3.

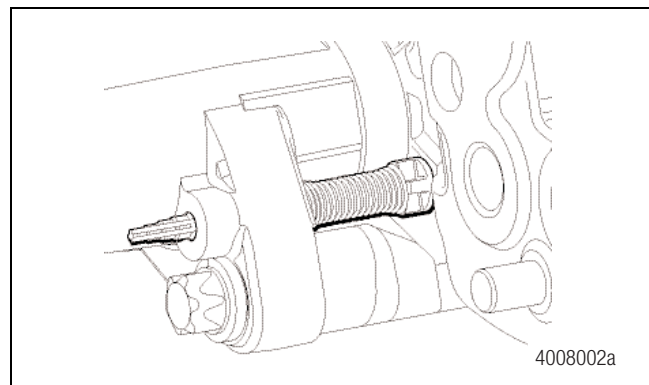

Figure 4.2

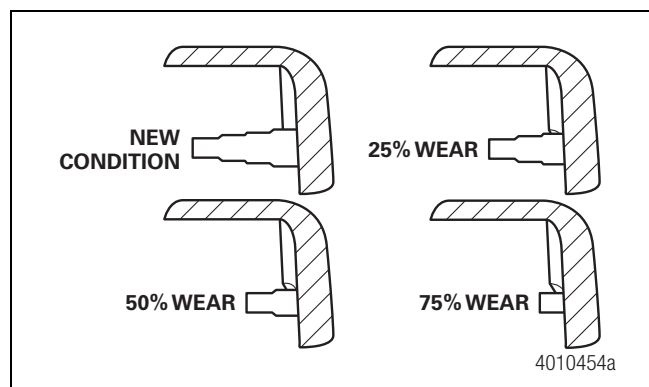

Figure 4.3

4 Preventive Maintenance Inspection

- **If the indicator shows more than 75% wear:** The pads require further inspection or replacement. Refer to Section 5.

To get an accurate indication of lining wear, it is important to ensure that the VWI is not seized in the hole. Check the VWI by grasping the VWI and rotating/pulling outward and releasing. If the VWI does not move when you pull on it, move it by hand as necessary to free it up. Figure 4.4.

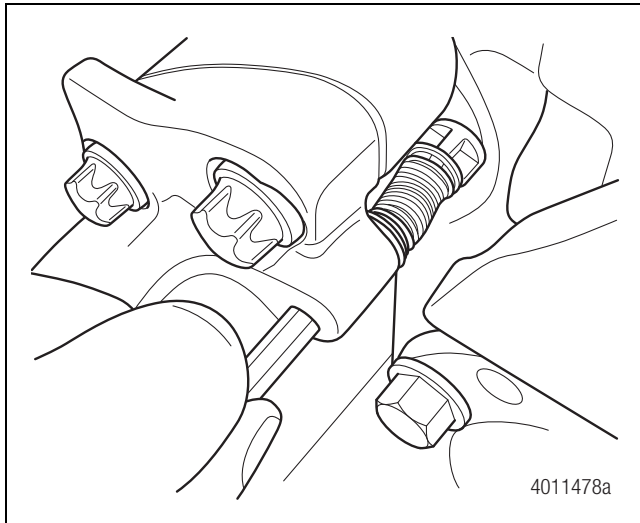

Figure 4.4

Rotor

Visually inspect the rotor for signs of cracks, deep grooves, blue marks and heat checking. Refer to Section 7.

Air Chamber

Inspect the air chamber to verify that the caliper mounting bolts and air lines are securely fastened and are not damaged.

5 Caliper Assembly and Brake Pad

Hazard Alert Messages

Read and observe all Warning and Caution hazard alert messages in this publication. They provide information that can help prevent serious personal injury, damage to components, or both.

WARNING

To prevent serious eye injury, always wear safe eye protection when you perform vehicle maintenance or service.

Park the vehicle on a level surface. Block the wheels to prevent the vehicle from moving. Support the vehicle with safety stands. Do not work under a vehicle supported only by jacks. Jacks can slip and fall over. Serious personal injury and damage to components can result.

Before you service a spring chamber, carefully follow the manufacturer's instructions to compress and lock the spring to completely release the brake. Verify that no air pressure remains in the service chamber before you proceed. Sudden release of compressed air can cause serious personal injury and damage to components.

ASBESTOS AND NON-ASBESTOS FIBERS WARNING

Some brake linings contain asbestos fibers, a cancer and lung disease hazard. Some brake linings contain non-asbestos fibers, whose long-term effects to health are unknown. You must use caution when you handle both asbestos and non-asbestos materials. Refer to page i for asbestos and non-asbestos safety information and recommended work practices.

Caliper Operation Overview

Operation with Adjustment

When the running clearance is greater than the built-in tolerance as a result of pad or rotor wear, adjustment is required. From the rest position, the push rod of the air chamber moves FORWARD, rotating the operating shaft. As the pistons move FORWARD beyond the built-in running clearance, the ball-ended drive pin starts to contact the driving side of the fork on the end of the adjuster shaft. Further operating shaft movement causes rotation of the adjuster shaft through the ball-ended drive pin.

Driving through the clutch plates and the unidirectional friction spring, the intermediate gear rotates. Due to the excessive running clearance, the tappets now rotate in the pistons. The pistons cannot rotate and are wound out from their housing. When the pads contact the rotor, the clamping force increases the thread friction in the tappets and pistons. The torque to turn the tappets increases and the clutch pack driving the intermediate gear starts to slip, preventing further adjustment. The adjustment is not wound back during the return of the actuation mechanism. As the operating shaft returns to the brake's off position, the ball-ended drive pin travels back through the clearance in the fork on the end of the adjuster shaft. Once this clearance is taken up, the adjuster shaft rotates in the reverse direction, rotating the inner drive sleeve through the clutch pack. However, in this direction, the unidirectional friction spring cannot drive the intermediate gear, leaving the tappets and intermediate gear in the adjusted state. The system is in its starting position.

Manual Adjustment and Deadadjustment During a Pad Change

Manual adjustment of the brake must only be made at a pad change. No manual intervention is required between pad changes.

A manual adjuster stem runs in constant mesh with the gear form on the outside of the tappets. The end of this stem comes out from the brake housing through a seal and is protected by an adjuster cover.

The automatic adjuster maintains a nominal pad-to-rotor clearance of 0.030-inch (0.75 mm).

Refer to Section 5 for adjustment and deadadjustment procedures.

Procedures

Caliper Inspection

1. Wear safe eye protection. Park the vehicle on a level surface. Block the wheels to prevent the vehicle from moving.
2. Apply air pressure to release the parking brake.
3. Remove all air from the air system. If the brake has spring chambers, carefully cage and lock the spring so that it cannot actuate during assembly or disassembly. Follow the chamber manufacturer's instructions to completely release the brake.
4. Use a jack to raise the vehicle so that the wheels to be serviced are off the ground. Support the vehicle with safety stands.
5. Remove the wheel and tire assembly.

5 Caliper Assembly and Brake Pad

⚠ WARNING

Remove dry brake dust with a vacuum brush or wipe the areas with a damp cloth. Never use an air line to blow dust from the brake and rotor area. Never try to accelerate drying time by using an air line. Serious personal injury and damage to components can result.

6. Use a vacuum brush or damp cloth to remove any dirt from the brake assembly.
7. Visually check the caliper housing, bridge and carrier for damage.
 - **If there is any damage:** Replace the component or caliper assembly.

Brake Deadadjustment Procedure

NOTE: Brake pad removal instructions are provided later in this section.

1. Remove the adjuster cover. Figure 5.1 and Figure 5.2.

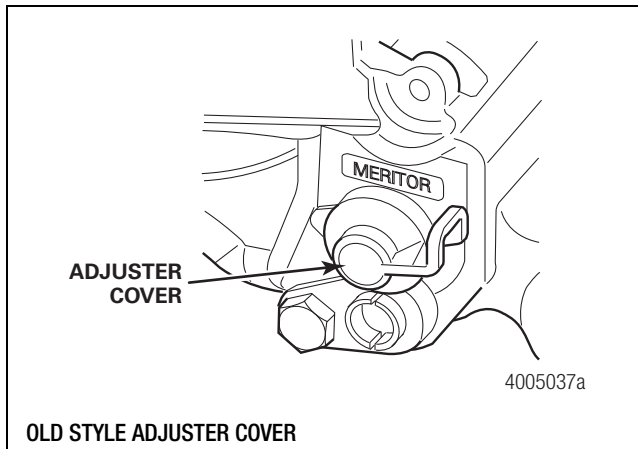

OLD STYLE ADJUSTER COVER

Figure 5.1

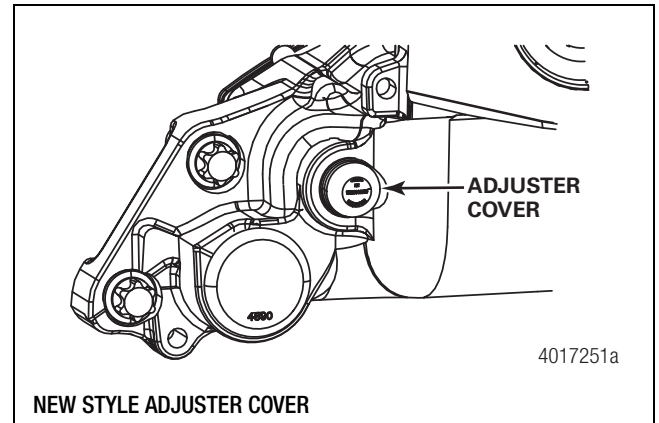

NEW STYLE ADJUSTER COVER

Figure 5.2

⚠ CAUTION

Always use a suitable wrench to carefully deadadjust and adjust the brake. Do not use air or power tools. Damage to components can result.

2. Use a 10 mm wrench to deadadjust the brake. Rotate the adjuster stem COUNTERCLOCKWISE until you feel the adjuster stem stop. Deadadjustment requires more force than adjustment. Do not exceed 30 lb-ft (40 N•m) in either direction. Figure 5.3, Figure 5.4 and Figure 5.5. **⚠**
 - **If the manual adjuster does not rotate in either direction:** Replace the caliper assembly and chamber assembly.

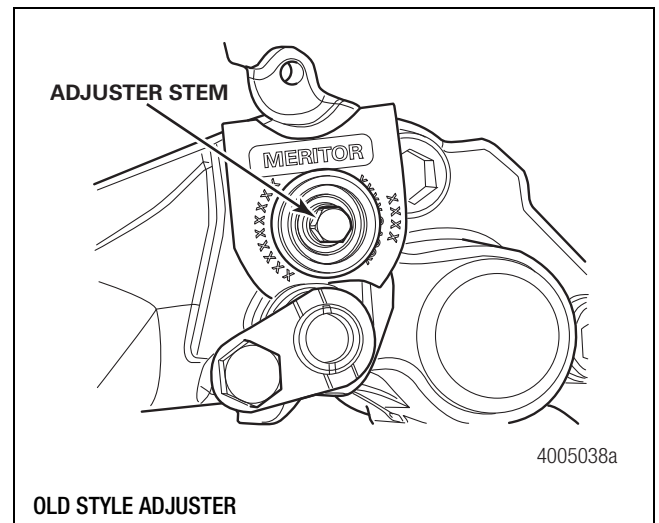

OLD STYLE ADJUSTER

Figure 5.3

5 Caliper Assembly and Brake Pad

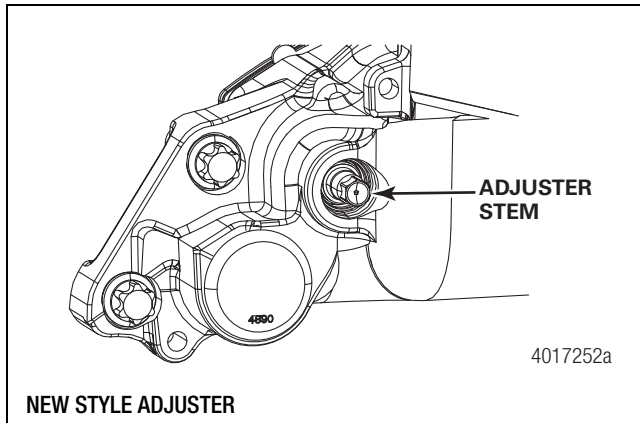

Figure 5.4

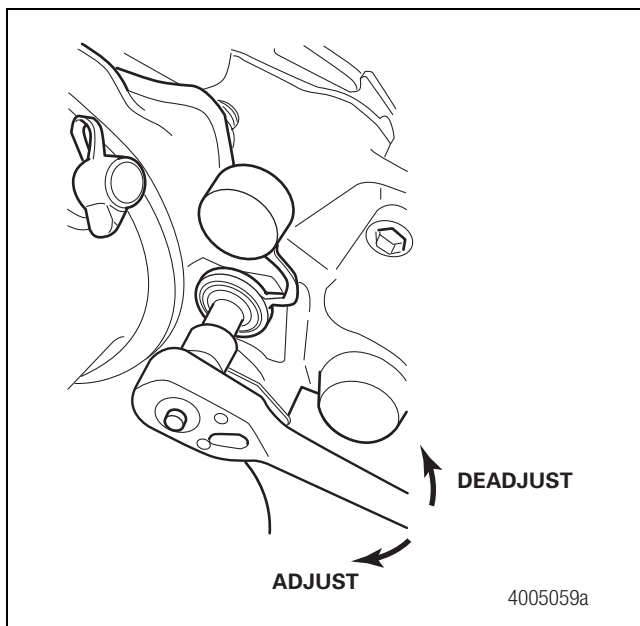

Figure 5.5

⚠ CAUTION

When re-adjusting the brakes (rotating the adjustment mechanism **CLOCKWISE**), do **NOT** extend the pistons beyond 2.5" (63.5 mm) or the pistons can come completely out of the housing assembly. Figure 5.6. Some brake housing assemblies do not have a travel stop feature to prevent the pistons from over traveling. The risk of pistons rotating out of the housing assembly may be increased further if the caliper assembly is removed from the vehicle, or if the caliper assembly is left on the vehicle, but the rotor is in a worn condition. If the pistons come out of the housing assembly, the housing assembly must be replaced. Do not attempt to reinsert pistons if they have come out of the housing assembly. If the pistons disengage, this may also affect the synchronizing mechanism, which can only be set at the manufacturing plant.

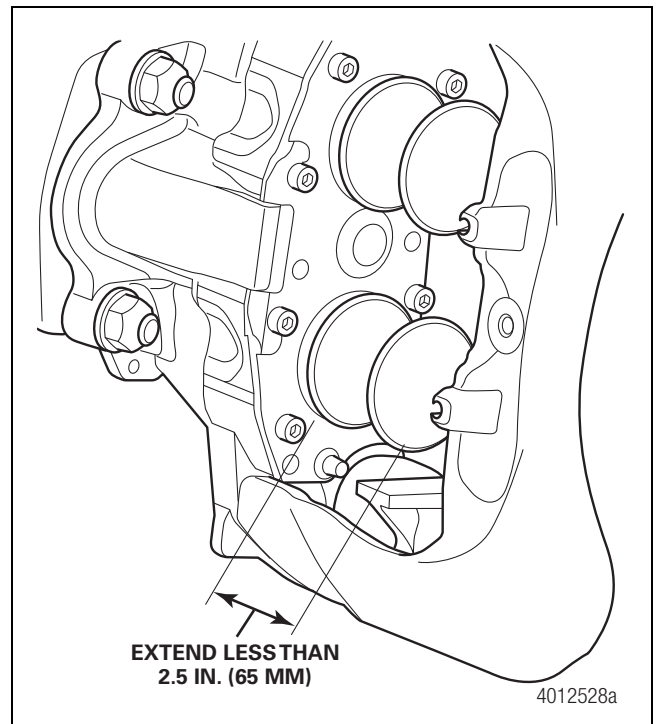

Figure 5.6

5 Caliper Assembly and Brake Pad

Check Brake Adjuster Operation

CAUTION

Before you check for correct brake adjustment, verify that the wrench will not be obstructed by the air chamber, hoses or other brake or axle components. Damage to the brake can result.

1. To check for correct brake adjustment, deadadjust the brake. Use a 10 mm wrench to rotate the adjuster stem one-half turn COUNTERCLOCKWISE. Figure 5.7.

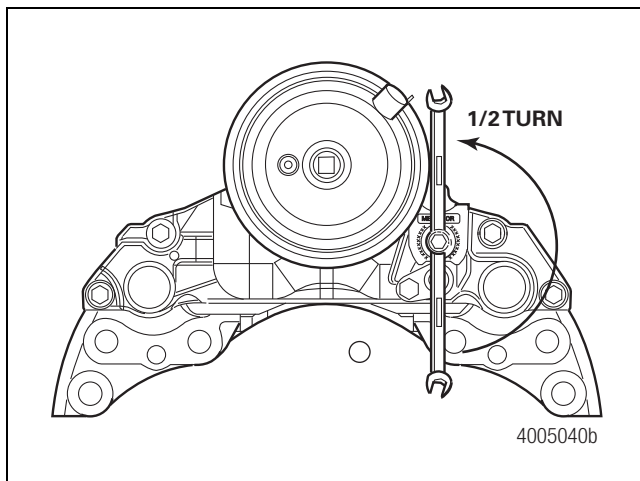

Figure 5.7

2. With the 10 mm wrench on the adjuster stem, actuate the brake one time.
Alternative Method: Instead of using the wrench as a reference for rotation, a paint marker can be used to mark the head of the adjuster stem with the housing for reference.
 - **If the wrench (or reference mark on the adjuster stem) rotates CLOCKWISE when you actuate the brake:** The adjuster mechanism is working correctly.
 - **If the wrench (or reference mark on the adjuster stem) does not rotate CLOCKWISE when you actuate the brake:** The adjuster mechanism is not working correctly. Replace the caliper assembly.

Brake Pad Removal and Inspection

1. Use a 17 mm wrench to remove the pad retainer bolt. Remove the pad retainer. Figure 5.8.

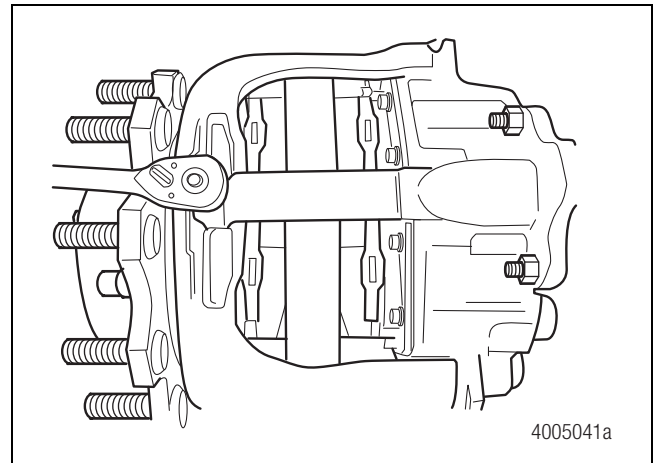

Figure 5.8

2. Visually inspect the pad retainer.
 - **If the pad retainer is bent or damaged:** Replace the pad retainer.
3. Remove the pad springs. Figure 5.9.
 - **If a pad wear warning indicator (PWWI) is present:** Lift the PWWI assembly and disengage the tang from the housing assembly. Do not remove the plastic block sensors from their locations in the pads unless the PWWI assembly is being replaced. Refer to Section 9 for PWWI service. Figure 5.10 and Figure 5.11.

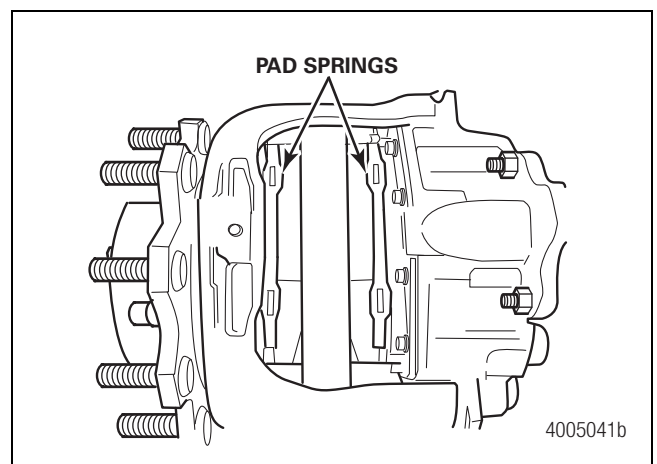

Figure 5.9

5 Caliper Assembly and Brake Pad

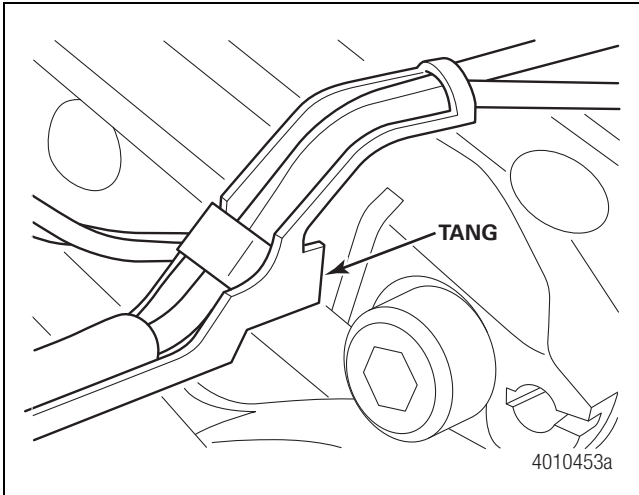

Figure 5.10

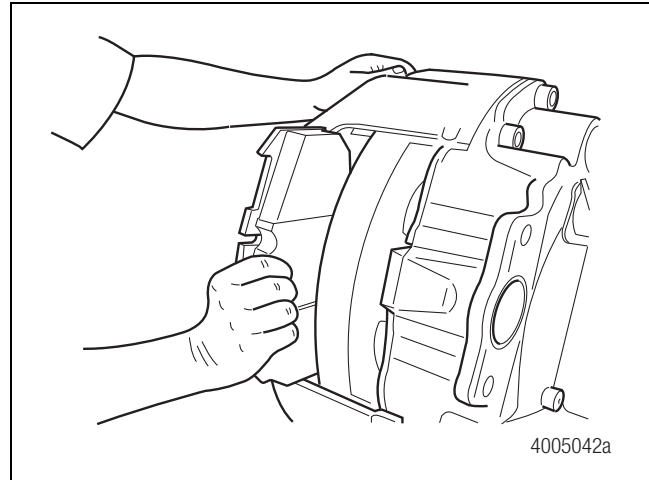

Figure 5.12

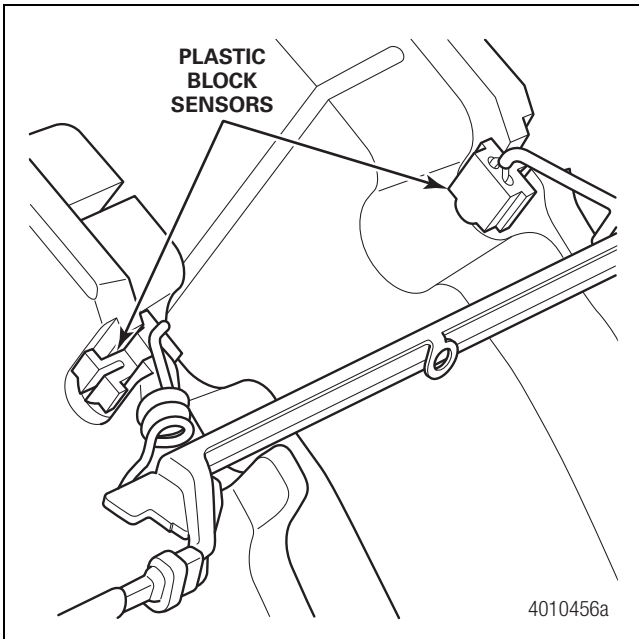

Figure 5.11

4. Remove the outboard brake pad from the caliper assembly and mark the brake pad "outboard". Figure 5.12.

⚠ CAUTION

Once the brake pads are removed, do NOT re-adjust the brake (rotate the adjustment mechanism **CLOCKWISE**) to the point the pistons extend beyond 2.5" (63.5 mm) or the pistons can come completely out of the housing assembly. Some brake housing assemblies do not have a travel stop feature to prevent the pistons from over traveling. The risk of pistons rotating out of the housing assembly may be increased further if the caliper assembly is removed from the vehicle, or if the caliper assembly is left on the vehicle, but the rotor is in a worn condition. If the pistons come out of the housing assembly, the housing assembly must be replaced. Do not attempt to reinsert pistons if they have come out of the housing assembly. If the pistons disengage, this may also affect the synchronizing mechanism, which can only be set at the manufacturing plant.

5. Remove the inboard brake pad from the caliper assembly and mark the brake pad "inboard".

5 Caliper Assembly and Brake Pad

Once the brake pads are removed, **do NOT re-adjust the brake (rotate the adjustment mechanism CLOCKWISE) to the point the pistons extend beyond 2.5" (63.5 mm) or the pistons can come completely out of the housing assembly.** Some brake housing assemblies do not have a travel stop feature to prevent the pistons from over traveling. The risk of pistons rotating out of the housing assembly may be increased further if the caliper assembly is removed from the vehicle, or if the caliper assembly is left on the vehicle, but the rotor is in a worn condition. If the pistons come out of the housing assembly, the housing assembly must be replaced.

Do NOT extend pistons to 2.5 IN. (65 mm) or pistons can fall out, requiring the entire housing assembly to be replaced.

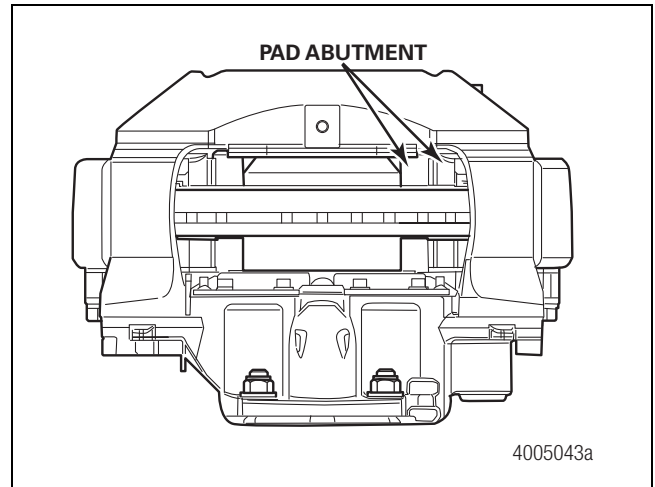
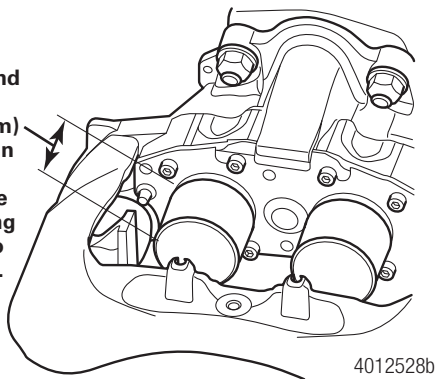

Figure 5.13

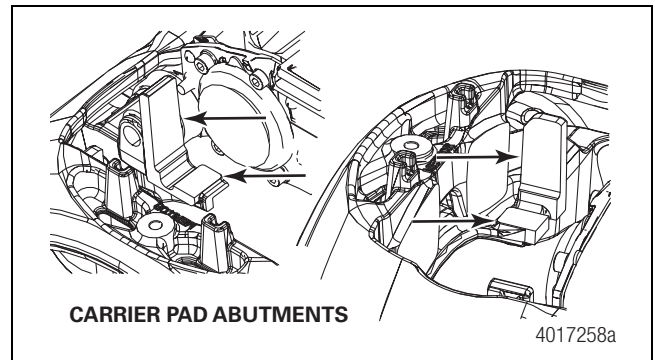

Figure 5.14

6. Use a vacuum brush or damp cloth to remove the dirt and dust from the carrier brake pad contact surfaces.
7. Inspect the carrier for signs of damage or wear. Pay particular attention to the pad abutments. Check for grooves on the pad abutments in excess of 0.02 inch (0.5 mm). Look for any carrier wear or damage that would cause the pad backing plate to catch and/or become cocked. Figure 5.13 and Figure 5.14.
 - **If any of the above conditions are found:** Replace the carrier.

CAUTION

Meritor recommends replacing the pads on both brakes of a single axle or all four brakes of a tandem axle at the same time. If you do not replace all the pads at the same time, poor brake performance may occur.

8. Inspect the brake pads for excessive grooving or cracked friction material. Check if the friction material is loose or detached from the backing plate. If necessary, replace all the brake pad assemblies.
9. Measure the friction material thickness on the brake pad. Replace brake pad assemblies before the lining thickness reaches 0.12-inch (3 mm). Figure 5.15.

5 Caliper Assembly and Brake Pad

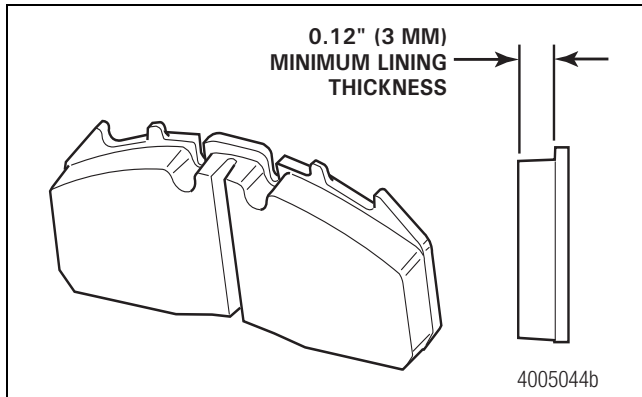

Figure 5.15

10. Inspect the pad springs. Replace bent, cracked or broken pad springs.
11. Verify that the caliper slides freely, by hand, on the slide pins. Take care not to trap your fingers while you check the sliding action of the brake.
 - **If the caliper does not slide:** Check the slide pin boots for damage and verify that they are seated correctly per Step 12.
12. With the pads removed, visually inspect the caliper slide pin boots and piston boots. All slide pin and piston boots should be correctly seated and free from damage as follows.

Boots Must Be Properly Seated — Boots must be correctly seated in the boot retainer grooves. Figure 5.16, Figure 5.17 and Figure 5.18.

Boots Must Have a Vacuum-Tight Seal — Boots must maintain a tight vacuum seal to ensure no contaminants enter the caliper. Boots should not extend outward and touch the backing plate of the pad when installed. Damage to the piston boot could exist if the boot is "blown up" and not compressed when piston is fully retracted in to caliper.

To check for a tight vacuum seal and ensure there is no air trapped underneath the slide pin boot, slide the caliper back and forth on the pins and verify the boots suck inwards around the pin as shown in Figure 5.18. If the boot sucks in and then loses that shape, the slide pin boot is either bad or not properly sealed on the pin.

To check for a tight vacuum seal and ensure there is no air trapped underneath the piston boot, extend and retract the pistons.

Damage and Excessive Heat — Extended brake application can produce excessive heat, causing the boots to melt through. Check the boots for signs of damage or melting due to excessive heat. Figure 5.19, Figure 5.20 and Figure 5.21.

- **If any of the piston boots or slide pin boots are damaged, melted or unseated:** Replace the boots. Refer to Section 6 for procedures.

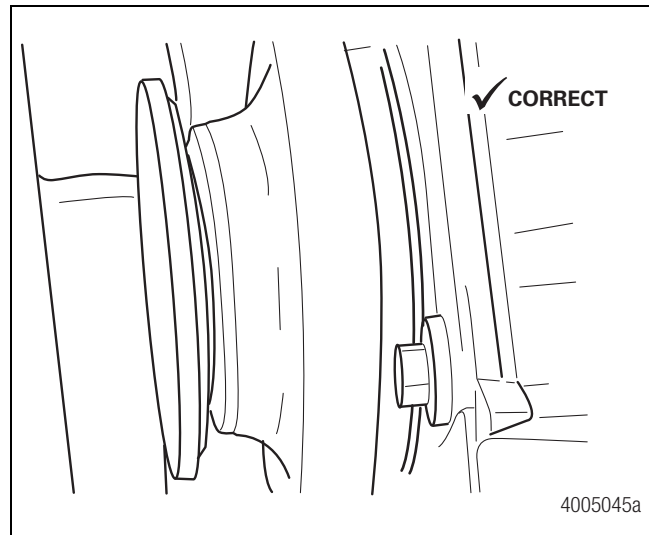

Figure 5.16

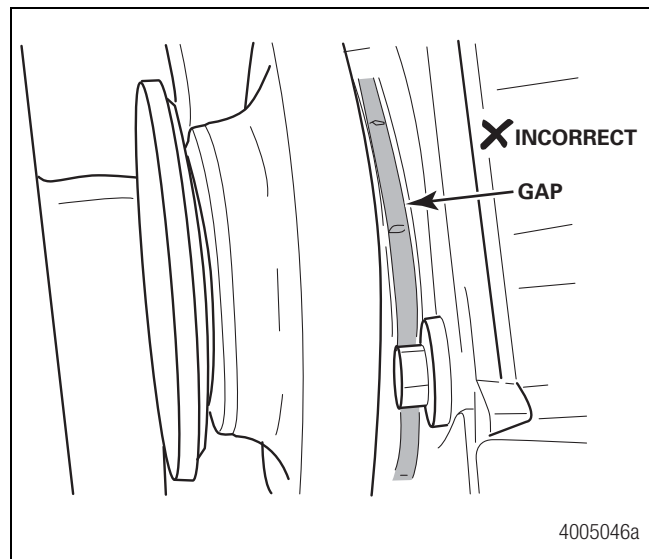

Figure 5.17

5 Caliper Assembly and Brake Pad

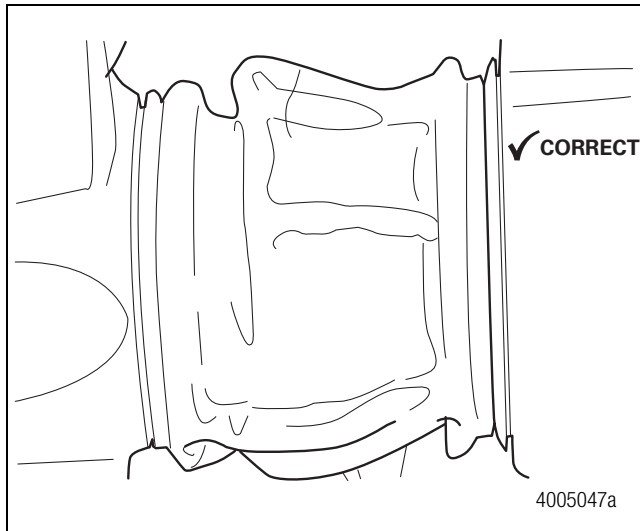

Figure 5.18

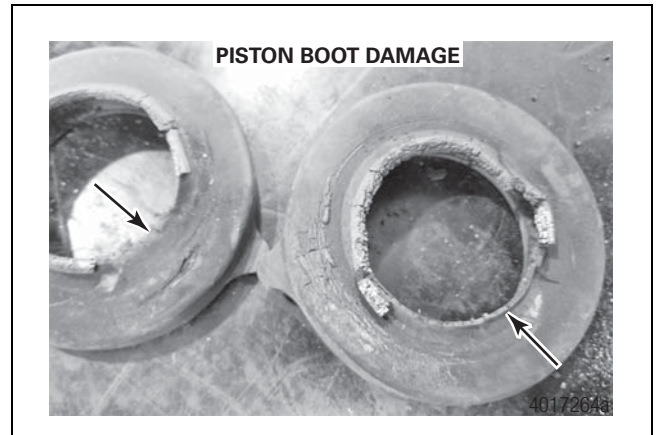

Figure 5.21

Check Slide Pin Bushing Wear

Check the slide pin bushing wear if you find tapered wear on the pads or other pad wear issues. This check should be performed with the brake assembly installed on the vehicle.

Radial Test

1. Loosen the pad strap and reposition it 180 degrees from the installed position. Retighten the pad strap bolt to 20 lb-ft (27 N•m) so that the strap does not move. Figure 5.22.

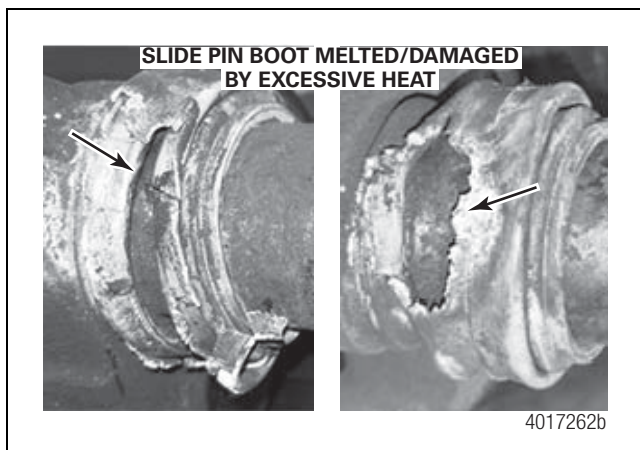

Figure 5.19

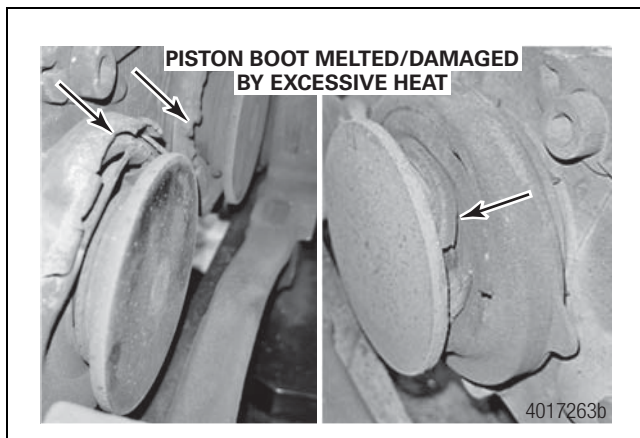

Figure 5.20

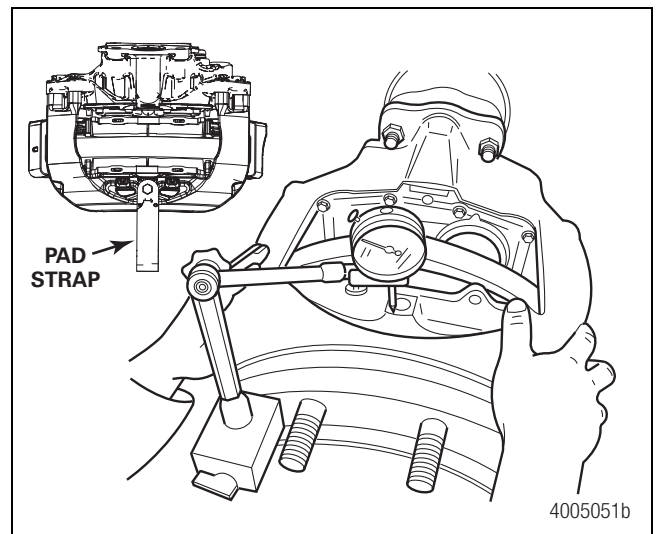

Figure 5.22

2. Position the brake at the new pad condition. Pull the caliper outboard in the direction of the arrow as far as possible and let it settle into resting position.

5 Caliper Assembly and Brake Pad

⚠ WARNING

When sliding the caliper forward, use care to avoid trapping fingers.

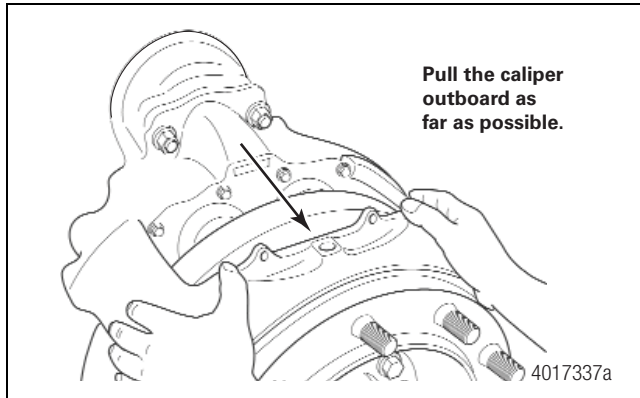

Figure 5.23

3. Attach a dial indicator onto the vehicle hub and set it against the caliper. Figure 5.22.
4. Position the dial indicator on the pad strap bolt and push downwards on the pad strap with ~10 lbs. of force; set the dial indicator to ZERO.
5. Lift up on the pad strap with ~10 lbs. force and record total movement of the dial indicator.

Alternative Method: Without using the pad strap, position the caliper in the new pad condition per Step 3. Position the dial indicator per Step 4. Press down on the edges of the bridge with ~10 lbs. force and set the indicator to '0'. Lift up at the edges of the bridge using your hands with ~10 lbs. force (do NOT use a pry bar to lift) and record total movement of the dial indicator.

Maximum acceptable reading is 0.100-inch (2.5 mm).

- **If the reading is more than 0.100-inch (2.5 mm):**
Replace the caliper assembly or the bushings and slide pins.

Brake Pad Installation

⚠ CAUTION

Install the pads with the friction material facing the rotor. Damage to components can result.

1. If necessary, deadjust the brakes and remove the brake pads. Refer to the procedures in this section.

2. Slide the caliper OUTWARD. Install the outboard pad and spring into the outboard side of the caliper. Figure 5.24.

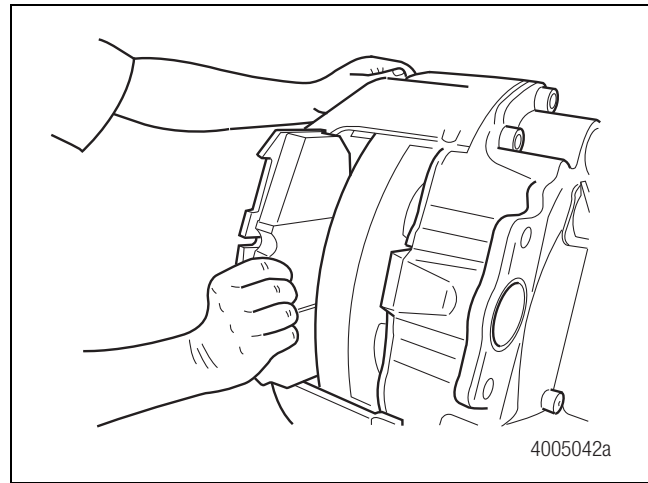

Figure 5.24

3. Slide the caliper INWARD. Install the inboard pad and spring into the inboard side of the caliper. Figure 5.24.
4. If necessary, slide the pad retainer through the pad shield.
5. Install the pad retainer and pad retainer bolt. Tighten the bolt to 25-30 lb-ft (34-40 N•m). Figure 5.25. **⚠**
 - **If you are replacing the pad retainer:** Do not use the original pad retainer bolt. Use the pad retainer bolt supplied with the kit.

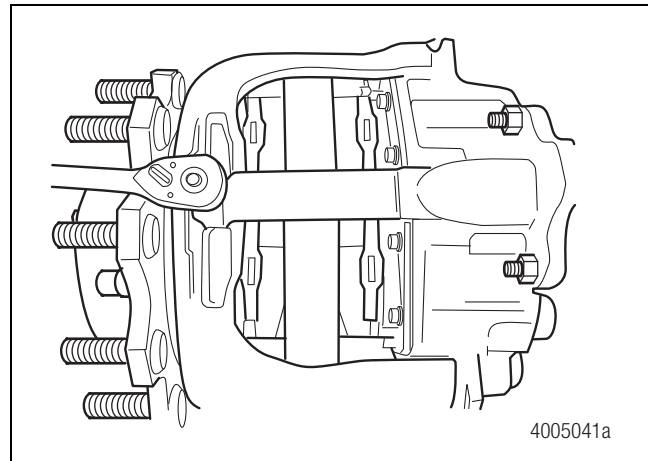

Figure 5.25

6. If necessary, install the PWWI assembly. Refer to Section 9 for procedures.

5 Caliper Assembly and Brake Pad

CAUTION

You must adjust the initial brake pad-to-rotor clearance or an inefficient, dragging brake can occur. Damage to components can result.

7. Set the initial brake pad-to-rotor running clearance. Refer to the procedure in this section.
8. Check brake adjuster operation. Refer to the procedure in this section.

New Pad Shield Installation

If you are installing a new pad shield on an assembled brake, it is not necessary to remove the pad assemblies, pad springs or PWVI.

1. Remove the pad retainer bolt and pad retainer from the brake.
2. Slide the pad retainer through the pad shield. It will be a tight fit.
3. Install the pad retainer and pad shield assembly on the brake.
4. Install the pad retainer bolt and tighten to 25-30 lb-ft (34-40 N•m). Figure 5.26. 

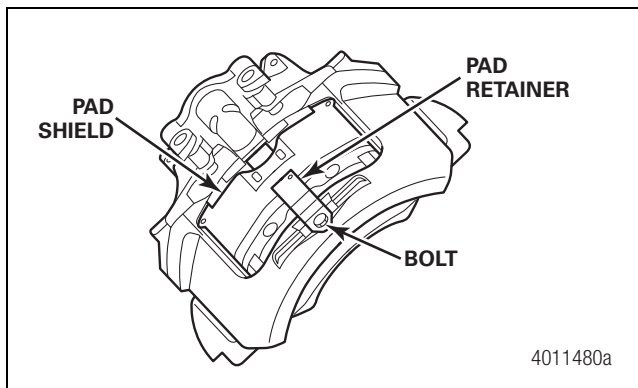

Figure 5.26

Set the Initial Brake Pad-to-Rotor Running Clearance

NOTE: Before setting the initial brake pad-to-rotor running clearance, Meritor recommends checking the self adjuster operation. Refer to the procedure in this section.

CAUTION

Always set the initial brake pad-to-rotor running clearance with the air chamber installed to prevent damage to components.

1. Remove the adjuster cover. Figure 5.27.

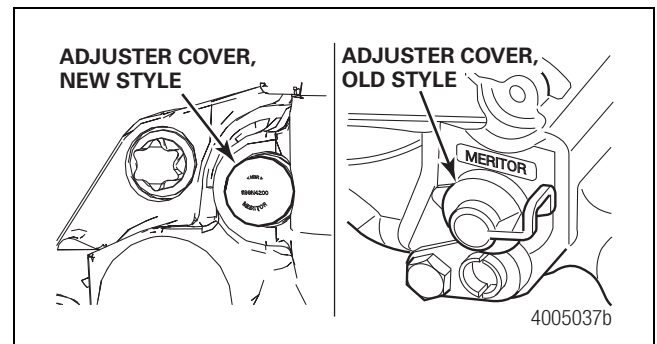

Figure 5.27

2. Use a 10 mm wrench to rotate the manual adjuster stem **CLOCKWISE** so that the brake pad-to-rotor clearance is **ZERO**. Figure 5.28.

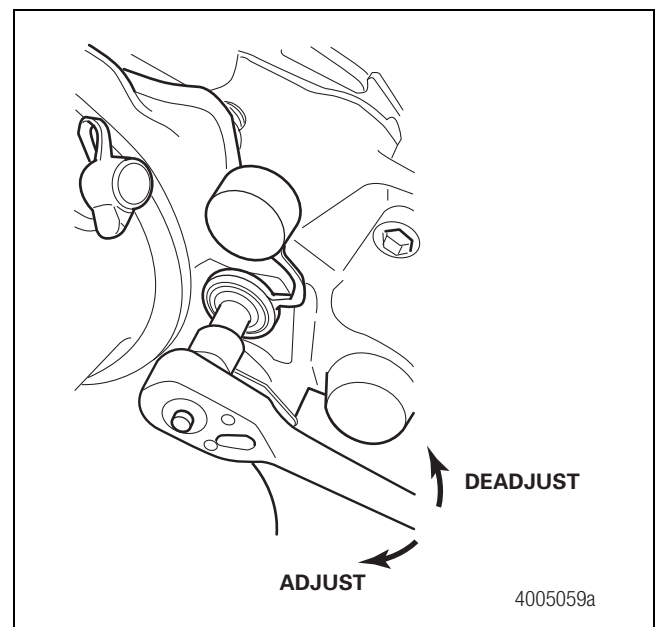

Figure 5.28

3. Deadadjust the manual adjuster stem one half turn **COUNTERCLOCKWISE** to set the initial running clearance. Reinstall the adjuster cover. Figure 5.28.

6 Caliper Components Replacement

Hazard Alert Messages

Read and observe all Warning and Caution hazard alert messages in this publication. They provide information that can help prevent serious personal injury, damage to components, or both.

⚠️ WARNING

To prevent serious eye injury, always wear safe eye protection when you perform vehicle maintenance or service.

Park the vehicle on a level surface. Block the wheels to prevent the vehicle from moving. Support the vehicle with safety stands. Do not work under a vehicle supported only by jacks. Jacks can slip and fall over. Serious personal injury and damage to components can result.

Before you service a spring chamber, carefully follow the manufacturer's instructions to compress and lock the spring to completely release the brake. Verify that no air pressure remains in the service chamber before you proceed. Sudden release of compressed air can cause serious personal injury and damage to components.

⚠️ ASBESTOS AND NON-ASBESTOS FIBERS WARNING

Some brake linings contain asbestos fibers, a cancer and lung disease hazard. Some brake linings contain non-asbestos fibers, whose long-term effects to health are unknown. You must use caution when you handle both asbestos and non-asbestos materials. Refer to page i for asbestos and non-asbestos safety information and recommended work practices.

Introduction

This section contains all the procedures required to completely disassemble the caliper. The disassembly procedures are presented in a specific sequence. If you are not completely disassembling the caliper, you will not be performing all the procedures in this section.

Remove the Caliper Assembly

1. If the caliper has a spring chamber, carefully cage and lock the spring. Follow the chamber manufacturer's instructions to completely release the brake. Use the correct wrench to remove the air chamber nuts and washers. Figure 6.1. Remove the air chamber assembly from the brake caliper and inspect the air chamber. Refer to Section 8.

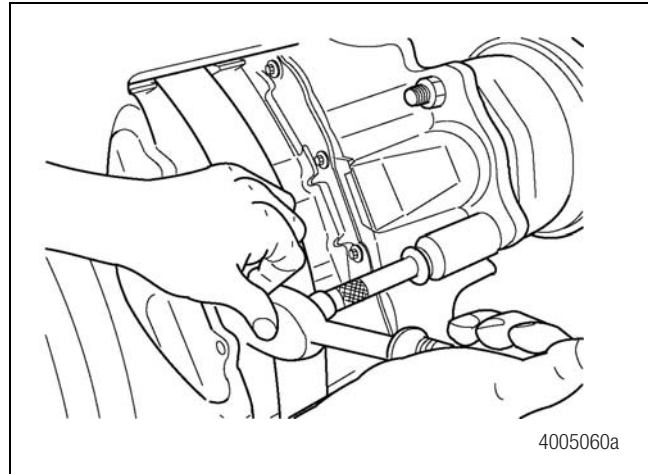

Figure 6.1

⚠️ CAUTION

Always cover the air chamber opening on the caliper with tape to prevent debris from entering the caliper housing. Debris or other contaminants can cause damage to the caliper.

2. Cover the exposed air chamber mounting aperture with tape to prevent debris from entering the caliper housing assembly. Figure 6.2.

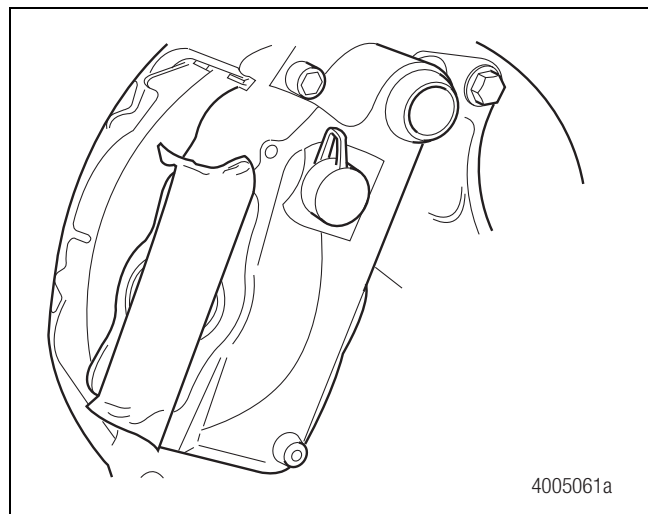

Figure 6.2

3. Deadadjust the caliper and remove the brake pads. Refer to Section 5.

6 Caliper Components Replacement

NOTE: Some brake housing assemblies do not have a travel stop to prevent the pistons from rotating completely out of the housing assembly. Use care when re-adjusting the brakes (rotating the adjustment mechanism **CLOCKWISE**) and follow the instructions in Section 5.

4. For both axial and radial mount carrier style brakes, use an appropriate size socket wrench (or if necessary, extension adapter MST225 5001 if available) to remove the carrier bolts and washers. Refer to Section 12, Figure 6.3 and Figure 6.4. Carefully remove the caliper assembly from the axle.

NOTE: Carrier-to torque plate mounting bolts may be furnished by the OEM so use the OEM's torque specification during reassembly. If no torque specification is provided by the OEM, use the Meritor torque specification.

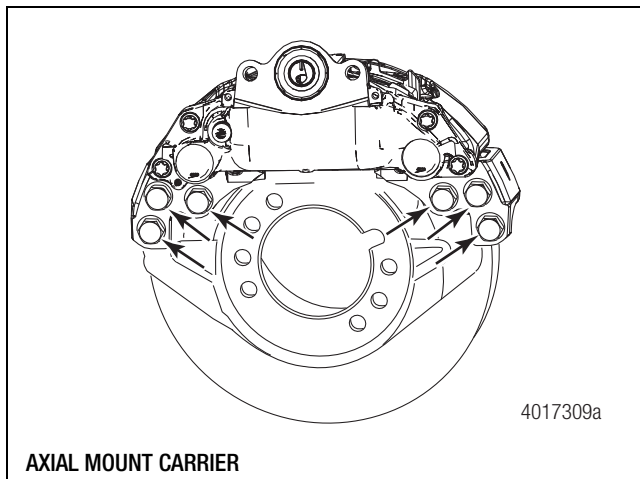

Figure 6.3

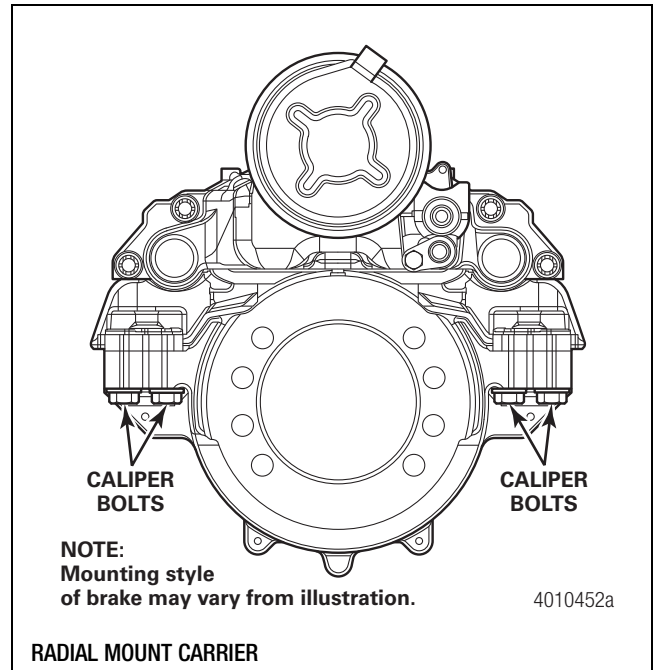

Figure 6.4

Install the Caliper Assembly

1. Place the caliper assembly over the rotor.
2. Align the caliper carrier bolt holes. Assemble the caliper to the torque plate using the carrier bolts and correct washers. The M20 fasteners use standard hardened washers. Special washers are used only with the M16 mounting bolts.

NOTE: On Ex+ optimized models, the arrow on the caliper indicates the direction of rotation. Figure 6.5.

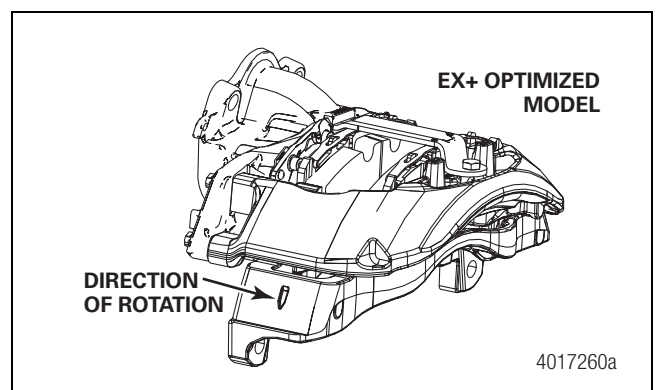



Figure 6.5

6 Caliper Components Replacement

- Use an appropriate size socket wrench (or extension adapter MST225 5001 if required), to tighten the carrier bolts to the torque values specified in Section 10. Figure 6.6. 
- If you use the extension adapter:** The torque wrench and extension adapter must be aligned to achieve the correct torque. Refer to Section 10 for all torque specifications and tightening information.

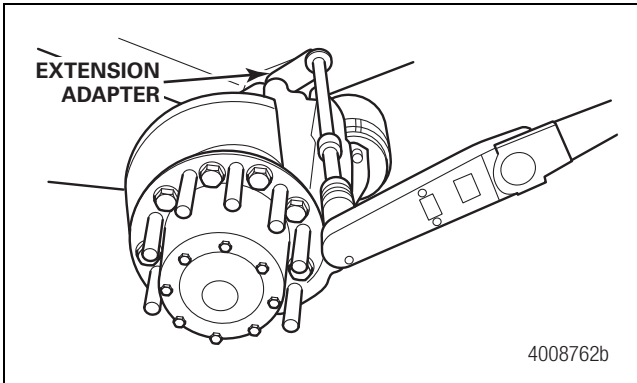

Figure 6.6

- Check the caliper assembly to verify that it slides by hand.
- Before you install the air chamber onto the caliper assembly, remove the perforated transit plug from the caliper chamber seal by pulling the tab. Figure 6.7 and Figure 6.8..

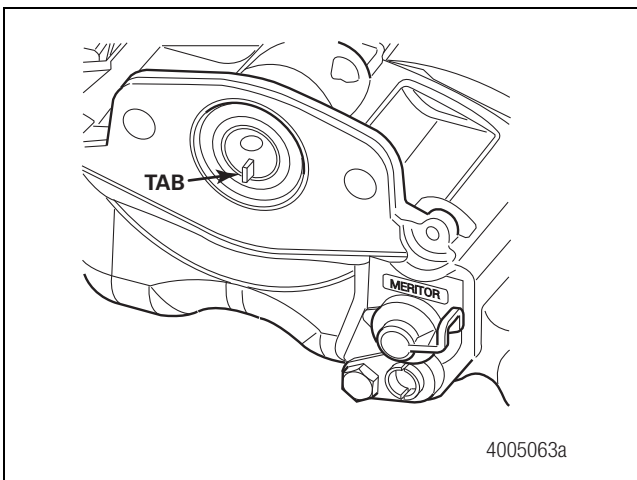

Figure 6.7

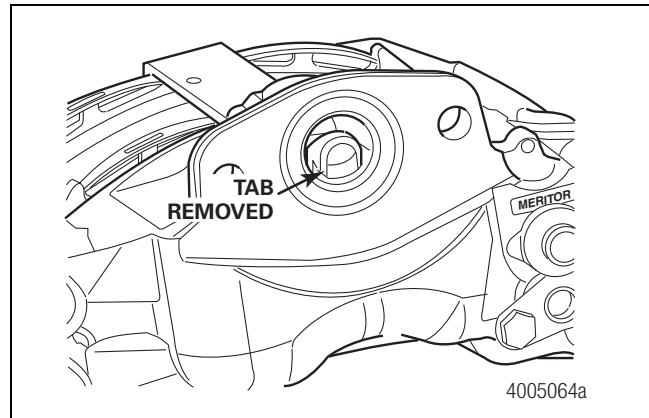

Figure 6.8

- Inspect the chamber mounting face on the caliper for corrosion. Remove any light corrosion with an abrasive. Figure 6.9. Check the chamber seal for damage, dents or defects. Replace the seal if the damage, dent or defect is enough to compromise the integrity of the seal.

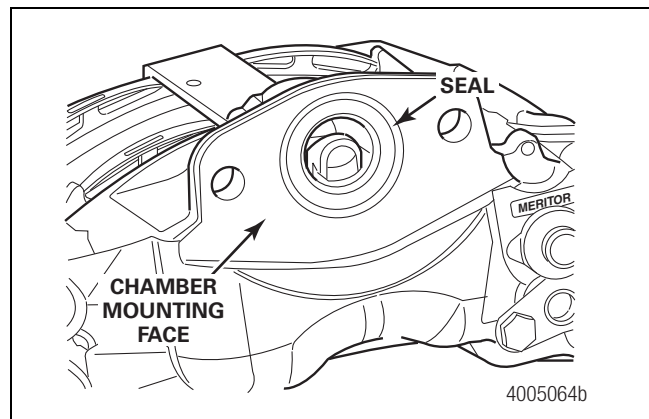

Figure 6.9

- Install the air chamber onto the caliper assembly. Refer to Section 8.
- Install the pads and set the initial brake pad-to-rotor clearance. Refer to Section 5.

Replace the Adjuster Cover

It is important for the adjuster head to be covered and ice not be allowed to rest in the adjuster hole. Always replace a missing or damaged cover to keep the adjuster and hole protected.

NOTE: The new style adjuster plugs are small and do not have a tether so are easy to lose when removed. If possible, keep extra adjuster plugs on hand for replacements when needed.

1. Remove the adjuster cover from the caliper assembly. Figure 6.10 and Figure 6.11.

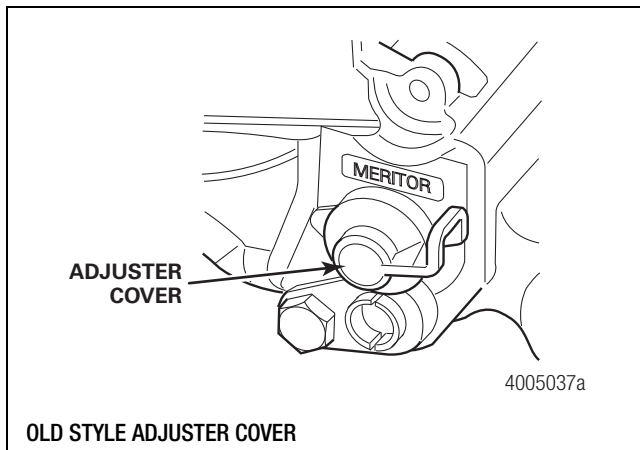

Figure 6.10

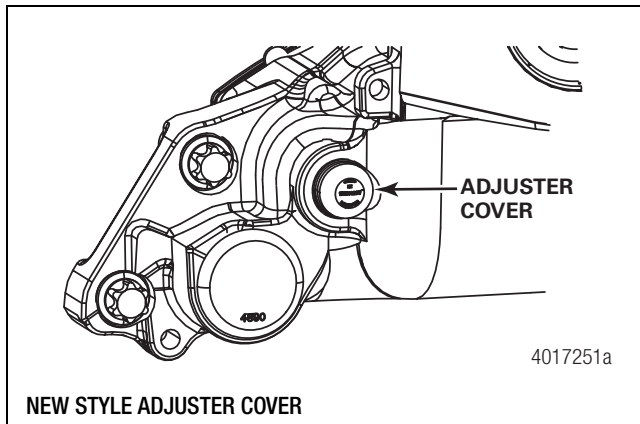

Figure 6.11

2. If you are installing a new style adjuster cover, verify the retaining ring is present and undamaged before installation. Figure 6.12.

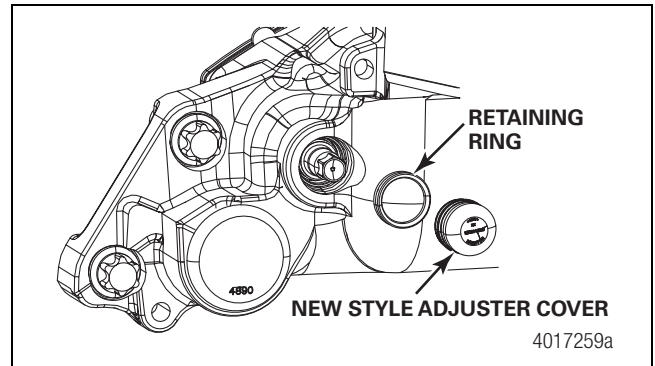

Figure 6.12

3. Install the new adjuster cover. Verify that it is correctly located on the adjuster cover retaining ring. When installing a new style adjuster plug, make sure it is snapped all the way and seated securely.

Replace the Piston Boots

⚠ WARNING

Before you service a spring chamber, carefully follow the manufacturer's instructions to compress and lock the spring to completely release the brake. Verify that no air pressure remains in the service chamber before you proceed. Sudden release of compressed air can cause serious personal injury and damage to components.

1. If the caliper has a spring chamber, carefully cage and lock the spring. Follow the chamber manufacturer's instructions to completely release the brake.
2. Deadadjust the caliper and remove the brake pads. Refer to Section 5.

⚠ CAUTION

When rotating the adjustment mechanism **CLOCKWISE**, do **NOT** extend the pistons beyond 2.5" (63.5 mm) or the pistons can come completely out of the housing assembly. Some brake housing assemblies do not have a travel stop feature to prevent the pistons from over traveling. The risk of pistons rotating out of the housing assembly may be increased further if the caliper assembly is removed from the vehicle, or if the caliper assembly is left on the vehicle, but the rotor is in a worn condition. If the pistons come out of the housing

6 Caliper Components Replacement

assembly, the housing assembly must be replaced. Do not attempt to reinsert pistons if they have come out of the housing assembly. If the pistons disengage, this may also affect the synchronizing mechanism, which can only be set at the manufacturing plant.

3. Use a 10 mm wrench to rotate the manual adjuster stem CLOCKWISE until the piston assemblies are extended approximately two-inches (50 mm). Figure 6.13 and Figure 6.14.

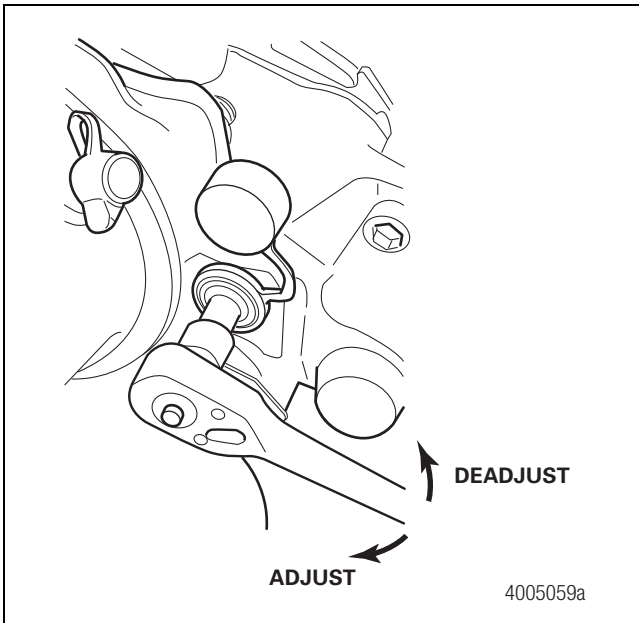

Figure 6.13

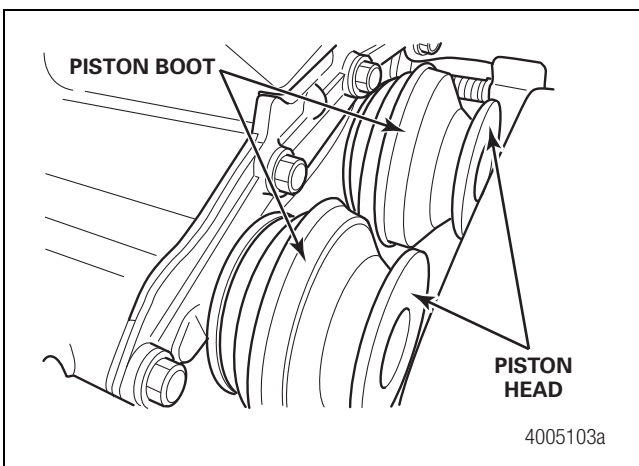

Figure 6.14

4. Remove the piston boots. Do not remove the piston heads from the piston assembly.
5. Use a suitable brake cleaner to clean the piston heads and housing.
6. Check the condition of the piston shafts. Use a wire brush to remove all rust and scale prior to installing a new piston boot.
 - **If excessive corrosion or wear is present:** Replace the caliper.
7. Use the grease supplied in the kit to lightly lubricate the piston shafts. Only use the grease supplied with the replacement components and kits.

⚠ CAUTION

When you install the new piston boots, do not use grease to aid assembly. Your hands must be clean and free from grease. Using grease may result in damage to the piston boots.

NOTE: Make sure there is no debris in the retainer groove. The piston boots and slide pin boots will not seat completely if any debris is left behind the retainer lip.

8. Carefully install a new piston boot over a piston head. The larger seal diameter with the tab goes over the piston head first. Do not install the piston boot bead into the housing assembly retaining groove at this time. Figure 6.15.

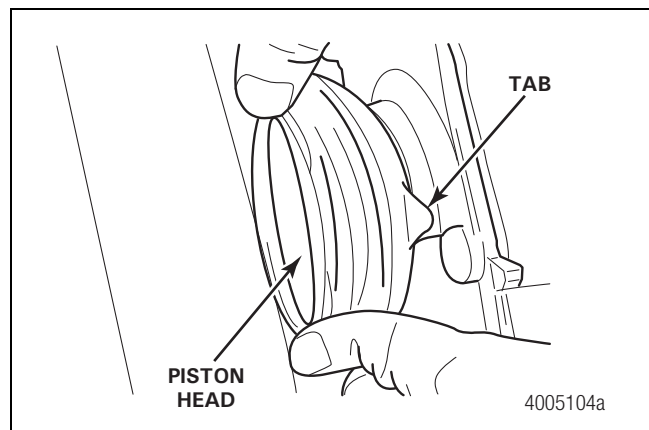

Figure 6.15

9. Carefully install the piston boot into the piston head groove. Verify that the boot is correctly seated in the piston head groove. Figure 6.16.

6 Caliper Components Replacement

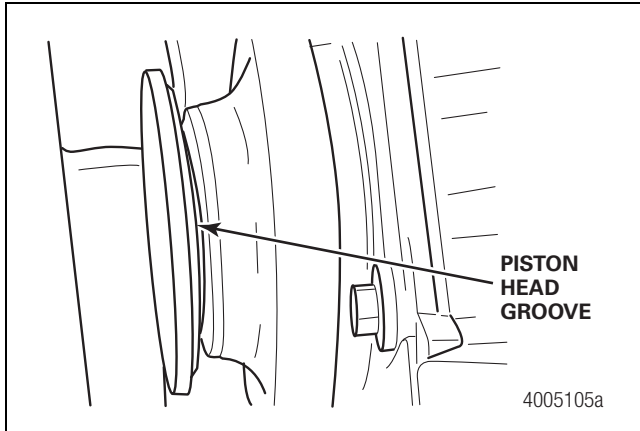

Figure 6.16

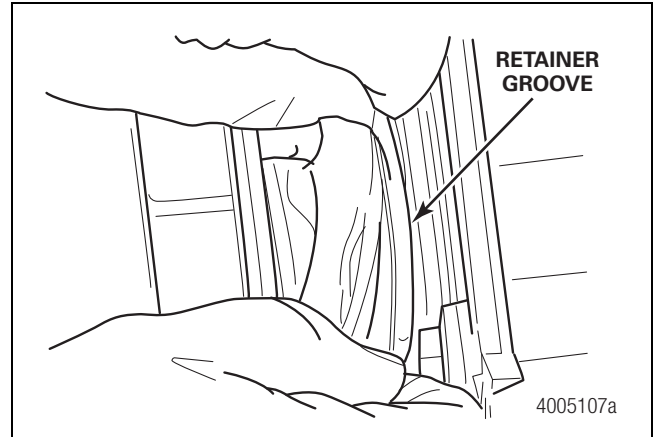

Figure 6.17

10. Use two fingers to stretch the piston boot and pull it over the housing assembly retainer groove. Figure 6.17.

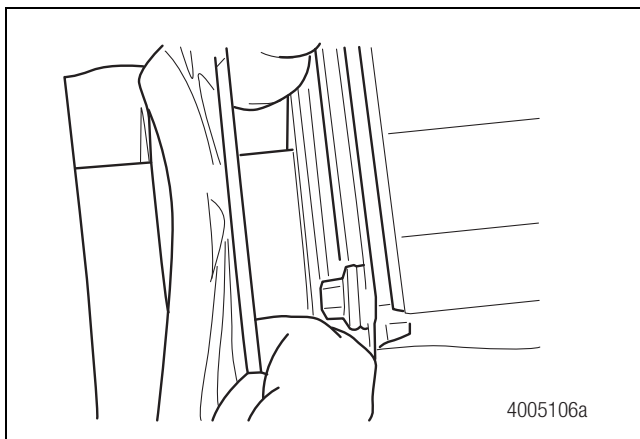

Figure 6.18

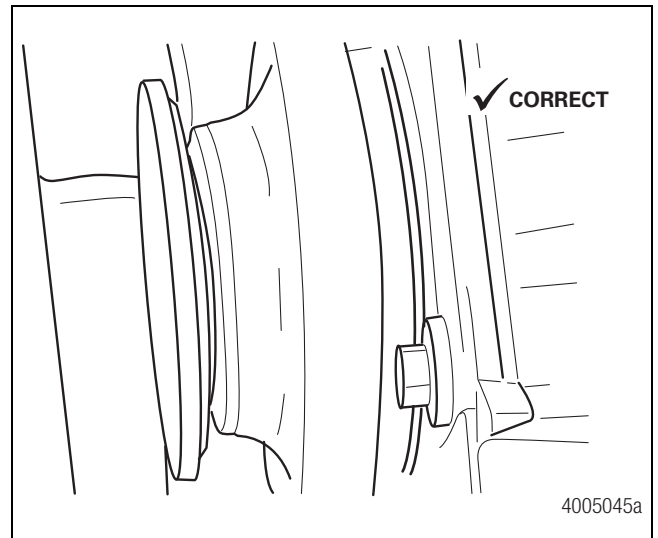

Figure 6.19

11. Rotate the piston boot and verify that the piston boot beads are correctly seated in the retainer groove. Figure 6.18. The piston boot beads must be correctly seated. Figure 6.19 and Figure 6.20.

6 Caliper Components Replacement

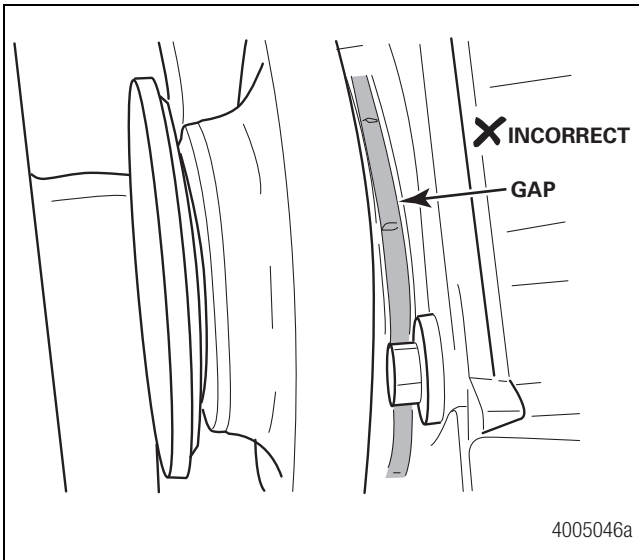

Figure 6.20

12. Repeat the procedure to install the second piston boot.
13. Use a 10 mm wrench to rotate the manual adjuster stem COUNTERCLOCKWISE and deadadjust the piston assemblies. With the brake fully deadadjusted, it may be necessary to lift the piston boot tab and release air that may be inflating the boot. Figure 6.21.

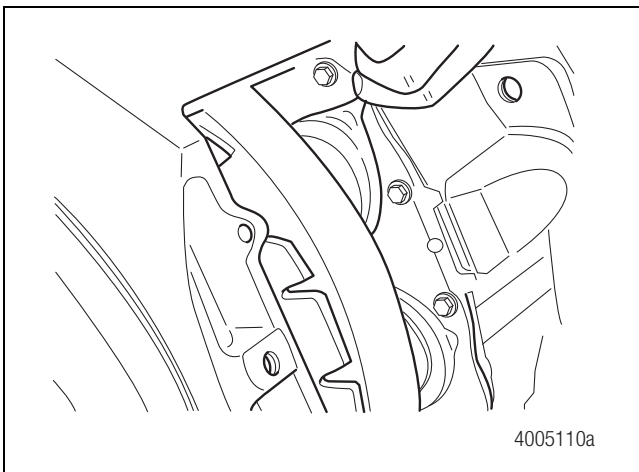

Figure 6.21

14. Install the pads and set the initial brake pad-to-rotor running clearance. Refer to Section 5.
 - **If other caliper components must be replaced:** Replace the components before you install the pads and set the initial brake pad-to-rotor running clearance. Refer to the procedures in this section.

Remove the Caliper Bridge

Removal of the bridge can eliminate the need to remove the caliper housing from the torque plate. Once repairs are complete, new bridge bolts can be installed with the caliper on the vehicle.

NOTE: New bridge bolts are included in the piston/slide pin boot kit. EX+ L model bridge bolts require a E18 Torx socket. EX+ H model bridge bolts require E20 Torx socket.

This procedure is required to replace the following caliper components:

- Housing assembly
 - Slide pin boots
 - Slide pins
1. Remove the caliper assembly from the axle. Refer to the procedure in this section.
 - **If there is adequate room in the wheel well to service the caliper assembly:** You don't have to remove the caliper assembly from the axle.
 2. Use the correct size Torx socket (E18 for EX+ L models, E20 for EX+ H models) to remove the four bridge bolts. Figure 6.22. Discard the bridge bolts after they have been removed. They are no longer usable.

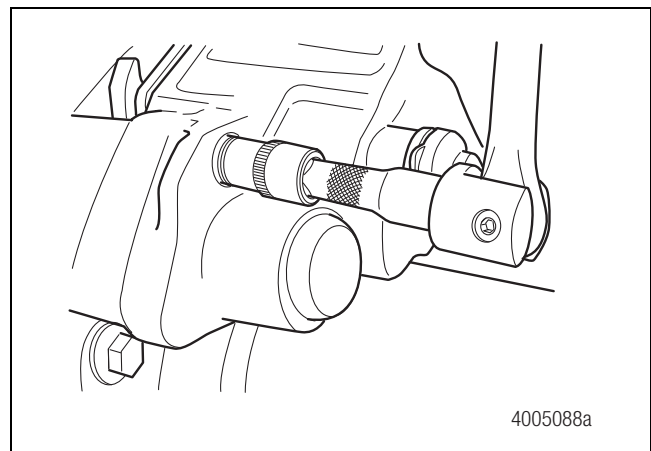

Figure 6.22

3. Carefully remove the bridge. Figure 6.23.
 - **If you are replacing the caliper housing assembly, slide pin boots or slide pins:** Proceed to the caliper housing assembly removal procedure in this section. Otherwise, proceed to the caliper bridge installation procedure in this section.

6 Caliper Components Replacement

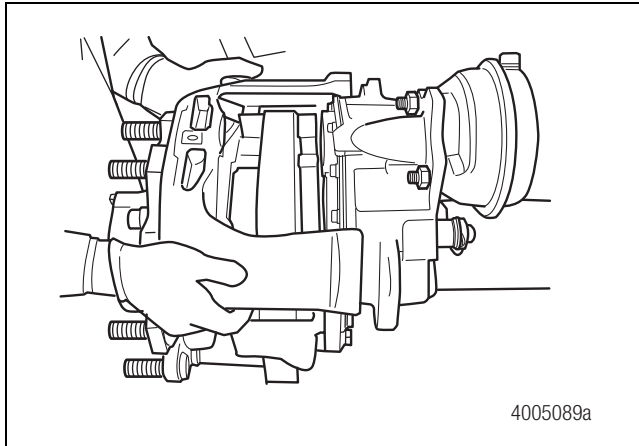

Figure 6.23

Remove the Caliper Housing Assembly

⚠ WARNING

The caliper housing assembly is not serviceable. Do not attempt to tighten or loosen the eight piston housing bolts, which can cause the caliper to malfunction. Serious personal injury and damage to components can result.

1. Where applicable, Meritor recommends that you retain the visual wear indicator and spring in position before you remove the housing to prevent the load from ejecting the indicator as the housing is removed.
2. Ensure the visual wear indicator is not damaged. Figure 6.24.

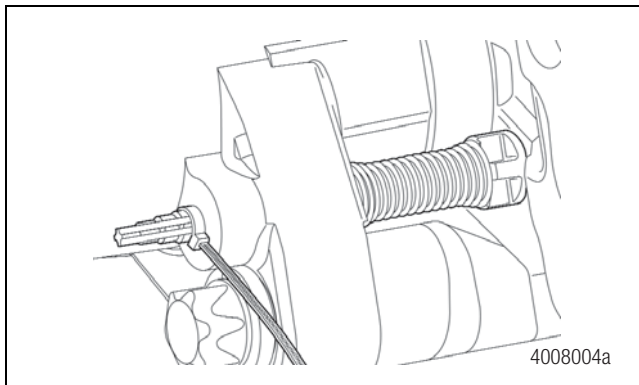

Figure 6.24

NOTE: Before removing the caliper, Meritor recommends tagging/ marking the location of the caliper on the vehicle so ensure it can be reinstalled on the same wheel end. If you are unsure of the correct caliper replacement location during installation, contact the OEM for verification.

3. Carefully remove the housing assembly from the slide pins. The assembly is not serviceable. Do not attempt to tighten or loosen the eight piston housing bolts. Figure 6.25.

- **If you are replacing the slide pin boots or slide pins:** Proceed to the slide pin boots removal procedure in this section. Otherwise, proceed to the caliper housing assembly installation procedure in this section.
- **If you are replacing the slide pin bushings or slide pin boot retainers:** Proceed to the slide pin bushing and slide pin boot retainer procedures in this section. Otherwise, proceed to the caliper housing assembly installation procedure in this section.

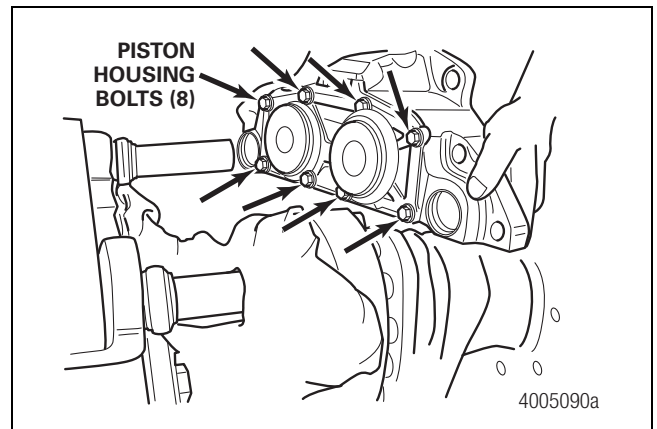

Figure 6.25

Remove the Slide Pin Boots

1. Remove the slide pin boots from the slide pins or the housing assembly retainers. Discard the slide pin boots.
 2. Clean and inspect the carrier for damage and wear. Refer to the inspection steps in Section 5. Pay particular attention to the pad abutment areas and slide pins. Figure 6.26.
- **If there is damage or excessive wear to the slide pins:** Replace the slide pins before proceeding. Refer to the procedure in this section.
 - **If there is excessive wear or damage to the carrier:** Replace the caliper assembly. Refer to the procedure in this section. Otherwise, proceed to the slide pin boots installation procedure in this section.

6 Caliper Components Replacement

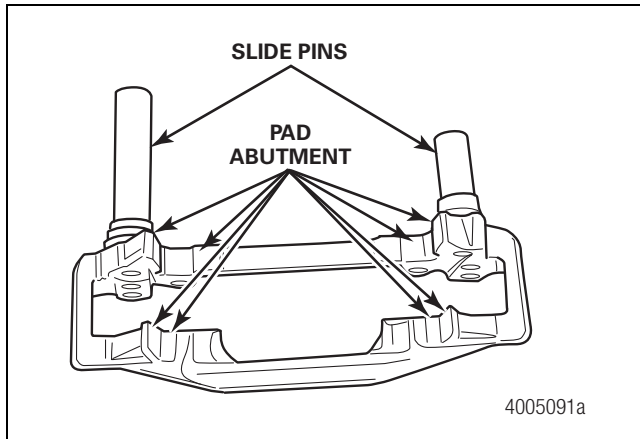

Figure 6.26

Remove the Slide Pin Bushings

NOTE: A dead blow hammer or press (recommended) is required to remove the bushings.

Axial and radial brakes incorporate a long and short slide pin arrangement. The long slide pin uses two round coated steel bushings. Figure 6.27.

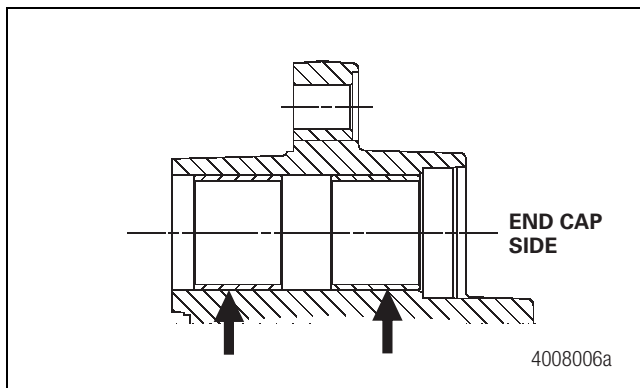

Figure 6.27

The short slide pin uses a single bronze oval bushing. Figure 6.28.

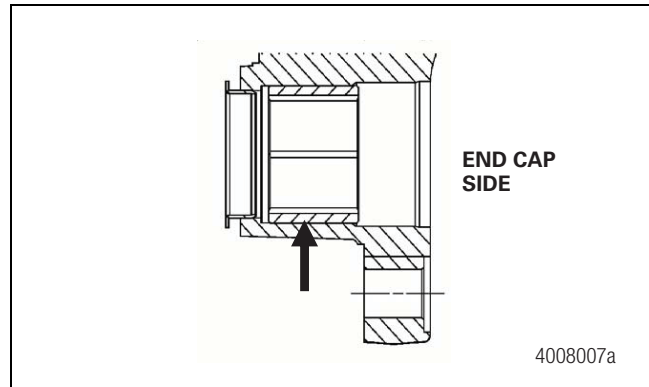

Figure 6.28

Before you remove the slide pin bushings, you must first remove the slide pin bushing end caps. If not already done so, carefully remove the end caps out from the slide pin bores. Figure 6.29.

CAUTION

Discard the end caps after removal. Always install new end caps during reassembly. Do not reinstall used end caps or damage to components can result.

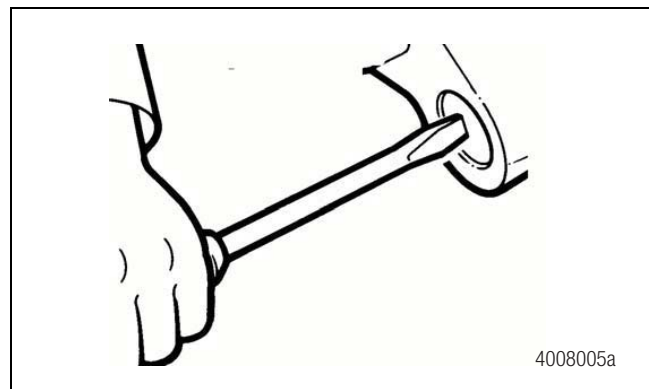

Figure 6.29

To Remove the Round Slide Pin Bushings

NOTE: The MST1000 bushing tool kit does not include a tool to pull the bushings out. A dead blow hammer can be used with the MST1000 tool kit to remove the bushings.

NOTE: When you remove the round slide pin bushings, the dust boot retainers which are pressed into the housing slide pin bores will be removed at the same time.

6 Caliper Components Replacement

WARNING

Observe all warnings and cautions provided by the press manufacturer to avoid damage to components and serious personal injury.

Use a suitable driver and a dead blow hammer or press to drive the bushing and dust boot retainer out of the housing. Figure 6.30.

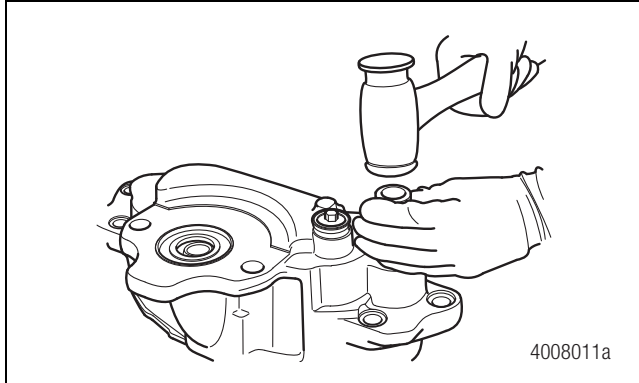

Figure 6.30

To Remove the Oval Slide Pin Bushings

NOTE: Due to the presence of a lip shown in Figure 6.31, the oval bushings must be removed in the opposite direction of the round bushings.

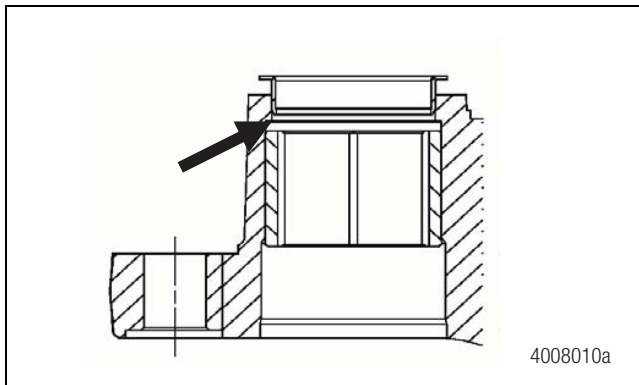

Figure 6.31

1. Remove the slide pin boot retainer from the bushing bore. Figure 6.32.

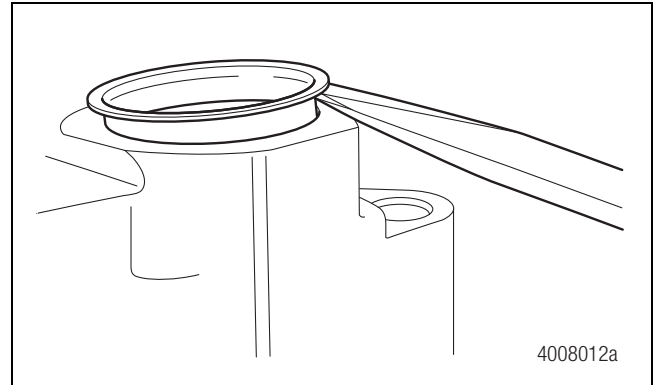

Figure 6.32

NOTE: When you install new slide pin bushings, it is important to ensure correct alignment. The notches in the bushing are aligned horizontal between the two slide pin bushing bores.

2. Before removal, check the alignment of the oval bushings and mark the housing so that the new bushings can be correctly aligned when installed. Figure 6.33 and Figure 6.34.

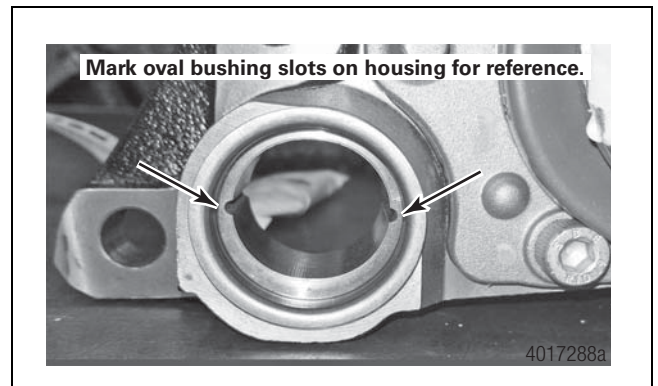

Figure 6.33

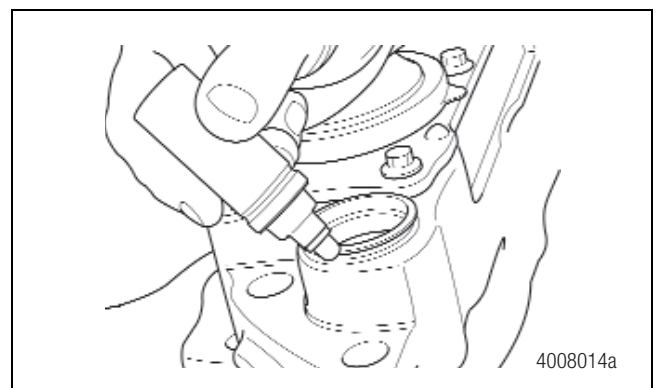

Figure 6.34

6 Caliper Components Replacement

- Use Meritor tool MST1000 and a dead blow hammer to drive out the bushing from the housing. Figure 6.35. Refer to Section 12 for tool details. The bushing must be pushed out in the direction of the end cap side of the bore. Figure 6.36.

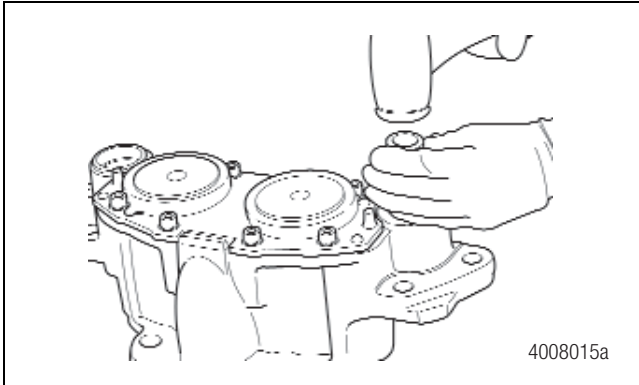

Figure 6.35

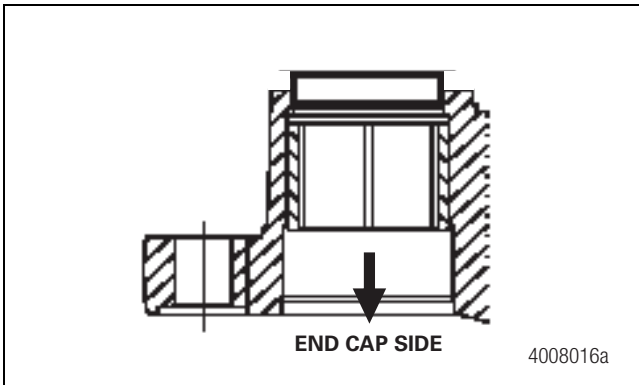

Figure 6.36

Install the Slide Pin Bushings

Clean and Inspect the Slide Pin Bushing Bores

- Before you install the bushings, clean the slide pin bushing bores with a suitable brake cleaner.
- Inspect the slide pin bushing bores for excessive wear, corrosion or damage.
 - If you find excessive wear, corrosion or damage:**
Replace the housing assembly.

To Install the Round Slide Pin Bushings

- Place one of the new bushings onto a suitable driver from Meritor tool MST1000.

- Insert the bushing into the housing bore from the slide pin boot retainer side of the bore. Figure 6.37.

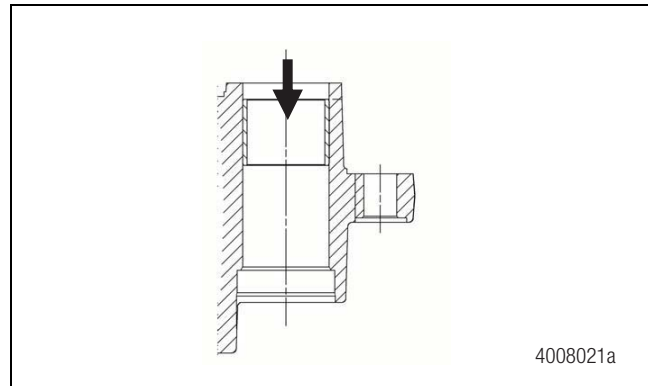

Figure 6.37

⚠ CAUTION

Do not apply excessive force when you pull the bushing into the housing or damage to the bushing can result.

- Using the applicable parts from Meritor tool MST1000, pull the bushing into the slide pin bore to a depth of 0.283- 0.299-inch (7.2-7.6 mm) measured from the end face of the housing (on the boot retainer side of the bore). Figure 6.38.

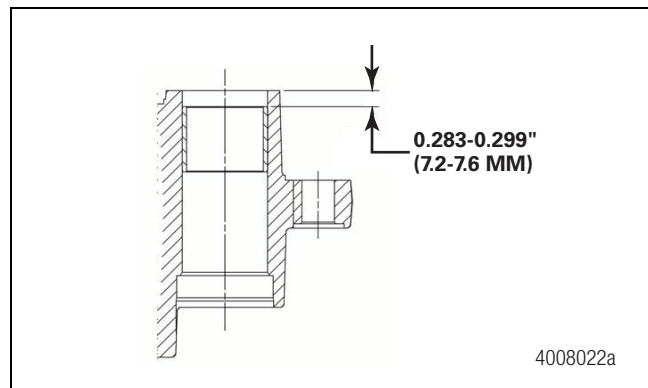

Figure 6.38

- Repeat Steps 1-3 to install the second bushing, but insert the bushing from the end cap side of the bore. To confirm the correct position for the second bushing, measure the distance from the same end face of the housing (on the boot retainer side of the bore) to the bottom of the second bushing. Refer to the following table for correct dimensions. Figure 6.39.

6 Caliper Components Replacement

Model	Inches	MM
EX225H2, H3, H4, H6	3.307 (±0.0078)	84 (±0.2)
EX225L201-212	3.307 (±0.0078)	84 (±0.2)
EX225L213+	2.693 (±0.0078)	68.4 (±0.2)
EX225L401+	2.693 (±0.0078)	68.4 (±0.2)

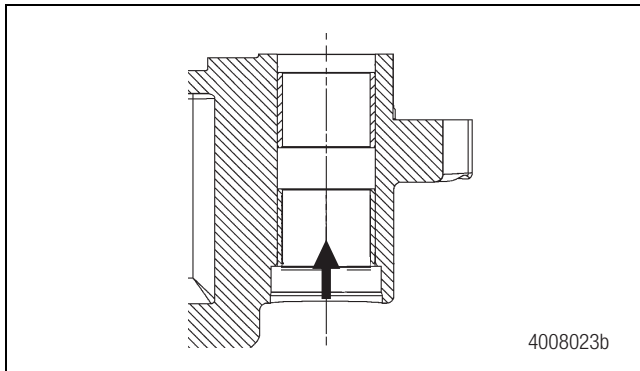

Figure 6.39

To Install the Boot Retainers for Round Slide Pins

1. Place the retainer onto a suitable driver from Meritor tool MST1000. Figure 6.40.

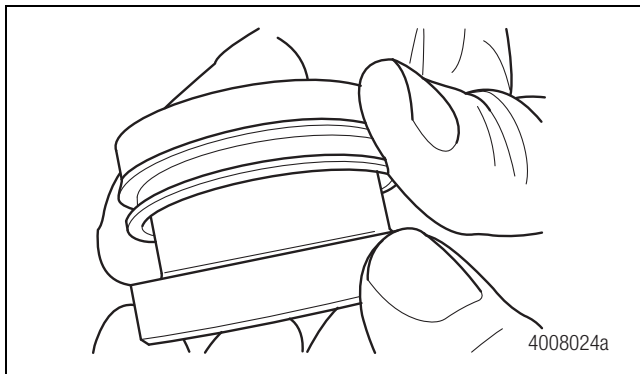

Figure 6.40

2. Place the retainer onto the housing.

⚠ CAUTION

Do not apply excessive force when you pull the retainer into the bore or damage to the bushing or retainer can result.

3. Use the applicable parts of Meritor tool MST1000 to draw the retainer into the slide pin bore until the flat face of the retainer is 0.183-0.202-inch (4.65-5.15 mm) from the end of the slide pin bore. Figure 6.41.

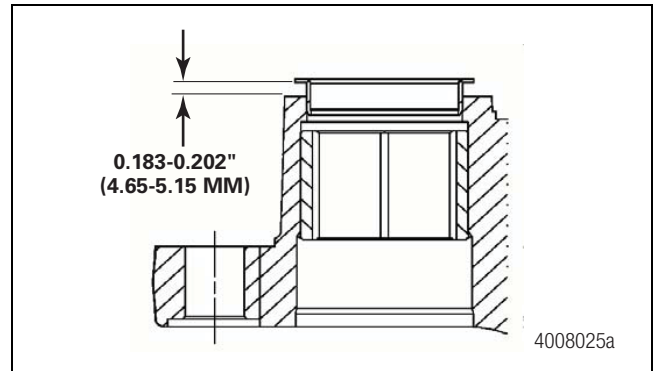

Figure 6.41

To Install the Oval Slide Pin Bushings

NOTE: The bushing must be assembled from the actuator side of the housing.

1. Align the new oval bronze bushing with the markings made on the housing previously. Figure 6.42.

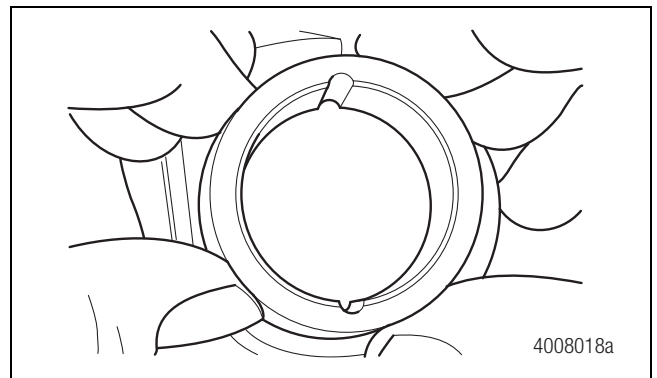

Figure 6.42

2. Place a suitable driver from Meritor tool MST1000 onto the bushing and install the bushing into the housing bore. Figure 6.43.

6 Caliper Components Replacement

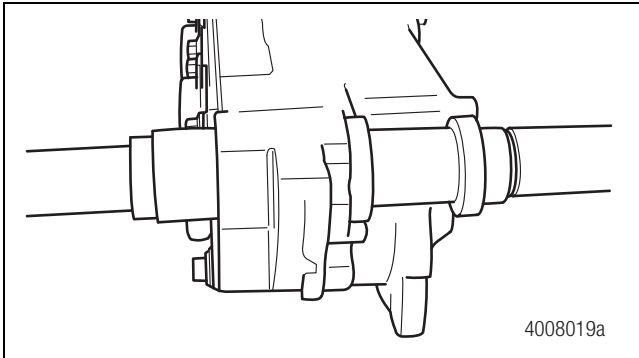

Figure 6.43

⚠ CAUTION

Do not use a drift to install the bushing. A drift can damage the edge and prevent correct fit of the slide pin.

3. Use the applicable parts of Meritor tool MST1000 to pull the bushing into the slide pin bore to a depth of 0.362- 0.378-inch (9.2-9.6 mm) from the end of the slide pin boot retainer side of the bore. Figure 6.44 and Figure 6.45.

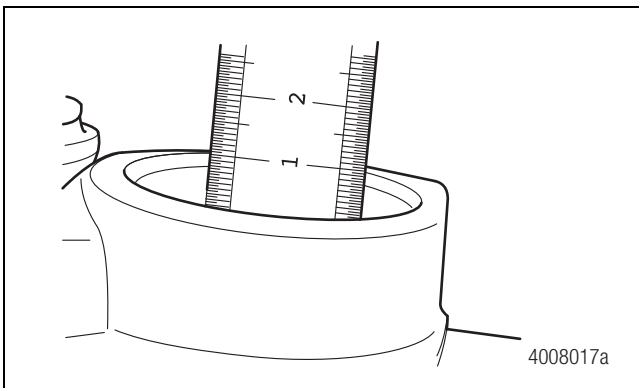

Figure 6.44

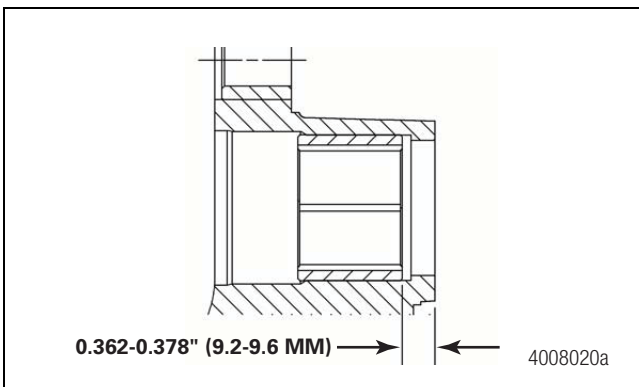

Figure 6.45

To Install the Boot Retainers for Oval Slide Pins

1. Place the retainer onto a suitable driver from Meritor tool MST1000. Figure 6.46.

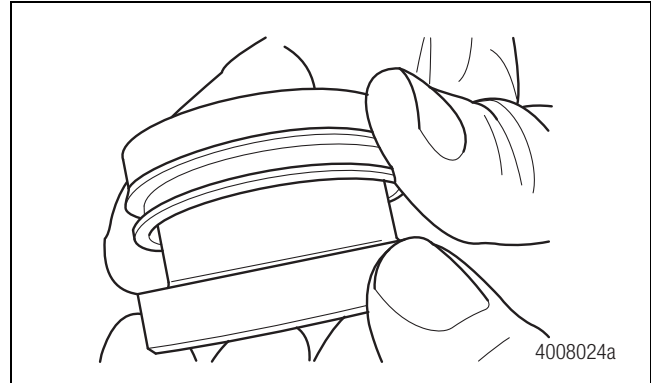

Figure 6.46

2. Place the retainer onto the housing.

⚠ CAUTION

Do not apply excessive force when you pull the retainer into the bore or damage to the bushing or retainer can result.

3. Use the applicable parts of Meritor tool MST1000 to draw the retainer into the slide pin bore until the flat face of the retainer is 0.183-0.202-inch (4.65-5.15 mm) from the end of the slide pin bore. Figure 6.47.

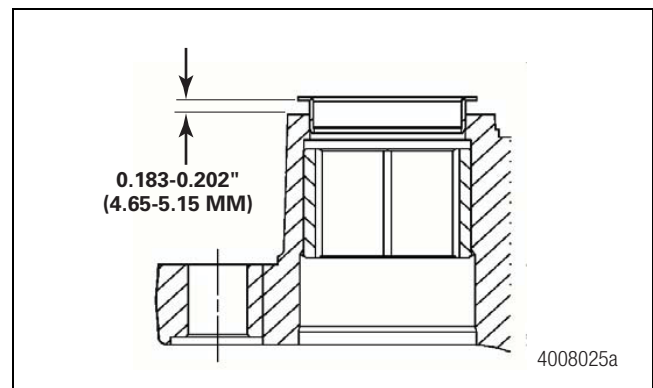

Figure 6.47

Replace the Slide Pins

1. Before you remove the slide pins, note the locations of the long and short slide pins. Remove the slide pin bolts retaining the slide pins to the carrier. Figure 6.48. If necessary, carefully release the slide pins from their location on the carrier using a rubber or soft metal hammer.

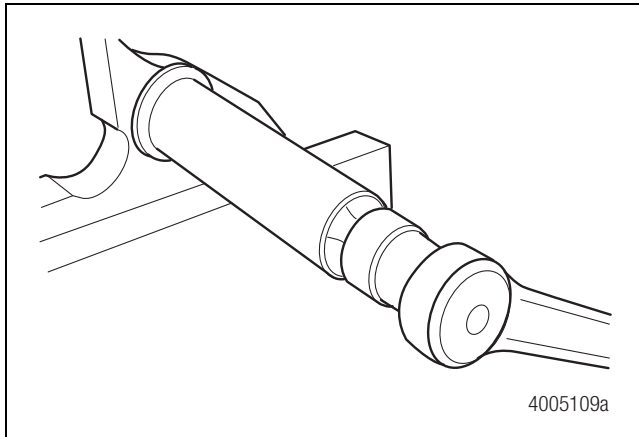



Figure 6.48

2. Clean the slide pin contact areas and the threaded holes in the carrier. Check for wear.
 - **If the carrier requires replacement:** Remove it from the axle and replace it with a new caliper. Refer to the procedure in this section.
3. To ensure correct function of the caliper, the long and short slide pins must be correctly located and installed onto the carrier. The long slide pin and short slide pin need no alignment. Locate the new slide pin positions on the carrier and secure with the corresponding slide pin bolts. Tighten the bolts to 310-332 lb-ft (420-450 N•m). 

Install the Slide Pin Boots

1. Use the grease provided in the kit to lightly lubricate the slide pins and the inside of the new slide pin boots. You must use the grease supplied with the replacement components and kits. Do not use any other type of grease.
2. Slide the new slide pin boots over the slide pins. Verify that the slide pin boot bead is in the slide pin retainer groove. Figure 6.49 and Figure 6.50.

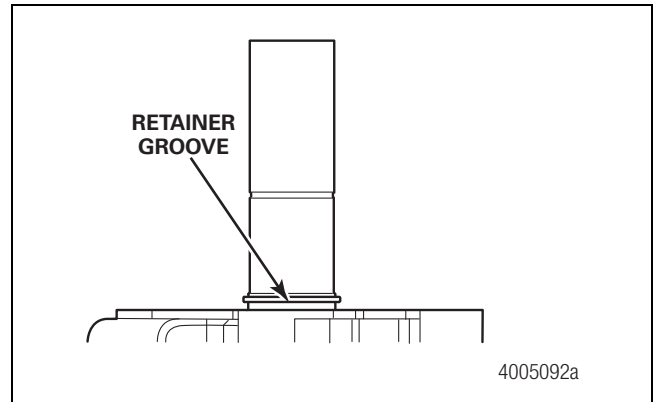

Figure 6.49

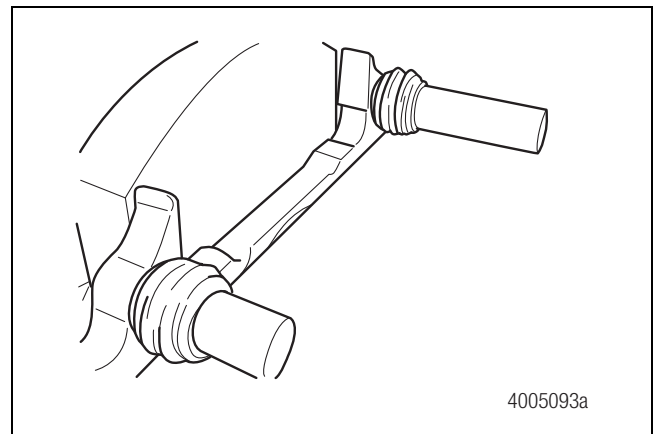

Figure 6.50

3. Proceed to the caliper housing assembly installation procedure in this section.

Install the Caliper Housing Assembly

1. Apply grease to the slide pins and slide bores in the housing assembly. Figure 6.51 and Figure 6.52.

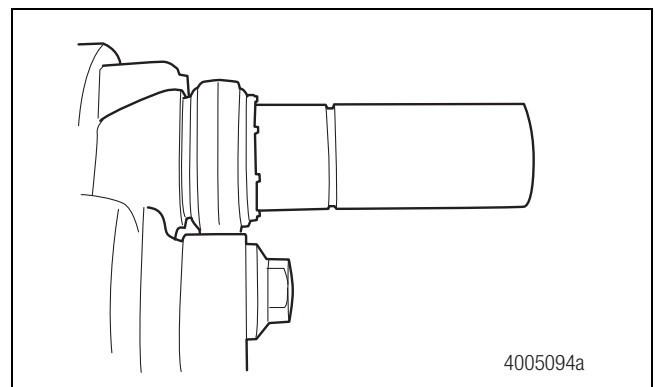

Figure 6.51

6 Caliper Components Replacement

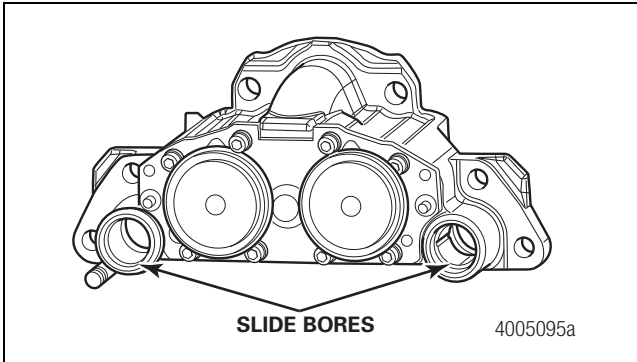

Figure 6.52

2. Carefully slide the housing assembly onto the slide pins. Be careful not to damage the slide pin boots when you install the housing assembly onto the slide pins. Figure 6.53.

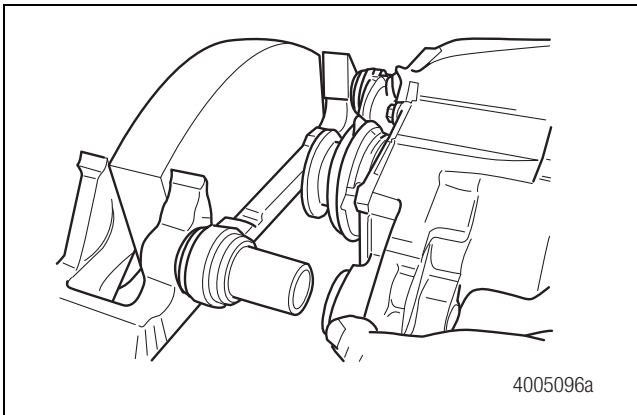

Figure 6.53

3. Install the slide pin boot beads into the housing retainer grooves. Figure 6.54 and Figure 6.55.

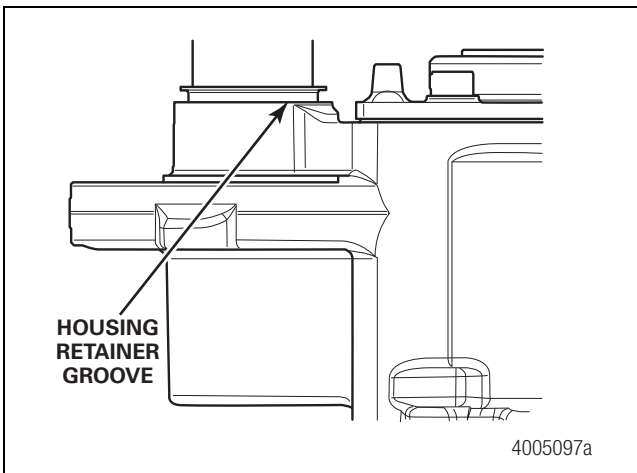

Figure 6.54

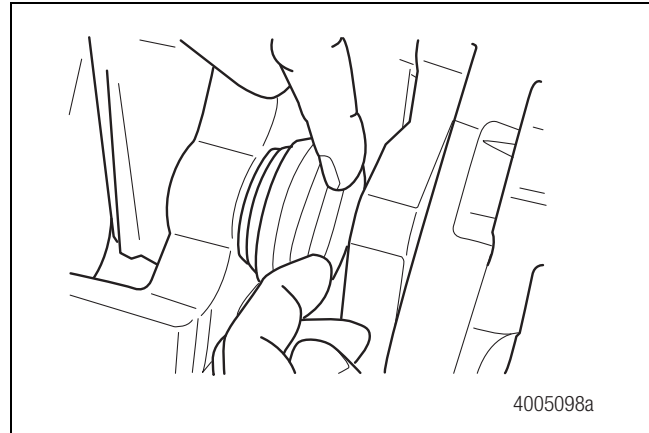

Figure 6.55

4. Verify that the slide pin boots are correctly located on both the carrier and housing retainers. Figure 6.56.

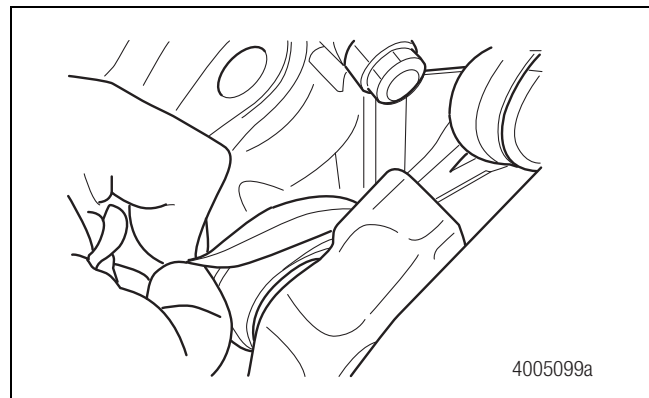

Figure 6.56

⚠ WARNING

Use a brass or synthetic mallet for assembly and disassembly procedures. Do not hit steel parts with a steel hammer. Pieces of a part can break off. Serious personal injury and damage to components can result.

5. For current EX225L2, H4, H6 and older revision of EX225H2 and H3 manufactured prior to 9/14/2010.

If you are installing a new housing, use a copper-faced mallet to carefully tap one of the new end caps into the caliper housing assembly until it retains itself. Use the correct size tool to tap the end cap into the bore 0.069-0.088-inch (1.75-2.25 mm) for the short slide pin side, Figure 6.57, and 0.228-0.251-inch (5.8-6.4 mm) for the long slide pin side, Figure 6.58. The caps must be installed to the correct depth.

6 Caliper Components Replacement

For the new revision of EX225H2 and H3 manufactured after 9/14/2010. If you are installing a new housing, use a copper-faced mallet to carefully tap one of the new end caps into the caliper assembly until it retains itself. Use the correct size tool to tap the end caps into the bore 0.069-0.088-inch (1.75-2.25 mm) for the short slide pin side, Figure 6.57, and 0.069-0.088-inch (1.75-2.25 mm) for the long slide pins Figure 6.58. The caps must be installed to the correct depth.

- **If the cap is pressed into the bore below the minimum dimension:** The full movement of the housing assembly will be restricted.

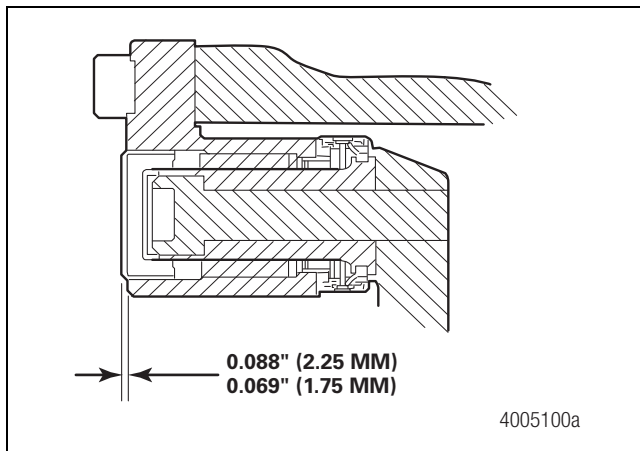

Figure 6.57

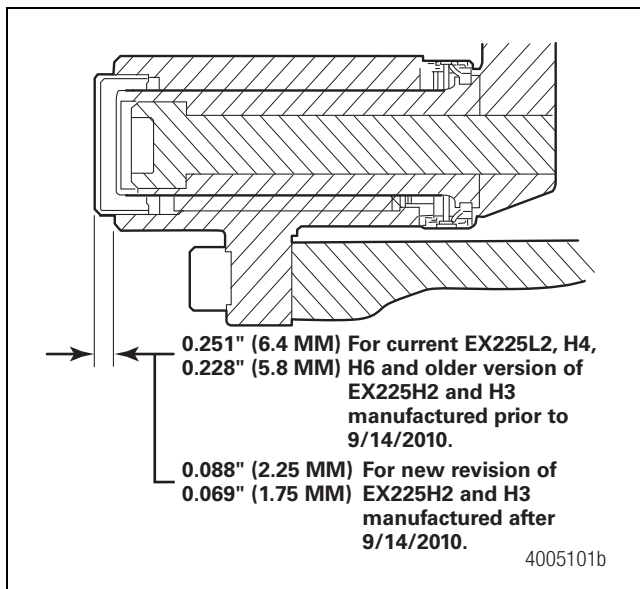

Figure 6.58

⚠ WARNING

When sliding the housing assembly, take care to avoid trapping your fingers or personal injury can result.

6. Check the housing assembly to verify that it slides by hand on the slide pins. Take care not to trap your fingers while you check the sliding action of the housing assembly. Slide the housing assembly back and forth several times to check for smooth movement on the slide pins. The boots are correctly installed if they collapse from the pressure changes within the slide pin mechanism. Figure 6.59.

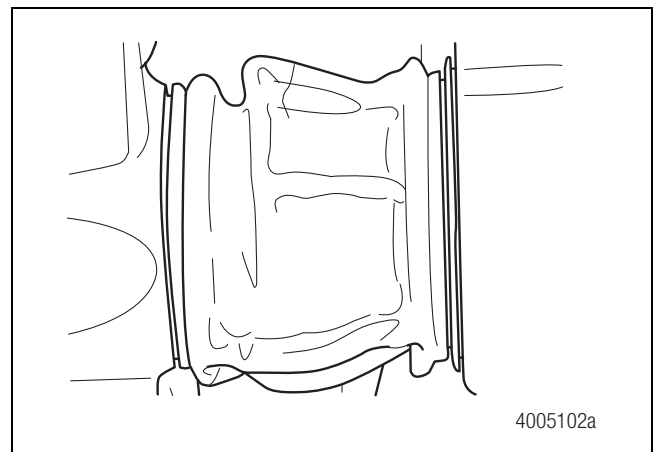
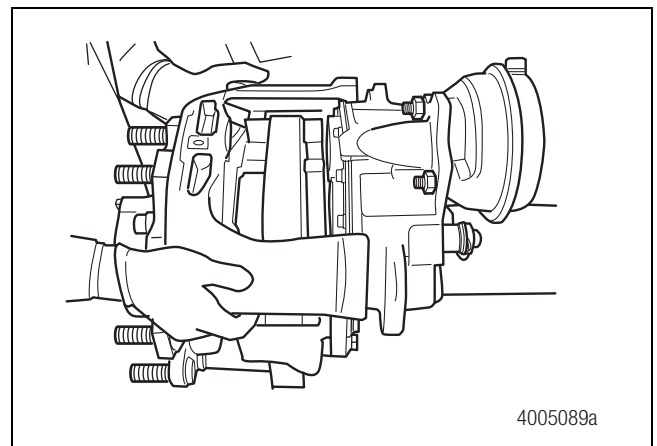

Figure 6.59

7. Proceed to the caliper bridge installation procedure in this section.

Install the Caliper Bridge

1. Position the bridge against the caliper housing assembly. Figure 6.60.



6 Caliper Components Replacement

Figure 6.60

⚠ WARNING

USE ONLY NEW BRIDGE BOLTS when you install the caliper bridge. Discard bridge bolts that were removed. Do not reuse bridge bolts, which can weaken under operating stress and may not tighten correctly. Sudden loss of braking performance, serious personal injury and damage to components can result.

NOTE: New bridge bolts are included in the slide pin/piston boot kit.

NOTE: EX+ L model bridge bolts require a E18 Torx socket. EX+ H model bridge bolts require E20 Torx socket.

2. Support the bridge in position. Install the four NEW bridge bolts included in the service kit. Do not reuse the bolts that were removed. Tighten the bolts to the torque specified in Section 10. Figure 6.61. If necessary, install the caliper assembly onto the axle. Refer to the procedure in this section.

- **If you are using M16 torx-head bridge bolts:** The preferred tightening method is “torque and angle”.

An alternative method is “torque only”. Before you proceed, follow these instructions.

- A. Inspect the NEW bridge bolts to ensure they are not damaged or corroded.
- B. The bridge bolts should thread into the hole with minimal torque, ideally by hand.
- C. The bridge bolts must be dry. Check for grease or oil on the threads or under the bolt head.

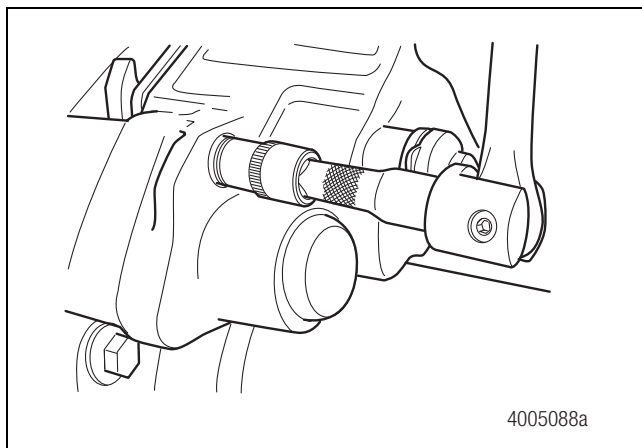

Figure 6.61

3. Remove the clip/retainer from the visual wear indicator where applicable. Figure 6.62.

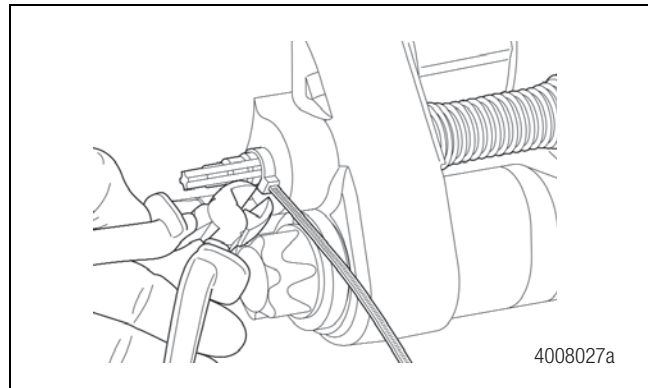

Figure 6.62

Hazard Alert Messages

Read and observe all Warning and Caution hazard alert messages in this publication. They provide information that can help prevent serious personal injury, damage to components, or both.

⚠️ WARNING

To prevent serious eye injury, always wear safe eye protection when you perform vehicle maintenance or service.

Park the vehicle on a level surface. Block the wheels to prevent the vehicle from moving. Support the vehicle with safety stands. Do not work under a vehicle supported only by jacks. Jacks can slip and fall over. Serious personal injury and damage to components can result.

Inspection

1. Wear safe eye protection. Park the vehicle on a level surface. Block the wheels to prevent the vehicle from moving.
2. Use a jack to raise the vehicle so that the wheels to be serviced are off the ground. Support the vehicle with safety stands.
3. With the pads removed, rotate the wheel and inspect the hub and rotor assembly for damage.
4. Inspect both sides of the rotor for cracks and heat checks. Replace the hub, rotor or entire assembly, if necessary.
5. Check the hub and rotor assembly for damaged, loose or missing fasteners. For the correct torque, refer to Section 10.

Cracks

⚠️ WARNING

Always replace a cracked rotor to avoid serious personal injury and damage to components.

When the crack extends through a section of the rotor, replace the rotor. Figure 7.1.

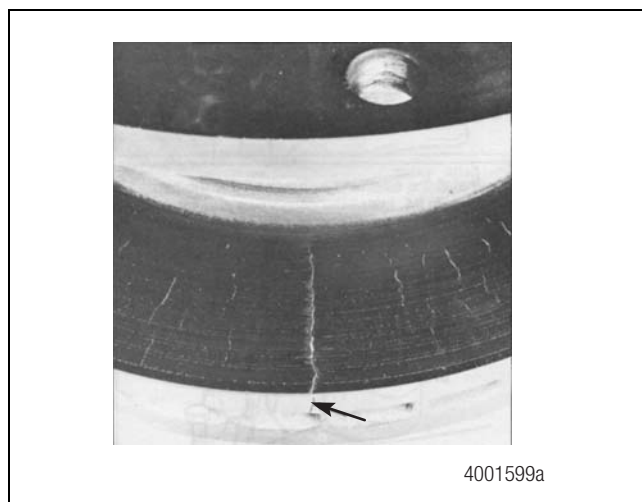

Figure 7.1

Heat Checking

Heat checks are short, thin, sometimes numerous, radial interruptions of the rotor braking surfaces. They are the result of disc brake operation. They are caused by the heating and cooling that occurs as the brakes are applied time after time. Heat checks will frequently wear away and reform, or they may become braking surface cracks, depending on such factors as the lining and rotor wear rate, brake balance, and how hard the brakes are used. There are two kinds of heat checking: light and heavy. Figure 7.2.

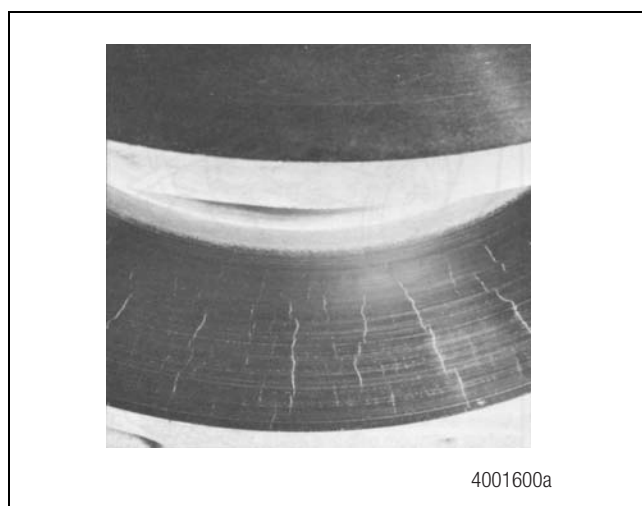

Figure 7.2

7 Rotor

Light Heat Checking

Cracks on the surface of the rotor that result from light heat checking are small and fine and do not require rotor replacement. Figure 7.2 and Figure 7.3.

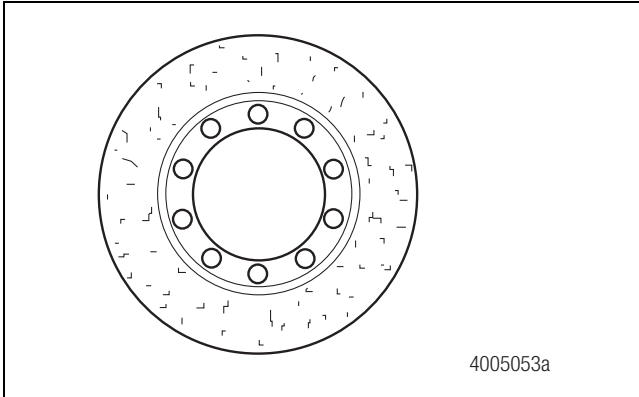

Figure 7.3

Heavy Heat Checking

Heavy heat checking is surface cracks that have width and depth. Replace the rotor if the heat checks have a width greater than 0.02-inch (0.5 mm), depth greater than 0.04-inch (1 mm) and extend across the surface more than 75% in the radial direction. Figure 7.4.

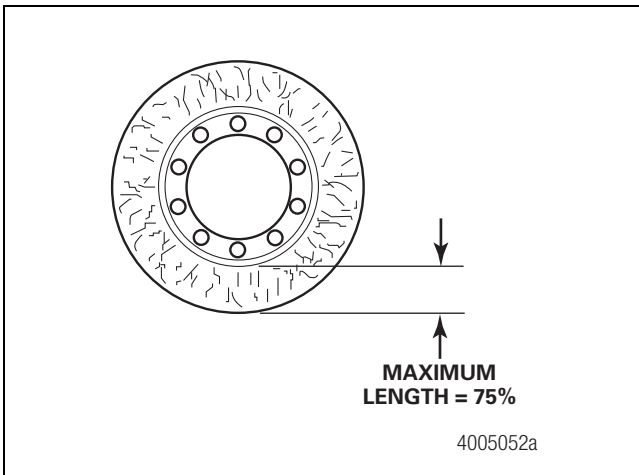

Figure 7.4

Deep Grooves or Scores

Inspect both sides of the rotor. If you find grooves or scores of a depth less than 0.02-inch (0.5 mm), continue to use the rotor. If the grooves are greater than 0.02-inch (0.5 mm), you may choose to resurface the rotor. If the rotor thickness measured across any groove is less than the minimum discard thickness found on the rotor casting, discard and replace the rotor. Figure 7.5.

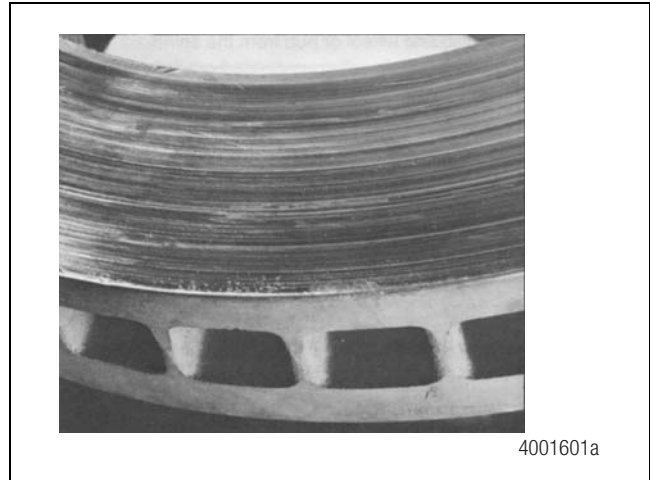

Figure 7.5

Blue Marks or Bands

Blue marks or bands indicate that the rotor was very hot. Determine the cause and correct the conditions. Figure 7.6.

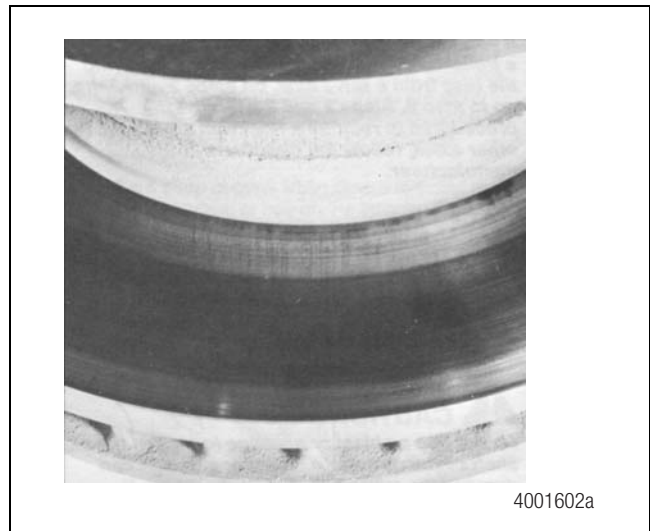

Figure 7.6

Measure the Rotor Thickness

⚠ CAUTION

Replace the rotor if it reaches the minimum allowable rotor thickness found on the rotor casting. Damage to components can result.

NOTE: The rotor can wear beyond its minimum thickness BEFORE the brake pads wear to their thickness limit and need to be changed. To ensure the rotor does not wear beyond its minimum thickness before the next brake pad change, it is typically necessary to replace the rotors BEFORE they reach their minimum thickness value.

1. Use a micrometer to measure the rotor thickness. If you are replacing the brake pads, the rotor should be replaced if the rotor thickness is less than the minimum discard thickness found on the rotor casting. Figure 7.7.

NOTE: Do not use a rotor that measures below 1.46 inches (37 mm). If it is reused below that measurement, the rotor will be undersized by the time the replacement pads wear out.

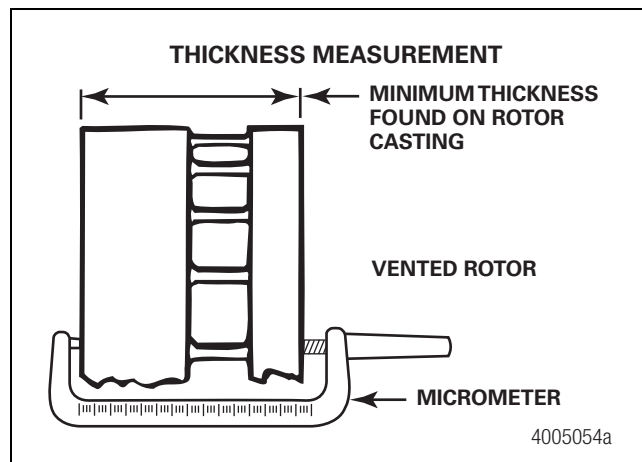

Figure 7.7

2. Check for uneven rotor wear on both the inboard and outboard sides of the rotor. To perform this check, place a feeler gauge between the rotor surface and carrier pad abutment. Maximum allowable gap is 0.236 inch (6 mm). Figure 7.8.
 - **If the gap between the rotor surface and carrier pad abutment exceeds 0.236 inch (6 mm) on either side:** Replace the rotor.

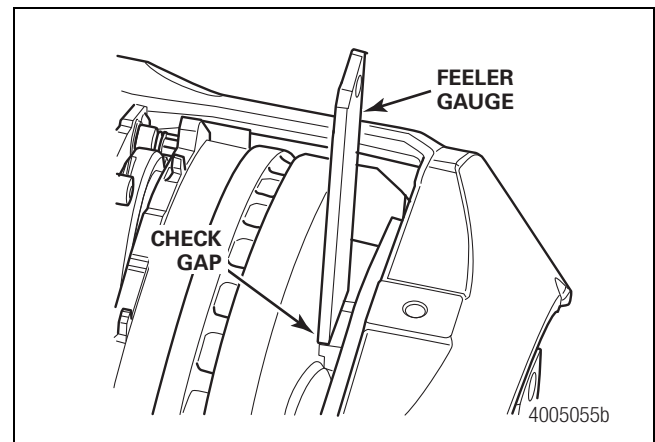

Figure 7.8

Measure the Rotor Runout

1. Attach a dial indicator to the caliper or axle frame.
2. Check the lateral runout of the rotor braking surface. Refer to the rotor manufacturer for correct procedures. The runout measurement should be taken from the center of the rotor braking surface. The end play of the hub bearings should not be included in this measurement. The runout should not exceed 0.02-inch (0.5 mm) through one full revolution of the rotor.
 - **If the runout is greater than 0.02-inch (0.5 mm):** Check the wheel bearings for correct adjustment. Refer to the manufacturer's instructions.

Removal and Installation

Replace the Rotor

1. Remove the caliper. Refer to Section 6.
2. Remove the hub and rotor assembly. Refer to the axle manufacturer's service manual.
3. Use the correct size socket wrench to remove the hub-to-rotor bolts and washers. Refer to Section 10. Remove the rotor from the hub.
4. Verify that the hub and rotor mating surfaces are clean and free of debris or burrs. Verify that the hub rotor pilots are correctly engaged to the rotor.

7 Rotor

⚠ WARNING

Use the correct fasteners and washers. Incorrect fasteners and washers may result in an insufficient clamping load or damage to the caliper or wheel. Serious personal injury and damage to components can result.

Take care when you use Loctite[®] adhesive to avoid serious personal injury. Read the manufacturer's instructions before using this product. Follow the instructions carefully to prevent irritation to the eyes and skin. If Loctite[®] adhesive material gets into your eyes, follow the manufacturer's emergency procedures. Have your eyes checked by a physician as soon as possible.

5. Apply Loctite[®] 620 retaining compound to the new hub-to-rotor bolts.
6. Use the new hub-to-rotor bolts and washers to attach the new rotor to the hub. Be careful not to damage or move the hub-mounted tone rings during new rotor installation.
7. Tighten the hub-to-rotor bolts in a crisscross pattern to the correct torque. Refer to Section 10. Figure 7.9 or Figure 7.10.

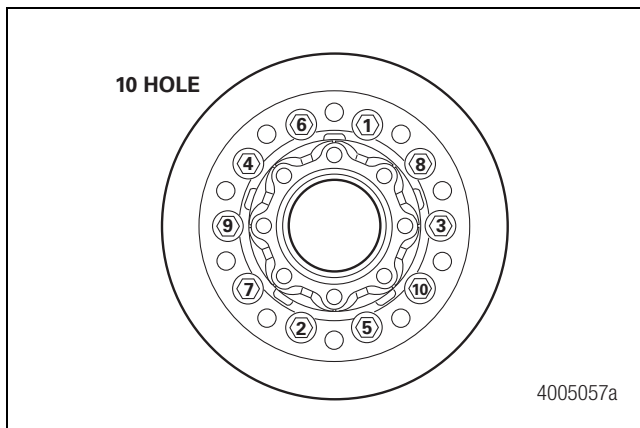

Figure 7.9

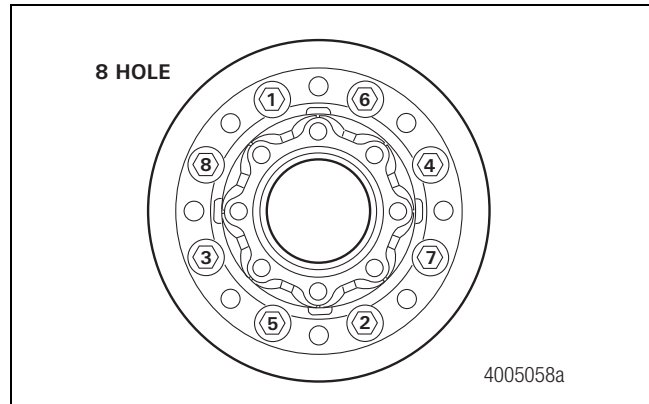

Figure 7.10

8. Ensure that all bolt heads do not protrude past the wheel-to-hub mounting surface.
9. Install the hub and rotor assembly to the axle. Refer to the axle manufacturer's service manual. Ensure that the rotor braking surfaces are free of oil, grease and other contaminants.
10. Install the caliper assembly and brake pads. Adjust the brake pad-to-rotor clearance. Refer to Section 6.

Hazard Alert Messages

Read and observe all Warning and Caution hazard alert messages in this publication. They provide information that can help prevent serious personal injury, damage to components, or both.

⚠️ WARNING

To prevent serious eye injury, always wear safe eye protection when you perform vehicle maintenance or service.

Park the vehicle on a level surface. Block the wheels to prevent the vehicle from moving. Support the vehicle with safety stands. Do not work under a vehicle supported only by jacks. Jacks can fall over. Serious personal injury and damage to components can result.

Introduction

The EX+ air disc brake uses a 0.59-inch (15 mm) chamber piston standout length. Figure 8.1. The air chamber part number is located on a nameplate.

⚠️ WARNING

Always install an air chamber with the correct chamber piston length. If an incorrect air chamber is installed, the difference in chamber piston length will result in partial brake application. Serious personal injury and damage to components can result.

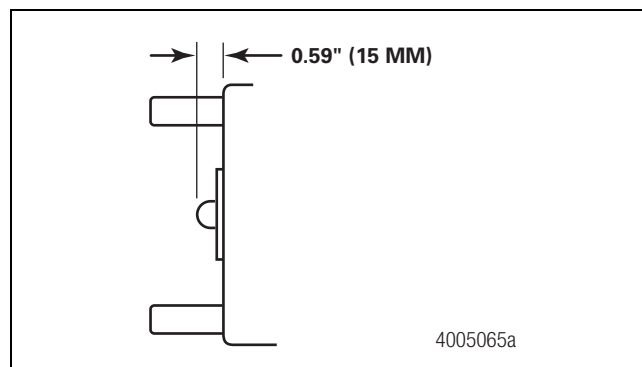

Figure 8.1

Removal and Inspection

Spring or Service Brake Chamber

⚠️ WARNING

Before you service a spring chamber, carefully follow the manufacturer's instructions to compress and lock the spring to completely release the brake. Verify that no air pressure remains in the service chamber before you proceed. Sudden release of compressed air can cause serious personal injury and damage to components.

1. If the brake chamber has a spring brake, carefully cage and lock the spring to completely release the brake prior to removal. Refer to the chamber manufacturer's instructions for complete procedures.
2. Remove the brake chamber. Refer to the chamber manufacturer's instructions for complete procedures.
3. With the air chamber removed, visually inspect the chamber mounting studs. Figure 8.2.
 - **If there are signs of uneven wear, broken, loose or missing studs:** Replace the chamber.

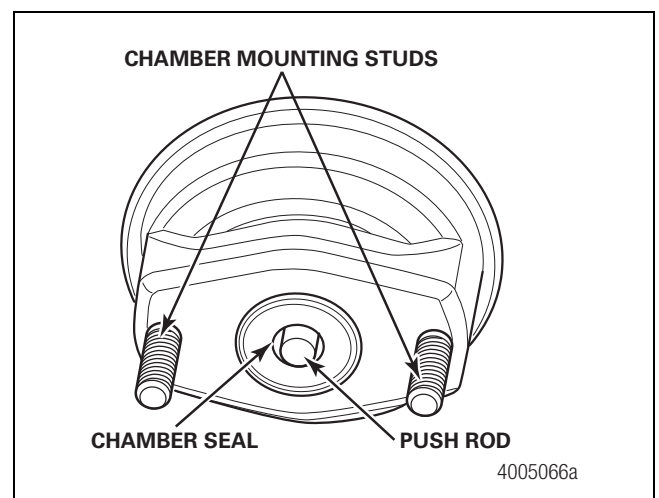

Figure 8.2

4. Visually inspect the chamber push rod and chamber seal on the chamber. Figure 8.2.
 - **If there is damage:** Replace the chamber.

8 Air Chamber

5. Inspect the inner boot on the brake chamber for damage and proper seal. If the inner boot of the brake chamber is damaged, water can enter the caliper housing assembly, resulting in damage to the component.

- **If the inner boot is damaged or not sealed properly:**
Replace the brake chamber per the chamber manufacturer's recommendations.

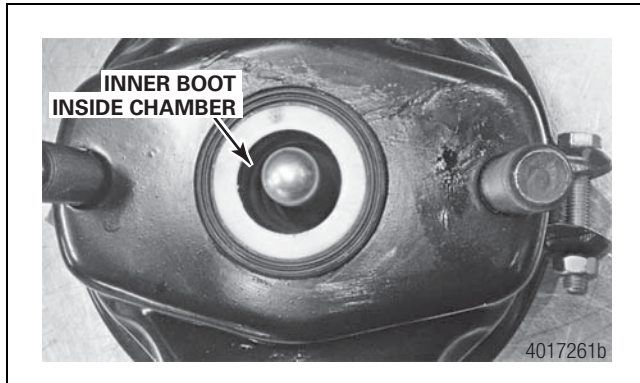

Figure 8.3

6. Check the caliper-to-air brake chamber seal on the caliper.
 - **If the seal is damaged:** Replace the seal. To obtain this seal, contact Meritor's Commercial Vehicle Aftermarket at 888-725-9355.
7. Visually inspect the chamber-mounting aperture on the caliper housing assembly for signs of water entry and corrosion. Figure 8.4.
 - **If signs of water entry and corrosion are present:**
Replace both the brake chamber and caliper assembly.

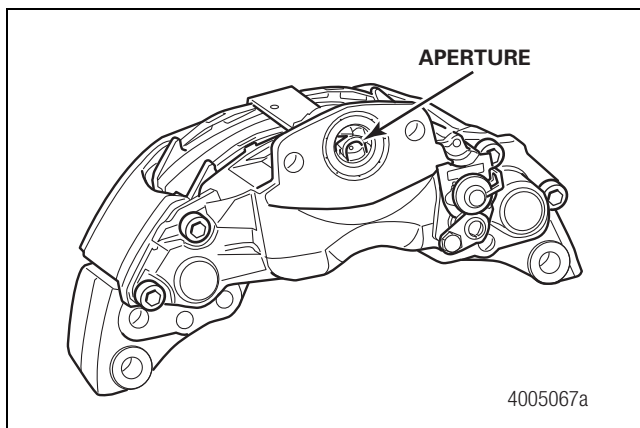

Figure 8.4

Installation

Spring or Service Brake Chamber

When installing service brake chambers, if there is no spring brake chamber to cage, proceed to the installation procedure. If the caliper has a spring chamber, carefully cage and lock the spring. Follow the chamber manufacturer's instructions completely to release the brake. Typically, new spring brake chambers are shipped caged.

1. Verify that the chamber seal is well seated, free of debris and shows no signs of damage. Check the mounting face for corrosion or debris. Do not install a brake chamber that shows signs of debris or excess flash on the seal.
2. Verify that the caliper seal surface and the mounting surface are free of oil, grease and debris and show no signs of damage.
3. If you are installing the brake chamber on an existing caliper, install a new caliper-to-air brake chamber seal on the caliper.
4. Before you install the air chamber onto the caliper assembly, ensure the perforated transit plug is removed from the caliper chamber seal by pulling the tab. Figure 8.5 and Figure 8.6.

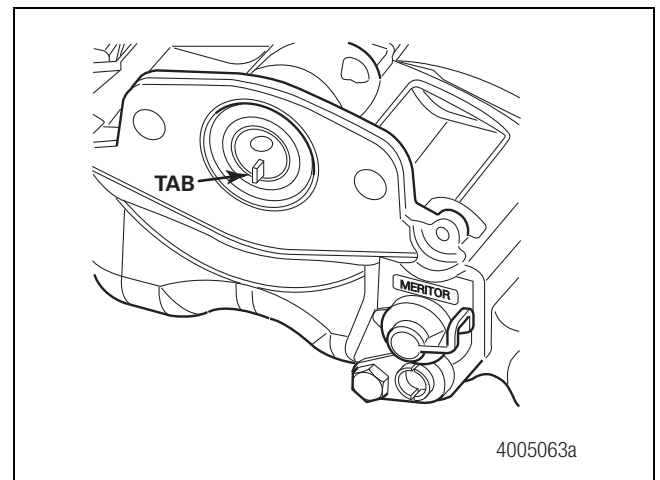

Figure 8.5

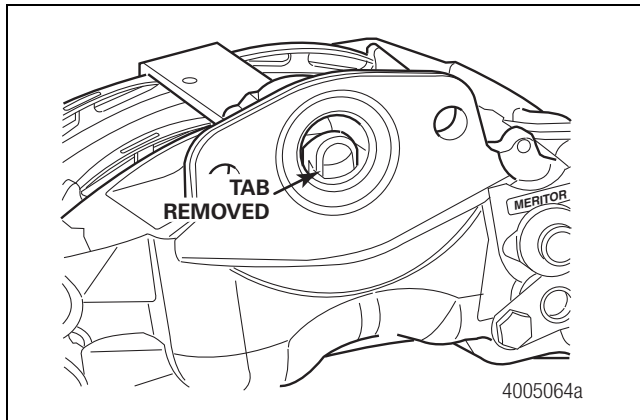



Figure 8.6

5. Position the chamber onto the caliper. Determine which of the two possible brake chamber orientations places the ports in the most accessible position.
6. As you position the chamber onto the caliper, visually check that the chamber push rod is nesting in the pocket of the operating shaft.
7. Firmly hold the chamber onto the caliper by hand. Place the two washers and nuts onto the mounting studs. Do not work from behind the spring brakes, always work from the side and front. Spring brake chambers are under more than 2,000 pounds (8900 N) of spring force.
8. Use a 24 mm wrench to tighten the nuts in an alternating sequence.
 - A. Tighten the nuts until the mating surfaces meet. Use minimal torque on the two nuts.
 - B. Use a torque wrench to tighten each nut to 59-75 lb-ft (80-100 N•m). Then, use a torque wrench to tighten each nut to 133-155 lb-ft (180-210 N•m). 
9. If breather plugs are supplied, locate the bottommost breather plug and remove it from the chamber. Figure 8.7 and Figure 8.8.

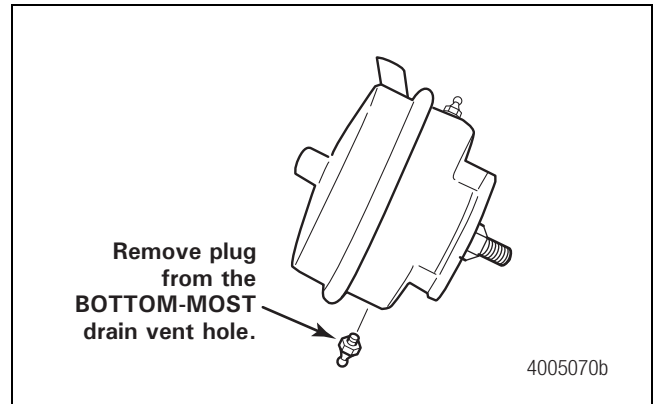

Figure 8.7

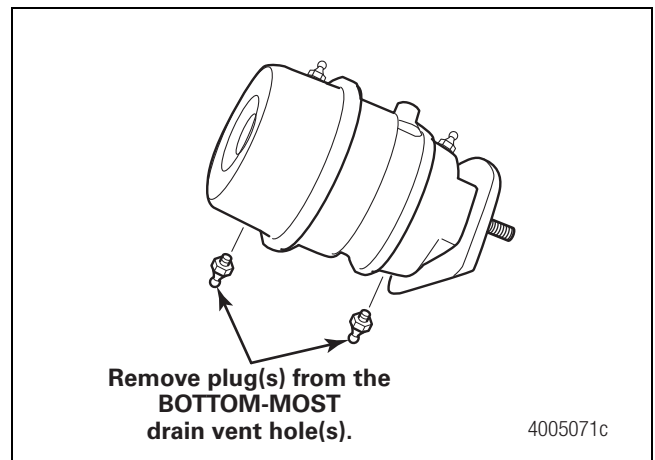

Figure 8.8

10. Install the air hoses to the chamber ports. Refer to the manufacturer's instructions.
11. If the caliper has a spring chamber, carefully uncage and unlock the spring. Follow the chamber manufacturer's instructions.

9 Pad Wear Warning Indicator (PWWI) System

Hazard Alert Messages

Read and observe all Warning and Caution hazard alert messages in this publication. They provide information that can help prevent serious personal injury, damage to components, or both.

⚠ WARNING

To prevent serious eye injury, always wear safe eye protection when you perform vehicle maintenance or service.

Park the vehicle on a level surface. Block the wheels to prevent the vehicle from moving. Support the vehicle with safety stands. Do not work under a vehicle supported only by jacks. Jacks can slip and fall over. Serious personal injury and damage to components can result.

Before you service a spring chamber, carefully follow the manufacturer's instructions to compress and lock the spring to completely release the brake. Verify that no air pressure remains in the service chamber before you proceed. Sudden release of compressed air can cause serious personal injury and damage to components.

⚠ ASBESTOS AND NON-ASBESTOS FIBERS WARNING

Some brake linings contain asbestos fibers, a cancer and lung disease hazard. Some brake linings contain non-asbestos fibers, whose long-term effects to health are unknown. You must use caution when you handle both asbestos and non-asbestos materials. Refer to page i for asbestos and non-asbestos safety information and recommended work practices.

Pad Wear Warning Indicator (PWWI) System

PWWI Overview

Some Meritor EX+ air disc brakes are equipped with pad wear warning indicators (PWWI) to monitor pad wear. In this electronic system, a pad wear warning indicator (PWWI) is fitted to the pad of each brake. When the lining thickness wears to a specified value, depending on the vehicle configuration, a warning signal will be given to indicate that a pad change is required. Figure 9.1.

NOTE: Brake pads and the PWWI, if applicable, must be replaced when the lining thickness has worn to the values listed in Section 10.

NOTE: A PWWI assembly must be replaced if either of the two sensors were worn into by a pad that has worn thin and the rotor has worn into the sensor.

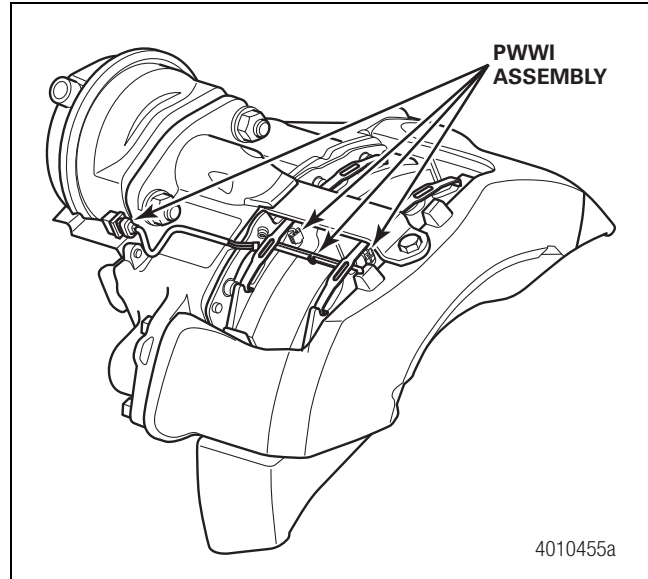

Figure 9.1

PWWI Service During Brake Pad Removal

When removing the pad springs during brake pad removal, lift the PWWI assembly and disengage the tang from the housing assembly. Do not remove the plastic block sensors from their locations in the pads unless the PWWI assembly is being replaced. Always replace a damaged PWWI assembly with genuine OE parts. Figure 9.2 and Figure 9.3.

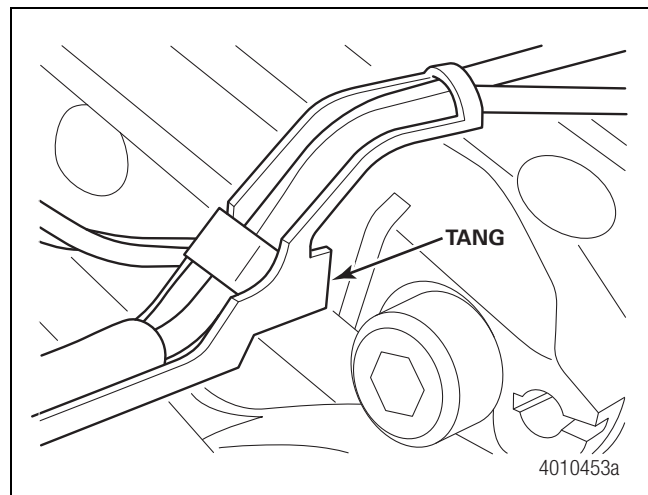

Figure 9.2

9 Pad Wear Warning Indicator (PWWI) System

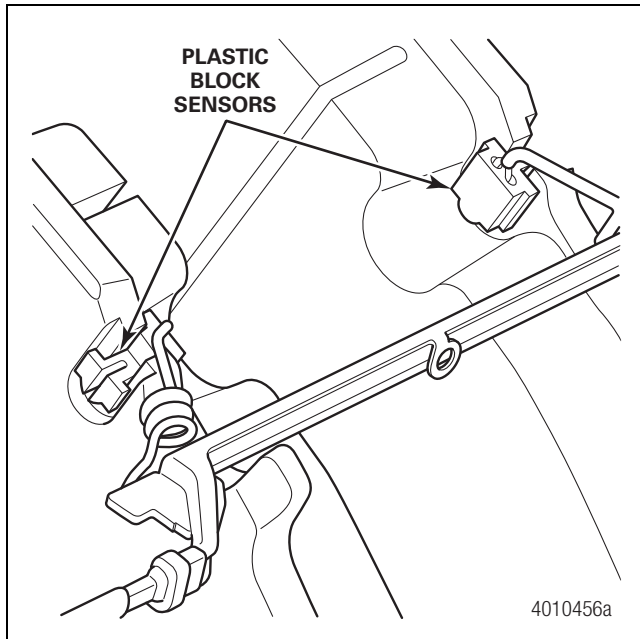
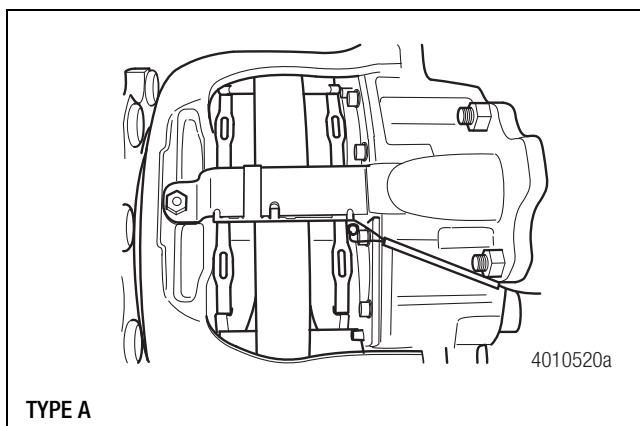

Figure 9.3

PWWI Installation During Brake Pad Installation

When the brake pads are being replaced, once you've installed the brake pads and pad strap, you must install the PWWI assembly on the brake. Once the PWWI assembly is installed, set the initial brake-to-rotor running clearance as usual.

EX+ air disc brakes can incorporate alternative PWWI arrangements to monitor pad wear. Refer to Figure 9.4 for Type A, Figure 9.5 for Type B and Figure 9.6 for Type C to identify the arrangement used on your brake. Follow the appropriate procedure below to install the PWWI assembly.



TYPE A

Figure 9.4

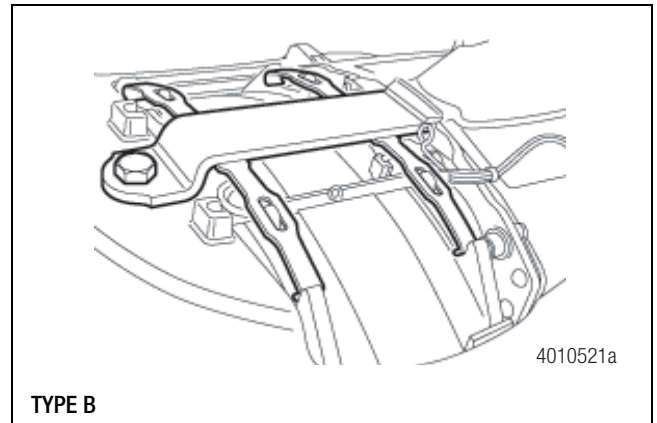

TYPE B

Figure 9.5

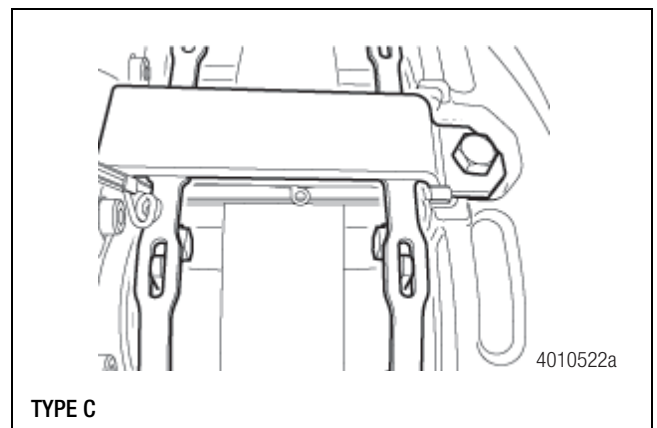

TYPE C

Figure 9.6

⚠ WARNING

To prevent serious eye injury, always wear safe eye protection when you perform vehicle maintenance or service.

Park the vehicle on a level surface. Block the wheels to prevent the vehicle from moving. Support the vehicle with safety stands. Do not work under a vehicle supported only by jacks. Jacks can slip and fall over. Serious personal injury and damage to components can result.

As per normal service instructions, always wear safe eye protection when servicing the brakes. Park the vehicle on a level surface. Block the wheels to prevent the vehicle from moving. Support the vehicle with safety stands.

9 Pad Wear Warning Indicator (PWWI) System

Type A Installation

1. If a new PWWI is to be installed, position the pad wear cable correctly and carefully clip the pad wear warning cable retainer to the pad retaining plate.
2. Carefully hold the pad retaining plate with the PWWI in position to allow for installation of the plastic sensor blocks. Install the plastic blocks of the PWWI into the pads. Do not use excessive force, but ensure they are pushed to the bottom of the slot.
3. Ensure the PWWI wiring is routed over the pad backplate, away from the rotor. Figure 9.7.

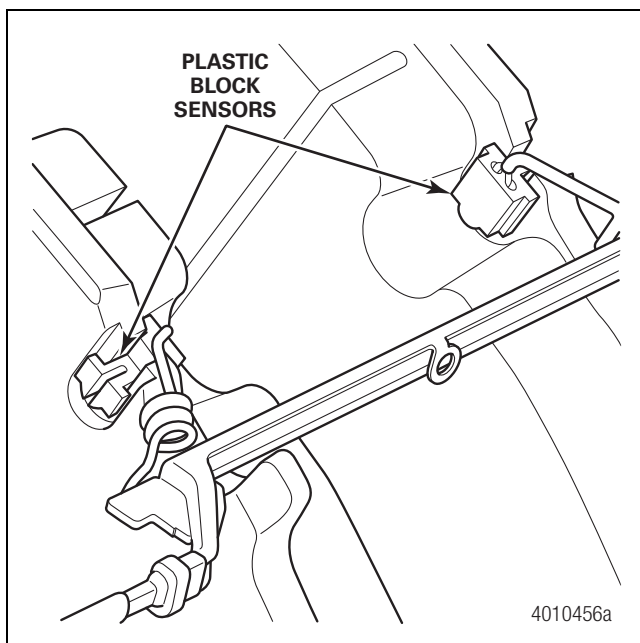

Figure 9.7

Type B and Type C Installation

1. Install the plastic blocks of the PWWI into the pads. Do not use excessive force, but ensure they are pushed to the bottom of the slot. Figure 9.7.
2. Position the PWWI assembly into the brake and engage the tang into the housing. Figure 9.8.

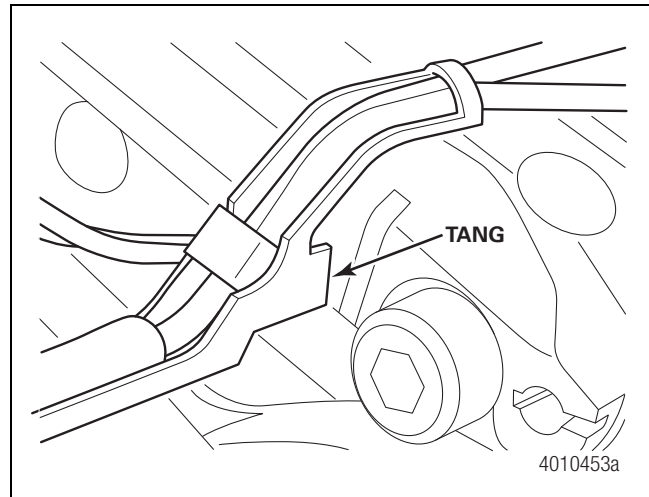

Figure 9.8

3. Ensure the PWWI wiring is routed over the pad backplate, away from the rotor.

Lining Wear Limits

Replace brake pad assemblies before the lining thickness reaches 0.12-inch (3 mm).

To obtain the lining thickness, measure the friction material thickness on the brake pad. Figure 10.1.

NOTE: Fleet wear limits should be determined by the specific operation to ensure linings are replaced prior to reaching the wear limit before the next inspection.

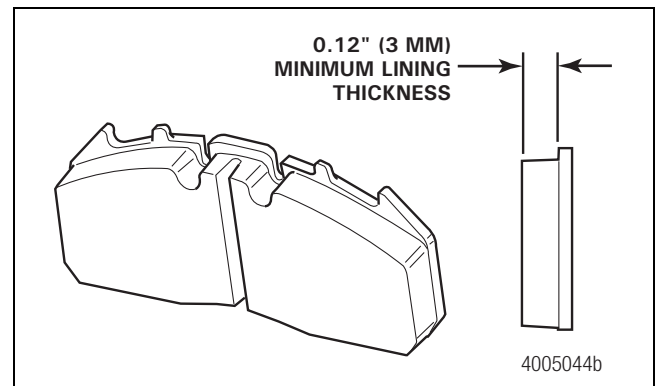

Figure 10.1

Torque Specifications

NOTE: Always refer to the vehicle manufacturer's torque specifications, if available.

Description	Fastener Size	Socket Size	lb-ft	N•m
Pad Retainer Bolt	M10	17 mm	25-30	34-40
Carrier Bolt on Axial Mount Carrier	M20	30 mm	350-450 ¹	474-610
Carrier Bolt on Radial Mount Carrier	M16	24 mm	205-235	277-318
	M20 Internal Head ²	17 mm	350-450	474-610
Bridge Bolt	M14 Torx Head	E18	174-202	235-275
Bridge Bolt	M16 Internal Head	14 mm	221-253	300-350
Bridge Bolt	M16 Torx Head	E20	Torque and Angle (Recommended)	
			70-77	95-105
			+75 degrees +/- 5 degrees	+75 degrees +/- 5 degrees
			Torque Only	
			211-217	285-295
Slide Pin Bolts	M18 Torx Head	T80	296-310	400-420
Hub-to-Rotor Bolt	5/8-inch	15/16-inch	220-240	298-325
Hub-to-Rotor Bolt	M16	24 mm	165-190	224-257
Air Chamber Nut, Initial	M16	24 mm	59-75	80-100
Air Chamber Nut, Final	M16	24 mm	133-155	180-210

¹ Torque wrench setting must be altered when using service tool MST225 5001.

² For DTNA radial mount calipers, refer to the separate procedure in this section.

10 Specifications

Torque Wrench Setting Using Extension Adapter MST225 5001 (ADB225 Wrench)

Extension adapter MST225 5001 (ADB225 Wrench) is a service tool designed to provide easier access to the axial type ADB carrier-to-torque plate bolts. When using this extension adapter, the torque wrench setting must be altered to obtain accurate tightening of the carrier-to-torque plate bolts. Refer to Section 12 for an illustration of the tool, Figure 10.2, and Table A for the altered torque wrench setting.

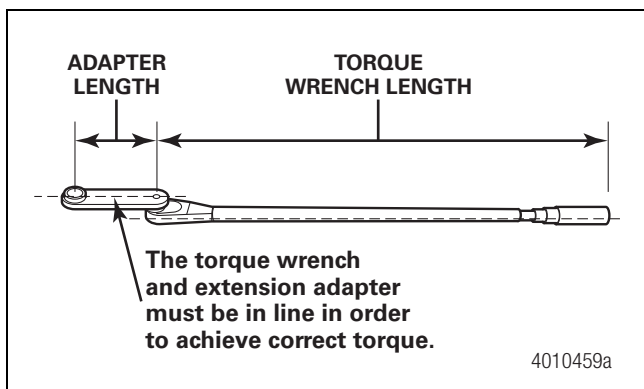

Figure 10.2

NOTE: If the extension adapter is installed at a 90 degree angle to the direction of torque application, no adjustment in torque needs to be made.

The following torque specifications are for 7-inch extension adapters only. If you are using a different size extension adapter, the torque specifications will be affected.

Table A: Carrier-to-Torque Plate Torque Using 7-Inch Extension Adapter

Description	lb-ft	N•m
Carrier Bolt Standard Torque Wrench Setting	450	610
2-Foot Torque Wrench Setting with 7-inch Extension Adapter	348	472
3-Foot Torque Wrench Setting with 7-inch Extension Adapter	377	511
4-Foot Torque Wrench Setting with 7-inch Extension Adapter	392	531
5-Foot Torque Wrench Setting with 7-inch Extension Adapter	402	545

Tightening Procedure for DTNA Radial Mount Caliper ONLY

Use the following steps and tightening sequence when installing carrier-to-torque plate bolts on DTNA radial mount calipers.

NOTE: These steps apply only to DTNA radial mount calipers. It is not necessary to follow a tightening sequence on any other EX+ brake models.

1. Tighten the four M20 bolts sufficiently to seat the brake caliper to the anchor plate using the sequence shown in Figure 10.3.

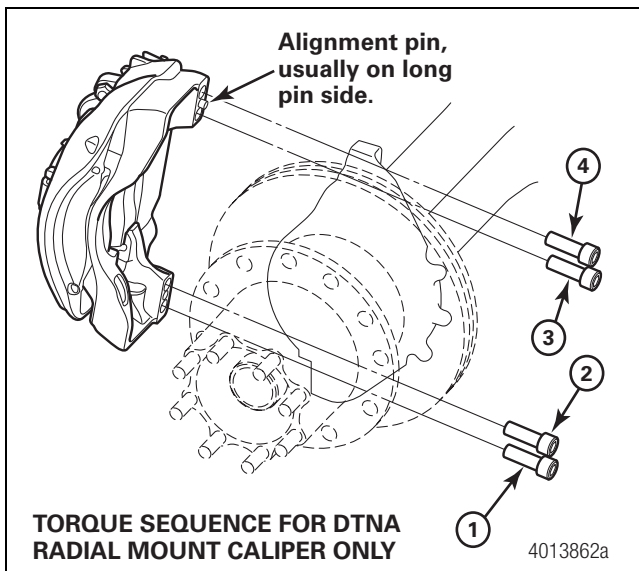



Figure 10.3

2. Tighten the bolts in the sequence shown to an initial torque of 40-50 lb-ft (54-68 N•m). 
3. Tighten the bolts in the sequence shown to a final torque of 350-450 lb-ft (474-610 N•m). 

11 Diagnostics

Troubleshooting

Table B: Air Disc Brake

Conditions	Possible Causes	Check For	Corrections
Brake drag	Incorrect initial adjustment	Correct pad-to-rotor clearance	Readjust to set the correct rotor-to-pad clearance.
	Incorrect pad-to-rotor clearance		
	Spring or service brake not releasing	Correct operation of air system or air chamber	Refer to the vehicle manufacturer's instructions. Repair or replace parts as required.
	Vehicle air system malfunction		
Brake not releasing	Damaged slide pin boots, caliper should move back and forth by hand with linings removed		Replace the caliper assembly.
	Water entry or seized operation shaft, internal		Replace the caliper assembly and air chamber.
	Air line too short	Correct air line length	Replace the air line. Refer to the vehicle manufacturer's instructions.
Short brake pad lining life	Refer to Brake drag.	Refer to Brake drag.	Refer to Brake drag.
	Caliper seized or sticking on slide pins	Damaged slide pin boots, caliper should move back and forth by hand with linings removed	Replace the caliper assembly.
	Damaged rotor surface	Cracks or heavy heat checking	Refer to Section 7.
	Vehicle overload	Refer to the weight limitations on the vehicle identification plate.	Observe the vehicle manufacturer's load recommendations.
	Companion brakes do not work correctly	Inspect the companion vehicle brakes and air system.	Adjust or repair as required.
	Abrasive environment	Contamination on the brake pad and rotor surface	Install pad or rotor shields where available.
Smoking brakes	High brake temperature	Refer to Brake drag and Short brake pad lining life.	Refer to Brake drag and Short brake pad lining life. Can be a temporary situation with new or low mileage pads.
	Contamination on the linings or rotor	Grease, oil, undercoating, paint, etc., on the linings or rotor	Inspect the hub seal. Replace as required. Clean the rotor and caliper assembly. Replace the pads.

Conditions	Possible Causes	Check For	Corrections
Poor stopping power <ul style="list-style-type: none"> • Long stopping distances • Poor driver feel • High brake pressures • Vehicle pulls to one side 	Vehicle air system malfunction	Correct air pressure at the chamber inlet	Have the air system evaluated by a qualified brake system specialist.
	Contamination on the linings or rotor	Grease, oil, undercoating, paint, etc., on the linings or rotor	Inspect the hub seal. Replace as required. Clean the rotor and caliper assembly. Replace the pads.
	Brakes out-of-adjustment	Excessive pad-to-rotor clearance	Readjust to set the correct pad-to-rotor clearance.
	Vehicle overload	Refer to the weight limitations on the vehicle identification plate.	Observe the vehicle manufacturer's load recommendations.
	Companion brakes not working correctly	Inspect the companion vehicle brakes and air system.	Adjust or repair as required.
	Incorrect pads installed	Refer to the vehicle manufacturer for the correct pads.	Replace the pads.
	Brake noise	Incorrect pad installation	Friction material facing the rotor surface
Brake pads not free to move in the caliper		Corrosion or debris on the pads or carrier abutments	Clean or replace the pads, if necessary. Clean the pad abutments on the carrier.
Worn brake pads		Lining thickness	Replace the pads, if necessary.
Brake component attachments are not installed to specification		Check for loose connections and fasteners.	Tighten the connections and fasteners to the specified torque.
Rotor cracks or excessive runout		Excessive cracking, heat checking or runout	Refer to Section 7.
Pad spring damaged or not installed		Correct pad spring installation	Install the pad springs.
Incorrect pads installed		Refer to the vehicle manufacturer for the correct pads.	Replace the pads.
Bent or loose pad retainer		Bent pad retainer or loose pad retainer bolt	Replace or tighten the pad retainer.

12 Special Tools

MST1000, Bushing Service Tool

To obtain this tool, call Meritor's Commercial Vehicle Aftermarket at 888-725-9355.

NOTE: This kit is for bushing installation. Bushings can be removed using the drivers in the kit and a dead blow hammer.

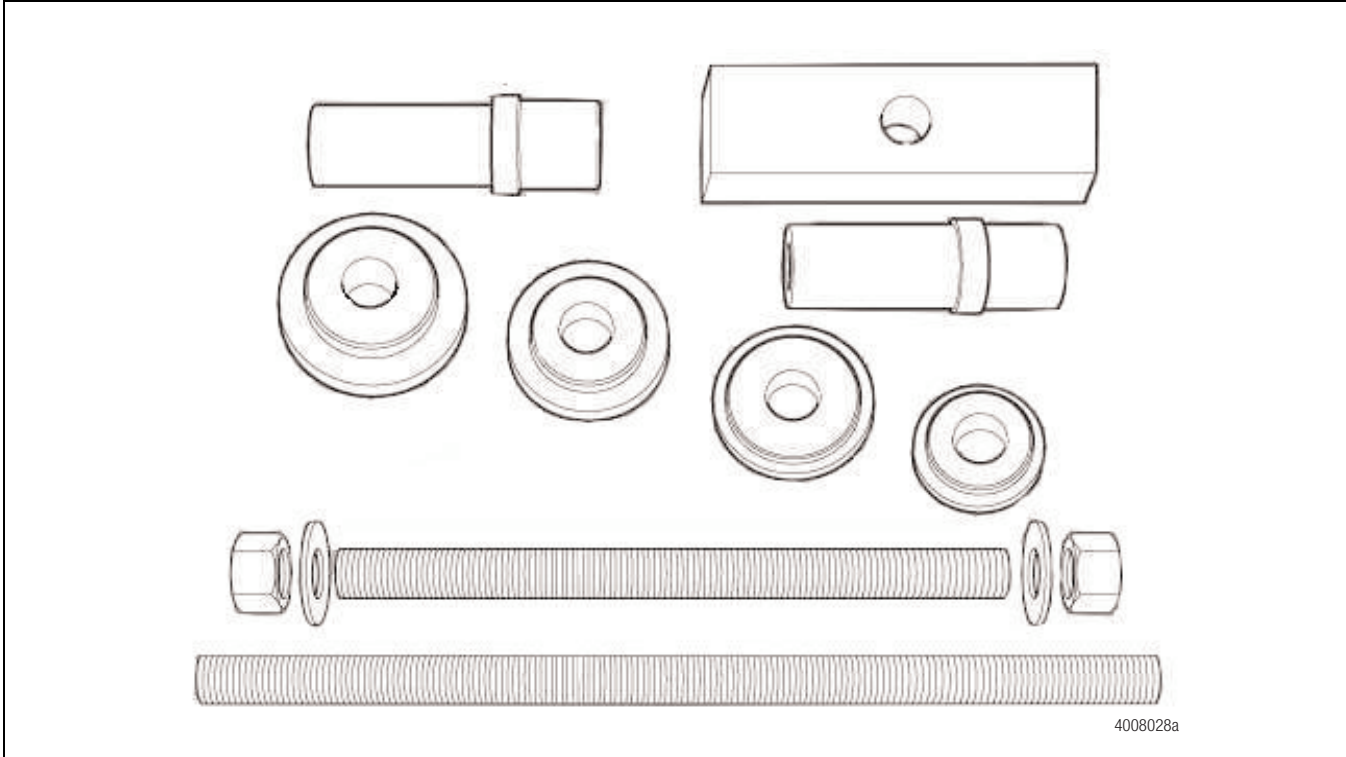

Figure 12.1

MST225 5001, ADB225 Wrench (Extension Adapter)

To obtain this tool, call Meritor's Commercial Vehicle Aftermarket at 888-725-9355. Refer to Section 10 for altered torque settings when using this tool.

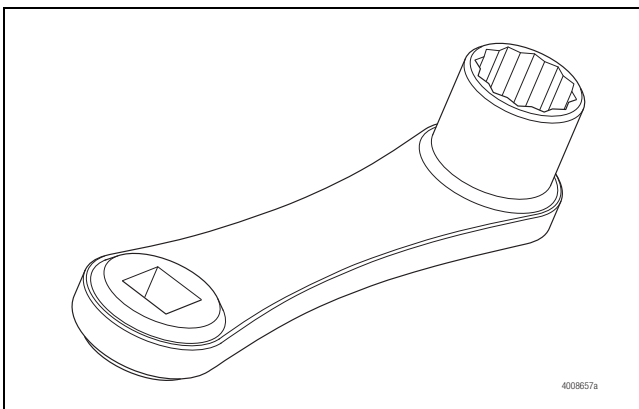

Figure 12.2

Meritor Heavy Vehicle Systems, LLC

2135 West Maple Road

Troy, MI 48084 USA

866-OnTrac1 (668-7221)

meritor.com

Copyright 2020
Meritor, Inc.

Printed in USA

Revised 05-20
Maintenance Manual MM-0467 (16579)



MERITOR®