

# VEHICLE EXTERIOR

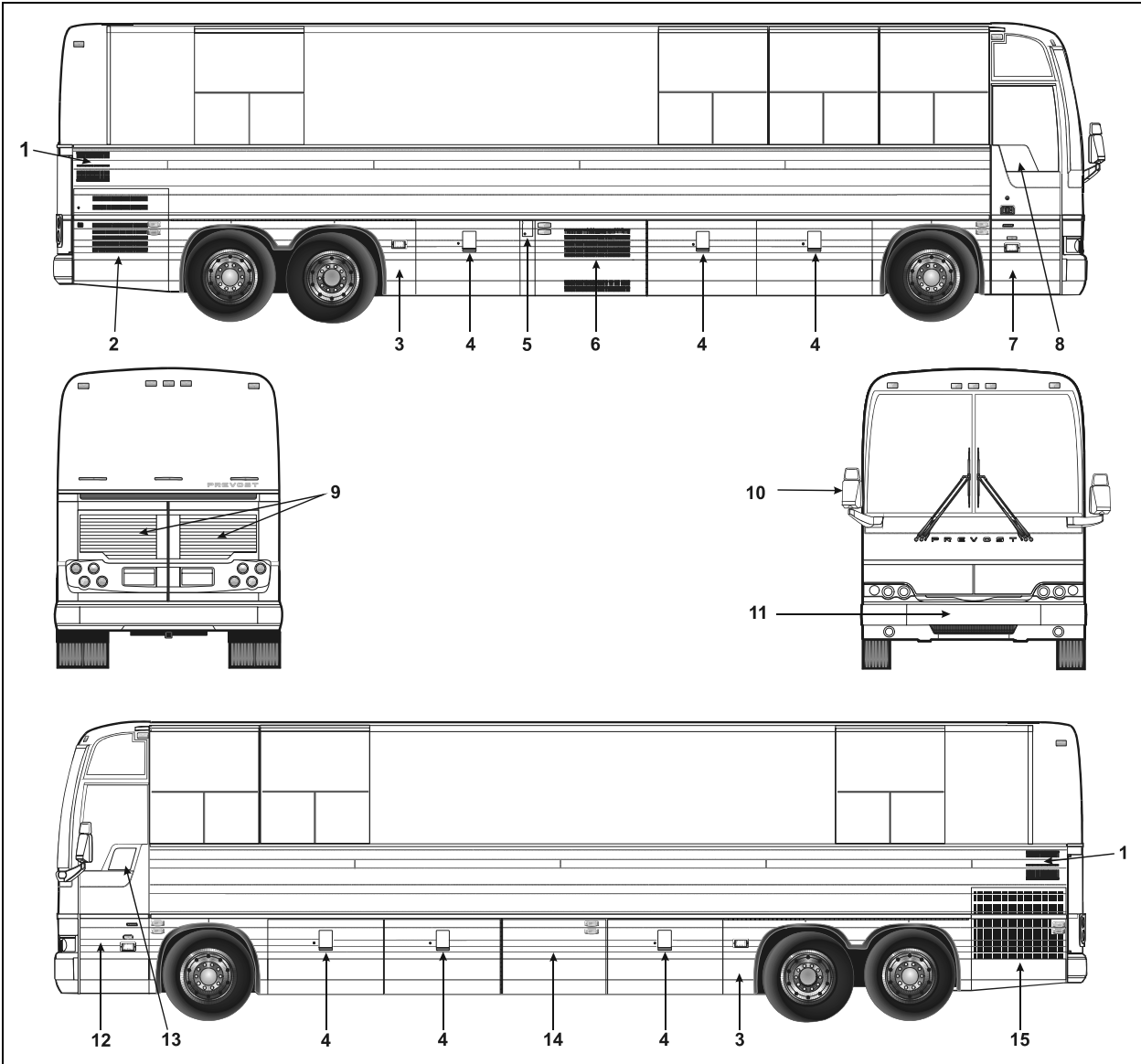

XL2-40 EXTERIOR VIEW (TYPICAL)

18XXX

- |                                      |                                       |
|--------------------------------------|---------------------------------------|
| 1. Engine air intake                 | 9. Engine compartment rear doors      |
| 2. Engine compartment R.H. side door | 10. Rear-view mirror                  |
| 3. Hinged rear fender                | 11. Reclining bumper                  |
| 4. Baggage compartment               | 12. Front service compartment         |
| 5. Fuel filler door                  | 13. Driver's power window             |
| 6. Condenser or baggage compartment  | 14. Evaporator or baggage compartment |
| 7. Entrance door                     | 15. Radiator door                     |
| 8. Entrance door power window        |                                       |

## VEHICLE EXTERIOR

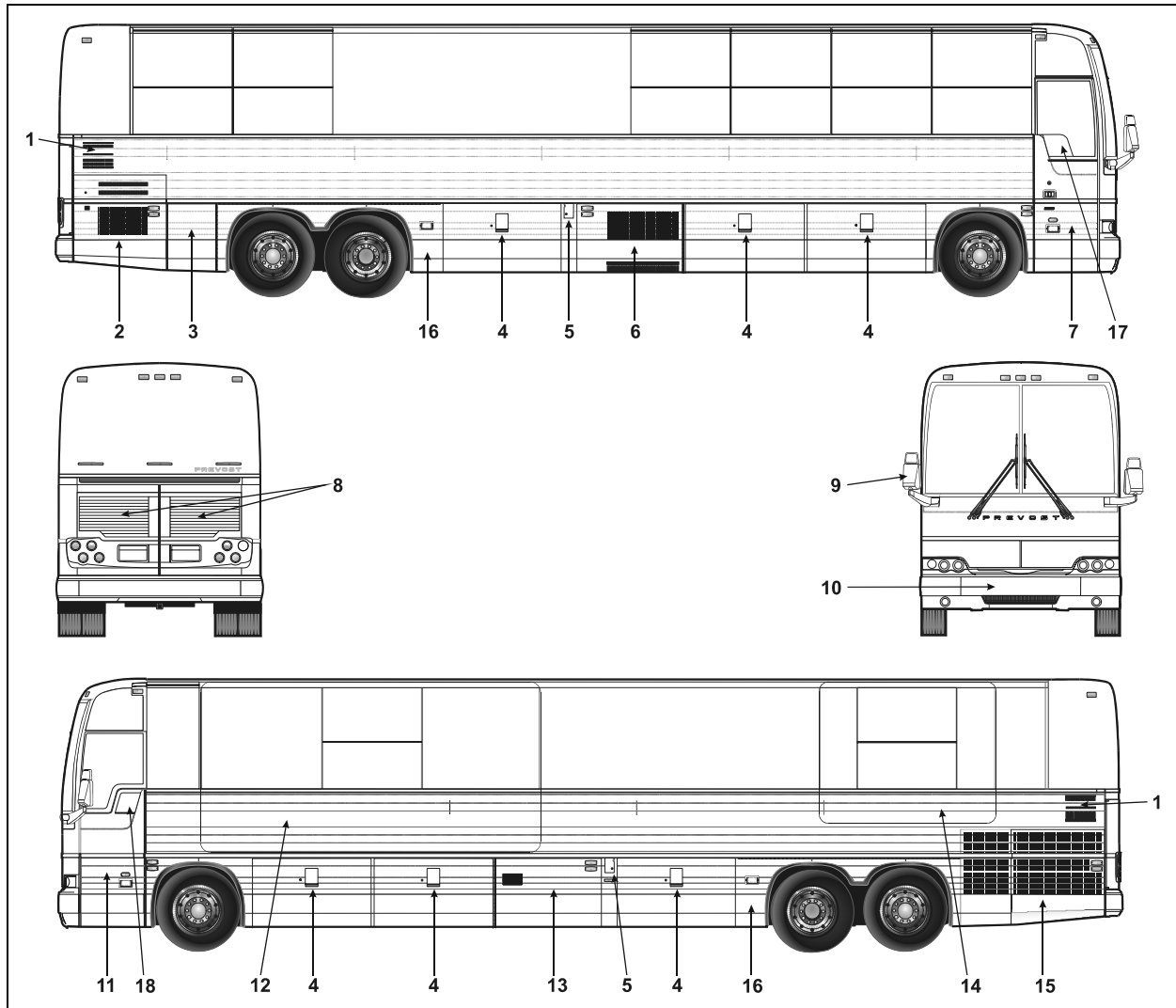

XL2-45 EXTERIOR VIEW (TYPICAL)

18XXX

- |                                       |  |
|---------------------------------------|--|
| 1. Engine air intake                  | 10. Reclining bumper   |
| 2. Engine compartment R.H. side door  | 11. Front service compartment  |
| 3. R.H. side rear service compartment | 12. Front Slide-Out (Optional)   |
| 4. Baggage compartment                | 13. Evaporator or baggage compartment and access to Slide-Out electrical panel |
| 5. Fuel filler door                   | 14. Rear Slide-Out (Optional)  |
| 6. Condenser or baggage compartment   | 15. Radiator door  |
| 7. Entrance door                      | 16. Hinged rear fender   |
| 8. Engine compartment rear doors      | 17. Entrance door power window   |
| 9. Rear-view mirror                   | 18. Driver's power window  |

## VEHICLE EXTERIOR

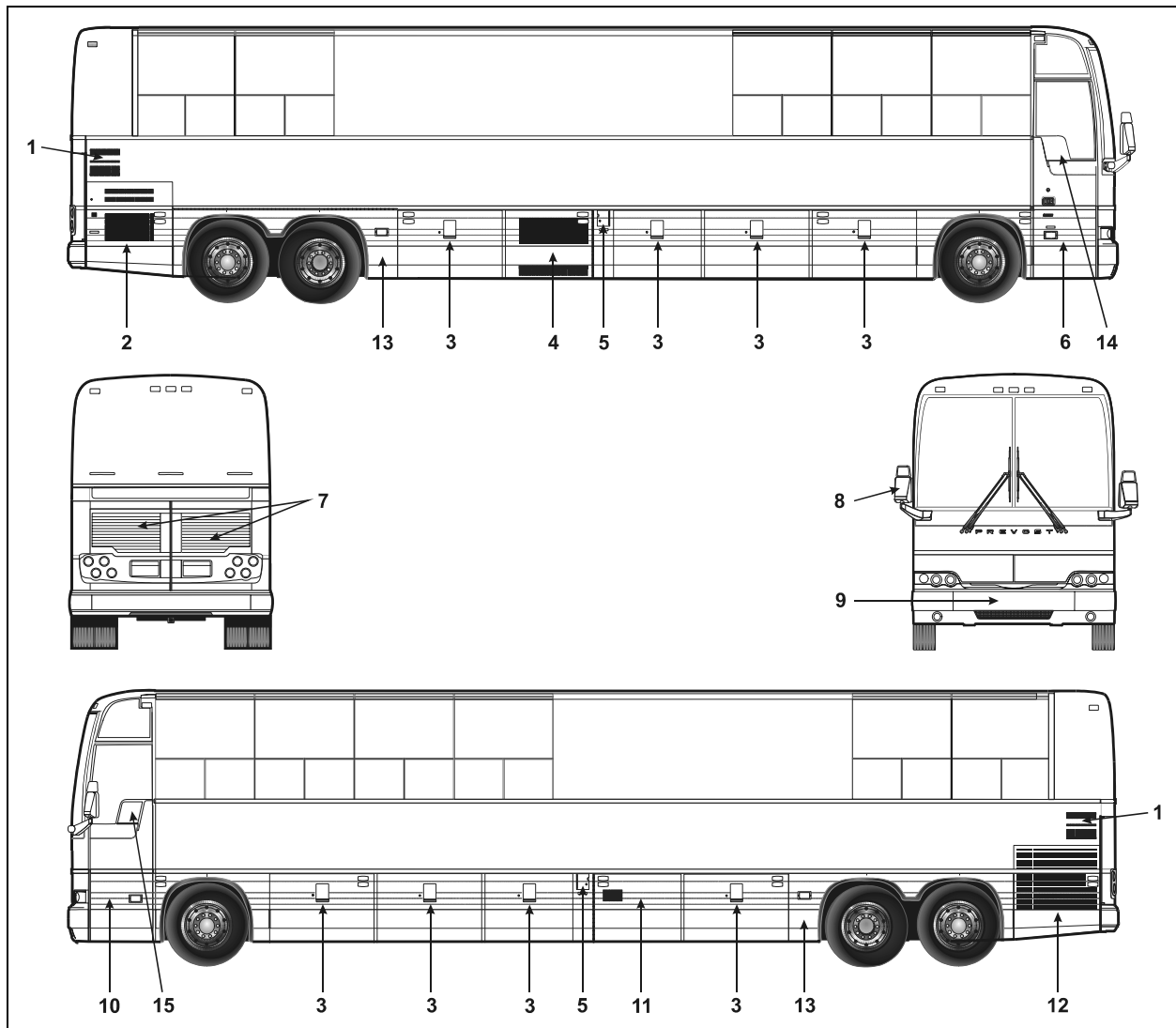

XL2-45E EXTERIOR VIEW (TYPICAL)

18XXX

- |                                      |                                       |
|--------------------------------------|---------------------------------------|
| 1. Engine air intake                 | 9. Reclining bumper                   |
| 2. Engine compartment R.H. side door | 10. Front service compartment         |
| 3. Baggage compartment               | 11. Evaporator or baggage compartment |
| 4. Condenser or baggage compartment  | 12. Radiator door                     |
| 5. Fuel filler door                  | 13. Hinged rear fender                |
| 6. Entrance door                     | 14. Entrance door power window        |
| 7. Engine compartment rear doors     | 15. Driver's power window             |
| 8. Rear-view mirror                  |                                       |

## VEHICLE EXTERIOR

### ENGINE COMPARTMENT COMPONENTS

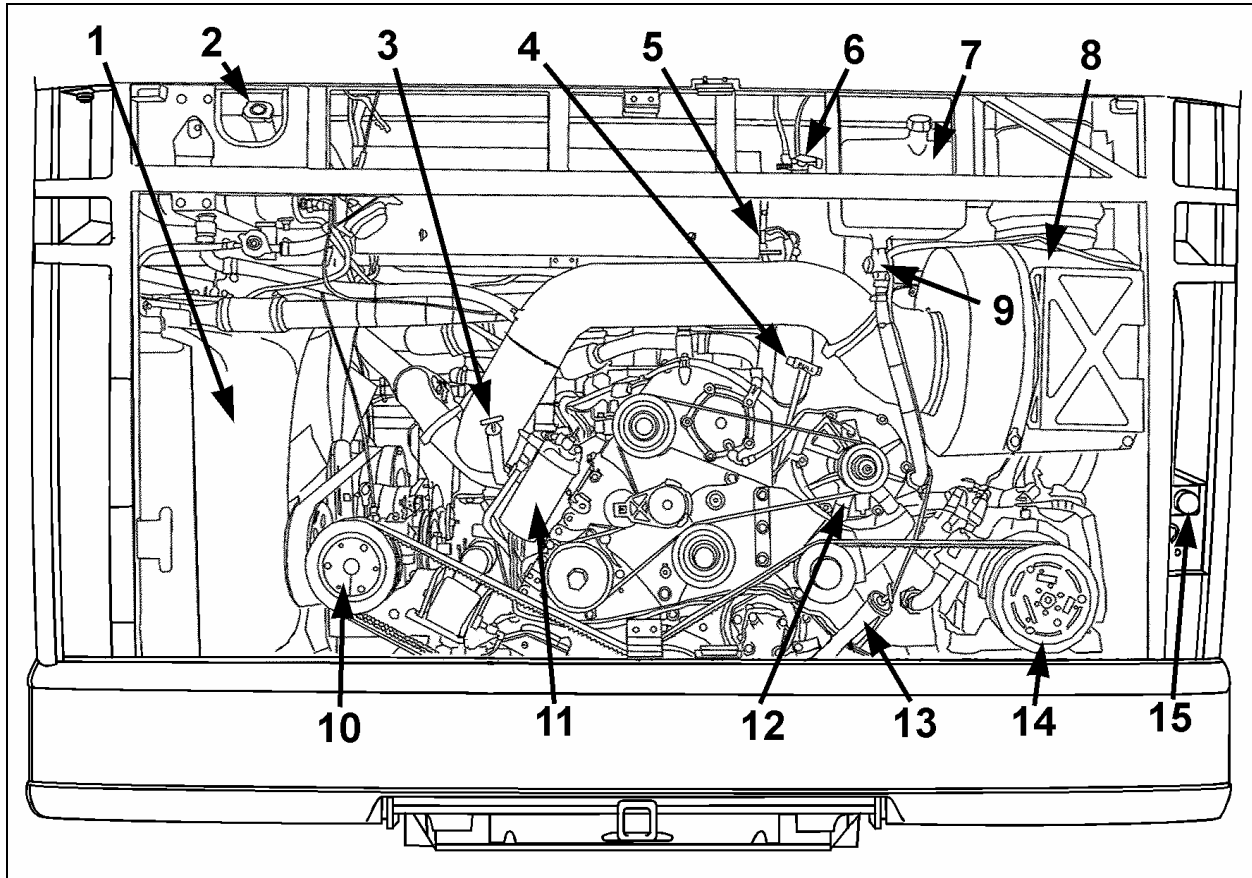

ENGINE COMPARTMENT

01112

- |  |  |
|--|--|
| 1. Radiator;   | 9. Oil reserve tank drain valve;       |
| 2. Coolant fluid surge tank;   | 10. Radiator fan gearbox;              |
| 3. Transmission oil dipstick;  | 11. Engine coolant filter/conditioner; |
| 4. Engine oil dipstick;  | 12. Alternator;                        |
| 5. Starter selector switch and Engine rear start push-button switch; | 13. Engine oil filler tube;            |
| 6. Belt tensioner control valve;                                     | 14. Main A/C compressor;               |
| 7. Engine oil reserve tank;  | 15. 110 – 120 volt connector.          |
| 8. Air filter;   |  |

Most serviceable parts may be accessed through exterior compartments. There may be slight differences in the location of parts and in the configuration of compartments between models, depending on options.

### ENGINE COMPARTMENT R.H. SIDE DOOR

The engine compartment R.H. side door provides access to the following (if equipped):

- Engine compartment rear door release lever;
- Batteries;
- Battery equalizer;
- Voltage regulator;(w/270A alternator only)
- Circuit breakers;
- Booster terminals;
- Alternator(s);
- Primary air circuit fill valve and drain cock;
- Fuel filter/water separator;
- Cold weather starting fluid bottle;
- A/C Compressor.

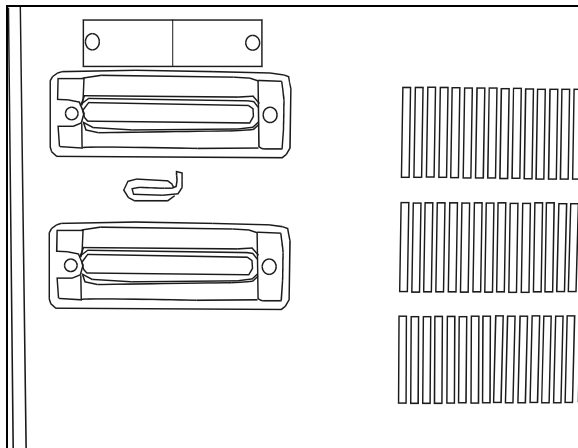

ENGINE COMPARTMENT R.H. DOOR 18559

This door can be locked or unlocked using the exterior compartment key or, if so equipped, by the central door locking system. To open, push sideways the small lever located between the marker lights.

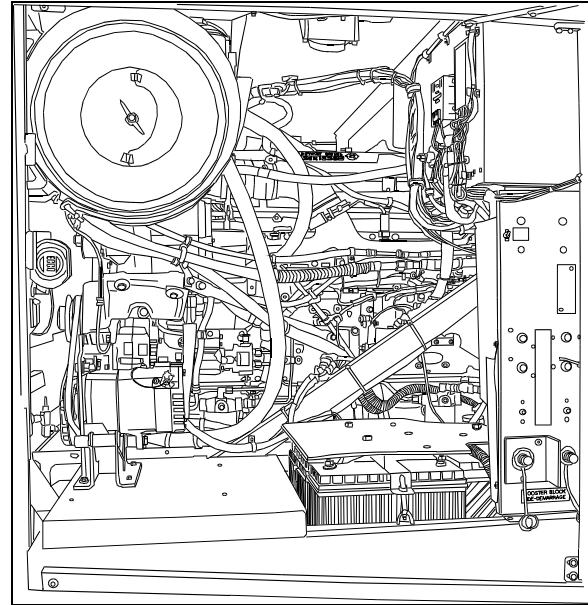

R.H. SIDE ENGINE COMPARTMENT 18513

Turn ON the light in the engine compartment using a switch on the right-hand side of the rear junction box.

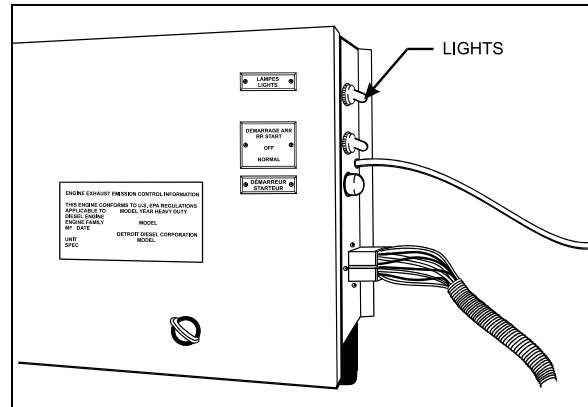

REAR JUNCTION BOX 06409

### ⚠ WARNING ⚠

Unless otherwise stated, do not run the engine when the engine R.H. side compartment door is open. Close engine R.H. side compartment door before starting engine.

### R.H. SIDE REAR SERVICE COMPARTMENT (XL2-45 MTH ONLY)

This compartment is closed off from the engine compartment and can be used for storage or to house custom mechanical components.

To open the door, first open the engine compartment R.H. side door and pull the lever close to the lower door hinge.

## VEHICLE EXTERIOR

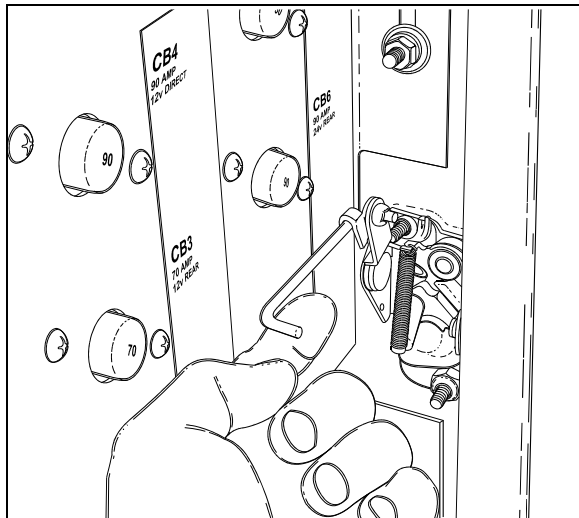

LEVER IN ENGINE COMPARTMENT R.H. SIDE DOOR  
18372

Lights in the compartment turn *ON* automatically when the door is opened.

## BAGGAGE COMPARTMENTS

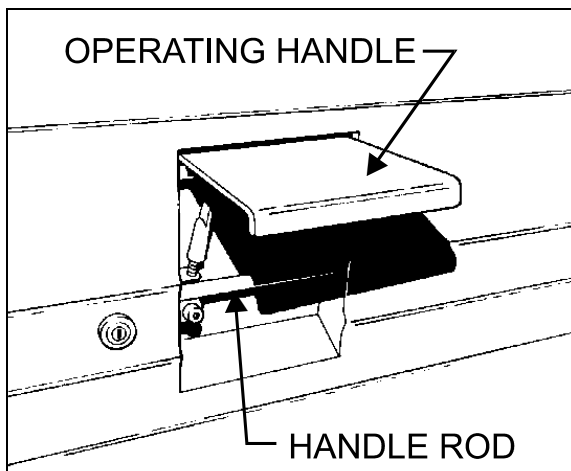

BAGGAGE DOOR LOCK AND LEVER  
18043

The baggage compartment doors of the XL2-45 model provide 407 ft<sup>3</sup> (11,53 m<sup>3</sup>) of storage space (the XL2-40 has 315 ft<sup>3</sup> [8,9 m<sup>3</sup>] of storage capacity). The compartments can be locked or unlocked by using the exterior compartment key. Pull up operating handle to release the latch, and then pull the door open. Pressurized cylinders assist the opening and closing of the baggage compartment doors and hold the doors open.

To close, pull the door down by the handle rod. Complete the closing of the door by returning the operating handle to its initial position.

### ⚠ CAUTION ⚠

Do not slam shut the baggage compartment doors. Damage to door weather-stripping or locking mechanism could result.

Lights in the baggage compartments turn *ON* automatically when the door is opened.

### ⚠ WARNING ⚠

To avoid injury, keep hands clear of baggage compartment door edge and door frame when closing.

### NOTE

To prevent theft and vandalism, always lock the baggage compartment doors before leaving the vehicle unattended.

### NOTE

In case of malfunction or special conditions, use the safety lock to keep the door securely opened.

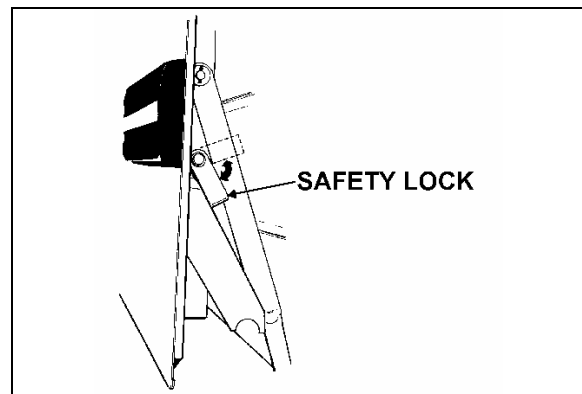

SAFETY LOCK  
18038

### NOTE

The baggage compartment doors can be locked/unlocked from the driver's position by the optional central locking system. The switch is on the L.H. control panel. Refer to "Controls & Instruments" chapter.

## FUEL FILLER DOOR

There is one fuel filler door on each side of the vehicle, providing easy fuel filling (MTH-40 has only one). Both fuel filler doors can be unlocked with the exterior compartment key. Springs keep the door either open or shut.

**NOTE**  
 Provided the vehicle is parked on level ground, an automatic nozzle will automatically shut off when tank is approximately 95% full.

**CAUTION**  
 Do not fill to more than 95% of the tank capacity. Do not "top off" the tank, doing so may result in fuel spillage when the fuel expands.

**NOTE**  
 The fuel filler door locks must be in the unlocked position before closing.

**A/C CONDENSER DOOR**

Pull the release latch located inside the adjacent baggage compartment to open the condenser door.

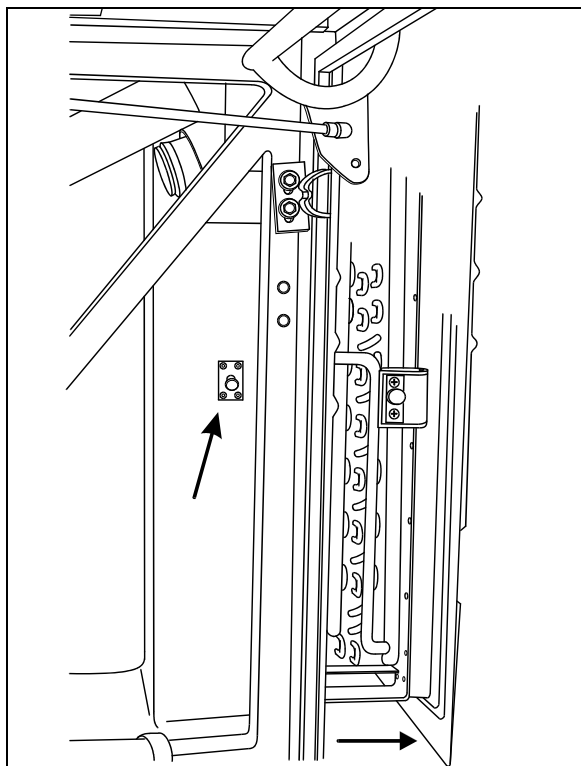

CONDENSER DOOR 18378

**ENGINE COMPARTMENT REAR DOORS**

To open the engine compartment rear doors, open the engine compartment R.H. side door and pull the lever located on the rear door, close to the bottom door hinge. The engine compartment doors swing out to provide access to the following:

- Engine;
- Alternator(s);
- Compressor(s);
- Belt tension valve (refer to Care and Maintenance chapter);
- Engine starting selector (refer to Starting and Stopping Procedures chapter);
- Rear junction compartment;
- Certification plates;
- Diagnostic Data Reader (DDR) receptacle (refer to Other Features chapter);
- Engine coolant surge tank;
- Air cleaner restriction indicator;
- Engine oil dipstick;
- Engine oil reserve tank;
- Power steering fluid reserve tank;
- Automatic transmission oil dipstick;
- Engine coolant filler cap;
- Primary air circuit fill valve and drain cock;
- 110-120 volt connector.

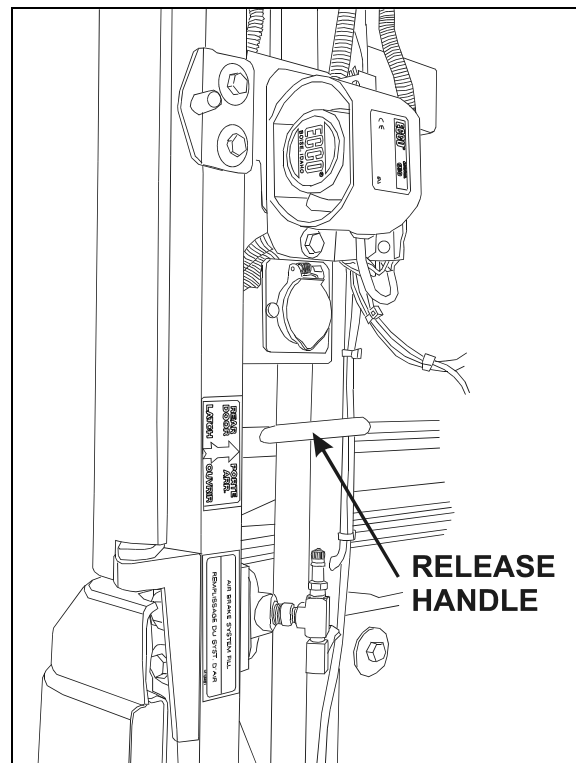

OPENING THE ENGINE COMPARTMENT REAR DOORS FROM R.H. SIDE DOOR 18547

## VEHICLE EXTERIOR

A catch holding each door open engages when the door is fully open. Release the catches before closing the doors. Close the L.H. door first, then firmly shut the R.H. door.

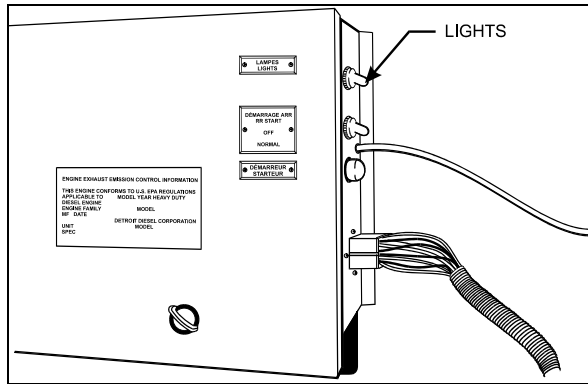

REAR JUNCTION BOX

06409

Turn the lights ON in the engine compartment using the switch on the right-hand side of the rear junction box.

### ⚠ WARNING ⚠

**Unless otherwise specified, do not run engine when the engine compartment rear door is open. Close the engine compartment rear door before starting the engine.**

## 110-120 VOLT CONNECTOR

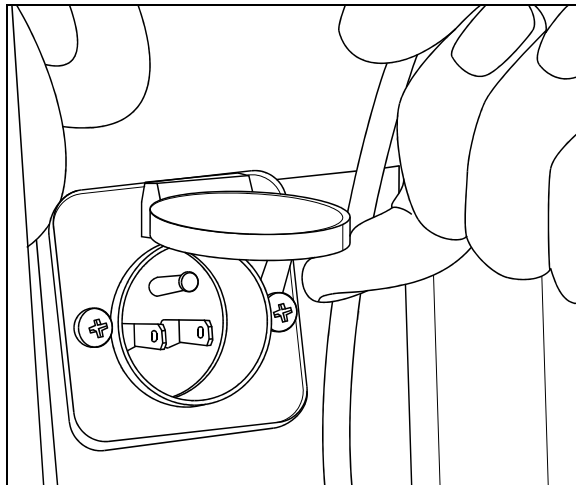

110 VOLT CONNECTOR

06390

This connector is used with a 110-120 volt supply and is connected to the engine block heater. Refer to "Starting and Stopping Procedures" chapter.

To access the connector, open the engine compartment R. H. side door. The connector is attached to the L. H. side frame post.

## RECLINING BUMPER COMPARTMENT

The front bumper can be tilted downward to give access to the bumper compartment. Pull the release handle located inside front service compartment to unlock. Tilt down the entire bumper assembly to access the compartment. Push the bumper back up firmly in place to lock in position.

### ⚠ WARNING ⚠

**The compartment behind the bumper is not designed for storage. Never store loose objects in this compartment since they can interfere with the steering linkage mechanism.**

**Use care when opening or closing the reclining bumper compartment to prevent personal injury.**

## FRONT SERVICE COMPARTMENT

To open the front compartment door, pull the rod inside the vehicle, next to the driver's power window or use the key to open from outside the vehicle. The front service compartment provides access to the following:

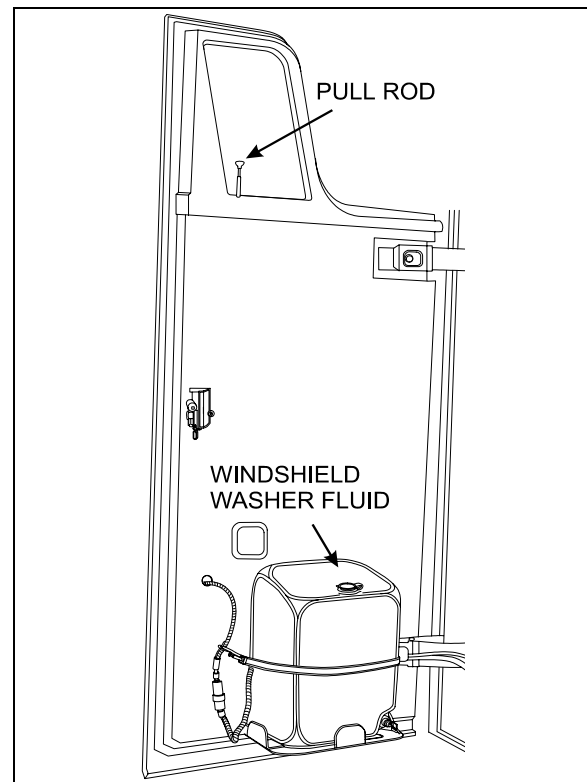

FRONT SERVICE COMPARTMENT DOOR

18381



- Front junction box;
- Windshield washer reservoir;
- Accessory air tank drain valve;
- Accessory system fill valve;
- (WTEC) transmission module (ECU);
- ABS electronic control unit.

The light in the front electric & service compartment turns *ON* automatically when the door is opened.

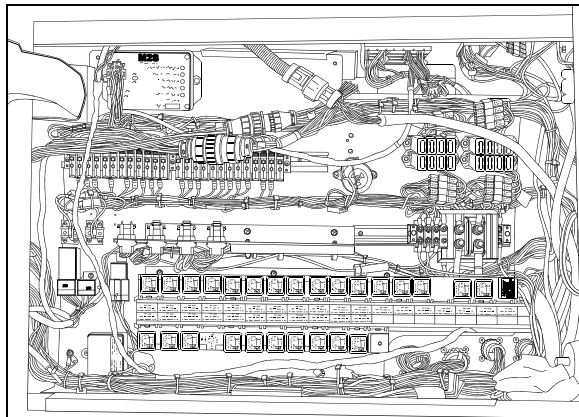

FRONT JUNCTION BOX IN SERVICE COMPARTMENT  
06397

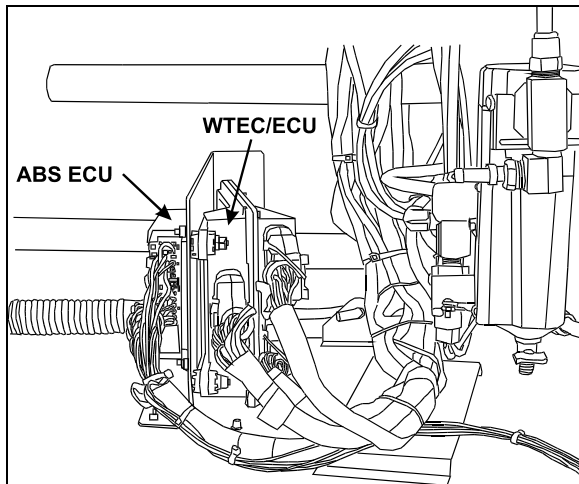

FRONT SERVICE COMPARTMENT  
06532

### EVAPORATOR COMPARTMENT

The HVAC (Heating, Ventilating and Air-Conditioning) breakers and power relays are found in this compartment.

The compartment door release latch is located on the left side of the baggage compartment and to the right of the HVAC compartment door. Pull the release latch then swing the HVAC compartment door open.

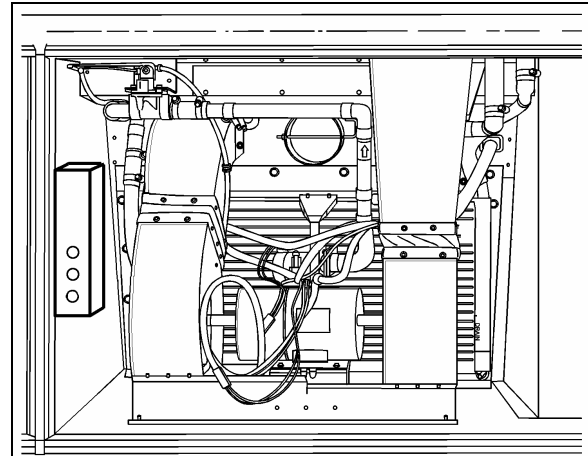

EVAPORATOR COMPARTMENT  
22178

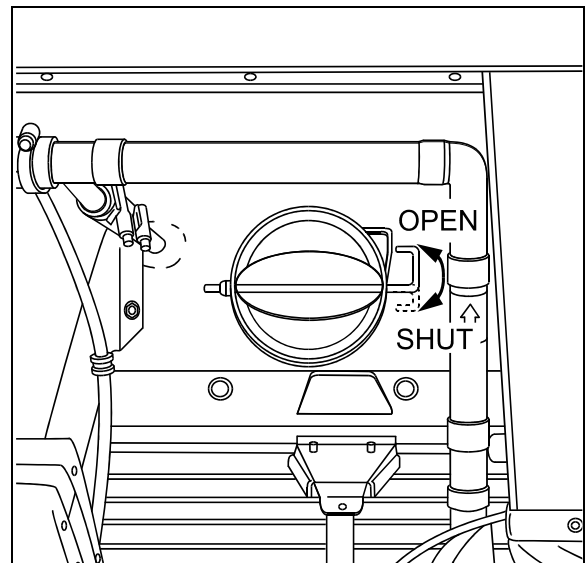

RECIRCULATION DAMPER IN HVAC COMPARTMENT  
22175

Open or close the recirculation damper with the lever shown in the illustration above

### RADIATOR DOOR

Open the engine radiator door by pushing sideways the release lever.

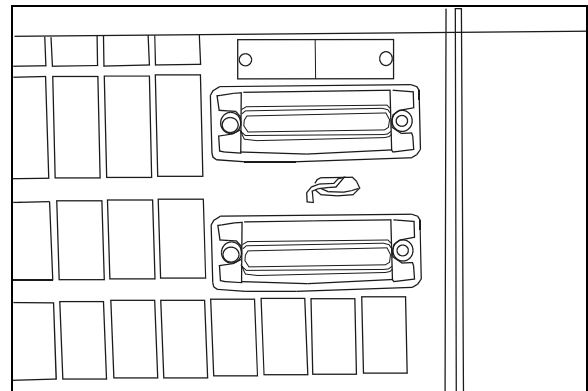

RADIATOR DOOR  
18560

## VEHICLE EXTERIOR

### ENTRANCE DOOR

Lock or unlock the entrance door from outside the vehicle by either turning the key in the door lock (counterclockwise to lock, clockwise to unlock), by using the outside key pad (see "Keyless Entry System" in this chapter), or by using the remote control (electronic key).

Open the door by pulling on the lever. Close by pushing the door shut.

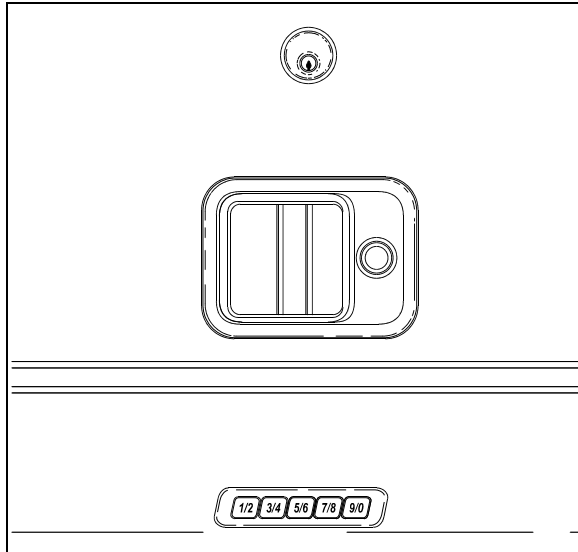

ENTRANCE DOOR

18380

There are two ways of unlocking the entrance door from the inside. The first consists in actuating the rocker switch on the R.H. dashboard panel. This operation will also unlock the baggage compartments. Also, you can unlock the entrance door by sliding its lock lever to the left. If the orange tab on the door-lock lever is visible, the door is unlocked.

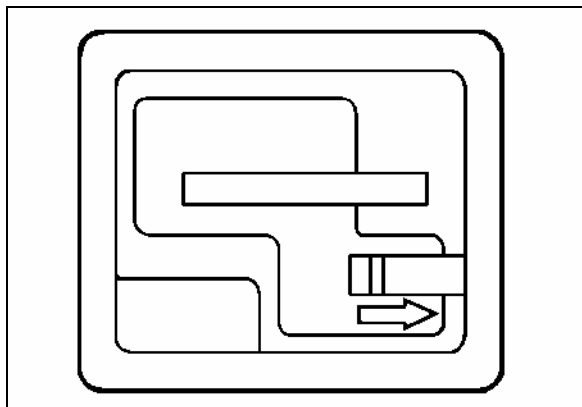

DOOR-LOCK PANEL

18187

### KEYLESS ENTRY SYSTEM

By using this system, you can lock or unlock the entrance door and the baggage and service compartment doors. The keyboard is located below the entrance door handle. The master code in the microprocessor/relay module is pre-programmed by the manufacturer and cannot be deleted. Moreover, you can program your own entry code (e.g. a birthday or part of a social security number).

The master code is:

- Printed on the owner's wallet card;
- Printed on three decals, joined to the owner's wallet card.
- Printed on decal affixed to the keyless system microprocessor/relay module in the front console;

When you use the keyless entry system, the keyboard and step lights illuminate.

Do not push the buttons with a key, pencil or any other hard or sharp object as the buttons could be damaged. Although each button is provided with two digits separated by a vertical line, there is only one contact per button. Press in the center of the button (between the two digits, on the vertical line).

You must unlock the entrance door before you unlock any other baggage or service compartment door. If you let more than five seconds pass between the numbers you press, the system shuts down, and you have to enter your code again. If the keyless entry system does not work properly, use the key to lock or unlock entrance or compartment doors.

### Keyless Operating Instructions

1. To unlock the entrance door, enter the five digits of the code. After pressing the fifth digit, the door will unlock. During the night, press any button to illuminate the keyboard, and then enter the code.
2. When pressing any button, the keyboard lights up for five seconds and the step lights illuminate for twenty-five seconds.
3. To unlock the baggage and service compartment doors, press button 3|4 within five seconds of entering the code.

- To lock entrance door and compartments all at the same time, press buttons 7|8 and 9|0 at the same time.

### Programming Your Personal Code

**NOTE**

To avoid erasing your personal code from the system memory, you should connect the keyless entry system to house batteries, otherwise the code will be erased each time battery main disconnect switches are set to the OFF position.

You can program a personal code to unlock the entrance door and compartments. This code does not replace the permanent code that is programmed into the system. Use your personal code in the same manner that you would use the original code.

Do not choose a code that presents the numbers in sequential order, such as 1|2, 3|4, 5|6, 7|8, 9|0. Studies show that people who idly press the buttons usually press a sequential pattern. Also, do not select a code that uses the same button five times. Thieves can easily figure out these types of codes.

- Choose and memorize your personal code.
- Enter the original code, and within five seconds, press button 1|2.
- Within five seconds of pressing button 1|2, enter your personal code, pressing each button within five seconds of the previous digit. The keyboard light will immediately turn OFF if the code is correctly entered.

The keyless entry system registers your personal code. To unlock the entrance door, you can use either code.

To erase your personal code, enter the original code, press button 1|2, then wait six seconds.

Refer to "Controls and instruments" chapter, for instructions on remote unlock key fob. Refer to "Other Features" chapter, for full details on keyless entry system.

### REAR VIEW MIRRORS

The vehicle is equipped with flat-type and convex-type rear-view mirrors. Convex mirrors give a wide angle view. Objects viewed in convex-type rear-view mirrors appear smaller and are actually closer than they appear.

To provide good visibility in cold weather, the mirrors are equipped with heating elements. The elements are activated by a rocker switch located on the dashboard. Refer to "Controls & Instruments" chapter. Thermostats are used to prevent continuous operation of the heating elements.

**CAUTION**

Do not attach stick-on type convex mirror accessories to the heated mirror glass. This could impede uniform heat distribution on the mirror surface and could break the mirror glass.

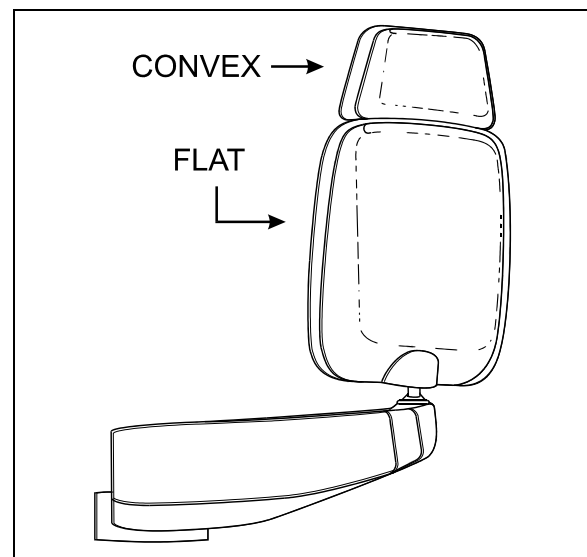

REAR VIEW MIRRORS

18376

The mirrors are adjusted using the controls located on the L.H. control panel. Refer to "Controls & Instruments" chapter. Manual adjustment is also possible.

Adjust the side-view mirrors until the side of the vehicle is visible. Adjust the flat-type mirror until the road behind is in full view.

### BACK-UP CAMERA

An optional back-up camera is available which provides the driver with visual assistance when backing-up. For additional information, refer to "Controls & Instruments" and 'Care and maintenance' chapters.

**TRAILER HITCH**

**20 000 lb max. Gross trailer weight capacity (optional)**

Your vehicle may be equipped with a factory installed trailer hitch which has been designed to meet the following rating:

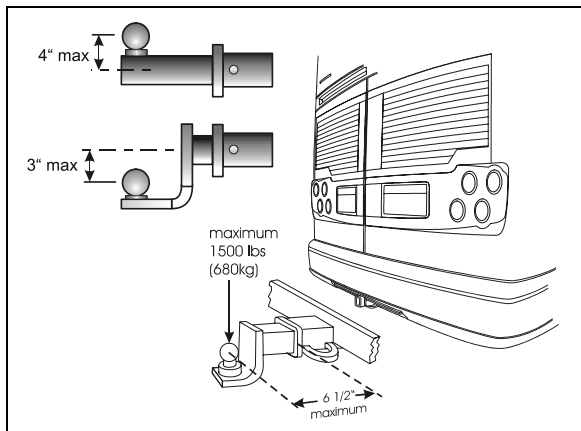

TRAILER HITCH

23337

- **Maximum gross trailer weight: 20,000 lb (9072 kg)**
- **Maximum tongue weight at 6 1/2 inches (165 mm) or less from coupling receiver: 1,500 lb (680 kg)**

**⚠ WARNING ⚠**

The draw bar and the ball used for towing the trailer should be rated for 20,000 lbs capacity or more.

**⚠ WARNING ⚠**

Pulling a trailer weighing more than the recommended maximum gross weight may cause engine and transmission overheating, and also possible hitch failure.

**NOTE**

Pulling a trailer over long distances is considered as a "severe operating condition" for the vehicle and therefore, power plant requires more frequent servicing.

**NOTE**

The minimum requirement for a trailer weighing up to 20,000 lbs when coupled to a 20,000 lb Prévost Trailer Hitch is as per the following:

1. Trailer must comply with **Federal Motor Carrier Safety Regulations 393.52** regarding trailer breaking capability.
2. The trailer coupling attachments meet the following minimum static test load requirements :
  - Longitudinal tension and compression: (1.5 x GVWR of trailer)
  - Transverse thrust: (0.5 x GVWR of trailer)
  - Vertical tension and compression: (0.5 x GVWR of trailer)

Loads indicated must be applied without incurring loss of attachments or distortion or failure which could affect the safe towing of trailer.

3. The ball and trailer coupling should meet the following minimum test load requirements without incurring failure:
  - Longitudinal tension and compression: (Gross Trailer Weight of trailer x 3)
  - Transverse thrust: (Gross Trailer Weight of trailer x 1)
  - Vertical tension and compression: (Gross Trailer Weight of trailer x 1.3)

In this case, failure is identified as the point at which the coupling or ball will accept no additional test load without separation of the ball from the coupling ball socket, or the occurrence of a metal fracture of either coupling ball or coupling assembly, which results in separation of the ball from the coupling ball socket.

4. Two lengths of safety chain shall be used. The strength rating (minimum breaking force) of each individual chain and its connecting means shall be equal to, or exceed the trailer GVWR.
5. Towing vehicle must be equipped with engine or transmission retarder. The engine or the transmission retarder on the vehicle must be functional at all time (to be inspected frequently).
6. This hitch must be used for recreational use only.