

SUBJECT: Transmission Fluid/Filter Change Recommendations

EQUIPMENT AFFECTED: AT 500 Series, MT 600 Series, HT 700 Series  
1000 and 2000 Product Families Transmissions  
3000 and 4000 Product Families Transmissions  
E<sup>V</sup> 40/50 Drive™

### **Introduction:**

Optimum performance and reliability of heavy-duty automatic transmissions can be noticeably influenced by the type of fluid used and the frequency with which that fluid is changed. Allison Transmission and General Motors have designed extensive programs including specifications and tests to verify the quality of fluids and consequently have specific fluid and filter change recommendations. Due to field studies, changes in emission requirements, vehicle design, and operating environments, Allison Transmission has realigned recommended fluid and filter change intervals. Heavy-duty Automatic Transmission change intervals have been revised to more closely match today's operating environments. Allison Transmission began final testing with TranSynd™ TES 295 approved fluid on the following dates:

- March 2002 — 3000 and 4000 Product Families transmissions, AT, MT, and HT transmissions
- March 2003 — 1000 and 2000 Product Families transmissions
- October 2003 — E<sup>V</sup> 40/50

Customers may continue to choose from a wide variety of approved DEXRON®-III/VI or Allison qualified C4 fluids. Customers may elect to use TranSynd™ or TES 295 equivalent and **extend** drain intervals. Equivalent TranSynd™ fluid must **meet or exceed** TES 295 requirements.

Effective with the release of this SIL, the following schedules list current fluid and filter change recommendations based upon vocation.

**Local conditions, severity of operation or duty cycle may require more or less frequent fluid change intervals that differ from the published recommended fluid change intervals of Allison Transmission. Allison Transmission recommends that customers use fluid analysis as the primary method for determining fluid change intervals. In the absence of a fluid analysis program the fluid change intervals listed in the charts to follow should be used.**

**For information concerning Vocational Models not listed in this publication, please call the Allison Technical Assistance Center at 1-800-252-5283.**

Filters must be changed at or before recommended intervals. Refer to Allison publication number GN2055EN, "Technicians' Guide to Automatic Transmission Fluid", SIL 13-TR-90, Rev E, and SIL 17-TR-96, Rev A for additional information on oil analysis and general knowledge about engine oils and transmission fluids.

### **Transmissions Not OEM Factory Filled with TranSynd™:**

New vehicles delivered from the OEM with a mixture of TranSynd™ and non-TranSynd™ fluid must follow fluid/filter change recommendations for **Non-TranSynd™/Non-TES 295/Mixture** outlined in flow charts. If the customer fills the transmission with TranSynd™ or TES 295 equivalent, the change recommendations of **Non-TranSynd™/Non-TES 295/Mixture** must be followed. Upon the next oil change, if the customer reinstalls TranSynd™ or TES 295 equivalent, the fluid/filter change recommendations outlined in 100 percent TES 295 approved fluids must be followed.

Allison Transmission  
General Motors Corporation  
Indianapolis, IN 46206-0894

JLH / SL4136EN

Copyright 2005 General Motors Corporation. All Rights Reserved

### Route To:

- General Manager     Service Manager     Dealer Manager     Transmission Technician     Other  
 Sales Manager     Parts Manager     Training     File

**Availability:**

TranSynd™ fluid is available from the Allison Distributor/Dealer network. TranSynd™ fluid is available in:

1. 1 Gallon Containers (6 per case)
2. 5 Gallon Pail
3. 55 Gallon Drum
4. 275 Gallon Tote
5. Bulk

**NOTE: For quantities other than listed, contact your local Allison or Castrol Dealer or Distributor.**

**Fluid Exchange:**

Fluid exchanging machines are not recommended or recognized due to variation and inconsistencies that may not guarantee removal of 100 percent of the used fluid.

**3000 and 4000 Product Families Transmissions Initial Filter Change Kit:**

Allison Transmission requires the following initial filter change intervals: An initial change main filter kit has been released for 3000/4000 Product Families transmissions. Initial main filter kit (2 inch kit P/N 29540495 or 4 inch kit P/N 29540496) contains **only one** Gold series filter and all necessary seals and gaskets to perform the first 5000 mile/8000 km/200 hour main filter change.

**Fluid Loss With Filter Change Only:**

When performing initial main filter change or changing main and lube filters at recommended intervals, approximate fluid loss for each filter as follows:

***1000 and 2000 Product Families Transmissions***

Control Main Filter = 1 pint (0.47 liters)

***3000 and 4000 Product Families Transmissions***

Main Filter = 2 quarts (1.9 liters)

Lube Filter = 8 quarts (7.6 liters)

***Ev 40/50***

Control Main Filter = 1 quart (0.94 liters)

Lube Filter = 3 quarts (2.84 liters)

**Gold Series Filters:**

Allison 3000 and 4000 Product Families transmissions Gold series filters were released into production beginning January 1, 2002. 3000 and 4000 Product Families transmissions Gold series filters allow increased fluid and filter change intervals when used with TranSynd™ fluid or TES 295 equivalent. 3000 and 4000 Product Families transmissions Gold series filters can be identified by P/N 29538231 or 29538232 stamped into the filter end cap. Previous Allison 3000/4000 Product Families transmissions filters can be identified by P/N 29501202 or 29509723 stamped into the filter end cap.

**Former Filter Kit**

2 inch Filter Kit P/N 29526899

4 inch Filter Kit P/N 29526898

**Current Gold Series Filter Kit**

2 inch Filter Kit P/N 29540493

4 inch Filter Kit P/N 29540494

**NOTE: Extended 3000 and 4000 Product Families transmissions TranSynd<sup>a</sup> fluid and filter change intervals are only allowed with Allison Gold series filters. Filters must be changed at or before recommended intervals.**

**Initial Transmission Filter Change Schedule (Production/ReTran®)**

1000 and 2000 Product Families Spin-On Control Main Filter	5000 miles (8000 km)/200 hours
3000 and 4000 Product Families Transmissions—Main Filter	5000 miles (8000 km)/200 hours
Ev 40/50 Spin-On Control Main Filter	5000 miles (8000 km)/200 hours
AT Auxiliary Filter	5000 miles (8000 km)/200 hours
MT Auxiliary Filter	5000 miles (8000 km)/200 hours
HT Main External Filter	5000 miles (8000 km)/200 hours

## 1000 and 2000 Product Families Transmissions

When referring to the oil change interval charts found on the following pages, all references to 1000 and 2000 Product Families transmissions will include the following model transmissions.

**Non-vocational models include the:**

1000, 2000, and 2400 Series Transmissions

**Vocational Models Include:**

### HIGHWAY SERIES

1000 HS  
2100 HS  
2200 HS  
2300 HS  
2500 HS

### RUGGED DUTY SERIES

1000 RDS  
2100 RDS  
2200 RDS  
2300 RDS  
2500 RDS

### EMERGENCY VEHICLE SERIES

1000 EVS  
2100 EVS  
2200 EVS  
2500 EVS

### PUPIL TRANSPORT/SHUTTLE SERIES

1000 PTS  
2100 PTS  
2200 PTS  
2500 PTS

### MOTORHOME SERIES

1000 MH  
2100 MH  
2200 MH  
2500 MH

### BUS SERIES

B 210  
B 220

## 3000 and 4000 Product Families Transmissions

When referring to the oil change interval charts found on the following pages, all references to 3000 and 4000 Product Families transmissions will include the following model transmissions.

**Non-vocational models include the:**

MD 3000, B 300, B 400, T 200, T 300, HD 4000, B 500, T 400, T 500 Series Transmissions

**Vocational Models Include:**

### HIGHWAY SERIES

3000 HS  
4000 HS  
4500 HS

### RUGGED DUTY SERIES

3000 RDS  
3500 RDS  
4000 RDS  
4500 RDS  
4700 RDS

### EMERGENCY VEHICLE SERIES

3000 EVS  
3500 EVS  
4000 EVS  
4500 EVS  
4700 EVS  
4800 EVS

### PUPIL TRANSPORT/SHUTTLE SERIES

3000 PTS

### MOTORHOME SERIES

3000 MH  
4000 MH

### BUS SERIES

B 300  
B 400  
B 500

**1000, 2000, 3000, 4000 Product Families Hours vs Miles Chart**

The following charts list the equivalent mileage based on the Allison recommended 2000 or 3000 hour fluid/filter change intervals for TES 295 approved fluids. Vocations or vehicles that operate with a high density shift cycle typically reach the 2000/3000 hour change limit **before** the recommended mileage limit.

An example could be a transit bus equipped with a B 500R that operates an average of 7 mph (11 km/h). Recommended fluid/filter change interval for a B 500R equipped with 2 inch control module in a transit vocation using a TES 295 fluid is 50,000 miles/80 000 km/2000 hours or 24 months whichever occurs first. Using Table 1, a vehicle operating at 7 mph, (11 km/h) will travel approximately 14,000 miles (22 600 km) in 2000 hours. If an odometer is used to determine when to change the transmission fluid and filters, this specific vehicle would change the fluid and filters every 14,000 miles (22 600 km).

Estimating average mph can be approximated by dividing total distance traveled in a typical day by the hours elapsed during that total distance. An example would be a vehicle that operates on average 96 miles (155 km) a day over an 8 hour period would average 12 mph (19 km/h).

**Table 1.**

2000 Hour Based Maintenance				3000 Hour Based Maintenance			
km/h Average	km Equivalent	MPH Average	Miles Equivalent	km/h Average	km Equivalent	MPH Average	Miles Equivalent
5	10000	3	6000	5	15000	3	9000
6	12000	4	8000	6	18000	4	12000
8	16000	5	10000	8	24000	5	15000
10	20000	6	12000	10	30000	6	18000
11	22000	7	14000	11	33000	7	21000
13	26000	8	16000	13	39000	8	24000
14	28000	9	18000	14	42000	9	27000
16	32000	10	20000	16	48000	10	30000
18	36000	11	22000	18	54000	11	33000
19	38000	12	24000	19	57000	12	36000
21	42000	13	26000	21	63000	13	39000
23	46000	14	28000	23	69000	14	42000
24	48000	15	30000	24	72000	15	45000
26	52000	16	32000	26	78000	16	48000
27	54000	17	34000	27	81000	17	51000
29	58000	18	36000	29	87000	18	54000
31	62000	19	38000	31	93000	19	57000
32	64000	20	40000	32	96000	20	60000
34	68000	21	42000	34	102000	21	63000
35	70000	22	44000	35	105000	22	66000
37	74000	23	46000	37	111000	23	69000
39	78000	24	48000	39	117000	24	72000
40	80000	25	50000	40	120000	25	75000

# 1000 and 2000 Product Families Transmissions

## Recommended Fluid and Filter Change Intervals

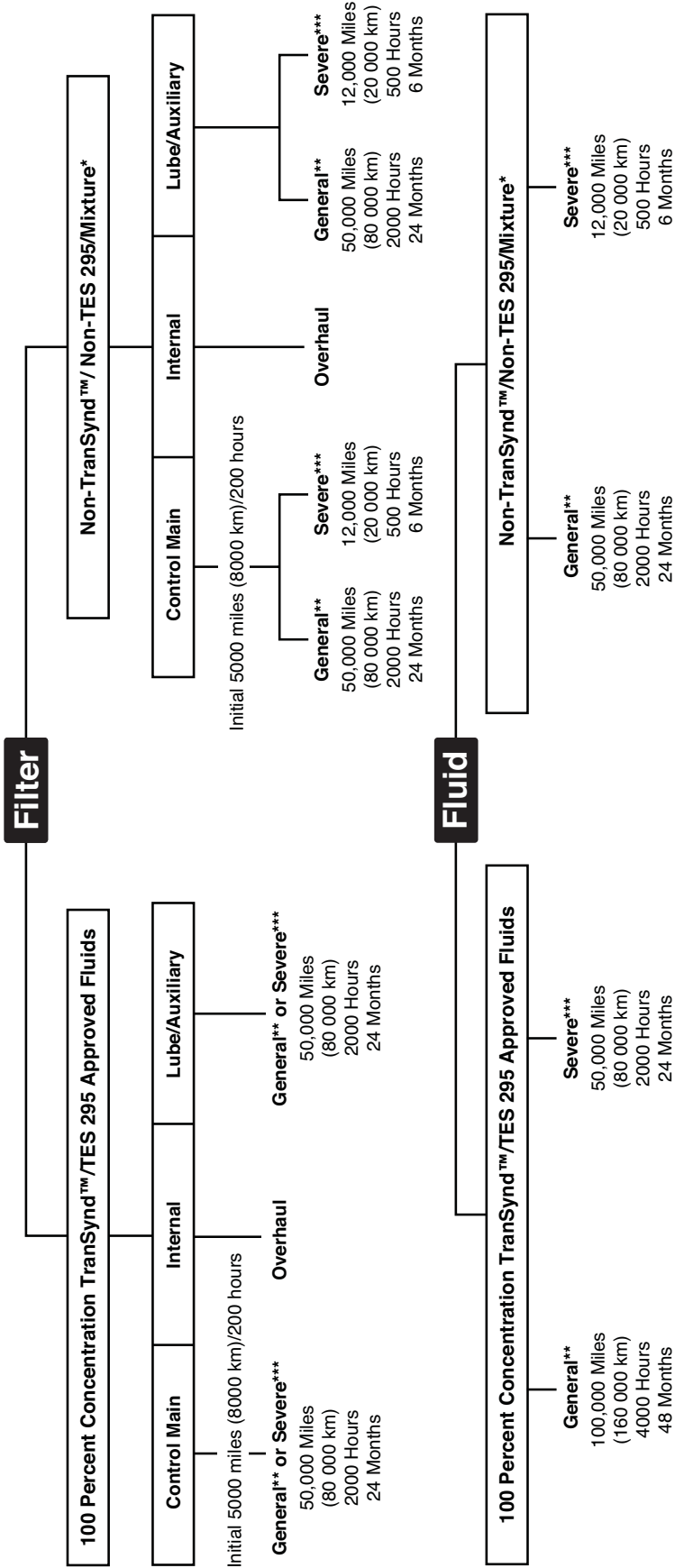

**NOTE:** Change fluid/filters at or before recommended mileage, months, or hours have elapsed, whichever occurs first. **NOTE:** Local conditions, severity of operation or duty cycle may require more or less frequent fluid change intervals that differ from the published recommended fluid change intervals of Allison Transmission. Allison Transmission recommends that customers use fluid analysis as the primary method for determining fluid change intervals. In the absence of a fluid analysis program the fluid change intervals listed in the charts above should be used.

\* Anything other than 100 percent concentration of TransSynd™ or TES 295 approved fluid, is considered a mixture and should utilize non TES 295 change intervals.  
 \*\* General Vocation: All other vocations.  
 \*\*\* Severe Vocation: 2000 MH, On/Off Highway, Refuse, City Transit, and Shuttle Transit.  
 †† Fluid fill capacity is dependent on vehicle configuration. Final fluid capacity must be determined by dipstick level (see Mechanic's Tips MT3190EN Section 1 or your Operator's Manual under "Care and Maintenance").

Capacities †† (Approximate)			
Transmissions Fluid Loss—Filter Change Only: Control Main (spin-on) = 1 pint (0.47 liters)			
Sump	Initial Fill††		Refill††
	Liters	Quarts	Quarts
Standard	14	14.8	10
Shallow	12	12.7	7
			7.4

†† Approximate quantities, do not include external lines and cooler hose.

Filters	
<b>Control Main</b>	<b>P/N 29539579</b>
Shallow Pan Suction (Overhaul Only)	P/N 29537965
Deep Pan Suction (Overhaul Only)	P/N 29537966

# 3000 and 4000 Product Families Transmissions

## Recommended Fluid and Filter Change Intervals

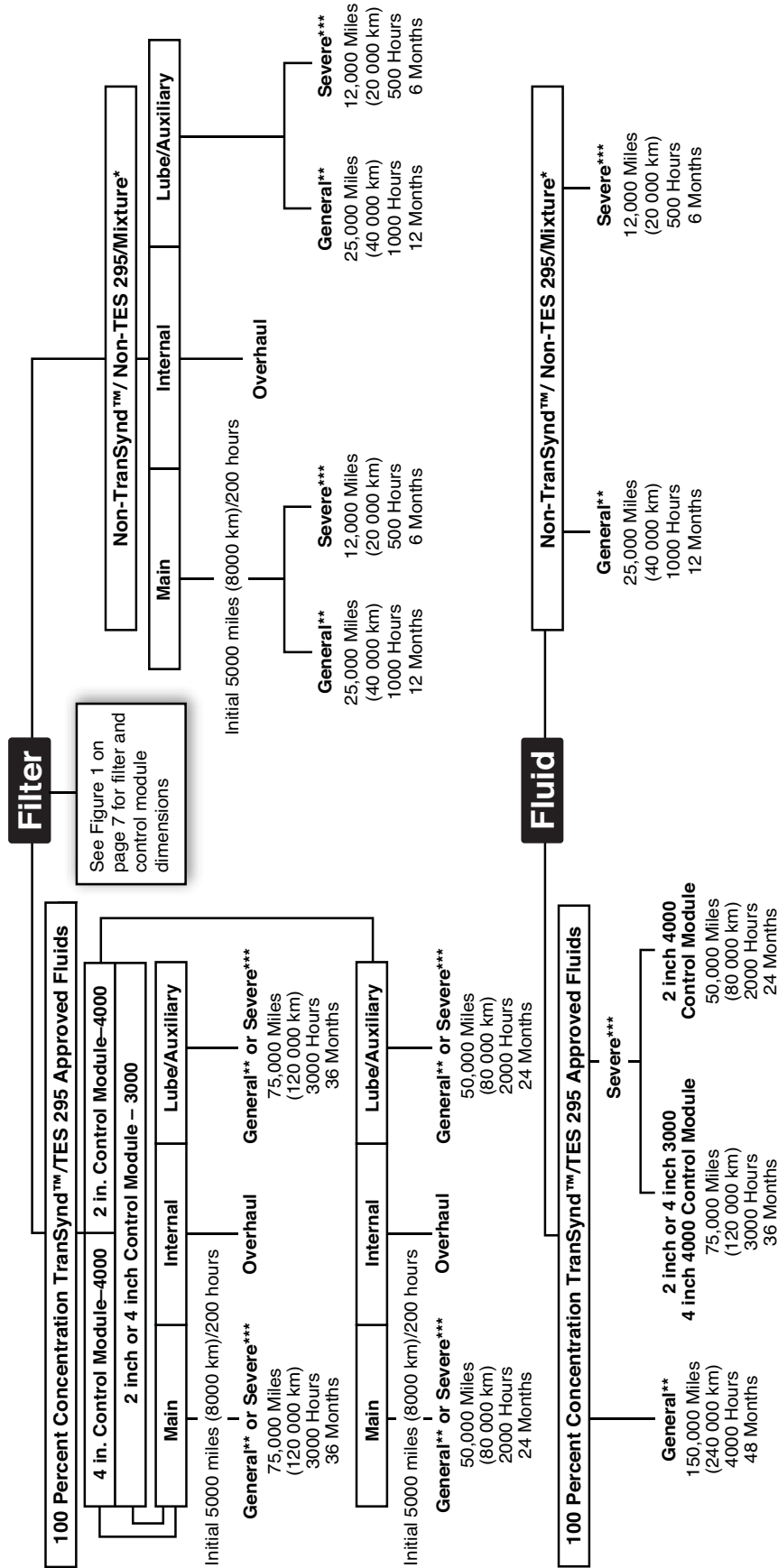

**NOTE:** Change fluid/filters at or before recommended mileage, months, or hours have elapsed, whichever occurs first.

**NOTE:** Local conditions, severity of operation or duty cycle may require more or less frequent fluid change intervals that differ from the published recommended fluid change intervals of Allison Transmission. Allison Transmission recommends that customers use fluid analysis as the primary method for determining fluid change intervals. In the absence of a fluid analysis program the fluid change intervals listed in the charts above should be used.

- \* Less than 100 percent concentration of TransSynd™ or TES 295 approved fluid, is considered a mixture and should utilize non TES 295 change intervals.
- \*\* General Vocation: Intercity Coach with duty cycle less than or equal to one (1) stop per mile and all other vocations not listed in severe vocation.
- \*\*\* Severe Vocation: All Retarders, On/Off Highway, Refuse, Transit, and Intercity Coach with duty cycle greater than one (1) stop per mile.
- †† Fluid fill capacity is dependent on vehicle configuration. Final fluid capacity must be determined by dipstick level (see Mechanic's Tips MT3004EN Section 1 or your Operator's Manual under "Care and Maintenance").

3000 and 4000 Capacities†† (Approximate)			
Transmissions Fluid Loss - Filter Change Only:			
Main Filter = 2 quarts (1.9 liters)			
Lube Filter = 8 quarts (7.6 liters)			
Model	Sump	Initial Fill†††	Refill†††
	Liters	Quarts	Liters
3000	4 inch	27	18
3000	2 inch	25	16
4000	4 inch**	45	37
4000	2 inch**	38	30

†† Add 2.8 Liters (3 Quarts) for Transmissions with PTO cooler hose.

Additional Fill for Allison Coolers/Accumulators		
Model	Cooler Type	Quarts
3000/4000	Non-Retarder/Direct Mount	1.0
3000/4000	Remote/Retarder/Sump	2.5
3000	Retarder Accumulator	1.2
4000	Direct Mount/Retarder	2.1
4000	Retarder Accumulator	0.6

Filter and Gasket Kits	
<b>Initial 5000 mile (8000 km) Gold Series Kit</b>	<b>Gold Series Filter Kit</b>
2 inch kit P/N 29540495	2 inch Filter Kit P/N 29540493
4 inch kit P/N 29540496	4 inch Filter Kit P/N 29540494



### 3000/4000 Product Families Filter Location

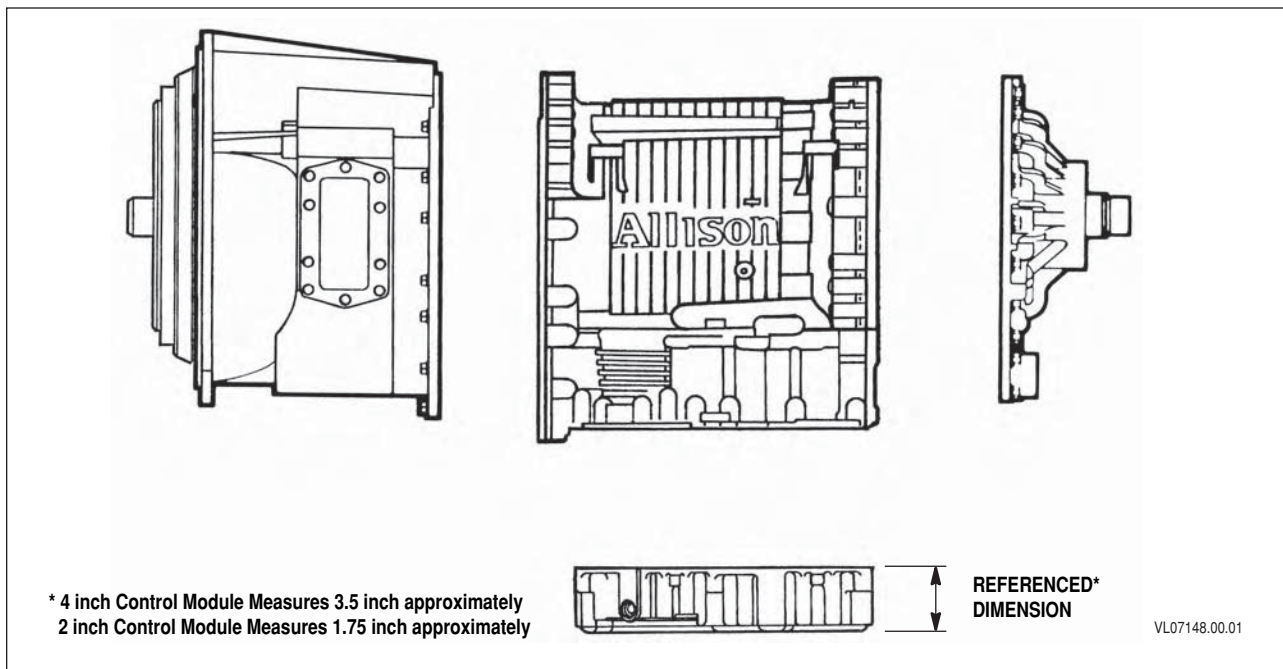
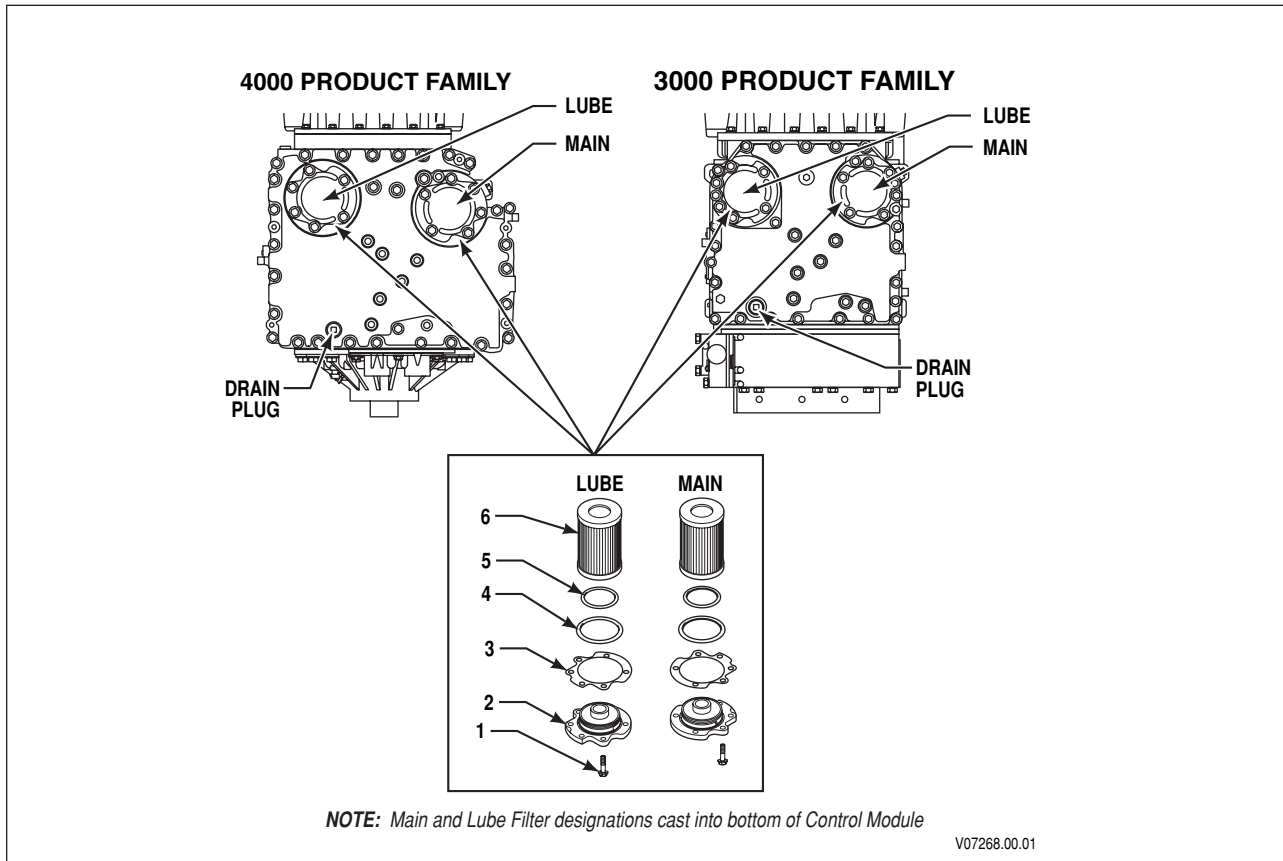
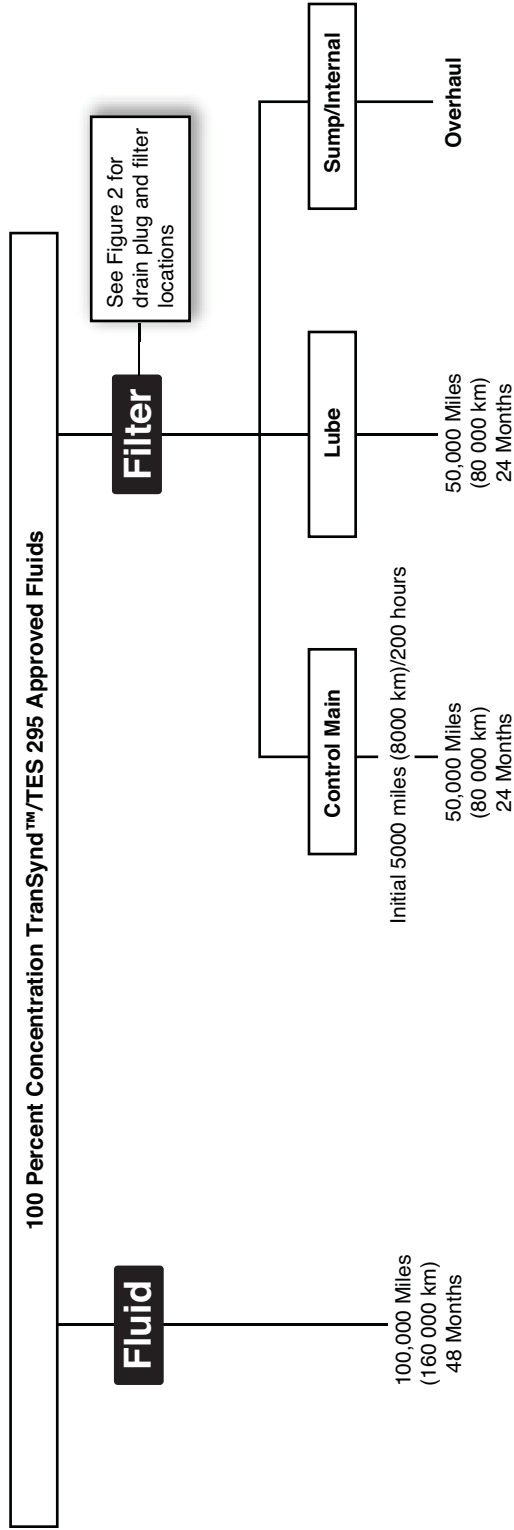

Figure 1.

# EV 40/50

## Recommended Fluid and Filter Change Intervals



### NOTES:

- Change fluid/filters at or before recommended mileage or months have elapsed, whichever occurs first.
- Local conditions, severity of operation or duty cycle may require more or less frequent fluid change intervals that differ from the published recommended fluid change intervals of Allison Transmission. Allison Transmission recommends that customers use fluid analysis as the primary method for determining fluid change intervals. In the absence of a fluid analysis program the fluid change intervals listed in the charts above should be used.
- The following recommendations are based upon the transmission containing 100 percent of TransSynd™ fluid.
- EV40/50 Lube Filter change intervals are only valid with the use of Allison Transmission Gold Series Filters
- **Fluid Exchange:** Fluid exchanging machines are not recommended or recognized due to variation and inconsistencies that may not guarantee removal of 100 percent of the used fluid.

Capacities <sup>††</sup> (Approximate)		
Transmissions Fluid Loss — Filter Change Only:		
Control Main Filter = 1 quart (0.94 liters)		
Lube Filter = 3 quarts (2.84 liters)		
Model	Refill <sup>†††</sup>	
	Liters	Quarts
EV40/50	15.1	16
†† Fluid fill capacity is dependent on vehicle configuration.		
††† Fluid capacity will vary based on location of DP/IM and the size of the oil-to-air heat exchanger.		
Filter and Gasket Kits		
Lube Filter and Gasket Kit		P/N 29541508
Control Main Filter		P/N 29539579



### E<sup>V</sup> 40/50 System Filter Location

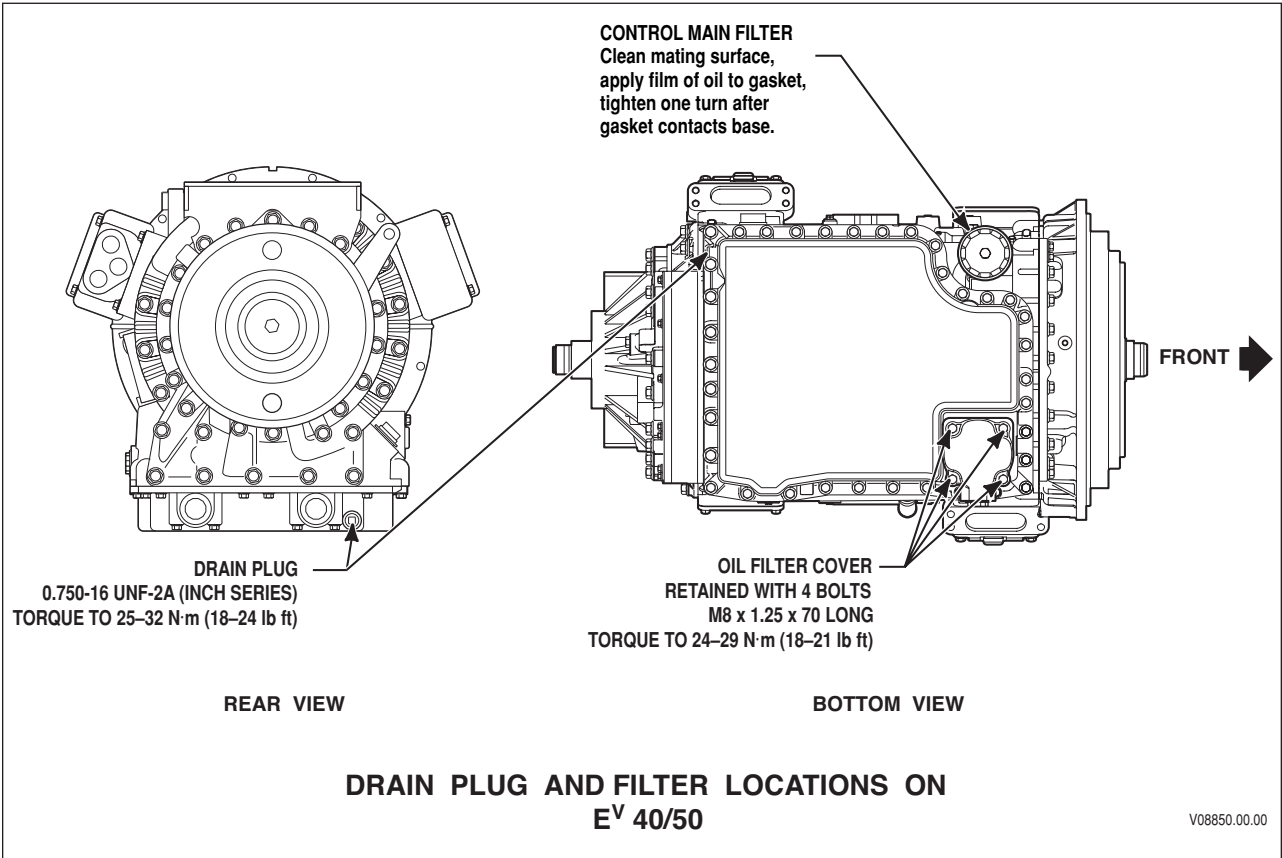
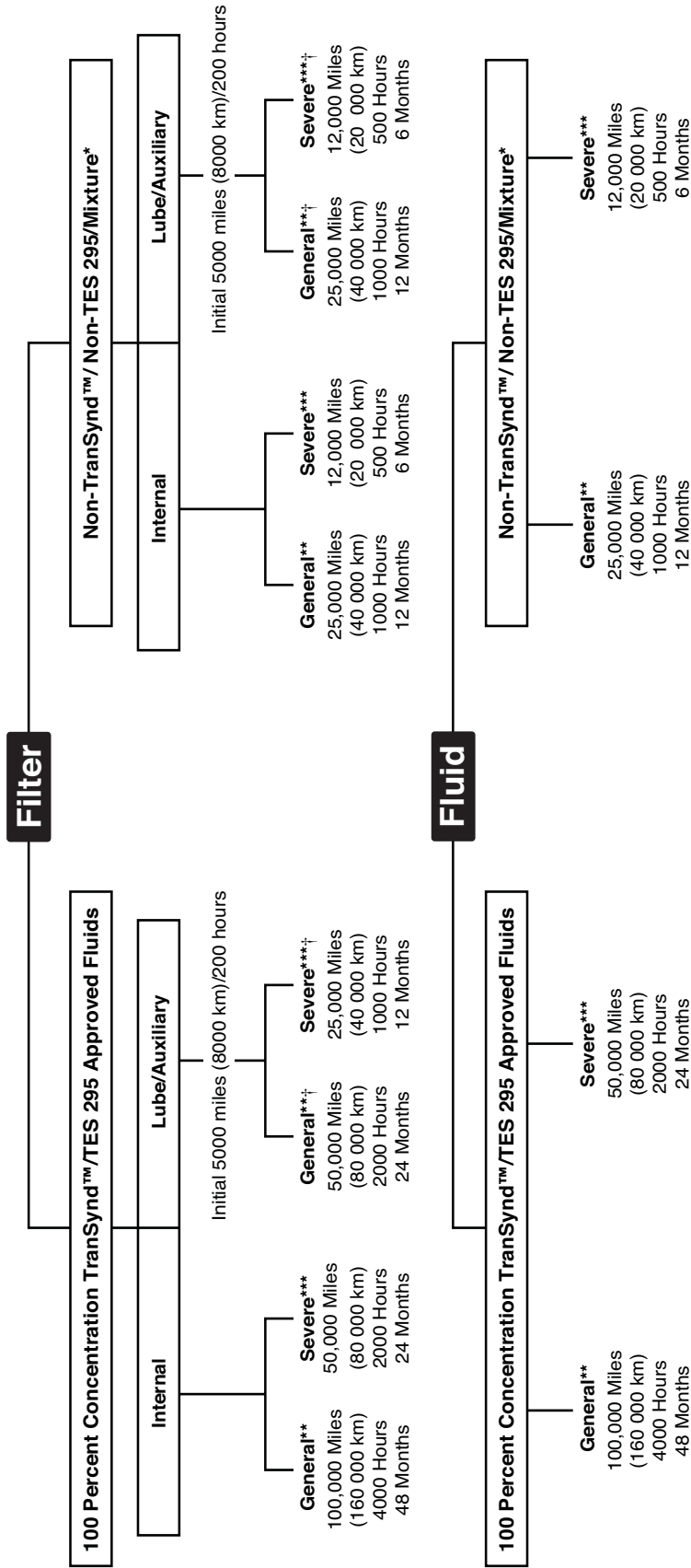

Figure 2.

# AT Series Transmissions

## Recommended Fluid and Filter Change Intervals



**NOTE: Change fluid/filters at or before recommended mileage, months, or hours have elapsed, whichever occurs first. NOTE: Local conditions, severity of operation or duty cycle may require more or less frequent fluid change intervals that differ from the published recommended fluid change intervals of Allison Transmission. Allison Transmission recommends that customers use fluid analysis as the primary method for determining fluid change intervals. In the absence of a fluid analysis program the fluid change intervals listed in the charts above should be used.**

\* Anything other than 100 percent concentration of TransSynd™ or TES 295 approved fluid, is considered a mixture and should utilize non-TES 295 change intervals.

\*\* General Vocation: less than one stop per mile.

\*\*\* Severe Vocation: more than one stop per mile.

† When an Allison recommended high-efficiency filter is used, the change interval is not until the Change Filter light indicates the filter is contaminated or until it has been in use for 3 years, whichever ever occurs first. No mileage restrictions apply. High efficiency filters are only approved for use with AT/MT/HT Series.

†† Fluid fill capacity is dependent on vehicle configuration. Final fluid capacity must be determined by dipstick level (see Mechanic's Tips MT1321EN Section 1 or your Operator's Manual under "Care and Maintenance").

Capacities †† (Approximate)		
Pan Depth	Initial Fill††	
	Quarts	Liters
3.8 inch (97 mm) oil pan	9	8.5
5.3 inch (135 mm) oil pan	16	15

††† Approximate quantities, do not include external lines and cooler hose.

### Filter and Gasket Kits

Oil Filter and Gasket Kit – 3.8 in. Pan 29540976  
 – 5.3 in. Pan 29538489  
 See SIL 09-TR-01 for additional information.

# MT Series Transmissions

## Recommended Fluid and Filter Change Intervals

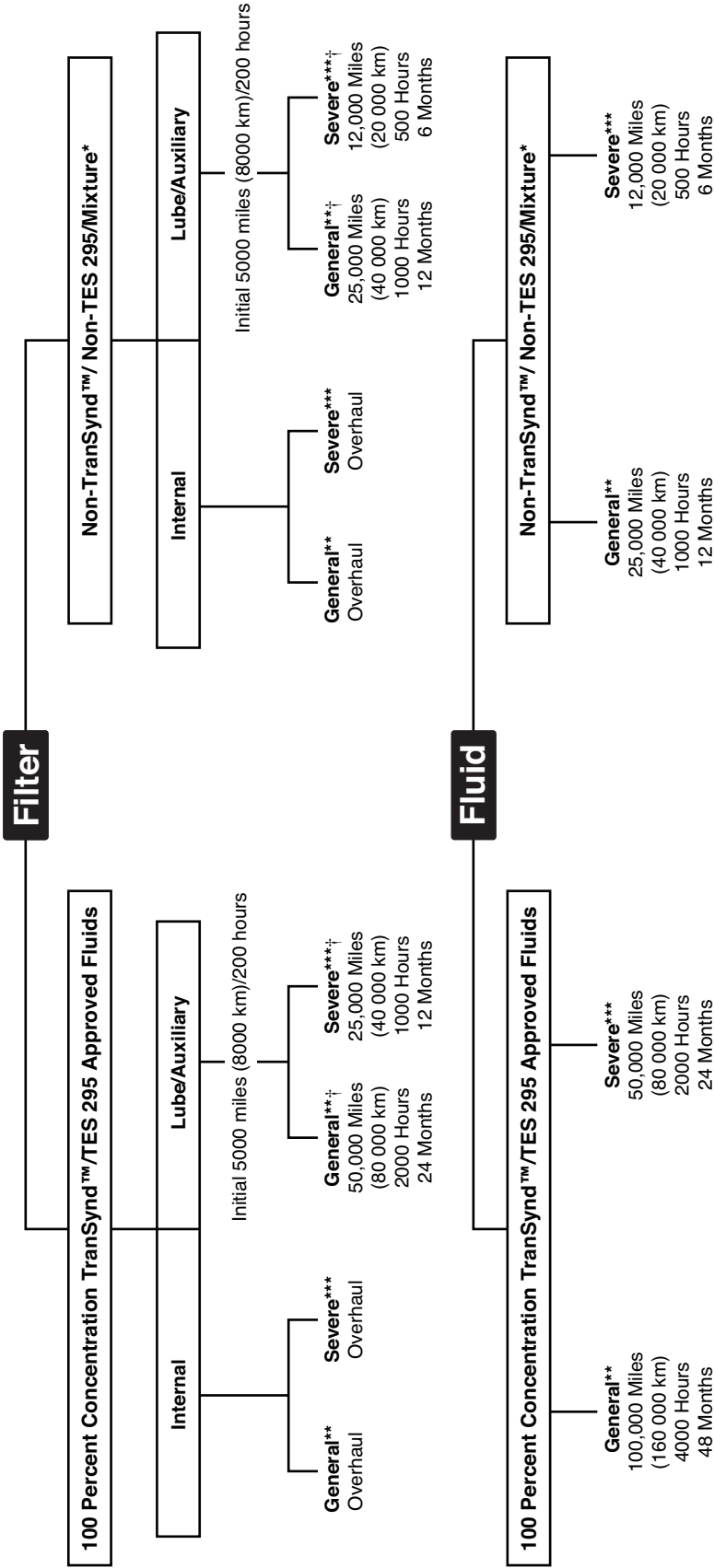

**NOTE: Change fluid/filters at or before recommended mileage, months, or hours have elapsed, whichever occurs first. NOTE: Local conditions, severity of operation or duty cycle may require more or less frequent fluid change intervals that differ from the published recommended fluid change intervals of Allison Transmission. Allison Transmission recommends that customers use fluid analysis as the primary method for determining fluid change intervals. In the absence of a fluid analysis program the fluid change intervals listed in the charts above should be used.**

\* Anything other than 100 percent concentration of TransSynd™ or TES 295 approved fluid, is considered a mixture and should utilize non-TES 295 change intervals.

\*\* General Vocation: less than one stop per mile.

\*\*\* Severe Vocation: more than one stop per mile.

† When an Allison recommended high-efficiency filter is used, the change interval is not until the Change Filter light indicates the filter is contaminated or until it has been in use for 3 years, whichever ever occurs first. No mileage restrictions apply. High efficiency filters are only approved for use with AT/MT/HT Series.

†† Fluid fill capacity is dependent on vehicle configuration. Final fluid capacity must be determined by dipstick level (see Mechanic's Tips MT1357EN Section 1 or your Operator's Manual under "Care and Maintenance").

Capacities†† (Approximate)		
Pan Depth	Initial Fill††	
	Quarts	Liters
4-3 inch (110 mm) oil pan	12	11
5.1 inch (130 mm) oil pan	15	14
††† Approximate quantities, do not include external lines and cooler hose.		
Filter and Gasket Kits		
Oil Filter and Gasket Kit	29538489	
See SIL 04-TR-01 for additional information.		

# HT Series Transmissions

## Recommended Fluid and Filter Change Intervals

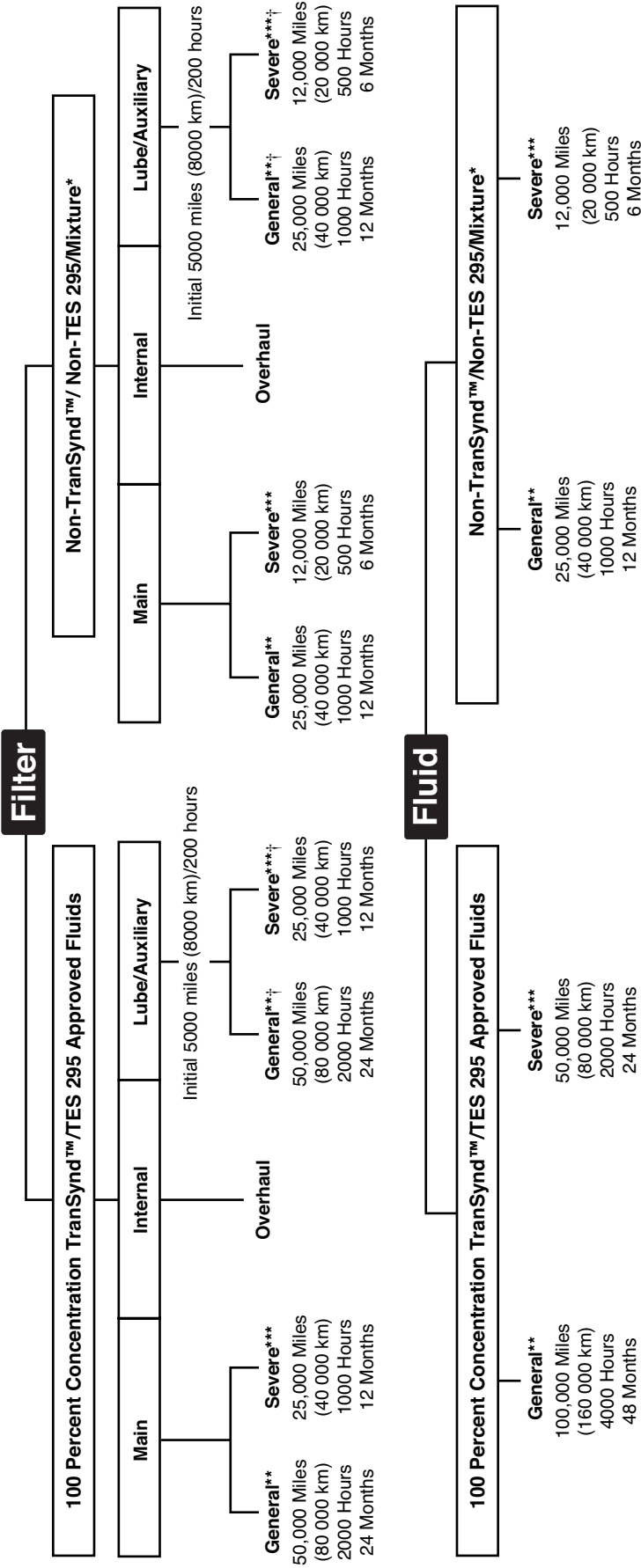

**NOTE: Change fluid/filters at or before recommended mileage, months, or hours have elapsed, whichever occurs first. Differ from the published recommended fluid change intervals of Allison Transmission. Allison Transmission recommends that customers use fluid analysis as the primary method for determining fluid change intervals. In the absence of a fluid analysis program the fluid change intervals listed in the charts above should be used.**

\* Anything other than 100 percent concentration of TranSynd™ or TES 295 approved fluid, is considered a mixture and should utilize non-TES 295 change intervals.

\*\* General Vocation: less than one stop per mile.

\*\*\* Severe Vocation: more than one stop per mile.

† When an Allison recommended high-efficiency filter is used, the change interval is not until the Change Filter light indicates the filter is contaminated or until it has been in use for 3 years, whichever ever occurs first. No mileage restrictions apply. High efficiency filters are only approved for use with AT/MT/HT Series.

†† Fluid fill capacity is dependent on vehicle configuration. Final fluid capacity must be determined by dipstick level (see Mechanic's Tips MT1366EN (Hydraulic Controls) or MT1958EN (Electronic Controls) Section 1 or your Operator's Manual under "Care and maintenance").

Capacities††(Approximate)		
Pan Depth	Refill†††	
	Quarts	Liters
4.5 inch (114 mm) oil pan	34	32
6 inch (152 mm) oil pan	30	28.5
7 inch (178 mm) oil pan	33	31
8.5 inch (216 mm) oil pan	42.8	40.5

††† Approximate quantities, do not include external lines and cooler hose.

Filter and Gasket Kits	
4.5 inch (114 mm) Oil Pan Filter Kit	29530562
4.5 inch (114 mm) Oil Pan Filter Kit with adapter 23016883 and pan 23016884 uses filter kit	29530563
6 inch (152 mm) Oil Pan Filter Kit	6839945
7 inch (178 mm) Oil Pan Filter Kit	29530564
8.5 inch (216) Hyd Oil Pan Filter Kit	23012407
8.5 inch (216) Elec Oil Pan Filter Kit	29530565

# Filter Change Intervals

Transmission Family	Non- TES 295 / DEXRON®-III/VI / Mixture Filters						TES 295/TranSynd™ Filters						TES 228 (C4) / MIL- PRF- 2104,21260,46167 Filters					
	Internal		Lube / Auxiliary		Main		Internal		Lube / Auxiliary		Main		Internal		Lube / Auxiliary		Main	
	General	Severe	General	Severe	General	Severe	General	Severe	General	Severe	General	Severe	General	Severe	General	Severe	General	Severe
AT	25,000 miles (40,000 km)	12,000 miles (20,000 km)	25,000 miles** (40,000 km)	12,000 miles** (20,000 km)	N.A.	N.A.	100,000 miles (160,000 km)	50,000 miles (80,000 km)	50,000 miles** (80,000 km)	25,000 miles** (40,000 km)	N.A.	N.A.	25,000 miles** (40,000 km)	12,000 miles** (20,000 km)	25,000 miles** (40,000 km)	12,000 miles** (20,000 km)	N.A.	N.A.
	1000 hours 12 months	500 hours 6 months	1000 hours 12 months	500 hours 6 months	N.A.	N.A.	4000 hours 48 months	2000 hours 24 months	2000 hours 24 months	1000 hours 12 months	N.A.	N.A.	1000 hours 12 months	500 hours 6 months	1000 hours 12 months	500 hours 6 months	N.A.	N.A.
MT	Overhaul	Overhaul	25,000 miles** (40,000 km)	12,000 miles** (20,000 km)	N.A.	N.A.	Overhaul	Overhaul	50,000 miles** (80,000 km)	25,000 miles** (40,000 km)	N.A.	N.A.	25,000 miles** (40,000 km)	12,000 miles** (20,000 km)	25,000 miles** (40,000 km)	12,000 miles** (20,000 km)	N.A.	N.A.
	Overhaul	Overhaul	1000 hours 12 months	500 hours 6 months	N.A.	N.A.	Overhaul	Overhaul	2000 hours 24 months	1000 hours 12 months	N.A.	N.A.	1000 hours 12 months	500 hours 6 months	1000 hours 12 months	500 hours 6 months	N.A.	N.A.
HT/CLT 700N 700	Overhaul	Overhaul	25,000 miles** (40,000 km)	12,000 miles** (20,000 km)	25,000 miles (40,000 km)	12,000 miles (20,000 km)	Overhaul	Overhaul	50,000 miles** (80,000 km)	25,000 miles** (40,000 km)	50,000 miles (80,000 km)	25,000 miles (40,000 km)	12,000 miles (20,000 km)	25,000 miles** (40,000 km)	12,000 miles** (20,000 km)	25,000 miles** (40,000 km)	12,000 miles** (20,000 km)	25,000 miles (40,000 km)
	Overhaul	Overhaul	1000 hours 12 months	500 hours 6 months	1000 hours 12 months	500 hours 6 months	Overhaul	Overhaul	2000 hours 24 months	1000 hours 12 months	2000 hours 24 months	1000 hours 12 months	500 hours 6 months	1000 hours 12 months	500 hours 6 months	1000 hours 12 months	500 hours 6 months	1000 hours 12 months
1000 and 2000 Series (Non-Pick-up)	Overhaul	Overhaul	50,000 miles (80,000 km)	25,000 miles (40,000 km)	Control Main Spin-on filter Only/Initial 5000 miles	Control Main Spin-on filter Only/Initial 5000 miles	Overhaul	Overhaul	50,000 miles (80,000 km)	25,000 miles (40,000 km)	50,000 miles (80,000 km)	25,000 miles (40,000 km)	50,000 miles (80,000 km)	25,000 miles (40,000 km)	50,000 miles (80,000 km)	25,000 miles (40,000 km)	N.A.	N.A.
	Overhaul	Overhaul	2000 hours 24 months	1000 hours 12 months	2000 hours 24 months	2000 hours 24 months	Overhaul	Overhaul	2000 hours 24 months	1000 hours 12 months	2000 hours 24 months	1000 hours 12 months	2000 hours 24 months	1000 hours 12 months	2000 hours 24 months	1000 hours 12 months	N.A.	N.A.
All 4000 Series with 4" Sump and all 3000 Series	Overhaul	Overhaul	25,000 miles (40,000 km)	12,000 miles (20,000 km)	Main Filter Only Initial 5000 miles	Main Filter Only Initial 5000 miles	Overhaul	Overhaul	75,000 miles (120,000 km)	50,000 miles (80,000 km)	75,000 miles (120,000 km)	50,000 miles (80,000 km)	75,000 miles (120,000 km)	50,000 miles (80,000 km)	75,000 miles (120,000 km)	50,000 miles (80,000 km)	Main Filter Only Initial 5000 miles	Main Filter Only Initial 5000 miles
	Overhaul	Overhaul	1000 hours 12 months	500 hours 6 months	1000 hours 12 months	500 hours 6 months	Overhaul	Overhaul	3000 hours 36 months	2000 hours 24 months	3000 hours 36 months	2000 hours 24 months	3000 hours 36 months	2000 hours 24 months	3000 hours 36 months	2000 hours 24 months	25,000 miles (40,000 km)	12,000 miles (20,000 km)
4000 Series (with 2" Sump)	Overhaul	Overhaul	25,000 miles (40,000 km)	12,000 miles (20,000 km)	Main Filter Only Initial 5000 miles	Main Filter Only Initial 5000 miles	Overhaul	Overhaul	50,000 miles (80,000 km)	25,000 miles (40,000 km)	50,000 miles (80,000 km)	25,000 miles (40,000 km)	50,000 miles (80,000 km)	25,000 miles (40,000 km)	50,000 miles (80,000 km)	25,000 miles (40,000 km)	Main Filter Only Initial 5000 miles	Main Filter Only Initial 5000 miles
	Overhaul	Overhaul	1000 hours 12 months	500 hours 6 months	1000 hours 12 months	500 hours 6 months	Overhaul	Overhaul	2000 hours 24 months	1000 hours 12 months	2000 hours 24 months	1000 hours 12 months	2000 hours 24 months	1000 hours 12 months	2000 hours 24 months	1000 hours 12 months	25,000 miles (40,000 km)	12,000 miles (20,000 km)
EP 40/50	N.A.	N.A.	N.A.	N.A.	N.A.	N.A.	Overhaul	Overhaul	50,000 miles (80,000 km)	25,000 miles (40,000 km)	50,000 miles (80,000 km)	25,000 miles (40,000 km)	50,000 miles (80,000 km)	25,000 miles (40,000 km)	50,000 miles (80,000 km)	25,000 miles (40,000 km)	N.A.	N.A.
	N.A.	N.A.	N.A.	N.A.	N.A.	N.A.	Overhaul	Overhaul	2000 hours 24 months	1000 hours 12 months	2000 hours 24 months	1000 hours 12 months	2000 hours 24 months	1000 hours 12 months	2000 hours 24 months	1000 hours 12 months	N.A.	N.A.

NOTE: Change fluid/filters at or before recommended mileage, months, or hours have elapsed, whichever occurs first.

NOTE: Local conditions, severity of operation or duty cycle may require more or less frequent fluid change intervals that differ from the published recommended fluid change intervals of Allison Transmission. Allison Transmission recommends that customers use fluid analysis as the primary method for determining fluid change intervals. In the absence of a fluid analysis program the fluid change intervals listed in the charts above should be used.

NOTE: General Vocation: Intercity Coach with duty cycle less than or equal to one (1) stop per mile and all other vocations not listed in severe vocation.

NOTE: Severe Vocation: All Retarders, On/Off Highway, Refuse, Transit, Shuttle Transit, 2000 MH, and Intercity Coach with duty cycle greater than one (1) stop per mile.

\*\* When an Allison recommended high-efficiency filter is used, the change interval is not until the Change Filter light indicates the filter is contaminated or until it has been in use for 3 years, whichever ever occurs first. No mileage restrictions apply. High efficiency filters are only approved for use with AT/MT/HT Series.

## Fluid Change Intervals

Transmission Family	Non-TES 295 DEXRON®-III/VI Mixture		TES-228 (C4) MIL-PRF-2104 MIL-PRF-21260 MIL-PRF-46167		TES 295 TranSynd™	
	General	Severe	General	Severe	General	Severe
AT 500 / MT 600	25,000 miles (40 000 km) 1000 hours 12 months	12,000 miles (20 000 km) 500 hours 6 months	25,000 miles (40 000 km) 1000 hours 12 months	12,000 miles (20 000 km) 500 hours 6 months	100,000 miles (160 000 km) 4000 hours 48 months	50,000 miles (80 000 km) 2000 hours 24 months
HT/CLT 700/V 700	25,000 miles (40 000 km) 1000 hours 12 months	12,000 miles (20 000 km) 500 hours 6 months	25,000 miles (40 000 km) 1000 hours 12 months	12,000 miles (20 000 km) 500 hours 6 months	100,000 miles (160 000 km) 4000 hours 48 months	50,000 miles (80 000 km) 2000 hours 24 months
1000/2000 Series <i>(non-pickup)</i>	50,000 miles (80 000 km) 2000 hours 24 months	12,000 miles (20 000 km) 500 hours 6 months	N.A.	N.A.	100,000 miles (160 000 km) 4000 hours 48 months	50,000 miles (80 000 km) 2000 hours 24 months
ALL 4000 Series with 4" Sump and all 3000 Series	25,000 miles (40 000 km) 1000 hours 12 months	12,000 miles (20 000 km) 500 hours 6 months	25,000 miles (40 000 km) 1000 hours 12 months	12,000 miles (20 000 km) 500 hours 6 months	150,000 miles (240 000 km) 4000 hours 48 months	75,000 miles (120 000 km) 3000 hours 36 months
4000 Series with 2" Sump	25,000 miles (40 000 km) 1000 hours 12 months	12,000 miles (20 000 km) 500 hours 6 months	25 000 miles (40 000 km) 1000 hours 12 months	12,000 miles (20 000 km) 500 hours 6 months	150,000 miles (240 000 km) 4000 hours 48 months	50,000 miles (80 000 km) 2000 hours 24 months
E <sup>P</sup> 40/50	N.A.	N.A.	N.A.	N.A.	100,000 miles (160 000 km) 48 months	100 000 miles (160 000 km) 48 months

NOTE: Change fluid/filters at or before recommended mileage, months, or hours have elapsed, whichever occurs first.

NOTE: Local conditions, severity of operation or duty cycle may require more or less frequent fluid change intervals that differ from the published recommended fluid change intervals of Allison Transmission. Allison Transmission recommends that customers use fluid analysis as the primary method for determining fluid change intervals. In the absence of a fluid analysis program the fluid change intervals listed in the charts above should be used.

NOTE: General Vocation: Intercity Coach with duty cycle less than or equal to one (1) stop per mile and all other vocations not listed in severe vocation.

NOTE: Severe Vocation: All Retarders, On/Off Highway, Refuse, Transit, Shuttle Transit, 2000 MH, and Intercity Coach with duty cycle greater than one (1) stop per mile.

\*\* When an Allison recommended high-efficiency filter is used, the change interval is not until the Change Filter light indicates the filter is contaminated or until it has been in use for 3 years, which ever occurs first. No mileage restrictions apply. High efficiency filters are only approved for use with AT/MT/HT Series.