

SECTION 04: EXHAUST SYSTEM

CONTENTS

1. EXHAUST AND AFTERTREATMENT SYSTEM OVERVIEW	2
1.1 MAINTENANCE	2
1.2 FLEXIBLE COUPLING INSTALLATION	3
2. AFTERTREATMENT DEVICE (ATD)	3
2.1 DIESEL PARTICULATE FILTER (DPF) REMOVAL.....	4
3. DIFFUSER ASSEMBLY	5
3.1 DIFFUSER ADJUSTMENT	5
3.2 MAINTENANCE	6
3.3 DIFFUSER ADAPTER.....	6

ILLUSTRATIONS

FIGURE 1: EXHAUST SYSTEM.....	2
FIGURE 2: FLEXIBLE COUPLING	3
FIGURE 3: AFTERTREATMENT DEVICE (ATD)	3
FIGURE 4: OPENING DPF COMPARTMENT ACCESS DOOR 4	
FIGURE 5: DPF REMOVAL	4
FIGURE 6: DIFFUSER ASSEMBLY	5
FIGURE 7: DIFFUSER POSITION ADJUSTMENT.....	6
FIGURE 8: DIFFUSER POSITION ADJUSTMENT.....	6
FIGURE 9: DIFFUSER POSITION ADJUSTMENT.....	6
FIGURE 10: DIFFUSER ADAPTER	6

Section 04: EXHAUST SYSTEM

1. EXHAUST AND AFTERTREATMENT SYSTEM OVERVIEW

Detroit Diesel's workhorse behind clean emissions technology is an exhaust **Aftertreatment Device (ATD)** which replaces today's muffler. The ATD primary function is to capture and oxidize (regenerate) the particulate matter (soot) in the engine exhaust gases. The ATD is split into two main sections. The exhaust gases first enter the **Diesel Oxidation Catalyst (DOC)** and then flow through the **Diesel Particulate Filter (DPF)**; together they capture and regenerate the soot on a regular or passive basis. Through constant monitoring of the exhaust gas temperature and the system back pressure, DDEC VI is able to manage regeneration.

The ATD is rubber mounted to the vehicle structure. This feature reduces the transmission of vibrations to the ATD thus resulting in extended life of ATD, brackets and also noise reduction.

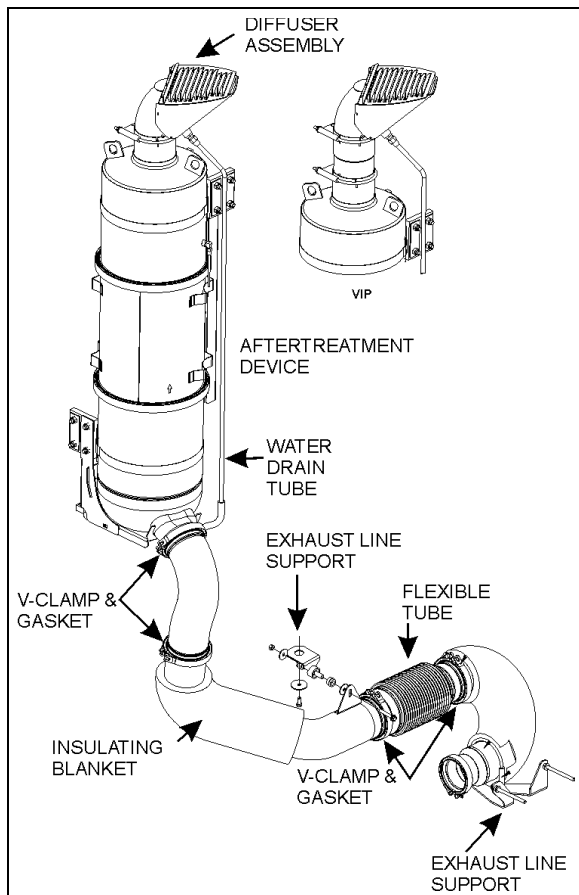

FIGURE 1: EXHAUST SYSTEM

04017

1.1 MAINTENANCE

Inspect the exhaust system periodically for restrictions and leaks. Figure 1 presents the major components of the exhaust system. Exhaust leaks are commonly the result of loose clamp bolts, corroded or punctured pipes. In addition to excessive noise, a leaking exhaust system could allow toxic gases to enter the vehicle. Damage to surrounding components from hot gases could result as well. Replace damaged or corroded exhaust components immediately.

Inspect the exhaust system as follows:

- * At vehicle inspection intervals ;
- * Whenever a change is noticed in the sound of the exhaust system ; and
- * Whenever the exhaust system is damaged.

Replace damaged or corroded exhaust system components without delay.

When operating the engine in a service garage or in a closed area, the exhaust must be vented to the outside. Place the shop vent hose over the exhaust outlet pipe.



DANGER

Avoid breathing exhaust gases since they contain carbon monoxide which is odorless and colorless but harmful. Carbon monoxide is a dangerous gas that can cause unconsciousness and can be lethal. If, at any time you suspect that exhaust fumes are entering the vehicle, locate and correct the cause(s) as soon as possible.

NOTE

The key to successful regeneration is high exhaust temperature for an extended period of time. For this reason, insulating blankets must remain permanently on the exhaust system.

If insulating blankets are removed from the system, the exhaust gases temperature may not be high enough to permit efficient particulate oxidation during passive regeneration, resulting in increased fuel consumption due to overuse of active or stationary regeneration.

1.2 FLEXIBLE COUPLING INSTALLATION

The flexible coupling contains a rigid interior pipe (Fig. 2). To allow appropriate flexibility once installed, be sure interior pipe is concentric to flexible part and that the flexible coupling is straight when installed. This piece of equipment handles vibration and thermal expansion.

CAUTION

Adequately support the exhaust system line. The load of the exhaust line **must not** be transferred to the turbocharger.

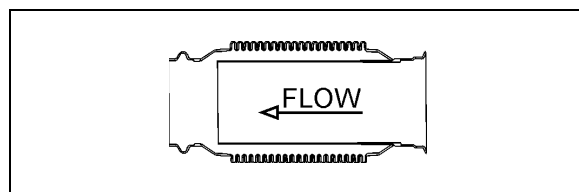

FIGURE 2: FLEXIBLE COUPLING

04022

2. AFTERTREATMENT DEVICE (ATD)

Besides trapping soot, the **DPF (Diesel Particulate Filter)** also traps the ash that has been generated when additives in engine oil are burned. However, unlike soot, ash cannot be oxidized. The ash that accumulates in the filter will eventually cause an increase in exhaust back pressure. DDEC VI will constantly monitor the ash accumulation and forecast the approximate time until DPF ash cleaning is required. This information is stored in DDEC VI and will be accessible by using the Detroit Diesel Diagnostic Link. This allows you the opportunity to plan for the DPF ash cleaning interval. If ash cleaning is not performed proactively, and the back pressure increases beyond the system limit, DDEC VI will flag the amber warning light on the telltale panel, notifying the operator that an ash cleaning is required. Clean remanufactured DPF cartridge will be available through Detroit Diesel on an exchange basis. For most vehicle applications and duty cycle, this will occur after approximately 200,000-400,000 miles (320,000-640,000 km) of operation.

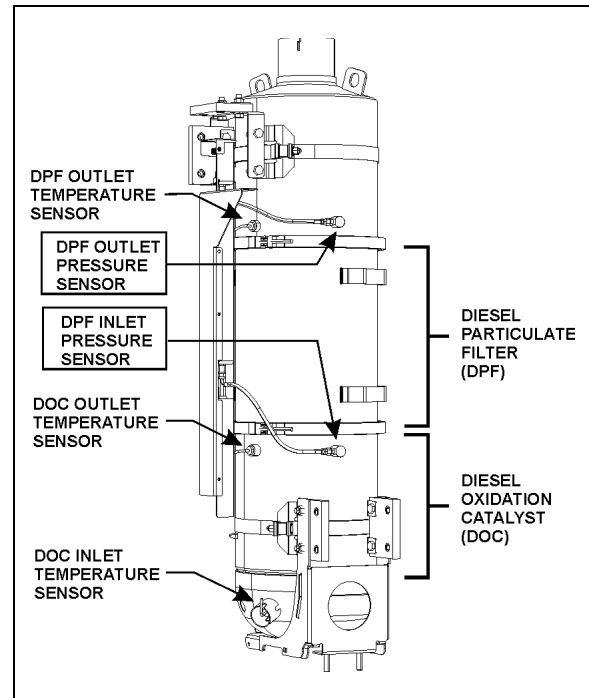

FIGURE 3: AFTERTREATMENT DEVICE (ATD)

04016

WARNING

HOT SURFACES

Keep yourself clear of hot Aftertreatment Device surfaces, particularly during and after active or stationary regeneration. Hot surfaces can cause serious burns.

Make sure Aftertreatment System components are cold before handling.

WARNING

TOXICITY

Do not initiate a stationary regeneration in a closed area like a garage. **Stationary regeneration must be undertaken outdoors only.**

Section 04: EXHAUST SYSTEM



WARNING

HOT EXHAUST

During stationary regeneration, exhaust gases temperature may reach up to 1200°F (650°C) at the DPF outlet. Do not direct at combustible materials. Before initiating stationary regeneration, make sure that the DPF outlet diffuser is clear of objects and that no one is working near the DPF outlet diffuser. Stationary regenerations must be undertaken outdoors only.

2.1 DIESEL PARTICULATE FILTER (DPF) REMOVAL

To remove the DPF, proceed as follow:



CAUTION

External and internal temperatures remain hot long after engine has been shutdown. Allow the Aftertreatment Device and DPF to cool before handling. Wear protective clothing and glove while servicing.

1. First, open the engine compartment door;
2. Under the ATD, on the left wall, pull the catch connecting rod to unlock the DPF compartment access door and lift the door open;
3. Hold the door open by inserting the support rod's free end into the receptacle located on the left side of the DPF;



CAUTION

After inserting the support rod into the receptacle, make sure the rod supports the door securely from falling down on to your head or body.

4. Loosen the support strap surrounding the upper part of the Aftertreatment Device (ATD);
5. Loosen the upper V-band clamp joining the DPF to the upper part of the ATD. Slide the V-band clamp out of the way;

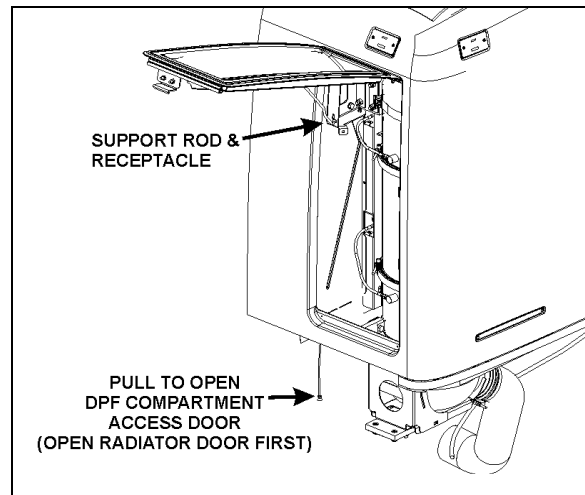

FIGURE 4: OPENING DPF COMPARTMENT ACCESS DOOR

04029

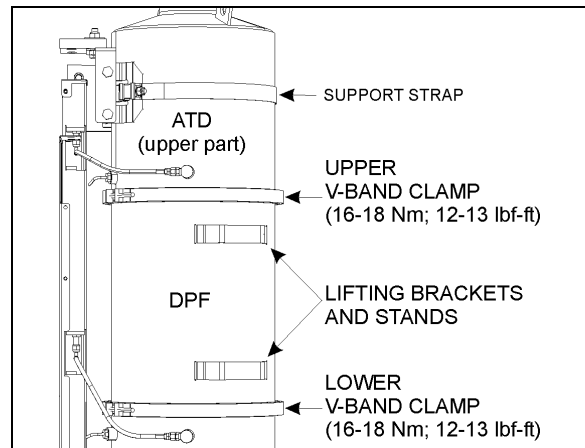

FIGURE 5: DPF REMOVAL

04019

6. Lift up the upper part of the ATD about 1/2" (12mm) and then tighten the strap to maintain it in that raised position;
 7. Loosen the lower V-band clamp and slide it out of the way;
- Pull the DPF section out of the compartment. Use appropriate handling equipment.



CAUTION

HEAVY DEVICE

A suitable lifting or holding device is required. Properly support and attach lifting equipment to prevent the DPF from falling when servicing.

CAUTION

FRAGILE - HANDLE WITH CARE

Use extreme care when handling DPF cartridge as it could be damaged or destroyed by dropping or sudden impact.

Clean remanufactured DPF cartridge will be available through Detroit Diesel on an exchange basis. For this reason, it is very important to maintain the cartridge in perfect condition. Damaged cartridge may not be refunded.

NOTE

When replacing the DPF cartridge, refer to the specifications on the DPF attached tag for proper replacement DPF selection.

Installation of the DPF is the same as removal, but in reverse order. However, take note of the following points:

1. To prevent exhaust losses, make sure that the DPF section is perfectly aligned with the DOC and the upper part of the ATD before tightening the V-band clamps.
2. Properly tighten all fasteners.
3. Be sure to return the support rod to its clip before closing the door, this prevents rattles.

3. DIFFUSER ASSEMBLY

During stationary regeneration, exhaust gases temperature may reach up to 1200°F (650°C) at the DPF outlet. The diffuser decreases the exhaust gasses temperature to 475°F (246°C) approximately, at 6 inches above the diffuser. The diffuser is an important component of the exhaust system and must remain on the vehicle at all times. Operating the vehicle without the diffuser may seriously damage the vehicle.

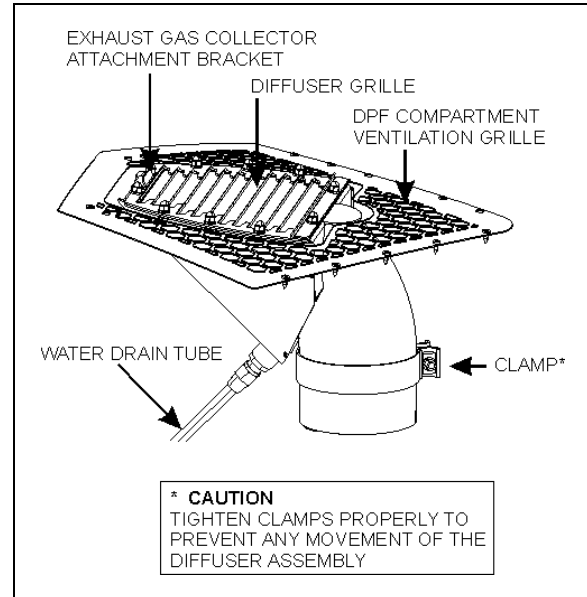

FIGURE 6: DIFFUSER ASSEMBLY

04014

3.1 DIFFUSER ADJUSTMENT

Should an adjustment of the diffuser position be necessary, first remove the DPF compartment ventilation grille.

CAUTION

To prevent damages caused by hot exhaust gases to the surrounding area, the diffuser grille must be flush with the roof surface or may not exceed the roof surface more than 1/4in (6mm).

CAUTION

Tighten clamps properly in order to prevent any movement of the diffuser assembly. An impact wrench is necessary.

1. Loosen the clamp securing the diffuser assembly to the ATD.
2. For proper angular position, make sure that the two edges shown on figure 7 are parallel with each other.
3. Using a straightedge, adjust the diffuser assembly level. The top surface of the tag fixed on the diffuser grille must be flush with the roof surface (fig.8). It may exceed about 1/4in (6mm). Place the straightedge as shown on figure 8.

Section 04: EXHAUST SYSTEM

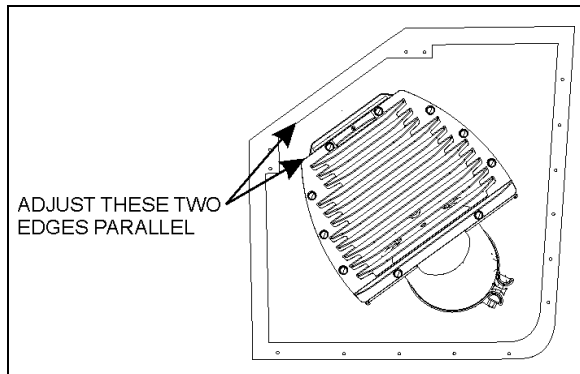

FIGURE 7: DIFFUSER POSITION ADJUSTMENT 04015_1

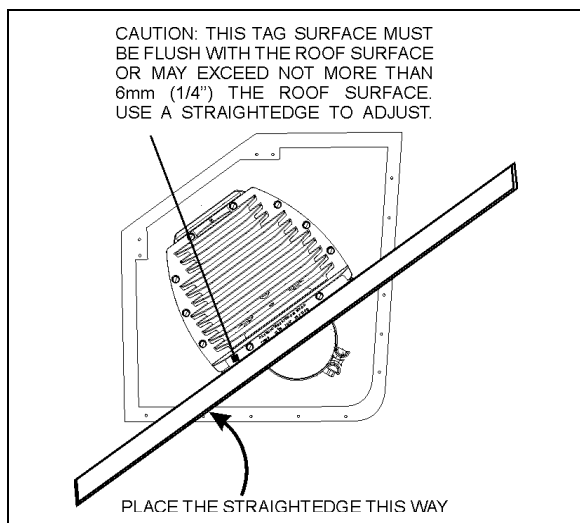

FIGURE 8: DIFFUSER POSITION ADJUSTMENT 04015_2

4. Tighten the clamp securing the diffuser assembly to the ATD.
5. Reinstall the DPF compartment grille. Put a small quantity of Sika 221 on screws (fig.9).

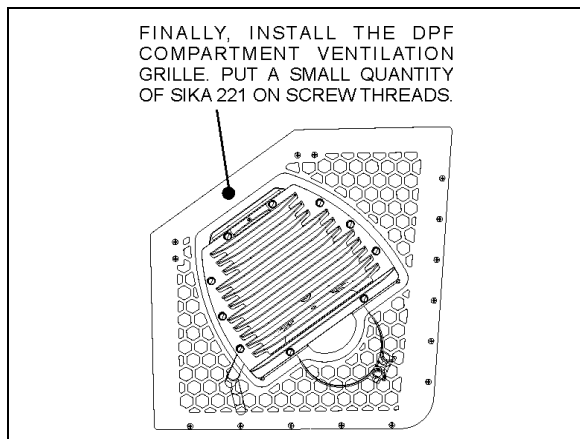

FIGURE 9: DIFFUSER POSITION ADJUSTMENT 04015_3

3.2 MAINTENANCE

Inspect the diffuser assembly as follows:

- At vehicle inspection intervals, inspect diffuser grille for stress cracking;
- Check for proper functioning of the rain cap inside the diffuser housing, make sure that it moves freely;
- Make sure that the water drain tube is not clogged. Pour a cup of water into the diffuser housing and assure that all the water is drained at once at the other end of the drain tube. If tube is clogged, remove tube and blow compressed air inside, in reverse flow.

3.3 DIFFUSER ADAPTER

A diffuser adapter (Prevost #040710) is available through Prevost Parts to permit connection with current exhaust gas collecting system.

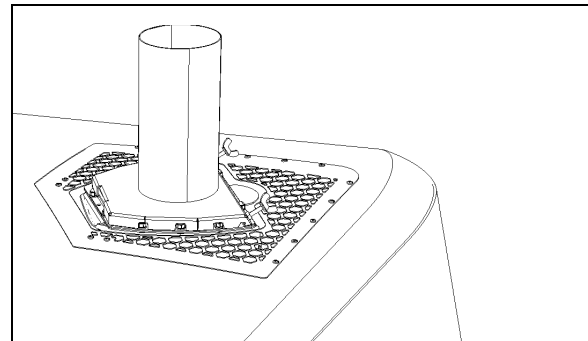

FIGURE 10: DIFFUSER ADAPTER

04020