

PREVOST®

COACH MANUFACTURER

MAINTENANCE MANUAL

X3-45 COMMUTER

DOB Bus Number Series 2490 - 2789



Final Version, Rev. 2

PA1605 November 2014 (first release)

Featuring:

- GHG14 regulations engine
- ZF A-132 Drive Axle

REVISION	DESCRIPTION	DATE
1	- Sec 22: Heating and Air Conditioning updated. - Sec 13: Wheels, Hubs and Tires: updated to reflect wheel dimensions on new build; Drive axle hub updated to "ZF" design.	Feb. 2015
2	- Addition of "Change Log" table at the end of each section. - Tightening torques changed in Section 16. Refer to Section 16 Change Log. - Addition of steering play inspection. See Section 14 & lubrication and SERVICING SCHEDULE. - Fuel tank strap torque was 60 lb-ft, is 20 lb-ft. - Section 24a LUBRICATION AND SERVICING SCHEDULE updated. - Section 03: FUEL. Fuel tank yearly inspection added. - Section 24a lubrication and servicing schedule updated. - Section 24a LUBRICATION AND SERVICING SCHEDULE updated. - Section 16 SUSPENSION revised.	April 2016 August 2016 October 2016 June 2017 May 2018 March 2019 April 2019

CRITICAL EMISSION-RELATED MAINTENANCE

Source of parts and repair:

A repair shop or person of the owner's choosing must maintain, replace, or repair emission control devices and systems per manufacturer's recommendations.

Replacement of tires that are GHG certified:

The original equipment tires installed on this vehicle at the factory were certified to the U.S. EPA Greenhouse Gas (GHG) and **National Highway Traffic Safety Administration (NHTSA)** Fuel Efficiency regulations. Replacement of these tires should be with a tire of equal or lower rolling resistance levels (TRRL or Crr). Please consult your tire supplier(s) for appropriate replacement tires.

Maintaining a GHG certified tire:

In order to maintain the certified rolling resistance of the tires which optimize fuel economy, the maintenance procedures provide by the tire manufacturer must be followed.

CONTENTS

1. FOREWORD	2
2. SCHEMATICS	2
3. PRECAUTIONS TO BE OBSERVED BEFORE WELDING	2
4. SAFETY NOTICE	4
4.1 DATA PLATES AND CERTIFICATIONS	4
4.1.1 Engine	5
4.1.2 Transmission	5
4.1.3 Drive Axle	5
4.1.4 Front Axle	5
4.1.5 Power Steering Pump.....	5
4.1.6 Coach Final Record.....	5
4.1.7 Safety Certification	5
4.1.8 DOT Certification Label	6
4.1.9 Fuel Tank Label	6
4.1.10 Vehicle Identification Number (VIN)	6
5. FASTENER STRENGTH IDENTIFICATION	8
5.1 STANDARD TORQUE SPECIFICATIONS	9
5.2 SELF-LOCKING FASTENERS.....	11
5.3 RECOMMENDATIONS FOR REUSE	11
5.4 SIX LOBED SOCKET HEAD	11
6. SECTION CHANGE LOG	15

ILLUSTRATIONS

FIGURE 1: VOLVO D13 ENGINE DATA PLATE.....	5
FIGURE 2: ALLISON TRANSMISSION	5
FIGURE 3: TYPICAL SERIAL & MODEL NUMBERS	5
FIGURE 4: I-BEAM AXLE TYPICAL SERIAL & MODEL NUMBERS.....	5
FIGURE 5: POWER STEERING PUMP	5
FIGURE 6: DOT CERTIFICATION PLATE	6
FIGURE 7: VEHICLE I.D.....	6
FIGURE 8: VEHICLE IDENTIFICATION NUMBER.....	7
FIGURE 9: THREAD NOTATION	8
FIGURE 10: BOLT STRENGTH MARKINGS	8
FIGURE 11: SELF-LOCKING FASTENERS	11
FIGURE 12: METRIC - US STANDARD CONVERSION TABLE.....	13
FIGURE 13: CONVERSION CHART	14

1. FOREWORD

This manual includes procedures for diagnosis, service, maintenance and repair for components of the X3-45 series coaches listed on the front cover page. This manual should be kept in a handy place for ready reference by the technician. If properly used, it will meet the needs of the technician and owner.

Information provided in Sections 1 through 24 pertain to standard equipment items, systems and components as well as the most commonly used optional equipment and special equipment offered on the vehicle models covered by this manual. At the beginning of each section: a Table of Contents and a list of illustrations give the page number on which each subject begins and where each figure is located. Vehicle operating information is provided in a separate Manual

More specific information on engine and transmission operating, maintenance, and overhaul information is contained in the applicable engine or transmission service manual published by the engine or transmission manufacturer. Engine and transmission parts information is contained in the applicable engine or transmission parts catalog published by the engine or transmission manufacturer. All information, illustrations and specifications contained in this manual are based on the latest product information available at the time of publication approval. The right is reserved to make product changes at any time without notice.

NOTE

Illustrations in this manual are used for reference only and may differ slightly from the actual vehicle, however, key components addressed in the manual are represented as accurately as possible.

Prevost occasionally sends Maintenance Information, Warranty Bulletins, Safety Recalls or other literature to update users with the latest service procedures. They are issued, when required, to supplement or supersede information in this manual. Update sheet should be filled out and bulletins should be filed at the end of their respective section for future reference.

2. SCHEMATICS

Vehicle Air Schematics are provided at the end of Section 12, "Brake". SUSPENSION AIR SCHEMATICS are provided at the end of Section 16: "Suspension". Moreover, Electrical Schematics are provided in the technical publications box. Refer to those schematics for detailed circuit information or during diagnosis.

3. PRECAUTIONS TO BE OBSERVED BEFORE WELDING



CAUTION

Precautions are to be observed before welding to minimize the risk of major and costly damage caused to the vehicle electronic components.

NOTE

For X3-45 Series Multiplex coaches, also execute procedure no: PR060041 "MULTIPLEX MODULES DISCONNECTION PROCEDURE PRIOR TO WELDING" included at the end of this section.



CAUTION

For vehicles equipped with a WCL system, disconnect electronic controller connector.



CAUTION

Cover electronic control components and wiring to protect from hot sparks, etc.



CAUTION

Position welding machine ground clamp as close as possible to the work. Ensure that the welding machine ground return clamp is well secured and makes a good electrical contact with a large metallic area of the chassis located as close as possible to the welding point.



CAUTION

Do not use TIG welding process on the vehicle. This high frequency current process can seriously damage the electronic components.

STEEL – STEEL WELDING**CAUTION**

Before welding, perform multiplex modules disconnection procedure.

NOTE

Welding surfaces must be free of scale, slag, rust, paint, grease, humidity or other foreign material that would render welding impossible.

**DANGER**

Only a qualified and experienced person must do welding.

- FCAW (Flux Cored Arc Welding) process ;
- Electrode wire conforms to A5.20 AWS (American Welding Society) specifications ;
- E4801T-9-CH, type electrode wire with 0,045" diameter (1,14 mm) ;

Material Thickness	Voltage	Current	Wire Feed Rate	Shielding Gas
1/8" to 1/2"	26 ± 2 volts	260 Amps	450 ipm. approx.	75% argon – 25% CO2 or 100% CO2

If necessary and with great care to prevent perforating the material, it is possible to use a conventional electric arc welding machine according to the following specifications:

- SMAW (Shielded Metal-Arc Welding) process ;
- Welding rod conforms to A5.1 of AWS (American Welding Society) specifications; E 7018 type welding rod with 1/8" diameter (3,2 mm).
- Current: 100 amperes to 150 amperes; optimum at 120 amps.

It is important to grind weld bead starts and stops and also to grind arc strikes from surfaces.

STEEL - STAINLESS STEEL OR STAINLESS STEEL - STAINLESS STEEL WELDING**CAUTION**

Before welding, perform multiplex modules disconnection procedure.

NOTE

Welding surfaces must be free of scale, slag, rust, paint, grease, humidity or other foreign material that would render welding impossible.

**DANGER**

Only a qualified and experienced person must do welding.

- GMAW (Gas Metal-Arc Welding) process;
- Welding wire conforms to AWS (American Welding Standards) A5.9 specifications;
- 308LSi type welding wire with 0.035" diameter (0,9 mm);

STEEL - STAINLESS STEEL WELDING

SECTION 00: GENERAL INFORMATION

Steel Thickness	SS Thickness	Voltage	Current	Wire Feed Rate	Shielding Gas
Less than 1/8"	Any type	20±1.5 volts	130±15 Amps	290 ipm approx.	90% He, 7.5% Ar, 2.5% CO2
1/8" and more	Any type	22±1.5 volts	160±15 Amps	330 ipm approx.	90% He, 7.5% Ar, 2.5% CO2

STAINLESS STEEL - STAINLESS STEEL WELDING

SS Thickness	Voltage	Current	Wire Feed Rate	Shielding Gas
Any type	20 ± 1.5 volts	130 ± 15 Amps	290 ipm approx.	90% He – 7.5% Ar, 2.5% CO2

If necessary and with great care to prevent perforating the material, it is possible to use a conventional electric arc welding machine according to the following specifications:

- SMAW (Shield Metal-Arc Welding) process;
- Welding rod conforms to AWS (American Welding Standards) A5.4 specifications; 308L-17 type welding rod with 3/32" diameter (2,4 mm);
- Current: - 50 amperes to 90 amperes, optimum at 60 amperes.

It is important to grind weld bead starts and stops and also to grind arc strikes from surfaces.

4. SAFETY NOTICE

This maintenance manual has been prepared in order to assist skilled mechanics in the efficient repair and maintenance of PREVOST vehicles.

This manual covers only the procedures as of manufacturing date.

Safety features may be impaired if other than genuine PREVOST parts are installed.

Torque wrench tightening specifications must be strictly observed. Locking devices must be installed or replaced by new ones, where specified. If the efficiency of a locking device is impaired, it must be replaced.

This manual emphasizes particular information outlined by the wording and symbols:



DANGER

Directs the operator's attention to unsafe practices which could result in serious personal injury or death.



WARNING

Directs the operator's attention to unsafe practices which could result in serious personal injury or severe damage to the vehicle.



CAUTION

Directs the operator's attention to unsafe practices where personal injury is not likely but damage to vehicle components could occur.

NOTE

Indicates supplementary information essential to the proper operation of the vehicle. Although, the mere reading of such information does not eliminate the hazard, understanding of the information will promote its correct use.

4.1 DATA PLATES AND CERTIFICATIONS

Delay and confusion can be avoided by placing the complete vehicle identification number of the vehicle and the serial numbers of the engine on parts orders and correspondence. Also, the transmission, axles, power steering pump chassis and other major components are identified by serial numbers.

4.1.1 Engine

Volvo D13 engine serial and model numbers are stamped on the cylinder head (Figure 1).

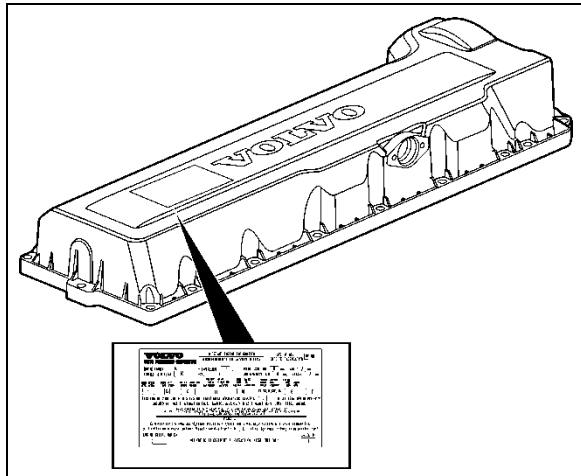

FIGURE 1: VOLVO D13 ENGINE DATA PLATE
00052

Also the engine data plate certifies that the engine conforms to federal and any state exhaust emissions regulations.

4.1.2 Transmission

The transmission identification plate is located on the oil level dipstick side of the transmission (WT) (Figure 2). The identification plate shows the transmission serial number, part number (assembly number), and model number. Use all three numbers when ordering parts.

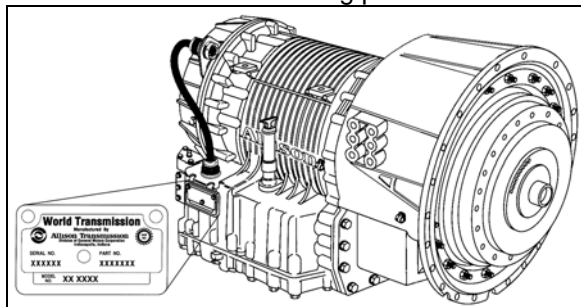

FIGURE 2: ALLISON TRANSMISSION
07076

4.1.3 Drive Axle

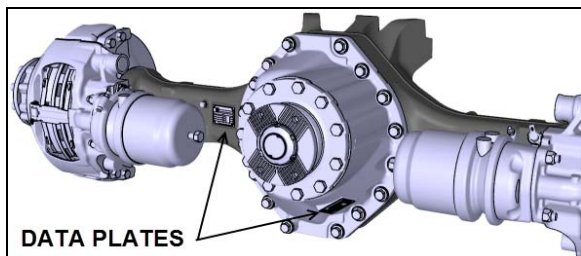

FIGURE 3: TYPICAL SERIAL & MODEL NUMBERS 00007

4.1.4 Front Axle

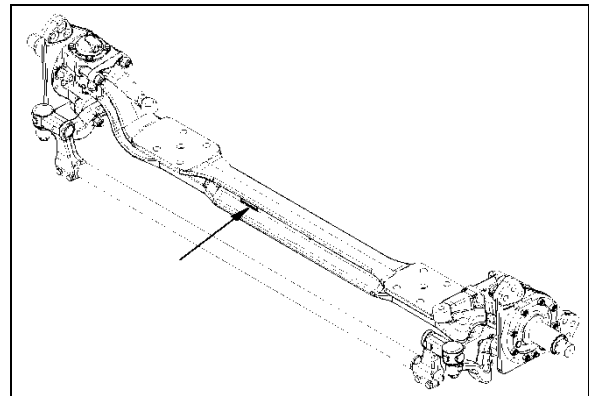

FIGURE 4: I-BEAM AXLE TYPICAL SERIAL & MODEL NUMBERS
00008

4.1.5 Power Steering Pump

Power steering pump is mounted on the engine and located underneath the air compressor (Figure 5).

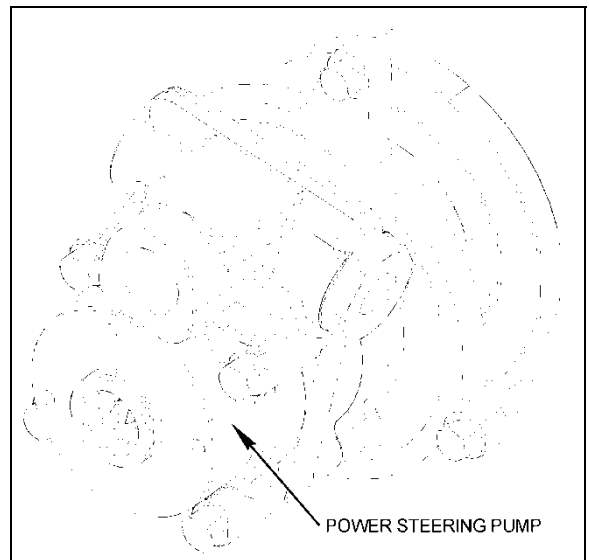

FIGURE 5: POWER STEERING PUMP

4.1.6 Coach Final Record

The Coach Final Record is a record of all data pertaining to the assembly of the vehicle. This record is shipped to the new customer via a courier company. Retain this record in the company records office for reference and safe-keeping.

4.1.7 Safety Certification

Vehicle components meet specifications and standards as follows:

- Material and parts conform to ASTM and/or SAE standards in effect at the time of manufacture.
- All factory-installed interior materials meet FMVSS 302 for fire resistance.
- Certified according to Provincial, State and Federal Safety standards (Canadian and US) BMCSS, FMVSS, and CMVSS.

Other applicable certification labels are affixed to the component.

4.1.8 DOT Certification Label

This certifies that vehicles manufactured by Prevest Inc., comply with all Federal Motor Vehicle Safety Standards at the time of manufacture. Information such as date of manufacture, model year, gross vehicle weight rating, tire types and inflation pressure is also etched on this plate. The DOT Certification plate is affixed to the side of the L.H. control panel.

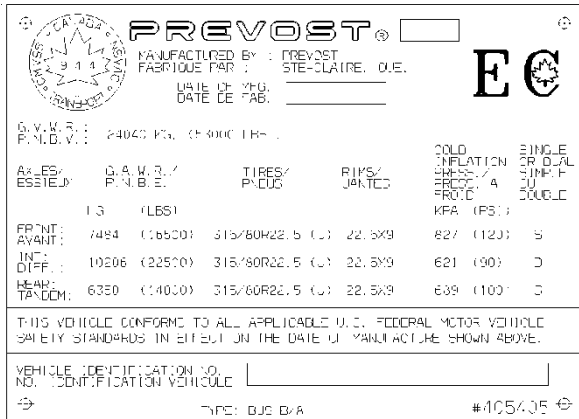

FIGURE 6: DOT CERTIFICATION PLATE 00016

4.1.9 Fuel Tank Label

The fuel tank label is molded on the side of the fuel tank. To read this label, unscrew the fuel tank access panel nuts located at the left in the condenser compartment.

4.1.10 Vehicle Identification Number (VIN)

The seventeen digit vehicle identification number (VIN) is located on a plate (Figure 8) located on the windshield frame pillar (Figure 7). The VIN is visible from the outside of the vehicle. Make sure the correct vehicle identification number is given when ordering replacement parts. Using the VIN when ordering parts will facilitate processing.

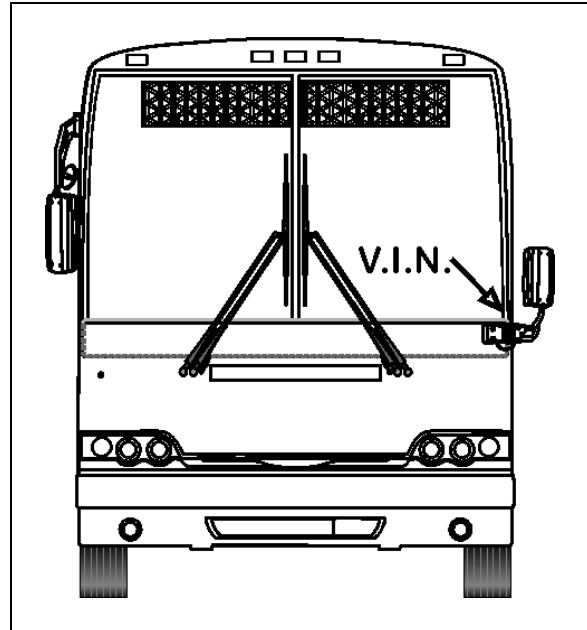

FIGURE 7: VEHICLE I.D. 00048

NOTE

Record the VIN in the vehicle documentation and keep with company records. The VIN will normally be used for vehicle registration and for obtaining vehicle insurance coverage.

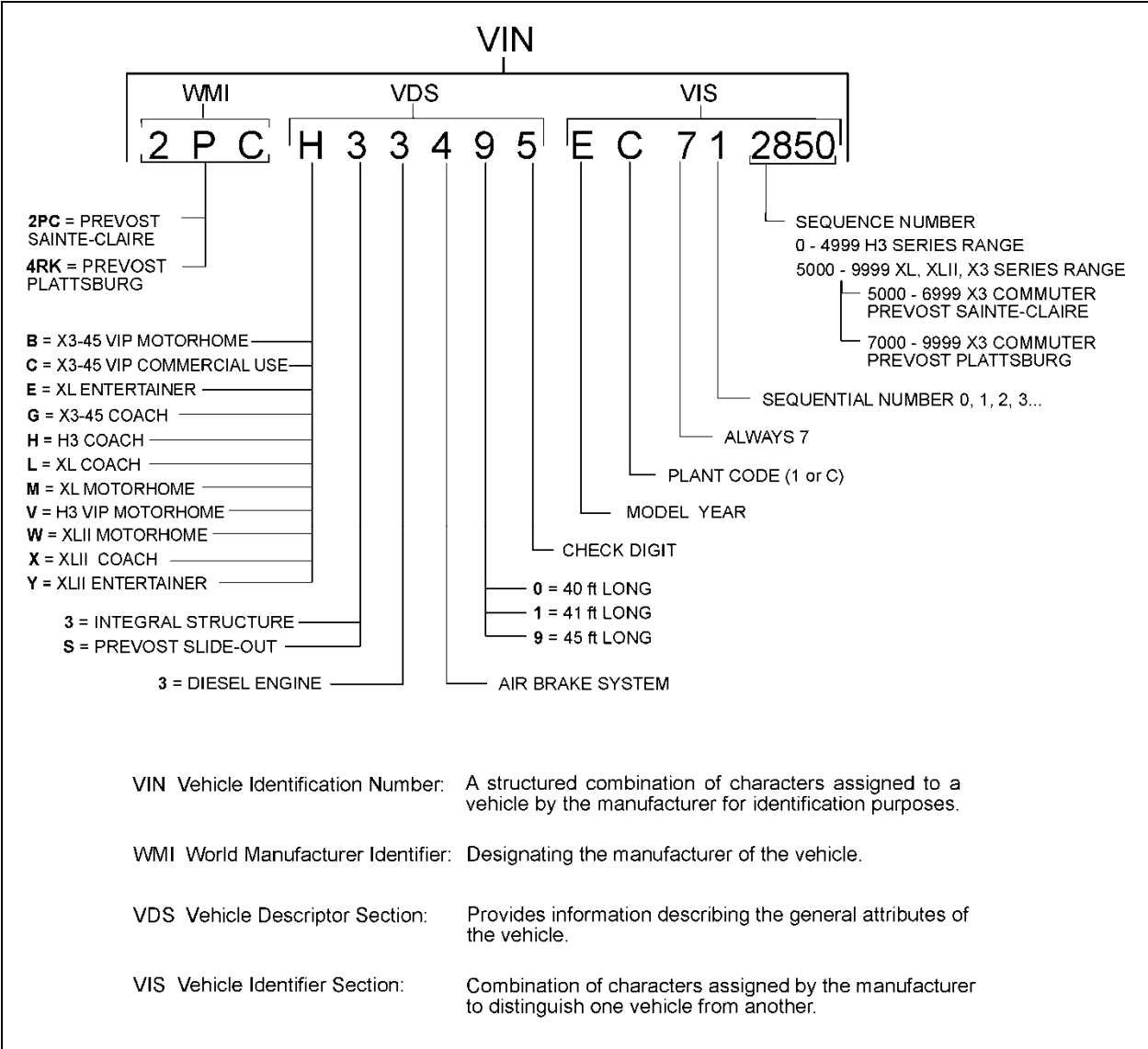

FIGURE 8: VEHICLE IDENTIFICATION NUMBER

00056

YEAR	CODE	YEAR	CODE	YEAR	CODE
2000	Y	2006	6	2012	C
2001	1	2007	7	2013	D
2002	2	2008	8	2014	E
2003	3	2009	9	2015	F
2004	4	2010	A	2016	G
2005	5	2011	B	2017	H

5. FASTENER STRENGTH IDENTIFICATION

Most commonly used metric fastener strength property classes are 9.8 and 10.9 with the class identification embossed on the head of each bolt. Customary (inch) strength classes range from grade 2 to 8 with radial line identification embossed on each bolt head actual grade (i.e., a grade 7 bolt will have 5 embossed radial lines on the bolt head). Some metric nuts will be marked with single digit strength identification numbers on the nut face. Figure 10 shows the different strength markings. When replacing

metric fasteners, be careful to use fasteners of the same or greater strength than the original fasteners (the same number marking or higher). It is also important to select replacement fasteners of the correct size. Correct replacement fasteners are available through the parts division. Some metric fasteners available in after-market parts sources were designed to metric standards of countries other than the United States and may be of a lower strength, may not have the numbered head marking system, and may be of a different thread pitch.

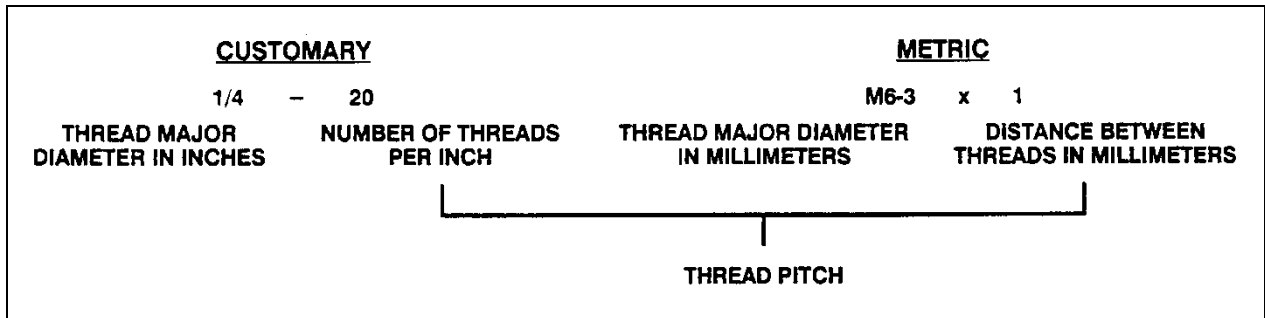

FIGURE 9: THREAD NOTATION

00002

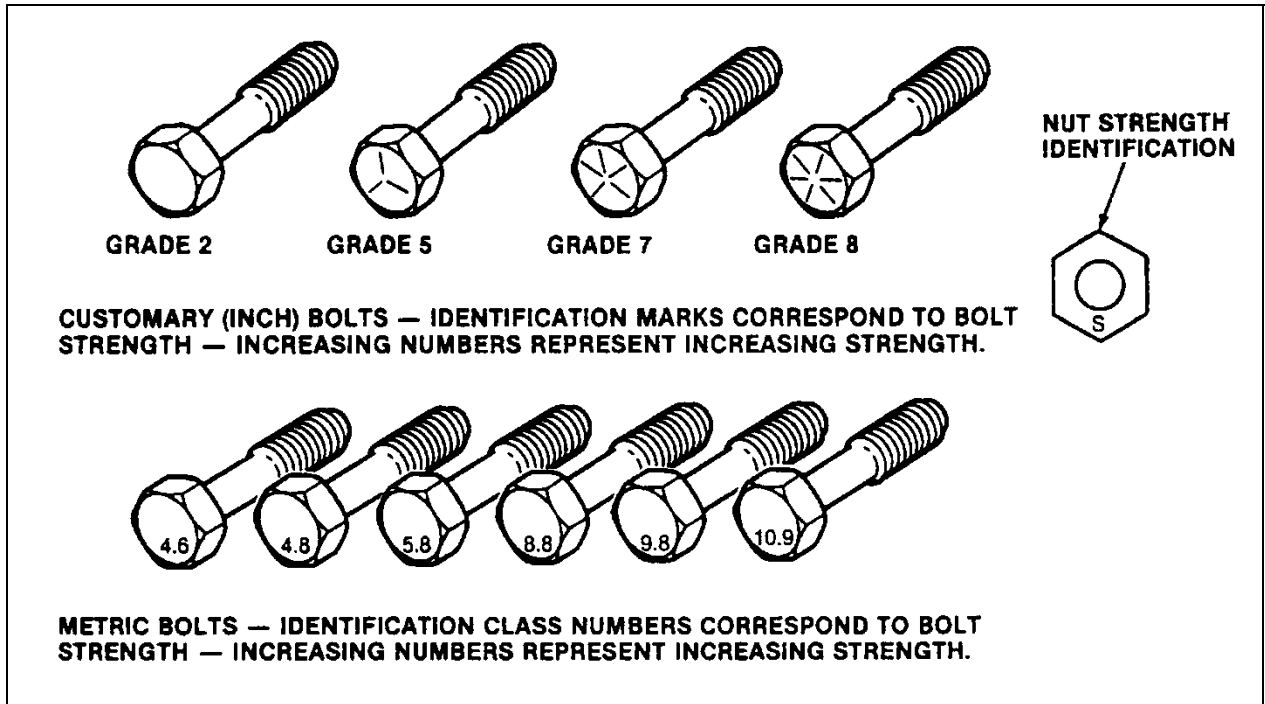

FIGURE 10: BOLT STRENGTH MARKINGS

00003

The metric fasteners used on the coach are designed to new standards and may not yet be manufactured by some non-domestic fastener suppliers. In general, except for special applications, the common sizes and pitches are:

- M 8 X 1.25;
- M 10 X 1.5;
- M 12 X 1.75;
- M 14 X 2;

5.1 STANDARD TORQUE SPECIFICATIONS

The following table lists the standard tightening torques for bolts and nuts, relating tightening torque to thread diameter. Use the following table as a general guide for tightening torques. Use this table only for the bolts and nuts which do not require a specific torque value. All of the values are for use with dry solvent-cleaned threads.

TYPE	DESCRIPTION	THREAD	GRADE	RECOMMENDED TORQUE	
				lbf-ft (dry) otherwise specified	Tolerance: $\pm 10\%$
SAE	1/4-20	unc	5	100	lbf-in (dry)
SAE	1/4-20	unc	8	143	lbf-in (dry)
SAE	1/4-28	unf	5	115	lbf-in (dry)
SAE	1/4-28	unf	8	163	lbf-in (dry)
SAE	5/16-18	unc	5	210	lbf-in (dry)
SAE	5/16-18	unc	8	305	lbf-in (dry)
SAE	5/16-24	unf	2	120	lbf-in (dry)
SAE	5/16-24	unf	5	230	lbf-in (dry)
SAE	5/16-24	unf	8	325	lbf-in (dry)
SAE	3/8-16	unc	5	31	
SAE	3/8-16	unc	8	44	
SAE	3/8-24	unf	5	35	
SAE	3/8-24	unf	8	50	
SAE	7/16-14	unc	5	50	
SAE	7/16-14	unc	8	70	
SAE	7/16-20	unf	5	55	
SAE	7/16-20	unf	8	78	
SAE	1/2-13	unc	5	75	
SAE	1/2-13	unc	8	107	
SAE	1/2-20	unf	5	85	
SAE	1/2-20	unf	8	120	
SAE	9/16-12	unc	5	109	
SAE	9/16-12	unc	8	154	
SAE	9/16-18	unf	5	122	
SAE	9/16-18	unf	8	172	
SAE	5/8-11	unc	5	151	
SAE	5/8-11	unc	8	211	
SAE	5/8-18	unf	5	170	

SECTION 00: GENERAL INFORMATION

TYPE	DESCRIPTION	THREAD	GRADE	RECOMMENDED TORQUE lbf-ft (dry) otherwise specified Tolerance: ±10%
SAE	5/8-18	unf	8	240
SAE	3/4-10	unc	5	266
SAE	3/4-10	unc	8	376
SAE	3/4-16	unf	5	298
SAE	3/4-16	unf	8	420
SAE	7/8-9	unc	5	430
SAE	7/8-9	unc	8	607
SAE	7/8-14	unf	5	470
SAE	7/8-14	unf	8	670
METRIC	M6 X 1		nut 9 / screw 8.8	7
METRIC	M6 X 1		nut 10 / screw 10.9	9
METRIC	M8 X 1.25		nut 9 / screw 8.8	16
METRIC	M8 X 1.25		nut 10 / screw 10.9	22
METRIC	M10 X 1.5		nut 9 / screw 8.8	32
METRIC	M10 X 1.5		nut 10 / screw 10.9	43
METRIC	M12 X 1.75		nut 9 / screw 8.8	60
METRIC	M12 X 1.75		nut 10 / screw 10.9	74
METRIC	M14 X 2		nut 9 / screw 8.8	90
METRIC	M14 X 2		nut 10 / screw 10.9	120
METRIC	M16 X 2		nut 9 / screw 8.8	140
METRIC	M16 X 2		nut 10 / screw 10.9	190
METRIC	M16 X 1.5		nut 10 / screw 10.9	230
METRIC	M20 X 2.5		nut 9 / screw 8.8	275
METRIC	M20 X 2.5		nut 10 / screw 10.9	450
METRIC	M20 X 1.5		nut 10 / screw 10.9	465
METRIC	M22 X 2.5		nut 9 / screw 8.8	345
METRIC	M22 X 2.5		nut 10 / screw 10.9	493
METRIC	M24 X 3		nut 9 / screw 8.8	475
METRIC	M24 X 3		nut 10 / screw 10.9	640

5.2 SELF-LOCKING FASTENERS

A self-locking fastener is designed with an interference fit between the nut and bolt threads. This is most often accomplished by distortion of the top thread of an all-metal nut or bolt or by using a nylon patch on the threads. A nylon insert or the use of adhesives may also be used as a method of interference between nut and bolt threads (Figure 11).

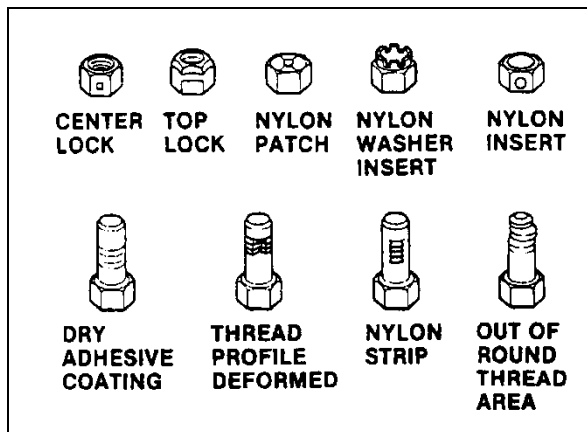

FIGURE 11: SELF-LOCKING FASTENERS

00004

are available commercially. However, in some cases, if the correct tool is not available, a hex socket head wrench may be used.

5.3 RECOMMENDATIONS FOR REUSE

Clean, rust-free self-locking fasteners may be reused as follows:

- a) Clean dirt and other foreign matter from the fastener;
- b) Inspect the fastener to ensure there is no crack, elongation, or other sign of fatigue or overtightening. If there is any doubt, replace with a new self-locking fastener of equal or greater strength;
- c) Assemble parts and hand start fastener;
- d) Observe that, before the fastener seats, it develops torque per the chart in table two. If there is any doubt, replace with a new self-locking fastener of equal or greater strength;
- e) Tighten the fastener to the torque specified in the applicable section of this manual;

Fasteners which are rusty or damaged should be replaced with new ones of equal or greater strength.

5.4 SIX LOBED SOCKET HEAD

Six lobed socket head (Torx) fasteners are used in some applications on vehicles covered in this manual. The tools designed for these fasteners

SELF-LOCKING FASTENER TORQUE CHART

METRIC		6 & 6.3	8	10	12	14	16	20	
NUTS AND ALL-METAL BOLTS	Nm	0.4	0.8	1.4	2.2	3.0	4.2	7.0	
	Lbf-in	4.0	7.0	12	18	25	35	57	
ADHESIVE OR NYLON COATED BOLTS	Nm	0.4	0.6	1.2	1.6	2.4	3.4	5.6	
	Lbf-in	4.0	5.0	10	14	20	28	46	
US STANDARD		¼	5/16	3/8	7/16	½	9/16	5/8	¾
NUTS AND ALL-METAL BOLTS	Nm	0.4	0.6	1.4	1.8	2.4	3.2	4.2	6.2
	Lbf-in	4.0	5.0	12	15	20	27	35	51
ADHESIVE OR NYLON COATED BOLTS	Nm	0.4	0.6	1.0	1.4	1.8	2.6	3.4	5.2
	Lbf-in	4.0	5.0	9.0	12	15	22	28	43

Multiply	by	to get equivalent number of:	Multiply	by	to get equivalent number of:
Inch Foot Yard Mile	LENGTH 25.4 0.305 0.914 1.609	millimeters (mm) meters (m) meters kilometers (km)	Foot/sec ² Inch/sec ²	ACCELERATION 0.305 0.026	meter/sec ² (m/s ²) meter/sec ²
Inch ² Foot ² Yard ²	AREA 645.2 6.45 0.093 0.836	millimeters ² (mm ²) centimeters ² (cm ²) meters ² (m ²) meters ²	Pound-inch Pound-foot	TORQUE 0.113 1.35	newton-meters (N·m) newton-meters
Inch ³ Quart Gallon Yard ³	VOLUME 16 387.0 16.387 0.016 0.946 3.785 0.765	mm ³ cm ³ liters (l) liters liters meters ³ (m ³)	Horsepower	POWER 0.746	kilowatts (kW)
Pound Ton Ton	MASS 0.453 907.18 0.907	kilograms (kg) kilograms (kg) ton (t)	Inches of water Pounds/sq. in.	PRESSURE OR STRESS 0.249 6.895	kilopascals (kPa) kilopascals
Kilogram Ounce Pound	FORCE 9.807 0.278 4.448	newtons (N) newtons newtons	BTU Foot-pound kilowatt-hour	ENERGY OR WORK 1 055.0 1.356 3 600 000.0 or 3.6 x 10 ⁶	joules (J) joules joules (J = one W's)
Degree Fahrenheit	TEMPERATURE (°F - 32) ÷ 1.8	Degree Celsius (C)	Foot candle	LIGHT 1.076	lumens/meter ² (lm/m ²)
			Miles/hour	VELOCITY 1.609	kilometers/hr (km/h)

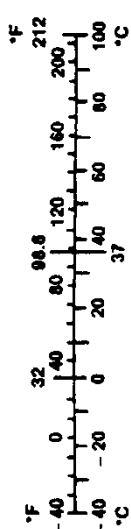

FIGURE 12: METRIC - US STANDARD CONVERSION TABLE

00005

DECIMAL AND METRIC EQUIVALENTS

FRACTIONS	DECIMAL IN.	METRIC MM	FRACTIONS	DECIMAL IN.	METRIC MM
1/64	.015625	.39688	33/64	.515625	13.09687
1/32	.03125	.79375	17/32	.53125	13.49375
3/64	.046875	1.19062	35/64	.546875	13.89062
1/16	.0625	1.58750	9/16	.5625	14.28750
5/64	.078125	1.98437	37/64	.578125	14.68437
3/32	.09375	2.38125	19/32	.59375	15.08125
7/64	.109375	2.77812	39/64	.609375	15.47812
1/8	.125	3.1750	5/8	.625	15.87500
9/64	.140625	3.57187	41/64	.640625	16.27187
5/32	.15625	3.96875	21/32	.65625	16.66875
11/64	.171875	4.36562	43/64	.671875	17.06562
3/16	.1875	4.76250	11/16	.6875	17.46250
13/64	.203125	5.15937	45/64	.703125	17.85937
7/32	.21875	5.55625	23/32	.71875	18.25625
15/64	.234375	5.95312	47/64	.734375	18.65312
1/4	.250	6.35000	3/4	.750	19.05000
17/64	.265625	6.74687	49/64	.765625	19.44687
9/32	.28125	7.14375	25/32	.78125	19.84375
19/64	.296875	7.54062	51/64	.796875	20.24062
5/16	.3125	7.93750	13/16	.8125	20.63750
21/64	.328125	8.33437	53/64	.828125	21.03437
11/32	.34375	8.73125	27/32	.84375	21.43125
23/64	.359375	9.12812	55/64	.859375	21.82812
3/8	.375	9.52500	7/8	.875	22.22500
25/64	.390625	9.92187	57/64	.890625	22.62187
13/32	.40625	10.31875	29/32	.90625	23.01875
27/64	.421875	10.71562	59/64	.921875	23.41562
7/16	.4375	11.11250	15/16	.9375	23.81250
29/64	.453125	11.50937	61/64	.953125	24.20937
15/32	.46875	11.90625	31/32	.96875	24.60625
31/64	.484375	12.30312	63/64	.984375	25.00312
1/2	.500	12.70000	1	1.00	25.40000

FIGURE 13: CONVERSION CHART

00006

6. SECTION CHANGE LOG

DESCRIPTION		DATE
1		
2		
3		
4		
5		
6		

PREVOST

MULTIPLEX MODULES DISCONNECTION PROCEDURE PRIOR TO WELDING

PROCEDURE NO: PR060041	REVISION 02 2013-04-08
-------------------------------	-----------------------------------

Material: N/A

Equipment(s): Phillips-head screwdriver
Ratchet handle
3/8" socket
Electric tape
Long nose pliers

Reference schematics: N/A

Safety rules:

- Wear safety goggles
- Set the battery master switch to the OFF position first

Recommendations: This procedure should be performed by qualified personnel only.

	Effective
Revision 00 : New procedure for cooling 2007	
Revision 01 : Modified for EPA 2010	
Revision 02 : Added: battery equalizer data connection (PRIME).	

X3 Series Coaches

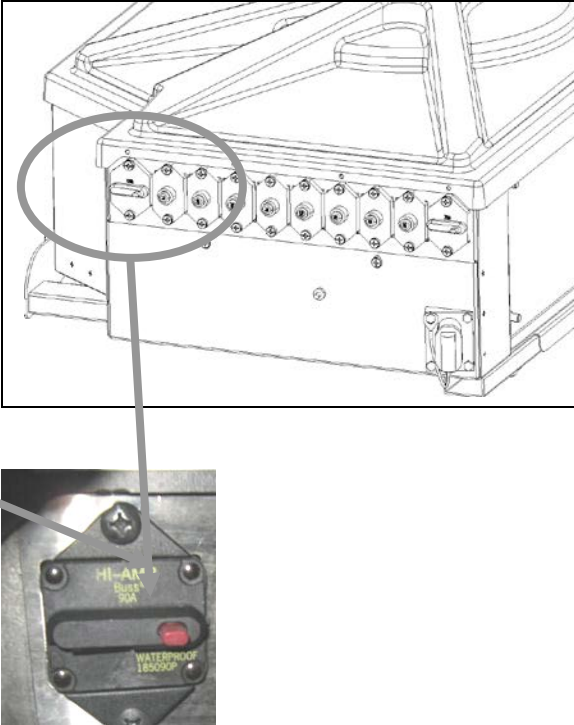
<p>2.00*</p>	<p>Location: Rear Electrical Panel and Dashboard Set the battery master switch to the OFF position Place the ignition switch to the OFF position.</p>	
<p>2.05*</p>	<p>Location: Rear Junction Panel Lift cover, trip circuit breakers CB2-CB6 located on junction panel. Push the red button to open the circuit</p>	

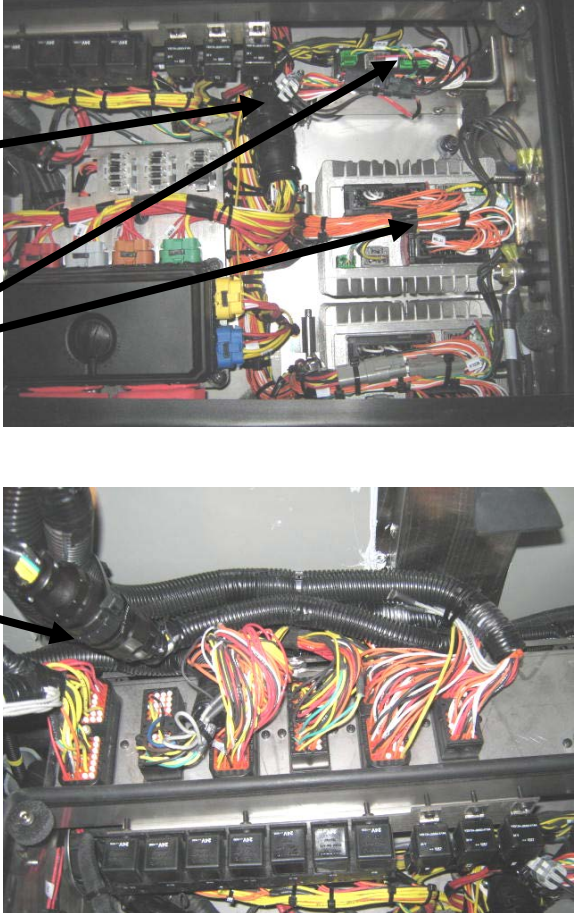
<p>2.10*</p>	<p>Location: Rear Electrical Panel</p> <p>Disconnect the electronic ground terminals from this stud.</p> <p>Use electric tape; make sure that cables do not touch each others and the vehicle body.</p> <p>Note :</p> <p><i>With disconnection of the electronic ground terminals, disconnecting the engine ECM, transmission TCM and the dashboard electronic components (telltale module, HVAC module, radio, control head ...) is not required.</i></p>	
<p>2.15*</p>	<p>Location: Rear Electrical Panel</p> <p>Disconnect the electronic modules:</p> <p>Disconnect all I/O A, I/O B modules.</p> <p style="padding-left: 100px;">Disconnect C717</p> <p>Disconnect 3 connectors from each I/O A module</p> <p>Disconnect 3 connectors from each I/O B module</p> <p style="padding-left: 100px;">Disconnect C397</p>	

2.15.2

Location: battery compartment:

Disconnect data connector on equalizer

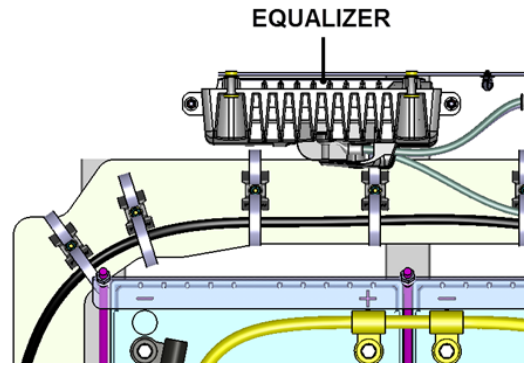

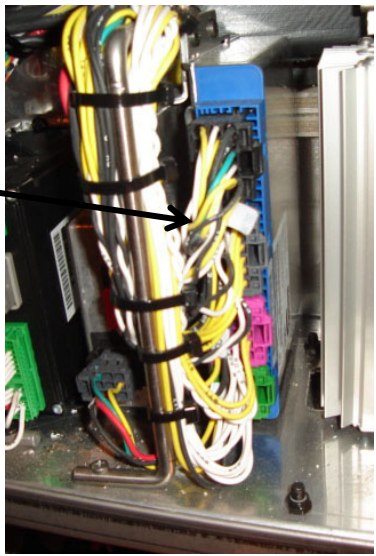
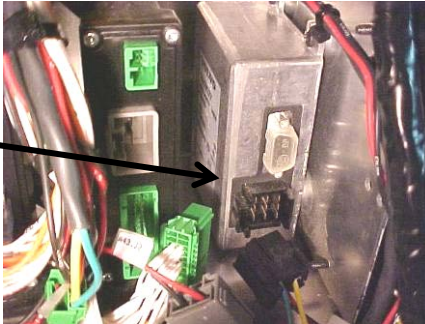
<p>2.20 *</p>	<p>Location: Front Electrical Compartment</p> <p>Disconnect the I/O A, I/O B, ABS, master ID, VECU, CECM, BERU, Volvo Link, Gsecu modules.</p> <p>Disconnect 3 connectors from I/O B and I/O A modules</p>	
	<p>Disconnect 4 connectors from the ABS module</p>	
	<p>Disconnect connector from master ID</p>	

Disconnect 3 connectors from VECU

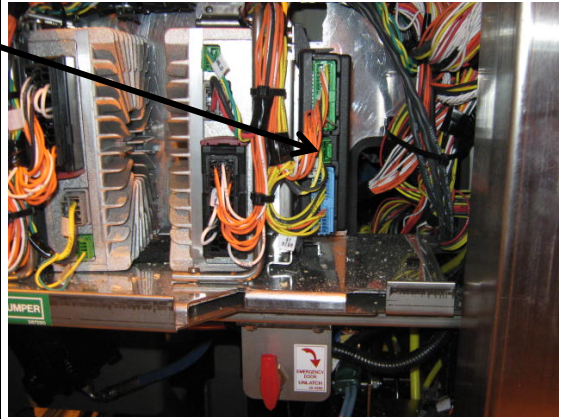

Disconnect 3 connectors from CECM



2.30

Location: Pneumatic accessory panel inside right console

Remove the access panel on the right console
(R.H. side of dashboard)

Disconnect both I/O B modules

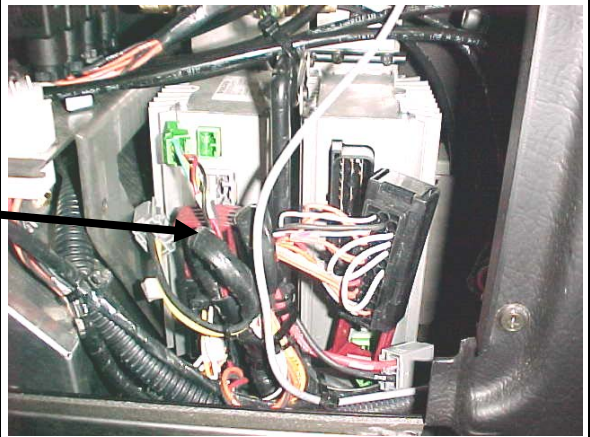

2.40

Location: Condenser Compartment

Disconnect connector A 137

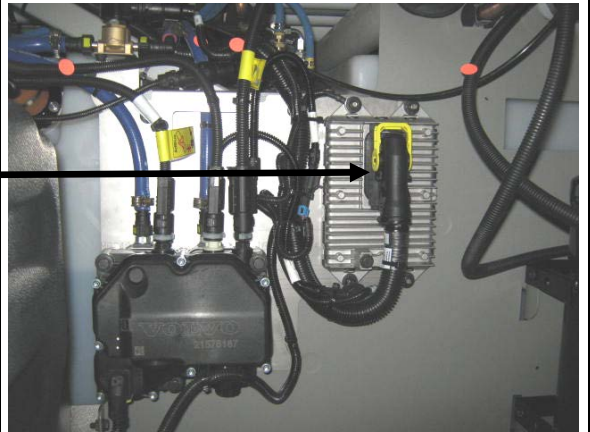

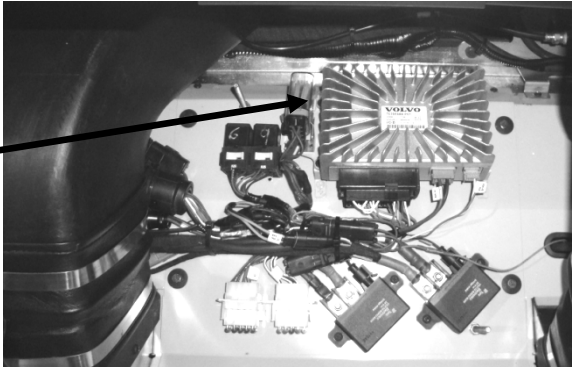
<p>2.50</p>	<p>Location: Evaporator Compartment</p> <p>Disconnect A54 module located inside the evaporator compartment</p>	
<p>2.60</p>	<p>When all the previous steps are done, you can do welding on the vehicle.</p>	<p>ENSURE THAT THE WELDING GROUND RETURN CLAMP IS WELL SECURED AND MAKES A GOOD ELECTRICAL CONTACT WITH A LARGE METALLIC AREA OF THE CHASSIS LOCATED NEAR THE WELDING POINT AS MUCH AS POSSIBLE.</p>
<p>2.70</p>	<p>When welding is completed, reconnect all the modules.</p> <p>Make sure that the connectors locking tab are well engaged!</p>	<p>BE CAREFUL TO MAKE THE PROPER CONNECTIONS, IF NOT, SOME SYSTEMS OR COMPONENTS MAY NOT BE USABLE.</p>

CONTENTS

1. VOLVO D13 ENGINE	2
1.1 SYSTEM OVERVIEW.....	2
1.2 ENGINE OVERVIEW.....	6
1.3 ENGINE OIL.....	8
1.3.1 General.....	8
1.3.2 Oil Quality.....	8
1.3.3 Oil Change Intervals.....	8
1.3.4 Oil Filters.....	8
1.3.5 Synthetic Lubrication.....	9
1.3.6 Oil Viscosity.....	9
1.3.7 Oil Additives.....	9
1.3.8 Oil Consumption.....	9
1.3.9 Oil Change.....	9
1.3.10 Oil Filters Change.....	10
1.3.11 Checking the Oil Level.....	11
1.4 POWER PLANT ASSEMBLY REMOVAL.....	11
1.5 POWER PLANT ASSY. INSTALLATION.....	14
1.6 ENGINE MOUNTS.....	15
2. ELECTRONIC FOOT PEDAL ASSEMBLY (EFPA) & THROTTLE POSITION SENSOR	16
3. AUTOMATIC BELT TENSIONERS AND IDLER PULLEYS INSPECTION	18
3.1 BEARING INSPECTION.....	18
3.2 AUTOMATIC BELT TENSIONER BUSHING WEAR.....	18
3.3 BELTS AND IDLERS VISUAL INSPECTION.....	19
4. ENGINE PROTECTION STRATEGY	19
5. SPECIFICATIONS	20
6. SECTION CHANGE LOG	21

ILLUSTRATIONS

FIGURE 1: ENGINE SENSORS LOCATION.....	5
FIGURE 2: D13H ENGINE OVERVIEW, ALTERNATOR SIDE (TYPICAL).....	6
FIGURE 3: D13H ENGINE OVERVIEW, TURBO SIDE (TYPICAL).....	7
FIGURE 4: D13H OIL FILTERS.....	9
FIGURE 5: OIL FILTER WRENCH.....	10
FIGURE 6: OIL FILTER REPLACEMENT.....	11
FIGURE 7: ENGINE OIL FILLING TUBE.....	11
FIGURE 8: ENGINE OIL LEVEL DIPSTICK.....	11
FIGURE 9: COOLER POSITION DURING ENGINE CRADLE INSERTION OR REMOVAL.....	12
FIGURE 10: ENGINE COMPARTMENT X3 COMMUTER (TYPICAL).....	14
FIGURE 11: NORMAL OIL COOLER POSITION.....	14
FIGURE 12: VOLVO ENGINE POWER PLANT CRADLE INSTALLATION.....	15
FIGURE 13: ELECTRONIC FOOT PEDAL ASSEMBLY.....	17
FIGURE 14: IDLER PULLEYS AND AUTOMATIC BELT TENSIONERS ON COOLING FAN DRIVE.....	18
FIGURE 15: IDLER AND AUTOMATIC BELT TENSIONER ON ALTERNATOR DRIVE.....	18
FIGURE 16: CHECKING BUSHING WEAR.....	19

1. VOLVO D13 ENGINE

1.1 SYSTEM OVERVIEW

NOTE

The “Premium Tech Tool” (PTT) is the preferred tool for performing diagnostic work. Contact your local dealer for more information.

The Engine Management System (EMS) controls many engine functions such as: fuel timing and delivery, engine protection functions, engine brake operation, EGR valve function and the turbocharger nozzle function. The Engine Electronic Control Unit (EECU) along with other supporting control units and sensors are responsible for monitoring and controlling these functions. These control units communicate through the J1939 high speed serial data line to share data.

In addition to their control functions, the modules have on-board diagnostic capabilities. The on-board diagnostics are designed to detect faults or abnormal conditions that are not within their operating parameters. When the system detects a fault or abnormal condition, the fault will be logged in one or both of the modules' memory. The vehicle operator will be advised that a fault has occurred by the illumination of a malfunction indicator lamp and a message in the driver information display, if equipped. The module may initiate the engine shutdown procedure if the system determines that the abnormal condition could damage the engine. In some situations, the system will enter the "limp home" mode. Limp home mode allows continued vehicle operation but, the system may substitute a sensor or signal value that may result in reduced engine performance.

Fault codes logged in the system memory, can later be read to aid in diagnosing the fault. These faults can be read via a diagnostic computer or through the instrument cluster display, if equipped. The “Premium Tech Tool” (PTT) is the preferred tool for performing diagnostic work. Using a diagnostic computer (or PTT) connected to the Serial Communication Port, expands the technicians' diagnostic capabilities with additional data and tests.

For diagnostic software, contact your local dealer.

The following is a list of engine sensors that provide input to the EMS:

- Ambient Air Temperature Sensor
- Ambient Pressure sensor
- Boost Air Pressure (BAP) Sensor
- Camshaft Position (Engine Position) Sensor
- Crankshaft Position (Engine Speed) Sensor
- Differential Pressure DPF Sensor
- EGR Differential Pressure Sensor
- EGR Temperature Sensor
- Engine Coolant Level (ECL) Sensor
- Engine Coolant Temperature (ECT) Sensor
- Engine Oil Pressure (EOP) Sensor
- Engine Oil Level (EOL) Sensor
- Engine Oil Temperature (EOT) Sensor
- Exhaust Temperature Sensor (DPF Sensors)
- Fuel Pressure Sensor
- Intake Air Temperature And Humidity (IATH) Sensor
- Intake Manifold (Boost) Temperature Sensor
- Throttle Position (TP) Sensor
- Turbo Speed Sensor
- Variable Geometry Turbocharger (VGT) Position Sensor

Sensors

Ambient Air Temperature Sensor

The Ambient Air Temperature Sensor is used to detect the outside air temperature. The sensor modifies a voltage signal from the ECM. The modified signal returns to the ECM as the ambient air temperature. The sensor uses a thermistor that is sensitive to the change in temperature. The electrical resistance of the thermistor decreases as temperature increases.

The Ambient Air Temperature Sensor is located in the front of the vehicle.

Ambient (Atmospheric) Pressure Sensor

The Ambient (Atmospheric) Pressure Sensor contains a pressure sensitive diaphragm and an electrical amplifier. Mechanical pressure applied to the diaphragm causes the diaphragm to deflect and the amplifier to produce an electrical signal proportional to the deflection.

The Ambient (Atmospheric) Pressure Sensor is built into the Engine Management System (EMS) Module.

Camshaft Position Sensor

The Camshaft Position (Engine Position) Sensor is located in the rear face of the timing gear cover at the rear of the engine, near the bottom of the valve cover. It uses magnetic induction to generate a pulsed electrical signal. It senses the passage of seven (7) timing bumps on the edge of the camshaft dampener. Six of the holes correspond to the phasing of the electronic unit injectors, while the seventh hole indicates the top dead center position.

Crankshaft Position (Engine Speed) Sensor

The Crankshaft Position (Engine Speed) Sensor uses magnetic induction to generate a pulsed electrical signal. Notches are machined into the edge of the flywheel. When one of the notches passes close to the sensor, electric pulses result.

The Crankshaft Position (Engine Speed) Sensor also indicates when the crankshaft is at the top dead center position.

Differential Pressure DP Sensor

The differential pressure sensor is used for flow measurement of the Diesel Particulate Filter (DPF). This sensor has two pressure ports and senses the difference in pressure between the two ports. Measurement of the pressure before and after the DPF is used to calculate diesel filter regeneration.

The Differential Pressure DPF Sensor is located on the side of the Diesel Particulate Filter (DPF).

EGR Differential Pressure Sensor

The EGR differential pressure sensor is used for flow measurement of the Exhaust Gas Recirculation (EGR) valve. This sensor has two pressure ports and senses the difference in pressure between the two ports. Measurement of the pressure before and after the EGR valve is used to calculate EGR flow.

The EGR Differential Pressure Sensor is located on the left or right side of the engine.

EGR Temperature Sensor

The EGR temperature sensor detects exhaust gas temperature for EGR system. The sensor modifies a voltage signal from the control unit. The modified signal returns to the control unit as

the exhaust temperature of the EGR system to confirm EGR operation. The sensor uses a thermistor that is sensitive to the change in temperature.

The EGR Temperature Sensor is located near the EGR valve.

Engine Coolant Level (ECL) Sensor

The Engine Coolant Level (ECL) Sensor is a switch. If engine coolant level falls below a calibrated point the contacts open and the driver will be notified of the low coolant level.

The Engine Coolant Level (ECL) Sensor is located in the cooling system reservoir tank.

Engine Coolant Temperature (ECT) Sensor

The Engine Coolant Temperature Sensor is located at the front of the engine. The sensor will indicate a high coolant temperature caused by problems like radiator blockage, thermostat failure, heavy load, or high ambient temperatures. This sensor is also used for cold start enhancement and for fan clutch engagement.

Engine Oil Pressure (EOP) Sensor

The Engine Oil Pressure Sensor contains a pressure sensitive diaphragm and an electrical amplifier. Mechanical pressure applied to the diaphragm causes the diaphragm to deflect and the amplifier to produce an electrical signal proportional to the deflection.

The Engine Oil Pressure Sensor is located on the oil filter assembly. The sensor monitors engine oil pressure to warn of lubrication system failure.

Engine Oil Level (EOL) Sensor

The Engine Oil Level Sensor is located in the oil pan.

Engine Oil Temperature (EOT) Sensor

The Engine Oil Temperature Sensor is a thermistor whose resistance varies inversely to temperature. The sensor has a negative temperature coefficient, which means the sensor resistance will decrease as the engine oil temperature increases.

The Engine Oil Temperature Sensor is located in the oil pan.

Exhaust Temperature Sensor (DPF Sensors)

The exhaust gas temperature sensor detects exhaust gas temperature for DPF protection as

well as DPF regeneration control. The sensor modifies a voltage signal from the control unit. The modified signal returns to the control unit as the exhaust temperature at that specific location of the exhaust. The sensor uses a thermistor that is sensitive to the change in temperature.

The Exhaust Temperature Sensors are located in the DPF assembly.

Fuel Pressure Sensor

The fuel pressure sensor contains a diaphragm that senses fuel pressure. A pressure change causes the diaphragm to flex, inducing a stress or strain in the diaphragm. The resistor value in the sensor change in proportion to the stress applied to the diaphragm and produces an electrical output.

The Fuel Pressure Sensor is located on top of the fuel filter housing.

Intake Air Temperature and Humidity (IATH) Sensor

The Intake Air Temperature and Humidity (IATH) Sensor contains a thermistor and a capacitive sensor. The resistance of the thermistor varies inversely to temperature. The output of the capacitive sensor increases as the humidity of the surrounding air increases. By monitoring the signals from both portions of the sensor, the Engine Management System (EMS) Module calculates the temperature and humidity of the air passing through the air filter housing.

The Intake Air Temperature and Humidity (IATH) Sensor is located in the air intake tube just downstream from the air filter canister.

Intake Manifold (Boost) Temperature Sensor

The Intake Manifold (Boost) Temperature Sensor is a thermistor whose resistance varies inversely to temperature. The sensor has a negative temperature coefficient, which means the sensor resistance will decrease as the inlet air temperature increases.

The Intake Manifold (Boost) Temperature Sensor is located in the intake manifold.

Intake Manifold Pressure Sensor

The Intake Manifold Pressure Sensor contains a pressure sensitive diaphragm and an electrical amplifier. Mechanical pressure applied to the diaphragm causes the diaphragm to deflect and the amplifier to produce an electrical signal proportional to the deflection.

The Intake Manifold Pressure Sensor is located on the air inlet pipe before the intake manifold.

Throttle Position (TP) Sensor

The Throttle Position Sensor is a potentiometer that is mechanically linked to the accelerator pedal. A potentiometer is a variable resistor whose resistance will change as the pedal is pressed. As the resistance changes, the signal voltage of the sensor changes, indicating the accelerator pedal position.

The Throttle Position Sensor is located above the accelerator pedal. The sensor is designed to improve the driver's control by reducing sensitivity to chassis motion. This sensor provides the driver's fuel request input to the VECU.

Turbo Speed Sensor

The Turbo Speed Sensor informs the EMS of the turbo shaft speed. The sensor does not read from the vanes, but reads from the shaft. The Engine Management System (EMS) Module uses this signal in conjunction with the VGT position sensor signal to control the speed of the turbocharger and therefore optimize the intake manifold pressure.

The Turbo Speed Sensor is mounted in the center of the turbocharger.

Variable Geometry Turbocharger Smart Remote Actuator (VGT SRA)

The Variable Geometry Turbocharger Smart Remote Actuator (VGT SRA) takes the position commands from the EMS, moves the nozzle of the turbocharger to the desired position, and performs all of the diagnostics and self-checks on the actuator.

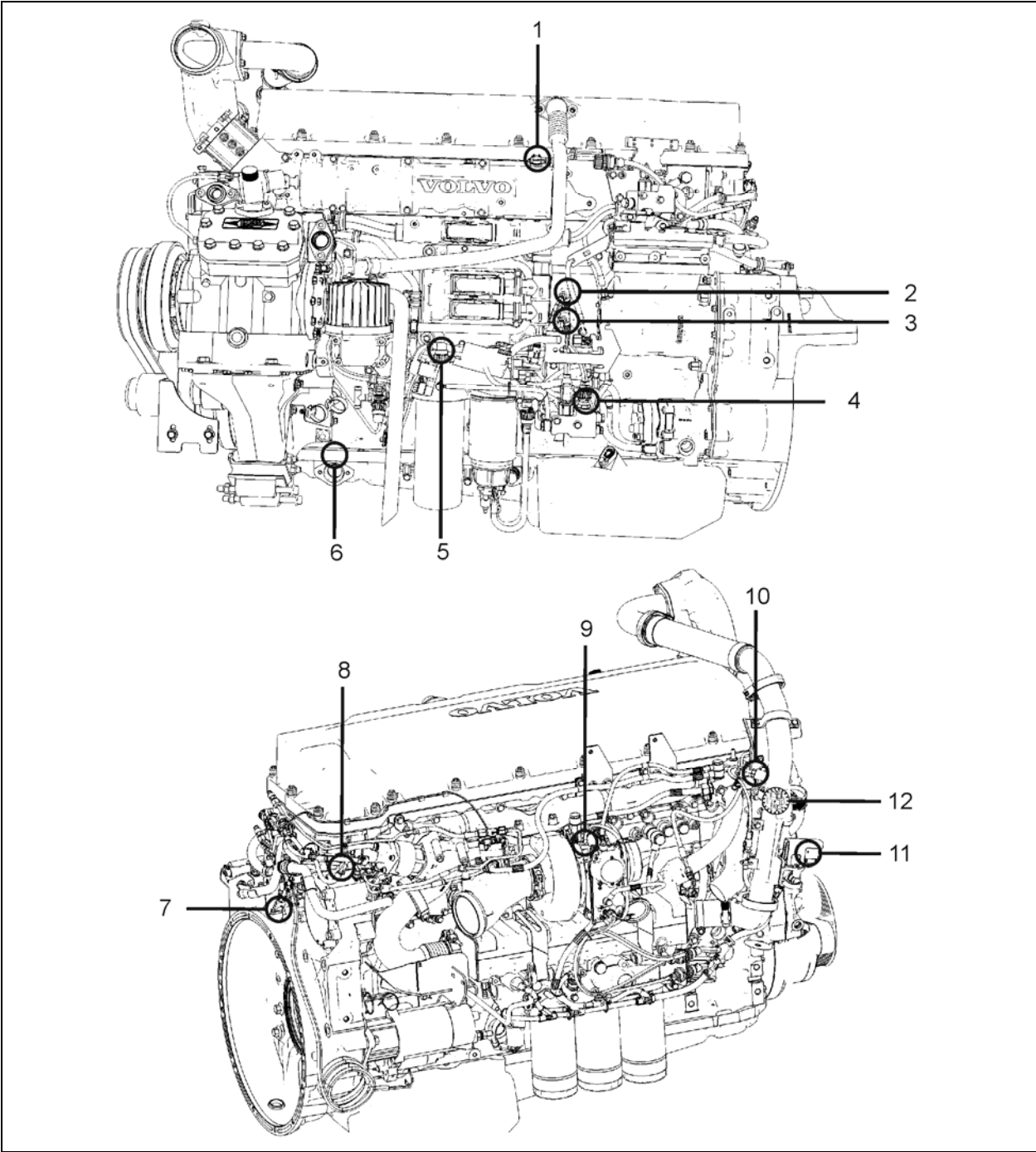

FIGURE 1: ENGINE SENSORS LOCATION

1	Intake Air Temperature /Pressure Sensor	8	Camshaft Position (CMP)
2	Engine Oil Pressure (EOP)	9	Turbine Speed
3	Crankcase pressure (CCP)	10	EGR Temperature
4	Aftertreatment Fuel Pressure	11	EGR Differential Pressure
5	Fuel Pressure	12	Engine Coolant Temperature (ECT)
6	Engine Oil Level / Temperature		
7	Crankshaft Position (CKP)		

1.2 ENGINE OVERVIEW

NOTE

For maintenance or repair of engine components or engine-related components, please refer to Volvo Trucks North America Web Site under: Parts & Service, purchase engine literature, D13H engine.

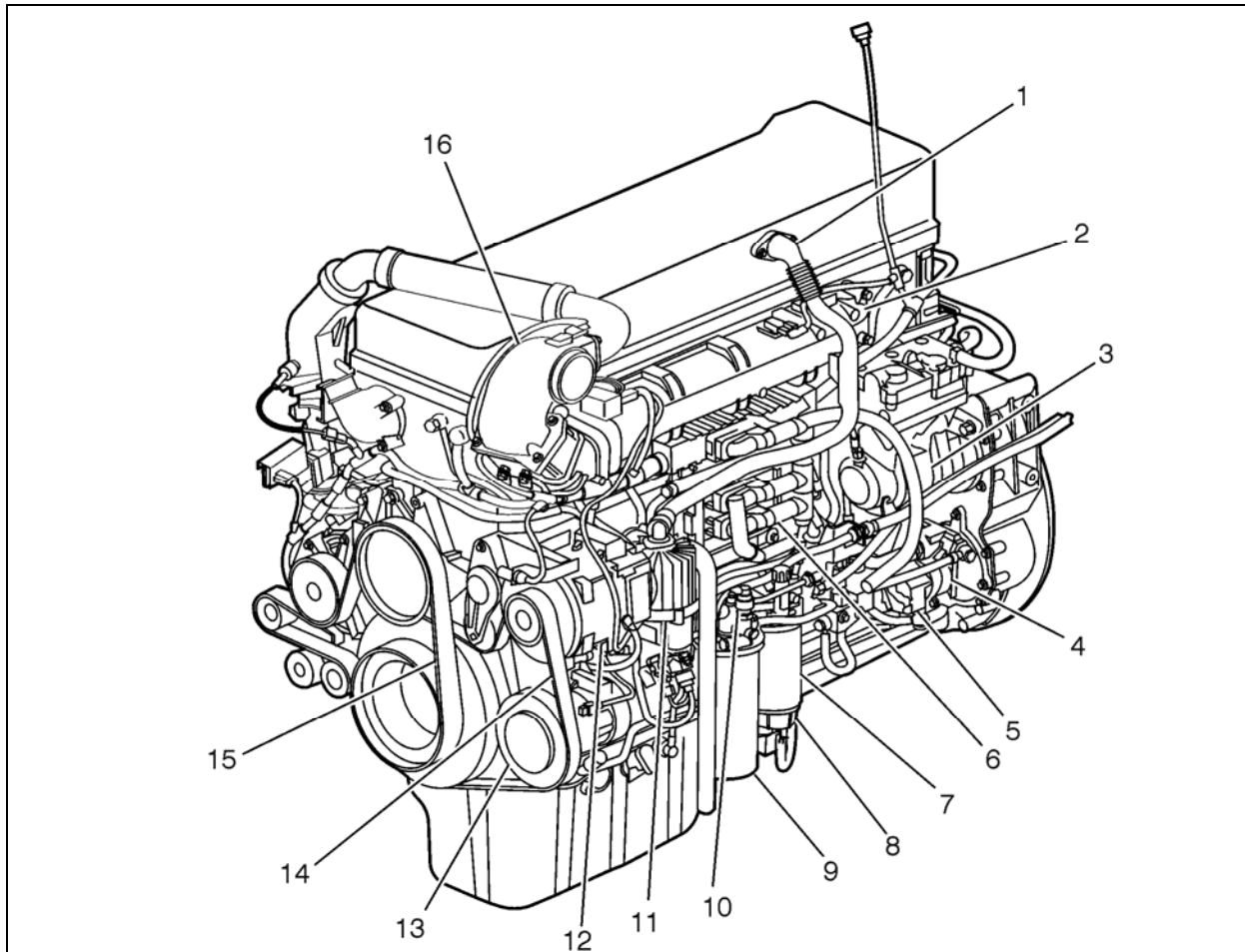

FIGURE 2: D13H ENGINE OVERVIEW, ALTERNATOR SIDE (TYPICAL)

1. Breather tube	10. Hand-priming Pump
2. Intake Manifold	11. Crankcase Ventilator
3. Air compressor	12. Alternator
4. Power steering pump	13. Alternator
5. Fuel pump	14. Alternator Belt
6. Engine Control module (ECM)	15. Water Pump Belt
7. Fuel filter	16. EGR mixing chamber
8. Fuel/Water Separator	
9. Fuel Filter	

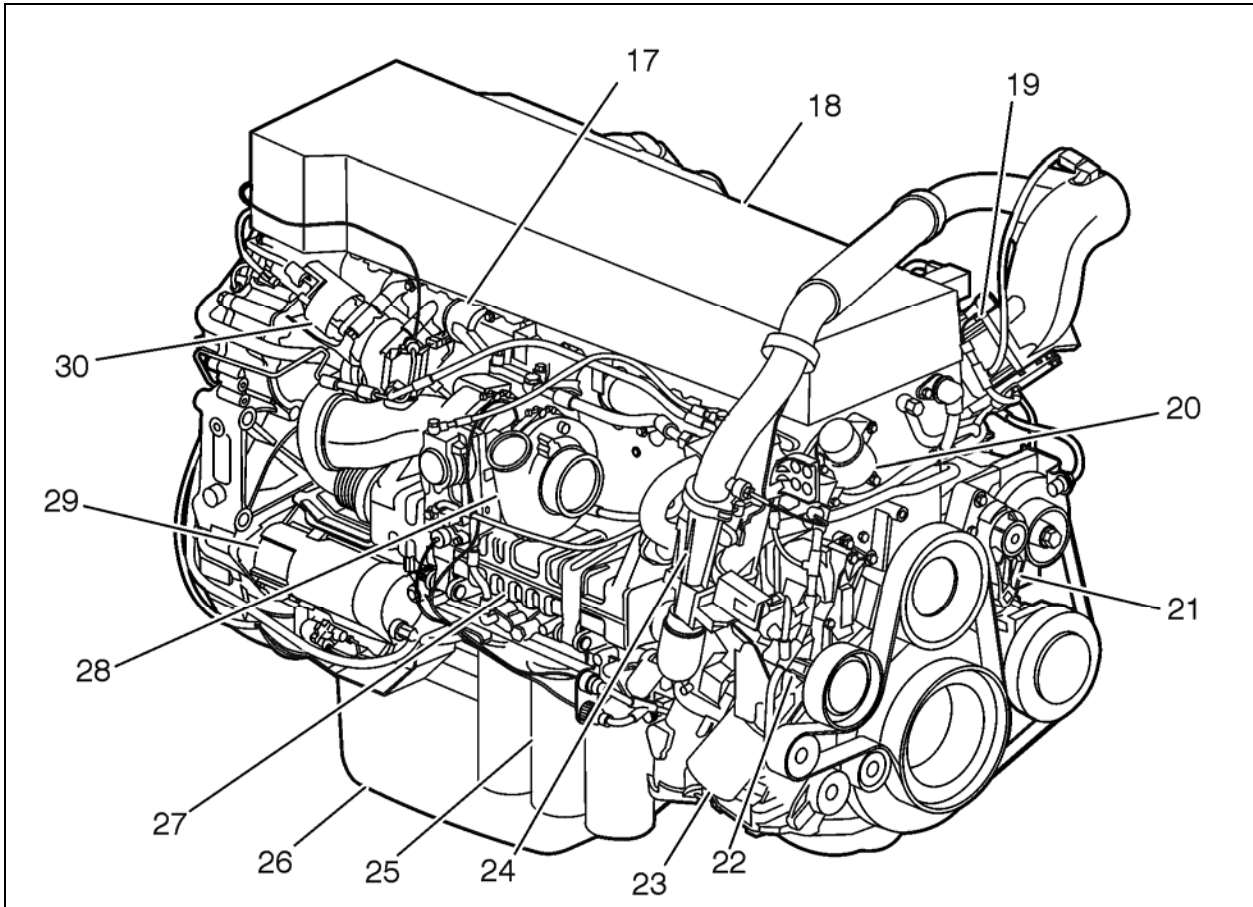

FIGURE 3: D13H ENGINE OVERVIEW, TURBO SIDE (TYPICAL)

17. Exhaust Manifold	24. Venturi Pipe
18. Valve Cover	25. Oil Filters
19. Intake Air Heater (IAH) Opt.	26. Oil Pan
20. Thermostat	27. EGR Cooler
21. Belt tensioner	28. Turbocharger
22. Coolant Pump	29. Starter Motor
23. Coolant Filter	30. EGR Valve

1.3 ENGINE OIL

1.3.1 General

Keep the engine oil at the proper level and change it at the recommended intervals. Always replace the oil filters at the same time as when the oil is changed.

1.3.2 Oil Quality

Volvo North America recognizes engine oils that meet or exceed the standards given by American Petroleum Institute (API) for the oil classifications listed in this manual. Only oils licensed to carry the API symbol should be used. Lubricants meeting API standards have provided maximum engine life when used together with the recommended oil and oil filter change intervals.

Diesel engine oil meeting VDS-4 quality standards is mandatory for use in all 2010 and later emission compliant Volvo engines. These engines, which can be identified by the presence of an exhaust aftertreatment system using Selective Catalytic Reduction (SCR), also require the use of Ultra Low Sulfur Diesel (ULSD) fuel. The VDS-4 quality standard is based on the newly developed API CJ-4 engine oil specification, but has additional performance requirements essential to adequately protect the Volvo engines at the drain intervals specified. VDS-4 oils exceed the new API service category CJ-4.

	<p>CAUTION</p>
<p>DO NOT add extra oil additives. Additives such as break-in oils, top oils, graphitizers, and friction-reducing liquids are not necessary and can harm the engine.</p>	

1.3.3 Oil Change Intervals

The length of time an engine can operate before an oil change depends on the quality oil used, the type of fuel used, fuel consumption, engine oil consumption, vehicle application, level of dust in the air, and fuel consumption. The change intervals given in this manual are maximum intervals. If the vehicle is operating in heavy-duty operation, dusty or off-road conditions, etc., reduce the intervals for more frequent oil changes.

<p><i>NOTE</i></p>
<p><i>Use the information in the table below to determine the operating condition and usage applicable to your vehicle.</i></p>

Engine oil change intervals as recommended by Volvo				
Engine Operating Condition	Medium	Heavy	Severe	
Total Fuel Consumption (mpg)	More than 6	More than 4.7	More than 3.7	
Total Fuel Consumption (L/100 KM)	Less than 39	Less than 50	Less than 64	
Engine Oil and Filter Change Interval, miles (km) – 41 U.S. quarts (39L) Oil capacity	35,000 (55 000)	25,000 (40 000)	15,000 (24 000)	
<p>NOTE: If idle time is greater than 25%, use the next lower drain interval.</p>				

<p><i>NOTE</i></p>
<p><i>Oil filters should always be changed when changing the oil.</i></p>

1.3.4 Oil Filters

There are three filters on the engine, one of which is a bypass filter. This should be changed at the same time as the full-flow filter(s).

	<p>CAUTION</p>
<p>Volvo branded oil filters are designed to provide the proper level of filtration and protection for Volvo engines. Filters that do not meet the same stringent requirements may void engine warranty.</p>	

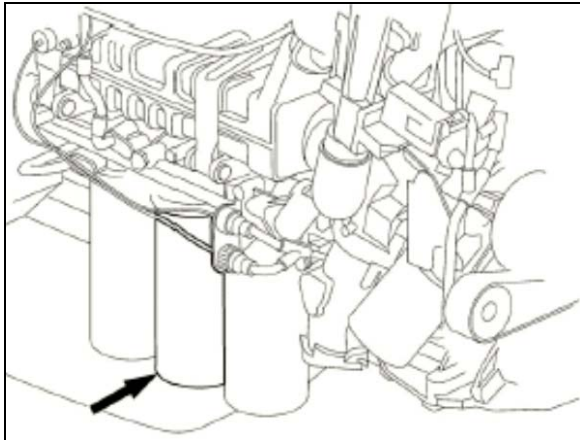

FIGURE 4: D13H OIL FILTERS

1.3.5 Synthetic Lubrication

Synthetic oils are offered by some oil suppliers as an alternative to the traditional, petroleum based oils for engines. These oils may be used in Volvo engines, provided they meet the quality levels specified on the previous pages, that is: both VDS-4 and EO-O Premium Plus.

The use of synthetic oils does not permit the extension of the recommended oil change intervals.

1.3.6 Oil Viscosity

The viscosity grade defines the thickness of the oil. The oil must be thin enough at low temperatures for easy cold starts and thick enough to protect at high temperatures. Oil is not fully defined until both the API quality classification and the viscosity grade are specified.

Choose the viscosity grade for the typical ambient temperature for the application. Multigrade oils have a broad range that suit operation in changing temperature.

Volvo North America recommends the viscosities shown in the viscosity/temperature table for Volvo engines.

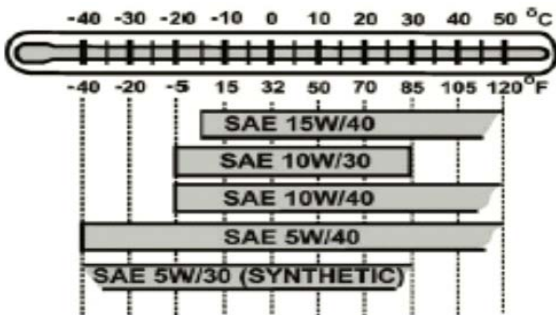

1.3.7 Oil Additives



CAUTION

Extra oil additives must never be added to any engine oil used. Additives such as break-in oils, top oils, graphitizers, and friction reducing liquids are not necessary and may even harm the engine.

Using oils to the quality standards recommended in this manual makes the use of extra oil additives unnecessary, as these oils already contain a balanced treatment of additives.

1.3.8 Oil Consumption

Once the engine is stopped, check the oil level daily. If the engine has just been stopped and it is warm, wait approximately five minutes to allow the oil to drain back to the oil pan before checking. Add oil as necessary.



CAUTION

DO NOT overfill engine with oil.

All diesel engines are designed to consume some oil, so it is normal to add oil periodically. An engine used in heavy-duty operation will consume more oil than one in normal operation.

1.3.9 Oil Change



WARNING

A hot engine or engine oil can be dangerous. Serious burns can result from contact with a hot engine or oil. Take precautions when draining the oil. Wear gloves or let the engine cool down before draining.



WARNING

When draining the oil, use the proper tools and keep away as far as possible. Raise the elbow so the forearm is parallel to the ground to prevent oil running down the arm, causing burns.



CAUTION

Always dispose of all lubricants (motor oil, coolant, gear box oils, etc.) and filters according to Federal or local regulations. Used oil disposed of in nature or waterways contaminates our drinking water and kills wildlife.



WARNING

Prolonged contact with used engine oil may be harmful. Use rubber gloves when handling used oil. Wash skin thoroughly if it comes in contact with used oil.

It is important to drain as much oil as possible. Try to change oil immediately after driving, when the oil is warm. Always replace the oil filters when changing the oil.

Component	Capacity (L)
Oil pan	24 (min) – 32 (max)
Engine block	1
Filters (3)	6
Total oil fill (empty)	39

NOTE

Since about 1 liter of oil remains in the engine after draining, approximately 38 liters will be needed for a complete oil change.

1.3.10 Oil Filters Change



WARNING

Hot oil can cause severe burns. DO NOT allow hot oil to contact the skin. When changing oil, wear protective gloves.



CAUTION

Volvo-branded oil filters are designed to provide the proper level of filtration and protection for Volvo engines. Filters that do not meet the same stringent requirements may cause unsatisfactory results.

- Clean around the oil filter housing and remove the filters using the oil filter wrench or the oil filter socket.

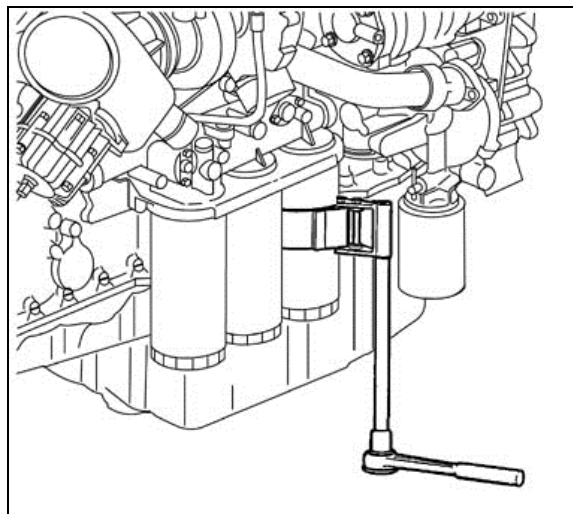

FIGURE 5: OIL FILTER WRENCH

- Prefill the new oil filters with approved engine oil. Also, lubricate the filter gaskets with engine oil (1). Hand tighten the oil filters until they contact the sealing surface of the oil filter housing (2). Manually tighten the oil filters an additional ¼ to 1 full turn (3).

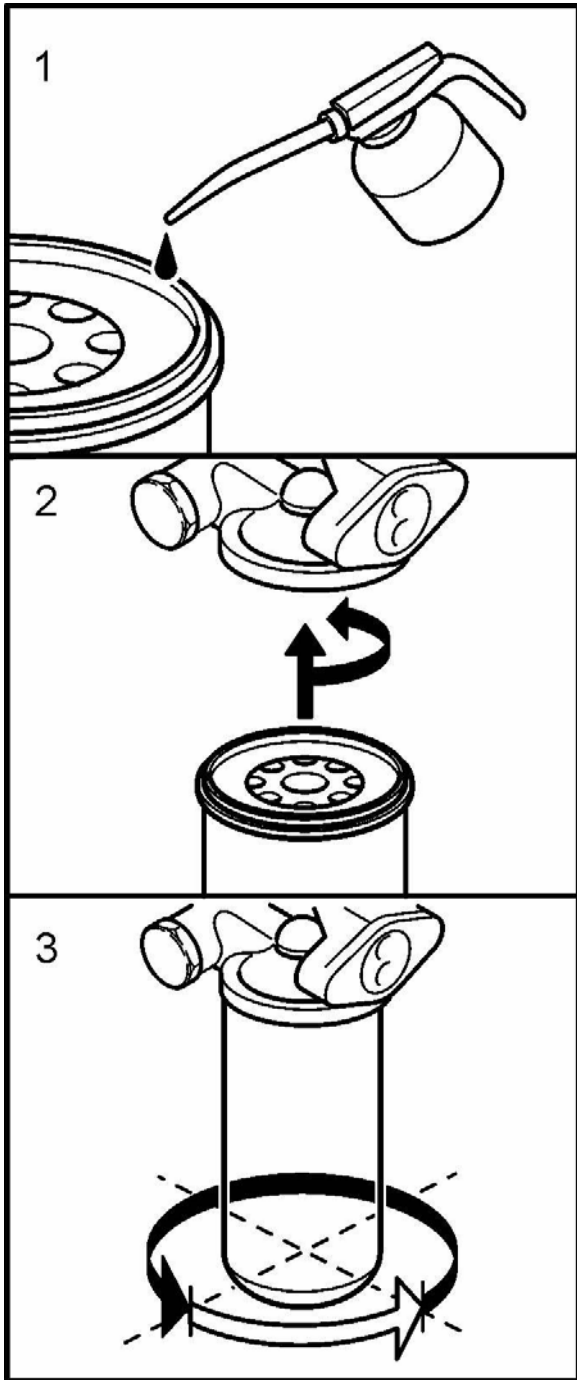

FIGURE 6: OIL FILTER REPLACEMENT

- Start the engine and check for leaks around the oil filter housing and filters.
- Check the oil level. Add approved engine oil to the recommended level, if necessary. Do not overfill.

1.3.11 Checking the Oil Level

Ensure that the vehicle is parked on level ground before checking the oil level. Wait five minutes after shutting off the engine and then proceed with checking the oil.

CAUTION

DO NOT let the oil level fall below the marking on the dipstick. **DO NOT** overfill so the level is above the upper marking on the dipstick. This could lead to excessive oil temperature and/or poor crankcase breather performance. Add oil through the oil filler pipe as required in order to maintain level within the safe range.

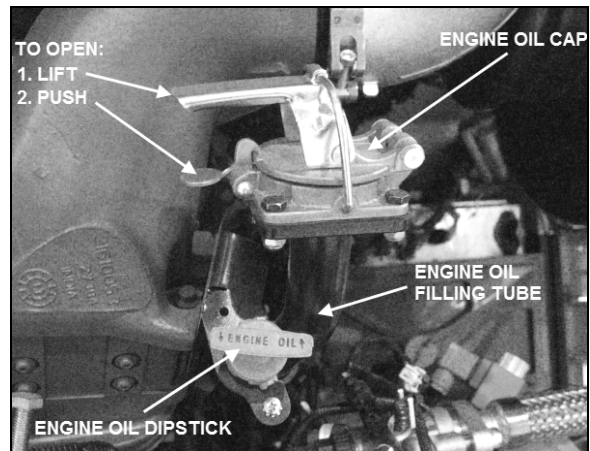

FIGURE 7: ENGINE OIL FILLING TUBE

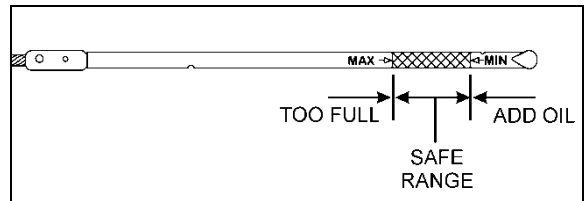

FIGURE 8: ENGINE OIL LEVEL DIPSTICK

1.4 POWER PLANT ASSEMBLY REMOVAL

To access the engine or engine-related components, the vehicle power plant assembly must be removed as a whole unit by means of a slide-out cradle. The power plant assembly includes the engine, transmission (including retarder if so equipped), air compressor, alternator and transmission oil cooler.

Remove the power plant assembly as follows:



CAUTION

Tag hoses and cables for identification before disconnecting in order to facilitate reinstallation. Plug all openings to prevent dirt from entering the system.

NOTE

No parts within the EECU are serviceable. If found defective, replace the EECU as a unit.

• First

1. Shut off the heater line shut-off valves.
2. Disconnect the battery or batteries from the starting system by removing one or both of the battery cables from each battery system. With the electrical circuit disrupted, accidental contact with the starter button will not produce an engine start.



WARNING

Due to the heavy load of the rear bumper assembly, it must be adequately supported before attempting to remove it.

3. Remove the rear bumper assembly complete with hitch if applicable from the vehicle. Refer to Section 18, BODY, under "REAR BUMPER REMOVAL".
4. Using the quick-connect drain hose, drain the engine cooling system. Refer to Section 05, COOLING under "DRAINING COOLING SYSTEM".
5. If applicable, disconnect the block heater connector located near the EGR mixing chamber.

• With Vehicle Raised

1. Using a vehicle lift or jack, raise vehicle to access transmission fasteners and wire harness.
2. Disconnect propeller shaft.
3. Partially remove L.H. side transmission protective panel to access connectors.
4. On vehicles equipped with an automatic transmission provided with a hydraulic output retarder, disconnect steel-braided airline from pressure regulator output. The

pressure regulator is mounted in the upper section of engine compartment backwall and is accessible through the engine compartment R.H. side door.

5. Untighten bolts A and C. Remove bolts B and D and pivot oil cooler towards transmission. Reinstall bolts B and D.

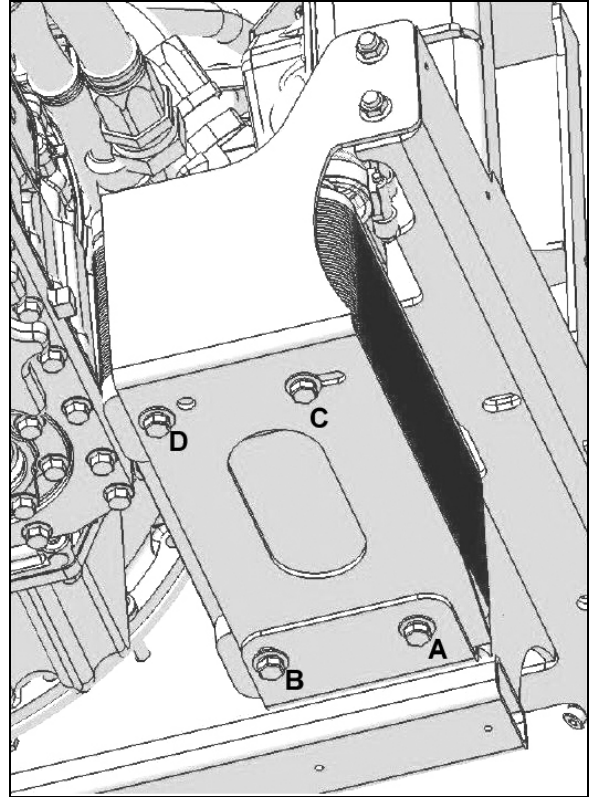

FIGURE 9: COOLER POSITION DURING ENGINE CRADLE INSERTION OR REMOVAL

6. From underneath, unfasten the bolts fixing the engine cradle.
7. Disconnect the engine coolant hose near the starter.
8. Disconnect air compressor suction and discharge hoses.

• With Vehicle Lowered

Lower the vehicle enough to access all components.

- Engine Compartment R.H. side
 - Disconnect cables from two chassis grounds located on diagonal member.
 - Inside engine compartment, disconnect starter, alternators and heater cables. Also disconnect AFSS cable if applicable.

- Disconnect from engine, connector C398 and vehicle interface harness connector located above EECU connectors. Also disconnect DPF cable.
- Disconnect power steering pump hoses.
- Shut off fuel line shut-off valve.
- Close engine fuel supply shut-off valve on primary fuel filter. Disconnect the fuel line located above fuel filters and connected to inlet port.
- Disconnect fuel return line located above fuel filters.
- Disconnect and remove the engine-air intake duct mounted between air cleaner housing and turbocharger inlet.



CAUTION

To avoid damage to turbocharger, cover the turbocharger inlet opening to prevent foreign material from entering.

- Disconnect and remove the exhaust pipe mounted between the flexible coupling and the pipe going to the Diesel Oxidation Catalyst (DOC) and Diesel Particulate Filter (DPF) assembly. If necessary, refer to Section 4: EXHAUST SYSTEM under "EXHAUST AFTERTREATMENT SYSTEM OVERVIEW".
- Disconnect and remove the air intake duct mounted between the charge air cooler outlet and the engine intake.

➤ Engine Compartment L.H. side

- Disconnect fan driving shaft from radiator fan drive mechanism support.



CAUTION

To avoid damage to cooling fan right angle gearbox, make sure the power plant cradle clears the gearbox when pulling the engine out.

- Disconnect and remove section of coolant pipe assembly mounted between the radiator outlet and the water pump inlet.
- Disconnect and remove a section of coolant pipe assembly mounted between the thermostat housing and the radiator inlet.

- Disconnect the electric fan-clutch connector located near the cooling fan right angle gearbox.
- Disconnect and remove the air intake duct mounted between the turbocharger outlet and the air cooler inlet.
- Disconnect and remove surge tank hose connected to pump inlet pipe and hose connected to engine.
- Unfasten and put aside engine compartment lighting fixture and turbocharger fire suppression nozzle if applicable.
- Disconnect Exhaust Aftertreatment System control cable.

• **Last**

1. Inspect the power plant assembly to ensure that nothing will interfere when sliding out the cradle. Check for connections or hoses not mentioned in this list as some vehicles are equipped with special or aftermarket components.
2. Make sure the ten retaining bolts, washers and nuts securing the power plant cradle to the vehicle rear subframe are removed (Figure 12).

NOTE
Check if any spacer(s) have been installed between power plant cradle and vehicle rear subframe, and if so, note position of each washer for reinstallation purposes.

3. Using a suitable equipment with a minimum capacity of 4,000 lbs (1 800 kg), slightly raise the power plant cradle.
4. Pull engine out slowly from the engine compartment. Make sure all lines, wiring and accessories are disconnected and are not tangled.

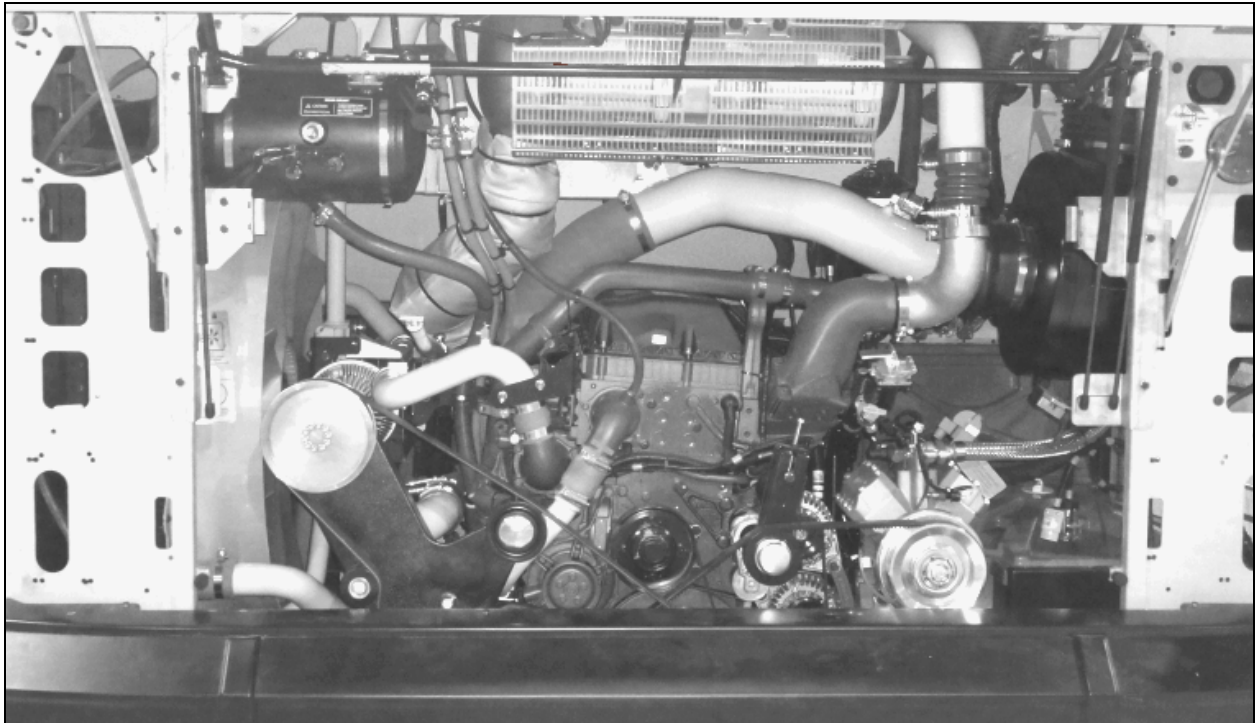

FIGURE 10: ENGINE COMPARTMENT X3 COMMUTER (TYPICAL)

01184_B

1.5 POWER PLANT ASSY. INSTALLATION

To install a power plant assembly, follow the same procedure as in "Power Plant Assembly Removal" except in reverse order, then proceed with the following:

1. Torque the power plant cradle mounting bolts to 190 lbf-ft (258 Nm).
2. Remove bolts B and D. Untighten bolts A and C then pivot oil cooler as per figure 12. Install bolts B and D and tighten all bolts.
3. Refill cooling system with saved fluid (refer to Section 05, COOLANT SYSTEM).
4. Once engine fuel system has been drained, it will aid restarting if fuel filters are filled with fuel oil (refer to Section 03, FUEL SYSTEM).
5. Start engine for a visual check. Check fuel, oil, cooling, pneumatic and hydraulic system connections for leakage. Test operation of engine controls and accessories.

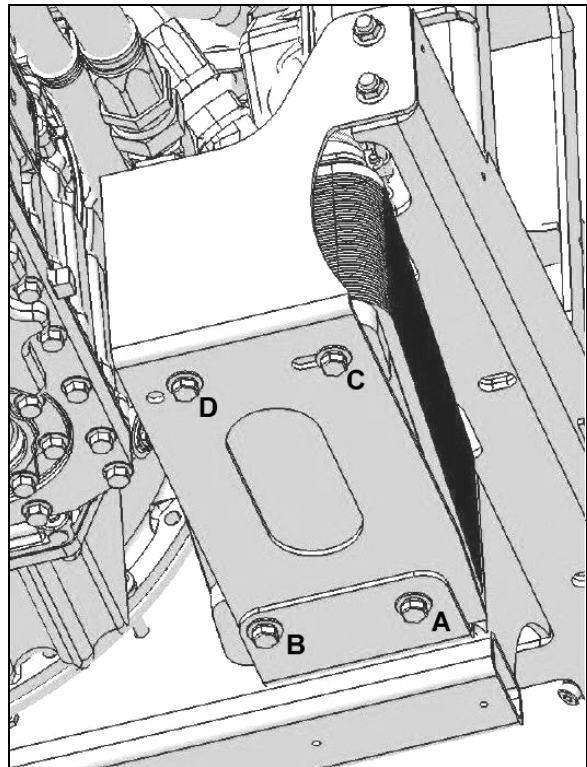

FIGURE 11: NORMAL OIL COOLER POSITION

1.6 ENGINE MOUNTS

The power plant assembly is mounted to the cradle by means of rubber mounts and supports.

Two engine support brackets are used at the front of the engine while two rubber mounts are mounted underneath the engine & radiator fan drive mechanism support and the engine & alternator support (Figure 12).

It is recommended that new rubber mounts be installed at each major overhaul.

NOTE
Refer to the table on the following page for engine cradle tightening torques.

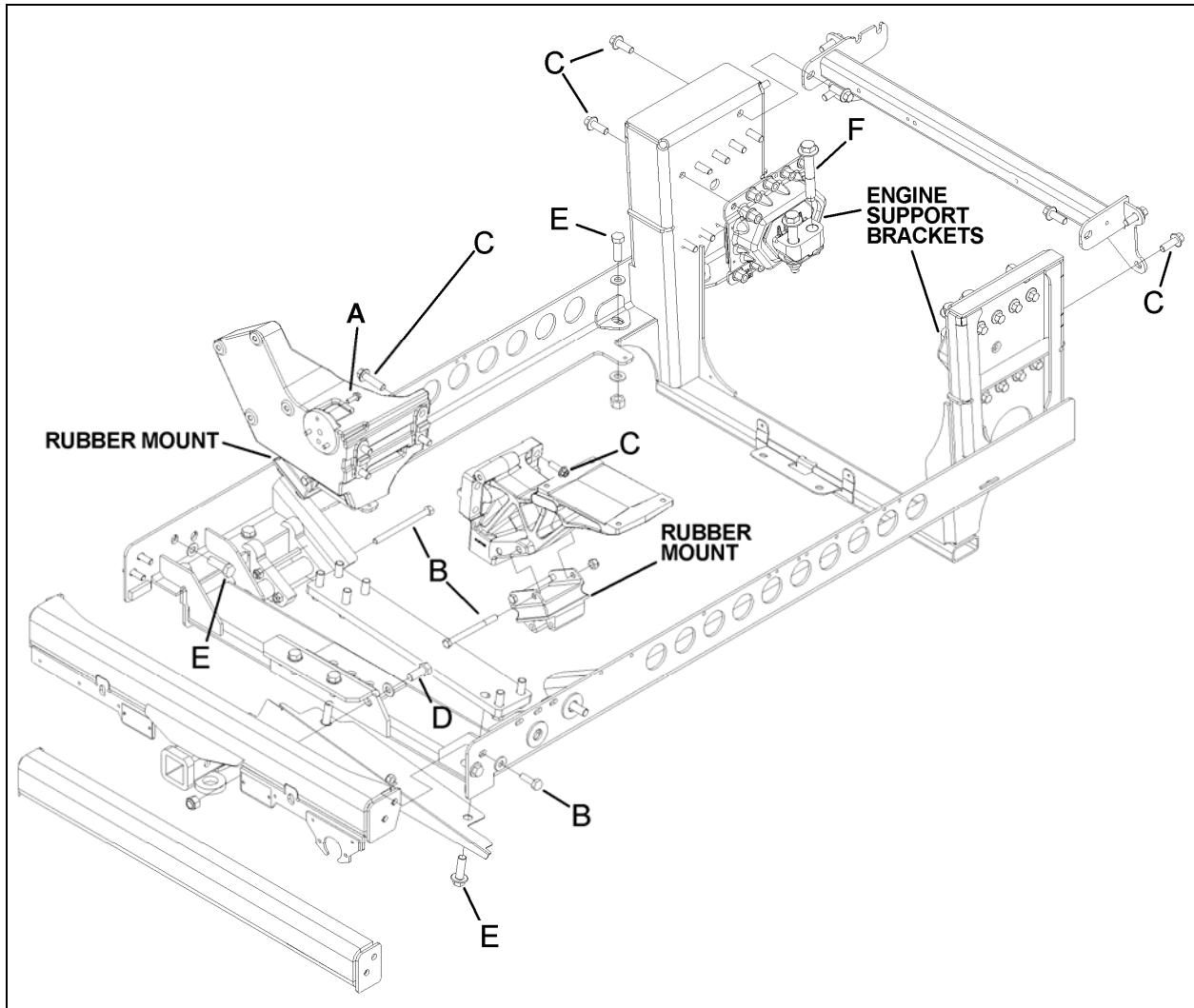

FIGURE 12: VOLVO ENGINE POWER PLANT CRADLE INSTALLATION

DRY TORQUES			
REFERENCE	DESCRIPTION	Lbf-Ft	Nm
A	SCREW, CAP HEXAGONAL HEAD M8 – 1.25 G8.8	16	22
B	SCREW, CAP HEXAGONAL HEAD M12 – 1.75 G8.8	60	81
C	SCREW, CAP HEXAGONAL HEAD M14 – 2.0 G8.8	90	122
D	SCREW, CAP HEXAGONAL HEAD M16 – 2.0 G8.8	140	190
E	SCREW, CAP HEXAGONAL HEAD M16 – 2.0 G10.9	190	258
F	SCREW, CAP HEXAGONAL HEAD M20 – 2.5 G10.9	450	610

2. ELECTRONIC FOOT PEDAL ASSEMBLY (EFPA) & THROTTLE POSITION SENSOR

The Electronic Foot Pedal Assembly (EFPA) connects the accelerator pedal to a Throttle Position Sensor (TPS). The (TPS) is a device, which sends an electrical signal to the Motor Control Module (MCM). The TPS varies in voltage depending on how far the pedal is depressed. The system is installed in the space normally occupied by a mechanical foot pedal. The (EFPA) has maximum and minimum stops that are built into the unit during manufacturing (Figure 13). The (TPS) converts the operator's foot pedal input into a signal for the MCM.

When installed by the equipment manufacturer, the TPS should not require adjustment. If the TPS is suspected of being misadjusted, confirm that the sensor is installed in accordance with the manufacturer's specifications. It is recommended that the idle count be at 50 or higher with a full throttle count of up to 200.

The TPS is self-calibrating and therefore has no optimum closed throttle or wide open throttle count value. If the counts are within the 50 to 200 range, the sensor is properly set.

Monitor the (TPS) at the controls as you move it through its full stroke. Be sure there is no misalignment or obstruction preventing the smooth movement of the TPS through the full stroke. Using a diagnostic data reader, check that idle and full throttle position counts do not fall within the error zones. The error zones occur when the idle position is less than 14 counts, or when the full throttle position is more than 233 counts. Should these conditions occur, the CPC will signal diagnostic codes of 21-12 for idle error and 21-23 for wide-open throttle error.

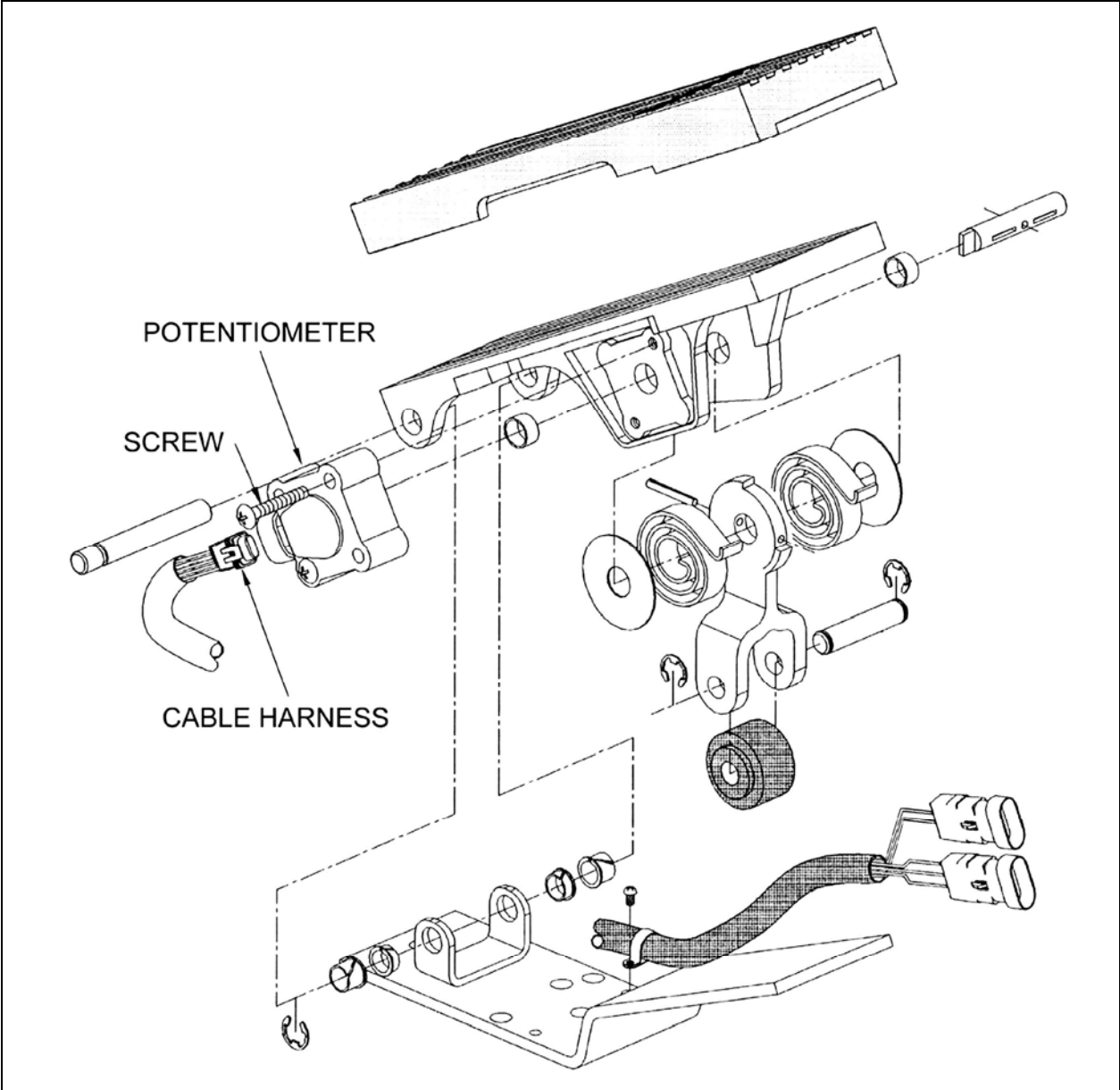



FIGURE 13: ELECTRONIC FOOT PEDAL ASSEMBLY

03035

3. AUTOMATIC BELT TENSIONERS AND IDLER PULLEYS INSPECTION

With the engine running, if noise is coming from the tensioners or drive system, an inspection with the engine off is necessary.



MAINTENANCE

Remove belts and inspect automatic belt tensioners, idler pulley bearings every 30 000 miles.

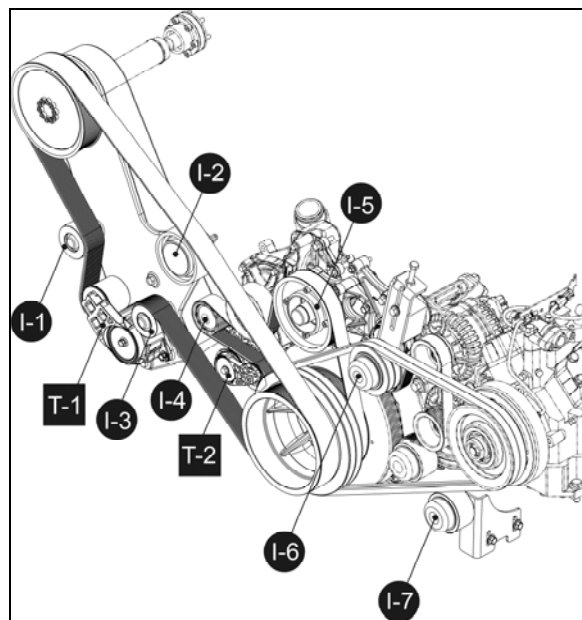

FIGURE 14: IDLER PULLEYS AND AUTOMATIC BELT TENSIONERS ON COOLING FAN DRIVE, WATER PUMP DRIVE AND A/C COMPRESSOR DRIVE

IDLERS		
Ref	System	Torque lbs-ft
I-1	cooling fan drive	50
I-2	cooling fan drive	35
I-3	cooling fan drive	50
I-4	water pump drive	43
I-5	water pump drive	16 (pulley) 32 (shaft)
I-6	A/C compressor drive	35
I-7	A/C compressor drive	82
I-8	alternator drive	82

AUTOMATIC BELT TENSIONERS		
Ref	System	Torque lbs-ft
T-1	cooling fan drive	32 (2x)
T-2	water pump drive	43
T-3	alternator drive	43

3.1 BEARING INSPECTION

1. First, set parking brake, turn the ignition OFF and set the rear start selector switch to the OFF position.
2. Remove all belts on cooling fan drive, water pump drive, A/C compressor drive and alternator drive.

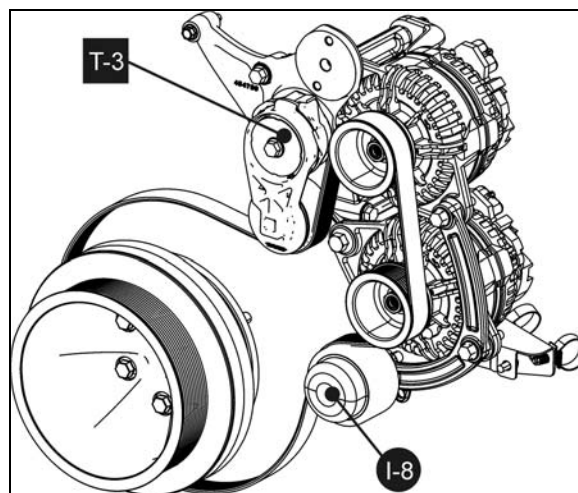

FIGURE 15: IDLER AND AUTOMATIC BELT TENSIONER ON ALTERNATOR DRIVE

3. Spin all idler pulleys, I-1 thru I-8, plus the idlers that are part of the automatic belt tensioners T-1 thru T-3.
4. Listen if some idlers are noisy and check for play in the bearings by hand.
5. Replace noisy idlers or if a play is found. Replace the automatic belt tensioner as a complete unit.
6. Record the results of the inspection.

3.2 AUTOMATIC BELT TENSIONER BUSHING WEAR

Automatic belt tensioner bushing wear may result in belt misalignment.

1. Check the automatic belt tensioner T-1 thru T-3.
2. Pry the automatic belt tensioner arm and check for a play between the arm and the spring case (see image below).

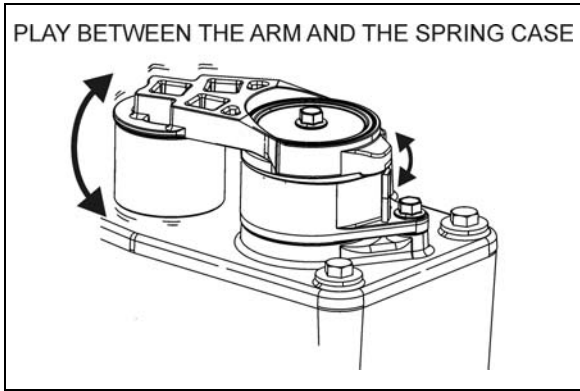

FIGURE 16: CHECKING BUSHING WEAR

3. If bushing wear is suspected, remove the tensioner. Inspect the tensioner for any signs of wear. Check for bearing noise as well as metal to metal contact between the arm and spring case which is a sign of bushing wear. Check for cracks in the tensioner body.
4. Replace the automatic belt tensioner if found defective.
5. Record the results of the inspection.

3.3 BELTS AND IDLERS VISUAL INSPECTION

1. Inspect drive belts for cracks, frayed material, missing chunks in the belt, abrasion and peeling. Replace belts if damaged.
2. Visually inspect all idlers for signs of deterioration, loose fasteners, etc.
3. Record the results of the inspection.

MAINTENANCE

Visually inspect belts and idlers for signs of deterioration, cracks, frayed material every 6 000 miles.

4. ENGINE PROTECTION STRATEGY

The engine protection system will automatically derate or derate and stop the engine when certain engine conditions reach a critical stage.

In the event of a serious fault, the red STOP telltale light comes on and an audible alarm will sound if the engine is running.



Prior to an actual automatic shutdown, the engine will automatically derate, go to idle, and then stop in 30 seconds.

ENGINE PROTECTION LOGIC (with yellow CHECK or red STOP telltale light)	
High engine coolant temperature	Shutdown
High engine oil temperature	Shutdown
Low engine oil pressure	Shutdown
High crankcase pressure (rate of change)	Shutdown
Low coolant level	Derate only
High intake manifold air temperature	Derate only
High transmission oil temperature	Derate only
High temperature of cooled exhaust gas (EGR) - after EGR cooler	Derate only
EGR valve and position error	Derate only
Variable Geometry Turbo (VGT) valve and position error	Derate only
High VGT actuator temperature	Derate only
High pre-Diesel Oxidation Catalyst (DOC) temperature	Derate only
High Compressor Discharge Temperature (CDT – measured)	Derate only
High soot load	Derate only
High Diesel Particulate Filter (DPF) pressure differential (DP)	Derate only

OUTSIDE ENGINE PROTECTION LOGIC (no yellow CHECK or red STOP telltale light)	
High altitude (ensures that high compressor discharge temp. is never reached)	Derate only
Turbo over-speed	Derate only
Low coolant temperature	Derate only
Crank sensor failure	Derate only
High crankcase pressure - Absolute Pressure	Shutdown

5. SPECIFICATIONS**Volvo D13 Engine**

Make	Volvo
Type	Diesel four cycle/in-line direct injection engine
Description	Turbo/Air to air charge cooled
No. of cylinders	6
Operating range	1400-1800 RPM
X3-45 Coaches Peak Power Rating	435 HP (324 kW)
X3-45 Coaches Peak Torque Rating	1700 Ft-lb (2304 Nm)
Low Idle	600 rpm
Fast Idle.....	2150 rpm
Maximum full load revolutions.....	1900 rpm

Engine oil level quantity

Oil pan capacity, low limit.....	25 quarts/24 liters
Oil pan capacity, high limit	34 quarts/32 liters
Total Engine Oil Capacity with Filters	41 quarts/39 liters

Lubricating oil filter elements

Type	By-pass
Prevost number	510938
Type	Full Flow
Prevost number	488736

Torque specification

Engine oil filter.....	Tighten $\frac{3}{4}$ of a turn to 1 full turn after gasket contact
------------------------	---

Filters

Engine Air Cleaner Filter	
Prevost number	530197
Engine Coolant Filter/Conditioner	
Prevost number	20458771

6. SECTION CHANGE LOG

DESCRIPTION		DATE
1		
2		
3		
4		
5		
6		

CONTENTS

1. FUEL SYSTEM DESCRIPTION 3

1.1 FUEL VALVES4

1.2 FUEL FILTERS4

 1.2.1 PRIMARY FUEL FILTER REPLACEMENT5

 1.2.2 SECONDARY FUEL FILTER REPLACEMENT5

1.3 PRIMING THE FUEL SYSTEM6

1.4 FUEL PUMP REMOVAL AND INSTALLATION6

2. FUEL LINES AND FLEXIBLE HOSES 7

3. FUEL TANK..... 7

3.1 FUEL TANK DRAIN PLUG8

3.2 TANK REMOVAL8

3.3 TANK INSTALLATION9

3.4 FUEL TANK YEARLY INSPECTION.....9

4. FUEL SPECIFICATIONS 11

4.1 FUEL TYPE..... 11

4.2 BLENDING 11

4.3 BIODIESEL FUELS 11

5. AIR CLEANER (DRY TYPE)..... 11

5.1 AIR CLEANER SERVICING 11

5.2 GENERAL RECOMMENDATIONS 12

5.3 AIR CLEANER RESTRICTION INDICATOR 12

6. FUEL PEDAL 12

6.1 FUEL PEDAL ADJUSTMENT 12

6.2 POTENTIOMETER REPLACEMENT 13

7. SECTION CHANGE LOG 14

ILLUSTRATIONS

FIGURE 1: FUEL SYSTEM SCHEMATIC (VOLVO D13 ENGINE)3

FIGURE 2: MANUAL SHUT-OFF VALVE (VOLVO D13 ENGINE)4

FIGURE 3: FUEL LINE COMPRESSION FITTING.....4

FIGURE 4: FUEL FILTERS WITH VOLVO D13 ENGINE 030855

FIGURE 5: HAND PRIMING PUMP6

FIGURE 6: FUEL PUMP REMOVAL.....7

FIGURE 7: FUEL PUMP DRIVE AXLE.....7

FIGURE 8: STEEL FUEL TANK ASSEMBLY8

FIGURE 9: FUEL TANK DRAIN PLUG8

FIGURE 10: FUEL TANK CONNECTION PANEL.....9

FIGURE 11: FUEL TANK SUPPORT MOUNTING BOLTS9

FIGURE 12: FUEL TANK SUPPORT MOUNTING BOLTS9

FIGURE 13: FUEL TANK STRAP MOUNTING9

FIGURE 14: JACK STANDS UNDER THE FUEL TANK CRADLE10

FIGURE 15: LOCATION OF MOUNTING POINTS10

FIGURE 16: TRANSVERSE SCREWS, 2 LOCATIONS10

FIGURE 17: LONGITUDINAL SCREWS, 4 LOCATIONS10

FIGURE 18: VISIBLE GAP ON TRANSVERSAL SCREW JOINT 10
FIGURE 19: SHIM INSTALLATION, TRANSVERSE SCREW. ARRANGEMENT MAY VARY 10
FIGURE 20: RESTRICTION INDICATOR 01052_1 12
FIGURE 21: RESTRICTION INDICATOR LIGHT 12
FIGURE 22: ELECTRONIC FOOT PEDAL ASSEMBLY03035 13

1. FUEL SYSTEM DESCRIPTION

NOTE

For detailed service procedures and part replacement information, about Volvo D13 engine and engine-related components, consult 'Impact' available under Volvo's Premium Tech Tool Software.

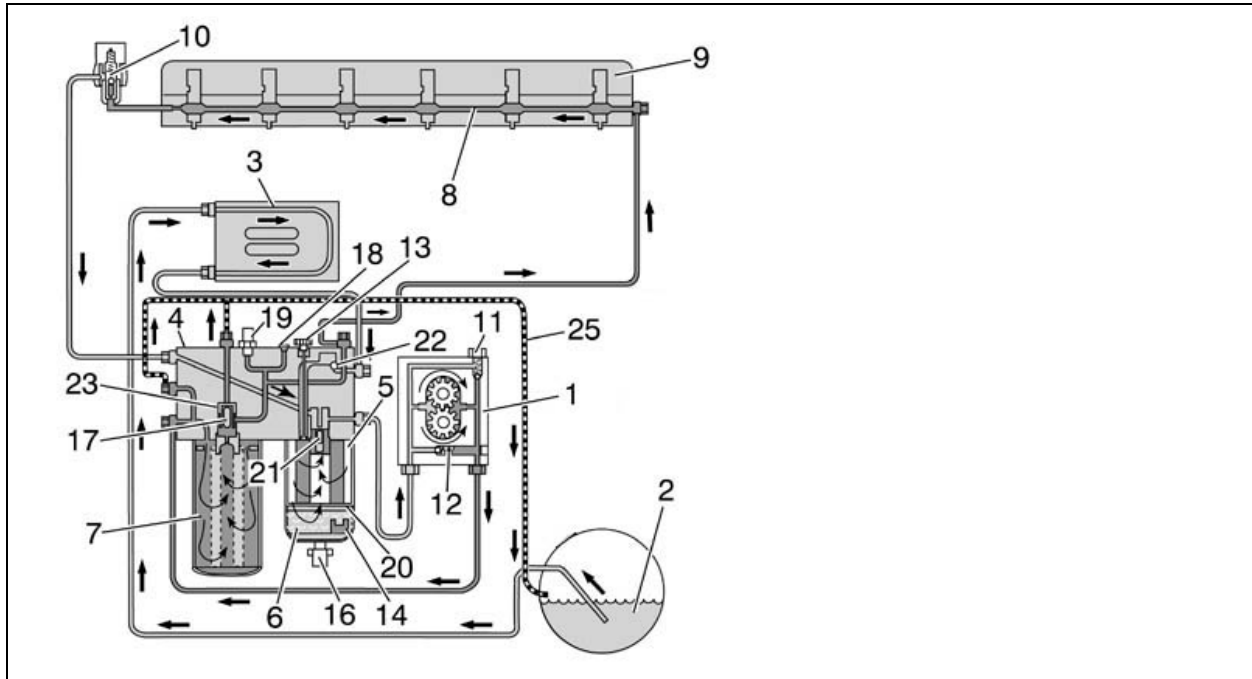

FIGURE 1: FUEL SYSTEM SCHEMATIC (VOLVO D13 ENGINE)

03086

Fuel is drawn up the fuel lines by the supply pump (1) through the pickup tube in the tank (2) and through the Engine Electronic Control Unit (EECU) cooling coil (3) and into the fuel filter housing (4). The fuel housing is equipped with a primary fuel filter (fuel/water separator) consisting of a filter cartridge and a water separation bowl.

The supply pump (1) forces the fuel into the fuel filter housing through the secondary filter (main) to a cylinder head longitudinal gallery (8). This channel supplies each unit injector (9) with pressurized fuel by a circular groove around each unit injector in the cylinder head. The overflow valve (10) controls the fuel supply pressure to the unit injectors.

The return fuel from the overflow valve (10) is returned back to the fuel filter housing and is mixed with the fuel from the fuel tank in a channel within the fuel filter housing (4).

Supply Pump Valves

Two valves are located in the supply pump (1). The safety valve (11) allows fuel to flow back to the suction side when the pressure becomes too high, e.g., if the fuel filter is blocked or is too restricted. The non-return valve (12) opens when the hand-priming pump is used.

Automatic Bleeding

If air gets into the system, it is bled when the engine starts. During bleeding, air is pressed out through the fuel filter housing over to the fuel tank through the return line (25). Bleeding for the filter replacement is controlled by valves (17) and (23).

Other

The fuel filter housing eliminates the need to drain the fuel when replacing the filter. The valve pegs (17) and (21) close when the fuel filter is removed. It is not necessary to bleed the fuel system after replacing the filter, since this is

performed automatically when the engine is started and runs for more than 2 minutes.

The plugged outlet (18) is fitted on the fuel filter housing. This outlet is used when measuring supply pressure after the fuel filter with an external pressure gauge. The pressure sensor (19) on the fuel filter housing monitors the supply pressure after the fuel filter. A fault code is displayed on the instrument cluster if the fuel supply pressure is less than the specified value.

Hand Priming Pump

The hand priming pump (13) is located on the fuel filter housing and is used to pump fuel (when engine is not running) after the fuel system has been drained for repair, etc. The non-return valve (22) for the hand priming pump is also located in the fuel filter housing.

1.1 FUEL VALVES

The manual shut-off valve on engine fuel-supply line is located on the R.H. side of engine compartment. A manual shut-off valve is located at the inlet side of the primary fuel filter.

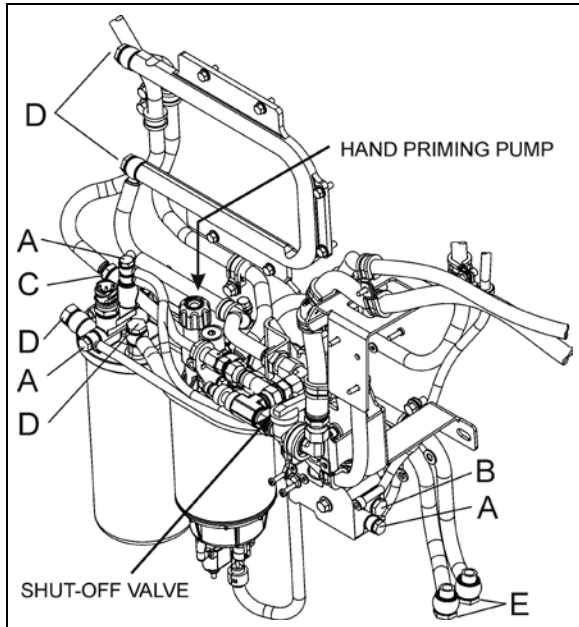

FIGURE 2: MANUAL SHUT-OFF VALVE (VOLVO D13 ENGINE) 03088

Shut-off valve is designed to prevent loss of fuel prime. No manual valve is required on preheater fuel-supply line, since the positive-displacement fuel pump (located close to the fuel tank) prevents fuel flow when not activated.

FUEL LINE FITTINGS – VOLVO D13 ENGINE		
A	13 ± 2 ft-lb	(18 ± 3 Nm)
B	20.5 ± 3 ft-lb	(28 ± 4 Nm)
C	22 ± 3 ft-lb	(30 ± 4 Nm)
D	26 ± 4 ft-lb	(35 ± 5 Nm)
E	29.5 ± 4 ft-lb	(40 ± 5 Nm)
F	35 ± 4 ft-lb	(48 ± 5 Nm)

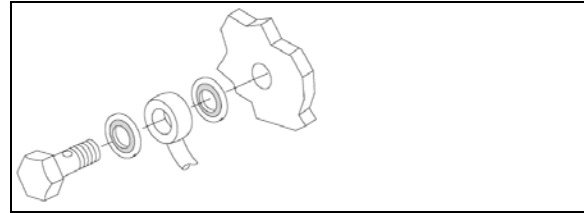

FIGURE 3: FUEL LINE COMPRESSION FITTING

CAUTION

Always replace the fuel line compression sealing washers when troubleshooting for fuel aeration or performing any service procedure that requires the removal of engine fuel lines.

1.2 FUEL FILTERS

A primary fuel filter is installed on the engine. This filter consists of a filter cartridge, a water separation bowl with a drain valve. It is used to prevent water from entering the fuel system.

MAINTENANCE

The primary and secondary fuel filters are of a spin-on type and must be replaced at **every engine oil change**.

The primary fuel filter should be drained periodically or when the telltale light on the dashboard illuminates if equipped with this system. To drain water, loosen the drain valve below the separator. Place an appropriate container under the filter. Close the drain valve when finished.

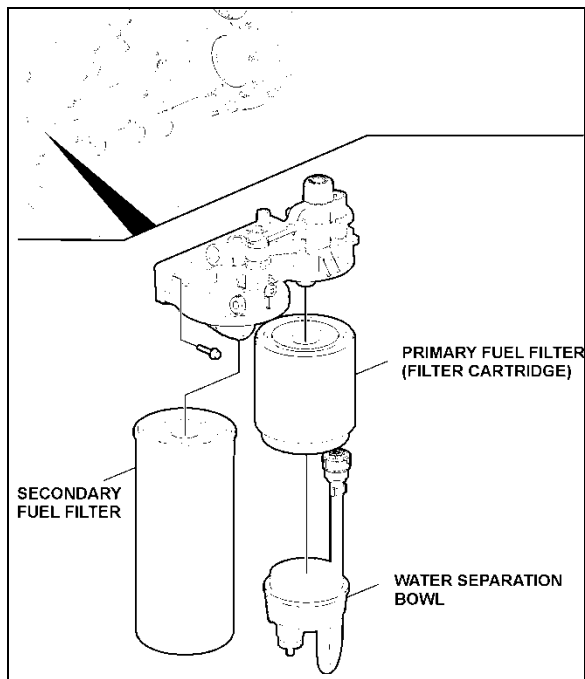
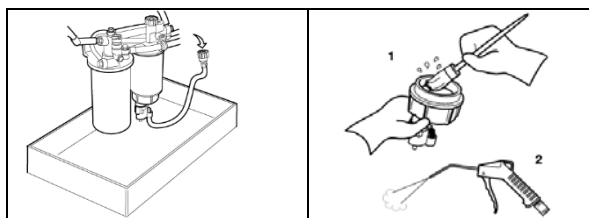

FIGURE 4: FUEL FILTERS WITH VOLVO D13 ENGINE
03085

1.2.1 Primary Fuel Filter Replacement

1. Stop engine, close the fuel supply line shut-off valve.
2. Place an appropriate container under the fuel filter housing, then drain the water from the water separation bowl.
3. Disconnect the fuel/water separator indicator electrical connector.



4. Unscrew and remove the primary fuel filter from the fuel filter housing. Drain filter.
5. Unscrew and remove the separation bowl from the filter cartridge.
6. Remove and discard the old gasket from the water separation bowl. Clean the bowl thoroughly and then blow dry with filtered compressed air.

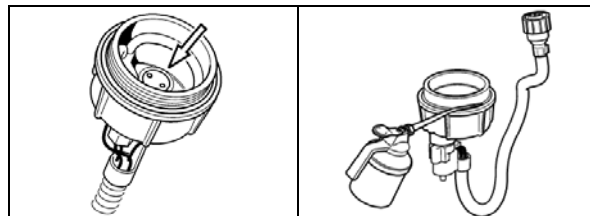

7. Check that the drainage hole in the water separator bowl is not blocked.
8. Apply a thin coating of clean engine oil to the surface of the water separation bowl.

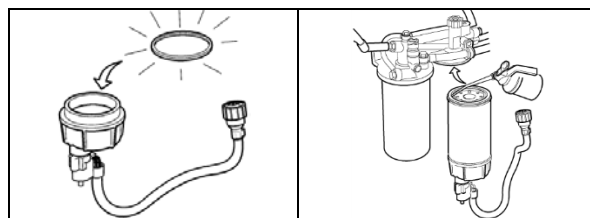

9. Install a new gasket to the water separation bowl and then reinstall the separation bowl to the new primary fuel filter cartridge.
10. Apply a thin coating of clean engine oil to the surface of the primary fuel filter, install the primary fuel filter to the fuel filter housing, then tighten the primary fuel filter $\frac{1}{2}$ - $\frac{3}{4}$ turn.

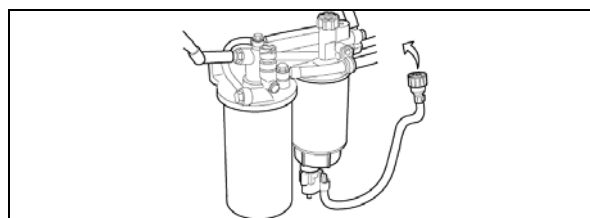

11. Connect the electrical connector for the water/fuel separation bowl indicator.
12. Open the fuel supply line shut-off valve.
13. Purge air from the filter by operating the priming pump to draw fuel and fill the filter. When using the hand priming pump, approximately 100 strokes will be required.
14. Start the engine and carry out a fuel-tightness check. Let the engine run for about 5 minutes to remove air pockets from the fuel system.

1.2.2 Secondary Fuel Filter Replacement

1. Stop engine, close the fuel supply line shut-off valve. Place an appropriate container under the fuel filter housing.

2. Clean around sealing area on fuel filter and housing.
3. Unscrew and remove the secondary fuel filter from the fuel filter housing.
4. Apply a thin coating of clean engine oil to the gasket of the secondary fuel filter. Screw the fuel filter into position. Tighten the filter $\frac{3}{4}$ to 1 turn after the gasket makes contact with the fuel filter housing.

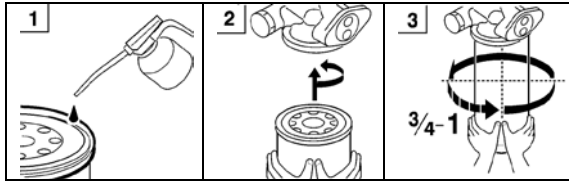

CAUTION

Fuel in the old filter **must absolutely not** be poured into the new filter. This kind of contaminated fuel can damage the unit injectors.

5. Prime the fuel system by pumping the hand priming pump on the fuel filter housing until resistance is felt indicating that the system is full of fuel.
6. Start the engine and carry out a fuel-tightness check. Let the engine run for about 5 minutes to remove air pockets from the fuel system.

1.3 PRIMING THE FUEL SYSTEM

The fuel system will need to be bled if:

- The vehicle has run out of fuel.
- The engine has not been running for an extended period of time.
- Service work has been done on the fuel system, (tank, fuel lines, filters, valves, etc.) for example cleaning or replacing fuel filter cartridges.
- The engine is new or rebuilt.

CAUTION

When priming the system, movement of the primer pump should be as up and down as possible. Avoid putting any side load on the pump or causing a binding condition. Failure to follow these instructions could prematurely damage the primer pump.

NOTE

When the fuel system is empty, 200 or more pump strokes may be needed to properly prime system. There are no bleed nipples to be opened to prime the fuel system.

1. Stop engine;
2. Unlock the hand pump by turning the handle counterclockwise.
3. Prime the system by moving the primer pump in an up and down pumping motion. Avoid putting any side load on the pump or causing a binding condition.

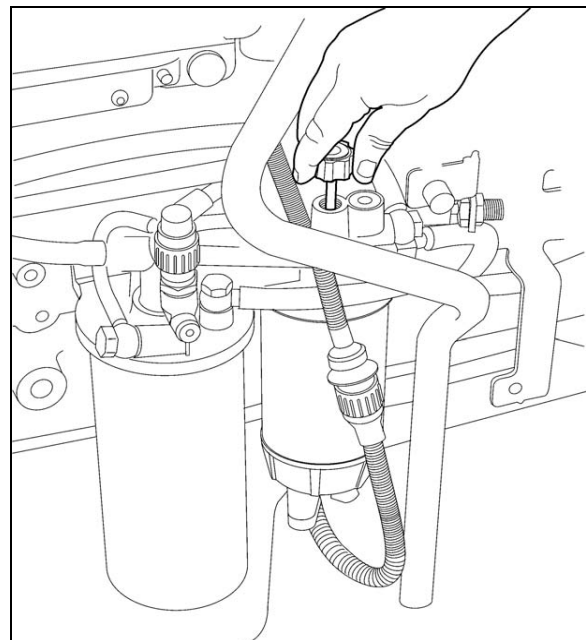

FIGURE 5: HAND PRIMING PUMP

4. Lock the hand primer pump by retracting it into the housing and turning it clockwise.
5. Start the engine and run it at an increased idle speed for approximately 5 minutes to remove any remaining air in the system. Check the fuel system for leaks.

1.4 FUEL PUMP REMOVAL AND INSTALLATION

The pump is located underneath the air compressor and is accessible through the engine compartment R.H. access door.

To remove the pump, proceed as follows:

- Clean around the fuel pump and fuel lines. Position a container to catch any fuel that might drain from the pump or lines.
- Remove the fuel pump.

NOTE
Only unfasten the bolts marked with arrows.

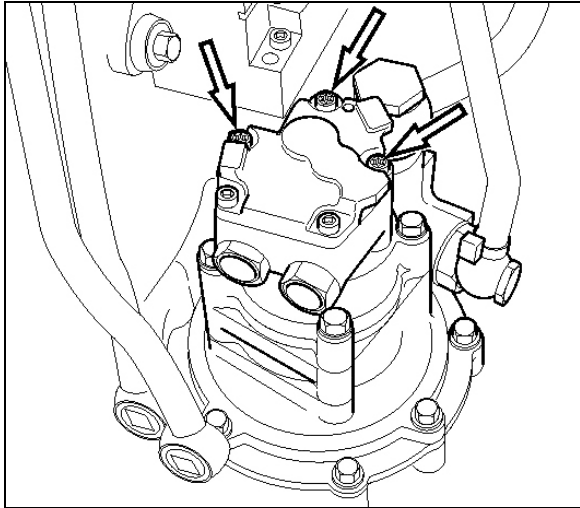

FIGURE 6: FUEL PUMP REMOVAL

CAUTION
Ensure to clean around the head of the bolts. Debris will prevent the tool from fitting properly and cause damage to the fasteners.

- Check that the adapter and fuel pump drive axle are not damaged.

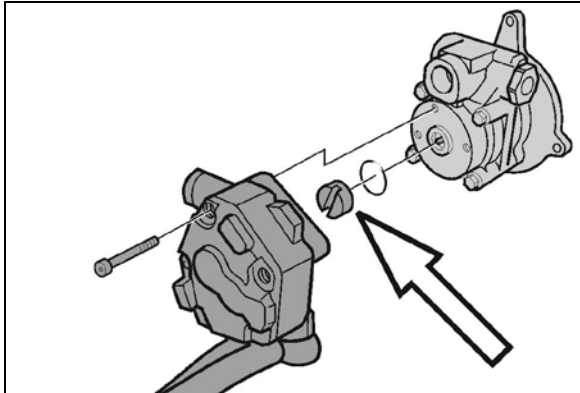

FIGURE 7: FUEL PUMP DRIVE AXLE

- Install the fuel pump. Torque-tighten bolt to specification.

NOTE
Use a new sealing ring. Check that the fuel pump drive axle sits correctly in the power steering pump.

- Using the hand primer on the fuel filter housing, prime the fuel system.
- Start the engine and let run for 5 minutes. Make sure that there are no leaks.

2. FUEL LINES AND FLEXIBLE HOSES

Make a visual check for fuel leaks at all engine-mounted fuel lines and connections and at the fuel tank suction and return lines. Since fuel tanks are susceptible to road hazards, leaks in this area may best be detected by checking for accumulation of fuel under the tank. Engine performance and auxiliary equipment is greatly dependent on the ability of flexible hoses to transfer lubricating oil, air, coolant and fuel oil. Diligent maintenance of hoses is an important step in ensuring efficient, economical and safe operation of engine and related equipment.

MAINTENANCE

Check hoses daily as part of the pre-start-up inspection. Examine hoses for leaks and check all fittings, clamps and ties carefully. Make sure that the hoses are not resting on or touching shafts, couplings, and heated surfaces, including exhaust manifolds, any sharp edges or other obviously hazardous areas.

Since all machinery vibrates and moves to a certain extent, clamps and ties can fatigue with age. To ensure continued proper support, inspect fasteners frequently and tighten or replace them as necessary. Refer to the schematic diagram of the fuel system (Figure 2).

CAUTION
Oil level above the dipstick full mark or a decrease in lube oil consumption may indicate internal fuel leaks. Check oil level frequently.

3. FUEL TANK

The X3-45 Commuter coach is equipped with a steel fuel tank with a legal capacity (corresponding to 95% of gross capacity) of 180 US gallons (681 liters) and 6.3 US gallons of unusable fuel.

The fuel filling access door is located on the R.H. side of vehicle providing easy fuel filling.

A Level Control Valve (LCV) on the fuel tank connection panel relieves pressure buildup and allows offset air in the tank to escape during filling. A whistle mounted at the LCV outlet can be heard as air escapes. During fueling, the LCV will close when the fuel reaches the level in the tank corresponding to 95% of the tank

volume, permitting a small build-up of pressure in the tank. When the back pressure reaches between 1.1 and 1.5 psig it forces the filling nozzle to close automatically.

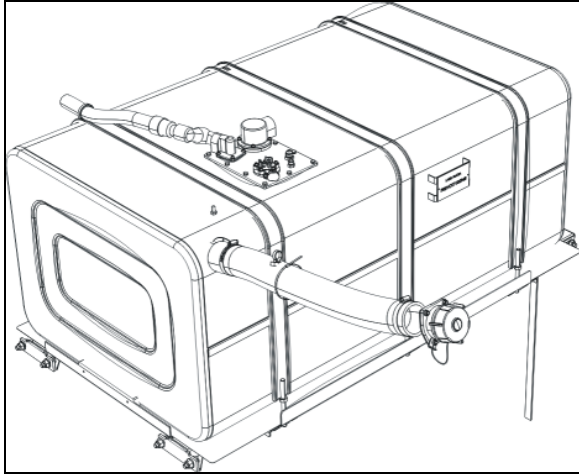

FIGURE 8: STEEL FUEL TANK ASSEMBLY

5% of tank inside space is kept filled with air with no exit opening, allowing for a fuel expansion safety margin. A drain plug, accessible from under the vehicle, is fitted at the bottom of the tank.

3.1 FUEL TANK DRAIN PLUG

NOTE

For faster emptying, it is recommended to siphon fuel through the opening left on the connection panel once the pressure relief valve is removed.

Apply **Loctite 567 Thread Sealant** on drain plug. With any sealant, the first one or two threads should be left uncovered to avoid system contamination.

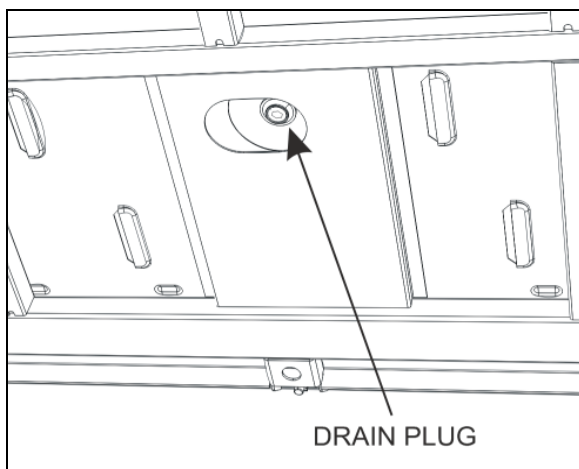

FIGURE 9: FUEL TANK DRAIN PLUG

The proper method of assembling this tapered threaded drain plug is to screw it to the finger tight position and then wrench tighten further 2-3 turns. If leakage persists, check for damaged threads.

3.2 TANK REMOVAL

DANGER

Park vehicle safely, apply parking brake, stop engine and set battery master switch(es) to the OFF position prior to working on the vehicle.

Before working under an air-suspended vehicle, it is strongly recommended to support the chassis at the recommended jacking points.

NOTE

Before removal, the fuel tank should be completely emptied by unscrewing the drain plug. For faster emptying, it is recommended to siphon fuel through the opening left on the connection panel once the pressure relief valve is removed.

Ensure that the container used has a capacity equal to the amount of fuel remaining in the tank.

1. Open the condenser door.
2. Unscrew clamps retaining R.H. side filler tube to fuel tank and filler neck. Disconnect tube and remove it.
3. Unscrew engine fuel supply and return lines from fuel tank connection panel.
4. Disconnect the fuel level sender electrical wires (3wires). Prior disconnecting, identify the wires and proper terminal on the fuel level sender as reference for reinstallation (Figure 10).
5. Using mobile column lifts, raise the vehicle to gain access to the fuel tank support from underneath.
6. Before removing the bolts securing the tank support to the chassis, lower the vehicle and make sure the tank support is adequately supported with jack stands or wood blocks. Failure to do so could result in injury as well as damage to the tank.

⚠ DANGER

Before removing the bolts securing the tank cradle to the frame, make sure the tank cradle is adequately supported with jack stands. Failure to do so could result in injury as well as damage to the tank.

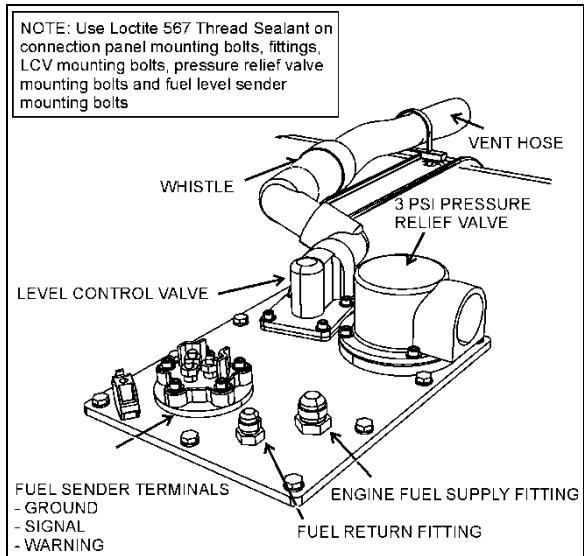

FIGURE 10: FUEL TANK CONNECTION PANEL

7. Once properly supported, unscrew the bolts (6) holding the fuel tank support to the vehicle chassis.
8. Lift the coach until it is high enough to clear the fuel tank. The fuel tank will rest on the floor.

3.3 TANK INSTALLATION

To install tank, simply reverse the "Tank Removal" procedure. Apply Valvoline anti-corrosion compound on retainer strap studs, nuts and fuel tank cradle mounting bolts.

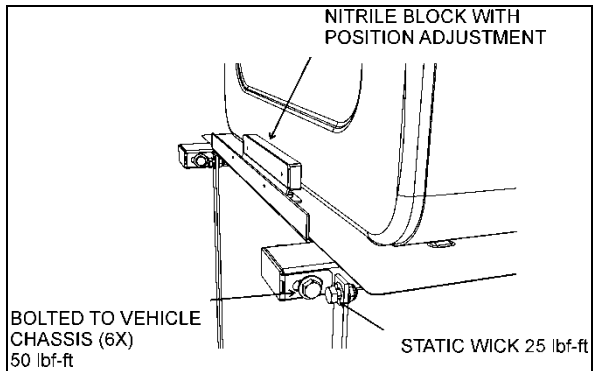

FIGURE 11: FUEL TANK SUPPORT MOUNTING BOLTS

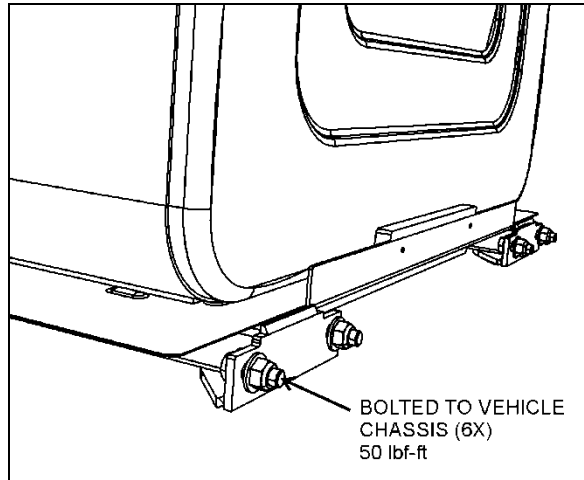

FIGURE 12: FUEL TANK SUPPORT MOUNTING BOLTS

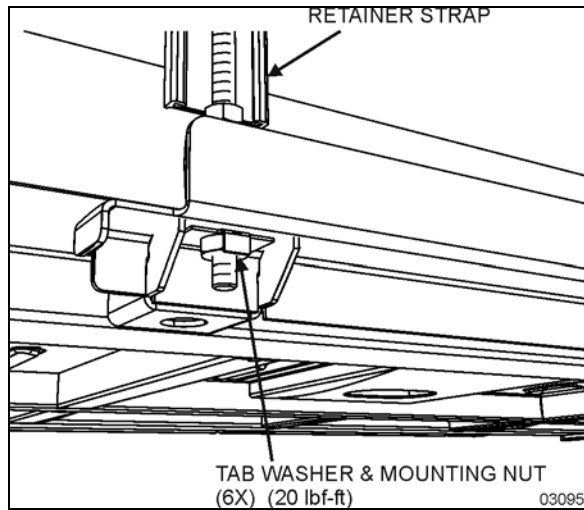

FIGURE 13: FUEL TANK STRAP MOUNTING

3.4 FUEL TANK YEARLY INSPECTION

Perform an external visual inspection of the fuel tank from under the vehicle to detect fuel traces or leaks.

Perform a visual inspection of the fuel tank connection panel. Make sure there are no loose connections. Investigate and correct the cause of any fuel leaks.

Inspect all fuel tank mountings and cradle attachment points. Inspect fasteners and replace them as necessary as described in the procedure that follows.

1. Raise the vehicle with safe lifting equipment and procedures.
2. Place jack stands under the fuel tank cradle.

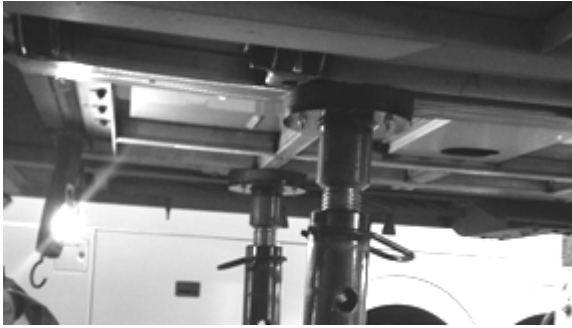

FIGURE 14: JACK STANDS UNDER THE FUEL TANK CRADLE

- Carefully inspect fuel cradle mounting bolts, 6 locations (Figure 15).

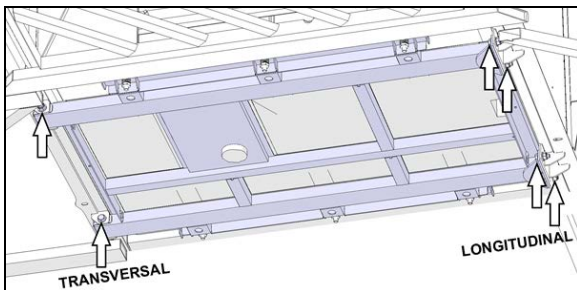

FIGURE 15: LOCATION OF MOUNTING POINTS

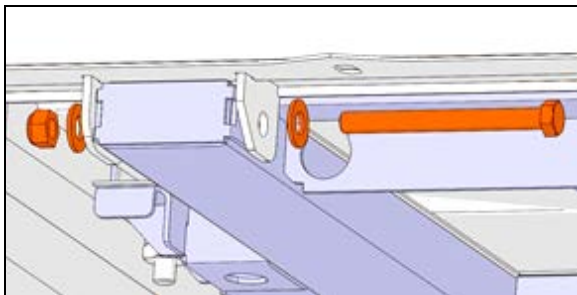

FIGURE 16: TRANSVERSE SCREWS, 2 LOCATIONS

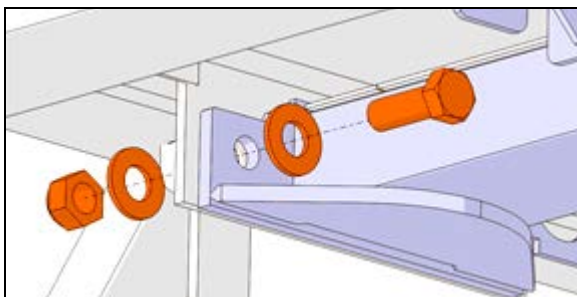

FIGURE 17: LONGITUDINAL SCREWS, 4 LOCATIONS

- Replace any bolt showing signs of wear by new hardware. **DO NOT REUSE NUTS. Perform replacement one screw location at a time with appropriate support.** Apply torque seal mark.

Torque: 82 lbf-ft.

Hardware part number and description

5001941 screw, cap hex M12x1.75x120 g10.9

500806 screw, cap hex M12x1.75x35 g10.9

500811 nut, hex sto M12-1.75 G10

500958 flat washer ss .531x1.062x.095

030082 U-shim 3.175mm thick (0.125 in)

030083 U-shim 0.953mm thick (0.038 in)

- On the transversal screw joints (Figure 18) any visible gap between cradle support tubing and vehicle frame mounting lugs is not acceptable.

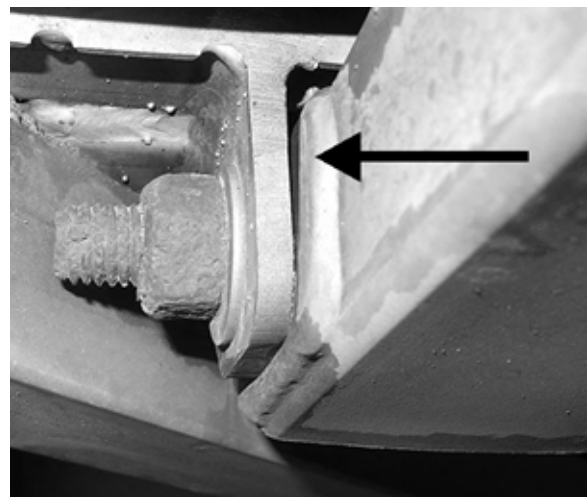

FIGURE 18: VISIBLE GAP ON TRANSVERSAL SCREW JOINT

- If shims are not present, the visible gap should be shimmed using U-shims #030082 and/or #030083 as required.

- Shim arrangement may vary and may be stacked on both sides (Figure 19).

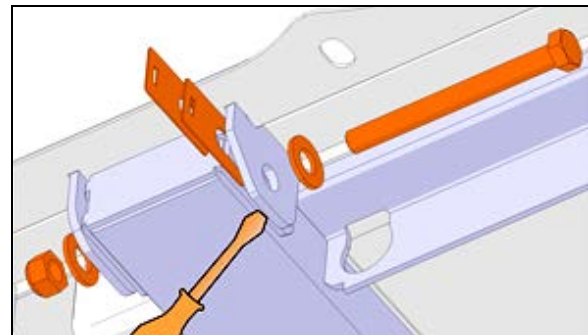

FIGURE 19: SHIM INSTALLATION, TRANSVERSE SCREW. ARRANGEMENT MAY VARY

4. FUEL SPECIFICATIONS

The quality of fuel oil used for high-speed diesel engine operation is a very important factor in obtaining satisfactory engine performance, long engine life and acceptable exhaust emission levels.

The U.S. Environmental Protection Agency (EPA) has issued new standards to improve air quality by significantly reducing emissions through a combination of cleaner-burning diesel engines and vehicles.

To meet EPA standards, the petroleum industry produces **Ultra Low Sulfur Diesel** (ULSD) fuel, also referred to as S15, containing a maximum 15ppm (parts-per-million) sulfur.

On-highway diesel engines meeting 2010 emission regulations are designed to operate **ONLY** with ULSD fuel. ULSD fuel will enable the use of cleaner technology diesel engines and vehicles with advanced emissions control devices, resulting in significantly improved air quality.

4.1 FUEL TYPE

EPA-10 and later engines like the Volvo D13 are designed to run on **Ultra Low Sulfur Diesel** (ULSD) fuel, which can contain no more than 15 ppm sulfur.

Fuel used must meet engine manufacturer's specification. Refer to Volvo engine specifications.

	CAUTION
ULSD fuel is necessary to avoid fouling the engine's Exhaust Aftertreatment System. Improper fuel use will reduce the efficiency of the engine's Aftertreatment System and may permanently damage the system.	

	CAUTION
Owners of 2010 and later model years on-highway diesel engine must refuel only with ULSD fuel.	

NOTE	
<i>Burning Low Sulfur Diesel fuel (instead of ULSD fuel) in 2010 and later model year diesel engines is illegal and punishable with civil penalties.</i>	

4.2 BLENDING

Only ultra low sulfur kerosene – No.1 diesel with no more than 15ppm sulfur may be blended with ULSD fuel to improve cold weather performance. With so many kerosene formulations on the market, care must be taken to select kerosene with a maximum of 15ppm sulfur.

Blend rates remain the same as with Low Sulfur Diesel fuel.

4.3 BIODIESEL FUELS

Biodiesel up to a maximum of 20% blend (B20) may be used and will not affect the manufacturer's mechanical warranty as to engine and emissions system related components, provided the biofuel used in the blend conforms to ASTM D6751, B1 to B5 blends conform to ASTM D975, and B6 to B20 blends conform to ASTM D7467. Also, any engine performance problem related to the use of biodiesel fuel would not be recognized nor considered as Volvo or Prevost's responsibility.

However, Volvo engines are certified to comply with U.S. EPA and California emissions standards based upon the use of test fuels with specifications established by these regulatory agencies. Alternative fuels, including biodiesel, that are not substantially similar to the required test fuels may adversely affect engine emissions compliance. As a result, Volvo does not warrant the engine will conform to applicable Federal or California emissions limits when operated on biodiesel or other alternative fuels that are not substantially similar to specified test fuels used for certification.

5. AIR CLEANER (DRY TYPE)

The vehicle is equipped with a dry-type replaceable element air cleaner, located in the engine compartment. Access the air cleaner through the engine R.H. side door. Engine air enters the air cleaner through one intake duct located just above engine R.H. side door.

5.1 AIR CLEANER SERVICING

Stop the engine, open the R.H. side engine compartment door, and loosen the wing nut retaining the air cleaner element to the air cleaner. Remove the element by pulling on the handle in the center of the air cleaner element.

Install cleaner element as follows:

1. Inspect the gasket-sealing surface inside the air cleaner. It must be smooth, flat and clean;
2. Install the air cleaner element;
3. Make sure that the element seals securely;
4. Inspect element cover gasket and replace if necessary.

Whenever it becomes necessary to remove the air cleaner assembly (dry type) for maintenance or other repair in this area, great care should be taken when installing air cleaner assembly.

5.2 GENERAL RECOMMENDATIONS

The following maintenance procedures will ensure efficient air cleaner operation:

1. Keep the air cleaner housing tight on the air intake pipe;
2. Make sure the correct filters are used for replacement;
3. Keep the air cleaner properly assembled so the joints are air-tight;
4. Immediately repair any damage to the air cleaner or related parts;
5. Inspect, clean or replace the air cleaner or elements as operating conditions warrant. Whenever an element has been removed from the air cleaner housing the inside surface of the housing must be cleaned with a soft clean cloth;
6. Periodically inspect the entire system. Dust-laden air can pass through an almost invisible crack or opening which may eventually cause damage to an engine;
7. Never operate the engine without an element in the air cleaner assembly;
8. Store new elements in a closed area free from dust and possible damage.

5.3 AIR CLEANER RESTRICTION INDICATOR

A resettable restriction indicator is installed on the engine air-intake duct, clearly visible from the rear engine compartment. The indicator monitors the vacuum level between the air filter and the engine. A red marker is displayed when the air filter is clogged and must be replaced, a warning light located on the rear control panel will also light-up. Reset by pressing on the indicator's extremity.

	<p>CAUTION</p>
<p>Do not ignore the Warning given by the air restriction indicator. This could result in</p>	

serious engine damage.

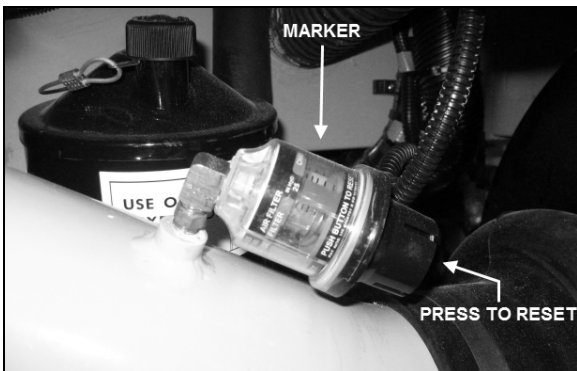

FIGURE 20: RESTRICTION INDICATOR 01052_1

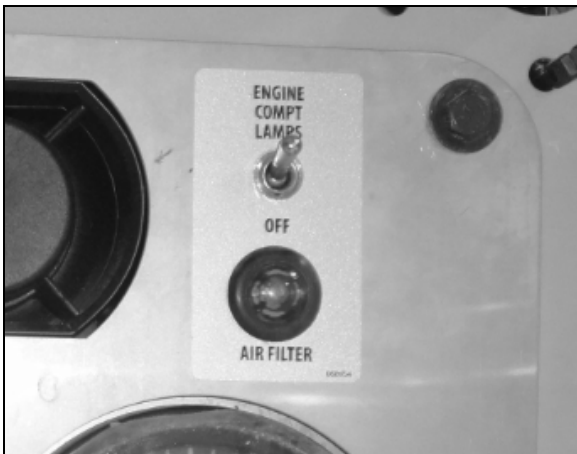

FIGURE 21: RESTRICTION INDICATOR LIGHT

6. FUEL PEDAL

The EFPA (Electronic Foot Pedal Assembly) connects the accelerator pedal to a potentiometer (a device that sends an electrical signal to the ECM, which varies in voltage, depending on how far down the pedal is depressed). The EFPA is installed in the space normally occupied by a mechanical foot pedal. It has maximum and minimum stops that are built into the unit during manufacturing.

6.1 FUEL PEDAL ADJUSTMENT

The EFPA contains a throttle position sensor that varies the electrical signal sent to the ECM. The sensor must be adjusted whenever an EFPA is serviced. In addition, the sensor should be adjusted any time codes 21 and 22 are flashed.

With the ignition "ON" and the proper diagnostic tool (DDR) (for information regarding the DDR,

see "01 ENGINE" in this manual), check the throttle counts at idle and full throttle positions.

Proper pedal output should be 20/30 counts at idle and 200/235 at full throttle. If adjustment is necessary, remove the potentiometer retaining screws and rotate the potentiometer clockwise to increase counts or counterclockwise to decrease. When correct output is confirmed, tighten retaining screws.

6.2 POTENTIOMETER REPLACEMENT

1. Disconnect cable harness connector.
2. Loosen the two screws and remove potentiometer. Retain for re-assembly.
3. Discard potentiometer (Figure 22).



CAUTION

Note the routing and clamping locations of the cable before disassembly. Proper cable routing and fastening is critical to the operation of this system. Marking the foot pedal assembly to record cable routing is recommended.

2. Position new potentiometer. Press potentiometer onto the potentiometer shaft, matching cutouts in shaft to drive tangs of potentiometer. Apply hand pressure until potentiometer has bottomed out in housing. Reinstall screws (Figure 22) and tighten just enough to secure potentiometer lightly. Tighten screws to 10 - 20 Lbf-in (1.13 - 2.26 Nm).
3. Reconnect electronic foot pedal assembly's cable harness to the ECM connector. If potentiometer calibration is necessary (see "FUEL PEDAL ADJUSTMENT" in this section).



CAUTION

Make sure the cable harness is routed correctly, and securely installed so that it does not become pinched, stretched, or otherwise damaged during vehicle operation.

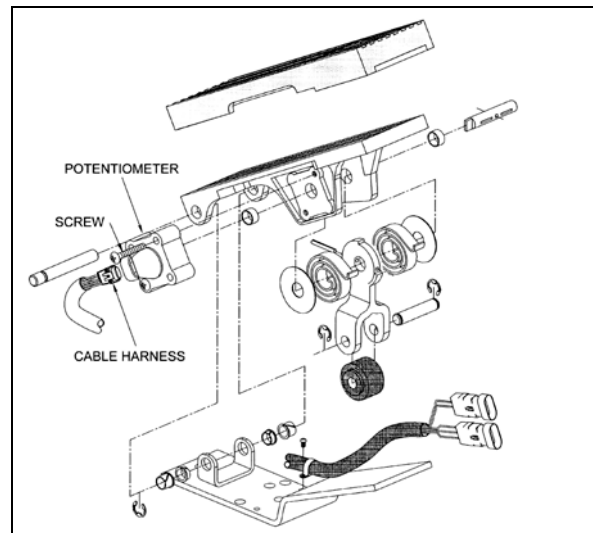

FIGURE 22: ELECTRONIC FOOT PEDAL ASSEMBLY⁰³⁰³⁵

7. SECTION CHANGE LOG

DESCRIPTION		DATE
1	Fuel tank strap torque was 60 lb-ft, changed to 20 lb-ft	Oct 2016
2	Paragraph 3.4 Fuel Tank Yearly Inspection added	May 2018
3		
4		
5		
6		

SECTION 04: EXHAUST AND AFTERTREATMENT SYSTEM

CONTENTS

1. EXHAUST AND AFTERTREATMENT SYSTEM OVERVIEW.....	2
1.1 MAINTENANCE	2
1.2 FLEXIBLE COUPLING INSTALLATION	3
2. DIESEL PARTICULATE FILTER (DPF)	3
2.1 DIESEL PARTICULATE FILTER ASSEMBLY REMOVAL	4
3. CATALYTIC CONVERTER	6
3.1 REMOVAL.....	6
3.2 ASSEMBLING CATALYTIC CONVERTER	7
4. DIFFUSER ASSEMBLY	9
4.1 DIFFUSER ADJUSTMENT	9
4.2 MAINTENANCE	9
5. DIESEL EXHAUST FLUID (DEF) TANK AND INJECTION SYSTEM.....	10
5.1 DIESEL EXHAUST FLUID	10
5.2 DEF TANK CLEANING	11
5.3 PUMP ASSEMBLY FILTER ELEMENT REPLACEMENT	11
6. AFTERTREATMENT FUEL INJECTOR.....	12
6.1 REPLACEMENT	12
7. TORQUE SPECIFICATIONS.....	14
8. SECTION CHANGE LOG	17

ILLUSTRATIONS

FIGURE 1: EXHAUST SYSTEM.....	2
FIGURE 2: FLEXIBLE COUPLING	3
FIGURE 3: DIESEL OXIDATION CATALYST (DOC) & DIESEL PARTICULATE FILTER (DPF)	4
FIGURE 4: TAKING DOC AND DPF APART	5
FIGURE 5: CATALYTIC CONVERTER	6
FIGURE 6: DIFFUSER ASSEMBLY	9
FIGURE 7: DIFFUSER POSITION ADJUSTMENT	9
FIGURE 8: DEF TANK AND PUMP LOCATION	10
FIGURE 9: AFTERTREATMENT FUEL INJECTOR	13
FIGURE 10: FUEL LINE FITTING	13
FIGURE 11: TORQUE SPECIFICATIONS	14
FIGURE 12: TORQUE SPECIFICATIONS	14
FIGURE 13: TORQUE SPECIFICATIONS	15
FIGURE 14: TORQUE SPECIFICATIONS	15
FIGURE 15: TORQUE SPECIFICATIONS	16
FIGURE 16: TORQUE SPECIFICATIONS	16

1. EXHAUST AND AFTERTREATMENT SYSTEM OVERVIEW

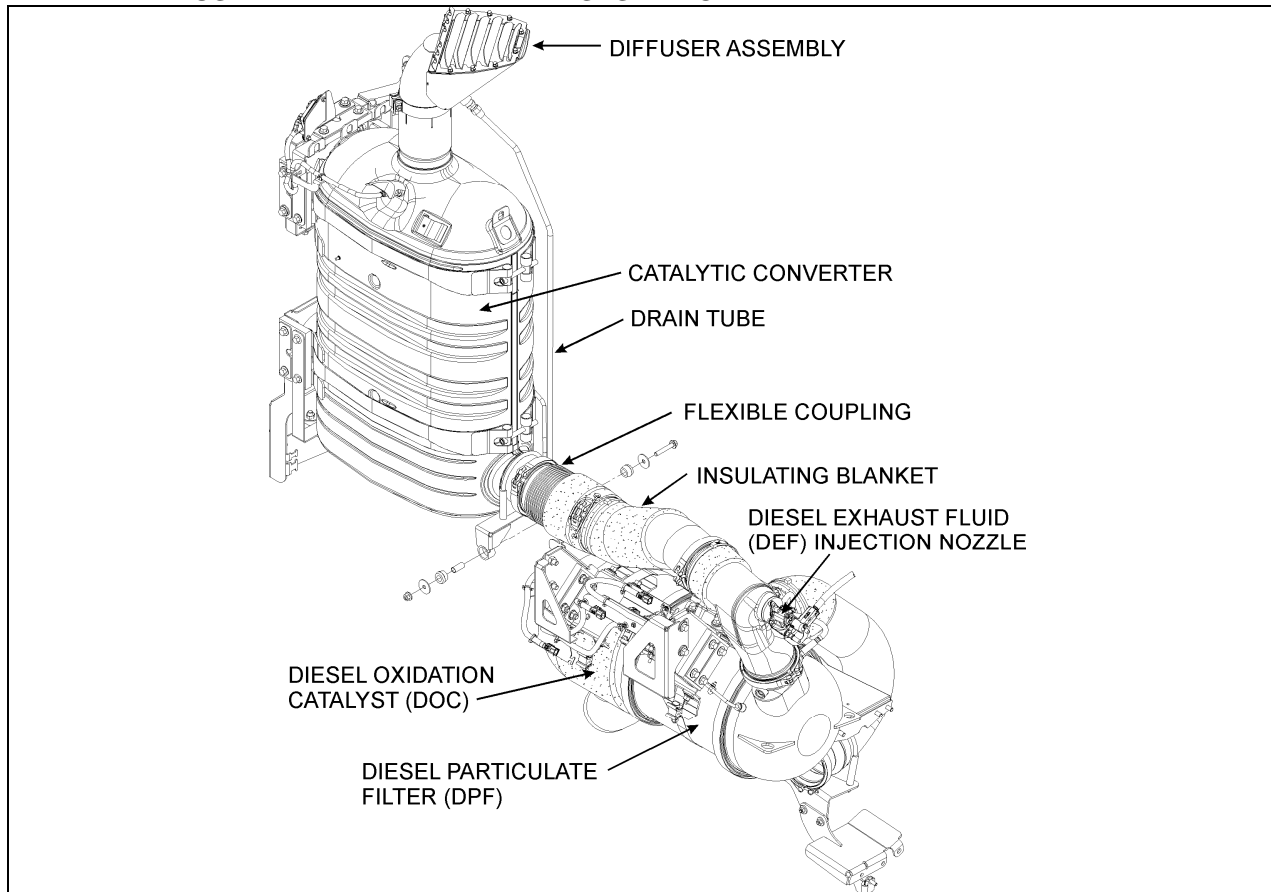

FIGURE 1: EXHAUST SYSTEM

The technology behind clean emissions is through the immediate aftertreatment of engine exhaust. The process for reducing NOx via aftertreatment is called Selective Catalytic Reduction (SCR). It requires a catalytic converter into which is injected Diesel Exhaust Fluid (DEF). The primary component of DEF is water; the active component is urea. Urea is a nitrogen compound that turns to ammonia when heated. When a urea-and-water solution is injected into the exhaust stream and passed over a catalyst, the urea reacts with the NOx to form nitrogen and water vapor – two clean and harmless components of the air we breathe. The aftertreatment system primary function is to capture and oxidize (regenerate) the particulate matter (soot) in the engine exhaust gases and to reduce NOx. To achieve this goal, the exhaust aftertreatment system is split into two main sections: the exhaust gases first enter the **Diesel Oxidation Catalyst (DOC)** and **Diesel Particulate Filter (DPF)** assembly to capture and regenerate the soot on a regular or passive basis, then the exhaust gases flow through the

catalytic converter to reduce NOx to minimum level. Through constant monitoring of the exhaust gas temperature and the system back pressure, the engine management system (EMS) is able to manage regeneration.

The exhaust aftertreatment system is rubber mounted to the vehicle structure. This feature reduces the transmission of vibrations to the exhaust aftertreatment system thus resulting in extended life of the system, brackets and also noise reduction.

1.1 MAINTENANCE

Inspect the exhaust system periodically for restrictions and leaks. Figure 1 presents the major components of the exhaust system. Exhaust leaks are commonly the result of loose clamp bolts, corroded or punctured pipes. In addition to excessive noise, a leaking exhaust system could allow toxic gases to enter the vehicle. Damage to surrounding components from hot gases could result as well. Replace

damaged or corroded exhaust components immediately.

Inspect the exhaust system as follows:

- At vehicle inspection intervals ;
- Whenever a change is noticed in the sound of the exhaust system ;
- When components close to the exhaust system get unnaturally dirty ;
- Whenever the exhaust system is damaged.

Replace damaged or corroded exhaust system components without delay.

When operating the engine in a service garage or in a closed area, the exhaust must be vented to the outside. Place the shop vent hose over the exhaust outlet pipe.

DANGER

Avoid breathing exhaust gases since they contain carbon monoxide which is odorless and colorless but harmful. Carbon monoxide is a dangerous gas that can cause unconsciousness and can be lethal. If, at any time you suspect that exhaust fumes are entering the vehicle, locate and correct the cause(s) as soon as possible.

WARNING

Diesel engine exhaust and some of its constituents are known to the State of California to cause cancer, birth defects and other reproductive harm.

NOTE

The key to successful regeneration is high exhaust temperature for an extended period of time. For this reason, insulating blankets must remain permanently on the exhaust system.

If insulating blankets are removed from the system, the exhaust gases temperature may not be high enough to permit efficient particulate oxidation during passive regeneration, resulting in increased fuel consumption due to overuse of active or stationary regeneration.

1.2 FLEXIBLE COUPLING INSTALLATION

The flexible coupling contains a rigid interior pipe (Figure 2). To allow appropriate flexibility once installed, be sure interior pipe is concentric to flexible part and that the flexible coupling is straight when installed. This piece of equipment handles vibration and thermal expansion.

CAUTION

Adequately support the exhaust system line. The load of the exhaust line **must not** be transferred to the turbocharger.

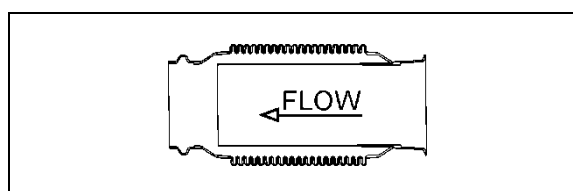



FIGURE 2: FLEXIBLE COUPLING

04022

2. DIESEL PARTICULATE FILTER (DPF)

Besides trapping soot, the **DPF (Diesel Particulate Filter)** also traps the ash that has been generated when additives in engine oil are burned. However, unlike soot, ash cannot be oxidized. The ash that accumulates in the filter will eventually cause an increase in exhaust back pressure. EMS will constantly monitor the ash accumulation and forecast the approximate time until DPF ash cleaning is required. This allows you the opportunity to plan for the DPF ash cleaning interval. If ash cleaning is not performed proactively, and the back pressure increases beyond the system limit, EMS will flag the amber warning light on the telltale panel, notifying the operator that an ash cleaning is required. Clean remanufactured DPF cartridge will be available through Prevest on an exchange basis. For most commuter vehicle applications and duty cycle, this will occur after approximately 4500 hours of operation.

WARNING

HOT SURFACES

Keep yourself clear of hot Aftertreatment System surfaces, particularly during and after active or stationary regeneration. Hot surfaces can cause serious burns.

Make sure Aftertreatment System components are cold before handling.

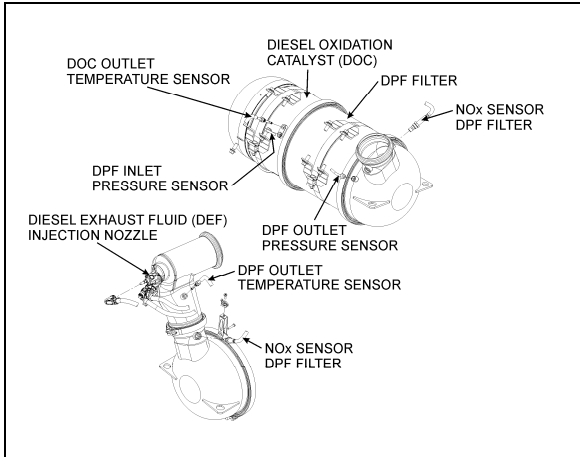

FIGURE 3: DIESEL OXIDATION CATALYST (DOC) & DIESEL PARTICULATE FILTER (DPF) ASSEMBLY
04016

1. First, open the engine compartment doors;
2. Put insulating blanket aside;
3. Disconnect pressure, temperature and NOx sensors;
4. Support Diesel Oxidation Catalyst (DOC) and Diesel Particulate Filter (DPF) assembly;



CAUTION

HEAVY DEVICE

A suitable lifting or holding device is required. Properly support and attach lifting equipment to prevent the DOC and DPF assembly from falling when servicing.



WARNING

HOT EXHAUST

During stationary regeneration, exhaust gases temperature may get very hot at the diffuser outlet. Do not direct diffuser at combustible materials. Before initiating stationary regeneration, make sure that the diffuser outlet is clear of objects and that no one is working near the diffuser outlet. Stationary regenerations must be undertaken outdoors only.

Never initiate regeneration when exhaust gas collection system is in place.



WARNING

TOXICITY

Do not initiate a stationary regeneration in a closed area like a garage. **Stationary regeneration must be undertaken outdoors only.**

2.1 DIESEL PARTICULATE FILTER ASSEMBLY REMOVAL

To remove the DPF, proceed as follows:



CAUTION

External and internal temperatures remain hot long after engine has been shut down. Allow the Exhaust Aftertreatment System to cool before handling. Wear protective clothing and glove while servicing.

NOTE

PREVOST # 35606 SUPPORT TOOL USE & INSTALLATION

- Install tool to a suitable engine crane.



- Position crane and support tool under DPF assembly.

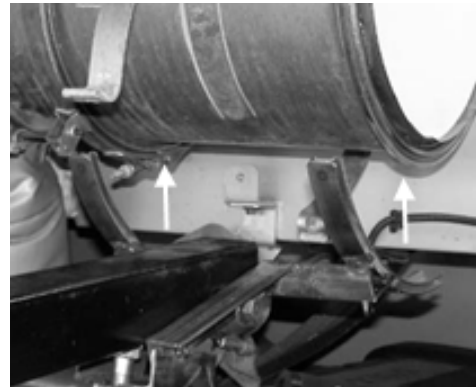

- Secure DPF to support tool using appropriate tie-down type strap.



- Loosen V-band clamp holding DOP to DPF.



- Lower and pull back to remove DPF from bus.

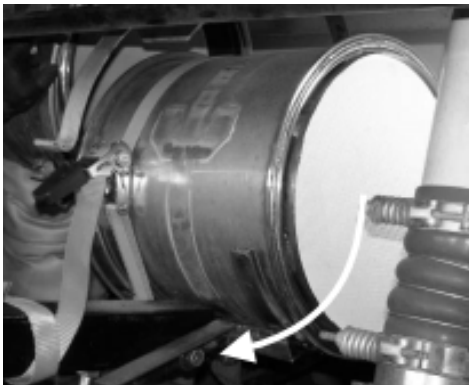

- Unfasten straps holding DOC and DPF assembly;
- Carefully lower DOC and DPF assembly;

- To make sure components are reinstalled in the same position, mark position of DOC, DPF and V-band clamps in relation with one another before taking apart;



CAUTION

FRAGILE - HANDLE WITH CARE

Use extreme care when handling DPF cartridge as it could be damaged or destroyed by dropping or sudden impact.

Clean remanufactured DPF cartridge will be available on an exchange basis. For this reason, it is very important to maintain the cartridge in perfect condition. Damaged cartridge may not be refunded.

- Also replace V-band clamps and gaskets when replacing DPF filtration module;

NOTE

When replacing the DPF cartridge, refer to the specifications on the DPF attached tag for proper replacement DPF selection.

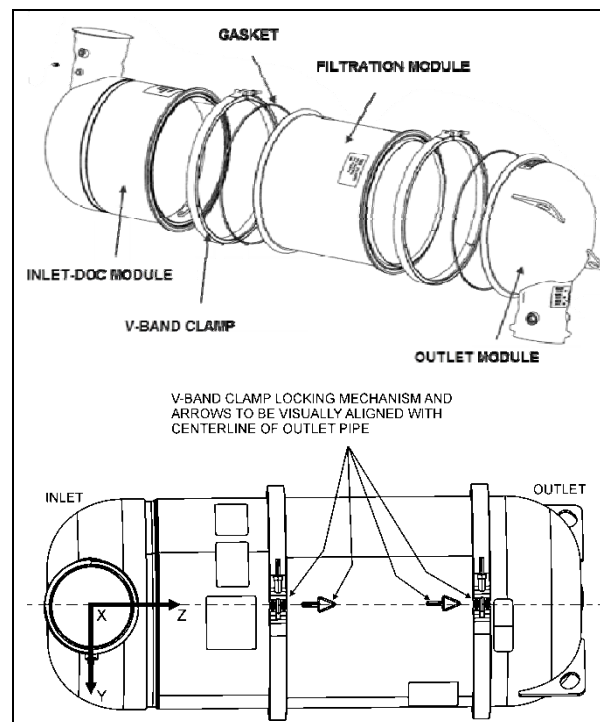
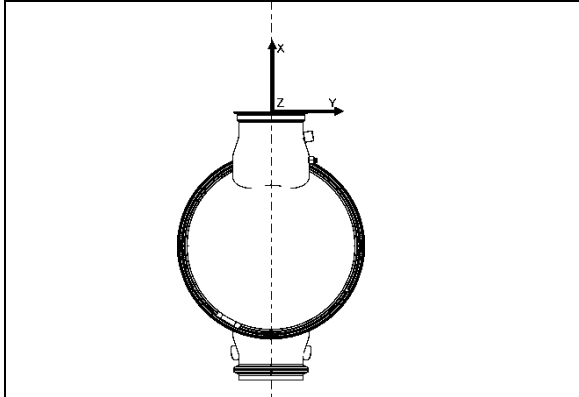

FIGURE 4: TAKING DOC AND DPF APART

- Always put DOC and DPF filtration module back together again in a vertical position to facilitate gaskets positioning;

For proper DPF assembly installation, inlet and outlet alignment is important. When reassembling the DPF, a straight edge must be used to align inlet and outlet.



10. Torque V-band clamps to 20 lbf-ft;



CAUTION

Always torque clamps by hand.

11. With a rubber mallet, hit clamps forcefully around circumference to make sure gasket is fully seated;
12. Support Diesel Oxidation Catalyst (DOC) and Diesel Particulate Filter (DPF) assembly during reinstallation;
13. Reconnect pressure, NOx and temperature sensors;
14. Fasten straps holding DOC and DPF assembly;
15. Put insulating blanket back.

3. CATALYTIC CONVERTER

In the first instance, the catalytic converter of the Selective Catalytic Reduction (SCR) does not need any maintenance. Unless an accident or damage occurs in the vicinity of the engine compartment; the catalytic converter will not have to be replaced.

However if the catalytic converter must be replaced, use one of the two following procedures:

3.1 REMOVAL

Procedure # 1

Radiator must be removed in order to lower the catalytic converter for replacement.

- Set the starter selector switch to the *OFF* position.
- Shut off the heater line shut-off valves.
- Using the quick-connect drain hose, drain the engine cooling system. Refer to Section 05, COOLING under "DRAINING COOLING SYSTEM".



CAUTION

Tag hoses and cables for identification before disconnecting in order to facilitate re-installation. Plug all openings to prevent dirt from entering the system.

- Disconnect and remove section of coolant pipe assembly mounted between the radiator outlet and the water pump inlet.

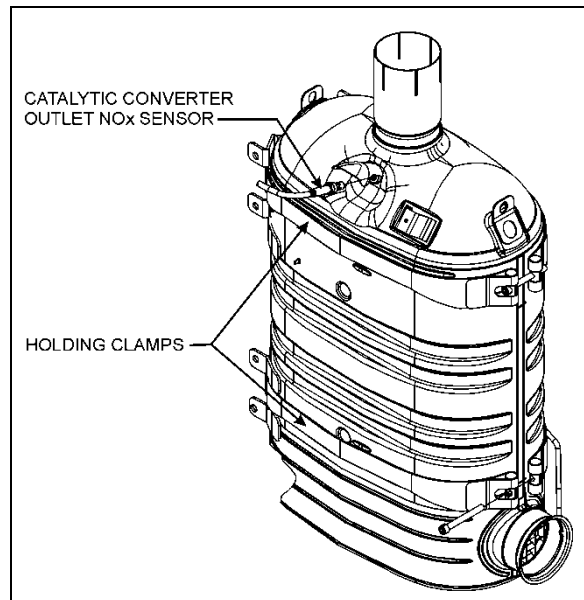

FIGURE 5: CATALYTIC CONVERTER

- Disconnect and remove a section of coolant pipe assembly mounted between the thermostat housing and the radiator inlet.
- Disconnect the electric fan-clutch connector located near the cooling fan right angle gearbox.
- Disconnect and remove the air intake duct mounted between the turbocharger outlet and the air cooler inlet.
- Open radiator door. Unfasten bolts and screws fixing radiator sealing frame.
- Remove radiator and air cooler assembly.

**WARNING**

Due to the heavy load of the radiator assembly, it must be adequately supported before attempting to remove it.

- Safely support catalytic converter from the top.
- Disconnect catalytic converter outlet NOx sensor.
- Remove clamps holding catalytic converter then lower.
- Remove or disconnect any piece of equipment or component that might be in the way or that might prevent removing the catalytic converter.

Procedure # 2

- Set the starter selector switch to the *OFF* position.
- Shut off the heater line shut-off valves.
- Remove DOC and DPF assembly (Refer to paragraph 2.1 in this Section).
- Remove pipe connecting DOC & DPF assembly to catalytic converter.
- Using the quick-connect drain hose, drain the engine cooling system. Refer to Section 05, COOLING under "DRAINING COOLING SYSTEM".

**CAUTION**

Tag hoses and cables for identification before disconnecting in order to facilitate re-installation. Plug all openings to prevent dirt from entering the system.

- Disconnect and remove section of coolant pipe assembly mounted between the radiator outlet and the water pump inlet.
- Disconnect and remove a section of coolant pipe assembly mounted between the thermostat housing and the radiator inlet.
- Disconnect and remove a section of air intake duct mounted between the air cooler outlet and the engine.
- Remove coolant surge tank.

- Release tension from drive belt (Refer to paragraph 12.1 and 15.1 in Section 05: Cooling System).
- Cut cable ties and disconnect electrical connector from fan clutch. Remove fan drive shaft fasteners at the gear box.
- Remove radiator fan drive mechanism support.
- Safely support catalytic converter from the top.
- Disconnect catalytic converter outlet NOx sensor.
- Remove clamps holding catalytic converter then lower.
- Remove or disconnect any piece of equipment or component that might be in the way or that might prevent removing the catalytic converter.

3.2 ASSEMBLING CATALYTIC CONVERTER**Before removing**

- Mark, with a vertical line the angular position of the lower (both sides) and upper clamps with regard to the clamps support located on the catalytic converter.

Lower

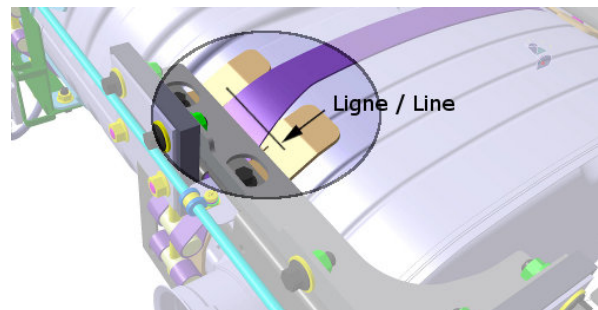

Upper

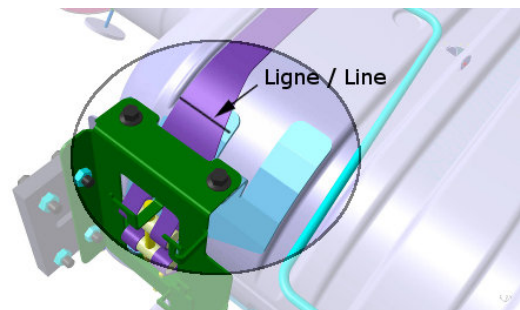

- Mark, with a vertical line the central position of the lower and upper clamps with regard to

SECTION 04: EXHAUST AND AFTERTREATMENT SYSTEM

the emboss located at the bottom and at the top of the catalytic converter.

Lower

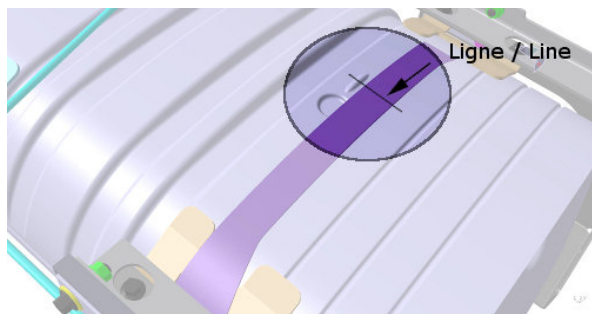

- Using the lines made earlier, line up the lower and upper clamps with regard to the emboss of the converter and afterward, line up the lines made earlier on the clamps with regard to the clamp supports on the catalytic converter.

Lower

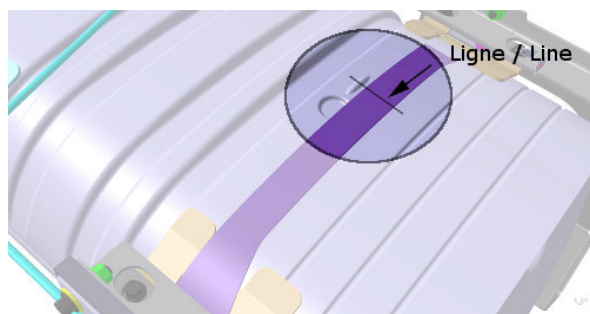

Upper

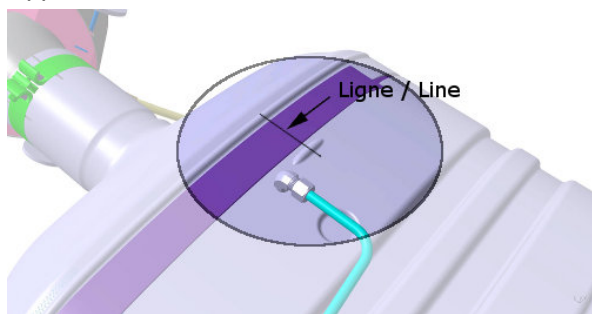

Upper

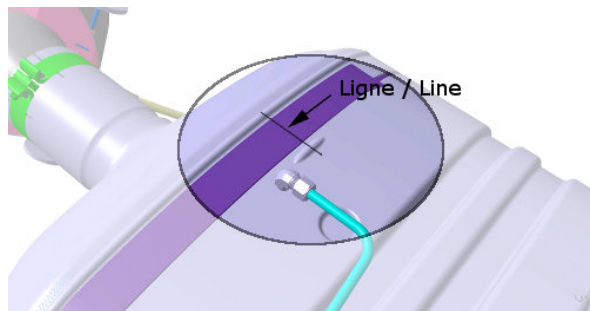

Assembling

- Position the upper clamps above the upper emboss and the lower clamps below the lower emboss of the catalytic converter.

Lower

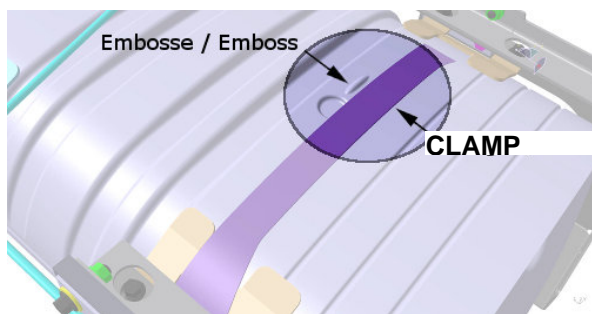

Lower

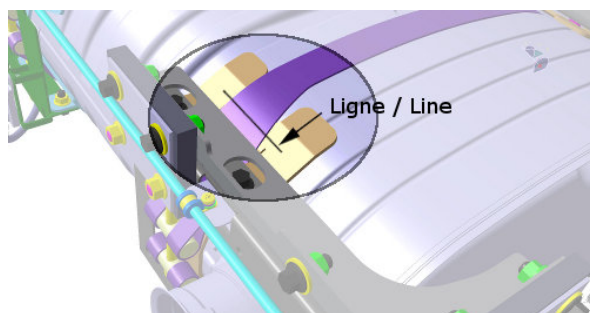

Upper

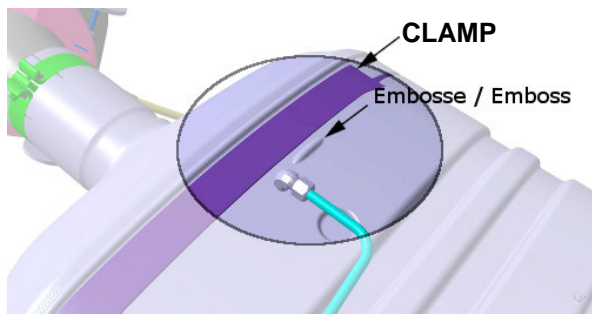

Upper

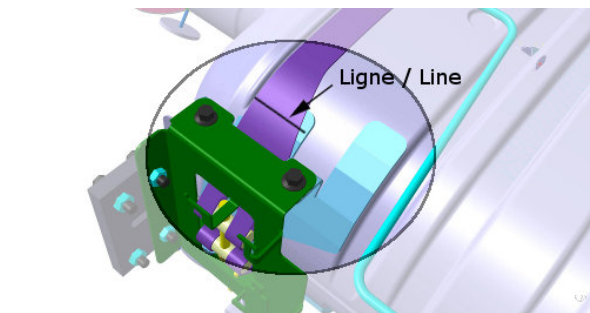

- Before tightening the parts, make sure that the catalytic converter lower support is well centered with the exhaust inlet of the catalytic converter.

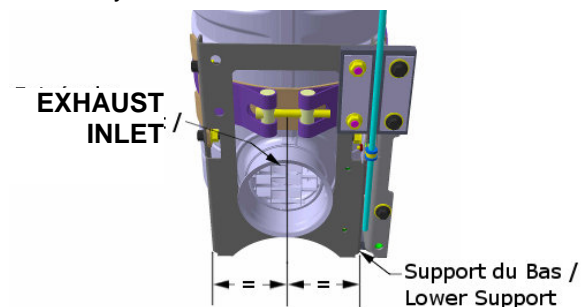

- While tightening the bolts, keep in mind to respect the alignment of the parts and keep the lower support as centered as possible with the catalytic converter exhaust inlet.

4. DIFFUSER ASSEMBLY

During stationary regeneration, exhaust gases temperature may get very hot at the DPF outlet. The diffuser decreases the exhaust gasses temperature by about half approximately, at 6 inches above the diffuser. The diffuser is an important component of the exhaust system and must remain on the vehicle at all times. Operating the vehicle without the diffuser may seriously damage the vehicle.

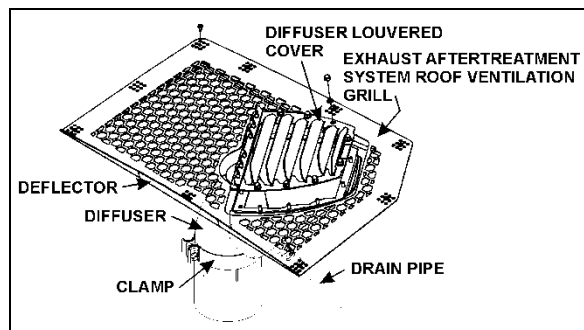

FIGURE 6: DIFFUSER ASSEMBLY

04014

4.1 DIFFUSER ADJUSTMENT

Should an adjustment of the diffuser position be necessary, first remove the exhaust aftertreatment roof ventilation grill.



CAUTION

To prevent paint damage and fiberglass overheating caused by hot exhaust gases, the diffuser louvered cover must be flush with the roof surface or may exceed the roof surface not more than 3/32" (2mm).



CAUTION

Tighten clamps properly in order to prevent any movement of the diffuser assembly. An impact wrench is necessary.

- Loosen the clamp securing the diffuser assembly to the catalytic converter.

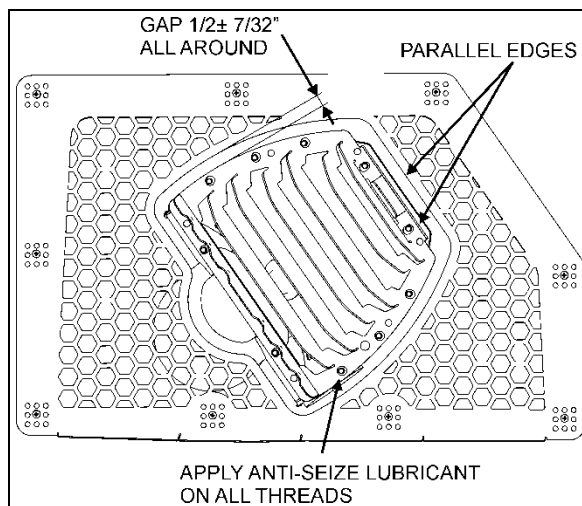

FIGURE 7: DIFFUSER POSITION ADJUSTMENT 04015_1

- For proper angular position, make sure that the two edges shown on figure 7 are parallel with each other.
- Using a straightedge, adjust the diffuser assembly level. The top surface of the warning plate fixed on the diffuser louvered cover must be flush with the roof surface or may exceed about 3/32".
- Tighten the clamp securing the diffuser assembly to the catalytic converter.
- Reinstall the exhaust aftertreatment system roof ventilation grill and deflector.

4.2 MAINTENANCE

At vehicle inspection intervals, inspect the diffuser assembly as follows:

- Inspect diffuser grille for stress cracking;
- Check for presence of foreign matter and debris inside the diffuser housing, remove and clean if applicable;
- Check for proper functioning of the rain cap inside the diffuser housing, make sure that it moves freely;
- Make sure that the water drain tube is not clogged. Pour a cup of water into the diffuser

housing and assure that all the water is drained at once at the other end of the drain tube. If tube is clogged, remove tube and blow compressed air inside in reverse flow;

- Check that the warning plate "THIS DIFFUSER SURFACE MUST BE FLUSH WITH THE ROOF SURFACE" is still in place.

5. DIESEL EXHAUST FLUID (DEF) TANK AND INJECTION SYSTEM

The DEF tank and injection system control unit continuously vary the amount of DEF injected in response to the engine's current load conditions.

Diesel Exhaust Fluid (DEF) is stored in a 16 gallons plastic tank located aft of the condenser compartment.

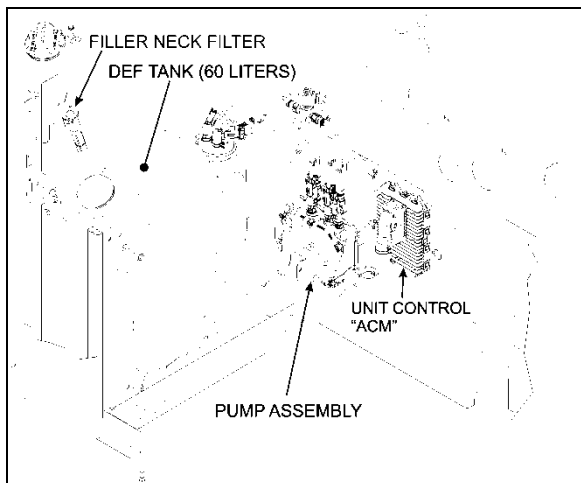

FIGURE 8: DEF TANK AND PUMP LOCATION

A pump located beside the DEF tank is used to pressurize the system and deliver the fluid.

A heating coil located inside the tank use engine coolant to keep the DEF warm during cold season.

DEF is injected into the exhaust gases through an injection nozzle located between the DPF and the catalytic converter (refer to figure 1).

In the catalytic converter, nitrogen oxides are transformed into harmless nitrogen gas and water.

The system notifies the driver when it is time to top up with DEF.

5.1 DIESEL EXHAUST FLUID

When handling DEF solution, it is important that electrical connectors to be connected or well encapsulated, otherwise there is a risk that the DEF will cause oxidation that cannot be

removed. Water or compressed air will not help, since DEF quickly oxidizes certain metals. If a disconnected connector comes into contact with the DEF solution, it must be replaced immediately to prevent the DEF solution from creeping further into the copper wiring, which takes place at a speed of about 2.4 in (60 mm) per hour.



CAUTION

Diesel Exhaust Fluid (DEF) is a nontoxic aqueous solution of urea (32.5%) and ultra-pure water (67.5%). Urea is a compound of nitrogen that turns to ammonia when heated. The fluid is non-flammable, and is not dangerous when handled as recommended. However, it is highly corrosive to certain metals, especially copper and brass.

When detaching hoses and components, do not spill DEF on disconnected or unsealed connectors. If DEF is spilled on a disconnected or unsealed connector, the connector must be removed immediately and replaced.

Things to know about spilt diesel exhaust fluid (DEF):

- If urea solution comes into contact with the skin, rinse with plenty of water and remove contaminated clothing.
- If urea solution comes into contact with the eyes rinse for several minutes and call for medical help if necessary.
- If inhaled breathe fresh air and call for medical help if necessary.
- Do not allow the DEF solution to come into contact with other chemicals.
- The DEF solution is not flammable. If the DEF solution is exposed to high temperatures, it breaks down into ammonia and carbon dioxide.
- The DEF solution is highly corrosive to certain metals, including copper and aluminum.
- If the DEF solution is spilled onto the vehicle, wipe off the excess and rinse with water. Spilled DEF solution can form concentrated white crystals on the vehicle. Rinse off these crystals with water.

**WARNING**

DEF spilt onto hot components will quickly vaporize. Turn your face away!

5.2 DEF TANK CLEANING

Removing the DEF tank for cleaning is not necessary.

1. Put a suitable container under the DEF tank.
2. Remove the DEF tank drain plug through the DEF tank support pan access hole.
3. Let all of the DEF drain from the tank. Discard the used DEF according to local regulations.
4. Remove the DEF tank filler neck insert. To do so, release the retaining tab and remove filler neck insert. Replace old seal if damaged.



5. Flush the tank with hot water. Let all of the water drain from the tank.
6. Clean the filler neck insert screen with hot water.
7. Reinstall the filler neck insert until the retaining tabs snap into filler neck. Reinstall DEF tank drain plug.

**MAINTENANCE**

Drain and clean DEF tank and filler neck insert filter with hot water every 50,000 miles, replace the filter every 100,000 miles.

5.3 PUMP ASSEMBLY FILTER ELEMENT REPLACEMENT

- Remove filter cover.

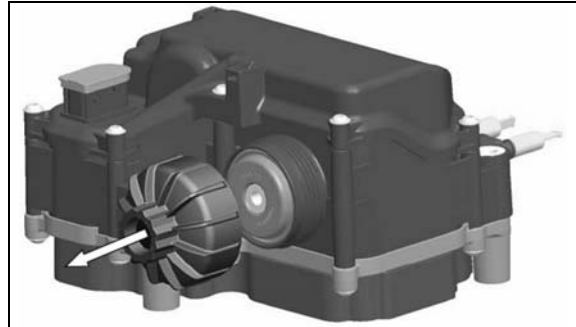
**CAUTION**

Contamination or damage of the sealing surface on the housing is not acceptable.

- Remove the equalizing element (a) and the filter element (b).

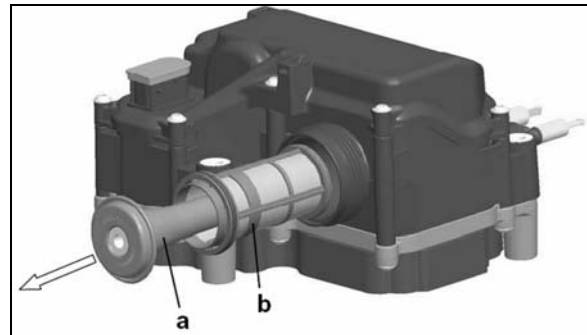

CAUTION

Protect filter area in the housing from contamination.

- Replace the filter element (a) and the equalizing element (b).

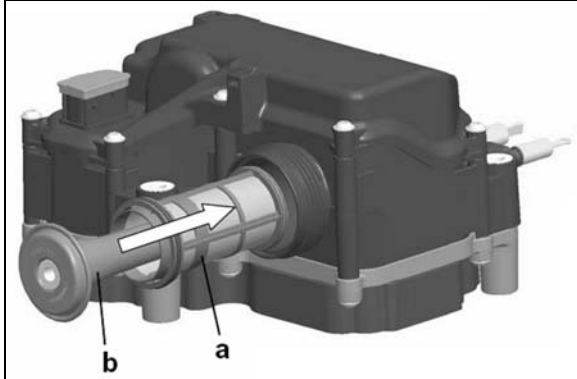

CAUTION

The sealing surfaces on the housing must be clean. No contamination or particles acceptable.

- Install filter cover. Torque to 16.5 lbf-ft.

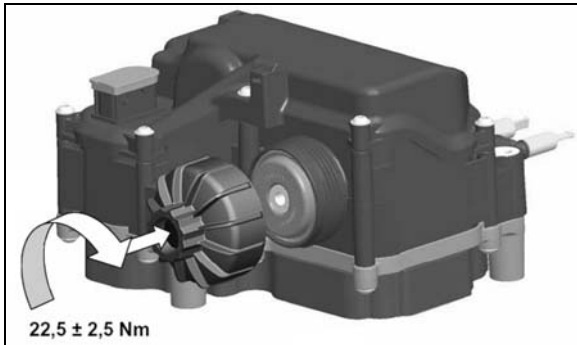

CAUTION

It must be checked if there are cracks around the area of the filter cover. No cracks in the material are allowed. If there are cracks in the housing, the entire Supply Module must be replaced! If there are cracks in the filter cover, the filter cover must be replaced.



MAINTENANCE

Replace pump assembly filter element after the first 100,000 miles and then every 150,000 miles.

6. AFTERTREATMENT FUEL INJECTOR

Proper functioning of the aftertreatment fuel injector a.k.a. aftertreatment hydrocarbon injector (AHI) is required in order to obtain efficient regeneration process of the DPF. Clogged aftertreatment fuel injector will result in clogged DPF.

In addition to the activation of the CHECK telltale, emission of diagnostic troubleshooting codes (DTC) by the engine ECM (MID128) will indicate malfunction of the aftertreatment system and/or aftertreatment fuel injector. DTC may be accessed through the Driver Information Display. Select DIAGNOSTICS menu then FAULT DIAGNOSTICS and ENGINE ECU submenus.

Check status of the aftertreatment system through the Driver Information Display. Select AFTERTREATMENT menu then ATS STATUS. Then check the DPF soot level with SOOT LEVEL GAUGE.

6.1 REPLACEMENT

1. Remove fastener and p-clamp securing the line to the mounting bracket on the diffuser pipe.



WARNING

Fuel leaked or spilled onto hot surfaces or electrical components can cause a fire and result in component damage and serious personal injury.

2. Disconnect the line from the aftertreatment hydrocarbon injector fitting. Collect any residual fuel that might be in the line in a suitable container.



CAUTION

Do not kink the line. Kinking the line may result in leakage.

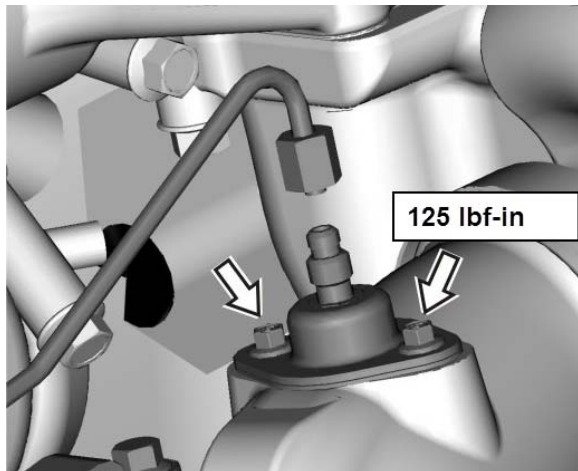

FIGURE 9: AFTERTREATMENT FUEL INJECTOR

3. Remove the aftertreatment hydrocarbon injector mounting fasteners. Remove the aftertreatment hydrocarbon injector from the diffuser pipe (which attaches to the turbocharger outlet).
4. Clean the sealing surface on the diffuser pipe before mounting the aftertreatment hydrocarbon injector.
5. Install the aftertreatment hydrocarbon injector onto the diffuser pipe (which attaches to the turbocharger outlet). Tighten the fasteners to **125 lbf-in**.

NOTE

The fasteners already include pre-applied high-temperature anti-seize compound.

6. Connect the line to the aftertreatment hydrocarbon injector. Tighten the line fitting to **135 lbf-in**.

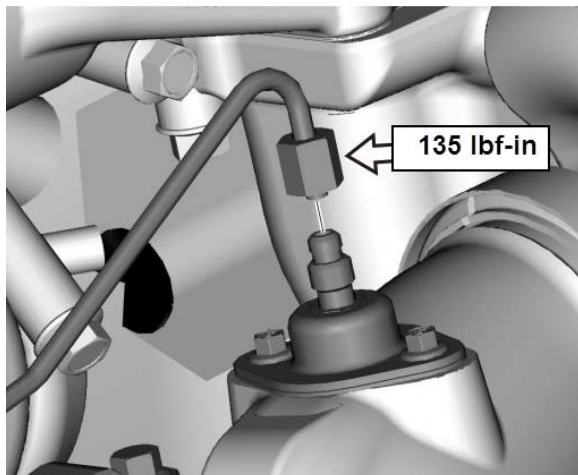

FIGURE 10: FUEL LINE FITTING

7. Install the P-clamp and fastener to secure the line to the mounting bracket on the diffuser pipe.
8. Start the service regeneration process. When fuel dosing starts, check for leaks starting on the hot side of the engine. Clear any diagnostic trouble codes, if needed.

NOTE

If fault tracing was performed using Guided Diagnostics, return to Guided Diagnostics for repair verification.

7. TORQUE SPECIFICATIONS

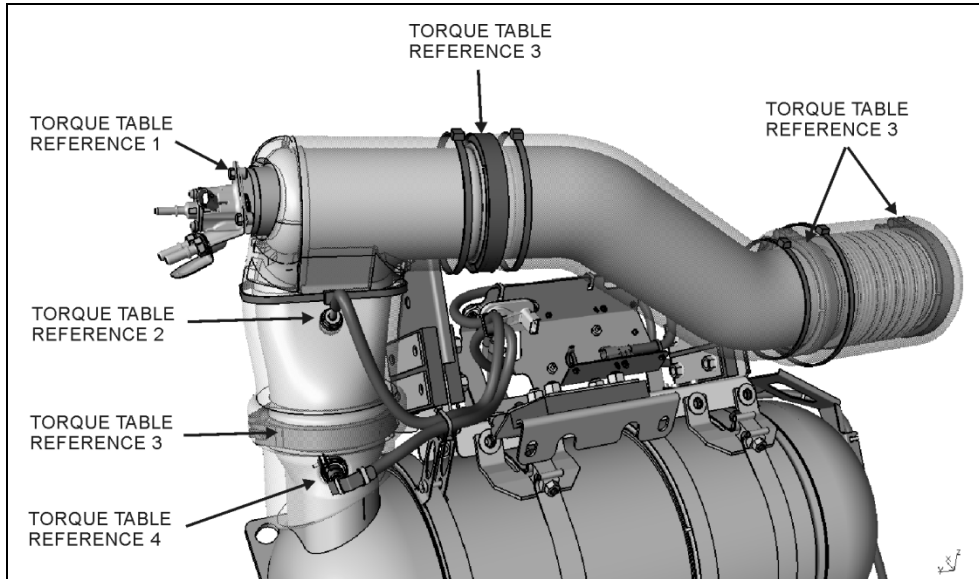

FIGURE 11: TORQUE SPECIFICATIONS

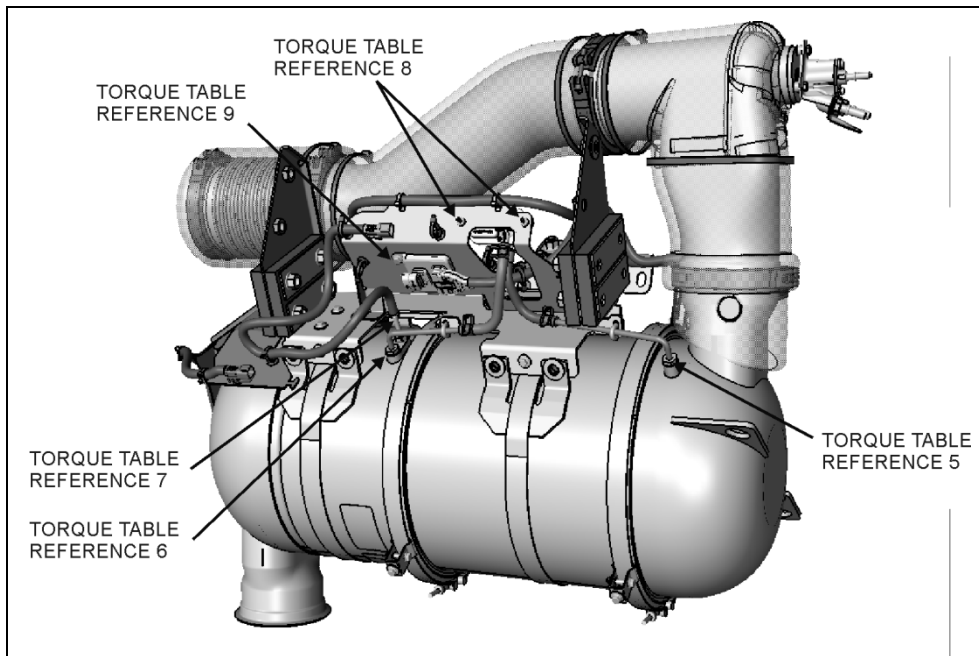

FIGURE 12: TORQUE SPECIFICATIONS

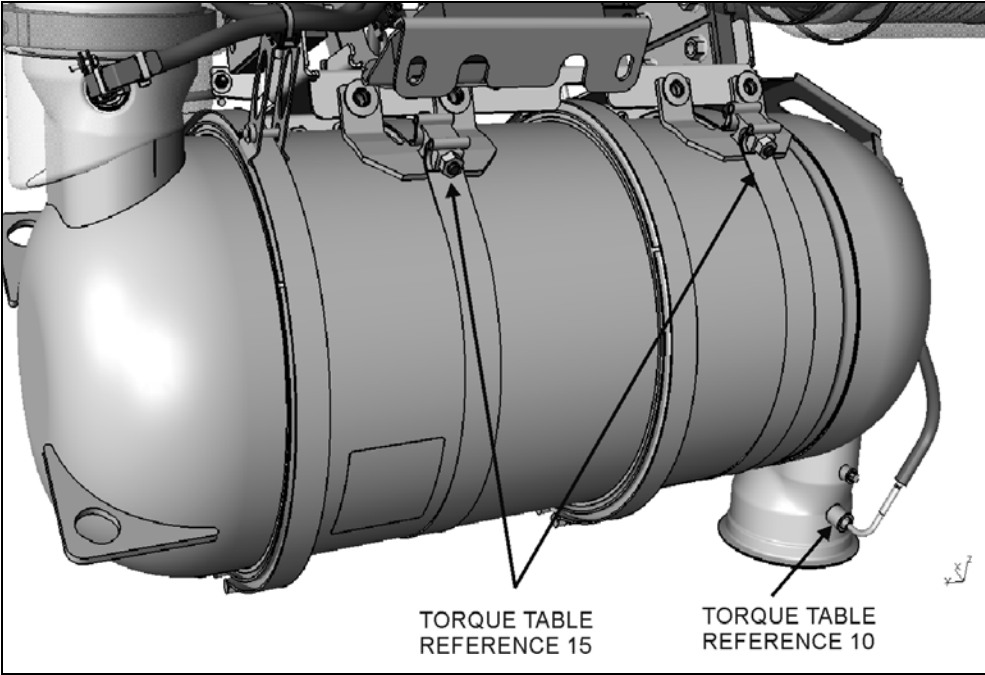

FIGURE 13: TORQUE SPECIFICATIONS

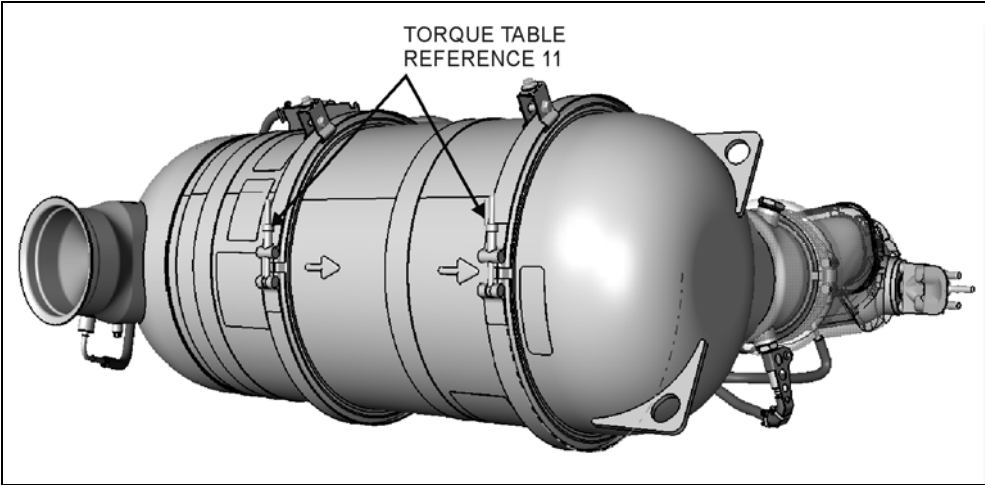

FIGURE 14: TORQUE SPECIFICATIONS

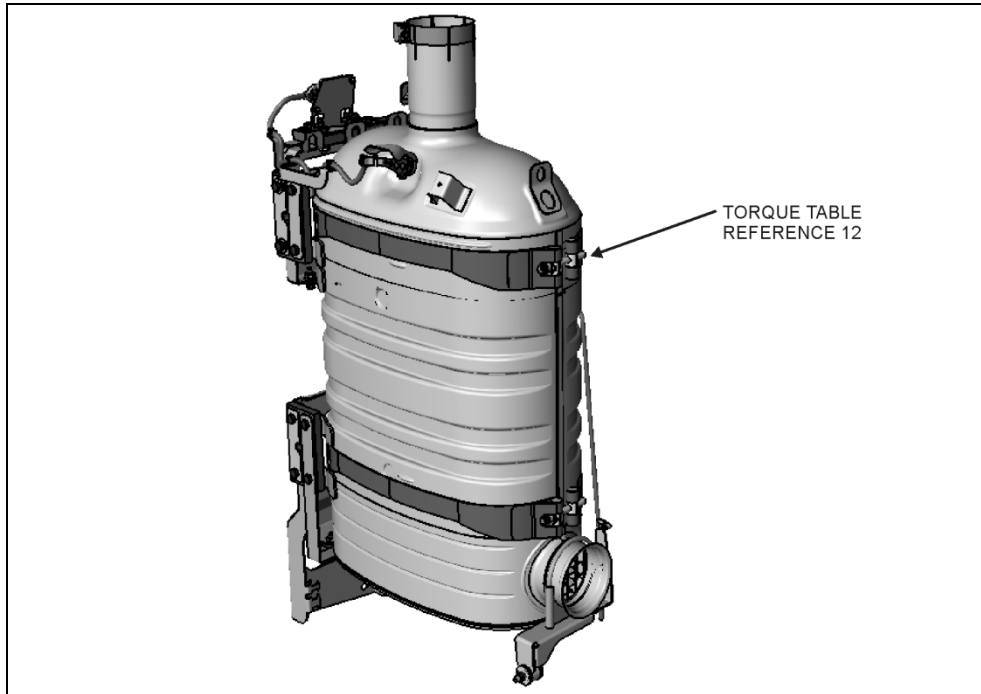

FIGURE 15: TORQUE SPECIFICATIONS

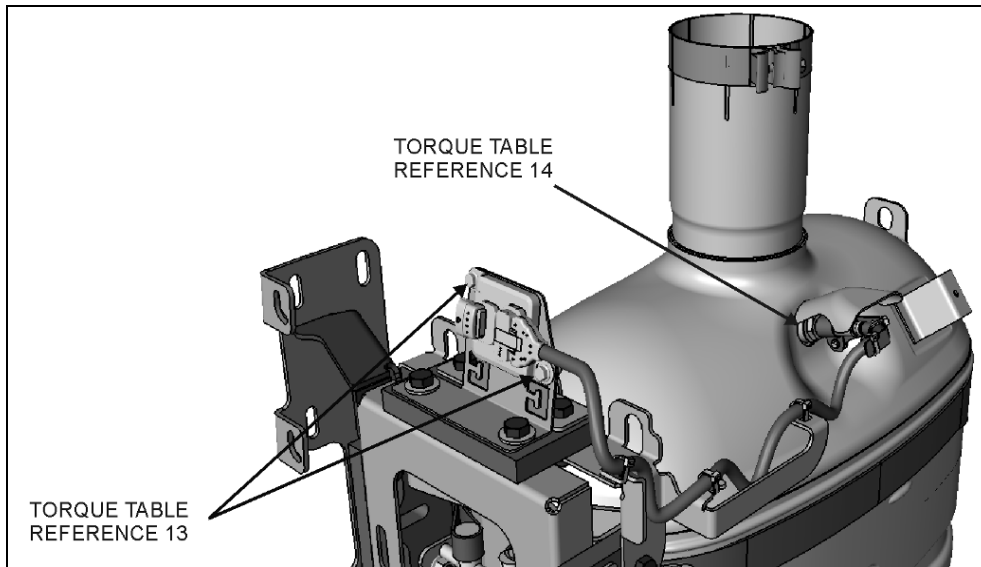

FIGURE 16: TORQUE SPECIFICATIONS

The following table lists the tightening torques for the bolts, nuts, etc. on the DPF assembly which do require a specific torque value. When no torque specifications are indicated, use the Standard Torque Specifications table found in Section 00: General Information of the Maintenance Manual.

SPECIFIC TORQUE TABLE			
DESCRIPTION	QTY	REFERENCE	TORQUE DRY (± 10 lbf-ft)
<i>DEF injection nozzle mounting bolt</i>	3	1	7.5
<i>DPF outlet temperature sensor *</i>	1	2	33
<i>V-band clamp 5 inch</i>	7	3	8
<i>NOx sensor *</i>	1	4	37
<i>DPF outlet pressure sensor *</i>	1	5	4
<i>DPF inlet pressure sensor *</i>	1	6	4
<i>Diesel Oxidation Catalyst (DOC) temperature sensor *</i>	1	7	33
<i>Cap screw</i>	2	8	4.5
<i>Cap screw</i>	-	9	7.5
<i>DPF inlet temperature sensor *</i>	1	10	33
<i>V-band clamp</i>	2	11	20
<i>Strap – SCR tank</i>	4	12	33
<i>NOx sensor – SCR tank</i>	1	13	37
<i>Bolts – SCR tank</i>	2	14	7.5
<i>Strap – DPF tank</i>	2	15	20

* Use Permatex 454G anti-seize lubricant or Loctite 76764 silver grade anti-seize

8. SECTION CHANGE LOG

	DESCRIPTION	DATE
1	DPF removal, tool info added paragraph 2.1	2016/06/09
2		
3		
4		
5		
6		

CONTENTS

1. DESCRIPTION	3
2. MAINTENANCE	4
2.1 GENERAL RECOMMENDATIONS	4
2.2 MTA VEHICLES EQUIPPED WITH VOLVO D13 ENGINE.....	4
3. HOSES	4
3.1 HOSE CLAMPS ON COOLANT LINES	4
3.2 CONSTANT-TORQUE HOSE CLAMPS ON CHARGE AIR COOLER (CAC)	6
3.2.1 <i>Maintenance</i>	6
4. THERMOSTAT OPERATION	6
4.1 CHECKING THERMOSTAT	6
5. COOLANT	7
5.1 COOLANT LEVEL VERIFICATION	7
5.2 COOLANT LEVEL SENSORS	7
5.3 THAWING COOLING SYSTEM	8
5.4 COOLING SYSTEM RECOMMENDATIONS.....	8
5.5 COOLANT RECOMMENDATIONS FOR MTA COACHES EQUIPPED WITH VOLVO D13 ENGINE.....	8
5.6 COOLANT SAMPLING	9
6. DRAINING COOLING SYSTEM	10
7. FILLING COOLING SYSTEM	11
8. FLUSHING	11
8.1 COOLING SYSTEM DESCALERS	11
8.2 REVERSE FLUSHING.....	11
9. SPIN-ON COOLANT FILTER	12
10. RADIATOR	13
10.1 MAINTENANCE.....	13
10.2 RADIATOR REMOVAL & INSTALLATION	13
11. CHARGE AIR COOLER LEAKAGE	16
12. COOLING FAN DRIVE MECHANISM	16
12.1 MOUNTING THE DRIVE BELT	16
12.2 DRIVE PULLEY AND UNIVERSAL JOINT SHAFT	16
12.3 IDLER REPLACEMENT	17
13. VARIABLE SPEED FAN CLUTCH	17
13.1 LOCKING FAN CLUTCH FOR EMERGENCY OPERATION	18
13.1.1 <i>Electrical Locking</i>	18
13.1.2 <i>Mechanical Locking</i>	18
14. RIGHT ANGLE GEARBOX	19
14.1 OIL CHANGE	19
14.2 REMOVAL / INSTALLATION	19
15. FAN REMOVAL AND INSTALLATION	20

15.1 MAINTENANCE.....20
 15.2 INSPECTION20
16. SPECIFICATIONS.....21
17. SECTION CHANGE LOG22

ILLUSTRATIONS

FIGURE 1: COOLANT SURGE TANK3
 FIGURE 2: HANSEN QUICK COUPLING4
 FIGURE 3: CLAMP TYPE USED ON HEATING & COOLING SYSTEMS5
 FIGURE 4: PROPER HOSE CLAMP INSTALLATION.....5
 FIGURE 5: DOUBLED CLAMP POSITIONING5
 FIGURE 6: COOLANT FLOW TO RADIATOR (VOLVO D13).....5
 FIGURE 7: COOLANT LINE TO THE RADIATOR.....5
 FIGURE 8: COOLANT LINE CONNECTED TO PUMP OUTLET5
 FIGURE 9: COOLANT LINE AT THE RADIATOR OUTLET.....6
 FIGURE 10: COOLANT LINE AT PUMP INLET6
 FIGURE 11: CHARGE AIR COOLER HOSE CLAMPS -6
 FIGURE 12: VOLVO D13 THERMOSTAT HOUSING6
 FIGURE 13: COOLANT LEVEL SIGHT GLASS7
 FIGURE 14: LOCATION OF HEATER LINE SHUT-OFF VALVES IN ENGINE COMPARTMENT.....8
 FIGURE 15: EXTRACTING COOLANT10
 FIGURE 16: COOLANT FILTER (VOLVO D13).....12
 FIGURE 17: ACCESS TO FILTER SHUT OFF VALVE12
 FIGURE 18: RADIATOR DRAIN PLUG13
 FIGURE 19: ACCESS PANEL (TYPICAL)13
 FIGURE 20: RADIATOR SEALING FRAME.....14
 FIGURE 21: RADIATOR & CHARGE AIR COOLER HOSE CLAMPS14
 FIGURE 22: UPPER SUPPORT BRACKET & TUBE PROTECTOR14
 FIGURE 23: RADIATOR ASSEMBLY LOWER MOUNTING FASTENERS14
 FIGURE 24: DISCONNECTING FAN DRIVE SHAFT15
 FIGURE 25: POSITIONING FORKLIFT15
 FIGURE 26: REMOVING FASTENERS15
 FIGURE 27: REMOVING UPPER FAN DRIVE SUPPORT BRACKET15
 FIGURE 28: REMOVING FAN SHROUD FROM RADIATOR.....15
 FIGURE 29: COOLING FAN DRIVE MECHANISM.....16
 FIGURE 30: DRIVE BELT ROUTING (VOLVO D13 ENGINE)16
 FIGURE 31: DISMOUNTING FAN DRIVE PULLEY.....17
 FIGURE 32: IDLER MOUNTED ON THE CAST ALUMINUM SUPPORT17
 FIGURE 33: TIGHTENING SPECIFICATION (VOLVO D13 ENGINE)17
 FIGURE 34: MECHANICAL LOCKING19
 FIGURE 35: RIGHT ANGLE GEARBOX19
 FIGURE 36: DISMOUNT THIS BRACKET20
 FIGURE 37: RIGHT ANGLE GEARBOX20
 FIGURE 38: RIGHT ANGLE GEARBOX20
 FIGURE 39: RADIATOR FAN MOUNTING BOLTS20

1. DESCRIPTION

A radiator and thermo-modulated fan are used to effectively dissipate the heat generated by the engine. A centrifugal-type water pump is used to circulate the engine coolant.

One full blocking-type thermostat is used in the water outlet passage to control the flow of coolant, providing fast engine warm-up and regulating coolant temperature.

The engine coolant is drawn from the lower portion of the radiator by the water pump and is forced through the transmission cooler before going through the oil cooler and into the cylinder block.

From the cylinder block, the coolant passes up through the cylinder head and, when the engine is at normal operating temperature, it goes through the thermostat housing and into the upper portion of the radiator. The coolant then passes through a series of tubes where its heat is dissipated by air streams created by the revolving fan and the motion of the vehicle.

Upon starting a cold engine or when the coolant is below normal operating temperature, the closed thermostat directs coolant flow from the thermostat housing through the by-pass tube to the water pump. Coolant is recirculated through the engine to aid engine warm up.

When the thermostat opening temperature is reached, coolant flow is divided between the radiator inlet and the by-pass tube. When the thermostat is completely open, all of the coolant flow is to the radiator inlet.

The cooling system is filled through a filler cap on the surge tank (Figure 1). A Pressure cap is also used to maintain pressure within the system. When system exceeds normal pressure rating (13 psi – 89.63 kPa), the cap releases air and if necessary, coolant through the overflow tube (Figure 1). A pressure relief valve is also provided to depressurize the system before servicing. The thermostat is located in the housing bolted to the engine on the L.H. side.

The engine cooling system also provides hot coolant fluid for the vehicle heating system. Refer to section 22, "HEATING AND AIR CONDITIONING" in this manual for information relating to heating system water circulation.

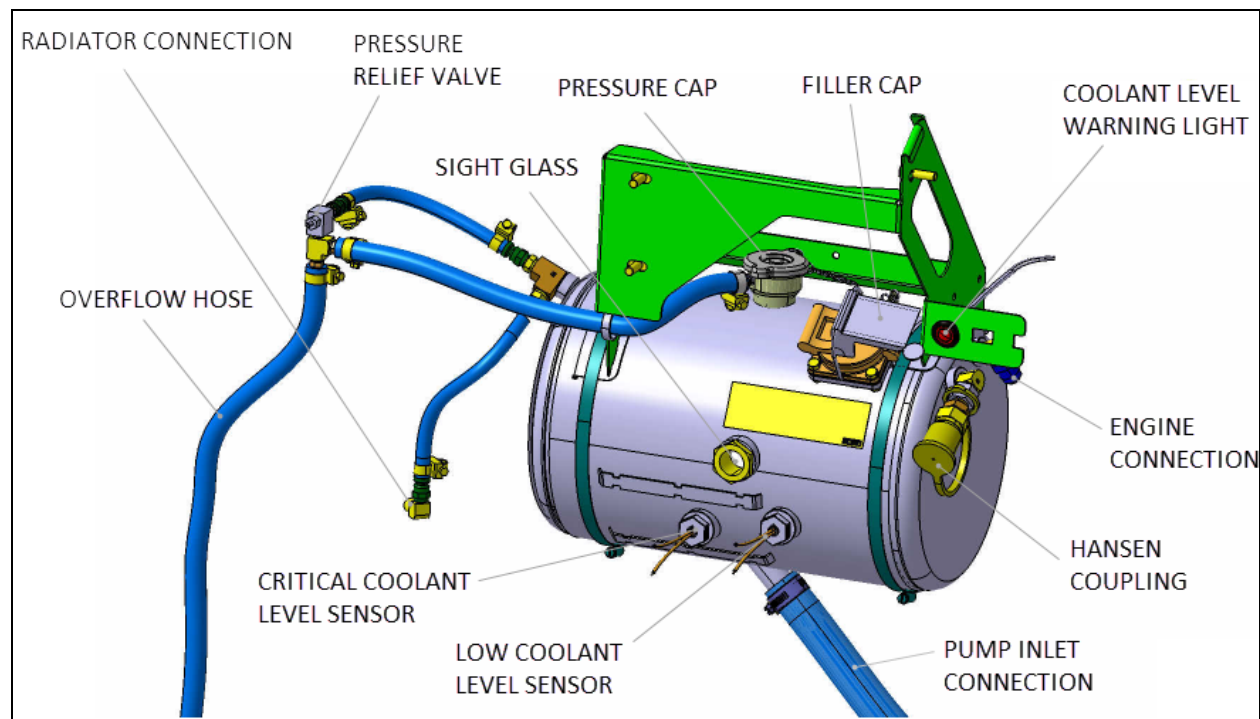

FIGURE 1: COOLANT SURGE TANK

05132_3

2. MAINTENANCE

2.1 GENERAL RECOMMENDATIONS

A systematic routine inspection of cooling system components is essential to ensure maximum engine and heating system efficiency.

- Check coolant level in the surge tank daily and correct if required. Test antifreeze strength.
- Check belts for proper tension; adjust as necessary and replace any frayed or badly worn belts.
- Check radiator cores for leaks and make sure the cores are not clogged with dirt or insects. To avoid damaging the fins, clean cores with a low-pressure air hose. Steam clean if required.
- Inspect the water pump operation. A leaky pump sucks in air, increasing corrosion.
- Repair all leaks promptly. Unrepaired leaks can lead to trouble. Inspect and tighten radiator mounts periodically. Test and replace thermostat regularly.
- Pressurize system periodically using Hansen Quick Coupling (Figure 2).

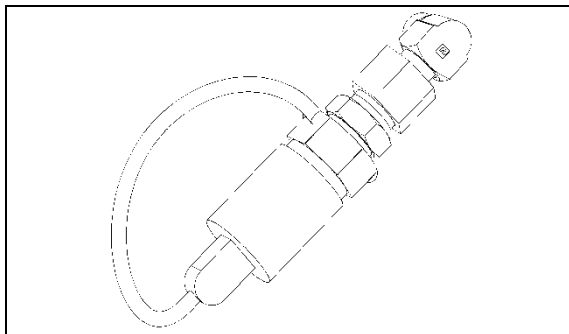

FIGURE 2: HANSEN QUICK COUPLING

NOTE

In order to ensure the integrity of the system, it is recommended that a periodic cooling system pressure check be made. Pressurize the cooling system to 10-15 psi using Hansen Quick Coupling. Do not exceed 15 psi.

Any measurable drop in pressure may indicate a leak. Whenever the oil pan is removed, the cooling system should be pressure checked as a means of identifying any incipient coolant leaks. Make sure the cause of the internal leak has been corrected before flushing the contaminated system.

Leaks at the thermostat housing hose connections may be caused by deformation of

connections or by rough surfaces on the castings of the hose mounting surfaces. It is recommended that "Dow Corning RTV-102 Compound" or any equivalent product be applied on cast surfaces prior to hose installation.



CAUTION

Castings should be clean and free of oil and grease before applying compound. No other sealer should be used with RTV-102 compound.

2.2 MTA VEHICLES EQUIPPED WITH VOLVO D13 ENGINE

NOTE

For additional information concerning Volvo D13 engine components or engine-related components, consult Volvo Trucks North America Web Site under: Parts & Service. On Volvo web site, you will find detailed service procedures for parts replacement, repair and maintenance.



MAINTENANCE

Drain, flush, thoroughly clean and refill the system with Fleet Charge 50/50 Fully Formulated Coolant every two years or every 100,000, whichever comes first. Change the coolant filter every 12,000 miles. When using Fleet Charge 50/50, use a filter that contains Supplemental Coolant Additives (SCA).

3. HOSES

Rotten, swollen, and worn out hoses or loose connections are frequent causes of cooling system problems.

Serious overheating is often caused by an old hose collapsing or from rotten rubber shedding from hoses and clogging the coolant passages.

Connections should be inspected periodically and hose clamps tightened. Replace any hose found to be cracked or swollen.

When installing a new hose, clean pipe connections and apply a thin layer of a non-hardening sealing compound. Replace worn out clamps or clamps that pinch hoses.

3.1 HOSE CLAMPS ON COOLANT LINES

All hose clamps used on the heating and cooling systems have a spring function (spring in the

housing) to compensate for the normal expansion/contraction of a hose and metal connection that occurs during vehicle operation and shutdown. These clamps are worm-driven, made of stainless steel.

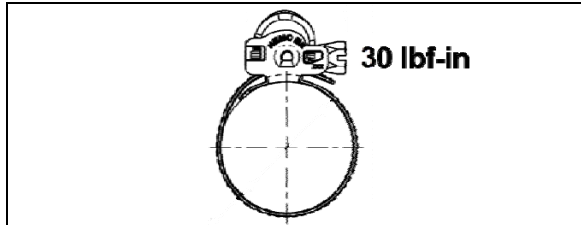

FIGURE 3: CLAMP TYPE USED ON HEATING & COOLING SYSTEMS

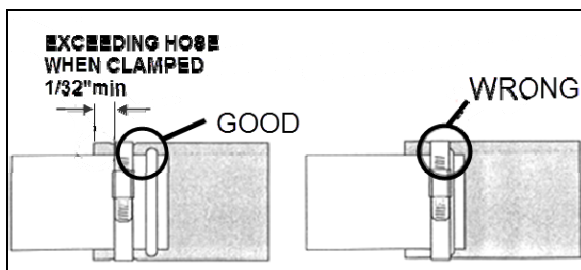

FIGURE 4: PROPER HOSE CLAMP INSTALLATION

All connections equal or greater than of 2-in OD have doubled clamps (two clamps side by side) with screw housing separated from at least 90°. A torque wrench should be used for proper installation. The recommended torque for these clamps is **30 lbf-in at room temperature**.

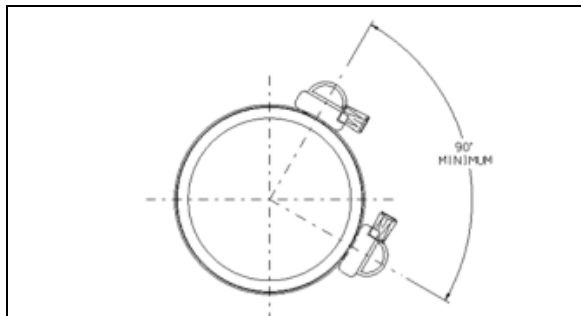

FIGURE 5: DOUBLED CLAMP POSITIONING

CAUTION

Do not over-tighten, especially during cold weather when hose has contracted.

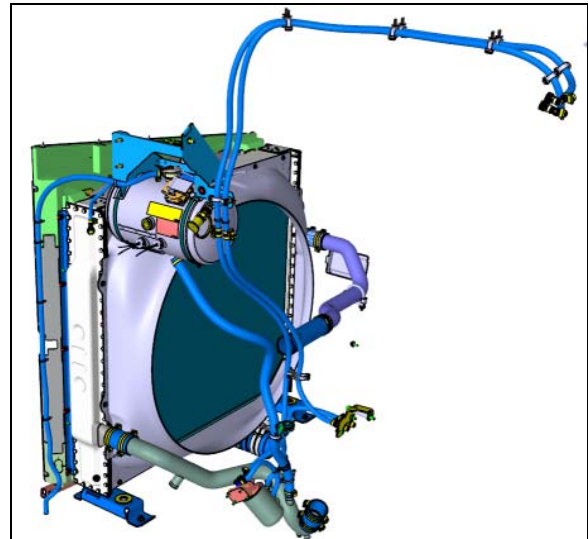

FIGURE 6: COOLANT FLOW TO RADIATOR (VOLVO D13)

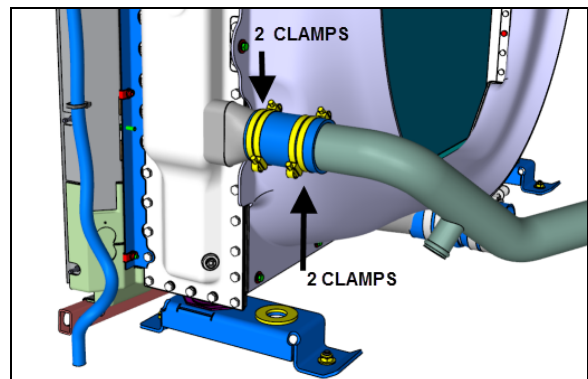

FIGURE 7: COOLANT LINE TO THE RADIATOR

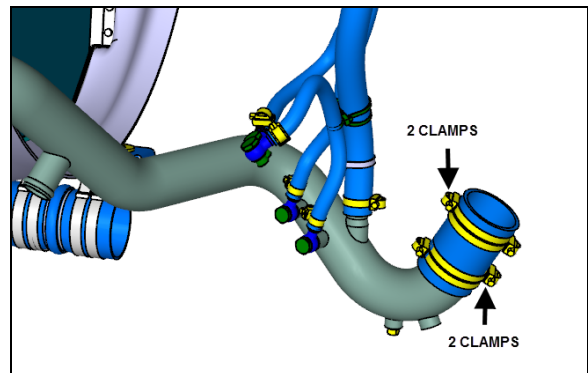

FIGURE 8: COOLANT LINE CONNECTED TO PUMP OUTLET

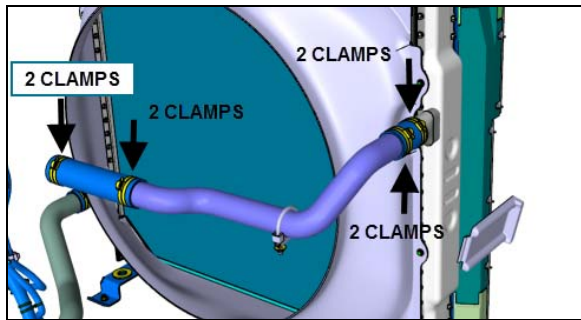

FIGURE 9: COOLANT LINE AT THE RADIATOR OUTLET

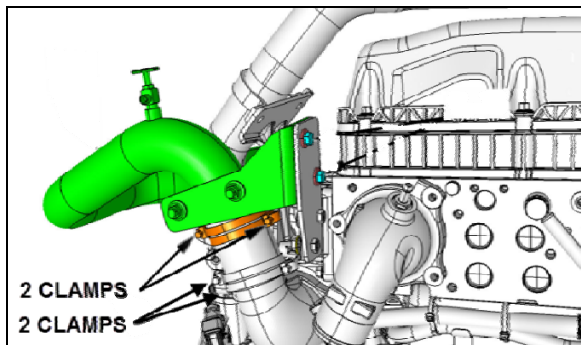

FIGURE 10: COOLANT LINE AT PUMP INLET

3.2 CONSTANT-TORQUE HOSE CLAMPS ON CHARGE AIR COOLER (CAC)

If for any reason such as an accident, hose clamps need to be changed; install and tighten hose clamps to **60 lbf-in** (dry) (Figure 11).



CAUTION

The hose clamps will break if over-tighten. Do not over-tighten, especially during cold weather when hose has contracted.

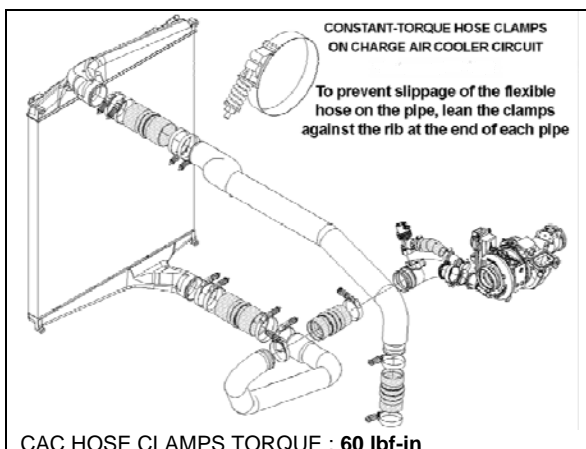

FIGURE 11: CHARGE AIR COOLER HOSE CLAMPS -

3.2.1 Maintenance

Since the constant-torque clamp automatically adjusts to keep a consistent sealing pressure, there is no need to torque again hose clamps on a regular basis. During vehicle operation and shutdown, the screw tip will adjust according to the temperature and pressure changes.

Checking for proper torque should be done at room temperature.

4. THERMOSTAT OPERATION

1. Drain the cooling system.
2. Remove the bolts, the thermostat housing and the thermostat. Carefully clean the thermostat seat and all cylinder head-to-thermostat housing mating surfaces.

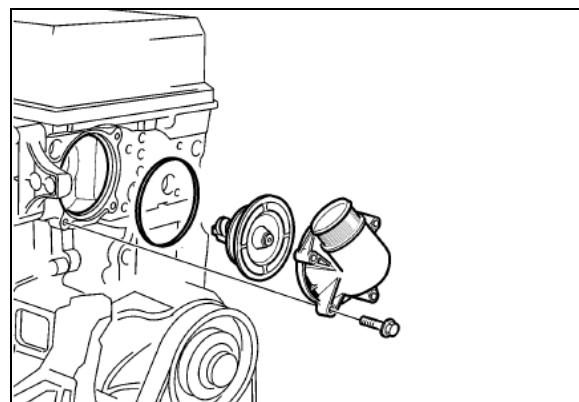

FIGURE 12: VOLVO D13 THERMOSTAT HOUSING

3. Install the new thermostat. Make sure that the rubber seal remains properly seated.
4. Position the thermostat housing to the cylinder head, install the bolts and torque-tighten to 24 ± 4 Nm (18 ± 3 ft-lb).
5. Install the rubber radiator hose to the thermostat housing. Position the clamp and tighten to secure.
6. Fill the system with the recommended coolant.
7. Start the engine, check for leaks and proper operation. After shutdown, replenish fluids as necessary.

4.1 CHECKING THERMOSTAT

A function check must be carried out before installing a new thermostat.

NOTE

Check to be sure that the thermostat closes fully. This can be done by holding it up to the light to check that there is no visible gap at the opening point. If the thermostat does not close properly, replace it.

1. Warm up water in a receptacle to 75°C (167°F) and immerse the thermostat in the water. Use a piece of wire attached to the thermostat.

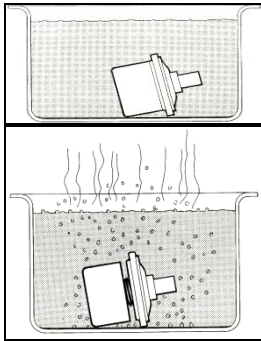

2. After at least 30 seconds, check that the thermostat is still closed.
3. Now warm the water to 100°C (212°F). After at least 30 seconds at the boiling point, check that the thermostat has opened at least 7mm (9/32"). If the thermostat has not opened, it must be replaced. A good thermostat starts to close at 95°C (203°F) and is fully closed at approximately 85°C (185°F).

5. COOLANT

5.1 COOLANT LEVEL VERIFICATION

Check the coolant level when the engine is cold (room or ambient temperature).

If the coolant level has reached the bottom of the sight glass, add coolant up to the middle of the sight glass.

Fill the tank as required with the same 50/50 water-antifreeze mixture already in the cooling system. **Do not** mix two different types of coolant. Refer to the Maintenance Manual for proper coolant type specifications or see the label affixed near the coolant surge tank on the vehicle.

When the coolant level reaches the low coolant sensor, the red warning light located next to the tank in the engine compartment will illuminate to indicate the need to add coolant to the system.

If the coolant level reaches the coolant surge tank critically low level sensor, the STOP telltale light illuminates, a beeping tone is heard and "ENGINE COOLANT LEVEL CRITICALLY LOW" message appears in the DID. Stop the vehicle in a safe location and add coolant to the cooling system surge tank as soon as possible.

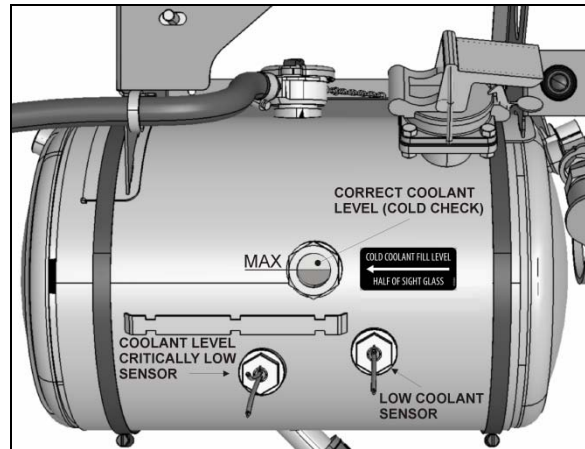

FIGURE 13: COOLANT LEVEL SIGHT GLASS

05094_3



WARNING

Hot engine coolant is under high pressure. Allow engine to cool down before adding coolant.

5.2 COOLANT LEVEL SENSORS

This warning device consists of two fluid level probes mounted on the surge tank. The first probe (upper) is a low coolant level warning and will send a signal to the indicator light located near the tank in the engine compartment (Figure 1).

The second probe (lower) is a critically low coolant level warning and will send a signal to the engine control module to indicate coolant level. If the coolant level drops below the probe, the "Check Engine" light flashes and a diagnostic code is registered (see section 01 "ENGINE").



CAUTION

Do not run engine with the "Check Engine" light flashing.

Both level probes are mounted on the front of the surge tank (Figure 13).

5.3 THAWING COOLING SYSTEM

If the cooling system becomes frozen solid, place the coach in a warm area until the ice is completely thawed.



CAUTION

Under no circumstances should the engine be operated when the cooling system is frozen, as it will result in engine overheating due to insufficient coolant.

Once thawed, check engine, radiator and related components for damage caused by expansion of frozen coolant fluid.

5.4 COOLING SYSTEM RECOMMENDATIONS

Always maintain cooling system at the proper coolant level. Check daily.

The cooling system must be pressurized to prevent localized boiling of coolant. The system must be kept clean and leak-free. The filler and pressure caps must be checked periodically for proper operation.

The coolant provides a medium for heat transfer and controls the internal temperature of the engine during operation. In an engine having proper coolant flow, some of the combustion heat is conveyed through the cylinder walls and the cylinder head into the coolant. Without adequate coolant, normal heat transfer cannot take place within the engine, and engine temperature rapidly rises. Coolant must therefore be carefully selected and properly maintained.

Select and maintain coolant in order to meet the following basic requirements:

- Provide for adequate heat transfer.
- Provide protection from cavitation damage.
- Provide a corrosion and erosion resistant environment within the cooling system.
- Prevent formation of scale or sludge deposits in the cooling system.
- Be compatible with the cooling system hose and seal materials.
- Provide adequate freeze protection during cold weather operation.

When freeze protection is required, a mixture of suitable water and antifreeze containing adequate inhibitors will provide a satisfactory coolant fluid.

Freeze protection down to:	Boiling up protection to:	% of antifreeze in mixture
-10°F (-25°C)	259°F (126°C)	40%
-34°F (-38°C)	265°F (129°C)	50%
-62°F (-46°C)	270°F (132°C)	60%

5.5 COOLANT RECOMMENDATIONS FOR MTA COACHES EQUIPPED WITH VOLVO D13 ENGINE

Fleet Charge Fully formulated Coolant mixture consisting of 50/50 antifreeze solution should be used year-round to provide freeze and boil-over protection as well as providing a stable environment for seals and hoses.

When topping up coolant, use the same coolant mixture type as the mixture already in the cooling system. Do not mix two different types of coolant.

Do not use antifreeze formulated for automobile gasoline engines, these have a very high silicate content that will clog the radiator and leave unwanted deposits in the engine.

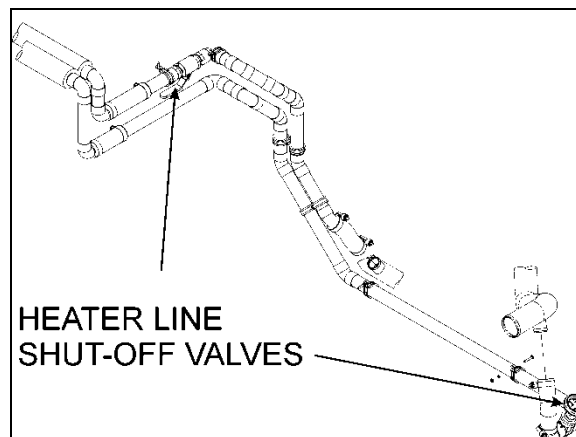

FIGURE 14: LOCATION OF HEATER LINE SHUT-OFF VALVES IN ENGINE COMPARTMENT 05105

5.6 COOLANT SAMPLING

Providing a sample of coolant for lab analysis may be required at some point in the life of the vehicle.

NOTE

The following procedure is provided for reference only.

Instructions coming with the laboratory test kit take precedence over this procedure.



WARNING

Before proceeding with the following steps, make sure the coolant has cooled down. The sudden release of pressure from a heated cooling system can result in loss of coolant and possible personal injury (scalding) from the hot liquid.

Sampling should be performed on a *cold* engine.

Typical material required:

- Hand Vacuum Pump w/ bottle provision

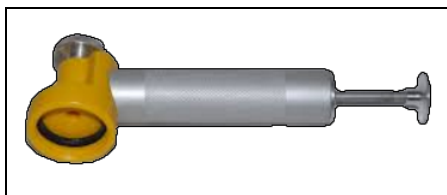

- Sample bottle
- Plastic tube (1/4 "refrigerator" tube)
- Nitrile gloves
- Security glasses
- Shop Towels

NOTE

Watch out for accidental contamination!

Hand vacuum pump should be used for coolant sampling only to prevent cross-contamination.

Also, ensure cleanliness throughout this procedure to make sure the coolant sample is not contaminated accidentally.

Sampling should be performed on the surge tank, on a cold engine.

If the vehicle has been standing still for a significant period, drive it around 30 min up to normal operating temperature. Then let it cool down.

1. Pull the pressure cap off the surge tank. Refer to Figure 1 for location of cap.
2. Thread the sample bottle to the pump. Hand tighten.
3. Slide the plastic tubing in the fitting on the pump until it exceeds about 1/2 inch into pump cavity.
4. Insert tube in the surge tank about half way to the bottom. (Do not draw sample in the bottom of the surge tank.)
5. Pump until sample bottle is about 2/3 full. Do not overfill.
6. Loosen pump fitting to remove tube from pump. Allow any coolant in the tube to flow in the bottle.
7. Remove sample bottle and install cap.
8. Throw plastic tube away. (Not to be re-used)
9. Complete any forms required by the laboratory.

6. DRAINING COOLING SYSTEM

Use the following procedures to drain the cooling system partially or completely.

To drain engine and related components:

1. Stop engine and allow engine to cool. Close both heater line shutoff valves.

On X3- 45 coaches, the valves are located in the engine compartment. One is located under the radiator fan drive mechanism support; another valve is on the L.H. side of the engine compartment in front of the radiator (Figure 14).

NOTE

Refer to section 22 under "Preheating System" for information about preheater access and heater line shutoff valve.



WARNING

Before proceeding with the following steps, make sure the coolant has cooled down. The sudden release of pressure from a heated cooling system can result in loss of coolant and possible personal injury (scalding) from the hot liquid.

2. Close the shut-off valve on the coolant filter mounting head and remove filter (perform only if filter as to be replaced).
3. Open the shut-off valve on the coolant filter mounting head and drain the coolant into a suitable container. Close the shut-off valve.
4. Unscrew the surge tank pressure cap counterclockwise, ¼ turn to let air enter the system and permit the coolant to drain completely from system.
5. Connect coolant extractor (Figure 15). Use coolant extractor to drain the coolant from the engine. An alternate method is to drain the coolant into a suitable container using the drain hose.



DANGER

Coolant is toxic; risk of poisoning. Do not drink coolant. Use proper hand protection when handling. Keep coolant out of reach of children and animals. Failure to follow these precautions can cause serious illness or death.

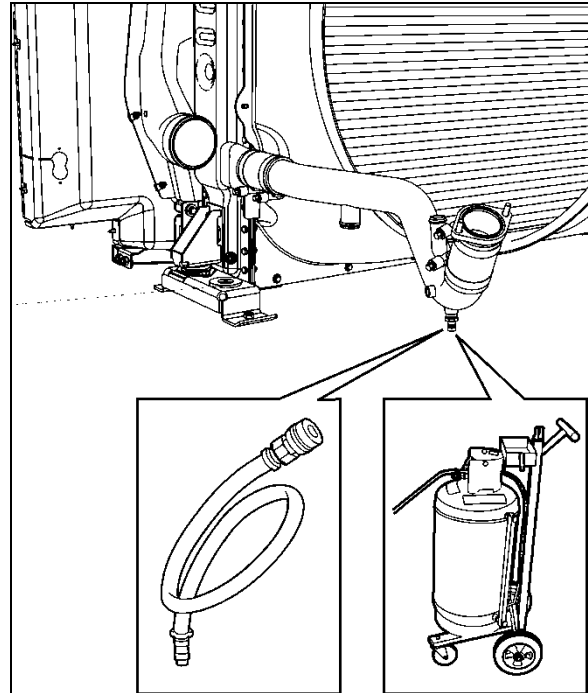

FIGURE 15: EXTRACTING COOLANT

05093

6. Open the radiator drain cock.
7. Remove the transmission oil cooler. Drain, flush and inspect. Refer to Section 7, "TRANSMISSION" for oil cooler maintenance or preventive replacement.



CAUTION

Drain water pump completely before extended storage to avoid possible water pump damage.

If freezing weather is anticipated and the engine is not protected with antifreeze, drain the cooling system completely when vehicle is not in use. Trapped water in the cylinder block, radiator or other components may freeze and expand resulting in damages. Leave the drain plugs open until the cooling system can be filled with coolant fluid. Do not run engine with cooling system empty.

To drain the entire system, do the previous steps while maintaining the shut-off valves in the open position; then follow the procedure under "Draining Heating System" in Section 22.

7. FILLING COOLING SYSTEM

If only the engine and related components were drained, maintain the two heater line shutoff valves in their closed position, then proceed as follows:

1. Close radiator drain cock.
2. Open the shut-off valve on the coolant filter mounting head.
3. **Refill cooling system from the surge tank filler cap** inlet with Fleet Charge Fully Formulated universal formula antifreeze of the required concentration using the coolant extractor.

NOTE
Make sure the purge lines are properly connected and not obstructed. The purge lines (thermostat housing dome, radiator top tank, transmission oil cooler or delivery line) are required to ensure complete engine fill and proper purging of air in the system.

4. Add coolant up to the top of the sight glass.
5. Close the filler and pressure cap, then start the engine and run it at fast idle until reaching normal operating temperature. Check for leaks.

NOTE
If for any reason, the coolant level drops below the surge tank critically low level probe, the Check Engine warning light will illuminate.

6. Stop engine and allow cooling.
7. Open the two heater line shutoff valves, check the coolant level in the surge tank, and then add as required.

 **CAUTION**
 Never pour cold coolant into a hot engine. The sudden change in temperature may crack the cylinder head or block.

If the entire system has been drained, redo the previous steps while maintaining the two heater line shutoff valves in the "Open" position. With engine running, activate the driver's and central heating systems to permit coolant circulation. Complete the procedure by bleeding the heater cores as explained in Section 22, under "Bleeding Heating System".

8. FLUSHING

If the cooling system is contaminated, flush the cooling system as follows:

1. Drain the coolant from the engine.
2. Refill with clean water.

 **CAUTION**
 If the engine is hot, fill slowly to prevent rapid cooling and distortion of the engine castings.

3. To thoroughly circulate the water, start and run the engine for 15 minutes after the thermostats have opened.
4. Fully drain system.
5. Refill with clean water and operate for 15 minutes after the thermostats have opened.
6. Stop engine and allow cooling.
7. Fully drain system.

Vehicles with coolant filters:
 Fill with a 50/50-antifreeze/water solution. Replace coolant filter as per the Lubrication and Servicing Schedule in section 24 if required.

Dispose of spent fluids in an environmentally responsible manner according to regulations in effect in your area.

COOLING SYSTEM CAPACITY (approximation)
 Includes heating system: 24 US gal (91 liters)

8.1 COOLING SYSTEM DESCALERS

If the engine overheats and the fan belt tension, coolant level and thermostat operation have been found to be satisfactory, it may be necessary to de-scale and flush the entire cooling system.

Remove scale formation by using a reputable and safe de-scaling solvent. Immediately after using the de-scaling solvent, neutralize with a neutralizing agent. It is important that product directions be thoroughly read and followed.

After using the solvent and neutralizer, fully drain the system, and then reverse flush the engine and radiator (see "Reverse Flushing" in this section) before filling the system with coolant solution.

8.2 REVERSE FLUSHING

After the engine and radiator have been thoroughly de-scaled, they should be reverse-flushed. The water pump should be removed

and the radiator and engine reverse-flushed separately to prevent dirt and scale deposits from clogging the radiator tubes or being forced through the pump. Reverse flushing is accomplished by hot water, under pressure, being forced through the cooling system in a direction opposite to the normal flow of coolant, loosening and forcing deposits out.

The radiator is reverse flushed as follows:

1. Remove the radiator inlet and outlet hoses and replace existing radiator cap with a new one.
2. Attach a hose to the top of the radiator to lead water away from the engine.
3. Attach a hose at the bottom of the radiator and insert a flushing gun in the hose.
4. Connect the water hose of the gun to the water outlet and the air hose to the compressed air outlet.
5. Turn on the water and when the radiator is full, turn on the air in short blasts, allowing the radiator to fill between blasts.

NOTE

Apply air gradually. Do not exert more than 15 psi air pressure. Too great a pressure may rupture a radiator tube.

6. Continue flushing until only clean water is expelled from the radiator.

The cylinder block and cylinder head water passages are reverse flushed as follows:

1. Remove the thermostats and the water pump.
2. Attach a hose to the water inlet of oil cooler housing to drain water away from engine.
3. Attach a hose to the water outlet at the top of the cylinder head (thermostat housing) and insert the flushing gun in the hose.
4. Turn on the water until the jackets are filled, and then turn on the air in short blasts. Allow jackets to fill with water between air blasts.
5. Continue flushing until the water from the engine runs clean.

If scale deposits in the radiator cannot be removed by chemical cleaners or reverse flushing as outlined above, it may be necessary to remove the upper tank and rod out the individual radiator tubes with flat steel rods. Circulate the water through the radiator core from the bottom to the top during this operation.

9. SPIN-ON COOLANT FILTER

The engine cooling system filter is used to filter out impurities such as scale or sand from the coolant and it also eliminates the process of adding inhibitors to the antifreeze/water solution. The filter is mounted onto the cooling fan drive mechanism aluminum casting (Figure 16)

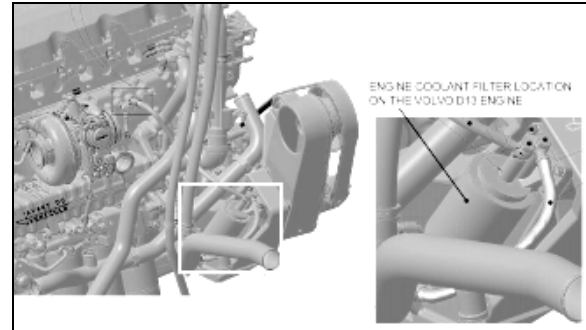

FIGURE 16: COOLANT FILTER (VOLVO D13)

05145

To replace a filter:



WARNING

Failure to relieve cooling system pressure may result in personal injury. Coolant may be hot.

1. Close the filter shutoff valve on the filter mounting head. The shutoff valve can be reached behind the fan pulley (Figure 17)

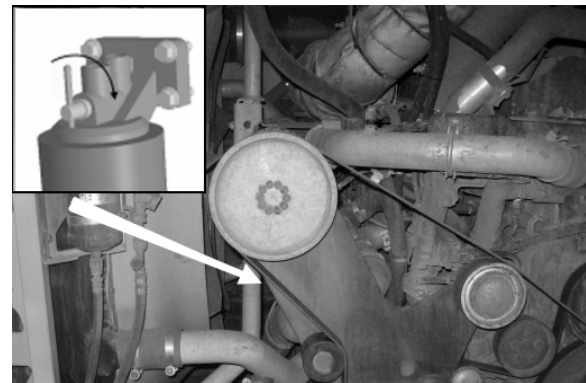



FIGURE 17: ACCESS TO FILTER SHUT OFF VALVE

2. From under the vehicle, unscrew the filter using a suitable filter wrench and discard the filter. Recover the coolant remaining in the filter in a suitable container.
3. Clean mounting base making sure the "O" ring from the old filter is not stuck to the filter mount.
4. Coat surface of gasket with a light coat of clean antifreeze.

5. Screw new filter on until gasket reaches base contact. Then tighten according to instructions on filter (usually around 2/3 turn).
6. Open the filter shutoff valve.
7. Start engine and check for leaks.



MAINTENANCE

VOLVO D13 ENGINE

Replace the coolant filter cartridge after 12,000 miles to prevent external rust damage to the filter walls. Use a coolant filter containing Supplemental Coolant Additives (SCA).



CAUTION

Do not exceed recommended service intervals.

10. RADIATOR

The radiator is mounted on the L.H. side of engine compartment. It is designed to reduce the temperature of the coolant under all operating conditions. It is essential that the radiator core be kept clean and free from corrosion and scale at all times.

10.1 MAINTENANCE

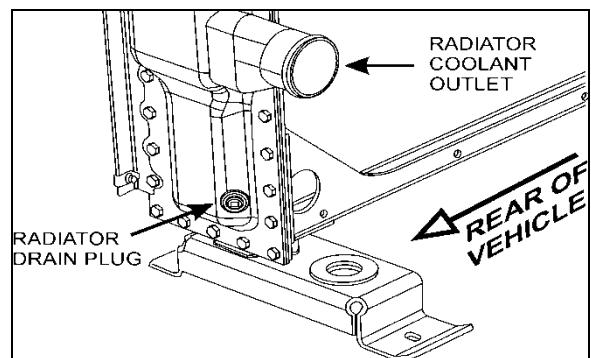



FIGURE 18: RADIATOR DRAIN PLUG 05139



MAINTENANCE

Inspect the exterior of the radiator core every 50,000 miles. Clean with a quality grease solvent, such as a mineral spirits and dry with compressed air. Do not use fuel oil, kerosene, gasoline, or any caustic material. It may be necessary to clean the radiator more

frequently if the vehicle is operated in extremely dusty or dirty areas. Refer to coolant system flushing and reverse flushing in this section for maintenance of radiator interior.

10.2 RADIATOR REMOVAL & INSTALLATION

1. Apply the parking brake and shift the transmission to neutral. Shut off all electrical loads. Turn the ignition switch to the OFF position.
2. Open engine compartment doors.
3. Set starter selector switch to the OFF position.
4. Connect coolant extractor (Figure 15). Use coolant extractor to drain the coolant from the engine. An alternate method is to drain the coolant into a suitable container using the drain hose.
5. Raise L.H. side hinged rear fender.
6. Remove tag axle L.H. side wheel.



DANGER

Coolant is toxic; risk of poisoning. Do not drink coolant. Use proper hand protection when handling. Keep coolant out of reach of children and animals. Failure to follow these precautions can cause serious illness or death.

7. Unfasten 4 cap screws and remove access panel located behind tag axle L.H. side wheel (refer to figure 14).

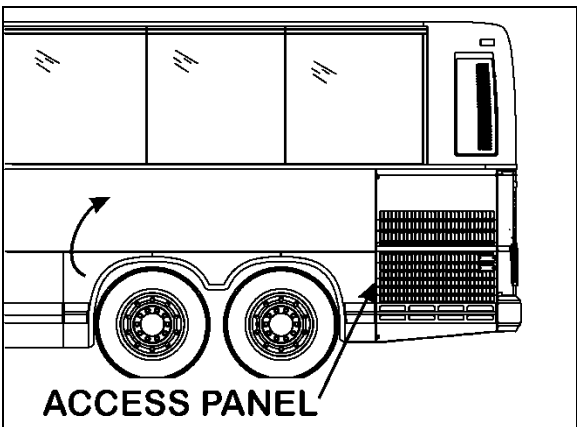

FIGURE 19: ACCESS PANEL (TYPICAL)

8. Open radiator door to access radiator assembly. Unfasten upper arm assembly.
9. Remove radiator sealing frame.

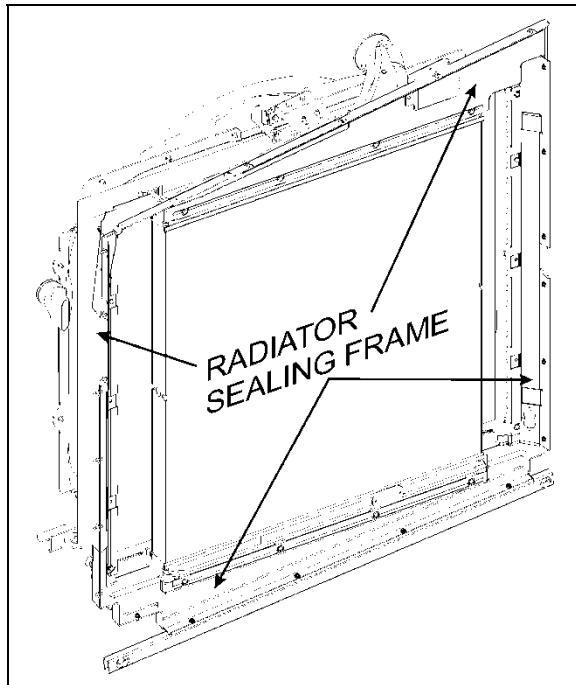

FIGURE 20: RADIATOR SEALING FRAME

10. Remove clamps and then break hoses from the front coolant and charge air pipes (Figure 21).

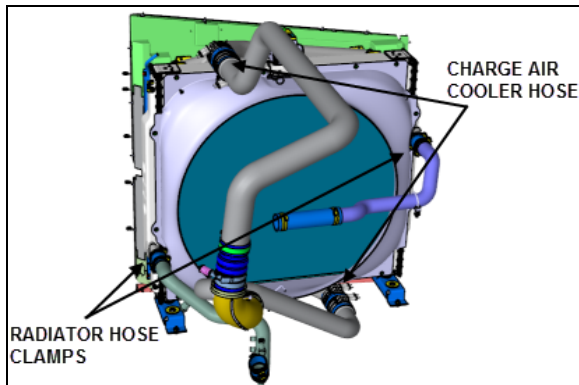

FIGURE 21: RADIATOR & CHARGE AIR COOLER HOSE CLAMPS

11. Remove rear coolant and charge air hose clamps then break hoses loose.
12. Remove the upper radiator assembly support bracket (Figure 22).

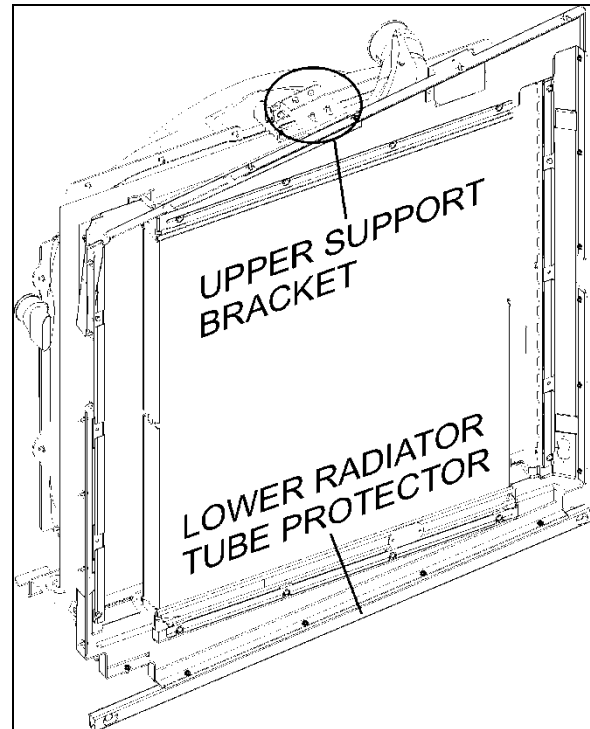

FIGURE 22: UPPER SUPPORT BRACKET & TUBE PROTECTOR

13. Remove the lower radiator assembly tube protector from the lower section (Figure 22).
14. Remove all lower radiator assembly mounting fasteners.

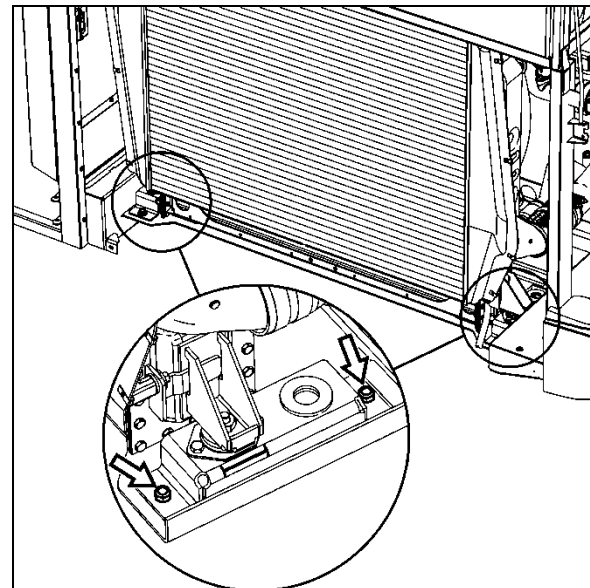

FIGURE 23: RADIATOR ASSEMBLY LOWER MOUNTING FASTENERS

15. Cut cable tie and disconnect electrical connector from fan clutch. Remove fan drive shaft fasteners at the gear box.

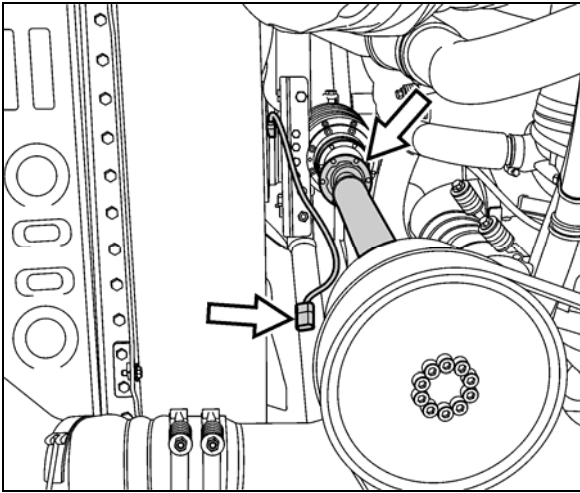

FIGURE 24: DISCONNECTING FAN DRIVE SHAFT

16. Position a forklift under the radiator assembly that is capable of safely lifting the radiator.

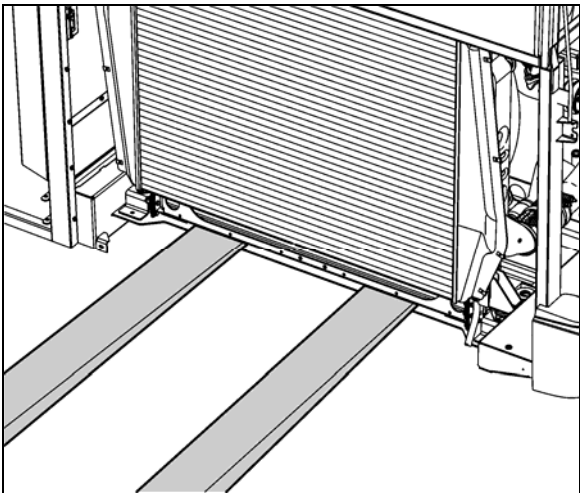

FIGURE 25: POSITIONING FORKLIFT

17. With assistance, slide radiator assembly out and onto the forklift. Transfer radiator assembly to a secure location.
18. Separate charge air cooler from radiator.
19. Lay radiator face down. Remove the fasteners that connect lower radiator mounts to radiator.

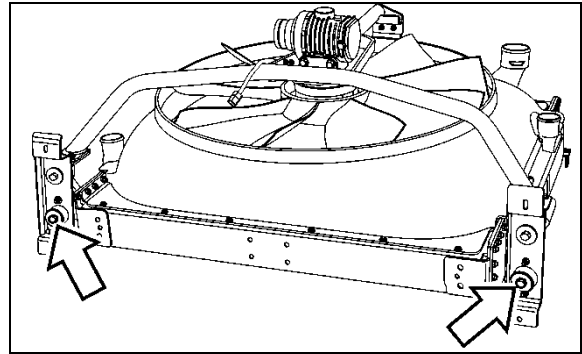

FIGURE 26: REMOVING FASTENERS

20. Remove upper fan drive support bracket from the upper section of the radiator.

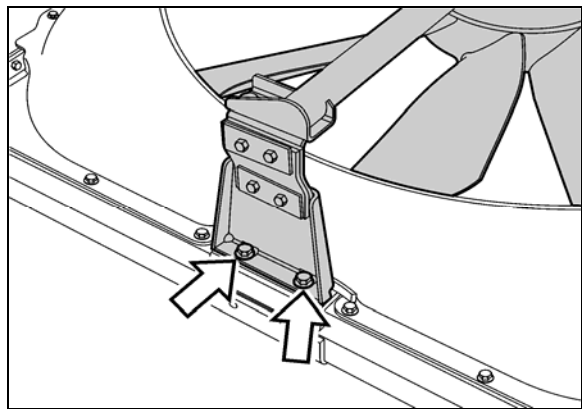

FIGURE 27: REMOVING UPPER FAN DRIVE SUPPORT BRACKET

21. With assistance, remove fan drive and drive frame from radiator.
22. Remove fan shroud from radiator.

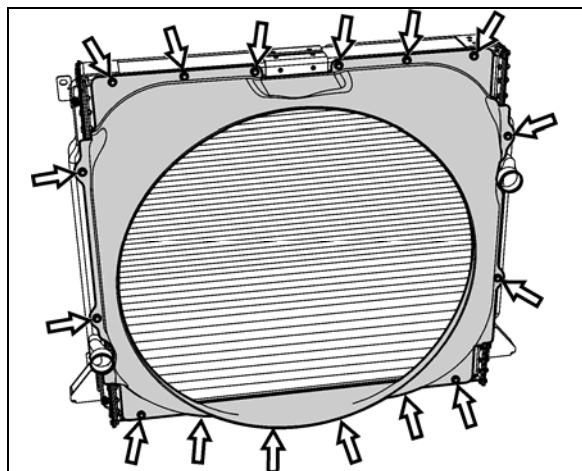

FIGURE 28: REMOVING FAN SHROUD FROM RADIATOR

23. Reverse removal procedure to reinstall radiator assembly.

11. CHARGE AIR COOLER LEAKAGE

Spec for CAC acceptable leakage:

“The CAC is considered acceptable if it can hold 30 psi (206 kPa) gauge pressure with less than 5 psi (34.5 kPa) loss in 15 seconds after turning off the hand valve.”

NOTE

This spec does not apply if there is any evidence that the leak was caused by a foreign object impact.

12. COOLING FAN DRIVE MECHANISM

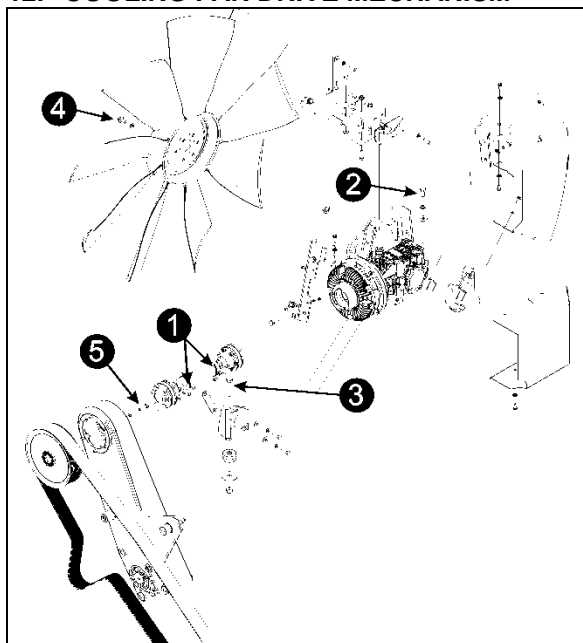

COOLING FAN DRIVE INSTALLATION

Ref	Note	Torque lbs-ft
1	Use Loctite 243	16 (12x)
2		60 (4x)
3		35 (2x)
4		32 (6x)
5	Use Loctite 243	16 (6x)

FIGURE 29: COOLING FAN DRIVE MECHANISM 05123B

12.1 MOUNTING THE DRIVE BELT

To install the cooling fan drive belt, proceed as follow:



WARNING

Turn the ignition switch and set rear start selector switch to the OFF position to prevent accidental starting of the engine.



WARNING

Potential Accident Risk. Always use extreme caution when working in the vicinity of hot, rotating or moving parts.

1. Wrap the new drive belt around the fan drive mechanism pulley, the idlers and the automatic tensioner idler as shown on figure 26.

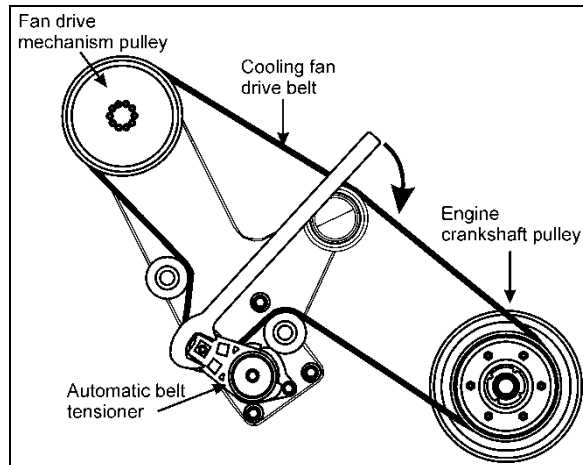

FIGURE 30: DRIVE BELT ROUTING (VOLVO D13 ENGINE)

2. Rotate the automatic tensioner in clockwise direction to relieve tension on the belt and hold the tensioner in that position (Figure 30).
3. Finally, place the drive belt around the engine crankshaft pulley.
4. Release the tensioner slowly and let it return to its natural position.

12.2 DRIVE PULLEY AND UNIVERSAL JOINT SHAFT

To disconnect the universal shaft, proceed as follow:



WARNING

Turn the ignition switch to the OFF position and set rear start selector switch to the OFF position to prevent accidental starting of the engine.

1. Unwrap the drive belt from around the pulley (see paragraph MOUNTING THE DRIVE BELT).
2. Dismount the fan drive pulley. Gain access to the 6 mounting bolts from behind the pulley, through the opening in the cast aluminum support (Figure 31).

3. Unscrew and remove the universal joint shaft mounting bolts (6 bolts) at the fan clutch.
4. Pull the shaft toward the rear of the vehicle.
5. Finally, dismount the universal joint shaft from the fan drive pulley (6 bolts).

Installation of the universal joint shaft is the same as removal, but in reverse order.

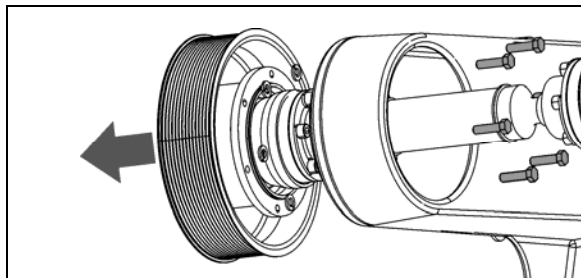

FIGURE 31: DISMOUNTING FAN DRIVE PULLEY 05123C

12.3 IDLER REPLACEMENT

If an idler is defective, replace as follow:

⚠ WARNING

Turn the ignition switch to the OFF position and set starter selector switch to the OFF position to prevent accidental starting of the engine.

1. Remove the protective cap (replace with a new one).
2. Unscrew the idler mounting bolt.
3. Replace idler with a new one.

⚠ CAUTION

When installing the idler, make sure it rests perfectly against the bearing surface on the cast aluminum support. If not, the drive belt may slip of the idler. See following figure.

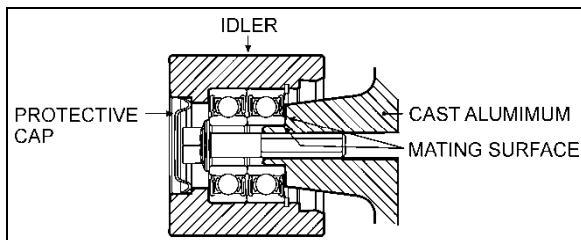
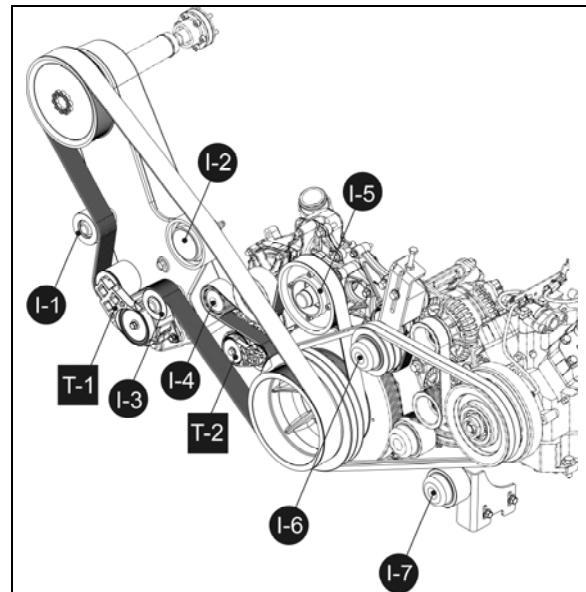

FIGURE 32: IDLER MOUNTED ON THE CAST ALUMINUM SUPPORT

4. Bolt the new idler on the cast aluminum support. Tighten as prescribed.
5. Place a new protective cap.





IDLERS		
Ref	System	Torque lbs-ft
I-1	cooling fan drive	50
I-2	cooling fan drive	32
I-3	cooling fan drive	50
I-4	water pump drive	43
I-5	water pump drive	16 (pulley) 32 (shaft)
I-6	A/C compressor drive	60
I-7	A/C compressor drive	74
AUTOMATIC BELT TENSIONERS		
Ref	System	Torque lbs-ft
T-1	cooling fan drive	32 (2x)
T-2	water pump drive	43

FIGURE 33: TIGHTENING SPECIFICATION (VOLVO D13 ENGINE)

13. VARIABLE SPEED FAN CLUTCH

The cooling fan clutch has two thermostatically controlled speeds, plus a neutral (clutch disengaged). The engine ECU controls the speed by comparing data from engine coolant temperature, charge air temperature, Allison transmission oil temperature (if applicable) and small A/C High side pressure to a set of calibration data. The fan drive clutch is electromagnetic; the engine control module sends an electric current to regulate speed by activating one magnetic coil for the first speed and two magnetic coils for the second speed.

The settings are:

	Engine coolant temp.	Air intake temp.	Allison trans. oil temp.
temperature rising 	208°F: fan engages in HIGH SPEED	194°F: fan engages in HIGH SPEED	230°F: fan engages in HIGH SPEED
	203°F: fan engages in LOW SPEED	176°F: fan engages in LOW SPEED	216°F: fan engages in LOW SPEED
temperature dropping 	203°F: fan HIGH SPEED disengages	189°F: fan HIGH SPEED disengages	225°F: fan HIGH SPEED disengages
	198°F: fan LOW SPEED disengages	170°F: fan LOW SPEED disengages	210°F: fan LOW SPEED disengages

 **WARNING**

DO NOT work near the fan with the engine running or the ignition switch in the ON position. The engine fan can engage at any time without warning. Anyone near the fan when it turns on could be seriously injured.

13.1 LOCKING FAN CLUTCH FOR EMERGENCY OPERATION

13.1.1 Electrical Locking

If the cooling fan clutch does not function due to an electrical control system malfunction and the engine is overheating, active the fan clutch execute the following procedure:

1. Turn the ignition switch to the ON position.
2. Activate the dashboard Telltale Light Test switch 3 times within 4 seconds.
3. In the engine compartment, set the starter selector switch to REAR START and then start the engine from the rear.

 **WARNING**

Potential Accident Risk. Always use extreme caution when working in the vicinity of hot, rotating or moving parts.

While in this mode, the rear start push-button can be used to manually engage the fan clutch. The multiplex system knows when the engine is

already running, and it will not activate the starter.

4. Press the push-button one time to engage the clutch to 1st speed, press a second time to engage to 2nd speed, press a third time to stop the fan, press once again to return to 1st speed.

You can activate the fan clutch through a Driver Information Display menu also. For more detail, refer to “Forced Activation of the Radiator Fan Clutch” paragraph in Section 06: ELECTRICAL.

NOTE

If the fan clutch does not engage using this procedure then the clutch is faulty or the wiring between the multiplex module and the clutch is faulty. Mechanically lock the fan as described hereafter in section 13.1.2.

13.1.2 Mechanical Locking

Once mechanically locked, the fan is rigidly connected to the drive mechanism and will rotate continuously, with no considerations for the cooling needs. This is an emergency situation and the vehicle shall not be operated in that situation for an extended period.

In case of a magnetic clutch malfunction:

1. Turn the ignition switch to the OFF position and set starter selector switch to the OFF position to prevent accidental starting of the engine.
2. Disconnect the fan clutch electrical connector.
3. Unscrew and remove the 4 spare M6x12 hex bolts screwed to the angle on the fan gearbox mounting support (see figure 30).
4. Screw in 4 hex bolts through the clutch anchor plate into the rotor. Using the automatic belt tensioner, release tension on the drive belt in order to be able to rotate the fan clutch drive mechanism by hand. Tightening torque: 7.5 lbf-ft.

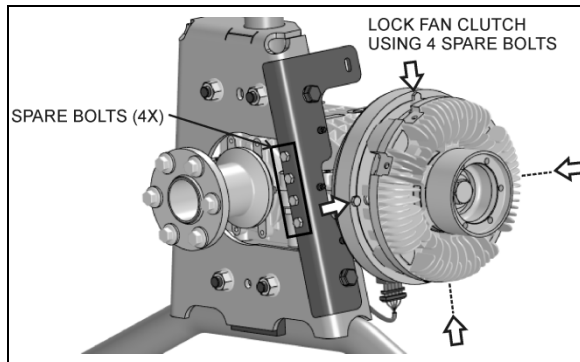

FIGURE 34: MECHANICAL LOCKING 05124

14. RIGHT ANGLE GEARBOX

The radiator fan is belt driven from the engine crankshaft pulley through a drive belt, a universal joint shaft, a clutch and right angle gearbox assembly.



MAINTENANCE

Change the right angle gearbox oil every 100,000 miles. Replace seals at every oil change.

Use **Shell transmission oil MA 75W90**.

14.1 OIL CHANGE

1. Stop engine and make sure that all engine safety precautions have been observed.
2. Set the ignition switch and set rear start selector switch to the OFF position to prevent accidental starting of the engine.
3. Clean gear case carefully.
4. Remove the drain plug located underneath the right angle gearbox case and allow the oil to drain into a suitable container.
5. Replace the seal and screw the drain plug back in. Torque as prescribed.
6. Unscrew and remove the oil level plug and the top filler plug/vent.
7. Add gear lubricant until oil level reaches the bottom of the side oil level check point.

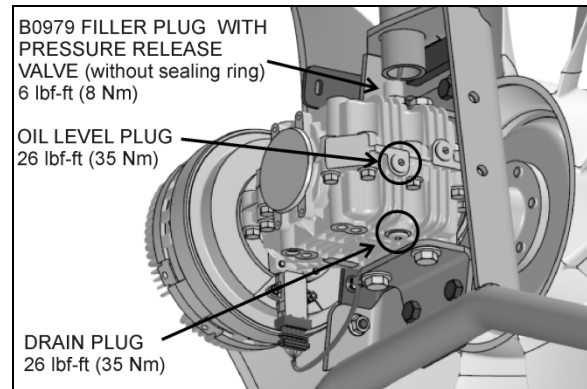

FIGURE 35: RIGHT ANGLE GEARBOX

8. Replace the seals and screw plugs back in. Torque as prescribed.
9. Clean gear case carefully.
10. Start the engine and allow running a few minutes. Stop the engine and check for leaks.



WARNING

Note that warranty may be voided if proper maintenance at oil change intervals is not respected.

14.2 REMOVAL / INSTALLATION

To remove the right angle gearbox, proceed as follow:

1. Turn the ignition switch to the OFF position and set rear start selector switch to the OFF position to prevent accidental starting of the engine.
2. Disconnect the fan clutch electrical connector.
3. Dismount the fan and lean it against the radiator.
4. Disconnect the universal joint shaft.
5. Remove the bracket shown on figure 30.

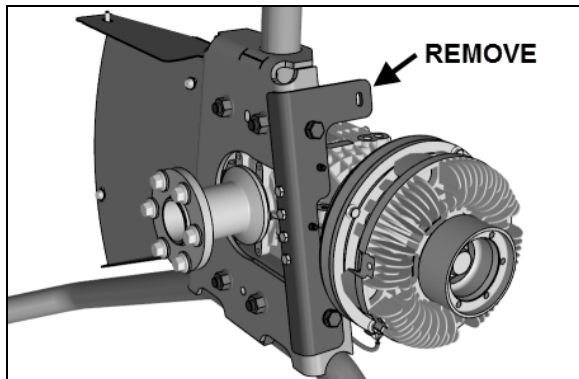

FIGURE 36: DISMOUNT THIS BRACKET

6. Loosen the gearbox support bracket top bolts (Figure 37).
7. Unscrew and remove 4 gearbox mounting bolts.
8. Slide the gearbox out of the support assembly.

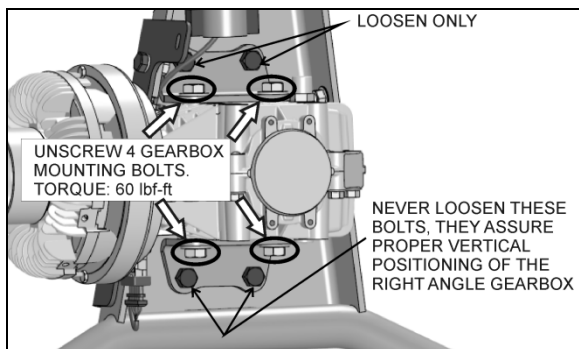

FIGURE 37: RIGHT ANGLE GEARBOX 05126

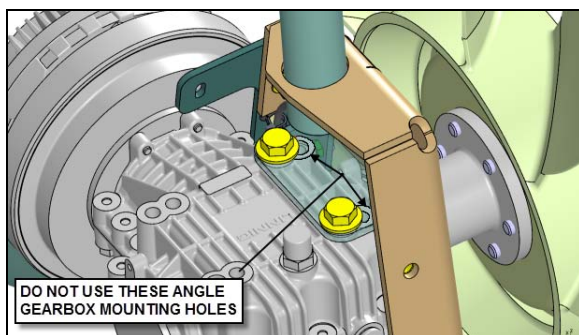

FIGURE 38: RIGHT ANGLE GEARBOX

15. FAN REMOVAL AND INSTALLATION

The fan is bolted to the right angle gearbox shaft flange. To remove the fan:

- Unscrew and remove the mounting bolts and washers.

To reinstall the fan:

- If the fan is still in the radiator fan shroud, place 2 of the mounting bolts on the opposite side of the flange, in reverse

direction, in order to use them as guide pins to position the fan.

- Once properly positioned, screw the 4 remaining bolts back in (finger tight).
- Finally, take the 2 bolts that were used as guide pins and screw them back in on the proper side of the fan. Tighten in a star pattern to 32 lbf-ft.

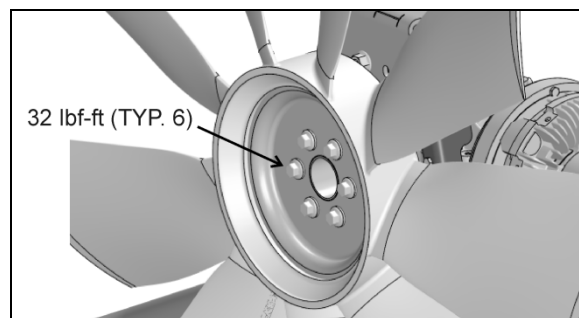

FIGURE 39: RADIATOR FAN MOUNTING BOLTS 05125

15.1 MAINTENANCE

1. Clean the fan and related parts with clean fuel oil and dry them with compressed air. Do not clean with steam or high-pressure jet.
2. Check the fan blades for cracks or other damage. Replace the fan if the blades are cracked or deformed.
3. Remove any rust or rough spots in the grooves of the fan pulley. If the grooves are damaged or severely worn, replace the pulley.
4. Do not restrict fan rotation during engine operation for any reason.
5. Do not operate fan-driving mechanism with a damaged fan assembly. Replace a damaged fan as soon as the fault is noted.
6. Immediately investigate and correct any operator complaint involving driving mechanism or cooling system performance.
7. When questions arise, obtain answers before proceeding. Assistance is available through the Prevost After-Sales Service Support serving your area.

15.2 INSPECTION



DANGER

Set the starter selector switch in engine compartment to the "Off" position to prevent accidental starting of the engine.

- Check security of fasteners securing fan blade assembly to right angle gearbox.
- Visually inspect fan driving mechanism, fan blade assembly, shroud, radiator, and surrounding area for evidence of contact between rotating and non-rotating parts.
- Check drive belt for fraying, cracking, and proper tension.
- Turn fan through at least 360° of rotation. It should turn smoothly with no resistance.

16. SPECIFICATIONS

Cooling System Capacity (Approximation)

Includes heating system 24 US gal (91 liters)

Thermostat - Volvo D13 Engine

Number used 1
 Start to close 203°F (95°C)
 Fully closed 185°F (85°C)

Cooling Fan Drive Belt – Volvo D13 Engine

Type Poly-Rib 14PK2526
 Qty 1

Coolant - Volvo D13 Engine

Type Fleet Charge 50/50 Fully Formulated Antifreeze

Coolant Filter Cartridge – Volvo D13 Engine

Number used 1
 Type Spin-on filter containing Supplemental Coolant Additives (SCA)

17. SECTION CHANGE LOG

DESCRIPTION		DATE
1	Added 5.6 coolant sampling.	April 8, 2016
2		
3		
4		
5		
6		

CONTENTS

1. GENERAL DESCRIPTION.....	5
1.1 WIRING DIAGRAMS.....	5
1.1.1 <i>Using Wiring Diagrams</i>	5
1.1.2 <i>Testing Circuits</i>	6
1.1.3 <i>Wire Sizes And Colors</i>	6
1.1.4 <i>Live Power Cables Color Code</i>	6
1.1.5 <i>Spare Wires</i>	7
1.1.6 <i>Cleaning Connectors</i>	7
1.1.7 <i>Circuit Breakers</i>	7
1.2 MULTIPLEX FUSES.....	8
1.3 RELAYS.....	8
1.4 PRECAUTIONS.....	8
1.5 X3 SERIES COMMUTER COACH ELECTRICAL COMPARTMENT OVERVIEW.....	12
1.6 MAINTENANCE.....	12
1.7 REAR ELECTRICAL PANEL, JUNCTION PANEL, BATTERY COMPARTMENT & EQUALIZER.....	12
1.7.1 <i>Rear Electrical Panel</i>	13
1.8 BATTERY COMPARTMENT.....	13
1.9 FRONT ELECTRICAL AND SERVICE COMPARTMENT.....	13
1.9.1 <i>A/C Junction Box</i>	13
1.10 ENGINE REAR START PANEL.....	14
1.11 ENTRANCE DOOR & WIPER CONTROL PANEL.....	14
1.11.1 <i>Parcel Rack Junction Box</i>	14
1.11.2 <i>NYCT Auxiliary Systems And Radio</i>	14
1.11.3 <i>Motorola Radio Power Mode</i>	15
2. BATTERIES.....	15
2.1 BATTERY DISCHARGE PROTECTION.....	16
2.2 MAIN BATTERY RELAYS.....	16
2.3 BATTERY REMOVAL AND INSTALLATION.....	16
2.4 BATTERY RATING.....	18
2.5 BATTERY MAINTENANCE.....	18
2.5.1 <i>Visual Inspection</i>	18
2.5.2 <i>Removing surface charge</i>	19
2.5.3 <i>Testing Battery Cables</i>	19
2.6 BATTERY CHARGING.....	19
2.6.1 <i>Booster Block</i>	20
2.7 AGM BATTERY CHARGING PRECAUTIONS.....	21
2.8 BATTERY EQUALIZATION AND AGM BATTERIES.....	21
2.9 COMMON CAUSES OF BATTERY FAILURE.....	21
2.10 TROUBLESHOOTING.....	22
2.11 "BATTERY VOLTAGE WARNING" PICTOGRAM.....	22
2.11.1 <i>Voltmeter Gauge Definitions</i>	22
3. PRIME ENERGY MANAGEMENT SYSTEM.....	23
3.1 COMPONENTS.....	23
3.1.1 <i>Vanner 80 Series Battery Equalizer Fault Codes</i>	24
3.2 DID DISPLAY.....	24
4. TROUBLESHOOTING AND TESTING THE MULTIPLEX VEHICLES.....	24
4.1 ELECTRICAL SYSTEM DIAGNOSTIC.....	24
4.2 PROBING VOLTAGE ON THE MULTIPLEX CIRCUITS.....	25

4.3	CAN NETWORK.....	25
4.3.1	Spare CAN	25
4.4	MULTIPLEX INPUT TEST MODE.....	26
4.5	MOTOR TEST SEQUENCE.....	26
4.5.1	Test Sequence	27
4.6	FORCED ACTIVATION OF THE RADIATOR FAN CLUTCH	28
4.7	CAN NETWORK OVERVIEW	28
4.8	MULTIPLEX TROUBLESHOOTING	29
4.9	MULTIPLEX ERROR MESSAGES TROUBLESHOOTING LIST	35
4.10	MULTIPLEX MODULE “NO RESPONSE” TROUBLESHOOTING LIST	35
4.11	ESSENTIAL FUNCTIONS TO OPERATE THE VEHICLE	35
4.11.1	Available Functions	36
4.12	LOWER PRIORITY MODULES FOR BREAKDOWN SERVICE.....	36
4.13	MULTIPLEX MODULES.....	36
4.13.1	MCM Module	36
4.13.2	IO-A Module.....	36
4.13.3	IO-B Module.....	36
4.14	MULTIPLEX MODULES REPLACEMENT.....	36
4.14.1	Replacing IO-A or IO-B Modules.....	36
4.14.2	Replacing The MCM.....	37
4.14.3	Uploading the vehicle specific multiplex program in the mcm	37
5.	BOSCH ALTERNATORS.....	39
5.1	ALTERNATOR PERIODIC INSPECTION	40
5.1.1	Identifying a Single Defective Alternator	40
5.2	ALTERNATOR DRIVE BELT	40
5.3	ADJUSTMENT	41
5.4	CURBSIDE DOOR FAN – ALTERNATOR COOLING.....	41
6.	BATTERY EQUALIZER.....	41
7.	BATTERY CHARGER.....	41
8.	POWER INVERTER.....	42
9.	STARTER.....	42
10.	EXTERIOR LIGHTING.....	42
10.1.1	Maintenance.....	42
10.1.2	Headlight adjustment	43
10.1.3	Sealed-Beam Unit	44
10.1.4	Front Turn Signal.....	44
10.1.5	Stop, tail, directional, back-up, and hazard warning lights	45
10.1.6	Lamp Removal And Replacement	45
10.1.7	Center Stoplights And Center High-Mounted Stop Light (Chsl) Removal And Replacement.....	46
10.1.8	License plate light	46
10.1.9	Clearance, identification and marker lights.....	46
10.1.10	Clearance and identification light removal and replacement.....	46
11.	INTERIOR LIGHTING EQUIPMENT	46
11.1	CONTROL PANEL LIGHTING.....	46
11.1.1	Switch lighting	46
11.1.2	Telltale light replacement	47
11.1.3	Gauge light bulb replacement	47
11.2	STEPWELL LIGHTS.....	47

11.2.1 *Bulb removal and replacement*.....47

11.3 DRIVER'S AREA LIGHTS.....47

11.3.1 *Bulb removal and replacement*.....47

11.3.2 *Engine Compartment Lighting*47

12. Specifications.....49

13. SECTION CHANGE LOG50

Illustrations

FIGURE 1: WIRE IDENTIFICATION6

FIGURE 2: CIRCUIT BREAKER PANEL8

FIGURE 3: MULTIPLEX MODULE CONNECTORS PIN-OUT9

FIGURE 4: ELECTRICAL COMPARTMENTS (X3-45 COMMUTER).....12

FIGURE 5: REAR ELECTRICAL PANEL, JUNCTION PANEL & BATTERY COMPARTMENT12

FIGURE 6: REAR ELECTRICAL PANEL13

FIGURE 7: BATTERY COMPARTMENT13

FIGURE 8: FRONT ELECTRICAL COMPARTMENT ELECTRIC PANEL.....13

FIGURE 9: A/C JUNCTION BOX14

FIGURE 10: REAR START PANEL14

FIGURE 11: ENTRANCE DOOR & WIPER CONTROL14

FIGURE 12: PARCEL RACK I/O B MODULE.....14

FIGURE 13: AUXILIARY SYSTEMS IDENTIFICATION14

FIGURE 14: RADIO POWER MODE CHANGE15

FIGURE 15: BATTERY COMPARTMENT OVERVIEW16

FIGURE 16: BATTERY PROTECTIVE COVER REMOVAL.....17

FIGURE 17: LATERAL PANEL OPENING.....17

FIGURE 18: BATTERY FIXING CLAMPS REMOVAL17

FIGURE 19: NEGATIVE TERMINALS17

FIGURE 20: ALLIGATOR CLAMPS.....20

FIGURE 21: BOOSTER BLOCK20

FIGURE 22: PRIME ELECTRICAL COMPONENTS23

FIGURE 23: PRIME DID DISPLAY.....24

FIGURE 24: BATTERY STATE OF CHARGE24

FIGURE 25: DRIVER INFORMATION DISPLAY25

FIGURE 26: X3-45 COACH NETWORK LAYOUT.....28

FIGURE 27: DATA WIRE IDENTIFICATION29

FIGURE 28: IO-B MODULE REMOVAL36

FIGURE 29: DB9 CONNECTOR AND MCM LOCATION37

FIGURE 30: USB TO SERIAL DB9 RS232 ADAPTOR AND PREVOST 066009 INTERFACE CABLE.....38

FIGURE 31: IDENTIFYING COM PORT NUMBER38

FIGURE 32: PROPER PORT SETTINGS38

FIGURE 33: ENTER PROPER COM PORT NUMBER38

FIGURE 34: VALIDATING PROGRAM VERSION38

FIGURE 35: ALTERNATORS DRIVE BELT39

FIGURE 36: TWIN ALTERNATORS INSTALLATION.....39

FIGURE 37: ALTERNATOR MOUNTING - TIGHTENING SEQUENCE.....39

FIGURE 40: ½" SOCKET DRIVE WRENCH40

FIGURE 41: CURBSIDE DOOR FAN CONTROL LOGIC41

FIGURE 42: HEADLIGHT ASSEMBLY42

FIGURE 43: HEADLIGHT ASSEMBLY OPENED FOR BULB REPLACEMENT42

FIGURE 44: ALIGNMENT OF HEADLIGHT AIMING SCREEN43

FIGURE 45: PROPER UPPER BEAM HIGH-INTENSITY ZONE AT 25FT 43

FIGURE 46: PROPER LOWER BEAM HIGH-INTENSITY ZONE AT 25FT..... 44

FIGURE 47: AIM INSPECTION LIMITS FOR UPPER-BEAM HEADLIGHTS..... 44

FIGURE 48: AIM INSPECTION LIMITS FOR LOWER-BEAM HEADLIGHTS 44

FIGURE 49: REAR TAIL LAMPS..... 45

FIGURE 50: TAILLAMP POD RETAINING SCREWS & NUTS 46

FIGURE 51: DASHBOARD ROCKER SWITCH..... 47

FIGURE 52: ENGINE COMPARTMENT LIGHT..... 47

FIGURE 53: VARIOUS LIGHTS LOCATION 48

1. GENERAL DESCRIPTION

These x3-45 coaches use a dual voltage system to obtain two different voltages (12 and 24 volts) for various electrical controls and accessories. The main power source incorporates four "odyssey" group 31 commercial batteries connected in parallel-series. All batteries are kept uniformly charged by means of a 100 amp battery equalizer (standard), giving a maximum possible output supply of 100 amps on the 12 volt system. Both the 12 and 24 volt systems are controlled through individual main battery relays. Two 28 volt self-regulated alternators are installed and are belt driven from the engine, and can be reached through the engine compartment doors.

1.1 WIRING DIAGRAMS

A master wiring diagram of the electric circuits, covering standard and optional accessories and systems, is located in the technical publications box. Usually, a separate wiring diagram page is provided for each major function or system. In some cases, more than one circuit may appear on one wiring diagram page; when this occurs, each circuit covered in this page is listed in the wiring diagram index. Moreover, a circuit may appear on several pages; in such case, the number(s) at the extremity of the diagram title will indicate the sheet reference number. Refer to the "wiring diagram index" to ensure that the correct diagram is being used to trace the circuit in question. In addition to the major functions page reference, the wiring diagram index contains the following information pages.

- The multiplex output / input list,
- Multiplex error message list,
- The arrangement-harness drawing showing the harness arrangement and harness numbers on the vehicle,
- Glossary,
- Circuit number listing,
- Circuit breaker code,
- Connector code,
- Diode number code,
- Resistor number code,
- Fuse code,
- Relay Code.

1.1.1 Using Wiring Diagrams

Three methods are used to "work" with electric wiring diagrams.

Situation: you have identified the defective part (breaker, diode, relay, etc.), and you wish to locate its corresponding circuit.

Problem: circuit breaker cb13 is released (open circuit) and you don't know which circuit is affected.

- a) Refer to wiring diagram index, and look for "circuit breaker code". You find that the circuit breaker list is on page f.
- b) At item cb13, you will find the location, the Prevost number, the breaker function, the breaker amp rating and the page on which to find the corresponding diagram.
- c) Refer to page 3.1.
- d) When you have located cb13, follow the wiring up to the end and find the diagram page number and function on which the circuit continues.

Situation: you have a problem with a specific system and you want to find the corresponding diagram.

Problem: the last three (3) speakers on the R.H. side of vehicle are inoperative and you must trace the electric circuit.

- a) Refer to wiring diagram index and look for "sound system".
- b) You will find on page 35.2 the components as well as the electric wiring, thus providing you with a complete understanding of this circuit.

Situation: using the driver information display (DID), you check on arrival if there are active errors in the vehicle electrical system. With the **diagnostics** menu, highlight **fault diagnostics**, highlight **electrical system** to request a diagnostic of the electrical system and then press the enter key. If applicable, the DID shows the fault messages or fault codes recorded. When more than one fault is recorded, an arrow pointing down appears on the right of the display. Use the down button to see all the fault messages.

Problem: DID displays the fault "elec. horn sw61 sw62; shorted to ground" as being active.

- a) Refer to wiring diagram index, and look for "multiplexed device index", pages b1-b8.

- b) In first column device id, look for device sw61, sw62.
- c) At device sw61,sw62, find the fault message, the minimum condition to activate, other inputs involved in logic, the multiplex module related to switch 61 and switch 62, the connector and pin number on the module and the page on which to find the corresponding diagram.
- d) Once the problem corrected, the DID still shows the fault as being active. You have to leave the **fault diagnostics** menu, wait approximately 20 to 30 seconds and then return to **fault diagnostics** to request a new diagnostic of the **electrical system** from the mcm. The DID should display the fault as being inactive.

Yellow	Multiplex Communication Can-H (Twisted With Green)	Modules
Green	Multiplex Communication Can-L (Twisted With Yellow)	Modules
Orange	Connected To Multiplex Outputs	
White	Connected To Multiplex Inputs	
Red	24 Volt System	
Yellow	12 Volt System	
Black	Grounded Wire	
Blue	110 V Ac System (Live)	
White	110 V Ac System (Neutral)	
Green	110 V Ac System (Ground)	
Orange	Speakers (+) (Coaches Only)	
Brown	Speakers (-) (Coaches Only)	
Grey	Spare Wire	

1.1.2 Testing Circuits

A careful study of the wiring diagrams should be made to determine the source and flow of current through each circuit. When a circuit is thoroughly understood, a point-to-point check can be made with the aid of the applicable wiring diagrams. Any circuit can be tested for continuity or short circuits with a multimeter or a suitable voltmeter.

All electrical connections must always be kept clean and adequately tight. Loose or corroded connections can result in discharged batteries, difficult starting, dim lights and improper functioning of other electric circuits. Inspect all wiring connections at regular intervals. Make sure knurled nuts on all Amphenol-type plugs are securely tightened. Knurled nuts on the plastic Amphenol-type connectors will click into a detent when properly tightened. Line connectors, who have the side locking tabs, must have the locks latched in place to ensure a proper electrical connection.

1.1.3 Wire Sizes And Colors

Each wire in the electrical system has a specific size as designated on the wiring diagram. When replacing a wire, the correct size must be used. Never replace a wire with one of a smaller size. The vehicle electrical system is provided with different voltages. The insulation on each wire is distinctly colored in order to determine visually the wiring voltage and to assist in making connectors. The wires are color coded as follows:

Note
Wires are identified at each 2-4 inch (5-10 cm) intervals by a printed number.

Each wire on a diagram is patterned to assist in tracing and testing circuits. The wire number identifies the voltage rating, the wire identification number and the basic wire gauge as illustrated in figure 1.

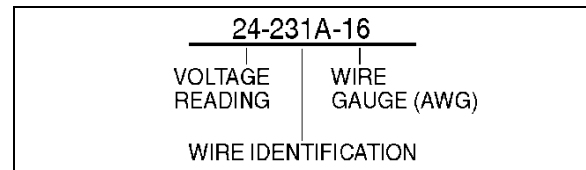

FIGURE 1: WIRE IDENTIFICATION 06048

1.1.4 Live Power Cables Color Code

Live 12v and 24V power cables are connected to a source of electrical power, so that direct contact with the conductor by some uninformed person may result in personal injury and equipment damage.

Live power cables in the battery compartment remain energized even though the ignition switch is set to the off position or the battery master switch is in the off position.

Live Power Cables Color Coded Circuits	
24-Volt	12-Volt
24VA	12VA
24VD	12VD
341	
210	

24d

The power cables are color coded as follows:

24V, larger than 12 GA: red ribbon winding around black cable with 9/16" between spires.

24V, 12 &14 GA: pieces of red tape around black cable, no windings, 9/16" spaced.

12V, larger than 12 GA: yellow ribbon winding around black cable with 9/16" between spires.

12V, 12 &14 GA: pieces of yellow tape around black cable, no windings, 9/16" spaced.

1.1.5 Spare Wires

When the vehicle leaves the factory, and even in the case of a fully-equipped vehicle, an important number of unconnected spare wires are routed between the junction boxes. Consequently, for any connection of an additional accessory, look in wiring diagram for "spare" wires in the circuit number listing of pages e.1 thru e.8 to determine the circuit number. Refer to page 8.1 in wiring diagram to find location of these wires.

 CAUTION
<p>Wire size is calibrated according to the breaker or fuse that protects it. When using a spare wire to replace a damaged wire, assure that the spare wire size is equal or larger than the wire being replaced. Using a wire too small for the breaker or fuse amperage might cause overheating of the wire.</p>

<p>NOTE</p> <p><i>Spare wires are identified by a wire identification number and by the letters "sp", to designate "spare".</i></p>
--

1.1.6 Cleaning Connectors

To clean electrical connections on the vehicle, a good quality aerosol contact cleaner is recommended. The use of a nonflammable product with fast evaporating qualities (that dries without leaving residue) will eliminate the possibility of having cleaning agent tapered in the connector, possibly affecting the connector seal.

To specifically clean oxidized cables, a product that offers the same qualities mentioned above

but with a moderate evaporation time may be substituted to provide deeper cleaning action into the cable.

 DANGER
<p>Contact cleaners can contain toxic base compounds and should always be used in a well-ventilated area, never in a confined space. Use outdoor whenever possible.</p> <p>Use of low hazardous (ROHS compliant) and ozone safe products is recommended.</p>

1.1.7 Circuit Breakers

Most electric circuits are protected by circuit breakers of the "manual reset" type. The main circuit breakers, as well as those protecting the a/c system, are located on the rear electrical junction panel and are accessible from the engine compartment curb-side door, on R.H. side of the vehicle.

This type of circuit breaker de-energizes the circuit without disconnecting any wire.

Circuit breakers CB2 & CB6 are different and can be used to open the circuit manually, to do so simply press down the red tab on breaker to open the circuit, repair defective circuit, and afterwards depress black button in center of breaker to close the circuit.

Smaller circuit breakers may be located in the VECF of the front service compartment.

Circuit Breakers			
CB1	Front Distribution	24VI	90 Amps
CB2	Distribution	12 VD	90 Amps
CB3	HVAC - Evaporator	24VI	90 Amps
CB5	Rear Distribution	24VI	150 Amps
CB6	Distribution	24 VD	70 Amps
CB7	HVAC - Condenser	24VI	70 Amps
CB8	Rear Distribution	12VI	40 Amps
CB9	WCL & Battery Charger	24VD	50 Amps
CB10	Front Distribution	12VI	70 Amps
CB13	Inverter	24VI	90 Amps

VD = Volts Direct. The electrical components connected to these circuit breakers are direct-connected to the battery.

VI = Volts Indirect. Electrical power is supplied via master relay R1 which engages when ignition key is in the ON or ACC position and battery master switch (master cut-out) is set to on.



Figure 2: Circuit Breaker Panel 06621

1.2 MULTIPLEX FUSES

The multiplex outputs are protected in current by an internal "soft-fuse". Each output has programmed specific maximum amperage. When an output is shorted, the current gets above the limit and the soft-fuse intervenes to turn the output off. The output stays off until the "soft-fuse" is reset.

Turn the ignition switch to the off position and turn to the on position again. This resets all "soft-fuses".

There is also hardware fuses used to protect the incoming power to the multiplex modules. These fuses are located inside the VECF (vehicle electrical center front) and VECR (vehicle electrical center rear).

1.3 RELAYS

Relays are used to automatically energize or de-energize a circuit from a remote location. The relay draws a very low current to energize its coil. Once the coil is energized, it develops a magnetic field that pulls a switch arm closed or open, to either energize or de-energize a given component. As the control current required for the coil is very low, the relay allows a remote station to control a high energy circuit without running great lengths of costly high capacity

cable, and also eliminates the need for high amperage switches and heavy connectors.

NOTE

Each relay is identified with "12v" or "24v" printed on its casing in order to identify the coil operating voltage.



CAUTION

The multiplex vehicle uses a VF4 relay designed specifically for Volvo that has different internal characteristics than the current VF4 relay. It is important to use only the new part marked Volvo as a replacement in multiplex vehicles. Regular relays have an inadequate lifespan for multiplex vehicles.

1.4 PRECAUTIONS



DANGER

Prior to working on a system inside vehicle, make sure to cut electrical power and air supply. A component could be supplied with electricity even if the ignition switch is set to the off position and/or a component could be pressurized even if air tanks are emptied. Always refer to the appropriate wiring and pneumatic diagrams prior to working on electrical and/or pneumatic systems.



CAUTION

Prior to arc welding on the vehicle, refer to "multiplex modules disconnection procedure prior to welding" in section 00 general of this manual to avoid serious damage to the vehicle components.

NOTE

When the ignition switch is set to the off position, most electrical components are not energized except for the fire suppression system (AFSS). MCM (master chassis module), ECM (engine control module), TCM (transmission control module) and specific multiplex modules will stay energized for a period of 5 minutes after the ignition switch has

been set to the off position.

Before working on one of these electrical components, set the master cut-out switch located above the rear electrical panel to the off position.

If the vehicle is out of service for a long period (more than 2 weeks), it is recommended to trip the main circuit breakers (cb2 and cb6) to prevent the batteries from discharging.

This will prevent small current drawn by the mcm memory and the instrument cluster clock from draining the battery. Note that the diagnostic codes history will be erased and the instrument cluster clock will have to be reset.

Setting the cluster clock is performed by the time/distance menu of the DID. Refer to the operator's manual for additional details.

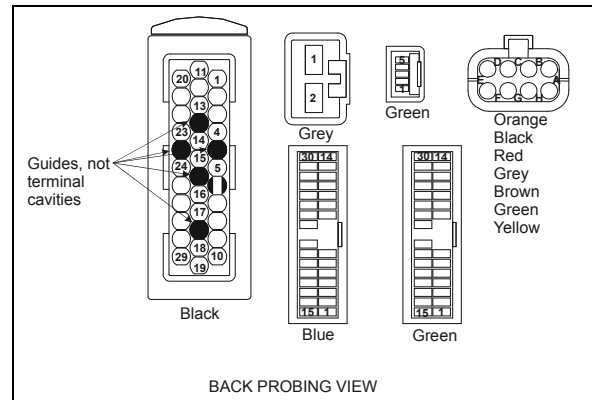
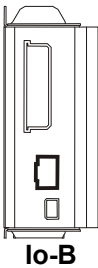
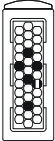
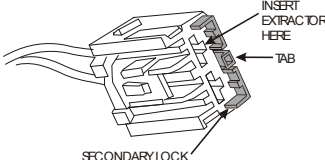

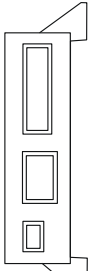
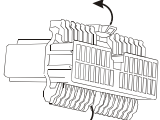
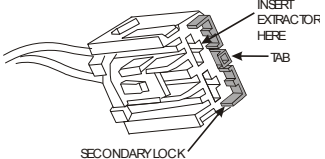
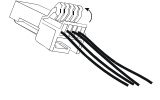
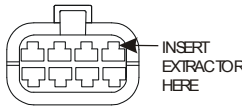
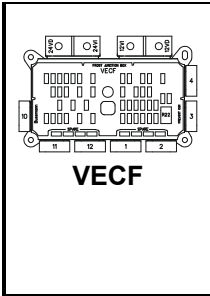

FIGURE 3: MULTIPLEX MODULE CONNECTORS PIN-OUT 06624

Multiplex Modules	Connector Type	Terminal Removal
 <p>Io-B</p>	 <p>AMP 06628</p>	<p>Extractor/Tool: Prevost #683594 Insert the extractor on the front of the connector. Remove the terminal by disengaging the flexible lock tabs on the terminal. Gently remove the terminal from the connector by pulling on the wire.</p>
	 <p>Grey Yazaki</p>	<p>Extractor/Tool: Packard #12094430 Using a small flat blade screwdriver, open the hinged secondary lock. Insert the extractor on the front of the connector, over the terminal cavity. Remove the terminal by disengaging the flexible lock tab on the terminal. Gently remove the terminal from the connector by pulling on the wire.</p>
	 <p>Green 06630 Jae</p>	<p>Extractor/Tool: Prevost #683766 Using a small flat blade screwdriver, open the hinged secondary lock. Insert the extractor on the front of the connector, over the terminal cavity. Remove the terminal by disengaging the flexible lock tab on the terminal. Gently remove the terminal from the connector by pulling on the wire.</p>
 <p>Io-A</p>	 <p>Green, Blue (Mcm) Jae</p>	<p>Extractor/Tool: Prevost #683766 Using a small flat blade screwdriver, open both hinged secondary locks. Insert the extractor on the front of the connector, over the terminal cavity. Remove the terminal by disengaging the flexible lock tab on the terminal. Gently remove the terminal from the connector by pulling on the wire.</p>
	 <p>Grey Yazaki</p>	<p>Extractor/Tool: Packard #12094430 Using a small flat blade screwdriver, open the hinged secondary lock. Insert the extractor on the front of the connector, over the terminal cavity. Remove the terminal by disengaging the flexible lock tab on the terminal. Gently remove the terminal from the connector by pulling on the wire.</p>
	 <p>Green Jae</p>	<p>Extractor/Tool: Prevost #683766 Using a small flat blade screwdriver, open the hinged secondary lock. Insert the extractor on the front of the connector, over the terminal cavity. Remove the terminal by disengaging the flexible lock tab on the terminal. Gently remove the terminal from the connector by pulling on the wire.</p>



- Orange
- Black
- Red
- Grey
- Brown
- Green
- Yellow

Bussman

Extractor/Tool: Previst #682256 (Packard 12094429)

Remove the terminal by disengaging the flexible lock tab on the terminal. Gently remove the terminal from the connector by pulling on the wire.

1.5 X3 SERIES COMMUTER COACH ELECTRICAL COMPARTMENT OVERVIEW

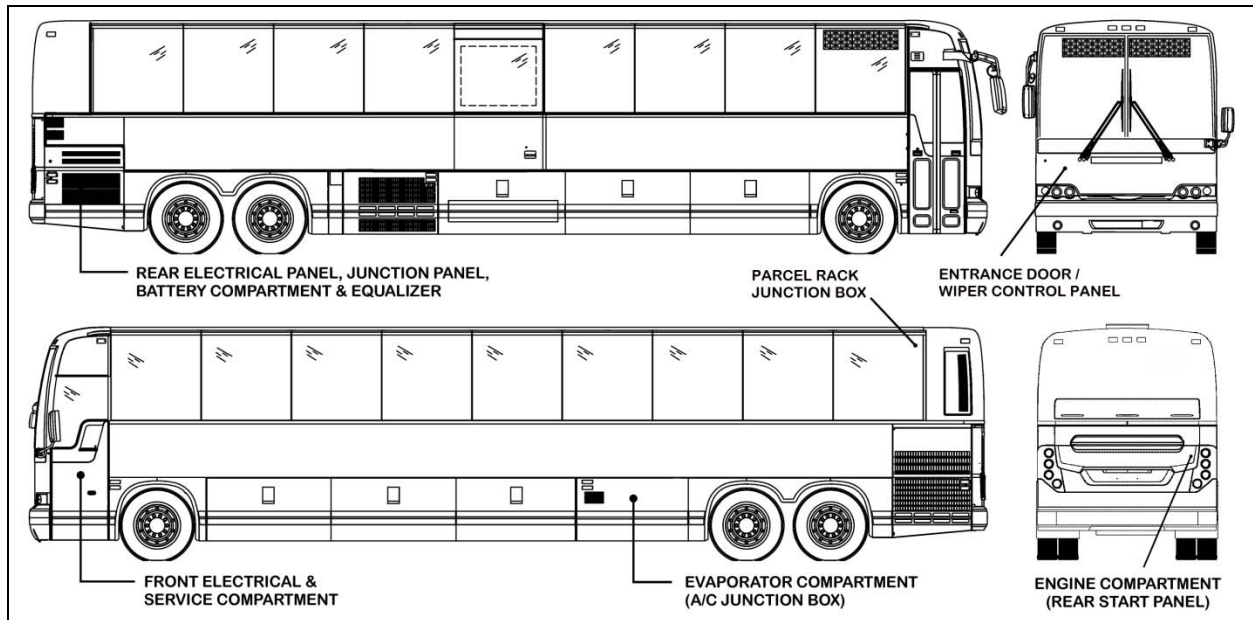



FIGURE 4: ELECTRICAL COMPARTMENTS (X3-45 COMMUTER)

06672_1

1.6 MAINTENANCE

A corrosion inhibitor has been sprayed on certain electrical components in order to protect them from corrosion. Refer to procedure sav00002e at the end of this section for recommended products and where they are used.

	<p>CAUTION</p>
<p>Never put grease or other product on the multiplex modules connector terminals.</p>	

	<p>DANGER</p>
<p>Use sprayed sealer in a well-ventilated area. Do not smoke. Avoid prolonged contact with skin and breathing of spray mist.</p>	

1.7 REAR ELECTRICAL PANEL, JUNCTION PANEL, BATTERY COMPARTMENT & EQUALIZER

The rear electrical panel, junction panel, battery compartment & battery equalizer are located on the R.H. side of the engine compartment and are accessible from the engine compartment curb-side door.

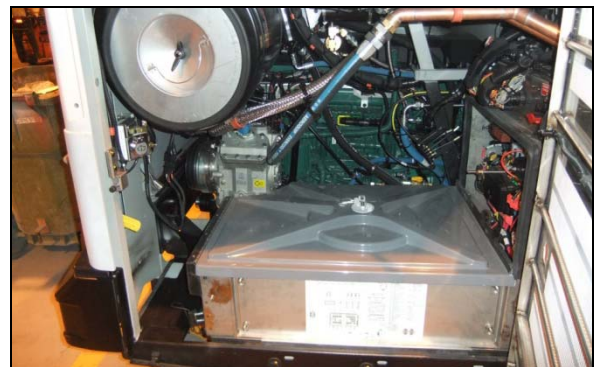

FIGURE 5: REAR ELECTRICAL PANEL, JUNCTION PANEL & BATTERY COMPARTMENT

1.7.1 Rear Electrical Panel

The rear electrical panel provides access to the following:

- Rear terminal block;
- Multiplex modules;
- Vehicle electrical center rear (VECR)
- Relays and fuses;
- Transmission control module (TCM);
- Battery master switch (master cut-out);
- OBD II diagnostic connector (refer to “other features” chapter).

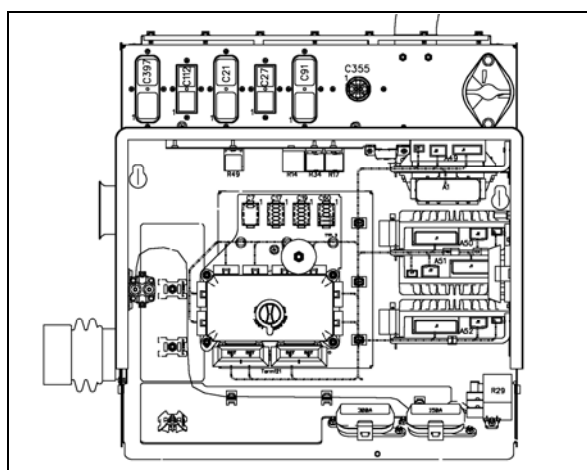

FIGURE 6: REAR ELECTRICAL PANEL

1.8 BATTERY COMPARTMENT

The battery compartment provides access to the batteries (4), battery equalizer, the master relay (r1), power relays (2) and to the prime battery monitoring components.

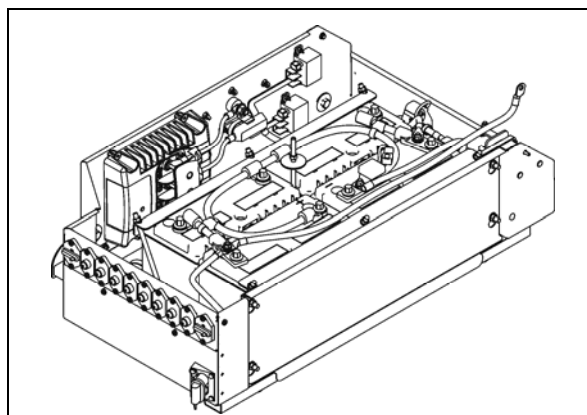

FIGURE 7: BATTERY COMPARTMENT 06773

1.9 FRONT ELECTRICAL AND SERVICE COMPARTMENT

The front electrical and service compartment is located on L.H. side of vehicle, under the driver's window. It contains the following components (Figure 8):

- Front terminal block;
- Master chassis module (MCM);
- C226 connector (MCM) type db9 for laptop diagnostic tool;
- Vehicle electrical center front (VECF) and multiplex modules;
- Relays and fuses;
- ABS electronic control unit (ECU);
- Vehicle electronic control unit (VECU);
- Master interlock cancel switch;
- Emergency door unlatch valve;
- Tag axle control valve.

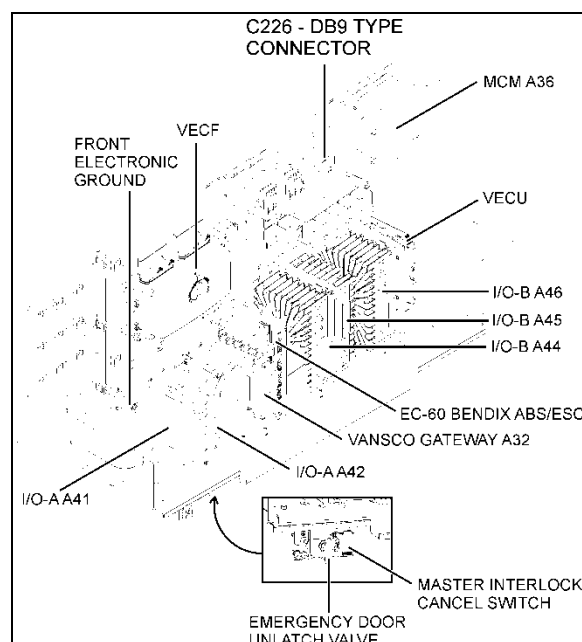

FIGURE 8: FRONT ELECTRICAL COMPARTMENT ELECTRIC PANEL

1.9.1 A/C Junction Box

The a/c junction box is located in the evaporator compartment, on the evaporator fan motor housing.

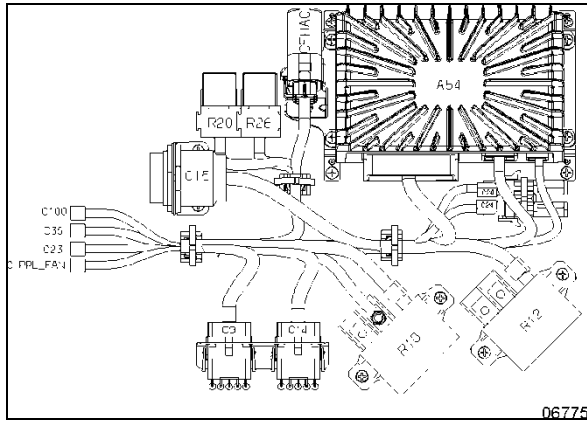

FIGURE 9: A/C JUNCTION BOX

1.10 ENGINE REAR START PANEL

This control panel is located in the R.H. side of engine compartment above the engine air filter. This control panel includes the engine starter selector switch, the rear start push button switch to start engine from engine compartment as well as the engine compartment lights switch, back-up alarm, air filter restriction indicator lamp and a multiplex connected tachometer.

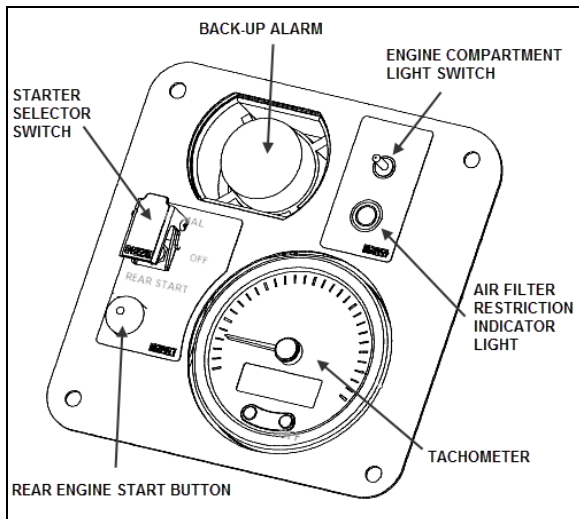

FIGURE 10: REAR START PANEL

06622_1

NOTE

When the ignition switch is set to the "off" position, the electrical supply from the batteries is cut off, with the exception of the fire detection system, the engine & transmission electronic controls, the battery equalizer and the cluster digital clock.

1.11 ENTRANCE DOOR & WIPER CONTROL PANEL

To access the entrance door & wiper control panel of the right console, remove the panel under the larger utility compartment at the base of the windshield.



FIGURE 11: ENTRANCE DOOR & WIPER CONTROL

1.11.1 Parcel Rack Junction Box.

You will find a single I/O B module (a53) located at the rear end of the left (road side) parcel rack. This module controls the passenger lighting and "next stop" functions.

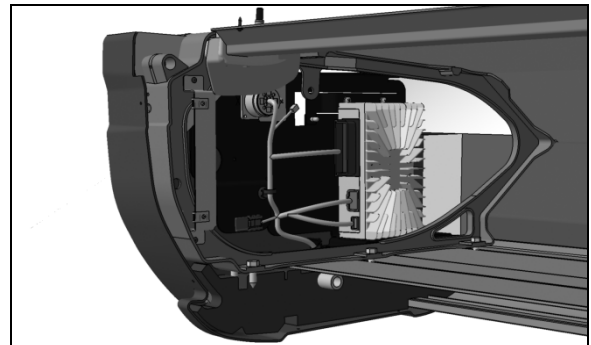

FIGURE 12: PARCEL RACK I/O B MODULE

1.11.2 NYCT Auxiliary Systems And Radio

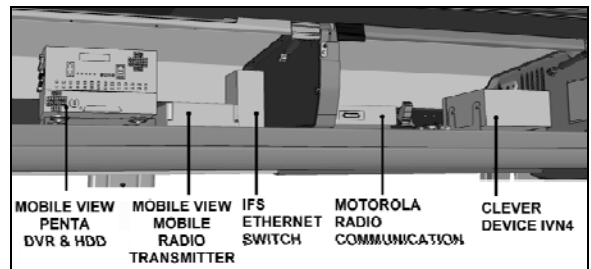

FIGURE 13: AUXILIARY SYSTEMS IDENTIFICATION

In the first road side overhead parcel rack, you will find the following systems (additional details are available in section 23, accessories):

- Clever devices' ivn4; relays and circuit breakers.
- Motorola communication radio hardware;
- IFS Ethernet managed switch;
- Mobile radio transmitter (wimax & wi-fi) ;
- Mobile View's penta c dvr & hdd

1.11.3 Motorola Radio Power Mode

The communication radio power mode can be changed to "battery direct" or "ignition". To change the power mode to "battery direct", open the first left hand (road side) overhead parcel rack and disconnect the two connectors below.

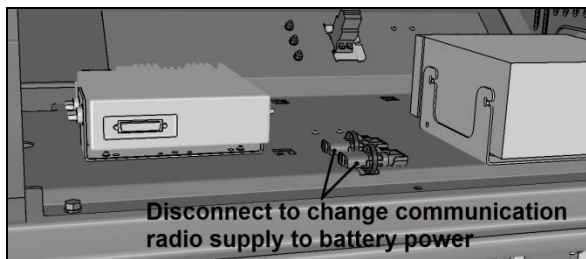

FIGURE 14: RADIO POWER MODE CHANGE

2. BATTERIES

This vehicle is provided with four (4) odyssey group 31 absorbed glass mat (agm) 12-volt batteries, model 31-pc2150s, connected in series-parallel (Figure 15).

These batteries require no maintenance for their lifetime. They can withstand deeper discharge cycles and several times the charging cycles of a standard battery.

These are sealed, valve regulated recombinant batteries which means that the oxygen created will recombine with the hydrogen in the battery, creating water and preventing water loss. Water never needs to be added to this type of battery.

The top-mounted negative and positive terminals are tightly sealed to prevent leaks.

The electrolyte in this type of battery is absorbed in micro-porous glass separators. This design prevents spills and results in greater resistance to vibration.

Always replace these batteries with identical make and model batteries as the system is balanced and optimized for this type of battery.

⚡ DANGER

Agm batteries generate hydrogen gas, which is highly flammable. If ignited by a spark or flame, the gas may explode violently, causing spraying of acid, fragmentation of the battery, which may result in severe personal injuries. Wear safety glasses and do not smoke when working near batteries. In case of contact with acid, flush immediately with water.

⚠ WARNING

Battery posts, terminals and other related accessories contain lead and lead compounds, chemical known to the state of california to cause cancer and other reproductive harm.

Batteries also contain other chemicals known to the state of california to cause cancer.

Wash hands after handling.

The battery has four (4) major functions:

1. Providing a source of current for starting the engine;
2. Stabilizing the voltage in the electrical system;
3. Supplying current for a limited time, when electrical demands of the equipment exceed the power output of the alternator;
4. Providing a limited source of power for connected accessories, when the engine is not running.

For further information regarding odyssey battery, please refer to odyssey manuals included with the technical publications.

Odyssey manuals available in pdf format:

- Odyssey battery_ technical manual us-ody-tm-001_0411_000
- Odyssey battery_spec sheet us-ody-31-003_1206
- Odyssey battery_owner's manual us-ody-om-009_0611

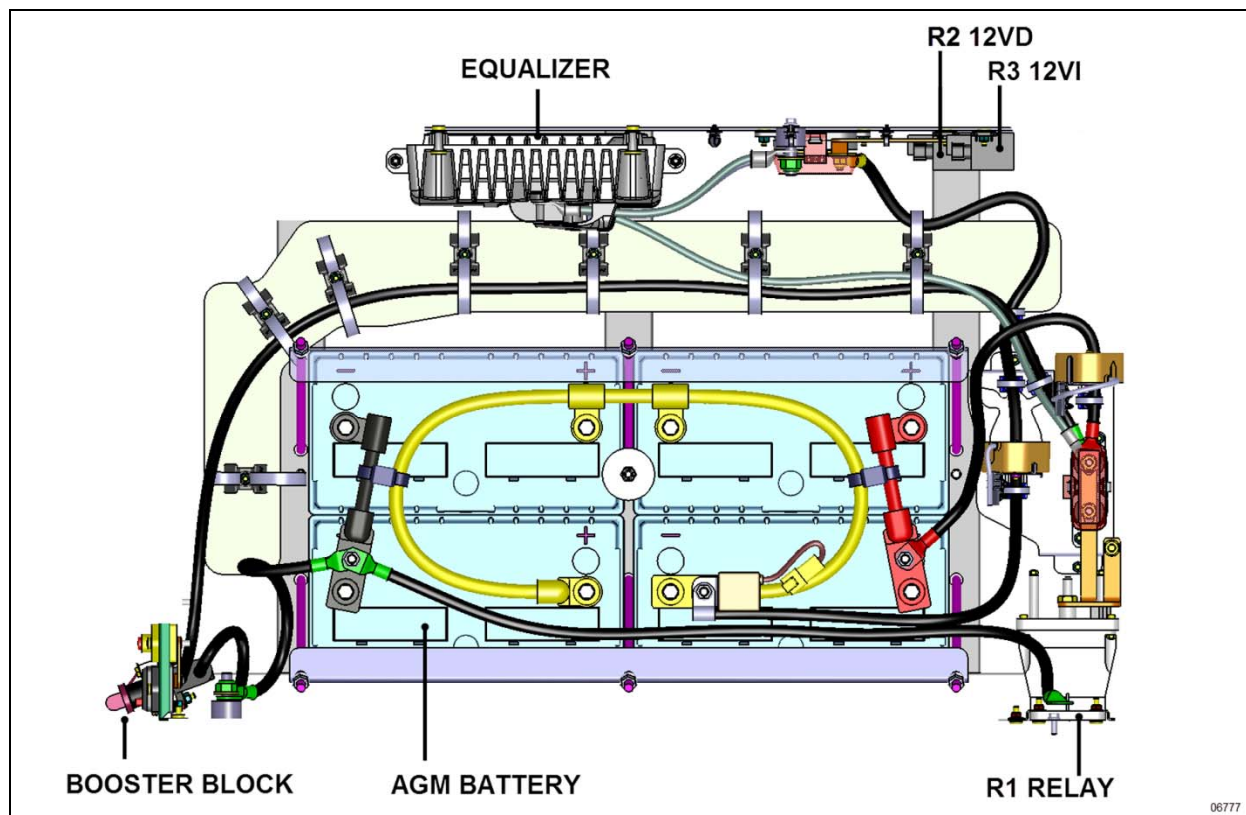

FIGURE 15: BATTERY COMPARTMENT OVERVIEW

2.1 BATTERY DISCHARGE PROTECTION

To prevent discharge of the batteries when the engine is not running, certain functions are automatically switched off if the battery voltage drops below 24 volts for more than 30 seconds. The "battery voltage warning" pictogram will show on the DID. Set the ignition key to the off position and then turn the ignition key to the on position to reactivate these functions for a period of 30 seconds before they switch off again.

If a prolonged use of the functions with the engine not running is necessary, connect the battery to a charger.

2.2 MAIN BATTERY RELAYS

Main battery (master) relays (12v and 24v) are provided for this vehicle. The relays are located in the battery compartment and in the rear electrical panel. The 24-volt battery relay (r1) engages when the ignition switch is in the on or acc position and the battery master switch (master cut-out) is turned on.

When the main battery relays (r1 & r3) are tripped to the *off* position, all electrical supply from the batteries is cut off, with the exception of the following items.

- Battery equalizer check module;
- MCM;
- TCM
- ECM (engine control module),
- Water recirculating pump;
- Bi-fold entrance door;
- Cluster memory.
- Communication radio (depending on chosen jumper configuration)

2.3 BATTERY REMOVAL AND INSTALLATION

The batteries are located in the battery compartment on the R.H. side of the engine compartment and are accessible from the engine compartment curb-side door.

AGM batteries should be replaced in pairs or four at a time.

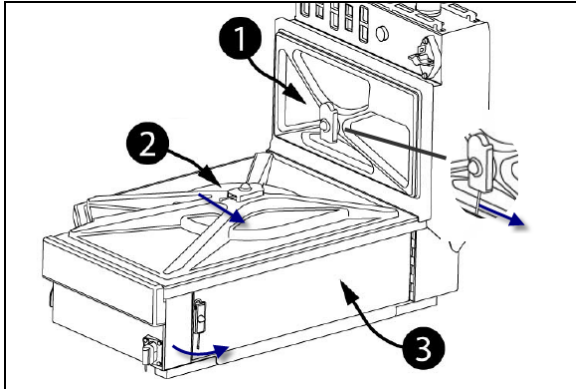

FIGURE 16: BATTERY PROTECTIVE COVER REMOVAL

1. Remove the battery compartment protective covers by pulling the rod on the spring latch to release and lift cover. Starting with (1) then (2) (Figure 16).
2. Lateral access panel (3) is hinged. Release it by pulling on the spring rod and swing open. (Figure 16 & Figure 17). Panel assembly is reverse of removal.

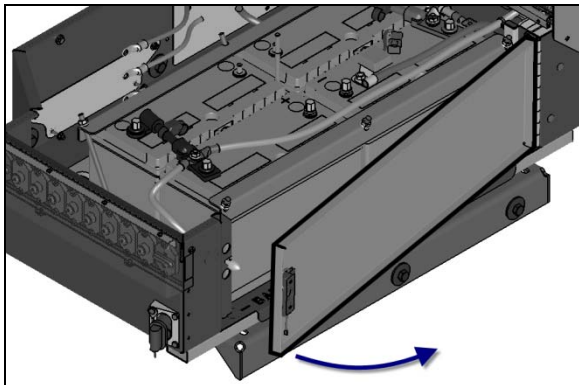

FIGURE 17: LATERAL PANEL OPENING



DANGER

To prevent possible electric shocks or sparking, the battery master switch should be in the "off" position before disconnecting cables from the batteries.



WARNING

24VD battery cable to r1 main battery relay (Figure 15) is still powered after battery master switch is set at the off position.

3. Unscrew tie-down nuts (6x) and remove clamps (2x).(Figure 18)

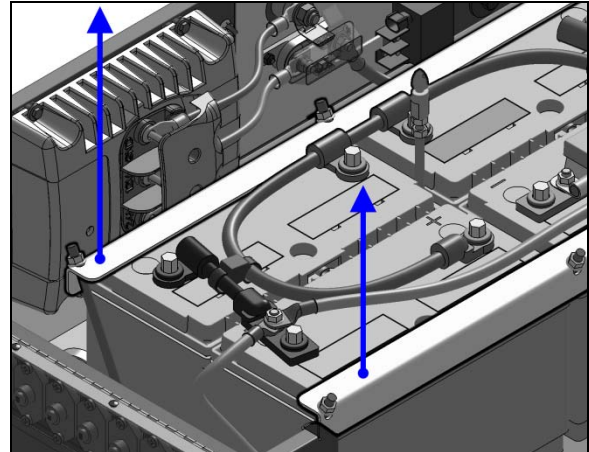

FIGURE 18: BATTERY FIXING CLAMPS REMOVAL

4. Remove battery cables from the batteries. Disconnect negative terminals first.

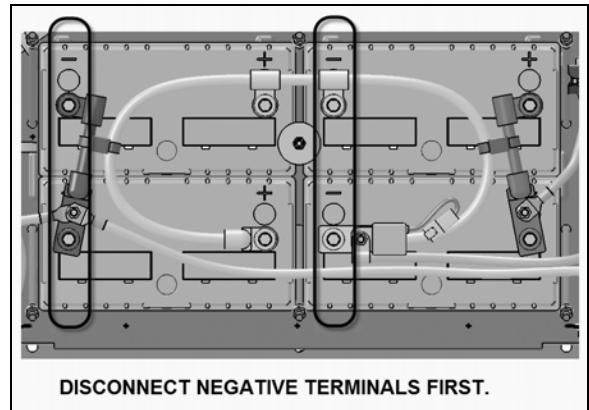

FIGURE 19: NEGATIVE TERMINALS

Note

When the battery cables have been removed from the batteries, wrap the battery terminals and cable ends with electric tape to prevent accidental grounding.

The ground (negative) cables should always be disconnected first and replaced last.

5. Remove the remainder of the connections.
6. Follow approved safe battery removal and handling procedure.



Caution

After performing battery replacement, make sure all protective covers are properly fitted and secured. This will protect battery terminals and circuit breaker bus bars against mist, dust and corrosion.

7. Installation is the reverse of removal.

**CAUTION**

AGM batteries should be replaced in pairs or four at a time.

Replace only with AGM type batteries of the same specification and capacity.

Prime system is programmed for the charging capacity of the batteries installed.

Installing a higher capacity battery will affect the battery life as the system will not fully charge the batteries, which is detrimental to battery performance.

Refer to “specifications” at the end of this section for further details.

**CAUTION**

Ensure that connections are not reversed when reinstalling batteries, since damage to electrical system components will result.

NOTE

When reinstalling batteries, battery connections must be tightened to 16 lbf-ft (200 lbf-in). A torque wrench is required to ensure an accurate tightening torque.

**DANGER**

To prevent possible electric shock or sparking, the battery master switch must be set to the “off” position before tightening an electrical connection.

NOTE

A protective coating should be applied on certain power connections that have been disconnected. Refer to procedure pr00002e included at the end of this section to know the recommended products and where they are used.

2.4 BATTERY RATING

Each of the 12 volt odyssey 31-pc2150s batteries used on the vehicle has the following rating:

Type: absorbed glass mat
Terminal type: top stud

Group size: 31
Volts: 12
Load test amperage (1/2 cca): 575
Reserve capacity (minutes): 205
Cold cranking (in amps) -at 0°f : 1150a

Maximum dimensions

Length (including flange): 13in/330mm
Width: 6.8in/173mm
Height (including top posts): 9.4in/239mm
Approximate weight: 77.8 lbs

Torque specifications

Battery post, battery terminal nut: 17 lbf-ft (200 lbf-in)

The reserve capacity is defined as the number of minutes a new, fully charged battery at 80of (26,6oc) can be discharged at 25 amperes and maintain a minimum of 1.75 volts per cell (10.5 volts total for one 12 volts battery). This rating can be used as a basis for determining how long a vehicle might run after an alternator failure. The cold cranking rating is defined as the minimum discharge current a battery will deliver in amperes for 30 seconds at 0of (-18oc) while maintaining a minimum of 1.2 volts per cell (7.2 volts total for one 12 volts battery). This rating can be used as a basis for comparing starting performance.

2.5 BATTERY MAINTENANCE

Several factors influence battery performance. The methods and inspection procedures proposed here will ensure your batteries are in good shape.

Local procedures and instructions take precedence over our proposed methods.

2.5.1 Visual Inspection

1. Check the outside of the battery for a broken or cracked cover or case that could permit loss of electrolyte. If obvious physical damage is noted, replace the battery. Also check for wet areas around the terminals.
2. Check for loose terminal posts, cable connections, damaged cables, and for evidence of corrosion. Correct conditions as required before proceeding with tests.
3. Check for damaged or loose battery tie-downs.

2.5.2 Removing surface charge

Disconnect cables from the battery and attach alligator clamps to the contact lead. Connect a load equal to half the cca (cold cranking amps) across the terminal for 5 seconds to remove surface charge from the battery.

2.5.3 Testing Battery Cables

Check all cable ring terminals and connections to determine if they are in good condition. Excessive resistance, generally caused by poor connections, produces an abnormal voltage drop which may lower voltage at the starter to such a low value that normal operation of the starter will not be obtained. An abnormal voltage drop can be detected with a low-reading voltmeter as follows:



DANGER

To prevent the engine from starting during these tests, remove circuit breakers cb91 and cb99 located in the vecr of the rear electrical compartment. Once the tests are completed, reinstall cb91 and cb99.

1. Check voltage drop between grounded (negative) battery terminal and vehicle frame by placing one prod of the voltmeter on the battery terminal and the other on a good ground (unpainted surface) on the vehicle. With the starter cranking the engine at a temperature of 70°f (21°c), voltage reading should be less than 0.3 volt. If the voltage reading exceeds 0.3 volt, there is excessive resistance in this circuit.
2. Check voltage drop between the positive battery terminal and the starter positive terminal stud while the motor is operated. If the reading is more than 2.5 volts, there is excessive resistance in this circuit.

Note
If it is necessary to extend the voltmeter lead for this test, use a #16 (awg) or larger wire.

3. Check voltage drop between the starter housing and a good ground on the vehicle. The reading should be less than 0.2 volt.



DANGER

Any procedure other than the following could cause personal injury or damages to the charging system resulting from battery explosion or electrical burns.

Wear adequate eye protection when working on or near the batteries. Ensure that metal tools or jumper cables do not contact the positive battery terminal (or a metal surface in contact with it) as a short circuit will result. Do not attempt to jump start a vehicle suspected of having a frozen battery because the battery may rupture or explode. Both the booster and discharged batteries must be treated carefully when using jumper cables. Follow exactly the procedure outlined later in this section, being careful not to cause sparks.

2.6 BATTERY CHARGING

The batteries used on this vehicle can be charged either on or off the vehicle. Use the booster block or the provided 110v receptacle to charge the batteries when they are left on vehicle and **make sure that the main battery disconnect switch is set to the “on” position.**

Caution

AGM (absorbed glass mat) batteries require a voltage-limited charger, ideally fitted with a battery temperature sensor for temperature correction of charging parameters.

Make sure your charger is multi-staged and minimally provides the following voltage values:
 Charge voltage: 13.8-14.6 volt @77°f (25°c)
 Float voltage: 13.4-13.6 volt @77°f (25°c)

Charging AGM battery on a typical constant current or taper current charger – even one time – may greatly shorten its life.

Please consult odyssey owner’s manual included with the OEM publications for charging tips and maintenance guidelines.

**DANGER**

During charging of the batteries, an explosive gas mixture forms in each cell. Part of this gas escapes through the vent holes and may form an explosive atmosphere around the battery itself if ventilation is poor. This explosive gas may remain in or around the battery for several hours after it has been charged. Sparks or flames can ignite this gas causing an internal explosion, which may shatter the battery.

1. Do not smoke near a battery which is being charged or which has been recently charged.
2. Do not break live circuits at battery terminals because a spark usually occurs at the point where a live circuit is broken. Care must always be taken when connecting or disconnecting booster leads or cable clamps on chargers. Poor connections are a common cause of electric arcs, which cause explosions.
3. The electrical system on this vehicle is negative ground. Installing the batteries with the positive terminals grounded or incorrect use of the booster battery and jumper cables will result in serious damage to the alternator, batteries and battery cables.

The alligator clamps of the tester or charger should make firm contact with the terminal battery adapter. **Never clamp charger or tester directly onto threaded studs or nuts.**

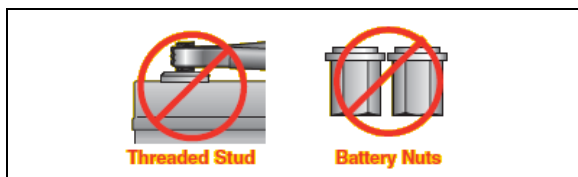

FIGURE 20: ALLIGATOR CLAMPS

**Warning**

Always turn off the charger before connecting or disconnecting to a battery.

Note

The charge rate must be doubled when the batteries are charged by the booster block, because of the series-parallel circuit.

**DANGER**

Do not use the “jump start boost” feature of an off-board battery charger to jump start the vehicle. This could damage the electrical system.

2.6.1 Booster Block

The booster block is located near the batteries in the engine compartment on the R.H. side and is accessible through the R.H. side door (Figure 21).

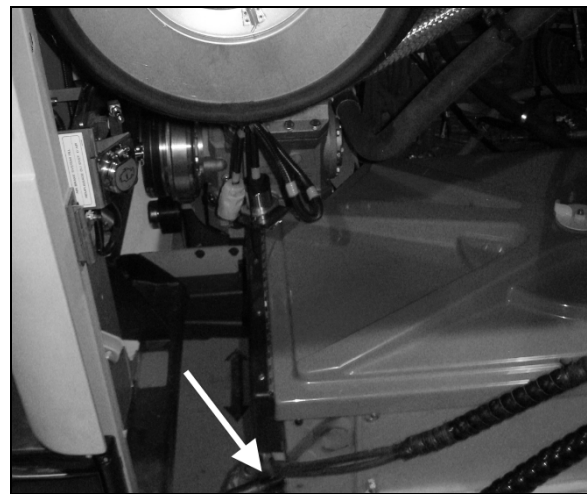

FIGURE 21: BOOSTER BLOCK

Both booster and discharged batteries should be treated carefully when using jumper cables. A vehicle with a discharged battery may be started by using energy from a booster battery or the battery from another vehicle.

**DANGER**

Jump starting may be dangerous and should be attempted only if the following conditions are met:

1. The booster battery or the battery in the other vehicle must be of the same voltage as the battery in the vehicle being started, and must be negative grounded.
2. **If the booster battery is in another vehicle, that vehicle's engine must be shut off before connecting and must remain off during jump starting.**
3. If the booster battery is a sealed-type battery without filler openings or caps, its test indicator must be dark or a green dot

must be visible. Do not attempt jump starting if the test indicator of the booster battery or the discharged battery has a light or bright center.

 **DANGER**
Follow the procedure exactly as outlined hereafter. Avoid making sparks.

Wear eye protection and remove rings, watches with metal bands and other metal jewelry.

Apply parking brake and place the transmission shift lever or push-button pads in neutral (n) position in both vehicles. Turn off lights, heater and other electrical loads.

1. Remove the protective plug from the booster block bulkhead connector located in the R.H. side engine compartment;
2. Connect to the bulkhead connector. **If the booster battery is in another vehicle, that vehicle's engine must be shut off before connecting and must remain off during jump starting;**
3. Disconnect the jumper cables in reverse order;
4. Install protective plug on the booster block terminal.

 **DANGER**
Any procedure other than the above could result in personal injury, property damage due to battery explosion, or damage to the charging system of the booster vehicle or of the boosted vehicle.

Note
Jumper cables must withstand 500 cranking amperes. If cable length is 20 feet (6m) or less, use 2/0 (awg) gauge wires. If cable length is between 20-30 feet (6-9m), use 3/0 (awg) wires.

2.7 AGM BATTERY CHARGING PRECAUTIONS

Agm (absorbed glass mat) batteries require a voltage-limited, temperature corrected charger. Make sure your charger is multi-staged and minimally provides the following voltage values:

Charge stage voltage:

13.8-14.6 @77°f (25°c)

Float stage voltage:

13.4-13.6 @77°f (25°c)

Charging agm battery on a typical constant current or taper current charger – even once – may greatly shorten its life.

2.8 BATTERY EQUALIZATION AND AGM BATTERIES

Equalization is a controlled over charge. Conventional flooded lead-acid batteries may benefit from this procedure, stirring the chemistry of the entire battery and countering stratification (layers of different concentration of electrolyte), and also countering sulfation that may have accumulated on the battery plates.

However, the "dry design" of agm batteries prevents chemical unbalance of the electrolyte. Manufacturers of this type of battery do not recommend performing equalization.

2.9 COMMON CAUSES OF BATTERY FAILURE

When a battery fails, the cause of failure may be related to something other than the battery. For this reason, when a battery failure occurs, do not be satisfied with merely recharging or replacing the battery. Locate and correct the cause of the failure to prevent recurrence. Some common external causes of battery failure are as follows:

1. A defect in charging system such as high resistance or a faulty alternator or regulator. The dashboard alternator telltale light illuminates if both alternators are defective.



Charging system warning light

2. A malfunction within the 12 volts system (equalizer).
3. Overloads caused by a defective starter or excessive use of accessories.
4. *Keep batteries clean.* Dirt and electrolyte on battery exterior shell may cause a constant drain.
5. Hardened battery plates, due to battery being in a low state of charge over a long period of time.

6. Shorted cells, loss of active material from plates.
7. Driving conditions or requirements under which the vehicle is driven for short periods of time.
8. A constant drain caused by a shorted circuit such as an exposed wire or water infiltration in junction boxes causing ground fault.
9. Failing to close disconnect switches during the night.

2.10 TROUBLESHOOTING

If a battery is known to be good and then has not performed satisfactorily in service for no apparent reason, the following factors may reveal the cause of trouble:

1. Vehicle accessories and disconnect switches inadvertently left on overnight.
2. Defects in the charging system, such as high wiring resistance, faulty alternator, regulator or battery equalizer.
3. A vehicle electrical load exceeding the alternator (or battery equalizer) capacity, with the addition of electrical devices, such as cb radio equipment, a cellular phone or additional lighting systems.
4. Defects in the electrical system, such as shorted or pinched wires.
5. Extended driving at a slow speed while using many accessories.
6. Loose or poor battery cable-to-post connections, previous improper charging of a run-down battery or loose hold-down clamp bolts.
7. High-resistance connections or defects in the cranking system.

2.11 "BATTERY VOLTAGE WARNING" PICTOGRAM

If the "battery voltage warning"  (battery voltage incorrect) pictogram shows up in the DID (driver information display), check the voltmeter gauge to determine if the battery voltage is too high or too low.

2.11.1 Voltmeter Gauge Definitions

Voltmeter drops below 24.4 volts dc

- Check alternator output.
- Check voltage regulator.
- Check battery connections.
- Check battery cells.
- Check battery equalizer connections.

Voltmeter exceeds 30 volts dc

- Check alternator output.
- Check voltage regulator.
- Check battery connections.

Battery balance

Note
<i>Allow at least 15 minutes to balance batteries after any corrective measure has been taken.</i>

1. Batteries out of balance (difference greater than 1.5 volts between the two battery banks).
 - Check battery equalizer connections.
 - Check equalizer cables for proper gauge.
 - Check battery connections.
2. Demand for 12-volt power exceeding rated amperage output of battery equalizers causing batteries to go out of balance.
 - Reduce 12-volt load or install additional battery equalizer(s).

3. PRIME ENERGY MANAGEMENT SYSTEM

The acronym “prime” stands for power recovery by intelligent management of energy.

This system focuses on eliminating parasitic loads on the engine by intelligent management of the alternators and air compressor duty cycle.

Instead of constantly charging, the alternators will use engine negative torque (braking, deceleration) to generate “free” electricity.

Depending on the compressed air requirement, prime will also trigger the production of compressed air on negative torque.

Prime also introduces maintenance-free absorbed glass mat (agm) batteries and a new vanner 80 series battery equalizer that monitors battery state of charge (soc).

Battery temperature, voltage and current are also monitored to prevent overcharging and overheating.

Maximum fuel economy is obtained on a ride when the mix of hilly and flat portions allows the batteries to be charged when the vehicle is in free wheel. It basically means that batteries are charged with free energy and that no fuel consumption is dedicated to charge the batteries.

3.1 COMPONENTS

New components includes agm batteries, an 80 series vanner battery equalizer, a temperature sensor located on the battery post and two voltage and current sensors monitoring 12v and 24 v circuits.

Refer to Figure 22 below.

The compressor duty cycle control is achieved by an electric air dryer. This is covered in section 12 of this manual.

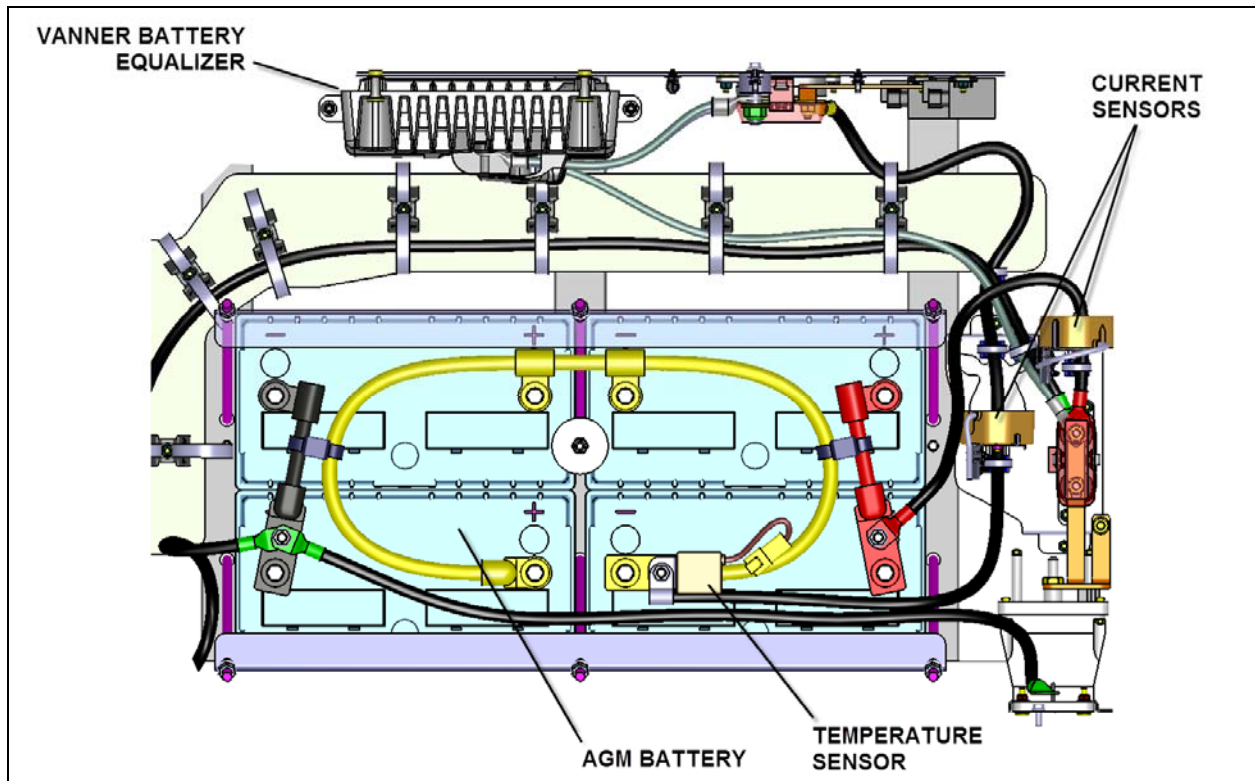

FIGURE 22: PRIME ELECTRICAL COMPONENTS

3.1.1 Vanner 80 Series Battery Equalizer Fault Codes

The 80 equalizer can bus interface supports sae j1939 diagnostic message 1 (dm1) for active diagnostic trouble codes. See list below. Refer to oem publication *Vanner Vann-guard 80 series owner's manual pdf* for additional details.

Description	Spn	Fmi
Over voltage fault (ovf)	168	0: data valid, but above normal operating range – most severe
Under voltage fault (uvf)	168	1: data valid, but below normal operating range – most severe
Imbalance (imb)	520448	0: data valid, but above normal operating range – most severe
Equalizer fault (eqflt)	520449	1: data valid, but below normal operating range – most severe
Temperature sensor fault (tsf)	520450	0: data valid, but above normal operating range
Temperature sensor fault (tsf)	520450	1: data valid, but below normal operating range
Temperature sensor fault (tsf)	520450	2: data erratic, intermittent, or incorrect – most severe
12v current sensor fault (scsf)	520451	0: data valid, but above normal operating range – most severe
12v current sensor fault (scsf)	520451	1: data valid, but below normal operating range
12v current sensor fault (scsf)	520451	2: data erratic, intermittent, or incorrect – most severe
24v current sensor fault (dcsf)	520452	0: data valid, but above normal operating range – most severe
24v current sensor fault (dcsf)	520452	1: data valid, but below normal operating range
24v current sensor fault (dcsf)	520452	2: data erratic, intermittent, or incorrect – most severe

3.2 DID DISPLAY

In the DID you will find the percentage of trip made with regenerated electricity displayed along with the instantaneous fuel consumption.

This value is reset each time the engine is restarted

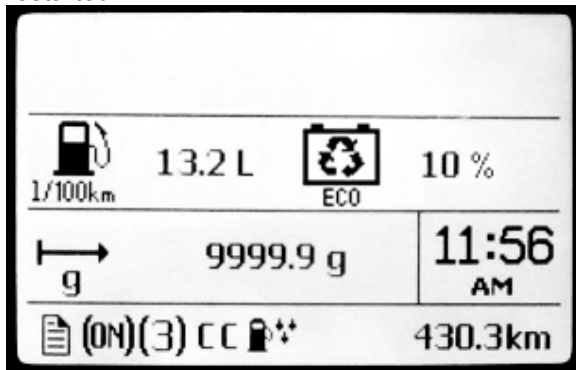

FIGURE 23: PRIME DID DISPLAY

In addition to the standard voltage gage, the DID also includes a state of charge gage for the batteries:

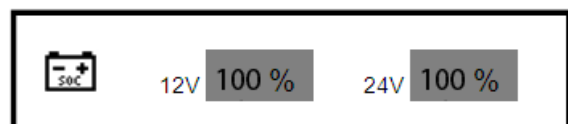

FIGURE 24: BATTERY STATE OF CHARGE

This gage displays the level of charge for the 12v and 24v battery banks in percentage.

4. TROUBLESHOOTING AND TESTING THE MULTIPLEX VEHICLES

4.1 ELECTRICAL SYSTEM DIAGNOSTIC

Using the driver information display (Figure 25), check if there are active errors in the vehicle electrical system. With the **diagnostics** menu, highlight **fault diagnostics** and then highlight **electrical system** to request a diagnostic of the electrical system from the mcm. Press the enter key. If applicable, the DID shows the multiplex device id, the fault messages or fault codes recorded. When more than one fault is recorded, an arrow pointing down appears on the right of

the display. Use the down arrow to see all the fault messages.

Once the problem corrected, the DID still shows the fault as being active. You have to leave the **fault diagnostics** menu, wait approximately 20 to 30 seconds and then return to **fault diagnostics** to request a new diagnostic of the **electrical system** from the mcm. The DID should display the fault as being inactive. The mcm can store up to 20 faults, i.e. the first 10 and the last 10. Middle faults will be erased. If cb6 breaker is tripped, the fault history will be erased from the mcm memory.

Note

It is of the utmost importance to have a DID (driver information display) in working condition because it is the most important tool to achieve troubleshooting on a multiplex vehicle.

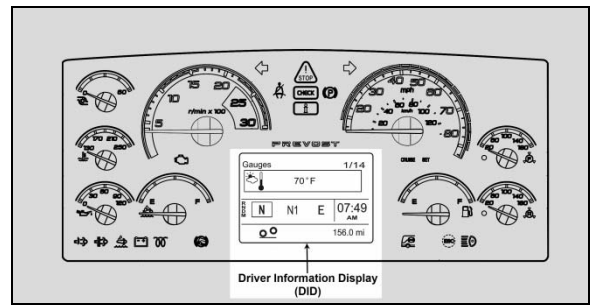

FIGURE 25: DRIVER INFORMATION DISPLAY

4.2 PROBING VOLTAGE ON THE MULTIPLEX CIRCUITS

Some multiplex modules are supplied by 12 volts while others are supplied by 24 volts. The 12-volt or 24-volt information is found on the modules symbol in the wiring diagram. Before taking voltage readings to track the source of a problem, first verify if the module is supplied by 12v or 24v, if not, residual voltage on the module inputs/outputs can draw an erroneous conclusion.

Inactive multiplex output = residual voltage of 18% to 33% of supply voltage.

Inactive multiplex input = residual voltage of 50% of supply voltage.

Note

- Verify on the wiring diagram whether the voltage is 12v or 24v,
- For a 12v module: an active voltage would be 12v or 0v but not in between. If you measure the intermediate tensions (ex. 6v, 2v, or 4v) this must be interpreted as if the input or the output is inactive.
- For a 24v module: an active voltage would be 24v or 0v but not in between. If you measure the intermediate tensions (ex. 12v, 4v, or 8v) this must be interpreted as if the input or the output is inactive.

4.3 CAN NETWORK

The can network wiring is separated in sections and uses connectors that are not shared with other circuits, with the exception of c27. This allows sections of the network to be isolated to help locate short-circuit on the can.

In case of short-circuit on the can network, this affects all the modules and they all act as “no response” in the error messages of the “**electrical system**” menu. To locate a short-circuit, proceed by disconnecting one module zone at a time while verifying if this makes inactive the errors in the modules still connected. Connector c1 (front electrical & service compartment) disconnects all the modules at the rear of the vehicle from the network. Connector c5 (front electrical & service compartment) disconnects all the modules from the entrance door & wiper control panel. Connector c3 (rear electrical panel) disconnects all the modules at the rear of the vehicle from the network.

Example: disconnect c5 and c1 and then verify the status of the errors. If the front modules (a41 to a46) now give inactive errors, which means short-circuit is elsewhere than in the front electrical & service compartment.

4.3.1 Spare CAN

A spare can network is installed between the front and the rear of the vehicle. It has connectors installed at each end to facilitate swapping from the regular can network to the

spare can network. Refer to the vehicle wiring diagram and section 4.6 for more information.

4.4 MULTIPLEX INPUT TEST MODE

The multiplex input test provides useful information to diagnose multiplexed inputs of switches and sensors, complimentary to the electrical system diagnosis.

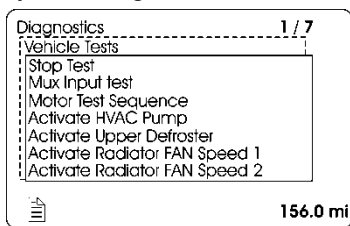

To initiate the test mode, use the driver information display (DID) diagnostics menu. Select vehicle tests submenu and then mux input test. Press enter button to start the test. The DID status line will show test to confirm the test mode is active. To exit test, press escape button, select stop test submenu and then press enter button twice. Test will disappear from the DID status line.

Instrument panel audible alarm emits a *beep* each time an off/on transition is detected on a multiplex input. This allows quick verifying if the switches and sensors are detected or seen by the multiplex modules. When the vehicle is parked, the back-up alarm also emits a *beep* that allows verification of the sensors at the rear of the vehicle.

Certain inputs are doubled (door operating buttons) and also other inputs activate at the same time (ex. Kneeling switch and kneeling proximity sensor switch). For these inputs, 2 *beeps* are emitted. If only one *beep* is heard, one of the inputs is defective.

Switches and sensors supported by the switch/sensor test mode
HVAC control unit driver's section on/off
HVAC control unit driver recirculate switch
HVAC overhead compartment fan switch
Engine rear start selector switch "rear start"
Engine rear start selector switch "normal"
Engine ignition front switch
Engine ignition rear switch
Entrance door inside opening /closing switch
Entrance door outside opening /closing switch
Kneeling down switch
Electric horn button
Lh turn signal

Rh turn signal
Headlights beam toggle switch
Windshield wipers intermittent position switch
Windshield washer switch
Kneeling up switch
Interior lighting switch, 2 positions
Driver's area lighting switch
Reading lights switch
Hazard warning flashers switch
Headlights switch, 2 positions
Tag axle lever
Wheelchair lift activation switch
Windshield lower wiper

The following inputs, either certain options or sensors which are difficult to activate, are not supported by the switch/sensor test:

- Service chime enable switch,
- Horn selector switch,
- Outside rear view mirror heat,
- Mirror control switches,
- Low-buoy switch,
- Starter sensor,
- Abs warning input,
- WCL switch,
- Driver's power window switch,
- Fog lights switch,
- Alternator sensors 1 & 2,
- Retarder active signal,
- Radiator fan speed 1 & 2 signals.

In test mode, with the parking brake applied and the passenger set point set to a value higher than 64°F (18°C), the circulator pump is not set to off as it would normally do when the outside temperature gets above 50°F (10°C). This feature allows verification of the pump when inside a garage. This is also useful when working on the heating system to remove air pockets trapped in the system. Motor test sequence

4.5 MOTOR TEST SEQUENCE

This test mode allows testing of the electrical motors and electric contactors without the need to have the engine running. Note that while in test mode, the engine cannot be started. Prerequisite conditions for the motor test mode:

- A. The battery charger must be connected to a 110-120 volt power supply. If not, the test will be interrupted when the voltage drops below 24 volts,
- B. Engine not running,
- C. Parking brake applied,

**Danger**

Before starting the test sequence, make sure nobody is working in the evaporator or condenser compartment.

Note

The back-up alarm will beep ten (10) times prior the test starts to warn people that may be working on the vehicle.

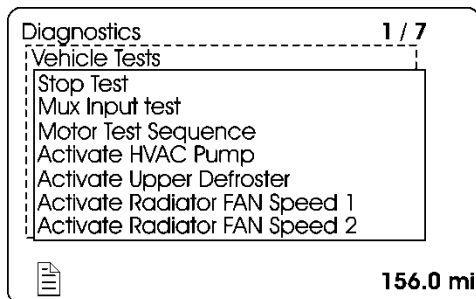
**To enter this mode:**

1. Using the dashboard DID, select diagnostics menu and press enter button ;
2. Select vehicle test, press enter button then select motor test sequence and press enter button to initiate the test mode for electrical motors;
3. Ten (10) beeps can be heard indicating the motor test mode has started.

Using the test mode:

During the entire test, the instrument panel audible alarm gives a signal each second to remind that the motor test mode is underway.

4.5.1 Test Sequence**Go to the condenser compartment:**

- The condenser fans run at speed 1 for 3 seconds, then after a short pause, run at speed 2 for 3 seconds.

- The passenger's unit refrigerant solenoid valve activates 2 times (audible "clicks" will be heard).
- The overhead compartments a/c unit refrigerant solenoid valve activates 2 times (audible "clicks" will be heard).
- The haldex consep oil separator automatic drain valve activates 3 times (audible "clicks" will be heard).

Then 5 beeps can be heard from the back-up alarm to indicate to go to the engine compartment.

In the engine compartment, the sequence is as follows:

- The fan mounted on the engine compartment curbside door engages in speed 1 and then in speed 2.
- A/c compressor clutch activates 3 times (audible "clicks" will be heard).
- Right compressor unloader activates 3 times (audible "clicks" will be heard).
- Fan clutch is disengaged (fan can be turned freely by hand, 3 seconds delay).
- Fan clutch engages in speed 1 for 3 seconds (fan can be turned by hand but a certain strength is needed).
- Fan clutch engages in speed 2 for 3 seconds (cannot be turned but hand).

5 beeps from the back-up alarm indicate to go to the evaporator compartment.

In the evaporator compartment:

- Evaporator fan motor runs at speed 1 for 3 seconds then runs at speed 2 for 2 seconds.
- Hot water pump starts running for 5 seconds and hot water pneumatic valve cycles 3 times.

5 beeps from the back-up alarm indicate to get to the driver's area inside the vehicle.

Inside the vehicle:

- The driver's HVAC unit refrigerant solenoid valve cycles 3 times and the hot water pneumatic valve cycles 3 times also (audible "clicks" will be heard).
- Left and right overhead compartment fans run one after the other for 5 seconds.

To exit the electric motors test sequence, press escape button, select stop test submenu and then press enter button twice.

4.6 FORCED ACTIVATION OF THE RADIATOR FAN CLUTCH

To prevent the engine from overheating in case of malfunction of the clutch activation system, it is possible to force activation of the clutch.

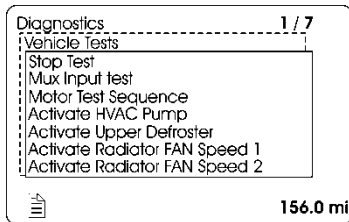

1. On the driver information display, select diagnostics menu. Select vehicle tests submenu and then activate radiator fan speed 1 or activate radiator fan speed 2 as required.
2. The DID status line will show test to confirm the forced activation of the radiator fan clutch. To cancel, turn the ignition switch to the off position or press escape button, select stop test submenu and then press enter button twice. Test will disappear from the DID status line.

If the fan clutch does not engage using this procedure then the clutch is faulty or the wiring between the multiplex module and the clutch is faulty. Mechanically lock the fan clutch as described in section 05: COOLING SYSTEM of the maintenance manual.

4.7 CAN NETWORK OVERVIEW

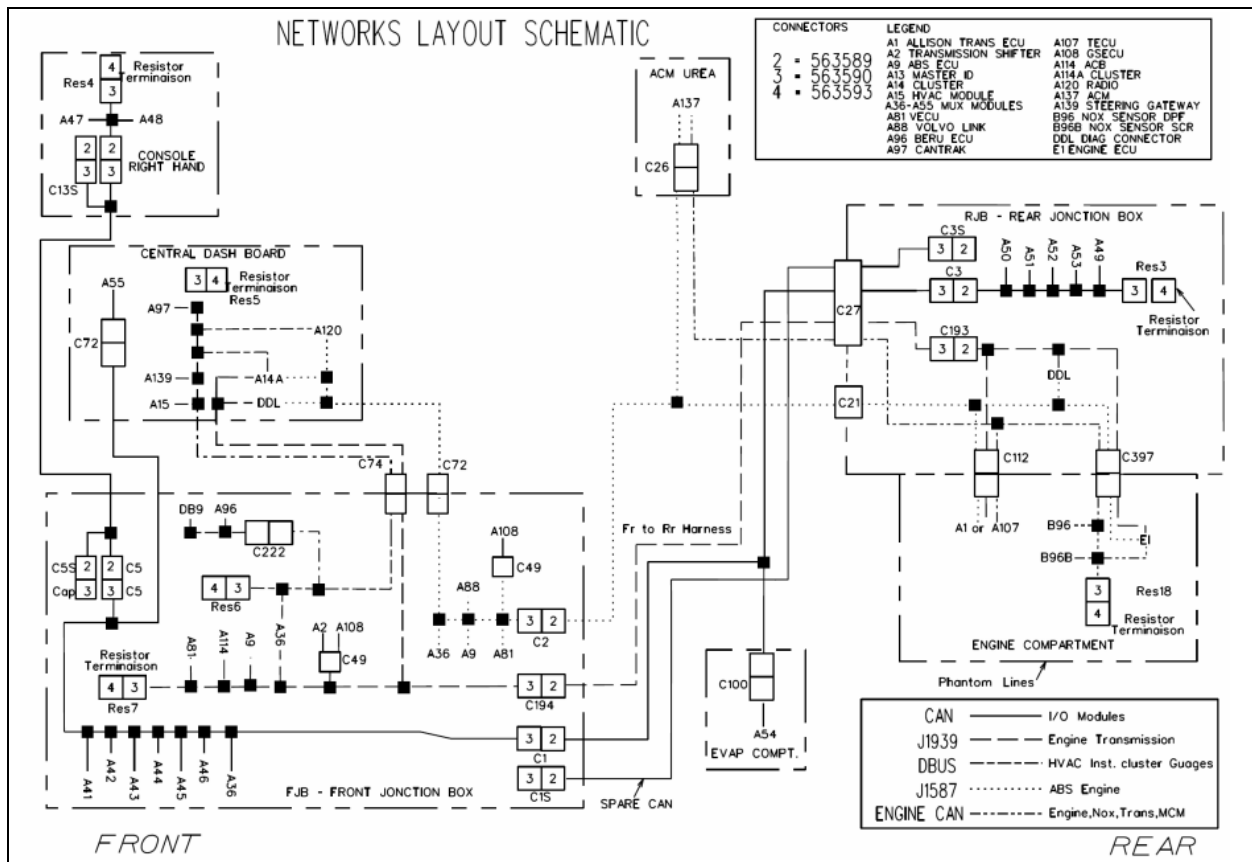

FIGURE 26: X3-45 COACH NETWORK LAYOUT

The multiplex modules are connected by a controller area network according to the layout above.

A backup spare network is pre-wired in the coach to quickly resolve any connectivity issue. Spare connectors for this network are identified by "s" e.g.: **c5s** is the spare for **c5**.

With the introduction of obd 2013 emissions standard, we now have a high speed can diagnostic and engine programming network, also known as an iso network.

Refer to the list below for cross reference between the current sae data line designation and the former designation:

- DI-0 = prevost can 1 or **b-bus**
- DI-1 = **j-1939** ecu communication, engine, abs, allison
- DI-2 = can **iso** for engine diagnostics and software download
- DI-3 = can 2 or **d-bus**
- DI-4 = **j1587** drive train information network
- DI-5 & 6 = not used

- DI-7 = power train subnet or engine can
- DI-8 = not used (eaton)
- DI-9 = not used on this vehicle (i-shift to volvo engine)

On wiring diagrams, the sae standard data link designation appears. The different networks will be identified on the data wire identification.

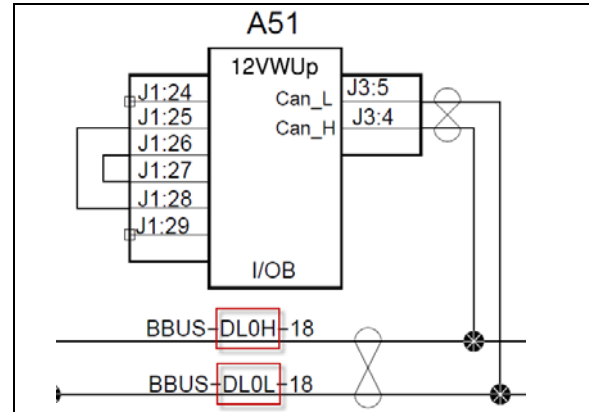

FIGURE 27: DATA WIRE IDENTIFICATION

4.8 MULTIPLEX TROUBLESHOOTING

Problem/symptom	Probable causes	Actions
Vehicle does not start	<p>Rear start selector switch is not in the normal position</p> <p>Master cut-out switch on the rear electrical panel is in the off position (down)</p>	<ol style="list-style-type: none"> 1. Check that the rear start selector switch is flipped up to normal start position and master cut-out switch is flipped up to on and retry cranking 2. Flip the rear start selector switch to "rear start" and start the vehicle from the rear

Problem/symptom	Probable causes	Actions
	<p>Can network problem (multiplex)</p> <p>Module a53 not powered or is defective</p> <p>Engine ecm does not receive the ignition signal</p> <p>Engine ecm is not powered</p>	<p>If the vehicle does not start from the rear:</p> <ol style="list-style-type: none"> 1. Verify that module a53 is powered: <ol style="list-style-type: none"> a) Check the diagnostics menu of driver information display (DID). Select fault diagnostics and electrical system. The message “no response moda53, active”, indicates a power problem on the module or a can network problem. b) Check / reset circuit breaker cb5 c) Check / replace fuse f65 d) Probe gray connector on module to see if it is powered. 2. Verify that the engine ecm is powered and get the ignition signal <ol style="list-style-type: none"> a) Check / reset circuit breaker cb8 check / replace fuse f74 b) Check / reset circuit breaker cb2 check / replace fuse f78
<p>None of the multiplexed functions are operating, including the basic limp-home functions (door opening, flashers, wipers in speed 1)</p> <p><i>Note: the sunshades are still functioning since these are not multiplexed</i></p>	<p>The program version in the mcm is different than the program in the i/o modules and the mcm is forcing all i/o modules to stay inactive</p>	<ol style="list-style-type: none"> 1. Engage the auto-programming of the i/o modules: turn the ignition switch to the off position, flip the master cut-out switch on the rear electrical panel to off and on and then turn the ignition switch back on. The letters can will appear in the telltale lcd panel for about 3 minutes everything shall get back to normal once the letters can are replaced with outside temperature display 2. Try disconnecting the green connector on the mcm and reconnect 3. Try disconnecting the mcm completely, leave it disconnected and see if the limp-home functions (start of the vehicle from the engine compartment, wipers speed 1, flashers, etc) are functioning

Problem/symptom	Probable causes	Actions
<p>Many secondary functions (not essential for driving) not functioning (interior lighting, driver's area lighting, wiper speed 2 and intermittent).</p> <p>Marker lights and clearance lights are turned on when setting ignition to the on position.</p>	<p>The mcm does not receive 24 v power.</p> <p>The can network is not working. It could be caused by a short on the network, an open circuit, a problem with the mcm or the mcm being disconnected from the network.</p>	<ol style="list-style-type: none"> 1. Check / reset circuit breaker cb6 (3rd from the left on the junction panel) check / replace fuse f1 2. Operate in limp-home mode by starting the vehicle from the engine compartment (rear start). All functions essential to drive are available <p>To close and lock the door, pull the door manually up to its closed position and it will lock by itself. The door opening button is still functioning</p>
<p>Entrance door does not open nor close using the control buttons</p> <p>Defroster fan not functioning</p> <p>Windshield wipers not functioning in speed 1 or intermittent</p>	<p>Module a47 is not powered or is faulty</p>	<ol style="list-style-type: none"> 1. Check the diagnostics menu of driver information display (DID). Select fault diagnostics and electrical system. The message "no response moda47, active" indicates a power problem on the module. (a can network problem would show the same message but doesn't produce these symptoms). 2. Check / reset circuit breaker cb6 3. Check / replace fuse f5 4. Check / replace relay r18 5. Probe gray connector on module to see if it is powered. 6. Use the air release valves near the entrance door and in the front service compartment to lock / unlock the door
<p>Windshield wipers not functioning in speed 1 or intermittent</p>	<p>No power on r23</p>	<p>Check / replace fuse f82</p>
<p>HVAC condenser fans not functioning in speed 1</p>	<p>Circuit breaker cb7 was manually tripped and not reset</p>	<p>Check / reset circuit breaker cb7</p>
<p>HVAC condenser fans not functioning in speed 2</p>	<p>Circuit breaker cb7 was manually tripped and not reset</p>	<p>Check / reset circuit breaker cb7</p>

SECTION 06: ELECTRICAL

Problem/symptom	Probable causes	Actions
<p>Windshield washer not functioning</p> <p>Windshield upper section de-icing system not functioning</p> <p>Defroster fan is functioning but no heat or cooling available in the driver area.</p>	<p>Module a46 is not powered or is faulty</p>	<ol style="list-style-type: none"> 1. Check the diagnostics menu of driver information display (DID). Select fault diagnostics and electrical system. The message “no response moda46, active” indicates a power problem on the module. (a can network problem would show the same message but doesn't produce these symptoms). 2. Check / reset circuit breaker cb1 3. Check / replace fuse f12 or f13 4. Probe gray connector on module to see if it is powered.
<p>Low beam headlights and front flasher on left side not functioning</p> <p>Electric horn not functioning</p>	<p>Module a45 is not powered or is faulty</p>	<ol style="list-style-type: none"> 1. Check the diagnostics menu of driver information display (DID). Select fault diagnostics and electrical system. The message “no response moda45, active” indicates a power problem on the module. (a can network problem would show the same message but doesn't produce these symptoms). 2. Check / reset circuit breaker cb2 3. Check / replace fuse f33 and f34 4. Check / replace relay r19 5. Probe gray connector on module to see if it is powered.
<p>Low beam headlights and flasher on right side not functioning</p>	<p>Module a48 is not powered or is faulty</p>	<ol style="list-style-type: none"> 1. Check the diagnostics menu of driver information display (DID). Select fault diagnostics and electrical system. The message “no response moda48, active” indicates a power problem on the module. (a can network problem would show the same message but doesn't produce these symptoms). 2. Check / reset circuit breaker cb2 3. Check / replace fuse f33 and f34 4. Check / replace relay r19 5. Probe gray connector on module to see if it is powered.

Problem/symptom	Probable causes	Actions
<p>Rear flashers not functioning</p> <p>Stoplights and center stoplights not functioning</p>	<p>Module a51 is not powered or is faulty</p>	<ol style="list-style-type: none"> 1. Check the diagnostics menu of driver information display (DID). Select fault diagnostics and electrical system. The message “no response moda51, active” indicates a power problem on the module. (a can network problem would show the same message but doesn't produce this symptom). 2. Check / reset circuit breaker cb2 3. Check / replace fuse f80 4. Probe gray connector on module to see if it is powered.
<p>Engine is overheating and radiator fan clutch does not engage</p> <p>The a/c compressor clutch does not engage</p>	<p>Module a52 is not powered or is faulty</p>	<ol style="list-style-type: none"> 1. Check the diagnostics menu of driver information display (DID). Select fault diagnostics and electrical system. The message “no response moda52, active” indicates a power problem on the module. (a can network problem would show the same message but doesn't produce this symptom). 2. Check / reset circuit breaker cb5 3. Check / replace fuse f65 4. Probe gray connector on module to see if it is powered.
<p>Evaporator fan not functioning</p>	<p>Circuit breaker cb3 tripped</p> <p>Module a54 is not powered or is faulty</p>	<ol style="list-style-type: none"> 1. Check / reset circuit breaker cb3 2. Check the diagnostics menu of driver information display (DID). Select fault diagnostics and electrical system. The message “no response moda54, active” indicates a power problem on the module. (a can network problem would show the same message but doesn't produce this symptom). 3. Check / reset circuit breaker cb5 4. Check / replace fuse f67 , f68 5. Probe gray connector on module to see if it is powered.

Problem/symptom	Probable causes	Actions
HVAC condenser fans not functioning in speed 1	Module a54 is not powered or is faulty	<ol style="list-style-type: none"> 1. Check the diagnostics menu of driver information display (DID). Select fault diagnostics and electrical system. The message “no response moda54, active” indicates a power problem on the module. (a can network problem would show the same message but doesn't produce this symptom). 2. Check / reset circuit breaker cb5 3. Check / replace fuse f67 , f68 4. Probe gray connector on module to see if it is powered.
Fire alarm telltale light and audible alarm always on and there is no fire or high temperature in the engine compartment	Short-circuited fire sensor or defective sensor	Prior to start the vehicle, cycle the ignition key to the on position, off position and then on position again and then start the vehicle. This will deactivate the fire alarm function. This has to be repeated each time the vehicle is re-started
The vehicle is parked and the electrical horn is activated to indicate a fire in the engine compartment but there is no fire	Short-circuited fire sensor or defective sensor	Cycle the ignition switch between the on and off position twice within 3 seconds. This will deactivate the fire alarm function. This has to be repeated each time the vehicle is parked
A single light, a group of led lights or another function of the vehicle is not functioning	The multiplex outputs are protected in current by an internal “soft-fuse”. When an output is shorted, it turns off and stays off until the "soft-fuse" is reset	Turn the ignition switch to the off position and turn to the on position again. This resets all "soft –fuses"
No backlighting in the instrument cluster	Circuit breaker cb10 is tripped or fuse f20 blown	<p>Check / reset circuit breaker cb10</p> <p>Check / replace fuse f20</p>

Problem/symptom	Probable causes	Actions
<p>The radiator fan clutch does not function and the engine is overheating</p>		<ol style="list-style-type: none"> 3. Set the ignition switch to the on position. 4. Activate the dashboard telltale light test switch 3 times within 4 seconds. 5. In the engine compartment, set the starter selector switch to rear start and then start the engine from the rear. <p>While in this mode, the rear start push-button can be used to manually engage the fan clutch. The multiplex system knows when the engine is already running, and it will not activate the starter.</p> <ol style="list-style-type: none"> 6. Press the push-button one time to engage the clutch in 1st speed, press a second time to engage in 2nd speed, press a third time to stop the fan, press once again to return to 1st speed. <p>If the fan clutch does not engage using this procedure then the clutch is faulty or the wiring between the multiplex module and the clutch is faulty. Mechanically lock the fan clutch as described in section 05: COOLING SYSTEM of the maintenance manual.</p>

4.9 MULTIPLEX ERROR MESSAGES TROUBLESHOOTING LIST

Multiplex error messages that can be displayed on driver information display (DID) are alphabetically listed in section 06b at the end of section 06 along with fmi description, fault condition, possible symptoms and possible causes.

4.10 MULTIPLEX MODULE “NO RESPONSE” TROUBLESHOOTING LIST

Multiplex module “no response” messages that can be displayed on driver information display (DID) are listed in section 06c at the end of section 06 along with fmi description, fault condition, possible symptoms and possible causes.

4.11 ESSENTIAL FUNCTIONS TO OPERATE THE VEHICLE

Even with a defective mcm (master chassis module) or a can network problem, essential base functions are maintained to rear start the vehicle from the engine compartment and drive in a secure manner.

However, many secondary functions are lost. In this case, the following directives must be followed.

- Never connect a battery charger when the ignition is at the on position on a vehicle with a can defective or certain functions will start up by themselves,
- Disconnect the charger before starting the vehicle, if not the default functions will not activate,
- If the default mode does not activate, try to turn the ignition off while ensuring that no

charger is connected and then restart the vehicle.

4.11.1 Available Functions

- Startup: turn on the ignition in the driver's area and rear start the vehicle from the engine compartment,
- Opening the door: functions normally,
- Closing the door: manually pull on the door panels and it will lock automatically,
- Windshield wipers: wipers functions at 1st speed only,
- Headlights: low beams only,
- Directional signals: rear and front only,
- Stoplights: 2 upper stoplights + high-mounted stoplight are functional,
- HVAC: functional with set point fixed at 68°F (20°C), evaporator and condenser fixed at speed 1, defroster fixed at speed 4.

4.12 LOWER PRIORITY MODULES FOR BREAKDOWN SERVICE

Modules A43 (I/O-A) and A44 (I/O-B) affect lower priority functions. These modules can therefore be used as spare parts for breakdown service while on the road.

Functions lost if A43 is removed and used as spare part:

- High beams,
- Ability to turn on the parking lights only,
- "watch your step" sign,
- Driver ceiling light,
- Tag axle activation,
- Courtesy flashers

Functions lost if A44 is removed and used as spare part:

- Fresh air damper mix trap control,
- Driver's area and entrance ceiling lights,
- Front clearance lights.

4.13 MULTIPLEX MODULES

4.13.1 MCM Module

The mcm plays the role of interface between the engine ECM, the transmission TCM, the telltale panel module and other IO-A, IO-B modules. When a multiplex module is being replaced, the mcm will inform the new module of its role and function accordingly to the vehicle options. The mcm keeps the back-up of the vehicle specific multiplex program.

4.13.2 IO-A Module

Io-a modules receive inputs and control outputs. Io-a's are used for all outputs of 1 amp or less.

4.13.3 IO-B Module

Io-b modules receive inputs and control outputs. Io-b's are used for outputs up to 30 amps.

4.14 MULTIPLEX MODULES REPLACEMENT

IO-A, IO-B multiplex modules can be replaced and reprogrammed without having to connect a computer to the vehicle.

The mcm must be reprogrammed using a laptop computer equipped with VPG software, connected to c226 (db9 connector) found in the front electrical compartment (see Figure 29). However, an updated vehicle multiplex program saved on a laptop computer can be uploaded into the mcm without the need of vpg software.

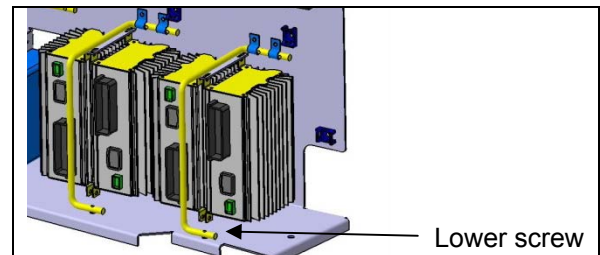

FIGURE 28: IO-B MODULE REMOVAL 06638

4.14.1 Replacing IO-A or IO-B Modules

Set the ignition switch to the on position and leave in that position at all time while performing this procedure.

1. On rear electrical junction panel, trip circuit breaker cb6.
2. Replace the module and plug connectors (*for IO-B modules, disconnect the green*

connector first, then the grey one and finish with the black connector. To disconnect the black connector, slide downwards the red latch. Remove the lower screw that holds the cable attachment rod onto the floor portion of the panel and flip the rod up, this will relieve the IO-B module, see Figure 28).

3. Reset circuit breaker cb6. Doing so will initiate the I/O reprogramming.

Note

Jb6 is a wake-up pin. Ja15 output remains active for 5 minutes after jb6 is inactive.

When initiating reprogramming:
 Switch sw83 (ignition key) remains closed, providing 24-volt on jb6, i/o modules and r18. All modules get power.

Cb6 is tripped and reset which is forcing mcm reboot.

When resetting cb6, all modules get power, mcm goes into "start mode". I/o modules needing new program will request reprogramming to mcm while in "start mode".

4. The DID indicates "mux autoprogramming i/o module please wait" until the reprogramming is complete unless a higher priority message must be displayed. If this is the case, press escape button repeatedly to acknowledge the higher priority messages.
5. Check the **diagnostics** menu of the driver information display (DID). Select **fault diagnostics** and **electrical system**. Verify the fault message to be certain the module is reprogrammed. If the module is not reprogrammed, the message "axx not responding" appears where axx is the module number (ex: a41, a42...etc).

4.14.2 Replacing The MCM

1. Set the ignition key to the on position and leave in that position at all time while performing this procedure.
2. On rear electrical junction panel, trip circuit breaker cb6.
3. Replace the module.
4. Reset circuit breaker cb6.
5. The vehicle specific multiplex program needs to be uploaded in the mcm.

4.14.3 Uploading the vehicle specific multiplex program in the mcm

A laptop computer running windows xp or windows 7 must be connected to the rs232 serial port db9 connector (identified c226) found on the front service compartment electrical panel. Please contact your Prevost service representative in order to get the vehicle specific multiplex program. Save the specific multiplex program on your computer desktop.

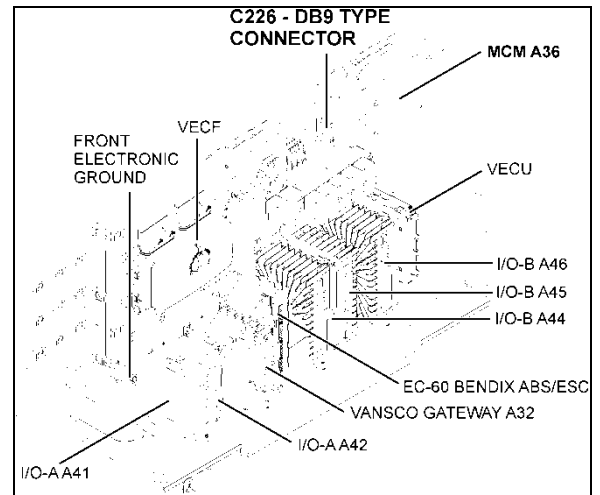

FIGURE 29: DB9 CONNECTOR AND MCM LOCATION

Set the ignition switch to the on position and leave in that position at all time while performing this procedure.

1. Assure that the vehicle battery charger is connected to 120-volt and that the laptop computer battery is fully charged.
2. Connect the laptop computer to the mcm through the db9 connector. To do so, you need (see Figure 30):

1x usb to serial db9 rs232 adapter (sold at staples);

1x prevost interface cable p/n 066009;



FIGURE 30: USB TO SERIAL DB9 RS232 ADAPTOR AND PREVOST 066009 INTERFACE CABLE

3. Identify com port number. To do so, right click on “my computer” to open “computer management”. Select “device manager” and note the com number (see Figure 31).

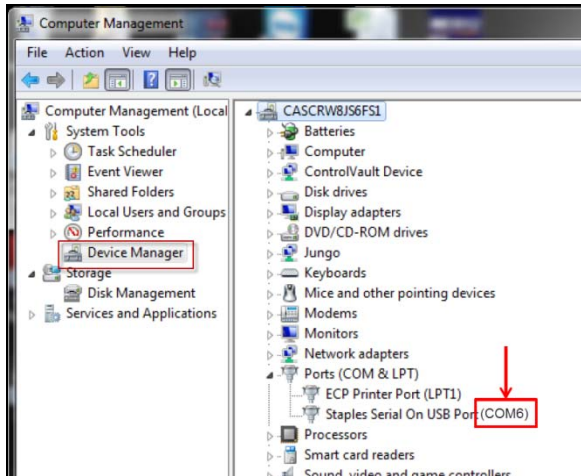

FIGURE 31: IDENTIFYING COM PORT NUMBER

4. Double-click on the com port and validate the port settings. Settings should be as shown on Figure 32.

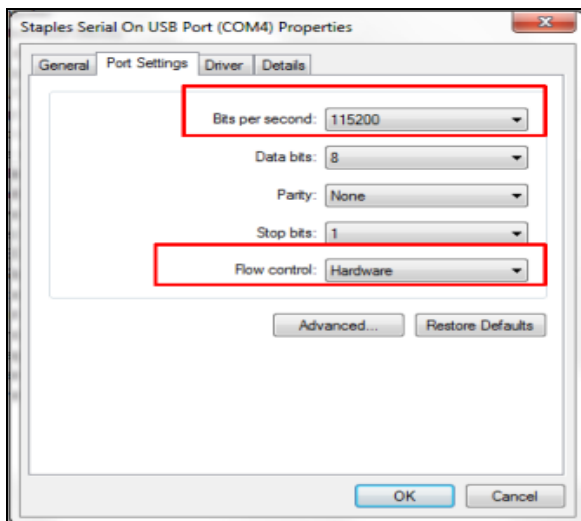

FIGURE 32: PROPER PORT SETTINGS

5. Locate the specific multiplex program file previously saved on your computer desktop. The file name should contain the vin's last 4 digits of the vehicle you are about to update (example: file mp_00125146a11 for bus #2408 which as vin 2pcg33491cc735146)
6. Double-click on the specific multiplex program file, a dialog box will open. You must enter a valid communication port to master id/mcm. Select the proper com port number previously identified and then click on “continue” (see Figure 33). The upload will begin.

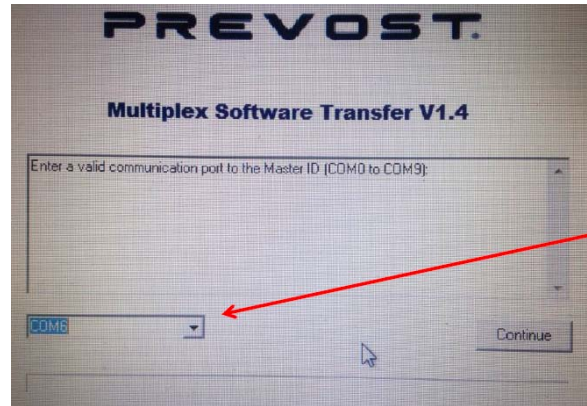

FIGURE 33: ENTER PROPER COM PORT NUMBER

7. Wait until the upload is completed. You should read: “software transfer successfully completed”.
8. Validate the program version using the DID. Look in diagnostic>part number>electrical system menus (see Figure 34). To confirm the update is has been successfully done, the last digits of the software number should match the file name (mp_00125146a11) uploaded.

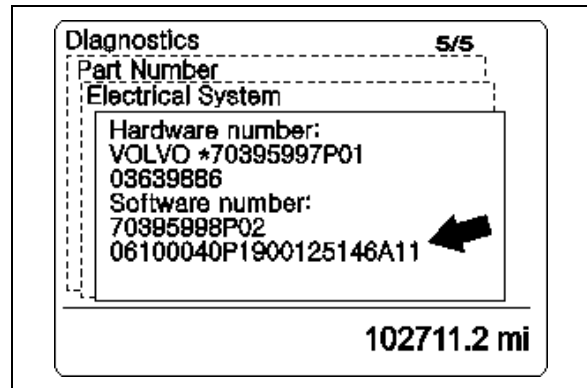

FIGURE 34: VALIDATING PROGRAM VERSION

9. On rear electrical junction panel, trip and reset circuit breaker cb6.
10. Clear all diagnostics troubleshooting codes.

5. BOSCH ALTERNATORS

Two 28 volt 150A, self-regulated, belt driven, air-cooled HD 10 Bosch alternators are used in the 24 volt electrical system.

If the alternators needed to be removed, reinstall as follows. Refer to Figure 36 for installation and to Figure 37 for tightening specifications:

1. If necessary, tighten screws (6) fixing alternators support assembly onto engine (1, Figure 36). Torque tighten to 43 lbf-ft, use some Loctite 243 blue (680038) onto the threads. Also tighten screw (1) fixing belt tensioner onto alternators support assembly (1, Figure 36). Torque tighten to 43 lbf-ft, use some Loctite 243 blue (680038) onto the threads.
2. If removed, reinstall screw (1) fixing alternators support assembly onto engine (2, Figure 36). Torque tighten to 22 lbf-ft, use some Loctite 243 blue (680038) onto the threads.

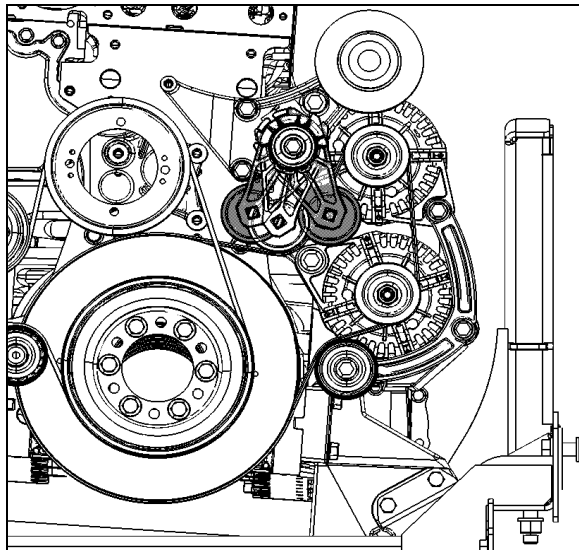

FIGURE 35: ALTERNATORS DRIVE BELT

3. Mount the a/c compressor idler pulley onto alternators support assembly (3, Figure 36). Torque tighten to 150 lb-ft, use some Loctite 243 blue (680038) onto the threads.
4. Install alternators arched support loosely onto engine. If removed, install alternators idler pulley (4, Figure 36) onto alternators arched support, torque tighten to 43 lb-ft.

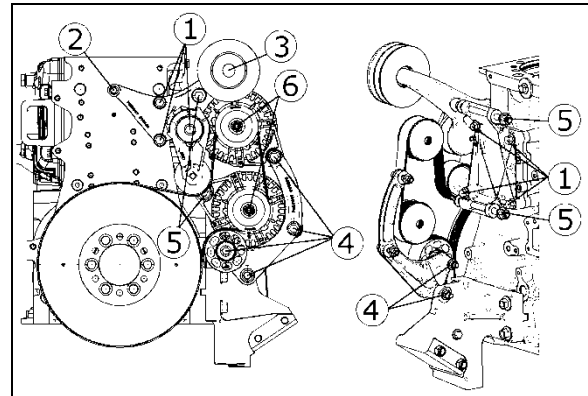

FIGURE 36: TWIN ALTERNATORS INSTALLATION

5. Fix lower and upper alternators loosely to alternators support assembly using bolts (5, Figure 36). Also, mount the lower and upper alternators onto alternators arched support. If removed install stone guard below lower alternator.
6. In order to assure installation, it is important to tighten the alternator mounting bolts in the following order (Figure 37).
 - 1st nut a, 43 lbf-ft.
 - 2nd nut b, 43 lbf-ft (2x).
 - 3rd nut c, 80 lbf-ft (2x)

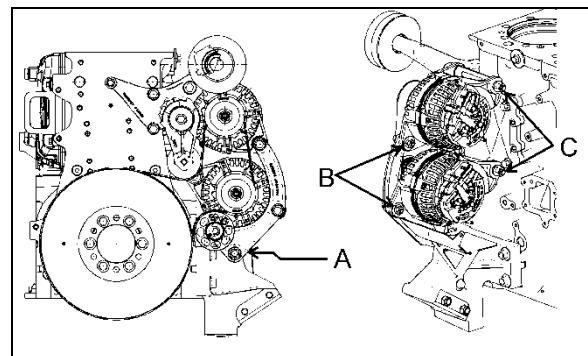

FIGURE 37: ALTERNATOR MOUNTING - TIGHTENING SEQUENCE

7. Mount pulleys (6, Figure 36) onto alternators. Torque tighten to 58 lb-ft.
8. Install alternators belt.

Note

Final tightening of the pulleys can be performed once the belt is installed. This will help keep the pulley from turning when tightening.

5.1 ALTERNATOR PERIODIC INSPECTION

When both alternators are not charging, the *charging system warning light* illuminates. This telltale will not illuminate if only one alternator is defective. However, a single defective alternator can be identified using the back-probing method described below.

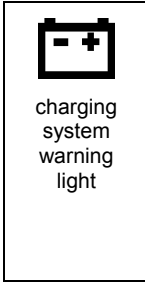

Maintenance

Alternator Periodic Inspection

Check that both alternators operate normally using back-probing method described at paragraph 5.1.1. Perform at the intervals specified by the Lubrication And Servicing Schedule in Section 24A.

- If multimeter reads 12 volts, you have an open circuit;
- If multimeter reads 26 volts or greater, the **upper** alternator operates normally.

Note

Validation

Confirm back-probing results before removing the defective alternator. In fact, the connectors on the alternators may have been interchanged by mistake.

1. Stop the engine and then disconnect the suspected defective alternator.
2. Start the engine. Back-probe the pin on the alternator known to be in good working condition.
3. If multimeter reads 1-2 volts, then this alternator is defective. A misconnection of the alternators exists. Check the regulators connectors.

5.1.1 Identifying a Single Defective Alternator

This method consists in back-probing specific pins on J1 connector, Multiplex Module A49.

Prerequisite conditions:

- a) Engine running;
- b) Parking brake applied.

On connector J1 of multiplex module A49, back-probe pin 8 (A49 J1:8) and a good ground (use ground stud in the compartment). Repeat for pin 9 (A49 J1:9).

Lower alternator: pin 8

Upper alternator: pin 9

1. Back-probe pin 8 (A49 J1:8).
 - If multimeter reads 1-2 volts, the **lower** alternator is defective;
 - If multimeter reads 12 volts, you have an open circuit;
 - If multimeter reads 26 volts or greater, the **lower** alternator operates normally.
2. Back-probe pin 9 (A49 J1:9).
 - If multimeter reads 1-2 volts, the **upper** alternator is defective;

5.2 ALTERNATOR DRIVE BELT

Removal

1. Insert a ½" socket drive wrench into the automatic belt tensioner opening (Figure 38).
2. Twist the tensioning arm to slacken belt.
3. Remove belt.



FIGURE 38: ½" SOCKET DRIVE WRENCH

Note

Belts specifications may vary. For proper belt selection, always consult your vehicle coach final record.

Installation

Installation of the alternator drive belt is the reverse of removal.

5.3 ADJUSTMENT

Correct belt tension is required to maximize belt life. The tensioning arm maintains proper belt tension, no adjustment is required.

 Maintenance
Check for wear and proper tension every 12,000 miles, replace every 50,000 miles.

5.4 CURBSIDE DOOR FAN – ALTERNATOR COOLING

Supplemental air cooling is provided to the alternator with a fan mounted on the engine compartment curbside door. This fan is of the same type as the ones used for the HVAC condenser.

 Warning
Automatic fan drive Keep clear of curbside door cooling fan when engine is running. Fan may engage without warning.

The engine compartment curbside door fan will blow outside air toward the alternators according to the following conditions:

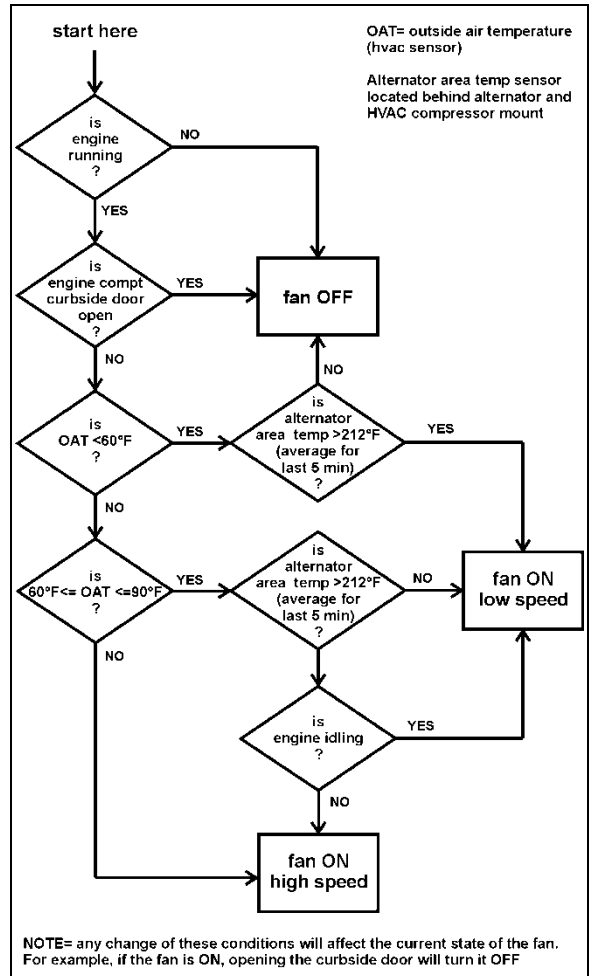

FIGURE 39: CURBSIDE DOOR FAN CONTROL LOGIC

6. BATTERY EQUALIZER

The Vanner Vann-Guard 80-series battery equalizer is located beside the batteries in battery compartment.

For further details, consult Vanner Vann-Guard 80 series owner’s manual included on your technical publications cd.

7. BATTERY CHARGER

Vanner battery charger model sp00155 is located in the battery charger and power inverter compartment; which is located at the rear of the coach, behind the last row of passenger’s seats. An access door is provided in the wall.

For further details, consult Vanner battery charger model sp00155 owner’s manual included on your technical publications cd.

8. POWER INVERTER

Xantrex power inverter is located in the battery charger and power inverter compartment; which is located at the rear of the coach, behind the last row of passenger's seats. An access door is provided in the wall.

The power inverter turns on and provides ac power to the vehicle outlets only when the engine is running.

For further details, consult Xantrex power inverter Prosine 1000-1800 owner's manual included on your technical publications cd.

9. STARTER

Refer to Mitsubishi electric corporation (Melco) service bulletin me003-p included on your technical publications cd for information and maintenance instruction on Melco 105p70 starter.



Caution

Do not engage starter for more than 15 seconds at a time. If engine does not start within 15 seconds, release ignition key and let starter cool for one minute before attempting to restart.

10. EXTERIOR LIGHTING

The circuit for exterior lights, as well as their control switches, relays and circuit breakers are shown on the applicable wiring diagrams. Wiring diagrams are located in the technical publication box.

Headlights

Each headlight assembly consists of two 90 mm (3½ inch) headlamp module, the high beam lamp is equipped with a 12-volt halogen bulb, the low beam lamp is a 12-volt led lamp. The turn/signal lamp is a 100 mm (4 inch) 12-volt led. Outer lamps have a double function (both low and high beam). Inner lamps are used for high beam or daytime running light.

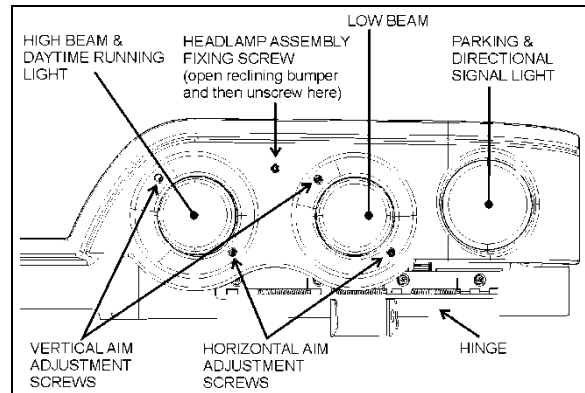

FIGURE 40: HEADLIGHT ASSEMBLY 06546

10.1.1 Maintenance

Clean headlights with soap and water. When a headlight burns out, a new bulb must be installed. Headlights must be properly aimed to provide maximum allowable road illumination. When using mechanical aiming devices, follow manufacturer's instructions.



FIGURE 41: HEADLIGHT ASSEMBLY OPENED FOR BULB REPLACEMENT 06547

Aiming can be performed without opening headlight assembly. Horizontal and vertical aiming of each module is provided by two adjusting screws that pivot the module in the housing for proper alignment (Figure 40). There is no adjustment for focus since the module is set for proper focus during manufacturing assembly.

Note

Make sure headlight assembly is properly positioned into its housing before securing using fixing screw.

 **Caution**
Use a soft cloth to clean the parking and front turn signal lamp.

10.1.2 Headlight adjustment

1. Headlight aiming and inspection can be accomplished by visual means. This is done on a screen located at a distance of 25 feet of the headlights. It should be of adequate size with a matte-white surface well shaded from extraneous light and properly adjusted to the floor area on which the vehicle stands. Provisions should be made for moving the screen or its vertical centerline so that it can be aligned with the vehicle axis. In addition to the vertical centerline, the screen should be provided with four laterally adjustable vertical tapes and two vertically adjustable horizontal tapes.
2. The four movable vertical tapes should be located on the screen at the left and right limits called for in the specification with reference to centerlines ahead of each headlight assembly.
3. The headlight centerlines shall be spaced either side of the fixed centerline on the screen by 1/2 the lateral distance between the light source centers of the pertinent headlights. The horizontal tapes should be located on the screen at the upper and lower limits called for in the specification with reference to the height of beam centers and the plane on which the vehicle rests, not the floor on which the screen rests.

Table 1 – vertical beam aim guidelines

Headlight (centerline) Mounting height	Nominal Vertical aim	Aim inspection limits for vertical aim
22 to 36 inch	0 vertical	4 inch up to 4 inch down
36 to 48 inch	2 inch down	2 inch up to 6 inch down
48 to 54 inch	4 inch down	1.5 inch up to 6.5 inch down

4. The nominal vertical aim position on lower beam headlights shall be adjusted based on the headlight mounting height, from the

ground to the light source center of the headlight, according to table 1.

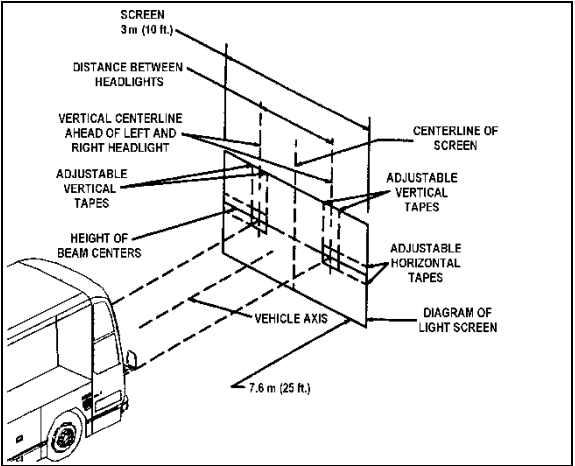

FIGURE 42: ALIGNMENT OF HEADLIGHT AIMING SCREEN 06502

5. High beam headlights are aimed so that the center of the high-intensity zone is located at the horizontal and straight ahead vertically (Figure 43).
6. Low beam headlights are aimed so that the top edge (the cutoff) of the high-intensity zone is at the vertical location as per table 1 and the left edge of the high-intensity zone is at the vertical centerline of the headlight (Figure 44).
7. The inspection limits for high-beam headlights shall be with the center of the high-intensity zone from 10 cm (4 in) up to 10 cm (4 in) down; and, from 10 cm (4 in) left to 10 cm (4 in) right on a screen at 7.6 m (25 ft) (Figure 45).

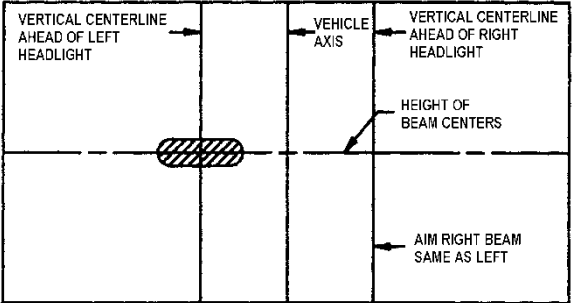

FIGURE 43: PROPER UPPER BEAM HIGH-INTENSITY ZONE AT 25FT 06503

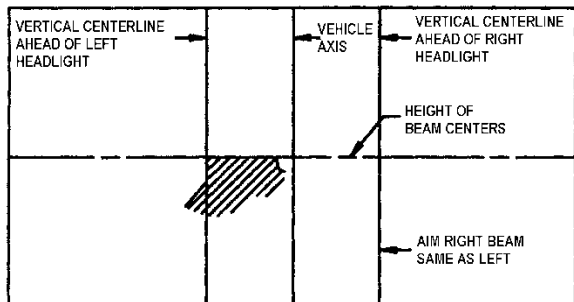

FIGURE 44: PROPER LOWER BEAM HIGH-INTENSITY ZONE AT 25FT 06504

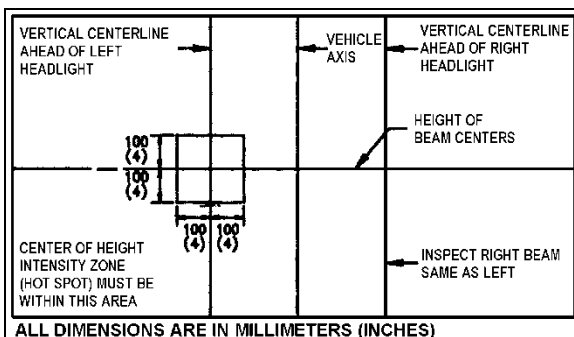

FIGURE 45: AIM INSPECTION LIMITS FOR UPPER-BEAM HEADLIGHTS 06505

7. The inspection limits in the vertical direction for low-beam headlights or the low beam of a dual-beam headlight, shall be as described in table 1. In the horizontal direction, the left edge of the high-intensity zone shall be located from 10 cm (4 in) left to 10 cm (4 in) right of the vertical centerline of the beam. The viewing screen shall be located 7.6 m (25 ft) in front of the vehicle (Figure 46).

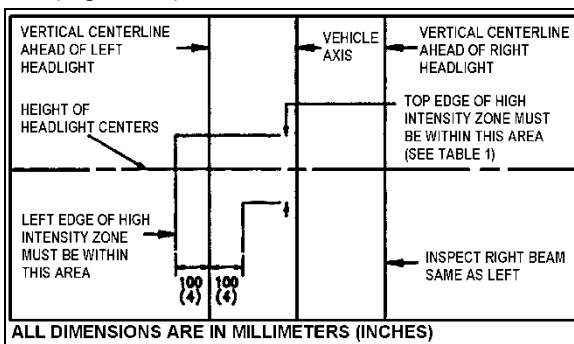

FIGURE 46: AIM INSPECTION LIMITS FOR LOWER-BEAM HEADLIGHTS 06506

10.1.3 Sealed-Beam Unit

Bulb removal and replacement

1. Pull the release handle located inside the front service compartment to tilt down the entire bumper assembly.

2. Remove the headlight screw fixing the headlight assembly, then tilt headlight assembly down (Figure 41).
3. Remove connector from headlight bulb.
4. Remove the bulb by pushing and rotating it out of the socket.
5. Install the new bulb by reversing the previous procedure.



Caution

During this step, avoid contacting the bulb with the fingers not to alter the bulb life.

Note

Do not disrupt headlight adjustment screws.

Module replacement

1. Pull the release handle located inside the front service compartment to tilt down the entire bumper assembly.
2. Remove the headlight screw fixing the headlight assembly, then tilt headlight assembly down (Figure 41).
3. Remove connector from headlight bulb.
4. Unfasten three metal clips attaching headlight unit to support.
5. Install new module and fasten metal clips.
6. Install wiring connector on back of new sealed beam unit.
7. Tilt headlight assembly up into its housing then secure using fixing screw.

Note

Make sure headlight assembly is properly positioned into its housing before securing using fixing screw.

8. Perform alignment procedure.

Note

The headlight aim must be checked and adjusted even if it was properly adjusted before the sealed beam unit was replaced.

10.1.4 Front Turn Signal

The front turn signal is part of the front headlight assembly. The turn signal is a sealed unit (led) located on each front corner and should be

replaced as an assembly. Turn signal is visible from both front and side.

Removal and replacement

1. Pull the release handle located inside the front service compartment to tilt down the entire bumper assembly.
2. Remove the headlight screw fixing the headlight assembly, then tilt headlight assembly down (Figure 41).
3. Partially unfasten back plate fixing screws, then remove signal lamp.
4. Remove socket from signal lamp.
5. Install wiring connector on back of new signal lamp then install signal lamp.
6. Fasten back plate fixing screws then tilt headlight assembly up into its housing then secure using fixing screw.

Note

Make sure headlight assembly is properly positioned into its housing before securing using fixing screw.

10.1.5 Stop, tail, directional, back-up, and hazard warning lights

A combination stoplight, taillight, directional signal light and back-up light assembly is mounted at the rear, on each side of the vehicle. Furthermore, when braking, two center stoplights (led) and a center high-mounted stop light (chsl) (led) will illuminate simultaneously with the stoplights on the sides for increased safety. The L.H. and R.H. side center stop lights are also used as directional signal and marker lights.

The stop, tail, directional signal and back-up lights consist of individual lamps, each equipped with 6 led lights, mounted on the engine rear door.

Led lights are not replaceable and each lamp is serviced individually as a complete unit.

The hazard warning flashing system uses the front, side and rear directional lights simultaneously. This system is energized by a switch on the L.H. dashboard.



FIGURE 47: REAR TAIL LAMPS

10.1.6 Lamp Removal And Replacement

1. Open engine compartment rear door.
2. Remove the lamp pod from the engine compartment door by unscrewing the Torx hold down screws (4) at the back of the door and the two (2) side retaining nuts.
3. Remove the lamp support retaining screws (2), and then from the outside, disconnect and remove the faulty lamp and its support.
4. From the outside, install the new lamp with its support then fasten the retaining screws.
5. Reinstall the lamp pod on the door and reconnect the lamp..

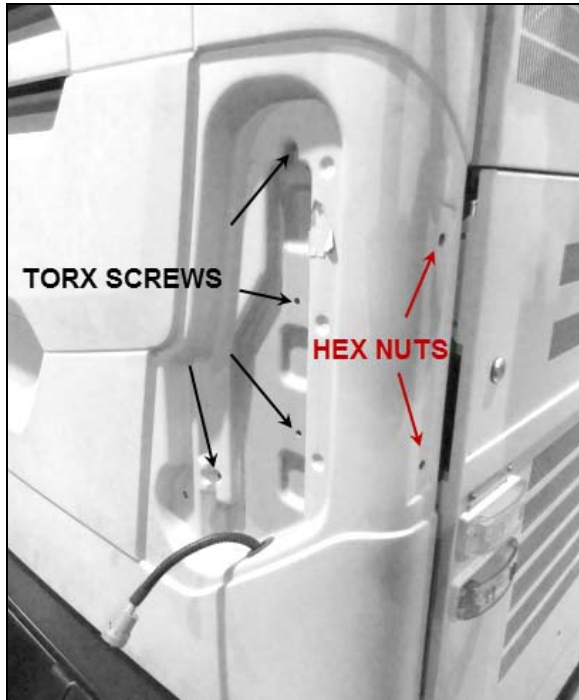

FIGURE 48: TAILLAMP POD RETAINING SCREWS & NUTS

10.1.7 Center Stoplights And Center High-Mounted Stop Light (Chsl) Removal And Replacement

These (led) lights are sealed unit and should be replaced as an assembly in accordance with the following procedure:

1. Unscrew both “Phillips” light screws then remove the light assembly.
2. Install new light assembly and secure using screws.

10.1.8 License plate light

Two led units are mounted above the rear license plate(s) of vehicle. In case of burn out, the led unit must be changed according to the following procedure.

1. Pry out the rubber seal with a small screwdriver. Pull on the led unit and disconnect it.
2. Reconnect new led unit, place rubber seal, and press on it until it is seated in position.

10.1.9 Clearance, identification and marker lights

The vehicle is equipped with marker, identification and clearance lights (led). The clearance lights are mounted at each corner of the coach near the top and the identification lights are in the upper center of rear and front sections.

The rear clearance and identification lights are red and the front ones are amber.

The amber marker lights are mounted along the sides of vehicle.

The side marker light is a sealed unit (led) and should be replaced as an assembly in accordance with the following procedure:

1. Unscrew both “phillips” light screws, and then remove the light assembly.
2. Position the new light assembly and install the “phillips” screws.

10.1.10 Clearance and identification light removal and replacement

The clearance and identification light are sealed units (led) and can be replaced in accordance with the following procedure:

1. Unscrew both “phillips” light screws, and then remove the light assembly.
2. Position the new light assembly, and then install the “phillips” screws.

11. INTERIOR LIGHTING EQUIPMENT

11.1 CONTROL PANEL LIGHTING

The instrument gauges and switches mounted on all control panels are energized whenever the exterior light switch is pushed to the first position. A control dimmer located on the dashboard is used to vary the brightness of the panel gauges, switches and indicator lights.

The gauge lights, panel lights, switch lights and indicator lights have a different bulb arrangement. Thus, the procedure to change a defective bulb can vary according to the application.

11.1.1 Switch lighting

1. Slightly pull the switch with a defective led away from the control panel.

2. Disconnect the electric cable from the switch.
3. To install a new switch, reverse the procedure (Figure 49).

Note
Switches are lighted by the use of led. When lighting on a switch fails, replace defective switch as a unit.

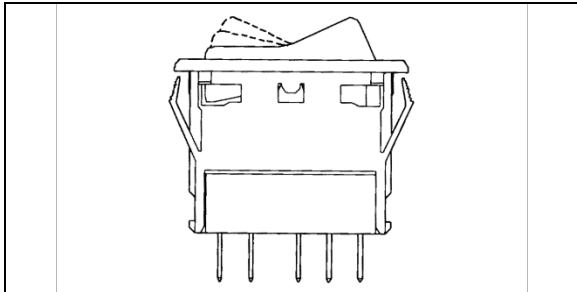

FIGURE 49: DASHBOARD ROCKER SWITCH 06321

11.1.2 Telltale light replacement

Telltale module is non-serviceable and must be replaced as a unit.

1. Unscrew and remove the top dashboard panel.
2. Remove the telltale back wire electric connectors.
3. Unscrew and remove the telltale module.
4. To replace the telltale module, reverse the procedure.

11.1.3 Gauge light bulb replacement

1. For any gauge light bulb replacement, the dashboard panel must be removed in order to have access to the rear of gauges.
2. Remove bulb socket from the gauge, turn the defective bulb counterclockwise and pull it out of the gauge.
3. Push a new bulb and socket asm and turn clockwise to lock in place.
4. Replace the rear dashboard housing.

11.2 STEPWELL LIGHTS

Two stepwell lights are illuminated when the door opening system is activated.

11.2.1 Bulb removal and replacement

Proceed as follows to replace a defective bulb:

1. Unscrew the two phillips-head screws retaining the lens to the wall, and remove it.
2. With the light lens removed, pull bulb from the lamp while applying lateral pressure.
3. Install the new bulb into the lamp.
4. Position the light lens and install it.

11.3 DRIVER'S AREA LIGHTS

Two halogen ceiling lights are installed over the stepwell and the driver's area. These lights are frequently used for night-time operation when passengers board or leave coach.

11.3.1 Bulb removal and replacement

1. Unsnap the lamp with a flat head screwdriver and remove it.
2. Pull the defective bulb out of the socket.
3. Install the new bulb by pushing it in position.
4. Replace the lamp by snapping it back in place.

	Caution
Do not touch halogen bulbs with bare hands as natural oils on skin will shorten bulb life span.	

11.3.2 Engine Compartment Lighting

A switch located on the upper right corner of the rear start panel can be used to actuate the engine compartment led lights.

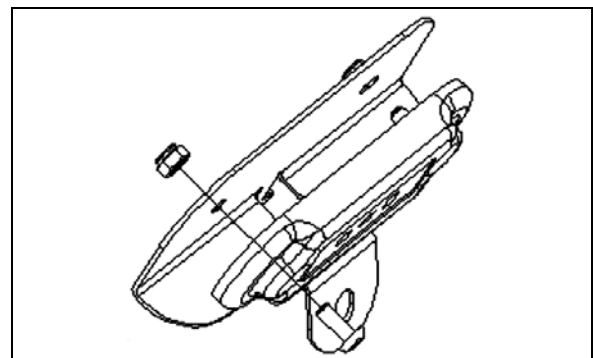

FIGURE 50: ENGINE COMPARTMENT LIGHT

SECTION 06: ELECTRICAL

Each light is sealed and can be replaced as follows:

1. Disconnect the light unit connection.
2. Unfasten the two fixing screws then remove the lamp.
3. Position and fasten new lamp.
4. Connect the light unit.

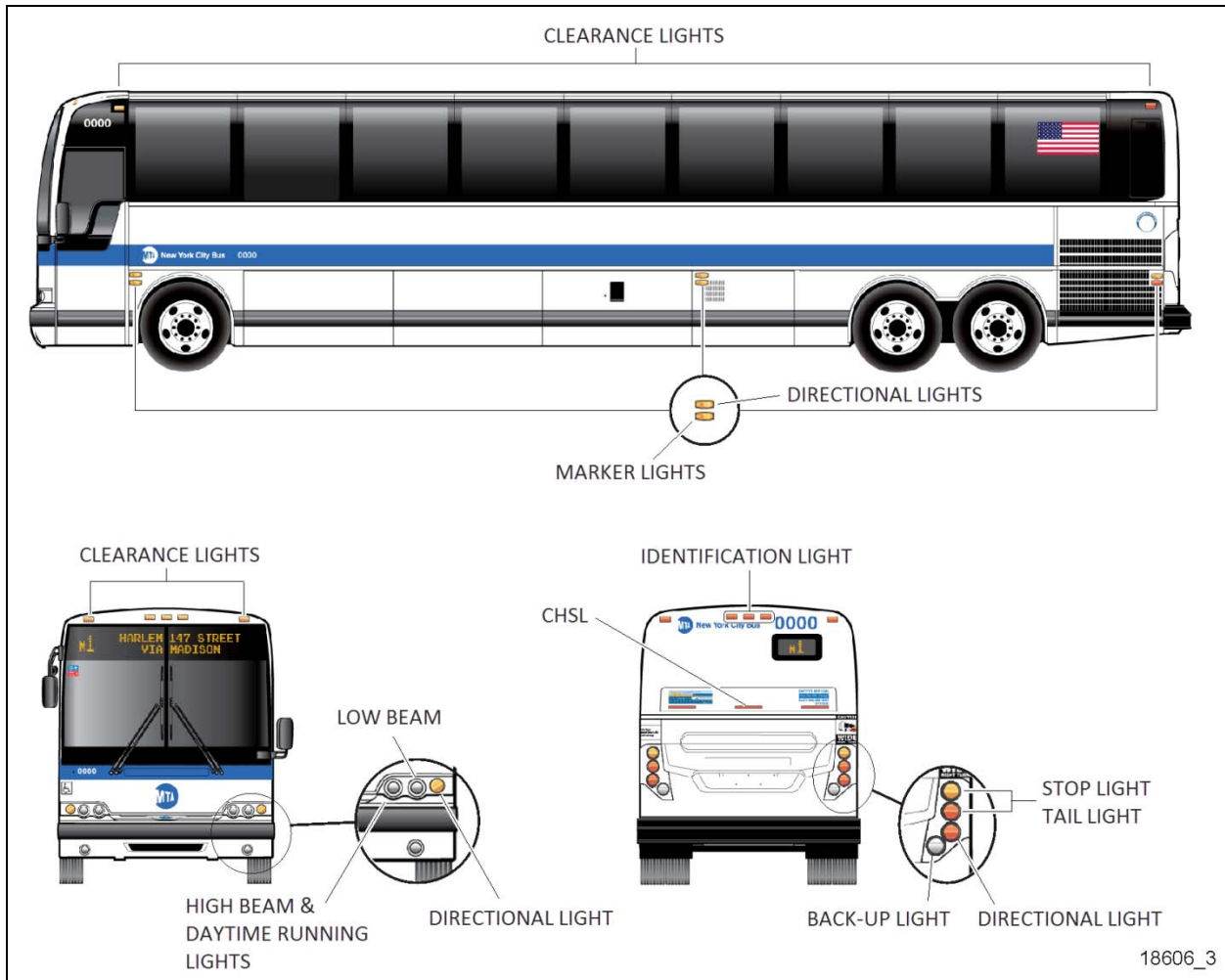

FIGURE 51: VARIOUS LIGHTS LOCATION

12. Specifications

Battery

Make.....	Odyssey
Model.....	31-Pc2150s
Type	Absorbed Glass Mat
Terminal Type	Top Stud
Group Size	31
Volts	12
Load Test Amperage (1/2 Cca).....	575
Reserve Capacity (Minutes).....	205
Cold Cranking (In Amps)	
-At 0°f (-18°c).....	1150a (Each Battery)
Maximum Dimensions	
-Length (Including Flange)	13in/330mm
-Width	6.8in/173mm
-Height (Including Top Posts).....	9.4in/239mm
-Approximate Weight.....	77.8 Lbs

Torque Specifications

Battery Cable To Post.....	17 Lbf-Ft (200 Lbf-In)
----------------------------	------------------------

Alternator

Make.....	Bosch
Series	Hd 10
Amperes	150
Volts	28.4
Output Power	3 Kw
Ground	Negative

Battery Equalizer

Make.....	Vanner
Model.....	Vann-Guard 80-Series
Amperes	100 Amps

Battery Charger

Make.....	Vanner
Model.....	Sp00155
Input	15 Amps @ 120 Vac
Output.....	42 Amps @ 24 Vdc
Bulk Voltage	28.6 Vdc
Float Voltage	26.6 Vdc

Inverter

Make.....	Xantrex
Model.....	Prosine 1800
Continuous Output Power	1800 W
Surge Rating (5 Seconds).....	2900 W
Peak Output Current	45 Amps
No Load Draw (Search Mode, Idle Mode)	1.5w, 20w
Input Voltage Range	20-32 Vdc
Output Voltage	120 Vac (Sine Wave)
Low Battery Cut-Out.....	20 Vdc
High Battery Cut-Out.....	32 Vdc
Protection	Automatic Overload, Short Circuit, Over-Temp, Over-Volt, Under-Volt
Transfert Relay Rating	15 Amps

Starter

SECTION 06: ELECTRICAL

Make..... Mitsubishi Electric Corporation (Melco)
 Type 105p70
 Voltage 24

No-Load Test

-Volts 23.5
 -Max. Current Draw 125 Amperes
 -Min. Rpm..... 3000 Rpm

Starter Solenoid

Make..... Mitsubishi Electric Corporation (Melco)
 Pull In Voltage 16 Volts Max.

13. SECTION CHANGE LOG

DESCRIPTION		DATE
1	Addition of "Alternator Periodic Inspection" & "Identifying a Single Defective Alternator" paragraphs. Removal of "Alternator Brush Replacement" procedure.	06/12/2017
2		
3		
4		
5		
6		

ELECTRICAL CONNECTORS PROTECTION

PROCEDURE NO SAV00002E

**NOVEMBER 2009
REVISION 02**

Kent Sealer

Sprayed sealer. It is used for structure ground connections. It prevents corrosion and ensures maximum contact. Refer to table for proper use.

Apply this product once installation is finished.

Warning: *It is very important to be in a well ventilated area when applying this product.*



680324

Nyogel Grease

Grease-type product.

It is used to facilitate connectors or terminals insertion.

Refer to table for proper use of Nyogel grease.

It is preferable to apply Nyogel into the female part of connector.

Apply this product as the last assembling operation.



3 Oz. tube: 681095

Container 500g: 683409

“Color Guard” black rubber coating

This product may be applied with a brush.

It is used for structure ground connections or other connections that will most likely not be disconnected later on.

Apply this product once installation is finished.

Warning : *Wear goggles and rubber gloves.*



684013

Vehicle Zones

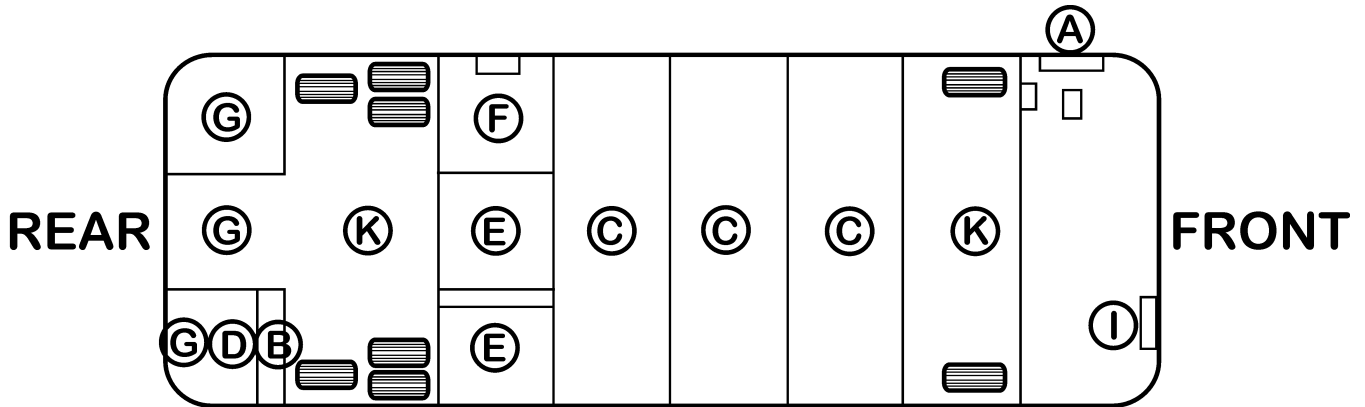

Electrical Connectors Protection Procedure Table

Zone	Component	Model	Product	Note
		X3-45		
A- Front Elect. Compt	Diode Block	X	Nyogel	Accepted to ease connection
A- Front Elect. Compt	Customer Terminal Block	X	Nothing	
A Front Elect. Compt	Terminal Block Electronic Ground	X	Kent	
A- Front Elect. Compt	Structure Ground	X	Kent	
A- Front Elect. Compt	Electronic Module	X	Nothing	
A- Front Elect. Compt	VEC Power	X	Nothing	
A- Front Elect. Compt	70A Relay	X	Nyogel	Accepted to ease connection
A- Front Elect. Compt	Control Relay	X	Nyogel	Accepted to ease connection
A- Front Elect. Compt	All connectors except those specified in this zone	X	Nothing	
A- Front Service Compt	All connectors except those specified in this zone	X	Nothing	
B- Rear Electrical panel	Customer Terminal Block	X	Nothing	
B- Rear Electrical panel	Power Terminal Block	X	Nothing	
B- Rear Electrical panel	Circuit Breaker	X	Nothing	
B- Rear Electrical panel	Structure Ground	X	Kent	
B- Rear Electrical panel	Electronic Module	X	Nothing	
B- Rear Electrical panel	VEC Power	X	Nothing	
B- Rear Electrical panel	70A Relay	X	Nyogel	Accepted to ease connection
B- Rear Electrical panel	Master Switch Relay	X	Nothing	
B- Rear Electrical panel	Control Relay	X	Nyogel	Accepted to ease connection
B- Rear Electrical panel	200A Power Relay	X	Nothing	
B- Rear Electrical panel	Power Relay Stud	X	Nothing	
B- Rear Electrical panel	All connectors except those specified in this zone	X	Nothing	

Zone	Component	Model	Product	Note
		X3-45		
C- Baggage Compt	Structure Ground	X	Color Guard or Kent	
C- Baggage Compt	Door Switch	X	Nyogel	Accepted to ease connection
C- Baggage Compt	Door lock Actuator Module (switch and solenoid)	X	Nyogel	Accepted to ease connection
C- Baggage Compt	Electronic Module	X	Nothing	
C- Baggage Compt	WCL Junction Panel	X	Nothing	
C- Baggage Compt	120V Inverter Connector	X	Nothing	
C- Baggage Compt	Stud inverter	X	Color Guard or Kent	
C- Baggage Compt	WCL Remote Control	X	Nyogel	Accepted to ease connection
C- Baggage Compt	All connectors except those specified in this zone	X	Nothing	
D- Battery Compt	Battery	X	Nyogel	
D- Battery Compt	Structure Ground	X	Color Guard or Kent	
D- Battery Compt	Electronic Module	X	Nothing	
D- Battery Compt	All connectors except those specified in this zone	X	Nothing	
D- Battery Compt	Battery Equalizer	X	Kent	
E- Condenser Compt	Fuel sender	X	Kent	
E- Condenser Compt	Structure Ground	X	Color Guard or Kent	
E- Condenser Compt	Door Switch	X	Nyogel	Accepted to ease connection
E- Condenser Compt	Condenser Motor	X	Nothing	
F- Evaporator Compt	Structure Ground	X	Color Guard or Kent	
F- Evaporator Compt	Evaporator Motor	X	Color Guard or Kent	
G- Engine Compt	120A Alternator	X	Color Guard	
G- Engine Compt	Booster Block (+)	X	Color Guard	
G- Engine Compt	Starter Terminal	X	Color Guard	
G- Engine Compt	Volvo Air Element Terminal	X	Color Guard	
G- Engine Compt	Power Terminal Block	X	Color Guard	
G- Engine Compt	Air Heater Fuse & Relay	X	Nyogel	Accepted here
G- Engine Compt	Engine Ground	X	Color Guard	
G- Engine Compt	Structure Ground	X	Color Guard	
G- Engine Compt	Starter Relay	X	Color Guard	
G- Engine Compt	All connectors except those specified in this zone	X	Nothing	

Zone	Component	Model	Product	Note
		X3-45		
H- Vehicle Exterior	ABS Sensor	X	Nothing	
H- Vehicle Exterior	Docking & Cornering Lamps	X	Nyogel	Accepted to ease connection
H- Vehicle Exterior	Marker Light	X	Nothing	
H- Vehicle Exterior	Mirror	X	Nothing	
H- Vehicle Exterior	Light Module	X	Nothing	
H- Vehicle Exterior	Stop light, Backup light, Directional Signal Light	X	Nothing	
I- Vehicle Interior	Diode Block	X	Nyogel	Accepted to ease connection
I- Vehicle Interior	Junction Block	X	Nothing	
I- Vehicle Interior	A3 & A4 Transmission Retarder Hand lever	X	Nyogel	Accepted to ease connection
I- Vehicle Interior	C258 & C259 Multi-function Lever Connector	X	Nyogel	Accepted to ease connection
I- Vehicle Interior	Audio - video Connection	X	Nothing	
I- Vehicle Interior	Defrost Compt Ground	X	Kent	
I- Vehicle Interior	Video Plate Direct Ground	X	Nothing	
I- Vehicle Interior	Structure Ground	X	Kent	
I- Vehicle Interior	Terminal Block Ground	X	Nothing	
I- Vehicle Interior	Dashboard Switch	X	Nothing	
I- Vehicle Interior	Electronic Module	X	Nothing	
I- Vehicle Interior	Wiper Motor	X	Nyogel	Accepted to ease connection
I- Vehicle Interior	200A Power Relay	X	Nothing	
I- Vehicle Interior	70A Relay	X	Nyogel	Accepted to ease connection
I- Vehicle Interior	Control Relay	X	Nyogel	Accepted to ease connection
I- Vehicle Interior	All connectors except those specified in this zone	X	Nothing	
I- Vehicle Interior	All components except those specified in this zone	X	Nothing	
K- Front & Rear Wheelhousing	All connectors except those specified in this zone	X	Nothing	
K- Front & Rear Wheelhousing	All components except those specified in this zone	X	Nothing	

MULTIPLEX ERROR MESSAGES TROUBLE SHOOTING LIST

- MID (Message Identification Description) : Identification of a control unit**
- PID (Parameter Identification Description) : Identification of a parameter (value)**
- PPID (Proprietary Parameter Identification Description) : Unique Identification of a parameter (value)**
- SID (Subsystem Identification Description) : Identification of a component**
- PSID (Proprietary Subsystem Identification Description) : Unique Identification of a component**
- FMI (Failure Mode Identifier) : Identification of fault types**

MID 188 PSID # 4 A/C Clutch So9 (A52 J1:20)

Type of fault:	FMI Description:	Fault Condition:	Possible Symptoms:	Possible Causes:
FMI 3	Shorted High	Voltage present on output A52 J1:20 but output not active	A/C clutch always ON	<ul style="list-style-type: none"> • A52 module failure • Connector C91 corroded • Circuit 77BA shorted to battery
FMI 4	Shorted Low	Output A52 J1:20 shorted to ground	A/C clutch not working	<ul style="list-style-type: none"> • A52 module failure • Connector C91 corroded • Circuit 77BA shorted to ground
FMI 5	Open Circuit	A52 module does not detect A/C clutch So9	A/C clutch not working	<ul style="list-style-type: none"> • A52 module failure • So9 open circuit • Se29 failure • Circuit 77BA open • Circuit 78 open • Circuit ORA2 open
FMI 6	Current above normal	Output A52 J1:20 internal software fuse active for overcurrent	A/C clutch not working	<ul style="list-style-type: none"> • A52 module failure • Connector C91 corroded • Circuit 77BA shorted to ground • A/C clutch resistance value lower than 5 ohms (7 ohms expected)

MID 188 PSID # 12 A/C Pres HiSd (A52 J1:13)

Type of fault:	FMI Description:	Fault Condition:	Possible Symptoms:	Possible Causes:
FMI 3	Shorted High	Voltage above normal on A52 J1:13	High side pressure not displayed on dash	<ul style="list-style-type: none"> • A52 module failure • Se23 failure • Connector C91 corroded • Circuit 77-20 shorted to battery
FMI 4	Shorted Low	Voltage below normal on A52 J1:13	High side pressure not displayed on dash	<ul style="list-style-type: none"> • A52 module failure • Se23 failure • Connector C91 corroded • Circuit 77-20 shorted to ground
FMI 5	Open Circuit	A52 module does not detect Se23	High side pressure not displayed on dash	<ul style="list-style-type: none"> • A52 module failure • Se23 failure • Circuit 77-20 open

MID 188 PSID # 13 A/C Pres LoSd (A52 J1:14)

Type of fault:	FMI Description:	Fault Condition:	Possible Symptoms:	Possible Causes:
FMI 3	Shorted High	Voltage above normal on A52 J1:14	Low side pressure not displayed on dash	<ul style="list-style-type: none"> • A52 module failure • Se24 failure • Connector C91 corroded • Circuit 93-20 shorted to battery
FMI 4	Shorted Low	Voltage below normal on A52 J1:14	Low side pressure not displayed on dash	<ul style="list-style-type: none"> • A52 module failure • Se24 failure • Connector C91 corroded • Circuit 93-20 shorted to ground
FMI 5	Open Circuit	A52 module does not detect Se24	Low side pressure not displayed on dash	<ul style="list-style-type: none"> • A52 module failure • Se24 failure • Circuit 93-20 open

MID 188 SID # 69 Aux Bypass Sw (A42 J1:10)

Type of fault:	FMI Description:	Fault Condition:	Possible Symptoms:	Possible Causes:
FMI 3	Shorted High	Voltage above normal on A42 J1:10	Aux bypass switch not working	<ul style="list-style-type: none"> • A42 module failure • Sw142 failure • Connector C71 corroded • Connector C171 corroded • Circuit AuxBP shorted to battery
FMI 4	Shorted Low	Voltage below normal on A42 J1:10	Aux bypass switch always ON	<ul style="list-style-type: none"> • A52 module failure • Sw142 failure • Connector C71 corroded • Connector C171 corroded • Circuit AuxBP shorted to ground

MID 188 SID # 61 (A45 J1:12)

Type of fault:	FMI Description:	Fault Condition:	Possible Symptoms:	Possible Causes:
FMI 3	Shorted High	Voltage above normal on A45 J1:12	Left side high and low beam not working	<ul style="list-style-type: none"> • A45 module failure • Sw2 failure • Connector C71 corroded • Circuit 61-20 shorted to battery
FMI 4	Shorted Low	Voltage below normal on A45 J1:12	Left high beam always ON	<ul style="list-style-type: none"> • A45 module failure • Sw2 failure • Connector C71 corroded • Circuit 61-20 shorted to ground

MID 188 SID # 76 Brake Interlock Sol (A42 J1:11)

Type of fault:	FMI Description:	Fault Condition:	Possible Symptoms:	Possible Causes:
FMI 3	Shorted High	Voltage present on output A42 J1:11 but output not active	Parking brake won't release	<ul style="list-style-type: none"> • A42 module failure • Connector C172 corroded • Connector C8 corroded • Circuit BrkAux shorted to battery
FMI 4	Shorted Low	Output A42 J1:11 shorted to ground	Brake interlock not working	<ul style="list-style-type: none"> • A42 module failure • Connector C172 corroded • Connector C8 corroded • Circuit BrkAux shorted to ground
FMI 5	Open Circuit	A42 module does not detect So55	Brake interlock not working	<ul style="list-style-type: none"> • A42 module failure • So55 open circuit • Circuit BrkAux open • Ground 618Rtn open
FMI 6	Current above normal	Output A42 J1:11 internal software fuse active for overcurrent	Brake interlock not working	<ul style="list-style-type: none"> • A42 module failure • Connector C172 corroded • Connector C8 corroded • Circuit BrkAux shorted to ground • So55 Low resistance value (expected value \pm 100 ohms)

MID 188 SID # 73 Brake Pres Driver (A45 J1:14)

Type of fault:	FMI Description:	Fault Condition:	Possible Symptoms:	Possible Causes:
FMI 3	Shorted High	Voltage above normal on A45 J1:14	Brake interlock pressure not displayed on dash	<ul style="list-style-type: none"> • A45 module failure • Se77 failure • Connector C8 corroded • Circuit ANA-BRKP shorted to battery
FMI 4	Shorted Low	Voltage below normal on A45 J1:14	Brake interlock pressure not displayed on dash	<ul style="list-style-type: none"> • A45 module failure • Se77 failure • Connector C8 corroded • Circuit ANA-BRKP shorted to ground

MID 188 SID # 74 Brake Pres Intrlk (A45 J1:13)

Type of fault:	FMI Description:	Fault Condition:	Possible Symptoms:	Possible Causes:
FMI 3	Shorted High	Voltage above normal on A45 J1:13	Brake interlock not working	<ul style="list-style-type: none"> • A45 module failure • Se78 failure • Connector C8 corroded • Circuit ANA-INTLK shorted to battery

SECTION 06B: ELECTRICAL

FMI 4	Shorted Low	Voltage below normal on A45 J1:13	Brake interlock not working	<ul style="list-style-type: none"> • A45 module failure • Se78 failure • Connector C8 corroded • Circuit ANA-INTLK shorted to ground
-------	-------------	-----------------------------------	-----------------------------	--

MID 188 PSID # 119 Brk Lts Sens (A36 JB:13)

Type of fault:	FMI Description:	Fault Condition:	Possible Symptoms:	Possible Causes:
FMI 3	Shorted High	Voltage above normal on A36 JB:13	Stop lights always ON	<ul style="list-style-type: none"> • A36 module failure • A51 module failure • Connector C4 corroded • Connector C2 corroded • Connector C21 corroded • Circuit 78 shorted to battery • Circuit 79A shorted to battery • Circuit 953 shorted to battery
FMI 4	Shorted Low	Voltage below normal on A36 JB:13	Stop lights not working	<ul style="list-style-type: none"> • A36 module failure • Se19 failure • Se19A failure • Connector C4 corroded • Connector C2 corroded • Connector C21 corroded • Circuit 78 shorted to ground • Circuit 79A shorted to ground • Circuit 953 shorted to ground

MID 188 PSID # 108 Ceiling Door Lt (A44 J1:5)

Type of fault:	FMI Description:	Fault Condition:	Possible Symptoms:	Possible Causes:
FMI 3	Shorted High	Voltage present on output A44 J1:5 but output not active	L17 always ON	<ul style="list-style-type: none"> • A44 module failure • Connector C45 corroded • Circuit 35 shorted to battery
FMI 4	Shorted Low	Output A44 J1:5 shorted to ground	L17 not working	<ul style="list-style-type: none"> • A44 module failure • Connector C45 corroded • Circuit 35 shorted to ground
FMI 5	Open Circuit	A44 module does not detect L17	L17 not working	<ul style="list-style-type: none"> • A44 module failure • L17 open circuit • Circuit 35 open
FMI 6	Current above normal	Output A44 J1:5 internal software fuse active for overcurrent	L17 not working	<ul style="list-style-type: none"> • A44 module failure • Connector C45 corroded • Circuit 35 shorted to ground

MID 188 PSID # 124 Center Flash LH (A50 J1:5)

Type of fault:	FMI Description:	Fault Condition:	Possible Symptoms:	Possible Causes:
FMI 3	Shorted High	Voltage present on output A50 J1:5 but output not active	L70 always ON	<ul style="list-style-type: none"> • A50 module failure • Connector C15 corroded • Connector C21 corroded • Circuit 21A shorted to battery

FMI 4	Shorted Low	Output A50 J1:5 shorted to ground	L70 not working	<ul style="list-style-type: none"> • A50 module failure • Connector C15 corroded • Connector C21 corroded • Circuit 21A shorted to ground
FMI 6	Current above normal	Output A50 J1:5 internal software fuse active for overcurrent	L70 not working	<ul style="list-style-type: none"> • A50 module failure • Connector C15 corroded • Connector C21 corroded • Circuit 21A shorted to ground • L70 low resistance value

MID 188 PSID # 125 Center Flash RH (A50 J1:7)

Type of fault:	FMI Description:	Fault Condition:	Possible Symptoms:	Possible Causes:
FMI 3	Shorted High	Voltage present on output A50 J1:7 but output not active	L68 always ON	<ul style="list-style-type: none"> • A50 module failure • Connector C58 corroded • Connector C21 corroded • Circuit 23A shorted to battery
FMI 4	Shorted Low	Output A50 J1:7 shorted to ground	L68 not working	<ul style="list-style-type: none"> • A50 module failure • Connector C58 corroded • Connector C21 corroded • Circuit 23A shorted to ground
FMI 6	Current above normal	Output A50 J1:7 internal software fuse active for overcurrent	L68 not working	<ul style="list-style-type: none"> • A50 module failure • Connector C58 corroded • Connector C21 corroded • Circuit 23A shorted to ground • L68 low resistance value

MID 188 PSID # 27 Center Mkr (A50 J1:8)

Type of fault:	FMI Description:	Fault Condition:	Possible Symptoms:	Possible Causes:
FMI 3	Shorted High	Voltage present on output A50 J1:8 but output not active	L67 and L69 always ON	<ul style="list-style-type: none"> • A50 module failure • Connector C21 corroded • Connector C58 corroded • Connector C15 Corroded • Circuit 46B shorted to battery
FMI 4	Shorted Low	Output A50 J1:8 shorted to ground	L67 and L69 not working	<ul style="list-style-type: none"> • A50 module failure • Connector C21 corroded • Connector C58 corroded • Connector C15 Corroded • Circuit 46B shorted to ground
FMI 5	Open Circuit	A50 module does not detect L67, L68, L69 or L70	L67 and L69 not working	<ul style="list-style-type: none"> • A50 module failure • L67, L68, L69 or L70 open circuit • Circuit 46B open
FMI 6	Current above normal	Output A50 J1:8 internal software fuse active for overcurrent	L67 and L69 not working	<ul style="list-style-type: none"> • A50 module failure • Connector C21 corroded • Connector C58 corroded • Connector C15 Corroded • Circuit 46B shorted to ground • L67 or L69 low resistance value

MID 188 PSID # 41 Cond Rly spd1 (A54 J1:5)

Type of fault:	FMI Description:	Fault Condition:	Possible Symptoms:	Possible Causes:
FMI 3	Shorted High	Voltage present on output A54 J1:5 but output not active	Condenser fans always ON speed 1	<ul style="list-style-type: none"> • A54 module failure • Cond Power Relay R10 failure • Circuit 67A shorted to battery
FMI 4	Shorted Low	Output A54 J1:5 shorted to ground	Condenser fans not working	<ul style="list-style-type: none"> • A54 module failure • Cond Power Relay R10 failure • Circuit 67A shorted to ground
FMI 5	Open Circuit	A54 module does not detect power relay R10	Condenser fans not working	<ul style="list-style-type: none"> • A54 module failure • Cond Power Relay R10 failure • Power Relay R10 open circuit • Circuit 67A open
FMI 6	Current above normal	Output A54 J1:5 internal software fuse active for overcurrent	Condenser fans not working	<ul style="list-style-type: none"> • A54 module failure • Circuit 67A shorted to ground

MID 188 PSID # 42 Cond Rly spd2 (A49 J1:16)

Type of fault:	FMI Description:	Fault Condition:	Possible Symptoms:	Possible Causes:
FMI 3	Shorted High	Voltage present on output A49 J1:16 but output not active	Condenser fans not working on speed 2	<ul style="list-style-type: none"> • A49 module failure • Connector C21 corroded • Connector C58 corroded • Circuit 2B shorted to battery
FMI 4	Shorted Low	Output A49 J1:16 shorted to ground	Condenser fans always ON speed 2	<ul style="list-style-type: none"> • A49 module failure • Connector C21 corroded • Connector C58 corroded • Circuit 2B shorted to ground
FMI 6	Current above normal	Output A49 J1:16 internal software fuse active for overcurrent	Condenser fans always ON speed 2	<ul style="list-style-type: none"> • A49 module failure • Condenser motors failure • Connector C21 corroded • Connector C58 corroded • Circuit 2B shorted to ground

MID 188 PSID # 116 Cyclope Lt (A51 J1:7)

Type of fault:	FMI Description:	Fault Condition:	Possible Symptoms:	Possible Causes:
FMI 3	Shorted High	Voltage present on output A51 J1:7 but output not active	Center High mounted stop light L81 always ON	<ul style="list-style-type: none"> • A51 module failure • Connector C12 corroded • Connector C91 corroded • Circuit 82A shorted to battery
FMI 4	Shorted Low	Output A51 J1:7 shorted to ground	Center High mounted stop light L81 not working	<ul style="list-style-type: none"> • A51 module failure • Connector C12 corroded • Connector C91 corroded • Circuit 82A shorted to ground
FMI 6	Current above normal	Output A51 J1:7 internal software fuse active for overcurrent	Center High mounted stop light L81 not working	<ul style="list-style-type: none"> • A51 module failure • Connector C12 corroded • Connector C91 corroded • Circuit 82A shorted to ground • Low resistance value

MID 188 PSID # 102 Direct Lts Relay (A49 J1:11)

Type of fault:	FMI Description:	Fault Condition:	Possible Symptoms:	Possible Causes:
FMI 3	Shorted High	Voltage present on output A49 J1:11 but output not active	Direct Lights Relay R6 always ON	<ul style="list-style-type: none"> • A49 module failure • Direct Lights Relay R6 failure • Circuit 38 shorted to battery
FMI 4	Shorted Low	Output A49 J1:11 shorted to ground	Direct lights not working	<ul style="list-style-type: none"> • A49 module failure • Direct Lights Relay R6 failure • Circuit 38 shorted to ground
FMI 5	Open Circuit	A49 module does not detect direct lights relay R6	Direct lights not working	<ul style="list-style-type: none"> • A49 module failure • Direct Lights Relay R6 failure • Direct Lights Relay R6 open circuit • Circuit 38 open
FMI 6	Current above normal	Output A49 J1:11 internal software fuse active for overcurrent	Direct lights not working	<ul style="list-style-type: none"> • A49 module failure • Circuit 38 shorted to ground

MID 188 PSID # 180 Driver Def Fan (A47 J1:1)

Type of fault:	FMI Description:	Fault Condition:	Possible Symptoms:	Possible Causes:
FMI 3	Shorted High	Voltage present on output A47 J1:1 but output not active	Defroster fans Mo24 and Mo25 not working	<ul style="list-style-type: none"> • A47 module failure • A24 module failure • Circuit 86 shorted to battery
FMI 4	Shorted Low	Output A47 J1:1 shorted to ground	Defroster fans Mo24 and Mo25 on full speed	<ul style="list-style-type: none"> • A47 module failure • A24 module failure • Circuit 86 shorted to ground
FMI 5	Open Circuit	A47 module does not detect Defroster Speed Ctrl A24	Defroster fans Mo24 and Mo25 on full speed	<ul style="list-style-type: none"> • A47 module failure • A24 module failure • Circuit 86 open
FMI 6	Current above normal	Output A47 J1:1 internal software fuse active for overcurrent	Defroster fans Mo24 and Mo25 on full speed	<ul style="list-style-type: none"> • A47 module failure • A24 module failure • Circuit 86 shorted to ground

MID 188 PSID # 16 Driver heat Sol (A46 J1:6)

Type of fault:	FMI Description:	Fault Condition:	Possible Symptoms:	Possible Causes:
FMI 3	Shorted High	Voltage present on output A46 J1:6 but output not active	No heat in driver's area	<ul style="list-style-type: none"> • A46 module failure • Connector C4 corroded • Circuit 50 shorted to battery
FMI 4	Shorted Low	Output A46 J1:6 shorted to ground	Full heat in driver's area	<ul style="list-style-type: none"> • A46 module failure • Connector C4 corroded • Circuit 50 shorted to ground

SECTION 06B: ELECTRICAL

FMI 5	Open Circuit	A46 module does not detect Driver Heat Solenoid So8	Full heat in driver's area	<ul style="list-style-type: none"> • A46 module failure • So8 open • Circuit 50 open
FMI 6	Current above normal	Output A46 J1:6 internal software fuse active for overcurrent	Full heat in driver's area	<ul style="list-style-type: none"> • A46 module failure • Connector C4 corroded • Circuit 50 shorted to ground • Driver heat solenoid So8 Low resistance value (expected value \pm 40 ohms)

MID 188 PSID # 104 Driver Light Sw (A44 J1:3)

Type of fault:	FMI Description:	Fault Condition:	Possible Symptoms:	Possible Causes:
FMI 3	Shorted High	Voltage present on output A44 J1:3 but output not active	Driver Light L16 always ON	<ul style="list-style-type: none"> • A44 module failure • Connector C45 corroded • Circuit 39D shorted to battery
FMI 4	Shorted Low	Output A44 J1:3 shorted to ground	Driver Light L16 not working	<ul style="list-style-type: none"> • A44 module failure • Connector C45 corroded • Circuit 39D shorted to ground
FMI 5	Open Circuit	A44 module does not detect Driver Light L16	Driver Light L16 not working	<ul style="list-style-type: none"> • A44 module failure • L16 open circuit • Circuit 39D open
FMI 6	Current above normal	Output A44 J1:3 internal software fuse active for overcurrent	Driver Light L16 not working	<ul style="list-style-type: none"> • A44 module failure • Connector C45 corroded • Circuit 39D shorted to ground • Low resistance value

MID 188 SID # 67 Driver Light Sw (A55 J1:5)

Type of fault:	FMI Description:	Fault Condition:	Possible Symptoms:	Possible Causes:
FMI 3	Shorted High	Voltage above normal on A55 J1:5	Driver Light not working	<ul style="list-style-type: none"> • A55 module failure • Sw24 failure • Circuit 39 shorted to battery
FMI 4	Shorted Low	Voltage below normal on A55 J1:5	Driver light always ON	<ul style="list-style-type: none"> • A55 module failure • Sw24 failure • Circuit 39 shorted to ground

MID 188 PSID # 29 Driver Rfg Sol (A46 J1:5)

Type of fault:	FMI Description:	Fault Condition:	Possible Symptoms:	Possible Causes:
FMI 3	Shorted High	Voltage present on output A46 J1:5 but output not active	Driver's A/C always ON	<ul style="list-style-type: none"> • A46 module failure • Connector C4 corroded • Connector C18 corroded • Circuit 116A shorted to battery
FMI 4	Shorted Low	Output A46 J1:5 shorted to ground	Driver's A/C not working	<ul style="list-style-type: none"> • A46 module failure • Connector C4 corroded • Connector C18 corroded • Circuit 116A shorted to ground
FMI 5	Open Circuit	A46 module does not detect Driver Liquid Solenoid Valve So7	Driver's A/C not working	<ul style="list-style-type: none"> • A46 module failure • So7 open • Circuit 116A open

FMI 6	Current above normal	Output A46 J1:5 internal software fuse active for overcurrent	Driver's A/C not working	<ul style="list-style-type: none"> • A46 module failure • Connector C4 corroded • Connector C18 corroded • Circuit 116A shorted to ground • Solenoid Valve So7 low resistance value (expected value \pm 40 ohms)
-------	----------------------	---	--------------------------	--

MID 188 PSID # 28 Driver Sensor (A55 J1:1)

Type of fault:	FMI Description:	Fault Condition:	Possible Symptoms:	Possible Causes:
FMI 3	Shorted High	Voltage above normal on A55 J1:1	Driver temperature not displayed on HVCA module. Driver is full heat with set point above 70°F and full A/C with set point below 70°F.	<ul style="list-style-type: none"> • A55 module failure • Se21 failure • Circuit ANA-89 shorted to battery
FMI 4	Shorted Low	Voltage below normal on A55 J1:1	Driver temperature not displayed on HVCA module. Driver is full heat with set point above 70°F and full A/C with set point below 70°F.	<ul style="list-style-type: none"> • A55 module failure • Se21 failure • Circuit ANA-89 shorted to ground
FMI 5	Open Circuit	A55 module does not detect Driver Temperature Sensor Se21	Driver temperature not displayed on HVCA module. Driver is full heat with set point above 70°F and full A/C with set point below 70°F.	<ul style="list-style-type: none"> • A55 module failure • Se21 failure • Circuit ANA-89 open

MID 188 PSID # 26 Passenger Sensor (A54 J1:13)

Type of fault:	FMI Description:	Fault Condition:	Possible Symptoms:	Possible Causes:
FMI 3	Shorted High	Voltage above normal on A54 J1:13	Following message appears on the DID: PSID 26 PASS. SENSOR {psid +26, 188, pass. sensor} Out of range	<ul style="list-style-type: none"> • A54 module failure • Se25 failure • Circuit ANA-86 shorted to battery
FMI 4	Shorted Low	Voltage below normal on A54 J1:13		<ul style="list-style-type: none"> • A54 module failure • Se25 failure • Circuit ANA-86 shorted to ground
FMI 5	Open Circuit	A54 module does not detect Passenger Temperature Sensor Se25		<ul style="list-style-type: none"> • A54 module failure • Se25 failure • Circuit ANA-86 open

MID 188 SID # 64 Drv air Trap (A44 J1:2)

Type of fault:	FMI Description:	Fault Condition:	Possible Symptoms:	Possible Causes:
----------------	------------------	------------------	--------------------	------------------

SECTION 06B: ELECTRICAL

FMI 3	Shorted High	Voltage present on output A44 J1:2 but output not active	Dash damper not moving	<ul style="list-style-type: none"> • A44 module failure • Dash Damper Mo3 failure • Connector C72 corroded • Circuit 68A shorted to battery
FMI 4	Shorted Low	Output A44 J1:2 shorted to ground	Dash damper not moving	<ul style="list-style-type: none"> • A44 module failure • Dash Damper Mo3 failure • Connector C72 corroded • Circuit 68A shorted to ground
FMI 6	Current above normal	Output A44 J1:2 internal software fuse active for overcurrent	Dash damper not moving	<ul style="list-style-type: none"> • A44 module failure • Connector C72 corroded • Circuit 68A shorted to ground • Mo3 low resistance value

MID 188 PSID # 30 Drv Rec Cylind (A47 J1:4)

Type of fault:	FMI Description:	Fault Condition:	Possible Symptoms:	Possible Causes:
FMI 3	Shorted High	Voltage present on output A47 J1:4 but output not active	Driver's area always in recirculation mode. Windshield could fog up	<ul style="list-style-type: none"> • A47 module failure • Gaz Cylinder driver LH L283 failure • Gaz Cylinder driver RH L203 failure • Circuit 65D shorted to battery
FMI 4	Shorted Low	Output A47 J1:4 shorted to ground	Recirculation mode not working, low A/C performance	<ul style="list-style-type: none"> • A47 module failure • Gaz Cylinder driver LH L283 failure • Gaz Cylinder driver RH L203 failure • Circuit 65D shorted to ground
FMI 5	Open Circuit	A47 module does not detect Gaz Cylinder driver LH L283 and RH L203	Recirculation mode not working. Low A/C performance	<ul style="list-style-type: none"> • A47 module failure • Gaz Cylinder driver LH L283 open circuit • Gaz Cylinder driver RH L203 open circuit • Circuit 65D open • Circuit ORC3 open
FMI 6	Current above normal	Output A47 J1:4 internal software fuse active for overcurrent	Recirculation mode not working. Low A/C performance	<ul style="list-style-type: none"> • A47 module failure • Circuit 65D shorted to ground • LH L283 or RH L203 low resistance value

MID 188 PSID # 82 Elec Horn SW61 (A45 J1:10)

Type of fault:	FMI Description:	Fault Condition:	Possible Symptoms:	Possible Causes:
FMI 3	Shorted High	Voltage above normal on A45 J1:10	Electrical horn not working	<ul style="list-style-type: none"> • A45 module failure • Connector C71 corroded • Circuit 69 shorted to battery
FMI 4	Shorted Low	Voltage below normal on A45 J1:10	Electrical horn always ON	<ul style="list-style-type: none"> • A45 module failure • Connector C71 corroded • Circuit 69 shorted to ground

MID 188 SID # 47 Emergency Lt R15 (A49 J1:13)

Type of fault:	FMI Description:	Fault Condition:	Possible Symptoms:	Possible Causes:
FMI 3	Shorted High	Voltage present on output A49 J1:13 but output not active	Emergency lights always ON	<ul style="list-style-type: none"> • A49 module failure • Relay R15 failure • Connector C35 corroded • Circuit 64 shorted to battery
FMI 4	Shorted Low	Output A49 J1:13 shorted to ground	Emergency lights not working	<ul style="list-style-type: none"> • A49 module failure • Relay R15 failure • Connector C35 corroded • Circuit 64 shorted to ground
FMI 5	Open Circuit	A49 module does not detect relay R15	Emergency lights not working	<ul style="list-style-type: none"> • A49 module failure • Relay R15 open circuit • Circuit 64 open
FMI 6	Current above normal	Output A49 J1:13 internal software fuse active for overcurrent	Emergency lights not working	<ul style="list-style-type: none"> • A49 module failure • Connector C35 corroded • Circuit 64 shorted to ground • Relay R15 low resistance value (expected value \pm 200 ohms)

MID 188 PSID # 44 Emergency Relay (A36 JA:24)

Type of fault:	FMI Description:	Fault Condition:	Possible Symptoms:	Possible Causes:
FMI 3	Shorted High	Voltage present on output A36 JA:24 but output not active	Engine will shut down or cannot be started	<ul style="list-style-type: none"> • A36 module failure • Relay R21 failure • Connector C2 corroded • Connector C21 corroded • Circuit 911 shorted to battery
FMI 4	Shorted Low	Output A36 JA:24 shorted to ground	Emergency cutout system not working	<ul style="list-style-type: none"> • A36 module failure • Relay R21 failure • Connector C2 corroded • Connector C21 corroded • Circuit 911 shorted to ground
FMI 5	Open Circuit	A36 module does not detect Emergency Cutout Relay R21	Emergency cutout system not working	<ul style="list-style-type: none"> • A36 module failure • Relay R21 open circuit • Circuit 911 open
FMI 6	Current above normal	Output A36 JA:24 internal software fuse active for overcurrent	Emergency cutout system not working	<ul style="list-style-type: none"> • A36 module failure • Connector C2 corroded • Connector C21 corroded • Circuit 911 shorted to ground • Relay R21 low resistance value

MID 188 PSID # 101 Emgy & Aisle Lts (A46 J1:4)

Type of fault:	FMI Description:	Fault Condition:	Possible Symptoms:	Possible Causes:
FMI 3	Shorted High	Voltage present on output A46 J1:4 but output not active	Aisle lights always ON	<ul style="list-style-type: none"> • A46 module failure • Connector C144 corroded • Circuit 5 shorted to battery
FMI 4	Shorted Low	Output A46 J1:4 shorted to ground	Aisle lights not working	<ul style="list-style-type: none"> • A46 module failure • Connector C144 corroded • Circuit 5 shorted to ground

SECTION 06B: ELECTRICAL

FMI 6	Current above normal	Output A46 J1:4 internal software fuse active for overcurrent	Aisle lights not working	<ul style="list-style-type: none"> • A46 module failure • Connector C144 corroded • Circuit 5 shorted to ground • Low resistance value
-------	----------------------	---	--------------------------	--

MID 188 PSID # 6 Engine Door Se (A49 J1:2)

Type of fault:	FMI Description:	Fault Condition:	Possible Symptoms:	Possible Causes:
FMI 3	Shorted High	Voltage above normal on A49 J1:2	Engine door switch Se30 & compressor door switch Se31 always ON	<ul style="list-style-type: none"> • A49 module failure • Se30 failure • Se31 failure • Connector C91 corroded • Circuit 9A shorted to battery
FMI 4	Shorted Low	Voltage below normal on A49 J1:2	Engine door switch Se30 & compressor door switch Se31 not working	<ul style="list-style-type: none"> • A49 module failure • Se30 failure • Se31 failure • Connector C91 corroded • Circuit 9A shorted to ground

MID 188 PSID # 53 Engine Fan Spd1 (A52 J1:1)

Type of fault:	FMI Description:	Fault Condition:	Possible Symptoms:	Possible Causes:
FMI 3	Shorted High	Voltage present on output A52 J1:1 but output not active	Radiator fan clutch Mo2 not working on speed 1	<ul style="list-style-type: none"> • A52 module failure • Radiator fan clutch Mo2 failure • Connector C91 corroded • Connector C426 corroded • Diode D37 shorted internally • Circuit 291 shorted to battery
FMI 4	Shorted Low	Output A52 J1:1 shorted to ground	Radiator fan clutch Mo2 always ON speed 1	<ul style="list-style-type: none"> • A52 module failure • Radiator fan clutch Mo2 failure • Connector C91 corroded • Connector C426 corroded • Circuit 291 shorted to ground
FMI 5	Open Circuit	A52 module does not detect radiator fan clutch Mo2	Radiator fan clutch Mo2 not working on speed 1	<ul style="list-style-type: none"> • A52 module failure • Radiator fan clutch Mo2 open circuit • Circuit 291 open
FMI 6	Current above normal	Output A52 J1:1 internal software fuse active for overcurrent	Radiator fan clutch Mo2 not working on speed 1	<ul style="list-style-type: none"> • A52 module failure • Connector C91 corroded • Connector C426 corroded • Circuit 291 shorted to battery

MID 188 PSID # 54 Engine Fan Spd2 (A52 J1:2)

Type of fault:	FMI Description:	Fault Condition:	Possible Symptoms:	Possible Causes:
FMI 3	Shorted High	Voltage present on output A52 J1:2 but output not active	Radiator fan clutch Mo2 not working on speed 2	<ul style="list-style-type: none"> • A52 module failure • Radiator fan clutch Mo2 failure • Connector C91 corroded • Connector C426 corroded • Diode D36 shorted internally • Circuit 292 shorted to battery
FMI 4	Shorted Low	Output A52 J1:2 shorted to ground	Radiator fan clutch Mo2 always ON speed 2	<ul style="list-style-type: none"> • A52 module failure • Radiator fan clutch Mo2 failure • Connector C91 corroded • Connector C426 corroded • Circuit 292 shorted to ground
FMI 5	Open Circuit	A52 module does not detect radiator fan clutch Mo2	Radiator fan clutch Mo2 not working on speed 2	<ul style="list-style-type: none"> • A52 module failure • Radiator fan clutch Mo2 open circuit • Connector C91 corroded • Connector C426 corroded • Circuit 292 open
FMI 6	Current above normal	Output A52 J1:2 internal software fuse active for overcurrent	Radiator fan clutch Mo2 not working on speed 2	<ul style="list-style-type: none"> • A52 module failure • Connector C91 corroded • Connector C426 corroded • Circuit 292 shorted to battery

MID 188 PSID # 70 Ent Close Out (A36 JB:17)

Type of fault:	FMI Description:	Fault Condition:	Possible Symptoms:	Possible Causes:
FMI 3	Shorted High	Voltage above normal on A36 JB:17	Entrance door cannot be opened	<ul style="list-style-type: none"> • A36 module failure • Sw34 failure • Connector C6 corroded • Circuit 49 shorted to battery
FMI 4	Shorted Low	Voltage below normal on A36 JB:17	Entrance door cannot be closed with switch	<ul style="list-style-type: none"> • A36 module failure • Sw34 failure • Connector C6 corroded • Circuit 49 shorted to ground

MID 188 PSID # 63 Ent Close Sens (A47 J1:10)

Type of fault:	FMI Description:	Fault Condition:	Possible Symptoms:	Possible Causes:
FMI 3	Shorted High	Voltage above normal on A47 J1:10	Entrance door cannot be opened	<ul style="list-style-type: none"> • A47 module failure • Se76 failure • Connector CXC1 corroded • Circuit 3 shorted to battery
FMI 4	Shorted Low	Voltage below normal on A47 J1:10	Entrance door cannot be closed with switch	<ul style="list-style-type: none"> • A47 module failure • Se76 failure • Connector CXC1 corroded • Circuit 3 shorted to ground

MID 188 PSID # 65 Ent Close Sol (A47 J1:6)

Type of fault:	FMI Description:	Fault Condition:	Possible Symptoms:	Possible Causes:
FMI 3	Shorted High	Voltage present on output A47 J1:6 but output not active	Close Solenoid Valve So6 always ON - Entrance door cannot be opened	<ul style="list-style-type: none"> • A47 module failure • Close solenoid valve So6 failure • Circuit 49A shorted to battery
FMI 4	Shorted Low	Output A47 J1:6 shorted to ground	Entrance door cannot be closed with switch	<ul style="list-style-type: none"> • A47 module failure • Close solenoid valve So6 failure • Circuit 49A shorted to ground
FMI 5	Open Circuit	A47 module does not detect Close Solenoid Valve So6	Entrance door cannot be closed with switch	<ul style="list-style-type: none"> • A47 module failure • Close solenoid valve So6 open • Circuit 49A open
FMI 6	Current above normal	Output A47 J1:6 internal software fuse active for overcurrent	Entrance door cannot be closed with switch	<ul style="list-style-type: none"> • A47 module failure • Circuit 49A shorted to ground • Close solenoid valve So6 shorted to ground

MID 188 PSID # 64 Ent Door Close (A36 JB:10)

Type of fault:	FMI Description:	Fault Condition:	Possible Symptoms:	Possible Causes:
FMI 3	Shorted High	Voltage above normal on A36 J1:10	Entrance door cannot be closed with switch	<ul style="list-style-type: none"> • A36 module failure • Connector C71 corroded • Circuit 49A shorted to battery
FMI 4	Shorted Low	Voltage below normal on A36 JB:10	Entrance door cannot be opened	<ul style="list-style-type: none"> • A36 module failure • Inside switch close Sw32 failure • Connector C71 corroded • Circuit 49A shorted to ground

MID 188 PSID # 71 Ent open out (A36 JB:15)

Type of fault:	FMI Description:	Fault Condition:	Possible Symptoms:	Possible Causes:
FMI 3	Shorted High	Voltage above normal on A36 J1:15	Entrance door cannot be closed	<ul style="list-style-type: none"> • A36 module failure • Sw34 failure • Connector C6 corroded • Circuit 47 shorted to battery
FMI 4	Shorted Low	Voltage below normal on A36 JB:15	Entrance door cannot be opened with switch	<ul style="list-style-type: none"> • A36 module failure • Sw34 failure • Connector C6 corroded • Circuit 47 shorted to ground

MID 188 PSID # 67 Ent Open Sol (A47 J1:7)

Type of fault:	FMI Description:	Fault Condition:	Possible Symptoms:	Possible Causes:
----------------	------------------	------------------	--------------------	------------------

FMI 3	Shorted High	Voltage present on output A47 J1:7 but output not active	Open Solenoid Valve So5 always ON - Entrance door cannot be closed	<ul style="list-style-type: none"> • A47 module failure • Open solenoid valve So5 failure • Connector C70 corroded • Connector C6 corroded • Circuit 48A shorted to battery
FMI 4	Shorted Low	Output A47 J1:7 shorted to ground	Entrance door cannot be opened with switch	<ul style="list-style-type: none"> • A47 module failure • Open solenoid valve So5 failure • Circuit 48A shorted to ground
FMI 5	Open Circuit	A47 module does not detect Open Solenoid Valve So5	Entrance door cannot be opened with switch	<ul style="list-style-type: none"> • A47 module failure • Open solenoid valve So5 open • Circuit 48A open
FMI 6	Current above normal	Output A47 J1:7 internal software fuse active for overcurrent	Entrance door cannot be opened with switch	<ul style="list-style-type: none"> • A47 module failure • Circuit 48A shorted to ground • Open solenoid valve So5 shorted internally

MID 188 PSID # 72 Ent Unlk Sol (A47 J1:8)

Type of fault:	FMI Description:	Fault Condition:	Possible Symptoms:	Possible Causes:
FMI 3	Shorted High	Voltage present on output A47 J1:8 but output not active	Unlk Solenoid Valve So3 or Unlk Solenoid Valve So4 always ON - Entrance door cannot be locked	<ul style="list-style-type: none"> • A47 module failure • Unlk solenoid valve So3 failure • Unlk solenoid valve So4 failure • Circuit 12W shorted to battery
FMI 4	Shorted Low	Output A47 J1:8 shorted to ground	Entrance door cannot be unlocked	<ul style="list-style-type: none"> • A47 module failure • Unlk solenoid valve So3 failure • Unlk solenoid valve So4 failure • Circuit 12W shorted to ground
FMI 5	Open Circuit	A47 module does not detect Unlk Solenoid Valve So3 or Unlk Solenoid Valve So4	Entrance door cannot be unlocked	<ul style="list-style-type: none"> • A47 module failure • Unlk solenoid valve So3 open • Unlk solenoid valve So4 open • Circuit 12W open
FMI 6	Current above normal	Output A47 J1:8 internal software fuse active for overcurrent	Entrance door cannot be unlocked	<ul style="list-style-type: none"> • A47 module failure • Circuit 12W shorted to ground • Unlk solenoid valve So3 or So4 shorted internally

MID 188 PSID # 77 Evap Motor Rly (A54 J1:7)

Type of fault:	FMI Description:	Fault Condition:	Possible Symptoms:	Possible Causes:
FMI 3	Shorted High	Voltage present on output A54 J1:7 but output not active	Evaporator fan always ON	<ul style="list-style-type: none"> • A54 module failure • Evaporator Relay R12 failure • Circuit 67 shorted to battery
FMI 4	Shorted Low	Output A54 J1:7 shorted to ground	Evaporator fan not working	<ul style="list-style-type: none"> • A54 module failure • Evaporator Relay R12 failure • Circuit 67 shorted to ground

SECTION 06B: ELECTRICAL

FMI 5	Open Circuit	A54 module does not detect evaporator relay R12	Evaporator fan not working	<ul style="list-style-type: none"> • A54 module failure • Evaporator Relay R12 open circuit • Circuit 67 open
FMI 6	Current above normal	Output A54 J1:7 internal software fuse active for overcurrent	Evaporator fan not working	<ul style="list-style-type: none"> • A54 module failure • Circuit 67 shorted to ground

MID 188 PSID # 133 Flash RH Sw (A48 J1:12)

Type of fault:	FMI Description:	Fault Condition:	Possible Symptoms:	Possible Causes:
FMI 3	Shorted High	Voltage present on input A48 J1:12 but output not active	RH flasher not working	<ul style="list-style-type: none"> • A48 module failure • Connector C4 corroded • Connector Foot:C corroded • Circuit 23 shorted to battery
FMI 4	Shorted Low	Input A48 J1:12 shorted to ground	RH flasher always ON	<ul style="list-style-type: none"> • A48 module failure • Foot switch Sw139 failure • Connector C4 corroded • Connector Foot:C corroded • Circuit 23 shorted to ground

MID 188 PSID # 130 Flasher LH (A45 J1:9)

Type of fault:	FMI Description:	Fault Condition:	Possible Symptoms:	Possible Causes:
FMI 3	Shorted High	Voltage present on input A45 J1:9 but output not active	LH flasher not working	<ul style="list-style-type: none"> • A45 module failure • Connector Foot:B corroded • Circuit 21 shorted to battery
FMI 4	Shorted Low	Input A45 J1:9 shorted to ground	LH flasher always ON	<ul style="list-style-type: none"> • A45 module failure • Foot switch Sw138 failure • Connector Foot:B corroded • Circuit 21 shorted to ground

MID 188 PSID # 37 Foot trap (A45 J1:2)

Type of fault:	FMI Description:	Fault Condition:	Possible Symptoms:	Possible Causes:
FMI 3	Shorted High	Voltage present on output A45 J1:2 but output not active	Foot damper Mo4 always ON	<ul style="list-style-type: none"> • A45 module failure • Foot Damper Mo4 failure • Connector C72 corroded • Circuit 65A shorted to battery
FMI 4	Shorted Low	Output A45 J1:2 shorted to ground	Foot damper Mo4 not working	<ul style="list-style-type: none"> • A45 module failure • Foot Damper Mo4 failure • Connector C72 corroded • Circuit 65A shorted to ground
FMI 6	Current above normal	Output A45 J1:2 internal software fuse active for overcurrent	Foot damper Mo4 not working	<ul style="list-style-type: none"> • A45 module failure • Connector C72 corroded • Circuit 65A shorted to ground

MID 188 PSID # 137 FR Clearance lights (A44 J1:8)

Type of fault:	FMI Description:	Fault Condition:	Possible Symptoms:	Possible Causes:
FMI 3	Shorted High	Voltage present on output A44 J1:8 but output not active	Front Clearance Lights always ON	<ul style="list-style-type: none"> • A44 module failure • Connector C45 corroded • Circuit 63A shorted to battery
FMI 4	Shorted Low	Output A44 J1:8 shorted to ground	Front Clearance Lights not working	<ul style="list-style-type: none"> • A44 module failure • Connector C45 corroded • Circuit 63A shorted to ground
FMI 5	Open Circuit	A44 module does not detect Front Clearance Lights	Front Clearance Lights not working	<ul style="list-style-type: none"> • A44 module failure • L16 open circuit • Circuit 63A open
FMI 6	Current above normal	Output A44 J1:8 internal software fuse active for overcurrent	Front Clearance Lights not working	<ul style="list-style-type: none"> • A44 module failure • Connector C45 corroded • Circuit 63A shorted to ground

MID 188 PSID # 128 Fr Flsh-Mkr LH (A45 J1:3)

Type of fault:	FMI Description:	Fault Condition:	Possible Symptoms:	Possible Causes:
FMI 3	Shorted High	Voltage present on output A45 J1:3 but output not active	Front LH flasher and marker lights always ON	<ul style="list-style-type: none"> • A45 module failure • Connector C4 corroded • Connector C242 corroded • Circuit 21A shorted to battery
FMI 4	Shorted Low	Output A45 J1:3 shorted to ground	Front LH flasher and marker lights not working	<ul style="list-style-type: none"> • A45 module failure • Connector C4 corroded • Connector C242 corroded • Circuit 21A shorted to ground
FMI 6	Current above normal	Output A45 J1:3 internal software fuse active for overcurrent	Front LH flasher and marker lights not working	<ul style="list-style-type: none"> • A45 module failure • Connector C4 corroded • Connector C242 corroded • Circuit 21A shorted to ground

MID 188 PSID # 10 Fr Side Flsh (A48 J1:20)

Type of fault:	FMI Description:	Fault Condition:	Possible Symptoms:	Possible Causes:
FMI 3	Shorted High	Voltage present on output A48 J1:20 but output not active	Flasher RH Front side L64 always ON	<ul style="list-style-type: none"> • A48 module failure • Flasher RH Front Side L64 failure • Circuit 23AA shorted to battery
FMI 4	Shorted Low	Output A48 J1:20 shorted to ground	Flasher RH Front side L64 not working	<ul style="list-style-type: none"> • A48 module failure • Flasher RH Front Side L64 failure • Circuit 23AA shorted to ground
FMI 6	Current above normal	Output A48 J1:20 internal software fuse active for overcurrent	Flasher RH Front side L64 not working	<ul style="list-style-type: none"> • A48 module failure • Circuit 23AA shorted to ground

MID 188 PSID # 58 Fr Start Sw (A36 JB:22)

SECTION 06B: ELECTRICAL

Type of fault:	FMI Description:	Fault Condition:	Possible Symptoms:	Possible Causes:
FMI 3	Shorted High	Voltage present on output A36 JB:22 but switch not in Start position	Engine will start on ignition	<ul style="list-style-type: none"> • A36 module failure • Front start switch Sw83 failure • Connector C40 corroded • Connector C71 corroded • Circuit 84B shorted to battery
FMI 4	Shorted Low	Input A36 JB:22 shorted to ground	Engine cannot be started from front	<ul style="list-style-type: none"> • A36 module failure • Front start switch Sw83 failure • Connector C40 corroded • Connector C71 corroded • Circuit 84B shorted to ground

MID 188 PSID # 126 Front Flash RH (A48 J1:6)

Type of fault:	FMI Description:	Fault Condition:	Possible Symptoms:	Possible Causes:
FMI 3	Shorted High	Voltage present on output A48 J1:6 but output not active	Front Flasher RH L61 always ON	<ul style="list-style-type: none"> • A48 module failure • Connector C243 corroded • Circuit 23A shorted to battery
FMI 4	Shorted Low	Output A48 J1:6 shorted to ground	Front Flasher RH L61 not working	<ul style="list-style-type: none"> • A48 module failure • Connector C243 corroded • Circuit 23A shorted to ground
FMI 6	Current above normal	Output A48 J1:6 internal software fuse active for overcurrent	Front Flasher RH L61 not working	<ul style="list-style-type: none"> • A48 module failure • Connector C243 corroded • Circuit 23A shorted to ground

MID 188 PSID # 148 FrontMkr Lts LH (A45 J1:21)

Type of fault:	FMI Description:	Fault Condition:	Possible Symptoms:	Possible Causes:
FMI 3	Shorted High	Voltage present on output A45 J1:21 but output not active	Front Flasher LH L62 always ON	<ul style="list-style-type: none"> • A45 module failure • Connector C4 corroded • Connector C242 corroded • Circuit 46A shorted to battery
FMI 4	Shorted Low	Output A45 J1:21 shorted to ground	Front Flasher LH L62 not working	<ul style="list-style-type: none"> • A45 module failure • Connector C4 corroded • Connector C242 corroded • Circuit 46A shorted to ground
FMI 5	Open Circuit	A45 module does not detect Front Flasher LH L62	Front Flasher LH L62 not working	<ul style="list-style-type: none"> • A45 module failure • Front Flasher LH L62 open circuit • Circuit 46A open
FMI 6	Current above normal	Output A45 J1:21 internal software fuse active for overcurrent	Front Flasher LH L62 not working	<ul style="list-style-type: none"> • A45 module failure • Connector C4 corroded • Connector C242 corroded • Circuit 46A shorted to ground

MID 188 PSID # 149 FrontMkr Lts RH (A48 J1:7)

Type of	FMI	Fault Condition:	Possible	Possible Causes:
---------	-----	------------------	----------	------------------

fault:	Description:		Symptoms:	
FMI 3	Shorted High	Voltage present on output A48 J1:7 but output not active	Front Flasher RH L61 and Marker L63 always ON	<ul style="list-style-type: none"> • A48 module failure • Connector C243 corroded • Circuit 46 shorted to battery
FMI 4	Shorted Low	Output A48 J1:7 shorted to ground	Front Flasher RH L61 and Marker L63 not working	<ul style="list-style-type: none"> • A48 module failure • Connector C243 corroded • Circuit 46 shorted to ground
FMI 5	Open Circuit	A48 module does not detect Front Flasher LH L62	Front Flasher RH L61 and Marker L63 not working	<ul style="list-style-type: none"> • A48 module failure • Front Flasher RH L61 and Marker L63 open circuit • Circuit 46 open
FMI 6	Current above normal	Output A48 J1:7 internal software fuse active for overcurrent	Front Flasher RH L61 and Marker L63 not working	<ul style="list-style-type: none"> • A48 module failure • Connector C243 corroded • Circuit 46 shorted to ground

MID 188 PSID # 56 FrStart Enable Sw (A53 J1:9)

Type of fault:	FMI Description:	Fault Condition:	Possible Symptoms:	Possible Causes:
FMI 3	Shorted High	Voltage present on input A53 J1:9 but switch Sw58 not active	Engine cannot be started or stopped from rear	<ul style="list-style-type: none"> • A53 module failure • Rear start switch Sw58 failure • Connector C91 corroded • Circuit 85C shorted to battery
FMI 4	Shorted Low	Output A53 J1:9 shorted to ground	Engine cannot be started from front	<ul style="list-style-type: none"> • A53 module failure • Rear start switch Sw58 failure • Connector C91 corroded • Circuit 85C shorted to ground

MID 188 PSID # 81 Fuel Filtr Sens (A49 J1:20)

Type of fault:	FMI Description:	Fault Condition:	Possible Symptoms:	Possible Causes:
FMI 3	Shorted High	Voltage present on input A49 J1:20	No warning of water in fuel filter on dash	<ul style="list-style-type: none"> • A49 module failure • Connector C91 corroded • Connector C78 corroded • Circuit 197 shorted to battery
FMI 4	Shorted Low	Input A49 J1:20 shorted to ground	Fuel water filter sensor always On on dash	<ul style="list-style-type: none"> • A49 module failure • Fuel water filter Se12 failure • Connector C91 corroded • Connector C78 corroded • Circuit 197 shorted to ground

MID 188 PSID # 138 Hazard Switch (A36 JB:4)

Type of fault:	FMI Description:	Fault Condition:	Possible Symptoms:	Possible Causes:
FMI 3	Shorted High	Voltage present on input A36 JB:4 but switch Sw4 not active	Hazard lights always ON	<ul style="list-style-type: none"> • A36 module failure • Hazard switch Sw4 failure • Connector C71 corroded • Circuit 22 shorted to battery

SECTION 06B: ELECTRICAL

FMI 4	Shorted Low	Input A36 JB:4 shorted to ground	Hazard lights not working	<ul style="list-style-type: none"> • A36 module failure • Hazard switch Sw4 failure • Connector C71 corroded • Circuit 22 shorted to ground
-------	-------------	----------------------------------	---------------------------	---

MID 188 SID # 48 HdLamp Wsh Pmp (A46 J1:21)

Type of fault:	FMI Description:	Fault Condition:	Possible Symptoms:	Possible Causes:
FMI 3	Shorted High	Voltage present on output A46 J1:21 but output not active	Headlamp washer pump Mo54 always ON	<ul style="list-style-type: none"> • A46 module failure • Connector C4 corroded • Circuit 202 shorted to battery
FMI 4	Shorted Low	Output A46 J1:21 shorted to ground	Headlamp washer pump Mo54 not working	<ul style="list-style-type: none"> • A46 module failure • Headlamp washer pump Mo54 failure • Connector C4 corroded • Circuit 202 shorted to ground
FMI 5	Open Circuit	A46 module does not detect Headlamp washer pump Mo54	Headlamp washer pump Mo54 not working	<ul style="list-style-type: none"> • A46 module failure • Headlamp washer pump Mo54 open circuit • Circuit 202 open
FMI 6	Current above normal	Output A46 J1:21 internal software fuse active for overcurrent	Headlamp washer pump Mo54 not working	<ul style="list-style-type: none"> • A46 module failure • Connector C4 corroded • Circuit 202 shorted to ground

MID 188 PSID # 143 Head Lights Pos1 (A43 J1:4)

Type of fault:	FMI Description:	Fault Condition:	Possible Symptoms:	Possible Causes:
FMI 3	Shorted High	Voltage present on input A43 J1:4 but switch Sw2 not active	Low Beam headlights not working	<ul style="list-style-type: none"> • A43 module failure • Headlight switch Sw2 failure • Connector C71 corroded • Circuit 66 shorted to battery
FMI 4	Shorted Low	Input A43 J1:4 shorted to ground	Headlights always ON low beam	<ul style="list-style-type: none"> • A43 module failure • Headlight switch Sw2 failure • Connector C71 corroded • Circuit 66 shorted to ground

MID 188 SID # 62 Hi Low Beam (A43 J1:8)

Type of fault:	FMI Description:	Fault Condition:	Possible Symptoms:	Possible Causes:
FMI 3	Shorted High	Voltage present on input A43 J1:8 but switch Sw141 not active	Headlights always ON High beam	<ul style="list-style-type: none"> • A43 module failure • Foot switch Sw141 failure • Connector Foot:A corroded • Connector C71 corroded • Circuit 59 shorted to battery
FMI 4	Shorted Low	Input A43 J1:8 shorted to ground	High Low Beam headlights foot switch not working	<ul style="list-style-type: none"> • A43 module failure • Foot switch Sw141 failure • Connector Foot:A corroded • Connector C71 corroded • Circuit 59 shorted to ground

MID 188 PSID # 141 High Beam LH (A45 J1:6)

Type of fault:	FMI Description:	Fault Condition:	Possible Symptoms:	Possible Causes:
FMI 3	Shorted High	Voltage present on output A45 J1:6 but output not active	LH High beam Headlamp L60B always ON	<ul style="list-style-type: none"> • A45 module failure • Connector C4 corroded • Connector C242 corroded • Circuit 57L shorted to battery
FMI 4	Shorted Low	Output A45 J1:6 shorted to ground	LH High beam Headlamp L60B not working	<ul style="list-style-type: none"> • A45 module failure • Connector C4 corroded • Connector C242 corroded • Circuit 57L shorted to ground
FMI 5	Open Circuit	A45 module does not detect LH High beam Headlamp L60B	LH High beam Headlamp L60B not working	<ul style="list-style-type: none"> • A45 module failure • LH High beam Headlamp L60B open circuit • Circuit 57L open
FMI 6	Current above normal	Output A45 J1:6 internal software fuse active for overcurrent	LH High beam Headlamp L60B not working	<ul style="list-style-type: none"> • A45 module failure • Connector C4 corroded • Connector C242 corroded • Circuit 57L shorted to ground

MID 188 PSID # 145 High Beam RH (A48 J1:3)

Type of fault:	FMI Description:	Fault Condition:	Possible Symptoms:	Possible Causes:
FMI 3	Shorted High	Voltage present on output A48 J1:3 but output not active	RH High beam Headlamp L59B always ON	<ul style="list-style-type: none"> • A48 module failure • Connector C243 corroded • Circuit 57R shorted to battery
FMI 4	Shorted Low	Output A48 J1:3 shorted to ground	RH High beam Headlamp L59B not working	<ul style="list-style-type: none"> • A48 module failure • Connector C243 corroded • Circuit 57R shorted to ground
FMI 5	Open Circuit	A48 module does not detect RH High beam Headlamp L59B	RH High beam Headlamp L59B not working	<ul style="list-style-type: none"> • A48 module failure • RH High beam Headlamp L59B open circuit • Circuit 57R open
FMI 6	Current above normal	Output A48 J1:3 internal software fuse active for overcurrent	RH High beam Headlamp L59B not working	<ul style="list-style-type: none"> • A48 module failure • Connector C243 corroded • Circuit 57R shorted to ground

MID 188 PSID # 83 Horn (A45 J1:20)

Type of fault:	FMI Description:	Fault Condition:	Possible Symptoms:	Possible Causes:
FMI 3	Shorted High	Voltage present on output A45 J1:20 but output not active	Electrical horn L185 and L186 always ON	<ul style="list-style-type: none"> • A45 module failure • Electrical horn L185 or L186 failure • Connector C4 corroded • Connector C101 corroded • Circuit 52A shorted to battery

SECTION 06B: ELECTRICAL

FMI 4	Shorted Low	Output A45 J1:20 shorted to ground	Electrical horn L185 and L186 not working	<ul style="list-style-type: none"> • A45 module failure • Electrical horn L185 or L186 failure • Connector C4 corroded • Connector C101 corroded • Circuit 52A shorted to ground
FMI 5	Open Circuit	A45 module does not detect Electrical horn L185 or L186	Electrical horn L185 and L186 not working	<ul style="list-style-type: none"> • A45 module failure • Electrical horn L185 or L186 open circuit • Circuit 52A open
FMI 6	Current above normal	Output A45 J1:20 internal software fuse active for overcurrent	Electrical horn L185 and L186 not working	<ul style="list-style-type: none"> • A45 module failure • Connector C4 corroded • Connector C101 corroded • Circuit 52A shorted to ground

MID 188 PSID # 110 Indir Lts Rly (A49 J1:12)

Type of fault:	FMI Description:	Fault Condition:	Possible Symptoms:	Possible Causes:
FMI 3	Shorted High	Voltage present on output A49 J1:12 but output not active	Indirect lighting always ON	<ul style="list-style-type: none"> • A49 module failure • Indirect Light Relay R13 failure • Circuit 132 shorted to battery
FMI 4	Shorted Low	Output A49 J1:12 shorted to ground	Indirect lighting not working	<ul style="list-style-type: none"> • A49 module failure • Indirect Light Relay R13 failure • Circuit 132 shorted to ground
FMI 5	Open Circuit	A49 module does not detect Indirect Light Relay R13	Indirect lighting not working	<ul style="list-style-type: none"> • A49 module failure • Indirect Light Relay R13 open circuit • Circuit 132 open
FMI 6	Current above normal	Output A49 J1:12 internal software fuse active for overcurrent	Indirect lighting not working	<ul style="list-style-type: none"> • A49 module failure • Circuit 132 shorted to ground • Relay R13 coil shorted to ground

MID 188 PSID # 89 Knee down Sol (A41 J1:14)

Type of fault:	FMI Description:	Fault Condition:	Possible Symptoms:	Possible Causes:
FMI 3	Shorted High	Voltage present on output A41 J1:14 but output not active	Kneeling down always ON, coach cannot be raised	<ul style="list-style-type: none"> • A41 module failure • Kneeling down solenoid valve So16 failure • Connector C4 corroded • Connector C172 corroded • Circuit 126F shorted to battery
FMI 4	Shorted Low	Output A41 J1:14 shorted to ground	Kneeling down not working	<ul style="list-style-type: none"> • A41 module failure • Kneeling down solenoid valve So16 failure • Connector C4 corroded • Connector C172 corroded

				<ul style="list-style-type: none"> • Circuit 126F shorted to ground
FMI 5	Open Circuit	A41 module does not detect Knee. Down Solenoid Valve So16	Kneeling down not working	<ul style="list-style-type: none"> • A41 module failure • Kneeling down solenoid valve So16 open circuit • Circuit 126F open
FMI 6	Current above normal	Output A41 J1:14 internal software fuse active for overcurrent	Kneeling down not working	<ul style="list-style-type: none"> • A41 module failure • Connector C4 corroded • Connector C172 corroded • Circuit 12W shorted to ground

MID 188 PSID # 93 Knee Down Sw (A41 J1:7)

Type of fault:	FMI Description:	Fault Condition:	Possible Symptoms:	Possible Causes:
FMI 3	Shorted High	Voltage present on input A41 J1:7 but switch Sw10A not active	Kneeling down not working	<ul style="list-style-type: none"> • A41 module failure • Kneeling switch Sw10A failure • Connector C71 corroded • Connector C170 corroded • Circuit 126A shorted to battery
FMI 4	Shorted Low	Input A41 J1:7 shorted to ground	Kneeling down always ON, coach cannot be raised	<ul style="list-style-type: none"> • A41 module failure • Kneeling switch Sw10A failure • Connector C71 corroded • Connector C170 corroded • Circuit 126A shorted to ground

MID 188 PSID # 94 Knee Up Sw (A41 J1:6)

Type of fault:	FMI Description:	Fault Condition:	Possible Symptoms:	Possible Causes:
FMI 3	Shorted High	Voltage present on input A41 J1:6 but switch Sw10A not active	Kneeling up not working	<ul style="list-style-type: none"> • A41 module failure • Kneeling switch Sw10A failure • Connector C71 corroded • Connector C170 corroded • Circuit 126B shorted to battery
FMI 4	Shorted Low	Input A41 J1:6 shorted to ground	Kneeling Up always ON, coach cannot be lowered	<ul style="list-style-type: none"> • A41 module failure • Kneeling switch Sw10A failure • Connector C71 corroded • Connector C170 corroded • Circuit 126B shorted to ground

MID 188 SID # 81 Kneeling Level Se (A46 J1:13)

Type of fault:	FMI Description:	Fault Condition:	Possible Symptoms:	Possible Causes:
FMI 3	Shorted High	Voltage present on signal A46 J1:13 but sensor Se79 not active	Momentary switch function lost, holding switch will raise coach past the normal ride height	<ul style="list-style-type: none"> • A46 module failure • Kneeling level sensor Se79 failure • Connector CSe79 corroded • Circuit ANA-KneeLevel shorted to battery
FMI 4	Shorted Low	Signal A46 J1:13 shorted to ground	Momentary switch function lost, holding switch will lower coach	<ul style="list-style-type: none"> • A46 module failure • Kneeling level sensor Se79 failure

SECTION 06B: ELECTRICAL

			below standard kneeling height and raise coach above the normal ride height	<ul style="list-style-type: none"> • Connector CSe79 corroded • Circuit ANA-KneeLevel shorted to ground
--	--	--	---	---

MID 188 PSID # 98 Lavatory Fan4 (A52 J1:4)

Type of fault:	FMI Description:	Fault Condition:	Possible Symptoms:	Possible Causes:
FMI 4	Shorted Low	Output A52 J1:4 shorted to ground	Air Exhaust Fan Mo14 not working	<ul style="list-style-type: none"> • A52 module failure • Air Exhaust Fan Mo14 failure • Connector C91 corroded • Circuit 225 shorted to ground
FMI 5	Open Circuit	A52 module does not detect Air Exhaust Fan Mo14	Air Exhaust Fan Mo14 not working	<ul style="list-style-type: none"> • A52 module failure • Air Exhaust Fan Mo14 open circuit • Circuit 225 open
FMI 6	Current above normal	Output A52 J1:4 internal software fuse active for overcurrent	Air Exhaust Fan Mo14 not working	<ul style="list-style-type: none"> • A52 module failure • Connector C91 corroded • Circuit 225 shorted to ground

MID 188 PSID # 142 Low Beam LH (A45 J1:7)

Type of fault:	FMI Description:	Fault Condition:	Possible Symptoms:	Possible Causes:
FMI 3	Shorted High	Voltage present on output A45 J1:7 but output not active	LH Low beam Headlamp L60A always ON	<ul style="list-style-type: none"> • A45 module failure • Connector C4 corroded • Connector C242 corroded • Circuit 58L shorted to battery
FMI 4	Shorted Low	Output A45 J1:7 shorted to ground	LH Low beam Headlamp L60A not working	<ul style="list-style-type: none"> • A45 module failure • Connector C4 corroded • Connector C242 corroded • Circuit 58L shorted to ground
FMI 6	Current above normal	Output A45 J1:7 internal software fuse active for overcurrent	LH Low beam Headlamp L60A not working	<ul style="list-style-type: none"> • A45 module failure • Connector C4 corroded • Connector C242 corroded • Circuit 58L shorted to ground

MID 188 PSID # 146 Low Beam RH (A48 J1:4)

Type of fault:	FMI Description:	Fault Condition:	Possible Symptoms:	Possible Causes:
FMI 3	Shorted High	Voltage present on output A48 J1:4 but output not active	RH Low beam Headlamp L59A always ON	<ul style="list-style-type: none"> • A48 module failure • Connector C243 corroded • Circuit 58R shorted to battery
FMI 4	Shorted Low	Output A48 J1:4 shorted to ground	RH Low beam Headlamp L59A not working	<ul style="list-style-type: none"> • A48 module failure • Connector C243 corroded • Circuit 58R shorted to ground
FMI 6	Current above normal	Output A48 J1:4 internal software fuse active for overcurrent	RH Low beam Headlamp L59A not	<ul style="list-style-type: none"> • A48 module failure • Connector C243 corroded

			working	• Circuit 58R shorted to ground
--	--	--	---------	---------------------------------

MID 188 PSID # 153 Lower Stop Lamps (A50 J1:6)

Type of fault:	FMI Description:	Fault Condition:	Possible Symptoms:	Possible Causes:
FMI 3	Shorted High	Voltage present on output A50 J1:6 but output not active	Lower stop lamps always ON	<ul style="list-style-type: none"> • A50 module failure • Circuit 82Low shorted to battery
FMI 4	Shorted Low	Output A50 J1:6 shorted to ground	Lower stop lamps not working	<ul style="list-style-type: none"> • A50 module failure • Circuit 82Low shorted to ground
FMI 6	Current above normal	Output A50 J1:6 internal software fuse active for overcurrent	Lower stop lamps not working	<ul style="list-style-type: none"> • A50 module failure • Circuit 82Low shorted to ground

MID 188 PSID # 181 Lower Washer pmp (A46 J1:3)

Type of fault:	FMI Description:	Fault Condition:	Possible Symptoms:	Possible Causes:
FMI 4	Shorted Low	Output A46 J1:3 shorted to ground	Windshield washer pumps Mo19 and Mo20 not working	<ul style="list-style-type: none"> • A46 module failure • Windshield washer pump Mo19 or Mo20 failure • Connector C4 corroded • Connector C61 corroded • Circuit 53F shorted to ground
FMI 5	Open Circuit	A46 module does not detect Windshield washer pumps Mo19 and Mo20	Windshield washer pumps Mo19 and Mo20 not working	<ul style="list-style-type: none"> • A46 module failure • Windshield washer pump Mo19 or Mo20 open circuit • Circuit 53F open
FMI 6	Current above normal	Output A46 J1:3 internal software fuse active for overcurrent	Windshield washer pumps Mo19 and Mo20 not working	<ul style="list-style-type: none"> • A46 module failure • Connector C4 corroded • Connector C61 corroded • Circuit 53F shorted to ground

MID 188 SID # 71 Master Interlock Sw (A36 JB:16)

Type of fault:	FMI Description:	Fault Condition:	Possible Symptoms:	Possible Causes:
FMI 3	Shorted High	Voltage present on input A36 JB:16 but switch Sw140 not active	Master Interlock Bypass not working	<ul style="list-style-type: none"> • A36 module failure • Circuit Master shorted to battery
FMI 4	Shorted Low	Input A36 JB:16 shorted to ground	Master Interlock Bypass always ON	<ul style="list-style-type: none"> • A36 module failure • Master Interlock Bypass switch Sw140 failure • Circuit Master shorted to ground

MID 188 SID # 80 Next Stop Sign (A41 J1:13)

Type of fault:	FMI Description:	Fault Condition:	Possible Symptoms:	Possible Causes:
FMI 3	Shorted High	Voltage present on output A41 J1:13 but output not active	Next Stop Light L310 always ON	<ul style="list-style-type: none"> • A41 module failure • Connector C70 corroded • Circuit 10 shorted to battery
FMI 4	Shorted Low	Output A41 J1:13 shorted to ground	Next Stop Light L310 not working	<ul style="list-style-type: none"> • A41 module failure • Connector C70 corroded • Circuit 10 shorted to ground
FMI 6	Current above normal	Output A41 J1:13 internal software fuse active for overcurrent	Next Stop Light L310 not working	<ul style="list-style-type: none"> • A41 module failure • Connector C70 corroded • Circuit 10 shorted to ground

MID 188 SID # 70 Next Stop Sw (A42 J1:9)

Type of fault:	FMI Description:	Fault Condition:	Possible Symptoms:	Possible Causes:
FMI 3	Shorted High	Voltage present on input A42 J1:9 but switch Sw5 not active	Next Stop Request not working	<ul style="list-style-type: none"> • A42 module failure • Connector C70 corroded • Connector C25A corroded • Circuit 4C shorted to battery
FMI 4	Shorted Low	Input A42 J1:9 shorted to ground	Next Stop Request always ON	<ul style="list-style-type: none"> • A42 module failure • Connector C70 corroded • Connector C25A corroded • Circuit 4C shorted to ground

MID 188 SID # 75 Oil Separator (A52 J1:6)

Type of fault:	FMI Description:	Fault Condition:	Possible Symptoms:	Possible Causes:
FMI 3	Shorted High	Voltage present on output A52 J1:6 but output not active	Drain valve discharge always ON	<ul style="list-style-type: none"> • A52 module failure • Oil separator L350A failure • Connector C27 corroded • Circuit OilSep shorted to battery
FMI 4	Shorted Low	Output A52 J1:6 shorted to ground	Drain valve discharge not working	<ul style="list-style-type: none"> • A52 module failure • Oil Separator L350A failure • Connector C27 corroded • Circuit OilSep shorted to ground
FMI 5	Open Circuit	A52 module does not detect oil Separator L350A	Drain valve discharge not working	<ul style="list-style-type: none"> • A52 module failure • Oil separator L350A open circuit

				<ul style="list-style-type: none"> • Circuit OilSep open
FMI 6	Current above normal	Output A52 J1:6 internal software fuse active for overcurrent	Drain valve discharge not working	<ul style="list-style-type: none"> • A52 module failure • Connector C27 corroded • Circuit OilSep shorted to ground

MID 188 SID # 78 Open Door Sw (A44 J1:4)

Type of fault:	FMI Description:	Fault Condition:	Possible Symptoms:	Possible Causes:
FMI 3	Shorted High	Voltage present on output A44 J1:4 but output not active	Interlock is disabled and the door can be opened even above 3m/hr (5 KM/h)	<ul style="list-style-type: none"> • A44 module failure • Inside switch open Sw33 or Inside switch close Sw32 failure • Connector C72 corroded • Circuit 2mph shorted to battery
FMI 4	Shorted Low	Output A44 J1:4 shorted to ground	Entrance door cannot be opened with Inside switches	<ul style="list-style-type: none"> • A44 module failure • Inside switch open Sw33 or Inside switch close Sw32 failure • Connector C72 corroded • Circuit 2mph shorted to ground
FMI 5	Open Circuit	A44 module does not detect Inside switch open Sw33 or Inside switch close Sw32	Entrance door cannot be opened with Inside switches	<ul style="list-style-type: none"> • A44 module failure • Inside switch open Sw33 or Inside switch close Sw32 open circuit • Circuit 2mph open
FMI 6	Current above normal	Output A44 J1:4 internal software fuse active for overcurrent	Entrance door cannot be opened with Inside switches	<ul style="list-style-type: none"> • A44 module failure • Connector C72 corroded • Circuit 2mph shorted to ground

MID 188 PSID # 19 P Rack Fan (A54 J1:1)

Type of fault:	FMI Description:	Fault Condition:	Possible Symptoms:	Possible Causes:
FMI 4	Shorted Low	Output A54 J1:1 shorted to ground	P Rack LH Fan Mo10 not working	<ul style="list-style-type: none"> • A54 module failure • P Rack LH Fan Mo10 failure • Connector C15, C21, C35 or C56 corroded • Circuit 44 shorted to ground
FMI 5	Open Circuit	A54 module does not detect P Rack LH Fan Mo10	P Rack LH Fan Mo10 not working	<ul style="list-style-type: none"> • A54 module failure • P Rack LH Fan Mo10 open circuit • Circuit 44 open
FMI 6	Current above normal	Output A54 J1:1 internal software fuse active for overcurrent	P Rack LH Fan Mo10 not working	<ul style="list-style-type: none"> • A54 module failure • Connector C15, C21, C35 or C56 corroded • Circuit 44 shorted to ground

MID 188 PSID # 20 P Rack Fan (A54 J1:2)

Type of fault:	FMI Description:	Fault Condition:	Possible Symptoms:	Possible Causes:
FMI 4	Shorted Low	Output A54 J1:2 shorted to ground	P Rack RH Fan Mo11 not working	<ul style="list-style-type: none"> • A54 module failure • P Rack RH Fan Mo11 failure

SECTION 06B: ELECTRICAL

				<ul style="list-style-type: none"> • Connector C15, C21, C35, C57 or C75 corroded • Circuit 43 shorted to ground
FMI 5	Open Circuit	A54 module does not detect P Rack RH Fan Mo11	P Rack RH Fan Mo11 not working	<ul style="list-style-type: none"> • A54 module failure • P Rack RH Fan Mo11 open circuit • Circuit 43 open
FMI 6	Current above normal	Output A54 J1:2 internal software fuse active for overcurrent	P Rack RH Fan Mo11 not working	<ul style="list-style-type: none"> • A54 module failure • Connector C15, C21, C35, C57 or C75 corroded • Circuit 43 shorted to ground

MID 188 PSID # 21 P Rack Fan (A41 J1:20)

Type of fault:	FMI Description:	Fault Condition:	Possible Symptoms:	Possible Causes:
FMI 3	Shorted High	Voltage present on input A41 J1:20 but Switch Sw27 not active	Parcel Rack Fans not working	<ul style="list-style-type: none"> • A41 module failure • Parcel Rack Fan switch Sw27 failure • Connector C74 corroded • Circuit 43G shorted to battery
FMI 4	Shorted Low	Output A41 J1:20 shorted to ground	Parcel Rack Fans always ON	<ul style="list-style-type: none"> • A41 module failure • Parcel Rack Fan switch Sw27 failure • Connector C74 corroded • Circuit 43G shorted to ground

MID 188 PSID # 162 Park brak Sens (A36 JB:9)

Type of fault:	FMI Description:	Fault Condition:	Possible Symptoms:	Possible Causes:
FMI 3	Shorted High	Voltage present on input A36 JB:9	Parking Brake sensor not working	<ul style="list-style-type: none"> • Vehicle ECU failure • A36 module failure • Connector C4 or C48 corroded • Circuit 91 shorted to battery
FMI 4	Shorted Low	Input A36 JB:9 shorted to ground	Parking Brake sensor always ON	<ul style="list-style-type: none"> • Vehicle ECU failure • A36 module failure • Parking Brake sensor Se18 failure • Connector C4 or C48 corroded • Circuit 91 shorted to ground

MID 188 PSID # 163 Park brake Sol (A42 J1:12)

Type of fault:	FMI Description:	Fault Condition:	Possible Symptoms:	Possible Causes:
FMI 3	Shorted High	Voltage present on output A42 J1:12 but output not active	Parking Brake solenoid valve So17 not working	<ul style="list-style-type: none"> • A42 module failure • Parking Brake solenoid valve So17 failure • Connector C4 or C172 corroded • Circuit 8 shorted to battery
FMI 6	Current above normal	Output A42 J1:12 internal software fuse active for overcurrent	Parking Brake solenoid valve So17 not working	<ul style="list-style-type: none"> • A42 module failure • Connector C4 or C172 corroded • Circuit 8 shorted to ground

				<ul style="list-style-type: none"> • Parking Brake solenoid valve So17 shorted to ground
--	--	--	--	---

MID 188 PSID # 24 Pass Heat Sol (A54 J1:8)

Type of fault:	FMI Description:	Fault Condition:	Possible Symptoms:	Possible Causes:
FMI 3	Shorted High	Voltage present on output A54 J1:8 but output not active	Pass heat Solenoid valve So13 always ON if R26 is ON	<ul style="list-style-type: none"> • A54 module failure • Pass heat Solenoid valve So13 failure • Circuit 45 shorted to battery
FMI 4	Shorted Low	Output A54 J1:8 shorted to ground	Pass heat Solenoid valve So13 not working	<ul style="list-style-type: none"> • A54 module failure • Pass heat Solenoid valve So13 failure if R26 is ON • Circuit 45 shorted to ground
FMI 6	Current above normal	Output A54 J1:8 internal software fuse active for overcurrent	Pass heat Solenoid valve So13 not working	<ul style="list-style-type: none"> • A54 module failure • Circuit 45 shorted to ground

MID 188 SID # 29 Pass On_Off Sig (A54 J1:21)

Type of fault:	FMI Description:	Fault Condition:	Possible Symptoms:	Possible Causes:
FMI 3	Shorted High	Voltage present on output A54 J1:21 but output not active	Pre-Heat relay R26 always ON	<ul style="list-style-type: none"> • A54 module failure • Pre-Heat relay R26 failure • Circuit 13 shorted to battery
FMI 4	Shorted Low	Output A54 J1:21 shorted to ground	Pre-Heat relay R26 not working	<ul style="list-style-type: none"> • A54 module failure • Pre-Heat relay R26 failure • Circuit 13 shorted to ground
FMI 5	Open Circuit	A54 module does not detect Pre-Heat relay R26	Pre-Heat relay R26 not working	<ul style="list-style-type: none"> • A54 module failure • Pre-Heat relay R26 open circuit • Circuit 13 open
FMI 6	Current above normal	Output A54 J1:21 internal software fuse active for overcurrent	Pre-Heat relay R26 not working	<ul style="list-style-type: none"> • A54 module failure • Circuit 13 shorted to ground

MID 188 SID # 63 Pass Rec. Cylinder (A54 J1:20)

Type of fault:	FMI Description:	Fault Condition:	Possible Symptoms:	Possible Causes:
FMI 3	Shorted High	Voltage present on output A54 J1:20 but output not active	Pass Gaz Cylinder L205 always ON	<ul style="list-style-type: none"> • A54 module failure • Pass Gaz Cylinder L205 failure • Circuit 65P or 0EV3 shorted to battery
FMI 4	Shorted Low	Output A54 J1:20 shorted to ground	Pass Gaz Cylinder L205 not working	<ul style="list-style-type: none"> • A54 module failure • Pass Gaz Cylinder L205 failure • Circuit 65P shorted to ground
FMI 5	Open Circuit	A54 module does not detect Pass Gaz Cylinder L205	Pass Gaz Cylinder L205 not working	<ul style="list-style-type: none"> • A54 module failure • Pass Gaz Cylinder L205 open circuit • Circuit 65P or 0EV3 open
FMI 6	Current above normal	Output A54 J1:20 internal software fuse	Pass Gaz Cylinder L205	<ul style="list-style-type: none"> • A54 module failure • Circuit 65P shorted to ground

		active for overcurrent	not working	
--	--	------------------------	-------------	--

MID 188 PSID # 23 Pass Rfg Sol (A54 J1:3)

Type of fault:	FMI Description:	Fault Condition:	Possible Symptoms:	Possible Causes:
FMI 3	Shorted High	Voltage present on output A54 J1:3 but output not active	Pass Liquid Solenoid Valve So11 always ON	<ul style="list-style-type: none"> • A54 module failure • Pass Liquid Solenoid Valve So11 failure • Connector C9, C15 or C58 corroded • Circuit 77C or 77B shorted to battery
FMI 4	Shorted Low	Output A54 J1:3 shorted to ground	Pass Liquid Solenoid Valve So11 not working	<ul style="list-style-type: none"> • A54 module failure • Pass Liquid Solenoid Valve So11 failure • Connector C9, C15 or C58 corroded • Circuit 77C or 77B shorted to ground
FMI 5	Open Circuit	A54 module does not detect Pass Liquid Solenoid Valve So11	Pass Liquid Solenoid Valve So11 not working	<ul style="list-style-type: none"> • A54 module failure • Pass Liquid Solenoid Valve So11 open circuit • Circuit 77C or 77B open
FMI 6	Current above normal	Output A54 J1:3 internal software fuse active for overcurrent	Pass Liquid Solenoid Valve So11 not working	<ul style="list-style-type: none"> • A54 module failure • Connector C9, C15 or C58 corroded • Circuit 77C or 77B shorted to ground

MID 188 PSID # 17 Pass Wtr pump (A54 J1:4)

Type of fault:	FMI Description:	Fault Condition:	Possible Symptoms:	Possible Causes:
FMI 3	Shorted High	Voltage present on output A54 J1:4 but output not active	Pass Water pump always ON	<ul style="list-style-type: none"> • A54 module failure • Water pump relay R20 failure • Connector C9 corroded • Circuit 57G shorted to battery
FMI 4	Shorted Low	Output A54 J1:4 shorted to ground	Pass Water pump not working	<ul style="list-style-type: none"> • A54 module failure • Water pump relay R20 failure • Connector C9 corroded • Circuit 57G shorted to ground
FMI 6	Current above normal	Output A54 J1:4 internal software fuse active for overcurrent	Pass Water pump not working	<ul style="list-style-type: none"> • A54 module failure • Connector C9 corroded • Circuit 57G shorted to ground • Water pump relay R20 shorted to ground

MID 188 SID # 68 Read Light Tst (A42 J1:19)

Type of fault:	FMI Description:	Fault Condition:	Possible Symptoms:	Possible Causes:
----------------	------------------	------------------	--------------------	------------------

FMI 3	Shorted High	Voltage present on input A42 J1:19 but switch Sw5 not active	Reading Lights not working	<ul style="list-style-type: none"> • A42 module failure • Reading Lamp Test switch Sw5 failure • Connector C72 corroded
FMI 4	Shorted Low	Input A42 J1:19 shorted to ground	Reading Lights always ON	<ul style="list-style-type: none"> • A42 module failure • Reading Lamp Test switch Sw5 failure • Connector C72 corroded • Wire between A42 J1:19 and Sw5 pin 3 shorted to ground

MID 188 PSID # 113 Read Lts Rly (A49 J1:15)

Type of fault:	FMI Description:	Fault Condition:	Possible Symptoms:	Possible Causes:
FMI 3	Shorted High	Voltage present on output A49 J1:15 but output not active	Reading Lights always ON	<ul style="list-style-type: none"> • A49 module failure • Reading Lights Master Relay R14 failure • Circuit 74C shorted to battery
FMI 4	Shorted Low	Output A49 J1:15 shorted to ground	Reading Lights not working	<ul style="list-style-type: none"> • A49 module failure • Reading Lights Master Relay R14 failure • Circuit 74C shorted to ground
FMI 5	Open Circuit	A49 module does not detect Reading Lights Master Relay R14	Reading Lights not working	<ul style="list-style-type: none"> • A49 module failure • Reading Lights Master Relay R14 open circuit • Circuit 74C open
FMI 6	Current above normal	Output A49 J1:15 internal software fuse active for overcurrent	Reading Lights not working	<ul style="list-style-type: none"> • A49 module failure • Circuit 74C shorted to ground • Relay R14 coil shorted to ground

MID 188 PSID # 114 Read Lts Sw (A41 J1:10)

Type of fault:	FMI Description:	Fault Condition:	Possible Symptoms:	Possible Causes:
FMI 3	Shorted High	Voltage present on input A41 J1:10 but switch Sw26 not active	Reading Lights not working	<ul style="list-style-type: none"> • A41 module failure • Reading Lamp Switch Sw26 failure • Connector C71 corroded • Circuit 74 shorted to battery
FMI 4	Shorted Low	Input A41 J1:10 shorted to ground	Reading Lights always ON	<ul style="list-style-type: none"> • A41 module failure • Reading Lamp Switch Sw26 failure • Connector C71 corroded • Circuit 74 shorted to ground

MID 188 PSID # 131 RearFish LH (A51 J1:21)

Type of fault:	FMI Description:	Fault Condition:	Possible Symptoms:	Possible Causes:
FMI 3	Shorted High	Voltage present on output A51 J1:21 but output not active	Rear Flasher Light LH L71, upper rear LH L286 and Rear Side markers LH L75 always ON	<ul style="list-style-type: none"> • A51 module failure • Connector C91 or C120 corroded • Circuit 21AA shorted to battery

SECTION 06B: ELECTRICAL

FMI 4	Shorted Low	Output A51 J1:21 shorted to ground	Rear Flasher Light LH L71, upper rear LH L286 and Rear Side markers LH L75 not working	<ul style="list-style-type: none"> • A51 module failure • Connector C91 or C120 corroded • Circuit 21AA and 21C shorted to ground
FMI 6	Current above normal	Output A51 J1:21 internal software fuse active for overcurrent	Rear Flasher Light LH L71, upper rear LH L286 and Rear Side markers LH L75 not working	<ul style="list-style-type: none"> • A51 module failure • Connector C91 or C120 corroded • Circuit 21AA and 21C shorted to ground

MID 188 PSID # 132 RearFlash RH (A51 J1:3)

Type of fault:	FMI Description:	Fault Condition:	Possible Symptoms:	Possible Causes:
FMI 3	Shorted High	Voltage present on output A51 J1:3 but output not active	Rear Flasher Light RH L73, upper rear RH L285 and Rear Side markers RH L76 always ON	<ul style="list-style-type: none"> • A51 module failure • Connector C91 or C119 corroded • Circuit 23AA shorted to battery
FMI 4	Shorted Low	Output A51 J1:3 shorted to ground	Rear Flasher Light RH L73, upper rear RH L285 and Rear Side markers RH L76 not working	<ul style="list-style-type: none"> • A51 module failure • Connector C91 or C119 corroded • Circuit 23AA shorted to ground
FMI 6	Current above normal	Output A51 J1:3 internal software fuse active for overcurrent	Rear Flasher Light RH L73, upper rear RH L285 and Rear Side markers RH L76 not working	<ul style="list-style-type: none"> • A51 module failure • Connector C91 or C119 corroded • Circuit 23AA shorted to ground

MID 188 PSID # 164 Retarder signal (A50 J1:12)

Type of fault:	FMI Description:	Fault Condition:	Possible Symptoms:	Possible Causes:
FMI 3	Shorted High	Voltage present on input A50 J1:12	Retarder active lamp not working	<ul style="list-style-type: none"> • Transmission ECU failure • A50 module failure • Connector C717 corroded • Circuit 125 shorted to battery
FMI 4	Shorted Low	Input A50 J1:12 shorted to ground	Retarder active lamp always ON	<ul style="list-style-type: none"> • A50 module failure • Connector C717 corroded • Circuit 125 shorted to ground

MID 188 PSID # 151 Rr Clearance lights (A50 J1:4)

Type of fault:	FMI Description:	Fault Condition:	Possible Symptoms:	Possible Causes:
FMI 3	Shorted High	Voltage present on output A50 J1:4 but output not active	Rear Clearance Lights L84, L85, L86, L87, L88, L89, L90, L285 and L286 always ON	<ul style="list-style-type: none"> • A50 module failure • Connector C91 or C10 corroded • Circuit 63 shorted to battery

FMI 4	Shorted Low	Output A50 J1:4 shorted to ground	Rear Clearance Lights L84, L85, L86, L87, L88, L89, L90, L285 and L286 not working	<ul style="list-style-type: none"> • A50 module failure • Connector C91 or C10 corroded • Circuit 63, 21C or 23C shorted to ground
FMI 5	Open Circuit	A50 module does not detect Rear Clearance Lights L84 and L85	Rear Clearance Lights L84, L85, L86, L87, L88, L89, L90, L285 and L286 not working	<ul style="list-style-type: none"> • A50 module failure • Circuit 63 open
FMI 6	Current above normal	Output A50 J1:4 internal software fuse active for overcurrent	Rear Clearance Lights L84, L85, L86, L87, L88, L89, L90, L285 and L286 not working	<ul style="list-style-type: none"> • A50 module failure • Connector C91 or C10 corroded • Circuit 63, 21C or 23C shorted to ground

MID 188 PSID # 59 Rear Start Sw (A53 J1:11)

Type of fault:	FMI Description:	Fault Condition:	Possible Symptoms:	Possible Causes:
FMI 3	Shorted High	Voltage present on output A53 J1:11 but output not active	Rear Start Switch Sw59 always ON	<ul style="list-style-type: none"> • A53 module failure • Rear Start Switch Sw59 failure • Connector C91 corroded • Circuit 85E shorted to battery
FMI 4	Shorted Low	Output A53 J1:11 shorted to ground	Rear Start Switch Sw59 not working	<ul style="list-style-type: none"> • A53 module failure • Rear Start Switch Sw59 failure • Connector C91 corroded • Circuit 85E shorted to ground

MID 188 PSID # 57 RrStart Enable Sw (A53 J1:10)

Type of fault:	FMI Description:	Fault Condition:	Possible Symptoms:	Possible Causes:
FMI 3	Shorted High	Voltage present on input A53 J1:10 but output not active at switch Sw58	Rear Start Selector Switch Sw58 always ON Rear Start	<ul style="list-style-type: none"> • A53 module failure • Rear Start Selector Switch Sw58 failure • Connector C91 corroded • Circuit 85D shorted to battery
FMI 4	Shorted Low	Input A53 J1:10 shorted to ground	Rear Start Selector Switch Sw58 not working, rear start switch Sw59 will not function	<ul style="list-style-type: none"> • A53 module failure • Rear Start Selector Switch Sw58 failure • Connector C91 corroded • Circuit 85D shorted to ground

MID 188 SID # 49 Ser Brake Trans (A51 J1:1)

Type of fault:	FMI Description:	Fault Condition:	Possible Symptoms:	Possible Causes:
FMI 3	Shorted High	Voltage present on output A51 J1:1 but output	Cruise control not working	<ul style="list-style-type: none"> • A51 module failure • Connector C717 corroded

SECTION 06B: ELECTRICAL

		not active		<ul style="list-style-type: none"> • Circuit 79 shorted to battery
FMI 4	Shorted Low	Output A51 J1:1 shorted to ground	Cruise control not working, transmission sees service brake signal ON all the time	<ul style="list-style-type: none"> • A51 module failure • Connector C717 corroded • Circuit 79 shorted to ground
FMI 6	Current above normal	Output A51 J1:1 internal software fuse active for overcurrent	Cruise control not working	<ul style="list-style-type: none"> • A51 module failure • Connector C717 corroded • Circuit 79 shorted to ground

MID 188 PSID # 60 Starter Relay (A53 J1:6)

Type of fault:	FMI Description:	Fault Condition:	Possible Symptoms:	Possible Causes:
FMI 4	Shorted Low	Output A53 J1:6 shorted to ground	Rear Starter not working	<ul style="list-style-type: none"> • Vehicle ECU failure • A53 module failure • Rear Starter Relay failure • Connector C397 corroded • Circuit 231A shorted to ground
FMI 6	Current above normal	Output A53 J1:6 internal software fuse active for overcurrent	Rear Starter not working	<ul style="list-style-type: none"> • A53 module failure • Connector C397 corroded • Circuit 231A shorted to ground

MID 188 SID # 77 Step Led light (A43 J1:30)

Type of fault:	FMI Description:	Fault Condition:	Possible Symptoms:	Possible Causes:
FMI 3	Shorted High	Voltage present on output A43 J1:30 but output not active	Step Nozzle Light L20A always ON	<ul style="list-style-type: none"> • A43 module failure • Connector C6 or C65 corroded • Circuit 35A shorted to battery
FMI 4	Shorted Low	Output A43 J1:30 shorted to ground	Step Nozzle Light L20A not working	<ul style="list-style-type: none"> • A43 module failure • Connector C6 or C65 corroded • Circuit 35A shorted to ground
FMI 6	Current above normal	Output A43 J1:30 internal software fuse active for overcurrent	Step Nozzle Light L20A not working	<ul style="list-style-type: none"> • A43 module failure • Connector C6 or C65 corroded • Circuit 35A shorted to ground

MID 188 PSID # 117 StepLts (A47 J1:5)

Type of fault:	FMI Description:	Fault Condition:	Possible Symptoms:	Possible Causes:
FMI 3	Shorted High	Voltage present on output A47 J1:5 but output not active	Step Lights L18, L19 or L20 always ON	<ul style="list-style-type: none"> • A47 module failure • Connector C63 corroded • Circuit 35 shorted to battery
FMI 4	Shorted Low	Output A47 J1:5 shorted to ground	Step Lights L18, L19 or L20 not working	<ul style="list-style-type: none"> • A47 module failure • Connector C63 corroded • Circuit 35 shorted to ground
FMI 5	Open Circuit	A47 module does not detect Step Lights L18, L19 or L20	Step Lights L18, L19 or L20 not working	<ul style="list-style-type: none"> • A47 module failure • Circuit 35 open
FMI 6	Current above normal	Output A47 J1:5 internal software fuse active for overcurrent	Step Lights L18, L19 or L20 not working	<ul style="list-style-type: none"> • A47 module failure • Connector C63 corroded • Circuit 35 shorted to ground

MID 188 PSID # 165 Tag axle Sw (A43 J1:19)

Type of fault:	FMI Description:	Fault Condition:	Possible Symptoms:	Possible Causes:
FMI 3	Shorted High	Voltage present on input A43 JB:19 but output not active	Pressure Tag Switch Sw64 not working	<ul style="list-style-type: none"> • A43 module failure • Connector C71 or C171 corroded • Circuit 160 shorted to battery
FMI 4	Shorted Low	Input A43 J1:19 shorted to ground	Pressure Tag Switch Sw64 always ON	<ul style="list-style-type: none"> • A43 module failure • Pressure Tag Switch Sw64 failure • Connector C71 or C171 corroded • Circuit 160 shorted to ground

MID 188 PSID # 152 Tail Lights (A51 J1:8)

Type of fault:	FMI Description:	Fault Condition:	Possible Symptoms:	Possible Causes:
FMI 3	Shorted High	Voltage present on output A51 J1:8 but output not active	Tail Lights L72, L74, L77, L78, L79, L80, L82 or L83 always ON	<ul style="list-style-type: none"> • A51 module failure • Connector C119, C91 or C120 corroded • Circuit 46 shorted to battery
FMI 4	Shorted Low	Output A51 J1:8 shorted to ground	Tail Lights L72, L74, L77, L78, L79, L80, L82 or L83 not working	<ul style="list-style-type: none"> • A51 module failure • Connector C119, C91 or C120 corroded • Circuit 46 shorted to ground
FMI 5	Open Circuit	A51 module does not detect Tail Lights L72, L74, L77, L78, L79, L80, L82 or L83	Tail Lights L72, L74, L77, L78, L79, L80, L82 or L83 not working	<ul style="list-style-type: none"> • A51 module failure • Circuit 46 open
FMI 6	Current above normal	Output A51 J1:8 internal software fuse active for overcurrent	Tail Lights L72, L74, L77, L78, L79, L80, L82 or L83 not working	<ul style="list-style-type: none"> • A51 module failure • Connector C119, C91 or C120 corroded • Circuit 46 shorted to ground

MID 188 SID # 25 Trans Inh Sig (A50 J1:2)

Type of fault:	FMI Description:	Fault Condition:	Possible Symptoms:	Possible Causes:
FMI 3	Shorted High	Voltage present on output A50 J1:2 but output not active	Transmission Shifting not working	<ul style="list-style-type: none"> • Transmission ECU failure • A50 module failure • Connector C717 corroded • Circuit 185 shorted to battery
FMI 4	Shorted Low	Output A50 J1:2 shorted to ground	Transmission Shifting not working	<ul style="list-style-type: none"> • A50 module failure • Connector C717 corroded • Circuit 185 shorted to ground
FMI 5	Open Circuit	A50 module does not detect Transmission ECU	Transmission Shifting not working	<ul style="list-style-type: none"> • A50 module failure • Circuit 185 open • Transmission ECU failure
FMI 6	Current above normal	Output A50 J1:2 internal software fuse active for overcurrent	Transmission Shifting not working	<ul style="list-style-type: none"> • A50 module failure • Connector C717 corroded • Circuit 185 shorted to ground

MID 188 PSID # 168 Trans Neutral Sens (A50 J1:11)

Type of fault:	FMI Description:	Fault Condition:	Possible Symptoms:	Possible Causes:
FMI 3	Shorted High	Voltage present on output A50 J1:11 but output not active	Transmission always on Neutral	<ul style="list-style-type: none"> • A50 module failure • Connector C717 corroded • Circuit 231 shorted to battery
FMI 4	Shorted Low	Output A50 J1:11 shorted to ground	Transmission Shifting not working	<ul style="list-style-type: none"> • A50 module failure • Connector C717 corroded • Circuit 231 shorted to ground

MID 188 PSID # 112 Under Floor lights (A47 J1:20)

Type of fault:	FMI Description:	Fault Condition:	Possible Symptoms:	Possible Causes:
FMI 4	Shorted Low	Output A47 J1:20 shorted to ground	Baggage compartment lights L176, L177, L180, L181, L182 or L183 not working	<ul style="list-style-type: none"> • A47 module failure • Connector C6, C2 or C59 corroded • Circuit 10A shorted to ground
FMI 6	Current above normal	Output A47 J1:20 internal software fuse active for overcurrent	Baggage compartment lights L176, L177, L180, L181, L182 or L183 not working	<ul style="list-style-type: none"> • A47 module failure • Connector C6, C2 or C59 corroded • Circuit 10A shorted to ground

MID 188 PSID # 31 Unloader LH (A52 J1:8)

Type of fault:	FMI Description:	Fault Condition:	Possible Symptoms:	Possible Causes:
FMI 3	Shorted High	Voltage present on output A52 J1:8 but output not active	Unloader LH L200 always ON	<ul style="list-style-type: none"> • A52 module failure • Connector C91 or C19 corroded • Circuit 33 shorted to battery
FMI 4	Shorted Low	Output A52 J1:8 shorted to ground	Unloader LH L200 not working	<ul style="list-style-type: none"> • A52 module failure • Unloader LH L200 failure • Connector C91 or C19 corroded • Circuit 33 shorted to ground
FMI 5	Open Circuit	A52 module does not detect Unloader LH L200	Unloader LH L200 not working	<ul style="list-style-type: none"> • A52 module failure • Unloader LH L200 failure • Circuit 33 open
FMI 6	Current above normal	Output A52 J1:8 internal software fuse active for overcurrent	Unloader LH L200 not working	<ul style="list-style-type: none"> • A52 module failure • Connector C91 or C19 corroded • Circuit 33 shorted to ground

MID 188 PSID # 32 Unloader RH (A52 J1:21)

Type of fault:	FMI Description:	Fault Condition:	Possible Symptoms:	Possible Causes:
FMI 3	Shorted High	Voltage present on output A52 J1:21 but output not active	Unloader RH L199 always ON	<ul style="list-style-type: none"> • A52 module failure • Connector C91 or C19 corroded • Circuit 31 shorted to battery
FMI 4	Shorted Low	Output A52 J1:21 shorted to ground	Unloader RH L199 not working	<ul style="list-style-type: none"> • A52 module failure • Unloader RH L199 failure • Connector C91 or C19 corroded • Circuit 31 shorted to ground

FMI 5	Open Circuit	A52 module does not detect Unloader RH L199	Unloader RH L199 not working	<ul style="list-style-type: none"> • A52 module failure • Unloader RH L199 failure • Circuit 31 open
FMI 6	Current above normal	Output A52 J1:21 internal software fuse active for overcurrent	Unloader RH L199 not working	<ul style="list-style-type: none"> • A52 module failure • Connector C91 or C19 corroded • Circuit 31 shorted to ground

MID 188 SID # 34 Up Def Heater1 (A46 J1:1)

Type of fault:	FMI Description:	Fault Condition:	Possible Symptoms:	Possible Causes:
FMI 3	Shorted High	Voltage present on output A46 J1:1 but output not active	Upper Defrost LH Heater Res37 always ON	<ul style="list-style-type: none"> • A46 module failure • Connector C45 or CMo5 corroded • Circuit 5A shorted to battery
FMI 4	Shorted Low	Output A46 J1:1 shorted to ground	Upper Defrost LH Heater Res37 not working	<ul style="list-style-type: none"> • A46 module failure • Upper Defrost LH Heater Res37 failure • Connector C45 or CMo5 corroded • Circuit 5A shorted to ground
FMI 5	Open Circuit	A46 module does not detect Upper Defrost LH Heater Res37	Upper Defrost LH Heater Res37 not working	<ul style="list-style-type: none"> • A46 module failure • Upper Defrost LH Heater Res37 failure • Circuit 5A open
FMI 6	Current above normal	Output A46 J1:1 internal software fuse active for overcurrent	Upper Defrost LH Heater Res37 not working	<ul style="list-style-type: none"> • A46 module failure • Connector C45 or CMo5 corroded • Circuit 5A shorted to ground

MID 188 SID # 35 Up Def Heater2 (A46 J1:2)

Type of fault:	FMI Description:	Fault Condition:	Possible Symptoms:	Possible Causes:
FMI 3	Shorted High	Voltage present on output A46 J1:2 but output not active	Upper Defrost RH Heater Res37 always ON	<ul style="list-style-type: none"> • A46 module failure • Connector C45 or CMo5 corroded • Circuit 5B shorted to battery
FMI 4	Shorted Low	Output A46 J1:2 shorted to ground	Upper Defrost RH Heater Res37 not working	<ul style="list-style-type: none"> • A46 module failure • Upper Defrost RH Heater Res37 failure • Connector C45 or CMo5 corroded • Circuit 5B shorted to ground
FMI 5	Open Circuit	A46 module does not detect Upper Defrost RH Heater Res37	Upper Defrost RH Heater Res37 not working	<ul style="list-style-type: none"> • A46 module failure • Upper Defrost RH Heater Res37 failure • Circuit 5B open
FMI 6	Current above normal	Output A46 J1:2 internal software fuse active for overcurrent	Upper Defrost RH Heater Res37 not working	<ul style="list-style-type: none"> • A46 module failure • Connector C45 or CMo5 corroded • Circuit 5B shorted to ground

MID 188 PSID # 43 Upper Brk Lamp (A51 J1:6)

Type of fault:	FMI Description:	Fault Condition:	Possible Symptoms:	Possible Causes:
FMI 3	Shorted High	Voltage present on output A51 J1:6 but output not active	Upper Stop Lights RH L78 or LH L80 always ON	<ul style="list-style-type: none"> • A51 module failure • Connector C91, C119 or C120 corroded • Circuit 82Up shorted to battery
FMI 4	Shorted Low	Output A51 J1:6 shorted to ground	Upper Stop Lights RH L78 or LH L80 not working	<ul style="list-style-type: none"> • A51 module failure • Connector C91, C119 or C120 corroded • Circuit 82Up shorted to ground
FMI 6	Current above normal	Output A51 J1:6 internal software fuse active for overcurrent	Upper Stop Lights RH L78 or LH L80 not working	<ul style="list-style-type: none"> • A51 module failure • Connector C91, C119 or C120 corroded • Circuit 82Up shorted to ground

MID 188 SID # 30 WakeUp Rly (A36 JA:15)

Type of fault:	FMI Description:	Fault Condition:	Possible Symptoms:	Possible Causes:
FMI 4	Shorted Low	Output A36 JA:15 shorted to ground	Various systems not working depending on relay or position	<ul style="list-style-type: none"> • A36 module failure • Various WUp Relays failure • Connector C2 or C21 corroded • Circuit 85B shorted to ground
FMI 5	Open Circuit	A36 module does not detect 24v Fr WUp relay R18, 12v Fr WUp relay R19, 12v Rr WUp relay R17 or 12v Rr Engine ECU relay R34	Various systems not working depending on relay or position	<ul style="list-style-type: none"> • A36 module failure • Various WUp Relays R17, R18, R19, R34 open circuit • Circuit 85B open
FMI 6	Current above normal	Output A36 JA:15 internal software fuse active for overcurrent	Various systems not working depending on relay or position	<ul style="list-style-type: none"> • A36 module failure • Connector C2 or C21 corroded • Circuit 85B shorted to ground

MID 188 PSID # 176 WCL Pump Rly (A53 J1:5)

Type of fault:	FMI Description:	Fault Condition:	Possible Symptoms:	Possible Causes:
FMI 3	Shorted High	Voltage present on output A53 J1:5 but output not active	WCL Pump Assy L207 can be operated is sensor Se100 is active	<ul style="list-style-type: none"> • A53 module failure • WCL Door open Relay R47 failure • Connector C27, C31 or C29 corroded • Circuit 304 shorted to battery
FMI 4	Shorted Low	Output A53 J1:5 shorted to ground	WCL Pump Assy L207 not working	<ul style="list-style-type: none"> • A53 module failure • WCL Door open Relay R47 failure • Connector C27, C31 or C29 corroded • Circuit 304 shorted to ground
FMI 6	Current above normal	Output A53 J1:5 internal software	WCL Pump Assy L207 not	<ul style="list-style-type: none"> • A53 module failure • Connector C27, C31 or C29

		fuse active for overcurrent	working	corroded • Circuit 304 shorted to ground
--	--	-----------------------------	---------	---

MID 188 SID # 24 WCLDorSig to USonic (A53 J1:7)

Type of fault:	FMI Description:	Fault Condition:	Possible Symptoms:	Possible Causes:
FMI 3	Shorted High	Voltage present on output A53 J1:7 but output not active	WCL Door open Relay R47 always ON	<ul style="list-style-type: none"> • A53 module failure • WCL Door open Relay R47 failure • Connector C27, C31 or C29 corroded • Circuit 306 shorted to battery
FMI 4	Shorted Low	Output A53 J1:7 shorted to ground	WCL Door open Relay R47 not working	<ul style="list-style-type: none"> • A53 module failure • WCL Door open Relay R47 failure • Connector C27, C31 or C29 corroded • Circuit 306 shorted to ground
FMI 5	Open Circuit	A53 module does not detect WCL Door open Relay R47	WCL Door open Relay R47 not working	<ul style="list-style-type: none"> • A53 module failure • WCL Door open Relay R47 failure • Circuit 306 open
FMI 6	Current above normal	Output A53 J1:7 internal software fuse active for overcurrent	WCL Door open Relay R47 not working	<ul style="list-style-type: none"> • A53 module failure • Connector C27, C31 or C29 corroded • Circuit 306 shorted to ground

MULTIPLEX MODULE “NO RESPONSE” TROUBLESHOOTING LIST FRONT JUNCTION BOX MODULES

MID 188 PSID # 216 A41 MODULE NO RESPONSE

Type of fault:	FMI Description:	Fault Condition:	Possible Symptoms:	Possible Causes:
FMI 2	Data Error	A41 Module not responding on CAN network	A41 module all inputs and outputs not responding	<ul style="list-style-type: none"> • CAN network open • Address Jumper open circuit • Fuse F110 defective • Relay R18 defective

MID 188 PSID # 217 A42 MODULE NO RESPONSE

Type of fault:	FMI Description:	Fault Condition:	Possible Symptoms:	Possible Causes:
FMI 2	Data Error	A42 Module not responding on CAN network	A42 module all inputs and outputs not responding	<ul style="list-style-type: none"> • CAN network open • Address Jumper open circuit • Fuse F12 or F13 defective

MID 188 PSID # 218 A43 MODULE NO RESPONSE

Type of fault:	FMI Description:	Fault Condition:	Possible Symptoms:	Possible Causes:
FMI 2	Data Error	A43 Module not responding on CAN network	A43 module all inputs and outputs not responding	<ul style="list-style-type: none"> • CAN network open • Address Jumper open circuit • Fuse F12 or F13 defective

MID 188 PSID # 219 A44 MODULE NO RESPONSE

Type of fault:	FMI Description:	Fault Condition:	Possible Symptoms:	Possible Causes:
FMI 2	Data Error	A44 Module not responding on CAN network	A44 module all inputs and outputs not responding	<ul style="list-style-type: none"> • CAN network open • Address Jumper open circuit • Fuse F21 defective

MID 188 PSID # 220 A45 MODULE NO RESPONSE

Type of fault:	FMI Description:	Fault Condition:	Possible Symptoms:	Possible Causes:
FMI 2	Data Error	A45 Module not responding on CAN network	A45 module all inputs and outputs not responding	<ul style="list-style-type: none"> • CAN network open • Address Jumper open circuit • Fuse F33 or F34 defective • Relay R19 defective

MID 188 PSID # 221 A46 MODULE NO RESPONSE

Type of fault:	FMI Description:	Fault Condition:	Possible Symptoms:	Possible Causes:
FMI 2	Data Error	A46 Module not responding on CAN network	A46 module all inputs and outputs not responding	<ul style="list-style-type: none"> • CAN network open • Address Jumper open circuit • Fuse F12 or F13 defective

ENTRANCE DOOR & WIPER CONTROL PANEL MODULES

MID 188 PSID # 222 A47 MODULE NO RESPONSE

Type of fault:	FMI Description:	Fault Condition:	Possible Symptoms:	Possible Causes:
FMI 2	Data Error	A47 Module not responding on CAN network	A47 module all inputs and outputs not responding	<ul style="list-style-type: none"> • CAN network open • Address Jumper open circuit • Fuse F5 defective • Relay R18 defective

MID 188 PSID # 223 A48 MODULE NO RESPONSE

Type of fault:	FMI Description:	Fault Condition:	Possible Symptoms:	Possible Causes:
FMI 2	Data Error	A48 Module not responding on CAN network	A48 module all inputs and outputs not responding	<ul style="list-style-type: none"> • CAN network open • Address Jumper open circuit • Fuse F33 or F34 defective • Relay R19 defective

A/C JUNCTION BOX MODULE**MID 188 PSID # 229 A54 MODULE NO RESPONSE**

Type of fault:	FMI Description:	Fault Condition:	Possible Symptoms:	Possible Causes:
FMI 2	Data Error	A54 Module not responding on CAN network	A54 module all inputs and outputs not responding	<ul style="list-style-type: none"> • CAN network open • Address Jumper open circuit • Fuse F67 or F68 defective

DASH MODULES**MID 188 SID # 51 A55 MODULE NO RESPONSE**

Type of fault:	FMI Description:	Fault Condition:	Possible Symptoms:	Possible Causes:
FMI 2	Data Error	A55 Module not responding on CAN network	A55 module all inputs and outputs not responding	<ul style="list-style-type: none"> • CAN network open • Address Jumper open circuit • Fuse F12 or F13 defective

REAR JUNCTION BOX MODULES**MID 188 PSID # 224 A49 MODULE NO RESPONSE**

Type of fault:	FMI Description:	Fault Condition:	Possible Symptoms:	Possible Causes:
FMI 2	Data Error	A49 Module not responding on CAN network	A49 module all inputs and outputs not responding	<ul style="list-style-type: none"> • CAN network open • Address Jumper open circuit • Fuse F65 defective

MID 188 PSID # 225 A50 MODULE NO RESPONSE

Type of fault:	FMI Description:	Fault Condition:	Possible Symptoms:	Possible Causes:
FMI 2	Data Error	A50 Module not responding on CAN network	A50 module all inputs and outputs not responding	<ul style="list-style-type: none"> • CAN network open • Address Jumper open circuit • Fuse F72 defective

MID 188 PSID # 226 A51 MODULE NO RESPONSE

Type of fault:	FMI Description:	Fault Condition:	Possible Symptoms:	Possible Causes:
FMI 2	Data Error	A51 Module not responding on CAN network	A51 module all inputs and outputs not responding	<ul style="list-style-type: none"> • CAN network open • Address Jumper open circuit • Fuse F80 defective

MID 188 PSID # 227 A52 MODULE NO RESPONSE

Type of fault:	FMI Description:	Fault Condition:	Possible Symptoms:	Possible Causes:
FMI 2	Data Error	A52 Module not responding on CAN network	A52 module all inputs and outputs not responding	<ul style="list-style-type: none"> • CAN network open • Address Jumper open circuit • Fuse F65 defective

MID 188 PSID # 228 A53 MODULE NO RESPONSE

Type of fault:	FMI Description:	Fault Condition:	Possible Symptoms:	Possible Causes:
FMI 2	Data Error	A53 Module not responding on CAN network	A53 module all inputs and outputs not responding	<ul style="list-style-type: none"> • CAN network open • Address Jumper open circuit • Fuse F65 defective



**MAINTENANCE
INFORMATION**

MI14-40B

DATE : JUNE 2014	SECTION : 06 - Electrical
SUBJECT : BOSCH HD10 ALTERNATOR REMOVAL & INSTALLATION	

REVISION B THIS REVISION SUPERSEDES THE PREVIOUS VERSION.
Part 500449 added in the material list and in step 9. Torque added in figure 12.

APPLICATION

Model	VIN
X3-45 Commuter Model Year : From 2012	 <p>APPLICABLE TO: DOB Bus Number Series 2400 - 2489 DOB Bus Number Series 2490 - 2789</p>

MATERIAL

Parts and product that might be required:

Part No.	Description	Qty
502573	WASHER, FLAT M6 STAINLESS STEEL	2
564590	ADAPTER	1
5001182	NUT, M6 STAINLESS STEEL	2
5001341	WASHER, FLAT M8 STAINLESS STEEL	3
5001787	NUT, M8 STAINLESS STEEL	2
500449	WASHER, FLAT 5/8 STAINLESS STEEL	2

Part No.	Description
684013	COLOR GUARD RUBBER COATING, 14.5 OZ CAN

REQUIRED TOOLS

<p>RATCHET AND SOCKET SET - METRIC</p> 	<p>TORQUE WRENCH</p> 	<p>BRASS WIRE CUP BRUSH</p> 
---	---	--

SPECIAL TOOLS REQUIRED TO TIGHTEN THE ALTERNATOR PULLEY MOUNTING NUT



METRIC 10mm 12-POINTS SPLINE DRIVE LONG (CARLYLE SLTS3810M AVAILABLE FROM NAPA)



OFFSET 7/8 WRENCH (CYLINDER HEAD WRENCH), SNAP-ON PART NUMBER M4201



7/8 SOCKET (PART NUMBER WA28-28A)

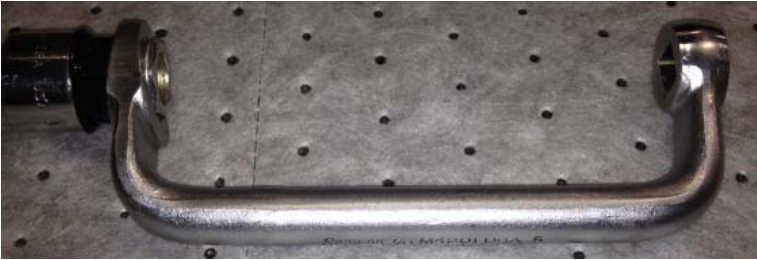

OFFSET 7/8 WRENCH FITTED WITH 7/8 SOCKET AND 10mm 12-POINTS SPLINE DRIVE



USING THE CYLINDER HEAD WRENCH WITH A RATCHET AND A FLEX SOCKET WRENCH

PROCEDURE



DANGER

Park vehicle safely, apply parking brake, stop engine. In the battery box, set the battery cut-off switch to the OFF position prior to working on the vehicle.

1. Remove the A/C compressor belts and then remove A/C compressor idler pulley bracket assembly (3 bolts to be removed, figure 1).



FIGURE 1

2. Remove the alternator belt (figure 2).
3. Unscrew the alternator pulley mounting nut (figure 2).
4. Remove the alternator pulley (2 pulleys) (figure 2).

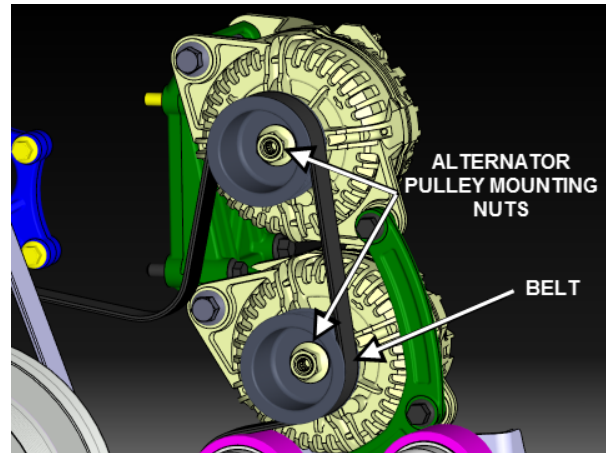

FIGURE 2

5. Remove the existing alternators. To do so, unscrew identified mounting bolts on figure 3 and retain for use if in good condition.
6. Identify alternator cables and then disconnect cables. Properly clean alternator stud terminals and cable ring terminals as applicable using a brass wire cup brush, a Scotch-Brite pad or an emery cloth.



BRASS WIRE CUP BRUSH

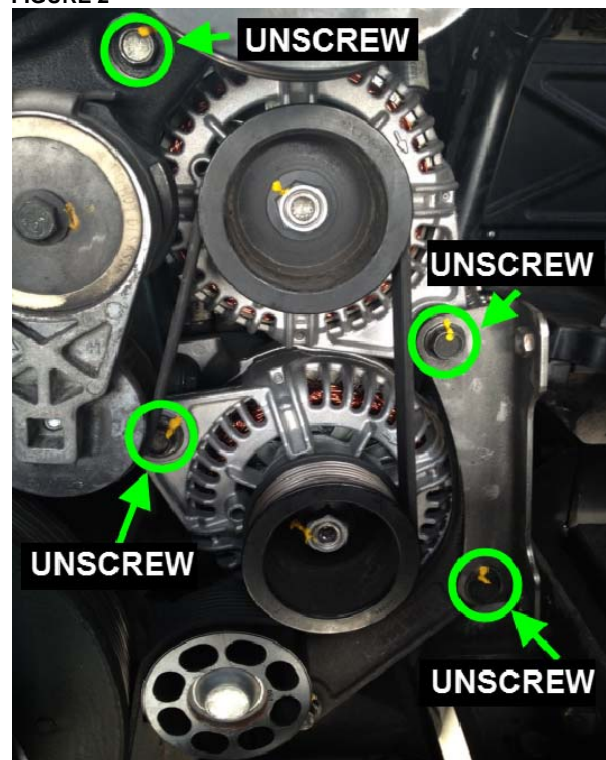

FIGURE 3

7. Install new alternators. Fix lower and upper alternators loosely to alternator supports using bolts **C**. Apply anti-seize compound inside the alternator mounting ears and inside the sleeves found on the support attached to the engine (see location **C** on figure 4). Also, mount arched support loosely onto alternators using bolts **B**. If applicable, install stone guard.

NOTE: Reuse existing bolts unless they are not in good condition (damaged, pitted, eroded).

8. In order to assure proper installation, it is important to tighten the alternator mounting bolts in proper sequence. Use Loctite 243 blue on threads (figure 4).

1st Bolt/Nut B, 43 lbf-ft (2x).

2nd Bolt/Nut C, 74 lbf-ft (2x).

For reference:

C= nut M12 #5001728

C= bolt M12 #5001853

B= nut M10 #5001727

B= bolt M10 #5001801 (upper one)

B= bolt M10 #5001843 (lower one)

9. Mount pulley onto alternators (figure 5). One (1) flat washer #500449 is required between the pulley and the flange nut. Use Loctite 243 blue on threads. Tighten pulley mounting nut to **75 lbf-ft** using offset 7/8 wrench and a M10 12-points spline drive mounted on a torque wrench.

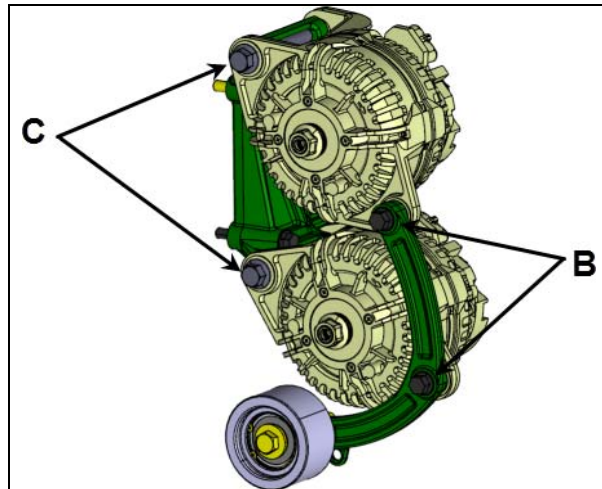

FIGURE 4

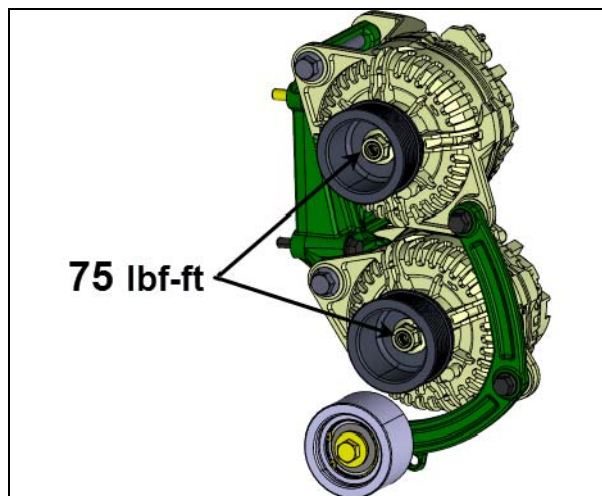

FIGURE 5

10. Install the alternator belt (figure 6)

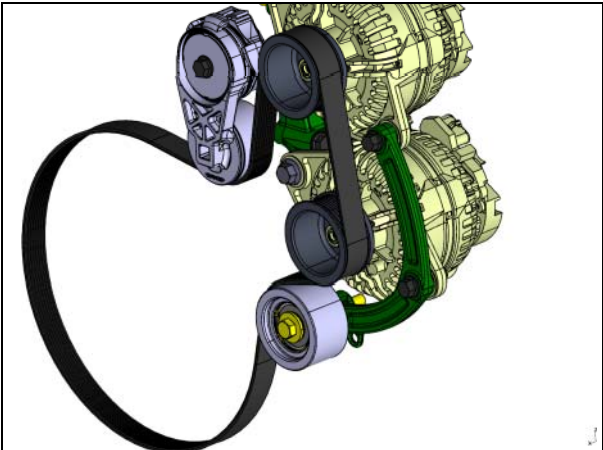

FIGURE 6

11. Cable connection overview. Upper and lower alternator (figure 7).

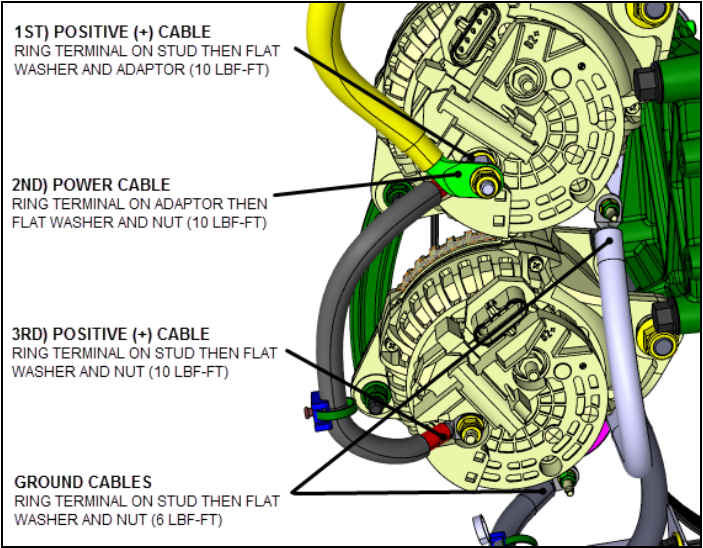

FIGURE 7

UPPER ALTERNATOR - (use new hardware for cable connection)

12. Power harness and jumper cable.

- a) Install jumper cable (a.k.a. positive cable) onto **B1+** stud terminal on upper alternator (figure 8).
- b) Place one new flat washer #5001341 against the jumper cable ring terminal (figure 8).
- c) Screw and tighten the adapter stud #564590 (torque: 10 lbf-ft) (figure 8) prior installing main battery cable (power cable).
- d) Fit the main battery cable onto adaptor stud, place one new flat washer #5001341 against the battery cable terminal and screw a new nut #5001787 (nut torque: 10 lbf-ft) (figure 8).

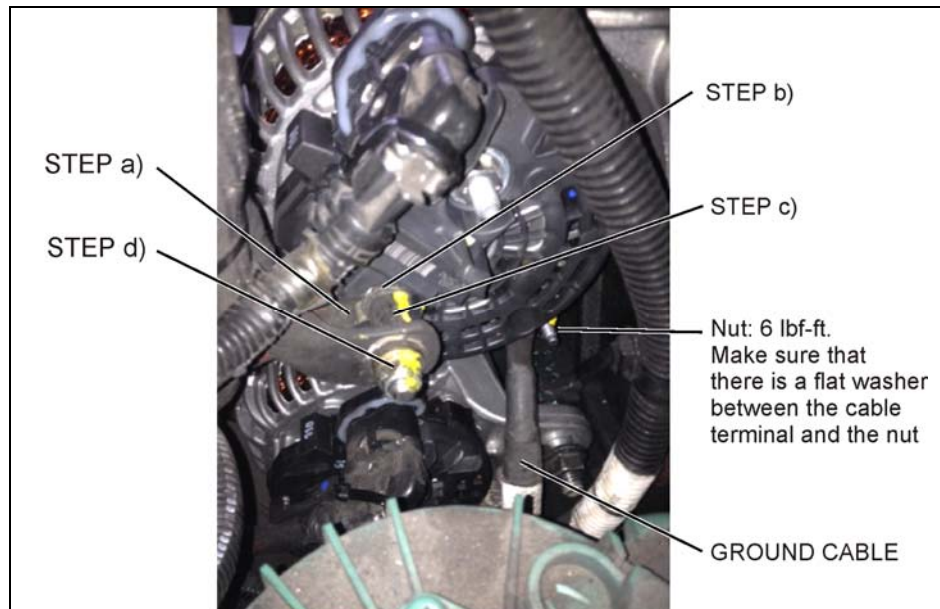

FIGURE 8 : STEP 12 a, b, c, d

13. Fit the ground cable onto the alternator ground stud, place one new flat washer #502573 against the ground cable terminal and screw a new nut #5001182 (nut torque: 6 lbf-ft) (figure 8).
14. Plug alternator harness onto upper alternator connector and secure using nylon cable ties (figure 9).

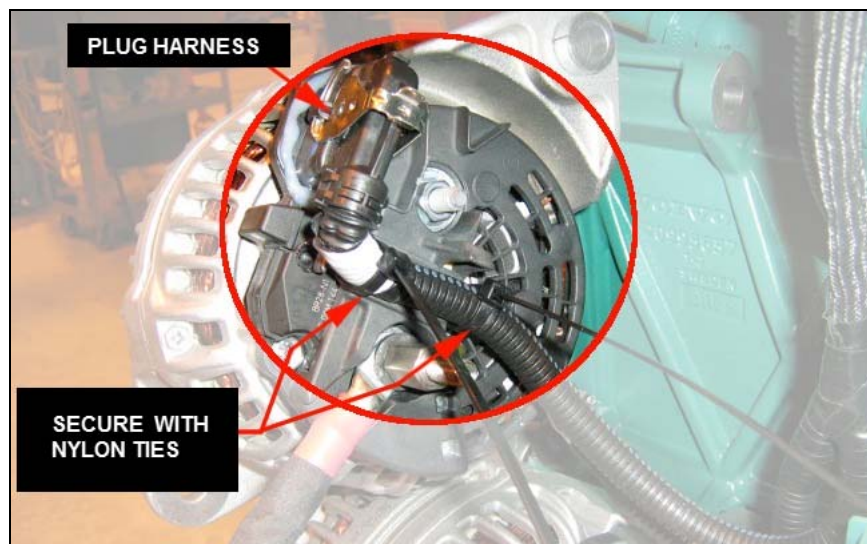

FIGURE 9

LOWER ALTERNATOR - (use new hardware for cable connection)

15. Jumper cable (positive cable) installation.

- a) Fit jumper cable (a.k.a. positive cable) onto **B1+** stud terminal on lower alternator (figures 7 & 10).
- b) Place one new flat washer #5001341 against the jumper cable ring terminal and screw new nut #5001787 (nut torque: 10 lbf-ft) (figure 10).

16. Fit the ground cable onto the alternator ground stud, place one new flat washer #502573 against the ground cable ring terminal and screw a new nut #5001182 (nut torque: 6 lbf-ft) (figure 10).

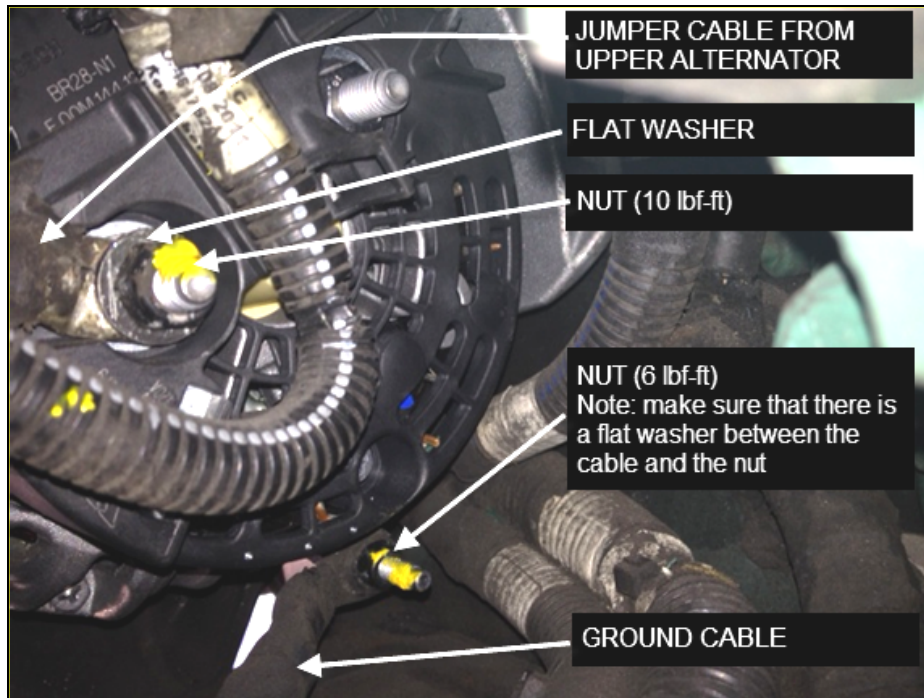

FIGURE 10

17. Plug alternator harness onto lower alternator connector and secure using two nylon cable ties #504637 (figure 11).

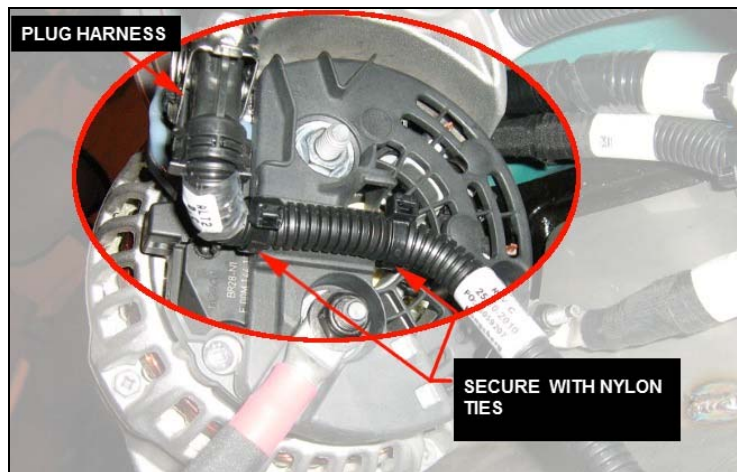

FIGURE 11

18. Apply torque seal according to normal procedure. Apply anti-corrosion compound on alternator terminals and cable ring terminals or use color guard rubber coating #684013 if available.
19. Reinstall the A/C compressor idler pulley bracket assembly (figure 12). Apply Loctite 243 on threads. Reinstall the A/C compressor belts.

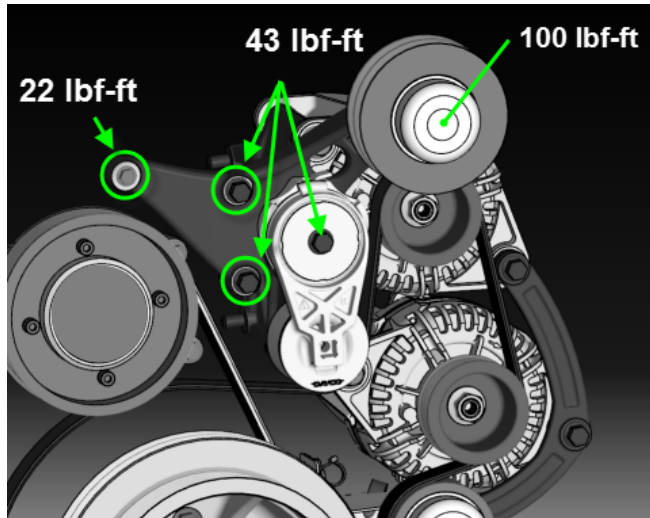

FIGURE 12

20. Finally, check that all cables are properly installed, start engine and check for proper functioning. Check for proper functioning of charging system.

PARTS / WASTE DISPOSAL

Discard according to applicable environmental regulations (Municipal/State[Prov.]/ Federal)

Access all our Service Bulletins on
<http://prevostparts.volvo.com/technicalpublicatios/en/pub.asp>
 Or scan the QR-Code with your smart phone.

E-mail us at technicalpublications_prev@volvo.com and type "ADD" in the subject to receive our warranty bulletins by e-mail.



CONTENTS

1. DESCRIPTION	3
1.1 ALLISON AUTOMATIC TRANSMISSION	3
1.1.1 Retarder (if applicable)	3
2. WELDING PROCEDURES	3
3. ALLISON TRANSMISSION MAINTENANCE	4
3.1 MANUAL FLUID LEVEL CHECK	4
3.1.1 Cold Check.....	4
3.1.2 Hot Check.....	5
3.2 FLUID LEVEL CHECK USING THE PUSHBUTTON SHIFT SELECTOR	5
3.3 RECOMMENDED AUTOMATIC TRANSMISSION FLUID.....	6
3.3.1 Importance of Proper Fluid Level.....	7
3.3.2 Keeping Fluid Clean.....	7
3.3.3 Oil Contamination.....	7
3.3.4 Metal Particles.....	7
3.3.5 Coolant Leakage	7
3.4 ALLISON RECOMMENDED OIL AND FILTER CHANGE INTERVAL	8
3.4.1 Oil and Filter Change Interval	9
3.5 FLUID AND FILTER CHANGE PROCEDURE	9
3.5.1 Drain	9
3.5.2 Refill transmission.....	10
3.6 CLEANING AND INSPECTION OF ALLISON AUTOMATIC TRANSMISSION.....	10
3.6.1 Breather.....	10
4. TRANSMISSION OIL COOLER REMOVAL	10
4.1 TRANSMISSION WITHOUT RETARDER	10
4.2 TRANSMISSION WITH RETARDER	11
5. ALLISON TRANSMISSION INSTALLATION	11
6. ALLISON TRANSMISSION TROUBLESHOOTING	12
6.1 DIAGNOSTIC TROUBLESHOOTING CODES (DTC) — ALLISON 5TH GENERATION CONTROLS	13
6.1.1 Using Shift Selector for Accessing Diagnostics Information.....	13
6.1.2 Display Sequence	13
6.1.3 Diagnostic Code Display and Clearing Procedure	13
6.1.4 Exiting Diagnostic Mode	14
6.1.5 Diagnostic Trouble Code Response	14
6.2 DIAGNOSTIC TROUBLESHOOTING CODES (DTC) LIST - ALLISON 5 TH GENERATION CONTROLS	15
7. SPECIFICATIONS	18
8. SECTION CHANGE LOG	19

ILLUSTRATIONS

FIGURE 1: ALLISON TRANSMISSION.....	3
FIGURE 2: ALLISON TRANSMISSION CONTROL PAD	3
FIGURE 3: OIL LEVEL DIPSTICK (AUTO. TRANS.).....	4
FIGURE 4: COLD CHECK.....	5
FIGURE 5: HOT CHECK	5
FIGURE 6: DRAIN PLUG AND FILTERS.....	10
FIGURE 7: COOLER WITH RETARDER	11
FIGURE 8: AIR PRESSURE REGULATOR (TYPICAL)	12
FIGURE 9: TRANSMISSION CONTROL MODULE	12

1. DESCRIPTION

X3 Series coaches may be provided with either an Allison automatic transmission or a Volvo I-Shift transmission while X3-45 VIP and XLII Bus Shells are provided with an Allison automatic transmission.

1.1 ALLISON AUTOMATIC TRANSMISSION

The Series 4000 (B500 for coaches and 4000MH for motorhomes) Allison Transmission has 6 speeds with two top range (fifth and sixth) overdrives. Total coverage is determined by dividing the highest gear ratio by the lowest gear ratio. Total coverage expresses the transmission gear ratio versatility. Transmissions with larger total coverage number have a wider variety of available ratios.

An electronic control allows the transmission to shift at exactly the right point on the engine's fuel consumption curve for best economy. Early lockup maintains the highest possible mechanical efficiency through the closely-spaced gear steps, culminating in two overdrive ratios. This combination allows progressive shifting techniques, where engine speeds are reduced for higher efficiency and lower fuel consumption.

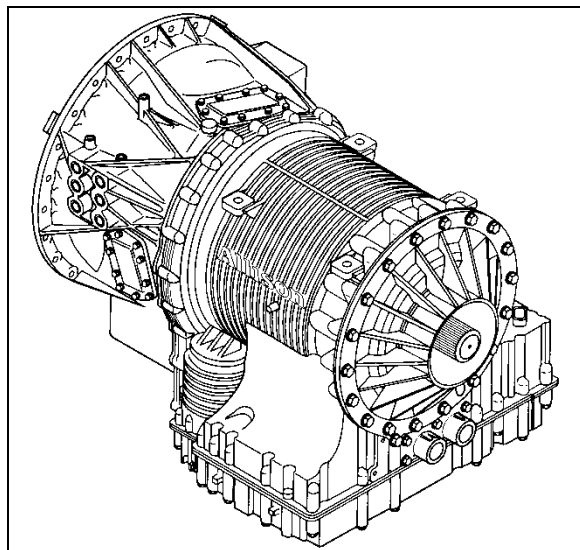

FIGURE 1: ALLISON TRANSMISSION 07136

Gear selection and torque converter modes are controlled by a microcomputer-based electronic transmission management system. It is fed information regarding throttle position, operator range selection, engine speed, turbine speed, transmission output speed and various system pressures from special electronic sensors. With this information, it computes shift points and clutch pressures to meet immediate needs.

Using closed loop adaptive logic; the electronic control looks at a number of parameters during the shift, and makes minute adjustments to match the shift to desired profile stored in its memory. It then looks at these adjustments and resets the parameters, which allow the transmission to quickly compensate for variations in load, terrain or environment and to adjust for clutch wear and engine power changes. A Diagnostic Data Reader can be connected to the electronic control unit to provide a self-check of all systems in the transmission. Five-digit trouble codes greatly reduce the time it takes to pinpoint potential problems. (Refer to paragraph "8. TROUBLESHOOTING" in this section).

1.1.1 Retarder (if applicable)

This optional auxiliary braking device for the automatic transmission is integrated into the basic envelope of the transmission and transmits its braking force directly to the propeller shaft. It requires no additional length and adds only 75 pounds (34 kg) of weight. Operation of the retarder is controlled electronically by the driver's use of the brake and/or by hand control lever.

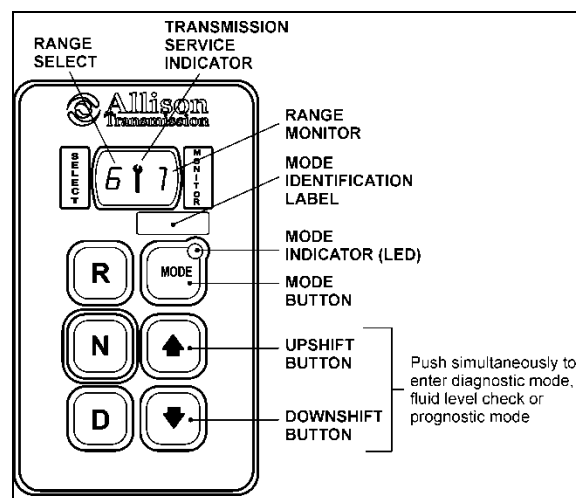

FIGURE 2: ALLISON TRANSMISSION CONTROL PAD 07142

When activated, fluid enters a cavity and provides resistance to the turning of rotor blades revolving with the output shaft. This effectively slows the vehicle to the point where the service brakes are needed only for final stopping. The retarder is fully modulated and is compatible with ABS.

2. WELDING PROCEDURES

These procedures are intended only for vehicles equipped with transmission electronic controls. When frame or other welding is required on the

vehicle, precautions are to be taken to protect the electronic control components. Refer to section 00: GENERAL INFORMATION, paragraph 3: "Precautions to be observed before welding" for complete procedure.

3. ALLISON TRANSMISSION MAINTENANCE

3.1 MANUAL FLUID LEVEL CHECK

Take note that an oil level sensor (OLS) is standard in your transmission. With the OLS and Allison 5th generation shift selector, you can get a more accurate electronic fluid level check than with a dipstick.

To gain access to the dipstick, open the engine compartment rear doors; dipstick is located on the radiator side of the engine (Figure 3).



DANGER

When checking the oil level, be sure that the parking brake and/or emergency brakes are set and properly engaged, and the wheels are chocked. Unexpected and possible sudden vehicle movement may occur if these precautions are not taken.

- Special care must be taken not to touch the engine coolant tubing and/or exhaust pipe, since this could cause severe burns.
- Do not wear loose clothing and, stay away from rotating parts during procedure; personal injury could occur.

Clean all dirt from around the end of the oil filler tube before removing the dipstick. Dirt or foreign matter must not be permitted to enter the oil system since it will cause valves to stick, undue wear of transmission parts, and clogged passages. Check the oil level using the procedures in Cold Check and Hot Check. Record any abnormal level on your "Maintenance Records".

Always check the oil level reading at least twice when the engine is running. Consistency is important in maintaining the accuracy of the reading. If inconsistent readings persist, check the transmission breather to ensure it is clean and free of debris.

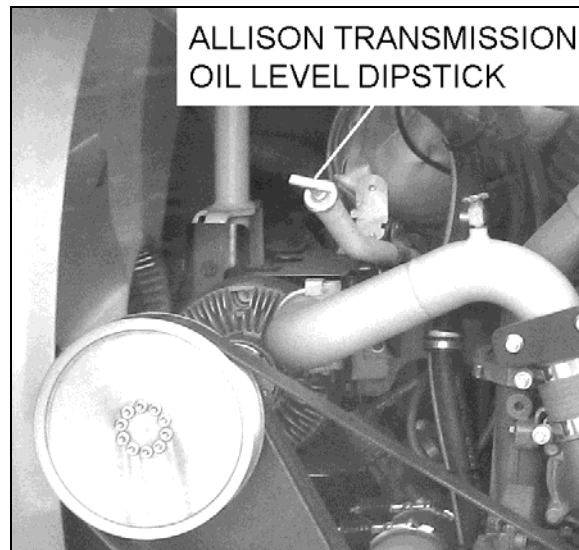

FIGURE 3: OIL LEVEL DIPSTICK (AUTO. TRANS.) 07113

3.1.1 Cold Check

The purpose of the **Cold Check** is to determine if the transmission has enough fluid to be operated safely until a **Hot Check** can be made.



CAUTION

The oil level rises as sump temperature increases. **DO NOT** fill above the Cold Run band if the transmission oil is below normal operating temperature. During operation, an overfull transmission can become overheated, leading to transmission damage.

1. Move the vehicle to a level surface, put transmission in «N» (Neutral), and set the parking brake.
2. With the engine idling (500 - 800 rpm), shift to «D» (Drive) and then shift to «R» (Reverse) to clear the hydraulic system of air.
3. Run the engine at idle in «N» (Neutral) for about one minute.
4. While the engine is running, remove the dipstick from the tube and wipe it clean (Figure 3). Insert the dipstick into the fill tube, pushing down until it stops.
5. Remove the dipstick and observe the fluid level. Repeat the check procedure to verify the reading. If the fluid on the dipstick is within the COLD CHECK band, the level is satisfactory for operating the transmission until the oil is hot enough to perform a **Hot Check**. If the fluid level is **not** within this

band, add or drain fluid as necessary to bring the level within the COLD CHECK band.

6. Perform a **Hot Check** at the first opportunity after the normal operating temperature of 160°F to 200°F (71°C to 93°C) is attained.

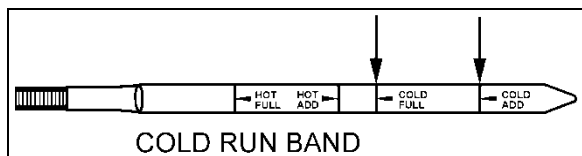

FIGURE 4: COLD CHECK

07050

**CAUTION**

DO NOT operate the transmission for extended periods of time until a **Hot Check** has verified proper fluid level. Transmission damage can result from extended operation at improper fluid level conditions.

**CAUTION**

Obtain an accurate fluid level by imposing the following conditions:

- Engine is idling (500-800 rpm) in «N» (Neutral).
- Transmission fluid is at normal operating temperature.
- The vehicle is on a level surface.

3.1.2 Hot Check

To perform a **Hot Check**, do the following:

1. The **Hot Check** can be performed when the transmission oil reaches the normal operating temperature (160°F to 200°F / 71°C to 93°C). The transmission oil temperature can be checked with the Driver Information Display (DID) when selecting the Gauge menu (refer to the “Operator’s Manual” for added information).

**CAUTION**

The oil **must be hot** to obtain an accurate check because the fluid level rises as temperature increases.

2. Park the vehicle on a level surface and shift to «N» (Neutral). Apply the parking brake and allow the engine to idle (500 - 800 rpm).

3. Remove the dipstick from the tube and wipe it clean. Insert the dipstick into the fill tube, pushing down until it stops.
4. Remove the dipstick and observe the fluid level. The safe operating level is anywhere within the HOT RUN band on the dipstick. Repeat the check procedure to verify the reading.
5. If the level is **not** within this band, add or drain fluid as necessary to bring the level within the HOT RUN band.
6. Be sure fluid level checks are consistent. Check level more than once and if readings are not consistent, check to be sure the transmission breather is clean and not clogged. If readings are still not consistent, contact your nearest Allison dealer or distributor.

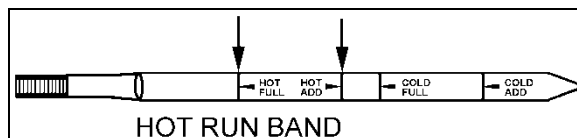

FIGURE 5: HOT CHECK

NOTE

The Cold Check is more appropriate for verifying the oil level after the first fill-up. In case of conflict, the Hot Check has priority over the Cold Check; the fluid level check using the pushbutton shift selector has priority over the Hot Check.

3.2 FLUID LEVEL CHECK USING THE PUSHBUTTON SHIFT SELECTOR

The oil level sensor (OLS) is standard in your transmission. With the OLS and Allison 5th generation shift selector, you can get a more accurate electronic fluid level check than with a dipstick.

Oil level codes are obtained as follows:

1. Park vehicle on a level surface, select «N» (neutral) on the pushbutton shift selector and apply parking brake.
2. Wait for at least 2 minutes to allow the oil to settle;
3. Press simultaneously the ▲ (Upshift) and ▼ (Downshift) arrow buttons once.
4. Oil level codes are displayed once the following parameters are met :

- The vehicle has been stationary for approximately 2 minutes to allow the oil to settle;
- Engine at idle;
- Oil at normal operating temperature, between 104°F (40°C) and 220°F (104°C);
- Transmission in «N» (Neutral);
- Transmission output shaft stopped;
- Oil level sensor present and working.

5. Correct fluid level is displayed as shown.



6. Low fluid level is displayed as shown. The number indicates the number of quarts of fluid the transmission requires.



7. High fluid level condition with the number of quarts in excess is displayed as shown.



NOTE
Confirm a low fluid level condition by making a manual fluid level check.

8. To exit the Oil Level Display Mode, press any range button «R», «N» or «D» at any time.

NOTE
Note that the quantities LO 4 and HI 3 are the largest values displayed and that the actual variation in oil level may exceed these numbers.

If the fluid level check cannot be completed, an Invalid for Display fault is reported. Refer to table below to review the codes and conditions.

CODE	CAUSE OF FAULT CODE
SETTLING OK	Settling time too short
ENG RPM TOO LOW	Engine speed (rpm) too low

CODE	CAUSE OF FAULT CODE
ENG RPM TOO HIGH	Engine speed (rpm) too high
MUST BE IN NEU	N (Neutral) must be selected
OIL TEMP TOO LOW	Sump fluid temperature too low
OIL TEMP TOO HIGH	Sump fluid temperature too high
VEH SPD TOO HI	Output shaft speed
SENSOR FAILED	Sensor failure

3.3 RECOMMENDED AUTOMATIC TRANSMISSION FLUID

Only use fluids meeting Allison Transmission specification TES295 or TES389 in your transmission. Refer to TES295 or TES389 Approved Fluids list, found under the Service/Fluids heading on the home page of the Allison Transmission web site www.allisontransmission.com.

Allison Transmission recommends you take the following into consideration when selecting the appropriate fluid type for your transmission:

- Fluids meeting specification TES295 are preferred over TES389 fluids for use in all 4000 Product Families transmission applications.
- TES295 fluids are fully qualified for Severe Duty and Extended Drain intervals.
- A TES295 fluid allows you to operate at a lower ambient temperature than a TES389 type fluid.
- TES389 fluid is the minimum fluid requirement approved for use in 4000 Product Families transmissions.
- To extend the TES389 fluid drain intervals beyond the recommended mileage or hours change interval, use a fluid analysis program.

When choosing a fluid type to use, consider what the minimum fluid operating temperature of the fluid will be based on the ambient temperatures reached in the geographical location for the vehicle.

Transmission Fluid Operating Temperature Requirements

Fluid type	Minimum operating temperature	
	Celsius	Fahrenheit
TES295	-35	-31
TES389	-25	-13

 **CAUTION**
 Disregarding minimum fluid temperature limits can result in transmission malfunction or reduced transmission life.

NOTE
The use of an arctic preheat kit is recommended at temperatures below -25°F (-32°C). If a preheat kit is not available, the TCM will restrict full operation until the sump temperature is increased.

3.3.1 Importance of Proper Fluid Level

It is important that the proper fluid level be maintained at all times because the transmission fluid cools, lubricates, and transmits hydraulic power. If the fluid level is too low, the converter and clutches do not receive an adequate supply of fluid. If fluid level is too high, the fluid can aerate, causing the transmission to shift erratically or overheat.

3.3.2 Keeping Fluid Clean

Oil must be handled in clean containers, fillers, etc., to prevent foreign material from entering the transmission. Place the dipstick on a clean surface area while filling the transmission.

 **CAUTION**
 Containers or fillers that have been used to handle antifreeze or engine coolant must NEVER be used for handling transmission fluid. Antifreeze and coolant solutions contain ethylene glycol that, if introduced into the transmission, can cause the clutch plates to fail.

3.3.3 Oil Contamination

At each oil change, examine the drained oil for evidence of dirt or water. A nominal amount of condensation will emulsify during operation of the transmission. However, if there is evidence of water; check the cooler (heat exchanger) for other signs of leakage. This, however, may also indicate leakage from the engine oil system.

3.3.4 Metal Particles

Metal particles in the oil (except for minute particles normally trapped in the oil filter) indicate damage has occurred in the transmission. When these particles are found in the sump, the transmission must be disassembled and closely inspected to find the source. Metal contamination will require complete disassembly of the transmission and cleaning of all internal and external circuits, coolers, and all other areas where the particles could lodge.

 **CAUTION**
 If excessive metal contamination has occurred, replacement of the oil cooler and replacement of all bearings within the transmission is recommended.

3.3.5 Coolant Leakage

If engine coolant leaks into the transmission oil system, immediate action must be taken to prevent malfunction and possible serious damage. The transmission must be completely disassembled, inspected, and cleaned. All traces of the coolant contamination must be removed. Friction clutch plates contaminated with ethylene glycol must be replaced.

3.4 ALLISON RECOMMENDED OIL AND FILTER CHANGE INTERVAL

TABLE 1

Allison Transmission Recommended Fluid And Filter Change Intervals (Prognostics Mode <u>Disabled</u>)					
Using TES389 or Mixture					
Severe vocation ³ Coaches or MTH equipped with retarder			General vocation ⁴ Coaches or MTH without retarder		
Fluid	Filters		Fluid	Filters	
	Main & Lube	Internal		Main & Lube	Internal
Whichever is the first of the following: 12,000 Miles (20 000 km) 6 Months/ 500hrs <i>Note: always replace main and lube filters with the fluid change</i>	Whichever is the first of the following: 12,000 Miles (20 000 km) 6 Months/ 500hrs <i>Note: always replace main and lube filters with the fluid change</i>	Overhaul	Whichever is the first of the following: 25,000 Miles 40 000 km 12 Months/ 1000hrs <i>Note: always replace main and lube filters with the fluid change</i>	Whichever is the first of the following: 25,000 Miles 40 000 km 12 Months/ 1000hrs <i>Note: always replace main and lube filters with the fluid change</i>	Overhaul

TABLE 2

Allison Transmission Recommended Fluid And Filter Change Intervals ¹ (Prognostics Mode <u>Disabled</u>)					
Using 100% TranSynd or TES295 Approved Fluid ²					
Severe vocation ³ Coaches or MTH equipped with retarder			General vocation ⁴ Coaches or MTH without retarder		
Fluid	Filters		Fluid	Filters	
	Main & Lube	Internal		Main & Lube	Internal
Whichever is the first of the following: 150,000 Miles (240 000 km) 48 Months/ 6000hrs <i>Note: always replace main and lube filters with the fluid change</i>	Whichever is the first of the following: 75,000 Miles (120 000 km) 36 Months/ 3000hrs <i>Note: always replace main and lube filters with the fluid change</i>	Overhaul	Whichever is the first of the following: 300,000 Miles (480 000 km) 48 Months 6000hrs <i>Note: always replace main and lube filters with the fluid change</i>	Whichever is the first of the following: 75,000 Miles (120 000 km) 36 Months 3000hrs <i>Note: always replace main and lube filters with the fluid change</i>	Overhaul

¹ Extended TrandSyndTES295 fluid and filter change intervals are only allowed with Allison High-Capacity filters.

² Less than 100% concentration of TranSynd or TES295 approved fluid is considered a mixture and should utilize TES389 change intervals. If the customer replaces non-TranSynd or non-TES295 fluid with TranSynd or TES295 equivalent, the change interval recommendations of TES389 or mixture must be followed. Upon the next oil change, if the customer reinstall TranSynd or TES295 equivalent, the fluid & filter change recommendation outlined in 100% TES295 approved fluids must be followed.

³ Severe vocation= All retarder, On/Off highway, transit and intercity coach with duty cycle greater than one (1) stop per mile.

⁴ General vocation= intercity coach with duty cycle less than or equal to one (1) stop per mile and all other vocations not listed in severe vocation.

3.4.1 Oil and Filter Change Interval

Allison transmissions are factory fill with **Castrol TranSynd** fluid. Oil change must be performed with the vehicle on a flat and level surface and with parking brake applied. Oil and filter change frequency is determined by the severity of service and operating conditions of the transmission and by the filter equipment installed. See "TABLE 1 or TABLE 2" for oil and filter change intervals. More frequent changes may be required when operations are subject to high levels of contamination or overheating. Filters must be changed at or before recommended intervals.

IMPORTANT NOTE
 Your transmission is equipped with **High Capacity filters**. High Capacity filters allow for increased fluid and filter change intervals in transmissions utilizing TES295 approved fluid or TranSynd. High Capacity filters eliminate the requirement of the initial 5000 miles (8000km) main filter change.

IMPORTANT NOTE
 Allison Transmission recommends that customers use fluid analysis as the primary method for determining fluid change intervals. Many customers have a systematical annual transmission fluid change while, in many cases, fluid analysis could demonstrate that the transmission fluid is still in good condition and a fluid change is not required. In the absence of a fluid analysis program, the fluid change interval listed in TABLE 1 & TABLE 2 should be used.

IMPORTANT NOTE
 A mixture of TES295 and TES389 fluid must continue to use the TES389 fluid change intervals, until two fluid changes with only TES295 fluid have occurred, at which time the TES295 schedule may be used.

2. Remove the drain plug from under the transmission (Figure 6) and allow the oil to drain into a suitable container. Check the condition of the oil as described previously.
3. Remove twelve bolts (item 1), two filter covers (item 2), two gaskets (item 3), two O-rings (item 4), two O-rings (item 5) and the two filters (item 6) from the bottom of the control module (Figure 6).
4. When reinstalling parts, lubricate and install new O-rings (4) and (5) on each cover (2). Lubricate O-ring inside filter (6) and push filter onto cover (2). Install new gaskets (3) on cover (2) and align holes in gaskets with holes in cover.



CAUTION

Do not use bolts to draw the cover to sump. This can damage the cover, seal, or sump.

5. Install filter and cover assemblies into the filter compartment. Align each filter/cover assembly with the holes in the channel plate/sump. Push the cover assemblies in by hand to seat the seals.
6. Install twelve bolts and both covers, and then tighten to 38-45 Ft-lbs (51-61 Nm).
7. Inspect the drain plug and O-ring. Replace if necessary. Reinstall the drain plug and tighten to 18-24 Ft-lbs (25-32 Nm).

3.5 FLUID AND FILTER CHANGE PROCEDURE

3.5.1 Drain

1. The transmission should be at an operating temperature of 160°F (71°C) to 200°F (93°C) when the oil is drained. This will ensure quicker and more complete fluid drainage.

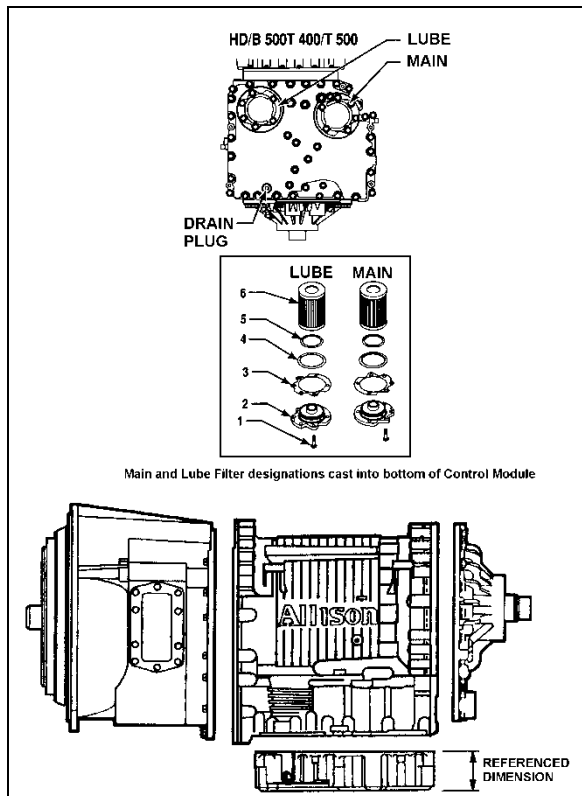

FIGURE 6: DRAIN PLUG AND FILTERS 07052

Fluid loss with filter change only

When changing main and lube filters at recommended intervals, approximate fluid loss for each filter as follows:

Main filter = 2 quarts (1.9 liters)

Lube filter = 8 quarts (7.6 liters)

3.5.2 Refill transmission

The amount of refill fluid is less than the amount used for the initial fill. Fluid remains in the external circuits and transmission cavities after draining the transmission.

NOTE

Quantities listed below are approximations and do not include external oil cooler lines.

Using the oil level dipstick filler tube, refill with 24 US qts (23 liters), 28 US qts (26.5 liters) if equipped with retarder, and check the oil level using the **Fluid Level Check Using Pushbutton Shift Selector** procedure in this section. Add transmission fluid according to pushbutton shift selector fluid level check.

3.6 CLEANING AND INSPECTION OF ALLISON AUTOMATIC TRANSMISSION

The exterior of the transmission should be cleaned and inspected at regular intervals. The length of service and severity of operating conditions will determine the frequency of such inspections. Inspect the transmission for:

1. Loosen bolts (transmission and mounting components);
2. Oil leaks (correct immediately);
3. Loose, dirty, or improperly adjusted throttle sensor linkage;
4. Damaged or loose oil lines;
5. Worn or frayed electrical harnesses, improper routing;
6. Worn or out of phase drive line U-joint and slip fittings.



CAUTION

DO NOT pressure wash the transmission electrical connectors. Water and detergent will cause the contacts to corrode or become faulty.

3.6.1 Breather

The breather is located on the engine, flywheel side near the valve cover. It serves to prevent pressure build-up within the transmission and must be cleaned to keep the passage opened. The prevalence of dust and dirt will determine the frequency at which the breather requires cleaning. Use care when cleaning the engine. Spraying steam, water or cleaning solution directly at the breather can force the water or solution into the transmission. Always use care when removing the hose connector from transmission to prevent the entry of foreign matter.

4. TRANSMISSION OIL COOLER REMOVAL

4.1 TRANSMISSION WITHOUT RETARDER

Stop engine and allow engine to cool. Close both heater line shutoff valves (refer to Section 05 "Cooling").

To drain the cooling system, proceed as per Section 05 "Cooling", paragraph 5: Draining. If the cooling system is contaminated, flush

system as per Section 05 "Cooling", paragraph 7: Flushing.

1. Remove the rear L.H. side tag axle wheel, then remove the rear L.H. side fender panel.
2. Disconnect the two transmission hoses from oil cooler. Cover hose ends and fittings to prevent fluid contamination (Figure 7).



WARNING

A significant amount of oil may drain from oil lines when they are disconnected.

3. Unfasten the constant-torque hose clamps and remove the two hoses.
4. Unscrew the four holding nuts and remove the U-bolts, remove the oil cooler from engine compartment.
5. Reinstall transmission oil cooler by using reverse procedure.

4.2 TRANSMISSION WITH RETARDER

Stop engine and allow engine to cool. Close both heater line shutoff valves (refer to Section 05 "Cooling").

1. To drain the cooling system, proceed as per Section 05 "Cooling", paragraph 5: Draining. If the cooling system is contaminated, flush system as per Section 05 "Cooling", paragraph 7: Flushing.
2. Remove the rear L.H. side tag axle wheel, then remove the rear L.H. side fender panel.
3. Disconnect the transmission hoses from oil cooler. Cover hose ends and fittings to prevent fluid contamination.

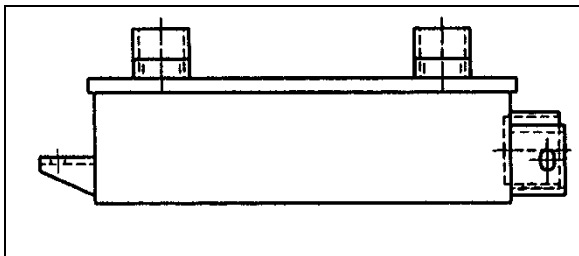

FIGURE 7: COOLER WITH RETARDER 07073



WARNING

A significant amount of oil may drain from oil lines when they are disconnected.

4. Unfasten the constant-torque hose clamps and remove the two hoses.
5. Unscrew the holding bolts and nuts and remove the oil cooler from engine compartment.

5. ALLISON TRANSMISSION INSTALLATION

1. Place the transmission on a transmission jack.
2. Install a headless guide bolt into one of the 12 threaded holes for flexible plate attaching screws in the flywheel.

NOTE

For more clearance between the tag axle and transmission, the tag axle may be unloaded and jacked up, or retracted (if applicable).

With the starter motor removed, align one of the 12 attaching screw holes in the flexible plate with the access opening.

3. Lubricate the flywheel center pilot boss with molybdenum disulfide grease (Molycote G, or equivalent).
4. Raise transmission and position the flywheel pilot boss into the flexible plate adapter. Align the guide bolt previously installed in the flywheel with the flexible plate hole facing the access opening in the flywheel housing.



WARNING

Severe damages and/or personal injury can occur if transmission is not adequately supported.

5. Seat the transmission against the engine flywheel housing. **NO FORCE IS REQUIRED.** If interference is encountered, move the transmission away from engine, then investigate the cause.



CAUTION

The torque converter housing must be seated against the flywheel housing prior to tightening any screws. **DO NOT USE SCREWS TO SEAT THE HOUSING.**

6. Start all torque converter housing screws, and then tighten four of them gradually and in a criss-cross sequence around the housing. Tighten the 12 remaining screws.

Recommended torque is between 42-50 Lbf-ft (57-68 Nm).

- Remove the guide bolt through the access opening in the flywheel housing. Replace it with a self-locking screw, finger-tighten then start the remaining screws; tighten to 17-21 lbf-ft (23-28 Nm). Place a wrench on the crankshaft pulley attaching screw to turn the converter to gain access to the threaded holes.

NOTE

Remove the plug located below starter motor and install cranking tool (88800014). Crank the engine to gain access to the threaded holes by turning the cranking tool using a suitable adapter.

Reinstall starter motor and connect cables.

Reinstall access plug below starter motor.

- Remove jack from under transmission.
- Connect all sensors.
- Connect the main wiring harness.
- Connect the air supply line (steel-braided hose) to the retarder control valve (if applicable).
- Connect the two transmission oil cooler hoses as they were previously.
- Reinstall clamps and brackets, and replace locking ties previously removed during removal procedure.
- Install propeller shaft and its safety guard. Refer to Section 09, "PROPELLER SHAFT".
- Install transmission dipstick and filler tube.
- Install cross member under transmission.
- Install engine splash guards.
- Adjust the retarder pressure to 80 ± 3 psi with the air pressure regulator. For more information refer to Section 12, "BRAKE AND AIR SYSTEM", under heading "AIR PRESSURE REGULATOR". The air pressure regulator is located at back of engine compartment, on R.H. side (Figure 8) or in the R.H. side rear service compartment.
- Make sure that the drain plug is in place, and then remove the transmission dipstick and pour approximately 24 US quarts (23 L) of automatic transmission fluid through the filler tube. Check and adjust oil level.

**CAUTION**

Do not overfill the transmission. Overfilling can cause oil aeration (milky appearance) and overheating. If overfilling occurs, drain oil as required to bring it to the proper level.

AIR PRESSURE REGULATOR

FIGURE 8: AIR PRESSURE REGULATOR (TYPICAL) 07037

6. ALLISON TRANSMISSION TROUBLESHOOTING

The Allison transmission has a new Transmission Control Module (TCM) which involves specific diagnostic incident codes. The TCM unit is located in the coach main power compartment.

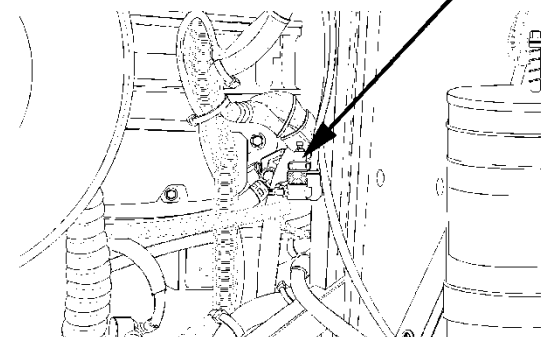
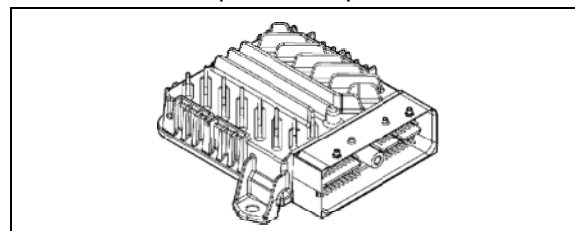

FIGURE 9: TRANSMISSION CONTROL MODULE 07140

TCM Replacement

The TCM is a non-serviceable electronic device. When it fails, it must be replaced using the following procedure:

- Open the coach main power compartment in order to get access to the TCM;
- Remove the electrical cable connectors;
- Unscrew the TCM unit;
- Replace by reversing the procedure.

**CAUTION**

Place the battery master switch to the "OFF" position.

6.1 DIAGNOSTIC TROUBLESHOOTING CODES (DTC) — ALLISON 5TH GENERATION CONTROLS

Diagnostic features are provided with the transmission control system to assist in troubleshooting of malfunctions and/or the monitoring of specific operating parameters. When a control system malfunction is detected, a series of Diagnostic Trouble Codes (DTCs) are used to identify and clarify the nature of the malfunction. These DTCs are each named by a 5 character alphanumeric string that refers to a diagnostic algorithm running pass/fail tests to help identify a malfunction in the transmission or vehicle operation. Most DTCs have some kind of diagnostic response that the operator notices, such as an illuminated CHECK light, selector display change, lock in range, or inhibit shifts condition.

DTCs are logged in the Transmission Control Module (TCM) memory by severity and by their active/inactive status with the most severe and active codes listed first. A maximum of five DTCs (numbered d1- d5) from most recent to oldest may be read from the shift selector. As DTCs are added, the oldest inactive DTC (historic) is dropped from the list. If all DTCs are active, the DTC with the lowest priority is dropped from the list.

An active code is any code that is current in the TCM decision-making process and has failed the DTC test(s) associated with that specific diagnostic algorithm. Historical codes, which are by definition inactive, are codes that are no longer failing their algorithm but are retained in the TCM in order to help the technician analyze possible causes and provide them direction if the vehicle is brought in before they are cleared from the queue.

DTCs can be cleared manually by the operator or they clear automatically from last (d5) to first (d1) in the queue after a number of engine starts, without becoming active again.

6.1.1 Using Shift Selector for Accessing Diagnostics Information

DTCs can be displayed on the display portion of the shift selector. A DTC is either active or historic. An active DTC is a DTC that is current in the TCM decision-making process. Historic DTCs are retained in the TCM memory and do not necessarily affect the TCM decision-making process.

6.1.2 Display Sequence

Up to five DTCs may be displayed one at a time from the selector once the diagnostic display mode has been initiated by the operator. Each DTC is 5 characters in length. The DTC status active or inactive is shown below the DTC.



Shows active DTC P0730

The operator presses the MODE button to read the next OTC in the queue (if any) or requests to exit diagnostics mode. The diagnostics mode times out and returns the selector to normal operating mode after approximately 10 minutes of operator inactivity.

6.1.3 Diagnostic Code Display and Clearing Procedure

Diagnostic codes can be read and cleared by two methods:

- Using an Allison DOC™ diagnostic tool. For specific instructions on how to use an Allison DOC™ diagnostic tool, refer to the User Guide.
- Using the pushbutton shift selector.

To begin the diagnostic process:

1. Bring the vehicle to a stop at a safe location.
2. Apply the parking brake.

To display stored codes:

1. Simultaneously press the ▲ (Upshift) and ▼ (Downshift) arrow buttons five times (Prognostics enabled) to access the Diagnostic Display Mode. With Prognostics disabled, press the ▲ (Upshift) and ▼ (Downshift) arrow buttons twice.
2. Press the MODE button to read the next code in the queue, if any.

To clear all active stored codes:

While in Diagnostic Mode, clear all active codes by pressing and holding the MODE button for approximately three seconds until the MODE message flashes. Release the MODE button. The MODE message should not remain illuminated if the active DTC shown in the display has cleared.

While in Diagnostic Mode, press and hold the MODE button for 10 seconds to clear both active

codes and inactive codes. The MODE message flashes a second time indicating all codes are cleared from the queue.

6.1.4 Exiting Diagnostic Mode

Exit the diagnostic mode by one of the following methods:

1. Press simultaneously the ▲ (Upshift) and ▼ (Downshift) arrow buttons at the same time on the pushbutton shift selector.
2. Press any range button «D», «N» or «R» on the pushbutton shift selector.
3. After approximately 10 minutes of inactivity at the pushbutton shift selector, the diagnostic mode automatically exits and returns to normal operating mode.
4. Turn off power to the TCM (shut off the engine using the ignition key).

NOTE

Be sure to record all codes displayed before they are cleared. This is essential for troubleshooting.

NOTE

If clearing a code while locked in a «D» (Drive) or «R» (Reverse) position (fail-to-range), the transmission will still be in «D» (Drive) or «R» (Reverse) when the clearing procedure is completed. «N» (Neutral) must be manually selected.

6.1.5 Diagnostic Trouble Code Response

The electronic control system is programmed to inform the operator of a problem with the transmission system via the CHECK light and shift selector display while it automatically takes action to protect the operator, vehicle, and transmission. When the Transmission Control Module (TCM) flags a Diagnostic Trouble Code (DTC) as active, the TCM may take a combination of diagnostic responses as listed in the following table.

6.2 DIAGNOSTIC TROUBLESHOOTING CODES (DTC) LIST - ALLISON 5TH GENERATION CONTROLS

DTC	Description	CHECK Light	Inhibited Operation Description
C1312	Retarder Request Sensor Failed Low	No	May inhibit retarder operation if not using J1939 datalink
C1313	Retarder Request Sensor Failed High	No	May inhibit retarder operation if not using J1939 datalink
P0122	Pedal Position Sensor Circuit Low Voltage	No	Use default throttle values. Freezes shift adapts.
P0123	Pedal Position Sensor Circuit High Voltage	No	Use default throttle values. Freezes shift adapts.
P0218	Transmission Fluid Over Temperature	Yes	Use default sump temp
P0562	System Voltage Low	No	Inhibit TCC Operation, DNA
P0602	TCM Not Programmed	Yes	Lock in Neutral
P0604	Control module random access memory (RAM)	Yes	Lock in Neutral
P0614	Torque Control Data Mismatch - ECM/TCM	Yes	Allows operation only in reverse and second range.
P0634	TCM Internal Temperature Too High	Yes	SOL OFF (hydraulic default)
P0642	Sensor Reference Voltage "A" Circuit Low	Yes	Default sensor data used
P0643	Sensor Reference Voltage "A" Circuit High	Yes	Default sensor data used
P0657	Actuator Supply Circuit Voltage 1 Open (HSD 1)	Yes	SOL OFF, DNA, Inhibit TCC operation, Inhibit main modulation
P0658	Actuator Supply Voltage 1 (HSD1) Low	Yes	DNS, SOL OFF (hydraulic default)
P0659	Actuator Supply Voltage 1 (HSD1) High	Yes	DNS, SOL OFF (hydraulic default)
P0703	Brake Switch Circuit Malfunction	No	No Neutral to Drive shifts for refuse packer. TCM inhibits retarder operation if a TPS code is also active.
P0708	Transmission Range Sensor Circuit High Input	Yes	Ignore defective strip selector inputs
P070C	Transmission Fluid Level Sensor Circuit – Low Input	No	None
P070D	Transmission Fluid Level Sensor Circuit – High Input	No	None
P0712	Transmission Fluid Temperature Sensor Circuit Low Input	Yes	Use default sump temp
P0713	Transmission Fluid Temperature Sensor Circuit High Input	Yes	Use default sump temp
P0715	Turbine Shaft Speed Sensor Circuit	Yes	DNS, Lock in current range
P0716	Turbine Shaft Speed Sensor Circuit Performance	Yes	DNS, Lock in current range
P0717	Turbine Shaft Speed Sensor Circuit No Signal	Yes	DNS, Lock in current range
P071A	RELS Input Failed On	Yes	Inhibit RELS operation
P071D	General Purpose Input Fault	Yes	None
P0720	Output Shaft Speed Sensor Circuit	Yes	DNS, Lock in current range
P0721	Output Shaft Speed Sensor Circuit Performance	Yes	DNS, Lock in current range
P0722	Output Speed Sensor Circuit No Signal	Yes	DNS, Lock in current range
P0725	Engine Speed Sensor Circuit	No	Default to turbine speed
P0726	Engine Speed Sensor Circuit Performance	No	Default to turbine speed
P0727	Engine Speed Sensor Circuit No Signal	No	Default to turbine speed
P0729	Incorrect 6 th Gear Ratio	Yes	DNS, Attempt 5 th , then 3 rd
P0731	Incorrect 1 st Gear ratio	Yes	DNS, Attempt 2 nd , then 5 th
P0732	Incorrect 2 nd Gear ratio	Yes	DNS, Attempt 3 rd , then 5 th
P0733	Incorrect 3 rd Gear ratio	Yes	DNS, Attempt 4 th , then 6 th
P0734	Incorrect 4 th Gear ratio	Yes	DNS, Attempt 5 th , then 3 rd
P0735	Incorrect 5 th Gear ratio	Yes	DNS, Attempt 6 th , then 3 rd , then 2 nd
P0736	Incorrect Reverse Gear ratio	Yes	DNS, Lock in Neutral
P0741	Torque Converter Clutch System Stuck Off	Yes	None
P0752	Shift Solenoid 1 Valve Performance-Stuck On	Yes	DNS
P0776	Pressure Control Solenoid (PCS) 2 Stuck Off	Yes	DNS, RPR
P0777	Pressure Control Solenoid 2 Stuck On	Yes	DNS, RPR
P0796	Pressure Control Solenoid 3 Stuck Off	Yes	DNS, RPR
P0797	Pressure Control Solenoid 3 Stuck On	Yes	DNS, RPR
P0842	Transmission Fluid Pressure Switch 1 Circuit Low	Yes	DNS, Lock in current range

SECTION 07: TRANSMISSION

DTC	Description	CHECK Light	Inhibited Operation Description
P0843	Transmission Fluid Pressure Switch 1 Circuit High	Yes	DNS, Lock in current range
P0847	Transmission Fluid Pressure Switch 2 Circuit Low	Yes	None
P0848	Transmission Fluid Pressure Switch 2 Circuit High	Yes	None
P088A	Transmission Fluid Filter Maintenance Alert	No	None
P088B	Transmission Fluid Filter Maintenance Required	No	None
P0880	TCM Power Input Signal	No	None
P0881	TCM Power Input Signal Performance	No	None
P0882	TCM Power Input Signal Low	Yes	DNS, SOL OFF (hydraulic default)
P0883	TCM Power Input Signal High	No	None
P0894	Unexpected Mechanical Gear Disengagement	Yes	DNS, Lock in first
P0897	Transmission Fluid Deteriorated	No	None
P0960	Main Pressure Modulator Solenoid Control Circuit Open	Yes	None
P0962	Main Pressure Modulator Solenoid Control Circuit Low	Yes	DNS, SOL OFF (hydraulic default)
P0963	Main Pressure Modulator Solenoid Control Circuit High	Yes	None
P0964	Pressure Control Solenoid 2 (PCS2) Control Circuit Open	Yes	DNS, SOL OFF (hydraulic default)
P0966	Pressure Control Solenoid 2 (PCS2) Control Circuit Low	Yes	DNS, SOL OFF (hydraulic default)
P0967	Pressure Control Solenoid 2 (PCS2) Control Circuit High	Yes	DNS, SOL OFF (hydraulic default)
P0968	Pressure Control Solenoid 3 (PCS3) Control Circuit Open	Yes	DNS, SOL OFF (hydraulic default)
P0970	Pressure Control Solenoid 3 (PCS3) Control Circuit Low	Yes	DNS, SOL OFF (hydraulic default)
P0971	Pressure Control Solenoid 3 (PCS3) Control Circuit High	Yes	DNS, SOL OFF (hydraulic default)
P0973	Shift Solenoid 1 (SS1) Control Circuit Low	Yes	DNS, SOL OFF (hydraulic default)
P0974	Shift Solenoid 1 (SS1) Control Circuit High	Yes	DNS, SOL OFF (hydraulic default)
P0976	Shift Solenoid 2 (SS2) Control Circuit Low	Yes	7-speed: Allow 2 through 6, N, R Inhibit TCC operation
P0977	Shift Solenoid 2 (SS2) Control Circuit High	Yes	7-speed: Allow 2 through 6, N, R
P097A	Shift Solenoid 1 (SS1) Control Circuit Open	Yes	Lock in range
P097B	Shift Solenoid 2 (SS2) Control Circuit Open	Yes	7-speed: Allow 2 through 6, N, R
P0989	Retarder Pressure Sensor Circuit Low	No	None
P0990	Retarder Pressure Sensor Circuit High	No	None
P1739	Incorrect Low Gear Ratio	Yes	Command 2 nd and allow shifts 2 through 6, N, R
P1790	Gear Shift Module 1 Calibrated Invalid	Yes	Shift selector language or units incorrect
P1791	Gear Shift Module 2 Calibrated Invalid	Yes	Shift selector language or units incorrect
P1891	Throttle Position Sensor PWM Signal Low	No	Use default throttle values
P1892	Throttle Position Sensor PWM Signal High	No	Use default throttle values
P2184	Engine Coolant Temperature Sensor 2 Circuit Low Input	No	Use default engine coolant values
P2185	Engine Coolant Temperature Sensor 2 Circuit High Input	No	Use default engine coolant values
P2637	Torque Management Feedback Signal (A)	Yes	Inhibit SEM
P2641	Torque Management Feedback Signal (B)	Yes	Inhibit LRTP
P2669	Actuator Supply Circuit Voltage 2 Open (HSD2)	Yes	SOL OFF, Inhibit TCC operation, Inhibit Main modulation, ONA
P2670	Actuator Supply Voltage 2 (HSD2) Low	Yes	DNS, SOL OFF (hydraulic default)
P2671	Actuator Supply Voltage 2 (HSD2) High	Yes	DNS, SOL OFF (hydraulic default)
P2684	Actuator Supply Circuit Voltage 3 Open (HSD3)	Yes	SOL OFF, Inhibit TCC operation, Inhibit Main modulation, ONA
P2685	Actuator Supply Voltage 3 (HSD3) Low	Yes	DNS, SOL OFF (hydraulic default)
P2686	Actuator Supply Voltage 3 (HSD3) High	Yes	DNS, SOL OFF (hydraulic default)
P2714	Pressure Control Solenoid 4 (PCS4) Stuck Off	Yes	DNS, RPR
P2715	Pressure Control Solenoid 4 (PCS4) Stuck On	Yes	DNS, SOL OFF (hydraulic default)
P2718	Pressure Control Solenoid 4 (PCS4) Control Circuit Open	Yes	DNS, SOL OFF (hydraulic default)
P2720	Pressure Control Solenoid 4 (PCS4) Control Circuit Low	Yes	DNS, SOL OFF (hydraulic default)
P2721	Pressure Control Solenoid 4 (PCS4) Control Circuit High	Yes	DNS, SOL OFF (hydraulic default)
P2723	Pressure Control Solenoid 1 (PCS1) Stuck Off	Yes	DNS, RPR
P2724	Pressure Control Solenoid 1 (PCS1) Stuck On	Yes	DNS, RPR

DTC	Description	CHECK Light	Inhibited Operation Description
P2727	Pressure Control Solenoid 1 (PCS1) Control Circuit Open	Yes	DNS, SOL OFF (hydraulic default)
P2729	Pressure Control Solenoid 1 (PCS1) Control Circuit Low	Yes	DNS, SOL OFF (hydraulic default)
P2730	Pressure Control Solenoid 1 (PCS1) Control Circuit High	Yes	DNS, SOL OFF (hydraulic default)
P2736	Pressure Control Solenoid 5 (PCS5) Control Circuit Open	Yes	Inhibit retarder operation
P2738	Pressure Control Solenoid 5 (PCS5) Control Circuit Low	Yes	Allow 2 through 6, N, R. Inhibit retarder and TCC operation
P2739	Pressure Control Solenoid 5 (PCS5) Control Circuit High	Yes	Inhibit retarder operation
P273F	Retarder Oil Temperature Sensor Over Temperature Condition	No	None
P2742	Retarder Oil Temperature Sensor Circuit – Low	No	Use default retarder temp values
P2743	Retarder Oil Temperature Sensor Circuit – High	No	Use default retarder temp values
P2761	TCC PCS Control Circuit Open	Yes	Inhibit TCC operation
P2763	TCC PCS Control Circuit High	Yes	Inhibit TCC operation
P2764	TCC PCS Control Circuit Low	Yes	7-speed: Allow 2 through 6, N, R. Inhibit TCC operation
P2789	Transmission Clutch Life Expired (Clutch Adaptive Learning at Limit)	No	None
P2793	Gear Shift Direction Circuit	Yes	Ignores PWM input from shift selector
P2808	Pressure Control Solenoid 6 (PCS6) Stuck Off	Yes	DNS, RPR
P2809	Pressure Control Solenoid 6 (PCS6) Stuck On	Yes	DNS, RPR
P2812	Pressure Control Solenoid 6 (PCS6) Control Circuit Open	Yes	DNS, SOL OFF (hydraulic default)
P2814	Pressure Control Solenoid 6 (PCS6) Control Circuit Low	Yes	DNS, SOL OFF (hydraulic default)
P2815	Pressure Control Solenoid 6 (PCS6) Control Circuit High	Yes	DNS, SOL OFF (hydraulic default)
U0073	CAN Communication Bus 1 Off	No	Use default values
U0074	CAN Communication Bus 2 Off	No	Use default values
U0100	Lost Communications with ECM A	Yes	Use default values
U0103	Lost Communication with Gear Shift Module (Shift Selector) 1	Yes	Maintain range selected, observe gear shift direction circuit
U0291	Lost Communication with Gear Shift Module (Shift Selector) 2	Yes	Maintain range selected, observe gear shift direction circuit
U0304	Incompatible Gear Shift Module 1 (Shift Selector)	Yes	Ignore shift selector inputs
U0333	Incompatible Gear Shift Module 2 (Shift Selector)	Yes	Ignore shift selector inputs
U0404	Invalid Data Received From Gear Shift Module (Shift Selector) 1	Yes	Maintain range selected, observe gear shift direction circuit
U0592	Invalid Data Received From Gear Shift Module (Shift Selector) 2	Yes	Maintain range selected, observe gear shift direction circuit

7. SPECIFICATIONS

ALLISON AUTOMATIC TRANSMISSION WITH RETARDER

X3-45

Gross input power (maximum).....	500 HP (373 kW)
Gross input torque (maximum)	1525 Lbf-ft- (2068 Nm)
Rated input speed (minimum-maximum)	1600-2300 rpm

Mounting:

Engine.....SAE #1 flywheel housing, flex disk drive

Torque converter:

Type One stage, three element, polyphase
 Stall torque ratio TC 551-1.8
 Lockup clutch with torsional damper Integral/standard

Gearing:

Type..... Patented, constant mesh, helical, planetary

Ratio:

First	3.51:1
Second.....	1.91:1
Third.....	1.43:1
Fourth.....	1.00:1
Fifth	0.74:1
Sixth	0.64:1
Reverse	4.80:1

Ratio coverage:

6 speed.....5.48:1

*** Gear ratios do not include torque converter multiplication.**

Oil System:

Oil type.....TRANSYND
 Capacity (excluding external circuits)..... Initial fill 47 US qts (45 liters)
 Oil change..... 24 US qts (23 liters)
 Oil change (with retarder) 27.6 US qts (26 liters)

Oil Filters:

Make Allison Transmission
 Type..... Disposable cartridge

8. SECTION CHANGE LOG

DESCRIPTION		DATE
1		
2		
3		
4		
5		
6		

CONTENTS

1. PROPELLER SHAFT DESCRIPTION 3

2. NYCT PROPELLER SHAFT MAINTENANCE DIRECTIVE 4

3. U-JOINT SERVICE – QUICK REFERENCE GUIDE 5

 3.1 LUBRICATION PROCEDURE 6

 3.2 INSPECTION RECOMMENDATIONS 6

 3.3 MARK PROPELLER SHAFT (PHASING MARKS) 7

 3.4 GREASE ZERKS..... 7

 3.5 OTHER INSPECTIONS..... 7

4. REMOVAL 7

 4.1 PROPELLER SHAFT REMOVAL..... 7

 4.1.1 *Inspect Companion Flange/Flange Yokes* 8

 4.2 REMOVAL PROCEDURE FOR UNIVERSAL JOINT KITS 9

 4.2.1 *Remove universal joint kit*..... 9

 4.2.2 *Inspect Tube Yoke and Flange Yoke (If Applicable)*..... 9

 4.3 REMOVAL PROCEDURE FOR SLIP MEMBER BOOT 10

5. INSTALLATION..... 10

 5.1 SLIP MEMBER AND BOOT INSTALLATION 10

 5.2 PROPELLER SHAFT INSTALLATION..... 11

 5.3 UNIVERSAL JOINT INSTALLATION 12

6. EXPLANATION OF COMMON DAMAGES..... 13

7. SPECIFICATIONS..... 14

8. SECTION CHANGE LOG..... 14

ILLUSTRATIONS

FIGURE 1: PROPELLER SHAFT ASSEMBLY DOB 2490-2789.....	3
FIGURE 2: COLD FORMED BEARING RETAINER AND BOLTS AS USED ON PREVOST X3-45 COMMUTER.....	4
FIGURE 3: BEARING LUBRICATION ZIRK.....	6
FIGURE 4: BEARING LUBRICATION	6
FIGURE 5: C-CLAMP	6
FIGURE 6: CHECK FOR LOOSENESS.....	7
FIGURE 7: PHASING MARKS	7
FIGURE 8: PHASING MARKS	7
FIGURE 9: PHASING MARKS	7
FIGURE 10: PHASING MARKS	8
FIGURE 11: PROPELLER SHAFT PROPER ORIENTATION	8
FIGURE 12: COLD FORMED BEARING RETAINERS.....	8
FIGURE 13: UNSEATING BEARING CUP ASSEMBLIES.....	8
FIGURE 14: RAISED METAL OR FRETTING ON OPEN YOKE CROSS HOLES.....	8
FIGURE 15: SPRING TAB BOLTS REMOVAL	9
FIGURE 16: CORRECT POSITIONING	9
FIGURE 17: INCORRECT POSITIONING	9
FIGURE 18	9
FIGURE 19	9
FIGURE 20: RAISED METAL OR FRETTING.....	10
FIGURE 21: BOOT CLAMP.....	10
FIGURE 22: CLEAN GREASE FROM SPLINE SLEEVE	10
FIGURE 23: APPLY GREASE	10
FIGURE 24: POSITION THE END OF THE BOOT AT THE 2.25 INCHES.....	11
FIGURE 25: ALIGN THE PHASING MARKS BETWEEN THE YOKE AND PROPELLER SHAFT	11
FIGURE 26: YOKE TAB (EAR).....	11
FIGURE 27: GREASING BEARING CUP.....	12
FIGURE 28: POSITION THE JOURNAL CROSS INTO THE YOKE CROSS HOLES.....	12
FIGURE 29	12
FIGURE 30	13
FIGURE 31	13

1. PROPELLER SHAFT DESCRIPTION

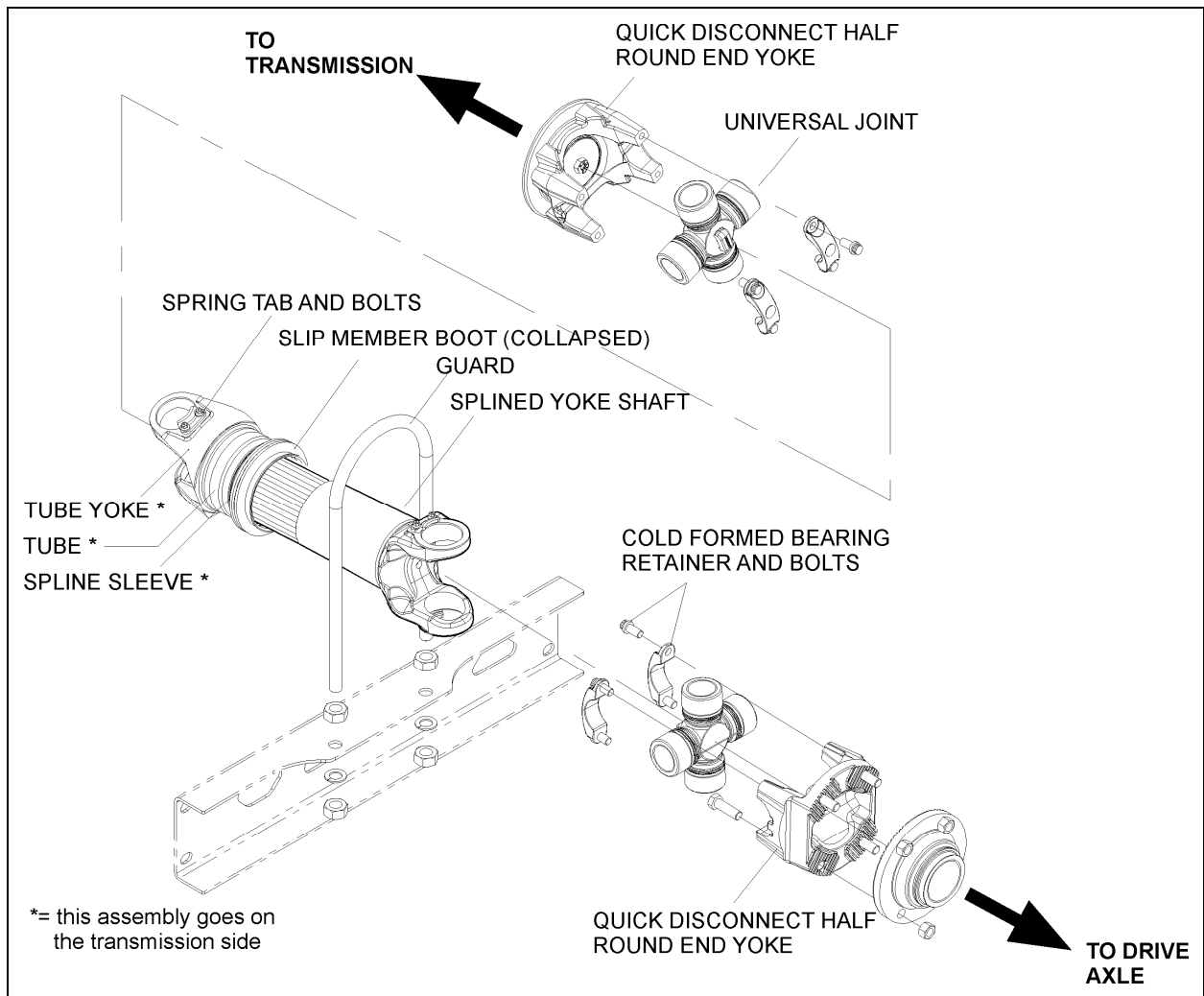

FIGURE 1: PROPELLER SHAFT ASSEMBLY DOB 2490-2789

09002_2

The propeller shaft transmits power from the transmission to the differential (Figure 1). The propeller shaft is Dana-Spicer Life Series SPL250 type with tubular shafts. It is provided with two heavy-duty universal joints (Figure 1).

The propeller shaft has a half round end yoke at each end. The splined yoke is connected to the differential by a half round end yoke with two needle bearings.

The other extremity (spline sleeve, tube and tube yoke assy) is connected to the transmission by a half round end yoke with two needle bearings.

Furthermore, a **permanently lubricated** slip joint on the propeller shaft compensates for variations in distance between the transmission and the differential. Grease should be cleaned and fresh grease should be applied if slip member components are disassembled.

The rise and fall of the drive axle bring about these variations as the vehicle passes over uneven surfaces. The slip joint also eases removal of the transmission or the drive axle.

WARNING

NYCT MAINTENANCE DIRECTIVE PROHIBITS REUSE OF PROPELLER SHAFT COLD FORMED BEARING RETAINERS AND BOLTS OR STAMPED STRAPS AND STRAP BOLTS

FIGURE 2: COLD FORMED BEARING RETAINER AND BOLTS AS USED ON PREVOST X3-45 COMMUTER
DO NOT reuse **cold formed bearing retainers** and **bolts**. Reuse of bearing retainer and bolts can cause driveline failure, which can result in separation of the driveline from the vehicle.

MAINTENANCE

Lubricate propeller shaft universal joints periodically, every 24,000 miles. Apply grease gun pressure to the lube fittings (1 grease fitting on each universal joint). Use a good quality lithium-base grease such as: NLGI No.2 E.P. Grease (suitable for most temperatures). Refer to Spicer Driveshaft's Service Manual DSSM-0100 for further details.

MAINTENANCE

Perform "Inspection Procedures" as per *Spicer Life Series Driveshafts Service Manual DSSM-0100* every **6,000 miles**.

NOTE

Do not assume that bearing cavities have been filled with new grease unless it has expelled around all seals.

2. NYCT PROPELLER SHAFT MAINTENANCE DIRECTIVE

- Before removing the driveshaft from vehicle, inspect all components (universal joints, slip joints, hardware, etc.) for deterioration (rust or corrosion) or excessive play. If all components pass inspection, grease universal joints they are able to be lubricated properly (fresh grease showing at all u-joint end caps. If any component does not accept grease, it must be replaced.
- Replace splined slip joint if seal is damaged or if welch plug (cap) is missing (when applicable).
- Unless the slip section (joint) is being replaced, the driveshaft must be removed as an assembly. The driveshaft must be completely disconnected from the differential and transmission yokes **only**; the slip section must not be disconnected unless it is being replaced.
- The driveshaft and yokes must be marked (phasing marks) (see paragraph 3.3 mark propeller shaft (PHASING MARKS)) before removal to ensure reinstallation in the same position as removed.

- **All universal joints securing hardware (bearing retainers and bearing retainers bolts, spring tabs and bolts) must be removed and replaced** using new OEM specified replacement parts (Figure 1, FIGURE 2).
- When removing the universal joint from the yoke, **the end caps must remain attached to the cross at all times** if the universal joint is to be reused (Electrical or masking tape can be used to keep the end caps in place while driveshaft is removed.)
- Unless the universal joint is being replaced, universal joint end caps **must not be removed** for any reason. If the end caps become dislodged while the driveshaft is removed from the vehicle, the universal joint must be replaced. If replacement is needed, the universal joint **must be replaced as a complete assembly**.
- Universal joints **must be treated as a single unit**. This means that parts (such as the cross, needle bearings, or end caps) **must not be interchanged** between new and used joints.
- Universal joints **must be positioned and seated correctly between the yoke tabs (ears)** on the input (tail shaft side) and carrier (differential side) yokes (FIGURE 26).
- The driveshaft must be installed facing the correct direction, in particular, with respect to the splined slip joint.
- The driveshaft must be phased correctly.
- All fasteners must be torqued to manufacturer's specifications and torque-marked. **DO NOT** use air or power tools to install and torque bolts or fasteners.
- Bolt locking tabs, if used, must be bent over the flats of the bolts after final torque is checked.
- The driveshaft guard (hoop) must be in place.
- Driveshaft universal joints must be greased properly.

NOTE: If necessary, rotate driveshaft to allow access to all grease fittings.

- It is the responsibility of the maintainer who begins the driveshaft installation to complete the procedure in its entirety. **The**

installation procedure must not be carried over (passed on) to the next shift.

Supervisors must witness and verify the correct installation of the driveshaft as follows:

- The universal joint caps must be seated properly between the yoke tabs (ears) (FIGURE 26).
- All universal joint bearing retainers must have been replaced using new hardware and fasteners.
- All fasteners have been torqued properly and are torque-marked.
- Locking tabs, if used, must be bent over the bolts.
- There must be no mixing of new and old parts on a universal joint.
- The driveshaft must be phased properly.
- Driveshaft guard (hoop) must be in place.
- Driveshaft universal joints must be greased after reinstallation of driveshaft in vehicle (fresh grease showing at all u-joint end caps).

3. U-JOINT SERVICE – QUICK REFERENCE GUIDE

This section is intended as a “quick reference” only. Refer to **Spicer Driveshaft’s Service Manual DSSM-0100** for detailed warnings and instructions.

Precautions

- Always follow all safety practices when servicing, removing, and/or installing a propeller shaft.
- Always use support strap to prevent this heavy propeller shaft from falling out of the vehicle during removal and installation.
- Always put the transmission in neutral before working on the propeller shaft.
- Never heat components or use a sledgehammer or floor jack to remove the propeller shaft from the vehicle.
- **Do NOT reuse spring tabs and bolts.**
- **Do NOT reuse bearing retainers and bolts.**
- Only replace u-joints with genuine Dana Spicer service parts.

3.1 LUBRICATION PROCEDURE

**WARNING**

Read “Spicer Life Series Driveshaft Lubrication Warnings and Cautions” in **Spicer Driveshaft’s Service Manual DSSM-0100**.

1. Use recommended lubricant to purge **all** four seals of each universal joint. This flushes abrasive contaminants from each bearing assembly and assures proper filling of **all** four bearings.

**WARNING**

Maximum grease gun pressure should not exceed 60 psi. Excessive grease gun pressures may cause seal damage.

2. Make sure fresh grease is evident at all u-joint bearing seals.



FIGURE 3: BEARING LUBRICATION ZIRK



FIGURE 4: BEARING LUBRICATION

3. If any of the seals fail to purge, try to move the propeller shaft from side-to-side while applying grease gun pressure.
 - a) If all four bearing positions still do not purge, releasing seal tension may be necessary.

- b) Remove the bearing retainer bolts and bearing retainers and discard. Do NOT reuse.
- c) Once the bearing cups are free, allow the propeller shaft to rest on the support strap.
- d) Apply a c-clamp around the inboard bearings.



FIGURE 5: C-CLAMP

- e) Apply grease gun pressure. Completely purge both bearings.
- f) If bearings still do not purge, complete the removal of the u-joint and inspect for blockage.
- g) If the u-joint still do not purge at all four positions after following the steps in this procedure, replace the u-joint.

3.2 INSPECTION RECOMMENDATIONS

- U-joint inspections should be performed every time a vehicle comes in for scheduled maintenance.
- Visually inspect for damaged bearing retainers, loose bearing retainer bolts, loose companion flange, bolts and nuts, loose or missing spring tabs or spring tab bolts, damaged tangs on end fittings, damaged or missing rotating bearing cups. If any of these situations are evident, replacement of the component is necessary.
- Check all input and output end fittings for looseness. Take hold of the end fitting with both hands. Try to move it vertically and horizontally to feel any looseness.



FIGURE 6: CHECK FOR LOOSENESS

- There should be less than **.006"** movement in the u-joint relative to the end yoke. If looseness is greater than **.006"**, the u-joint should be replaced.
- Check for the presence of all grease zerk fittings. Damaged zerks should be replaced. Loose zerks should be tightened.

3.3 MARK PROPELLER SHAFT (PHASING MARKS)

- Mark all mating propeller shaft components with a paint marker to assure proper phasing during reassembly.
- Reassembly of a propeller shaft that is out of phase can cause vibration and failure to propeller shaft components.



FIGURE 7: PHASING MARKS

3.4 GREASE ZERKS

- Replace damaged zerks.
- Torque zerks to 15 lbf-ft.
- Zerks should be lined up with outboard bearings.
- Clean zerk nipples before greasing.

3.5 OTHER INSPECTIONS

Refer to **Spicer Driveshaft's Service Manual DSSM-0100** for detailed information on:

- The slip member inspection,
- Grease zerk inspection,

- Tubing inspection.

4. REMOVAL



WARNING

Read "Spicer Life Series Driveshaft Removal Warnings and Cautions" in **Spicer Driveshaft's Service Manual DSSM-0100**.

4.1 PROPELLER SHAFT REMOVAL

1. Mark propeller shaft (phasing marks). It is imperative to mark all the mating components of a propeller shaft, as illustrated below. Mark the propeller shaft with a marking stick, paint marker or other legible marking device. In addition, be sure to mark all bearing positions, spline positions and shaft locations. This assures proper reassembly of the propeller shaft into the vehicle, in its original position.

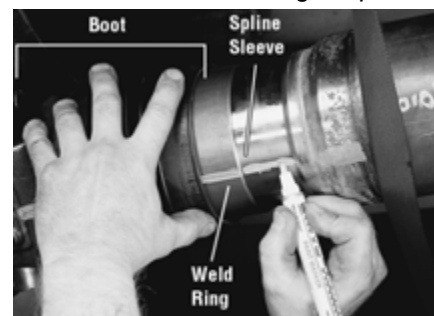

FIGURE 8: PHASING MARKS



FIGURE 9: PHASING MARKS

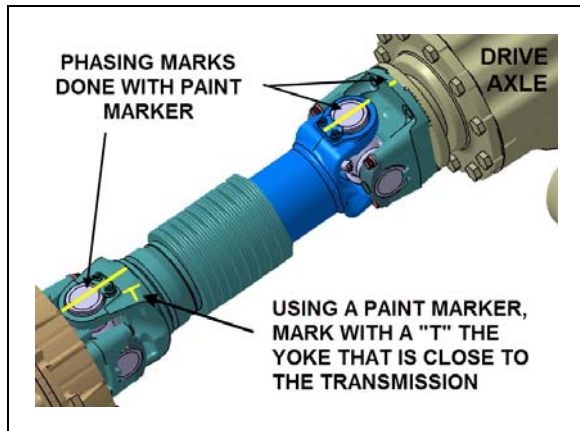

FIGURE 10: PHASING MARKS

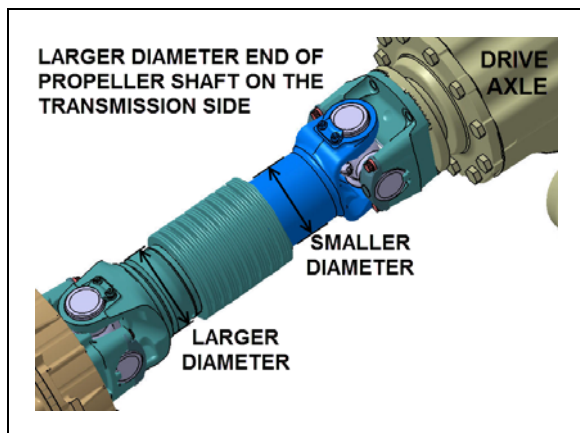

FIGURE 11: PROPELLER SHAFT PROPER ORIENTATION

2. Be sure to ALWAYS use support straps to prevent the propeller shaft from falling out of the vehicle.
3. Remove the bearing retainers and bolts at rear end. Discard bolts, and bearing retainers.



FIGURE 12: COLD FORMED BEARING RETAINERS

4. It may be necessary to unseat bearing cup assemblies by tapping on yoke or bearing cup with a soft-faced hammer. Once the bearing cup assemblies are free, collapse the propeller shaft until both bearing

assemblies clear the open end yoke cross holes. Allow the propeller shaft to rest on support strap.



FIGURE 13: UNSEATING BEARING CUP ASSEMBLIES

5. Remove bearing retainers and bolts at the front end.
6. Inspect all end yoke cross hole surfaces and bolt hole threads for damage. If the bolt hole threads are damaged, the yoke must be replaced.
7. Inspect for raised metal or fretting on open yoke cross holes can be removed with a fine-toothed file and/or emery cloth.



FIGURE 14: RAISED METAL OR FRETTING ON OPEN YOKE CROSS HOLES

8. Inspect the end yoke cross holes for distortion and damage.

4.1.1 Inspect Companion Flange/Flange Yokes

1. Inspect all flange bolt hole threads or through holes for damage. If the bolt hole threads or through holes are damaged, the flange must be replaced.
2. Inspect all flange faces for galling or damage. If damaged, the flange must be replaced.

4.2 REMOVAL PROCEDURE FOR UNIVERSAL JOINT KITS

4.2.1 Remove universal joint kit

1. **For Quick Disconnect Style:** Remove spring tab bolts and discard, and remove outboard bearing cap assemblies.



FIGURE 15: SPRING TAB BOLTS REMOVAL

2. Make sure universal joints cross assembly is not tilted in the yoke. Place bearing cup spacer onto the base of the arbor press and under the yoke. If the arbor is larger than the bearing cup diameter, a smaller diameter push rod will be needed to avoid damaging the yoke or bearing.



FIGURE 16: CORRECT POSITIONING



FIGURE 17: INCORRECT POSITIONING

3. Using an arbor press, press down on the upper bearing cup assembly until the shoulder of the journal cross makes contact with the inside of the yoke ear.



CAUTION

DO NOT over press the bearing cup and journal cross. This can damage the inside of the yoke ear.

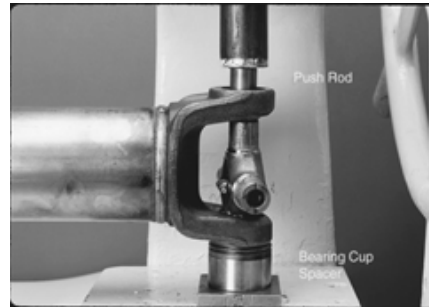

FIGURE 18

4. The bearing cup is not designed to drop out of the yoke. Move the partially pressed-out bearing cup from side to side, to "walk" the bearing cup out of the yoke ear. Remove the bearing cup from the trunnion.
5. Place the yoke in the press, with the remaining bearing cup face down. Using a push rod, press on the end of the journal cross trunnion. Continue to press down on the journal cross trunnion until the shoulder of the journal cross makes contact with the inside of the yoke ear.



FIGURE 19

4.2.2 Inspect Tube Yoke and Flange Yoke (If Applicable)

1. Inspect the tube yoke and flange yoke (if applicable) cross hole surfaces for damage or raised metal. Raised metal or fretting can be removed from yoke cross holes with a fine-toothed file and/or emery cloth.



FIGURE 20: RAISED METAL OR FRETTING CAN BE REMOVED FROM YOKE CROSS HOLES WITH A FINE-TOOTHED FILE

4.3 REMOVAL PROCEDURE FOR SLIP MEMBER BOOT

1. It is imperative to mark all mating components of the propeller shaft. Mark the propeller shaft with a marking stick, paint marker or other legible marking device.
2. Remove and discard both boot clamps. Clamps may be separated using a chisel to disengage locking hooks. **DO NOT** reuse clamps.



FIGURE 21: BOOT CLAMP

3. Completely collapse the boot toward the yoke shaft to expose weld ring and spline sleeve area. Wipe weld ring and spline sleeve areas clean.
4. Remove the yoke shaft and boot from the spline sleeve. Discard boot.
5. Inspect the yoke shaft spline surface for damage. If the splines are damaged, missing or twisted, or any Glidecote is missing, complete propeller shaft replacement is necessary.
6. Inspect the spline sleeve for damage. If the splines are damaged, missing or twisted, complete propeller shaft replacement is necessary.
7. Inspect the entire slip assembly for contaminants. If the slip assembly shows evidence of rust or the lube is severely

contaminated, complete propeller shaft replacement is necessary.

5. INSTALLATION



WARNING

Read "Spicer Life Series Driveshaft Installation Warnings and Cautions" in **Spicer Driveshaft's Service Manual DSSM-0100**.

5.1 SLIP MEMBER AND BOOT INSTALLATION

1. Clean ALL grease from yoke shaft and spline sleeve. Make sure grease-cutting solvent does not intrude into the tube through the vent hole in the spline sleeve plug. Be sure the phasing marks made during disassembly are not removed.



FIGURE 22: CLEAN GREASE FROM SPLINE SLEEVE

2. After all traces of grease and cutting solvent have been removed from the yoke shaft and spline sleeve, apply half of the grease provided to the yoke shaft splines and the other half to the spline sleeve, cover the entire splined surface.



FIGURE 23: APPLY GREASE

3. Measure and place a mark 2.25 inches (55-60mm) from yoke shaft shoulder with a marking stick, paint marker or other legible marking device.

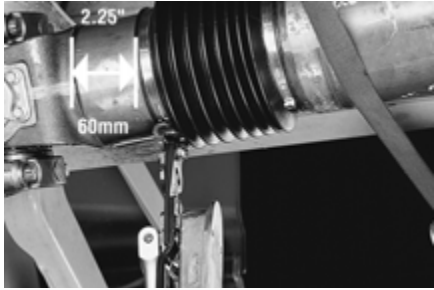

FIGURE 24: POSITION THE END OF THE BOOT AT THE 2.25 INCHES (55-60MM) MARK MADE ON THE YOKE SHAFT SHOULDER

4. Position a clamp on each end of the new boot. Slide the boot onto the grease-free yoke shaft shoulder.
5. Collapse the boot and insert the yoke shaft into the splined sleeve, making sure phasing marks are in line. Position the end of the boot at the 2.25 inches (55-60mm) mark made on the yoke shaft shoulder and tighten boot clamps to the specified torque. Yoke shaft shoulder must be clean, dry and grease free.

Failure to properly install and tighten boot clamps could allow intrusion of contaminants and can cause driveline failure, which can result in separation of the driveline from the vehicle.

6. Before the propeller shaft is completely installed in the vehicle, slowly collapse and extend the propeller shaft to make sure the boot clamps are stationary. If the clamps are not stationary, recheck for proper clamp torque. If clamps still are not stationary, repeat disassembly and assembly procedure. **DO NOT** reuse clamps.

5.2 PROPELLER SHAFT INSTALLATION

1. Before installing the propeller shaft, inspect the yoke surface for burrs and damage. Mating surfaces should be clear of rust, contamination and grease.
2. With safety straps in place, align the phasing marks between the yoke and propeller shaft.

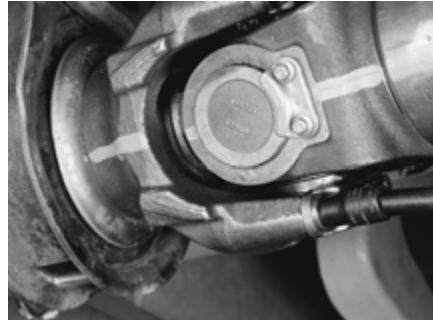

FIGURE 25: ALIGN THE PHASING MARKS BETWEEN THE YOKE AND PROPELLER SHAFT

3. Align the bearing cups with the yoke ears making sure that the cups are evenly spaced between the tabs (ears) of the yoke. A soft faced hammer can be used to fully seat the bearing cups into the yoke.

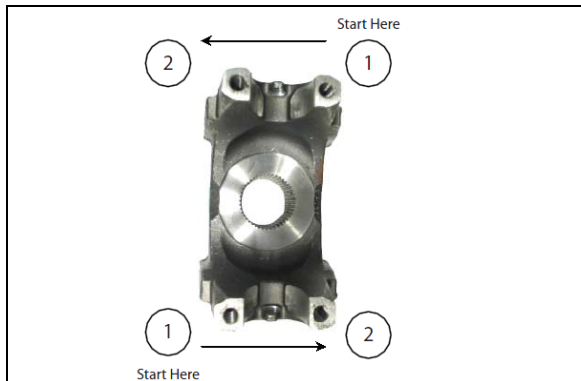

FIGURE 26: YOKE TAB (EAR)

Note: Bearing cups must be fully seated between the yoke tabs (ears). Failure to seat the cups properly will result in a premature failure.

4. Install bearing retainers and lock bolts.
5. It is important that the bearing retainer bolts are torqued in the correct sequence. Following the diagram below. Torque the number one bolt before moving to the number two bolt. Always torque in a counter clockwise direction starting with the number one position.

Failure to torque bearing retainer bolts in the proper sequence could result in premature failure.



BEARING RETAINER BOLT TORQUE (HALF ROUND)

Series	Head size	Size	Bolt torque
SPL250	12 point	12-1.25mm	100 lbf-ft ¹

- Grease the U-joint and slip member after propeller shaft installation. Refer to 3.1 *lubrication procedure*.

5.3 UNIVERSAL JOINT INSTALLATION

- Remove needle retaining plugs from all bearing cup assemblies. Using a high quality National Lubricating Grease Institute E. P. Grade 2 lubricating grease, wipe each bearing cup assembly with grease. Fill all cavities between the needle rollers. Also apply a liberal coating of grease on the bottom of each bearing cup assembly and on the lip of the seal.



FIGURE 27: GREASING BEARING CUP

Caution - Spicer DOES NOT recommend wiping the outside of bearing cup assemblies or yoke cross holes with grease, oil or silicone-based sprays. This could result in bearing cup assembly rotation in yokes.

- Position the journal cross into the yoke cross holes with the grease zerk fitting inward toward tubing. The double-headed, grease

zerk (nipple) fitting should be perpendicular to the yoke cross holes.

Note: Failure to properly position the universal joint will result in the inability to grease the universal joint.



FIGURE 28: POSITION THE JOURNAL CROSS INTO THE YOKE CROSS HOLES WITH THE GREASE ZERK FITTING INWARD TOWARD TUBING

Note: Always inspect bearing cups for rollers that may have fallen (downed rollers) out of place before installation.

- Move one end of the journal cross to cause a trunnion to project through the cross hole beyond the outer machined face of the yoke ear. Take one bearing cup assembly and position an installation height tool on the end of the bearing cup assembly. Place the bearing cup assembly over the protruding trunnion diameter and align it to the yoke cross.



FIGURE 29

- Align the yoke in an arbor press with the bearing assembly resting on the base of the press. Cover the yoke ear with a metal plate that has 0.25 inch (6.4mm) minimum thickness. Push the yoke onto the bearing cup assembly until it is flush with the cross hole face. Do not remove the installation height tool.

¹ Prevost production line torque value

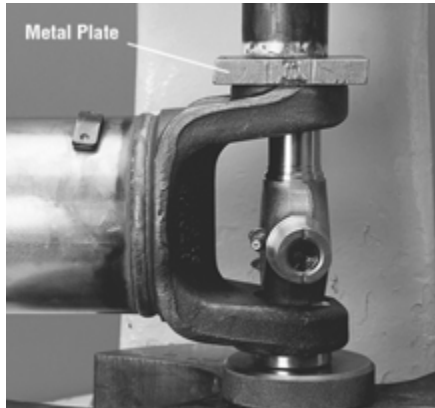

FIGURE 30

5. Flip yoke 180 degrees. Position the remaining installation height tool on the end of another bearing cup assembly. Place bearing cup assembly over trunnion diameter and align it to the yoke cross hole. Push the bearing cup assembly until both installation height tools are flush with the cross hole face.
6. Install new spring tabs and 8mm thread bolts. Make sure that no grease or foreign material is present between the contact areas of the spring tabs, bearing cups and yoke cross hole faces. Tighten bolts to the required torque.



FIGURE 31



SPRING TAB BOLT TORQUE

Bolts are specially heat-treated. DO NOT substitute inferior grade bolts.

Series	Head size	Size	Bolt torque
SPL250	6 point	8-1mm	25-30 lbf-ft

6. EXPLANATION OF COMMON DAMAGES

1. Cracks: Stress lines due to metal fatigue. Severe and numerous cracks will weaken the metal until it breaks.
2. Galling: Scraping off of metal or metal displacement due to friction between surfaces. This is commonly found on trunnion ends.
3. Spalling (surface fatigue): Breaking off of chips, scales, or flakes of metal due to fatigue rather than wear. It is usually found on splines and U-joint bearings.
4. Pitting: Small pits or craters in metal surfaces due to corrosion. If excessive, pitting can lead to surface wear and eventual failure.
5. Brinelling: Surface wear failure due to the wearing of grooves in metal. It is often caused by improper installation procedures. Do not confuse the polishing of a surface (false brinelling), where no structural damage occurs, with actual brinelling.
6. Structural Overloading: Failure caused by a load greater than the component can stand. A structural overload may cause propeller shaft tubing to twist under strain or it may cause cracks or breaks in U-joints and spline plugs.

7. SPECIFICATIONS

PROPELLER SHAFT

MakeSpicer
Series.....SPL250

8. SECTION CHANGE LOG

	DESCRIPTION	DATE
1		
2		
3		
4		
5		
6		

CONTENTS

1. DESCRIPTION	2
1.1 REFERENCE MANUALS.....	2
2. LUBRICATION	5
3. MAINTENANCE	5
4. REMOVAL AND REPLACEMENT	5
4.1 REMOVAL.....	5
4.2 REPLACEMENT	6
5. SERVICE INSTRUCTIONS FOR STEER AXLE	6
5.1 STEERING KNUCKLE KINGPIN INSPECTION	6
5.1.1 <i>Checking Lateral Slackness</i>	6
5.1.2 <i>Checking Vertical Slackness</i>	6
6. FRONT WHEEL ALIGNMENT	7
6.1 INSPECTION BEFORE ALIGNMENT	7
6.2 MINOR FRONT WHEEL ALIGNMENT	7
6.3 MAJOR FRONT WHEEL ALIGNMENT	7
6.4 TURNING ANGLE ADJUSTMENT	7
6.4.1 <i>R.H. Turn Adjustment</i>	8
6.4.2 <i>L.H. Turn Adjustment</i>	8
6.5 HYDRAULIC STOP	8
6.6 FRONT WHEEL CAMBER.....	8
6.6.1 <i>Camber Check</i>	9
6.7 FRONT AXLE CASTER.....	9
6.8 FRONT WHEEL TOE-IN	9
6.8.1 <i>Inspection and Adjustment</i>	10
7. TROUBLESHOOTING	11
8. SPECIFICATIONS	12
9. TORQUE SPECIFICATIONS	12
10. SECTION CHANGE LOG	12

ILLUSTRATIONS

FIGURE 1: FRONT AXLE ASSEMBLY	3
FIGURE 2: FRONT AXLE GREASING POINTS	5
FIGURE 3: CAMBER.....	9
FIGURE 4: CASTER	9
FIGURE 5: TOE-IN MEASUREMENTS	10

1. DESCRIPTION

The Dana Spicer S84U front axle is of the "Reverse Elliot" type manufactured by Dana Spicer Europe. The front axle consists of a girder section axle bed or beam with stub axles. Each stub axle is carried on a taper king pin, with a plain phosphor bronze bushing at the top and at the bottom. The unitized hub bearings used on the NDS range of axles, are non-serviceable items. Bearings are pre-adjusted, lubricated and have seals fitted as part of the manufacturing process. The bearings are greased for life and there is no need or facility for re-lubrication. Brakes are manufactured by KNORR-BREMSE. Steering ball joints with hardened balls and rubbing pads incorporate compression springs which automatically take up any wear.

The tie rod simplifies toe-in adjustment. The maximum turning angle is set through stop screws installed on the inner side of the knuckle.

Steering stabilizer (damper) and steering drag link which are mounted on the front axle are described in Section 14: STEERING of this manual.

1.1 REFERENCE MANUALS

Additional information is found in the following manuals included on your vehicle technical publications CD:

For king pin rework:

Dana Parts & Service Instructions S84U Steer Axle KING PIN REWORK_ Manual NO 1985 B iss A

For hub bearing rework:

Dana Parts & Service Instructions S84U Steer Axle HUB BEARING REWORK_ Manual NO 1963 a + B iss A

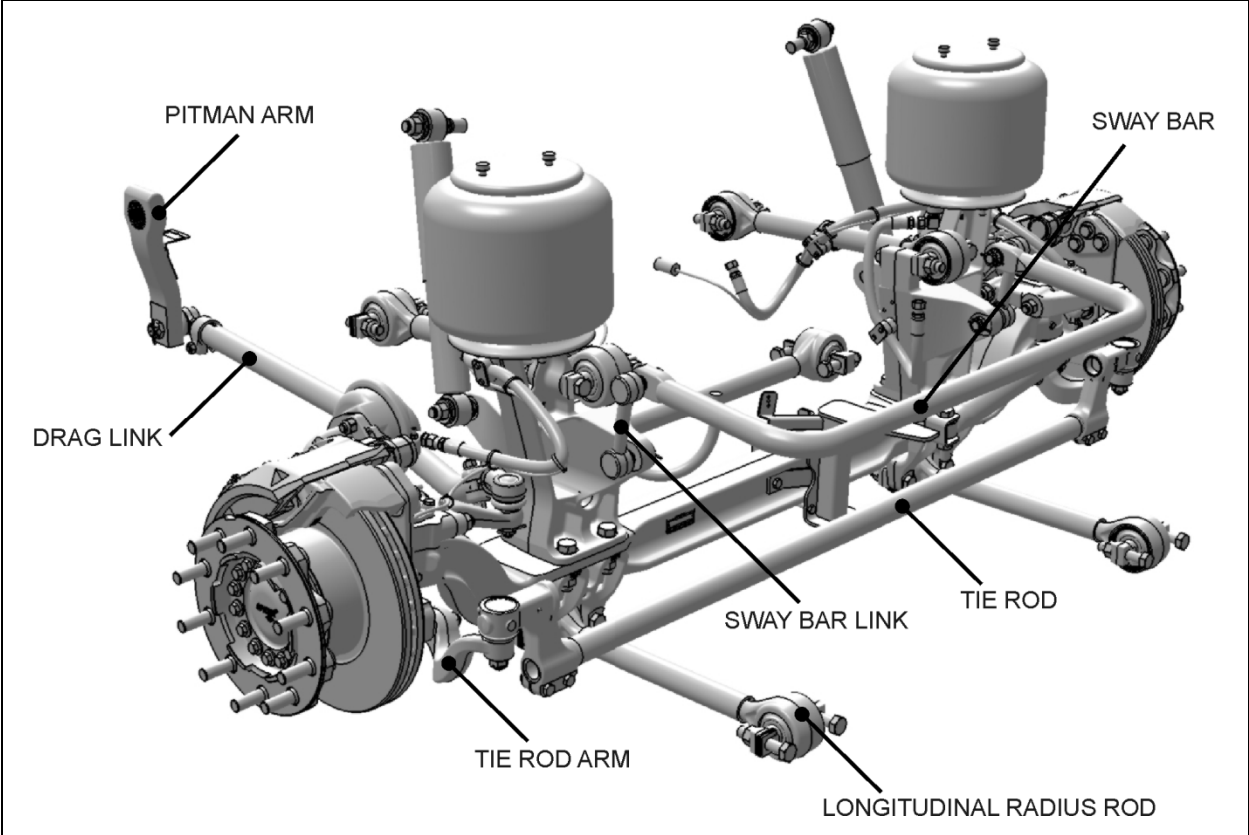
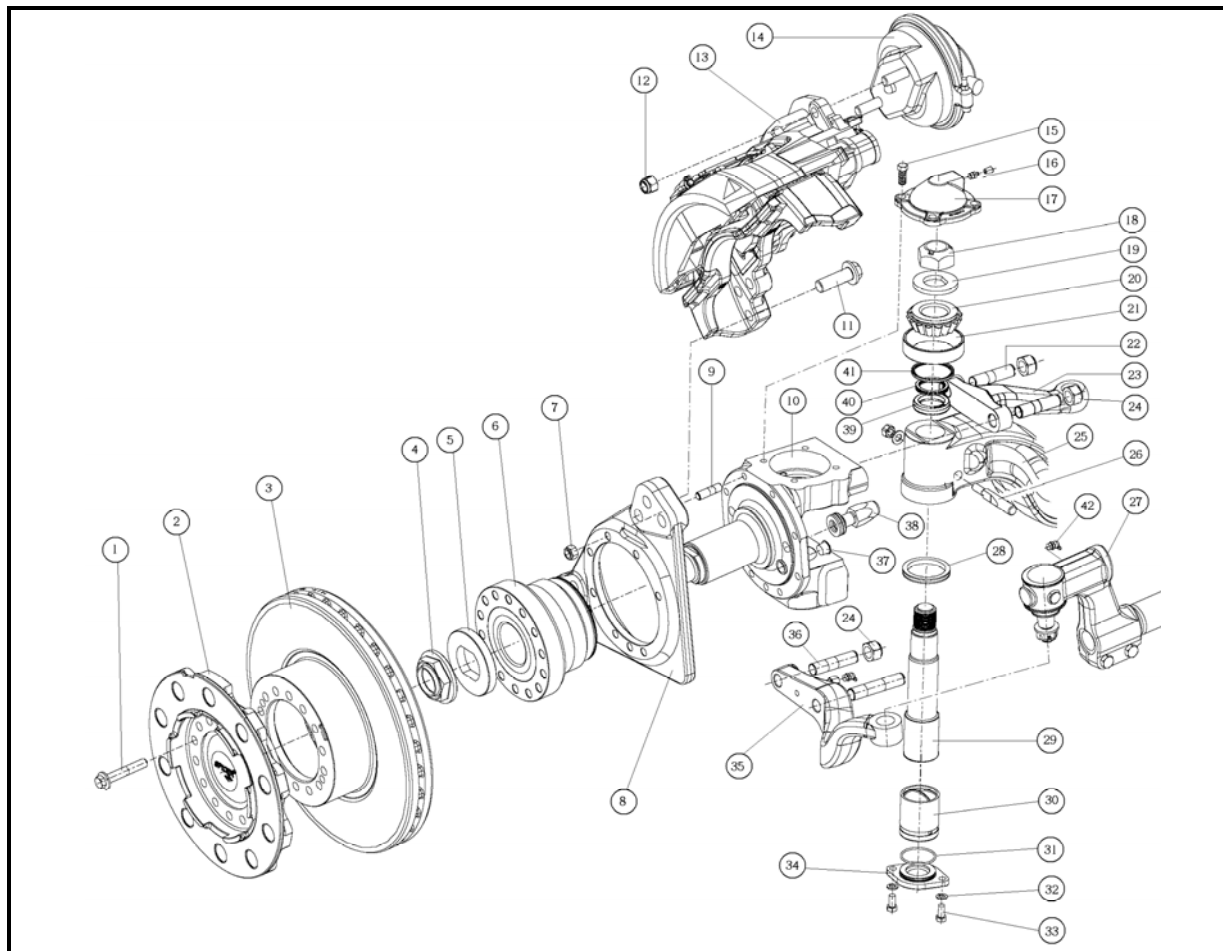

FIGURE 1: FRONT AXLE ASSEMBLY

10025

SECTION 10: FRONT AXLE



TYPICAL S84U AXLE

ITEM	DESCRIPTION	QTY	ITEM	DESCRIPTION	QTY		
1	Flanged Bolt	174-192 lbf-ft	28	26	Draw key, Nut, Washer	51-62 lbf-ft	2
2	Hub		2	27	Tie Rod End		2
3	Brake Disc		2	28	V" Ring Seal		2
4	Stake Hub Nut	600±25 lbf-ft	2	29	Kingpin		2
5	Collet Washer		2	30	Kingpin - Bushing		2
6	Hub Bearing		2	31	O-Ring Seal		2
7	Nut – Self Lock	85-103 lbf-ft	16	32	Washer		4
8	Brake Mounting Bracket		2	33	Screw	26-32 lbf-ft	4
9	Stud		16	34	Cap - Knuckle Bottom		2
10	Knuckle		2	35	Bottom Steering Lever		2
11	Brake Fixing – Bolt	350-393 lbf-ft	12	36	Bottom Steering Lever - Stud		4
12	Nut – Self Lock	133-155 lbf-ft	4	37	ABS Sensor - Bush		2
13	Brake		1	38	Back Lock - Stop Bolt	85-103 lbf-ft	2
14	Brake Chamber		2		Front Lock - Stop Bolt	85-103 lbf-ft	1
15	Screw	51-62 lbf-ft	8	39	Sleeve - Knuckle Bearing		2
16	Grease Fitting		4	40	Shim .005"		8
17	Cap - Knuckle Top		2		Shim .010"		8
18	Nut – Self Lock	500-700 lbf-ft	2		Shim .015"		8
19	Washer		2		Shim .008"		4
20	Bearing Cone		2		Shim .006"		2
21	Bearing Cup		2	41	Oil Seal		2
22	Steering Lever - Stud		4	42	Grease Fitting		2
23	Steering Lever		2				
24	Nut - Self Lock		4				
25	Axle, I-Beam		1				

2. LUBRICATION



MAINTENANCE

Knuckle pins are provided with grease fittings for pressure lubrication. These grease fittings should be serviced every 6,000 miles.

Good quality lithium-base roller bearing mineral grease NLGI No.1 and 2 like Shell Retinax LX are recommended.

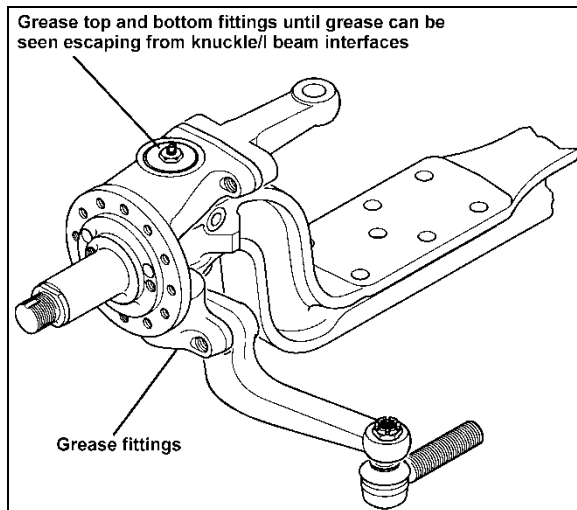

FIGURE 2: FRONT AXLE GREASING POINTS

3. MAINTENANCE

A periodic inspection of the front axle assembly should be made to check that all bolts are tight, and that no damage and distortion have taken place. Suspension support stud nuts, U-bolt nuts, tie rod arms, steering arm nuts and stop screws should be checked and tightened, as required, to the torque specifications (refer to Section 16: SUSPENSION of this manual). Also check the condition of the steering knuckle pins and bushings. In case of excessive looseness, the bushings and pins should be replaced.

Any looseness in the steering linkage, under normal steering loads, is sufficient cause to immediately check all pivot points for wear, regardless of accumulated mileage. Steering linkage pivot points should be checked each time the front axle assembly is lubricated. Any looseness can be visually detected while rotating the steering wheel in both directions.

Steering knuckles, knuckle pins and bushings can be overhauled or replaced without removing the

axle from the vehicle. However, if extensive overhaul work is necessary, the axle assembly should be removed.



CAUTION

Should removal of a locking device be required when undergoing repairs, disassembly or adjustments, always replace with a new one.

4. REMOVAL AND REPLACEMENT

The following procedure deals with the removal of the front axle assembly. The method used to support the axle assembly and suspension components during removal and disassembly depends upon local conditions and available equipment.

4.1 REMOVAL

1. Raise the vehicle by its jacking points on the body (see Section 18, "Body" under heading 16; Vehicle Jacking Points) until vehicle body is approximately 30 inches (760 mm) from the floor. Place jack stands under frame. Remove the wheels (if required, refer to Section 13, "Wheels, Hubs and Tires").



CAUTION

Use only the recommended jacking points as outlined in section 18 "Body".

2. Exhaust compressed air from the air supply system by opening the drain valve of each reservoir.
3. Install jacks under axle jacking points to support the axle weight.



DANGER

To help prevent injury caused by the axle rolling off the jacks, these should be equipped with U-adapters, or similar precautions must be taken.

4. Disconnect the steering drag link from the steering arm.
5. Remove the ABS sensors from their location in hubs (if applicable).
6. Disconnect the height control valve link from its support on the axle.

7. Disconnect air lines from front brake chambers, and cover line ends and fittings to prevent the entry of foreign matter.



CAUTION

Position the air lines and electric wires so they will not be damaged while removing the front axle assembly.

8. Proceed with steps a, b and c, while referring to Section 16: "Suspension".
- Disconnect sway bar links from axle brackets.
 - Remove shock absorbers.
 - Disconnect five radius rods: one transversal and two longitudinal from subframe, and two upper rods from axle.
9. Remove the bolts and nuts fixing the axle to the left-hand and right-hand side air bellows mounting supports.
10. Using the jacks, slowly lower the axle assembly, and carefully pull away from underneath vehicle.

4.2 REPLACEMENT

Reverse front axle "Removal" procedure. Ensure cleanliness of air bellows support mounting plates.

NOTE

Refer to Section 16: Suspension for recommended tightening torques.

5. SERVICE INSTRUCTIONS FOR STEER AXLE

5.1 STEERING KNUCKLE KINGPIN INSPECTION



MAINTENANCE

An inspection should be made at intervals of 30,000 miles (48 000 km) or twice a year whichever comes first.

Check permissible slackness in the kingpins as follows:

Aspects to be considered are:

- **Lateral slackness**
- **Vertical slackness**

NOTE

Before commencing checks, apply parking brake, raise wheels off ground and support axle on stands.

5.1.1 Checking Lateral Slackness

Following regular and thorough greasing practices will maximise bushing life. This procedure measures the upper bearing & lower bushing wear due to side and vertical loading. While this is being carried out, the brake must be applied.

- Place a set-square with its stock on ground and its blade against tire wall.
- Place a mark on the ground to indicate position of stock end.
- Insert a lever through bottom cut-out of wheel and lever it upwards thus moving set-square outboard.
- Mark the changed position of the stock end.
- Maximum allowable stock displacement (for 22.5" wheels) is **0.315 in (8mm)**.
- If displacement exceeds stated allowance then need for bushing / bearing attention and possible renewal, is in evidence.

NOTE

To avoid inaccurate measurements, be careful not to let the knuckle turn while moving assembly in and out. Applying brakes will help lock wheel assembly.

5.1.2 Checking Vertical Slackness

- This is measured by a dial indicator anchored to axle beam and having its pointer placed vertical against knuckle top.
- Place a jack against underside of knuckle and, while applying a lifting force, observe any movement on indicator dial.
- If vertical movement is evident and it exceeds 0.030" (0.76mm)** then readjustment of knuckle is required by adjusting thickness of bearing adjusting shims. In this case, refer to:

Dana Parts & Service Instructions S84U Steer Axle KING PIN REWORK_ Manual NO 1985 B iss A.

6. FRONT WHEEL ALIGNMENT

Correct front wheel alignment must be maintained for steering comfort and satisfactory tire life. Road shocks and vibrations, as well as normal stress and strains on the front-end system can, under normal operating conditions, result in loss of front wheel alignment.

Check the front wheel alignment when the following occurs:

1. Every 200,000 miles (320 000 km) or 24 months (normal maintenance);
2. When the vehicle does not steer correctly; or
3. To correct a tire wear condition.

There are two types of front wheel alignment: **minor alignment** and **major alignment**.

6.1 INSPECTION BEFORE ALIGNMENT

Check the following before doing a front wheel alignment:

1. Ensure that the vehicle is at normal riding height. See Section 16, "Suspension" under heading 7: "Suspension Height Adjustment".
2. Ensure that front wheels are not the cause of the problem. See Section 13, "Wheels, Hubs and Tires". Inspect the tires for wear patterns indicating suspension damage or misalignment.
 - a. Make sure the tires are inflated to the specified pressure.
 - b. Make sure the front tires are the same size and type.
 - c. Make sure the wheels are balanced.
 - d. Check wheel installation and straightness.
3. Check the wheel bearing adjustment.
4. Check steering linkage for bending and pivot points for looseness.
5. Check knuckle pins for evidence of excessive wear.
6. Check radius rods for bending and rubber bushings for evidence of excessive wear.
7. Make sure all fasteners are tightened to the specified torque. Use a torque wrench for verification. As soon as the fastener starts to move, record the torque. Correct if necessary. Replace any worn or damaged fasteners.

6.2 MINOR FRONT WHEEL ALIGNMENT

Perform a minor front wheel alignment for all normal maintenance conditions.

Perform the minor front wheel alignment in the following sequence:

1. Inspect all the systems that affect the wheel alignment. See paragraph 6.1, "Inspection Before Alignment" in this section.
2. Check the hub bearings. See section 13, "Wheels, hubs and Tires" under heading 8: Front and Tag Axle Wheel Hubs.
3. Check and adjust the toe-in.

6.3 MAJOR FRONT WHEEL ALIGNMENT

Perform a major front wheel alignment to correct steering and tire wear conditions.

Perform the major front wheel alignment in the following sequence:

1. Inspect all systems affecting the wheel alignment. See paragraph 6.1, "Inspection Before Alignment" in this section.
2. Check the hub bearings. See section 13, "Wheels, hubs and Tires" under heading 8: Front and Tag Axle Wheel Hubs.

NOTE

If steering angle stoppers are changed, a special procedure is required for readjusting gearbox steering limiter. See paragraph 6.5 "Hydraulic Stop" in this section.

3. Check and adjust the turning angle adjustment.
4. Check the camber angle.
5. Check and adjust the caster angle.
6. Check and adjust the toe-in.

6.4 TURNING ANGLE ADJUSTMENT

The maximum turning angle is set through the two steering stop screws installed on the axle center. The turning angle is factory adjusted to accommodate the chassis design, and therefore, does not require adjustment on new vehicles. However, it should be checked and adjusted any time any component of the steering system is repaired, disassembled or adjusted.

Check if front tires rub against the frame or if the steering gear has been serviced.

Proceed with the following method to check the steering maximum turning angle :

6.4.1 R.H. Turn Adjustment



CAUTION

To prevent the steering damper from interfering with the adjustment of turning angles, make sure its fixing bracket is at the correct location on the axle center (refer to section 14 "Steering").

1. Turn steering wheel to the right until the boss on the axle center touches the right stop screw.
2. Verify the nearest point of contact of the ball socket body with the air bellows support assembly. Measure the distance between those two points.
3. The distance between these two points should be approximately 1/8 inch (3 mm). If not, the steering stop screws must be readjusted.
4. Verify the nearest point of contact of the drag link with the tire. Measure the distance between those two points.
5. The distance should be 1 inch (25 mm) or more. If not, the steering stop screws must be readjusted.
6. This must be done for a full right turn.
7. If readjustment is required:
 - a. Remove the swivel stop screw.
 - b. Add to the stop screw the required number of washers to obtain the proper measure, tighten the stop screw afterwards. Two washers of different thickness are available: 1/16 inch and 3/16 inch.

6.4.2 L.H. Turn Adjustment

1. Turn steering wheel to the left until the boss on the axle center touches the left stop screw.
2. Verify the nearest point of contact of the ball socket body with the air bellows support assembly. Measure the distance between those two points.
3. The distance between these two points should be approximately 1/8 inch (3 mm). If

not, the steering stop screws must be readjusted.

4. Check the stroke of the steering stabilizer cylinder (damper). It should not exceed 12.59 inches (320 mm).
5. This must be done for a full left turn.
6. If readjustment is required:
 - a. Remove the swivel stop screw.
 - b. Add to the stop screw the required number of washers to obtain the proper measure, tighten the stop screw afterwards. Two washers of different thickness are available: 1/16 inch and 3/16 inch.

NOTE

If steering angle stoppers are changed, a special procedure is required for readjusting gearbox steering limiter. See paragraph 6.5 "Hydraulic Stop" in this section.

6.5 HYDRAULIC STOP

NOTE

Before steering limiter readjustment, verify vehicle wheel alignment and ensure that oil level is checked and that air bleeding is done.

Refer to "ZF-Servocom Repair Manual" annexed at the end of Section 14 "Steering" under heading 'Setting and Functional Test.

6.6 FRONT WHEEL CAMBER

Wheel camber is the number of degrees the top of the wheel tilts outward (positive) or inward (negative) from a vertical angle (Figure 3).

The camber angle is not adjustable. Camber variations may be caused by wear at the wheel bearings, steering knuckle pins or by a bent knuckle or sagging axle center. Steering effort is affected by improper camber, and uneven tire wear will result. Excessive positive camber causes an irregular wear of tire at the outer shoulder and excessive negative camber causes wear at the inner shoulder.

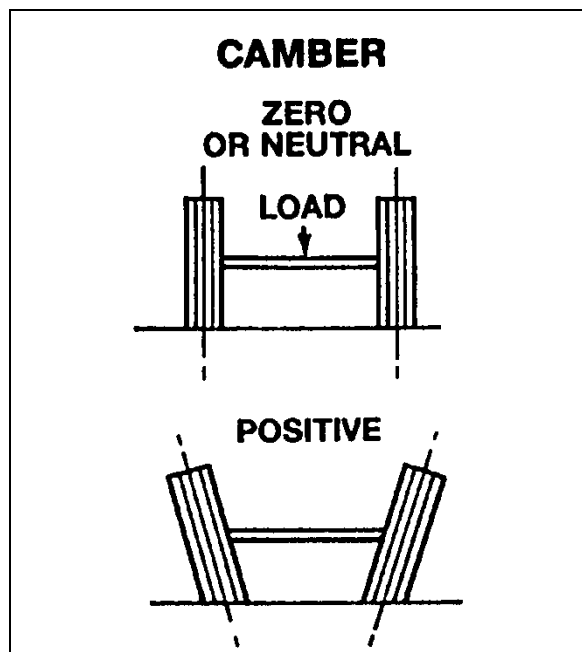

FIGURE 3: CAMBER

10006

6.6.1 Camber Check

For camber specifications, refer to paragraph 8: "Specifications" in this section

1. Use an alignment machine to check the camber angle.
2. If camber reading is not in the specifications, check the wheel bearings and repeat the check. If the reading is still not within specifications, verify the steering knuckle pins and axle center.
3. Check the wheel lateral distortion as instructed in Section 13, "Wheels, Hubs and Tires" under heading, "Checking for Distorted Wheel on Vehicle". If distortion is excessive, straighten or replace wheel(s).

6.7 FRONT AXLE CASTER

For caster specifications, refer to paragraph 8: "Specifications" in this section.

Positive caster is the rearward tilt from the vertical axis of the knuckle pin. Negative caster is the forward tilt from the vertical axis of the knuckle pin (Figure 4). This vehicle is designed with a positive caster. The purpose of the caster angle is to give a trailing effect. This results in stabilized steering and a tendency for the wheels to return to the straight-ahead position after taking a turn.

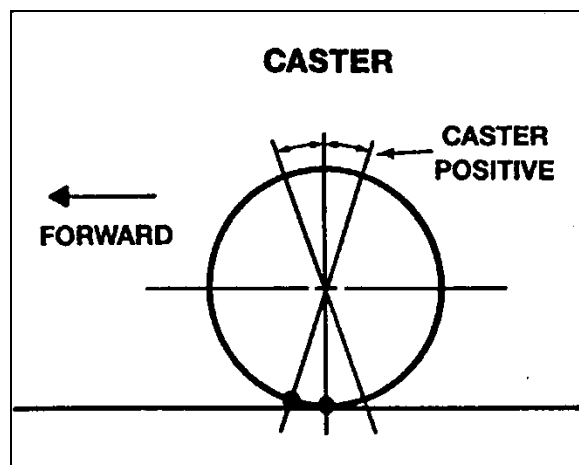

FIGURE 4: CASTER

10007

Excessive caster results in hard steering around corners. A shimmy may also develop when returning to the straight ahead position (pulling out of curves).

Insufficient caster will cause wandering and steering instability. Caster variations may be caused by a bent axle, tilting or distortion of the side suspension supports, damaged radius rod bushings, or unequal tightening of the front and rear suspension support bolts. Incorrect caster must be corrected by replacing the damaged suspension parts. A precision instrument should be used to measure the caster.

NOTE

The caster of this vehicle is factory set and is not adjustable. However, if after replacing damaged parts or in case of improper caster due to irregular setting, the front axle caster needs adjustment; it can be adjusted by means of shims (Prevost #110663) on the left-hand side upper radius rod support in order to obtain minor adjustment.

6.8 FRONT WHEEL TOE-IN

Wheel toe-in is the degree (usually expressed in fractions of an inch) to which the forward part of the vehicle front wheels are closer together than the rear part, measured at wheel centerline height with the wheels in the normal "straight-ahead" position of the steering gear.

Incorrect toe-in results in excessive tire wear caused by side slippage and also steering instability with a tendency to wander. Toe-in may be measured from the center of tire tread or from the inside of the tires. Take measurements at both front and rear of axle (see "A and "B" in Figure 5).

SECTION 10: FRONT AXLE

When setting toe-in adjustment, the front suspension must be neutralized; that is, all component parts must be in the same relative position when marking the adjustment as they will be when in operation.

To neutralize the suspension, the vehicle must be rolled forward, approximately ten feet.

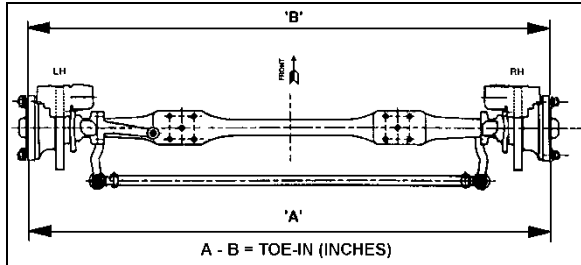

FIGURE 5: TOE-IN MEASUREMENTS

10032

For toe-in specifications, refer to paragraph 8 “Specifications” in this section.

By rolling the vehicle forward, all tolerances in the front suspension are taken up and the suspension is then in its normal operating position. Neutralizing the front suspension is extremely important, especially if the vehicle has been jacked up in order to mark the tires. Otherwise, the front wheels will not return to their normal operating position due to the tires gripping the floor surface when the vehicle jack is lowered.

NOTE

“Toe-in” measurements must be taken at the horizontal axis of the wheel centerline.

6.8.1 Inspection and Adjustment

Before checking front wheel toe-in, first check the camber angles and make the necessary corrections.

1. Measure the toe-in.
2. If the toe-in measurement is not within the specified tolerance, carry out the following procedure :
 - a. Loosen the pinch bolt nuts and bolts on each tie rod end.
 - b. Turn the tie rod until the specified toe-in measurement is obtained.
 - c. Tighten the pinch bolt nuts alternately and progressively to 65-75 lbf-ft (88-102 Nm), thus securing all tie rod joints.

FRONT WHEEL ALIGNMENT SPECIFICATIONS			
Front Wheel Alignment	Minimal	Nominal	Maximal
Camber, (degrees) R.H. and L.H. *	-0.250	0.125	0.375
Caster, (degrees) R.H. and L.H.	2	2.75	3.5
Toe-in (A minus B), (degrees)	0.04	0.06	0.08

NOTE

Camber angle changes with loading. The given numbers are for an empty vehicle.

7. TROUBLESHOOTING

CONDITION	CAUSE	CORRECTION
Tires wear out quickly or have uneven tire tread wear.	<ol style="list-style-type: none"> 1. Tires have incorrect air pressure. 2. Tires out-of-balance. 3. Incorrect tag axle alignment. 4. Incorrect toe-in setting. 5. Incorrect steering arm geometry. 	<ol style="list-style-type: none"> 1. Put specified air pressure in tires. 2. Balance or replace tires. 3. Align tag axle. 4. Adjust toe-in specified setting. 5. Service steering system as necessary.
Vehicle is hard to steer.	<ol style="list-style-type: none"> 1. Low pressure in the power steering system. 2. Steering gear not assembled correctly. 3. Steering linkage needs lubrication. 4. Kingpins binding. 5. Incorrect steering arm geometry. 6. Caster improperly adjusted. 7. Tie rod ends hard to move. 8. Worn thrust bearing. 	<ol style="list-style-type: none"> 1. Repair power steering system. 2. Assemble steering gear correctly. 3. Lubricate steering linkage. 4. Replace kingpins. 5. Service steering system as necessary. 6. Adjust caster as necessary. 7. Replace tie rod ends. 8. Replace thrust bearing.
Bent or broken steering arm, steering top lever or tie rod assembly.	<ol style="list-style-type: none"> 1. Too much pressure in the power steering system. 2. Cut-off pressure of the power steering system improperly adjusted. 3. Vehicle not powered on correctly. 4. Power steering system not installed correctly. 	<ol style="list-style-type: none"> 1. Replace damaged part(s), adjust power steering system to specified pressure. 2. Make sure vehicle is powered on correctly. 3. Correctly install the power steering system. 4. Correctly install the power steering system.
Worn or broken steering ball stud.	<ol style="list-style-type: none"> 1. Drag link fasteners tightened past specified torque. 2. Lack of lubrication or incorrect lubricant. 3. Power steering stops improperly adjusted. 	<ol style="list-style-type: none"> 1. Replace damaged part(s), tighten drag link fasteners to specified torque. 2. Lubricate linkage with specified lubricant. 3. Adjust stops to specified dimension.
Worn king pins and knuckle bushings.	<ol style="list-style-type: none"> 1. Worn or missing seals and gaskets. 2. Incorrect lubricant. 3. Axle not lubricated at scheduled frequency. 4. Incorrect lubrication procedures. 5. Lubrication schedule does not match operating conditions. 	<ol style="list-style-type: none"> 1. Replace damaged part(s), replace seals and gaskets. 2. Lubricate axle with specified lubricant. 3. Lubricate axle at scheduled frequency. 4. Use correct lubrication schedule to match operating conditions. 5. Change lubrication schedule to match operating conditions.
Vibration or shimmy of front axle during operation.	<ol style="list-style-type: none"> 1. Caster not adjusted properly. 2. Wheels and/or tires out-of balance. 3. Worn steering stabilizer cylinder. 	<ol style="list-style-type: none"> 1. Adjust caster. 2. Balance or replace wheels and/or tires. 3. Replace steering stabilizer cylinder.

8. SPECIFICATIONS

Front Axle

Make DANA SPICER EUROPE
 Model S84U
 Front Track 84.4 inches (2 145 mm)
 Rated load capacity 16,500 lbs (7 500 kg)

9. TORQUE SPECIFICATIONS

The torque specifications applicable to the front axle are grouped with information regarding the front suspension. Please refer to Section 16: SUSPENSION of this manual.

For more torque specifications, refer to Dana Spicer manuals.

10. SECTION CHANGE LOG

DESCRIPTION		DATE
1	Vertical slackness corrected. Was 0.040" changed for 0.030"	Jan. 2017
2		
3		
4		
5		
6		

CONTENTS

1. DRIVE AXLE.....	2
1.1 MAINTENANCE	2
1.1.1 Differential Oil Type	2
1.1.2 Checking and Adjusting the Differential Oil Level	2
1.1.3 Differential Oil Change.....	2
1.1.4 Compact Bearing (Hub Unit) Axial Play Check	3
1.1.5 Compact bearing (hub unit) Grease Change.....	3
1.1.6 Speed Sensors (Anti-Lock Brake system, ABS).....	4
1.2 DRIVE AXLE FLANGE SHAFT REMOVAL/INSTALLATION	4
1.3 REMOVAL AND REINSTALLATION	5
1.4 DISASSEMBLY, REASSEMBLY, ADJUSTMENT AND TORQUE CHART	5
1.5 DRIVE AXLE ALIGNMENT.....	6
1.5.1 Procedure.....	6
2. TAG AXLE.....	8
2.1 UNLOADING TAG AXLE	8
2.2 RETRACTING TAG AXLE	8
2.3 RETRACTING TAG AXLE FOR REPAIR PURPOSES	9
2.4 GREASE LUBRICATED WHEEL BEARINGS	9
2.5 REMOVAL AND INSTALLATION	9
2.5.1 Removing Tag Axle Only	9
2.5.2 Removing Tag Axle Along With Suspension Components.....	9
2.5.3 Removing Transversal radius Rod.....	10
2.6 TAG AXLE ALIGNMENT.....	10
3. SPECIFICATIONS.....	11
4. SECTION CHANGE LOG.....	11

ILLUSTRATIONS

FIGURE 1: ZF A132 DRIVE AXLE	2
FIGURE 2: ZF A132 DRIVE AXLE	3
FIGURE 3: ZF A-132 DRIVE AXLE HUB ASSEMBLY	4
FIGURE 4: SUPPORT THE DRIVE AXLE SUBFRAME AT	5
FIGURE 5: FRONT & DRIVE AXLE ALIGNMENT	8
FIGURE 6: TAG AXLE ALIGNMENT.....	8
FIGURE 7: JACKING POINTS ON TAG AXLE	10
FIGURE 8: INSTALLING EXTRACTOR TOOL	10

1. DRIVE AXLE

This vehicle is equipped with a ZF model A132 Hypoid Single Reduction drive axle, fitted with two Knorr Bremse brake chambers, Knorr Bremse SN7 disc brake with a visual wear indicator, potentiometer wear indicator and companion flange for Dana Spicer SPL250 propeller shaft. The carrier gear ratio is 3.82.

Additional information is found in the following manuals, included on your vehicle technical publications CD:

- OPERATING INSTRUCTIONS ZF AXLE A132 (version with US hub) #5871 207 982 EN.
- ZF AXLE A132 REPAIR MANUAL #5871 207 002E

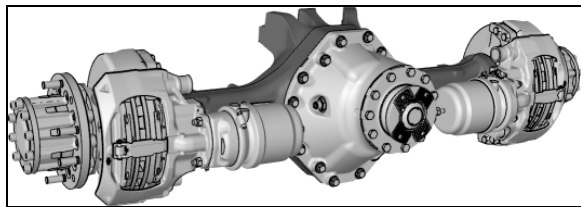

FIGURE 1: ZF A132 DRIVE AXLE

11019

1.1 MAINTENANCE

Proper vehicle operation begins with preventive maintenance, such as good differential use. The most common types of drive axle carrier failures are spinout, shock, fatigue, overheating and lubrication. Avoid neglecting these points since they would be the first steps to improper maintenance, expensive repairs, and excessive downtime.

Inspect at the pinion oil seal, axle shaft flange and carrier housing joint for evidence of lubricant leakage. Tighten the bolts and nuts, or replace the gaskets and seals to correct leaks.

Maintenance of the axle mountings consists primarily in a regular and systematic inspection of the radius rods, as directed in Section 16, "Suspension".

1.1.1 Differential Oil Type

Use **Mobil Delvac synthetic gear oil 80W140** for best performance and extreme conditions. Additional lubrication information is covered in ZF's list of lubricants TE-ML 12. Check in Lubricant class 12M.

1.1.2 Checking and Adjusting the Differential Oil Level

- Place the vehicle on a level surface.
- Level check plug must be cleaned carefully before opening.
- Check oil level at room temperature only.



MAINTENANCE

Oil level check

Check differential oil level and add if necessary every 50 000 miles.



WARNING

Check the oil level when the axle is at room temperature. When hot, the oil temperature may be 190°F (88°C) or more and can cause burns. Also, a correct reading is not obtained when the axle is warm or hot.

1. Make sure the axle is at room temperature.
2. Clean the area around the level check plug. Remove the level check plug from the differential case.
3. The oil level must be even with the bottom of the level check bore.

If oil flows from the hole when the plug is loosened, the oil level is too high. Let drain the oil to the correct level.

If the oil level is below the bottom of the level check bore, add the specified oil through the level check bore.

4. Reinstall the level check plug using a new seals (O-ring) and tighten to 52 lbf-ft.

1.1.3 Differential Oil Change

- Place the vehicle on a level surface.
- Drain, filler and level check plugs must be cleaned carefully before opening.
- Drain oil only at operating temperature, immediately after the vehicle has been operated for an extended period of time.
- Renew seals components (O-rings).

 **MAINTENANCE**

Oil change interval – Lubricant class 12M
 Change differential oil and breather, clean the drain plug's magnetic inserts after 100 000 miles or 3 years, whichever comes first.
Note: Oil change interval recommended by ZF in LIST OF LUBRICANTS TE-ML 12 is 110 000 miles/3 years, whichever comes first.

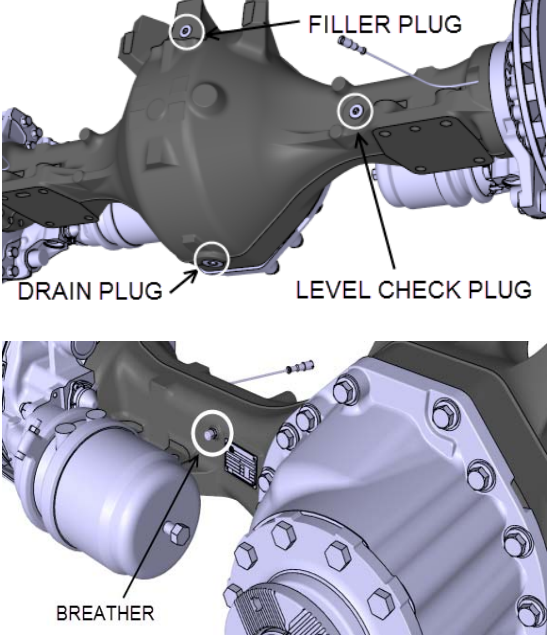

TORQUES

Filler plug:	52 lbf-ft (70 Nm)
Drain plug:	96 lbf-ft (130 Nm)
Level check plug:	52 lbf-ft (70 Nm)
Breather:	4 lbf-ft (5.5 Nm)

FIGURE 2: ZF A132 DRIVE AXLE

5. Put a large container under the differential case drain plug. The differential case contains approximately 19 quarts of oil.
6. Remove the drain plug from the bottom of the differential case. Drain all the oil and discard in an environment friendly manner.
7. Clean the magnetic insert of the drain plug, fit a new seal (O-ring) and reinstall drain plug.

 **WARNING**

The oil temperature may be extremely high!
 Risk of burn injuries.

8. Remove the filler plug and the level check plug.
9. Reinstall the drain plug and tighten to 96 lbf-ft (130 Nm).
10. Add the specified oil at the filler plug until the oil level is even with the bottom of the level check bore.
Filling volume is about 19 quarts (18 liters) at the level check bore
11. Allow the oil to flow through the axle and check the oil level again after some minutes. Refill if necessary until specified level is reached and remains constant.
12. Reinstall the filler plug and level check plug using new seals (O-ring) and tighten to 52 lbf-ft (70 Nm).
13. Replace the breather with every oil change. Tighten to 4 lbf-ft (5.5 Nm).

1.1.4 Compact Bearing (Hub Unit) Axial Play Check

Check the compact bearing (hub unit) axial play every 100 000 miles. Furthermore, the bearing must be checked in case of brake disk change, ABS fault message and rising noise level at increasing speed.

Perform compact bearing (hub unit) axial play check as described in paragraph 6.2 HOW TO CHECK THE AXIAL PLAY of the following manual: OPERATING INSTRUCTIONS ZF AXLE A132 (version with US hub) #5871 207 982 EN.

 **MAINTENANCE**

Compact bearing (hub unit) axial play
 Check axial play every 100 000 miles.

1.1.5 Compact bearing (hub unit) Grease Change

The compact bearing grease must be change every 4 years or 300 000 miles, whichever comes first.

SECTION 11: REAR AXLES

The list of approved grease types for ZF A-132 compact bearing is found in ZF's list of lubricants TE-ML 12. Check in Lubricant class 12H.

Perform compact bearing (hub unit) grease change as described in paragraph 7.3 GREASE CHANGE IN THE HUB of the following manual: OPERATING INSTRUCTIONS ZF AXLE A132 (version with US hub) #5871 207 982 EN.

- OPERATING INSTRUCTIONS ZF AXLE A132 (version with US hub) #5871 207 982 EN.

1.1.6 Speed Sensors (Anti-Lock Brake system, ABS)

For removing and installing the drive axle speed sensors (for anti-lock brake systems, ABS), refer to Section 12: Brake and Air System.

1.2 DRIVE AXLE FLANGE SHAFT REMOVAL/INSTALLATION

Refer to "Replacement of Axle Insert" in the following manuals, included on your vehicle technical publications CD:

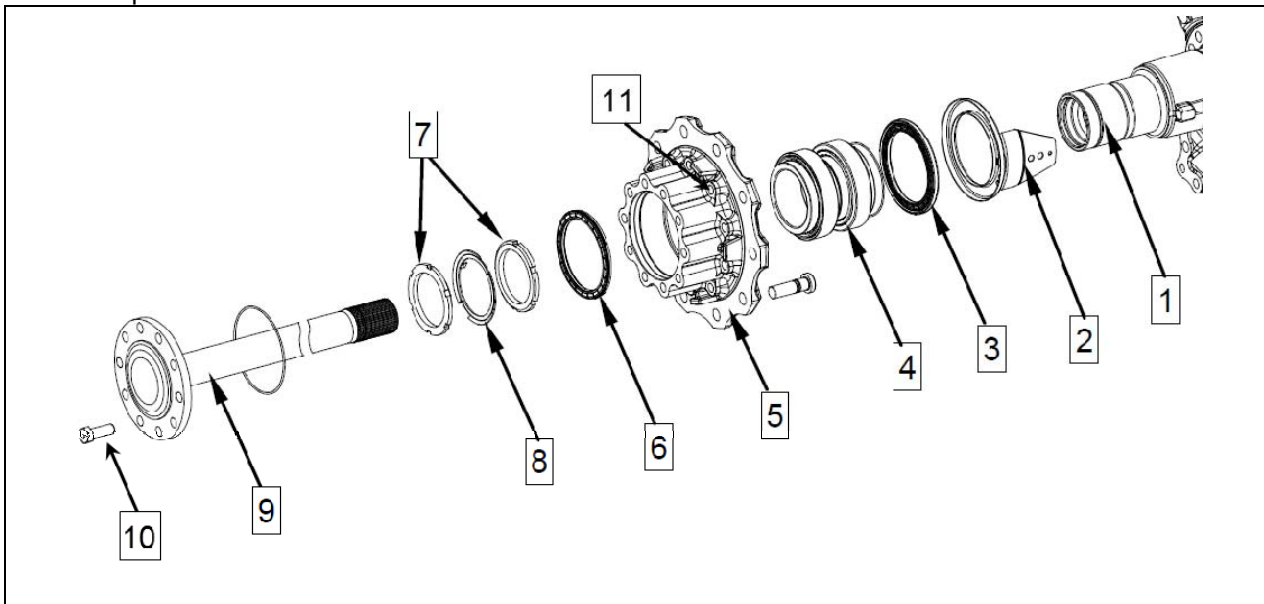
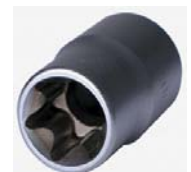

FIGURE 3: ZF A-132 DRIVE AXLE HUB ASSEMBLY

1	hub carrier	10	cap screw M18x1.5x50mm G10.9 torque=325 lbf-ft (use 14mm hex socket driver "Allen")
2	screen sheet		
3	shaft seal (with impulse disc)		
4	compact bearing (hub unit)		
5	hub		
6	shaft seal	11	cap screw Torx M16x1.5x60 torque=221 lbf-ft (use E20 Torx socket)
7	slotted nut		
8	locking plate		
9	flange shaft		



1.3 REMOVAL AND REINSTALLATION

The following procedure deals with the removal of the drive axle assembly and its attachments as a unit. The method used to support the axle during removal and disassembly depends upon local conditions and available equipment.

1. Raise vehicle from the front wheels and drive axle wheels. Place jack stands under the rear chassis hoisting points. Remove drive axle wheels (if required, refer to Section 13, "Wheels, Hubs and Tires".
2. Exhaust compressed air from the air supply system by opening the drain cock on each air reservoir.
3. Disconnect the propeller shaft as directed in Section 9, "Propeller Shaft", in this manual.
5. Disconnect the lower end both height control valve link then move the arm up to exhaust air suspension.
6. Disconnect the ABS speed sensors connector located over the differential housing.

NOTE
<i>When removing drive axle, if unfastening cable ties is necessary for ease of operation, remember to replace them afterwards.</i>

7. Disconnect the air brake supply hoses over the differential carrier.

NOTE
<i>Position the hoses so they will not be damaged when removing the axle.</i>

8. Install jack stands under the drive axle subframe at the four locations shown on figure 4.

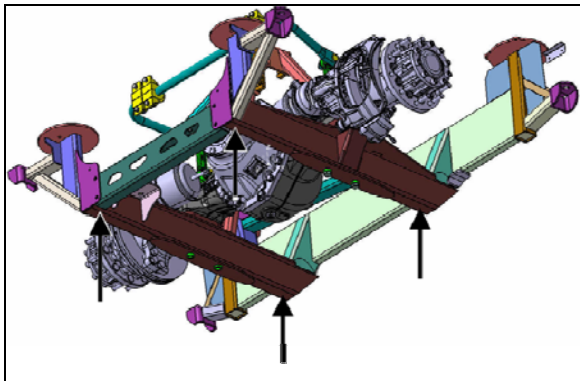

FIGURE 4: SUPPORT THE DRIVE AXLE SUBFRAME AT THE FOUR LOCATIONS SHOWN

9. Disconnect the lower ends of the four shock absorbers as outlined in Section 16, "Suspension" under heading "Shock Absorber Removal".
10. Remove the two sway bar links.
11. Remove the lower and upper longitudinal radius rod supports as outlined in Section 16, "Suspension", under heading "Radius Rod Removal".
12. Remove the transversal radius rod (panhard bar).
13. Remove the two retaining nuts from each of the four air springs lower mounting supports.
14. Disconnect the drive axle speed sensor.
15. Use the jacks to lower axle. Carefully pull away the drive axle assembly from underneath vehicle.
16. Reverse removal procedure to reinstall drive axle.

NOTE
<i>Refer to Section 16, "Suspension" for suspension components' proper tightening torques.</i>

NOTE
<i>Refer to section 13 "Wheels, Hubs And Tires" for correct wheel bearing adjustment procedure.</i>

1.4 DISASSEMBLY, REASSEMBLY, ADJUSTMENT AND TORQUE CHART

Disassembly and re-assembly procedures are covered in the following manual:

- ZF AXLE A132 REPAIR MANUAL #5871 207 002E

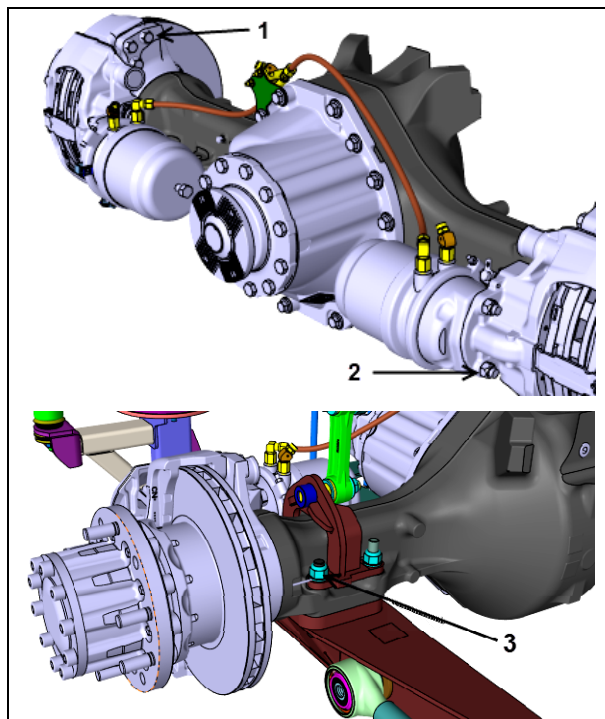

REF	QTY	TORQUE DRY (lbf-ft) <i>Threads must be free of oil or other lubricant</i>
1	12	200
2	4	120-150
3	8	405-495

1.5 DRIVE AXLE ALIGNMENT

The drive axle alignment consists in aligning the axle according to the frame. The axle must be perpendicular to the frame. The alignment is achieved with the use of shims inserted between the lower longitudinal radius rod supports and the frame.

Drive axle alignment is factory set and is not subject to any change, except if the vehicle has been damaged by an accident or if there are requirements for replacement.

If the axle has been removed for repairs or servicing and if all the parts are reinstalled exactly in the same place, the axle alignment is not necessary. However, if the suspension supports have been replaced or altered, proceed with the following instructions to verify or adjust the drive axle alignment.

NOTE
When drive axle alignment is modified, tag axle alignment must be re-verified.

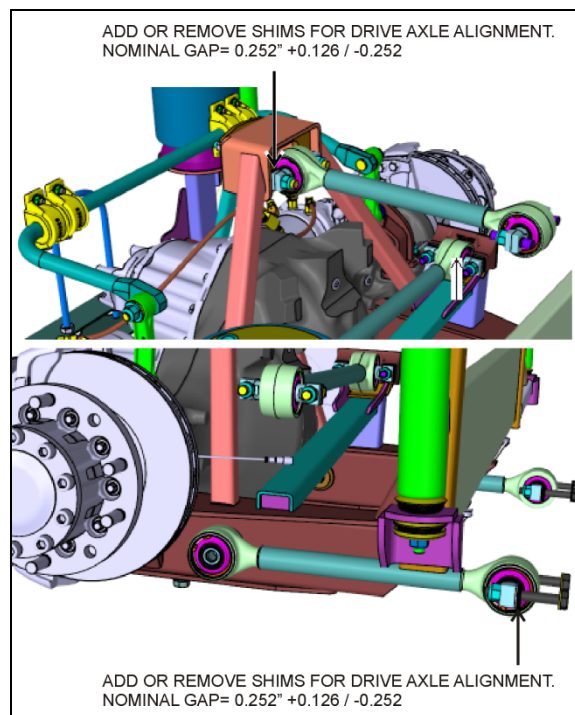

1.5.1 Procedure

1. Park vehicle on a level surface, then chock front vehicle wheels.
2. Using two jacking points (which are at least 30 inches [76 cm] apart) on drive axle, raise the vehicle sufficiently so that wheels can turn freely at about 1/2 inch from ground. Secure in this position with safety stands, and release parking brake.
3. Install wheel mount sensors on front end and drive axle wheels (Figure 5).

NOTE
See reference numbers on wheel mount sensors (Figure 6).

NOTE
Select axle specifications in the appropriate chart.

DRIVE AXLE ALIGNMENT

- With the system installed as in Figure 6, adjust drive axle according to specifications' chart below.

DRIVE AXLE ZF A-132			
	Minimum value	Nominal value	Maximum value
Thrust angle	±0.11°		
Total toe	0.15° toe-in	0°	0.15° toe-out

TAG AXLE ALIGNMENT

- Remove and reinstall all wheel mount sensors on the drive and tag axles (Figure 6);

NOTE
For an accurate alignment, the tag axle must be aligned with the drive axle.

NOTE
Reinstall wheel mount sensors as shown in figure 7.

Adjust tag axle according to specifications' chart below in reference with drive axle.

TAG AXLE			
	Minimum value	Nominal value	Maximum value
Thrust angle* (degrees)	-0.02	0	0.02
Total toe	0.08° toe-in	0°	0.02° toe-out
(*) Use the drive axle as reference			

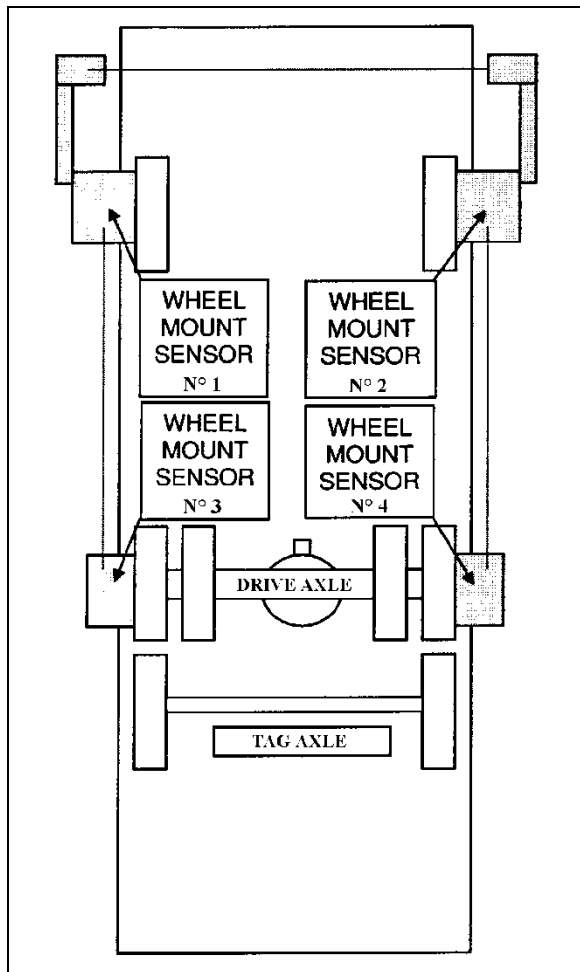

FIGURE 5: FRONT & DRIVE AXLE ALIGNMENT 11025

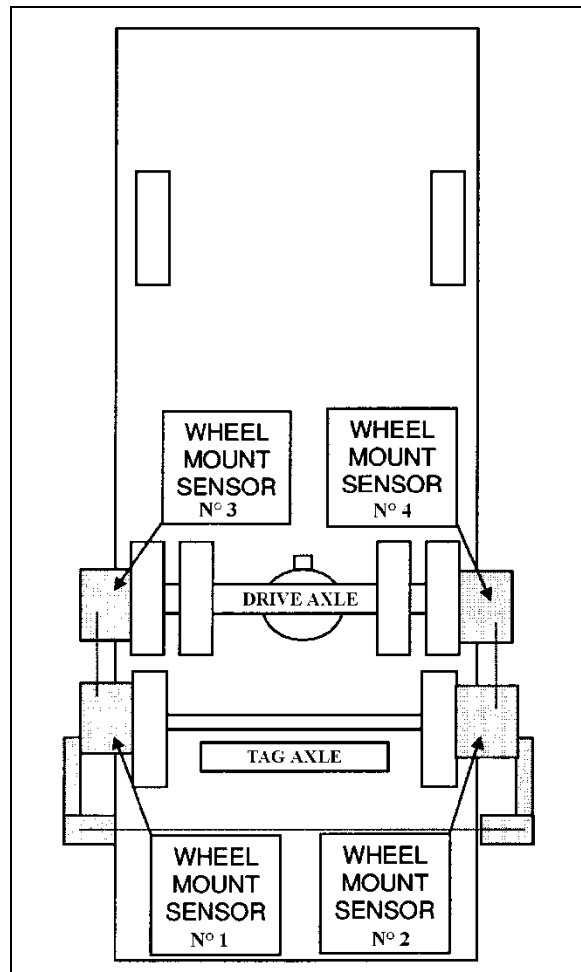

FIGURE 6: TAG AXLE ALIGNMENT 11026

NOTE

Refer to Section 16, "Suspension", for proper torque tightening of the longitudinal radius rod support nuts.

NOTE

When the drive alignment is changed, the tag alignment must also be adjusted.

2. TAG AXLE

The tag axle is located behind the drive axle. It carries a single wheel and tire on each side.

2.1 UNLOADING TAG AXLE

To reduce the turning radius, the air springs pressure will be automatically reduced by 75% when the coach is moving at speed lower than 5 mph (8 km/h) and with more than 1½ turn from the steering.

2.2 RETRACTING TAG AXLE

The standard tag axle retraction system is controlled by a valve located on the left lateral console and enables unloading and raising the tag axle (refer to the "OPERATOR'S MANUAL" for location of controls). This system has been designed for the following purposes:

1. Shortening of wheelbase, thus allowing tighter turning in tight maneuvering areas such as parking lots or when making a sharp turn.
2. Transferring extra weight and additional traction to the drive wheels on slippery surfaces.

The tag axle service brakes operate only when the axle is in normal driving (loaded) position.

**CAUTION**

Do not use tag axle in raised position for an

extended period. Raising tag axle increases load on the drive axle, suspension and tires.

Do not drive vehicle with tag axle raised when speed is exceeding 12mph (20 km/h).

In order to prevent damage to the suspension, always raise the tag axle before lifting the coach.

2.3 RETRACTING TAG AXLE FOR REPAIR PURPOSES

- Connect an external air pressure line to the emergency fill valve in the engine compartment.
- Lift the axle by pushing the lever forward.



WARNING

Install a protective cover to prevent unfortunate lever operation while work is being carried out under the vehicle.

- Raise the vehicle using the lifts.



WARNING

Lift manufacturers recommend lowering the vehicle to the ground or installing some safety stands before activating the suspension to prevent the lifts from becoming unstable.

- For added safety, install nylon slings over tag axle shock absorbers.

2.4 GREASE LUBRICATED WHEEL BEARINGS

The unitized hub bearings used on the NDS range of axles, are non-serviceable items. Bearings are pre-adjusted, lubricated and have seals fitted as part of the manufacturing process. The bearings are greased for life and there is no need or facility for re-lubrication.



MAINTENANCE

Front and tag axle hub bearings need to be checked at intervals of 30,000 miles (48 000 km) or twice a year whichever comes first.

NOTE

For more information on front and tag axle wheel hub, refer to "DANA SPICER Service

Manual NDS Axle Range" found in the OEM manuals folder.

2.5 REMOVAL AND INSTALLATION

2.5.1 Removing Tag Axle Only

The following procedure deals with the removal of the tag axle while keeping the air springs installed. The method used to support the axle and suspension components during removal and disassembly depends upon local conditions and available equipment.

- Connect an external air pressure line to the emergency fill valve in the engine compartment.
- Lift the axle by pushing the lever forward.



WARNING

Install a protective cover to prevent unfortunate lever operation while work is being carried out under the vehicle.

- Disconnect tag axle air springs pneumatic hoses and install valves or plugs.
- Raise the vehicle using the lifts.
- Dismount tag axle components.
- Before reinstalling air spring hoses, make sure there is no pressure left inside by opening the valves or unloading tag axle.

2.5.2 Removing Tag Axle Along With Suspension Components

The following procedure deals with the removal of the tag axle assembly along with the suspension components. The method used to support the axle and suspension components during removal and disassembly depends upon local conditions and available equipment.

1. Raise vehicle by its jacking points on the body. Place jack under frame. Remove drive axle wheels (if required, refer to Section 13, "Wheels, Hubs and Tires").
2. Exhaust compressed air from the air supply system by opening the drain cock on each air reservoir and deplete air bags by moving leveling valve arm down.
3. Install jacks under tag axle jacking points to support the axle weight (refer to figure 8).

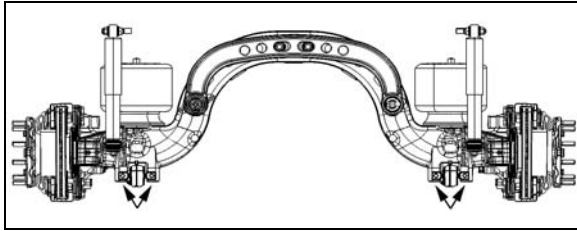

FIGURE 7: JACKING POINTS ON TAG AXLE 11029

4. Disconnect tag axle lifting chain collars from lower longitudinal radius rods.
5. Remove the propeller shaft as directed in Section 9, "Propeller Shaft", in this manual.
6. Disconnect the tag axle brake chamber hoses.



CAUTION

Position the hoses so they will not be damaged when removing axle.

7. Disconnect hose from the air spring upper mounting plate.
8. Remove the two shock absorbers as outlined in Section 16, "Suspension", under "Shock Absorber Removal".
9. Disconnect the lower longitudinal radius rods as outlined in Section 16, "Suspension", under "Radius Rod Removal".
10. Disconnect the transversal radius rod.
11. Disconnect the upper longitudinal radius rod.
12. Remove the air bellows retaining nuts from each of the two upper mounting plates.
13. Use the jacks to move the axle forward to clear the axle off the transmission. Lower the axle.



CAUTION

On vehicles equipped with an output retarder and an automatic transmission, move tag assembly very carefully. Pay special attention to the U-shaped section, as the transmission end components may be easily damaged through a false maneuver.

14. Reverse removal procedure to reinstall tag axle.

NOTE

Refer to Section 16, "Suspension", for proper torque tightening of suspension components.

NOTE

Refer to section 13 "Wheels, Hubs And Tires" for correct wheel bearing adjustment procedure.

2.5.3 Removing Transversal radius Rod

Unfasten bolts and nuts fixing transversal radius rod ball joint to rear underframe.

Install extractor tool G32952 onto transversal rod.

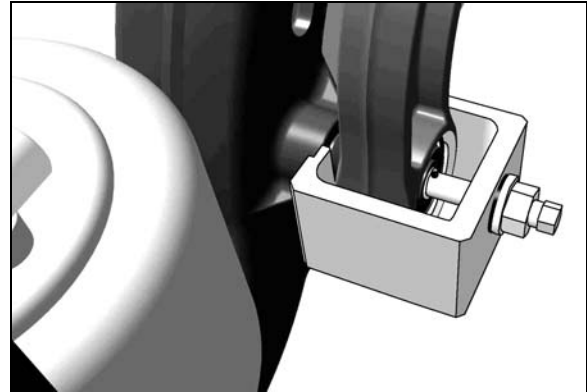

FIGURE 8: INSTALLING EXTRACTOR TOOL



CAUTION

It is strongly suggested to use the extractor tool in order to remove transversal radius rod.

Partially unscrew ball joint fixing bolt. Tighten extractor threaded rod.

Supporting the transversal radius rod at all times, gradually extract transversal radius rod from tag axle.

Reinstall by reversing procedure. Torque bolt to 190 lbf-ft (255 Nm) dry.

2.6 TAG AXLE ALIGNMENT

The tag axle alignment consists in aligning the tag axle parallel to the drive axle position. Before aligning the tag axle, proceed with the drive axle alignment (paragraph 1.10). Tag axle alignment is achieved with the use of shims inserted between the lower longitudinal radius rod supports and axle. Tag axle alignment is factory set and is not subject to any change, except if vehicle has been damaged by an accident or if there are requirements for parts replacement.



CAUTION

If this setting is altered significantly, it will cause excessive tire wear.

NOTE
It may be necessary to adjust the axle TOE as well as its alignment. In this case, insert shims (7 min. - P/N 121203 or 15 min. - P/N 121240) in between mounting plate and spindle, as required.

necessary. However, if the suspension supports have been replaced or have changed position, proceed with the following instructions to verify or adjust the tag axle alignment.

If axle has been removed for repair or servicing and if all parts are reinstalled exactly in their previous locations, axle alignment is not

3. SPECIFICATIONS

Drive Axle

Make and model.....ZF A132
 Drive track..... 76.7 inches (1 949 mm)
 Gear type Hypoid
 Axle type Full floating
 Oil fill quantity 19.5 quarts (39 pints)
 Ratio..... 3.82

Tag Axle

Make Prevost
 Rear track 83.6 inches (2 124 mm)
 Axle type Forged

NOTE
The tag axle alignment consists in aligning the tag axle parallel to the drive axle.

4. SECTION CHANGE LOG

DESCRIPTION		DATE
1		
2		
3		
4		
5		
6		

CONTENTS

1. AIR SYSTEM	4
2. BRAKES	4
3. AIR RESERVOIRS	4
3.1 WET TANK AUTOMATIC DRAIN VALVE.....	4
3.1.1 <i>Installation</i>	4
3.2 MAINTENANCE.....	5
3.2.1 <i>Ping Tank</i>	5
3.2.2 <i>Wet (Main) Air Tank</i>	5
3.2.3 <i>Primary Air Tank</i>	5
3.2.4 <i>Accessory Air Tank</i>	5
3.2.5 <i>Secondary Air Tank</i>	5
3.2.6 <i>Kneeling Air Tank</i>	5
3.2.7 <i>Parking Brakes Override Air Tank</i>	5
4. AIR SYSTEM EMERGENCY FILL VALVES	5
5. ACCESSORY AIR FILTER	6
5.1 FILTER ELEMENT REPLACEMENT.....	6
5.2 CLEANING.....	6
6. AIR GAUGES (PRIMARY, SECONDARY AND ACCESSORY)	6
7. AIR DRYER	7
7.1 AIR DRYER REPLACEMENT.....	8
7.1.1 <i>Testing the installation</i>	8
7.1.2 <i>Final check</i>	9
7.2 DESICCANT CARTRIDGE REPLACEMENT.....	9
8. HALDEX CONDENSER - SEPARATOR	9
8.1 MAINTENANCE.....	10
9. AIR LINES	10
9.1 FLEXIBLE HOSES.....	10
9.2 NYLON TUBING.....	10
9.3 AIR LINE OPERATING TEST.....	10
9.4 AIR LINE LEAKAGE TEST.....	10
9.5 MAINTENANCE.....	10
10. PRESSURE REGULATING VALVES	11
10.1 MAINTENANCE.....	11
10.2 PRESSURE SETTING PROCEDURE.....	11
11. AIR COMPRESSOR	11
11.1 COMPRESSOR REMOVAL AND INSTALLATION.....	12
12. EMERGENCY/PARKING BRAKE CONTROL VALVE (PP-1)	12
13. EMERGENCY / PARKING BRAKES OVERRULE CONTROL VALVE (RD-3)	12
14. FLIP-FLOP CONTROL VALVE (TW-1)	13
15. DUAL BRAKE APPLICATION VALVE (E-8P)	13
15.1 BRAKE PEDAL ADJUSTMENT.....	13
15.2 STOPLIGHT SWITCHES.....	14

16.	PARKING BRAKE ALARM SWITCH.....	14
17.	BRAKE RELAY VALVE (R-14).....	14
18.	ANTILOCK TRACTION RELAY VALVES (ATR-6).....	14
19.	SPRING BRAKE VALVE (SR-7).....	14
20.	PRESSURE PROTECTION VALVE (PR-4).....	15
21.	SHUTTLE-TYPE DOUBLE CHECK VALVE (DC-4).....	15
22.	EMERGENCY BI-FOLD ENTRANCE DOOR OPENING VALVES.....	15
23.	AIR SYSTEM TROUBLESHOOTING.....	16
24.	BRAKE OPERATION.....	16
25.	DISC BRAKES.....	17
25.1	INSPECTION POINTS.....	17
25.2	PAD REPLACEMENT PROCEDURE.....	18
25.3	CHECKING DISC BRAKE PADS.....	18
25.3.1	<i>Drive Axle – Equipped With L-bracket Wear Indicator.....</i>	<i>18</i>
25.3.2	<i>Front and Tag Axle – Equipped With L-bracket Wear Indicator.....</i>	<i>19</i>
25.3.3	<i>Continuous Wear Sensor.....</i>	<i>20</i>
25.4	BRAKE PADS AND DISCS MINIMAL TOLERANCE LIMITS.....	20
25.4.1	<i>Brake Pads.....</i>	<i>20</i>
25.4.2	<i>Brake Disc.....</i>	<i>20</i>
25.5	CALIPER RUNNING CLEARANCE.....	21
25.6	TORQUE SPECIFICATIONS.....	21
26.	SAFE SERVICE PROCEDURES.....	21
27.	AIR BRAKE TROUBLESHOOTING.....	23
28.	BRAKE AIR CHAMBER.....	24
28.1	MAINTENANCE.....	24
28.2	EMERGENCY/PARKING BRAKE MANUAL RELEASE.....	25
28.3	BRAKE CHAMBER REMOVAL AND INSTALLATION.....	25
28.4	BRAKE CHAMBER DISASSEMBLY.....	26
29.	ANTI-LOCK BRAKING SYSTEM (ABS).....	26
29.1	TROUBLESHOOTING AND TESTING.....	27
29.2	ABS COMPONENTS.....	27
29.3	BENDIX EC-60 ADVANCED CONTROLLER.....	27
29.4	SENSORS.....	27
29.5	SPRING CLIP.....	28
30.	BENDIX AUTOMATIC TRACTION CONTROL (ATC) – ELECTRONIC STABILITY CONTROL (ESC) 28	
30.1	COMPONENTS.....	29
30.1.1	<i>The EC-60™ controller's ABS function utilizes the following components:.....</i>	<i>29</i>
30.1.2	<i>The EC-60™ controller's ATC function utilizes the following components:.....</i>	<i>29</i>
30.1.3	<i>The EC-60™ controller's ESC/RSP function utilizes the following components:.....</i>	<i>29</i>
30.2	BENDIX M-40QR PRESSURE MODULATOR VALVE.....	29
30.3	ADVANCED ABS WITH ELECTRONIC STABILITY CONTROL (ESC).....	30
30.4	BENDIX® SAS-70 STEERING ANGLE SENSOR.....	31
30.4.1	<i>Removal of the steering angle sensor.....</i>	<i>31</i>
31.	FITTING TIGHTENING TORQUES.....	32
32.	SPECIFICATIONS.....	33

33. SECTION CHANGE LOG 33

ILLUSTRATIONS

FIGURE 1: I-BEAM FRONT SUSPENSION AIR RESERVOIRS LOCATION.....	4
FIGURE 2: WET TANK AUTOMATIC DRAIN VALVE.....	5
FIGURE 3: EMERGENCY AIR SYSTEM FILL VALVES AND DRAIN COCK.....	5
FIGURE 4: FRONT SERVICE COMPARTMENT.....	6
FIGURE 5: ACCESSORY AIR FILTER.....	6
FIGURE 6: AIR DRYER.....	7
FIGURE 7: AIR DRYER LOCATION.....	7
FIGURE 8: WABCO AIR DRYER CONNECTIONS.....	8
FIGURE 9: FITTINGS DIRECTION.....	8
FIGURE 10: DESICCANT CARTRIDGE REPLACEMENT.....	9
FIGURE 11: HALDEX CONSEP CONDENSER SEPARATOR.....	9
FIGURE 12: AIR PRESSURE REGULATING VALVE.....	11
FIGURE 13: AIR COMPRESSOR LOCATION.....	12
FIGURE 14: PP-1.....	12
FIGURE 15: RD-3.....	13
FIGURE 16: TW-1.....	13
FIGURE 17: E-8P DUAL BRAKE VALVE.....	13
FIGURE 18: BRAKE PEDAL ADJUSTMENT.....	13
FIGURE 19: PINS.....	13
FIGURE 20: R-14.....	14
FIGURE 21: ATR-6.....	14
FIGURE 22: SR-7.....	15
FIGURE 23: PR-4.....	15
FIGURE 24: DC-4.....	15
FIGURE 25: THREE-WAY VALVE.....	15
FIGURE 26: BRAKE COMPONENTS.....	18
FIGURE 27: BRAKE PAD WEAR CHECK ON DRIVE AXLE.....	19
FIGURE 28: PAD WEAR CHECK FRONT AND TAG AXLE.....	19
FIGURE 29: PAD WEAR CHECK FRONT AND TAG AXLE.....	19
FIGURE 30: POTENTIOMETER.....	20
FIGURE 31: MINOR BREAKOUTS AT THE EDGES ARE PERMITTED.....	20
FIGURE 32: MAJOR BREAKOUTS ON THE SURFACE OF THE BRAKE PAD ARE NOT PERMITTED.....	20
FIGURE 33: BRAKE PAD DIMENSIONS.....	20
FIGURE 34: CALIPER AXIAL DIRECTION.....	21
FIGURE 35: CALIPER CARRIER MOUNTING BOLTS TORQUE SPECIFICATION - I-BEAM AXLE.....	21
FIGURE 36: CALIPER CARRIER MOUNTING BOLTS TORQUE SPECIFICATION - ZF A132 DRIVE AXLE.....	21
FIGURE 37: CALIPER CARRIER MOUNTING BOLTS TORQUE SPECIFICATION - TAG AXLE.....	21
FIGURE 38: FRONT AXLE BRAKE AIR CHAMBER.....	24
FIGURE 39: DRIVE AXLE BRAKE AIR CHAMBER.....	24
FIGURE 40: TYPICAL AIR CHAMBER MOUNTING NUTS TORQUE – ZF A132 DRIVE AXLE SHOWN.....	25
FIGURE 41: ABS ECU LOCATION.....	27
FIGURE 42: ABS SENSOR LOCATION.....	28
FIGURE 43: SPRING CLIP.....	28
FIGURE 44: M-40QR PRESSURE MODULATOR VALVE.....	30
FIGURE 45: HOSE FITTING.....	32

1. AIR SYSTEM

The basic air system consists of an air compressor, reservoirs, valves, filters and interconnecting lines and hoses. It provides a means for braking; operating controls and accessories, and suspension (refer to Section 16, "Suspension", for complete information on suspension description and maintenance). An air system schematic diagram is annexed in the technical publications box provided with the vehicle for better understanding of the system.

2. BRAKES

This vehicle uses both the service brake and emergency/parking brake. The service brake air system is divided into two independent circuits to isolate front brakes from rear brakes, thus providing safe braking in the event that one circuit fails. Front axle brakes operate from the secondary air system, while brakes on both the drive axle and tag axle operate from the primary air system.

NOTE

The tag axle service brake operates only when the axle is in normal ride position (loaded and down).

Furthermore, the brake application or release, which is speed up by a pneumatic relay valve, will start with the rear axles and will be followed by the front axle, thus providing uniform braking on a slippery road. The vehicle is also equipped with an Anti-Lock Braking System (ABS), which is detailed later in this section.

The drive axle is provided with spring-loaded emergency/parking brakes, which are applied automatically whenever the control valve supply pressure drops below 60 psi (414 kPa).

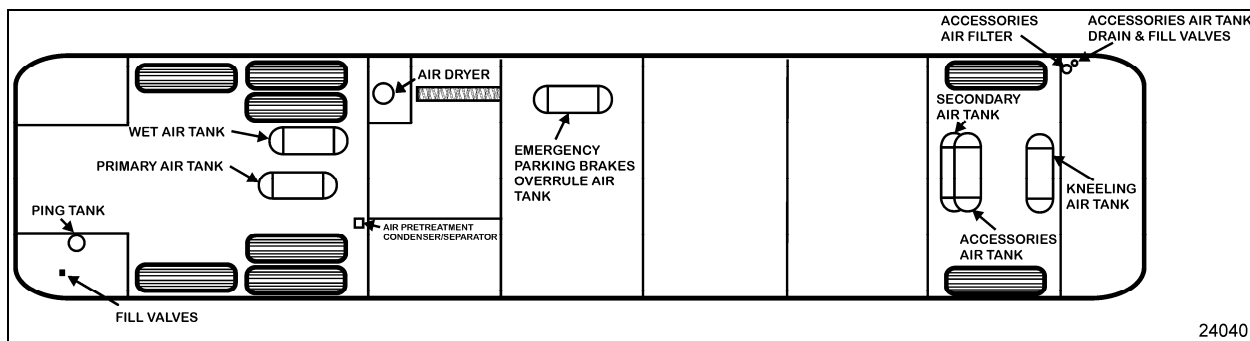

FIGURE 1: I-BEAM FRONT SUSPENSION AIR RESERVOIRS LOCATION

12213

3. AIR RESERVOIRS

The air coming from the compressor is first forwarded to the ping tank, then to the Haldex condenser-separator, the air dryer, the wet air tank, the primary (for the primary brake system), secondary (for the secondary brake system), and accessory (for the pneumatic accessories) air tanks (Figure 1).

Two additional air reservoirs are installed on the vehicle: the kneeling air tank and the parking brakes overrule air tank.

3.1 WET TANK AUTOMATIC DRAIN VALVE

The wet tank automatic drain valve (Figure 2) is designed to remove liquids from the wet tank each time the brake is applied as the solenoid is

connected to the stop light circuit. A built-in heater prevents freeze-ups and keeps the air system clean in all temperature.

3.1.1 Installation

1. Make sure that there is no pressure in the wet tank (emptied tank).
2. Fit the automatic drain valve to the wet tank. Tighten valve finger tight and then tighten an additional 1 ½ turns, do not over tighten.
3. Connect the power cable to the valve connector.
4. Charge the air system and make sure there is no leakage. Also check functioning of the drain valve by applying the service brake.

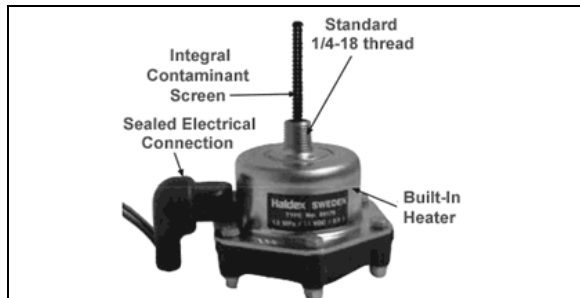

FIGURE 2: WET TANK AUTOMATIC DRAIN VALVE

3.2 MAINTENANCE

Except when equipped with an automatic drain valve, air tanks must be purged at every 12,000 miles or once every year, whichever comes first.

3.2.1 Ping Tank

The ping tank is located in the engine compartment; it is accessible through the engine compartment R.H. side door. It is used to dissipate heat and to reduce noise produced by the air compressor cycling on and off. The ping tank is not provided with a drain valve. Confirm proper operation once a year.

3.2.2 Wet (Main) Air Tank

This reservoir, located above the L.H. wheel of drive axle in the rear wheelhousing, is provided with an automatic drain valve and doesn't need to be purged manually.

3.2.3 Primary Air Tank

This reservoir is located above the R.H. wheel of the drive axle and is provided with a bottom drain valve (Figure 1 & Figure 3). It is recommended to purge the primary air tank every 12,000 miles or once a year, whichever comes first.

3.2.4 Accessory Air Tank

The accessory air tank is installed close to the front axle and is provided with a bottom drain valve (Figure 1).

Purge the reservoir by its drain valve every 12,000 miles.

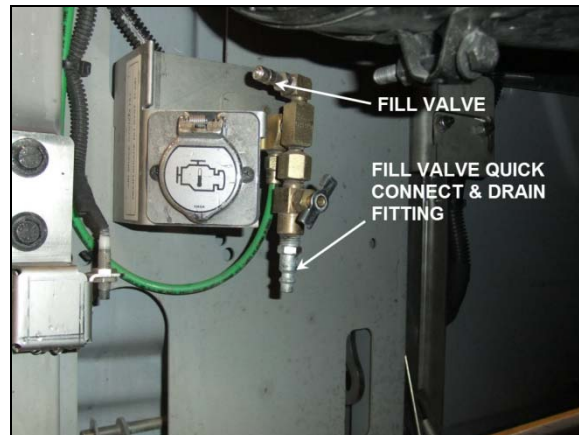

FIGURE 3: EMERGENCY AIR SYSTEM FILL VALVES AND DRAIN COCK 12211_1

3.2.5 Secondary Air Tank

This tank is located in the front wheelhousing, behind the steering axle (Figure 1). It is provided with a bottom drain valve.

Purge this reservoir every 12,000 miles.

3.2.6 Kneeling Air Tank

The kneeling air tank is located in the front wheelhousing (Figure 1), and is provided with a bottom drain valve.

3.2.7 Parking Brakes Override Air Tank

The parking brakes override air tank is installed at the ceiling of the rear baggage compartment, on the L.H. side, and is provided with a bottom drain valve.

4. AIR SYSTEM EMERGENCY FILL VALVES

All vehicles come equipped with two emergency fill valves that enable system pressurization by an external source such as an air compressor. The rear valve is located in the engine compartment and is accessible from engine R.H. side door (Figure 3). It is positioned close to the door opening.



CAUTION

Maximum allowable air pressure is 140 psi (965 kPa). Air filled through these two points will pass through the standard air filtering system provided by Prevost. Do not fill system by any point on the system.

The front valve is located in the front service compartment close to R.H. side of door frame (Figure 4).

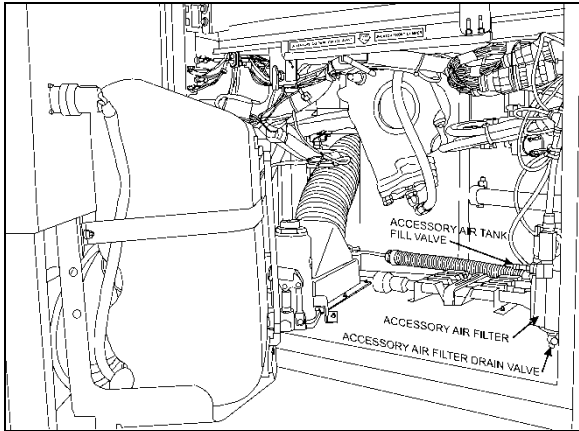

FIGURE 4: FRONT SERVICE COMPARTMENT 12210

These two air system emergency fill valves are fitted with the same valve stems as standard tires, and can be filled by any standard external air supply line.

The rear air system emergency fill valve will supply air for all systems (brakes, suspension and accessories) while the front fill valve will supply air for accessories only.

5. ACCESSORY AIR FILTER

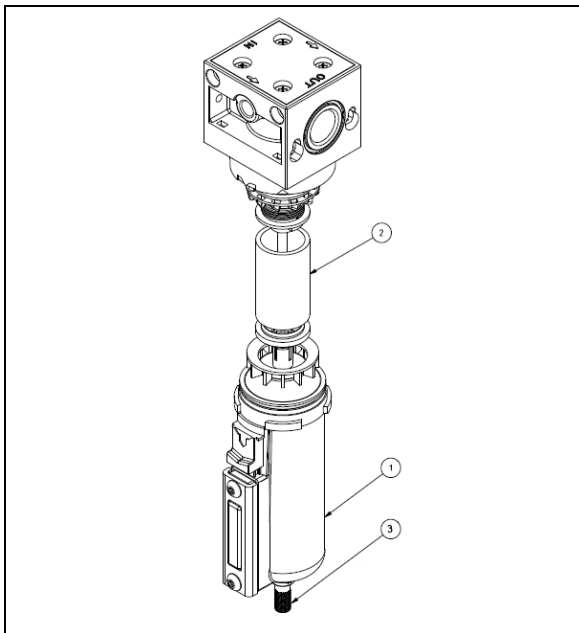

FIGURE 5: ACCESSORY AIR FILTER

Item	Description
1	FILTER
2	METAL BOWL W/ MANUAL DRAIN
3	PURGE

This filter is located inside the front service compartment (Figure 4). Its main function consists in filtering the air supplied to the accessory air system, when connected to an external supply line. Ensure filter is purged whenever supplying the system with an external air line and at least every 12,000 miles. To purge, open drain valve (Figure 5), let the moisture come out, then close the drain valve.

5.1 FILTER ELEMENT REPLACEMENT

Replace filter element whichever of the following occurs first: every 100,000 miles (160 000 km), every two years, or whenever differential pressure exceeds 15 psi (105 kPa) between filter inlet and outlet ports. Check condition of all three O-rings for damage. Replace when necessary (Figure 5).

5.2 CLEANING

Clean filter body and bowl with a warm water and soap solution. Rinse thoroughly with clean water. Blow dry with compressed air making sure the air stream is moisture free and clean. Pay particular attention to the internal passages. Inspect all parts for damage and replace if necessary.

6. AIR GAUGES (PRIMARY, SECONDARY AND ACCESSORY)

The air pressure gauges, located on the dashboard (see "Operator's Manual"), are fed from pressure transducers connected to the DC-4 double check valve, located on the pneumatic accessory panel in the front service compartment.

The latter is connected to the air lines running from the primary and secondary air tanks, as shown on the pneumatic system diagram provided in the technical publications box. The accessory air gauge is connected to the accessory air tank using the drain valve connector. The vehicle should never be set in motion until the buzzer alarm and warning lights turn off, i.e. when air pressure registers at least 75 psi (517 kPa). Moreover, if pressure drops below 75 psi (517 kPa), the "Low air pressure" warning lights will turn on, and the "Low air pressure" buzzer will sound. Stop the vehicle immediately, determine and correct the cause(s) of pressure loss. Check the gauges regularly with an accurate test gauge. Replace the gauge with a new unit if there is a difference of 4 psi (27 kPa) or more in the reading.

7. AIR DRYER

Meritor Wabco air dryer port identification

PORT	DESCRIPTION
1	From compressor
21	To wet tank
3	Exhaust
4	To governor unloader
6	Electrical control

Torque for connections:

3/8"-18 NPTF= 12 lbf-ft

1/4"-18 NPTF= 12 lbf-ft

1/2"-14 NPTF= 37 lbf-ft

Safety valve dynamic pressure: 290 psi



FIGURE 6: AIR DRYER 12226

The electric air dryer works according to the same principles as its air-controlled predecessor. The difference is that this air dryer is controlled by the multiplex system. If the air dryer should for some reason become powerless, it will cease to function and the desiccant will become *wet through*, while the compressor will continue to charge. Relief is provided via the safety valve.

By using the information from the vehicle electronic system, the air dryer and compressor control is optimized, so that drying of the air is guaranteed and fuel consumption is reduced. This will be noticed as a different compressor start/stop pattern.

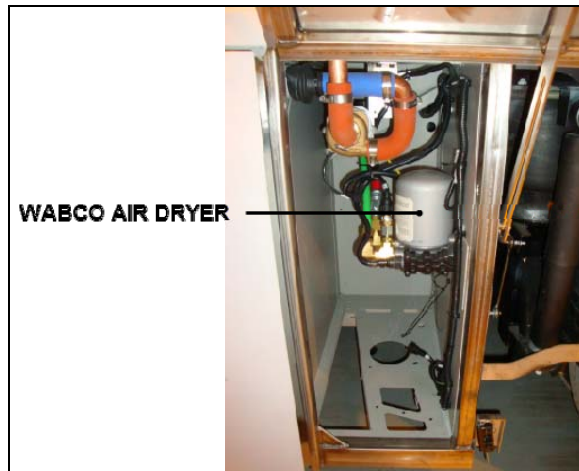

FIGURE 7: AIR DRYER LOCATION

The air dryer has a built-in function to prevent freezing or blockage. The function provides temporary relief (air dryer blow clean) at engine shut down. This function eliminates the problem of freezing on a stationary vehicle.

An additional feature at vehicle start-up prevents the compressor from charging air during engine cranking and start-up.

The air filter/dryer is located in the coolant heater compartment; driver's side, front of the rear wheelhousing.

Its purpose is to remove moisture that could damage the air system before the air enters the system reservoir. The air filter/dryer also filters the air to remove dirt, compressor oil, and other contaminants that can damage the system.

MAINTENANCE

AIR DRYER DESICCANT CARTRIDGE

Change cartridge every 100,000 miles or once every two years, whichever comes first.

The air dryer and wet tank may be purged simultaneously for maintenance purposes using the drain cock on the emergency air system fill valve located in the engine compartment and accessible through the engine compartment R.H. side door (Figure 3).

For more information on Meritor Wabco Air dryer, refer to the following manuals included on your technical publications CD:

- *Meritor Wabco System Saver Series Single Cartridge Air Dryers Maintenance Manual 34*

SECTION 12: BRAKE AND AIR SYSTEM

- *Meritor Wabco Installing the Meritor Wabco System Saver 1000, 1200 Series Air Dryers TP-92116*

7.1 AIR DRYER REPLACEMENT

5. Apply parking brakes, set the ignition switch to the OFF position.



WARNING

Relieve the air pressure in the air system prior servicing any component in the air system. Pressurized air can cause personal injury.

6. Purge the air dryer and wet air tank. To do so, open the air system emergency air-fill valve drain cock (Figure 3).
7. Unplug the air dryer electrical connector (L350AA, port II) (Figure 8).
8. Unplug the air pressure sensor connector (L350AB, port 21).

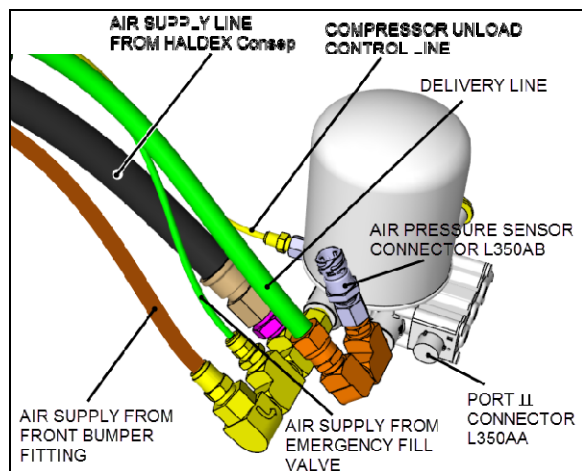

FIGURE 8: WABCO AIR DRYER CONNECTIONS

9. Disconnect the three following air lines:
 - Air supply from Haldex Consep condenser-separator (#12 black textile braid with two green stripes, port 1);
 - Air supply from emergency fill valve (1/4 green, port 1);
 - Air supply from front bumper fitting (1/2 brown, port 1).
10. Disconnect the compressor governor unloader control line (1/4 yellow, port 4).
11. Disconnect the delivery line to wet tank (3/4 green, port 21).
12. Unscrew and remove three bolts mounting the air dryer to the bulkhead.

13. Remove and transfer the inlet (port 1) fittings assembly as a single unit to the new air dryer assembly. Install the fitting assembly with an angle of 50° as shown on Figure 9.

NOTE

Use Loctite 567 Thread Sealant on all NPT threads.

14. Remove and transfer the outlet (port 21) fittings assembly (1 elbow + 1 tee) as a single unit to the new air dryer assembly. Install the fitting assembly with an angle of 45° as shown on Figure 9.
15. Remove and transfer the compressor governor unloader control line fitting to the new air dryer assembly.

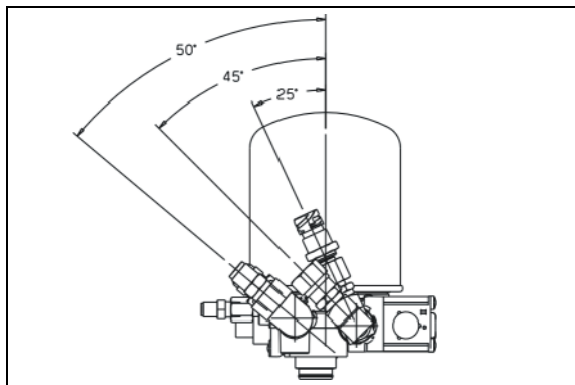

FIGURE 9: FITTINGS DIRECTION

16. Mount the new air dryer assembly similarly. Torque mounting bolts to **22-30 lbf-ft**.
17. Connect air lines and electrical connectors to new air dryer as previously installed (Figure 8).
18. Close the air system emergency air-fill valve drain cock (Figure 3).

7.1.1 Testing the installation

1. Close the drain cocks on all reservoirs.
2. Start the bus. Wait for the air system to reach full operating pressure (122psi-140psi).
3. If the air dryer exhausts air for 10-20 seconds after the governor cuts out, it is working correctly.
4. Apply vehicle brakes several times until the compressor cuts in.
5. If the air dryer exhausts air for 10-20 seconds after the compressor cuts out, it is working correctly.

7.1.2 Final check

1. Start the vehicle. Wait for the air system to reach full operating pressure. When the compressor cuts out, listen to the air dryer. If either of the following conditions exist, refer to Meritor Wabco System Saver 1000 Maintenance Manual No. 34.
 - The air dryer continues to exhaust air for longer than 30 seconds.
 - The air dryer does not exhaust air after initial decompression.
2. Shut engine OFF. Apply a soap solution to each connection that contains pressurized air:
 - If soap bubbles do not appear, connections are sealed properly.
3. If soap bubbles appear:
 - Drain all reservoirs.
 - Remove leaking connection.
 - Inspect for damaged threads or cracks; replace as necessary.
 - Apply pipe sealant (Loctite 567) or teflon tape to the connection.
 - Repeat process.

7.2 DESICCANT CARTRIDGE REPLACEMENT

1. Apply parking brakes, set the ignition switch to the OFF position.
2. Replacement kit contains one desiccant cartridge and one O-ring.
3. Purge the air filter and wet air tank. To do so, open the air system emergency air-fill valve drain cock (Figure 3).
4. Loosen and remove the old cartridge. Use strap wrench if necessary.
5. Remove and discard O-ring from dryer base. Inspect and clean seal seat (Figure 10).
6. Repair any minor damage.
7. Lubricate with clean machine oil and install new O-ring on stem.
8. Lubricate cartridge seal with clean machine oil.
9. Thread replacement cartridge onto the base until the seal touches the base. Then,

tighten the cartridge **ONE** additional turn. **DO NOT OVERTIGHTEN.**

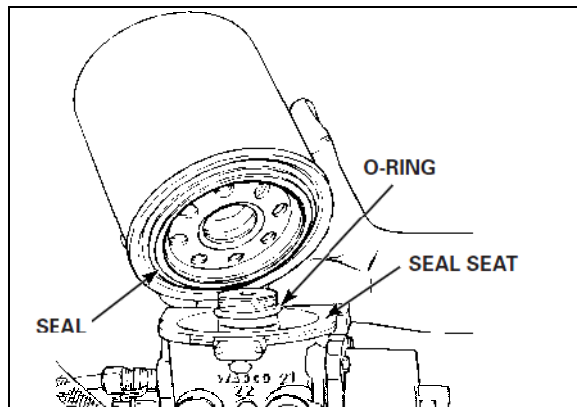

FIGURE 10: DESICCANT CARTRIDGE REPLACEMENT

8. HALDEX CONDENSER - SEPARATOR

The Consep Air Condenser-Separator is located in the rear wheelhousing, fore of drive axle (Figure 1). The Consep is mounted in the air line between the compressor and the air dryer. It condenses, separates and removes 90% of the oils, liquids and other contaminants. It reduces corrosion and possible failure of air brake system components caused by contamination and significantly increases the air dryer desiccant life.

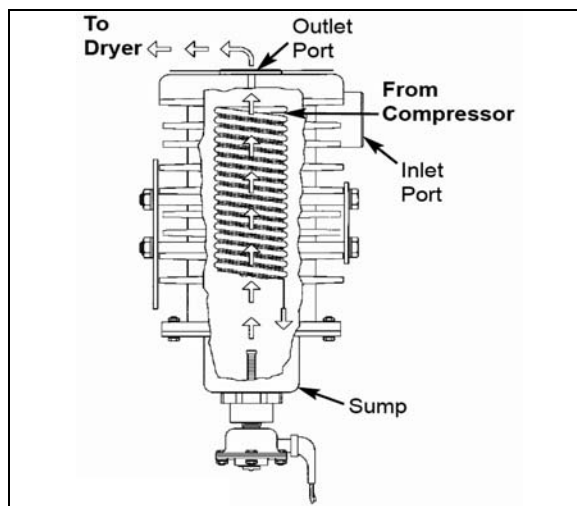

FIGURE 11: HALDEX CONSEP CONDENSER SEPARATOR

The automatic heated drain valve installed on the Consep ensures that liquids are removed upon each brake application for optimum performance. The drain valve's integrated filter prevents damage from large debris.

The automatic drain valve activates when the rear stop lights turn ON, with the prerequisite

conditions of having a vehicle speed greater than 2 mph and the engine running.

The solenoid remains energized simultaneously with activation of the rear stop lights to heat up air output to prevent it from freezing. However, Multiplex programming will ensure that the solenoid remains energized for at least of 45 seconds but not longer than 5 minutes.

8.1 MAINTENANCE

The Consep requires little maintenance during its long service life. The Consep must be inspected periodically for proper operation. The interval between inspections is determined by the type of service (every 12,000 miles for City Transit). High compressor duty cycles and high temperatures can cause a buildup of carbon in the condenser, drain valve and filter. This contamination must be removed for proper operation.

For more information on the periodic inspection, refer to **Haldex Consep Condenser Separator, Installation, Maintenance & Inspection L31167** included on your technical publications CD.

9. AIR LINES

Copper piping, nylon-reinforced tubing, and flexible hoses are used to connect the units in the pneumatic system, including air brake system, suspension system and accessory systems such as the entrance door, fresh air damper cylinder, air horns, etc. Furthermore, the nylon tubing is color coded to ease identification. Refer to the following table for the complete color identification code. Service instructions for each type of air line are also provided under the applicable headings.

Color	Circuit
Green	Primary Brake System and Supply
Red	Secondary Brake System
Brown	Parking / Emergency Brake System
Yellow	Compressor Governor Signal
Black	Accessories Air System
Blue	Suspension

9.1 FLEXIBLE HOSES

A flexible hose is used normally where it is impractical to use copper or nylon tubing due to constant flexing during operation, such as brake chamber hoses. Hose connections should be

tested for leakage at least every 6,250 miles (10 000 km) or twice a year, whichever comes first and tightened or replaced if necessary. Any hose which is chafed, worn or kinked should be replaced.

Teflon-braided stainless steel hoses used in the engine compartment must be replaced only with similar hoses.

9.2 NYLON TUBING

Nylon tubing is used for air lines in areas where usage of this material is suitable. Nylon tubing is flexible, durable, and weather resistant. When replacing an air line, use nylon tubing only where it has been used previously.

Nylon air lines must never be routed in areas where temperature could exceed 200°F (93°C).

	CAUTION
<p>Nylon air lines should be used to replace existing nylon lines only, and must comply with the color identification code to ease pneumatic system troubleshooting.</p>	

9.3 AIR LINE OPERATING TEST

If any trouble symptom such as slow brake application or slow brake release indicates a restricted or clogged air line, disconnect the suspected tube or hose at both ends and blow through it to clear the passage.

Inspect tubing and hose for partial restriction that may be caused by dents or kinks. If such a condition is found, the tubing or hose should be replaced.

9.4 AIR LINE LEAKAGE TEST

With air system fully charged and the brakes applied, coat all tubing and hose connections with a soapy solution to check for air leakage. No leakage is permitted. Leakage can sometimes be corrected by tightening the connection. If this fails to correct the leakage, new fittings, nylon tubing, copper tubing, teflon-braided stainless steel and flexible hoses must be installed as applicable.

9.5 MAINTENANCE

Inspect all lines for cuts, swelling, kinks or other damage or deterioration. Check for lines being pinched by other components. Retaining clips and ties must be in place.

Any support or bracket should be in good condition and mounted firmly in position. Hose spring guards should be in usable condition and

not distorted. Particular attention should be given to long lines. Any supporting component (clips, ties, grommets, etc.) must be secured to prevent against unnecessary vibration and eventual loosening of connection. Any detected leak should be repaired. Be sure nylon lines are not near areas of intense heat. Check for any missing grommets or loose material where chafing or cutting may occur. Replace with new material as required. In general, lines should be securely located in position and free from any binding condition which would hinder air flow.

10. PRESSURE REGULATING VALVES

There is one pressure regulator for the belt tensioners, and another one installed on vehicles equipped with the World transmission output retarder.

The other regulator is located in the engine compartment, on the engine cradle R.H. side (accessible through the engine R.H. side door). It is used for transmission retarder and should be adjusted to 85 ± 3 psi (586 ± 20 kPa).

	Air Pressure (psi)	Air Pressure (kPa)
Retarder	85	586

10.1 MAINTENANCE

Every 100,000 miles, disassemble the regulating valve and wash all metal parts in a cleaning solvent (Figure 12). Examine the diaphragm; if cracked, worn or damaged, replace with a new one. If the valve is excessively grooved or pitted, it should be replaced. Replace any other part that appears worn or damaged. After reassembly, adjust to the specified pressure setting and check for air leakage.

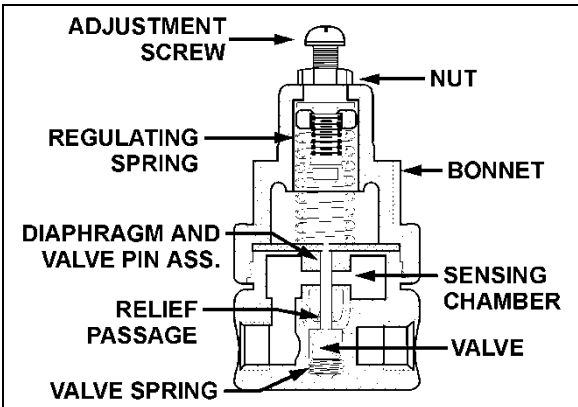

FIGURE 12: AIR PRESSURE REGULATING VALVE
12141A

10.2 PRESSURE SETTING PROCEDURE

Remove the dust cap from the pressure check valve (Figure 12). Attach a pressure gauge at this port and check the pressure reading. If the pressure reading is incorrect, adjust as follows:

10. Loosen the locking nut, turn the adjustment screw counterclockwise to decrease pressure by approximately 10 psi (70 kPa) below the required pressure.
11. Turn the adjustment screw clockwise to increase the pressure slowly until the required pressure setting is reached. Tighten the locking nut.
12. Remove pressure gauge and replace dust cap on the air pressure check valve.

11. AIR COMPRESSOR

The Wabco System Saver 636 Twin Cylinder air compressor is located on the alternator side of the engine, at the flywheel end (Figure 13). Its function is to provide and maintain air under pressure to operate devices in brake and air systems.

The compressor is driven by the ring gear, and is water cooled. Engine coolant is fed to the compressor through a flexible hose tapped into the block water jacket and connected to the rear of the compressor. Coolant returns from the top of the compressor (governor side) through a flexible hose to the engine pump.

The air is taken from the air intake manifold and entered in the top of the compressor. The compressed air is pushed into the discharge line located on side of the compressor, which sends air to the air dryer. Lubricating oil is supplied to the compressor by a line from the cylinder block oil gallery connected to the air compressor. Lubricating oil returns to the engine crankcase through the air compressor drive assembly.

Refer to Wabco 636 Twin Cylinder Service Documentation for Maintenance and repair information.

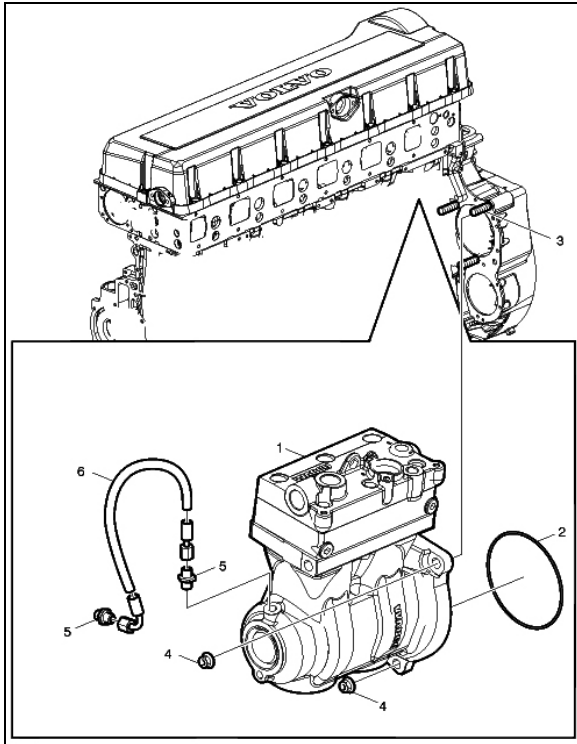

FIGURE 13: AIR COMPRESSOR LOCATION 03061

11.1 COMPRESSOR REMOVAL AND INSTALLATION

1. Exhaust compressed air from air system by opening the drain valve of each air tank.
2. Drain the engine cooling system. See Section 5: "Cooling System".
3. Access the compressor by the engine R.H. side compartment. Identify and disconnect all air, coolant and oil lines from the compressor assembly.
4. Remove the three compressor flange mounting nuts.
5. Slide air compressor rearward to disengage the hub from coupling. Remove the air compressor.

Remove and retain the oil supply tube that runs between the compressor and the engine

Reverse removal procedure for installation.

12. EMERGENCY/PARKING BRAKE CONTROL VALVE (PP-1)

A push-pull control valve mounted on the L.H. lateral console is provided for parking brake application or release. The spring brakes are self-actuated whenever the control valve supply pressure drops below 60 psi (414 kPa). In the

UP position, brakes are ON. In the DOWN position, brakes are RELEASED. A protective case around the knob prevents accidentally releasing the brakes.

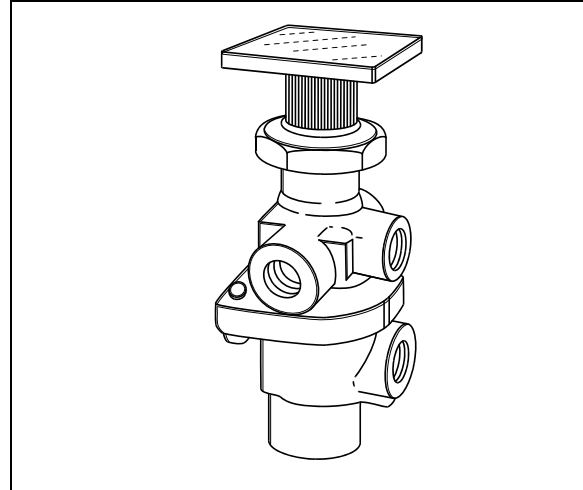

FIGURE 14: PP-1 12142

Maintenance and repair information on this valve is supplied in the applicable booklet annexed to this section under reference number

Item	Description	Notes
1	Air Compressor	Wabco 636
2	O'Ring	
3	Stud (3)	M12
4	Flange Nut (3)	Torque to 63lb-ft (85 Nm)
5	Nipple (2)	
6	Hose Assembly	

SD-03-3611.

Remove the valve the following way:

1. Drain the air system.
2. Access this valve by tearing out the finishing panel, which holds the controls in place (Figure 14).
3. Disconnect the air tubes.
4. Remove the retaining screws.
5. Service or replace the valve.
6. Installation is the reverse of removal.

13. EMERGENCY / PARKING BRAKES OVERRULE CONTROL VALVE (RD-3)

A RD-3 control valve is used with the parking brake overrule system. In the case of self-application of spring brakes due to a pressure drop, the brakes can be released by holding down this control valve. Maintenance and repair

information on this valve is supplied in the applicable booklet annexed to this section under reference number SD-03-3611.

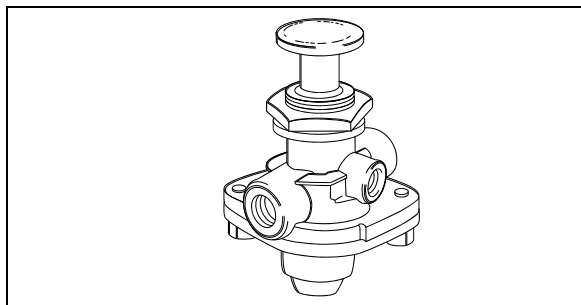

FIGURE 15: RD-3

12136

14. FLIP-FLOP CONTROL VALVE (TW-1)

A flip-flop control valve mounted on the L.H. lateral console is provided to unload tag axle air springs and to lift tag axle. It is a manually operated "on-off" valve. Maintenance and repair information on this valve is supplied in the applicable booklet annexed to this section under reference number SD-03-3602.

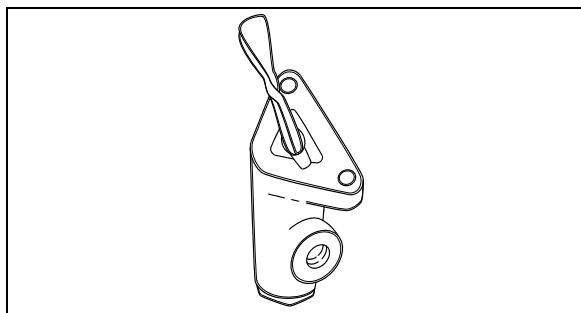

FIGURE 16: TW-1

12138

15. DUAL BRAKE APPLICATION VALVE (E-8P)

The E-8P dual brake application valve is a floor mounted, foot-operated type brake valve with two separate supply and delivery circuits. This valve is located in the front service compartment (Figure 18).

Maintenance and repair information on the E-8P this valve is supplied in the applicable booklet annexed to this section under reference number SD-03-830.

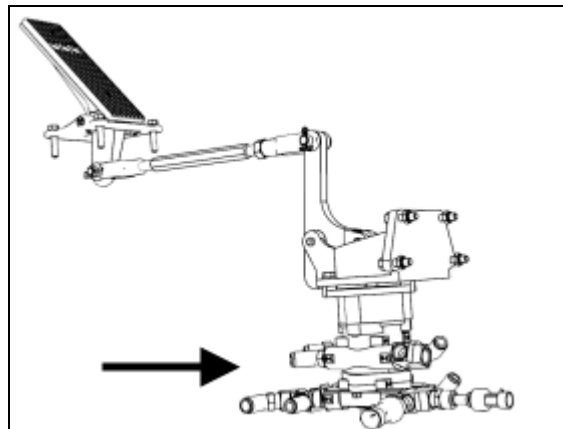

FIGURE 17: E-8P DUAL BRAKE VALVE

15.1 BRAKE PEDAL ADJUSTMENT

After brake pedal replacement or repair, adjust the pedal to its proper position according to the following procedure.

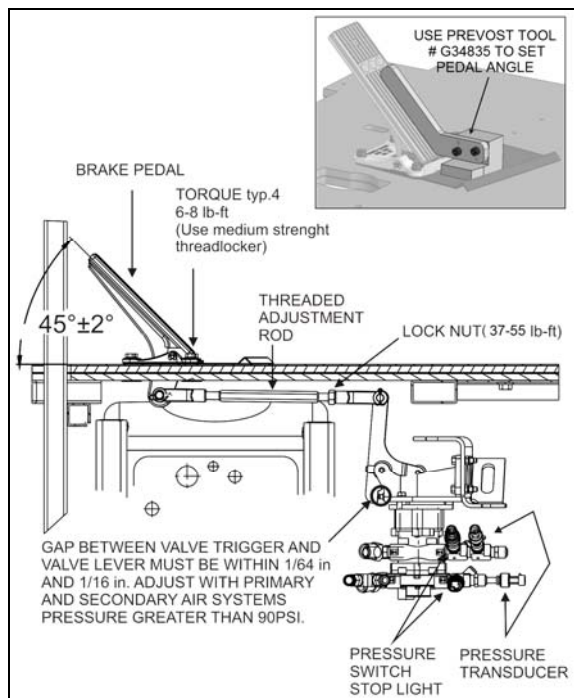

FIGURE 18: BRAKE PEDAL ADJUSTMENT

12208_1

1. Connect the linkage yokes and install cotter pin and ring cotter.

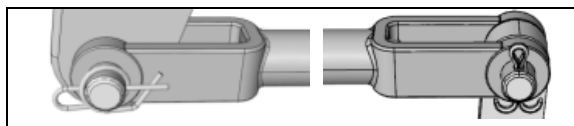

FIGURE 19: PINS

2. Loosen threaded rod lock nut and turn the threaded rod CW or CCW in order to obtain a 45° brake pedal inclination. Use *Prevost*

Tool # G34835 to ensure proper pedal angle (Figure 18).

3. Tighten threaded rod lock nuts to 37-55 lb-ft.

NOTE

When replacing a brake pedal assembly, make sure to:

- Push the brake pedal assembly all the way toward the front of the vehicle.
- Apply blue Loctite (242 or similar medium strength threadlocker) to the four pedal retaining bolts.
- Torque each of the four retaining bolts to 6-8 lb-ft.
- Apply torque seal lacquer to the bolts after final torque.

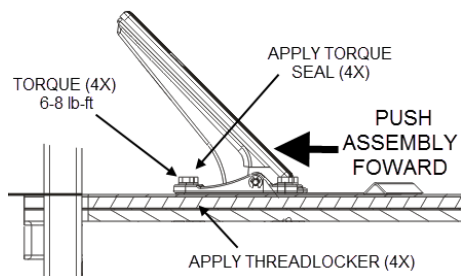

15.2 STOPLIGHT SWITCHES

Two stoplight switches are mounted on the dual brake application valve (Figure 18). The upper one is used for the primary air circuit while the lower one is used for the secondary air circuit. Both switches have the same purpose, i.e. sending a signal that indicates when a brake application is made.

16. PARKING BRAKE ALARM SWITCH

Refer to the appropriate booklet (Bendix, SL-5 Stop Light Switch; reference no. SD-06-2501).

The parking brake alarm uses the same switch as the stoplights. It is mounted on the spring brake valve and operates in conjunction with a NC relay to sound a warning alarm by completing the electrical circuit when the ignition switch is turned OFF with parking brake released.

17. BRAKE RELAY VALVE (R-14)

The primary air system includes three brake relay valves being supplied by the dual brake valve, and which function is to speed up the application and release of the service brakes.

One R-14 valve located in the rear underframe supplies the drive axle service brake air line, while the other R-14 valves supplies the tag axle service brake air line. These valves are accessible from under the vehicle at the level of the tag axle.

Maintenance and repair information on these valves is supplied in the applicable booklet annexed to this section under reference number SD-03-1064.

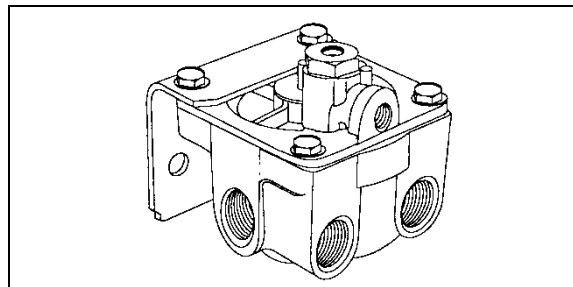

FIGURE 20: R-14 12207

18. ANTILOCK TRACTION RELAY VALVES (ATR-6)

This valve combines service braking and traction control as well as electronic stability system functions. It is located above the front axle.

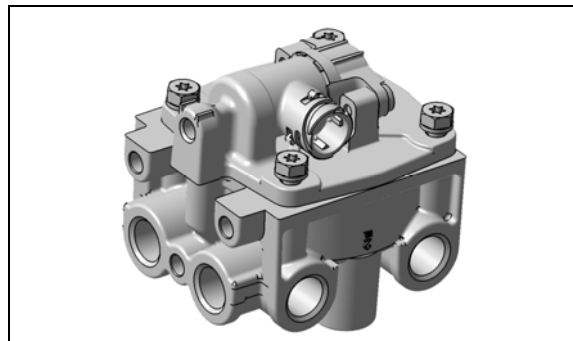

FIGURE 21: ATR-6

12075

Maintenance and repair information on this valve is supplied in the applicable booklet annexed to this section under reference number SD-13-4861

19. SPRING BRAKE VALVE (SR-7)

The spring brake valve is located in the rear underframe. The SR-7 Modulating Valve is used in conjunction with a dual air brake system and spring brake actuator and performs the following functions:

- Provides a rapid application of the spring brake actuator when parking.
- Modulates the spring brake actuator application using the dual brake valve should a primary failure occur in the service brake system.
- Prevents compounding of service and spring forces.

Maintenance and repair information on the spring brake valve is supplied in the applicable booklet annexed to this section under reference number SD-03-9043.

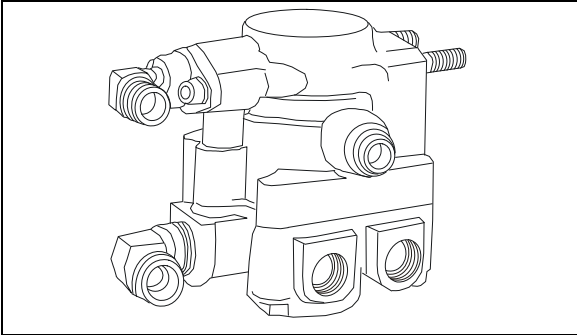

FIGURE 22: SR-7 12206

20. PRESSURE PROTECTION VALVE (PR-4)

Maintenance and repair information on the pressure protection valve is supplied in the applicable booklet annexed to this section under reference number SD-03-2010.

The air system includes two pressure protection valves (Figure 23). One valve is installed on the manifold block, and insures at all times a minimum pressure of 75 psi (517 kPa) in the suspension air system in the event that a pressure drop occurs in either the suspension air system or accessory air system. This valve is located in the front service compartment beside the air filter.

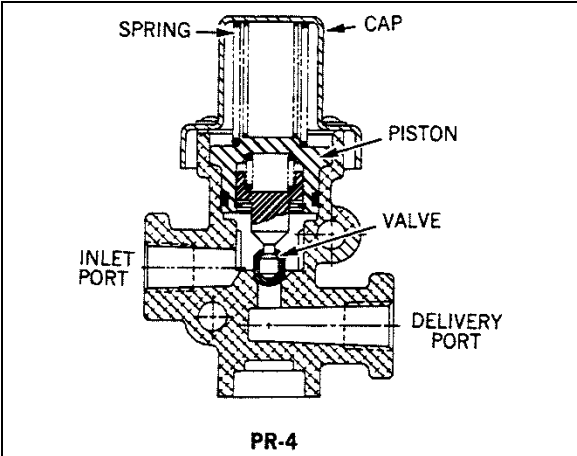

FIGURE 23: PR-4 12174

The other valve is installed on the accessory air tank, and insures a minimum pressure of 75 psi (517 kPa) in the accessory air system in the event that a pressure drop occurs in either the suspension air system or braking air system (refer to Figure 1 for accessory air tank location).

21. SHUTTLE-TYPE DOUBLE CHECK VALVE (DC-4)

Maintenance and repair information on the shuttle-type double check valve is supplied in the applicable booklet annexed to this section under reference number SD-03-2202.

The double check valve is located on the pneumatic accessory panel in the front service compartment. In the event of a pressure drop in either the primary or secondary system, this unit will protect the emergency /parking brake control valve and the intact portion of the air system from pressure loss.

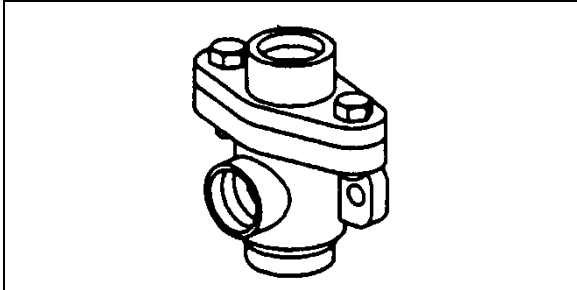

FIGURE 24: DC-4 12134

22. EMERGENCY BI-FOLD ENTRANCE DOOR OPENING VALVES

Two emergency door opening three-way valves are installed on the coach. One is in the front service compartment, readily accessible. The other one is below the R.H. dashboard panel. When used, the valve releases pressure in the entrance door locking cylinders, thus allowing the door to be manually opened.

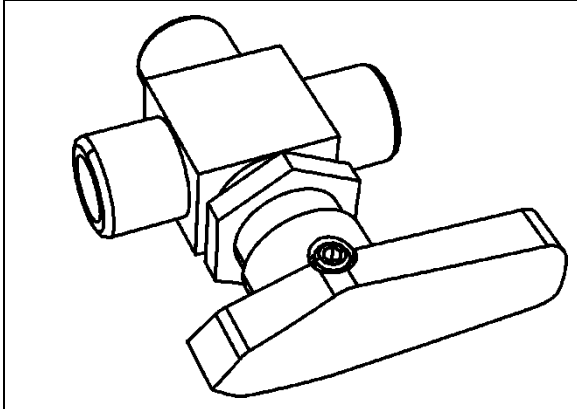

FIGURE 25: THREE-WAY VALVE 12186

23. AIR SYSTEM TROUBLESHOOTING

The following list has been designed to help in troubleshooting some of the most common problems in the air system and main causes. For air brakes troubleshooting, refer to “*Air Brakes Troubleshooting*” in this section. For more troubleshooting information, refer to the manufacturer's brochures annexed to this section.

Air pressure doesn't rise to, or doesn't maintain, a normal setting:

- Defective air gauge (registering incorrectly).
- Excessive leaking in air system.
- Reservoir drain cock open.
- False sensor.
- Defective compressor.
- Worn compressor or excessive wear on piston and/or ring.
- Air pressure rises to normal setting too slowly.

Excessive leaking in air system:

- Clogged engine air cleaner.
- Worn compressor or excessive wear on piston and/or ring.
- Engine speed too low.

Air pressure rises above a normal setting:

- Defective air gauge (registering incorrectly).
- Governor poorly adjusted or defective.
- Restriction in line between governor and compressor unloading mechanism.

Air pressure drops quickly when engine is stopped:

- Leaks in compressor discharge valve.
- Leaks in governor.
- Leaks in air lines.
- Leaks in air system valves.

24. BRAKE OPERATION

The vehicle braking system uses both service and parking air-operated brakes. The air system is divided into two independent circuits to isolate the front axle brakes and the rear axle brakes (drive and tag), thus providing safe brake operation in the event that one circuit of the system fails. The primary circuit is connected to the drive and tag axle brakes, while the secondary circuit is connected to the front axle

brakes. The tag axle service brakes operate only when the axle is in the normal driving (loaded) position. The spring-type emergency brakes are mounted on the drive axle, and will apply automatically if primary system pressure falls below 60 psi (414 kPa).

Furthermore, brake application or release, which is speed up by a pneumatic relay valve (R-14), will start with the rear axles and be followed by the front axle, thus providing uniform braking on a slippery surface. The vehicle is also equipped with an Anti-lock Brake System (ABS), detailed later in this section.

Brake and air system maintenance consists of periodic inspections. Check all parts for damage and brake adjustment (refer to subsequent headings in this section for more details). Ensure all fasteners are tight (refer to “*Specifications*” for recommended tightening torques).

25. DISC BRAKES

Knorr-Bremse SN7000 disc brakes are used on all axles. The front and drive axle discs are actuated by 24 inch² effective area air brake chambers, while on tag axle, the brake chambers have a 16 inch² effective area for service brake. The *Knorr-Bremse SN7000* brakes are supplied with automatic clearance (slack) adjusters as standard equipment for easier adjustment.

For more information on disc brake components and scheduled maintenance, refer to **Knorr-Bremse Pneumatic Disc Brake SN7 Service Manual Y006471** included on your technical publications CD.

25.1 INSPECTION POINTS

The following inspection points will ensure long-life and trouble-free operation of the disc brake.

IMPORTANT NOTE

Moisture and dirt is the enemy. So, as a general recommendation, special care should be awarded to the condition of the various sealing elements, boots and caps to prevent any moisture or dirt intrusion in the caliper. Any missing or damaged sealing element, boot or cap should be replaced immediately.

IMPORTANT NOTE

These frequencies are a minimum. Depending on the operating conditions of the vehicle, these inspections may need to be carried-out more frequently.

Refer to Knorr-Bremse Y006471 Service Manual for detailed maintenance procedures about these inspection points.



MAINTENANCE

Every 6,000 miles:

Check brake pad wear visually. This is independent of any electronic wear indicator fitted to the vehicle.

Check condition of the slack adjuster cap and sliding pin covers.

(see Knorr-Bremse Y006471 Service Manual)



MAINTENANCE

Every 12,000 miles or with every pad replacement whichever comes first:

Check proper functioning of the slack adjuster (see Knorr-Bremse Y006471 Service Manual)

Check that caliper operates smoothly over its full range of movement along guide pins.

Inspect all sealing elements boots and caps.



MAINTENANCE

When replacing pads:

Check the caliper running clearance

(see Knorr-Bremse Y006471 Service Manual)

At each pad replacement, make sure the caliper operates smoothly over its full range of movement. If the caliper shows the following signs, replacement of the guide sleeve (6c, Figure 26), guide pin, screw (39) and cap is required.

- excessive or abnormal play
- movement along guide pins is hard or impossible (due to corrosion or dirt)
- A missing guide pin cap

Additionally, inspect the tappet and boot assemblies (13, Figure 26), the adjuster cap (37) and the sealing elements (9, 58) for correct fitting and condition as well as the caliper bearing in the area of the rubber bush/guide sleeve (6) (see **Knorr-Bremse Y006471 Service Manual**).

If an individual wheel has heated abnormally, Please refer to Bendix *BW7514_Single wheel end thermal overload checklist*. This checklist will help you through standard verifications required by the brake manufacturer before filing a warranty claim.

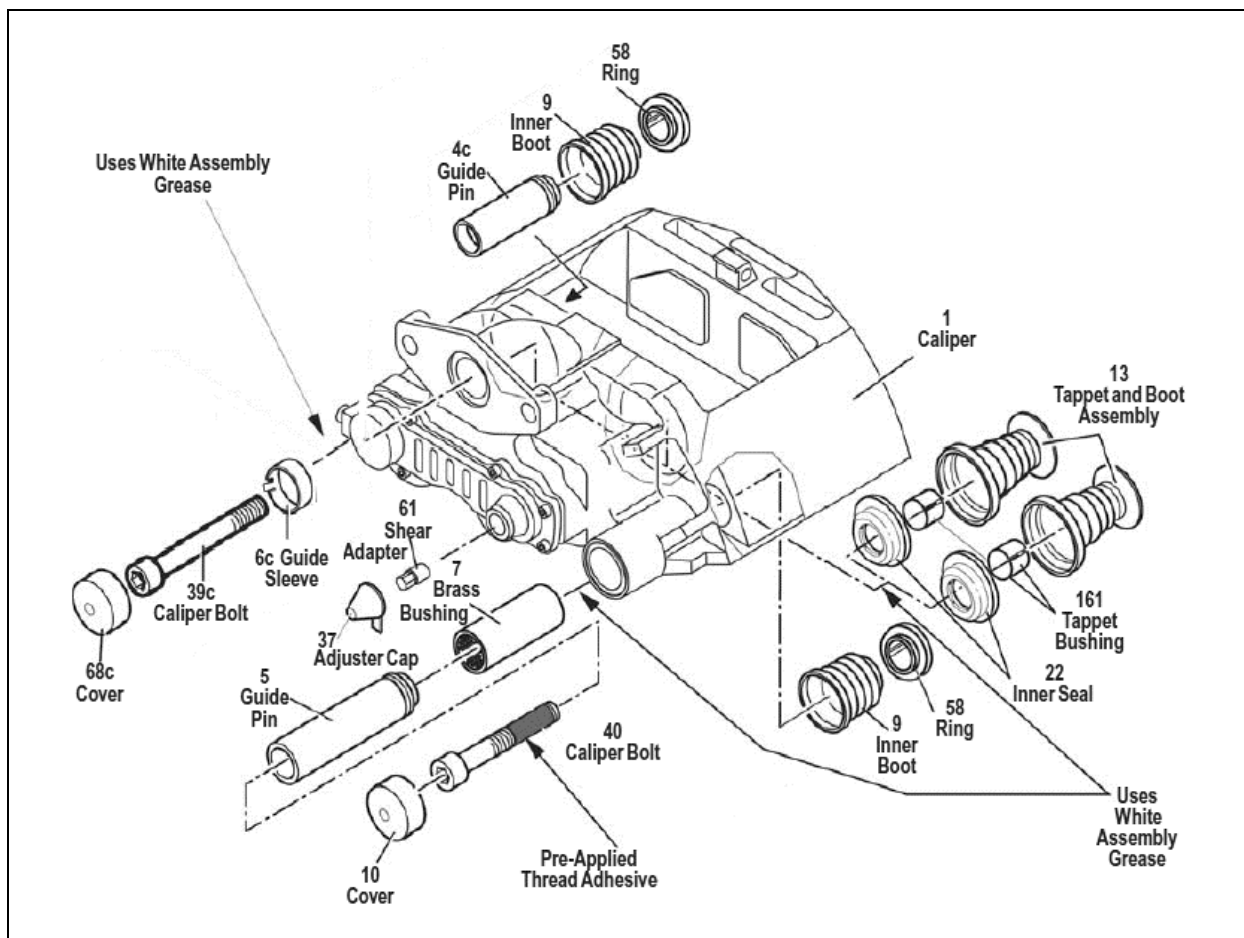

FIGURE 26: BRAKE COMPONENTS

25.2 PAD REPLACEMENT PROCEDURE

Brake pad replacement procedure has slightly changed with the introduction of brakes with improved slack adjusters on our vehicles.

After fitting new pads, adjuster has to be turned clockwise until pads come in contact with the disc. Then turn anti-clockwise **three clicks** to give the correct running clearance.

Please refer to **Knorr-Bremse Y006471 Service Manual, Section 6** for the latest brake pad replacement procedure.

25.3 CHECKING DISC BRAKE PADS

Brake pads have to be checked on a regular basis depending on the vehicle operation. The remaining thickness of the pads should never be less than 0.079 in (2 mm). When replacing brake pads, all four pads on an axle have to be changed at the same time. There is no inner or outer pad, since all pads are the same.

Once removed, worn pads should be replaced in their original position. Please refer to Knorr-Bremse Y006471 Service Manual for further detail.

25.3.1 Drive Axle – Equipped With L-bracket Wear Indicator

The condition of the pads can quickly be checked without removing the wheel by checking the position of the caliper compared to the tip of the wear indicator.

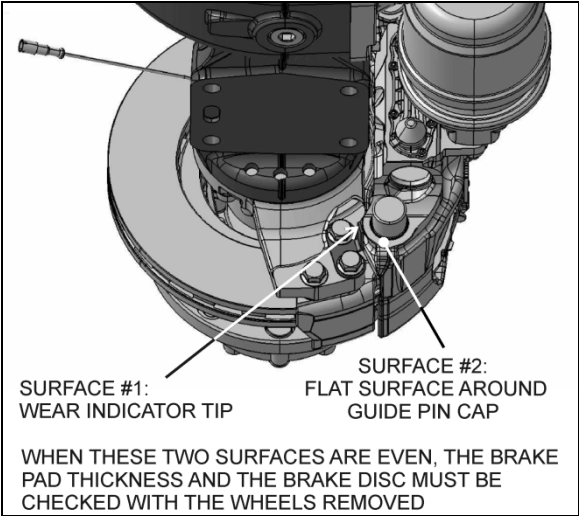

FIGURE 27: BRAKE PAD WEAR CHECK ON DRIVE AXLE

If the side of the caliper (flat surface around guide pin cap) lines up with the tip of the wear indicator, then the brake pad thickness and the brake disc must be checked with the wheel removed. If any minimal tolerance limits have been reached, the pads and/or disc must be changed.

Please refer to Knorr-Bremse Y006471 Service Manual for further information on wear check of pads and brake discs.

25.3.2 Front and Tag Axle – Equipped With L-bracket Wear Indicator

The condition of the pads can be checked without removing the wheel by checking the position of the caliper compared to the tip of the wear indicator or carrier depending on vehicles.

In one variant of the visual wear indicator (Figure 28), the side of the caliper (flat surface around guide pin cap) lines up with the tip of the wear indicator (i.e. measurement “A” would be 0.0 in). In this condition, the brake pad thickness and the brake disc must be checked with the wheel removed. If any minimal tolerance limits have been reached, the pads and/or disc must be changed.

Alternately, brake pad wear can be checked using carrier to caliper position. When points “P” and “R” align, the brake pad thickness and brake disc must be checked with the wheels removed (Figure 29). If any minimal tolerance limits have been reached, the pads and/or disc must be changed.

Please refer to *Knorr-Bremse Service Manual* for additional details.

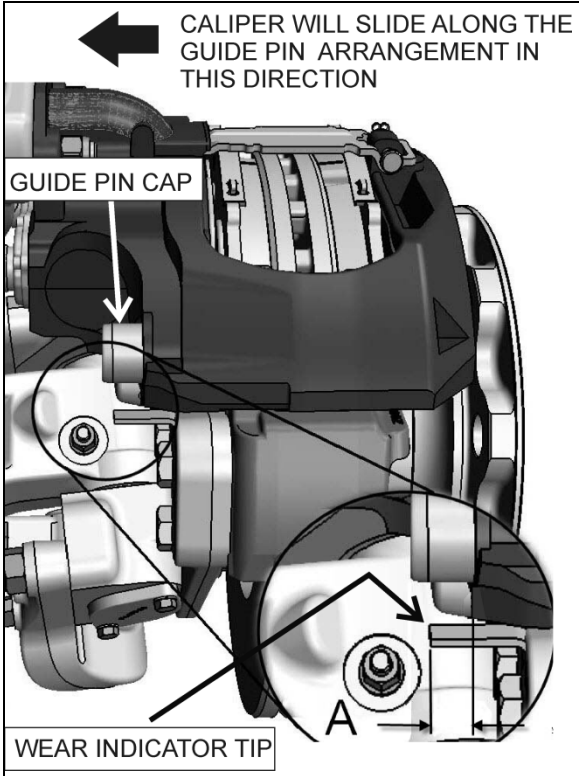

FIGURE 28: PAD WEAR CHECK FRONT AND TAG AXLE

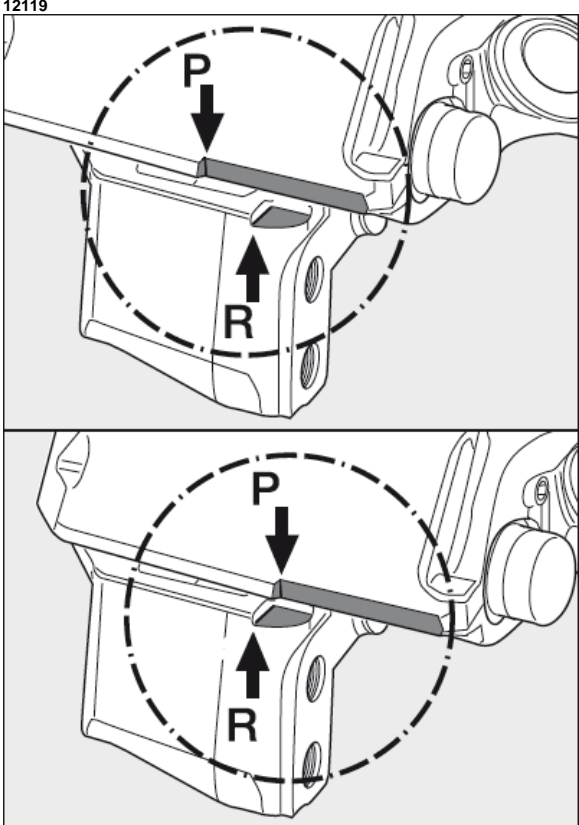

FIGURE 29: PAD WEAR CHECK FRONT AND TAG AXLE

25.3.3 Continuous Wear Sensor.

These vehicles have a potentiometer installed directly on the brake caliper.

Wear percentage can be consulted via the DID. Access the « Brake Lining Remaining » MENU

Front axle wear sensors are connected to multiplex module **A44**.

Right hand (curbside) wear sensors for both rear axles are connected to **A50**

Left hand (road side) wear sensors for both rear axles are connected to **A51**

From the multiplex modules, the signal is sent to Clever System's IVN connection
Refer to wiring diagram for details

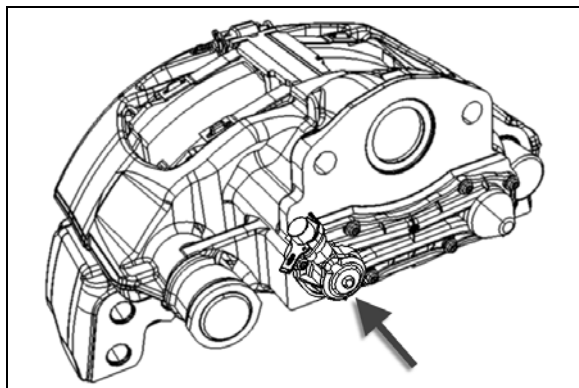

FIGURE 30: POTENTIOMETER

25.4 BRAKE PADS AND DISCS MINIMAL TOLERANCE LIMITS

25.4.1 Brake Pads

The thickness of the pads must be checked regularly dependent on the usage of the vehicle. The pads should be checked corresponding to any legal requirements that may apply. Even if a wear indicator is fitted and connected, this must be at least every 12 months.

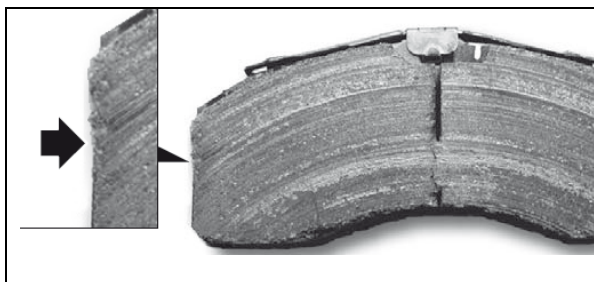

FIGURE 31: MINOR BREAKOUTS AT THE EDGES ARE PERMITTED



FIGURE 32: MAJOR BREAKOUTS ON THE SURFACE OF THE BRAKE PAD ARE NOT PERMITTED

If the thickness of the friction material at its thinnest point is less than 0.079 inch or 2 mm (measurement C), the pads must be replaced.

- A= Overall thickness of new brake pad: 1.18 in (30 mm)
- B= Back plate SN7 type: 0.354 in (9 mm)
- C= Minimal thickness of friction material: 0.079 in (2 mm)
- D= Minimum allowed thickness in worn condition for back plate and friction material: 0.433 in (11 mm)

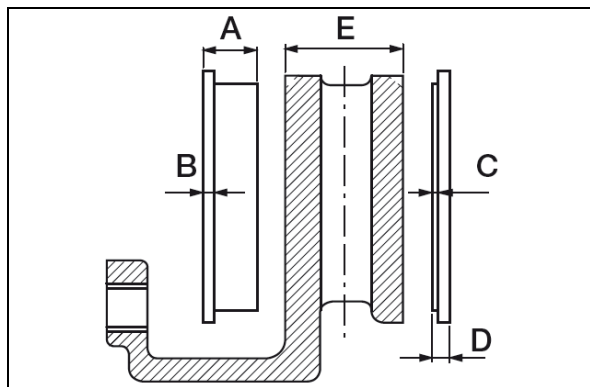

FIGURE 33: BRAKE PAD DIMENSIONS

25.4.2 Brake Disc

Measure the thickness of the brake disc at the thinnest point. Be aware of possible burring at the edge of the disc.

- E= Total thickness of the brake disc
New condition = 1.77 in (45mm)
Worn condition = 1.457 in (37mm) (the disc must be replaced)
If the disc dimension E ≤ 1.535 in (39mm), it is recommended that the disc should be renewed when the brake pads are changed.

Refer to Knorr-Bremse Pneumatic Disc Brake SN7 Service Manual included on the technical manuals CD for additional brake disc visual checks.

25.5 CALIPER RUNNING CLEARANCE

The Knorr Bremse/Bendix air disc brake is designed to move freely, with minimal force. By pushing and pulling the caliper in an axial direction by hand (see arrows in Figure 34), a movement of 0.6 - 1.1 mm must be possible.

If, even using a high level of hand pressure (no tools), the caliper is not moveable, the caliper guidance must be further examined.

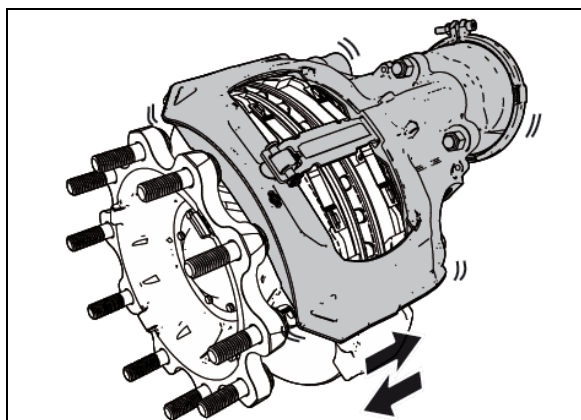

FIGURE 34: CALIPER AXIAL DIRECTION

25.6 TORQUE SPECIFICATIONS

For proper caliper maintenance, refer to the following figures. For other tightening torques, please refer to ZF and Knorr-Bremse literature.

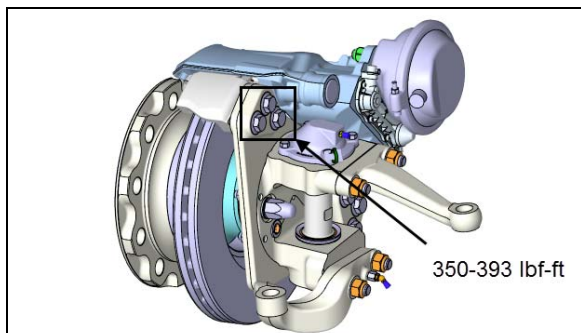

FIGURE 35: CALIPER CARRIER MOUNTING BOLTS TORQUE SPECIFICATION - I-BEAM AXLE

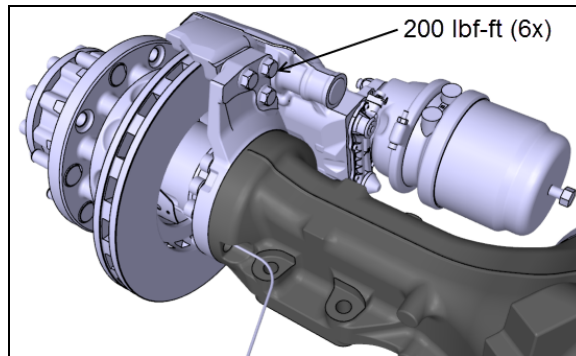

FIGURE 36: CALIPER CARRIER MOUNTING BOLTS TORQUE SPECIFICATION - ZF A132 DRIVE AXLE

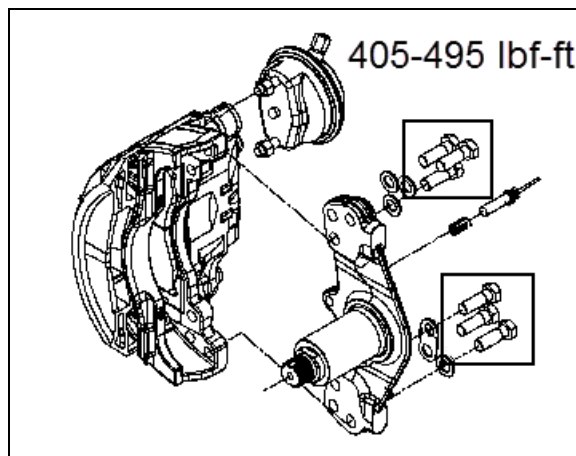

FIGURE 37: CALIPER CARRIER MOUNTING BOLTS TORQUE SPECIFICATION - TAG AXLE

26. SAFE SERVICE PROCEDURES

Most recently manufactured brake linings no longer contain asbestos fibers. Instead of asbestos, these linings contain a variety of ingredients, including glass fibers, mineral wool, aramid fibers, ceramic fibers, and carbon fibers. At present, OSHA (Occupational Safety and Health Administration) does not specifically regulate these non-asbestos fibers, except as nuisance dust. Medical experts do not agree about the potential long-term risks from working with and inhaling non-asbestos fibers. Nonetheless some experts think that long-term exposure to some non-asbestos fibers could cause diseases of the lung, including pneumoconiosis, fibrosis, and cancer. Therefore, lining suppliers recommend that workers use caution to avoid creating and breathing dust when working on brakes that contain non-asbestos fibers.

**WARNING**

NEVER use compressed air or dry brushing to clean brake parts or assemblies. OSHA recommends that you use cylinders that enclose the brake. These cylinders have vacuums with high efficiency (HEPA (Health and Environment Protection Agency)) filters and workmans' arm sleeves. But, if such equipment is not available, carefully clean parts and assemblies in the open air.

Clean brake parts and assemblies in the open air. During disassembly, carefully place all parts on the floor to avoid getting dust into the air. Use an industrial vacuum cleaner with a HEPA filter system to clean dust from the brake drums, backing plates and other brake parts. After using the vacuum, remove any remaining dust with a rag soaked in water and wrung until nearly dry.

If you must grind or machine brake linings, take additional precautions because contact with fiber dust is higher during these operations. In addition to wearing an approved respirator, do such work in an area with exhaust ventilation.

When cleaning the work area, NEVER use compressed air or dry sweeping to clean the work area. Use an industrial vacuum with a HEPA filter and rags soaked in water and wrung until nearly dry. Dispose of used rags with care to avoid getting dust into the air. Use an approved respirator when emptying vacuum cleaners and handling used rags.

Wash your hands before eating, drinking or smoking. Do not wear your work clothes home. Vacuum your work clothes after use and then launder them separately, without shaking, to prevent fiber dust from getting into the air.

Material safety data sheets on this product, as required by OSHA, are available from Rockwell and Knorr-Bremse.

**WARNING**

Whenever possible, work on brakes in a separate area away from other operations.

Always wear a respirator approved by NIOSH (National Institute of Occupational Safety and Health) or MSHA (Mine Safety and Health Administration) during all brake service procedures. Wear the respirator from removal of the wheels through assembly.

27. AIR BRAKE TROUBLESHOOTING

The following tests and check lists have been designed to identify the cause(s) of a sluggish performance and/or leaks in the system. These tests require very little time to perform, and give you a general idea of the system condition. Each test is provided with a corresponding check list which will guide you to the most common causes of problems.

Before performing any test, check all air lines for kinks or dents, and hoses for signs of wear, drying out or overheating.

**WARNING**

When working on or around a brake system and its related components, the following precautions should be observed:

Always block vehicle wheels. Stop engine when working under a vehicle. Keep hands away from chamber push rods and slack adjusters as they may apply when system pressure drops.

Never connect or disconnect a hose or line containing air pressure. It may whip as air escapes. Never remove a component or pipe plug unless you are sure all system pressure has been depleted.

Never exceed recommended air pressure and always wear safety glasses when working with air pressure. Never look into air jets or direct them at anyone.

Never attempt to disassemble a component until you have read and understood the recommended procedures. Some components contain powerful springs and injury can result if not properly disassembled. Use only proper tools and observe all precautions pertaining to the use of those tools.

Always clean connecting piping and/or fittings, and coat pipe threads with Teflon pipe sealant before installing any air brake system component.

Pressure Build-Up / Low Pressure Warning / Cutoff Point / Air Filter/Dryer Built-in Governor Cutout

CONDITION: Vehicle leveled, parking brake applied.

4. Completely drain wet, primary and secondary air reservoirs only.

5. Start engine and run at fast idle. Low pressure warning lights should be "On".
6. Start checking pressure at 50 psi (344 kPa).
7. Low pressure warning lights and buzzer should go off at or above 60 psi (415 kPa).
8. At 85 psi (586 kPa), run engine at max recommended rpm, then check that build up time to 100 psi (690 kPa) is 13 seconds or less.
9. Air filter/dryer built-in governor cut-out. Cuts out at the correct pressure of 140 psi.
10. Air filter/dryer built-in governor cut-in. Cuts in around 122 psi.

For common corrections, refer to the following check list:

High or Low Warning Cutoff Point

- Perform a telltale light and gauge test. Replace entire cluster if found defective.

High or Low Air Filter/Dryer Built-in Governor Cutout Point

- Perform a telltale light and gauge test. Replace entire cluster if found defective.

OR

- Repair or replace air filter/dryer as necessary after checking that compressor unloader mechanism operates correctly.

More than 13 seconds to build-up pressure from 85 to 100 psi (585 - 690 kPa) at full engine RPM

- Perform a telltale light and gauge test. Replace entire cluster if found defective.
- Check compressor strainer or inlet line. If restricted, clean or replace element or faulty line.
- Check compressor head or discharge line for carbonization or restriction. Clean or replace as necessary.
- If discharge valves leak, pull head and correct or replace cylinder head.
- If drive is slipping, replace gear.
- If inlet valves are stuck, open or leaking severely, replace unloader kit, inlet valves and/or seats as necessary.
- If drain cock is found open, close it.
- Listen for air leaks and repair.
- Redo list to check all items repaired or replaced.

Air Supply Reservoir Leakage

CONDITION: Full pressure, engine stopped, parking brake applied

1. Allow at least 1 minute for pressure to stabilize.
2. Stop engine, then check air pressure gauge for 2 minutes. Note any pressure drop.
3. Pressure should not drop by more than 3 psi (20 kPa) per minute.

For common corrections, refer to the following check list:

Excessive air loss:

- With the primary air system at normal operating pressure 122-140 psi, coat all air line connections and pneumatic components with a water and soap solution. Bubbles will indicate an air leak, and none should be permissible. Repair or replace defective parts.
- Listen for leaks and correct as required.
- Redo test to check all items repaired or replaced.

Brake System Air Leakage

CONDITION: Full pressure, engine stopped, parking brake released.

1. Apply service (foot) brakes, allow at least 1 minute for pressure to stabilize.
2. Hold down foot valve for 1 minute while observing air pressure gauge on the dashboard.
3. Pressure drop should not be more than 3 psi (20 kPa) per minute.

For common corrections, refer to the following check list:

Excessive leakage on brake service side:

- With the primary air system at normal operating pressure 122-140 psi and foot brake applied, coat all air line connections and brake pneumatic components with a water and soap solution. Bubbles will indicate an air leak, and none should be permissible. Repair or replace defective parts.
- Listen for leaks and correct as required.
- Redo test to check all items repaired or replaced.

IMPORTANT NOTE

To maintain your vehicle's air disc brakes at their original performance standard, we strongly recommend use of only genuine, approved service replacement parts on Bendix

and Knorr-Bremse air disc brake systems.

If non-approved friction materials or replacement components are used, neither Prevost Car nor Bendix Spicer Foundation Brake LLC will accept any air disc brake-related warranty returns or claims.

For more information on this policy, refer to Bendix-Prevost product notification.

28. BRAKE AIR CHAMBER

This vehicle is equipped with *Knorr-Bremse SN7000* disc brakes on all axles, it also uses "Knorr-Bremse" brake chambers. The drive axle chambers consist of two separate air chambers, each having its own diaphragm and push rod. They are used as a service brake chamber, an emergency brake in case of air pressure loss and a spring-applied parking brake. Refer to Figure 38 and Figure 39. The front and tag axle brake air chambers are used only for service brake duty.

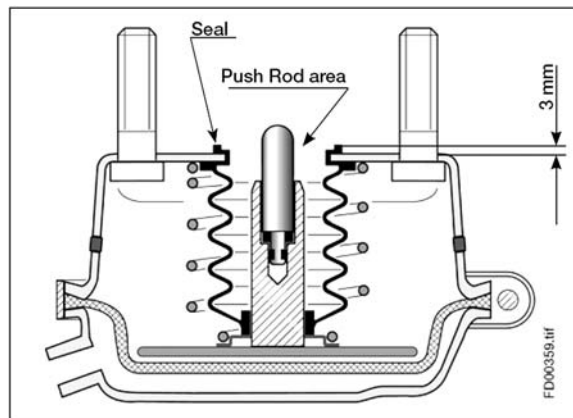

FIGURE 38: FRONT AXLE BRAKE AIR CHAMBER 12158

28.1 MAINTENANCE

Every 6,250 Miles (10 000 km) or twice a year, whichever comes first depending on type of operation:

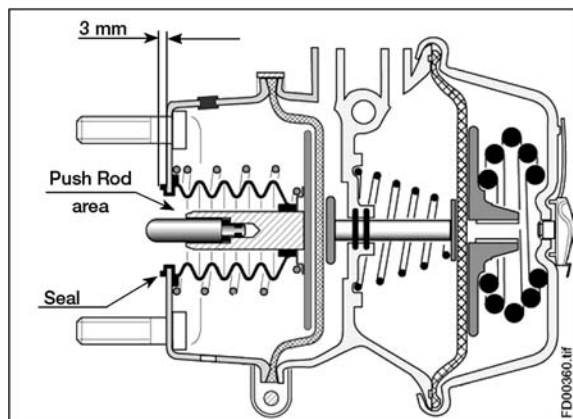

FIGURE 39: DRIVE AXLE BRAKE AIR CHAMBER 12126

Check all hoses and lines. They should be secure and in good condition.

Every 100,000 Miles (160 000 km) or once a year, whichever comes first depending on type of operation:

1. Disassemble and clean all parts.
2. Install new diaphragm or any other part if worn or deteriorated.

NOTE

When the diaphragm, spring, or both are replaced, they should be replaced in the corresponding chamber on the same axle.

3. Perform an airtightness test:
 - a) Make and hold a full brake application.
 - b) Coat clamping ring(s) with a soapy solution. If leakage is detected, tighten clamping ring only enough to stop leakage. **Do not overtighten** as this can distort sealing surface or clamping ring. Coat area around push rod hole (loosen boot if necessary). No leakage is permitted. If leakage is detected, the diaphragm must be replaced.

28.2 EMERGENCY/PARKING BRAKE MANUAL RELEASE



DANGER

Never stand in the axis line of the spring brake chambers, especially when caging the spring.

Drive Axle

1. Block the wheels to prevent the vehicle from moving.
2. Screw-out the spring brake release bolt (arrow) with a maximum of 26 lbf-ft (35 Nm) to the release position.

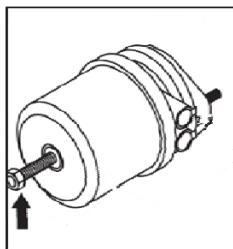

3. To manually reset the emergency/parking brake, screw in the spring brake release bolt with a maximum of 52 lbf-ft (70 Nm).

28.3 BRAKE CHAMBER REMOVAL AND INSTALLATION



WARNING

To prevent personal injuries, brakes should be inoperative prior to working on any of their components.

To prevent personal injuries, brake chambers should be made inoperative by releasing spring tension prior to disposal.

Use the following steps in conjunction with Brake Actuator Replacement procedure found in Knorr-Bremse Pneumatic Disc Brake SN7 Service Manual Y006471.

Removal

1. Block the wheels to prevent the vehicle from moving.
2. Safely support vehicle at the recommended body jacking points.
3. To gain access to a given brake air chamber, the corresponding wheel can be removed (refer to Section 13: "Wheels, Hubs and Tires").
4. Exhaust compressed air from system by opening the drain valve of each reservoir.
5. For the drive axle brake chambers, manually release spring brakes (refer to "Emergency/Parking Brake, Manual Release" procedure in this section).
6. Disconnect air line(s) from brake chamber.
7. Unbolt and remove the brake chamber from vehicle.

Installation

1. Reverse removal procedure and then check brake adjustment.

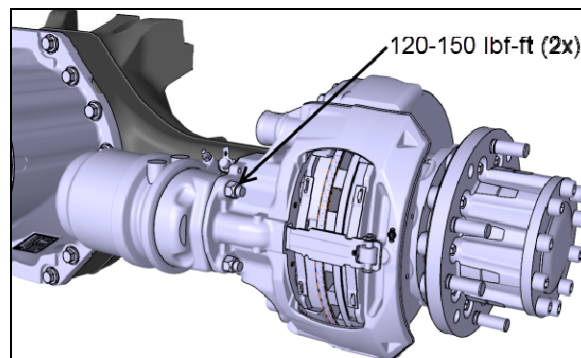

FIGURE 40: TYPICAL AIR CHAMBER MOUNTING NUTS TORQUE – ZF A132 DRIVE AXLE SHOWN

**CAUTION**

Always clean air lines and fittings, and coat pipe threads with teflon pipe sealant before reconnecting air lines. Make sure the drain hole of the brake chamber is in the lower position for proper moisture evacuation.

28.4 BRAKE CHAMBER DISASSEMBLY

**DANGER**

Spring brake chambers, on drive and tag axles contain an extremely high compressive force spring, which can possibly cause serious injury if special precautions are not taken when working around this area.

To avoid such injury, the following recommendations must be applied:

- Prevost recommends the installation of a new spring brake chamber if it is found to be defective.
- Spring brake chamber maintenance and/or repair must be performed by trained and qualified personnel only.
- Before manually releasing spring brakes, visually check spring brake for cracks and/or corrosion.
- On “MGM” brake chambers (drive axle), make sure the release stud is properly anchored in spring plate receptacle prior to caging the spring.
- Never stand in the axis line of the spring brake chambers, especially when caging the spring.

**WARNING**

To prevent personal injuries, brakes should be inoperative prior to working on any of their components.

1. Block the wheels to prevent the vehicle from moving.
2. Safely support vehicle at the recommended body jacking points.

NOTE

To gain access to a given brake air chamber, the corresponding wheel can be removed (refer to Section 13: "Wheels, Hubs and Tires").

3. Exhaust compressed air from air system by opening the drain valve of each reservoir.
4. For the drive axle brake chambers, manually release spring brakes (refer to “Emergency/Parking Brake Manual Release” procedure in this section).
5. Remove clamp ring, remove and discard the existing diaphragm. Install the new diaphragm squarely on body.
6. Reverse the procedure for assembly. Tap clamp ring to ensure proper seating. Check for proper operation before placing vehicle in service.

29. ANTI-LOCK BRAKING SYSTEM (ABS)

This device has been designed to ensure stability and permit steering control of vehicle during hard braking, and to minimize its stopping distance whatever the road conditions are. On slippery roads and generally in emergency situations, over-braking frequently induces wheel lock. The anti-lock braking system provides maximum braking performance while maintaining adequate steering control on slippery roads.

The ABS continuously monitors wheel behavior during braking. Sensors on each wheel of front and drive axles (tag axle is slave to drive axle) transmit data to a four channel electronic processor which senses when any wheel is about to lock. Modulator valves quickly adjust the brake pressure (up to 5 times per second) to prevent wheel locking. Each wheel is therefore controlled according to the grip available between its tire and the road.

With this device, the vehicle is brought to a halt in the shortest possible time, while remaining stable and under the driver's control.

Since the braking system has dual circuits, the ABS is also provided with a secondary system should a fault develop in the ABS. Anti-lock systems are a parallel system which does not hinder brake functioning in case of failure. Braking system functions in normal, non anti-lock controlled operation during ABS system failure.

The ABS system consists of two diagonally related circuits, only the half of the system which has sustained damage or other fault is switched off (i.e. wheels return to normal non-ABS braking). The other diagonal half remains under full ABS control.

NOTE

ABS is active on service brake, transmission retarder, Jake brake, but is inactive on emergency/parking brake.

NOTE

The ABS system is inoperative at speeds under 4 mph (6 Km/h). Illumination of ABS telltale indicator at these speeds is normal.

**CAUTION**

Disconnect the ECU or pull the ABS fuse before towing vehicle.

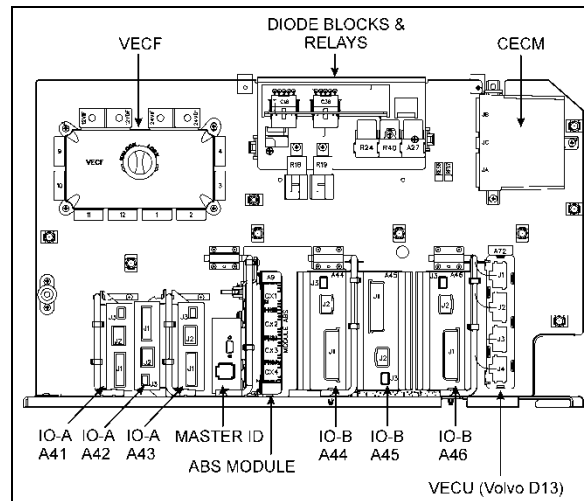

FIGURE 41: ABS ECU LOCATION

06617

**CAUTION**

In order to protect the ABS electronic control unit from voltage surges, always disconnect before performing any welding procedure on vehicle.

29.1 TROUBLESHOOTING AND TESTING

For troubleshooting and testing of the vehicle's anti-lock braking system, refer to Bendix applicable booklet annexed to this section under reference number SD-13-4869.

29.2 ABS COMPONENTS

The main components of the ABS system are listed hereafter. Refer to each component for its specific function in the system and for proper maintenance.

29.3 BENDIX EC-60 ADVANCED CONTROLLER

This control unit, also known as ABS module, is located in the front electrical and service compartment. According to the data transmitted by the sensors (number of pulses/sec is proportional to the speed of each wheel), the electronic control unit determines which wheel is accelerating or decelerating. It then establishes a reference speed (average speed) from each wheel data, and compares the speed of each wheel with this reference speed to determine which wheel is accelerating or decelerating.

As soon as wheel deceleration or wheel slip threshold values are exceeded, the electronic control unit signals a solenoid control valve to limit the excessive brake pressure produced by the driver in the appropriate brake chamber.

Maintenance

No specific maintenance is required. The ECU is not serviceable. When found to be defective, replace.

29.4 SENSORS

The sensors are mounted on the front, drive and tag axle (if applicable) wheel hubs. The inductive sensors consist essentially of a permanent magnet with a round pole pin and a coil. The rotation of the toothed wheel alters the magnetic flux picked up by the coil, producing an alternating voltage, the frequency of which is proportional to wheel speed. When wheel speed decreases, magnetic flux decreases proportionately. Consequently, the electronic control unit will command the solenoid control valve to decrease the pressure at the corresponding brake chamber.

Maintenance

No specific maintenance is required for sensors, except if the sensors have to be removed for axle servicing. In such a case, sensors should be lubricated with special grease (Prevost #680460) before reinstallation. Refer to paragraph "Sensor Installation" for details.

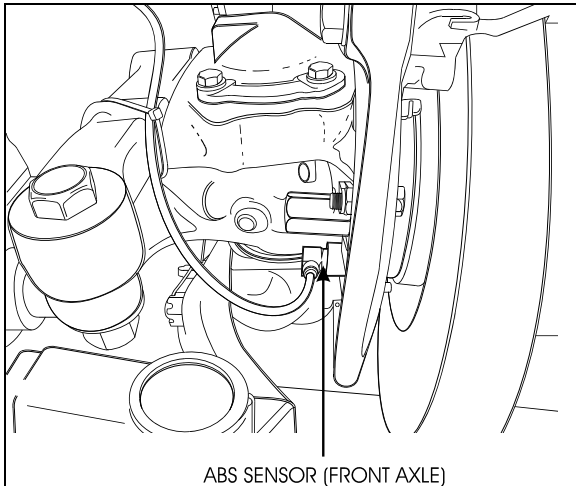

FIGURE 42: ABS SENSOR LOCATION

12153

NOTE

The resistance value, when sensors are checked as a unit, must be equal to 1,75 k ohms. To check the sensors for proper output voltage after the sensors and toothed wheels have been assembled to the axle, connect a suitable AC voltmeter across the output terminals. With the hubs rotating at 30 rpm, the output voltages should read from 50 to 1999 mV to be acceptable.

Sensor Installation

The following procedure deals with sensor installation on the axle wheel hubs. Read procedure carefully before reinstalling a sensor, as its installation must comply with operational tolerances and specifications.

1. Apply recommended lubricant (Prevost #680460) to spring clip and sensor.

**CAUTION**

Use only this type of grease on the sensors.

2. Insert spring clip in the holder on hub. Make sure the spring clip tabs are on the inboard side of the vehicle. Push in until the clip stops.
3. Push the sensor completely inside the spring clip until it is in contact with the tooth wheel. Ensure mounting is rigid, as it is an important criterion for adequate sensor operation.

NOTE

This installation should be of the "press fit" type.

29.5 SPRING CLIP

The spring clip retains the sensor in its mounting bracket close to the toothed pulse wheel. The gap between the sensor end and teeth is set automatically by pushing the sensor in the clip hard up against the tooth wheel, and the latter knocks back the sensor to its adjusted position (Figure 43).

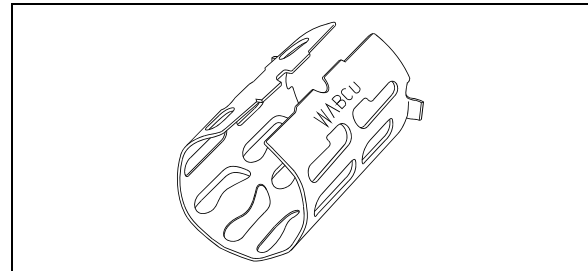

FIGURE 43: SPRING CLIP

12161

Maintenance

The spring clip requires no specific maintenance.

30. BENDIX AUTOMATIC TRACTION CONTROL (ATC) – ELECTRONIC STABILITY CONTROL (ESC)

In addition to the ABS function, vehicle is equipped with a Traction Control System (TCS) feature. This feature is provided by the Bendix EC-60 advanced controller. Bendix refers to this feature as **Automatic Traction Control (ATC)**. Bendix ATC can improve vehicle traction during acceleration, and lateral stability while accelerating through curves. ATC utilizes **Engine Torque Limiting (ETL)** where the ECU communicates with the engine's controller and/or **Differential Braking (DB)** where individual wheel brake applications are used to improve vehicle traction.

The EC-60 advanced model controller also provides an ABS-based Electronic Stability Control (ESC) feature. Bendix refers to it as **ESC Electronic Stability Control**.

The Bendix ESC system is an ABS-based stability system that enhances vehicle stability by both reducing engine throttle and by applying vehicle braking based on actual vehicle dynamics

ESC stability system consists of Yaw Control (YC) and Roll Stability Program (RSP) features.

**CAUTION**

Even with ESC-equipped vehicles, the driver remains responsible for ensuring vehicle stability during operation.

**MAINTENANCE****ABS & ELECTRONIC STABILITY CONTROL SYSTEMS****Every 12 months,**

Check the proper functioning of ABS and ESC systems. To do so, perform the "Component Test" using Bendix ACom Diagnostics software.

Bendix ACom Diagnostics software is available for download at www.bendix.com.

30.1 COMPONENTS

30.1.1 The EC-60™ controller's ABS function utilizes the following components:

- Six (6) Bendix® WS-24™ wheel speed sensors. Each sensor is installed with a Bendix Sensor Clamping Sleeve;
- Five (5) Bendix® Pressure Modulator Valves (M-40QR);
- Dash-mounted vehicle ABS Indicator Lamp;
- Service brake relay valve;
- Dash-mounted trailer ABS Indicator Lamp.

30.1.2 The EC-60™ controller's ATC function utilizes the following components:

- Drive axle traction control valve;
- Dash-mounted ESC/TCS status/indicator lamp (also serves as the ESC status/indicator lamp);
- Dash-mounted TCS Mud/Snow switch;
- J1939 serial communication to engine control module.

30.1.3 The EC-60™ controller's ESC/RSP function utilizes the following components:

- Front Axle Traction Control Valve integral to the service brake relay valve;

- Dash-mounted ESC/TCS status/indicator lamp (also serves as the ATC status/indicator lamp);
- Bendix SAS-70 Steering Angle Sensor (mounted to the steering column);
- Bendix YAS-70 Yaw Rate/Lateral Acceleration Sensor (mounted to a cross member forward of the drive axle);
- Brake Demand Sensors (installed in the primary and secondary delivery circuits);
- An additional Modulator Valve (Bendix® M-40QR™ Pressure Modulator Valve) that controls pressure applied to the trailer brakes during system intervention.

30.2 BENDIX M-40QR PRESSURE MODULATOR VALVE

This Bendix M-40QR (quick release) Pressure Modulator Valve (PMV) is operated by the EC-60 controller to modify driver applied air pressure to the service brakes during ABS, ATC, RSP or YC activation. The PMV is an electro pneumatic control valve and is the last valve that air passes through on its way to the brake chamber. The modulator hold and release solenoids are activated to "modulate" or "control" the brake pressure during an antilock braking event. The hold solenoid is normally open and the release solenoid is normally closed, such that the PMV nominally allows air to flow through. This design allows for air delivery to brake chambers in the event of electrical trouble. This is an "On/Off" type valve, i.e., during an antilock activity, the valve exhausts air from the brake chamber when in a ABS event, the electronic unit senses that the corresponding wheel speed is decreasing in relation to the other wheels.

The Advanced EC-60 controller also utilizes an additional PMV for control of the trailer service brakes during stability interventions.

6s/5m Configuration

Prevost vehicles utilize a 6 sensors/5 pressure modulator valves configuration, with the tag axle having two sensors, but only one Pressure Modulator Valve. In this case, the PMV controls both wheels on the tag axle. The tag axle wheels would receive equal brake pressure, based on the wheel that is currently experiencing the most wheel slip.

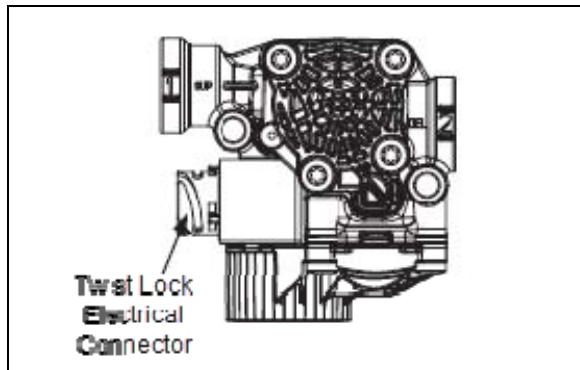

FIGURE 44: M-40QR PRESSURE MODULATOR VALVE

Maintenance

NOTE

On older vehicles, when replacing for the first time the older modulator valve M-32QR by the newer M-40QR modulator valve, it is important to replace both left and right valves on the vehicles drive axle or front suspension.

Modulator valve model can be easily identified by their different side cover and exhaust section.



Mixing valve type on the left and right sides of the vehicle may result in slight pull to one side when braking.

Maintenance, removal and installation information of this valve is supplied in Bendix booklet, reference number SD-13-4958.

30.3 ADVANCED ABS WITH ELECTRONIC STABILITY CONTROL (ESC)

Overview

Bendix ESC stability system reduces the risk of rollovers, jackknifing and other loss of control. ESC features include Roll Stability Program (RSP) and Yaw Control. During operation, the ECU of the Bendix Advanced ABS system constantly compares performance models to the vehicle's actual movement, using the wheel

speed sensors of the ABS system, as well as lateral, yaw, and steering angle sensors. If the vehicle shows a tendency to leave an appropriate travel path, or if critical threshold values are approached, the system will intervene to assist the driver.

Roll Stability Program

Bendix RSP, an element of the overall ESC system, addresses rollover conditions. In the case of a potential roll event, the ECU will override the throttle and quickly apply pressure at all wheel ends to slow the vehicle combination. The level of braking application during an RSP event will be proportional to roll risk.

Yaw Stability

Yaw stability counteracts the tendency of a vehicle to spin about its vertical axis. During operation, if the friction between the road surface and the tires is not sufficient to oppose lateral (side) forces, one or more of the tires can slide, causing the vehicle to spin. These events are referred to as either an "under-steer" situation (where there is a lack of vehicle response to steering input due to the slide on the front axle) or an "over-steer" (where the vehicle's rear end slides out due to tire slide on the rear axle) situation. Factors that influence yaw stability are: wheelbase, suspension, steering geometry, weight distribution front to rear, and vehicle track width.

Yaw Control

Yaw Control corresponds to a wide range of low to high friction surface scenarios including rollover, jackknife and loss of control. It is the recommended system for all power vehicles and especially critical for vehicles pulling trailers. In the case of vehicle slide (over-steer or under-steer situations), the system will reduce the throttle and then brake one or more of the "four corners" of the vehicle (in addition to potentially applying the trailer brakes), thus applying a counter-force to better align the vehicle with an appropriate path of travel.

For example, in an over-steer situation, the system applies the "outside" front brake; while in an under-steer condition, the "inside" rear brake is applied.

**DANGER**

Bendix ESC system may reduce the vehicle speed automatically.

ESC can make the vehicle **decelerate automatically**. ESC can slow the vehicle with or **without the operator applying the brake**, and **even when the throttle is being applied**.

30.4 BENDIX® SAS-70 STEERING ANGLE SENSOR

The Steering Angle Sensor (SAS) is used to provide driver steering input to the controller. It reports the steering wheel position to the controller utilizing a dedicated serial communications link that is shared with the YAS-70 sensor. The controller supplies the power and ground inputs to the SAS-70 sensor.

The SAS-70 sensor installed on Prevost vehicles is the 90° connector.

30.4.1 Removal of the steering angle sensor

Service Checks:

1. Check all wiring and connectors. Some installations also include an intermediate connector from the steering angle sensor to the main vehicle wire harness. Make sure all connections are free from visible damage.
2. Examine the sensor. Make sure the sensor, its mounting screws, and the interface between the hub and the steering column are not damaged.

Diagnostics:

The steering angle sensor is only operational in conjunction with an Advanced ECU. No independent diagnostics can be performed on the sensor.

Removal:

1. Remove steering column upper, middle and lower covers.
2. The steering angle sensor is located near the universal joint.
3. Unplug sensor cable assembly from body of sensor. Squeeze the mounting tabs and pull gently on connector until it disengages.
4. Disconnect steering column upper U-joint.
5. Unscrew all three of the mounting screws that hold the body of the sensor to the steering column body.

6. Slide the sensor over the column to remove. Take note if the sensor label is facing upward or downward.

Installation:

1. Obtain a new sensor. The sensor is not repairable in the field.
2. Slide the sensor over the column. The center hub of the sensor must be aligned with the corresponding notch in the column. The sensor label should be facing in the same direction as the removed sensor.
3. Reconnect the steering column U-joint.
4. Assemble the column non-moving plate with three self-locking screws.
5. Tighten screws between 48 lbf-ft (65 Nm) and 74 lbf-ft (100 Nm).
6. Reconnect the connector. Ensure that there will be no force applied to the sensor because the connector is pulling on the sensor body.
7. If the wire harness leading to the sensor is being replaced, ensure that it is adequately tie wrapped so that the full motion of the steering column can be achieved without pulling apart the connectors.
8. Reinstall the steering column covers. The sensor is not protected against dirt or water intrusion, so care must be taken not to introduce these elements during installation.

Steering Angle Sensor Calibration

The steering angle sensor calibration can only be achieved when the sensor is powered by the Advanced ABS ECU. No stand-alone sensor calibration can be carried out. The calibration procedure is performed using Bendix® ACom™ Diagnostic V4.0 or higher. See “Troubleshooting Diagnostic Trouble Codes: Steering Angle Sensor (SAS-60)” for the calibration procedure using this tool.

The sensor **must** be recalibrated after any of these situations:

- Replacement of the steering angle sensor;
- Any opening of the connector hub from the steering angle sensor to the column;
- Any maintenance or repair work on the steering linkage, steering gear or other related mechanism;
- Adjustment of the wheel alignment or wheel track;

- After an accident that may have led to damage of the steering angle sensor or assembly.



WARNING

If the steering angle sensor is not properly recalibrated as needed, the yaw control system may not function properly, which can result in incidents leading to loss of vehicle control.

31. FITTING TIGHTENING TORQUES

NTA-Type Plastic Tubing: Hand tighten nut (Figure 45). From that point, tighten using a wrench the number of turns indicated in the following chart.

Tubing diameter (inches)	Number of additional turns required following hand tightening
1/4	3
3/8 to 1/2	4
5/8 to 3/4	3 1/2

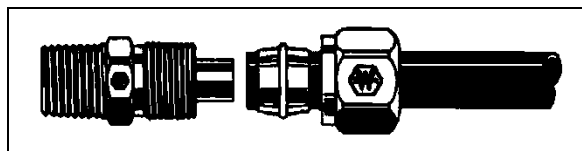

FIGURE 45: HOSE FITTING

12055

NOTE

Use Loctite pipe sealant to seal pipe thread (Prevost number 680098).

32. SPECIFICATIONS

Air Compressor

Make.....Meritor Wabco
 Model..... SS636
 Capacity (at 1250 rpm).....37.4 cfm (1,059 m³/min.)

Air dryer

Make..... WABCO
 Model..... System Saver 1200 Series
 Prevest number 21440978
 Electrical control 12-Volt
 Desiccant cartridge Prevest number 642199
 Cut in pressure 122 psi
 Cut-out pressure 140 psi

33. SECTION CHANGE LOG

DESCRIPTION		DATE
1	Added information to the brake pedal replacement & adjustment paragraph (15.1)	2016/06/17
2		
3		
4		
5		
6		

CONTENTS

1. WHEELS	3
2. WHEEL MAINTENANCE	3
2.1 INSPECTION	3
2.2 SINGLE WHEEL REMOVAL.....	3
2.3 SINGLE WHEEL INSTALLATION.....	4
3. DUAL WHEELS	4
3.1 OUTER WHEEL REMOVAL	4
3.2 INNER WHEEL REMOVAL	4
3.3 INNER WHEEL INSTALLATION	4
3.4 OUTER WHEEL INSTALLATION	4
3.5 INSPECTION	4
4. WHEEL STRAIGHTNESS TEST	4
5. WHEEL STUDS	5
5.1 DRIVE AXLE WHEEL STUDS.....	5
5.2 FRONT AND TAG AXLE WHEEL STUDS	5
6. HUB MOUNTED WHEELS	5
6.1 CARE OF WHEELS.....	6
7. TAG AXLE WHEEL HUBS	6
7.1 TAG AXLE HUB BEARING INSPECTION	8
7.2 TAG AXLE HUB BEARING REMOVAL.....	8
8. FRONT AXLE WHEEL HUBS	11
8.1 FRONT AXLE HUB BEARING INSPECTION	11
8.2 FRONT AXLE HUB BEARING REMOVAL	12
8.3 FRONT AXLE HUB BEARING INSTALLATION	12
9. DRIVE AXLE WHEEL HUBS	13
9.1 COMPACT BEARING AXIAL PLAY AND GREASE CHANGE	14
10. TIRE MAINTENANCE	14
10.1 INFLATION PRESSURE	14
10.2 TIRE MATCHING	16
10.3 WHEEL BALANCING	16
10.4 TIRE ROTATION	16
11. SPECIFICATIONS	17
12. SECTION CHANGE LOG	17

ILLUSTRATIONS

FIGURE 1: STEEL WHEEL ARRANGEMENT	3
FIGURE 2: TIGHTENING SEQUENCE.....	3
FIGURE 3: DIAL GAUGE INSTALLATION.....	5
FIGURE 4: DRIVE AXLE WHEELS	5
FIGURE 5: SINGLE WHEEL.....	5
FIGURE 6: TAG AXLE HUB AND ROTOR ASSEMBLY	7
FIGURE 7: TAG AXLE UNITIZED BEARING & WHEEL HUB.....	7
FIGURE 8: INSERTION TOOL	8
FIGURE 9: APPLY GLEITMO 805 GREASE.....	9
FIGURE 10: SLIP UNITIZED HUB BEARING OVER SPINDLE	9
FIGURE 11: INSTALL THRUST WASHER AND HUB NUT.....	9
FIGURE 12: CLEANING HUB BEARING, ROTOR AND HUB FLANGE CLAMPING SURFACES.....	9
FIGURE 13: ROTOR.....	10
FIGURE 14: HUB FLANGE HEX CAP SCREW	10
FIGURE 15: HUB FLANGE HEX CAP SCREW TIGHTENING SEQUENCE	10
FIGURE 16: FRONT AXLE HUB AND ROTOR ASSEMBLY	11
FIGURE 17: INSERTION TOOL	12
FIGURE 18: APPLY GLEITMO 805 GREASE.....	12
FIGURE 19: SLIDE UNITIZED HUB BEARING OVER SPINDLE.....	12
FIGURE 20: INSTALL THRUST WASHER	12
FIGURE 21: CLEANING HUB BEARING, ROTOR AND HUB FLANGE CLAMPING SURFACES.....	13
FIGURE 22: HUB FLANGE HEX CAP SCREW	13
FIGURE 23: HUB FLANGE HEX CAP SCREW TIGHTENING SEQUENCE	13
FIGURE 24: COMPACT BEARING	13
FIGURE 25: TIRE INFLATION.....	15
FIGURE 26: TIRE LIFE / INFLATION PRESSURE	15

1. WHEELS

The vehicle is equipped with hub-mounted wheels, all studs and nuts have right-hand threads. Steel wheels are installed on the vehicle and are mounted with radial tubeless tires.

All wheel dimensions are 22.50 X 9.0 inches (571.5 X 228.6 mm) for 315/80 R22.5 tires

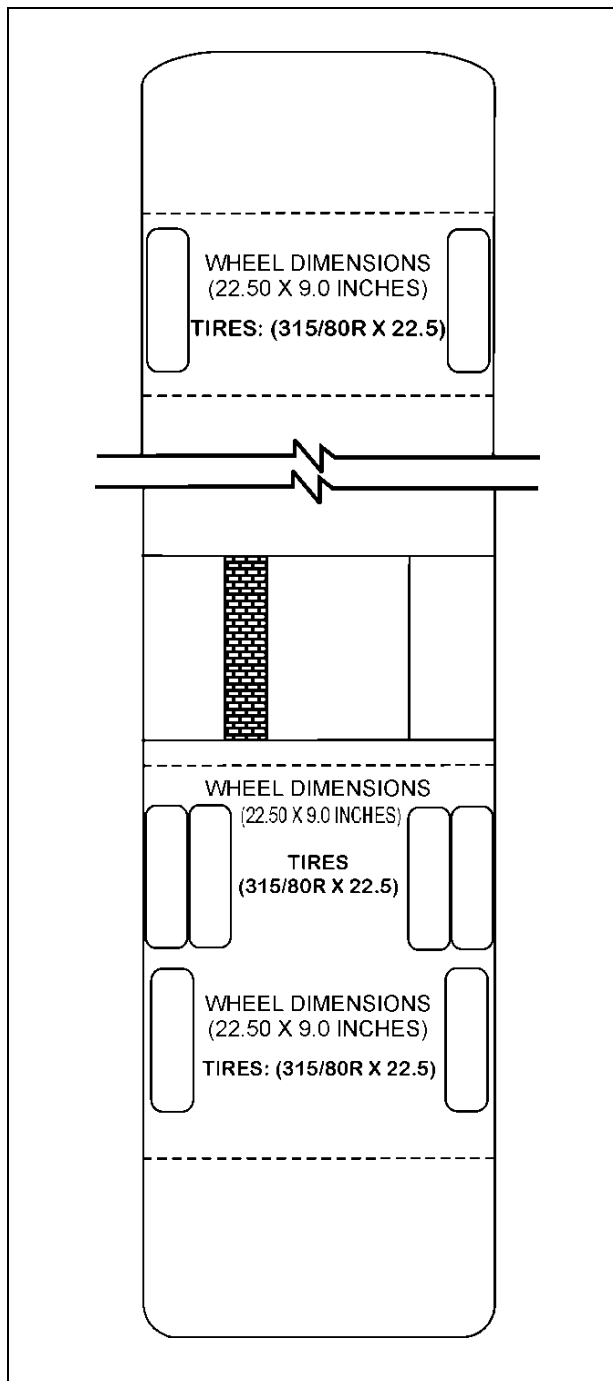

FIGURE 1: STEEL WHEEL ARRANGEMENT¹³⁰⁰¹

2. WHEEL MAINTENANCE

Wheel maintenance consists of periodic inspections. Check all parts for damage and make sure that wheel nuts are tightened to the proper torque. In the case of a new vehicle, or after a wheel installation, stud nuts should be tightened every 100 miles (160-km) for the first 500 miles (800-km) to allow setting in of clamping surfaces.

Wheel studs and nuts must be kept free from grease and oil. No lubricant whatsoever should be used. Cleanliness of the wheel and its rotor mating surfaces is important for proper wheel mounting.

However, for hub mounted wheels, it is recommended to add some rust protection lubricant on the pilot diameter of the hub (to facilitate future removal).

It is also important that wheel stud nuts be tightened alternately on opposite sides of the wheel. Refer to Figure 2 for the suggested tightening sequence.

2.1 INSPECTION

Tighten stud nuts progressively as shown in Figure 2. The final tightening should be done with a torque wrench. Tighten stud nuts to 450 - 500 lbf-ft (610 - 680 Nm) for steel wheels.

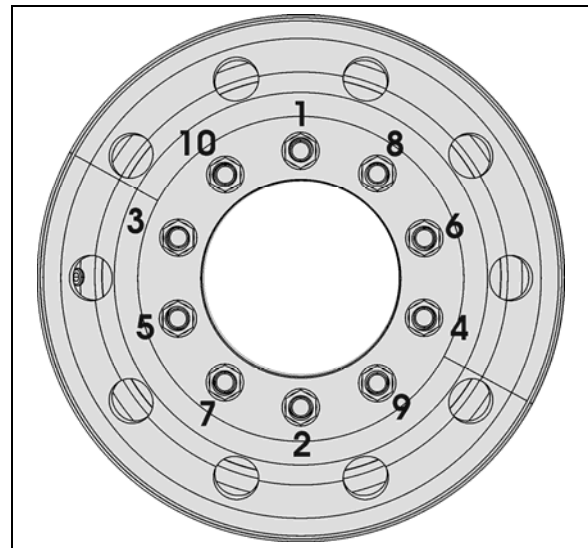

FIGURE 2: TIGHTENING SEQUENCE

13018

2.2 SINGLE WHEEL REMOVAL

1. Stop engine and apply parking brake.
2. Loosen wheel nuts about one turn (do not remove the nuts). This is not necessary if equipped with hydraulic powered gun.

- Raise the vehicle by its jacking points on the body. See Section 18, "Body", under heading "Vehicle Jacking Points";
- Unscrew wheel hex stud nuts and remove the wheel;

**CAUTION**

Always mark position of the wheel on the axle prior to removal in order to replace wheel at the same location, thus avoiding a new wheel balancing.

2.3 SINGLE WHEEL INSTALLATION

- Mount the wheel over studs, being careful not to damage stud threads;
- Screw in the hex stud nuts (refer to Figure 2 for sequence) so that wheel will position itself concentrically with hub. This is important, otherwise wheel may be eccentric with hub and will not run straight. In this initial step, slightly tighten the nuts to correctly position the wheel;
- Tighten stud nuts progressively as shown in Figure 2. The final tightening should be done with a torque wrench. Tighten stud nuts to 450 - 500 lbf-ft (610 - 680 Nm) for all steel wheel.

**CAUTION**

Insufficient mounting-torque can result in damage to parts. Excessive mounting torque can cause studs to break and the wheel to crack in stud hole area.

3. DUAL WHEELS**3.1 OUTER WHEEL REMOVAL**

Same as described in "Single Wheel Removal" procedure described previously.

3.2 INNER WHEEL REMOVAL

- Remove outer wheel;
- Remove inner wheel.

3.3 INNER WHEEL INSTALLATION

Mount the wheel over studs, being careful not to damage stud threads;

3.4 OUTER WHEEL INSTALLATION

With inner and outer wheels installed, tighten the stud nuts progressively as shown in Figure 2. The final tightening should be done with a torque

wrench. Tighten stud nuts to 450 - 500 lbf-ft (610 - 680 Nm) for all steel wheel.

**CAUTION**

Insufficient mounting-torque can result in damage to parts. Excessive mounting torque can cause studs to break and the wheel to crack in stud hole area.

NOTE

On dual wheel assemblies, position the wheels with the tire valves 180° apart in order to have access to both the inner and outer valves.

3.5 INSPECTION

- Loosen a hex stud nut three turns (Figure 4);
- Retighten the hex stud nut to 450 - 500 lbf-ft (610 - 680 Nm).

Repeat for each of the 10 "hex stud nuts" according to the tightening sequence in Figure 2.

**CAUTION**

The actual length of thread engagement present in an assembled wheel can not always be determined by visual inspection of measurement of a tightened assembly. The relationship of the wheel cap nut seat to the end of the stud may vary. If there is any doubt that enough thread engagement is present, the number of engaged threads may be counted. Tighten all nuts in the regular manner, then loosen one to hand-tightness. The number of turns to disengage a 1-1/8-inch nut should be at least five full turns.

At least seven full turns should be required to disengage a 3/4-inch nut or a M22 nut. Ideally, when torqued to the proper load, the stud should be flush with the face of the nut. The face of the nut may be recessed in nuts that are taller for improved wrenching. With most of the nuts in present use, a few unengaged threads at the outer end will cause no problem provided at least 5-7 full turns are required to disengage the nut depending on thread size.

4. WHEEL STRAIGHTNESS TEST

- Slightly raise axle to be checked and place a safety support underneath;

- Check wheel lateral run-out. Install a dial gauge as shown in Figure 3, then rotate the wheel by hand one full turn. As the wheel turns, note any variation on the dial gauge;



CAUTION

Damage to the dial gauge could occur if it strikes a wheel balancing weight.

- If the variation in lateral run-out exceeds 0.0625 inch (1,6 mm), the wheel must be replaced.

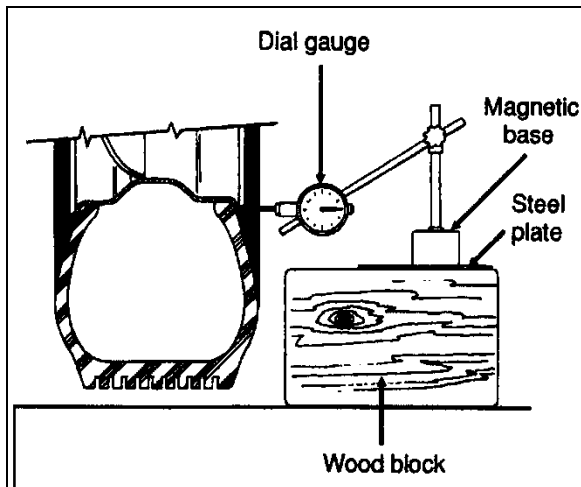

FIGURE 3: DIAL GAUGE INSTALLATION 13008

If doubt exists whether wheel or hub is distorted, hub may be checked as follows:

- Replace the existing wheel with a wheel known to be correct;
- Check wheel lateral run-out as outlined in step 2;
- If, within specifications, the hub is correct but the suspected wheel must be replaced.

5. WHEEL STUDS

Stripped threads may be the result of excessive torquing or may have been damaged during wheel installation when placing the wheel over the studs. A stud having damaged threads must be replaced. Broken studs are a direct result of operating with loose stud nuts or improperly seated wheels. When a broken stud is replaced, the adjacent studs, on each side of the broken one must also be replaced since they could have been subjected to excessive strain and may be fatigued.

When installing wheel studs to hubs, check nuts retaining the wheel stud to wheel hub and replace if they are deformed, damaged or

severely corroded. Install nut (and washer where applicable) to new stud. Torque to 450 - 500 Ft-lbs (610 - 680 Nm).

5.1 DRIVE AXLE WHEEL STUDS

Hub-mounted wheels are mounted with M22 x 1.5 studs and an M22 flange nut.

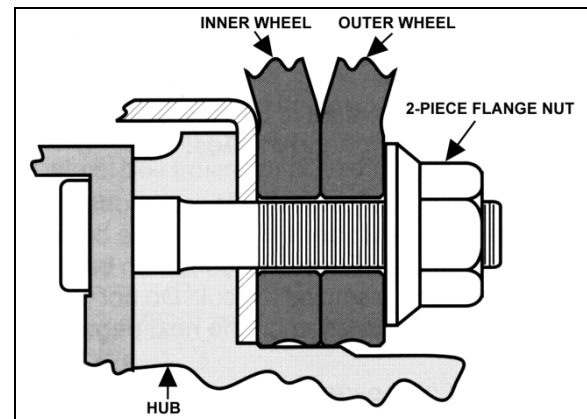

FIGURE 4: DRIVE AXLE WHEELS 13007

5.2 FRONT AND TAG AXLE WHEEL STUDS

Wheel is hub mounted on front and tag axle (M22 x 1.5 thread).

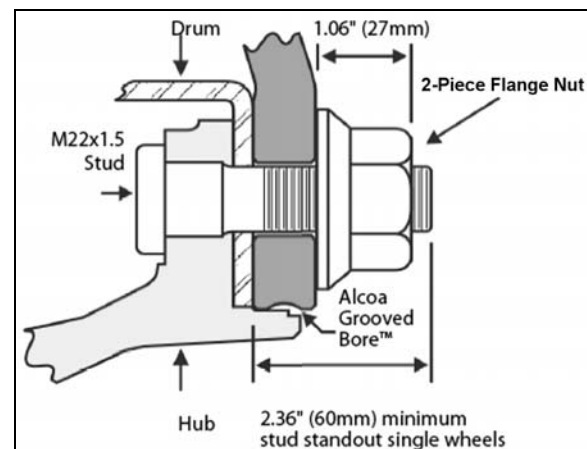

FIGURE 5: SINGLE WHEEL 13025

NOTE

Wheel studs and nuts must be kept free from grease and oil. No lubricant whatsoever should be used.

6. HUB MOUNTED WHEELS

Wheel surfaces in contact with hubs, nuts or other wheels should be kept free of all rust, grease and paint (except for initial "E" coat protection, applied to stop rusting and to facilitate wheel removal). The reason for this is to assure that all faces are clamped together

without buildup of any coating. The threads of the wheel studs and the wheel nuts should be clean and undamaged.

NOTE

When painting wheels, make sure to mask all surfaces identified above.

Using a calibrated torque wrench, tighten wheel nuts to 450 - 500 lbf-ft (610 - 680 Nm) of torque. Do not use power tools or long bars for tightening. Tighten wheel nuts alternately as shown in Figure 2.

NOTE

Tightening should not be done immediately after prolonged braking or when wheel ends are hot.

Check wheel nut torque at every 100 miles (160 km) for 500 miles (800 km) after fitting wheels. Let cool before checking. If any relaxation of the initial 450 - 500 lbf-ft (610 - 680 Nm) of torque has occurred, retighten. Relaxation of initial torque may occur because of the “bedding down” of the hub and wheel surfaces.

NOTE

Torque relaxation occurs when wheel ends are hot but should revert to original setting when cool. Retightening when hot will produce a higher torque reading than recommended.

6.1 CARE OF WHEELS

Check for cracks in wheels, especially around the fixing holes, studs, nuts and washers. If in doubt, renew.

Do not simply retighten very loose wheel fixings or wheels that are continually becoming loose. Find out why they are loose and whether any damage has been caused.

Use trained personnel and keep records of all attention to wheels and fixings, including which parts were renewed and when.

7. TAG AXLE WHEEL HUBS

The FAG unitized hub bearings used on the tag axle are non-serviceable items. Bearings are pre-adjusted, lubricated and have seals fitted as part of the manufacturing process. The bearings are greased for life and there is no need or facility for re-lubrication.

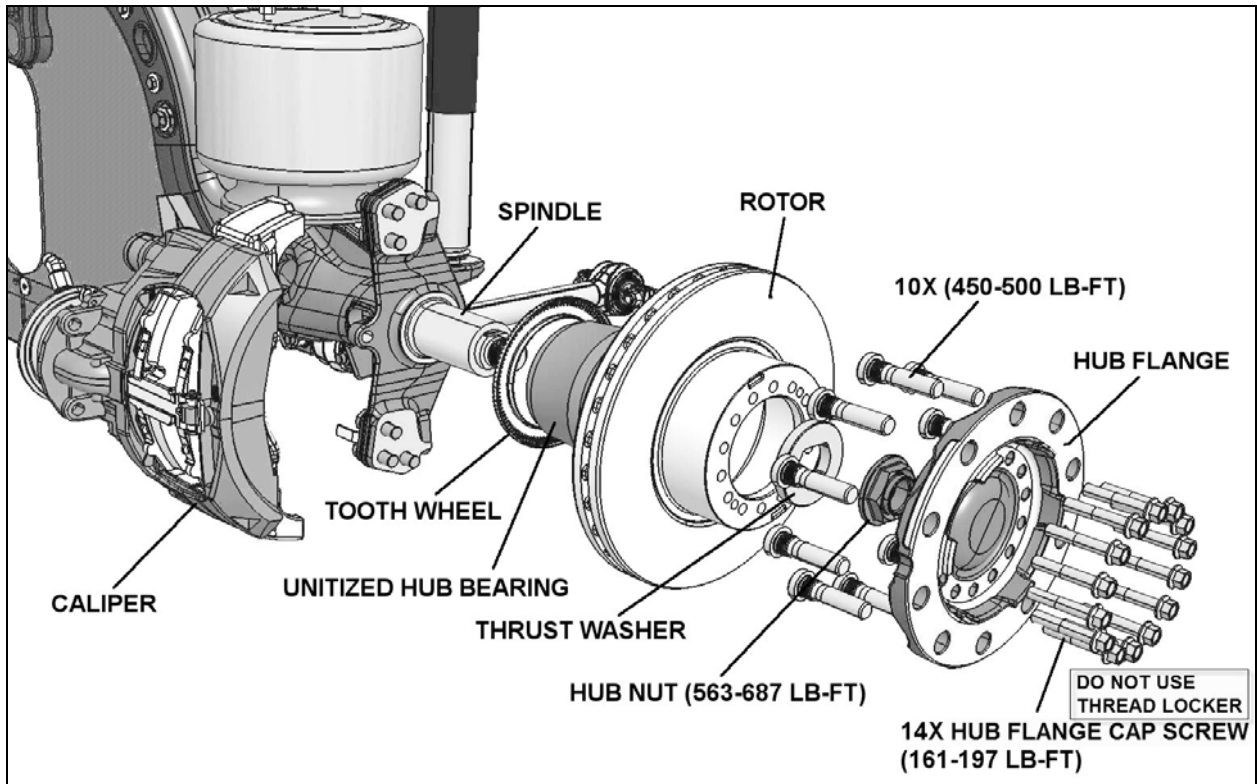

FIGURE 6: TAG AXLE HUB AND ROTOR ASSEMBLY

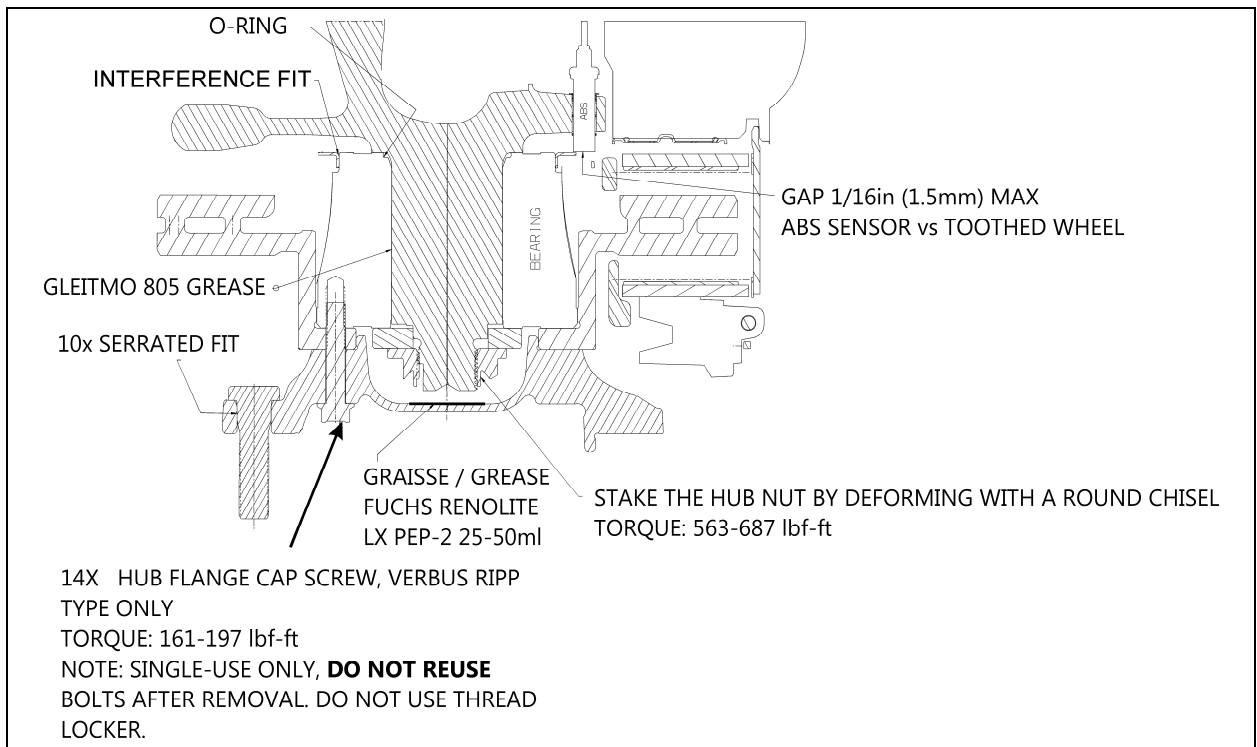



FIGURE 7: TAG AXLE UNITIZED BEARING & WHEEL HUB

13040

7.1 TAG AXLE HUB BEARING INSPECTION

 <h2 style="margin: 0;">MAINTENANCE</h2>
<p>A bearing inspection should be made at intervals of 30,000 miles (48 000 km) or once a year whichever comes first.</p>

1. Apply parking brake, raise wheels off the ground and support axle on stands.
2. When the wheels are raised, they should revolve quite freely without roughness.
3. Place magnetic base of a dial indicator on brake caliper and position dial indicator stem against a convenient marked spot on face of hub flange.
4. With dial indicator in position pull hard but steadily on hub flange and oscillate at same time until a steady reading is achieved.
5. Without releasing the pressure, turn bearing so that dial indicator stem contacts marked spot and note reading on indicator.
6. Push bearing flange hard and oscillate as before until a steady reading is achieved.
7. Without releasing the pressure, turn bearing so that indicator stem again contacts the marked spot and note new reading on indicator.
8. The difference between readings is the amount of mounted end play in bearing unit.
9. Refer to the following table for allowed end plays:

NewTag Axle Unitized Hub Bearing Axial Endplay	
Maximum axial clearance/end play	0.0024 inch (0.061mm) based on clamp load of 20000 lbf (90kN).
Tag Axle Unitized Hub Bearing Axial Endplay In Service	
<ul style="list-style-type: none"> • If the endplay is between 0 – 0.002 in (0 – 0.05 mm), the inspection is complete. • If the endplay is greater than 0.002 in (0.05 mm), but less than <u>0.008 in (0.20mm)</u>, check and retighten the wheel bearing adjusting nut. Again check endplay to make sure that the clamping process is done properly. • If the endplay is equal to or greater than 0.008 in (0.20mm), replace the unitized hub bearing as 	

soon as possible since the hub assembly may not be safe to operate.

7.2 TAG AXLE HUB BEARING REMOVAL

1. Stop engine and apply parking brake.
2. Loosen wheel nuts about one turn (do not remove the nuts). This is not necessary if equipped with hydraulic powered gun.
3. Raise the vehicle by its jacking points on the body. See Section 18, "Body", under heading "Vehicle Jacking Points".
4. Unscrew 10 wheel hex stud nuts and remove the wheel.
5. Unscrew 14 hub flange hex cap screws. **Discard hub flange cap screws (single-use only).**
6. Remove hub flange and rotor.
7. Unscrew hub nut.
8. Remove hub nut and thrust washer.

7.3 TAG AXLE HUB BEARING INSTALLATION

1. Clean spindle using EFX degreaser (Prevost #685313)
2. Screw insertion tool onto spindle (FIGURE 8).



FIGURE 8: INSERTION TOOL

3. Apply a thin layer of antifriction/antifretting lubricant on spindle where bearing will be located (use Gleitmo 805 grease, Prevost #685274).



FIGURE 9: APPLY GLEITMO 805 GREASE

4. Slip unitized hub bearing over spindle.

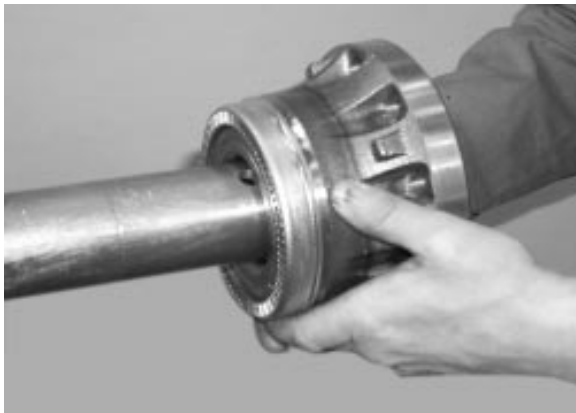

FIGURE 10: SLIP UNITIZED HUB BEARING OVER SPINDLE

NOTE

If the inner rings are not properly guided (i.e. not in line to spindle) there may occur a seizing between inner ring and spindle before the assembly be completed. By pushing abruptly the hub unit back, there is a risk of separation of inner rings. The clip can be dislodged as per the two pictures below.



5. Clean thrust washer both sides and hub nut using EFX degreaser.
6. Install thrust washer and hub nut then torque hub nut to **563-687 lbf-ft** (763-931 Nm)]. Rotate bearing, minimum 10 revolutions necessary (simultaneous rotation till final clamp torque is achieved).
7. Stake the hub nut by deforming with a round nosed chisel.

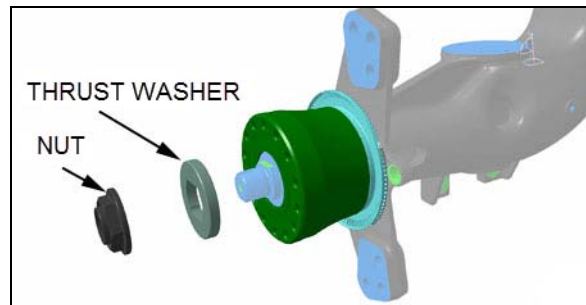

FIGURE 11: INSTALL THRUST WASHER AND HUB NUT

8. Clean hub bearing, rotor and hub flange clamping surfaces using EFX degreaser.

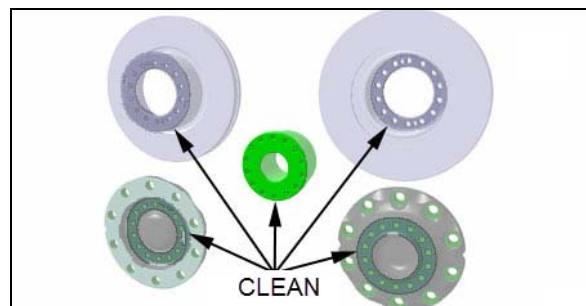

FIGURE 12: CLEANING HUB BEARING, ROTOR AND HUB FLANGE CLAMPING SURFACES

9. Install rotor onto hub bearing.

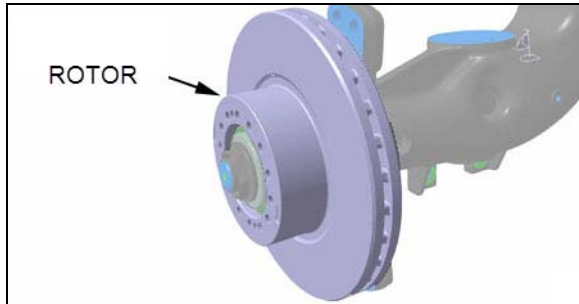

FIGURE 13: ROTOR

10. Add some grease (25-50 ml) (Fuchs Renolite LX PEP-2) (Prevost #685325) into the bottom of the hub flange cap. Mount hub flange onto rotor.
11. Secure hub flange and rotor to unitized hub bearing using 14 new cap screws (single-use only). Torque to 161-197 lbf-ft (Refer to FIGURE 15 for tightening sequence).
12. Once the hub flange has been correctly fitted; it is necessary to check the axial run out of the brake disc. *Refer to 7.1 tag axle Hub Bearing Inspection.*

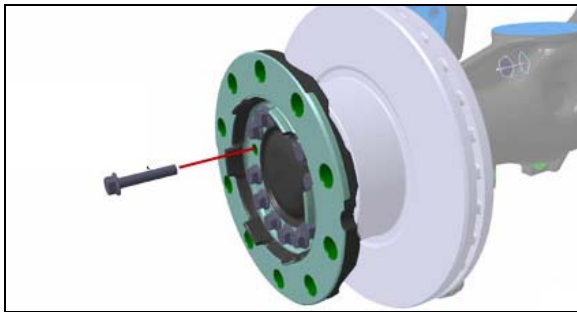

FIGURE 14: HUB FLANGE HEX CAP SCREW

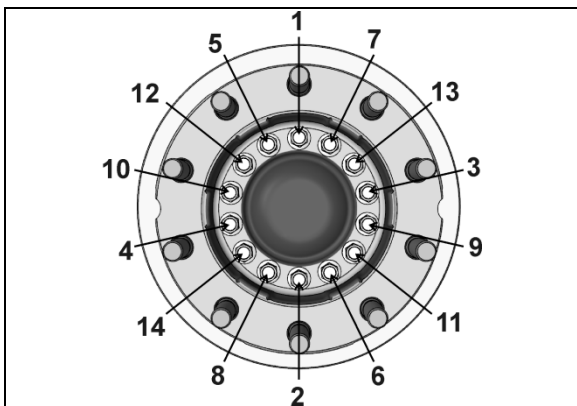

FIGURE 15: HUB FLANGE HEX CAP SCREW TIGHTENING SEQUENCE

13. Mount the wheel over studs, being careful not to damage stud threads.
14. Screw in the hex stud nuts (refer to Figure 2 for sequence) so that wheel will position itself concentrically with hub. This is important, otherwise wheel may be eccentric

with hub and will not run straight. In this initial step, slightly tighten the nuts to correctly position the wheel.

15. Tighten stud nuts progressively as shown in Figure 2. The final tightening should be done with a torque wrench. Tighten stud nuts to [450 - 500 lbf-ft (610 - 680 Nm)] for aluminum as well as steel wheel.

8. FRONT AXLE WHEEL HUBS

The FAG unitized hub bearings used on the NDS range of axles, are non-serviceable items. Bearings are pre-adjusted, lubricated and have seals fitted as part of the manufacturing process. The bearings are greased for life and there is no need or facility for re-lubrication.

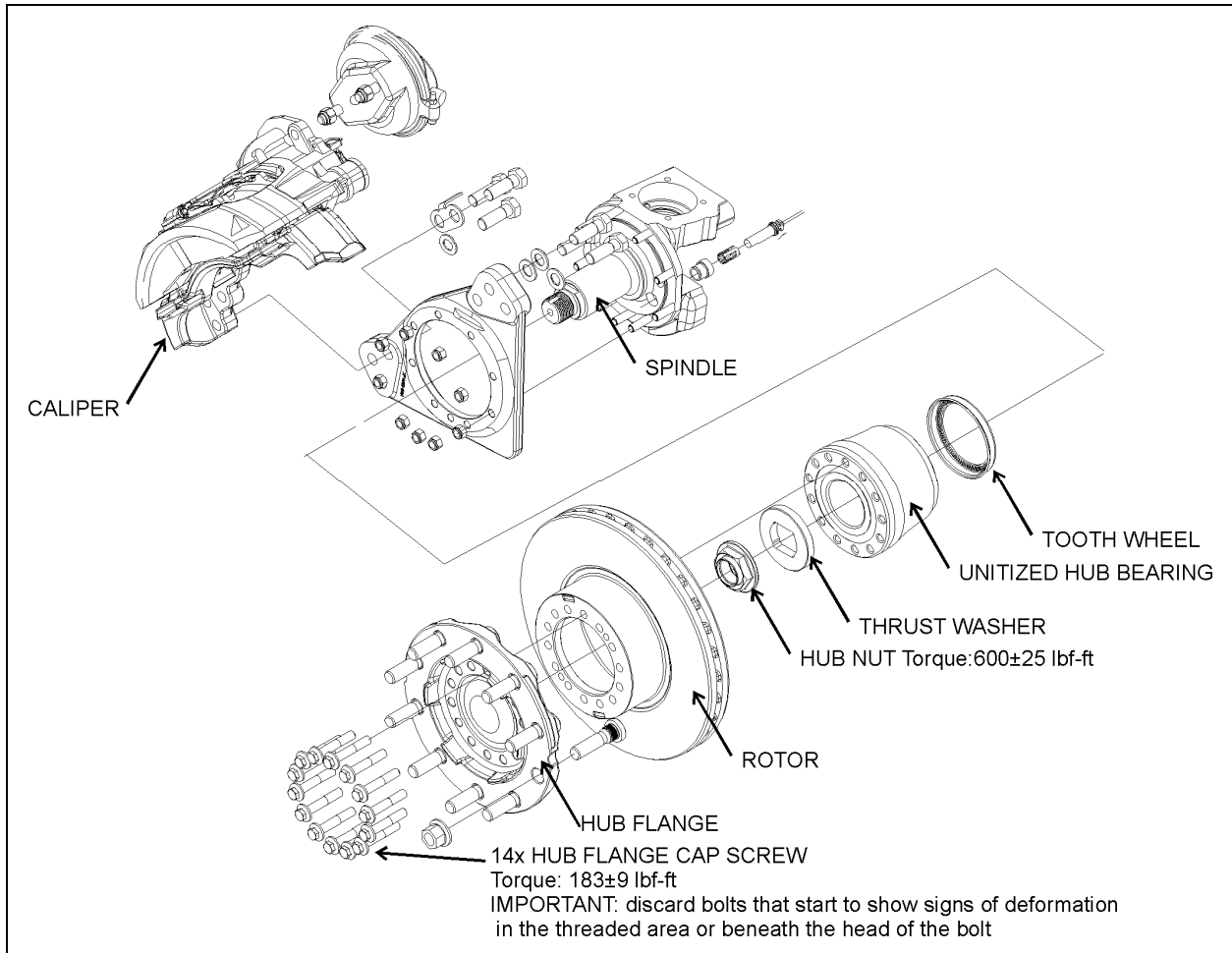



FIGURE 16: FRONT AXLE HUB AND ROTOR ASSEMBLY

13041

8.1 FRONT AXLE HUB BEARING INSPECTION

 <h3 style="margin: 0;">MAINTENANCE</h3>
<p>An inspection should be made at intervals of 30,000 miles (48 000 km) or once a year whichever comes first.</p>

1. Apply parking brake, raise wheels off the ground and support axle on stands.
2. When the wheels are raised, they should revolve quite freely without roughness.
3. Place magnetic base of a dial indicator on brake caliper and position dial indicator stem against a convenient marked spot on face of hub flange.
4. With dial indicator in position pull hard but steadily on hub flange and oscillate at same time until a steady reading is achieved.
5. Without releasing the pressure, turn bearing so that dial indicator stem contacts marked spot and note reading on indicator.
6. Push bearing flange hard and oscillate as before until a steady reading is achieved.
7. Without releasing the pressure, turn bearing so that indicator stem again contacts the marked spot and note new reading on indicator.

8. The difference between readings is the amount of mounted end play in bearing unit.
9. The mounted end play figure should not exceed:
 - **0.050 mm (0.002")** for a new bearing,
 - **0.20 mm (0.008")** for a bearing which has been in service.

NOTE

If original bearing unit is re-fitted, and end-float is measured at 1 mm, with hub not fully tightened to correct torque 600 ± 25 lbf-ft, then the retaining clip within the unit is damaged and a new unit must be fitted.

8.2 FRONT AXLE HUB BEARING REMOVAL

For detailed information on front axle wheel hub bearing removal, refer to the following manual included on your vehicle Technical Publications CD in PDF format:

Dana Parts & Service Instructions S84U Steer Axle HUB BEARING REWORK_ Manual NO 1963 A+B iss A.

See OVERHAUL PROCEDURES, HUB END DISASSEMBLY, pages No. B3, B4, B5 & B6.

8.3 FRONT AXLE HUB BEARING INSTALLATION

You can refer to the following manual included on your vehicle Technical Publications CD in PDF format:

Dana Parts & Service Instructions S84U Steer Axle HUB BEARING REWORK_ Manual NO 1963 A+B iss A.

See OVERHAUL PROCEDURES, HUB END REASSEMBLY, pages No. B23 up to B30.

1. Clean spindle using EFX degreaser (Prevost #685313).
2. Screw insertion tool onto spindle (FIGURE 17).



FIGURE 17: INSERTION TOOL

3. Apply a thin layer of lubricant on spindle where bearing will be located, use Gleitmo 805 grease (Prevost #685274).



FIGURE 18: APPLY GLEITMO 805 GREASE

4. Slide unitized hub bearing over spindle.

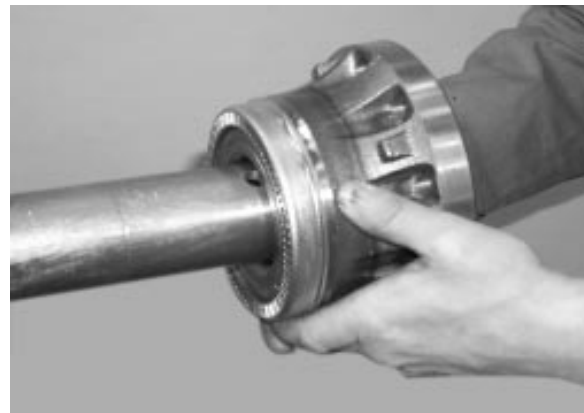

FIGURE 19: SLIDE UNITIZED HUB BEARING OVER SPINDLE

5. Clean thrust washer both sides and hub nut using EFX degreaser.
6. Install thrust washer and hub nut then tighten hub nut to specified torque **600 ± 25 lbf-ft**. Rotate unitized hub bearing whilst tightening. Do not stake hub nut at this stage.

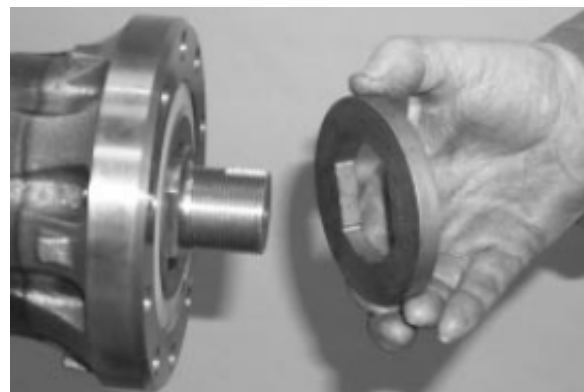

FIGURE 20: INSTALL THRUST WASHER

7. Check the bearing end play as described in 8.1 FRONT AXLE Hub Bearing Inspection
8. Stake the hub nut by deforming with a round nosed chisel.
9. Clean hub bearing, rotor and hub flange clamping surfaces using EFX degreaser.

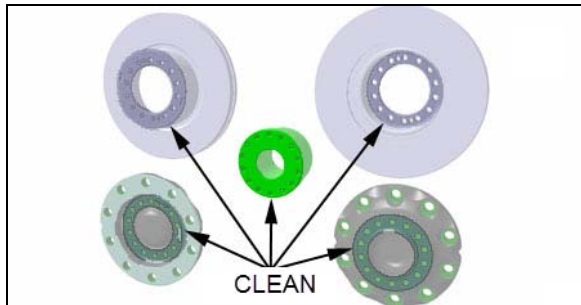

FIGURE 21: CLEANING HUB BEARING, ROTOR AND HUB FLANGE CLAMPING SURFACES

10. Install rotor onto hub bearing.
11. Add some grease (25-50 ml) (Fuchs Renolite LX PEP-2) (Prevost #685325) into the bottom of the hub flange cap. Mount hub flange onto rotor.
12. Secure hub flange and rotor to unitized hub bearing using 14 hub flange cap screws. Torque to 183±9 lbf-ft. Refer to FIGURE 23 for tightening sequence. **NOTE: discard bolts that start to show signs of deformation in the threaded area or beneath the head of the bolt.**
13. Once the hub flange has been correctly fitted; it is necessary to check the axial run out of the brake disc. Refer to page No.B29 of the following manual: included on your vehicle Technical Publications CD in PDF format to complete this step:

Dana Parts & Service Instructions S84U Steer Axle HUB BEARING REWORK Manual NO 1963 A+B iss A

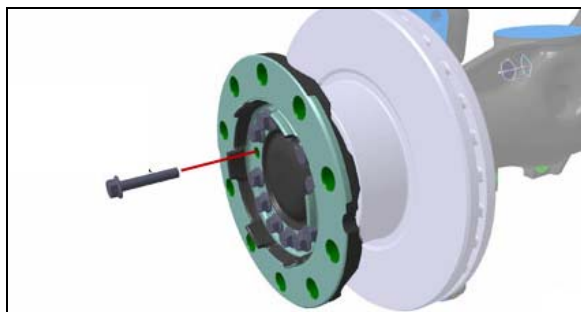

FIGURE 22: HUB FLANGE HEX CAP SCREW

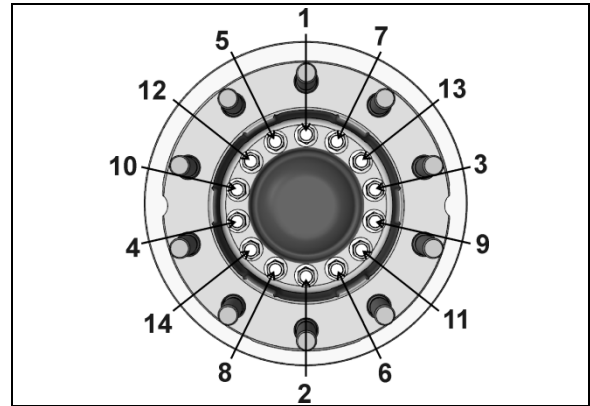

FIGURE 23: HUB FLANGE HEX CAP SCREW TIGHTENING SEQUENCE

14. Mount the wheel over studs, being careful not to damage stud threads.
15. Screw in the hex stud nuts (refer to Figure 2 for sequence) so that wheel will position itself concentrically with hub. This is important, otherwise wheel may be eccentric with hub and will not run straight. In this initial step, slightly tighten the nuts to correctly position the wheel.
16. Tighten stud nuts progressively as shown in **Erreur ! Source du renvoi introuvable.** The final tightening should be done with a torque wrench. Tighten stud nuts to 450 - 500 lbf-ft (610 - 680 Nm) for aluminum as well as steel wheel.

9. DRIVE AXLE WHEEL HUBS

Drive axle wheels hubs feature a compact bearing design. (Figure 24)

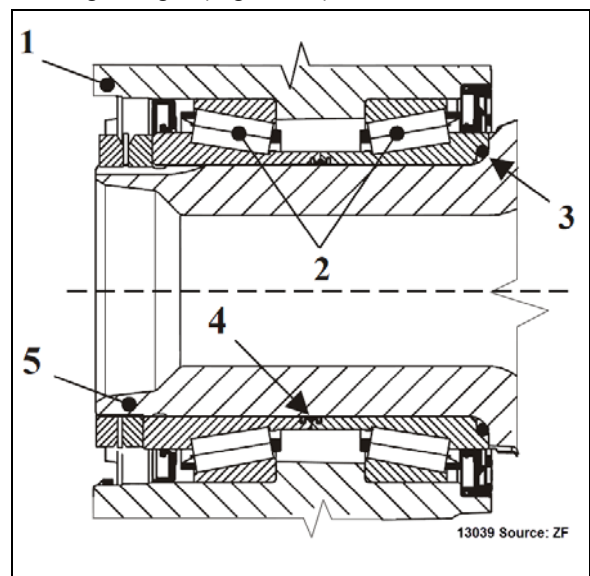

FIGURE 24: COMPACT BEARING

1 = Hub

- 2 = Compact bearing
- 3 = O-ring
- 4 = Retaining ring
- 5 = Hub carrier

9.1 COMPACT BEARING AXIAL PLAY AND GREASE CHANGE.

Bearing axial play verification and grease change must be performed periodically, refer to Section 11 "Rear Axles" for maintenance, removal and reinstallation instructions and Section 24a "Lubrication and service schedule" for proper grease selection and service intervals.

10. TIRE MAINTENANCE

The most critical factor in tire maintenance is proper inflation (Figure 25). No tire is impervious to loss of air pressure. To avoid the hazards of under inflation, always maintain tires at their recommended inflation pressure. Improper inflation decreases tire life.

An under inflated tire builds up heat that can cause sudden tire destruction, resulting in improper vehicle handling and possible loss of vehicle control. At least once a week, before driving (when tires are cold), check inflation pressure on all the tires, including the spare tire. This is especially important in cases when different drivers operate the vehicle.



WARNING

Failure to maintain correct tire inflation pressure may result in sudden tire destruction, improper vehicle handling, and will cause rapid and irregular tire wear. Inflation pressure should be checked weekly and always before long distance trips.

10.1 INFLATION PRESSURE

The condition and pressure of the tires can greatly affect both useful tire life and road safety.

At regular intervals, verify the tire pressures. Use an accurate tire pressure gauge when checking inflation pressures. Never exceed the maximum inflation pressure specified on each tire.

NOTE

Inflation pressure should be checked when tires are cold. Cold tire inflation pressure can be measured when a vehicle has not been driven for at least 3 hours or less than 1 mile (1.6 km). Driving, even for a short distance, causes tires to heat up and air pressure to increase. Check inflation pressure on all tires (including the spare tire) using an accurate tire gauge.

NOTE

The recommended tire inflation pressures are given in the applicable documents supplied with the vehicle. In addition, cold tire inflation pressures are listed on the Department of Transport's certification plate, affixed on the panel behind the driver's seat. For special tire selection, a "PREVOST COACH SPECIAL SPECIFICATION" chart is supplied with the vehicle and is affixed on the left wall near the driver's seat. Remember, tire inflation pressure must be adjusted according to vehicle loading - see table in "Coach Final Record"



CAUTION

Never bleed air from hot tires as tires will then be under inflated. Use an accurate tire gauge to check pressures (Do not kick tires as an inflation check. This is an unreliable method).

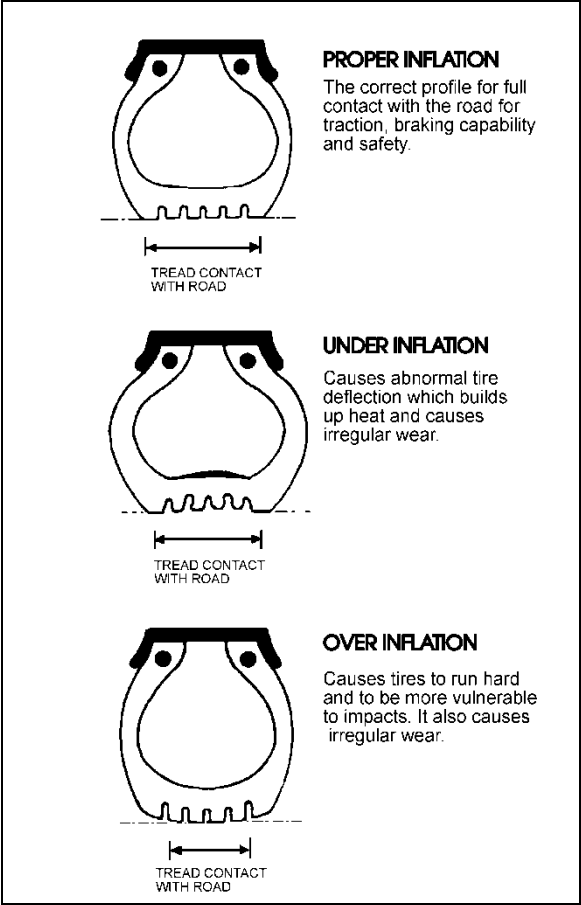

FIGURE 25: TIRE INFLATION

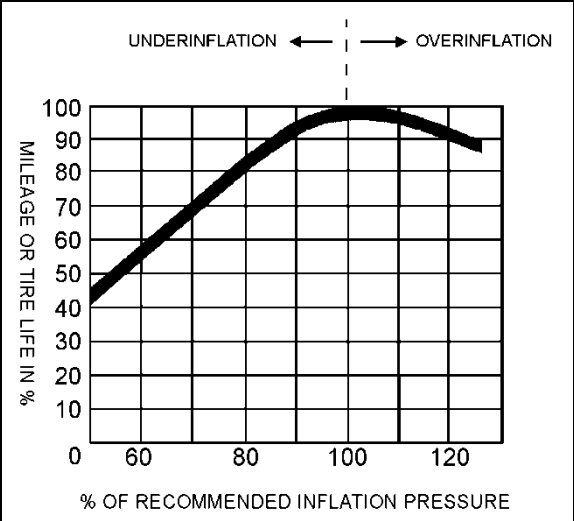

FIGURE 26: TIRE LIFE / INFLATION PRESSURE¹³⁰¹⁰

WARNING

Recommended tire inflation pressures and maximum allowable loads apply to speeds up to 65 mph (105 km/hr). Do not drive vehicle at a higher speed than 65 mph (105 km/h) or above the posted speed limit.

CAUTION

These tire pressures are established in accordance with the maximum allowable load on each axle. A lower pressure is recommended if the axle load is less than the above specifications. Weigh vehicle fully loaded and pressurize according to tire manufacturer's recommendations. For other tire and wheel specifications, see Prevost tire pressure tabulation in "Coach Final Record".

WARNING

Incorrect tire pressures cause increased tire wear and adversely affect road holding of the vehicle, which may lead to loss of vehicle control.

**WARNING**

All tires on the same axle should always be inflated to the same pressure. There should not be a difference in pressure between right and left tires on the same axle.

A 5-psi (35-kPa) under-inflation in one front tire can not only reduce vehicle maneuverability, but will create steering hazards which can lead to an accident.

10.2 TIRE MATCHING

Unmatched tires on drive axle will cause tire wear and scuffing, as well as possible damage to the drive unit. Consequently, we recommend that tires be matched within 1/8" (3 mm) of the same rolling radius.

NOTE

It is recommended that all tires on coach be of the same type.

10.3 WHEEL BALANCING

Before balancing, wheels must be clean and free from all foreign matter. The tires should be in good condition and properly mounted. An unbalanced wheel can be due to a bent wheel or improper mounting. Before removing the wheel from the vehicle, check for swaying movement and if necessary, check the wheel lateral runout as outlined under heading "*Wheel Straightness Check*".

**WARNING**

When balancing wheel and tire assemblies, it is strongly recommended to closely follow instructions covering the operation of wheel balancer.

**CAUTION**

A maximum of 16-oz (450 g) of balancing weight is recommended. If more weight is necessary, check and correct the cause.

10.4 TIRE ROTATION

Radial tires should be rotated only when necessary. If the tires are wearing evenly, there is no need to rotate. If irregular wear becomes apparent or if the wear rate on the tires is perceptively different (from axle to axle), then tires should be rotated in such a manner as to alleviate the condition.

NOTE

There is no restriction on crisscross rotation.

11. SPECIFICATIONS

STEEL WHEELS

Wheel size..... 9.0" X 22.5"
 Wheel nut torque..... 450 - 500 lbf-ft (610 - 680 Nm)
 Tire size..... 315/80 R 22.5

RECOMMENDED TIRE INFLATION PRESSURE AT MAXIMUM LOAD (cold)

NOTE
 Vehicle is delivered with the specific inflation pressure certification plate according to the tire selection.

 **WARNING**
 Special tire selection may lower maximum allowable speed limit, even below posted speed limit. For maximum safety, check with tire manufacturer.

 **WARNING**
 Recommended tire inflation pressures and maximum allowable loads apply to speeds up to 65 mph (105 km/hr). Do not drive vehicle at a higher speed than 65 mph (105 km/h) or above the posted speed limit.

12. SECTION CHANGE LOG

	DESCRIPTION	DATE
1		
2		
3		
4		
5		
6		

CONTENTS

1. STEERING SYSTEM DESCRIPTION	3
2. POWER STEERING GEAR	4
2.1 DESCRIPTION	4
2.2 POWER STEERING GEAR REMOVAL.....	5
2.3 POWER STEERING GEAR INSTALLATION	5
2.4 TROUBLESHOOTING	5
3. BLEEDING POWER STEERING HYDRAULIC SYSTEM	5
4. HYDRAULIC PRESSURE TEST	5
5. POWER STEERING HYDRAULIC PUMP	5
5.1 REMOVAL AND INSTALLATION	5
6. STEERING COLUMN REMOVAL	6
7. STEERING WHEEL	7
7.1 REMOVAL.....	7
7.2 INSTALLATION.....	8
7.3 CLOCKSPrING REPLACEMENT	8
8. TURNING ANGLE ADJUSTMENT	8
9. STEERING LINKAGE ADJUSTMENT	9
10. PITMAN ARM	9
10.1 REMOVAL.....	9
10.2 INSTALLATION.....	10
10.3 ADJUSTMENT	10
10.4 TAG AXLE UNLOADING SWITCH ADJUSTMENT	10
11. DRAG LINK	11
11.1 FINE ADJUSTMENT	11
12. STEERING SYSTEM MAINTENANCE	11
12.1 STEERING SYSTEM PLAY INSPECTION	12
12.2 POWER STEERING RESERVOIR AND FILTER	12
12.2.1 <i>Oil Level Check Procedure</i>	12
12.2.2 <i>Filter Element Replacement</i>	13
12.2 STEERING STABILIZER CYLINDER (DAMPER).....	13
12.3 DRAG LINK.....	14
12.3.1 <i>Front I-beam Axle</i>	14
12.4 TIE ROD	15
12.5 DRAG LINK AND TIE ROD BALL JOINTS INSPECTION FOR CORROSION	15
12.6 DROP TYPE BALL JOINT (SOCKET)	15
12.6.1 <i>Drop Type Ball Joint End Play</i>	15
12.6.2 <i>End Play Adjustment Limitation</i>	16
12.6.3 <i>Dismantling Drop Type Ball Joint</i>	16
12.6.4 <i>Assembling Drop Type Ball Joint</i>	16
12.7 STRAIGHT BODY TYPE BALL JOINT	17
12.7.1 <i>Visual Inspection</i>	17
12.7.2 <i>Straight Body Type Ball Joint End Play And Looseness</i>	17

13. DRIVING TIPS18

14. TROUBLESHOOTING.....19

15. TORQUE SPECIFICATIONS.....20

16. SPECIFICATIONS.....20

17. SECTION CHANGE LOG20

ILLUSTRATIONS

FIGURE 1: I-BEAM AXLE STEERING SYSTEM SETUP 3

FIGURE 2: POWER STEERING GEAR 4

FIGURE 3: FRONT SERVICE COMPARTMENT 4

FIGURE 4: FUEL PUMP REMOVAL 5

FIGURE 5: FUEL PUMP DRIVE AXLE..... 6

FIGURE 6: POWER STEERING PUMP REMOVAL 6

FIGURE 7: STEERING COLUMN 6

FIGURE 8: STEERING COLUMN COVERS 7

FIGURE 9: REMOVING THE HORN PAD..... 7

FIGURE 10: STEERING HARNESS & HORN WIRE 7

FIGURE 11: LOCKING THE CLOCKSPrING IN PLACE 8

FIGURE 12: CLOCKSPrING INSTALLATION..... 8

FIGURE 13: PROPER CLOCKSPrING POSITION..... 8

FIGURE 14: PITMAN ARM ADJUSTMENT..... 9

FIGURE 15: FIXING NUT PUNCH MARK 16098..... 10

FIGURE 16: TAG AXLE UNLOADING SWITCH ADJUSTMENT 10

FIGURE 17: DRAG LINK 11

FIGURE 18: DRAG LINK ADJUSTMENT 11

FIGURE 19: HYDRAULIC FLUID RESERVOIR LOCATION 13

FIGURE 20: POWER STEERING FLUID RESERVOIR..... 13

FIGURE 21: STEERING STABILIZER (DAMPER) 14

FIGURE 22: I-BEAM FRONT AXLE DRAG LINK..... 14

FIGURE 23: TIE ROD 15

FIGURE 24: DROP TYPE BALL JOINT FOUND ON TIE ROD (2X)..... 15

FIGURE 25: BALL PIN HAS LOCAL WORN FLATS..... 16

FIGURE 25: STRAIGHT BODY TYPE BALL JOINT 17

FIGURE 26: ADEQUATE CLAMPING CONDITION 17

1. STEERING SYSTEM DESCRIPTION

The steering system consists of the steering wheel and column assembly, a vane-type hydraulic pump, reservoir, filter, interconnecting system lines and hoses, integral power steering gear, linkage and steering damper (Figure 1). The steering linkage includes the pitman arm, drag link, steering arm, tie rod arms and tie rod.

Hydraulic components are added to transmit, increase and regulate steering control forces. These elements are:

- 1. Steering stabilizer (damper);
- 2. A vane type hydraulic pump; and
- 3. Hydraulic reservoir and hoses.

The steering stabilizer reduces road shocks and vibrations in the system. The steering gearbox is self powered and provides movement with power assistance to the left wheel.

Steering stability and tire wear are influenced by wheels, hubs, tires, air suspension, brakes, front suspension and front end alignment which are all covered in their respective sections in this manual.

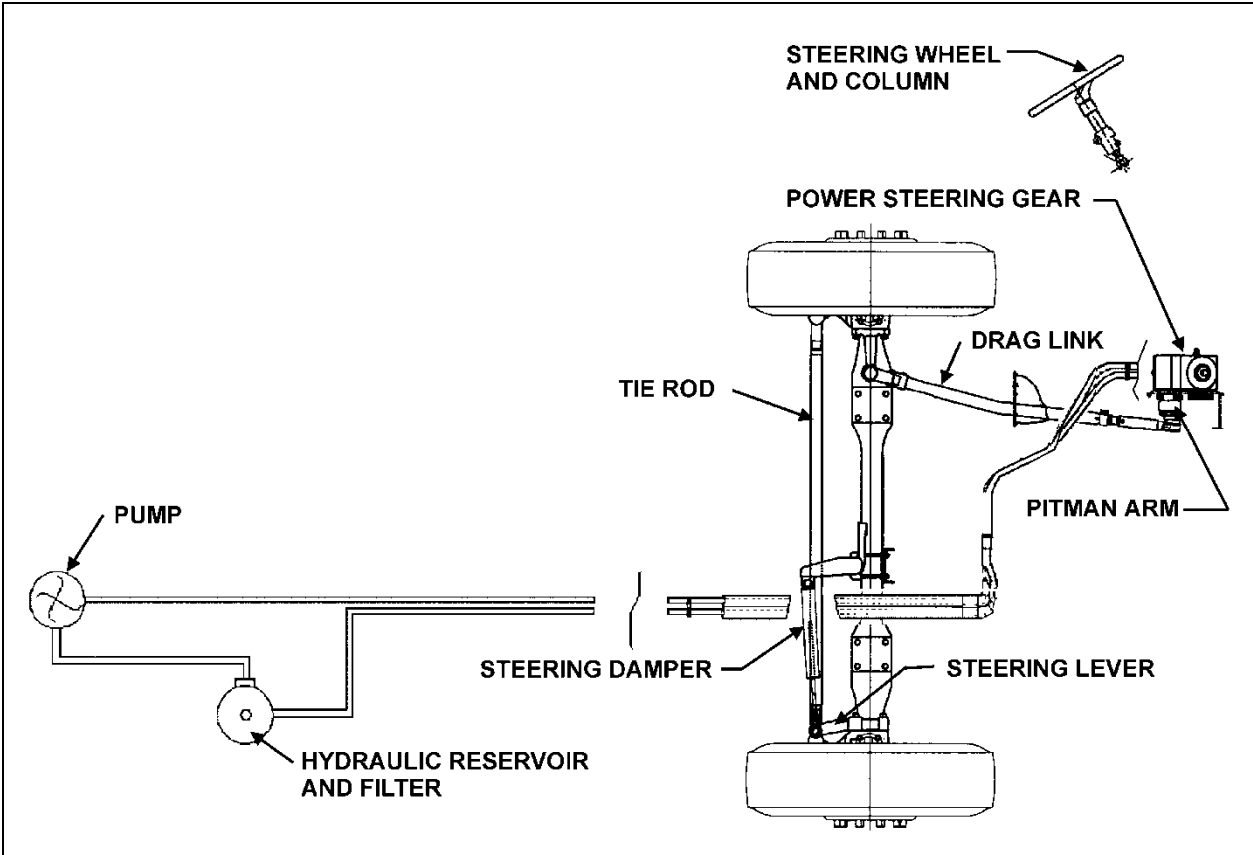

FIGURE 1: I-BEAM AXLE STEERING SYSTEM SETUP 14041

2. POWER STEERING GEAR

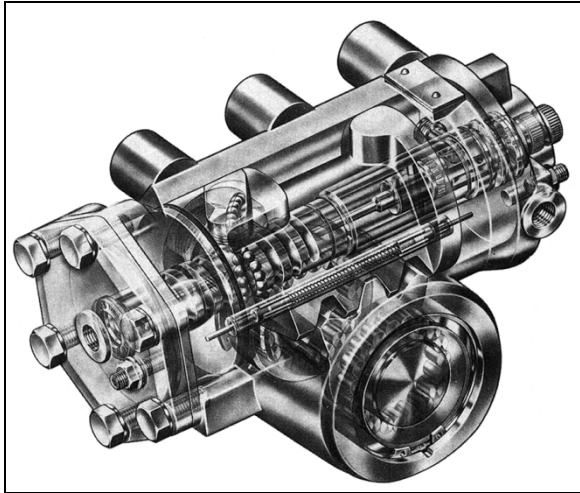

FIGURE 2: POWER STEERING GEAR

14035

2.1 DESCRIPTION

The power steering gear is located in the lower part of front service compartment (Figs. 2 & 3). The housing of the ZF-Servocom contains a control valve, working cylinder and a complete mechanical steering gear. The pressure oil for the steering is delivered by a motor-driven oil pump which is supplied with oil from an oil tank.

The housing is designed as a cylinder for the piston, which converts the rotation of the steering shaft and the worm into an axial movement and transfers this to the steering worm sector shaft. The serration of the sector shaft is straight-cut with a high surface quality in such a way that it is only possible to set a unique setting without play on installation in the straight-ahead driving area by means of the two eccentrically designed lateral housing covers.

The piston and worm are connected via a ball chain. When the worm is turned, the balls are collected by a circulating pipe at one end of the chain and fed in again at the other end, thus producing an endless ball chain.

The control valve consists of the valve slide in a needle bearing in the worm, with six control grooves on the circumference and the control sleeve on the worm, which also has six control grooves. The valve slide, designed with steering shaft connection, turns together with the worm as the steering wheel is turned.

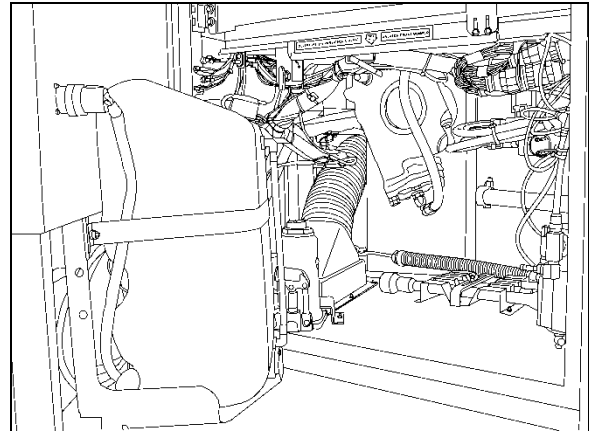

FIGURE 3: FRONT SERVICE COMPARTMENT

18611

A torsion bar, which is pinned with the valve slide and the worm, keeps the control valve in the neutral position as long as no opposing force is applied to the steering wheel. The steering housing contains a pressure relief valve, which limits the discharge pressure of the oil pump to the maximum value required. A replenishing valve can also be used, through which oil is sucked from the return if steering is not hydraulically boosted.

Compared with constant ratio, steering versions with variable ratio are more directly designed in the center area than outside the center area. The resulting smaller steering corrections benefit steering behavior in straight-ahead driving. At the same time, the indirect transmission means that there is a higher hydraulic torque available at the steering arm in parking movement. If the hydraulic assistance fails, the operating forces on the steering wheel are correspondingly lower in this area. This is achieved through a piston/steering worm sector shaft serration with differing modulus and angle of pressure.

Upon transfer of a torque from the steering shaft to the worm, or vice versa, the torsion bar is deformed in the elastic area so that there is torsion between the valve slide and the control sleeve. When the steering wheel is released, the torsion bar ensures that the valve is returned to the neutral position.

Refer to the *"ZF-SERVOCOM Repair Manual"* and *"ZF-SERVOCOM Operating, Servicing /Maintenance and Inspection Instructions"* for the functional aspects and maintenance procedure of the steering gear.

2.2 POWER STEERING GEAR REMOVAL



WARNING

The steering gearbox weighs approximately 100 lbs (45 kg) dry. Exercise caution when handling.

1. Put a container into place, then disconnect both the inlet and outlet hoses from the power steering gear. Cover fittings to prevent fluid contamination.
2. Mark both the pitman arm and sector shaft with a line, then remove pitman arm. Refer to "11.1 Pitman Arm Removal" procedure.
3. Mark both the steering shaft universal joint yoke and steering gear input shaft with a line, then disconnect universal joint.
4. Unscrew and remove the power steering gear.

2.3 POWER STEERING GEAR INSTALLATION

Reverse "Power Steering Gear Removal" procedure paying particular attention to the following:

1. Tighten fasteners as recommended under paragraph 14: "Torque Specifications".
2. Bleed air from the system as per step 3, next.

2.4 TROUBLESHOOTING

Perform troubleshooting of the steering gear as outlined in the "ZF-SERVOCOM Repair Manual", the "ZF-SERVOCOM Operating, Servicing /Maintenance and Inspection Instructions".

3. BLEEDING POWER STEERING HYDRAULIC SYSTEM

To bleed the power steering hydraulic system, refer to the "ZF-SERVOCOM Repair Manual", under heading "Setting And Functional Test".

4. HYDRAULIC PRESSURE TEST

Perform a pressure test as outlined in the "ZF-SERVOCOM Repair Manual" under heading "Setting And Functional Test".

5. POWER STEERING HYDRAULIC PUMP

The power steering pump is a gear driven hydraulic unit which supplies hydraulic pressure for the operation of the steering gear. The pump is mounted on the engine, at the flywheel end and is also used for driving the fuel pump.

5.1 REMOVAL AND INSTALLATION

The pump is accessible through the engine compartment R.H. access door.

To remove the pump, proceed as follows:

- You must first remove the fuel feed pump.
- Clean around the fuel pump and fuel lines. Position a container to catch any fuel that might drain from the pump or lines.
- Remove the fuel pump.

NOTE

Only unfasten the bolts marked with arrows.

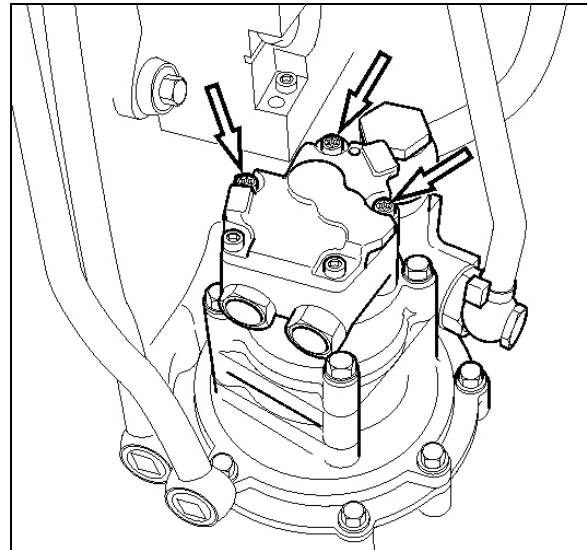

FIGURE 4: FUEL PUMP REMOVAL



CAUTION

Ensure to clean around the head of the bolts. Debris will prevent the tool from fitting properly and cause damage to the fasteners.

- Check that the adapter and fuel pump drive axle are not damaged.

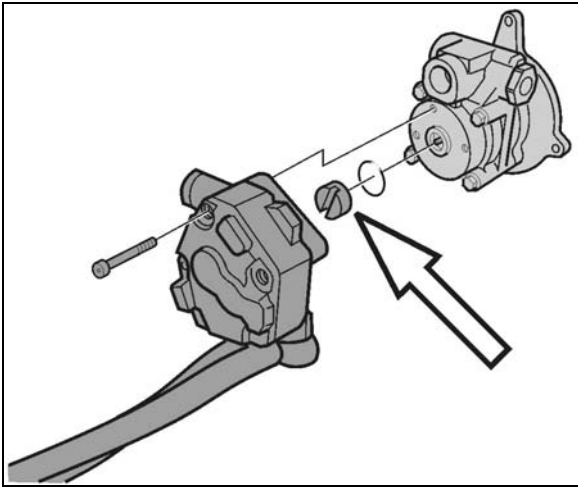

FIGURE 5: FUEL PUMP DRIVE AXLE

- Set the fuel pump aside.
- Clean around the power steering pump and loosen the steering lines. Position a container to catch any hydraulic fluid that might drain from the pump or lines.
- Unfasten the power steering pump bolts.

NOTE

Only unfasten the bolts marked with arrows.

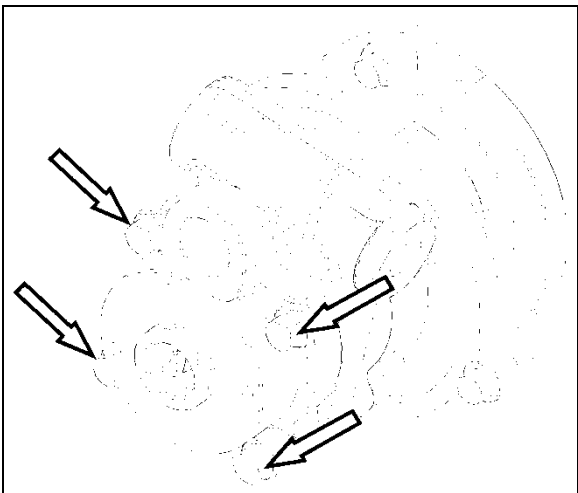

FIGURE 6: POWER STEERING PUMP REMOVAL

- Install the new power steering pump. Torque-tighten bolts to specification.

NOTE

Use a new gasket.

- Connect the hydraulic lines to the power steering pump.
- Install the fuel pump. Torque-tighten bolts to specification.

NOTE

Use a new sealing ring. Check that the fuel pump drive axle sits correctly in the power steering pump.

- Start the engine and let run for 5 minutes. Make sure that there are no leaks.

6. STEERING COLUMN REMOVAL

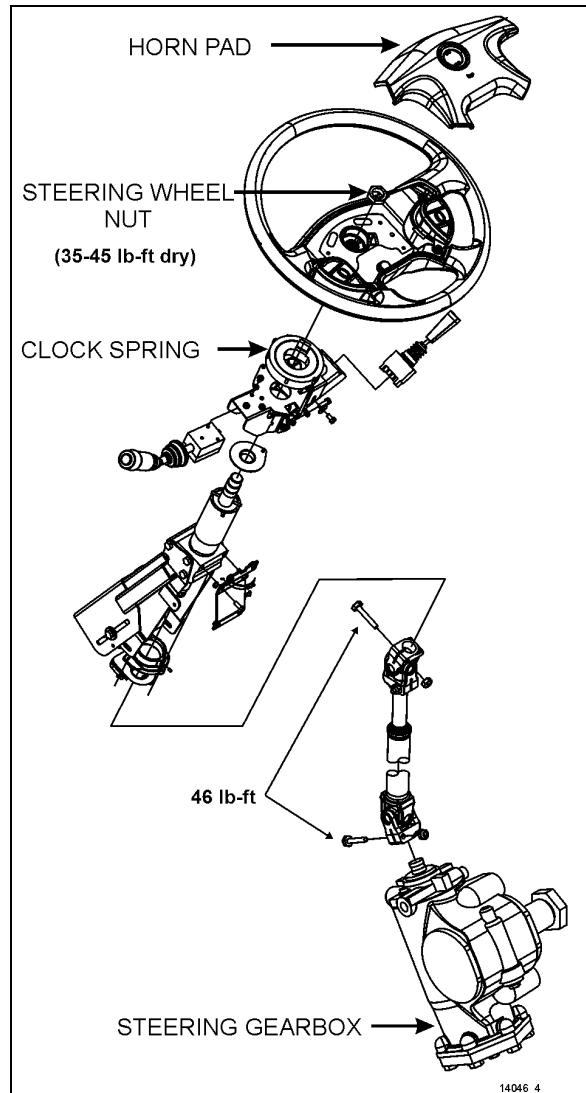

FIGURE 7: STEERING COLUMN

To disassemble the steering column from system, refer to figure 7 & 8. The steering column has no lubrication points. The lower steering column U-joint is easily accessible through the front service compartment. The upper steering column U-joint and the steering slip joint are accessible from the front driver's area. To access these joints, proceed as follows:

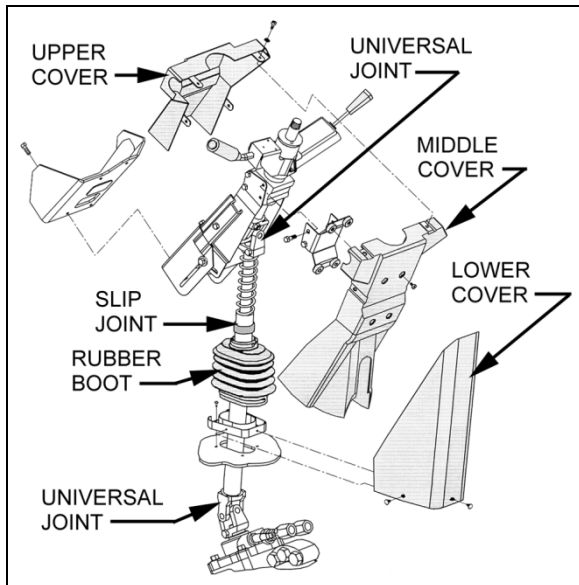

FIGURE 8: STEERING COLUMN COVERS

14040

1. From the front driver's compartment area, remove the three plastic fasteners on steering column lower cover. Remove the lower cover (Figure 8).
2. Unscrew the four retaining screws on steering column middle cover.
3. Unscrew the four retaining screws fixing steering column upper cover to middle cover. Remove the steering column middle and upper covers.
4. Position the steering wheel in order to gain access to the joints.

7. STEERING WHEEL

7.1 REMOVAL

NOTE

Before undertaking the steering wheel removal, assure that the front wheels are pointing straight ahead, aligned with the vehicle.

1. Set the battery master switch located on the rear electrical panel to the "OFF" position.
2. Pull the horn pad straight up gently to detach it from the steering wheel (Figure 9).
3. Disconnect the horn wire (white) connected to the horn pad and the steering wheel harness 4-pin connector.

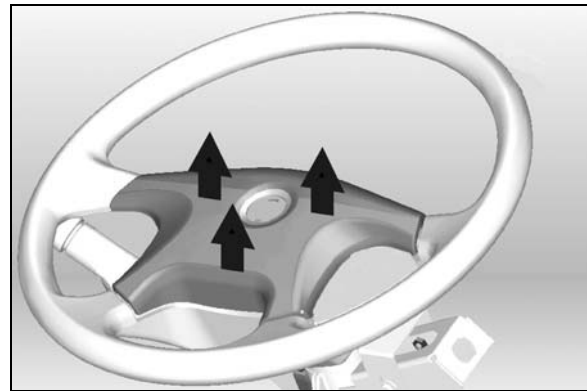

FIGURE 9: REMOVING THE HORN PAD

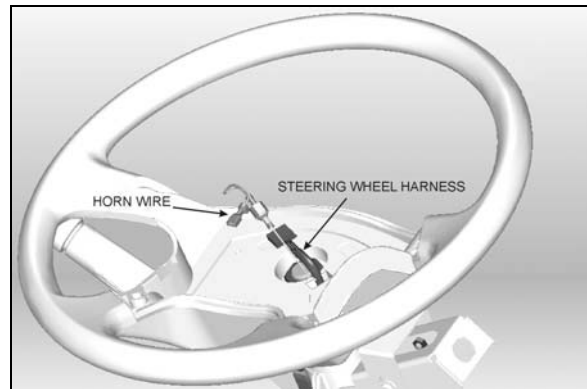

FIGURE 10: STEERING HARNESS & HORN WIRE

4. Unscrew the steering wheel nut. To simplify installation and ensure steering wheel alignment, mark the relationship of the spline shaft to the steering wheel hub (if marks don't already exist or don't line up).
5. Using an appropriate puller, separate the steering wheel from the spline shaft.
6. From behind the steering wheel, pull gently on the electrical wires passing through the rectangular opening in the steering wheel to finish removal of the steering wheel.
7. Once the steering wheel is removed, it is important to block any rotating movement of the clockspring in order to prevent it from losing its neutral position. Use two pieces of masking tape to lock it in place (Figure 11).

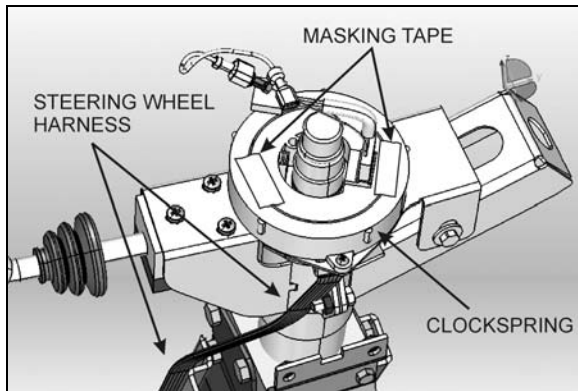

FIGURE 11: LOCKING THE CLOCKSPRING IN PLACE

NOTE

The clockspring mechanism permits a certain number of turns in each direction. At the moment of reinstalling the steering wheel, if the clockspring is not at its neutral position, the number of available turns will be reduced. That may damage the clockspring if the steering wheel is turned to its maximum amplitude.

7.2 INSTALLATION

1. Route the white horn wire and the 4-pin connector through the opening on the steering wheel.
2. Align the mark on the steering wheel hub with the mark on the spline shaft and slide the wheel onto the shaft.
3. Tighten wheel retaining nut to a torque of 35-45 lbf-ft.
4. Plug the 4-pin connector and connect the white horn wire to the center pad.
5. Reinstall the center pad and test for proper horn functioning.

7.3 CLOCKSPRING REPLACEMENT

1. Remove the steering wheel.
2. Remove the 2 clockspring mounting screws and then remove the clockspring. You will have to disconnect the clockspring harness connector located lower along the steering wheel column. If necessary, remove the steering column covers (Figure 8).
3. Route the new clockspring harness through the opening in the clockspring support

(Figure 12). Plug the connector at the base of the steering wheel column and fix harness along the steering wheel column.

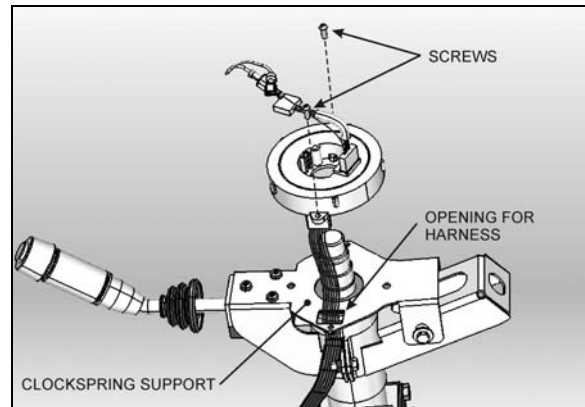

FIGURE 12: CLOCKSPRING INSTALLATION

4. Mount the clockspring in place with 2 screws.
5. Break the paper seal and rotate the center part of the clockspring about 50° clockwise (Figure 13). This step is necessary for the installation of the steering wheel.

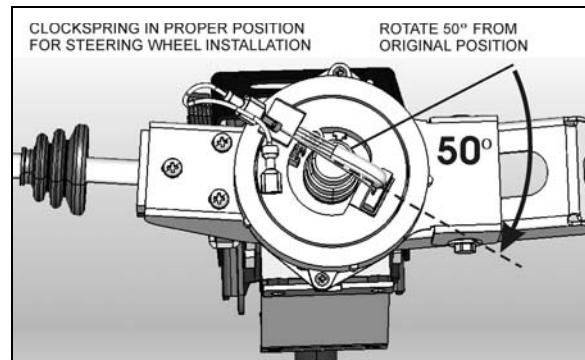

FIGURE 13: PROPER CLOCKSPRING POSITION

6. Reinstall the steering wheel.

8. TURNING ANGLE ADJUSTMENT

The maximum turning angle is set through two (2) steering stop screws installed on the axle center. Steering stop screws are factory adjusted to accommodate the chassis design, and therefore, do not require adjustment on new vehicles. However, these should be checked and adjusted if necessary, any time a steering system component is repaired, disassembled or adjusted. Refer to section 10 "Front Axle" under heading "6.4 "Turning Angle Adjustment".

**CAUTION**

To prevent the steering damper from interfering with the adjustment of turning angles, make sure its fixing bracket is at correct location on the axle (refer to "12.2 Steering Stabilizer Cylinder (Damper)").

Hydraulic Stop**CAUTION**

Reduce or shut off the power steering hydraulic pressure before the boss on the axle touches the stop screw. If not, the components of the front axle will be damaged (refer to "ZF-SERVOCOM Repair Manual" and "ZF-SERVOCOM Operating, Servicing /Maintenance and Inspection Instructions", under heading "Setting The Steering Limiter").

**CAUTION**

Never maintain the relief pressure for more than 5 seconds, since damage to the power steering pump may occur.

9. STEERING LINKAGE ADJUSTMENT

The steering linkage includes the pitman arm, drag link, steering arm, tie rod arms and tie rod. Perform lubrication according to "DANA SPICER Service Manual NDS Axle Range" found in the OEM manuals folder.

Steering linkage pivot points should be checked each time they are lubricated. Looseness can be visually detected while rotating the steering wheel in both directions. Replace defective parts.

**CAUTION**

Front wheel alignment should be checked and adjusted if necessary, any time a component of the steering system is repaired, disassembled or adjusted. Refer to section 10 "Front Axle" under heading 6. "Front Wheel Alignment".

10. PITMAN ARM**10.1 REMOVAL**

1. Remove cotter pin, nut and washers from drag link ball stud at pitman arm.
2. Disconnect drag link from pitman arm, using jaw style pullers (pressure screw type).

**WARNING**

Always wear approved eye protection when operating pullers.

**CAUTION**

Do not drive (hammer in) pitman arm on or off pitman shaft as this can damage the steering gear.

**CAUTION**

Heating of components to aid in disassembly is not allowed because it has a detrimental effect on axle components and steering linkages.

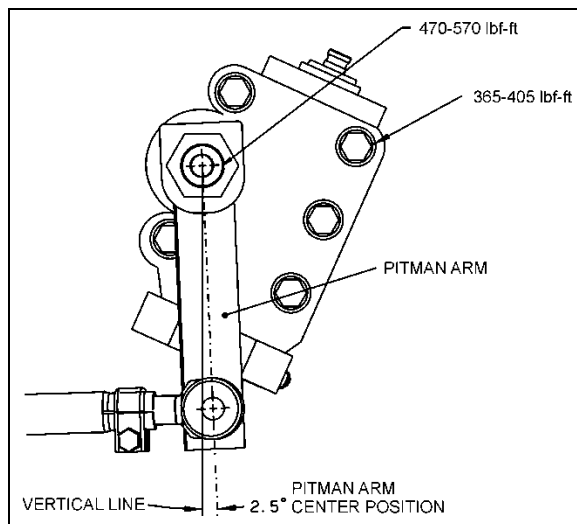
**FIGURE 14: PITMAN ARM ADJUSTMENT**

3. Using a cold chisel, undo punch mark that locks fixing nut to the pitman arm.
4. Remove pitman arm fixing nut.
5. Check the radial position of the pitman arm in relation to the sector shaft prior to removal of pitman arm.

8. Add reference marks to the arm and shaft if necessary to ensure correct alignment at reassembly.
7. You must use a puller to remove pitman arm.

10.2 INSTALLATION

1. Position pitman arm on sector gear shaft with reference marks aligned.
2. Install fixing nut (Prevost #661050). Tighten nut to 470-570 lbf-ft (637-773 Nm).

NOTE

Use a new nut if the previously removed nut was punched.

1. Lock nut with sector shaft using a punch mark into the groove (Refer to figure 15).

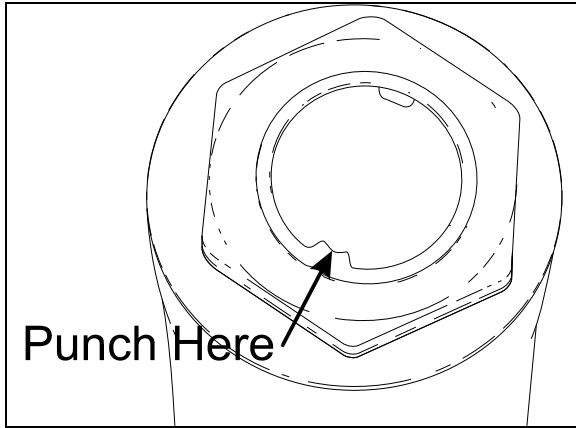

FIGURE 15: FIXING NUT PUNCH MARK 16098

2. Connect drag link to pitman arm while ensuring that rubber stabilizer is in place on the rod end. Install washers. Tighten nut to 150-200 lbf-ft (203-271 Nm). Afterwards, install a new cotter pin.



CAUTION

Input shaft marks must be aligned before adjusting pitman arm.

10.3 ADJUSTMENT

1. Disconnect the drag link from pitman arm. Center steering wheel by dividing the total number of steering wheel turns in two. Scribe a reference mark on steering gearbox at the center previously determined.

2. Using a protractor, check the angle of the pitman arm (refer to Figure 14 for details).
3. The pitman arm should be adjusted to an angle of 2.5° in relation with the vertical axis (towards front of vehicle). If not, unscrew and remove fixing nut. Remove the pitman arm according to the procedure outlined under previous heading "Pitman arm removal". Adjust to the proper angle.
4. When adjustment is achieved, replace fixing nut and torque to 470-570 lbf-ft (637-773Nm).

10.4 TAG AXLE UNLOADING SWITCH ADJUSTMENT

1. Make sure vehicle wheels are straight and facing forward.
2. Line up switch lever with reference to the bracket center (Refer to figure 16).

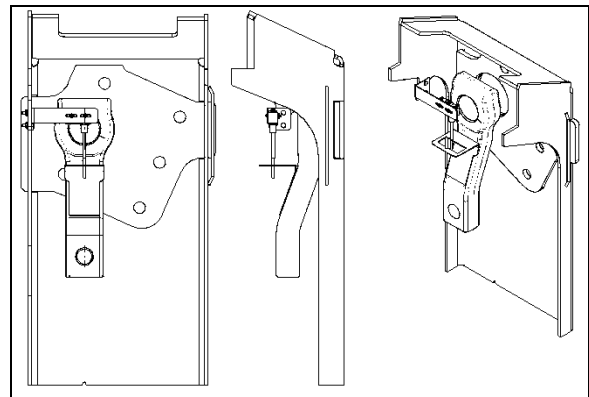



FIGURE 16: TAG AXLE UNLOADING SWITCH ADJUSTMENT 14061

11. DRAG LINK

The drag link on your vehicle connects the steering gear pitman arm to the front axle's steering arm.

For additional details please refer to ZF assembly instructions LMN404-3 and Lemförder service information leaflet for the fine adjustment system.



PINCH HAZARD

Keep hands and fingers clear of pinch zones around pitman arm.

Pinch zones are between pitman arm and clamp, and between front of pitman arm and vehicle structure.

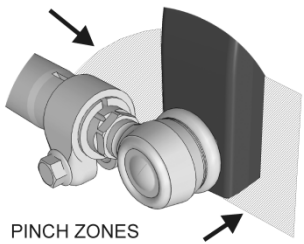

PINCH ZONES

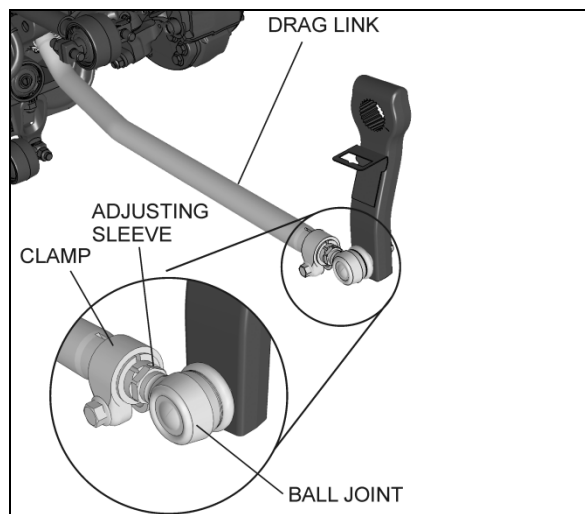

FIGURE 17: DRAG LINK

11.1 FINE ADJUSTMENT

The drag link fore end is provided with an adjusting sleeve which has internal and external left and right threads. Turning this sleeve allows fine adjustments to the length of the drag link.

Apply a small amount anti-seize compound on the threads for corrosion protection. Be sure to avoid smearing the ball joint boot.

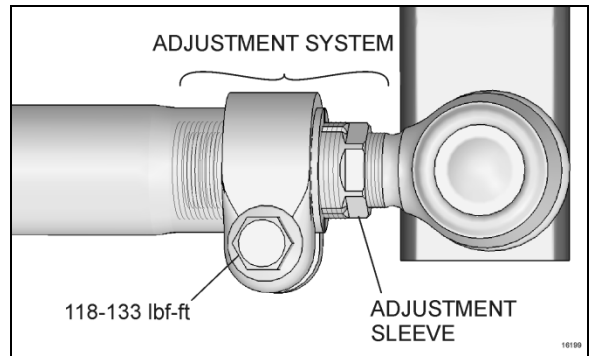



FIGURE 18: DRAG LINK ADJUSTMENT

12. STEERING SYSTEM MAINTENANCE

The power steering system requires little maintenance. However, the system should be kept clean to ensure maximum operating performance and trouble-free service. Periodic inspections should also be made to check for leakage and all parts for damage or distortion. Insure all fasteners are tight (see "14. Specifications" for recommended tightening torques).

When the slightest evidence of dirt, sludge or water is discovered in the system, disconnect fluid lines at the power steering gear to drain the system. Drain and refill the system.

Air in the hydraulic system will cause spongy action and noisy operation. When a hose has been disconnected or when fluid has been lost for any reason, the system must be bled. Bleed system as outlined under heading 3: "Bleeding Power Steering Hydraulic System".



CAUTION

Do not operate the pump without fluid in the power steering fluid reservoir.

If the steering linkage between the steering gear and the two front wheels is not properly adjusted, or if it is bent, twisted or worn, the steering of the vehicle will be seriously impaired. Whenever a steering linkage part is repaired, replaced or adjusted, steering geometry and front wheel alignment must be checked and necessary corrections made. Refer to section 10 "Front Axle" under heading 6: "Front Wheel Alignment".

At regular lubrication intervals, the steering linkage should be thoroughly inspected for worn or loose components.

After the vehicle has been operated continually and high mileage figures have been reached, overhaul of the various steering units will be required. General overhaul procedure normally requires removal of the entire assembly, cleaning and inspection of all parts and final assembly. Careful inspection of all parts during overhaul is very important and must not be neglected.

Lubrication fittings must all be cleaned before applying lubricant. Moreover, always be sure the equipment used in applying lubricant is clean. Every precaution should be taken to prevent entry of dirt, grit, lint or other foreign matter into lubricant containers. Replace fittings that have become broken or damaged. Lubrication intervals, as well as the recommended lubricants for the steering components, are given in the "Lubrication And Servicing Schedule" in Section 24 of this manual. The intervals given in the schedule are recommended for normal service. More frequent intervals may be required under severe operating conditions.

12.1 STEERING SYSTEM PLAY INSPECTION

Basically, the steering system play is checked with the engine running and the front wheels in the straight ahead driving position. The steering wheel is slowly turned in one direction until there is a perceptible movement of a front wheel. If a point on the steering wheel rim moves more than the value indicated below before perceptible return movement of the wheel under observation, there is excessive free play in the steering system.

Steering wheel travel covered

Maximum value: 1.732 inch (44mm) with
Prevost 18-inch steering
wheel

NOTE

The full procedure is described under paragraph 1.6.7 Checking the Steering Gear Play in ZF SERVOCOM DESIGN, OPERATION, MAINTENANCE, INSPECTION (8090) manual.

Take note that the maximum travel covered value specified in ZF's manual doesn't apply to the Prevost design which uses a

18-inch steering wheel.

If the maximum value is exceeded, the steering system should be thoroughly inspected for worn or loose components, beginning with the steering linkage. If the steering linkage is in good condition, then the steering column and the steering gear should be inspected.



MAINTENANCE

Perform the steering system play inspection every 100 000 miles.

12.2 POWER STEERING RESERVOIR AND FILTER

The power steering reservoir is located on R.H. side of engine compartment and accessible through the engine compartment doors. (Figure 19).

12.2.1 Oil Level Check Procedure

1. Stop engine. Open engine compartment doors.
2. Unscrew and remove the dipstick located on top of reservoir and wipe with a clean rag.
3. Insert dipstick in reservoir. Remove it again to check fluid level (Figure 19).
4. Adjust level to "**FULL**" mark using proper dipstick side depending on fluid temperature, use 80W140 full synthetic gear oil.
5. Reinsert and tighten the dipstick.
6. At regular intervals, fluid level should be checked in the reservoir and filter assembly.

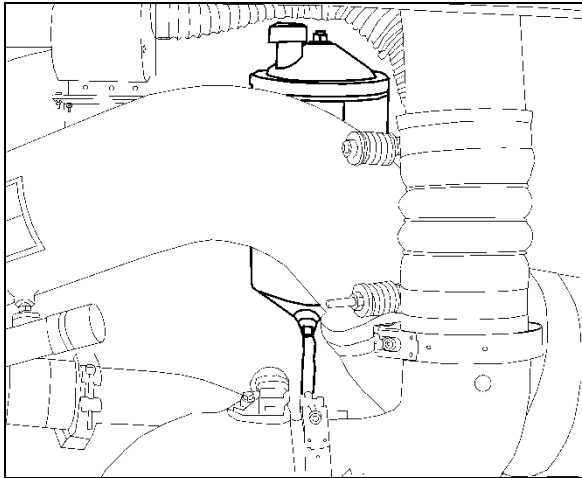

FIGURE 19: HYDRAULIC FLUID RESERVOIR LOCATION
14059

MAINTENANCE

Replace the oil filter element in the power steering reservoir every 50,000 miles.

Drain system and refill with fresh power steering fluid every 150,000 miles. Use Mobil DEXRON-VI ATF (Automatic Transmission Fluid)

12.2.2 Filter Element Replacement

Before removing the cover, clean the upper part of the steering fluid reservoir to prevent dirt and other contaminant from falling inside the reservoir.

Unscrew the cover nut and keep the gasket located found on top of the reservoir cover.

Remove the reservoir cover and the gasket.

Remove the retaining spring, the element retainer and finally the filter element.

The power steering fluid reservoir is equipped with a magnetic drain plug. When element replacement coincide with the power steering fluid replacement, check for trapped metal particle before installation of the new filter cartridge element.

Pass the reservoir threaded rod through the element and install the element with the element's writing "THIS END UP" on top.

Pass the reservoir threaded rod through the retainer and rest the retainer on top of the element, followed by the compression spring.

Clean the large gasket and the mating surfaces on the cover and reservoir.

Properly place the large gasket in the cover. Install the cover, making sure the gasket is properly placed.

Clean the small gasket and install with the rubber side against the cover. Screw and tighten the nut as necessary to prevent leaks.

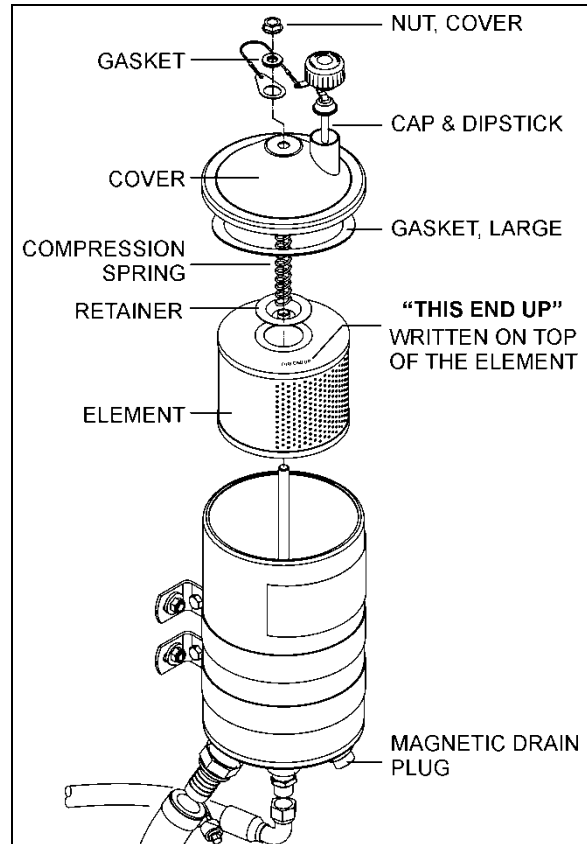

FIGURE 20: POWER STEERING FLUID RESERVOIR 14018

12.2 STEERING STABILIZER CYLINDER (DAMPER)

The steering damper is located on R.H. side, aft of front axle (Figure 21).

The cylinder is non-adjustable and non-repairable. Check for oil leaks or lack of resistance. Disconnect the cylinder from axle, then carefully attempt to extend and collapse it manually.



MAINTENANCE

Steering damper ball joint (rod end) is provided with a grease fitting for pressure lubrication. This grease fitting should be serviced every 6,000 miles.

Check the ball joint for wear, and replace if necessary.

Good quality lithium-base mineral grease NLGI No. 1 and 2 like Shell Retinax LX are recommended.

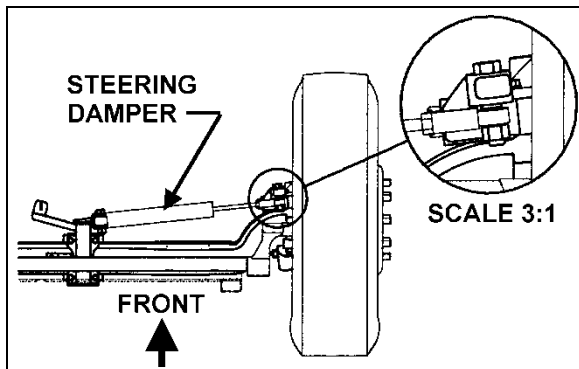

FIGURE 21: STEERING STABILIZER (DAMPER) 14042

12.3 DRAG LINK

Visually inspect drag link components for broken, corroded or deformed clamps, loose, bent or corroded nuts and gauges on tube from rubbing parts.

12.3.1 Front I-beam Axle

On vehicles equipped with I-beam front axle, the drag link features “lubricated for life” ball joints and a compact fine adjustment system.

Visual inspection

Inspect the adjustment system to ensure the threads are firmly seated. Also, a visual inspection should be carried-out looking for damage or corrosion to the adjustment system components. Replace any part showing corrosion or damage.

Functional inspection

Clean the adjustment system with a brush and compressed air prior to inspection, if required.

With the engine running and the vehicle on the ground (with a load on the axle) turn the steering wheel left and right.

To verify that the threads are tight and do not present any play, use one of the following methods:

- Visual inspection
- Place a finger on the separation line from the adjuster sleeve to the threaded ball joint shaft.
Keep fingers clear of pinch zones.
- Use a dial gage clamped to the tube and feelers aligned on the ball joint to indicate any play

When play is discovered in the adjusting system, replace the complete drag link.



CAUTION

Do not re-use clamp hardware.

Bolt and nut should be replaced every time they are unsecured.

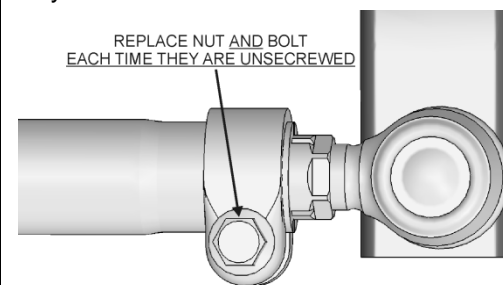

While assembling the clamp, make sure the bolt does not touch the drag link tube.

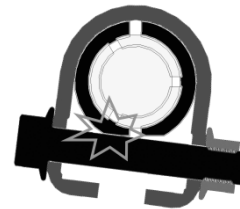

FIGURE 22: I-BEAM FRONT AXLE DRAG LINK

12.4 TIE ROD

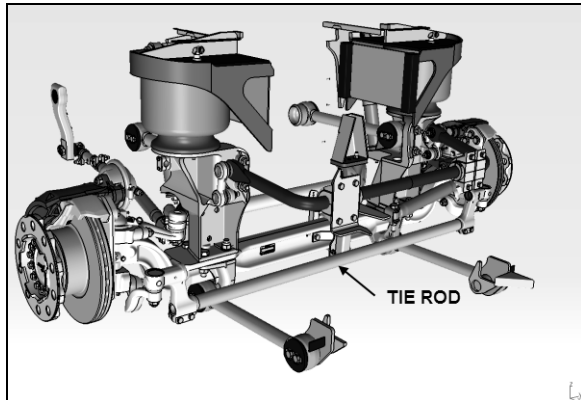

FIGURE 23: TIE ROD

MAINTENANCE

Tie rod ends (ball joint) are provided with grease fittings for pressure lubrication. These grease fittings should be serviced every 6,000 miles.

To prevent corrosion from forming around the ball pin, remove the old grease bead and assure sufficient grease is applied to purge the old grease and fill the joint and dust seal.

Good quality lithium-base mineral grease NLGI No. 2 like Shell Retinax LX are recommended.

12.5 DRAG LINK AND TIE ROD BALL JOINTS INSPECTION FOR CORROSION

Inspection of ball joints is important. Damaged sealing boots, salt and climatic conditions can cause loss of the corrosion protection coating applied at time of manufacturing.

MAINTENANCE

Inspect tie rod end ball joints for corrosion once a year.

1. Carefully clean the sealing boot or dirt seal contact area to ensure that no contaminants can get under the sealing boot or dirt seal during the following inspection procedure.
2. Use an appropriate inspection tool (e.g. spatula with cut out) to push up (sealing boot) or down (dirt seal) the seal (without damaging it) until ball pin surface is visible.

Degrease the ball pin surface and inspect carefully.

3. If there is corrosion of the ball pin or the sealing boot has deteriorated through ageing or is damaged, replace the ball joint.
4. If there is corrosion of the steering arm or tie rod arm area which is in contact with the sealing boot or dirt seal, clean and eliminate all surface irregularities.
5. If there is no corrosion or damage to the sealing boot or dirt seal, smear the steering arm and tie rod arm with Lithium grease and push seal back into its properly seated position.

When dismantling tie rod, ensure that no damage is caused to the sealing boots, dirt seals or ball joint housings.

12.6 DROP TYPE BALL JOINT (SOCKET)

Refer to "**Dana Instructions for Maintenance and overhaul of Straight and Drop Ball Sockets iss A**", found on Prevost Technical Publications web site for detailed instructions on disassembly, strip down and rebuilding of a drop type ball joint.

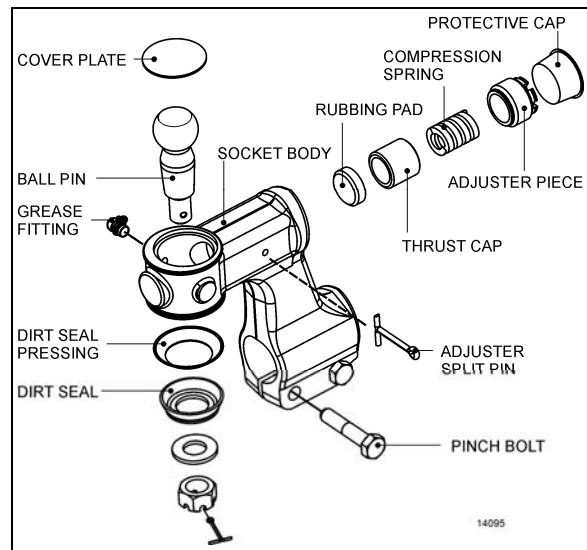

FIGURE 24: DROP TYPE BALL JOINT FOUND ON TIE ROD (2X)

12.6.1 Drop Type Ball Joint End Play Adjustment

If end play exceeds 0.047" (1.2 mm), readjustment is necessary.

1. Remove protective cap, using a suitable tool i.e.: a 1" x 1/8" x 9" long flat bar, tighten

adjuster piece fully home (SOLID) locating thrust cup onto ball pin.

2. Still with tool located on adjuster piece, back off carefully (LEAST AMOUNT) until adjuster piece cotter pin is allowed to pass through body, then remove tool.
3. Reinstall protective cap.

12.6.2 End Play Adjustment Limitation

If ball pin does not rotate when re-adjusted in line with above instructions, this suggests that ball pin has local worn flats as shown in FIGURE 25 (a). In this instance ball pin, thrust cup and rubbing pad MUST be replaced, if not FAILURE could occur in service, i.e. ball pin not being able to move in assembly when turning from lock to lock as shown in FIGURE 25 (b).

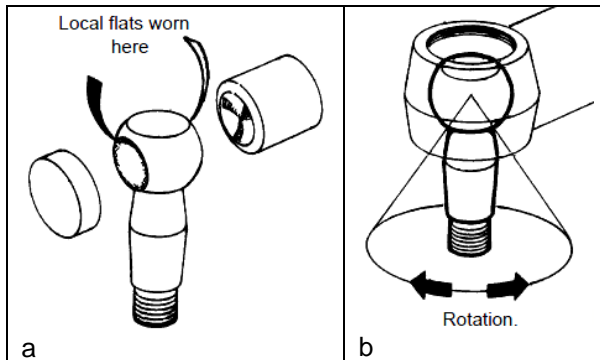

FIGURE 25: BALL PIN HAS LOCAL WORN FLATS

12.6.3 Dismantling Drop Type Ball Joint

1. Remove dirt seal and dirt seal pressing from ball pin.
2. Slacken pinch bolt nut then unscrew and remove ball socket assembly from tie rod having first marked ball socket body and tie rod to enable tracking on re-assembly.
3. Remove adjuster split pin from ball socket body.
4. Remove cap then using a suitable tool i.e.: a piece or 1"x1/8"x 9" flat bar, unscrew and remove adjuster piece. Waggle ball pin to free thrust cap.
5. Remove compression spring and thrust cap from ball socket body.
6. Relieve peening on socket body top then using a hide faced mallet, tap ball pin out of body. This operation will also remove cover plate from body.

7. The rubbing pad can now be removed from body.

Thoroughly clean all parts and check for wear, renewing where necessary.

12.6.4 Assembling Drop Type Ball Joint

1. Apply a bead of Loctite 638 sealant to mating corner of rubbing pad in socket body then knock rubbing pad into its recess in ball socket body.
2. Thoroughly grease rubbing pad and ball pin with Shell Retinax LX or equivalent.
3. Insert ball pin into body.
4. Insert thrust cap, compression spring and adjuster piece into body.
5. Tighten adjuster piece fully home (SOLID) locating thrust cup onto ball pin.
6. Still with tool located on adjuster piece, back off carefully (LEAST AMOUNT) until adjuster piece split pin is allowed to pass through body, and that ball pin shank can be moved by force of hand, then remove tool.

NOTE: If ball pin does not rotate when re-adjusted in line with above instructions, this suggests that ball pin has local worn flats. In this instance ball pin, thrust cup and rubbing pad MUST be replaced, if not FAILURE could occur in service, i.e. ball pin not being able to move in assembly when turning from lock to lock (see FIGURE 25).

7. Fit cover plate into top of ball socket body, re-peen using a cold chisel to secure.
8. Screw assembled ball socket onto tie rod. Lining up marks on both body and tie rod previously made, or retracking using manual instructions.
9. Fit pinch bolts and nuts then tighten nuts alternately and progressively to 65- 75 lbf-ft (88-102 Nm.) thus securing ball joint to tie rod.
10. Fit dirt seal (pressing) and dirt seal (rubber) onto ball pin.
11. Locate ball socket and tie rod assembly with lever, carefully align and fit ball pin into hole in tie rod arm.

NOTE: Ball pin and ball pin tapers in bottom tie rod arms must be clean, dry and free from oil prior to assembly.

12. Fit pin washer onto ball pin.
13. Screw pin nut onto ball pin then tighten to 175 lbf-ft (237 Nm) torque.
14. Using a 2lb hammer, tap tie rod arm to "shock" ball pin into taper hole.
15. Re-torque pin nut to 175 lbf-ft (23 7Nm).
16. Fit split pin, if slot/hole are not in line, adjust up to next slot.

Pin nut torque 175 lbf-ft, max pin nut torque 200 lbf-ft.

17. Re-charge ball socket with Shell "Retinax LX" or equivalent grease through grease fitting.

12.7 STRAIGHT BODY TYPE BALL JOINT

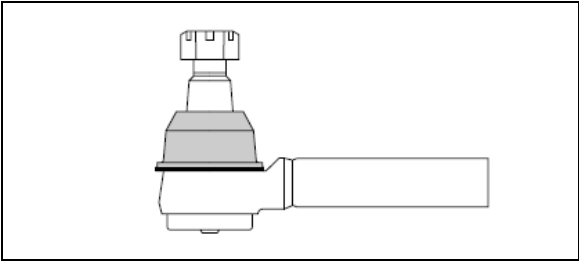

FIGURE 26: STRAIGHT BODY TYPE BALL JOINT

12.7.1 Visual Inspection

- Visually inspect for missing or damages grease fittings and replace if required.
- Damaged sealing boot or improper sealing requires seal replacement.
- Check ball joint connection for missing cotter pins.
- Check for looseness in the ball/socket assembly.

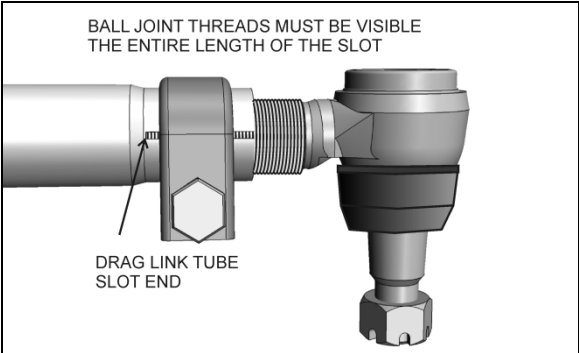

FIGURE 27: ADEQUATE CLAMPING CONDITION

For adequate clamping, the ball joint threads must be visible the entire length of the tube slot. If not, the drag link must be adjusted or replaced. It is either the wrong size, or improper adjustment was used to compensate for another problem (e.g. bent steering arm).

12.7.2 Straight Body Type Ball Joint End Play And Looseness

What creates movement in sockets?

In each straight body type ball joints, the compressive force of the spring creates resistive torque by applying a constant load on the bearing and stud.

As wear occurs on the components, the spring creates less resistive torque. With less torque, you no longer have the precise joint needed for optimum steering, but you do still have a safe linkage. **When all compression is lost, it's time to replace the linkage.** This wear can be caused by impact, lack of lubrication and normal wear.

1. With vehicle engine on, lightly rock the steering wheel while checking for looseness in any threaded joint. Observe any looseness in the two mating tapers or any movement of the ball pin nut. Any looseness requires further inspection. If either of the mating tapered parts shows distortion or wear, both parts must be replaced.

2. With the engine off and wheels straight ahead and no force is being exerted on the linkage by the steering gear, push and pull the ball joint in and out by hand (approximately 100 lbs. force) in the direction of the ball pin. If no movement is detected, the ball joint is safe. **Any movement detected by hand requires replacement of the ball joint.**

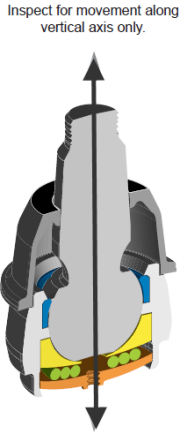



CAUTION

Do not use a wrench or other object to apply leverage when inspecting ball joint. Applying leverage can give distorted results and damage components.

13. DRIVING TIPS

In order to maximize power steering pump service life, do not attempt to turn the steering wheel when the vehicle is stationary, and especially when service brakes are applied (wheel locking will oppose the effect of steering geometry which tends to make the front wheels rotate in opposite directions).

Persisting in turning, or maintaining the steering wheel with an extra effort, could make the hydraulic system work at the relief pressure, and consequently, cause the hydraulic fluid to become overheated.



CAUTION

Never maintain the hydraulic system at the relief pressure for longer than 5/10 seconds to avoid damaging the power steering pump.

NOTE

Unequal or low tire pressure, oversize tires, and vehicle overloading are some of the causes that may increase steering effort.

14. TROUBLESHOOTING

CONDITION	CAUSE	CORRECTION
Tires wear out quickly or have uneven tire tread wear.	<ol style="list-style-type: none"> 1. Tires have incorrect air pressure. 2. Tires out-of-balance. 3. Incorrect tag axle alignment. 4. Incorrect toe-in setting. 5. Incorrect steering arm geometry. 	<ol style="list-style-type: none"> 1. Put specified air pressure in tires. 2. Balance or replace tires. 3. Align tag axle. 4. Adjust toe-in specified setting. 5. Service steering system as necessary.
Vehicle is hard to steer.	<ol style="list-style-type: none"> 1. Low pressure in the power steering system. 2. Steering gear not assembled correctly. 3. Steering linkage needs lubrication. 4. Kingpins binding. 5. Incorrect steering arm geometry. 6. Caster improperly adjusted. 7. Tie rod ends hard to move. 8. Worn thrust bearing. 	<ol style="list-style-type: none"> 1. Repair power steering system. 2. Assemble steering gear correctly. 3. Lubricate steering linkage. 4. Replace kingpins. 5. Service steering system as necessary. 6. Adjust caster as necessary. 7. Replace tie rod ends. 8. Replace thrust bearing.
Bent or broken steering arm, steering top lever or tie rod assembly.	<ol style="list-style-type: none"> 1. Too much pressure in the power steering system. 2. Cut-off pressure of the power steering system improperly adjusted. 3. Vehicle not powered on correctly. 4. Power steering system not installed correctly. 	<ol style="list-style-type: none"> 1. Replace damaged part(s), adjust power steering system to specified pressure. 2. Make sure vehicle is powered on correctly. 3. Correctly install the power steering system. 4. Correctly install the power steering system.
Worn or broken steering ball pin.	<ol style="list-style-type: none"> 1. Drag link fasteners tightened past specified torque. 2. Lack of lubrication or incorrect lubricant. 3. Power steering stops improperly adjusted. 	<ol style="list-style-type: none"> 1. Replace damaged part(s), tighten drag link fasteners to specified torque. 2. Lubricate linkage with specified lubricant. 3. Adjust stops to specified dimension.
Worn kingpins and knuckle bushings.	<ol style="list-style-type: none"> 1. Worn or missing seals and gaskets. 2. Incorrect lubricant. 3. Axle not lubricated at scheduled frequency. 4. Incorrect lubrication procedures. 5. Lubrication schedule does not match operating conditions. 	<ol style="list-style-type: none"> 1. Replace damaged part(s), replace seals and gaskets. 2. Lubricate axle with specified lubricant. 3. Lubricate axle at scheduled frequency. 4. Use correct lubrication schedule to match operating conditions. 5. Change lubrication schedule to match operating conditions.
Vibration or shimmy of front axle during operation.	<ol style="list-style-type: none"> 1. Caster not adjusted properly. 2. Wheels and/or tires out-of balance. 3. Worn steering stabilizer cylinder. 	<ol style="list-style-type: none"> 1. Adjust caster. 2. Balance or replace wheels and/or tires. 3. Replace steering stabilizer cylinder.

15. TORQUE SPECIFICATIONS

The torque specifications applicable to the front axle steering are grouped with information regarding the front suspension. Please refer to Section 16: SUSPENSION of this manual.

16. SPECIFICATIONS

Power Steering Gear

Make ZF-SERVOCOM
 Model 8098
 F.E.W. 16,600 lbs (7 545 kg)
 Pressure rating2,175 psi (150 Bar)
 Gear ratio (center)22.2 : 1
 Gear ratio (extremities)26.2 : 1
 Minimum pump flow for 1.5 hwt/sec 4.22 gpm (16 lpm)

Power Steering Reservoir

Make Nelson Muffler
 Oil capacity 4 US qts (3.7 liters)
 Make Nelson Muffler

Steering Stabilizer Cylinder (Damper)

MakeArvin
 Extended length 32.73±0.12"
 Collapsed length..... 20.26±0.12"
 Stroke..... 12.47±0.12"

17. SECTION CHANGE LOG

DESCRIPTION		DATE
1	Addition of section 12.1 STEERING SYSTEM PLAY INSPECTION	08/16/2016
2	Addition of section 12.6.2 END PLAY ADJUSTMENT LIMITATION	04/30/2018
3		
4		
5		
6		

CONTENTS

1. DESCRIPTION	3
2. FRONT I-BEAM AXLE SUSPENSION	3
2.1 AIR SPRINGS.....	3
2.1.1 Inspection.....	3
2.1.2 Removal.....	3
2.1.3 Installation.....	4
2.2 SHOCK ABSORBERS.....	4
2.2.1 Inspection.....	5
2.2.2 Removal.....	5
2.2.3 Installation.....	5
2.3 RADIUS RODS.....	6
2.3.1 Inspection.....	6
2.3.2 Radius Rod Removal	6
2.3.3 Stripping Down	7
2.3.4 Radius Rod Assembly	7
2.3.5 Radius Rod Installation	8
2.4 SWAY BAR.....	8
2.4.1 Removal.....	8
2.4.2 Installation.....	8
2.5 TORQUE SPECIFICATIONS - FRONT I-BEAM AXLE SUSPENSION AND STEERING.....	8
3. REAR SUSPENSION	12
3.1 AIR SPRINGS.....	13
3.1.1 Inspection.....	13
3.1.2 Removal.....	13
3.1.3 Installation.....	13
3.2 SHOCK ABSORBERS.....	14
3.2.1 Inspection.....	14
3.2.2 Removal.....	15
3.2.3 Installation.....	15
3.3 RADIUS RODS.....	15
4. REAR SUSPENSION TORQUE SPECIFICATIONS	16
5. SUSPENSION AIR SYSTEM	18
5.1 INSPECTION	18
5.2 AIR LINE TEST	18
6. SUSPENSION HEIGHT ADJUSTMENT	18
7. HEIGHT CONTROL VALVE	20
7.1 MAINTENANCE	20
7.2 REMOVAL AND INSTALLATION	20
8. AIR SYSTEM	21
8.1 AIR TANK MAINTENANCE	21
8.1.1 Wet Air Tank.....	21
8.1.2 Primary Air Tank	21
8.1.3 Secondary Air Tank	21
8.1.4 Accessory Air Tank	21
8.1.5 Kneeling Air Tank.....	21

8.1.6	<i>Parking Brakes Override Air Tank</i>	21
8.2	EMERGENCY FILL VALVES	22
9.	FRONT KNEELING SYSTEM	22
9.1	PRINCIPLE OF OPERATION	22
9.2	MAINTENANCE	22
9.3	BELLOWS CONTROL SOLENOID VALVES	23
9.3.1	<i>Removal and installation</i>	23
10.	TROUBLESHOOTING	23
11.	SECTION CHANGE LOG	24

ILLUSTRATIONS

FIGURE 1:	FRONT I-BEAM AXLE SUSPENSION.....	3
FIGURE 2:	AIR SPRING	3
FIGURE 3:	AIR SPRING UPPER MOUNTING PLATE	4
FIGURE 4:	SHOCK ABSORBER.....	5
FIGURE 5:	BALL PIN JOINT CONSTRUCTION	6
FIGURE 6:	BALL PIN BUSHING	6
FIGURE 7:	SWAY BAR.....	8
FIGURE 8:	REAR SUSPENSION COMPONENTS	12
FIGURE 9:	SWAY BAR (REAR SUSPENSION)	12
FIGURE 10:	TAG AXLE SUSPENSION	12
FIGURE 11:	AIR SPRING.....	13
FIGURE 12:	TYPICAL SHOCK ABSORBER SETUP	15
FIGURE 13:	TORQUE SPECIFICATIONS – DRIVE AXLE.....	16
FIGURE 14:	TORQUE SPECIFICATIONS – DRIVE AXLE.....	16
FIGURE 15:	TORQUE SPECIFICATIONS – TAG AXLE	17
FIGURE 16:	TORQUE SPECIFICATIONS – TAG AXLE	17
FIGURE 17:	FRONT I-BEAM AXLE AIR SPRING CLEARANCE	19
FIGURE 18:	DRIVE AXLE AIR SPRING CLEARANCE	19
FIGURE 19:	TAG AXLE AIR SPRING CLEARANCE.....	19
FIGURE 20:	FRONT HEIGHT CONTROL VALVE	19
FIGURE 21:	REAR HEIGHT CONTROL VALVE.....	20
FIGURE 22:	I-BEAM FRONT SUSPENSION AIR TANKS LOCATION	21
FIGURE 23:	REAR VALVE LOCATION	22
FIGURE 24:	FRONT SERVICE COMPARTMENT	22

1. DESCRIPTION

The vehicle is provided with an air suspension system. The system consists of air springs, height control valves, radius rods, sway bars, tripod and shock absorbers (Figure 1 to Figure 6). The system operation is fully automatic and maintains a constant vehicle height regardless of load, or load distribution.

The vehicle is also equipped with a front kneeling system.

2. FRONT I-BEAM AXLE SUSPENSION

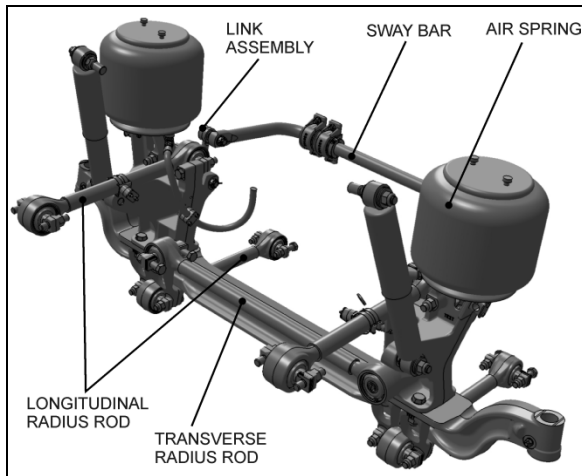

FIGURE 1: FRONT I-BEAM AXLE SUSPENSION 16105

2.1 AIR SPRINGS

The air springs are made from a special compound rubber molded to the proper contour and dimensions. The entire vertical load of the vehicle is supported by these springs. Each of the three axles is provided with air springs that are attached to the subframe and to the axles.

2.1.1 Inspection

1. Check operation of bellows.
2. Visually inspect bellows for evidence of cracks, punctures, deterioration, or chafing. Replace the bellows if any damage is evident.
3. With the primary air system at normal operating pressure (95 - 125 psi (655 - 860 kPa)), coat all suspension air line connections and bellows mounting areas with a water and soap solution. Bubbles will indicate an air leak, and none is permissible. Repair or replace defective parts.

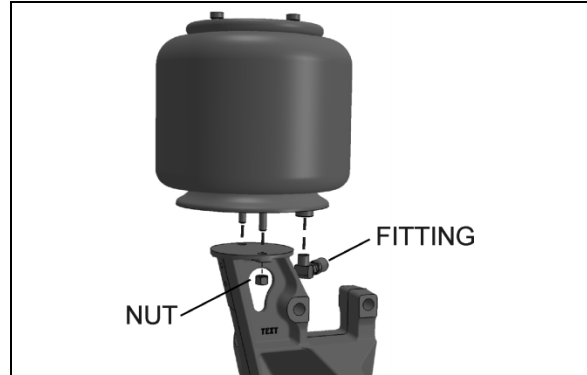

FIGURE 2: AIR SPRING

16052

NOTE

If air spring is removed from vehicle, bellows can be lightly inflated and submerged in water to detect any leakage. If any leakage is detected, replace bellows.



WARNING

To prevent personal injury, do not apply more than 10 psi (69 kPa) of air pressure to the uninstalled air spring.

2.1.2 Removal

NOTE

Front suspension air springs can be removed without removing the entire axle assembly.

1. Safely support vehicle at the recommended body jacking points. To gain access to a given air spring, the corresponding wheel can be removed as follows:
 - a) Jack vehicle until the tire clears the ground, and place safety supports underneath body.



CAUTION

Only the recommended jacking points must be used as outlined in Section 18, "Body".

- b) Support the axle with a suitable hydraulic floor jack at the recommended jacking points. Make sure that the measurement between the air spring mounting plates is greater than the normal clearance (normal ride height).
- c) Remove wheel.

2. Exhaust compressed air from accessory air tank by opening drain cock under reservoir.
3. Disconnect the height control valve link and pull down the overtravel lever to ensure all air is exhausted from air springs.

NOTE

While performing this step, do not change the height control valve overtravel lever adjustment.

4. Disconnect air line from air spring and cover both the line end and fitting to prevent the entry of foreign matter.
5. Unscrew the two air spring lower mounting nuts.
6. Rotate the air spring counterclockwise to free the upper attachments from the mounting plate.
7. Remove the air springs.

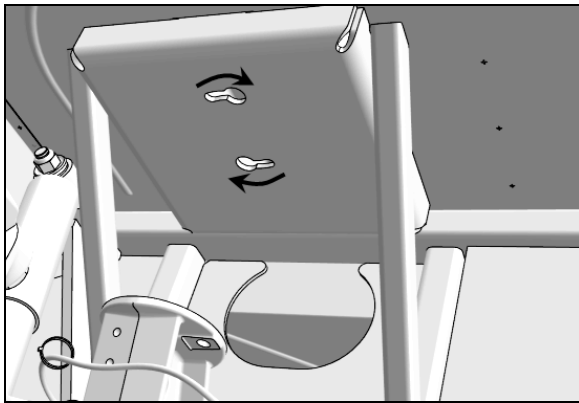

FIGURE 3: AIR SPRING UPPER MOUNTING PLATE

2.1.3 Installation

1. Compress air spring as necessary and position air spring between both the lower and upper mounting plates.
2. Align the upper attachments with holes in the mounting plate. Rotate air spring clockwise.
3. Thread the lower nuts a few turns.

NOTE

To facilitate air spring installation, compress it manually then put a piece of tape over the air line threaded fitting. This prevents air from getting back into the air spring and keeps it compressed, thus enabling to place the air spring in between the mounting plates and greatly easing installation.

4. Tighten and torque the lower stud nuts according to Torque Table under heading Torque Specifications.
5. Install fitting (if applicable), then connect air line.
6. Connect the height control valve link.
7. Build up air pressure in system.

NOTE

To accelerate this operation, air reservoirs can be filled from an exterior air supply connected to the accessory tank fill valve or to the emergency fill valve.

7. Check operation of bellows and with the primary air system at normal operating pressure (95 – 125 psi (655 – 860 kPa)), coat the air line connections and air spring mounting areas with a water and soap solution. Bubbles will indicate an air leak, and none is permissible. Repair or replace defective parts.
8. Reinstall wheel.
9. Remove the hydraulic floor jack from under the axle, then lower vehicle to ground.

2.2 SHOCK ABSORBERS

Double-action, telescoping-type shock absorbers ensure a smooth ride and enhance vehicle stability on the road. All shock absorbers are eye-type mountings. The front and tag axles are each provided with two shock absorbers while the drive axle is provided with four of them.

Shock absorbers are non-adjustable and non-repairable. Maintenance requirements involve replacement of the rubber mounting bushings, and tightening of all shock absorber pins according to Torque Table under heading Torque Specifications when shock absorber replacement occurs. If a shock absorber becomes inoperative, complete unit must be replaced.

**CAUTION**

When a shock absorber is found defective, always replace with a new set on affected axle, except if there has been a recent replacement of one unit. The following method will help in determining if both shock absorbers on the same axle have to be replaced.

2.2.1 Inspection

Loosen lower mounting of both shocks, and then carefully attempt to raise and lower the bottom portion of each shock. Note the rate of effort for distance of travel. Replace both shocks if a definite differential rate is found.

The shock must be bench checked in an upright, vertical position. If checked in any other position, air will enter the cylinder tube and make the shock absorber appear defective.

Proceed as follows to check shock absorbers:

1. With the shock absorber in a vertical position (top end up), clamp the bottom mount in a vise.



CAUTION

Do not clamp the reservoir tube or the dust tube.

2. Rotate the dust tube. Notice any binding condition (may be compared with new unit). Binding condition indicates a scored rod. Units with scored rods should be replaced.
3. Fully extend shocks and check for leaks in the seal cover area. Shock fluid is a very thin hydraulic fluid that has a characteristic odor and dark brown tint. A slight trace of shock fluid around the seal cover area is not a cause for replacement (Refer to the SACHS document "Guideline to Evaluate Warranty Claims" before replacing a shock). The shock seal is designed to permit a very slight seepage to lubricate the rod. Units that leak should be replaced.
4. Visually check shock for dents that could cause the shock to bind. Also, check for a bent rod.
5. Extend and collapse shock several times to determine that it has control (resistance) in both rebound and compression.
6. Visually inspect the shock mountings and vehicle mounting for:
 - a. Broken mounts;
 - b. Extreme bushing wear;
 - c. Shifted bushing or sleeve;
 - d. Deep cracks in bushing material (shallow surface cracks are normal);
 - e. Loose shock absorber pins;
 - f. Presence of convex washers, and their position relative to the rubber bushing.

2.2.2 Removal

1. Remove nuts and washers from shock absorbers on upper and lower mounting pins, taking care to identify the inner and outer washers to ease reinstallation. Refer to Figure 4 for details.
2. Remove the shock absorber assembly from pins.
3. Remove the two inner bushings from the shock absorber and discard them.

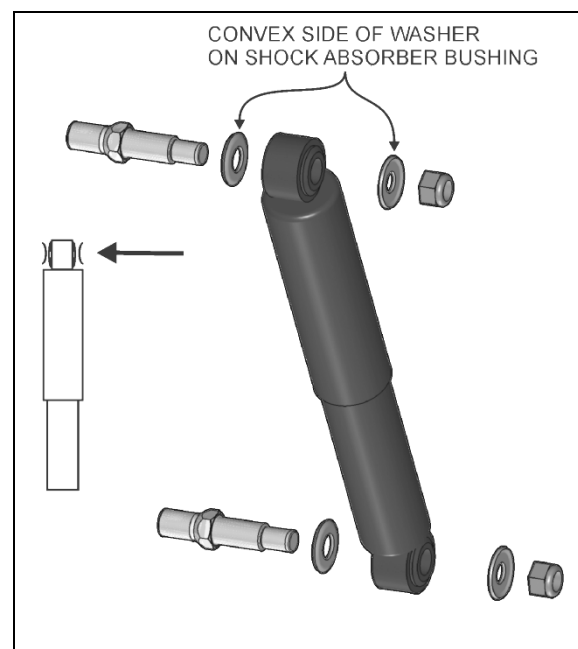

FIGURE 4: SHOCK ABSORBER

16008

2.2.3 Installation

1. Ensure that the shock absorber mounting pins are tight and that the threads are not stripped.
2. Install new rubber mounting bushings on shock absorbers (upper and lower).
3. Place the inner washers (with washer convex side facing the shock absorber rubber bushing) on each shock absorber pin.
4. Install the shock absorber eyes over the mounting pins, then the outer washers (with washer convex side facing the shock absorber rubber bushing) on each shock extremity.

NOTE

If shock absorber pins are removed, they must be reinstalled using “Loctite” (see “Parts Specifications” in this section).

- Place the lower and upper mounting pin stud nuts and torque according to paragraph 13 Torque Specifications.

2.3 RADIUS RODS

Radius rods are used to secure the axles in the proper transversal and longitudinal positions. Five radius rods are provided on the front I-beam axle suspension (four longitudinal and one transversal). Refer to Figure 1 and Figure 5 for details. These rods transmit both braking and driving forces from the axles to the vehicle body.

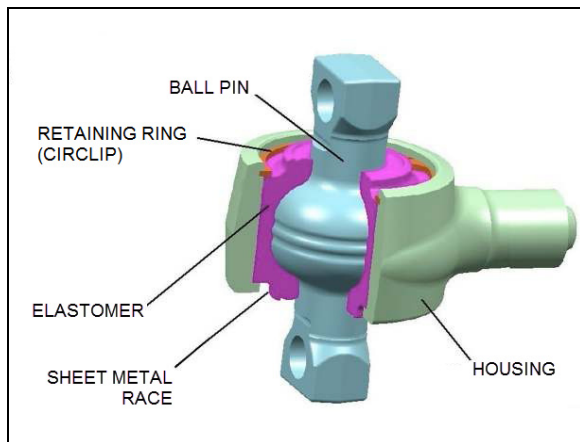

FIGURE 5: BALL PIN JOINT CONSTRUCTION 16186

2.3.1 Inspection

- Clean all parts thoroughly.
- Inspect radius rods for distortion and cracks. We recommend the “Magnaflux” process to detect cracks in the radius rod. Any damaged part should be replaced with a new one.

NOTE

New bushings should be used when rods are replaced.

- The radius rod bushings should be checked periodically for signs of shearing, deterioration, or damage. Any defective part should be replaced with a new one.

Take off the load from the ball joint by lifting the vehicle. Apply a load on the joint in all of the

degrees of freedom in an axial, radial, etc. sense with a suitable lever tool. After the load is taken off, the joint has to spring back into its starting position. Free play is not acceptable.

Separation of rubber from ball pin or sheet metal race is permissible up to a third of the circumference.

When the following characteristics are noted, the joint is to be changed:

- Free play between ball pin and housing;
- Radial cracking of the external sheet-metal race (Figure 6)
- Any crack or fracture of a metal part
- Plastic deformation of the sheet metal race
- Loosened bolt
- Broken bolt
- Loss of bolt
- Circlip (retaining ring) detached from groove
- Broken Circlip
- Loss of Circlip
- Incipient crack

If damage to the inner housing contour or the Circlip groove is found during replacement of the molecular bearing, the entire radius rod must be replaced.

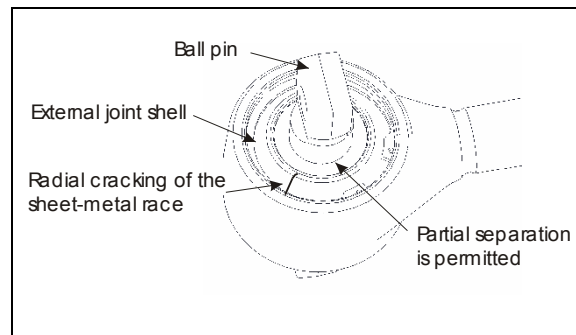

FIGURE 6: BALL PIN BUSHING

2.3.2 Radius Rod Removal

- Unscrew the nuts (or bolts) at each extremity of the radius rod.
- Remove the radius rod.

NOTE

One end of the transversal radius rod is fitted with a conical (tapper) pin that will require the use of an air hammer and a pointed 13mm (1/2inch) diameter chisel to remove it from the chassis (after the retaining nut is removed from the rod end). **Care must be taken not to damage the rod pin threads.**

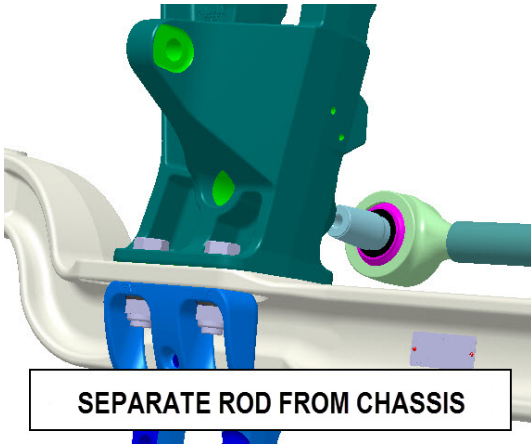
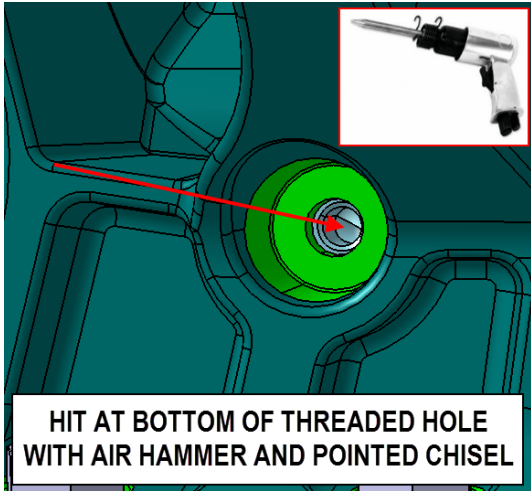
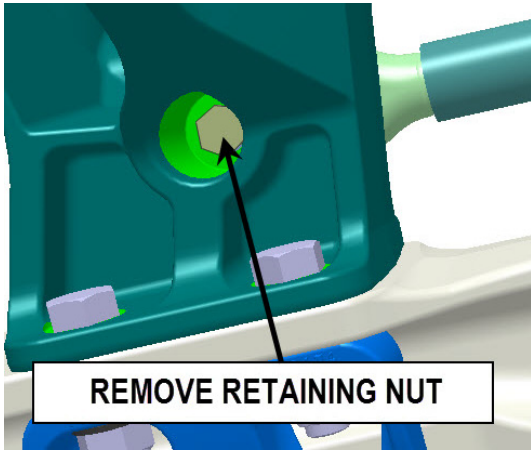

CAUTION

Do not hit the cast parts of the chassis to disengage taper radius rods; this could lead to cracking and/or deformations of the cast parts.

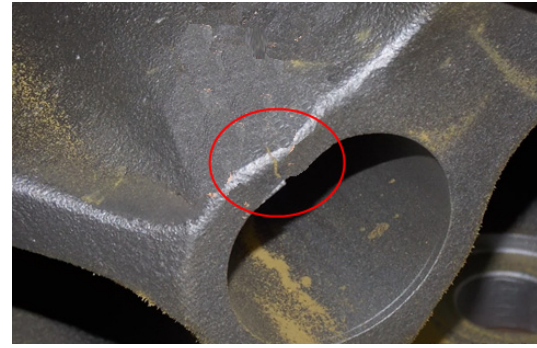

2.3.3 Stripping Down

Strip down the defective joint by removing the Circlip, and ball pin/bushing assembly.

Clean out housing bore and Circlip groove.

2.3.4 Radius Rod Assembly

The assembly work may be done only by a recognized specialized workshop. Ensure that old and new parts do not get mixed up with each other. It is for this reason that all the old parts are to be scrapped immediately after a joint has been stripped down.

A complete repair set must be used for each joint repaired, i.e. use of only part of a repair set is not permissible.

Execute assembly of the new joint parts in the following sequence:

1. Complete moistening of the contact surface between housing bore and ball pin elastomer through application of grease.

NOTE

Apply the supplied grease, only if you are using a repair kit.

2. Insert ball pin/bushing, assembly. Ensure that the bolt bores are in the correct position in relation to the axis of the tube.
3. Place joint in receiving fixture and mount annular assembly tool on the housing. Then locate Circlip in the housing using axial load with the aid of assembly stamp.

- Opening of the Circlip is located at 45° to the housing shaft axis. Make sure that the Circlip is perfectly engaged in the housing.

2.3.5 Radius Rod Installation

- Snug up the nuts (or bolts) and repeat at the other end.
- Refer to heading "*Suspension Height Adjustment*" later in this section, and set the vehicle to normal ride height.
- With the vehicle at normal ride height, tighten all radius rod anchor pin nuts or bolts as prescribed.



CAUTION

It is extremely important upon reconnection of the rods that the proper clearance height between the axle and body be maintained. Otherwise, the rubber bushings in radius rod ends will become preloaded, thus reducing their life span.

2.4 SWAY BAR

A sway bar is provided on the front axle to increase vehicle stability. It controls lateral motion (swaying movement) of vehicle (Figure 7).

2.4.1 Removal

- Disconnect the two links from sway bar.
- Safely support the sway bar. Unbolt the four bushing brackets from subframe.
- Remove sway bar.

2.5 TORQUE SPECIFICATIONS - FRONT I-BEAM AXLE SUSPENSION AND STEERING

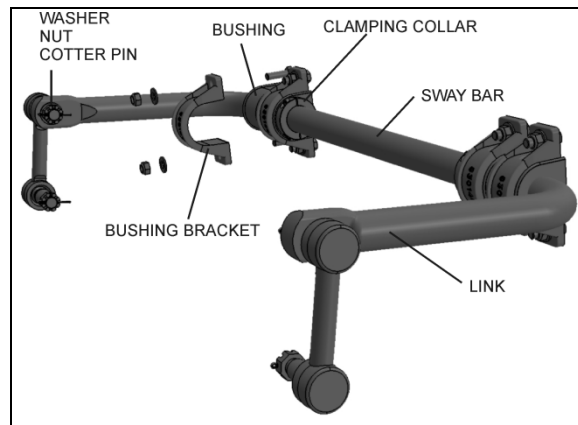
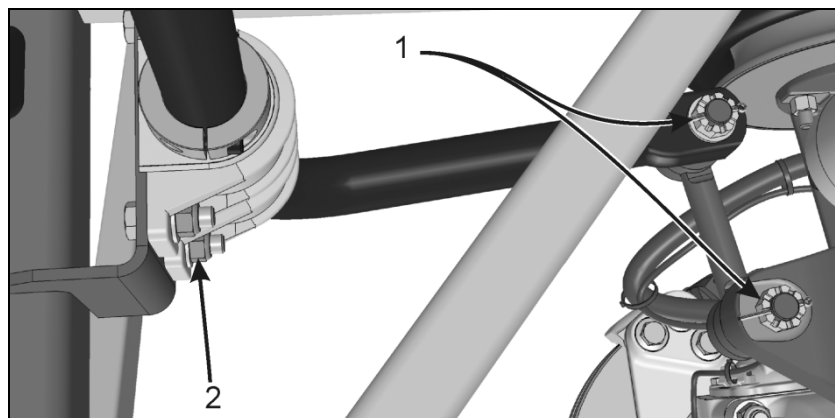

FIGURE 7: SWAY BAR

16028

NOTE

Sway bar bushings are slit to ease their removal.

2.4.2 Installation

- Loosely install the sway bar.
- Tighten the eight bushing brackets nuts according to Torque Table 1 under heading Torque Specifications.
- Tighten sway bar link upper nuts and lower nuts according to Torque Table 1 under heading Torque Specifications.

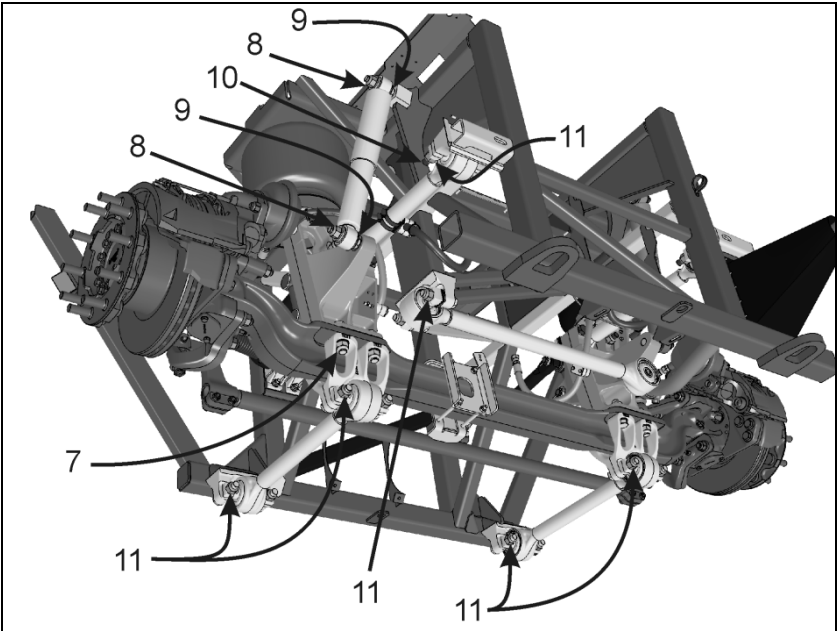
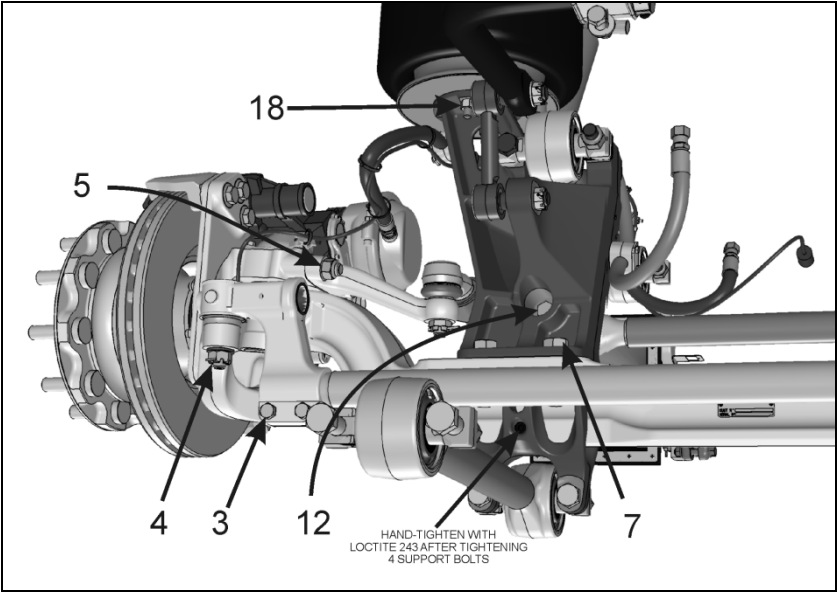

SECTION 16: SUSPENSION

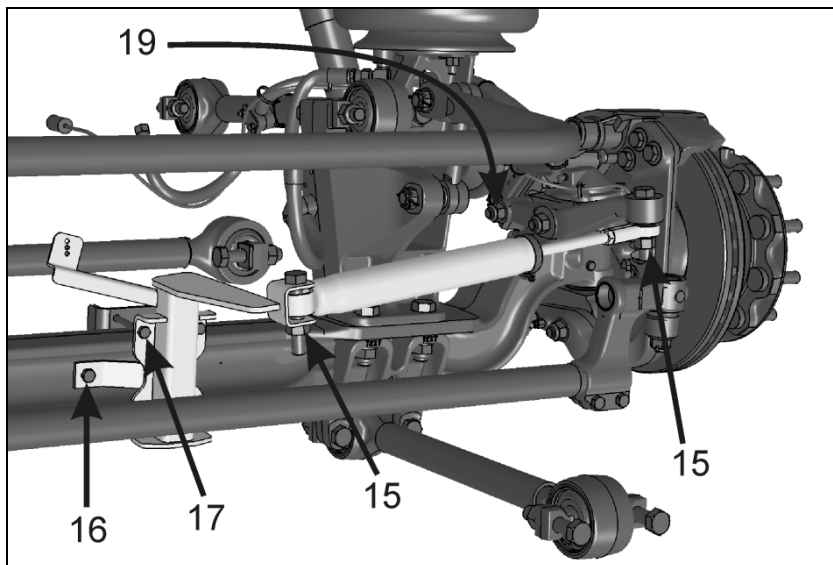
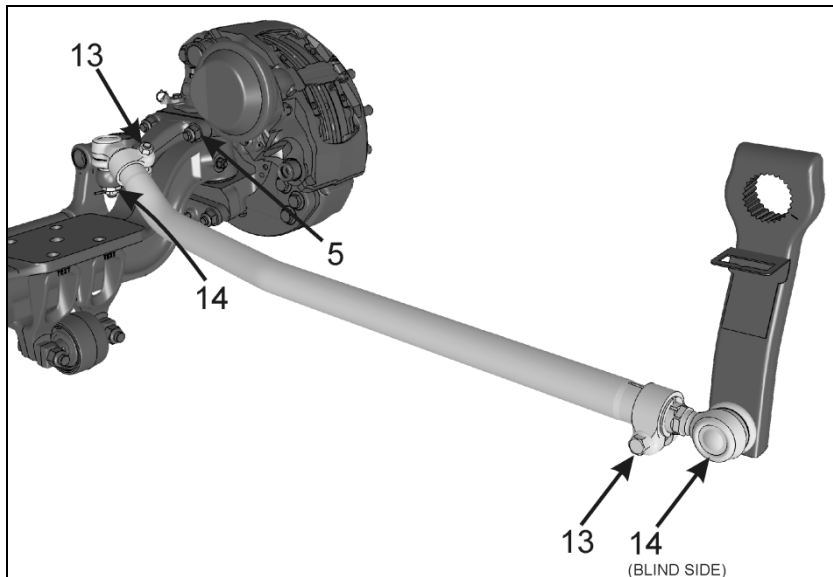
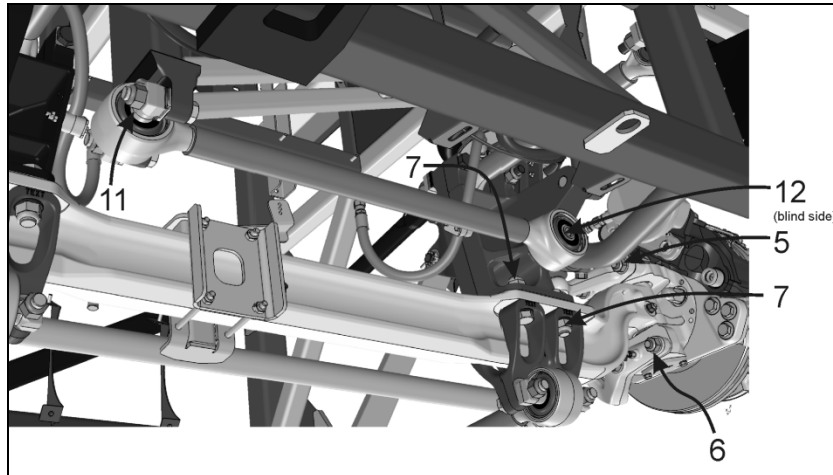

The following table lists the tightening torques that require a specific torque value. When no torque specifications are indicated, use the Standard Torque Specifications table found in Section 00: General Information of the Maintenance Manual.

SPECIFIC TORQUE TABLE 1 – FRONT I-BEAM AXLE SUSPENSION & STEERING				
REFERENCE	DESCRIPTION	QTY	TORQUE DRY (lbf-ft / Nm) <i>threads must be free of oil or other lubricant</i>	
1	SWAY BAR LINK, UPPER AND LOWER NUTS	4	165-200	224-271
2	SWAY BAR BUSHING BRACKET	8	80-100	108-136
3	TIE ROD END CLAMP BOLTS	4	65-75	88-102
4	TIE ROD END BALL PIN NUTS	2	150-200	203-271
5	STEERING ARM STUD NUTS	2	285-315	386-427
6	TIE ROD ARM STUD NUTS	4	285-315	386-427
7	I-BEAM AXLE MOUNT NUTS	8	230-280	311-378
8	SHOCK ABSORBER UPPER & LOWER MOUNTING NUTS	2	99-121	134-164
9	SHOCK ABSORBER PINS, UPPER & LOWER	2	350-400	475-545
10	RADIUS ROD RETAINING STUDS	4	90-100	122-136
11	RADIUS ROD RETAINING NUTS	18	225-255	305-346
12	TRANSVERSE RADIUS ROD TAPER PIN NUT	1	207-253	281-343
13	DRAG LINK CLAMP BOLTS	2	118-133	160-180
14	DRAG LINK BALL JOINT STUD NUT	2	150-200	203-271
15	STEERING DAMPER NUTS	2	100-120	135-160
16	STEERING DAMPER BRACKET BOLT	1	39-45	53-61
17	STEERING DAMPER BRACKET NUTS	4	29-34	39-46
18	AIR SPRING NUT	4	31-38	42-52
19	STEERING DAMPER ARM NUTS	2	285-315	386-427

For more torque specifications, see 'Dana Spicer Maintenance Manual NDS Axles and Maintenance Manual Model NDS'.

3. REAR SUSPENSION

For a description of all these systems, refer to the appropriate heading in this section.

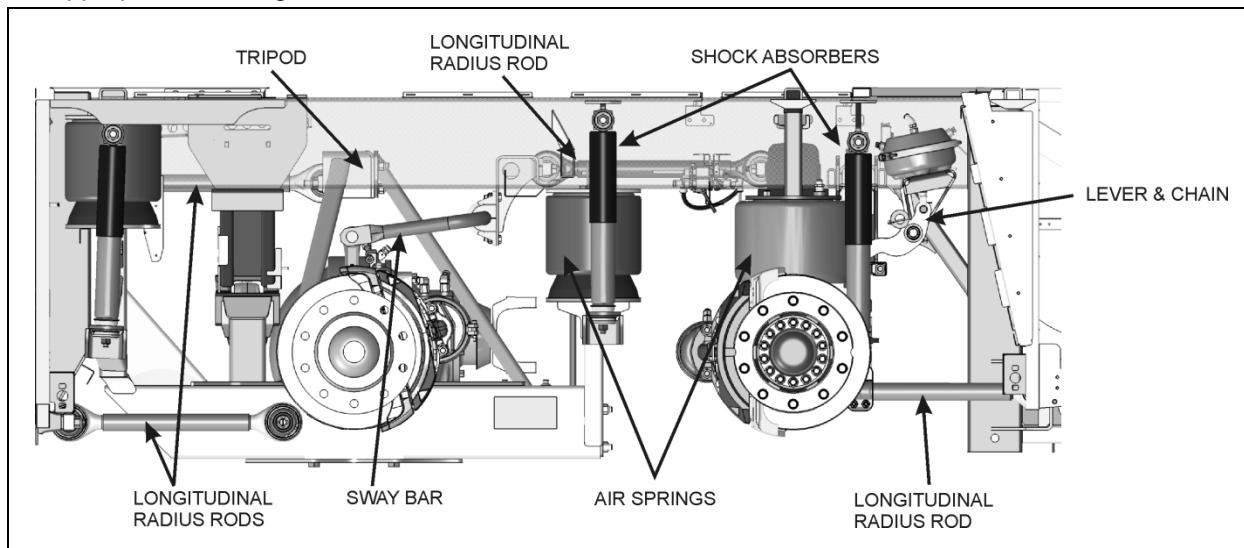

FIGURE 8: REAR SUSPENSION COMPONENTS

16184

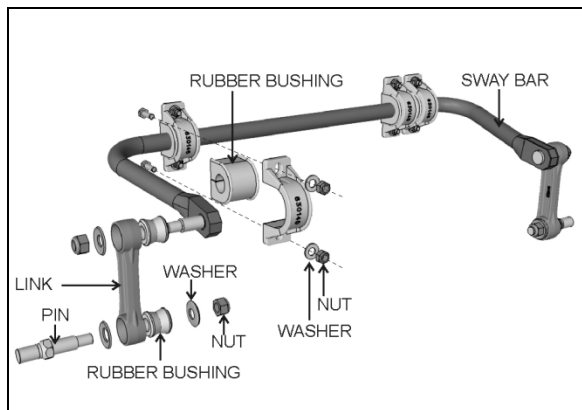

FIGURE 9: SWAY BAR (REAR SUSPENSION)

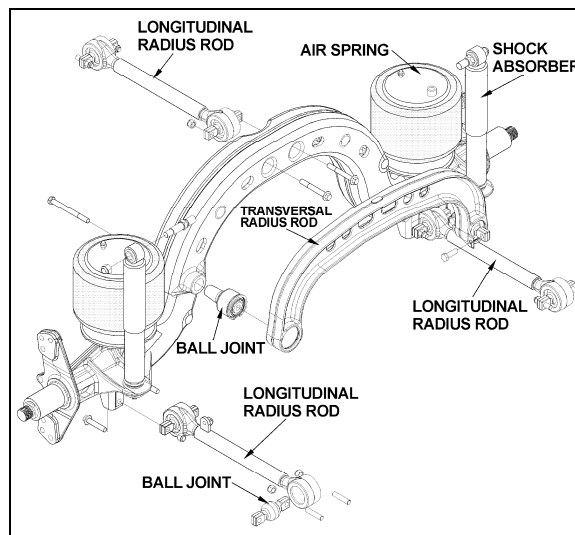

Figure 10: TAG AXLE SUSPENSION
16107

16144

3.1 AIR SPRINGS

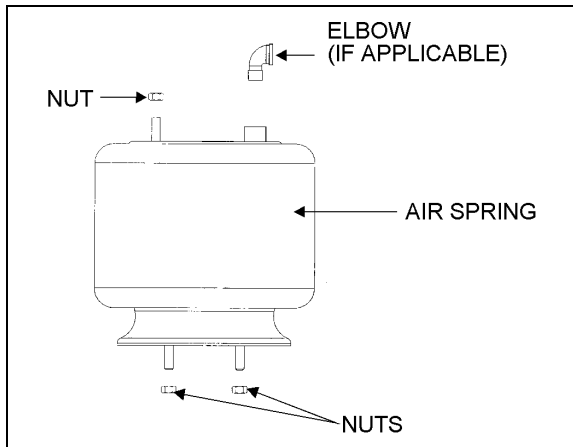

FIGURE 11: AIR SPRING 16052

The air springs are made from a special compound rubber molded to the proper contour and dimensions. The entire vertical load of the vehicle is supported by these springs. Each of the two axles is provided with air springs that are attached to the subframe and to the axles.

3.1.1 Inspection

1. Check operation of bellows.
2. Visually inspect bellows for evidence of cracks, punctures, deterioration, or chafing. Replace the bellows if any damage is evident.

MAINTENANCE

Inspect air bellows every 6,000 miles.

3. With the primary air system at normal operating pressure (95 - 125 psi (655 - 860 kPa)), coat all suspension air line connections and bellows mounting areas with a water and soap solution. Bubbles will indicate an air leak, and none is permissible. Repair or replace defective parts.

NOTE

If air spring is removed from vehicle, bellows can be lightly inflated and submerged in water to detect any leakage. If any leakage is detected, replace bellows.

WARNING

To prevent personal injury, do not apply more than 10 psi (69 kPa) of air pressure to the uninstalled air spring.

3.1.2 Removal

NOTE

Suspension air springs (drive and tag axles) can be removed without removing the entire axle assembly.

1. Safely support vehicle at the recommended body jacking points. To gain access to a given air spring, the corresponding wheel can be removed as follows.
 - a) Jack vehicle until the tire clears the ground, and place safety supports underneath body.

CAUTION

Only the recommended jacking points must be used as outlined in Section 18, "Body".

- b) Support the axle with a suitable hydraulic floor jack at the recommended jacking point.
 - c) Remove wheel.
2. Exhaust compressed air from accessory air tank by opening drain cock under reservoir.
3. Disconnect the height control valve link and pull down the overtravel lever to ensure all air is exhausted from air springs.

NOTE

While performing this step, do not change the height control valve overtravel lever adjustment.

4. Disconnect air line from air spring, remove elbow (if applicable), and cover both the line end and fitting to prevent the entry of foreign matter.
5. Remove the air spring upper nut, and then the two lower nuts. Remove air spring.

3.1.3 Installation

1. Compress air spring as necessary, then aligning studs with their holes, position air spring between both the lower and upper

supports. Thread the lower nuts and the small upper nut a few turns.

NOTE

To facilitate air spring installation, compress it manually then put a piece of tape over the air line threaded fitting. This prevents air from getting back into the bag and keeps it compressed, thus enabling to place the bag in between the mounting plates and greatly easing installation.

2. Tighten and torque the lower stud nuts, and then the upper one according to Torque Table under heading Torque Specifications.
3. Screw on the remaining upper nut (large nut) and tighten according to Torque Table under heading Torque Specifications.
4. Install elbow (if applicable), then connect air line.
5. Connect the height control valve link.
6. Build up air pressure in system.

NOTE

To accelerate this operation, air reservoirs can be filled from an exterior air supply connected to the accessory tank fill valve or to the emergency fill valve.

7. Check operation of bellows, with the primary air system at normal operating pressure (95 – 125 psi (655 – 860 kPa)), coat the air line connections and air spring mounting areas with water and soap solution. Bubbles will indicate an air leak, and none is permissible. Repair or replace defective parts.
8. Reinstall wheel.
9. Remove the hydraulic floor jack from under the axle, then lower vehicle to ground.

3.2 SHOCK ABSORBERS

Double-action, telescoping-type shock absorbers ensure a smooth ride and enhance vehicle stability on the road. All shock absorbers are eye-type mountings. The tag axle is provided with two shock absorbers while the drive axle is provided with four of them (Figure 12 & Figure 13).

Shock absorbers are non-adjustable and non-repairable. Maintenance requirements involve replacement of the rubber mounting bushings, and tightening of all shock absorber pins at the proper torque of 500 - 550 lbf-ft (680 - 750 Nm)

when shock absorber replacement occurs. If a shock absorber becomes inoperative, complete unit must be replaced.

**CAUTION**

When a shock absorber is found defective, always replace with a new set on affected axle, except if there has been a recent replacement of one unit. The following method will help in determining if both shock absorbers on the same axle have to be replaced.

3.2.1 Inspection

Loosen lower mounting of both shocks, and then carefully attempt to raise and lower the bottom portion of each shock. Note the rate of effort for distance of travel. Replace both shocks if a definite differential rate is found.

The shock must be bench checked in an upright, vertical position. If checked in any other position, air will enter the cylinder tube and make the shock absorber appear defective.

Proceed as follows to check shock absorbers:

1. With the shock absorber in a vertical position (top end up), clamp the bottom mount in a vise.

**CAUTION**

Do not clamp the reservoir tube or the dust tube.

2. Rotate the dust tube. Notice any binding condition (may be compared with new unit). Binding condition indicates a scored rod. Units with scored rods should be replaced.
3. Fully extend shocks and check for leaks in the seal cover area. Shock fluid is a very thin hydraulic fluid that has a characteristic odor and dark brown tint. A slight trace of shock fluid around the seal cover area is not a cause for replacement. The shock seal is designed to permit a very slight seepage to lubricate the rod. Units that leak should be replaced.
4. Visually check shock for dents that could cause the shock to bind. Also, check for a bent rod.

5. Extend and collapse shock several times to determine that it has control (resistance) in both rebound and compression.
6. Visually inspect the shock mountings and vehicle mounting for:
 - a) Broken mounts;
 - b) Extreme bushing wear;
 - c) Shifted bushing or sleeve;
 - d) Deep cracks in bushing material (shallow surface cracks are normal);
 - e) Loose shock absorber pins;
 - f) Presence of convex washers, and their position relative to the rubber bushing.

3.2.2 Removal

1. Remove nuts and washers from shock absorbers on upper and lower mounting pins, taking care to identify the inner and outer washers to ease reinstallation. Refer to Figure 12 for details.
2. Remove the shock absorber assembly from pins.

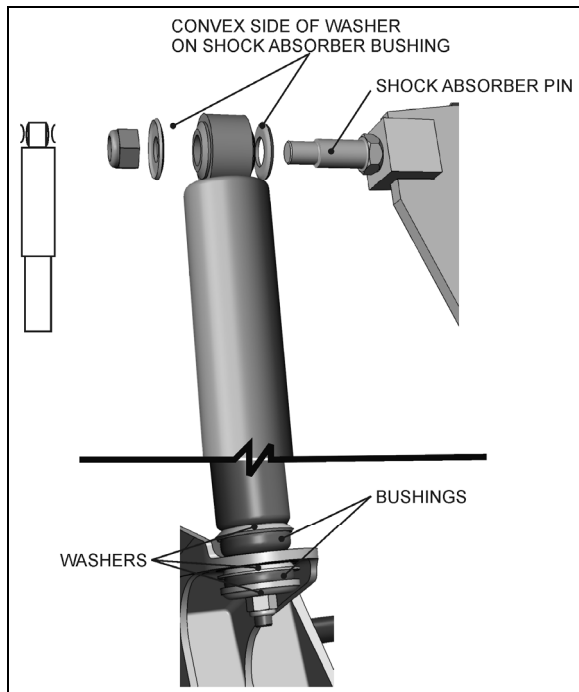

FIGURE 12: TYPICAL SHOCK ABSORBER SETUP 16009

3.2.3 Installation

1. Ensure that the shock absorber mounting pin is tight and that the threads are not stripped.
2. Install new rubber mounting bushings on shock absorbers (upper and lower).
3. At the upper mounting pin, place the inner washer with washer convex side facing the shock absorber rubber bushing.
4. Install the shock absorber eyes over the mounting pin, then the outer washers (with washer convex side facing the shock absorber rubber bushing).

NOTE
If shock absorber pins are removed, they must be reinstalled using "Loctite" (see "Parts Specifications" in this section).

5. Place the lower and upper mounting pin stud nuts and torque as prescribed in Torque Table 3.

3.3 RADIUS RODS

Radius rods are used to secure the axles in the proper transversal and longitudinal positions. Four radius rods are provided on the drive axle suspension (three longitudinal and one transversal) and also four on the tag axle with a layout similar to the drive axle. These rods transmit both braking and driving forces from the axles to the vehicle body.

Refer to section 2.3 for additional details.

4. REAR SUSPENSION TORQUE SPECIFICATIONS

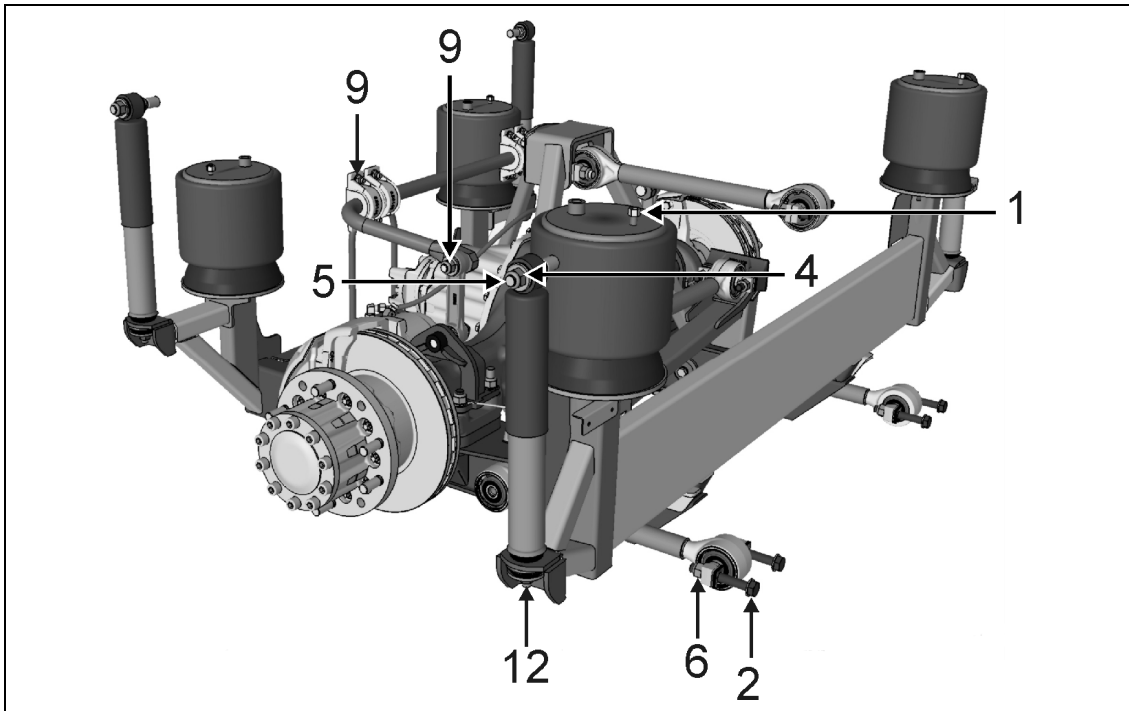

FIGURE 13: TORQUE SPECIFICATIONS – DRIVE AXLE

16158_A

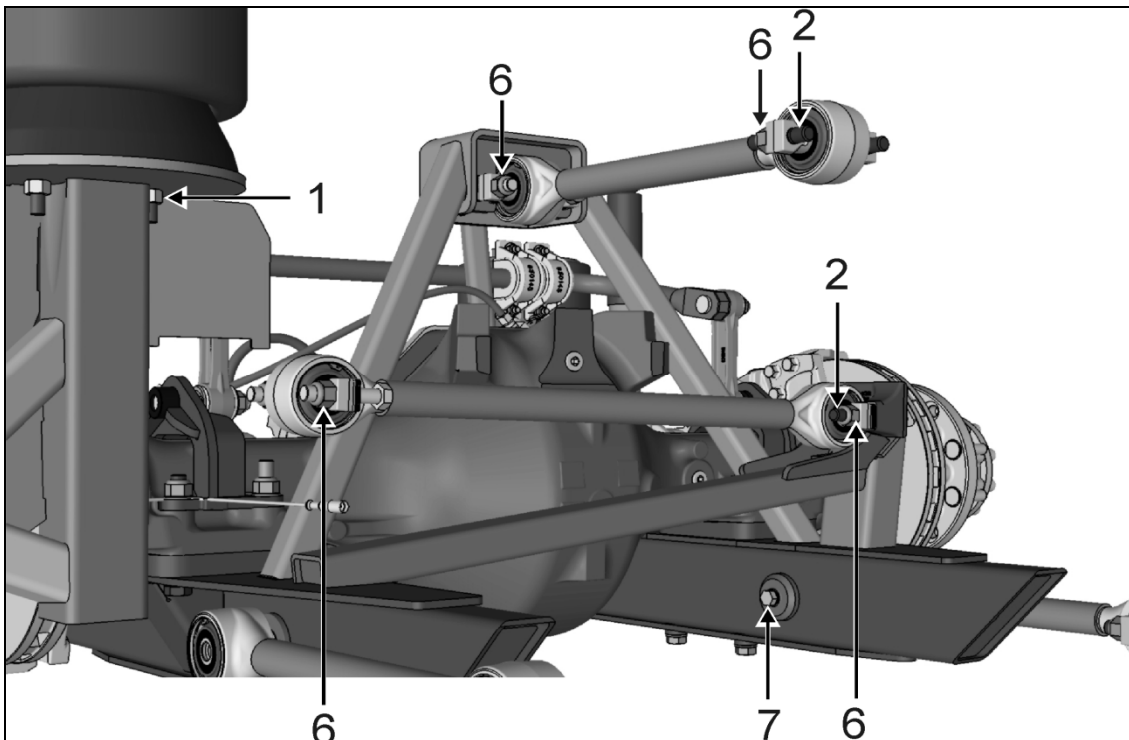

FIGURE 14: TORQUE SPECIFICATIONS – DRIVE AXLE

16159

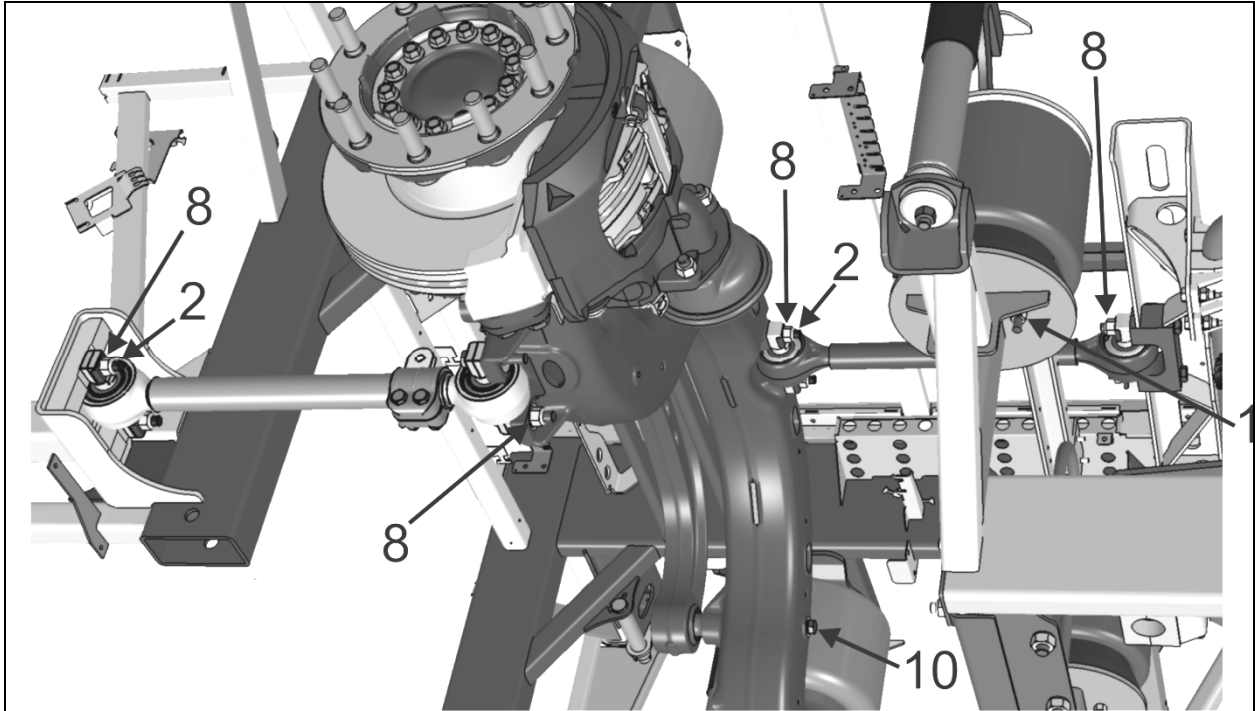

FIGURE 15: TORQUE SPECIFICATIONS – TAG AXLE

16160

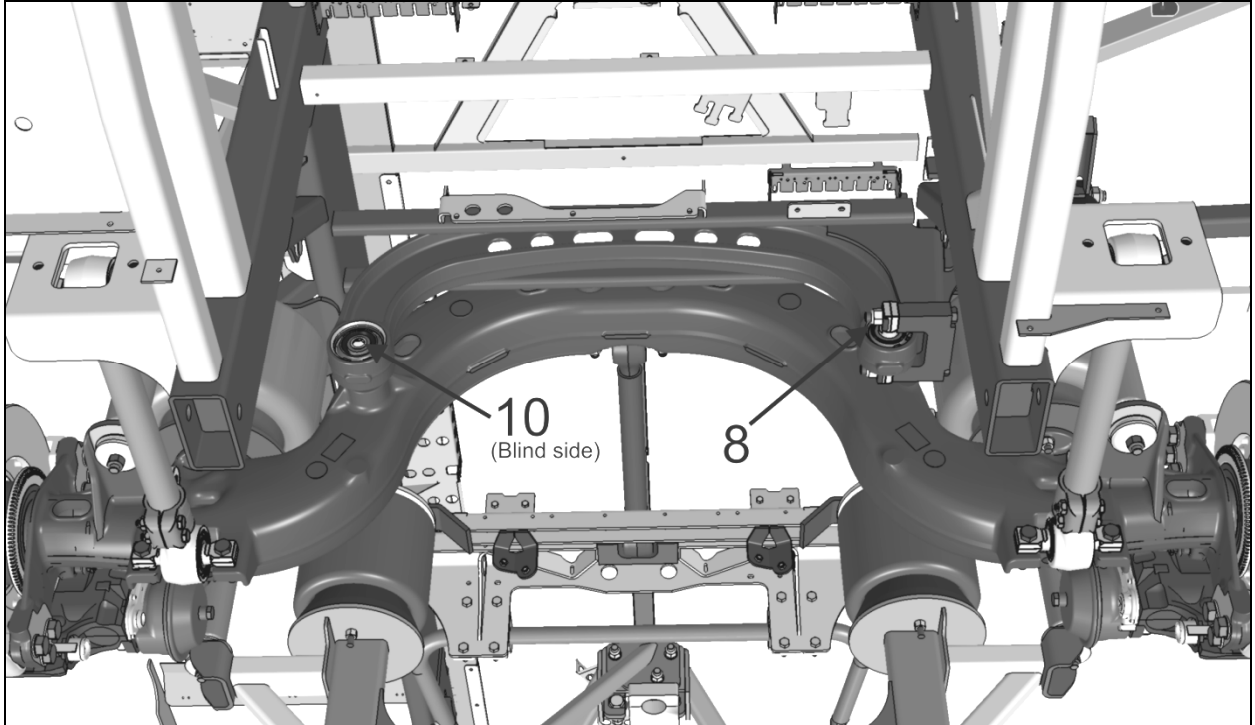

FIGURE 16: TORQUE SPECIFICATIONS – TAG AXLE

16161

The following table lists the tightening torques of bolts and nuts requiring a specific torque value. When no torque specifications are indicated, use the Standard Torque Specifications table found in Section 00: General Information of the Maintenance Manual.

SPECIFIC TORQUE TABLE 3 – REAR SUSPENSION

REFERENCE	DESCRIPTION	TORQUE DRY (lb-ft / Nm)	
1	Air Spring Upper & Lower Stud Nut (6 air springs)	31-38	42-52
2	Drive & Tag Axle Radius Rod threaded stud (12 supports)	90-110	122-149
3	Sway Bar Link Upper & Lower Nut	99-121	134-164
4	Shock Absorber Pin Nut (6 shock absorbers)	99-121	134-164
5	Shock Absorber Pin (6 shock absorbers)	350-400	475-545
6	Drive axle Radius Rod Nut/bolt (6 supports)	225-255	305-346
7	Drive Axle Radius Rod Retaining Bolts (2 longitudinal radius rods)	171-209	231-283
8	Tag Axle Radius Rods Nut (6 supports)	228-252	309-341
9	Sway Bar Bushing Collar Bolt	80-100	108-136
10	Tag Axle Transversal Radius Rod (Casting) Retaining Bolt	171-209	231-283
11	Sway Bar Link Pin Stud	350-400	475-545
12	Shock Absorber Lower Nut (6 shock absorbers)	60-75	81-101

NOTE

Apply corrosion-protective compound on exposed threads.

5. SUSPENSION AIR SYSTEM

The suspension air system has its own air reservoir (accessory tank) which is located in the reclining bumper compartment. Pressurized air from the main tank (wet tank) flows through a pressure protection valve (PR-4), to the accessory air tank and through an air filter which is located in front service compartment.

The pressure protection valve (PR-4) is mounted to the supply port of the tank. This valve controls the pressure at which compressed air is delivered to the accessory air tank. The valve remains closed until a preset pressure is reached (approximately 70 psi (485 kPa)). It then opens and passes air out the delivery port.

The main use for this valve is to protect the main air system by ensuring at all times a sufficient air pressure in the main system (i.e. air delivered to the accessories will be shut off in case of a decrease in pressure). Maintenance and repair information on the pressure protection valve is supplied in the applicable booklet, under reference number SD-03-2010.

**WARNING**

Depressurize parts prior to removal.

5.1 INSPECTION

The following inspection should be performed at established service inspection periods. Performing these procedures will allow substandard performance to be discovered before the condition becomes bad enough to cause operator complaints and failure on a run.

1. Visually inspect the suspension air lines for evidence of chafing on metal parts or other damage.
2. Visually inspect the air springs for cracks, abrasion or other damage.
3. Replace any parts found to be damaged.

5.2 AIR LINE TEST

With the main air system at normal operating pressure, coat all suspension air line connections and air spring mountings with a solution of soap and water. Air leakage will produce soap bubbles. Any leak found must be corrected as no air leakage is permissible.

6. SUSPENSION HEIGHT ADJUSTMENT

The flow of pressurized air from the accessory air tank to the air springs is controlled by three

height control valves. The two rear valves are mounted to the subframe and connected to the rear axles through an arm and link connection. The front valve is mounted to the subframe and connected to the front air tank support. These connections allow the valves to apportion air pressure in the springs to the vehicle load, maintaining normal ride height.

Immediate response height control valves increase or decrease the air pressure in the suspension system as required. One height control valve is located **at center of front sway bar**, and regulates air to front suspension air springs in order to maintain the vehicle at the required height. Two are located at the drive axle, one on each inner side of rear wheelhousing.

The appropriate vehicle body height is obtained by measuring the clearance of all the air springs installed on the vehicle. Refer to Figure 17, Figure 18, Figure 19, to identify the correct area to take measurement and proper value. At this point, it should not be necessary to make an adjustment under normal service conditions. However, if an adjustment is required, change the position of the overtravel lever in relation to the overtravel control body. The lever should be moved up to raise vehicle height, and down to lower it. Check that main air pressure is at normal operating pressure and raise the vehicle to the specified height.

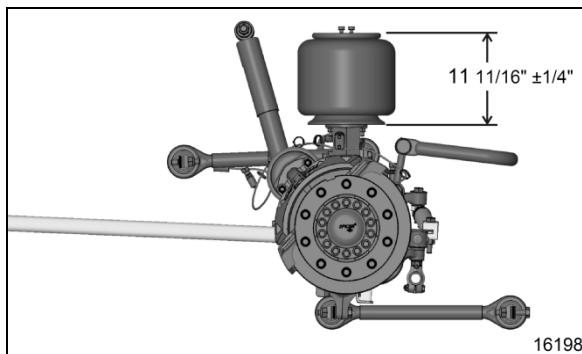

FIGURE 17: FRONT I-BEAM AXLE AIR SPRING CLEARANCE

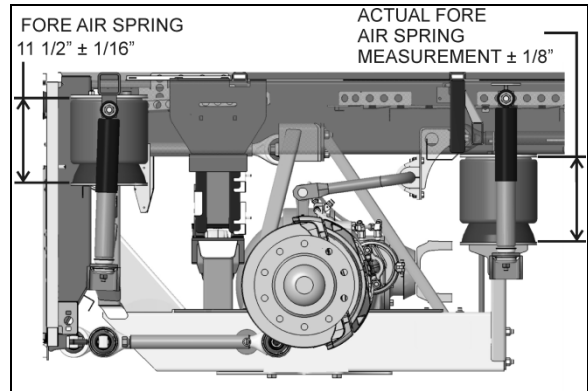

FIGURE 18: DRIVE AXLE AIR SPRING CLEARANCE 16195

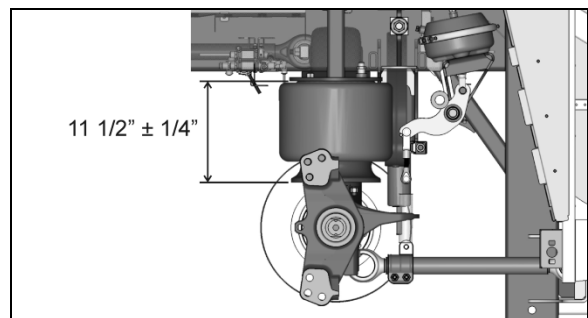

FIGURE 19: TAG AXLE AIR SPRING CLEARANCE 16195



CAUTION

Always adjust on "fill cycle". If it is necessary to lower vehicle height, release sufficient air to be well below height, and adjust to height or fill cycle.

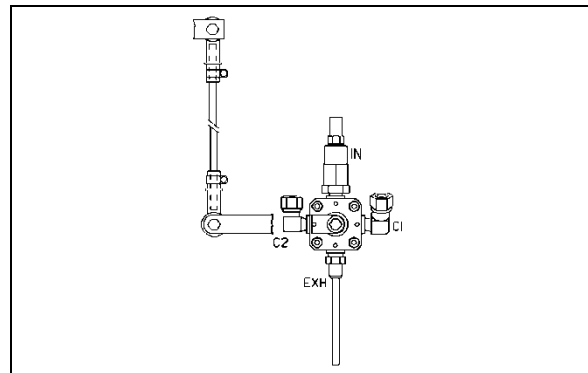

FIGURE 20: FRONT HEIGHT CONTROL VALVE 16100

The normal ride height is obtained by adjusting air spring clearance of both front and rear suspension as follows:

Front I-beam axle air spring clearance

1. With the vehicle at normal operating air pressure [100 - 125 psi (689 - 860 kPa)], measure air spring clearance. This

clearance should be $11\ 11/16'' \pm 1/4''$ (297 ± 6 mm).

NOTE

The measurement should be taken from underneath the upper air spring support on subframe to top of the lower air spring support on axle (refer to Figure 17 for more details). If adjustment is required, begin with the drive axle.

- Loosen the clamp on the height control valve rubber coupling and bring it up or down (Figure 21).

NOTE

Allow suspension to stabilize before taking reading.

When the desired height is obtained, tighten clamp.

Rear air spring clearance

- With the vehicle at normal operating air pressure [122 - 140 psi], measure air spring clearance. This clearance should be as per Figure 18 and Figure 19.

NOTE

The measurement should be taken from underneath the upper air spring support on subframe to top of the lower air spring support on axle.

- Loosen the clamp on the height control valve rubber coupling and bring it up or down (Figure 21).

NOTE

Allow suspension to stabilize before taking reading.

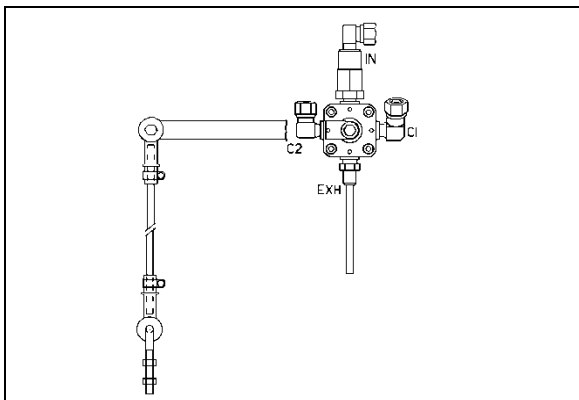

FIGURE 21: REAR HEIGHT CONTROL VALVE

16093

When the desired height is obtained, tighten clamp.

7. HEIGHT CONTROL VALVE

The height control valves automatically add air to, or release air from air springs to maintain constant suspension height regardless of load, or load distribution. Each valve adjusts independently according to the following conditions:

Loading Position

As the load increases and lowers the vehicle body, the overtravel lever commands the height control valve to add air to air springs.

Neutral Position

When vehicle body reaches the normal ride height, the height control valve overtravel lever reaches the "neutral" position and keeps both the supply and exhaust ports closed to ensure normal ride height is maintained. This condition remains static until the vehicle load is altered.

Unloading Position

As the load decreases and raises the vehicle body, the overtravel lever commands the height control valve to release air from air springs.

7.1 MAINTENANCE

The height control valve requires no periodic maintenance. Height control valve linkage operates on rubber bushings and no lubrication should be attempted at this location. Inspect the valve for loose joints, air leaks and worn bushings.

7.2 REMOVAL AND INSTALLATION

Before disconnecting a height control valve air line, securely support the vehicle by its jacking points on the body, and place safety supports underneath body. Refer to paragraph "16. Vehicle Jacking Points" in Section 18, "Body".

- Exhaust air from air system by opening all air tank drain cocks. Remove height control valves.
- Disconnect overtravel lever from link and pull down lever to exhaust remaining air from air springs.
- Disconnect air supply and delivery lines from the height control valve. Cover line ends with tape to prevent entry of foreign matter.
- Remove the nuts retaining the height control valve to the mounting bracket, then remove valve assembly.

Reverse removal procedure to replace height control valve. After installation, check for leakage using a soap and water solution.

8. AIR SYSTEM

The basic air system consists of an air compressor, tanks, valves, filters and interconnecting lines and hoses (refer to Maintenance Manual, Section 12, "Brake and Air System" for complete information). It provides a means for braking, operating controls and accessories, and suspension. An air system schematic diagram is provided for a better understanding of the system.

The air coming from the air dryer is first directed to the wet air tank, then to the primary (for the primary brake system), secondary (for the secondary brake system), and accessory (for the pneumatic accessories) air tanks (Figure 22).

8.1 AIR TANK MAINTENANCE

Ensure that the accessories air tank is purged during pre-starting inspection. A good practice is to purge this tank at the end of every driving day by the remote air tank drain valve located in the front service compartment (Figure 24).

Moreover, purge all tanks by their bottom drain valves at specified intervals.

8.1.1 Wet Air Tank

This tank is installed above the drive axle on the L.H. side, and is provided with a bottom drain valve. It is recommended to **purge** the wet air tank by its bottom drain valve every 12,000 miles.

A remote valve located in engine compartment and accessible through engine R.H. side door is used to **drain** the air dryer (Figure 23).

8.1.2 Primary Air Tank

The primary air tank is located above the drive axle on the R.H. side (Figure 22).

This tank is provided with a bottom drain valve. It is recommended to purge the primary air tank by its bottom drain valve every 12,000 mile.

8.1.3 Secondary Air Tank

This tank is located in front wheelhousing, between air springs. The tank is provided with a bottom drain valve (Figure 22).

It is recommended to purge the tank by its bottom drain valve, every 12,000 miles.

8.1.4 Accessory Air Tank

The accessory air tank is installed next to the secondary air tank. The tank is provided with a bottom drain valve (Figure 22).

It is recommended to purge the tank by its bottom drain valve, every 12,000 miles.

A remote drain valve is located in front service compartment (Figure 23) underneath the accessory air filter. Refer to Section 12, paragraph "4. Accessory Air Filter" of the maintenance manual for daily purge procedure.

8.1.5 Kneeling Air Tank

The kneeling air tank is located in the front wheelhousing (Figure 22), and is provided with a bottom drain valve.

8.1.6 Parking Brakes Override Air Tank

The parking brakes override air tank is installed at the ceiling of the rear baggage compartment, on the L.H. side and is provided with a bottom drain valve.

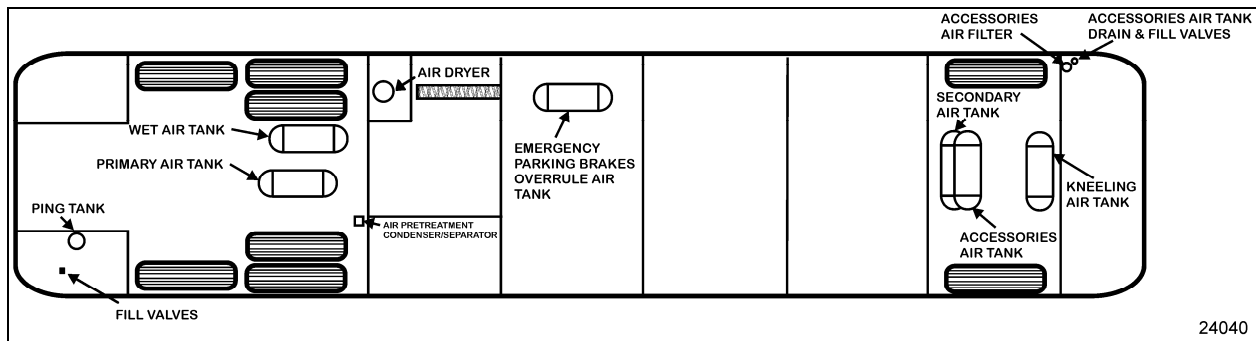

FIGURE 22: I-BEAM FRONT SUSPENSION AIR TANKS LOCATION

24040

8.2 EMERGENCY FILL VALVES

The vehicle is equipped with two air system fill valves to supplement the air system when air pressure is low and engine cannot be operated.

The **rear valve** is located in engine compartment and accessible from engine R.H. side door (Figure 23).

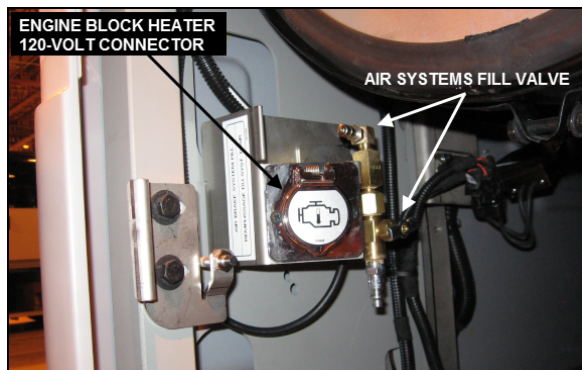

FIGURE 23: REAR VALVE LOCATION

12211_1



CAUTION

No other point should be used to supply air system. The maximum allowable air pressure is 125 psi (860 kPa).

The front valve is located in the front service compartment close to accessory air filter (Figure 24).

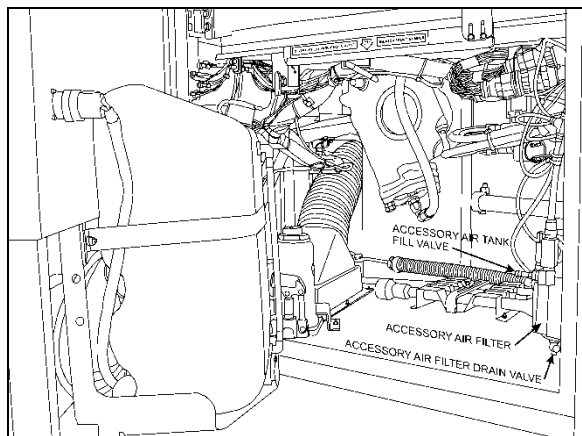

FIGURE 24: FRONT SERVICE COMPARTMENT

These two air valves are fitted with the same valve stems as standard tires, and can be filled by any standard external air supply line.

The rear valve will supply air for all systems (brakes, suspension and accessories) while the front valve will supply air for accessories only.



CAUTION

Air filled through these two points will pass through the standard air filtering system provided by Prevost. Do not fill air through any other points.

9. FRONT KNEELING SYSTEM

The kneeling system is used to lower the front of vehicle. This allows passengers to board the vehicle with greater ease. The kneeling action is achieved by exhausting air from the front air springs (bellows). This system bypasses the height control valve to provide a fast up and down movement of the front suspension. Only four seconds are required to lower vehicle from normal level to the lowered position, and approximately the same time to raise the vehicle back to normal level. The quick response is achieved by an auxiliary air tank installed beside the secondary air reservoir (for exact position, refer to Section 12, "Brake and Air System"). This tank provides sufficient air supply to the kneeling system for some successive operations.

The system is provided with two safety features; first, a speed switch will enable the kneeling system to work only at less than 5 mph (8 km/h). Secondly, the parking brake is automatically applied, and a limit switch will keep it applied as long as the vehicle has not returned to a certain height where the driver will be able to manually remove the parking brake.

9.1 PRINCIPLE OF OPERATION

Refer to the air system schematic diagram.

DOWN (FRONT KNEELING):

Both the bellows control and bellows exhaust solenoid valves are energized, so the air control valves release air from front air springs. The height control valve is bypassed to ensure no air is forwarded to air springs while lowering the front suspension.

9.2 MAINTENANCE

Since the kneeling action is issued from both the air system and electrical system, refer to Section: 12, "Brake and Air System" and Section 06, "Electrical System".

For diagnosis and understanding of the system, refer to wiring diagrams, and to the appropriate air system schematic.

9.3 BELLOWS CONTROL SOLENOID VALVES

9.3.1 Removal and installation

1. On the rear side of steering compartment, locate both the bellows control and bellows exhaust solenoid valves.
2. Identify hoses and wires to ease reinstallation. Disconnect solenoid wires and the three flexible black hoses from solenoid valves.
3. Unscrew and remove the control solenoid valve and exhaust solenoid valve assembly. Place on a clean working place.

Reverse removal procedure to reinstall.

 <b style="font-size: 1.2em; margin-left: 10px;">CAUTION
Any cable tie that has been cut during removal procedure should be replaced with a new one.

10. TROUBLESHOOTING

Condition	Cause	Correction
Bellows deflate over time	<ol style="list-style-type: none"> 1. Defective check valve assembly. 2. Defective exhaust valve assembly. 3. Leak in air line and/or bellows. 4. Defective valve cover, rubber O-rings or gasket. 	<ol style="list-style-type: none"> 1. Replace check valve assembly. 2. Replace exhaust valve assembly. 3. Replace air line or bellows. 4. Replace valve cover, O-rings or gasket.
Bellows raise to full height and fail to exhaust air pressure	<ol style="list-style-type: none"> 1. A clogged exhaust screen in height control valve assembly. 2. A combination clogged exhaust screen and defective air inlet valve assembly. 	<ol style="list-style-type: none"> 1. Remove and clean screen. 2. Clean exhaust screen and replace air inlet valve assembly.
Erratic valve action	<ol style="list-style-type: none"> 1. Dirt or foreign matter in the air valve lever chamber. 2. Defectives valves. 	<ol style="list-style-type: none"> 1. Remove valve cover and blow out dirt. Install cover using new gasket. 2. Overhaul height control valve assembly
Vehicle body fails to level to satisfactory ride height	<ol style="list-style-type: none"> 1. Improper height control valve overtravel lever adjustment 	Adjust lever as directed.

11. SECTION CHANGE LOG

DESCRIPTION		DATE
1	page 11, reference 12 was 171-209 lbf-ft, changed for 207-253 lbf-ft page 18, reference 7 was 228-252 lbf-ft, changed for 171-209 lbf-ft	Apr.04,2016
2	page 14, air spring nut wrong torque value 20-25 lbf-ft removed	Apr.16,2019
3		
4		
5		
6		



**MAINTENANCE
INFORMATION**

MI15-41

DATE :	AUGUST 2015	SECTION :	18 - Body
SUBJECT :	CRACKING OF POLYCARBONATE TAILLIGHTS CAUSED BY INAPPROPRIATE CLEANING PRODUCTS		

APPLICATION

Model	VIN	
ALL MODELS		

DESCRIPTION

Prevost would like to remind its customers that only **cleaning products designed for external washing of vehicles** should be used for exterior vehicle wash and in particular, for the washing of polycarbonate taillights.

POLYCARBONATE CRACKING

Degreasers designed to clean motors **must not be used** to clean the engine compartment door. These products are not compatible with polycarbonate. They cause cracking of the polycarbonate taillights housing and cracking of the bosses in which the mounting threaded rods are inserted (figures 2 & 3).

CLEANING PRODUCT COMPATIBLE WITH POLYCARBONATE

Cleaning products designed for external washing of vehicles shall be used to clean your vehicle. Prevost suggests a high PH cleaner compatible with polycarbonate. See the description of the product in the following table

Part No	Description	Qty
686037	EXTERIOR CLEANER (BODY)	1 gallon / 4 liters
686036	EXTERIOR CLEANER (BODY)	5.28 gallons / 20 liters
685841	EXTERIOR CLEANER (BODY)	55 gallons / 210 liters

NOTE
<i>Material can be obtained through regular channels.</i>

High PH cleaning product compatible with polycarbonate - product sheet

Traffic film remover

Will not make plastics crack

Perfect for trucks, cars, trains, buses and machinery. Safe for all types of plastics including polycarbonate. Designed for automatic or pressure washing.

ADVANTAGES	DIRECTIONS	MORE DETAILS
<ul style="list-style-type: none"> - Easily removes traffic film, insects and grease. - Safe for car and truck paint. - Safe for use on metal, rubber, chrome, glass and plastic surfaces. - Does not leave any deposit. - Concentrated. - Eco-friendly. - Easy to rinse. - Dries evenly. 	<p>Pressure washing :</p> <ol style="list-style-type: none"> 1. Use product accordingly to dilution ratio. 2. Spray evenly on vehicle surface starting by the bottom. 3. Rinse thoroughly with cold or lukewarm water. 	<p>Do not wash in direct sunlight. Do not allow product to dry on surface.</p>

DILUTION RATIO

DIRT	RATIO	
Mild	1 oz / 20 oz	50 ml / L
Average	1 oz / 10 oz	100 ml / L
Strong	1 oz / 6.67 oz	150 ml / L

PRECAUTIONS

Avoid all contact with eyes.
Avoid all contact with skin.
Wash hands with soap and water after handling.

FIRST AID

- Skin: Wash contaminated skin with soap and water.
- Eyes: Flush immediately with running water for at least 15 minutes, occasionally lifting the upper and lower eyelids. Seek medical help.
- Ingestion: Do not induce vomiting. If the person is conscious, have them drink several glasses of water or milk. Seek medical help.

PHYSICAL ATTRIBUTE

PHYSICAL STATE:	Liquid
APPEARANCE:	Clear
COLOR:	Transparent
SCENT:	Chemical
PH:	13.1
DENSITY (25°C):	1.1

SECURITY

HEALTH	1
FLAMMABILITY	0
REACTIVITY	0
PERSONAL PROTECTION	B

0 =	NEGLIGIBLE
1 =	LOW
2 =	MODERATE
3 =	HIGHT
4 =	EXTREME

FIGURE 1: PRODUCT SHEET

IMAGES SHOWING THE CRACKING ISSUE

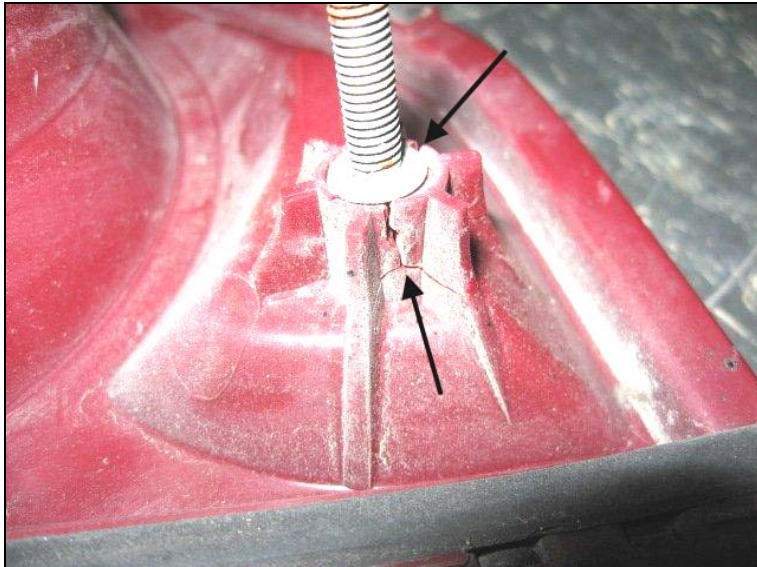

FIGURE 2: Cracks at the boss and ribs due to the use of engine degreaser



FIGURE 3: Cracking of the outer surface of the taillight due to the use of engine degreaser



Access all our Service Bulletins on <https://secureus5.volvo.com/technicalpublications/en/pub.asp>
Or scan the QR-Code with your smart phone.

E-mail us at technicalpublications_prev@volvo.com and type "ADD" in the subject to receive our warranty bulletins by e-mail.

CONTENTS

1. VEHICLE EXTERIOR	4
2. VEHICLE STRUCTURE	6
2.1 WELDING.....	6
3. VEHICLE EXTERIOR MAINTENANCE	6
4. CORROSION PREVENTION	6
5. PREVENTIVE MAINTENANCE SCHEDULE	8
6. RUST INHIBITOR APPLICATION	8
7. COMMON FIBERGLASS REPAIR PROCEDURE	14
8. REPAIR USING FIBERGLASS CLOTH	14
9. REPAIR USING FIBERGLASS PASTE	14
10. TYPICAL FIBERGLASS HOLE REPAIR PROCEDURE	15
11. COMMON PAINTING PROCEDURE	16
12. NEW PAINT CARE	16
13. PAINT TOUCHUP	16
14. PAINTING	17
14.1 SAFETY.....	17
14.2 SURFACE PREPARATION AND PAINT APPLICATION RECOMMENDATION	18
15. X3-45 COACHES EXTERIOR FINISHING AND BODY REPAIR	19
15.1 ZONE 1	19
15.1.1 <i>Front Bumper</i>	20
15.1.2 <i>Headlights</i>	21
15.1.3 <i>Rear View Mirrors (Rosco)</i>	21
15.1.4 <i>Windshield Wipers</i>	22
15.1.5 <i>Windshield</i>	22
15.1.6 <i>Bi-Fold Entrance Door</i>	24
15.1.7 <i>Front Electrical & Service Compartment Door</i>	28
15.1.8 <i>Front Cap</i>	31
15.2 ZONE 2	32
15.2.1 <i>Lateral Fixed Window</i>	33
15.2.2 <i>Emergency Exit Windows</i>	34
15.2.3 <i>Roof Escape Hatch</i>	35
15.3 ZONE 3.....	37
15.3.1 <i>Rear Cap</i>	38
15.3.2 <i>Engine Compartment Door</i>	38
15.3.3 <i>Rear Bumper</i>	38
15.3.4 <i>Exhaust Aftertreatment System Access Door</i>	38
15.4 ZONE 4.....	39
15.4.1 <i>Rear Fender</i>	40
15.4.2 <i>Engine Compartment R. H. Side Door</i>	40
15.4.3 <i>Engine Radiator Door</i>	40
15.5 ZONE 5.....	42
15.5.1 <i>Baggage Compartment Doors (Aluminum)</i>	43
15.5.2 <i>Wheelchair Lift Cassette Compartment Door</i>	45
15.5.3 <i>Evaporator Compartment Door</i>	47

15.5.4	Condenser Compartment Door	49
15.5.5	Fuel Filler Door	49
15.5.6	Baggage Compartment Floor	49
15.5.7	Fuel Filler Door	53
15.6	ZONE 6	54
15.6.1	Front Fender	54
15.7	ZONE 7	54
15.7.1	X3 Smooth Side Panel Replacement Procedure	55
15.7.2	Side Crest	61
16.	BODY PANEL AND WINDOW SPACING	62
17.	PASSENGER SEATS	63
17.1	REMOVING FIXED SEATS	63
17.2	UPHOLSTERY MAINTENANCE	63
18.	TARABUS FLOOR COVERING REPAIR OR REPLACEMENT	65
18.1	FRONT STEPS REPLACEMENT PROCEDURE	67
18.1.1	Welding Of Joint Between White Safety Strip And "Tarabus" Floor Covering	69
18.2	REPAIR OF A WELDED JOINT	71
19.	SECTION CHANGE LOG	72

ILLUSTRATIONS

FIGURE 1:	X3-45 COMMUTER EXTERIOR VIEW	4
FIGURE 2:	FIBERGLASS HOLE REPAIR	15
FIGURE 3:	FIBERGLASS HOLE REPAIR	15
FIGURE 4:	FIBERGLASS HOLE REPAIR	15
FIGURE 5:	FIBERGLASS HOLE REPAIR	16
FIGURE 6:	FIBERGLASS HOLE REPAIR	16
FIGURE 7:	X3 SERIES COACH ZONES	19
FIGURE 8:	ZONE 1	19
FIGURE 9:	BUMPER TOP RETAINING BOLTS	20
FIGURE 10:	FRONT BUMPER AIR LINES	20
FIGURE 11:	FRONT BUMPER SPRING	20
FIGURE 12:	BUMPER SUPPORT ARM	20
FIGURE 13:	BUMPER HINGE BOLTS	21
FIGURE 14:	L/H REAR VIEW MIRROR (ROSCO)	21
FIGURE 15:	R/H OUTSIDE REAR-VIEW MIRROR	22
FIGURE 16:	REAR VIEW MIRROR GLASS REMOVAL	22
FIGURE 17:	WINDSHIELD INSTALLATION USING ROPE	23
FIGURE 18:	APPLICATION OF SIKA 221 BLACK	24
FIGURE 19:	ENTRANCE DOOR & WIPER CONTROL PANEL	24
FIGURE 20:	ENTRANCE DOOR - VIEW FROM INSIDE	24
FIGURE 21:	ENTRANCE DOOR OPERATING BUTTONS	25
FIGURE 22:	ENTRANCE DOOR CONTROL SWITCH	25
FIGURE 23:	ENTRANCE DOOR - VIEW FROM OUTSIDE	26
FIGURE 24:	EXTERIOR UNLATCH AIR VALVE	26
FIGURE 25:	INTERIOR UNLATCH AIR VALVE	26
FIGURE 26:	DAMPER	27
FIGURE 27:	DOOR PANEL ADJUSTMENTS	28
FIGURE 28:	ZONE 2	32
FIGURE 29:	X3-45 COMMUTER	34
FIGURE 30:	EMERGENCY EXIT WINDOW	34
FIGURE 31:	ESCAPE HATCH	36

FIGURE 32: ESCAPE HATCH 36

FIGURE 33: ZONE 3..... 37

FIGURE 34: ENGINE COMPARTMENT DOOR..... 38

FIGURE 35: REAR BUMPER 38

FIGURE 36: ZONE 4..... 39

FIGURE 37: LEFT REAR FENDER..... 40

FIGURE 38: ENGINE COMPARTMENT R.H. SIDE DOOR..... 40

FIGURE 39: RADIATOR DOOR 41

FIGURE 40: RADIATOR DOOR DETAILS 41

FIGURE 41: STRIKER PIN ENGAGEMENT 41

FIGURE 42: HINGE DETAIL..... 42

FIGURE 43: ZONE 5..... 42

FIGURE 44: EVAPORATOR DOOR (ALUMINUM)..... 47

FIGURE 45: CONDENSER DOOR..... 49

FIGURE 46: FUEL FILLER DOOR 49

FIGURE 47: FUEL FILLER DOOR 53

FIGURE 48: ZONE 6..... 54

FIGURE 49: ZONE 7..... 55

FIGURE 50: SIDE CREST POSITIONING 61

FIGURE 51: BODY PANEL AND WINDOW SPACING (TYPICAL) 63

FIGURE 52: CUSHION REMOVAL 63

FIGURE 53: WALL BRACKET 63

FIGURE 54: SEAT PEDESTAL ASSEMBLY..... 63

FIGURE 55: TARABUS FLOOR COVERING ADHESIVE APPLICATION 66

FIGURE 56: APPLICATION OF SIKA 221 GRAY 66

1. VEHICLE EXTERIOR

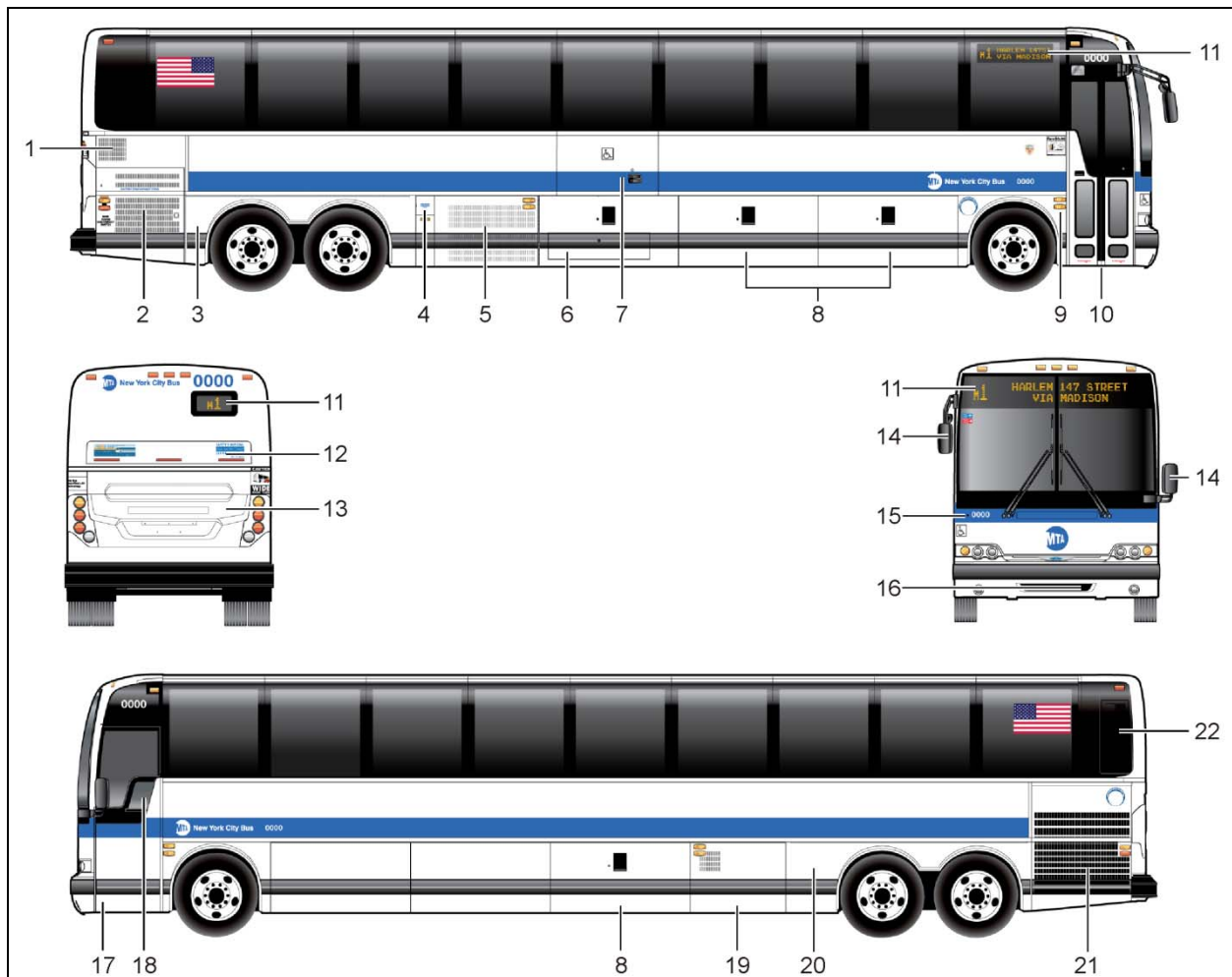

FIGURE 1: X3-45 COMMUTER EXTERIOR VIEW

18606

- | | |
|---|--|
| 1. Engine air intake | 12. Exhaust aftertreatment system access door |
| 2. Engine compartment curb-side door | 13. Engine compartment rear door |
| 3. Hinged rear fender | 14. Rear-view mirrors |
| 4. Fuel filler neck & DEF filler neck door | 15. Transmission retarder off indicator light |
| 5. Condenser compartment | 16. Front towing air supply connectors access door |
| 6. Lift mechanism access door | 17. Front electrical and service compartment |
| 7. Wheelchair access door | 18. Driver's power window |
| 8. Baggage compartment | 19. Evaporator compartment |
| 9. Entrance door control switch | 20. Coolant heater & air dryer compartment |
| 10. Bi-fold entrance door | 21. Radiator door |
| 11. Electronic destination sign or route number | |

22. SCR converter access door

2. VEHICLE STRUCTURE

The body of the X3-45 coaches is an integral structure made of 14, 16 and 18 gauge welded and braced high tensile steel and stainless steel members. All stainless exterior panels are glued to anti-corrosion coated members. The complete structure is protected against corrosion prior to assembly. The front and rear caps are made of molded fiberglass. The main roof is made of high tensile aluminum panels riveted to the roof structure. The floor is made of 2 layers of ½" (13 mm) thick plywood separated by a 1/8" (3 mm) insulation to reduce power train and road noises.

2.1 Welding

Since welding is a procedure that may be carried out either as specific instructions from Prevost or by an independent decision of the owner, the following information pertaining to welding should be read before beginning any welding procedure. The prohibitions and requirements outlined below must be followed during welding procedure:

1. Welding must be done only by a qualified and experienced person.
2. Adequate ground contacts and shields must be positioned as required to protect components from damage due to heat, contact by weld splatter, arcing, or other potentially damaging events associated with welding.
3. The following precautions are to be taken to protect the electronic control components. Refer to section 00, paragraph 3: "PRECAUTIONS TO BE OBSERVED BEFORE WELDING" in this manual.
4. Always wear the appropriate safety equipment.
5. Weld in clean and well ventilated area, and always have an appropriate fire extinguisher within your reach.

3. VEHICLE EXTERIOR MAINTENANCE

Regular washing to remove dust and dirt is recommended. See *"Operator's Manual"* for more details on washing and cleaning your vehicle.

4. CORROSION PREVENTION

Preventive maintenance is a key factor in avoiding corrosion and must be considered as part of the regular service intervals. The entire underside of the vehicle is sprayed with a heavy application of asphalt base undercoating.

The operating environment the vehicle is subjected to will largely influence the amount of dirt and corrosion that will accumulate over a given period. Corrosion is one of the most costly factors of part failure and shortened part life. It is, however, an item that can be controlled when it is conscientiously looked after and the proper steps are taken in a timely manner.

Certain areas of the coach are more vulnerable to corrosion than others, and it is these areas that should be addressed. For example, the rear baggage compartment bulkhead in the rear wheelhousing area contains many key components and should be examined regularly for corrosion. Other areas include the front wheelhousing area and the engine compartment.

Road splash will affect undercarriage, condenser coil and engine compartment. These areas must be thoroughly cleaned to remove dirt accumulations from flanges, channels and ledges. These places accumulate dirt and salt and hold it in direct contact with steel and aluminum surfaces. Use an understructure high pressure spray as part of a regular wash. Damaged undercoating or paint should be promptly repaired before corrosion can start.

Frequency of wash periods depends on operating conditions. During periods of exposure to salt, daily washing as described above is recommended. If underbody parts show evidence of rust or corrosion, treat as follows:

1. Remove dirt, grease and oil by solvent washing.
2. Remove corrosion as well as all loose coating by cleaning with a wire brush or sandblasting.



CAUTION

Sandblasting can be used for cleaning bulkheads, brackets and other structural members. It should not be used for exterior side paneling. Extreme care should be taken not to sandblast excessively.

3. Apply correct primer, paint and undercoating after removing all corrosion to prevent further damage.

5. PREVENTIVE MAINTENANCE SCHEDULE

NOTE

TECTYL 185 GW rust inhibitor has been applied on your vehicle underbody, follow this procedure thoroughly. For future application of product, refer to paragraph 3.3 in this section.



DESCRIPTION	INTERVALS		MAINTENANCE	CORRECTIVE ACTION	REFERENCE
	MONTHS	KM MILES			
BODY, EXTERNAL WINDOW FRAME	6	40 000 25 000	VISUALLY INSPECT SEALING BEADS CONDITION	REPAIR OR REPLACE SEALING BEADS IF NECESSARY	
VEHICLE UNDERBODY	12	100 000 60 000	USE A LOW PRESSURE SPRAY TO CLEAN UNDERSTRUCTURE AND VISUALLY INSPECT FOR CALCIUM DEPOSIT, CORROSION OR ANY DIRT ACCUMULATED ONTO EXPOSED SURFACES. VISUALLY INSPECT SEALING BEADS CONDITION. VISUALLY INSPECT IF UNDERFLOOR IS PEELING. VISUALLY INSPECT WHEELHOUSING COATING. MAKE SURE DISCHARGE TUBES ARE FREE FROM OBSTRUCTIONS	APPLY UNDERCOATING LOCALLY AS NECESSARY. APPLY UNDERCOATING LOCALLY AS NECESSARY REMOVE ANY OBSTRUCTION OR REPLACE DEFECTIVE TUBE	
SUSPENSION AND UNDERSTRUCTURE	12	100 000 60 000	VERIFY THE CONDITION OF ALL SUSPENSION AND UNDERSTRUCTURE FASTENERS AND CLAMPS	TIGHTEN OR REPLACE DEFECTIVE OR MISSING FASTENERS	
FLOOR COVERING	3	20 000 12 500	VISUALLY INSPECT IF FLOOR COVERING IS SHOWING SIGNS OF DETERIORATION SUCH AS CUTS, BURNS, ETC. ALSO, VISUALLY INSPECT SEALANT ALONGSIDE TRACKS. INSPECT WALL PANELS FROM BOTTOM TO WINDOWS	REPAIR OR REPLACE DEFECTIVE COVERING. MAKE SURE PROPER SEALANT IS USED.	
FLOOR CLEANING			CLEAN FLOOR COVERING AS NECESSARY		

**WARNING**

Failure to follow this preventive maintenance schedule will result in warranty void.

6. RUST INHIBITOR APPLICATION

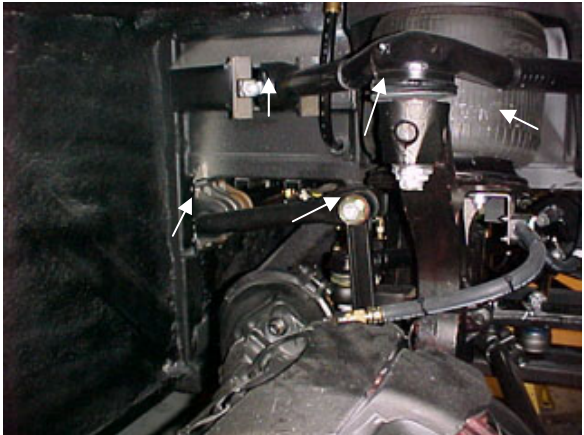
Material: Tectyl 185 GW R1KG21
 Safety Rules: Use safety glasses
 Supplied air hood
 Solvent-resistant rubber gloves

<p>1.0 Wash both wheelhousing mechanical parts before masking.</p>	<p>A water-hose nozzle is recommended. Water may be hot to reduce washing time especially during winter. If parts are soiled with oil, clean using R1KG21. Avoid rubber parts.</p>
<p>2.0 Dry all water sprayed parts. Surface temperature and dew point must be respected before applying rust inhibitor.</p>	<p>Air pressure system may be used, refer to annex 1 for surface temperature and dew point.</p>
<p>3.0 Front wheelhousing a) Mask all rubber joints. Braking system must also be protected (refer to arrows). Commercial aluminum foil may be used for masking.</p>	
<p>3.1 Front wheelhousing Front view</p>	

3.2 Front wheelhousing

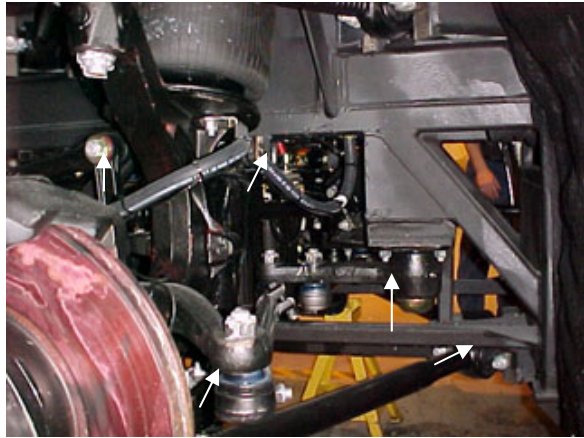

3.3 Front wheelhousing

(Entire braking system)

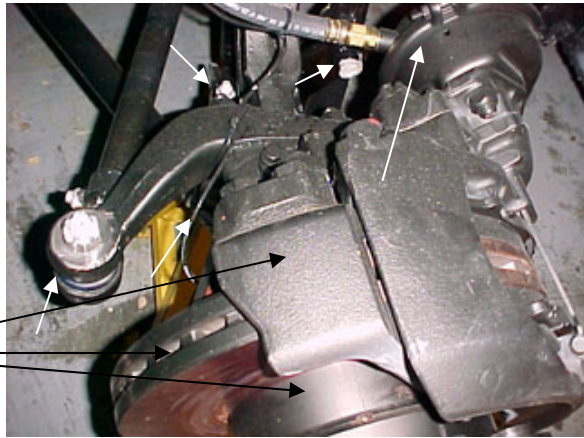

4.0 Rear wheelhousing

a) Mask all rubber joints. Braking system must also be protected (refer to arrows). Commercial aluminum foil may be used for masking

(Entire braking system)

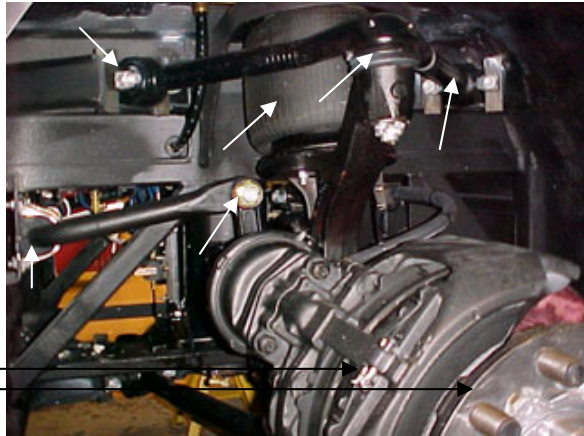

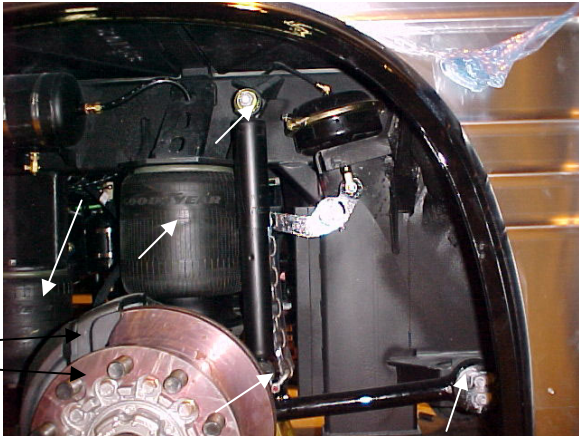
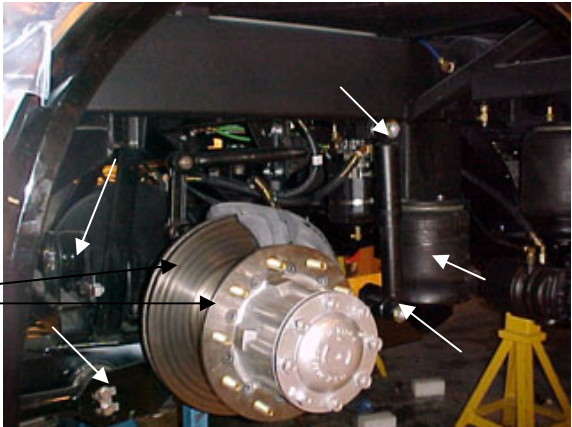
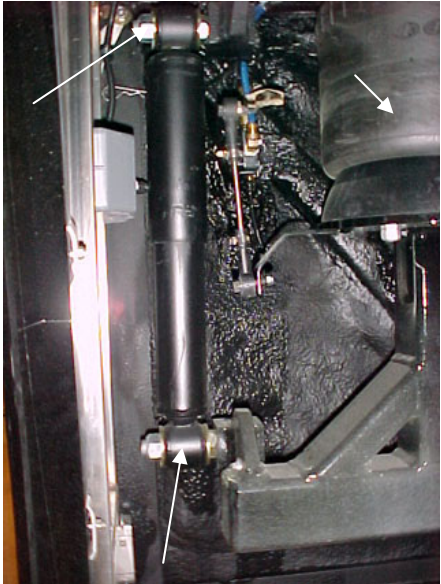
<p>4.1 Rear wheelhousing</p> <p>(Entire braking system)</p>	
<p>4.2 Rear wheelhousing</p> <p>(Entire braking system)</p>	
<p>4.3 Rear wheelhousing</p>	
<p>5.0 Close off wheelhousing using masking paper.</p>	<p>Prevent rust inhibitor from coming in contact with paint. To close off wheelhousing, a polythene sheet may be used.</p>
<p>6.0 Apply TECTYL 185 GW black rust inhibitor onto wheelhousing mechanical parts.</p>	<p>A spray gun and pumping system are required to apply the rust inhibitor. If the application is done inside a paint room, select high speed ventilation. Minimum required</p>

SECTION 18: BODY

	thickness is 10 mils wet or 5 mils dry.
7.0 Remove all masking material 30 minutes after application.	

ANNEX 1

1. Check and confirm that dew point and surface temperature are in accordance with to the following criteria:

Surface temperature > 10°C

Surface temperature > or = to dew point + 3°C

NOTE

Use the following table to determine dew point.

2. Check and confirm that TECTYL temperature is between 10°C and 35°C.

DEW POINT

	Relative Humidity (%)									
	10	20	30	40	50	60	70	80	90	100
Temp (c)										
0	---	-16	-11	-8	-5	-3	-1	0	1	3
1	---	-15	-10	-7	-5	-3	-1	1	2	4
2	---	-14	-10	-6	-4	-1	0	2	3	5
3	---	-13	-9	-5	-3	-1	1	2	4	6
4	---	-13	-8	-5	-2	0	2	4	5	7
5	---	-11	-7	-4	-1	1	3	5	6	8
6	---	-11	-8	-3	0	2	4	6	7	9
7	-18	-10	-6	-2	0	2	5	6	8	10
8	-17	-9	-5	-1	1	4	6	7	9	11
9	-16	-9	-4	-1	2	4	6	9	10	12
10	-16	-8	-3	0	3	5	7	10	11	13
11	-15	-7	-3	1	4	6	9	10	12	14
12	-14	-6	-1	2	5	7	10	11	13	15
13	-14	-6	-1	2	6	8	10	12	14	16
14	-13	-5	0	4	6	9	11	14	15	17
15	-12	-4	1	4	7	10	12	14	16	18
16	-11	-4	1	5	9	11	13	15	17	19
17	-10	-3	2	6	9	12	14	16	18	20
18	-10	-2	3	7	10	13	15	17	19	21
19	-9	-1	4	8	11	14	16	18	20	22
20	-9	0		5	9	12	15	17	19	21 23
21	-8	0		5	10	13	16	18	20	22 24
22	-7	1		6	11	14	16	19	21	23 25
23	-6	2		7	11	15	17	20	22	24 26
24	-6	2		8	12	16	19	21	23	25 27
25	-5	3		9	13	16	20	22	24	26 28
26	-4	4		10	14	17	20	23	25	27 29
27	-4	5		11	15	19	21	24	26	28 30

28	-3	6	11	16	19	22	25	27	29	31
29	-2	6	12	17	20	23	26	28	30	32
30	-1	7	13	17	21	24	27	29	31	33
31	-1	8	14	19	22	25	27	30	32	34
32	0	9	15	20	23	26	29	31	33	35

7. COMMON FIBERGLASS REPAIR PROCEDURE

All repairs to fiberglass parts consist of filling the damaged area with fiberglass cloth and resin or strand fiberglass and resin. The repair is allowed to harden, and then finishing operations may be performed. Use of the various materials is determined by the type of repair to be made. Large holes, torn sections and separate joints require the adhesive qualities of the resin and the reinforcing qualities of the fiberglass. Small dents, scratches or pits can be repaired using resin and strand fiberglass and filler mixed into paste. Instructions for either mix are explained under their respective headings in this section. For best results when making repairs, temperature should be between 70 and 75 °F (21-24 °C). Some people experience a skin reaction to resins. In such cases, wipe resin off with denatured alcohol or a good thinner. Use of protective hand cream is recommended.



WARNING

Always wear a respirator and goggles when grinding or sanding.

Extreme care must be taken if the sander is electrically operated, as dust from some resins is combustible when subjected to sparks or open flames. The proper tool for sanding resin is a low speed, air driven disc sander with a water attachment or a dry sander having a vacuum bag. Either will eliminate flying glass and resin dust.

The following additional tools and materials will assist in making repairs: hacksaw blade, assorted files, emery paper or cloth (150 or finer), scissors or tin snips, wax paper or cellophane sheets, a 3" (75 mm) paint roller, paint brush, putty knife, acetone and one or more heat lamps.

8. REPAIR USING FIBERGLASS CLOTH

Where necessary, sand paint away around damaged area and scrape away undercoating, if any, and wipe clean with solvent. Grind or file the damaged area to form a "V" at the broken or cracked portion. Sides of "V" should have a shallow pitch for maximum bonding area.

NOTE

Roughening the surface improves adhesion of resin.

If part is warped from original shape, use clamping equipment to straighten the surface. Preheat area to be repaired with one or two heat lamps placed 18 to 24 inches (450-610 mm) from repair.



CAUTION

Temperature should not exceed 140 °F (60 °C) during 30 minutes in order to avoid distortion.

Cut fiberglass cloth with scissors or tin snips, 1 to 3 inches (25-75 mm) larger than area to be repaired. Build area to desired height.

Mix resin and hardener following instructions on their containers. Saturate layers of fiberglass with mixture and place laminates over damaged area. Smooth out wrinkles and make sure general contour of area is maintained. Bubbles and wrinkles can be eliminated with a roller.



CAUTION

The pot life of the mix is approximately 15 minutes. Any accidental contamination to the skin, clothing, tools, etc. must be removed within this period. Use acetone to remove uncured resin.

Heat resin material again by placing heat lamps 18 to 24 inches (450-610 mm) from repaired area. Allow 12 to 15 minutes for repair to cure. After repair is cured, grind, file or sand to contour. Files other than body files may be more suitable. Featheredge and finish sanding.

If small pits or irregularities appear after making repair, correct by using a liberal amount of chopped strand or filler mixed with resin to form a paste. Refer to heading "Repair using Fiberglass Paste" in this section.

9. REPAIR USING FIBERGLASS PASTE

Fiberglass paste is used for repairing small dents, scratches, and pits. Paste is made by

mixing resin, hardener and fiberglass strand or filler to the consistency of putty. Where it may be necessary, sand paint away around damaged area. On underside of coach, scrape away undercoating from damaged area, and wipe clean with solvent.

Preheat the area to be repaired using heat lamps. Mix desired quantities of resin and hardener according to manufacturer's instructions. Add powdered fiberglass strand into mixture to thicken it into a putty state.

NOTE
If repair is made on a vertical surface, adding powdered filler material to mixture will reduce tendency of hot resin to flow or run.

Apply the material with a putty knife or similar object, building material up to the desired contour. For deep filling and on vertical surfaces, several layers of material may be used.

A hacksaw blade, held flat to adjacent contour and then moved in a sawing action across the repair when the resin is in a gel state, will remove excess resin from repair. Finish repair with the same procedure as when using fiberglass cloth.

10. TYPICAL FIBERGLASS HOLE REPAIR PROCEDURE

Remove all loose particles or damaged material using a power sander or rasp. Clean area, overlapping hole approximately 1" to 1-1/2" (25-40 mm) all around. Remove all dirt, grease and paint from area to ensure good bonding surface. Feather the cleaned area all around (Figure 2).

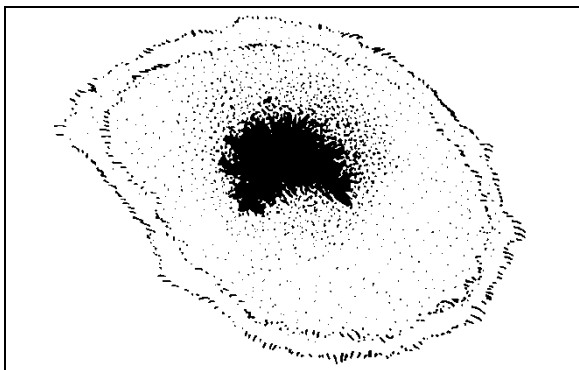

FIGURE 2: FIBERGLASS HOLE REPAIR 18089

Cut a piece of fiberglass mat slightly larger than area being repaired. Impregnate mat with general purpose polyester resin catalyzed normally. Use a clean paint brush to apply the polyester resin. Apply impregnated mat over hole and press onto surface with brush to obtain good adherence. Another coat of general purpose polyester resin can be applied at this time (Figure 4).

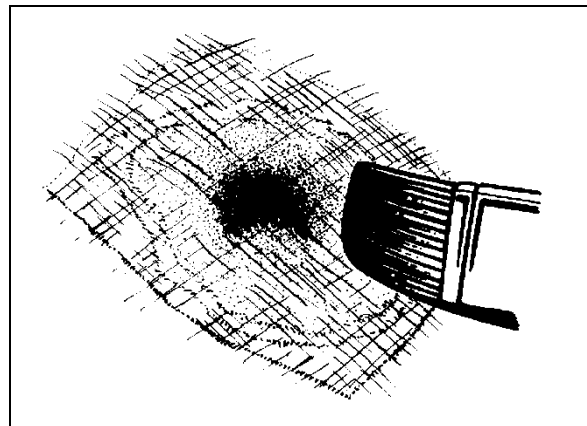

FIGURE 3: FIBERGLASS HOLE REPAIR 18090

NOTE
Remove all air between surfaces being joined. Allow area to harden and sand surface to remove any wax.

Apply another mat, followed by a cloth patch, and another mat. All layers must be thoroughly impregnated with polyester resin, brushed well and free of air. Apply more layers of mat and cloth as required until the desired strength and thickness is obtained, minimum two 1-1/2 oz (43 g) mats and one 9 oz (255 g) cloth (Figure 3).

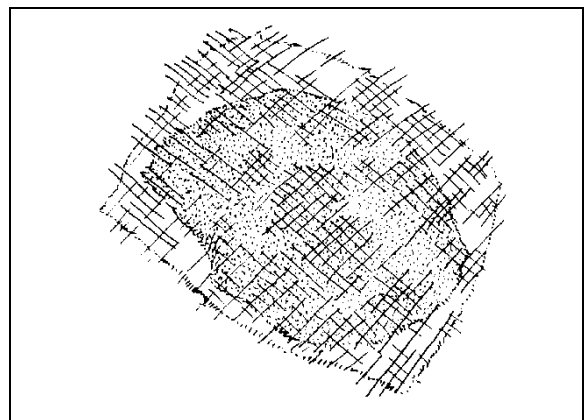

FIGURE 4: FIBERGLASS HOLE REPAIR 18091

Allow area to harden and contour the area with coarse sandpaper #100 (Figure 5).

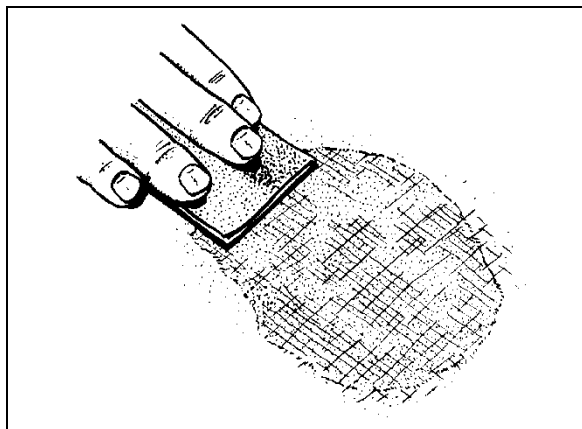

FIGURE 5: FIBERGLASS HOLE REPAIR 18092

Cover the area with a layer of resin putty and allow drying for approximately 15 to 20 minutes (Figure 6).

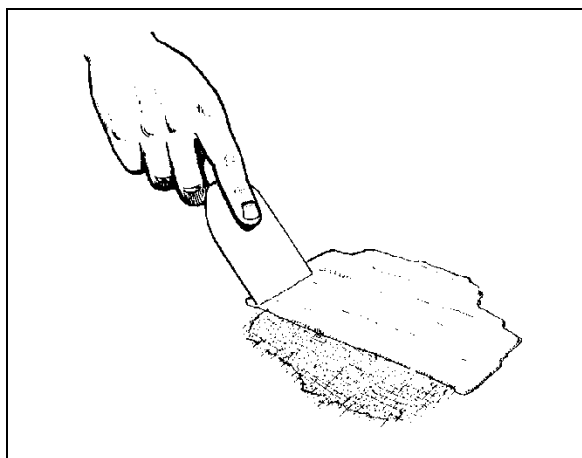

FIGURE 6: FIBERGLASS HOLE REPAIR 18093

Smooth off surface with coarse sandpaper #100 to desired shape. Further smooth surface with fine sandpaper #120 up to #600 until repaired surface matches surrounding area paneling. Prime and paint the area to match surrounding paintwork.

11. COMMON PAINTING PROCEDURE

12. NEW PAINT CARE

Our paint supplier recommends that you follow these simple precautions the first months of your new vehicle's life.



CAUTION

Apply these recommendations after repainting vehicle.

During the first 30 days:

- Do not use a commercial bus wash. Stiff brushes or sponges could mar the finish and damage the surface. Wash the vehicle by hand only and with cool water and a very mild bus wash solution. Be careful to use only a soft cloth or sponge;
- Wash vehicle in the shade, never in direct sunlight;
- Do not "dry wipe" vehicle –always use clean water. Dry wiping could scratch the finish;
- Avoid extreme heat and cold. Park vehicle in the shade whenever possible;
- Do not park under trees which drop sap or near factories with heavy smoke fallout. Tree sap and industrial fallout may mar or spot a freshly painted surface;
- Trees are also likely to attract birds. Bird droppings are highly acidic and will damage a freshly painted surface. Bird droppings, tree sap and industrial fallout should be washed off as soon as possible;
- Do not spill oil, gasoline, antifreeze, transmission fluid or windshield solvent on new finish. IMMEDIATELY rinse off any such spill with clean water, DO NOT WIPE;
- Do not drive on gravel roads. Paint finish easily chips during the first 30 days;
- Do not scrape ice or snow from the surface. A snow scraper can act like a paint scraper if the finish is new. Brush off loose material with a soft snow brush.

During the first 90 days:

- Do not wax or polish the vehicle. This will allow the finish to dry and harden completely.

13. PAINT TOUCHUP

When paint touchup or partial repainting is necessary, refer to the vehicle's paint scheme for color codes and paint brand.

Prévost recommends using the original paint brand to ease color matching.

In the event you sand through to the gelcoat surface you should prime the area with Stadox “Non Stop Fill Primer (ST-11000)”.

If you sand through to metal surface, first prime with Stadox “Etch Primer (ST-11858)” then with Stadox “Non Stop Fill Primer (ST-11000)”.

 CAUTION
Be sure to heed all paint manufacturer’s recommendations, especially concerning paint dilution and application.

14. PAINTING

The standard paint used on the exterior of the vehicle is Stadox Basislack. It is a high gloss polyurethane enamel finish designed for exposure to extreme conditions. Other types of paint may be called for as options by owner but are not dealt with in this section.

14.1 SAFETY

Care should be exercised in storing, handling, mixing, and applying paint and chemicals listed in this manual. The topcoat, primer, solvent, catalysts, accelerators, and cleaners are highly volatile and/or toxic if not properly used. Observe all safety instructions marked on the different packaging, as well as the following:

1. Do not smoke in the paint room or in adjacent area exposed to residue fumes.
2. Wear respirators approved by the governing safety and health regulations.
3. Maintain adequate ventilation at all times.
4. Dispose of any leftover paint mix properly.
5. Wear rubber gloves, rubber apron, and face shield during all phases of paint and chemical handling

14.2 SURFACE PREPARATION AND PAINT APPLICATION RECOMMENDATION

	Aluminum and / or Stainless Steel	Fiberglass	Comments
Surface Preparation	Sand using P-150 grit sandpaper. It is recommended to sandblast rivets and panel edges with OLIMAG 35-70 blast media.	Sand using P-180 or P-240 sandpaper.	Do not use paint remover over aluminum or fiberglass.
Cleaning	STANDOX silicone remover ST-16203		
Priming	STANDOX Reactive Etch Primer ST-13908 * Wait 30 minutes then apply STANDOX HS primer ST-15161	STANDOX Non-Stop Füllprimer ST-11000 (68-2973)	Refer to product Technical Data sheet for proper mixing
Basecoat	Refer to paint scheme or coach record for proper color code and paint brand. We recommend using the same paint brand to ease color matching.		Refer to product Technical Data sheet for proper mixing
Clearcoat	Axalta Imron Clear 8430 S Allow 16 hours for drying		Refer to product Technical Data sheet for proper mixing

NOTE

Product listing above is based on factory applied products. Local VOC (Volatile Organic Compound) regulations may vary, consult your paint supplier and use a VOC compliant product that matches the factory recommendations if required to do so.

15. X3-45 COACHES EXTERIOR FINISHING AND BODY REPAIR

The following procedures explain the steps to be followed for proper repair, installation and replacement for various doors, panels and windows. The paragraph divides the vehicle into zones to facilitate the search; each zone is then sub-divided into components.

Refer to the appropriate zone then component for complete procedure.

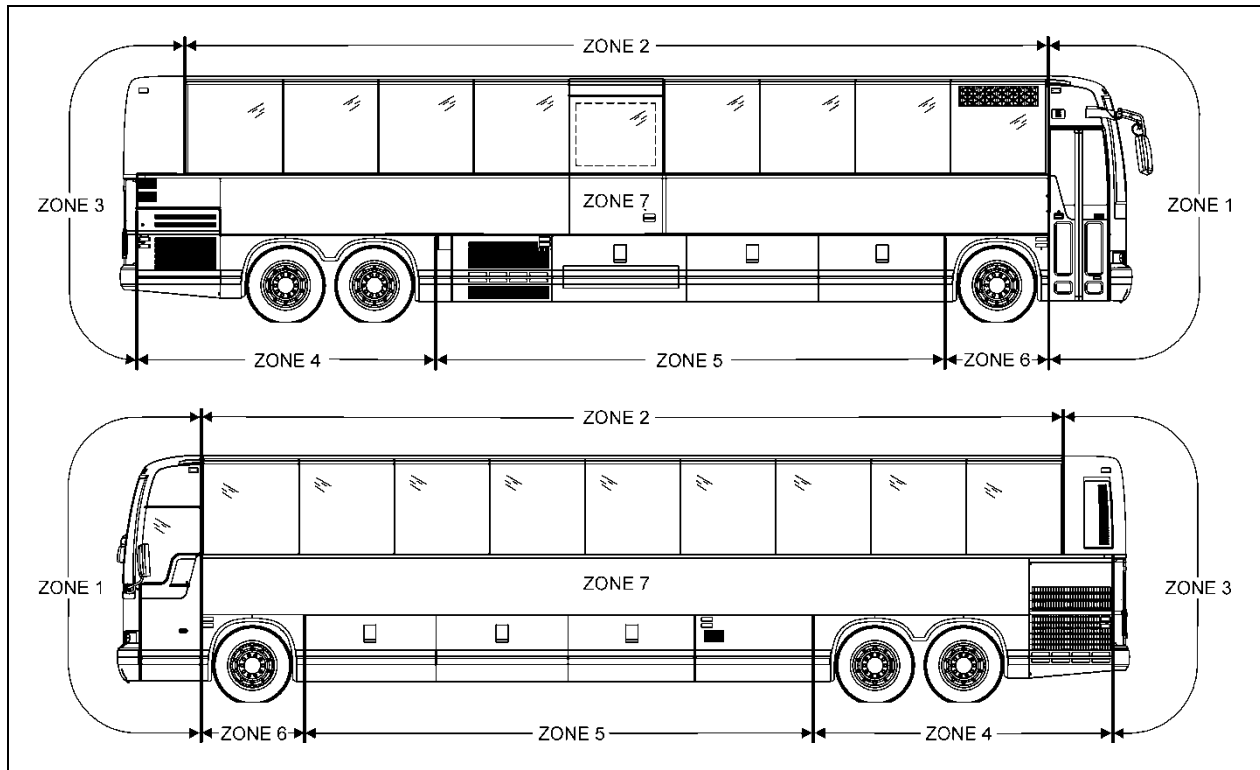

FIGURE 7: X3 SERIES COACH ZONES

18623

15.1 ZONE 1

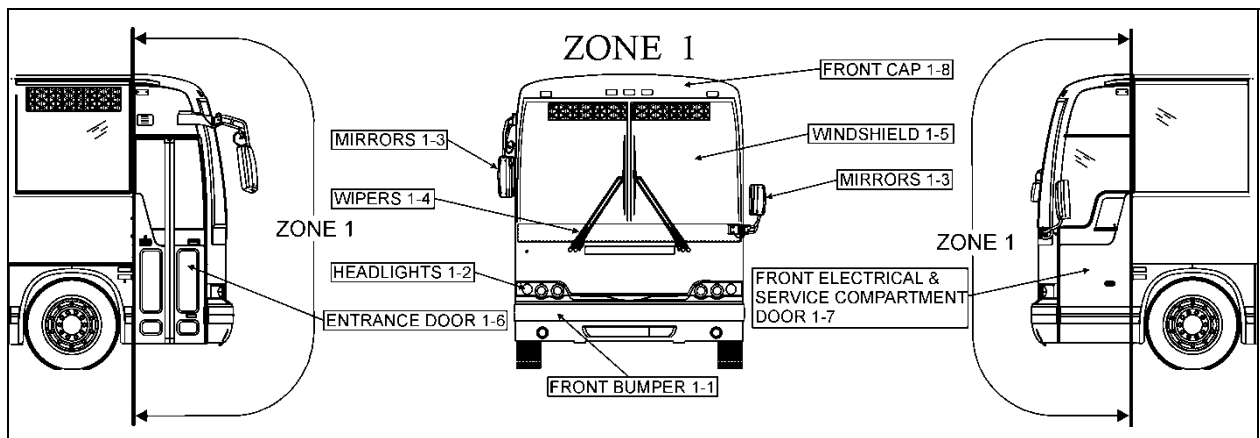

FIGURE 8: ZONE 1

18624

15.1.1 FRONT BUMPER

The front bumper is hinged to give access to the steering gear and to facilitate removal and installation. To remove the bumper, unscrew the top retaining bolts (2) and tilt down the bumper.



WARNING

Front bumper is heavy. Use proper lifting equipment to support the bumper during the removal and installation operations to avoid personal injury.

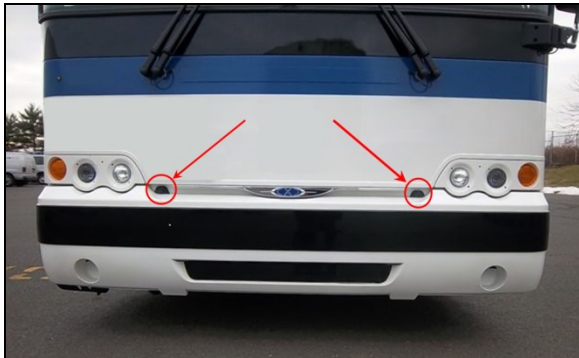

FIGURE 9: BUMPER TOP RETAINING BOLTS 18700

Disconnect both emergency air supply lines from the bumper (hoses are not pressurized).



FIGURE 10: FRONT BUMPER AIR LINES 18701

Using the spring adjustment hex nut, remove bumper spring tension until the end hook can be disconnected from the bumper bracket.

NOTE

To facilitate spring tension adjustment during re-installation, take note of the spring hook length (taken from the

adjustment nut face to the bumper bracket hole) before removal.



WARNING

Bumper spring is under heavy tension; do not pry out the spring hook without completely removing the spring tension.

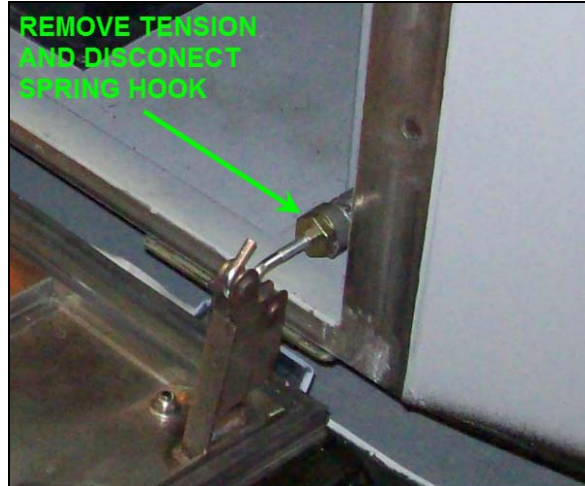

FIGURE 11: FRONT BUMPER SPRING 18702

Disconnect the bumper supporting arm.

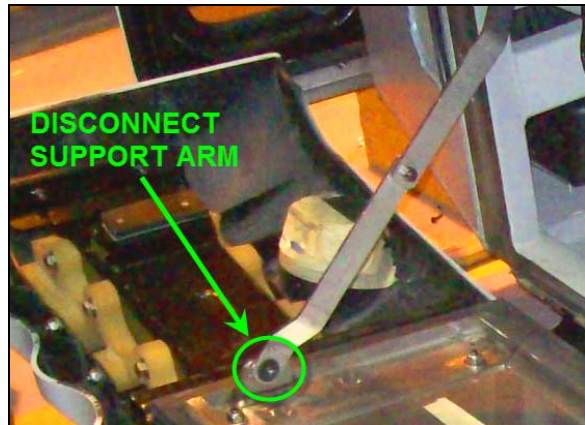

FIGURE 12: BUMPER SUPPORT ARM 18703

Unscrew the four (4) hinge bolts that secure the bumper hinges to the vehicle and remove the bumper.

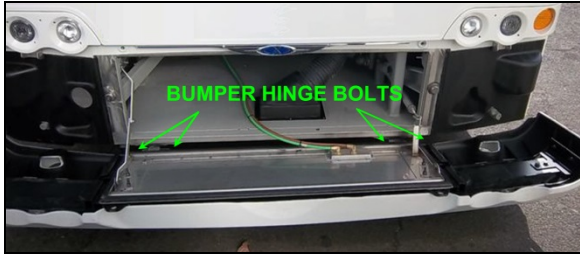

FIGURE 13: BUMPER HINGE BOLTS 18704

15.1.2 HEADLIGHTS

Refer to Paragraph Headlights, included in Section 06: Electrical of the Maintenance Manual for complete information on headlights.

15.1.3 REAR VIEW MIRRORS (ROSCO)

Your vehicle is equipped with two Rosco exterior mirrors.

The mirrors can easily be adjusted by using the remote controls located on the L.H. side control panel. The mirrors have easy to replace glass in case of breakage. Remote control motors can also be replaced.

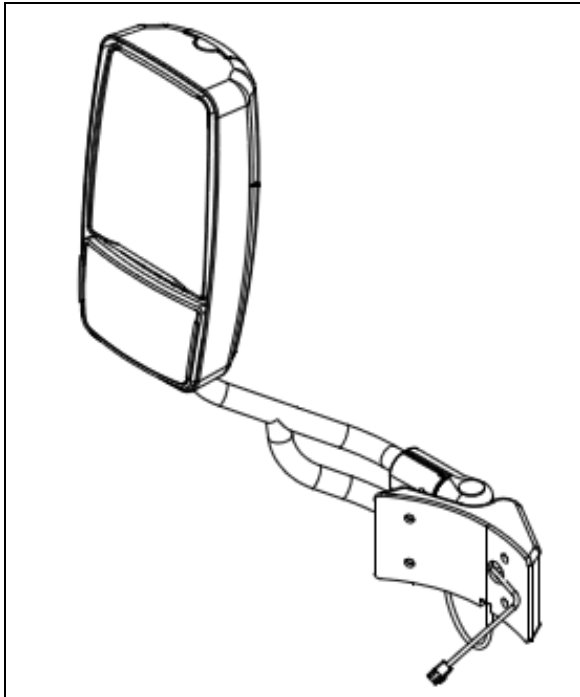

FIGURE 14: L/H REAR VIEW MIRROR (ROSCO) 18398B

- **Adjustment**

At the base of the mirror arm, loosen the mounting bolt to swing arm in or out.

To pivot the mirror head, loosen the setscrews on each side of the ball stub at the base of the mirror head to facilitate the adjustment.

- **Disassembly**

At end of mirror arm, loosen the setscrews to relieve tension on the ball stem. Remove the ball stem from the arm.

Remove the four screws fastening the mirror arm base to the coach.

- **Assembly**

Mount the mirror arm base to the coach. Insert the ball stem into the mirror arm and tighten the socket setscrews.

NOTE
Position the ball cup halves so the joint between them lies on the centerline of the arm. Ensure that the setscrews are not on the joint between the cup halves.

- **Remote Controlled Rear View Mirrors**

The remote controlled external rear view mirrors attach to support arms using a pivot collar secured by setscrews. Loosening the setscrews allows the whole head assembly to turn on the support arm for initial adjustment. A mounting bolt and washer hold the arm support to the mounting bracket. The arm support can be moved to position the mirror head into or away from the coach body.

- **Mirror Control**

The remote control pointer knob(s) for the mirrors is (are) mounted on the L.H. side control panel. The harness to the mirror head runs through the arm support. The remote motor is mounted to the mirror head behind the mirror glass.

Choose the side to be adjusted by pressing the “L” (left) or “R” (right) button on the control pad. The flat mirror is then adjusted by pressing the “upper” button and the convex mirror by pressing the “lower” button. The selected mirror can now be adjusted left to right or up and down by using the arrow keys on the control pad. The R/H side round mirror is non-adjustable.

NOTE

The mirrors heater function (HTR button and LED indicator) is optional and not connected on this vehicle.

- **Disassembly**

At end of mirror arm, loosen the setscrews to relieve tension on the ball stud. Remove the ball stud. Remove the ball stud from the arm and gently pull the harness out until the connector is exposed.

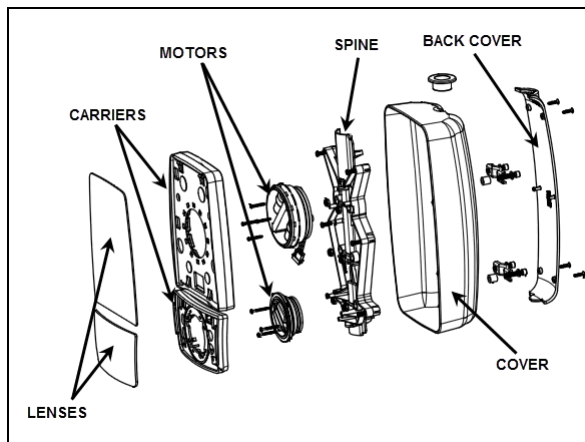

FIGURE 15: R/H OUTSIDE REAR-VIEW MIRROR 18694

Remove the four screws fastening the mirror arm base to the coach. Slide the harness free of the mirror arm base.

- **Assembly**

Attach a stiff wire (snake) to the end of the harness and insert the wire through the mirror arm base and arm, gently pull the harness through the arm and disconnect the "snake".

Connect the mirror head harness. Insert the harness connector back into the mirror arm. Insert the ball stud into the mirror arm and tighten the socket setscrews.

NOTE

Position the ball cup halves so the joint between them lies on the centerline of the arm. Ensure that the setscrews are not on the joint between the cup halves.

- **Glass removal and installation**

Using a non-metallic flat wedge, insert the edge under the over-hang tab covering the mirror glass.

Raise the wedge to spread the over-hang tab. By continuing to raise the wedge, the glass will begin to pop out.

Do not force the glass further than half an inch outward. A secondary adhesive holds the glass. This adhesive is used to cushion the glass and dampen vibration. It is soft and can be cut fairly easily.

Slide a straight edge, such as a ruler, behind the glass and make a slicing motion back and forth. The mirror glass will come free.

Remove the glass after the adhesive has been cut. Some adhesive will remain on the mirror carrier. These adhesive spots are soft and pressure sensitive. They will adhere again when the glass is reinserted.

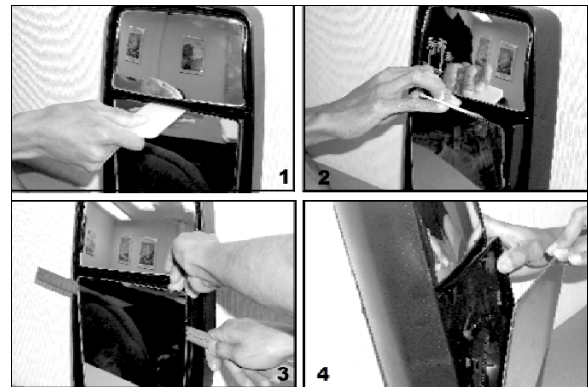

FIGURE 16: REAR VIEW MIRROR GLASS REMOVAL

To re-insert the glass, slide one side under the over-hang tab and spread the opposite over-hang tab with the wedge until the mirror glass is permitted to snap or drop in place.

15.1.4 WINDSHIELD WIPERS

Refer to Paragraph 3 WINDSHIELD WIPERS AND WASHERS, included in Section 23: Accessories of the Maintenance Manual for complete information on windshield wipers.

15.1.5 WINDSHIELD

For the removal or installation of windshield, you will need:

- A rope,
- A plastic spatula to lift the rubber seal lip,
- A metal rod or screwdriver to clean the seal groove,
- A filler insertion tool,
- Goggles and protective gloves.

- From inside of vehicle, remove center post and interior finishing panels surrounding the windshield. In this case, we are replacing the R.H. side windshield.
- From outside of vehicle, remove filler located inside rubber seal to ease damaged windshield removal.
- From inside of vehicle, push against the top L.H. side corner of windshield for the removal of a R.H. side windshield. If the L.H. side windshield had to be removed, you would have to push against the top R. H. side corner.

NOTE
We are referring to the L.H and R.H. side as viewed from the inside of the vehicle.

- At the same time, another person gradually lifts the rubber lip from the vehicle exterior using a plastic spatula from top to bottom.
- Remove the entire damaged windshield and broken glass if applicable.
- If applicable, using a screwdriver or metal rod, remove black butyl sealant residue from rubber seal then clean with Sika 205.

Windshield Installation

NOTE
Rubber seal may have to be replaced if it was used on several windshield replacements.

- Spray rubber seal with soapy water to ease windshield insertion.
- Insert rope into rubber extrusion leaving enough length at each corner to make a loop. Spray soapy water onto rope and rubber extrusion (Figure 17).
- Slide windshield into rubber seal groove starting with the bottom curved side edge. Using a plastic spatula, move the rubber seal lip aside to gradually insert the windshield into the groove.
- Spray soapy water on a regular basis to ease this operation.
- Using the same type of plastic spatula, repeat the same operation from inside of vehicle, gradually inserting the windshield into the groove.

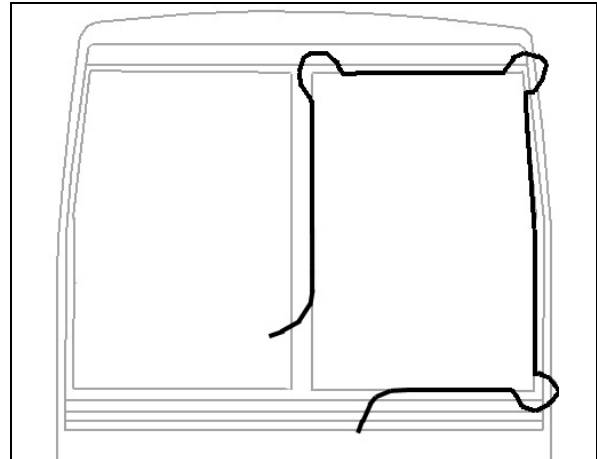

FIGURE 17: WINDSHIELD INSTALLATION USING ROPE

NOTE
Make sure windshield bottom edge is well inserted into the rubber seal groove before proceeding with the sides.

- Then, working from both sides of windshield bottom to top, gradually move the rubber seal lip aside to insert the windshield into the groove. Use also soapy water on the inside of vehicle to insert the windshield into the rubber seal groove.
- Insert the top curved corner then finish with the top of windshield.
- At the top of windshield, clean surface between fiberglass and rubber extrusion using Sika 205.
- Apply Sika 221 black between fiberglass and rubber extrusion (Figure 18).
- Spray filler and rubber seal groove generously with soapy water.
- Using the special filler insertion tool, insert the filler into the rubber seal groove.
- Gradually insert filler into the rubber seal groove ensuring to leave a 2 inch excess length at the filler extremity.
- Every 6 inches or so, it is important to compress the filler due to its tendency to contract during drying process.
- When filler insertion is almost complete, cut filler leaving ¼" of excess length to thwart filler contraction over time then insert filler into groove.

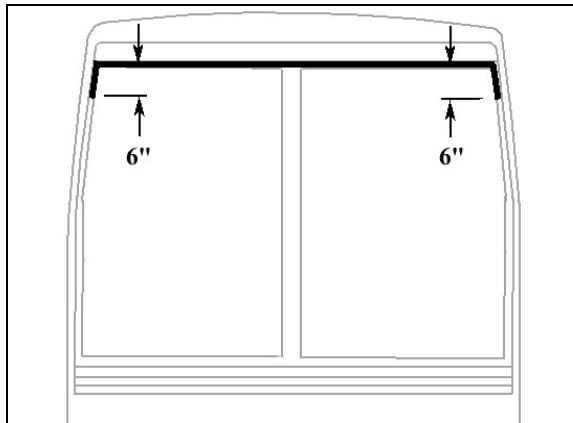

FIGURE 18: APPLICATION OF SIKA 221 BLACK

- Reinstall center post and interior finishing panels.
- Clean windshield surface of butyl residue.

15.1.6 BI-FOLD ENTRANCE DOOR

An air operated “bi-fold type” entrance door, with an air door cylinder and damper assembly installed under the right hand dash for the R.H. door panel opening. Another air door cylinder is installed behind the wall to the right of the first curb-side passengers’ seat for the L.H. door panel opening. The opening and closing door speed cycle is adjustable by a damper mounted in parallel with the R.H. door panel cylinder on the door hinge. Door activation is controlled by a panel (Figure 19), located near the defroster and wiper motors. The accessory air reservoir supplies air to this system.

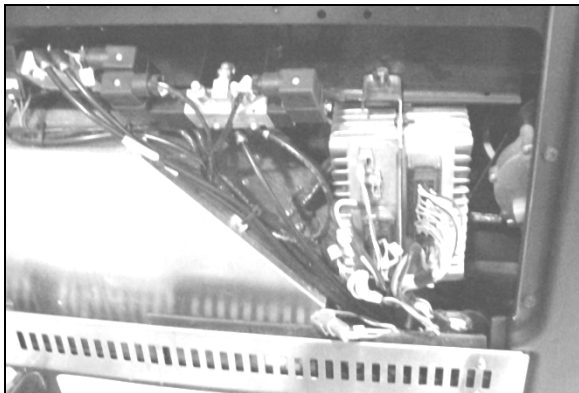

FIGURE 19: ENTRANCE DOOR & WIPER CONTROL PANEL 06619

The door is held in the closed position during coach operation by a two air cylinder locking mechanisms (Figure 20).

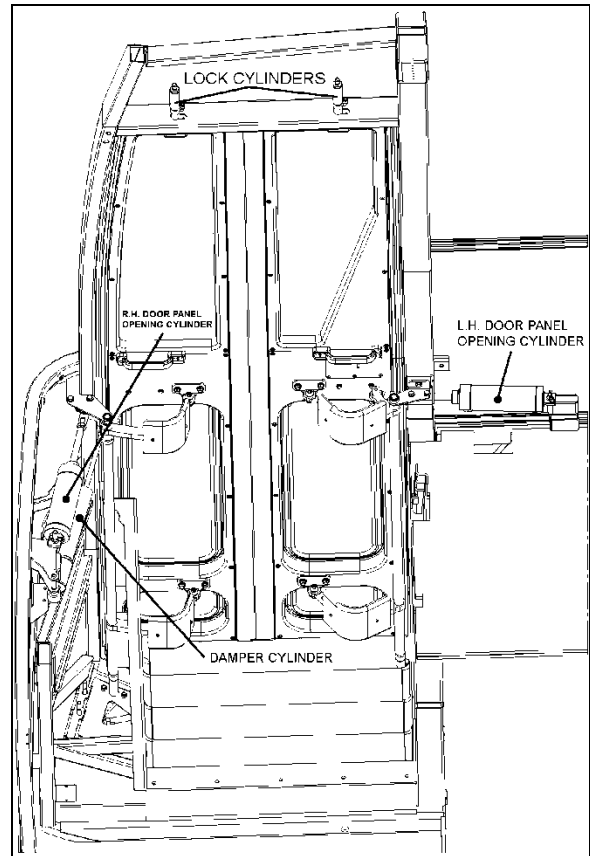

FIGURE 20: ENTRANCE DOOR - VIEW FROM INSIDE

Air cylinders with return spring in the cylinder body are used. Air cylinders are controlled by an electrically operated solenoid valve energized by a multiplex module located under the right hand dashboard.

To open the door, initial action from multiplex module output energizes the air lock solenoid valve, venting the door locking cylinders. The return locking spring pulls the door lock away from the latch, unlocking the door. Door movement starts only when pressure in the central air door lock is below 10 psi. The “air cylinder open solenoid valve” opens and allows air to flow to the door cylinders, “the air cylinder close solenoid valve” exhausts air from the rod side of the cylinders.

To close the door, initial movement of the switch energizes the “air cylinder close solenoid valve” and air flows to the cylinders by their rod side ports. The “air cylinder open solenoid valve” exhausts air from cylinders. When the sensor signals the door as closed, the air lock solenoid valve is de-energized and loads the door lock cylinders. The cylinder moves the door lock in a

position which engages a latch on the entrance door, holding the door positively closed.

Emergency exit valve, which opens the air valve circuit should be used only in emergencies, or when the door control system does not function properly.

Refer to the air system schematic diagram and to page 29.1 of the wiring diagram.

• **Operation**

Lock or unlock the bi-fold entrance door from outside the vehicle by turning the key in the door lock (counterclockwise to lock, clockwise to unlock). The entrance door can be unlocked from the inside using the small lever located on the door.

The air-operated door is controlled from inside the coach by two push-button switches located on the R.H. dashboard.

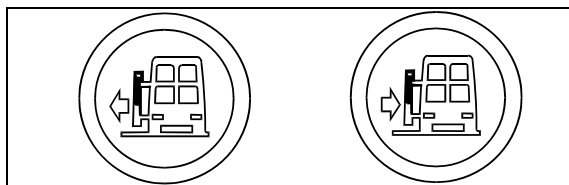

FIGURE 21: ENTRANCE DOOR OPERATING BUTTONS
06464

From the inside, open the door by pressing the door opening switch (L.H. button) on the R.H. dashboard panel. The door will open to full open position within 5 seconds.

Close by pressing and holding the door closing switch (R.H. button) on the dashboard. If the closing switch is released before the door is fully closed, the door will stop in that position.

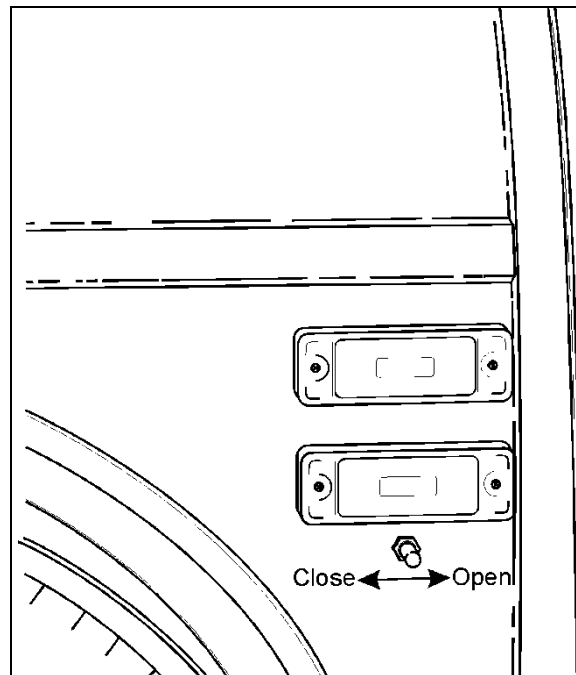

FIGURE 22: ENTRANCE DOOR CONTROL SWITCH 18599

Opening and closing of the door from outside the coach is accomplished by a momentary toggle switch located under the front R.H. side marker light (Figure 22).

To close the door, the switch must be pushed towards the rear of the coach and held in position until the door has completed its movement. The door can be closed to any position by releasing the switch (or button, if inside) when the desired position is attained. However, the door is not locked in any position other than fully closed. The door can then be closed further by pushing or pulling on the door.

To open the door, the switch must be pushed towards the front of the coach and held in position. When the door reaches the fully opened position, the system will keep pressure in the cylinder locking the door in that position.

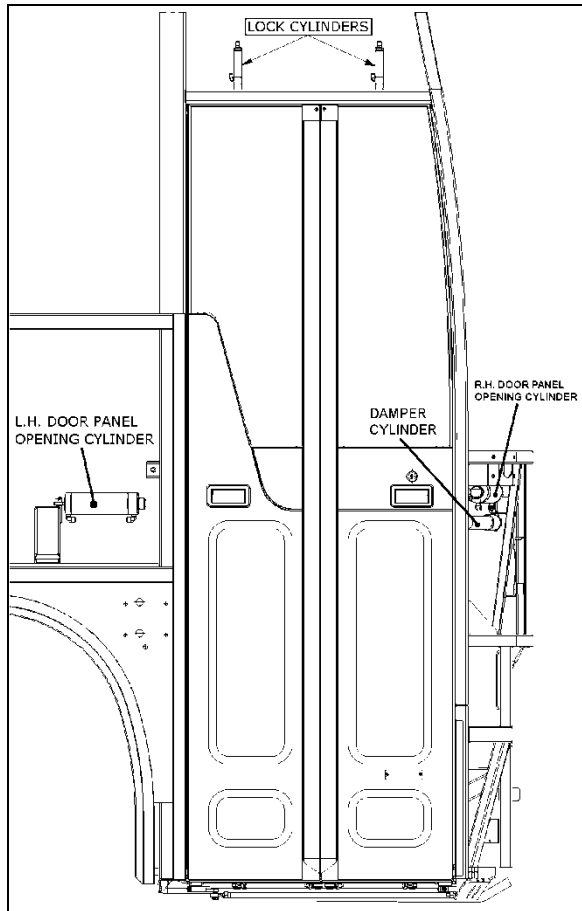

FIGURE 23: ENTRANCE DOOR - VIEW FROM OUTSIDE

- **Emergency Exit Valves**

From inside the vehicle, an emergency exit valve located on the dashboard R.H. side near the entrance door, releases the pressure from the lock cylinders. From the exterior, an emergency exit valve located in the front service compartment, also releases the air from the lock cylinders.

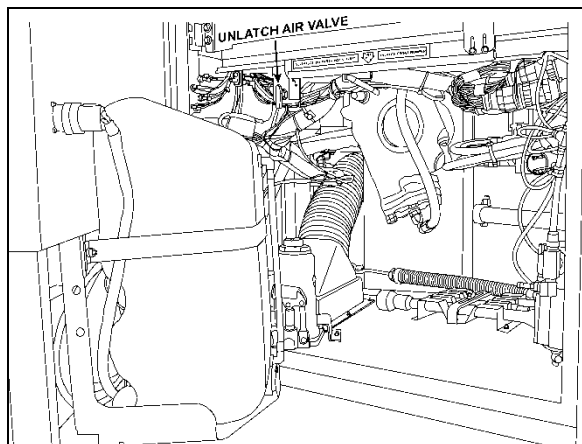

FIGURE 24: EXTERIOR UNLATCH AIR VALVE 12209

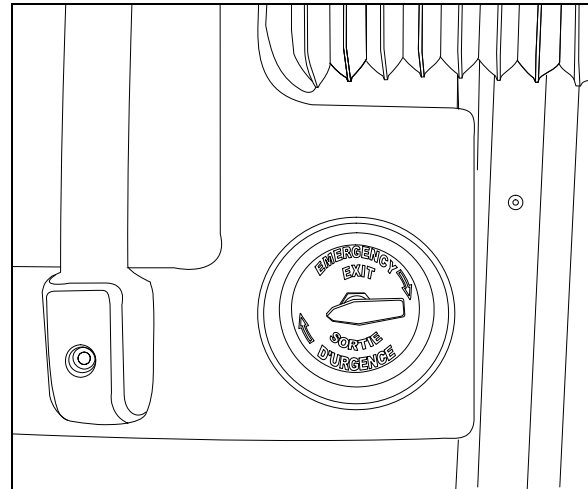

FIGURE 25: INTERIOR UNLATCH AIR VALVE 18330

Without Air and/or Without Electricity

If the air pressure drops while the coach has or hasn't any electricity, the spring loaded cylinders will unlatch the door. In such a case, unlock the door by moving the lever on the door or by using the key, then open the door manually.

With Air but Without Electricity

From inside the vehicle, turn the emergency exit valve to the "UNLOCK" position. Move the lever. From the exterior, turn the emergency exit valve to the "UNLOCK" position. Open the door. Close it, lock with the key and reset the outside emergency exit valve to the "NORMAL" position.

- **Door Cycle Speed Adjustment**

To do any adjustment, remove the panels located next to the R.H door panel hinges.



CAUTION

It is important to make sure that damper does not reach end of stroke when bi-fold entrance door is completely closed or opened. The door cylinders must stop the door on opening. Screw or unscrew rod end to adjust if necessary.

To adjust opening and closing cycle speed on damper (Figure 26):

1. Remove the damper from the vehicle and hold it vertically with the lower eye or pin attachment in a vice. Use clamp plates to prevent damage.

2. Fully close the damper while turning the dust cap or piston rod slowly CCW until it is felt that the cams of the adjusting nut engage in the recesses of the foot valve assembly (Figure 26).

NOTE
 In figure 23, if there is an indentation (B) in the dust cap (C) and the cover shows two holes (A), the damper is fitted with a bump rubber (D). If so, fully extend the damper and insert a round bar or screwdriver through the holes. Push the bump rubber down and remove. Remove the split plastic collar (E) (if fitted) from the piston rod.

3. The damper may have already been adjusted. Therefore check whether the damper is adjusted or not by keeping it closed and gently turning further CCW, counting at the same time the half-turns until a stop is felt. Stop turning and do not force.
4. While keeping the damper closed, make two CW half-turns. In case of prior adjustment, add the number of half-turns previously counted. The total range is about five half-turns. Pull the damper out vertically without turning for at least 3/8" (1cm) to disengage the adjusting mechanism. The dust cap or piston rod may now be turned freely.
5. The damper can now be refitted in the vehicle.

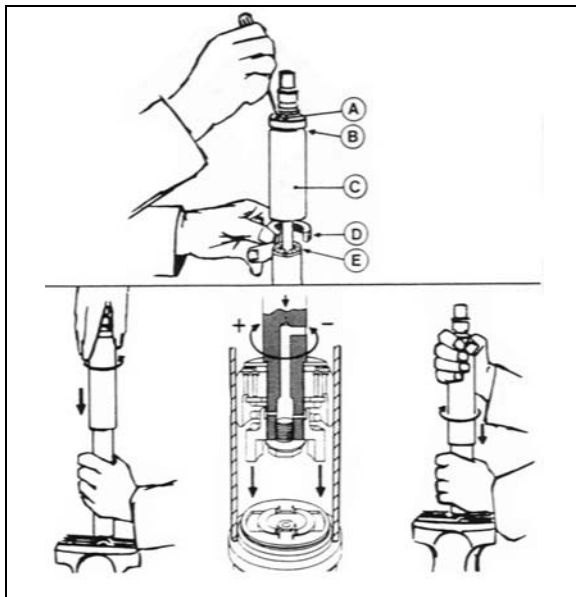

FIGURE 26: DAMPER 18643

NOTE
 Where a bump rubber was installed, refit same inside the dust cap and by fully closing the damper, the rubber will seat again at top of the dust cap. Refit the split plastic collar E (Figure 26).

6. Reinstall panels and R.H. entrance door panel hinge cover.

• **Entrance Door Panel Adjustments**

Before attempting to correct any bi-fold entrance door operating problem by adjusting any part of the air cylinder assembly, first perform the following mechanical checks and procedure.

Check around the perimeter of the door for binding. If any binding is found, adjust as follows:

- o Horizontal and vertical adjustment
1. Support the door panel with a wooden block and a hydraulic jack.
 2. Unfasten the bolts fixing the door panel plates. See figure 24

NOTE
 Ask an assistant to help you to perform the following adjustments.

3. Adjust the door horizontally and vertically with the jack. Tighten the bolts. Remove the jack and the wooden block.

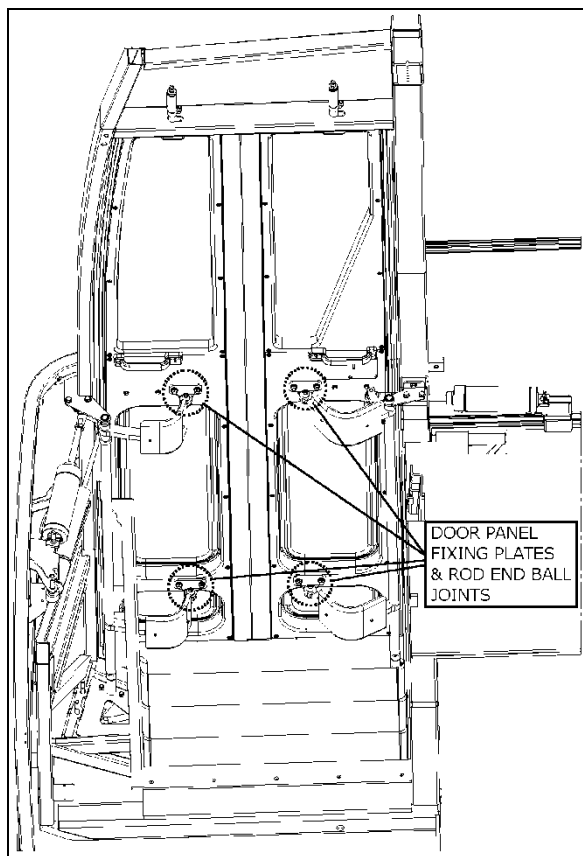

FIGURE 27: DOOR PANEL ADJUSTMENTS

- Depth adjustment
1. Support the door panel with a wooden block and a hydraulic jack.
 2. Unfasten and then disconnect rod ends from door panel fixing plates. Screw or unscrew rod end in order to adjust door panel depth.
 3. Tighten the bolts. Remove the jack and the wooden block

15.1.7 FRONT ELECTRICAL & SERVICE COMPARTMENT DOOR

• Body Panel and Window

For the removal of front electrical & service compartment door body panel, you will need:

Pneumatic “Zip gun” type tool;

Razor sharp window scraper;

- Open service door.
- Remove interior finishing panels to access rub rail fixing bolts, then remove rub rail.
- Remove windshield washer reservoir, door lock and power window connector.

- Using the “Zip Gun”, cut Sika bead located ¼ inch (7-8 mm) from each body panel edge.

NOTE

Wear ear plugs during this operation.

- Separate body panel from door.
- Using a razor sharp window scraper, remove from door frame Sika bead and double-face self adhesive tape residue.
- Clean door frame using anti-silicone.
- Using a scratch pad “Scotch Brite”, scratch the perimeter of the door frame where the adhesive will be applied.
- Clean door frame again using anti-silicone.
- Apply some Sika 206 G+P onto door frame.

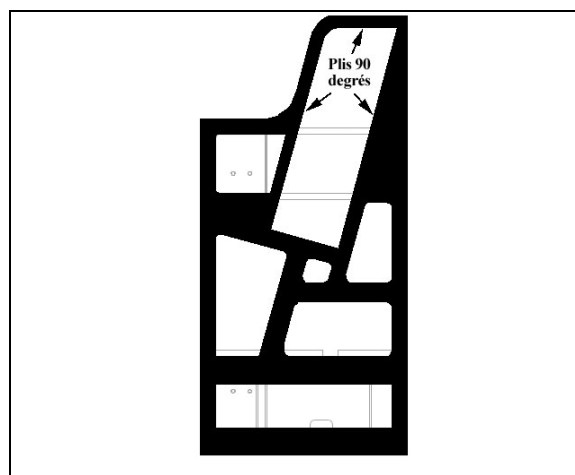

- Prepare new body panel using a scratch pad “Scotch Brite”.
- Use a tack cloth to remove any dust or residue from the body panel surface.
- Clean body panel using anti-silicone.
- Apply some Sika 206 G+P onto body panel.

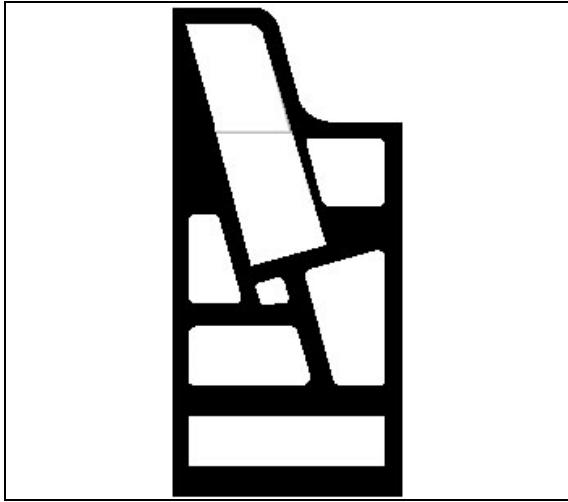

- Apply an even coat of Sika 255 onto the door frame.

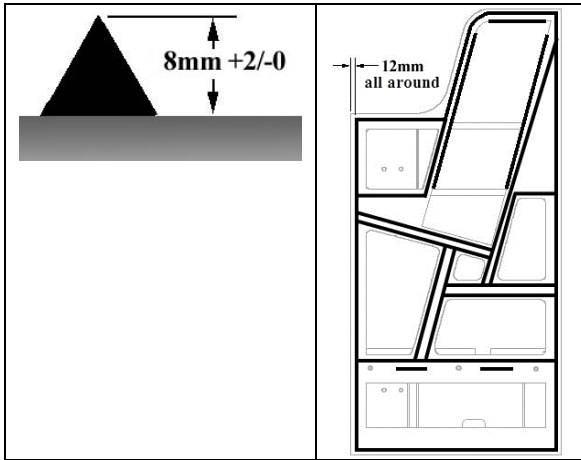

- Position body panel onto door frame and compress with your hands. Use a ruler.

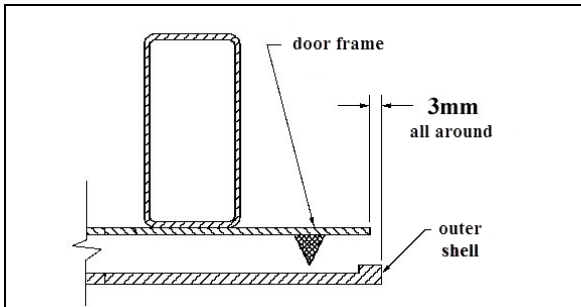

- Check body panel flatness using a 2-foot ruler (must be within 2mm).



- Check proper power window sliding inside window frame.
- If applicable, remove excess of Sika adhesive all around door frame using Sika 208.
- From the inside of the door, apply some Sika 221 between door body panel and frame and on welding spots as per figure.

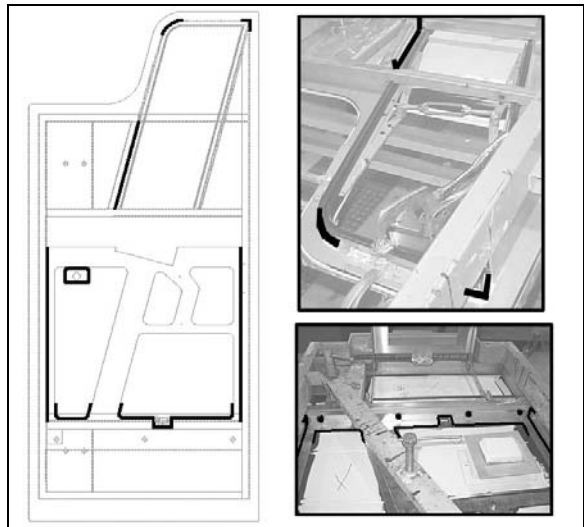

- Apply some #680066 glue inside fiber glass groove and fix power window wiper.

NOTE
Anti-friction side must be on glass side.

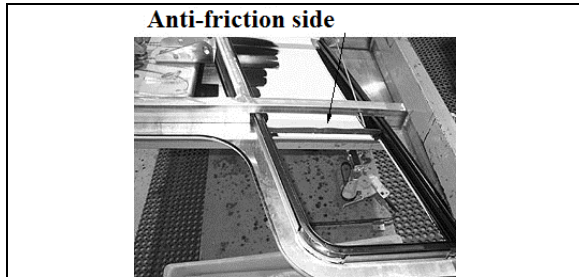

- From inside the door, apply some Sika 252 at the corners of window wiper.

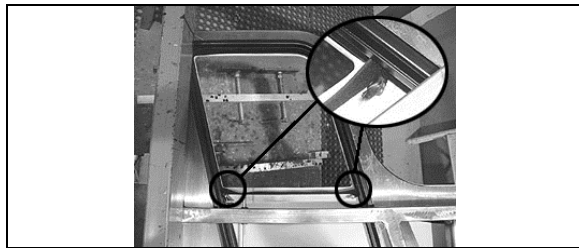

- Apply some #680066 glue inside finishing panel groove and fix power window wiper.

NOTE

Anti-friction side must be on glass side.

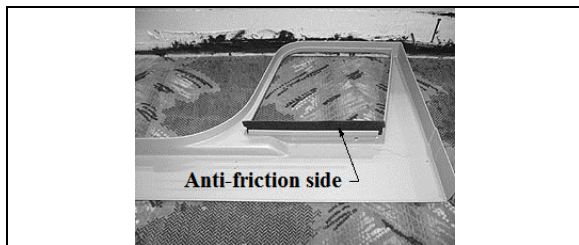

- Discard waste according to applicable environmental regulations, use dangerous waste containers.

Electrical Power Window

- Insert 2 seals in the window frame.
- Apply some #680066 glue at the intersection of the 2 seals and also sparingly in order to fix the seal to the window frame.

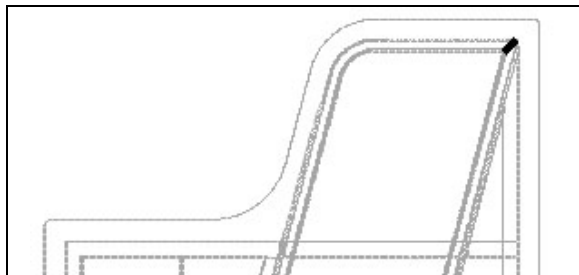

- Clean window using window cleaner.

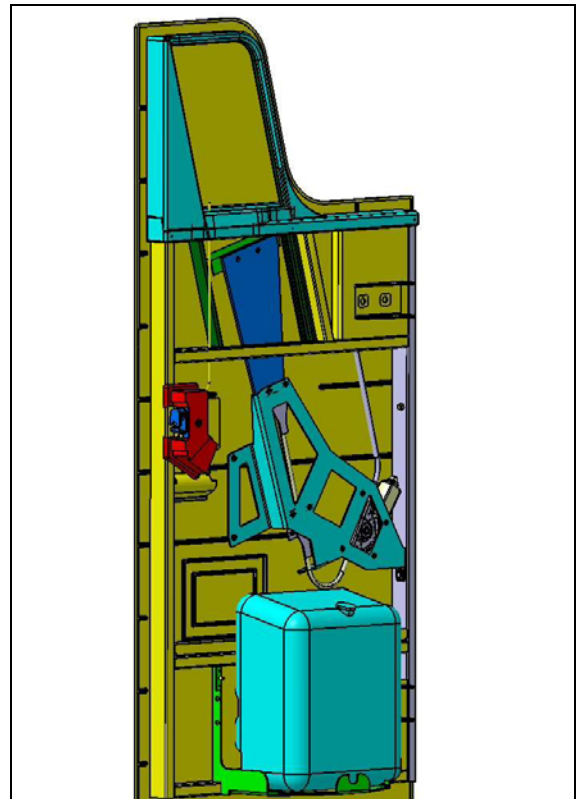

- Insert window into frame.
- Secure window pane to raising mechanism.
- Adjust window travel ($6\pm 3\text{mm}$ above window wiper).

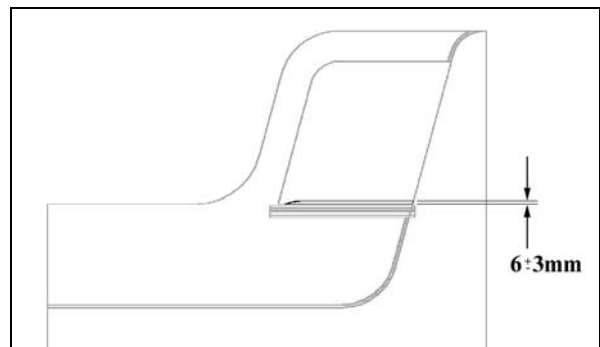

Driver's Window Gutter

- Dry fit the gutter on the vehicle. If required, straighten up gutter using a hammer and a wooden block.

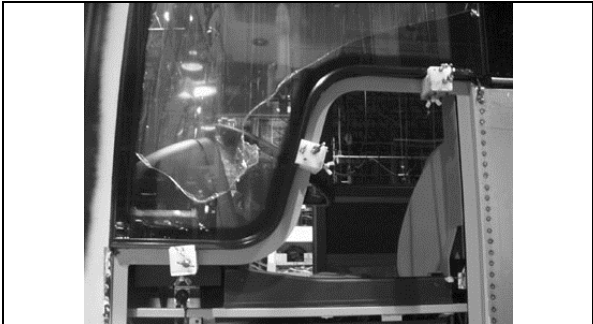
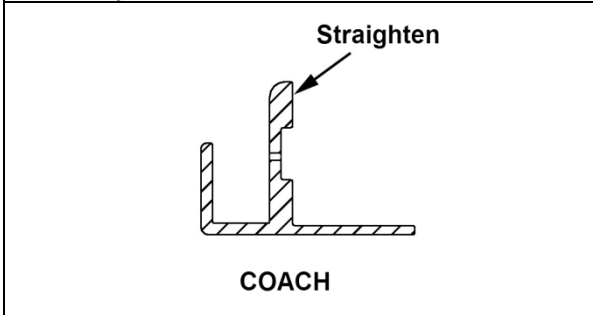

15.1.8 FRONT CAP

The fiberglass front cap does not need any maintenance except painting as needed. It is held in place with adhesive. If ever it has to be replaced, make an appointment at a Prévost service center near you. For minor damages, refer to section 4 "Fiberglass Repair" and section 5 "Painting".

- If applicable, remove plastic film at the bottom of driver's window.
- Remove excess of Sika underneath driver's window.
- Clean bottom of driver's window using window cleaner.
- Apply Sika Aktivator at the bottom of driver's window.
- Install gutter under driver's window then compress in order to fix double face self-adhesive tape.
- Install 3 clamps and allow curing for 4 hours.

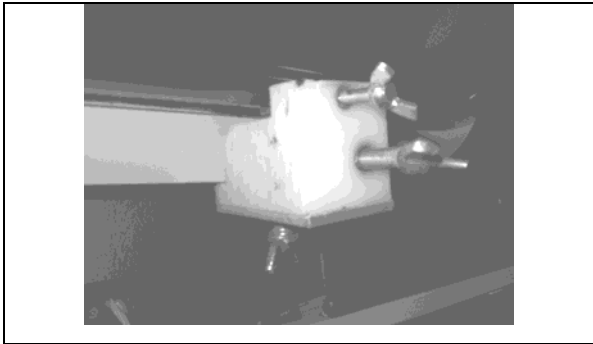

15.2 ZONE 2

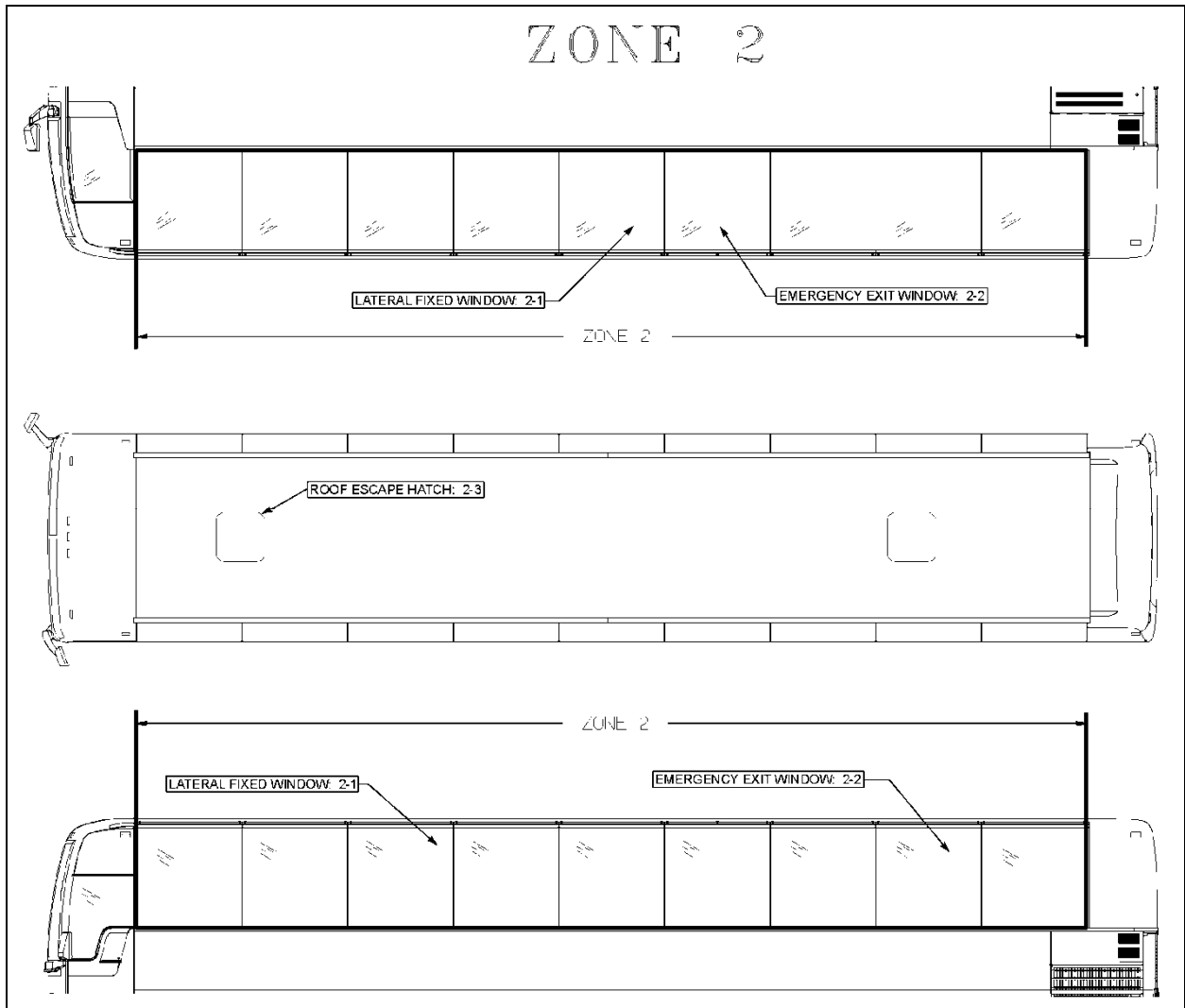

FIGURE 28: ZONE 2

18625

15.2.1 LATERAL FIXED WINDOW

Nine passenger side windows are provided on each side on X3-45. They are made of fixed, single or double-glazed, heat absorbing AS-3 glass. Windows are mounted in painted aluminum extrusions, which hold the glass in place from the top rail of the coach. The extrusion also serves as a hinge to allow the window to swing open when needed. The single-glazed windows are made of tinted tempered safety glass, while the double-glazed windows are made of tinted tempered safety glass outside and clear tempered glass inside.

For fixed side window removal or installation, you will need:

- Hammer or;
- Drill equipped with a sharp pointed rod into which a small hole was drilled;
- Braided windshield wire and a pair of handles;
- Gloves, goggles or face shield.

• Fixed Window Removal

Method A

- Apply a sticky plastic film onto window outside surface (thermos) and break window. For single pane, apply a sticky plastic film on both sides of window.

Method B

- Using a drill equipped with the special sharp pointed rod, drill through the window seal into one of the bottom corners, from a 30° angle with reference to the vehicle.
- This procedure requires accuracy and it is possible not to succeed on the first attempt. From the inside of vehicle, a second person ensures the rod passes through.
- Remove the rod, thread the wire into the small hole. Reinsert the rod and the wire into the hole far enough so that the person inside the vehicle can pull the rod using a pair of pliers.
- Attach the wire ends to the specially designed handles.
- Pull in turn from the inside and the outside of vehicle to gradually cut the Sika bead on the window perimeter.

- When you reach top corner, detach wire from the outside handle, secure it to a fish wire or rod and thread it underneath the aluminum molding behind the rivets.
- Detach wire from fish wire and continue cutting using the handle.
- Cut Sika bead until you come back to starting point, then you can remove the window by carefully pushing it out from the inside of vehicle.

• Preparation of Structure and Installation of Window

Preparation of Structure

- Remove old Sika adhesive.
- If primer was removed at the same time than Sika, perform the following steps:
 - * Clean using anti-silicone.
 - * Remove from structure old primer using a sander (120-150 grit).
 - * Clean again using anti-silicone.
 - * Apply 206 G+P primer.
- Reactivate 206 G+P primer.

Installation of Window

- Use window cleaner around window interior perimeter and edges to remove any oily film while inspecting for damages.
- Apply Sika Aktivator.
- Using a triangular nozzle (20mm X 10mm), apply Sika Ultrafast II onto structure.

NOTE
You only have 8 minutes to install window once the SIKA ULTRAFAST II product is applied.

- Install window.

 **CAUTION**
 To prevent damaging the Sika joint, do not raise the window once it as touched the bead.

- Before compressing window against Sika joint, install two stops into the aluminum extrusion one inch from each window edge.

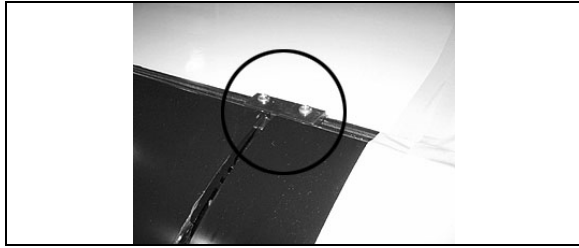

- Verify window alignment with reference to adjacent surfaces.
- Vehicle must remain stationary for 30 minutes at more than 23°C.

15.2.2 EMERGENCY EXIT WINDOWS

Three of the windows on curb side of the X3-45 serve as emergency exits, while there are four on driver's side. See figure 28. With the exception of the top window edge, the glass edges are unprotected. Be exceptionally careful when manipulating or installing such windows.

When it becomes necessary to lay down the unprotected edges of the glass window, never use a steel or concrete floor support. It is recommended to use a wooden support or a padded surface.

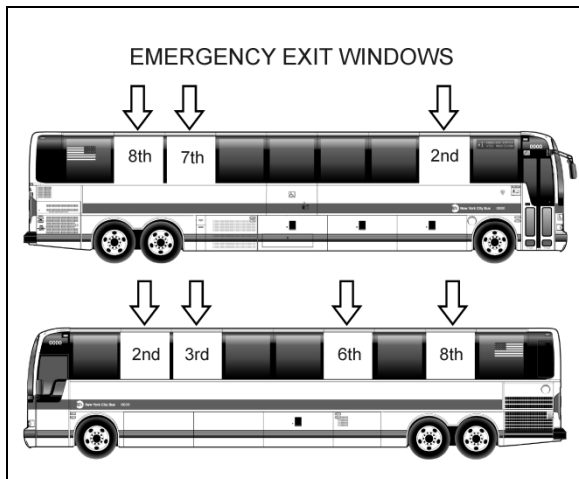

FIGURE 29: X3-45 COMMUTER 18617

An emergency exit window can be opened by pulling the lower part of the release bar to disengage the safety latches, and then by pushing out the window frame (Figure 30).

Emergency operating instructions are affixed under each emergency exit window. To close the window, pull back the window and push down the release bar.

- **Emergency Exit Release Bar**

The emergency exit release bar system is generally maintenance free. It has been designed to answer the twenty pound resistance criteria for opening the emergency window. If this handle should be replaced:

1. Remove the screws and bolts securing it to the emergency exit window;
2. Install a new release bar, reverse the procedure.

NOTE

Check the legal twenty pound maximum resistance to be sure to comply with regulations.

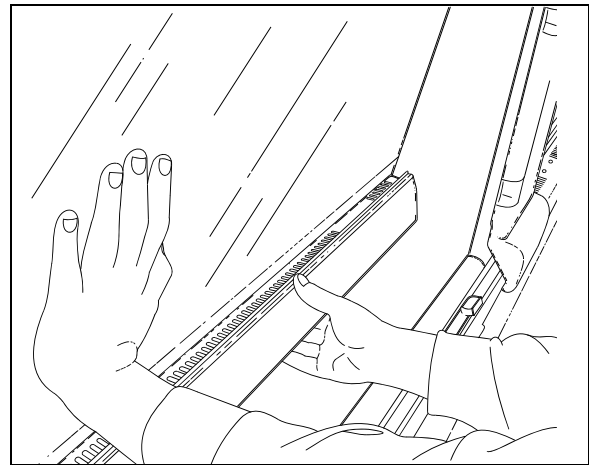

FIGURE 30: EMERGENCY EXIT WINDOW 18008

- **Emergency Exit Window Adjustment**

Emergency exit windows should be checked periodically for easy opening and closing. Pulling the lower part of the release bar with both hands placed near the safety latches should disengage both locks on the window simultaneously. The tension required to release the window should not exceed twenty pounds (9 kg) of force.

The release bar mechanism itself has been designed such as no adjustments are necessary.

If too much effort is required to disengage the locks when pulling the release bar or if the window doesn't close tightly or rattles, check for interference by foreign objects or nearby parts into mechanism, such as rubber seal, wires, etc. Correct situation immediately.

NOTE

Tangs on the lock must be in a horizontal

position.

• **Emergency Exit Window Replacement**

1. Lift the bar release system;
2. Remove the stop blocks from the top exterior of the window.
3. Push the glass window out ninety degrees (90°).

 WARNING
The window may fall out.

4. The window is free and can be unhooked.
- Reverse the procedure to install a new emergency exit window.

15.2.3 ROOF ESCAPE HATCH

The vehicle is equipped with two escape hatches. The escape hatches are designed to provide years of reliable service with a minimum of maintenance. All components are rust proof, and moving parts are Teflon coated to eliminate need for lubrication. Should water infiltrate the vehicle from the escape hatch, refer to the heading "Sealing" in this paragraph for procedures on how to seal this area.

 CAUTION
Use of lubricants, paints, or other coatings such as graffiti deterring sprays is not recommended.

Suggested maintenance includes periodic inspection of fasteners for evidence of loosening due to tampering, and regular cleaning with mild soap and water.

Although there are other cleaning solutions available, some contain solvents and other chemicals that can attack the high strength materials used in the production of the escape hatch.

 CAUTION
Ensure that cleaning solutions are compatible with the materials used on the escape hatch.

Graffiti removing cleaners often contain acetone, ether, lacquer thinner or other solvents known to

destroy the high strength properties of many plastics. Use of these cleaners must be avoided. Graffiti-resisting coatings often leave a sticky residue that interferes with smooth up/down movement of the hatch mechanism. Some of these coatings also contain solvents that will reduce the strength of certain components.

 CAUTION
Use of these coatings is at considerable risk and should be avoided.

• **Repair**

All components used in the production of the escape hatch are available as service parts, except for one hinge that represents a possible hazard when improperly reattached to a hidden tapping plate, itself often damaged whenever the hinge is damaged. The tapping plate is permanently laminated between the inner and outer cover assemblies, and it cannot be inspected or replaced. It is therefore necessary to replace the entire assembly following damage to the hinge. See figure 30.

 CAUTION
Hinge assembly is critical and hinge should never be removed from cover assembly. Fasteners used in this assembly are special and have critical torque requirements and tamper-resistant heads to discourage tampering.

• **Sealing**

1. Open and tilt up the escape hatch cover.
2. Join the 2 ends of the rubber seal.

 CAUTION
Seal joint should be toward rear of vehicle.

3. Apply rubber adhesive CA-40 (Prévost # 681285) in the gap between the seal ends.
4. Apply Sikaflex 221 sealant (Prévost # 680532) along the outline of the escape hatch on the roof of vehicle.

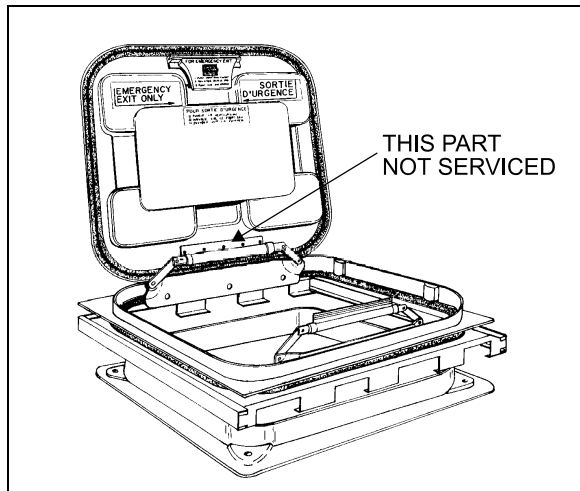

FIGURE 31: ESCAPE HATCH

18104

• Escape Hatch Panel Assembly

The frame of the escape hatch is riveted to the roof of the vehicle. The escape hatch panel assembly can be replaced as a unit and a new panel assembly installed in the existing frame. To remove the panel assembly, remove the 4 bolts fastening the 2 hinges to the escape hatch frame and retain the 4 flat washers. Reinstall the panel assembly by fastening the 2 hinges with the 4 bolts and flat washers removed earlier.

• Escape Hatch Frame

When necessary, the escape hatch frame can be removed and replaced in the following way:

1. Support the frame from inside the vehicle.
2. Remove rivets.
3. Cut the rubber seal with a sharp edge knife and remove the hatch frame.
4. On vehicle top, using the knife, remove as much as possible the remaining rubber seal.
5. Drill holes (if needed) in the new metal frame.
6. Clean both vehicle top and new hatch frame with SIKA 205.
7. Apply rubber adhesive SIKA 221 under the hatch frame surface.
8. Install the frame in place and fix it with rivets.
9. Remove excess adhesive and clean all around.



CAUTION

When installing, roof escape hatch's hinge must be toward the front of vehicle, to prevent the hatch from being ripped out if accidentally opened while vehicle is running.

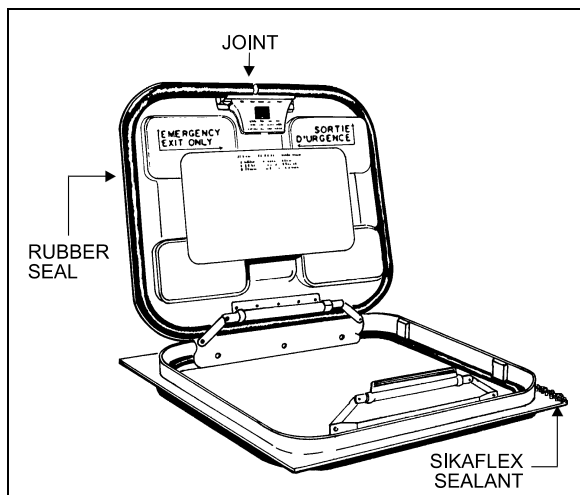

FIGURE 32: ESCAPE HATCH

18105

15.3 ZONE 3

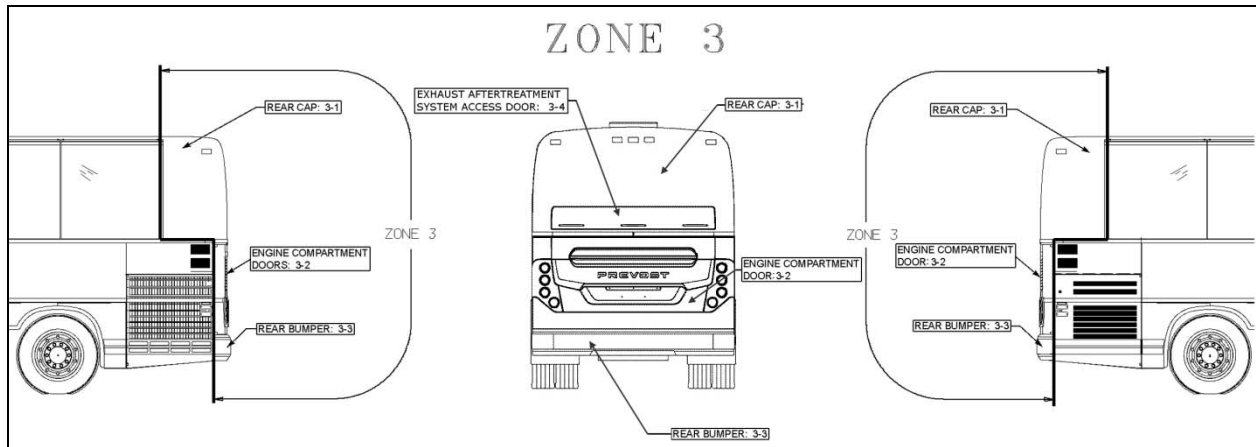

FIGURE 33: ZONE 3

18626

15.3.1 REAR CAP

The fiberglass rear cap does not need any maintenance except painting as needed. If ever it has to be replaced, make an appointment at a Prévost service center near you. For minor damages, refer to Paragraph 4 "Common Fiberglass Repair Procedure" and Paragraph 5 "Common Painting Procedure".

15.3.2 ENGINE COMPARTMENT DOOR

The engine compartment door may be adjusted for proper fit by untightening support bolts:

NOTE

Consult the "BODY PANEL AND WINDOW SPACING DIAGRAM" for proper door gaps adjustment. (Figure 51 Page 61 of this section)

1. To adjust the door VERTICAL position, loosen the bolts (4 on each side) holding the door supporting arm and gas springs bracket to the vehicle structure (Figure 34).
2. To adjust the door LATERAL position, loosen the 3 bolts on the right side bracket holding two of the door supporting arm and gas springs bracket to the door (Figure 34).
3. Adjust the door FORE & AFT position by screwing/unscrewing the rubber door stops on each side of the door opening (Figure 34).
4. Check that the door swings freely and close properly. *It may be necessary to adjust the door latch to get proper fit and operation.*

To adjust the latch mechanism and the striker pin:

1. Open the door to access the striker pin.
2. Slightly loosen the striker pin.
3. Using a hammer, adjust the striker pin to center it in the door latch mechanism.
4. Tighten the striker pin.
5. Check door fit and operation.

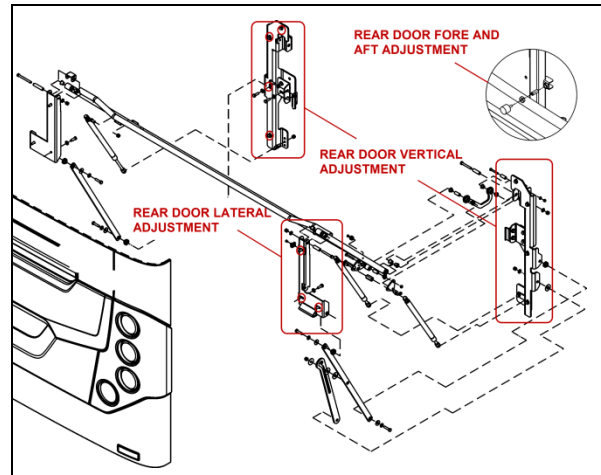

FIGURE 34: ENGINE COMPARTMENT DOOR

18633_1

15.3.3 REAR BUMPER

Remove three bolts on each side holding bumper to vehicle and remove bumper.

To install bumper, reverse the procedure.

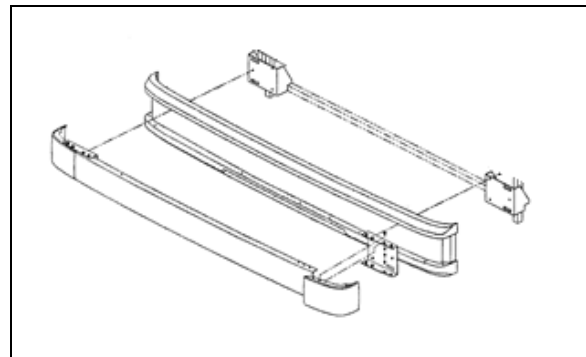

FIGURE 35: REAR BUMPER

18634

15.3.4 EXHAUST AFTERTREATMENT SYSTEM ACCESS DOOR

1. Open exhaust aftertreatment system access door.
2. Loosen the screws holding the panel to hinge assembly.
3. Adjust the door position according to distance required between exterior finishing parts.
4. Tighten the nuts.
5. Check that the door swings freely and closes properly.

15.4 ZONE 4

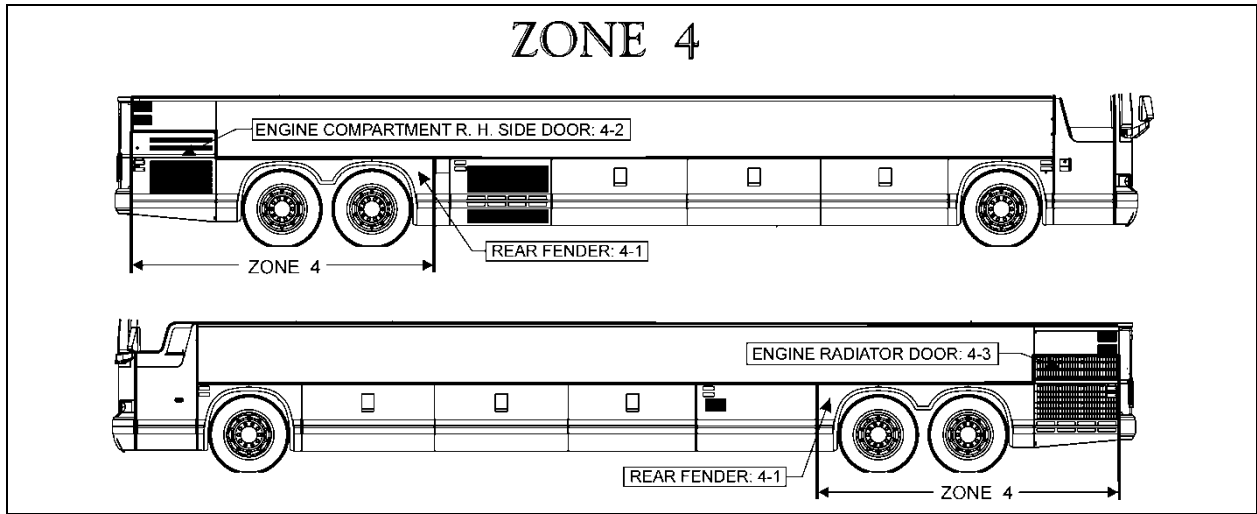

FIGURE 36: ZONE 4

18627

15.4.1 REAR FENDER

On the "X3" series vehicle, rear fenders are hinged for maintenance on brakes and suspension. Each rear fender panel has two mechanical spring loaded holding devices fixing it to the vehicle's structure. Push the spring type rod sideways to disengage the lock.

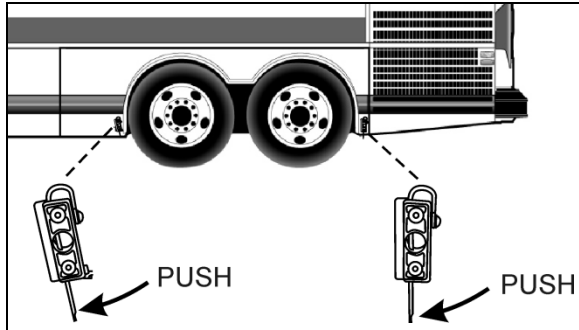

FIGURE 37: LEFT REAR FENDER

15.4.2 ENGINE COMPARTMENT R. H. SIDE DOOR

Engine compartment R. H. side door may be adjusted for proper fit by untightening hinge bolts:

1. Loosen the bolts, (1, Figure 38) holding the hinge to the vehicle structure to shift the door "LEFT or RIGHT".
2. Loosening the bolts (2, Figure 38) allows the door to be shifted "UP or DOWN".

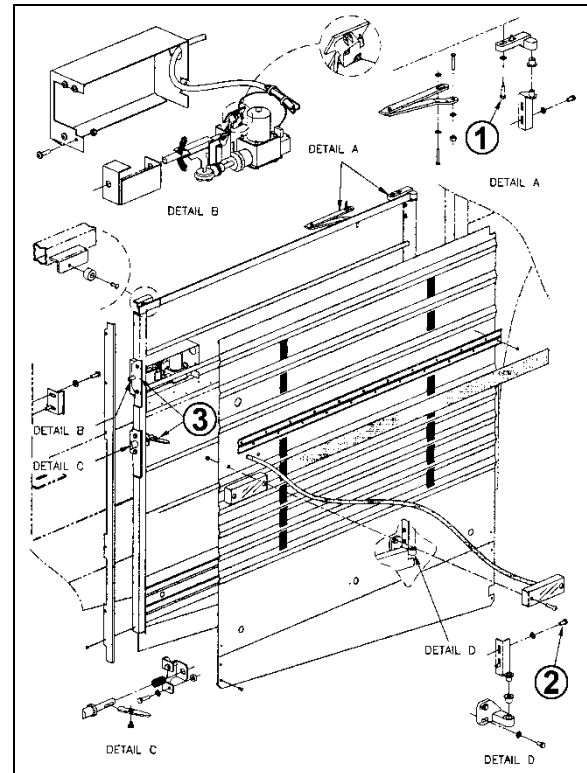

FIGURE 38: ENGINE COMPARTMENT R.H. SIDE DOOR

18635

3. Adjust the door position depending on the gap needed between exterior finishing panels (See 6.8, BODY PANEL AND WINDOW SPACING).
4. Tighten the bolts.
5. Check that the door swings freely and closes properly. It may be necessary to adjust the door latch to get proper fit and operation.

To adjust the latch mechanism (3, Figure 38) and the striker pin:

1. Open the door to access the striker pin latch.
2. Slightly loosen the latch on the vehicle.
3. Adjust the latch position to allow easy door closing.
4. Tighten the striker pin latch bolts.
5. Check door fit and operation.

15.4.3 ENGINE RADIATOR DOOR

Radiator door may be adjusted for proper fit by untightening hinge bolts:

1. Loosen the bolts, (1, Figure 40) holding the hinge to the vehicle structure to shift the door "LEFT or RIGHT".
2. Loosening the bolts (2, Figure 40) allows the door to be shifted "UP or DOWN".

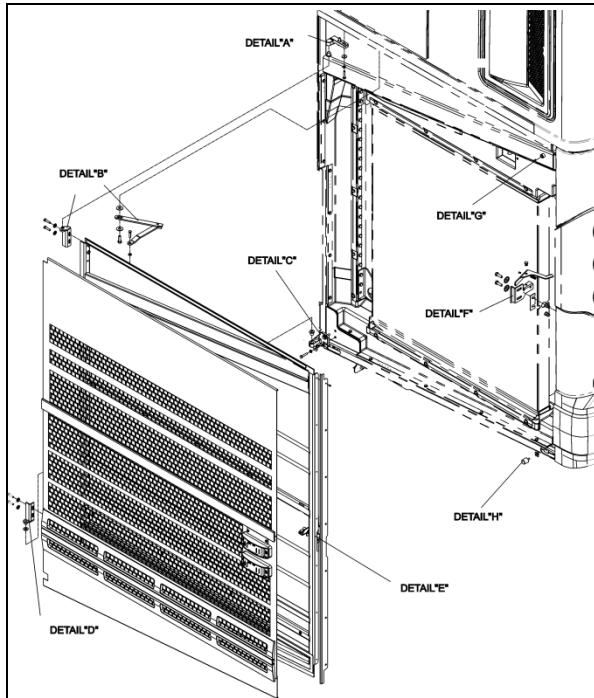

FIGURE 39: RADIATOR DOOR 18636_1

3. Adjust the door position depending on the gap needed between exterior finishing panels (See 6.8, BODY PANEL AND WINDOW SPACING).
4. Tighten the bolts.
5. Check that the door swings freely and closes properly. It may be necessary to adjust the door latch to get proper fit and operation.

To adjust the latch mechanism (3, Figure 40) and the striker pin:

6. Open the door to access the striker pin latch.
7. Slightly loosen the latch on the vehicle.
8. Adjust the latch position to allow easy door closing.
9. Tighten the striker pin latch bolts.
10. Check door fit and operation.

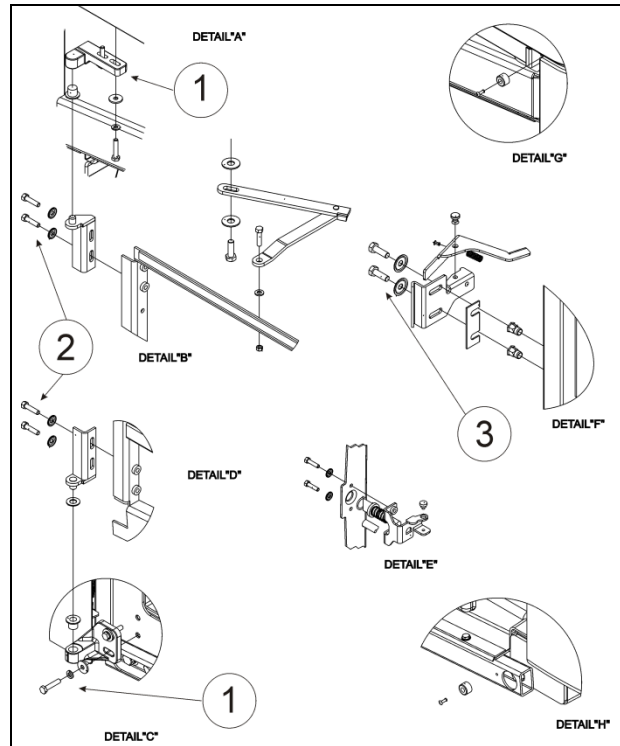

FIGURE 40: RADIATOR DOOR DETAILS 18636_2

NOTE

The striker pin must engage at least 13/32" (10mm). Add spacers between the latch and the vehicle body to adjust the engagement.

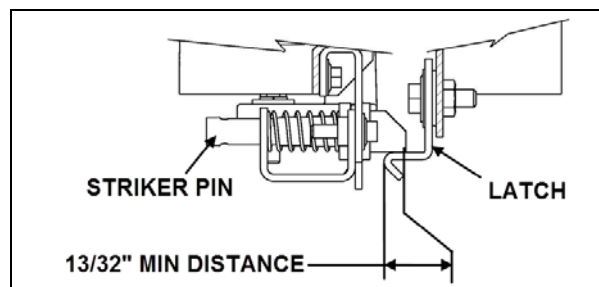

FIGURE 41: STRIKER PIN ENGAGEMENT 18695

NOTE

There should be no gap between the washer and the hinge upper and lower halves.

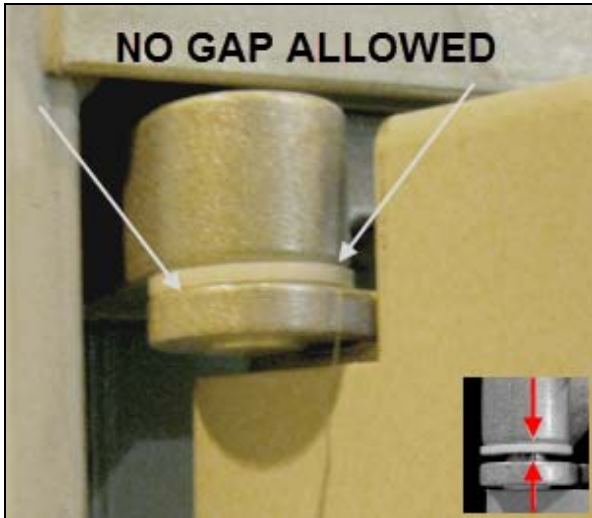

FIGURE 42: HINGE DETAIL

15.5 ZONE 5

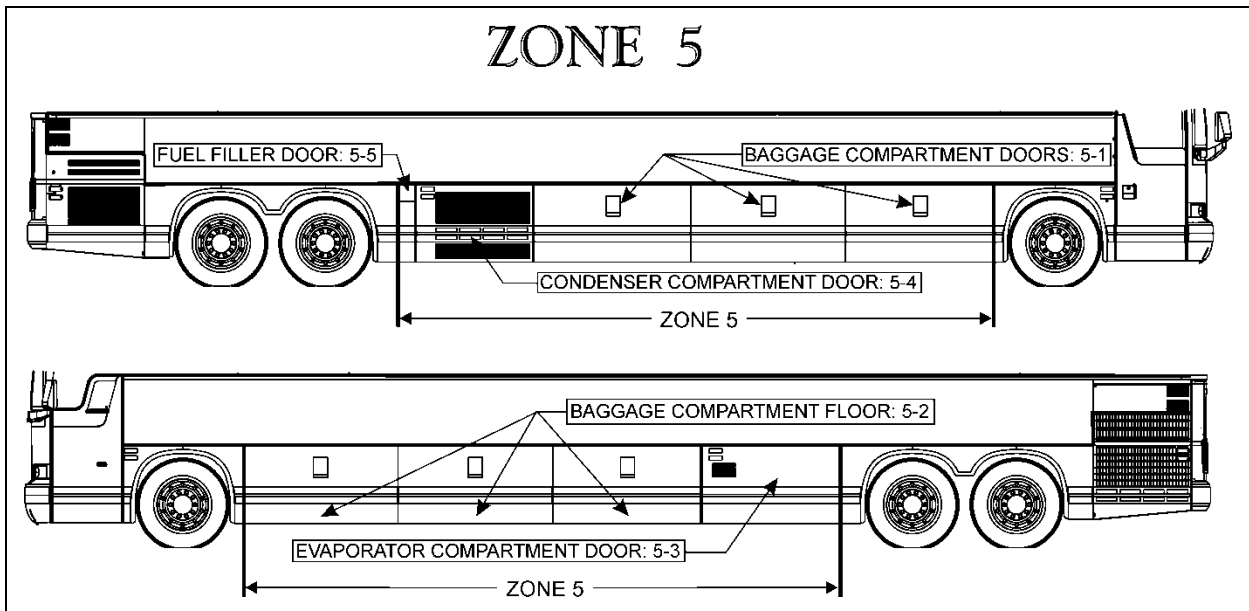
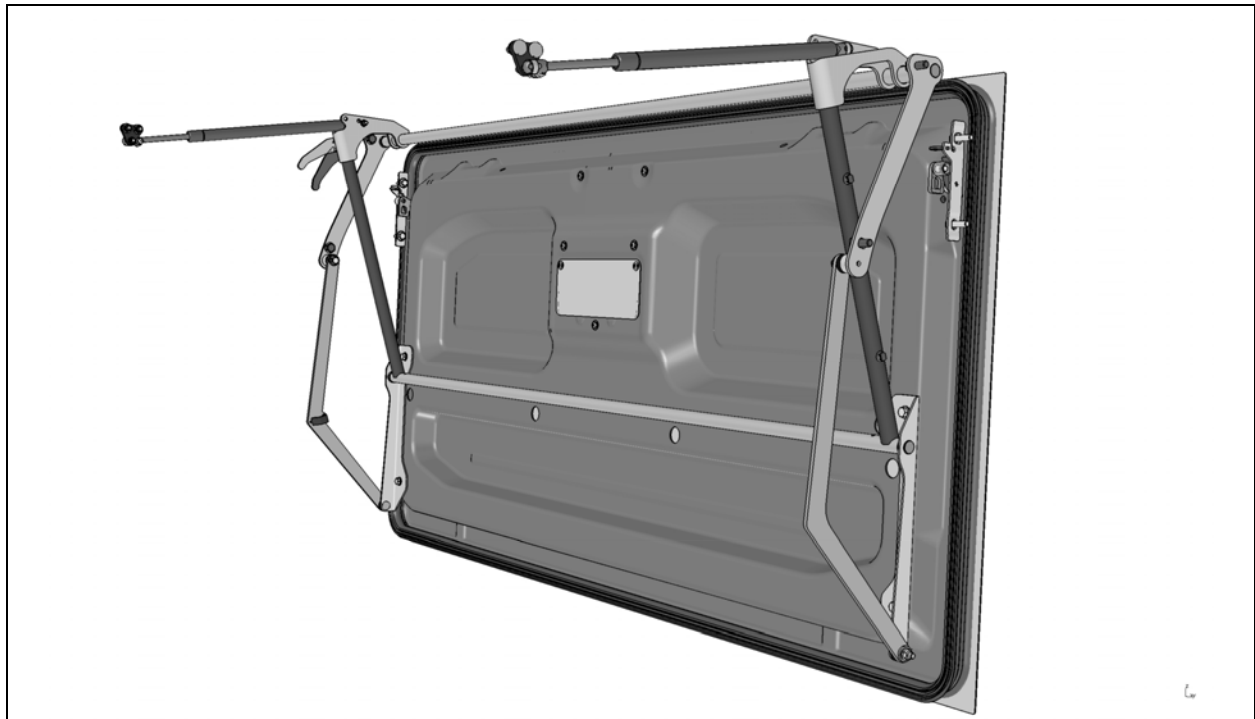

FIGURE 43: ZONE 5

18628

15.5.1 BAGGAGE COMPARTMENT DOORS (ALUMINUM)



For the removal and installation of a baggage compartment door body panel, you will need:

A drill with drill bits;

Pneumatic hammer tool (Zip Gun);

Razor sharp window scraper or putty knife;

- Open damaged compartment door and unfasten rub rail fixing bolts. Remove rub rail.
- Unfasten bolts and disconnect cable if necessary in order to remove door from vehicle.
- Preferably install the door onto a work surface where it can be solidly fixed.

• **Door Panel replacement**

- Refer to SAV10054-67.

• **Baggage Compartment Door Adjustment**

- Adjust door to get a 6mm gap at the top.
- All adjustments are to be made with door closed, unless specified.

NOTE
Vertical adjustment is achieved by moving the door along the mounting plate slots.

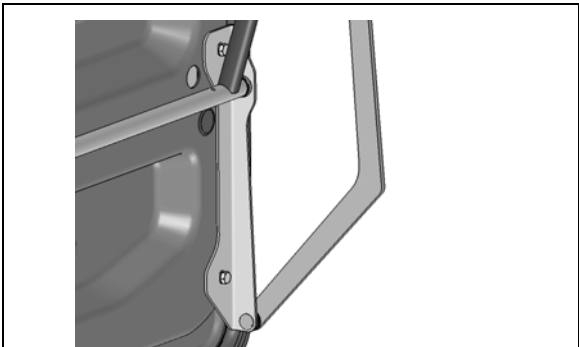

- Center door in the opening using the retaining rings.

NOTE
Lateral adjustment is made by adding/removing retaining rings in these locations.

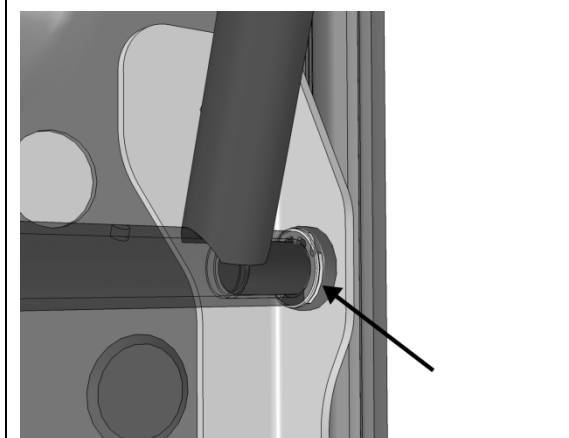
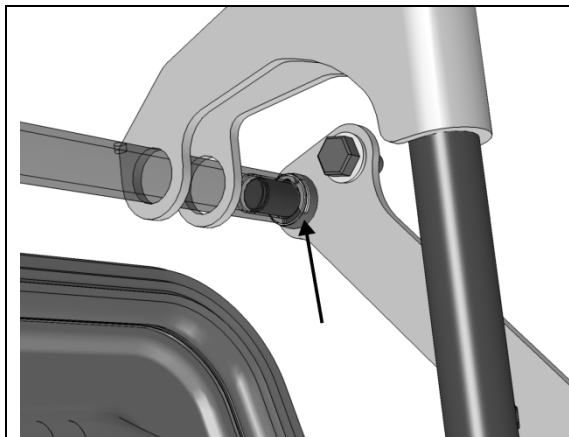

- Adjust door position and evenness with reference to adjacent panels and doors.

NOTE

Adjustment is made by moving *IN* or *OUT* the lock plates. Adjust one corner at a time.

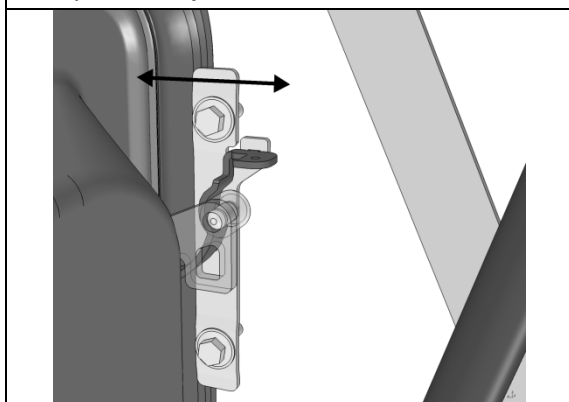

- Check handle adjustment. Handle must remain tight against its plastic housing.

NOTE

Adjustment is made by moving *UP* or *DOWN* the lock plates.

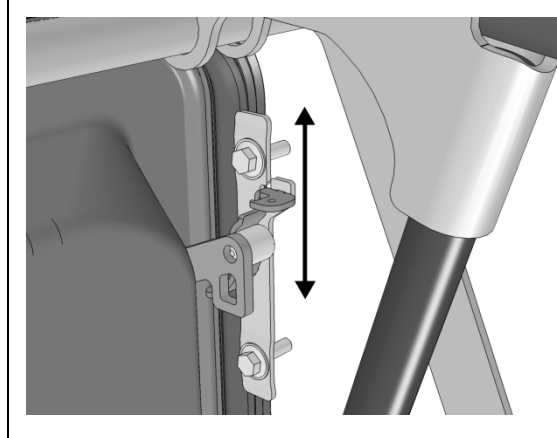

- Open baggage compartment door and adjust using the cylinder mounting block.

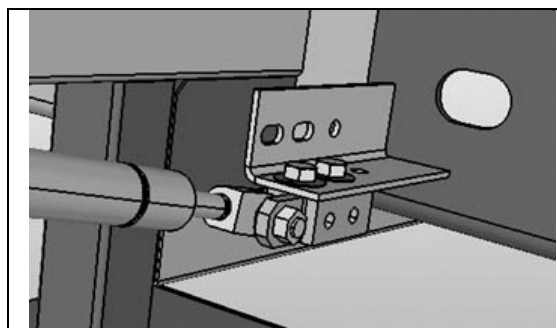

- Door should be adjusted in reference to neighboring doors.
- Target is to have 5 1/2" (140mm) from bus body panel to door panel and +/- 2mm vertically between doors.

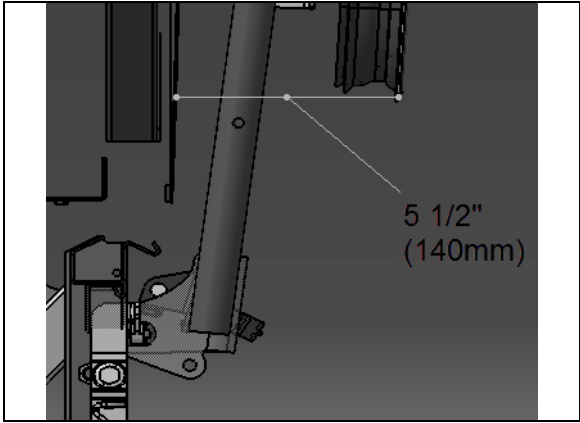

➤ Tighten cylinder block fixing screws.

➤ Door bottom edge compression can be adjusted by moving in or out the pantograph arms at this location.

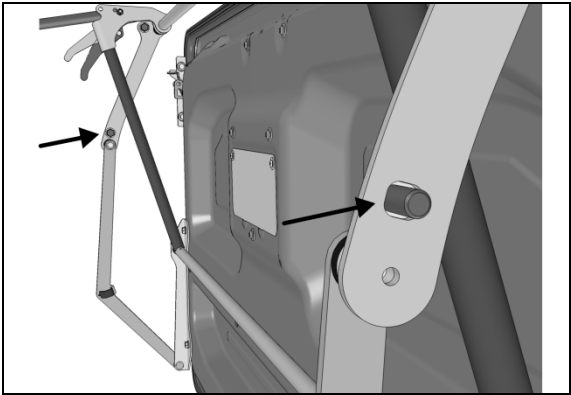

15.5.2 WHEELCHAIR LIFT CASSETTE COMPARTMENT DOOR

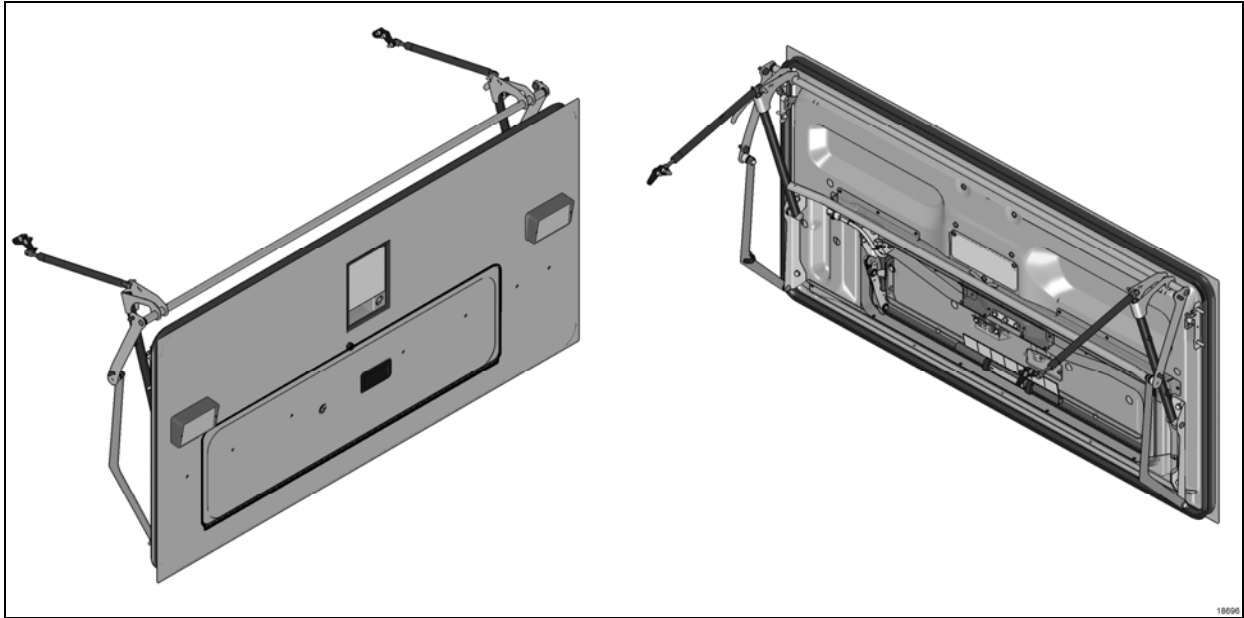

For the removal and installation of a wheelchair lift (WCL) cassette compartment door body panel, you will need:

- A drill with drill bits;
- Pneumatic hammer tool (Zip Gun);
- Razor sharp window scraper or putty knife;

- Open damaged compartment door and unfasten rub rail fixing bolts. Remove rub rail.
- Unfasten bolts and disconnect cable if necessary in order to remove door from vehicle.

➤ Preferably install the door onto a work surface where it can be solidly fixed.

- **Door Panel replacement**
 - Refer to SAV10054-67.
- **Compartment Door Adjustment**
 - Refer to baggage compartment door procedure.
- **WCL Cassette Door Adjustment**

SECTION 18: BODY

The small door has a piano hinge on its lower edge.

1. Install only two of the mounting screws, at each end to adjust the door.

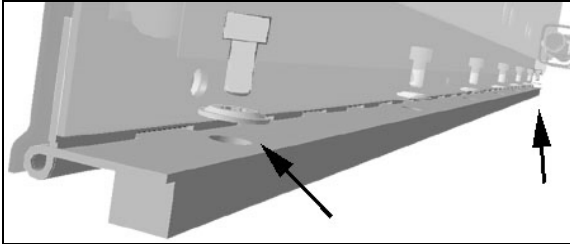

2. Close the door to center the latch mechanism.
3. Tighten screws
4. Check that the door swings freely and closes properly without interference or excessive force

2. Close door and adjust in opening. A 1mm maximum difference between left and right measured gap is accepted.
3. Door should close flush with the larger door panel. Maximum flatness deviation within 1mm.
4. Install the remaining screws and seal with liquid Teflon #680098.

• WCL Cassette Door latch adjustment

To allow adjustment of the latch mechanism, lightly tighten the retaining hardware on receptacle and striker support (arrows).

1. Place centering tool G34148_500 in the receptacle cavity.

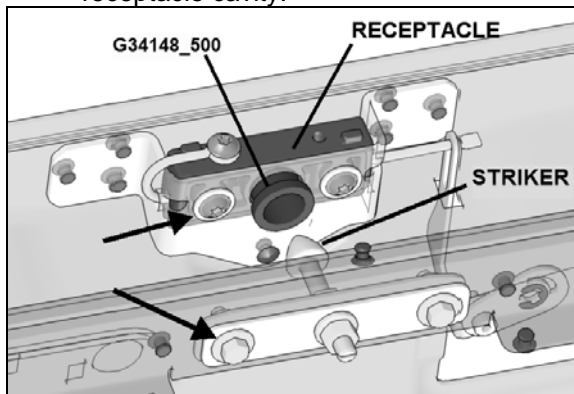

15.5.3 EVAPORATOR COMPARTMENT DOOR

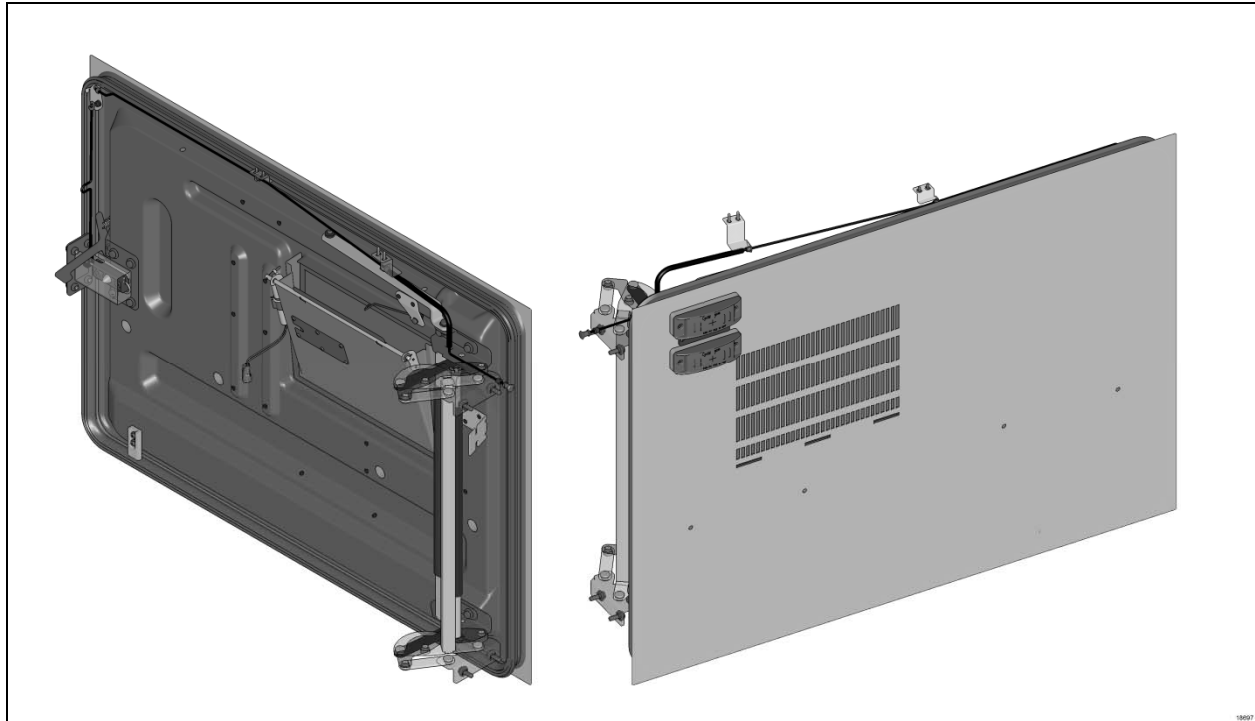
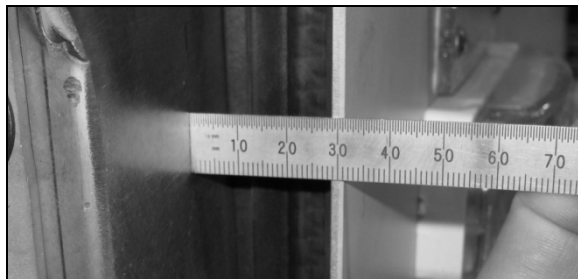

FIGURE 44: EVAPORATOR DOOR (ALUMINUM)

For the adjustment of an evaporator door, you will need:

- Centering tool G34148_500
- **Door adjustment**
 1. Open the evaporator door.
 2. Loosen the screws fixing the hinge to hinge attachment or hinge to door assembly. Loosening the screws allows the evaporator door assembly to be shifted "LEFT or RIGHT" and "UP or DOWN" or "IN and OUT".
 3. Adjust evaporator door assembly position at the hinge.
 4. Door exterior panel on hinge side should be positioned at 29mm +/- 2mm measured from bus frame out.



5. Respect the required gap between exterior finishing panels.
6. Tighten the hinge screws.
7. To allow adjustment of the latch mechanism, lightly tighten the retaining hardware on receptacle and receptacle support to frame.
8. Place centering tool G34148_500 in the receptacle cavity.

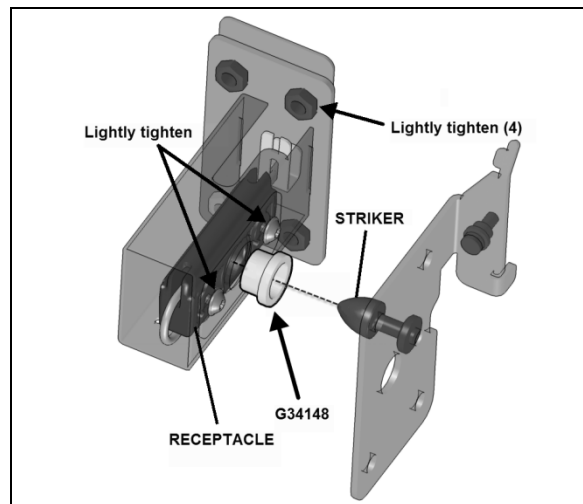

9. Close door to center the latch assembly.
10. Tighten the Receptacle screws only.

SECTION 18: BODY

- 11..Door exterior panel on latch side should be positioned at 8mm +1mm from frame. Make the adjustments by moving the receptacle support.

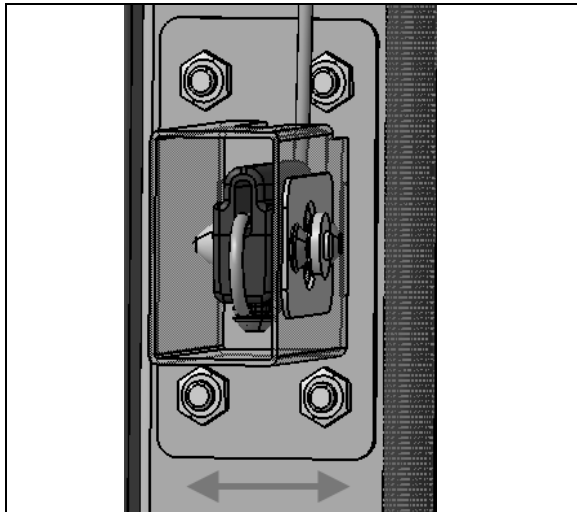
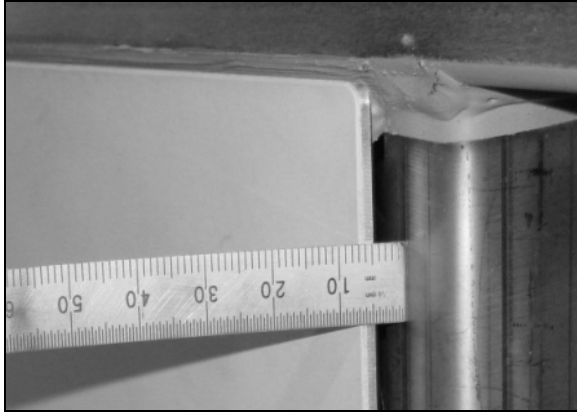

12. Make sure that backing plate is parallel to structure before tightening hardware
13. Make sure that skid bar only touches slightly bus structure at bottom. The door should not move up when closing.

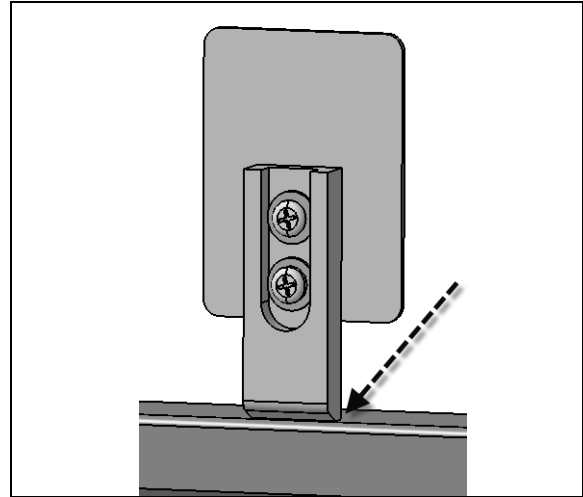

14. Check that the door swings freely and closes properly.

- **Door release in the event of a latch failure.**

If the door release mechanism is damaged or ceases to function for any reason, the door can be released by removing these screws on the fore wall of the fender side, in the water circulation pump and heater compartment

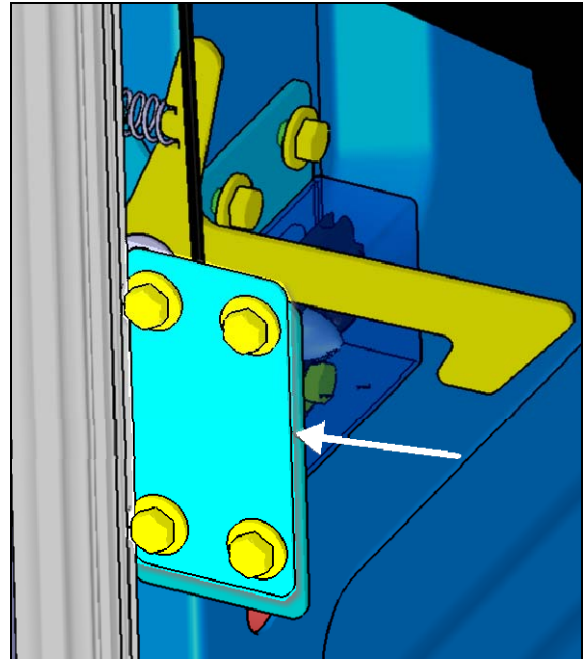

15.5.4 CONDENSER COMPARTMENT DOOR

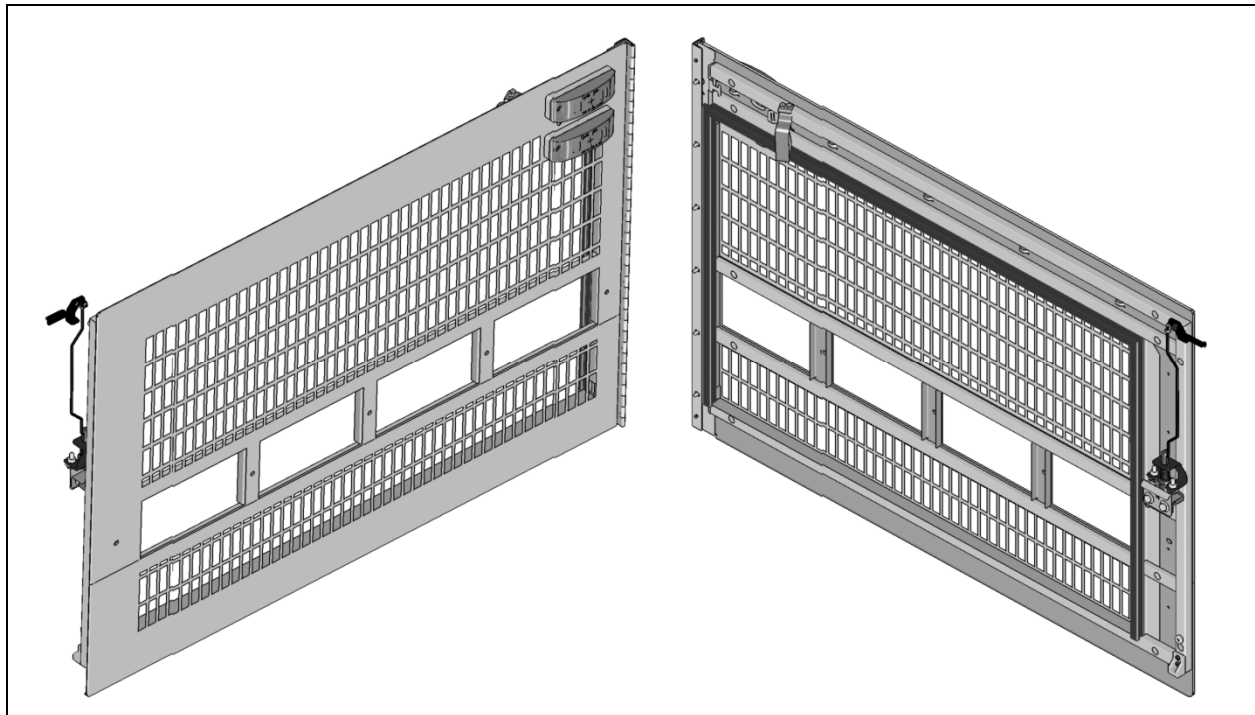

FIGURE 45: CONDENSER DOOR

1. Open the condenser door.
2. Loosen the screws fixing the hinge to hinge attachment or hinge to door assembly. Loosening the screws allows the condenser door assembly to be shifted "LEFT or RIGHT" and "UP or DOWN" or "IN and OUT".
3. Adjust condenser door assembly position at the hinge.
4. Respect the required gap between exterior finishing panels.
5. Tighten the screws.
6. Check that the door swings freely and closes properly. It may be necessary to adjust the door latch to get proper fit and operation.

4. Tighten the nuts.
5. Check that the door swings freely and closes properly.

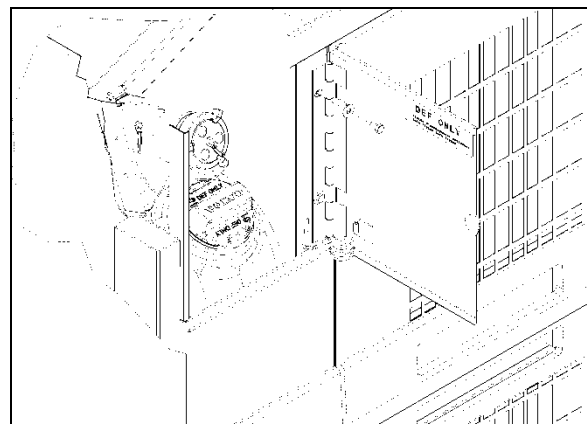

FIGURE 46: FUEL FILLER DOOR

03046

15.5.5 FUEL FILLER DOOR

1. Open the fuel filler door.
2. Loosen the screws holding the panel to hinge assembly.
3. Adjust the fuel filler door position according to distance required between exterior finishing panels.

15.5.6 BAGGAGE COMPARTMENT FLOOR

• **Repair of Mantex Urethane Covering**

Minor Repair

Use "Dupont IMRON" paint. Apply using a paint brush or roller depending on gravity.

SECTION 18: BODY

Paint Code: #J4099U

Major Repair (Hole)

Chamfer the whole perimeter of the damaged area. If applicable, remove loose covering. Remove dust and particles.

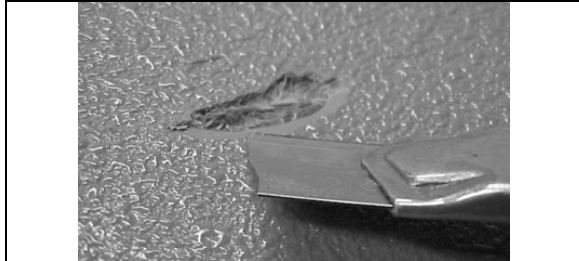

Cover and protect damaged area surroundings.

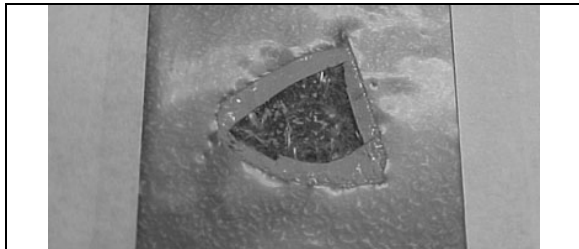

Using a plastic spatula, apply some Sika 221 grey onto the damaged area.

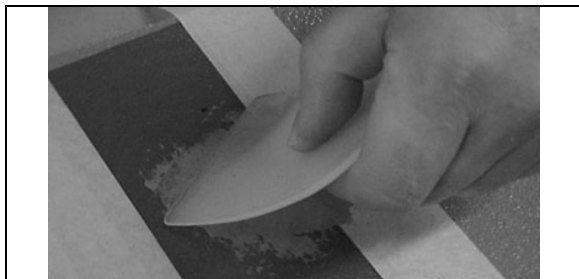

Remove masking tape and protection around damaged area.

Spray pure water onto Sika. Use a floor sample to create some texture onto the adhesive.

If possible spray some more water onto the adhesive to accelerate curing.

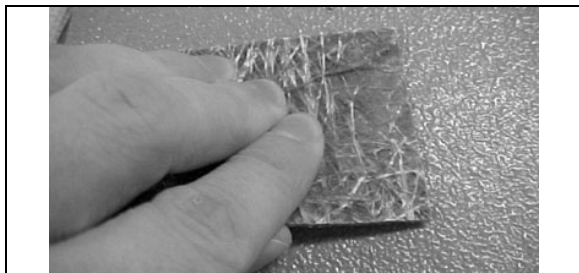

Allow drying for at least **2 hours** then repaint as per paragraph: Minor Repair.

• Baggage Compartment Floor Installation

Preparation and Installation

Clean baggage compartment support structure using anti-silicone.

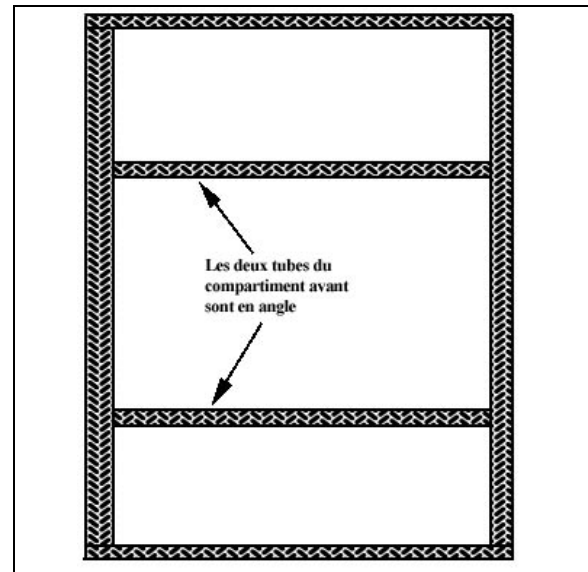

Glue spacers (790392) about 16-inch apart.

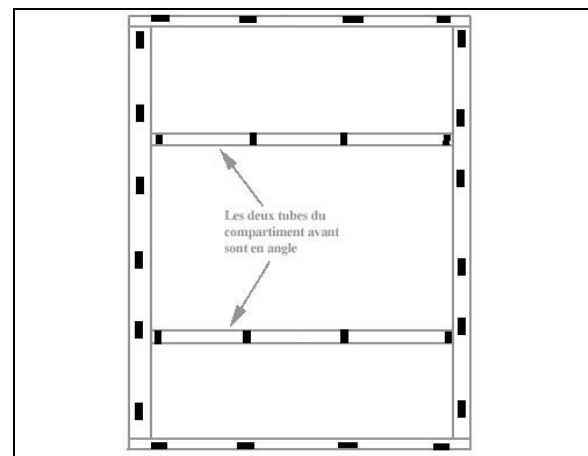

Rear baggage compartment without WCL.

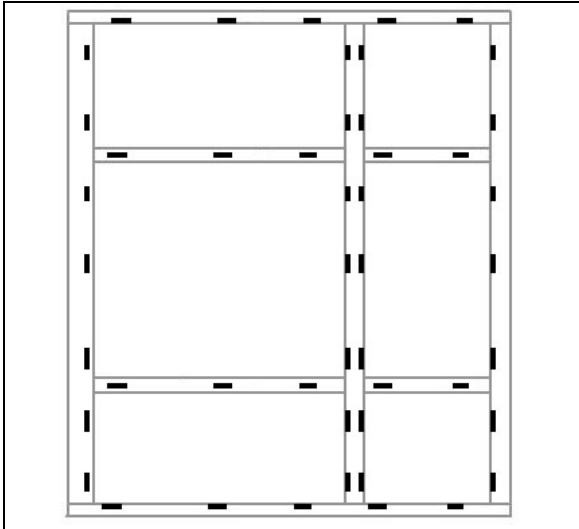

Rear baggage compartment equipped with WCL

Using a triangular nozzle, apply "Simson" glue (685126) onto support structure.

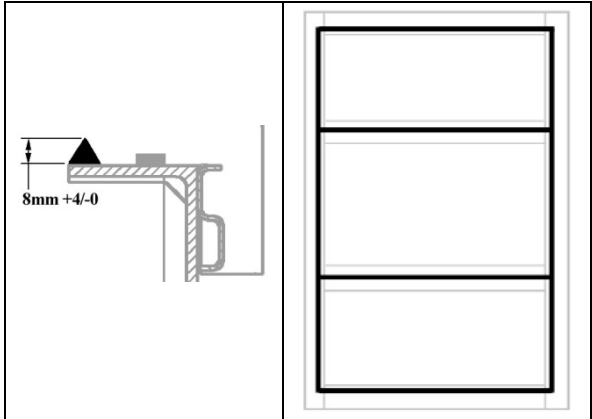

Rear baggage compartment without WCL.

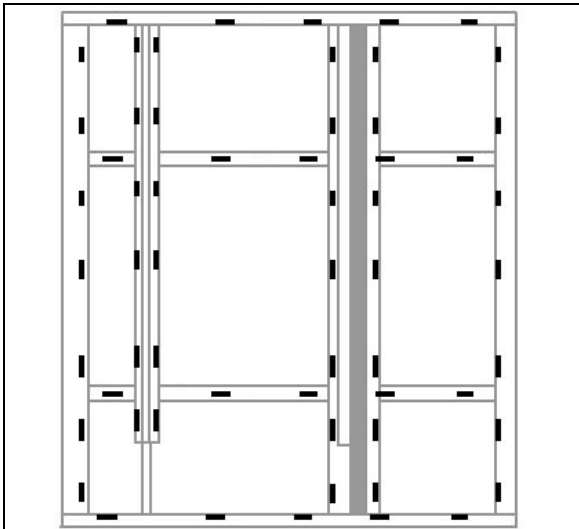

Prepare baggage compartment Mantex floor. Clean panel underside and edges.

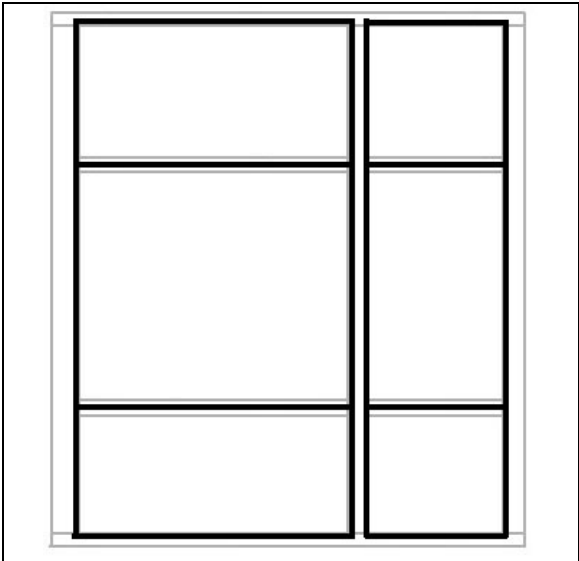

Rear baggage compartment equipped with WCL

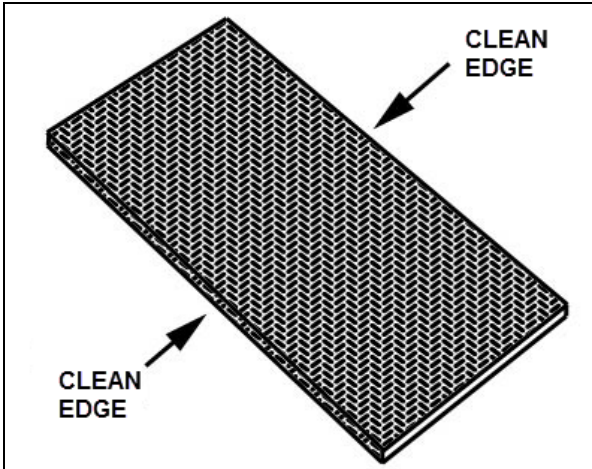

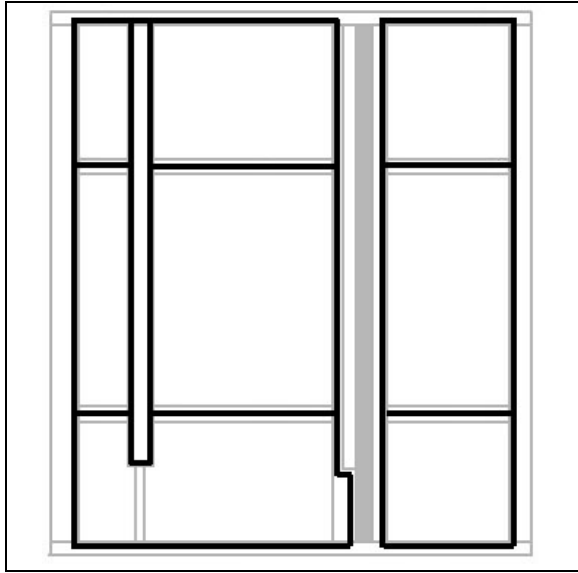

Carefully install panel onto support structure.

Evenly distribute and install conforming weights (6 to 8) (80 to 100 lbs **total**) onto panel for at least **4 hours**. Make sure panel does not move.

Finishing Joints

In the case of lateral finishing joint, apply some masking tape $\frac{1}{4}$ " from panel edge and $\frac{1}{4}$ " above panel.

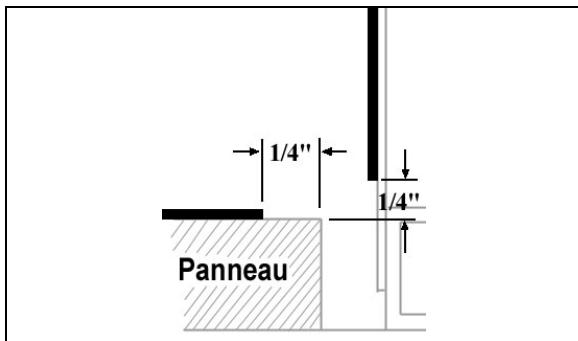

In the case of front finishing joint, apply some masking tape on each side of joint.

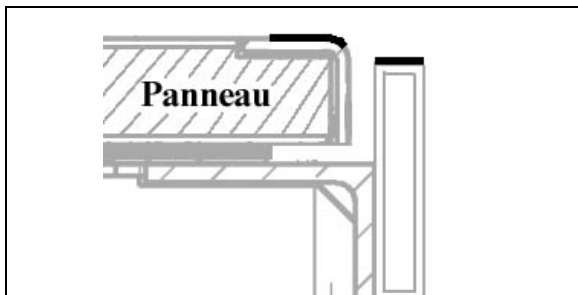

Clean with anti-silicone the area where the Simson glue will be applied.

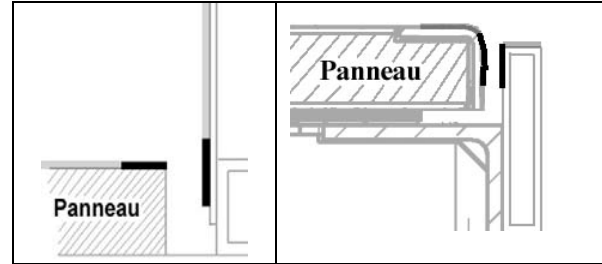

Apply some Simson glue to fill the gap.

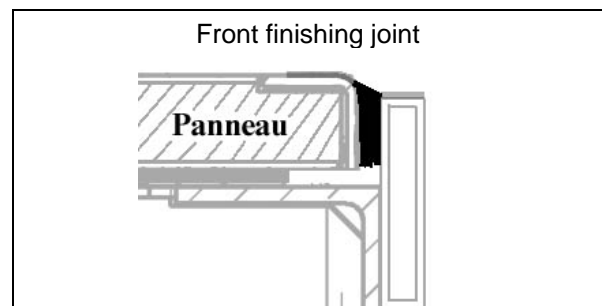
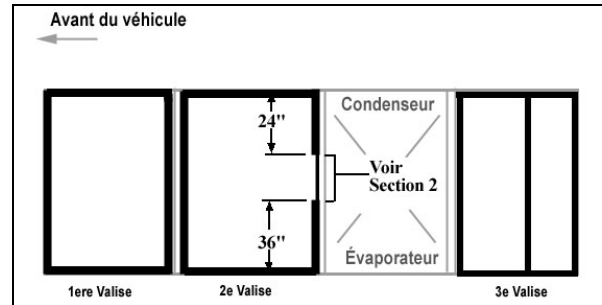

Front finishing joint

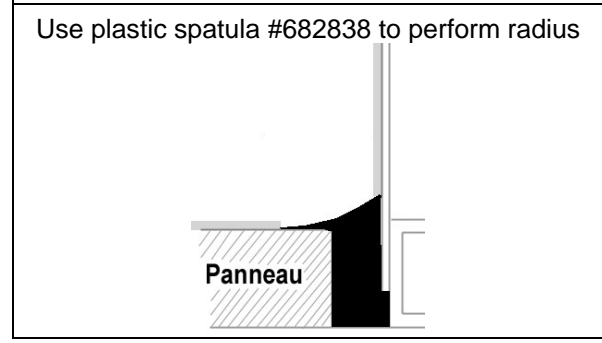
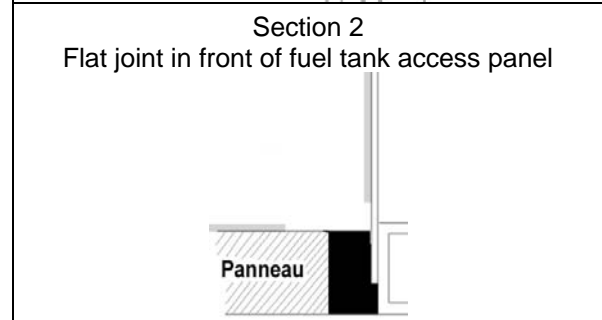

Use plastic spatula #682838 to perform radius

Rear baggage compartment equipped with WCL

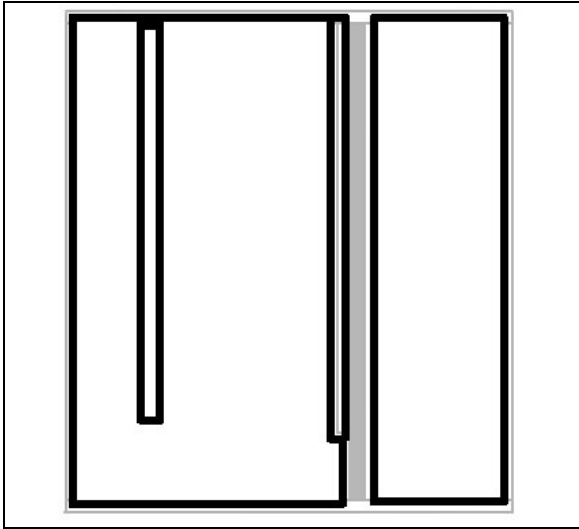

Rear baggage compartment without WCL.

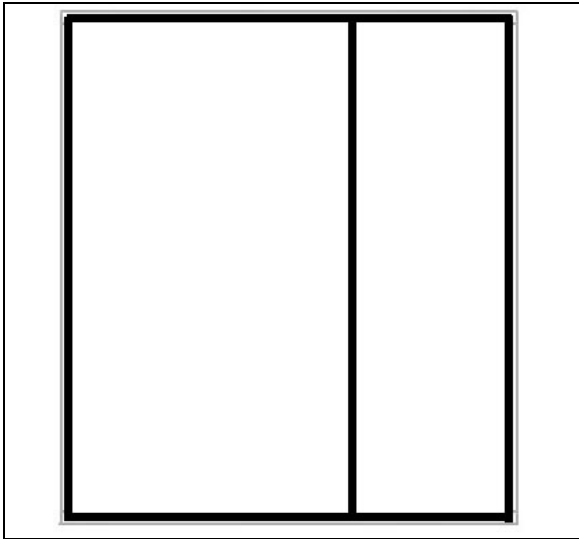

Remove masking tape.

Smooth down joints using soapy water.

15.5.7 FUEL FILLER DOOR

6. Open the fuel filler door.
7. Loosen the screws holding the panel to hinge assembly.
8. Adjust the fuel filler door position according to distance required between exterior finishing panels.
9. Tighten the nuts.
10. Check that the door swings freely and closes properly.

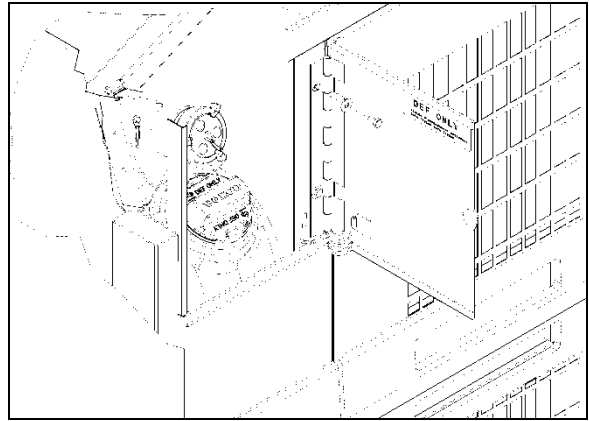

FIGURE 47: FUEL FILLER DOOR

03046

15.6 ZONE 6

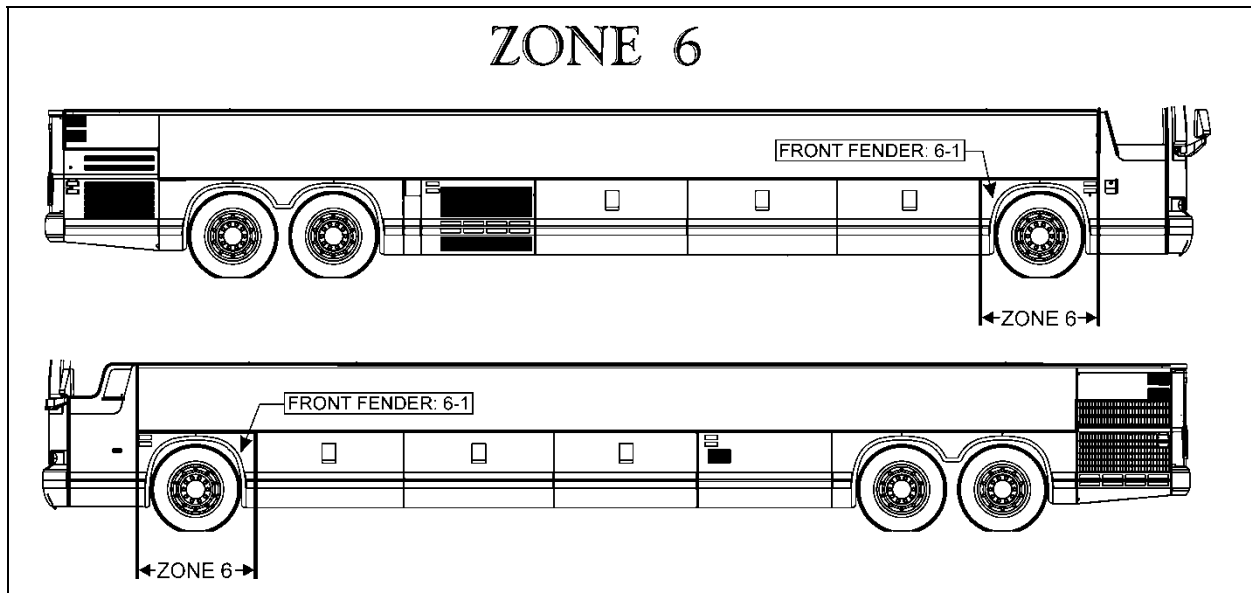

FIGURE 48: ZONE 6

18629

15.6.1 FRONT FENDER

Front fender may be removed using the following procedure:

Remove the nuts on the inside of the fender. Remove the fender from the vehicle. To reinstall, reverse the procedure.

15.7 ZONE 7

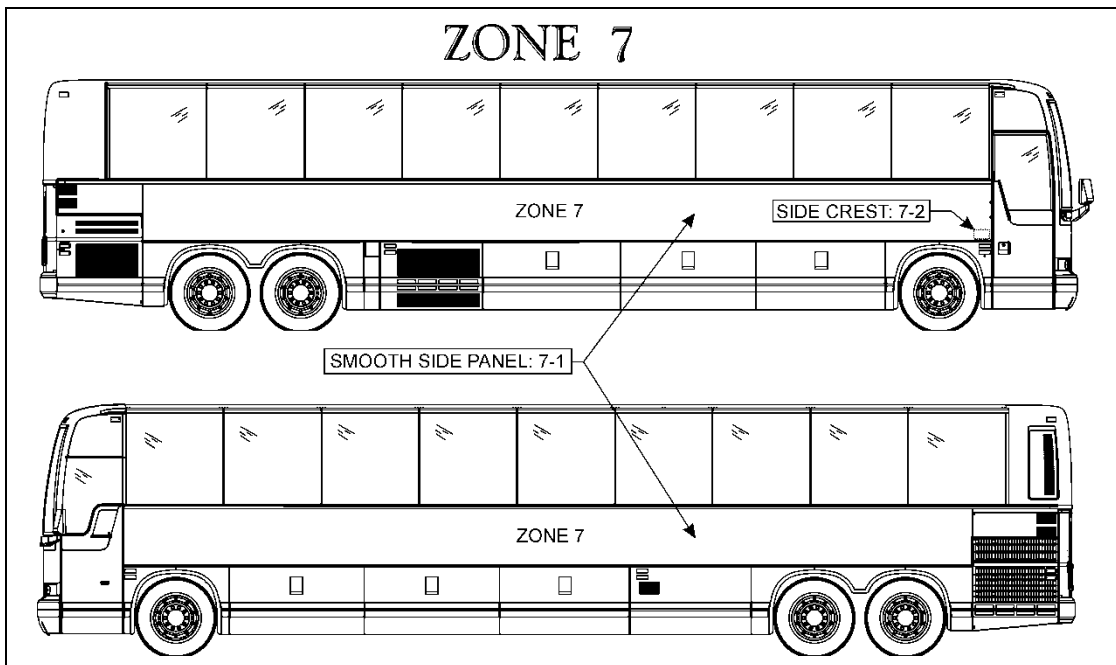

FIGURE 49: ZONE 7

18630

15.7.1 X3 SMOOTH SIDE PANEL REPLACEMENT PROCEDURE



Material:

Anti-silicone (682989)	√	Scotchbrite gray (680226)	√	Sika 221 gray	√
CHIX cloth (682384)	√	Sika 205 1liter (683097)	√	Sika 252 black	√
Blue cloth (682383)	√				

Equipment:

Glue gun	√	
Pencil	√	

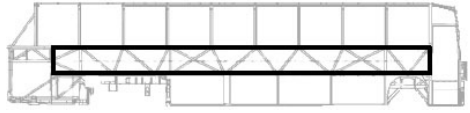
SECTION 1 SMOOTH SIDE PANEL REMOVAL		
1.00	REMOVAL	
	A)	Remove finishing molding. Insert a screwdriver into snap-on finishing molding joint. Bend finishing molding enough to be able to fix a pair of locking pliers. Using the pair of locking pliers, pull the stainless steel molding and at the same time gradually cut Sika bead with a sharp knife.
	B)	Using a hammer and punch, drive out rivet shanks from top and bottom and from front and rear finishing molding supports. Use a #11 titanium drill bit to remove rivet heads.
	C)	Grind tig weld spots at each end of side panel.
	D)	Safely support or temporary fix side panel.
	E)	Insert a flat screwdriver between the side panel and the vehicle chassis, in the top left and right corners. Make sure to separate side panel from structure.
	F)	Use the c-clamp to separate the side panel from the back structural panel and at the same time gradually cut Sika bead with a sharp knife.
	G)	Remove as much glue as possible from the structure using a putty knife or pneumatic knife without damaging 206 G+P primer.
H)	Check panel horizontal supports for straightness using a straight edge. Take measurements with a ruler.	
		Be careful not to damage the adjacent surfaces.
		Warning: Panel weights over 200 pounds
		Be careful not to damage the adjacent surfaces.
		Ideally, the hoist or chain block must be fastened to the floor while pulling from a 45° angle so as not to damage the vehicle structure
		Never heat SikaFlex adhesive to remove.
		Tolerance : 1mm towards the outside and 1.5mm towards the inside.

SECTION 2 SURFACE PREPARATION			
2.00	VEHICLE SURFACE PREPARATION		
	A)	Clean using "anti-silicone" until all clothes come clean. See PR000001 section A.	
	B)	Use the belt sander (grit coarse) Use a new paper on each vehicle side.	
	C)	Clean using "anti-silicone" until all clothes come clean. See PR000001 section A.	
D)	Apply – Sika 205 See PR000001 section B.		
2.05	SIDE PANEL PREPARATION		
	A)	Clean using "anti-silicone" until all clothes come clean. See PR000001 section A.	
	B)	Use the belt sander (grit coarse) Use a new paper on each vehicle side panel.	
	C)	Clean using "anti-silicone" until all clothes come clean. See PR000001 section A.	
D)	Apply – Sika 205 See PR000001 section B.		

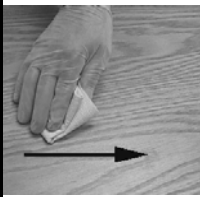
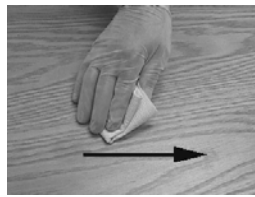
SAV00001 Section A Alcohol or Anti-silicone	
	1. Apply <div style="border: 1px dashed black; padding: 2px; display: inline-block;">CHIX cloth</div>
	2. Dry immediately <div style="border: 1px dashed blue; padding: 2px; display: inline-block;">Blue cloth</div>
3. Allow to dry	
Mandatory	Minimum time : Wait for product to evaporate <hr/> After 2 hours: Start cleaning operation again
Before applying any other product	If surface seems dusty, greasy or with finger marks, start cleaning operation again.

Section B Sika 205

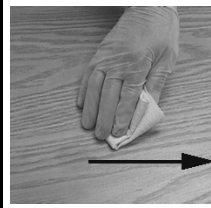

1. Apply

CHIX cloth







2. Allow drying

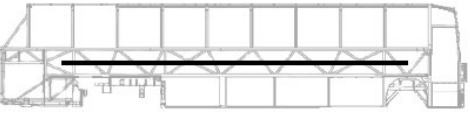
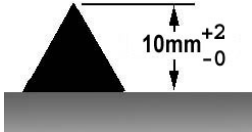
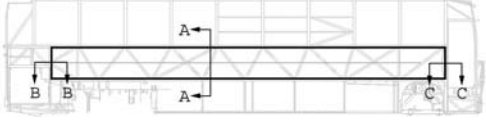
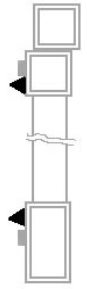

Mandatory	Minimum time	- For a smooth surface (aluminum, stainless steel, fiber glass (gelcoat side), etc.):	2 minutes
		- Pour a porous surface (fiber glass (non gelcoat side), etc.)	10 minutes
After 2 hours : Reactivate surface with Sika 205			
Before applying any other product	If surface seems dusty, greasy or with finger marks, start operation again.		

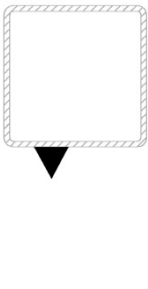
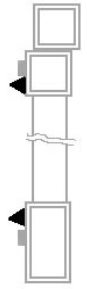
SECTION 3 SIDE PANEL INSTALLATION

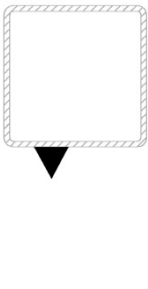
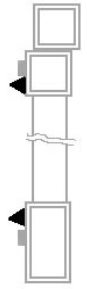
3.00	A)	Using a pencil, mark the double-face self adhesive tape position onto vehicle side.	
	B)	Apply 1/8 X 1/2" double-face tape as per marking.	
	C)	Compress tape	
	D)	Remove protective film from double-face self adhesive tape center section.	

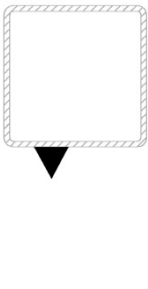
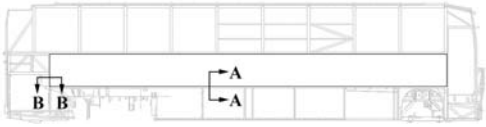
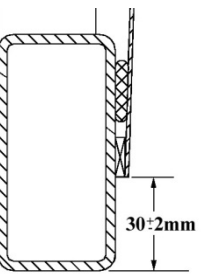
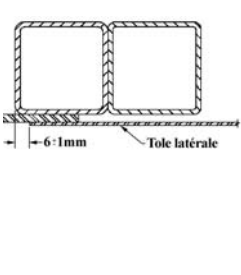
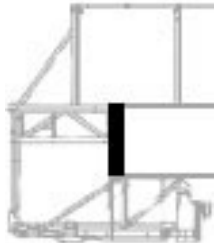
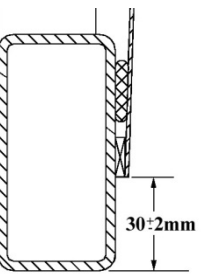
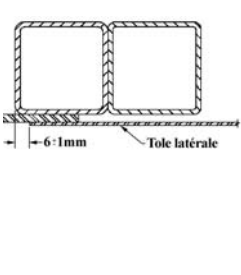
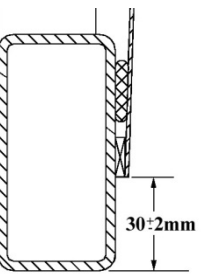
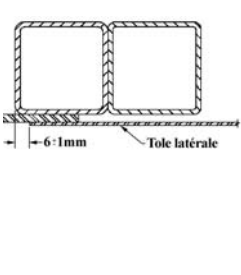
SECTION 18: BODY

3.05	Install 1/8 X 1/2" foam tape onto middle reinforcement then compress.							
3.10	<p>Apply Sika 252</p>  <ul style="list-style-type: none"> - Onto vehicle surface - Cut nozzle as per template - Use the guide for the application <p>Bead must be continuous for the whole perimeter.</p>	 <table border="1" style="width: 100%; text-align: center;"> <tr> <th style="width: 33%;">Section A-A</th> <th style="width: 33%;">Section B-B</th> <th style="width: 33%;">Section C-C</th> </tr> <tr> <td></td> <td></td> <td></td> </tr> </table>	Section A-A	Section B-B	Section C-C			
Section A-A	Section B-B	Section C-C						
								
3.15	<p>A) Install side panel onto support jig.</p> <p>B) Position side panel in front of vehicle structure</p> <p>C) Perform final adjustment to make sure that side panel is true and square</p> <p>D) Sand rear of side panel 2" wide</p> <p>E) Perform tig spot welding (1" apart)</p>	 <table border="1" style="width: 100%; text-align: center;"> <tr> <th style="width: 50%;">Section A-A</th> <th style="width: 50%;">Section B-B</th> </tr> <tr> <td></td> <td></td> </tr> </table> <ul style="list-style-type: none"> - 30 mm. ± 2 with reference to bottom tubing - 6 mm ± 1 with reference to vertical tubing  <p>Quantity of "tig spot": 30 minimum.</p>	Section A-A	Section B-B				
Section A-A	Section B-B							
								



3.20	A)	Install pulling equipment at the other end of side panel	
	B)	Make a final adjustment in height	
	C)	Sand front of side panel 2" wide	
	D)	Pull side panel so that panel moves 1/8"	Make sure the equipment pulls along the whole width of side panel
	E)	Perform tig spot welding	Quantity of "tig spot": 30 minimum.
3.30	Remove pulling equipment		
3.40	A)	Remove protective film from double-face self-adhesive tape.	
	B)	Compress top and bottom section of side panel	
3.50	A)	Cut excess of side panel. Make sure that cut is parallel with tubing.	
	B)	Grind side panel end to line up with door tubing.	
3.60	To seal each panel end, apply masking tape on each side of side panel joint. Use a caulking nozzle and grey Sikaflex 221 adhesive to fill the cavity between the panel and vehicle structure. Clean using Sika 205. Allow 5 minutes minimum for drying.		



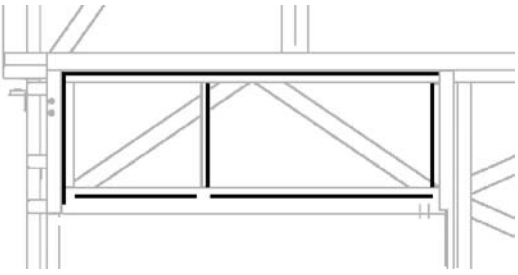

SECTION 18: BODY

	Wear surgical gloves and smooth down the joint with your finger.	
--	--	--

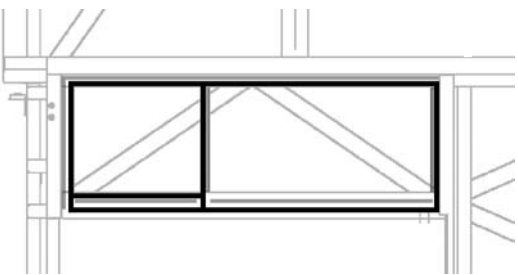
SECTION 4 ENGINE AIR INTAKE PANEL INSTALLATION

4.00	Make sure that sealing of structure has been performed properly	
4.05	Prepare vehicle surface as for side panel.	Refer to step # 2.00
4.10	Prepare air intake panel as for side panel	Refer to step # 2.05

4.15	Install foam tape 1/8" X 1/4" onto structure, as shown in picture	
4.20	Install foam tape 1/16" X 1/4" onto air intake panel pleat	
4.25	Apply a bead of 252 onto structure as per picture Important: Make sure bead is continuous Triangular bead: 10mm x 8mm	
4.30	Install panel onto structure	Use a jig to make sure that panel is lined up with engine door tubing.
4.40	Use a brush to compress Sika bead	

5.00 *	Finition Joint		
	A)	Install a protective tape onto the tubing above welding	
	B)	Apply Sika 205 Use a plastic spatula inside a Chix cloth to ensure that Sika 205 reaches as far as the corner. See PR000001 section B.	
	C)	Apply Sika 252 black at the junction of both tubing. Smooth down the joint	
	D)	Remove protective tape	

15.7.2 SIDE CREST

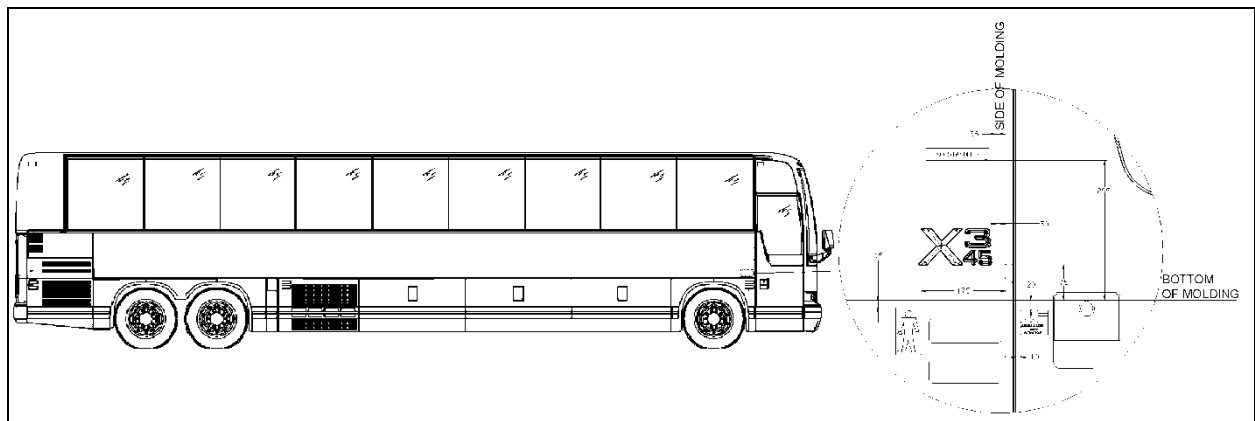

FIGURE 50: SIDE CREST POSITIONING

18639

- Clean vehicle surface using anti-silicone where the side crest and stickers will be applied.
- Using hands apply and compress side crest.
- Apply required stickers.

FIGURE 51: BODY PANEL AND WINDOW SPACING (TYPICAL)

17. PASSENGER SEATS

This vehicle is equipped with American Seating W2005 model seats:

Each pair of fixed seats is built on a welded steel frame fastened to the side wall and on a track-mounted pedestal.

W2005 model; seats have 2 armrests. The aisle armrests can be folded up and down manually, while the window armrest is fixed.

Sliding flip-up seats are installed in the mid-section of the bus to accommodate wheelchairs. These seats are track mounted.

17.1 Removing Fixed Seats

NOTE
Curb side and street side seats are not interchangeable.

To remove fixed seats, proceed as follows:

1. For ease of access, remove the nuts holding each seat cushion from under the front part of the seat frame.
2. Lift front part of cushions and remove.

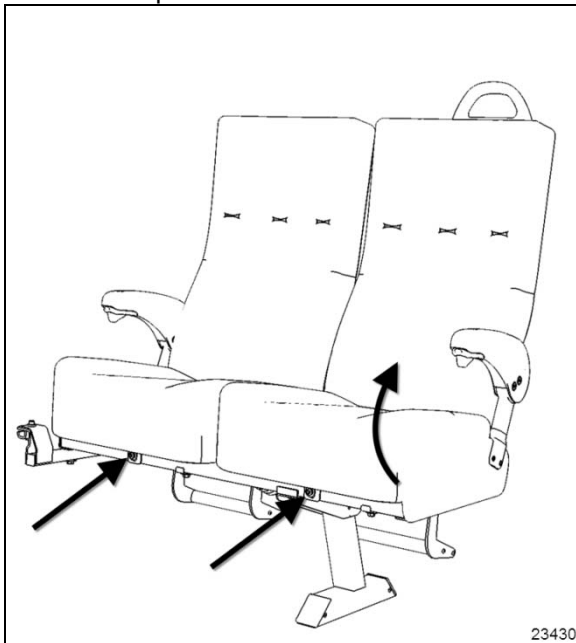

FIGURE 52: CUSHION REMOVAL

3. On wall side, remove the cap screws and washers holding seat frame to wall and keep the "J" clamp brackets.

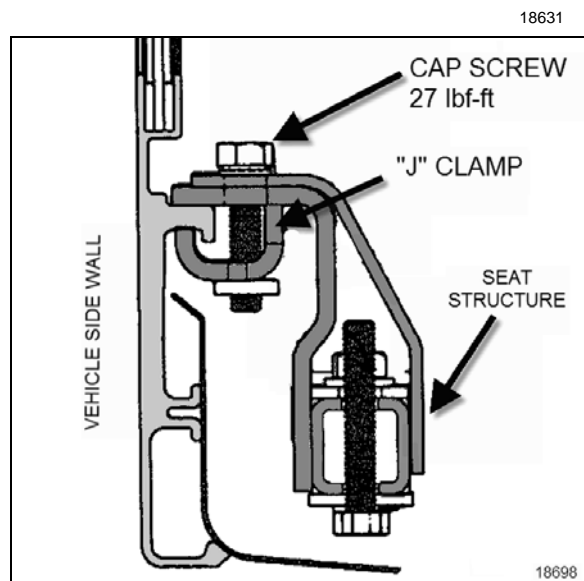

FIGURE 53: WALL BRACKET

4. Remove the T-pedestal caps. Remove the 2 nuts and washers holding seat to track.

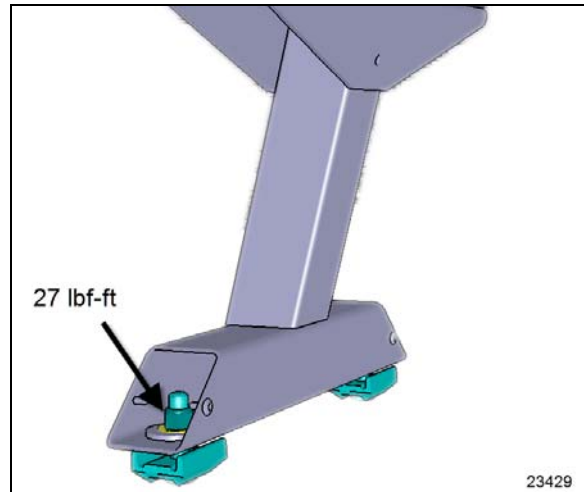

FIGURE 54: SEAT PEDESTAL ASSEMBLY

5. Remove seat assembly.
6. Follow procedure in reverse order to re-install seat.
7. Tighten rail and pedestal hardware to 27 lbf-ft (dry). Apply torque seal mark.

17.2 Upholstery Maintenance

Seat fabric for this vehicle is Holdsworth BVD011.

For both appearance and wear resistance, clean at regular intervals before dirt, dust and grit have been ground into the fabric.

Always begin with lukewarm water and a white cloth for most stain removal before applying any cleaning agent.

- **Cleaning With Covers in Place**

The most effective and economical method to clean the fabric seat covers is by washing with either an approved foam upholstery cleaner or with a mild household detergent.

Thoroughly vacuum the upholstery. Remove any spots or stains before the seats are washed to avoid a cleaning ring.

Dilute household detergent or liquid foam cleaner according to directions on the container. Pour a small quantity into a flat pan and work into a thick foam with a sponge or brush.

Apply only the foam to the fabric with a sponge or brush. Clean a small area of the fabric at a time with the foam. **DO NOT SOAK.** Rub vigorously. Sponge the suds from the fabric with a clean sponge or cloth moistened with water. Rinse the sponge or cloth often and change the water when it becomes dirty.

Allow the upholstery to dry completely before the coach goes back into service. To speed up drying, excess moisture can be blown off the fabric with compressed air.

**CAUTION**

Oil in the air line will spoil the fabric. Blow the line clear and test air discharge against a plain white piece of paper. It is also effective to press the edge of a flat hardwood stick down on the cushion and slowly draw it across the fabric.

Even very soiled areas can be returned to their original appearance by a thorough cleaning, but a regular schedule of cleaning that keeps the upholstery reasonably clean at all times will greatly enhance the life span of upholstery.

18. TARABUS FLOOR COVERING REPAIR OR REPLACEMENT

On X3-45 coaches equipped with “Gerflor” covering, it is possible to replace or repair this covering. The purpose of this paragraph is to explain the steps to be followed to ensure the best results and adherence.

MATERIAL

Part No	Description	Qty
680028	Adhesive, Tarabus Floor Covering (White)	A/R
684655	Adhesive, Contact (3M)	3.8L
684654	Adhesive, Contact (3M)	18.9L
680532	Sikaflex 221 Gray	A/R

NOTE
Material can be obtained through regular channels.

1. Remove number of passenger seats required to perform repair.
2. Cut and remove damaged section of floor covering.

NOTE
It would be preferable to cut under two rows of seats so that repair is not as noticeable.

3. Clean plywood using a scraper.

NOTE
Make sure that no staples are sticking out beyond surface. Adjacent plywood sheets must be leveled.

4. Fill up holes and imperfections using MAPI PRP 110 then sand.
5. Remove dirt and adhesive residue.

 **CAUTION**
 Do not leave floor covering folded down except temporarily during installation.

6. Apply floor covering adhesive (680028) onto plywood using a serrated spreader with 1/8-inch serration. If required, apply contact adhesive (3M) (684655 or 684654) onto aluminum molding and also onto section of floor covering, which will be in contact with molding (refer to figure 47).

NOTE
Allow adhesive to dry (3 to 5 minutes).

7. Compress floor covering using a roller so as to remove any trapped air bubble.
8. Apply Sikaflex 221 gray sealant (680532) alongside passenger seat fixing tracks (refer to figure 48).

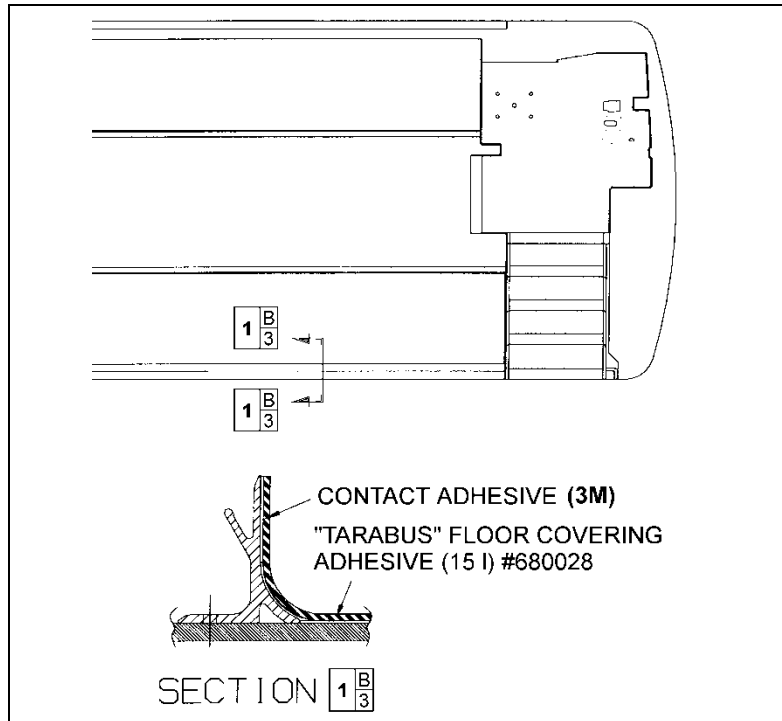

FIGURE 55: TARABUS FLOOR COVERING ADHESIVE APPLICATION 18640

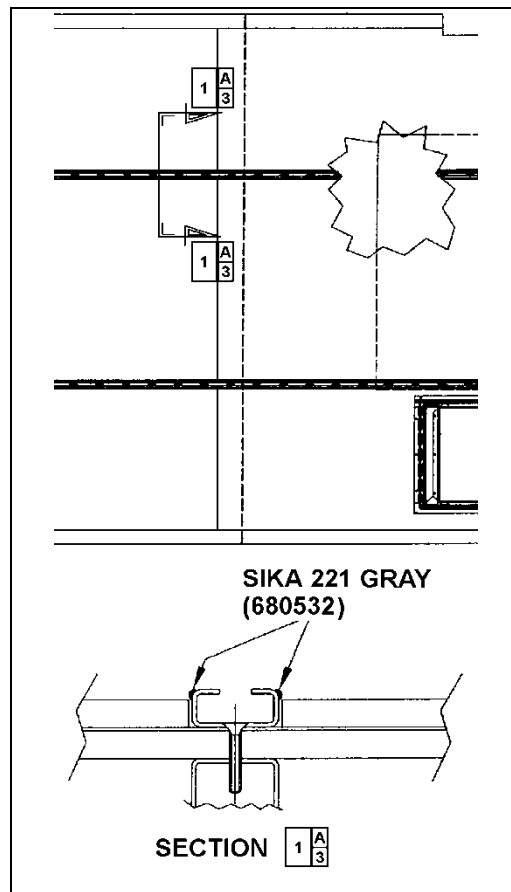

FIGURE 56: APPLICATION OF SIKA 221 GRAY 18641

18.1 Front Steps Replacement Procedure

MATERIAL

Part No	Description	Qty
682989	Anti-silicone	A/R
683097	Sika 205 (1 liter)	A/R
685101	Sika Remover 208	A/R
683916	Sika 215 (1 liter)	A/R

1. Cut and remove damaged step(s).
2. Remove dirt and adhesive residue.

NOTE
In wintertime, condensation and cold temperature may greatly influence bonding parameters. Working area must be at a temperature sufficient to prevent reaching condensation point. Mechanically preheat working area (heat lamp or heat gun) or wait until vehicle reaches room temperature.

PREPARATION OF “TARABUS” FLOOR COVERING

1. Sand under step using “Scotchbrite”.
2. Clean using anti-silicone (refer to Section A).

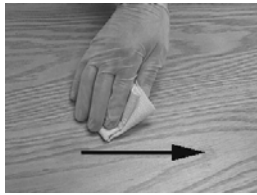
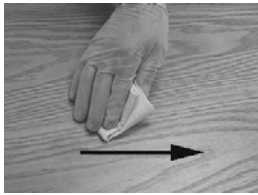
Section A Alcohol or Anti-silicone	
	<p>1. Apply</p> <p>CHIX cloth</p>
	<p>2. Dry immediately</p> <p>Blue cloth</p>
3. Allow drying	
Mandatory	Minimum time : Wait for product to evaporate
	After 2 hours: Start cleaning operation again
Before applying any other product	If surface seems dusty, greasy or with finger marks, start cleaning operation again.

3. Apply Sika Primer 215 (refer to Section D).

Section D Sika Primer 215

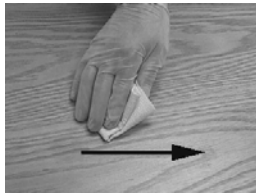

1. Shake bottle to mix product
2. Apply a thin layer

CHIX cloth

3. Allow drying

Mandatory	215	Minimum time : 20 minutes
		After 2 hours : Remove dust using damp cloth (pure water)
Before applying any other product		If surface seems dusty, dust using damp cloth.
		If surface seems greasy or with finger marks, reactivate with Aktivator.

PREPARATION OF FIBERGLASS

1. Clean using anti-silicone (refer to Section A).
2. Apply Sika 205 (refer to Section B).

Section B Sika 205

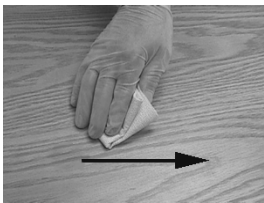

1. Apply

CHIX cloth

2. Allow drying

Mandatory	Minimum time	- For a smooth surface (aluminum, stainless, steel, fiberglass (gelcoat side), etc.):	2 minutes
		- For a porous surface (fiberglass (non gelcoat side), etc.)	10 minutes

After 2 hours : Reactivate surface with Sika 205

Before applying any other product	If surface seems dusty, greasy or with finger marks, start operation again.
--	---

X3 VEHICLES FRONT STEPS GLUING

1. Use step nosing to measure and cut necessary length of white safety strip.
2. Use a screw to check depth of countersinking in step nosing. Screw top must not stick out beyond the aluminum surface. Countersink if needed.

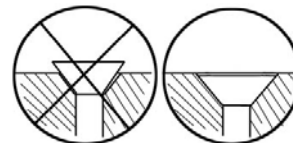

3. Apply some Sika 252 onto the step; make sure to cover the whole surface of the step. Use a serrated spreader with 1/8-inch serration to spread Sika.
4. Apply a bead of Sika 221 onto the perimeter of the step.

5. Install step and press with hands. If Sika overflows, clean with Sika 208. Repeat previous stages for each step if applicable.
6. Remove protective film from double-coated self adhesive tape located underneath step nosing, position step nosing then press. Drill and fix using screws.

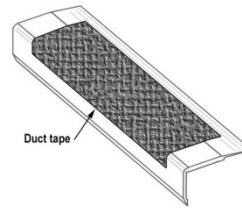

7. Clean top of step nosing using Sika 205 (refer to Section B).



8. Apply some Sika 221 onto white safety strip, spread with a spatula to cover the whole surface.

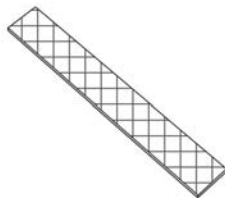

9. Position white safety strip then press using hands. If Sika overflows, clean with Sika 208.

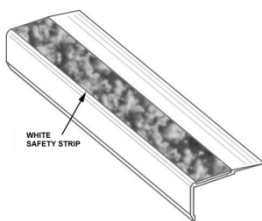

10. Temporarily fix white safety strip with a piece of duct tape, leaving 1 to 2 inches free at each end.

11. Apply some masking tape onto the step perimeter, clean using Sika 205 (refer to Section B) then apply a bead of Sika 252 black. Smooth out the joints then remove masking tape.

12. Install weights onto the steps. Minimum waiting time: 2 hours.

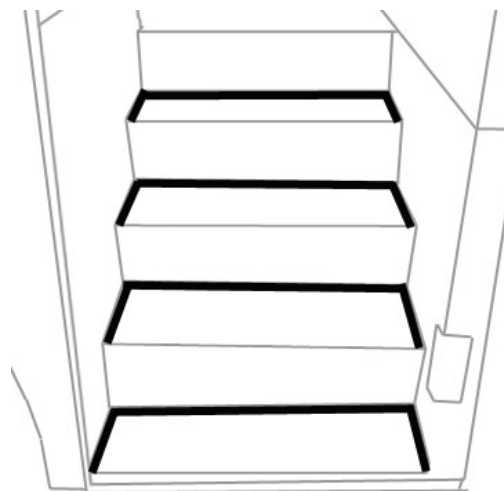

18.1.1 WELDING OF JOINT BETWEEN WHITE SAFETY STRIP AND "TARABUS" FLOOR COVERING

1. Pre-heat welding torch;
 - Set welding torch to position #4.5 (temperature of 500 °C),
 - Heating time: 5 minutes.
2. Before welding, visually ensure that a 1 to 1.5 mm gap exists between white safety strip and "Tarabus" floor covering. Use a knife if this is not the case.

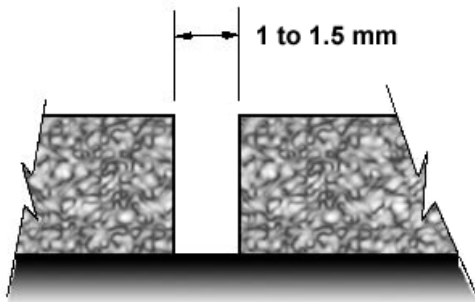

NOTE

There should be no excess of adhesive on top of surfaces, clean if required using "All-Sol".

3. Chamfer the joint.

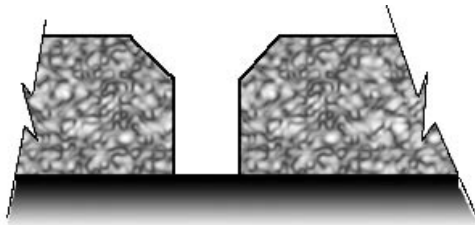

NOTE

The chamfer width must always be less than the filler bead diameter (between 2.5 and 3 mm).

4. Use chamfer knife. **Be careful not to overcut or to cut to the side to prevent damaging "Tarabus" covering.**



5. Add (about 6 inches) some length to the required length of filler bead to make the joint then cut.
6. Take position with welding torch. The proper position is with a slight slope to the rear.



7. Once the welding torch is ready, insert the filler bead into the nozzle and immediately start welding. Move in a regular manner while pressing slightly with torch.



8. The heel of the fast nozzle must not lean against "Tarabus" covering (always parallel to the surface).



9. Allow cooling down of filler bead (about 5 minutes).

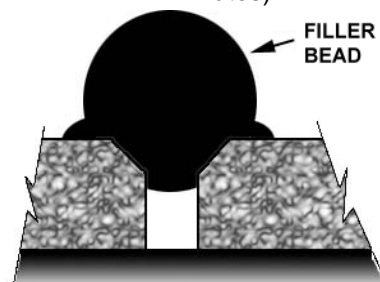

- Shave filler bead to make it level to the floor.
Use supplied knife designed for that purpose.

NOTE
To facilitate the cut, you can spray some soapy water onto the joint.

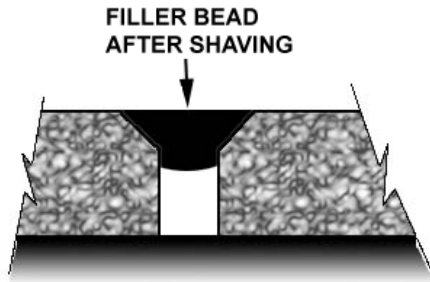

CAUTION
The procedure for turning the torch off must absolutely be followed. If this step is not taken, the element may burn.

- Set temperature potentiometer to "0" position. Fan will evacuate residual heat. Leave the torch in operation as it is for 3 minutes.
- Perform adhesion test using the tip of a flat screwdriver; apply a slight pressure on the joint.

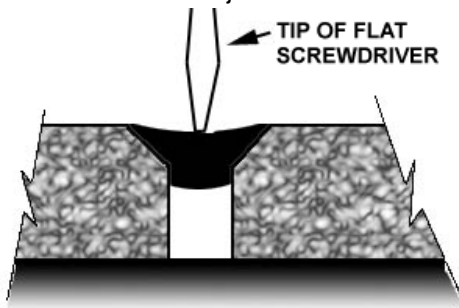

- If welding was not performed properly, there will be a loss of adhesion on one side. If this is the case, repair the joint.

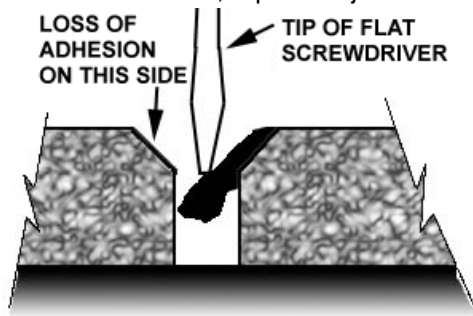

18.2 Repair Of A Welded Joint

NOTE
In wintertime, condensation and cold temperature may greatly influence bonding parameters. Working area must be at a temperature sufficient to prevent reaching condensation point. Mechanically preheat working area (heat lamp or heat gun) or wait until vehicle reaches room temperature.

- Using a knife, remove portion of joint to be repaired.

NOTE
Loss of adhesion may be local. If this is the case, repair may also be local.

- Chamfer the joint again as indicated in paragraph 6.10.2, Section: Welding Of Joint Between White Safety Strip And "Tarabus" Floor Covering.
- Re-weld the joint as indicated in paragraphs 6, 7 and 8. Use your thumb to hold the filler bead end.

WARNING
Nozzle is hot.



- Always add an extra inch of filler bead at the beginning and at the end of repair.
- Perform steps indicated in paragraphs 9, 10 and 11.
-

19. SECTION CHANGE LOG

	DESCRIPTION	DATE
1		
2		
3		
4		
5		
6		



PREVOST

ENREGISTRÉ - REGISTERED
ISO 9001 & ISO 14001

MAINTENANCE Mi14-01B INFORMATION



DATE : JANUARY 2014

**SUBJECT : HOISTING AND TOWING PROCEDURE FOR
NYCT X3-45 COMMUTER BUSES**

APPLICABLE TO:

DOB Bus Number Series 2400 – 2489

DOB Bus Number Series 2490 - 2789

- Revision A:
- Addition of comments following front tow demonstration at Zerega CMF, Bus 2491, March 19, 2014
 - Addition of comments following rear tow demonstration at Zerega CMF, Bus 2425, December 13, 2013
 - MI14-01A merged with MI12-03. MI12-03 is canceled
- Revision B:
- Introduction of ZF A-132 drive axle
 - Addition of comments following rear tow demonstration, June 2, 2014

TABLE OF CONTENT

1. HOISTING AND TOWING POINTS.....	3
1.1 GENERAL DESCRIPTION	3
1.2 CHASSIS HOISTING POINTS.....	3
1.3 AXLES HOISTING POINTS	5
1.4 WHEELS AS HOISTING POINTS.....	8
2. TOWING	9
2.1 BEFORE TOWING PREPARATION	10
2.1.1 Air Supply	10
2.1.2 Drive Axle Flange Shafts Removal.....	12
2.2 TOWING FROM THE FRONT.....	14
2.2.1 First Lift.....	15
2.2.2 Second Lift- Front Tow Eye Pads as Lifting Point for Towing.....	17
2.2.3 Second Lift- Front Axle as Lifting Point for Towing.....	21
2.3 TOWING WITH ALL WHEELS ON THE GROUND USING REAR TOW EYES – FITTED ON DOB BUS NUMBER SERIES 2490-2789 ONLY	25
3. REAR TOW USING NOT APPROVED LIFTING POINTS - FOR EMERGENCY SITUATIONS ONLY	26
3.1 PRECAUTIONS	26
3.2 FIRST LIFT.....	27
3.3 SECOND LIFT.....	28

1. HOISTING AND TOWING POINTS

1.1 GENERAL DESCRIPTION

This procedure applies to NYCT X3-45 Commuter buses DOB bus number series 2400-2489 and 2490-2789.

There are several hoisting and towing points. Use only these points when performing hoisting and towing of the bus (fig.1).

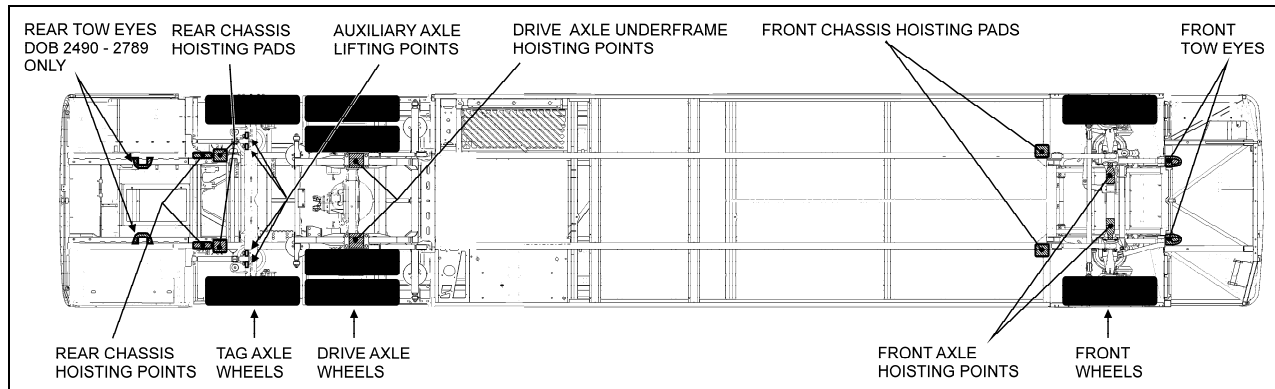

FIG.1 HOISTING AND LIFTING POINTS DIAGRAM

1.2 CHASSIS HOISTING POINTS

The vehicle is provided with six chassis hoisting points. Use chassis hoisting points in replacement of wheels as lifting points when the vehicle cannot be supported from an axle on which repair or maintenance is being done, otherwise use wheels as lifting points.

When using the chassis hoisting points to support the bus, **the tag axle must be unloaded at all time.** To prevent damages to the suspension, **always support the drive and front axles using jack stands** when using chassis hoisting points.

CHASSIS HOISTING POINTS
2 hoisting pads with receptacles located aft of the front axle (fig.4)
2 hoisting pads with receptacles located aft of the tag axle (fig.3)
2 hoisting points located aft of the tag axle (fig.2)



FIG. 2 CHASSIS HOISTING POINTS - AFT OF TAG AXLE



FIG.3 CHASSIS HOISTING RECEPTACLES - AFT OF TAG AXLE



FIG.4 CHASSIS HOISTING RECEPTACLES - AFT OF FRONT AXLE



FIG.5 JACK STAND AT CHASSIS HOISTING RECEPTACLE - AFT OF FRONT AXLE, ROAD SIDE



FIG.6 JACK STAND AT CHASSIS HOISTING RECEPTACLE - AFT OF FRONT AXLE, CURB SIDE



FIG.7 JACK STAND AT CHASSIS HOISTING RECEPTACLE - AFT OF TAG AXLE, ROAD SIDE



FIG.8 JACK STAND AT CHASSIS HOISTING RECEPTACLE - AFT OF TAG AXLE, CURB SIDE



FIG.9 10-TON CAPACITY JACK STAND



FIG.10 16500 LBF CAPACITY



FIG.11 20-TON CAPACITY JACK STAND



WARNING

Prior hoisting, park the bus on a level surface and apply parking brake.

The bus can be supported at the chassis hoisting pads (refer to HOISTING AND LIFTING POINTS diagram). Use a jack stand of 10 tons capacity at each of the four chassis hoisting pads.



WARNING

Hydraulic jacks are intended for lifting only. Do not get under the bus for any reason unless it is properly supported with safety jack stands.

1.3 AXLES HOISTING POINTS

AXLES HOISTING POINTS

2 front axle hoisting points (fig.12-15)

2 drive axle underframe hoisting points (fig.16-17)

2 hoisting points under the tag axle (tag axle must be unloaded) (fig.18)

To assure stability, always use the two hoisting points under a specific axle simultaneously.

Two hoisting points are located under the tag axle. Using the tag axle as rear hoisting points for the vehicle should be avoided. When possible, use the drive axle as hoisting point.

The vehicle can be lifted from the front axle and the drive axle underframe using lifting equipment of appropriate capacity.

APPROXIMATE WEIGHT PER AXLE

vehicle supported at front axle and drive axle underframe

Front axle: 12,000 lb. (5 443 kg)

Drive axle: 26,500 lb. (12 020 kg)



WARNING

The suspension must be in the normal ride position before hoisting.



WARNING

To prevent damage to suspension components, always unload the tag axle before hoisting the bus.



WARNING

The hoisting points on the tag axle must be used for raising the tag axle only.

FRONT AXLE HOISTING POINTS – DOB Bus Number Series 2400 - 2489

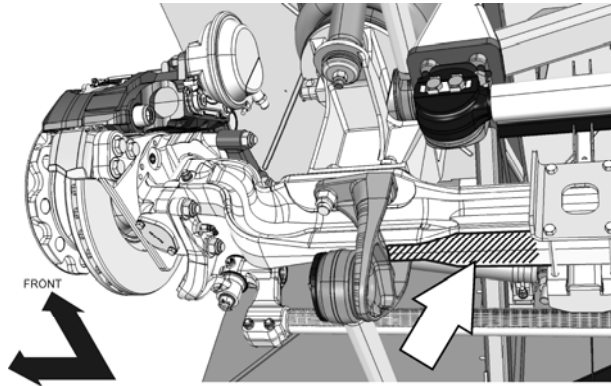

FIG.12 FRONT AXLE HOISTING POINT - CURBSIDE

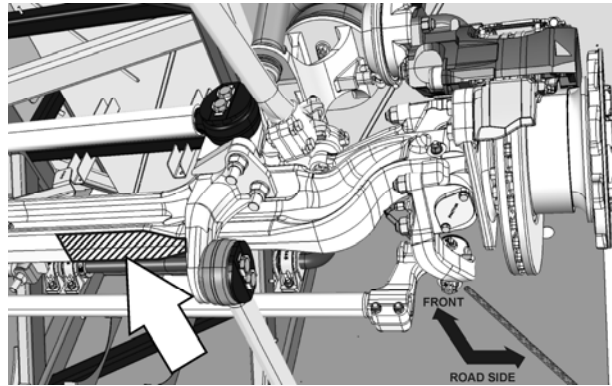

FIG.13 FRONT AXLE HOISTING POINT – ROAD SIDE

FRONT AXLE HOISTING POINTS – DOB Bus Number Series 2490 - 2789

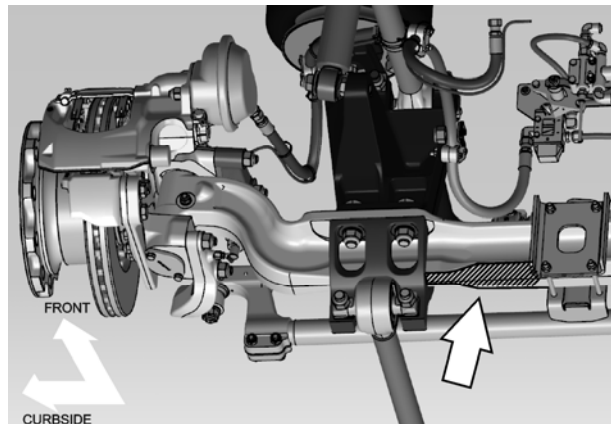

FIG.14 FRONT AXLE HOISTING POINT - CURBSIDE

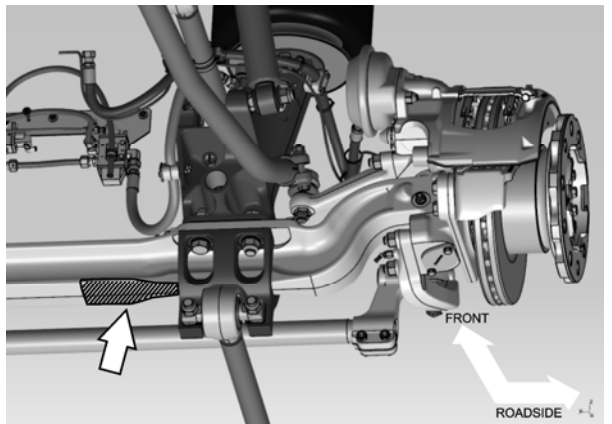

FIG. 15 FRONT AXLE HOISTING POINT – ROAD SIDE

DRIVE AXLE UNDERFRAME HOISTING POINTS – DOB Bus Number Series 2400 - 2489

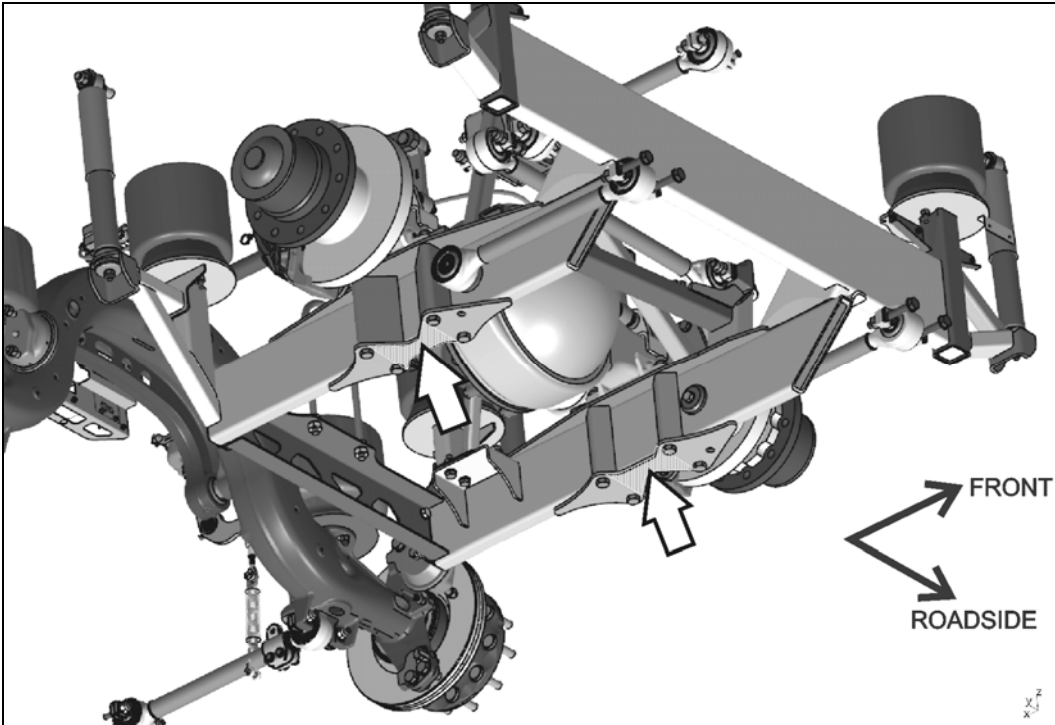

FIG.16 DRIVE AXLE UNDERFRAME HOISTING POINTS – DOB BUS NUMBER SERIES 2400 - 2489

DRIVE AXLE UNDERFRAME HOISTING POINTS – DOB Bus Number Series 2490 - 2789

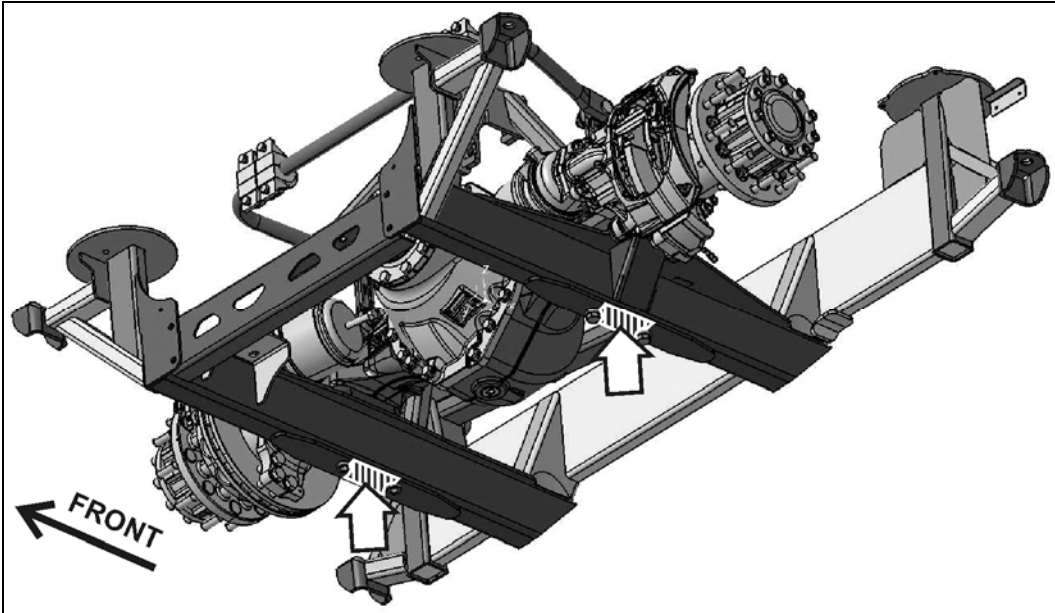

FIG.17 DRIVE AXLE UNDERFRAME HOISTING POINTS – DOB BUS NUMBER SERIES 2490 - 2789

TAG AXLE HOISTING POINTS

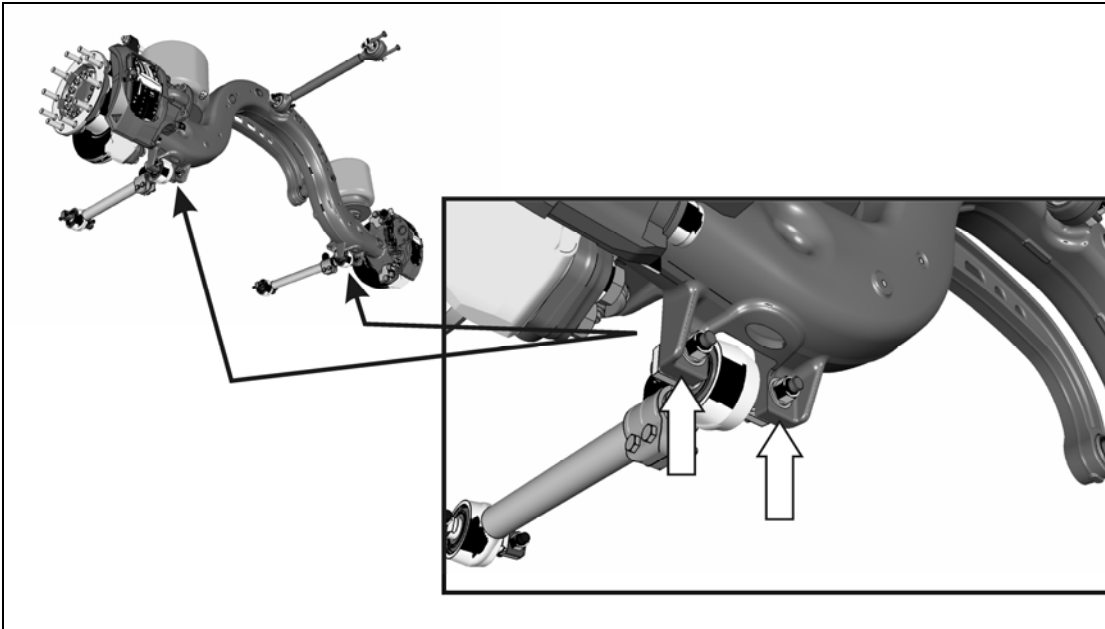

FIG.18 TAG AXLE HOISTING POINTS (use only to support the tag axle)

1.4 WHEELS AS HOISTING POINTS

Use the front and drive axle wheels to lift the bus when using **mobile column lifts**. When doing so, the tag axle must be unloaded at all time.

Using the tag axle wheels as the only lifting point for the rear of the bus should be avoided. However, if the rear of the bus has to be lifted using the tag axle wheels only, the tag axle must be unloaded at all time.

2. TOWING

Towing from the front is recommended in order to move an immobilized bus. Prevost does not recommend towing from the rear using hoisting points that are not approved as the bus may sustain structural damage.

The bus should be towed by truck operators authorized and experienced in towing highway buses.

Observe normal precautions including, but not limited to, the ones listed below when towing the bus:

- Make sure the parking brake or the emergency brake is released at time of towing.
- Do not allow passengers to ride onboard the towed bus.
- Tow the bus at a safe speed as dictated by road and weather conditions.
- Accelerate and decelerate slowly and cautiously.
- Avoid sharp turns where possible.



WARNING

Do not carry passengers while the bus is being towed.



CAUTION

Avoid towing the bus from the rear using hoisting points that are not approved as this will cause structural damage. In case of damage to the drive train components, use a low bed semi-trailer.



WARNING

Engage the parking brake to prevent the bus from moving before you begin maintenance or service procedures that require you to be under the bus. Serious personal injury can result.



CAUTION

Lift the bus at the minimal height required for the bus to trail the tow truck.

2.1 BEFORE TOWING PREPARATION

1. Set the transmission to neutral and apply parking brake.
2. Chock the wheels to prevent the bus from moving at time of releasing the parking brake during the towing preparation.
3. On the L.H. dashboard panel, turn on the hazard warning flashers. Preferably, use a towing light bar.



FIG.19

4. Place the front wheels in a straight-ahead position and keep the steering wheel from turning. To do so, slide the driver's seat close to the steering wheel. Wrap the safety belt around and through the steering wheel and then fasten safety belt.

This will assure the bus to roll in straight direction and eventually to be stopped by the tow truck in the eventuality of a mechanical failure of the tow truck lifting equipment.



FIG.20

2.1.1 Air Supply

Operate the engine when towing to maintain brake system air pressure. If the engine cannot be operated, connect external air pressure lines from the tow truck.



CAUTION

Do not tow the bus without external air pressure applied to the emergency fill valve if the engine does not operate. Without brake system air pressure, the emergency spring brakes may apply automatically if system air drops below 40 psi (275 kPa). If failure prevents releasing the parking brakes with air pressure, disengage the parking brakes mechanically.

“Brake” quick connect fitting

Flip down the access door located on the front bumper, connect an auxiliary air supply from the tow truck in order to supply air for operation of the bus **service brake** from the tow truck (fig.21 & 22).

“Air supply” quick connect fitting

While the vehicle is being towed, connect an auxiliary air supply from the tow truck to the quick connect fitting identified AIR SUPPLY to supply air for all systems (brakes, suspension, accessories) through the air dryer (fig.21 & 22).



FIG.21

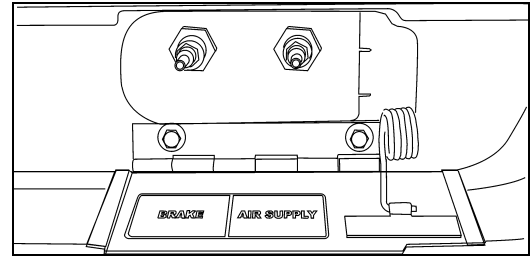

FIG.22 FRONT TOWING AIR SUPPLY ACCESS PANEL QUICK CONNECT FITTINGS

Engine compartment emergency air-fill valve

An additional emergency fill valves is available to supplement the air system when air pressure is low and the engine cannot be operated. This valve is located in the engine compartment (fig.23) and supplies air for all systems (brakes, suspension and accessories).



FIG.23 ENGINE COMPARTMENT EMERGENCY AIR-FILL VALVE

2.1.2 Drive Axle Flange Shafts Removal

1. Apply the bus parking brake.
2. Remove the stud nuts and the washers (with Meritor drive axle) or cap screws (with ZF drive axle) from the flange shaft.

NOTE: there is oil behind the flange shaft which comes out during disassembly

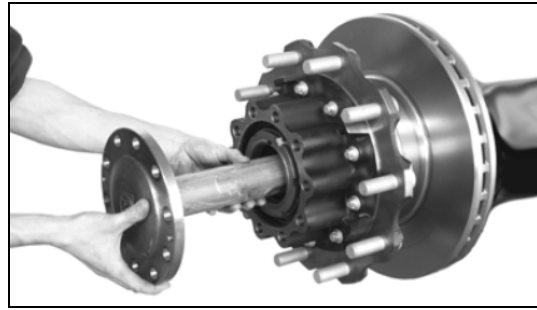

FIG. 24 ZF A-132 AXLE

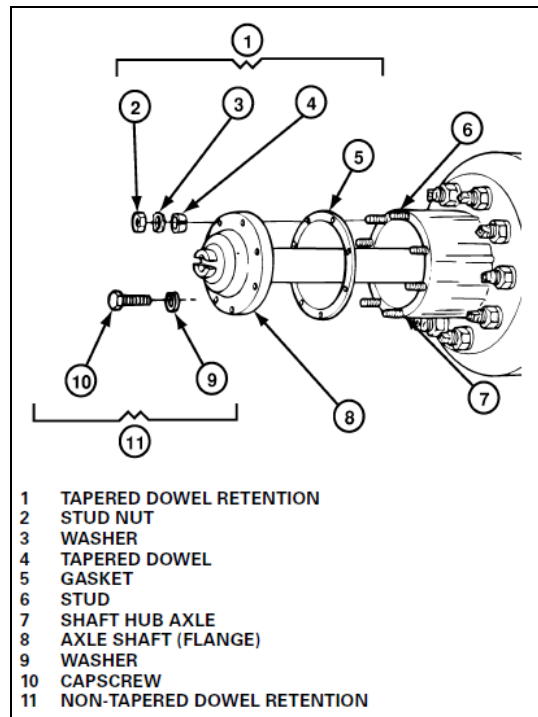

FIG.25: MERITOR RC23-165 AXLE



CAUTION

Do not use a chisel or wedge to loosen the axle flange shaft and tapered dowels. Using a chisel or edge can result in damage to the axle shaft, the gasket and seal, and/or the axle hub.

3. **Meritor axle:** Loosen the tapered dowels in the flange of the axle shaft using the following methods.
 - a) Do not strike the round driving lugs on the flange of an axle shaft. Pieces can break off and cause serious personal injury. A 1.5-inch (38.1 mm) diameter brass hammer can be used as a drift.
 - b) Hold a 1.5-inch (38.1 mm) diameter brass drift against the center of the axle shaft flange, **inside the round driving lugs.**
 - c) Hit the end of the drift with a large hammer (5 to 6 lbs.) to loosen the axle shaft and tapered dowels from the hub.
4. Identify each axle shaft that is removed from the axle assembly so they can be installed in the same location after transporting or repair is completed. (Example: Match mark a mating axle shaft and hub).

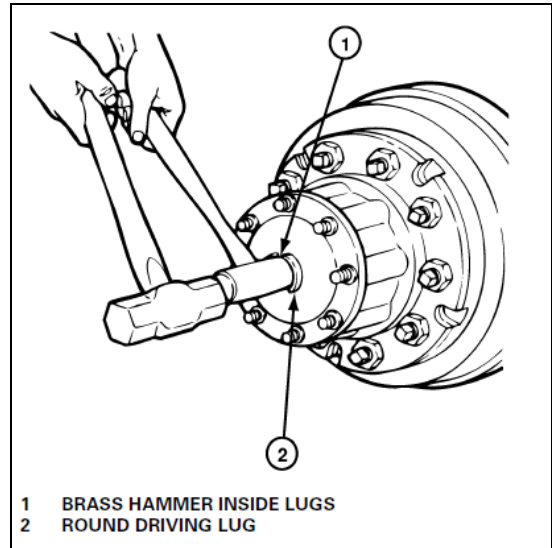

FIG.26: MERITOR RC23-165 AXLE

5. Remove the tapered dowels (if used), gasket or O-ring and the axle shaft from the axle assembly. Use a container to recover the oil.
6. Remove opposite flange shaft similarly.
7. Install a temporary cover over the open end of each hub where an axle shaft was removed. This will prevent dirt from entering the bearing cavity and loss of lubricant.

After Towing

1. Remove the covers from the hubs.
2. Install the gasket or O-ring, and axle shaft into the axle housing and carrier in the same location it was removed from. The gasket and flange of the axle shaft must be flat against the hub. Rotate the axle shaft and/or the driveline as necessary to align the splines and the holes in the flange with the studs or holes in the hub.
3. **Meritor axle only:** Install the dowels over each stud and into the tapered holes of the flange.
4. Install the washers and stud nuts or cap screws.

MERITOR RC23-165 AXLE	ZF A-132 AXLE
Determine the size of the fasteners and tighten the nuts to the corresponding torque value shown below. <ul style="list-style-type: none"> • 9/16-18 plain nut: 110 - 165 lbf-ft (149-224 Nm) • 5/8-18 plain nut: 150 - 230 lbf-ft (203- 312 Nm) 	Tightening torque M18x1.5 G10.9 screw 325 lbf-ft (440 Nm)

5. Mount opposite flange shaft similarly.
6. Inspect the lubricant level in the axles and hubs where the axle shafts were removed. Add the correct type and amount of lubricant if necessary.



CAUTION

Make sure axle shafts or driveshaft are installed correctly after towing. Tighten axle shaft and driveshaft nuts to the correct torque settings. Do not invert shafts.

2.2 TOWING FROM THE FRONT

The towed bus must be lifted from the front with front wheels off the ground. The tow truck must be equipped with the proper lifting equipment i.e. tow bar, axle forks and holders to reach under the **front axle** or the **front tow eye pads** since no other lifting points are recommended for towing. Lifting and towing from any other point are not authorized as it may cause structural damage. **To prevent overloading the drive axle, do not unload or raise the tag axle when towing the bus.**

To prevent damage to the bus, use the **front tow eye pads** fixed to the bus chassis between the front axle and the front bumper. Use only a solid link tow bar and safety chains to tow the bus.

1. Block the wheels to prevent the bus from moving.
2. Perform the BEFORE TOWING PREPARATION. Refer to paragraphs 2.1 and 2.1.1.
3. Disconnect both drive axle shafts to prevent damage to the transmission. Plug axle tube to prevent oil loss. Refer to **2.1.2 DRIVE AXLE SHAFTS REMOVAL**.



CAUTION

Transmission lubrication is inadequate when towing. The axle shafts must be disconnected to avoid serious damage to the transmission.

To prevent damage to the drive train components, disconnect drive axle shafts before towing. Do not attempt to push or pull-start a bus equipped with an automatic transmission.

Failure to disconnect the propeller shaft, remove the drive axle shafts or lift the drive wheels off the ground before towing can cause serious transmission damage and void the warranty.

2.2.1 First Lift

To allow lifting equipment fitted with axle forks to reach under the front axle or tow eyes, it is necessary to perform a first lift of the front of the bus using the tow eye pads as lifting points. This first lift will allow tow cans or blocks to be placed underneath front tires.

1. Retract the tow truck stinger arm.
2. On the first lift, position the tow bar fork holders under the front tow eye pads (fig.27-29) to lift the bus in order to place the front wheels firmly on the tow cans or blocks.

Center to center measurement between tow eyes= 37 inches (fig.27)

Note: No axle forks are needed for this first lift

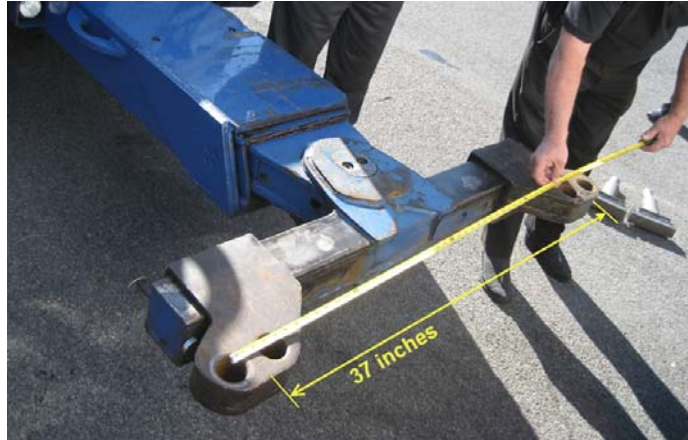

FIG.27

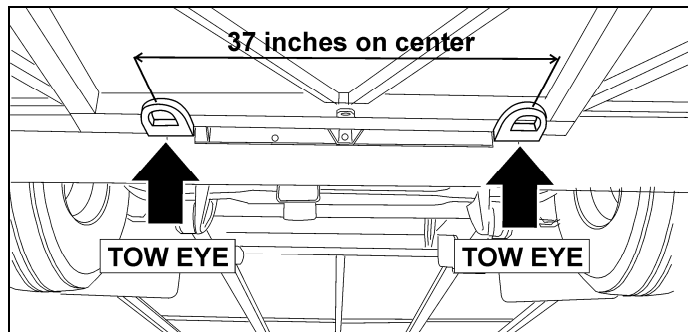

FIG.28



FIG.29 TOW EYE

3. Deploy the tow truck stinger arm, placing the axle fork holders under the tow eye pads (fig. 30).

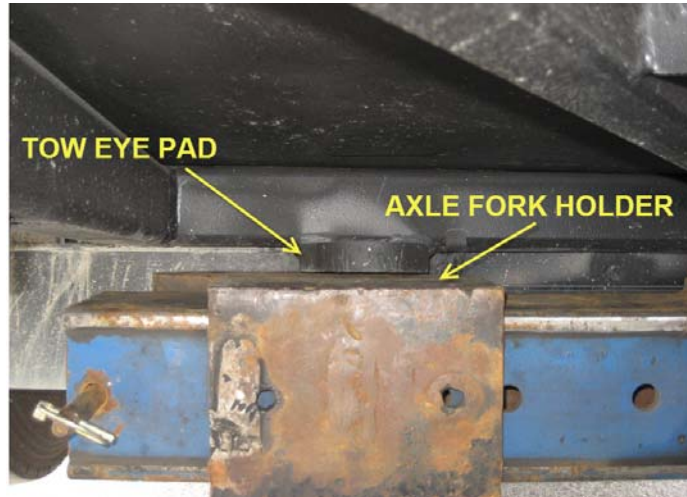

FIG.30

4. Lift the front end of the bus high enough to allow installation of tow cans or blocks. Place the tow cans or blocks perfectly centered underneath each front wheel (fig. 31).
5. With precaution, lower the front of the bus



FIG.31

2.2.2 Second Lift- Front Tow Eye Pads as Lifting Point for Towing

The tow eye pads fixed to the vehicle chassis, fore of the front axle will be used as front end lifting point for towing.

1. Perform the first lift as instructed in paragraph 2.2.1 if not already done.
2. Place the axle forks on the tow bar fork holders (fig.32).

Use 3" to 4 ½" mouth axle forks preferably



REGULAR

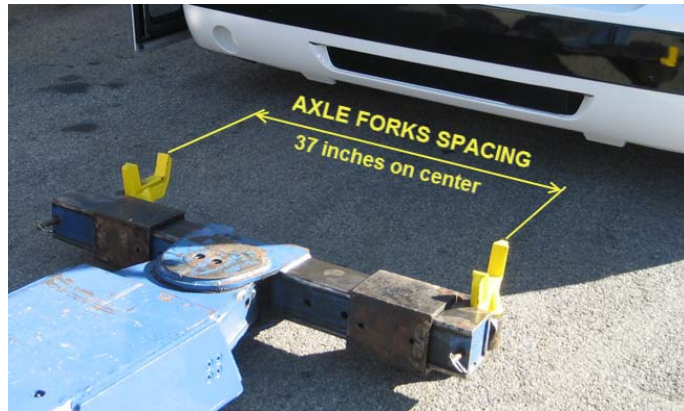

FIG.32

Pre-adjust spacing between axle forks to = 37 inches

3. Lower the tow bar and position under the front tow eye pads.
4. Adjust fork holders position and hand guide the forks into each front tow eye (fig.32).
5. Lift the tow bar until the axle forks fit snugly into the front tow eyes (fig.33).



FIG.33

Axle forks properly engaged in tow eyes (fig. 33 & 34)



FIG.34

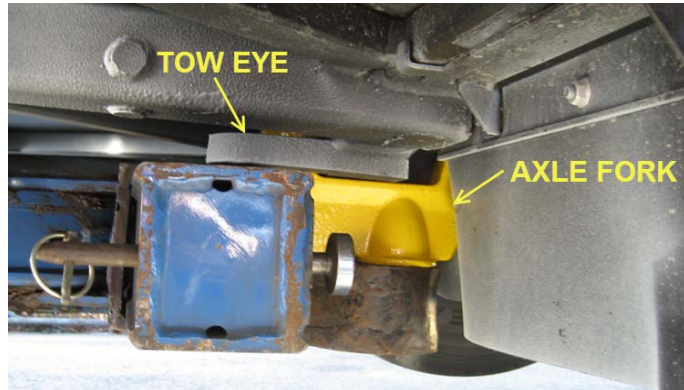

FIG.35

6. Raise the front of the bus.
7. Install a jack stand under the stinger arm for support and safety purposes and then lower the stinger arm so it rests on the jack stand (fig.36). The tow cans or blocks can be removed from under the front axle wheels.



FIG.36

8. Tie the two choke chains together to secure the tow eyes to the tow bar attachment (fig.37).



FIG.37

9. Attach the two tow truck safety chains from each of the two front lower radius rods (fig.38) of the bus to the truck's tow eyes (fig.39).



FIG.38

10. Connect the two truck air lines to the service and brake supply air quick connect fittings adjacent and right above the front bumper (for more details, refer to paragraph 2.1.1 Air Supply in this document).



FIG.39

11. Raise the stinger arm and remove the support jack stand.
12. Lower the bus. The front tires should be 7" to 8" above the ground before the tow can proceed.
13. Use bungee cords to support the safety chains (fig.40).



FIG.40

14. If required, use the appropriate jig to assure that the highest point on the bus **does not exceed** the maximum allowable height for towing (fig.41).
15. Make sure the **parking brake** is released before moving the vehicle.
16. Observe safety precautions when towing.



FIG.41

Avoid sharp turns where possible as safety chains may rub and damage the front bumper (fig.42)



FIG.42

2.2.3 Second Lift- Front Axle as Lifting Point for Towing

This method uses the front axle as lifting point for towing (see fig.12-15).

1. Perform the first lift as instructed in paragraph 2.2.1 if not already done.
2. Install regular axle forks onto tow bar fork holders.

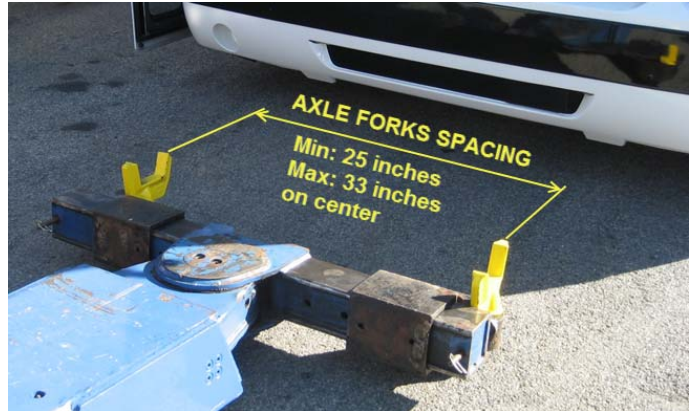

FIG.43

Pre-adjust spacing between axle forks

Minimum spacing: 25 inches
Maximum spacing: 33 inches

3. Lower the stinger arm to position the axle forks under the front axle hoisting points (fig.12-15).
4. Lift the tow bar until the axle forks grab the front axle I-beam at the hoisting points (fig.44 & 45).
5. Raise the front of the bus.



FIG.44

6. Install a jack stand under the stinger arm for support and safety purposes and then lower the stinger arm so it rests on the jack stand (fig.46). The tow cans or blocks can be removed from under the front axle wheels.
7. Tie the two choke chains together to secure the front axle to the tow bar. Take up any slack that may remain and maintain proper tension on chains.



FIG.45



FIG.46

8. Attach the two tow truck safety chains from each of the two front tow eyes of the bus to the truck's tow eyes (fig.47 & 48).
9. Connect the two truck air lines to the service and brake air supply quick connect fittings adjacent and right above the front bumper (for more details, refer to paragraph 2.1.1 Air Supply in this document).
10. Raise the tow bar in order to remove the jack stand from under the stinger arm.
11. Lower the bus. The front tire should be about 7" to 8" above the ground before the tow can proceed.



FIG.47



FIG.48

12. Use bungee cords to support the safety chains (fig.49).



FIG.49

13. Make sure that the **parking brake** is released before moving the vehicle.
14. Observe safety precautions when towing.



FIG.50

Avoid sharp turns where possible as safety chains may rub and damage the front bumper (fig.51)



FIG.51



CAUTION

Make sure a safe distance is kept between the front of the bus and the tow truck. This space ensures that bus does not suffer damages when being towed.



CAUTION

Make sure axle shafts or driveshaft are installed correctly after towing. Tighten axle shaft and driveshaft nuts to the correct torque settings. Do not invert shafts.



DANGER

Do not carry passengers while the bus is being towed.

2.3 TOWING WITH ALL WHEELS ON THE GROUND USING REAR TOW EYES – FITTED ON DOB BUS NUMBER SERIES 2490-2789 ONLY

To recover a bus which is no longer on a drivable surface, chains can be looped around or hooked to the rear tow eyes.

This method should be used when the bus has to be moved with its wheels on the ground over a short distance only. After the bus has been brought back on a drivable surface, it should be lifted and towed from the front, with front wheels off the ground.

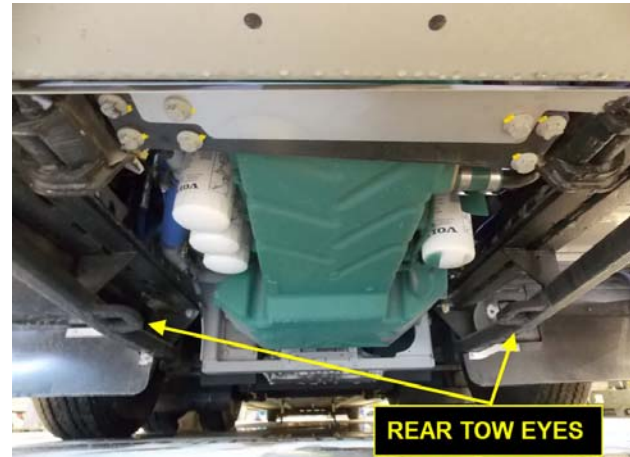

FIG.52 REAR TOW EYES ON SIDE-MEMBERS LOCATED UNDER ENGINE CRADLE SUPPORT RAILS

3. REAR TOW USING NOT APPROVED LIFTING POINTS - FOR EMERGENCY SITUATIONS ONLY

FOR EMERGENCY SITUATION ONLY



CAUTION

The bus should **NOT** be lifted and towed from the rear unless an emergency situation occurs or when the bus has already been damaged and must be moved over a very short distance such as in a parking lot.

Lifting the rear end from the engine cradle or from the side-members located under the engine cradle support rails should be avoided. Doing so may cause structural damage (see image further in this document).

3.1 PRECAUTIONS

In an emergency situation or if the vehicle has to be moved over a short distance, the side-members may be used as lifting point. Try to lift from the strongest location along the side-members which is near the rear subframe vertical member (fig.53).

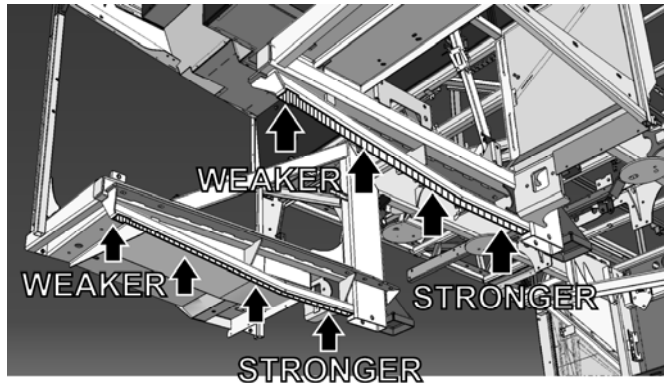

FIG.53: LIFTING POINTS NOT APPROVED FOR REAR-END TOWING – SIDE-MEMBERS LOCATED UNDER THE ENGINE CRADLE SUPPORT RAILS

Lift with precautions as the vehicle may sustain structural damage at the vertical structure shown on the image at right (fig.54).

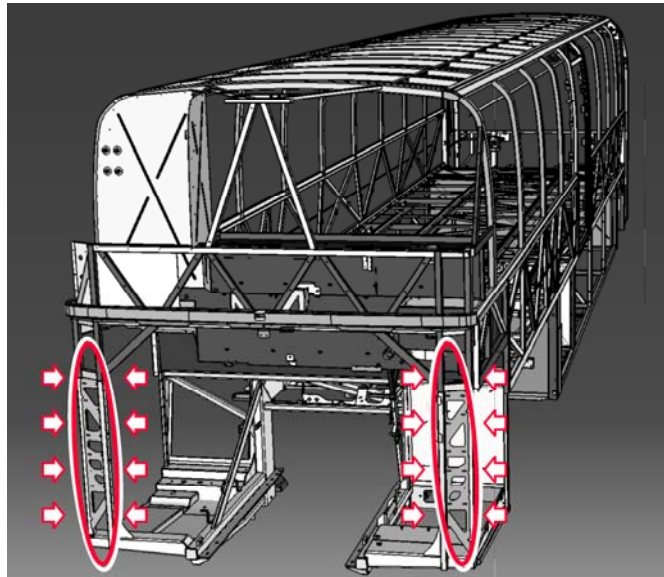

FIG.54: THE VEHICLE MAY SUSTAIN STRUCTURAL DAMAGE WHERE INDICATED WITH ARROWS DURING TOWING FROM THE REAR



DANGER

Do not carry passengers while the bus is being towed.

3.2 FIRST LIFT

A first lift of the bus is necessary. This first lift will allow tow cans or blocks to be placed underneath the drive axle tires.

1. Prepare the bus for towing as instructed in paragraphs 2.1 and 2.1.1
2. If not already done, chock the front wheels.
3. Retract the tow truck stinger arm (fig.55).
4. Pre-adjust spacing between the axle fork holders. The spacing between the most distant edges of the fork holders should be **30 inches** (fig.55).

No axle forks will be used for this first lift

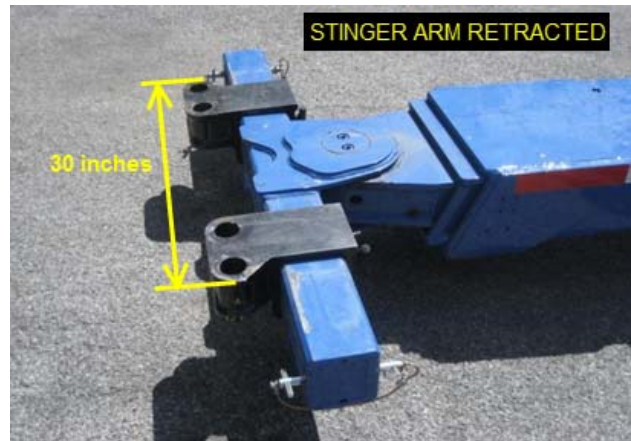

FIG.55

5. Deploy the tow truck stinger arm. Place the fork holders under the engine cradle transverse beam as shown on fig.56. Lift the tow bar until the fork holders come into contact with the cradle transverse beam.

Lifting from the engine cradle is the least preferred option and should be done only if lifting from under the side-members shown on figure 53 cannot be achieved



CAUTION

Remember, lifting the rear end from the side-members located under the engine cradle or by the engine cradle itself may cause structural damage.



CAUTION

Use caution when lifting from the engine cradle transverse beam. Maintain the bus in that situation during the shortest period of time.

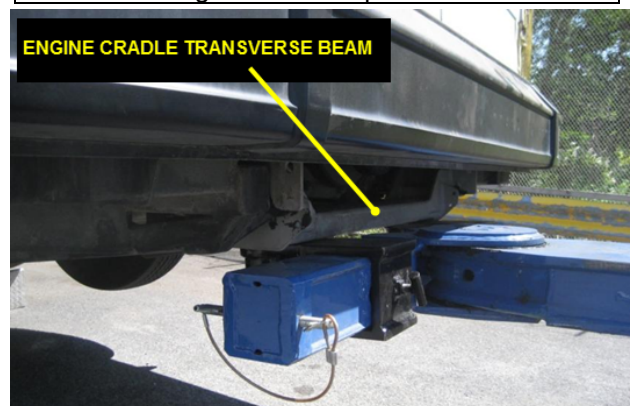

FIG.56

6. Raise the tag axle to prevent it from hanging unsupported. To do so, open the front service compartment located on street side and move the tag axle air valve lever forward as shown on figure 57.

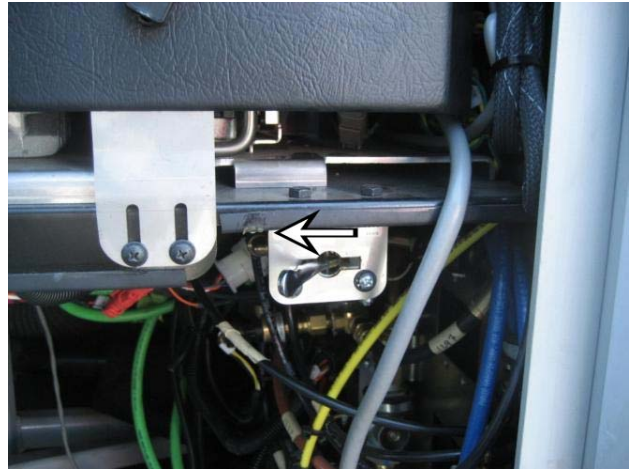

FIG.57

7. Lift the rear end of the bus high enough to allow installation of tow cans or blocks underneath the drive axle wheels (fig.58).
8. With precaution, lower the rear of bus.



FIG.58

3.3 SECOND LIFT

1. Perform the first lift as instructed in paragraph 3.2 if not already done.
2. Retract the tow truck stinger arm.
3. Pre-adjust spacing between the axle fork holders to **43 inches**.

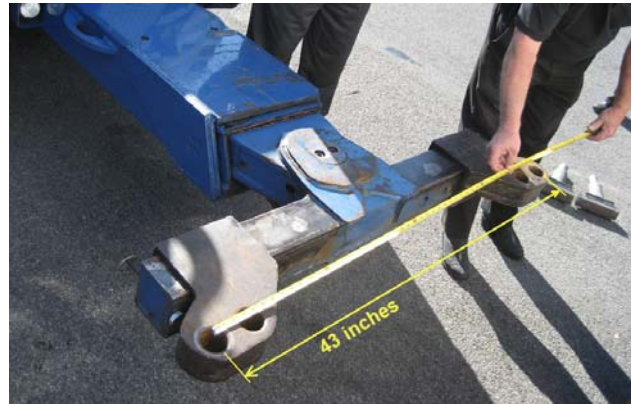
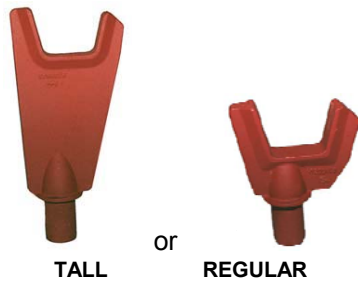

FIG.59

4. Install either long or short axle forks into fork holders.



5. Deploy the tow truck stinger arm. Place the axle forks under the rear tow eyes if equipped or under the side-members (fig.60 & 61).

Place the forks in a transversal position i.e. perpendicularly to the side-members (fig.61).

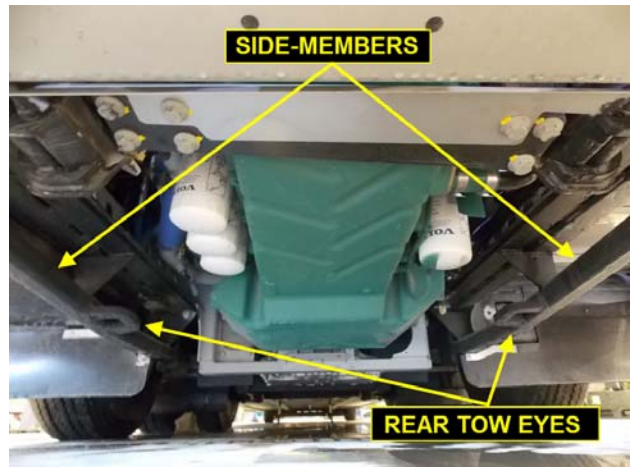

FIG.60 REAR TOW EYES ON SIDE-MEMBERS LOCATED UNDER ENGINE CRADLE SUPPORT RAILS

6. **DOB 2400 – 2489:** Lift the tow bar until the axle forks grab the side-members (fig.61).

DOB 2490 – 2789: Lift the tow bar until the axle forks fit snugly into the side-members tow eyes.

Avoid lifting at the side-members further toward the rear of the bus (close to the bumper)



FIG.61 PROPER LOCATION WHEN LIFTING THE SIDE-MEMBERS

7. Place the fork's shorter finger outboard for better clearance (see fig. 62).



FIG.62 PROPER LOCATION WHEN LIFTING THE SIDE-MEMBERS – ON THIS PICTURE, THE BUS IS EQUIPPED WITH REAR TOW EYES

8. Raise the rear of the bus.
9. Install a jack stand under the stinger arm for support and safety purposes and then lower the stinger arm so it rests on the jack stand (fig.63). The tow cans or blocks can be removed from under the drive axle wheels.



FIG.63

10. Install the choke chains. Tie the two choke chains together to secure the side members to the tow bar (fig.64 & 65). Take up any slack that may remain and maintain proper tension on chains.



FIG.64

11. Shorten the stinger arm to the minimum safest distance between the bus and the tow truck to allow the towed bus to be as close as possible to the truck yet allowing enough room for the bus to avoid collision with the tow truck during turns.

Stinger to the rear bumper: Between 59" and 63"



FIG.65

12. Attach the two tow truck safety chains from the bus engine cradle cross-member to the truck's tow eyes (fig.66).
13. Raise the stinger arm and remove the support jack stand.
14. Lower the bus. The drive axle tires should be 5" to 6" above the ground before the short distance tow can proceed.



FIG.66

SECTION 22: HEATING AND AIR CONDITIONING

CONTENTS

1. HEATING AND AIR CONDITIONING SYSTEM OVERVIEW	5
2. AIR CIRCULATION	8
2.1 DRIVER'S AREA	8
2.2 PASSENGERS' AREA	8
3. HVAC SYSTEM OPERATION	9
3.1 HVAC CONTROL UNIT	9
3.2 PASSENGERS' SECTION OPERATION	10
4. HVAC UNIT BASIC MAINTENANCE	11
4.1 COIL CLEANING	11
4.2 DRIVER'S SECTION AIR FILTERS	12
4.3 PASSENGERS' SECTION AIR FILTER	13
4.4 PARCEL RACK FAN AIR FILTER	13
5. HVAC SYSTEM PARTICULARITIES, TESTING AND TROUBLESHOOTING	13
5.1 ON DEMAND DISPLAY OF A/C COMPRESSOR HIGH AND LOW SIDE PRESSURE	13
5.2 ON DEMAND ACTIVATION OF HOT WATER CIRCULATING PUMP	14
5.3 HVAC SYSTEM AND TEST MODE FOR ELECTRIC MOTORS	14
5.4 MODES OF OPERATION	15
5.5 HVAC SYSTEM MULTIPLEX TROUBLESHOOTING	16
6. AIR CONDITIONING SYSTEM	18
6.1 A/C CYCLE	18
6.2 REFRIGERANT	18
6.2.1 Procurement	18
6.2.2 Precautions in Handling Refrigerant	18
6.2.3 Treatment in Case of Injury	19
6.2.4 Precautions in Handling Refrigerant Lines	19
6.3 PUMPING DOWN	20
6.3.1 Procedure	20
6.4 LIQUID REFRIGERANT RECOVERY	21
6.5 EVACUATING SYSTEM	22
6.6 ADDING VAPOR STATE REFRIGERANT	22
6.6.1 Verification	22
6.6.2 Refrigerant addition	23
6.7 CHARGING SYSTEM	24
6.8 REFRIGERANT SYSTEM CLEAN-OUT AFTER COMPRESSOR FAILURE	24
6.8.1 Determining Severity of Failure	24
6.8.2 Clean-out after Minor Compressor Failure	25
6.8.3 Clean-out After Major Compressor Failure	25
7. A/C SYSTEM COMPONENTS	25
7.1 COMPRESSOR	25
7.1.1 Belt Replacement	25
7.1.2 Belt Tension Adjustment –A/C drive belt	25
7.1.3 Suction and Discharge Hose Connection	26
7.1.4 Compressor Maintenance	27
7.1.5 Oil Level Check and Oil Change	27
7.1.6 Troubleshooting Guide	27

SECTION 22: HEATING AND AIR CONDITIONING

7.2	ELECTRO-MAGNETIC CLUTCH	28
7.3	EVAPORATOR MOTOR	28
7.3.1	Removal	28
7.3.2	Installation	29
7.4	CONDENSER	29
7.4.1	Condenser Fan Motors	29
7.4.2	Condenser Fan Motor Removal	30
7.5	RECEIVER TANK	30
7.6	FILTER-DRYER	30
7.6.1	Replacement of the Filter-Dryer After Pumping Down	30
7.7	MOISTURE INDICATOR	31
7.8	SHUT-OFF VALVE WITH SERVICE PORT	32
7.9	LIQUID REFRIGERANT SOLENOID VALVE	32
7.9.1	Typical malfunctions	33
7.9.2	Electrical Bypass/On Demand Opening of liquid refrigerant solenoid valves	33
7.9.3	Coil Replacement	33
7.9.4	Valve Disassembly	33
7.9.5	Valve Reassembly	34
7.10	THERMOSTATIC EXPANSION VALVE	35
7.10.1	Passengers' Section HVAC Unit	35
7.10.2	Driver's HVAC Unit	37
7.11	TORCH BRAZING	37
7.12	TROUBLESHOOTING	38
7.12.1	Expansion Valve	38
7.12.2	A/C	39
7.13	TEMPERATURES & PRESSURES CHART	41
7.14	LEAK TESTING	42
8.	CENTRAL HEATING SYSTEM	42
8.1	DRAINING HEATING SYSTEM	42
8.2	FILLING HEATING SYSTEM	44
8.3	BLEEDING HEATING SYSTEM	44
8.4	SOLDERING	44
8.5	DRIVER'S HOT WATER PNEUMATIC VALVE ASSEMBLY	45
8.5.1	Pneumatic Water Valve Disassembly	45
8.5.2	Pneumatic Water Valve Reassembly	45
8.5.3	Pilot Solenoid Valve	46
8.6	CENTRAL HOT WATER PNEUMATIC VALVE ASSEMBLY	46
8.6.1	Description	46
8.6.2	Pneumatic Water Valve Disassembly	46
8.6.3	Pneumatic Water Valve Reassembly	46
8.6.4	Pilot Solenoid Valve	47
8.7	HOT WATER CIRCULATING PUMP	47
9.	SPECIFICATIONS	49
10.	SECTION CHANGE LOG	50

ILLUSTRATIONS

FIGURE 1: PASSENGERS' UNIT AIR CIRCULATION	5
FIGURE 2: HEATING CIRCUIT	5
FIGURE 3: REFRIGERANT CIRCUIT	6
FIGURE 4: EVAPORATOR COMPARTMENT ARRANGEMENT	7
FIGURE 5: DRIVER'S AIR CIRCULATION	8
FIGURE 6: PASSENGERS' AREA FRESH AIR DAMPER	8
FIGURE 7: PASSENGERS' PARCEL RACK VENTILATION SYSTEM.....	8
FIGURE 8: HVAC SYSTEM CONTROL UNIT.....	10
FIGURE 9: TEMPERATURE SENSOR.....	10
FIGURE 10: EVAPORATOR COMPARTMENT	10
FIGURE 11: HVAC MODULE	11
FIGURE 12: DRIVER'S HVAC UNIT COIL ACCESS PANEL	11
FIGURE 13: EVAPORATOR COIL ACCESS PANEL (TYPICAL).....	12
FIGURE 14: EVAPORATOR COIL CLEANING.....	12
FIGURE 15: CONDENSER COMPARTMEN	12
FIGURE 16: DRIVER'S HVAC UNIT ACCESS GRILL	12
FIGURE 17: REMOVING RECIRCULATING AIR FILTER.....	13
FIGURE 18: PASSENGERS' SECTION AIR FILTER	13
FIGURE 19: PARCEL RACK FAN AIR FILTER	13
FIGURE 20: COMPRESSOR SHUT-OFF VALVE BACKSEATED POSITION (NORMAL OPERATING POSITION).....	20
FIGURE 21: COMPRESSOR SHUT-OFF VALVE IN FRONT SEATED POSITION.....	21
FIGURE 22: RECOVERY UNIT CONNECTED TO RECEIVER SERVICE PORT	22
FIGURE 23: MOISTURE INDICATOR SIGHT GLASS	23
FIGURE 24: COMPRESSOR BELT TENSIONER	26
FIGURE 25: STANDARD BELT ARRANGEMENT.....	26
FIGURE 26: TORQUES.....	26
FIGURE 27: PRESSURE TRANSDUCERS	26
FIGURE 28: SHAFT SEAL OIL COLLECTING TUBE.....	27
FIGURE 29: MOUNTING BOLTS TORQUE – 4 BOLTS.....	27
FIGURE 30: UNLOADER COIL ASSEMBLY.....	28
FIGURE 31: EVAPORATOR COMPARTMENT	28
FIGURE 32: EVAPORATOR MOTOR ASSY FIXING BOLTS	29
FIGURE 33: EVAPORATOR MOTOR ASSEMBLY	29
FIGURE 34: CONDENSER FAN SPEED IN RELATION WITH HIGH SIDE PRESSURE.....	30
FIGURE 35: CONDENSER FAN MOTOR.....	30
FIGURE 36: RECEIVER TANK	30
FIGURE 37: ISOLATED SECTION.....	31
FIGURE 38: CONDITIONS THAT MAY BE OBSERVED IN THE MOISTURE INDICATOR SIGHT GLASS	32
FIGURE 39: REFRIGERANT CIRCUIT SHUT-OFF VALVE	32
FIGURE 40: REFRIGERANT CIRCUIT SHUT-OFF VALVE	32
FIGURE 41: DRIVER'S UNIT LIQUID SOLENOID VALVE	32
FIGURE 42: LIQUID REFRIGERANT SOLENOID VALVES INSIDE CONDENSER COMPARTMENT	33
FIGURE 43: TYPICAL REFRIGERANT SOLENOID VALVE	34
FIGURE 44: REFRIGERANT SOLENOID VALVE	34
FIGURE 45: EXPANSION VALVE.....	35
FIGURE 46: SUPERHEAT ADJUSTMENT INSTALLATION	36
FIGURE 47: HIGH & LOW SWING TEMPERATURE AT REMOTE BULB.....	36
FIGURE 48: CEILING OF THE SPARE WHEEL COMPARTMENT	42
FIGURE 49: DRIVER'S HVAC/DEFROST UNIT	42

FIGURE 50: DRIVER'S HVAC UNIT 43
FIGURE 51: DRIVER'S HVAC UNIT 43
FIGURE 52: HEATER LINE SHUT-OFF VALVES 44
FIGURE 53: EVAPORATOR COMPARTMENT 44
FIGURE 54: TYPE 1 (UP TO VIN F-7014) DRIVER'S UNIT HOT WATER PNEUMATIC VALVE
ASSEMBLY 45
FIGURE 55: TYPE 2 (FROM VIN F-7015) DRIVER'S UNIT HOT WATER PNEUMATIC VALVE
ASSEMBLY 45
FIGURE 56: PNEUMATIC WATER VALVE..... 46
FIGURE 57: CENTRAL HOT WATER PNEUMATIC VALVE ASSEMBLY 46
FIGURE 58: PNEUMATIC WATER VALVE..... 47
FIGURE 59: PUMP LOCATION..... 47

1. HEATING AND AIR CONDITIONING SYSTEM OVERVIEW

The vehicle is equipped with a central HVAC system. Air flow and controls divide the vehicle in two areas: driver's area and passengers' area. The interior of the vehicle should always be slightly pressurized to prevent dust and moisture from entering vehicle. Each section has its own fresh air, returning air and discharge air ducting. The exhaust is mainly done through the rear ventilator and through normal air-tightness losses.

NOTE

Air conditioning

Air conditioning is the artificial treatment of air to render the living conditions of persons more comfortable and healthful. Complete air conditioning involves adjustment and control of following operations performed on the air supply :

- 1) heating or cooling;
- 2) dehumidification;
- 3) ventilation;
- 4) Filtering;

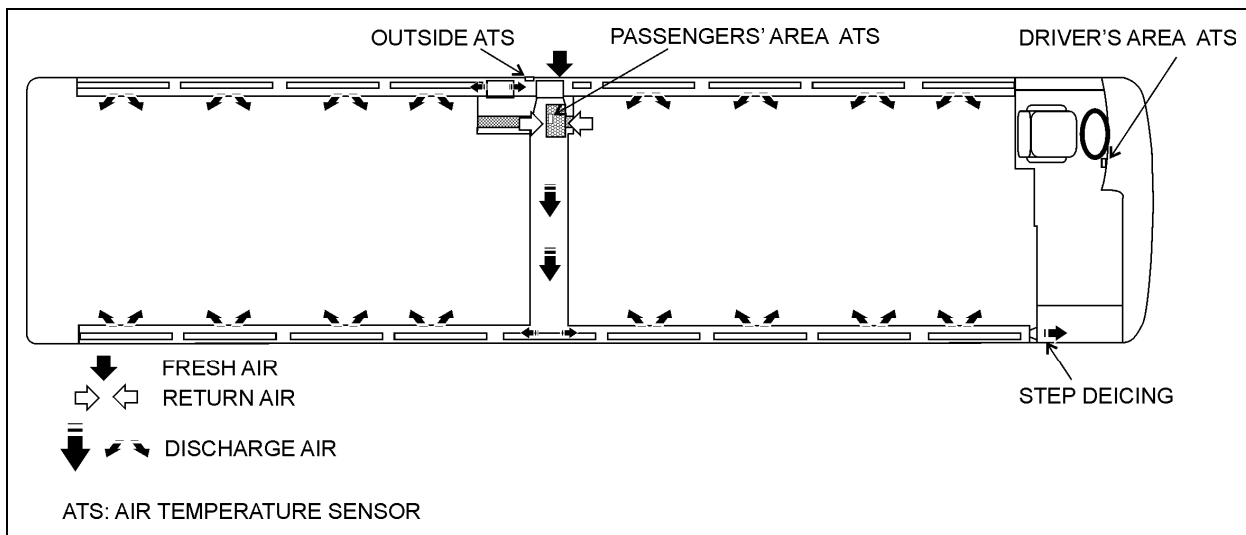

FIGURE 1: PASSENGERS' UNIT AIR CIRCULATION

22308

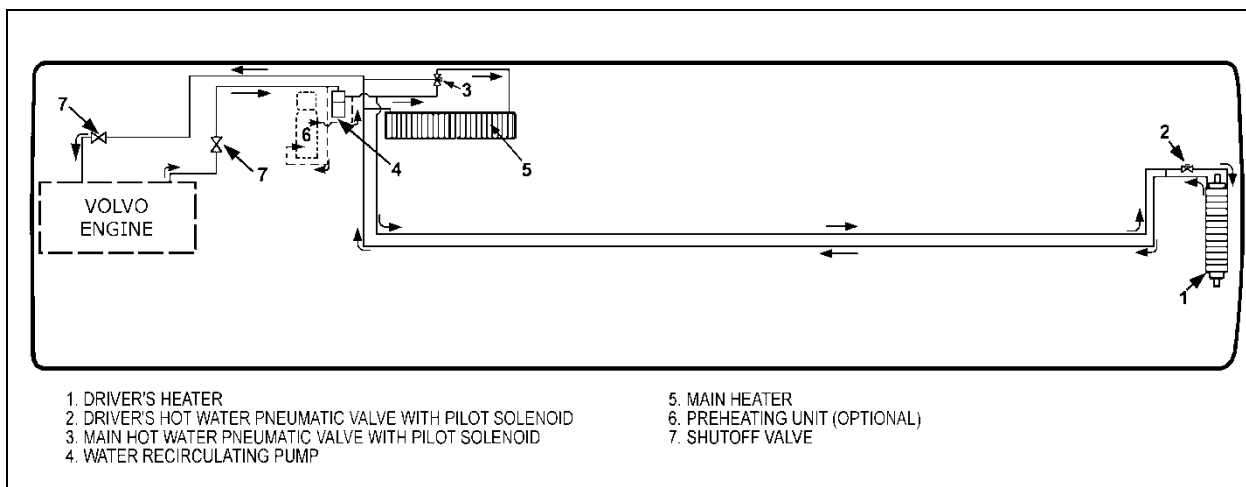

FIGURE 2: HEATING CIRCUIT

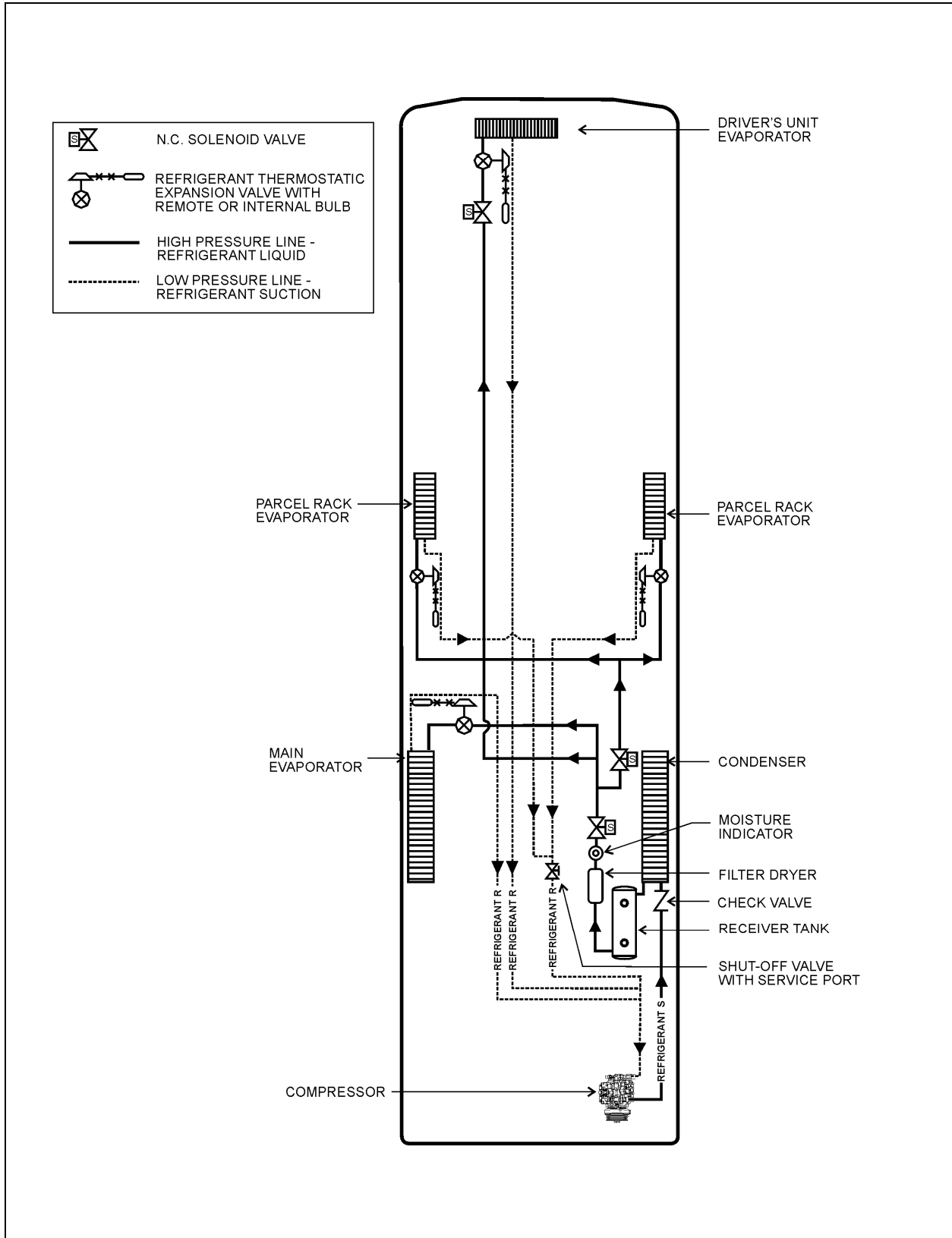

FIGURE 3: REFRIGERANT CIRCUIT

22220C

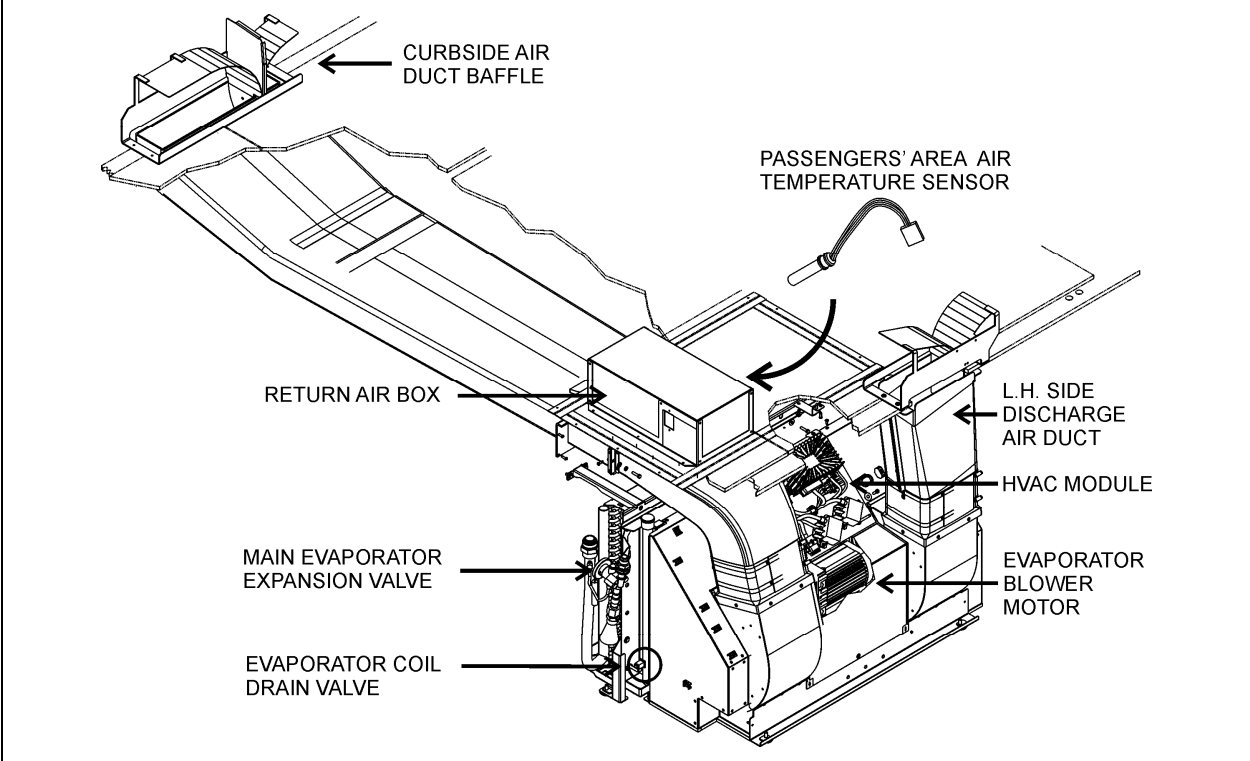

FIGURE 4: EVAPORATOR COMPARTMENT ARRANGEMENT

2. AIR CIRCULATION

2.1 DRIVER'S AREA

Fresh air is taken from a plenum underneath the front service compartment and enters the mixing box through an ON/OFF damper. Return air is taken through the base of the dashboard panel utility compartments into the mixing box. Mixed air goes through cooling and heating coils, fans and discharge ducts.

Both right and left discharge ducts defrost one half of the windshield. The driver can also divert some air flow to the console, from which he can direct air to his knees and/or upper body with adjustable HVAC air registers and to his feet with the appropriate button (see Figure 5 and Operator's manual).

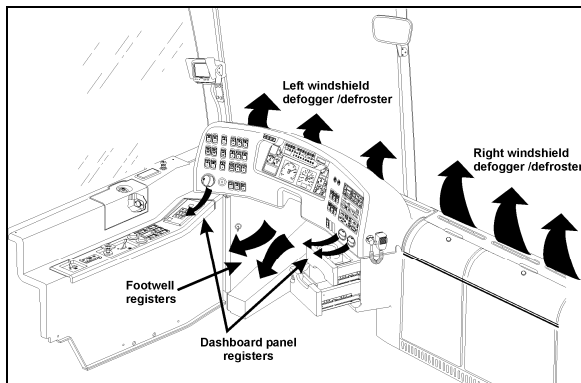

FIGURE 5: DRIVER'S AIR CIRCULATION

22307

2.2 PASSENGERS' AREA

Fresh air enters the vehicle on the L.H. side, through the recirculation damper located inside the evaporator compartment door (Figure 6). The damper can be fully opened for normal operation or closed for extreme weather or highly polluted areas (Refer to the Operator's Manual for more details). The recirculation REC button is located on the HVAC control unit. Press down the button to partially close the fresh air damper. Return air is drawn from inside the vehicle through the register duct located on L.H. side of vehicle (Figure 1).

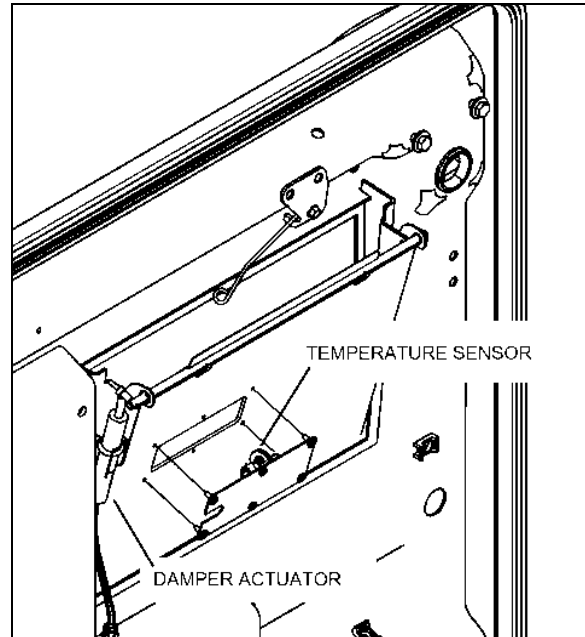

FIGURE 6: PASSENGERS' AREA FRESH AIR DAMPER

22302

A double blower fan unit, which is activated by the evaporator motor, draws mixed air through an air filter, cooling and heating coils, then forces this air in the ventilation ducts (FIGURE 4) along the walls, and finally exhausts it just below side windows.

X3-45 Commuter coaches are also equipped with parcel rack A/C system. An ON-OFF rocker switch located on R.H. dashboard panel allows activation of both fans. Return air is drawn just below the middle side windows through an air filter into the parcel rack A/C system fan. Discharge air is fed to the rotating registers through the ventilation duct (Figure 7).

The parcel rack air registers are used to control air flow for the passenger seats. Direct air flow by pointing or rotating the register. Open or close the register to adjust the air flow.

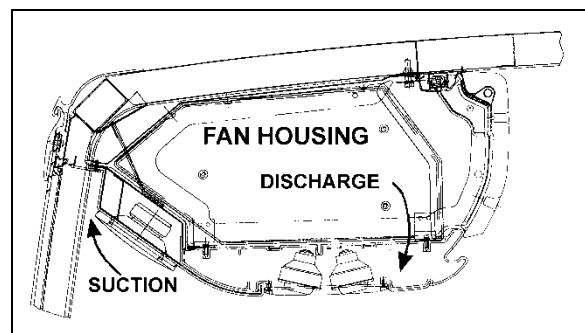

FIGURE 7: PASSENGERS' PARCEL RACK VENTILATION SYSTEM

22211

3. HVAC SYSTEM OPERATION

To operate the air conditioning system when vehicle is stationary, engine should run at fast idle. During operation of the air conditioning system, windows should be kept closed and door not left open longer than necessary. In order to prevent battery discharge, the HVAC system will not operate if the battery voltage drops below 24 volts.

3.1 HVAC CONTROL UNIT

The vehicle is divided into two areas:

- 1 - Driver's area (driver's HVAC unit)
- 2 - Passengers' area (passengers' HVAC unit)

Fresh air is fed in each area and has a separate return air and discharge air duct.

Both driver and passengers HVAC units turn on automatically at starting of the engine but the driver can turn both off if desired and can then turn them back on using the ON/OFF button on the HVAC control unit.

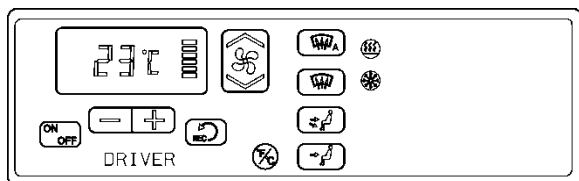

22333

The HVAC control unit is used to control heating, ventilation, air conditioning and defroster in the driver's area only. The passengers' area HVAC unit (passengers' unit) temperature and fan speed is fully automatic. It has a preset temperature of 68°F (20°C). The temperature and fan speed cannot be changed by the driver.

NOTE

It is recommended to run engine at fast idle to operate the air conditioning system when vehicle is stationary.

This will improve A/C compressor performance and provide adequate electrical power to the multiple A/C system fans.

When the system is running, keep roof ventilation hatch and door closed to prevent cooling loss.

To prevent battery run-down, the central HVAC unit will not operate if the battery voltage drops below 24 volts.

When the HVAC system is in operation, park at least 4 feet from other vehicles or buildings to allow sufficient air flow through the condenser coil.

The HVAC control unit performs a self-test every time it is turned on. Codes are shown on displays or flashed on control buttons.

The A/C compressor starts automatically when the two following conditions are satisfied:

1. The outside temperature is above 32°F (0°C).
2. The passengers' area temperature is within 7° of the set point or higher (set point is 68°F, so return air temperature must be above 61°F, at this moment, enough heat is available from the engine to warm up the area while the air conditioning will remove moisture in air and prevent fogging up of the windows).

NOTE

Upon starting, if the outside temperature is above 32°F (0°C) and then drops below 32°F (0°C), the compressor will keep running down to a temperature of 15°F (-9°C) to prevent fogging up of the windows.

The driver's HVAC unit piping is paralleled with the passengers' HVAC unit piping. Both sections use the same refrigerant and hot water, and are linked to the same condenser and compressor, even if they are individually controlled. In order for the driver to have air conditioning, the passenger air conditioning system must be operating (A/C compressor must be operating).

NOTE

The driver's and passengers' HVAC unit turn on automatically at starting of the engine (multiplex receives the "engine running" signal) when the multiplex system receives an "engine running" signal.

NOTE

To perform a test of the driver's section windshield defroster, it is possible to run the system without running the engine.

The following table can be used for troubleshooting the following temperature sensors:

NOTE

The driver's area air temperature sensor is located below the dashboard, just ahead of the driver's right knee.

- 1) Driver's area temperature sensor (SE21);
- 2) Passengers' area temperature sensor (SE25);
- 3) Outside air temperature sensor (SE20).

The table values are for unloaded, disconnected temperature sensor (thermistor) probed at the temperature sensor connector pins.

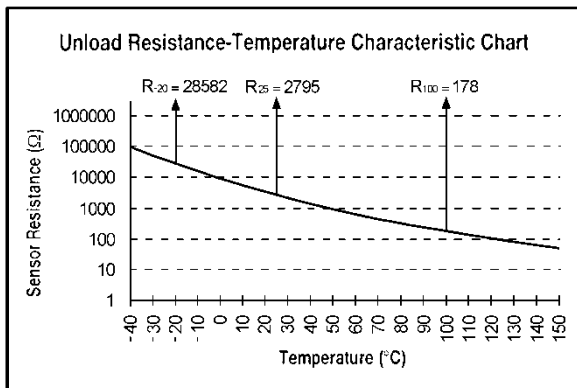

TEMPERATURE SENSOR		
Temp °C	Temp °F	Resistance Ohms
-40	-40	100865
-35	-31	72437
-30	-22	52594
-25	-13	38583
-20	-4	28582
-15	5	21371
-10	14	16120
-5	23	12261
0	32	9399
5	41	7263
10	50	5658
15	59	4441
20	68	3511
25	77	2795
30	86	2240
35	95	1806
40	104	1465
45	113	1195
50	122	980
55	131	808
60	140	670

3.2 PASSENGERS' SECTION OPERATION

The passengers' section has a preset temperature of 68°F (20°C).

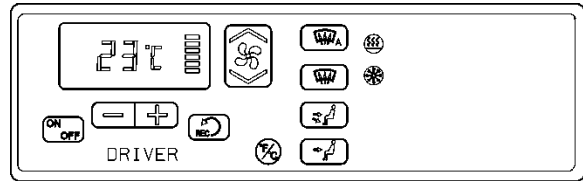

FIGURE 8: HVAC SYSTEM CONTROL UNIT

Temperature control is provided in conjunction with a thermistor sensor inside register duct, located on L.H. side of vehicle (FIGURE 3 & Figure 6).

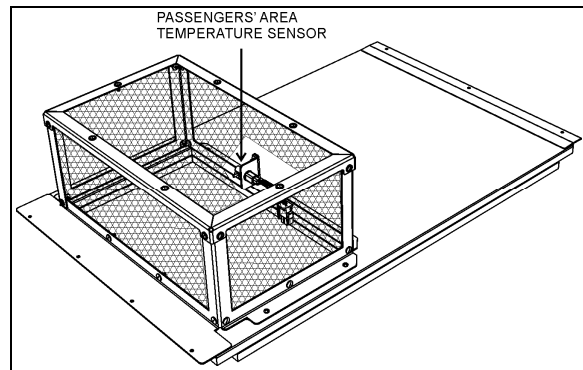

FIGURE 9: TEMPERATURE SENSOR

The flow of water to the vehicle's main heater core is controlled by a pneumatic water valve which varies the cycling rate depending on selected temperature. A red LED, located on HVAC control unit, illuminates when heating mode is selected. A green LED illuminates when compressor clutch is in operation.

NOTE

It is not uncommon for both the red Heat LED and the green AC LED to be illuminated at the same time. This indicates that the temperature control is requesting heat and the HVAC control is calling for compressor operation for dehumidification.

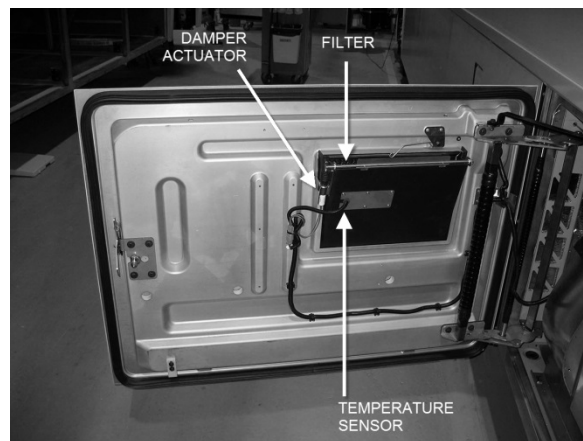

FIGURE 10: EVAPORATOR COMPARTMENT

22301

The evaporator fan motor, located in the evaporator compartment, is protected by a 90 amps, manually-resettable (CB3) circuit breaker located on the rear junction panel and is accessible from the engine compartment curb-side door, on R.H. side of the vehicle (refer to Section 06, "Electrical System" in this manual for details).

The condenser coil mounted on the condenser compartment door is ventilated by four axial fans. The fan motors are protected by a manually-resettable 70 amp circuit breaker (CB7) mounted on the rear junction panel and accessible from the engine compartment curb-side door.

Furthermore, the following relays, diodes and multiplex module are located in the evaporator compartment. They are mounted in the HVAC module located inside the evaporator compartment on top of the fan housing (FIGURE 4 & FIGURE 11).

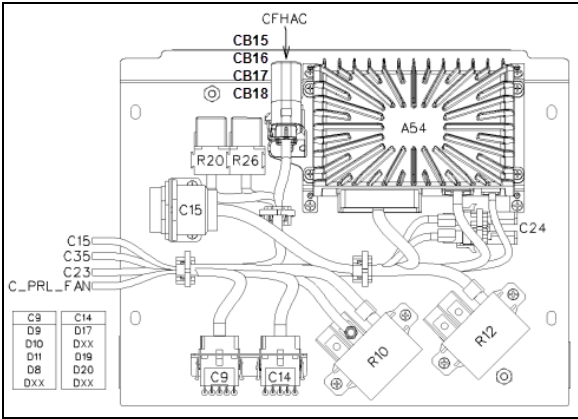

FIGURE 11: HVAC MODULE

A/C Junction Box	
Multiplex Module	
A54	I/O-B
Relays	
R10	Condenser fan power
R12	Evaporator fan power
R20	Water circulating pump relay
R26	Water Preheater Relay
Diodes	
D8	Parcel rack Liq. Sol. Valve
D9	Water circulating pump
D10	Water circulating pump
D11	Pass. Liq. Sol. Valve
D17	3 rd Bagg. Cmpt Lights
D19	2 nd Bagg. Cmpt Lights
D20	1 st Bagg. Cmpt Lights

Relevant Breakers	
CB15	15A, Condenser fan up-fore
CB16	15A Condenser fan down-fore
CB17	15A Condenser fan up-aft
CB18	15A Condenser fan down-aft

4. HVAC UNIT BASIC MAINTENANCE

Basic maintenance required on the passengers' and driver's units consists in cleaning their respective coils and cleaning or replacing air filters.

However, periodic inspection for broken drains, hoses and charging of system should be done.

MAINTENANCE

Squeeze rubber discharge tubes located underneath the appropriate compartment to eliminate the accumulated water and dirt every three months.

4.1 COIL CLEANING

Check the external surface of the coil at regular intervals for dirt or any foreign matter.

MAINTENANCE

For the driver's HVAC unit, remove the grill and the coil access panel. Clean the driver's unit evaporator and heater coils with low-pressure air jet every 100 000 miles, taking care not to damage fins. Clean the bottom of the defrost plenum.

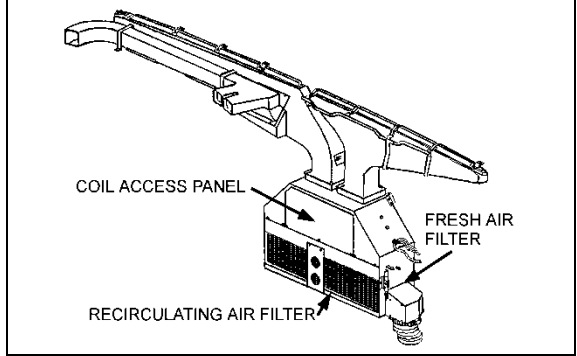

FIGURE 12: DRIVER'S HVAC UNIT COIL ACCESS PANEL

MAINTENANCE

With the air filters removed, clean the **passengers' unit** evaporator and heater coils with low-pressure air jet or a stream of low-

pressure water, every 100 000 miles. Do not use a pressure washer as this will damage the fins. Remove the air filter and brush the evaporator coil from behind.

Clean the condenser with low-pressure air jet or a stream of low-pressure water, taking care not to damage fins.



CAUTION

Direct the pressure straight through the coil to prevent bending of fins and do not use extremely high pressure. Do not use hot water, steam or caustic soap.

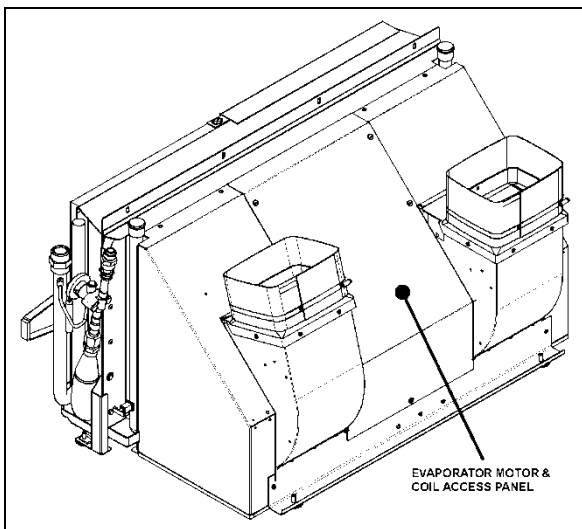

FIGURE 13: EVAPORATOR COIL ACCESS PANEL (TYPICAL) 22309

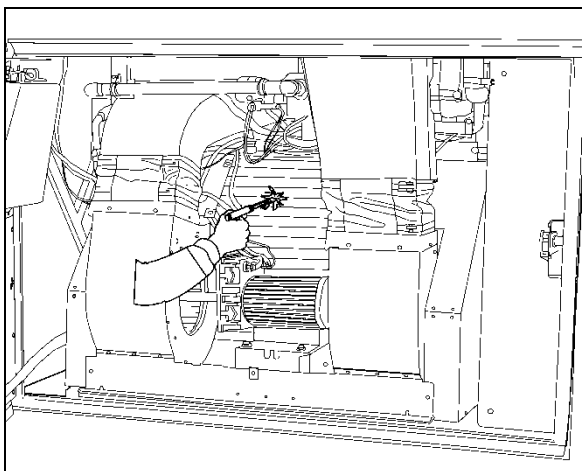

FIGURE 14: EVAPORATOR COIL CLEANING 22373

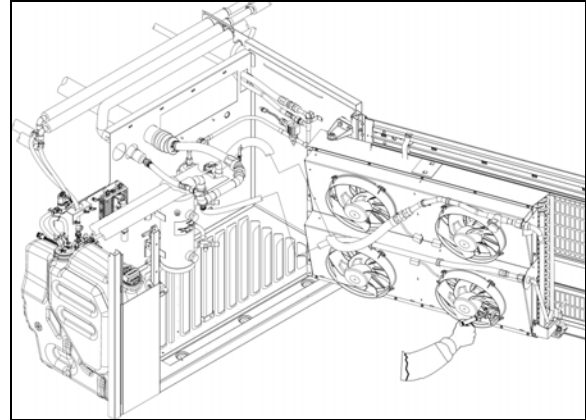

FIGURE 15: CONDENSER COMPARTMENT 22311

4.2 DRIVER'S SECTION AIR FILTERS

The driver's HVAC unit is located behind the dashboard's R.H. side panel. To gain access to the A/C filters, unscrew the grille located at the top entrance step (FIGURE 16). Unscrew the plastic cover and slide out the recirculating air filter (Figure 17). Doing so will give you access to the fresh air filter (see item 18, Figure 51).



MAINTENANCE

Back flush driver's unit air filters with water and then dry with air every 6000 miles.

NOTE

If the windshield is continuously fogged, check that :

- the driver's unit fresh air filter is not clogged;
- the fresh air damper (flapper door) is open, i.e. the RECirculation button on the HVAC control unit is not engaged.

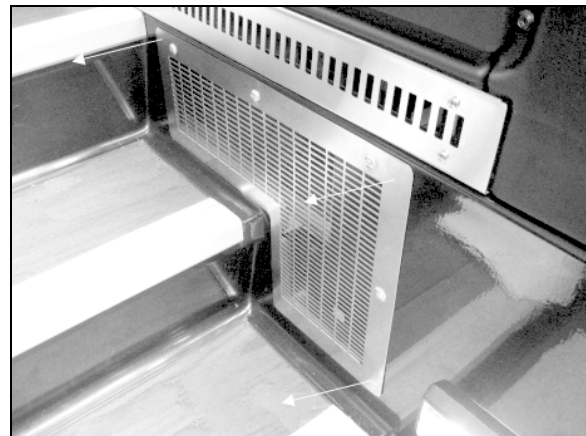

FIGURE 16: DRIVER'S HVAC UNIT ACCESS GRILL

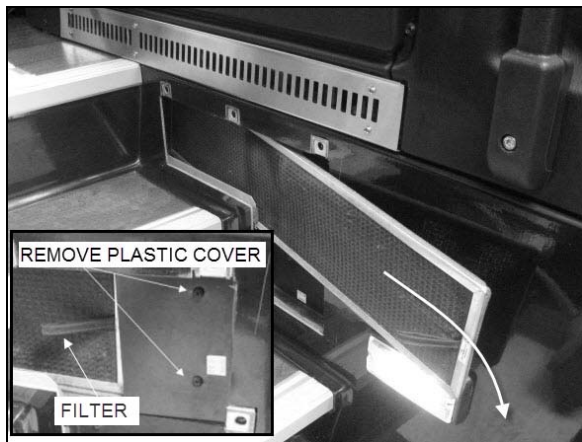

FIGURE 17: REMOVING RECIRCULATING AIR FILTER

4.3 PASSENGERS' SECTION AIR FILTER

The passengers' section air filter is located in the evaporator compartment above the Evaporator coil and fans (Figure 18).

The vehicle is fitted with disposable filters.

Open access panel by turning the quarter-turn screws, and slide out filters to exchange.

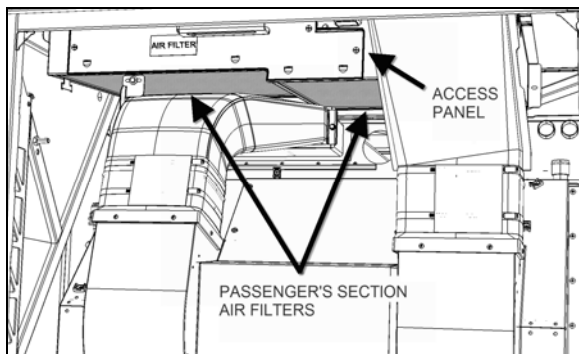

FIGURE 18: PASSENGERS' SECTION AIR FILTER 22375

MAINTENANCE

Replace filters every 6000 miles.

CAUTION

Do not use high pressure water jet to avoid damaging filter. Be sure not to reverse filter upon installation.

4.4 PARCEL RACK FAN AIR FILTER

The air filters are accessible from the two vehicle parcel racks equipped with A/C units (center of the vehicle, both side). Slide the filter

in and out using the tab fixed on the side of the filter. (Figure 19)

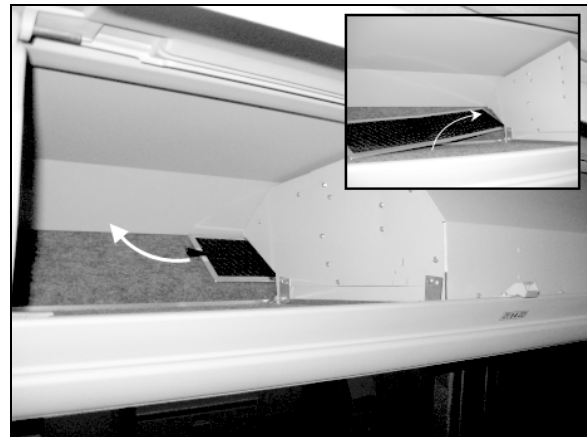

FIGURE 19: PARCEL RACK FAN AIR FILTER

MAINTENANCE

Slide out filters, back flush with water then dry with air and reinstall. This procedure should be done every 6000 miles.

5. HVAC SYSTEM PARTICULARITIES, TESTING AND TROUBLESHOOTING

Before undertaking any troubleshooting on the HVAC system, study the appropriate wiring diagrams to get a complete understanding of the HVAC components circuitry, read and understand section 06: ELECTRICAL of this manual under "Troubleshooting And Testing The Multiplex Vehicles" and "Test Mode For Switches And Sensors". The information included in these paragraphs is necessary for troubleshooting the HVAC system on Multiplex vehicles.

5.1 ON DEMAND DISPLAY OF A/C COMPRESSOR HIGH AND LOW SIDE PRESSURE

Refrigerant pressures can be displayed in the Driver Information Display (DID) by selecting "Gauges" menu and pressing the down arrow to the fifth displayed screen.

A/C Compressor Pressure

<div style="border: 1px solid black; padding: 2px;"> <p>Gauges</p> <p style="text-align: center;"> ❄️ -- PSI -- PSI A/C LoS HiS </p> <hr/> <p style="text-align: center;"> 🌡️ 71 °F 07:49 AM </p> <p style="text-align: right;">156.0 mi</p> </div>	<p>Displays the A/C compressor suction pressure value (LoS=low side) and discharge pressure value (HiS=high side).</p>
---	--

NOTE

When starting the A/C compressor, allow enough time before checking pressures in order to give the system a chance to build its pressure. During the first 3 seconds after startup, the compressor is active on 4 cylinders and the A/C valve is open regardless of the pressure readings.

5.2 ON DEMAND ACTIVATION OF HOT WATER CIRCULATING PUMP

In Diagnostics/Vehicle Test mode on the DID, the heating system circulating pump can be turned on manually by selecting ACTIVATE HVAC PUMP command. This feature allows verification of the circulating pump when inside a garage. This is also useful when working on the heating system to remove air pockets trapped in the system.

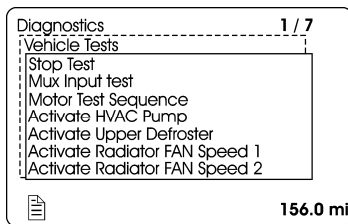

In normal operation, the heating system circulating pump operates only when the ambient temperature is 50°F or lower.

5.3 HVAC SYSTEM AND TEST MODE FOR ELECTRIC MOTORS

The test mode allows testing the motors and electric contactors without the need to have the engine running.

Use this test mode for testing of the condenser fans, evaporator fans, parcel rack fans, A/C compressor clutch activation, A/C compressor unloader activation, driver's unit hot water solenoid valve and refrigerant solenoid valve, passengers' unit hot water solenoid valve and refrigerant solenoid valve, water circulating pump. Refer to Section 06: ELECTRICAL under "TEST MODE FOR ELECTRICAL MOTORS" for complete information.

5.4 MODES OF OPERATION

<p>COOLING DEMAND Conditions for engaging the 2nd speed on the evaporator motor</p>	<p>The 2nd speed engages if the passengers' area temperature is 1 degree above the set point and it revert to speed 1 if the temperature gets equal or below the set point.</p>
<p>HEATING DEMAND Conditions for hot water circulating pump activation</p>	<p>The pump turns ON if the outside temperature is equal or less than 50°F (10°C), when heating is more likely to be needed Note: To test pump operation, it is possible to keep it active even if the outside temperature is above 50°F (10°C). See paragraph 5.2 ON DEMAND ACTIVATION OF HOT WATER CIRCULATING PUMP.</p>
<p>The compressor unloader operation is based on pressure and on the difference between the passengers' area temperature and set point.</p>	<p>right compressor cylinders Stop if: The passengers' area decreasing temperature becomes less than 0.4°F above the set point (68°F) or if compressor discharge pressure is above 280 psi, or if compressor suction pressure is below 23 psi. Restart if: The Passengers' area temperature is 1.3°F or more above the set point and compressor discharge pressure is less than 220 psi and compressor suction pressure is above 32 psi.</p>
<p>A/C compressor deactivation pressure</p>	<p>320 psi In case of high pressure, the high pressure transducer connected to the multiplex module deactivates the compressor There is also a 350 psi pressure switch that acts to stop the compressor in the instance that the multiplex module fails.</p>
<p>Compressor turns on automatically if (2 required conditions)</p>	<p>outside temperature is above 32°F and return air temperature in passengers' area is 61°F or above ($\Delta T=7^\circ$ with set point)</p>
<p>passengers' area temperature set point</p>	<p>68°F</p>

SECTION 22: HEATING AND AIR CONDITIONING

5.5 HVAC SYSTEM MULTIPLEX TROUBLESHOOTING

Problem/Symptom	Probable Causes	Actions
Defroster fan not functioning	Module A47 is not powered or is faulty Module A24 is not powered or is faulty	<ol style="list-style-type: none"> 1. Check the Diagnostics menu of the Driver Information Display (DID). Select Fault Diagnostics and Electrical System. The message "No Response ModA47 (or ModA24), Active" indicates a power problem on the module. (A CAN network problem would show the same message but doesn't produce these symptoms). 2. Check / reset circuit breaker CB1 3. Check CB16V (VECF) 4. Probe gray connector on module to see if it is powered.
HVAC condenser fans not functioning	Circuit breaker CB7 tripped Seized bearing Bad wiring Module A54 is not powered or is faulty	<ol style="list-style-type: none"> 1. Check / reset circuit breaker CB7 2. Check/reset CB15, CB16, CB17, CB18 on HVAC control module 3. Check / replace condenser power relay R10 (probe R10 coil power circuit 67A, should be 24 volts). 4. Check the Diagnostics menu of Driver Information Display (DID). Select Fault Diagnostics and Electrical System. The message "No Response ModA54, Active" indicates a power problem on the module. (A CAN network problem would show the same message but doesn't produce this symptom). 5. Check CB5, CB67.
HVAC condenser fans not functioning in <u>speed 1</u>	Module A42 is not powered or is faulty	<ol style="list-style-type: none"> 1. Check the Diagnostics menu of Driver Information Display (DID). Select Fault Diagnostics and Electrical System. The message "No Response ModA42, Active" indicates a power problem on the module. (A CAN network problem would show the same message but doesn't produce this symptom). 2. Check / reset circuit breaker CB1, CB5, CB7 3. Check CB67 4. Probe gray connector on module to see if it is powered.
HVAC condenser fans not functioning in <u>speed 2</u>	Circuit breaker CB7 tripped Seized bearing Bad wiring	<ol style="list-style-type: none"> 1. Check / reset circuit breaker CB7 2. See <i>HVAC condenser fans not functioning & HVAC condenser fans not functioning in <u>speed 1</u></i> above.
Defroster fan is functioning but no heat or cooling	Module A46 is not powered or is faulty	<ol style="list-style-type: none"> 1. Check the Diagnostics menu of Driver Information Display (DID). Select Fault

Problem/Symptom	Probable Causes	Actions
available in the driver's area	Bad wiring	<p>Diagnostics and Electrical System. The message "No Response ModA46, Active" indicates a power problem on the module. (A CAN network problem would show the same message but doesn't produce these symptoms).</p> <ol style="list-style-type: none"> 2. Check / reset circuit breaker CB1 3. Check fuse CB12V or CB13V (VECF) 4. Probe gray connector on module to see if it is powered.
The A/C compressor clutch does not engage	Module A52 is not powered or is faulty	<ol style="list-style-type: none"> 1. Check the Diagnostics menu of Driver Information Display (DID). Select Fault Diagnostics and Electrical System. The message "No Response ModA52, Active" indicates a power problem on the module. (A CAN network problem would show the same message but doesn't produce this symptom). 2. Check / reset circuit breaker CB5 3. Check CB65V (VECR) 4. Probe gray connector on module to see if it is powered.
Evaporator fan not functioning	<p>Circuit breaker CB3 tripped</p> <p>Module A54 is not powered or is faulty</p>	<ol style="list-style-type: none"> 1. Check / reset circuit breaker CB3 2. Check the Diagnostics menu of Driver Information Display (DID). Select Fault Diagnostics and Electrical System. The message "No Response ModA54, Active" indicates a power problem on the module. (A CAN network problem would show the same message but doesn't produce this symptom). 3. Check / reset circuit breaker CB5 4. Check CB67 5. Probe gray connector on module to see if it is powered. 6. Check / replace condenser power relay R12 (probe R12 coil power circuit 67, should be 24 volts).

6. AIR CONDITIONING SYSTEM

The schematic of FIGURE 3 shows the A/C systems and their components.

The HVAC system is equipped with a 4 cylinder, 4NFCY Bitzer compressor with an air conditioning capacity of 7½ tons. The receiver tank and filter-dryer are mounted inside the condenser compartment.

6.1 A/C CYCLE

Refrigeration may be defined as "the transfer of heat from a place where it is not wanted to a place where it is unobjectionable". Components required for a closed circuit refrigeration system are shown in FIGURE 3.

The air conditioning system used on X series vehicles is of the "Closed" type using "R-134a".

1. The refrigerant flowing to the compressor is compressed to high pressure and reaches a temperature higher than the surrounding air. It is passed through the air-cooled fins and tubes of the condenser causing the hot, high pressure gas to be condensed into a liquid form.
2. The liquid refrigerant flows to the receiver tank, then passes through a filter-dryer where moisture, acids and dirt are removed and then through a moisture indicator which indicates if any moisture is present in the system.
3. By its own pressure, the liquid refrigerant flows through a thermal expansion valve where the pressure drop causes the refrigerant to vaporize in a vapor-liquid state at a low temperature pressure.
4. The cold low pressure refrigerant passes through the passengers and the driver's evaporator coils which absorbs heat from the air passing over the fins and tubes, and changes into gas. In this form, the refrigerant is drawn into the compressor to repeat the air conditioning cycle.
5. The success of the air conditioning system depends on retaining the conditioned air within the vehicle. All windows and intake vents should be closed. An opening of approximately 8 in² (5162 mm²) could easily neutralize the total capacity of the system.
6. Other causes of inadequate cooling are dirty coils or filter. Dirt acts as insulation and is also serves as a restriction to the air flow.

7. The refrigeration load is not constant and varies. It is also affected by outside temperature, relative humidity, passenger load, compressor speed, the number of stops, etc.
8. The compressor will load or unload depending on operating conditions.

6.2 REFRIGERANT

The A/C system of this vehicle has been designed to use R134a refrigerant. Regardless of the brand, only R-134a must be used in this system. The chemical name for this refrigerant is Ethane, 1, 1, 1, 2-Tetrafluoro.



DANGER

Refrigerant in itself is nonflammable, but if it comes in contact with an open flame, it will decompose.

6.2.1 Procurement

Refrigerant is shipped and stored in 30 and 100 pound metal cylinders. Approximately 24 lbs are used in the HVAC system plus an additional 2.0 lbs will be needed for the parcel rack A/C system.

Refrigerant charge (Approximately)

A/C system:	24 lbs
Parcel rack A/C system:	2 lbs
Total:	26 lbs

It will be impossible to draw the entire refrigerant out of the cylinder. However, the use of warm water or heating blanket when charging the system will assure the extraction of a maximum amount of refrigerant from the cylinder.

6.2.2 Precautions in Handling Refrigerant

1. Do not leave refrigerant cylinder uncapped.
2. Do not subject cylinder to high temperatures, do not weld or steam clean near system or cylinder.
3. Do not fill cylinder to more than 80% liquid full to allow for refrigerant expansion.
4. Do not discharge vapor into an area where a flame is exposed.
5. Do not expose the eyes to liquid refrigerant.

All refrigerant cylinders are shipped with a heavy metal screw cap. The purpose of the cap is to protect the valve and safety plug from damage.

It is a good practice to replace the cap after each use of the cylinder for the same reason. If the cylinder is exposed to the sun's radiant heat pressure increase resulting may cause release of the safety plug or the cylinder may burst.

For the same reason, the refrigerant cylinder should never be subjected to excessive temperature when charging a system. The refrigerant cylinder should be heated for charging purposes by placing it in 125°F (52°C) water. Never heat above 125°F (52°C) or use a blowtorch, radiator, or stove to heat the cylinder. Welding or steam cleaning on or near any refrigerant line or components of the A/C system could build up dangerous and damaging pressures in the system.

If a small cylinder is ever filled from a large one, never fill the cylinder completely. Space should always be allowed above the liquid for expansion. Weighing cylinders before and during the transfer will determine the fullness of the cylinders.



WARNING

One of the most important precautions when handling refrigerant consists in protecting the eyes. Any liquid refrigerant which may accidentally escape is approximately -40°F (-40°C). If refrigerant comes in contact with the eyes, serious injury could result. Always wear goggles to protect the eyes when opening refrigerant connections.

6.2.3 Treatment in Case of Injury

If liquid refrigerant comes in contact with the skin, treat the injury as if the skin was frost-bitten or frozen. If liquid refrigerant comes in contact with the eyes, consult an eye specialist or doctor immediately. Give the following first aid treatment:

1. Do not rub the eyes. Splash eyes with cold water to gradually bring the temperature above the freezing point.
2. Apply drops of sterile mineral oil (obtainable at any drugstore) in the eyes to reduce the possibility of infection. The mineral oil will also help in absorbing the refrigerant.

6.2.4 Precautions in Handling Refrigerant Lines

1. All metal tubing lines should be free of kinks, because of the resulting restrictions on the flow of refrigerant. A single kink can greatly reduce the refrigeration capacity of the entire system.
2. The flexible hose lines should never be allowed to come within a distance of 2-½" (6,3 cm) from the exhaust manifold.
3. Use only sealed lines from parts stock.
4. When disconnecting any fitting in the refrigeration system, the system must first be discharged of all refrigerant. However, proceed very cautiously, regardless of gauge readings. If liquid refrigerant happens to be in the line, disconnect fittings very slowly, keeping face and hands away so that no injury can occur. If pressure is noticed when fitting is loosened, allow it to bleed off very slowly.



WARNING

Always wear safety goggles and gloves when opening refrigerant lines.

5. Any line is opened to the atmosphere should be immediately capped to prevent entrance of moisture and dirt.
6. The use of the proper wrenches when making connections on O-ring fittings is important. The use of improper wrenches may damage the connection. The opposing fitting should always be backed up with a wrench to prevent distortion of connection lines or components. When connecting the flexible hose connections, it is important that the swaged fitting and the flare nut, as well as the coupling to which it is attached, be held at the same time using three different wrenches to prevent turning the fitting and damaging the ground seat.
7. The O-rings and seats must be in perfect condition. The slightest burr or piece of dirt may cause a leak.
8. **O-rings and gaskets should be coated with refrigeration oil** and installed on the line before the line is inserted into the fitting to prevent damaging the O-ring. If leaks are encountered at the couplings or connectors,

no attempt should be made to correct the leaks by tightening the connections beyond the recommended torque. The O-rings are designed to seal at the specified torque and overtightening the connection does not result in a satisfactory and permanently sealed connection. The connection must be disassembled and the cause of the leak (damaged O-ring, defective lines, etc.) corrected. Use new O-ring.

6.3 PUMPING DOWN

This procedure is intended to reduce refrigerant loss by isolating it in the compressor and receiver tank, as well as in their connecting line, in order to carry out repairs on other sections of the air conditioning system (lines and components).

NOTE

Once this pull down procedure has been properly done, any component from the outlet hose on the receiver tank, the filter-dryer, the liquid solenoid valves, the evaporators, the expansion valves, and all lines associated with them can be serviced, **then properly evacuated.**

It must be noted that there is STILL refrigerant under pressure in the compressor, the discharge lines, condenser, and receiver tank and that these items cannot be serviced. To service these items, it is required to recover the refrigerant using a recovery unit.



CAUTION

The filter-dryer must be replaced after a severe system failure or if a line in the system has been opened over a prolonged period of time. The line will then have to be properly evacuated.

Best practice would be to replace the filter-dryer each time a line is opened.

NOTE

Before attempting any repair between compressor and receiver tank, use a recovery unit to remove refrigerant from the system.



WARNING

To prevent any injury, when air conditioning

system must be opened, refer to previous paragraph "PRECAUTIONS IN HANDLING REFRIGERANT".

NOTE

For this procedure to be done properly, it is assumed the proper amount of refrigerant is in the refrigeration system. If there is any doubt, use a recovery unit to recover and weight the amount of refrigerant in the system.

6.3.1 Procedure

1. Energize driver's unit and passengers' unit (main HVAC system) section liquid solenoid valve. To do so, connect male and female connector housings of C24 together for the passengers' area (found on the HVAC module in evaporator compartment) and C44 for the driver's area (located on the ceiling of the spare wheel compartment). During normal use, both male and female housings of connector C24 or C44 are kept unplugged.



CAUTION

Connectors C24 & C44 must be disconnected and their caps reinstalled after this procedure. Leaving them connected will keep the driver's, passengers' and parcel rack liquid solenoid valves open, and result in battery draining if the vehicle remains unused for several days.

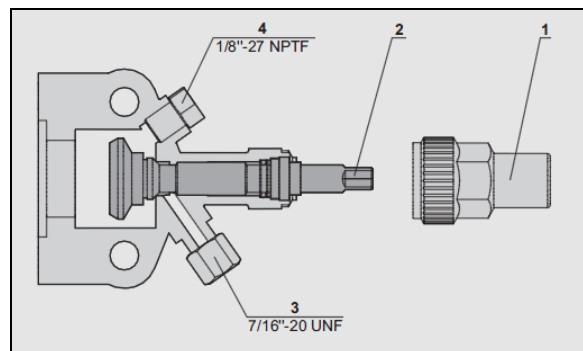

FIGURE 20: COMPRESSOR SHUT-OFF VALVE BACKSEATED POSITION (NORMAL OPERATING POSITION)

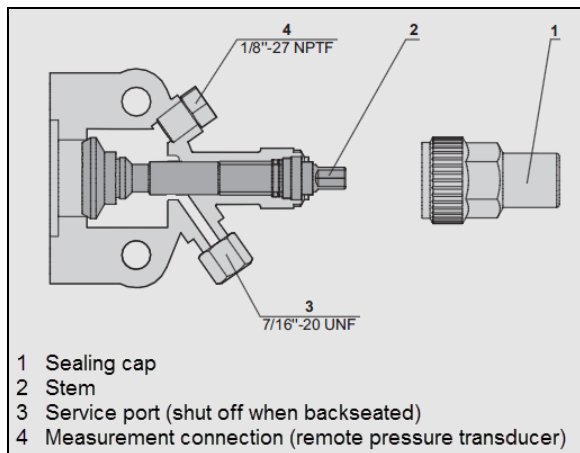

FIGURE 21: COMPRESSOR SHUT-OFF VALVE IN FRONT SEATED POSITION

2. Run the system for 10 minutes and then shut it off.
3. Close (frontseat) the receiver tank outlet shut-off valve by turning the stem clockwise (Figure 36).
4. Backseat the compressor suction shut-off valve (FIGURE 20), install an appropriate pressure gauge set on the service port and then turn the shut-off valve forward $\frac{1}{4}$ turn more or less until a visual check of the suction pressure is possible.
5. Disconnect the low pressure transducer (FIGURE 27). The multiplex system will establish a default value of 34 psig and this will allow pulling down the A/C compressor to 0 psig. **Note: the low pressure transducer must be reconnected after the pumping down operation is complete.**
6. Run the A/C compressor until suction pressure is pulled down to 0 psig.
7. Disconnect the compressor clutch to stop the compressor from pulling the system into a vacuum. Vacuum is not required. The pressure will probably slowly increase on the suction side. When it reaches 10 psig, reconnect the clutch and repeat the pull down to pull down this residual pressure. This process might need to be repeated a couple of times until the suction pressure drops and remains to 0 psig.
8. Stop the compressor.
9. Close (frontseat) the suction shut-off valve on the compressor (FIGURE 21).
10. At this point, C24 can be disconnected to isolate the section of the system located between the receiver tank outlet shut-off valve and the passengers' unit liquid solenoid valve. Doing so would be useful to perform replacement of the filter-dryer for example.

NOTE

During this operation, care must be taken not to fill the receiver tank over the upper sight glass. If so, stop process immediately. Always allow refrigerant piping and units to warm up to the ambient air temperature before opening system or sweating will take place inside the lines.

6.4 LIQUID REFRIGERANT RECOVERY

Liquid recovery is performed the same way as standard vapor recovery except that liquid recovery will be done by connecting to the high side of the system. Recovering liquid is ideal for recovering large amounts of refrigerant.

1. Energize driver's unit and passengers' unit (main HVAC system) section liquid solenoid valve. To do so, connect male and female connector housings of C24 together for the passengers' area (located on the HVAC module in evaporator compartment) and C44 for the driver's area (located on the ceiling of the spare wheel compartment). During normal use, both male and female housings of connector C24 or C44 are kept unplugged.
2. Backseat (normal operating position) the compressor suction and discharge shut-off valves.
3. Connect manifold gauges on the service port and then turn the compressor shut-off valves forward just enough to enable a visual check of the suction and discharge pressure.
4. Make sure the receiver outlet shut-off valve is in backseated position (normal operating position). Connect the recovery unit hose to the receiver outlet shut-off valve service port (FIGURE 22).



FIGURE 22: RECOVERY UNIT CONNECTED TO RECEIVER SERVICE PORT

5. Perform the recovery of the refrigerant as prescribed by the recovery unit manufacturer.

6.5 EVACUATING SYSTEM

When A/C system has been opened or if there are any questions about the air or moisture in the system, evacuate the system.

Backseat (stem out) both compressor shut-off valves. Evacuate the entire system including compressor using a **vacuum pump** connected to the high and low pressure sides.

A steady vacuum (i.e. pressure does not rise within two hours) less than 0.02 psi (1.5 mbar) must be maintained once the vacuum pump is turned off.



CAUTION

The evacuation of the system must be made by authorized and qualified personnel only. Refer to local laws for R-134a recuperation.

1. Make sure both receiver tank shut-off valves are in the normal backseated position (stem turned out).
2. Clean the area around the compressor shut-off valves.
3. Remove the blue and red caps from the service ports on suction and discharge shut-off valves. Connect two hoses to the vacuum pump.
4. Backseat the compressor suction and discharge shut-off valves.
5. Using connector C24 and C44, energize and open the liquid solenoid valves (driver's unit, passengers' unit and parcel rack units). To do so, uncap and connect male and female connector housings of C24 together for the passengers' area (located on the

HVAC module in evaporator compartment) or C44 for the driver's area (located on the ceiling of the spare wheel compartment).

6. Start the vacuum pump.
7. The pressure will drop to approximately 29 in-HG vacuum.
8. Evacuate to a system pressure of 500 micron.
9. Shut down the vacuum pump. Validate that the vacuum holds. If the pressure rises, it indicates a leak.
10. Backseat the compressor shut-off valves by turning "out" all the way.
11. Remove the hoses.
12. Reinstall the red and blue caps at the suction and discharge shut-off valves service ports.
13. Disconnect C24 & C44.

6.6 ADDING VAPOR STATE REFRIGERANT

Addition of vapor state refrigerant is carried-out to compensate for hose permeation and shaft seal losses over a long period and is done from the suction side while compressor is in operation.

A typical sign of refrigerant low charge would be A/C lower performance experienced by the user.

Perform the usual leak inspection and correct any leaks before adding refrigerant.

6.6.1 Verification

Perform the following verifications:

- 1- A vehicle stopped for more than 4 hours should show the lower receiver tank sight glass full at room temperature or with some level if ambient temperature is high. This method is less accurate when ambient temperature gets high.
- 2- With the AC on for at least 10 minutes, the moisture indicator sight glass (FIGURE 23) should be clear, not milky, without bubbles in the stream of refrigerant. Bubbles in the moisture indicator sight glass are sign of refrigerant low charge. The filter-dryer nearby should be near constant temperature, less than 5°F differential between inlet and outlet. A partially blocked filter will make some flash gas and give a "milky" sight glass.

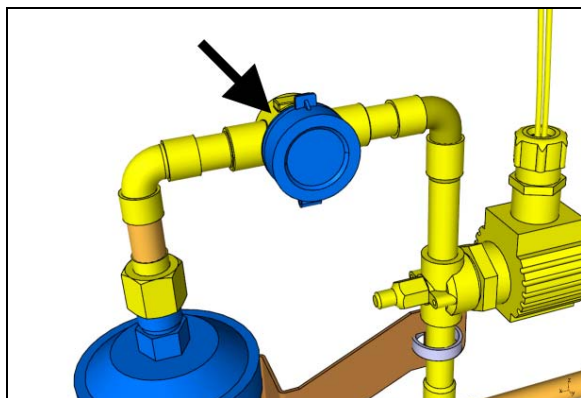

FIGURE 23: MOISTURE INDICATOR SIGHT GLASS

- At fast idle, the high side pressure should be near the following calculation: add 30° F to the ambient temperature in Fahrenheit. In the refrigerant chart (see 7.13 Temperatures & Pressure), find this temperature and the corresponding saturation pressure and add 10 psi for the pressure drop between compressor and condenser.

Calculation example:

At 70°F outside, add 30°F. In the chart (paragraph 7.13), find the pressure value for a temperature of 100°F. For 134a refrigerant gas, you will find a value of 124 psi. Add 10 psi to this value for the compressor to condenser line, this result gives 134 psi. So a high side pressure value between 129 to 139 psi should be OK.

6.6.2 Refrigerant addition

NOTE

*Use a bottle that is more than half full.
Always charge the system with the cylinder upright and the valve on top to avoid drawing liquid out of the cylinder.*

- Install a heated refrigerant bottle at the back of the vehicle, on a scale, straight up. Refer to section “Precautions in Handling Refrigerant” for the proper heating method.
- Connect the yellow hose of your manifold gage set to the red (vapor) valve on the bottle. Connect the blue valve of the gage set on the suction shut-off valve service port of the compressor. Connect the red valve of the gage set to the discharge shut-off valve service port. Hoses should be purged of air at installation (evacuated).



WARNING

Secure manifold gage hoses so they will not be damaged by engine belts and pulley.

- Midseat the compressor suction and discharge shut-off valves.
- In order to speed up the charging, unplug the unloader to keep all compressor cylinders active.



CAUTION

When unplugging the unloader, use exceptional caution so as not to rotate the blue unloader solenoid coil on the Bitzer compressor R.H. cylinder. The aluminum cap on top of the coil may become loose; it can result in failure of the unloader stem/valve (FIGURE 30).

Make sure the aluminum cap on top of the blue unloader coil remains tight.

- Let the door and hatches open and maybe open side windows to prevent cooling down the coach too rapidly. Preferably, the interior would be hot, at least over 68°F.



WARNING

If discharge pressure is above 138 psig, the condenser fans will be running. Keep hands clear of fans

- Start engine.
- Switch to fast idle for faster fill and battery protection.
- Open the blue gage valve. The suction pressure should go up meaning the compressor is sucking from the tank also. If there is almost no pressure rise, the tank is too low or too cold.
- Check the moisture indicator sight glass and the discharge pressure to meet the criteria described above.
- When the sight glass gets clear, you can add some reserve, up to 2 pounds, as long as the high pressure does not move up.
- When finished, close gage valves and bottle valve.
- Before stopping the engine, check the compressor oil level and note it in the repair

book as well as the amount of refrigerant added.

13. Shut down engine and backseat suction and discharge shut-off valves (FIGURE 20).
14. Remove gages and replace caps.
15. Perform a road test for final verification.

6.7 CHARGING SYSTEM

When a system has been opened or if there are any questions about the air or moisture in the system, evacuate the system. **Charging of an evacuated system** may be accomplished by **forcing liquid R-134a directly into the receiver tank**. This may be accomplished by placing the refrigerant cylinder upside down on a scale with the valves at the bottom. This ensures that only liquid will enter the **receiver tank**.

When charging an empty system, weigh the amount of refrigerant put into the system. This will eliminate any possibility of overfilling. A nominal charge requires **24 pounds plus an additional 2 lbs for parcel rack A/C system**.

After charging the system, it may be necessary to add refrigerant. Vapor state refrigerant will be done from the suction side of the compressor while the compressor is in operation. Refer to 6.6 Adding Vapor State Refrigerant

1. Using connector C24 and C44, energize and open the liquid solenoid valves (driver's unit, passengers' unit and parcel rack units). To do so, uncap and connect male and female connector housings of C24 together for the passengers' area (located on the HVAC module in evaporator compartment) or C44 for the driver's area (located on the ceiling of the spare wheel compartment).
2. Backseat (stem out) the two compressor shut-off valves (FIGURE 20).
3. Install A/C pressure gauges at the compressor shut-off valves service ports (item 4, FIGURE 20).
4. Midseat the two compressor shut-off valves.
5. Ensure that the two receiver shut-off valves are in backseated position (stem out).
6. Remove the cover cap from the service port on the receiver inlet shut-off valve (Figure 36).
7. Attach an evacuated charging hose (purged from air and moisture) to the R-134a tank.

8. Connect the evacuated charging hose to the service port on the receiver tank inlet shut-off valve.
9. Open the R-134a tank valve. The refrigerant supply tank should be kept warm to allow more refrigerant to be transferred into the system. Use a heating blanket for this matter.
10. Midseat the receiver inlet shut-off valve. The R-134a will now enter the system.
11. The proper charge of R-134a is 24 lbs, to this, add 2 lbs for parcel racks A/C system. When the scale indicates this amount of charge, backseat the receiver valve and close the R-134a tank valve.
12. Disconnect the charging hose. Replace the cover caps.
13. Disconnect C24 & C44.
14. The system is now ready for operation.

6.8 REFRIGERANT SYSTEM CLEAN-OUT AFTER COMPRESSOR FAILURE

Although the vast majority of reciprocating refrigerant compressors manufactured today are extremely reliable, a small percentage do fail. These failures usually result in minor or extensive system contamination depending on the severity of the failure. When an open type compressor becomes damaged internally, this provokes small particles of bearings, steel, brass, copper, and aluminum and, in severe cases, carbonized oil, which could contaminate the system. To prevent repeated failures, the problem which caused the failure should be corrected, and depending upon the severity of the failure, the system should be thoroughly cleaned out using one of the clean-out procedures mentioned.

6.8.1 Determining Severity of Failure

The severity of compressor failure can be categorized as minor or major. A failure is considered minor when the contamination is limited to the compressor with little or no system contamination. A major failure, or burnout, results in extensive system contamination as well as compressor damage. Extensive system contamination can be determined by withdrawing a small sample of compressor oil and checking its color, odor and acidity. A Virginia Chemical "TKO" one step acid test kit is one of several compressor oil test kits that may be used. A high acid content would indicate a

major failure or burnout. A small amount of refrigerant gas may be discharged. A characteristic burned odor would also indicate severe system contamination.

6.8.2 Clean-out after Minor Compressor Failure

1. Be sure to correct the problem which caused the failure.
2. Change liquid line filter-dryer.
3. Run the unit for 2 hours on high speed cool only.
4. Check compressor oil level to ensure compressor is not overcharged with oil. Sometimes a significant amount of oil is pumped out of the compressor to other parts of the system when a compressor fails. This oil will return to the replacement compressor when it is started, causing an overcharge of oil in the sump of the replacement compressor. In this case, it is important that the oil level be adjusted to the proper level.
5. Withdraw a sample of the compressor oil and check its color, odor, and acidity, using instructions supplied above. If the oil is contaminated, change the oil and filter-dryer, and repeat the procedure until the system is clean.

6.8.3 Clean-out After Major Compressor Failure

1. Reclaim the refrigerant into a refrigerant bottle through a filter-dryer to filter out contaminants.
2. Remove the failed compressor and repair it if possible.
3. Install new or repaired compressor.
4. Change the filter-dryer using method described earlier.
5. Circulate clean R-134a or nitrogen using a pressurized metal cylinder or a reclaiming machine to clean out many of the contaminants collected in the coil valves, TXV (Thermal Expansion Valve), solenoid valves, check valves, and any other mechanical component that may have collected contaminants.
6. Evacuate and charge the system normally.
7. Run the unit for 8 hours and monitor the pressure drop across the filter-dryer. Also

check the liquid line dryer for signs of restriction. If the pressure drop across the filter-dryer exceeds 12 to 14 psig (82,75 to 96,5 kPa) with a 40°F (5°C) evaporator coil temperature, stop the unit and change the liquid line and suction line filter-dryer. After 4 or 5 hours of operation, stop the unit and replace the filter-dryer.

8. After 8 hours of operation, stop the unit and remove a sample of the compressor oil and check its color, odor, and acidity, using instructions supplied above. If the oil is contaminated, replace the oil and repeat step 7. If the oil is not contaminated, change the filter-dryer again and replace the moisture-liquid indicator.
9. After approximately 7 days of operation, recheck the compressor oil for cleanliness and acidity.

7. A/C SYSTEM COMPONENTS

7.1 COMPRESSOR

The A/C compressor is a **Bitzer 4-cylinder model 4NFCY**. Refer to the “Specifications” section at the end of this chapter.

7.1.1 Belt Replacement



DANGER

Set the battery master switch to the “Off” position. For greater safety, set the engine starter selector switch in engine compartment to the “Off” position.

1. Open engine compartment rear doors and locate the belt tensioner.
2. Remove the radiator fan driving mechanism belt (Refer to Section 05: Cooling).
3. Slip the old A/C compressor belts off and the new ones on.

NOTE

Double belts must always be replaced in pairs to ensure equal distribution of load on each belt.

7.1.2 Belt Tension Adjustment –A/C drive belt

On the mechanical tensioner, slightly loosen Lock Bolt (A). Adjust tension by turning Adjustment Screw (B). Tighten the Lock Bolt (A) to 43 lbf-ft. to preserve adjustment.



CAUTION

When unplugging the unloader, use exceptional caution so as not to rotate the blue unloader solenoid coil on the Bitzer compressor R.H. cylinder. The aluminum cap on top of the coil may become loose; it can result in failure of the unloader stem/valve (FIGURE 30).

Make sure the aluminum cap on top of the blue unloader coil remains tight.

Should the idler bearing need to be serviced, tighten shoulder bolt (C) to **35 lbf-ft.** at reassembly.

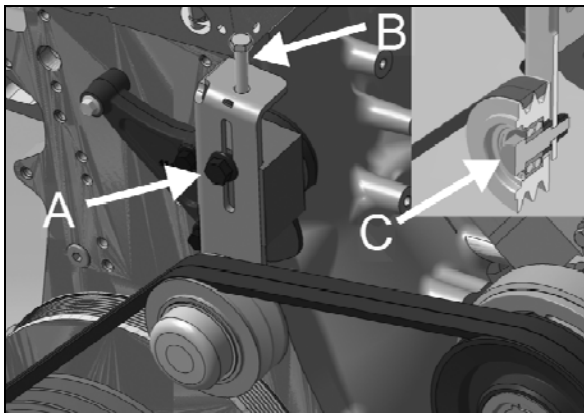

FIGURE 24: COMPRESSOR BELT TENSIONER

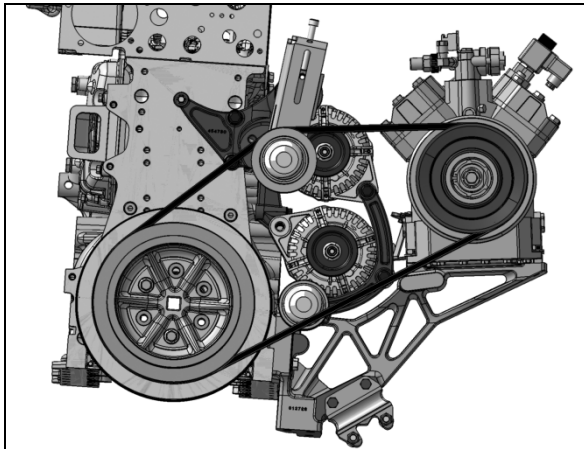

FIGURE 25: STANDARD BELT ARRANGEMENT

Belt tensions should be within the following values:

BX71 Double Belt

90 - 100 lbs. – new

75 - 85 lbs. – used

7.1.3 Suction and Discharge Hose Connection

1. Before connecting suction and discharge refrigerant hoses to the compressor, apply POE compressor oil on new gaskets, **do not dip in oil.**
2. Tighten flanged hose by hand in 2 sequences.
3. Apply a final torque of 33 lbf-ft on cap screws.

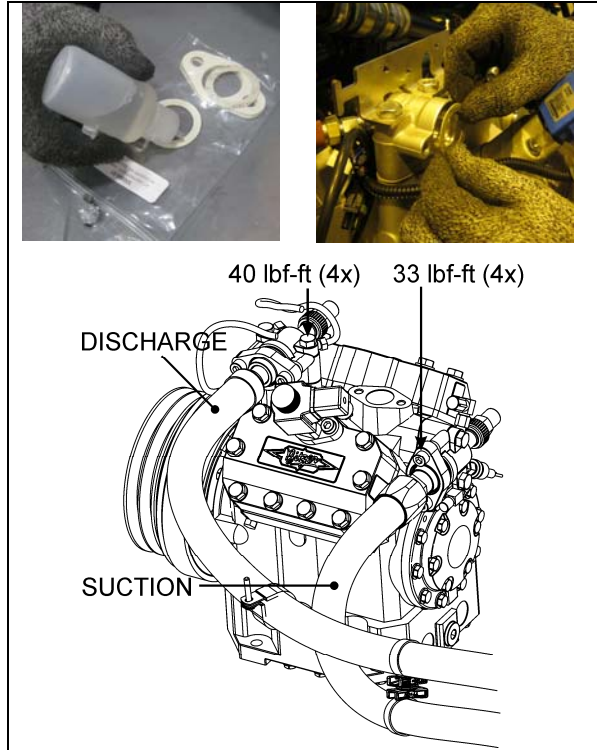

FIGURE 26: TORQUES

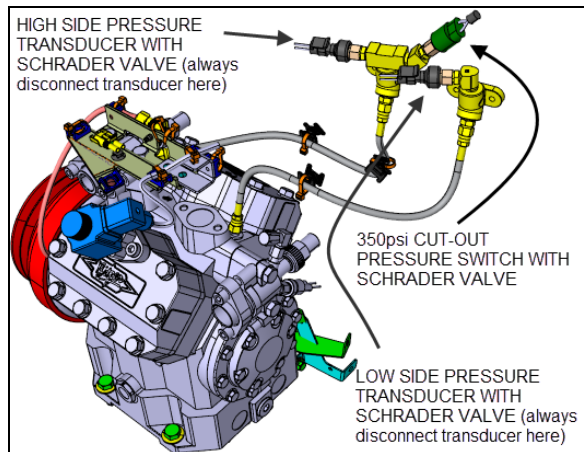

FIGURE 27: PRESSURE TRANSDUCERS

7.1.4 Compressor Maintenance

For complete information on Bitzer A/C compressor maintenance, installation, torque chart, approved oils, refer to the following Bitzer manuals included with the technical publications in PDF format.

- Bitzer kb-540-3 Operating Instructions
- Bitzer ke-540-7 Spare Parts List
- Bitzer kw-541-2 Exchanging Shaft Seal
- Bitzer kt-510-5 Tech Info oils
- Bitzer kw-555-3 Tightening Torques
- Bitzer kt-100-3 Capacity Control (unloader)
- Bitzer kw-540-1 Maintenance Instruction

7.1.5 Oil Level Check and Oil Change

Oil level should be at $\frac{1}{4}$ to $\frac{3}{4}$ of sight glass height.

Oil Type: Polyoester ISO68.

- Bitzer BSE55 (POE)
- Castrol Icematic SW 68
- Mobil EAL Arctic 68
- Shell S4 FR-F 68, Clavus R68

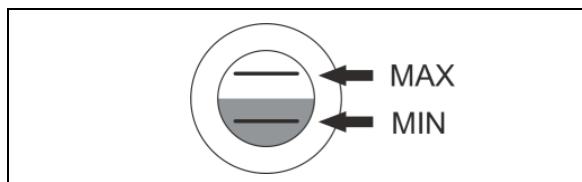

Changing the compressor oil is not necessarily required for A/C systems which are operated in a normal fashion. Only impurities from the system components or operation outside the application ranges can lead to deposits in the lubrication oil and darken its color. Change the oil in this case. At the same time, clean the oil filter and magnetic plug as well. Determine and eliminate the cause for operation outside the application ranges.

However, compressor oil does wear down; therefore, it is strongly recommended to change the oil approximately every 4 years (10000-12000 operating hours). Clean the oil filter and the magnetic plug with every oil change.

Once every 6 months empty the shaft seal oil collecting tube. This tube collects oil seeping through the shaft seal.

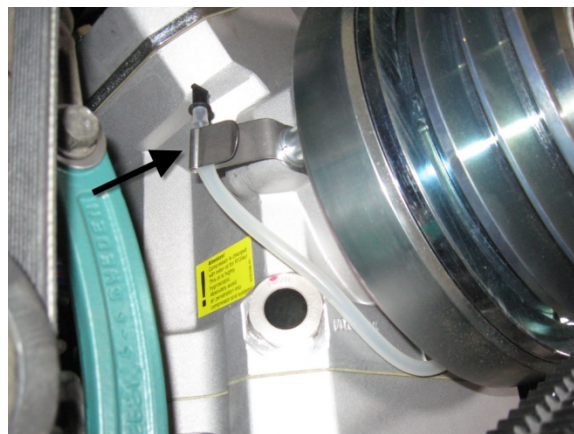

FIGURE 28: SHAFT SEAL OIL COLLECTING TUBE

During the 250 hour run-in period of the shaft seal, an increased oil leak rate may occur.

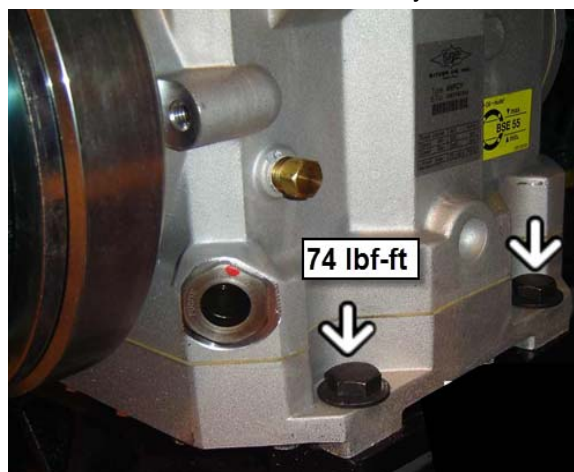

FIGURE 29: MOUNTING BOLTS TORQUE – 4 BOLTS

7.1.6 Troubleshooting Guide

A preliminary check may be made by simply feeling the cylinder heads with the unit in operation at ambient temperatures of 35°F (2°C) and over. The cylinder heads are internally divided into suction and discharge areas. The upper central section of the cylinder is the suction side and it should be relatively cool to the touch, as opposed to the hot discharge area which is the lower perimeter area of the cylinder head. If a valve plate or head gasket is blown, or a compressor unloader is stuck open, partially compressed refrigerant vapor will be circulated between the suction and discharge sides of the head. The affected cylinder head will then have a relatively even temperature across its surface and be neither as hot as the normal discharge temperature nor as cool as the normal suction temperature.

Blown Head GasketsSymptom:

- * Loss of unit capacity at low temperature.
- * Even cylinder head temperature.

Cause:

- * Improperly torqued cylinder head bolts.
- * Improperly positioned gasket at assembly.
- * Warped cylinder head.
- * Severe liquid refrigerant floodback.

Blown Valve Plate GasketsSymptom:

- * Loss of unit capacity at medium and low temperatures.
- * Very hot cylinder head surface.
- * Higher than normal suction pressure.

Cause:

- * Improperly torqued cylinder head bolts.
- * Severe liquid refrigerant floodback.
- * Oil slugging caused by an overcharge of oil or flood starts.
- * Discharge valves not seated properly (liquid drainback during shutdown).

Broken Suction ValvesSymptom:

- * Loss of unit capacity at all temperatures.
- * Compressor unable to pull extremely low vacuum with suction shut-off valve frontseated.

Cause:

- * Repeated liquid refrigerant floodback.
- * Flooded starts.
- * Overcharge of oil.
- * Discharge valves not seated properly (liquid drainback during shutdown).
- * Expansion valve not controlling properly.

Unloader Valve Stuck OpenSymptom:

- * Loss of unit capacity at all temperatures.
- * Higher than normal suction pressure.
- * Even cylinder head temperature.

Cause:

- * Unloader body stem bent.
- * Foreign material binding unloader plunger.

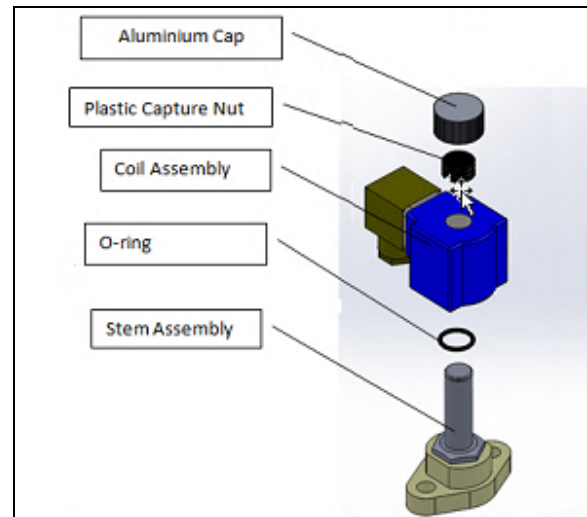

FIGURE 30: UNLOADER COIL ASSEMBLY

7.2 ELECTRO-MAGNETIC CLUTCH

Refer to *Lang Electromagnetic clutch mounting-dismounting* and *Bitzer Maintenance Instruction kw-540-1* provided with the technical publications in PDF format for further details on electro-magnetic clutch removal and installation.

7.3 EVAPORATOR MOTOR

The evaporator motor is installed in the evaporator compartment (L.H. side of vehicle) (Figure 31). It is a 27.5 volt, 2 HP (1.5 kW) motor which activates a double blower fan unit.

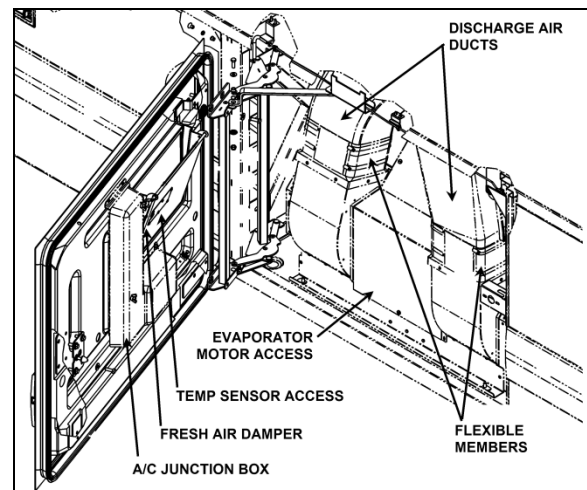

FIGURE 31: EVAPORATOR COMPARTMENT 22301_B

7.3.1 Removal

- Set the battery master switch (Kissling switch) to the OFF position.

- Open the evaporator compartment door.
- On the HVAC module (FIGURE 11). Disconnect circuit 90H1 from evaporator relay R12.
- Remove the evaporator motor and coil access panel.
- Identify the L.H. side discharge duct inside compartment and remove the Phillips head screws retaining the flexible member to duct.
- Repeat step 4 for the R.H. side air duct.
- Disconnect the electrical motor speed control connections on the motor plate.
- From under the vehicle, remove the eight bolts retaining the evaporator fan motor support. Remove the complete unit from the evaporator compartment (Figure 32).

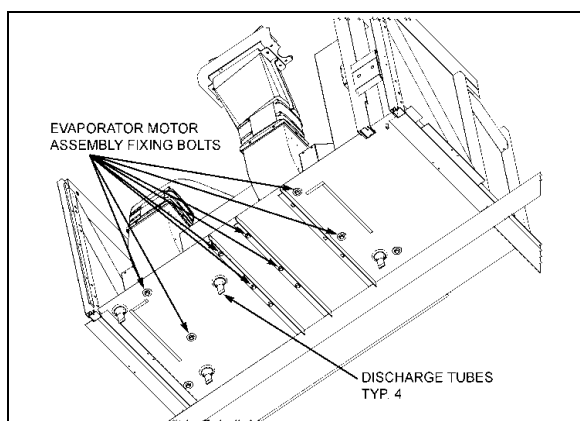

FIGURE 32: EVAPORATOR MOTOR ASSY FIXING BOLTS

22315



CAUTION

Never support evaporator motor by its output shafts while moving it.

- On a work bench, unscrew the fan square head set screws, the Phillips head screws retaining cages to support and slide out the assemblies from the evaporator motor output shaft.

7.3.2 Installation

To reinstall the evaporator motor, reverse "Evaporator Motor Removal" procedure.

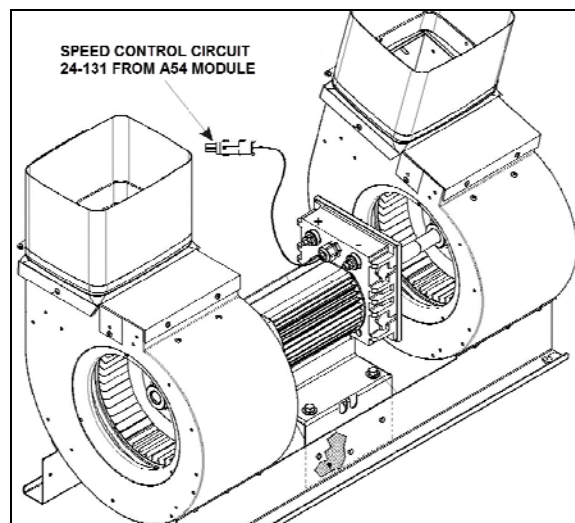

FIGURE 33: EVAPORATOR MOTOR ASSEMBLY

7.4 CONDENSER

The A/C system condenser coil is hinge mounted on the R.H. side of the vehicle on the A/C condenser door. Since condenser's purpose is to dissipate heat from the hot refrigerant, it is important to keep the cooling coils and fins clean. A clogged coil will cause high discharge pressure and insufficient cooling.

7.4.1 Condenser Fan Motors

Four 2-speed brushless fan motors (Figure 35), 28.5 V - (0.6 HP - 0.42 kW) are mounted on the condenser coil and swing out with it. The fans draw outside air through the condenser coil and discharge it through an opening at bottom of compartment. When temperature drops inside condenser, the pressure in the refrigerant line also drops. Consequently, when pressure drops to 175 psi, the motors will run at low speed and if the pressure continues to drop to 120 psi, a pressure switch stops the motors so that fans do not operate needlessly. When pressure rises to 145 psi, the pressure switch reactivates the motors at low speed. If the pressure rises to 205 psi, the motors will switch to high speed.

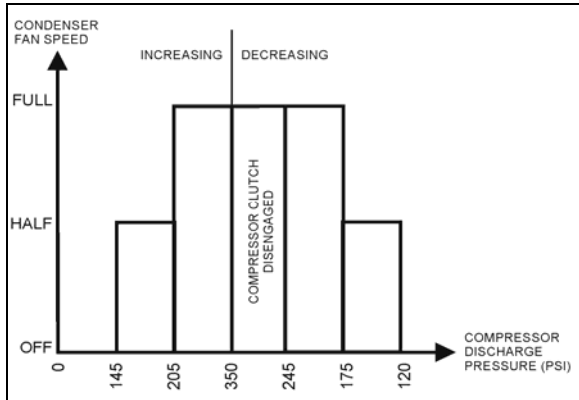

FIGURE 34: CONDENSER FAN SPEED IN RELATION WITH HIGH SIDE PRESSURE

For details about electrical wiring, refer to “A/C and Heat system” in the master wiring diagram.

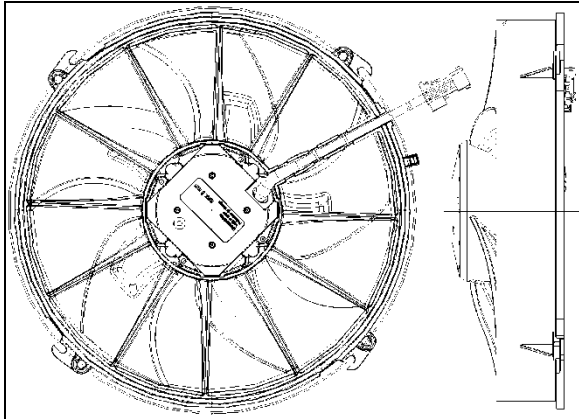

FIGURE 35: CONDENSER FAN MOTOR

22322

7.4.2 Condenser Fan Motor Removal

1. Set the battery master switch to the “Off” position.
2. Disconnect wiring from terminals on motor. Tag each wire to aid in identification at time of reconnection.
3. Remove the four hexagonal head cap screws retaining the fan motor assembly to the mounting support.
4. Remove the motor.

7.5 RECEIVER TANK

The receiver tank is located in the condenser compartment (Figure 36). The function of the receiver tank is to store the liquid refrigerant. During normal operation, the level of the refrigerant should be approximately at the mid-point of the lower sight glass.

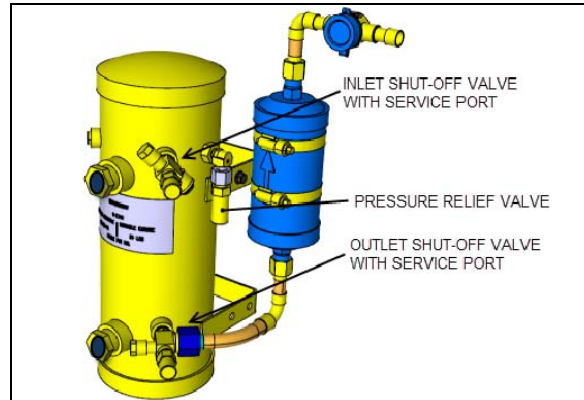

FIGURE 36: RECEIVER TANK

In case of extreme pressure there will be a rise in the liquid receiver tank. A **pressure relief valve** will break at 450 psi and relieve the receiver tank pressure.



MAINTENANCE

Check refrigerant level and add if necessary, every 12 000 miles or twice a year, whichever comes first.

The receiver tank incorporates an inlet valve on the inlet side (upper section) which allows the tank to be isolated or serviced. An outlet valve on the outlet side (lower section) permits complete isolation from the rest of the system.

During **normal operation**, inlet and outlet shut-off valves are in backseated position (stem out). When connecting a gauge to the service port, make sure the shut-off valve is in backseated position because the service port is not fitted with a Schrader valve.

7.6 FILTER-DRYER

A filter-dryer, also located in the condenser compartment, is installed on the liquid refrigerant line after the receiver tank. It is used to absorb moisture and foreign matter from refrigerant before it reaches the expansion valves.

The filter-dryer should be replaced after a severe system failure, after a prolonged exposure and most important, when the moisture indicator sight glass turns to pink.

7.6.1 Replacement of the Filter-Dryer After Pumping Down

The filter-dryer is of the disposable type. When replacement is required, remove and discard the

complete unit and replace with a new unit of the same type according to this procedure:

1. Perform the pumping down procedure to isolate refrigerant in the receiver tank.
2. Disconnect C24 to isolate the section of the system located between the receiver tank outlet shut-off valve and the passengers' unit liquid solenoid valve.
3. Change the filter-dryer.

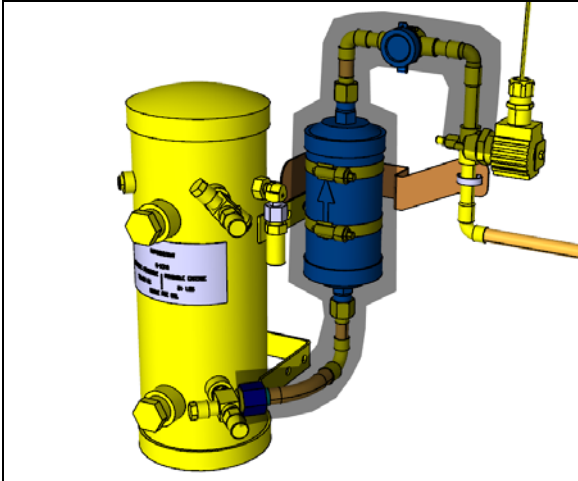

FIGURE 37: ISOLATED SECTION

4. Once the filter-dryer has been replaced, it is necessary to evacuate the opened section of the refrigerant circuit. Evacuate the isolated section of the system using a vacuum pump connected to the service port of the receiver outlet shut-off valve.
5. Evacuate the section of the refrigerant piping as needed and in accordance with best practices, using a micron gauge to monitor the depth of vacuum. Evacuate to a system pressure less than 1000 microns.
6. Turn off the vacuum pump.
7. Backseat the outlet shut-off valve and then disconnect the vacuum pump hose.

CAUTION

Do not use carbon tetrachloride or similar solvents to clean parts. Do not use a steam gun. Use mineral spirits or naphtha. All parts should be thoroughly cleaned. Use a stiff brush to wash dirt from grooves, holes, etc.

DANGER

Cleaning products are flammable and may explode under certain conditions. Always handle in a well-ventilated area.

7.7 MOISTURE INDICATOR

The moisture sensitive element consists of a color changing ring which is reversible from pink to blue and vice versa as the moisture content in the refrigerant changes.



- PINK: high levels of moisture detected.
- PURPLE (caution): low levels of moisture detected.
- BLUE: dry, optimal operating conditions.

Since temperature changes affect the solubility, color change will also vary with the refrigerant temperature. The above table shows the color change for R-134a at various moisture levels and liquid line refrigerant temperatures.

MAINTENANCE

Check refrigerant moisture indicator every 50 000 miles or twice a year, whichever comes first. Replace filter-dryer unit according to moisture indicator

COLOR INDICATOR			
TEMPERATURE	BLUE (ppm)	LIGHT VIOLET (ppm)	PINK (ppm)
75°F (24°C)	20	35	130
100°F (38°C)	35	55	160
125°F (52°C)	60	65	190

p.p.m.= parts per million (moisture content)

A moisture level of less than 15 p.p.m. for R-134a indicated in the blue color range of the above table is generally considered dry and safe. A color indication of light blue to light violet indicates the caution range of moisture level. For positive protection, the drying of the system should be continued until the color of the element turns to deep blue.

The liquid refrigerant is readily visible through the center opening of the moisture element where the presence of bubbles or flash gas indicates an insufficient system charge, low

head pressure, insufficient liquid subcooling or some form of restriction in the liquid line.

Moisture is one of the main causes of chemical instability or contamination in air conditioning systems. If moisture is present, it can corrode the valves, condenser and evaporator coils, compressor and other components causing a malfunction and eventual failure of the system. Uncontrolled moisture in the system can result in very expensive multiple component replacements if not corrected at an early stage. The moisture indicator permits an early detection of moisture in the system and when corrected by a desiccant charge, system contamination is greatly minimized.

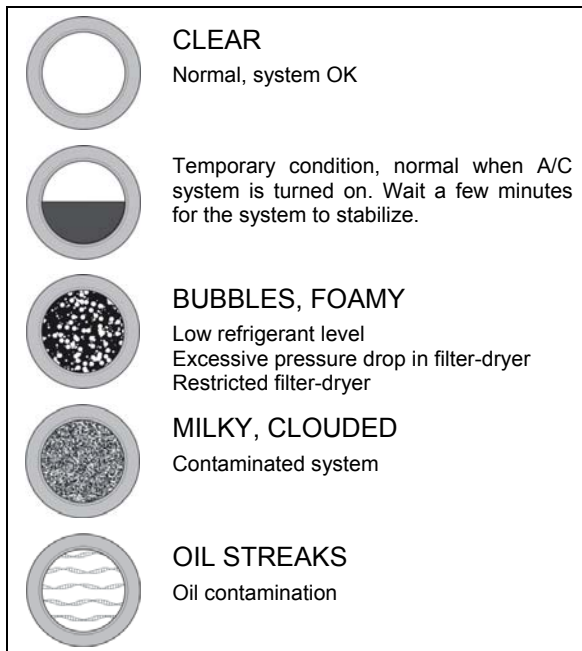

FIGURE 38: CONDITIONS THAT MAY BE OBSERVED IN THE MOISTURE INDICATOR SIGHT GLASS

7.8 SHUT-OFF VALVE WITH SERVICE PORT

This shut-off valve (FIGURE 39) is located in the condenser compartment. It is used to isolate one section of the refrigerant circuit. The service port is equipped with a Schrader valve.

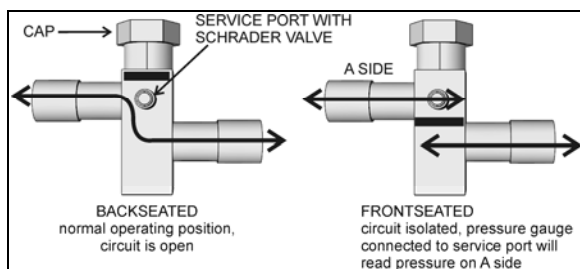

FIGURE 39: REFRIGERANT CIRCUIT SHUT-OFF VALVE

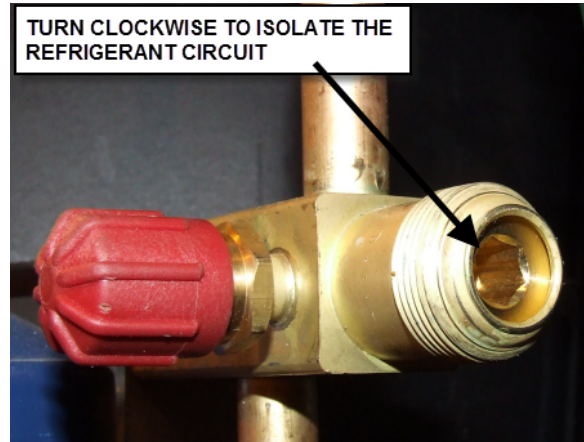

FIGURE 40: REFRIGERANT CIRCUIT SHUT-OFF VALVE

7.9 LIQUID REFRIGERANT SOLENOID VALVE

The flow of liquid refrigerant to the driver's unit evaporator, passengers' unit evaporator (main evaporator) and parcel racks evaporator is controlled by one NC (normally closed) solenoid valve on each circuit, for a total of three solenoid valves.

The driver's unit solenoid valve is located on the ceiling of the spare wheel compartment (FIGURE 41) and is accessible through the reclining bumper.

Two identical NC (normally closed) refrigerant solenoid valves are found in the condenser compartment (FIGURE 42). One is used to control flow of refrigerant to the parcel racks evaporator while the other is used to control flow to the main evaporator.

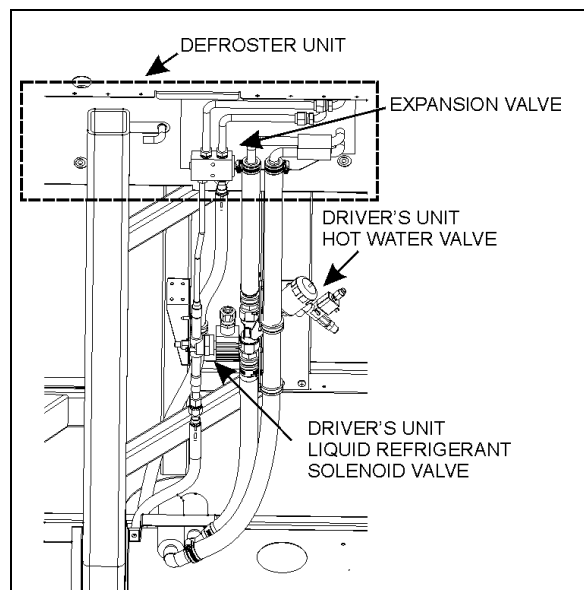

FIGURE 41: DRIVER'S UNIT LIQUID SOLENOID VALVE

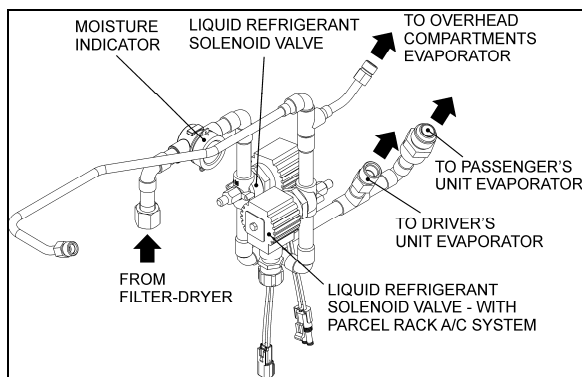

FIGURE 42: LIQUID REFRIGERANT SOLENOID VALVES INSIDE CONDENSER COMPARTMENT

7.9.1 Typical malfunctions

Faulty control circuit: Check the electric system by energizing the solenoid with 24-V DC. A metallic clicking noise indicates that the solenoid is operating. Absence of clicking indicates a loss of power or a defective solenoid. Check for open breaker, open-circuited or grounded coil, broken lead wires.

Burned-out coil: Check for open-circuited coil. Replace coil if necessary.

Low voltage: Check voltage across the coil leads. Voltage must be at least 85% of nameplate rating.

Excessive leakage: Disassemble valve and clean all parts. Replace worn or damaged parts with a complete repair kit for best results.

There are only three main possible malfunctions:

1. Coil burnout.
2. Failure to open.
3. Failure to close.

Each is discussed in *Sporlan Parker Hannifin Solenoid Valve Installation and Servicing* bulletin included on your Technical Publications CD.

7.9.2 Electrical Bypass/On Demand Opening of liquid refrigerant solenoid valves

To ease purging, pumping down and refilling of refrigerant, it is possible to open the liquid solenoid valves (normally closed NC). To do so, uncap and connect plug and socket housings of connector **C24 together for the passengers' unit and parcel rack units liquid solenoid valves** (located on the HVAC module in evaporator compartment) or **C44 for the driver's unit liquid solenoid valve** (located on the ceiling of the spare wheel compartment).

During normal use, both plug and socket housings of connector C24 or C44 are to be kept unplugged and capped.



CAUTION

Connectors C24 & C44 must be disconnected and their caps reinstalled after this procedure. Leaving them connected will keep the driver's, passengers' and parcel rack liquid solenoid valves open, and result in battery draining if the bus remains unused for several days.

7.9.3 Coil Replacement

1. Unplug coil connector.
2. Take out the retaining screw at the top of the coil housing. The entire coil assembly can then be lifted off the enclosing tube.
3. Place the new coil on the enclosing tube. Lay data identification plate in place.
4. Insert the coil retaining screw, rotate coil housing to proper position and tighten screw securely.
5. Plug coil connector.

7.9.4 Valve Disassembly

1. Because of possible damage to valve components due to the high temperature of soldering and brazing, it is necessary to completely disassemble the **A & B series** valves before any heat is applied to the valve body. For **E series** (extended copper connections), braze into the line without disassembly because the valve contains extended connections. Use caution by placing a wet cloth or chill block on the extensions at the body to prevent excessive overheating.
2. Remove the coil as stated previously.
3. Pump down the system as stated in this section.
4. Remove the enclosing tube and locknut, all internal parts, and manual lift stem assembly.

NOTE

The previous procedure must be followed before brazing solder-type bodies into the line.



CAUTION

Be careful not to damage the machined faces while the valve is apart.

7.9.5 Valve Reassembly

1. Place the seat disc into the valve body with the smaller diameter end facing up.
2. Place the enclosing tube gasket onto the valve body above the threads.
3. Hold the plunger with one hand so that the pointed end is resting in the pilot port of the disk. Make sure the small spring is in place on the top of the plunger.
4. With the other hand, place the enclosing tube over the plunger, making sure the enclosing tube gasket is in position.
5. Put back the enclosing tube locknut and tighten **20-40 lbf-ft**. Do not over tighten.
6. Put back manual lift stem. Tighten lift stem assembly and seal cap to **11 lbf-ft**.
7. Place the coil assembly.

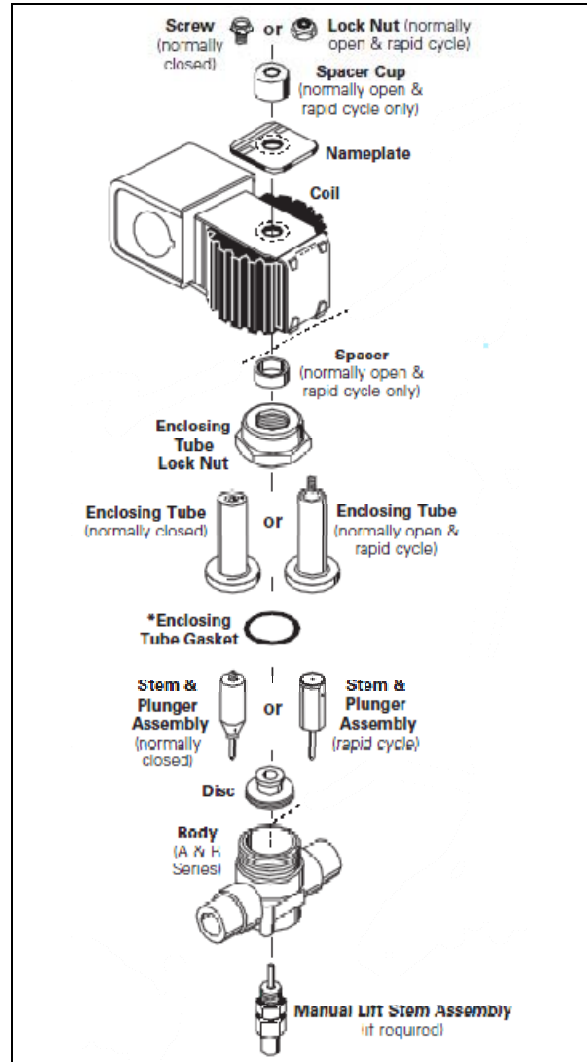

FIGURE 43: TYPICAL REFRIGERANT SOLENOID VALVE 22044

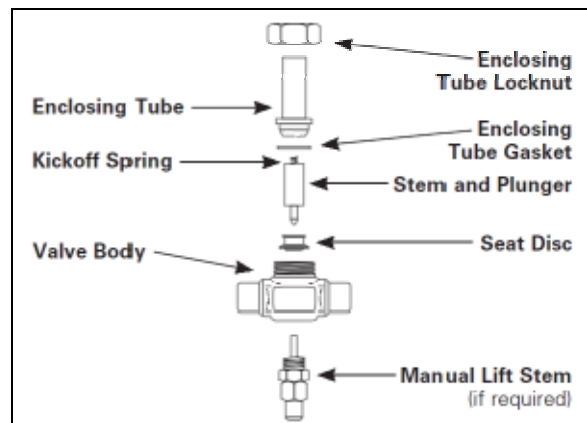

FIGURE 44: REFRIGERANT SOLENOID VALVE 22044



CAUTION

The filter-dryer must be replaced after a severe system failure or if a line in the system has been opened over a prolonged period of time. The line will then have to be properly evacuated.

Best practice would be to replace the filter-dryer each time a line is opened.



CAUTION

Be careful not to damage the machined faces while the valve is apart.

7.10 THERMOSTATIC EXPANSION VALVE

7.10.1 Passengers' Section HVAC Unit

The expansion valve for the passengers' section HVAC unit is a thermo-sensitive valve with a remote control bulb head attached to the evaporator outlet line and is accessible by the evaporator coil access door (Figure 45). The valve regulates the flow of refrigerant liquid into the evaporator coils and is controlled by the suction gas temperature leaving the evaporator. The bulb head senses the refrigerant gas temperature as it leaves the evaporator. High temperature will cause expansion and pressure on the power head and spring. Such action causes the assembly valve to open, allowing a flow of refrigerant liquid into the evaporator.

The remote bulb and power assembly is a closed system. The pressure within the remote bulb and power assembly corresponds to the saturation pressure of the refrigerant temperature leaving the evaporator and moves the valve pin in the opening direction. Opposed to this force, on the underside of the diaphragm and acting in the closing direction, is the force exerted by the spring.

As the temperature of the refrigerant gas at the evaporator outlet increases above the saturation temperature corresponding to the evaporator pressure, it becomes superheated. The pressure thus generated in the remote bulb and power assembly surpasses the combined pressures of the evaporator pressure and the spring, causing the valve pin to move in the opening direction. Conversely, as the temperature of the **refrigerant** gas leaving the evaporator decreases, the pressure in the remote bulb and power assembly also decreases and the combined evaporator and spring pressures

cause the valve pin to move in the closing position.

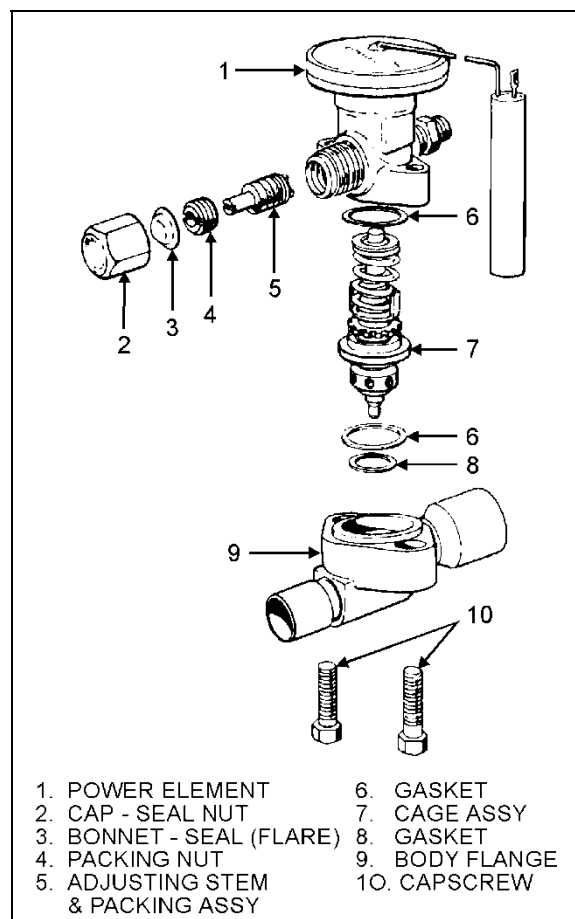

FIGURE 45: EXPANSION VALVE

22045

As the operating superheat is raised, the evaporator capacity decreases, since more of the evaporator surface is required to produce the superheat necessary to open the valve. It is obvious, then, that it is most important to adjust the operating superheat correctly and that a minimum change in superheat to move the valve pin to full open position, is of vital importance because it provides savings in evaporator cost of operation.

Accurate and sensitive control of the refrigerant liquid flowing to the evaporator is necessary to provide maximum evaporator capacity under load conditions. **The spring should be adjusted to give 12°F to 16°F of superheat at the evaporator outlet.**

This ensures that the refrigerant leaving the evaporator is in a completely gaseous state when drawn into the suction side of the compressor. Liquid would damage the

compressor valve, piston and heads if allowed to return in the suction line.

A vapor is said to be superheated when its temperature is higher than the saturation temperature corresponding to its pressure. The amount of the superheat is, of course, the temperature increase above the saturation temperature at the existing pressure.

As the refrigerant moves along in the evaporator, the liquid boils off into a vapor and the amount of liquid decreases until all the liquid has evaporated due to the absorption of a quantity of heat from the surrounding atmosphere equal to the latent heat of vaporization of the refrigerant. The gas continues along in the evaporator and remains at the same pressure. However, its temperature increases due to the continued absorption of heat from the surrounding atmosphere. The degree to which the gas refrigerant is superheated is related to the amount of refrigerant being fed to the evaporator and the load to which the evaporator is exposed.

Superheat Adjustment

Expansion valves are factory preset for optimum superheat settings. This setting should be modified only if absolutely necessary. The readjustment should be at the lowest expected evaporating temperature.

1. Operate coach for at least one-half hour at fast idle with temperature control set at 82°F (27,7°C), Then set temperature to minimum to keep the compressor on 4 cylinders, full charge.
2. Install the pressure gauge at compressor suction, but then add 3 PSI to reading.

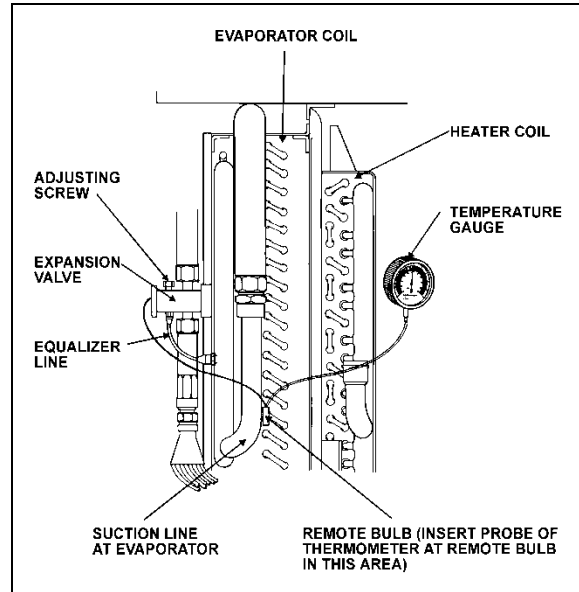

FIGURE 46: SUPERHEAT ADJUSTMENT INSTALLATION
22046

3. Install a remote reading thermometer to the evaporator outlet line near the existing remote bulb (Figure 46).
4. Apply thermostatic tape around the bulb and evaporator outlet line to get a true reading of the line temperature.
5. Block condenser if necessary to keep pressure over 150 psi.

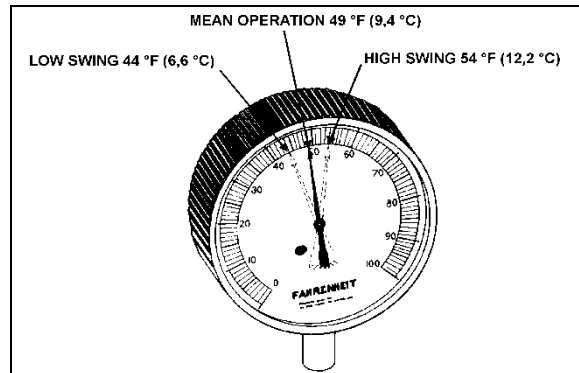

FIGURE 47: HIGH & LOW SWING TEMPERATURE AT REMOTE BULB
22047

6. Check approximately 5 readings of suction pressure at 2-minute intervals and convert to temperature using the temperatures & pressures table (paragraph 7.13). Likewise check the temperature reading at the remote bulb at the same 2-minute intervals and record the low and high swing readings of the needle (refer to Figure 47).

Example of readings taken:

A/C pressure gauge at	40°F
-----------------------	------

compressor suction converted to temperature with chart	
Temperature on remote bulb	Low swing 44°F High swing 54°F
Average of low and high swing	49°F
Formula for superheat $T^{\circ} \text{ at bulb} - T^{\circ} \text{ suction} = T^{\circ} \text{ superheat}$ $49^{\circ}\text{F} - 40^{\circ}\text{F} = 9^{\circ}\text{F}$	

NOTE
The low swing of the superheat should be a minimum of 4°F higher at the remote bulb and have an average of 8 to 12°F higher range at the bulb than the fitting at the expansion valve.

NOTE
The thermal expansion valve has a MOP (maximum operating pressure) of 55 psi. At this setting, the valve is completely opened. If the temperature at the bulb is greater than 50°F, do not try to adjust superheat as the valve is almost completely opened.

NOTE
To reduce the superheat, flow of refrigerant is increased by turning adjusting screw of expansion valve lower evaporator temperature counterclockwise. To increase temperature or increase superheat, flow of refrigerant is reduced by turning adjustment screw of expansion valve clockwise.

6. Regulate suction pressure to temperature reading according to temperature chart or to the R-134a temperature scale on the pressure gauge.

Example: Suction pressure 30 psi converted to 32°F on chart. If temperature reading is 40°F, subtract 32°F and the result will be **8°F of superheat.**

 **CAUTION**
 Before proceeding to the expansion valve adjustment, check for restriction on suction side for plugged filter-dryer and partially open valves. These conditions will give a high superheat.

Maintenance

1. Pump down the system as previously indicated in this section.
2. Disconnect the external equalizer line from the underside of the power head, and unclamp the remote control bulb from the evaporator coil outlet line.
3. Remove the two cap screws holding the power assembly to the valve body flange. Lift off the power assembly and remove the cage assembly.
4. When reassembling, replace with the new gaskets in proper location. Make sure the two lugs on the cage assembly fit into grooves provided in the power assembly. Do not force the valves together. The cage must fit properly before tightening the body flange. Tighten bolts evenly.
5. Check for leaks.

Safety Instructions

1. Make sure the valve is installed with the flow arrow on the valve body corresponding to the flow direction through the piping system.
2. Before opening any system, make sure the pressure in the system is brought to and remains at the atmospheric pressure. Failure to comply may result in system damage and/or personal injury.

7.10.2 Driver's HVAC Unit

The function and operation of the expansion valve for the driver's HVAC unit are similar to the passengers' HVAC unit but no superheat adjustment is required (see **FIGURE 3** and **FIGURE 41**).

7.11 TORCH BRAZING

Use electrode containing 35% silver.

 **CAUTION**
 When using heat near a valve, wrap with water saturated rag to prevent overheating of vital parts.

 **DANGER**
 Before welding any part of refrigeration system, make sure the area is well ventilated.

SECTION 22: HEATING AND AIR CONDITIONING

7.12 TROUBLESHOOTING

7.12.1 Expansion Valve

PROBABLE CAUSE	PROBABLE REMEDY
LOW SUCTION PRESSURE-HIGH SUPERHEAT	
EXPANSION VALVE LIMITING FLOW:	
Gas in liquid line due to pressure drop in the line or insufficient refrigerant charge.	Locate cause of line flash and correct by use of any of the following methods. Add R-134a. Replace or clean filter-dryer.
Inlet pressure too low from excessive low condensing temperature. Resulting pressure difference across valve too small.	Increase head pressure. Verify pressure switch for fan speed control.
Superheat adjustment too high.	Adjust superheat as outlined under "Superheat Adjustment".
Power assembly failure or partial loss of charge.	Replace power assembly or replace valve.
Air filter screen clogged.	Clean or replace air filter.
Plugged lines.	Clean, repair or replace lines.
LOW SUCTION PRESSURE-LOW SUPERHEAT	
Uneven or inadequate evaporator loading due to poor air distribution or liquid flow.	Balance evaporator load distribution by providing correct air or liquid distribution.
HIGH SUCTION PRESSURE-HIGH SUPERHEAT	
Compressor discharge valve leaking.	Replace or repair valve.
HIGH SUCTION PRESSURE-LOW SUPERHEAT (DEFECTIVE UNLOADER)	
Valve superheat setting too low.	Adjust superheat as outlined under "Superheat Adjustment".
Compressor discharge valves leaking.	Replace or repair discharge valve.
Incorrect superheat adjustment.	Superheat adjustment 12 to 16°F.
FLUCTUATING DISCHARGE PRESSURE	
Insufficient charge.	Add R-134a to system.
HIGH DISCHARGE PRESSURE	
Air or non-condensable gases in condenser.	Purge and recharge system.
Overcharge or refrigerant.	Bleed to proper charge.
Condenser dirty.	Clean condenser.

7.12.2 A/C

TROUBLE	CAUSE
Low suction pressure and frosting at dryer outlet.	Clogged filter.
Low Oil Level.	Check for oil leaks and for leaking oil seal. Do not attempt to check oil level unless system has been stabilized at least 20 minutes. See oil level verification.
Excessively cold suction line.	Loss of contact between the expansion valve bulb and the suction line or sticking of the expansion valve. Check for foreign matter and clean, repair or replace the valve.
Excessively cold suction line and noisy compressor.	Check superheat adjustment. Check remote bulb contact. Check expansion valve for sticking.
Compressor squeaks or squeals when running.	Check oil level. Replace oil seal.
Noisy or knocking compressor.	Check for broken internal parts. Overhaul if required.
Compressor vibrates.	Check and tighten compressor mounting bolts and belt tension.
Low refrigerant level	Check for refrigerant leaks and add refrigerant if required.
Suction pressure rises faster than 5 pounds per minute after shutdown.	Check compressor valve for breakage or damage.
Insufficient cooling.	Check for refrigerant leaks. Check condition of air filter and motors.
Insufficient air flow.	Dirty or iced evaporator. Dirty air filter. Blowers inactive. Clogged ducts.
No flow of refrigerant through expansion valve.	Filter-dryer is clogged. Remote bulb has lost charge or expansion valve is defective.
Expansion valve hisses. Bubbles in moisture and liquid indicator.	Gas in liquid line. Add refrigerant.
Loss of capacity	Clogged filter. Obstructed or defective expansion valve.
Superheat too high.	Reset superheat adjustment. Check for clogged external equalizer line, or filter-dryer.
Reduced air flow: a. Dirty or clogged air filter; b. Evaporator motor inoperative; or c. Plugged return air ducts.	Dirty or iced evaporator coil. Clean or replace air filter. Check return ducts for obstructions. Check blower motor.
Frequent starting and stopping on low pressure control switch.	Lack of refrigerant. Check for leaks. Recharge.
Compressor intermittently starts and stops.	Intermittent contact in electrical control circuit. Compressor valves not in operating position.
Non-condensable in the refrigeration system.	Leak on system, system in vacuum in low temp. Specific symptom, pressure in system will not correspond to ambient temperature on shutdown. Only non-condensable will cause this. (Example: Pressure of idle R-134a system in 80°F (26.6°C) room should be 86.4 psi (595.7 kPa). See temperature chart in this section.)

TROUBLE	CAUSE
	<p>An evaporator just does a proper cooling job without sufficient air. Shortage of air can be caused by the following:</p> <ul style="list-style-type: none"> * Dirty filters; or * Dirty coils.
<p>Testing condenser pressure.</p> <p><i>NOTE: R-134A pressure is function of the temperature variation.</i></p> <p>Example, for an exterior temperature of 100°F. Exterior temperature (100°F) + 30°F = 130°F. Take note: 30°F is added to ambient temperature by definition. Refer to paragraph "7.13 Temperature & Pressure". Note the corresponding pressure for a temperature of 130°F, 199.8 psi. Read the condenser pressure, example 171.9 psi. 171.9 psi & 199.8 psi, the pressure in the condenser is inferior to the pressure corresponding to the exterior temperature, in this case the condenser pressure may be too low. Check for refrigerant leaks and add refrigerant if necessary. If the pressure corresponding to the condenser temperature is superior to the pressure corresponding to the exterior temperature, then the air cooled condenser pressure may be too high. Most frequent causes are:</p> <p>Reduced air quantity. This may be due to:</p> <ul style="list-style-type: none"> * Non-condensable in system; * Dirt on the coil; * Restricted air inlet or outlet; * Dirty fan blades; * Incorrect rotation of fan; * Fan speed too low; * Fan motor going out on overload; or * Prevailing winds. * Too much refrigerant in system. Remove refrigerant if necessary. 	

7.13 TEMPERATURES & PRESSURES CHART

VAPOR-PRESSURE R134A			
TEMPERATURE		PRESSURE	
°F	°C	psi	kPa
-100	-73.3	27.8	191.7
-90	-67.8	26.9	185.5
-80	-62.2	25.6	176.5
-70	-56.7	23.8	164.1
-60	-51.1	21.5	148.2
-50	-45.6	18.5	127.6
-40	-40.0	14.7	101.4
-30	-34.4	9.8	67.6
-20	-29	3.8	26.2
-10	-23	1.8	12.4
0	-18	6.3	43.4
10	-12	11.6	80
20	-7	18.0	124.1
30	-1	25.6	176.5
40	4	34.5	237.9
50	10	44.9	309.6
60	16	56.9	392.3
70	21.1	70.7	487.5
80	27	86.4	595.7
90	32.2	104.2	718.5
100	38	124.3	857.0
110	43.3	146.8	1012.2
120	49	171.9	1185.3
130	54.4	199.8	1377.6
140	60	230.5	1589.3
150	65.6	264.4	1823.0
160	71	301.5	2078.8
170	76.7	342.0	2358.1
180	82.2	385.9	2660.8
190	87.8	433.6	2989.7
200	93.3	485.0	3344.1
210	98.9	540.3	3725.4

7.14 LEAK TESTING

Some methods such as nitrogen pressure, soap and electronic sniffer can be used for leak testing.

8. CENTRAL HEATING SYSTEM

As seen earlier in this section, the vehicle interior is pressurized by its Heating, Ventilation and Air Conditioning (HVAC) system. The vehicle interior should always be slightly pressurized to prevent cold and moisture from entering. Air flow and controls divide the vehicle into two areas: driver's area and passengers' area.

The schematic of Figure 2 shows the heating system with its components.

8.1 DRAINING HEATING SYSTEM

To drain the entire system, refer to Section 05, "Cooling". If only the driver's or main heater core must be drained, refer to the following instructions.

- **Draining Driver's Heater Core**

1. Stop engine and allow engine coolant to cool.
2. Locate the normally open hot water pneumatic valve on the ceiling of the spare wheel compartment (Figure 48), disconnect its wiring connector, and then connect a 24-volt external power source, using jumper cables, to close valve.
3. Close the hot water lines shut-off valves located next the engine on street side (see Figure 2 & Figure 52).

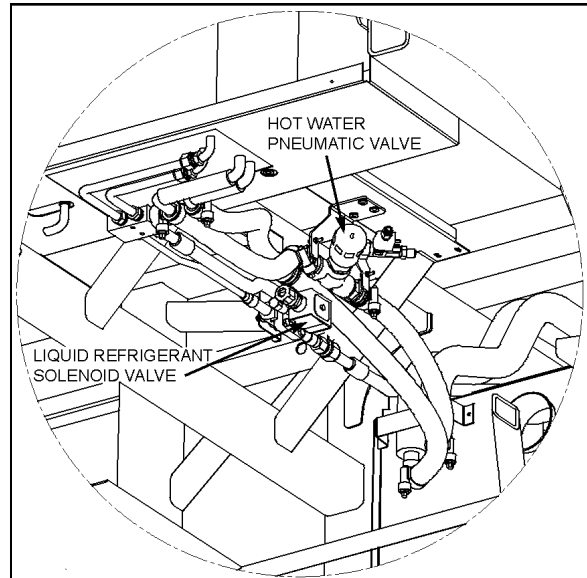

FIGURE 48: CEILING OF THE SPARE WHEEL COMPARTMENT

**WARNING**

Before proceeding with the following steps, check that coolant has cooled down.

3. Loosen hose clamp, install an appropriate container to recover coolant, and disconnect silicone hose from hot water solenoid valve.
4. From inside of vehicle, remove the two finishing panels in front of unit. Remove the three screws fixing the unit front panel. Open the manual vent located inside the driver's HVAC unit, on the driver's side (Figure 49) to ensure an efficient draining.

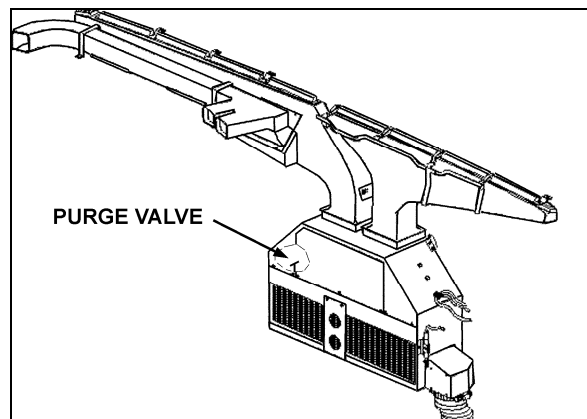

FIGURE 49: DRIVER'S HVAC/DEFROST UNIT

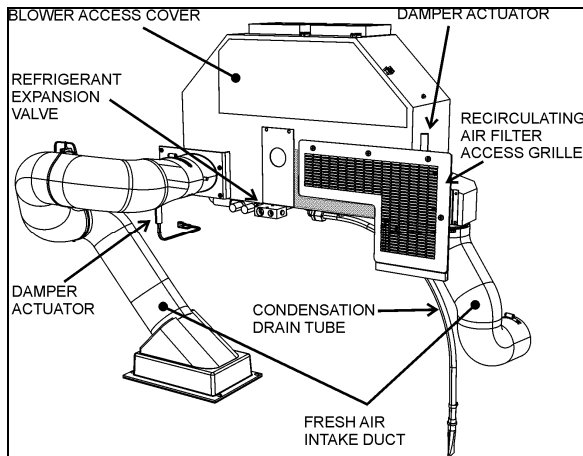

FIGURE 50: DRIVER'S HVAC UNIT

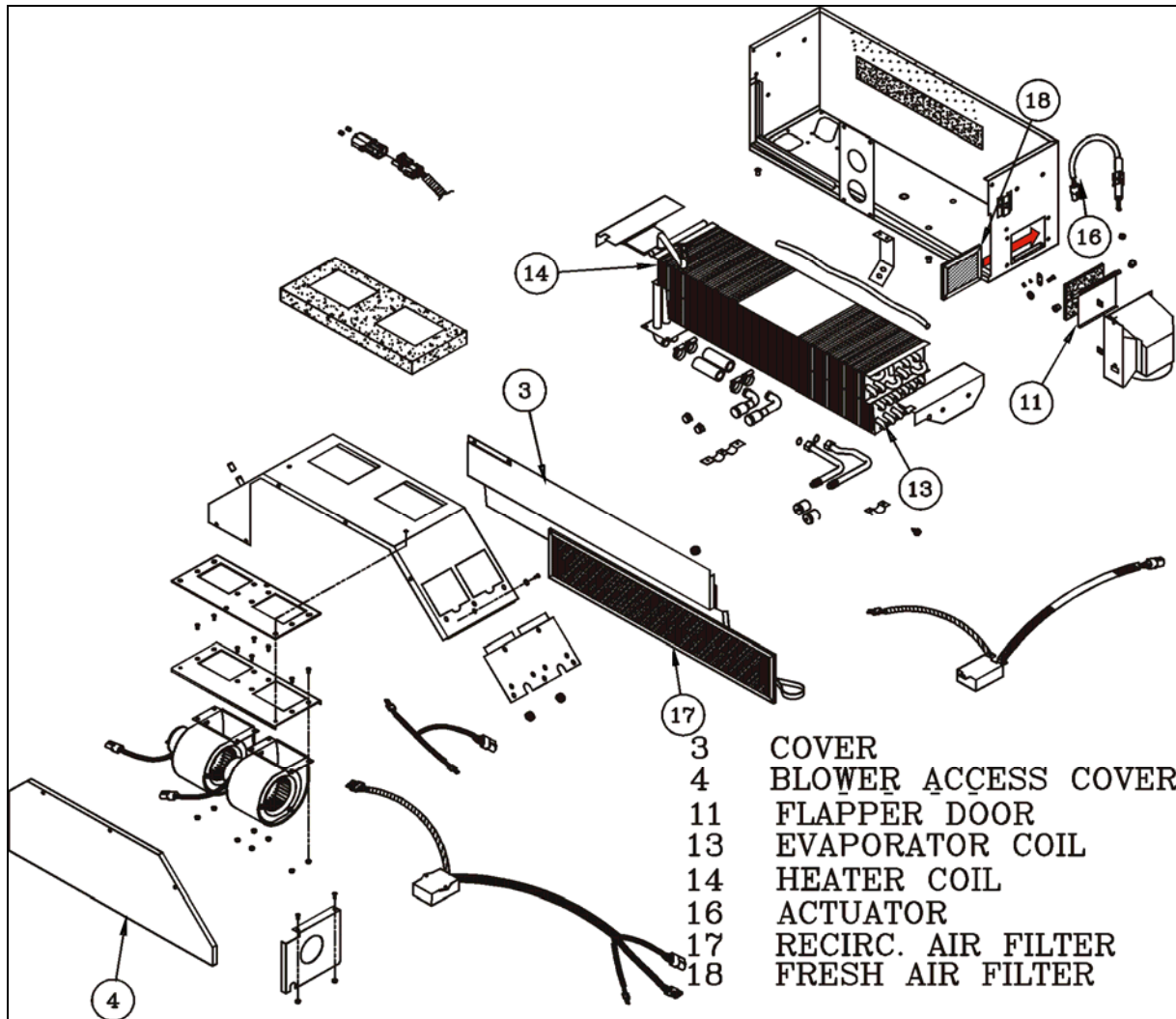

FIGURE 51: DRIVER'S HVAC UNIT

- **Draining Main Heater Core**

1. Stop engine and allow engine coolant to cool.
2. Close both heater line shutoff valves.

The valves are located in the engine compartment. One is on the L.H. side of compartment in front of the radiator and the other valve is located under the radiator fan gearbox (Figure 52).

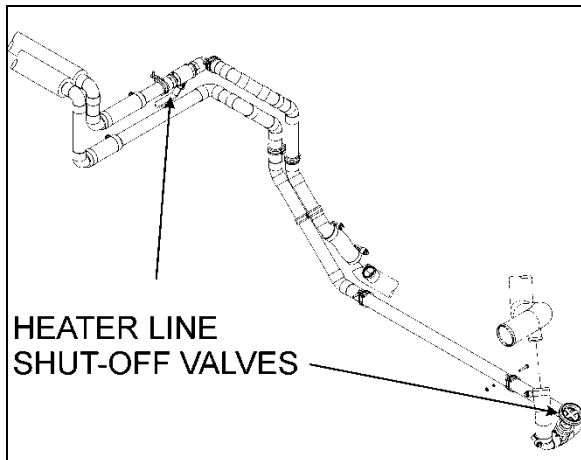

FIGURE 52: HEATER LINE SHUT-OFF VALVES

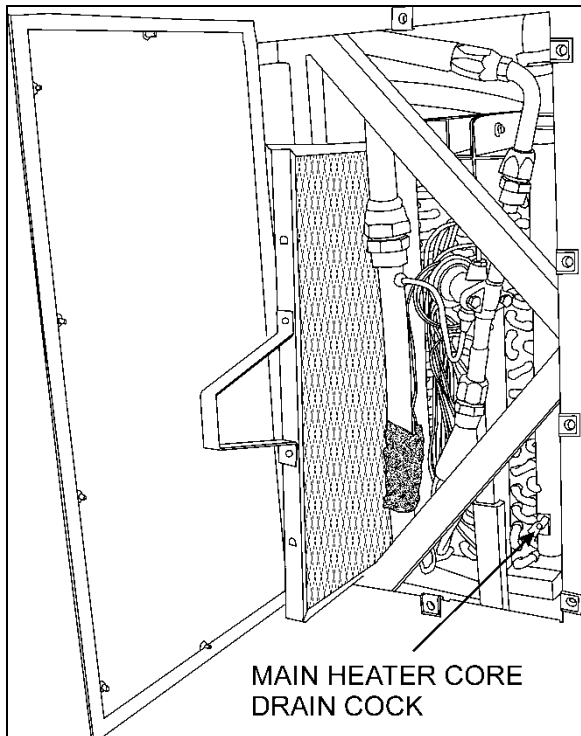

FIGURE 53: EVAPORATOR COMPARTMENT

3. The main heater core drain cock is located in the evaporator compartment. To access

the valve on X3-45 coaches, open baggage compartment door located in front of the evaporator compartment (L.H. side). Open access panel by turning the three screws of panel ¼ of a turn.



WARNING

Before proceeding with the following steps, check that coolant has cooled down.

4. Open drain cock in bottom of heater core, you can unfasten a hose connection on top of heater core (Figure 53) in order to allow air to enter while draining.

8.2 FILLING HEATING SYSTEM

1. Ensure that the drain hose is reconnected and the manual vent and drain cock are closed.
2. Open the surge tank filler cap and slowly fill the system to level of filler neck.
3. After initial filling, the water shut-off valves should be open and the water circulating pump should be energized to assist in circulating coolant through the heating system. To perform this operation, start the engine, switch on the HVAC control unit, both driver and passengers' sections, and set temperature to the maximum position in order to request the heating mode in each of these sections.
4. When coolant level drops below the surge tank filler neck, slowly fill the system to level of filler neck.
5. Once the level has been stabilized, replace cap.

8.3 BLEEDING HEATING SYSTEM

Whenever the heating system has been drained and refilled, or the system has run low on coolant and coolant has been added, it is necessary to bleed air from heating system. Locate the manual vent illustrated in Figure 49 , and open momentarily until no air escapes from the line.

8.4 SOLDERING

Before soldering any part of the system, make sure the area is well ventilated. Use (stay clean) flux sparingly and apply solder (95-5 round wire 1/8 inch). After completing repairs, test for leaks.

When using heat at or near a valve, wrap with water saturated rag to prevent overheating of vital parts.

8.5 DRIVER'S HOT WATER PNEUMATIC VALVE ASSEMBLY

• Description

The flow of hot water to the driver's heater core is controlled by a normally open (N.O.) pneumatic water valve assembly. The valve, located at the ceiling of the spare wheel compartment, is designed so that the pilot solenoid valve, which is part of the assembly, opens and closes a port which directs air pressure to the actuator casing, thereby opening or closing the valve.

When the vehicle is operating without electrical supply to the pilot solenoid valve, no air pressure is admitted to the actuator casing, the cylinder spring pushes up against the cylinder, thereby keeping the water valve open.

Air pressure at port + 24-V signal at coil = valve closed

The driver's heater water valve requires a minimum amount of maintenance. The valve should be free of dirt sediment that might interfere with its operation. No other maintenance is needed unless a malfunction occurs.

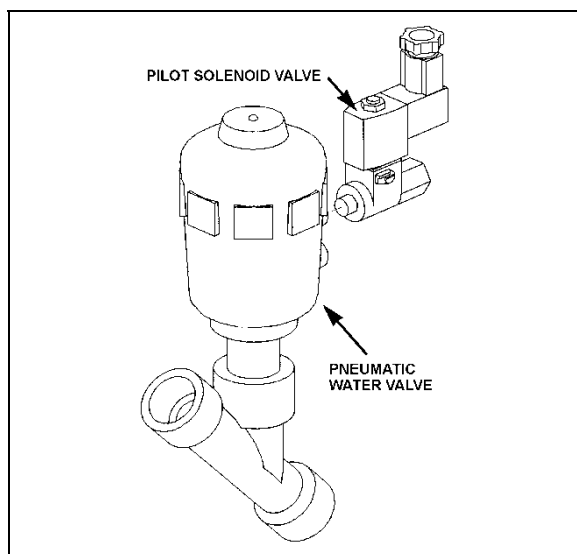

FIGURE 54: TYPE 1 (UP TO VIN F-7014) DRIVER'S UNIT HOT WATER PNEUMATIC VALVE ASSEMBLY

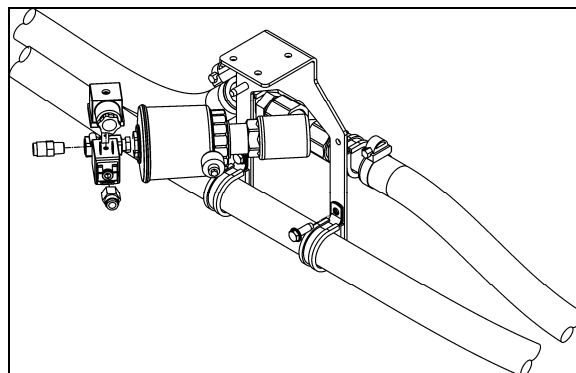

FIGURE 55: TYPE 2 (FROM VIN F-7015) DRIVER'S UNIT HOT WATER PNEUMATIC VALVE ASSEMBLY

8.5.1 Pneumatic Water Valve Disassembly

1. Shut off air supply pressure and electrical current to the pilot solenoid valve. Disconnect wires.
2. The water valve need not be removed from the line. Unscrew nipple, the actuator casing, tube, spindle and closure member can be removed (Figure 56).
3. Remove the snap ring using a pair of pliers.
4. You can now access all seals for replacement. See your vehicle Parts Manual for replacement parts availability.

8.5.2 Pneumatic Water Valve Reassembly

1. Assemble the actuator casing, tube, nipple, spindle and closure member.
2. Tighten the nipple in place in the body cavity as per Figure 56. Fasten pilot solenoid valve to the pneumatic water valve. Reconnect air supply pressure and electrical current to the pilot solenoid valve.
3. Check for proper operation.

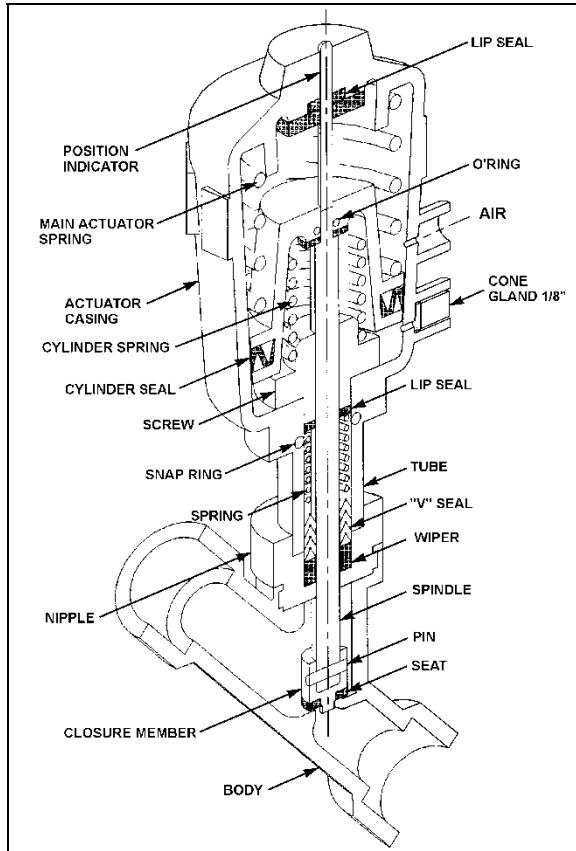

FIGURE 56: PNEUMATIC WATER VALVE

8.5.3 Pilot Solenoid Valve

1. No maintenance is needed unless a malfunction occurs.
2. A pilot solenoid valve replacement seal kit is available. See your vehicle Parts Manual for replacement parts.

8.6 CENTRAL HOT WATER PNEUMATIC VALVE ASSEMBLY

8.6.1 Description

The flow of hot water to the vehicle's central heater core is controlled by a 3-way pneumatic water valve assembly. The valve, located in the evaporator compartment, is designed so that the pilot solenoid valve, which is part of the assembly, opens and closes a port which directs air pressure to the actuator casing, thereby allowing the hot water to enter the main heater core or bypassing it.

When the vehicle is operating with no current to the pilot solenoid valve, no air pressure is admitted to the actuator casing, the cylinder spring pushes up against the cylinder, thereby

allowing the hot water to enter the main heater core.

The central heater water valve requires a minimum amount of maintenance. The valve should be free of dirt sediment that might interfere with its operation. No other maintenance is needed unless a malfunction occurs.

8.6.2 Pneumatic Water Valve Disassembly

1. Shut off air supply pressure and electrical current to the pilot solenoid valve. Disconnect wires.
2. The water valve need not be removed from the line. Unscrew nipple, the actuator casing, tube, spindle and closure member can be removed (Figure 58).
3. Remove the snap ring using a pair of pliers.

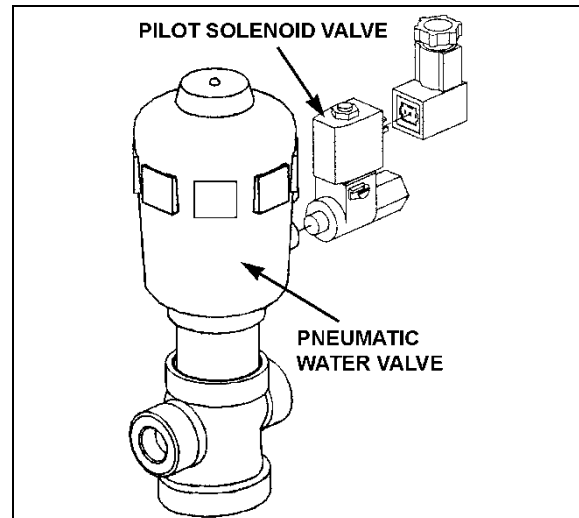

FIGURE 57: CENTRAL HOT WATER PNEUMATIC VALVE ASSEMBLY

22329

5. You can now access all seals for replacement. See your vehicle Parts Manual for replacement parts availability.

8.6.3 Pneumatic Water Valve Reassembly

1. Assemble the actuator casing, tube, nipple, spindle and closure member.
2. Tighten the nipple in place in the body cavity as per Figure 58. Fasten pilot solenoid valve to the pneumatic water valve. Reconnect air supply pressure and electrical current to the pilot solenoid valve.
3. Check for proper operation.

8.6.4 Pilot Solenoid Valve

1. No maintenance is needed unless a malfunction occurs.
2. A pilot solenoid valve replacement seal kit is available. See your vehicle Parts Manual for replacement parts.

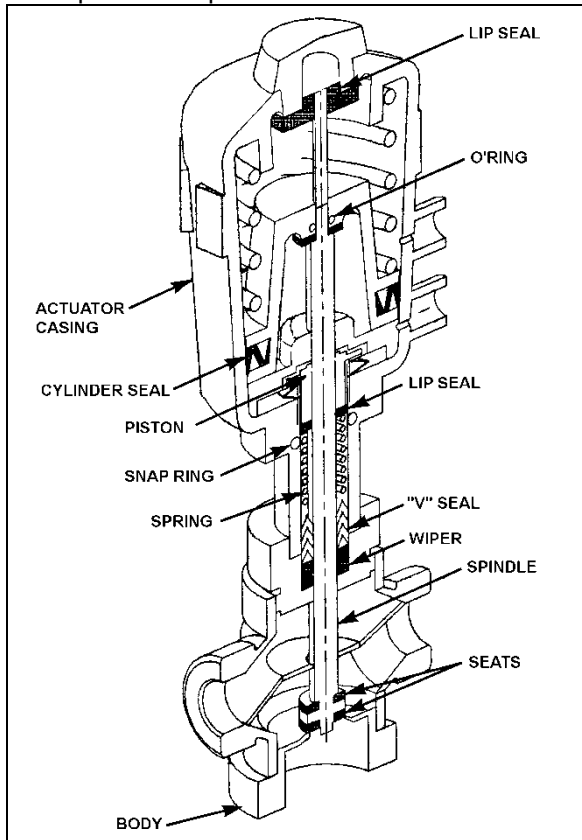

FIGURE 58: PNEUMATIC WATER VALVE 22330

• Valve Troubleshooting

PROBLEM	PROCEDURE
Valve fails to close	<ol style="list-style-type: none"> 1. Check electrical supply with a voltmeter. It should agree with nameplate rating. 2. Check pressure at pilot solenoid valve inlet. It must be at least equal to the minimum pressure stamped on the nameplate. It should not go below minimum while valve is operating.
Valve fails to open.	<ol style="list-style-type: none"> 1. Check that the closure member assembly, and that main actuator and cylinder springs are free to travel. 2. Check that there is no restriction to the air escaping

	<p>from the actuator casing.</p> <ol style="list-style-type: none"> 3. Make sure that pilot solenoid valve operates properly.
--	--

8.7 HOT WATER CIRCULATING PUMP

This vehicle is provided with a brushless/sealess water circulation pump which is in the compartment located aft of the evaporator compartment (Figure 59). The assembly consists of a centrifugal pump and an electric motor which are mounted in a compact assembly.

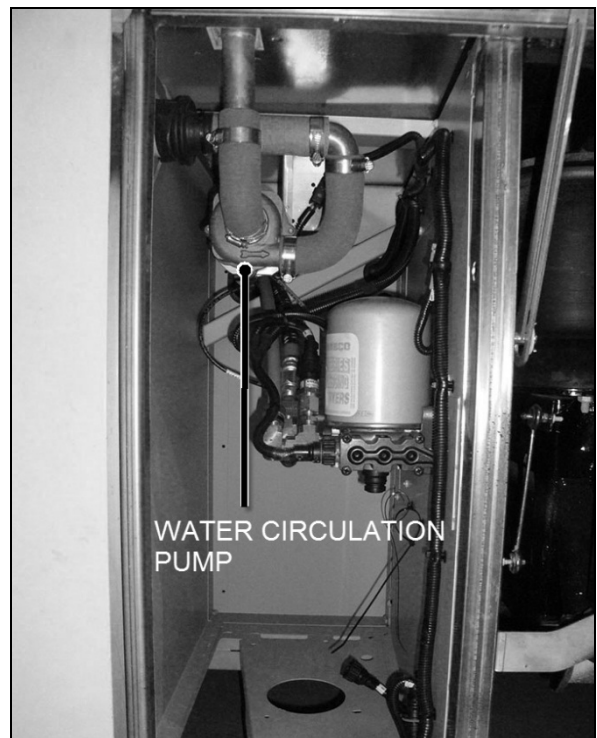

FIGURE 59: PUMP LOCATION

The brushless DC sealess circulating pump requires no periodic maintenance. The sealess design offers leak-proof protection and the capability to resist harsh environmental conditions. The pump magnetically couples to the brushless DC motor without a wet seal to wear or replace, this coupling method also enables easy motor removal without requiring system draining. The pump electronically commutated brushless DC motor provides virtually maintenance-free operation over time by eliminating brush maintenance and associated brush motor failure.

Inspection of the circulating pump, to determine if the pump is working properly, should be made while the pump is in operation.

If there is evidence that the circulating pump is not operating as per specifications, the unit must be disassembled for repair.

Disassembly of the pump will be necessary only in the case of a rotor failure or motor failure.

- **Removal**

1. Stop engine and allow engine coolant time to cool.
2. Close shutoff valves. Refer to "05 COOLING" under heading "*Draining Cooling System*" for location of valves.
3. Disconnect the electrical wiring from the motor.



WARNING

Before proceeding with the following steps, check that coolant has cooled down.

4. Disconnect water lines from pump at flange connections. Place a container to recover the residual coolant in the line.
5. Remove the two clamps holding the pump motor to its mounting bracket. Remove the pump with the motor as an assembly.

- **Installation**

1. Apply gasket cement to the line flanges, put the two gaskets in place, and connect water lines to the pump at the flange connections. Position the pump and motor assembly on the mounting bracket. Position the mounting clamps over the motor and secure with mounting bolts.
2. Connect electrical wiring to the pump motor.
3. Open shutoff valve. Refer to "05 COOLING" under heading "*Draining Cooling System*" for location of valves.
4. Fill the cooling system as previously instructed in this section under "*8.2 Filling Heating System*", then bleed the system as previously instructed in this section under "*8.3 Bleeding Heating System*".

9. SPECIFICATIONS**Main evaporator motor**

Make..... AMETEK
 Type BRUSHLESS DC MICROPROCESSOR CONTROLLED
 Voltage 27.6 V DC
 Current draw 68 amps
 Horsepower 2
 Revolution 1400 & 1700 rpm
 Insulation Class F

Condenser fan motors

Make..... EBMPAPST
 Type AXIAL BRUSHLESS
 Voltage 24 V DC
 Qty..... 4

Driver's unit evaporator motors

Make..... MCC
 Voltage 24 V DC
 Quantity 1

Hot water circulating pump

Make..... AMETEK
 Flow 15 gpm
 Inlet/outlet OD 3/8"

Driver's unit evaporator air filters

Make..... MCC
 TYPE Recirculating air 6-1/4" x 28" Washable
 Make..... MCC
 TYPE Fresh air 3-5/8" X 5-1/4" Washable

Refrigerant

Type R-134a
 Quantity (standard) 24 lbs (10.89 Kg)
 Quantity (A/C system located in parcel racks) 2 lbs (1.8 Kg)

Compressor

Make..... Bitzer
 Displacement 41 CFM
 Model, R-134a 4NFCY
 No. of cylinders 4
 Cylinder volume 39 in³ (647 cm³)
 Operating speed 500 to 3500 rpm
 Oil capacity 0.66 U.S. gal (2.5 liters)

SECTION 22: HEATING AND AIR CONDITIONING

Weight 74 lbs (33 kg)
 Approved oil Bitzer BSE55 (POE ISO68)

Compressor V belt (Bitzer)

BX71 Set of 2, two Bosch alternators arrangement, Prevost Number 5060134

A/C Compressor Electro-magnetic clutch

Make..... Lang
 Type KK73.1
 Voltage 24 V DC

Liquid refrigerant solenoid valve

Make..... Sporlan Parker Hannifin
 Type Normally closed with manual bypass
 Voltage 24 V DC

Driver's unit hot water pneumatic valve (type 1)

Make..... BURKERT
 Type Normally open
 Voltage 24 V DC

Driver's unit hot water pneumatic valve (type 2)

Make..... Asco
 Type Normally open
 Voltage 24 V DC

Passengers' unit hot water pneumatic valve

Make..... BURKERT
 Type Normally open 3 ways/2 positions
 Voltage 24 V DC

10. SECTION CHANGE LOG

	DESCRIPTION	DATE
1		
2		
3		
4		
5		
6		

CONTENTS

1. HUBODOMETER..... 2

1.1 DESCRIPTION2

1.2 OPERATION.....2

1.3 REMOVAL.....2

1.4 INSTALLATION.....2

2. HORN INSTALLATION 2

2.1 ELECTRIC HORN MAINTENANCE2

3. WINDSHIELD WIPERS AND WASHERS..... 2

3.1 GENERAL DESCRIPTION2

3.2 WIPER ARM.....3

3.2.1 *Wiper Arms Positioning*3

3.3 WINDSHIELD WIPER MOTOR4

3.3.1 *Windshield Wiper Motor Replacement*.....4

3.4 TROUBLESHOOTING5

4. AUTOMATIC FIRE SUPPRESSION SYSTEM (AFSS)..... 6

4.1 PERIODIC MAINTENANCE7

5. NYCT AUXILIARY SYSTEMS AND RADIO IN PARCEL RACK 8

5.1 CLEVER DEVICES’ IVN4 AND SPEAK EASY2.....8

5.2 MOTOROLA COMMUNICATION RADIO POWER9

5.3 MOBILE VIEW BUS CAMERA SECURITY SYSTEM (BCSS).....9

6. SECTION CHANGE LOG10

ILLUSTRATIONS

FIGURE 1: HUBODOMETER2

FIGURE 2: ELECTRIC HORN INSTALLATION2

FIGURE 3: R.H. DASHBOARD PANEL.....3

FIGURE 4: WINDSHIEL WASHER - WIPERS CONTROL3

FIGURE 5: WINSHIELD WASHER RESERVOIR3

FIGURE 6: WINDSHIELD WIPER INSTALLATION3

FIGURE 7: WINDSHIELD WIPER (MOTOR SIDE).....4

FIGURE 8: WINDSHIELD WIPER (DRIVER SIDE).....4

FIGURE 9: DRIVING MECHANISM (DRIVER SIDE).....4

FIGURE 10: DRIVING MECHANISM (MOTOR SIDE)4

FIGURE 11: WIPER ARMS POSITIONING.....5

FIGURE 12: FIRE SYSTEM OVERVIEW6

FIGURE 13: TLSE (ACTUAL ROUTING MAY DIFFER)6

FIGURE 14: MONITORING AND COMMUNICATION EQUIPMENT.....8

FIGURE 15: IVN4 MODULE8

FIGURE 16: FOOT SWITCH8

FIGURE 17: RADIO POWER MODE CHANGE9

FIGURE 18: CAMERAS AND MICROPHONE (UPPER FRONT OF VEHICLE) 10

FIGURE 19: CAMERA LOCATIONS (TOP VIEW) 10

1. HUBODOMETER

1.1 DESCRIPTION

A wheel hubodometer (Figure 1) has been installed on the R.H. side of the drive axle. It indicates the total distance in miles covered by the coach since it has left the factory, including road testing.

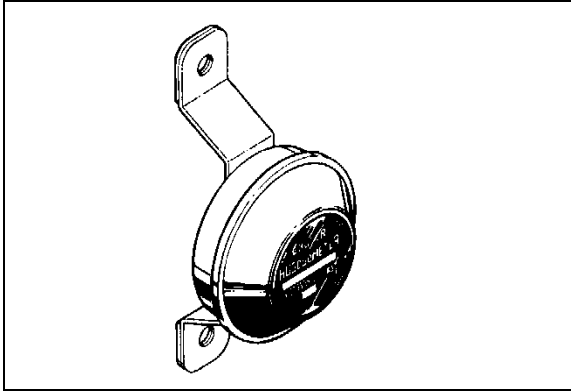

FIGURE 1: HUBODOMETER

23024

1.2 OPERATION

The hubodometer is calibrated for a specific wheel size (diameter). Wheel rotation causes a mechanism inside the hubodometer to record distance after a predetermined number of rotations. The unit should be serviced at a competent speedometer repair facility.

NOTE

Do not use paint, solvent or thinner on hubodometer face or on plastic hubcaps. Do not weld on hubodometer.

1.3 REMOVAL

To remove the unit, remove the two lock nuts and washers securing it to the wheel hub, and pull the unit off the studs.

1.4 INSTALLATION

Place the hubodometer unit over the wheel hub studs. Replace the lock washers and nuts. Torque stud nuts to 110-165 Lbf-ft.(150-225 Nm).

2. HORN INSTALLATION

The electric horn is located in a plastic box under the front stepwell and is accessible from the front body understructure. Refer to Operator's Manual for operation.

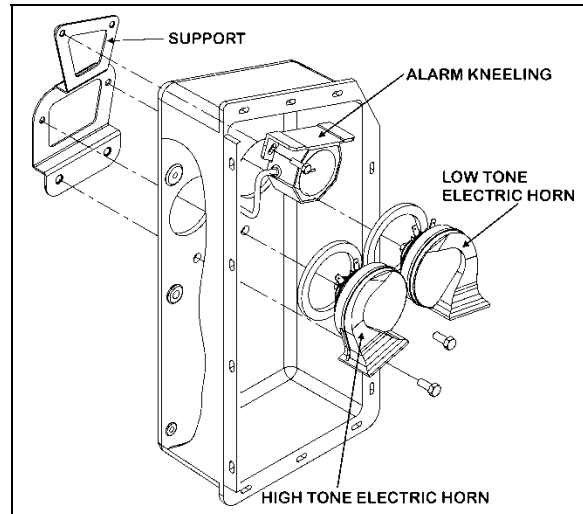

FIGURE 2: ELECTRIC HORN INSTALLATION

23420

2.1 ELECTRIC HORN MAINTENANCE

When needed, the electric horn can be serviced or replaced using the following procedure:

1. Raise vehicle by the jacking points;
2. Unplug the cable connector;
3. Loosen the retaining bolts;
4. Service or replace the defective horn;
5. Reinstall by reversing procedure.

3. WINDSHIELD WIPERS AND WASHERS

3.1 GENERAL DESCRIPTION

NOTE

When installing a wiper motor, arm or blade, follow recommended procedures to prevent misalignment, binding or malfunction. Check the windshield washer liquid hoses, fittings and connectors to be sure they are properly connected and seal with no restriction to the flow of washer liquid. Check that wiper arms have the proper sweep position and the washer nozzles are aimed so that spray is within the proper wiper pattern.

The windshield wipers are controlled by one electric wiper motor that is accessible for maintenance after removing the appropriate access panel beside the footwell (refer to figure 5).

The wiper/washer control button is located on the R.H. dashboard panel. Push the button to activate the windshield washer. Turn the button to activate the wipers. The first position activates the wipers intermittently. The second position is

the slow speed and the third position is for high speed wiping.

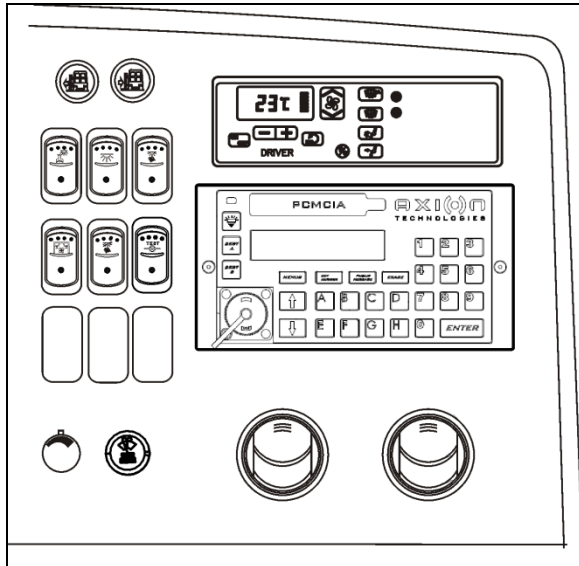

FIGURE 3: R.H. DASHBOARD PANEL



FIGURE 4: WINDSHIEL WASHER - WIPERS CONTROL

23133

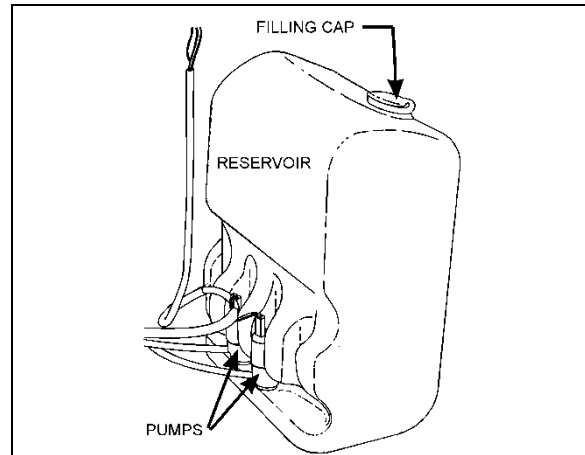

FIGURE 5: WINDSHIELD WASHER RESERVOIR

23220

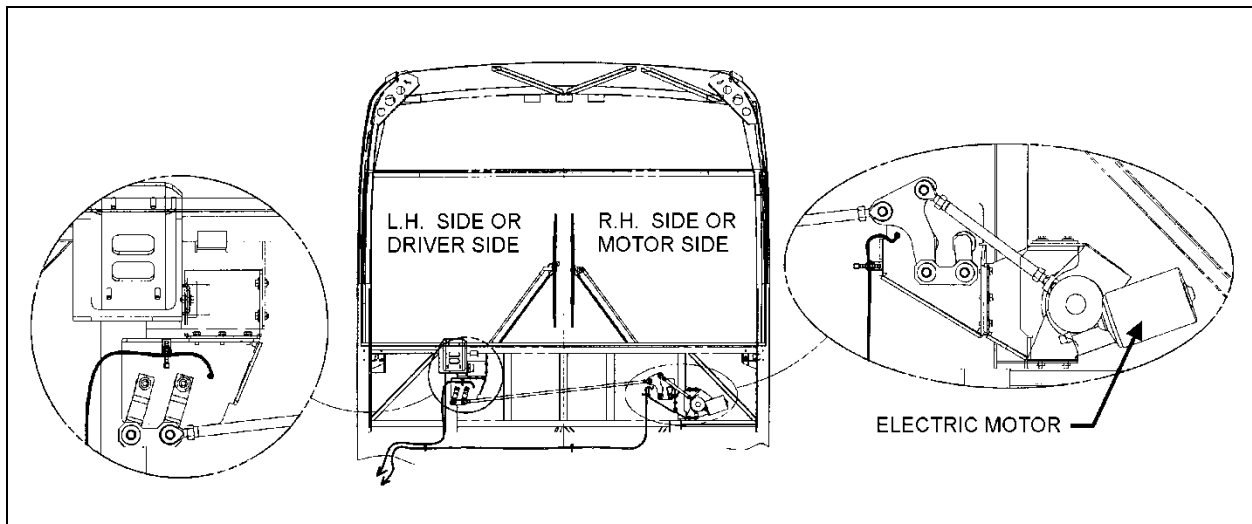

FIGURE 6: WINDSHIELD WIPER INSTALLATION

23287

The windshield washer reservoir is located in the front service compartment (Figure 5). This unit pumps the washer liquid to the spray nozzles where it is dispersed across the windshield.

3.2 WIPER ARM

Check operation of the wipers for proper blade sweep and angle.

3.2.1 Wiper Arms Positioning

1. Reinstall the wiper arms and position as shown in figure 11. Before positioning the wipers at their final position, tighten the nuts to 9 Ft-lbs (12 Nm) at first.
2. To find the final position of the wiper arms, lift then release the wiper arm so it falls back on the windshield.

**CAUTION**

Do not attempt to manually move the wiper arms to make wiper blade sweep adjustments as damage to the wiper linkage or motor may occur. If it is necessary to adjust the sweep of blades, remove the arms and make adjustment by positioning the arms using serration on the wiper arm pivot shafts.

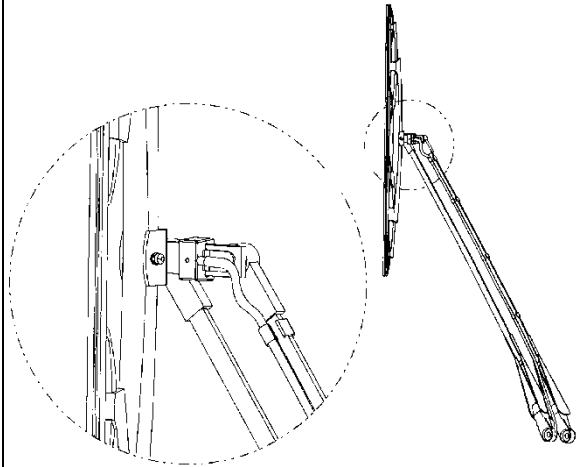
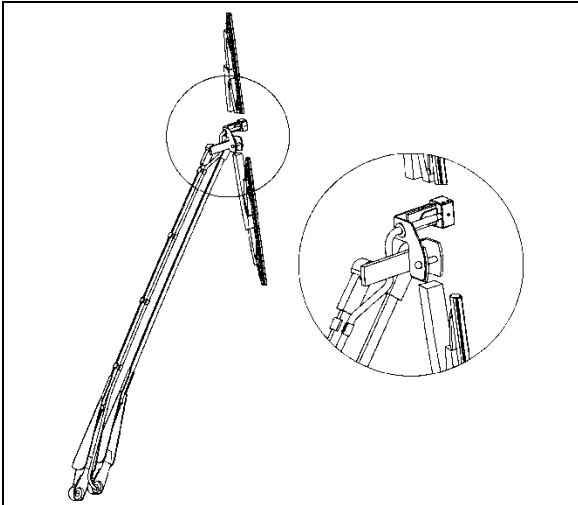
**FIGURE 7: WINDSHIELD WIPER (MOTOR SIDE)** 23329**FIGURE 8: WINDSHIELD WIPER (DRIVER SIDE)** 23328

3. When the final position is found, tighten the wiper arm nuts to 22 Ft-lbs (30 Nm). Wait 30 minutes and tighten again to 22 Ft-lbs.
4. Lower the protective cover.
5. Connect the windshield washer tubing at the base of the wiper arm.
6. Check the adjustment on a wet windshield.

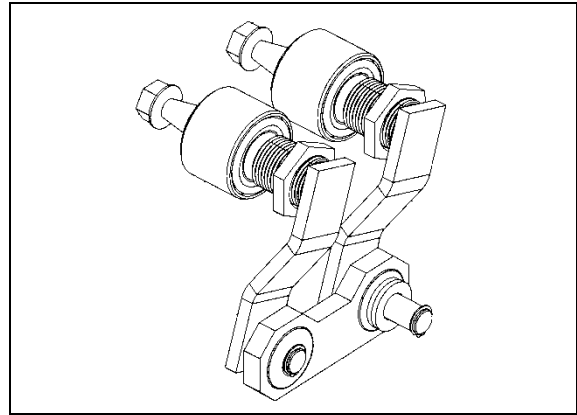
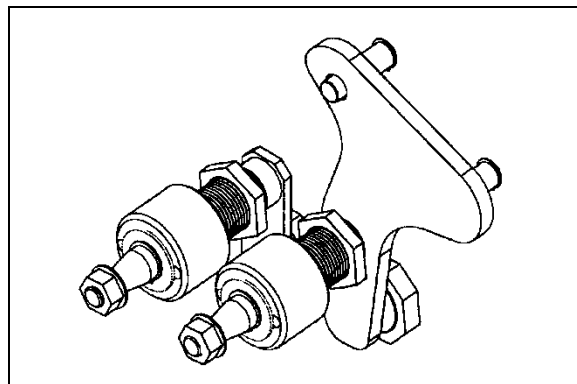
**FIGURE 9: DRIVING MECHANISM (DRIVER SIDE)** 23284**FIGURE 10: DRIVING MECHANISM (MOTOR SIDE)** 23285

3.3 WINDSHIELD WIPER MOTOR

3.3.1 Windshield Wiper Motor Replacement

The windshield wiper motor is located at lower front of the vehicle, behind the defroster panel. Refer to figure 6 for motor location.

**WARNING**

Park vehicle safely, apply parking brake, stop engine and set battery master switch to the "OFF" position prior to working on the vehicle.

1. Remove the Phillips-head screws retaining the defroster panels, and remove panels.
2. Disconnect wiring connector from the windshield wiper motor.
3. Loosen clamping screw retaining the lever at the end of the motor driving shaft.
4. Remove the three bolts holding the motor to the steel plate.
5. Remove the windshield wiper motor (Prevost #800328), reverse removal procedure to reinstall.

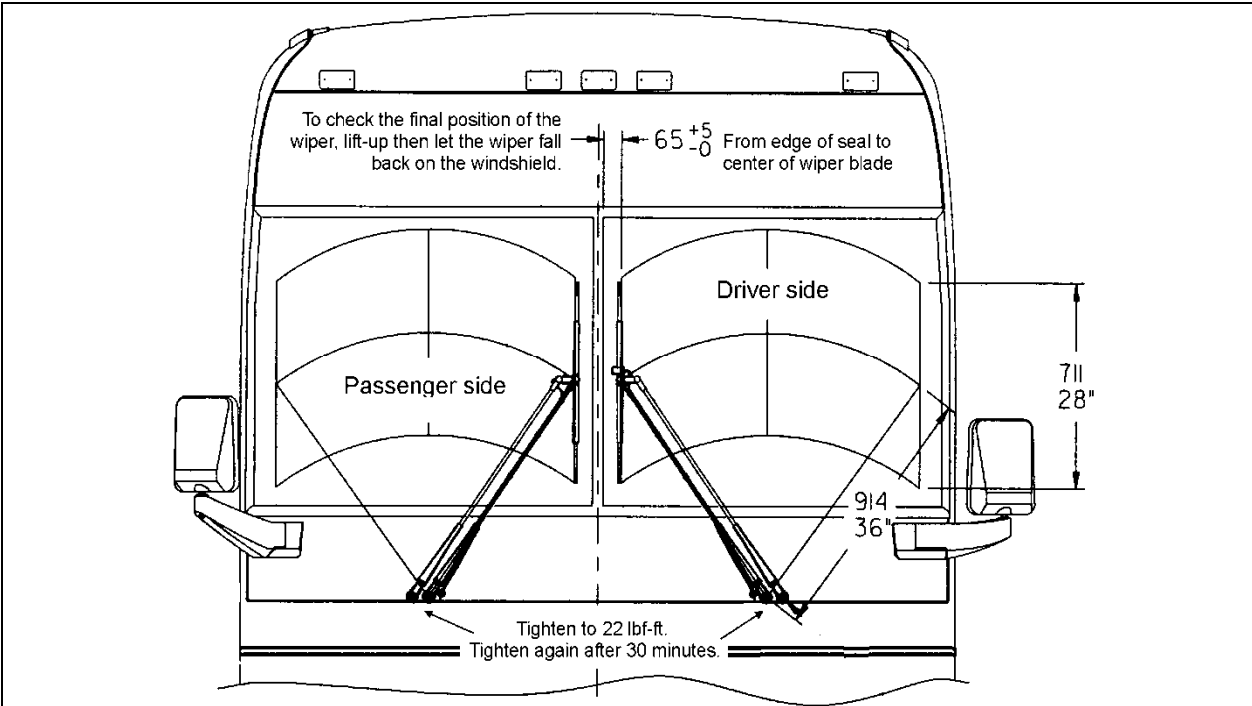

FIGURE 11: WIPER ARMS POSITIONING

23253

3.4 TROUBLESHOOTING

SYMPTOM	PROBABLE CAUSE	REMEDY
FAIL TO SPRAY WASHER FLUID	A. Reservoir empty. B. If below 32°F (0°C), improper washer fluid frozen. C. Contamination in tubing or nozzles. D. Tubing damage. E. Tubing bent (kinked) or off one or more connections.	A. Add proper fluid. B. Store coach or parts in heated area, then purge system with low-temperature solution. C. Remove with compressed air, if severely clogged, replace items. D. Replace section. E. Realign tubing and/or refit. Trim end to ensure proper fit or replace.
INADEQUATE SPRAYING	A. Tubing failure.	A. Replace tubing.
SLOW OPERATION	A. Improper solution. B. Jet stream improperly directed. C. Check if valve is stuck in the open position.	A. Replace with proper type solution. B. Reposition nozzles. C. Remove, clean or replace.

4. AUTOMATIC FIRE SUPPRESSION SYSTEM (AFSS)

This system is used to shut down the engine and to extinguish a fire in the engine. System operation is fully automatic and does not require assistance from the operator. However, the system may be manually activated by the operator at any time.

Refer to Prevost Operator's Manual for system operation and operational sequence (fire).

If more information is needed on the system, please refer to Kidde Dual Spectrum "Operation & Maintenance Manual."

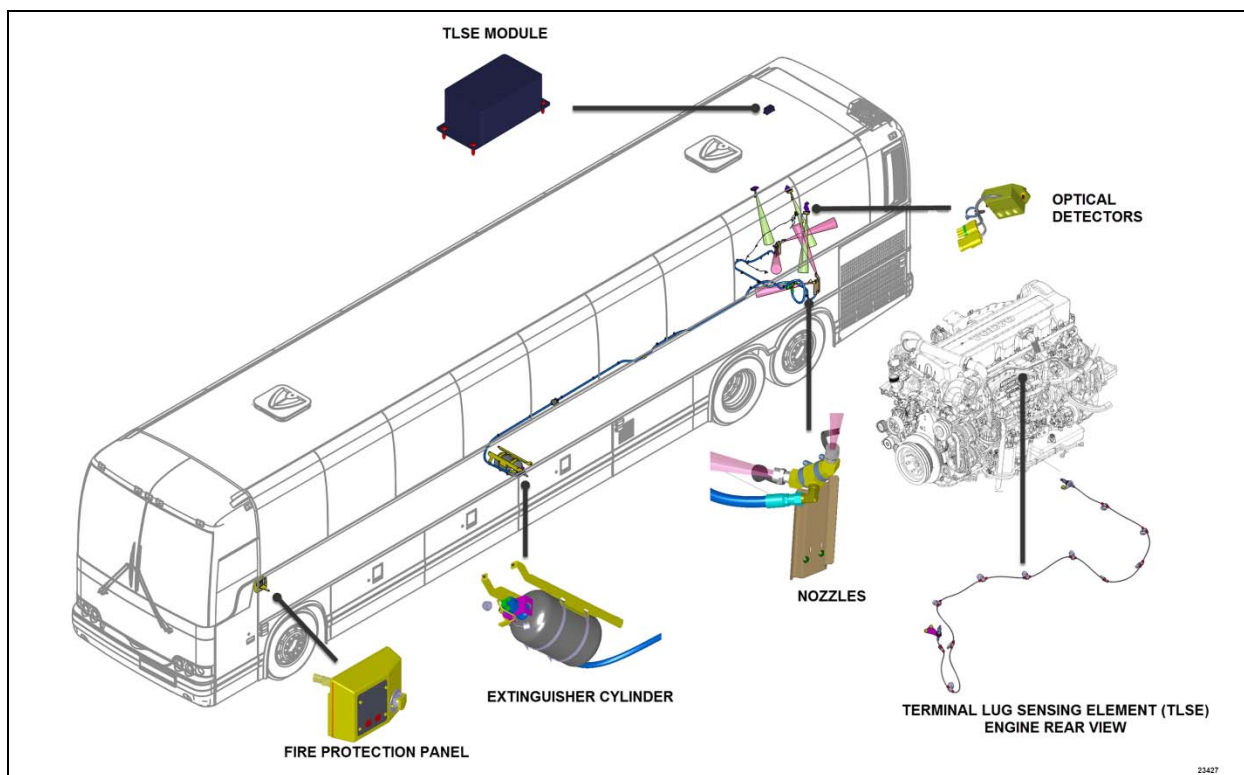

FIGURE 12: FIRE SYSTEM OVERVIEW

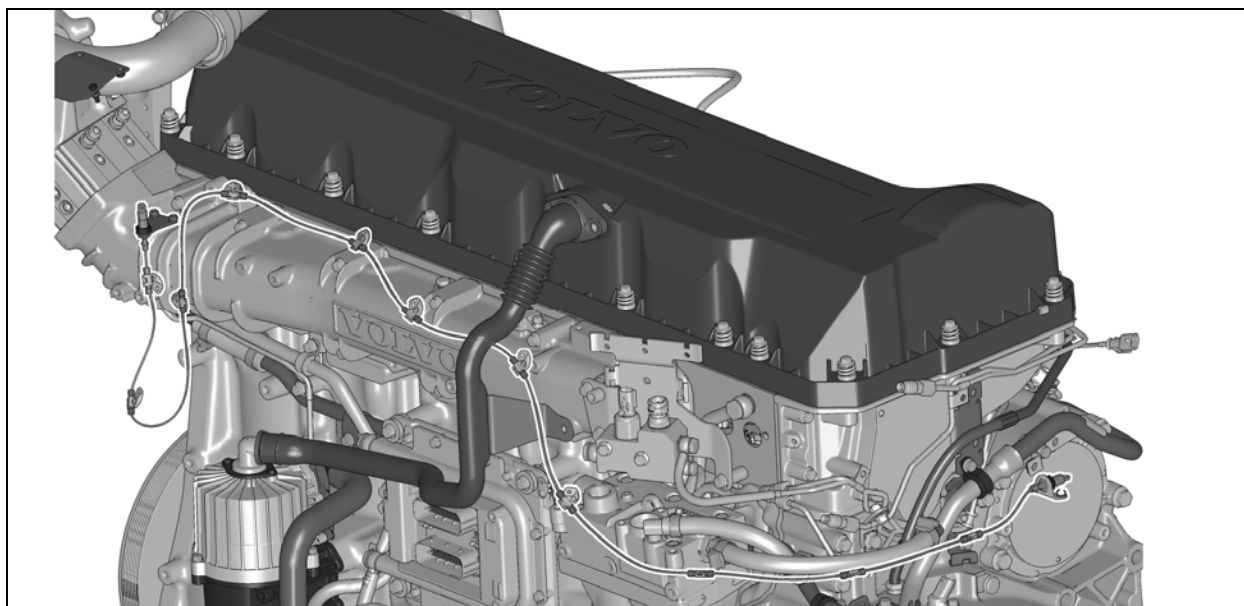

FIGURE 13: TLSE (ACTUAL ROUTING MAY DIFFER)

4.1 PERIODIC MAINTENANCE

PRE-TRIP

- Verify that the Protection Panel "SYSTEM OK" lamp is on solid green.

EVERY 3000 MILES OR MONTHLY (whichever comes first)

General

- Verify that neither the protected equipment nor the hazard has changed.
- Verify that no obvious physical damage or condition exists that might prevent system operation.

Protection Panel

- Verify that all warning lamps and the audible alarm are operational by pressing the "TEST/RESET" button.

Manual Activation Switch

- Verify that the tamper seal is intact and access to the switch is unobstructed.

Fire Detectors

- Optical
 - Verify that the status lamp on the detector face is on solid green.
 - Verify that nothing is blocking the detector's field of view.
 - Verify that the windows on the face of the detector are free of excess contamination (dirt, oil, grease, etc.) – if necessary, clean using a water soaked non-abrasive towel.
- Terminal lug sensing element (TLSE)
 - Verify that there is no obvious physical damage and that the unit is free of excess contamination (dirt, oil, grease, etc) – if necessary, clean using a water soaked non-abrasive towel.
 - Verify that mounting is secure and taught.

Electrical Harness

- Verify that electrical connectors and electrical wiring have no visible damage and all connectors are securely seated.

Extinguisher & Distribution System

- Verify that the extinguisher pressure gauge pointer is in the green arc at room temperature.

- Verify that distribution piping and nozzles are intact and unobstructed and that nozzle blow-off caps are in place.

EVERY 18000 MILES OR SEMI-ANNUALLY (whichever comes first)

- Perform a comprehensive fire system test using a Kidde Dual Spectrum System Test Set (Optical Test Kit P/N 420871-2).
- Service the extinguisher in accordance with KDS Document 160296, "KDS Pre-Engineered Fire Suppression System: Installation, Operation and Maintenance Manual".

EVERY SIX YEARS

- Have the fire extinguisher rebuilt by a qualified fire protection equipment company familiar with Kidde Dual Spectrum equipment and in accordance with KDS Document 160296, "KDS Pre-Engineered Fire Suppression System: Installation, Operation and Maintenance Manual". Rebuilt shall include actuator, o-ring seals and dry chemical replacement.

EVERY TWELVE YEARS

- Have the Extinguisher cylinder hydrostatically tested by a qualified fire protection equipment company familiar with Kidde Dual Spectrum equipment and in accordance with KDS Document 160296, "KDS Pre-Engineered Fire Suppression System: Installation, Operation and Maintenance Manual".

5. NYCT AUXILIARY SYSTEMS AND RADIO IN PARCEL RACK

In the first two left hand (road side) overhead parcel rack compartments you will find the following vehicle monitoring, surveillance and communications equipment:

- Clever Devices' IVN4;
- Motorola communication radio and antenna;

- IFS Ethernet managed switch;
- Mobile Radio Transmitter (WiMAX & Wi-Fi) ;
- Mobile View's Penta C DVR & HDD

A provision for Bus Customer Information System (BCIS) from Verifone equipment is also provided.

Refer to the equipment manufacturer's documentation for these particular items.

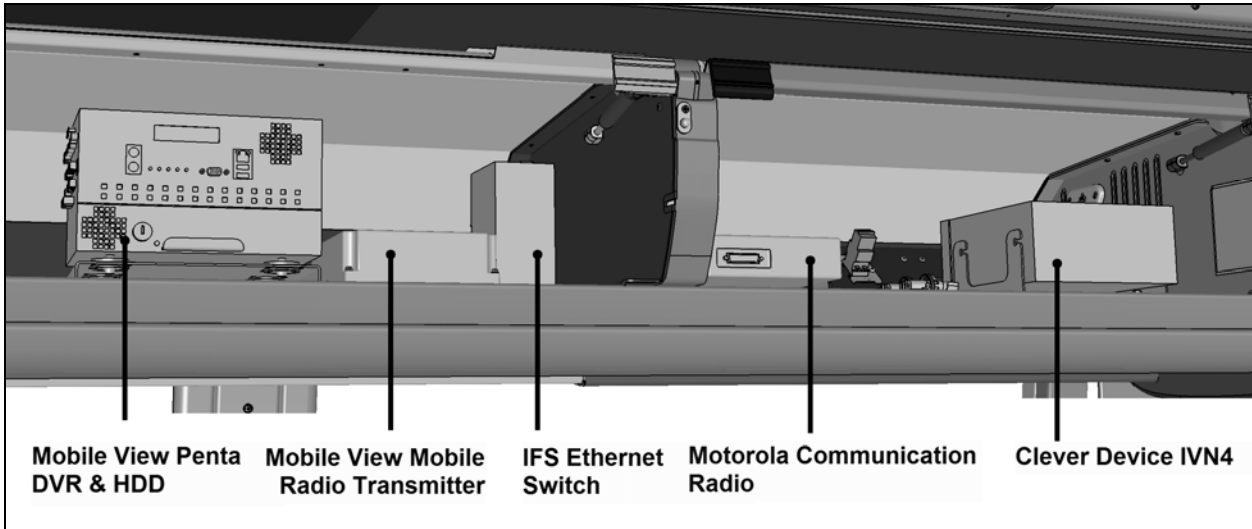

FIGURE 14: MONITORING AND COMMUNICATION EQUIPMENT

5.1 CLEVER DEVICES' IVN4 AND SPEAK EASY2

Installed in the vehicle's first left (road side) overhead compartment, you will find an IVN4 module configured for the following features:

- Automatic Vehicle monitoring®
- Geo-Fenced Auto Regeneration Control
- Public Service Announcement.

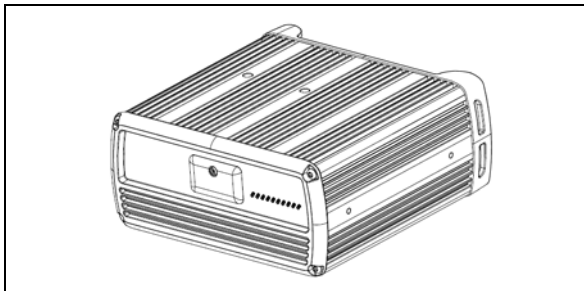

FIGURE 15: IVN4 MODULE

Also installed in the vehicle is Clever Devices' SpeakEasy2 system. The foot switch is located along the left console.

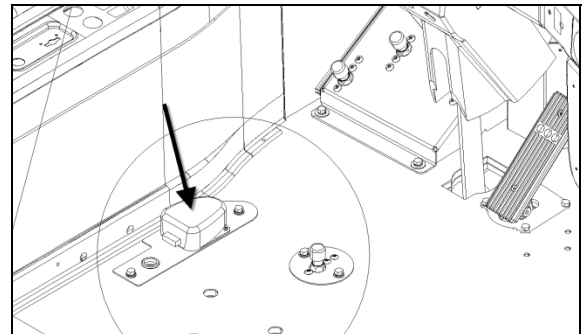

FIGURE 16: FOOT SWITCH

The control head module is installed on the left windshield post.

One interior speaker is located along the driver's right knee.

Another exterior speaker is located above the entrance door.

A volume control microphone (AVC) is located in the bus mid-section, in the overhead module above the road side wheelchair provision area.

5.2 MOTOROLA COMMUNICATION RADIO POWER

The communication radio power can be supplied either directly from the battery or from ignition.

To change the power mode to “battery power”, open the first left hand (road side) overhead compartment and disconnect the two connectors shown in Figure below.

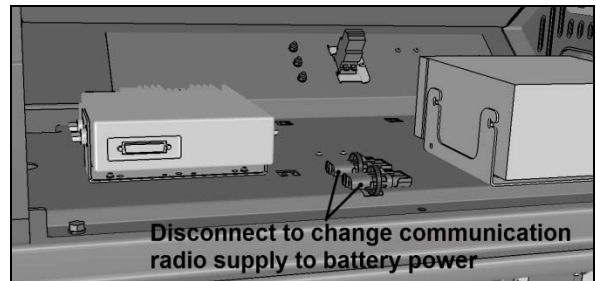

FIGURE 17: RADIO POWER MODE CHANGE

5.3 MOBILE VIEW BUS CAMERA SECURITY SYSTEM (BCSS)

In addition to the components installed in the overhead parcel rack, the BCSS on this vehicle includes seven (7) cameras. One of the cameras is hidden in the “stop request” sign area. A motion sensor (final location still to be determined) and a microphone are also installed inside the vehicle.

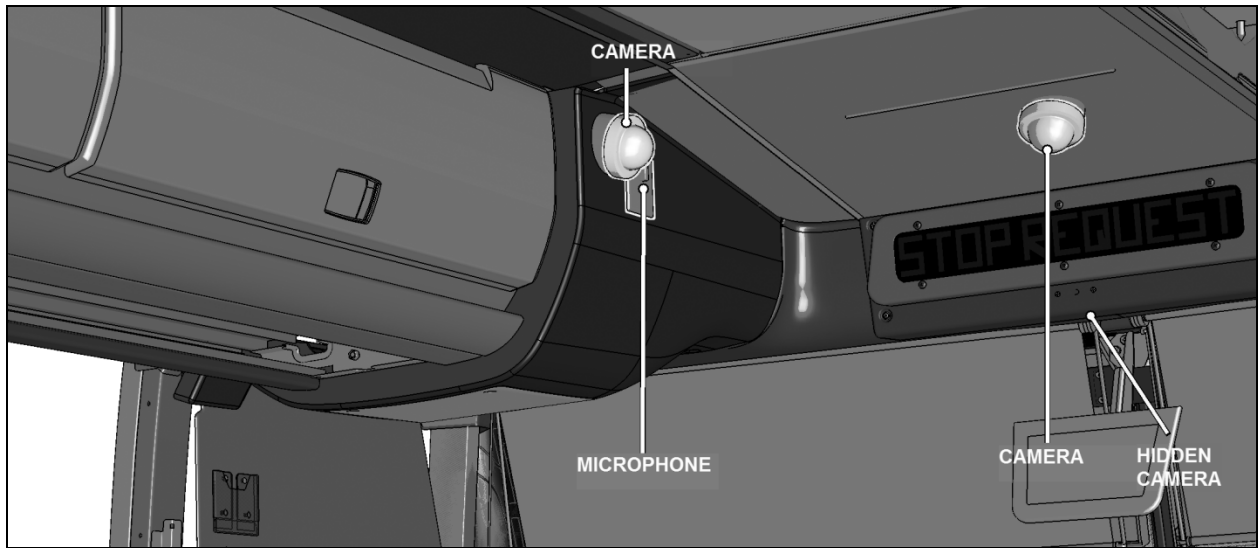

FIGURE 18: CAMERAS AND MICROPHONE (UPPER FRONT OF VEHICLE)

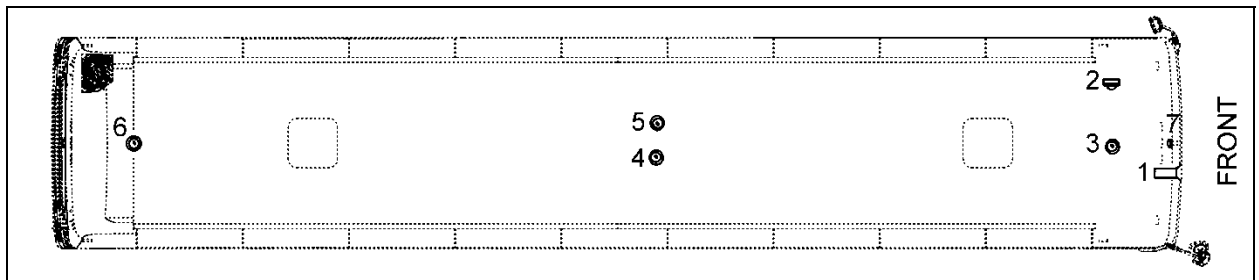

FIGURE 19: CAMERA LOCATIONS (TOP VIEW)

6. SECTION CHANGE LOG

DESCRIPTION		DATE
1		
2		
3		
4		
5		
6		

CONTENTS

1. LUBRICATION2

2. LUBRICATION AND SERVICE SCHEDULE2

 2.1 FLEXIBLE HOSE MAINTENANCE.....2

 2.1.1 *Hose Inspection*.....2

 2.1.2 *Leaks*.....2

 2.1.3 *Service life*.....2

 2.2 LUBRICATION AND SERVICING SCHEDULE.....5

3. SECTION CHANGE LOG7

ILLUSTRATIONS

FIGURE 1: LUBRICATION AND SERVICING POINTS, I-BEAM AXLE FRONT SUSPENSION VEHICLES 4

FIGURE 2: COMPONENTS IDENTIFICATION (COMPONENTS REPRESENTATION MAY DIFFER SLIGHTLY FROM AN ACTUAL VEHICLE) 5

1. LUBRICATION

The efficiency and life expectancy of mechanical equipment is largely dependent on proper lubrication and servicing. All mechanical components rely on a lubricating film between moving parts to reduce friction, prevent wear and oxidation. Proper lubrication also helps cool the parts and keep dirt particles away from mating surfaces. Efficient lubrication depends upon using the right type of lubricant, at specified intervals and by filling to correct capacities. Past experience shows that many service problems can be traced to an improper lubricant or to incorrect lubrication procedures.

A comprehensive maintenance and lubrication program is important to ensure the long service life this vehicle was designed for and to avoid costly repairs and associated downtime caused by premature part failure.

A lubrication schedule is included in this section to give the location of key service points on the vehicle as well as the lubricant specifications for each component to be serviced. Specific instructions on how to check and service different components are covered in their respective sections in this maintenance manual.

The recommended lubrication intervals are based on normal operating conditions and mileage accumulation.

Shorten the intervals if your vehicle operates in more severe conditions. Severe conditions include heavy towing, high vehicle weight or operation in mountainous areas. Some parts and equipment referred to in this section may not be installed on your vehicle. Check your vehicle's "Coach Final Record" for equipment list.

Dispose of used lubricants and filters in an environmentally safe manner, according to federal and/or local recommendations.

2. LUBRICATION AND SERVICE SCHEDULE

Following this service schedule is the most economical and easiest way to ensure your vehicle performs at its best, safest and longest. Also, unscheduled maintenance will be minimized since inspection should expose potential problems before they become major ones.

2.1 FLEXIBLE HOSE MAINTENANCE

The performance of engine and equipment are greatly related to the ability of flexible hoses to supply lubricating oil, air, coolant, and fuel oil.

Maintenance of hoses is an important step to ensure efficient, economical, and safe operation of the engine and related equipment.

2.1.1 Hose Inspection

Check hoses daily as part of the pre-starting inspection. Examine hose for leaks, and check all fittings, clamps, and ties carefully. Ensure that hoses are not resting on or touching shafts, couplings, heated surfaces including exhaust manifolds, any sharp edges, or other obviously damaging areas. Since all machinery vibrates and moves to a certain extent, clamps and ties can fatigue with time. To ensure proper support, inspect fasteners frequently and tighten or replace them as necessary.

2.1.2 Leaks

Investigate leaks immediately to determine if fittings have loosened or cracked, and also if hoses have ruptured or worn through. Take corrective action immediately. Leaks are not only potentially detrimental to machine operation, but can also result in added expenses caused by the need to replace lost fluids.



WARNING

Personal injury and/or property damage may result from fire due to the leakage of flammable fluids, such as fuel or lube oil.

2.1.3 Service life

The limited service life of a hose is determined by the temperature and pressure of the gas or fluid within it, the time in service, its installation, the ambient temperatures, amount of flexing, and the vibration it is subjected to. With this in mind, it is recommended that all hoses be thoroughly inspected at least every 500 operating hours or after 15,000 miles (24 000 km). Look for surface damage or indications of damaged, twisted, worn, crimped, brittle, cracked, or leaking lines. Hoses having a worn outer surface or hoses with a damaged metal reinforcement should be considered unfit for further service.

It is also recommended that all hoses in this vehicle be replaced during major overhaul and/or after a maximum of five service years. Quality of replacement hose assemblies should always be equal to or superior to those supplied by the Original Equipment Manufacturer.

SECTION 24: LUBRICATION

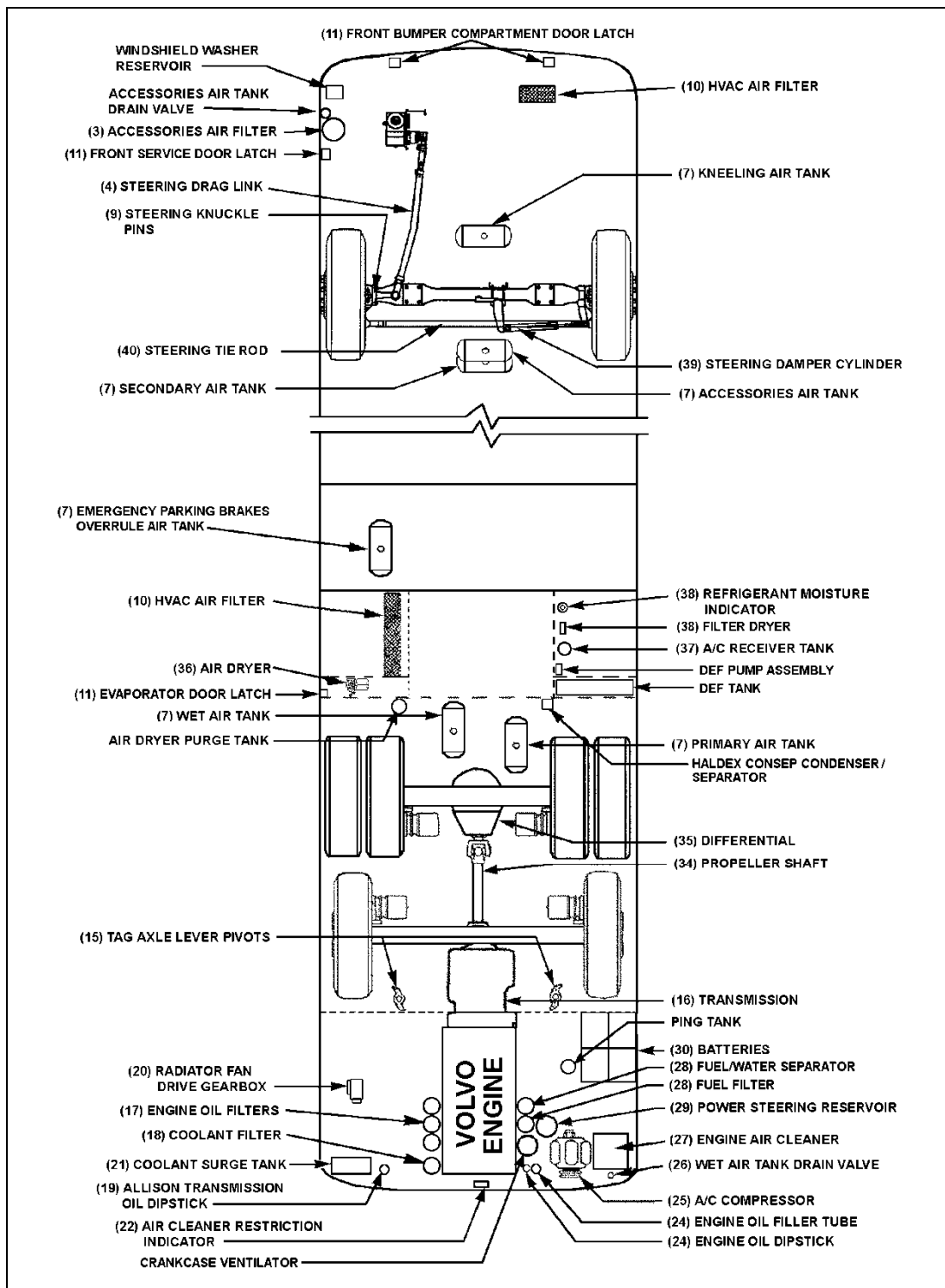

FIGURE 1: LUBRICATION AND SERVICING POINTS, I-BEAM AXLE FRONT SUSPENSION VEHICLES 24030_1

2.2 LUBRICATION AND SERVICING SCHEDULE



24039_4

FIGURE 2: COMPONENTS IDENTIFICATION (COMPONENTS REPRESENTATION MAY DIFFER SLIGHTLY FROM AN ACTUAL VEHICLE)

SECTION 24: LUBRICATION

1	Accessories air tank drain cock	25	Cooling fan gearbox
2	Accessories air filter	26	Allison transmission oil dipstick
3	Steering drag link	27	Engine coolant surge tank
4	Height control valve (front)	28	Coolant filter & conditioner
5	Steering tie rod	29	Engine air filter restriction indicator
6	Accessories air tank	30	Engine air filter
7	Steering column U-joints	31	Engine oil dipstick and filler tube
8	Steering knuckle pins	32	DEF tank
9	Steering damper cylinder	33	Diesel particulate filter (DPF)
10	Secondary air tank	34	SCR catalytic converter
11	Kneeling air tank	35	Diesel fuel tank
12	Air dryer	36	Power steering pump
13	Height control valve (rear)	37	Air compressor
14	Wet air tank	38	Alternators
15	Primary air tank	39	Emergency / parking Brakes Overrule Control Valve
16	Differential	40	Air dryer purge tank
17	Propeller shaft	41	Haldex Condenser / Separator
18	Tag axle lever pivot	42	DEF pump
19	Transmission	43	Diffuser assembly
20	Starter	44	Radiator core & Charge Air Cooler (CAC)
21	Primary fuel filter	45	Cooling system drain plug
22	Secondary fuel filter	46	Brake caliper
23	Power steering fluid tank	47	Steering gear
24	Engine oil filter		

IMPORTANT NOTE

Refer to the manufacturers documentation included in this maintenance manual for specific manufacturer's maintenance requirements.

A Lubrication and Servicing Schedule is included in this section to emphasize key service and lubrication points on the vehicle. Other maintenance requirements and specific instructions on how to check and service different components are covered in their respective sections in this maintenance manual.

3. SECTION CHANGE LOG

DESCRIPTION		DATE
1	Item numbers added in figure 2	12 Oct. 2016
2		
3		
4		
5		
6		

LUBRICATION AND SERVICING SCHEDULE NYCT X3-45 Commuter DOB 2490-2789		Proceed to maintenance operation every (miles)										Lubricant / Spec.tool ¹ ★	
		Figure item	6 000	12 000	18 000	24 000	30 000	50 000	100 000	150 000	200 000		250 000
#	SECTION												
GENERAL													
1	Flexible hoses – thoroughly inspect all hoses						●						
01 ENGINE													
1	Engine oil & filter – heavy operation condition, change	24	●										A
2	Drive belts and idlers – visually inspect for signs of deterioration, cracks or frayed material		●										★
3	Drive belts – change						●						
4	Air cleaner – replace filter element when indicated by differential pressure sensor or according to this interval whichever comes first	29 30					●						
5	Valves & injectors – initial adjust						●						★
6	Valves & injectors – check & adjust									●			★
7	Automatic belt tensioners & idler pulleys inspection – remove belts, check for noisy bearings, play, bushing play. Perform “AUTOMATIC BELT TENSIONER AND IDLER PULLEYS INSPECTION” procedure						●						
8	Coolant pump bearing inspection – release coolant pump drive belt tension, check pump unit drive pulley/shaft for any appreciable axial or radial play in the shaft bearing. Rotate the pulley and check for noise or binding in the bearing						●						
03 FUEL													
1	Primary & secondary fuel filters – change at every engine oil change	21	●										★
2	Fuel tank – perform yearly inspection	35					●						
04 EXHAUST AND AFTERTREATMENT SYSTEM													
1	DEF tank – clean filler neck strainer	32					●						
2	DEF tank – drain & clean with water	32						●					
3	DEF pump filter element – replace	42						●					
4	DPF filter – either clean or replace every 66 000 miles²	33											★
5	Diffuser assembly, rain cap & drain tube – check proper functioning, clean	43			●								
05 COOLING													
1	Coolant surge tank – test coolant solution	27	●										★
2	Coolant filter – change (Fleet Charge Fully Formulated Coolant)	28	●										
3	Radiator fan gearbox – check oil level	25	●										G
4	Radiator – inspect exterior core & clean with low pressure water jet if necessary	44					●						
5	Radiator fan gearbox – change oil	25						●					G
6	Cooling system – drain, flush & refill (Fleet Charge 50/50 Fully Formulated Coolant)	45						●					C / ★
06 ELECTRICAL													
1	HD10 Bosch alternators drive belt – replace	38					●						
2	Alternators – perform “ALTERNATOR PERIODIC INSPECTION” procedure	38	●										
3	Battery terminals – clean & coat terminals						●						
07 TRANSMISSION ³													

¹ ★ = Specialty tool required. You will find the SPECIALTY TOOLS REQUIRED FOR REGULAR MAINTENANCE table and the LUBRICANTS SPECIFICATIONS table following this Lubrication and Servicing Schedule.

² Based on 71347 mi on average before 4500 hrs at Yukon depot and 55782 mi on average before 4500 hrs at Ulmer depot. Median value=63565 mi, increased to 66000 mi to fit with 6000 mi interval based schedule.

SECTION 24A : LUBRICATION & SERVICING SCHEDULE

LUBRICATION AND SERVICING SCHEDULE NYCT X3–45 Commuter DOB 2490-2789		Proceed to maintenance operation every (miles)										Lubricant / Spec.tool★ ¹	
		Figure item	6 000	12 000	18 000	24 000	30 000	50 000	100 000	150 000	200 000		250 000
#	SECTION												
1	Filled with TES389 approved fluid – change transmission fluid, Main & Lube filters	19	●										I
2	Severe vocation, filled with TranSynd or TES295 synthetic fluid only, no mixture ⁴ & using High-Capacity filters ⁵ . Transmission fluid – change every 84 000 miles	19											H
3	Severe vocation, filled with TranSynd or TES295 synthetic fluid only, no mixture & using High-Capacity filters. Transmission Main & Lube filters – change every 42 000 miles	19											
09 PROPELLER SHAFT													
1	Perform Spicer’s Driveshaft “Inspection Procedures”	17	●										
2	Grease one fitting on each universal joint	17			●								K
10 FRONT AXLE													
1	Steering knuckle (king) pins – grease two fittings per knuckle	8	●										K
2	Steering knuckle (king) pins – inspect	8				●							K
11 REAR AXLES													
1	Tag axle lever pivot – grease one fitting on each pivot	18	●										K
2	Drive axle – check differential oil level, add if necessary	16					●						F
3	Drive axle – change differential oil & breather	16						●					F
4	Drive axle – check compact bearing axial play	16						●					★
5	Drive axle – change grease in compact bearing (hub unit)	16								●			E / ★
12 BRAKE & AIR SYSTEM													
1	Brakes – check caliper running clearance at brake pad replacements	46											
2	Brakes – check pad wear indicator. Visually check condition of the slack adjuster cap & guide pin covers	46	●										
3	Air tanks – drain water from all tanks not equipped with manual drain valve			●									
4	Haldex Consep Condenser/Separator – inspect	41		●									
5	Brakes – check caliper movement along guide pins, check sealing elements (boots). Check proper functioning of the adjuster	46		●									
6	ABS & Electronic Stability Control systems – check proper functioning						●						★
7	Accessories air filter – change filter element	2						●					
8	Air dryer – change cartridge	12						●					
13 WHEELS, HUBS & TIRES													
1	Hub bearing, front and tag axle – inspect					●							★
14 STEERING													
1	Steering tie rod ends – clean & grease one fitting at each end	5	●										K

³ Allison Transmission recommends that customers use fluid analysis as the primary method for determining fluid change intervals. In the absence of a fluid analysis program, the fluid change interval listed in the chart above should be used. Change filters according to chart above even if a fluid analysis shows that the fluid doesn’t need to be changed.

⁴ When the transmission contains a mixture of fluids (defined as the quantity of non-TranSynd or non-TES 295 fluid remaining in the transmission after a fluid change combined with the quantity of TranSynd or TES295 required to fill the transmission to the proper level), perform the fluid & filter change according to the TES389 intervals.

⁵ Extended TranSynd or TES 295 fluid & filter change intervals are only allowed with Allison High-Capacity filters.

LUBRICATION AND SERVICING SCHEDULE NYCT X3-45 Commuter DOB 2490-2789		Proceed to maintenance operation every (miles)										Lubricant / Spec.tool ★ ¹		
		Figure item	6 000	12 000	18 000	24 000	30 000	50 000	100 000	150 000	200 000		250 000	300 000
#	SECTION													
2	Steering damper cylinder – grease one fitting at rod end	9	●											K
3	Drag link end ball joints – inspect for corrosion	3	●											
4	Power steering reservoir filter cartridge – replace	23					●							
5	Power steering fluid – replace	23							●					B
6	Steering system – check play	47						●						
16 SUSPENSION														
1	Air bellows – inspect		●											
18 BODY														
1	Front bumper, front service compartment & evaporator compartment door latch, grease fitting						●							K
22 HEATING & AIR CONDITIONING														
1	Passengers HVAC unit disposable return air filters (2) – replace		●											
2	Evaporator compartment door fresh air intake filter – clean		●											
3	Parcel rack fans air filter – clean		●											
4	Driver HVAC unit return & fresh air filters – clean		●											
5	A/C compressor – check oil level, add if necessary. Change the oil if it has darkened. Refer to Oil Color And Level Check in Maintenance Information MI18-21		●											D
6	A/C receiver tank – check refrigerant level, add if necessary			●										
7	A/C compressor – empty shaft seal oil collection tube		●											
8	Refrigerant moisture indicator – check, replace filter dryer unit according to moisture indicator						●							
9	Driver’s HVAC units – clean heater & evaporator cores with low-pressure air jet							●						
10	Passengers’ HVAC unit – clean evaporator & heater cores with a stream of low-pressure water or low-pressure air jet							●						
11	Passengers’ HVAC unit – clean condenser core with a stream of low-pressure water or low pressure air jet							●						
12	A/C compressor – change oil, clean oil filter ⁶								●					★

⁶ (approximately every 4 years, 10000-12000 operating hours)

LUBRICANT AND COOLANT SPECIFICATIONS

REF	DESCRIPTION	SPECIFICATIONS
A	Engine Oil	Total Rubia TIR 10W-30 FE for best fuel economy. SAE Viscosity Grade 5W-30 & 15W-40 oils, meeting Volvo specification VDS-4 and CJ4, are also approved
B	Power Steering Oil	Mobil DEXRON-VI ATF (Automatic Transmission Fluid)
C	Engine Coolant	Fleet Charge Fully Formulated Antifreeze 50% antifreeze/water solution is normally used
D	A/C Compressor Oil	Central HVAC system: Polyolester oil, HFC 134a compatible; Castrol SW-68 (POE) or equivalent
E	ZF Drive axle compact bearing (hub unit)	Fuchs Europe Schmierstoffe GMBS/Renolit LXPEP-2 Lithium saponified, multipurpose grease, NLGI No. 2,
F	Differential Oil	Mobil Delvac Synthetic Gear Oil 80W-140
G	Radiator Fan Gearbox Synthetic Oil (Approved by Linnig)	Agip Rota HY DB Synth 75W90 - BP Energear MTB 75W90 Castrol Syntrans-AT 75W90 - Deagear Synth 75W90 Fuchs Titan Cytrac MB Synth 75W90 - Mobiltrans MTB 75W90 OMV gear oil MPX 75W90 - Panolin Super Duty Synth MB 75W90 Shell Transmission MA 75W90 - Total Transmission XI 75W90
H	Allison Automatic Transmission Oil	Castrol TranSynd™ Synthetic Transmission Fluid for Allison or TES 295 approved equivalent
I	Allison Automatic Transmission Oil	Approved equivalent 1 Schedule 1 TES-389 fluids
K	Multi Purpose Grease	Good quality lithium-base grease: NLGI No.2 Grade is suitable for most temperatures NLGI No.1 Grade is suitable for extremely low temperatures

SPECIALTY TOOLS REQUIRED FOR REGULAR MAINTENANCE OF THE VEHICLES

Use this list of specialty tools in conjunction with the LUBRICATION AND SERVICING SCHEDULE

#	MAINTENANCE DESCRIPTION	TOOL #	SPECIALITY TOOL DESCRIPTION	PART #
01 ENGINE				
2	drive belts and idlers	1	belt tensioner wrench	010032
5, 6	valves & injectors	2	engine cranking adapter	88840317
		3	feeler gauge 2.45-2.55	88880052
		4	feeler gauge set	85111377
		5	setting tool 3.20, 3.85	88800232
03 FUEL				
1	Davco Fuel Pro 382 system	6	collar spanner wrench	530224
04 EXHAUST AND AFTERTREATMENT SYSTEM				
4	DPF filter – either clean or replace	7	DPF removal tool	680790
05 COOLING				
1	test coolant solution	8	refractometer coolant/DEF	88890105
6	cooling system drain, flush & refill	9	coolant extractor (optional)	85112740
		10	tube with connector (optional)	9996049
06 ELECTRICAL				
		11	none	
07 TRANSMISSION				
		12	none	
09 PROPELLER SHAFT				
		13	none	
10 FRONT AXLE				
		14	none	
11 REAR AXLE				
4	check compact bearing axial play	15	14 mm hex socket driver (Allen)	*
		16	E20 Torx socket	*
		17	dial indicator with magnetic base	*
5	change grease in compact bearing	15	14 mm hex socket driver (Allen)	*
		16	E20 Torx socket	*
		18	slotted nut wrench 5870 401 146	N67817-21
		19	lifting bracket 5870 281 043	19400451
		20	driver 5870 050 007	19400449

SECTION 24A : LUBRICATION & SERVICING SCHEDULE

#	MAINTENANCE DESCRIPTION	TOOL #	SPECIALITY TOOL DESCRIPTION	PART #
		21	handle 5870 260 004	N67817-19
		22	driver 5870 051 053	N67817-16
		23	seal installer 5870 651 085	19400265
		24	pry bar 5870 345 071	N78017-20
12 BRAKE & AIR SYSTEM				
6	ABS & Electronic Stability Control systems – check proper functioning	25	ACOM diagnostic software available free of charge	Bendix website
13 WHEEL, HUBS & TIRES				
1	Hub bearing, front & tag axle – inspect	26	dial indicator with magnetic base	*
14 STEERING				
		27	none	
16 SUSPENSION				
		29	none	
18 BODY				
		29	none	
22 HEATING & AIR CONDITIONING				
12	A/C compressor – change oil, clean oil filter	30	Refrigerant recovery unit	

*: Common tool. Contact your local tool supplier

CHANGE LOG - LUBRICATION AND SERVICING SCHEDULE		DATE m/d/y
1	ADDED: 04 EXHAUST & AFTERTREATMENT SYSTEM - Diffuser assembly, rain cap & drain tube – check proper functioning, clean	04/16/2014
2	UPDATED: 11 REAR AXLES – Differential oil level check, breather & oil replacement, bearing axial play & grease change for new ZF A-132 drive axle	08/28/2014
3	In table heading, “ODOMETER READING IN MILE” removed	09/12/2014
4	UPDATED: 01 ENGINE – Drive belts & idlers visual inspection was 12 000 mi, changed to 6 000 mi. Automatic belt tensioners & idlers bearing play etc. was 12 000 mi, changed to 50 000 mi	
5	UPDATED: 01 ENGINE – Automatic belt tensioners & idlers bearing play etc. was 50 000 mi, changed to 30 000 mi	10/02/2014
6	UPDATED: 12 BRAKE & AIR SYSTEM – Brake calipers visual and functional checks moved. Visual check was 12 000 mi, changed to 6 000 mi	10/10/2014
7	UPDATED: 01 ENGINE – Automatic belt tensioners & idlers bearing play etc. was 30 000 mi, changed to 50 000 mi	12/08/2014
8	ADDED: 22 HEATING & AIR CONDITIONING - Recommended maintenance: A/C compressor – change oil, clean oil filter	02/17/2015
9	UPDATED: 12 BRAKE & AIR SYSTEM – Caliper running clearance check was 6 000 mi, changed to “at brake pad replacements”	03/25/2015
10	UPDATED: 07 TRANSMISSION – Filled with TES389 approved fluid – change transmission fluid, Main & Lube filters was 12 000 mi, changed to 6 000 mi	11/11/2015
11	UPDATED: 07 TRANSMISSION – Severe vocation, filled with TranSynd or TES295 synthetic fluid only, no mixture & using High Capacity filters – change transmission fluid was 150 000 mi, changed to 84 000 mi.	
12	ADDED: 07 TRANSMISSION – Severe vocation, filled with TranSynd or TES295 synthetic fluid only, no mixture & using High Capacity filters – change Main & Lube filters every 42 000 mi	
13	CHANGED: 04 EXHAUST AND AFTERTREATMENT SYSTEM – DEF tank cleaning, was 50 000 mi, changed to 100 000 mi	07/12/2016
14	CHANGED: 04 EXHAUST AND AFTERTREATMENT SYSTEM – DEF pump filter element replacement, was 150 000 mi, changed to 100 000 mi	
15	ADDED: 14 STEERING – Steering system play inspection	08/16/2016
16	ADDED: 06 ELECTRICAL – Alternators – perform “Alternator Periodic Inspection” procedure	06/12/2017
17	REMOVED: 06 ELECTRICAL – HD10 Bosch alternators brushes – check & replace brushes if necessary	06/12/2017
18	CHANGED: 22 HEATING & AIR CONDITIONING – Empty shaft seal oil collection tube, was 50 000 mi, changed to 6 000 mi	06/13/2017
19	CHANGED: 22 HEATING & AIR CONDITIONING – change oil, clean oil filter – recommended servicing changed for a formal servicing	06/13/2017
20	ADDED: 07 FUEL - Fuel tank – perform yearly inspection	05/28/2018
21	ADDED: 01 ENGINE – Coolant pump inspection	03/20/2019
22	ADDED: 22 HEATING & AIR CONDITIONING – A/C compressor check oil level “change the oil if it has darkened”	04/08/2019
23	CHANGED: 22 HEATING & AIR CONDITIONING – A/C compressor oil change: was every 3 years, changed to 4 years	04/08/2019

CHANGE LOG - LUBRICANT AND COOLANT SPECIFICATIONS TABLE		DATE m/d/y
1	Dexron-VI removed from Ref I. Dexron-VI is no longer recommended for use in commercial on-highway transmission. Allison Service Tip #1099revS	06/02/2014
2	Ref. E, removed, was regular differential oil, not used on NYCTA X3-45 Commuter bus	06/27/2014
3	Ref. F, updated to reflect differential oil used on NYCTA Prevost X3-45 Commuter bus	06/27/2014
4	Ref. E, added for ZF A132 compact bearing (hub unit)	08/28/2014
5		
6		
7		
8		
9		
10		
11		
12		
13		
14		
15		