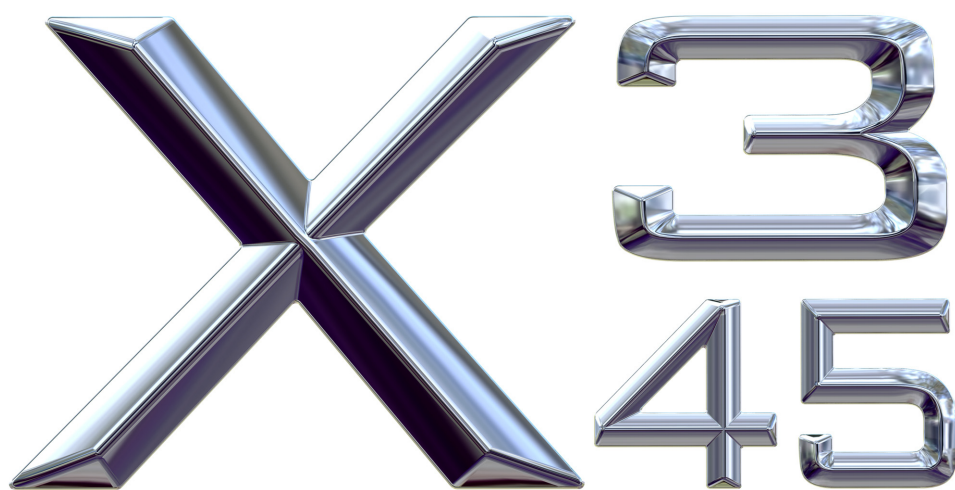


**PREVOST**  
**COACH MANUFACTURER**

# **MAINTENANCE MANUAL**

**X3 COACHES**



**PA1562**  
(2<sup>nd</sup> edition)

PA1562 2<sup>nd</sup> edition

Date: February 2008

Starting from vehicle: 8-9451

Featuring: Volvo D13 engine & DDC S60-2007 engine with Aftertreatment System



# SECTION 00: GENERAL INFORMATION

## CONTENTS

|   |          |
|---|----------|
| <b>1. FOREWORD</b> .....                                  | <b>2</b> |
| <b>2. SCHEMATICS</b> .....                                | <b>2</b> |
| <b>3. PRECAUTIONS TO BE OBSERVED BEFORE WELDING</b> ..... | <b>2</b> |
| <b>4. SAFETY NOTICE</b> .....                             | <b>4</b> |
| 4.1 DATA PLATES AND CERTIFICATIONS .....                  | 4        |
| 4.1.1 <i>Engine</i> .....                                 | 4        |
| 4.1.2 <i>Transmission</i> .....                           | 5        |
| 4.1.3 <i>Drive Axle</i> .....                             | 5        |
| 4.1.4 <i>Front Axle</i> .....                             | 5        |
| 4.1.5 <i>Power Steering Pump</i> .....                    | 6        |
| 4.1.6 <i>Coach Final Record</i> .....                     | 6        |
| 4.1.7 <i>Safety Certification</i> .....                   | 6        |
| 4.1.8 <i>DOT Certification Label</i> .....                | 6        |
| 4.1.9 <i>EPA Engine Label</i> .....                       | 6        |
| 4.1.10 <i>Fuel Tank Label</i> .....                       | 6        |
| 4.1.11 <i>Vehicle Identification Number (VIN)</i> .....   | 7        |
| <b>5. FASTENER STRENGTH IDENTIFICATION</b> .....          | <b>9</b> |
| 5.1 SELF-LOCKING FASTENERS .....                          | 10       |
| 5.2 RECOMMENDATIONS FOR REUSE.....                        | 10       |
| 5.3 SIX LOBED SOCKET HEAD .....                           | 10       |

## ILLUSTRATIONS

|  |    |
|--|----|
| FIGURE 1: DETROIT DIESEL SERIES 60 .....                   | 5  |
| FIGURE 2: VOLVO D13 ENGINE DATA PLATE .....                | 5  |
| FIGURE 3: ALLISON TRANSMISSION .....                       | 5  |
| FIGURE 4: ZF-ASTRONIC TRANSMISSION .....                   | 5  |
| FIGURE 5: TYPICAL SERIAL & MODEL NUMBERS.....              | 5  |
| FIGURE 6: ISS TYPICAL SERIAL & MODEL NUMBERS .....         | 5  |
| FIGURE 7: I-BEAM AXLE TYPICAL SERIAL & MODEL NUMBERS ..... | 5  |
| FIGURE 8: POWER STEERING PUMP NAMEPLATE .....              | 6  |
| FIGURE 9: POWER STEERING PUMP .....                        | 6  |
| FIGURE 10: DOT CERTIFICATION PLATE .....                   | 6  |
| FIGURE 11: VEHICLE I.D. ....                               | 7  |
| FIGURE 12: VEHICLE IDENTIFICATION NUMBER .....             | 8  |
| FIGURE 13: THREAD NOTATION.....                            | 9  |
| FIGURE 14: BOLT STRENGTH MARKINGS .....                    | 9  |
| FIGURE 15: SELF-LOCKING FASTENERS.....                     | 10 |
| FIGURE 16: METRIC - US STANDARD CONVERSION TABLE.....      | 11 |
| FIGURE 17: CONVERSION CHART .....                          | 12 |

## Section 00: GENERAL INFORMATION

### 1. FOREWORD

This manual includes procedures for diagnosis, service, maintenance and repair for components of the X3 series coaches listed on the front cover page. This manual should be kept in a handy place for ready reference by the technician. If properly used, it will meet the needs of the technician and owner.

Information provided in Section 1 through 24 pertains to standard equipment items, systems and components as well as the most commonly used optional equipment and special equipment offered on the coach models covered by this manual. At the beginning of each section: a Table of Contents and a list of illustrations give the page number on which each subject begins and where each figure is located. Coach operating information is provided in a separate Operator's Manual. Audio/Video system operator instructions are also included in a separate manual.

More specific information on engine and transmission operating, maintenance, and overhaul information is contained in the applicable engine or transmission service manual published by the engine or transmission manufacturer. Engine and transmission parts information is contained in the applicable engine or transmission parts catalog published by the engine or transmission manufacturer. All information, illustrations and specifications contained in this manual are based on the latest product information available at the time of publication approval. The right is reserved to make product changes at any time without notice.

#### NOTE

*Typical illustrations may be used; therefore minor illustration difference may exist when compared to actual parts or other publications.*

Prevost occasionally sends Maintenance Information, Warranty Bulletins, Safety Recalls or other literature to update users with the latest service procedures. They are issued, when required, to supplement or supersede information in this manual. Update sheet should be filled out and bulletins should be filed at the end of their respective section for future reference.

### 2. SCHEMATICS

Vehicle AIR SCHEMATICS are provided at the end of Section 12, "Brake". SUSPENSION AIR SCHEMATICS are provided at the end of Section 16, "Suspension". Moreover, ELECTRICAL SCHEMATICS are provided in the technical publications box. Refer to those schematics for detailed circuit information or during diagnosis.

### 3. PRECAUTIONS TO BE OBSERVED BEFORE WELDING



#### CAUTION

Precautions are to be observed before welding to minimize the risk of major and costly damage caused to the vehicle electronic components.

#### NOTE

*For X3-45 Multiplex vehicles, also execute procedure no: PR060034 "MULTIPLEX MODULES DISCONNECTION PROCEDURE PRIOR TO WELDING" included at the end of this section.*



#### CAUTION

For vehicles equipped with a WCL system, disconnect electronic controller connector.



#### CAUTION

Cover electronic control components and wiring to protect from hot sparks, etc.



#### CAUTION

Position welding machine ground clamp as close as possible to the work. Ensure that the welding machine ground return clamp is well secured and makes a good electrical contact with a large metallic area of the chassis located as close as possible to the welding point.



#### CAUTION

Do not use TIG welding process on the vehicle. This high frequency current process can seriously damage the electronic components.

**STEEL – STEEL WELDING**



**CAUTION**

Before welding, perform multiplex modules disconnection procedure.

*NOTE*

*Welding surfaces must be free of scale, slag, rust, paint, grease, humidity or other foreign material that would render welding impossible.*



**DANGER**

Only a qualified and experienced person must do welding.

- FCAW (Flux Cored Arc Welding) process ;
- Electrode wire conforms to A5.20 AWS (American Welding Society) specifications ;
- E4801T-9-CH, type electrode wire with 0,045" diameter (1,14 mm) ;

| Material Thickness | Voltage      | Current  | Wire Feed Rate   | Shielding Gas                   |
|--------------------|--------------|----------|------------------|---------------------------------|
| 1/8" to 1/2"       | 26 ± 2 volts | 260 Amps | 450 ipm. approx. | 75% argon – 25% CO2 or 100% CO2 |

If necessary and with great care to prevent perforating the material, it is possible to use a conventional electric arc welding machine according to the following specifications:

- SMAW (Shielded Metal-Arc Welding) process ;
- Welding rod conforms to A5.1 of AWS (American Welding Society) specifications; E 7018 type welding rod with 1/8" diameter (3,2 mm).
- Current: 100 amperes to 150 amperes; optimum at 120 amps.

It is important to grind weld bead starts and stops and also to grind arc strikes from surfaces.

**STEEL - STAINLESS STEEL OR STAINLESS STEEL - STAINLESS STEEL WELDING**



**CAUTION**

Before welding, perform multiplex modules disconnection procedure.

*NOTE*

*Welding surfaces must be free of scale, slag, rust, paint, grease, humidity or other foreign material that would render welding impossible.*



**DANGER**

Only a qualified and experienced person must do welding.

- GMAW (Gas Metal-Arc Welding) process;
- Welding wire conforms to AWS (American Welding Standards) A5.9 specifications;
- 308LSi type welding wire with 0.035" diameter (0,9 mm);

**STEEL - STAINLESS STEEL WELDING**

| Steel Thickness | SS Thickness | Voltage      | Current     | Wire Feed Rate  | Shielding Gas             |
|-----------------|--------------|--------------|-------------|-----------------|---------------------------|
| Less than 1/8"  | Any type     | 20±1.5 volts | 130±15 Amps | 290 ipm approx. | 90% He, 7.5% Ar, 2.5% CO2 |
| 1/8" and more   | Any type     | 22±1.5 volts | 160±15 Amps | 330 ipm approx. | 90% He, 7.5% Ar, 2.5% CO2 |

## Section 00: GENERAL INFORMATION

### STAINLESS STEEL - STAINLESS STEEL WELDING

| SS Thickness | Voltage        | Current       | Wire Feed Rate  | Shielding Gas                             |
|--------------|----------------|---------------|-----------------|---|
| Any type     | 20 ± 1.5 volts | 130 ± 15 Amps | 290 ipm approx. | 90% He – 7.5% Ar,<br>2.5% CO <sub>2</sub> |

If necessary and with great care to prevent perforating the material, it is possible to use a conventional electric arc welding machine according to the following specifications:

- SMAW (Shield Metal-Arc Welding) process;
- Welding rod conforms to AWS (American Welding Standards) A5.4 specifications; 308L-17 type welding rod with 3/32" diameter (2,4 mm);
- Current: - 50 amperes to 90 amperes, optimum at 60 amperes.

It is important to grind weld bead starts and stops and also to grind arc strikes from surfaces.

#### 4. SAFETY NOTICE


This maintenance manual has been prepared in order to assist skilled mechanics in the efficient repair and maintenance of PRÉVOST vehicles.


This manual covers only the procedures as of manufacturing date.


Safety features may be impaired if other than genuine PRÉVOST parts are installed.

Torque wrench tightening specifications must be strictly observed. Locking devices must be installed or replaced by new ones, where specified. If the efficiency of a locking device is impaired, it must be replaced.

This manual emphasizes particular information outlined by the wording and symbols:

|  |               |
|--|---------------|
|                           | <b>DANGER</b> |
| Directs the operator's attention to unsafe practices which could result in serious personal injury or death. |               |

|   |                |
|---|----------------|
|    | <b>WARNING</b> |
| Directs the operator's attention to unsafe practices which could result in serious personal injury or severe damage to the vehicle. |                |

|  |                |
|--|----------------|
|   | <b>CAUTION</b> |
| Directs the operator's attention to unsafe practices where personal injury is not likely but damage to vehicle components could occur. |                |

#### NOTE

*Indicates supplementary information essential to the proper operation of the vehicle. Although, the mere reading of such information does not eliminate the hazard, understanding of the information will promote its correct use.*

#### 4.1 DATA PLATES AND CERTIFICATIONS

Delay and confusion can be avoided by placing the complete vehicle identification number of the coach and the serial numbers of the engine on parts orders and correspondence. Also, the transmission, axles, power steering pump chassis and other major components are identified by serial numbers.

##### 4.1.1 Engine

###### • DDC Series 60 Engine

The engine serial and model numbers are stamped on the cylinder block (as viewed from the flywheel end) on the left side just below the fire deck and above the cast-in Detroit Diesel logo (Fig. 1).

In addition, option plates made of laminated paper are located on the rocker cover (starter side). The engine serial and model number and a list of the optional engine equipment are written on the option plates. Refer to this information when ordering replacement parts (Fig. 1).

###### • Volvo D13 Engine

Volvo D13 engine serial and model numbers are stamped on the cylinder head (Fig. 2).

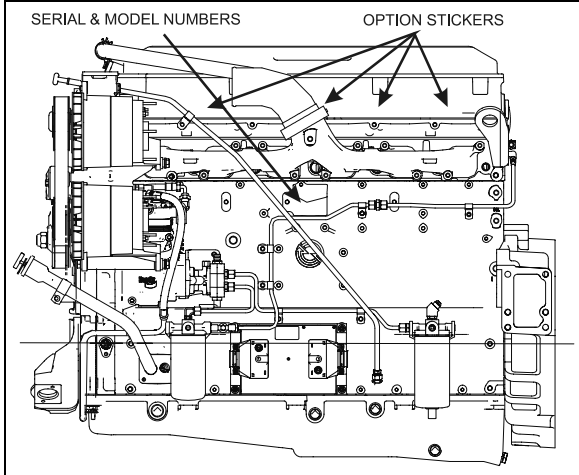


FIGURE 1 : DETROIT DIESEL SERIES 60 00043

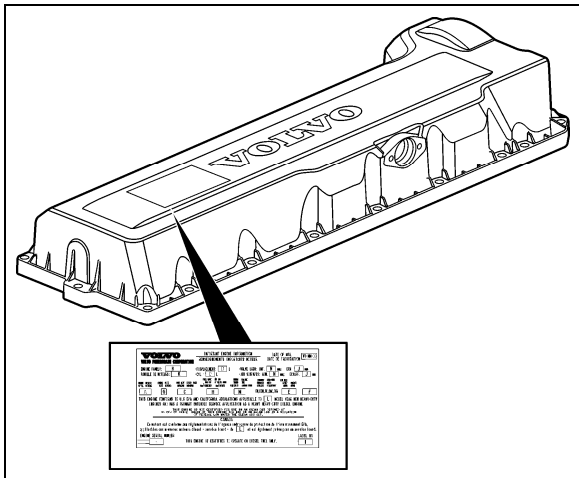


FIGURE 2: VOLVO D13 ENGINE DATA PLATE 00052

4.1.2 Transmission

The transmission identification plate is located on the oil level dipstick side of the transmission (WT) or on transmission, on the vehicle R.H. side (ZF) (Fig. 3 & 4). The identification plate shows the transmission serial number, part number (assembly number), and model number. Use all three numbers when ordering parts.

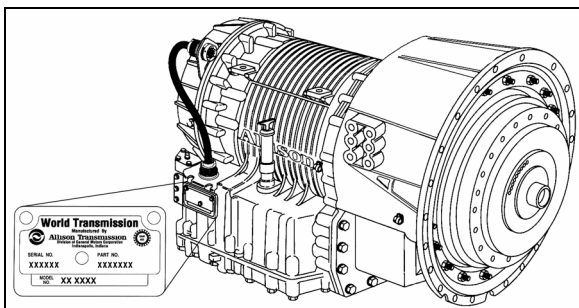


FIGURE 3: ALLISON TRANSMISSION 07076

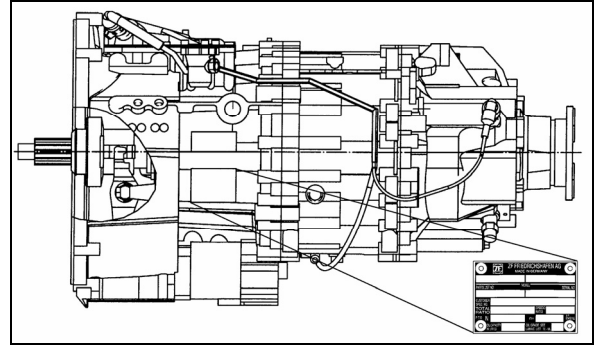


FIGURE 4: ZF-ASTRONIC TRANSMISSION 00040

4.1.3 Drive Axle

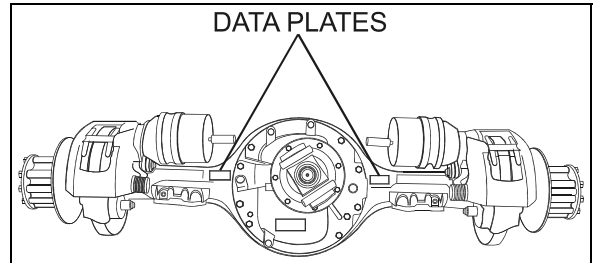


FIGURE 5: TYPICAL SERIAL & MODEL NUMBERS 00007

4.1.4 Front Axle

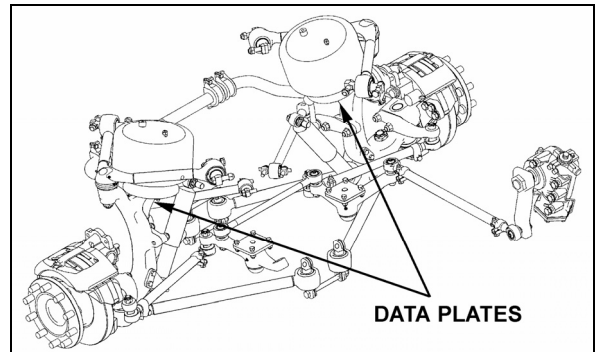


FIGURE 6: ISS TYPICAL SERIAL & MODEL NUMBERS 16136

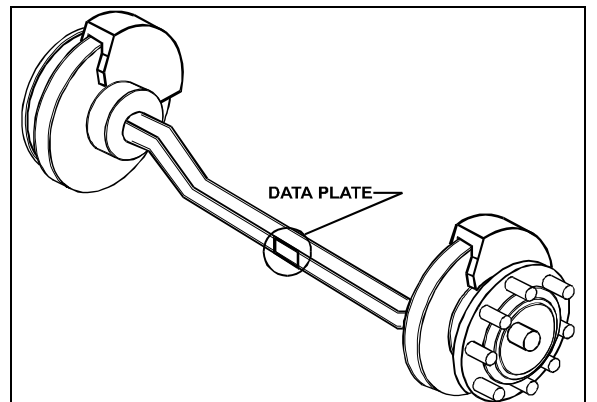


FIGURE 7: I-BEAM AXLE TYPICAL SERIAL & MODEL NUMBERS 00008

## Section 00: GENERAL INFORMATION

### 4.1.5 Power Steering Pump

- **DDC SERIES 60 ENGINE**

Power steering pump serial number is located on a tag on the pump (Fig. 8). The pump is mounted on the engine beside the crankshaft pulley.

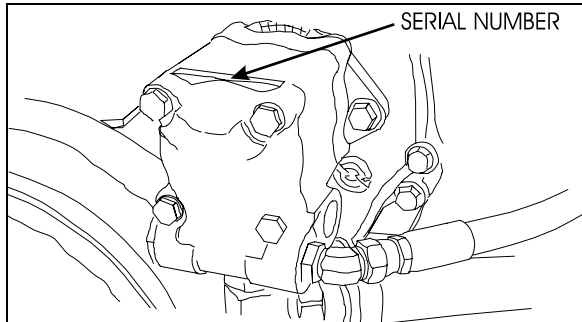


FIGURE 8 : POWER STEERING PUMP NAMEPLATE 00035

- **Volvo D13 Engine**

Power steering pump is mounted on the engine and located underneath the air compressor (Fig. 9).

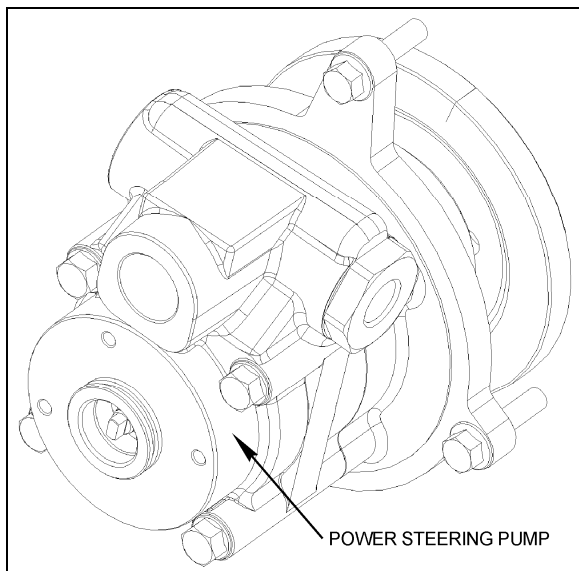


FIGURE 9: POWER STEERING PUMP

### 4.1.6 Coach Final Record

The Coach Final Record is a record of all data pertaining to the assembly of the coach. This record is included in the technical publication package supplied with the coach. Retain this record in the company records office for reference and safe-keeping.

### 4.1.7 Safety Certification

Coach components meet specifications and standards as follows:

- Material and parts conform to ASTM and/or SAE standards in effect at the time of manufacture.

- All factory-installed interior materials meet FMVSS 302 for fire resistance.

- Certified according to Provincial, State and Federal Safety standards (Canadian and US) BMCSS, FMVSS, and CMVSS.

Other applicable certification labels are affixed to the component.

### 4.1.8 DOT Certification Label

This certifies that coaches manufactured by Prevost Car Inc., comply with all Federal Motor Vehicle Safety Standards at the time of manufacture. Information such as date of manufacture, model year, gross vehicle weight rating, tire types and inflation pressure is also etched on this plate. The DOT Certification plate is affixed to the side of the L.H. control panel.

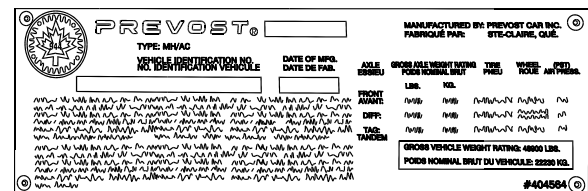


FIGURE 10: DOT CERTIFICATION PLATE 00016

### 4.1.9 EPA Engine Label

The exhaust emission certification label affixed inside the engine compartment above the lavatory maintenance service valves certifies that the engine conforms to federal and any state exhaust emission regulations. It gives the operating conditions under which certification was made.

### 4.1.10 Fuel Tank Label

The fuel tank label is molded on the side of the fuel tank. To read this label, unscrew the fuel tank access panel nuts located at the left in the condenser compartment.

4.1.11 Vehicle Identification Number (VIN)

The seventeen digit vehicle identification number (VIN) is located on a plate (Fig. 11 & 12) located on the windshield frame pillar (driver's side). The VIN is visible from the outside of the coach. Make sure the correct vehicle identification number is given when ordering replacement parts. Using the VIN when ordering parts will facilitate processing.

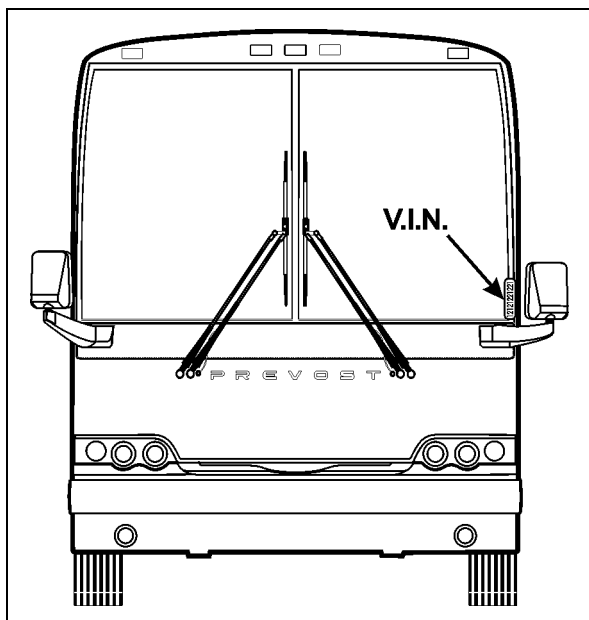


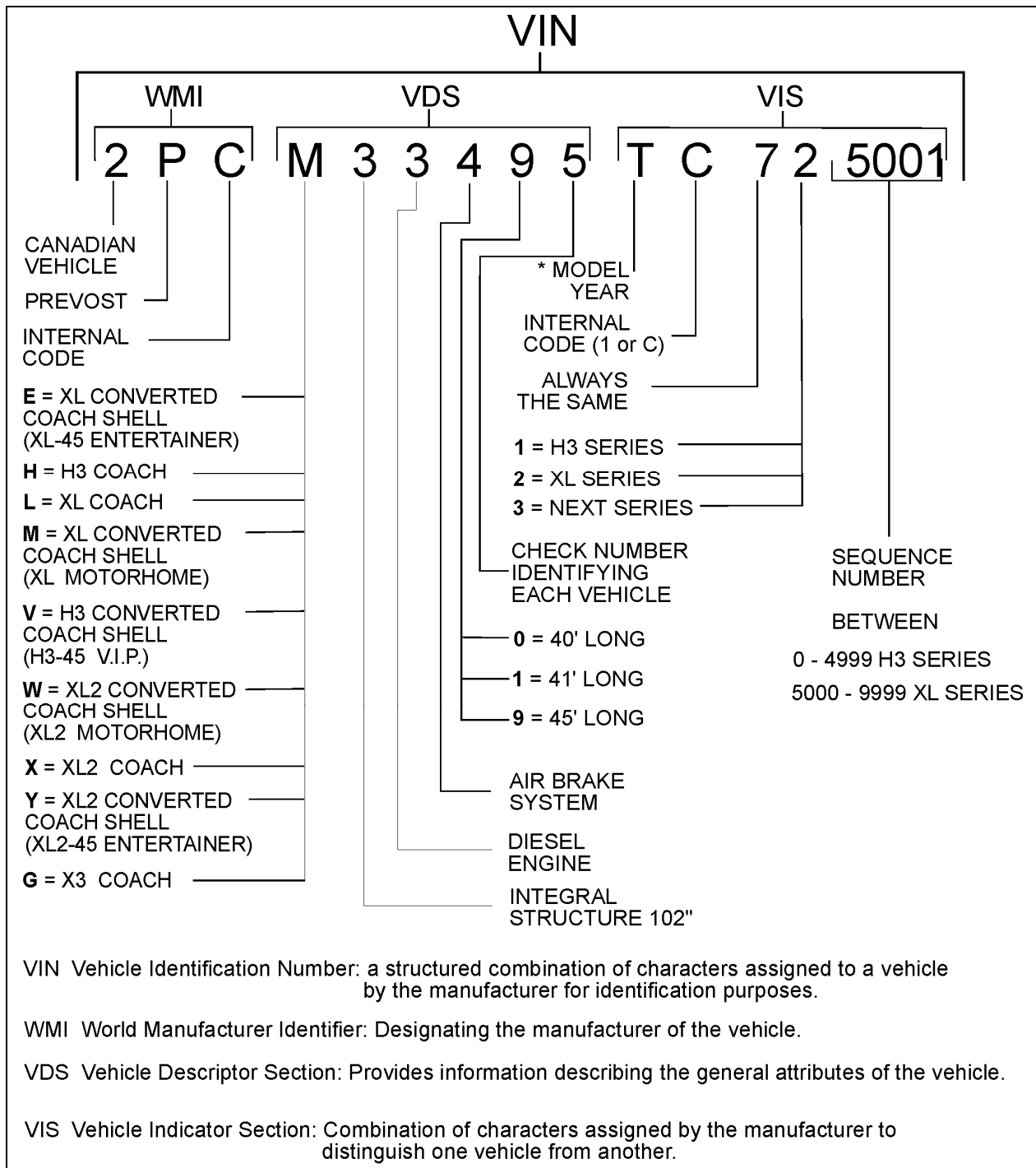
FIGURE 11 : VEHICLE I.D.

00048

**NOTE**

*Record the VIN in the coach documentation and keep with company records. The VIN will normally be used for vehicle registration and for obtaining vehicle insurance coverage.*

**Section 00: GENERAL INFORMATION**



**FIGURE 12 : VEHICLE IDENTIFICATION NUMBER**

00050

| YEAR | CODE | YEAR | CODE |
|------|------|------|------|
| 2000 | Y    | 2006 | 6    |
| 2001 | 1    | 2007 | 7    |
| 2002 | 2    | 2008 | 8    |
| 2003 | 3    | 2009 | 9    |
| 2004 | 4    | 2010 | A    |
| 2005 | 5    | 2011 | B    |



**5. FASTENER STRENGTH IDENTIFICATION**

Most commonly used metric fastener strength property classes are 9.8 and 10.9 with the class identification embossed on the head of each bolt. Customary (inch) strength classes range from grade 2 to 8 with radial line identification embossed on each bolt head actual grade (i.e., a grade 7 bolt will have 5 embossed radial lines on the bolt head). Some metric nuts will be marked with single digit strength identification numbers on the nut face. Fig. 14 shows the different strength markings. When replacing

metric fasteners, be careful to use fasteners of the same or greater strength than the original fasteners (the same number marking or higher). It is also important to select replacement fasteners of the correct size. Correct replacement fasteners are available through the parts division. Some metric fasteners available in after-market parts sources were designed to metric standards of countries other than the United States and may be of a lower strength, may not have the numbered head marking system, and may be of a different thread pitch.

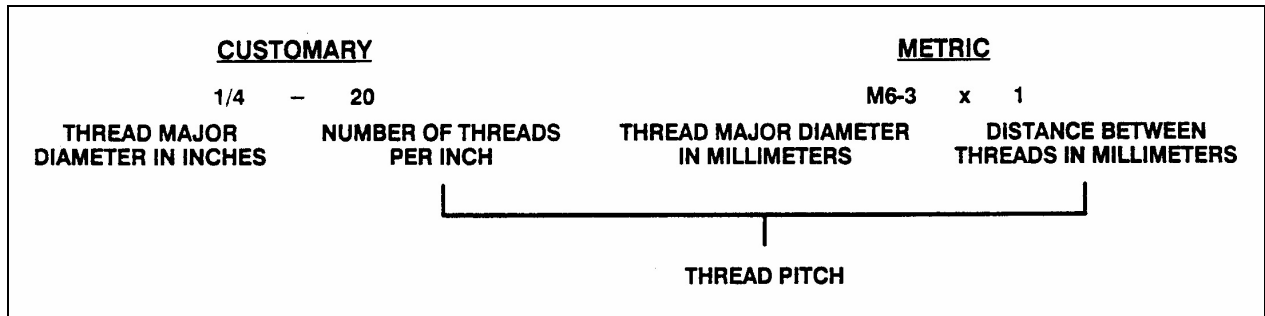


FIGURE 13 : THREAD NOTATION

00002

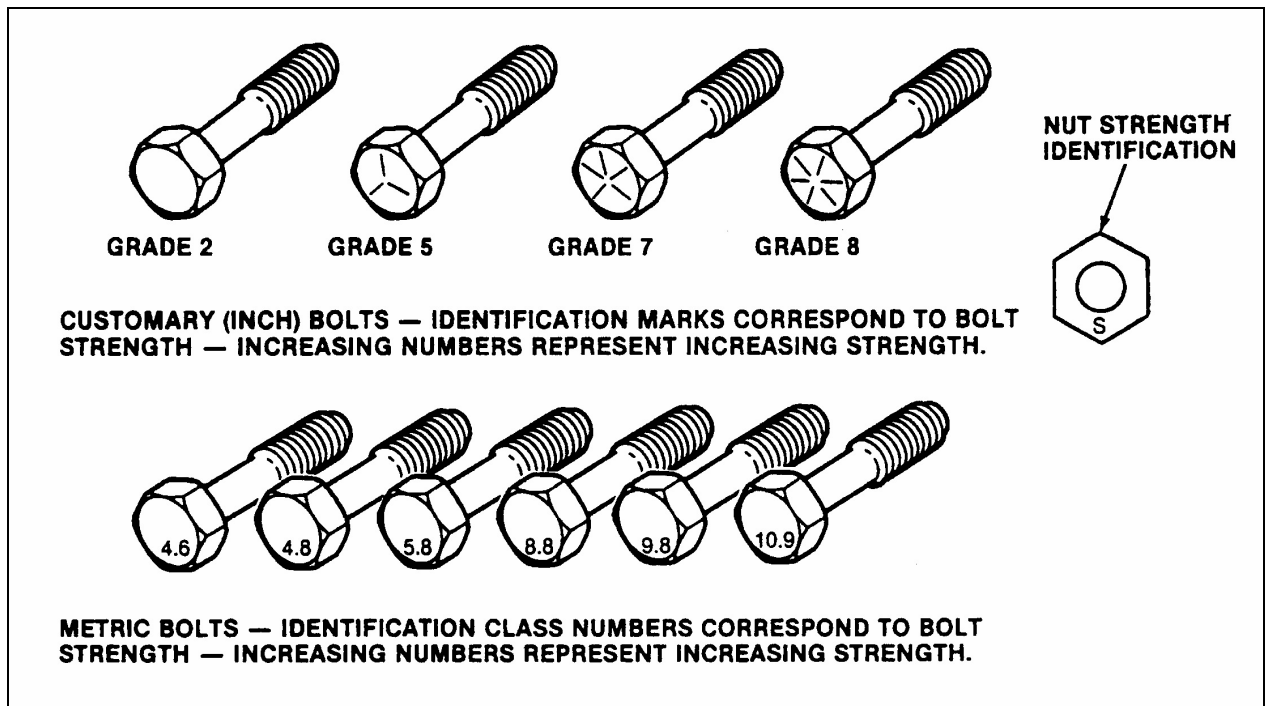


FIGURE 14: BOLT STRENGTH MARKINGS

00003

The metric fasteners used on the coach are designed to new standards and may not yet be manufactured by some non-domestic fastener suppliers. In general, except for special applications, the common sizes and pitches are:

- M 8 X 1.25;
- M 10 X 1.5;
- M 12 X 1.75;
- M 14 X 2;

## Section 00: GENERAL INFORMATION

### 5.1 SELF-LOCKING FASTENERS

A self-locking fastener is designed with an interference fit between the nut and bolt threads. This is most often accomplished by distortion of the top thread of an all-metal nut or bolt or by using a nylon patch on the threads. A nylon insert or the use of adhesives may also be used as a method of interference between nut and bolt threads (Fig. 15).

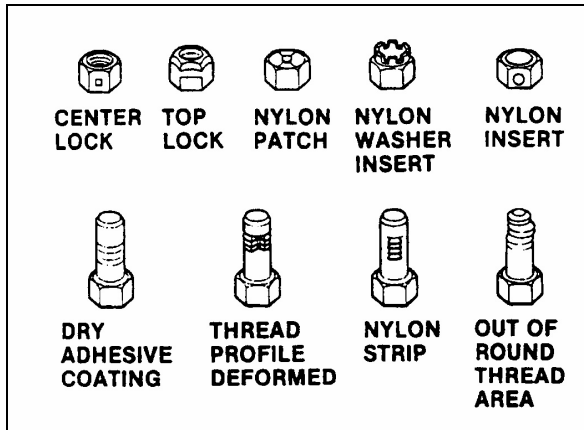


FIGURE 15 : SELF-LOCKING FASTENERS

00004

### 5.2 RECOMMENDATIONS FOR REUSE

Clean, unruined self-locking fasteners may be reused as follows:

- Clean dirt and other foreign matter from the fastener;
- Inspect the fastener to ensure there is no crack, elongation, or other sign of fatigue or overtightening. If there is any doubt, replace with a new self-locking fastener of equal or greater strength;
- Assemble parts and hand start fastener;
- Observe that, before the fastener seats, it develops torque per the chart in table two. If there is any doubt, replace with a new self-locking fastener of equal or greater strength;
- Tighten the fastener to the torque specified in the applicable section of this manual;

Fasteners which are rusty or damaged should be replaced with new ones of equal or greater strength.

### SELF-LOCKING FASTENER TORQUE CHART

| METRIC                         |        | 6 & 6.3 | 8    | 10  | 12   | 14  | 16   | 20  |     |
|--------------------------------|--------|---------|------|-----|------|-----|------|-----|-----|
| NUTS AND ALL-METAL BOLTS       | Nm     | 0.4     | 0.8  | 1.4 | 2.2  | 3.0 | 4.2  | 7.0 |     |
|                                | Lbf-in | 4.0     | 7.0  | 12  | 18   | 25  | 35   | 57  |     |
| ADHESIVE OR NYLON COATED BOLTS | Nm     | 0.4     | 0.6  | 1.2 | 1.6  | 2.4 | 3.4  | 5.6 |     |
|                                | Lbf-in | 4.0     | 5.0  | 10  | 14   | 20  | 28   | 46  |     |
| US STANDARD                    |        | ¼       | 5/16 | 3/8 | 7/16 | ½   | 9/16 | 5/8 | ¾   |
| NUTS AND ALL-METAL BOLTS       | Nm     | 0.4     | 0.6  | 1.4 | 1.8  | 2.4 | 3.2  | 4.2 | 6.2 |
|                                | Lbf-in | 4.0     | 5.0  | 12  | 15   | 20  | 27   | 35  | 51  |
| ADHESIVE OR NYLON COATED BOLTS | Nm     | 0.4     | 0.6  | 1.0 | 1.4  | 1.8 | 2.6  | 3.4 | 5.2 |
|                                | Lbf-in | 4.0     | 5.0  | 9.0 | 12   | 15  | 22   | 28  | 43  |

### 5.3 SIX LOBED SOCKET HEAD

Six lobed socket head (Torx) fasteners are used in some applications on vehicles covered in this manual. The tools designed for these fasteners are available commercially. However, in some cases, if the correct tool is not available, a hex socket head wrench may be used.

| Multiply           | by              | to get equivalent number of:                | Multiply                            | by          | to get equivalent number of:                   |
|--------------------|-----------------|---|-------------------------------------|-------------|--|
| <b>LENGTH</b>      |                 |   |                                     |             |  |
| Inch               | 25.4            | millimeters (mm)                            | Foot/sec <sup>2</sup>               | 0.305       | meter/sec <sup>2</sup> (m/s <sup>2</sup> )     |
| Foot               | 0.305           | meters (m)                                  | Inch/sec <sup>2</sup>               | 0.026       | meter/sec <sup>2</sup>                         |
| Yard               | 0.914           | meters                                      | <b>TORQUE</b>                       |             |  |
| Mile               | 1.609           | kilometers (km)                             | Pound-inch                          | 0.113       | newton-meters (N·m)                            |
|                    |                 |   | Pound-foot                          | 1.35        | newton-meters                                  |
| <b>AREA</b>        |                 |   |                                     |             |  |
| Inch <sup>2</sup>  | 645.2           | millimeters <sup>2</sup> (mm <sup>2</sup> ) | <b>POWER</b>                        |             |  |
| Foot <sup>2</sup>  | 6.45            | centimeters <sup>2</sup> (cm <sup>2</sup> ) | Horsepower                          | 0.746       | kilowatts (kW)                                 |
| Yard <sup>2</sup>  | 0.093           | meters <sup>2</sup> (m <sup>2</sup> )       | <b>PRESSURE OR STRESS</b>           |             |  |
|                    | 0.836           | meters <sup>2</sup>                         | <b>ENERGY OR WORK</b>               |             |  |
| <b>VOLUME</b>      |                 |   |                                     |             |  |
| Inch <sup>3</sup>  | 16              | mm <sup>3</sup>                             | <b>LIGHT</b>                        |             |  |
|                    | 16.387          | cm <sup>3</sup>                             | Foot-pound                          | 1.356       | joules (J)                                     |
| Quart              | 0.016           | liters (l)                                  | Kilowatt-hour                       | 3 600 000.0 | joules (J = one W's)                           |
| Gallon             | 0.946           | liters                                      | <b>VELOCITY</b>                     |             |  |
| Yard <sup>3</sup>  | 3.785           | liters                                      | Miles/hour                          | 1.609       | kilometers/hr (km/h)                           |
|                    | 0.765           | meters <sup>3</sup> (m <sup>3</sup> )       | <b>TEMPERATURE</b>                  |             |  |
| <b>MASS</b>        |                 |   |                                     |             |  |
| Pound              | 0.453           | kilograms (kg)                              | <b>TO GET EQUIVALENT NUMBER OF:</b> |             |  |
| Ton                | 907.18          | kilograms (kg)                              | <b>ACCELERATION</b>                 |             |  |
| Ton                | 0.907           | ton (t)                                     | <b>TORQUE</b>                       |             |  |
| <b>FORCE</b>       |                 |   |                                     |             |  |
| Kilogram           | 9.807           | newtons (N)                                 | <b>POWER</b>                        |             |  |
| Ounce              | 0.278           | newtons                                     | <b>PRESSURE OR STRESS</b>           |             |  |
| Pound              | 4.448           | newtons                                     | <b>ENERGY OR WORK</b>               |             |  |
| <b>TEMPERATURE</b> |                 |   |                                     |             |  |
| Degree Fahrenheit  | (°F - 32) ÷ 1.8 | Degree Celsius (C)                          | <b>LIGHT</b>                        |             |  |
|                    |                 |   | Foot candle                         | 1.076       | lumens/meter <sup>2</sup> (lm/m <sup>2</sup> ) |

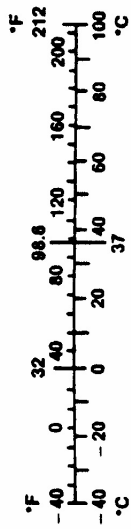


FIGURE 16: METRIC - US STANDARD CONVERSION TABLE

00005

| <b>DECIMAL AND METRIC EQUIVALENTS</b> |                        |                      |                  |                        |                      |
|---------------------------------------|------------------------|----------------------|------------------|------------------------|----------------------|
| <b>FRACTIONS</b>                      | <b>DECIMAL<br/>IN.</b> | <b>METRIC<br/>MM</b> | <b>FRACTIONS</b> | <b>DECIMAL<br/>IN.</b> | <b>METRIC<br/>MM</b> |
| 1/64                                  | .015625                | .39688               | 33/64            | .515625                | 13.09687             |
| 1/32                                  | .03125                 | .79375               | 17/32            | .53125                 | 13.49375             |
| 3/64                                  | .046875                | 1.19062              | 35/64            | .546875                | 13.89062             |
| 1/16                                  | .0625                  | 1.58750              | 9/16             | .5625                  | 14.28750             |
| 5/64                                  | .078125                | 1.98437              | 37/64            | .578125                | 14.68437             |
| 3/32                                  | .09375                 | 2.38125              | 19/32            | .59375                 | 15.08125             |
| 7/64                                  | .109375                | 2.77812              | 39/64            | .609375                | 15.47812             |
| 1/8                                   | .125                   | 3.1750               | 5/8              | .625                   | 15.87500             |
| 9/64                                  | .140625                | 3.57187              | 41/64            | .640625                | 16.27187             |
| 5/32                                  | .15625                 | 3.96875              | 21/32            | .65625                 | 16.66875             |
| 11/64                                 | .171875                | 4.36562              | 43/64            | .671875                | 17.06562             |
| 3/16                                  | .1875                  | 4.76250              | 11/16            | .6875                  | 17.46250             |
| 13/64                                 | .203125                | 5.15937              | 45/64            | .703125                | 17.85937             |
| 7/32                                  | .21875                 | 5.55625              | 23/32            | .71875                 | 18.25625             |
| 15/64                                 | .234375                | 5.95312              | 47/64            | .734375                | 18.65312             |
| 1/4                                   | .250                   | 6.35000              | 3/4              | .750                   | 19.05000             |
| 17/64                                 | .265625                | 6.74687              | 49/64            | .765625                | 19.44687             |
| 9/32                                  | .28125                 | 7.14375              | 25/32            | .78125                 | 19.84375             |
| 19/64                                 | .296875                | 7.54062              | 51/64            | .796875                | 20.24062             |
| 5/16                                  | .3125                  | 7.93750              | 13/16            | .8125                  | 20.63750             |
| 21/64                                 | .328125                | 8.33437              | 53/64            | .828125                | 21.03437             |
| 11/32                                 | .34375                 | 8.73125              | 27/32            | .84375                 | 21.43125             |
| 23/64                                 | .359375                | 9.12812              | 55/64            | .859375                | 21.82812             |
| 3/8                                   | .375                   | 9.52500              | 7/8              | .875                   | 22.22500             |
| 25/64                                 | .390625                | 9.92187              | 57/64            | .890625                | 22.62187             |
| 13/32                                 | .40625                 | 10.31875             | 29/32            | .90625                 | 23.01875             |
| 27/64                                 | .421875                | 10.71562             | 59/64            | .921875                | 23.41562             |
| 7/16                                  | .4375                  | 11.11250             | 15/16            | .9375                  | 23.81250             |
| 29/64                                 | .453125                | 11.50937             | 61/64            | .953125                | 24.20937             |
| 15/32                                 | .46875                 | 11.90625             | 31/32            | .96875                 | 24.60625             |
| 31/64                                 | .484375                | 12.30312             | 63/64            | .984375                | 25.00312             |
| 1/2                                   | .500                   | 12.70000             | 1                | 1.00                   | 25.40000             |

FIGURE 17: CONVERSION CHART

00006

# PREVOST

## MULTIPLEX MODULES DISCONNECTION PROCEDURE PRIOR TO WELDING

**PROCEDURE NO: PR060034**

**REVISION 4  
2007-05-31**

**Material :** N/A

**Equipment(s) :** Phillips-head screwdriver  
Ratchet handle  
3/8" socket  
Electric tape  
Long nose pliers

**Reference schematics:** N/A

**Safety rules :**

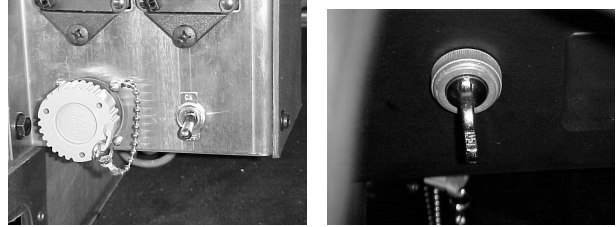
- Wear safety goggles
- Set the battery master switch to the OFF position first

**Recommendations:** This procedure should be performed by qualified personnel only.

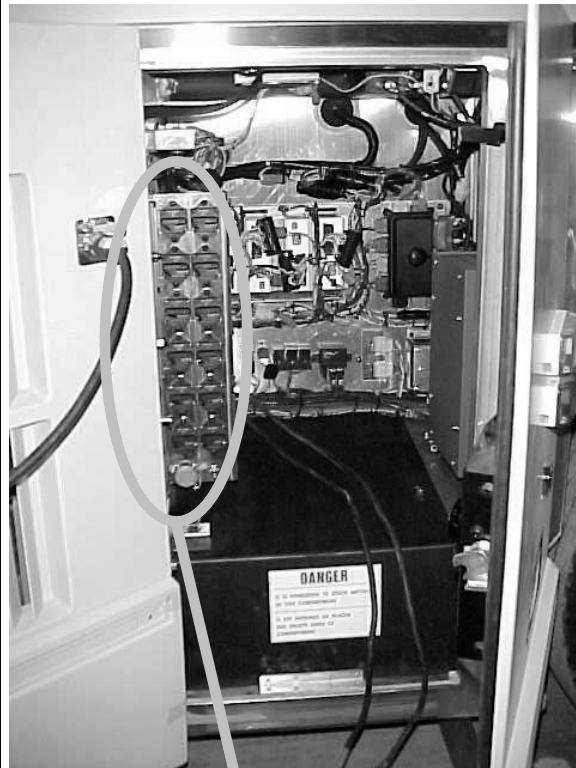
|  | Effective                                    |
|--|--|
| <b>Revision 0 : Issued with multiplex</b>  |  |
| <b>Revision 1 : Modified for Fire Protection System and also for VIP with multiplex</b>                                  |  |
| <b>Revision 2 : Step 5 modified for introduction of VIP with multiplex</b>   | <b>-0436</b>                                 |
| <b>Revision 3 : Step 1.15 added C397<br/>Addition of SECTION 2 for X3 Coaches<br/>Addition of SECTION 3 for XLII MTH</b> |  |
| <b>Revision 4 : Modified for introduction of CPC module for VIP,H3 Coach, X3</b>   | <b>7-0942VIP<br/>8-1037 H3<br/>8-9282 X3</b> |

SECTION 1 H3 Coaches & VIP

1.00 **Location: Main power compartment and dashboard**  
Set the battery master switch to the OFF position.  
Place the ignition switch to the OFF position.



1.05 **Location: Main power compartment**  
Trip circuit breakers CB2, CB4, CB6

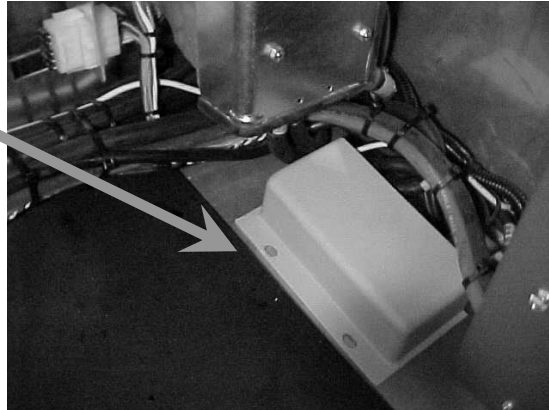


Push the red button to open the circuit



1.10 Location: Main power compartment

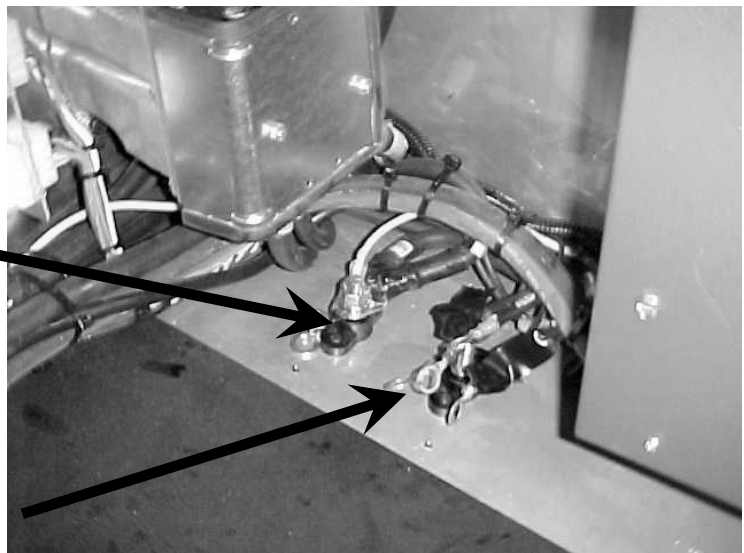
Remove the protective cover



**△ WARNING △**

**LIVE WIRE**

**This 12-volt terminal remains energized**

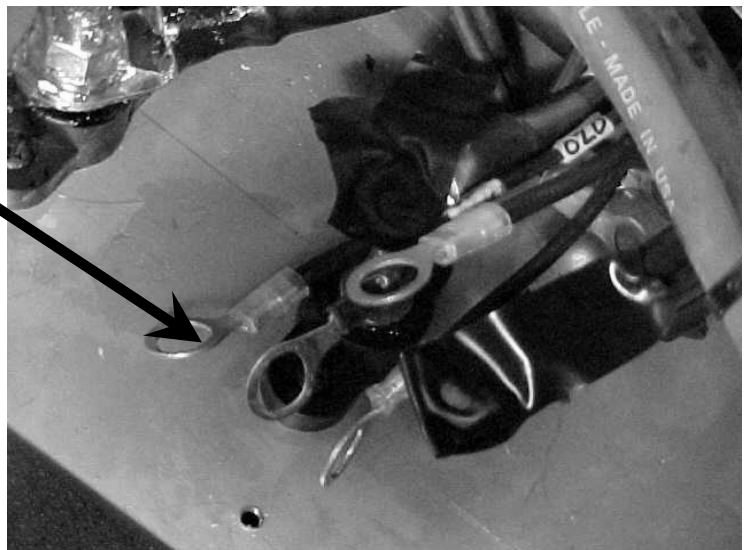


Disconnect the electronic ground terminals from the stud

Using electric tape, insulate the 2 largest gage wires. Make sure the ring terminals do not touch each others and the vehicle body.

*NOTE*

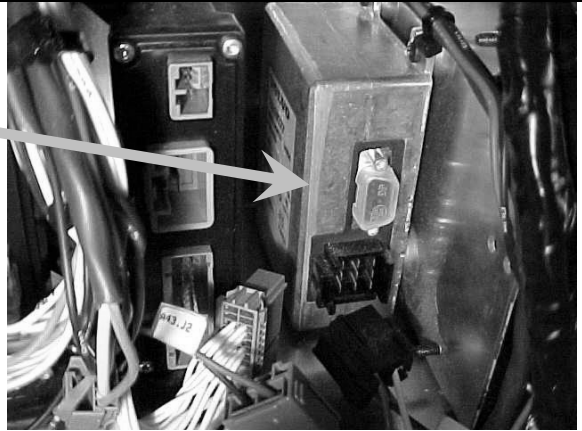
***With disconnection of the electronic ground terminals, disconnecting the engine ECM, transmission TCM and the dashboard electronic components (telltale module, HVAC module, radio, control head, ...) is not required.***



|   |  |
|---|--|
| <p>1.15 <b>Location: Main power compartment</b></p> <p>Disconnect the electronic modules :</p> <hr/> <p>Disconnect the I/O A and I/O B modules</p> <p style="padding-left: 40px;">Disconnect C397</p> <p>Disconnect connector C717</p> <p>Unplug 3 connectors per I/O B modules</p> <p>Unplug 3 connectors on the I/O A module</p>  |  |
| <p>1.20 <b>Location: Front electrical compartment</b></p> <p><b>VIP + COACH:</b> Disconnect the I/O A, I/O B, ABS, master ID, CECM and CPC modules. Unplug connector C92</p> <p><b>VIP:</b> Disconnect all keyless module connectors.</p> <p>Unplug 3 connectors per I/O B modules and 3 connectors per I/O A modules.</p> <p>Unplug 2 connectors from the ABS module</p> |  |



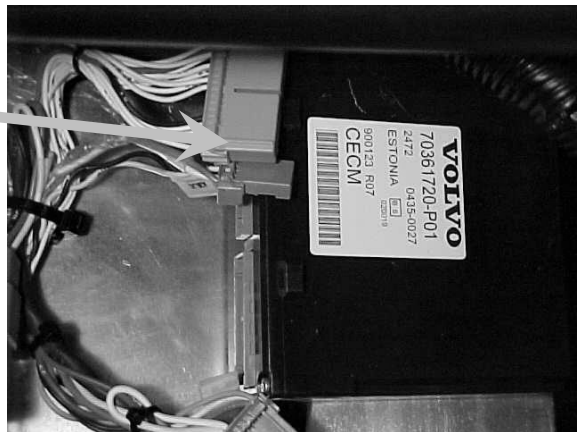
Unplug 1 connector from the master ID



Disconnect CPC connectors


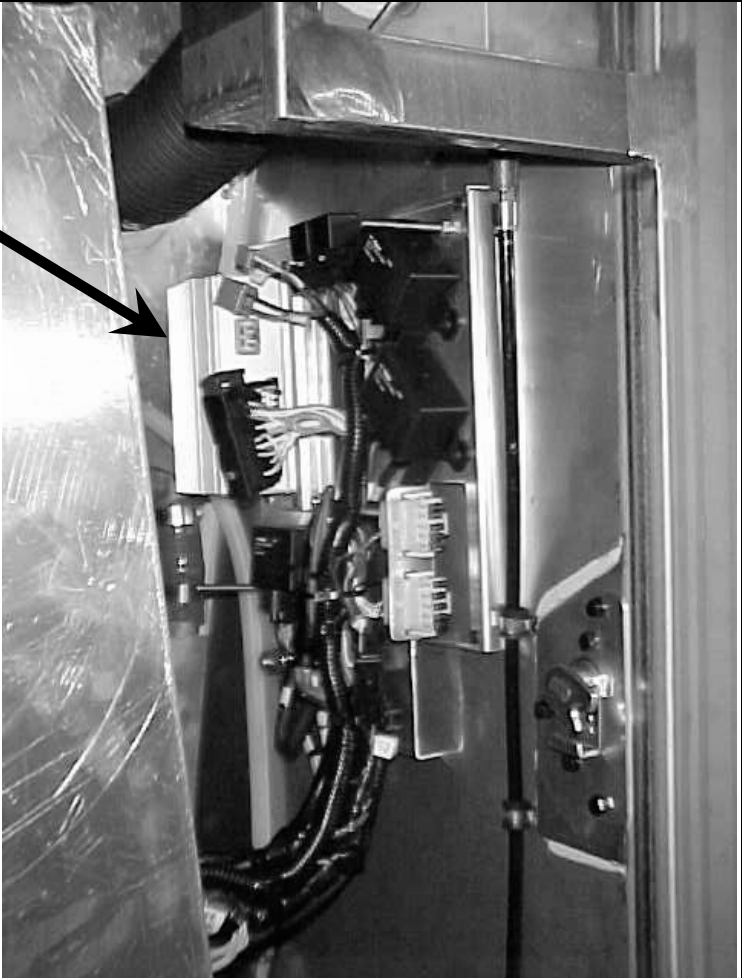


Unplug 3 connectors from the CECM



Unplug connector C92



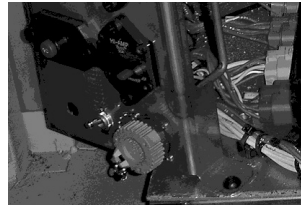
|   |   |
|---|---|
| <p>1.25 <b>Location: pneumatic accessory panel inside right console</b></p> <p>Remove the access panel on the right console (R.H. side of dashboard)</p> <p>Disconnect both I/O B modules</p> |   |
| <p>1.30 <b>Location: Evaporator compartment</b></p> <p>Remove the protective cover and disconnect the I/O B module</p>  |  |

|             |   |   |
|-------------|---|---|
| <p>1.40</p> | <p><b>Kidde Automatic Fire Detection and Suppression System (optional)</b></p> <p>Disconnect C466</p> <p>Kidde AFSS module is located on the lateral control panel.</p> |   |
| <p>1.45</p> | <p>When all the previous steps are done, you can do welding on the vehicle</p>  | <p><b>ENSURE THAT THE WELDING GROUND RETURN CLAMP IS WELL SECURED AND MAKES A GOOD ELECTRICAL CONTACT WITH A LARGE METALLIC AREA OF THE CHASSIS LOCATED NEAR THE WELDING POINT AS MUCH AS POSSIBLE.</b></p> |
| <p>1.50</p> | <p><b>When welding is completed, reconnect all the modules.</b></p> <p>Make sure that the connectors locking tab are well engaged</p>                                   | <p><b>BE CAREFUL TO MAKE THE PROPER CONNECTIONS, IF NOT, SOME SYSTEMS OR COMPONENTS MAY NOT BE USABLE</b></p>   |

**SECTION 2 X3 Coaches**

2.00 **Location: Rear electrical compartment and dashboard**

Set the battery master switch to the OFF position.  
Place the ignition switch to the OFF position.

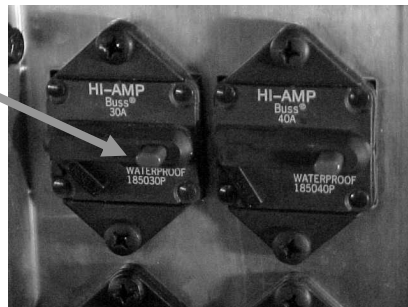


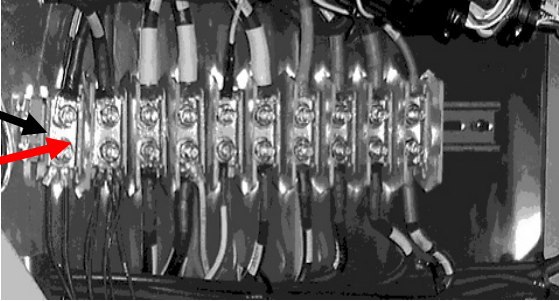
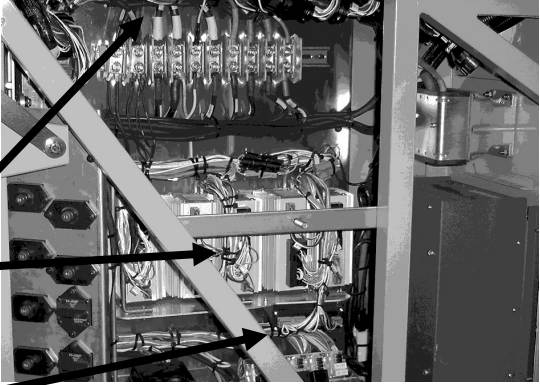
2.05 **Location: Rear electrical compartment**

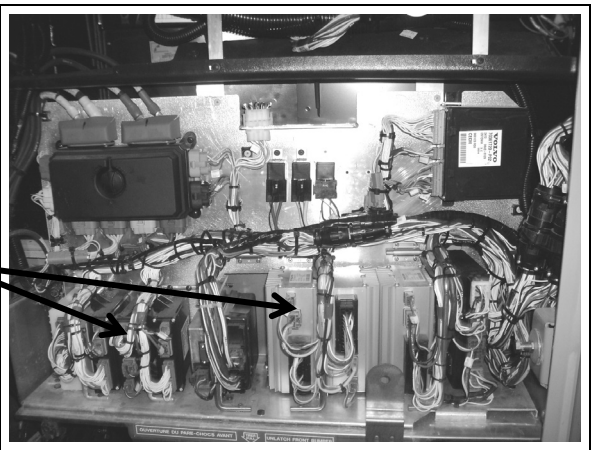
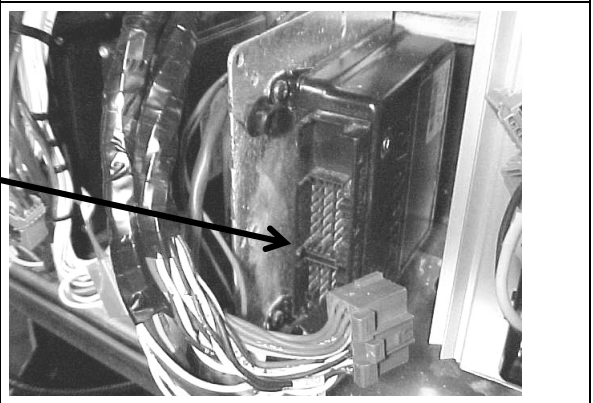
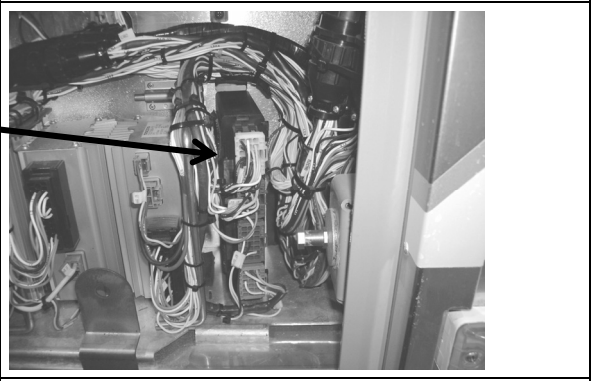
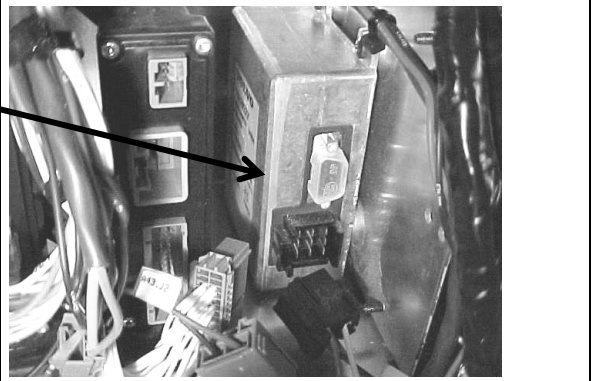
Trip circuit breakers CB2-CB4-CB6 located on rear junction panel

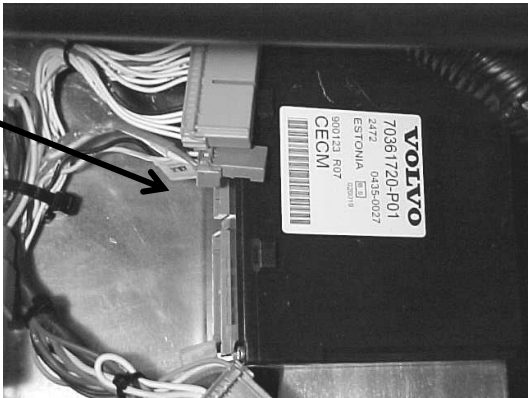



Push the red button in to open the circuit


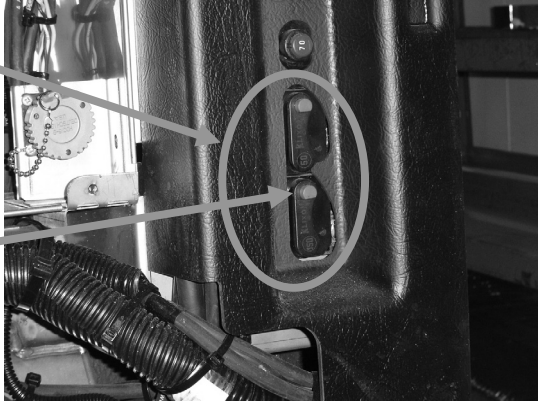
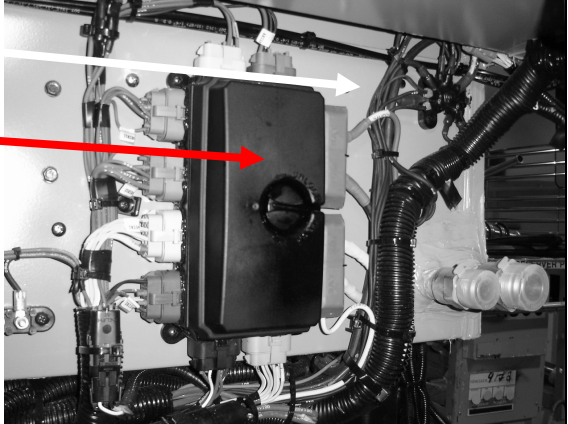


|             |  |   |
|-------------|--|---|
| <p>2.10</p> | <p><b>Location: Rear electrical compartment</b></p> <p>Disconnect the electronic ground terminals from this stud</p> <div style="border: 2px solid red; padding: 5px; margin: 10px 0;"> <p><b>Warning: The remaining terminals may still be energized</b></p> </div> <p>Use electric tape; make sure that cables do not touch each others and the vehicle body.</p> <p style="text-align: center;"><i>NOTE</i></p> <p><i>With disconnection of the electronic ground terminals, disconnecting the engine ECM, transmission TCM and the dashboard electronic components (telltale module, HVAC module, radio, control head, ...) is not required.</i></p> |   |
| <p>2.15</p> | <p><b>Location: Rear electrical compartment</b></p> <p>Disconnect the electronic modules:</p> <p>Disconnect all I/O A and I/O B modules</p> <p style="padding-left: 40px;">Disconnect C397 and C717</p> <p>Disconnect 3 connectors from each I/O B module</p> <p>Disconnect 3 connectors from each I/O A module</p>  |  |

|             |   |  |
|-------------|---|--|
| <p>2.20</p> | <p><b>Location: front electrical compartment</b></p> <p>Disconnect I/O A, I/O B, ABS, master ID, CECM and CPC modules and also disconnect connector C92</p> <p>Disconnect the 3 connectors from the I/O B and I/O A modules</p> |    |
|             | <p>Disconnect the 2 connectors from the ABS module</p>  |   |
|             | <p>Disconnect CPC connectors</p>  |  |
|             | <p>Disconnect connector from master ID</p>  |  |

|  |   |  |
|--|---|--|
|  | <p>Disconnect the 3 connectors from CECM</p>  |    |
| <p>2.25 <b>Location: Entrance door &amp; wiper control panel</b></p> <p>Remove windshield wiper motor access panel and disconnect both I/O B modules</p> | <p>Disconnect connector C92</p>   |   |
| <p>2.30</p>  | <p>When all the previous steps are done, you can do welding on the vehicle</p>  | <p><b>ENSURE THAT THE WELDING GROUND RETURN CLAMP IS WELL SECURED AND MAKES A GOOD ELECTRICAL CONTACT WITH A LARGE METALLIC AREA OF THE CHASSIS LOCATED NEAR THE WELDING POINT AS MUCH AS POSSIBLE</b></p> |
| <p>2.40</p>  | <p><b>When welding is completed, reconnect all the modules.</b><br/>Make sure that the connectors locking tab are well engaged!</p> | <p><b>BE CAREFUL TO MAKE THE PROPER CONNECTIONS, IF NOT, SOME SYSTEMS OR COMPONENTS MAY NOT BE USABLE</b></p>  |

**SECTION 3 XLII MTH**

|             |   |  |
|-------------|---|--|
| <p>2.00</p> | <p><b>Location: Dashboard</b></p> <p>Place the ignition switch to the OFF position.</p>   |    |
| <p>2.05</p> | <p><b>Location: Engine compartment R. H. side area</b></p> <p>Trip circuit breakers CB1-CB2 located on circuit breaker panel.</p> <p>Push the blue button in to open the circuit</p>  |   |
| <p>2.10</p> | <p><b>Location: Rear Junction Box</b></p> <p>Disconnect the electronic ground terminals from this stud.</p> <div style="border: 2px solid red; padding: 5px; margin: 10px 0;"> <p><b>Warning: The remaining terminals may still be energized.</b></p> </div> <p>Use electric tape; make sure that cables do not touch each others and the vehicle body.</p> <p style="text-align: center;"><i>NOTE</i></p> <p><b><i>With disconnection of the electronic ground terminals, disconnecting the engine ECM, transmission TCM and the dashboard electronic components (telltale module, HVAC module, radio, control head, ...) is not required.</i></b></p> |  |



2.15

**Location: Rear Junction Box**

Disconnect the electronic modules:

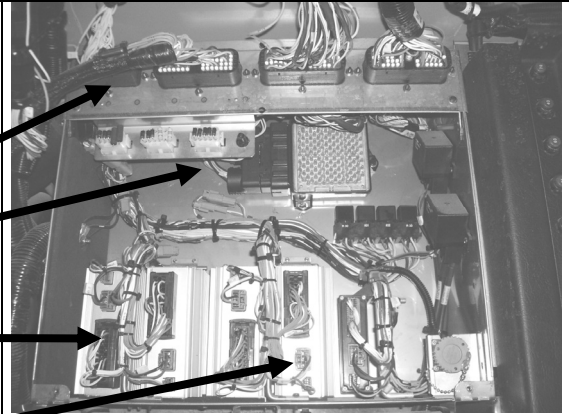
Disconnect all I/O A and I/O B modules

Disconnect C397

Disconnect transmission module (A1)

Disconnect 3 connectors from each I/O B

Disconnect 3 connectors from each I/O A



2.20

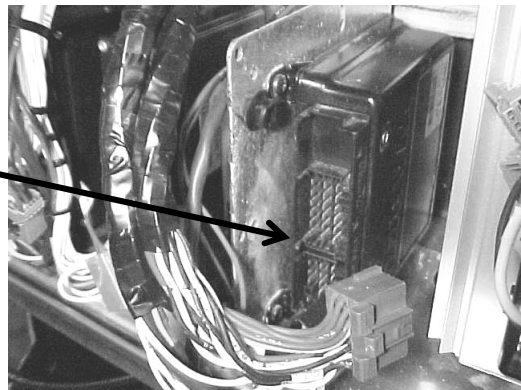
**Location: Front Electrical Compartment**

Disconnect I/O A, I/O B, ABS, master ID, CECM, CPC, keyless modules and also disconnect connector C92.

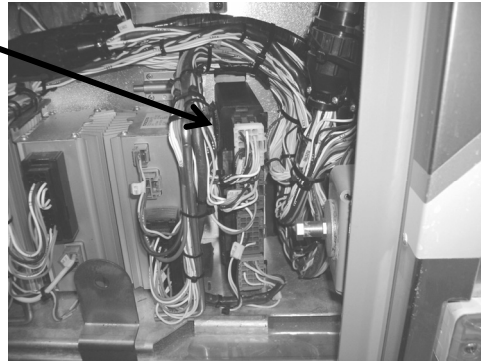
Disconnect 3 connectors from the I/O B and I/O A modules

Disconnect connectors from Keyless module

Disconnect 2 connectors from ABS module



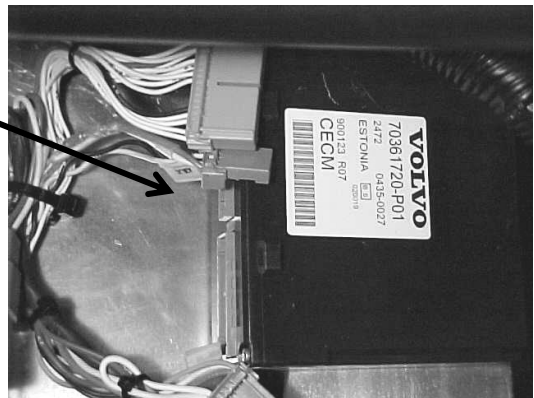
Disconnect connectors from CPC



Disconnect connector from master ID



Disconnect 3 connectors from CECM



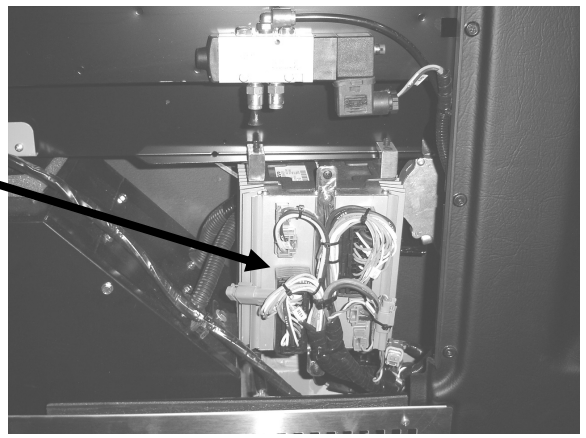
Disconnect connector C92



**Location: Wiper Control Panel**

Remove windshield wiper motor access panel

And disconnect I/O B modules



|      |   |   |
|------|---|---|
| 2.30 | When all the previous steps are done, you can do welding on the vehicle   | <b>ENSURE THAT THE WELDING GROUND RETURN CLAMP IS WELL SECURED AND MAKES A GOOD ELECTRICAL CONTACT WITH A LARGE METALLIC AREA OF THE CHASSIS LOCATED NEAR THE WELDING POINT AS MUCH AS POSSIBLE</b> |
| 2.35 | <b>When welding is completed, reconnect all the modules.</b><br>Make sure that the connectors locking tab are well engaged! | <b>BE CAREFUL TO MAKE THE PROPER CONNECTIONS, IF NOT, SOME SYSTEMS OR COMPONENTS MAY NOT BE USABLE</b>  |



## CONTENTS

|  |           |
|--|-----------|
| <b>1. VOLVO D13 ENGINE</b> .....   | <b>3</b>  |
| 1.1 SYSTEM OVERVIEW.....   | 3         |
| 1.2 ENGINE OVERVIEW .....  | 6         |
| 1.3 ENGINE OIL .....   | 8         |
| 1.3.1 <i>General</i> .....   | 8         |
| 1.3.2 <i>Oil Quality</i> .....   | 8         |
| 1.3.3 <i>Oil Change Intervals</i> .....  | 9         |
| 1.3.4 <i>Oil Filters</i> .....   | 9         |
| 1.3.5 <i>Synthetic Lubrication</i> .....   | 9         |
| 1.3.6 <i>Oil Viscosity</i> .....   | 10        |
| 1.3.7 <i>Oil Additives</i> .....   | 10        |
| 1.3.8 <i>Oil Consumption</i> .....   | 10        |
| 1.3.9 <i>Oil Change</i> .....  | 10        |
| 1.3.10 <i>Oil Filters Change</i> .....   | 11        |
| 1.3.11 <i>Checking the Oil Level</i> .....   | 12        |
| 1.4 POWER PLANT ASSEMBLY REMOVAL.....  | 12        |
| 1.5 POWER PLANT ASSY. INSTALLATION .....   | 15        |
| 1.6 ENGINE MOUNTS .....  | 16        |
| <b>2. DDC SERIES 60 ENGINE</b> .....   | <b>17</b> |
| 2.1 DDEC VI SYSTEM .....   | 17        |
| 2.2 HARNESSES.....   | 18        |
| 2.3 ENGINE OVERVIEW .....  | 19        |
| 2.4 DDEC VI SENSORS .....  | 20        |
| 2.5 OTHER SENSORS.....   | 21        |
| 2.6 MOTOR CONTROL MODULE (MCM).....  | 21        |
| 2.7 COMMON POWERTRAIN CONTROLLER (CPC).....  | 21        |
| 2.8 DDEC VI DIAGNOSTICS .....  | 21        |
| 2.8.1 <i>Diagnostic system</i> .....   | 21        |
| 2.8.2 <i>Check Engine Telltale Light (AWL)</i> .....                                 | 22        |
| 2.8.3 <i>Stop Engine Warning Light (RSL)</i> .....                                   | 22        |
| 2.8.4 <i>Stop Engine Override Switch (SEO)</i> .....                                 | 22        |
| 2.8.5 <i>Diagnostic Data Link (DDL) Connectors</i> .....                             | 22        |
| 2.9 READING DIAGNOSTIC CODES – FLASHING LIGHT METHOD: .....                          | 22        |
| 2.10 DDEC VI CPC DIAGNOSTIC CODES LIST.....  | 23        |
| 2.11 DDEC VI MCM DIAGNOSTIC CODES LIST.....  | 30        |
| 2.12 ENGINE OIL LEVEL .....  | 42        |
| 2.13 ENGINE OIL AND FILTER CHANGE .....  | 42        |
| 2.14 RECOMMENDED ENGINE OIL TYPE .....   | 44        |
| 2.15 POWER PLANT ASSEMBLY REMOVAL.....   | 44        |
| 2.16 POWER PLANT ASSY. INSTALLATION .....  | 47        |
| 2.17 JAKE BRAKE .....  | 47        |
| 2.18 ENGINE MOUNTS .....   | 47        |
| <b>3. ELECTRONIC FOOT PEDAL ASSEMBLY (EFPA) &amp; THROTTLE POSITION SENSOR</b> ..... | <b>48</b> |
| <b>4. ENGINE TROUBLESHOOTING GUIDE</b> .....   | <b>49</b> |
| <b>5. SPECIFICATIONS</b> .....   | <b>50</b> |

**ILLUSTRATIONS**

FIGURE 1: ENGINE SENSORS LOCATION ..... 6

FIGURE 2: D13F ENGINE, ALTERNATOR SIDE (TYPICAL)..... 7

FIGURE 3: D13F ENGINE, TURBO SIDE (TYPICAL) ..... 8

FIGURE 4: D13F OIL FILTERS ..... 9

FIGURE 5: OIL FILTER WRENCH ..... 11

FIGURE 6: OIL FITER REPLACEMENT ..... 11

FIGURE 7: ENGINE OIL FILLING TUBE..... 12

FIGURE 8: ENGINE OIL LEVEL DIPSTICK..... 12

FIGURE 9: COOLER POSITION DURING ENGINE CRADLE INSERTION OR REMOVAL ..... 13

FIGURE 10: BELT TENSIONER VALVE ..... 13

FIGURE 11: ENGINE COMPARTMENT X3 COACHES (TYPICAL)..... 15

FIGURE 12: NORMAL OIL COOLER POSITION ..... 15

FIGURE 13: VOLVO ENGINE POWER PLANT CRADLE INSTALLATION..... 16

FIGURE 14: VEHICLE INTERFACE HARNESS (GENERAL APPLICATION SHOWN) ..... 18

FIGURE 15: DETROIT DIESEL 2007 SERIES 60 ENGINE (TYPICAL)..... 20

FIGURE 16: MOTOR CONTROL MODULE (MCM) ..... 21

FIGURE 17: CPC ..... 21

FIGURE 18: THE CPC COMMUNICATES OVER THE J1587 AND J1939 DATA LINKS TO THE VEHICLE..... 21

FIGURE 19: FLASHING FAULTS CODES ..... 23

FIGURE 20: ENGINE OIL LEVEL DIPSTICK..... 42

FIGURE 21: OIL RESERVE TANK..... 42

FIGURE 22: ENGINE DRAIN PLUG AND OIL FILTERS..... 43

FIGURE 23: BELT TENSIONER VALVE ..... 44

FIGURE 24: ENGINE COMPARTMENT X3 COACHES (TYPICAL)..... 46

FIGURE 25: DDC SERIES 60 POWER PLANT CRADLE INSTALLATION ..... 47

FIGURE 26: ELECTRONIC FOOT PEDAL ASSEMBLY ..... 48

## 1. VOLVO D13 ENGINE

### 1.1 SYSTEM OVERVIEW

**NOTE**

*The "Premium Tech Tool" (PTT) is the preferred tool for performing diagnostic work. Contact your local dealer for more information.*

The Engine Management System (EMS) controls many engine functions such as: fuel timing and delivery, engine protection functions, engine brake operation, EGR valve function and the turbocharger nozzle function. The Engine Electronic Control Unit (EECU) along with other supporting control units and sensors are responsible for monitoring and controlling these functions. These control units communicate through the J1939 high speed serial data line to share data.

In addition to their control functions, the modules have on-board diagnostic capabilities. The on-board diagnostics are designed to detect faults or abnormal conditions that are not within their operating parameters. When the system detects a fault or abnormal condition, the fault will be logged in one or both of the modules' memory. The vehicle operator will be advised that a fault has occurred by the illumination of a malfunction indicator lamp and a message in the driver information display, if equipped. The module may initiate the engine shutdown procedure if the system determines that the abnormal condition could damage the engine. In some situations, the system will enter the "limp home" mode. Limp home mode allows continued vehicle operation but, the system may substitute a sensor or signal value that may result in reduced engine performance.

Fault codes logged in the system memory, can later be read to aid in diagnosing the fault. These faults can be read via a diagnostic computer or through the instrument cluster display, if equipped. The "Premium Tech Tool" (PTT) is the preferred tool for performing diagnostic work. Using a diagnostic computer (or PTT) connected to the Serial Communication Port, expands the technicians diagnostic capabilities with additional data and tests.

For diagnostic software, contact your local dealer.

The following is a list of engine sensors that provide input to the EMS:

- Ambient Air Temperature Sensor
- Ambient Pressure sensor
- Boost Air Pressure (BAP) Sensor
- Camshaft Position (Engine Position) Sensor
- Crankshaft Position (Engine Speed) Sensor
- Differential Pressure DPF Sensor
- EGR Differential Pressure Sensor
- EGR Temperature Sensor
- Engine Coolant Level (ECL) Sensor
- Engine Coolant Temperature (ECT) Sensor
- Engine Oil Pressure (EOP) Sensor
- Engine Oil Level (EOL) Sensor
- Engine Oil Temperature (EOT) Sensor
- Exhaust Temperature Sensor (DPF Sensors)
- Fuel Pressure Sensor
- Intake Air Temperature And Humidity (IATH) Sensor
- Intake Manifold (Boost) Temperature Sensor
- Throttle Position (TP) Sensor
- Turbo Speed Sensor
- Variable Geometry Turbocharger (VGT) Position Sensor

### Sensors

#### Ambient Air Temperature Sensor

The Ambient Air Temperature Sensor is used to detect the outside air temperature. The sensor modifies a voltage signal from the ECM. The modified signal returns to the ECM as the ambient air temperature. The sensor uses a thermistor that is sensitive to the change in temperature. The electrical resistance of the thermistor decreases as temperature increases.

The Ambient Air Temperature Sensor is located in the front of the vehicle.

#### Ambient (Atmospheric) Pressure Sensor

The Ambient (Atmospheric) Pressure Sensor contains a pressure sensitive diaphragm and an electrical amplifier. Mechanical pressure applied to the diaphragm causes the diaphragm to deflect and the amplifier to produce an electrical signal proportional to the deflection.

## Section 01: ENGINE

---

The Ambient (Atmospheric) Pressure Sensor is built into the Engine Management System (EMS) Module.

### **Camshaft Position Sensor**

The Camshaft Position (Engine Position) Sensor is located in the rear face of the timing gear cover at the rear of the engine, near the bottom of the valve cover. It uses magnetic induction to generate a pulsed electrical signal. It senses the passage of seven (7) timing bumps on the edge of the camshaft dampener. Six of the holes correspond to the phasing of the electronic unit injectors, while the seventh hole indicates the top dead center position.

### **Crankshaft Position (Engine Speed) Sensor**

The Crankshaft Position (Engine Speed) Sensor uses magnetic induction to generate a pulsed electrical signal. Notches are machined into the edge of the flywheel. When one of the notches passes close to the sensor, electric pulses result.

The Crankshaft Position (Engine Speed) Sensor also indicates when the crankshaft is at the top dead center position.

### **Differential Pressure DP Sensor**

The differential pressure sensor is used for flow measurement of the Diesel Particulate Filter (DPF). This sensor has two pressure ports and senses the difference in pressure between the two ports. Measurement of the pressure before and after the DPF is used to calculate diesel filter regeneration.

The Differential Pressure DPF Sensor is located on the side of the Diesel Particulate Filter (DPF).

### **EGR Differential Pressure Sensor**

The EGR differential pressure sensor is used for flow measurement of the Exhaust Gas Recirculation (EGR) valve. This sensor has two pressure ports and senses the difference in pressure between the two ports. Measurement of the pressure before and after the EGR valve is used to calculate EGR flow.

The EGR Differential Pressure Sensor is located on the left or right side of the engine.

### **EGR Temperature Sensor**

The EGR temperature sensor detects exhaust gas temperature for EGR system. The sensor modifies a voltage signal from the control unit. The modified signal returns to the control unit as

the exhaust temperature of the EGR system to confirm EGR operation. The sensor uses a thermistor that is sensitive to the change in temperature.

The EGR Temperature Sensor is located near the EGR valve.

### **Engine Coolant Level (ECL) Sensor**

The Engine Coolant Level (ECL) Sensor is a switch. If engine coolant level falls below a calibrated point the contacts open and the driver will be notified of the low coolant level.

The Engine Coolant Level (ECL) Sensor is located in the cooling system reservoir tank.

### **Engine Coolant Temperature (ECT) Sensor**

The Engine Coolant Temperature Sensor is located at the front of the engine. The sensor will indicate a high coolant temperature caused by problems like radiator blockage, thermostat failure, heavy load, or high ambient temperatures. This sensor is also used for cold start enhancement and for fan clutch engagement.

### **Engine Oil Pressure (EOP) Sensor**

The Engine Oil Pressure Sensor contains a pressure sensitive diaphragm and a electrical amplifier. Mechanical pressure applied to the diaphragm causes the diaphragm to deflect and the amplifier to produce an electrical signal proportional to the deflection.

The Engine Oil Pressure Sensor is located on the oil filter assembly. The sensor monitors engine oil pressure to warn of lubrication system failure.

### **Engine Oil Level (EOL) Sensor**

The Engine Oil Level Sensor is located in the oil pan.

### **Engine Oil Temperature (EOT) Sensor**

The Engine Oil Temperature Sensor is a thermistor whose resistance varies inversely to temperature. The sensor has a negative temperature coefficient, which means the sensor resistance will decrease as the engine oil temperature increases.

The Engine Oil Temperature Sensor is located in the oil pan.



**Exhaust Temperature Sensor (DPF Sensors)**

The exhaust gas temperature sensor detects exhaust gas temperature for DPF protection as well as DPF regeneration control. The sensor modifies a voltage signal from the control unit. The modified signal returns to the control unit as the exhaust temperature at that specific location of the exhaust. The sensor uses a thermistor that is sensitive to the change in temperature.

The Exhaust Temperature Sensors are located in the DPF assembly.

**Fuel Pressure Sensor**

The fuel pressure sensor contains a diaphragm that senses fuel pressure. A pressure change causes the diaphragm to flex, inducing a stress or strain in the diaphragm. The resistor values in the sensor change in proportion to the stress applied to the diaphragm and produces an electrical output.

The Fuel Pressure Sensor is located on top of the fuel filter housing.

**Intake Air Temperature and Humidity (IATH) Sensor**

The Intake Air Temperature and Humidity (IATH) Sensor contains a thermistor and a capacitive sensor. The resistance of the thermistor varies inversely to temperature. The output of the capacitive sensor increases as the humidity of the surrounding air increases. By monitoring the signals from both portions of the sensor, the Engine Management System (EMS) Module calculates the temperature and humidity of the air passing through the air filter housing.

The Intake Air Temperature and Humidity (IATH) Sensor is located in the air intake tube just downstream from the air filter canister.

**Intake Manifold (Boost) Temperature Sensor**

The Intake Manifold (Boost) Temperature Sensor is a thermistor whose resistance varies inversely to temperature. The sensor has a negative temperature coefficient, which means the sensor resistance will decrease as the inlet air temperature increases.

The Intake Manifold (Boost) Temperature Sensor is located in the intake manifold.

**Intake Manifold Pressure Sensor**

The Intake Manifold Pressure Sensor contains a pressure sensitive diaphragm and an electrical amplifier. Mechanical pressure applied to the diaphragm causes the diaphragm to deflect and the amplifier to produce an electrical signal proportional to the deflection.

The Intake Manifold Pressure Sensor is located on the air inlet pipe before the intake manifold.

**Throttle Position (TP) Sensor**

The Throttle Position Sensor is a potentiometer that is mechanically linked to the accelerator pedal. A potentiometer is a variable resistor whose resistance will change as the pedal is pressed. As the resistance changes, the signal voltage of the sensor changes indicating the accelerator pedal position.

The Throttle Position Sensor is located above the accelerator pedal. The sensor is designed to improve the driver's control by reducing sensitivity to chassis motion. This sensor provides the driver's fuel request input to the VECU.

**Turbo Speed Sensor**

The Turbo Speed Sensor informs the EMS of the turbo shaft speed. The sensor does not read from the vanes, but reads from the shaft. The Engine Management System (EMS) Module uses this signal in conjunction with the VGT position sensor signal to control the speed of the turbocharger and therefore optimize the intake manifold pressure.

The Turbo Speed Sensor is mounted in the center of the turbocharger.

**Variable Geometry Turbocharger Smart Remote Actuator (VGT SRA)**

The Variable Geometry Turbocharger Smart Remote Actuator (VGT SRA) takes the position commands from the EMS, moves the nozzle of the turbocharger to the desired position, and performs all of the diagnostics and self checks on the actuator.

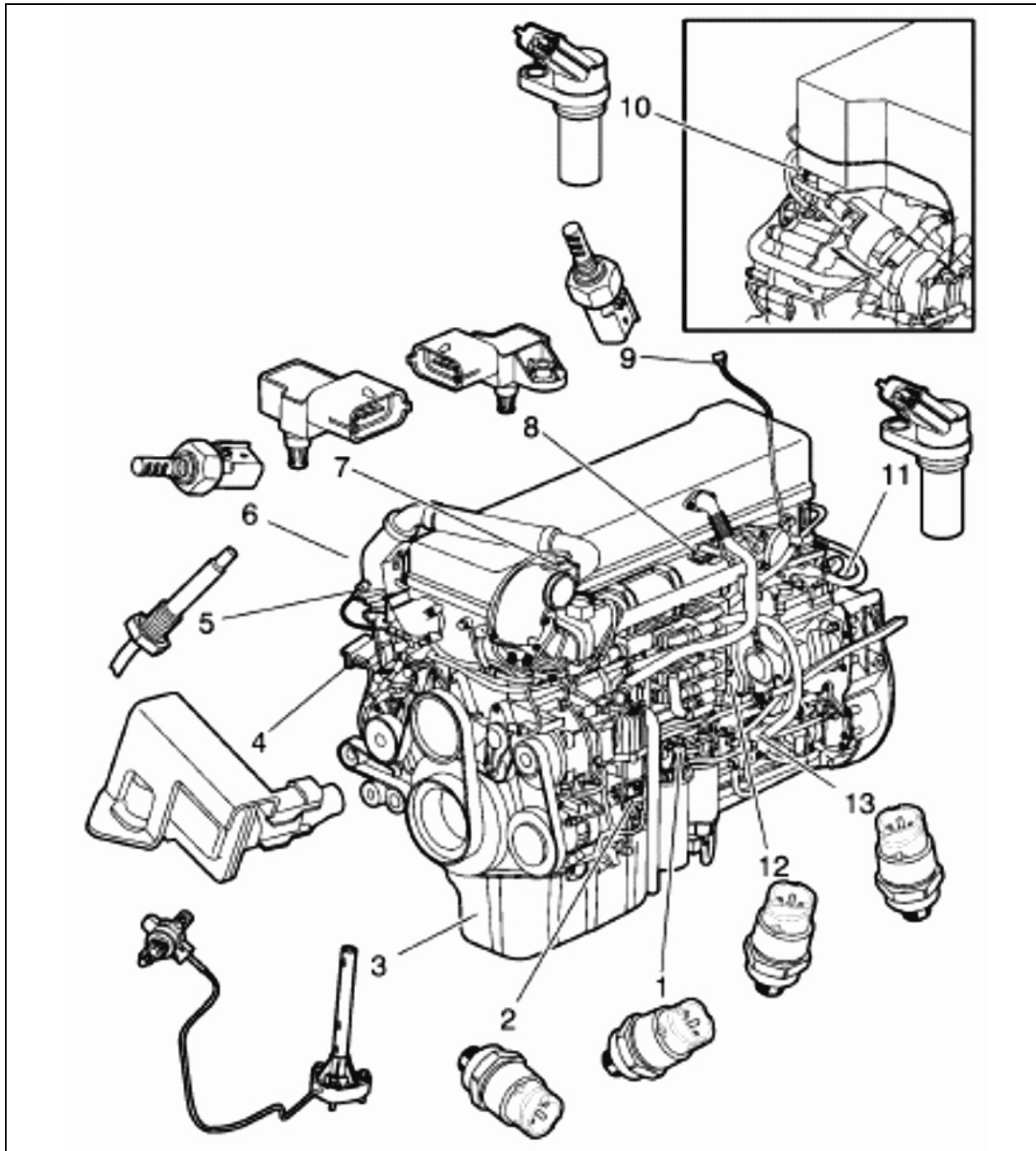


FIGURE 1: ENGINE SENSORS LOCATION

|   |                           |    |                                  |
|---|---------------------------|----|----------------------------------|
| 1 | Fuel Pressure             | 8  | Air Temperature                  |
| 2 | Crankcase Pressure        | 9  | Humidity/Ambient Air Temperature |
| 3 | Oil Level/Temperature     | 10 | Camshaft Speed                   |
| 4 | EGR Differential Pressure | 11 | Crankshaft Speed                 |
| 5 | EGR Temperature           | 12 | Oil Pressure                     |
| 6 | Coolant Temperature       | 13 | AFI Fuel Pressure                |
| 7 | Boost Pressure            |    |                                  |

## 1.2 ENGINE OVERVIEW

**NOTE**

For maintenance on or repair of engine components or engine-related components, please refer to Volvo Trucks Canada or Volvo Trucks North America Web Site under: Parts & Service, purchase engine literature, D13F engine.

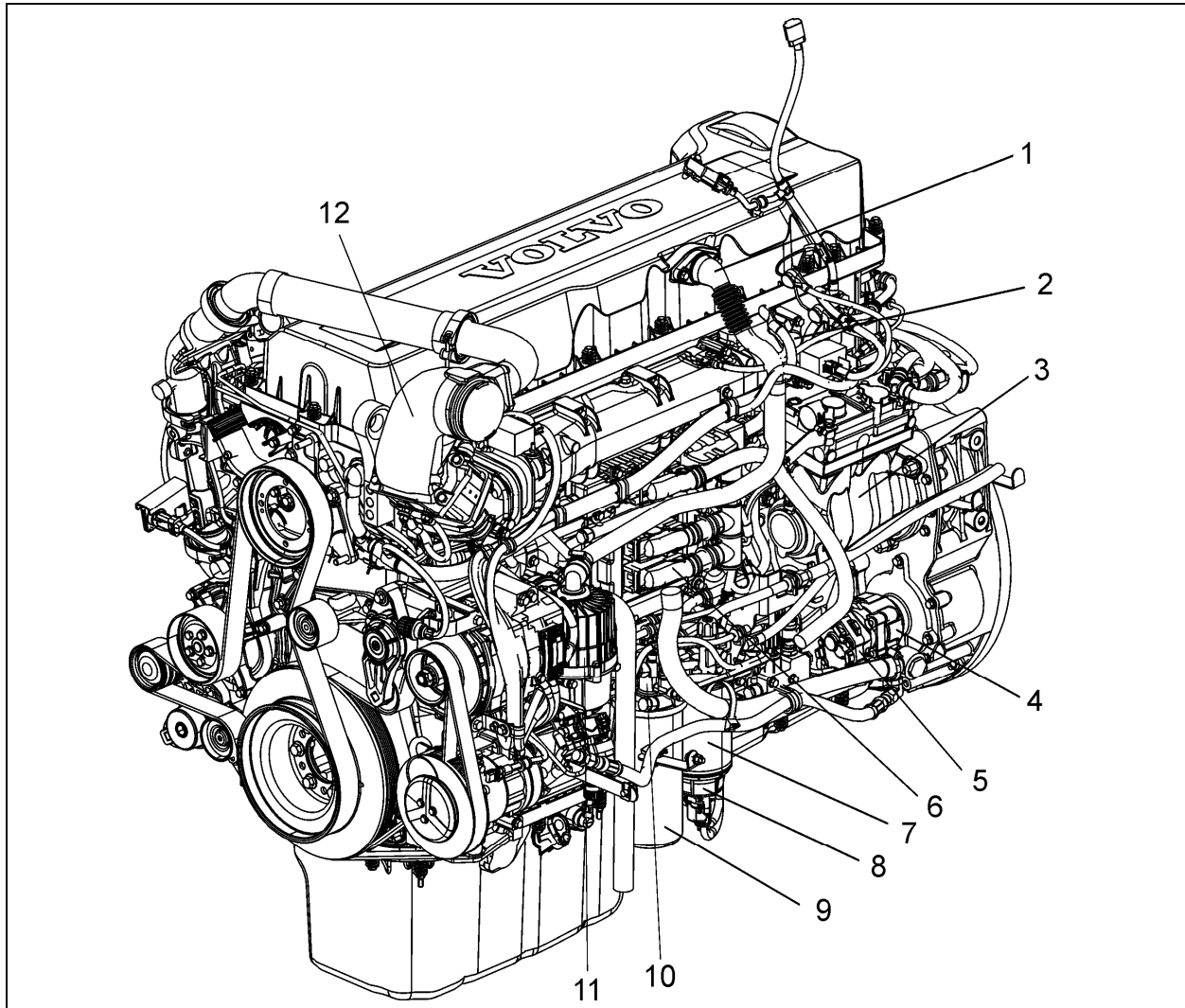


FIGURE 2: D13F ENGINE, ALTERNATOR SIDE (TYPICAL)

|  |                          |
|--|--------------------------|
| 1. Breather Tube                         | 7. Fuel Filter           |
| 2. Intake Manifold                       | 8. Fuel/Water Separator  |
| 3. Air Compressor                        | 9. Fuel Filter           |
| 4. Power Steering Pump                   | 10. Hand-Priming Pump    |
| 5. Fuel Pump                             | 11. Crankcase Ventilator |
| 6. Engine Electronic Control Unit (EECU) | 12. EGR Mixing Chamber   |

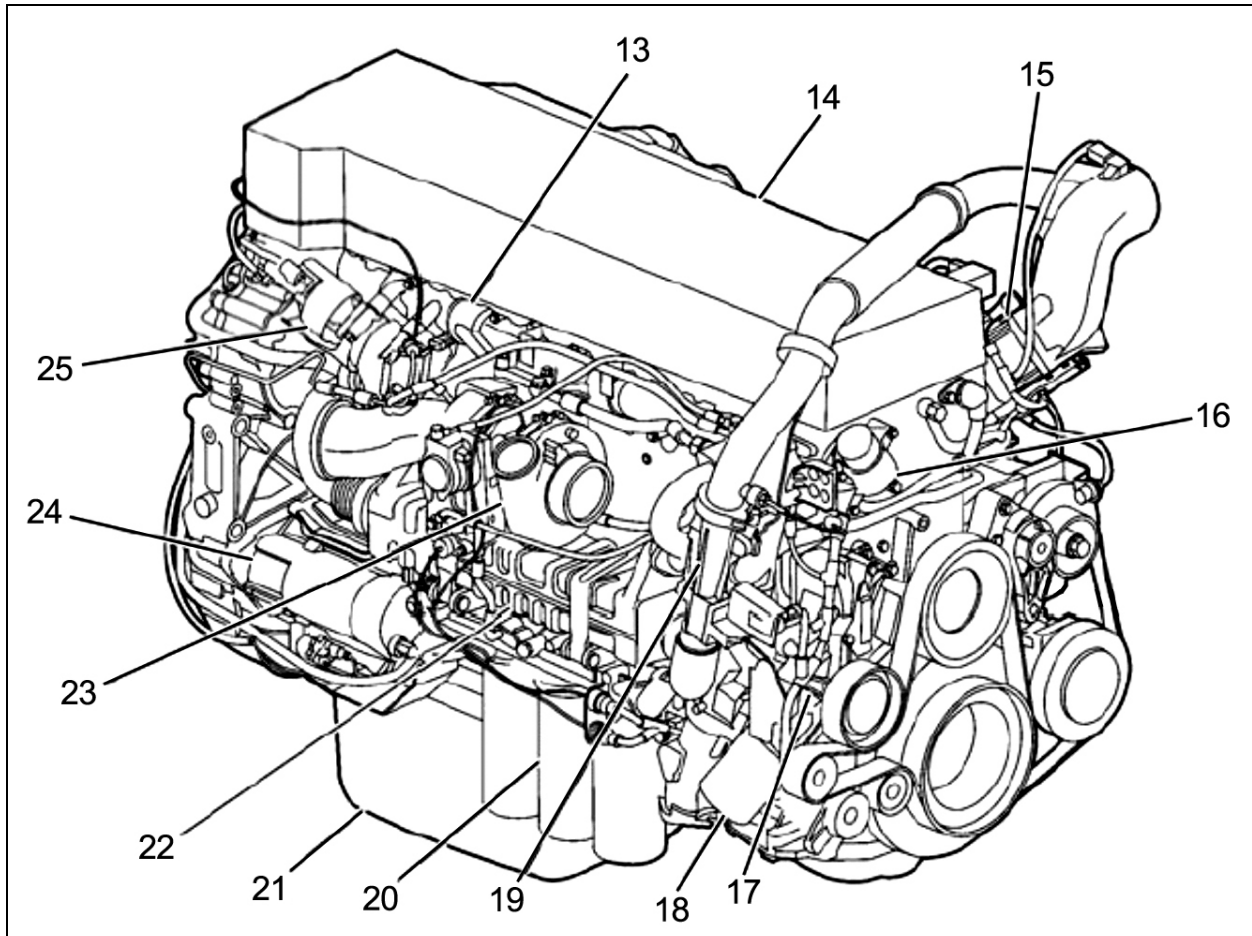


FIGURE 3: D13F ENGINE, TURBO SIDE (TYPICAL)

|   |                          |
|---|--------------------------|
| <b>13. Exhaust Manifold</b>                     | <b>20. Oil Filters</b>   |
| <b>14. Valve Cover</b>                          | <b>21. Oil Pan</b>       |
| <b>15. Engine Pre-Heater Element (Optional)</b> | <b>22. EGR Cooler</b>    |
| <b>16. DRV Valve</b>                            | <b>23. Turbocharger</b>  |
| <b>17. Coolant Pump</b>                         | <b>24. Starter Motor</b> |
| <b>18. Coolant Filter</b>                       | <b>25. EGR Valve</b>     |
| <b>19. Venturi Pipe</b>                         |                          |

### 1.3 ENGINE OIL

#### 1.3.1 General

Keep the engine oil at the proper level and change it at the recommended intervals. Always replace the oil filters at the same time as when the oil is changed.

#### 1.3.2 Oil Quality

Volvo North America recognizes engine oils that meet or exceed the standards given by American Petroleum Institute (API) for the oil classifications listed in this manual. Only oils licensed to carry the API symbol should be used. Lubricants meeting API standards have provided maximum engine life when used together with the recommended oil and oil filter change intervals.

EO-O Premium Plus (or VDS-4) diesel engine oil is mandatory for use in all 2007 emission compliant Volvo engines. Chassis equipped with a 2007 emission compliant engine, which can be identified by the presence of a Diesel Particulate Filter (DPF), also require the use of Ultra Low Sulfur Diesel (ULSD) fuel. EO-O Premium Plus oils exceed the new API service category CJ-4.



**CAUTION**

DO NOT add extra oil additives. Additives such as break-in oils, top oils, graphitizers, and friction-reducing liquids are not necessary and can harm the engine.

**1.3.3 Oil Change Intervals**

The length of time an engine can operate before an oil change depends on the quality oil used, the type of fuel used, fuel consumption, engine oil consumption, vehicle application, level of dust in the air, and fuel consumption. The change intervals given in this manual are maximum intervals. If the vehicle is operating in heavy-duty operation, dusty or off-road conditions, etc., reduce the intervals for more frequent oil changes.

**NOTE**

Use the information in the table below to determine the operating condition and usage applicable to your vehicle.

| <b>Engine Operating Condition</b>  | <b>Medium</b>   | <b>Heavy</b>    | <b>Severe</b>   |
|--|-----------------|-----------------|-----------------|
| Total Fuel Consumption (mpg)   | More than 6     | More than 4.7   | More than 3.7   |
| Total Fuel Consumption (L/100 KM)  | Less than 39    | Less than 50    | Less than 64    |
| Engine Oil and Filter Change Interval, miles (km) – 41 U.S. quarts (39L)<br>Oil capacity | 35,000 (55 000) | 25,000 (40 000) | 15,000 (24 000) |

**NOTE:** If idle time is greater than 25%, use the next lower drain interval.

**NOTE**

Oil filters should always be changed when changing the oil.

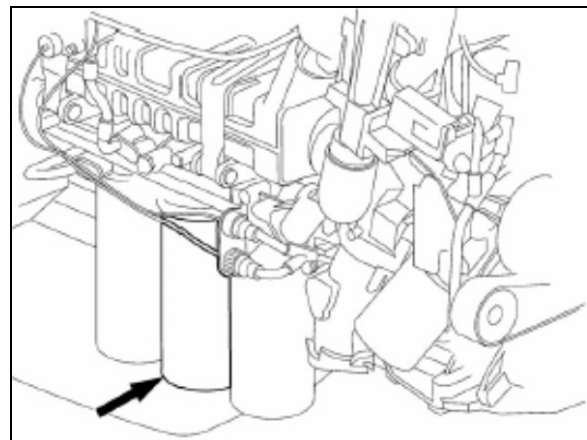
**1.3.4 Oil Filters**

There are three filters on the engine, one of which is a bypass filter. This should be changed at the same time as the full-flow filter(s).



**CAUTION**

Volvo branded oil filters are designed to provide the proper level of filtration and protection for Volvo engines. Filters that do not meet the same stringent requirements may void engine warranty.



**FIGURE 4: D13F OIL FILTERS**

**1.3.5 Synthetic Lubrication**

Synthetic oils are offered by some oil suppliers as an alternative to the traditional, petroleum based oils for engines. These oils may be used in Volvo engines, provided they meet the quality

## Section 01: ENGINE

levels specified on the previous pages, that is: both VDS-4 and EO-O Premium Plus.

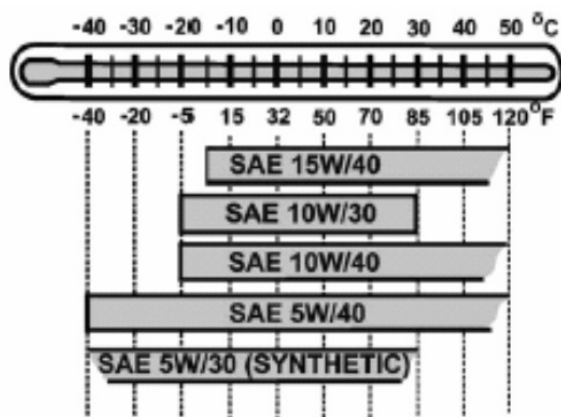
**The use of synthetic oils does not permit the extension of the recommended oil change intervals.**

### 1.3.6 Oil Viscosity

The viscosity grade defines the thickness of the oil. The oil must be thin enough at low temperatures for easy cold starts and thick enough to protect at high temperatures. An oil is not fully defined until both the API quality classification and the viscosity grade are specified.

Choose the viscosity grade for the typical ambient temperature for the application. Multigrade oils have a broad range that suit operation in changing temperature.

Volvo North America recommends the viscosities shown in the viscosity/temperature table for Volvo engines.



### 1.3.7 Oil Additives



#### CAUTION

Extra oil additives must never be added to any engine oil used. Additives such as break-in oils, top oils, graphitizers, and friction reducing liquids are not necessary and may even harm the engine.

Using oils to the quality standards recommended in this manual makes the use of extra oil additives unnecessary, as these oils already contain a balanced treatment of additives.

### 1.3.8 Oil Consumption

Once the engine is stopped, check the oil level daily. If the engine has just been stopped and it is warm, wait approximately five minutes to allow the oil to drain back to the oil pan before checking. Add oil as necessary.



#### CAUTION

DO NOT overfill engine with oil.

All diesel engines are designed to consume some oil, so it is normal to add oil periodically. An engine used in heavy-duty operation will consume more oil than one in normal operation.

### 1.3.9 Oil Change



#### WARNING

A hot engine or engine oil can be dangerous. Serious burns can result from contact with a hot engine or oil. Take precautions when draining the oil. Wear gloves or let the engine cool down before draining.



#### WARNING

When draining the oil, use the proper tools and keep away as far as possible. Raise the elbow so the forearm is parallel to the ground to prevent oil running down the arm, causing burns.



#### CAUTION

Always dispose of all lubricants (motor oil, coolant, gear box oils, etc) and filters according to Federal or local regulations. Used oil disposed of in nature or waterways contaminates our drinking water and kills wildlife.



#### WARNING

Prolonged contact with used engine oil may be harmful. Use rubber gloves when handling used oil. Wash skin thoroughly if it comes in contact with used oil.

It is important to drain as much oil as possible. Try to change oil immediately after driving, when the oil is warm. Always replace the oil filters when changing the oil.

| Component              | Capacity (L)        |
|------------------------|---------------------|
| Oil pan                | 24 (min) – 32 (max) |
| Engine block           | 4.5                 |
| Filters (3)            | 6                   |
| Total oil fill (empty) | 42.5                |

**NOTE**

Since about 4.5 liters of oil remains in the engine after draining, approximately 38 liters will be needed for a complete oil change.

1.3.10 Oil Filters Change



**WARNING**

Hot oil can cause severe burns. DO NOT allow hot oil to contact the skin. When changing oil, wear protective gloves.



**CAUTION**

Volvo-branded oil filters are designed to provide the proper level of filtration and protection for Volvo engines. Filters that do not meet the same stringent requirements may cause unsatisfactory results.

- Clean around the oil filter housing and remove the filters using the oil filter wrench or the oil filter socket.

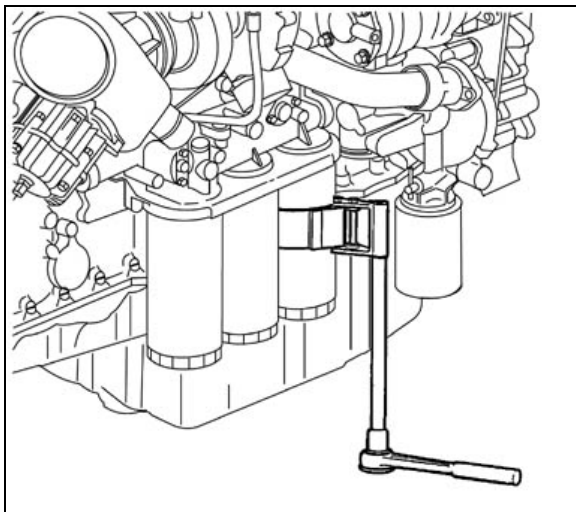


FIGURE 5: OIL FILTER WRENCH

- Prefill the new oil filters with approved engine oil. Also, lubricate the filter gaskets with engine oil (1). Hand tighten the oil filters until they contact the sealing surface of the oil filter housing (2). Manually tighten the oil filters an additional ¼ to 1 full turn (3).

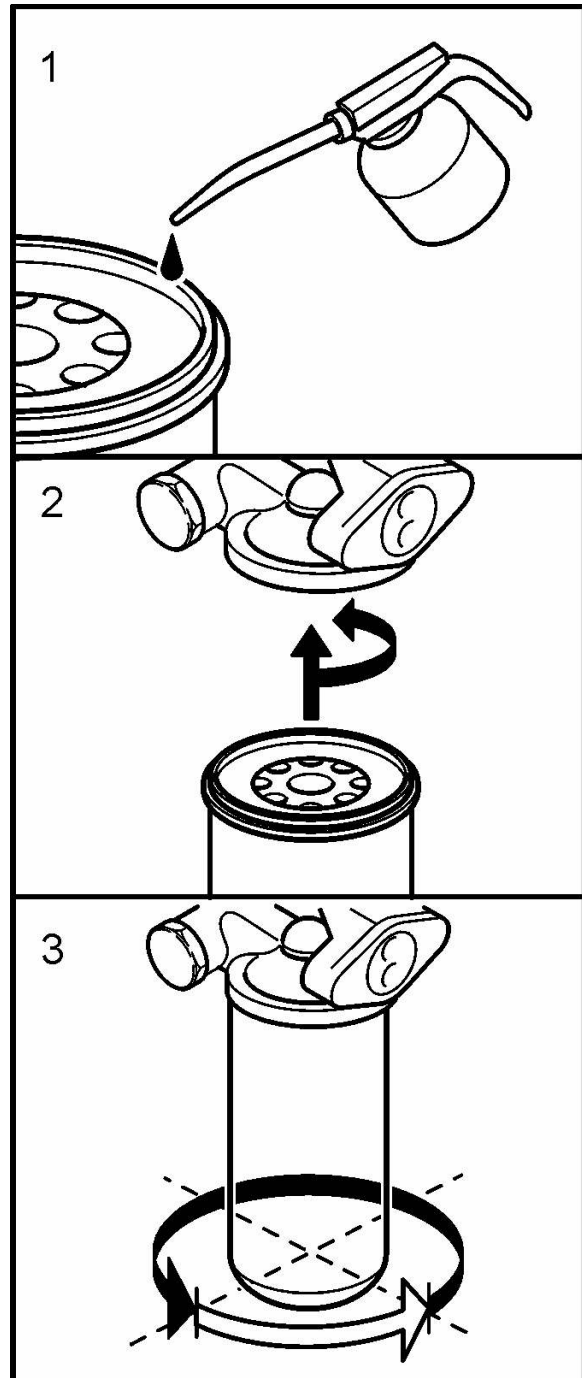


FIGURE 6: OIL FILTER REPLACEMENT

- Start the engine and check for leaks around the oil filter housing and filters.

## Section 01: ENGINE

- Check the oil level. Add approved engine oil to the recommended level, if necessary. Do not overfill.

### 1.3.11 Checking the Oil Level

Ensure that the vehicle is parked on level ground before checking the oil level. Wait five minutes after shutting off the engine and then proceed with checking the oil.



#### CAUTION

**DO NOT** let the oil level fall below the marking on the dipstick. **DO NOT** overfill so the level is above the upper marking on the dipstick. This could lead to excessive oil temperature and/or poor crankcase breather performance. Add oil through the oil filler pipe as required in order to maintain level within the safe range.

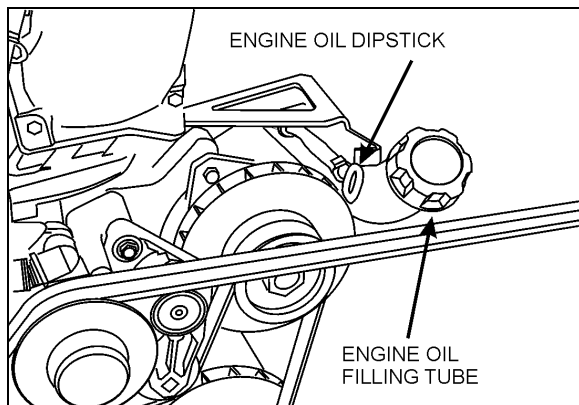


FIGURE 7: ENGINE OIL FILLING TUBE

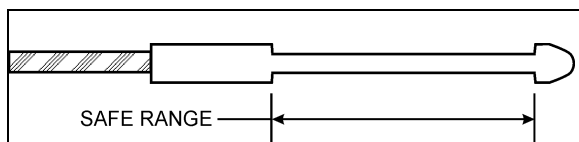


FIGURE 8: ENGINE OIL LEVEL DIPSTICK

### 1.4 POWER PLANT ASSEMBLY REMOVAL

To access the engine or engine-related components, the vehicle power plant assembly must be removed as a whole unit by means of a slide-out cradle. The power plant assembly includes the engine, transmission (including retarder if so equipped), air compressor, alternator and transmission oil cooler.

Remove the power plant assembly as follows:



#### CAUTION

Tag hoses and cables for identification before disconnecting in order to facilitate reinstallation. Plug all openings to prevent dirt from entering the system.

#### NOTE

*No parts within the EECU are serviceable. If found defective, replace the EECU as a unit.*

#### • First

1. Shut off the heater line shut-off valves.
2. Disconnect the battery or batteries from the starting system by removing one or both of the battery cables from each battery system. With the electrical circuit disrupted, accidental contact with the starter button will not produce an engine start.



#### WARNING

Due to the heavy load of the rear bumper assembly, it must be adequately supported before attempting to remove it.

3. Remove the rear bumper assembly complete with hitch if applicable from the vehicle. Refer to Section 18, BODY, under "REAR BUMPER REMOVAL".
4. Using the quick-connect drain hose, drain the engine cooling system. Refer to Section 05, COOLING under "DRAINING COOLING SYSTEM".
5. If applicable, disconnect the block heater connector located near the EGR mixing chamber.

#### • With Vehicle Raised

1. Using a vehicle lift or jack, raise vehicle to access transmission fasteners and wire harness.
2. Disconnect propeller shaft.
3. Partially remove L.H. side transmission protective panel to access connectors.
4. On vehicles equipped with an automatic transmission provided with a hydraulic output retarder, disconnect steel-braided airline from pressure regulator output. The



pressure regulator is mounted in the upper section of engine compartment backwall and is accessible through the engine compartment R.H. side door.

5. Untighten bolts A and C. Remove bolts B and D and pivot oil cooler towards transmission. Reinstall bolts B and D.

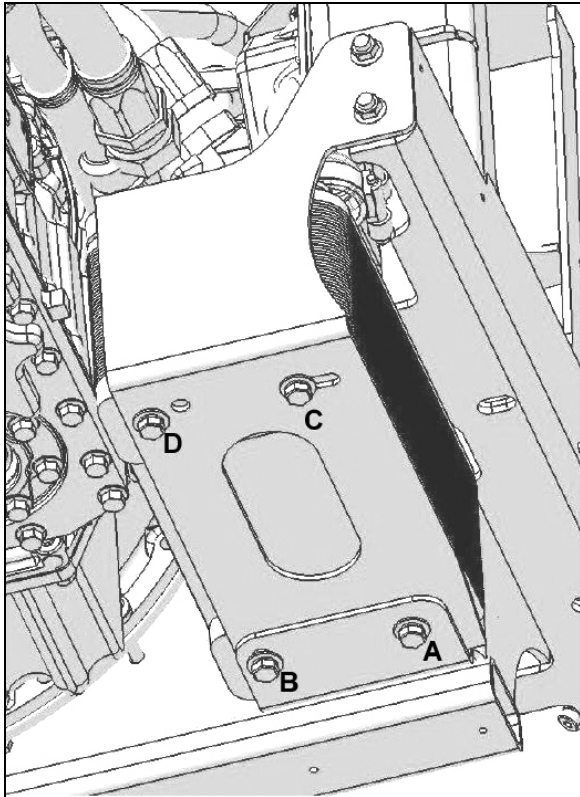


FIGURE 9: COOLER POSITION DURING ENGINE CRADLE INSERTION OR REMOVAL

6. From underneath, unfasten the bolts fixing the engine cradle.
7. Disconnect the engine coolant hose near the starter.
8. Disconnect air compressor suction and discharge hoses.

- **With Vehicle Lowered**

Lower the vehicle enough to access all components.

- Engine Compartment R.H. side
  - If applicable, remove auxiliary sump tank to ease access.
  - Disconnect cables from two chassis grounds located on diagonal member.

- Inside engine compartment, disconnect starter, alternators and heater cables. Also disconnect AFSS cable if applicable.
- Disconnect from engine, connector C398 and vehicle interface harness connector located above EECU connectors. Also disconnect DPF cable.
- Disconnect power steering pump hoses.
- Shut off fuel line shut-off valve.
- Close engine fuel supply shut-off valve on primary fuel filter or Fuel Pro. Disconnect the fuel line located above fuel filters and connected to inlet port. On vehicles equipped with the optional water-separator-fuel-filter, disconnect the connector and remove cable ties from cradle.
- Disconnect fuel return line located above fuel filters.
- Disconnect alternators cooling duct and put aside.

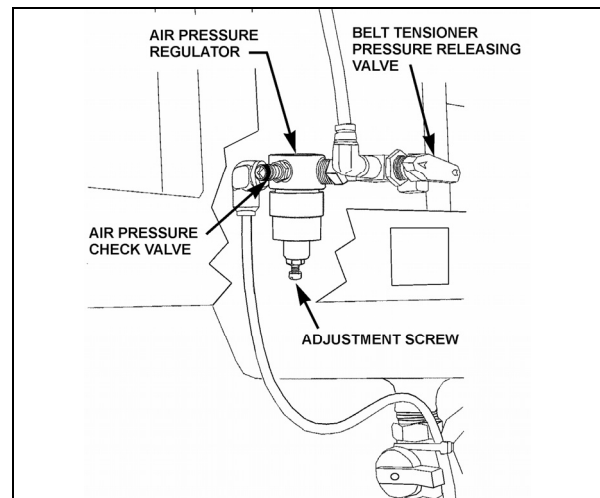


FIGURE 10: BELT TENSIONER VALVE

12200

- Locate the A/C compressor belt tensioner pressure releasing valve (Fig. 10). Turn pressure releasing valve handle counterclockwise in order to release pressure in belt-tensioner air bellows and loosen belts. Remove the belts.
- Disconnect and remove the engine-air intake duct mounted between air cleaner housing and turbocharger inlet.



### CAUTION

To avoid damage to turbocharger, cover the turbocharger inlet opening to prevent foreign material from entering.

- Disconnect and remove the exhaust pipe mounted between the flexible coupling and the pipe going to the Aftertreatment Device (ATD). If necessary, refer to Section EXHAUST SYSTEM under "EXHAUST AND AFTERTREATMENT SYSTEM OVERVIEW".

- Disconnect and remove the air intake duct mounted between the charge air cooler outlet and the engine intake.

➤ Engine Compartment L.H. side

- Disconnect fan driving shaft from radiator fan drive mechanism support.



### CAUTION

To avoid damage to cooling fan right angle gearbox, make sure the power plant cradle clears the gearbox when pulling the engine out.

- Disconnect and remove section of coolant pipe assembly mounted between the radiator outlet and the water pump inlet.
- Disconnect and remove a section of coolant pipe assembly mounted between the thermostat housing and the radiator inlet.
- Disconnect the electric fan-clutch connector located near the cooling fan right angle gearbox.

- Disconnect and remove the air intake duct mounted between the turbocharger outlet and the air cooler inlet.
- Disconnect and remove surge tank hose connected to pump inlet pipe and hose connected to engine.
- Unfasten and put aside engine compartment lighting fixture and turbocharger fire suppression nozzle if applicable.
- Disconnect Aftertreatment Device (ATD) control cable.

• **Last**

1. Inspect the power plant assembly to ensure that nothing will interfere when sliding out the cradle. Check for connections or hoses not mentioned in this list as some vehicles are equipped with special or aftermarket components.
2. Make sure the ten retaining bolts, washers and nuts securing the power plant cradle to the vehicle rear subframe are removed (Fig. 13).

#### **NOTE**

*Check if any spacer(s) have been installed between power plant cradle and vehicle rear subframe, and if so, note position of each washer for reinstallation purposes.*

3. Using a suitable equipment with a minimum capacity of 4,000 lbs (1 800 kg), slightly raise the power plant cradle.
4. Pull engine out slowly from the engine compartment. Make sure all lines, wiring and accessories are disconnected and are not tangled.

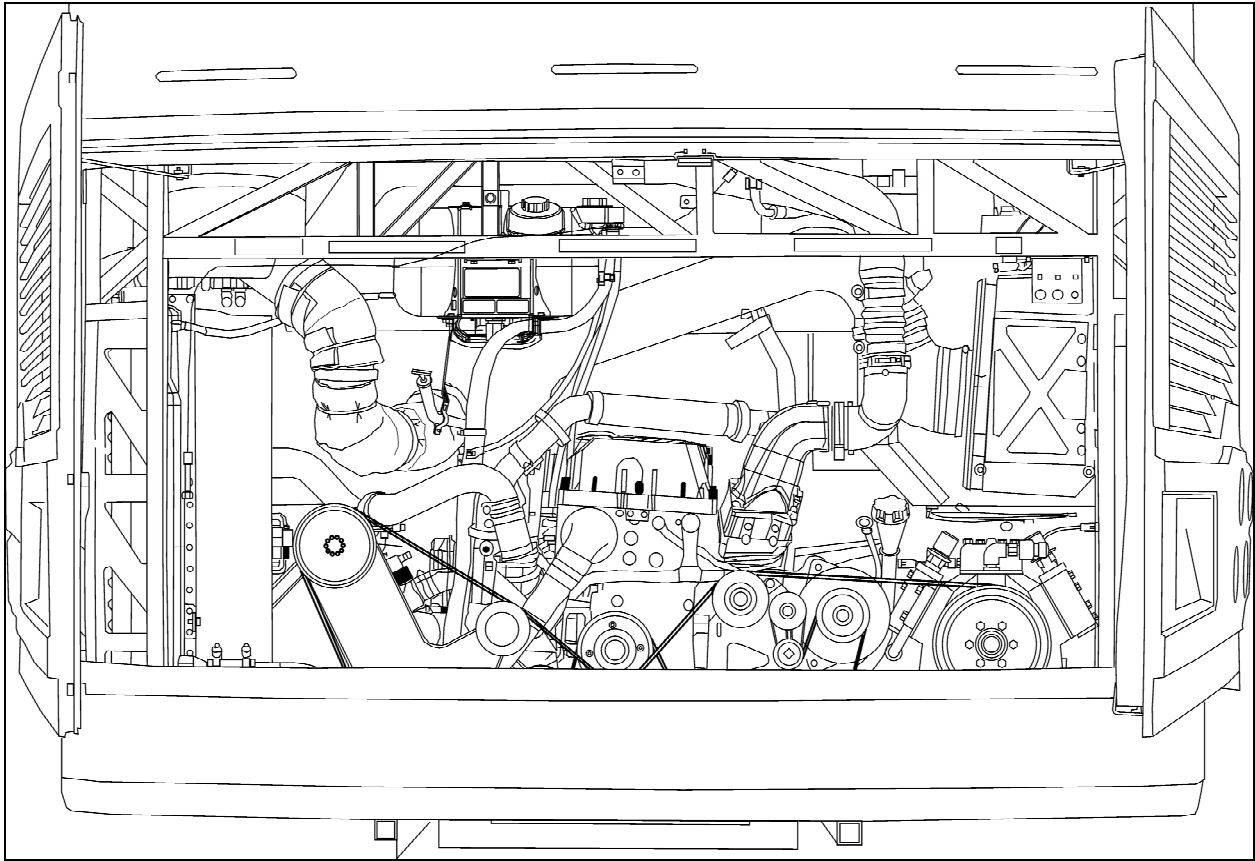


FIGURE 11: ENGINE COMPARTMENT X3 COACHES (TYPICAL)

01184\_A

### 1.5 POWER PLANT ASSY. INSTALLATION

To install a power plant assembly, follow the same procedure as in "Power Plant Assembly Removal" except in reverse order, then proceed with the following:

1. Torque the power plant cradle mounting bolts to 190 lbf-ft (258 Nm).
2. Remove bolts B and D. Untighten bolts A and C then pivot oil cooler as per figure 12. Install bolts B and D and tighten all bolts.
3. Refill cooling system with saved fluid (refer to Section 05, COOLANT SYSTEM).
4. Once engine fuel system has been drained, it will aid restarting if fuel filters are filled with fuel oil (refer to Section 03, FUEL SYSTEM).
5. Start engine for a visual check. Check fuel, oil, cooling, pneumatic and hydraulic system connections for leakage. Test operation of engine controls and accessories.

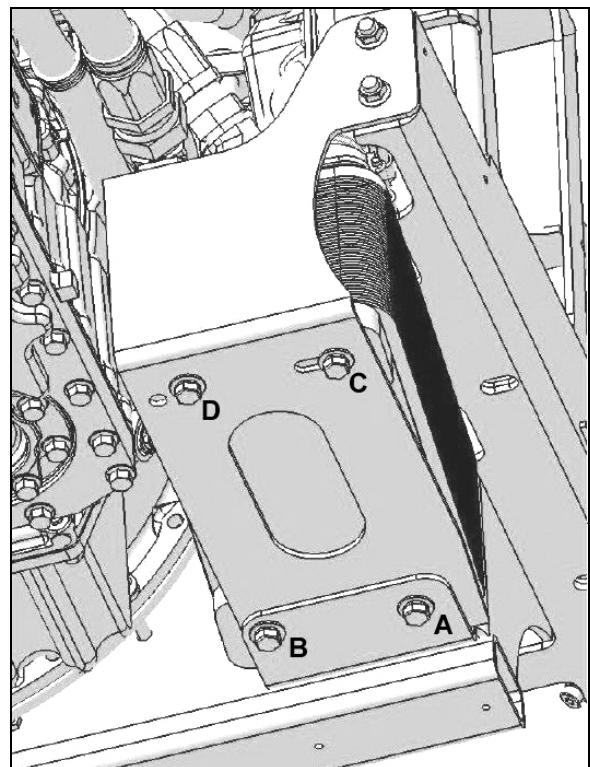


FIGURE 12: NORMAL OIL COOLER POSITION

## Section 01: ENGINE

### 1.6 ENGINE MOUNTS

The power plant assembly is mounted to the cradle by means of rubber mounts and supports.

Two engine support brackets are used at the front of the engine while two rubber mounts are mounted underneath the engine & radiator fan drive mechanism support and the engine & alternator support (Fig. 13).

It is recommended that new rubber mounts be installed at each major overhaul.

#### **NOTE**

*Refer to the table on the following page for engine cradle tightening torques.*

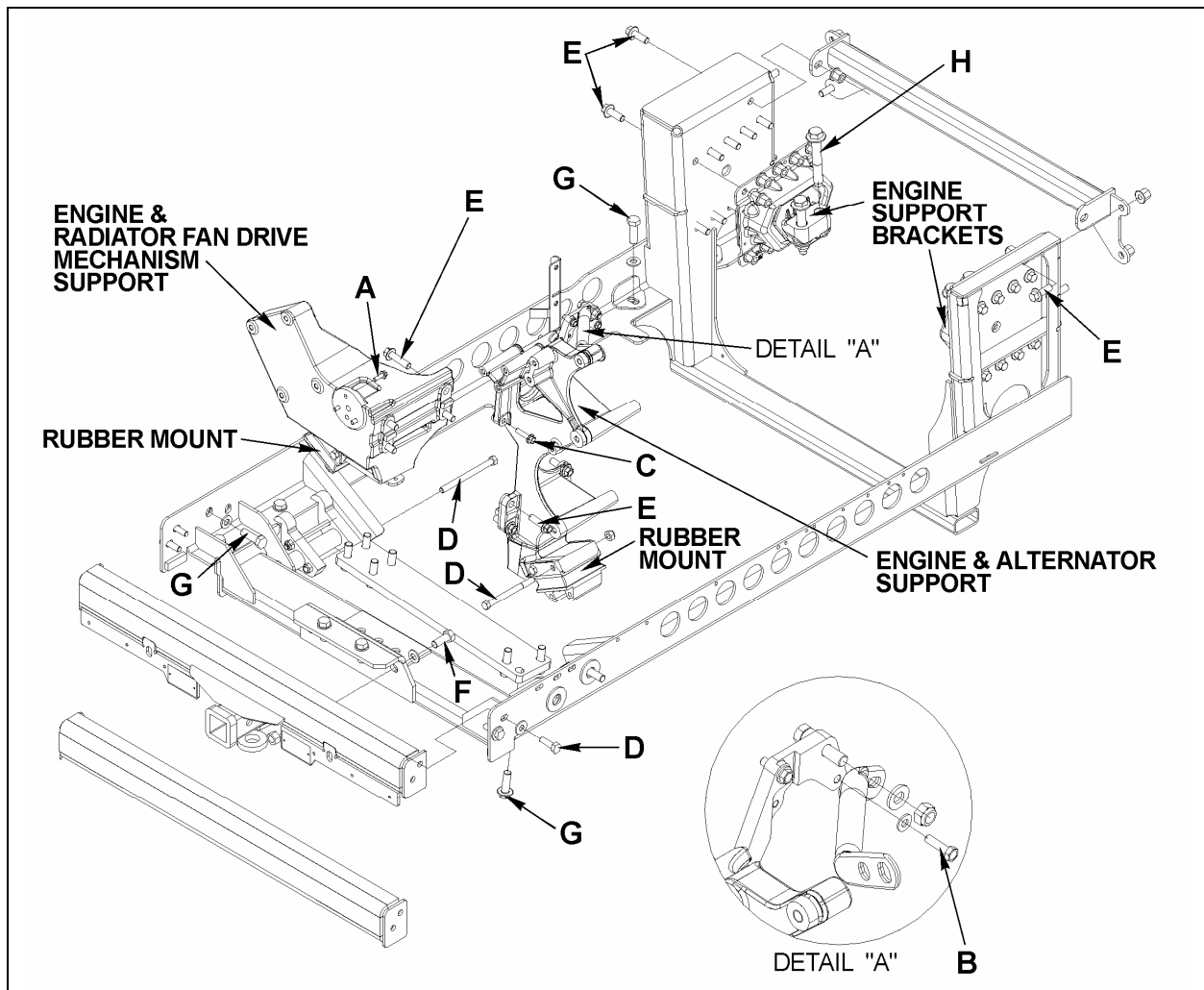


FIGURE 13: VOLVO ENGINE POWER PLANT CRADLE INSTALLATION

| DRY TORQUES |   |        |     |
|-------------|---|--------|-----|
| REFERENCE   | DESCRIPTION                               | Lbf-Ft | Nm  |
| A           | SCREW, CAP HEXAGONAL HEAD M8 – 1.25 G8.8  | 16     | 22  |
| B           | SCREW, CAP HEXAGONAL HEAD M8 – 1.25 G10.9 | 22     | 30  |
| C           | SCREW, CAP HEXAGONAL HEAD M10 – 1.5 G10.9 | 43     | 58  |
| D           | SCREW, CAP HEXAGONAL HEAD M12 – 1.75 G8.8 | 60     | 81  |
| E           | SCREW, CAP HEXAGONAL HEAD M14 – 2.0 G8.8  | 90     | 122 |
| F           | SCREW, CAP HEXAGONAL HEAD M16 – 2.0 G8.8  | 140    | 190 |
| G           | SCREW, CAP HEXAGONAL HEAD M16 – 2.0 G10.9 | 190    | 258 |
| H           | SCREW, CAP HEXAGONAL HEAD M20 – 2.5 G10.9 | 450    | 610 |

## 2. DDC SERIES 60 ENGINE

Detroit Diesel series 60 engine is a 6-cylinder, four-cycle engine, equipped with an electronic control system (DDEC VI).

One engine displacement is used in the X3 Coaches Series 60 engines: 14.0 liters. Summary information on the Electronic Control System is given in this section.

Complete maintenance and repair information on the engine will be found in the current DETROIT DIESEL SERIES 60 2007 ON-HIGHWAY SERVICE MANUAL 6SE2007. This essential manual contains complete instructions on operation, adjustment (tune-up), preventive maintenance and lubrication, parts verification, repair or replacement. This manual's sections cover complete systems such as:

- Engine main assembly;
- Fuel system;
- Lubrication system;
- Cooling system;
- Fuel, lubricating oil and coolant;
- Air intake system;
- Exhaust system;
- Exhaust gas recirculation components;
- Electrical equipment;
- Operation and verification;
- Engine tune-up;
- Preventive maintenance;
- Storage;

Refer to Series 60 DDEC VI Troubleshooting Guide published by Detroit Diesel for more complete information on diagnosis of components and system problems.

Procedures for engine removal and installation are given at the end of this section. The DDEC system is self-diagnostic. It can identify faulty components and other engine-related problems by providing the technician with diagnostic codes.

### 2.1 DDEC VI SYSTEM

DDEC VI (**D**etroit **D**iesel **E**lectronic **C**ontrol) is a system that monitors and determines all values required for the operation of the engine. A diagnostic interface is provided to connect to an external diagnosis tester. Besides the engine related sensors and the engine-resident control unit, the Motor Control Module (MCM), this system has a chassis-mounted control unit for vehicle engine management, the Common Powertrain Controller (CPC). The connection to the vehicle is made via a CAN interface which digitally transmits the nominal values (e.g. torque, engine speed specification, etc.) and the actual values (e.g. engine speed, oil pressure, etc.).

DDEC VI controls the timing and amount of fuel injected by the electronic unit injectors (EUI). The system also monitors several engine functions using electrical sensors, which send electrical signals to the Motor Control Module (MCM). The MCM computes the electrical signals and determines the correct fuel output and timing for optimum power, fuel economy and emissions. The MCM also has the ability to display warnings or shut down the engine

## Section 01: ENGINE

completely (depending on option selection) in the event of damaging engine conditions, such as low oil pressure or high engine temperature.

### 2.2 HARNESSSES

There are two major harnesses: the Engine Harness (EH) and the Vehicle Interface Harness (VIH). The Engine Harness is installed at the Detroit Diesel factory and is delivered connected to all engine sensors, the fuel injection system, and the MCM.

The OEM supplied Vehicle Interface Harness connects the CPC to other vehicle systems.

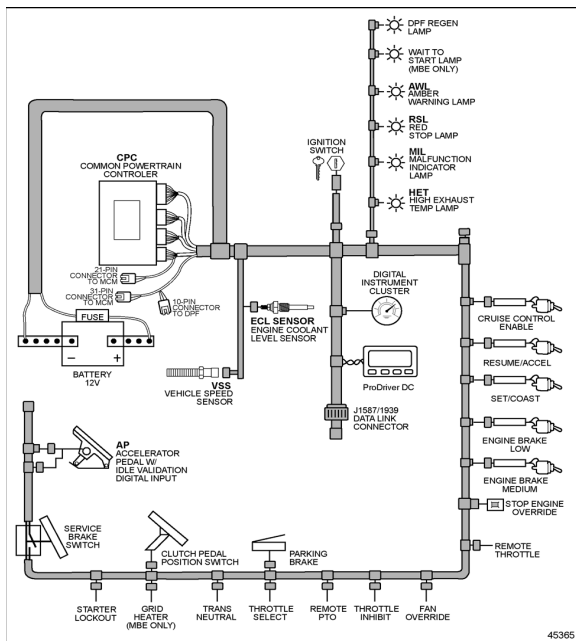
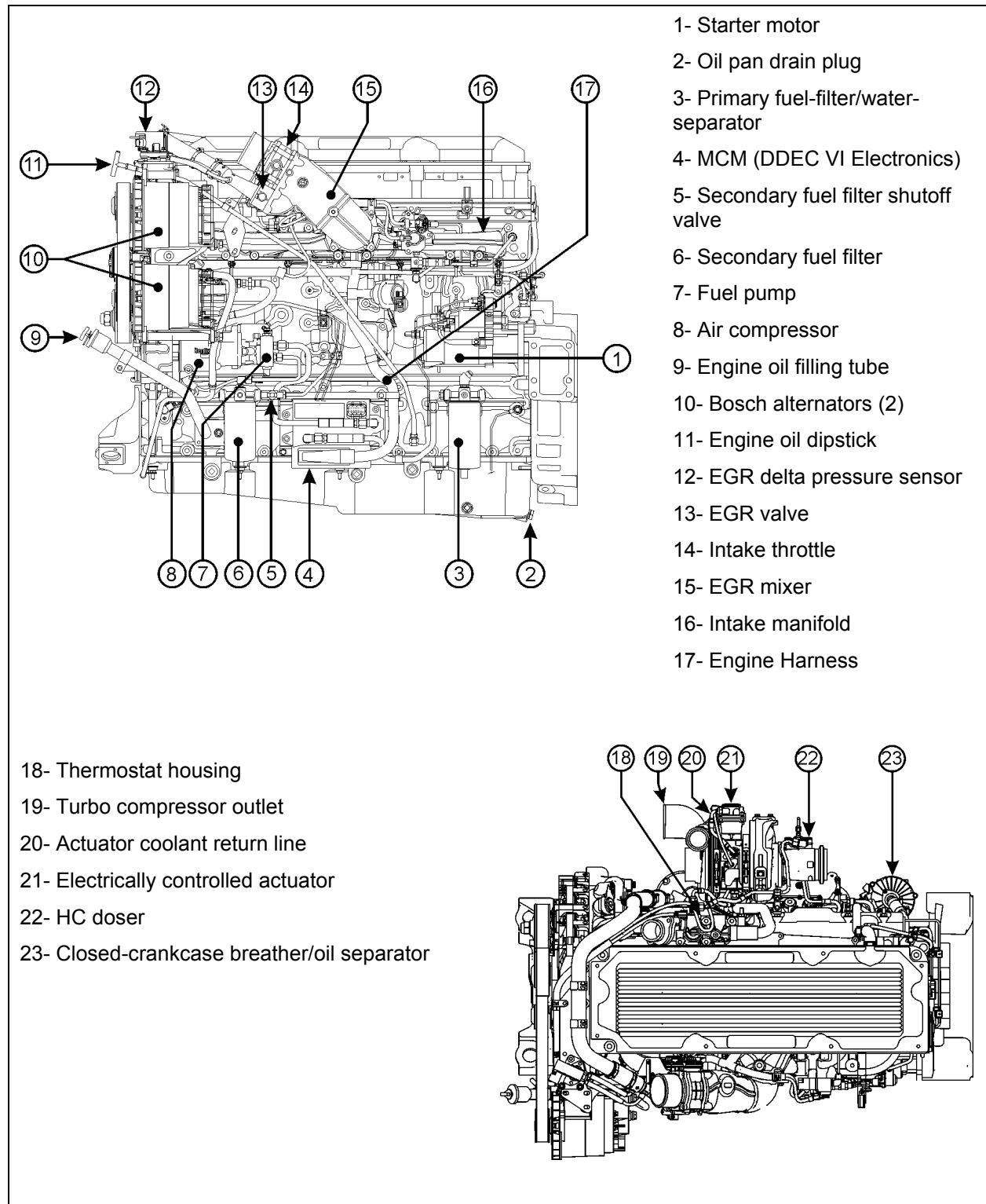


FIGURE 14: VEHICLE INTERFACE HARNESS (GENERAL APPLICATION SHOWN)

2.3 ENGINE OVERVIEW



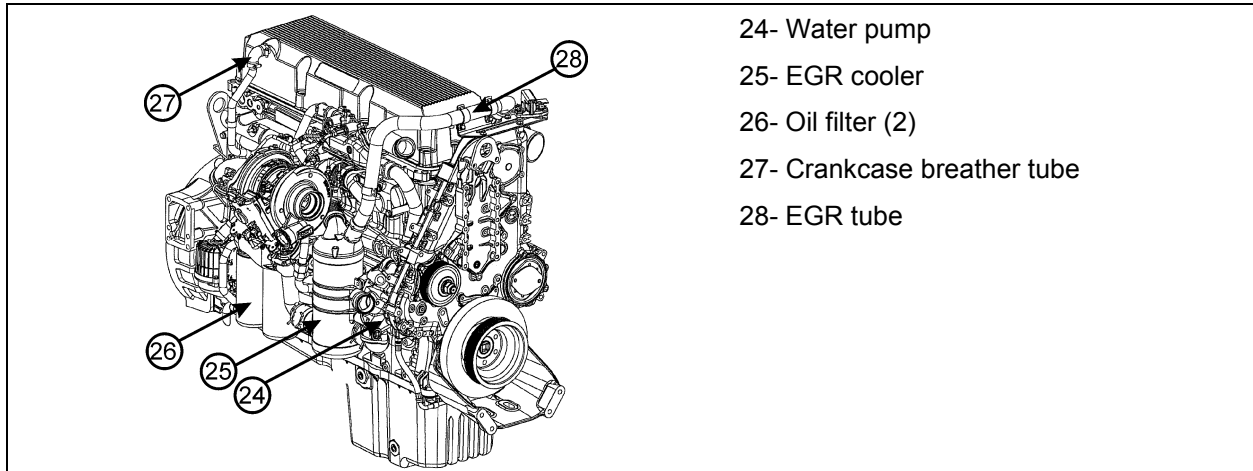


FIGURE 15: DETROIT DIESEL 2007 SERIES 60 ENGINE (TYPICAL)

01150

## 2.4 DDEC VI SENSORS

- **Camshaft Position Sensor (CMP Sensor):** Indicates a specific cylinder in the firing order.
- **Crankshaft Position Sensor (CKP Sensor):** Senses crankshaft position and engine speed for functions such as fuel control strategy.
- **DPF Inlet Pressure Sensor:** Measures pressure between the Diesel Oxidation Catalyst (DOC) and the Diesel Particulate Filter (DPF) in the aftertreatment assembly.
- **DPF Outlet Pressure Sensor:** Measures pressure on the outlet of the aftertreatment device in the exhaust system of the vehicle.
- **DPF Outlet Temperature Sensor:** Temperature measured at the outlet of the after-treatment system that is installed within the exhaust system of the vehicle.
- **DOC Inlet Temperature Sensor:** Temperature measured at the outlet of the after-treatment.
- **DOC Outlet Temperature Sensor:** Temperature measured between the DOC and the DPF in the aftertreatment assembly.
- **EGR Delta Pressure Sensor:** Senses EGR pressure for EGR control.
- **EGR Temperature Sensor:** Senses EGR exhaust temperature after EGR cooler. Used for EGR system diagnosis.
- **Engine Coolant Temperature Sensor (ECT Sensor):** Senses coolant temperature for functions such as engine protection, fan control and engine fueling.
- **Engine Oil Pressure Sensor (EOP Sensor):** Senses gallery oil pressure for functions such as engine protection.
- **Engine Oil Temperature Sensor (EOT Sensor):** Senses oil temperature for functions such as reducing variation in fuel injection and fan control.
- **Fuel Line Pressure Sensor:** Senses fuel line pressure.
- **Fuel Compensation Pressure Sensor:** Compensates fuel line pressure.
- **Intake Manifold Pressure Sensor (IMP Sensor):** Senses turbo boost for functions such as smoke control and engine protection.
- **Intake Manifold Air Temperature Sensor (IMT Sensor):** Senses pressure. The MCM uses this information to compute the amount of air entering the engine.
- **Supply Fuel Temperature Sensor (SFT Sensor):** Senses fuel temperature for functions such as engine fueling.
- **Turbo Compressor Temperature Out Sensor:** Senses turbo out air temperature.
- **Turbo Speed Sensor (TSS):** Monitors turbo speed for overspeed conditions.
- **VGT Position Sensor/EGR Valve Position Sensor.**
- **Intake Air Throttle Valve Sensor.**
- **Exhaust Valve Recirculation Valve (EGR) Sensor.**



2.5 OTHER SENSORS

- **Engine Coolant Level Sensor (ECL Sensor):** Senses coolant level for engine protection (mounted on coolant surge tank).
- **Turbo Compressor In Temperature Sensor:** Senses the air temperature at the turbo compressor inlet.

2.6 MOTOR CONTROL MODULE (MCM)

The Motor Control Module is mounted, on the starter side of the engine (Fig. 15). Considered the "Brain" of the DDEC VI system, it provides overall monitoring and control of the engine. It does so by comparing input data from the various sensors to a set of calibration data stored in the EEPROM (Electrically Erasable, Programmable, Read-Only Memory) within the Motor Control Module. After comparing the input data with the calibration data, the MCM sends high-current command pulses to the Electronic Unit Injectors (EUI) to initiate fuel injection. The MCM also receives feedback regarding the start and end of injection for a given cylinder. The EEPROM within the Motor Control Module is factory programmed by Detroit Diesel. Reprogramming must be done at a Detroit Diesel authorized service center. However, some changes may be performed to the cruise control and road speed limiter using a diagnostic data reader (see paragraph "DDEC VI Diagnostic Codes" in this section).

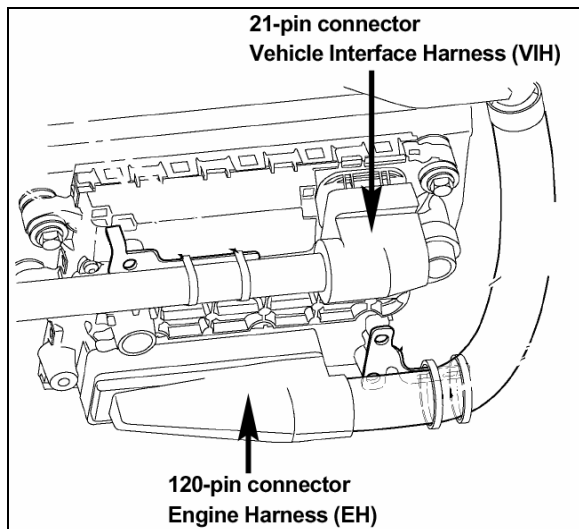


FIGURE 16: MOTOR CONTROL MODULE (MCM) 01145

2.7 COMMON POWERTRAIN CONTROLLER (CPC)

The CPC is the interface between the MCM and the vehicle/equipment for engine control and manages other vehicle/equipment functions.

Within the CPC, sets of data for specific applications are stored. These include idle speed, maximum running speed, and speed limitation. Customer programmable parameters are also stored here. The CPC receives data from the operator (accelerator pedal position, switches and various sensors) and other electronic control units. From this data, instructions are computed for controlling the engine and transmitted to the MCM via the proprietary data link.

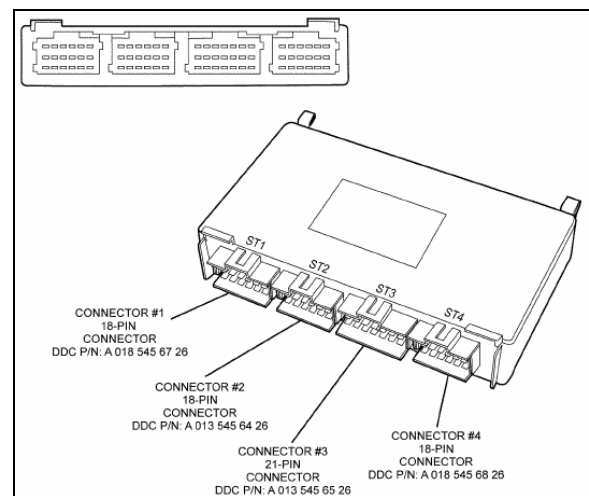


FIGURE 17: CPC

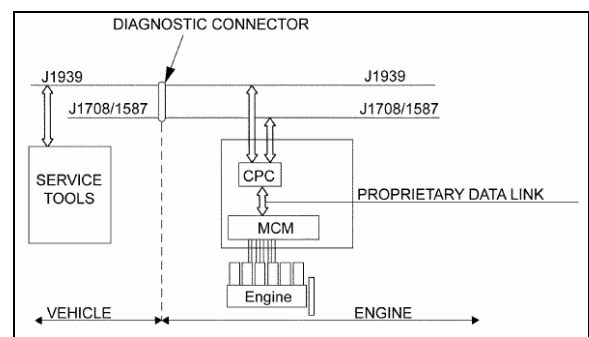


FIGURE 18: THE CPC COMMUNICATES OVER THE J1587 AND J1939 DATA LINKS TO THE VEHICLE

2.8 DDEC VI DIAGNOSTICS

2.8.1 Diagnostic system

Diagnostics is a standard feature of DDEC VI. The purpose of this feature is to provide information for problem identification and

## Section 01: ENGINE

---

problem solving in the form of a code. The MCM and CPC continuously perform self diagnostic checks and monitor the other system components. Information for problem identification and problem solving is enhanced by the detection of faults, retention of fault codes and separation of active from inactive codes.

The engine-mounted MCM includes control logic to provide overall engine management. System diagnostic checks are made at ignition on and continue throughout all engine operating modes. Sensors provide information to the MCM and CPC regarding various engine and vehicle performance characteristics. The information is used to regulate engine and vehicle performance, provide diagnostic information, and activate the engine protection system.

The DDEC VI on-board diagnostic system accessories include the following:

- Check Engine telltale light (AWL);
- Stop Engine telltale light (RSL);
- Stop Engine Override switch (SEO);
- Diagnostic Data Link (DDL) connectors.

The AWL is illuminated and a code is stored if an electronic system fault occurs. This indicates the problem should be diagnosed as soon as possible. The CPC illuminates the AWL and RSL and stores a malfunction code if a potentially engine damaging fault is detected. These codes can be accessed in one of four ways:

- Commercially available J1587/J1939 diagnostic tools.
- Detroit Diesel Diagnostic Link® (DDDL 7.0).
- Flashing the AWL and RSL with the SEO/Diagnostic Request Switch.
- Dashboard's Message Center Display (MCD).

### 2.8.2 Check Engine Telltale Light (AWL)

The CPC illuminates the Check Engine telltale, mounted on the telltale light panel to indicate that a problem has been detected and that a code has been stored in the MCM memory. This light also has a 5-second bulb check when the ignition is first turned on.

### 2.8.3 Stop Engine Warning Light (RSL)

This light, also mounted on the telltale light panel, illuminates to indicate that a major engine problem is occurring (with the exception of a 5-second bulb check when the ignition is first turned on).

### 2.8.4 Stop Engine Override Switch (SEO)

This switch, mounted on the dashboard, may be used to extend the 30-second delay period before engine shutdown when the Stop engine telltale light is illuminated. This switch can be repeatedly depressed in order to move the vehicle out of traffic.

#### **NOTE**

*The stop engine override switch will be operative only if it has been depressed before the end of the 30 second delay period.*



#### **CAUTION**

The OVERRIDE switch must be used only in emergency cases, such as to move the vehicle out of traffic. Excessive use of this switch can cause serious damage to the engine.

This switch is also used for DDEC diagnostic code requests. Press this switch with the engine at idle or off but with the ignition in the "ON" position and active codes will be flashed on the CHECK ENGINE and STOP ENGINE telltale lights alternately.

### 2.8.5 Diagnostic Data Link (DDL) Connectors

A connector is mounted on the L.H. footwell wall. Another connector is located in the rear electric compartment. They allow the connection of the Diagnostic Data Reader (DDR) to read the codes or to access pertinent data on the condition of the engine. This enables a more complete analysis of any defect found in the DDEC system operation. For more information, see Detroit Diesel Troubleshooting Guide #6SE492.

## 2.9 READING DIAGNOSTIC CODES – FLASHING LIGHT METHOD:

DDEC VI makes use of two types of codes: Active and inactive. The difference between the two types of codes is as follows:

**Active Codes:** Codes that are currently keeping the Check Engine or Stop Engine telltale light illuminated. Active codes are flashed via the Stop Engine Light when checked with the stop-engine-override switch.

**Inactive Codes:** These are all the codes logged in the CPC, which have previously occurred, (whether or not they are currently turning on the Stop or Check Engine Light). Inactive codes are flashed via the Check Engine telltale light when checked with the stop-engine-override switch.

In most instances, only the DDR can provide the information necessary for a quick diagnosis of the problem. If you just need to read out codes, however, and do not have a DDR available, the following procedure will let you read out codes. Make sure the rear-starting switch (located in the engine compartment) is in the normal position. With the ignition ON, the engine idling or engine shut-off, momentarily depress the Stop Engine Override (SEO) switch. Active codes will be flashed on the stop engine telltale, followed by the inactive codes being flashed on the check-engine telltale panel. The cycle repeats itself until the operator depresses the stop engine override switch again.

Flashing codes provide a four digit number. Each fault code is flashed twice in order to help with counting the flashes. If there are no active faults or if there are no inactive faults the number "3" is flashed once followed by an ~3s delay.

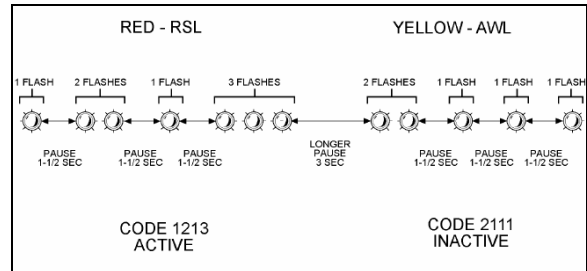


FIGURE 19: FLASHING FAULTS CODES

Refer to DDEC Troubleshooting Manual 6SE567 for more information and SAE codes.

**NOTE**

Active codes are flashed in ascending numerical flash code order. Inactive codes are flashed in most recent to least recent order.

**NOTE**

Fault codes can only be cleared using the DDR.

**NOTE**

The listed codes may not be used in all applications. A default value in the normal operating range is used by the MCM to provide for engine operation if a sensor failure is present.

2.10 DDEC VI CPC DIAGNOSTIC CODES LIST

| SPN | FMI | PID/SID | PID/SID ID | FLASH CODES | FAULT DESCRIPTION  |
|-----|-----|---------|------------|-------------|--|
| 70  | 2   | PID     | 70         | 2111        | Park Brake Status Not Plausible (Vehicle Moving)         |
| 70  | 19  | SID     | 234        | 2112        | J1939 Park Brake Switch Signal from Source #1 is erratic |
| 70  | 13  | SID     | 234        | 2112        | J1939 Park Brake Switch Signal from Source #1 is missing |
| 70  | 19  | SID     | 234        | 2112        | J1939 Park Brake Switch Signal from Source #2 is erratic |
| 70  | 13  | SID     | 234        | 2112        | J1939 Park Brake Switch Signal from Source #2 is missing |
| 70  | 19  | SID     | 234        | 2112        | J1939 Park Brake Switch Signal from Source #3 is erratic |
| 70  | 13  | SID     | 234        | 2112        | J1939 Park Brake Switch Signal from Source #3 is missing |

**Section 01: ENGINE**

| SPN | FMI | PID/SID | PID/SID ID | FLASH CODES | FAULT DESCRIPTION  |
|-----|-----|---------|------------|-------------|--|
| 84  | 21  | PID     | 84         | 2113        | Vehicle Speed Failure  |
| 84  | 3   | PID     | 84         | 2113        | Vehicle Speed Sensor Circuit Failed High                           |
| 84  | 4   | PID     | 84         | 2113        | Vehicle Speed Sensor Circuit Failed Low                            |
| 84  | 2   | PID     | 84         | 2113        | VSS Anti Tamper Detection via Virtual Gear Ratio                   |
| 84  | 8   | PID     | 84         | 2113        | VSS Anti Tamper Detection via Fixed Frequency Device               |
| 84  | 6   | PID     | 84         | 2113        | VSS Anti-Tamper Detection via ABS Vehicle Speed Comparison         |
| 84  | 19  | PID     | 84         | 2113        | J1939 Wheel-Based Vehicle Speed Signal from Source#1 is erratic    |
| 84  | 13  | PID     | 84         | 2113        | J1939 Wheel-Based Vehicle Speed Signal from Source#1 is missing    |
| 84  | 19  | SID     | 84         | 2113        | J1939 Wheel-Based Vehicle Speed Signal from Source#2 is erratic    |
| 84  | 13  | PID     | 84         | 2113        | J1939 Wheel-Based Vehicle Speed Signal from Source#2 is missing    |
| 84  | 19  | PID     | 84         | 2113        | J1939 Wheel-Based Vehicle Speed Signal from Source#3 is erratic    |
| 84  | 13  | PID     | 84         | 2113        | J1939 Wheel-Based Vehicle Speed Signal from Source#3 is missing    |
| 84  | 20  | PID     | 84         | 2113        | Vehicle Speed Sensor Drifted High Error (VSS signal not plausible) |
| 91  | 13  | PID     | 91         | 2114        | Accelerator Pedal Learn Error                                      |
| 91  | 3   | PID     | 91         | 2114        | Accelerator Pedal Circuit Failed High                              |
| 91  | 4   | PID     | 91         | 2114        | Accelerator Pedal Circuit Failed Low                               |
| 91  | 8   | PID     | 91         | 2114        | Pwm Accelerator Pedal Signal 1 Frequency Out Of Range              |
| 91  | 14  | PID     | 91         | 2114        | Pwm Accelerator Pedal Not Learned                                  |
| 91  | 7   | PID     | 91         | 2114        | Pwm Accelerator Pedal Idle Not Recognized                          |
| 91  | 31  | PID     | 91         | 2114        | Pwm Accelerator Pedal Learned Range to Large                       |
| 91  | 3   | PID     | 91         | 2114        | Accelerator Pedal Signal Circuit Failed High                       |
| 91  | 9   | SID     | 231        | 2615        | J1939 EEC2 Message is missing                                      |
| 98  | 0   | PID     | 98         | 2115        | Oil Level High   |
| 98  | 18  | PID     | 98         | 2115        | Oil Level Low  |
| 98  | 1   | PID     | 98         | 2115        | Oil Level Very Low   |
| 100 | 18  | PID     | 100        | 2121        | Oil Pressure Low   |
| 100 | 1   | PID     | 100        | 2121        | Oil Pressure Very Low  |
| 107 | 0   | PID     | 107        | 2122        | Air Filter Restriction High  |

**SECTION 01: ENGINE**

| SPN | FMI | PID/SID | PID/SID ID | FLASH CODES | FAULT DESCRIPTION   |
|-----|-----|---------|------------|-------------|---|
| 107 | 4   | PID     | 107        | 2122        | Air Filter Signal Circuit Failed Low                                  |
| 107 | 3   | PID     | 107        | 2122        | Air Filter Signal Circuit Failed High                                 |
| 110 | 16  | PID     | 110        | 2123        | Coolant Temperature High  |
| 110 | 0   | PID     | 110        | 2123        | Coolant Temperature Very High   |
| 111 | 18  | PID     | 111        | 2124        | Coolant Level Low   |
| 111 | 3   | PID     | 111        | 2124        | Coolant Level Circuit Failed High                                     |
| 111 | 4   | PID     | 111        | 2124        | Coolant Level Circuit Failed Low                                      |
| 111 | 1   | PID     | 111        | 2124        | Coolant Level Very Low  |
| 168 | 0   | PID     | 168        | 2125        | Battery Voltage Very Low  |
| 168 | 0   | PID     | 168        | 2125        | Battery Voltage High  |
| 168 | 18  | PID     | 168        | 2125        | Battery Voltage Low   |
| 168 | 14  | PID     | 168        | 2125        | Opt Idle Detected Charging System or Battery Failure                  |
| 168 | 14  | PID     | 168        | 2125        | ECU powerdown not completed (Main Battery Terminal Possibly Floating) |
| 171 | 2   | PID     | 171        | 2131        | Ambient Temperature Sensor Data Erratic                               |
| 171 | 14  | PID     | 171        | 2131        | J1587 Ambient Air Temp Sensor Data Not Received This Ign Cycle        |
| 171 | 9   | PID     | 171        | 2131        | J1587 Ambient Air Temp Sensor Data Message Stopped Arriving           |
| 191 | 9   | SID     | 231        | 2615        | J1939 ETC1 Message is missing   |
| 191 | 19  | SID     | 231        | 2132        | J1939 Transmission Output Shaft Speed Signal is erratic               |
| 191 | 13  | SID     | 231        | 2132        | J1939 Transmission Output Shaft Speed Signal is missing               |
| 247 | 9   | PID     | 247        | 2615        | MCM Engine Hours Data not received or stopped arriving                |
| 247 | 10  | PID     | 247        | 2615        | MCM Engine Hours Data increasing at an implausible rate               |
| 247 | 0   | PID     | 247        | 2615        | MCM Engine Hours Data higher than expected                            |
| 247 | 1   | PID     | 247        | 2615        | MCM Engine Hours Data lower than expected                             |
| 523 | 19  | PID     | 163        | 2133        | J1939 Transmission Current Gear Signal is erratic                     |
| 523 | 13  | PID     | 163        | 2133        | J1939 Transmission Current Gear Signal is missing                     |
| 524 | 9   | SID     | 231        | 2615        | J1939 ETC2 Message is missing   |
| 527 | 9   | SID     | 231        | 2615        | J1939 CCVS Message from Source #1 is missing                          |
| 527 | 9   | SID     | 231        | 2615        | J1939 CCVS Message from Source #2 is missing                          |
| 527 | 9   | SID     | 231        | 2615        | J1939 CCVS Message from Source #3 is missing                          |
| 558 | 2   | SID     | 230        | 2134        | Idle Validation Switch Inputs Reversed                                |
| 558 | 5   | SID     | 230        | 2134        | Idle Validation Switch 2 Circuit Failed Low                           |

**Section 01: ENGINE**

| SPN | FMI | PID/SID | PID/SID ID | FLASH CODES | FAULT DESCRIPTION   |
|-----|-----|---------|------------|-------------|---|
| 558 | 6   | SID     | 230        | 2134        | Idle Validation Switch 2 Circuit Failed High                            |
| 558 | 4   | SID     | 230        | 2134        | Idle Validation Switch 1 Circuit Failed Low                             |
| 558 | 3   | SID     | 230        | 2134        | Idle Validation Switch 1 Circuit Failed High                            |
| 596 | 19  | SID     | 244        | 2135        | J1939 Cruise Control Enable Switch Signal from Source #1 is erratic     |
| 596 | 13  | SID     | 244        | 2135        | J1939 Cruise Control Enable Switch Signal from Source #1 is missing     |
| 596 | 19  | SID     | 244        | 2135        | J1939 Cruise Control Enable Switch Signal from Source #2 is erratic     |
| 596 | 13  | SID     | 244        | 2135        | J1939 Cruise Control Enable Switch Signal from Source #2 is missing     |
| 596 | 19  | SID     | 244        | 2135        | J1939 Cruise Control Enable Switch Signal from Source #3 is erratic     |
| 596 | 13  | SID     | 244        | 2135        | J1939 Cruise Control Enable Switch Signal from Source #3 is missing     |
| 597 | 2   | SID     | 246        | 2141        | Service Brake Status Not Plausible                                      |
| 597 | 19  | SID     | 246        | 2141        | J1939 Service Brake Switch Signal from Source #1 is erratic             |
| 597 | 13  | SID     | 246        | 2141        | J1939 Service Brake Switch Signal from Source #1 is missing             |
| 597 | 19  | SID     | 246        | 2141        | J1939 Service Brake Switch Signal from Source #2 is erratic             |
| 597 | 13  | SID     | 246        | 2141        | J1939 Service Brake Switch Signal from Source #2 is missing             |
| 597 | 19  | SID     | 246        | 2141        | J1939 Service Brake Switch Signal from Source #3 is erratic             |
| 597 | 13  | SID     | 246        | 2141        | J1939 Service Brake Switch Signal from Source #3 is missing             |
| 599 | 4   | SID     | 243        | 2142        | Cruise Control SET and RESUME Circuits Failed Low                       |
| 600 | 19  | SID     | 243        | 2143        | J1939 Cruise Control Coast Switch Signal from Source #1 is erratic      |
| 600 | 13  | SID     | 243        | 2143        | J1939 Cruise Control Coast Switch Signal from Source #1 is missing      |
| 600 | 19  | SID     | 243        | 2143        | J1939 Cruise Control Coast Switch Signal from Source #2 is erratic      |
| 600 | 13  | SID     | 243        | 2143        | J1939 Cruise Control Coast Switch Signal from Source #2 is missing      |
| 600 | 19  | SID     | 243        | 2143        | J1939 Cruise Control Coast Switch Signal from Source #3 is erratic      |
| 600 | 13  | SID     | 243        | 2143        | J1939 Cruise Control Coast Switch Signal from Source #3 is missing      |
| 602 | 19  | SID     | 242        | 2144        | J1939 Cruise Control Accelerate Switch Signal from Source #1 is erratic |
| 602 | 13  | SID     | 242        | 2144        | J1939 Cruise Control Accelerate Switch Signal from Source #1 is missing |

**SECTION 01: ENGINE**

| SPN | FMI | PID/SID | PID/SID ID | FLASH CODES | FAULT DESCRIPTION   |
|-----|-----|---------|------------|-------------|---|
| 602 | 19  | SID     | 242        | 2144        | J1939 Cruise Control Accelerate Switch Signal from Source #2 is erratic |
| 602 | 13  | SID     | 242        | 2144        | J1939 Cruise Control Accelerate Switch Signal from Source #2 is missing |
| 602 | 19  | SID     | 242        | 2144        | J1939 Cruise Control Accelerate Switch Signal from Source #3 is erratic |
| 602 | 13  | SID     | 242        | 2144        | J1939 Cruise Control Accelerate Switch Signal from Source #3 is missing |
| 608 | 14  | SID     | 250        | 2145        | J1708 Data Link Failure   |
| 609 | 12  | SID     | 233        | 2145        | CPC2 Hardware Failure   |
| 615 | 9   | SID     | 231        | 2615        | J1939 DM1 Message from Transmission is missing                          |
| 625 | 13  | SID     | 248        | 2151        | ECAN ID_1629 Diagnostic Message Not Received This Ignition Cycle        |
| 625 | 9   | SID     | 248        | 2151        | ECAN ID_1629 Diagnostic Message No Longer Being Received                |
| 625 | 10  | SID     | 248        | 2151        | ECAN ID_1629 Reporting Inconsistent Number of Frames                    |
| 625 | 2   | SID     | 248        | 2151        | ECAN ID_1629 Diagnostic Message Reporting Data Not Available            |
| 625 | 14  | SID     | 248        | 2151        | ECAN ID_1629 Diagnostic Message Reporting an Unknown MUID               |
| 625 | 9   | SID     | 248        | 2151        | Incorrect MCM System ID Received  |
| 625 | 9   | SID     | 248        | 2151        | MCM System ID Not Received or Stopped Arriving                          |
| 625 | 4   | SID     | 248        | 2151        | ECAN Link Circuit Failure   |
| 628 | 14  | SID     | 254        | 2151        | XFLASH Static Fault Code Memory Page Read Write Failure                 |
| 628 | 13  | SID     | 155        | 2615        | 20ms ECU OS Task Locked in an Endless Loop                              |
| 628 | 13  | SID     | 155        | 2615        | 20ms ECU OS Task Timed out Prior to Completion                          |
| 628 | 13  | SID     | 155        | 2615        | 1000ms ECU OS Task Locked in an Endless Loop                            |
| 628 | 13  | SID     | 155        | 2615        | 1000ms ECU OS Task Timed out Prior to Completion                        |
| 629 | 2   | SID     | 254        | 2151        | CPC Hardware/Software Mismatch  |
| 629 | 12  | SID     | 254        | 2151        | DDEC Data Xflash Write Error. Replace CPC2.                             |
| 630 | 2   | SID     | 253        | 2152        | EEPROM Checksum Failure   |
| 630 | 2   | SID     | 253        | 2152        | EEPROM Checksum Failure for the SCR Block                               |
| 630 | 13  | SID     | 253        | 2152        | SCR Number Out of Range   |

**Section 01: ENGINE**

| SPN | FMI | PID/SID | PID/SID ID | FLASH CODES | FAULT DESCRIPTION  |
|-----|-----|---------|------------|-------------|--|
| 630 | 14  | SID     | 155        | 2615        | MCM Fault Codes Unavailable via J1939 and J1587                      |
| 630 | 14  | SID     | 155        | 2615        | MCM Fault Code Table Inconsistent - Upgrade MCM Software             |
| 630 | 14  | SID     | 155        | 2615        | Insufficient Static Fault Code Storage Memory - Upgrade CPC Software |
| 630 | 14  | SID     | 155        | 2615        | MCM Fault Code Table Inconsistent - Upgrade MCM Software             |
| 639 | 14  | SID     | 231        | 2153        | J1939 Data Link Failure  |
| 701 | 3   | SID     | 26         | 2211        | Digital Output 4 09 Circuit Failed High                              |
| 701 | 4   | SID     | 26         | 2211        | Digital Output 4 09 Circuit Failed Low                               |
| 702 | 3   | SID     | 40         | 2212        | Digital Output 3 17 Circuit Failed High                              |
| 702 | 4   | SID     | 40         | 2212        | Digital Output 3 17 Circuit Failed Low                               |
| 703 | 3   | SID     | 51         | 2213        | Digital Output 3 09 Circuit Failed High                              |
| 703 | 4   | SID     | 51         | 2213        | Digital Output 3 09 Circuit Failed Low                               |
| 704 | 3   | SID     | 52         | 2214        | Digital Output 4 07 Circuit Failed High                              |
| 704 | 4   | SID     | 52         | 2214        | Digital Output 4 07 Circuit Failed Low                               |
| 705 | 3   | SID     | 53         | 2215        | Digital Output 1 13 Circuit Failed High                              |
| 705 | 4   | SID     | 53         | 2215        | Digital Output 1 13 Circuit Failed Low                               |
| 706 | 3   | SID     | 54         | 2221        | Digital Output 3 10 Circuit Failed High                              |
| 706 | 4   | SID     | 54         | 2221        | Digital Output 3 10 Circuit Failed Low                               |
| 707 | 3   | SID     | 55         | 2222        | Digital Output 2 10 Circuit Failed High (CEL / AWL Lamp)             |
| 707 | 4   | SID     | 55         | 2222        | Digital Output 2 10 Circuit Failed Low (CEL / AWL Lamp)              |
| 708 | 3   | SID     | 56         | 2223        | Digital Output 3 12 Circuit Failed High                              |
| 708 | 4   | SID     | 56         | 2223        | Digital Output 3 12 Circuit Failed Low                               |
| 709 | 3   | SID     | 257        | 2224        | Digital Output 3 16 Circuit Failed High                              |
| 709 | 4   | SID     | 257        | 2224        | Digital Output 3 16 Circuit Failed Low                               |
| 710 | 3   | SID     | 258        | 2225        | Digital Output 4 06 Circuit Failed High                              |
| 710 | 4   | SID     | 258        | 2225        | Digital Output 4 06 Circuit Failed Low                               |
| 711 | 3   | SID     | 259        | 2231        | Digital Output 1 05 Circuit Failed High                              |
| 711 | 4   | SID     | 259        | 2231        | Digital Output 1 05 Circuit Failed Low                               |
| 712 | 3   | SID     | 260        | 2232        | Digital Output 1 04 Circuit Failed High                              |
| 712 | 4   | SID     | 260        | 2232        | Digital Output 1 04 Circuit Failed Low                               |
| 713 | 3   | SID     | 261        | 2234        | Digital Output 3 07 Circuit Failed High                              |
| 713 | 4   | SID     | 261        | 2234        | Digital Output 3 07 Circuit Failed Low                               |
| 713 | 5   | SID     | 261        | 2234        | Digital Output 3 07 Open Circuit                                     |
| 713 | 7   | SID     | 261        | 2234        | TOP2 Shift Failure   |
| 714 | 3   | SID     | 262        | 2235        | Digital Output 3 08 Circuit Failed High                              |
| 714 | 4   | SID     | 262        | 2235        | Digital Output 3 08 Circuit Failed Low                               |
| 714 | 5   | SID     | 262        | 2235        | Digital Output 3 08 Open Circuit                                     |
| 715 | 3   | SID     | 263        | 2241        | Digital Output 4 10 Circuit Failed High                              |
| 904 | 9   | SID     | 231        | 2615        | J1939 EBC2 Message from ABS is missing                               |



**SECTION 01: ENGINE**

| SPN  | FMI | PID/SID | PID/SID ID | FLASH CODES | FAULT DESCRIPTION  |
|------|-----|---------|------------|-------------|--|
| 904  | 19  | SID     | 231        | 2242        | J1939 Front Axle Speed Signal is erratic                                 |
| 904  | 13  | SID     | 231        | 2242        | J1939 Front Axle Speed Signal is missing                                 |
| 972  | 2   | SID     | 203        | 2243        | Throttle inhibit switch signal not plausible due to excess vehicle speed |
| 973  | 9   | SID     | 231        | 2615        | J1939 EBC1 Message is missing  |
| 973  | 13  | SID     | 231        | 2244        | J1939 Engine Retarder Selection Signal Missing                           |
| 973  | 19  | SID     | 231        | 2244        | J1939 Engine Retarder Selection Signal Erratic                           |
| 974  | 2   | PID     | 372        | 2245        | Remote Accelerator Pedal Supply Voltage Out of Range                     |
| 974  | 3   | PID     | 372        | 2245        | Remote Accelerator Pedal Circuit Failed High                             |
| 974  | 4   | PID     | 372        | 2245        | Remote Accelerator Pedal Circuit Failed Low                              |
| 981  | 0   | SID     | 155        | 2311        | PTO CC+ and CC- Switches Pressed Simultaneously                          |
| 986  | 9   | SID     | 231        | 2615        | J1939 CM1 Message is missing   |
| 1267 | 4   | SID     | 123        | 2312        | Digital Output 4 10 Circuit Failed Low                                   |
| 1267 | 3   | SID     | 123        | 2312        | Digital Output 4 10 Circuit Failed Open                                  |
| 1321 | 4   | SID     | 128        | 2314        | Starter Lockout Output Shorted to Ground                                 |
| 1321 | 3   | SID     | 128        | 2314        | Starter Lockout Output Open Circuit                                      |
| 1590 | 19  | SID     | 155        | 2615        | Adaptive Cruise Control Message Not Received                             |
| 1590 | 9   | SID     | 231        | 2615        | Adaptive Cruise Control Device Reporting Error                           |
| 1624 | 9   | SID     | 231        | 2615        | J1939 TCO1 Message is missing  |
| 1624 | 19  | SID     | 231        | 2315        | J1939 Tachograph Vehicle Speed Signal is erratic                         |
| 1624 | 13  | SID     | 231        | 2315        | J1939 Tachograph Vehicle Speed Signal is missing                         |
| 1663 | 7   | SID     | 123        | 2321        | Optimized Idle Safety Loop Faulted                                       |
| 1716 | 9   | SID     | 231        | 2615        | J1939 ERC1 Message is missing  |
| 1845 | 9   | SID     | 231        | 2615        | J1939 TCFG2 Message is missing   |
| 2623 | 14  | PID     | 91         | 2322        | Pwm Accelerator Pedal GAS1 and GAS2 Signal Missing                       |
| 2623 | 8   | PID     | 91         | 2322        | Pwm Accelerator Pedal Signal 2 Frequency Out Of Range                    |
| 2900 | 9   | SID     | 231        | 2615        | J1939 ETC7 Message is missing  |
| 3510 | 3   | SID     | 211        | 2333        | Accelerator Pedal Supply Voltage Circuit Failed High                     |
| 3510 | 4   | SID     | 211        | 2333        | Accelerator Pedal Supply Voltage Circuit Failed Low                      |
| 3510 | 4   | SID     | 211        | 2333        | Pwm Accelerator Pedal Supply Voltage Missing                             |
| 3510 | 3   | SID     | 211        | 2333        | Accelerator Pedal Supply Voltage Circuit Failed High                     |
| 3606 | 9   | SID     | 231        | 2615        | J1939 ESS Message is missing   |

## Section 01: ENGINE

| SPN  | FMI | PID/SID | PID/SID ID | FLASH CODES | FAULT DESCRIPTION  |
|------|-----|---------|------------|-------------|--|
| 3695 | 2   | SID     | 155        | 2334        | Manual DPF Regen and DPF Inhibit Switch Rationality Fault          |
| 3695 | 19  | SID     | 155        | 2334        | DPF Regen Inhibit MUX Switch Message Contains Data Error Indicator |
| 3695 | 13  | SID     | 155        | 2334        | DPF Regen Inhibit MUX Switch Message Contains SNV Indicator        |
| 3695 | 9   | SID     | 155        | 2334        | DPF Regen Inhibit MUX Switch Message Stopped Arriving              |
| 3695 | 14  | SID     | 155        | 2334        | DPF Regen Inhibit MUX Switch Message Not Received this Ign Cycle   |
| 3696 | 19  | SID     | 155        | 2335        | DPF Regen Force MUX Switch Message Contains Data Error Indicator   |
| 3696 | 13  | SID     | 155        | 2335        | DPF Regen Force MUX Switch Message Contains SNV Indicator          |
| 3696 | 9   | SID     | 155        | 2335        | DPF Regen Force MUX Switch Message Stopped Arriving                |
| 3696 | 14  | SID     | 155        | 2335        | DPF Regen Force MUX Switch Message Not Received this Ign Cycle     |

### 2.11 DDEC VI MCM DIAGNOSTIC CODES LIST

| SPN | FMI | PID/SID | PID/SID ID | FLASH CODE | FAULT DESCRIPTION                                     |
|-----|-----|---------|------------|------------|---|
| 27  | 4   | PID     | 27         | 1111       | EGR Valve Position Circuit Failed Low                 |
| 27  | 3   | PID     | 27         | 1111       | EGR Valve Position Circuit Failed High                |
| 27  | 2   | PID     | 27         | 1111       | EGR Valve Position Feedback Failed                    |
| 27  | 0   | PID     | 27         | 1111       | EGR Valve Position Feedback Failed (High Box)         |
| 27  | 1   | PID     | 27         | 1111       | EGR Valve Position Feedback Failed (Low Box)          |
| 27  | 14  | PID     | 27         | 1111       | EGR Valve Position Positive Torque Error              |
| 27  | 7   | PID     | 27         | 1111       | EGR Valve Stuck Open                                  |
| 27  | 19  | PID     | 27         | 1521       | Smart Actuator Indicates EGR Position Error           |
| 51  | 4   | SID     | 51         | 1112       | Intake Air Throttle Circuit Failed Low                |
| 51  | 3   | SID     | 51         | 1112       | Intake Air Throttle Circuit Failed High               |
| 51  | 2   | PID     | 51         | 1112       | Intake Throttle Position Deviation Error              |
| 51  | 0   | PID     | 51         | 1112       | Intake Air Throttle Position High                     |
| 51  | 1   | PID     | 51         | 1112       | Intake Air Throttle Position Low                      |
| 51  | 7   | PID     | 51         | 1112       | Intake Throttle Auto Calibration Error                |
| 94  | 4   | PID     | 94         | 1112       | Fuel Compensation Pressure Sensor Circuit Failed Low  |
| 94  | 3   | PID     | 94         | 1112       | Fuel Compensation Pressure Sensor Circuit Failed High |
| 94  | 1   | PID     | 94         | 1112       | Fuel Pressure Too High/Too Low                        |
| 97  | 4   | PID     | 97         | 1615       | Water in Fuel Circuit Failed Low                      |
| 97  | 3   | PID     | 97         | 1615       | Water in Fuel Circuit Failed High                     |
| 98  | 1   | PID     | 98         | 1114       | Oil Level Circuit Failed Low                          |
| 98  | 0   | PID     | 98         | 1114       | Oil Level Circuit Failed High                         |
| 98  | 13  | PID     | 98         | 1634       | Oil Level Measurement, Configuration Error            |
| 98  | 14  | PID     | 98         | 1634       | Oil Level Measurement, Oil Level Too Low or Too High  |
| 100 | 4   | PID     | 100        | 1114       | Engine Oil Pressure Circuit Failed Low                |
| 100 | 3   | PID     | 100        | 1114       | Engine Oil Pressure Circuit Failed High               |
| 100 | 1   | PID     | 100        | 1114       | Engine Oil Pressure Low                               |
| 100 | 2   | PID     | 100        | 1114       | Oil Pressure Plausibility - Engine Running            |
| 100 | 2   | PID     | 100        | 1114       | Oil Pressure Plausibility - Stop                      |

**SECTION 01: ENGINE**

| SPN | FMI | PID/SID | PID/SID ID | FLASH CODE | FAULT DESCRIPTION   |
|-----|-----|---------|------------|------------|---|
| 103 | 2   | PID     | 103        | 1115       | Turbocharger Speed Not Plausible                                |
| 103 | 1   | PID     | 103        | 1115       | Turbo Charger Speed Below Threshold (High Box)                  |
| 103 | 0   | PID     | 103        | 1115       | Turbo Charger Speed Above Threshold (Low Box)                   |
| 103 | 4   | PID     | 103        | 1115       | Turbo Charger Speed Sensor Circuit Failed Low                   |
| 103 | 3   | PID     | 103        | 1115       | Turbo Charger Speed Sensor Circuit Failed High                  |
| 108 | 4   | PID     | 108        | 1211       | Barometric Pressure Circuit Failed Low                          |
| 108 | 3   | PID     | 108        | 1211       | Barometric Pressure Circuit Failed High                         |
| 108 | 2   | PID     | 108        | 1211       | Ambient Pressure Plausibility Fault (Low Box)                   |
| 108 | 20  | PID     | 108        | 1211       | Ambient Pressure Plausibility Fault (High Box)                  |
| 110 | 4   | PID     | 110        | 1212       | Engine Coolant Outlet Temperature Circuit Failed Low            |
| 110 | 3   | PID     | 110        | 1212       | Engine Coolant Outlet Temperature Circuit Failed High           |
| 110 | 0   | PID     | 110        | 1212       | Coolant Temperature High  |
| 110 | 14  | PID     | 110        | 1212       | Coolant Temperature / Engine Oil Temperature Plausibility Fault |
| 110 | 2   | PID     | 110        | 1212       | Engine Coolant Sensor (OUT), General Temp. Plausibility Error   |
| 132 | 7   | PID     | 132        | 1213       | Intake Air Throttle Valve Closure Detection- Positive Torque    |
| 132 | 14  | PID     | 132        | 1213       | Intake Air Throttle Valve Closure Detection -Braking Condition  |
| 132 | 14  | PID     | 322        | 1635       | HC-Doser Fuel Pressure Not Plausible                            |
| 132 | 1   | PID     | 322        | 1213       | Air Mass Flow Too Low   |
| 132 | 13  | PID     | 132        | 1213       | Air Mass Auto Calibration Failed                                |
| 158 | 2   | PID     | 43         | 1214       | Ignition Switch Not Plausible                                   |
| 164 | 4   | PID     | 164        | 1215       | Rail Pressure Governor Sensor Circuit Failed Low                |
| 164 | 3   | PID     | 164        | 1215       | Rail Pressure Governor Sensor Circuit Failed High               |
| 164 | 0   | PID     | 164        | 1215       | Rail Pressure Governor (High Side) Error                        |
| 164 | 0   | PID     | 164        | 1215       | Rail Pressure Governor (Low Side) Error                         |
| 168 | 1   | PID     | 168        | 1221       | Battery Voltage Low   |
| 168 | 0   | PID     | 168        | 1221       | Battery Voltage High  |
| 171 | 4   | PID     | 171        | 1222       | Ambient Temperature Circuit Failed Low                          |
| 171 | 3   | PID     | 171        | 1222       | Ambient Temperature Circuit Failed High                         |
| 174 | 4   | PID     | 174        | 1223       | Fuel Temperature Circuit Failed Low                             |
| 174 | 3   | PID     | 174        | 1223       | Fuel Temperature Circuit Failed High                            |
| 174 | 2   | PID     | 174        | 1223       | Fuel Temperature Sensor, General Temp. Plausibility             |
| 174 | 0   | PID     | 174        | 1223       | Fuel Temperature Too High                                       |
| 175 | 4   | PID     | 175        | 1224       | Engine Oil Temperature Circuit Failed Low                       |
| 175 | 3   | PID     | 175        | 1224       | Engine Oil Temperature Circuit Failed High                      |
| 175 | 14  | PID     | 175        | 1224       | Engine Oil Temperature Sensor Plausibility Fault                |
| 175 | 2   | PID     | 175        | 1224       | Engine Oil Temperature Sensor, General Temp. Plausibility       |
| 190 | 2   | PID     | 190        | 1225       | Engine Speed High   |
| 354 | 4   | PID     | 354        | 1231       | Relative Humidity Circuit Failed Low                            |
| 354 | 3   | PID     | 354        | 1231       | Relative Humidity Circuit Failed High                           |
| 411 | 4   | PID     | 411        | 1232       | EGR Delta Pressure Sensor Circuit Low                           |
| 411 | 3   | PID     | 411        | 1232       | EGR Delta Pressure Sensor Circuit High                          |
| 411 | 0   | PID     | 411        | 1232       | EGR Differential Pressure Failed (High Box)                     |
| 411 | 1   | PID     | 411        | 1232       | EGR Differential Pressure Failed (Low Box)                      |
| 411 | 5   | PID     | 411        | 1232       | EGR Sampling Range Failed                                       |
| 411 | 13  | PID     | 411        | 1232       | EGR Delta Pressure Sensor Out Of Calibration                    |
| 411 | 13  | PID     | 411        | 1232       | EGR Delta Pressure Sensor Out Of Calibration                    |
| 412 | 3   | PID     | 412        | 1233       | EGR Temperature Sensor Circuit Failed High                      |
| 412 | 4   | PID     | 412        | 1233       | EGR Temperature Sensor Circuit Failed Low                       |
| 412 | 20  | PID     | 412        | 1233       | EGR Temperature Drift (High Box)                                |
| 412 | 21  | PID     | 412        | 1233       | EGR Temperature Drift (Low Box)                                 |
| 412 | 2   | PID     | 412        | 1233       | EGR Temperature Sensor, General Temp. Plausibility Error        |

## Section 01: ENGINE

| SPN | FMI | PID/SID | PID/SID ID | FLASH CODE | FAULT DESCRIPTION   |
|-----|-----|---------|------------|------------|---|
| 412 | 0   | PID     | 412        | 1512       | EGR Temperature Very High   |
| 412 | 16  | PID     | 412        | 1233       | EGR Temperature Sensor / Temperature Too High   |
| 615 | 4   | SID     | 155        | 1615       | Reserved Monitoring Unit For Temperature Diagnostics, Circuit Failed Low MU_ISP_T_TBD4_SRL  |
| 615 | 3   | SID     | 155        | 1615       | Reserved Monitoring Unit For Temperature Diagnostics, Circuit Failed High MU_ISP_T_TBD4_SRH |
| 615 | 4   | SID     | 155        | 1615       | Reserved Monitoring Unit For Temperature Diagnostics, Circuit Failed Low MU_ISP_T_TBD1_SRL  |
| 615 | 3   | SID     | 155        | 1615       | Reserved Monitoring Unit For Temperature Diagnostics, Circuit Failed High MU_ISP_T_TBD1_SRH |
| 615 | 4   | SID     | 155        | 1615       | Reserved Monitoring Unit For Temperature Diagnostics, Circuit Failed Low MU_ISP_T_TBD2_SRL  |
| 615 | 3   | SID     | 155        | 1615       | Reserved Monitoring Unit For Temperature Diagnostics, Circuit Failed High MU_ISP_T_TBD2_SRH |
| 615 | 4   | SID     | 155        | 1615       | Reserved Monitoring Unit For Temperature Diagnostics, Circuit Failed Low MU_ISP_T_TBD3_SRL  |
| 615 | 3   | SID     | 155        | 1615       | Reserved Monitoring Unit For Temperature Diagnostics, Circuit Failed High MU_ISP_T_TBD3_SRH |
| 615 | 4   | SID     | 155        | 1615       | Catalyst Temperature Sensor Circuit High Input (Bank 1 Sensor 1)                            |
| 615 | 3   | SID     | 155        | 1615       | Catalyst Temperature Sensor Circuit Low Input (Bank 1 Sensor 1)                             |
| 615 | 4   | SID     | 155        | 1615       | Catalyst Temperature Sensor Circuit High (Bank 1 Sensor 2)                                  |
| 615 | 3   | SID     | 155        | 1615       | Catalyst Temperature Sensor Circuit Low (Bank 1 Sensor 2)                                   |
| 615 | 4   | SID     | 51         | 1322       | Water Pump 1 Circuit Failed Low   |
| 615 | 3   | SID     | 51         | 1322       | Water Pump 1 Circuit Failed High  |
| 615 | 5   | SID     | 51         | 1322       | Water Pump 1 Circuit Failed Open  |
| 615 | 4   | SID     | 55         | 1331       | Turbo Compound Valve Circuit Failed Low   |
| 615 | 3   | SID     | 55         | 1331       | Turbo Compound Valve Circuit Failed High  |
| 615 | 5   | SID     | 55         | 1331       | Turbo Compound Valve Circuit Failed Open  |
| 615 | 4   | SID     | 259        | 1335       | Turbo Brake Sleeve Circuit Failed Low   |
| 615 | 3   | SID     | 259        | 1335       | Turbo Brake Sleeve Circuit Failed High  |
| 615 | 5   | SID     | 259        | 1335       | Turbo Brake Sleeve Circuit Failed Open  |
| 615 | 4   | SID     | 261        | 1355       | Function 20 Circuit Failed Low  |
| 615 | 3   | SID     | 261        | 1355       | Function 20 Circuit Failed High   |
| 615 | 5   | SID     | 261        | 1355       | Function 20 Circuit Failed Open   |
| 615 | 3   | SID     | 155        | 1451       | Service Push Button Circuit Failed High   |
| 615 | 14  | SID     | 155        | 1615       | Turbocharger/Supercharger Boost System Performance  |
| 615 | 14  | SID     | 155        | 1615       | Starter Electronic Fault / ECU internal (Res)   |
| 615 | 14  | SID     | 155        | 1615       | Starter Jammed (Tooth to Tooth Jam)   |
| 615 | 14  | SID     | 155        | 1615       | Rail Pressure Governor, Valve Stays Open  |
| 615 | 14  | SID     | 155        | 1615       | MU_RPG_INT_MON_SRH, I Term Value Too High   |
| 615 | 14  | SID     | 155        | 1615       | Rail Pressure Governor, Leakage in High Pressure Too High                                   |
| 615 | 14  | SID     | 155        | 1615       | Rail Pressure Governor Sensor, Signal Drift   |
| 615 | 14  | SID     | 155        | 1615       | Rail Pressure Governor Sensor, Sensor Supply Line Broken                                    |
| 615 | 4   | SID     | 155        | 1615       | Compressor Differential Pressure Outlet Failed Low  |
| 615 | 3   | SID     | 155        | 1615       | Compressor Differential Pressure Outlet Failed High   |
| 615 | 14  | SID     | 155        | 1615       | Doser Metering and Safety Unit Valve Seals Check  |
| 615 | 14  | SID     | 155        | 1615       | High Pressure Pump, Leakage or TDC Position Wrong   |
| 615 | 4   | SID     | 155        | 1615       | Flap In Front of EGR Cooler Circuit Failed Low  |
| 615 | 3   | SID     | 155        | 1615       | Flap In Front of EGR Cooler Circuit Failed High   |
| 615 | 5   | SID     | 155        | 1615       | Flap In Front of EGR Cooler Circuit Failed Open   |
| 615 | 4   | SID     | 155        | 1615       | Water Pump 2 Circuit Failed Low   |

**SECTION 01: ENGINE**

| SPN | FMI | PID/SID | PID/SID ID | FLASH CODE | FAULT DESCRIPTION  |
|-----|-----|---------|------------|------------|--|
| 615 | 3   | SID     | 155        | 1615       | Water Pump 2 Circuit Failed High   |
| 615 | 5   | SID     | 156        | 1615       | Water Pump 2 Circuit Failed Open   |
| 615 | 4   | SID     | 157        | 1615       | RCP Test Function 1 Circuit Failed Low   |
| 615 | 3   | SID     | 158        | 1615       | RCP Test Function 1 Circuit Failed High  |
| 615 | 5   | SID     | 159        | 1615       | RCP Test Function 1 Circuit Failed Open  |
| 615 | 4   | SID     | 160        | 1615       | RCP Test Function 2 Circuit Failed Low   |
| 615 | 3   | SID     | 161        | 1615       | RCP Test Function 2 Circuit Failed High  |
| 615 | 5   | SID     | 162        | 1615       | RCP Test Function 2 Circuit Failed Open  |
| 615 | 4   | SID     | 163        | 1615       | Volute Control Valve, Shorted to Ground  |
| 615 | 3   | SID     | 164        | 1615       | Volute Control Valve, Shorted to Battery                                       |
| 615 | 5   | SID     | 165        | 1615       | Volute Control Valve, Open Load  |
| 615 | 4   | SID     | 166        | 1615       | Volute Shut Off Valve, Shorted to Ground                                       |
| 615 | 3   | SID     | 167        | 1615       | Volute Shut Off Valve, Shorted to Battery                                      |
| 615 | 5   | SID     | 168        | 1615       | Volute Shut Off Valve, Open Load   |
| 615 | 4   | SID     | 169        | 1615       | Function 30 Circuit Failed Low   |
| 615 | 3   | SID     | 170        | 1615       | Function 30 Circuit Failed High  |
| 615 | 5   | SID     | 171        | 1615       | Function 30 Circuit Failed Open  |
| 615 | 4   | SID     | 172        | 1615       | Function 31 Circuit Failed Low   |
| 615 | 3   | SID     | 173        | 1615       | Function 31 Circuit Failed High  |
| 615 | 5   | SID     | 174        | 1615       | Function 31 Circuit Failed Open  |
| 615 | 14  | SID     | 155        | 1453       | Smart Remote Actuator 2, No Failsafe Mode, Motor Off                           |
| 615 | 9   | SID     | 155        | 1453       | Smart Remote Actuator 2, Failsafe Mode, Motor Off                              |
| 615 | 16  | SID     | 155        | 1453       | Smart Remote Actuator 2, Temperature Fault                                     |
| 615 | 7   | SID     | 155        | 1453       | Smart Remote Actuator 2, Failsafe Mode, Motor On                               |
| 615 | 11  | SID     | 155        | 1453       | Smart Remote Actuator 2, Restricted Operability                                |
| 615 | 15  | SID     | 155        | 1453       | Smart Remote Actuator 2, Temperature Warning                                   |
| 615 | 8   | SID     | 155        | 1453       | Smart Remote Actuator 2, Internal Test Running                                 |
| 615 | 31  | SID     | 155        | 1453       | Smart Remote Actuator 2, Unknown Error Code                                    |
| 615 | 13  | SID     | 155        | 1454       | Turbocharger Compressor Outlet Differential Pressure Sensor Out of Calibration |
| 615 | 13  | SID     | 155        | 1454       | Turbocharger Compressor Outlet Differential Pressure Sensor Out of Calibration |
| 615 | 19  | SID     | 155        | 1637       | Smart Actuator Indicates Actuator Position Error                               |
| 625 | 2   | SID     | 248        | 1234       | Invalid Data on Engine CAN Link  |
| 625 | 9   | SID     | 248        | 1234       | No Data Received from Engine CAN Link  |
| 625 | 9   | SID     | 248        | 1234       | Engine CAN Low Wire Defect - (wire 1)  |
| 625 | 9   | SID     | 248        | 1234       | Engine CAN High Wire Defect - (wire 2)   |
| 630 | 12  | SID     | 253        | 1452       | EEPROM Read / Write Operation Failed   |
| 630 | 13  | SID     | 253        | 1455       | Calibration Data Not Plausible   |
| 630 | 13  | SID     | 253        | 1455       | Calibration Data Not Plausible (CPLD)  |
| 634 | 4   | SID     | 40         | 1321       | Constant Throttle Valve Circuit Failed Low                                     |
| 634 | 3   | SID     | 40         | 1321       | Constant Throttle Valve Circuit Failed High                                    |
| 634 | 5   | SID     | 40         | 1321       | Constant Throttle Valve Circuit Failed Open                                    |
| 636 | 1   | SID     | 21         | 1235       | Crankshaft Position Sensor Signal Voltage Too Low                              |
| 636 | 3   | SID     | 21         | 1235       | Crankshaft Position Sensor Open Circuit  |
| 636 | 4   | SID     | 21         | 1235       | Crankshaft Position Sensor Short to Ground                                     |
| 636 | 8   | SID     | 21         | 1235       | Crankshaft Position Sensor Time Out  |
| 636 | 14  | SID     | 21         | 1235       | Crankshaft Position Sensor Pins Swapped  |

## Section 01: ENGINE

| SPN | FMI | PID/SID | PID/SID ID | FLASH CODE | FAULT DESCRIPTION  |
|-----|-----|---------|------------|------------|--|
| 636 | 2   | SID     | 21         | 1235       | No Match of Camshaft and Crankshaft Signals  |
| 641 | 4   | SID     | 27         | 1542       | Turbo Control Circuit Failed Low   |
| 641 | 3   | SID     | 27         | 1542       | Turbo Control Circuit Failed High  |
| 641 | 5   | SID     | 27         | 1542       | Turbo Control Circuit Open   |
| 641 | 14  | SID     | 147        | 1241       | Smart Remote Actuator 5 (VGT), No Failsafe Mode, Motor Off                               |
| 641 | 9   | SID     | 147        | 1241       | Smart Remote Actuator 5 (VGT), Failsafe Mode, Motor Off                                  |
| 641 | 7   | SID     | 147        | 1241       | Smart Remote Actuator 5 (VGT), Failsafe Mode, Motor On                                   |
| 641 | 11  | SID     | 147        | 1241       | Smart Remote Actuator 5 (VGT), Restricted Operability                                    |
| 641 | 8   | SID     | 147        | 1241       | Smart Remote Actuator 5 (VGT), Internal Test Running                                     |
| 641 | 31  | SID     | 147        | 1241       | Smart Remote Actuator 5 (VGT), Unknown Error Code  |
| 647 | 4   | SID     | 33         | 1334       | Fan Stage 1 Circuit Failed Low   |
| 647 | 3   | SID     | 33         | 1334       | Fan Stage 1 Circuit Failed High  |
| 647 | 5   | SID     | 33         | 1334       | Fan Stage 1 Circuit Failed Open  |
| 651 | 14  | SID     | 1          | 1242       | Injector Cylinder #1 Needle Control Valve Abnormal Operation                             |
| 651 | 10  | SID     | 1          | 1242       | Injector Cylinder #1 Needle Control Valve Abnormal Rate of Change                        |
| 651 | 5   | SID     | 1          | 1242       | Injector Cylinder 1, Nozzle Control Valve or Spill Control Valve, Jammed Closed          |
| 651 | 7   | SID     | 1          | 1242       | Injector Cylinder 1, Nozzle Control Valve or Spill Control Valve, Jammed Open or Leakage |
| 651 | 6   | SID     | 1          | 1242       | Injector Cylinder #1 Needle Control Valve, Valve Shorted Circuit                         |
| 651 | 31  | SID     | 1          | 1242       | Engine Smoothness Control / Cylinder #1 Value Out of Range                               |
| 652 | 14  | SID     | 2          | 1243       | Injector Cylinder #2 Needle Control Valve Abnormal Operation                             |
| 652 | 10  | SID     | 2          | 1243       | Injector Cylinder #2 Needle Control Valve Abnormal Rate of Change                        |
| 652 | 5   | SID     | 2          | 1243       | Injector Cylinder 2, Nozzle Control Valve or Spill Control Valve, Jammed Closed          |
| 652 | 7   | SID     | 2          | 1243       | Injector Cylinder 2, Nozzle Control Valve or Spill Control Valve, Jammed Open or Leakage |
| 652 | 6   | SID     | 2          | 1243       | Injector Cylinder #2 Needle Control Valve, Valve Shorted Circuit                         |
| 652 | 31  | SID     | 2          | 1243       | Engine Smoothness Control / Cylinder #2 Value Out of Range                               |
| 653 | 14  | SID     | 3          | 1244       | Injector Cylinder #3 Needle Control Valve Abnormal Operation                             |
| 653 | 10  | SID     | 3          | 1244       | Injector Cylinder #3 Needle Control Valve Abnormal Rate of Change                        |
| 653 | 5   | SID     | 3          | 1244       | Injector Cylinder 3, Nozzle Control Valve or Spill Control Valve, Jammed Closed          |
| 653 | 7   | SID     | 3          | 1244       | Injector Cylinder 3, Nozzle Control Valve or Spill Control Valve, Jammed Open or Leakage |
| 653 | 6   | SID     | 3          | 1244       | Injector Cylinder #3 Needle Control Valve, Valve Shorted Circuit                         |
| 653 | 31  | SID     | 3          | 1244       | Engine Smoothness Control / Cylinder #3 Value Out of Range                               |
| 654 | 14  | SID     | 4          | 1245       | Injector Cylinder #4 Needle Control Valve Abnormal Operation                             |
| 654 | 10  | SID     | 4          | 1245       | Injector Cylinder #4 Needle Control Valve Abnormal Rate of Change                        |
| 654 | 5   | SID     | 4          | 1245       | Injector Cylinder 4, Nozzle Control Valve or Spill Control Valve, Jammed Closed          |
| 654 | 7   | SID     | 4          | 1245       | Injector Cylinder 4, Nozzle Control Valve or Spill Control Valve, Jammed Open or Leakage |
| 654 | 6   | SID     | 4          | 1245       | Injector Cylinder #4 Needle Control Valve, Valve Shorted Circuit                         |
| 654 | 31  | SID     | 4          | 1245       | Engine Smoothness Control / Cylinder #4 Value Out of Range                               |
| 655 | 14  | SID     | 5          | 1251       | Injector Cylinder #5 Needle Control Valve Abnormal Operation                             |
| 655 | 10  | SID     | 5          | 1251       | Injector Cylinder #5 Needle Control Valve Abnormal Rate of Change                        |
| 655 | 5   | SID     | 5          | 1251       | Injector Cylinder 5, Nozzle Control Valve or Spill Control Valve, Jammed Closed          |

**SECTION 01: ENGINE**

| SPN  | FMI | PID/SID | PID/SID ID | FLASH CODE | FAULT DESCRIPTION  |
|------|-----|---------|------------|------------|--|
| 655  | 7   | SID     | 5          | 1251       | Injector Cylinder 5, Nozzle Control Valve or Spill Control Valve, Jammed Open or Leakage |
| 655  | 6   | SID     | 5          | 1251       | Injector Cylinder #5 Needle Control Valve, Valve Shorted Circuit                         |
| 655  | 31  | SID     | 5          | 1251       | Engine Smoothness Control / Cylinder #5 Value Out of Range                               |
| 656  | 14  | SID     | 6          | 1252       | Injector Cylinder #6 Needle Control Valve Abnormal Operation                             |
| 656  | 10  | SID     | 6          | 1252       | Injector Cylinder #6 Needle Control Valve Abnormal Rate of Change                        |
| 656  | 5   | SID     | 6          | 1252       | Injector Cylinder 6, Nozzle Control Valve or Spill Control Valve, Jammed Closed          |
| 656  | 7   | SID     | 6          | 1252       | Injector Cylinder 6, Nozzle Control Valve or Spill Control Valve, Jammed Open or Leakage |
| 656  | 6   | SID     | 6          | 1252       | Injector Cylinder #6 Needle Control Valve, Valve Shorted Circuit                         |
| 656  | 31  | SID     | 6          | 1252       | Engine Smoothness Control / Cylinder #6 Value Out of Range                               |
| 657  | 14  | SID     | 7          | 1253       | Injector Cylinder #7 Needle Control Valve Abnormal Operation                             |
| 657  | 10  | SID     | 7          | 1253       | Injector Cylinder #7 Needle Control Valve Abnormal Rate of Change                        |
| 657  | 6   | SID     | 7          | 1253       | Injector Cylinder #7 Needle Control Valve, Valve Shorted Circuit                         |
| 657  | 31  | SID     | 7          | 1253       | Engine Smoothness Control / Cylinder #7 Value Out of Range                               |
| 658  | 14  | SID     | 8          | 1254       | Injector Cylinder #8 Needle Control Valve Abnormal Operation                             |
| 658  | 10  | SID     | 8          | 1254       | Injector Cylinder #8 Needle Control Valve Abnormal Rate of Change                        |
| 658  | 6   | SID     | 8          | 1254       | Injector Cylinder #8 Needle Control Valve, Valve Shorted Circuit                         |
| 658  | 31  | SID     | 8          | 1254       | Engine Smoothness Control / Cylinder #8 Value Out of Range                               |
| 677  | 2   | SID     | 39         | 1255       | Starter Switch Inconsistent  |
| 677  | 5   | SID     | 39         | 1255       | Engine Starter Relay Circuit Failed Low  |
| 677  | 4   | SID     | 39         | 1255       | Engine Starter Relay Open Circuit  |
| 677  | 14  | SID     | 39         | 1255       | Starter Electronic Fault / ECU internal (Main)   |
| 677  | 7   | SID     | 39         | 1255       | Engine Starter Relay - Starter Does Not Engage   |
| 677  | 3   | SID     | 39         | 1255       | Engine Starter Relay Shorted to High Source  |
| 677  | 7   | SID     | 39         | 1255       | Engine Starter Relay Jammed  |
| 698  | 4   | SID     | 58         | 1312       | Gridheater Circuit Failed Low  |
| 698  | 3   | SID     | 58         | 1312       | Gridheater Circuit Failed High   |
| 698  | 5   | SID     | 58         | 1312       | Gridheater Circuit Failed Open   |
| 715  | 4   | SID     | 263        | 1412       | High Side Digital Output # 1 Circuit Failed Low  |
| 715  | 3   | SID     | 263        | 1412       | High Side Digital Output # 1 Circuit Failed High   |
| 715  | 5   | SID     | 263        | 1412       | High Side Digital Output # 2 Circuit Failed Open   |
| 716  | 4   | SID     | 264        | 1413       | High Side Digital Output # 2 Circuit Failed Low  |
| 723  | 1   | SID     | 64         | 1415       | Camshaft Position Sensor Signal Voltage Too Low  |
| 723  | 3   | SID     | 64         | 1415       | Camshaft Position Sensor Open Circuit  |
| 723  | 4   | SID     | 64         | 1415       | Camshaft Position Sensor Short to Ground   |
| 723  | 8   | SID     | 64         | 1415       | Camshaft Position Sensor Time Out  |
| 723  | 14  | SID     | 64         | 1415       | Camshaft Position Sensor Pins Swapped  |
| 729  | 4   | PID     | 45         | 1421       | Grid Heater Circuit Failed Low   |
| 729  | 14  | PID     | 45         | 1421       | Grid Heater Special Instructions   |
| 729  | 3   | PID     | 45         | 1421       | Grid Heater Circuit Failed High  |
| 729  | 7   | PID     | 45         | 1421       | Grid Heater Defect   |
| 729  | 0   | PID     | 45         | 1421       | Grid Heater Permanently On   |
| 1071 | 4   | SID     | 60         | 1314       | Fan Stage 2 Circuit Failed Low   |
| 1071 | 3   | SID     | 60         | 1314       | Fan Stage 2 Circuit Failed High  |
| 1071 | 5   | SID     | 60         | 1314       | Fan Stage 2 Circuit Failed Open  |
| 1072 | 4   | SID     | 79         | 1422       | Jake Brake Stage 1 Circuit Failed Low  |
| 1072 | 3   | SID     | 79         | 1422       | Jake Brake Stage 1 Circuit Failed High   |
| 1072 | 5   | SID     | 79         | 1422       | Jake Brake Stage 1 Circuit Failed Open   |

## Section 01: ENGINE

| SPN  | FMI | PID/SID | PID/SID ID | FLASH CODE | FAULT DESCRIPTION  |
|------|-----|---------|------------|------------|--|
| 1073 | 4   | SID     | 80         | 1315       | Jake Brake Stage 2 Circuit Failed Low  |
| 1073 | 3   | SID     | 80         | 1315       | Jake Brake Stage 2 Circuit Failed High                                       |
| 1073 | 5   | SID     | 80         | 1315       | Jake Brake Stage 2 Circuit Failed Open                                       |
| 1074 | 4   | SID     | 81         | 1345       | Exhaust Brake Circuit Failed Low   |
| 1074 | 3   | SID     | 81         | 1345       | Exhaust Brake Circuit Failed High  |
| 1074 | 5   | SID     | 81         | 1345       | Exhaust Brake Circuit Failed Open  |
| 1077 | 14  | PID     | 164        | 1241       | Rail Pressure Governor Error, Open Loop Error                                |
| 1077 | 5   | PID     | 164        | 1423       | Rail Pressure Governor Error, Current Governor, Current Too Low              |
| 1077 | 7   | PID     | 164        | 1423       | Rail Pressure Governor Error, Pressure Governor, Pressure Not Plausible      |
| 1077 | 6   | SID     | 155        | 1423       | Rail Pressure Governor Error, Current Too High                               |
| 1127 | 4   | SID     | 273        | 1424       | Turbocharger Compressor Outlet Pressure Circuit Failed Low                   |
| 1127 | 3   | SID     | 273        | 1424       | Turbocharger Compressor Outlet Pressure Circuit Failed High                  |
| 1172 | 4   | PID     | 351        | 1425       | Turbocharger Compressor Inlet Temperature Circuit Failed Low                 |
| 1172 | 3   | PID     | 351        | 1425       | Turbocharger Compressor Inlet Temperature Circuit Failed High                |
| 1172 | 2   | PID     | 351        | 1425       | Coolant Temp/Compressor Inlet Temp Plausibility Error                        |
| 1172 | 2   | PID     | 351        | 1425       | Turbocharger Compressor Inlet Temp. Sensor, General Temp. Plausibility Error |
| 1176 | 4   | SID     | 314        | 1431       | Turbocharger Compressor Inlet Pressure Circuit Failed Low                    |
| 1176 | 3   | SID     | 314        | 1431       | Turbocharger Compressor Inlet Pressure Circuit Failed High                   |
| 1176 | 2   | PID     | 314        | 1431       | Compressor Pressure Plausibility Fault (High Box)                            |
| 1176 | 5   | PID     | 314        | 1431       | Compressor Inlet Pressure Plausibility Fault (Delta)                         |
| 1176 | 20  | SID     | 314        | 1431       | Compressor Inlet Pressure Plausibility Error, Pressure Too High (High Box)   |
| 1188 | 4   | SID     | 32         | 1325       | Waste Gate Circuit Failed Low  |
| 1188 | 3   | SID     | 32         | 1325       | Waste Gate Circuit Failed High   |
| 1188 | 5   | SID     | 32         | 1325       | Waste Gate Circuit Failed Open   |
| 1188 | 14  | SID     | 32         | 1432       | Smart Remote Actuator 1 (Wastegate), No Failsafe Mode, Motor Off             |
| 1188 | 9   | SID     | 32         | 1432       | Smart Remote Actuator 1 (Wastegate), Failsafe Mode, Motor Off                |
| 1188 | 16  | SID     | 32         | 1432       | Smart Remote Actuator 1 (Wastegate), Temperature Fault                       |
| 1188 | 7   | SID     | 32         | 1432       | Smart Remote Actuator 1 (Wastegate), Failsafe Mode, Motor On                 |
| 1188 | 11  | SID     | 32         | 1432       | Smart Remote Actuator 1 (Wastegate), Restricted Operability                  |
| 1188 | 15  | SID     | 32         | 1432       | Smart Remote Actuator 1 (Wastegate), Temperature Warning                     |
| 1188 | 8   | SID     | 32         | 1432       | Smart Remote Actuator 1 (Wastegate), Internal Test Running                   |
| 1188 | 31  | SID     | 32         | 1432       | Smart Remote Actuator 1 (Wastegate), Unknown Error Code                      |
| 1188 | 19  | SID     | 32         | 1432       | Smart Actuator Indicates Turbocharger Wastegate Position Error               |
| 1213 | 4   | SID     | 257        | 1333       | MIL Lamp Circuit Failed Low  |
| 1213 | 3   | SID     | 257        | 1333       | MIL Lamp Circuit Failed High   |
| 1213 | 5   | SID     | 257        | 1333       | MIL Lamp Circuit Failed Open   |
| 1323 | 31  | SID     | 155        | 1433       | Cylinder 1 Misfire detected  |
| 1323 | 14  | SID     | 156        | 1434       | Misfire Detected   |
| 1324 | 31  | SID     | 155        | 1435       | Cylinder 2 Misfire detected  |
| 1325 | 31  | SID     | 155        | 1441       | Cylinder 3 Misfire detected  |
| 1326 | 31  | SID     | 155        | 1442       | Cylinder 4 Misfire detected  |
| 1327 | 31  | SID     | 155        | 1443       | Cylinder 5 Misfire detected  |
| 1328 | 31  | SID     | 155        | 1444       | Cylinder 6 Misfire Detected  |
| 1329 | 31  | SID     | 155        | 1445       | Cylinder 7 Misfire Detected  |
| 1330 | 31  | SID     | 155        | 1446       | Cylinder 8 Misfire Detected  |
| 1351 | 4   | SID     | 155        | 1615       | Switchable Air Compressor Circuit Failed Low                                 |
| 1351 | 3   | SID     | 155        | 1615       | Switchable Air Compressor Circuit Failed High                                |



**SECTION 01: ENGINE**

| SPN  | FMI | PID/SID | PID/SID ID | FLASH CODE | FAULT DESCRIPTION  |
|------|-----|---------|------------|------------|--|
| 1351 | 5   | SID     | 155        | 1615       | Switchable Air Compressor Circuit Failed Open  |
| 1636 | 4   | PID     | 105        | 1511       | Intake Manifold Temperature Circuit Failed Low   |
| 1636 | 3   | PID     | 105        | 1511       | Intake Manifold Temperature Circuit Failed High  |
| 1636 | 2   | PID     | 105        | 1511       | Intake Manifold Temperature Plausibility Error   |
| 1636 | 21  | PID     | 105        | 1511       | Difference Intake Manifold Temperature and EGR Temp. Less Than Threshold (Low Box)     |
| 1636 | 2   | PID     | 105        | 1511       | Difference Intake Manifold and I Cooler Temperature Out Less Than Threshold (Low Box)  |
| 1636 | 2   | PID     | 105        | 1511       | Difference Intake Manifold and I Cooler Temperature Out Less Than Threshold (High Box) |
| 1636 | 20  | PID     | 105        | 1511       | Intake Manifold Temperature Drift (Low Box)  |
| 1636 | 21  | PID     | 105        | 1511       | Intake Manifold Temperature Drift (High Box)   |
| 2629 | 4   | PID     | 404        | 1513       | Turbocharger Compressor Outlet Temperature Circuit Failed Low                          |
| 2629 | 3   | PID     | 404        | 1513       | Turbocharger Compressor Outlet Temperature Circuit Failed High                         |
| 2629 | 20  | PID     | 404        | 1513       | Turbocharger Out Temperature, Temperature Too High (Low Box)                           |
| 2629 | 21  | PID     | 404        | 1513       | Turbocharger Out Temperature, Temperature Too Low (High Box)                           |
| 2629 | 2   | PID     | 404        | 1513       | Turbocharger Compressor Outlet Temp. Sensor, General Temp. Plausibility Error          |
| 2630 | 4   | SID     | 272        | 1514       | Charge Air Cooler Outlet Temperature Circuit Failed Low                                |
| 2630 | 3   | SID     | 272        | 1514       | Charge Air Cooler Outlet Temperature Circuit Failed High                               |
| 2630 | 2   | SID     | 272        | 1514       | Charge Air Cooler Outlet Temperature Sensor Plausibility Error                         |
| 2630 | 20  | SID     | 272        | 1514       | Charge Air Outlet Temperature Drift (Low box)  |
| 2630 | 21  | SID     | 272        | 1514       | Charge Air Outlet Temperature Drift (High box)   |
| 2631 | 4   | SID     | 273        | 1515       | Charge Air Cooler Outlet Pressure Circuit Failed Low                                   |
| 2631 | 3   | SID     | 273        | 1515       | Charge Air Cooler Outlet Pressure Circuit Failed High                                  |
| 2659 | 1   | SID     | 277        | 1515       | EGR Flow Target Error Diagnostic - Low Flow  |
| 2659 | 0   | SID     | 277        | 1515       | EGR Flow Target Error Diagnostic - High Flow   |
| 2791 | 4   | PID     | 146        | 1521       | EGR Valve Circuit Failed Low   |
| 2791 | 3   | PID     | 146        | 1521       | EGR Valve Circuit Failed High  |
| 2791 | 5   | PID     | 146        | 1521       | EGR Valve Circuit Failed Open  |
| 2791 | 7   | SID     | 146        | 1521       | EGR Valve Position Incorrect   |
| 2791 | 14  | SID     | 146        | 1521       | Smart Remote Actuator 3 (EGR), No Failsafe Mode, Motor Off                             |
| 2791 | 9   | SID     | 146        | 1521       | Smart Remote Actuator 3 (EGR), Failsafe Mode, Motor Off                                |
| 2791 | 16  | SID     | 146        | 1521       | Smart Remote Actuator 3 (EGR), Temperature Fault                                       |
| 2791 | 7   | SID     | 146        | 1521       | Smart Remote Actuator 3 (EGR), Failsafe Mode, Motor On                                 |
| 2791 | 11  | SID     | 146        | 1521       | Smart Remote Actuator 3 (EGR), Restricted Operability                                  |
| 2791 | 15  | SID     | 146        | 1521       | Smart Remote Actuator 3 (EGR), Temperature Warning                                     |
| 2791 | 8   | SID     | 146        | 1521       | Smart Remote Actuator 3 (EGR), Internal Test Running                                   |
| 2791 | 31  | SID     | 146        | 1521       | Smart Remote Actuator 3 (EGR), Unknown Error Code                                      |
| 2795 | 9   | SID     | 269        | 1241       | CAN3 Communication Error   |
| 2795 | 4   | SID     | 269        | 1522       | Position Waste Gate (VNT) Failed Low   |
| 2795 | 3   | SID     | 269        | 1522       | Position Waste Gate (VNT) Failed High  |
| 2795 | 2   | SID     | 269        | 1522       | VNT Valve Position Feedback Failed   |
| 2795 | 0   | SID     | 269        | 1522       | VNT Valve Position Feedback, Position Too Low (High Box)                               |
| 2795 | 1   | SID     | 269        | 1522       | VNT Valve Position Feedback, Position Too High (Low Box)                               |
| 2795 | 19  | SID     | 147        | 1522       | Smart Actuator Indicates Turbocharger Vane Position Error                              |
| 2797 | 4   | SID     | 317        | 1523       | Injector Needle Control Valve Cylinder 1, 2, 3 Shorted to Ground                       |
| 2797 | 4   | SID     | 317        | 1524       | Injector Needle Control Valve Cylinder 4, 5, 6 Shorted to Ground                       |

## Section 01: ENGINE

| SPN  | FMI | PID/SID | PID/SID ID | FLASH CODE | FAULT DESCRIPTION   |
|------|-----|---------|------------|------------|---|
| 2797 | 4   | SID     | 317        | 1615       | Injector Needle Control Valve Bank 3, Shorted to Ground               |
| 2797 | 3   | SID     | 317        | 1523       | Injector Needle Control Valve Cylinder 1,2,3 Shorted to Battery       |
| 2797 | 3   | SID     | 317        | 1524       | Injector Needle Control Valve Cylinder 4,5,6, Shorted to Battery      |
| 2797 | 3   | SID     | 317        | 1615       | Injector Needle Control Valve Bank 3, Shorted to Battery              |
| 2798 | 4   | SID     | 317        | 1615       | Injector Spill Control Valve Cylinder 1, 2, 3 Shorted to Ground       |
| 2798 | 4   | SID     | 317        | 1615       | Injector Spill Control Valve Cylinder 4, 5, 6 Shorted to Ground       |
| 2798 | 4   | SID     | 317        | 1615       | Injector Spill Control Valve ("Amplifier") Bank 6, Shorted to Ground  |
| 2798 | 3   | SID     | 317        | 1615       | Injector Spill Control Valve Cylinder 1,2,3, Shorted to Battery       |
| 2798 | 3   | SID     | 317        | 1615       | Injector Spill Control Valve Cylinder 4,5,6, Shorted to Battery       |
| 2798 | 3   | SID     | 317        | 1615       | Injector Spill Control Valve ("Amplifier") Bank 6, Shorted to Battery |
| 2988 | 4   | SID     | 262        | 1411       | EGR Water Cooling Regulator Circuit Failed Low                        |
| 988  | 3   | SID     | 262        | 1411       | EGR Water Cooling Regulator Circuit Failed High                       |
| 2988 | 5   | SID     | 262        | 1411       | EGR Water Cooling Regulator Circuit Failed Open                       |
| 3050 | 0   | SID     | 155        | 1525       | Engine Air Flow Out of Range Low                                      |
| 3050 | 1   | SID     | 324        | 1525       | Active Regen Temp Out of Range Low                                    |
| 3058 | 13  | PID     | 146        | 1615       | EGR System Parametrization Failure                                    |
| 3064 | 13  | SID     | 155        | 1615       | DPF System Parametrization Failure                                    |
| 3242 | 4   | PID     | 318        | 1531       | DOC Inlet Temperature Circuit Failed Low                              |
| 3242 | 3   | PID     | 318        | 1531       | DOC Inlet Temperature Circuit Failed High                             |
| 3242 | 10  | SID     | 318        | 1531       | DOC Inlet Temperature Sensor Stuck                                    |
| 3242 | 2   | SID     | 318        | 1531       | DOC Inlet Temperature Sensor - Plausibility Error                     |
| 3246 | 4   | SID     | 320        | 1532       | DPF Outlet Temperature Circuit Failed Low                             |
| 3246 | 3   | SID     | 320        | 1532       | DPF Outlet Temperature Circuit Failed High                            |
| 3246 | 14  | SID     | 320        | 1532       | Abnormal DPF Temperature Rise b)                                      |
| 3246 | 0   | SID     | 320        | 1532       | DPF Outlet Temperature High   |
| 3246 | 10  | SID     | 320        | 1532       | DPF Outlet Temperature Sensor Stuck                                   |
| 3246 | 2   | SID     | 320        | 1532       | DPF Outlet Sensor, General Temp. Plausibility                         |
| 3246 | 31  | SID     | 323        | 1532       | Abnormal DPF Temperature Rise   |
| 3250 | 4   | PID     | 322        | 1533       | DOC Outlet Temperature Circuit Failed Low                             |
| 3250 | 3   | PID     | 322        | 1533       | DOC Outlet Temperature Circuit Failed High                            |
| 3250 | 14  | PID     | 322        | 1533       | Abnormal DOC Temperature Rise   |
| 3250 | 10  | SID     | 322        | 1533       | DOC Outlet Temperature Sensor Stuck                                   |
| 3250 | 2   | SID     | 322        | 1533       | DOC Outlet Temperature Sensor - Plausibility Error                    |
| 3250 | 31  | PID     | 322        | 1533       | Abnormal DOC Temperature Rise   |
| 3250 | 0   | PID     | 322        | 1533       | DOC Outlet Temperature High   |
| 3251 | 0   | SID     | 324        | 1534       | DPF Pressure - Out of Range Very High                                 |
| 3251 | 1   | SID     | 324        | 1534       | DPF Pressure - Out of Range Low                                       |
| 3251 | 9   | SID     | 324        | 1534       | Abnormal Soot Rate  |
| 3251 | 16  | SID     | 324        | 1534       | DPF Pressure - Out of Range High                                      |
| 3358 | 4   | SID     | 155        | 1535       | EGR Pressure Failed Low   |
| 3358 | 3   | SID     | 155        | 1535       | EGR Pressure Failed High  |
| 3464 | 4   | SID     | 59         | 1313       | Intake Throttle Valve Circuit Failed Low                              |
| 3464 | 3   | SID     | 59         | 1313       | Intake Throttle Valve Circuit Failed High                             |
| 3464 | 5   | SID     | 59         | 1313       | Intake Throttle Valve Circuit Failed Open                             |
| 3464 | 14  | SID     | 59         | 1615       | Intake Air Throttle Control Electrical Fault                          |
| 3464 | 2   | PID     | 51         | 1541       | Intake Throttle Valve, Spring Response Time Not Plausible             |
| 3464 | 7   | PID     | 51         | 1541       | Intake Throttle Valve, Stuck  |

**SECTION 01: ENGINE**

| SPN  | FMI | PID/SID | PID/SID ID | FLASH CODE | FAULT DESCRIPTION  |
|------|-----|---------|------------|------------|--|
| 3464 | 14  | PID     | 51         | 1541       | Intake Throttle Valve, Integrated Absolute Error Plausibility            |
| 3464 | 8   | PID     | 51         | 1541       | Intake Throttle Valve, Current Deviation Too High                        |
| 3470 | 4   | SID     | 57         | 1311       | Actuator Turbo Compound Bypass Circuit Failed Low                        |
| 3470 | 3   | SID     | 57         | 1311       | Actuator Turbo Compound Bypass Circuit Failed High                       |
| 3470 | 5   | SID     | 57         | 1311       | Actuator Turbo Compound Bypass Circuit Failed Open                       |
| 3471 | 4   | SID     | 334        | 1323       | HC Doser Circuit Failed Low  |
| 3471 | 3   | SID     | 334        | 1323       | HC Doser Circuit Failed High   |
| 3471 | 5   | SID     | 334        | 1323       | HC Doser Circuit Failed Open   |
| 3471 | 1   | SID     | 155        | 1542       | EDV Failed Self Test   |
| 3480 | 2   | SID     | 332        | 1543       | Doser Fuel Line Pressure Abnormal  |
| 3480 | 1   | SID     | 332        | 1543       | Doser Fuel Supply Pressure Abnormal                                      |
| 3480 | 14  | SID     | 332        | 1543       | Doser FLP Sensors Failed Self Test                                       |
| 3482 | 4   | SID     | 56         | 1332       | Fuel Cut Off Valve Circuit Failed Low                                    |
| 3482 | 3   | SID     | 56         | 1332       | Fuel Cut Off Valve Circuit Failed High                                   |
| 3482 | 5   | SID     | 56         | 1332       | Fuel Cut Off Valve Circuit Failed Open                                   |
| 3482 | 7   | SID     | 155        | 1544       | FCV Failed Self Test   |
| 3509 | 3   | SID     | 212        | 1631       | Multiplexer 1 Channel 1, Shorted High                                    |
| 3509 | 3   | SID     | 212        | 1631       | Multiplexer 1 Channel 2, Shorted High                                    |
| 3510 | 3   | SID     | 211        | 1632       | Multiplexer 2 Channel 1, Shorted High                                    |
| 3510 | 3   | SID     | 211        | 1632       | Multiplexer 2 Channel 2, Shorted High                                    |
| 3511 | 3   | SID     | 211        | 1633       | Multiplexer 3 Channel 1, Shorted High                                    |
| 3511 | 3   | SID     | 211        | 1633       | Multiplexer 3 Channel 2, Shorted High                                    |
| 3556 | 1   | SID     | 155        | 1545       | Regen Temperature - Out of Range Low                                     |
| 3556 | 0   | SID     | 155        | 1551       | Regen Temperature - Out of Range High                                    |
| 3563 | 4   | PID     | 106        | 1551       | Intake Manifold Pressure Circuit Failed Low                              |
| 3563 | 3   | PID     | 106        | 1551       | Intake Manifold Pressure Circuit Failed High                             |
| 3563 | 20  | PID     | 106        | 1551       | Ambient and Inlet Manifold Pressure Difference (Low Box)                 |
| 3563 | 21  | PID     | 106        | 1551       | Ambient and Inlet Manifold Pressure Difference (High Box)                |
| 3563 | 1   | PID     | 106        | 1551       | Inlet Manifold Pressure Failed Low                                       |
| 3563 | 0   | PID     | 106        | 1551       | Inlet Manifold Pressure Failed High                                      |
| 3563 | 3   | PID     | 106        | 1551       | Inlet Manifold Pressure Sampling Range Failed                            |
| 3563 | 20  | PID     | 106        | 1551       | Intake Manifold Pressure Plausibility (Low Box)                          |
| 3563 | 21  | PID     | 106        | 1551       | Intake Manifold Pressure Plausibility Error, Pressure Too Low (High Box) |
| 3588 | 4   | SID     | 156        | 1552       | Ether Start, Shorted to Ground   |
| 3588 | 3   | SID     | 157        | 1552       | Ether Start, Shorted to Battery  |
| 3588 | 5   | SID     | 158        | 1552       | Ether Start, Open Load   |
| 3597 | 3   | SID     | 155        | 1553       | Proportional Valve Bank 1 Circuit Failed Low                             |
| 3597 | 3   | SID     | 155        | 1615       | Proportional Valve Bank 1 Circuit Failed High                            |
| 3597 | 6   | SID     | 155        | 1325       | Current Flow on HS1 IM1 Too High   |
| 3598 | 4   | SID     | 155        | 1615       | Proportional Valve Bank 2 Circuit Failed Low                             |
| 3598 | 3   | SID     | 155        | 1615       | Proportional Valve Bank 2 Circuit Failed High                            |
| 3599 | 4   | SID     | 317        | 1615       | Switching Power Supply Voltage Failed Low                                |
| 3599 | 3   | SID     | 317        | 1615       | Switching Power Supply Voltage Failed High                               |
| 3609 | 4   | PID     | 370        | 1554       | DPF Inlet Pressure Circuit Failed Low                                    |
| 3609 | 3   | PID     | 370        | 1554       | DPF Inlet Pressure Circuit Failed High                                   |
| 3609 | 10  | SID     | 370        | 1554       | DPF Inlet Pressure Sensor Stuck  |
| 3609 | 20  | SID     | 370        | 1554       | DPF Inlet Pressure Sensor Drifted High In Range Fault (Low Box)          |
| 3609 | 2   | SID     | 370        | 1554       | DPF Inlet Pressure Sensor Drifted High In Range Fault (High Box)         |
| 3609 | 21  | SID     | 370        | 1554       | DPF Inlet Pressure Sensor Drifted Low In Range Fault (Low Box)           |
| 3609 | 21  | SID     | 370        | 1554       | DPF Inlet Pressure Sensor Drifted Low In Range Fault (High Box)          |

## Section 01: ENGINE


| SPN  | FMI | PID/SID | PID/SID ID | FLASH CODE | FAULT DESCRIPTION  |
|------|-----|---------|------------|------------|--|
| 3610 | 3   | SID     | 371        | 1555       | DPF Outlet Pressure Circuit Failed High  |
| 3610 | 4   | SID     | 371        | 1555       | DPF Outlet Pressure Circuit Failed Low   |
| 3610 | 0   | SID     | 371        | 1334       | DPF System Back Pressure Too High  |
| 3610 | 10  | SID     | 371        | 1555       | DPF Outlet Pressure Sensor Stuck   |
| 3610 | 2   | SID     | 371        | 1555       | DPF Pressure Sensors - Plausibility Error                                      |
| 3610 | 20  | SID     | 371        | 1555       | DPF Outlet Pressure Sensor Drifted High In Range Fault (Low Box)               |
| 3610 | 14  | SID     | 371        | 1555       | DPF Outlet Pressure Sensor Drifted High In Range Fault (High Box)              |
| 3610 | 21  | SID     | 371        | 1555       | DPF Outlet Pressure Sensor Drifted Low In Range Fault (Low Box)                |
| 3610 | 31  | SID     | 371        | 1555       | DPF Outlet Pressure Sensor Drifted Low In Range Fault (High Box)               |
| 3659 | 14  | SID     | 362        | 1611       | Injector Cylinder #1 Spill Control Valve Abnormal Operation                    |
| 3659 | 10  | SID     | 362        | 1611       | Injector Cylinder #1 Spill Control Valve ("Amplifier") Abnormal Rate of Change |
| 3659 | 6   | SID     | 362        | 1611       | Injector Cylinder #1 Spill Control Valve ("Amplifier"), Valve Shorted Circuit  |
| 3660 | 14  | SID     | 363        | 1612       | Injector Cylinder #2 Spill Control Valve Abnormal Operation                    |
| 3660 | 10  | SID     | 363        | 1612       | Injector Cylinder #2 Spill Control Valve ("Amplifier") Abnormal Rate of Change |
| 3660 | 6   | SID     | 363        | 1612       | Injector Cylinder #2 Spill Control Valve ("Amplifier"), Valve Shorted Circuit  |
| 3661 | 14  | SID     | 364        | 1613       | Injector Cylinder #3 Spill Control Valve Abnormal Operation                    |
| 3661 | 10  | SID     | 364        | 1613       | Injector Cylinder #3 Spill Control Valve ("Amplifier") Abnormal Rate of Change |
| 3661 | 6   | SID     | 364        | 1613       | Injector Cylinder #3 Spill Control Valve ("Amplifier"), Valve Shorted Circuit  |
| 3662 | 14  | SID     | 365        | 1614       | Injector Cylinder #4 Spill Control Valve Abnormal Operation                    |
| 3662 | 10  | SID     | 365        | 1614       | Injector Cylinder #4 Spill Control Valve ("Amplifier") Abnormal Rate of Change |
| 3662 | 6   | SID     | 365        | 1614       | Injector Cylinder #4 Spill Control Valve ("Amplifier"), Valve Shorted Circuit  |
| 3663 | 14  | SID     | 366        | 1615       | Injector Cylinder #5 Spill Control Valve Abnormal Operation                    |
| 3663 | 10  | SID     | 366        | 1615       | Injector Cylinder #5 Spill Control Valve ("Amplifier") Abnormal Rate of Change |
| 3663 | 6   | SID     | 366        | 1615       | Injector Cylinder #5 Spill Control Valve ("Amplifier"), Valve Shorted Circuit  |
| 3664 | 14  | SID     | 367        | 1621       | Injector Cylinder #6 Spill Control Valve Abnormal Operation                    |
| 3664 | 10  | SID     | 367        | 1621       | Injector Cylinder #6 Spill Control Valve ("Amplifier") Abnormal Rate of Change |
| 3664 | 6   | SID     | 367        | 1621       | Injector Cylinder #6 Spill Control Valve ("Amplifier"), Valve Shorted Circuit  |
| 3665 | 14  | SID     | 368        | 1622       | Injector Cylinder #7 Spill Control Valve Abnormal Operation                    |
| 3665 | 10  | SID     | 368        | 1622       | Injector Cylinder #7 Spill Control Valve ("Amplifier") Abnormal Rate of Change |
| 3665 | 6   | SID     | 368        | 1622       | Injector Cylinder #7 Spill Control Valve ("Amplifier"), Valve Shorted Circuit  |
| 3666 | 14  | SID     | 369        | 1623       | Injector Cylinder #8 Spill Control Valve Abnormal Operation                    |
| 3666 | 10  | SID     | 369        | 1623       | Injector Cylinder #8 Spill Control Valve ("Amplifier") Abnormal Rate of Change |
| 3666 | 6   | SID     | 369        | 1623       | Injector Cylinder #8 Spill Control Valve ("Amplifier"), Valve Shorted Circuit  |
| 3719 | 16  | SID     | 155        | 1624       | Soot Level High  |
| 3719 | 0   | SID     | 155        | 1624       | Soot Level Very High   |
| 3719 | 31  | SID     | 155        | 1635       | DPF Zone 2 Condition   |
| 3719 | 15  | SID     | 155        | 1636       | DPF Zone 3 Condition   |

**SECTION 01: ENGINE**


| SPN  | FMI | PID/SID | PID/SID ID | FLASH CODE | FAULT DESCRIPTION   |
|------|-----|---------|------------|------------|---|
| 3720 | 15  | SID     | 155        | 1625       | DPF Ash Clean Request   |
| 3720 | 16  | SID     | 155        | 1625       | DPF Ash Clean Request - Derate  |
| 4076 | 4   | PID     | 110        | 1212       | Engine Coolant Inlet Temperature Circuit Failed Low                           |
| 4076 | 3   | PID     | 110        | 1212       | Engine Coolant Inlet Temperature Circuit Failed High                          |
| 4076 | 2   | SID     | 155        | 1615       | Engine Coolant Sensor (IN), General Temp. Plausibility Error                  |
| 4077 | 4   | SID     | 332        | 1543       | Doser Fuel Line Pressure Sensor Circuit Failed Low                            |
| 4077 | 3   | SID     | 332        | 1543       | Doser Fuel Line Pressure Sensor Circuit Failed High                           |
| 4077 | 14  | SID     | 332        | 1543       | Doser Fuel Line Pressure Failed Self Test                                     |
| 4226 | 4   | SID     | 155        | 1615       | Compressor Differential Pressure Inlet Failed Low                             |
| 4226 | 3   | SID     | 155        | 1615       | Compressor Differential Pressure Inlet Failed High                            |
| 4226 | 0   | SID     | 155        | 1615       | Turbocharger Compressor Inlet Differential Pressure Too High (Low Box)        |
| 4226 | 1   | SID     | 155        | 1615       | Turbocharger Compressor Inlet Differential Pressure Too Low (High Box)        |
| 4226 | 5   | SID     | 155        | 1615       | Turbocharger Compressor Inlet Differential Pressure Sampling Range Failure    |
| 4226 | 13  | SID     | 155        | 1454       | Turbocharger Compressor Inlet Differential Pressure Sensor Out Of Calibration |
| 4226 | 13  | SID     | 155        | 1454       | Turbocharger Compressor Inlet Differential Pressure Sensor Out Of Calibration |
| 4227 | 4   | SID     | 53         | 1324       | Electrostatic Oil Separator Circuit Failed Low                                |
| 4227 | 3   | SID     | 53         | 1324       | Electrostatic Oil Separator Circuit Failed High                               |
| 4227 | 5   | SID     | 53         | 1324       | Electrostatic Oil Separator Circuit Failed Open                               |
| 4227 | 4   | SID     | 155        | 1615       | Oil Separator Circuit Failed Low  |
| 4227 | 3   | SID     | 155        | 1615       | Oil Separator Circuit Failed High   |
| 4227 | 7   | SID     | 155        | 1615       | Oil Separator, Max. Duration Time Reached                                     |
| 4228 | 16  | SID     | 147        | 1241       | Smart Remote Actuator 5 (VGT), Temperature Fault                              |
| 4228 | 15  | SID     | 147        | 1241       | Smart Remote Actuator 5 (VGT), Temperature Warning                            |

## Section 01: ENGINE


### 2.12 ENGINE OIL LEVEL

 **MAINTENANCE**


Check the oil level daily with the engine stopped. If the engine has just been stopped and is warm, wait at least 10 minutes to allow the oil to drain back to the oil pan before checking. Wipe the dipstick clean then check oil level. The level should always be within the safe range on the dipstick (Fig. 20). Add the proper grade of oil to maintain the correct level on the dipstick. All diesel engines are designed to consume some oil, so a periodic addition of oil is normal.

 **WARNING**

Touching a hot engine can cause serious burns.

 **CAUTION**

Do not overfill. Oil may be blown out through the crankcase breather if the crankcase is overfilled.

 **CAUTION**

Clean end of tube before removing the dipstick to prevent oil contamination.

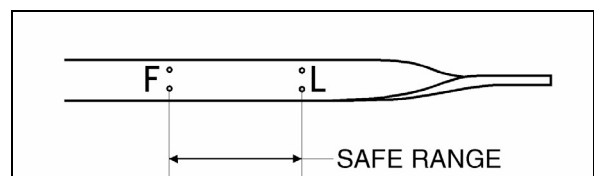



FIGURE 20: ENGINE OIL LEVEL DIPSTICK 01027

 **CAUTION**

If the oil level is constantly above normal and excess lube oil has not been added to the crankcase, consult with an authorized Detroit Diesel service outlet for the cause. Fuel or coolant dilution of lube oil can result in serious engine damage.

The vehicle may be provided with an oil reserve tank in the engine compartment. To adjust oil level, open the oil reserve tank drain valve and allow oil to discharge into the engine until the "Full" mark on the dipstick is reached then close the valve. Check oil reserve tank level and pour oil in the reserve tank if necessary (Fig. 21).

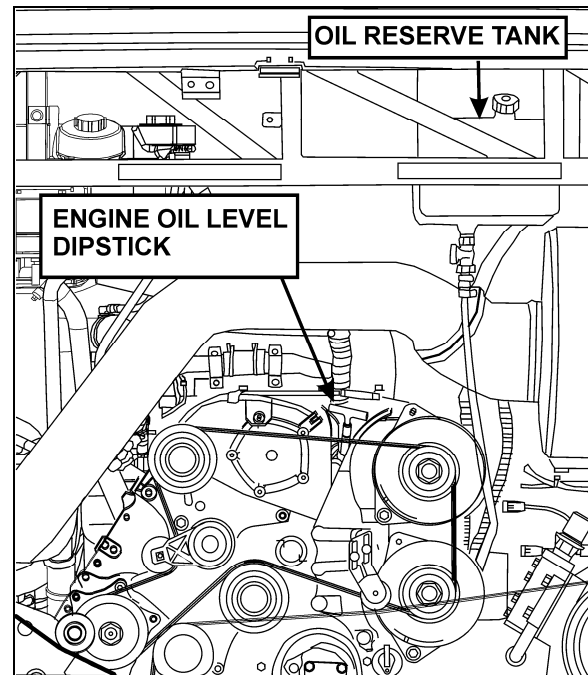



FIGURE 21: OIL RESERVE TANK 01187

### 2.13 ENGINE OIL AND FILTER CHANGE

 **MAINTENANCE**

Both the engine oil and filter should be changed according to the following maximum interval (based on an oil analysis program).

**Short Haul:** 15,000 miles (24,000km) or once a year, whichever comes first.

**Long Haul:** 30,000 miles (48,000km) or once a year, whichever comes first.

Oil analysis program may be used to determine whether this interval should be shorter, but should not be used to lengthen the interval.

Short haul: 6,000 miles (10,000km) to 60,000 miles (100,000 km) annual.

Long haul: over 60,000 miles (100,000 km) annual.

However, changes that are more frequent may be required when the engine is subject to high levels of contamination and/or overheating. Change intervals may be decreased or gradually increased with experience on specific lubricants until the most practical service condition has been established. Always refer to the lubricant manufacturer's recommendations (analysis of drained oil can be helpful).

**CAUTION**

Do not use solvents to dilute the engine oil when draining. Dilution of fresh oil can occur which may be detrimental to the engine.

Change engine oil with the vehicle on a flat and level surface and with the parking brake applied. It is best to drain the oil when the engine is still warm.

1. From under the vehicle, remove the engine drain plug on the oil pan. Allow oil to drain (Fig. 22).

**WARNING**

Hot engine oil can cause serious burns. Wear coveralls with sleeves pulled down and gloves to protect hands.

2. Reinstall the drain plug.
3. Remove the spin-on filter cartridge using a ½" drive socket wrench and extension.
4. Dispose of the used oil and filter in an environmentally responsible manner in accordance with state and/or federal (EPA) recommendations.

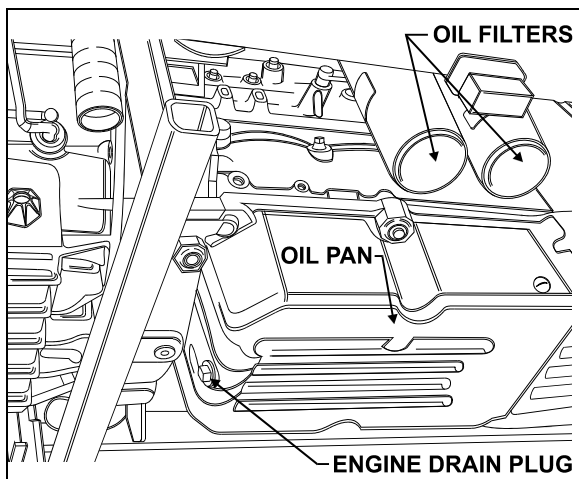


FIGURE 22: ENGINE DRAIN PLUG AND OIL FILTERS  
01029

5. Clean the filter adapter with a clean rag.
6. Lightly coat the filter gasket (seal) with clean engine oil.
7. Install the new filter on the adapter and tighten manually until the gasket touches the mounting adapter head. Tighten full-flow filters an additional two-thirds of a turn manually. Then, manually tighten bypass filter one full turn.

**CAUTION**

Overtightening may distort or crack the filter adapter.

8. Remove the engine-oil filler cap and pour oil in the engine until it reaches the "FULL" mark on the dipstick (Fig. 20).
9. Start and run the engine for a short period and check for leaks. After any leaks have been corrected, stop the engine long enough for oil from various parts of the engine to drain back to the crankcase (approximately 20 minutes).
10. Add oil as required to bring the level within the safe range on the dipstick (Fig. 20).

**MAINTENANCE**

Engine oil temperature should be checked every 25,000 miles (40 000 km) to determine oil cooler efficiency. This check should be made by inserting a steel jacketed thermometer in the dipstick opening, immediately after stopping a hot, loaded engine. If the oil temperature exceeds the coolant temperature by more than 60 °F (33 °C), the oil cooler may be clogged.

For detailed oil specifications, refer to DETROIT DIESEL SERIES 60 2007 ON-HIGHWAY SERVICE MANUAL 6SE2007 under heading «Lubricating Oil for Detroit Diesel Engines».

## Section 01: ENGINE

### 2.14 RECOMMENDED ENGINE OIL TYPE

To provide maximum engine life, lubricants shall meet the following specifications: SAE Viscosity Grade: 15W-40 API Classification: CJ-4.



#### CAUTION

Low ash oil formulation designated API CJ-4 is required in EPA-07 engines.

CJ-4 contains less than 1% ash which is the key to achieving maximum diesel particulate filter cleaning intervals. Use of high ash engine oils will reduce the cleaning interval on the Diesel Particulate Filter (DPF). DPF regenerates the combustible soot, but the ash (a product of the oil lubricant package) slowly accumulates in the channels of the DPF.

#### NOTE

*Monograde oils should not be used in these engines regardless of API Service Classification.*

#### NOTE

*The use of supplemental oil additives is discouraged from use in Detroit Diesel Engines.*

**Synthetic oils:** Synthetic oils may be used in Detroit Diesel engines provided they are API-licensed and meet the performance and chemical requirements of non-synthetic oils outlined previously. Synthetic oils do not permit extension of recommended oil drain intervals.

### 2.15 POWER PLANT ASSEMBLY REMOVAL

To access the engine or engine-related components, the vehicle power plant assembly must be removed as a whole unit by means of a slide-out cradle. The power plant assembly includes the engine, transmission (including retarder if so equipped), air compressor, alternator and transmission oil cooler.

Remove the power plant assembly as follows:



#### CAUTION

Tag hoses and cables for identification before disconnecting in order to facilitate reinstallation. Plug all openings to prevent dirt from entering the system.

#### NOTE

*No parts within the MCM are serviceable. If found defective, replace the MCM as a unit.*

1. Disconnect the battery or batteries from the starting system by removing one or both of the battery cables from each battery system. With the electrical circuit disrupted, accidental contact with the starter button will not produce an engine start. In addition, the Electronic Unit Injectors (EUI) will be disabled, preventing any fuel delivery to the injector tips.



#### WARNING

Due to the heavy load of the rear bumper assembly, it must be adequately supported before attempting to remove it.

2. Remove the rear bumper assembly from the vehicle. Refer to Section 18, BODY, under "REAR BUMPER REMOVAL".
3. Drain the engine cooling system. Refer to Section 05, COOLING under "DRAINING COOLING SYSTEM".

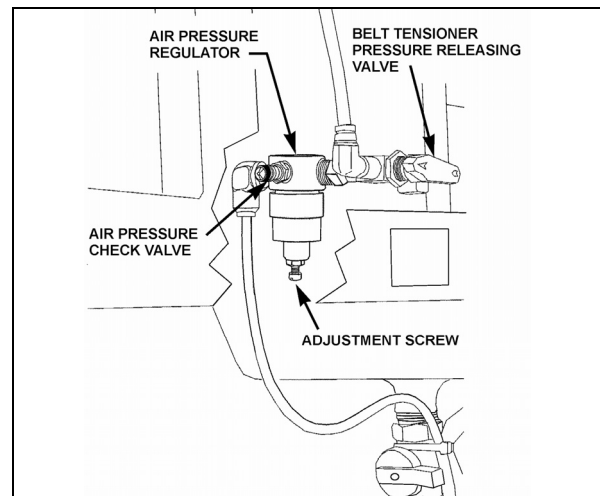


FIGURE 23: BELT TENSIONER VALVE

12200

4. Locate the A/C compressor belt tensioner pressure releasing valve (Fig. 23). Turn pressure releasing valve handle counterclockwise in order to release pressure in belt-tensioner air bellows and loosen belts. Remove the belts.
5. To release all pressure from the air system. Refer to Section 12, BRAKES & AIR SYSTEM for instructions.



6. Disconnect and remove the engine-air intake duct mounted between air cleaner housing and turbocharger inlet.

**CAUTION**

To avoid damage to turbocharger, cover the turbocharger inlet opening to prevent foreign material from entering.

7. Disconnect and remove the air intake duct mounted between the air cooler outlet and the engine intake.
8. Disconnect and remove section of coolant pipe assembly mounted between the radiator outlet and the water pump inlet.
9. Disconnect the coolant delivery hose located close to the water pump.
10. Disconnect the electric fan-clutch connector located near the cooling fan right angle gearbox.
11. Disconnect the cooling fan drive shaft.
12. Disconnect and remove the air intake duct mounted between the turbocharger outlet and the air cooler inlet.
13. Disconnect two vent hoses from the thermostat housing and from the coolant pipe assembly.
14. Disconnect and remove a section of coolant pipe assembly mounted between the thermostat housings and the radiator inlet.
15. Disconnect and remove the small hose connected to the heater line valve and to the water pump.
16. Disconnect the small heater hose located on the cylinder head at the back of the engine.
17. Disconnect and remove the exhaust pipe mounted between the turbocharger outlet and the flexible coupling. If necessary, refer to Section EXHAUST SYSTEM under "EXHAUST AND AFTERTREATMENT SYSTEM OVERVIEW".

**CAUTION**

To avoid damage to turbocharger, cover the turbocharger outlet opening to prevent foreign material from entering.

18. Disconnect the steel-braided airline from the A/C compressor air bellows.
19. Remove the power steering pump, leaving the supply and discharge hoses connected to it.
20. Disconnect the oil delivery hose from the valve located at the reserve tank drain .
21. Disconnect the block heater connector located near the power steering pump if applicable.
22. Close engine fuel supply shutoff valve on primary fuel filter. Disconnect the fuel line connected to inlet port. On vehicles equipped with the optional water-separator-fuel-filter, disconnect the connector and remove cable ties from cradle.
23. Disconnect the air compressor discharge, governor steel-braided airlines and manual filling airlines from compressor. Remove retaining clips.
24. Disconnect the hose connecting the compressor head to the sump tank.
25. Disconnect ground cables from rear subframe ground-stud located close to the starter motor.
26. Disconnect positive cable (red terminal) from starting motor solenoid.
27. Disconnect VIH (vehicle interface harness) connector from MCM.
28. On vehicles equipped with an automatic transmission provided with a hydraulic output retarder, disconnect steel-braided airline from pressure regulator output. The pressure regulator is mounted in the upper section of engine compartment backwall and is accessible through the engine compartment R.H. side door.
29. Disconnect fuel return line from bulkhead fixed on engine cylinder head end.
30. On vehicles equipped with an electrically operated cold-starting aid, disconnect the delivery hose from the starting-aid cylinder solenoid valve. Remove cable ties securing hoses.
31. Disconnect turbo boost pressure gauge airline from engine air intake.
32. Disconnect connectors from transmission. On the left side: four on rear side with one

## Section 01: ENGINE

close to yoke. On right side: close to the solenoid valve of the output retarder.

33. From under the vehicle, disconnect the propeller shaft as detailed in Section 09, under heading "Propeller Shaft Removal".
34. Inspect the power plant assembly to ensure that nothing will interfere when sliding out the cradle. Check for connections or hoses not mentioned in this list as some vehicles are equipped with special or aftermarket components.
35. Remove the six retaining bolts, washers and nuts securing the power plant cradle to the vehicle rear subframe (Fig. 25).

### NOTE

*Check if any spacer(s) have been installed between power plant cradle and vehicle rear subframe, and if so, note position of each washer for reinstallation purposes.*

36. Using a suitable equipment, with a minimum capacity of 4,000 lbs (1 800 kg), slightly raise the power plant cradle.
37. Pull engine out slowly from the engine compartment. Make sure all lines, wiring and accessories are disconnected and are not tangled.



### CAUTION

Due to the minimum clearance between the power plant equipment and the top of the engine compartment, extreme care should be used to raise the power plant cradle, just enough to free the cradle. Clearance between power plant cradle and mounting rail should range between ¼" and ½" (6-12 mm).

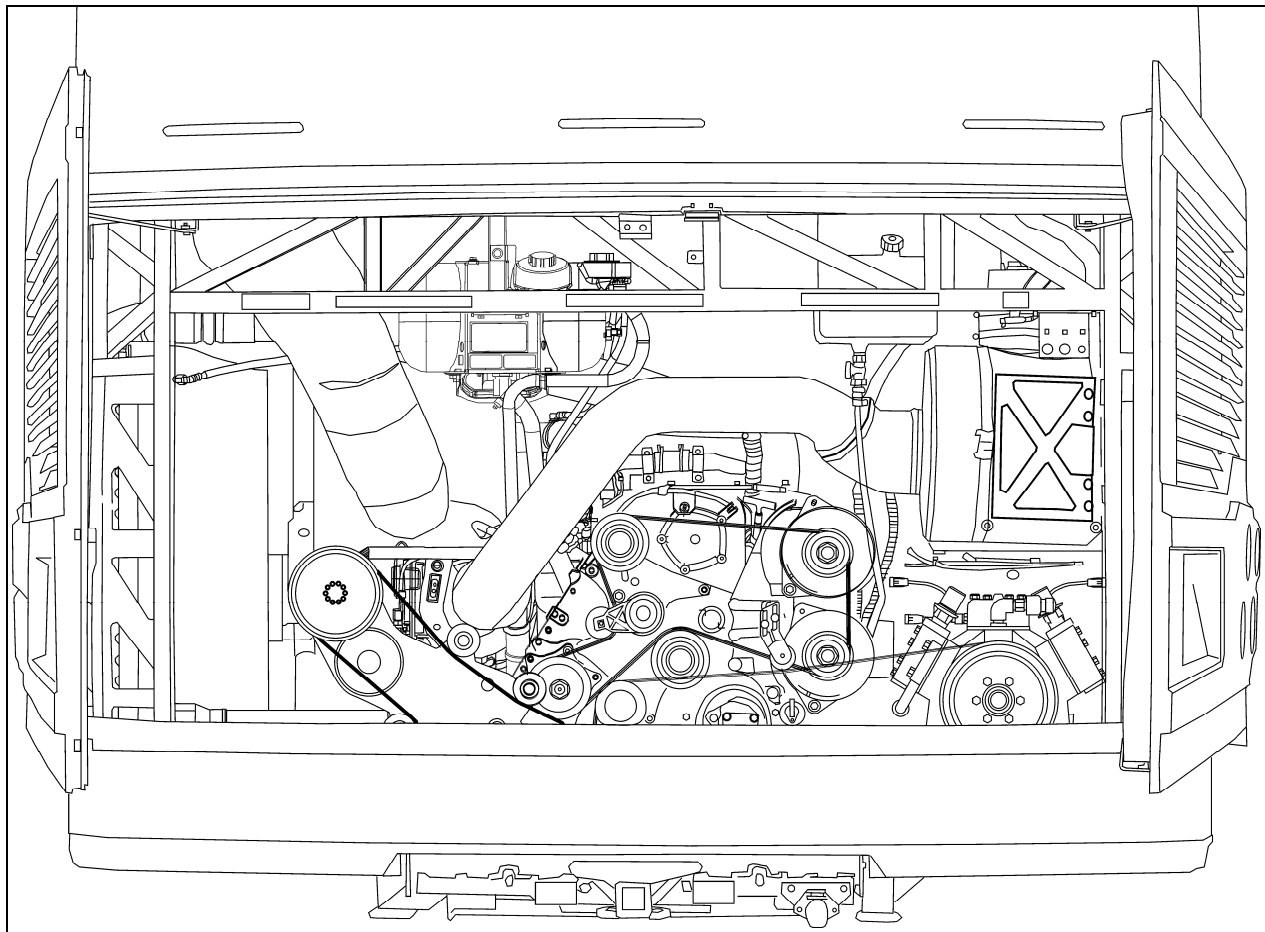


FIGURE 24: ENGINE COMPARTMENT X3 COACHES (TYPICAL)

01184\_A

## 2.16 POWER PLANT ASSY. INSTALLATION

To install a power plant assembly, follow the same procedure as in "Power Plant Assembly Removal" except in reverse order, then proceed with the following:

1. Torque the power plant cradle mounting bolts to 190 lbf-ft (255 Nm).
2. If fan drive has been removed, reinstall and align as per Section 05, COOLING SYSTEM, under "FAN DRIVE ALIGNMENT".
3. Refill cooling system with saved fluid (refer to Section 05, COOLANT SYSTEM).
4. Once engine fuel system has been drained, it will aid restarting if fuel filters are filled with fuel oil (refer to Section 03, FUEL SYSTEM).
5. Start engine for a visual check. Check fuel, oil, cooling, pneumatic and hydraulic system connections for leakage. Test operation of engine controls and accessories.

## 2.17 JAKE BRAKE

Refer to both "The Jake Brake Troubleshooting and Maintenance Manual" and "Installation Manual for Model 790 Engine Brakes" for troubleshooting and installation procedures. They are annexed at the end of this section.

## 2.18 ENGINE MOUNTS

The power plant assembly is mounted to the cradle by means of rubber mounts.

Two rubber mounts are used at the front of the engine while two others are mounted on each side of the flywheel housing (Fig. 25).

It is recommended that new rubber mounts be installed at each major overhaul.

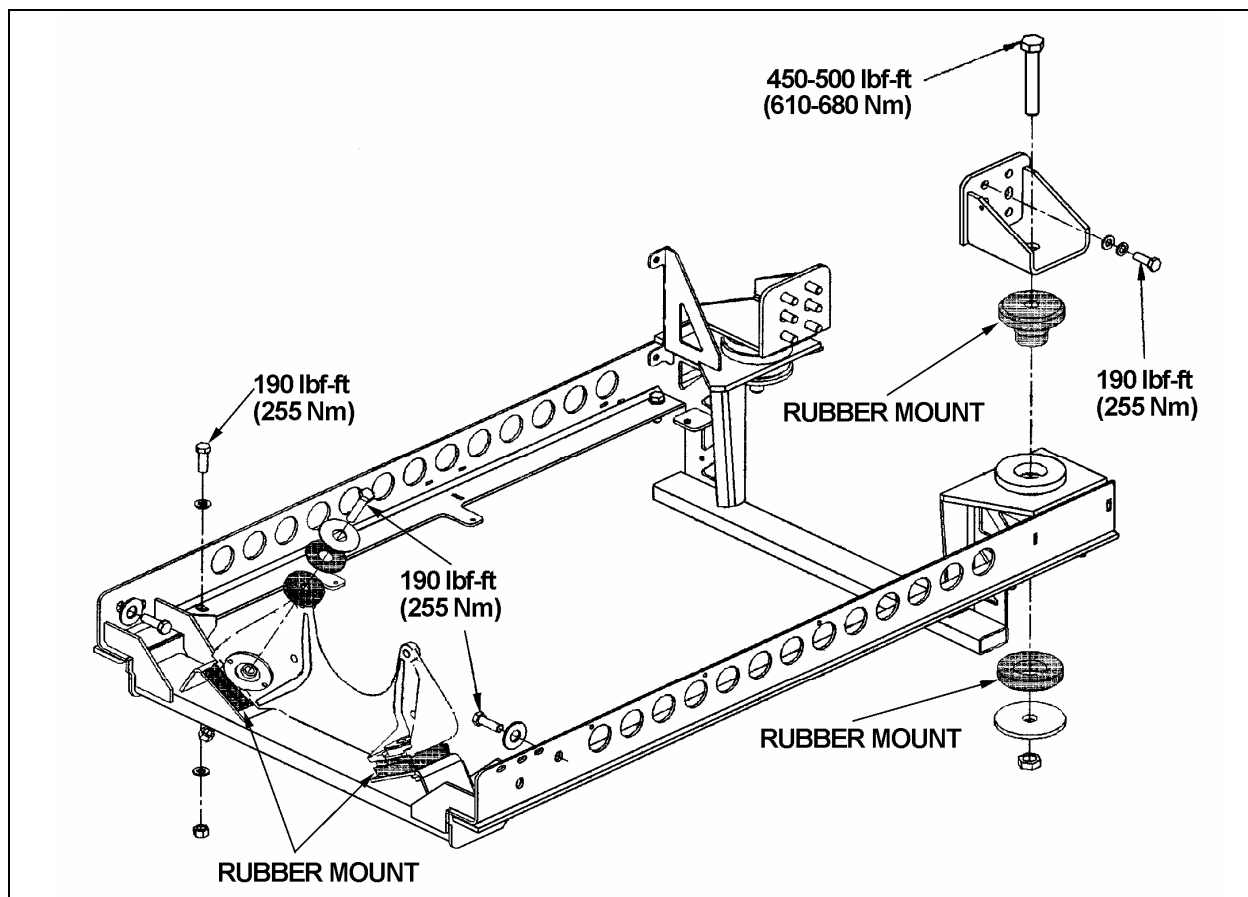


FIGURE 25: DDC SERIES 60 POWER PLANT CRADLE INSTALLATION

01140

### 3. ELECTRONIC FOOT PEDAL ASSEMBLY (EFPA) & THROTTLE POSITION SENSOR

The Electronic Foot Pedal Assembly (EFPA) connects the accelerator pedal to a Throttle Position Sensor (TPS). The (TPS) is a device, which sends an electrical signal to the Motor Control Module (MCM). The TPS varies in voltage depending on how far the pedal is depressed. The system is installed in the space normally occupied by a mechanical foot pedal. The (EFPA) has maximum and minimum stops that are built into the unit during manufacturing (Fig. 26). The (TPS) converts the operator's foot pedal input into a signal for the MCM.

When installed by the equipment manufacturer, the TPS should not require adjustment. If the TPS is suspected of being misadjusted, confirm that the sensor is installed in accordance with the manufacturer's specifications. It is recommended that the idle count be at 50 or higher with a full throttle count of up to 200.

The TPS is self-calibrating and therefore has no optimum closed throttle or wide open throttle count value. If the counts are within the 50 to 200 range, the sensor is properly set.

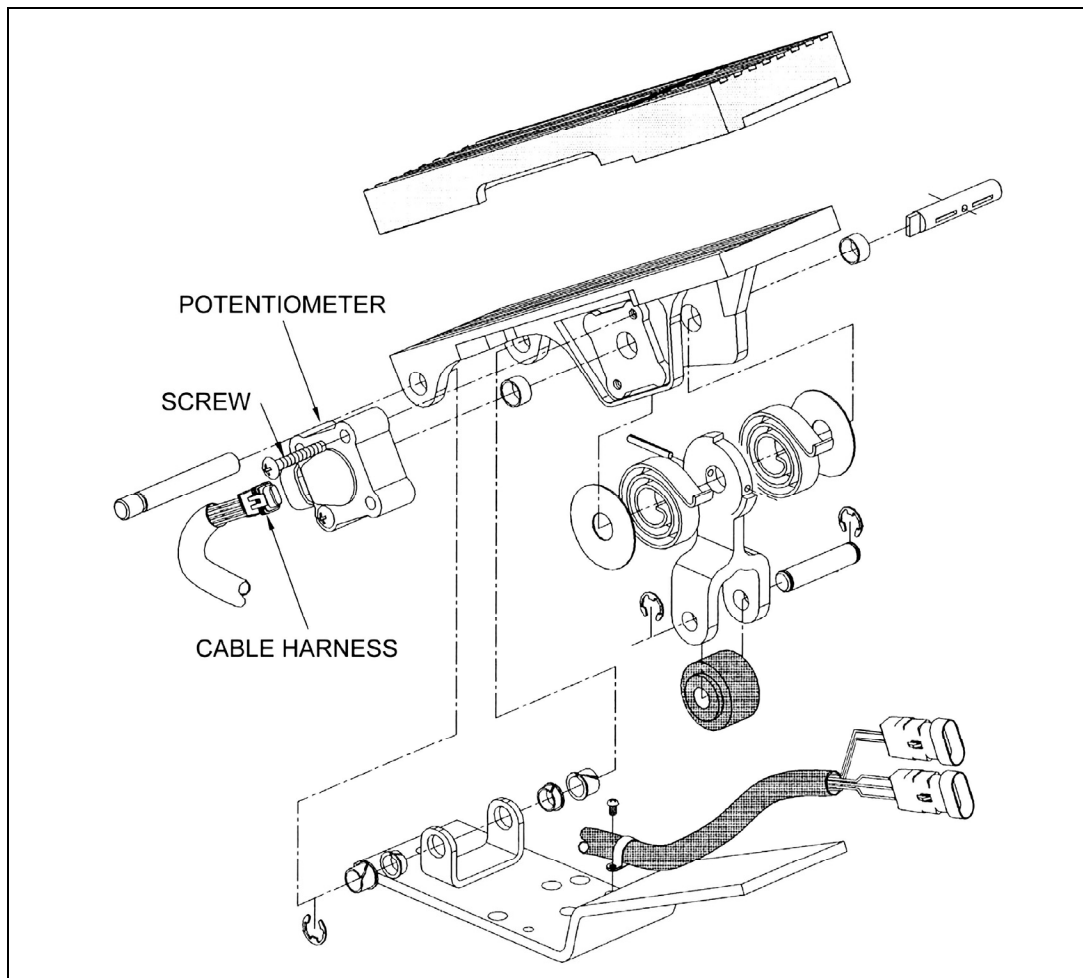
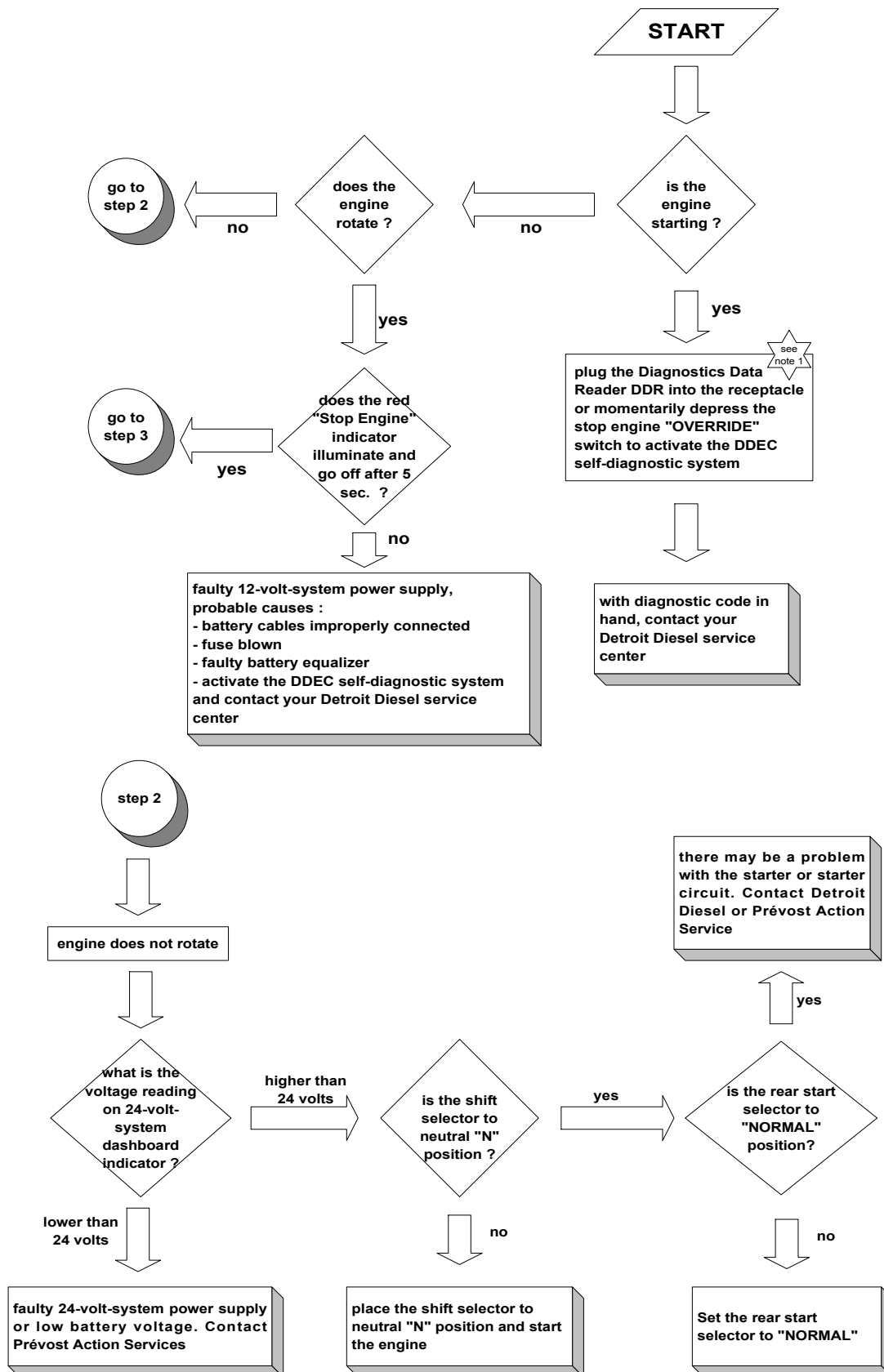


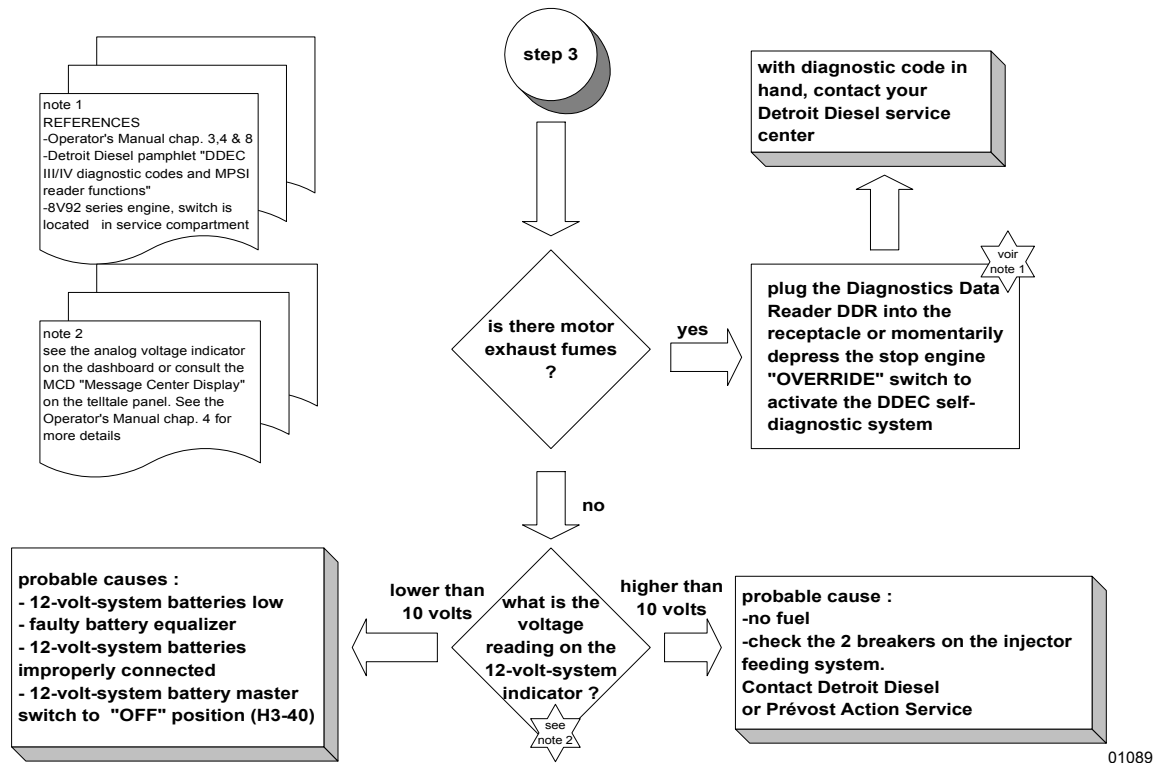
FIGURE 26: ELECTRONIC FOOT PEDAL ASSEMBLY 03035

Monitor the (TPS) at the controls as you move it through its full stroke. Be sure there is no misalignment or obstruction preventing the smooth movement of the TPS through the full stroke. Using a diagnostic data reader, check that the idle and full throttle position counts do not fall within the error zones. The error zones occur when the idle position is less than 14 counts, or when the full throttle position is more than 233 counts. Should these conditions occur, the CPC will signal diagnostic codes of 21-12 for idle error and 21-23 for wide-open throttle error.

4. ENGINE TROUBLESHOOTING GUIDE



## Section 01: ENGINE



## 5. SPECIFICATIONS

### Volvo D13 Engine

Make ..... Volvo

Type ..... Diesel four cycle/in-line direct injection engine

Description ..... Turbo/Air to air charge cooled

No. of cylinders ..... 6

Operating range ..... 1400-1800 RPM

Peak Power Rating ..... 435 HP (324 kW)

Peak Torque Rating ..... 1650 Ft-lb (2237 Nm)

Low Idle ..... 600 rpm

Fast Idle ..... 2150 rpm

Maximum full load revolutions ..... 1900 rpm

### Engine oil level quantity

Oil Pan Capacity, Low Limit ..... 25 quarts/24 liters

Oil Pan Capacity, High Limit ..... 34 quarts/32 liters

Total Engine Oil Capacity with Filters ..... 41 quarts/39 liters

### Lubricating oil filter elements

Type ..... By-pass

Prevost number ..... 510938  
 Type ..... Full Flow  
 Prevost number ..... 488736

**Torque specification**

Engine oil filter..... Tighten ¾ of a turn to 1 full turn after gasket contact

**Filters**

**Engine Air Cleaner Filter**

Make ..... Nelson # 70337-N  
 Prevost number ..... 530197

**Engine Coolant Filter/Conditioner**

Make ..... Nalco Chemical Company # DDF3000  
 Prevost number ..... 20458771

**Detroit Diesel Series 60 Engine**

Make ..... Detroit Diesel  
 Type ..... Diesel four cycle/in-line engine  
 Description ..... Turbo/Air to air charge cooled  
 No. of cylinders ..... 6  
 Operating range ..... 1200-2100 RPM  
 Maximum RPM..... 2100

**Detroit Diesel Series 60 engine ratings**

Series 60 engine ratings used in Prevost Car Models are listed in the following tables. The standard engine ratings are written in bold, customer may easily switch from one rating to another within the same table by having the DDEC V system reprogrammed.

| <b>Coach Engine (14.0L)</b> |  |
|-----------------------------|--|
| 425 HP                      | @1800 rpm; 1450 lb-ft @1200 rpm        |
| <b>445 HP</b>               | <b>@1800 rpm; 1450 lb-ft @1200 rpm</b> |

**Capacity**

Oil reserve tank ..... 8.4 US qts (8.0 L)

**Engine oil level quantity**

Oil Pan Capacity, Low Limit ..... 26 quarts/25 liters  
 Oil Pan Capacity, High Limit ..... 32 quarts/30 liters  
 Total Engine Oil Capacity with Filters ..... 38 quarts/36 liters

**Section 01: ENGINE**

---

**Lubricating oil filter elements**

Make..... AC Rochester Div. GMC # 25014505  
Make..... A/C Filter # PF-2100  
Type ..... Full Flow  
Prévost number..... 510458

**Torque specification**

Engine oil filter..... Tighten 2/3 of a turn after gasket contact

**Filters**

Engine Air Cleaner Filter

Make ..... Nelson # 70337-N  
Prévost number ..... 530197

Engine Coolant Filter/Conditioner

Make ..... Nalco Chemical Company # DDF3000  
Make ..... Detroit Diesel # 23507545  
Prévost number ..... 550630

|                    |
|--------------------|
| <b><i>NOTE</i></b> |
|--------------------|

|  |
|--|
| <i>For primary and secondary fuel filters, refer to Specifications in section 03</i> |
|--|



## SECTION 03: FUEL SYSTEM

### CONTENTS

|  |           |
|--|-----------|
| <b>1. FUEL SYSTEM WITH DETROIT DIESEL SERIES 60 ENGINE</b>   | <b>3</b>  |
| 1.1 DESCRIPTION  | 3         |
| 1.2 FUEL VALVES  | 3         |
| 1.3 FUEL FILTERS   | 4         |
| 1.4 RACOR FUEL/WATER SEPARATOR SERVICING                     | 4         |
| 1.5 SPIN-ON TYPE FUEL FILTER SERVICING (PRIMARY & SECONDARY) | 5         |
| 1.6 FUEL PUMP INSTALLATION                                   | 6         |
| <b>2. FUEL SYSTEM WITH VOLVO D13 ENGINE</b>                  | <b>7</b>  |
| 2.1 DESCRIPTION  | 7         |
| 2.2 FUEL VALVES  | 8         |
| 2.3 FUEL FILTERS   | 8         |
| 2.3.1 Primary Fuel Filter Replacement                        | 9         |
| 2.3.2 Secondary Fuel Filter Replacement                      | 10        |
| 2.4 PRIMING THE FUEL SYSTEM                                  | 10        |
| 2.5 FUEL PUMP REMOVAL AND INSTALLATION                       | 11        |
| <b>3. DAVCO FUEL PRO 382</b>                                 | <b>11</b> |
| <b>4. FUEL LINES AND FLEXIBLE HOSES</b>                      | <b>13</b> |
| <b>5. PREHEATER FUEL FILTER</b>                              | <b>13</b> |
| <b>6. FUEL TANK</b>  | <b>13</b> |
| 6.1 TANK REMOVAL   | 13        |
| 6.2 TANK INSTALLATION  | 14        |
| 6.3 FUEL TANK VERIFICATION                                   | 15        |
| 6.4 POLYETHYLENE FUEL TANK REPAIR                            | 15        |
| <b>7. FUEL SPECIFICATIONS</b>                                | <b>15</b> |
| 7.1 FUEL TYPE  | 15        |
| 7.2 BLENDING   | 16        |
| 7.3 BIODIESEL FUELS  | 16        |
| <b>8. AIR CLEANER (DRY TYPE)</b>                             | <b>16</b> |
| 8.1 PRE-CLEANER SERVICING                                    | 16        |
| 8.2 AIR CLEANER SERVICING                                    | 16        |
| 8.3 GENERAL RECOMMENDATIONS                                  | 17        |
| 8.4 AIR CLEANER RESTRICTION INDICATOR                        | 17        |
| <b>9. FUEL COOLER – DETROIT DIESEL SERIES 60 ONLY</b>        | <b>17</b> |
| <b>10. FUEL PEDAL</b>  | <b>18</b> |
| 10.1 FUEL PEDAL ADJUSTMENT                                   | 18        |
| 10.2 POTENTIOMETER REPLACEMENT                               | 18        |
| <b>11. SPECIFICATIONS</b>                                    | <b>19</b> |

**ILLUTRATIONS**

FIGURE 1: FUEL SYSTEM SCHEMATIC (DDC SERIES 60 ENGINE)..... 3  
FIGURE 2: MANUAL SHUT-OFF VALVES LOCATION (DDC S60 ENGINE)..... 3  
FIGURE 3: MANUAL SHUT-OFF VALVE WITH DAVCO FUEL PRO 382 (DDC S60 ENGINE)..... 4  
FIGURE 4: ENGINE R.H. SIDE ..... 4  
FIGURE 5: RACOR FUEL /WATER SEPARATOR..... 4  
FIGURE 6: FUEL PUMP LOCATION ..... 6  
FIGURE 7: FUEL SYSTEM SCHEMATIC (VOLVO D13 ENGINE) ..... 7  
FIGURE 8: MANUAL SHUT-OFF VALVE (VOLVO D13 ENGINE)..... 8  
FIGURE 9: MANUAL SHUT-OFF VALVE LOCATION WITH DAVCO FUEL PRO 382 (VOLVO D13 ENGINE)..... 8  
FIGURE 10: FUEL LINE COMPRESSION FITTING ..... 8  
FIGURE 11: FUEL FILTERS WITH VOLVO D13 ENGINE..... 9  
FIGURE 12: HAND PRIMING PUMP ..... 10  
FIGURE 13: FUEL PUMP REMOVAL ..... 11  
FIGURE 14: FUEL PUMP DRIVE AXLE ..... 11  
FIGURE 15: DAVCO FUEL PRO 382 FUEL FILTER ..... 12  
FIGURE 16: DAVCO FUEL PRO 382 EXPLODED VIEW ..... 12  
FIGURE 17: 208 US GAL. FUEL TANK..... 14  
FIGURE 18: FUEL TANK REPAIR..... 15  
FIGURE 20: RESTRICTION INDICATOR ..... 17  
FIGURE 21: FUELRETURN LINE..... 17  
FIGURE 22: FUEL COOLER LOCATION ..... 18  
FIGURE 23: ELECTRONIC FOOT PEDAL ASSEMBLY ..... 18

## 1. FUEL SYSTEM WITH DETROIT DIESEL SERIES 60 ENGINE

### 1.1 DESCRIPTION

Figure 1 shows a schematic of the fuel system. Fuel is drawn from the fuel tank through a manual shut-off valve, a primary fuel filter (fuel-filter/water-separator) before it enters the MCM and the fuel pump. If the vehicle is equipped with the optional “Davco Fuel Pro 382”, this one replaces the primary fuel filter. Leaving the pump under pressure, the fuel flows through a secondary fuel filter and a shut-off valve, then to the cylinder head. The fuel reaches the injectors in the cylinder head through passages within the head. Excess fuel exits at the rear of the head just above the inlet, through a restrictive return fitting which maintains fuel pressure in the system. Finally, the fuel flows through the check valve and the fuel cooler before it returns to the fuel tank. One preheater is available: 104 000 BTU. If the vehicle is equipped with the 104 000 BTU preheater, the fuel is drawn from the fuel tank through the fuel filter to the preheater. Excess fuel returns to the fuel tank.

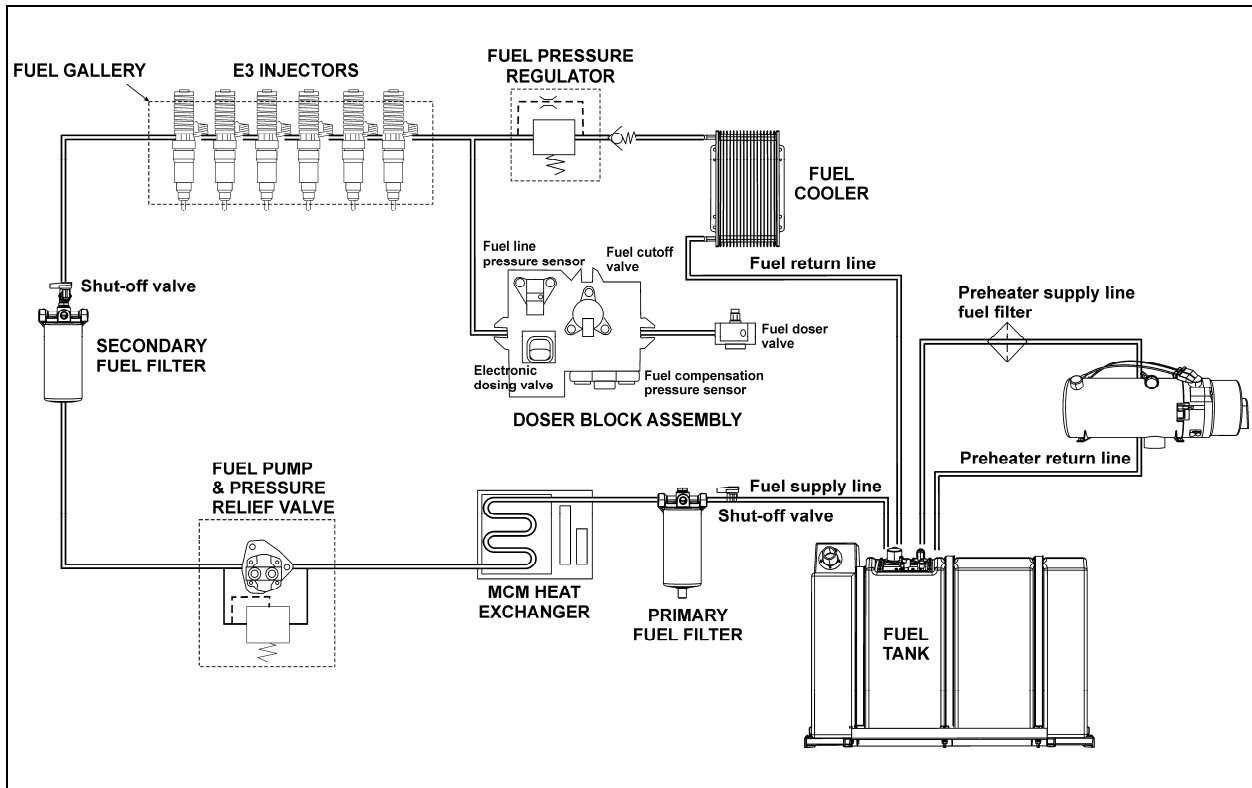


FIGURE 1: FUEL SYSTEM SCHEMATIC (DDC SERIES 60 ENGINE)

03075

### 1.2 FUEL VALVES

Manual shut-off valves on engine fuel-supply line are located on the R.H. side of engine compartment. A manual shut-off valve is located at the inlet side of the primary fuel filter under the starter or at the inlet side of Davco Fuel Pro 382 fuel filter. Another manual shut-off valve is located at the outlet side of the secondary fuel filter. Shut-off valve are designed to prevent loss of fuel prime at time of filter replacement. No manual valve is required on preheater fuel-supply line, since the positive-displacement fuel pump (located close to the fuel tank) prevents fuel flow when not activated.

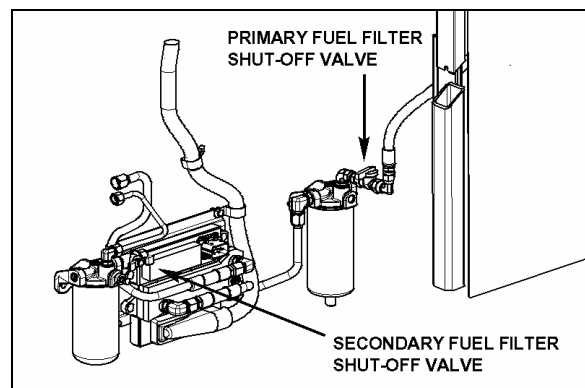


FIGURE 2: MANUAL SHUT-OFF VALVES LOCATION (DDC S60 ENGINE)

03072

## Section 03: FUEL SYSTEM

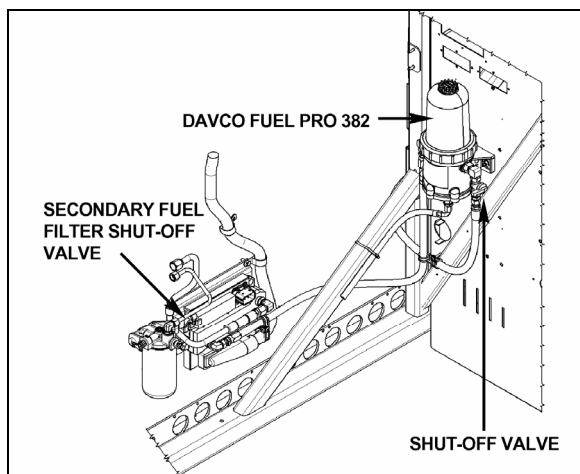


FIGURE 3: MANUAL SHUT-OFF VALVE WITH DAVCO FUEL PRO 382 (DDC S60 ENGINE) 03073

### 1.3 FUEL FILTERS

The fuel system is equipped with primary (strainer or optional fuel/water separator) and secondary fuel filters for additional protection of the injectors. A Racor fuel/water separator can be installed in primary filter location (Fig. 4).

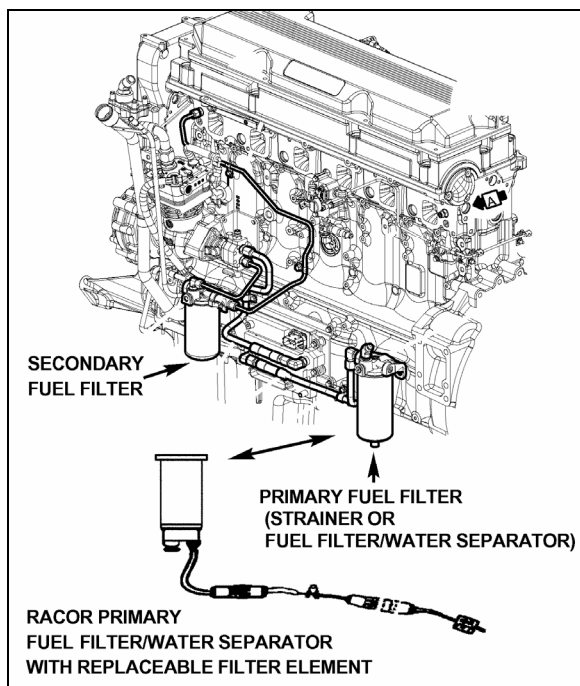


FIGURE 4: ENGINE R.H. SIDE 03069

#### NOTE

The operating conditions and cleanliness of type of fuel used determine the service intervals of the filter/water separator element and the secondary fuel filter cartridge.

#### NOTE

For information on the Davco Fuel Pro 382 fuel filter, refer to paragraph 3.

### 1.4 RACOR FUEL/WATER SEPARATOR SERVICING



#### MAINTENANCE

The Racor fuel/water separator should be drained periodically, or when the water separator telltale light on the dashboard illuminates.

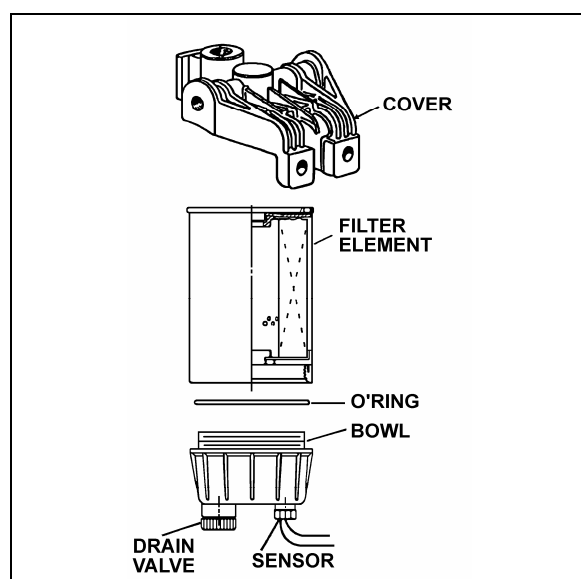


FIGURE 5: RACOR FUEL /WATER SEPARATOR 03025

Replace the fuel/water separator element as follows:


1. Drain the fuel /water separator by opening the drain valve.
2. With engine "OFF" and engine fuel supply line shut-off valves closed; remove the filter cartridge and bowl assembly from cover (for valve location, see "1.2. FUEL VALVES" in this section).
3. Separate bowl from filter cartridge. Clean bowl and O-ring groove.

#### NOTE


Bowl is reusable, do not discard.

4. Lubricate O-ring with clean diesel fuel or motor oil and place it in bowl groove.

- Screw bowl onto new filter cartridge snugly by hand.

|  |
|--|
|  <b>CAUTION</b> |
| Do not use tool to tighten. Tighten by hand only.  |

- Lubricate filter seal with clean diesel fuel or motor oil.
- Fill filter cartridge with clean diesel fuel and attach onto cover. Handtighten an additional 1/3 to 1/2 turn after making full seal contact.
- Open shut-off valves of the engine fuel supply line.
- Run the engine and check for leaks.

|   |
|---|
|  <b>CAUTION</b>  |
| If the fuel/water separator continuously requires draining, it is possible that water or sediment has accumulated in the fuel tank. To correct this situation, open the drain plug under the tank when the fuel gauge indicates tank is 1/4 full in order to drain any contaminant. |

### 1.5 SPIN-ON TYPE FUEL FILTER SERVICING (PRIMARY & SECONDARY)


The primary and secondary fuel filters are located on the R.H. side of the engine. The primary filter is located below the starter, and the secondary fuel filter is below the air compressor. The threaded sleeves that accept the filters body are different sizes to prevent mismatching. Primary filter thread is 1" X 12 while secondary is 13/16" X 12. The word "primary" or "secondary" is cast onto the top of the respective adaptor.

|  |
|--|
| <b>NOTE</b>  |
| <i>The fuel filter adaptors are mounted to the engine block with two bolts each. Torque these bolts to 43-54 lbf•ft (58-73 N•m).</i> |

A method of determining when filters are clogged to the extent that they should be changed is based on the fuel pressure at the cylinder head fuel inlet fitting and the inlet restriction at the fuel pump. In a clean system, the maximum pump-inlet restriction should not exceed 6 inches of mercury (20.3 kPa) and must

not exceed 12 inches of mercury (41 kPa) with a dirty system.


At normal operating speeds and with the standard fuel pressure regulator, the fuel pressure at the cylinder head inlet is 58-72 psi (400-50 kPa). Change the fuel filters whenever the inlet restriction at the fuel pump reaches 12 inches of mercury (41 kPa) at normal operating speeds. Also, change whenever the fuel pressure at the cylinder head inlet fitting falls to the minimum fuel pressure given above.

|  |
|--|
|  <b>MAINTENANCE</b>   |
| The primary and secondary fuel filters are of a spin-on type and must be replaced every 12,500 miles (20 000 km) or once a year, whichever comes first. If the primary fuel filter is a fuel filter/water separator type, it is equipped with a positive seal drain-valve to prevent water infiltration in engine fuel system. To drain, loosen positive seal drain-valve below filter and tighten after water has been flushed out. |

Change the filter cartridge(s) as follows:

|  |
|--|
| <b>NOTE</b>  |
| <i>Use a suitable band wrench or filter wrench, such as J22775, to remove the filters.</i> |

- Stop engine, place a suitable container under the filter.
- Close the secondary and primary filter shut-off valve (for valve location, See paragraph 1.2. FUEL VALVES").
- Using a band filter wrench, unscrew and discard filters.
- Fill new filter cartridge(s) with clean fuel oil. Apply a thin coat of clean fuel oil on gasket.
- Install new filters. Tighten until filter is snug against the gasket, with no side movement. Rotate an additional 1/2 turn by hand.

|   |
|---|
|  <b>CAUTION</b>  |
| Mechanical tightening of the fuel filters is not recommended and may result in seal and/or cartridge damage. Tighten the fuel filters by hand only. |

- Open engine fuel supply line shut-off valves.

## Section 03: FUEL SYSTEM

7. Start the engine and check for leaks.

### **NOTE**

There is a fuel system shut-off valve on the discharge side of the secondary fuel filter. This check valve is designed to prevent fuel loss at time of filter replacement.

### 1.6 FUEL PUMP INSTALLATION

The fuel pump is driven off of the rear of the air compressor.

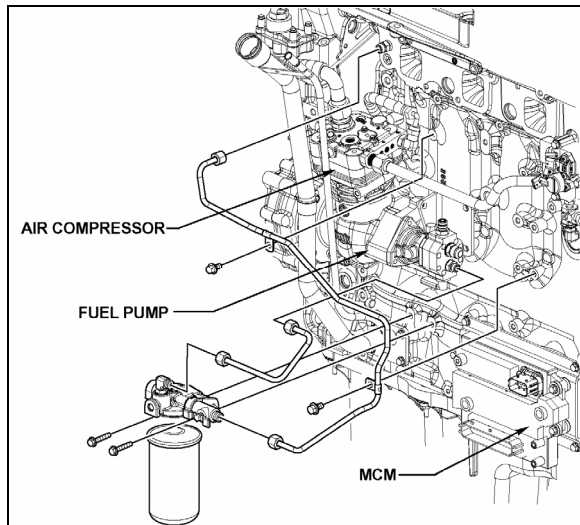


FIGURE 6: FUEL PUMP LOCATION

03070

1. If removed, install inlet and outlet fittings in the cover of the fuel pump.

### **NOTE**

New fittings have sealant already applied. When reusing fittings, coat the threads lightly with Loctite Pipe Sealant, Detroit Diesel number J 26558-92, or equivalent, before installing. To prevent sealant from entering fuel system, do not apply to the first two threads of the fitting. Do not use Teflon tape or paste on the fittings.

2. Install drive coupling in drive hub of the fuel pump. Install a new gasket to the mounting flange of the pump.
3. Index the drive coupling with the drive hub on the end of the air compressor crankshaft and align the pump mounting bolt holes with those in the air-compressor rear cover.

### **NOTE**

When correctly positioned, the outlet fitting on the pump should be in approximately an 8 o'clock position when viewed from the rear, and the drain opening in the pump body facing down.

4. Seat the fuel pump squarely against the air compressor. Pilot the flange on the pump body, in the opening in the rear cover of the compressor. Install three mounting bolts and tighten them to 22-28 lbf-ft (30-38 Nm).
5. Connect the fuel inlet and outlet lines to the fuel pump and tighten.
6. Prime engine fuel system before starting engine to ensure pump seal lubrication and prompt engine starting.

## 2. FUEL SYSTEM WITH VOLVO D13 ENGINE

### 2.1 DESCRIPTION

#### *NOTE*

For additional information concerning Volvo D13 engine components or engine-related components, consult Volvo Trucks Canada or Volvo Trucks North America Web Site under: Parts & Service. On Volvo web site, you will find detailed service procedures for parts replacement, repair and maintenance.

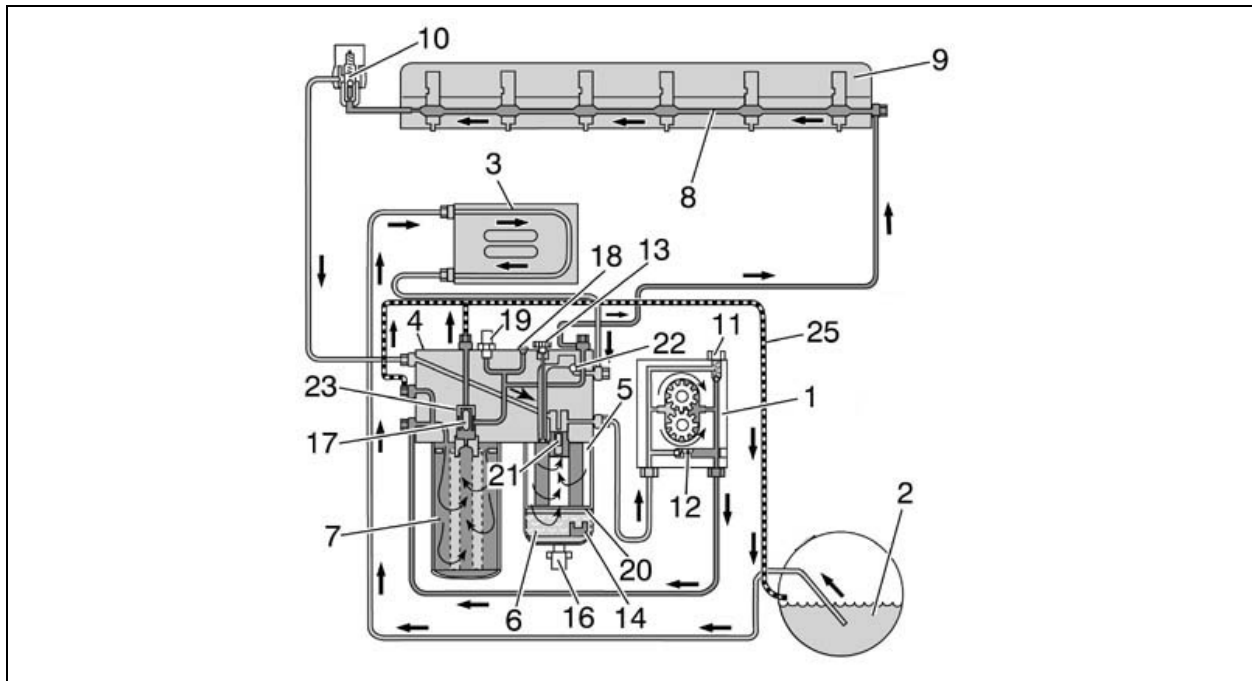


FIGURE 7: FUEL SYSTEM SCHEMATIC (VOLVO D13 ENGINE)

03086

Fuel is drawn up the fuel lines by the supply pump (1) through the pickup tube in the tank (2) and through the Engine Electronic Control Unit (EECU) cooling coil (3) and into the fuel filter housing (4). The fuel housing is equipped with a primary fuel filter (fuel/water separator) consisting of a filter cartridge and a water separation bowl.

The supply pump (1) forces the fuel into the fuel filter housing through the secondary filter (main) to a cylinder head longitudinal gallery (8). This channel supplies each unit injector (9) with pressurized fuel by a circular groove around each unit injector in the cylinder head. The overflow valve (10) controls the fuel supply pressure to the unit injectors.

The return fuel from the overflow valve (10) is returned back to the fuel filter housing and is mixed with the fuel from the fuel tank in a channel within the fuel filter housing (4).

#### Supply Pump Valves

Two valves are located in the supply pump (1). The safety valve (11) allows fuel to flow back to the suction side when the pressure becomes too high, e.g., if the fuel filter is blocked or is too restricted. The non-return valve (12) opens when the hand-priming pump is used.

#### Automatic Bleeding

If air gets into the system, it is bled when the engine starts. During bleeding, air is pressed out through the fuel filter housing over to the fuel tank through the return line (25). Bleeding for the filter replacement is controlled by valves (17) and (23).

#### Other

The fuel filter housing eliminates the need to drain the fuel when replacing the filter. The valve pegs (17) and (21) close when the fuel filter is

## Section 03: FUEL SYSTEM

removed. It is not necessary to bleed the fuel system after replacing the filter, since this is performed automatically when the engine is started and runs for more than 2 minutes.

The plugged outlet (18) is fitted on the fuel filter housing. This outlet is used when measuring supply pressure after the fuel filter with an external pressure gauge. The pressure sensor (19) on the fuel filter housing monitors the supply pressure after the fuel filter. A fault code is displayed on the instrument cluster if the fuel supply pressure is less than the specified value.

### Hand Priming Pump

The hand priming pump (13) is located on the fuel filter housing and is used to pump fuel (when engine is not running) after the fuel system has been drained for repair, etc. The non-return valve (22) for the hand priming pump is also located in the fuel filter housing.

## 2.2 FUEL VALVES

The manual shut-off valve on engine fuel-supply line is located on the R.H. side of engine compartment. A manual shut-off valve is located at the inlet side of the primary fuel filter or at the inlet side of Davco Fuel Pro 382 fuel filter. Shut-off valve is designed to prevent loss of fuel prime. No manual valve is required on preheater fuel-supply line, since the positive-displacement fuel pump (located close to the fuel tank) prevents fuel flow when not activated.

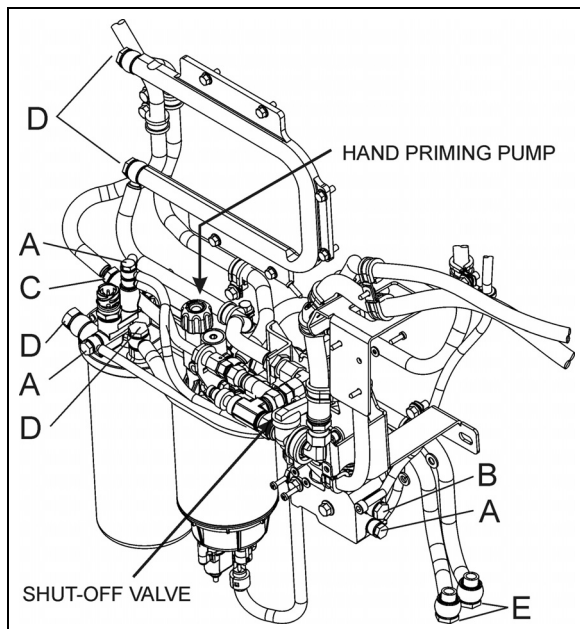


FIGURE 8: MANUAL SHUT-OFF VALVE (VOLVO D13 ENGINE)

03088

| FUEL LINE FITTINGS – VOLVO D13 ENGINE |                |             |
|---------------------------------------|----------------|-------------|
| A                                     | 13 ± 2 ft-lb   | (18 ± 3 Nm) |
| B                                     | 20.5 ± 3 ft-lb | (28 ± 4 Nm) |
| C                                     | 22 ± 3 ft-lb   | (30 ± 4 Nm) |
| D                                     | 26 ± 4 ft-lb   | (35 ± 5 Nm) |
| E                                     | 29.5 ± 4 ft-lb | (40 ± 5 Nm) |
| F                                     | 35 ± 4 ft-lb   | (48 ± 5 Nm) |

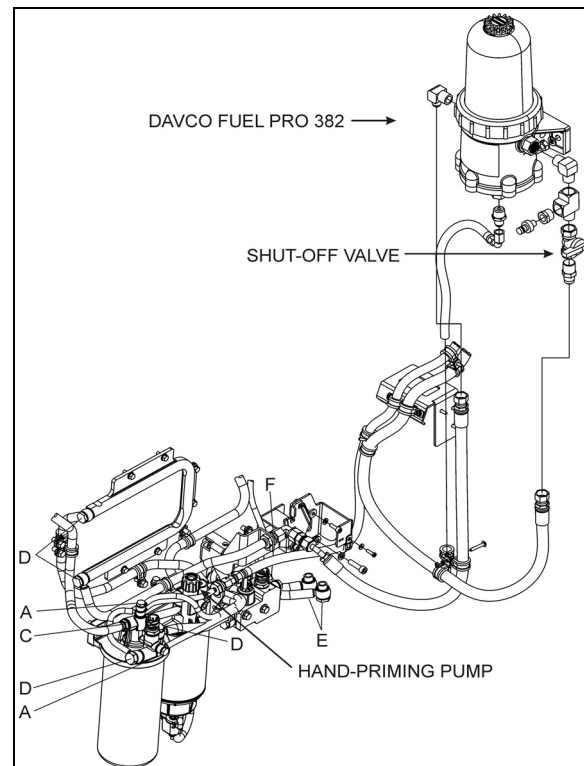


FIGURE 9: MANUAL SHUT-OFF VALVE LOCATION WITH DAVCO FUEL PRO 382 (VOLVO D13 ENGINE)

03087

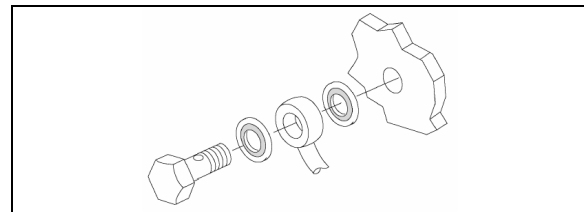


FIGURE 10: FUEL LINE COMPRESSION FITTING



## CAUTION

Always replace the fuel line compression sealing washers when troubleshooting for fuel aeration or performing any service procedure that requires the removal of engine fuel lines.

## 2.3 FUEL FILTERS

A primary fuel filter is installed on the engine. This filter consists of a filter cartridge, a water separation bowl with a drain valve. It is used to prevent water from entering the fuel system.





## MAINTENANCE

The primary and secondary fuel filters are of a spin-on type and must be replaced at **every engine oil change**.

The primary fuel filter should be drained periodically or when the telltale light on the dashboard illuminates if equipped with this system. To drain water, loosen the drain valve below the separator. Place an appropriate container under the filter. Close the drain valve when finished.

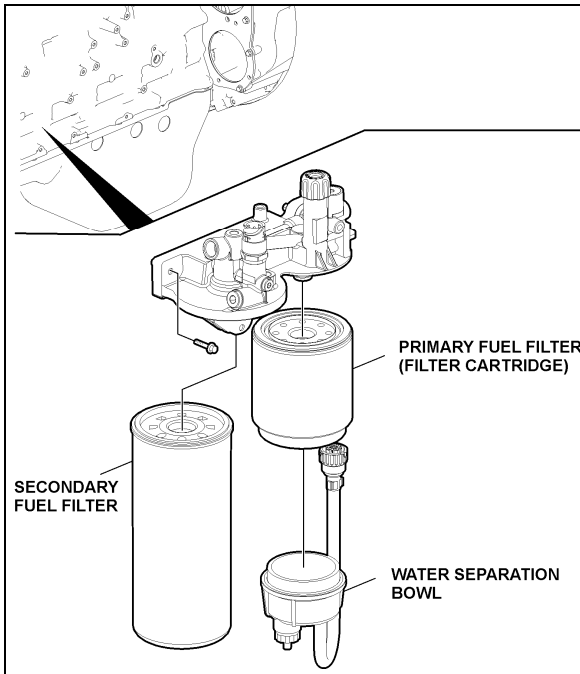
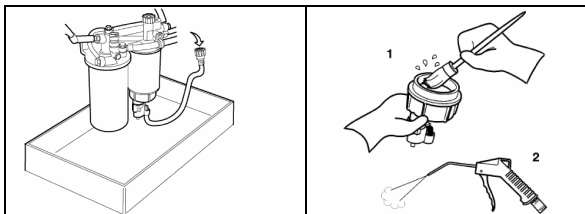


FIGURE 11: FUEL FILTERS WITH VOLVO D13 ENGINE  
03085

### 2.3.1 Primary Fuel Filter Replacement

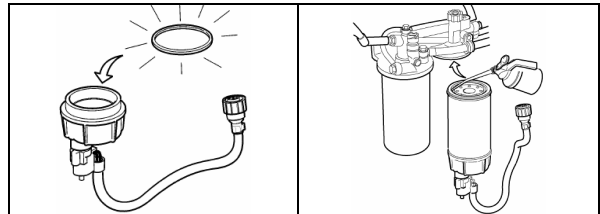
1. Stop engine, close the fuel supply line shut-off valve.
2. Place an appropriate container under the fuel filter housing, then drain the water from the water separation bowl.
3. Disconnect the fuel/water separator indicator electrical connector.



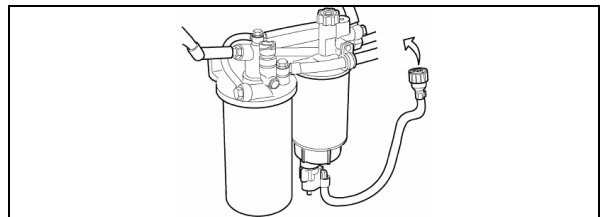
4. Unscrew and remove the primary fuel filter from the fuel filter housing. Drain filter.
5. Unscrew and remove the separation bowl from the filter cartridge.
6. Remove and discard the old gasket from the water separation bowl. Clean the bowl thoroughly and then blow dry with filtered compressed air.



7. Check that the drainage hole in the water separator bowl is not blocked.
8. Apply a thin coating of clean engine oil to the surface of the water separation bowl.



9. Install a new gasket to the water separation bowl and then reinstall the separation bowl to the new primary fuel filter cartridge.
10. Apply a thin coating of clean engine oil to the surface of the primary fuel filter, install the primary fuel filter to the fuel filter housing, then tighten the primary fuel filter 1/2-3/4 turn.



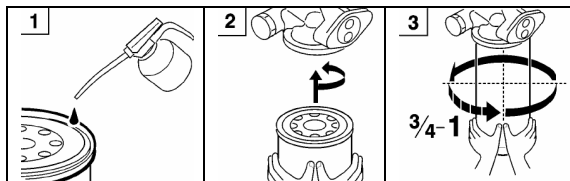
11. Connect the electrical connector for the water/fuel separation bowl indicator.
12. Open the fuel supply line shut-off valve.
13. Purge air from the filter by operating the priming pump to draw fuel and fill the filter. When using the hand priming pump, approximately 100 strokes will be required.

## Section 03: FUEL SYSTEM

14. Start the engine and carry out a fuel-tightness check. Let the engine run for about 5 minutes to remove air pockets from the fuel system.

### 2.3.2 Secondary Fuel Filter Replacement

1. Stop engine, close the fuel supply line shut-off valve. Place an appropriate container under the fuel filter housing.
2. Clean around sealing area on fuel filter and housing.
3. Unscrew and remove the secondary fuel filter from the fuel filter housing.
4. Apply a thin coating of clean engine oil to the gasket of the secondary fuel filter. Screw the fuel filter into position. Tighten the filter  $\frac{3}{4}$  to 1 turn after the gasket makes contact with the fuel filter housing.



### CAUTION

Fuel in the old filter **must absolutely not** be poured into the new filter. This kind of contaminated fuel can damage the unit injectors.

5. Prime the fuel system by pumping the hand priming pump on the fuel filter housing until resistance is felt indicating that the system is full of fuel.
6. Start the engine and carry out a fuel-tightness check. Let the engine run for about 5 minutes to remove air pockets from the fuel system.

### 2.4 PRIMING THE FUEL SYSTEM

The fuel system will need to be bled if:

- The vehicle has run out of fuel.
- The engine has not been running for an extended period of time.
- Service work has been done on the fuel system, (tank, fuel lines, filters, valves, etc.) for example cleaning or replacing fuel filter cartridges.
- The engine is new or rebuilt.



### CAUTION

When priming the system, movement of the primer pump should be as up and down as possible. Avoid putting any side load on the pump or causing a binding condition. Failure to follow these instructions could prematurely damage the primer pump.

### NOTE

When the fuel system is empty, 200 or more pump strokes may be needed to properly prime system. There are no bleed nipples to be opened to prime the fuel system.

1. Stop engine;
2. Unlock the hand pump by turning the handle counterclockwise.
3. Prime the system by moving the primer pump in an up and down pumping motion. Avoid putting any side load on the pump or causing a binding condition.
4. Lock the hand primer pump by retracting it into the housing and turning it clockwise.
5. Start the engine and run it at an increased idle speed for approximately 5 minutes to remove any remaining air in the system. Check the fuel system for leaks.

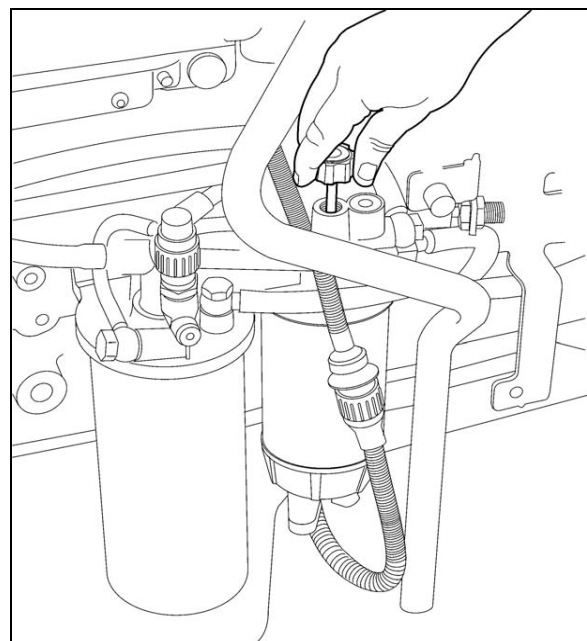


FIGURE 12: HAND PRIMING PUMP

## 2.5 FUEL PUMP REMOVAL AND INSTALLATION

The pump is located underneath the air compressor and is accessible through the engine compartment R.H. access door.

To remove the pump, proceed as follows:

- Clean around the fuel pump and fuel lines. Position a container to catch any fuel that might drain from the pump or lines.
- Remove the fuel pump.

**NOTE**

Only unfasten the bolts marked with arrows.

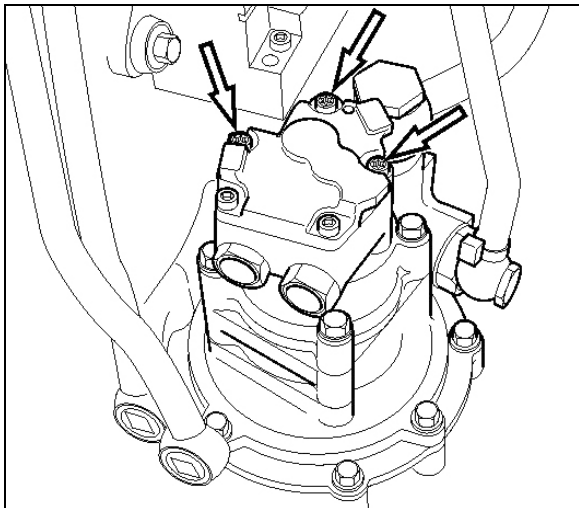


FIGURE 13: FUEL PUMP REMOVAL



**CAUTION**

Ensure to clean around the head of the bolts. Debris will prevent the tool from fitting properly and cause damage to the fasteners..

- Check that the adapter and fuel pump drive axle are not damaged.

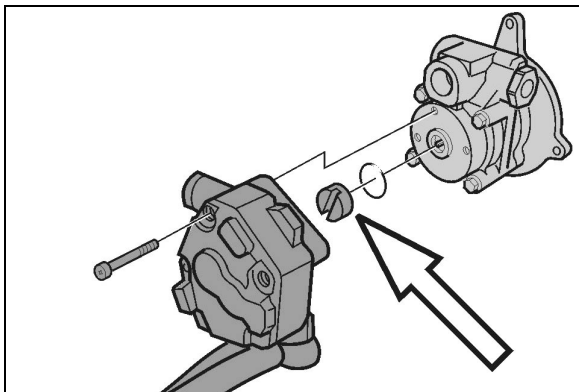


FIGURE 14: FUEL PUMP DRIVE AXLE

- Install the fuel pump. Torque-tighten bolts to specification.

**NOTE**

Use a new sealing ring. Check that the fuel pump drive axle sits correctly in the power steering pump.

- Using the hand primer on the fuel filter housing, prime the fuel system.
- Start the engine and let run for 5 minutes. Make sure that there are no leaks.

### 3. DAVCO FUEL PRO 382

The optional Fuel Pro 382 diesel fuel filter system consists of a permanently mounted fuel processor, a replaceable filter element, a filter element cover and collar and a fluid filter base assembly. This system is installed between the fuel tank and the fuel pump and is designed to be the only fuel filter in the fuel system. The filter serves as a water separator as well as a fuel filter (refer to figure 15).

The filter fibers used in the Davco Fuel Pro 382 element may cause the fuel level to read artificially high when the filter is first installed. Over the first few days, the filter fibers eventually become fully saturated and the fuel level will drop to normal levels. Do not be concerned about an abnormally high fuel level when a new Davco element is installed.

When new, the fuel level as seen through the clear cover in the 382 filter is very low. It rises as dirt collects on the filter from the bottom up. Restriction remains consistently low because fuel always flows through clean, new media.



**MAINTENANCE**

Replace Fuel Pro 382 filter element when the fuel level in the see-thru filter cover reaches the top of the filter element or after one year of service, whichever comes first.

## Section 03: FUEL SYSTEM

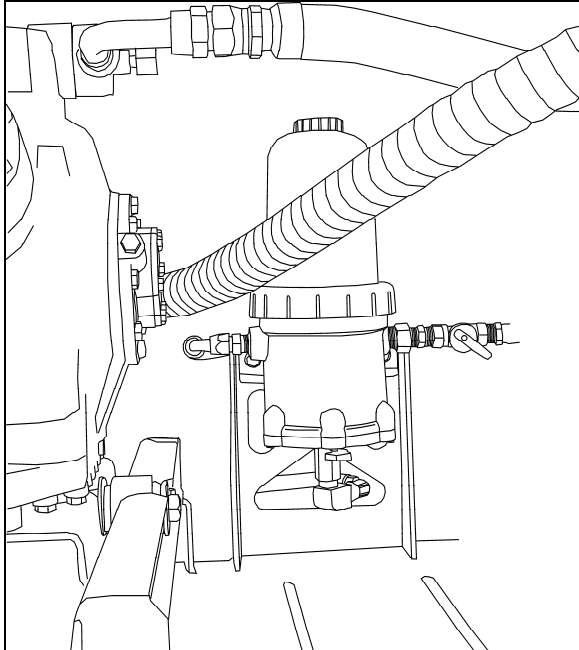


FIGURE 15: DAVCO FUEL PRO 382 FUEL FILTER 03062

### Filter replacement:

1. Stop engine;
2. Place a suitable container under the fuel processor;
3. Close the shut-off valve at the inlet side of the fuel filter;
4. Open the drain valve at the base of the fuel processor and drain the fuel until it is below the level of the filter;
5. Untighten upper collar, remove cover, filter hold down spring, filter element and cover seal;
6. Dispose of used filter element;
7. Ensure the filter grommet is included at the base of the new filter element and then install the element onto the center stud;
8. Ensure the filter spring is installed at the top of the cover. If missing, the spring must be replaced to insure proper filter operation.
9. Wipe the cover lid and seal clean. After ensuring the seal is properly positioned at the base of the cover, install the cover and collar onto the fuel processor. Tighten the collar by hand until secure;
10. Fill the cover full of clean fuel through spin off cap located on top of cover. Install vent cap seal and then reinstall the cap and tighten by hand only;

11. Open the shut-off valve;
12. Start engine, raise rpm for 2-3 minutes, hand tighten collar again;
13. After the air is purged and with the engine still running, slowly loosen the vent cap on the filter cover. The fuel level in the cover will start falling. When the fuel level falls to the top of the collar, tighten the vent cap quickly by hand;
14. Shut down the engine and hand-tighten the collar again.

### NOTE

*Fuel Pro 382 also accepts standard secondary spin-on fuel filters.*

### ENVIRONMENTAL NOTICE

*Diesel fuel is an environmentally hazardous product. Dispose in an environmentally friendly manner.*

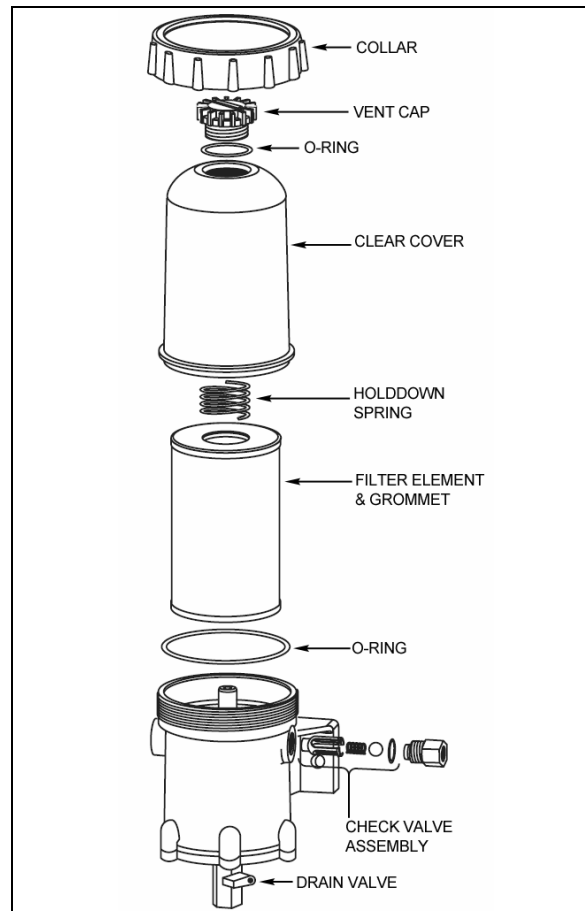




FIGURE 16: DAVCO FUEL PRO 382 EXPLODED VIEW 03034

**4. FUEL LINES AND FLEXIBLE HOSES**

Make a visual check for fuel leaks at all engine-mounted fuel lines and connections and at the fuel tank suction and return lines. Since fuel tanks are susceptible to road hazards, leaks in this area may best be detected by checking for accumulation of fuel under the tank. Engine performance and auxiliary equipment is greatly dependent on the ability of flexible hoses to transfer lubricating oil, air, coolant and fuel oil. Diligent maintenance of hoses is an important step in ensuring efficient, economical and safe operation of engine and related equipment.


|  |
|--|
|  <p><b>MAINTENANCE</b></p>  |
| <p>Check hoses daily as part of the pre-start-up inspection. Examine hoses for leaks and check all fittings, clamps and ties carefully. Make sure that the hoses are not resting on or touching shafts, couplings, and heated surfaces, including exhaust manifolds, any sharp edges or other obviously hazardous areas.</p> |

Since all machinery vibrates and moves to a certain extent, clamps and ties can fatigue with age. To ensure continued proper support, inspect fasteners frequently and tighten or replace them as necessary. Refer to the schematic diagram of the fuel system (Fig. 1 & 7).

|   |
|---|
|  <p><b>CAUTION</b></p>   |
| <p>Oil level above the dipstick full mark or a decrease in lube oil consumption may indicate internal fuel leaks. Check oil level frequently.</p> |

**5. PREHEATER FUEL FILTER**

The preheater fuel filter is located beside the preheater in the dedicated compartment above the rear wheelhousing, on the L.H. side of vehicle.

|   |
|---|
|  <p><b>MAINTENANCE</b></p> |
| <p>Replace preheater fuel filter every 50,000 miles (80 000 km) or once a year, whichever comes first.</p>    |


**6. FUEL TANK**

X3-45 coaches are equipped with a high-density cross-link polyethylene fuel tank with a capacity of 208 US gallons (787 liters).

On all vehicles, fuel filling access doors on both sides of vehicle provide direct access to filler necks; offering the added advantage of refueling from either side of vehicle.

A pressure relief valve on the fuel tank connection-panel relieves high-pressure buildup and an overflow tube allows offset air in the tank to escape during filling. For 95% of the tank volume, 5% of tank inside space is kept filled with air with no exit opening, allowing for a fuel expansion safety margin. A drain plug, accessible from under the vehicle, is fitted at the bottom of the tank.

**6.1 TANK REMOVAL**

|  |
|--|
|  <p><b>DANGER</b></p>   |
| <p>Park vehicle safely, apply parking brake, stop engine and set battery master switch(es) to the OFF position prior to working on the vehicle. Before working under an air-suspended vehicle, it is strongly recommended to support the body at the recommended jacking points.</p> |

|   |
|---|
| <p><i><b>NOTE</b></i></p>   |
| <p><i>Before removal, the fuel tank should be completely drained by unscrewing the drain plug. Ensure that the container used has a capacity equal to the amount of fuel remaining in the tank.</i></p> |

1. Open the condenser door and remove the fuel tank access panel. The rear baggage compartment fuel tank access panel may also be removed to facilitate access to components.
2. If applicable, unscrew clamps retaining L.H. side filler tube to the fuel tank, then disconnect tube and remove it.
3. Unscrew clamps retaining R.H. side filler tube to fuel tank and filler neck. Disconnect tube and remove it.
4. If applicable, unscrew preheater supply line, preheater return line, auxiliary return line and/or auxiliary return line from fuel tank connection-panel.

## Section 03: FUEL SYSTEM

5. Unscrew engine supply and return lines from fuel tank connection-panel, identify them for reinstallation.
6. Disconnect electrical wiring from tank on connection plate.
7. From under the vehicle, on R.H. side, unscrew the 4 bolts (2 in front, 2 in back) retaining the tank support to the frame.
8. From under the vehicle, on the L.H. side, unscrew the 2 bolts (1 in front, 1 in back) retaining the tank support to the frame.
9. Carefully remove tank from under the vehicle.



### DANGER

Before removing the bolts securing the tank support to the frame, make sure the tank is supported adequately. Failure to do so could result in injury as well as damage to the tank.

### 6.2 TANK INSTALLATION

To install tank, simply reverse the "Tank Removal" procedure.

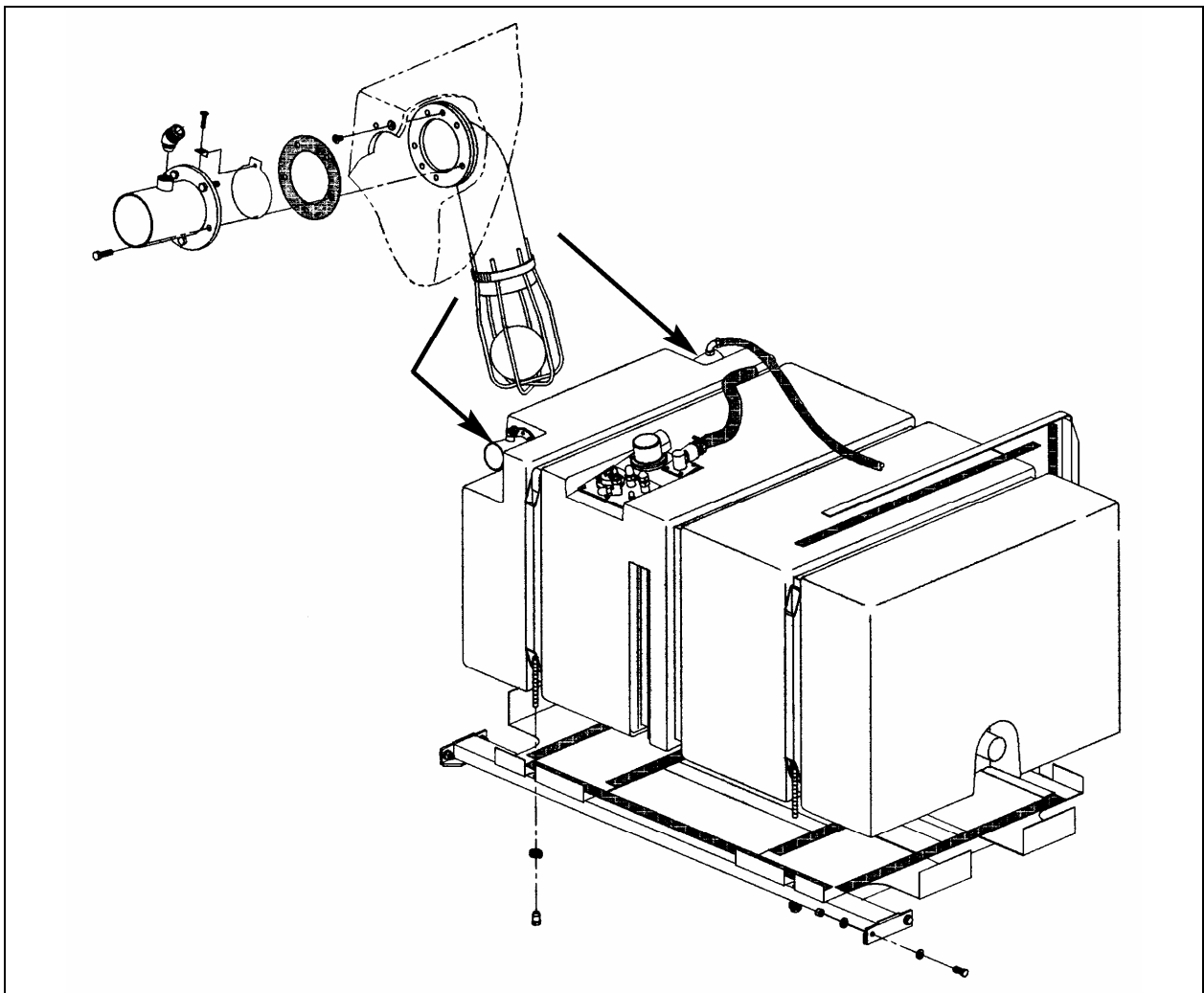


FIGURE 17: 208 US GAL. FUEL TANK

03063

### 6.3 FUEL TANK VERIFICATION

Inspect fuel tank from under vehicle for leaks or fuel traces. If a leak is detected, repair immediately as per "Polyethylene Fuel Tank Repair" in this section.

**DANGER**

Park vehicle safely, apply parking brake, stop engine and set battery master switch(es) to the OFF position prior to working on the vehicle.

Before working under an air-suspended vehicle, it is strongly recommended to support the body at the recommended jacking points.

### 6.4 POLYETHYLENE FUEL TANK REPAIR

**NOTE**

Fuel level must be lower than perforation to carry out this procedure.

**DANGER**

Park vehicle safely, apply parking brake, stop engine and set battery master switch(es) to the OFF position prior to working on the vehicle.

1. Locate perforation on fuel tank.
2. If necessary, remove fuel tank as per instructions in this section.
3. Drill perforation with a 23/64" bit. Make sure drill hole is perfectly round.
4. Insert a screw (Prevost #500196) and a washer (Prevost #5001244) into anchor nut (Prevost #500331).
5. Place assembly in drill hole. Tighten screw by 10 complete turns. Refer to Fig. 18.
6. Apply sealant on head plug (Prevost #507300) and seal hole with the head plug.

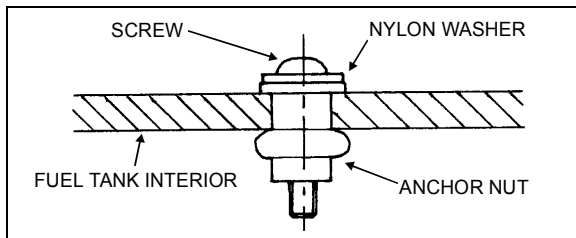


FIGURE 18: FUEL TANK REPAIR 03014

## 7. FUEL SPECIFICATIONS

The quality of fuel oil used for high-speed diesel engine operation is a very important factor in obtaining satisfactory engine performance, long engine life and acceptable exhaust emission levels.

The U.S. Environmental Protection Agency (EPA) has issued new standards to improve air quality by significantly reducing emissions through a combination of cleaner-burning diesel engines and vehicles.

To meet EPA standards, the petroleum industry produces **Ultra Low Sulfur Diesel** (ULSD) fuel, also referred to as S15, containing a maximum 15ppm (parts-per-million) sulfur.

On-highway diesel engines meeting 2007 emission regulations are designed to operate **ONLY** with ULSD fuel. ULSD fuel will enable the use of cleaner technology diesel engines and vehicles with advanced emissions control devices, resulting in significantly improved air quality.

### 7.1 FUEL TYPE

EPA-07 engines like the DDC 2007 Series 60 are designed to run on **Ultra Low Sulfur Diesel** (ULSD) fuel, which can contain no more than 15 ppm sulfur.

Fuel used must meet engine manufacturer's specification. For Detroit Diesel engines refer to "Diesel Fuel Specifications" as stated in DDC publication 7SE270 LUBRICATING OIL, FUEL, AND FILTERS. Similarly for Volvo engine.

**CAUTION**

ULSD fuel is necessary to avoid fouling the engine's Aftertreatment Device (ATD). Improper fuel use will reduce the efficiency of the engine's Aftertreatment System and may permanently damage the system.

**CAUTION**

Owners of 2007 and later model year on-highway diesel engine must refuel only with ULSD fuel.

## Section 03: FUEL SYSTEM

### **NOTE**

*Burning Low Sulfur Diesel fuel (instead of ULSD fuel) in 2007 and later model year diesel engines is illegal and punishable with civil penalties.*

### **NOTE**

*Engine and vehicle manufacturers expect ULSD fuel to be fully compatible with the existing fleet, including 2006 and earlier model year vehicles. In some instances, the introduction of ULSD fuel to older vehicles may affect fuel system components or loosen deposits in fuel tanks. As part of a good maintenance program, owners and operators of existing cars, trucks and buses are encouraged to monitor their diesel-powered vehicles closely for potential fuel system leaks or premature fuel filter plugging during the change-over to ULSD fuel.*

### **NOTE**

*Like Low Sulfur Diesel fuel, ULSD fuel requires good lubricity and corrosion inhibitors to prevent unacceptable engine wear. As necessary, additives to increase lubricity and to inhibit corrosion will be added to ULSD fuel prior to its retail sale.*

### 7.2 BLENDING

Only ultra low sulfur kerosene – No.1 diesel with no more than 15ppm sulfur may be blended with ULSD fuel to improve cold weather performance. With so many kerosene formulations on the market, care must be taken to select kerosene with a maximum of 15ppm sulfur.

Blend rates remain the same as with Low Sulfur Diesel fuel.

### 7.3 BIODIESEL FUELS

ULSD-B5 biodiesel may be used. B5 tells you the percentage of biodiesel mixed in with ULSD. B5 is 5% biodiesel and 95% ULSD.

Fuel used must meet engine manufacturer's specification for biodiesel fuel. For Detroit Diesel engines refer to "Diesel Fuel Specifications" as stated in DDC publication 7SE270 LUBRICATING OIL, FUEL, AND FILTERS. Similarly for Volvo engines.

Biodiesel fuels are alkyl esters of long chain fatty acids derived from renewable resources. Detroit Diesel highly recommends biodiesel fuels made from soybean or rapeseed oil through the proper transesterification reaction process. Other feedstock source of biodiesel fuels such as animal fat and used cooking oils are not recommended by Detroit Diesel. Biodiesel fuels meeting ASTM D6751 specification and from BQ-9000 accredited producer, prior to blending can be mixed up to 5% maximum by volume in petroleum diesel fuel. The resulting mixture must meet the fuel properties listed in Table 5-1 (see Detroit Diesel publication 7SE270 LUBRICATING OIL, FUEL, AND FILTERS.) and ASTM D975 specification. Failures attributed to the use of biodiesel fuel will not be covered by Volvo, Detroit Diesel or Prevost product warranty. Also, any engine performance problem related to the use of biodiesel fuel would not be recognized nor considered as Volvo, Detroit Diesel or Prevost's responsibility.

### 8. AIR CLEANER (DRY TYPE)

The vehicle is equipped with a dry-type replaceable element air cleaner, located in the engine compartment. Access the air cleaner through the engine R.H. side door. Engine air enters the air cleaner through (2) two intake ducts located just above engine side doors. It then flows through a pre-cleaner and finally through the air cleaner. The pre-cleaner removes dust and moisture by means of a discharge tube at the bottom of the element. It is in series with a replaceable impregnated paper filter element (air cleaner).

#### 8.1 PRE-CLEANER SERVICING



### **MAINTENANCE**

The pre-cleaner is designed to be self-cleaning; however, it should be inspected and any accumulated foreign material removed during the periodic replacement of the impregnated paper filter element.

#### 8.2 AIR CLEANER SERVICING

Stop the engine, open the R.H. side engine compartment door, and loosen the wing nut retaining the air cleaner element to the air cleaner. Remove the element by pulling on the handle in the center of the air cleaner element.



Install cleaner element as follows:

1. Inspect the gasket-sealing surface inside the air cleaner. It must be smooth, flat and clean;
2. Install the air cleaner element;
3. Make sure that the element seals securely;
4. Inspect element cover gasket and replace if necessary.


Whenever it becomes necessary to remove the air cleaner assembly (dry type) for maintenance or other repair in this area, great care should be taken when installing air cleaner assembly.

The pre-filter should be installed snugly in the air duct and clamped tightly to the air cleaner inlet to prevent any dust infiltration into the air cleaner.

### 8.3 GENERAL RECOMMENDATIONS

The following maintenance procedures will ensure efficient air cleaner operation:

1. Keep the air cleaner housing tight on the air intake pipe;
2. Make sure the correct filters are used for replacement;
3. Keep the air cleaner properly assembled so the joints are air-tight;
4. Immediately repair any damage to the air cleaner or related parts;
5. Inspect, clean or replace the air cleaner or elements as operating conditions warrant. Whenever an element has been removed from the air cleaner housing the inside surface of the housing must be cleaned with a soft clean cloth;
6. Periodically inspect the entire system. Dust-laden air can pass through an almost invisible crack or opening which may eventually cause damage to an engine;
7. Never operate the engine without an element in the air cleaner assembly;

|  |                       |
|--|-----------------------|
|                                   | <p><b>CAUTION</b></p> |
| <p>Do not ignore the Warning given by the air restriction indicator. This could result in serious engine damage.</p> |                       |

8. Store new elements in a closed area free from dust and possible damage.

### 8.4 AIR CLEANER RESTRICTION INDICATOR

A resettable restriction indicator may be installed on the engine air-intake duct, clearly visible from the rear engine compartment. The indicator monitors the vacuum level between the air filter and the engine. A red marker is displayed when the air filter is clogged and must be replaced. Reset by pressing on the indicator's extremity.

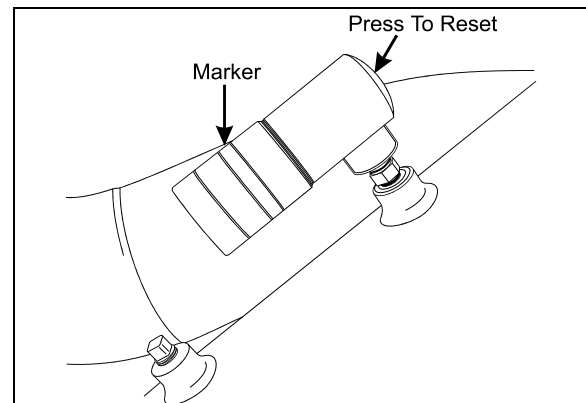


FIGURE 19: RESTRICTION INDICATOR

01052

### 9. FUEL COOLER – DETROIT DIESEL SERIES 60 ONLY

The fuel cooler serves to cool the surplus diesel fuel after it has exited the cylinder head, on its way back to the fuel tank. It is accessible through the engine radiator door, and is located in front of the charge air cooler (CAC) and the coolant radiator (Fig. 21 & 22).

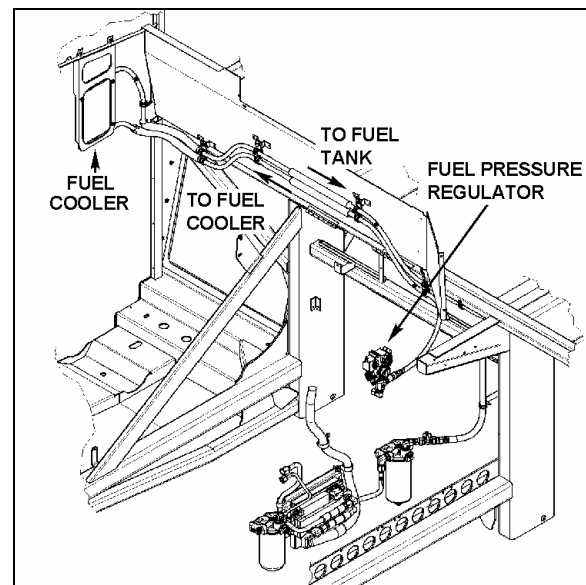


FIGURE 20: FUELRETURN LINE

03078

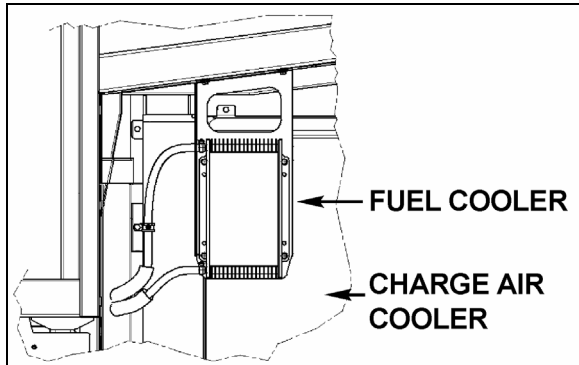


FIGURE 21: FUEL COOLER LOCATION 03079

## 10. FUEL PEDAL

The EFPA (Electronic Foot Pedal Assembly) connects the accelerator pedal to a potentiometer (a device that sends an electrical signal to the ECM, which varies in voltage, depending on how far down the pedal is depressed). The EFPA is installed in the space normally occupied by a mechanical foot pedal. It has maximum and minimum stops that are built into the unit during manufacturing.

### 10.1 FUEL PEDAL ADJUSTMENT

The EFPA contains a throttle position sensor that varies the electrical signal sent to the ECM. The sensor must be adjusted whenever an EFPA is serviced. In addition, the sensor should be adjusted any time codes 21 and 22 are flashed.

With the ignition "ON" and the proper diagnostic tool (DDR) (for information regarding the DDR, see "01 ENGINE" in this manual), check the throttle counts at idle and full throttle positions. Proper pedal output should be 20/30 counts at idle and 200/235 at full throttle. If adjustment is necessary, remove the potentiometer retaining screws and rotate the potentiometer clockwise to increase counts or counterclockwise to decrease. When correct output is confirmed, tighten retaining screws.

### 10.2 POTENTIOMETER REPLACEMENT

1. Disconnect cable harness connector.
2. Loosen the two screws and remove potentiometer. Retain for re-assembly.
3. Discard potentiometer (Fig. 23).



## CAUTION

Note the routing and clamping locations of the cable before disassembly. Proper cable routing and fastening is critical to the operation of this system. Marking the foot pedal assembly to record cable routing is recommended.

2. Position new potentiometer. Press potentiometer onto the potentiometer shaft, matching cutouts in shaft to drive tangs of potentiometer. Apply hand pressure until potentiometer has bottomed out in housing. Reinstall screws (Fig. 23) and tighten just enough to secure potentiometer lightly. Tighten screws to 10 - 20 Lbf-in (1.13 - 2.26 Nm).
3. Reconnect electronic foot pedal assembly's cable harness to the ECM connector. If potentiometer calibration is necessary (see "FUEL PEDAL ADJUSTMENT" in this section).



## CAUTION

Make sure the cable harness is routed correctly, and securely installed so that it does not become pinched, stretched, or otherwise damaged during vehicle operation.

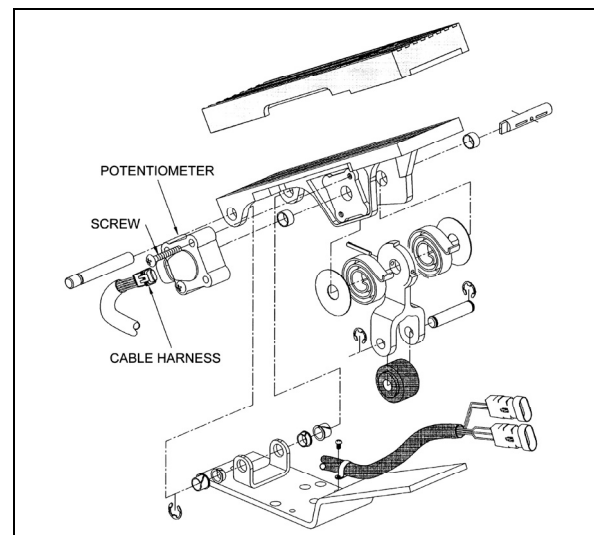


FIGURE 22: ELECTRONIC FOOT PEDAL ASSEMBLY 03035

**11. SPECIFICATIONS**

**Davco Fuel Pro 382 Fuel Filter / Water Separator Element**

Prevost number .....510795

**Racor Primary Fuel Filter / Water Separator (optional)**

(May be used instead of regular primary filter (never use with a primary filter).

Make ..... Racor

Type ..... Replaceable cartridge

ELEMENT

Prevost number .....531390

BOWL

Prevost number .....531389

DRAIN VALVE AND SEAL

Prevost number .....531397

O-RING

Prevost number .....531398

PROBE/WATER SENSOR

Prevost number .....531391

**Primary Fuel Filter (Fuel/Water Separator) With Detroit Diesel Series 60 Engine**

Make .....AC

Type ..... Spin-on

Filter No. ....T-915D

Prevost number .....032700

Element torque ..... 1/2 turn after gasket contact

**Primary Fuel Filter (Fuel/Water Separator) With Volvo D13 Engine**

Part number .....20879806

Filter torque..... 1/2-3/4 turn after gasket contact

**Secondary Fuel Filter With Detroit Diesel Series 60 Engine**

Make .....AC

Type ..... Spin-on

Filter No. ....T-916D

Prevost number .....510794

Element torque ..... 1/2 turn after gasket contact

**Secondary Fuel Filter With Volvo D13 Engine**

Part number .....20405160

Filter torque..... 3/4- 1 turn after gasket contact

**Section 03: FUEL SYSTEM**

---

**Fuel tank Capacity**

Standard (X3-45).....208 US gallons (787 liters)

**Air Cleaner**

Make ..... Nelson

Prevost Number .....530206

Service Part No ..... 7182 8N

Prevost number (element cartridge) .....530197

**Air Cleaner Restriction Indicator**

Make ..... Donaldson

Model .....RBX00-2220

Indicates .....at 20" (508 mm) of water

Prevost number .....530161

**Preheater Fuel Filter**

Make ..... Webasto

Prevost number .....871037

**Fuel Cooler**

Make ..... Long Manufacturing

Prevost number .....531422

# SECTION 04: EXHAUST SYSTEM

## CONTENTS

|  |          |
|--|----------|
| <b>1. EXHAUST AND AFTERTREATMENT SYSTEM OVERVIEW .....</b>       | <b>2</b> |
| 1.1 MAINTENANCE .....  | 2        |
| 1.2 FLEXIBLE COUPLING INSTALLATION .....                         | 3        |
| <b>2. AFTERTREATMENT DEVICE (ATD) .....</b>                      | <b>3</b> |
| 2.1 DIESEL PARTICULATE FILTER (DPF) REMOVAL - BOTH ENGINES ..... | 4        |
| <b>3. DIFFUSER ASSEMBLY .....</b>                                | <b>6</b> |
| 3.1 DIFFUSER ADJUSTMENT .....                                    | 6        |
| 3.2 MAINTENANCE .....  | 7        |
| 3.3 DIFFUSER ADAPTER .....                                       | 7        |

## ILLUSTRATIONS

|  |   |
|--|---|
| FIGURE 1: EXHAUST SYSTEM (DDC S60 SYSTEM SHOWN, VOLVO D13 SIMILAR) .....   | 2 |
| FIGURE 2: FLEXIBLE COUPLING .....  | 3 |
| FIGURE 3: AFTERTREATMENT DEVICE (ATD USED WITH DDC S60 ENGINE SHOWN, ATD USED WITH VOLVO D13<br>ENGINE IS SLIGHTLY DIFFERENT ..... | 3 |
| FIGURE 4: OPENING DPF COMPARTMENT ACCESS DOOR .....  | 4 |
| FIGURE 5: MARKING THE SUPPORT STRAP BRACKET .....  | 4 |
| FIGURE 6: DISCONNECTING THE LOWER PRESSURE PICK-UP TUBE (VOLVO D13 ONLY) .....   | 4 |
| FIGURE 7: PRESSURE DIFFERENTIAL SENSOR AND TAKE UP TUBES (VOLVO D13 ONLY) .....  | 5 |
| FIGURE 8: DPF REMOVAL .....  | 5 |
| FIGURE 9: DIFFUSER ASSEMBLY .....  | 6 |
| FIGURE 10: DIFFUSER POSITION ADJUSTMENT .....  | 6 |
| FIGURE 11: DIFFUSER POSITION ADJUSTMENT .....  | 6 |
| FIGURE 12: DIFFUSER POSITION ADJUSTMENT .....  | 7 |
| FIGURE 13: DIFFUSER ADAPTER .....  | 7 |

## Section 04: EXHAUST SYSTEM

### 1. EXHAUST AND AFTERTREATMENT SYSTEM OVERVIEW

The technology behind clean emissions technology is an exhaust **Aftertreatment Device (ATD)** which replaces today's muffler. The ATD primary function is to capture and oxidize (regenerate) the particulate matter (soot) in the engine exhaust gases. The ATD is split into two main sections. The exhaust gases first enter the **Diesel Oxidation Catalyst (DOC)** and then flow through the **Diesel Particulate Filter (DPF)**; together they capture and regenerate the soot on a regular or passive basis. Through constant monitoring of the exhaust gas temperature and the system back pressure, DDEC VI (Detroit Diesel) or EMS (Volvo) is able to manage regeneration.

The ATD is rubber mounted to the vehicle structure. This feature reduces the transmission of vibrations to the ATD thus resulting in extended life of ATD, brackets and also noise reduction.

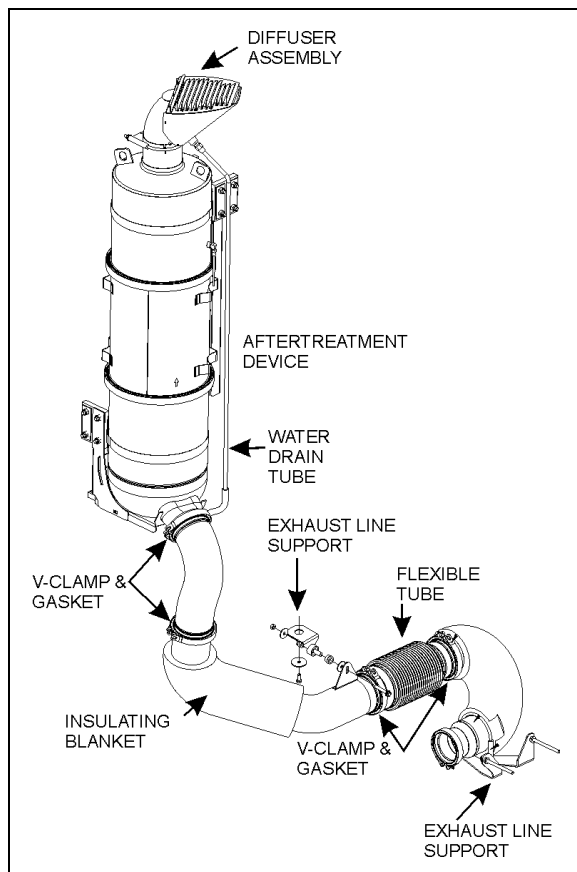


FIGURE 1: EXHAUST SYSTEM (DDC S60 SYSTEM SHOWN, VOLVO D13 SIMILAR) 04017

### 1.1 MAINTENANCE

Inspect the exhaust system periodically for restrictions and leaks. Figure 1 presents the major components of the exhaust system. Exhaust leaks are commonly the result of loose clamp bolts, corroded or punctured pipes. In addition to excessive noise, a leaking exhaust system could allow toxic gases to enter the vehicle. Damage to surrounding components from hot gases could result as well. Replace damaged or corroded exhaust components immediately.

Inspect the exhaust system as follows:

- At vehicle inspection intervals ;
- Whenever a change is noticed in the sound of the exhaust system ;
- When components close to the exhaust system get unnaturally dirty ; and
- Whenever the exhaust system is damaged.

Replace damaged or corroded exhaust system components without delay.

When operating the engine in a service garage or in a closed area, the exhaust must be vented to the outside. Place the shop vent hose over the exhaust outlet pipe.

**DANGER**

Avoid breathing exhaust gases since they contain carbon monoxide which is odorless and colorless but harmful. Carbon monoxide is a dangerous gas that can cause unconsciousness and can be lethal. If, at any time you suspect that exhaust fumes are entering the vehicle, locate and correct the cause(s) as soon as possible.

**NOTE**

*The key to successful regeneration is high exhaust temperature for an extended period of time. For this reason, insulating blankets must remain permanently on the exhaust system.*

*If insulating blankets are removed from the system, the exhaust gases temperature may not be high enough to permit efficient particulate oxidation during passive regeneration, resulting in increased fuel consumption due to overuse of active or stationary regeneration.*

### 1.2 FLEXIBLE COUPLING INSTALLATION

The flexible coupling contains a rigid interior pipe (Fig. 2). To allow appropriate flexibility once installed, be sure interior pipe is concentric to flexible part and that the flexible coupling is straight when installed. This piece of equipment handles vibration and thermal expansion.

## CAUTION

Adequately support the exhaust system line. The load of the exhaust line **must not** be transferred to the turbocharger.

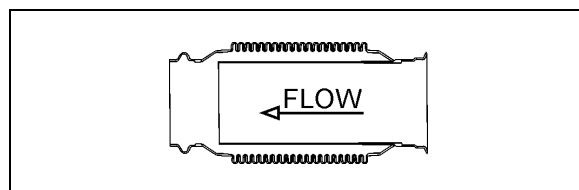


FIGURE 2: FLEXIBLE COUPLING

04022

## 2. AFTERTREATMENT DEVICE (ATD)

Besides trapping soot, the **DPF (Diesel Particulate Filter)** also traps the ash that has been generated when additives in engine oil are burned. However, unlike soot, ash cannot be oxidized. The ash that accumulates in the filter will eventually cause an increase in exhaust back pressure. DDEC VI or EMS will constantly monitor the ash accumulation and forecast the approximate time until DPF ash cleaning is required. This allows you the opportunity to plan for the DPF ash cleaning interval. If ash cleaning is not performed proactively, and the back pressure increases beyond the system limit, DDEC VI or EMS will flag the amber warning light on the telltale panel, notifying the operator that an ash cleaning is required. Clean remanufactured DPF cartridge will be available through Detroit Diesel on an exchange basis. For most vehicle applications and duty cycle, this will occur after approximately 200,000-400,000 miles (320,000-640,000 km) of operation.

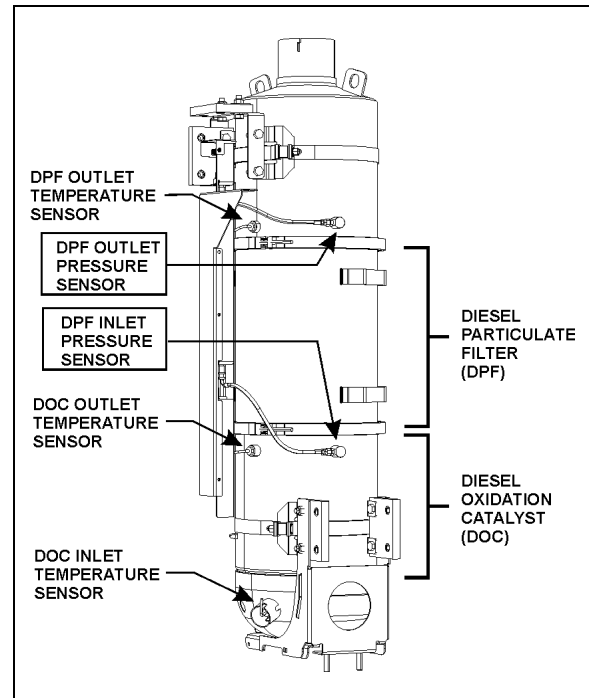


FIGURE 3: AFTERTREATMENT DEVICE (ATD USED WITH DDC S60 ENGINE SHOWN, ATD USED WITH VOLVO D13 ENGINE IS SLIGHTLY DIFFERENT

04016

## WARNING

### HOT SURFACES

Keep yourself clear of hot Aftertreatment Device surfaces, particularly during and after active or stationary regeneration. Hot surfaces can cause serious burns.

Make sure Aftertreatment System components are cold before handling.

## WARNING

### HOT EXHAUST

During stationary regeneration, exhaust gases temperature may reach up to 1200°F (650°C) at the DPF outlet. Do not direct at combustible materials. Before initiating stationary regeneration, make sure that the DPF outlet diffuser is clear of objects and that no one is working near the DPF outlet diffuser. Stationary regenerations must be undertaken outdoors only.

## Section 04: EXHAUST SYSTEM



### WARNING

#### TOXICITY

Do not initiate a stationary regeneration in a closed area like a garage. **Stationary regeneration must be undertaken outdoors only.**

### 2.1 DIESEL PARTICULATE FILTER (DPF) REMOVAL - BOTH ENGINES

To remove the DPF, proceed as follow:



### CAUTION

External and internal temperatures remain hot long after engine has been shutdown. Allow the Aftertreatment Device and DPF to cool before handling. Wear protective clothing and glove while servicing.

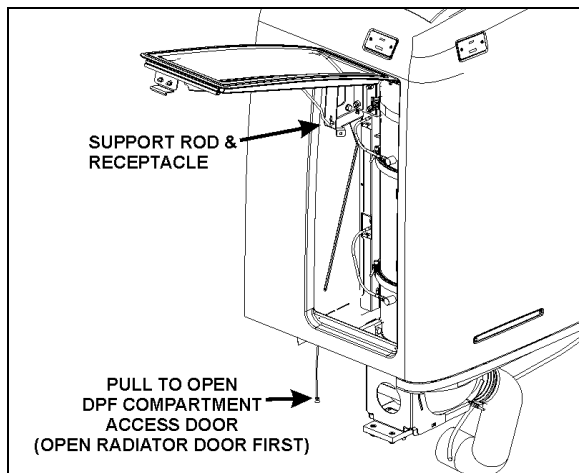


FIGURE 4: OPENING DPF COMPARTMENT ACCESS DOOR

04023

1. First, open the engine compartment door;
2. Under the ATD (Aftertreatment Device), on the left wall, pull the catch connecting rod to unlock the DPF compartment access door and lift the door open;
3. Hold the door open by inserting the support rod's free end into the receptacle located on the left side of the DPF;



### CAUTION

After inserting the support rod into the receptacle, make sure the rod supports the door securely from falling down on to your head or body.

4. From under the ATD, loosen the water drain tube hose clamp to set free the tube as it will move up with the ATD later in this procedure.
5. To ease proper positioning of the ATD and the diffuser at the time of reinstallation, using a marker, draw a line along the support strap bracket on the ATD. This will be helpful to reposition the ATD exactly as it was before removal (figure 5).

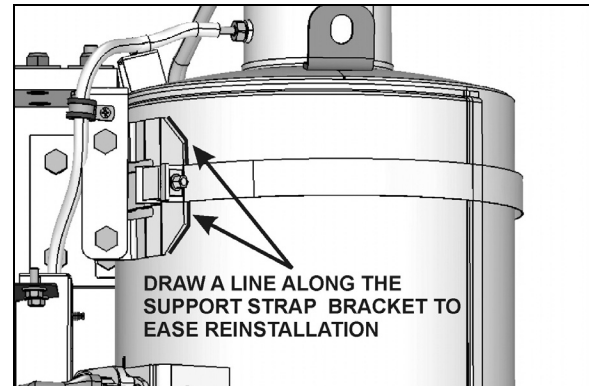


FIGURE 5: MARKING THE SUPPORT STRAP BRACKET

04024

6. **With Volvo D13 engine:** Disconnect the DPF inlet pressure pick-up tube, this will help to clear the way off for removal of the DPF cartridge from the compartment (figure 6).

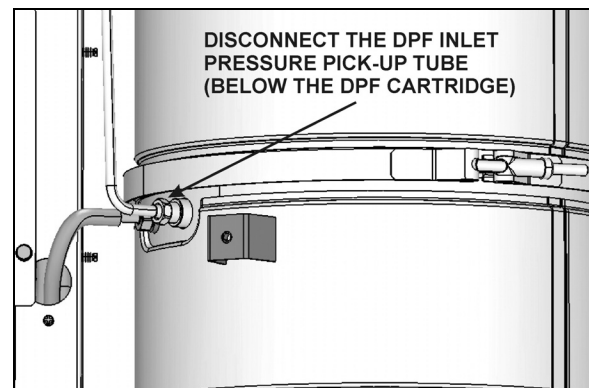


FIGURE 6: DISCONNECTING THE LOWER PRESSURE PICK-UP TUBE (VOLVO D13 ONLY)

04025

7. **With Volvo D13 engine;** Dismount the differential pressure sensor and detach the two hoses from the differential pressure sensor. Detach the two pressure pick-up tubes from the support bracket. This will help to clear the way off for removal of the DPF cartridge from the compartment (figure 7).



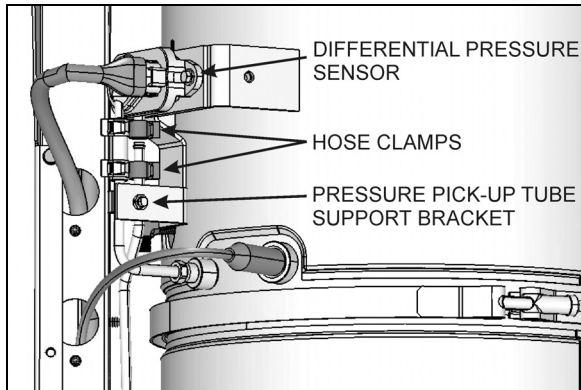


FIGURE 7: PRESSURE DIFFERENTIAL SENSOR AND TAKE UP TUBES (VOLVO D13 ONLY) 04026

8. Loosen the support strap surrounding the upper part of the Aftertreatment Device (ATD).
9. Loosen the upper V-band clamp joining the DPF to the upper part of the ATD. Slide the V-band clamp out of the way.

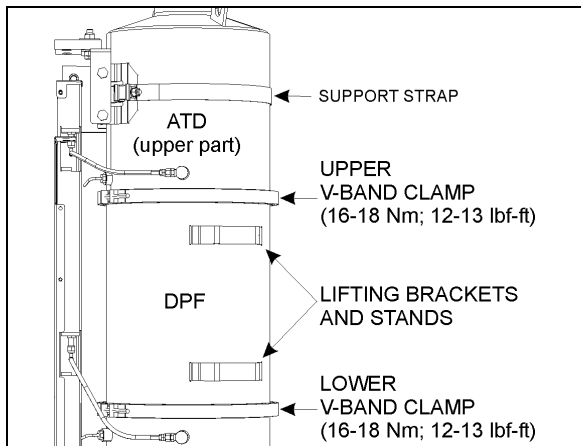


FIGURE 8: DPF REMOVAL 04019

10. Lift up the upper part of the ATD about 1" to 1 1/2" and then tighten the strap to maintain it in that raised position;

**NOTE**

On vehicles equipped with Volvo D13 engines, you can use the vehicle's hydraulic jack to lift the upper part of the ATD. Install the jack on a wood block inside the DPF compartment and lift the upper part at the differential sensor bracket. Use a 1 1/2"X1 1/2" angle to reach the bracket after having fixed it with a C-clamp on the bracket.

11. Loosen the lower V-band clamp and slide it out of the way;

12. Set the pressure pick-up tubes aside and pull the DPF cartridge out of the compartment. Use appropriate handling equipment.



**CAUTION**

**HEAVY DEVICE**

A suitable lifting or holding device is required. Properly support and attach lifting equipment to prevent the DPF from falling when servicing. The DPF cartridge weighs between 50 to 54 lbs.



**CAUTION**

**FRAGILE - HANDLE WITH CARE**

Use extreme care when handling DPF cartridge as it could be damaged or destroyed by dropping or sudden impact.

Clean remanufactured DPF cartridge will be available through Detroit Diesel on an exchange basis. For this reason, it is very important to maintain the cartridge in perfect condition. Damaged cartridge may not be refunded.

**NOTE**

When replacing the DPF cartridge, refer to the specifications on the DPF attached tag for proper replacement DPF selection.

Installation of the DPF is the same as removal, but in reverse order. However, take note of the following points:

1. To prevent exhaust losses, make sure that the DPF section is perfectly aligned with the DOC and the upper part of the ATD before tightening the V-band clamps.
2. **On Volvo D13 equipped vehicles**, the DPF cartridge is used with two gaskets. Before reinstalling the DPF cartridge, maintain the gaskets in position using masking tape. Place the masking tape outside the DPF cartridge shoulder in order to avoid tape residue inside the filtering cells. Take note that the definite DPF cartridge positioning is done by the use of pins and receptacles on the DPF cartridge and ATD upper and lower sections.
3. Properly tighten all fasteners.

## Section 04: EXHAUST SYSTEM

4. Be sure to return the support rod to its clip before closing the door, this prevents rattles.

### 3. DIFFUSER ASSEMBLY

During stationary regeneration, exhaust gases temperature may reach up to 1200°F (650°C) at the DPF outlet. The diffuser decreases the exhaust gasses temperature to 475°F (246°C) approximately, at 6 inches above the diffuser. The diffuser is an important component of the exhaust system and must remain on the vehicle at all times. Operating the vehicle without the diffuser may seriously damage the vehicle.

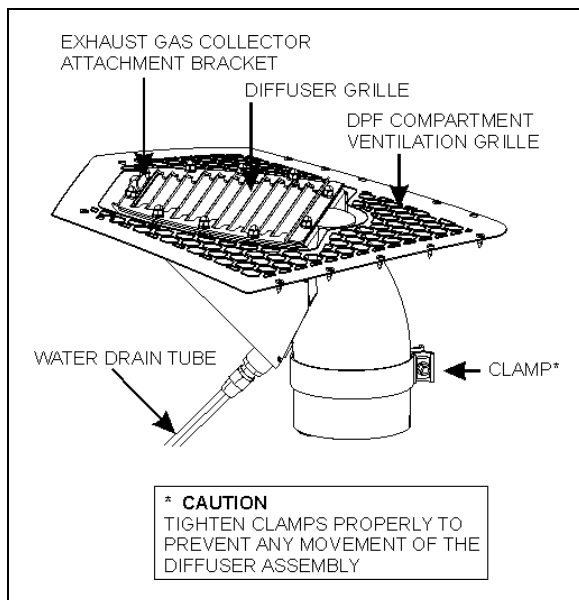


FIGURE 9: DIFFUSER ASSEMBLY

04014

#### 3.1 DIFFUSER ADJUSTMENT

Should an adjustment of the diffuser position be necessary, first remove the DPF compartment ventilation grille.



### CAUTION

To prevent damages caused by hot exhaust gases to the surrounding area, the diffuser grille must be flush with the roof surface or may not exceed the roof surface more than 1/4in (6mm).



### CAUTION

Tighten clamps properly in order to prevent any movement of the diffuser assembly. An impact wrench is necessary.

1. Loosen the clamp securing the diffuser assembly to the ATD.
2. For proper angular position, make sure that the two edges shown on figure 10 are parallel with each other.

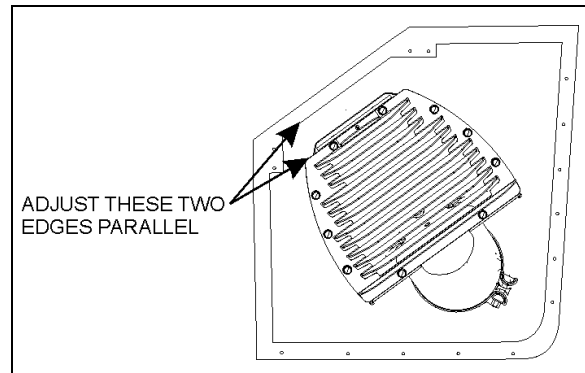


FIGURE 10: DIFFUSER POSITION ADJUSTMENT

04015\_1

3. Using a straightedge, adjust the diffuser assembly level. The top surface of the tag fixed on the diffuser grille must be flush with the roof surface (fig.9). It may exceed about 1/4in (6mm). Place the straightedge as shown on figure 11.

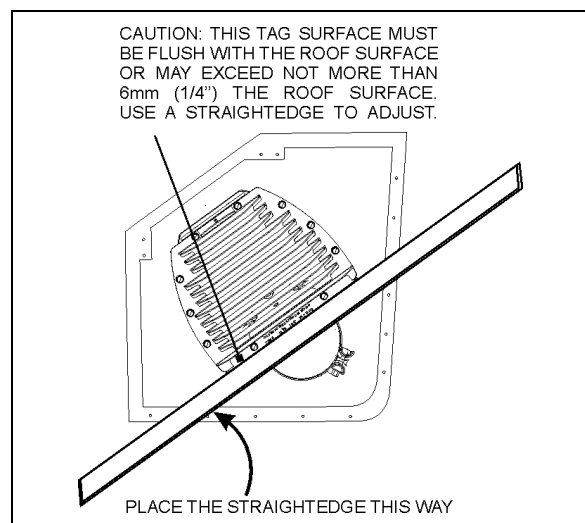


FIGURE 11: DIFFUSER POSITION ADJUSTMENT

04015\_2

4. Tighten the clamp securing the diffuser assembly to the ATD.
5. Reinstall the DPF compartment grille. Put a small quantity of Sika 221 on screws (fig.12).

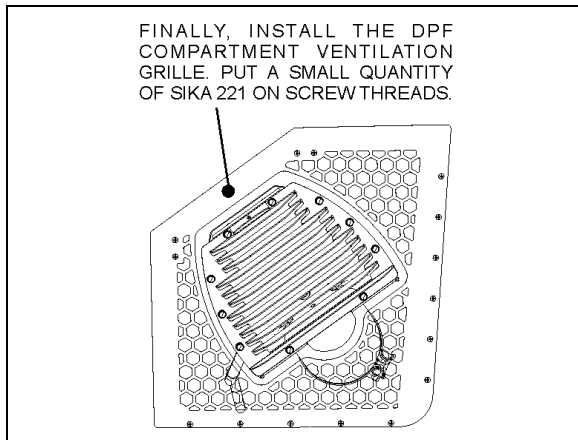


FIGURE 12: DIFFUSER POSITION ADJUSTMENT 04015\_3

### 3.2 MAINTENANCE

Inspect the diffuser assembly as follows:

- At vehicle inspection intervals, inspect diffuser grille for stress cracking;
- Check for proper functioning of the rain cap inside the diffuser housing, make sure that it moves freely;
- Make sure that the water drain tube is not clogged. Pour a cup of water into the diffuser housing and assure that all the water is drained at once at the other end of the drain tube. If tube is clogged, remove tube and blow compressed air inside, in reverse flow.

### 3.3 DIFFUSER ADAPTER

A diffuser adapter (Prevost #040710) is available through Prevost Parts to permit connection with current exhaust gas collecting system.

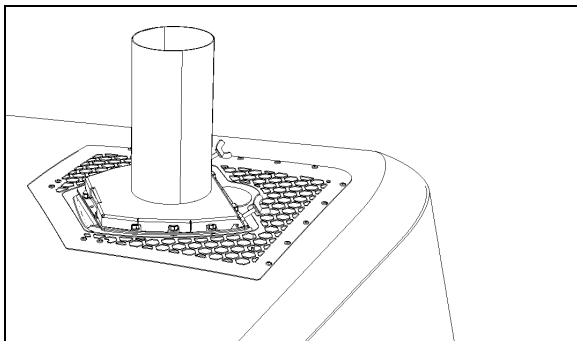


FIGURE 13: DIFFUSER ADAPTER 04020

# SECTION 05: COOLING SYSTEM

## CONTENTS

|  |           |
|--|-----------|
| <b>1. DESCRIPTION</b> .....  | <b>3</b>  |
| <b>2. MAINTENANCE</b> .....  | <b>4</b>  |
| 2.1 GENERAL RECOMMENDATIONS .....  | 4         |
| 2.2 VEHICLES EQUIPPED WITH DDC SERIES 60 ENGINE .....                        | 4         |
| 2.2.1 <i>Vehicles without coolant filters</i> .....                          | 5         |
| 2.2.2 <i>Vehicles with coolant filters</i> .....                             | 5         |
| 2.3 VEHICLES EQUIPPED WITH VOLVO D13 ENGINE .....                            | 5         |
| <b>3. HOSES</b> .....  | <b>5</b>  |
| 3.1 CONSTANT-TORQUE HOSE CLAMPS ON COOLANT LINES – DDC S60 & VOLVO D13 ..... | 5         |
| 3.1.1 <i>Installation</i> .....  | 6         |
| 3.1.2 <i>Maintenance</i> .....   | 6         |
| 3.2 CONSTANT-TORQUE HOSE CLAMPS ON CHARGE AIR COOLER (CAC) .....             | 6         |
| 3.2.1 <i>Maintenance</i> .....   | 7         |
| <b>4. THERMOSTAT OPERATION</b> .....   | <b>7</b>  |
| 4.1 DETROIT DIESEL SERIES 60 ENGINE .....                                    | 7         |
| 4.2 VOLVO D13 ENGINE .....   | 7         |
| 4.2.1 <i>Thermostat Checking</i> .....                                       | 8         |
| <b>5. COOLANT</b> .....  | <b>8</b>  |
| 5.1 COOLANT LEVEL VERIFICATION .....   | 8         |
| 5.2 COOLANT LEVEL SENSOR .....   | 8         |
| 5.3 THAWING COOLING SYSTEM .....   | 8         |
| 5.4 COOLING SYSTEM RECOMMENDATIONS .....                                     | 8         |
| 5.5 COOLANT RECOMMENDATIONS FOR DETROIT DIESEL SERIES 60 ENGINE .....        | 9         |
| 5.5.1 <i>Coolant Not Recommended</i> .....                                   | 10        |
| 5.5.2 <i>Inhibitors</i> .....  | 10        |
| 5.5.3 <i>Inhibitor Test Procedures</i> .....                                 | 10        |
| 5.5.4 <i>Additives Not Recommended</i> .....                                 | 10        |
| 5.6 COOLANT RECOMMENDATIONS FOR VOLVO D13 ENGINE .....                       | 11        |
| <b>6. DRAINING COOLING SYSTEM</b> .....                                      | <b>12</b> |
| <b>7. FILLING COOLING SYSTEM</b> .....                                       | <b>12</b> |
| <b>8. FLUSHING</b> .....   | <b>13</b> |
| 8.1 COOLING SYSTEM DESCALERS .....   | 13        |
| 8.2 REVERSE FLUSHING .....   | 14        |
| <b>9. SPIN-ON COOLANT FILTER</b> .....                                       | <b>14</b> |
| <b>10. RADIATOR</b> .....  | <b>15</b> |
| 10.1 MAINTENANCE .....   | 15        |
| <b>11. CHARGE AIR COOLER LEAKAGE</b> .....                                   | <b>16</b> |
| <b>12. COOLING FAN DRIVE MECHANISM</b> .....                                 | <b>16</b> |
| 12.1 DRIVE PULLEY AND UNIVERSAL JOINT SHAFT .....                            | 16        |
| 12.2 IDLER REPLACEMENT .....   | 16        |
| <b>13. VARIABLE SPEED COOLING FAN</b> .....                                  | <b>17</b> |

## Section 05: COOLING SYSTEM

---

|            |   |           |
|------------|---|-----------|
| 13.1       | LOCKING RADIATOR FAN FOR EMERGENCY OPERATION..... | 18        |
| 13.1.1     | <i>Electrical Locking</i> .....                   | 18        |
| 13.1.2     | <i>Mechanical Locking</i> .....                   | 18        |
| 13.2       | MAINTENANCE .....                                 | 18        |
| 13.3       | INSPECTION .....                                  | 19        |
| 13.4       | FAN REMOVAL / INSTALLATION.....                   | 19        |
| <b>14.</b> | <b>FAN RIGHT ANGLE GEARBOX.....</b>               | <b>19</b> |
| 14.1       | MAINTENANCE .....                                 | 19        |
| 14.2       | OIL CHANGE .....                                  | 19        |
| 14.3       | REMOVAL / INSTALLATION .....                      | 20        |
| <b>15.</b> | <b>COOLING FAN DRIVE BELT.....</b>                | <b>20</b> |
| 15.1       | MOUNTING THE DRIVE BELT .....                     | 20        |
| <b>16.</b> | <b>SPECIFICATIONS .....</b>                       | <b>21</b> |

## ILLUSTRATIONS

|            |   |    |
|------------|---|----|
| FIGURE 1:  | COOLANT FLOW SCHEMATIC .....  | 3  |
| FIGURE 2:  | COOLING SYSTEM COMPONENTS (DDC S60 ENGINE).....                     | 3  |
| FIGURE 3:  | COOLANT SURGE TANK .....  | 3  |
| FIGURE 4:  | SURGE TANK (WITH DDC S60) .....                                     | 4  |
| FIGURE 5:  | SURGE TANK (WITH VOLVO D13) .....                                   | 4  |
| FIGURE 6:  | COOLANT FLOW TO RADIATOR (DDC S60) .....                            | 6  |
| FIGURE 7:  | COOLANT FLOW TO RADIATOR (VOLVO D13).....                           | 6  |
| FIGURE 8:  | CONSTANT-TORQUE CLAMP .....   | 6  |
| FIGURE 9:  | CHARGE AIR COOLER HOSE CLAMPS (DDC S60) .....                       | 7  |
| FIGURE 10: | CHARGE AIR COOLER HOSE CLAMPS (VOLVO D13).....                      | 7  |
| FIGURE 11: | THERMOSTAT HOUSING (DDC S60 ENGINE) .....                           | 7  |
| FIGURE 12: | THERMOSTAT HOUSING (VOLVO D13 ENGINE) .....                         | 8  |
| FIGURE 13: | SURGE TANK SIGHT GLASS.....   | 8  |
| FIGURE 14: | LOCATION OF HEATER LINE SHUT-OFF VALVES IN ENGINE COMPARTMENT ..... | 11 |
| FIGURE 15: | WATER PUMP DRAIN PLUG .....   | 12 |
| FIGURE 16: | COOLANT FILTER (DDC S60 ENGINE).....                                | 14 |
| FIGURE 17: | COOLANT FILTER (VOLVO D13).....                                     | 15 |
| FIGURE 18: | RADIATOR DRAIN PLUG .....   | 15 |
| FIGURE 19: | COOLING FAN DRIVE MECHANISM .....                                   | 16 |
| FIGURE 20: | TIGHTENING SPECIFICATION.....                                       | 16 |
| FIGURE 21: | TIGHTENING SPECIFICATION (DDC S60 ENGINE) .....                     | 17 |
| FIGURE 22: | TIGHTENING SPECIFICATION (VOLVO D13 ENGINE).....                    | 17 |
| FIGURE 23: | IDLER MOUNTED ON THE CAST ALUMINUM SUPPORT .....                    | 17 |
| FIGURE 24: | MECHANICAL LOCKING.....   | 18 |
| FIGURE 25: | RADIATOR FAN MOUNTING BOLTS .....                                   | 19 |
| FIGURE 26: | RIGHT ANGLE GEARBOX.....  | 19 |
| FIGURE 27: | RIGHT ANGLE GEARBOX MOUNTING .....                                  | 20 |
| FIGURE 28: | DRIVE BELT ROUTING (DDC S60 ENGINE) .....                           | 20 |
| FIGURE 29: | DRIVE BELT ROUTING (VOLVO D13 ENGINE) .....                         | 21 |

## 1. DESCRIPTION

A radiator and thermo-modulated fan are used to effectively dissipate the heat generated by the engine. A centrifugal-type water pump is used to circulate the engine coolant (Fig. 1).

Two full blocking-type thermostats are used in the water outlet passage to control the flow of coolant, providing fast engine warm-up and regulating coolant temperature.

The engine coolant is drawn from the lower portion of the radiator by the water pump and is forced through the transmission cooler before going through the oil cooler and into the cylinder block.

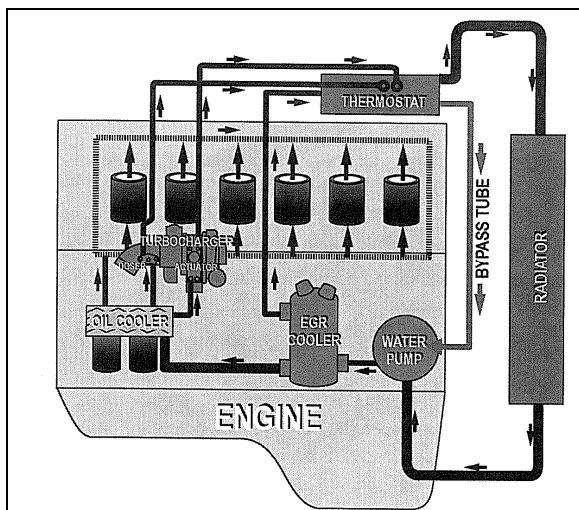


FIGURE 1: COOLANT FLOW SCHEMATIC (IMAGE DDC)

From the cylinder block, the coolant passes up through the cylinder head and, when the engine is at normal operating temperature, it goes through the thermostat housing and into the upper portion of the radiator. The coolant then passes through a series of tubes where its heat is dissipated by air streams created by the revolving fan and the motion of the vehicle.

Upon starting a cold engine or when the coolant is below normal operating temperature, the closed thermostats direct coolant flow from the thermostat housing through the by-pass tube to the water pump. Coolant is recirculated through the engine to aid engine warm up.

When the thermostat opening temperature is reached, coolant flow is divided between the radiator inlet and the by-pass tube. When the thermostats are completely open, all of the coolant flow is to the radiator inlet.

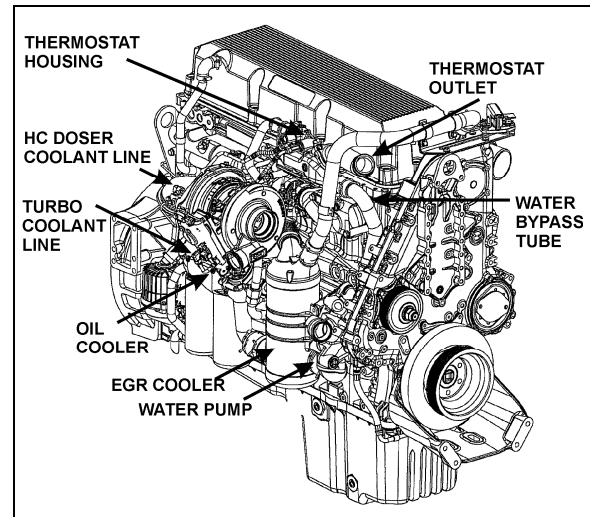


FIGURE 2: COOLING SYSTEM COMPONENTS (DDC S60 ENGINE) 05116

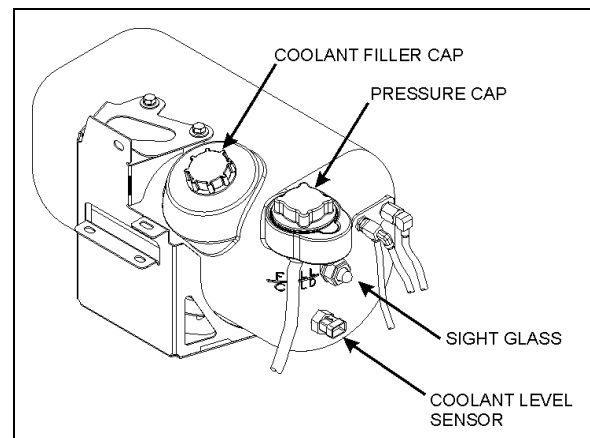


FIGURE 3: COOLANT SURGE TANK 05132

The cooling system is filled through a filler cap on the surge tank (Fig. 3). A pressure cap on top of the surge tank is used to maintain pressure within the system. When system exceeds normal pressure rating (14 psi - 96.53 kPa), the cap releases air and if necessary, coolant through the overflow tube (Fig. 4). Two thermostats are located in the housing attached to the right side of the cylinder head (Fig. 2). Furthermore, a water temperature sensor mounted on the cylinder head (radiator side) is also supplied for engine protection purposes (DDC S60).

The engine cooling system also provides hot coolant fluid for the vehicle heating system. Refer to section 22, "HEATING AND AIR CONDITIONING" in this manual for information relating to heating system water circulation.

## Section 05: COOLING SYSTEM

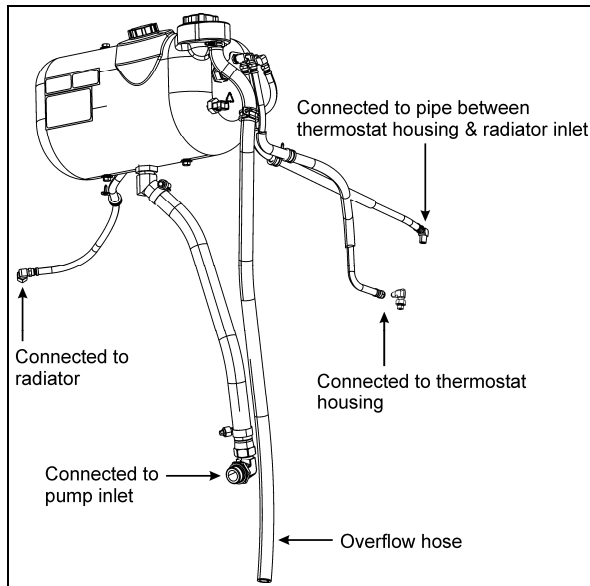


FIGURE 4: SURGE TANK (WITH DDC S60) 05115

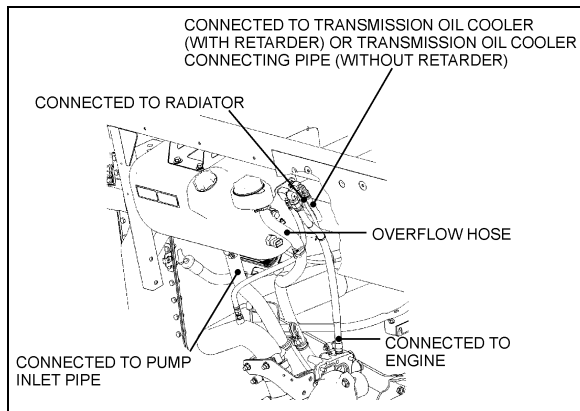


FIGURE 5: SURGE TANK (WITH VOLVO D13) 05143

## 2. MAINTENANCE

### 2.1 GENERAL RECOMMENDATIONS

A systematic routine inspection of cooling system components is essential to ensure maximum engine and heating system efficiency.

- Check coolant level in the surge tank daily, and correct if required. Test antifreeze strength.
- Check belts for proper tension; adjust as necessary and replace any frayed or badly worn belts.
- Check radiator cores for leaks and make sure the cores are not clogged with dirt or insects. To avoid damaging the fins, clean cores with a low-pressure air hose. Steam clean if required.

- Inspect the water pump operation. A leaky pump sucks in air, increasing corrosion.
- Repair all leaks promptly. Unrepaired leaks can lead to trouble. Inspect and tighten radiator mounts periodically. Test and replace thermostats regularly.

### NOTE

*In order to ensure the integrity of the system, it is recommended that a periodic cooling system pressure check be made. Pressurize the cooling system to 103-138 kPa (15-20 psi) using Radiator and Cooling System Tester, J24460-1. Do not exceed 138 kPa (20 psi).*

*Any measurable drop in pressure may indicate a leak. Whenever the oil pan is removed, the cooling system should be pressure checked as a means of identifying any incipient coolant leaks. Make sure the cause of the internal leak has been corrected before flushing the contaminated system.*

Leaks at the thermostat housing hose connections may be caused by deformation of connections or by rough surfaces on the castings of the hose mounting surfaces. It is recommended that "Dow Corning RTV-102 Compound" or any equivalent product be applied on cast surfaces prior to hose installation.



### CAUTION

Castings should be clean and free of oil and grease before applying compound. No other sealer should be used with RTV-102 compound.

### 2.2 VEHICLES EQUIPPED WITH DDC SERIES 60 ENGINE



### MAINTENANCE

Maintain the prescribed inhibitor strength levels as required. Coolant and inhibitor concentration must be checked at each engine oil change, every 12,500 miles (20 000 km) or once a year, whichever comes first to ensure inhibitor strength. For vehicles equipped with coolant filters replace precharge element filter with a maintenance element filter as per "SPIN-ON COOLANT FILTER" in this section. If the vehicle is not equipped with a filter, add the recommended inhibitor concentration to the antifreeze/water solution.



## MAINTENANCE

Drain, flush, thoroughly clean and refill the system every two years or every 200,000 miles (320 000 km), whichever comes first. For vehicle equipped with coolant filters, change the precharge element filter or the existing maintenance element filter for a new precharge element filter. If the vehicle is not equipped with filters add the recommended inhibitor concentration to the antifreeze/water solution.

### NOTE

*Do not add inhibitors to the antifreeze / water solution if vehicle is equipped with a coolant filter containing Supplemental Coolant Additives (SCA).*

Coolant must be discarded in an environmentally safe manner.

#### 2.2.1 Vehicles without coolant filters

Refer to Nalcool 3000 with Stabil-Aid bulletin annexed to the end of this section for preventive maintenance (at each oil change) and initial treatment instructions (each time the cooling system is drained and flushed).

#### 2.2.2 Vehicles with coolant filters

Change the coolant precharge element filter for a maintenance element filter at initial oil change (see "Specifications" at the end of this section) and replace existing maintenance element filter with a new one as per "SPIN-ON COOLANT FILTER" in this section. A precharge element filter must be installed each time the cooling system is drained and flushed prior to installing a maintenance element filter.

### NOTE

*The precharge coolant filter contains inhibitors.*

#### 2.3 VEHICLES EQUIPPED WITH VOLVO D13 ENGINE

### NOTE

*For additional information concerning Volvo D13 engine components or engine-related components, consult Volvo Trucks Canada or Volvo Trucks North America Web Site under: Parts & Service. On Volvo web site, you will find detailed service procedures for parts replacement, repair and maintenance.*



## MAINTENANCE

Drain, flush, thoroughly clean and refill the system with Extended Life Coolant (ELC) every four years or every 600,000 miles (1 000 000 km), whichever comes first. Change the coolant filter once a year or every 150,000 miles (240 000 km), whichever comes first. When using ELC, **do not** use a filter that contains Supplemental Coolant Additives (SCA).

### 3. HOSES

Rotten, swollen, and worn out hoses or loose connections are frequent causes of cooling system problems.

Serious overheating is often caused by an old hose collapsing or from rotten rubber shedding from hoses and clogging the coolant passages.

Connections should be inspected periodically and hose clamps tightened. Replace any hose found to be cracked or swollen.

When installing a new hose, clean pipe connections and apply a thin layer of a non-hardening sealing compound. Replace worn out clamps or clamps that pinch hoses.

#### 3.1 CONSTANT-TORQUE HOSE CLAMPS ON COOLANT LINES – DDC S60 & VOLVO D13

All hose clamps of 1 3/8" ID and over, used on the heating and cooling systems, are of the "Constant-torque" type. These clamps are worm-driven, made of stainless steel, and supplied with a series of Belleville spring washers. They also feature an extended integral liner that covers the band slots to protect soft/silicone hoses from damage, and help maintain consistent sealing pressure.

This type of clamp is designed to automatically adjust its diameter to compensate for the normal expansion/contraction of a hose and metal connection that occurs during vehicle operation and shutdown. The constant-torque clamp virtually eliminates coolant losses due to "Cold flow" leakage and greatly minimizes clamp maintenance.



## Section 05: COOLING SYSTEM

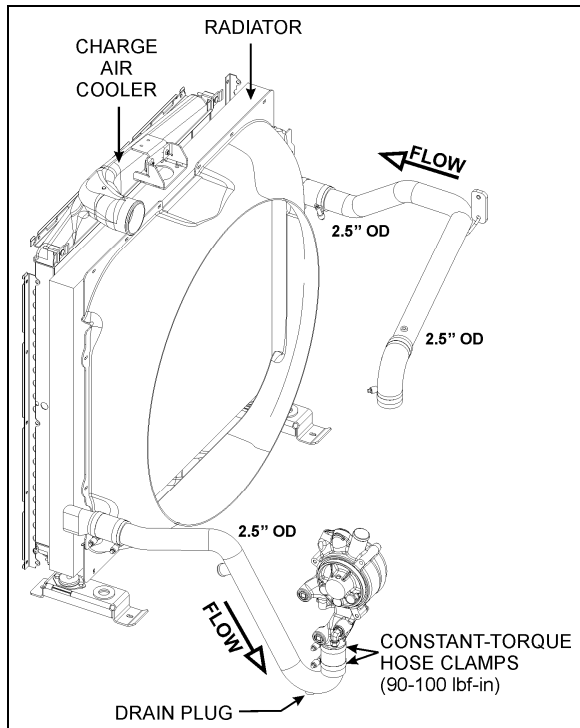


FIGURE 6: COOLANT FLOW TO RADIATOR (DDC S60)  
05133

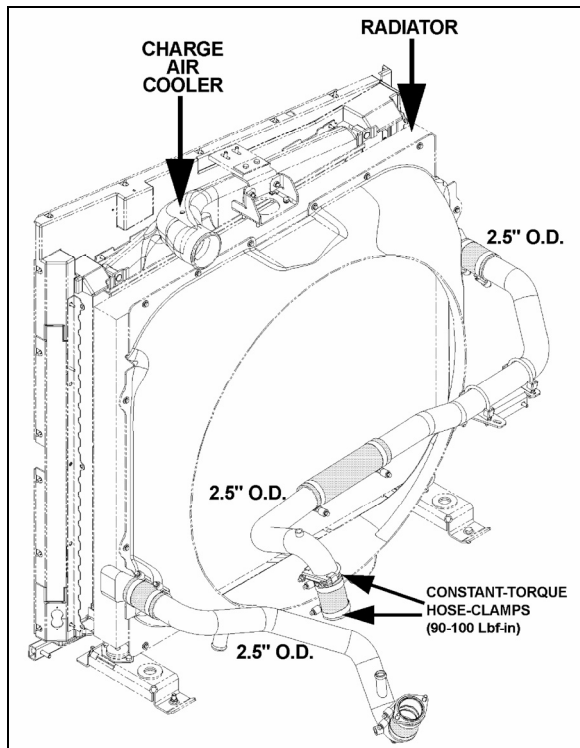


FIGURE 7: COOLANT FLOW TO RADIATOR (VOLVO D13)

### 3.1.1 Installation

A torque wrench should be used for proper installation. The recommended torque is 90 to

100 lbf-in. (10 to 11 Nm). The Belleville spring washer stacks should be nearly collapsed flat and the screw tip should extend 1/4" (6 mm) beyond the housing (Fig. 8).

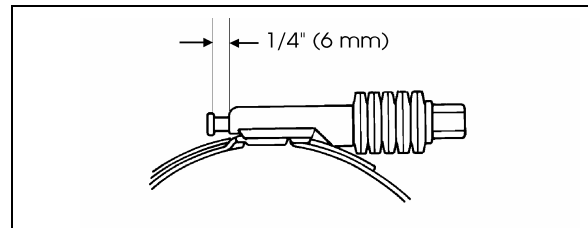


FIGURE 8: CONSTANT-TORQUE CLAMP

05037



### CAUTION

The hose clamps will break if over-torqued. Do not over-tighten, especially during cold weather when hose has contracted.

### 3.1.2 Maintenance

The constant-torque clamps contain a "Visual torque check" feature. When the tip of the screw is extending 1/4" (6 mm) out of the housing, the clamp is properly installed and maintains a leak-proof connection. Since the constant-torque clamp automatically adjusts to keep a consistent sealing pressure, there is no need to re-torque hose clamps on a regular basis. During vehicle operation and shutdown, the screw tip will adjust according to the temperature and pressure changes. **Checking for proper torque should be done at room temperature.**

### 3.2 CONSTANT-TORQUE HOSE CLAMPS ON CHARGE AIR COOLER (CAC)

If for any reason such as an accident, hose clamps need to be changed; install and tighten hose clamps to 10±1 lbf-ft (dry) (Fig. 9 & 10).



### CAUTION

The hose clamps will break if over-tighten. Do not over-tighten, especially during cold weather when hose has contracted.

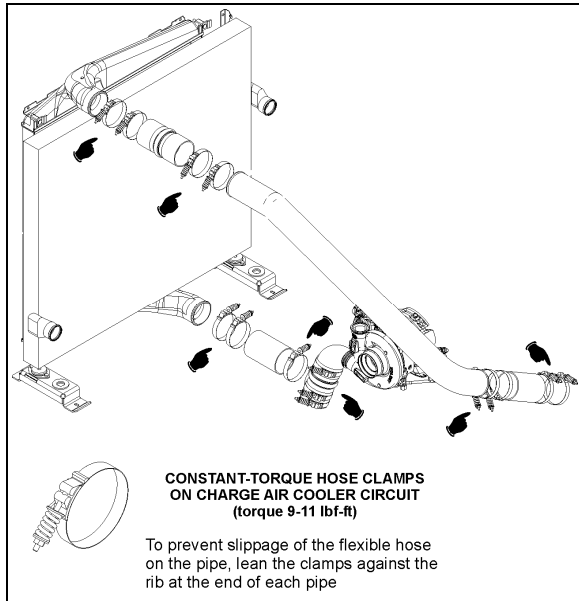


FIGURE 9: CHARGE AIR COOLER HOSE CLAMPS (DDC S60) 05134

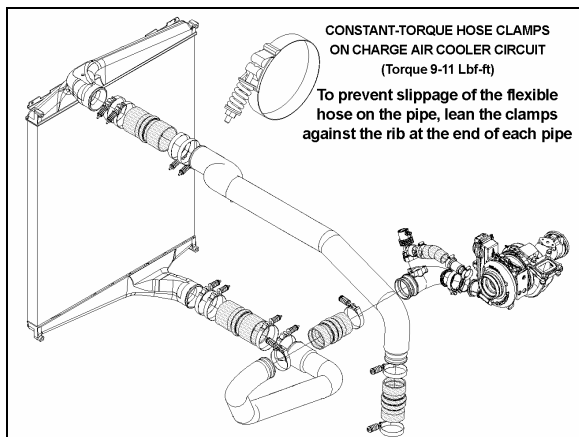


FIGURE 10: CHARGE AIR COOLER HOSE CLAMPS (VOLVO D13)

**NOTE**

*Detroit Diesel Series 60 and Volvo D13 engines have similar CAC piping designs and they use the same constant-torque hose clamps. Tighten hose clamps as specified above.*

3.2.1 Maintenance

Since the constant-torque clamp automatically adjusts to keep a consistent sealing pressure, there is no need to retorque hose clamps on a regular basis. During vehicle operation and shutdown, the screw tip will adjust according to the temperature and pressure changes.

**Checking for proper torque should be done at room temperature.**

4. THERMOSTAT OPERATION

4.1 DETROIT DIESEL SERIES 60 ENGINE

Coolant temperature is controlled by two blocking-type thermostats located in a housing attached to the cylinder head, on the turbo side of the engine (Fig. 11).

At coolant temperature below approximately 182°F-188°F (83°C-86°C), the thermostat valves remain closed and block the flow of coolant from the engine to the radiator. During this period, all of the coolant in the system is recirculated through the engine and directed back to the suction side of the water pump via a bypass tube. As the coolant temperature rises above 182°F -188°F (83°C-86°C) the thermostat valves start to open, restricting the bypass system, and allowing a portion of the coolant to recirculate through the radiator. When the coolant temperature reaches approximately 202°F (95°C) thermostat valves are fully open, the bypass system is blocked off and the coolant is directed through the radiator.

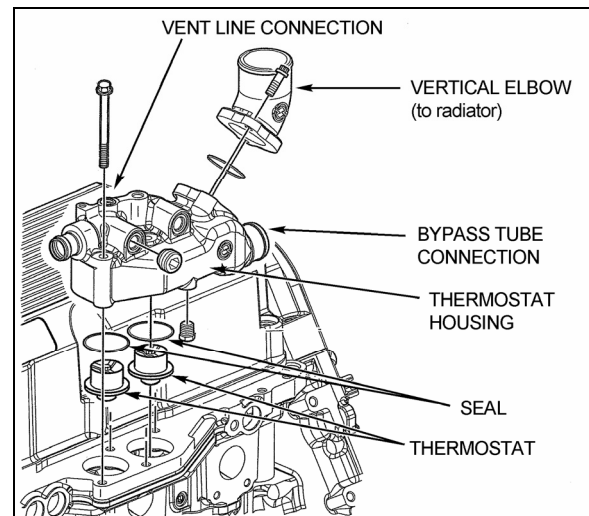


FIGURE 11: THERMOSTAT HOUSING (DDC S60 ENGINE) 05117

4.2 VOLVO D13 ENGINE

1. Drain the cooling system.
2. Remove the bolts, the thermostat housing and the thermostat. Carefully clean the thermostat seat and all cylinder head-to-thermostat housing mating surfaces.

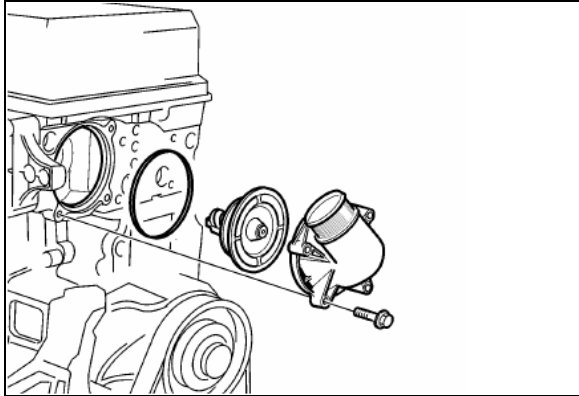


FIGURE 12: THERMOSTAT HOUSING (VOLVO D13 ENGINE)

3. Install the new thermostat. Make sure that the rubber seal remains properly seated.
4. Position the thermostat housing to the cylinder head, install the bolts and torque-tighten to  $24 \pm 4$  Nm ( $18 \pm 3$  ft-lb).
5. Install the rubber radiator hose to the thermostat housing. Position the clamp and tighten to secure.
6. Fill the system with the recommended coolant.
7. Start the engine, check for leaks and proper operation. After shutdown, replenish fluids as necessary.

#### 4.2.1 Thermostat Checking

A function check must be carried out before installing a new thermostat.

#### NOTE

*Check to be sure that the thermostat closes fully. This can be done by holding it up to the light to check that there is no visible gap at the opening point. If the thermostat does not close properly, replace it.*

1. Warm up water in a receptacle to  $75^{\circ}\text{C}$  ( $167^{\circ}\text{F}$ ) and immerse the thermostat in the water. Use a piece of wire attached to the thermostat.
2. After at least 30 seconds, check that the thermostat is still closed.
3. Now warm the water to  $100^{\circ}\text{C}$  ( $212^{\circ}\text{F}$ ). After at least 30 seconds at the boiling point, check that the thermostat has opened at least 7mm ( $9/32$ in). If the thermostat has not opened, it must be replaced. A good thermostat starts to close at  $95^{\circ}\text{C}$  ( $203^{\circ}\text{F}$ ) and is fully closed at approximately  $85^{\circ}\text{C}$  ( $185^{\circ}\text{F}$ ).

## 5. COOLANT

### 5.1 COOLANT LEVEL VERIFICATION

Coolant level is correct when cold coolant is visible through the surge tank sight glass (Fig. 13). If coolant level is low, fill cooling system.

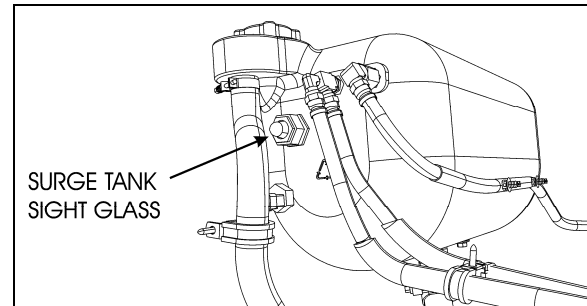


FIGURE 13: SURGE TANK SIGHT GLASS 05114

### 5.2 COOLANT LEVEL SENSOR

This warning device consists of a fluid level probe mounted on the surge tank. The probe sends a signal to the engine control module to indicate coolant level. If the coolant level drops below the probe, the "Check Engine" light flashes and a diagnostic code is registered (see section 01 "ENGINE").



#### CAUTION

Do not run engine with the "Check Engine" light flashing.

The level probe is mounted on the R.H. side of the surge tank.

### 5.3 THAWING COOLING SYSTEM

If the cooling system becomes frozen solid, place the coach in a warm area until the ice is completely thawed. Under no circumstances should the engine be operated when the cooling system is frozen, as it will result in engine overheating due to insufficient coolant.

Once thawed, check engine, radiator and related components for damage caused by expansion of frozen coolant fluid.

### 5.4 COOLING SYSTEM RECOMMENDATIONS

Always maintain cooling system at the proper coolant level. Check daily.

The cooling system must be pressurized to prevent localized boiling of coolant. The system must be kept clean and leak-free. The filler and pressure caps must be checked periodically for proper operation.

The coolant provides a medium for heat transfer and controls the internal temperature of the engine during operation. In an engine having proper coolant flow, some of the combustion heat is conveyed through the cylinder walls and the cylinder head into the coolant. Without adequate coolant, normal heat transfer cannot take place within the engine, and engine temperature rapidly rises. Coolant must therefore be carefully selected and properly maintained.

Select and maintain coolant in order to meet the following basic requirements:

- Provide for adequate heat transfer.
- Provide protection from cavitation damage.
- Provide a corrosion and erosion resistant environment within the cooling system.
- Prevent formation of scale or sludge deposits in the cooling system.
- Be compatible with the cooling system hose and seal materials.
- Provide adequate freeze protection during cold weather operation.

When freeze protection is required, a mixture of suitable water and antifreeze containing adequate inhibitors will provide a satisfactory coolant fluid.

| Freeze protection down to: | percentage of antifreeze in mixture |
|----------------------------|-------------------------------------|
| -13°F (-25°C)              | 40%                                 |
| -22°F (-30°C)              | 46%                                 |
| -36°F (-38.5°C)            | 54%                                 |
| -51°F (-46°C)              | 60%                                 |

### 5.5 COOLANT RECOMMENDATIONS FOR DETROIT DIESEL SERIES 60 ENGINE

A decal (052635) located on the surge tank provides information on recommended coolants.



**Recommended phosphate free coolants for Detroit Diesel Series 60 engine:**

- Prevost #685125;

- Detroit Diesel “DDC Power Cool” (P/N 23512138);
- Prestone AF977 (bulk), 72702 (3.78 L), 70119 (205L), 70102 (4L).

Combining suitable water with reliable inhibitors satisfies the first five requirements. When freeze protection is required, a solution of suitable water and antifreeze containing adequate inhibitors will provide a satisfactory coolant fluid. Ethylene glycol-based antifreeze is recommended for use in Series 60 engines. The cooling system capacity is 24 US gal (91 liters).

**NOTE**  
In general, antifreeze does not contain adequate inhibitors. For this reason, supplemental coolant additives are required.

For a complete overview of engine coolants used with Detroit Diesel Engines, refer to “Coolant Selections” For Engine Cooling Systems Guide at the end of this section (#7se298).

1. Always use recommended antifreeze, inhibitor and water at proper concentration levels. A 50% coolant/water solution is normally used as factory fill. Antifreeze concentration over 70% is not recommended because of poor heat transfer capability, adverse freeze protection and silicate dropout. Antifreeze concentration below 30% offers little freeze, boilover or corrosion protection.
2. Use only ethylene glycol antifreeze meeting the Detroit Diesel #7se298 or TMC RP-329 “Type A” formulation.
3. Use an antifreeze solution year-round for freeze and boil-over protection. Seasonal changing of coolant from an antifreeze solution to an inhibitor/water solution is recommended.
4. Pre-mix coolant makeup solutions at proper concentrations before adding to the cooling system.
5. Maintain the prescribed inhibitor strength levels as required.
6. Do not mix different base inhibitor packages.
7. Always maintain proper coolant level.

## Section 05: COOLING SYSTEM



### CAUTION

Always test the solution before adding water or antifreeze.

8. If cooling system is not at the proper protection level. Mix coolant/water solution to the proper concentration before adding to the cooling system
9. Use only non-chromate inhibitors.
10. Distilled water is recommended.

#### 5.5.1 Coolant Not Recommended

- All antifreeze and coolant containing phosphorous;
- Automotive type coolants;
- Methoxy propanol-base antifreeze;
- Methyl alcohol-base antifreeze;
- Sealer additives or antifreezes containing sealer additives.

#### 5.5.2 Inhibitors

A coolant solution, which has insufficient inhibitors or no inhibitors at all, invites the formation of rust, scale, sludge and mineral deposits within the cooling system. These deposits can cause water pump seal wear and coat the interior of coolant system passages. Heat transfer is reduced as deposits build up, leading to an overheating condition. Continued operation with this condition can lead to serious engine damage: liner scuffing, scoring, piston seizure and cylinder head cracking. These damages can occur quickly or over a longer period of time, depending of location and amount of deposits. Improperly inhibited coolants can become corrosive enough to "eat away" coolant passages and seal ring grooves and cause leaks to develop. Hydrostatic lock can occur if leak is internal and accumulates on top of a piston. The result may be a bent connecting rod. Cavitation erosion may occur in improperly inhibited coolants. Cavitation erosion is caused by the implosion of tiny bubbles against localized surfaces of the system. Such implosion causes pinpoint pressures high enough to erode pump impellers, cylinder liners and cylinder blocks. In extreme cases, their surfaces are so deeply pitted that they appear to

be spongy, and holes can develop completely through them.

#### 5.5.3 Inhibitor Test Procedures

Test Kits are commercially available to check engine coolant for nitrite concentration. Nitrite concentration is an indication of Supplemental Coolant Additive (SCA) level. Nitrite must be maintained within recommended levels. Coolant must be tested at each oil change to insure that inhibitor levels are maintained within the ranges shown hereafter:

| DDC Fully Formulated Glycol Coolant Limits |                   |
|--|-------------------|
| -30 — 50(°F)                               | Freeze Point (°F) |
| 125 — 500 ppm                              | Boron (ppm)       |
| 800 — 3200 ppm                             | Nitrite (ppm)     |
| 200 — 750 ppm                              | Nitrate (ppm)     |
| 50 — 250 ppm                               | Silicon (ppm)     |
| 0 ppm MAX                                  | Phosphorus (ppm)  |
| 8.0 — 11.0                                 | pH                |
| 40 ppm MAX                                 | Chlorides (ppm)   |
| 100 ppm MAX                                | Sulfates (ppm)    |

#### NOTE

*Above SCA values with Detroit Diesel #7se298 or TMC RP-329 "Type A". Use Nalco Chemical Company nitrite test kits (CO-318). A factory coolant analysis program is available through Detroit Diesel distributors under part number 23508774.*

#### 5.5.4 Additives Not Recommended

- Soluble Oils;
- Chromates.



### WARNING

Never remove filler cap while coolant is hot. When coolant is at ambient temperature, release pressure from system by turning the pressure cap counterclockwise 1/4 turn; then remove filler cap slowly. A sudden release of pressure from the heated cooling system can result in severe burns from the expulsion of hot coolant fluid.

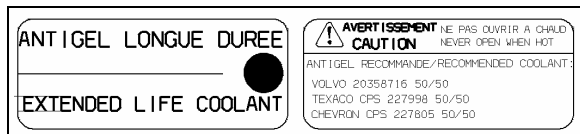
5.6 COOLANT RECOMMENDATIONS FOR VOLVO D13 ENGINE

Coolant mixture consisting of 50/50 antifreeze and deionized water solution should be used year-round to provide freeze and boil-over protection as well as providing a stable environment for seals and hoses.

When topping up coolant, use the same coolant mixture type as the mixture already in the cooling system. Do not mix two different types of coolant.

Do not use antifreeze formulated for automobile gasoline engines, these have a very high silicate content that will clog the radiator and leave unwanted deposits in the engine.

A decal (053487) located on the surge tank provides information on recommended coolants.



**Recommended coolants for Volvo D13 engine:**

- Prevost #685241 (pre-diluted 50/50 mixture);
- Texaco CPS#227998 (pre-diluted 50/50 mixture);
- Chevron CPS#227805 (pre-diluted 50/50 mixture);
- Volvo 20358716 (pre-diluted 50/50 mixture);

**CAUTION**

On Volvo D13 engine, use **only** Extended Life Coolant (ELC). **Do not** add supplemental coolant additives (SCA) to extended life coolant. **Do not** use a coolant filter containing Supplemental Coolant Additives (SCA).

**CAUTION**

Extended Life Coolant (ELC) will test as out of additives (SCA), but SCA should not be added. Shortened engine life may be the result of adding SCA.

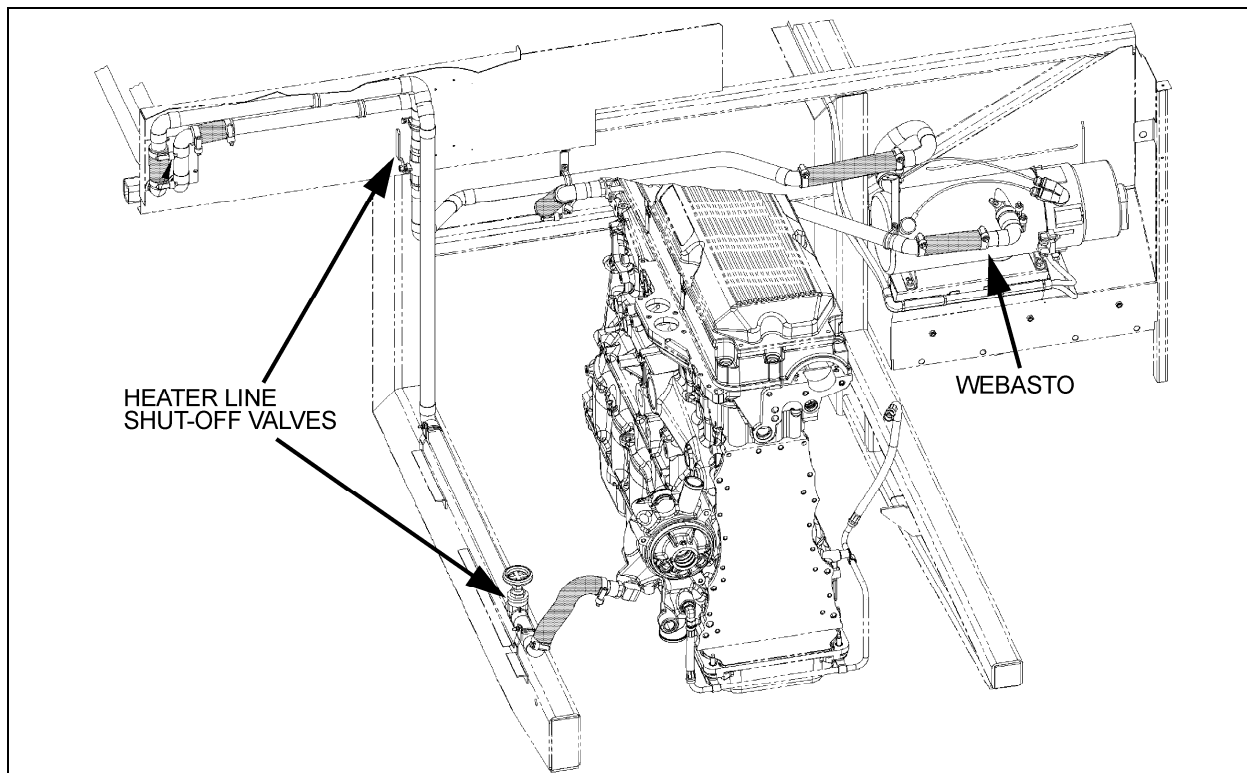


FIGURE 14: LOCATION OF HEATER LINE SHUT-OFF VALVES IN ENGINE COMPARTMENT

05105

## Section 05: COOLING SYSTEM

### 6. DRAINING COOLING SYSTEM

Use the following procedures to drain the cooling system partially or completely.

To drain engine and related components:

1. Stop engine and allow engine to cool. Close both heater line shutoff valves.

On X3- 45 coaches, the valves are located in the engine compartment. One is located under the cooling fan right angle gearbox; another valve is on the L.H. side of the engine compartment in front of the radiator (Fig. 14).

#### NOTE

Refer to section 22 under "Preheating System" for information about preheater access and heater line shutoff valve.



#### WARNING

Before proceeding with the following steps, make sure the coolant has cooled down. The sudden release of pressure from a heated cooling system can result in loss of coolant and possible personal injury (scalding) from the hot liquid.

2. Close the shut-off valves on the coolant filter mounting head (if applicable) and remove filter (perform only if filter as to be replaced).
3. Open the shut-off valves on the coolant filter mounting head (if applicable) and drain the coolant into a suitable container. Close the shut-off valves.
4. Unscrew the surge tank pressure cap counterclockwise, ¼ turn to let air enter the system and permit the coolant to drain completely from system.
5. Unscrew the water pump housing inlet line drain plug (Fig. 15) plus the transmission oil cooler delivery line drain plug. Drain the coolant into an approved container.

#### NOTE

On Volvo D13 engine, the regular drain plugs are replaced by quick connect fittings to ease draining and filling of coolant system.

6. Open drain cock at bottom of thermostat housing to drain the coolant trapped above the thermostats (Fig. 11).
7. Open the radiator drain cock.

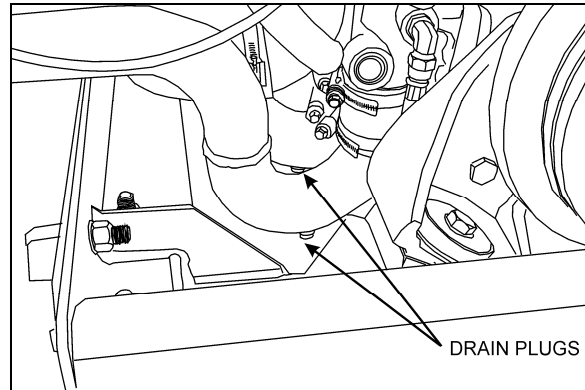


FIGURE 15: WATER PUMP DRAIN PLUG

05093

8. Remove the transmission oil cooler. Drain, flush and inspect. Refer to Section 7, "TRANSMISSION" for oil cooler maintenance or preventive replacement.



#### CAUTION

Drain water pump completely before extended storage to avoid possible water pump damage.

If freezing weather is anticipated and the engine is not protected with antifreeze, drain the cooling system completely when vehicle is not in use. Trapped water in the cylinder block, radiator or other components may freeze and expand resulting in damages. Leave the drain plugs open until the cooling system can be filled with coolant fluid. Do not run engine with cooling system empty.

To drain the entire system, do the previous steps while maintaining the shutoff valves in the open position; then follow the procedure under "Draining Heating System" in Section 22.

### 7. FILLING COOLING SYSTEM

If only the engine and related components were drained, maintain the two heater line shutoff valves in their closed position, then proceed as follows:

1. Close all drain cocks. Reinstall the drain plugs with new seals. Refer to draining procedure for the location of draining points.
2. Open the shut-off valves on the coolant filter mounting head (if applicable).
3. Refill cooling system from the surge tank filler cap inlet with the recommended ethylene glycol-based antifreeze and water solution of the required concentration.

**NOTE**

On Volvo D13 engine, the regular drain plugs are replaced by quick connect fittings to ease draining and filling of coolant system. Coolant system may be refilled by the use of the quick connect fittings.

**NOTE**

Make sure the purge lines are properly connected and not obstructed. The purge lines (thermostat housing dome, radiator top tank, transmission oil cooler or delivery line) are required to ensure complete engine fill and proper purging of air in the system.

**NOTE**

The coolant level should remain within two inches of the surge tank filler neck.

4. Install the filler and pressure caps, then start the engine and run it at fast idle until reaching normal operating temperature. Check for leaks.

**NOTE**

If for any reason, the coolant level drops below the surge tank level probe, the Check Engine warning light will illuminate.

5. Stop engine and allow cooling.
6. Open the two heater line shutoff valves, check the coolant level in the surge tank, and then add as required.



**CAUTION**

Never pour cold coolant into a hot engine. The sudden change in temperature may crack the cylinder head or block.

If the entire system has been drained, redo the previous steps while maintaining the two heater line shutoff valves in the "Open" position. With engine running, activate the driver's and central heating systems to permit coolant circulation. Complete the procedure by bleeding the heater cores as explained in Section 22, under "Bleeding Heating System".

**8. FLUSHING**

If the cooling system is contaminated, flush the cooling system as follows:

1. Drain the coolant from the engine.

2. Refill with clean water.



**CAUTION**

If the engine is hot, fill slowly to prevent rapid cooling and distortion of the engine castings.

3. To thoroughly circulate the water, start and run the engine for 15 minutes after the thermostats have opened.
4. Fully drain system.
5. Refill with clean water and operate for 15 minutes after the thermostats have opened.
6. Stop engine and allow cooling.
7. Fully drain system.

Vehicles without coolant filters:

Fill with a 50/50-antifreeze/water solution and add required inhibitors.

Vehicles with coolant filters (DDC Series 60 engine):

Replace the coolant filter with a precharge element filter; in this case do not mix inhibitors with antifreeze/water solution.

Vehicles with coolant filters (Volvo D13 engine):

Fill with a 50/50-antifreeze/water solution. Replace coolant filter as per the Lubrication And Servicing Schedule in section 24 if required.

Dispose of spent fluids in an environmentally responsible manner according to regulations in effect in your area.

| COOLING SYSTEM CAPACITY (approximation)        |
|--|
| Includes heating system: 24 US gal (91 liters) |

**8.1 COOLING SYSTEM DESCALERS**

If the engine overheats and the fan belt tension, coolant level and thermostat operation have been found to be satisfactory, it may be necessary to de-scale and flush the entire cooling system.

Remove scale formation by using a reputable and safe de-scaling solvent. Immediately after using the de-scaling solvent, neutralize with a neutralizing agent. It is important that product directions be thoroughly read and followed.



## Section 05: COOLING SYSTEM

After using the solvent and neutralizer, fully drain the system, and then reverse flush the engine and radiator (see "Reverse Flushing" in this section) before filling the system with coolant solution.

### 8.2 REVERSE FLUSHING

After the engine and radiator have been thoroughly de-scaled, they should be reverse-flushed. The water pump should be removed and the radiator and engine reverse-flushed separately to prevent dirt and scale deposits from clogging the radiator tubes or being forced through the pump. Reverse flushing is accomplished by hot water, under pressure, being forced through the cooling system in a direction opposite to the normal flow of coolant, loosening and forcing deposits out.

The radiator is reverse flushed as follows:

1. Remove the radiator inlet and outlet hoses and replace existing radiator cap with a new one.
2. Attach a hose to the top of the radiator to lead water away from the engine.
3. Attach a hose at the bottom of the radiator and insert a flushing gun in the hose.
4. Connect the water hose of the gun to the water outlet and the air hose to the compressed air outlet.
5. Turn on the water and when the radiator is full, turn on the air in short blasts, allowing the radiator to fill between blasts.

#### **NOTE**

*Apply air gradually. Do not exert more than 138 kPa (20 psi) air pressure. Too great a pressure may rupture a radiator tube.*

6. Continue flushing until only clean water is expelled from the radiator.

The cylinder block and cylinder head water passages are reverse flushed as follows:

1. Remove the thermostats and the water pump.
2. Attach a hose to the water inlet of oil cooler housing to drain water away from engine.
3. Attach a hose to the water outlet at the top of the cylinder head (thermostat housing) and insert the flushing gun in the hose.

4. Turn on the water until the jackets are filled, and then turn on the air in short blasts. Allow jackets to fill with water between air blasts.
5. Continue flushing until the water from the engine runs clean.

If scale deposits in the radiator cannot be removed by chemical cleaners or reverse flushing as outlined above, it may be necessary to remove the upper tank and rod out the individual radiator tubes with flat steel rods. Circulate the water through the radiator core from the bottom to the top during this operation.

### 9. SPIN-ON COOLANT FILTER

The optional engine cooling system filter is used to filter out impurities such as scale or sand from the coolant and it also eliminates the process of adding inhibitors to the antifreeze/water solution. The filter is mounted onto the cooling fan drive mechanism aluminum casting (Fig. 16 & 17).

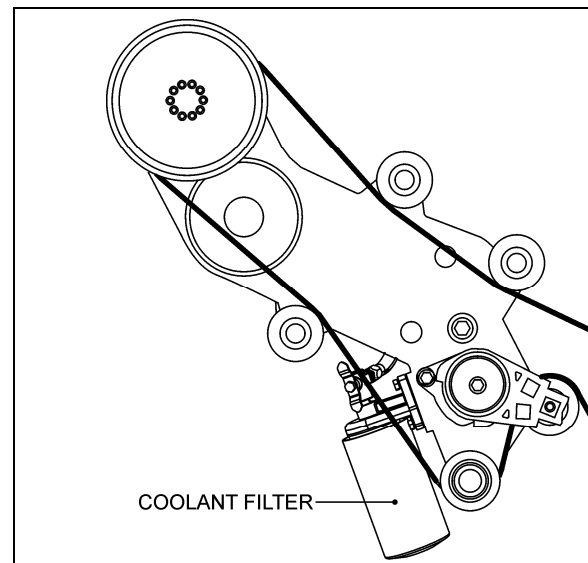


FIGURE 16: COOLANT FILTER (DDC S60 ENGINE) 05138

#### **To replace a filter:**

1. Close the two filter shutoff cocks (two on DDC S60, one on Volvo D13) on the filter mounting head and unscrew the old filter from mounting.



#### **WARNING**

Failure to relieve cooling system pressure may result in personal injury.

2. Remove and discard the filter. Recover the coolant remaining in the filter with a suitable container.
3. Clean the filter adapter with a clean, lint-free cloth.
4. Coat surface of gasket with clean antifreeze, tighten 2/3 to 1 turn after gasket makes contact with head.
5. Open the two filter shutoff cocks.
6. Start engine and check for leaks.



**CAUTION**

Do not exceed recommended service intervals.



**MAINTENANCE**

**DETROIT DIESEL S60 ENGINE**

The precharge element filter lasts for 12,500 miles (20 000 km) or one year, whichever comes first. Replace the precharge element filter with a maintenance element filter, which lasts for 200,000 miles (320 000 km) or two years, whichever comes first. Each time the coolant is renewed, a precharge element filter must be installed before installing a maintenance element filter.

**PRECHARGE ELEMENT FILTER**

Prevost number: 550629

**MAINTENANCE ELEMENT FILTER**

Prevost number: 550630

**CORROSION INHIBITOR & COOLANT STABILIZER**

Make: Detroit Diesel      Number: 23507857

Make: Nalco                      Number: DD3000-15

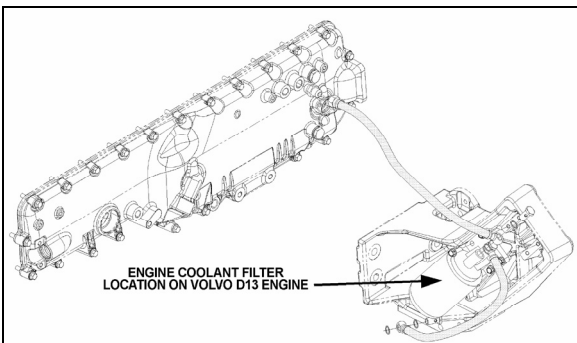


FIGURE 17: COOLANT FILTER (VOLVO D13) 05145



**MAINTENANCE**

**VOLVO D13 ENGINE**

Replace the coolant filter cartridge after 150,000 miles (240 000 km) or one year to prevent external rust damage to the filter walls. **Do not** use a coolant filter containing Supplemental Coolant Additives (SCA).

**Coolant filter cartridge** (Volvo D13): #20458771

**10. RADIATOR**

The radiator is mounted on the L.H. side of engine compartment. It is designed to reduce the temperature of the coolant under all operating conditions. It is essential that the radiator core be kept clean and free from corrosion and scale at all times.

10.1 MAINTENANCE



**MAINTENANCE**

Inspect the exterior of the radiator core every 25,000 miles (40 000 km) or once a year, whichever comes first. Clean with a quality grease solvent, such as a mineral spirits and dry with compressed air. Do not use fuel oil, kerosene, gasoline, or any caustic material. It may be necessary to clean the radiator more frequently if the vehicle is operated in extremely dusty or dirty areas. Refer to coolant system flushing and reverse flushing in this section for maintenance of radiator interior.

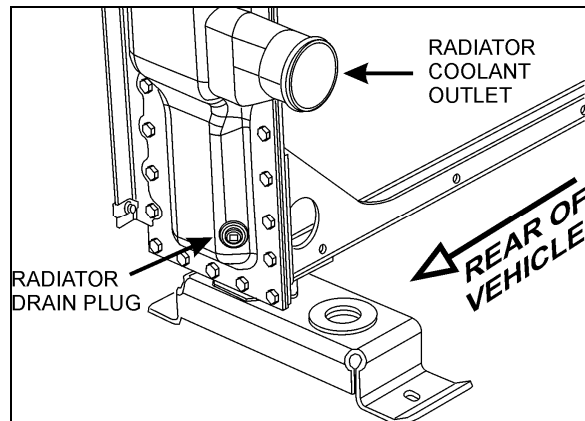


FIGURE 18: RADIATOR DRAIN PLUG 05139

## Section 05: COOLING SYSTEM

### 11. CHARGE AIR COOLER LEAKAGE

Spec for CAC acceptable leakage:

“The CAC is considered acceptable if it can hold 30 psi (206 kpa) gauge pressure with less than 5 psi (34.5 kpa) loss in 15 seconds after turning off the hand valve.”

#### **NOTE**

*This spec does not apply if there is any evidence that the leak was caused by a foreign object impact.*

### 12. COOLING FAN DRIVE MECHANISM

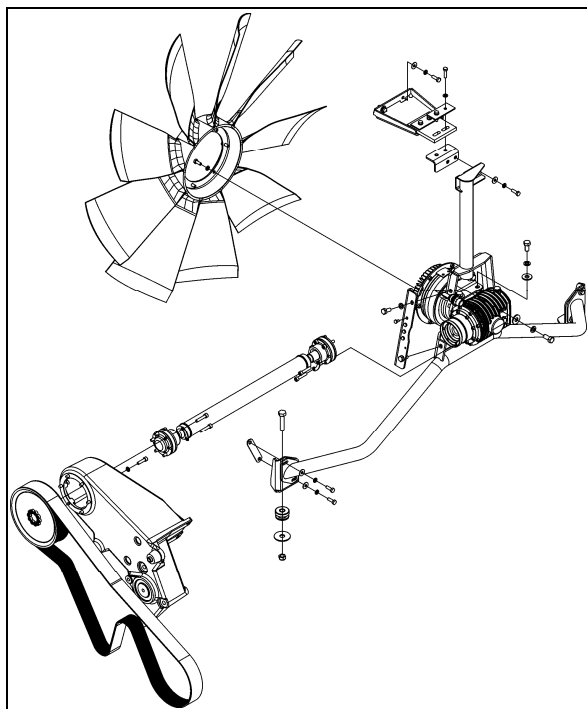


FIGURE 19: COOLING FAN DRIVE MECHANISM

#### 12.1 DRIVE PULLEY AND UNIVERSAL JOINT SHAFT

To disconnect the universal shaft, proceed as follow:



#### **WARNING**

Set the ignition to the OFF position and remove the key from the contact switch to prevent accidental starting of the engine.

1. Unwrap the drive belt from around the pulley (see paragraph MOUNTING THE DRIVE BELT).

2. Dismount the drive pulley. Gain access to the 6 mounting bolts from behind the pulley, through the opening in the cast aluminum support (Fig. 15).
3. Unscrew and remove the universal joint shaft mounting bolts (6) at the right angle gearbox.
4. Slowly, move the shaft toward the rear of the vehicle.
5. Finally, dismount the universal joint shaft from the drive pulley (6 bolts).

Installation of the universal joint shaft is the same as removal, but in reverse order.

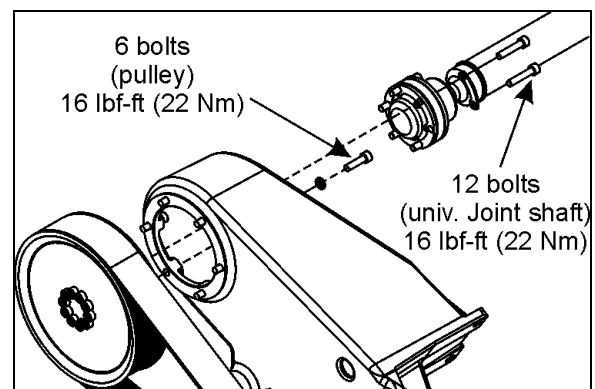


FIGURE 20: TIGHTENING SPECIFICATION

05123A

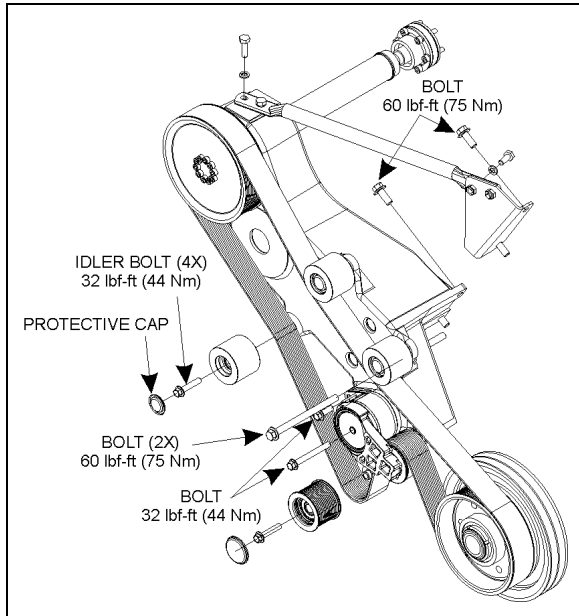
#### 12.2 IDLER REPLACEMENT

If an idler is defective, replace as follow:



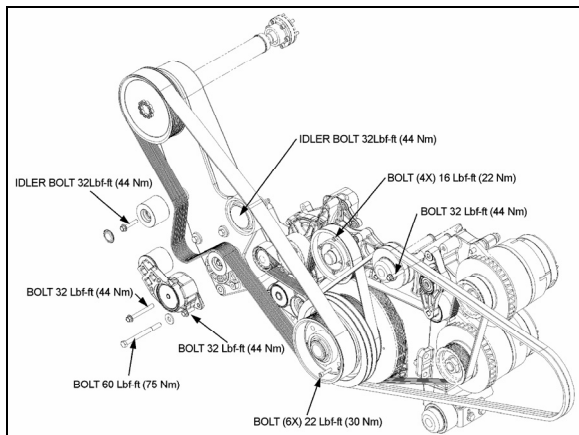
#### **WARNING**

Set the ignition to the OFF position and remove the key from the contact switch to prevent accidental starting of the engine.



**FIGURE 21: TIGHTENING SPECIFICATION (DDC S60 ENGINE)** 05140

1. Remove the protective cap (replace with a new one).
2. Unscrew the idler mounting bolt.
3. Replace idler with a new one.

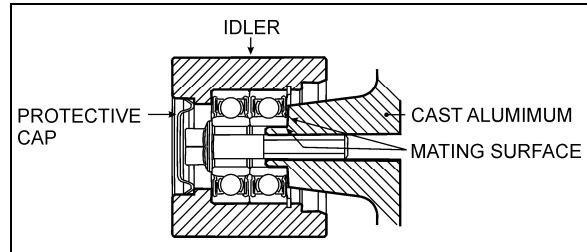


**FIGURE 22: TIGHTENING SPECIFICATION (VOLVO D13 ENGINE)**



**CAUTION**

When installing the idler, make sure it rests perfectly against the bearing surface on the cast aluminum support. If not, the drive belt may slip of the idler. See figure below.



**FIGURE 23: IDLER MOUNTED ON THE CAST ALUMINUM SUPPORT**

4. Bolt the new idler on the cast aluminum support. Tighten to 32 lbf-ft (44 Nm).
5. Place a new protective cap.

**13. VARIABLE SPEED COOLING FAN**


The cooling fan clutch has two thermostatically controlled speeds, plus a neutral (clutch disengaged). The engine control module controls the speed by comparing data from engine coolant temperature, charge air temperature, Allison transmission oil temperature and small A/C High side pressure to a set of calibration data. The fan drive clutch is electromagnetic; the engine control module sends an electric current to regulate speed by activating one magnetic coil for the first speed and two magnetic coils for the second speed.

The settings are:

|                           | Engine coolant temp.             | Air intake temp.                 | Allison trans. oil temp.         |
|---------------------------|----------------------------------|----------------------------------|----------------------------------|
| temperature rising<br>↑   | 208°F: fan engages in HIGH SPEED | 194°F: fan engages in HIGH SPEED | 230°F: fan engages in HIGH SPEED |
|                           | 203°F: fan engages in LOW SPEED  | 176°F: fan engages in LOW SPEED  | 216°F: fan engages in LOW SPEED  |
| temperature dropping<br>↓ | 203°F: fan HIGH SPEED disengages | 189°F: fan HIGH SPEED disengages | 225°F: fan HIGH SPEED disengages |
|                           | 198°F: fan LOW SPEED disengages  | 170°F: fan LOW SPEED disengages  | 210°F: fan LOW SPEED disengages  |

|                      | Small A/C high side pressure       |
|----------------------|------------------------------------|
| pressure rising<br>↑ | 170 psi: fan engages in HIGH SPEED |
|                      | 120 psi: fan engages in LOW SPEED  |

## Section 05: COOLING SYSTEM

|  |                                    |
|--|------------------------------------|
| pressure dropping<br> | 130 psi: fan HIGH SPEED disengages |
|  | 90 psi: fan LOW SPEED disengages   |



### WARNING

DO NOT work near the fan with the engine running or the ignition in the ON position. The engine fan can engage at any time without warning. Anyone near the fan when it turns on could be seriously injured.

### 13.1 LOCKING RADIATOR FAN FOR EMERGENCY OPERATION

#### 13.1.1 Electrical Locking

If the cooling fan clutch does not function due to an electrical control system malfunction and the engine is overheating, execute the following procedure:

1. Set the ignition key to the ON position.
2. Activate the dashboard Telltale Light Test switch 3 times within 4 seconds.
3. In the engine compartment, set the starter selector switch to REAR START and then start the engine from the rear.



### WARNING

Potential Accident Risk. Always use extreme caution when working in the vicinity of hot, rotating or moving parts.

While in this mode, the rear start push-button can be used to manually engage the fan clutch. The multiplex system knows when the engine is already running, and it will not activate the starter.

4. Press the push-button one time to engage the clutch to 1<sup>st</sup> speed, press a second time to engage to 2<sup>nd</sup> speed, press a third time to stop the fan, press once again to return to 1<sup>st</sup> speed.

### NOTE

If the fan clutch does not engage using this procedure then the clutch is faulty or the wiring between the multiplex module and the clutch is faulty. Mechanically lock the fan as described in section 13.1.2.

#### 13.1.2 Mechanical Locking

Once mechanically locked, the fan is rigidly connected to the drive mechanism and will rotate continuously, with no considerations for the cooling needs. This is an emergency situation and the vehicle shall not be operated in that situation for an extended period.

In case of a magnetic clutch malfunction:

1. Set the ignition to the OFF position and remove the key from the contact switch to prevent accidental starting of the engine.
2. Disconnect the fan clutch electrical connector.
3. Unscrew and remove the 4 spare bolts screwed to the angle on the fan gearbox mounting support.
4. Turn the fan blades in order to position the locking plate bores over the rotor's threaded sockets.
5. Screw in and tighten the spare bolts (Fig. 24).
6. Using the automatic belt tensioner, release tension on the drive belt in order to be able to rotate the fan clutch drive mechanism by hand.
7. Rotate the shaft to get access to the second locking plate and rotor threaded sockets.
8. Screw in and tighten the spare bolts.

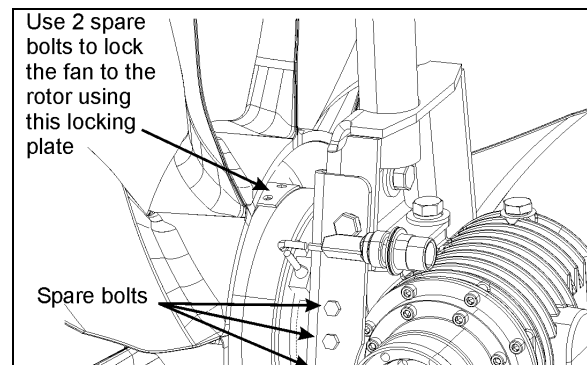


FIGURE 24: MECHANICAL LOCKING


05124

#### 13.2 MAINTENANCE

1. Clean the fan and related parts with clean fuel oil and dry them with compressed air. Do not clean with steam or high-pressure jet.
2. Check the fan blades for cracks or other damage. Replace the fan if the blades are cracked or deformed.

3. Remove any rust or rough spots in the grooves of the fan pulley. If the grooves are damaged or severely worn, replace the pulley.
4. Do not restrict fan rotation during engine operation for any reason.
5. Do not operate fan-driving mechanism with a damaged fan assembly. Replace a damaged fan as soon as the fault is noted.
6. Immediately investigate and correct any operator complaint involving driving mechanism or cooling system performance.
7. When questions arise, obtain answers before proceeding. Assistance is available through the Prevest After-Sales Service Support serving your area.

### 13.3 INSPECTION



DANGER

Set the starter selector switch in engine compartment to the "Off" position to prevent accidental starting of the engine.

- Check security of fasteners securing fan blade assembly to fan clutch.
- Visually inspect fan driving mechanism, fan blade assembly, shroud, radiator, and surrounding area for evidence of contact between rotating and non-rotating parts.
- Check drive belt for fraying, cracking, and proper tension.
- Turn fan through at least 360° of rotation. It should turn smoothly with no resistance.

### 13.4 FAN REMOVAL / INSTALLATION

The fan is bolted to the magnetic clutch. To remove the fan:

- Unscrew and remove the mounting bolts and washers.

To reinstall the fan:

- If the fan is still in the radiator fan shroud, place 2 of the mounting bolts on the opposite side of the clutch, in reverse direction, in order to use them as guide pins to position the fan.

- Once properly positioned, screw the 4 remaining bolts back in and tighten properly (16 lbf-ft; 22 Nm).
- Finally, take the 2 bolts that were used as guide pins and screw them back in on the proper side of the clutch and tighten properly.

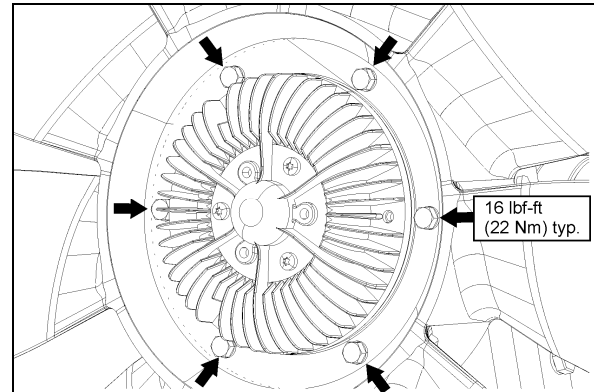


FIGURE 25: RADIATOR FAN MOUNTING BOLTS 05125

### 14. FAN RIGHT ANGLE GEARBOX

The radiator fan is belt driven from the engine crankshaft pulley through a drive belt, a universal joint shaft, a right angle gear and clutch assembly.

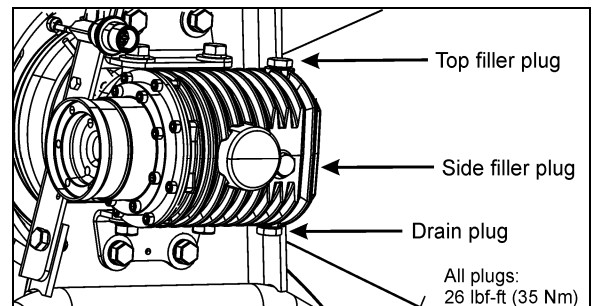



FIGURE 26: RIGHT ANGLE GEARBOX 05118

### 14.1 MAINTENANCE



MAINTENANCE

Change the right angle gearbox oil every 50,000 miles (80,000-km) or once a year, whichever comes first.

Use **Synthetic Gear Lubricant SAE 75W-90**.

### 14.2 OIL CHANGE

1. Stop engine and make sure that all engine safety precautions have been observed.

## Section 05: COOLING SYSTEM

2. Set the ignition to the OFF position and remove the key from the contact switch to prevent accidental starting of the engine or set the rear start panel selector switch to the OFF position.
3. Remove the drain plug located underneath the right angle gearbox case and allow the oil to drain into a suitable container.
4. Replace the seal and screw the drain plug back in (torque: 26 lbf-ft).
5. Unscrew and remove the side filler plug.
6. Unscrew and remove the top filler plug.
7. Add gear lubricant. The oil level is correct once the top of the oil has reached the bottom of the side filling point.
8. Replace the seals and screw side and top filler plug back in (torque: 26 lbf-ft).
9. Clean gear case carefully.
10. Start the engine and allow running a few minutes. Stop the engine and check for leaks.

### 14.3 REMOVAL / INSTALLATION

To remove the right angle gearbox, proceed as follow:

1. Set the ignition to the OFF position and remove the key from the contact switch to prevent accidental starting of the engine.
2. Disconnect the fan clutch electrical connector.
3. Dismount the fan and lean it against the radiator (refer to previous paragraph).
4. Disconnect the universal joint shaft.

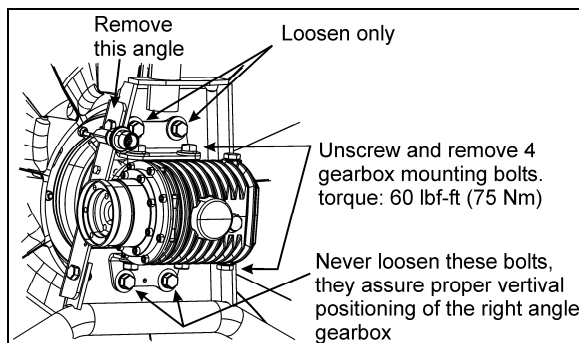


FIGURE 27: RIGHT ANGLE GEARBOX MOUNTING 05126

5. Dismount the angle (see fig. 27).

6. Loosen the gearbox support bracket top bolts.
7. Unscrew and remove 4 gearbox mounting bolts.
8. Slide the gearbox out of the support assembly.

Installation procedure is the same as removal but in reverse order. Tighten the 4 mounting bolts as specified.

## 15. COOLING FAN DRIVE BELT

### 15.1 MOUNTING THE DRIVE BELT

To install the cooling fan drive belt, proceed as follow:



### WARNING

Set the ignition to the OFF position and remove the key from the contact switch to prevent accidental starting of the engine.



### WARNING

Potential Accident Risk. Always use extreme caution when working in the vicinity of hot, rotating or moving parts.

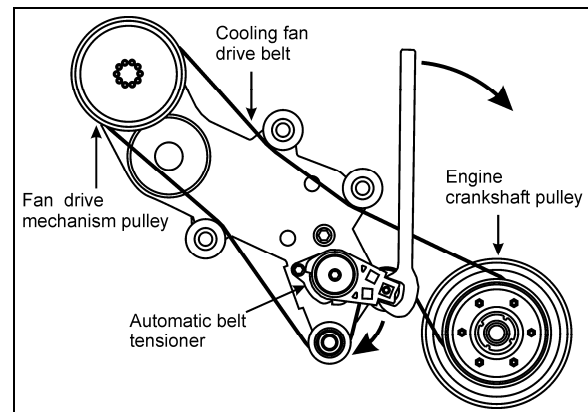


FIGURE 28: DRIVE BELT ROUTING (DDC S60 ENGINE) 05137

1. Wrap the new drive belt around the fan drive mechanism pulley, the idlers and the automatic tensioner idler as shown on figure 28 & 29.
2. Using the special tool included with your vehicle (see inside the Warning Reflectors box located in the first curb-side baggage bay), rotate the automatic tensioner in

clockwise direction to relieve tension on the belt and hold the tensioner in that position (Fig. 28 & 29).

3. Finally, place the drive belt around the engine crankshaft pulley.

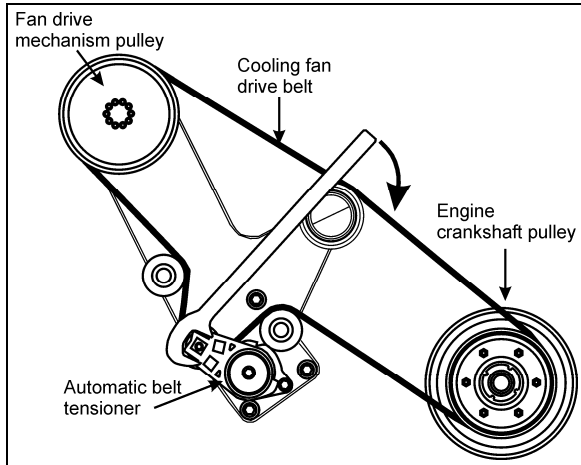


FIGURE 29: DRIVE BELT ROUTING (VOLVO D13 ENGINE)

4. Release the tensioner slowly and let it return to its natural position.

**COOLING FAN DRIVE BELT**

**With Detroit Diesel Series 60 engine**

Type: 14PK2605

Prevost number: 550926

**With Volvo D13 engine**

Type: 14PK2526

Prevost number: 5060097

**16. SPECIFICATIONS**

**Cooling System Capacity (Approximation)**

Includes heating system..... 24 US gal (91 liters)

**Thermostat - Detroit Diesel Series 60 Engine**

Number used ..... 2

Start to open ..... 182-188°F (83-86°C)

Fully open ..... 202°F (95°C)



## Section 05: COOLING SYSTEM

---

### Thermostat - Volvo D13 Engine

Number used ..... 1  
Start to close ..... 203°F (95°C)  
Fully closed ..... 185°F (85°C)

### Cooling Fan Drive Belt - Detroit Diesel Series 60 Engine

Type ..... Poly-Rib 14PK2605  
Qty ..... 1  
Prevost number ..... 550926

### Cooling Fan Drive Belt – Volvo D13 Engine

Type ..... Poly-Rib 14PK2526  
Qty ..... 1  
Prevost number ..... 5060097

### Coolant - Detroit Diesel Series 60 Engine

Prevost Number ..... 685125  
DDC (Power Cool) ..... 23512138  
Prestone (Heavy Duty) ..... AF977 (bulk), 72702 (3.78 L), 70119 (205L), 70102 (4L)

### Coolant - Volvo D13 Engine

Prevost Number ..... 685241  
Texaco CPS ..... 227998  
Chevron CPS ..... 2227805

### Corrosion Inhibitor and Coolant Stabilizer - Detroit Diesel Series 60 Engine

Supplier number.....Detroit Diesel ..... 23507857  
Supplier number.....Nalco ..... DD3000-15

### Coolant Filter - Detroit Diesel Series 60 Engine

Number used ..... 1  
Make ..... Nalco  
Type ..... Spin-on

#### MAINTENANCE ELEMENT FILTER

Supplier number. ....Detroit Diesel ..... 23507545  
Supplier number.....Nalco ..... DDF3000  
Prevost number ..... 550630

#### PRECHARGE ELEMENT FILTER

Supplier number.....Detroit Diesel ..... 23507189  
Supplier number.....Nalco ..... DDF60  
Prevost number ..... 550629

### Coolant Filter Cartridge – Volvo D13 Engine

Number used ..... 1  
Type ..... Spin-on  
Prevost number ..... 20458771

# SECTION 06: ELECTRICAL

## CONTENTS

|   |           |
|---|-----------|
| <b>1. GENERAL DESCRIPTION.....</b>  | <b>4</b>  |
| 1.1 WIRING DIAGRAMS.....  | 4         |
| 1.1.1 <i>Using Wiring Diagrams</i> .....  | 4         |
| 1.1.2 <i>Testing Circuits</i> .....   | 5         |
| 1.2 WIRE SIZES AND COLORS.....  | 5         |
| 1.3 SPARE WIRES.....  | 5         |
| 1.4 CLEANING CONNECTORS.....  | 6         |
| 1.5 CIRCUIT BREAKERS.....   | 6         |
| 1.6 MULTIPLEX FUSES.....  | 7         |
| 1.7 RELAYS.....   | 7         |
| 1.8 PRECAUTIONS.....  | 7         |
| <b>2. X3 COACHES ELECTRICAL COMPARTMENTS.....</b>   | <b>9</b>  |
| 2.1 MAINTENANCE.....  | 9         |
| 2.2 REAR ELECTRICAL COMPARTMENT.....  | 9         |
| 2.3 FRONT ELECTRICAL AND SERVICE COMPARTMENT.....   | 10        |
| 2.4 ENGINE REAR START PANEL.....  | 11        |
| 2.5 CONDENSER COMPARTMENT.....  | 12        |
| 2.5.1 <i>Battery equalizer</i> .....  | 12        |
| 2.6 ENTRANCE DOOR & WIPER CONTROL PANEL.....  | 12        |
| <b>3. BATTERIES.....</b>  | <b>12</b> |
| 3.1 BATTERY DISCHARGE PROTECTION.....   | 14        |
| 3.2 MAIN BATTERY RELAYS.....  | 14        |
| 3.3 BATTERY REMOVAL AND INSTALLATION.....   | 14        |
| 3.4 BATTERY RATING.....   | 15        |
| 3.5 BATTERY TESTING.....  | 15        |
| 3.5.1 <i>Visual Inspection</i> .....  | 16        |
| 3.5.2 <i>Removing Surface Charge</i> .....  | 16        |
| 3.5.3 <i>Load Test</i> .....  | 16        |
| 3.5.4 <i>Testing Battery Cables</i> .....   | 17        |
| 3.6 BATTERY CHARGING.....   | 17        |
| 3.6.1 <i>Battery Charging Guide</i> .....   | 19        |
| 3.6.2 <i>Emergency Jump Starting With Auxiliary (Booster) Battery</i> .....                     | 19        |
| 3.7 CLEANING AND INSPECTION.....  | 20        |
| 3.8 COMMON CAUSES OF BATTERY FAILURE.....   | 20        |
| 3.9 TROUBLESHOOTING.....  | 21        |
| 3.10 "BAT" BATTERY VOLTAGE INCORRECT TELLTALE LIGHT.....  | 21        |
| 3.10.1 <i>"Bat" Telltale Light Definitions</i> .....  | 21        |
| <b>4. TROUBLESHOOTING AND TESTING THE MULTIPLEX VEHICLES.....</b>                               | <b>21</b> |
| 4.1 ELECTRICAL SYSTEM DIAGNOSTIC.....   | 21        |
| 4.2 PROBING VOLTAGE ON THE MULTIPLEX CIRCUITS.....  | 22        |
| 4.3 CAN NETWORK.....  | 22        |
| 4.3.1 <i>Can Connection On The Telltale Panel And The Hvac Control Unit</i> .....               | 22        |
| 4.3.2 <i>Spare Can</i> .....  | 23        |
| 4.4 TEST MODE FOR SWITCHES AND SENSORS.....   | 23        |
| 4.4.1 <i>Information Available And Impact On The Functions In Switch/Sensor Test Mode</i> ..... | 23        |
| 4.5 TEST MODE FOR ELECTRIC MOTORS.....  | 24        |
| 4.5.1 <i>Test Sequence</i> .....  | 24        |
| 4.6 CAN NETWORK LAYOUT AND TROUBLESHOOTING.....   | 25        |
| 4.7 TROUBLESHOOTING.....  | 26        |
| 4.8 ESSENTIAL FUNCTIONS TO OPERATE THE VEHICLE.....   | 31        |

## Section 06: ELECTRICAL

---

|            |   |           |
|------------|---|-----------|
| 4.8.1      | Available Functions .....   | 31        |
| 4.9        | LOWER PRIORITY MODULES FOR BREAKDOWN SERVICE.....                 | 31        |
| 4.10       | MULTIPLEX MODULES.....  | 32        |
| 4.10.1     | CECM.....   | 32        |
| 4.10.2     | MASTER ID.....  | 32        |
| 4.10.3     | IO-A.....   | 32        |
| 4.10.4     | IO-B.....   | 32        |
| 4.11       | MULTIPLEX MODULES REPLACEMENT .....                               | 32        |
| 4.11.1     | Replacing IO-A Or IO-B Modules.....                               | 32        |
| 4.11.2     | Replacing The CECM Module.....                                    | 32        |
| <b>5.</b>  | <b>BOSCH ALTERNATOR.....</b>                                      | <b>33</b> |
| 5.1        | TWIN BOSCH ALTERNATORS INSTALLATION (DDEC SERIES 60).....         | 33        |
| 5.1.1      | Alternator Drive Belt .....                                       | 33        |
| 5.1.2      | Adjustment.....   | 33        |
| 5.2        | TWIN BOSCH ALTERNATORS INSTALLATION (VOLVO D13).....              | 35        |
| 5.2.1      | Alternator Drive Belt .....                                       | 37        |
| 5.2.2      | Adjustment.....   | 37        |
| <b>6.</b>  | <b>BATTERY EQUALIZER.....</b>                                     | <b>37</b> |
| <b>7.</b>  | <b>STARTER.....</b>   | <b>37</b> |
| <b>8.</b>  | <b>ENGINE BLOCK HEATER.....</b>                                   | <b>37</b> |
| 8.1        | MAINTENANCE .....   | 37        |
| <b>9.</b>  | <b>EXTERIOR LIGHTING.....</b>                                     | <b>38</b> |
| 9.1        | HEADLIGHTS.....   | 38        |
| 9.1.1      | Headlight Beam Toggle Switch.....                                 | 38        |
| 9.1.2      | Maintenance.....  | 38        |
| 9.1.3      | Headlight Adjustment.....   | 39        |
| 9.1.4      | Sealed-Beam Unit.....   | 40        |
| 9.1.5      | Front Turn Signal.....  | 41        |
| 9.1.6      | Optional Xenon Headlamp.....                                      | 41        |
| 9.2        | STOP, TAIL, DIRECTIONAL, BACK-UP, AND HAZARD WARNING LIGHTS ..... | 42        |
| 9.2.1      | Lamp Removal and Replacement.....                                 | 42        |
| 9.2.2      | Center Stoplights and Cyclops Light Removal and Replacement.....  | 42        |
| 9.3        | LICENSE PLATE LIGHT.....  | 42        |
| 9.4        | CLEARANCE, IDENTIFICATION AND MARKER LIGHTS .....                 | 43        |
| 9.4.1      | Clearance and Identification Light Removal and Replacement.....   | 43        |
| 9.5        | FOG LIGHTS.....   | 43        |
| 9.5.1      | Bulb Removal and Replacement.....                                 | 43        |
| <b>10.</b> | <b>INTERIOR LIGHTING EQUIPEMENT.....</b>                          | <b>43</b> |
| 10.1       | CONTROL PANEL LIGHTING.....                                       | 43        |
| 10.1.1     | Switch Lighting.....  | 43        |
| 10.1.2     | Telltale Light Replacement.....                                   | 44        |
| 10.1.3     | Gauge Light Bulb Replacement.....                                 | 44        |
| 10.2       | STEPWELL LIGHTS .....   | 44        |
| 10.2.1     | Bulb Removal and Replacement.....                                 | 44        |
| 10.3       | LAVATORY NIGHT-LIGHT.....   | 44        |
| 10.3.1     | Bulb Removal and Replacement.....                                 | 44        |
| 10.4       | DRIVER'S AREA LIGHTS.....   | 44        |
| 10.4.1     | Bulb Removal and Replacement.....                                 | 44        |
| 10.5       | PASSENGER SECTION LIGHTING .....                                  | 45        |
| 10.5.1     | Fluorescent Tube Replacement.....                                 | 45        |

|            |   |           |
|------------|---|-----------|
| 10.5.2     | Removal and Replacement of In-Station Fluorescent Tubes ..... | 45        |
| 10.5.3     | Removal and Replacement of Reading Lamp Bulb .....            | 45        |
| 10.6       | ENGINE COMPARTMENT LIGHTING .....                             | 46        |
| 10.7       | LAVATORY LIGHT .....  | 46        |
| <b>11.</b> | <b>LIGHT BULB DATA .....</b>                                  | <b>46</b> |
| <b>12.</b> | <b>SPECIFICATIONS .....</b>                                   | <b>49</b> |

## ILLUSTRATIONS

|            |   |    |
|------------|---|----|
| FIGURE 1:  | WIRE IDENTIFICATION .....   | 5  |
| FIGURE 2:  | REAR ELECTRICAL JUNCTION PANEL .....  | 6  |
| FIGURE 3:  | MULTIPLEX MODULE CONNECTORS PIN-OUT .....   | 7  |
| FIGURE 4:  | ELECTRICAL COMPARTMENTS (X3-45 COACH) .....   | 9  |
| FIGURE 5:  | REAR ELECTRICAL COMPARTMENT .....   | 10 |
| FIGURE 6:  | FRONT ELECTRICAL COMPARTMENT .....  | 11 |
| FIGURE 7:  | REAR START PANEL .....  | 11 |
| FIGURE 8:  | LOCATION OF BATTERIES IN CONDENSER COMPARTMENT .....  | 12 |
| FIGURE 9:  | BATTERY EQUALIZER .....   | 12 |
| FIGURE 10: | ENTRANCE DOOR & WIPER CONTROL PANEL .....   | 12 |
| FIGURE 11: | BATTERY CONNECTIONS .....   | 14 |
| FIGURE 12: | TEST INDICATOR .....  | 16 |
| FIGURE 13: | LOAD TEST .....   | 16 |
| FIGURE 14: | ALLIGATOR CLAMPS AND BATTERY .....  | 18 |
| FIGURE 15: | BOOSTER BLOCK .....   | 19 |
| FIGURE 16: | X3-45 COACHES CAN NETWORK LAYOUT .....  | 25 |
| FIGURE 17: | IO-B MODULE REMOVAL .....   | 32 |
| FIGURE 18: | ALTERNATOR DRIVE BELT .....   | 34 |
| FIGURE 19: | TWIN BOSCH ALTERNATORS INSTALLATION (DDEC SERIES 60) .....  | 34 |
| FIGURE 20: | ALTERNATORS AND ACCESSORIES MOUNTING TORQUES (DDEC SERIES 60) .....   | 35 |
| FIGURE 21: | BOSCH ALTERNATORS MOUNTING TORQUES (VOLVO D13) .....  | 36 |
| FIGURE 22: | TWIN BOSCH ALTERNATORS INSTALLATION (VOLVO D13) .....   | 36 |
| FIGURE 23: | ELECTRIC HEATER PLUG LOCATION .....   | 38 |
| FIGURE 24: | HEADLIGHT ASSEMBLY .....  | 38 |
| FIGURE 25: | OPENING HEADLIGHT ASSEMBLY .....  | 38 |
| FIGURE 26: | ALIGNMENT OF HEADLIGHT AIMING SCREEN .....  | 39 |
| FIGURE 27: | HIGH-INTENSITY ZONE (SHADED AREA) OF A PROPERLY AIMED UPPER BEAM ON THE AIMING SCREEN<br>7.6 M (25FT) IN FRONT OF VEHICLE ..... | 39 |
| FIGURE 28: | HIGH-INTENSITY ZONE (SHADED AREA) OF A PROPERLY AIMED LOWER BEAM ON THE AIMING SCREEN<br>7.6 M (25FT) IN FRONT OF VEHICLE ..... | 40 |
| FIGURE 29: | AIM INSPECTION LIMITS FOR UPPER-BEAM HEADLIGHTS .....   | 40 |
| FIGURE 30: | AIM INSPECTION LIMITS FOR LOWER-BEAM HEADLIGHTS .....   | 40 |
| FIGURE 31: | XENON HEADLAMP LOCATION .....   | 41 |
| FIGURE 33: | SWITCH .....  | 43 |
| FIGURE 32: | VARIOUS LIGHTS LOCATION .....   | 44 |
| FIGURE 34: | PARCEL RACK LIGHTING .....  | 46 |
| FIGURE 35: | ENGINE COMPARTMENT LIGHT .....  | 46 |

### 1. GENERAL DESCRIPTION

This vehicle uses a dual voltage system to obtain two different voltages (12 and 24 volts) for various electrical controls and accessories. The main power source incorporates four maintenance-free "Volvo" model 20359831 batteries connected in parallel-series. All batteries are kept uniformly charged by means of a 100 amp battery equalizer (standard), giving a maximum possible output supply of 100 amps on the 12 volt system. Both the 12 and 24 volt systems are controlled through individual main battery relays. Two 24 volt self-rectified alternators are belt driven from the engine, and can be reached through the engine compartment doors.

#### 1.1 WIRING DIAGRAMS

A master wiring diagram of the electric circuits, covering standard and optional accessories and systems, is located in the technical publications box. Usually, a separate wiring diagram page is provided for each major function or system. In some cases, more than one circuit may appear on one wiring diagram page; when this occurs, each circuit covered in this page is listed in the wiring diagram index. Moreover, a circuit may appear on several pages; in such case, the number(s) at the extremity of the diagram title will indicate the sheet reference number. Refer to the "*Wiring Diagram Index*" to ensure that the correct diagram is being used to trace the circuit in question. In addition to the major functions page reference, the wiring diagram index contains the following information pages.

- The Multiplexed Device Index,
- The Arrangement-Harness drawing showing the harnesses arrangement and harness number on the vehicle,
- Glossary,
- Circuit number listing,
- Circuit breaker code,
- Connector code,
- Diode number code,
- Resistor number code,
- Fuse code.

##### 1.1.1 Using Wiring Diagrams

Three methods are used to "work" with electric wiring diagrams.

**Situation:** You have identified the defective part (breaker, diode, relay, etc.), and you wish to locate its corresponding circuit.

**Problem:** Circuit breaker CB12 is released (open circuit) and you don't know which circuit is affected.

- a) Refer to wiring diagram index, and look for "*Circuit breaker code*", pages F.
- b) At item CB12, you will find the location, the Prevost number, the breaker function, the breaker ampere rating and the page on which to find the corresponding diagram.
- c) Refer to page 3.1.
- d) When you have located CB12, follow the wiring up to the end and find the diagram page number and function on which the circuit continues.

**Situation:** You have a problem with a specific system and you want to find the corresponding diagram.

**Problem:** The last three (3) speakers on the R.H. side of vehicle are inoperative and you must trace the electric circuit.

- d) Refer to wiring diagram index and look for "*Sound system*".
- e) You will find on page 35.1 & 35.2 the components as well as the electric wiring, thus providing you with a complete understanding of this circuit.

**Situation:** Using the message center display (MCD), you check on arrival if there are active errors in the vehicle electrical system. With the SYSTEM DIAGNOSTIC menu, highlight FAULT DIAGNOSTIC, highlight ELECTRICAL SYSTEM to request a diagnostic of the electrical system and then press the enter key. If applicable, the MCD shows the fault messages or fault codes recorded. When more than one fault is recorded, an arrow pointing down appears on the right of the display. Use the down to see all the fault messages.

**Problem:** MCD displays the fault "Elec. Horn SW61 SW62; shorted to ground" as being active.

- a) Refer to wiring diagram index, and look for "*Multiplexed Device Index*", pages B1-B8.

- b) In first column DEVICE ID, look for device SW61, SW62.
- c) At device SW61,SW62, find the fault message, the minimum condition to activate, other inputs involved in logic, the multiplex module related to switch 61 and switch 62, the connector and pin number on the module and the page on which to find the corresponding diagram.
- d) Once the problem corrected, the MCD still shows the fault as being active. You have to leave the FAULT DIAGNOSTIC menu, wait approximately 20 to 30 seconds and then return to FAULT DIAGNOSTIC to request a new diagnostic of the ELECTRICAL SYSTEM from the CECM. The MCD should display the fault as being inactive.

### 1.1.2 Testing Circuits

A careful study of the wiring diagrams should be made to determine the source and flow of current through each circuit. When a circuit is thoroughly understood, a point-to-point check can be made with the aid of the applicable wiring diagrams. Any circuit can be tested for continuity or short circuits with a multimeter or a suitable voltmeter.

All electrical connections must always be kept clean and adequately tight. Loose or corroded connections can result in discharged batteries, difficult starting, dim lights and improper functioning of other electric circuits. Inspect all wiring connections at regular intervals. Make sure knurled nuts on all amphenol-type plugs are securely tightened. Knurled nuts on the plastic amphenol-type connectors will click into a detent when properly tightened. Line connectors, who have the side locking tabs, must have the locks latched in place to ensure a proper electrical connection.

### 1.2 WIRE SIZES AND COLORS

Each wire in the electrical system has a specific size as designated on the wiring diagram. When replacing a wire, the correct size must be used. Never replace a wire with one of a smaller size. The vehicle electrical system is provided with different voltages. The insulation on each wire is distinctly colored in order to determine visually the wiring voltage and to assist in making connectors. The wires are color coded as follows:

|        |   |
|--------|---|
| Yellow | Multiplex modules communication CAN-H (twisted with green)  |
| Green  | Multiplex modules communication CAN-L (twisted with yellow) |
| Orange | Connected to multiplex outputs                              |
| White  | Connected to multiplex inputs                               |
| Red    | 24 volt system  |
| Yellow | 12 volt system  |
| Black  | grounded wire   |
| Blue   | 110 V ac system (live)                                      |
| White  | 110 V ac system (neutral)                                   |
| Green  | 110 V ac system (ground)                                    |
| Orange | speakers (+)  |
| Brown  | speakers (-)  |
| Grey   | spare wire  |

#### NOTE

*Wires are identified at each 2-4 inch (5-10 cm) intervals by a printed number.*

Each wire on a diagram is patterned to assist in tracing and testing circuits. The wire number identifies the voltage rating, the wire identification number and the basic wire gauge as illustrated in figure 1.

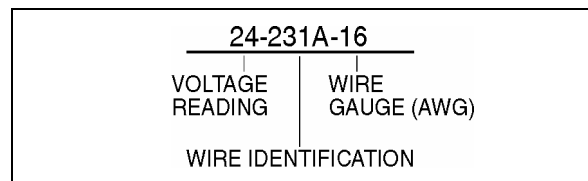


FIGURE 1: WIRE IDENTIFICATION

06048

### 1.3 SPARE WIRES

When the vehicle leaves the factory, and even in the case of a fully-equipped vehicle, an important number of unconnected spare wires are routed between the junction boxes. Consequently, for any connection of an additional accessory, refer to page D "Spare wires" in master wiring diagram to determine the number, the gauge and location of these wires.

#### CAUTION

Wire size is calibrated according to the breaker or fuse that protects it. When using a spare wire to replace a damaged wire, assure that the spare wire size is equal or larger than the wire being replaced. Using a wire too small for the breaker or fuse amperage might cause overheating of the wire.

## Section 06: ELECTRICAL


### NOTE

Spare wires are identified by a wire identification number and by the letters "SP", to designate "spare".

### 1.4 CLEANING CONNECTORS

When the pins and sockets of connectors become dirty, clean them with a good quality solvent containing HFC 134A refrigerant as its active ingredient. HFC 134A has two qualities that recommend it. First, it does not conduct electricity and therefore, will not cause shorting between connector pins and sockets. Second, it evaporates quickly, eliminating the possibility of condensation within the connectors.

Always shake out or gently blow out any excess HFC 134A before assembling a connector to its mating connector or hardware. HFC 134A trapped in the connector can affect the connector seal.



DANGER

HFC 134A is toxic. HFC 134A bases compounds should always be used in a well-ventilated area, never in a confined space. Use outdoor whenever possible.

### 1.5 CIRCUIT BREAKERS

Most electric circuits are protected by circuit breakers of the "Manual Reset" type. The main circuit breakers, as well as those protecting the A/C system, are located on the rear electrical junction panel in the rear electrical compartment, on L.H. side of the vehicle.

This type of circuit breaker deenergizes the circuit without disconnecting any wire. Simply press down the red tab on breaker to open the circuit, repair defective circuit, and afterwards depress black button in center of breaker to close the circuit.

Smaller circuit breakers may be located in the VECF of the front service compartment.

| CIRCUIT BREAKERS |                    |       |          |
|------------------|--------------------|-------|----------|
| CB1              | Front distribution | 24 VI | 90 amps  |
| CB2              | Distribution       | 12 VD | 90 amps  |
| CB3              | HVAC - evaporator  | 24 VI | 90 amps  |
| CB4              | Sound system       | 12 VD | 30 amps  |
| CB5              | Rear distribution  | 24 VI | 150 amps |
| CB6              | Distribution       | 24 VD | 70 amps  |
| CB7              | HVAC - condenser   | 24 VI | 70 amps  |

|      |                        |       |         |
|------|------------------------|-------|---------|
| CB8  | Rear distribution      | 12 VI | 40 amps |
| CB9  | WCL or other option    | 24VD  | 50 amps |
| CB10 | Front distribution     | 12 VI | 70 amps |
| CB11 | Sound system           | 24 VD | 50 amps |
| CB13 | Galley or other option | 24 VI | 90 amps |

VD= volts direct. The electrical components connected to these circuit breakers are direct-connected to the battery.

VI= volts indirect. Electrical power is supplied via master relay R1 which engages when ignition key is in the ON or ACC position and battery master switch (master cut-out) is set to ON.

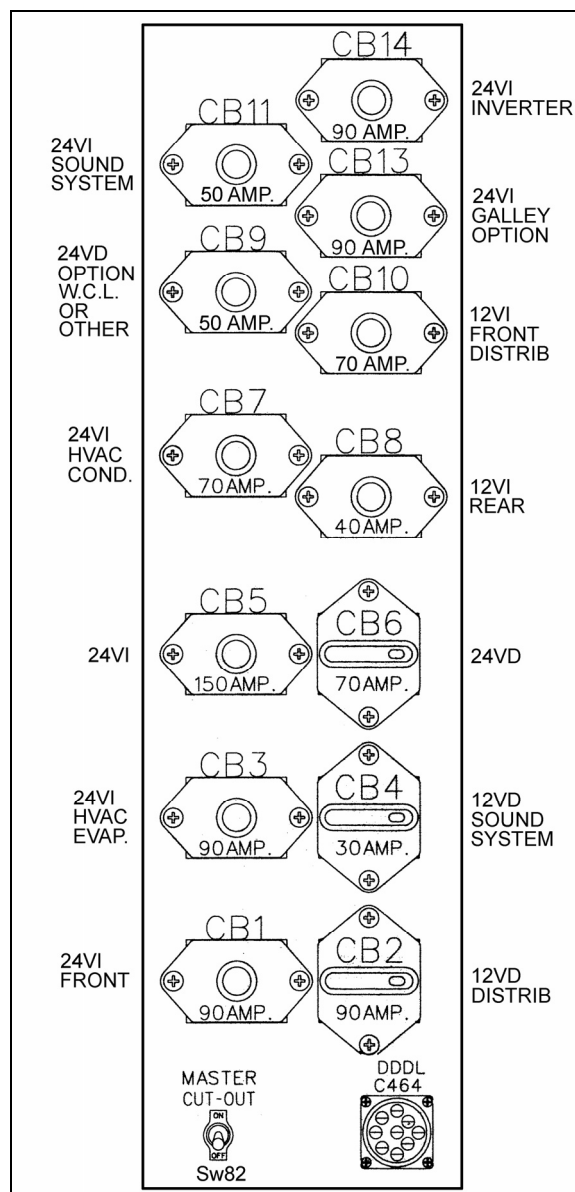


FIGURE 2: REAR ELECTRICAL JUNCTION PANEL 06621

1.6 MULTIPLEX FUSES

The multiplex outputs are protected in current by an internal "soft-fuse". Each output has programmed specific maximum amperage. When an output is shorted, the current gets above the limit and the soft-fuse intervenes to turn the output OFF. The output stays OFF until the "soft-fuse" is reset.

Turn the ignition key to the OFF position and turn to the ON position again. This resets all "soft-fuses".

There is also hardware fuses used to protect the incoming power to the multiplex modules. These fuses are located inside the VECF (Vehicle Electrical Center Front) and VECR (Vehicle Electrical Center Rear).

1.7 RELAYS

Relays are used to automatically energize or deenergize a circuit from a remote location. The relay draws a very low current to energize its coil. Once the coil is energized, it develops a magnetic field that pulls a switch arm closed or open, to either energize or deenergize a given component. As the control current required for the coil is very low, the relay allows a remote station to control a high energy circuit without running great lengths of costly high capacity cable, and also eliminates the need for high amperage switches and heavy connectors.

**NOTE**

Each relay is identified with "12V" or "24V" printed on its casing in order to identify the coil operating voltage.



**CAUTION**

The Multiplex vehicle uses a VF4 relay designed specially for Volvo that has different internal characteristics than the current VF4 relay. It is important to use only the new part marked Volvo as a replacement in Multiplex vehicles. Regular relays have an inadequate lifespan for Multiplex vehicles.

1.8 PRECAUTIONS



**DANGER**

Prior to working on a system inside vehicle, make sure to cut electrical power and air supply. A component could be supplied with electricity even if the ignition switch is set to

the OFF position and/or a component could be pressurized even if air tanks are emptied. Always refer to the appropriate wiring and pneumatic diagrams prior to working on electrical and/or pneumatic systems.

**NOTE**

When the ignition switch is set to the OFF position, the electrical components are not energized except for the CECM (Chassis Electronic Control Module), engine MCM, transmission ECU, instrument cluster module, the battery equalizer, the preheater system, the wheelchair lift system and some Multiplex modules which are energized during 15 minutes after the ignition has been set to the OFF position. Prior to working on one of these electrical components, set the master cut-out switch in the rear electrical compartment to the OFF position. If the vehicle will not be operated for a long period (more than 2 weeks), it is recommended, in order to prevent the batteries from discharging, to trip main circuit breakers (2, 4 and 6) located in the rear electrical compartment to stop the small current drawn by the radio preset station memory, the CECM memory and the instrument cluster clock. Note that the radio station presets will be erased, same thing for the diagnostic codes history and the instrument cluster clock will have to be reset.



**CAUTION**

Prior to arc welding on the vehicle, refer to "Multiplex Modules Disconnection Procedure Prior To Welding" in section 00 GENERAL of this manual to avoid serious damage to the vehicle components.

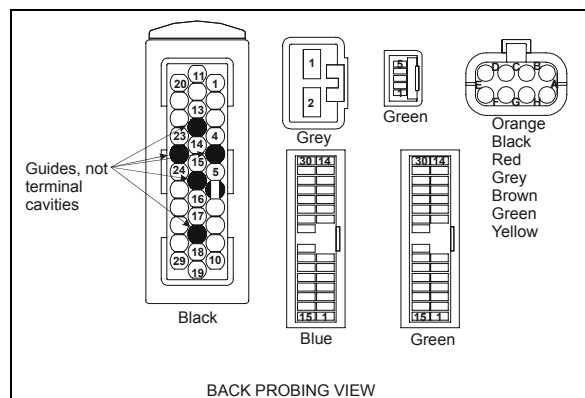
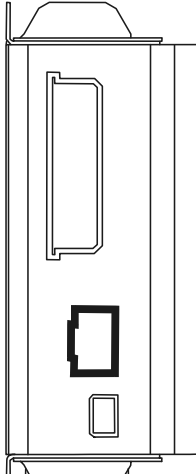
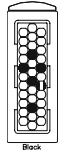
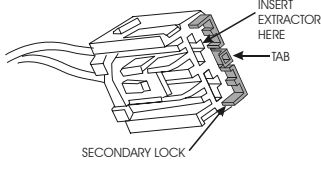
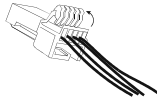
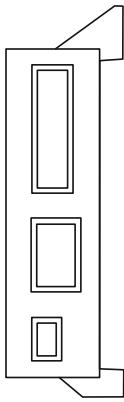
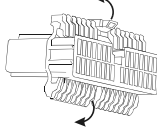
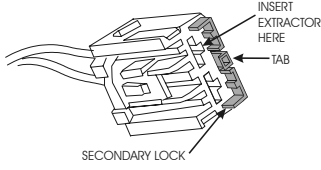
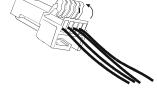
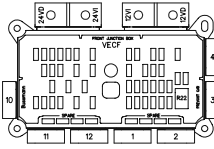
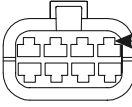


FIGURE 3: MULTIPLEX MODULE CONNECTORS PIN-OUT

06624



**Section 06: ELECTRICAL**

| Multiplex modules  | Connector type   | Terminal removal  |
|--|--|---|
|  <p><b>IO-B</b><br/>06625</p>   |  <p>AMP 06628</p>   | <p>EXTRACTOR/TOOL: Prevost #683594</p> <p>Insert the extractor on the front of the connector. Remove the terminal by disengaging the flexible lock tabs on the terminal. Gently remove the terminal from the connector by pulling on the wire.</p>  |
|  |  <p>grey 06629<br/><b>YAZAKI</b></p>  | <p>EXTRACTOR/TOOL: Packard #12094430</p> <p>Using a small flat blade screwdriver, open the hinged secondary lock. Insert the extractor on the front of the connector, over the terminal cavity. Remove the terminal by disengaging the flexible lock tab on the terminal. Gently remove the terminal from the connector by pulling on the wire.</p> |
|  |  <p>green 06630<br/><b>JAE</b></p>  | <p>EXTRACTOR/TOOL: Prevost #683766</p> <p>Using a small flat blade screwdriver, open the hinged secondary lock. Insert the extractor on the front of the connector, over the terminal cavity. Remove the terminal by disengaging the flexible lock tab on the terminal. Gently remove the terminal from the connector by pulling on the wire.</p>   |
|  <p><b>IO-A</b><br/>06626</p> |  <p>green, blue (CECM)<br/><b>JAE</b> 06631</p>  | <p>EXTRACTOR/TOOL: Prevost #683766</p> <p>Using a small flat blade screwdriver, open both hinged secondary locks. Insert the extractor on the front of the connector, over the terminal cavity. Remove the terminal by disengaging the flexible lock tab on the terminal. Gently remove the terminal from the connector by pulling on the wire.</p> |
|  |  <p>grey 06629<br/><b>YAZAKI</b></p>  | <p>EXTRACTOR/TOOL: Packard #12094430</p> <p>Using a small flat blade screwdriver, open the hinged secondary lock. Insert the extractor on the front of the connector, over the terminal cavity. Remove the terminal by disengaging the flexible lock tab on the terminal. Gently remove the terminal from the connector by pulling on the wire.</p> |
|  |  <p>green 06630<br/><b>JAE</b></p>  | <p>EXTRACTOR/TOOL: Prevost #683766</p> <p>Using a small flat blade screwdriver, open the hinged secondary lock. Insert the extractor on the front of the connector, over the terminal cavity. Remove the terminal by disengaging the flexible lock tab on the terminal. Gently remove the terminal from the connector by pulling on the wire.</p>   |
|  <p><b>VECF</b><br/>06627</p> |  <p>Orange<br/>Black<br/>Red<br/>Grey<br/>Brown<br/>Green<br/>Yellow<br/><b>BUSSMAN</b> 06632</p> | <p>EXTRACTOR/TOOL: Prevost #682256 (Packard 12094429)</p> <p>Remove the terminal by disengaging the flexible lock tab on the terminal. Gently remove the terminal from the connector by pulling on the wire.</p>  |

2. X3 COACHES ELECTRICAL COMPARTMENTS

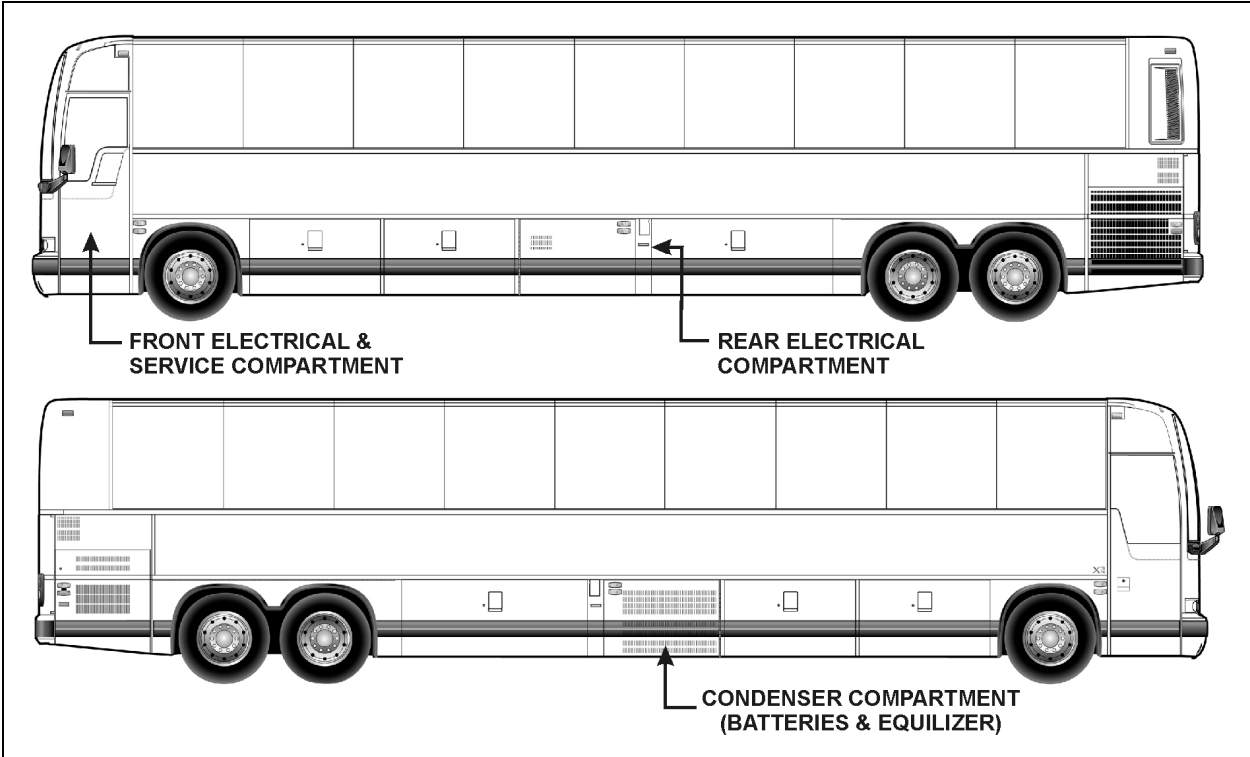


FIGURE 4: ELECTRICAL COMPARTMENTS (X3-45 COACH)

06672

2.1 MAINTENANCE

A Cortec VCI-238 corrosion inhibitor has been sprayed in all electrical compartments to protect components from corrosion. The life expectancy of this product is five years, so it is recommended to reapply it every five years. It is also recommended to spray it on new components when added or replaced.

|  |                |
|--|----------------|
|  | <b>CAUTION</b> |
| Never put grease, Cortec VCI-238 or other product on the multiplex module connector terminals. |                |

|  |               |
|--|---------------|
|  | <b>DANGER</b> |
| Use VCI-238 in a well ventilated area. Do not smoke. Avoid prolonged contact with skin and breathing of spray mist. Harmful or fatal if swallowed. Do not induce vomiting. Call physician immediately. |               |

the last baggage compartment (Super bay) on the driver side of the vehicle. The compartment is accessible from the last baggage compartment by removing a plastic access cover. The rear electrical compartment provides access to the following:

- Rear junction panel;
- Rear terminal block;
- Multiplex modules;
- Vehicle Electrical Center Rear (VECR)
- Battery charger;
- Relays and fuses;
- Transmission TCM;
- Battery master switch (Master cut-out);
- Diagnostic Data Reader (DDR) receptacle, (refer to "Other Features" chapter).

2.2 REAR ELECTRICAL COMPARTMENT

The rear electrical compartment is located in the space between the evaporator compartment and

## Section 06: ELECTRICAL

| Rear Electrical Compartment |                          |       |   |
|-----------------------------|--------------------------|-------|---|
| <b>Multiplex Modules</b>    |                          |       |   |
| A49                         | I/O-A                    | A52   | I/O-B   |
| A50                         | I/O-B                    | A53   | I/O-B   |
| A51                         | I/O-B                    | A54   | I/O-B   |
|                             |                          | Spare | I/O-B   |
| <b>Relays</b>               |                          |       |   |
| R1                          | Master relay             | R15   | Aisle & Emerg. Lts                            |
| R2                          | ZF Trans.                | R17   | 12V Rr wake-up                                |
| R3                          | 12V IGN & A/C            | R20   | Water Pump Relay                              |
| R5                          | Preheat / Charger        | R26   | Water Pre-heater Realy                        |
| R6                          | Direct lights            | R21   | Emergency cut-out                             |
| R8                          | Service brakes           | R30   | Luggage Door Lock                             |
| R10                         | Condenser Fan Sp. 2      | R31   | Luggage Door Lock                             |
| R11                         | ZF Trans. Ign.           | R32   | Luggage Door Unlock                           |
| R12                         | Evaporator Fan           | R33   | Luggage Door Unlock                           |
| R13                         | Indirect lights          | Rxx   | Spare   |
| R14                         | Reading lights           |       |   |
| <b>Fuses</b>                |                          |       |   |
| F50                         | Engine Pre-heating       | F69   | Overhead storage compartment lighting RH & LH |
| F51                         | Engine Pre-heating       | F70   | Customer (24VI)                               |
| F52                         | ZF Trans.                | F71   | Spare fuse                                    |
| F53                         | Power Mux A54            | F72   | Power Mux A50                                 |
| F54                         | Customer (24VD)          | F73   | Spare fuse                                    |
| F55                         | Aisle & emergency lights | F74   | ECM engine IGN                                |
| F56                         | Indirect lights          | F75   | ECU trans IGN                                 |
| F57                         | Indirect lights          | F76   | Customer (12VI)                               |
| F58                         | Direct lights            | F77   | ECU transmission wake-up                      |
| F59                         | Direct lights            | F78   | MCM engine wake-up                            |
| F60                         | Reading Lamp RH          | F79   | MCM engine wake-up                            |
| F61                         | Reading Lamp LH          | F80   | Power Mux A51                                 |
| F62                         | Lavatory night light     | F81   | Alternators excitation resistor               |
| F63                         | Engine Pre-heater        | F85   | ZF Trans.                                     |
| F64                         | Spare                    | F86   | Spare fuse                                    |
| F65                         | Power Mux Module RJB     | F87   | Spare fuse                                    |
| F66                         | Radiator Fan Clutch      | F88   | Spare fuse                                    |
| F67                         | Power Mux A54            | F89   | Spare fuse                                    |
| F68                         | Power Mux A54            |       |   |
| <b>Resistors</b>            |                          |       |   |
| RES13                       | Excit. res. ALT-1        | RES16 | Rear marker lights                            |
| RES14                       | Excit. res. ALT-2        | RES17 | Rear marker lights                            |
| <b>Diodes</b>               |                          |       |   |
| D6                          | Master relay             | D29   | Unloader RH                                   |
| D9                          | Water Pre-Heater         | D31   | Main A/C Clutch                               |
| D10                         | Water Pre-Heater         | D33   | Toilet flush pump                             |
| D11                         | Pass. Liq. Valve         | D36   | Fan Clutch 2                                  |
| D15                         | Wake-up mode             | D37   | Fan Clutch 1                                  |

|     |                |     |             |
|-----|----------------|-----|-------------|
| D17 | Luggage 4-Cmpt | D49 | Parcel Rack |
| D19 | Luggage 2-Cmpt | D67 | Rear Lights |
| D20 | Luggage 1-Cmpt | D68 | Rear Lights |
| D23 | Condenser fans | D69 | Rear Lights |
| D24 | Condenser fans | D70 | Rear Lights |
| D28 | Unloader LH    | DXX | Not used    |

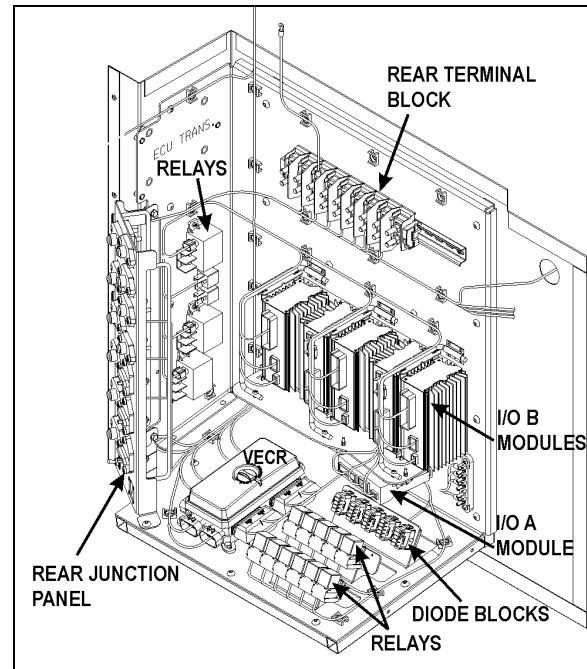


FIGURE 5: REAR ELECTRICAL COMPARTMENT 06634

### 2.3 FRONT ELECTRICAL AND SERVICE COMPARTMENT

The front electrical and service compartment is located on L.H. side of vehicle, under the driver's window. It contains the following components (Fig. 6):

- Front terminal block;
- CECM;
- Vehicle Electrical Center Front (VECF) and Multiplex Modules;
- Relays and fuses;
- ABS Electronic Control Unit (ECU);
- Common Powertrain Controller (CPC);
- VECU with Volvo D13 engine;

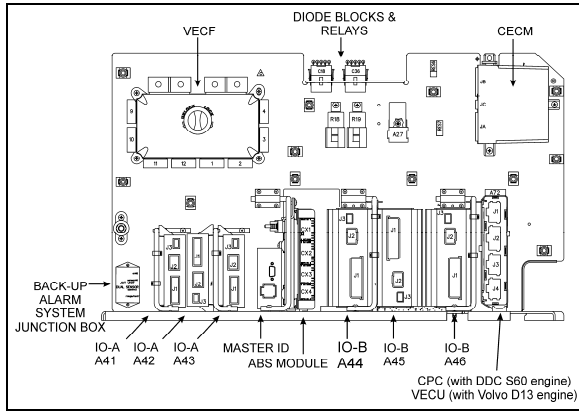


FIGURE 6: FRONT ELECTRICAL COMPARTMENT 06673

| Front Electrical & Service Compartment |  |     |  |
|--|--|-----|--|
| Modules                                |  |     |  |
| VECF                                   | Vehicle Electrical Center Front            | A43 | I/O-A  |
| A9                                     | ABS-ECU                                    | A44 | I/O-B  |
| A13                                    | MASTER ID                                  | A45 | I/O-B  |
| A36                                    | CECM                                       | A46 | I/O-B  |
| A41                                    | I/O-A                                      | A72 | CPC  |
| A42                                    | I/O-A                                      |     |  |
| Relays                                 |  |     |  |
| R18                                    | Wake-up 24V                                | R22 | Engine brake                                 |
| R19                                    | Wake-up 12V                                | A27 | Steering Control soft module                 |
| Fuses                                  |  |     |  |
| F1                                     | CECM Power                                 | F23 | ABS  |
| F2                                     | Front start main switch                    | F24 | Mirror                                       |
| F3                                     | Pre-heating & driver liquid solenoid valve | F25 | Back-up camera                               |
| F4                                     | Wireless microphone                        | F26 | Spare fuse                                   |
| F5                                     | Wake-up mode 24V                           | F27 | Customer                                     |
| F6                                     | Free/customer                              | F28 | Driver's power window                        |
| F7                                     | ABS & pre-heat control                     | F29 | Instrument cluster & data reader             |
| F8                                     | Air horn                                   | F30 | Cigarette lighter & 12-volt accessory outlet |
| F9                                     | Spare fuse                                 | F31 | Keyless entry module                         |
| F10                                    | Spare fuse                                 | F32 | Spare fuse                                   |
| F11                                    | Sun visor                                  | F33 | Wake-up mode 12VD                            |
| F12                                    | Power multiplex A41                        | F34 | Wake-up mode 12VD                            |
| F13                                    | Power multiplex A41                        | F35 | 12-volt accessory outlet                     |
| F14                                    | Customer                                   | F36 | HVAC & telltale panel                        |

|     |                     |     |               |
|-----|---------------------|-----|---------------|
| F15 | R22                 | F37 | Spare fuse    |
| F16 | Defroster unit      | F38 | Digital Clock |
| F17 | Spare               | F39 | Spare fuse    |
| F18 | Upper Defroster     | F40 | Spare fuse    |
| F19 | Pro Driver          | F41 | Spare fuse    |
| F20 | Witness red LED     | F82 | Lower wipers  |
| F21 | Power Mux A44       | F83 | Sound system  |
| F22 | ZF Steering Control | F84 | Customer      |

| Diodes |                     |     |               |
|--------|---------------------|-----|---------------|
| D1     | Accessories         | D22 | Service brake |
| D2     | Driver Liq Sol Vlve | D44 | Ignition      |
| D12    | Engine Brake        | Dxx | Not used      |
| D13    | ABS                 |     |               |

## 2.4 ENGINE REAR START PANEL

This control panel is located in the R.H. side of engine compartment above the engine air filter. This control panel includes the engine starter selector switch, the rear start push button switch to start engine from engine compartment as well as the engine compartment lights switch.

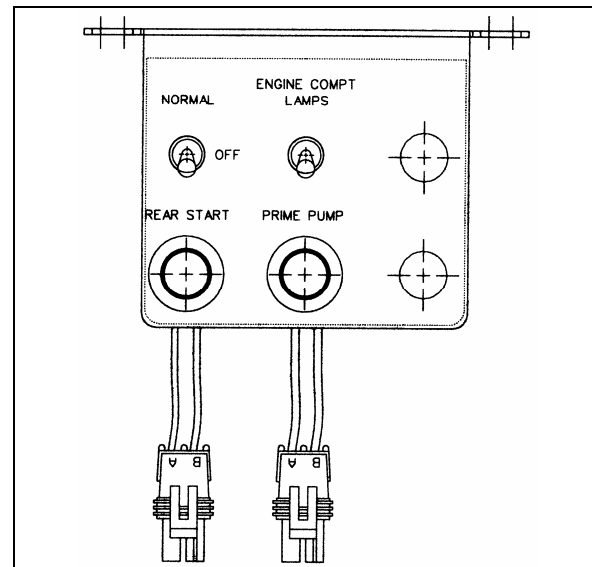


FIGURE 7: REAR START PANEL 06622

### NOTE

When the ignition key switch is set to the "OFF" position, the electrical supply from the batteries is cut off, with the exception of the Fire Detection System, the Engine & Transmission Electronic Controls, the Auxiliary Heating System, the Battery Equalizers and the Digital Clock.

## Section 06: ELECTRICAL

### 2.5 CONDENSER COMPARTMENT

The batteries are located inside the condenser compartment on the X3-45 coach.

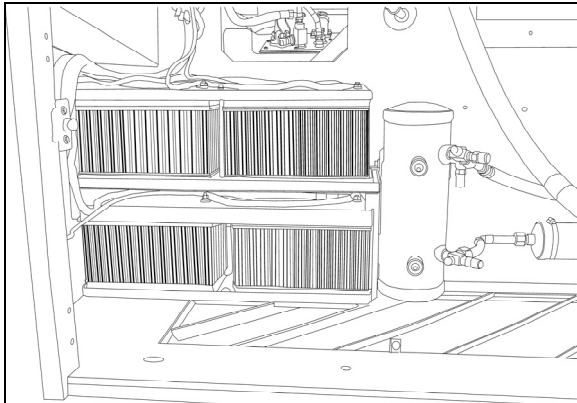


FIGURE 8: LOCATION OF BATTERIES IN CONDENSER COMPARTMENT

22300

#### 2.5.1 Battery equalizer

On X3-45 coaches the battery equalizer is located on the L.H. side of the condenser compartment (Fig. 9).

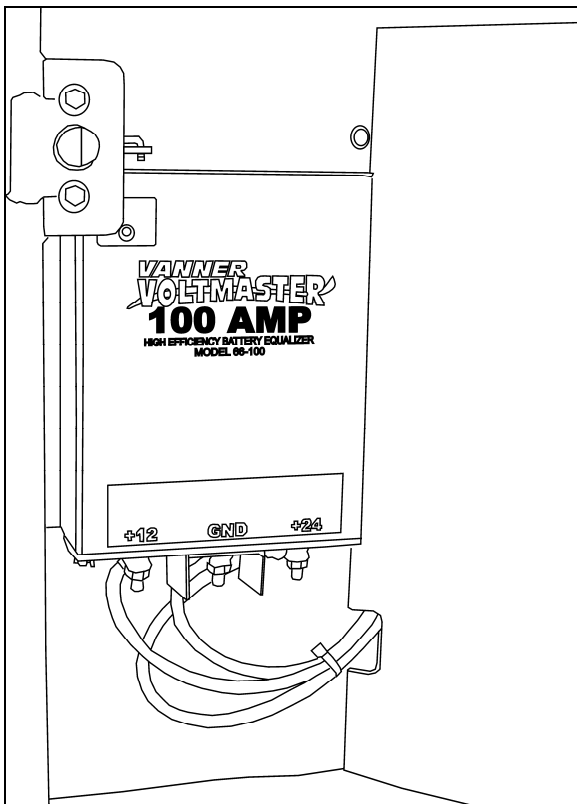


FIGURE 9: BATTERY EQUALIZER

06635

### 2.6 ENTRANCE DOOR & WIPER CONTROL PANEL

To access the entrance door & wiper control panel of the right console, remove the panel under the larger utility compartment at the base of the windshield.

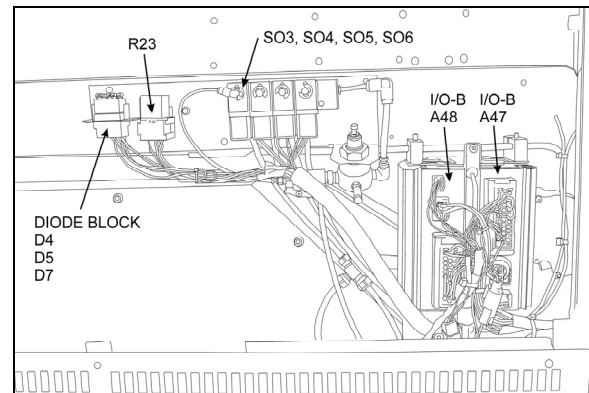


FIGURE 10: ENTRANCE DOOR & WIPER CONTROL PANEL

06619


| Entrance Door & Wiper Control Panel |                            |     |                             |
|-------------------------------------|----------------------------|-----|-----------------------------|
| Multiplex Modules                   |                            |     |                             |
| A47                                 | I/O-B                      | A48 | I/O-B                       |
| Relays                              |                            |     |                             |
| R23                                 | Windshield wipers          |     |                             |
| Solenoids                           |                            |     |                             |
| SO3                                 | Door unlock solenoid valve | SO5 | Door opening solenoid valve |
| SO4                                 | Door unlock solenoid valve | SO6 | Door closing solenoid valve |
| Diodes                              |                            |     |                             |
| D4                                  | Windshield wipers speed 2  | D7  | Entrance door               |
| D5                                  | Windshield wipers speed 1  |     |                             |

### 3. BATTERIES

The vehicle is provided with four (4) maintenance-free 12 volt heavy-duty batteries connected in series-parallel (Fig. 8 & 11). The top-mounted negative and positive terminals are tightly sealed to prevent leaks. Water never needs to be added to this type of battery. There are no filler caps in the cover. The battery is sealed, except for small vent holes in the cover. The vents must not be restricted as they allow small amounts of gases produced in the battery to escape. The special chemical composition inside the battery reduces gassing to a very small amount at normal charging voltages. Besides reducing gassing, the special chemistry


greatly reduces the possibility of overcharge damage.

The vents require keeping the battery in an upright position to prevent electrolyte leakage. Tipping the battery beyond a 45° angle in any direction can allow a small amount of electrolyte to leak out of the vent holes.

|  |
|--|
|  <b>WARNING</b> |
| DO NOT tip battery by more than 45° when carrying or installing the battery.                     |

|  |
|--|
| <b>NOTE</b>  |
| <i>Evidence of electrolyte leakage does not necessarily mean the battery is defective.</i> |

With special cables properly attached to batteries, the metal surfaces that carry the current are completely sealed from the atmosphere. This prevents terminal oxidation and corrosion that may cause starting and charging problems. If new cables are required, sealed terminal cable replacements should be used to retain the reliability of the original maintenance-free connections.

|  |
|--|
|  <b>DANGER</b>  |
| All lead-acid batteries generate hydrogen gas, which is highly flammable. If ignited by a spark or flame, the gas may explode violently, causing spraying of acid, fragmentation of the battery, which may result in severe personal injuries. Wear safety glasses and do not smoke when working near batteries. In case of contact with acid, flush immediately with water. |

The battery has four (4) major functions:

1. Providing a source of current for starting the engine;
2. Stabilizing the voltage in the electrical system;
3. Supplying current for a limited time, when electrical demands of the equipment exceed the power output of the alternator;
4. Providing a limited source of power for connected accessories, when the engine is not running.

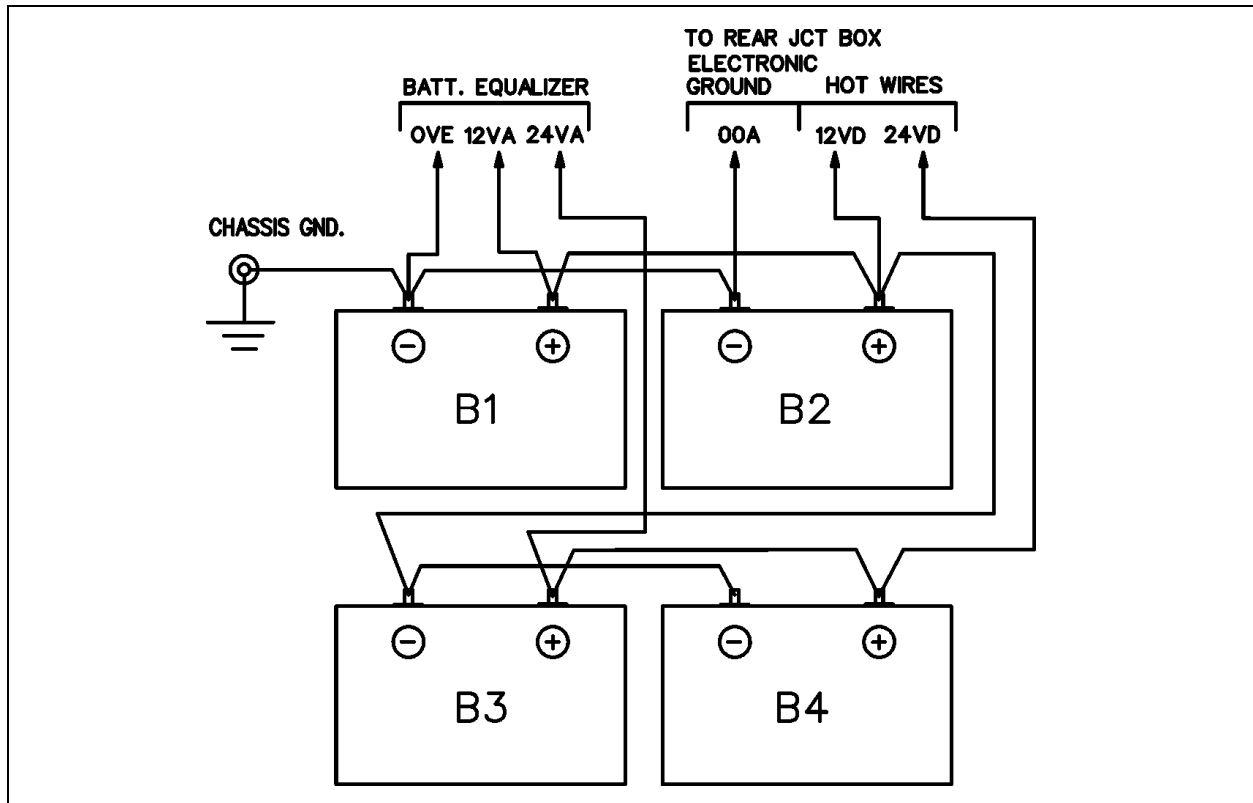


FIGURE 11: BATTERY CONNECTIONS

06636

### 3.1 BATTERY DISCHARGE PROTECTION

To prevent discharge of the batteries when the engine is not running, some functions are automatically switched off if the batteries voltage drops below 24.4 volts for more than 30 seconds. The "BAT" telltale light blinks while this protection mode is active. Set the ignition key to the OFF position and then turn the ignition key to the ON position to reactivate the functions for a period of 30 seconds before they switch off again.

If a prolonged use of the functions with the engine not running is necessary, connect the battery to a charger.

### 3.2 MAIN BATTERY RELAYS

Main battery (master) relays (12V and 24V) are provided for this vehicle. The relays are located in the rear electrical compartment. The 24-volt battery relay (R1) engages when ignition key is in the ON or ACC position and battery master switch (master cut-out) is flipped ON.

When the main battery relays (R1 & R3) are turned to the OFF position, all electrical supply from the batteries is cut off, with the exception of the following items.

- Battery equalizer check module;
- MCM;
- TCM (World transmission);
- Preheater electronic timer;
- Preheater and water recirculating pump;
- Sedan entrance door;
- Radio memory;
- CECM;
- Cluster memory.

### 3.3 BATTERY REMOVAL AND INSTALLATION

The batteries are located in the condenser compartment.

1. Remove the two quarter turn nuts to remove the protective cover (Fig. 8)

DANGER

To prevent possible electric shocks or sparking, the battery master switches should be in the "Off" position before disconnecting

cables from the batteries (see paragraph "3.8 Battery safety switches").

2. Remove the supports, and unscrew terminal nuts of each defective battery.
3. Remove battery cables from the batteries.
4. Remove batteries.
5. Installation is the reverse of removal.

**NOTE**

*When the battery cables have been removed from the batteries, wrap the battery terminals and cable ends with electric tape to prevent accidental grounding. The ground cables should always be disconnected first and replaced last.*

**NOTE**

*In replacing batteries, only batteries of the same specification should be used. Refer to "Specifications" at the end of this section for further details.*

**CAUTION**

Ensure that connections are not reversed when reinstalling batteries, since damage to electrical system components will result.

**NOTE**

*When reinstalling batteries, battery connections must be tightened to 13-15 lbf-ft (18-20 Nm). A torque wrench is required to ensure an accurate tightening torque.*

**DANGER**

To prevent possible electric shock or sparking, the battery master switch must be set to the "Off" position before tightening an electrical connection.

**NOTE**

*A protective silicone free, coating should be applied on all terminals that have been disconnected. We recommend the use of Cortec VCI-238 (Prévost #682460) on all electrical connections.*

**3.4 BATTERY RATING**

Each of the 12 volt batteries used on the vehicle has the following rating:

- Reserve capacity: 195 minutes
- Cold cranking (amps): 950 @ 0°F (-18°C)
- Cold cranking (amps): 745 @ -20°F (-29°C)
- Weight (filled): 59 lb (26,7 kg)

The reserve capacity is defined as the number of minutes a new, fully charged battery at 80°F (26,6°C) can be discharged at 25 amperes and maintain a minimum of 1.75 volts per cell (10.5 volts total for one 12 volts battery). This rating can be used as a basis for determining how long a vehicle might run after an alternator failure. The cold cranking rating is defined as the minimum discharge current a battery will deliver in amperes for 30 seconds at 0°F (-18°C) while maintaining a minimum of 1.2 volts per cell (7.2 volts total for one 12 volts battery). This rating can be used as a basis for comparing starting performance.

**3.5 BATTERY TESTING**

The maintenance-free battery has a strong ability to withstand the damaging effects of overcharge. The test indicator in the cover is used only to determine if the battery can be tested in case of a cranking problem.

The test indicator in the battery cover is to be used with accepted diagnostic procedures only. It must not be used to determine if the battery is good or bad, charged or discharged. The test indicator is a built-in hydrometer in one cell that provides visual information for battery testing (Fig. 12).

It is important when observing the test indicator, that the battery be relatively level and has a clean indicator top to see the correct indication. Some lighting may be required in poorly lit areas. Under normal operation, two indications can be observed.



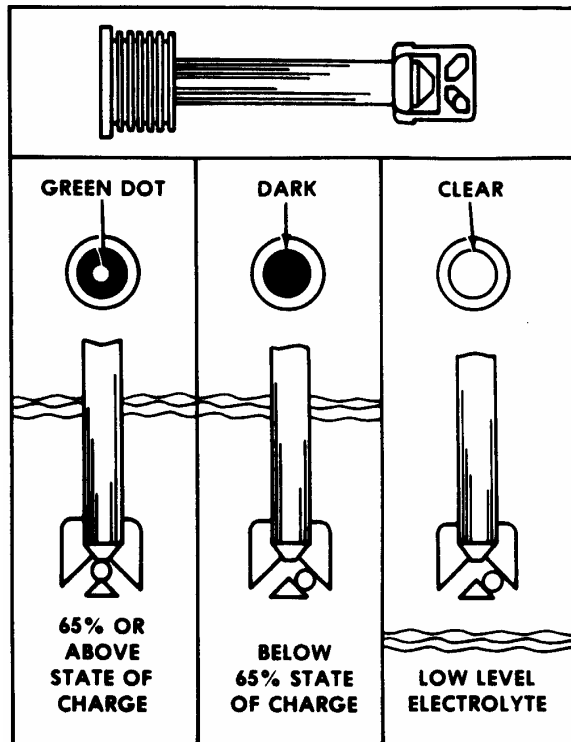


FIGURE 12: TEST INDICATOR 06096

### Green Dot Visible

Any green appearance is interpreted as a "green dot", and the battery is ready for testing. On rare occasions, following prolonged cranking, the green dot may still be visible when the battery is obviously discharged. Should this occur, charge the battery as described under "Charging Procedure" in "Battery Charging" later in this section.

### Dark - Green Dot Not Visible

If there is difficulty cranking the engine, the battery should be tested as described in this section. On rare occasions, the test indicator may turn light yellow. In this case, the integral charging system should be checked. Normally, the battery is capable of further service; however, if difficult start has been reported, replace the battery. **DO NOT CHARGE, TEST, OR JUMP-START.**

### 3.5.1 Visual Inspection

1. Check the outside of the battery for a broken or cracked cover or case that could permit loss of electrolyte. If obvious physical damage is noted, replace the battery.
2. Check for loose terminal posts, cable connections, damaged cables, and for

evidence of corrosion. Correct conditions as required before proceeding with tests.

### 3.5.2 Removing Surface Charge

Disconnect cables from the battery and attach alligator clamps to the contact lead pad on the battery as shown in figure 16. Connect a 300 ampere load across the terminal for 15 seconds to remove surface charge from the battery.

### 3.5.3 Load Test

This test is one means of checking the battery to determine its ability to function as required in the vehicle.

To make this test, use test equipment that will withstand a heavy electrical load from the battery, such as a carbon pile resistor or other suitable means.

1. Connect a voltmeter, ammeter, and a variable load resistance as illustrated in figure 13.

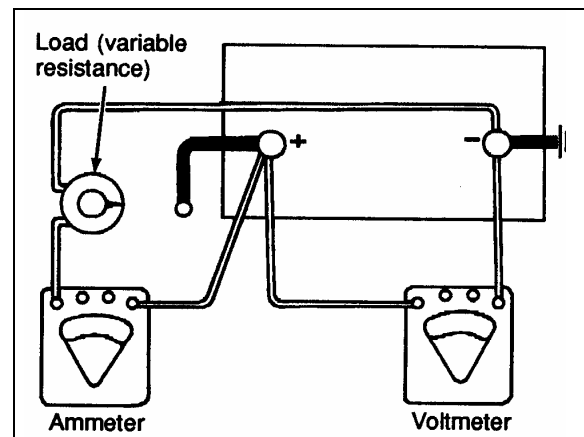


FIGURE 13: LOAD TEST 06064



## CAUTION

Observe polarity of the meters and the battery when making connections, and select the correct meter range.

2. Apply a 290 amperes load to the battery for 15 seconds.
3. With an ammeter reading specified load, read voltage. The voltage should be at least 9.6 volts. Disconnect the load. If the voltmeter indicates 9.6 volts or more, the battery is good. If the voltmeter reading is less than 9.6 volts, replace the battery. This voltage is to be used for battery ambient temperatures of 70°F (21°C) and above. For

temperatures below 70°F (21°C), refer to the following "Voltage and Temperature Chart".

#### Voltage and Temperature Chart

| Ambient Temperature   | Minimum Voltage |
|-----------------------|-----------------|
| 70°F (21°C) and above | 9.6             |
| 60°F (16°C)           | 9.5             |
| 50°F (10°C)           | 9.4             |
| 40°F (4°C)            | 9.3             |
| 30°F (-1°C)           | 9.1             |
| 20°F (-7°C)           | 8.9             |
| 10°F (-12°C)          | 8.7             |
| 0°F (-18°C)           | 8.5             |

#### NOTE

*The accuracy of this test procedure is dependent upon close adherence to the proper load, time and temperature specifications.*

#### 3.5.4 Testing Battery Cables

Check all cable ring terminals and connections to determine if they are in good condition. Excessive resistance, generally caused by poor connections, produces an abnormal voltage drop which may lower voltage at the starter to such a low value that normal operation of the starter will not be obtained. An abnormal voltage drop can be detected with a low-reading voltmeter as follows:



#### DANGER

To prevent the engine from starting during these tests, remove fuses F78 and F79 located in the VECR of the rear electrical compartment. Once the tests are completed, reinstall F78 and F79.

1. Check voltage drop between grounded (negative) battery terminal and vehicle frame by placing one prod of the voltmeter on the battery terminal and the other on a good ground (unpainted surface) on the vehicle. With the starter cranking the engine at a temperature of 70°F (21°C), voltage reading should be less than 0.3 volt. If the voltage reading exceeds 0.3 volt, there is excessive resistance in this circuit.
2. Check voltage drop between the positive battery terminal and the starter positive terminal stud while the motor is operated. If the reading is more than 2.5 volts, there is excessive resistance in this circuit.

#### NOTE

*If it is necessary to extend the voltmeter lead for this test, use a #16 (AWG) or larger wire.*

3. Check voltage drop between the starter housing and a good ground on the vehicle. The reading should be less than 0.2 volt.



#### DANGER

Any procedure other than the following could cause personal injury or damages to the charging system resulting from battery explosion or electrical burns.

Wear adequate eye protection when working on or near the batteries. Ensure that metal tools or jumper cables do not contact the positive battery terminal (or a metal surface in contact with it) as a short circuit will result. Do not attempt to jump start a vehicle suspected of having a frozen battery because the battery may rupture or explode. Both the booster and discharged batteries must be treated carefully when using jumper cables. Follow exactly the procedure outlined later in this section, being careful not to cause sparks.

#### 3.6 BATTERY CHARGING

The batteries used on this vehicle can be charged either on or off the vehicle; however, when they are removed from the vehicle, it is recommended that an adapter kit, which is available from any "A/C DELCO" dealer, be used in charging sealed-terminal batteries. Use the booster block to charge the batteries when they are left on vehicle and **make sure that the main battery disconnect switch is set to the "On" position.**



#### DANGER

During charging of the batteries, an explosive gas mixture forms in each cell. Part of this gas escapes through the vent holes and may form an explosive atmosphere around the battery itself if ventilation is poor. This explosive gas may remain in or around the battery for several hours after it has been charged. Sparks or flames can ignite this gas causing an internal explosion, which may shatter the battery.

1. Do not smoke near a battery which is being charged or which has been recently charged.

## Section 06: ELECTRICAL

2. Do not break live circuits at battery terminals because a spark usually occurs at the point where a live circuit is broken. Care must always be taken when connecting or disconnecting booster leads or cable clamps on chargers. Poor connections are a common cause of electric arcs, which cause explosions.
3. The electrical system on this vehicle is negative ground. Installing the batteries with the positive terminals grounded or incorrect use of the booster battery and jumper cables will result in serious damage to the alternator, batteries and battery cables.

The alligator clamps of the tester or charger must be placed between the terminal nuts and the lead pads of the terminal studs (Fig. 14) after the vehicle cables are detached. The alligator clamps should make firm contact with the lead pads.

### **NOTE**

*If this connection cannot be made because of the alligator clamp design, the load value for testing must be reduced from 290 to 260 amperes.*

On rare occasions, such as those that occur following prolonged cranking, the green dot in the test indicator may still be visible when the battery is obviously discharged. Should this occur, a boost charge of 20 amperes-hour is recommended. Under normal operating conditions, do not charge battery if the green dot is visible. The battery should never be charged if the test indicator (hydrometer) is clear or light yellow. If this occurs, replace the battery.

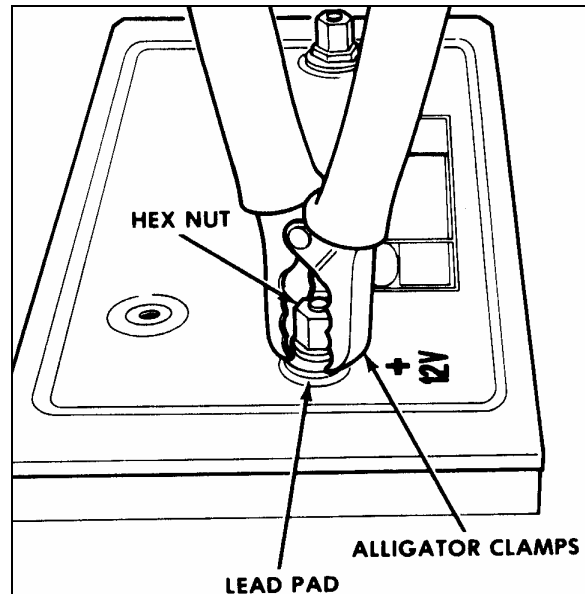


FIGURE 14: ALLIGATOR CLAMPS AND BATTERY 06065

A charge rate between 3 and 50 amperes is generally satisfactory for any maintenance-free battery as long as spewing of electrolyte does not occur or the battery does not feel excessively hot (over 125°F (52°C)). If spewing or violent gassing of electrolyte occurs or battery temperature exceeds 125°F (52°C), the charging rate must be reduced or temporarily stopped to allow cooling and to avoid damaging the battery. Battery temperature can be estimated by touching or feeling the battery case. The battery is sufficiently charged when the green dot in the built-in hydrometer is visible. No further charging is required. Shake or tilt the battery at hourly intervals during charging to mix the electrolyte and see if the green dot appears.



### **WARNING**

Always turn off the charger before connecting or disconnecting to a battery.

### **NOTE**

*The charge rate must be doubled when the batteries are charged by the booster block, because of the series-parallel circuit.*

Battery charging consists of a charge current in amperes for a period of time in hours. Thus, a 25 ampere charging rate for 2 hours would be a 50 ampere-hour charge to the battery. Most batteries, whose load test values are greater than 200 amperes, will have the green dot visible after at least a 75 ampere-hour charge. In the event that the green dot does not appear, replace the battery.

## 3.6.1 Battery Charging Guide

**Fast Charging Rate**

20 amps @ 3-¾ hours

30 amps @ 2-½ hours

40 amps @ 2 hours

50 amps @ 1-½ hours

**Slow Charging Rate**

5 amps @ 15 hours

10 amps @ 7-½ hours

The time required for a charge will vary according to the following factors:

**Size of Battery**

For example, a completely discharged large heavy-duty battery requires more than twice the recharging time of a completely discharged small passenger car battery.

**Temperature**

For example, a longer time will be needed to charge any battery at 0°F (-18°C) than at 80°F (27°C). When a fast charger is connected to a cold battery, the current accepted by the battery will be very low at first, and then in time, the battery will accept a higher rate as it warms.

**State of Charge**

For example, a completely discharged battery requires more than twice as much charge than a half-charged battery. Since the electrolyte is nearly pure water and a poor conductor in a completely discharged battery, the current accepted is very low at first. Later, as the charging current causes the electrolyte acid content to increase, the charging current will likewise increase.

**Charger Capacity**

For example, a charger which can supply only 5 amperes will require a much longer period of charging than a charger that can supply 30 amperes or more.

## 3.6.2 Emergency Jump Starting With Auxiliary (Booster) Battery.

**DANGER**

Off-board battery charger with a start boost facility must not be used to jump start the vehicle. This could damage the electrical system. Do not jump start vehicles equipped with maintenance-free batteries if the test indicator is light yellow.

**Booster Block**

On X3-45 coaches, booster block is located near the preheater in the engine compartment on the R.H. side and is accessible through engine R.H. side door (Fig. 15).

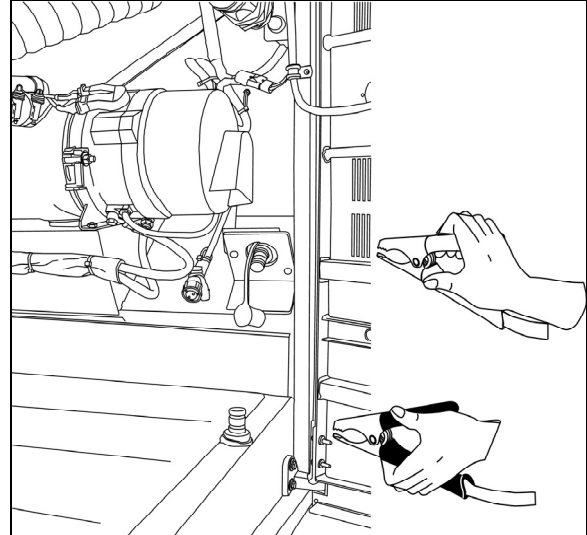


FIGURE 15: BOOSTER BLOCK

06623

Both booster and discharged batteries should be treated carefully when using jumper cables. A vehicle with a discharged battery may be started by using energy from a booster battery or the battery from another vehicle.

**DANGER**

Jump starting may be dangerous and should be attempted only if the following conditions are met:

The booster battery or the battery in the other vehicle must be of the same voltage as the battery in the vehicle being started, and must be negative grounded.

If the booster battery is a sealed-type battery without filler openings or caps, its test indicator must be dark or a green dot must be visible. Do not attempt jump starting if the test indicator of the booster battery or the discharged battery has a light or bright center.

**DANGER**


Follow the procedure exactly as outlined hereafter. Avoid making sparks.

Wear eye protection and remove rings, watches with metal bands and other metal jewelry.

## Section 06: ELECTRICAL

Apply parking brake and place the transmission shift lever or push-button pads in Neutral (N) position in both vehicles. Turn off lights, heater and other electrical loads. Observe the charge indicator. If the indicator in the discharged battery is illuminated, replace the battery. **Do not** attempt jump starting when indicator is illuminated. If the test indicator is dark and has a green dot in the center, failure to start is not due to a discharged battery and the cranking system should be checked. If charge indicator is dark but the green dot does not appear in center, proceed as follows:

1. Connect one end of one red jumper cable to the positive (+) terminal of the booster power source and the other end to the positive (+) post of the booster power block, located on the R.H. side of the engine compartment (refer to fig. 4).
2. Connect one end of the remaining negative jumper cable (black) to the negative (-) terminal of the booster power source, and the other end of the black jumper cable to the negative (-) post of the booster power block.
3. Make sure the clips from one cable do not inadvertently touch the clips on the other cable. Do not lean over the battery when making connections. The ground connection must provide good electrical conductivity and current carrying capacity.
4. Start the engine in the vehicle that is providing the jump start. Let the engine run for a few minutes, then start the engine in the vehicle that has the discharged batteries.
5. When removing the jumper cables, perform the above procedure exactly in reverse order, and replace protective caps on booster block terminals.

|  |
|--|
|  <b>DANGER</b>  |
| Any procedure other than the above could result in personal injury, property damage due to battery explosion, or damage to the charging system of the booster vehicle or of the boosted vehicle. |

### NOTE

*Jumper cables must withstand 500 cranking amperes. If cable length is 20 feet (6m) or less, use 2/0 (AWG) gauge wires. If cable length is between 20-30 feet (6-9m), use 3/0 (AWG) wires.*

### 3.7 CLEANING AND INSPECTION

The external condition of the battery and the battery cables should be checked periodically. The top of the battery should be kept clean and the battery hold-down clamp bolts should be kept properly tightened. For best results when cleaning the battery, wash first with a diluted solution of ammonia or soda to neutralize any acid present then wash out with clean water. The battery hold-down bolts should be kept tight enough to prevent the batteries from moving, but they should not be tightened to the point that excessive strain is placed on the battery hold-down cover (proper tightening torque: 45-55 lbf-in (5-6 Nm)).

To insure good contact, the battery cable ring terminals should be tight on the battery posts. If the posts or cable ring terminals are corroded, the cables should be disconnected and the posts and clamps cleaned separately with a soda solution and a wire brush. Install cable ring terminals on battery posts and tighten to a torque of 10-15 lbf-ft (13-20 Nm). Replace protective caps to prevent corrosion and sparks.

### 3.8 COMMON CAUSES OF BATTERY FAILURE

When a battery fails, the cause of failure may be related to something other than the battery. For this reason, when a battery failure occurs, do not be satisfied with merely recharging or replacing the battery. Locate and correct the cause of the failure to prevent recurrence. Some common external causes of battery failure are as follows:

1. A defect in charging system such as high resistance or a faulty alternator or regulator.
2. A malfunction within the 12 volts system (equalizer).
3. Overloads caused by a defective starter or excessive use of accessories.
4. Dirt and electrolyte on top of the batteries causing a constant drain.
5. Hardened battery plates, due to battery being in a low state of charge over a long period of time.
6. Shorted cells, loss of active material from plates.
7. Driving conditions or requirements under which the vehicle is driven for short periods of time.

8. A constant drain caused by a shorted circuit such as an exposed wire or water infiltration in junction boxes causing ground fault.
9. Extended operation of preheating system with engine not running.
10. Failing to close disconnect switches during the night.

### 3.9 TROUBLESHOOTING

If a battery is known to be good and then has not performed satisfactorily in service for no apparent reason, the following factors may reveal the cause of trouble:

1. Vehicle accessories and disconnect switches inadvertently left on overnight.
2. Defects in the charging system, such as high wiring resistance, faulty alternator, regulator or battery equalizer.
3. A vehicle electrical load exceeding the alternator (or battery equalizer) capacity, with the addition of electrical devices, such as CB radio equipment, a cellular phone or additional lighting systems.
4. Defects in the electrical system, such as shorted or pinched wires.
5. Extended driving at a slow speed while using many accessories.
6. Loose or poor battery cable-to-post connections, previous improper charging of a run-down battery, or loose hold-down clamp bolts.
7. High-resistance connections or defects in the cranking system.

### 3.10 "BAT" BATTERY VOLTAGE INCORRECT TELLTALE LIGHT

If the "BAT" (battery voltage incorrect) telltale light is illuminated, check the 24-volt voltmeter to determine if the battery voltage is too high or too low.

**NOTE**

*According to the battery charging condition, it is normal that "BAT" telltale light illuminates upon starting the engine and stays illuminated for a few seconds. This is caused by the normal voltage drop of the battery during starting.*

#### 3.10.1 "Bat" Telltale Light Definitions

Voltmeter drops below 24.4 volts dc

Check alternator output.

Check voltage regulator.

Check battery connections.

Check battery cells.

- Check battery equalizer connections.

Voltmeter exceeds 30 volts dc

- Check alternator output.

- Check voltage regulator.

- Check battery connections.

#### Battery Balance

**NOTE**

*Allow at least 15 minutes to balance batteries after any corrective measure has been taken.*

1. Batteries out of balance (difference greater than 1.5 volts between the two battery banks).

- Check battery equalizer connections.
- Check equalizer cables for proper gauge.
- Check battery connections.

2. Demand for 12-volt power exceeding rated amperage output of battery equalizers causing batteries to go out of balance.

- Reduce 12-volt load or install additional battery equalizer(s).

## 4. TROUBLESHOOTING AND TESTING THE MULTIPLEX VEHICLES

### 4.1 ELECTRICAL SYSTEM DIAGNOSTIC

Using the message center display (MCD), check if there are active errors in the vehicle electrical system. With the SYSTEM DIAGNOSTIC menu, highlight FAULT DIAGNOSTIC and then highlight ELECTRICAL SYSTEM to request a diagnostic of the electrical system from the CECM. Press the enter key. If applicable, the MCD shows the multiplex device ID, the fault messages or fault codes recorded. When more than one fault is recorded, an arrow pointing down appears on the right of the display. Use the down arrow to see all the fault messages.

## Section 06: ELECTRICAL

---

Once the problem corrected, the MCD still shows the fault as being active. You have to leave the FAULT DIAGNOSTIC menu, wait approximately 20 to 30 seconds and then return to FAULT DIAGNOSTIC to request a new diagnostic of the ELECTRICAL SYSTEM from the CECM. The MCD should display the fault as being inactive. The CECM can store up to 20 faults, i.e. the first 10 and the last 10. Middle faults will be erased. If the breakers are tripped, the fault history will be erased from the CECM memory.

### **NOTE**

*It is of the utmost importance to have a MCD (message center display) in working condition because it is the most important tool to achieve troubleshooting on a multiplex vehicle.*

### 4.2 PROBING VOLTAGE ON THE MULTIPLEX CIRCUITS

Some Multiplex modules are supplied by 12 volts while others are supplied by 24 volts. The 12-volt or 24-volt information is found on the modules symbol in the wiring diagram. Before taking voltage readings to track the source of a problem, first verify if the module is supplied by 12V or 24V, if not, residual voltage on the module inputs/outputs can draw an erroneous conclusion.

Inactive Multiplex output = Residual voltage of 18% to 33% of supply voltage.

Inactive Multiplex input = Residual voltage of 50% of supply voltage.

### **NOTE**

- *Verify on the wiring diagram whether the voltage is 12V or 24V,*
- *For a 12V module: an active voltage would be 12V or 0V but not in between. If you measure the intermediate tensions (ex. 6V, 2V, or 4V) this must be interpreted as if the input or the output is inactive.*
- *For a 24V module: an active voltage would be 24V or 0V but not in between. If you measure the intermediate tensions (ex. 12V, 4V, or 8V) this must be interpreted as if the input or the output is inactive.*

### 4.3 CAN NETWORK

The CAN network wiring is separated in sections and uses connectors that are not shared with other circuits. This allows sections of the network to be isolated to help locate short-circuit on the CAN.

In case of a short-circuit on the CAN network, this affects all the modules and they all act as "No response" in the error messages of the "ELECTRICAL SYSTEM" menu. To locate a short-circuit, proceed by disconnecting one module zone at a time while verifying if this makes inactive the errors in the modules still connected. Connector C1 (front electrical & service compartment) disconnects all the modules at the rear of the vehicle from the network. Connector C5 (front electrical & service compartment) disconnects all the modules from the entrance door & wiper control panel. Connector C3 (rear electrical compartment) disconnects all the modules at the rear of the vehicle from the network.

Example: Disconnect C5 and C1 and then verify the status of the errors. If the front modules (A41 to A46) now give inactive errors, which means short-circuit is elsewhere than in the front electrical & service compartment.

#### 4.3.1 Can Connection On The Telltale Panel And The Hvac Control Unit

The telltale panel module and HVAC module are linked to the CECM by a CAN connection. In case of a CAN connection default, the telltale panel LCD display shows "CAN", and on the HVAC control unit, the temperature display indicates "---". To confirm a CAN connection default, check that the fan speed on the driver's section HVAC control unit cannot be adjusted.

Moreover, specific error messages from these 2 modules can be read in the ELECTRICAL SYSTEM menu.

### **NOTE**

*While downloading a new vehicle program in the CECM from a computer, the CAN network is temporarily interrupted and therefore a CAN reference appears in the telltale panel LCD display.*

4.3.2 Spare Can

A spare CAN network is installed between the front and the rear of the vehicle. It has connectors installed at each end to facilitate swapping from the regular CAN network to the spare CAN network. Refer to the vehicle wiring diagram and the section 4.6 for more information.

4.4 TEST MODE FOR SWITCHES AND SENSORS

The switch/sensor test mode provides useful information to diagnose problems complimentary to the electrical system diagnosis.

To enter this mode, activate the dashboard "Telltale Light Test" switch 3 times within 4 seconds. To exit the switch/sensor test mode, reactivate the test switch 1 time or turn OFF the ignition.

4.4.1 Information Available And Impact On The Functions In Switch/Sensor Test Mode

Telltale panel audible alarm emits a *beep* each time an OFF/ON transition is detected on a multiplex input. This allows quick verifying if the switches and sensors are detected or seen by the multiplex modules. When the vehicle is parked, the back-up alarm also emits a sound that allows verification of the sensors at the rear of the vehicle.

Certain inputs are doubled (ex. turn signal switch on multi-function lever, door operating buttons) and also other inputs activate at the same time (ex. kneeling switch and Kneeling proximity sensor switch). For these inputs, 2 *beeps* are emitted. If only one *beep* is heard, one of the inputs is defective.

| <b>SWITCHES AND SENSORS SUPPORTED BY THE SWITCH/SENSOR TEST MODE</b> |
|--|
| HVAC control unit driver's section ON/OFF                            |
| A/C door ajar open sensor  |
| HVAC control unit driver recirculate switch                          |
| HVAC overhead compartment fan switch                                 |
| HVAC control unit passenger's section ON/OFF                         |
| Engine ether start switch  |
| Radiator fan clutch switch   |
| Engine front start enable switch                                     |
| Engine rear start enable switch                                      |
| Engine ignition front switch   |

|  |
|--|
| Engine ignition rear switch                        |
| Entrance door inside closing switch                |
| Entrance door outside opening /closing switch      |
| Entrance door electric window down switch          |
| Entrance door electric window up switch            |
| Electric horn button                               |
| Kneeling down switch                               |
| Kneeling up switch                                 |
| Lavatory emergency switch                          |
| Interior lighting switch, 2 positions              |
| Driver's area lighting switch                      |
| Reading lights switch                              |
| Multi-function lever LH turn signal                |
| Multi-function lever RH turn signal                |
| Fog lights switch                                  |
| Hazard warning flashers switch                     |
| Multi-function lever courtesy blinkers switch      |
| Headlights switch, 2 positions                     |
| Multi-function lever headlights beam toggle switch |
| Baggage compartment door lock/unlock switch        |
| Tag axle signal                                    |
| Wheelchair lift activation switch                  |
| Windshield lower wiper                             |
| Multi-function lever windshield wipers intermit.   |
| Multi-function lever windshield wipers speed 1,2   |
| Windshield wipers backup switch                    |
| Windshield washer switch                           |

The following inputs, either certain options or sensors which are difficult to activate, are not supported by the switch/sensor test:

- Low-Buoy switch,
- Starter Sensor,
- ABS Warning input,
- WCL switch,
- Driver's Power Window Switch (up & down),
- Fog Lights Switch,
- Alternator Sensors 1 & 2,
- Retarder Active Signal,
- Radiator fan speed 1 & 2 signals.

When in switch/sensor test mode, the A/C compressor HI and LO pressure values are displayed one after the other instead of the outside temperature in the telltale panel LCD display. This feature can be used when the vehicle is traveling to check the A/C compressor pressure values, but no *beep* can be heard.



## Section 06: ELECTRICAL

---

In test mode, with the parking brake applied and the passenger set point set to a value higher than 64°F (18°C), the circulator pump is not set to OFF as it would normally do when the outside temperature gets above 50°F (10°C). This feature allows verification of the pump when inside a garage. This is also useful when working on the heating system to remove air pockets trapped in the system.

When performing an A/C cooling test and having the water pump shut off in switch/sensor test mode is required, just set the passenger set point temperature to the minimum 64°F (18°C) to shut off the pump.

### 4.5 TEST MODE FOR ELECTRIC MOTORS

The test mode allows testing the motors and electric contactors without the need to have the engine running. Note that while in test mode, the engine cannot be started.

Prerequisite conditions for the motor test mode:

- A. The battery charger must be connected to a 110-120 volt power supply. If not, the test will be interrupted when the voltage drops below 24.4 volts,
- B. Engine not running,
- C. Parking brake applied,



### DANGER

Before starting the test sequence, make sure nobody is working in the evaporator or condenser compartment.

### NOTE

*A delay of 15 seconds during which the back-up alarm will sound is introduced prior the test start to advise people that may be working on the vehicle.*

#### To enter this mode:

- Activate the dashboard Telltale Light Test switch 3 times within 4 seconds;
- Push the ON/OFF button on the driver's side HVAC control unit 5 times (that makes 3 transitions from OFF to ON),
- A *beep* can be heard indicating the motor test mode has started.

#### Using the test mode:

- During the entire test, the telltale panel audible alarm gives a signal each second to remind that the motor test mode is underway.

#### 4.5.1 Test Sequence

##### Go to the condenser compartment.

- The condenser fans runs for 3 seconds at speed 1.
- 1 second delay.
- Speed 2 activates for 3 seconds.
- 3 seconds delay.
- Passenger's unit refrigerant solenoid valve activates 3 times at 1 second interval.

**Then 5 beeps can be heard from the back-up alarm to indicate to go to the engine compartment (15 SECONDS DELAY).**

**In the engine compartment, the sequence is as follows:**

- Toilet fan motor runs for 3 seconds.
- 1 second delay.
- A/C compressor clutch activates 3 times at 1 second interval.
- 1 second delay.
- Left compressor unloader activates 3 times at 1 second interval.
- 1 second delay.
- Right compressor unloader activates 3 times at 1 second interval.

**5 beeps from the back-up alarm indicate to go to the engine radiator fan (5 SECONDS DELAY).**

- Fan clutch is disengaged for 3 seconds (fan can be turned freely by hand).
- Fan clutch engages for 3 seconds in speed 1 (fan can be turned by hand but with a certain resistance).
- 3 seconds delay.
- Fan clutch engages for 3 seconds in speed 2 (cannot be turned but hand).
- 10 seconds delay.

- Auxiliary A/C clutch (parcel rack cooling system) activates 3 times at 1 second interval.

**5 beeps from the back-up alarm indicate to go to the evaporator compartment (10 SECONDS DELAY).**

**In the evaporator compartment:**

- Evaporator fan motor runs at speed 1 for 3 seconds then runs at speed 2 for 3 seconds.
- Hot water pump starts running for 5 seconds and hot water pneumatic valve activates 3 times at 1 second interval.

**5 beeps from the back-up alarm indicate to go to the spare wheel compartment (20 SECONDS DELAY).**

**Inside the compartment:**

- Driver's refrigerant solenoid valve activates 3 times at 1 second interval.
- 1 second delay.
- Driver's water solenoid valve activates 3 times at 1 second interval.

**5 beeps from the back-up alarm indicate to go to inside the vehicle (10 SECONDS DELAY).**

**Inside the vehicle:**

- Upper section defroster fan motor runs for 5 seconds.
- 10 seconds delay.
- Left and right overhead compartment fans start running one after the other for 5 seconds.
- 1 second delay.
- Overhead storage compartment refrigerant solenoid valve activates 3 times at 1 second interval.

**This ends the test. Activate the dashboard Telltale Light Test switch one time to leave the motor test mode.**

#### 4.6 CAN NETWORK LAYOUT AND TROUBLESHOOTING

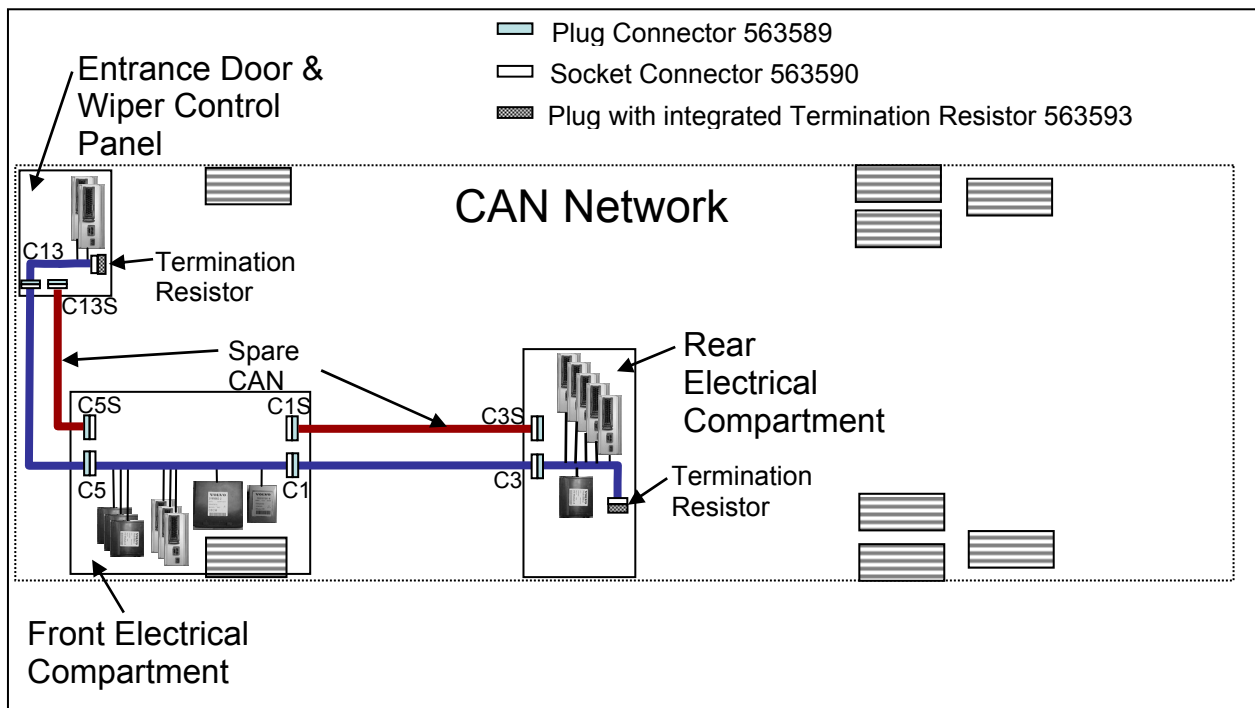


FIGURE 16: X3-45 COACHES CAN NETWORK LAYOUT

06637

## Section 06: ELECTRICAL

### 4.7 TROUBLESHOOTING

| Problem/Symptom   | Probable Causes  | Actions  |
|---|--|--|
| <p>Vehicle does not Start</p>   | <p>Rear Start selector switch is not in the NORMAL position</p> <p>Master cut-out switch in the rear electrical compartment is in the OFF position (down)</p> <hr/> <p>CAN network problem (Multiplex)</p> <p>Module A53 not powered or is defective</p> <p>Engine MCM does not receive the ignition signal</p> <p>Engine MCM is not powered</p> | <ol style="list-style-type: none"> <li>1. Check that the rear start selector switch is flipped up to NORMAL start position and master cut-out switch is flipped up to ON and retry cranking</li> <li>2. Flip the rear start selector switch to "Rear Start" and start the vehicle from the rear</li> </ol> <hr/> <p>If the vehicle does not start from the rear:</p> <ol style="list-style-type: none"> <li>1. Verify that module A53 is powered:               <ol style="list-style-type: none"> <li>a) Check the SYSTEM DIAGNOSTIC menu of the message center display (MCD). Select FAULT DIAGNOSTIC and ELECTRICAL SYSTEM. The message "No Response ModA53, Active", indicates a power problem on the module or a CAN network problem.</li> <li>b) Check / reset circuit breaker CB5</li> <li>c) Check / replace fuse F65</li> <li>d) Probe gray connector on module to see if it is powered.</li> </ol> </li> <li>2. Verify that the engine MCM is powered and get the ignition signal               <ol style="list-style-type: none"> <li>a) Check / reset circuit breaker CB8<br/>Check / replace fuse F74</li> <li>b) Check / reset circuit breaker CB2<br/>Check / replace fuse F78</li> </ol> </li> </ol> |
| <p>None of the Multiplexed functions are operating, including the basic limp-home functions (door opening, flashers, wipers in speed 1)</p> <p>Three dashes "---" appear in the telltale panel instead of the outside temperature</p> <p><i>Note: The sunshades are still functioning since these are not multiplexed</i></p> | <p>The program version in the CECM is different than the program in the I/O modules and the CECM is forcing all I/O modules to stay inactive</p>   | <ol style="list-style-type: none"> <li>1. Engage the auto-programming of the I/O modules: Turn the ignition key to the OFF position, flip the master cut-out switch in the rear electrical compartment to OFF and ON and then turn the ignition key ON. The letters CAN will appear in the telltale LCD panel for about 3 minutes Everything shall get back to normal once the letters CAN are replaced with outside temperature display</li> <li>2. Try disconnecting the green connector on the CECM and reconnect</li> <li>3. If step 1 and 2 are ineffective, try disconnecting the Master ID module completely and repeat step 1</li> </ol>   |

| Problem/Symptom   | Probable Causes  | Actions   |
|---|--|---|
|   |  | 4. Try disconnecting the CECM completely, leave it disconnected and see if the limp-home functions (start of the vehicle from the engine compartment, wipers speed 1, flashers, etc ) are functioning   |
| <p>Many secondary functions (not essential for driving) not functioning (interior lighting, driver's area lighting, wiper speed 2 and intermittent).</p> <p>Outside temperature display in the telltale LCD panel displays three dashes "---"</p> <p>Marker lights and clearance lights are turned ON when setting ignition to the ON position.</p> | <p>The CECM module does not receive 24 V power.</p> <p>The CAN network is not working. It could be caused by a short on the network, an open circuit, a problem with the CECM or the CECM being disconnected from the network.</p> | <p>1. Check / reset circuit breaker CB6 (3<sup>rd</sup> from the bottom on the right side column) Check / replace fuse F1</p> <p>2. Operate in limp-home mode by starting the vehicle from the engine compartment (REAR START). All functions essential to drive are available</p> <p>To close and lock the door, pull the door manually up to its closed position and it will lock by itself. The door opening button is still functioning</p>   |
| <p>No temperature control in the passenger area</p> <p>Passenger temperature display indicates two dashes "--"</p>  | <p>Problem with the temperature sensor located in the evaporator compartment air intake or the sensor wiring</p>   | <p>Instruct the driver to manually control the temperature by playing with the passenger set point. Set above 22°C (72°F) to heat and below 22° C (72°F) to cool</p>  |
| <p>Entrance door does not open nor close using the control buttons</p> <p>Defroster fan not functioning</p> <p>Windshield wipers not functioning in speed 1 or intermittent</p>   | <p>Module A47 is not powered or is faulty</p>  | <p>1. Check the SYSTEM DIAGNOSTIC menu of the message center display (MCD). Select FAULT DIAGNOSTIC and ELECTRICAL SYSTEM. The message "No Response ModA47, Active" indicates a power problem on the module. (A CAN network problem would show the same message but doesn't produce these symptoms).</p> <p>2. Check / reset circuit breaker CB6</p> <p>3. Check / replace fuse F5</p> <p>4. Probe gray connector on module to see if it is powered.</p> <p>5. Use the air release valves near the entrance door and in the front service compartment to lock / unlock the door</p> |
| <p>Windshield wipers not functioning in speed 1 or intermittent</p>   | <p>No power on R23</p>   | <p>Check / replace fuse F82</p>   |

## Section 06: ELECTRICAL

| Problem/Symptom   | Probable Causes  | Actions  |
|---|--|--|
| HVAC condenser fans not functioning in speed 1  | Circuit breaker CB7 was manually tripped and not reset | Check / reset circuit breaker CB7  |
| HVAC condenser fans not functioning in speed 2  | Circuit breaker CB7 was manually tripped and not reset | Check / reset circuit breaker CB7  |
| <p>Windshield washer not functioning</p> <p>Windshield upper section de-icing system not functioning</p> <p>Defroster fan is functioning but no heat or cooling available in the driver area.</p> | Module A46 is not powered or is faulty                 | <ol style="list-style-type: none"> <li>1. Check the SYSTEM DIAGNOSTIC menu of the message center display (MCD). Select FAULT DIAGNOSTIC and ELECTRICAL SYSTEM. The message "No Response ModA46, Active" indicates a power problem on the module. (A CAN network problem would show the same message but doesn't produce these symptoms).</li> <li>2. Check / reset circuit breaker CB1</li> <li>3. Check / replace fuse F12 or F13</li> <li>4. Probe gray connector on module to see if it is powered.</li> </ol>  |
| <p>Low beam headlights and front flasher on left side not functioning</p> <p>Electric horn not functioning</p>  | Module A45 is not powered or is faulty                 | <ol style="list-style-type: none"> <li>1. Check the SYSTEM DIAGNOSTIC menu of the message center display (MCD). Select FAULT DIAGNOSTIC and ELECTRICAL SYSTEM. The message "No Response ModA45, Active" indicates a power problem on the module. (A CAN network problem would show the same message but doesn't produce these symptoms).</li> <li>2. Check / reset circuit breaker CB2</li> <li>3. Check / replace fuse F33 and F34</li> <li>4. Probe gray connector on module to see if it is powered.</li> </ol> |
| Low beam headlights and flasher on right side not functioning   | Module A48 is not powered or is faulty                 | <ol style="list-style-type: none"> <li>1. Check the SYSTEM DIAGNOSTIC menu of the message center display (MCD). Select FAULT DIAGNOSTIC and ELECTRICAL SYSTEM. The message "No Response ModA48, Active" indicates a power problem on the module. (A CAN network problem would show the same message but doesn't produce these symptoms).</li> <li>2. Check / reset circuit breaker CB2</li> <li>3. Check / replace fuse F33 and F34</li> <li>4. Probe gray connector on module to see if it is powered.</li> </ol> |

| Problem/Symptom   | Probable Causes  | Actions  |
|---|--|--|
| <p>Rear flashers not functioning</p> <p>Stoptlights and center stoptlights not functioning</p>                        | <p>Module A51 is not powered or is faulty</p>                                    | <ol style="list-style-type: none"> <li>1. Check the SYSTEM DIAGNOSTIC menu of the message center display (MCD). Select FAULT DIAGNOSTIC and ELECTRICAL SYSTEM. The message "No Response ModA51, Active" indicates a power problem on the module. (A CAN network problem would show the same message but doesn't produce this symptom).</li> <li>2. Check / reset circuit breaker CB2</li> <li>3. Check / replace fuse F80</li> <li>4. Probe gray connector on module to see if it is powered.</li> </ol>   |
| <p>Engine is overheating and radiator fan clutch does not engage</p> <p>The A/C compressor clutch does not engage</p> | <p>Module A52 is not powered or is faulty</p>                                    | <ol style="list-style-type: none"> <li>1. Check the SYSTEM DIAGNOSTIC menu of the message center display (MCD). Select FAULT DIAGNOSTIC and ELECTRICAL SYSTEM. The message "No Response ModA52, Active" indicates a power problem on the module. (A CAN network problem would show the same message but doesn't produce this symptom).</li> <li>2. Check / reset circuit breaker CB5</li> <li>3. Check / replace fuse F65</li> <li>4. Probe gray connector on module to see if it is powered.</li> </ol>   |
| <p>Evaporator fan not functioning</p>   | <p>Circuit breaker CB3 tripped</p> <p>Module A54 is not powered or is faulty</p> | <ol style="list-style-type: none"> <li>1. Check / reset circuit breaker CB3</li> <li>2. Check the SYSTEM DIAGNOSTIC menu of the message center display (MCD). Select FAULT DIAGNOSTIC and ELECTRICAL SYSTEM. The message "No Response ModA54, Active" indicates a power problem on the module. (A CAN network problem would show the same message but doesn't produce this symptom).</li> <li>3. Check / reset circuit breaker CB5</li> <li>4. Check / replace fuse F67 , F68</li> <li>5. Probe gray connector on module to see if it is powered.</li> </ol> |
| <p>HVAC condenser fans not functioning in speed 1</p>   | <p>Module A54 is not powered or is faulty</p>                                    | <ol style="list-style-type: none"> <li>1. Check the SYSTEM DIAGNOSTIC menu of the message center display (MCD). Select FAULT DIAGNOSTIC and ELECTRICAL SYSTEM. The message "No Response ModA54,</li> </ol>   |

## Section 06: ELECTRICAL

| Problem/Symptom  | Probable Causes   | Actions   |
|--|---|---|
|  |   | <p>Active” indicates a power problem on the module. (A CAN network problem would show the same message but doesn't produce this symptom).</p> <ol style="list-style-type: none"> <li>2. Check / reset circuit breaker CB5</li> <li>3. Check / replace fuse F67 , F68</li> <li>4. Probe gray connector on module to see if it is powered.</li> </ol>   |
| Sound system not functioning   | Circuit breaker CB4 or CB11 was manually tripped and not reset  | Check / reset circuit breaker CB4 or CB11   |
| Fire alarm telltale light and audible alarm always ON and there is no fire or high temperature in the engine compartment     | Short-circuited fire sensor or defective sensor   | Prior to start the vehicle, cycle the ignition key to the ON position, OFF position and then ON position again and then start the vehicle. This will deactivate the fire alarm function. This has to be repeated each time the vehicle is re-started  |
| The vehicle is parked and the electrical horn is activated to indicate a fire in the engine compartment but there is no fire | Short-circuited fire sensor or defective sensor   | Cycle the ignition key between the ON and OFF position twice within 3 seconds. This will deactivate the fire alarm function. This has to be repeated each time the vehicle is parked  |
| A single light, a group of LED lights or another function of the vehicle is not functioning                                  | The multiplex outputs are protected in current by an internal “soft-fuse”. When an output is shorted, it turns OFF and stays OFF until the "soft-fuse" is reset | Turn the ignition key to the OFF position and turn to the ON position again. This resets all "soft –fuses"  |
| No backlighting in the instrument cluster  | Circuit breaker CB10 is tripped or fuse F20 blown   | <p>Check / reset circuit breaker CB10</p> <p>Check / replace fuse F20</p>   |
| The radiator fan clutch does not function and the engine is overheating  |   | <ol style="list-style-type: none"> <li>1. Set the ignition key to the ON position.</li> <li>2. Activate the dashboard Telltale Light Test switch 3 times within 4 seconds.</li> <li>3. In the engine compartment, set the starter selector switch to REAR START and then start the engine from the rear.</li> </ol> <p>While in this mode, the rear start push-button can be used to manually engage the fan clutch. The Multiplex system knows when the engine is already running, and it will not activate the starter.</p> |

| Problem/Symptom | Probable Causes | Actions   |
|-----------------|-----------------|---|
|                 |                 | <p>4. Press the push-button one time to engage the clutch in 1<sup>st</sup> speed, press a second time to engage in 2<sup>nd</sup> speed, press a third time to stop the fan, press once again to return to 1<sup>st</sup> speed.</p> <p>If the fan clutch does not engage using this procedure then the clutch is faulty or the wiring between the multiplex module and the clutch is faulty. Mechanically lock the fan clutch as described in section 05: COOLING SYSTEM of the maintenance manual.</p> |

#### 4.8 ESSENTIAL FUNCTIONS TO OPERATE THE VEHICLE

Even with a defective CECM (Chassis Electronic Control Module) or a CAN network problem, essential base functions are maintained to rear start the vehicle from the engine compartment and drive in a secure manner.

However, many secondary functions are lost. In this case, the following directives must be followed.

- Never connect a battery charger when the ignition is at the ON position on a vehicle with a CAN defective or certain functions will start up by themselves,
- Disconnect the charger before starting the vehicle, if not the default functions will not activate,
- If the default mode does not activate, try to turn the ignition OFF while ensuring that no charger is connected and then restart the vehicle.

##### 4.8.1 Available Functions

- Startup: Turn on the ignition in the driver's area and rear start the vehicle from the engine compartment,
- Opening the door: Functions normally,
- Closing the door: Manually pull on the door and it will lock automatically,
- Windshield wipers: Wipers functions at 1st speed only,
- Headlights: Low beams only,

- Directional signals: Rear and front only,
- Stoplights: 2 upper stoplights + high-mounted stoplight are functional,
- HVAC: Functional with set point fixed at 70°F (22°C), evaporator and condenser fixed at speed 1, defroster fixed at speed 4.

#### 4.9 LOWER PRIORITY MODULES FOR BREAKDOWN SERVICE

Modules A43 (IO-A) and A44 (IO-B) affect lower priority functions. These modules can therefore be used as spare parts for breakdown service while on the road.

Functions lost if A43 is removed and used as spare part:

- High beams,
- Ability to turn on the parking lights only,
- « Watch your step » sign,
- Driver's area lighting,
- Tag axle activation,
- Courtesy lights.

Functions lost if A44 is removed and used as spare part:

- Fresh air damper mix trap control,
- Driver's area and entrance overhead light,
- Front clearance lights.



## Section 06: ELECTRICAL

### 4.10 MULTIPLEX MODULES

#### 4.10.1 CECM

The CECM plays the role of interface between the engine ECM, the transmission ECU, the telltale panel module and other IO-A, IO-B modules. When a multiplex module is being replaced, the CECM will inform the new module of its role and function accordingly to the vehicle options.

#### 4.10.2 MASTER ID

The Master ID works in conjunction with the CECM. It keeps the specific back-up program of the vehicle. So, a specific Master ID cannot be removed from a vehicle and installed on another vehicle.

#### 4.10.3 IO-A

IO-A modules receive inputs and control outputs. IO-A's are used for all outputs of 1 amp or less.

#### 4.10.4 IO-B

IO-B modules receive inputs and control outputs. IO-B's are used for outputs up to 30 amps.

### 4.11 MULTIPLEX MODULES REPLACEMENT

IO-A, IO-B and CECM multiplex modules can be replaced and reprogrammed without having to connect a computer to the vehicle.

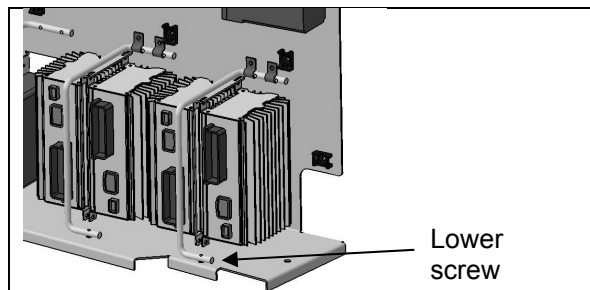


FIGURE 17: IO-B MODULE REMOVAL

06638

#### 4.11.1 Replacing IO-A Or IO-B Modules

- Set the ignition key to the ON position and leave it in that position at all time while performing this procedure.
- Inside rear electrical compartment, trip circuit breaker CB6.
- Replace the module (for IO-B modules, disconnect the green connector first, then the grey one and finish with the black connector.

To disconnect the black connector, slide downwards the red latch. Remove the lower screw that holds the cable attachment rod onto the floor portion of the panel and flip the rod up, this will relieve the IO-B module, (see Fig. 17).

- Reset circuit breaker CB6. This engages the automatic reprogramming.
- The telltale panel LCD display indicates "CAN" until the reprogramming is complete. Once completed, "CAN" disappears and the temperature reappears.
- Check the SYSTEM DIAGNOSTIC menu of the message center display (MCD). Select FAULT DIAGNOSTIC and ELECTRICAL SYSTEM. Verify the fault message to be certain the module is reprogrammed. If the module is not reprogrammed, the message « Axx Not Responding » appears where Axx is the module number (Ex: A41, A42...etc).

#### 4.11.2 Replacing The CECM Module

- Set the ignition key to the ON position and leave it in that position at all time while performing this procedure.
- Inside rear electrical compartment, trip circuit breaker CB6.
- Replace the module.
- Reset circuit breaker CB6. This engages the program transfer from the Master ID to the CECM module (the back-up program is inside the Master ID. The Master ID will identify the CECM as being new and will send the correct program to it). The telltale panel LCD display indicates "CAN" during 3 minutes approximately. "CAN" disappears and "---" is displayed alternately with "CAN" (during that sequence, "---" will be displayed up to 6 times and the audible alarm will ring). Wait until "CAN" is replaced by "---" that remains for more than 10 seconds. At this point the MasterID module has finished loading the program in the CECM.
- Go to the rear electrical compartment and trip circuit breaker CB6 once again. Wait 1 second and reset it. This engages I/O's modules automatic reprogramming.
- The telltale panel LCD display indicates "CAN" until the reprogramming is completed. Once completed, "CAN" disappears and the temperature reappears. Check the SYSTEM

DIAGNOSTIC menu of the message center display (MCD). Select FAULT DIAGNOSTIC and ELECTRICAL SYSTEM. Check the error messages. All modules appear in error but are not active. If an active error appears for a module, this one was not reprogrammed. In this case, trip CB6 once again. Wait 1 second and reset CB6. Re-verify the error messages when "CAN" disappears from the telltale panel LCD display.

- Do an error reset to remove all errors (requires Password) from non-active modules, leave the SYSTEM DIAGNOSTIC menu and reopen to verify there are no more errors.

### 5. BOSCH ALTERNATOR

Two 24 volt 140A, self regulated, belt driven, air-cooled BOSCH alternators are used in the 24 volt electrical system.

|  |
|--|
|  <h2 style="margin: 0;">MAINTENANCE</h2>  |
| <p>Change the brushes and voltage regulator as per "Repair and Testing Instructions for T1 Alternator 0120 69 552" every 100,000 miles (160 000 fm) or once every two years, whichever comes first.</p> <p>Replace bearings as per "Repair and Testing Instructions for T1 Alternator 0120 69 552" every 200,000 miles (320 000 fm) or once every four years, whichever comes first.</p> <p>Refer to Bosh T1 Alternator Maintenance Manual Annexed at the end of this section.</p> |

**NOTE**

Use Polyrex EM grease (684922) when repacking the bearings. Grease comes in 14.1 oz (400gr) cartridges.

#### 5.1 TWIN BOSCH ALTERNATORS INSTALLATION (DDEC SERIES 60)

If the alternators needed to be removed, reinstall as follows. Refer to figure 18 for installation and to figure 19 for tightening specifications:

1. Install alternator mounting bracket (1, figure 19) to the gear case. Use the four flanged phosphor alloy bolts on the pulley end of the bracket and the flanged nuts at the transmission end of the bracket;

2. Bolt the upper alternator to the bracket using the 4 inch bolt at the top (2, fig 19) and two inch bolts at the lower mounting bosses (3 and 4, figure 19). Bolt the other alternator using the 6 inch bolt at the top (2a, fig 19) and two inch bolts at the lower mounting bosses (3a and 4a, figure 19);
3. On the drive shafts of both alternators, install key, pulley, spring washer and nut (5, figure 19);

**NOTE**

Final tightening of the pulleys can be performed once the belt is installed. This will help keep the pulley from turning when tightening.

4. Install the snubber bracket (fig. 20) using three flanged bolts. Do not tighten the adjustment bolts on the snubber until after final tightening;
5. Install the A/C compressor belt idler pulley (fig. 20) as shown. A stud inserts into one of the mounting holes of the pulley assembly. Fasten this one using a nut and bolts for the other two.
6. Install alternators belt (6, figure 19).

#### 5.1.1 Alternator Drive Belt

**Removal**

1. Insert a 3/4" socket drive into the automatic belt tensioner opening (Fig. 18).
2. Twist the tensioning arm to slacken belt.
3. Remove belt.

**NOTE**

Belts specifications may vary. For proper belt selection, always consult your vehicle Coach Final Record.

**Installation**

Installation of the alternator drive belt is the reverse of removal.

#### 5.1.2 Adjustment

Correct belt tension is required to maximize belt life. The tensioning arm maintains proper belt tension, no adjustment is required.



## MAINTENANCE

Check for wear and proper tension every 6,250 miles (10 000 km) or twice a year, whichever comes first.

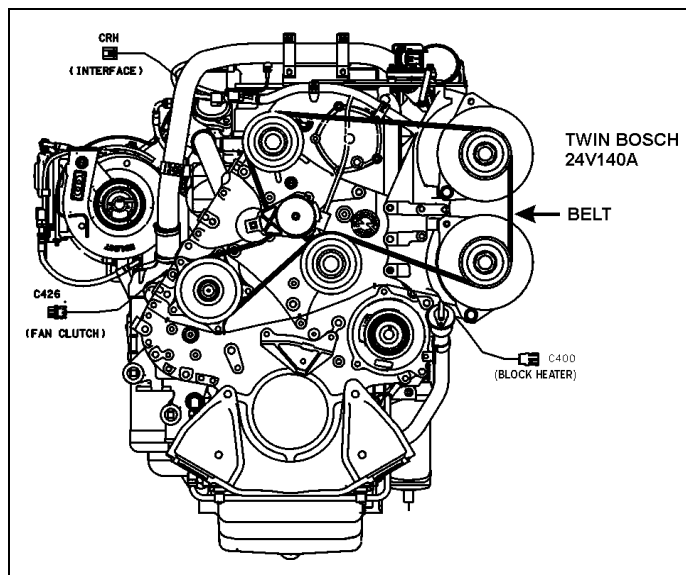


FIGURE 18: ALTERNATOR DRIVE BELT

01180

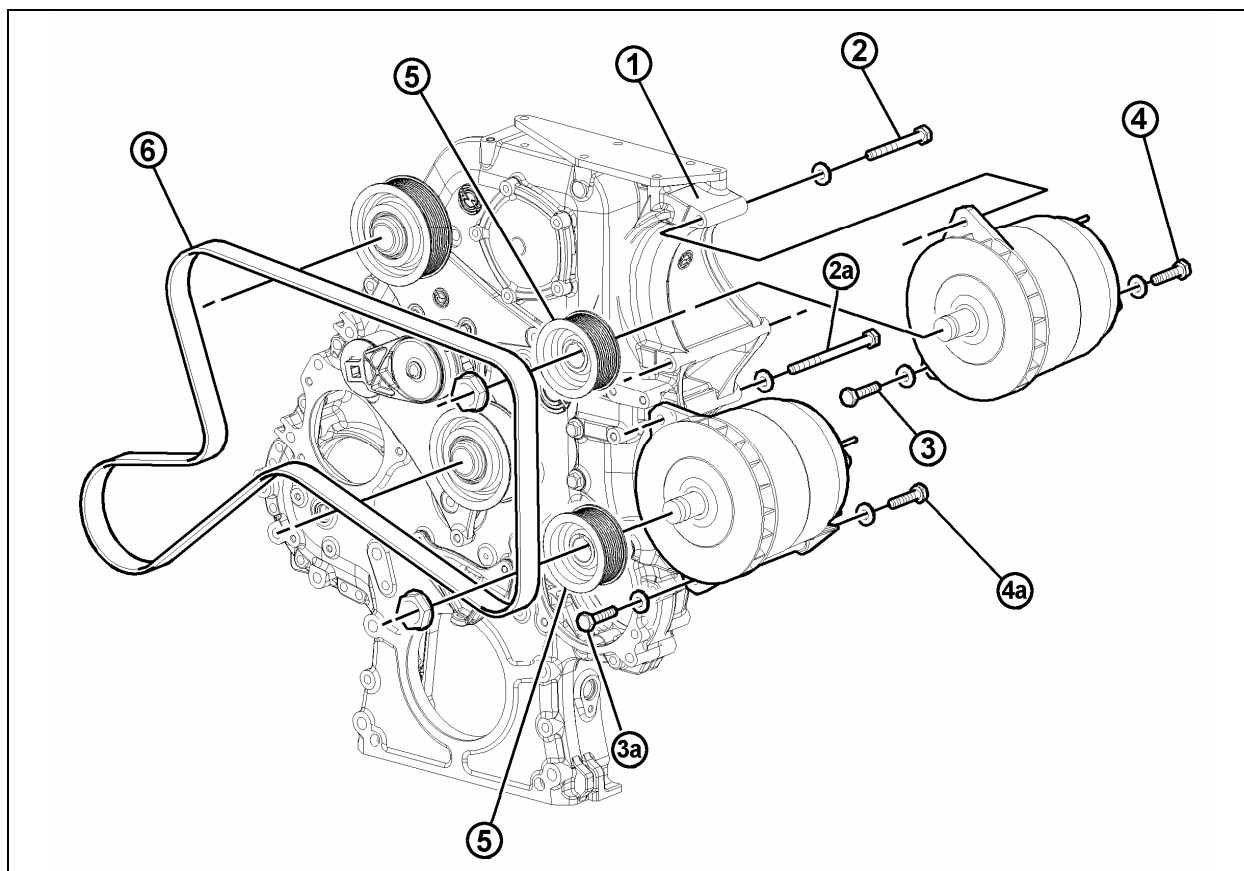


FIGURE 19: TWIN BOSCH ALTERNATORS INSTALLATION (DDEC SERIES 60)

01077

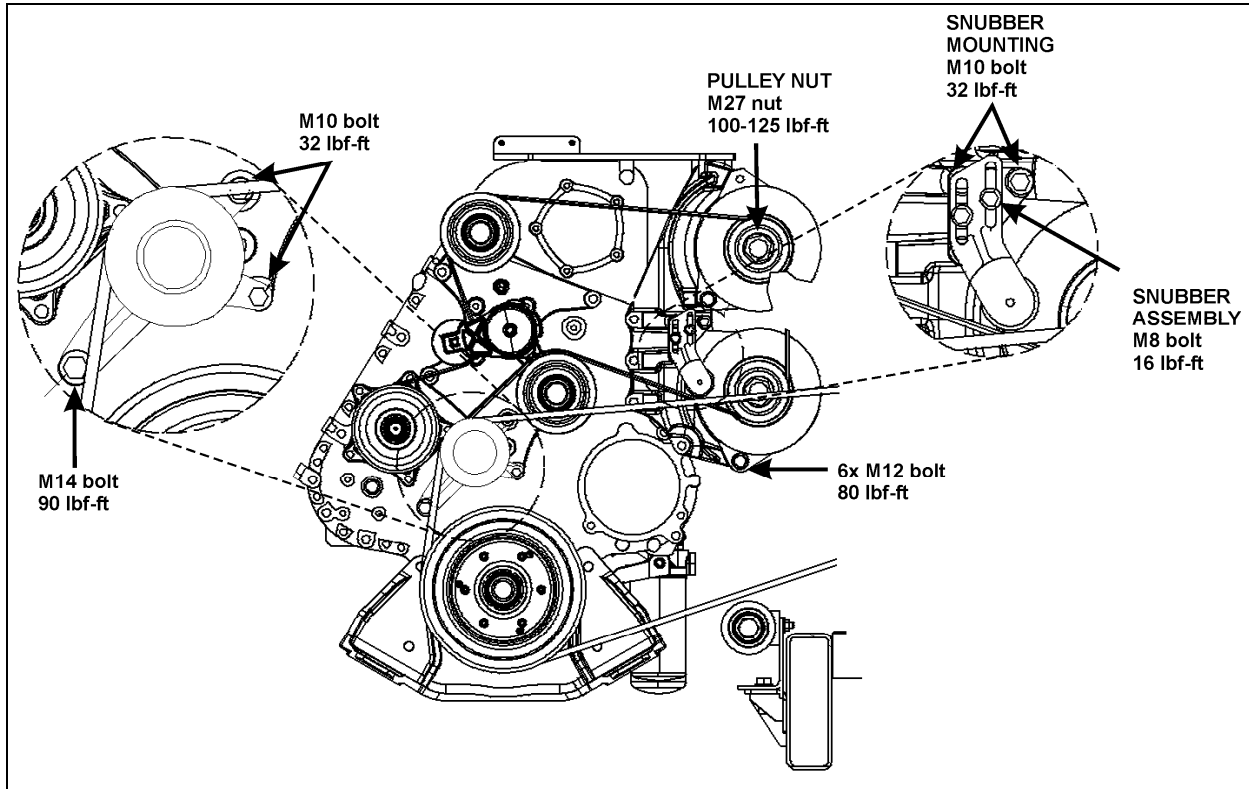


FIGURE 20: ALTERNATORS AND ACCESSORIES MOUNTING TORQUES (DDEC SERIES 60)

01182

## 5.2 TWIN BOSCH ALTERNATORS INSTALLATION (VOLVO D13)

If the alternators needed to be removed, reinstall as follows. Refer to figures 21 and 22 for installation and tightening specifications:

1. If not already done, mount the alternator brace to the engine and alternator support (figure 21);
2. Bolt the alternators to the bracket using one 3.5 inch bolt at the top and two 1¾ inch bolts at the lower mounting bosses (fig. 21);
3. On the drive shafts of both alternators, install key, pulley, spring washer and nut;

### **NOTE**

*Final tightening of the pulleys can be performed once the belt is installed. This will help keep the pulley from turning when tightening.*

4. Install the alternators belt, the coolant pump belt, the A/C compressor belt and then the radiator fan driving mechanism belt (figure 22).

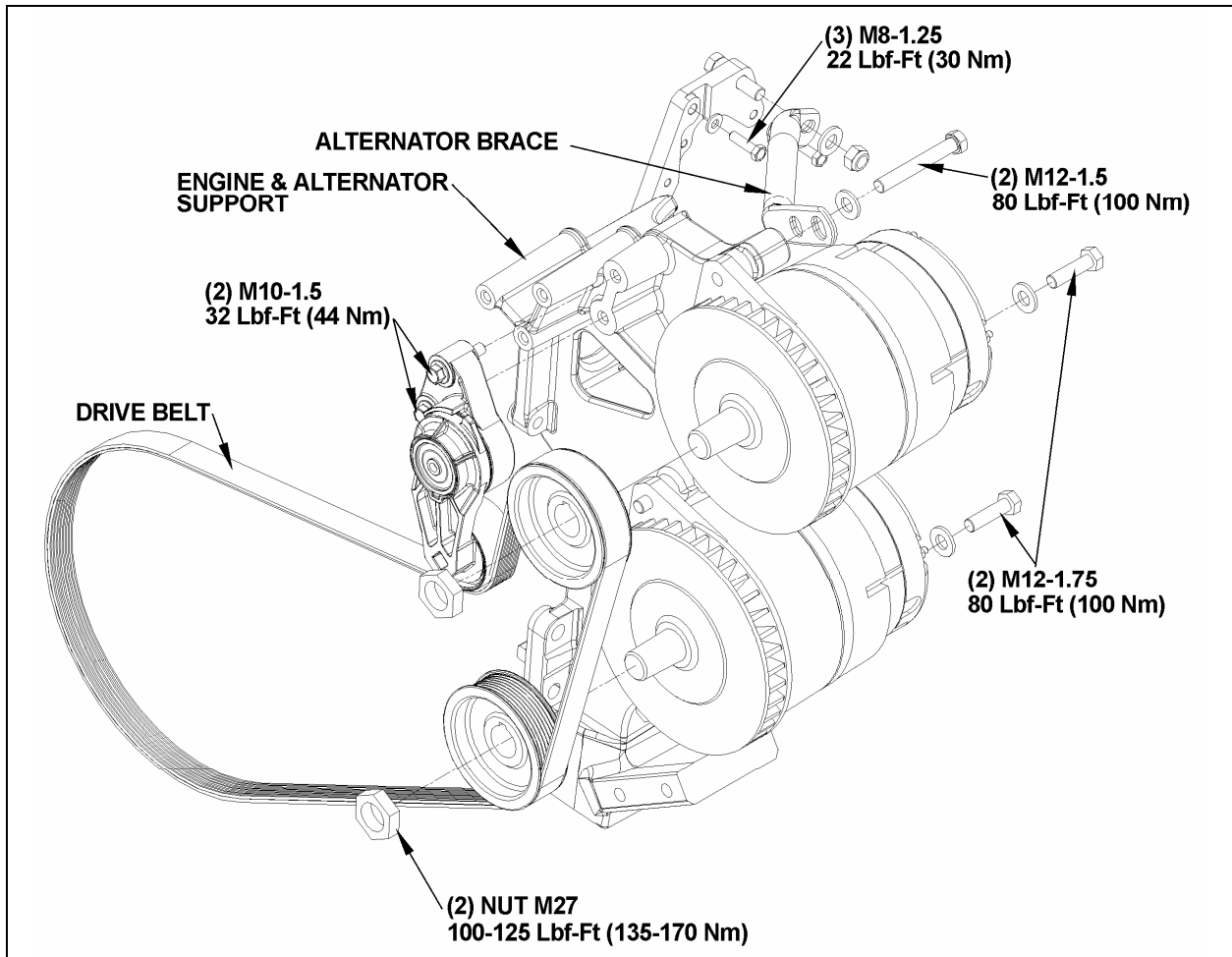


FIGURE 21: BOSCH ALTERNATORS MOUNTING TORQUES (VOLVO D13)

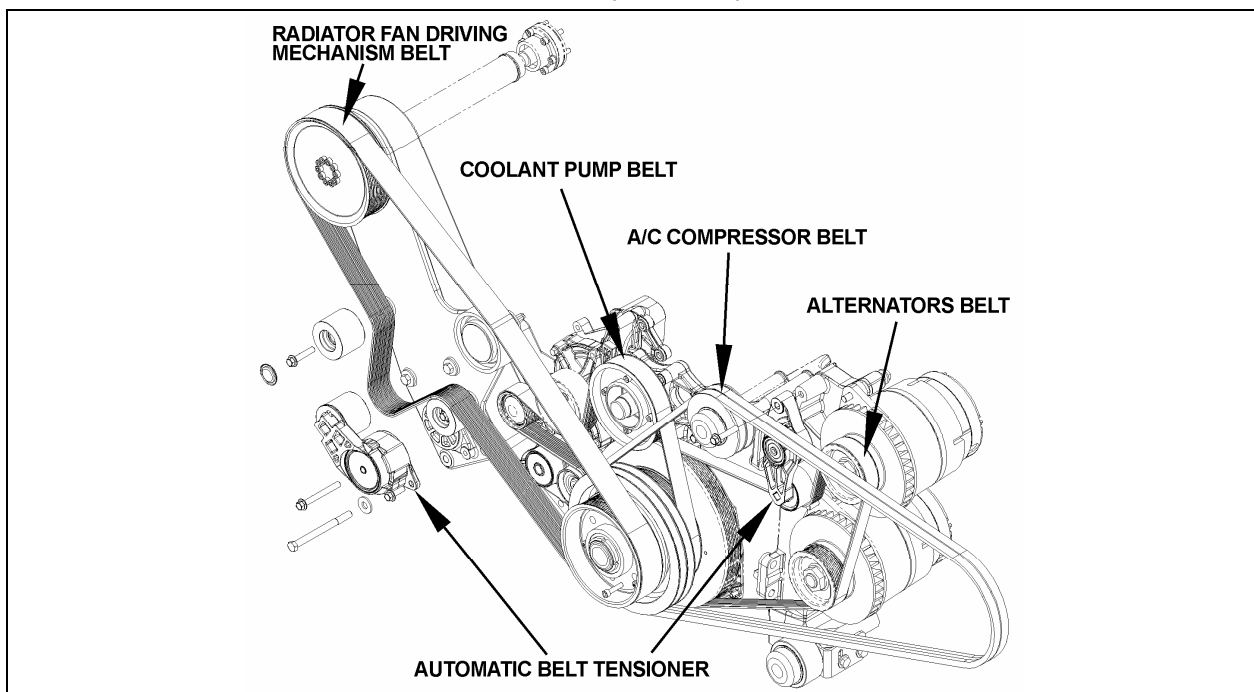


FIGURE 22: TWIN BOSCH ALTERNATORS INSTALLATION (VOLVO D13)

## 5.2.1 Alternator Drive Belt

**Removal**

1. Remove the radiator fan driving mechanism belt, the A/C compressor belt, and then the coolant pump belt.
2. Insert a 3/4" socket drive into the automatic belt tensioner opening (Fig. 22).
3. Twist the tensioning arm to slacken the alternator drive belt.
4. Remove belt.

**NOTE**

*Belts specifications may vary. For proper belt selection, always consult your vehicle Coach Final Record.*

**Installation**

Installation of the alternator drive belt is the reverse of removal.

## 5.2.2 Adjustment

Correct belt tension is required to maximize belt life. The tensioning arm maintains proper belt tension, no adjustment is required.

**MAINTENANCE**

Check for wear and proper tension every 6,250 miles (10 000 km) or twice a year, whichever comes first.

**6. BATTERY EQUALIZER**

VoltMaster Battery Equalizer Owner's Manual (100 amps) is annexed at the end of this section.

Refer to "Electrical Compartments" in this section, for location.

**7. STARTER**

Refer to Mitsubishi Electric Corporation (MELCO) Service bulletin ME003-P annexed at the end of this section for information and maintenance instruction on MELCO 105P70 starter.

**CAUTION****DDEC SERIES 60 ENGINE ONLY**

Prior to the installation of the Mitsubishi starter, the Flywheel Ring Gear must be examined for excess wear or damage. Service Bulletin A1-M1N-1729EN included at the end of Section 06 shows acceptable levels of wear, and illustrates the proper measuring procedure. Maximum wear is 0.5mm. Ring Gears with more than 0.5mm of wear or damage must be replaced before installing the new starter to prevent engagement and/or disengagement problems. Failure to do so will render the Warranty null and void.

**CAUTION**

Do not engage starter for more than 15 seconds at a time. If engine does not start within 15 seconds, release ignition key and let starter cool for one minute before attempting to restart.

**8. ENGINE BLOCK HEATER**

The vehicle may be equipped with an engine immersion-type electric block heater to assist cold weather starting. The heater male electric plug is easily accessible through the engine compartment R.H. side door (Fig. 23). To use it, connect the female plug of an electrical extension cord to the heater plug. The extension cord must be plugged into a 110-120 V AC power source only. The engine block heater should be used whenever the vehicle is parked for an extended period of time in cold weather and a suitable power source is available.

**8.1 MAINTENANCE**

This heater is non-serviceable except for the cord, and if faulty, must be replaced as a unit.

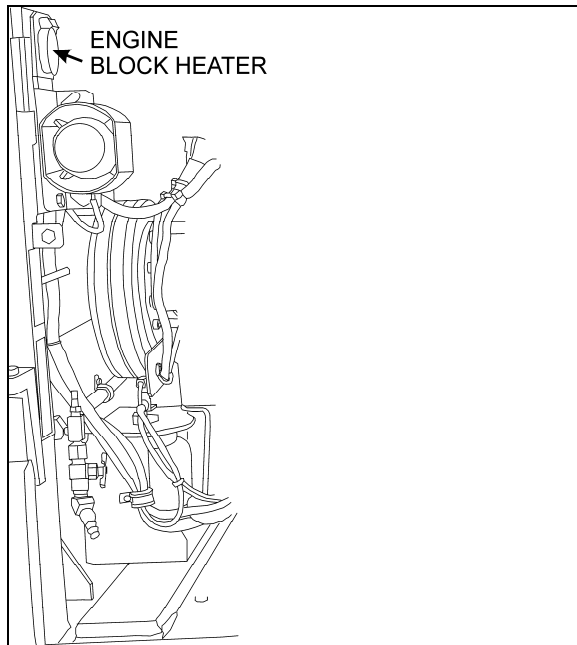


FIGURE 23: ELECTRIC HEATER PLUG LOCATION 06639

## 9. EXTERIOR LIGHTING

The circuit for exterior lights, as well as their control switches, relays and circuit breakers are shown on the applicable wiring diagrams. Wiring diagrams are located in the technical publication box.

### 9.1 HEADLIGHTS

Each headlight assembly consists of two headlamp module 90 mm (3½ inch) equipped with a 12-volt halogen bulb and one 100 mm (4 inch) 12-volt LED turn/signal lamp. Outer lamps have a double function (both low and high beam). Inner lamps are used for high beam or daytime running light. The inner or outer lamp uses the same single filament halogen bulb part number.

**NOTE**

*If vehicle is equipped with optional Xenon headlamps, refer to paragraph 9.1.6.*

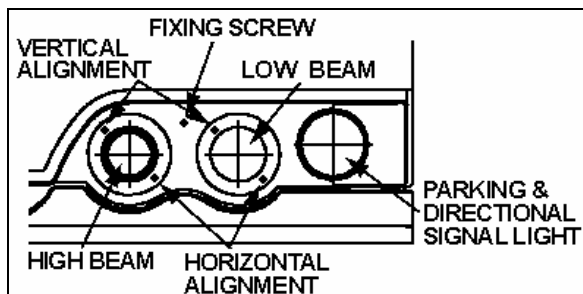


FIGURE 24: HEADLIGHT ASSEMBLY 06546

### 9.1.1 Headlight Beam Toggle Switch

The multifunction lever located on the steering column is used to select proper lighting. High beams or low beams can be selected by pulling the lever rearward. A high beam indicator on the central dashboard panel is illuminated when the high beam circuit is energized.

**NOTE**

*Pulling the lever rearward while the lights are off will flash the headlights.*

### 9.1.2 Maintenance

Clean headlights with soap and water and a good glass cleaner whenever dirty. For maximum illumination, headlight connections must be coated with a dielectric grease to prevent oxidation and proper voltage must be maintained. Low battery voltage, loose or dirty contacts in wiring system and poor ground contribute to a decrease in voltage. Check wiring and connections regularly and keep battery properly charged. When a headlight burns out, a new bulb must be installed. Headlights must be properly aimed to provide maximum allowable road illumination. When using mechanical aiming devices, follow manufacturer's instructions.

Headlight aim should be checked after installing a new bulb. Aiming can be performed without opening headlight assembly. Horizontal and vertical aiming of each module is provided by two adjusting screws that pivot the module in the housing for proper alignment (fig. 24). There is no adjustment for focus since the module is set for proper focus during manufacturing assembly.

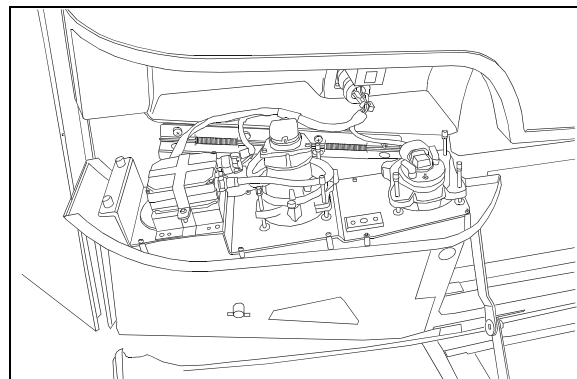



FIGURE 25: OPENING HEADLIGHT ASSEMBLY 06547

**NOTE**

*Make sure headlight assembly is properly positioned into its housing before securing using fixing screw.*

|  |
|--|
|  <b>CAUTION</b> |
| Use a soft cloth to clean the parking and front turn signal lamp.                                |

9.1.3 Headlight Adjustment

1. Headlight aiming and inspection can be accomplished by visual means. This is done on a screen located at a distance of 25 feet (7,6 m) of the headlights. It should be of adequate size with a matte-white surface well shaded from extraneous light and properly adjusted to the floor area on which the vehicle stands. Provisions should be made for moving the screen or its vertical centerline so that it can be aligned with the vehicle axis. In addition to the vertical centerline, the screen should be provided with four laterally adjustable vertical tapes and two vertically adjustable horizontal tapes.
2. The four movable vertical tapes should be located on the screen at the left and right limits called for in the specification with reference to centerlines ahead of each headlight assembly.
3. The headlight centerlines shall be spaced either side of the fixed centerline on the screen by 1/2 the lateral distance between the light source centers of the pertinent headlights. The horizontal tapes should be located on the screen at the upper and lower limits called for in the specification with reference to the height of beam centers and the plane on which the vehicle rests, not the floor on which the screen rests (Fig. 26).

TABLE 1 – VERTICAL BEAM AIM GUIDELINES

| Headlight (centerline) Mounting Height | Nominal Vertical Aim | Aim Inspection Limits for Vertical Aim        |
|--|----------------------|---|
| 56 to 90 cm (22 to 36 inch)            | 0 Vertical           | 10 cm (4 inch) up to 10 cm (4 inch) down      |
| 90 to 120 cm (36 to 48 inch)           | 5 cm (2 inch) down   | 5 cm (2 inch) up to 15 cm (6 inch) down       |
| 120 to 140 cm (48 to 54 inch)          | 6.4 cm (4 inch) down | 4 cm (1.5 inch) up to 16.5 cm (6.5 inch) down |

4. The nominal vertical aim position on lower beam headlights shall be adjusted based on the headlight mounting height, from the

ground to the light source center of the headlight, according to table 1.

5. High beam headlights are aimed so that the center of the high-intensity zone is located at the horizontal and straight ahead vertically (Fig. 26).
6. Low beam headlights are aimed so that the top edge (the cutoff) of the high-intensity zone is at the vertical location as per Table 1 and the left edge of the high-intensity zone is at the vertical centerline of the headlight (Fig. 27).
7. The inspection limits for high-beam headlights shall be with the center of the high-intensity zone from 10 cm (4 in) up to 10 cm (4 in) down; and, from 10 cm (4 in) left to 10 cm (4 in) right on a screen at 7.6 m (25 ft) (Fig. 28).

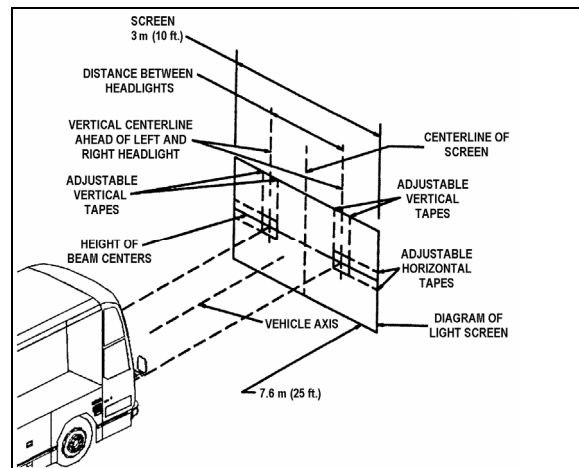


FIGURE 26: ALIGNMENT OF HEADLIGHT AIMING SCREEN

06502

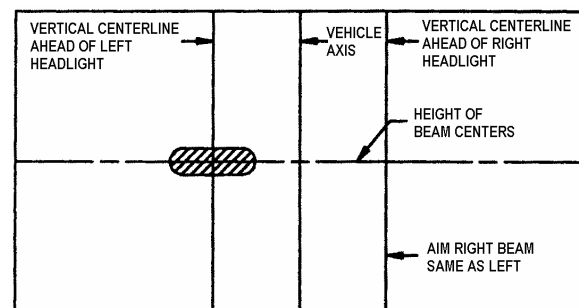
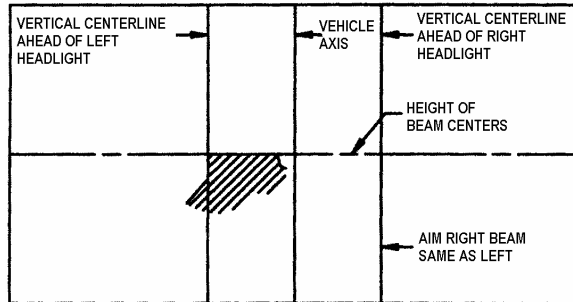


FIGURE 27: HIGH-INTENSITY ZONE (SHADED AREA) OF A PROPERLY AIMED UPPER BEAM ON THE AIMING SCREEN 7.6 M (25FT) IN FRONT OF VEHICLE

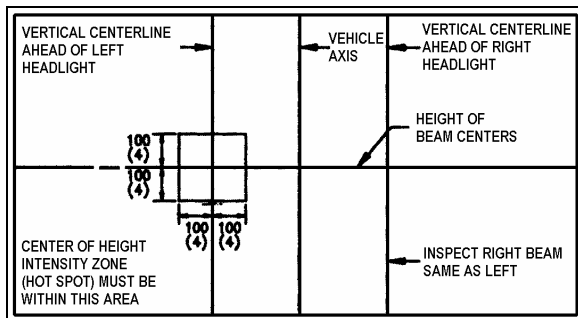
06503



## Section 06: ELECTRICAL

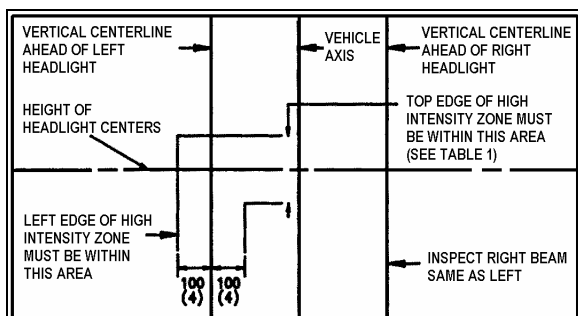


**FIGURE 28: HIGH-INTENSITY ZONE (SHADED AREA) OF A PROPERLY AIMED LOWER BEAM ON THE AIMING SCREEN 7.6 M (25FT) IN FRONT OF VEHICLE** 06504



**FIGURE 29: AIM INSPECTION LIMITS FOR UPPER-BEAM HEADLIGHTS** 06505

- The inspection limits in the vertical direction for low-beam headlights or the low beam of a dual-beam headlight, shall be as described in Table 1. In the horizontal direction, the left edge of the high-intensity zone shall be located from 10 cm (4 in) left to 10 cm (4 in) right of the vertical centerline of the beam. The viewing screen shall be located 7.6 m (25 ft) in front of the vehicle (Fig. 30).



**FIGURE 30: AIM INSPECTION LIMITS FOR LOWER-BEAM HEADLIGHTS** 06506

### 9.1.4 Sealed-Beam Unit

#### Bulb Removal and Replacement

- Pull the release handle located inside the front service compartment to tilt down the entire bumper assembly.
- Remove the headlight screw fixing the headlight assembly, then tilt headlight assembly down (Fig. 24 and 25).
- Remove connector from headlight bulb.
- Remove the bulb by pushing and rotating it out of the socket.
- Install the new bulb by reversing the previous procedure.



#### CAUTION

During this step, avoid contacting the bulb with the fingers not to alter the bulb life.

#### NOTE

Do not disrupt headlight adjustment screws.

#### Module Replacement

- Pull the release handle located inside the front service compartment to tilt down the entire bumper assembly.
- Remove the headlight screw fixing the headlight assembly, then tilt headlight assembly down (Fig. 24 and 25).
- Remove connector from headlight bulb.
- Unfasten three metal clips attaching headlight unit to support.
- Install new module and fasten metal clips.
- Install wiring connector on back of new sealed beam unit.
- Tilt headlight assembly up into its housing then secure using fixing screw.

#### NOTE

Make sure headlight assembly is properly positioned into its housing before securing using fixing screw.

- Perform alignment procedure.

**NOTE**

The headlight aim must be checked and adjusted even if it was properly adjusted before the sealed beam unit was replaced.

## 9.1.5 Front Turn Signal

The front turn signal is part of the front headlight assembly. The turn signal is a sealed unit (LED) located on each front corner and should be replaced as an assembly. Turn signal is visible from both front and side.

**Removal and Replacement**

1. Pull the release handle located inside the front service compartment to tilt down the entire bumper assembly.
2. Remove the headlight screw fixing the headlight assembly, then tilt headlight assembly down (Fig. 24 and 25).
3. Partially unfasten back plate fixing screws, then remove signal lamp.
4. Remove socket from signal lamp.
5. Install wiring connector on back of new signal lamp then install signal lamp.
6. Fasten back plate fixing screws then tilt headlight assembly up into its housing then secure using fixing screw.

**NOTE**

Make sure headlight assembly is properly positioned into its housing before securing using fixing screw.

## 9.1.6 Optional Xenon Headlamp

The outer lamps of each headlight assembly may be equipped with the optional Xenon lamps. These lamps improve visibility and provide better lifespan.

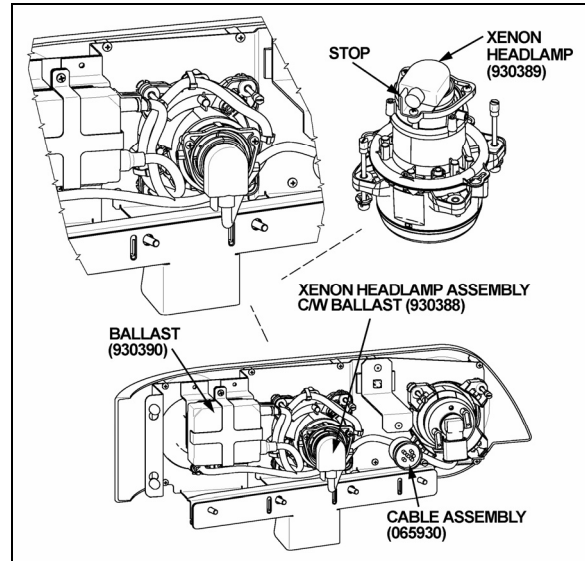


FIGURE 31: XENON HEADLAMP LOCATION

06549

**Bulb Removal and Replacement**

1. Pull the release handle located inside the front service compartment to tilt down the entire bumper assembly.
2. Remove the headlight screw fixing the headlight assembly, then tilt headlight assembly down (Fig. 24 and 25).
3. Remove main cable connector (066011).
4. Remove connector from headlamp bulb by turning counterclockwise.
5. Unscrew the three Phillips head screws, pull the retainer and bulb out.

**CAUTION**

To avoid breaking the bulb, make sure the socket is in proper position against the stop.

6. Install the new bulb by reversing the previous procedure.

**CAUTION**

During this step, avoid contacting the bulb with the fingers not to alter the bulb life.

**NOTE**

Do not disrupt headlight adjustment screws.



### CAUTION

Never connect a voltmeter or V.O.M. to measure bulb voltage as instrument will be destroyed.

#### Troubleshooting and Safety

When switching on the Xenon headlamp using the rocker switch, a lamp short-circuit test is performed.

Current is detected in the lamp circuit before the ignition time and ignition prevented. Connection of the "hot" lamp to the body mass also prevents ignition. In both cases, the system is cut off within  $< 0.2$  s and can only be restarted via the rocker switch.

In general, the maximum ignition time is  $< 0.2$  s, which period is followed by cutoff. This would happen if a lamp was defected.

Lamp missing: system is cut off after  $< 0.2$  s.

If lamp components or cables are damaged by force (accident) so that contact with hazardous parts is possible, the current in these lines is earthed by the vehicle body and - as with a defective household appliance - switched off when 30 mA are reached within  $< 0.2$  s. the cutoff time is shortened by a more powerful defect current.

To protect the ballast, a counter in the electronic safety system ensures that a defective lamp can only be switched off 7 times consecutively after a successful ignition, after which the device is cut off. This prevents flutter and flashing. This counter is put out of action when the lamp cutoff time repetition interval is longer than 1.3 s so that temporary non-defect disturbances that result in immediate invisible re-ignition do not cause lamp cutoff.

A warning notice on the lamp plug makes you aware of the fact that the lamp is operated in this system on a higher voltage (you should therefore switch off the lamp before working on this part).

After taking out the lamp, the contact pins are in a practically idle state ( $< 34$  Volt) after  $< 0.5$  seconds so that there is no immediate danger of electric shock even if the warning is disregarded.

With this safety concept there is no danger to check the ballast with a new bulb. There is a

very high probability that the ballast is OK if the ballast can ignite the bulb.

One simple test to check the ballast would be to measure the Nominal current of 1.58 A after one minute for the 24V ballast.

#### 9.2 STOP, TAIL, DIRECTIONAL, BACK-UP, AND HAZARD WARNING LIGHTS

A combination stoplight, taillight, directional signal light and back-up light assembly is mounted at the rear, on each side of the vehicle. Furthermore, when braking, two center stoplights (LED) and a cyclops light (LED) will illuminate simultaneously with the stoplights on the sides for increased safety. The L.H. and R.H. side center stop lights are also used as directional signal and marker lights.

The stop, tail, directional signal and back-up lights consist of individual LED lights mounted on the engine rear door, and each light is serviced individually as a complete unit. The back-up light uses a regular tungsten bulb.

The hazard warning flashing system uses the front, side and rear directional lights simultaneously. This system is energized by a switch on the L.H. dashboard.

##### 9.2.1 Lamp Removal and Replacement

1. Open engine compartment rear door.
2. Remove the lamp support retaining screws (2), and then from the outside, remove the lamp and its support.
3. From the outside, install the new lamp with its support then fasten the retaining screws.

##### 9.2.2 Center Stoplights and Cyclops Light Removal and Replacement

These (LED) lights are sealed unit and should be replaced as an assembly in accordance with the following procedure:

1. Unscrew both "Phillips" light screws then remove the light assembly.
2. Install new light assembly and secure using screws.

#### 9.3 LICENSE PLATE LIGHT

Two LED units are mounted above the rear license plate(s) of vehicle. In case of burn out, the LED unit must be changed according to the following procedure.

1. Pry out the rubber seal with a small screwdriver. Pull on the LED unit and disconnect it.
2. Reconnect new LED unit, place rubber seal, and press on it until it is seated in position.

#### 9.4 CLEARANCE, IDENTIFICATION AND MARKER LIGHTS

The vehicle is equipped with marker, identification and clearance lights (LED). The clearance lights are mounted at each corner of the coach near the top and the identification lights are in the upper center of rear and front sections.

The rear clearance and identification lights are red and the front ones are amber.

The amber marker lights are mounted along the sides of vehicle.

The side marker light is a sealed unit (LED) and should be replaced as an assembly in accordance with the following procedure:

1. Unscrew both "Phillips" light screws, and then remove the light assembly.
2. Position the new light assembly and install the "Phillips" screws.

##### 9.4.1 Clearance and Identification Light Removal and Replacement

The clearance and identification light are sealed units (LED) and can be replaced in accordance with the following procedure:

1. Unscrew both "Phillips" light screws, and then remove the light assembly.
2. Position the new light assembly, and then install the "Phillips" screws.

#### 9.5 FOG LIGHTS

Optional halogen fog lights can be mounted on this vehicle to give the driver better visibility in foggy weather, or to improve the range of vision just ahead of the coach.

##### 9.5.1 Bulb Removal and Replacement

1. Pull on the release handle located in the front service compartment, near the door lower hinge. The bumper will lower gradually.
2. Unscrew the wing nut and pivot assembly upwards.

3. Unscrew the outer ring. Disconnect the light unit connection and remove the bulb.
4. Install the new bulb, reconnect the light unit and replace in its proper position.



### CAUTION

During this step, avoid contacting the bulb with your fingers. This could alter the bulb life.

5. Reinstall the outer ring, pivot the assembly downwards.

Fasten the wing nut and securely close the bumper.

## 10. INTERIOR LIGHTING EQUIPEMENT

### 10.1 CONTROL PANEL LIGHTING

The instrument gauges and switches mounted on all control panels are energized whenever the exterior light switch is pushed to the first position. A control dimmer located on the dashboard is used to vary the brightness of the panel gauges, switches and indicator lights.

The gauge lights, panel lights, switch lights and indicator lights have a different bulb arrangement. Thus, the procedure to change a defective bulb can vary according to the application.

#### 10.1.1 Switch Lighting

1. Slightly pull the switch with a defective LED away from the control panel.
2. Disconnect the electric cable from the switch.
3. To install a new switch, reverse the procedure (Fig. 33).

### NOTE

Switches are lighted by the use of LED. When lighting on a switch fails, replace defective switch as a unit.

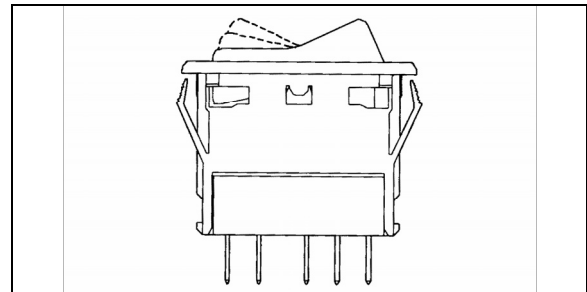


FIGURE 32: SWITCH

06321

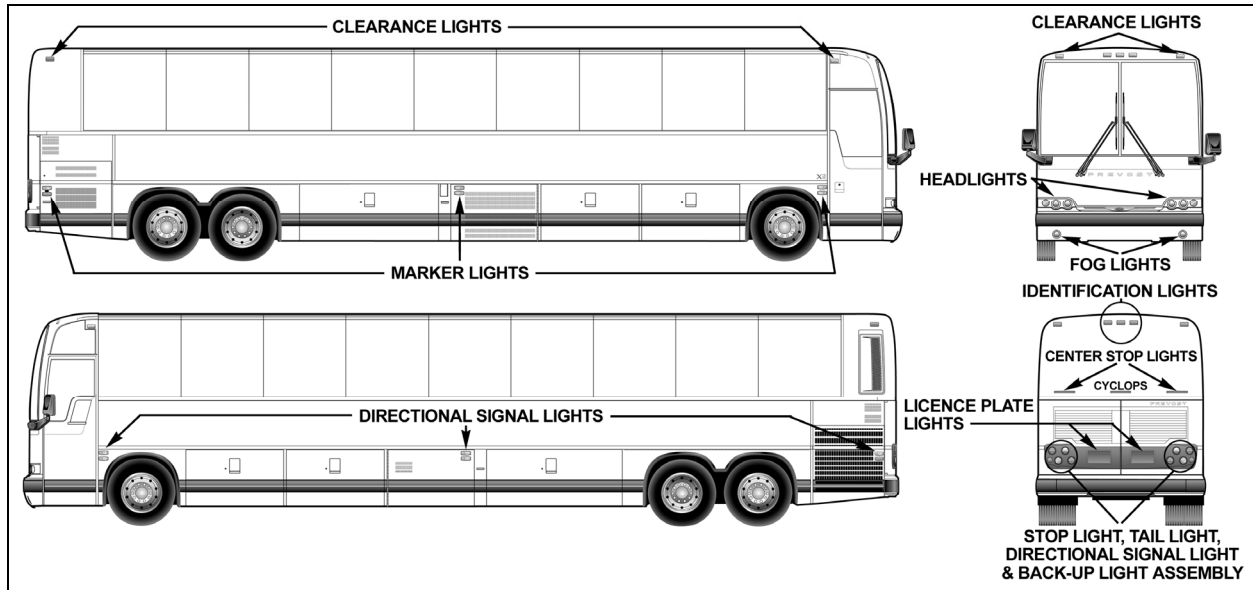


FIGURE 33: VARIOUS LIGHTS LOCATION

06640

### 10.1.2 Telltale Light Replacement

Telltale module is non-serviceable and must be replaced as a unit.

1. Unscrew and remove the top dashboard panel.
2. Remove the telltale back wire electric connectors.
3. Unscrew and remove the telltale module.
4. To replace the telltale module, reverse the procedure.

### 10.1.3 Gauge Light Bulb Replacement

1. For any gauge light bulb replacement, the dashboard panel must be removed in order to have access to the rear of gauges.
2. Remove bulb socket from the gauge, turn the defective bulb counterclockwise and pull it out of the gauge.
3. Push a new bulb and socket ASM and turn clockwise to lock in place.
4. Replace the rear dashboard housing.

## 10.2 STEPWELL LIGHTS

Two Stepwell lights are illuminated when the door opening system is activated.

### 10.2.1 Bulb Removal and Replacement

Proceed as follows to replace a defective bulb:

1. Unscrew the two Phillips-head screws retaining the lens to the wall, and remove it.
2. With the light lens removed, pull bulb from the lamp while applying lateral pressure.
3. Install the new bulb into the lamp.
4. Position the light lens and install it.

## 10.3 LAVATORY NIGHT-LIGHT

The lavatory night-light is illuminated as soon as the ignition switch is set to the "ON" position.

### 10.3.1 Bulb Removal and Replacement

1. Unscrew the two Phillips-head screws retaining the lens to the wall, and remove it.
2. With the light lens removed, pull bulb from the lamp while applying lateral pressure.
3. Install the new bulb into the lamp.
4. Position the light lens and install it


## 10.4 DRIVER'S AREA LIGHTS

Two halogen ceiling lights are installed over the stepwell and the driver's area. These lights are frequently used for night-time operation when passengers board or leave coach.

### 10.4.1 Bulb Removal and Replacement

1. Unsnap the lamp with a flat head screwdriver and remove it.
2. Pull the defective bulb out of the socket.

3. Install the new bulb by pushing it in position.
4. Replace the lamp by snapping it back in place.

|  |
|--|
|  <b>CAUTION</b>       |
| <p>Do not touch halogen bulbs with bare hands as natural oils on skin will shorten bulb life span.</p> |

### 10.5 PASSENGER SECTION LIGHTING

The passenger section of coach is lit by two types of fluorescent tube lamps installed on the parcel racks. The aisle or indirect lights are located on front of parcel racks, and provide soft, indirect cabin lighting and parcel rack interior lighting. More powerful lighting for general and in-station applications is provided by fluorescent tubes located under the parcel racks, close to the windows. A dual power system is available for this lighting either from the 24 volt vehicle power supply or from a 110 volt outlet supply. In order to save batteries during extended periods of in-station lighting, no current is drawn from the batteries as soon as the 110 volt circuit is connected.

Moreover, adjustable reading lamps are installed under the parcel racks for passenger accommodation.

#### 10.5.1 Fluorescent Tube Replacement

##### Indirect Fluorescent Light


1. Open the parcel rack access door, if so equipped, unscrew the two Phillips screws (one each end). Let the hinged cover down.
2. Remove fluorescent tube from light socket.
3. Install a new fluorescent tube.
4. Lift the hinged cover and replace the two retaining screws (Fig. 34).

##### Parcel Rack Interior Lighting

1. Open the parcel rack access door, if so equipped, unscrew the two Phillips screws (one each end). Pull the hinged cover down.
2. Push on the bulb, turn and then, pull it from the socket.
3. Install a new bulb.
4. Lift the hinged cover and replace the two retaining screws.

#### 10.5.2 Removal and Replacement of In-Station Fluorescent Tubes

1. Start by pulling out the corner of the lens then delicately peeling it out of its seat.

|  |
|--|
|  <b>CAUTION</b> |
| <p>The lens is fragile. Be very careful when removing and handling.</p>                          |

2. Rotate and pull the fluorescent tube from its sockets.
3. Install a new fluorescent tube, rotating the tube to secure it in the sockets.
4. Replace the screen lens by first inserting one side in the seat, then push the other side in and snap it in place by running it in from one corner to the next.

#### 10.5.3 Removal and Replacement of Reading Lamp Bulb

1. Engage the tool (#830164) over the lamp and turn one quarter turn counterclockwise. Then, remove the tool slowly.
2. Pull the bulb socket off the reading lamp unit.
3. Push and turn bulb counterclockwise, then pull it out of the socket.
4. Install new bulb in the socket, then push and turn clockwise to lock bulb in position.
5. Push the bulb socket in the reading lamp unit.
6. Position the reading lamp with the tool (#830164), turn one quarter turn clockwise.

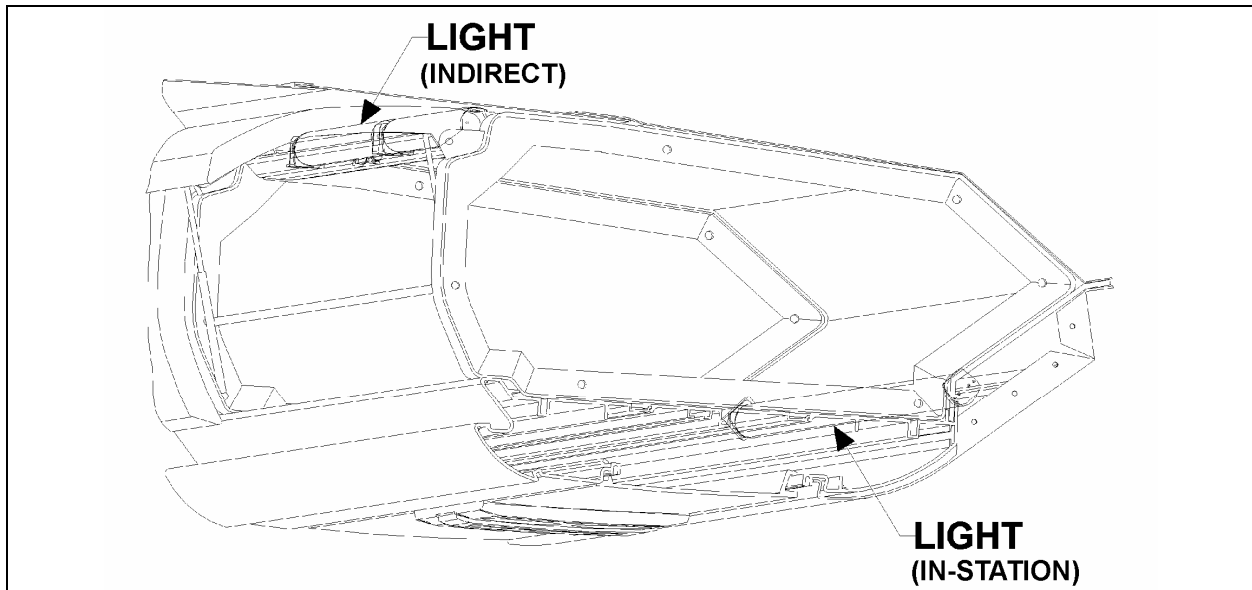


FIGURE 34: PARCEL RACK LIGHTING

06419

### 10.6 ENGINE COMPARTMENT LIGHTING

A switch located on R.H. side of rear junction box can be used to actuate the two oval engine compartment lights.

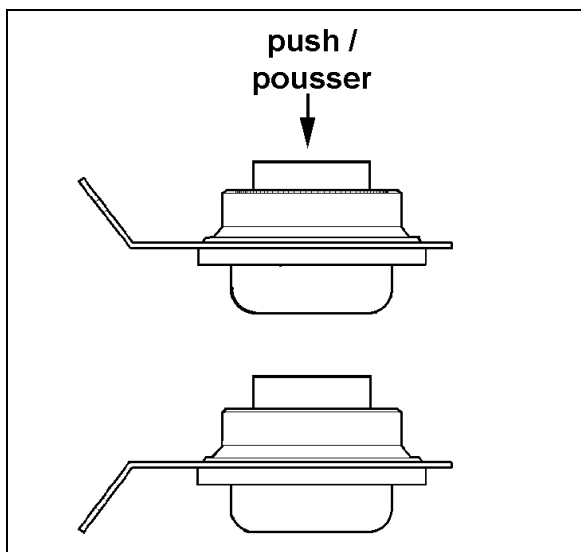


FIGURE 35: ENGINE COMPARTMENT LIGHT

Each light is sealed and can be replaced as follows:

1. Disconnect the light unit connection.
2. Remove the lamp.
3. Position new lamp.
4. Connect the light unit.
5. Make sure the retaining ring is installed properly.

### 10.7 LAVATORY LIGHT

The halogen lavatory light is installed on ceiling. A microswitch, mounted in the door exterior frame, is activated by the door lock mechanism upon locking to energize the circuit. This switch is readily serviced by removing the two Phillips-head screws securing the mounting plate to the door exterior frame.

Bulb removal and replacement:

1. Unsnap the lamp with a flat head screwdriver and remove it.
2. Pull the defective bulb out of the socket.
3. Install the new bulb by pushing it into position.
4. Replace the lamp by snapping it back in place.



### CAUTION

Do not touch halogen bulbs with bare hands as natural oils on skin will shorten bulb life span.

### 11. LIGHT BULB DATA

When replacing a light bulb, special attention must be paid to the voltage rating (refer to light bulb data hereafter).

| LIGHT BULB DATA                      |                  |                     |                       |       |     |
|--------------------------------------|------------------|---------------------|-----------------------|-------|-----|
| APPLICATION                          | PREVOST PART NO. | TRADE OR SAE NUMBER | WATTS OR CANDLE POWER | VOLTS | QTY |
| <b>EXTERIOR LIGHTING</b>             |                  |                     |                       |       |     |
| Hi/Lo-beam                           | 930291           | 9004                | 65/45 W               | 12    | 2   |
| Lo-Beam Xenon (optional)             | 930388           | D2S                 | 35 W                  | 12    | 2   |
| Docking & cornering                  | 930319           | 9415                | 37.5W                 | 12    | 4   |
| Fog                                  | 930361           | H3                  | 55 W                  | 12    | 2   |
| License plate (sealed)               | 930266           | TL 15206            | ---                   | 12    | 2   |
| Marker Light (red)                   | 930340           | Grote 47072-3       | ---                   | 12    | 2   |
| Marker Light (amber)                 | 930341           | Grote 47073         | ---                   | 12    | 10  |
| Identification (red)                 | 930334           | TL 25420R           | ---                   | 12    | 3   |
| Clearance (red)                      | 930334           | TL 25420R           | ---                   | 12    | 4   |
| Identification (amber)               | 930337           | TL 25450Y           | ---                   | 12    | 3   |
| Clearance (amber)                    | 930337           | TL 25450Y           | ---                   | 12    | 4   |
| Front directional (hazard & marker)  | 562135           | 3057                | 32/3W                 | 12    | 2   |
| Rear directional                     | 560589           | 1156                | 32 W                  | 12    | 4   |
| Stop                                 | 560589           | 1156                | 32 W                  | 12    | 8   |
| Back-up                              | 560589           | 1156                | 32 W                  | 12    | 4   |
| Center stop                          | 930330           | HELLA 96208         | ---                   | 12    | 2   |
| Cyclops                              | 930330           | HELLA 96208         | ---                   | 12    | 1   |
| Tail                                 | 560123           | 67                  | 4 W                   | 12    | 4   |
| Exterior compartment (except engine) | 562278           | 6429                | 10 W                  | 24    | 12  |
| Engine compartment                   | 930383           | SEALED              | 25 W                  | 12    | 2   |

| LIGHT BULB DATA           |                  |                     |                       |       |     |
|---------------------------|------------------|---------------------|-----------------------|-------|-----|
| APPLICATION               | PREVOST PART NO. | TRADE OR SAE NUMBER | WATTS OR CANDLE POWER | VOLTS | QTY |
| <b>INTERIOR LIGHTING</b>  |                  |                     |                       |       |     |
| Instrument cluster lights | 562838           | 2721 MFX            | ---                   | 12    | --- |
| Telltale panel assy.      | 563333           | ---                 | ---                   | ---   | 1   |
| Step light                | 562278           | 6429                | 10 W                  | 24    | 2   |
| Lavatory                  | 830176           | Q20MR16             | 20 W                  | 12    | 1   |



**Section 06: ELECTRICAL**

| <b>LIGHT BULB DATA</b>       |                         |                            |                              |              |            |
|------------------------------|-------------------------|----------------------------|------------------------------|--------------|------------|
| <b>APPLICATION</b>           | <b>PREVOST PART NO.</b> | <b>TRADE OR SAE NUMBER</b> | <b>WATTS OR CANDLE POWER</b> | <b>VOLTS</b> | <b>QTY</b> |
| Parcel rack                  | 560144                  | 1820                       | 1.6 W                        | 12           | A R        |
| Driver's area                | 830176                  | Q20MR16                    | 20 W                         | 12           | 2          |
| "EMERGENCY EXIT" decal       | 560601                  | 456                        | 2 W                          | 24           | A R        |
| "LAVATORY OCCUPIED"          | 563108                  | 168                        | 3 W                          | 12           | 1          |
| "WATCH YOUR STEP"            | 561166                  | 1820                       | 1.6 cp                       | 24           | 2          |
| Aisle                        | 560141                  | 1251                       | 3 W                          | 24           | A R        |
| Reading                      | 563349                  | 303                        | 6 W                          | 24           | A R        |
| Fluorescent (In-Station)     | 830153                  | F32T8/SP41                 | 32 W                         | ---          | A R        |
| Destination sign fluorescent | 830120                  | F30T8CW4                   | 30 W                         | ---          | 1          |
| Fluorescent (Indirect)       | 830152                  | F13T5/CW                   | 13 W                         | ---          | A R        |
| Baggage Compartment          | 562411                  | #6424                      | 5 W                          | 24VDC        | AR         |

**12. SPECIFICATIONS****Battery**

|                                     |                    |
|-------------------------------------|--------------------|
| Make.....                           | Volvo              |
| Model.....                          | 20359831           |
| Type .....                          | Maintenance-free   |
| Terminal type .....                 | Top Stud           |
| Group size .....                    | 31                 |
| Volts .....                         | 12                 |
| Load test amperage .....            | 290                |
| Reserve capacity (minutes) .....    | 195                |
| Cold cranking (in amps)             |                    |
| -At 0°F (-18°C).....                | 950 (each battery) |
| Maximum dimensions (inches/mm)      |                    |
| -Length (including flange) .....    | 13.0/330,2         |
| -Width .....                        | 6.7/169,3          |
| -Height (including top posts) ..... | 9.3/237,0          |
| -Approximate weight (lbs/kg) .....  | 59/26,7            |

\* Battery tester cable clamps should be between terminal nuts and lead pads of terminals. If not possible, load value should be 210 amperes.

**Torque specifications**

|                             |                         |
|-----------------------------|-------------------------|
| Battery cable to post ..... | 10-15 Ft-lbs (13-20 Nm) |
| Battery cover .....         | 45-50 Ft-lbs (5-6 Nm)   |

**Alternator**

|                       |                       |
|-----------------------|-----------------------|
| Make.....             | BOSCH                 |
| Model Number.....     | 0120689552            |
| Series .....          | T1                    |
| Hot output            |                       |
| -Amperes.....         | 140 at 25°C (AMBIENT) |
| -Volts .....          | 28                    |
| -Approximate rpm..... | 6000                  |
| Ground .....          | negative              |
| Prevost Number .....  | 562752                |

**Battery equalizer**

|                      |          |
|----------------------|----------|
| Make.....            | Vanner   |
| Model.....           | 66-100   |
| Amperes .....        | 100 amps |
| Prevost Number ..... | 563334   |

**Starter**

|                          |   |
|--------------------------|---|
| Make.....                | Mitsubishi Electric Corporation (MELCO) |
| Model Number.....        | M009T82479                              |
| Type .....               | 105P70                                  |
| Voltage .....            | 24                                      |
| Prevost Number .....     | 510752                                  |
| No-load test             |   |
| -Volts .....             | 23.5                                    |
| -Max. current draw ..... | 125 amperes                             |
| -Min. rpm .....          | 3000 rpm                                |

**Section 06: ELECTRICAL**

---

**Starter solenoid**

Make.....Mitsubishi Electric Corporation (MELCO)  
Model Number..... 1115557  
Pull In Voltage ..... 16 volts max.

# SECTION 07: TRANSMISSION

## CONTENTS

|  |           |
|--|-----------|
| <b>1. DESCRIPTION</b>  | <b>3</b>  |
| 1.1 ALLISON AUTOMATIC TRANSMISSION   | 3         |
| 1.1.1 <i>Retarder (if applicable)</i>  | 3         |
| 1.2 ZF-ASTRONIC TRANSMISSION   | 4         |
| <b>2. WELDING PROCEDURES</b>   | <b>4</b>  |
| <b>3. MAINTENANCE</b>  | <b>4</b>  |
| 3.1 ALLISON TRANSMISSION   | 4         |
| 3.1.1 <i>Manual Fluid level Check</i>  | 4         |
| 3.1.2 <i>Cold Check</i>  | 5         |
| 3.1.3 <i>Hot Check</i>   | 5         |
| 3.1.4 <i>Fluid Level Check Using the Pushbutton Shift Selector</i>   | 6         |
| 3.1.5 <i>Importance of Proper Fluid Level</i>  | 6         |
| 3.1.6 <i>Keeping Oil Clean</i>   | 6         |
| 3.1.7 <i>Recommended Automatic Transmission Fluid</i>  | 7         |
| 3.1.8 <i>Oil Contamination</i>   | 7         |
| 3.1.9 <i>Metal Particles</i>   | 7         |
| 3.1.10 <i>Coolant Leakage</i>  | 7         |
| 3.1.11 <i>Oil and Filter Change</i>  | 9         |
| 3.2 ZF AS-TRONIC TRANSMISSION  | 10        |
| 3.2.1 <i>Oil Change</i>  | 10        |
| 3.2.2 <i>ZF AS-TRONIC / SACHS Clutch Installation Procedure</i>  | 10        |
| <b>4. INSTALLATION OF ZF OR ALLISON TRANSMISSION BRACKETS ON VEHICLES EQUIPPED WITH DETROIT DIESEL ENGINE ONLY</b> | <b>12</b> |
| <b>5. ALLISON TRANSMISSION REMOVAL</b>   | <b>12</b> |
| <b>6. TRANSMISSION OIL COOLER REMOVAL</b>  | <b>13</b> |
| 6.1 TRANSMISSION WITHOUT RETARDER  | 13        |
| 6.1.1 <i>Detroit Diesel Series 60 Engine</i>   | 13        |
| 6.1.2 <i>Volvo D13 engine</i>  | 14        |
| 6.2 TRANSMISSION WITH RETARDER   | 14        |
| 6.2.1 <i>Detroit Diesel Series 60 Engine</i>   | 14        |
| 6.2.2 <i>Volvo D13 Engine</i>  | 15        |
| <b>7. CLEANING AND INSPECTION OF ALLISON AUTOMATIC TRANSMISSION</b>  | <b>15</b> |
| 7.1 BREATHER   | 15        |
| <b>8. ALLISON TRANSMISSION INSTALLATION</b>  | <b>15</b> |
| <b>9. ALLISON AUTOMATIC TRANSMISSION TROUBLESHOOTING</b>   | <b>17</b> |
| 9.1 4 <sup>TH</sup> GENERATION TRANSMISSION CONTROL MODULE   | 17        |
| 9.2 DIAGNOSTIC TROUBLESHOOTING CODES (DTC) — ALLISON 4 <sup>TH</sup> GENERATION CONTROLS                           | 17        |
| 9.3 DIAGNOSTIC CODES – ALLISON 4 <sup>TH</sup> GENERATION CONTROLS   | 18        |
| 9.4 DIAGNOSTIC CODE DISPLAY AND CLEARING PROCEDURE – ALLISON 4 <sup>TH</sup> GENERATION CONTROLS                   | 18        |
| 9.5 DIAGNOSTIC CODE RESPONSE   | 19        |
| 9.6 DIAGNOSTIC TROUBLESHOOTING CODES (DTC) LIST - ALLISON 4 <sup>TH</sup> GENERATION CONTROLS                      | 20        |
| <b>10. ZF-ASTRONIC TRANSMISSION SYSTEM FAULTS AND ERROR MESSAGES</b>   | <b>23</b> |
| 10.1 SYSTEM FAULTS (ERROR MESSAGES)  | 23        |

11. SPECIFICATIONS ..... 29

**ILLUSTRATIONS**

FIGURE 1: ALLISON TRANSMISSION ..... 3  
FIGURE 2: ALLISON TRANSMISSION CONTROL PAD ..... 3  
FIGURE 3: ZF-ASTRONIC TRANSMISSION ..... 4  
FIGURE 4: OIL LEVEL DIPSTICK (AUTO. TRANS.) ..... 4  
FIGURE 5: COLD CHECK ..... 5  
FIGURE 6: HOT CHECK ..... 5  
FIGURE 7: DRAIN PLUG AND FILTERS ..... 9  
FIGURE 8: RELEASE BEARING RETAINING CLIP ..... 11  
FIGURE 9: ZF OR ALLISON TRANSMISSION BRACKETS ..... 12  
FIGURE 10: ENGINE CRANKING POSITION ..... 13  
FIGURE 11: VOLVO ENGINE CRANKING POSITION ..... 13  
FIGURE 12: MODINE OIL COOLER ..... 14  
FIGURE 13: COOLER WITH RETARDER ..... 15  
FIGURE 14: ALLISON OIL COOLER ..... 15  
FIGURE 15: AIR PRESSURE REGULATOR (TYPICAL) ..... 17  
FIGURE 16: TRANSMISSION CONTROL MODULE ..... 17

## 1. DESCRIPTION

X3 Series coaches may be provided with either an Allison automatic transmission or a ZF-AsTronic transmission.

### NOTE

*Volvo D13 engines may only be provided with an Allison automatic transmission*

### 1.1 ALLISON AUTOMATIC TRANSMISSION

The B500 and B500R (with retarder) Allison Transmissions have 6 speeds with two top range (fifth and sixth) overdrives. Total coverage is determined by dividing the highest gear ratio by the lowest gear ratio. Total coverage expresses the transmission gear ratio versatility. Transmissions with larger total coverage number have a wider variety of available ratios.

An electronic control allows the transmission to shift at exactly the right point on the engine's fuel consumption curve for best economy. Early lockup maintains the highest possible mechanical efficiency through the closely-spaced gear steps, culminating in two overdrive ratios. This combination allows progressive shifting techniques, where engine speeds are reduced for higher efficiency and lower fuel consumption.

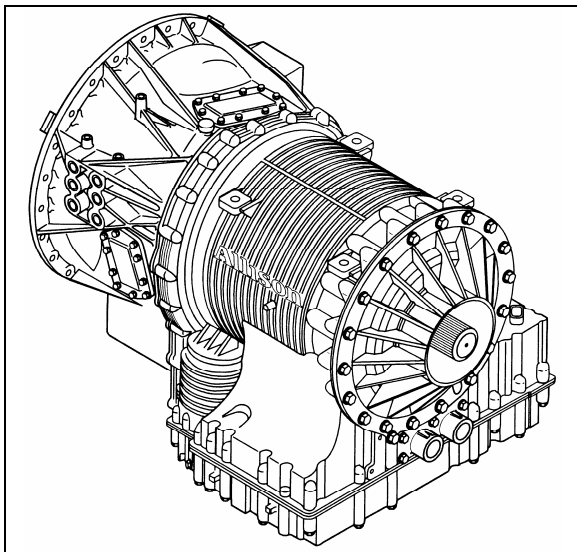


FIGURE 1: ALLISON TRANSMISSION

07136

Gear selection and torque converter modes are controlled by a microcomputer-based electronic transmission management system. It is fed information regarding throttle position, operator range selection, engine speed, turbine speed, transmission output speed and various system pressures from special electronic sensors. With

this information, it computes shift points and clutch pressures to meet immediate needs. Using closed loop adaptive logic; the electronic control looks at a number of parameters during the shift, and makes minute adjustments to match the shift to desired profile stored in its memory. It then looks at these adjustments and resets the parameters, which allow the transmission to quickly compensate for variations in load, terrain or environment and to adjust for clutch wear and engine power changes. A Diagnostic Data Reader can be connected to the electronic control unit to provide a self-check of all systems in the transmission. Five-digit trouble codes greatly reduce the time it takes to pinpoint potential problems. (Refer to paragraph "10. TROUBLESHOOTING" in this section).

#### 1.1.1 Retarder (if applicable)

This optional auxiliary braking device for the automatic transmission is integrated into the basic envelope of the transmission and transmits its braking force directly to the propeller shaft. It requires no additional length and adds only 75 pounds (34 kg) of weight. Operation of the retarder is controlled electronically by the driver's use of the brake and/or by hand control lever.

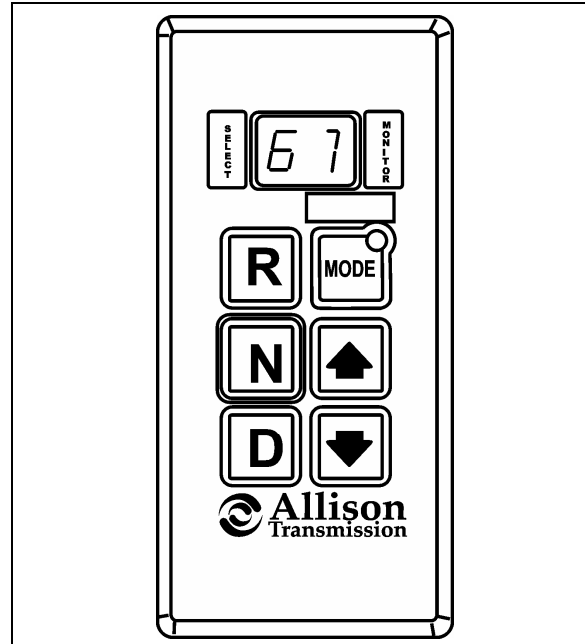


FIGURE 2: ALLISON TRANSMISSION CONTROL PAD 07025

When activated, fluid enters a cavity and provides resistance to the turning of rotor blades revolving with the output shaft. This effectively slows the vehicle to the point where the service brakes are needed only for final stopping. The retarder is fully modulated and is compatible with ABS.

## Section 07: TRANSMISSION

### 1.2 ZF-ASTRONIC TRANSMISSION

The AS TRONIC gear shift system is a combination of an electro-pneumatically shifted constant-mesh gearbox and an automated dry clutch.

If the AS TRONIC transmission system is to be used, the vehicle must have an electronic engine control unit as well as CAN communication. Since the clutch is automated (clutch pedal no longer fitted), the driver no longer has to activate the clutch.

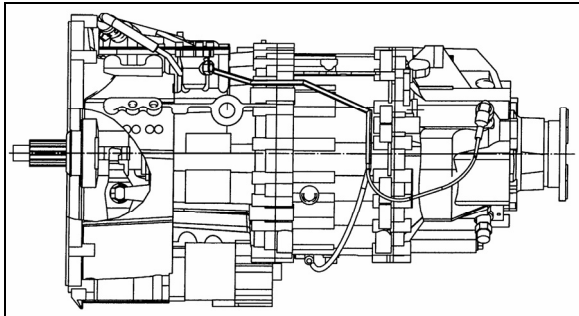


FIGURE 3: ZF-ASTRONIC TRANSMISSION 07078

The actual shift procedure is performed by the electronic transmission control unit. The driver has the option of driving the vehicle in both semi-automatic mode as well as fully automatically. When in semi-automatic mode, manual shifting with the range selector is made easier.

When in fully automatic mode, gears are selected and shifts made by the electronic control unit. The driver can still intervene if he wishes to. All system functions required are shown on the display, e.g. neutral, gear change, clutch overload and diagnosis information.

## 2. WELDING PROCEDURES

These procedures are intended only for vehicles equipped with transmission electronic controls. When frame or other welding is required on the vehicle, precautions are to be taken to protect the electronic control components. Refer to section 00: GENERAL INFORMATION, paragraph 3: "Precautions to be observed before welding" for complete procedure.

## 3. MAINTENANCE

### 3.1 ALLISON TRANSMISSION

To gain access to the dipstick, open the engine compartment rear doors; dipstick is located on the radiator side of the engine (Fig. 4).

### 3.1.1 Manual Fluid level Check



## DANGER

When checking the oil level, be sure that the parking brake and/or emergency brakes are set and properly engaged, and the wheels are chocked. Unexpected and possible sudden vehicle movement may occur if these precautions are not taken.

- Special care must be taken not to touch the engine coolant tubing and/or exhaust pipe, since this could cause severe burns.
- Do not wear loose clothing and, stay away from rotating parts during procedure; personal injury could occur.

Clean all dirt from around the end of the oil filler tube before removing the dipstick. Dirt or foreign matter must not be permitted to enter the oil system since it will cause valves to stick, undue wear of transmission parts, and clogged passages. Check the oil level using the procedures in Cold Check and Hot Check. Record any abnormal level on your "Maintenance Records".

Always check the oil level reading at least twice when the engine is running. Consistency is important in maintaining the accuracy of the reading. If inconsistent readings persist, check the transmission breather to ensure it is clean and free of debris.

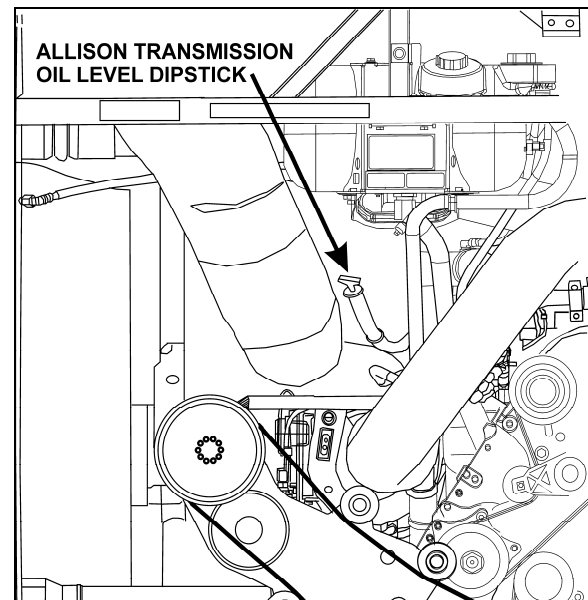


FIGURE 4: OIL LEVEL DIPSTICK (AUTO. TRANS.) 07113

## 3.1.2 Cold Check

The purpose of the **Cold Check** is to determine if the transmission has enough fluid to be operated safely until a **Hot Check** can be made.

1. If the engine has been shut down for an extended period of time, park the vehicle on a level surface and apply the parking brake.

**CAUTION**

The oil level rises as sump temperature increases. **DO NOT** fill above the "Cold Run" band if the transmission oil is below normal operating temperature. During operation, an overfull transmission can become overheated, leading to transmission damage.

2. Run the engine at idle in «N» (Neutral) for about one minute.
3. Shift to Drive (D) and operate the engine for 30 seconds at 1000-1500 rpm; then shift to Reverse (R) to clear the hydraulic system of air.
4. Move the vehicle to a level surface, put transmission in «N» (Neutral), and set the parking brake.
5. Finally shift to Neutral (N) and allow the engine to idle (500 - 800 rpm).
6. While the engine is running, remove the dipstick from the tube and wipe it clean (Figs. 4 & 5). Insert the dipstick into the fill tube, pushing down until it stops.

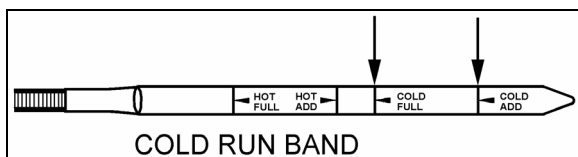


FIGURE 5: COLD CHECK

07050

7. Remove the dipstick and observe the fluid level. Repeat the check procedure to verify the reading. If the fluid on the dipstick is within the COLD CHECK band, the level is satisfactory for operating the transmission until the oil is hot enough to perform a **Hot Check**. If the fluid level is **not** within this band, add or drain fluid as necessary to bring the level within the COLD CHECK band.
8. Perform a **Hot Check** at the first opportunity after the normal operating temperature of 160°F (71°C) to 200°F (93°C) is attained.

**CAUTION**

**DO NOT** operate the transmission for extended periods of time until a **Hot Check** has verified proper fluid level. Transmission damage can result from extended operation at improper fluid level conditions.

**CAUTION**

Obtain an accurate fluid level by imposing the following conditions:

- Engine is idling (500-800 rpm) in «N» (Neutral).
- Transmission fluid is at normal operating temperature.
- The vehicle is on a level surface.

## 3.1.3 Hot Check

**CAUTION**

The oil **must be hot** to ensure an accurate check for this procedure. The oil level rises as temperature increases.

To perform a **Hot Check**, do the following:

1. The **Hot Check** can be performed when the transmission oil reaches the normal operating temperature (160°F to 200°F / 71°C to 93°C). The transmission oil temperature can be checked with the dashboard message center display (MCD) when selecting the Gauge Mode (refer to the "Operator's Manual" for added information).
2. Park the vehicle on a level surface and shift to Neutral (N). Apply the parking brake and allow the engine to idle (500 - 800 rpm).
3. Remove the dipstick from the tube and wipe it clean. Insert the dipstick into the fill tube, pushing down until it stops.
4. Remove the dipstick and observe the fluid level. The safe operating level is anywhere within the HOT RUN band on the dipstick. Repeat the check procedure to verify the reading.
5. If the level is **not** within this band, add or drain fluid as necessary to bring the level within the HOT RUN band. (Fig. 6).

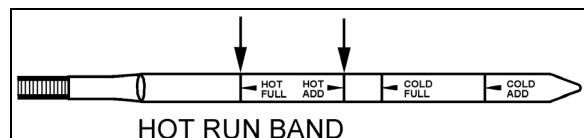


FIGURE 6: HOT CHECK

07049



## Section 07: TRANSMISSION

6. Be sure fluid level checks are consistent. Check level more than once and if readings are not consistent, check to be sure the transmission breather is clean and not clogged. If readings are still not consistent, contact your nearest Allison dealer or distributor.

### NOTE

*The Cold Check is more appropriate for verifying the oil level after the first fill-up. In case of conflict, the Hot Check has priority over the Cold Check; the fluid level check using the pushbutton shift selector has priority over the Hot Check.*

#### 3.1.4 Fluid Level Check Using the Pushbutton Shift Selector

Oil level codes are obtained as follows:

1. Park vehicle on a level surface, select «N» (neutral) on the pushbutton shift selector and apply parking brake.
2. Press simultaneously the ▲ (Up) and ▼ (Down) arrow buttons once.
3. Oil level codes are displayed in 2 minutes (e.g. display will flash and 8, 7, 6, 5, ...; countdown will occur during the 2 minutes) once the following parameters are met:
  - **Waiting time, vehicle must be stationary for at least 2 minutes to allow the oil to settle;**
  - **Engine at idle;**
  - **Oil at normal operating temperature, between 140°F (60°C) and 220°F (104°C);**
  - **Transmission in «N» (Neutral);**
  - **Transmission output shaft stopped;**
  - **Oil level sensor present and working.**

After 2 minutes, the display will flash one of the codes shown below:

| CODE         | CAUSE OF CODE        |
|--------------|----------------------|
| OL...OK      | Oil level is correct |
| OL...LO...01 | One quart low        |
| OL...LO...02 | Two quarts low       |
| OL...HI...01 | One quart high       |
| OL...HI...02 | Two quarts high      |

### NOTE

*Failure to meet one of the above parameters will stop the two minute countdown. One of the codes shown hereafter will indicate the cause of the countdown interruption. Once all parameters are met, the countdown will continue from where it left off.*

| CODE    | CAUSE OF CODE                 |
|---------|-------------------------------|
| OL...0X | Waiting time too short        |
| OL...50 | Engine speed (rpm) too low    |
| OL...59 | Engine speed (rpm) too high   |
| OL...65 | Neutral must be selected      |
| OL...70 | Sump oil temperature too low  |
| OL...79 | Sump oil temperature too high |
| OL...89 | Output shaft rotation         |
| OL...95 | Sensor failure                |

To exit the Oil Level Display Mode, press any range button: «R», «N» or «D».

#### 3.1.5 Importance of Proper Fluid Level

It is important that the proper fluid level be maintained at all times because the transmission fluid cools, lubricates, and transmits hydraulic power. If the fluid level is too low, the converter and clutches do not receive an adequate supply of fluid. If fluid level is too high, the fluid can aerate, causing the transmission to shift erratically or overheat.

#### 3.1.6 Keeping Oil Clean

Oil must be handled in clean containers, fillers, etc., to prevent foreign material from entering the transmission. Place the dipstick on a clean surface area while filling the transmission.



### CAUTION

Containers or fillers that have been used to handle antifreeze or engine coolant must NEVER be used for handling transmission fluid. Antifreeze and coolant solutions contain ethylene glycol that, if introduced into the transmission, can cause the clutch plates to fail.

3.1.7 Recommended Automatic Transmission Fluid

Hydraulic fluids used in the transmission are important influences on transmission performance, reliability and durability. **Castrol TranSynd™ Synthetic Fluid, DEXRON-III®** and **DEXRON-VI®** fluids are recommended for on-highway applications.

- **TranSynd™** is a full synthetic transmission fluid developed by Allison Transmission and Castrol Ltd. This fluid meets Allison specifications for Severe Duty and Extended Drain Intervals. TranSynd™ is fully qualified to the Allison TES295 specifications and is available through Prevost Parts
- To be sure a fluid is qualified for use in Allison transmission, check for the **DEXRON-III®** or **DEXRON-VI®** license numbers on the container or consult the lubricant manufacturer. Consult your Allison Transmission dealer or distributor before using other fluid types.


Customers may use TranSynd™/TES 295 equivalent and extend drain intervals. Equivalent TranSynd™ fluid must meet or exceed TES 295 requirements. Customers may choose from a wide variety of approved Dexron-III® fluids.

Customers may choose from a wide variety of approved non-TES 295 like Dexron-III®, Dexron-VI® or approved Schedule 1 TES-389 fluids.

The Transmission Fluid Operating Temperature Requirements table lists the minimum fluid temperatures at which the transmission may be safely operated without preheating. Preheat with auxiliary heating equipment or by running the equipment or vehicle with the transmission in «N» (Neutral) for a minimum of 20 minutes before attempting range operation.

Transmission Fluid Operating Temperature Requirements

| Fluid type | Minimum operating temperature |            |
|------------|-------------------------------|------------|
|            | Celsius                       | Fahrenheit |
| TranSynd™  | -30                           | -22        |
| DEXRON-VI® | -25                           | -13        |



**CAUTION**

Disregarding minimum fluid temperature limits can result in transmission malfunction or reduced transmission life.

***NOTE***


*The use of an arctic preheat kit is recommended at temperatures below -25°F (-32°C). If a preheat kit is not available, the TCM will restrict full operation until the sump temperature is increased.*

3.1.8 Oil Contamination

At each oil change, examine the drained oil for evidence of dirt or water. A nominal amount of condensation will emulsify during operation of the transmission. However, if there is evidence of water; check the cooler (heat exchanger) for other signs of leakage. This, however, may also indicate leakage from the engine oil system.

3.1.9 Metal Particles

Metal particles in the oil (except for minute particles normally trapped in the oil filter) indicate damage has occurred in the transmission. When these particles are found in the sump, the transmission must be disassembled and closely inspected to find the source. Metal contamination will require complete disassembly of the transmission and cleaning of all internal and external circuits, coolers, and all other areas where the particles could lodge.



**CAUTION**

If excessive metal contamination has occurred, replacement of the oil cooler and replacement of all bearings within the transmission is recommended.

3.1.10 Coolant Leakage

If engine coolant leaks into the transmission oil system, immediate action must be taken to prevent malfunction and possible serious damage. The transmission must be completely disassembled, inspected, and cleaned. All traces of the coolant contamination must be removed. Friction clutch plates contaminated with ethylene glycol must be replaced.

**TABLE 1**

| Recommended Fluid and Filter Change Intervals Using Dexron-III/ Dexron-VI/ Non-TranSynd™/Non-TES 295/Mixture |   |          |   |  |  |          |  |
|--|---|----------|---|--|--|----------|--|
| Severe <sup>3</sup><br>Coaches equipped with retarder  |   |          |   | General <sup>4</sup><br>Coaches without retarder |  |          |  |
| Fluid  | Filters                                 |          |   | Fluid  | Filters                                |          |  |
|  | Main                                    | Internal | Lube/<br>Auxiliary                      |  | Main                                   | Internal | Lube/<br>Auxiliary                       |
| 12,000 Miles<br>(20 000 km)<br>6 Months  | 12,000 Miles<br>(20 000 km)<br>6 Months | Overhaul | 12,000 Miles<br>(20 000 km)<br>6 Months | 25,000 Miles<br>40 000 km<br>12 Months           | 25,000 Miles<br>40 000 km<br>12 Months | Overhaul | 25,000 Miles<br>(40 000 km)<br>12 Months |

2 inch Control Module (1.75 approximately) – Requires High-Capacity Filter kit Allison P/N 571709

**TABLE 2**

| Recommended Fluid and Filter Change Intervals <sup>1</sup> Using 100% TranSynd™/TES 295 Approved Fluid <sup>2</sup> |   |          |   |  |   |          |   |
|---|---|----------|---|--|---|----------|---|
| Severe <sup>3</sup><br>Coaches equipped with retarder   |   |          |   | General <sup>4</sup><br>Coaches without retarder |   |          |   |
| Fluid   | Filters                                   |          |   | Fluid  | Filters                                   |          |   |
|   | Main                                      | Internal | Lube/<br>Auxiliary                        |  | Main                                      | Internal | Lube/<br>Auxiliary                        |
| 150,000 Miles<br>(240 000 km)<br>48 Months  | 75,000 Miles<br>(120 000 km)<br>36 Months | Overhaul | 75,000 Miles<br>(120 000 km)<br>36 Months | 300,000 Miles<br>480 000 km<br>48 Months         | 75,000 Miles<br>(120 000 km)<br>36 Months | Overhaul | 75,000 Miles<br>(120 000 km)<br>36 Months |

**TABLE 3**

| Recommended Fluid and Filter Change Intervals Using 100% TranSynd™/TES 295 Approved Fluid And Gold Series Filters |  |          |  |  |  |          |  |
|---|--|----------|--|--|--|----------|--|
| Coaches equipped with retarder  |  |          |  | Coaches without retarder                 |  |          |  |
| Fluid   | Filters                                  |          |  | Fluid                                    | Filters                                |          |  |
|   | Main                                     | Internal | Lube/<br>Auxiliary                       |  | Main                                   | Internal | Lube/<br>Auxiliary                       |
|   | Initial Break-in                         |          |  |  | Initial Break-in                       |          |  |
| 50,000 Miles<br>(80 000 km)<br>24 Months  | 50,000 Miles<br>(80 000 km)<br>24 Months | Overhaul | 50,000 Miles<br>(80 000 km)<br>24 Months | 150,000 Miles<br>240 000 km<br>48 Months | 50,000 Miles<br>80 000 km<br>24 Months | Overhaul | 50,000 Miles<br>(80 000 km)<br>24 Months |

<sup>1</sup> Extended TrandSynd™/TES 295 fluid and filter change intervals are only allowed with Allison High-Capacity filters.

<sup>2</sup> Less than 100% concentration of TranSynd™/TES 295 approved fluid is considered a mixture and should utilize non-TES 295 change intervals. If the customer replaces non-TranSynd™/non-TES 295 fluid with TranSynd™/TES 295 equivalent, the change interval recommendations of non-TranSynd™/non-TES 295/mixture must be followed. Upon the next oil change, if the customer reinstall TranSynd™/TES 295 equivalent, the fluid & filter change recommendation outlined in 100% TES 295 approved fluids must be followed.

<sup>3</sup> Severe vocation= All retarder, On/Off highway, transit and intercity coach with duty cycle greater than one (1) stop per mile.

<sup>4</sup> General vocation= intercity coach with duty cycle less than or equal to one (1) stop per mile and all other vocations not listed in severe vocation.

## 3.1.11 Oil and Filter Change

Allison transmissions are factory fill with **Castrol TranSynd™** fluid. Oil change must be performed with the vehicle on a flat and level surface and with parking brake applied. Oil and oil filter change frequency is determined by the severity of service and operating conditions of the transmission and by the filter equipment installed. See "TABLE 1, TABLE 2 or TABLE 3" for oil and filter change intervals. More frequent changes may be required when operations are subject to high levels of contamination or overheating. Filters must be changed at or before recommended intervals.

**IMPORTANT NOTE**

Allison Transmission recommends that customers use fluid analysis as the primary method for determining fluid change intervals. Many customers have a systematical annual transmission fluid change while, in many cases, fluid analysis could demonstrate that the transmission fluid is still in good condition and a fluid change is not required. In the absence of a fluid analysis program, the fluid change interval listed in TABLE 1, TABLE 2 & TABLE 3 should be used.

**IMPORTANT NOTE**

Your transmission is equipped with **High Capacity filters**. High Capacity filters allow for increased fluid and filter change intervals in transmissions utilizing TES 295 approved fluid/TranSynd™. High Capacity filters eliminate the requirement of the initial 5000 miles (8000km) main filter change.

Former Gold Series filter kits are completely cancelled and serviced with current High Capacity filter kits. However, if you are using stocked Gold Series filter kits with TES 295 approved fluid/TranSynd™, use TABLE 3 for oil and filter change intervals.

The procedure for changing the transmission oil and oil filters is as follows:

**Drain**

1. The transmission should be at an operating temperature of 160°F (71°C) to 200°F (93°C) when the oil is drained. This will ensure quicker and more complete fluid drainage.

**NOTE**

Remove transmission protective panel located underneath transmission for easier access.

2. Remove the drain plug from under the transmission (Fig. 7) and allow the oil to drain into a suitable container. Check the condition of the oil as described previously.
3. To replace the integral filters, remove twelve bolts (6 on each cover), two filter covers, two O-rings, two square cut seals and the two filters from the bottom of the control module (Fig. 7).
4. To install filters, pre-lube and install the two O-rings, the two square cut seals followed by the filters (lube the O-ring in filter cartridge only) into the filter compartment. Index each filter/cover assembly to holes in channel plate/sump. Push the cover assembly in by hand to seat the seals.

**CAUTION**

Do not use bolts to draw the cover to sump. This can damage the cover, seal, or sump.

5. Install twelve bolts and both covers, and then tighten to 38-45 lbf-ft (51-61 Nm).
6. Inspect the drain plug and O-ring. Replace if necessary. Reinstall the drain plug and tighten to 18-24 lbf-ft (25-32 Nm).
7. Reinstall transmission protective panel

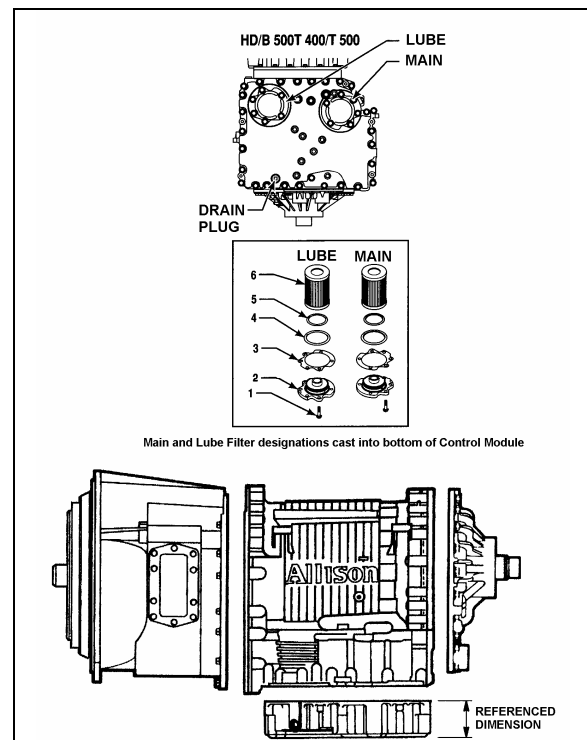


FIGURE 7: DRAIN PLUG AND FILTERS

07074

### Fluid loss with filter change only

When changing main and lube filters at recommended intervals, approximate fluid loss for each filter as follows:

Main filter = 2 quarts (1.9 liters)

Lube filter = 8 quarts (7.6 liters)

### Refilling Transmission

The amount of refill fluid is less than the amount used for the initial fill. Fluid remains in the external circuits and transmission cavities after draining the transmission.

|             |
|-------------|
| <b>NOTE</b> |
|-------------|

|   |
|---|
| <i>Quantities listed above are approximations and do not include external oil cooler lines.</i> |
|---|

Using the oil level dipstick filler tube, refill with 24 US qts (23 liters) [28 US qts (26.5 liters) if equipped with retarder] and check the oil level using the **Fluid Level Check Using Pushbutton Shift Selector** procedure in this section.

### 3.2 ZF AS-TRONIC TRANSMISSION

All information needed for the removal /installation or maintenance of the ZF transmission is included in the documents annexed at the end of this section.

#### 3.2.1 Oil Change

Approximately 11 liters is needed for a complete oil change.

#### 3.2.2 ZF AS-TRONIC / SACHS Clutch Installation Procedure

#### **Important Note:**

The clutch hub splines, input shaft, release bearing, clutch fork, and clutch push rod ends all come pre-lubed from the factory.

- Clean the flywheel, clutch disc, and pressure plate surfaces, removing any grease prior to assembly.
- Slide the clutch disk onto the transmission input shaft to check for smooth engagement. Remove clutch disk.

- Apply a very thin coating of Optimol Olista Longtime synthetic grease to the transmission input shaft. Slide the clutch disk along the full length of the input shaft to transfer grease to the clutch hub splines. Remove clutch disc, and remove any excess grease from the exterior of the clutch disc hub. **It is very important that no excess grease is left on the exterior of the clutch hub or clutch disk!**
- Install two temporary pilot studs (7/16-14, 3" long), placing them on the same diameter, 180° apart. These are used to aid in the alignment of the clutch pressure plate.
- Verify that the pilot bearing is seated properly in the flywheel. Insert a clutch alignment tool (SAE 2" DIA, 10 Spline) through the clutch disc and into the pilot bearing. PLEASE NOTE: the direction matters – the large side of the hub should face the clutch pressure plate. The clutch disc hub should be marked "flywheel side" – this side should face the flywheel.
- Use the clutch alignment tool to keep the clutch disc in the proper position and align the clutch cover with the two studs. Push the cover in place in the direction of the flywheel and start installing the clutch bolts. Use Lock-Tite for each bolt. Install, but do not torque, the 10 bolts. Remove the two pilot studs and in their place install the remaining 2 bolts.
- When the bolts are hand tight, be sure that the clutch cover fits into the flywheel centering ring. Tighten each bolt a little at a time, in a crisscross pattern, until the pressure plate cover contacts the flywheel face. Once the cover has touched the face of the flywheel, torque the clutch bolts to 55 ft-lbs, again in a crisscross fashion.
- Remove the clutch alignment tool. If the installation was successful, it should slide out smoothly.
- Ensure that the release bearing retaining clip (located on the "fingers" of the pressure plate) is closed. Refer to figure 8.
- Remove the Clutch Inspection Cover from the bottom of the transmission.

- The transmission should have been shipped in gear. This will allow the installer to rotate the output shaft in order to align the input shaft with the clutch disc hub. If the transmission is in neutral, a “strap wrench” (with a rubber or leather strap) can be used to align the input shaft. Do not use a wrench of the “chain” variety, as damage to the input shaft may result. When aligned, push the transmission towards the engine. Be sure that the bell housing contacts the flywheel housing.

### Warning!

- Insure that the transmission moves in a straight line. It can very easily go off center relative to the clutch disc and pilot bearing.
- Insure that the bell housing interfaces evenly with the flywheel housing. Even surface contact should be attained before tightening bolts.
- Do not try to correct relative position of the bell housing and flywheel housing by pulling the transmission into place with the bell housing bolts. The transmission bell housing should seat into the flywheel housing freely.
- When the bell housing and flywheel housing surfaces and bolt holes are aligned, install the transmission bolts. Only hardened steel flat washers should be used, **SERRATED LOCK WASHERS ARE NOT ALLOWED**. Torque the transmission bolts to 55 ft-lbs. in a crisscross fashion.
- From underneath, push the clutch release bearing forward (in the direction of flywheel) using the release fork. Use force to snap the bearing into the retaining clip located on the “fingers” of the pressure plate. The installer should be able to both hear and feel the bearing seat into place. Refer to figure 8.

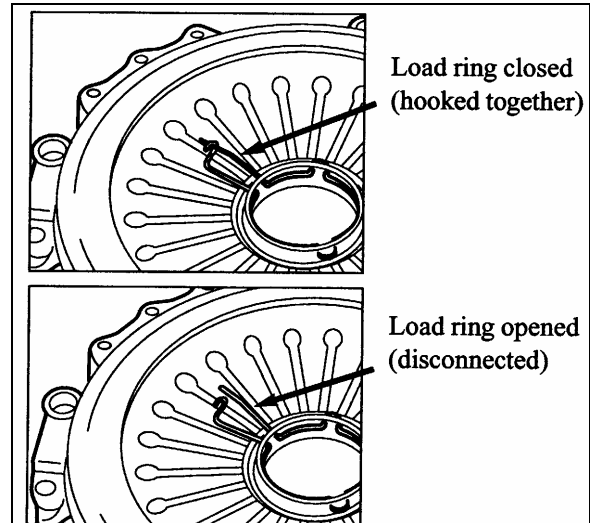


FIGURE 8: RELEASE BEARING RETAINING CLIP 07112

- Install the Clutch Actuator inspection cover.
- The clutch/transmission installation is now complete.

4. INSTALLATION OF ZF OR ALLISON TRANSMISSION BRACKETS ON VEHICLES EQUIPPED WITH DETROIT DIESEL ENGINE ONLY

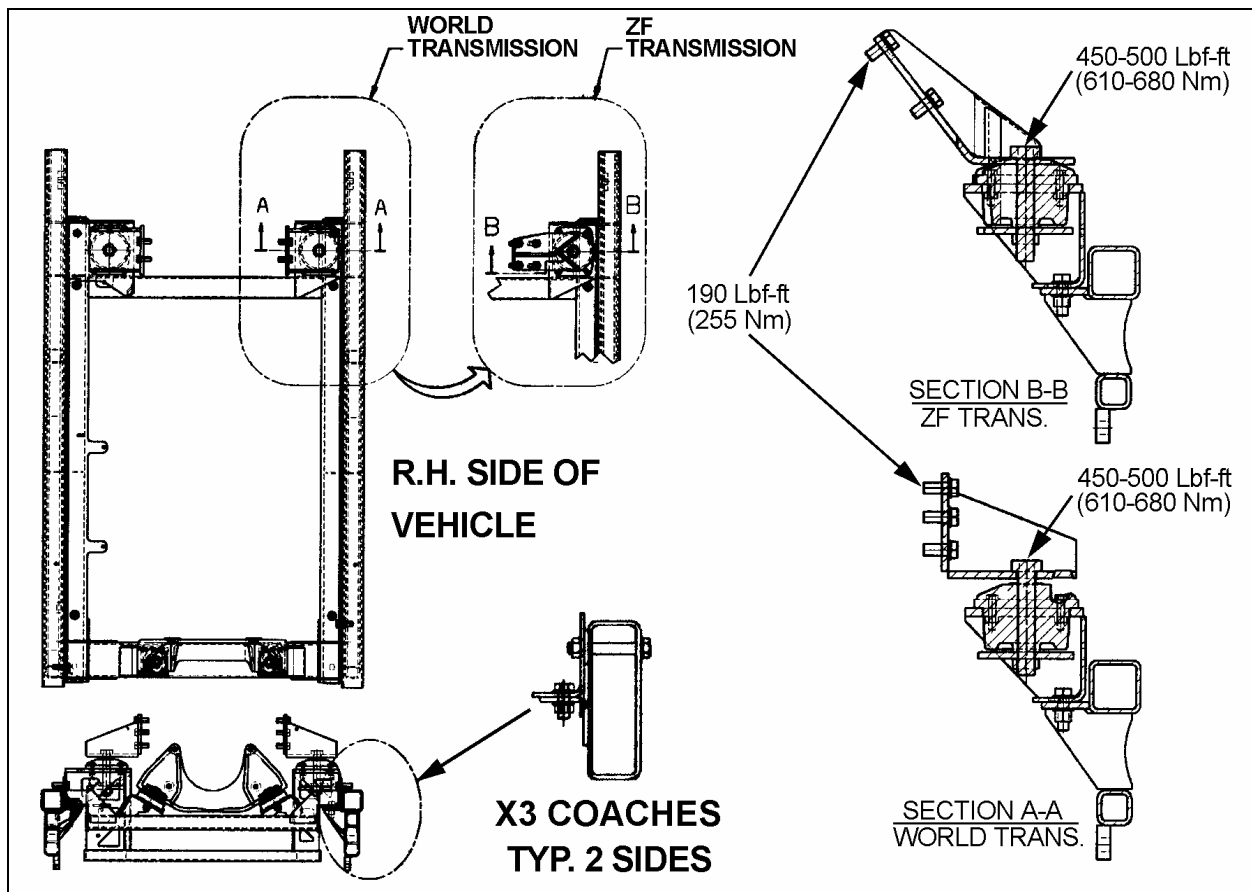



FIGURE 9: ZF OR ALLISON TRANSMISSION BRACKETS

07131

5. ALLISON TRANSMISSION REMOVAL

The following procedure deals with the removal of the Allison transmission without removing the power plant cradle from vehicle. The methods used to support the transmission and engine depend upon conditions and available equipment.

1. Select transmission's "NEUTRAL" position, apply parking brake, then set battery master switch to the "OFF" position.
2. Jack up vehicle, then place safety supports underneath body.

|  |                       |
|--|-----------------------|
|         | <p><b>CAUTION</b></p> |
| <p>Only the recommended jacking points must be used as outlined in Section 18, "BODY".</p> |                       |

**NOTE**

*For more clearance between the tag axle and transmission, the tag axle may be unloaded and jacked up or retracted (if applicable).*


3. Remove engine splash guards and protective panels surrounding transmission.
4. Remove cross member from under transmission.
5. Remove the transmission drain plug and allow oil to drain. Inspect the drain plug washer and replace it if necessary. Reinstall the drain plug and tighten to 33-41 lbf-ft (45-56 Nm) (see "3.1.11 Oil and Filter Change" in this section.



**WARNING**

It is better to drain oil when it is still warm. Avoid contact with oil since it can be very hot and cause personal injury.

6. Remove transmission dipstick and filler tube.
7. Disconnect propeller shaft from transmission and remove its safety guard. Refer to Section 09, "PROPELLER SHAFT".
8. Disconnect the two oil cooler hoses from transmission. Cover hose ends and fittings to prevent fluid contamination.

|  |
|--|
|  <b>WARNING</b> |
| A significant amount of oil may drain from oil lines when they are disconnected.                 |

9. Disconnect all sensors on L.H. side of the transmission.
10. Disconnect main wiring harness.
11. Disconnect the air supply line (steel-braided hose) from retarder control valve (if applicable).
12. Remove any locking tie, clamp and bracket that may interfere with the removal of transmission.
13. Support transmission using a suitable transmission jack.

▪ **Detroit Diesel Series 60 Engine Only**

*Remove the access plug from the flywheel housing on the R.H. side below starter. From access plug, remove the 12 converter-to-flexible plate attaching screws. Cranking the engine to gain access to the attaching screws may be done by turning the crankshaft pulley using a suitable adapter (fig. 10).*

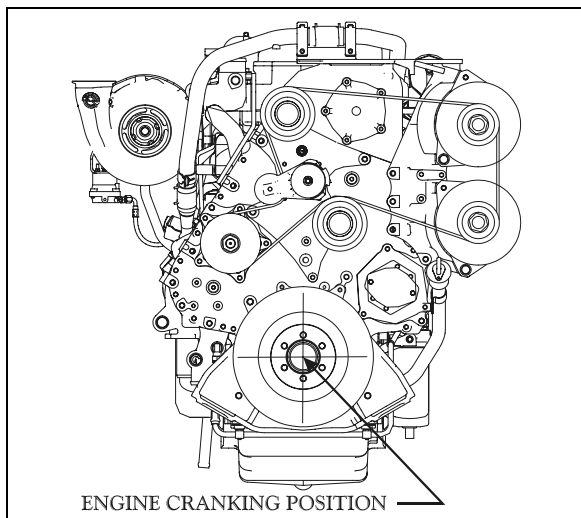


FIGURE 10: ENGINE CRANKING POSITION

01153

▪ **Volvo D13 Engine Only**

*Remove starter motor located on engine L.H. side. Removing the starter motor will allow access to unfasten the 12 converter-to-flexible plate attaching screws. Remove the plug located below starter motor and install cranking tool (88800014). Cranking the engine to gain access to the attaching screws may be done by turning the cranking tool using a suitable adapter (fig. 11).*

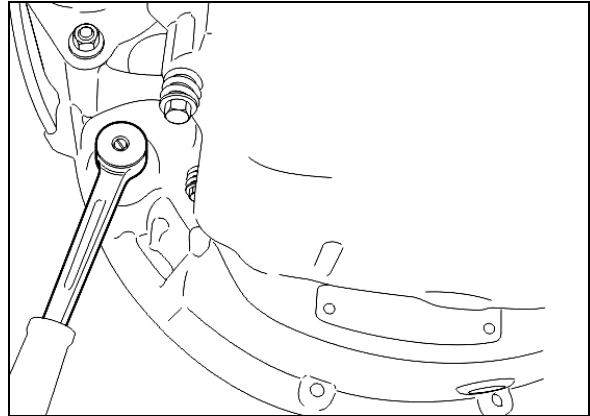


FIGURE 11: VOLVO ENGINE CRANKING POSITION



**CAUTION**

Do not rotate alternator shaft clockwise to avoid removing tension on belt.

14. Remove the 12 screws retaining the torque converter housing to the flywheel housing.



**CAUTION**

Make sure transmission-to-engine alignment is maintained when removing screws to avoid damaging torque converter housing.

15. Slowly pull transmission straight out to clear the engine.
16. Remove the transmission.

**6. TRANSMISSION OIL COOLER REMOVAL**

**6.1 TRANSMISSION WITHOUT RETARDER**

**6.1.1 Detroit Diesel Series 60 Engine**

Stop engine and allow engine to cool. Close both heater line shutoff valves (refer to Section 05 "Cooling").

To drain the cooling system, proceed as per Section 05 "Cooling", paragraph 5: Draining. If the cooling system is contaminated, flush



## Section 07: TRANSMISSION

system as per Section 05 "Cooling", paragraph 7: Flushing.

1. Disconnect and remove the engine air intake duct mounted between the air cleaner housing and the turbocharger inlet.



### CAUTION

To avoid damage to turbocharger, cover the turbocharger inlet opening to prevent foreign material from entering.

2. Disconnect the two transmission hoses from oil cooler. Cover hose ends and fittings to prevent fluid contamination (Refer to fig.12).



### WARNING

A significant amount of oil may drain from oil lines when they are disconnected.

3. Unfasten the constant-torque hose clamps and remove the two hoses.

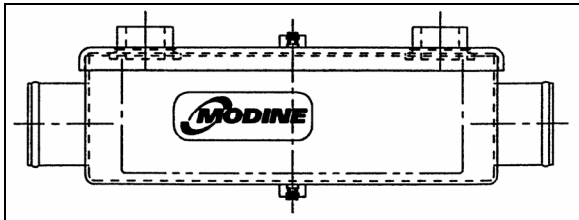


FIGURE 12: MODINE OIL COOLER

07072

4. Unscrew the four holding nuts and remove the U-bolts, remove the oil cooler from engine compartment.
5. Reinstall transmission oil cooler by using reverse procedure.

### 6.1.2 Volvo D13 engine

Stop engine and allow engine to cool. Close both heater line shutoff valves (refer to Section 05 "Cooling").

To drain the cooling system, proceed as per Section 05 "Cooling", paragraph 5: Draining. If the cooling system is contaminated, flush system as per Section 05 "Cooling", paragraph 7: Flushing.

1. Remove the rear L.H. side tag axle wheel, then remove the rear L.H. side fender panel.
2. Disconnect the two transmission hoses from oil cooler. Cover hose ends and fittings to prevent fluid contamination (Refer to fig.12).



### WARNING

A significant amount of oil may drain from oil lines when they are disconnected.

3. Unfasten the constant-torque hose clamps and remove the two hoses.
4. Unscrew the four holding nuts and remove the U-bolts, remove the oil cooler from engine compartment.
5. Reinstall transmission oil cooler by using reverse procedure.

## 6.2 TRANSMISSION WITH RETARDER

### 6.2.1 Detroit Diesel Series 60 Engine

Stop engine and allow engine to cool. Close both heater line shutoff valves (refer to Section 05 "Cooling").

1. To drain the cooling system, proceed as per Section 05 "Cooling", paragraph 5: Draining. If the cooling system is contaminated, flush system as per Section 05 "Cooling", paragraph 7: Flushing.
2. Disconnect and remove the engine air intake duct mounted between the air cleaner housing and the turbocharger inlet.



### CAUTION

To avoid damage to turbocharger, cover the turbocharger inlet opening to prevent foreign material from entering.

3. Disconnect the transmission hoses from oil cooler. Cover hose ends and fittings to prevent fluid contamination.



### WARNING

A significant amount of oil may drain from oil lines when they are disconnected.

4. Unfasten the constant-torque hose clamps and remove the two hoses.
5. Unscrew the holding bolts and nuts and remove the oil cooler from engine compartment.
6. Reinstall transmission oil cooler by using reverse procedure.

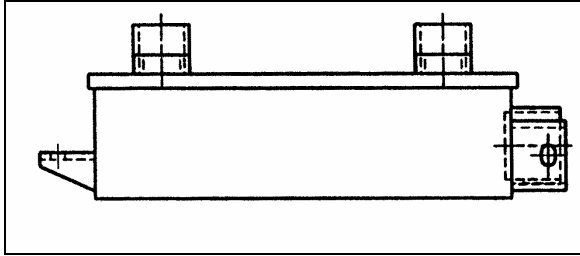


FIGURE 13: COOLER WITH RETARDER

07073

### 6.2.2 Volvo D13 Engine

Stop engine and allow engine to cool. Close both heater line shutoff valves (refer to Section 05 "Cooling").

1. To drain the cooling system, proceed as per Section 05 "Cooling", paragraph 5: Draining. If the cooling system is contaminated, flush system as per Section 05 "Cooling", paragraph 7: Flushing.
2. Remove the rear L.H. side tag axle wheel, then remove the rear L.H. side fender panel.
3. Disconnect the transmission hoses from oil cooler. Cover hose ends and fittings to prevent fluid contamination.

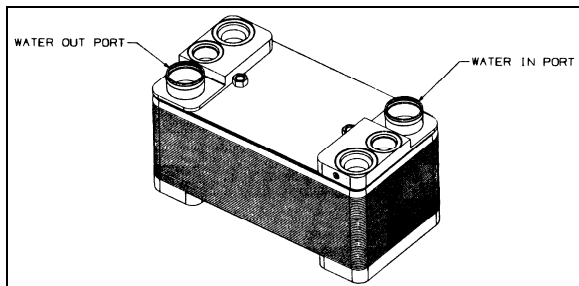


FIGURE 14: ALLISON OIL COOLER



## WARNING

A significant amount of oil may drain from oil lines when they are disconnected.

4. Unfasten the constant-torque hose clamps and remove the two hoses.
5. Unscrew the holding bolts and nuts and remove the oil cooler from engine compartment.

### 7. CLEANING AND INSPECTION OF ALLISON AUTOMATIC TRANSMISSION

The exterior of the transmission should be cleaned and inspected at regular intervals. The length of service and severity of operating

conditions will determine the frequency of such inspections. Inspect the transmission for:

1. Loose bolts (transmission and mounting components);
2. Oil leaks (correct immediately);
3. Loose, dirty, or improperly adjusted throttle sensor linkage;
4. Damaged or loose oil lines;
5. Worn or frayed electrical harnesses, improper routing;
6. Worn or out of phase drive line U-joint and slip fittings.



## CAUTION

DO NOT pressure wash the transmission electrical connectors. Water and detergent will cause the contacts to corrode or become faulty.

### 7.1 BREATHER

The breather is located on the engine, flywheel side near the valve cover. It serves to prevent pressure build-up within the transmission and must be cleaned to keep the passage opened. The prevalence of dust and dirt will determine the frequency at which the breather requires cleaning. Use care when cleaning the engine. Spraying steam, water or cleaning solution directly at the breather can force the water or solution into the transmission. Always use care when removing the hose connector from transmission to prevent the entry of foreign matter.

### 8. ALLISON TRANSMISSION INSTALLATION

#### NOTE

For more clearance between the tag axle and transmission, the tag axle may be unloaded and jacked up, or retracted (if applicable).

#### ▪ Detroit Diesel Series 60 Engine Only

With the access plug removed, align one of the 12 attaching screw holes in the flexible plate with the access opening (starter side).

#### ▪ Volvo D13 Engine Only

With the starter motor removed, align one of the 12 attaching screw holes in the flexible plate with the access opening.

## Section 07: TRANSMISSION

1. Place the transmission on a transmission jack.
2. Install a headless guide bolt into one of the 12 threaded holes for flexible plate attaching screws in the flywheel.
3. Lubricate the flywheel center pilot boss with molybdenum disulfide grease (Molycote G, or equivalent).
4. Raise transmission and position the flywheel pilot boss into the flexible plate adapter. Align the guide bolt previously installed in the flywheel with the flexible plate hole facing the access opening in the flywheel housing.



### DANGER

Severe damages and/or personal injury can occur if transmission is not adequately supported.

5. Seat the transmission against the engine flywheel housing. **NO FORCE IS REQUIRED.** If interference is encountered, move the transmission away from engine, then investigate the cause.



### CAUTION

The torque converter housing must be seated against the flywheel housing prior to tightening any screws. **DO NOT USE SCREWS TO SEAT THE HOUSING.**

6. Start all torque converter housing screws, and then tighten four of them gradually and in a criss-cross sequence around the housing. Tighten the 12 remaining screws. Recommended torque is between 42-50 lbf-ft (57-68 Nm).
7. Remove the guide bolt through the access opening in the flywheel housing. Replace it with a self-locking screw, finger-tighten then start the remaining screws; tighten to 17-21 lbf-ft (23-28 Nm).

#### ▪ Detroit Diesel Series 60 Engine Only

*Place a wrench on the crankshaft pulley attaching screw to turn the converter to gain access to the threaded holes.*

*Reinstall the access plug.*

#### ▪ Volvo D13 Engine Only

*Remove the plug located below starter motor and install cranking tool (88800014). Crank the engine to gain access to the threaded holes by turning the cranking tool using a suitable adapter (Refer to fig. 11).*

*Reinstall starter motor and connect cables.*

*Reinstall access plug below starter motor.*

8. Remove jack from under transmission.
9. Connect all sensors.
10. Connect the main wiring harness.
11. Connect the air supply line (steel-braided hose) to the retarder control valve (if applicable).
12. Connect the two transmission oil cooler hoses as they were previously.
13. Reinstall clamps and brackets, and replace locking ties previously removed during removal procedure.
14. Install propeller shaft and its safety guard. Refer to Section 09, "PROPELLER SHAFT".
15. Install transmission dipstick and filler tube.
16. Install cross member under transmission.
17. Install engine splash guards.
18. Adjust the retarder pressure to  $80 \pm 3$  psi with the air pressure regulator. For more information refer to Section 12, "BRAKE AND AIR SYSTEM", under heading "AIR PRESSURE REGULATOR". The air pressure regulator is located near the Webasto in engine compartment, on R.H. side (Fig. 13).
19. Make sure that the drain plug is in place, and then remove the transmission dipstick and pour approximately 24 US quarts (23 L) of automatic transmission fluid through the filler tube. Check and adjust oil level.



### CAUTION

Do not overfill the transmission. Overfilling can cause oil aeration (milky appearance) and overheating. If overfilling occurs, drain oil as required to bring it to the proper level.

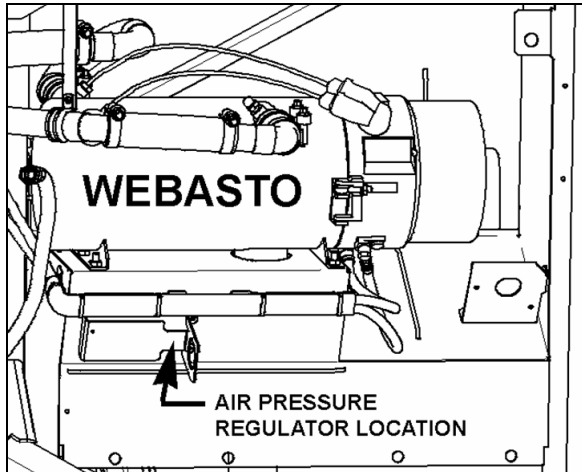


FIGURE 15: AIR PRESSURE REGULATOR (TYPICAL) 07130

## 9. ALLISON AUTOMATIC TRANSMISSION TROUBLESHOOTING

For complete information about Allison transmission troubleshooting, refer to "Allison 4<sup>th</sup> Generation Controls – Troubleshooting Manual: 3000 and 4000 Product families (TS3989)".

### 9.1 4<sup>TH</sup> GENERATION TRANSMISSION CONTROL MODULE

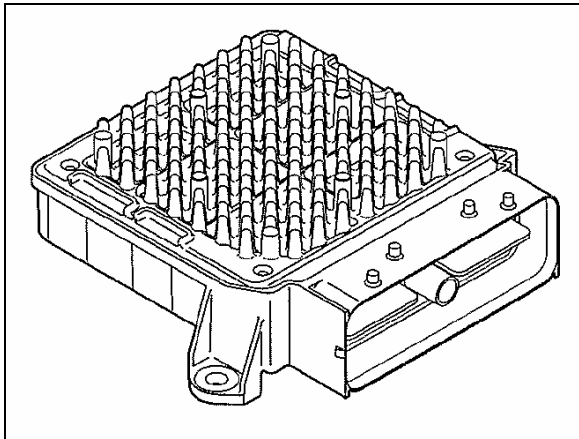


FIGURE 16: TRANSMISSION CONTROL MODULE 07140

The Allison transmission has a new Transmission Control Module (TCM) which involves specific diagnostic incident codes. The TCM unit is located in the coach rear electrical compartment.

#### TCM Replacement

The TCM is a non-serviceable electronic device. When it fails, it must be replaced using the following procedure:

- Open the coach rear baggage compartment then remove the rear electrical compartment door in order to get access to the TCM;

- Remove the electrical cable connectors;
- Unscrew the TCM unit;
- Replace by reversing the procedure.



### CAUTION

Place the battery master switch to the "OFF" position.

### 9.2 DIAGNOSTIC TROUBLESHOOTING CODES (DTC) — ALLISON 4TH GENERATION CONTROLS

Diagnostic codes (DTC) are numerical indications relating to a malfunction in transmission operation. These codes are logged in a list in the TCM memory with the most severe or most recent code listed first. A maximum of five codes (numbered d1 to d5) may be listed in memory at one time. As codes are added, the oldest inactive code is dropped from the list. If all codes are active, the code with the lowest priority that is not included on the severity list is dropped from the list.

Diagnostic codes (DTC) and code information may be accessed through the pushbutton shift selector or using an Allison DOC™ diagnostic tool.

The TCM separately stores the active and inactive codes. An active code is any code that is current in the TCM decision-making process. Inactive codes are codes that are retained in the TCM memory and will not necessary affect the TCM decision-making process. Inactive codes are useful in determining if a problem is:

- Isolated ;
- Intermittent ;
- Result from a previous malfunction.



The TCM may automatically delete a code from memory if it has not recurred. If the MODE INDICATOR (LED) is not illuminated, the displayed code is not active. An illuminated MODE INDICATOR (LED) during normal operation signifies secondary shift mode operation.

## Section 07: TRANSMISSION

### 9.3 DIAGNOSTIC CODES – ALLISON 4<sup>TH</sup> GENERATION CONTROLS

When the diagnostic mode is entered, the first code (position d1) is displayed as follows:

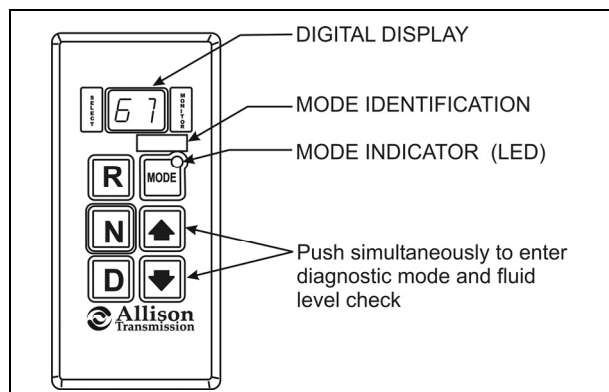
Example: Code P0722

Displayed as: **d1...P...07...22**

The code list position is the first item displayed, followed by the DTC. Each item is displayed for about one second. The display cycles continuously until the next code list position is accessed by pressing the **MODE** button. The following example shows how DTC P0722 is displayed on the pushbutton shift selector.

|        |   |   |         |
|--------|---|---|---------|
| SELECT | d | 1 | MONITOR |
|        |   | P |         |
|        | 0 | 7 |         |
|        | 2 | 2 |         |

- d1 (code list position) – The position which a code occupies in the list. Positions are displayed as « d1 » through « d5 » (code list position 1 through code list position 5).
- P0722 (DTC) – The diagnostic troubleshooting code number referring to the general condition or area of fault detected by the TCM.



### 9.4 DIAGNOSTIC CODE DISPLAY AND CLEARING PROCEDURE – ALLISON 4<sup>TH</sup> GENERATION CONTROLS

Diagnostic codes can be read and cleared by two methods:

- Using an Allison DOC™ diagnostic tool. For specific instructions on how to use an Allison DOC™ diagnostic tool, refer to the User Guide.
- Using the pushbutton shift selector.

#### To begin the diagnostic process:

1. Bring the vehicle to a stop at a safe location.
2. Apply the parking brake.

#### To display stored codes:

1. Simultaneously press the ▲ (Up) and ▼ (Down) arrow buttons twice to access the Diagnostic Display Mode.

#### NOTE

To access the Oil Level Display Mode, simultaneously press the ▲ (Up) and ▼ (Down) arrow buttons once. Consult paragraph: « ALLISON TRANSMISSION OIL LEVEL CHECK USING THE PUSHBUTTON SHIFT SELECTOR » at the end of this section.

2. Observe the digital display for code (d1).
3. Press the MODE button to see the next code (d2) – repeat for subsequent codes (d3, d4 & d5).

#### NOTE

Be sure to record all codes displayed before they are cleared. This is essential for troubleshooting.

#### NOTE

The Diagnostic Display Mode can be entered for viewing codes at any speed. Codes can only be cleared when the output speed = 0 and no output speed sensor failure is active

Active indicators (MODE INDICATOR LED) and inactive codes can be cleared manually, while in the diagnostic display mode, after the condition causing the code is identified.

#### To clear active indicators and inactive codes:

1. While in Diagnostic Display Mode, press and hold the MODE button for 10 seconds to clear both active indicators and inactive codes.
2. Begin operating as normal. Have the transmission checked at the earliest opportunity by an Allison Transmission distributor or dealer.

**NOTE**

All active indicators are cleared at TCM power down.

Some codes will clear their active indicator when the condition causing the code is no longer detected by the TCM.

The Diagnostic Display Mode can be exited by any of the following methods:

- Press simultaneously the ▲ (Up) and ▼ (Down) arrow buttons at the same time on the pushbutton shift selector.
- Press any range button «D», «N» or «R» on the pushbutton shift selector (the shift will be commanded if it is not inhibited by an active code).
- Wait until the calibrated time (approximately 10 minutes) has passed. The system will automatically return to the normal operating mode.
- Turn off power to the TCM (shut off the engine using the ignition key).

**NOTE**

If clearing a code while locked in a «D» (Drive) or «R» (Reverse) position (fail-to-range), the transmission will still be in «D» (Drive) or «R» (Reverse) when the clearing procedure is completed. «N» (Neutral) must be manually selected.

## 9.5 DIAGNOSTIC CODE RESPONSE

The following responses are used in the "Diagnostic Troubleshooting Code List and Inhibited Operation Description" table to command safe operation when diagnostic codes are sent.

### DNS - Do Not Shift Response

Release lock up clutch and inhibit lock up operation.

Inhibit all shifts.

Turn ON the CHECK TRANS light.

Display the range attained.

Ignore any range selection inputs from the shift selector.

### DNA - Do Not Adapt Response

The TCM stops adaptive shift control while the code is active.

### SOL OFF - SOLenoid OFF Response

All solenoids are commanded OFF (turning solenoids "A" and "B" off electrically cause them to be on hydraulically).

### RPR - Return to Previous Range Response

When the speed sensor ratio or C3 pressure switch test associated with a shift not successful, the TCM commands the same range as commanded before the shift.

### NNC - Neutral No Clutches Response

When certain speed sensor ratio or C3 pressure switch tests are not successful, the TCM commands a neutral condition with no clutches applied.

## Section 07: TRANSMISSION

### 9.6 DIAGNOSTIC TROUBLESHOOTING CODES (DTC) LIST - ALLISON 4<sup>TH</sup> GENERATION CONTROLS

| DTC   | Description   | CHECK TRANS Light | Inhibited Operation Description   |
|-------|---|-------------------|---|
| C1312 | Retarder Request Sensor Failed Low                        | No                | May inhibit retarder operation if not using J1939 datalink  |
| C1313 | Retarder Request Sensor Failed High                       | No                | May inhibit retarder operation if not using J1939 datalink  |
| P0122 | Pedal Position Sensor Low Voltage                         | No                | Use default throttle values. Freezes shift adapts.  |
| P0123 | Pedal Position Sensor High Voltage                        | No                | Use default throttle values. Freezes shift adapts.  |
| P0218 | Transmission Fluid Over Temperature                       | No                | Use hot mode shift schedule. Holds fourth range. TCC is inhibited. Freezes shift adapts.                    |
| P0602 | TCM Not Programmed  | Yes               | Lock in Neutral   |
| P0610 | TCM Vehicle Options (Trans ID) Error                      | Yes               | Use TID A calibration   |
| P0613 | TCM Processor   | No                | All solenoids off   |
| P0614 | Torque Control Data Mismatch - ECM/TCM                    | Yes               | Allows operation only in reverse and second range.  |
| P0634 | TCM Internal Temperature Too High                         | Yes               | SOL OFF (hydraulic default)   |
| P063E | Auto Configuration Throttle Input Not Present             | Yes               | Use default throttle values   |
| P063F | Auto Configuration Engine Coolant Temp Input Not Present  | No                | None  |
| P0658 | Actuator Supply Voltage 1 (HSD1) Low                      | Yes               | DNS, SOL OFF (hydraulic default)  |
| P0659 | Actuator Supply Voltage 1 (HSD1) High                     | Yes               | DNS, SOL OFF (hydraulic default)  |
| P0702 | Transmission Control System Electrical (TransID)          | Yes               | Use TID A calibration   |
| P0703 | Brake Switch Circuit Malfunction                          | No                | No Neutral to Drive shifts for refuse packer. TCM inhibits retarder operation if a TPS code is also active. |
| P0708 | Transmission Range Sensor Circuit High Input              | Yes               | Ignore defective strip selector inputs  |
| P070C | Transmission Fluid Level Sensor Circuit – Low Input       | No                | None  |
| P070D | Transmission Fluid Level Sensor Circuit – High Input      | No                | None  |
| P0711 | Transmission Fluid Temperature Sensor Circuit Performance | Yes               | Use default sump temp   |
| P0712 | Transmission Fluid Temperature Sensor Circuit Low Input   | Yes               | Use default sump temp   |
| P0713 | Transmission Fluid Temperature Sensor Circuit High Input  | Yes               | Use default sump temp   |
| P0716 | Turbine Speed Sensor Circuit Performance                  | Yes               | DNS, Lock in current range  |
| P0717 | Turbine Speed Sensor Circuit No Signal                    | Yes               | DNS, Lock in current range  |
| P0719 | Brake Switch ABS Input Low                                | No                | TCM assumes ABS is OFF  |
| P071A | RELS Input Failed On                                      | Yes               | Inhibit RELS operation  |
| P071D | General Purpose Input Fault                               | Yes               | None  |
| P0721 | Output Speed Sensor Circuit Performance                   | Yes               | DNS, Lock in current range  |
| P0722 | Output Speed Sensor Circuit No Signal                     | Yes               | DNS, Lock in current range  |
| P0726 | Engine Speed Sensor Circuit Performance                   | No                | Default to turbine speed  |
| P0727 | Engine Speed Sensor Circuit No Signal                     | No                | Default to turbine speed  |
| P0729 | Incorrect 6 <sup>th</sup> Gear Ratio                      | Yes               | DNS, Attempt 5 <sup>th</sup> , then 3 <sup>rd</sup>   |
| P0731 | Incorrect 1 <sup>st</sup> Gear ratio                      | Yes               | DNS, Attempt 2 <sup>nd</sup> , then 5 <sup>th</sup>   |

| DTC   | Description   | CHECK TRANS Light | Inhibited Operation Description  |
|-------|---|-------------------|--|
| P0732 | Incorrect 2 <sup>nd</sup> Gear ratio                    | Yes               | DNS, Attempt 3 <sup>rd</sup> , then 5 <sup>th</sup>                        |
| P0733 | Incorrect 3 <sup>rd</sup> Gear ratio                    | Yes               | DNS, Attempt 4 <sup>th</sup> , then 6 <sup>th</sup>                        |
| P0734 | Incorrect 4 <sup>th</sup> Gear ratio                    | Yes               | DNS, Attempt 5 <sup>th</sup> , then 3 <sup>rd</sup>                        |
| P0735 | Incorrect 5 <sup>th</sup> Gear ratio                    | Yes               | DNS, Attempt 6 <sup>th</sup> , then 3 <sup>rd</sup> , then 2 <sup>nd</sup> |
| P0736 | Incorrect Reverse Gear ratio                            | Yes               | DNS, Lock in Neutral   |
| P0741 | Torque Converter Clutch System Stuck Off                | Yes               | None   |
| P0776 | Pressure Control Solenoid 2 Stuck Off                   | Yes               | DNS, RPR   |
| P0777 | Pressure Control Solenoid 2 Stuck On                    | Yes               | DNS, RPR   |
| P0796 | Pressure Control Solenoid 3 Stuck Off                   | Yes               | DNS, RPR   |
| P0797 | Pressure Control Solenoid 3 Stuck On                    | Yes               | DNS, RPR   |
| P0842 | Transmission Pressure Switch 1 Circuit Low              | Yes               | DNS, Lock in current range   |
| P0843 | Transmission Pressure Switch 1 Circuit High             | Yes               | DNS, Lock in current range   |
| P0880 | TCM Power Input Signal                                  | No                | None   |
| P0881 | TCM Power Input Signal Performance                      | No                | None   |
| P0882 | TCM Power Input Signal Low                              | Yes               | DNS, SOL OFF (hydraulic default)   |
| P0883 | TCM Power Input Signal High                             | No                | None   |
| P0894 | Transmission Component Slipping                         | Yes               | DNS, Lock in first   |
| P0960 | Pressure Control Solenoid Main Mod Control Circuit Open | Yes               | None   |
| P0962 | Pressure Control Solenoid Main Mod Control Circuit Low  | Yes               | DNS, SOL OFF (hydraulic default)   |
| P0963 | Pressure Control Solenoid Main Mod Control Circuit High | Yes               | None   |
| P0964 | Pressure Control Solenoid 2 (PCS2) Control Circuit Open | Yes               | DNS, SOL OFF (hydraulic default)   |
| P0966 | Pressure Control Solenoid 2 (PCS2) Control Circuit Low  | Yes               | DNS, SOL OFF (hydraulic default)   |
| P0967 | Pressure Control Solenoid 2 (PCS2) Control Circuit High | Yes               | DNS, SOL OFF (hydraulic default)   |
| P0968 | Pressure Control Solenoid 3 (PCS3) Control Circuit Open | Yes               | DNS, SOL OFF (hydraulic default)   |
| P0970 | Pressure Control Solenoid 3 (PCS3) Control Circuit Low  | Yes               | DNS, SOL OFF (hydraulic default)   |
| P0971 | Pressure Control Solenoid 3 (PCS3) Control Circuit High | Yes               | DNS, SOL OFF (hydraulic default)   |
| P0973 | Shift Solenoid 1 (SS1) Control Circuit Low              | Yes               | DNS, SOL OFF (hydraulic default)   |
| P0974 | Shift Solenoid 1 (SS1) Control Circuit High             | Yes               | DNS, SOL OFF (hydraulic default)   |
| P0975 | Shift Solenoid 2 (SS2) Control Circuit Open             | Yes               | 7-speed: Allow 2 through 6, N, R   |
| P0976 | Shift Solenoid 2 (SS2) Control Circuit Low              | Yes               | 7-speed: Allow 2 through 6, N, R<br>Inhibit TCC operation                  |
| P0977 | Shift Solenoid 2 (SS2) Control Circuit High             | Yes               | 7-speed: Allow 2 through 6, N, R   |
| P0989 | Retarder Pressure Sensor Failed Low                     | No                | None   |
| P0990 | Retarder Pressure Sensor Failed High                    | No                | None   |
| P1739 | Incorrect Low Gear Ratio                                | Yes               | Command 2 <sup>nd</sup> and allow shifts 2 through 6, N, R                 |
| P1891 | Throttle Position Sensor PWM Signal Low Input           | No                | Use default throttle values  |
| P1892 | Throttle Position Sensor PWM Signal High Input          | No                | Use default throttle values  |
| P2184 | Engine Coolant Temperature Sensor Circuit Low Input     | No                | Use default engine coolant values  |
| P2185 | Engine Coolant Temperature Sensor Circuit High Input    | No                | Use default engine coolant values  |
| P2637 | Torque Management Feedback Signal (SEM)                 | Yes               | Inhibit SEM  |
| P2641 | Torque Management Feedback Signal (LRTP)                | Yes               | Inhibit LRTP   |
| P2670 | Actuator Supply Voltage 2 (HSD2) Low                    | Yes               | DNS, SOL OFF (hydraulic default)   |

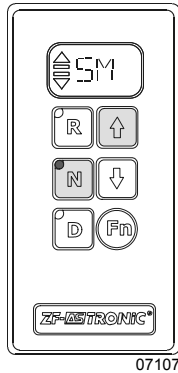


**Section 07: TRANSMISSION**

| <b>DTC</b> | <b>Description</b>  | <b>CHECK TRANS Light</b> | <b>Inhibited Operation Description</b>                        |
|------------|---|--------------------------|---|
| P2671      | Actuator Supply Voltage 2 (HSD2) High                           | Yes                      | DNS, SOL OFF (hydraulic default)                              |
| P2685      | Actuator Supply Voltage 3 (HSD3) Low                            | Yes                      | DNS, SOL OFF (hydraulic default)                              |
| P2686      | Actuator Supply Voltage 3 (HSD3) High                           | Yes                      | DNS, SOL OFF (hydraulic default)                              |
| P2714      | Pressure Control Solenoid 4 (PCS4) Stuck Off                    | Yes                      | DNS, RPR  |
| P2715      | Pressure Control Solenoid 4 (PCS4) Stuck On                     | Yes                      | DNS, SOL OFF (hydraulic default)                              |
| P2718      | Pressure Control Solenoid 4 (PCS4) Control Circuit Open         | Yes                      | DNS, SOL OFF (hydraulic default)                              |
| P2720      | Pressure Control Solenoid 4 (PCS4) Control Circuit Low          | Yes                      | DNS, SOL OFF (hydraulic default)                              |
| P2721      | Pressure Control Solenoid 4 (PCS4) Control Circuit High         | Yes                      | DNS, SOL OFF (hydraulic default)                              |
| P2723      | Pressure Control Solenoid 1 (PCS1) Stuck Off                    | Yes                      | DNS, RPR  |
| P2724      | Pressure Control Solenoid 1 (PCS1) Stuck On                     | Yes                      | DNS, RPR  |
| P2727      | Pressure Control Solenoid 1 (PCS1) Control Circuit Open         | Yes                      | DNS, SOL OFF (hydraulic default)                              |
| P2729      | Pressure Control Solenoid 1 (PCS1) Control Circuit Low          | Yes                      | DNS, SOL OFF (hydraulic default)                              |
| P2730      | Pressure Control Solenoid 1 (PCS1) Control Circuit High         | Yes                      | DNS, SOL OFF (hydraulic default)                              |
| P2736      | Pressure Control Solenoid 5 (PCS5) Control Circuit Open         | Yes                      | Inhibit retarder operation                                    |
| P2738      | Pressure Control Solenoid 5 (PCS5) Control Circuit Low          | Yes                      | Allow 2 through 6, N, R. Inhibit retarder and TCC operation   |
| P2739      | Pressure Control Solenoid 5 (PCS5) Control Circuit High         | Yes                      | Inhibit retarder operation                                    |
| P2740      | Retarder Oil Temperature Hot                                    | No                       | None  |
| P2742      | Retarder Oil Temperature Sensor Circuit – Low Input             | No                       | Use default retarder temp values                              |
| P2743      | Retarder Oil Temperature Sensor Circuit – High Input            | No                       | Use default retarder temp values                              |
| P2761      | TCC PCS Control Circuit Open                                    | Yes                      | Inhibit TCC operation   |
| P2763      | TCC PCS Control Circuit High                                    | Yes                      | Inhibit TCC operation   |
| P2764      | TCC PCS Control Circuit Low                                     | Yes                      | 7-speed: Allow 2 through 6, N, R. Inhibit TCC operation       |
| P278A      | Kickdown Input Failed ON  | No                       | Inhibit kickdown operation                                    |
| P2793      | Gear Shift Direction Circuit                                    | Yes                      | Ignores PWM input from shift selector                         |
| P2808      | Pressure Control Solenoid 6 (PCS6) Stuck Off                    | Yes                      | DNS, RPR  |
| P2809      | Pressure Control Solenoid 6 (PCS6) Stuck On                     | Yes                      | DNS, RPR  |
| P2812      | Pressure Control Solenoid 6 (PCS6) Control Circuit Open         | Yes                      | DNS, SOL OFF (hydraulic default)                              |
| P2814      | Pressure Control Solenoid 6 (PCS6) Control Circuit Low          | Yes                      | DNS, SOL OFF (hydraulic default)                              |
| P2815      | Pressure Control Solenoid 6 (PCS6) Control Circuit High         | Yes                      | DNS, SOL OFF (hydraulic default)                              |
| U0001      | Hi Speed CAN Bus Reset Counter Overrun (IESCAN)                 | No                       | Use default values, inhibit SEM                               |
| U0010      | CAN BUS Reset Counter Overrun                                   | No                       | Use default values, inhibit SEM                               |
| U0100      | Lost Communications with ECM/PCM (J1587)                        | Yes                      | Use default values  |
| U0103      | Lost Communication with Gear Shift Module (Shift Selector) 1    | Yes                      | Maintain range selected, observe gear shift direction circuit |
| U0115      | Lost Communication with ECM                                     | Yes                      | Use default values  |
| U0291      | Lost Communication with Gear Shift Module (Shift Selector) 2    | Yes                      | Maintain range selected, observe gear shift direction circuit |
| U0304      | Incompatible Gear Shift Module 1 (Shift Selector) ID            | Yes                      | Ignore shift selector inputs                                  |
| U0333      | Incompatible Gear Shift Module 2 (Shift Selector) ID            | Yes                      | Ignore shift selector inputs                                  |
| U0404      | Invalid Data Received From Gear Shift Module (Shift Selector) 1 | Yes                      | Maintain range selected, observe gear shift direction circuit |
| U0592      | Invalid Data Received From Gear Shift Module (Shift Selector) 2 | Yes                      | Maintain range selected, observe gear shift direction circuit |

**10. ZF-ASTRONIC TRANSMISSION SYSTEM FAULTS AND ERROR MESSAGES**

**10.1 SYSTEM FAULTS (ERROR MESSAGES)**



If the “SM” symbol appears in the display, a system error has occurred.

- **Stop the vehicle**
- **Vehicle may no longer be driven**

Error messages and the reactions resulting from these errors can be deleted with the vehicle at a standstill and the “Ignition OFF”. (Wait until the display goes out). If the display does not go out once the ignition has been turned “OFF”, set the battery master switch to the **OFF** position. Switch the ignition back on. If the error message is still in place, the transmission has to be repaired. The transmission is inoperative. The vehicle will have to be taken to a service point. The error number(s) must be specified when the service point is contacted.

**ERROR CODES**

**Remark to titles in table:**

ZF fault number: defined by ZF.

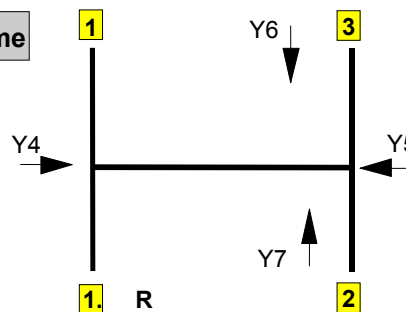
Display SM-Symbol : (0=NO, 1=YES) Display shows “SM”(severe failure)

Warning lamp : (0=NO, 1=YES) Telltale panel warning lamp “**check trans**“(less severe failure)

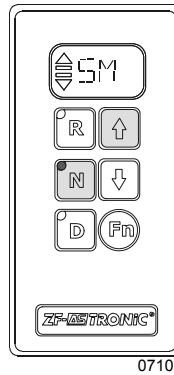
Shift schemes of transmissions:

- Y2 Splitter K2
- Y3 Splitter K1
- Y8 Range (GP) low
- Y9 Range (GP)

**10/12-Gear Scheme**

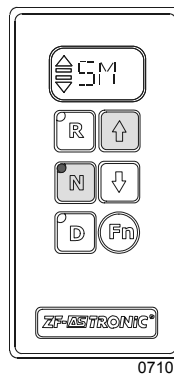


**Calling up error numbers**



- Switch on ignition
- Depress “N” key
- Hold down “↑” key
- \* One or more error numbers appear on the display. These correspond to the errors presently active in the system.

**Calling up error numbers from the error memory:**



- Switch on ignition
- Press “N” key and at the same time depress the foot-operated brake
- Hold down the foot-operated brake and depress and hold down “↑” key
- \* The errors stored in the transmission ECU are shown on the display one after another.

**Section 07: TRANSMISSION**

| ON MESSAGES CENTER DISPLAY (MCD) SAE-J1587 Codes | ON SHIFT SELECTOR DISPLAY | ISO CODES WITH TESTMAN TOOL | DESCRIPTION  |
|--|---------------------------|-----------------------------|--|
| 8, 7   | 8                         | 161                         | Easy Start, Brake doesn't open completely  |
| 8, 14  | 8                         | 162                         | Easy Start, Not Available  |
| 20,6   | 14                        | 22                          | Short circuit to ground at output ACC (wakeup control signal for ZMTEC, keep alive signal for voltage doubler, and power signal for speed sensor #2)   |
| 20,5   | 14                        | 54                          | Interruption at output ACC (wakeup control signal for ZMTEC, keep alive signal for voltage doubler, and power signal for speed sensor #2)              |
| 20,3   | 14                        | 86                          | Short circuit to positive at output ACC (wakeup control signal for ZMTEC, keep alive signal for voltage doubler, and power signal for speed sensor #2) |
| 21,2   | 15                        | 127                         | Error on ECU temperature sensor signal   |
| 21,0   | 15                        | 193                         | ECU temperature too high   |
| 31,3   | 1F                        | 137                         | No range change group (GP) sensor signal (Short circuit to positive)   |
| 31,6   | 1F                        | 138                         | No range change group (GP) sensor signal (Short circuit to ground)   |
| 31,5   | 1F                        | 139                         | No range change group (GP) sensor signal (Interruption)  |
| 31,13  | 1F                        | 140                         | Self adjustment error of range change group sensor in position fast  |
| 31,7   | 1F                        | 159                         | Range-change group sensor signal leaves engaged position during driving  |
| 32,3   | 20                        | 141                         | No splitter group (GV) sensor signal (Short circuit to positive)   |
| 32,6   | 20                        | 142                         | No splitter group (GV) sensor signal (Short circuit to ground)   |
| 32,5   | 20                        | 143                         | No splitter group (GV) sensor signal (Interruption)  |
| 32,13  | 20                        | 144                         | Splitter group (GV) sensor self adjustment error   |
| 32,7   | 20                        | 160                         | Splitter sensor signal leaves engaged position during driving  |
| 33,14  | 21                        | 107                         | Stabilised voltage supply at output AU (clutch sensor supply) too high or too low  |
| 33,13  | 21                        | 117                         | Error in clutch self-adjustment process  |
| 33,2   | 21                        | 124                         | Error on clutch travel signal  |
| 34,7   | 22                        | 120                         | Mechanical failure of small clutch disengagement valve   |
| 34,7   | 22                        | 121                         | Mechanical failure of large clutch disengagement valve   |
| 34,7   | 22                        | 122                         | Mechanical failure of small clutch engagement valve  |
| 34,7   | 22                        | 123                         | Mechanical failure of large clutch engagement valve  |
| 34,6   | 22                        | 18                          | Short circuit to ground at output stage to small disengagement clutch valve  |
| 34,6   | 22                        | 19                          | Short circuit to ground at output stage to small engagement clutch valve   |
| 34,6   | 22                        | 20                          | Short circuit to ground at output stage to large disengagement clutch valve  |
| 34,6   | 22                        | 21                          | Short circuit to ground at output stage to large engagement clutch valve   |
| 34,5   | 22                        | 50                          | Interruption at output stage to small disengagement clutch valve   |
| 34,5   | 22                        | 51                          | Interruption at output stage to small engagement clutch valve  |
| 34,5   | 22                        | 52                          | Interruption at output stage to large disengagement clutch valve   |
| 34,5   | 22                        | 53                          | Interruption at output stage to large engagement clutch valve  |

| ON MESSAGES CENTER DISPLAY (MCD) SAE-J1587 Codes | ON SHIFT SELECTOR DISPLAY | ISO CODES WITH TESTMAN TOOL | DESCRIPTION   |
|--|---------------------------|-----------------------------|---|
| 34,3   | 22                        | 82                          | Short circuit to positive at output stage to small disengagement clutch valve |
| 34,3   | 22                        | 83                          | Short circuit to positive at output stage to small engagement clutch valve    |
| 34,3   | 22                        | 84                          | Short circuit to positive at output stage to large disengagement clutch valve |
| 34,3   | 22                        | 85                          | Short circuit to positive at output stage to large engagement clutch valve    |
| 35,5   | 23                        | 41                          | Interruption at output stage to Y9 (Valve Range)                              |
| 35,3   | 23                        | 73                          | Short circuit to positive at output stage to Y9 (Valve range)                 |
| 35,6   | 23                        | 9                           | Short circuit to ground at output stage to Y9 (Valve Range)                   |
| 36,5   | 24                        | 40                          | Interruption at output stage to Y8 (Valve Range)                              |
| 36,3   | 24                        | 72                          | Short circuit to positive at output stage to Y8 (Valve range)                 |
| 36,6   | 24                        | 8                           | Short circuit to ground at output stage to Y8 (Valve Range)                   |
| 37,6   | 25                        | 2                           | Short circuit to ground at output stage to Y2 (Valve Splitter)                |
| 37,5   | 25                        | 34                          | Interruption at output stage to Y2 (Valve Splitter)                           |
| 37,3   | 25                        | 66                          | Short circuit to positive at output stage to Y2 (Valve Splitter)              |
| 38,6   | 26                        | 3                           | Short circuit to ground at output stage to Y3 (Valve Splitter)                |
| 38,5   | 26                        | 35                          | Interruption at output stage to Y3 (Valve Splitter)                           |
| 38,3   | 26                        | 67                          | Short circuit to positive at output stage to Y3 (Valve Splitter)              |
| 39,5   | 27                        | 36                          | Interruption at output stage to Y4 (Valve Select)                             |
| 39,6   | 27                        | 4                           | Short circuit to ground at output stage to Y4 (Valve Select)                  |
| 39,3   | 27                        | 68                          | Short circuit to positive at output stage to Y4 (Valve Select)                |
| 40,5   | 28                        | 38                          | Interruption at output stage to Y6 (Valve Shift)                              |
| 40,6   | 28                        | 6                           | Short circuit to ground at output stage to Y6 (Valve Shift)                   |
| 40,3   | 28                        | 70                          | Short circuit to positive at output stage to Y6 (Valve Shift)                 |
| 43,2   | 2B                        | 175                         | Error on "Ignition lock" signal (terminal 15)                                 |
| 48,3   | 30                        | 129                         | No shift sensor signal (Short circuit to positive)                            |
| 48,6   | 30                        | 130                         | No shift sensor signal (Short circuit to ground)                              |
| 48,5   | 30                        | 131                         | No shift sensor signal (Interruption)   |
| 48,13  | 30                        | 132                         | Self adjustment error of shift sensor   |
| 48,7   | 30                        | 157                         | Selector sensor signal leaves position during driving                         |
| 48,7   | 30                        | 158                         | Engage sensor signal leaves engaged position during driving                   |
| 50,5   | 32                        | 37                          | Interruption at output stage to Y5 (Valve Select)                             |
| 50,6   | 32                        | 5                           | Short circuit to ground at output stage to Y5 (Valve Select)                  |
| 50,3   | 32                        | 69                          | Short circuit to positive at output stage to Y5 (Valve Select)                |
| 51,5   | 33                        | 39                          | Interruption at output stage to Y7 (Valve Shift)                              |
| 51,6   | 33                        | 7                           | Short circuit to ground at output stage to Y7 (Valve Shift)                   |

**Section 07: TRANSMISSION**

| ON MESSAGES CENTER DISPLAY (MCD) SAE-J1587 Codes | ON SHIFT SELECTOR DISPLAY | ISO CODES WITH TESTMAN TOOL | DESCRIPTION  |
|--|---------------------------|-----------------------------|--|
| 51,3   | 33                        | 71                          | Short circuit to positive at output stage to Y7 (Valve Shift)          |
| 54,6   | 36                        | 17                          | Short circuit to ground at output stage to Y1 (inertia brake valve)    |
| 54,5   | 36                        | 49                          | Interruption at output stage to Y1 (inertia brake valve)               |
| 54,3   | 36                        | 81                          | Short circuit to positive at output stage to Y1 (inertia brake valve)  |
| 55,7   | 37                        | 114                         | Clutch engaged unintentionally at standstill, gear engaged             |
| 55,7   | 37                        | 118                         | Clutch does not disengage  |
| 55,7   | 37                        | 119                         | Clutch does not engage / does not transmit engine torque               |
| 56,7   | 38                        | 145                         | Range change group (GP) disengagement error                            |
| 56,7   | 38                        | 146                         | Changeover error during range change group (GP) shifting               |
| 56,7   | 38                        | 147                         | Range change group (GP) does not engage                                |
| 57,2   | 39                        | 108                         | Error in shift lever   |
| 57,14  | 39                        | 110                         | ZF CAN timeout (can also means shift lever error through ZMP06400.hex) |
| 58,7   | 3A                        | 154                         | Main transmission gear does not disengage                              |
| 58,7   | 3A                        | 155                         | Main transmission gear does not engage                                 |
| 58,7   | 3A                        | 156                         | Wrong gear shifting  |
| 59,7   | 3B                        | 151                         | Selector cylinder does not disengage                                   |
| 59,7   | 3B                        | 152                         | Change over error during gate selection procedure                      |
| 59,7   | 3B                        | 153                         | Selector cylinder does not engage                                      |
| 60,3   | 3C                        | 133                         | No gate select sensor signal (Short circuit to positive)               |
| 60,6   | 3C                        | 134                         | No gate select sensor signal (Short circuit to ground)                 |
| 60,5   | 3C                        | 135                         | No gate select sensor signal (Interruption)                            |
| 60,13  | 3C                        | 136                         | Gate select sensor self adjustment error                               |
| 61,7   | 3D                        | 148                         | Splitter (GV) does not disengage                                       |
| 61,7   | 3D                        | 149                         | Change over error during splitter shifting                             |
| 61,7   | 3D                        | 150                         | Splitter (GV) does not engage  |
| 63,14  | 3F                        | 100                         | Error on output speed signal 2   |
| 106,0  | 6A                        | 125                         | Error on pressure reduction valve                                      |
| 106,14   | 6A                        | 126                         | Error on pressure sensor signal  |
| 150,14   | 96                        | 59                          | Acknowledge fault of PTO 1   |
| 150,14   | 96                        | 60                          | Acknowledge fault of PTO 2   |
| 150,7  | 96                        | 61                          | Disengagement fault of PTO 1   |
| 150,7  | 96                        | 62                          | Disengagement fault of PTO 2   |
| 150,7  | 96                        | 63                          | Engagement fault of PTO1   |
| 150,7  | 96                        | 64                          | Engagement fault of PTO2   |

| ON MESSAGES CENTER DISPLAY (MCD) SAE-J1587 Codes | ON SHIFT SELECTOR DISPLAY | ISO CODES WITH TESTMAN TOOL | DESCRIPTION  |
|--|---------------------------|-----------------------------|--|
| 151,14   | 97                        | 102                         | Plausibility error between transmission input speed and output speed             |
| 152,6  | 98                        | 10                          | Short circuit to ground at output stage to Y10 (Main valve)                      |
| 152,5  | 98                        | 42                          | Interruption at output stage to Y10 (Main valve)                                 |
| 152,3  | 98                        | 74                          | Short circuit to positive at output stage to Y10 (Main valve)                    |
| 153,14   | 99                        | -                           | Error on ISO 14320 communications line   |
| 154,14   | 9A                        | 101                         | Error on both output speed signals   |
| 161,14   | A1                        | 98                          | Error on transmission input speed signal   |
| 177,2  | B1                        | 128                         | Error on oil temperature sensor signal   |
| 191,14   | BF                        | 194                         | Both sources of vehicle speed are faulty   |
| 191,14   | BF                        | 99                          | Error on output speed signal 1   |
| 230,14   | E6                        | 166                         | Permanent idle signal  |
| 230,14   | E6                        | 168                         | No idle signal or error on "idle signal switch" signal (EEC2)                    |
| 230,14   | E7                        | 103                         | Error on "Wheel-based vehicle speed" signal (CCV)                                |
| 231,7  | E7                        | 163                         | Engine does not react on torque intervention                                     |
| 231,14   | E7                        | 164                         | Error on "Drivers demand engine percent torque" (EEC1)                           |
| 231,14   | E7                        | 165                         | Error on "Accelerator pedal position" (EEC2)                                     |
| 231,14   | E7                        | 167                         | Error on "Percent load at current speed" signal (EEC2)                           |
| 231,14   | E7                        | 171                         | Error on "Actual engine percent torque" signal (EEC1)                            |
| 231,14   | E7                        | 172                         | Permanent engine brake request signal  |
| 231,14   | E7                        | 173                         | Error on "Brake switch" signal (CCVS)  |
| 231,14   | E7                        | 177                         | System-CAN Busoff error  |
| 231,11   | E7                        | 178                         | CAN error frames   |
| 231,11   | E7                        | 179                         | CAN queue overrun  |
| 231,14   | E7                        | 180                         | CAN EEC1 timeout   |
| 231,14   | E7                        | 181                         | CAN EEC2 timeout   |
| 231,14   | E7                        | 182                         | CAN CCVS timeout   |
| 231,14   | E7                        | 183                         | CAN ERC1_ER timeout  |
| 231,14   | E7                        | 197                         | Error on "Front axle speed" (WSI)  |
| 231,14   | E7                        | 198                         | Error on "Relative wheel speeds" (WSI)   |
| 231,14   | E7                        | 199                         | CAN WSI timeout  |
| 231,14   | E7                        | 26                          | CAN engine configuration timeout   |
| 231,14   | E7                        | 27                          | Error on "engine configuration message" (engine configuration)                   |
| 231,14   | E7                        | 31                          | Error on "Actual engine retarder - percent torque" signal (ERC1_ER)              |
| 231,14   | E7                        | 32                          | Error on "Engine retarder configuration message" (Engine retarder configuration) |

**Section 07: TRANSMISSION**

| ON MESSAGES CENTER DISPLAY (MCD) SAE-J1587 Codes | ON SHIFT SELECTOR DISPLAY | ISO CODES WITH TESTMAN TOOL | DESCRIPTION   |
|--|---------------------------|-----------------------------|---|
| 231,14   | E7                        | 33                          | CAN "Engine retarder configuration" timeout               |
| 231,14   | E7                        | 91                          | CAN EBC1 timeout  |
| 231,14   | E7                        | 92                          | Error on "ABS active" signal (EBC1)                       |
| 231,14   | E7                        | 93                          | Error on "ASR engine control active" signal (EBC1)        |
| 231,14   | E7                        | 94                          | Error on "ASR brake control active" signal (EBC1)         |
| 231,14   | E7                        | 95                          | Error on "Cruise control active" signal (CCVS)            |
| 231,14   | E7                        | 96                          | Error on "Cruise control set speed" (CCVS)                |
| 231,14   | E7                        | 97                          | Error on "Engine speed" signal (EEC1)                     |
| -  | EE                        | -                           | Communication error between GS3 and ZMTEC on display line |
| 248,6  | F8                        | 25                          | Short circuit to ground at output SD to display           |
| 248,3  | F8                        | 89                          | Short circuit to positive at output SD to display         |

**11. SPECIFICATIONS****ALLISON AUTOMATIC TRANSMISSION WITH OR WITHOUT RETARDER**X3 Coaches

|   |                        |
|---|------------------------|
| Gross input power (maximum).....          | 500 HP (373 kW)        |
| Gross input torque (maximum) .....        | 1525 Lbf-ft- (2068 Nm) |
| Rated input speed (minimum-maximum) ..... | 1600-2300 rpm          |

**Mounting:**

Engine..... SAE #1 flywheel housing, flex disk drive

**Torque converter:**

Type..... One stage, three element, polyphase  
 Stall torque ratio .....

|            |
|------------|
| TC 551-1.8 |
|------------|

Lockup clutch with torsional damper .....

|                   |
|-------------------|
| Integral/standard |
|-------------------|

**Gearing:**

Type..... Patented, constant mesh, helical, planetary

## Ratio:

|               |        |
|---------------|--------|
| First.....    | 3.51:1 |
| Second.....   | 1.91:1 |
| Third.....    | 1.43:1 |
| Fourth.....   | 1.00:1 |
| Fifth.....    | 0.74:1 |
| Sixth.....    | 0.64:1 |
| Reverse ..... | 4.80:1 |

**Ratio coverage:**

6 speed.....5.48:1

**\* Gear ratios do not include torque converter multiplication.**

**Oil System:**

Oil type..... TRANSYND, DEXRON-III, DEXRON-VI  
 Capacity (excluding external circuits)..... Initial fill 47 US qts (45 liters)  
 Oil change..... 24 US qts (23 liters)  
 Oil change (with retarder)..... 27.6 US qts (26 liters)

**Oil Filters:**

Make..... Allison Transmission  
 Type..... Disposable cartridge  
 Previst Part Number (2-filter replacement kit)..... 571709



# SECTION 09: PROPELLER SHAFT

---

## CONTENTS

|   |          |
|---|----------|
| <b>1. PROPELLER SHAFT .....</b>                                   | <b>2</b> |
| 1.1 DESCRIPTION.....  | 2        |
| <b>2. REMOVAL, DISASSEMBLY, REASSEMBLY AND INSTALLATION .....</b> | <b>2</b> |
| <b>3. CLEANING, INSPECTION AND LUBRICATION .....</b>              | <b>3</b> |
| 3.1 CLEANING AND INSPECTION.....                                  | 3        |
| 3.2 LUBRICATION .....   | 3        |
| <b>4. EXPLANATION OF COMMON DAMAGES.....</b>                      | <b>3</b> |
| <b>5. TROUBLESHOOTING .....</b>                                   | <b>3</b> |
| <b>6. SPECIFICATIONS.....</b>                                     | <b>4</b> |

## ILLUSTRATIONS

|  |   |
|--|---|
| FIGURE 1: PROPELLER SHAFT ASSEMBLY ..... | 2 |
|--|---|

## Section 09: PROPELLER SHAFT

### 1. PROPELLER SHAFT

#### 1.1 DESCRIPTION

The propeller shaft transmits power from the transmission to the differential (Fig. 1). Refer to paragraph "6. SPECIFICATIONS" at the end of this section for propeller shaft length. The propeller shaft is "Dana 1810" type with tubular shafts. It is provided with two heavy-duty universal joints (Fig. 1).

The propeller shaft has a full round end yoke at one end and a half round end yoke at the other end. The tube yoke is connected to the differential by a full round end yoke with four needle bearings.

The other extremity (slip yoke assembly) is connected to the transmission by a half round end yoke with two needle bearings.

Furthermore, a slip joint on the propeller shaft compensates for variations in distance between the transmission and the differential, or between the output retarder (optional on the automatic transmission) and differential.

The rise and fall of the drive axle bring about these variations as the vehicle passes over uneven surfaces. The slip joint also eases removal of the transmission or the drive axle.

### 2. REMOVAL, DISASSEMBLY, REASSEMBLY AND INSTALLATION

Refer to "SPICER UNIVERSAL JOINTS AND DRIVESHAFTS" annexed to this section, under headings "Heavy Duty - removal, disassembly, reassembly and installation".

Where applicable:

- Remove or install propeller shaft safety guard.
- Screw bolts to the specified torque (Fig. 1).

#### **NOTE**

*Disregard the procedure on "Lock straps" mentioned in the "Spicer Universal Joints and Driveshafts Manual".*

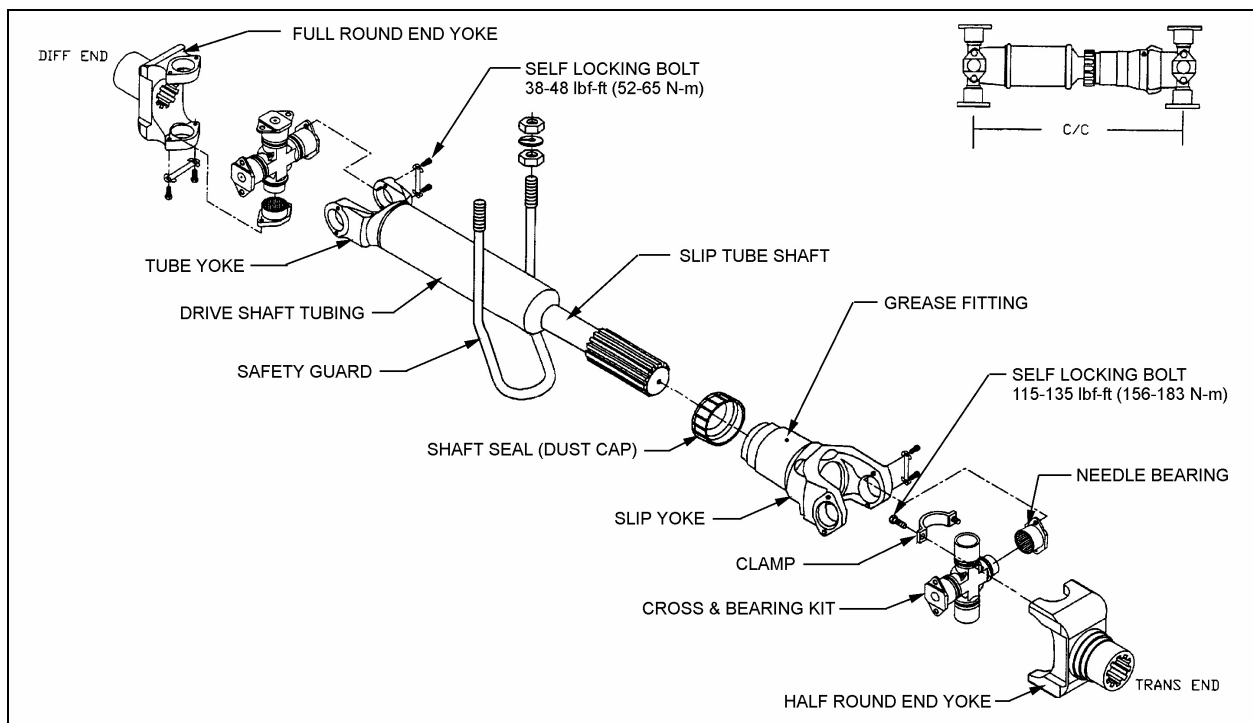


FIGURE 1: PROPELLER SHAFT ASSEMBLY

09002

### 3. CLEANING, INSPECTION AND LUBRICATION

#### 3.1 CLEANING AND INSPECTION

Thoroughly clean grease from bearings, journal, lubricating grease fittings and other parts. Needle bearing assemblies may be soaked in a cleaning solution to soften hard grease particles. It is extremely important that bearing assemblies be absolutely clean and blown out with compressed air, since small particles of dirt or grit can cause rapid bearing wear. Do not attempt to disassemble needle bearings.

Bearing journal areas should be inspected for roughness or grooving. If light honing does not remove roughness, the entire bearing assembly should be replaced. Excessive wear of the needle bearing is indicated if the needles drop out of the retainer, or if marks are present on the journal bearing surface. In such case, replace bearing assembly. Finally, inspect yokes for cracks, wear or distortion.

#### **NOTE**

*Repair kits are available for overhaul of the propeller shaft assembly. Refer to the paragraph "6. Specifications" of this section.*

#### 3.2 LUBRICATION

Lubricate propeller shaft universal joints and slip yoke periodically, every 6,250 miles (10 000 km) or twice a year, whichever comes first. Apply grease gun pressure to the lube fitting. Use a good quality lithium-base grease such as: NLGI No.2 (suitable for most temperatures) or NLGI No.1 (suitable for extremely low temperatures). Refer to "Spicer Universal Joints and Driveshafts, Service Manual", under heading, "Inspection and Lubrication". See lubrication procedures for U-joints and lubrication for slip splines.

#### **NOTE**

*Do not assume that bearing cavities have been filled with new grease unless it has expelled around all seals.*

### 4. EXPLANATION OF COMMON DAMAGES

**1. Cracks:** Stress lines due to metal fatigue. Severe and numerous cracks will weaken the metal until it breaks.

**2. Galling:** Scraping off of metal or metal displacement due to friction between surfaces. This is commonly found on trunnion ends.

**3. Spalling (surface fatigue):** Breaking off of chips, scales, or flakes of metal due to fatigue rather than wear. It is usually found on splines and U-joint bearings.

**4. Pitting:** Small pits or craters in metal surfaces due to corrosion. If excessive, pitting can lead to surface wear and eventual failure.

**5. Brinelling:** Surface wear failure due to the wearing of grooves in metal. It is often caused by improper installation procedures. Do not confuse the polishing of a surface (false brinelling), where no structural damage occurs, with actual brinelling.

**6. Structural Overloading:** Failure caused by a load greater than the component can stand. A structural overload may cause propeller shaft tubing to twist under strain or it may cause cracks or breaks in U-joints and spline plugs.

### 5. TROUBLESHOOTING

Refer to "Spicer Service Manual - Universal Joints and Driveshafts" under heading "Troubleshooting".

**6. SPECIFICATIONS**

**PROPELLER SHAFT**

**X3-45 COACHES EQUIPPED WITH ALLISON WORLD TRANSMISSION**

Make ..... Hayes-Dana Inc.  
Series..... 1810  
Supplier number ..... 819299-1  
Prevost number .....580075

**X3-45 COACHES EQUIPPED WITH ZF TRANSMISSION**

Make ..... Hayes-Dana Inc.  
Series..... 1810  
Supplier number (Traction) ..... 17937CCF  
Prevost number .....580083

**Repair kits**

Make ..... Hayes-Dana Inc.  
U-joint kit (tube yoke), Supplier number ..... 5-281X  
U-joint kit (tube yoke), Prevost number .....580043  
U-joint kit (slip yoke), Supplier number ..... 5-510X  
U-joint kit (slip yoke), Prevost number .....580062  
Cap and bolt kit, bolt torque 115-135 lbf•ft (156-183 N•m), Supplier number ..... 6.5-70-18X  
Cap and bolt kit, bolt torque 115-135 lbf•ft (156-183 N•m), Prevost number .....580063  
Bolts kit, bolt torque 38-48 lbf•ft (52-65 N•m), Supplier number ..... 6-73-209  
Bolts kit, bolt torque 38-48 lbf•ft (52-65 N•m), Prevost number .....580071

**Half Round End Yoke**

Make ..... Covington Detroit Diesel  
Supplier number .....29511516

|  |
|--|
| <p><b><i>NOTE</i></b></p> <p><i>U-joint kits will come equipped with the serrated bolt and lock patch and will no longer contain a lock strap.</i></p> |
|--|

# SECTION 10: FRONT AXLE

## CONTENTS

|   |           |
|---|-----------|
| <b>1. FRONT AXLE</b> .....                          | <b>2</b>  |
| 1.1 DESCRIPTION.....                                | 2         |
| <b>2. LUBRICATION</b> .....                         | <b>2</b>  |
| <b>3. MAINTENANCE</b> .....                         | <b>2</b>  |
| 3.1 TIE ROD END PLAY ADJUSTMENT .....               | 3         |
| <b>4. REMOVAL AND REPLACEMENT</b> .....             | <b>3</b>  |
| 4.1 REMOVAL .....                                   | 3         |
| 4.2 REPLACEMENT.....                                | 4         |
| <b>5. SERVICE INSTRUCTIONS FOR STEER AXLE</b> ..... | <b>4</b>  |
| 5.1 HUB BEARING INSPECTION .....                    | 4         |
| 5.2 KING PIN INSPECTION.....                        | 4         |
| 5.2.1 <i>Checking Lateral Slackness</i> .....       | 4         |
| 5.2.2 <i>Checking Vertical Slackness</i> .....      | 4         |
| <b>6. FRONT WHEEL ALIGNMENT</b> .....               | <b>5</b>  |
| 6.1 MINOR FRONT WHEEL ALIGNMENT.....                | 5         |
| 6.2 MAJOR FRONT WHEEL ALIGNMENT .....               | 5         |
| 6.3 INSPECTION BEFORE ALIGNMENT .....               | 5         |
| 6.4 TURNING ANGLE ADJUSTMENT .....                  | 5         |
| 6.4.1 <i>R.H. Turn Adjustment</i> .....             | 6         |
| 6.4.2 <i>L.H. Turn Adjustment</i> .....             | 6         |
| 6.5 HYDRAULIC STOP.....                             | 6         |
| 6.6 FRONT WHEEL CAMBER .....                        | 6         |
| 6.6.1 <i>Camber Check</i> .....                     | 7         |
| 6.7 FRONT AXLE CASTER.....                          | 7         |
| 6.8 FRONT WHEEL TOE-IN .....                        | 7         |
| 6.8.1 <i>Inspection and Adjustment</i> .....        | 8         |
| <b>7. TROUBLESHOOTING</b> .....                     | <b>9</b>  |
| <b>8. SPECIFICATIONS</b> .....                      | <b>10</b> |

## ILLUSTRATIONS

|   |    |
|---|----|
| FIGURE 1: FRONT AXLE ASSEMBLY .....                   | 2  |
| FIGURE 2: FRONT AXLE GREASING POINTS.....             | 2  |
| FIGURE 3: TIE ROD END PLAY ADJUSTMENT .....           | 3  |
| FIGURE 4: CAMBER .....                                | 7  |
| FIGURE 5: CASTER.....                                 | 7  |
| FIGURE 6: TOE-IN MEASUREMENTS .....                   | 8  |
| FIGURE 7: AIR BELLOWS MOUNTING SUPPORT AND AXLE ..... | 10 |

## Section 10: FRONT AXLE

### 1. FRONT AXLE

#### 1.1 DESCRIPTION

This front axle is of the "Reverse Elliot" type manufactured by Dana Spicer Europe. The front axle consists of a girder section axle bed or beam with stub axles. Each stub axle is carried on a taper kingpin, with a plain phosphor bronze bushing at the top and at the bottom. The unitized hub bearings used on the NDS range of axles, are non-serviceable items. Bearings are pre-adjusted, lubricated and have seals fitted as part of the manufacturing process. The bearings are greased for life and there is no need or facility for re-lubrication. Brakes are manufactured by KNORR-BREMSE. Steering ball joints with hardened balls and rubbing pads incorporate compression springs which automatically take up any wear.

The tie rod simplifies toe-in adjustment. The maximum turning angle is set through stop screws installed on the inner side of the knuckle.

Steering stabilizer (damper) and steering drag link which are mounted on the front axle are described in Section 14; "Steering" of this manual.

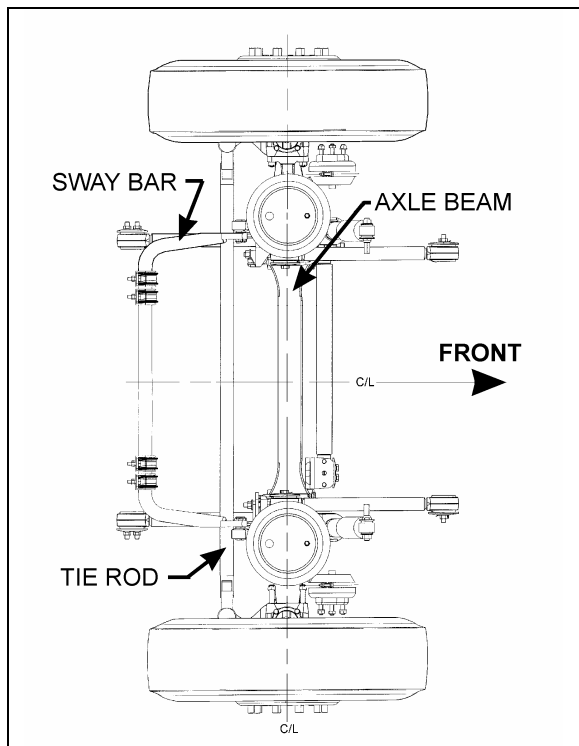


FIGURE 1: FRONT AXLE ASSEMBLY

10026

### 2. LUBRICATION

Pressure lubricate axle every 6 months or 30,000 miles (48 000 km) whichever comes first (Fig. 2). Tie rod ends and knuckle pins are provided with grease fittings for pressure lubrication. These grease fittings should be serviced every 6,250 miles (10 000 km) or twice a year whichever comes first. Good quality lithium-base roller bearing grease NLGI No.1 and 2 are recommended.

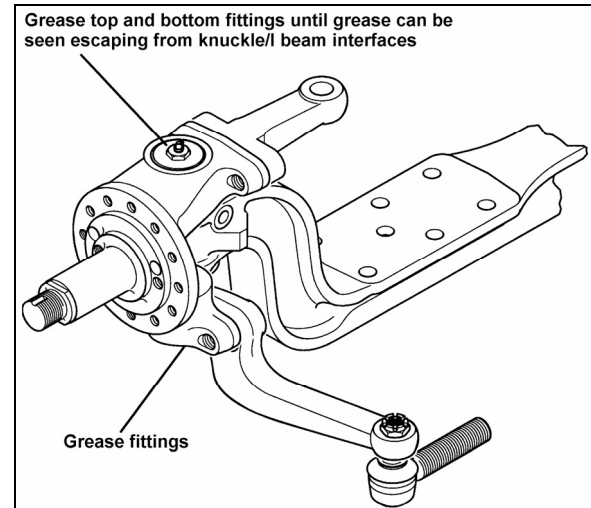


FIGURE 2: FRONT AXLE GREASING POINTS

10031

### 3. MAINTENANCE

A periodic inspection of the front axle assembly should be made to check that all bolts are tight, and that no damage and distortion have taken place. Suspension support stud nuts, U-bolt nuts, tie rod arms, steering arm nuts and stop screws should be checked and tightened, as required, to the torque specifications given at the end of this section. Also check the condition of the steering knuckle pins and bushings. In case of excessive looseness, the bushings and pins should be replaced.

Any looseness in the steering linkage, under normal steering loads, is sufficient cause to immediately check all pivot points for wear, regardless of accumulated mileage. Steering linkage pivot points should be checked each time the front axle assembly is lubricated. Any looseness can be visually detected while rotating the steering wheel in both directions.

Steering knuckles, knuckle pins and bushings can be overhauled or replaced without removing the axle from the vehicle. However, if extensive

overhaul work is necessary, the axle assembly should be removed.



### CAUTION

Should removal of a locking device be required when undergoing repairs, disassembly or adjustments, always replace with a new one.

#### 3.1 TIE ROD END PLAY ADJUSTMENT

If end play exceeds 0.047" (1.2 mm), readjustment is necessary.

Remove protective cap, using a suitable tool ie: a 1" x 1/8" x 9" long flat bar, tighten adjuster piece fully home (SOLID) locating thrust cup onto ball pin.

Still with tool located on adjuster piece, back off carefully (LEAST AMOUNT) until adjuster piece cotter pin is allowed to pass through body, then remove tool.

Reinstall protective cap.

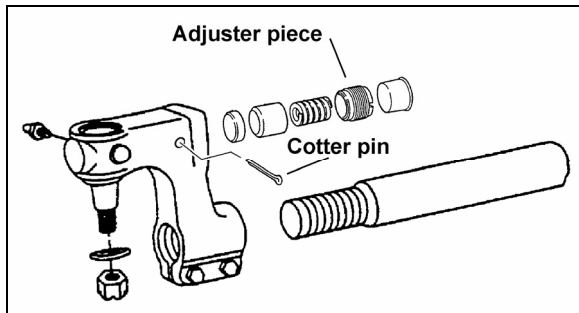


FIGURE 3: TIE ROD END PLAY ADJUSTMENT 10029

#### 4. REMOVAL AND REPLACEMENT

The following procedure deals with the removal of the front axle assembly. The method used to support the axle assembly and suspension components during removal and disassembly depends upon local conditions and available equipment.

##### 4.1 REMOVAL

1. Raise the vehicle by its jacking points on the body (see Section 18, "Body" under heading 16; Vehicle Jacking Points) until vehicle body is approximately 30 inches (760 mm) from the floor. Place jack stands under frame. Remove the wheels (if required, refer to Section 13, "Wheels, Hubs and Tires").



### CAUTION

Use only the recommended jacking points as outlined in section 18 "Body".

2. Exhaust compressed air from the air supply system by opening the drain valve of each reservoir.
3. Install jacks under axle jacking points to support the axle weight.



### DANGER

To help prevent injury caused by the axle rolling off the jacks, these should be equipped with U-adapters, or similar precautions must be taken

4. Disconnect the steering drag link from the steering arm.
5. Remove the ABS sensors from their location in hubs (if applicable).
6. Disconnect the height control valve link from its support on the axle.
7. Disconnect air lines from front brake chambers, and cover line ends and fittings to prevent the entry of foreign matter.



### CAUTION

Position the air lines and electric wires so they will not be damaged while removing the front axle assembly.

8. Proceed with steps a, b and c, while referring to Section 16: "Suspension".
  - a) Disconnect sway bar links from axle brackets.
  - b) Remove shock absorbers.
  - c) Disconnect five radius rods: one transversal and two longitudinal from subframe, and two upper rods from axle.
9. Remove the bolts and nuts fixing the axle to the left-hand and right-hand side air bellows mounting supports.
10. Using the jacks, slowly lower the axle assembly, and carefully pull away from underneath vehicle.

## Section 10: FRONT AXLE

---

### 4.2 REPLACEMENT

Reverse front axle "Removal" procedure. Ensure cleanliness of air bellows support mounting plates.

#### **NOTE**

*Refer to Section 16, "Suspension", Section 14, "Steering" and to paragraph 8 "Specifications" at the end of this section for applicable checks and recommended tightening torques.*

### 5. SERVICE INSTRUCTIONS FOR STEER AXLE

#### 5.1 HUB BEARING INSPECTION

An inspection should be made at intervals of 30,000 miles (48 000 km).

- Apply parking brake, raise wheels off the ground and support axle on stands. When the wheels are raised, they should revolve quite freely without roughness.
- Place magnetic base of a dial indicator on brake caliper and position dial indicator stem against a convenient marked spot on face of hub flange.
- With dial indicator in position pull hard but steadily on hub flange and oscillate at same time until a steady reading is achieved.
- Without releasing the pressure, turn bearing so that dial indicator stem contacts marked spot and note reading on indicator.
- Push bearing flange hard and oscillate as before until a steady reading is achieved.
- Without releasing the pressure, turn bearing so that indicator stem again contacts the marked spot and note new reading on indicator.
- The difference between readings is the amount of mounted end play in bearing unit.
- The mounted end play figure should not exceed **0.050 mm (0.002")** for a new bearing and **0.20 mm (0.008")** for a bearing which has been in service.

#### **NOTE**

*If original bearing unit is re-fitted, and end-float is measured at 1 mm, with hub not fully tightened to correct torque, then the retaining clip within the unit is damaged and a new unit must be fitted.*

#### 5.2 KING PIN INSPECTION

An inspection should be made at intervals of 30,000 miles (48 000 km).

Aspects to be considered are: Lateral slackness and Vertical slackness.

#### **NOTE**

*Before commencing checks, apply parking brake, raise wheels off ground and support axle on stands.*

##### 5.2.1 Checking Lateral Slackness

- While this is being carried out the brake must be applied.
- Place a set-square with its stock on ground and its blade against tire wall.
- Place a mark on ground to indicate position of stock end.
- Insert a lever through bottom cut-out of wheel and lever it upwards thus moving set-square outwards.
- Mark changed position of stock end.
- Maximum allowable stock displacement is given as follows: **for 22.5" wheels = 8mm (5/16")**.
- If displacement exceeds stated allowance then need for bush / bearing attention and possible renewal, is in evidence.

##### 5.2.2 Checking Vertical Slackness

- This is measured by a dial indicator anchored to axle beam and having its pointer placed vertical against swivel top.
- Place a jack against underside of swivel and, while applying a lifting force, observe any movement on indicator dial.
- **If vertical movement is evident and it exceeds 0.040" (1.02mm)** then readjustment of swivel is required by adjusting thickness of bearing adjusting washers.

Refer to "DANA SPICER Maintenance Manual Model NDS and Maintenance Manual NDS Axles" annexed at the end of this section.



## 6. FRONT WHEEL ALIGNMENT

Correct front wheel alignment must be maintained for steering comfort and satisfactory tire life. Road shocks and vibrations, as well as normal stress and strains on the front-end system can, under normal operating conditions, result in loss of front wheel alignment.

Check the front wheel alignment when the following occurs:

1. Every 200,000 miles (320 000 km) or 24 months (normal maintenance);
2. When the vehicle does not steer correctly; or
3. To correct a tire wear condition.

There are two types of front wheel alignment: **minor alignment** and **major alignment**.

### 6.1 MINOR FRONT WHEEL ALIGNMENT

Perform a minor front wheel alignment for all normal maintenance conditions.

Perform the minor front wheel alignment in the following sequence :

1. Inspect all the systems that affect the wheel alignment. See paragraph 6.3, "*Inspection Before Alignment*" in this section.
2. Check the hub bearings. See section 13, "*Wheels, hubs and Tires*" under heading 8: Front and Tag Axle Wheel Hubs.
3. Check and adjust the toe-in.

### 6.2 MAJOR FRONT WHEEL ALIGNMENT

Perform a major front wheel alignment to correct steering and tire wear conditions.

Perform the major front wheel alignment in the following sequence:

1. Inspect all systems affecting the wheel alignment. See paragraph 6.3, "*Inspection Before Alignment*" in this section.
2. Check the hub bearings. See section 13, "*Wheels, hubs and Tires*" under heading 8: Front and Tag Axle Wheel Hubs.

**NOTE**

*If steering angle stoppers are changed, a special procedure is required for readjusting gearbox steering limiter. See paragraph 6.5 "Hydraulic Stop" in this section.*

3. Check and adjust the turning angle adjustment.
4. Check the camber angle.
5. Check and adjust the caster angle.
6. Check and adjust the toe-in.

### 6.3 INSPECTION BEFORE ALIGNMENT

Check the following before doing a front wheel alignment:

1. Ensure that the vehicle is at normal riding height. See Section 16, "*Suspension*" under heading 7: "*Suspension Height Adjustment*".
2. Ensure that front wheels are not the cause of the problem. See Section 13, "*Wheels, Hubs and Tires*". Inspect the tires for wear patterns indicating suspension damage or misalignment.
  - a. Make sure the tires are inflated to the specified pressure.
  - b. Make sure the front tires are the same size and type.
  - c. Make sure the wheels are balanced.
  - d. Check wheel installation and straightness.
3. Check the wheel bearing adjustment.
4. Check steering linkage for bending and pivot points for looseness.
5. Check knuckle pins for evidence of excessive wear.
6. Check radius rods for bending and rubber bushings for evidence of excessive wear.
7. Make sure all fasteners are tightened to the specified torque. Use a torque wrench for verification. As soon as the fastener starts to move, record the torque. Correct if necessary. Replace any worn or damaged fasteners.

### 6.4 TURNING ANGLE ADJUSTMENT

The maximum turning angle is set through the two steering stop screws installed on the axle center. The turning angle is factory adjusted to accommodate the chassis design, and therefore, does not require adjustment on new vehicles. However, it should be checked and

## Section 10: FRONT AXLE

adjusted any time any component of the steering system is repaired, disassembled or adjusted.

Check if front tires rub against the frame or if the steering gear has been serviced.

Proceed with the following method to check the steering maximum turning angle :

### 6.4.1 R.H. Turn Adjustment



#### CAUTION

To prevent the steering damper from interfering with the adjustment of turning angles, make sure its fixing bracket is at the correct location on the axle center (refer to section 14 "Steering").

1. Turn steering wheel to the right until the boss on the axle center touches the right stop screw.
2. Verify the nearest point of contact of the ball socket body with the air bellows support assembly. Measure the distance between those two points.
3. The distance between these two points should be approximately 1/8 inch (3 mm). If not, the steering stop screws must be readjusted.
4. Verify the nearest point of contact of the drag link with the tire. Measure the distance between those two points.
5. The distance should be 1 inch (25 mm) or more. If not, the steering stop screws must be readjusted.
6. This must be done for a full right turn.
7. If readjustment is required:
  - a. Remove the swivel stop screw.
  - b. Add to the stop screw the required number of washers to obtain the proper measure, tighten the stop screw afterwards. Two washers of different thickness are available: 1/16 inch and 3/16 inch.

### 6.4.2 L.H. Turn Adjustment

1. Turn steering wheel to the left until the boss on the axle center touches the left stop screw.

2. Verify the nearest point of contact of the ball socket body with the air bellows support assembly. Measure the distance between those two points.
3. The distance between these two points should be approximately 1/8 inch (3 mm). If not, the steering stop screws must be readjusted.
4. Check the stroke of the steering stabilizer cylinder (damper). It should not exceed 12.59 inches (320 mm).
5. This must be done for a full left turn.
6. If readjustment is required:
  - a. Remove the swivel stop screw.
  - b. Add to the stop screw the required number of washers to obtain the proper measure, tighten the stop screw afterwards. Two washers of different thickness are available: 1/16 inch and 3/16 inch.

#### NOTE

*If steering angle stoppers are changed, a special procedure is required for readjusting gearbox steering limiter. See paragraph 6.5 "Hydraulic Stop" in this section.*

### 6.5 HYDRAULIC STOP

#### NOTE

*Before steering limiter readjustment, verify vehicle wheel alignment and ensure that oil level is checked and that air bleeding is done.*

Refer to "ZF-Servocom Repair Manual" annexed at the end of Section 14 "Steering" under heading 'Setting and Functional Test'.

### 6.6 FRONT WHEEL CAMBER

Wheel camber is the number of degrees the top of the wheel tilts outward (positive) or inward (negative) from a vertical angle (Fig. 4).

The camber angle is not adjustable. Camber variations may be caused by wear at the wheel bearings, steering knuckle pins or by a bent knuckle or sagging axle center. Steering effort is affected by improper camber, and uneven tire wear will result. Excessive positive camber causes an irregular wear of tire at the outer shoulder and excessive negative camber causes wear at the inner shoulder.

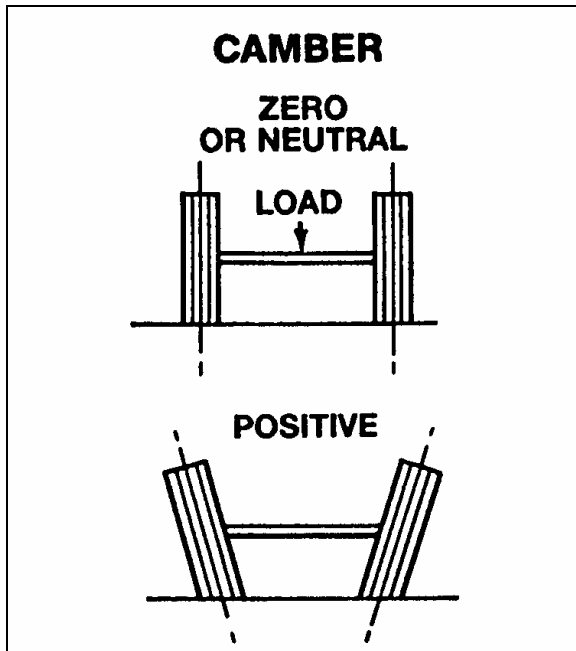


FIGURE 4: CAMBER

10006

#### 6.6.1 Camber Check

**For camber specifications, refer to paragraph 8: "Specifications" in this section**

1. Use an alignment machine to check the camber angle.
2. If camber reading is not in the specifications, check the wheel bearings and repeat the check. If the reading is still not within specifications, verify the steering knuckle pins and axle center.

See instructions in "DANA SPICER Maintenance Manual Model NDS and Maintenance Manual NDS Axles" annexed at the end of this section.

3. Check the wheel lateral distortion as instructed in Section 13, "Wheels, Hubs and Tires" under heading, "Checking for Distorted Wheel on Vehicle". If distortion is excessive, straighten or replace wheel(s).

#### 6.7 FRONT AXLE CASTER

**For caster specifications, refer to paragraph 8: "Specifications" in this section.**

Positive caster is the rearward tilt from the vertical axis of the knuckle pin. Negative caster is the forward tilt from the vertical axis of the knuckle pin (Fig. 5). This vehicle is designed with a positive caster. The purpose of the caster angle is to give

a trailing effect. This results in stabilized steering and a tendency for the wheels to return to the straight-ahead position after taking a turn.

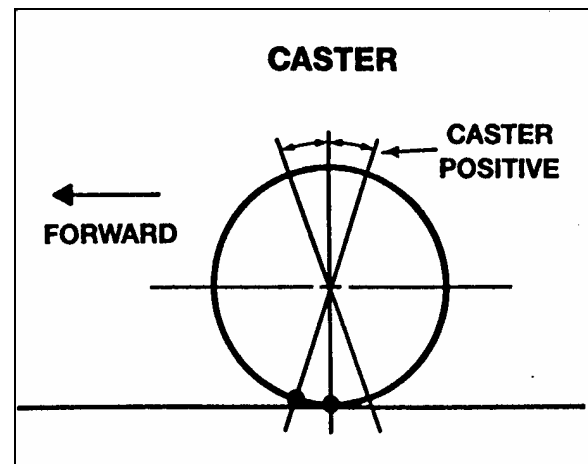


FIGURE 5: CASTER

10007

Excessive caster results in hard steering around corners. A shimmy may also develop when returning to the straight ahead position (pulling out of curves).

Insufficient caster will cause wandering and steering instability. Caster variations may be caused by a bent axle, tilting or distortion of the side suspension supports, damaged radius rod bushings, or unequal tightening of the front and rear suspension support bolts. Incorrect caster must be corrected by replacing the damaged suspension parts. A precision instrument should be used to measure the caster.

#### NOTE

*The caster of this vehicle is factory set and is not adjustable. However, if after replacing damaged parts or in case of improper caster due to irregular setting, the front axle caster needs adjustment; it can be adjusted by means of shims (Prévost #110663) on the left-hand side upper radius rod support in order to obtain minor adjustment.*

#### 6.8 FRONT WHEEL TOE-IN

Wheel toe-in is the degree (usually expressed in fractions of an inch) to which the forward part of the vehicle front wheels are closer together than the rear part, measured at wheel centerline height with the wheels in the normal "straight-ahead" position of the steering gear.

Incorrect toe-in results in excessive tire wear caused by side slippage and also steering instability with a tendency to wander. Toe-in may

## Section 10: FRONT AXLE

be measured from the center of tire tread or from the inside of the tires. Take measurements at both front and rear of axle (see "A and "B" in fig. 6).

When setting toe-in adjustment, the front suspension must be neutralized; that is, all component parts must be in the same relative position when marking the adjustment as they will be when in operation.

To neutralize the suspension, the vehicle must be rolled forward, approximately ten feet.

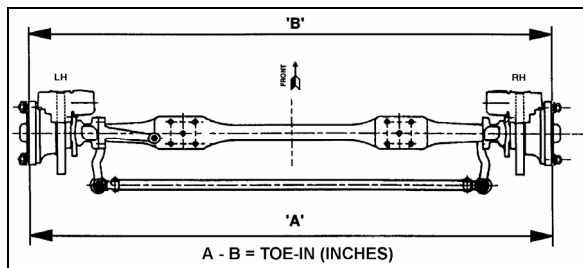


FIGURE 6: TOE-IN MEASUREMENTS

10032

For toe-in specifications, refer to paragraph 8 "Specifications" in this section.

By rolling the vehicle forward, all tolerances in the front suspension are taken up and the suspension is then in its normal operating position. Neutralizing the front suspension is extremely important, especially if the vehicle has been jacked up in order to mark the tires. Otherwise, the front wheels will not return to their normal operating position due to the tires gripping the floor surface when the vehicle jack is lowered.

### **NOTE**

*"Toe-in" measurements must be taken at the horizontal axis of the wheel centerline.*

### 6.8.1 Inspection and Adjustment

Before checking front wheel toe-in, first check the camber angles and make the necessary corrections.

1. Measure the toe-in.
2. If the toe-in measurement is not within the specified tolerance, carry out the following procedure :
  - a. Loosen the pinch bolt nuts and bolts on each tie rod end.
  - b. Turn the tie rod until the specified toe-in measurement is obtained.
  - c. Tighten the pinch bolt nuts alternately and progressively to 65-75 lbf-ft (88-102 Nm), thus securing all tie rod joints.

## 7. TROUBLESHOOTING

| CONDITION  | CAUSE  | CORRECTION  |
|--|--|---|
| Tires wear out quickly or have uneven tire tread wear.               | <ol style="list-style-type: none"> <li>1. Tires have incorrect air pressure.</li> <li>2. Tires out-of-balance.</li> <li>3. Incorrect tag axle alignment.</li> <li>4. Incorrect toe-in setting.</li> <li>5. Incorrect steering arm geometry.</li> </ol>   | <ol style="list-style-type: none"> <li>1. Put specified air pressure in tires.</li> <li>2. Balance or replace tires.</li> <li>3. Align tag axle.</li> <li>4. Adjust toe-in specified setting.</li> <li>5. Service steering system as necessary.</li> </ol>  |
| Vehicle is hard to steer.  | <ol style="list-style-type: none"> <li>1. Low pressure in the power steering system.</li> <li>2. Steering gear not assembled correctly.</li> <li>3. Steering linkage needs lubrication.</li> <li>4. King pins binding.</li> <li>5. Incorrect steering arm geometry.</li> <li>6. Caster improperly adjusted.</li> <li>7. Tie rod ends hard to move.</li> <li>8. Worn thrust bearing.</li> </ol> | <ol style="list-style-type: none"> <li>1. Repair power steering system.</li> <li>2. Assemble steering gear correctly.</li> <li>3. Lubricate steering linkage.</li> <li>4. Replace king pins.</li> <li>5. Service steering system as necessary.</li> <li>6. Adjust caster as necessary.</li> <li>7. Replace tie rod ends.</li> <li>8. Replace thrust bearing.</li> </ol> |
| Bent or broken steering arm, steering top lever or tie rod assembly. | <ol style="list-style-type: none"> <li>1. Too much pressure in the power steering system.</li> <li>2. Cut-off pressure of the power steering system improperly adjusted.</li> <li>3. Vehicle not powered on correctly.</li> <li>4. Power steering system not installed correctly.</li> </ol>   | <ol style="list-style-type: none"> <li>1. Replace damaged part(s), adjust power steering system to specified pressure.</li> <li>2. Make sure vehicle is powered on correctly.</li> <li>3. Correctly install the power steering system.</li> <li>4. Correctly install the power steering system.</li> </ol>  |
| Worn or broken steering ball stud.                                   | <ol style="list-style-type: none"> <li>1. Drag link fasteners tightened past specified torque.</li> <li>2. Lack of lubrication or incorrect lubricant.</li> <li>3. Power steering stops improperly adjusted.</li> </ol>  | <ol style="list-style-type: none"> <li>1. Replace damaged part(s), tighten drag link fasteners to specified torque.</li> <li>2. Lubricate linkage with specified lubricant.</li> <li>3. Adjust stops to specified dimension.</li> </ol>   |
| Worn king pins and knuckle bushings.                                 | <ol style="list-style-type: none"> <li>1. Worn or missing seals and gaskets.</li> <li>2. Incorrect lubricant.</li> <li>3. Axle not lubricated at scheduled frequency.</li> <li>4. Incorrect lubrication procedures.</li> <li>5. Lubrication schedule does not match operating conditions.</li> </ol>   | <ol style="list-style-type: none"> <li>1. Replace damaged part(s), replace seals and gaskets.</li> <li>2. Lubricate axle with specified lubricant.</li> <li>3. Lubricate axle at scheduled frequency.</li> <li>4. Use correct lubrication schedule to match operating conditions.</li> <li>5. Change lubrication schedule to match operating conditions.</li> </ol>     |
| Vibration or shimmy of front axle during operation.                  | <ol style="list-style-type: none"> <li>1. Caster not adjusted properly.</li> <li>2. Wheels and/or tires out-of balance.</li> <li>3. Worn steering stabilizer cylinder.</li> </ol>  | <ol style="list-style-type: none"> <li>1. Adjust caster.</li> <li>2. Balance or replace wheels and/or tires.</li> <li>3. Replace steering stabilizer cylinder.</li> </ol>   |

## Section 10: FRONT AXLE

### 8. SPECIFICATIONS

#### Front Axle

Make ..... DANA SPICER EUROPE

Model ..... NDS

Front Track ..... 84.4 inches (2 145 mm)

Rated load capacity ..... 16,500 lbs (7 500 kg)

#### Torque specifications

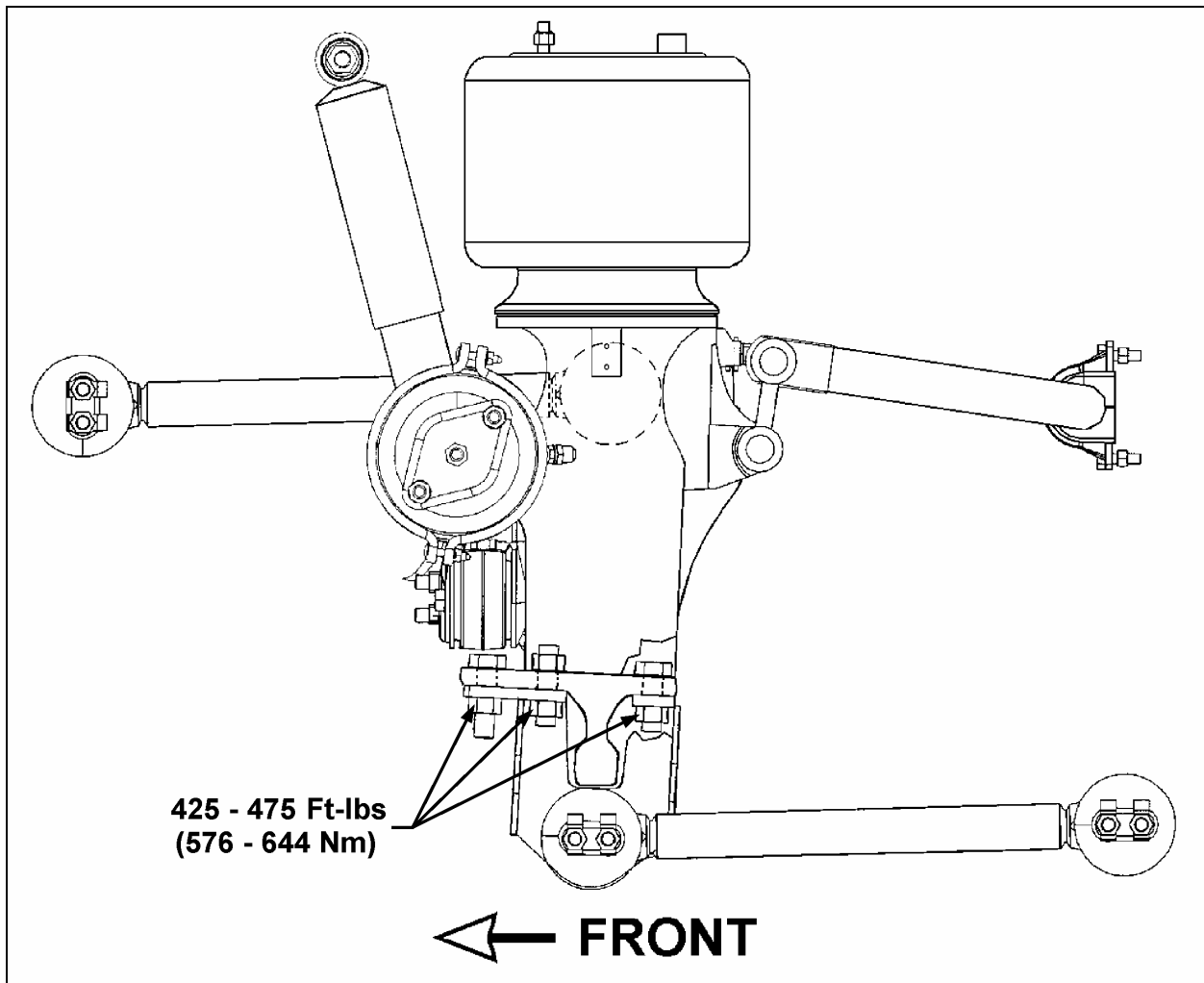


FIGURE 7: AIR BELLOWS MOUNTING SUPPORT AND AXLE

10030

For more torque specifications, see 'Dana Spicer Maintenance Manual NDS Axles and Maintenance Manual Model NDS' annexed at the end of this section.

| FRONT WHEEL ALIGNMENT SPECIFICATIONS |         |         |         |
|--------------------------------------|---------|---------|---------|
| Front Wheel Alignment                | Minimal | Nominal | Maximal |
| Camber, (degrees)<br>R.H. and L.H. * | -0.250  | 0.125   | 0.375   |
| Caster, (degrees)<br>R.H. and L.H.   | 2       | 2.75    | 3.5     |
| Toe-in (A minus B),<br>(degrees)     | 0.06    | 0.08    | 0.10    |

**NOTE**

*Camber angle changes with loading. The given numbers are for an empty vehicle.*

# SECTION 11: REAR AXLES

## CONTENTS

- 1. DRIVE AXLE ..... 2**
  - 1.1 DESCRIPTION..... 2
  - 1.2 DCDL (DRIVER-CONTROLLED MAIN DIFFERENTIAL LOCK) ..... 2
  - 1.3 DRIVE AXLE LUBRICATION ..... 2
  - 1.4 MAINTENANCE ..... 3
    - 1.4.1 *Checking and Adjusting the Oil Level* ..... 3
    - 1.4.2 *Draining and Replacing the Oil* ..... 3
    - 1.4.3 *Speed Sensors (Anti-Lock Brake system, ABS)* ..... 4
  - 1.5 REMOVAL AND REINSTALLATION ..... 4
  - 1.6 DISASSEMBLY AND REASSEMBLY ..... 4
  - 1.7 GEAR SET IDENTIFICATION ..... 5
  - 1.8 ADJUSTMENTS ..... 5
  - 1.9 FASTENER TORQUE CHART ..... 5
  - 1.10 TIRE MATCHING ..... 5
  - 1.11 DRIVE AXLE ALIGNMENT ..... 5
    - 1.11.1 *Procedure* ..... 5
  - 1.12 AXLE SHAFT SEALING METHOD..... 7
- 2. TAG AXLE ..... 7**
  - 2.1 UNLOADING TAG AXLE ..... 7
  - 2.2 RETRACTING TAG AXLE..... 7
  - 2.3 RETRACTING TAG AXLE FOR REPAIR PURPOSES..... 8
  - 2.4 GREASE LUBRICATED WHEEL BEARINGS..... 8
  - 2.5 REMOVAL AND INSTALLATION ..... 8
    - 2.5.1 *Removing Tag Axle Only*..... 8
    - 2.5.2 *Removing Tag Axle Along With Suspension Components*..... 8
  - 2.6 TAG AXLE ALIGNMENT..... 9
- 3. SPECIFICATIONS..... 10**

## ILLUSTRATIONS

- FIGURE 1: DRIVE AXLE ..... 2
- FIGURE 2: DIFFERENTIAL ASSEMBLY ..... 2
- FIGURE 3: DRIVER-CONTROLLED DIFFERENTIAL LOCK ..... 2
- FIGURE 4: DIFFERENTIAL HOUSING BOWL ..... 3
- FIGURE 5: JACKING POINTS ON FRAME ..... 4
- FIGURE 6: JACKING POINTS ON DRIVE AXLE ..... 4
- FIGURE 7: FRONT & DRIVE AXLE ALIGNMENT ..... 6
- FIGURE 8: TAG AXLE ALIGNMENT..... 6
- FIGURE 9: AXLE SHAFT INSTALLATION ..... 7
- FIGURE 10: TORQUE SPECIFICATION ..... 7
- FIGURE 11: JACKING POINTS ON TAG AXLE ..... 9



## Section 11: REAR AXLES

### 1. DRIVE AXLE

#### 1.1 DESCRIPTION

The Meritor drive axle is equipped with a single reduction standard carrier mounted in front of the axle housing. The carrier consists of a hypoid drive pinion, a ring gear set and gears in the differential assembly.

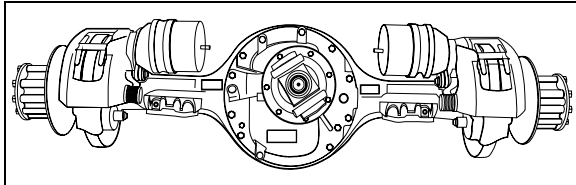


FIGURE 1: DRIVE AXLE

11019

A straight roller bearing (spigot) is mounted on the head of the drive pinion. All other bearings in the carrier are tapered roller bearings. When the carrier operates, there is a normal differential action between the wheels all the time.

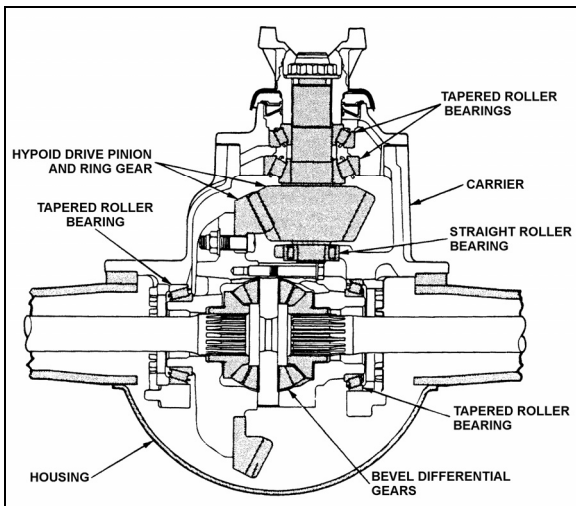


FIGURE 2: DIFFERENTIAL ASSEMBLY

11024

Several speed ratios are available for the drive axle. These ratios depend upon the motor and transmission. Also, special applications may suggest slightly different gear ratios.

#### 1.2 DCDL (DRIVER-CONTROLLED MAIN DIFFERENTIAL LOCK)

Meritor Single-reduction carriers with driver-controlled main differential lock (DCDL) have the same type of gears and bearings as the standard-type carriers. The differential lock is operated by an air actuated shift assembly that is mounted on the carrier.

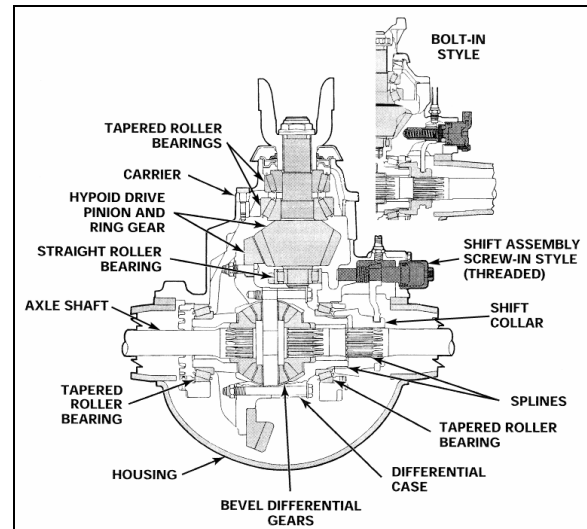


FIGURE 3: DRIVER-CONTROLLED DIFFERENTIAL LOCK

11028

#### 1.3 DRIVE AXLE LUBRICATION

Additional lubrication information is covered in the Meritor Technical Bulletin TP-9539: "Approved Rear Drive Axle Lubricants" annexed to this section. During initial stage of normal operation, tiny metal particles originating from moving parts can be found on mating surfaces. These particles are carried by the lubricant through the assembly and act as lapping compound, which accelerates wear of all parts. To ensure maximum life of the differential and prevent premature failure, the original "factory fill" lubricant should be drained. Change break-in oil before 3,000 miles (4 800 km) of initial operation (drain the unit while it is still warm from operation), in accordance with the lubrication and servicing schedule.

Change differential oil and clean the breathers, magnetic fill and drain plugs, every 100,000 miles (160 000 km) or once every two years, whichever comes first.

Use Multigrade gear oil MIL-L-2105-D. Use the 75W90-gear oil for northern climates and the 80W140 for southern climates. In extreme conditions, or for better performance, fill with synthetic gear oil. Check oil level and add (if necessary) every 6,250 miles (10 000 km) or twice a year, whichever comes first (Fig. 4).

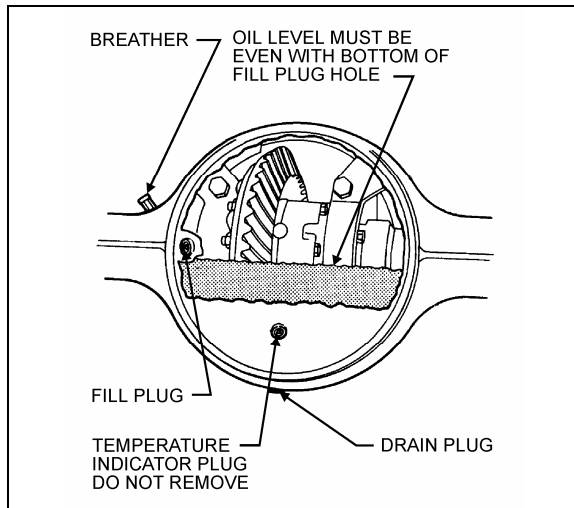


FIGURE 4: DIFFERENTIAL HOUSING BOWL 11007

1.4 MAINTENANCE

Proper vehicle operation begins with preventive maintenance, such as good differential use. The most common types of drive axle carrier failures are spinout, shock, fatigue, overheating and lubrication. Avoid neglecting these points since they would be the first steps to improper maintenance, expensive repairs, and excessive downtime.

Inspect the pinion oil seal, axle shaft flange and carrier housing gaskets for evidence of lubricant leakage. Tighten the bolts and nuts, or replace the gaskets and seals to correct leaks. Maintenance of the axle mountings consists primarily in a regular and systematic inspection of the air suspension units and radius rods, as directed in Section 16, "Suspension".

1.4.1 Checking and Adjusting the Oil Level

**DANGER**

Before servicing, park safely over a repair pit, apply parking brake, stop engine and set battery master switch to the "OFF" position.

1. Make sure the vehicle is parked on a level surface.

**WARNING**

Check the oil level when the axle is at room temperature. When hot, the oil temperature may be 190°F (88°C) or more and can cause burns. Also, a correct reading is not obtained when the axle is warm or hot.

2. Make sure the axle is "cold" or at room temperature.
3. Clean the area around the fill plug. Remove the fill plug from the differential axle housing bowl (Fig. 4).
4. The oil level must be even with the bottom of the hole of the fill plug.
  - a. If oil flows from the hole when the plug is loosened, the oil level is high. Drain the oil to the correct level.
  - b. If the oil level is below the bottom of the hole of the fill plug, add the specified oil.
5. Install and tighten the fill plug to 35-50 lbf-ft (48-67 Nm).

1.4.2 Draining and Replacing the Oil

**DANGER**

Before servicing, park safely over a repair pit, apply parking brake, stop engine and set battery master switch to the "OFF" position.

1. Make sure the vehicle is parked on a level surface. Put a large container under the axle's drain plug.

**NOTE**

Drain the oil when the axle is warm.

2. Remove the drain plug from the bottom of the axle. Drain and discard the oil in an environment friendly manner.
3. Install and tighten the drain plug to 35-50 lbf-ft (48-67 Nm).
4. Clean the area around the fill plug. Remove the fill plug from the differential housing bowl.
5. Add the specified oil until the oil level is even with the bottom of the hole of the fill plug. Allow the oil to flow through the axle and check the oil level again (lube capacity 41 pints [13,3 liters]).

**CAUTION**

The differential overheats when the oil temperature rises above 250°F (120°C).

6. Install and tighten the fill plug to 35-50 lbf-ft (48-67 Nm).

## Section 11: REAR AXLES

### 1.4.3 Speed Sensors (Anti-Lock Brake system, ABS)

For removing and installing the drive axle speed sensors (for anti-lock brake systems, ABS), refer to Section 12: "Brake and Air System" and to Rockwell WABCO Maintenance Manual: "Anti-Lock Brake Systems For Trucks, Tractors and Buses", annexed at the end of section 12.

### 1.5 REMOVAL AND REINSTALLATION

The following procedure deals with the removal of the drive axle assembly and its attachments as a unit. The method used to support the axle during removal and disassembly depends upon local conditions and available equipment.

1. Raise vehicle by its jacking points on the body (fig. 5 or see Section 18, "Body" under heading "Vehicle Jacking Points"). Place jack stands under frame. Remove drive axle wheels (if required, refer to Section 13, "Wheels, Hubs And Tires".

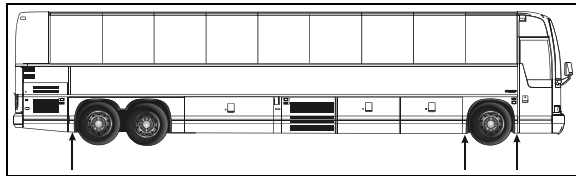


FIGURE 5: JACKING POINTS ON FRAME 18618

2. Exhaust compressed air from the air supply system by opening the drain cock on each air reservoir.
3. Disconnect the propeller shaft as directed in Section 9, "Propeller Shaft", in this manual.
4. On both sides of the vehicle, unscrew fasteners retaining front wheel housing plastic guards, and remove them from vehicle.
5. Disconnect both height control valve links from air spring mounting plate brackets then move the arm down to exhaust air suspension.
6. Remove cable ties securing the ABS cables (if vehicle is so equipped) to service brake chamber hoses. Disconnect the ABS cable plugs from the drive axle wheel hubs.

#### NOTE

When removing drive axle, if unfastening cable ties is necessary for ease of operation, remember to replace them afterwards.

7. Disconnect the brake chamber hoses.

#### NOTE

Position the hoses so they will not be damaged when removing the axle.

8. Install jacks under the axle jacking points to support the axle weight (refer to figure 6).

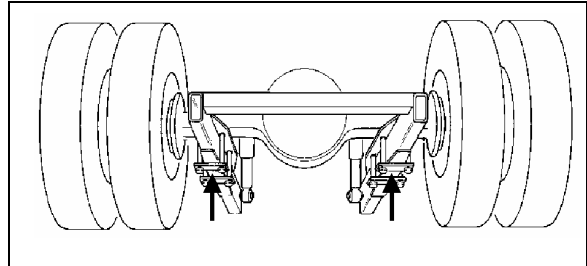


FIGURE 6: JACKING POINTS ON DRIVE AXLE 11005

9. Remove the four shock absorbers as outlined in Section 16, "Suspension" under heading "Shock Absorber Removal".
10. Remove the sway bar.
11. Remove the lower and upper longitudinal radius rod supports from vehicle sub-frame as outlined in Section 16, "Suspension", under heading "Radius Rod Removal".
12. Remove the transversal radius rod support from the vehicle sub-frame.
13. Remove the two retaining nuts from each of the four air bellows lower mounting supports.
14. Use the jacks to lower axle. Carefully pull away the jacks axle assembly from underneath vehicle.
15. Reverse removal procedure to reinstall drive axle.

#### NOTE

Refer to Section 16, "Suspension" for suspension components' proper tightening torques.

#### NOTE

Refer to section 13 "Wheels, Hubs And Tires" for correct wheel bearing adjustment procedure.

### 1.6 DISASSEMBLY AND REASSEMBLY

Disassembly and re-assembly procedures are covered under applicable headings in Meritor's "MAINTENANCE MANUAL, NO. 5", annexed to this section.

1.7 GEAR SET IDENTIFICATION

Gear set identification is covered under applicable heading in Meritor's "MAINTENANCE MANUAL NO. 5", annexed to this section.

1.8 ADJUSTMENTS

Adjustments are covered under applicable headings in Meritor's "MAINTENANCE MANUAL NO. 5", annexed to this section.

1.9 FASTENER TORQUE CHART

A differential fastener torque chart is provided in Meritor's "MAINTENANCE MANUAL NO. 5", annexed to this section.

1.10 TIRE MATCHING

Drive axle tire matching is covered under the applicable heading in Section 13, "Wheels, Hubs And Tires" in this manual.

1.11 DRIVE AXLE ALIGNMENT

**NOTE**  
For drive axle alignment specifications, refer to paragraph 3: "Specifications" in this section.

The drive axle alignment consists in aligning the axle according to the frame. The axle must be perpendicular to the frame. The alignment is achieved with the use of shims inserted between the lower longitudinal radius rod supports and the frame.

Drive axle alignment is factory set and is not subject to any change, except if the vehicle has been damaged by an accident or if there are requirements for replacement.

**DRIVE AXLE ALIGNMENT**

- With the system installed as in figure 7, adjust drive axle according to specifications' chart below.

| <b>DRIVE AXLE<br/>ALL VEHICLES</b> |               |               |               |
|------------------------------------|---------------|---------------|---------------|
| Alignment / value                  | Minimum value | Nominal value | Maximum value |
| Thrust angle (deg.)                | -0.04         | 0             | 0.04          |
| Total Toe (deg.)                   | 0.18 Toe-in   | 0             | 0.18 Toe-out  |

**TAG AXLE ALIGNMENT**

- Remove and reinstall all wheel mount sensors on the drive and tag axles (fig. 8);

If the axle has been removed for repairs or servicing and if all the parts are reinstalled exactly in the same place, the axle alignment is not necessary. However, if the suspension supports have been replaced or altered, proceed with the following instructions to verify or adjust the drive axle alignment.

**NOTE**  
When drive axle alignment is modified, tag axle alignment must be re-verified.

1.11.1 Procedure

1. Park vehicle on a level surface, then chock front vehicle wheels.
2. Using two jacking points (which are at least 30 inches [76 cm] apart) on drive axle, raise the vehicle sufficiently so that wheels can turn freely at about 1/2 inch from ground. Secure in this position with safety stands, and release parking brake.
3. Install wheel mount sensors on front end and drive axle wheels (fig. 7).

**NOTE**  
See reference numbers on wheel mount sensors (fig.7).

**NOTE**  
Select axle specifications in the appropriate chart

## Section 11: REAR AXLES

**NOTE**

For an accurate alignment, the tag axle must be aligned with the drive axle.

**NOTE**

Reinstall wheel mount sensors as shown in figure 8.

- Adjust tag axle according to specifications' chart below in reference with drive axle.

| TAG AXLE<br>ALL VEHICLES |               |               |               |
|--------------------------|---------------|---------------|---------------|
| Alignment / value        | Minimum value | Nominal value | Maximum value |
| Parallelism (deg.)       | -0.02         | 0             | 0.02          |
| Total Toe (deg.)         | 0.18 Toe-in   | 0             | 0.18 Toe-out  |

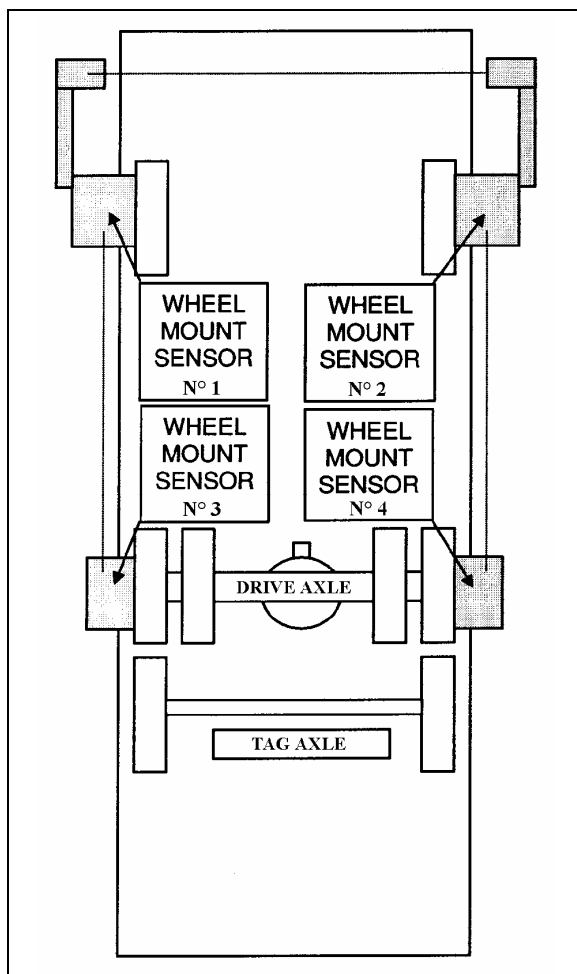


FIGURE 7: FRONT & DRIVE AXLE ALIGNMENT 11025

**NOTE**

Refer to Section 16, "Suspension", for proper torque tightening of the longitudinal radius rod support nuts.

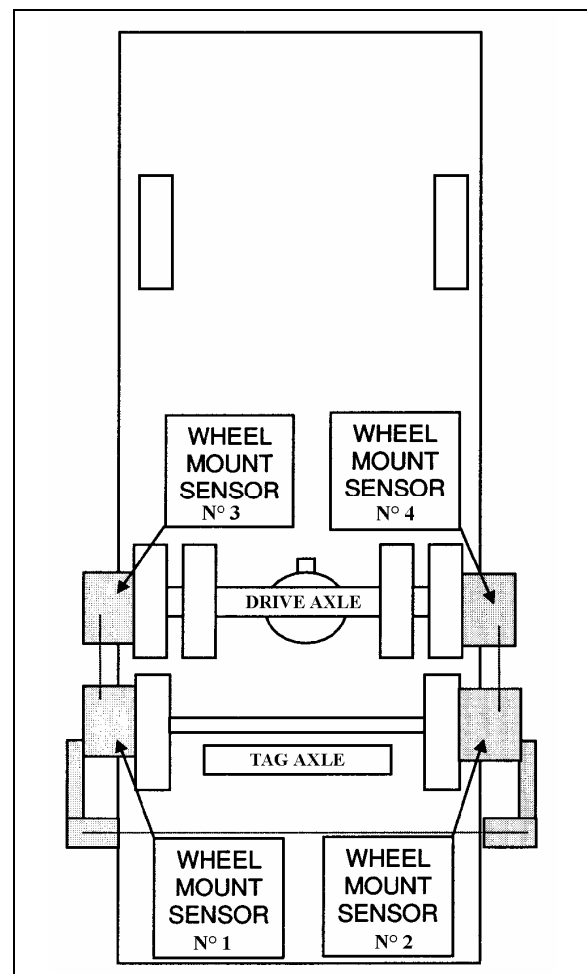


FIGURE 8: TAG AXLE ALIGNMENT 11026

**NOTE**

When the drive alignment is changed, the tag alignment must also be adjusted.

1.12 AXLE SHAFT SEALING METHOD

The following method is to be used to ensure that axle shaft installation is fluid-tight:

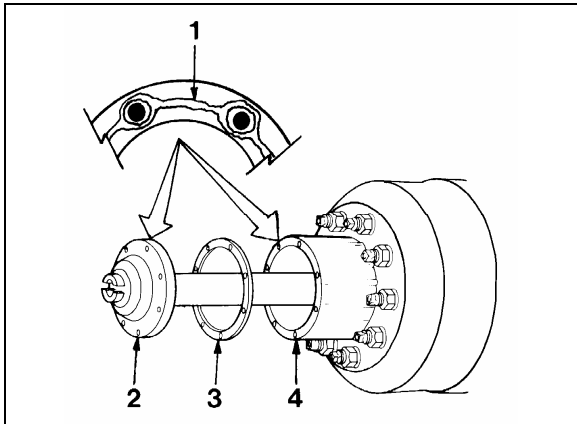


FIGURE 9: AXLE SHAFT INSTALLATION 11003

- 1 ..... Silicone sealant\*
- 2 ..... Axle shaft
- 3 ..... Gasket
- 4 ..... Wheel hub

1. Clean the mounting surfaces of both the axle shaft flange and wheel hub where silicone sealant will be applied. Remove all old silicone sealant, oil, grease, dirt and moisture. Dry both surfaces.
2. Apply a continuous thin bead of silicone sealant\* (Prévost P/N 680053) on the mounting surfaces and around the edge of all fastener holes of both the axle shaft flange and wheel hub.

\* GENERAL ELECTRIC Silicone Rubber Adhesive Sealant RTV 103 Black.

**⚠ WARNING**

Carefully read cautions and instructions on the tube of silicone sealant and its packing.

3. Assemble components immediately to permit the silicone sealant to compress evenly between parts.
  - a. Place a new gasket and then install the axle shaft into the wheel hub and differential carrier. The gasket and flange of the axle shaft must fit flat against the wheel hub.
  - b. Install the tapered dowels at each stud and into the flange of the axle shaft. Use a punch or drift and hammer if needed.

- c. Install the lock washers and nuts on the studs. Tighten nuts to the correct torque value.

**NOTE**

Torque values are for fasteners that have a light application of oil on the threads (refer to Meritor Maintenance Manual).

9/16-18 plain nut: 110 - 165 lbf-ft (149 -224 Nm)

5/8-18 plain nut: 150 - 230 lbf-ft (203 - 312 Nm)

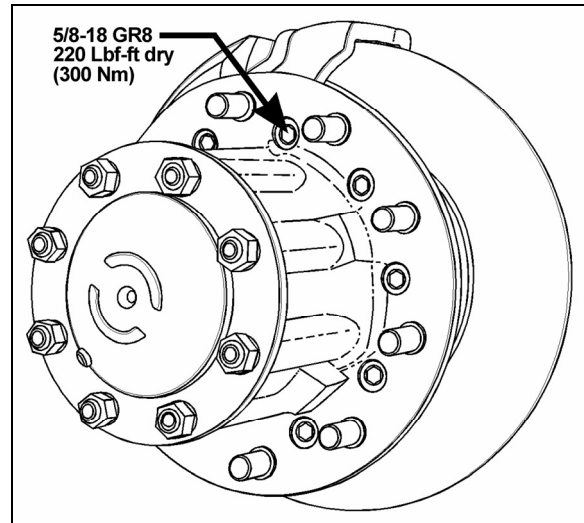


FIGURE 10: TORQUE SPECIFICATION

2. TAG AXLE

The tag axle is located behind the drive axle. It carries a single wheel and tire on each side.

2.1 UNLOADING TAG AXLE

To reduce the turning radius, the air springs pressure will be automatically reduced by 75% when the coach is moving at speed lower than 5 mph (8 km/h) and with more than 1½ turn from the steering.

2.2 RETRACTING TAG AXLE

The standard tag axle retraction system is controlled by a valve located on the right lateral console and enables unloading and raising the tag axle (refer to the "OPERATOR'S MANUAL" for location of controls). This system has been designed for the following purposes:

1. Shortening of wheelbase, thus allowing tighter turning in tight maneuvering areas such as parking lots or when making a sharp turn.

## Section 11: REAR AXLES

2. Transferring extra weight and additional traction to the drive wheels on slippery surfaces.

The tag axle service brakes operate only when the axle is in normal driving (loaded) position.



### CAUTION

Do not use tag axle in raised position for an extended period. Raising tag axle increases load on the drive axle, suspension and tires.

Do not drive vehicle with tag axle raised when speed is exceeding 9mph (15 km/h).

In order to prevent damage to the suspension, always raise the tag axle before lifting the coach.

### 2.3 RETRACTING TAG AXLE FOR REPAIR PURPOSES

- Connect an external air pressure line to the emergency fill valve in the engine compartment.
- Lift the axle by pushing the lever forward.



### WARNING

Install a protective cover to prevent unfortunate lever operation while work is being carried out under the vehicle.

- Raise the vehicle using the lifts.



### WARNING

Lift manufacturers recommend lowering the vehicle to the ground or installing some safety stands before activating the suspension to prevent the lifts from becoming unstable.

- For added safety, install nylon slings over tag axle shock absorbers.

### 2.4 GREASE LUBRICATED WHEEL BEARINGS

The unitized hub bearings used on the NDS range of axles, are non-serviceable items. Bearings are pre-adjusted, lubricated and have seals fitted as part of the manufacturing process. The bearings are greased for life and there is no need or facility for re-lubrication

Front and tag axle hub bearings need to be checked every 30,000 miles (48 000 km).

### NOTE

*For more information on front and tag axle wheel hub, refer to "DANA SPICER Maintenance Manual Model NDS and Maintenance Manual NDS Axles" annexed at the end of this Section.*

## 2.5 REMOVAL AND INSTALLATION

### 2.5.1 Removing Tag Axle Only

The following procedure deals with the removal of the tag axle while keeping the air springs installed. The method used to support the axle and suspension components during removal and disassembly depends upon local conditions and available equipment.

- Connect an external air pressure line to the emergency fill valve in the engine compartment.
- Lift the axle by pushing the lever forward.



### WARNING

Install a protective cover to prevent unfortunate lever operation while work is being carried out under the vehicle.

- Disconnect tag axle air springs pneumatic hoses and install valves or plugs.
- Raise the vehicle using the lifts.
- Dismount tag axle components.
- Before reinstalling air spring hoses, make sure there is no pressure left inside by opening the valves or unloading tag axle.

### 2.5.2 Removing Tag Axle Along With Suspension Components

The following procedure deals with the removal of the tag axle assembly along with the suspension components. The method used to support the axle and suspension components during removal and disassembly depends upon local conditions and available equipment.

1. Raise vehicle by its jacking points on the body (fig. 5 or see Section 18, "Body" under heading: "Vehicle Jacking Points"). Place jack under frame. Remove drive axle wheels (if

required, refer to Section 13, "Wheels, Hubs And Tires").

2. Exhaust compressed air from the air supply system by opening the drain cock on each air reservoir and deplete air bags by moving leveling valve arm down.
3. Install jacks under tag axle jacking points to support the axle weight (refer to figure 11).

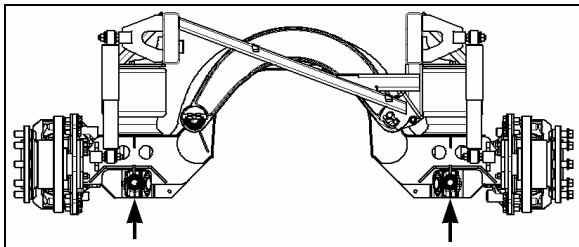


FIGURE 11: JACKING POINTS ON TAG AXLE 11029

4. Disconnect tag axle lifting chain collars from lower longitudinal radius rods.
5. Remove the propeller shaft as directed in Section 9, "Propeller Shaft", in this manual.
6. Disconnect the tag axle brake chamber hoses.



**CAUTION**

Position the hoses so they will not be damaged when removing axle.

7. Disconnect hose from the air spring upper mounting plate.
8. Remove the two shock absorbers as outlined in Section 16, "Suspension", under "Shock Absorber Removal".
9. Disconnect the lower longitudinal radius rods as outlined in Section 16, "Suspension", under "Radius Rod Removal".
10. Disconnect the transversal radius rod.
11. Disconnect the upper longitudinal radius rod.
12. Remove the air bellows retaining nuts from each of the two upper mounting plates.
13. Use the jacks to move the axle forward to clear the axle off the transmission. Lower the axle.



**CAUTION**

On vehicles equipped with an automatic transmission (with or without the output retarder), move tag assembly very carefully. Pay special attention to the U-shaped section, as the transmission end components may be easily damaged through a false maneuver.

14. Reverse removal procedure to reinstall tag axle.

**NOTE**

Refer to Section 16, "Suspension", for proper torque tightening of suspension components.

**NOTE**

Refer to section 13 "Wheels, Hubs And Tires" for correct wheel bearing adjustment procedure.

2.6 TAG AXLE ALIGNMENT

The tag axle alignment consists in aligning the tag axle parallel to the drive axle position. Before aligning the tag axle, proceed with the drive axle alignment (paragraph 1.11). Tag axle alignment is achieved with the use of shims inserted between the lower longitudinal radius rod supports and axle. Tag axle alignment is factory set and is not subject to any change, except if vehicle has been damaged by an accident or if there are requirements for parts replacement.



**CAUTION**

If this setting is altered significantly, it will cause excessive tire wear.

**NOTE**

It may be necessary to adjust the axle TOE as well as its alignment. In this case, insert shims (7 min. - P/N 121203 or 15 min. - P/N 121240) in between mounting plate and spindle, as required.

If axle has been removed for repair or servicing and if all parts are reinstalled exactly in their previous locations, axle alignment is not necessary. However, if the suspension supports have been replaced or have changed position, proceed with the following instructions to verify or adjust the tag axle alignment.



## Section 11: REAR AXLES

---

### 3. SPECIFICATIONS

#### Drive Axle

Make .....Meritor  
Drive track..... 76.7 inches (1 949 mm)  
Gear type .....Hypoid  
Axle type ..... Full floating  
Lube capacity ..... 41 pints (19,3 liters)

#### Drive axle ratio

##### World Transmission

4.30:1 Standard  
4.10:1 Optional  
4.56:1 Optional  
4.88:1 Optional

##### ZF Transmission

3.73:1 Standard  
3.42:1 Optional  
3.58:1 Optional

#### ***NOTE***

*The drive axle alignment consists in aligning the axle with reference to the frame. The axle must be perpendicular to the frame.*

#### Tag Axle

Make .....Prévost  
Rear track ..... 83.6 inches (2 124 mm)  
Axle type ..... Dana Spicer Europe TS8U Hub Unit

#### ***NOTE***

*The tag axle alignment consists in aligning the tag axle parallel to the drive axle.*

# SECTION 12: BRAKE AND AIR SYSTEM

## CONTENTS

|  |           |
|--|-----------|
| <b>1. AIR SYSTEM .....</b>   | <b>5</b>  |
| <b>2. BRAKES .....</b>   | <b>5</b>  |
| <b>3. AIR RESERVOIRS.....</b>  | <b>5</b>  |
| 3.1 MAINTENANCE .....  | 5         |
| 3.1.1 <i>Wet (Main) Air Tank</i> .....                                   | 6         |
| 3.1.2 <i>Primary Air Tank</i> .....                                      | 6         |
| 3.1.3 <i>Accessory Air Tank</i> .....                                    | 6         |
| 3.1.4 <i>ZF transmission Air Tank</i> .....                              | 6         |
| 3.1.5 <i>Secondary Air Tank</i> .....                                    | 6         |
| 3.1.6 <i>Kneeling Air Tank</i> .....                                     | 7         |
| 3.2 PING TANK .....  | 7         |
| <b>4. AIR SYSTEM EMERGENCY FILL VALVES.....</b>                          | <b>7</b>  |
| <b>5. ACCESSORY AIR FILTER.....</b>                                      | <b>7</b>  |
| 5.1 FILTER ELEMENT REPLACEMENT .....                                     | 7         |
| 5.2 CLEANING.....  | 7         |
| <b>6. AIR GAUGES (PRIMARY, SECONDARY AND ACCESSORY) .....</b>            | <b>8</b>  |
| <b>7. AIR FILTER/DRYER.....</b>  | <b>8</b>  |
| 7.1 AIR FILTER/DRYER PURGE TANK.....                                     | 8         |
| <b>8. AIR LINES.....</b>   | <b>8</b>  |
| 8.1 COPPER PIPING .....  | 8         |
| 8.2 FLEXIBLE HOSES .....   | 9         |
| 8.3 NYLON TUBING .....   | 9         |
| 8.4 AIR LINE OPERATING TEST .....  | 9         |
| 8.5 AIR LINE LEAKAGE TEST .....  | 9         |
| 8.6 MAINTENANCE .....  | 9         |
| <b>9. PRESSURE REGULATING VALVES .....</b>                               | <b>9</b>  |
| 9.1 MAINTENANCE .....  | 10        |
| 9.2 PRESSURE SETTING PROCEDURE .....                                     | 10        |
| <b>10. AIR COMPRESSOR .....</b>  | <b>10</b> |
| 10.1 WITH DETROIT DIESEL SERIES 60 ENGINE .....                          | 10        |
| 10.1.1 <i>Compressor Removal and Installation</i> .....                  | 11        |
| 10.2 WITH VOLVO D13 ENGINE .....   | 11        |
| 10.2.1 <i>Compressor Removal and Installation</i> .....                  | 11        |
| <b>11. EMERGENCY/PARKING BRAKE CONTROL VALVE (PP-1).....</b>             | <b>12</b> |
| <b>12. EMERGENCY / PARKING BRAKE OVERRULE CONTROL VALVE (RD-3) .....</b> | <b>12</b> |
| <b>13. FLIP-FLOP CONTROL VALVE (TW-1) .....</b>                          | <b>12</b> |
| <b>14. DUAL BRAKE APPLICATION VALVE (E-10P) .....</b>                    | <b>12</b> |
| 14.1 BRAKE PEDAL ADJUSTMENT .....  | 12        |
| 14.1.1 <i>Maintenance</i> .....  | 13        |

## Section 12: BRAKE AND AIR SYSTEM

---

|         |  |    |
|---------|--|----|
| 15.     | STOPLIGHT SWITCHES.....  | 13 |
| 16.     | PARKING BRAKE ALARM SWITCH .....   | 13 |
| 17.     | BRAKE RELAY VALVE (R-12 & R-14) .....                                      | 13 |
| 18.     | QUICK RELEASE VALVES (QR-1) .....  | 14 |
| 19.     | SPRING BRAKE VALVE (SR-7).....   | 14 |
| 20.     | PRESSURE PROTECTION VALVE (PR-4).....                                      | 14 |
| 21.     | LOW PRESSURE INDICATOR (LP-3).....   | 15 |
| 22.     | SHUTTLE-TYPE DOUBLE CHECK VALVE (DC-4).....                                | 15 |
| 23.     | EMERGENCY DOOR OPENING VALVES .....  | 15 |
| 24.     | AIR HORN VALVE .....   | 15 |
| 25.     | AIR SYSTEM TROUBLESHOOTING .....   | 15 |
| 26.     | BRAKE OPERATION .....  | 16 |
| 27.     | AIR BRAKES .....   | 16 |
| 27.1    | DISC BRAKES.....   | 16 |
| 27.1.1  | Disc Brake Pads.....   | 16 |
| 27.1.2  | Caliper Maintenance .....  | 17 |
| 27.1.3  | Roadside Inspection for Knorr/Bendix Air Disc Brakes.....                  | 18 |
| 27.1.4  | Pad Removal.....   | 18 |
| 27.1.5  | Checking Pad Wear .....  | 19 |
| 27.1.6  | Important Pad and Rotor Measurements .....                                 | 19 |
| 27.1.7  | Checking Caliper Guidance and Seal Condition.....                          | 19 |
| 27.1.8  | Checking the Tappet Boots.....   | 20 |
| 27.1.9  | Pad Installation.....  | 20 |
| 27.1.10 | Adjusting the Running Clearance .....                                      | 20 |
| 27.1.11 | Brake Tools.....   | 21 |
| 27.1.12 | Checking Brake Pads.....   | 21 |
| 27.1.13 | Torque specifications.....   | 21 |
| 28.     | SAFE SERVICE PROCEDURES .....  | 21 |
| 29.     | AIR BRAKE TROUBLESHOOTING .....  | 22 |
| 30.     | BRAKE AIR CHAMBER.....   | 24 |
| 30.1    | MAINTENANCE.....   | 24 |
| 30.2    | EMERGENCY/PARKING BRAKE MANUAL RELEASE .....                               | 25 |
| 30.3    | BRAKE CHAMBER REMOVAL.....   | 25 |
| 30.4    | BRAKE CHAMBER INSTALLATION.....  | 25 |
| 30.5    | BRAKE CHAMBER DISASSEMBLY .....  | 25 |
| 31.     | ANTI-LOCK BRAKING SYSTEM (ABS).....  | 26 |
| 31.1    | TROUBLESHOOTING AND TESTING.....   | 27 |
| 31.2    | AUTOMATIC TRACTION CONTROL (ATC) – ELECTRONIC STABILITY PROGRAM (ESP)..... | 27 |

|            |   |           |
|------------|---|-----------|
| 31.3       | ABS COMPONENTS .....                    | 27        |
| 31.3.1     | Electronic Control Unit (ECU) .....     | 27        |
| 31.3.2     | ABS Modulator Valve .....               | 28        |
| 31.3.3     | Sensors .....                           | 28        |
| 31.3.4     | Spring clip.....                        | 29        |
| <b>32.</b> | <b>FITTING TIGHTENING TORQUES .....</b> | <b>29</b> |
| <b>33.</b> | <b>SPECIFICATIONS .....</b>             | <b>31</b> |

**ILLUSTRATIONS**

|            |  |    |
|------------|--|----|
| FIGURE 1:  | IFS AIR RESERVOIRS LOCATION .....                    | 5  |
| FIGURE 2:  | I-BEAM FRONT SUSPENSION AIR RESERVOIRS LOCATION..... | 6  |
| FIGURE 3:  | REAR VALVE LOCATION (TYPICAL) .....                  | 6  |
| FIGURE 4:  | FRONT SERVICE COMPARTMENT.....                       | 7  |
| FIGURE 5:  | ACCESSORY AIR FILTER .....                           | 7  |
| FIGURE 6:  | HALDEX AIR FILTER DRYER.....                         | 8  |
| FIGURE 7:  | AIR PRESSURE REGULATING VALVE .....                  | 10 |
| FIGURE 8:  | AIR PRESSURE REGULATOR .....                         | 10 |
| FIGURE 9:  | AIR COMPRESSOR LOCATION .....                        | 10 |
| FIGURE 10: | AIR COMPRESSOR LOCATION .....                        | 11 |
| FIGURE 11: | PP-1 .....   | 12 |
| FIGURE 12: | RD-3 .....   | 12 |
| FIGURE 13: | TW-1.....  | 12 |
| FIGURE 14: | BRAKE PEDAL ADJUSTMENT .....                         | 13 |
| FIGURE 15: | DELCO SWITCH .....                                   | 13 |
| FIGURE 16: | BENDIX SWITCH .....                                  | 13 |
| FIGURE 17: | R-12 .....   | 14 |
| FIGURE 18: | R-14 .....   | 14 |
| FIGURE 19: | QR-1 .....   | 14 |
| FIGURE 20: | SR-7 .....   | 14 |
| FIGURE 21: | PR-4 .....   | 14 |
| FIGURE 22: | LP-3.....  | 15 |
| FIGURE 23: | DC-4 .....   | 15 |
| FIGURE 24: | THREE-WAY VALVE.....                                 | 15 |
| FIGURE 25: | BRAKE PAD CHECK.....                                 | 16 |
| FIGURE 26: | CLEARANCE INSPECTION .....                           | 17 |
| FIGURE 27: | RUNNING CLEARANCE .....                              | 17 |
| FIGURE 28: | ADJUSTER PINION .....                                | 18 |
| FIGURE 29: | BOX WRENCH ON ADJUSTER PINION .....                  | 18 |
| FIGURE 30: | CALIPER AXIAL MOVEMENT .....                         | 18 |
| FIGURE 31: | BRAKE PAD CHECK.....                                 | 18 |
| FIGURE 32: | PAD REMOVAL .....                                    | 19 |
| FIGURE 33: | PAD WEAR .....                                       | 19 |
| FIGURE 34: | ROTOR AND PAD WEAR LIMITS.....                       | 19 |
| FIGURE 35: | CALIPER GUIDANCE .....                               | 20 |
| FIGURE 36: | RUBBER BOOTS .....                                   | 20 |
| FIGURE 37: | PAD INSTALLATION .....                               | 20 |
| FIGURE 38: | RUNNING CLEARANCE .....                              | 21 |
| FIGURE 39: | BRAKE PAD CHECK .....                                | 21 |
| FIGURE 40: | TORQUE SPECIFICATION .....                           | 21 |
| FIGURE 41: | TORQUE SPECIFICATION .....                           | 21 |
| FIGURE 42: | FRONT AXLE BRAKE AIR CHAMBER.....                    | 24 |
| FIGURE 43: | DRIVE AXLE BRAKE AIR CHAMBER.....                    | 24 |
| FIGURE 44: | ABS ECU LOCATION .....                               | 27 |

## Section 12: BRAKE AND AIR SYSTEM

---

|                                      |    |
|--------------------------------------|----|
| FIGURE 45: ABS MODULATOR VALVE ..... | 28 |
| FIGURE 46: ABS SENSOR LOCATION ..... | 28 |
| FIGURE 47: SPRING CLIP .....         | 29 |
| FIGURE 48: HOSE FITTINGS .....       | 29 |
| FIGURE 49: HOSE FITTING .....        | 29 |
| FIGURE 50: HOSE FITTING .....        | 29 |
| FIGURE 51: HOSE FITTING .....        | 30 |

**1. AIR SYSTEM**

The basic air system consists of an air compressor, reservoirs, valves, filters and interconnecting lines and hoses. It provides a means for braking; operating controls and accessories, and suspension (refer to Section 16, "Suspension", for complete information on suspension description and maintenance). An air system schematic diagram is annexed in the technical publications box provided with the vehicle for better understanding of the system.

**2. BRAKES**

This vehicle uses both the service brake and emergency/parking brake. The service brake air system is divided into two independent circuits to isolate front brakes from rear brakes, thus providing safe braking in the event that one circuit fails. Front axle brakes operate from the secondary air system, while brakes on both the drive axle and tag axle operate from the primary air system.

**NOTE**  
*The tag axle service brake operates only when the axle is in normal ride position (loaded and down).*

Furthermore, the brake application or release, which is speed up by a pneumatic relay valve (R-12), will start with the rear axles and will be followed by the front axle, thus providing uniform braking on a slippery road. The vehicle is also equipped with an Anti-Lock Braking System (ABS), which is detailed later in this section.

The drive axle is provided with spring-loaded emergency/parking brakes, which are applied automatically whenever the control valve supply pressure drops below 40 psi (275 kPa).

**3. AIR RESERVOIRS**

The air coming from the air dryer is first forwarded to the wet air tank, then to the primary (for the primary brake system), secondary (for the secondary brake system), and accessory (for the pneumatic accessories) air tanks (Fig. 1 & 2).

Two additional air reservoirs may be installed on the vehicle: the kneeling air tank and ZF transmission air tank.

**3.1 MAINTENANCE**

Ensure that the wet (main) air tank is purged during pre-starting inspection. In addition, it is good practice to purge this reservoir at the end of every working day. The remaining reservoirs must be purged at every 12,500 miles (or 20 000 km) or once every year, whichever comes first.

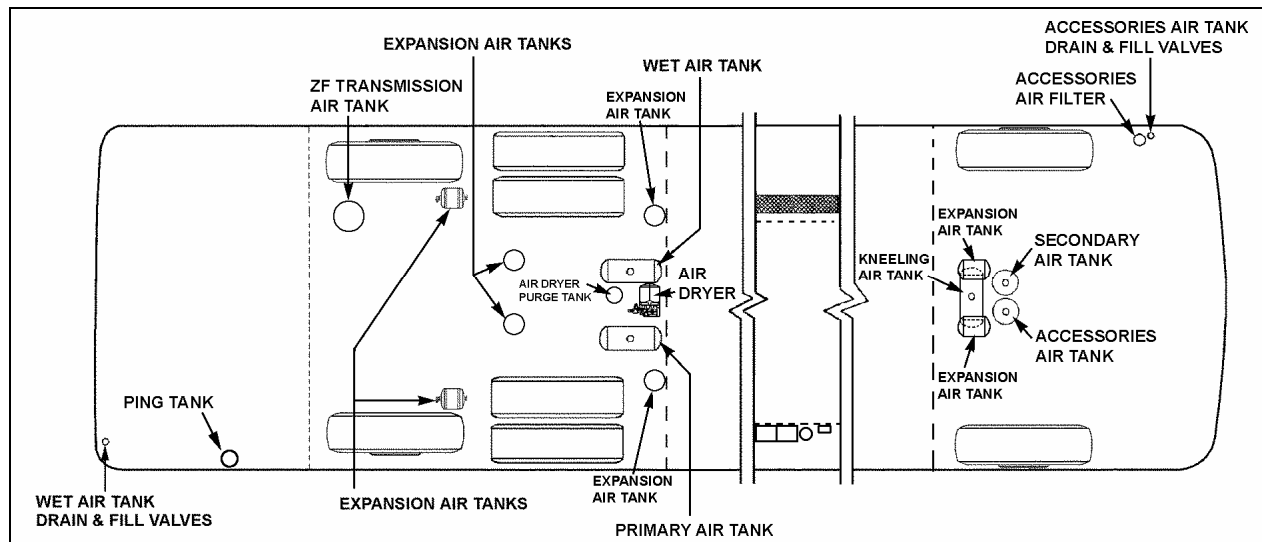


FIGURE 1: IFS AIR RESERVOIRS LOCATION

12212

## Section 12: BRAKE AND AIR SYSTEM

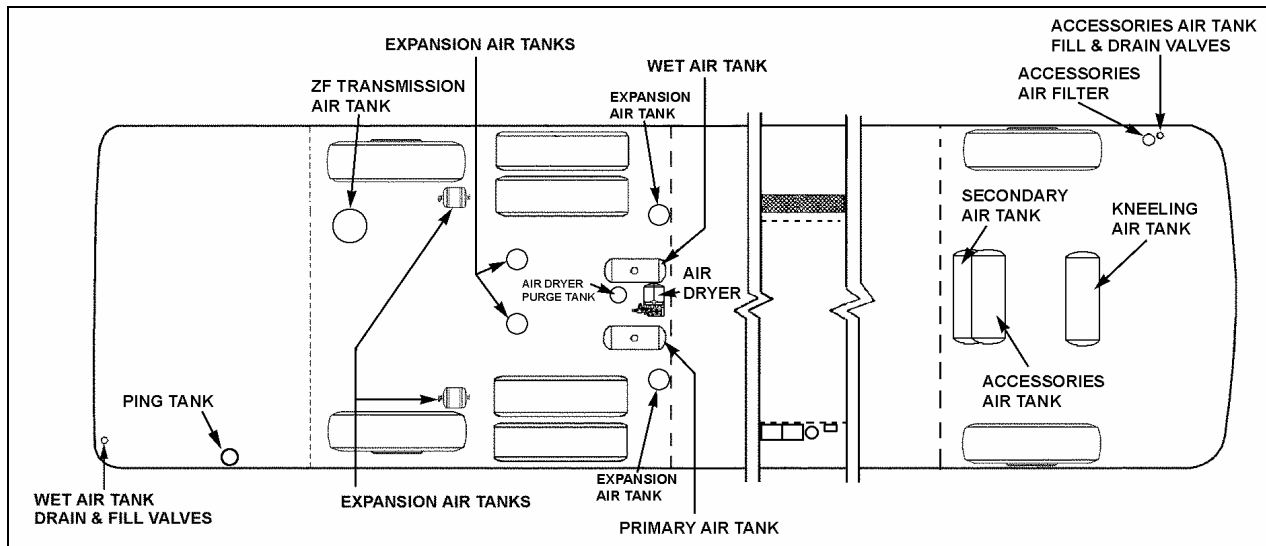


FIGURE 2: I-BEAM FRONT SUSPENSION AIR RESERVOIRS LOCATION

12213

### 3.1.1 Wet (Main) Air Tank

This reservoir, located above the L.H. wheel of drive axle in the rear wheelhousing, is provided with a bottom drain valve. A recommended purge using the bottom drain valve should be done every 12,500 miles (20 000 km), or once a year, whichever comes first.

### 3.1.2 Primary Air Tank

This reservoir is located above the R.H. wheel of the drive axle and is provided with a bottom drain valve (Fig. 1 & 2). It is recommended to purge the primary air tank every 12,500 miles (20 000 km) or once a year, whichever comes first.

### 3.1.3 Accessory Air Tank

The accessory air tank is installed close to the front axle and is provided with a bottom drain valve (Fig. 1 & 2).

Purge the reservoir by it's drain valve every 12,500 miles (20 000 km) or once a year, whichever comes first.

### 3.1.4 ZF transmission Air Tank

Installed on vehicles equipped with this option, this reservoir is located in the rear wheelhousing, beside the transmission on the L.H. side of the vehicle (Fig. 1 & 2). It is provided with a bottom drain valve.

Purge this reservoir every 12,500 miles (20 000 km) or once a year, whichever comes first.

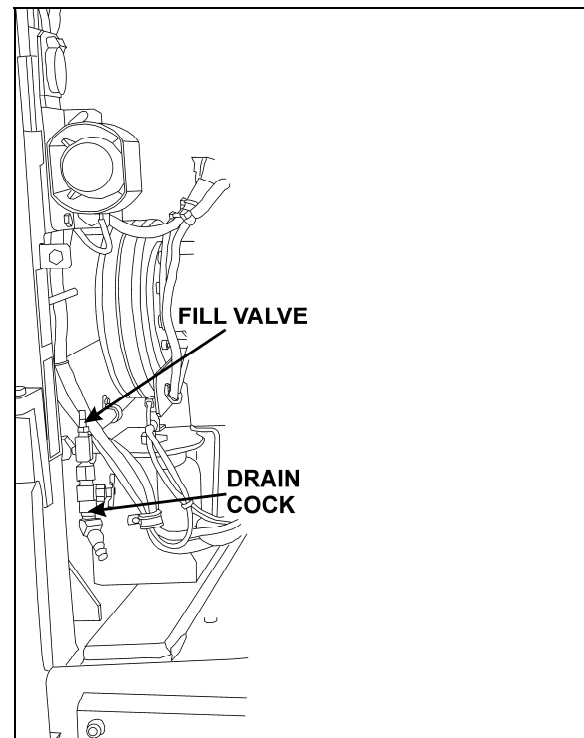


FIGURE 3: REAR VALVE LOCATION (TYPICAL)

12211

### 3.1.5 Secondary Air Tank

This tank is located in the front wheelhousing, behind the steering axle (Fig. 1 & 2). It is provided with a bottom drain valve.

Purge this reservoir every 12,500 miles (20 000 km) or once a year, whichever comes first.

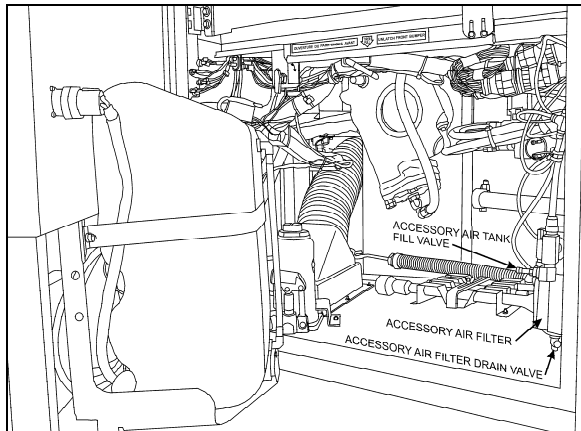


FIGURE 4: FRONT SERVICE COMPARTMENT 12210

### 3.1.6 Kneeling Air Tank

The kneeling air tank is installed on vehicles equipped with the Kneeling or Hi/Low-Buoy options. It is located in the front wheelhousing (Fig. 1 & 2), and is provided with a bottom drain valve.

### 3.2 PING TANK

The ping tank may be located behind the tag axle or in the engine compartment; in this case, it is accessible through the engine compartment R.H. side door. It is used to dissipate heat and to reduce noise produced by the air compressor cycling on and off.

## 4. AIR SYSTEM EMERGENCY FILL VALVES

All vehicles come equipped with two emergency fill valves that enable system pressurization by an external source such as an air compressor. The rear valve is located in the engine compartment and is accessible from engine R.H. side door (Fig 3). It is positioned close to the door opening.



### CAUTION

Maximum allowable air pressure is 125 psi (860 kPa). Air filled through these two points will pass through the standard air filtering system provided by Prevost. Do not fill system by any point on the system.

The front valve is located in the front service compartment close to R.H. side of door frame (Fig. 4).

These two air system emergency fill valves are fitted with the same valve stems as standard

tires, and can be filled by any standard external air supply line.

The rear air system emergency fill valve will supply air for all systems (brakes, suspension and accessories) while the front fill valve will supply air for accessories only.

## 5. ACCESSORY AIR FILTER

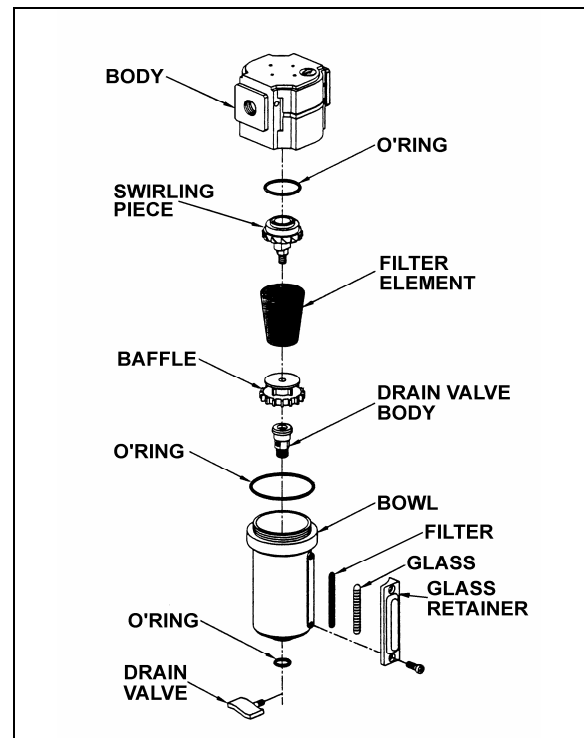


FIGURE 5: ACCESSORY AIR FILTER 12088

This filter is located inside the front service compartment (Fig. 4). Its main function consists in filtering the air supplied to the accessory air system, when connected to an external supply line. Ensure filter is purged whenever supplying the system with an external air line and at least every 12,500 miles (20 000 km). To purge, open drain valve (Fig. 4), let the moisture come out, then close the drain valve.

### 5.1 FILTER ELEMENT REPLACEMENT

Replace filter element whichever of the following occurs first: every 100,000 miles (160 000 km), every two years, or whenever differential pressure exceeds 15 psi (105 kPa) between filter inlet and outlet ports. Check condition of all three O'rings for damage. Replace when necessary (Fig. 5).

### 5.2 CLEANING

Clean filter body and bowl with a warm water and soap solution. Rinse thoroughly with clean



## Section 12: BRAKE AND AIR SYSTEM

water. Blow dry with compressed air making sure the air stream is moisture free and clean. Pay particular attention to the internal passages. Inspect all parts for damage and replace if necessary.

### 6. AIR GAUGES (PRIMARY, SECONDARY AND ACCESSORY)

The air pressure gauges, located on the dashboard (see *"Operator's Manual"*), are connected to the DC-4 double check valve, located on the pneumatic accessory panel in the front service compartment.

The latter is connected to the air lines running from the primary and secondary air tanks, as shown on the pneumatic system diagram provided in the technical publications box. The accessory air gauge is connected to the accessory air tank using the drain valve connector. The vehicle should never be set in motion until the buzzer alarm and warning lights turn off, i.e. when air pressure registers at least 66 psi (455 kPa). Moreover, if pressure drops below 66 psi (455 kPa), the *"Low air pressure"* warning lights will turn on, and the *"Low air pressure"* buzzer will sound. Stop the vehicle immediately, determine and correct the cause(s) of pressure loss. Check the gauges regularly with an accurate test gauge. Replace the gauge with a new unit if there is a difference of 4 psi (27 kPa) or more in the reading.

### 7. AIR FILTER/DRYER

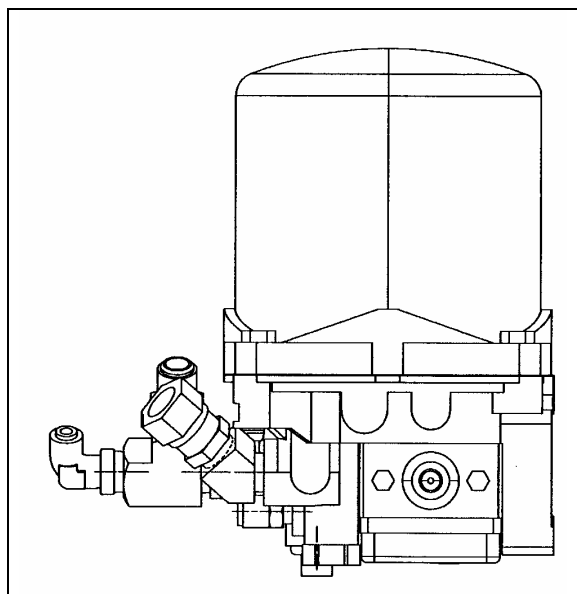


FIGURE 6: HALDEX AIR FILTER DRYER

12194

The air filter/dryer is located in front of rear wheelhousing above drive axle (Fig. 1, 2 & 6). Its purpose is to remove moisture that could damage the air system before the air enters the system reservoir. The air filter/dryer also filters the air to remove dirt, compressor oil, and other contaminants that can damage the system. Change cartridge every 100,000 miles (160 000 km) or once every two years, whichever comes first. The air dryer may be purged for maintenance purposes using the remote drain valve located in the engine compartment and accessible through the engine compartment R.H. side door. The valve is positioned close to the L.H. side of door opening (Fig. 3). The air filter/dryer has a built-in governor to maintain the system between 108 psig and 123 psig.

Maintenance and repair information is supplied in the maintenance information annexed to this section.

#### 7.1 AIR FILTER/DRYER PURGE TANK

A tank is supplied to purge the air filter/dryer to remove moisture and contaminants.

### 8. AIR LINES

Copper piping, nylon-reinforced tubing, and flexible hoses are used to connect the units in the pneumatic system, including air brake system, suspension system and accessory systems such as the entrance door, fresh air damper cylinder, air horns, etc. Furthermore, the nylon tubing is color coded to ease identification. Refer to the following table for the complete color identification code. Service instructions for each type of air line are also provided under the applicable headings.

| Color  | Circuit              |
|--------|----------------------|
| Red    | Secondary            |
| Green  | Primary and Delivery |
| Yellow | Parking Brake        |
| Blue   | Suspension           |
| Black  | Accessory            |
| Brown  | Trailer Brake        |

#### 8.1 COPPER PIPING

A heat dissipation copper piping assembly is used to dissipate the heat coming from the compressor before it enters the air filter/dryer. Connections should be checked for leakage at least every 6,250 miles (10 000 km) or twice a

year, whichever comes first. Tighten or replace when necessary. When replacing copper piping, the parts must be free of burrs, copper cuttings, and dirt. Blow out piping with compressed air. Any such particles will destroy sealing seats in air control units. Also, new piping must be the same size as the old one.

**8.2 FLEXIBLE HOSES**


A flexible hose is used normally where it is impractical to use copper or nylon tubing due to constant flexing during operation, such as brake chamber hoses. Hose connections should be tested for leakage at least every 6,250 miles (10 000 km) or twice a year, whichever comes first and tightened or replaced if necessary. Any hose which is chafed, worn or kinked should be replaced.

Teflon-braided stainless steel hoses used in the engine compartment must be replaced only with similar hoses.

**8.3 NYLON TUBING**

Nylon tubing is used for air lines in areas where usage of this material is suitable. Nylon tubing is flexible, durable, and weather resistant. When replacing an air line, use nylon tubing only where it has been used previously.

Nylon air lines must never be routed in areas where temperature could exceed 200°F (93°C).

|  |                       |
|--|-----------------------|
|   | <p><b>CAUTION</b></p> |
| <p>Nylon air lines should be used to replace existing nylon lines only, and must comply with the color identification code to ease pneumatic system troubleshooting.</p> |                       |

**8.4 AIR LINE OPERATING TEST**

If any trouble symptom such as slow brake application or slow brake release indicates a restricted or clogged air line, disconnect the suspected tube or hose at both ends and blow through it to clear the passage.

Inspect tubing and hose for partial restriction that may be caused by dents or kinks. If such a condition is found, the tubing or hose should be replaced.

**8.5 AIR LINE LEAKAGE TEST**

With air system fully charged and the brakes applied, coat all tubing and hose connections

with a soapy solution to check for air leakage. No leakage is permitted. Leakage can sometimes be corrected by tightening the connection. If this fails to correct the leakage, new fittings, nylon tubing, copper tubing, teflon-braided stainless steel and flexible hoses must be installed as applicable.

**8.6 MAINTENANCE**

Inspect all lines for cuts, swelling, kinks or other damage or deterioration. Check for lines being pinched by other components. Retaining clips and ties must be in place.

Any support or bracket should be in good condition and mounted firmly in position. Hose spring guards should be in usable condition and not distorted. Particular attention should be given to long lines. Any supporting component (clips, ties, grommets, etc.) must be secured to prevent against unnecessary vibration and eventual loosening of connection. Any detected leak should be repaired. Be sure nylon lines are not near areas of intense heat. Check for any missing grommets or loose material where chafing or cutting may occur. Replace with new material as required. In general, lines should be securely located in position and free from any binding condition which would hinder air flow.

**9. PRESSURE REGULATING VALVES**

There is one pressure regulator for the belt tensioners, and an optional one installed on vehicles equipped with the World transmission output retarder.

The belt tensioner pressure regulating valve is located in the engine compartment above the doors and is used to limit the air pressure in belt tensioners to 50 ± 2 psi (345 ± 15 kPa) (Fig. 7).

The optional regulator is located near the Webasto in the engine compartment (accessible through the engine R.H. side door). It is used for transmission retarder and should be adjusted to 80 ± 3 psi (550 ± 20 kPa).

|                | Air Pressure<br>(psi)  | Air Pressure<br>(kPa)   |
|----------------|------------------------|-------------------------|
| Belt Tensioner | <b>Series 60</b><br>50 | <b>Series 60</b><br>345 |
| Retarder       | 80 ± 3                 | 550 ± 20                |

## Section 12: BRAKE AND AIR SYSTEM

### 9.1 MAINTENANCE

Every 100,000 miles (160 000 km) or once every two years, whichever comes first, disassemble the regulating valve and wash all metal parts in a cleaning solvent (Fig. 7). Examine the diaphragm; if cracked, worn or damaged, replace with a new one. If the valve is excessively grooved or pitted, it should be replaced. Replace any other part that appears worn or damaged. After reassembly, adjust to the specified pressure setting and check for air leakage.

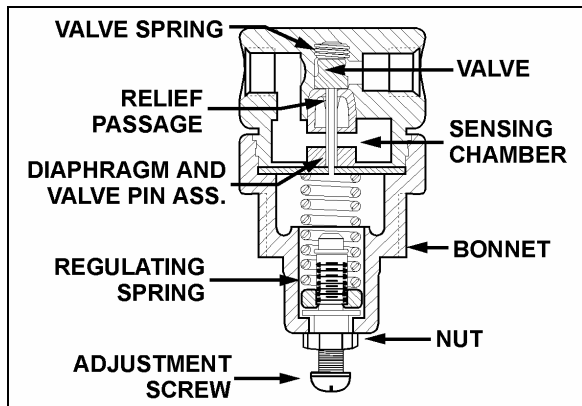


FIGURE 7: AIR PRESSURE REGULATING VALVE 12141B

### 9.2 PRESSURE SETTING PROCEDURE

Remove the dust cap from the pressure check valve (Fig. 8). Attach a pressure gauge at this port and check the pressure reading. If the pressure reading is incorrect, adjust as follows:

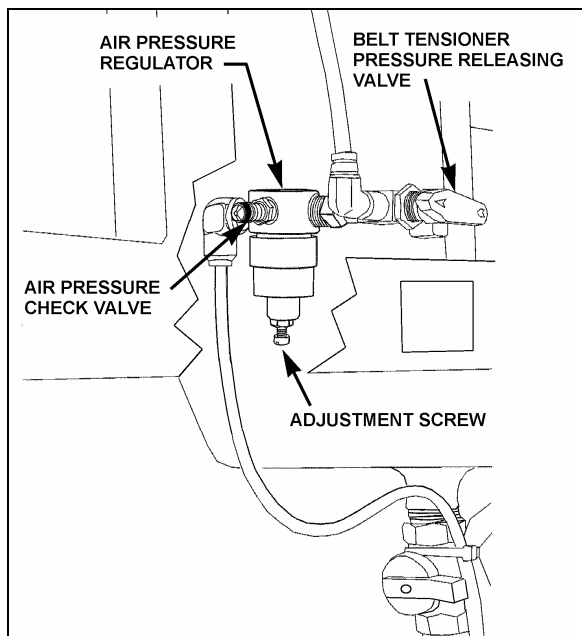


FIGURE 8: AIR PRESSURE REGULATOR 12200

1. Loosen the locking nut, turn the adjustment screw counterclockwise to decrease pressure by approximately 10 psi (70 kPa) below the required pressure.
2. Turn the adjustment screw clockwise to increase the pressure slowly until the required pressure setting is reached. Tighten the locking nut.
3. Remove pressure gauge and replace dust cap on the air pressure check valve.

## 10. AIR COMPRESSOR

### 10.1 WITH DETROIT DIESEL SERIES 60 ENGINE

The BA-921 Bendix air compressor is located on starter side of the engine, on the rear of the engine gear case (Fig. 9). Its function is to provide and maintain air under pressure to operate devices in brake and air systems.

This air compressor also drives the engine fuel pump which is bolted to the rear end of the compressor. The compressor crankshaft is designed to accept a drive coupling which is placed between the compressor and fuel pump.

The compressor is driven by the bull gear, and is water cooled. Engine coolant is fed to the compressor through a flexible hose tapped into the block water jacket and connected to the rear of the compressor. Coolant returns from the top of the compressor (governor side) through a flexible hose to the engine pump.

The air is taken from the air intake manifold and entered in the top of the compressor. The compressed air is pushed into the discharge line located on side of the compressor, which sends air to the air dryer. Lubricating oil is supplied to the compressor by a line from the cylinder block oil gallery connected to the air compressor. Lubricating oil returns to the engine crankcase through the air compressor drive assembly.

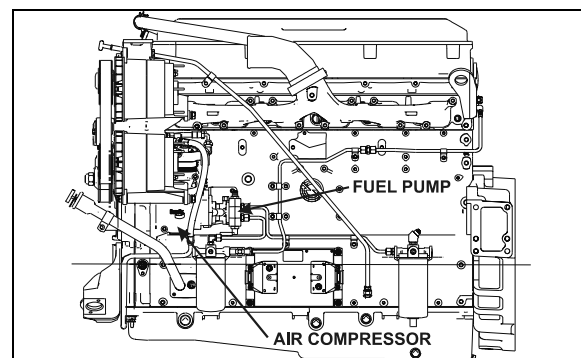


FIGURE 9: AIR COMPRESSOR LOCATION 03061

Maintenance and repair information on the Bendix BA-921 air compressor is supplied in the applicable booklet annexed to this section under reference number SD-01-676.

10.1.1 Compressor Removal and Installation

1. Exhaust compressed air from air system by opening the drain valve of each air tank.
2. Drain the engine cooling system. See Section 5: "Cooling System".
3. Identify and disconnect all air, coolant and oil lines from the compressor assembly.
4. Access the compressor by the engine R.H. side compartment. Remove the four compressor mounting bolts and the two fuel pump support bracket bolts.
5. Slide air compressor rearward to disengage the hub from coupling. Remove the air compressor.

Reverse removal procedure for installation.

10.2 WITH VOLVO D13 ENGINE

The Wabco System Saver 636 Twin Cylinder air compressor is located on the alternator side of the engine, at the flywheel end (Fig. 10). Its function is to provide and maintain air under pressure to operate devices in brake and air systems.

The compressor is driven by the ring gear, and is water cooled. Engine coolant is fed to the compressor through a flexible hose tapped into the block water jacket and connected to the rear of the compressor. Coolant returns from the top of the compressor (governor side) through a flexible hose to the engine pump.

The air is taken from the air intake manifold and entered in the top of the compressor. The compressed air is pushed into the discharge line located on side of the compressor, which sends air to the air dryer. Lubricating oil is supplied to the compressor by a line from the cylinder block oil gallery connected to the air compressor. Lubricating oil returns to the engine crankcase through the air compressor drive assembly.

Maintenance and repair information on the Wabco 636 Twin Cylinder air compressor is supplied in the applicable booklet annexed at the end of this section.

| Item | Description    | Notes     |
|------|----------------|-----------|
| 1    | Air Compressor | Wabco 636 |

|   |                |                           |
|---|----------------|---------------------------|
| 2 | O'Ring         |                           |
| 3 | Stud (3)       | M12                       |
| 4 | Flange Nut (3) | Torque to 15lb-ft (20 Nm) |
| 5 | Nipple (2)     |                           |
| 6 | Hose Assembly  |                           |

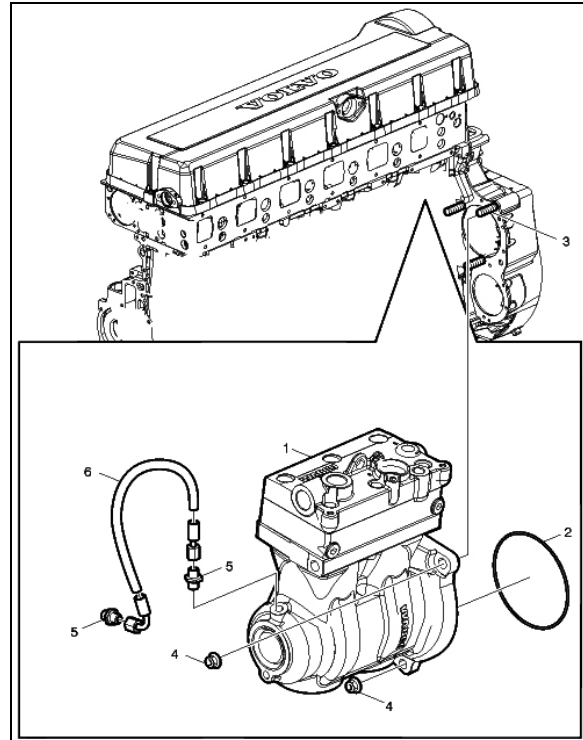


FIGURE 10: AIR COMPRESSOR LOCATION 03061

10.2.1 Compressor Removal and Installation

1. Exhaust compressed air from air system by opening the drain valve of each air tank.
2. Drain the engine cooling system. See Section 5: "Cooling System".
3. Access the compressor by the engine R.H. side compartment. Identify and disconnect all air, coolant and oil lines from the compressor assembly.
4. Remove the three compressor flange mounting nuts.
5. Slide air compressor rearward to disengage the hub from coupling. Remove the air compressor.

**Remove and retain the oil supply tube that runs between the compressor and the engine**

Reverse removal procedure for installation.

## Section 12: BRAKE AND AIR SYSTEM

### 11. EMERGENCY/PARKING BRAKE CONTROL VALVE (PP-1)

A push-pull control valve mounted on the L.H. lateral console is provided for parking brake application or release. The spring brakes are self-actuated whenever the control valve supply pressure drops below 40 psi (275 kPa). In the UP position, brakes are ON. In the DOWN position, brakes are RELEASED. A protective case around the knob prevents accidentally releasing the brakes.

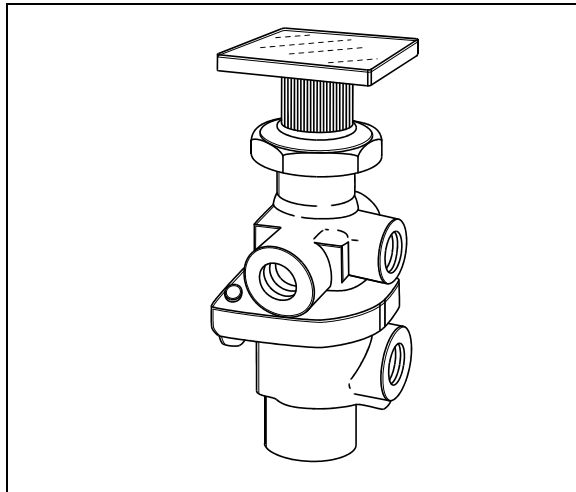


FIGURE 11: PP-1

12142

Maintenance and repair information on this valve is supplied in the applicable booklet annexed to this section under reference number SD-03-3611.

Remove the valve the following way:

1. Drain the air system.
2. Access this valve by tearing out the finishing panel, which holds the controls in place (Fig. 11).
3. Disconnect the air tubes.
4. Remove the retaining screws.
5. Service or replace the valve.
6. Installation is the reverse of removal.

### 12. EMERGENCY / PARKING BRAKE OVERRULE CONTROL VALVE (RD-3)

A RD-3 control valve is used with the optional parking brake overrule system. In the case of self-application of spring brakes due to a pressure drop, the brakes can be released by holding down this control valve. Maintenance and repair information on this valve is supplied

in the applicable booklet annexed to this section under reference number SD-03-3611.

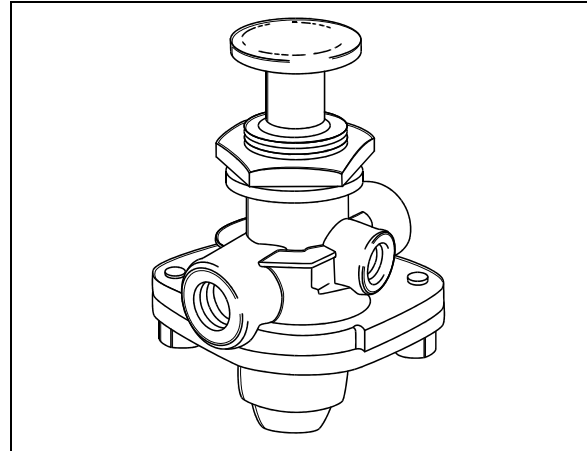


FIGURE 12: RD-3

12136

### 13. FLIP-FLOP CONTROL VALVE (TW-1)

A flip-flop control valve mounted on the L.H. lateral console is provided to unload tag axle air springs (and to lift tag axle if vehicle is so equipped). Another one controls the low-buoy system (coaches only). It is a manually operated "on-off" valve. Maintenance and repair information on this valve is supplied in the applicable booklet annexed to this section under reference number SD-03-3602.

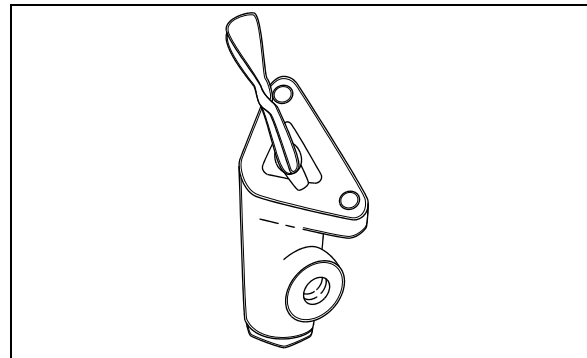


FIGURE 13: TW-1

12138

### 14. DUAL BRAKE APPLICATION VALVE (E-10P)

The E-10P dual brake valve is a floor mounted, foot-operated type brake valve with two separate supply and delivery circuits. This valve is located in the front service compartment (Fig. 14).

#### 14.1 BRAKE PEDAL ADJUSTMENT

After brake pedal replacement or repair, adjust the pedal to its proper position according to the following procedure:

1. Replace the linkage, loosen threaded rod lock nuts and screw or unscrew the threaded adjustment rod in order to obtain a 45° brake pedal inclination (Fig. 14).
2. Tighten threaded rod lock nuts.

#### 14.1.1 Maintenance

Maintenance and repair information on the E-10P dual brake application valve is supplied in the applicable booklet annexed to this section under reference number SD-03-830.

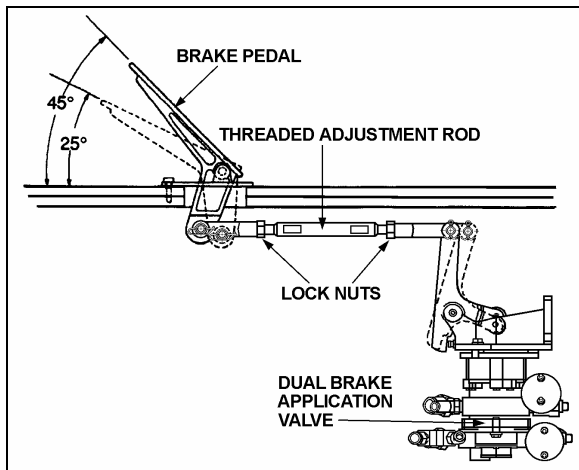


FIGURE 14: BRAKE PEDAL ADJUSTMENT 12208

### 15. STOPLIGHT SWITCHES

Two electro-pneumatic stoplight switches are mounted on the dual brake application valve (E-12). The upper one is used for the primary air circuit while the lower one is used for the secondary air circuit. Both switches are connected in parallel and have the same purpose, i.e. completing the electrical circuit and lighting the stoplights when a brake application is made. The upper switch (AC Delco) is designed to close its contact between 2 psi and 4 psi (14 kPa to 28 kPa) (Fig. 15), while the lower one (Bendix, SL-5) closes its contact at 4 psi (28 kPa) (Fig. 16). The switches are not serviceable items; if found defective, the complete unit must be replaced.

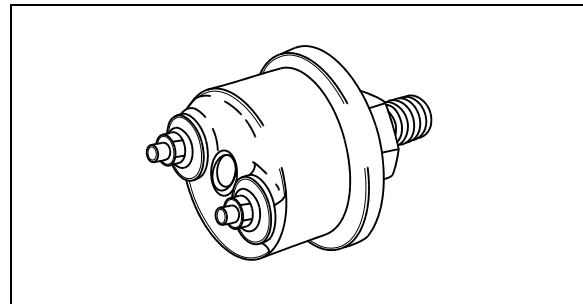


FIGURE 15: DELCO SWITCH 12139

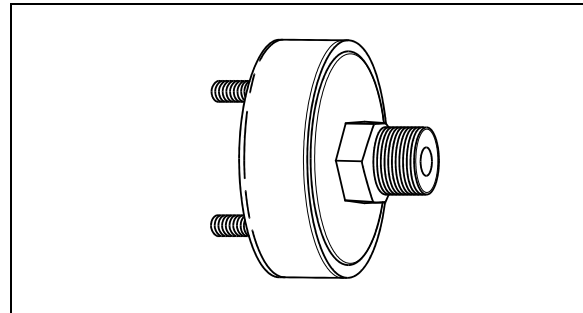


FIGURE 16: BENDIX SWITCH 12140

### 16. PARKING BRAKE ALARM SWITCH

Refer to the appropriate annexed booklet (Bendix, SL-5 Stop Light Switch; reference no. SD-06-2501).

The parking brake alarm uses the same switch as the stoplights. It is mounted on the spring brake valve and operates in conjunction with a NC relay to sound a warning alarm by completing the electrical circuit when the ignition key is turned OFF with parking brake released.

### 17. BRAKE RELAY VALVE (R-12 & R-14)

The primary air system includes three brake relay valves being supplied by the dual brake valve, and which function is to speed up the application and release of the service brakes.

One Wabco R-14 valve located in the rear underframe supplies the drive axle service brake air line, while the other two R-12 valves supply independently both the tag axle right and left service brake air line and act as interlock valves. These valves are accessible from under the vehicle at the level of the tag axle. Maintenance and repair information on these valves is supplied in the applicable booklet annexed to this section under reference number SD-03-1064.

## Section 12: BRAKE AND AIR SYSTEM

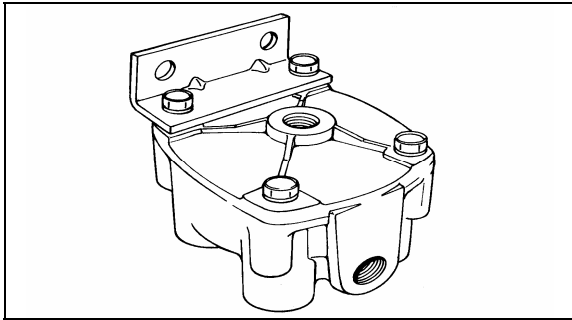


FIGURE 17: R-12

12074

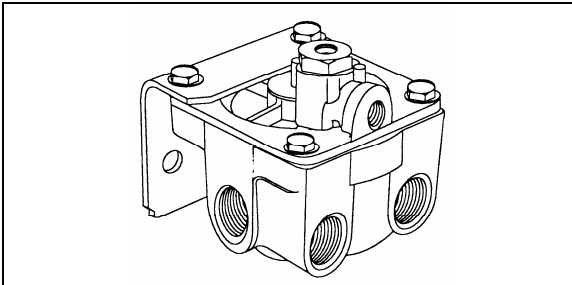


FIGURE 18: R-14

12207

### 18. QUICK RELEASE VALVES (QR-1)

The quick release valve is located on the front axle service brakes air line and permit rapid exhaust of air pressure from brakes, thus decreasing the brake release time.

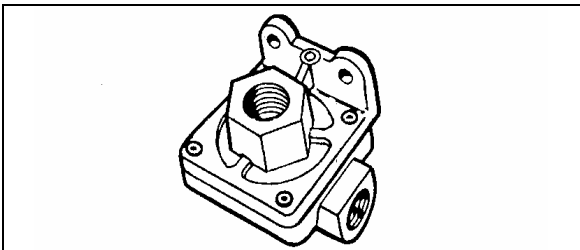


FIGURE 19: QR-1

12075

Maintenance and repair information on this valve is supplied in the applicable booklet annexed to this section under reference number SD-03-901.

### 19. SPRING BRAKE VALVE (SR-7)

The spring brake valve is located in the rear underframe. The SR-7 Modulating Valve is used in conjunction with a dual air brake system and spring brake actuator and performs the following functions:

- Provides a rapid application of the spring brake actuator when parking.
- Modulates the spring brake actuator application using the dual brake valve

should a primary failure occur in the service brake system.

- Prevents compounding of service and spring forces.

Maintenance and repair information on the spring brake valve is supplied in the applicable booklet annexed to this section under reference number SD-03-9043.

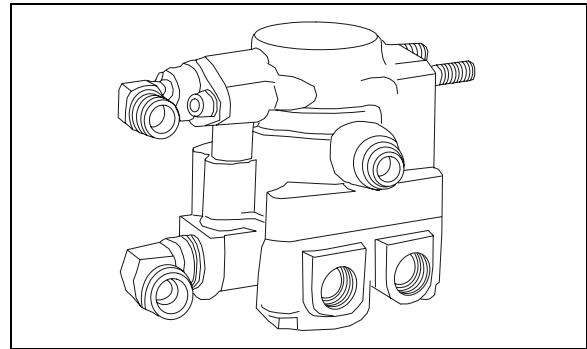


FIGURE 20: SR-7

12206

### 20. PRESSURE PROTECTION VALVE (PR-4)

Maintenance and repair information on the pressure protection valve is supplied in the applicable booklet annexed to this section under reference number SD-03-2010.

The air system includes two pressure protection valves (Fig. 21). One valve is installed on the manifold block, and insures at all times a minimum pressure of 70 psi (482 kPa) in the suspension air system in the event that a pressure drop occurs in either the suspension air system or accessory air system. This valve is located in the front service compartment beside the air filter.

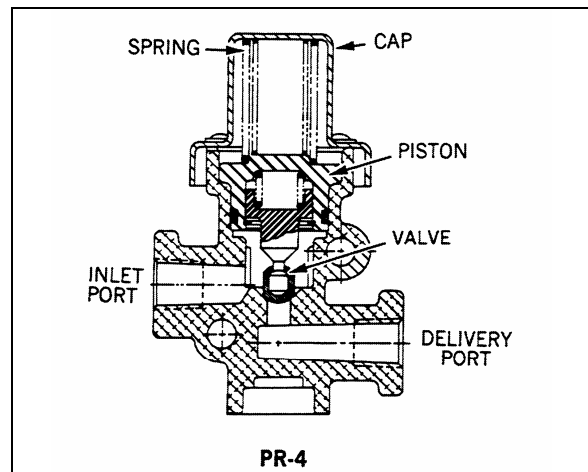


FIGURE 21: PR-4

12174

The other valve is installed on the accessory air tank, and insures a minimum pressure of 70 psi (482 kPa) in the accessory air system in the event that a pressure drop occurs in either the suspension air system or braking air system (refer to Fig. 1 & 2 for accessory air tank location).

**21. LOW PRESSURE INDICATOR (LP-3)**

Maintenance and repair information on the low pressure indicators is supplied in the applicable booklet annexed to this section under reference number SD-06-1600.

The air system includes two low pressure switches (Fig. 22), both located on the pneumatic accessory panel in the front service compartment. One serves for the parking brake signal, its pressure setting is  $66 \pm 6$  psi ( $455 \pm 40$  kPa). The remaining pressure switch monitors the parking brake telltale panel indicator; its pressure setting is 30 psi (205 kPa).

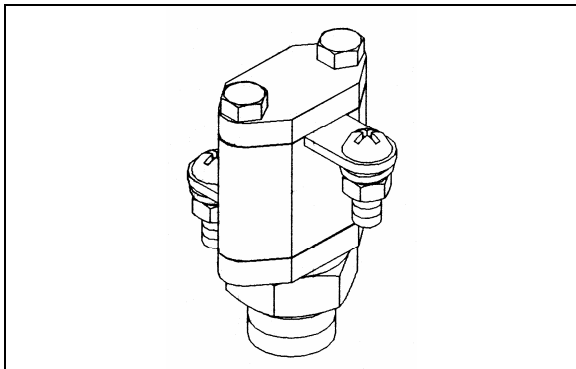


FIGURE 22: LP-3 12214

**22. SHUTTLE-TYPE DOUBLE CHECK VALVE (DC-4)**

Maintenance and repair information on the shuttle-type double check valve is supplied in the applicable booklet annexed to this section under reference number SD-03-2202.

The double check valve is located on the pneumatic accessory panel in the front service compartment. In the event of a pressure drop in either the primary or secondary system, this unit will protect the emergency /parking brake control valve and the intact portion of the air system from pressure loss.

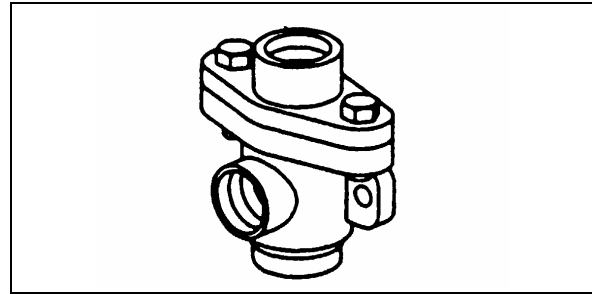


FIGURE 23: DC-4 12134

**23. EMERGENCY DOOR OPENING VALVES**

Two emergency door opening three-way valves are installed on coaches. One is in the front service compartment, readily accessible. The other one is on the R.H. side lateral console, close to the entrance door. When used, the valve releases pressure in the door locking cylinder, thus allowing the door to be manually opened.

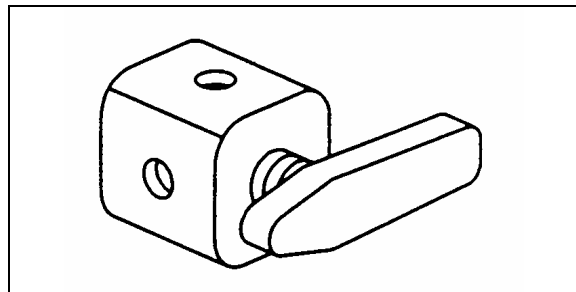


FIGURE 24: THREE-WAY VALVE 12186

**24. AIR HORN VALVE**

The air horn valve is located in the L.H. front service compartment. The air horn button is on the center of the steering wheel. Refer to section 23 "ACCESSORIES" for more information.

**25. AIR SYSTEM TROUBLESHOOTING**

The following list has been designed to help in troubleshooting some of the most common problems in the air system and main causes. For air brakes troubleshooting, refer to "Air Brakes Troubleshooting" in this section. For more troubleshooting information, refer to the manufacturer's brochures annexed to this section.

Air pressure doesn't rise to, or doesn't maintain, a normal setting:

- Defective air gauge (registering incorrectly).
- Excessive leaking in air system.



## Section 12: BRAKE AND AIR SYSTEM

- Reservoir drain cock open.
- Governor poorly adjusted or defective.
- Defective compressor.
- Worn compressor or excessive wear on piston and/or ring.
- Air pressure rises to normal setting too slowly.

Excessive leaking in air system:

- Clogged engine air cleaner.
- Worn compressor or excessive wear on piston and/or ring.
- Engine speed too low.

Air pressure rises above a normal setting:

- Defective air gauge (registering incorrectly).
- Governor poorly adjusted or defective.
- Restriction in line between governor and compressor unloading mechanism.

Air pressure drops quickly when engine is stopped:

- Leaks in compressor discharge valve.
- Leaks in governor.
- Leaks in air lines.
- Leaks in air system valves.

### 26. BRAKE OPERATION

The vehicle braking system uses both service and parking air-operated brakes. The air system is divided into two independent circuits to isolate the front axle brakes and the rear axle brakes (drive and tag), thus providing safe brake operation in the event that one circuit of the system fails. The primary circuit is connected to the drive and tag axle brakes, while the secondary circuit is connected to the front axle brakes. The tag axle service brakes operate only when the axle is in the normal driving (loaded) position. The spring-type emergency brakes are mounted on the drive axle, and will apply automatically if primary system pressure falls below 40 psi (276 kPa).

Furthermore, brake application or release, which is speed up by a pneumatic relay valve (R-12), will start with the rear axles and be followed by the front axle, thus providing uniform braking on

a slippery surface. The vehicle is also equipped with an Anti-lock Brake System (ABS), detailed later in this section.

Brake and air system maintenance consists of periodic inspections. Check all parts for damage and brake adjustment (refer to subsequent headings in this section for more details). Ensure all fasteners are tight (refer to "Specifications" for recommended tightening torques).

### 27. AIR BRAKES

#### 27.1 DISC BRAKES

*Knorr-Bremse SN7000* disc brakes are used on all axles. The front and drive axle discs are actuated by 24 square inch effective area air brake chambers, while on tag axle, the brake chambers have a 14 or 16 square inch effective area for service. The *Knorr-Bremse SN7000* brakes are supplied with automatic clearance (slack) adjusters as standard equipment for easier adjustment. For more information on disc brake components and maintenance, refer to the manufacturer's brochure at the end of this section.

##### 27.1.1 Disc Brake Pads

Brake pads have to be checked on a regular basis depending on the vehicle operation. The remaining thickness of the pads should never be less than 3/32 in (2 mm). To check pad condition without removing the wheel, verify the position of guide bushing (6) relatively to guide sleeve (4) (see Fig. 25). When guide sleeve is in alignment with guide bushing, brake pad thickness has to be checked more precisely with the wheel removed. When replacing brake pads, all four pads on an axle have to be changed at the same time. There is no inner or outer pad, since all pads are the same. Once removed, worn pads should be replaced in their original position.

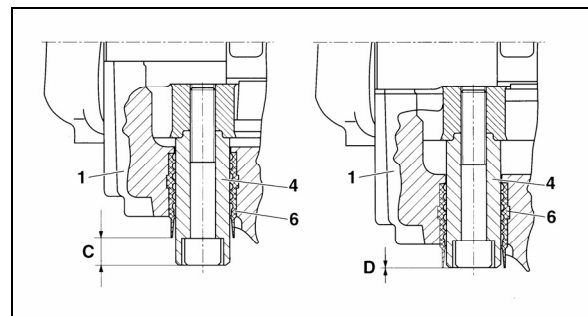


FIGURE 25: BRAKE PAD CHECK

12117

27.1.2 Caliper Maintenance

Use the following procedure for brake calipers servicing. The procedure must be followed in proper sequence to ensure that only needed repairs or replacements are performed on calipers. Problems such as hot brakes or cracked rotors may be effects of sticking calipers, too-small clearance between rotor and pad or possible trapped air pressure in the brake chamber. If any of these symptoms occur, perform this procedure before replacing the rotor to ensure the cause of the problem is properly solved.

1. Check for presence of residual pressure:

To check if there is any residual air pressure in the brake chamber, make four or five brake applications, then try to turn the wheel manually, if the wheel does not turn, use a wrench to crack the air line and listen for trapped air in the brake chamber then try to turn the wheel manually again. If you find trapped air in the brake booster, ensure that all pneumatic components in the braking system are functioning properly.

**NOTE**

*A residual pressure of 2-3 PSI in the system is sufficient to prevent the brakes from releasing. Also the stop light switch can operate with as little as 1 PSI, therefore an illuminated brake light does not mean brakes are dragging.*

2. Pad to rotor clearance inspection:

Remove clip and washer (26 & 45, Fig. 26), push down retainer bar (11), pull out pin (44) and remove retainer bar. Push caliper toward actuator (center of vehicle) for maximum clearance.

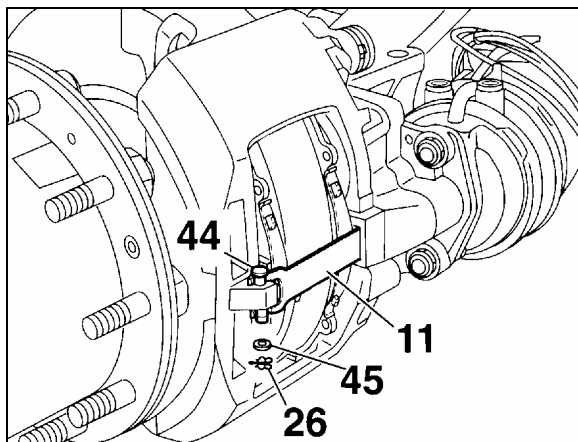


FIGURE 26: CLEARANCE INSPECTION 12119

3. Measure pad to rotor clearance:

Place a long feeler gauge (long enough to measure across entire tappet surface) between the tappet and the backing plate of the pad, measure clearance at both tappets. Clearance should range between 0.020 and 0.035 inch (0.5 mm and 0.9 mm), with a maximum difference between tappet measurements on same brake of 0.008 inch (0.2 mm).

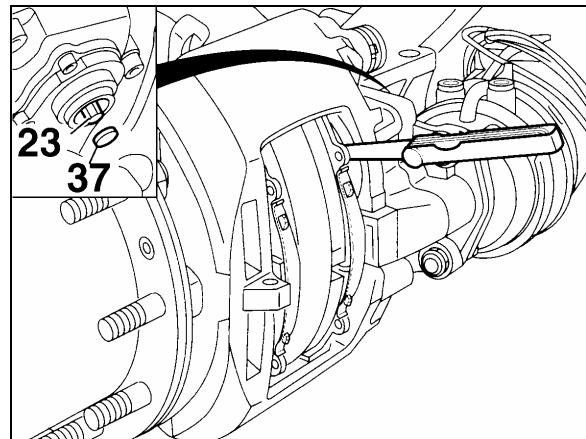


FIGURE 27: RUNNING CLEARANCE 12116

4. Checking the adjuster



**CAUTION**

Use only a standard box wrench on the adjuster hexagonal pinion. Do not overtorque the pinion as overtightening will damage the pinion.

- a) Remove cap (37, Fig. 27).
- b) Using a box wrench (8 mm), turn the adjuster pinion (23, Fig. 28) counterclockwise about 2 - 3 clicks to increase running clearance. By operating the braking system about 5 - 10 times (30 PSI or 2 bar), the wrench should turn clockwise in small increments if the adjuster is functioning correctly (Figs. 28 and 29).

**NOTE**

*With increasing number of applications, the incremental adjustment will decrease.*

- c) In case of malfunction, i. e. the pinion or box wrench:
  - i) Does not turn.
  - ii) Turns only with the first application.

## Section 12: BRAKE AND AIR SYSTEM

- iii) Turns forwards then backwards with every application.

In any of the above cases, the automatic adjuster has failed and the caliper must be replaced. In such cases the brakes can be adjusted manually to run a short distance.

- d) Take the box wrench off. Replace the cap and check for proper sealing.

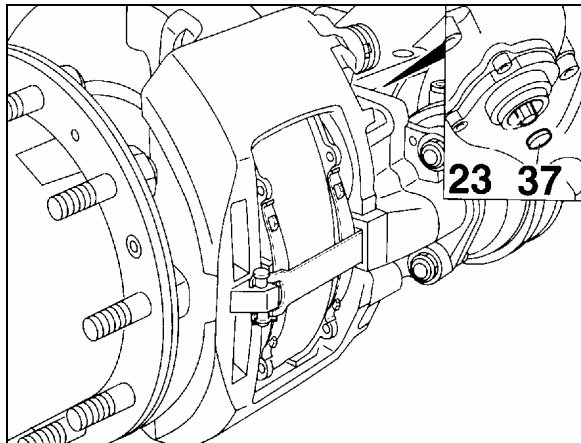


FIGURE 28: ADJUSTER PINION

12120

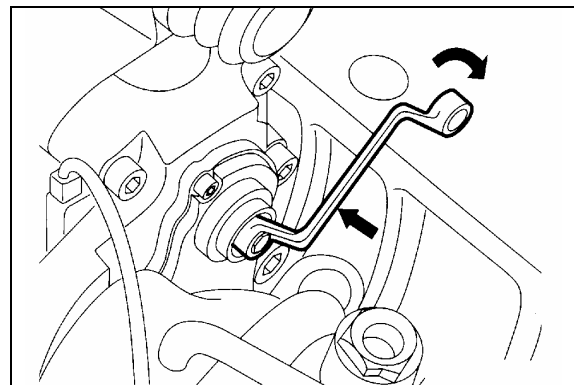


FIGURE 29: BOX WRENCH ON ADJUSTER PINION

12118

### 27.1.3 Roadside Inspection for Knorr/Bendix Air Disc Brakes

The coach is equipped with air disc brakes and therefore, cannot be inspected using the requirements for chamber stroke or visible lining clearance or lining thickness as specified for drum brakes. The roadside inspector should use the following instructions to determine that the air disc brakes are within proper adjustment and have sufficient pad wear thickness.

The Knorr/Bendix air disc brake is designed to move freely, with minimal force, in the axial direction on the two sliding pins as identified in figure 30. The movement in the axial direction should not exceed 2 mm (5/64").

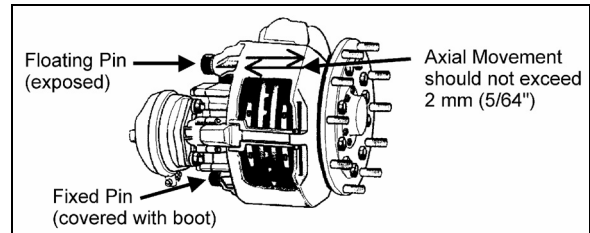


FIGURE 30: CALIPER AXIAL MOVEMENT

12132

The pad thickness can be seen but would require removal of the tire and rim. An indicator of the pad wear condition is available by inspecting the floating pin location in relation to the rubber bushing as shown in figure 31. When pads are in new thickness condition, the pin will be exposed (C) 19 mm (3/4"). When the pads are worn to replacement conditions, the pin will be nearly flush to the bushing (D) or within 1 mm (3/64") of the edge of the rubber bushing.

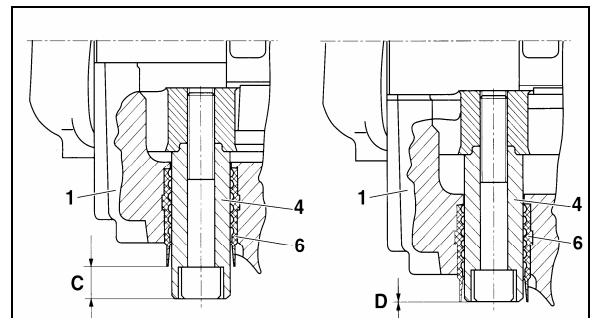


FIGURE 31: BRAKE PAD CHECK

12117

#### 27.1.4 Pad Removal

Turn adjuster pinion (23) counterclockwise to increase pad to rotor clearance (a clicking noise will be heard). Push caliper toward actuator and remove pads (12).



### CAUTION

Do not apply brakes while pads are removed as this could cause over stroke damage to the adjusting mechanism.

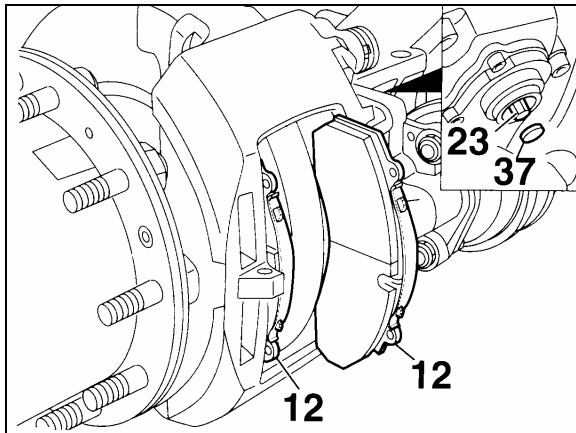


FIGURE 32: PAD REMOVAL 12111

27.1.5 Checking Pad Wear

Minimum friction material thickness is 2 mm (A, Fig. 33)

New friction material has a thickness of 21 mm (B, Fig. 33)

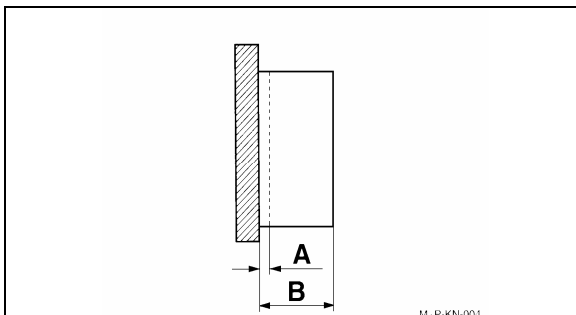


FIGURE 33: PAD WEAR 12112

27.1.6 Important Pad and Rotor Measurements

- A = Rotor thickness (new): 45 mm;
- B = Rotor thickness (worn): 37 mm, requires replacement;
- C = Overall thickness of pad (new): 30 mm;
- D = Backplate: 9 mm;
- E = Minimum thickness of pad material: 2 mm;
- F = Minimum allowed thickness of overall backplate and friction material: 11 mm.  
**Replacement necessary.**

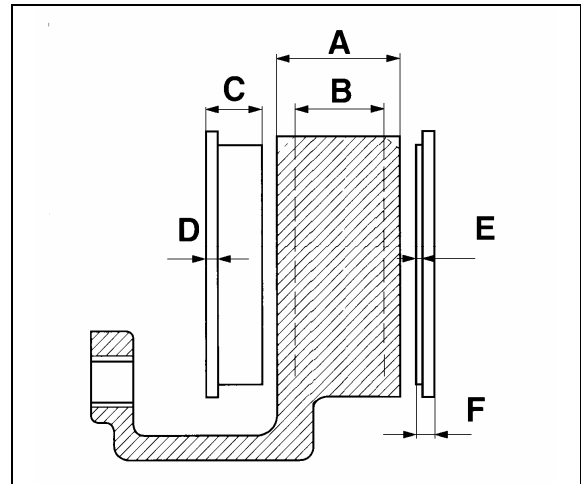


FIGURE 34: ROTOR AND PAD WEAR LIMITS 12113

27.1.7 Checking Caliper Guidance and Seal Condition

Perform sliding test. You must be able to slide the caliper easily at any time. Sliding test should be performed at least every three months or more often depending on the type of operation.

Sliding Test (Refer to Fig. 35):

- a) Using hand pressure only, the caliper (1) must slide freely with its guide pin arrangements (4-7) across a distance of 1 3/16 inch (30 mm) when the pads are removed. The sleeve (5) is sealed using the boot (9) and the cap (10).
- b) The rubber components (9 and 10) should show no damage. The positioning must be checked. If necessary the caliper has to be repaired using the guide kit (part #611168) or with the seal and guide kit (part #611199). When repairing a caliper with the above kits, make sure all parts in the kit are used. Use special green grease (Prévost #683344) to reassemble the slide pin into the bushing, white or yellow grease (Prévost #683345) may be used for all other lubrication needs.
- c) Depending on caliper manufacturing date, black paint may be present on the unsealed pin (short pin). Paint on the slide pin can prevent the caliper from sliding properly especially when the pad starts to wear. If paint is present on the pin, separate the pin from the bushing, clean and reinstall the pin according to procedure.

**NOTE**

Do not attempt to use thinner or alcohol to clean the pin without removing it as it may damage the rubber bushing.

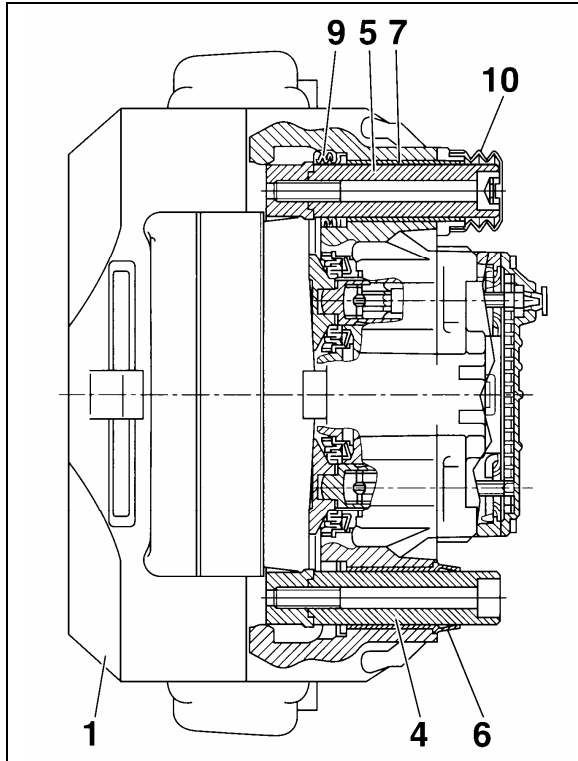


FIGURE 35: CALIPER GUIDANCE

12114

27.1.8 Checking the Tappet Boots

- a) The rubber boots (13, Fig. 36) should show no damage, check the attachment.

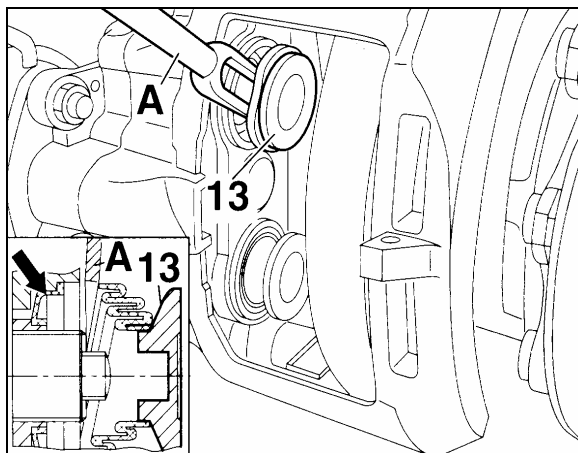


FIGURE 36: RUBBER BOOTS

12115



**CAUTION**

Any ingress of water and dirt will lead to corrosion and may affect the function of the actuation mechanism and adjuster unit.

- b) If boots are damaged but show no corrosion, the boots and tappets should be replaced (Prévost #611177).

27.1.9 Pad Installation

Turn adjuster pinion (23, Fig. 37) counterclockwise until tappets are fully retracted and clean pad seat area. Slide caliper to full outboard position and install outside pad. Slide caliper to full inboard position and install inside pad.



**WARNING**

It is recommended to change all pads on an axle at the same time.

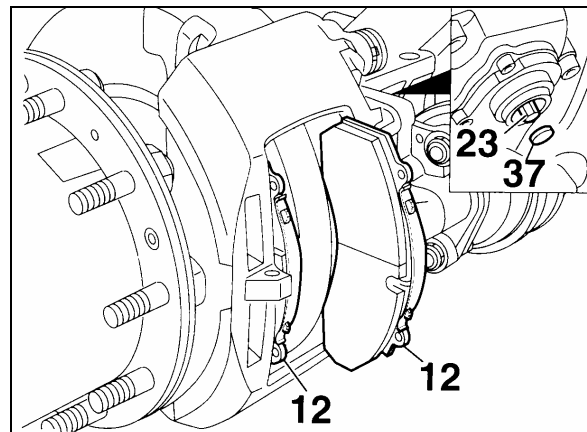


FIGURE 37: PAD INSTALLATION

12111

27.1.10 Adjusting the Running Clearance

- a) Insert a feeler gauge 0.028 inch (0.7 mm thickness) between tappet and pad backplate (Fig. 38). Turn adjuster pinion clockwise until 0.028 inch (0.7 mm) clearance is achieved. Replace cap (37) (Prévost # 641313).
- b) To ensure a constant running clearance between the rotor and pads, the brake is equipped with an automatic adjuster unit. When the pads and rotor wear, the running clearance between the pads and rotor increases. The adjuster (23, Fig. 38) and turning device turn the threaded tubes by the amount necessary to compensate the wear.

Total running clearance should be between 0.020 and 0.035 inch (0.5 and 0.9 mm). Smaller clearances may lead to overheating problems.

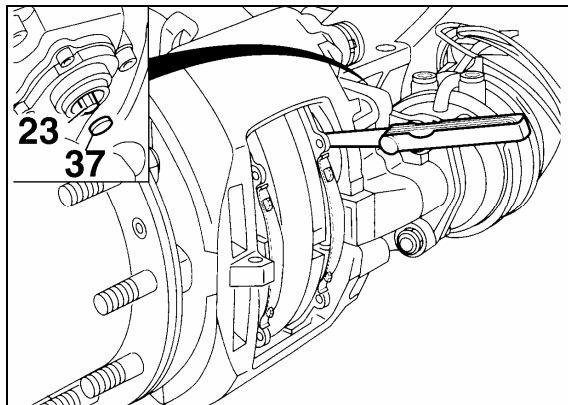


FIGURE 38: RUNNING CLEARANCE 12116

### 27.1.11 Brake Tools

Four brake tools are available from Prévost to facilitate disc brake maintenance:

- a) #641321, Tappet with boot (item 13).
- b) #641322, Caliper inner boot (item 9).
- c) #641323, Caliper bushing (item 7).
- d) #641435, Fork for boot tappet (item 13).

### Maintenance tip

Using the following procedure, pad wear can be determined without removing the wheel.

### 27.1.12 Checking Brake Pads

Brake pads have to be checked on a regular basis depending on the vehicle operation. The remaining thickness of the pads should never be less than 3/32 inch (2 mm). To check pad condition without removing the wheel, verify the position of guide bushing (6) relatively to guide sleeve (4) (Fig. 39). When guide sleeve is in alignment with guide bushing, brake pad thickness must be checked more precisely with wheel removed. When replacing the brake pads, all four pads on an axle have to be changed at the same time. There is no inner or outer pad, since all pads are the same. Worn pads should be replaced in the same position.

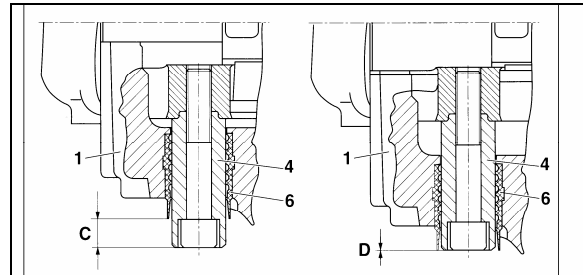


FIGURE 39: BRAKE PAD CHECK 12117

### 27.1.13 Torque specifications

For proper caliper maintenance, refer to the following figures.

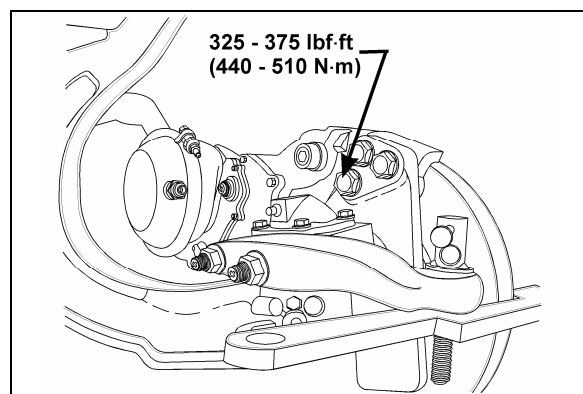


FIGURE 40: TORQUE SPECIFICATION 12145

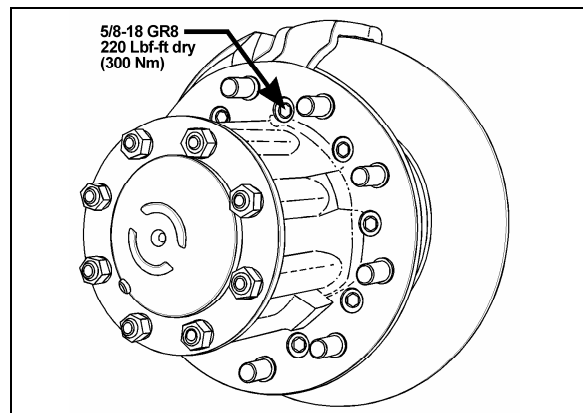


FIGURE 41: TORQUE SPECIFICATION 11030

## 28. SAFE SERVICE PROCEDURES

Most recently manufactured brake linings no longer contain asbestos fibers. Instead of asbestos, these linings contain a variety of ingredients, including glass fibers, mineral wool, aramid fibers, ceramic fibers, and carbon fibers. At present, OSHA (Occupational Safety and Health Administration) does not specifically regulate these non-asbestos fibers, except as nuisance dust. Medical experts do not agree about the potential long-term risks from working

## Section 12: BRAKE AND AIR SYSTEM

with and inhaling non-asbestos fibers. Nonetheless some experts think that long-term exposure to some non-asbestos fibers could cause diseases of the lung, including pneumoconiosis, fibrosis, and cancer. Therefore, lining suppliers recommend that workers use caution to avoid creating and breathing dust when working on brakes that contain non-asbestos fibers.



### WARNING

Whenever possible, work on brakes in a separate area away from other operations.

Always wear a respirator approved by NIOSH (National Institute of Occupational Safety and Health) or MSHA (Mine Safety and Health Administration) during all brake service procedures. Wear the respirator from removal of the wheels through assembly.

NEVER use compressed air or dry brushing to clean brake parts or assemblies. OSHA recommends that you use cylinders that enclose the brake. These cylinders have vacuums with high efficiency (HEPA (Health and Environment Protection Agency)) filters and workmans' arm sleeves. But, if such equipment is not available, carefully clean parts and assemblies in the open air.

Clean brake parts and assemblies in the open air. During disassembly, carefully place all parts on the floor to avoid getting dust into the air. Use an industrial vacuum cleaner with a HEPA filter system to clean dust from the brake drums, backing plates and other brake parts. After using the vacuum, remove any remaining dust with a rag soaked in water and wrung until nearly dry.

If you must grind or machine brake linings, take additional precautions because contact with fiber dust is higher during these operations. In addition to wearing an approved respirator, do such work in an area with exhaust ventilation.

When cleaning the work area, NEVER use compressed air or dry sweeping to clean the work area. Use an industrial vacuum with a HEPA filter and rags soaked in water and wrung until nearly dry. Dispose of used rags with care to avoid getting dust into the air. Use an approved respirator when emptying vacuum cleaners and handling used rags.

Wash your hands before eating, drinking or

smoking. Do not wear your work clothes home. Vacuum your work clothes after use and then launder them separately, without shaking, to prevent fiber dust from getting into the air.

Material safety data sheets on this product, as required by OSHA, are available from Rockwell and Knorr-Bremse.

## 29. AIR BRAKE TROUBLESHOOTING

The following tests and check lists have been designed to identify the cause(s) of a sluggish performance and/or leaks in the system. These tests require very little time to perform, and give you a general idea of the system condition. Each test is provided with a corresponding check list which will guide you to the most common causes of problems.

Before performing any test, check all air lines for kinks or dents, and hoses for signs of wear, drying out or overheating.



### WARNING

When working on or around brake system and its related components, the following precautions should be observed:

Always block vehicle wheels. Stop engine when working under a vehicle. Keep hands away from chamber push rods and slack adjusters as they may apply when system pressure drops.

Never connect or disconnect a hose or line containing air pressure. It may whip as air escapes. Never remove a component or pipe plug unless you are sure all system pressure has been depleted.

Never exceed recommended air pressure and always wear safety glasses when working with air pressure. Never look into air jets or direct them at anyone.

Never attempt to disassemble a component until you have read and understood the recommended procedures. Some components contain powerful springs and injury can result if not properly disassembled. Use only proper tools and observe all precautions pertaining to the use of those tools.

Always clean connecting piping and/or fittings, and coat pipe threads with Teflon pipe sealant before installing any air brake system component.

### **Pressure Build-Up / Low Pressure Warning / Cutoff Point / Air Filter/Dryer Built-in Governor Cutout**

CONDITION: Vehicle leveled, parking brake applied.

1. Completely drain wet, primary and secondary air reservoirs only.
2. Start engine and run at fast idle. Low pressure warning lights should be "On".
3. Start checking pressure at 50 psi (344 kPa).
4. Low pressure warning lights and buzzer should go off at or above 60 psi (415 kPa).
5. At 85 psi (586 kPa), run engine at full rpm, then check that build up time to 100 psi (690 kPa) is 30 seconds or less.
6. Air filter/dryer built-in governor cut-out. Cuts out at the correct pressure of 123 psi  $\pm$ 3 (847 $\pm$ 21 kPa).
7. Air filter/dryer built-in governor cut-in. Cuts in around 110 psi (758 kPa).

For common corrections, refer to the following check list:

#### **High or Low Warning Cutoff Point**

- Perform a telltale light and gauge test. Replace entire cluster if found defective.

#### **High or Low Air Filter/Dryer Built-in Governor Cutout Point**

- Perform a telltale light and gauge test. Replace entire cluster if found defective.

OR

- Repair or replace air filter/dryer as necessary after checking that compressor unloader mechanism operates correctly.

#### **More than 30 seconds to build-up pressure from 85 to 100 psi (585 - 690 kPa) at full engine RPM**

- Perform a telltale light and gauge test. Replace entire cluster if found defective.
- Check compressor strainer or inlet line. If restricted, clean or replace element or faulty line.
- Check compressor head or discharge line for carbonization or restriction. Clean or replace as necessary.

- If discharge valves leak, pull head and correct or replace cylinder head.
- If drive is slipping, replace gear.
- If inlet valves are stuck, open or leaking severely, replace unloader kit, inlet valves and/or seats as necessary.
- If drain cock is found open, close it.
- Listen for air leaks and repair.
- Redo list to check all items repaired or replaced.

#### **Air Supply Reservoir Leakage**

CONDITION: Full pressure, engine stopped, parking brake applied

1. Allow at least 1 minute for pressure to stabilize.
2. Stop engine, then check air pressure gauge for 2 minutes. Note any pressure drop.
3. Pressure should not drop by more than 3 psi (20 kPa) per minute.

For common corrections, refer to the following check list:

Excessive air loss:

- With the primary air system at normal operating pressure (95 - 125 psi (655 - 860 kPa)), coat all air line connections and pneumatic components with a water and soap solution. Bubbles will indicate an air leak, and none should be permissible. Repair or replace defective parts.
- Listen for leaks and correct as required.
- Redo test to check all items repaired or replaced.

#### **Brake System Air Leakage**

CONDITION: Full pressure, engine stopped, parking brake released.

1. Apply service (foot) brakes, allow at least 1 minute for pressure to stabilize.
2. Hold down foot valve for 2 minutes while observing air pressure gauge on the dashboard.
3. Pressure drop should not be more than 4 psi (27 kPa) per minute.

For common corrections, refer to the following check list.



## Section 12: BRAKE AND AIR SYSTEM

### Excessive leakage on brake service side:

- With the primary air system at normal operating pressure (95 - 125 psi (655 - 860 kPa)) and foot brake applied, coat all air line connections and brake pneumatic components with a water and soap solution. Bubbles will indicate an air leak, and none should be permissible. Repair or replace defective parts.
- Listen for leaks and correct as required.
- Redo test to check all items repaired or replaced.

#### **IMPORTANT NOTE**

To maintain your vehicle's air disc brakes at their original performance standard, we strongly recommend use of only genuine, approved service replacement parts on Bendix and Knorr-Bremse air disc brake systems. If non-approved friction materials or replacement components are used, neither Prévost Car nor Bendix Spicer Foundation Brake LLC will accept any air disc brake-related warranty returns or claims.

For more information on this policy, refer to Bendix-Prévost product notification annexed at the end of Section 12 of Maintenance Manual.

### 30. BRAKE AIR CHAMBER

If this vehicle is equipped with *Knorr-Bremse SN7000* disc brakes on all axles, it also uses "Knorr-Bremse" brake chambers. The drive axle chambers consist of two separate air chambers, each having its own diaphragm and push rod. They are used as a service brake chamber, an emergency brake in case of air pressure loss and a spring-applied parking brake. Refer to figures 42 and 43.

The front and tag axle brake air chambers are used only for service brake duty (Fig. 42).

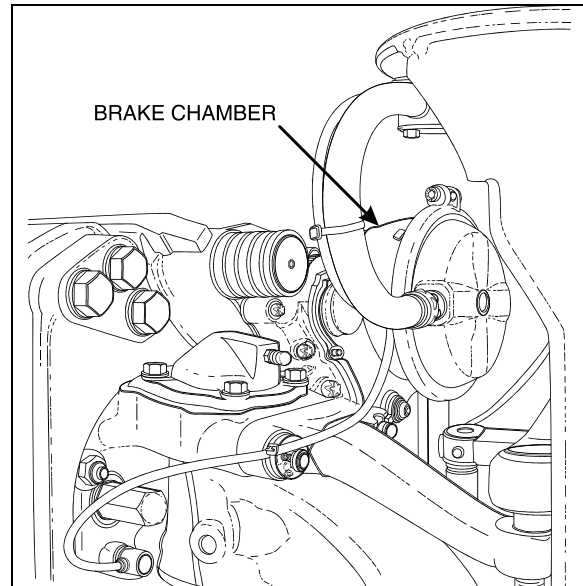


FIGURE 42: FRONT AXLE BRAKE AIR CHAMBER 12158

#### 30.1 MAINTENANCE

**Every 6,250 Miles (10 000 km) or twice a year, whichever comes first depending on type of operation:**

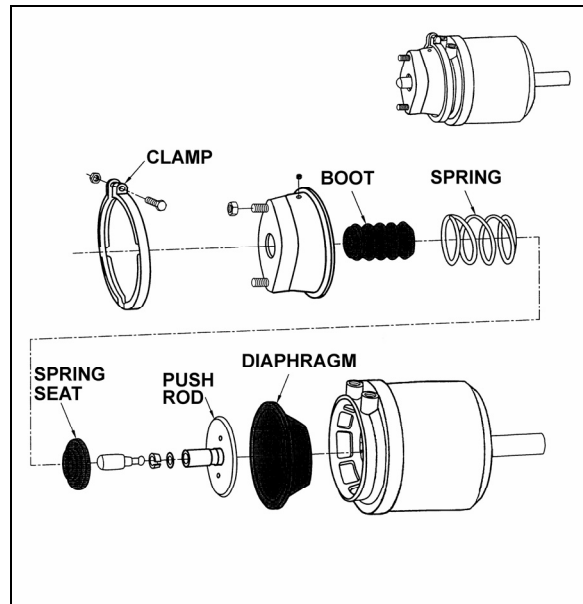


FIGURE 43: DRIVE AXLE BRAKE AIR CHAMBER 12126

Check all hoses and lines. They should be secure and in good condition.

**Every 100,000 Miles (160 000 km) or once a year, whichever comes first depending on type of operation:**

1. Disassemble and clean all parts.

2. Install new diaphragm or any other part if worn or deteriorated.

**NOTE**

*When the diaphragm, spring, or both are replaced, they should be replaced in the corresponding chamber on the same axle.*

3. Perform an airtightness test:
  - a) Make and hold a full brake application.
  - b) Coat clamping ring(s) with a soapy solution. If leakage is detected, tighten clamping ring only enough to stop leakage. **Do not overtighten** as this can distort sealing surface or clamping ring. Coat area around push rod hole (loosen boot if necessary). No leakage is permitted. If leakage is detected, the diaphragm must be replaced.

30.2 EMERGENCY/PARKING BRAKE MANUAL RELEASE



**DANGER**

Never stand in the axis line of the spring brake chambers, especially when caging the spring.

**Drive Axle**

1. Block the wheels to prevent the vehicle from moving.
2. Remove the release stud tool from its storage place on drive axle brake air chamber.
3. Remove the access plug from the end of the spring chamber and then insert the release stud through the opening. Turn the release stud ¼ turn (clockwise) to anchor it into the spring plate. Install the flat washer and nut, then turn the nut clockwise to cage the spring. Repeat on the opposite side.



**DANGER**

Make sure the release stud is properly anchored in spring plate receptacle prior to caging the spring.

4. To manually reset the emergency/parking brake, turn the nut counterclockwise. Reinstall access plugs on the spring chambers, and release stud tools in their storage places.

30.3 BRAKE CHAMBER REMOVAL



**WARNING**

To prevent personal injuries, brakes should be inoperative prior to working on any of their components.

To prevent personal injuries, brake chambers should be made inoperative by releasing spring tension prior to disposal.

1. Block the wheels to prevent the vehicle from moving.
2. Safely support vehicle at the recommended body jacking points.
3. To gain access to a given brake air chamber, the corresponding wheel can be removed (refer to Section 13: "Wheels, Hubs and Tires").
4. Exhaust compressed air from system by opening the drain valve of each reservoir.
5. For the drive axle brake chambers, manually release spring brakes (refer to "Emergency/Parking Brake, Manual Release" procedure in this section).
6. Disconnect air line(s) from brake chamber.
7. Remove the cotter pin connecting brake chamber and slack adjuster (drive axle).
8. Unbolt and remove the brake chamber from vehicle.

30.4 BRAKE CHAMBER INSTALLATION

Reverse removal procedure and then check brake adjustment.



**CAUTION**

Always clean air lines and fittings, and coat pipe threads with teflon pipe sealant before reconnecting air lines.

30.5 BRAKE CHAMBER DISASSEMBLY



**DANGER**

Spring brake chambers, on drive and tag axles contain an extremely high compressive force spring, which can possibly cause serious injury if special precautions are not taken when working around this area.

To avoid such injury, the following recommendations must be applied:

- Prévost recommends the installation of a new spring brake chamber if it is found to be defective.
- Spring brake chamber maintenance and/or repair must be performed by trained and qualified personnel only.
- Before manually releasing spring brakes, visually check spring brake for cracks and/or corrosion.
- On “MGM” brake chambers (drive axle), make sure the release stud is properly anchored in spring plate receptacle prior to caging the spring.
- Never stand in the axis line of the spring brake chambers, especially when caging the spring.



### WARNING

To prevent personal injuries, brakes should be inoperative prior to working on any of their components.

1. Block the wheels to prevent the vehicle from moving.
2. Safely support vehicle at the recommended body jacking points.

### NOTE

*To gain access to a given brake air chamber, the corresponding wheel can be removed (refer to Section 13: "Wheels, Hubs and Tires").*

3. Exhaust compressed air from air system by opening the drain valve of each reservoir.
4. For the drive axle brake chambers, manually release spring brakes (refer to “Emergency/Parking Brake Manual Release” procedure in this section).
5. Remove clamp ring, remove and discard the existing diaphragm. Install the new diaphragm squarely on body.
6. Reverse the procedure for assembly. Tap clamp ring to ensure proper seating. Check for proper operation before placing vehicle in service.

### 31. ANTI-LOCK BRAKING SYSTEM (ABS)

This device has been designed to ensure stability and permit steering control of vehicle during hard braking, and to minimize its stopping distance whatever the road conditions are. On slippery roads and generally in emergency situations, over-braking frequently induces wheel lock. The anti-lock braking system provides maximum braking performance while maintaining adequate steering control on slippery roads.

The ABS continuously monitors wheel behavior during braking. Sensors on each wheel of front and drive axles (tag axle is slave to drive axle) transmit data to a four channel electronic processor which senses when any wheel is about to lock. Modulator valves quickly adjust the brake pressure (up to 5 times per second) to prevent wheel locking. Each wheel is therefore controlled according to the grip available between its tire and the road.

With this device, the vehicle is brought to a halt in the shortest possible time, while remaining stable and under the driver's control.

Since the braking system has dual circuits, the ABS is also provided with a secondary system should a fault develop in the ABS. Anti-lock systems are a parallel system which does not hinder brake functioning in case of failure. Braking system functions in normal, non anti-lock controlled operation during ABS system failure.

The ABS system consists of two diagonally related circuits, only the half of the system which has sustained damage or other fault is switched off (i.e. wheels return to normal non-ABS braking). The other diagonal half remains under full ABS control.

### NOTE

*ABS is active on service brake, transmission retarder, Jake brake, but is inactive on emergency/parking brake.*

### NOTE

*The ABS system is inoperative at speeds under 4 mph (6 Km/h). Illumination of ABS telltale indicator at these speeds is normal.*

**CAUTION**

Disconnect the ECU or pull the ABS fuse before towing vehicle.

31.1 TROUBLESHOOTING AND TESTING

For troubleshooting and testing of the vehicle's anti-lock braking system, refer to Meritor Wabco Maintenance Manual MM-0112: "Anti-Lock Braking System (ABS) for Trucks, Tractors and Buses", at the end of this section. Use dashboard Message Center Display (MCD) Diagnostic Mode for troubleshooting and repair.

31.2 AUTOMATIC TRACTION CONTROL (ATC) – ELECTRONIC STABILITY PROGRAM (ESP)

In addition to the ABS function, vehicle may be equipped with an advanced model of Bendix EC-60 controller to provide an **Automatic Traction Control (ATC)** feature. Bendix ATC can improve vehicle traction during acceleration, and lateral stability while accelerating through curves. ATC utilizes **Engine Torque Limiting (ETL)** where the ECU communicates with the engine's controller and/or **Differential Braking (DB)** where individual wheel brake applications are used to improve vehicle traction.

The EC-60 advanced model controller also provides ABS-based stability features referred to as **ESP® Electronic Stability Program**.

**NOTE**

Vehicles equipped with the ATC/ESP system have one more modulator valve and two additional sensors located on the tag axle wheels (6S/5M). Basic ABS consists of 4 sensors and 4 modulator valves (4S/4M).

**CAUTION**

Even with ESP-equipped vehicles, the driver remains responsible for ensuring vehicle stability during operation.

**DANGER**

ESP may reduce the vehicle speed automatically.

**DANGER**

ESP can make the vehicle **decelerate automatically**. ESP can slow the vehicle with or **without the operator applying the brake**, and **even when the throttle is being applied**.

31.3 ABS COMPONENTS

The main components of the ABS system are listed hereafter. Refer to each component for its specific function in the system and for proper maintenance.

31.3.1 Electronic Control Unit (ECU)

This control unit is located in the front electrical compartment, (refer to figure 44 for location). According to the data transmitted by the sensors (number of pulses/sec is proportional to the speed of each wheel), the electronic control unit determines which wheel is accelerating or decelerating. It then establishes a reference speed (average speed) from each wheel data, and compares the speed of each wheel with this reference speed to determine which wheel is accelerating or decelerating.

As soon as wheel deceleration or wheel slip threshold values are exceeded, the electronic control unit signals a solenoid control valve to limit the excessive brake pressure produced by the driver in the appropriate brake chamber.

**Maintenance**

No specific maintenance is required. The ECU is not serviceable. When found to be defective, replace.

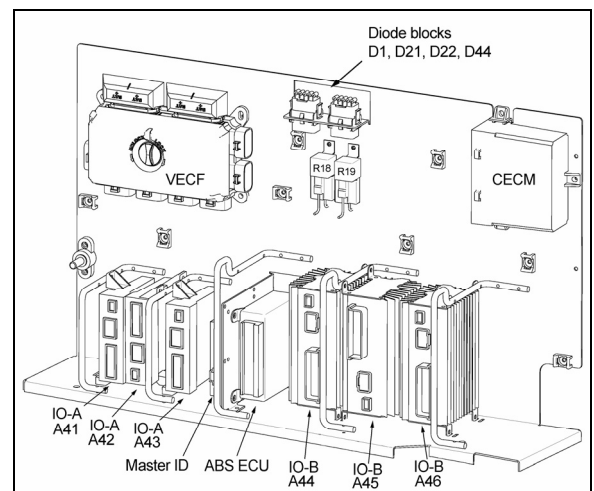


FIGURE 44: ABS ECU LOCATION

06617



**CAUTION**

In order to protect the ABS electronic control unit from voltage surges, always disconnect before performing any welding procedure on vehicle.

31.3.2 ABS Modulator Valve

This ABS system is equipped with four or five modulator valves, located between the brake chamber and the relay valve or quick release valve (Fig. 45). Note that on the basic ABS system, there is only one solenoid valve controlling the drive and tag axle wheels on the same side (tag axle is slave to drive axle).

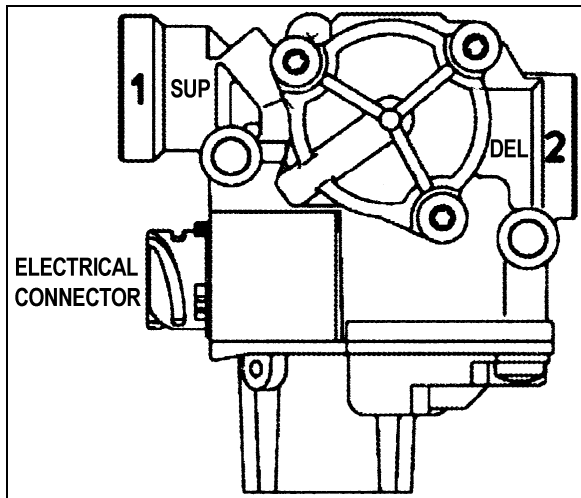


FIGURE 45: ABS MODULATOR VALVE 12221

This is an "On/Off" type valve, i.e., at brake application, the valve exhausts air from the brake chamber when the electronic unit senses that the corresponding wheel speed is decreasing in relation to the other wheels.

**Maintenance**

Refer to Bendix Service Data sheet SD-13-4870 located at the end of this section..

31.3.3 Sensors

The sensors are mounted on the front, drive and tag axle (if applicable) wheel hubs (Fig. 46). The inductive sensors consist essentially of a permanent magnet with a round pole pin and a coil. The rotation of the toothed wheel alters the magnetic flux picked up by the coil, producing an alternating voltage, the frequency of which is proportional to wheel speed. When wheel speed decreases, magnetic flux decreases proportion-

ately. Consequently, the electronic control unit will command the solenoid control valve to decrease the pressure at the corresponding brake chamber.

**Maintenance**

No specific maintenance is required for sensors, except if the sensors have to be removed for axle servicing. In such a case, sensors should be lubricated with special grease (Prévost #680460) before reinstallation. Refer to paragraph "Sensor Installation" for details.

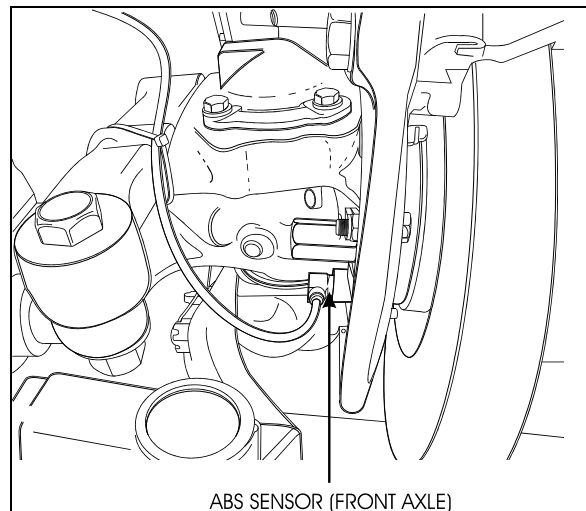


FIGURE 46: ABS SENSOR LOCATION 12153

**NOTE**

*The resistance value, when sensors are checked as a unit, must be equal to 1,75 k ohms. To check the sensors for proper output voltage after the sensors and toothed wheels have been assembled to the axle, connect a suitable AC voltmeter across the output terminals. With the hubs rotating at 30 rpm, the output voltages should read from 50 to 1999 mV to be acceptable.*

**Sensor Installation**

The following procedure deals with sensor installation on the axle wheel hubs. Read procedure carefully before reinstalling a sensor, as its installation must comply with operational tolerances and specifications.

1. Apply recommended lubricant (Prévost #680460) to spring clip and sensor.



**CAUTION**

Use only this type of grease on the sensors.

2. Insert spring clip in the holder on hub. Make sure the spring clip tabs are on the inboard side of the vehicle. Push in until the clip stops.
3. Push the sensor completely inside the spring clip until it is in contact with the tooth wheel. Ensure mounting is rigid, as it is an important criterion for adequate sensor operation.

**NOTE**

*This installation should be of the "press fit" type.*

31.3.4 Spring clip

The spring clip retains the sensor in its mounting bracket close to the toothed pulse wheel. The gap between the sensor end and teeth is set automatically by pushing the sensor in the clip hard up against the tooth wheel, and the latter knocks back the sensor to its adjusted position (Fig. 47).

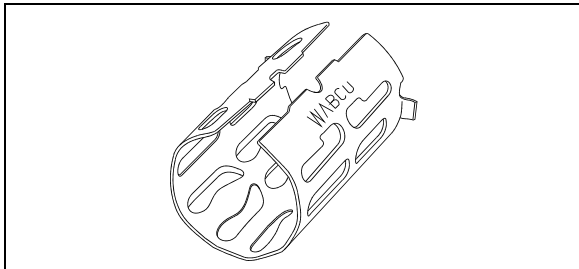


FIGURE 47: SPRING CLIP

12161

**Maintenance**

The spring clip requires no specific maintenance.

**32. FITTING TIGHTENING TORQUES**

**45° Flare and Inverted Flare:** Tighten assembly with a wrench until a solid feeling is encountered. From that point, tighten 1/6 turn (Fig. 48).

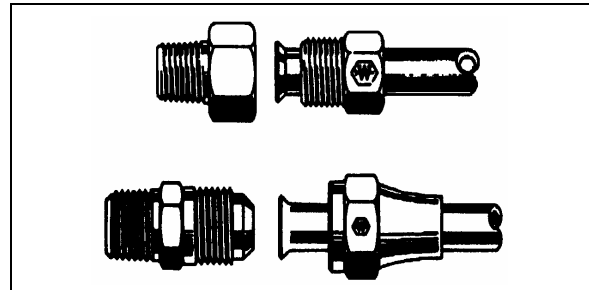


FIGURE 48: HOSE FITTINGS 12053

**Compression:** Tighten nut by hand (Fig. 49). From that point, tighten using a wrench the number of turns indicated in the chart hereafter.

| Fitting size | Pipe diameter (inches) | Number of additional turns required following hand tightening |
|--------------|------------------------|---|
| 2            | 1/8                    | 1 ¼   |
| 3            | 3/16                   | 1 ¼   |
| 4            | 1/4                    | 1 ¼   |
| 5            | 5/16                   | 1 ¾   |
| 6            | 3/8                    | 2 ¼   |
| 8            | 1/2                    | 2 ¼   |
| 10           | 5/8                    | 2 ¼   |
| 12           | 3/4                    | 2 ¼   |
| 16           | 1                      | 2 ¼   |

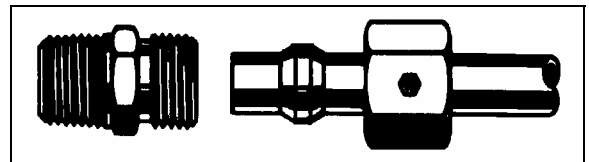


FIGURE 49: HOSE FITTING

12054

**NTA-Type Plastic Tubing:** Hand tighten nut (Fig. 50). From that point, tighten using a wrench the number of turns indicated in the following chart.

| Tubing diameter (inches) | Number of additional turns required following hand tightening |
|--------------------------|---|
| 1/4                      | 3   |
| 3/8 to 1/2               | 4   |
| 5/8 to 3/4               | 3 ½   |

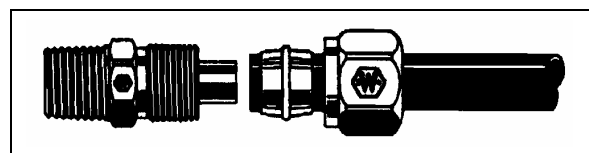


FIGURE 50: HOSE FITTING

12055

## Section 12: BRAKE AND AIR SYSTEM

---

**AB-Type Copper Piping:** Hand tighten nut (Fig. 51). From that point, tighten with a wrench the number of turns indicated in the following chart.

| Piping diameter (inches) | Number of additional turns required following hand tightening |
|--------------------------|---|
| 1/4, 3/8, 1/2            | 2   |
| 5/8, 3/4                 | 3   |

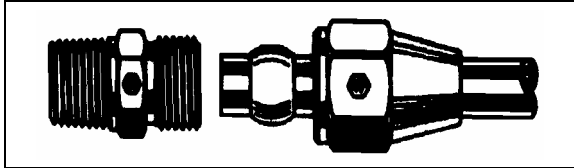


FIGURE 51: HOSE FITTING

12056

**Pipe Tightening:** All connections must be hand tightened. From that point, tighten a minimum of 2 ½ additional turns.

***NOTE***

*Use Loctite (Prévost number 680098) pipe sealant to seal pipe thread.*

**33. SPECIFICATIONS**

**Air Compressor (with Detroit Diesel Series 60 Engine)**

Make..... Bendix Westinghouse  
 Model..... BA-921  
 Capacity (at 1250 rpm) ..... 15.7 cfm (0,445 m<sup>3</sup>/min.)  
 Prévost number ..... 641990

**BA-921 Service Kits**

ST-4 Safety Valve  
 Prévost number ..... 641989

Series 60 Seal Kit  
 Prévost number ..... 641988

Compressor Seal Kit  
 Prévost number ..... 641987

Cylinder Head Gasket Kit  
 Prévost number ..... 641986

**Air Compressor (with Volvo D13 Engine)**

Make..... Meritor Wabco  
 Model..... SS636  
 Capacity (at 1250 rpm) ..... 37.4 cfm (1,059 m<sup>3</sup>/min.)  
 Prévost number .....

**Air Dryer**

Make..... Haldex  
 Model..... AT-87192  
 Prévost number ..... 70303498  
 Desiccant cartridge Prévost number..... 3097369

**Flip-Flop Control Valve**

Make..... Bendix Westinghouse  
 Model..... TW-1  
 Type ..... On-Off  
 Prévost number ..... 640136

**Emergency/Parking Brake Control Valve**

Make..... Bendix Westinghouse  
 Model..... PP-1  
 Automatic release pressure ..... 40 psi (275 kPa) nominal  
 Prévost number ..... 641128

**Dual Brake Application Valve**

Make..... Bendix Westinghouse  
 Model..... E-10P  
 Prévost number ..... 641856

**Stoplight Switches**

Make..... Bendix Westinghouse  
 Model..... SL-5  
 Contact close (ascending pressure) ..... 4 psi and more (28 kPa)  
 Prévost number ..... 641462

**Brake Relay Valves**

Make..... Bendix Westinghouse



## Section 12: BRAKE AND AIR SYSTEM

---

Model..... R-12  
Supplier number.....  
Prévost number.....

### Brake Relay Valve

Make..... Meritor Wabco  
Model..... R-14  
Prévost number.....

### Quick Release Valve

Make..... Bendix Westinghouse  
Model..... QR-1  
Prévost number..... 641429

### Spring Brake Valve

Make..... Bendix Westinghouse  
Model..... SR-7  
Prévost number.....

### Pressure Protection Valve

Make..... Bendix Westinghouse  
Model..... PR-4  
Nominal closing pressure..... 70 psi (482 kPa)  
Prévost number..... 641137

### Shuttle-Type Double Check Valve

Make..... Bendix Westinghouse  
Model..... DC-4  
Prévost number..... 641015

### Low Pressure Indicators

Make..... Bendix Westinghouse  
Model..... LP-3  
Contact close..... 66 psi (455 kPa)  
Prévost number..... 640975

### Air Pressure Regulator

Make..... Norgren  
Adjustable output range..... 0-80/85 psi (0-552/586 kPa)  
Recommended pressure setting..... 75 psi (517 kPa)  
Prévost number..... 641472

### Air Filter Element

Make..... Norgren  
Type..... With manual drain  
Prévost number..... 641338

### Front Axle Brake Chambers

Make..... Knorr-Bremse  
Type..... 24  
Prévost number (R.H.)..... 641414  
Prévost number (L.H.)..... 641413

### Drive Axle Brake Chambers

Make..... Knorr-Bremse  
Type..... 24 as service -24 as emergency  
Prévost number..... 641432

**Piggy Back (On Drive Brakes)**

Make.....Knorr-Bremse  
Type ..... 24 as emergency  
Prévost number..... 641433

**Tag Axle Brake Chambers**

Make.....Knorr-Bremse  
Type ..... 14  
Prévost number..... 642087

**Tag Axle Brake Chambers**

Make.....Knorr-Bremse  
Type ..... 16  
Prévost number..... 642086

**Brake Lining (All Axles)**

Make.....Knorr-Bremse  
Prévost number..... 611049  
Prévost number..... 641226

**ABS ANTILOCK BRAKING SYSTEM**

**ABS MODULATOR VALVE**

Make.....Bendix  
Voltage ..... 12 V  
Prévost number..... 642077

**Sensor**

Prévost number..... 642085

**Sensor (90°)**

Prévost number..... 642084

# SECTION 13: WHEELS, HUBS & TIRES

## CONTENTS

|  |           |
|--|-----------|
| <b>1. WHEELS</b> .....                                   | <b>3</b>  |
| <b>2. WHEEL MAINTENANCE</b> .....                        | <b>3</b>  |
| 2.1 INSPECTION .....                                     | 3         |
| 2.2 SINGLE WHEEL REMOVAL .....                           | 3         |
| 2.3 SINGLE WHEEL INSTALLATION .....                      | 4         |
| <b>3. DUAL WHEELS</b> .....                              | <b>4</b>  |
| 3.1 OUTER WHEEL REMOVAL .....                            | 4         |
| 3.2 INNER WHEEL .....                                    | 4         |
| 3.3 INNER WHEEL INSTALLATION .....                       | 4         |
| 3.4 OUTER WHEEL INSTALLATION .....                       | 4         |
| 3.5 INSPECTION .....                                     | 4         |
| <b>4. ALUMINUM WHEEL ANTI-CORROSION PROTECTION</b> ..... | <b>5</b>  |
| <b>5. WHEEL STRAIGHTNESS TEST</b> .....                  | <b>5</b>  |
| <b>6. WHEEL STUDS</b> .....                              | <b>6</b>  |
| 6.1 DRIVE AXLE STUDS .....                               | 6         |
| 6.2 FRONT AND TAG AXLE STUDS .....                       | 6         |
| <b>7. HUB MOUNTED WHEELS</b> .....                       | <b>7</b>  |
| 7.1 CARE OF WHEELS .....                                 | 7         |
| <b>8. FRONT AND TAG AXLE WHEEL HUBS</b> .....            | <b>7</b>  |
| 8.1 HUB BEARING INSPECTION .....                         | 7         |
| <b>9. DRIVE AXLE WHEEL HUBS</b> .....                    | <b>8</b>  |
| 9.1 BEARING ADJUSTMENT .....                             | 8         |
| 9.2 DISASSEMBLY AND REPAIR .....                         | 8         |
| <b>10. SPARE WHEEL (IF APPLICABLE)</b> .....             | <b>9</b>  |
| 10.1 PULLING OUT SPARE WHEEL .....                       | 9         |
| 10.2 CHANGING A FLAT .....                               | 10        |
| 10.3 SPARE WHEEL MAINTENANCE .....                       | 10        |
| <b>11. TIRE MAINTENANCE</b> .....                        | <b>10</b> |
| 11.1 INFLATION PRESSURE .....                            | 10        |
| 11.2 TIRE MATCHING .....                                 | 12        |
| 11.3 WHEEL BALANCING .....                               | 12        |
| 11.4 TIRE ROTATION.....                                  | 12        |
| <b>12. SPECIFICATIONS</b> .....                          | <b>13</b> |

**ILLUSTRATIONS**

FIGURE 1: ALUM/STEEL WHEEL ARRANGEMENT ..... 3  
FIGURE 2: TIGHTENING SEQUENCE ..... 3  
FIGURE 3: DIAL GAUGE INSTALLATION ..... 6  
FIGURE 4: STUD-MOUNTED WHEELS..... 6  
FIGURE 5: HUB-MOUNTED WHEELS ..... 7  
FIGURE 6: WARNING REFLECTORS LOCATION..... 9  
FIGURE 7: SPARE WHEEL COMPARTMENT ..... 9  
FIGURE 8: SPARE WHEEL AND TIRE ..... 9  
FIGURE 9: FRONT SERVICE COMPARTMENT..... 9  
FIGURE 10: TIRE INFLATION ..... 11  
FIGURE 11: TIRE LIFE / INFLATION PRESSURE ..... 12

## 1. WHEELS

The vehicle is equipped with hub-mounted wheels as standard equipment, all studs and nuts have right-hand threads. When the vehicle is provided with stud-mounted wheels, wheel studs and nuts on the left side of the vehicle have left-hand threads whereas those on the right side have right-hand threads. Either steel wheels or optional aluminum-polished wheels may be installed on the vehicle. Both are mounted with radial tubeless tires.

All wheel dimensions are 22.50 X 9.0 inches (571.5 X 228.6 mm) for 315/80 R 22.5 tires except inner drive wheels, which are always steel wheels and 22.50 X 8.25 inches (571.5 X 209.6 mm) for 315/80 R 22.5 tires. All other wheels can either be steel or aluminum wheels.

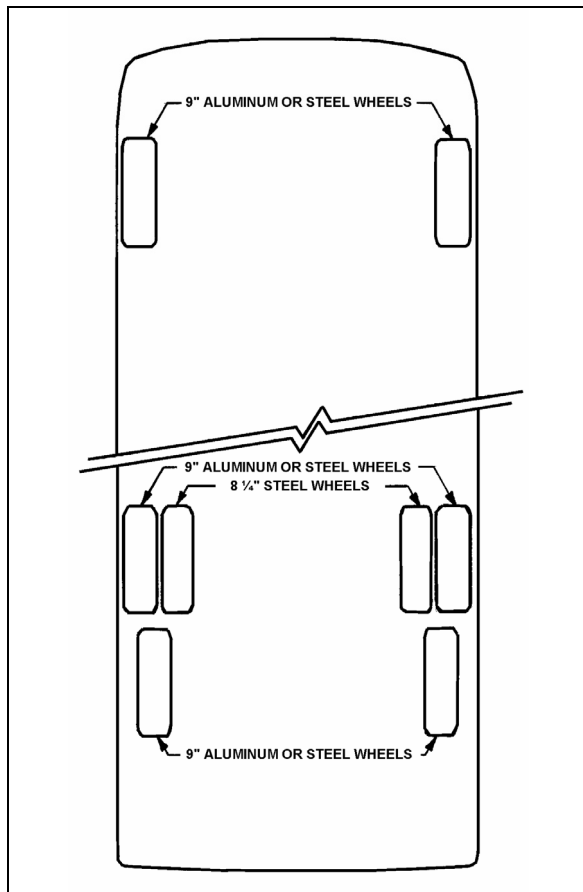


FIGURE 1: ALUM/STEEL WHEEL ARRANGEMENT 13001

## 2. WHEEL MAINTENANCE

Wheel maintenance consists of periodic inspections. Check all parts for damage and make sure that wheel nuts are tightened to the proper torque. In the case of a new vehicle, or after a wheel installation, stud nuts should be

tightened every 100 miles (160-km) for the first 500 miles (800-km) to allow setting in of clamping surfaces.

Wheel studs and nuts must be kept free from grease and oil. No lubricant whatsoever should be used. Cleanliness of the wheel and its rotor mating surfaces is important for proper wheel mounting.

However, for hub mounted wheels, it is recommended to add some rust protection lubricant on the pilot diameter of the hub (to facilitate future removal).

It is also important that wheel stud nuts be tightened alternately on opposite sides of the wheel. Refer to Figure 2 for the suggested tightening sequence.

### 2.1 INSPECTION

Tighten stud nuts progressively as shown in Figure 2. The final tightening should be done with a torque wrench. Tighten stud nuts to 450 - 500 lbf-ft (610 - 680 Nm) for aluminum as well as steel wheels.

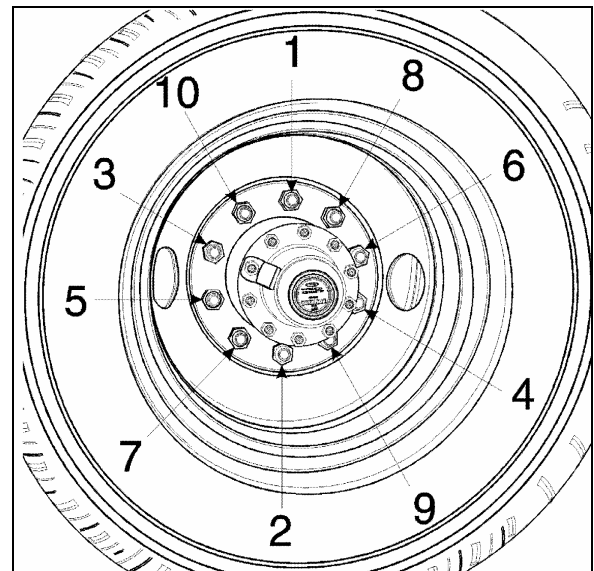


FIGURE 2: TIGHTENING SEQUENCE 13018

### 2.2 SINGLE WHEEL REMOVAL

1. Stop engine and apply parking brake.
2. Loosen wheel nuts about one turn (do not remove the nuts). This is not necessary if equipped with hydraulic powered gun.

## Section 13: WHEELS, HUBS & TIRES

### NOTE

For stud-mounted wheels, turn nuts counterclockwise for R.H. side and clockwise for the L.H. side of vehicle. For hub-mounted wheels, turn nuts counterclockwise on both sides of the vehicle.

3. Raise the vehicle by its jacking points on the body. See Section 18, "Body", under heading "Vehicle Jacking Points";
4. Unscrew wheel hex stud nuts and remove the wheel;



### CAUTION

Always mark position of the wheel on the axle prior to removal in order to replace wheel at the same location, thus avoiding a new wheel balancing.

### 2.3 SINGLE WHEEL INSTALLATION

1. Mount the wheel over studs, being careful not to damage stud threads;
2. Screw in the hex stud nuts (refer to Figure 2 for sequence) so that wheel will position itself concentrically with hub. This is important, otherwise wheel may be eccentric with hub and will not run straight. In this initial step, slightly tighten the nuts to correctly position the wheel;
3. Tighten stud nuts progressively as shown in Figure 2. The final tightening should be done with a torque wrench. Tighten stud nuts to 450 - 500 lbf-ft (610 - 680 Nm) for aluminum as well as steel wheel.



### CAUTION

Insufficient mounting-torque can result in damage to parts. Excessive mounting torque can cause studs to break and the wheel to crack in stud hole area.

## 3. DUAL WHEELS

### 3.1 OUTER WHEEL REMOVAL

Same as described in "Single Wheel Removal" procedure described previously.

### 3.2 INNER WHEEL

1. Remove outer wheel;

2. Unscrew inner cap nuts
3. Remove inner wheel.

### 3.3 INNER WHEEL INSTALLATION

1. Mount the wheel over studs, being careful not to damage stud threads;
2. Screw in the inner cap nuts (Fig. 4), so that wheel will position itself concentrically with hub. Refer to Figure 2 for sequence;
3. Tighten inner cap nuts progressively according to sequence shown in Figure 2. Final tightening should be done with a torque wrench. Tighten inner cap nuts to 450 - 500 lbf-ft (610 - 680 Nm) for aluminum as well as steel wheel.



### CAUTION

Insufficient mounting-torque can result in damage to parts. Excessive mounting torque can cause studs to break and the wheel to crack in stud hole area.

### 3.4 OUTER WHEEL INSTALLATION

With inner wheel installed, tighten the hex stud nuts (Fig. 4) using the single wheel installation procedure described previously.

### NOTE

On dual wheel assemblies, position the wheels with the tire valves 180° apart in order to have access to both the inner and outer valves.

### 3.5 INSPECTION

1. Loosen a hex stud nut three turns (Fig. 4);
2. Tighten the inner cap nut to 450 - 500 lbf-ft (610 - 680 Nm);
3. Tighten the hex stud nut to 450 - 500 lbf-ft (610 - 680 Nm).

Repeat for each of the 10 "hex stud nut - inner cap nut assemblies" according to the tightening sequence in figure 2.



### CAUTION

Do not attempt to tighten an inner cap nut without having previously loosened the hex stud nut.



**CAUTION**

The actual length of thread engagement present in an assembled wheel can not always be determined by visual inspection or measurement of a tightened assembly. The relationship of the wheel cap nut seat to the end of the stud may vary. If there is any doubt that enough thread engagement is present, the number of engaged threads may be counted. Tighten all nuts in the regular manner, then loosen one to hand-tightness. The number of turns to disengage a 1-1/8-inch nut should be at least five full turns. At least seven full turns should be required to disengage a 3/4-inch nut or a M22 nut. Ideally, when torqued to the proper load, the stud should be flush with the face of the nut. The face of the nut may be recessed in nuts that are taller for improved wrenching. With most of the nuts in present use, a few unengaged threads at the outer end will cause no problem provided at least 5-7 full turns are required to disengage the nut depending on thread size.

**4. ALUMINUM WHEEL ANTI-CORROSION PROTECTION**

Clean wheels often by means of a high pressure water jet. Cleaning may be accelerated with mild soap. Do not use concentrated alkaline cleaning products.

When tire is removed, clean and inspect wheel thoroughly. Remove dirt and corrosion on rim by means of a wire brush. Do not use a wire brush on the outer surface of the wheel.

The following measures should be taken to maintain original appearance of the aluminum wheels:

1. Remove any tar from wheel surface with a good quality tar remover.
2. Spray Alcoa Cleaner (Prévost #683529) evenly on cool outer surface of wheel. Let work 15-20 minutes (keep wet by spraying more Cleaner if necessary).
3. Rinse thoroughly with clean water and let air dry. Heavy oxidation may require a repeat application of cleaner.
4. Apply Alcoa Polish (Prévost #683528) sparingly to a small area using a clean, soft cloth. Work polish into surface as you would a rubbing compound.

5. Buff, turning cloth frequently, until surface is clean and shiny. Let air dry. Use power buffer to improve ease of use and gloss uniformity.
6. On completely dry, clean and polished surface, generously apply Alcoa sealant (Prévost #683527). Rinse thoroughly with water while surface is still wet in appearance (have water source ready as the dry time is very short, usually less than 2 minutes).
7. For best results, finish by wiping the surface with a clean rag to remove excess water, then allow surface to dry.

Clean aluminum wheels as required to maintain original look.



**WARNING**

Wheel surfaces may have sharp or cutting edges that may cause injury to the hands. To prevent contact with sharp edges, it is strongly recommended to wear rubber gloves when washing or polishing wheels.

**5. WHEEL STRAIGHTNESS TEST**

1. Slightly raise axle to be checked and place a safety support underneath;
2. Check wheel lateral run-out. Install a dial gauge as shown in figure 3, then rotate the wheel by hand one full turn. As the wheel turns, note any variation on the dial gauge;



**CAUTION**

Damage to the dial gauge could occur if it strikes a wheel balancing weight.

3. If the variation in lateral run-out exceeds 0.0625 inch (1,6 mm), the wheel must be replaced.

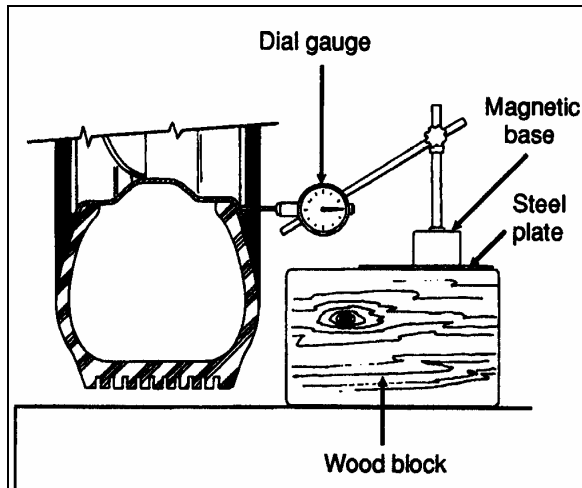


FIGURE 3: DIAL GAUGE INSTALLATION 13008

If doubt exists whether wheel or hub is distorted, hub may be checked as follows:

- Replace the existing wheel with a wheel known to be correct;
- Check wheel lateral run-out as outlined in step 2;
- If, within specifications, the hub is correct but the suspected wheel must be replaced.



## WARNING

**NEVER STRAIGHTEN ALUMINUM WHEELS.** Never heat aluminum wheels to repair damages incurred after hitting a curb or resulting from other causes. The special alloy in wheels has been heat treated, and any uncontrolled heating could alter wheel structure. Furthermore, never weld aluminum-forged wheels for any reason whatsoever.

## 6. WHEEL STUDS

Stripped threads may be the result of excessive torquing or may have been damaged during wheel installation when placing the wheel over the studs. A stud having damaged threads must be replaced. Broken studs are a direct result of operating with loose stud nuts or improperly seated wheels. When a broken stud is replaced, the adjacent studs, on each side of the broken one must also be replaced since they could have been subjected to excessive strain and may be fatigued.

When installing wheel studs to hubs, check nuts retaining the wheel stud to wheel hub and replace if they are deformed, damaged or severely corroded. Install nut (and washer where applicable) to new stud. Torque to 450 - 500 Ft-lbs (610 - 680 Nm).

### NOTE

For stud-mounted wheels, turn nuts counterclockwise for R.H. side and clockwise for the L.H. side of vehicle. For hub-mounted wheels, turn nuts counterclockwise on both sides of the vehicle.

## 6.1 DRIVE AXLE STUDS

Stud-mounted wheels are mounted on the drive axle with  $\frac{3}{4}$ "-16 studs with an inner cap nut, and a 1-1/8"-16 nut. Hub-mounted wheels are mounted with M22 x 1.5 studs and an M22 flange nut.

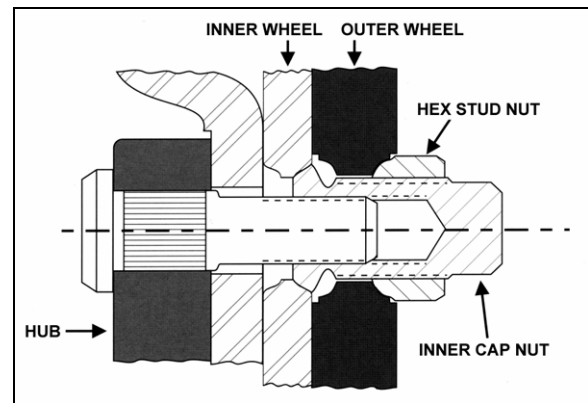


FIGURE 4: STUD-MOUNTED WHEELS 13007

## 6.2 FRONT AND TAG AXLE STUDS

Wheel can be mounted on tag axle with studs (1-1/8"-16 thread) or hub mounted (M22 x 1.5 thread).

### NOTE

Wheel studs and nuts must be kept free from grease and oil. No lubricant whatsoever should be used.



## WARNING

The two wheel mounting systems are not interchangeable. They have their specific wheel, nut and stud types. Use only the specific hardware suitable for a mounting type. Always install a wheel to the corresponding mounting type hub.



## 7. HUB MOUNTED WHEELS

Wheel surfaces in contact with hubs, nuts or other wheels should be kept free of all rust, grease and paint (except for initial “E” coat protection, applied to stop rusting and to facilitate wheel removal). The reason for this is to assure that all faces are clamped together without buildup of any coating. The threads of the wheel studs and the wheel nuts should be clean and undamaged.

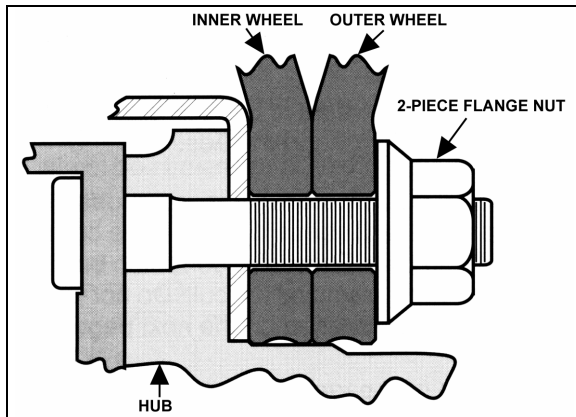


FIGURE 5: HUB-MOUNTED WHEELS

13025

### NOTE

*When painting wheels, make sure to mask all surfaces identified above.*

Using a calibrated torque wrench, tighten wheel nuts to 450 - 500 lbf-ft (610 - 680 Nm) of torque. Do not use power tools or long bars for tightening. Tighten wheel nuts alternately as shown in figure 2.

### NOTE

*Tightening should not be done immediately after prolonged braking or when wheel ends are hot*

Check wheel nut torque at every 100 miles (160 km) for 500 miles (800 km) after fitting wheels. Let cool before checking. If any relaxation of the initial 450 - 500 lbf-ft (610 - 680 Nm) of torque has occurred, retighten. Relaxation of initial torque may occur because of the “bedding down” of the hub and wheel surfaces.

### NOTE

*Torque relaxation occurs when wheel ends are hot but should revert to original setting when cool. Retightening when hot will produce a higher torque reading than recommended.*

## 7.1 CARE OF WHEELS

Check for cracks in wheels, especially around the fixing holes, studs, nuts and washers. If in doubt, renew.

Do not simply retighten very loose wheel fixings or wheels that are continually becoming loose. Find out why they are loose and whether any damage has been caused.

Use trained personnel and keep records of all attention to wheels and fixings, including which parts were renewed and when.

## 8. FRONT AND TAG AXLE WHEEL HUBS

The unitized hub bearings used on the NDS range of axles, are non-serviceable items. Bearings are pre-adjusted, lubricated and have seals fitted as part of the manufacturing process. The bearings are greased for life and there is no need or facility for re-lubrication

### 8.1 HUB BEARING INSPECTION

An inspection should be made at intervals of 30,000 miles (48 000 km).

- Apply parking brake, raise wheels off the ground and support axle on stands. When the wheels are raised, they should revolve quite freely without roughness.
- Place magnetic base of a dial indicator on brake caliper and position dial indicator stem against a convenient marked spot on face of hub flange.
- With dial indicator in position pull hard but steadily on hub flange and oscillate at same time until a steady reading is achieved.
- Without releasing the pressure, turn bearing so that dial indicator stem contacts marked spot and note reading on indicator.
- Push bearing flange hard and oscillate as before until a steady reading is achieved.
- Without releasing the pressure, turn bearing so that indicator stem again contacts the marked spot and note new reading on indicator.
- The difference between readings is the amount of mounted end play in bearing unit.
- The mounted end play figure should not exceed 0.050 mm (0.002”) for a new bearing and 0.20 mm (0.008”) for a bearing which has been in service.

## Section 13: WHEELS, HUBS & TIRES

### NOTE

If original bearing unit is re-fitted, and end-float is measured at 1 mm, with hub not fully tightened to correct torque, then the retaining clip within the unit is damaged and a new unit must be fitted.

### NOTE

For more information on front and tag axle wheel hub, refer to "DANA SPICER Maintenance Manual Model NDS and Maintenance Manual NDS Axles" annexed at the end of Section 11.

## 9. DRIVE AXLE WHEEL HUBS

Drive wheels use a single oil-seal assembly. They are lubricated from the oil supply in the differential housing. Bearings are tapered rollers, adjustable to compensate wear. Maintain differential oil level with general-purpose gear lubricant (refer to Section 24 "Lubrication" for proper oil grade selection) to ensure adequate oil supply to wheel bearings at all times.

### 9.1 BEARING ADJUSTMENT

To adjust drive wheel bearings:

1. Raise vehicle until both dual wheels can be turned freely (approximately 6 inches from the ground). Position jack stands under drive axle, then lower vehicle approximately 2 inches in order to avoid entire weight of the axle being supported by the suspension air bellows and the shock absorber pins.
2. Remove axle shaft as indicated in "Meritor - Maintenance Manual No. 5" under heading "Single Reduction Differential Carriers" annexed to "Section 11" of this manual. Remove gaskets. Unscrew lock nut and remove adjusting nut lock ring.
3. To adjust, tighten adjusting nut until the wheel binds. Rotate the wheel while tightening so that all surfaces are in proper contact. Back off adjusting nut approximately, 1/4 to 1/3 turn to assure 0.001/0.007" (0.0254/0.1778 mm) endplay and to ensure that wheel turns freely. Replace the lock ring, and adjust nut dowel pin in one of the holes. The ring may be turned over if necessary to allow more accurate bearing adjustment.

4. Tighten lock nut and check bearing adjustment. Replace the axle shaft using a new gasket.

### 9.2 DISASSEMBLY AND REPAIR

1. Jack vehicle as per "Bearing Adjustment" and remove axle shaft as indicated in "Meritor - Maintenance Manual No. 5" entitled "Single Reduction Differential Carriers" annexed to Section 11 of this manual.
2. Remove wheels and tires.



### CAUTION

To replace wheel at the same location, always mark position of the wheel on the axle before removal, thus avoiding a new wheel balancing.

3. Remove lock nut, lock ring and adjusting nut from axle housing to prevent the outer bearing from falling out. Remove outer bearing cone and roller assembly.
4. Remove screws attaching inner oil seal retainer to hub, and remove inner oil seal assembly. Remove inner bearing cone and roller assembly. Bearing cups can be separated from the hub using a hammer and a long brass drift.
5. Thoroughly clean all parts. Bearing cone and roller assemblies can be cleaned in a suitable cleaning solvent using a stiff brush to remove old lubricant.
6. In case that excessive wear, deterioration, cracking or pitting is present on the bearing cups, rollers or cones, the bearings should be replaced. Seals should be replaced each time they are removed from the hub. To install new oil seal, use a suitable adapter and drive the seal into the retainer bore until it bottoms.
7. When installing wheel on spindle, center the wheel hub with spindle to avoid damaging the seal with the end of the spindle. Push wheel straight over the spindle until inside diameter of seal press fits on wiper ring. Fill hub cavity with general-purpose gear lubricant (refer to Section 24 "Lubrication" for proper oil grade selection). Lubricate, then install outer bearing cone. Adjust bearing and lock.

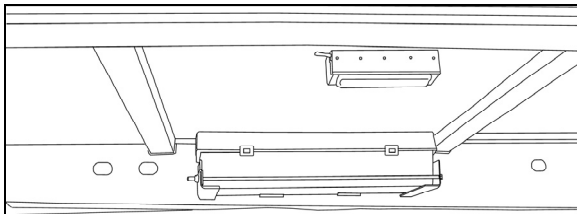
- Assemble axle flange to axle using a new gasket. Apply sealant in stud area. After both wheels have been assembled according to above procedure, fill the differential with the recommended lubricant to the proper factory recommended level.

**NOTE**

*During regular inspection, do not forget to check lubricant level in differential. Clean thoroughly or replace vent as required.*

**10. SPARE WHEEL**

Tire failure is a rare event if tires are properly cared for. In case of a flat tire, move vehicle a safe distance away from traffic and apply parking brake. Remember to use the hazard flashers and according to the Highway Code regulations, set up the triangular reflectors (see "Emergency Warning Reflectors" in the Operator's Manual) at an adequate distance, to warn incoming motorists. This kit is located at the ceiling of the first baggage compartment, on the R.H. side.



**FIGURE 6: WARNING REFLECTORS LOCATION** 23376

The spare wheel is stored in a dedicated compartment behind the front bumper. To access, pull the release handle located in the front service compartment. Although the bumper is heavy, sprung hinges permit one person operation.

When closing bumper compartment, make sure bumper is securely installed.



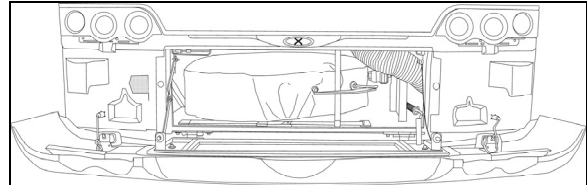
**WARNING**

This compartment has not been designed for storage. Never leave loose objects in this area since they may interfere with steering linkage mechanism. Make sure bumper is safely locked in place after closing the compartment.

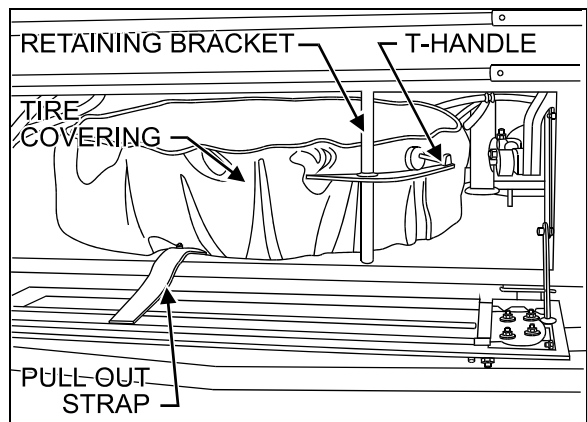
**10.1 PULLING OUT SPARE WHEEL**

To remove the spare, untighten the pressure screw holding the tire in place, then press down

on the spring loaded locking pin located at the top of the retaining bracket and remove the bracket. Using the strap, pull the spare out of the compartment (refer to the following illustrations). Rollers ease manipulation. Remove the protective cover. Install the flat in place of the spare by reversing the procedure. Do not forget to have the flat repaired as soon as possible.



**FIGURE 7: SPARE WHEEL COMPARTMENT** 18614



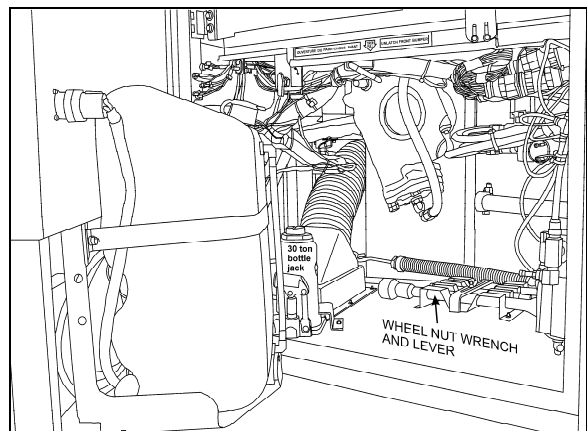
**FIGURE 8: SPARE WHEEL AND TIRE** 18415

**NOTE**

*The jack and wheelnut wrench are stored in front service compartment.*

The jack/tools kit stowed in the front service compartment contains a:

- 30 ton hydraulic jack;
- Wheel nut wrench and lever.



**FIGURE 9: FRONT SERVICE COMPARTMENT** 23377

## Section 13: WHEELS, HUBS & TIRES

### NOTE

Check the inflation pressure of the spare tire periodically to keep it ready for use. Inflate spare tire to the pressure of the tire, which has the highest pressure on the vehicle. When installing, deflate to correct pressure if necessary.

### 10.2 CHANGING A FLAT

In case of flat tire, refer to appropriate procedure under "Wheel Maintenance" heading in this section.

### NOTE

For hydraulic jack placement, refer to Section 18 "Body", under heading "Vehicle Jacking Points".



### DANGER

Place jack on stable and level ground; if necessary, place a board under the jack. Do not raise the vehicle until you are sure the jack is securely engaged.



### WARNING

To prevent personal injury and/or equipment damage, use only the recommended jacking points. Passengers must not remain inside vehicle while wheel is being replaced.



### CAUTION

Adjust tire pressure according to the appropriate cold tire inflation-pressure.

### NOTE

Store damaged wheel in spare tire compartment. Repair and balance the flat tire as soon as possible.

### 10.3 SPARE WHEEL MAINTENANCE

Maintenance of the spare wheel and tire consists in ensuring that tire inflation pressure is the same as the tire on the coach that has the highest inflation pressure (refer to "Specifications" in this section for the recommended tire inflation pressure). Inspect rim to ensure that there is no important

corrosion. In addition, check if spare wheel covering is in good condition and check that spare tire is securely fastened in compartment.

## 11. TIRE MAINTENANCE

The most critical factor in tire maintenance is proper inflation (Fig. 9). No tire is impervious to loss of air pressure. To avoid the hazards of under inflation, always maintain tires at their recommended inflation pressure. Improper inflation decreases tire life.

An under inflated tire builds up heat that can cause sudden tire destruction, resulting in improper vehicle handling and possible loss of vehicle control. At least once a week, before driving (when tires are cold), check inflation pressure on all the tires, including the spare tire. This is especially important in cases when different drivers operate the vehicle.



### WARNING

Failure to maintain correct tire inflation pressure may result in sudden tire destruction, improper vehicle handling, and will cause rapid and irregular tire wear. Inflation pressure should be checked weekly and always before long distance trips.

### 11.1 INFLATION PRESSURE

- Vehicles equipped with BERU TPMS

On vehicles equipped with the Beru Tire Pressure Monitoring System (TPMS), it is better to use the TPMS display as the primary reference to judge when tire pressure need adjustment.

The TPMS presents pressure readings of each tire as a +/- deviation from the wanted target.

If a tire reads within +/- 3 PSI no adjustment is needed.

If a tire reads -4 PSI and below, re-inflate by the marked amount.

If a tire reads +4 PSI and above, deflate by the marked amount.

Relying on the TPMS system is better than relying on a hand gage since the TPMS is temperature compensated and remain accurate no matter if the tires are cold or hot.

Tires take up to 3 hours to get down to ambient temperature after a ride. A common mistake

consist of checking pressure while the tires have not fully cooled down which leads into under-inflated tires. Relying on the TPMS eliminate this mistake.

Running tires at optimal pressure reduce tire wear, improve safety and fuel economy.

**NOTE**

*It is more accurate to use the TPMS display to set the tire pressures than a pressure gauge.*

The TPMS target pressures are factory set to equal the prevailing tire pressure at delivery time.

When tire pressures are increased to account for higher vehicle weight, the TPMS set point need to be increased accordingly.

- Vehicles not equipped with BERU TPMS

The condition and pressure of the tires can greatly affect both useful tire life and road safety.

At regular intervals, verify the tire pressures. Use an accurate tire pressure gauge when checking inflation pressures. Never exceed the maximum inflation pressure specified on each tire.

**NOTE**

*Inflation pressure should be checked when tires are cold. Cold tire inflation pressure can be measured when a vehicle has not been driven for at least 3 hours or less than 1 mile (1.6 km). Driving, even for a short distance, causes tires to heat up and air pressure to increase. Check inflation pressure on all tires (including the spare tire) using an accurate tire gauge.*

**NOTE**

*The recommended tire inflation pressures are given in the applicable documents supplied with the vehicle. In addition, cold tire inflation pressures are listed on the Department of Transport's certification plate, affixed on the panel behind the driver's seat. For special tire selection, a "PRÉVOST COACH SPECIAL SPECIFICATION" chart is supplied with the vehicle and is affixed on the left wall near the driver's seat. Remember, tire inflation pressure must be adjusted according to vehicle loading - see table in "Coach Final Record"*

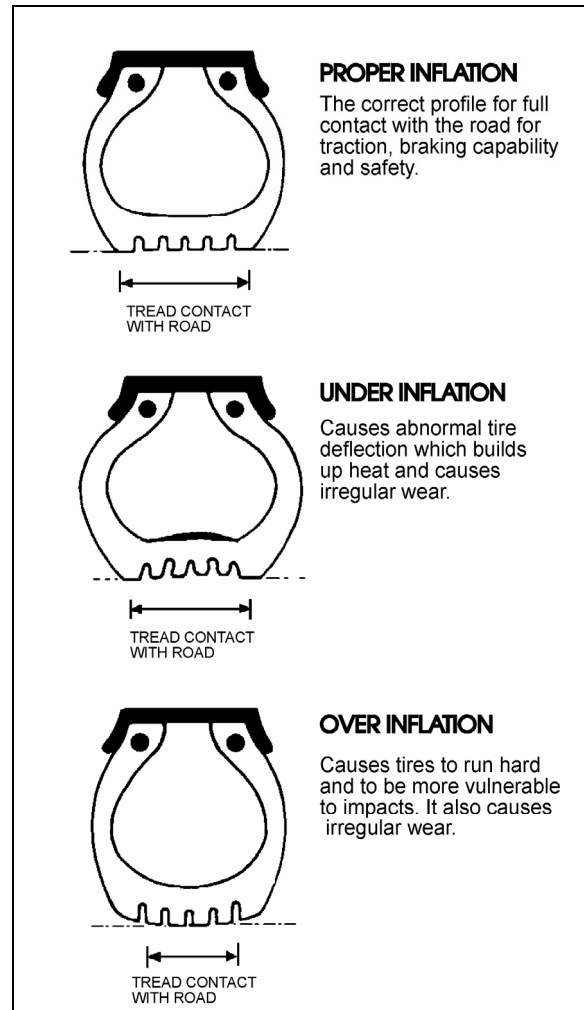


FIGURE 10: TIRE INFLATION

13009



**CAUTION**

Never bleed air from hot tires as tires will then be under inflated. Use an accurate tire gauge to check pressures (Do not kick tires as an inflation check. This is an unreliable method).



**CAUTION**

These tire pressures are established in accordance with the maximum allowable load on each axle. A lower pressure is recommended if the axle load is less than the above specifications. Weigh vehicle fully loaded and pressurize according to tire manufacturer's recommendations. For other tire and wheel specifications, see Prévost tire pressure tabulation in "Coach Final Record".

## Section 13: WHEELS, HUBS & TIRES



### WARNING

Incorrect tire pressures cause increased tire wear and adversely affect road holding of the vehicle, which may lead to loss of vehicle control.

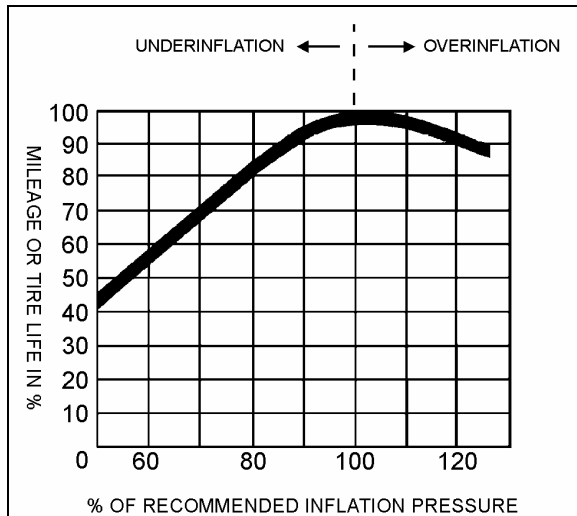


FIGURE 11: TIRE LIFE / INFLATION PRESSURE 13010



### WARNING

Recommended tire inflation pressures and maximum allowable loads apply to speeds up to 65 mph (105 km/hr). Do not drive vehicle at a higher speed than 65 mph (105 km/h) or above the posted speed limit.



### WARNING

All tires on the same axle should always be inflated to the same pressure. There should not be a difference in pressure between right and left tires on the same axle. A 5-psi (35-kPa) underinflation in one front tire can not only reduce vehicle maneuverability, but will create steering hazards which can lead to an accident.

### 11.2 TIRE MATCHING

Unmatched tires on drive axle will cause tire wear and scuffing, as well as possible damage to the drive unit. Consequently, we recommend that tires be matched within 1/8" (3 mm) of the same rolling radius.

### NOTE

*It is recommended that all tires on coach be of the same type.*

### 11.3 WHEEL BALANCING

Before balancing, wheels must be clean and free from all foreign matter. The tires should be in good condition and properly mounted. An unbalanced wheel can be due to a bent wheel or improper mounting. Before removing the wheel from the vehicle, check for swaying movement and if necessary, check the wheel lateral runout as outlined under heading "Wheel Straightness Check".



### WARNING

When balancing wheel and tire assemblies, it is strongly recommended to closely follow instructions covering the operation of wheel balancer.



### CAUTION

A maximum of 16-oz (450 g) of balancing weight is recommended. If more weight is necessary, check and correct the cause.

### 11.4 TIRE ROTATION

Radial tires should be rotated only when necessary. If the tires are wearing evenly, there is no need to rotate. If irregular wear becomes apparent or if the wear rate on the tires is perceptively different (from axle to axle), then tires should be rotated in such a manner as to alleviate the condition.

### NOTE

*There is no restriction on criss-cross rotation.*

**12. SPECIFICATIONS**

STEEL WHEELS (except inner drive axle)

Wheel size..... 9.0" X 22.5"  
 Wheel nut torque..... 450 - 500 lbf-ft (610 - 680 Nm)  
 Tire size..... 315/80 R 22.5

STEEL WHEELS (inner drive axle)


Wheel size..... 8.25" X 22.5"  
 Wheel nut torque..... 450 - 500 lbf-ft (610 - 680 Nm)  
 Tire size..... 315/80 R 22.5


ALUMINUM WHEELS (All wheels are 9" X 22.5" except inner drive axle)

Wheel size..... 9" X 22.5"  
 Wheel nut torque..... 450 - 500 lbf-ft (610 - 680 Nm)  
 Tire size..... 315/80 R 22.5

RECOMMENDED TIRE INFLATION PRESSURE AT MAXIMUM LOAD (cold)

|   |
|---|
| <b>NOTE</b>   |
| <i>Vehicle is delivered with the specific inflation pressure certification plate according to the tire selection.</i> |

|  |
|--|
|  <b>WARNING</b>   |
| Special tire selection may lower maximum allowable speed limit, even below posted speed limit. For maximum safety, check with tire manufacturer. |

|   |
|---|
|  <b>WARNING</b>  |
| Recommended tire inflation pressures and maximum allowable loads apply to speeds up to 65 mph (105 km/hr). Do not drive vehicle at a higher speed than 65 mph (105 km/h) or above the posted speed limit. |

ALUMINUM WHEEL CLEANING AND MAINTENANCE PRODUCTS

Aluminum Wheel Cleaner (22 Oz bottle) .....Prévost #683529  
 Aluminum Wheel Polish (16 Oz bottle) .....Prévost #683528  
 Aluminum Wheel Sealer (13 Oz bottle) .....Prévost #683527

# SECTION 14: STEERING

## CONTENTS

|  |           |
|--|-----------|
| <b>1. STEERING SYSTEM</b> .....                                  | <b>3</b>  |
| 1.1 I-BEAM AXLE STEERING SYSTEM DESCRIPTION.....                 | 3         |
| 1.2 INDEPENDENT FRONT SUSPENSION STEERING SYTEM DESCRIPTION..... | 4         |
| <b>2. POWER STEERING GEAR</b> .....                              | <b>5</b>  |
| 2.1 DESCRIPTION.....   | 5         |
| 2.2 POWER STEERING GEAR REMOVAL.....                             | 6         |
| 2.3 POWER STEERING GEAR INSTALLATION.....                        | 6         |
| <b>3. BLEEDING POWER STEERING HYDRAULIC SYSTEM</b> .....         | <b>6</b>  |
| <b>4. HYDRAULIC PRESSURE TEST</b> .....                          | <b>6</b>  |
| <b>5. TROUBLESHOOTING</b> .....                                  | <b>6</b>  |
| <b>6. POWER STEERING HYDRAULIC PUMP</b> .....                    | <b>6</b>  |
| 6.1 WITH DDC SERIES 60 ENGINE.....                               | 6         |
| 6.1.1 <i>Description</i> .....                                   | 6         |
| 6.1.2 <i>Removal And Installation</i> .....                      | 6         |
| 6.1.3 <i>Maintenance</i> .....                                   | 7         |
| 6.2 WITH VOLVO D13 ENGINE.....                                   | 7         |
| 6.2.1 <i>Description</i> .....                                   | 7         |
| 6.2.2 <i>Removal And Installation</i> .....                      | 7         |
| <b>7. STEERING COLUMN</b> .....                                  | <b>8</b>  |
| 7.1 REMOVAL.....   | 8         |
| <b>8. STEERING WHEEL</b> .....                                   | <b>8</b>  |
| 8.1 REMOVAL.....   | 8         |
| 8.2 INSTALLATION.....  | 9         |
| 8.3 CLOCKSPRING REPLACEMENT.....                                 | 9         |
| <b>9. TURNING ANGLE ADJUSTMENT</b> .....                         | <b>10</b> |
| <b>10. STEERING LINKAGE ADJUSTMENT</b> .....                     | <b>10</b> |
| <b>11. PITMAN ARM</b> .....                                      | <b>11</b> |
| 11.1 REMOVAL.....  | 11        |
| 11.2 INSTALLATION.....   | 11        |
| 11.3 ADJUSTMENT.....   | 11        |
| 11.4 TAG AXLE UNLOADING SWITCH ADJUSTMENT.....                   | 12        |
| <b>12. MAINTENANCE</b> .....                                     | <b>12</b> |
| 12.1 POWER STEERING RESERVOIR AND FILTER.....                    | 12        |
| 12.1.1 <i>Oil Level Check Procedure</i> .....                    | 12        |
| 12.1.2 <i>Filter Replacement</i> .....                           | 13        |
| 12.2 STEERING STABILIZER CYLINDER (DAMPER).....                  | 13        |
| 12.3 DRAG LINK.....  | 13        |
| 12.4 POWER STEERING HYDRAULIC PUMP.....                          | 14        |
| <b>13. DRIVING TIPS</b> .....                                    | <b>14</b> |



## Section 14: STEERING

---

|                                |    |
|--------------------------------|----|
| 14. TORQUE SPECIFICATIONS..... | 15 |
| 15. SPECIFICATIONS .....       | 16 |

## ILLUSTRATIONS

|   |    |
|---|----|
| FIGURE 1: I-BEAM AXLE STEERING SYSTEM SETUP .....     | 3  |
| FIGURE 2: IFS STEERING SYSTEM SETUP .....             | 4  |
| FIGURE 3: POWER STEERING GEAR .....                   | 5  |
| FIGURE 4: FRONT SERVICE COMPARTMENT.....              | 5  |
| FIGURE 5: FUEL PUMP REMOVAL .....                     | 7  |
| FIGURE 6: FUEL PUMP DRIVE AXLE .....                  | 7  |
| FIGURE 7: POWER STEERING PUMP REMOVAL.....            | 7  |
| FIGURE 8: STEERING COLUMN .....                       | 8  |
| FIGURE 9: STEERING COLUMN COVERS .....                | 8  |
| FIGURE 10: REMOVING THE HORN PAD .....                | 9  |
| FIGURE 11: STEERING HARNESS & HORN WIRE .....         | 9  |
| FIGURE 12: LOCKING THE CLOCKSPrING IN PLACE .....     | 9  |
| FIGURE 13: CLOCKSPrING INSTALLATION .....             | 10 |
| FIGURE 14: PROPER CLOCKSPrING POSITION.....           | 10 |
| FIGURE 15: PITMAN ARM ADJUSTMENT .....                | 11 |
| FIGURE 16: FIXING NUT PUNCH MARK.....                 | 11 |
| FIGURE 17: TAG AXLE UNLOADING SWITCH ADJUSTMENT ..... | 12 |
| FIGURE 18: HYDRAULIC FLUID RESERVOIR LOCATION .....   | 13 |
| FIGURE 19: POWER STEERING FLUID RESERVOIR.....        | 13 |
| FIGURE 20: STEERING STABILIZER (DAMPER).....          | 14 |
| FIGURE 21: DRAG LINK COMPONENTS .....                 | 15 |
| FIGURE 22: TIE ROD END.....                           | 15 |
| FIGURE 23: FRONT AXLE COMPONENTS.....                 | 15 |

## 1. STEERING SYSTEM

### 1.1 I-BEAM AXLE STEERING SYSTEM DESCRIPTION

The steering system consists of the steering wheel and column assembly, a vane-type hydraulic pump, reservoir, filter, interconnecting system lines and hoses, integral power steering gear, linkage and steering damper (Fig. 1). The steering linkage includes the pitman arm, drag link, steering arm, tie rod arms and tie rod.

Hydraulic components are added to transmit, increase and regulate steering control forces.

These elements are:

1. Steering stabilizer (damper);
2. A vane type hydraulic pump; and
3. Hydraulic reservoir and hoses.

The steering stabilizer reduces road shocks and vibrations in the system. The steering gearbox is self powered and provides movement with power assistance to the left wheel.

Steering stability and tire wear are influenced by wheels, hubs, tires, air suspension, brakes, front suspension and front end alignment which are all covered in their respective sections in this manual.

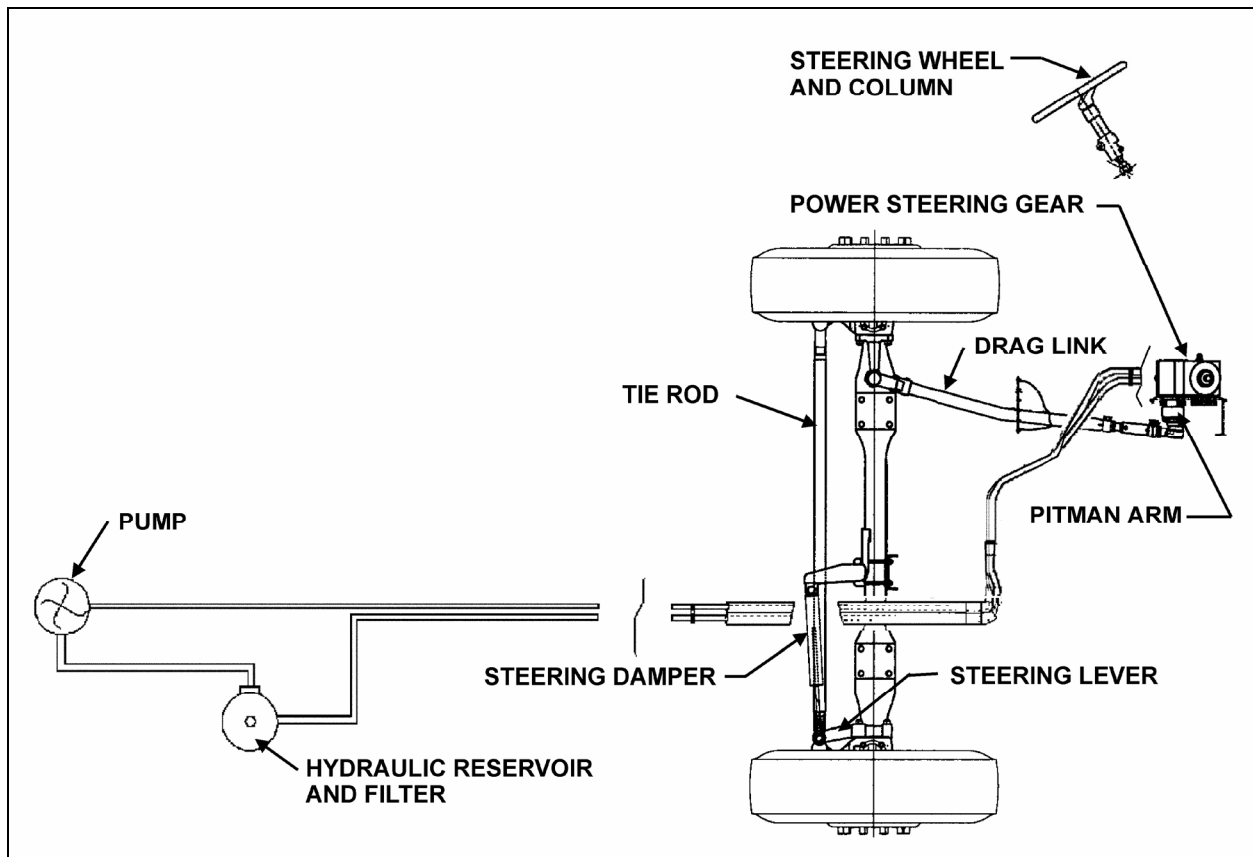


FIGURE 1: I-BEAM AXLE STEERING SYSTEM SETUP

14041

## Section 14: STEERING

### 1.2 INDEPENDENT FRONT SUSPENSION STEERING SYSTEM DESCRIPTION

The steering system consists of the steering wheel and column assembly, a vane-type hydraulic pump, reservoir, filter, interconnecting system lines and hoses, integral power steering gear and linkage (Fig. 2). The steering linkage consists of tie rods connected to the bell crank and the steering arm at the left side of the coach, and to the idler arm and steering arm at the right side of the coach. The bell crank and idler arm are connected by a relay rod. A drag link connected to the bell crank and the pitman arm, which is mounted to the steering gear, transfers the turning motion of the steering wheel to the steering arms.

Hydraulic components are added to transmit, increase and regulate steering control forces.

These elements are:

1. A vane type hydraulic pump; and
2. Hydraulic reservoir and hoses.

The steering gearbox is self powered and provides movement with power assistance to the left wheel.

Steering stability and tire wear are influenced by wheels, hubs, tires, air suspension, brakes, front suspension and front end alignment which are all covered in their respective sections in this manual.

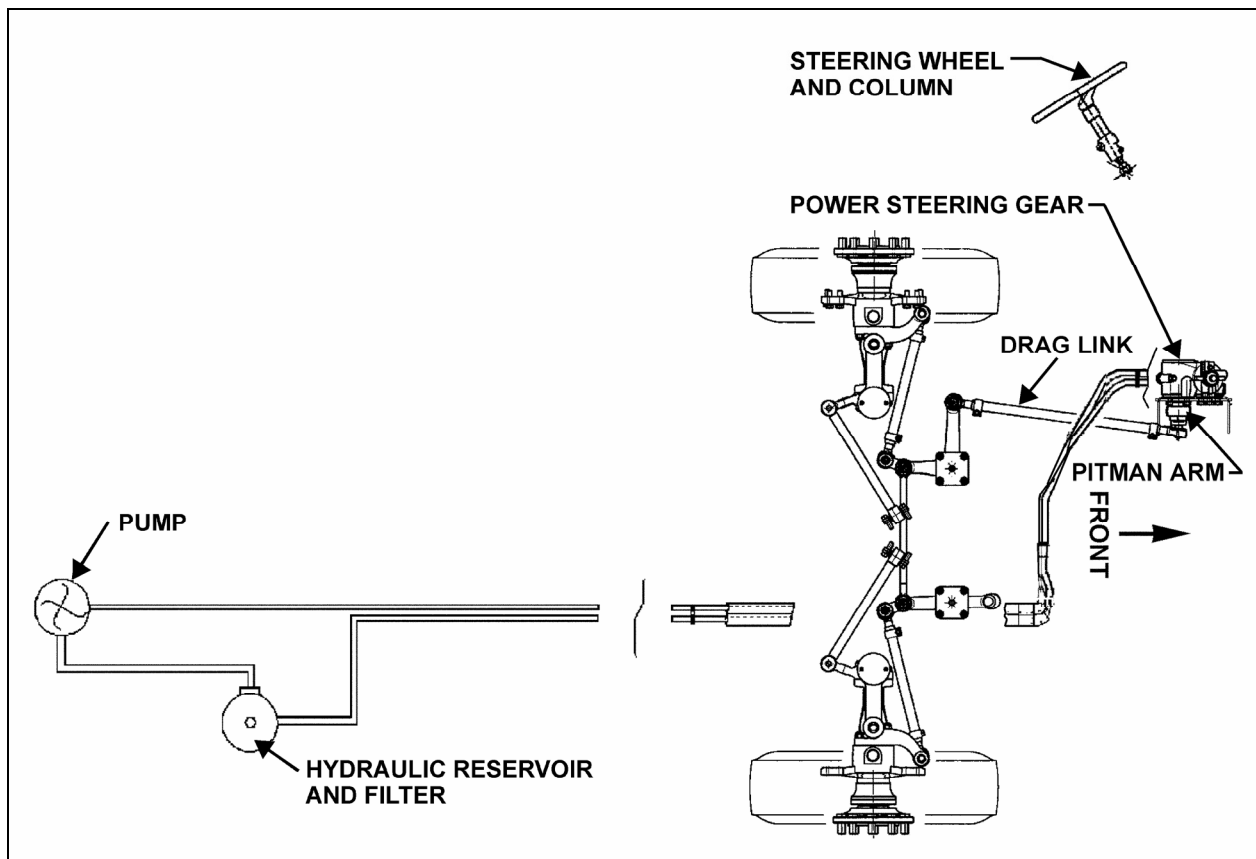


FIGURE 2: IFS STEERING SYSTEM SETUP

14060

## 2. POWER STEERING GEAR

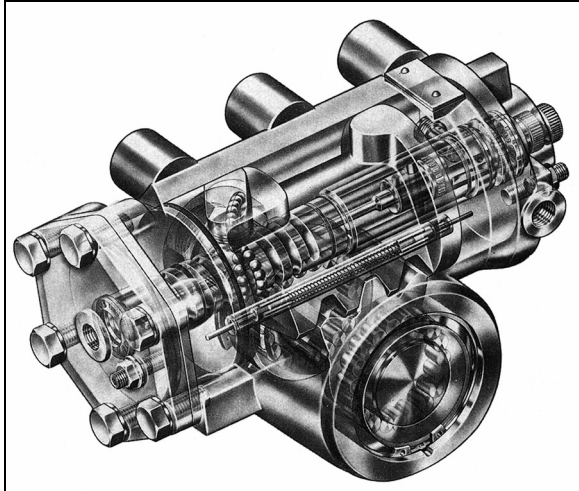


FIGURE 3: POWER STEERING GEAR 14035

### 2.1 DESCRIPTION

The power steering gear is located in the lower part of front service compartment (Figs. 3 & 4). The housing of the ZF-Servocom contains a control valve, working cylinder and a complete mechanical steering gear. The pressure oil for the steering is delivered by a motor-driven oil pump which is supplied with oil from an oil tank.

The housing is designed as a cylinder for the piston, which converts the rotation of the steering shaft and the worm into an axial movement and transfers this to the steering worm sector shaft. The serration of the sector shaft is straight-cut with a high surface quality in such a way that it is only possible to set a unique setting without play on installation in the straight-ahead driving area by means of the two eccentrically designed lateral housing covers.

The piston and worm are connected via a ball chain. When the worm is turned, the balls are collected by a circulating pipe at one end of the chain and fed in again at the other end, thus producing an endless ball chain.

The control valve consists of the valve slide in a needle bearing in the worm, with six control grooves on the circumference and the control sleeve on the worm, which also has six control grooves. The valve slide, designed with steering shaft connection, turns together with the worm as the steering wheel is turned.

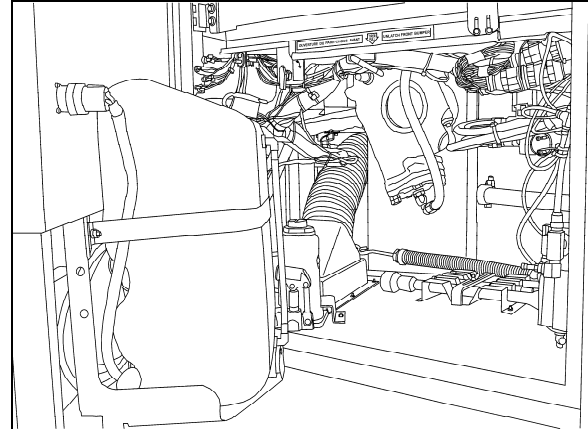


FIGURE 4: FRONT SERVICE COMPARTMENT 18611

A torsion bar, which is pinned with the valve slide and the worm, keeps the control valve in the neutral position as long as no opposing force is applied to the steering wheel. The steering housing contains a pressure relief valve, which limits the discharge pressure of the oil pump to the maximum value required. A replenishing valve can also be used, through which oil is sucked from the return if steering is not hydraulically boosted.

Compared with constant ratio, steering versions with variable ratio are more directly designed in the center area than outside the center area. The resulting smaller steering corrections benefit steering behavior in straight-ahead driving. At the same time, the indirect transmission means that there is a higher hydraulic torque available at the steering arm in parking movement. If the hydraulic assistance fails, the operating forces on the steering wheel are correspondingly lower in this area. This is achieved through a piston/steering worm sector shaft serration with differing modulus and angle of pressure.

Upon transfer of a torque from the steering shaft to the worm, or vice versa, the torsion bar is deformed in the elastic area so that there is torsion between the valve slide and the control sleeve. When the steering wheel is released, the torsion bar ensures that the valve is returned to the neutral position.

Refer to the "ZF-SERVOCOM Repair Manual" and "ZF-SERVOCOM Operating, Servicing /Maintenance and Inspection Instructions" annexed to this section for the functional aspects and maintenance procedure of the steering gear.

#### NOTE

Also available is the ZF-Servocomtronic, which provides variable assistance in function of speed.

## Section 14: STEERING

### 2.2 POWER STEERING GEAR REMOVAL



#### WARNING

The steering gearbox weighs approximately 100 lbs (45 kg) dry. Exercise caution when handling.

1. Put a container into place, then disconnect both the inlet and outlet hoses from the power steering gear. Cover fittings to prevent fluid contamination.
2. Mark both the pitman arm and sector shaft with a line, then remove pitman arm. Refer to "11.1 Pitman Arm Removal" procedure.
3. Mark both the steering shaft universal joint yoke and steering gear input shaft with a line, then disconnect universal joint.
4. Unscrew and remove the power steering gear.

### 2.3 POWER STEERING GEAR INSTALLATION

Reverse "Power Steering Gear Removal" procedure paying particular attention to the following:

1. Tighten fasteners as recommended under paragraph 14: "Torque Specifications".
2. Bleed air from the system as per step 3, next.

### 3. BLEEDING POWER STEERING HYDRAULIC SYSTEM

To bleed the power steering hydraulic system, refer to the "ZF-SERVOCOM Repair Manual" annexed to this section, under heading "Setting And Functional Test".

### 4. HYDRAULIC PRESSURE TEST

Perform a pressure test as outlined in the "ZF-SERVOCOM Repair Manual" annexed to this section under heading "Setting And Functional Test".

### 5. TROUBLESHOOTING

Perform troubleshooting of the steering gear as outlined in the "ZF-SERVOCOM Repair Manual", the "ZF-SERVOCOM Operating, Servicing /Maintenance and Inspection Instructions and the "TRW - Power Steering Pump Service Manual".

#### NOTE

For vehicles equipped with ZF-SERVOCOMTRONIC unit, refer to the supplement to the repair manual ZF-SERVOCOM.

### 6. POWER STEERING HYDRAULIC PUMP

#### 6.1 WITH DDC SERIES 60 ENGINE

##### 6.1.1 Description

The TRW PS Series power steering pump is a vane type, gear driven, hydraulic unit which supplies hydraulic pressure for the operation of the steering gear. The pump is mounted on the engine, on the crankshaft pulley's R.H. side.

##### 6.1.2 Removal And Installation

The pump is accessible through the engine compartment rear door.

To remove the pump, proceed as follows:

1. Put an empty container directly below pump, then disconnect both the inlet and outlet hoses from the pump. Block fitting cavities to prevent fluid contamination.
2. Remove the two (2) mounting screws, then slowly pry out the pump.
3. Remove and discard gasket.



#### CAUTION

Inspect the drive coupling thoroughly, and replace if necessary (the drive coupling is a fiber component located between the engine and the pump).

For pump installation, reverse the removal procedure paying particular attention to the following:



#### CAUTION

Ensure that drive coupling is correctly positioned before reinstalling the pump.

1. Install a new gasket (Prévost P/N 510488).
2. Bleed air from the system as per step 3, "Bleeding Power Steering Hydraulic System".

6.1.3 Maintenance

Refer to the "ZF-SERVOCOM Repair Manual" and the "TRW - Power Steering Pump Service Manual" annexed to this section.

6.2 WITH VOLVO D13 ENGINE

6.2.1 Description

The power steering pump is a gear driven hydraulic unit which supplies hydraulic pressure for the operation of the steering gear. The pump is mounted on the engine, at the flywheel end and is also used for driving the fuel pump.

6.2.2 Removal And Installation

The pump is accessible through the engine compartment R.H. access door.

To remove the pump, proceed as follows:

- You must first remove the fuel feed pump.
- Clean around the fuel pump and fuel lines. Position a container to catch any fuel that might drain from the pump or lines.
- Remove the fuel pump.

**NOTE**  
Only unfasten the bolts marked with arrows.

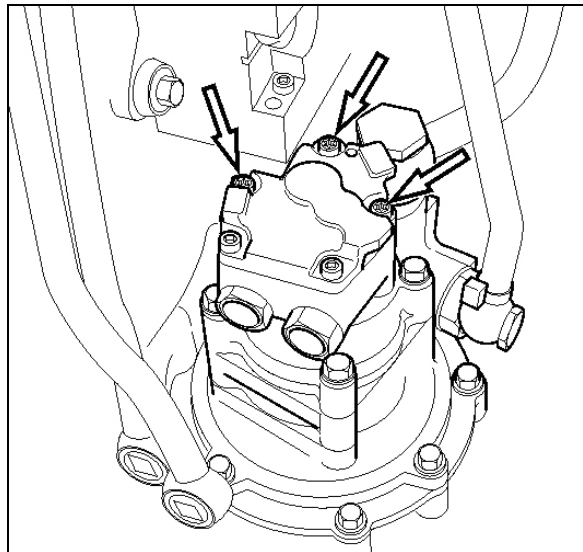


FIGURE 5: FUEL PUMP REMOVAL

**CAUTION**  
Ensure to clean around the head of the bolts. Debris will prevent the tool from fitting properly and cause damage to the fasteners.

- Check that the adapter and fuel pump drive axle are not damaged.

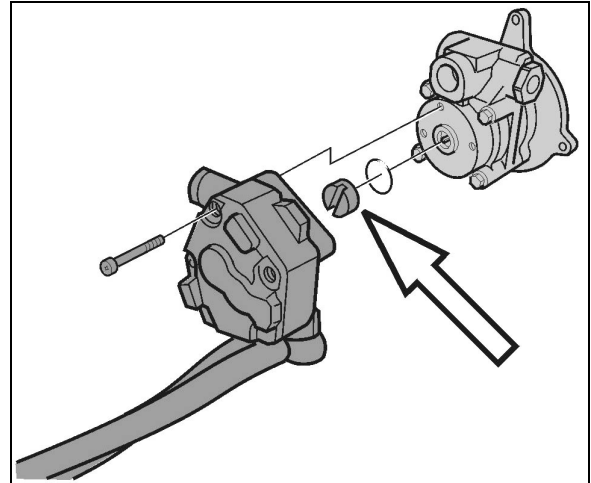


FIGURE 6: FUEL PUMP DRIVE AXLE

- Set the fuel pump aside.
- Clean around the power steering pump and loosen the steering lines. Position a container to catch any hydraulic fluid that might drain from the pump or lines.
- Unfasten the power steering pump bolts.

**NOTE**  
Only unfasten the bolts marked with arrows.

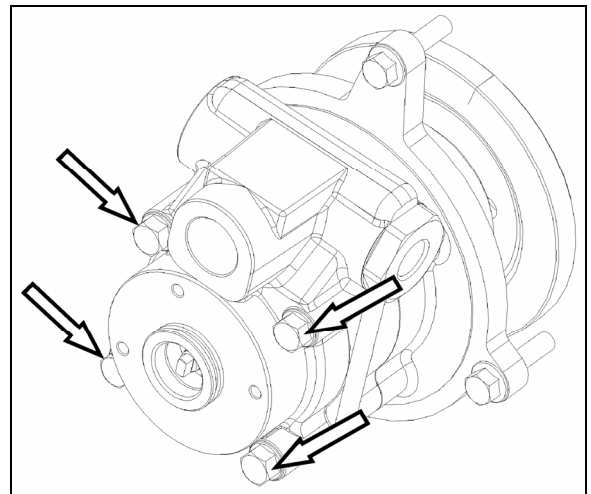


FIGURE 7: POWER STEERING PUMP REMOVAL

- Install the new power steering pump. Torque-tighten bolts to specification.

**NOTE**  
Use a new gasket.

## Section 14: STEERING

- Connect the hydraulic lines to the power steering pump.
- Install the fuel pump. Torque-tighten bolts to specification.

### NOTE

Use a new sealing ring. Check that the fuel pump drive axle sits correctly in the power steering pump.

- Start the engine and let run for 5 minutes. Make sure that there are no leaks.

## 7. STEERING COLUMN

### 7.1 REMOVAL

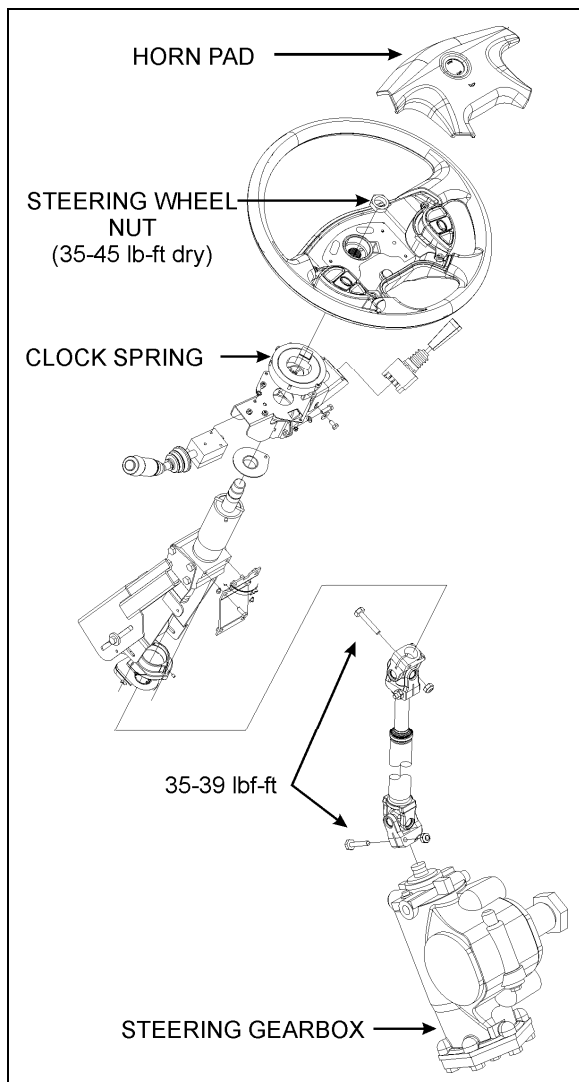


FIGURE 8: STEERING COLUMN

To disassemble the steering column from system, refer to figure 8 & 9. The steering column has no lubrication points. The lower steering column U-joint is easily accessible through the front service compartment. The upper steering column U-joint and the steering slip joint are accessible from the front driver's area. To access these joints, proceed as follows:

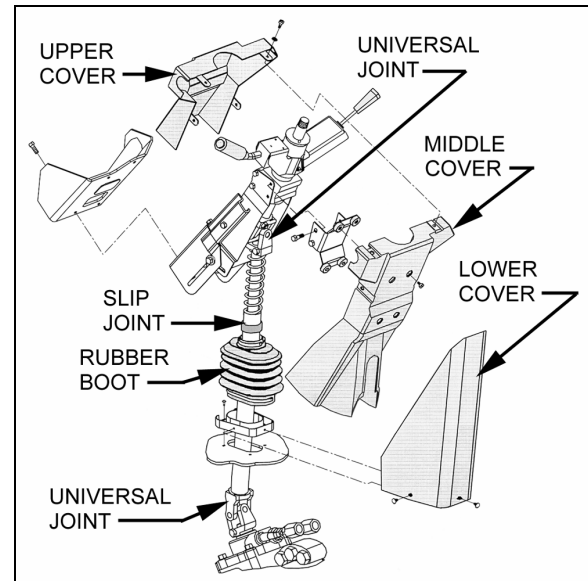


FIGURE 9: STEERING COLUMN COVERS

14040

1. From the front driver's compartment area, remove the three plastic fasteners on steering column lower cover. Remove the lower cover (Fig. 9).
2. Unscrew the four retaining screws on steering column middle cover.
3. Unscrew the four retaining screws fixing steering column upper cover to middle cover. Remove the steering column middle and upper covers.
4. Position the steering wheel in order to gain access to the joints.

## 8. STEERING WHEEL

### 8.1 REMOVAL

### NOTE

Before undertaking the steering wheel removal, assure that the front wheels are pointing straight ahead, aligned with the vehicle.

1. Set the battery master switch located in the rear electrical compartment to the "OFF" position.
2. Pull the horn pad straight up gently to detach it from the steering wheel (Fig. 10).
3. Disconnect the horn wire (white) connected to the horn pad and the steering wheel harness 4-pin connector.

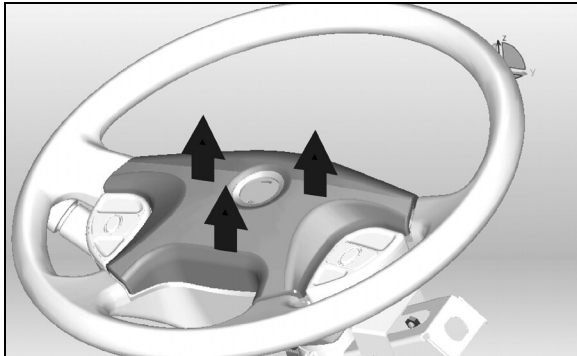


FIGURE 10: REMOVING THE HORN PAD

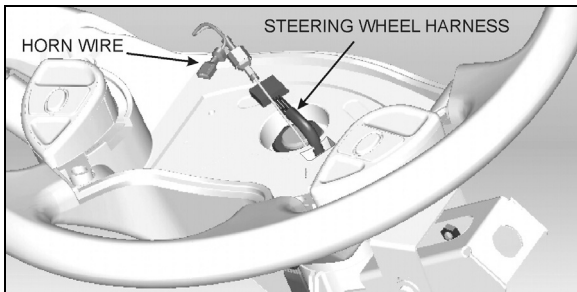


FIGURE 11: STEERING HARNESS & HORN WIRE

4. Unscrew the steering wheel nut. To simplify installation and ensure steering wheel alignment, mark the relationship of the spline shaft to the steering wheel hub (if marks don't already exist or don't line up).
5. Using an appropriate puller, separate the steering wheel from the spline shaft.
6. From behind the steering wheel, pull gently on the electrical wires passing through the rectangular opening in the steering wheel to finish removal of the steering wheel.
7. Once the steering wheel is removed, it is important to block any rotating movement of the clockspring in order to prevent it from losing its neutral position. Use two pieces of masking tape to lock it in place (Fig. 12).

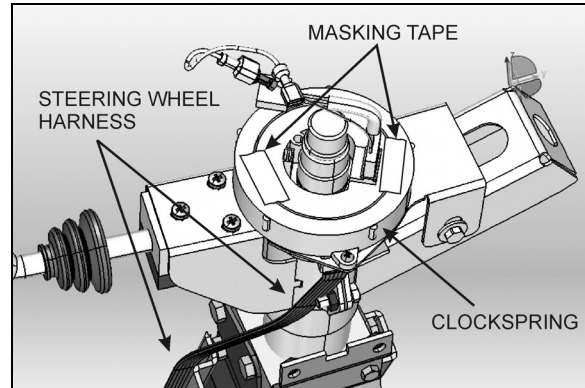


FIGURE 12: LOCKING THE CLOCKSPRING IN PLACE

**NOTE**

The clockspring mechanism permits a certain number of turns in each direction. At the moment of reinstalling the steering wheel, if the clockspring is not at its neutral position, the number of available turns will be reduced. That may damage the clockspring if the steering wheel is turned to its maximum amplitude.

**8.2 INSTALLATION**

1. Route the white horn wire and the 4-pin connector through the opening on the steering wheel.
2. Align the mark on the steering wheel hub with the mark on the spline shaft and slide the wheel onto the shaft.
3. Tighten wheel retaining nut to a torque of 35-45 lbf-ft.
4. Plug the 4-pin connector and connect the white horn wire to the center pad.
5. Reinstall the center pad and test for proper horn functioning.

**8.3 CLOCKSPRING REPLACEMENT**

1. Remove the steering wheel.
2. Remove the 2 clockspring mounting screws and then remove the clockspring. You will have to disconnect the clockspring harness connector located lower along the steering wheel column. If necessary, remove the steering column covers (Fig. 9).
3. Route the new clockspring harness through the opening in the clockspring support (Fig. 13). Plug the connector at the base of the



## Section 14: STEERING

steering wheel column and fix harness along the steering wheel column.

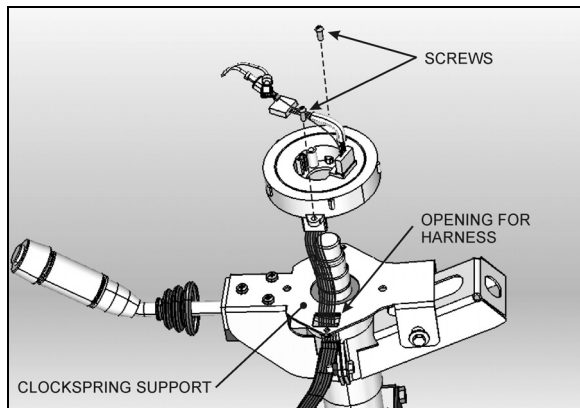


FIGURE 13: CLOCKSPRING INSTALLATION

4. Mount the clockspring in place with 2 screws.
5. Break the paper seal and rotate the center part of the clockspring about 50° clockwise (Fig. 14). This step is necessary for the installation of the steering wheel.

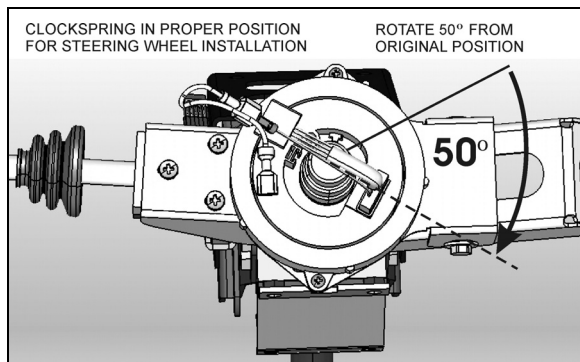


FIGURE 14: PROPER CLOCKSPRING POSITION

6. Reinstall the steering wheel.

### 9. TURNING ANGLE ADJUSTMENT

The maximum turning angle is set through two (2) steering stop screws installed on the axle center. Steering stop screws are factory adjusted to accommodate the chassis design, and therefore, do not require adjustment on new vehicles. However, these should be checked and adjusted if necessary, any time a steering system component is repaired, disassembled or adjusted. Refer to section 10 "Front Axle" under heading "6.4 "Turning Angle Adjustment".



### CAUTION

To prevent the steering damper from interfering with the adjustment of turning angles, make sure its fixing bracket is at correct location on the axle (refer to "12.2 Steering Stabilizer Cylinder (Damper)").

### Hydraulic Stop



### CAUTION

Reduce or shut off the power steering hydraulic pressure before the boss on the axle touches the stop screw. If not, the components of the front axle will be damaged (refer to "ZF-SERVOCOM Repair Manual" and "ZF-SERVOCOM Operating, Servicing/Maintenance and Inspection Instructions" annexed to this section, under heading "Setting The Steering Limiter").



### CAUTION

Never maintain the relief pressure for more than 5 seconds, since damage to the power steering pump may occur.

### 10. STEERING LINKAGE ADJUSTMENT

The steering linkage includes the pitman arm, drag link, steering arm, tie rod arms and tie rod.

Perform lubrication according to "DANA SPICER NDS Axles Lubrication and Maintenance" annexed to section 10 "Front Axle".

Drag link ends are provided with grease fittings. Under normal conditions, these should be serviced every 6,250 miles (10 000 km). Refer to section 24 "Lubrication".

Steering linkage pivot points should be checked each time they are lubricated. Looseness can be visually detected while rotating the steering wheel in both directions. Replace defective parts.




### CAUTION


Front wheel alignment should be checked and adjusted if necessary, any time a component of the steering system is repaired, disassembled or adjusted. Refer to section 10 "Front Axle" under heading 6. "Front Wheel Alignment".


## 11. PITMAN ARM

### 11.1 REMOVAL

1. Remove cotter pin, nut and washers from drag link ball stud at pitman arm.
2. Disconnect drag link from pitman arm, using jaw style pullers (pressure screw type).

|   |                  |
|---|------------------|
|  | <h3>WARNING</h3> |
| <p>Always wear approved eye protection when operating pullers.</p>                |                  |

|   |                  |
|---|------------------|
|                        | <h3>CAUTION</h3> |
| <p>Do not drive (hammer in) pitman arm on or off pitman shaft as this can damage the steering gear.</p> |                  |

|   |                  |
|---|------------------|
|    | <h3>CAUTION</h3> |
| <p>Heating of components to aid in disassembly is not allowed because it has a detrimental effect on axle components and steering linkages.</p> |                  |

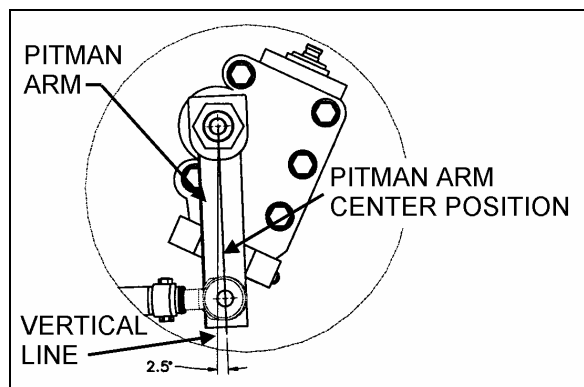


FIGURE 15: PITMAN ARM ADJUSTMENT 14037

3. Using a cold chisel, undo punch mark that locks fixing nut to the pitman arm.
4. Remove pitman arm fixing nut.
5. Check the radial position of the pitman arm in relation to the sector shaft prior to removal of pitman arm.
8. Add reference marks to the arm and shaft if necessary to ensure correct alignment at reassembly.
7. You must use a puller to remove pitman arm.

### 11.2 INSTALLATION

1. Position pitman arm on sector gear shaft with reference marks aligned.
2. Install fixing nut (Prévost #661050). Tighten nut to 470-570 lbf-ft (637-773 Nm).

|  |
|--|
| <p><i><b>NOTE</b></i></p>  |
| <p><i>Use a new nut if the previously removed nut was punched.</i></p> |

3. Lock nut with sector shaft using a punch mark into the groove (Refer to figure 16).

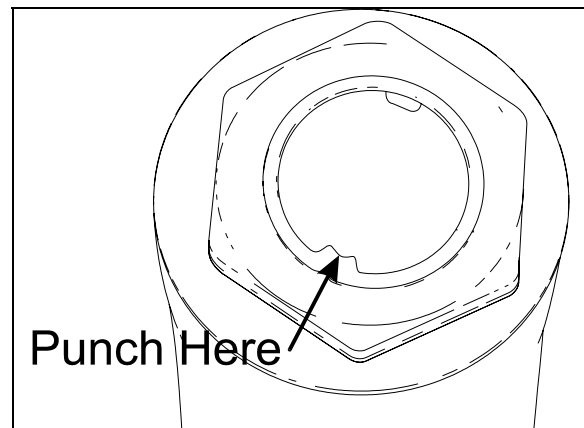



FIGURE 16: FIXING NUT PUNCH MARK 16098

4. Connect drag link to pitman arm while ensuring that rubber stabilizer is in place on the rod end. Install washers. Tighten nut to 160-215 lbf-ft (220-290 Nm). Afterwards, install a new cotter pin.

|   |                  |
|---|------------------|
|  | <h3>CAUTION</h3> |
| <p>Input shaft marks must be aligned before adjusting pitman arm.</p>               |                  |

### 11.3 ADJUSTMENT

1. Disconnect the drag link from pitman arm. Center steering wheel by dividing the total number of steering wheel turns in two. Scribe a reference mark on steering gearbox at the center previously determined.
2. Using a protractor, check the angle of the pitman arm (refer to Fig. 15 for details).
3. The pitman arm should be adjusted to an angle of 2.5° in relation with the vertical axis (towards front of vehicle). If not, unscrew and remove fixing nut. Remove the pitman arm according to the procedure outlined under

## Section 14: STEERING

previous heading "Pitman arm removal". Adjust to the proper angle.

4. When adjustment is achieved, replace fixing nut and torque to 400-450 lbf-ft (545-610 Nm).

### 11.4 TAG AXLE UNLOADING SWITCH ADJUSTMENT

1. Make sure vehicle wheels are straight and facing forward.
2. Line up switch lever with reference to the bracket center (Refer to figure 17).

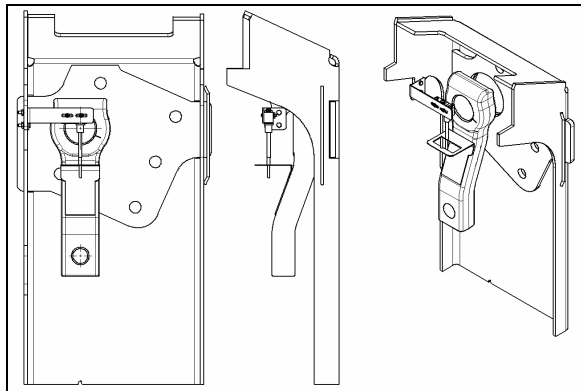


FIGURE 17: TAG AXLE UNLOADING SWITCH ADJUSTMENT 14061

## 12. MAINTENANCE

The power steering system requires little maintenance. However, the system should be kept clean to ensure maximum operating performance and troublefree service. Periodic inspections should also be made to check for leakage and all parts for damage or distortion. Insure all fasteners are tight (see "14. Specifications" for recommended tightening torques).

When the slightest evidence of dirt, sludge or water is discovered in the system, disconnect fluid lines at the power steering gear to drain the system. Drain and refill the system with "Dexron-II E or Dexron-III" automatic transmission oil.

Air in the hydraulic system will cause spongy action and noisy operation. When a hose has been disconnected or when fluid has been lost for any reason, the system must be bled. Bleed system as outlined under heading 3: "Bleeding Power Steering Hydraulic System".



### CAUTION

Do not operate the pump without fluid in the power steering fluid reservoir.

If the steering linkage between the steering gear and the two front wheels is not properly adjusted, or if it is bent, twisted or worn, the steering of the vehicle will be seriously impaired. Whenever a steering linkage part is repaired, replaced or adjusted, steering geometry and front wheel alignment must be checked and necessary corrections made. Refer to section 10 "Front Axle" under heading 6: "Front Wheel Alignment".

At regular lubrication intervals, the steering linkage should be thoroughly inspected for worn or loose components.

After the vehicle has been operated continually and high mileage figures have been reached, overhaul of the various steering units will be required. General overhaul procedure normally requires removal of the entire assembly, cleaning and inspection of all parts and final assembly. Careful inspection of all parts during overhaul is very important and must not be neglected.

Lubrication fittings must all be cleaned before applying lubricant. Moreover, always be sure the equipment used in applying lubricant is clean. Every precaution should be taken to prevent entry of dirt, grit, lint or other foreign matter into lubricant containers. Replace fittings that have become broken or damaged. Lubrication intervals, as well as the recommended lubricants for the steering components, are given in the "Lubrication And Servicing Schedule" in Section 24 of this manual. The intervals given in the schedule are recommended for normal service. More frequent intervals may be required under severe operating conditions.

### 12.1 POWER STEERING RESERVOIR AND FILTER

The power steering reservoir is located on R.H. side of engine compartment and accessible through the engine compartment doors. (Fig. 18).

#### 12.1.1 Oil Level Check Procedure

1. Stop engine. Open engine compartment doors.
2. Unscrew and remove the dipstick located on top of reservoir and wipe with a clean rag.

3. Insert dipstick in reservoir. Remove it again to check fluid level (Fig. 19).
4. Adjust level to "FULL" mark using proper dipstick side depending on fluid temperature, use "Dexron-II E or Dexron-III" automatic transmission oil.
5. Reinsert and tighten the dipstick.

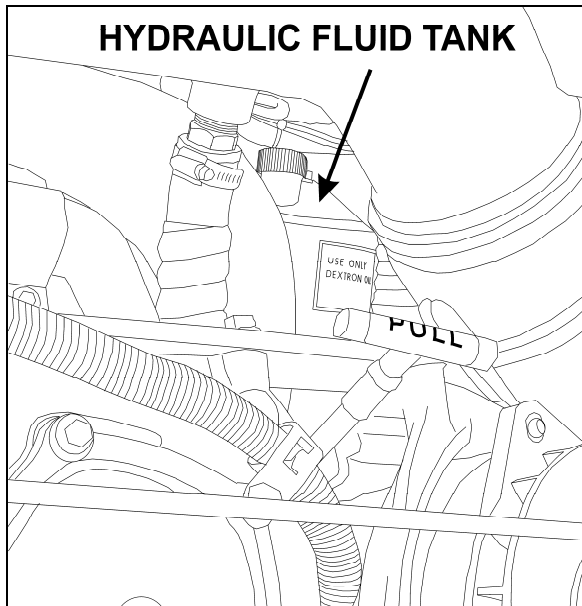


FIGURE 18: HYDRAULIC FLUID RESERVOIR LOCATION  
14059

At regular intervals, fluid level should be checked in the reservoir and filter assembly. Furthermore, the oil filter cartridge element in the power steering reservoir should be replaced every 50,000 miles (80 000 km) or once a year, whichever comes first.

#### 12.1.2 Filter Replacement

1. Unscrew and remove the cover nut located on top of the power steering reservoir.
2. Remove the reservoir cover and the gasket.
3. Remove the retaining spring and finally the filter cartridge element.

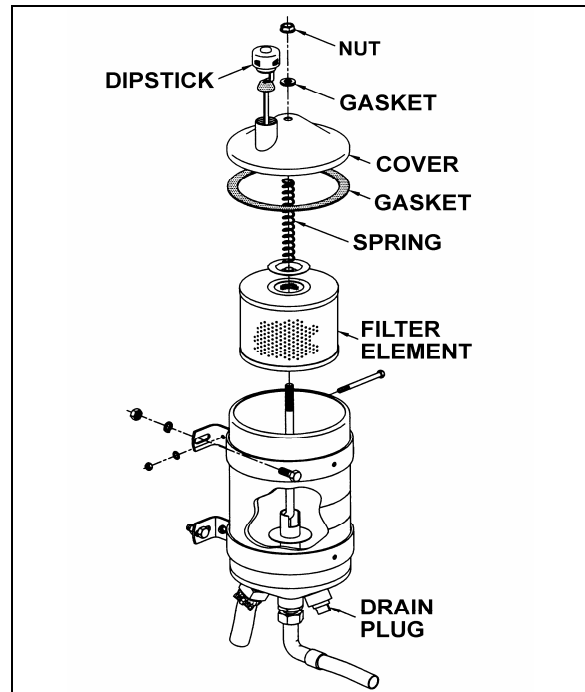


FIGURE 19: POWER STEERING FLUID RESERVOIR  
14018A

#### 12.2 STEERING STABILIZER CYLINDER (DAMPER)

The steering damper is located on R.H. side, at back of front axle (Fig. 20).

The cylinder is nonadjustable and non-repairable. Check for oil leaks or lack of resistance. Disconnect the cylinder from axle, then carefully attempt to extend and collapse it manually.

The rod end (ball joint) is provided with a grease fitting. Under normal conditions, it should be serviced every 6,250 miles (10 000 km) or twice a year, whichever comes first. Good quality lithium-base grease NLGI No. 1 and 2 are recommended (refer to section 24 "Lubrication"). Check the ball joint for wear, and replace if necessary.

#### 12.3 DRAG LINK

Lubricate the fittings every 6,250 miles (10 000 km) or twice a year, whichever comes first. Good quality lithium-base grease NLGI No. 1 and 2 are recommended (refer to section 24 "Lubrication").

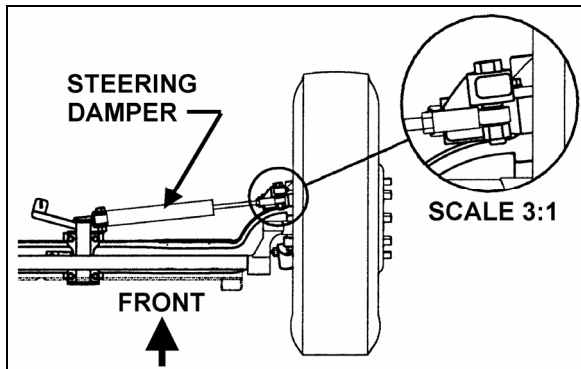


FIGURE 20: STEERING STABILIZER (DAMPER) 14042

### 12.4 POWER STEERING HYDRAULIC PUMP

- **With DDC Series 60 Engine**

For maintenance of the power steering hydraulic pump, refer to the *"TRW - Power Steering Pump Service Manual"* annexed to this section.

### 13. DRIVING TIPS

In order to maximize power steering pump service life, do not attempt to turn the steering wheel when the vehicle is stationary, and especially when service brakes are applied (wheel locking will oppose the effect of steering geometry which tends to make the front wheels rotate in opposite directions).

Persisting in turning, or maintaining the steering wheel with an extra effort, could make the hydraulic system work at the relief pressure, and consequently, cause the hydraulic fluid to become overheated.



#### **CAUTION**

Never maintain the hydraulic system at the relief pressure for longer than 5/10 seconds to avoid damaging the power steering pump.

#### ***NOTE***

*Unequal or low tire pressure, oversize tires, and vehicle overloading are some of the causes that may increase steering effort.*

14. TORQUE SPECIFICATIONS

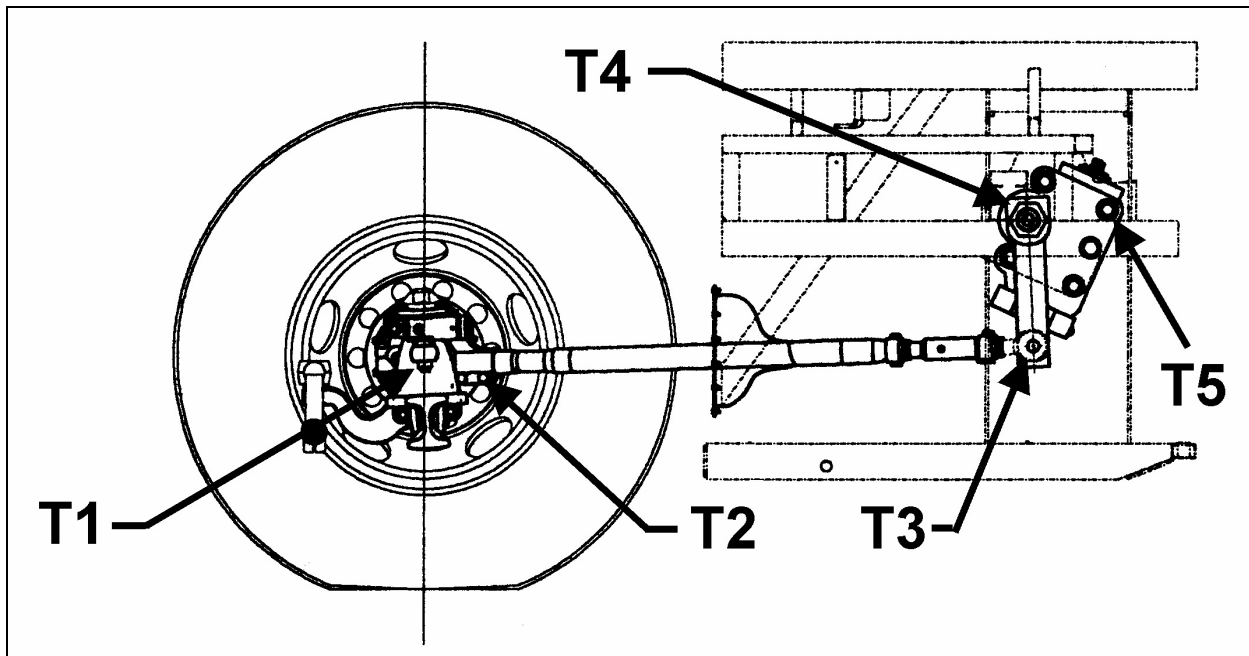


FIGURE 21: DRAG LINK COMPONENTS

14038

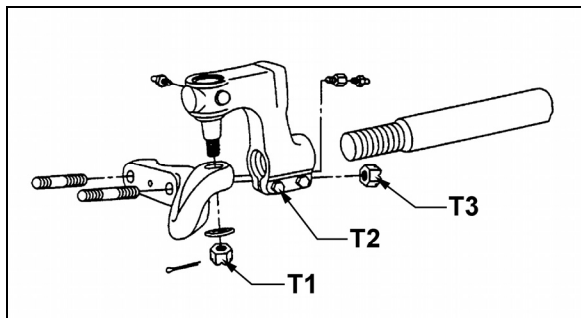


FIGURE 22: TIE ROD END

14036

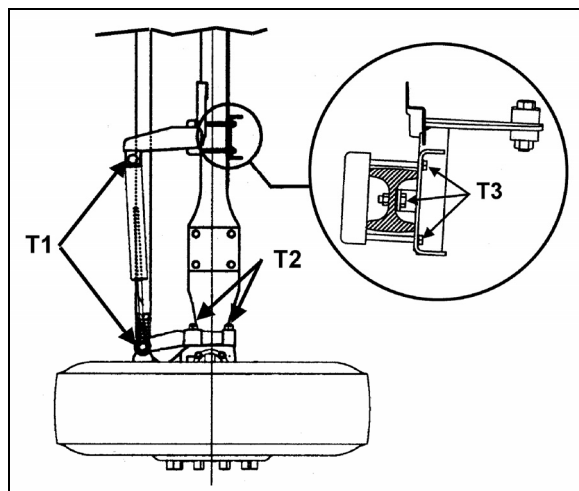


FIGURE 23: FRONT AXLE COMPONENTS

14045

## Section 14: STEERING

| DRY TORQUES                              |             |         |         |
|--|-------------|---------|---------|
| Description                              | Reference   | Lbf-ft  | Nm      |
| Drag Link End Stud Nut (on steering arm) | Fig. 21, T1 | 160-300 | 220-410 |
| Drag Link End Pinch Bolt Nuts            | Fig. 21, T2 | 40-60   | 55-80   |
| Drag Link End Stud Nut (on pitman arm)   | Fig. 21, T3 | 150-200 | 203-271 |
| Pitman Arm Fixing Nut                    | Fig. 21, T4 | 470-570 | 637-773 |
| Steering Gear Fixing Bolts (5)           | Fig. 21, T5 | 365-405 | 495-550 |
| Tie Rod End Screw Pin Nut                | Fig. 22, T1 | 100-175 | 135-240 |
| Tie Rod End Pinch bolt Nuts              | Fig. 22 T2  | 65-75   | 90-100  |
| Lower Lever Stud Nuts                    | Fig. 22, T3 | 190-275 | 260-375 |
| Steering Stabilizer (damper) Fixing Nuts | Fig. 23, T1 | 100-120 | 135-165 |
| Steering Top Lever Nuts                  | Fig. 23, T2 | 150-200 | 205-275 |
| Steering Damper Mounting Support Nuts    | Fig. 23, T3 | 65-70   | 90-95   |

## 15. SPECIFICATIONS

### Power Steering Gear

Make ..... ZF-SERVOCOMTRONIC  
 Model ..... 8098  
 Supplier number ..... 8098-988-571  
 Prevost number ..... 661044  
 F.E.W. .... 16,600 lbs (7 545 kg)  
 Pressure rating ..... 2,175 psi (150 Bar)  
 Gear ratio (center) ..... 22.2 : 1  
 Gear ratio (extremities) ..... 26.2 : 1  
 Minimum pump flow for 1.5 hwt/sec ..... 4.22 gpm (16 lpm)

### Power Steering Gear

Make ..... ZF-SERVOCOM  
 Model ..... 8098  
 Supplier number ..... 8098-988-570  
 Prevost number ..... 661045  
 F.E.W. .... 16,600 lbs (7 545 kg)  
 Pressure rating ..... 2,175 psi (150 Bar)  
 Gear ratio (center) ..... 22.2 : 1  
 Gear ratio (extremities) ..... 26.2 : 1  
 Minimum pump flow for 1.5 hwt/sec ..... 4.22 gpm (16 lpm)

**Power Steering Pump (with Detroit Diesel Series 60 Engine)**

Make .....TRW  
 Type .....PS Series  
 Relief valve setting .....2,175 psi (14 990 kPa)  
 Controlled flow rate .....4.23 gpm (16 lpm)  
 Inlet port .....1 1/4 NPT  
 Outlet port .....3/4-16 straight thread SAE O' ring boss conn.  
 Supplier number .....PS251615L10200  
 Prevost number .....661009  
 Gasket - Supplier number .....23516100  
 Gasket - Prevost number .....510488

**Power Steering Reservoir**

Make .....Nelson Muffler  
 Oil capacity .....4 US qts (3.7 liters)  
 Supplier number .....91410A  
 Prevost number .....660982  
 Make .....Nelson Muffler  
 Element filter - Supplier number .....83804 E  
 Element filter - Prevost number .....660987

**Steering Stabilizer Cylinder (Damper)**

Make .....Arvin  
 Extended length.....32.73±0.12"  
 Collapsed length.....20.26±0.12"  
 Stroke.....12.47±0.12"  
 Supplier number .....651535  
 Prevost number .....660979  
 Dust cap - Prevost number .....660980



# SECTION 16: SUSPENSION

## CONTENTS

|   |           |
|---|-----------|
| <b>1. DESCRIPTION .....</b>                                       | <b>5</b>  |
| <b>2. I-BEAM AXLE FRONT SUSPENSION .....</b>                      | <b>5</b>  |
| 2.1 AIR SPRINGS .....   | 5         |
| 2.1.1 <i>Inspection</i> .....                                     | 5         |
| 2.1.2 <i>Removal</i> .....  | 6         |
| 2.1.3 <i>Installation</i> .....                                   | 6         |
| 2.2 SHOCK ABSORBERS .....   | 6         |
| 2.2.1 <i>Inspection</i> .....                                     | 7         |
| 2.2.2 <i>Removal</i> .....  | 7         |
| 2.2.3 <i>Installation</i> .....                                   | 8         |
| 2.3 RADIUS RODS .....   | 8         |
| 2.3.1 <i>Inspection</i> .....                                     | 8         |
| 2.3.2 <i>Removal</i> .....  | 8         |
| 2.3.3 <i>Bushing removal</i> .....                                | 8         |
| 2.3.4 <i>Bushing installation</i> .....                           | 9         |
| 2.3.5 <i>Installation</i> .....                                   | 9         |
| 2.4 SWAY BAR .....  | 10        |
| 2.4.1 <i>Removal</i> .....  | 10        |
| 2.4.2 <i>Installation</i> .....                                   | 10        |
| <b>3. INDEPENDENT FRONT SUSPENSION (IFS) .....</b>                | <b>10</b> |
| 3.1 STEERING LINKAGE .....  | 10        |
| 3.2 POWER STEERING HYDRAULIC PUMP .....                           | 13        |
| 3.3 STEERING LINKAGE ADJUSTMENT .....                             | 13        |
| 3.4 PITMAN ARM REMOVAL .....                                      | 13        |
| 3.5 PITMAN ARM INSTALLATION .....                                 | 14        |
| 3.6 DRAG LINK .....   | 14        |
| 3.6.1 <i>Adjustment</i> .....                                     | 14        |
| 3.7 BELL CRANK AND IDLER ARM .....                                | 14        |
| 3.7.1 <i>Bell Crank and Idler Arm Removal</i> .....               | 14        |
| 3.7.2 <i>Bell crank or Idler Arm Ball Joint Disassembly</i> ..... | 15        |
| 3.7.3 <i>Bell Crank or Idler Arm Ball Joint Reassembly</i> .....  | 15        |
| 3.8 RELAY ROD .....   | 16        |
| 3.8.1 <i>Replacement</i> .....                                    | 16        |
| 3.9 TIE RODS .....  | 16        |
| 3.9.1 <i>Removal</i> .....  | 17        |
| 3.9.2 <i>Installation</i> .....                                   | 17        |
| 3.10 STEERING ARMS .....  | 17        |
| 3.10.1 <i>Removal</i> .....                                       | 17        |
| 3.10.2 <i>Installation</i> .....                                  | 17        |
| 3.11 LUBRICATION FITTINGS .....                                   | 17        |
| 3.12 BALL JOINTS .....  | 19        |
| 3.13 LOWER AND UPPER A-ARM BALL JOINT .....                       | 19        |
| 3.13.1 <i>Inspection</i> .....                                    | 19        |
| 3.13.2 <i>Stripping Down</i> .....                                | 19        |
| 3.13.3 <i>Assembly</i> .....                                      | 20        |
| 3.14 LOWER A- ARM CENTRAL BALL JOINT .....                        | 20        |
| 3.14.1 <i>Inspection</i> .....                                    | 20        |
| 3.14.2 <i>Stripping Down</i> .....                                | 20        |
| 3.14.3 <i>Assembly</i> .....                                      | 20        |
| 3.15 UPPER A-ARM CENTRAL BALL JOINT .....                         | 21        |

## Section 16: SUSPENSION

---

|           |   |           |
|-----------|---|-----------|
| 3.15.1    | Visual Inspection .....                   | 21        |
| 3.15.2    | Play Measurement .....                    | 21        |
| 3.16      | FRONT END ALIGNMENT .....                 | 21        |
| 3.16.1    | Alignment Terminology.....                | 22        |
| 3.16.2    | Front End Inspection .....                | 22        |
| 3.16.3    | Front Wheel Camber.....                   | 23        |
| 3.16.4    | Front Wheel Toe-In .....                  | 23        |
| 3.16.5    | Front Axle Caster .....                   | 23        |
| 3.16.6    | Major Damage .....                        | 25        |
| 3.17      | FRONT AIR SPRINGS .....                   | 25        |
| 3.17.1    | Inspection .....                          | 25        |
| 3.17.2    | Removal .....                             | 25        |
| 3.17.3    | Installation .....                        | 25        |
| 3.18      | SHOCK ABSORBERS.....                      | 26        |
| 3.18.1    | Shock Absorber Removal .....              | 27        |
| 3.18.2    | Shock Absorber Installation .....         | 27        |
| 3.19      | SWAY BAR.....                             | 27        |
| 3.19.1    | Removal .....                             | 27        |
| 3.19.2    | Installation .....                        | 27        |
| <b>4.</b> | <b>REAR SUSPENSION .....</b>              | <b>29</b> |
| 4.1       | AIR SPRINGS .....                         | 30        |
| 4.1.1     | Inspection .....                          | 30        |
| 4.1.2     | Removal .....                             | 30        |
| 4.1.3     | Installation .....                        | 30        |
| 4.2       | SHOCK ABSORBERS.....                      | 31        |
| 4.2.1     | Inspection .....                          | 31        |
| 4.2.2     | Removal .....                             | 32        |
| 4.2.3     | Installation .....                        | 32        |
| 4.3       | RADIUS RODS.....                          | 32        |
| 4.3.1     | Inspection .....                          | 33        |
| 4.3.2     | Removal .....                             | 33        |
| 4.3.3     | Bushing removal.....                      | 33        |
| 4.3.4     | Bushing installation .....                | 33        |
| 4.3.5     | Installation .....                        | 34        |
| <b>5.</b> | <b>SUSPENSION HEIGHT ADJUSTMENT .....</b> | <b>34</b> |
| <b>6.</b> | <b>HEIGHT CONTROL VALVE .....</b>         | <b>35</b> |
| 6.1       | MAINTENANCE .....                         | 36        |
| 6.1.1     | Removal and Installation .....            | 36        |
| <b>7.</b> | <b>AIR SYSTEM .....</b>                   | <b>36</b> |
| 7.1       | AIR TANK MAINTENANCE .....                | 36        |
| 7.1.1     | Wet Air Tank.....                         | 36        |
| 7.1.2     | Primary Air Tank.....                     | 36        |
| 7.1.3     | Secondary Air Tank.....                   | 36        |
| 7.1.4     | Accessory Air Tank .....                  | 38        |
| 7.1.5     | Expansion Air Tank .....                  | 38        |
| 7.2       | EMERGENCY FILL VALVES .....               | 38        |
| <b>8.</b> | <b>HUB UNIT AND SWIVEL ASSEMBLY .....</b> | <b>38</b> |
| <b>9.</b> | <b>FRONT KNEELING SYSTEM .....</b>        | <b>39</b> |
| 9.1       | PRINCIPLE OF OPERATION .....              | 39        |
| 9.2       | MAINTENANCE .....                         | 39        |

|            |  |           |
|------------|--|-----------|
| 9.3        | BELLOWS CONTROL SOLENOID VALVES .....      | 39        |
| 9.3.1      | <i>Removal and installation</i> .....      | 39        |
| <b>10.</b> | <b>HIGH-BUOY SYSTEM</b> .....              | <b>39</b> |
| 10.1       | PRINCIPLES OF OPERATION .....              | 39        |
| 10.2       | MAINTENANCE .....                          | 40        |
| 10.3       | HIGH-BUOY – PRESSURE REGULATING VALVE..... | 40        |
| 10.3.1     | <i>Adjustment</i> .....                    | 40        |
| 10.3.2     | <i>Disassembly</i> .....                   | 40        |
| 10.3.3     | <i>Cleaning</i> .....                      | 40        |
| 10.3.4     | <i>Reassembly</i> .....                    | 40        |
| <b>11.</b> | <b>LOW-BUOY SYSTEM</b> .....               | <b>41</b> |
| 11.1       | PRINCIPLES OF OPERATION .....              | 41        |
| 11.2       | MAINTENANCE .....                          | 41        |
| <b>12.</b> | <b>TROUBLESHOOTING</b> .....               | <b>41</b> |
| <b>13.</b> | <b>PARTS SPECIFICATIONS</b> .....          | <b>42</b> |
| <b>14.</b> | <b>TORQUE SPECIFICATIONS</b> .....         | <b>43</b> |

## ILLUSTRATIONS

|            |   |    |
|------------|---|----|
| FIGURE 1:  | FRONT SUSPENSION COMPONENTS .....           | 5  |
| FIGURE 2:  | DETAILS OF FRONT SUSPENSION .....           | 5  |
| FIGURE 3:  | AIR SPRING.....                             | 5  |
| FIGURE 4:  | SHOCK ABSORBER .....                        | 7  |
| FIGURE 5:  | TYPICAL SHOCK ABSORBER SETUP .....          | 8  |
| FIGURE 6:  | TYPICAL RADIUS ROD SETUP .....              | 8  |
| FIGURE 7:  | RADIUS ROD BUSHING REMOVAL.....             | 9  |
| FIGURE 8:  | RADIUS ROD BUSHING INSTALLATION .....       | 9  |
| FIGURE 9:  | RADIUS ROD INSTALLATION .....               | 9  |
| FIGURE 10: | I-BEAM FRONT AXLE SWAY BAR .....            | 10 |
| FIGURE 11: | SUSPENSION AND STEERING LINKAGE.....        | 11 |
| FIGURE 12: | LOCATION OF CLAMPS .....                    | 12 |
| FIGURE 13: | CLAMP POSITIONING.....                      | 12 |
| FIGURE 14: | CLAMP POSITIONING.....                      | 12 |
| FIGURE 15: | CLAMP POSITIONING.....                      | 13 |
| FIGURE 16: | CLAMP POSITIONING.....                      | 13 |
| FIGURE 17: | PITMAN ARM ALIGNMENT.....                   | 13 |
| FIGURE 18: | FIXING NUT PUNCH MARK.....                  | 14 |
| FIGURE 19: | BELL CRANK .....                            | 15 |
| FIGURE 20: | BELL CRANK .....                            | 15 |
| FIGURE 21: | BELL CRANK AND IDLER ARM BALL JOINT .....   | 16 |
| FIGURE 22: | LUBRICATION FITTINGS' LOCATION DIAGRAM..... | 18 |
| FIGURE 23: | BALL JOINTS LOCATION.....                   | 19 |
| FIGURE 24: | A-ARM BALL JOINTS.....                      | 19 |
| FIGURE 25: | LOWER A-ARM BALL JOINTS .....               | 20 |
| FIGURE 26: | UPPER A-ARM BALL JOINTS .....               | 20 |
| FIGURE 27: | LOWER A-ARM CENTRAL BALL JOINT .....        | 21 |
| FIGURE 28: | UPPER A-ARM CENTRAL BALL JOINT.....         | 21 |

## Section 16: SUSPENSION

---

|   |    |
|---|----|
| FIGURE 29: STEERING LINKAGE MEASURE .....                   | 22 |
| FIGURE 30: FRONT END ALIGNMENT DIAGRAM.....                 | 24 |
| FIGURE 31: AIR SPRINGS .....                                | 25 |
| FIGURE 32: AIR SPRING AND SHOCK ABSORBER .....              | 26 |
| FIGURE 33: SHOCK ABSORBER .....                             | 27 |
| FIGURE 34: SWAY BAR (FRONT SUSPENSION) .....                | 28 |
| FIGURE 35: SWAY BAR (REAR SUSPENSION) .....                 | 28 |
| FIGURE 36: REAR SUSPENSION COMPONENTS .....                 | 29 |
| FIGURE 37: DETAILS OF REAR SUSPENSION .....                 | 29 |
| FIGURE 38: TAG AXLE SUSPENSION .....                        | 29 |
| FIGURE 39: AIR SPRING.....                                  | 30 |
| FIGURE 40: SHOCK ABSORBER .....                             | 32 |
| FIGURE 41: TYPICAL SHOCK ABSORBER SETUP .....               | 32 |
| FIGURE 42: TYPICAL RADIUS ROD SETUP .....                   | 32 |
| FIGURE 43: RADIUS ROD BUSHING REMOVAL.....                  | 33 |
| FIGURE 44: RADIUS ROD BUSHING INSTALLATION .....            | 33 |
| FIGURE 45: RADIUS ROD INSTALLATION .....                    | 34 |
| FIGURE 46: TYPICAL AIR SPRING CLEARANCE .....               | 34 |
| FIGURE 47: FRONT HEIGHT CONTROL VALVE.....                  | 35 |
| FIGURE 48: REAR HEIGHT CONTROL VALVE.....                   | 35 |
| FIGURE 49: IFS AIR TANKS LOCATION .....                     | 37 |
| FIGURE 50: I-BEAM FRONT SUSPENSION AIR TANKS LOCATION ..... | 37 |
| FIGURE 51: REAR VALVE LOCATION .....                        | 38 |
| FIGURE 52: FRONT VALVE LOCATION.....                        | 38 |
| FIGURE 53: REGULATING VALVE.....                            | 40 |

## 1. DESCRIPTION

The vehicle is provided with an air suspension system. The system consists of air springs, height control valves, radius rods, sway bars, tripod and shock absorbers (Fig. 1, 2, 11, 36, 37 and 38). The system operation is fully automatic and maintains a constant vehicle height regardless of load, or load distribution.

The vehicle can also be equipped with systems such as:

- Front Kneeling (w/ Front High-Buoy);
- Front Kneeling (w/ Full High-Buoy);
- Front Kneeling (w/ Front High-Buoy) and Low-Buoy Combination;
- Front Kneeling (w/ Full High-Buoy) and Low-Buoy Combination;

## 2. I-BEAM AXLE FRONT SUSPENSION

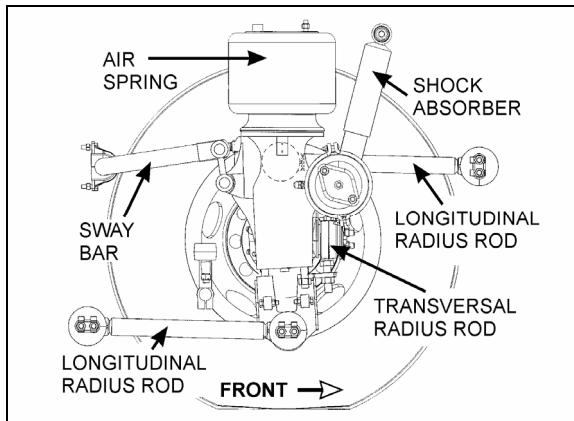


FIGURE 1: FRONT SUSPENSION COMPONENTS 16096

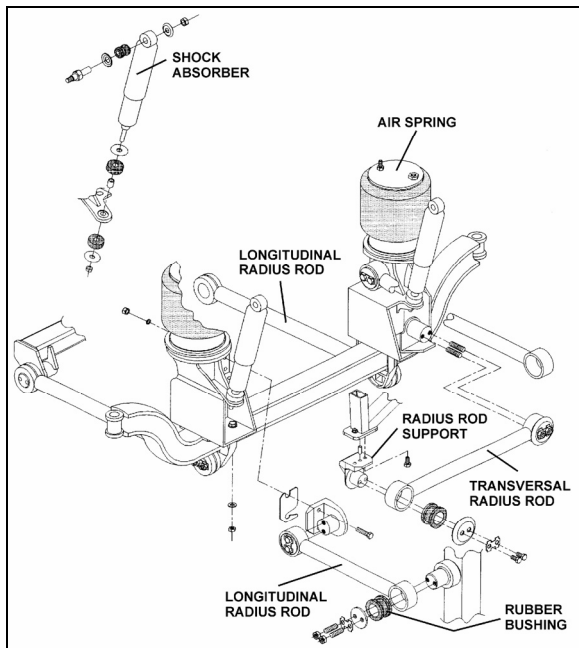


FIGURE 2: DETAILS OF FRONT SUSPENSION 16110

### 2.1 AIR SPRINGS

The air springs are made from a special compound rubber molded to the proper contour and dimensions. The entire vertical load of the vehicle is supported by these springs. The I-beam front axle is provided with air springs that are attached to the subframe and to the axle (Fig. 3).

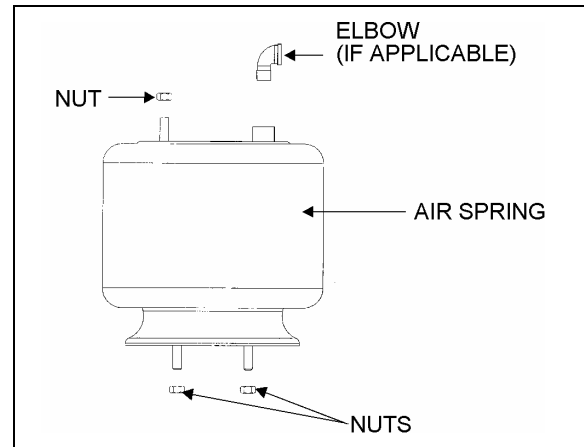


FIGURE 3: AIR SPRING 16052

#### 2.1.1 Inspection

1. Check operation of bellows.
2. Visually inspect bellows for evidence of cracks, punctures, deterioration, or chafing. Replace the bellows if any damage is evident.
3. With the primary air system at normal operating pressure (95 - 125 psi (655 - 860 kPa)), coat all suspension air line connections and bellows mounting areas with a water and soap solution. Bubbles will indicate an air leak, and none is

## Section 16: SUSPENSION

permissible. Repair or replace defective parts.

### **NOTE**

*If air spring is removed from vehicle, bellows can be lightly inflated and submerged in water to detect any leakage. If any leakage is detected, replace bellows.*



### **WARNING**

To prevent personal injury, do not apply more than 10 psi (69 kPa) of air pressure to the uninstalled air spring.

### 2.1.2 Removal

#### **NOTE**

*Front suspension air springs can be removed without removing the entire axle assembly.*

1. Safely support vehicle at the recommended body jacking points. To gain access to a given air spring, the corresponding wheel can be removed as follows.
  - a) Jack vehicle until the tire clears the ground, and place safety supports underneath body.



### **CAUTION**

Only the recommended jacking points must be used as outlined in Section 18, "Body".

- b) Support the axle with a suitable hydraulic floor jack at the recommended jacking point.
  - c) Remove wheel.
2. Exhaust compressed air from accessory air tank by opening drain cock under reservoir.
  3. Disconnect the height control valve link and pull down the overtravel lever to ensure all air is exhausted from air springs.

#### **NOTE**

*While performing this step, do not change the height control valve overtravel lever adjustment.*

4. Disconnect air line from air spring, remove elbow (if applicable), and cover both the line end and fitting to prevent the entry of foreign matter.

5. Remove the air spring upper nut, and then the two lower nuts. Remove air spring.

### 2.1.3 Installation

1. Compress air spring as necessary, then aligning studs with their holes, position air spring between both the lower and upper supports. Thread the lower nuts and the small upper nut a few turns.

#### **NOTE**

*To facilitate air spring installation, compress it manually then put a piece of tape over the air line threaded fitting. This prevents air from getting back into the bag and keeps it compressed, thus enabling to place the bag in between the mounting plates and greatly easing installation.*

2. Tighten and torque the lower stud nuts, and then the upper one to 20 – 25 lbf-ft (27 – 34 Nm).
3. Thread the remaining upper nut (large nut) and tighten to 20 – 25 lbf-ft (27 – 34 Nm).
4. Install elbow (if applicable), then connect air line.
5. Connect the height control valve link.
6. Build up air pressure in system.

#### **NOTE**

*To accelerate this operation, air reservoirs can be filled from an exterior air supply connected to the accessory tank fill valve or to the emergency fill valve.*


7. Check operation of bellows, and with the primary air system at normal operating pressure (95 – 125 psi (655 – 860 kPa)), coat the air line connections and air spring mounting areas with a water and soap solution. Bubbles will indicate an air leak, and none is permissible. Repair or replace defective parts.
8. Reinstall wheel.
9. Remove the hydraulic floor jack from under the axle, then lower vehicle to ground.

## 2.2 SHOCK ABSORBERS

Double-action, telescoping-type shock absorbers ensure a smooth ride and enhance vehicle stability on the road. All shock absorbers

are eye-type mountings. The front axle is provided with two shock absorbers (Fig. 1, 2, and 4).

Shock absorbers are non-adjustable and non-repairable. Maintenance requirements involve replacement of the rubber mounting bushings, and tightening of all shock absorber pins at the proper torque of 500 - 550 lbf-ft (680 - 750 Nm) when shock absorber replacement occurs. If a shock absorber becomes inoperative, complete unit must be replaced.

|   |                  |
|---|------------------|
|    | <h2>CAUTION</h2> |
| <p>When a shock absorber is found defective, always replace with a new set on affected axle, except if there has been a recent replacement of one unit. The following method will help in determining if both shock absorbers on the same axle have to be replaced.</p> |                  |


### 2.2.1 Inspection

Loosen lower mounting of both shocks, and then carefully attempt to raise and lower the bottom portion of each shock. Note the rate of effort for distance of travel. Replace both shocks if a definite differential rate is found.

The shock must be bench checked in an upright, vertical position. If checked in any other position, air will enter the cylinder tube and make the shock absorber appear defective.

Proceed as follows to check shock absorbers:

1. With the shock absorber in a vertical position (top end up), clamp the bottom mount in a vise.

|   |                  |
|---|------------------|
|  | <h2>CAUTION</h2> |
| <p>Do not clamp the reservoir tube or the dust tube.</p>                            |                  |

2. Rotate the dust tube. Notice any binding condition (may be compared with new unit). Binding condition indicates a scored rod. Units with scored rods should be replaced.
3. Fully extend shocks and check for leaks in the seal cover area. Shock fluid is a very thin hydraulic fluid that has a characteristic odor and dark brown tint. A slight trace of shock fluid around the seal cover area is not a cause for replacement. The shock seal is

designed to permit a very slight seepage to lubricate the rod. Units that leak should be replaced.

4. Visually check shock for dents that could cause the shock to bind. Also, check for a bent rod.
5. Extend and collapse shock several times to determine that it has control (resistance) in both rebound and compression.
6. Visually inspect the shock mountings and vehicle mounting for:
  - a. Broken mounts;
  - b. Extreme bushing wear;
  - c. Shifted bushing or sleeve;
  - d. Deep cracks in bushing material (shallow surface cracks are normal);
  - e. Loose shock absorber pins;
  - f. Presence of convex washers, and their position relative to the rubber bushing.

### 2.2.2 Removal

1. Remove nuts and washers from shock absorbers on upper and lower mounting pins, taking care to identify the inner and outer washers to ease reinstallation. Refer to figure 4 for details.
2. Remove the shock absorber assembly from pins.
3. Remove the two inner bushings from the shock absorber and discard them.

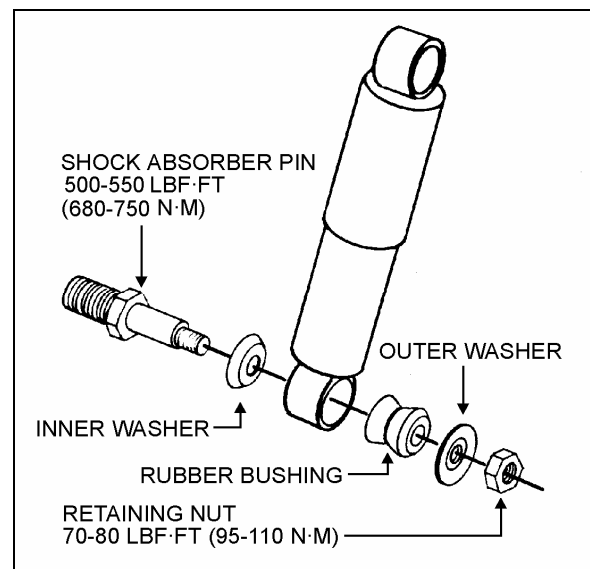


FIGURE 4: SHOCK ABSORBER

16008

## Section 16: SUSPENSION

### 2.2.3 Installation

1. Ensure that the shock absorber mounting pins are tight and that the threads are not stripped.
2. Install new rubber mounting bushings on shock absorbers (upper and lower).
3. Place the inner washers (with washer convex side facing the shock absorber rubber bushing) on each shock absorber pin (Fig. 5).
4. Install the shock absorber eyes over the mounting pins, then the outer washers (with washer convex side facing the shock absorber rubber bushing) on each shock absorber extremity.

#### **NOTE**

*If shock absorber pins are removed, they must be reinstalled using "loctite" (see "Parts Specifications" in this section).*

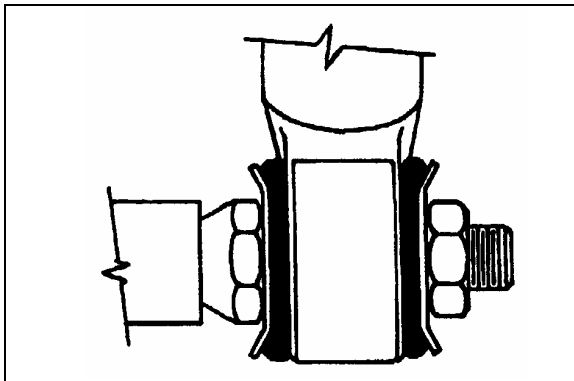


FIGURE 5: TYPICAL SHOCK ABSORBER SETUP 16009

5. Place the lower and upper mounting pin stud nuts and torque to 70 - 80 lbf-ft (95 - 110 Nm).

### 2.3 RADIUS RODS

Radius rods are used to secure the axles in the proper transversal and longitudinal positions. Four radius rods are provided on the front axle suspension (three longitudinal and one transversal). Refer to figures 1, 2 and 6 for details. These rods transmit both braking and driving forces from the axles to the vehicle body.

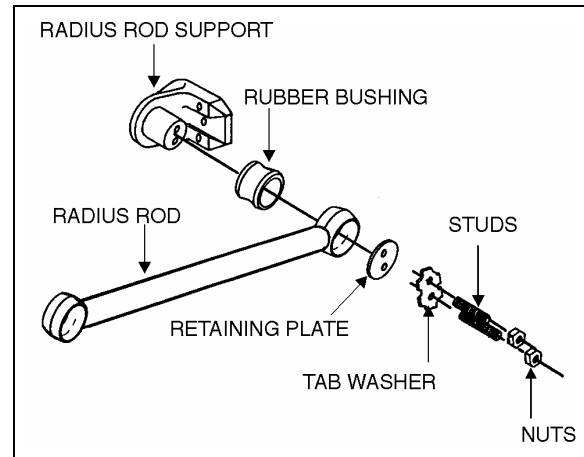


FIGURE 6: TYPICAL RADIUS ROD SETUP

16010

#### 2.3.1 Inspection

The following instructions apply to all radius rods used on this vehicle:

1. Clean all parts thoroughly.
2. Inspect radius rods for distortion and cracks. We recommend the "Magnaflux" process to detect cracks in the radius rod. Any damaged part should be replaced with a new one.

#### **NOTE**

*New bushings should be used when rods are replaced.*

3. The radius rod bushings should be checked periodically for signs of shearing, deterioration, or damage. Any defective part should be replaced with a new one.

#### 2.3.2 Removal

1. Flatten the tab washer which secures the two retaining nuts (or bolts), then unscrew the nuts (or bolts) at each extremity of the radius rod (Fig. 6).
2. Remove the tab washer and the retaining plates and radius rod ends from anchor pins, and then remove the radius rod.

#### 2.3.3 Bushing removal

1. Safely support the radius rod as shown in figure 7.



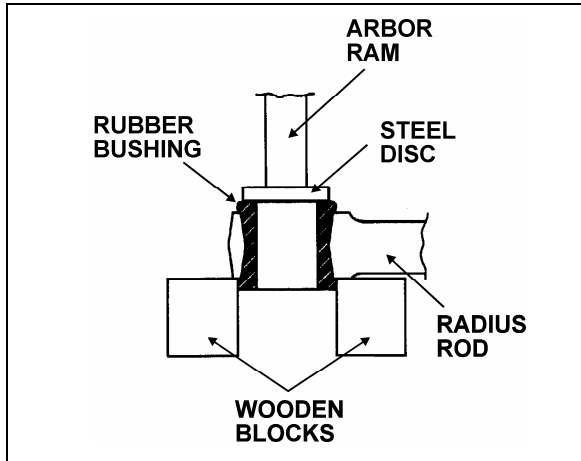


FIGURE 7: RADIUS ROD BUSHING REMOVAL 16011

2. Place a flat steel disc, slightly smaller than the outside diameter of the bushing (Fig. 7).
3. Using an arbor press or a suitable driving tool, press or drive the old bushing out of the rod and discard the bushing.

**CAUTION**

Make sure to prevent the steel disc from contacting the radius rod end.

### 2.3.4 Bushing installation

1. Lightly spray the inner and outer surfaces of radius rod bushing with water.

**CAUTION**

No lubricant whatsoever is to be used on the rubber bushing.

2. Safely support the radius rod, and place new bushing on top of the radius rod end (Fig. 8).
3. Place a block of wood on top of bushing and press on it manually.
4. If necessary, use an arbor press or a suitable driving tool. Press or drive the bushing into the radius rod end until it extends equally on both sides of the rod.
5. It is also possible to proceed differently. Place radius rod bushing on a plane surface. Spray a light coat of water on the inner and outer surfaces of radius rod bushing.
6. Take radius rod, align the bushing. Tap radius rod on bushing until latter is positioned correctly.

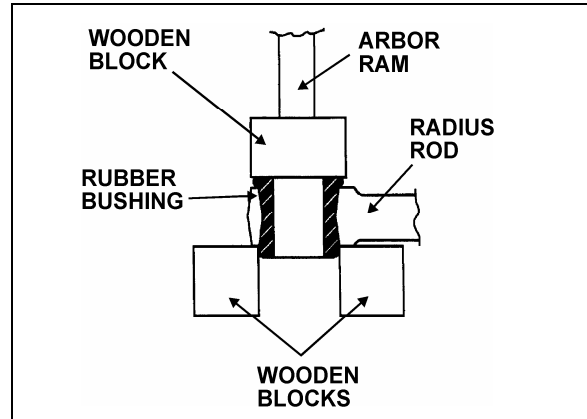


FIGURE 8: RADIUS ROD BUSHING INSTALLATION 16012

### 2.3.5 Installation

1. Lightly spray the radius rod support with water. Place the radius rod end over the radius rod support (Fig. 9).
2. Position the retaining plate. Install the tab washer and nuts (or bolts).

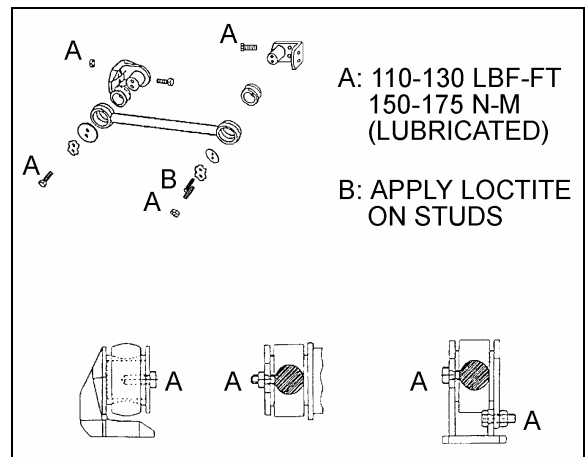


FIGURE 9: RADIUS ROD INSTALLATION 16028

**CAUTION**

Always use new tab washers at installation.

3. Tighten the nuts (or bolts) lightly, and repeat at the other end.
4. Refer to heading "Suspension Height Adjustment" later in this section, and set the vehicle to normal ride height.
5. With the vehicle at normal ride height, apply oil on threads and tighten all radius rod anchor pin nuts or bolts to 110 – 130 lbf-ft (150 – 175 Nm).

## Section 16: SUSPENSION



### CAUTION

It is extremely important upon reconnection of the rods that the proper clearance height between the axle and body be maintained. Otherwise, the rubber bushings in radius rod ends will become preloaded, thus reducing their life span.

### 2.4 SWAY BAR

A sway bar is provided on the front axle to increase vehicle stability. It controls lateral motion (swaying movement) of the vehicle (Fig. 10).

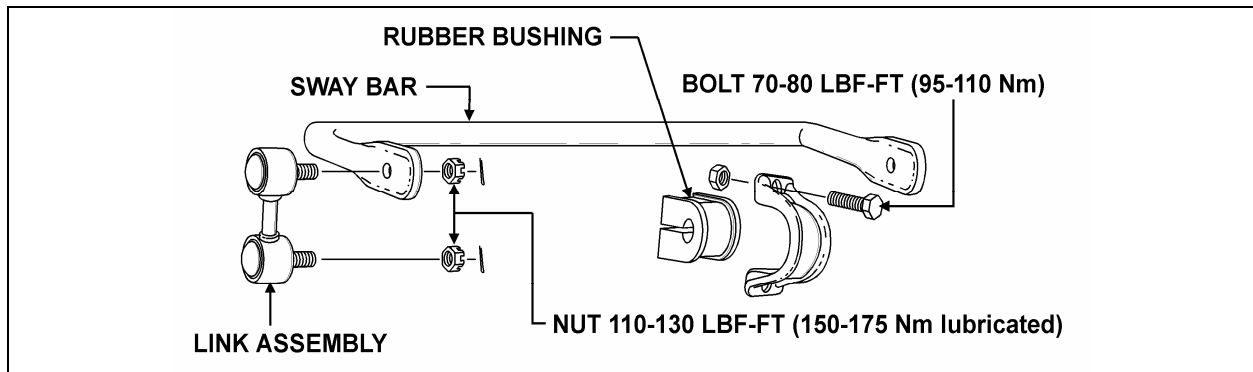


FIGURE 10: I-BEAM FRONT AXLE SWAY BAR

16099

#### 2.4.1 Removal

1. Disconnect the two links from sway bar.
2. Safely support the sway bar. Unbolt the four bushing collars from subframe.
3. Remove sway bar.

#### NOTE

*Sway bar bushings are slitted to ease their removal.*

#### 2.4.2 Installation

1. Loosely install the sway bar.
2. Tighten the eight bushing collar nuts to 70 - 80 lbf-ft (95 - 110 Nm) (Fig. 10).
3. Install two sway bar link upper and lower nuts and tighten to 100 - 130 lbf-ft (150 - 175 Nm) (Fig. 10).
4. Install a cotter pin on each nut and bend.

## 3. INDEPENDENT FRONT SUSPENSION (IFS)

### 3.1 STEERING LINKAGE

Turning motion of the steering wheel is transferred by the steering gear and steering linkage to the steering arms at the right and left front wheels. The steering linkage consists of tie rods connected to the bell crank and the steering arm at the left side of the coach, and to the idler arm and steering arm at the right side of the coach. The bell crank and idler arm are connected by a relay rod. A drag link connected to the bell crank and the pitman arm, which is mounted to the steering gear, transfers the turning motion of the steering wheel to the steering arms (Fig. 11).

Lower and upper A-arms are widely spaced. They are mounted on ball joints. Torque rods prevent rotation of the uprights around the lower and upper ball joints.

If the steering linkage is bent, twisted or worn, steering action of the coach will be seriously affected. Any time steering linkage components are replaced or adjusted, steering geometry and front wheel alignment must be checked as explained in this section.

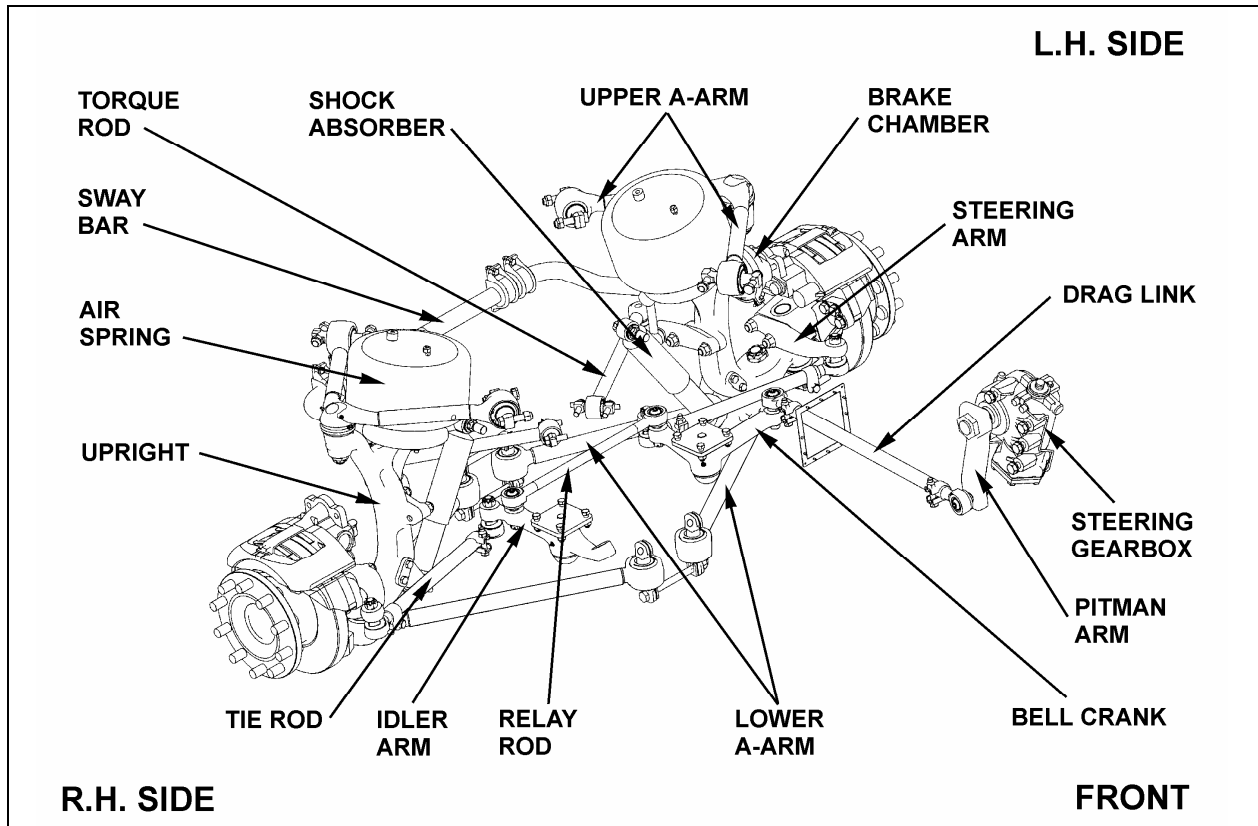


FIGURE 11: SUSPENSION AND STEERING LINKAGE

16125

### Turning Angle

The maximum turning angle is set mechanically through the two steering stop screws installed on the swivel assembly. The turning angle ( $58^{\circ} + 0^{\circ} - 1^{\circ}$ ) mechanical stop is factory adjusted to accommodate the chassis design, and therefore, does not require adjustment on new vehicles.

However, turning angle should be checked and adjusted hydraulically, if necessary, any time a component of the steering system is repaired, disassembled or adjusted.

Before checking the turning angle, be sure the front end is properly aligned as described under paragraph "3.16 Front End Alignment" in this supplement.

To check steering maximum turning angle, proceed with the following method:

1. Check if front tires rub against the frame or if the steering gear has been serviced.



### CAUTION

If clamps are not correctly installed, they can interfere with other parts.

2. For a full left and right turn, check clamps' position and for interfering parts. Refer to figures 12 to 16 for location and positioning of clamps. If readjustment is required, make the proper adjustment.

### NOTE

*Prior to steering limiter adjustment, verify vehicle wheel alignment, and ensure that oil level is adequate and that air bleeding is done.*

3. If necessary readjust steering limiter. Refer to "ZF-SERVOCOM Repair Manual" annexed to Section 14 of Maintenance Manual, "Steering", under heading: "Setting and Functional Test".

Section 16 : SUSPENSION

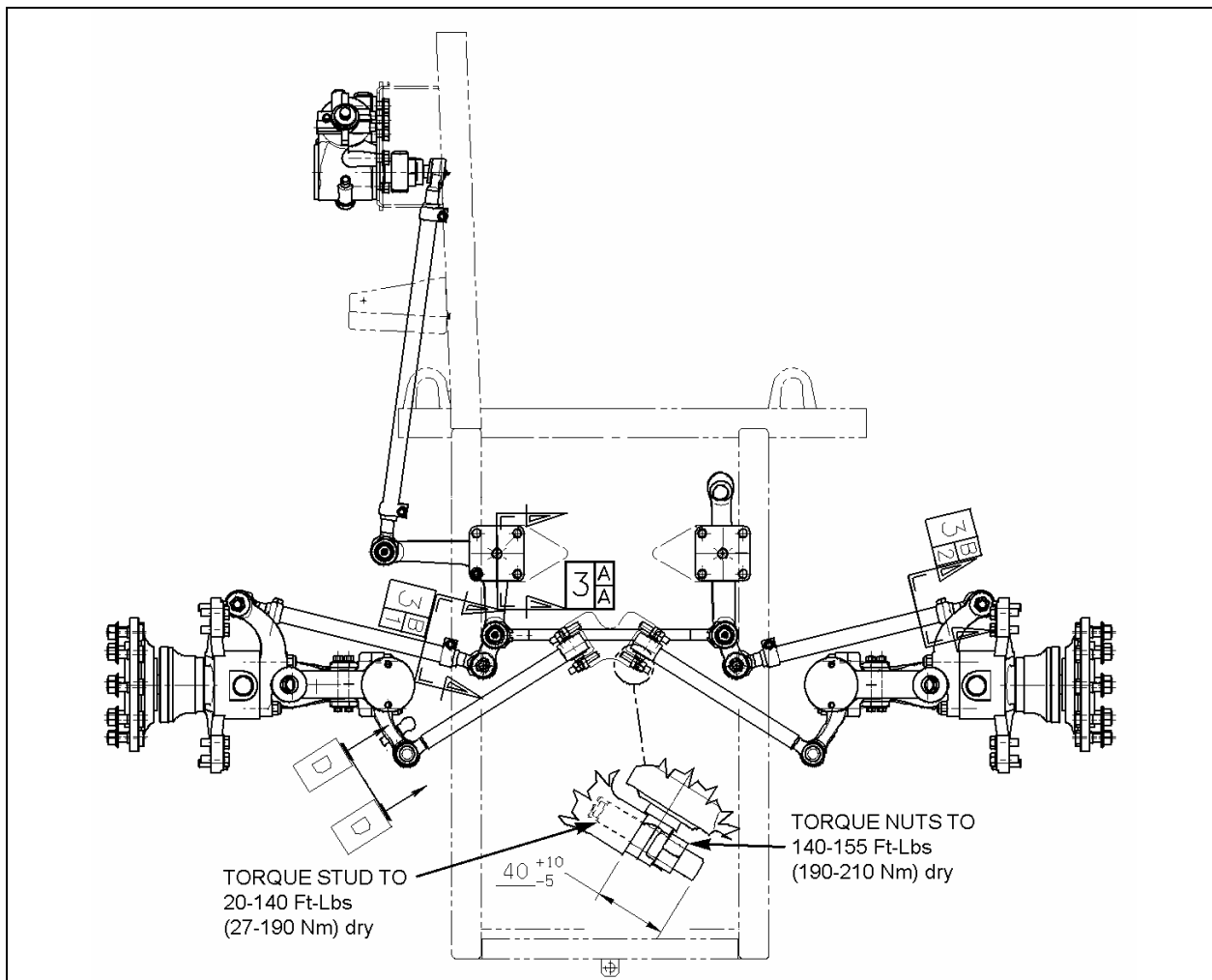


FIGURE 12: LOCATION OF CLAMPS

16168

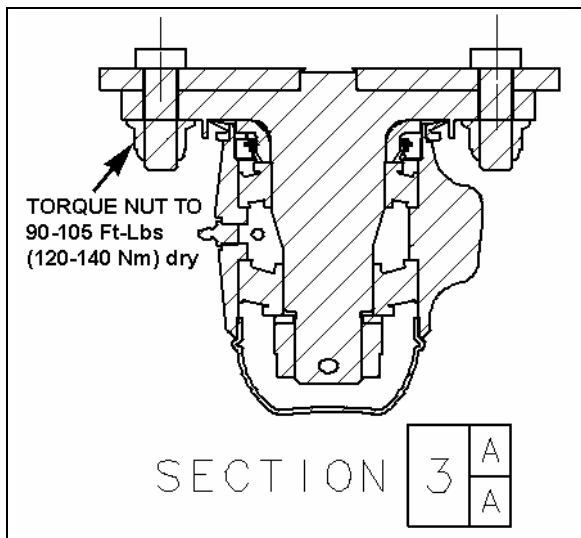


FIGURE 13: CLAMP POSITIONING

16169

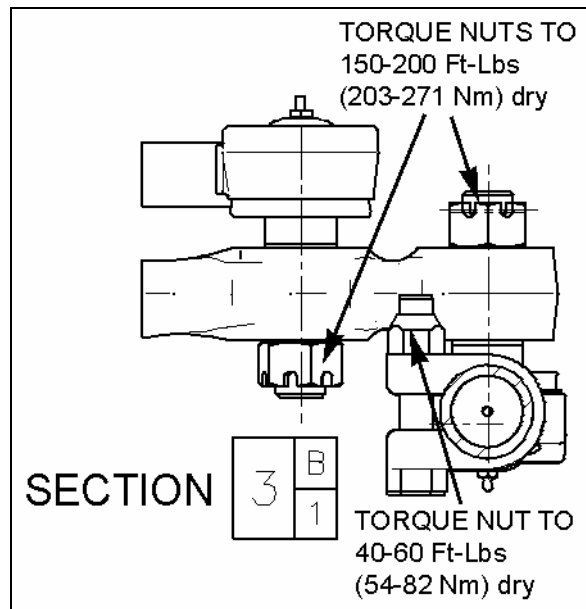


FIGURE 14: CLAMP POSITIONING

16170

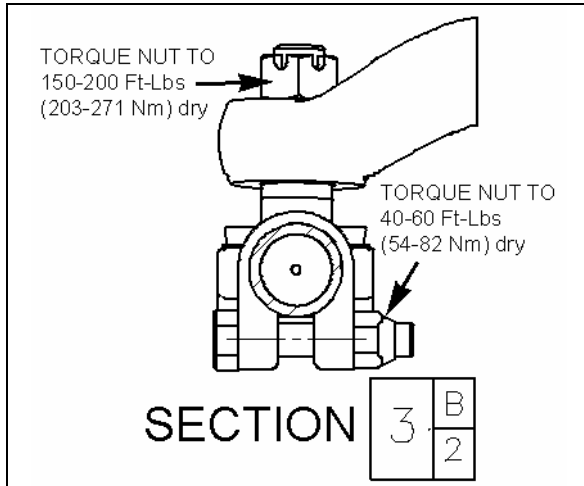


FIGURE 15: CLAMP POSITIONING 16171

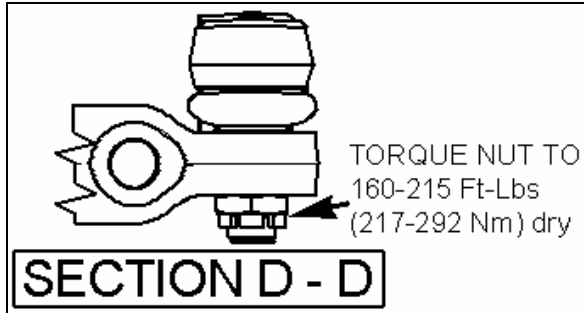


FIGURE 16: CLAMP POSITIONING 16172

### 3.2 POWER STEERING HYDRAULIC PUMP

Refer to the "TRW Power Steering Pump Service Manual" annexed at the end of Section 14.

### 3.3 STEERING LINKAGE ADJUSTMENT

**NOTE**

Whenever a steering linkage component has been removed and replaced, check steering geometry and front end alignment as directed in this Section. Check to insure that all stud nuts and mounting bolts and nuts have been tightened to proper torques listed under "14. Torque Specifications" at the end of this section.

1. First, align input shaft marks.
2. Afterwards, the pitman arm should be adjusted with reference mark aligned or to an angle of 90° in relation with the horizontal axis (Fig. 17).
3. Locate centerline of vehicle then install relay rod in boss at steering bell crank and idler arm. Align center of relay rod with centerline of vehicle.

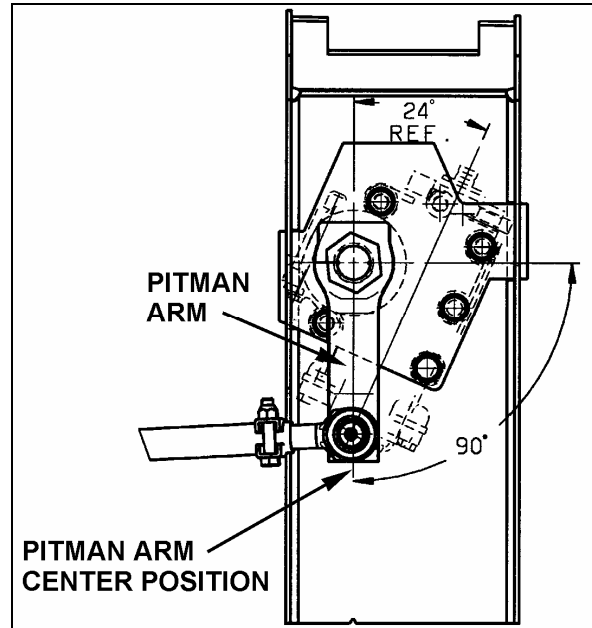


FIGURE 17: PITMAN ARM ALIGNMENT 14057

4. Install drag link to pitman arm and adjust opposite end of drag link to fit mounting stud hole in bell crank.
5. Install tie rods, and then adjust toe-in as per "Front End Alignment" in this Section.

### 3.4 PITMAN ARM REMOVAL

1. Remove cotter pin, nut and washer from drag link ball stud at pitman arm.
2. Disconnect drag link from pitman arm, using jaw style pullers (pressure screw type).



**WARNING**

Always wear approved eye protection when operating pullers.



**CAUTION**

Do not drive pitman arm on or off pitman shaft as this can damage the steering gear.



**CAUTION**

Heating of components to aid in disassembly is not allowed because it has a detrimental effect on axle components and steering linkages.

3. Remove pitman arm fixing nut.

## Section 16 : SUSPENSION

4. Check the radial position of the pitman arm in relation to the sector shaft prior to removal of pitman arm.
5. Add reference marks to the arm and shaft if necessary to ensure correct alignment at reassembly.
6. Use a puller to remove pitman arm.

### 3.5 PITMAN ARM INSTALLATION

1. Position pitman arm on sector gear shaft with reference marks aligned.
2. Install fixing nut. Tighten nut to 400-450 lbf-ft (545-610 Nm).

#### **NOTE**

Use a new nut if the previously removed nut was punched.

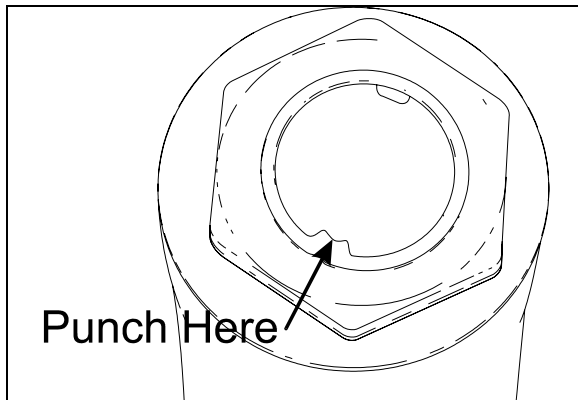


FIGURE 18: FIXING NUT PUNCH MARK 16098



#### **CAUTION**

Lock nut with sector shaft using a punch mark into the groove (Refer to figure 18).

3. Connect drag link to pitman arm. Install washers. Tighten nut to 160-215 lbf-ft (220-290 Nm). Advance nut to next alignment cotter pin slot and install a new cotter pin.

### 3.6 DRAG LINK

Drag link assembly consists of three parts; a drag link and two end assemblies. Both end assemblies are identical and they are retained on the drag link with a clamp bolt and nut.

Stud nuts at the pitman arm and bell crank ends of the drag link must be kept tight or hole at ball stud end of drag link and hole in pitman arm may become enlarged as a result of excessive looseness. Subsequent tightening of stud nuts

may draw studs too far into holes and dust cover parts may become damaged which can result in component failure.

Drag link end sockets are equipped with lubrication fittings and should be lubricated as directed in "Lubrication Fittings" in this section.

### 3.6.1 Adjustment

It should not be necessary to alter the length of the drag link except when a new link is installed or when removable end assembly has been replaced. If drag link adjustment is necessary, proceed as follows:

1. Position front wheels in straight ahead position.
2. Center steering gear as previously explained in paragraph "3.3 Steering Linkage Adjustment".
3. Remove cotter pin and stud from drag link at bell crank. Locate centerline of vehicle and center of relay rod. With center of relay rod aligned with centerline of vehicle, loosen clamp bolt at socket end (bell crank end) of drag link and adjust length of socket end assembly to fit in boss of bell crank.

#### **NOTE**

Do not change position of pitman arm.

4. Install stud nut and torque to 160 lbf-ft (220 Nm). Align nut with cotter pin slot (tighten) and install a new cotter pin.
5. Torque mounting clamp bolt nut to 40-60 lbf-ft (55-80 Nm), then test the adjustment. Front wheels should turn from right to left extremities without noticeable binding at drag link ends.

### 3.7 BELL CRANK AND IDLER ARM

Bell crank and idler arm are equipped with one lubrication fitting and should be lubricated as directed in paragraph "3.11 Lubrication Fittings" of this Section.

#### 3.7.1 Bell Crank and Idler Arm Removal

#### **NOTE**

Use a piece of wire to anchor loosen end of relay rod and tie rod in order to prevent placing an excessive load on opposite socket end.

**Bell crank:** Disconnect drag link, tie rod and relay rod from bell crank by removing cotter pins, stud nuts and washers from ball studs. Separate socket assemblies from the bell crank.

**Idler arm:** Remove cotter pins, nuts and washers from ball studs connecting relay rod and tie rod to idler arm. Separate socket assemblies from idler arm.

Remove nuts and washers from bolt attaching bell crank or idler arm mounting bracket to vehicle understructure. Remove bell crank or idler arm mounting bracket.

**3.7.2 Bell crank or Idler Arm Ball Joint Disassembly**

1. Remove adjacent link assemblies from bell crank or idler arm as previously described.
2. Remove the cap (Fig.21).
3. Remove the cotter pin, nut and tongue washer. Remove bearings, grease seal, bearing bushing and the bell crank or idler arm from its mounting bracket stud (Fig. 21).

**3.7.3 Bell Crank or Idler Arm Ball Joint Reassembly**

**NOTE**  
For bearing installation use tool Prévost # 110684.

1. Install bearing bushing on bell crank or idler arm mounting bracket stud.
2. Install bearing and grease seal in bell crank or idler arm eye (Fig. 21).

**NOTE**  
Install grease seal according to figure 21. Grease must be able to exit the bell crank or idler arm mechanism. For grease seal installation use tool Prévost # 110683.

3. Install bell crank or idler arm on its mounting bracket stud (Fig. 21).
4. Install bearing and nut.

**NOTE**  
Apply grease on bearing before installation.

5. Firmly tighten nut (Fig. 19).
6. Unscrew nut until bell crank or idler arm starts to turn by the application of 1 to 3 pounds load (Fig. 20).

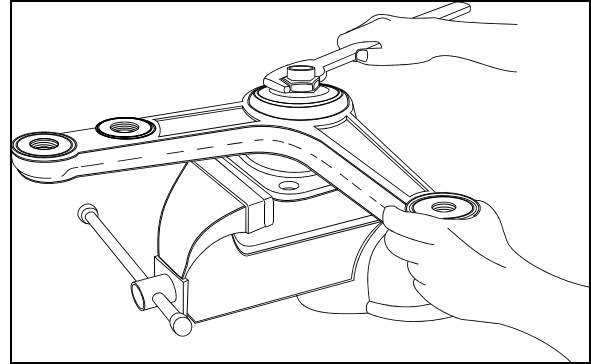


FIGURE 19: BELL CRANK 16044

7. Check for loose bearings by applying an up and down load on bell crank or idler lever (Fig. 20). The lever is not supposed to move in the vertical axis direction.

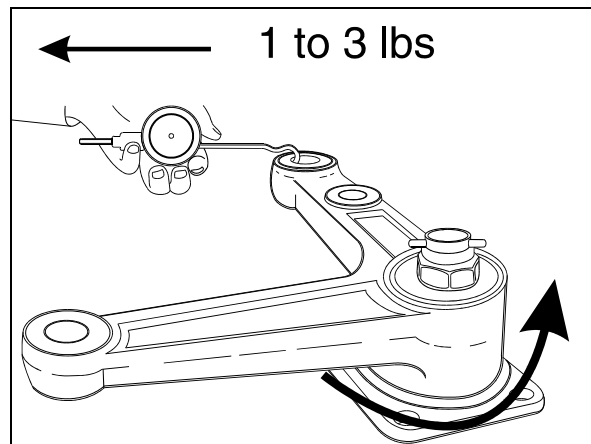


FIGURE 20: BELL CRANK 16045

8. Align nut with cotter pin slot (tighten) and install a new cotter pin.

**NOTE**  
Bend cotter pin around the nut (Fig. 21). Do not bend the cotter pin in the direction of the cap, because it may interfere with the cap.

9. Install the cap.
10. **Bell crank:** Install drag link, tie rod and relay rod as directed herein under each specific subject.
11. **Idler arm:** Install tie rod and relay rod as directed herein under each specific subject.
12. Adjust turning angle as previously directed under paragraph "Turning Angle" and check front end alignment as specified in paragraph "3.16. Front End Alignment" of this section.

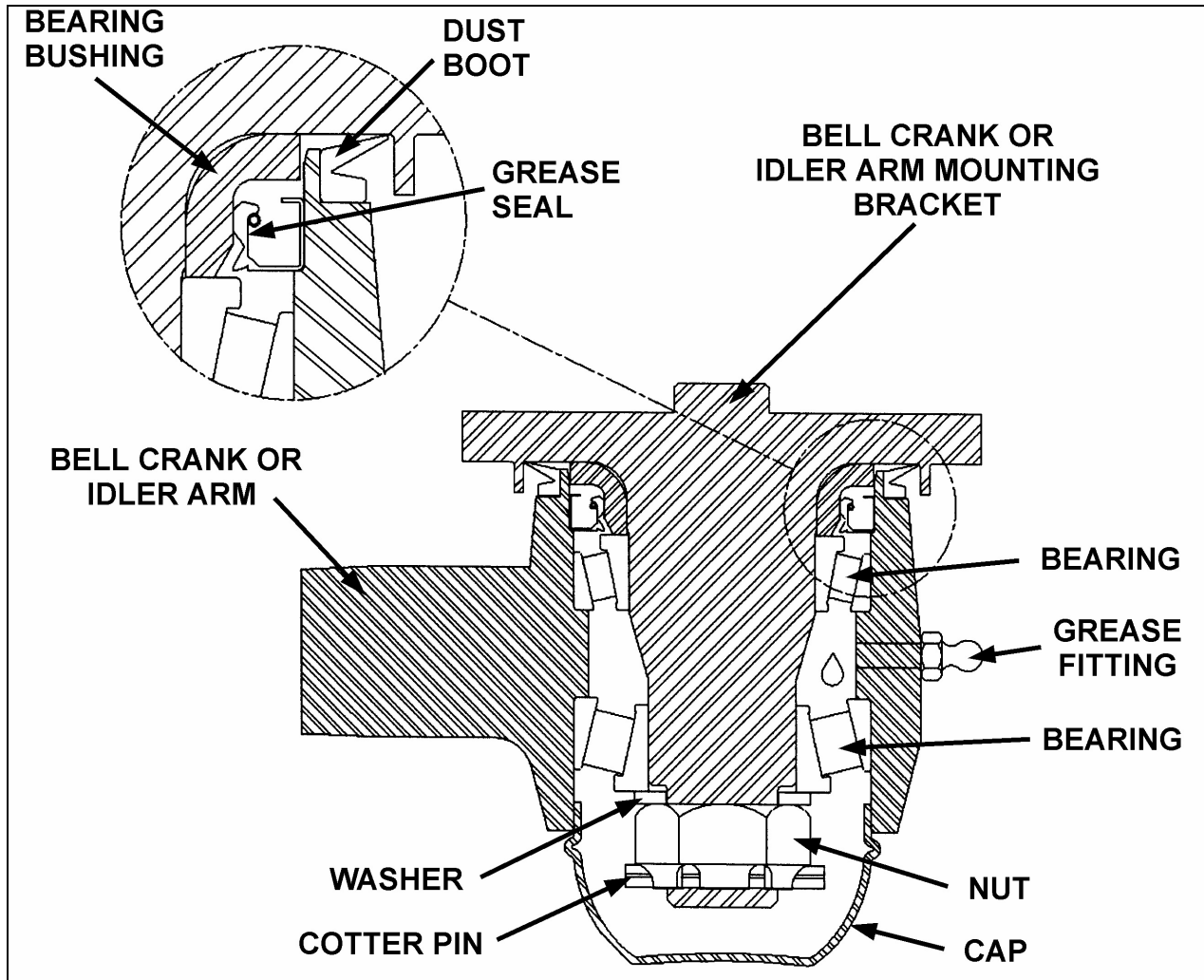


FIGURE 21: BELL CRANK AND IDLER ARM BALL JOINT

16109

### 3.8 RELAY ROD

Relay rod ends are equipped with lubrication fittings and should be lubricated as directed in paragraph "3.11 Lubrication Fittings" in this section.

**NOTE**

*The relay rod is crimped in place and it is not possible to remove the ball joints.*

#### 3.8.1 Replacement

1. Remove cotter pins from bell crank and idler arm end of relay rod. Loosen nuts flush with end of studs.
2. Use a puller or place a sledge hammer behind the adjacent part to absorb shocks. Strike the studs with a brass hammer to loosen end assemblies.
3. Remove stud nuts and washers then remove studs.
4. Position relay rod studs into bell crank and idler arm then tap stud ends with a brass hammer to seat tapered surfaces.
5. Install washers and stud nuts. Tighten nuts to 160 lbf-ft (220 Nm) torque. Align cotter pin slot (tighten) and install a new cotter pin.

### 3.9 TIE RODS

Tie rod ends are connected to the bell crank and left steering arm, and to the idler arm and right steering arm. Each tie rod assembly consists of three parts; a tube and two socket end assemblies. The tie rod ends are threaded into the tube and secured with clamp bolts. Right and left hand threads are provided to ease toe-in adjustment. Tie rod assemblies are interchangeable from the right to the left side of the coach.



Tie rod end sockets require no maintenance other than periodic lubrication and inspection to see that ball studs are tight. Replace socket ends when there is excessive up and down motion, lost motion or end play at ball end of stud.

1. Periodically check bolt nut for tightness.
2. Inspect tie rod for bent condition and inspect tube for damaged threads. If tie rod is bent or threads are damaged, replace the assembly.
3. Lubricate tie rod end fittings as directed in paragraph "3.11 Lubrication Fittings" of this section.

### 3.9.1 Removal

1. Remove cotter pins and stud nuts which attach tie rod socket ends to bell crank and left steering arm (or idler arm) and right steering arm.
2. Remove tie rod ball stud by tapping on steering arm and bell crank or idler arm with hammer, while using a sledge hammer to absorb shocks.

**NOTE**

*If tie rod end assemblies are damaged in any way, they must be replaced*

### 3.9.2 Installation

1. Install socket end assemblies on tie rod. Be sure both ends are threaded an equal distance into the tube.
2. Make sure threads on stud and in stud nut are clean and not damaged.
3. Position ball studs (socket ends of tie rod) in holes in steering arm and bell crank or idler arm. Install a ball stud nut on each stud and tighten firmly.
4. Torque stud nuts to 160 lbf-ft (220 Nm). Align cotter pin slot (tighten) and install a new cotter pin.

**NOTE**

*Adjust toe-in as directed in paragraph "3.16.4 Toe-In Adjustment" of this section.*

5. Make sure tie rod ends are properly aligned with ball studs, then torque tie rod end clamp bolts to 40-60 lbf-ft (55-80 Nm).

**NOTE**

*If tie rod is not properly aligned with stud, binding will result.*

## 3.10 STEERING ARMS

The left and right wheel steering arms are secured to a swivel at one end and to a tie rod at the other end.

### 3.10.1 Removal

1. Remove wheel as directed in Section 13, "Wheel, Hubs and Tires" of the maintenance manual.
2. Remove cotter pin, washer and nut from stud securing tie rod to steering arm. Remove ball stud from steering arm by tapping on arm with a hammer, placing a sledge hammer underneath steering arm to absorb shocks.
3. Remove cotter pin and nut securing steering arm to swivel assembly. Remove steering arm from swivel.

### 3.10.2 Installation

1. Insert steering arm in swivel.
2. Torque steering arm to swivel nut to 190 lbf-ft (260 Nm). Align cotter pin slot (tighten) and install a new cotter pin.
3. Position tie rod ball stud in steering arm and tap with a brass hammer to seat ball stud in steering arm. Install washer and nut on stud. Torque nut to 160 lbf-ft (220 Nm). Tighten nut to nearest cotter pin slot and install a new cotter pin.
4. Install wheel as directed in Section 13, "Wheel, Hubs and Tires" under paragraph "2.3 Installation" of the maintenance manual.

## 3.11 LUBRICATION FITTINGS

All lubrication fittings must be clean before applying lubricant. Also, always be sure equipment used in applying lubricant is clean. Every precaution should be taken to prevent entry of dirt, grit, lint or other foreign matter into lubricant containers. Replace fitting when they become broken or damaged.

Intervals of application given in the following paragraphs are recommended for normal service. More frequent intervals may be applied under severe operating conditions. In selecting proper lubricants, supplier reputation must be considered. The supplier must be responsible for product quality. The diagram (Fig. 22) shows approximate location of steering lubrication fittings.

## Section 16 : SUSPENSION

1. **Drag Link Ends:** Lubricate at two fittings, one at each end of link, every 6,250 miles (10 000 km) with good quality lithium-base grease NLGI No. 2 (Shell Retinax LX or equivalent).
2. **Relay Rod Ends:** Lubricate at two fittings, one at each end of rod, every 6,250 miles (10 000 km) with good quality lithium-base grease NLGI No. 2 (Shell Retinax LX or equivalent).
3. **Tie Rod Ends:** Lubricate at four fittings, one at each end of both tie rods, every 6,250 miles (10 000 km) with good quality lithium-base grease NLGI No. 2 (Shell Retinax LX or equivalent).
4. **Swivel Assembly:** Refer to DANA SPICER MAINTENANCE MANUAL NDS AXLES Lubrication and Maintenance" annexed at the end of Section 10.
5. **Idler Arm and Crank bell:** Lubricate at two fittings, one on the idler arm and the other on the crank bell, every 6,250 miles (10 000 km) with good quality lithium-base grease NLGI No. 2 (Shell Retinax LX or equivalent). Apply grease gun pressure to the fitting until lubricant appears at the top seal.
6. **Upper A-Arm Central Ball Joint:** Lubricate at fitting until you see some grease on the relief valve nearby, every 6,250 miles (10 000 km) with good quality lithium-base grease NLGI No. 2 (Shell Retinax LX or equivalent).

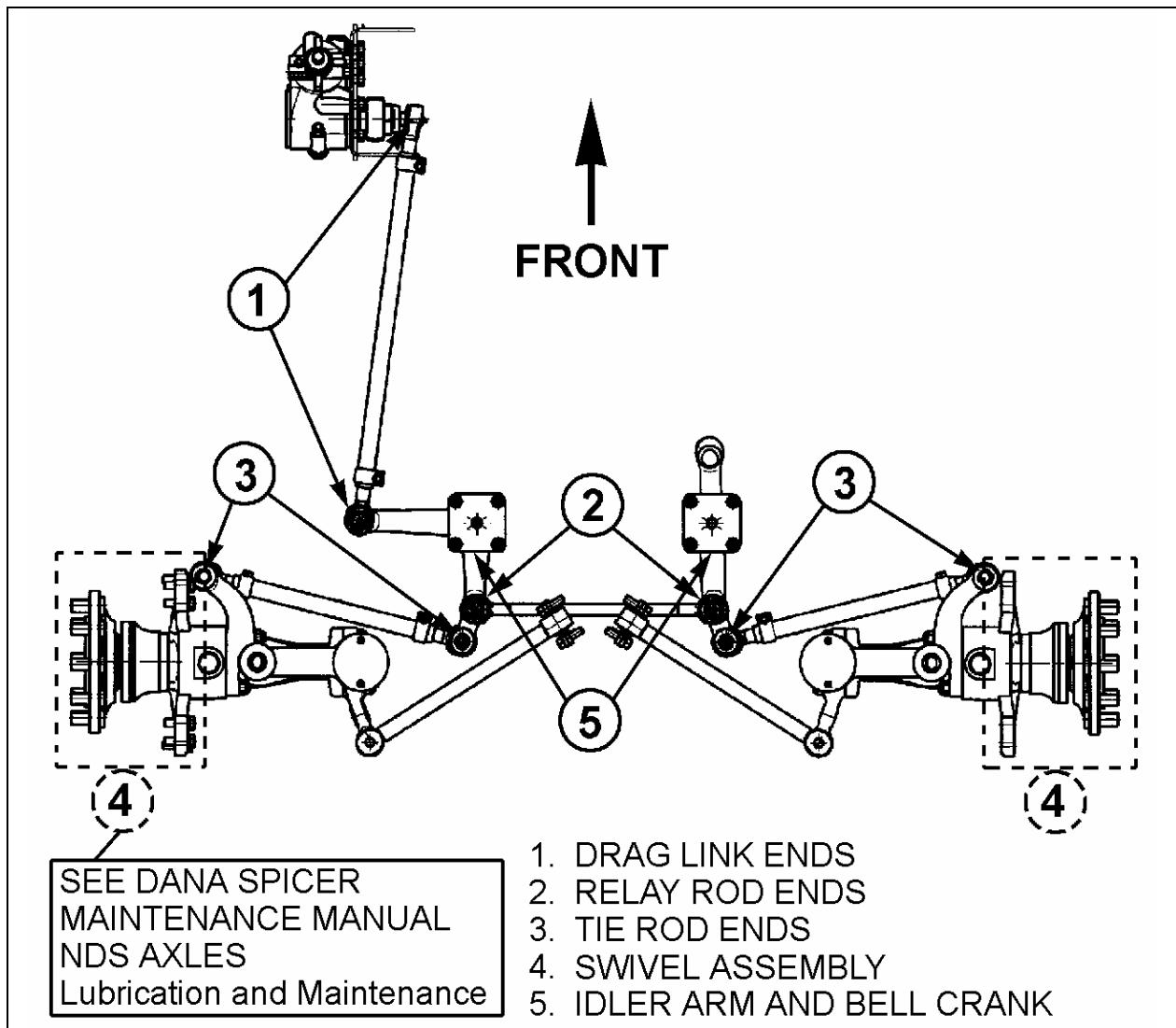


FIGURE 22: LUBRICATION FITTINGS' LOCATION DIAGRAM

16119

## 3.12 BALL JOINTS

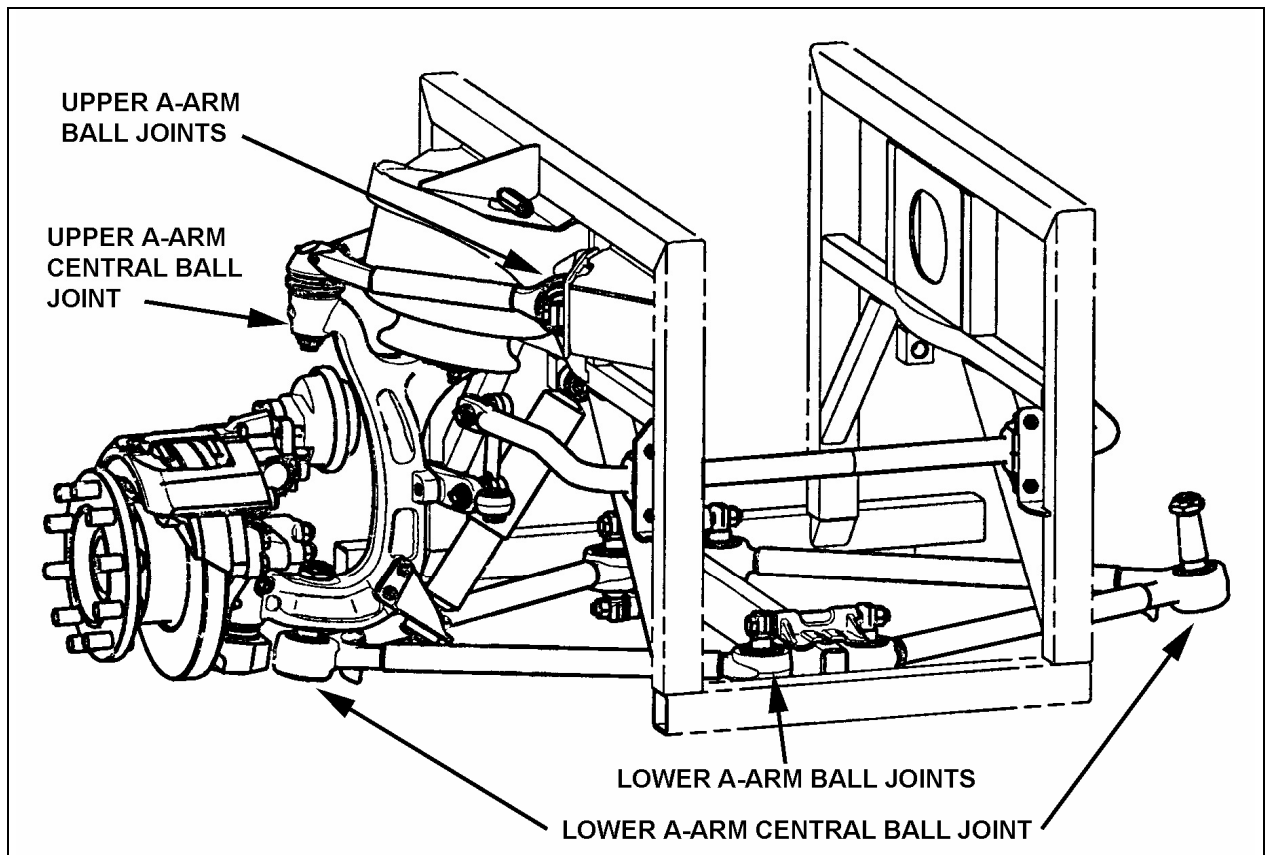


FIGURE 23: BALL JOINTS LOCATION

16137

## 3.13 LOWER AND UPPER A-ARM BALL JOINT

The assembly work may be done only by a recognized specialized workshop. Ensure that old and new parts do not get mixed up with each other. It is for this reason that all the old parts are to be scrapped immediately after a joint has been stripped down. A complete repair set must be used for each joint repaired, i.e. use of only part of a repair set is not permissible.

## 3.13.1 Inspection

Take off the load from the ball joint by lifting the front of the vehicle. Apply a load on the joint in all of the degrees of freedom in an axial, radial, etc. sense with a suitable lever tool. After the load is taken off, the joint has to spring back into its starting position. Free play is not acceptable.

Separation of rubber from ball pin or external joint shell is in accordance with "normal wear characteristics".

When the following characteristics are noted, the joint is to be changed:

- Free play;
- Radial cracking of the external sheet-metal race.

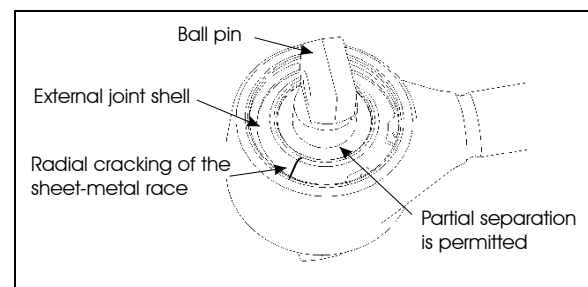


FIGURE 24: A-ARM BALL JOINTS

16173

## 3.13.2 Stripping Down

Strip down the defective joint through removal of retaining ring, annular spacer and ball pin/bushing, assembly and thereafter clean out housing bore and locking circlips groove.

### 3.13.3 Assembly

Execute assembly of the new joint parts in the following sequence:

1. Complete moistening of the contact surface between housing bore and ball pin through application of the grease.

**NOTE**

Apply grease, only in the case of repair kit (Prévost # 611114).

2. Insert ball pin/bushing, assembly. In case of the two-bolt type, ensure that the bolt bores are in the correct position in relation to the axis of the tube.
3. Place joint in receiving fixture and mount annular assembly tool on the housing. Then locate annular spacer and retaining ring in the housing using axial load with the aid of assembly matrix. If the ends of the annular spacer are not in contact with each other, the thus formed opening must be located at 180° to the opening of the retaining ring. Pay attention during assembly to ensure that the retaining ring eyelets are located at each side of the housing shaft axis (retaining ring eyelet lug points to tube), and that retaining ring is properly engaged in the groove of the housing.
4. When repairing defective ball pin assemblies, the necked down-bolt must regularly be replaced with a new one.

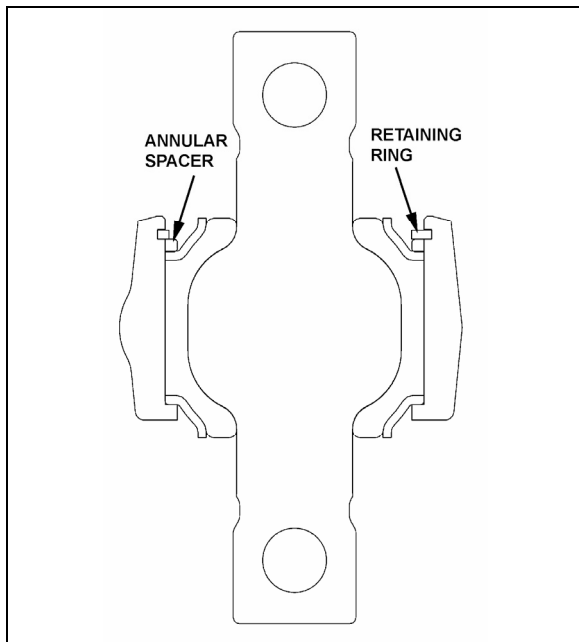


FIGURE 25: LOWER A-ARM BALL JOINTS 16114

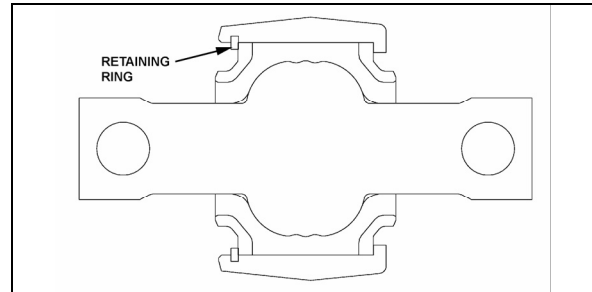


FIGURE 26: UPPER A-ARM BALL JOINTS 16115

### 3.14 LOWER A- ARM CENTRAL BALL JOINT

#### 3.14.1 Inspection

Take off the load from the ball joint by lifting the front of the vehicle. Apply a load on the joint in all of the degrees of freedom in an axial, radial, etc. sense with a suitable lever tool. After the load is taken off, the joint has to spring back into its starting position. Free play is not acceptable. Separation of rubber from ball pin or external joint bushing shell is in accordance with "normal wear characteristics".

When the following characteristics are noted, the joint is to be changed:

- Free play;
- Radial cracking of the external bushing shell.

#### 3.14.2 Stripping Down

Strip down the defective joint through removal of retaining ring, annular spacer and ball pin/bushing, assembly and thereafter clean out housing bore and locking circlips groove.

#### 3.14.3 Assembly

Assemble the new component parts of the joint in the following sequence:

1. Complete moistening of the contact surface between housing bore and ball pin through application of the grease.
2. Place joint in receiving fixture and mount annular assembly tool on the housing. Then locate annular spacer and retaining ring in the housing using axial load with the aid of assembly matrix. If the ends of the annular spacer are not in contact with each other, the thus formed opening must be located at 180° to the opening of the retaining ring. Pay attention during assembly to ensure that the retaining ring eyelets are located at each side of the housing shaft axis (retaining ring eyelet lug points to tube), and that retaining ring is properly engaged in the groove of the housing.

- Faultlessly apply grease by mechanical means to bracket-outer core and ball-inner cone. Insert bracket outer cone in fixture with distance ring and then use press tool to apply pressure to press mount with ball-inner cone.

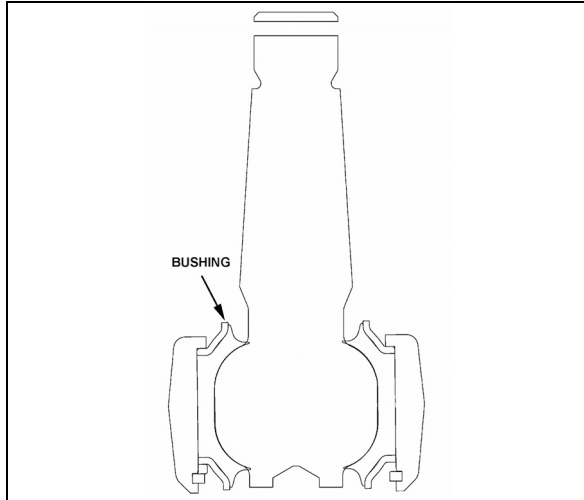


FIGURE 27: LOWER A-ARM CENTRAL BALL JOINT 16113

### 3.15 UPPER A-ARM CENTRAL BALL JOINT

#### 3.15.1 Visual Inspection

Check the condition of the sealing boot, in particular:

Check if the retainer ring, which secures the sealing boot at the conical section of the ball stud, is still present.

Check if grease is present on the external surface of the sealing boots. Escaped fluid and accumulations of grease on the sealing boot may be the result of the sealing boot's rupturing. In this case, the ball joint must be systematically replaced.

#### 3.15.2 Play Measurement

- Raise the vehicle and support through axle jacking points.
- Using a caliper, measure dimension A on figure 28.
- With a lever tool, exert sufficient force under the upper A-arm as to separate the upper A-arm from the upright in order to have the ball joint to its maximum extent. Remeasure dimension A. If the difference between the two dimensions is greater than 0.060" (1.5 mm), then the ball joint should be replaced.

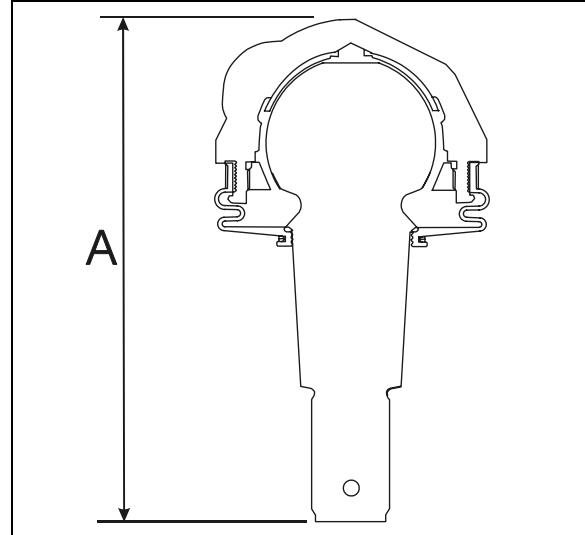


FIGURE 28: UPPER A-ARM CENTRAL BALL JOINT 16116

### 3.16 FRONT END ALIGNMENT

Proper front end alignment must be maintained to insure ease of steering and provide satisfactory tire life. When making front end alignment inspections, the vehicle must be level and empty with the full weight of the vehicle on the wheels.

Front end alignment inspections fall into two groups: regular service inspections performed at periodic intervals, and inspections to determine the extent of damage after a collision or severe service.

Regular service inspections concern toe-in, camber and caster.

Any variation from the specified alignment will indicate either a need for adjustment or a more thorough inspection to determine if parts replacement is required.



#### WARNING

During alignment, both camber and caster among other angles are adjusted. When adjusting these we install or remove shims from the lower "A" arms of the ISS suspension. After performing alignment, make sure that the following is done:

- Installing a new lock nut after all shims are finalized.
- Torque replaced nuts as per figure 32.
- Installing a longer bolt if less the 2 threads are remaining after the nut.
- Using a Torque mark on the nut for future visual inspection.

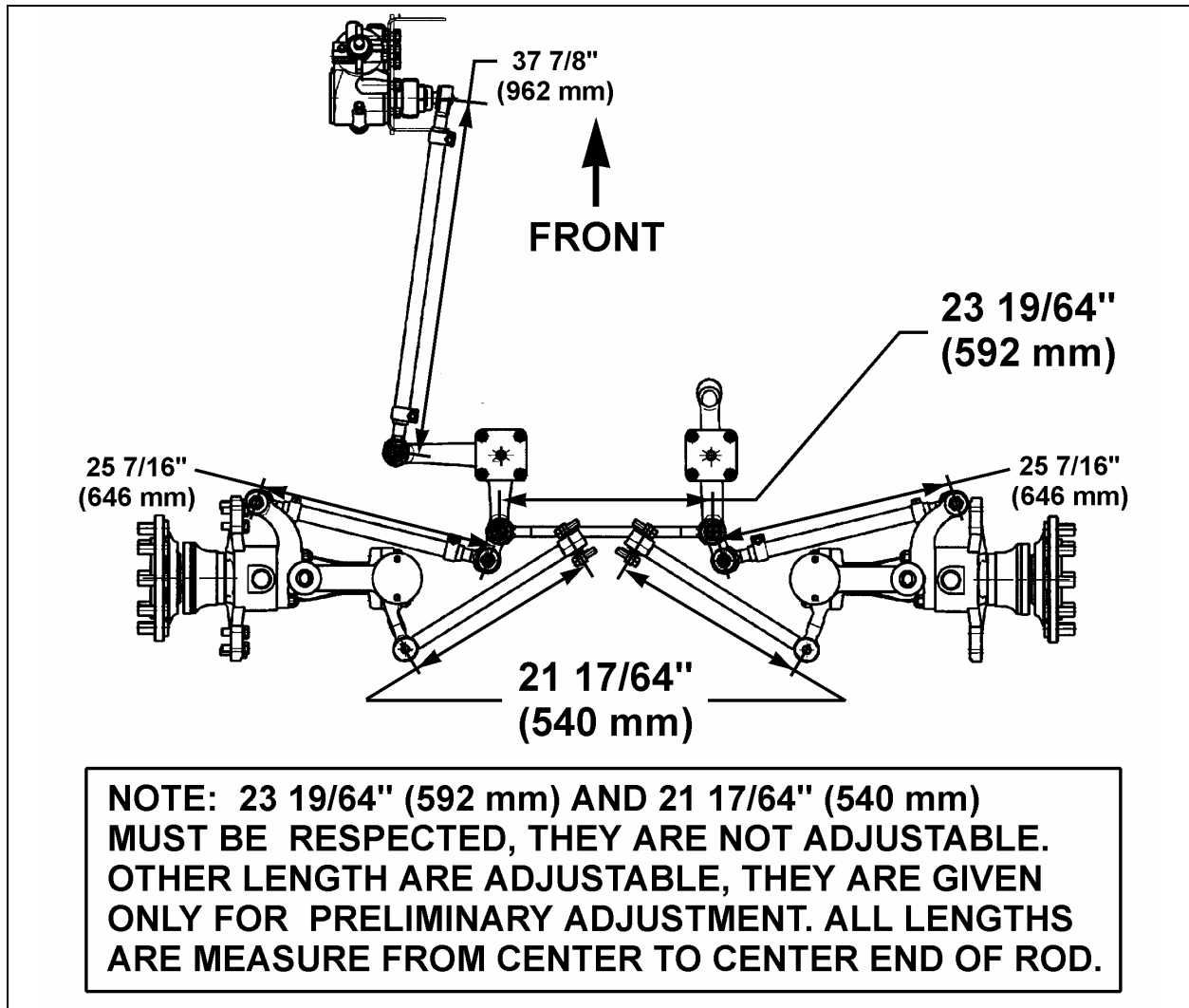


FIGURE 29: STEERING LINKAGE MEASURE

16130

### 3.16.1 Alignment Terminology

#### Wheel Camber

The amount the wheels are inclined from the vertical plane (A, Fig. 30).

#### Wheel Toe-In

The distance the front wheels are closer together at the front than at the rear of the tires (D minus E, Fig. 30).

#### King Pin Inclination

The inclination of the king pin from vertical toward the center of the vehicle at the top and outward at the bottom (B, Fig. 30).

#### Front Axle Caster

The inclination of the king pin from vertical in the fore and aft direction (C, Fig. 30).

### 3.16.2 Front End Inspection

Before checking front end alignment, make the following inspection:

1. Check that the vehicle is at normal ride height (see paragraph "5. Suspension Height Adjustment").
2. Check the tires for proper inflation.
3. Check wheel installation and run-out.
4. Check wheel bearing adjustment.
5. Check tie rods and drag link ends for looseness.
6. Check king pins for looseness.
7. Check if the length of the torque rod is 21 17/64" (540 mm) (Fig. 29). Check if the length of the relay rod is 23 19/64" (592 mm).

### 3.16.3 Front Wheel Camber

Positive camber is the outward inclination of the wheels at the top, negative or reverse camber is the inward inclination of the wheels at the top. Camber variations may be caused by wear at the wheel bearings, wheel spindle bushings, or bent suspension parts.

Check camber, with an accurate gauge. If camber is incorrect, check suspension parts for wear and replace worn parts. If wear is not perceptible, suspension parts may be bent or lower suspension arm may be improperly shimmed.

Check King pin inclination. If King pin inclination is incorrect, readjust the camber and check king pin inclination again.

#### NOTE

*Camber is more important than king pin inclination, so adjust camber and verify king pin inclination.*

Shim the lower suspension arm to adjust camber. If the king pin inclination is incorrect, the wheel king pin assembly may be bent and therefore should be replaced.

Excessive positive camber results in irregular wear of the tires at the outer shoulders. Negative or reverse camber causes wear at the inner shoulders.

#### NOTE

*Shim only the lower suspension arm to adjust the front wheel camber.*



#### CAUTION

Once the perfect shim combination is achieved, always install new stover nuts because the self locking effect is lost after tightening and loosening of the nut. It is recommended to punch marks to detect loosening of the nuts during future visual inspections.

### 3.16.4 Front Wheel Toe-In

Toe-in is measured from the center of the tire treads. Measurements at the front and rear of the tires must be made at the same height from the floor. Incorrect toe-in results in excessive tire wear and steering instability with a tendency to wander.

#### Toe-In Check

1. Check the camber adjustment and adjust if necessary.

2. Hoist the front of the vehicle and spin the wheels marking the centerline of the tire treads.
3. Place the wheels in the straight ahead position and lower the vehicle to rest on the floor.
4. Roll the vehicle ahead several feet. This removes any slack caused by looseness in the wheel bearings or steering connections.
5. Check the distance between the tire centerlines at the front and rear of the front tires. These two measurements must be made at the same height above the floor. The front measurement must be  $3/32 \pm 1/32$  of an inch less than the rear measurement.

#### Toe-In Adjustment

1. Loosen the tie rod clamp bolts.
2. Using a pipe wrench, turn the tie rod tubes to obtain the toe-in measurement specified in step 5 under paragraph "**Toe-in Check**" of this section.
3. Tighten the tie rod clamp bolts and recheck toe-in.
4. Check that the angular relationship of the pitman arm to the steering gear is as shown in figure 17.

#### NOTE

*Use only tie rods to adjust toe-in.*

### 3.16.5 Front Axle Caster

Positive caster is the inclination of the top of the king pins toward the rear of the vehicle. Negative or reverse caster is the inclination of the king pins toward the front of the vehicle. This vehicle is designed with positive caster. The purpose of caster is to provide steering stability by keeping the wheels in a straight ahead position.

Caster variations may be caused by bent upper suspension arm, lower suspension arm, or king pin housing. Caster should be adjusted with shims. Precision instruments should be used to measure caster. Shim bell crank and idler arm to adjust caster.

Variations from the specified caster will affect steering stability, cause wandering, wheel shimmy, and reduce returnability when pulling out of curves.

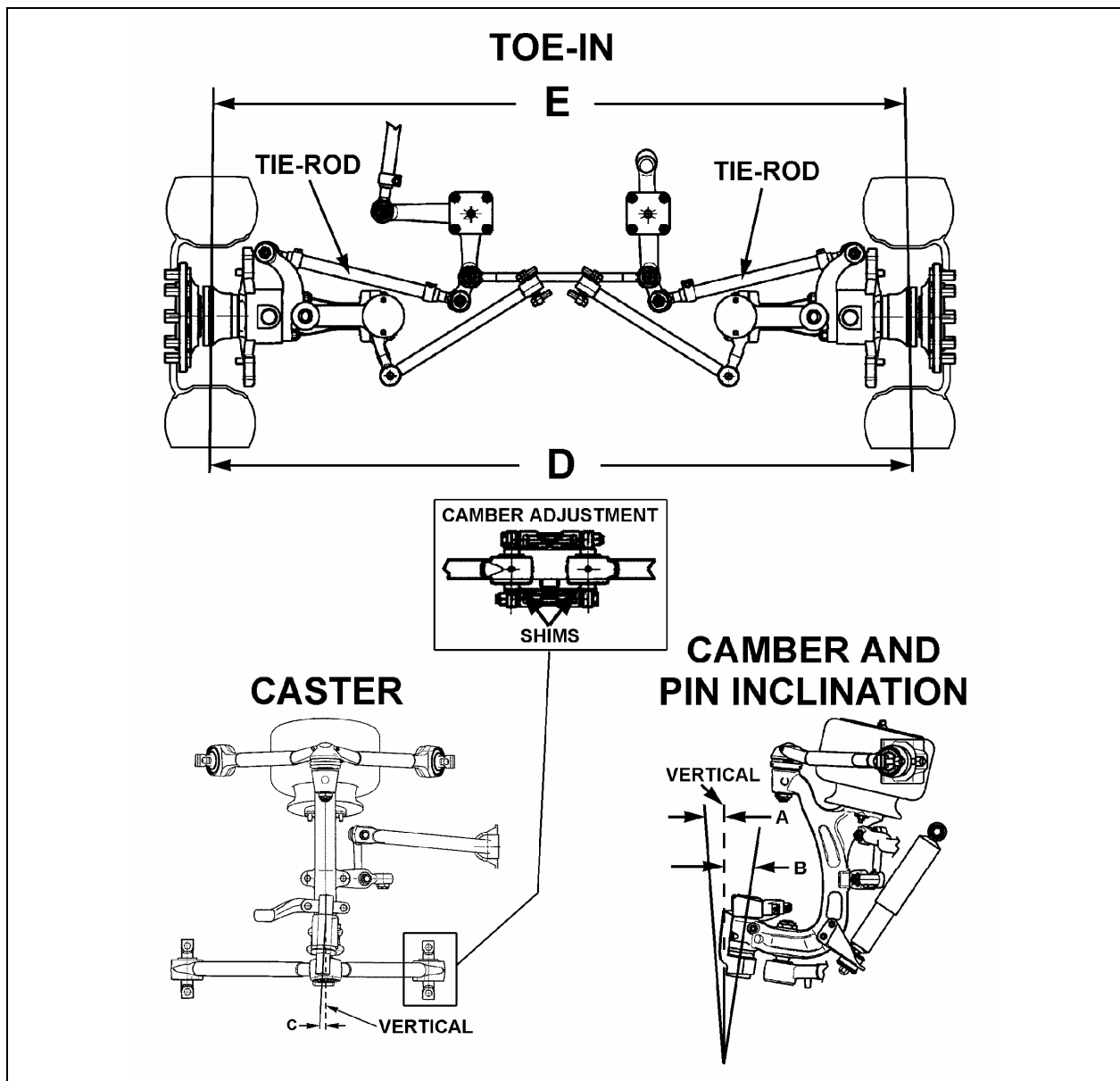


FIGURE 30: FRONT END ALIGNMENT DIAGRAM

16134

| ALIGNMENT SPECS (See Figure 30) |                      |                     |         |         |
|---------------------------------|----------------------|---------------------|---------|---------|
|                                 |                      | Minimal             | Nominal | Maximal |
| A                               | WHEEL CAMBER         | 0.0                 | 0.150   | 0.35    |
| B                               | KING PIN INCLINATION | 8° (not adjustable) |         |         |
| C                               | CASTER               | 2.35                | 2.6     | 2.85    |
| D-E                             | TOTAL TOE            | 0.06                | 0.08    | 0.10    |



### 3.16.6 Major Damage

If the suspension has sustained major damage, it may be necessary to shim the bell crank and the idler arm to avoid the bump steer or roll steer. Moreover refer to paragraph "3.16: Front End Alignment".

### 3.17 FRONT AIR SPRINGS

Two "rolling lobe" type air springs are used with the independent front suspension, one at each wheel. These air springs are special and use the complete piston as an extra reservoir to lower the spring stiffness. Front air springs are attached to the subframe and to uprights.

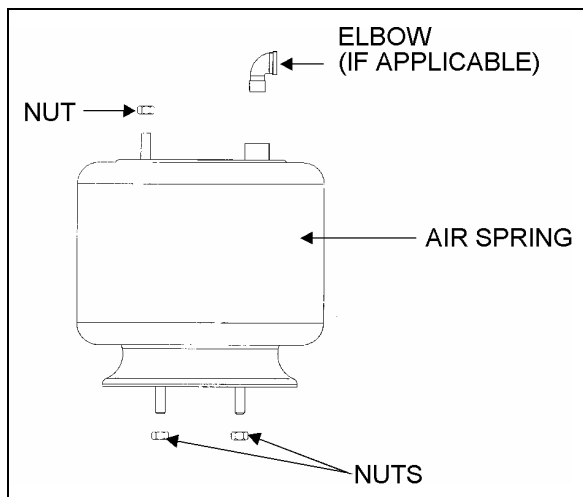


FIGURE 31: AIR SPRINGS

16052

#### 3.17.1 Inspection

1. Check operation of bellows.
2. Visually inspect bellows for evidence of cracks, punctures, deterioration, or chafing. Replace the bellows if damage is evident.
3. With the primary air system at normal operating pressure (95 - 125 psi (655 - 860 kPa)), coat all suspension air line connections and bellow mounting areas with a water and soap solution. Bubbles will indicate an air leak, and none is permissible. Repair or replace defective parts.

#### NOTE

If air spring is removed from vehicle, bellows can be lightly inflated and submerged in water to detect any leakage. If leakage is detected, replace bellows.



### WARNING

To prevent personal injury, do not apply more than 10 psi (69 kPa) air pressure to the unmounted air spring.

#### 3.17.2 Removal

#### NOTE

Front air springs can be removed without removing the entire suspension assembly.

1. Safely support vehicle at the recommended body jacking points and jack up body understructure.
2. To gain access to a given air spring, the corresponding wheel can be removed.



### CAUTION

Only the recommended jacking points must be used as outlined in Section 18, "Body" in the maintenance manual.

3. Support the assembly with a suitable jack.
4. Exhaust compressed air from accessory air tank by opening drain cock under reservoir.
5. Disconnect the height control valve link and pull down the overtravel lever to ensure all air is exhausted from air springs.

#### NOTE

While performing this step, do not change the height control valve overtravel lever adjustment.

6. Disconnect air line from air spring, remove elbow (if applicable), and cover both the line end and fitting to prevent the entry of foreign matter.
7. Remove the air spring upper nut, and then the two lower nuts. Remove air spring and remove the back up plate from the top of the air spring.

#### 3.17.3 Installation

#### NOTE

To facilitate air spring installation, compress it manually then put a piece of tape over the air line threaded fitting. This prevents air from getting back into the bag and keeps it compressed, thus enabling to place the bag in between the mounting plates and greatly easing installation.

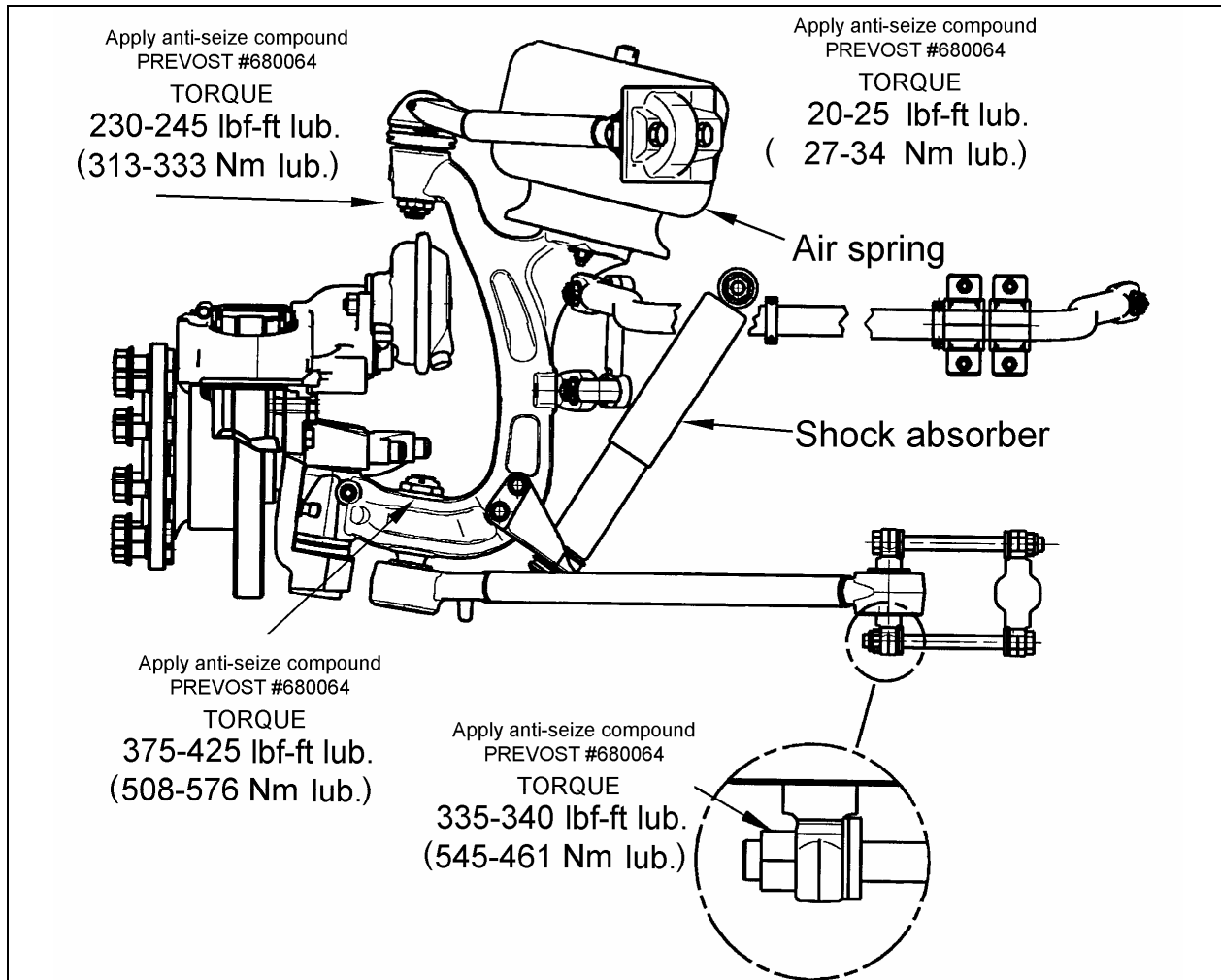


FIGURE 32: AIR SPRING AND SHOCK ABSORBER

16145

1. Compress air spring as necessary, then aligning studs with their holes, position air spring between both the lower and upper supports. Thread the lower nuts and the small upper nut a few turns.
2. Tighten and torque the lower stud nuts, and then the upper nut to 20-25 lbf-ft (27-34 Nm).
3. Install elbow (if applicable), then connect air line.
4. Connect the height control valve link.
5. Build up air pressure in system.

**NOTE**

*To accelerate this operation, air reservoirs can be filled from an exterior air supply connected to the accessory tank fill valve or to the emergency fill valve.*

6. Check operation of bellows and with the primary air system at normal operating pressure (95 - 125 psi (655 - 860 kPa), coat the air line connections and air spring mounting areas with a water and soap solution. Bubbles will indicate an air leak, and none is permissible. Repair or replace defective parts.
7. Remove the hydraulic floor jack from underneath shock absorber bracket.

**3.18 SHOCK ABSORBERS**

The two front shock absorbers are double-acting and telescopic type. Shock absorbers ensure a smooth ride and enhance vehicle stability on the road. Front shock absorbers have eye-type mountings on the upper side and bayonet type on lower side. Shock absorbers are non-adjustable and non-repairable.

**CAUTION**

When a shock absorber is found defective, always replace with a new set on affected axle, except if there has been a recent replacement of one unit. The following method will help in determining if both shock absorbers on the same axle have to be replaced.

**3.18.1 Shock Absorber Removal**

1. Remove the nut, washer and rubber joint from shock absorber mounting stud. Discard the rubber joints.
2. Remove the nut and washer from shock absorber mounting pin (upper side), taking care to identify the inner and outer washers to ease reinstallation. Refer to figure 33 for details.
3. Remove the shock absorber from the vehicle.
4. Remove inner: washers, rubber joint and bushings from the shock absorber. Discard bushings and rubber joint.

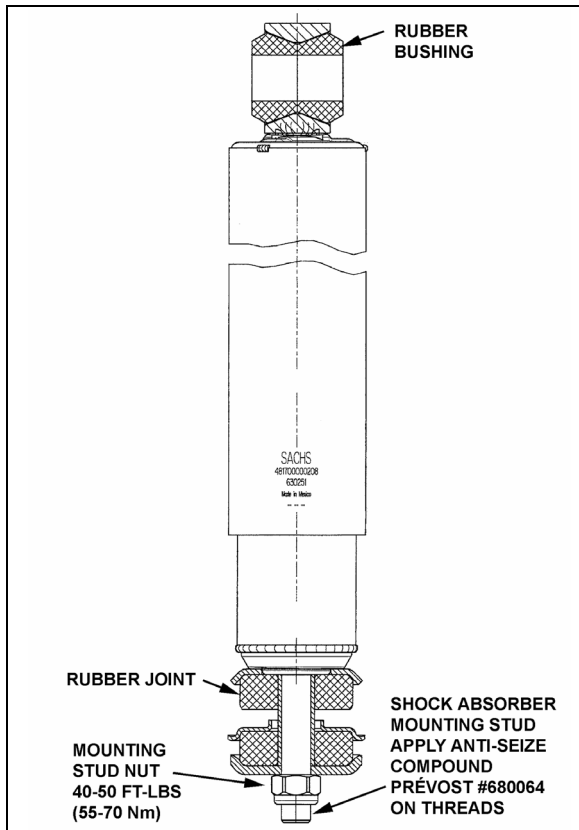


FIGURE 33: SHOCK ABSORBER

16112

**3.18.2 Shock Absorber Installation**

1. Check that the shock absorber mounting pin torque is proper (350-400 lbf-ft (475-545 Nm)). Ensure that the stud is clean and not stripped (upper side).
2. Install new rubber (mounting) bushing on shock absorber (upper side).
3. Place the inner washer on shock absorber pin (Fig. 33).
4. Install washer and rubber joint on shock absorber mounting stud (lower side).
5. Install the shock absorber as shown in figure 32 with the mounting stud protruding through the hole in the mounting bracket and the shock absorber eyes over the mounting pins. Install the outer washer.
6. Place a rubber joint and washer on the shock absorber mounting stud. Place the lower shock absorber mounting stud nut and torque to 40-50 lbf-ft (55-70 Nm).
7. Place the upper mounting pin stud nut and torque to 70-85 lbf-ft (95-115 Nm).

**3.19 SWAY BAR**

A sway bar is provided on the front and rear suspensions to increase vehicle stability. It controls lateral motion (swaying movement) of vehicle.

**3.19.1 Removal**

1. Disconnect the two links from sway bar.
2. Safely support the sway bar. Unbolt bushing collars from subframe.
3. Remove sway bar.

**NOTE**

*Sway bar bushings are slit to ease their removal.*

**3.19.2 Installation**

1. Loosely install the sway bar.
2. Torque bushing collar nuts to 60 lbf-ft (82 Nm).
3. Torque sway bar link upper nuts to 120-140 lbf-ft (163-190 Nm) on front suspension and to 100-120 lbf-ft (136-163 Nm) on rear suspension.
4. Torque sway bar link lower nuts to 120-140 lbf-ft (163-190 Nm) on front suspension and to 70-80 lbf-ft (95-110 Nm) on rear suspension.

Section 16: SUSPENSION

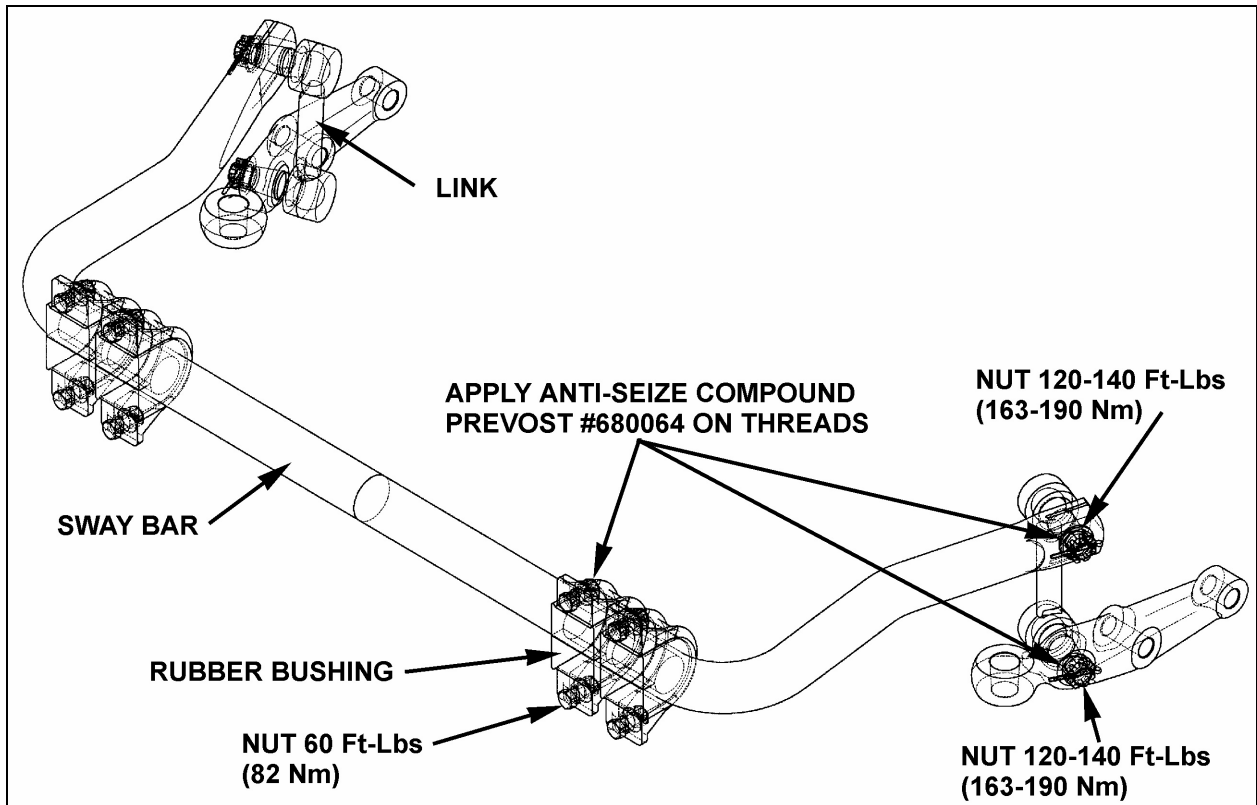


FIGURE 34: SWAY BAR (FRONT SUSPENSION)

16138B

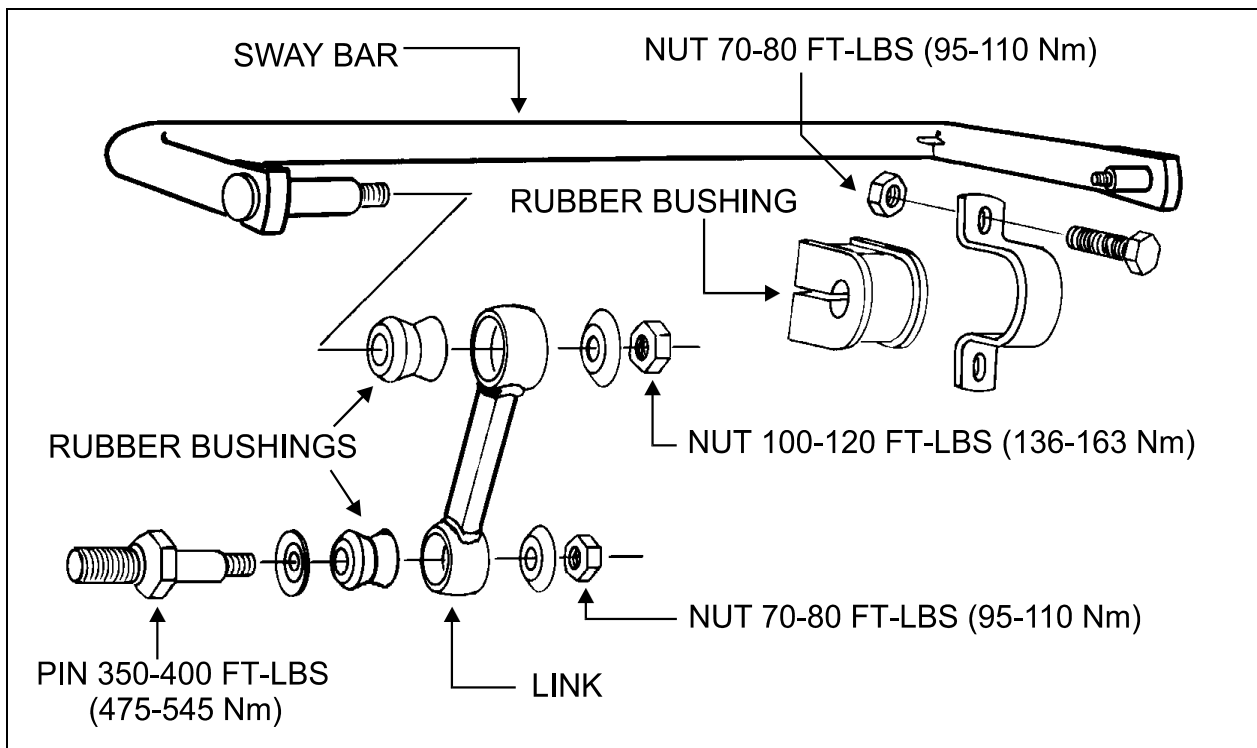


FIGURE 35: SWAY BAR (REAR SUSPENSION)

16144

4. REAR SUSPENSION

For a description of all these systems, refer to the appropriate heading in this section.

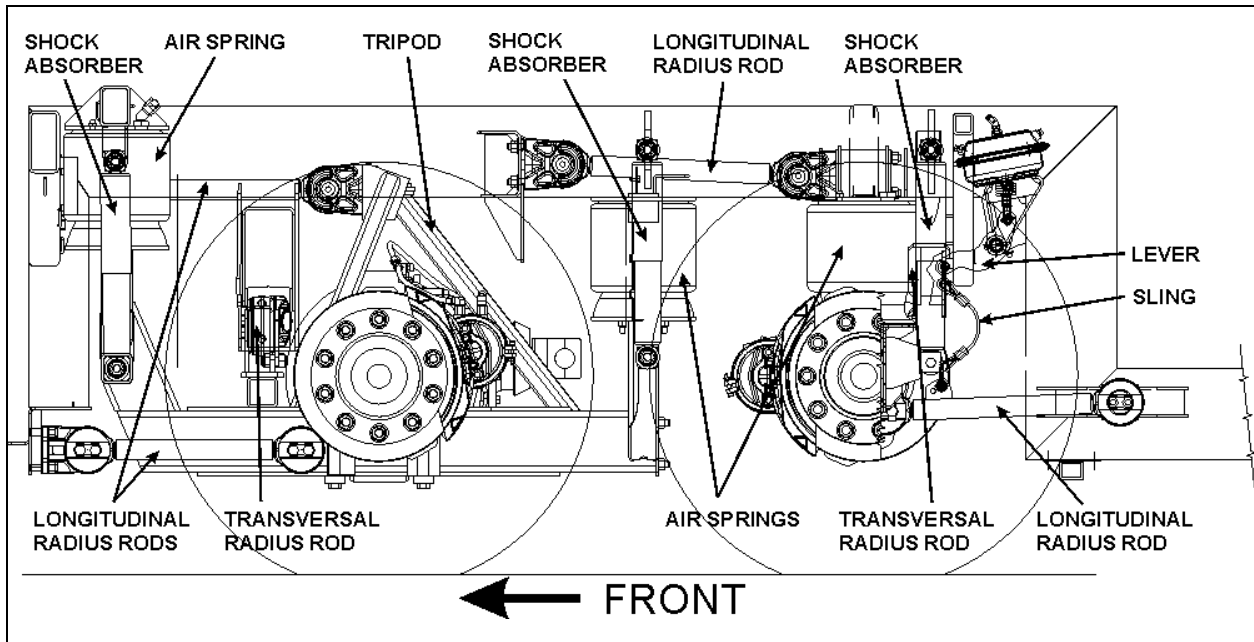


FIGURE 36: REAR SUSPENSION COMPONENTS

16167

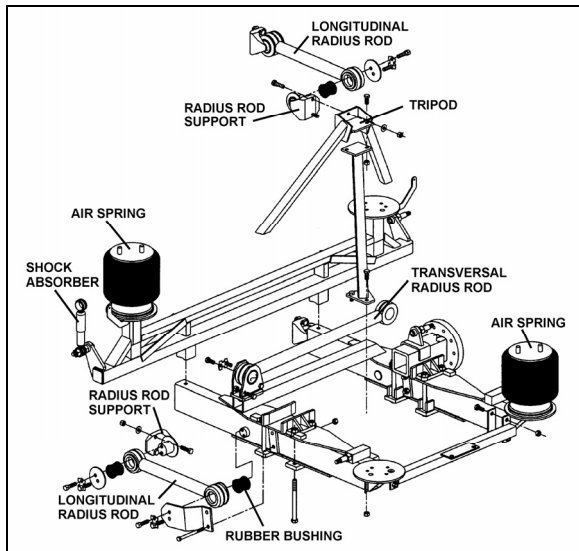


FIGURE 37: DETAILS OF REAR SUSPENSION

16106

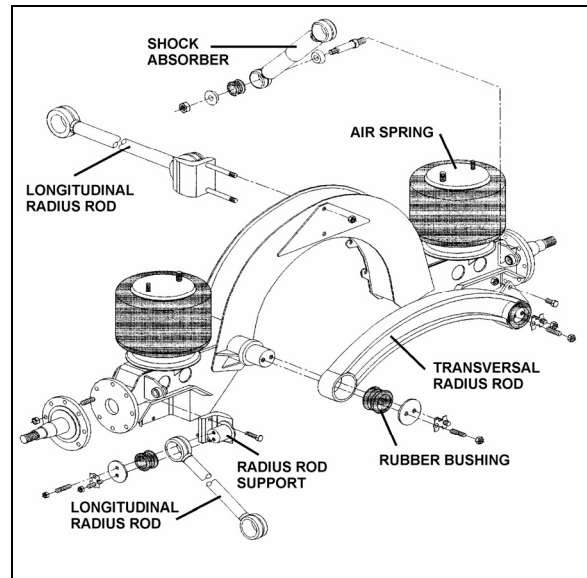


FIGURE 38: TAG AXLE SUSPENSION

16107

#### 4.1 AIR SPRINGS

The air springs are made from a special compound rubber molded to the proper contour and dimensions. The entire vertical load of the vehicle is supported by these springs. Each of the two axles is provided with air springs that are attached to the subframe and to the axles (Fig. 39).

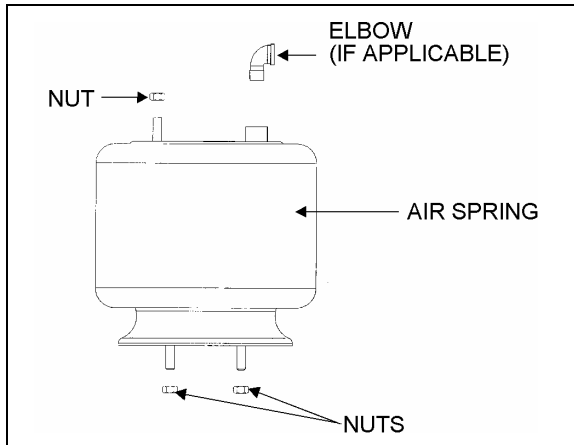


FIGURE 39: AIR SPRING 16052

##### 4.1.1 Inspection

1. Check operation of bellows.
2. Visually inspect bellows for evidence of cracks, punctures, deterioration, or chafing. Replace the bellows if any damage is evident.
3. With the primary air system at normal operating pressure (95 - 125 psi (655 - 860 kPa)), coat all suspension air line connections and bellows mounting areas with a water and soap solution. Bubbles will indicate an air leak, and none is permissible. Repair or replace defective parts.

**NOTE**

*If air spring is removed from vehicle, bellows can be lightly inflated and submerged in water to detect any leakage. If any leakage is detected, replace bellows.*



**WARNING**

To prevent personal injury, do not apply more than 10 psi (69 kPa) of air pressure to the uninstalled air spring.

##### 4.1.2 Removal

**NOTE**

*Suspension air springs (drive and tag axles) can be removed without removing the entire axle assembly.*

1. Safely support vehicle at the recommended body jacking points. To gain access to a given air spring, the corresponding wheel can be removed as follows.
  - a) Jack vehicle until the tire clears the ground, and place safety supports underneath body.



**CAUTION**

Only the recommended jacking points must be used as outlined in Section 18, "Body".

- b) Support the axle with a suitable hydraulic floor jack at the recommended jacking point.
  - c) Remove wheel.
2. Exhaust compressed air from accessory air tank by opening drain cock under reservoir.
3. Disconnect the height control valve link and pull down the overtravel lever to ensure all air is exhausted from air springs.

**NOTE**

*While performing this step, do not change the height control valve overtravel lever adjustment.*

4. Disconnect air line from air spring, remove elbow (if applicable), and cover both the line end and fitting to prevent the entry of foreign matter.
5. Remove the air spring upper nut, and then the two lower nuts. Remove air spring.

##### 4.1.3 Installation

1. Compress air spring as necessary, then aligning studs with their holes, position air spring between both the lower and upper supports. Thread the lower nuts and the small upper nut a few turns.

**NOTE**

*To facilitate air spring installation, compress it manually then put a piece of tape over the air line threaded fitting. This prevents air from getting back into the bag and keeps it compressed, thus enabling to place the bag in between the mounting plates and greatly easing installation.*

2. Tighten and torque the lower stud nuts, and then the upper one to 20 – 25 lbf-ft (27 – 34 Nm).
3. Thread the remaining upper nut (large nut) and tighten to 20 – 25 lbf-ft (27 – 34 Nm).
4. Install elbow (if applicable), then connect air line.
5. Connect the height control valve link.
6. Build up air pressure in system.

**NOTE**

*To accelerate this operation, air reservoirs can be filled from an exterior air supply connected to the accessory tank fill valve or to the emergency fill valve.*

7. Check operation of bellows, and with the primary air system at normal operating pressure (95 – 125 psi (655 – 860 kPa)), coat the air line connections and air spring mounting areas with a water and soap solution. Bubbles will indicate an air leak, and none is permissible. Repair or replace defective parts.
8. Reinstall wheel.
9. Remove the hydraulic floor jack from under the axle, then lower vehicle to ground.

#### 4.2 SHOCK ABSORBERS

Double-action, telescoping-type shock absorbers ensure a smooth ride and enhance vehicle stability on the road. All shock absorbers are eye-type mountings. The tag axle is provided with two shock absorbers while the drive axle is provided with four of them (Fig. 36, 37 and 38).

Shock absorbers are non-adjustable and non-repairable. Maintenance requirements involve replacement of the rubber mounting bushings, and tightening of all shock absorber pins at the proper torque of 500 - 550 lbf-ft (680 - 750 Nm) when shock absorber replacement occurs. If a

shock absorber becomes inoperative, complete unit must be replaced.

**CAUTION**

When a shock absorber is found defective, always replace with a new set on affected axle, except if there has been a recent replacement of one unit. The following method will help in determining if both shock absorbers on the same axle have to be replaced.

#### 4.2.1 Inspection

Loosen lower mounting of both shocks, and then carefully attempt to raise and lower the bottom portion of each shock. Note the rate of effort for distance of travel. Replace both shocks if a definite differential rate is found.

The shock must be bench checked in an upright, vertical position. If checked in any other position, air will enter the cylinder tube and make the shock absorber appear defective.

Proceed as follows to check shock absorbers:

1. With the shock absorber in a vertical position (top end up), clamp the bottom mount in a vise.

**CAUTION**

Do not clamp the reservoir tube or the dust tube.

2. Rotate the dust tube. Notice any binding condition (may be compared with new unit). Binding condition indicates a scored rod. Units with scored rods should be replaced.
3. Fully extend shocks and check for leaks in the seal cover area. Shock fluid is a very thin hydraulic fluid that has a characteristic odor and dark brown tint. A slight trace of shock fluid around the seal cover area is not a cause for replacement. The shock seal is designed to permit a very slight seepage to lubricate the rod. Units that leak should be replaced.
4. Visually check shock for dents that could cause the shock to bind. Also, check for a bent rod.
5. Extend and collapse shock several times to determine that it has control (resistance) in both rebound and compression.

## Section 16: SUSPENSION

6. Visually inspect the shock mountings and vehicle mounting for:
  - a) Broken mounts;
  - b) Extreme bushing wear;
  - c) Shifted bushing or sleeve;
  - d) Deep cracks in bushing material (shallow surface cracks are normal);
  - e) Loose shock absorber pins;
  - f) Presence of convex washers, and their position relative to the rubber bushing.

### 4.2.2 Removal

1. Remove nuts and washers from shock absorbers on upper and lower mounting pins, taking care to identify the inner and outer washers to ease reinstallation. Refer to figure 40 for details.
2. Remove the shock absorber assembly from pins.
3. Remove the two inner bushings from the shock absorber and discard them.

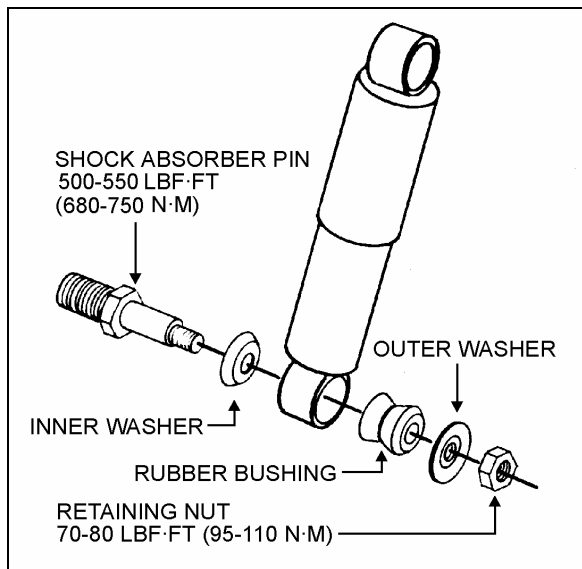


FIGURE 40: SHOCK ABSORBER

16008

### 4.2.3 Installation

1. Ensure that the shock absorber mounting pins are tight and that the threads are not stripped.
2. Install new rubber mounting bushings on shock absorbers (upper and lower).
3. Place the inner washers (with washer convex side facing the shock absorber rubber bushing) on each shock absorber pin (Fig. 41).

4. Install the shock absorber eyes over the mounting pins, then the outer washers (with washer convex side facing the shock absorber rubber bushing) on each shock extremity.

#### NOTE

If shock absorber pins are removed, they must be reinstalled using "loctite" (see "Parts Specifications" in this section).

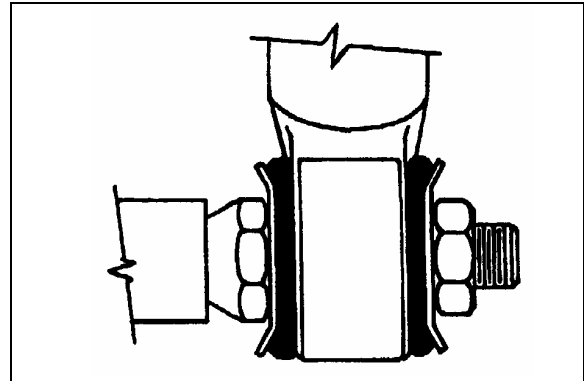


FIGURE 41: TYPICAL SHOCK ABSORBER SETUP

16009

5. Place the lower and upper mounting pin stud nuts and torque to 70 - 80 lbf-ft (95 - 110 Nm).

### 4.3 RADIUS RODS

Radius rods are used to secure the axles in the proper transversal and longitudinal positions. Four radius rods are provided on the drive axle suspension (three longitudinal and one transversal) and also four on the tag axle with a layout similar to the drive axle. Refer to figures 36, 37 and 38 for details. These rods transmit both braking and driving forces from the axles to the vehicle body.

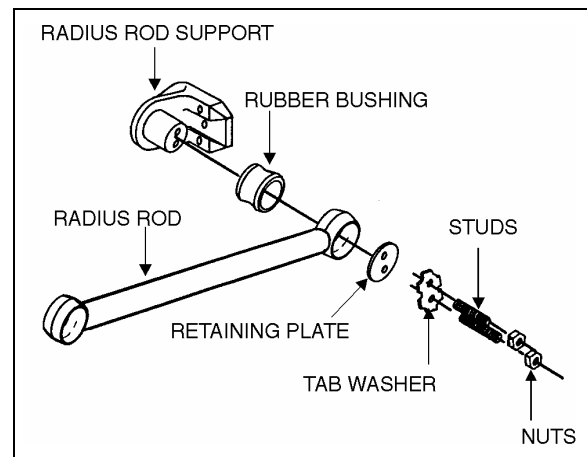


FIGURE 42: TYPICAL RADIUS ROD SETUP

16010



### 4.3.1 Inspection

The following instructions apply to all radius rods used on this vehicle:

1. Clean all parts thoroughly.
2. Inspect radius rods for distortion and cracks. We recommend the "Magnaflux" process to detect cracks in the radius rod. Any damaged part should be replaced with a new one.

#### NOTE

*New bushings should be used when rods are replaced.*

3. The radius rod bushings should be checked periodically for signs of shearing, deterioration, or damage. Any defective part should be replaced with a new one.

### 4.3.2 Removal

1. Flatten the tab washer which secures the two retaining nuts (or bolts), then unscrew the nuts (or bolts) at each extremity of the radius rod (Fig. 42).
2. Remove the tab washer and the retaining plates and radius rod ends from anchor pins, and then remove the radius rod.

### 4.3.3 Bushing removal

1. Safely support the radius rod as shown in figure 43.

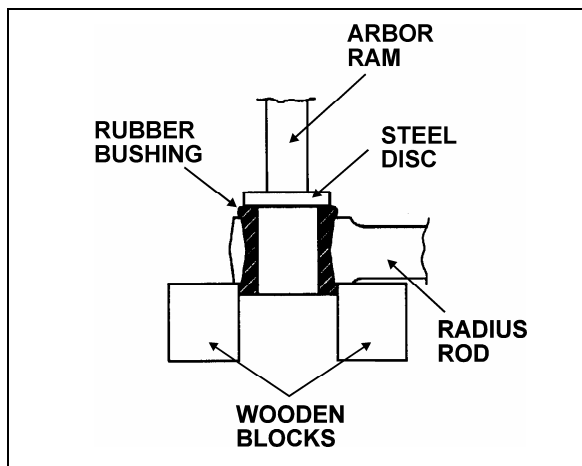


FIGURE 43: RADIUS ROD BUSHING REMOVAL 16011

2. Place a flat steel disc, slightly smaller than the outside diameter of the bushing (Fig. 43).

3. Using an arbor press or a suitable driving tool, press or drive the old bushing out of the rod and discard the bushing.



#### CAUTION

Make sure to prevent the steel disc from contacting the radius rod end.

### 4.3.4 Bushing installation

1. Lightly spray the inner and outer surfaces of radius rod bushing with water.



#### CAUTION

No lubricant whatsoever is to be used on the rubber bushing.

2. Safely support the radius rod, and place new bushing on top of the radius rod end (Fig. 44).
3. Place a block of wood on top of bushing and press on it manually.
4. If necessary, use an arbor press or a suitable driving tool. Press or drive the bushing into the radius rod end until it extends equally on both sides of the rod.
5. It is also possible to proceed differently. Place radius rod bushing on a plane surface. Spray a light coat of water on the inner and outer surfaces of radius rod bushing.
6. Take radius rod, align the bushing. Tap radius rod on bushing until latter is positioned correctly.

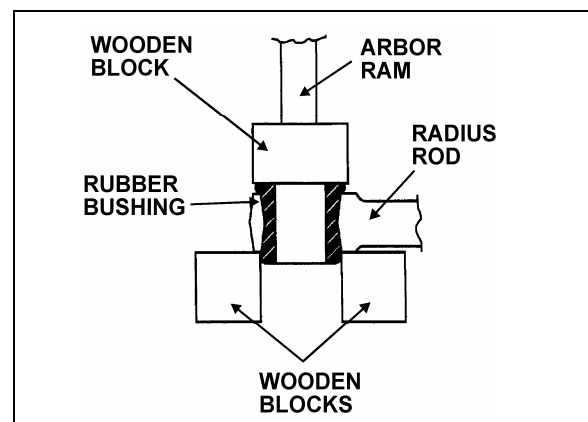


FIGURE 44: RADIUS ROD BUSHING INSTALLATION 16012

### 4.3.5 Installation

1. Lightly spray the radius rod support with water. Place the radius rod end over the radius rod support (Fig. 45).
2. Position the retaining plate. Install the tab washer and nuts (or bolts).

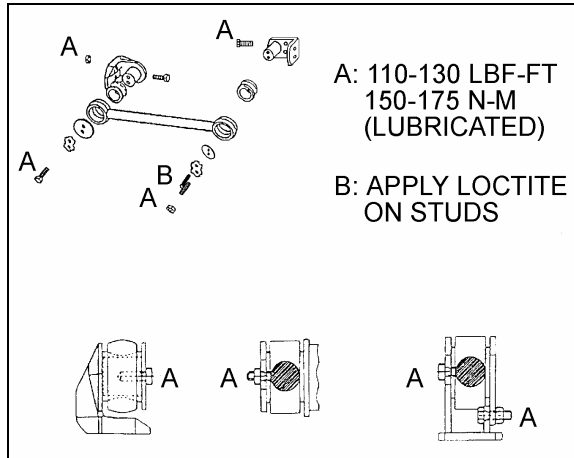


FIGURE 45: RADIUS ROD INSTALLATION 16028



### CAUTION

Always use new tab washers at installation.

3. Tighten the nuts (or bolts) lightly, and repeat at the other end.
4. Refer to heading "*Suspension Height Adjustment*" later in this section, and set the vehicle to normal ride height.
5. With the vehicle at normal ride height, apply oil on threads and tighten all radius rod anchor pin nuts or bolts to 110 – 130 lbf-ft (150 – 175 Nm).



### CAUTION

It is extremely important upon reconnection of the rods that the proper clearance height between the axle and body be maintained. Otherwise, the rubber bushings in radius rod ends will become preloaded, thus reducing their life span.

## 5. SUSPENSION HEIGHT ADJUSTMENT

The flow of pressurized air from the accessory air tank to the air springs is controlled by three height control valves. The two rear valves are mounted to the subframe and connected to the rear axles through an arm and link connection. The front valve is mounted to the subframe and

connected to the front air tank support. These connections allow the valves to apportion air pressure in the springs to the vehicle load, maintaining normal ride height.

Immediate response height control valves increase or decrease the air pressure in the suspension system as required. One height control valve is located **at center of front sway bar**, and regulates air to front suspension air springs in order to maintain the vehicle at the required height. Two are located at the drive axle, one on each inner side of rear wheelhousing.

The appropriate vehicle body height is obtained by measuring the clearance of all the air springs installed on the vehicle. The two front air springs clearance should be  $11 \pm \frac{1}{4}$ " (279  $\pm$  6 mm). Refer to figure 46 to identify the correct area to take measurement. The rear air springs clearance should be  $11 \frac{1}{2} \pm \frac{1}{4}$ " (292  $\pm$  6 mm).

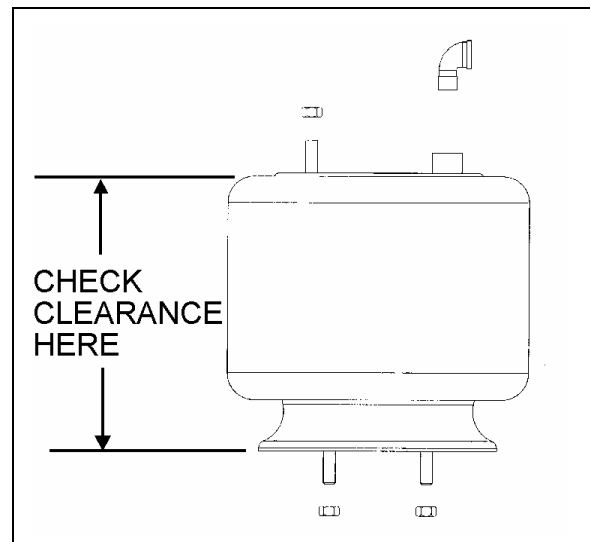


FIGURE 46: TYPICAL AIR SPRING CLEARANCE 16058

At this point, it should not be necessary to make an adjustment under normal service conditions. However, if an adjustment is required, change the position of the overtravel lever in relation to the overtravel control body. The lever should be moved up to raise vehicle height, and down to lower it. Check that main air pressure is at normal operating pressure and raise the vehicle to the specified height.



### CAUTION

Always adjust on "fill cycle". If it is necessary to lower vehicle height, release sufficient air to be well below height, and adjust to height or fill cycle.

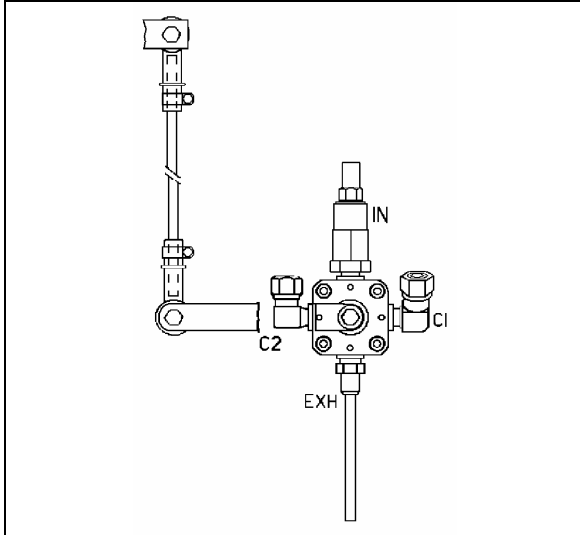


FIGURE 47: FRONT HEIGHT CONTROL VALVE 16100

The normal ride height is obtained by adjusting air spring clearance of both front and rear suspension as follows:

#### Front air spring clearance

1. With the vehicle at normal operating air pressure [100 - 125 psi (689 - 860 kPa)], measure air spring clearance. This clearance should be  $11 \pm \frac{1}{4}$ " (279  $\pm$  6 mm).

#### NOTE

The measurement should be taken from underneath the upper air spring support on subframe to top of the lower air spring support on axle (refer to figure 46 for more details). If adjustment is required, begin with the drive axle.

2. Loosen the clamp on the height control valve rubber coupling and bring it up or down (Fig. 47).

#### NOTE

Allow suspension to stabilize before taking reading.

When the desired height is obtained, tighten clamp.

#### Rear air spring clearance

1. With the vehicle at normal operating air pressure [100 - 125 psi (689 - 860 kPa)], measure air spring clearance. This clearance should be  $11 \frac{1}{2} \pm \frac{1}{4}$ " (292  $\pm$  6 mm).

#### NOTE

The measurement should be taken from underneath the upper air spring support on subframe to top of the lower air spring support on axle (refer to figure 46 for more details).

2. Loosen the clamp on the height control valve rubber coupling and bring it up or down (Fig. 48).

#### NOTE

Allow suspension to stabilize before taking reading.

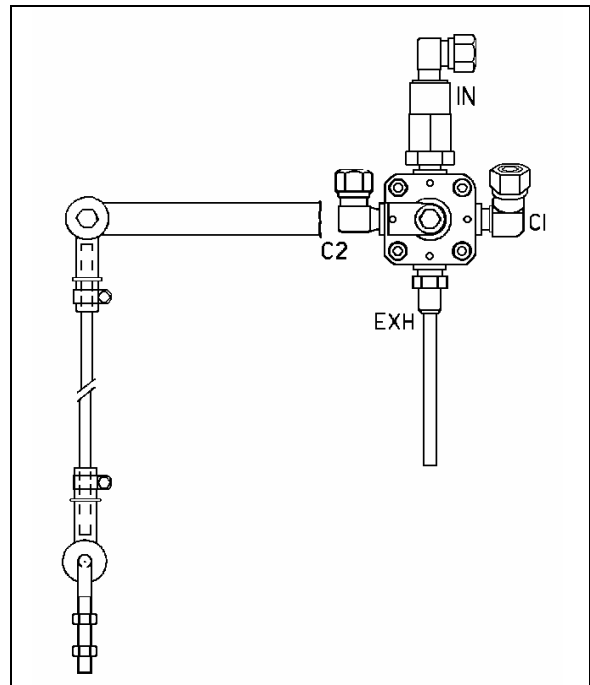


FIGURE 48: REAR HEIGHT CONTROL VALVE 16093

When the desired height is obtained, tighten clamp.

## 6. HEIGHT CONTROL VALVE

The height control valves automatically add air to, or release air from air springs to maintain constant suspension height regardless of load, or load distribution. Each valve adjusts independently according to the following conditions:

#### Loading Position

As the load increases and lowers the vehicle body, the overtravel lever commands the height control valve to add air to air springs.

### Neutral Position

When vehicle body reaches the normal ride height, the height control valve overtravel lever reaches the "neutral" position and keeps both the supply and exhaust ports closed to ensure normal ride height is maintained. This condition remains static until the vehicle load is altered.

### Unloading Position

As the load decreases and raises the vehicle body, the overtravel lever commands the height control valve to release air from air springs.

## 6.1 MAINTENANCE

The height control valve requires no periodic maintenance. Height control valve linkage operates on rubber bushings and no lubrication should be attempted at this location. Inspect the valve for loose joints, air leaks and worn bushings.

### 6.1.1 Removal and Installation

Before disconnecting a height control valve air line, securely support the vehicle by its jacking points on the body, and place safety supports underneath body. Refer to paragraph "16. Vehicle Jacking Points" in Section 18, "Body".

1. Exhaust air from air system by opening all air tank drain cocks. Remove height control valves.
2. Disconnect overtravel lever from link and pull down lever to exhaust remaining air from air springs.
3. Disconnect air supply and delivery lines from the height control valve. Cover line ends with tape to prevent entry of foreign matter.
4. Remove the nuts retaining the height control valve to the mounting bracket, then remove valve assembly.

Reverse removal procedure to replace height control valve. After installation, check for leakage using a soap and water solution.

## 7. AIR SYSTEM

The basic air system consists of an air compressor, tanks, valves, filters and interconnecting lines and hoses (refer to Section 12, "Brake and Air System" for complete information). It provides a means for braking, operating controls and accessories, and

suspension. An air system schematic diagram is annexed at the end of this section for better understanding of the system.

The air coming from the air dryer is first directed to the wet air tank, then to the primary (for the primary brake system), secondary (for the secondary brake system), and accessory (for the pneumatic accessories) air tanks (Fig. 49 and 50).

In addition, an expansion air tank may be installed in series with each air spring.

## 7.1 AIR TANK MAINTENANCE

Ensure that the accessories air tank is purged during pre-starting inspection. A good practice is to purge this tank at the end of every driving day by the remote air tank drain valve located in the steering compartment (Fig. 52).

Moreover, purge all tanks by their bottom drain valves at specified intervals.

### 7.1.1 Wet Air Tank

This tank is installed above the drive axle on the L.H. side, and is provided with a bottom drain valve. It is recommended to **purge** the wet air tank by its bottom drain valve every 12,500 miles (20 000 km), or once a year, whichever comes first.

A remote valve located in engine compartment and accessible through engine R.H. side door is used to **drain** the air dryer (Fig. 51).

### 7.1.2 Primary Air Tank

The primary air tank is located above the drive axle on the R.H. side.

This tank is provided with a bottom drain valve (Fig. 49 and 50). It is recommended to purge the primary air tank by its bottom drain valve every 12,500 miles (20 000 km) or once a year, whichever comes first.

### 7.1.3 Secondary Air Tank

This tank is located in front wheelhousing, between air springs. The tank may be installed vertically depending on type of front suspension and is provided with a bottom drain valve (Fig. 49 and 50).

It is recommended to purge the tank by its bottom drain valve, every 12,500 miles (20 000 km) or once a year, whichever comes first.

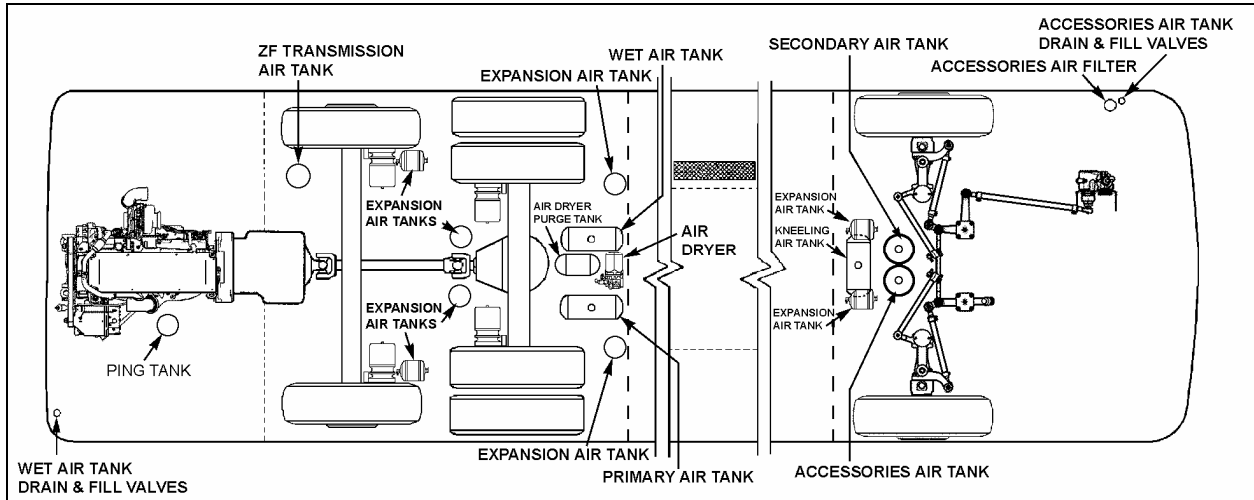


FIGURE 49: IFS AIR TANKS LOCATION

24034

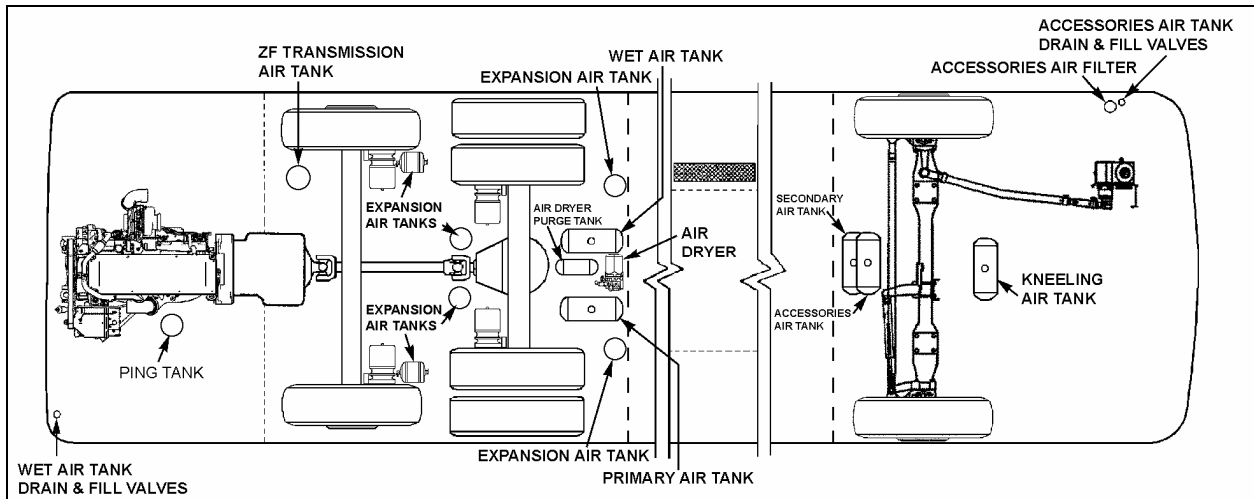


FIGURE 50: I-BEAM FRONT SUSPENSION AIR TANKS LOCATION

24035

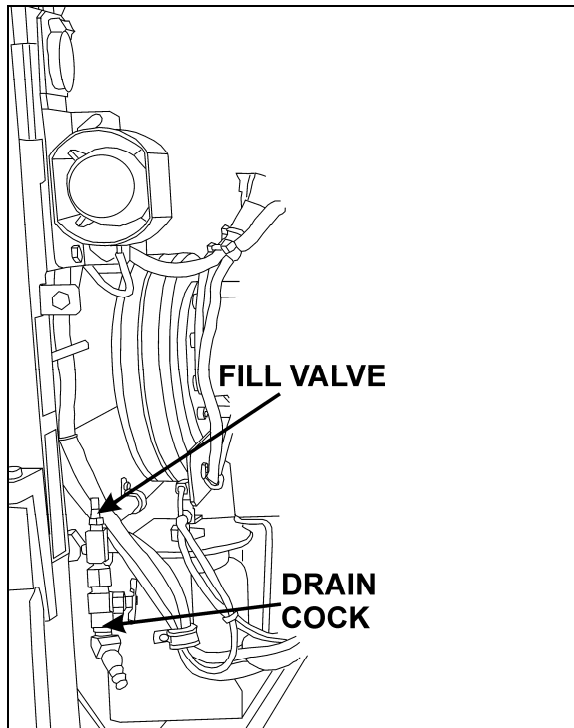


FIGURE 51: REAR VALVE LOCATION 12211

### 7.1.4 Accessory Air Tank

The accessory air tank is installed next to the secondary air tank. The tank may be installed vertically depending on type of front suspension and is provided with a bottom drain valve (Fig. 38).

It is recommended to purge the tank by its bottom drain valve, every 12,500 miles (20 000 km) or once a year, whichever comes first.

A remote drain valve is located in front service compartment (Fig. 52) underneath the accessory air filter. Refer to Section 12, paragraph "4. Accessory Air Filter" of the maintenance manual for daily purge procedure.

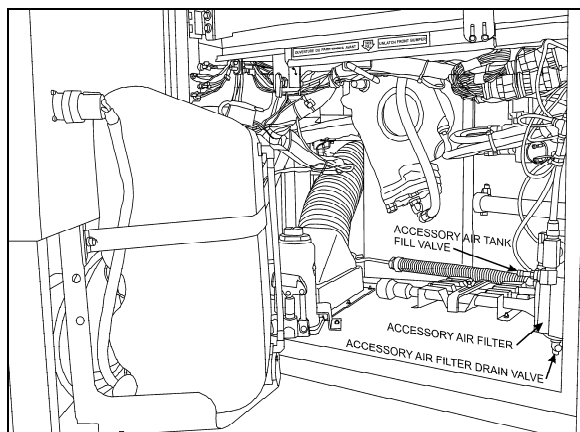


FIGURE 52: FRONT VALVE LOCATION 12210

### 7.1.5 Expansion Air Tank

Two expansion tanks will be installed in front wheelhousing if the IFS was chosen as an option. These air tanks are located behind secondary and accessory air tank. Also, six expansion tanks are located near rear air springs (Fig. 49 and 50). Expansion tanks are connected in series with air springs. Expansion tanks are used to lower the stiffness of the air spring. They are provided with a bottom drain valve.

It is recommended to purge them, with all other tanks, every 12,500 miles (20 000 km) or once a year, whichever comes first.

### 7.2 EMERGENCY FILL VALVES

The vehicle is equipped with two air system emergency fill valves to supplement the air system when air pressure is low and engine cannot be operated.

**The rear valve** is located in engine compartment and accessible from engine R.H. side door (Fig. 51).



### CAUTION

No other point should be used to supply air system. The maximum allowable air pressure is 125 psi (860 kPa).

The front valve is located in the front service compartment close to accessory air filter (Fig. 52).

These two air valves are fitted with the same valve stems as standard tires, and can be filled by any standard external air supply line.

The rear valve will supply air for all systems (brakes, suspension and accessories) while the front valve will supply air for accessories only.



### CAUTION

Air filled through these two points will pass through the standard air filtering system provided by Prévost. Do not fill air through any other points.

## 8. HUB UNIT AND SWIVEL ASSEMBLY

Refer to "DANA SPICER Service Manual General Information, Maintenance Manual Model NDS and Maintenance Manual NDS Axles" annexed to Section 10 of the maintenance manual.

## 9. FRONT KNEELING SYSTEM

The kneeling system is used to lower front of vehicle. This allows passengers to board the vehicle with greater ease. The kneeling action is achieved by exhausting air from the front air springs (bellows). This system bypasses the height control valve to provide a fast up and down movement of the front suspension. Only seven seconds are required to lower vehicle from normal level to the lowered position, and approximately the same time to raise the vehicle back to normal level. The quick response is achieved by an auxiliary air tank installed beside the secondary air reservoir (for exact position, refer to Section 12, *“Brake and Air System”*). This tank provides sufficient air supply to the kneeling system for some successive operations.

The system is provided with two safety features; first, a speed switch will enable the kneeling system to work only at less than 5 mph (8 km/h). Secondly, the parking brake is automatically applied, and a limit switch will keep it applied as long as the vehicle has not returned to a certain height where the driver will be able to manually remove the parking brake.

The purpose of the hi-buoy function in this system is to raise the front end of the vehicle to allow an extra ground clearance for particular situations. In driving condition, the height control valve is in operation and only the hi-buoy can be operated.

### 9.1 PRINCIPLE OF OPERATION

Refer to the air system schematic diagram annexed at the end of Section 12, *“Brake and Air System”*.

#### DOWN (FRONT KNEELING):

Both the bellows control and bellows exhaust solenoid valves are energized, so the air control valves release air from front air springs. The height control valve is bypassed to ensure no air is forwarded to air springs while lowering the front suspension.

#### UP (FRONT HIGH-BUOY):

Only the bellows control solenoid valve is energized, so the air coming from the kneeling air tank is routed through air control valves, and up to front air springs.

The height control valve is bypassed until the kneeling proximity switch signals the kneeling

module to cut off the bellows control solenoid valve, about 1" (25 mm) below normal ride height. The final height adjustment is achieved by the height control valve.

### 9.2 MAINTENANCE

Since the kneeling action is issued from both the air system and electrical system, refer to Section: 12, *“Brake and Air System”* and Section 06, *“Electrical System”*.

For diagnosis and understanding of the system, refer to wiring diagrams, and to the appropriate air system schematic diagram annexed to Section 12, *“Brake and Air System”*.

### 9.3 BELLOWS CONTROL SOLENOID VALVES

#### 9.3.1 Removal and installation

1. On the rear side of steering compartment, locate both the bellows control and bellows exhaust solenoid valves.
2. Identify hoses and wires to ease reinstallation. Disconnect solenoid wires and the three flexible black hoses from solenoid valves.
3. Unscrew and remove the control solenoid valve and exhaust solenoid valve assembly. Place on a clean working place.

Reverse removal procedure to reinstall.



### CAUTION

Any cable tie that has been cut during removal procedure should be replaced with a new one.

## 10. HIGH-BUOY SYSTEM

The purpose of the rear high-buoy system is to raise the entire vehicle body about 4" (100 mm) in order to increase ground clearance to board a ferryboat, to jump a curb, etc. This system can be put into service during normal vehicle operation.

### 10.1 PRINCIPLES OF OPERATION

The rear high-buoy system is added over the front kneeling (with front high-buoy). The front end uses the same valves as the front kneeling (with front high-buoy). A solenoid valve is added to send air to the double shuttle valves for the rear end. It uses the same dash switch as the kneeling (with front high-buoy).

UP:

The air coming from the control valve flows through double shuttle valves, to supply air springs. The double shuttle valves prevent height control valves from releasing air from air springs.

DOWN:

The control valve, on the dashboard, cuts off air supply, so the double shuttle valves allow height control valves to accomplish their function. Height control valves release air from air springs until suspension returns to its normal position.

## 10.2 MAINTENANCE

Refer to the air system schematic diagram “Opt. Front Kneeling With Rear High-Buoy Combination” annexed at the end of this Section.

### 10.3 HIGH-BUOY – PRESSURE REGULATING VALVE

The regulating valve is located in the front service compartment. This valve should be adjusted to 90 psi (621 kPa).

#### 10.3.1 Adjustment

1. Before turning on system air pressure, release jam nut (2, Fig. 53) then turn regulator adjustment counterclockwise until all load is removed from the regulating spring.
2. Turn on system pressure.
3. Turn regulator adjustment clockwise until the desired outlet pressure is reached.
4. To avoid minor readjustment after making a change in pressure setting, always approach the desired pressure from a lower pressure. When reducing from a higher to a lower setting, first reduce the pressure at a lower pressure, and then increase it to the desired level of pressure.
5. Tighten jam nut (2, Fig. 53) to lock pressure setting.

#### 10.3.2 Disassembly

1. Shut off inlet pressure and reduce pressure in inlet and outlet lines to zero. Turn regulator adjustment (1, Fig. 53) counterclockwise until all load is removed from regulating spring. Regulator can be disassembled without removal from air line.

2. Disassemble regulator in accordance with the item numbers on the exploded view.

#### 10.3.3 Cleaning

1. Clean parts with warm water and soap. Dry parts and blow out internal passages in body using clean, dry compressed air.
2. Inspect parts. Replace those found to be damaged.

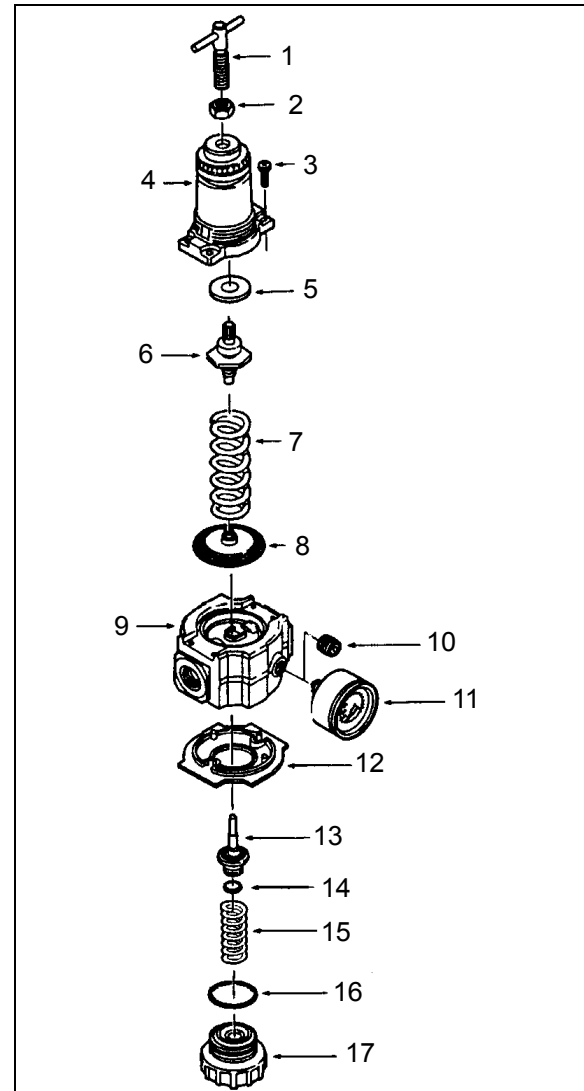


FIGURE 53: REGULATING VALVE

16035

#### 10.3.4 Reassembly

1. Lubricate O-ring (14 and 16, Fig. 53), valve stem (13, Fig. 53), tip of adjusting screw (1, Fig. 53), and the outer circumference and both sides of the thrust washer (9, Fig. 53) with a light coat of good quality O-ring grease.



- Assemble the regulator as shown on the exploded view.

| Torque Table     |                         |
|------------------|-------------------------|
| Item             | Torque in lbf-inch (Nm) |
| 3 (Screw)        | 25-35 (2.8-3.9)         |
| 17 (Bottom plug) | 20-25 (2.3-2.8)         |

### 11. LOW-BUOY SYSTEM

The purpose of the low-buoy system is to lower the whole suspension by about 4" (100 mm) in order to reduce the overall height for low clearances. This system can be put into service during normal vehicle operation.

#### 11.1 PRINCIPLES OF OPERATION

On X3 coaches, the rear low-buoy is added over the front kneeling system. The control valve on the left console panel sends an electric signal from its pressure switch to control the front suspension as if kneeling. It also removes air from a relay valve that exhausts air supply to all leveling valves and the quick release in the rear section. Air from the rear suspension can then be depleted through the check valve-quick release assembly.

### 12. TROUBLESHOOTING

| Condition   | Cause  | Correction  |
|---|--|---|
| Bellows deflate over time                                     | <ol style="list-style-type: none"> <li>Defective check valve assembly.</li> <li>Defective exhaust valve assembly.</li> <li>Leak in air line and/or bellows.</li> <li>Defective valve cover, rubber O-rings or gasket.</li> </ol> | <ol style="list-style-type: none"> <li>Replace check valve assembly.</li> <li>Replace exhaust valve assembly.</li> <li>Replace air line or bellows.</li> <li>Replace valve cover, O-rings or gasket.</li> </ol> |
| Bellows raise to full height and fail to exhaust air pressure | <ol style="list-style-type: none"> <li>A clogged exhaust screen in height control valve assembly.</li> <li>A combination clogged exhaust screen and defective air inlet valve assembly.</li> </ol>                               | <ol style="list-style-type: none"> <li>Remove and clean screen.</li> <li>Clean exhaust screen and replace air inlet valve assembly.</li> </ol>  |
| Erratic valve action  | <ol style="list-style-type: none"> <li>Dirt or foreign matter in the air valve lever chamber.</li> <li>Defectives valves.</li> </ol>   | <ol style="list-style-type: none"> <li>Remove valve cover and blow out dirt. Install cover using new gasket.</li> <li>Overhaul height control valve assembly</li> </ol>   |
| Vehicle body fails to level to satisfactory ride height       | <ol style="list-style-type: none"> <li>Improper height control valve overtravel lever adjustment</li> </ol>  | <ol style="list-style-type: none"> <li>Adjust lever as directed.</li> </ol>   |

#### Down:

The control valve, on the L.H. control panel, cuts off air supply, so air is released from air springs. A relay valve prevents height control valves from supplying air springs.

#### Up:

The control valve, on the L.H. control panel, supplies air to close the passage between both the delivery and supply ports. A relay valve opens and provides air springs until the suspension reaches the normal ride height.

#### 11.2 MAINTENANCE

Refer to the air system schematic diagram "Opt. Front Kneeling With Rear Low-Buoy Combination" annexed at the end of this Section.

**13. PARTS SPECIFICATIONS**

**Front suspension and tag axle air springs**

Make..... Goodyear Tire and Rubber  
 Model..... 1200  
 Type ..... Mae West  
 Nominal diameter ..... 12" (304 mm)  
 Supplier number..... 1R12-319  
 Prévost number.....630125

**Drive axle air springs**

Make..... Goodyear Tire and Rubber  
 Model..... 1100  
 Type ..... Double Flare  
 Nominal diameter ..... 11.5" (292 mm)  
 Supplier number..... 1R11-088  
 Prévost number.....630104

**Independent Front suspension shock absorbers**

Make..... Arvin  
 Color.....Black  
 Piston Diam. .... 1 5/8 inch  
 Collapsed length ..... 14.16 inches  
 Extended length ..... 22.44 inches  
 Supplier number..... 680510-40J  
 Prévost number.....630136

**I-Beam Front suspension shock absorbers**

Make.....Sachs  
 Color.....Black  
 Type ..... NUV45X230HA  
 Ext. Diam. ....75 mm  
 Collapsed length ..... 14.88" (378 mm)  
 Extended length ..... 23.86" (606 mm)  
 Supplier number..... 481700000206  
 Prévost number.....630254

**Drive and tag axle shock absorbers**

Make ..... Sachs  
 Color ..... Black  
 Type ..... N45X225HA  
 Ext. Diam. .... 75 mm  
 Collapsed length ..... 15.51" (394 mm)  
 Extended length ..... 24.37" (619 mm)  
 Supplier number .....481700000209  
 Prévost number ..... 630253

**Height control valve (Front only)**

Make ..... Barksdale  
 Quantity used..... 1  
 Supplier number ..... 52321POAQ3-Q62  
 Prévost number ..... 630157

**Height control valve (Rear only)**

Make ..... Barksdale  
 Quantity.....2  
 Supplier number ..... 52321POAQ3-Q26  
 Prévost number ..... 630156

**Bellows control and exhaust solenoid valve assembly**

Make ..... Norgren

**Solenoid valve manifold**

Supplier number ..... D0043B  
 Prévost number ..... 641130

**Coil**

Voltage..... 24 V DC  
 Current draw .....29 amperes  
 Supplier number .....54932-27  
 Prévost number ..... 641144

**Valve (3 way, 2 positions)**

Type ..... N/C  
 Supplier number ..... 411-C-456235W  
 Prévost number ..... 641357  
 Type ..... N/O  
 Supplier number ..... 411-D-456236X  
 Prévost number ..... 641356

**Radius rod bushing**

Make ..... Prévost  
 Prévost number ..... 630021

**Loctite**

Make ..... Loctite  
 Prévost number ..... 680039

**Sway bar bushing (Front Suspension)**

Make ..... Prévost  
 Prévost number ..... 630020

**Sway bar link**

Make ..... Tennaco Automotive  
 Supplier number ..... 934400  
 Prévost number ..... 630230

**Shock absorber bushings**

Make ..... Monroe  
 Supplier number ..... 45380  
 Prévost number ..... 630062

**Air regulator**

Make ..... Norgren  
 Recommended pressure sett. . 90 psi (621 kPa)  
 Supplier number ..... R74G-4AT-RMN  
 Prévost number ..... 641352

**14. TORQUE SPECIFICATIONS**

- |    |  |   |
|----|--|---|
| 1- | Shock absorber pin .....               | 500-550 lbf-ft (680-750 Nm)                       |
| 2- | Shock absorber pin nut .....           | 70-80 lbf-ft (95-110 Nm)                          |
| 3- | Radius rod stud .....                  | 20-40 lbf-ft (27-54 Nm)                           |
| 4- | Radius rod retaining nut or bolt ..... | 110-130 lbf-ft lubricated (150-175 Nm lubricated) |
| 5- | Radius rod support nut .....           | 110-130 lbf-ft lubricated (150-175 Nm lubricated) |
| 6- | Axle attachment nut .....              | 425-475 lbf-ft (580-645 Nm)                       |
| 7- | Air spring stud nut .....              | 20-25 lbf-ft (27-34 Nm)                           |
| 8- | Sway bar link nuts .....               | 110-130 lbf-ft lubricated (150-175 Nm lubricated) |
| 9- | Sway bar bushing collar bolts .....    | 70-80 lbf-ft (95-110 Nm)                          |

**NOTE**

*During assembly, use "Loctite 242" (Prévost No 680038) with item 1 and 3. After assembly, apply "anti-seize compound" (Prévost No 680064) on all threads nuts.*

## SECTION 18: BODY

### CONTENTS

|          |  |           |
|----------|--|-----------|
| <b>1</b> | <b>VEHICLE EXTERIOR VIEW .....</b>   | <b>5</b>  |
| <b>2</b> | <b>VEHICLE STRUCTURE.....</b>  | <b>6</b>  |
| <b>3</b> | <b>VEHICLE EXTERIOR MAINTENANCE .....</b>  | <b>6</b>  |
| 3.1      | CORROSION PREVENTION .....   | 6         |
| 3.2      | PREVENTIVE MAINTENANCE SCHEDULE.....   | 7         |
| 3.3      | RUST INHIBITOR APPLICATION .....   | 7         |
| <b>4</b> | <b>COMMON FIBERGLASS REPAIR PROCEDURE .....</b>                                    | <b>12</b> |
| 4.1      | REPAIR USING FIBERGLASS CLOTH.....   | 12        |
| 4.2      | REPAIR USING FIBERGLASS PASTE .....  | 12        |
| 4.3      | TYPICAL FIBERGLASS REPAIR PROCEDURE .....  | 13        |
| <b>5</b> | <b>COMMON PAINTING PROCEDURE.....</b>  | <b>14</b> |
| 5.1      | NEW PAINT CARE .....   | 14        |
| 5.2      | PAINT TOUCHUP .....  | 14        |
| 5.3      | PAINTING.....  | 15        |
| 5.3.1    | <i>Safety</i> .....  | 15        |
| 5.3.2    | <i>Surface Preparation And Paint Application</i> .....                             | 15        |
| <b>6</b> | <b>GENERAL DESCRIPTION .....</b>   | <b>16</b> |
| <b>7</b> | <b>ZONE 1 .....</b>  | <b>16</b> |
| 7.1      | FRONT BUMPER.....  | 16        |
| 7.2      | FRONT CREST .....  | 17        |
| 7.3      | HEADLIGHTS.....  | 17        |
| 7.4      | REAR VIEW MIRRORS (RAMCO).....   | 18        |
| 7.4.1    | <i>Adjustment</i> .....  | 18        |
| 7.4.2    | <i>Disassembly</i> .....   | 18        |
| 7.4.3    | <i>Assembly</i> .....  | 18        |
| 7.4.4    | <i>Replacement of Mirror Glass</i> .....   | 18        |
| 7.4.5    | <i>Heated / Remote Controlled Rear View Mirrors</i> .....                          | 18        |
| 7.5      | WINDSHIELD WIPERS .....  | 19        |
| 7.6      | WINDSHIELD .....   | 19        |
| 7.6.1    | <i>Windshield Installation</i> .....   | 19        |
| 7.7      | ENTRANCE DOOR.....   | 20        |
| 7.7.1    | <i>Operation</i> .....   | 21        |
| 7.7.2    | <i>Emergency Exit Valves</i> .....   | 22        |
| 7.7.3    | <i>Door Cycle Speed Adjustment</i> .....   | 22        |
| 7.7.4    | <i>Horizontal And Vertical Adjustment</i> .....                                    | 23        |
| 7.7.5    | <i>Troubleshooting</i> .....   | 24        |
| 7.7.6    | <i>Lubrication</i> .....   | 25        |
| 7.7.7    | <i>Entrance Door Body Panel and Window</i> .....                                   | 25        |
| 7.7.8    | <i>Front Electrical &amp; Service Compartment Door Body Panel and Window</i> ..... | 28        |
| 7.7.9    | <i>Upper Lateral Window</i> .....  | 31        |
| 7.7.10   | <i>Front Cap</i> .....   | 34        |
| <b>8</b> | <b>ZONE 2 .....</b>  | <b>35</b> |
| 8.1      | LATERAL FIXED WINDOW.....  | 35        |

## Section 18: BODY

---

|           |   |           |
|-----------|---|-----------|
| 8.1.1     | Fixed Window Removal.....   | 35        |
| 8.1.2     | Preparation of Structure and Installation of Window.....                      | 36        |
| 8.2       | EMERGENCY EXIT WINDOWS.....   | 36        |
| 8.2.1     | Emergency Exit Release Bar.....   | 37        |
| 8.2.2     | Emergency Exit Window Adjustment.....   | 37        |
| 8.2.3     | Emergency Exit Window Replacement.....  | 37        |
| 8.3       | ROOF ESCAPE HATCH.....  | 37        |
| 8.3.1     | Repair.....   | 38        |
| 8.3.2     | Sealing.....  | 38        |
| 8.3.3     | Escape Hatch Panel Assembly.....  | 38        |
| 8.3.4     | Escape Hatch Frame.....   | 39        |
| <b>9</b>  | <b>ZONE 3.....</b>  | <b>39</b> |
| 9.1       | REAR CAP.....   | 39        |
| 9.2       | ENGINE COMPARTMENT DOORS.....   | 39        |
| 9.3       | REAR BUMPER.....  | 40        |
| <b>10</b> | <b>ZONE 4.....</b>  | <b>40</b> |
| 10.1      | REAR FENDER.....  | 41        |
| 10.2      | ENGINE COMPARTMENT R. H. SIDE DOOR.....                                       | 41        |
| 10.3      | ENGINE RADIATOR DOOR.....   | 41        |
| <b>11</b> | <b>ZONE 5.....</b>  | <b>42</b> |
| 11.1      | BAGGAGE COMPARTMENT DOORS.....  | 42        |
| 11.1.1    | Door Lower Panel.....   | 42        |
| 11.1.2    | Door Upper Panel.....   | 43        |
| 11.2      | BAGGAGE COMPARTMENT FLOOR.....  | 44        |
| 11.2.1    | Repair of Mantex Urethane Covering.....                                       | 44        |
| 11.2.2    | Baggage Compartment Floor Installation.....                                   | 45        |
| 11.3      | EVAPORATOR COMPARTMENT DOOR.....  | 47        |
| 11.4      | CONDENSER COMPARTMENT DOOR.....   | 48        |
| 11.5      | FUEL FILLER DOOR.....   | 48        |
| <b>12</b> | <b>ZONE 6.....</b>  | <b>49</b> |
| 12.1      | FRONT FENDER.....   | 49        |
| <b>13</b> | <b>ZONE 7.....</b>  | <b>49</b> |
| 13.1      | X3 SMOOTH SIDE PANEL REPLACEMENT PROCEDURE.....                               | 50        |
| 13.2      | SIDE CREST.....   | 56        |
| <b>14</b> | <b>BODY PANEL AND WINDOW SPACING.....</b>                                     | <b>57</b> |
| <b>15</b> | <b>PASSENGER SEATS.....</b>   | <b>58</b> |
| 15.1      | ROTATING SEATS.....   | 58        |
| 15.2      | REMOVING FIXED SEATS.....   | 58        |
| 15.3      | UPHOLSTERY MAINTENANCE.....   | 59        |
| 15.3.1    | Routine Cleaning.....   | 59        |
| 15.3.2    | Dry Cleaning.....   | 59        |
| 15.3.3    | Cleaning With Covers in Place.....  | 59        |
| <b>16</b> | <b>TARABUS FLOOR COVERING REPAIR OR REPLACEMENT.....</b>                      | <b>60</b> |
| 16.1      | FRONT STEPS REPLACEMENT PROCEDURE.....  | 62        |
| 16.2      | WELDING OF JOINT BETWEEN WHITE SAFETY STRIP AND "TARABUS" FLOOR COVERING..... | 65        |
| 16.3      | REPAIR OF A WELDED JOINT.....   | 68        |

|           |                                     |           |
|-----------|-------------------------------------|-----------|
| <b>17</b> | <b>VEHICLE JACKING POINTS .....</b> | <b>68</b> |
| 17.1      | HYDRAULIC JACK.....                 | 69        |
| <b>18</b> | <b>TOWING THE VEHICLE.....</b>      | <b>70</b> |
| 18.1      | LIFTING AND TOWING .....            | 70        |
| 18.2      | TOWING WITHOUT LIFTING.....         | 71        |
| <b>19</b> | <b>SPECIFICATIONS .....</b>         | <b>72</b> |

## ILLUSTRATIONS

|            |   |    |
|------------|---|----|
| FIGURE 1:  | X3 COACHES EXTERIOR VIEW.....             | 5  |
| FIGURE 2:  | FIBERGLASS REPAIR.....                    | 13 |
| FIGURE 3:  | FIBERGLASS REPAIR.....                    | 13 |
| FIGURE 4:  | FIBERGLASS REPAIR.....                    | 13 |
| FIGURE 5:  | FIBERGLASS REPAIR.....                    | 14 |
| FIGURE 6:  | FIBERGLASS REPAIR.....                    | 14 |
| FIGURE 7:  | X3 COACHES ZONING .....                   | 16 |
| FIGURE 8:  | ZONE 1.....                               | 16 |
| FIGURE 9:  | FRONT BUMPER RELEASE HANDLE.....          | 17 |
| FIGURE 10: | FRONT BUMPER .....                        | 17 |
| FIGURE 11: | FRONT BUMPER REMOVAL .....                | 17 |
| FIGURE 12: | REAR VIEW MIRROR (RAMCO).....             | 18 |
| FIGURE 13: | WINDSHIELD INSTALLATION USING ROPE .....  | 20 |
| FIGURE 14: | APPLICATION OF SIKA 221 BLACK .....       | 20 |
| FIGURE 15: | ENTRANCE DOOR & WIPER CONTROL PANEL ..... | 20 |
| FIGURE 16: | ENTRANCE DOOR OPERATING BUTTONS.....      | 21 |
| FIGURE 17: | COACH ENTRANCE DOOR.....                  | 21 |
| FIGURE 18: | ENTRANCE DOOR CONTROL SWITCH.....         | 21 |
| FIGURE 19: | INTERIOR UNLATCH AIR VALVE .....          | 22 |
| FIGURE 20: | EXTERIOR UNLATCH AIR VALVE .....          | 22 |
| FIGURE 21: | DAMPER .....                              | 23 |
| FIGURE 22: | UPPER DOOR HINGE .....                    | 23 |
| FIGURE 23: | SEAL COMPRESSION ADJUSTMENT .....         | 23 |
| FIGURE 24: | ZONE 2.....                               | 35 |
| FIGURE 25: | X3-45 COACH .....                         | 37 |
| FIGURE 26: | EMERGENCY EXIT WINDOW .....               | 37 |
| FIGURE 27: | ESCAPE HATCH.....                         | 38 |
| FIGURE 28: | ESCAPE HATCH.....                         | 39 |
| FIGURE 29: | ZONE 3.....                               | 39 |
| FIGURE 30: | ENGINE COMPARTMENT DOORS .....            | 40 |
| FIGURE 31: | REAR BUMPER .....                         | 40 |
| FIGURE 32: | ZONE 4.....                               | 40 |
| FIGURE 33: | ENGINE COMPARTMENT R.H. SIDE DOOR .....   | 41 |
| FIGURE 34: | RADIATOR DOOR .....                       | 41 |
| FIGURE 35: | ZONE 5.....                               | 42 |
| FIGURE 36: | EVAPORATOR DOOR.....                      | 48 |
| FIGURE 37: | CONDENSER DOOR .....                      | 48 |
| FIGURE 38: | FUEL FILLER DOOR.....                     | 48 |
| FIGURE 39: | ZONE 6.....                               | 49 |
| FIGURE 40: | ZONE 7.....                               | 49 |
| FIGURE 41: | SIDE CREST POSITIONING .....              | 56 |
| FIGURE 42: | BODY PANEL AND WINDOW SPACING.....        | 57 |
| FIGURE 43: | ARMREST .....                             | 58 |

**Section 18: BODY**

---

FIGURE 44: SEAT PEDESTAL ASSEMBLY..... 59  
FIGURE 45: TARABUS FLOOR COVERING ADHESIVE APPLICATION ..... 61  
FIGURE 46: APPLICATION OF SIKA 221 GRAY ..... 61  
FIGURE 47: JACKING POINTS ON FRAME ..... 69  
FIGURE 48: FRONT END JACKING POINTS..... 69  
FIGURE 49: REAR END JACKING POINTS..... 69  
FIGURE 50: JACKING POINTS ON IND. SUSPENSION ..... 69  
FIGURE 51: JACKING POINT ON FRONT AXLE ..... 69  
FIGURE 52: JACKING POINTS ON DRIVE AXLE ..... 69  
FIGURE 53: JACKING POINTS ON TAG AXLE ..... 69  
FIGURE 54: TOW EYES ..... 71

## 1 VEHICLE EXTERIOR VIEW

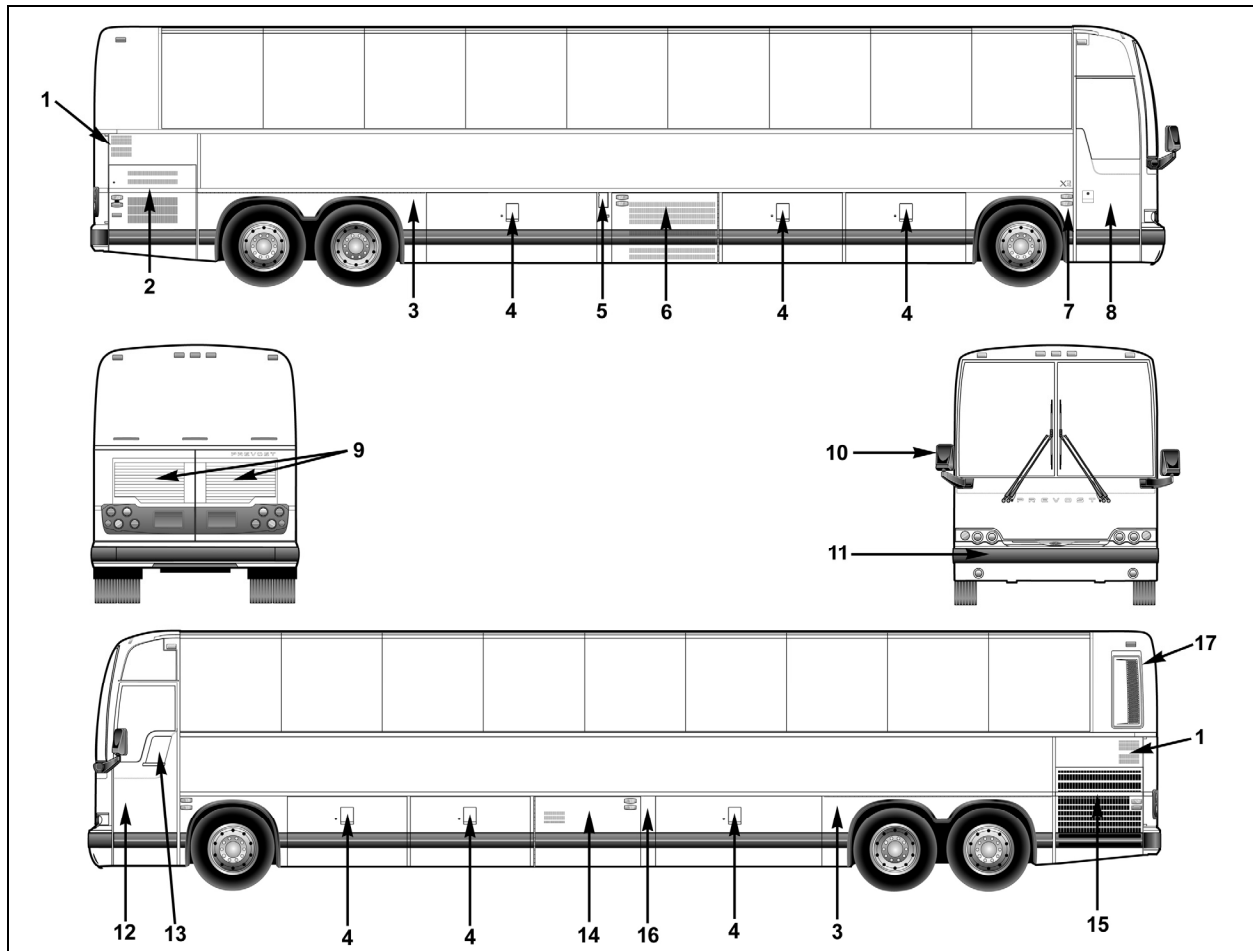


FIGURE 1: X3 COACHES EXTERIOR VIEW

18606

- |  |   |
|--|---|
| 1. Engine air intake                         | 17. Diesel Particulate Filter (DPF) compartment access door |
| 2. Engine compartment curb-side door         |   |
| 3. Hinged rear fender                        |   |
| 4. Baggage compartment                       |   |
| 5. Fuel filler door                          |   |
| 6. Condenser compartment                     |   |
| 7. Entrance door control switch              |   |
| 8. Entrance door                             |   |
| 9. Engine compartment rear doors             |   |
| 10. Rear-view mirrors                        |   |
| 11. Spare wheel compartment                  |   |
| 12. Front electrical and service compartment |   |
| 13. Driver's power window                    |   |
| 14. Evaporator compartment                   |   |
| 15. Radiator door                            |   |
| 16. Rear electrical compartment              |   |



## 2 VEHICLE STRUCTURE

The body of the X3 vehicles is an integral structure made of 14, 16 and 18 gauge welded and braced high tensile steel and stainless steel members. All stainless exterior panels are glued to anti-corrosion coated members. The complete structure is protected against corrosion prior to assembly. The front and rear caps are made of molded fiberglass. The main roof is made of high tensile aluminum panels riveted to the roof structure. The floor is made of 2 layers of ½" (13 mm) thick plywood separated by a 1/8" (3 mm) insulation to reduce power train and road noises.

### Welding

Since welding is a procedure that may be carried out either as specific instructions from Prévost or by an independent decision of the owner, the following information pertaining to welding should be read before beginning any welding procedure. The prohibitions and requirements outlined below must be followed during welding procedure:

1. Welding must be done only by a qualified and experienced person.
2. Adequate ground contacts and shields must be positioned as required to protect components from damage due to heat, contact by weld splatter, arcing, or other potentially damaging events associated with welding.
3. The following precautions are to be taken to protect the electronic control components. Refer to section 00, paragraph 3: "PRECAUTIONS TO BE OBSERVED BEFORE WELDING" in this manual.
4. Always wear the appropriate safety equipment.
5. Weld in clean and well ventilated area, and always have an appropriate fire extinguisher within your reach.

## 3 VEHICLE EXTERIOR MAINTENANCE

Regular washing to remove dust and dirt is recommended. See *"Operator's Manual"* for more details on washing and cleaning your vehicle.

### 3.1 CORROSION PREVENTION

Preventive maintenance is a key factor in avoiding corrosion and must be considered as part of the regular service intervals. The entire

underside of the vehicle is sprayed with a heavy application of asphalt base undercoating.

The operating environment the vehicle is subjected to will largely influence the amount of dirt and corrosion that will accumulate over a given period. Corrosion is one of the most costly factors of part failure and shortened part life. It is, however, an item that can be controlled when it is conscientiously looked after and the proper steps are taken in a timely manner.

Certain areas of the coach are more vulnerable to corrosion than others, and it is these areas that should be addressed. For example, the rear baggage compartment bulkhead in the rear wheelhousing area contains many key components and should be examined regularly for corrosion. Other areas include the front wheelhousing area and the engine compartment.

Road splash will affect undercarriage, condenser coil and engine compartment. These areas must be thoroughly cleaned to remove dirt accumulations from flanges, channels and ledges. These places accumulate dirt and salt and hold it in direct contact with steel and aluminum surfaces. Use an understructure high pressure spray as part of a regular wash. Damaged undercoating or paint should be promptly repaired before corrosion can start. Frequency of wash periods depends on operating conditions. During periods of exposure to salt, daily washing as described above is recommended. If underbody parts show evidence of rust or corrosion, treat as follows:

1. Remove dirt, grease and oil by solvent washing.
2. Remove corrosion as well as all loose coating by cleaning with a wire brush or sandblasting.



### CAUTION

Sandblasting can be used for cleaning bulkheads, brackets and other structural members. It should not be used for exterior side paneling. Extreme care should be taken not to sandblast excessively.

3. Apply correct primer, paint and undercoating after removing all corrosion to prevent further damage.

## 3.2 PREVENTIVE MAINTENANCE SCHEDULE

**NOTE**

*TECTYL 185 GW rust inhibitor may have been applied on your vehicle underbody as an option, if this is the case, follow this procedure thoroughly. For future application of product, refer to paragraph 3.3 in this section.*

| DESCRIPTION                   | INTERVALS |                   | MAINTENANCE  | CORRECTIVE ACTION   | REFERENCE |
|-------------------------------|-----------|-------------------|--|---|-----------|
|                               | MONTHS    | KM MILES          |  |   |           |
| BODY, EXTERNAL WINDOW FRAME   | 6         | 40 000<br>25 000  | VISUALLY INSPECT SEALING BEADS CONDITION   | REPAIR OR REPLACE SEALING BEADS IF NECESSARY  |           |
| VEHICLE UNDERBODY             | 12        | 100 000<br>60 000 | USE A LOW PRESSURE SPRAY TO CLEAN UNDERSTRUCTURE AND VISUALLY INSPECT FOR CALCIUM DEPOSIT, CORROSION OR ANY DIRT ACCUMULATED ONTO EXPOSED SURFACES. VISUALLY INSPECT SEALING BEADS CONDITION.<br><br>VISUALLY INSPECT IF UNDERFLOOR IS PEELING. VISUALLY INSPECT WHEELHOUSING COATING.<br><br>MAKE SURE DISCHARGE TUBES ARE FREE FROM OBSTRUCTIONS | APPLY UNDERCOATING LOCALLY AS NECESSARY.<br><br>APPLY UNDERCOATING LOCALLY AS NECESSARY<br><br>REMOVE ANY OBSTRUCTION OR REPLACE DEFECTIVE TUBE |           |
| SUSPENSION AND UNDERSTRUCTURE | 12        | 100 000<br>60 000 | VERIFY THE CONDITION OF ALL SUSPENSION AND UNDERSTRUCTURE FASTENERS AND CLAMPS   | TIGHTEN OR REPLACE DEFECTIVE OR MISSING FASTENERS   |           |
| FLOOR COVERING                | 3         | 20 000<br>12 500  | VISUALLY INSPECT IF FLOOR COVERING IS SHOWING SIGNS OF DETERIORATION SUCH AS CUTS, BURNS, ETC. ALSO, VISUALLY INSPECT SEALANT ALONGSIDE TRACKS. INSPECT WALL PANELS FROM BOTTOM TO WINDOWS   | REPAIR OR REPLACE DEFECTIVE COVERING. MAKE SURE PROPER SEALANT IS USED.   |           |
| FLOOR CLEANING                |           |                   | CLEAN FLOOR COVERING AS NECESSARY  |   |           |

**WARNING**

Failure to follow this preventive maintenance schedule will result in warranty void.

## 3.3 RUST INHIBITOR APPLICATION

Material: Tectyl 185 GW



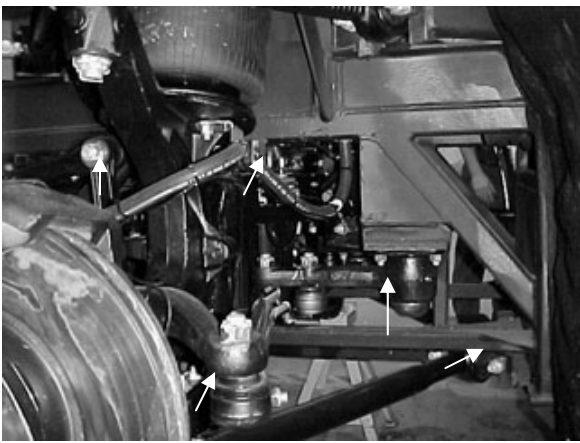
R1KG21

Safety Rules: Use safety glasses

Supplied air hood

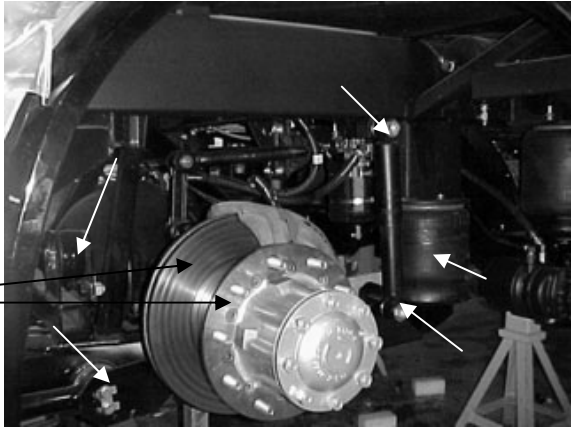
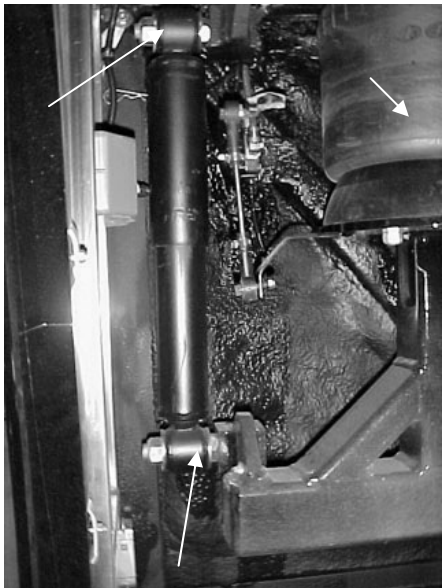
Solvent-resistant rubber gloves

## Section 18: BODY

|  |  |
|--|--|
| <p>1.0 Wash both wheelhousing mechanical parts before masking.</p>   | <p>A water-hose nozzle is recommended. Water may be hot to reduce washing time especially during winter. If parts are soiled with oil, clean using R1KG21. Avoid rubber parts.</p> |
| <p>2.0 Dry all water sprayed parts. Surface temperature and dew point must be respected before applying rust inhibitor.</p>  | <p>Air pressure system may be used, refer to annex 1 for surface temperature and dew point.</p>  |
| <p>3.0 <b>Front wheelhousing</b><br/>a) Mask all rubber joints. Braking system must also be protected (refer to arrows). Commercial aluminum foil may be used for masking.</p> |    |
| <p>3.1 <b>Front wheelhousing</b><br/>Front view</p>  |   |
| <p>3.2 <b>Front wheelhousing</b></p>   |    |

|  |  |
|--|--|
| <p><b>3.3 Front wheelhousing</b></p> <p>(Entire braking system)</p>  |  |
| <p><b>4.0 Rear wheelhousing</b></p> <p>a) Mask all rubber joints. Braking system must also be protected (refer to arrows). Commercial aluminum foil may be used for masking</p> <p>(Entire braking system)</p> |  |
| <p><b>4.1 Rear wheelhousing</b></p> <p>(Entire braking system)</p>   |  |

**Section 18: BODY**

|   |  |
|---|--|
| <p><b>4.2 Rear wheelhousing</b></p> <p>(Entire braking system)</p>                      |    |
| <p><b>4.3 Rear wheelhousing</b></p>   |   |
| <p>5.0 Close off wheelhousing using masking paper.</p>                                  | <p>Prevent rust inhibitor from coming in contact with paint. To close off wheelhousing, a polythene sheet may be used.</p>   |
| <p>6.0 Apply TECTYL 185 GW black rust inhibitor onto wheelhousing mechanical parts.</p> | <p>A spray gun and pumping system are required to apply the rust inhibitor. If the application is done inside a paint room, select high speed ventilation. <b>Minimum required thickness is 10 mils wet or 5 mils dry.</b></p> |
| <p>7.0 Remove all masking material 30 minutes after application.</p>                    |  |

**ANNEX 1**

1. Check and confirm that dew point and surface temperature are in accordance with to the following criteria:  
 Surface temperature > 10°C  
 Surface temperature > or = to dew point + 3°C

**NOTE**

*Use the following table to determine dew point.*


2. Check and confirm that TECTYL temperature is between 10°C and 35°C.

## DEW POINT

|          | Relative Humidity (%) |     |     |    |    |    |    |    |    |       |
|----------|-----------------------|-----|-----|----|----|----|----|----|----|-------|
|          | 10                    | 20  | 30  | 40 | 50 | 60 | 70 | 80 | 90 | 100   |
| Temp (c) |                       |     |     |    |    |    |    |    |    |       |
| 0        | ---                   | -16 | -11 | -8 | -5 | -3 | -1 | 0  | 1  | 3     |
| 1        | ---                   | -15 | -10 | -7 | -5 | -3 | -1 | 1  | 2  | 4     |
| 2        | ---                   | -14 | -10 | -6 | -4 | -1 | 0  | 2  | 3  | 5     |
| 3        | ---                   | -13 | -9  | -5 | -3 | -1 | 1  | 2  | 4  | 6     |
| 4        | ---                   | -13 | -8  | -5 | -2 | 0  | 2  | 4  | 5  | 7     |
| 5        | ---                   | -11 | -7  | -4 | -1 | 1  | 3  | 5  | 6  | 8     |
| 6        | ---                   | -11 | -8  | -3 | 0  | 2  | 4  | 6  | 7  | 9     |
| 7        | -18                   | -10 | -6  | -2 | 0  | 2  | 5  | 6  | 8  | 10    |
| 8        | -17                   | -9  | -5  | -1 | 1  | 4  | 6  | 7  | 9  | 11    |
| 9        | -16                   | -9  | -4  | -1 | 2  | 4  | 6  | 9  | 10 | 12    |
| 10       | -16                   | -8  | -3  | 0  | 3  | 5  | 7  | 10 | 11 | 13    |
| 11       | -15                   | -7  | -3  | 1  | 4  | 6  | 9  | 10 | 12 | 14    |
| 12       | -14                   | -6  | -1  | 2  | 5  | 7  | 10 | 11 | 13 | 15    |
| 13       | -14                   | -6  | -1  | 2  | 6  | 8  | 10 | 12 | 14 | 16    |
| 14       | -13                   | -5  | 0   | 4  | 6  | 9  | 11 | 14 | 15 | 17    |
| 15       | -12                   | -4  | 1   | 4  | 7  | 10 | 12 | 14 | 16 | 18    |
| 16       | -11                   | -4  | 1   | 5  | 9  | 11 | 13 | 15 | 17 | 19    |
| 17       | -10                   | -3  | 2   | 6  | 9  | 12 | 14 | 16 | 18 | 20    |
| 18       | -10                   | -2  | 3   | 7  | 10 | 13 | 15 | 17 | 19 | 21    |
| 19       | -9                    | -1  | 4   | 8  | 11 | 14 | 16 | 18 | 20 | 22    |
| 20       | -9                    | 0   |     | 5  | 9  | 12 | 15 | 17 | 19 | 21 23 |
| 21       | -8                    | 0   |     | 5  | 10 | 13 | 16 | 18 | 20 | 22 24 |
| 22       | -7                    | 1   |     | 6  | 11 | 14 | 16 | 19 | 21 | 23 25 |
| 23       | -6                    | 2   |     | 7  | 11 | 15 | 17 | 20 | 22 | 24 26 |
| 24       | -6                    | 2   |     | 8  | 12 | 16 | 19 | 21 | 23 | 25 27 |
| 25       | -5                    | 3   |     | 9  | 13 | 16 | 20 | 22 | 24 | 26 28 |
| 26       | -4                    | 4   |     | 10 | 14 | 17 | 20 | 23 | 25 | 27 29 |
| 27       | -4                    | 5   |     | 11 | 15 | 19 | 21 | 24 | 26 | 28 30 |
| 28       | -3                    | 6   |     | 11 | 16 | 19 | 22 | 25 | 27 | 29 31 |
| 29       | -2                    | 6   |     | 12 | 17 | 20 | 23 | 26 | 28 | 30 32 |
| 30       | -1                    | 7   |     | 13 | 17 | 21 | 24 | 27 | 29 | 31 33 |
| 31       | -1                    | 8   |     | 14 | 19 | 22 | 25 | 27 | 30 | 32 34 |
| 32       | 0                     | 9   |     | 15 | 20 | 23 | 26 | 29 | 31 | 33 35 |

#### 4 COMMON FIBERGLASS REPAIR PROCEDURE

All repairs to fiberglass parts consist of filling the damaged area with fiberglass cloth and resin or strand fiberglass and resin. The repair is allowed to harden, and then finishing operations may be performed. Use of the various materials is determined by the type of repair to be made. Large holes, torn sections and separate joints require the adhesive qualities of the resin and the reinforcing qualities of the fiberglass. Small dents, scratches or pits can be repaired using resin and strand fiberglass and filler mixed into paste. Instructions for either mix are explained under their respective headings in this section. For best results when making repairs, temperature should be between 70 and 75°F (21-24°C). Some people experience a skin reaction to resins. In such cases, wipe resin off with denatured alcohol or a good thinner. Use of protective hand cream is recommended.

|   |                |
|---|----------------|
|  | <b>WARNING</b> |
| Always wear a respirator and goggles when grinding or sanding.                    |                |

Extreme care must be taken if the sander is electrically operated, as dust from some resins is combustible when subjected to sparks or open flames. The proper tool for sanding resin is a low speed, air driven disc sander with a water attachment or a dry sander having a vacuum bag. Either will eliminate flying glass and resin dust.


The following additional tools and materials will assist in making repairs: hacksaw blade, assorted files, emery paper or cloth (150 or finer), scissors or tin snips, wax paper or cellophane sheets, a 3" (75 mm) paint roller, paint brush, putty knife, acetone and one or more heat lamps.

##### 4.1 REPAIR USING FIBERGLASS CLOTH

Where necessary, sand paint away around damaged area and scrape away undercoating, if any, and wipe clean with solvent. Grind or file the damaged area to form a "V" at the broken or cracked portion. Sides of "V" should have a shallow pitch for maximum bonding area.


|   |
|---|
| <i>NOTE</i>   |
| <i>Roughening the surface improves adhesion of resin.</i> |

If part is warped from original shape, use clamping equipment to straighten the surface. Preheat area to be repaired with one or two heat lamps placed 18 to 24 inches (450-610 mm) from repair.

|  |                |
|--|----------------|
|             | <b>CAUTION</b> |
| Temperature should not exceed 140 °F (60 °C) during 30 minutes in order to avoid distortion. |                |

Cut fiberglass cloth with scissors or tin snips, 1 to 3 inches (25-75 mm) larger than area to be repaired. Build area to desired height.

Mix resin and hardener following instructions on their containers. Saturate layers of fiberglass with mixture and place laminates over damaged area. Smooth out wrinkles and make sure general contour of area is maintained. Bubbles and wrinkles can be eliminated with a roller.

|   |                |
|---|----------------|
|    | <b>CAUTION</b> |
| The pot life of the mix is approximately 15 minutes. Any accidental contamination to the skin, clothing, tools, etc. must be removed within this period. Use acetone to remove uncured resin. |                |

Heat resin material again by placing heat lamps 18 to 24 inches (450-610 mm) from repaired area. Allow 12 to 15 minutes for repair to cure. After repair is cured, grind, file or sand to contour. Files other than body files may be more suitable. Featheredge and finish sanding.

If small pits or irregularities appear after making repair, correct by using a liberal amount of chopped strand or filler mixed with resin to form a paste. Refer to heading "*Repair using Fiberglass Paste*" in this section.

##### 4.2 REPAIR USING FIBERGLASS PASTE

Fiberglass paste is used for repairing small dents, scratches, and pits. Paste is made by mixing resin, hardener and fiberglass strand or filler to the consistency of putty. Where it may be necessary, sand paint away around damaged area. On underside of coach, scrape away undercoating from damaged area, and wipe clean with solvent.

Preheat the area to be repaired using heat lamps. Mix desired quantities of resin and hardener according to manufacturer's instructions. Add powdered fiberglass strand into mixture to thicken it into a putty state.

**NOTE**

*If repair is made on a vertical surface, adding powdered filler material to mixture will reduce tendency of hot resin to flow or run.*

Apply the material with a putty knife or similar object, building material up to the desired contour. For deep filling and on vertical surfaces, several layers of material may be used.

A hacksaw blade, held flat to adjacent contour and then moved in a sawing action across the repair when the resin is in a gel state, will remove excess resin from repair. Finish repair with the same procedure as when using fiberglass cloth.

#### 4.3 TYPICAL FIBERGLASS REPAIR PROCEDURE

Remove all loose particles or damaged material using a power sander or rasp. Clean area, overlapping hole approximately 1" to 1-½" (25-40 mm) all around. Remove all dirt, grease and paint from area to ensure good bonding surface. Feather the cleaned area all around (Fig. 2).

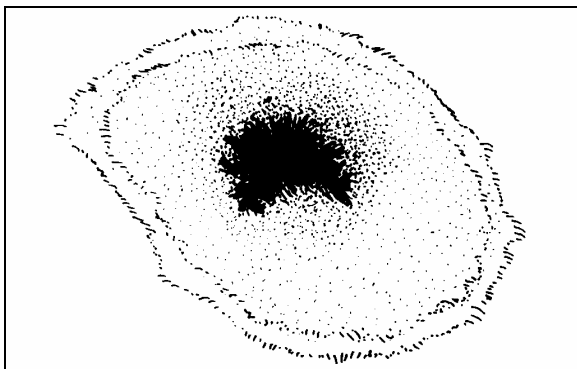


FIGURE 2: FIBERGLASS REPAIR

18089

Cut a piece of fiberglass mat slightly larger than area being repaired. Impregnate mat with general purpose polyester resin catalyzed normally. Use a clean paint brush to apply the polyester resin. Apply impregnated mat over hole and press onto surface with brush to obtain good adherence. Another coat of general purpose polyester resin can be applied at this time (Fig. 3).

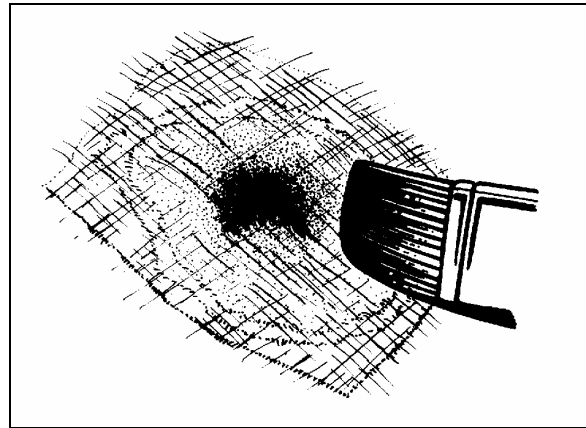


FIGURE 3: FIBERGLASS REPAIR

18090

**NOTE**

*Remove all air between surfaces being joined. Allow area to harden and sand surface to remove any wax.*

Apply another mat, followed by a cloth patch, and another mat. All layers must be thoroughly impregnated with polyester resin, brushed well and free of air. Apply more layers of mat and cloth as required until the desired strength and thickness is obtained, minimum two 1-½ oz (43 g) mats and one 9 oz (255 g) cloth (Fig. 4).

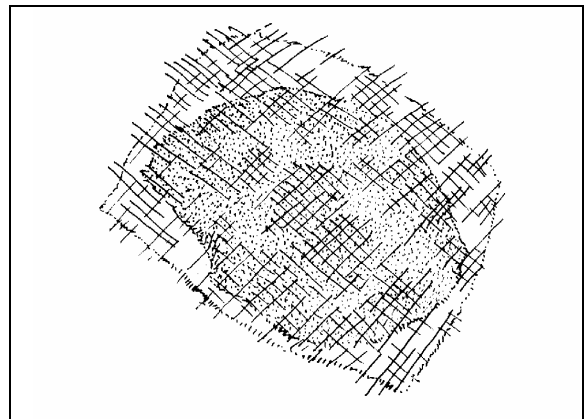


FIGURE 4: FIBERGLASS REPAIR

18091

Allow area to harden and contour the area with coarse sandpaper #100 (Fig. 5).



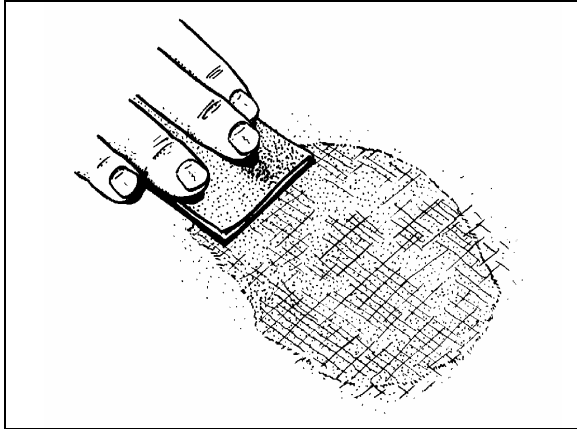


FIGURE 5: FIBERGLASS REPAIR 18092

Cover the area with a layer of resin putty and allow drying for approximately 15 to 20 minutes (Fig. 6).

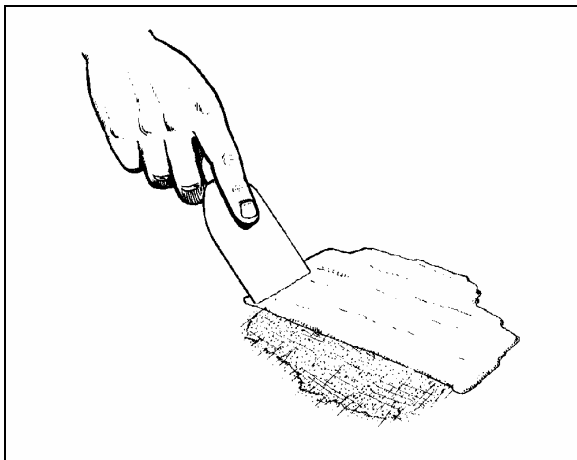


FIGURE 6: FIBERGLASS REPAIR 18093

Smooth off surface with coarse sandpaper #100 to desired shape. Further smooth surface with fine sandpaper #120 until repaired surface matches surrounding area paneling. Prime and paint the area to match surrounding paintwork.

## 5 COMMON PAINTING PROCEDURE

### 5.1 NEW PAINT CARE

Our paint supplier recommends that you follow these simple precautions the first months of your new vehicle's life.



### CAUTION

Apply these recommendations after repainting vehicle.

### During the first 30 days:

- Do not use a commercial bus wash. Stiff brushes or sponges could mar the finish and damage the surface. Wash the vehicle by hand only and with cool water and a very mild bus wash solution. Be careful to use only a soft cloth or sponge;
- Wash vehicle in the shade, never in direct sunlight;
- Do not "dry wipe" vehicle –always use clean water. Dry wiping could scratch the finish;
- Avoid extreme heat and cold. Park vehicle in the shade whenever possible;
- Do not park under trees which drop sap or near factories with heavy smoke fallout. Tree sap and industrial fallout may mar or spot a freshly painted surface;
- Trees are also likely to attract birds. Bird droppings are highly acidic and will damage a freshly painted surface. Bird droppings, tree sap and industrial fallout should be washed off as soon as possible;
- Do not spill oil, gasoline, antifreeze, transmission fluid or windshield solvent on new finish. IMMEDIATELY rinse off any such spill with clean water, DO NOT WIPE;
- Do not drive on gravel roads. Paint finish easily chips during the first 30 days;
- Do not scrape ice or snow from the surface. A snow scraper can act like a paint scraper if the finish is new. Brush off loose material with a soft snow brush.

### During the first 90 days:

- Do not wax or polish the vehicle. This will allow the finish to dry and harden completely.


### 5.2 PAINT TOUCHUP

When paint touchup or partial repainting is necessary, refer to the vehicle's paint scheme for color codes and paint brand.

Prévost recommends using the original paint brand to ease color matching.

In the event you sand through to the gelcoat surface you should prime the area with Standox "Non Stop Fill Primer (ST-11000)".

If you sand through to metal surface, first prime with Standox “Etch Primer (ST-11858)” then with Standox “Non Stop Fill Primer (ST-11000)”.

|   |
|---|
|  <b>CAUTION</b>                |
| Be sure to heed all paint manufacturer's recommendations, especially concerning paint dilution and application. |

### 5.3 PAINTING

The standard paint used on the exterior of the vehicle is Standox Basislack. It is a high gloss polyurethane enamel finish designed for exposure to extreme conditions. Other types of paint may be called for as options by owner but are not dealt with in this section.

#### 5.3.1 Safety

Care should be exercised in storing, handling, mixing, and applying paint and chemicals listed in this manual. The topcoat, primer, solvent, catalysts, accelerators, and cleaners are highly volatile and/or toxic if not properly used. Observe all safety instructions marked on the different packaging, as well as the following:

1. Do not smoke in the paint room or in adjacent area exposed to residue fumes.
2. Wear respirators approved by the governing safety and health regulations.
3. Maintain adequate ventilation at all times.
4. Dispose of any leftover paint mix properly.
5. Wear rubber gloves, rubber apron, and face shield during all phases of paint and chemical handling.

#### 5.3.2 Surface Preparation And Paint Application

|                            | <b>Aluminum and / or<br/>Stainless Steel</b>  | <b>Fiberglass</b>                              | <b>Comments</b>   |
|----------------------------|---|--|---|
| <b>Surface Preparation</b> | Sand using P-150 grit sandpaper. It is recommended to sandblast rivets and panel edges with OLIMAG 35-70 blast media.                           | Sand using P-180 or P-240 sandpaper.           | Do not use paint remover over aluminum or fiberglass.   |
| <b>Cleaning</b>            | STANDOX silicone remover ST-11654 (68-2989)   |  |   |
| <b>Priming</b>             | STANDOX Reactive Etch Primer ST-13908<br>* Wait 30 minutes then apply STANDOX Non-Stop Fullprimer ST-11000 (68-2973)                            | STANDOX Non-Stop Fullprimer ST-11000 (68-2973) | Refer to product Technical Data sheet for proper mixing |
| <b>Basecoat</b>            | Refer to paint scheme or coach record for proper color code and paint brand.<br>We recommend using the same paint brand to ease color matching. |  | Refer to product Technical Data sheet for proper mixing |
| <b>Clearcoat</b>           | STANDOX 2K MS Rapid Clear ST-11760 (68-2979)<br>Allow 16 hours for drying   |  | Refer to product Technical Data sheet for proper mixing |

If assistance or technical information on STANDOX products is needed, please dial: 1 (800) 551-9296

## Section 18: BODY

### 6 GENERAL DESCRIPTION

The following procedures explain the steps to be followed for proper repair, installation and replacement for various doors, panels and windows. The paragraph divides the vehicle into zones to facilitate the search; each zone is then sub-divided into components.

Refer to the appropriate zone then component for complete procedure.

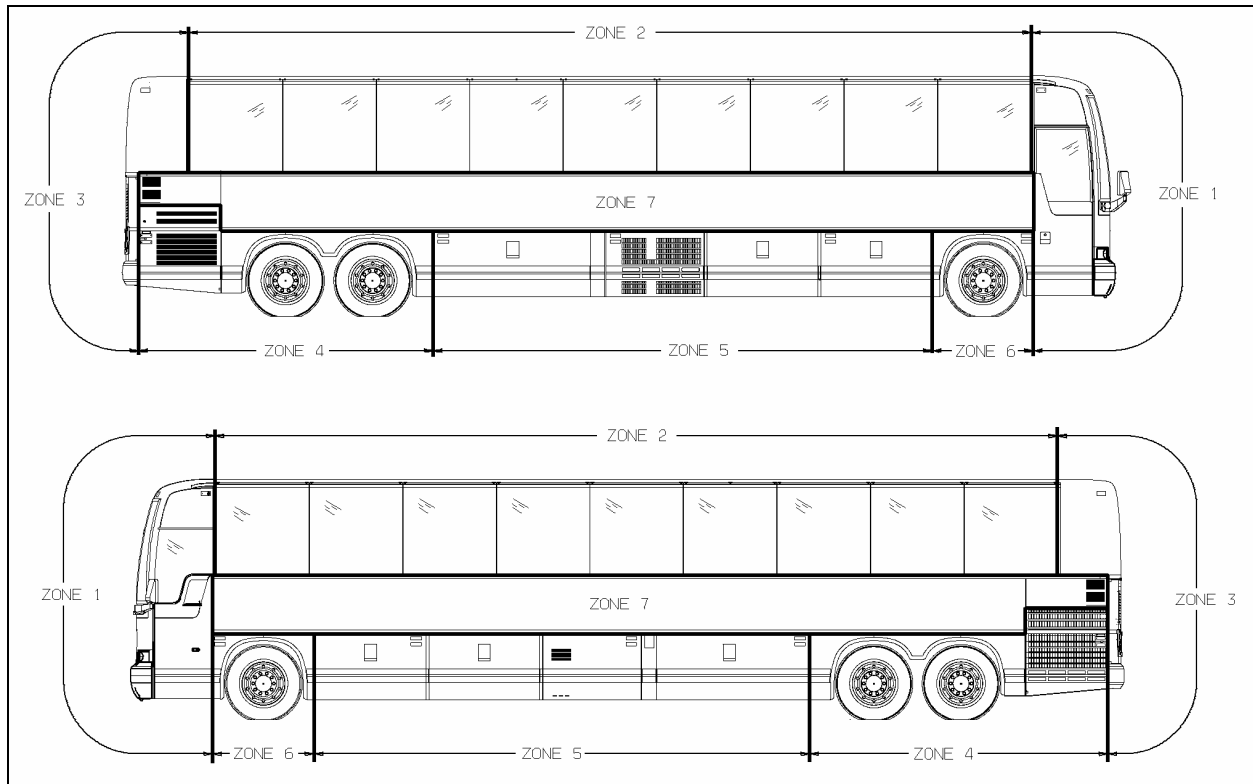


FIGURE 7: X3 COACHES ZONING

18623

### 7 ZONE 1

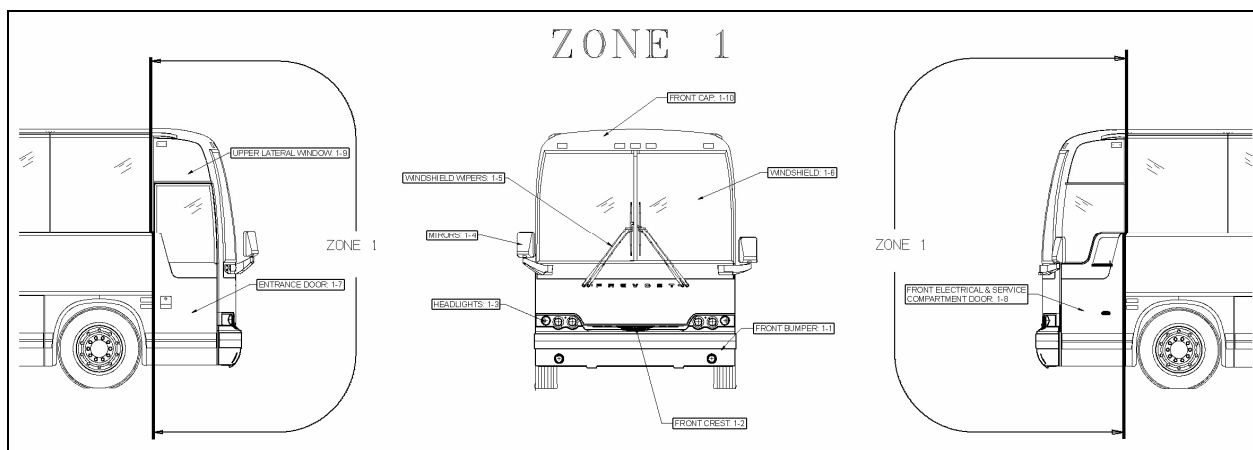


FIGURE 8: ZONE 1

18624

#### 7.1 FRONT BUMPER

The front bumper is hinged to give access to the spare wheel and tire compartment. Pull the

handle located in the front service compartment to open the spare wheel and tire compartment. Bumper must first be tilted down before its removal. Two people are required to remove

and install the front bumper. Safely support the bumper and remove the two bolts on each bumper side to separate the bumper from the spare wheel compartment door. To install bumper, reverse the removal procedure.

**WARNING**

Front bumper is heavy. Use proper lifting equipment to support the bumper during the removal and installation operations to avoid personal injury.

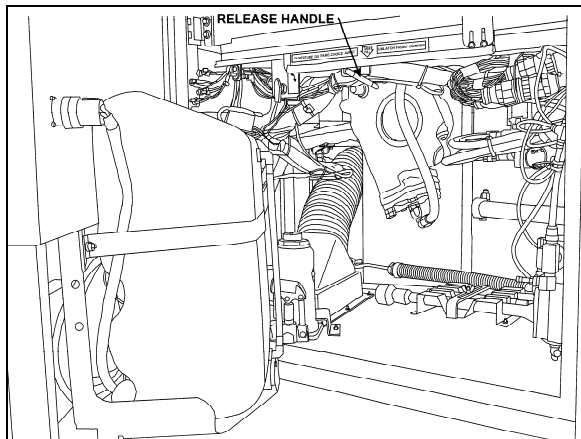


FIGURE 9: FRONT BUMPER RELEASE HANDLE 18613

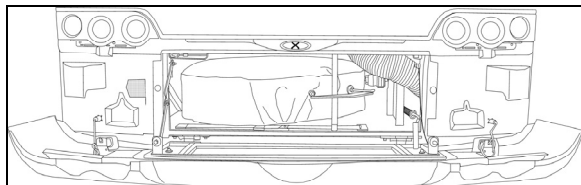


FIGURE 10: FRONT BUMPER 18614

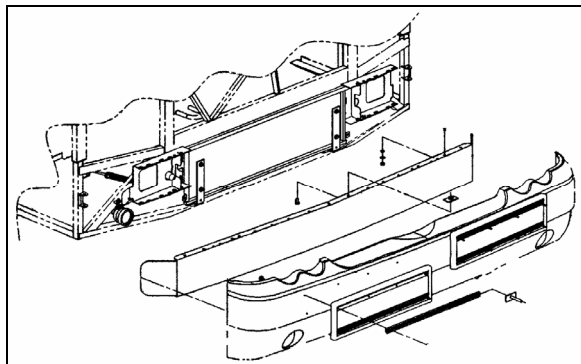


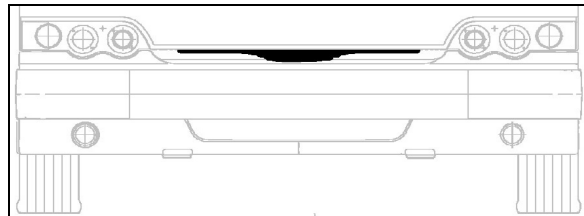
FIGURE 11: FRONT BUMPER REMOVAL 18565

## 7.2 FRONT CREST

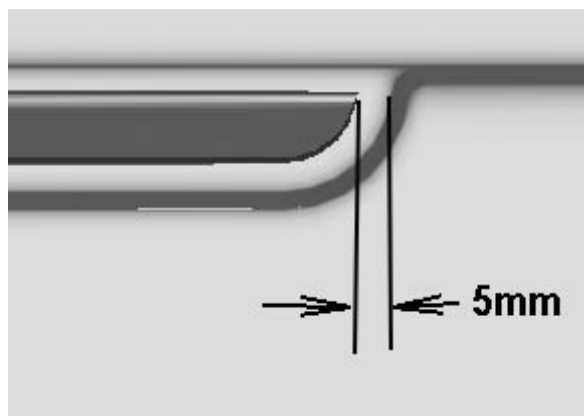
- Use a Chix cloth and anti-silicone to clean the surface where the crest will be applied.

**CAUTION**

Do not exceed the crest dedicated surface.



- Peel the back from the self adhesive crest side pieces.



- Peel the back from the self adhesive crest center piece. Center crest and apply.
- Compress the crest three pieces using your hands.



## 7.3 HEADLIGHTS

Refer to Paragraph 9.1 Headlights, included in Section 06: Electrical of the Maintenance Manual for complete information on headlights.

## Section 18: BODY

### 7.4 REAR VIEW MIRRORS (RAMCO)

Your vehicle is equipped with two exterior mirrors.

The mirrors may be equipped with an optional electric heating system which serves to minimize ice and condensation on the mirror glass in extreme weather conditions. Integral thermostats are installed in both mirrors to avoid continuous heating. Use the appropriate switch on the dashboard to activate the defroster system on both mirrors simultaneously. The mirrors can easily be adjusted by using the remote controls located on the L.H. side control panel. The mirrors have easy to replace glass in case of breakage. Remote control motors can also be replaced.

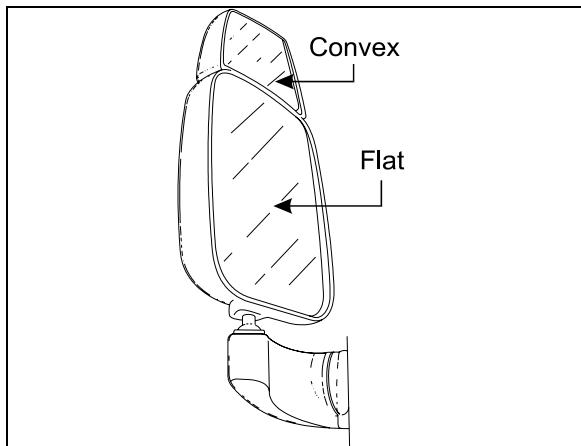


FIGURE 12: REAR VIEW MIRROR (RAMCO) 18398A

#### 7.4.1 Adjustment

At the base of the mirror arm, loosen the mounting bolt to swing arm in or out.

To pivot the mirror head, loosen the setscrews on each side of the ball stub at the base of the mirror head to facilitate the adjustment.

#### 7.4.2 Disassembly

At end of mirror arm, loosen the setscrews to relieve tension on the ball stem. Remove the ball stem from the arm.

Remove the four screws fastening the mirror arm base to the coach.

#### 7.4.3 Assembly

Mount the mirror arm base to the coach. Insert the ball stem into the mirror arm and tighten the socket setscrews.

#### NOTE

Position the ball cup halves so the joint between them lies on the centerline of the arm. Ensure that the setscrews are not on the joint between the cup halves.

#### 7.4.4 Replacement of Mirror Glass

Remove the broken glass.

Position new glass in mirror head and press to lock the Velcro in place.

#### 7.4.5 Heated / Remote Controlled Rear View Mirrors

Heated/remote controlled external rear view mirrors may be provided to prevent the mirrors from frosting up in cold weather.

The remote controlled external rear view mirrors attach to support arms using a pivot collar secured by setscrews. Loosening the setscrews allows the whole head assembly to turn on the support arm for initial adjustment. A mounting bolt and washer hold the arm support to the mounting bracket. The arm support can be moved to position the mirror head into or away from the coach body.

The mirror heat switch is located to the left of the driver on the dashboard. This switch must be activated before the mirror heating element will energize. Once energized, the mirror heating element is kept at a sustained temperature (between 60-80°F) by a thermostat. Refer to wiring diagram annexed in the technical publication box.



#### CAUTION

Do not attach stick-on type convex mirror accessories to the heated mirror glass. This could impede uniform heat distribution on the mirror surface which could break the mirror.

#### Mirror Control

The remote control pointer knob(s) for the mirrors is (are) mounted on the L.H. side control panel. The harness to the mirror head runs through the arm support. The remote motor is mounted to the mirror head behind the mirror glass.

Turn pointer knob to the left for mirror head adjustments and to the right for convex mirror adjustment, then push down on either of the

button's (4) sides to adjust the selected mirror viewing angle.

### Disassembly

At end of mirror arm, loosen the setscrews to relieve tension on the ball stud. Remove the ball stud. Remove the ball stud from the arm and gently pull the harness out until the connector is exposed.

Remove the four screws fastening the mirror arm base to the coach. Slide the harness free of the mirror arm base.

### Assembly

Attach a stiff wire (snake) to the end of the harness and insert the wire through the mirror arm base and arm, gently pull the harness through the arm and disconnect the "snake". Connect the mirror head harness. Insert the harness connector back into the mirror arm. Insert the ball stud into the mirror arm and tighten the socket setscrews.

#### **NOTE**

*Position the ball cup halves so the joint between them lies on the centerline of the arm. Ensure that the setscrews are not on the joint between the cup halves.*

### Convex & Flat Mirror Removal

The mirror glass assembly is mounted to the control mechanism or to mirror base with Velcro strips. Remove the mirror glass by gently pulling the lens to release the Velcro. Disconnect the heater grid at the two connectors.

Connect the connectors of the new mirror's grid to the harness. Install the lens by positioning the lens in the mirror frame and pressing to lock the Velcro in place.

## 7.5 WINDSHIELD WIPERS

Refer to Paragraph 23.8 Windshield Wipers and Washers, included in Section 23: Accessories of the Maintenance Manual for complete information on windshield wipers.

## 7.6 WINDSHIELD

For the removal or installation of windshield, you will need:

A rope,  
A plastic spatula to lift the rubber seal lip,

A metal rod or screwdriver to clean the seal groove,

A filler insertion tool,

Goggles and protective gloves.

- From inside of vehicle, remove center post and interior finishing panels surrounding the windshield. In this case, we are replacing the R.H. side windshield.
- From outside of vehicle, remove filler located inside rubber seal to ease damaged windshield removal.
- From inside of vehicle, push against the top L.H. side corner of windshield for the removal of a R.H. side windshield. If the L.H. side windshield had to be removed, you would have to push against the top R. H. side corner.

#### **NOTE**

*We are referring to the L.H and R.H. side as viewed from the inside of the vehicle.*

- At the same time, another person gradually lifts the rubber lip from the vehicle exterior using a plastic spatula from top to bottom.
- Remove the entire damaged windshield and broken glass if applicable.
- If applicable, using a screwdriver or metal rod, remove black butyl sealant residue from rubber seal then clean with Sika 205.

### 7.6.1 Windshield Installation

#### **NOTE**

*Rubber seal may have to be replaced if it was used on several windshield replacements.*

- Spray rubber seal with soapy water to ease windshield insertion.
- Insert rope into rubber extrusion leaving enough length at each corner to make a loop. Spray soapy water onto rope and rubber extrusion (Fig. 7).
- Slide windshield into rubber seal groove starting with the bottom curved side edge. Using a plastic spatula, move the rubber seal lip aside to gradually insert the windshield into the groove.
- Spray soapy water on a regular basis to ease this operation.

## Section 18: BODY

- Using the same type of plastic spatula, repeat the same operation from inside of vehicle, gradually inserting the windshield into the groove.

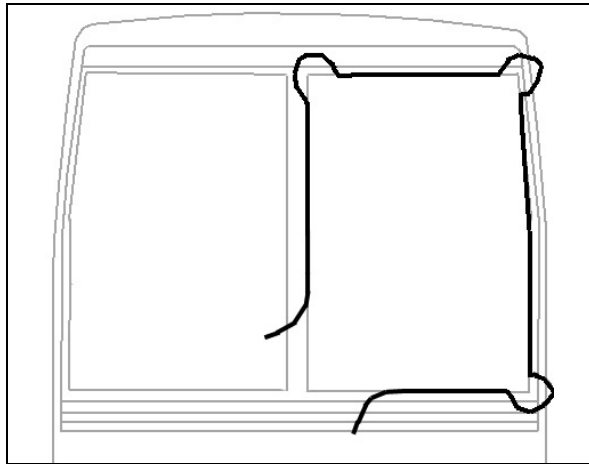


FIGURE 13: WINDSHIELD INSTALLATION USING ROPE

### NOTE

*Make sure windshield bottom edge is well inserted into the rubber seal groove before proceeding with the sides.*

- Then, working from both sides of windshield bottom to top, gradually move the rubber seal lip aside to insert the windshield into the groove. Use also soapy water on the inside of vehicle to insert the windshield into the rubber seal groove.
- Insert the top curved corner then finish with the top of windshield.
- At the top of windshield, clean surface between fiberglass and rubber extrusion using Sika 205 (Fig. 9).
- Apply Sika 221 black between fiberglass and rubber extrusion
- Spray filler and rubber seal groove generously with soapy water.
- Using the special filler insertion tool, insert the filler into the rubber seal groove.
- Gradually insert filler into the rubber seal groove ensuring to leave a 2 inch excess length at the filler extremity.
- Every 6 inches or so, it is important to compress the filler due to its tendency to contract during drying process.
- When filler insertion is almost complete, cut filler leaving  $\frac{1}{4}$ " of excess length to thwart

filler contraction over time then insert filler into groove.

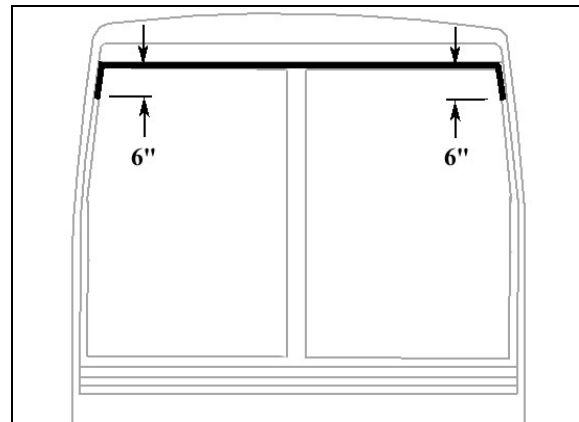


FIGURE 14: APPLICATION OF SIKA 221 BLACK

- Reinstall center post and interior finishing panels.
- Clean windshield surface of butyl residue.

### 7.7 ENTRANCE DOOR

An air operated "sedan type" entrance door, with an air door cylinder and damper assembly are installed under the right hand dash. The opening and closing door speed cycle is adjustable by a damper mounted in parallel with the door cylinder on the door hinge. Door activation is controlled by a panel (Fig. 15), located near the defroster and wiper motors. The accessory air reservoir supplies air to this system.

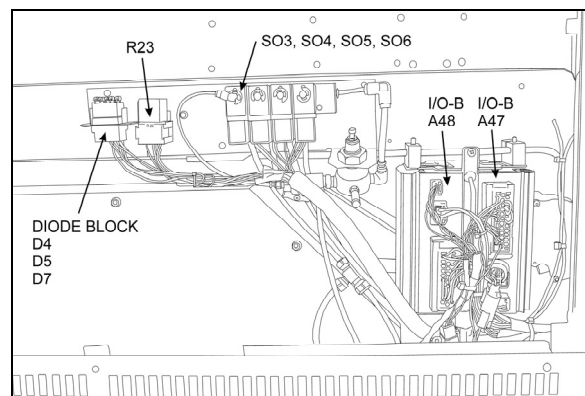


FIGURE 15: ENTRANCE DOOR & WIPER CONTROL PANEL

06619

The door is held in the closed position during coach operation by a two air cylinder locking mechanisms (Fig. 17). Air cylinders with return spring in the cylinder body are used. Air cylinders are controlled by an electrically operated solenoid valve energized by a rocker switch located under the right hand dashboard.

To open the door, initial movement of the rocker switch de-energizes the air lock solenoid valve, venting the door locking cylinders. The return locking spring pulls the door lock away from the latch, unlocking the door. Door movement starts only when pressure in the central air door lock is below 10 psi. The “air cylinder open solenoid valve” opens and allows air to flow to the door cylinder, “the air cylinder close solenoid valve” exhausts air from the rod side of the cylinder.

To close the door, initial movement of the switch energizes the “air cylinder close solenoid valve” and air flows to the cylinder by its rod side port. The “air cylinder open solenoid valve” exhausts air from cylinder. When entrance door latch is grounded with the door frame, the air lock solenoid valve is de-energized and loads the door lock cylinders. The cylinder moves the door lock in a position which engages a latch on the entrance door, holding the door positively closed.

Emergency exit valve, which opens the air valve circuit should be used only in emergencies, or when the door control system does not function properly.

Refer to the air system schematic diagram annexed at the end of section 12, “Brakes” and to page 22 of the wiring diagram.

### 7.7.1 Operation

The air-operated door is controlled from inside the coach by two push-button switches located on the R.H. dashboard.

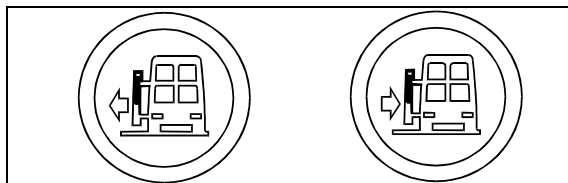


FIGURE 16: ENTRANCE DOOR OPERATING BUTTONS  
06464

Opening and closing of the door from outside the coach is accomplished by a momentary toggle switch located under the front R.H. side marker light (Fig. 18).

To close the door, the switch must be pushed towards the rear of the coach and held in position until the door has completed its movement.

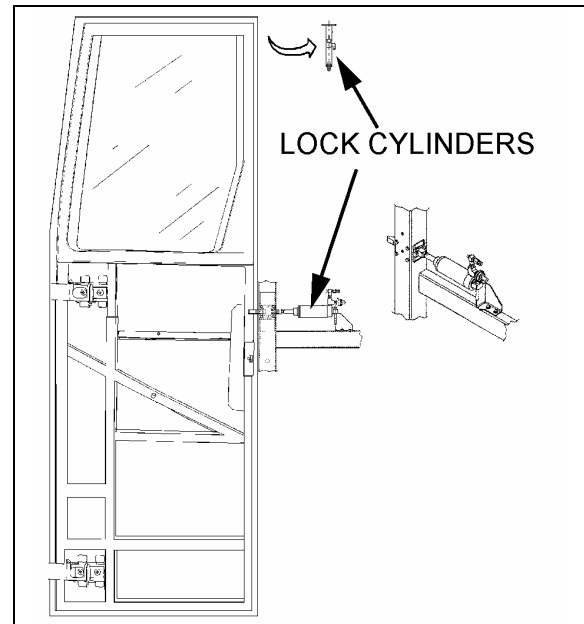


FIGURE 17: COACH ENTRANCE DOOR

18642

To open the door, the switch must be pushed towards the front of the coach and held in position. When the door reaches the fully opened position, the system will keep pressure in the cylinder locking the door in that position. The door can be stopped in any position by releasing the switch. The door is not locked in position when not fully opened or closed.

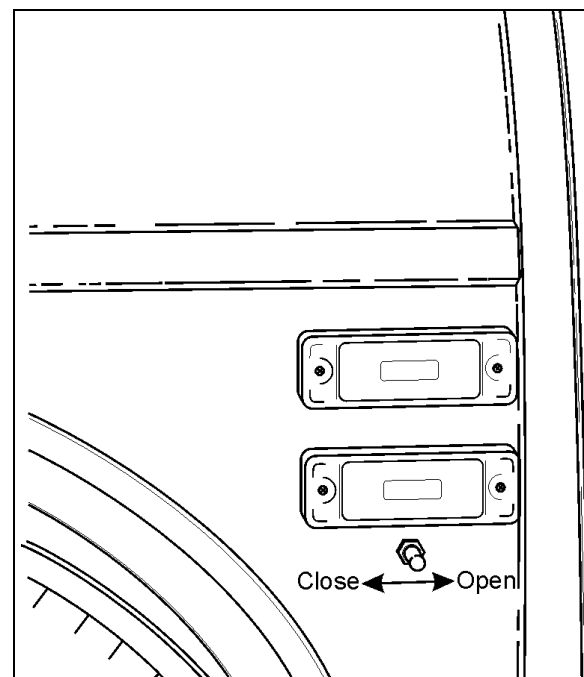


FIGURE 18: ENTRANCE DOOR CONTROL SWITCH

18599

If the door has been locked with the key, a lever on the door can be moved to unlock.



## Section 18: BODY

### 7.7.2 Emergency Exit Valves

From inside the vehicle, an emergency exit valve located near the door on the dash panel, releases the pressure from the lock cylinder. From the exterior, an emergency exit valve located in the front service compartment, also releases the air from the lock cylinder.

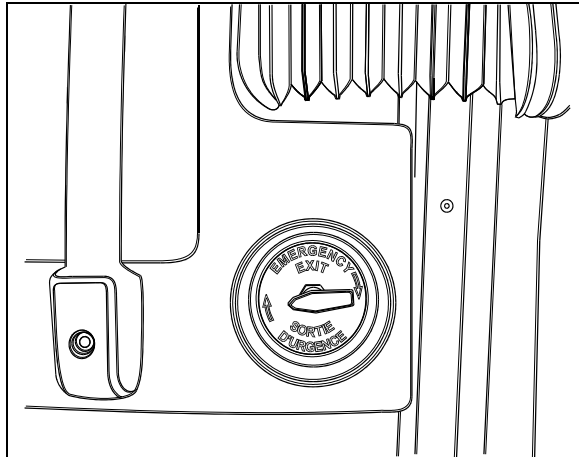


FIGURE 19: INTERIOR UNLATCH AIR VALVE 18330

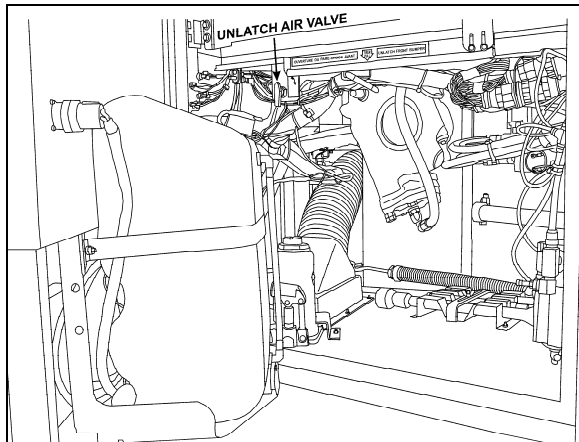


FIGURE 20: EXTERIOR UNLATCH AIR VALVE 12209

#### Without Air and/or Without Electricity

If the air pressure drops while the coach has or hasn't any electricity, the spring loaded cylinders will unlatch the door. In such a case, unlock the door by moving the lever on the door or by using the key, then open the door manually.

#### With Air but Without Electricity

From inside the vehicle, turn the emergency exit valve to the "UNLOCK" position. Move the lever. From the exterior, turn the emergency exit valve to the "UNLOCK" position. Open the door. Close it, lock with the key and reset the outside emergency exit valve to the "NORMAL" position.

### 7.7.3 Door Cycle Speed Adjustment

To do any adjustment, remove the two panels located next to the door hinge, as well as the door's upper hinge control.



#### CAUTION

It is important to make sure that damper does not reach end of stroke when door is completely closed or opened. The door cylinder must stop the door on opening. Screw or unscrew rod end to adjust if necessary.

To adjust opening and closing cycle speed on damper (Fig. 21):

1. Remove the damper from the vehicle and hold it vertically with the lower eye or pin attachment in a vice. Use clamp plates to prevent damage.
2. Fully close the damper while turning the dust cap or piston rod slowly CCW until it is felt that the cams of the adjusting nut engage in the recesses of the foot valve assembly (Fig. 21).

#### NOTE

In figure 21, if there is an indentation (B) in the dust cap (C) and the cover shows two holes (A), the damper is fitted with a bump rubber (D). If so, fully extend the damper and insert a round bar or screwdriver through the holes. Push the bump rubber down and remove. Remove the split plastic collar (E) (if fitted) from the piston rod.

3. The damper may have already been adjusted. Therefore check whether the damper is adjusted or not by keeping it closed and gently turning further CCW, counting at the same time the half-turns until a stop is felt. Stop turning and do not force.
4. While keeping the damper closed, make two CW half-turns. In case of prior adjustment, add the number of half-turns previously counted. The total range is about five half-turns. Pull the damper out vertically without turning for at least 3/8" (1cm) to disengage the adjusting mechanism. The dust cap or piston rod may now be turned freely.

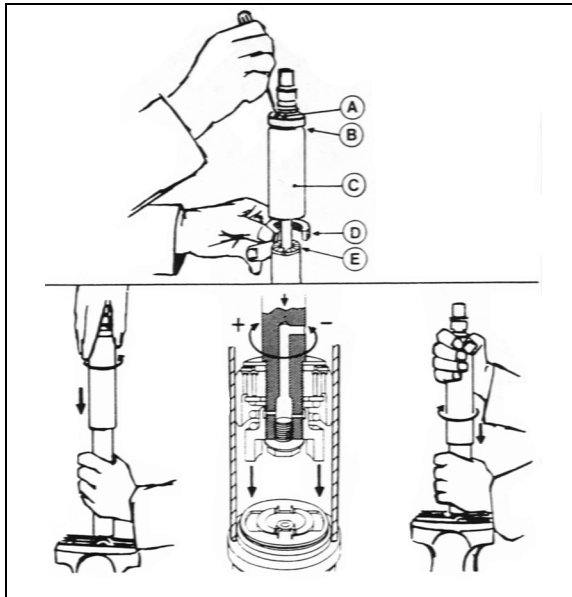


FIGURE 21: DAMPER

18643

**NOTE**

Where a bump rubber was installed, refit same inside the dust cap and by fully closing the damper, the rubber will seat again at top of the dust cap. Refit the split plastic collar E (Fig. 21).

5. The damper can now be refitted in the vehicle.
6. Reinstall panels and entrance door hinge cover.

**7.7.4 Horizontal And Vertical Adjustment**

Before attempting to correct any door operating problem by adjusting any part of the air cylinder assembly, first perform the following mechanical checks and procedure.

Check around the perimeter of the door for binding. If any binding is found, adjust as follows:

1. Remove the screws and the plastic molding covering each of the hinges.

**NOTE**

Ask an assistant to help you to perform the following adjustments.

2. Remove the Allen button head screw and the washer retaining the rod end with bearing to the upper hinge. See figure 22.
3. Support the door with a wooden block and a hydraulic jack.

4. Loosen the horizontal bolts retaining the door to the hinges. Adjust the door horizontally and vertically with the jack. Tighten the bolts to 30-36 Lbf-ft (40-50 Nm). Remove the jack and the wooden block.



**CAUTION**

Make sure the front side door does not interfere with the exterior panel.

5. Pull and fasten the rod end to the hinge with the washer and the button screw.
6. Screw the plastic moldings covering the hinges.

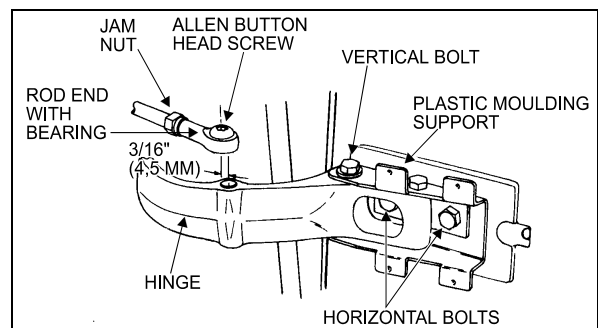


FIGURE 22: UPPER DOOR HINGE

18058

**Seal Compression Adjustment**

1. Turn the emergency exit valve to the "UNLOCK" position and close the door.
2. From the outside of vehicle, insert a straight edge in the gap along the door outside perimeter. Measure the distance between the door frame and the door outside surface at the door four corners (refer to figure 23).

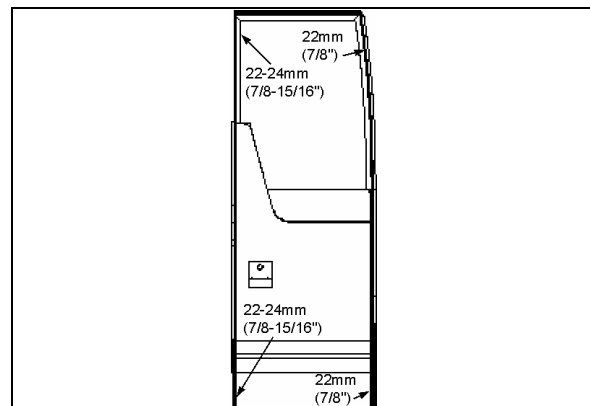


FIGURE 23: SEAL COMPRESSION ADJUSTMENT

18632

**NOTE**

The front measurements are the most important. If required, ask an assistant to help you to perform the following adjustments.

## Section 18: BODY

- If required loosen the bolts retaining the door to the hinges. Adjust the bolts to obtain the proper seal compression.

### Door Seal Replacement

- Inspect the seal; if cracked or torn, it must be replaced:
- Remove the old seal and with a sharp edge knife, scrape tape left on the fiberglass door surface.
- Sand the surface of the door where a new seal will be applied with 240 grit sandpaper.

- Clean the surface with alcohol.



### WARNING

Wear rubber gloves and do not smoke when cleaning.

- Peel off protective paper from the seal. Position the seal flush with the top, sides and lower edges of the door.
- Progress slowly all around the door.
- Cut the seal and glue both ends with LOCTITE 414 glue.
- To assure bonding, press a small roller on top of the new seal.

### 7.7.5 Troubleshooting

| SYMPTOM  | PROBABLE CAUSE   | REMEDY  |
|--|--|---|
| DOOR WILL NOT OPEN FROM EXTERIOR SWITCH.                                 | Manual door locks engaged.                               | Release manual door locks.  |
|  | Upper and lower solenoid locks do not disengage.         | Check voltage at solenoid locks when door is open. If the voltage is 24 volts then replace solenoid #641217. Else, check circuit power.                           |
|  | Relay module do not receive current.                     | Reset breaker "ON" or check batteries power supply.   |
|  | Opening solenoid door does not receive current.          | Check voltage at opening solenoid door. If the voltage is 24 volts then replace it. Else replace control relay.   |
|  | Switch malfunction.                                      | Replace switch.   |
| DOOR WILL NOT CLOSE FROM EXTERIOR SWITCH.                                | Switch malfunction.                                      | Replace switch.   |
|  | Solenoid failure.  | Check voltage at solenoid. If the voltage is 24 volts then replace solenoid. Else replace control relay.  |
| DOOR WILL NOT OPEN FROM INTERIOR SWITCH.                                 | Manual door locks engaged.                               | Release manual door locks (open position) from vehicle exterior.  |
|  | Upper and lower solenoid locks do not disengage.         | Check voltage at solenoid locks when door is open. If the voltage is 24 volts then replace solenoid #641217. Else, check circuit power and replace control relay. |
|  | Module relay does not receive electric current.          | Reset breaker "ON" or check batteries power supply.   |
|  | Door opening solenoid does not receive current.          | Check voltage at door opening solenoid. If the voltage is 24 volts then replace it. Else replace control relay.   |
|  | Switch malfunction.                                      | Replace switch.   |
|  | Upper lock stays engaged                                 | Lubricate upper lock assembly. Check wear and replace parts if necessary.   |
| DOOR WILL NOT CLOSE FROM INTERIOR SWITCH.                                | Switch malfunction.                                      | Replace switch.   |
|  | Door closing solenoid does not receive electric current. | Check voltage at door closing solenoid. If the voltage is 24 volts then replace it. Else replace control relay.   |
| DOOR WILL NOT OPEN AFTER DRAINING AIR FROM SYSTEM BY EMERGENCY VALVE(S). | Manual door locks engaged.                               | Release manual door locks (open position) from vehicle exterior.  |
|  | Damper cylinder blocks the door.                         | Adjust or replace damper cylinder.  |

| SYMPTOM                                     | PROBABLE CAUSE                    | REMEDY   |
|---|-----------------------------------|--|
|   | The upper lock blocks the door.   | Adjust upper lock. Lubricate upper latch bolt. Adjust upper latch height.  |
| DOOR LOCKS STAY ENGAGED WHEN DOOR IS OPEN.  | Power supply is cut at solenoid.  | Place switch in open position.   |
|   | Lock solenoid does not disengage. | Check voltage at solenoid lock when door is OPEN. If the voltage is 24 volts then replace solenoid #641217. Else, check circuit power and replace control relay. |
| DOOR LOCKS DO NOT LOCK WHEN DOOR IS CLOSED. | Emergency valve is open.          | Close emergency valve.   |
|   | Lock solenoid stays electrified.  | Check latch bolt ground on door frame. If needed clean locks for better contact. Check ground circuit.   |
|   | Lock solenoid works in reverse.   | Reverse air hoses at solenoid locks.   |
|   | Relay does not function.          | Replace relay.   |

7.7.6 Lubrication

| Part   | Lubricant              | Frequency        |
|--|------------------------|------------------|
| Latches<br>Upper door catch<br>Door cylinder rod end with bearing grease fitting | Low temperature grease | Every six months |
| Door locking mechanism   | White grease           | Every six months |
| Key hole<br>Damper pins<br>Hinges  | Low viscosity oil      | Every six months |

7.7.7 Entrance Door Body Panel and Window

**Window**

For the removal of entrance door window, you will need:

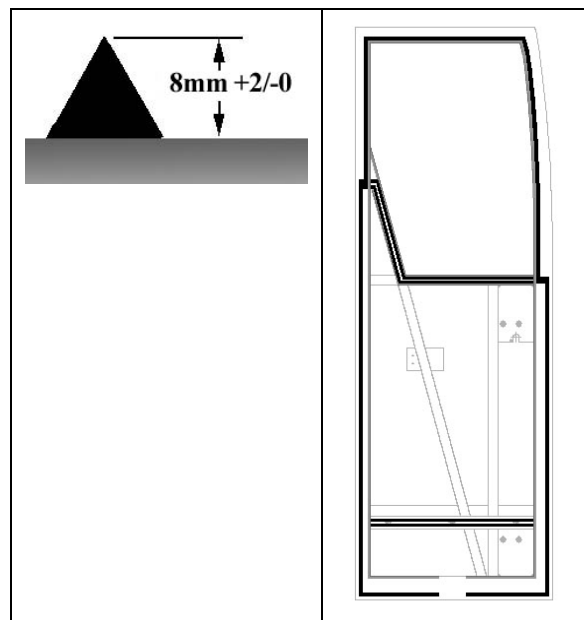
Pneumatic “Zip gun” type tool;  
Razor sharp window scraper;  
“Olfa” knife;  
Face shield.

- Open entrance door.
- Mark the position of the entrance door window for future reference.
- Remove interior finishing panel.
- From inside of vehicle, cut Sika bead around window perimeter using a “Zip gun” while another person hold the window from the outside.

|  |
|--|
| <b>NOTE</b>                                  |
| <i>Wear ear plugs during this operation.</i> |

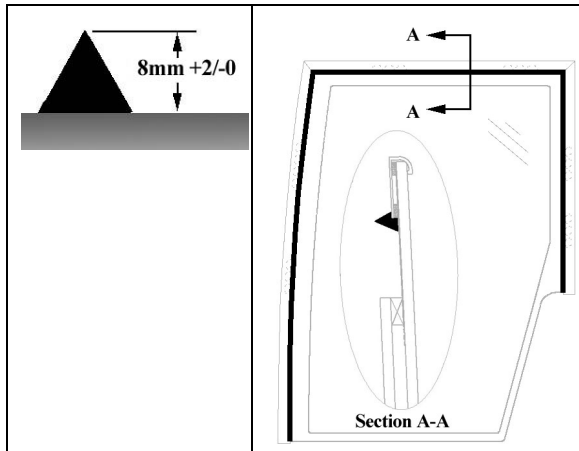
- Then, move outside of vehicle and cut Sika bead to free window while somebody else hold the window from the inside.

- Carefully remove window from frame, ask for help if needed.
- Using a razor sharp window scraper, remove from window frame Sika bead and double-face self adhesive tape residue.
- Clean window using window cleaner.
- Apply Sika Aktivator around window perimeter.
- Clean door frame using anti-silicone.
- Using a scratch pad “Scotch Brite”, scratch the perimeter of the window frame where the adhesive will be applied.
- Clean door frame again using anti-silicone.
- Apply some Sika 206 G+P onto door frame.
- Apply Sika 255 onto door frame structure.



## Section 18: BODY

- Apply Sika 255 at junction of frame and window.



- Install and center window onto door frame. Using your hands, compress window.
- Discard waste according to applicable environmental regulations, use dangerous waste containers.
- Apply masking tape before applying Sika glue to protect paint and adjacent surfaces during surface treatment

### Body Panel

For the removal of entrance door body panel, you will need:

Pneumatic “Zip gun” type tool;  
Razor sharp window scraper;

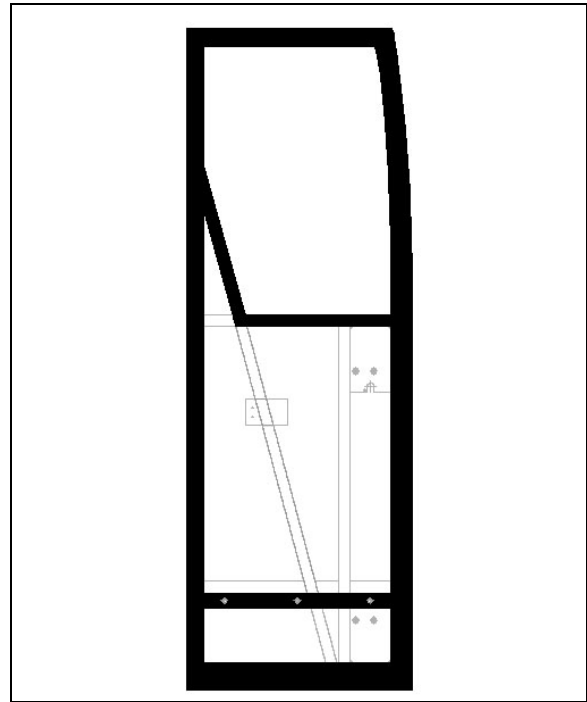
- Open entrance door.
- Remove interior finishing panels to access rub rail fixing bolts, then remove rub rail.
- Remove door lock and interior lighting.
- Using the “Zip Gun”, cut Sika bead located ¼ inch (7-8 mm) from each body panel edge.

#### **NOTE**

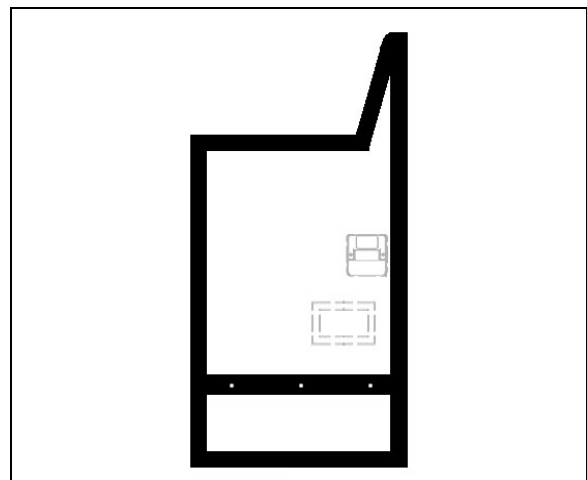
*Wear ear plugs during this operation.*

- Separate body panel from door.
- Using a razor sharp window scraper, remove from door frame Sika bead and double-face self adhesive tape residue.
- Using a scratch pad “Scotch Brite”, scratch the perimeter of the door frame where the adhesive will be applied.

- Clean door frame again using anti-silicone.
- Apply some Sika 206 G+P onto door frame.



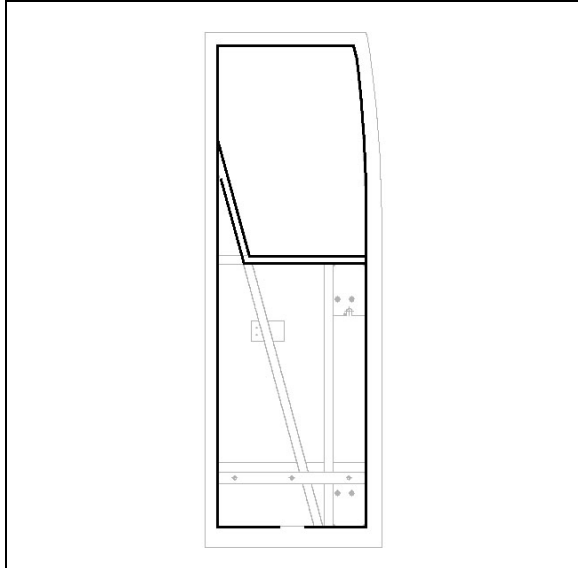
- Using a scratch pad “Scotch Brite”, scratch the perimeter of the body panel where the adhesive will be applied.
- Clean body panel using anti-silicone.
- Apply some Sika 206 G+P onto body panel.



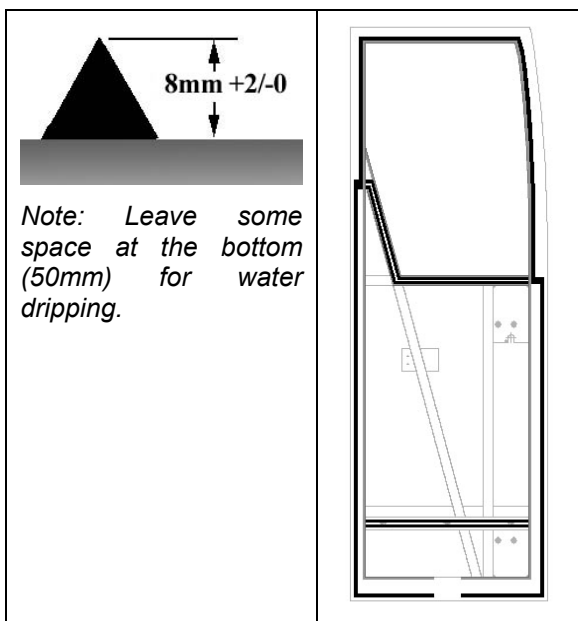
- Apply 1/8 x1/4 double face self-adhesive tape onto door frame.

#### **NOTE**

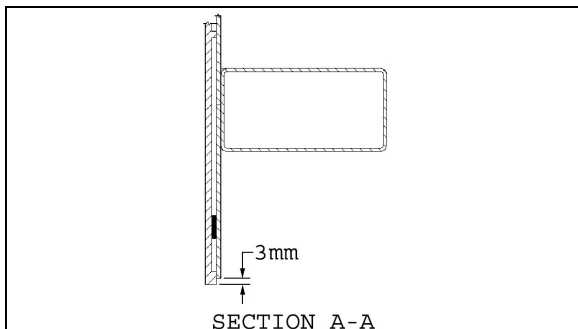
*Leave some space at the bottom (50mm) for water dripping.*



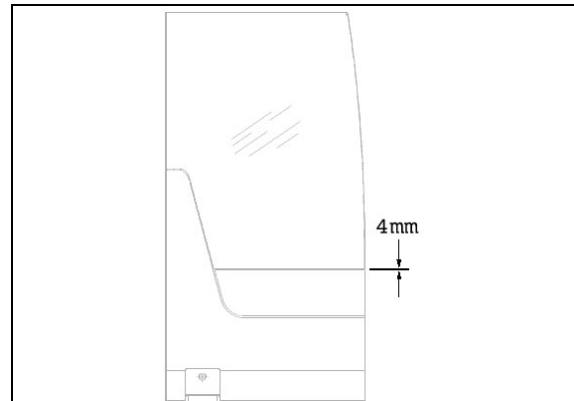
- Apply Sika 255 onto door frame structure.



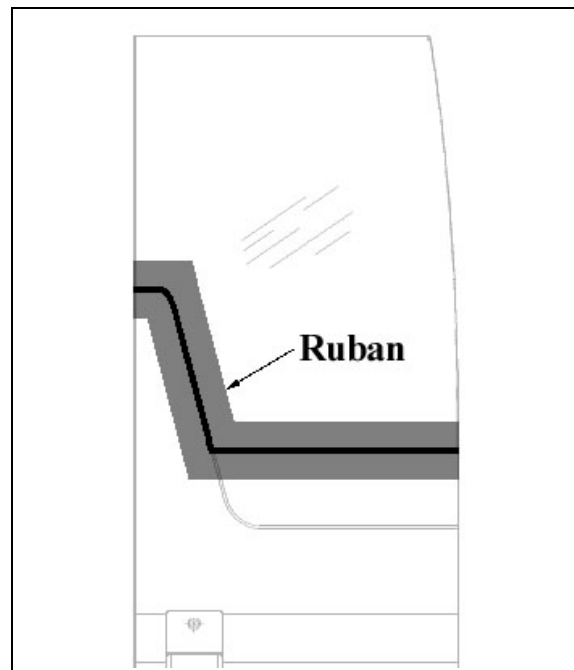
- Install and center fiber glass body panel onto door frame leaving an excess of 3mm all around the frame.



- Line-up body panel with window. There must be a gap of  $4\pm 2\text{mm}$  between window and body panel.



- Apply some masking tape **1mm** from window edge and body panel.
- Fill the gap between window and body panel with Sika 255.
- Smooth down the joint with a plastic scraper then remove masking tape.
- Wet Sika joint using water to accelerate the curing process and put the finishing touch with your finger.



- Discard waste according to applicable environmental regulations, use dangerous waste containers.

## Section 18: BODY

### 7.7.8 Front Electrical & Service Compartment Door Body Panel and Window

#### Door Body Panel

For the removal of front electrical & service compartment door body panel, you will need:

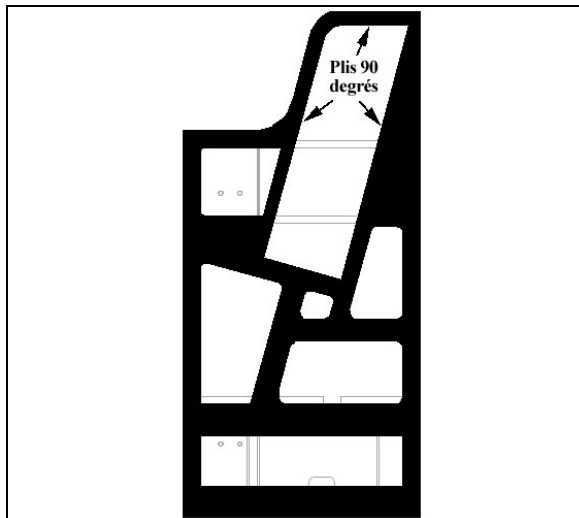
Pneumatic “Zip gun” type tool;  
Razor sharp window scraper;

- Open service door.
- Remove interior finishing panels to access rub rail fixing bolts, then remove rub rail.
- Remove windshield washer reservoir, door lock and power window connector.
- Using the “Zip Gun”, cut Sika bead located  $\frac{1}{4}$  inch (7-8 mm) from each body panel edge.

#### NOTE

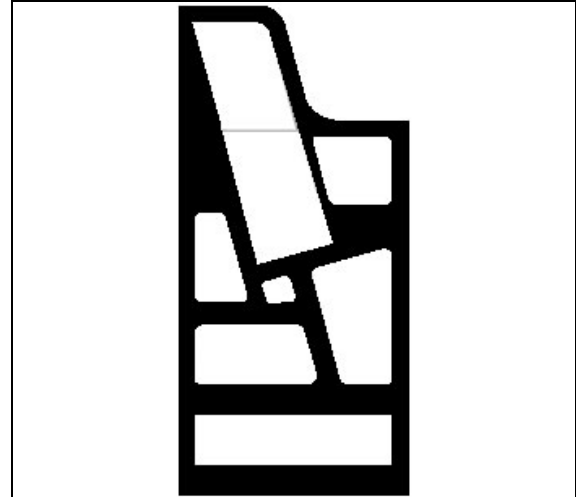
*Wear ear plugs during this operation.*

- Separate body panel from door.
- Using a razor sharp window scraper, remove from door frame Sika bead and double-face self adhesive tape residue.
- Clean door frame using anti-silicone.
- Using a scratch pad “Scotch Brite”, scratch the perimeter of the door frame where the adhesive will be applied.
- Clean door frame again using anti-silicone.
- Apply some Sika 206 G+P onto door frame.

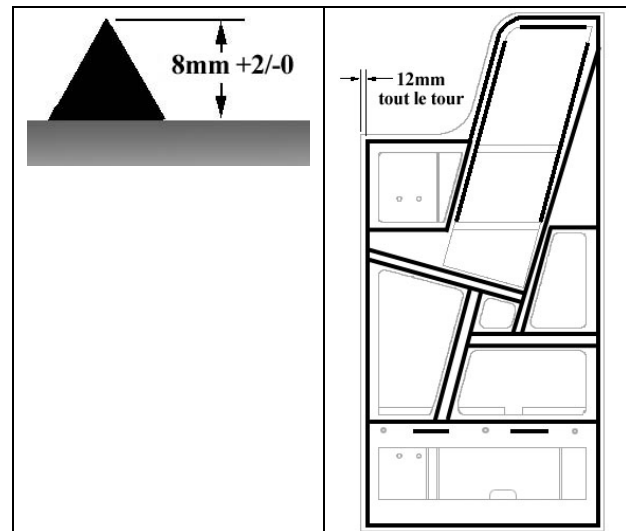


- Prepare new body panel using a scratch pad “Scotch Brite”.

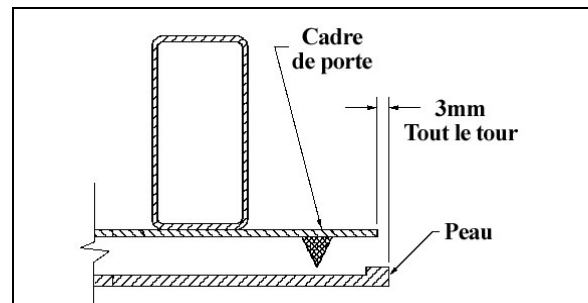
- Use a tack cloth to remove any dust or residue from the body panel surface.
- Clean body panel using anti-silicone.
- Apply some Sika 206 G+P onto body panel.



- Apply an even coat of Sika 255 onto the door frame.



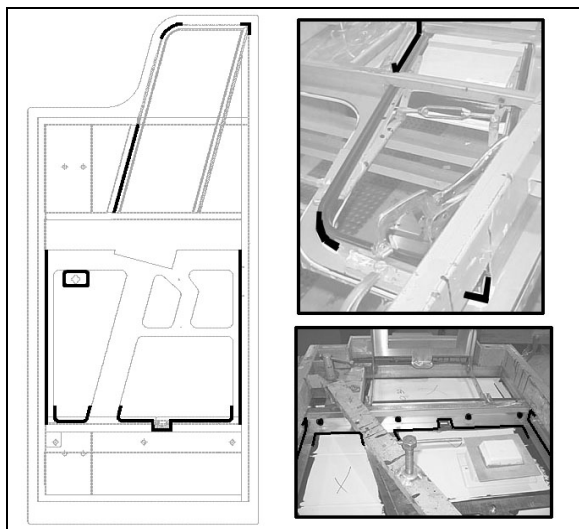
- Position body panel onto door frame and compress with your hands. Use a ruler.



- Check body panel flatness using a 2-foot ruler (must be within 2mm).



- Check proper power window sliding inside window frame.
- If applicable, remove excess of Sika adhesive all around door frame using Sika 208.
- From the inside of the door, apply some Sika 221 between door body panel and frame and on welding spots as per figure.

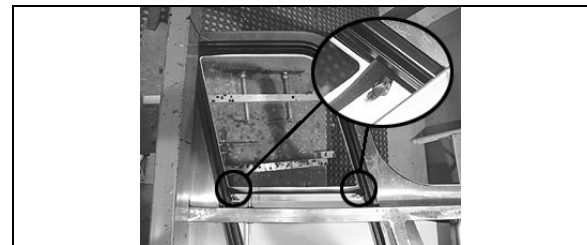


- Apply some #680066 glue inside fiber glass groove and fix power window wiper.

**NOTE**  
Anti-friction side must be on glass side.

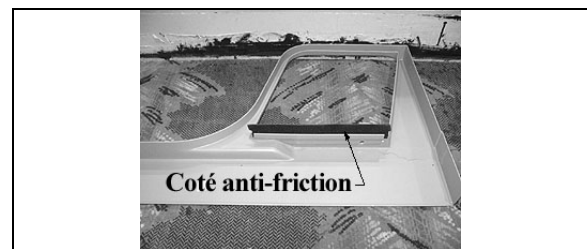


- From inside the door, apply some Sika 252 at the corners of window wiper.



- Apply some #680066 glue inside finishing panel groove and fix power window wiper.

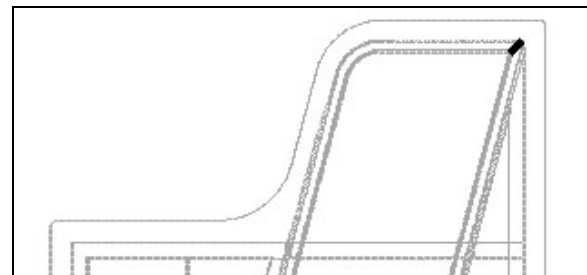
**NOTE**  
Anti-friction side must be on glass side.



- Discard waste according to applicable environmental regulations, use dangerous waste containers.

**Electrical Power Window**

- Insert 2 seals in the window frame.
- Apply some #680066 glue at the intersection of the 2 seals and also sparingly in order to fix the seal to the window frame.

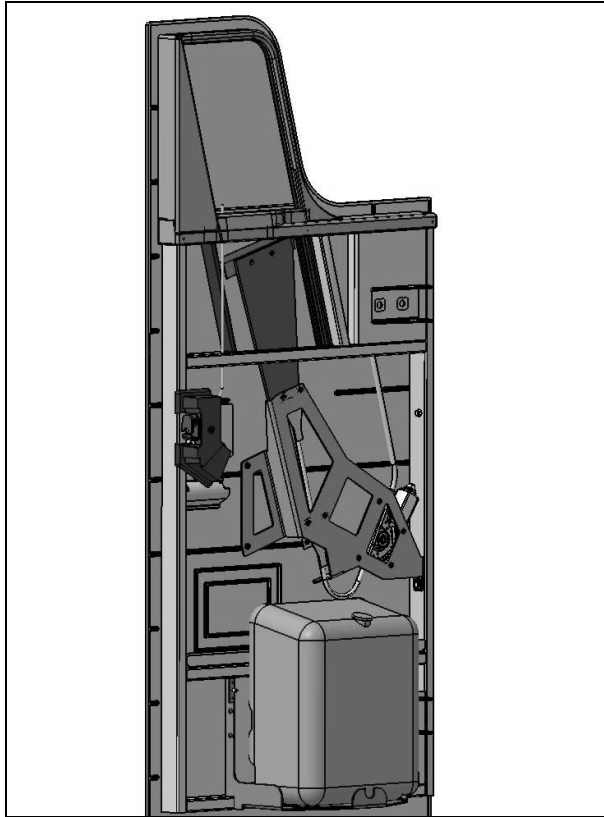


- Clean window using window cleaner.

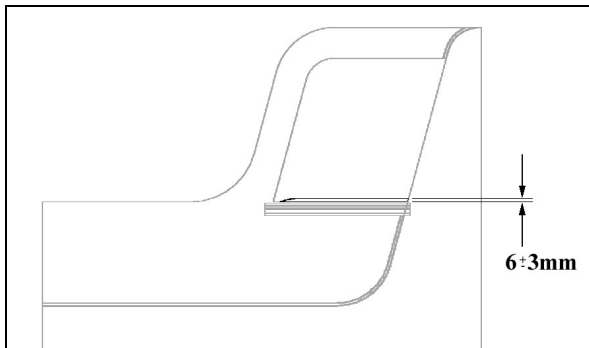


## Section 18: BODY

- Insert window into frame.
- Secure window pane to raising mechanism.

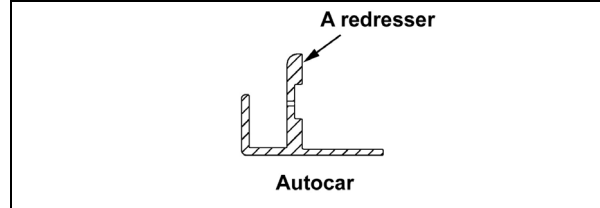


- Adjust window travel ( $6\pm 3\text{mm}$  above window wiper).

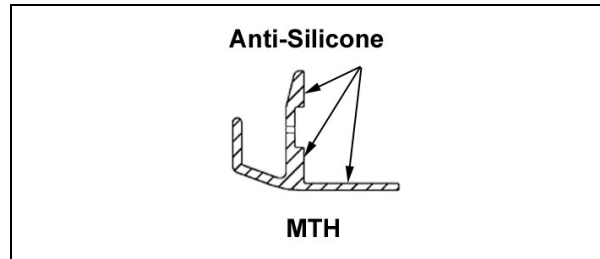


### Driver's Window Gutter

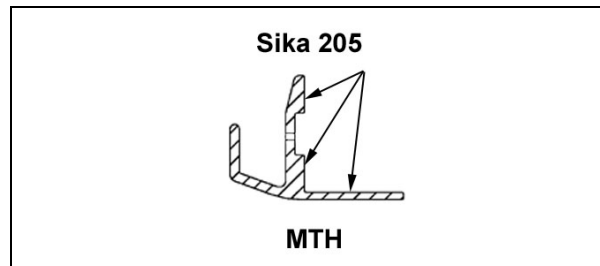
- Dry fit the gutter on the vehicle. If required, straighten up gutter using a hammer and a wooden block.



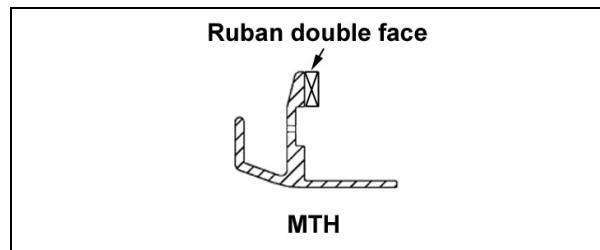
- Apply anti-silicone inside right angle.



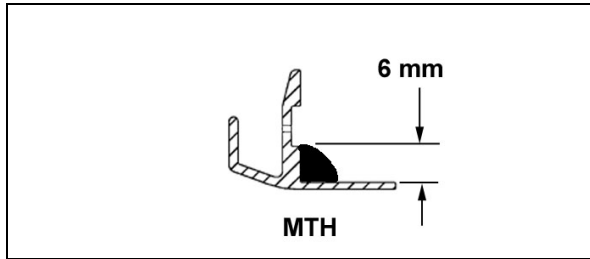
- Apply Sika 205 inside right angle.



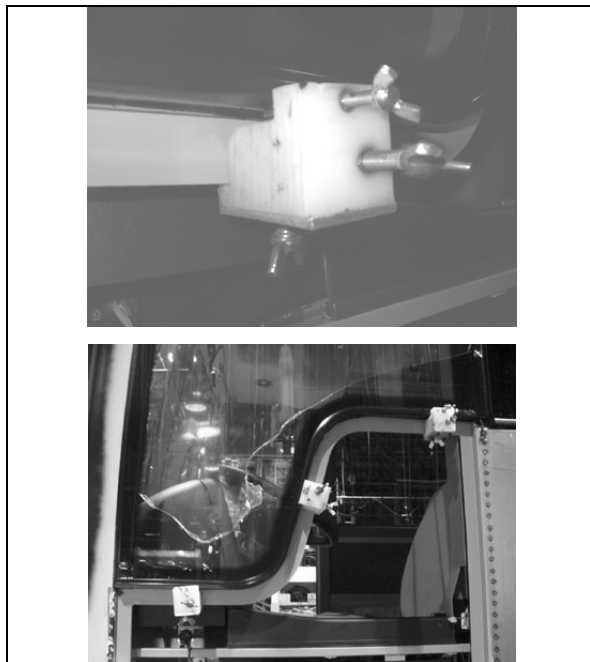
- Apply 1/16 x 1/4 double face self-adhesive tape onto gutter.



- Peel the back from double face self-adhesive tape.
- Apply Sika 252 inside right angle.



- If applicable, remove plastic film at the bottom of driver's window.
- Remove excess of Sika underneath driver's window.
- Clean bottom of driver's window using window cleaner.
- Apply Sika Aktivator at the bottom of driver's window.
- Install gutter under driver's window then compress in order to fix double face self-adhesive tape.
- Install 3 clamps and allow curing for 4 hours.



### 7.7.9 Upper Lateral Window

For the removal of upper lateral window, you will need:

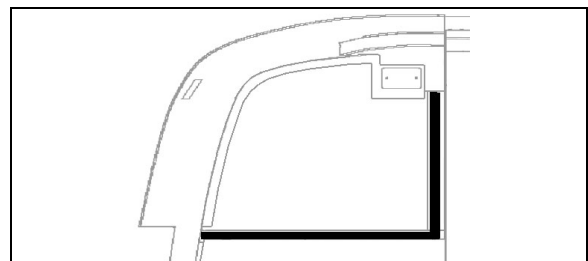
Pneumatic «Zip gun» type tool;  
Razor sharp window scraper;  
"Olfa" knife;  
Face shield.

- From inside of vehicle, cut Sika bead around window perimeter using a "Zip gun" while another person hold the window from the outside.

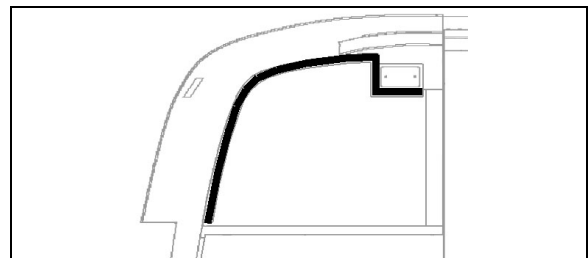
**NOTE**

*Wear ear plugs during this operation.*

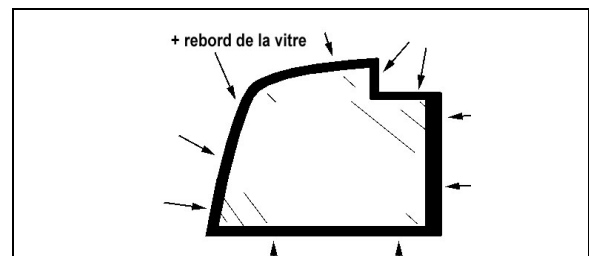
- Then, move outside of vehicle and cut Sika bead to free window while somebody else hold the window from the inside.
- Carefully remove window from frame, ask for help if needed.
- Using a razor sharp window scraper, remove from window frame Sika bead and double-face self adhesive tape residue.
- Remove clearance light
- Apply some water to vehicle structure to clean surface.



- Clean inside and outside of fiberglass using anti-silicone.
- Apply some Sika 206 G+P.

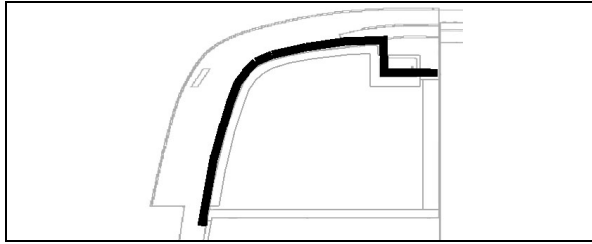


- Clean window perimeter and edges using window cleaner.
- Apply Sika Aktivator.

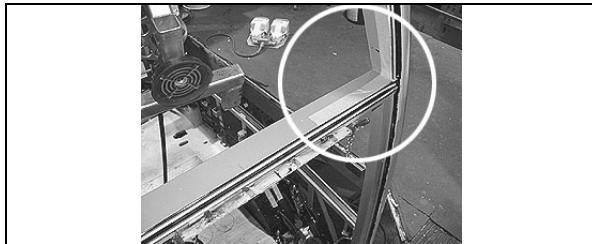


## Section 18: BODY

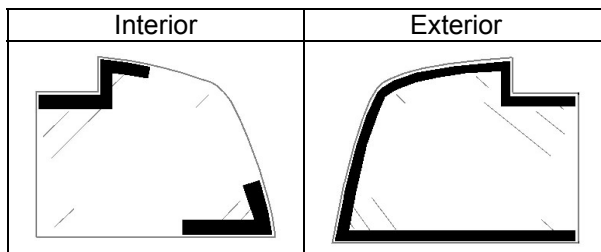
- Apply masking tape onto front face before applying Sika glue to protect paint and adjacent surfaces.



- Apply masking tape onto structure.



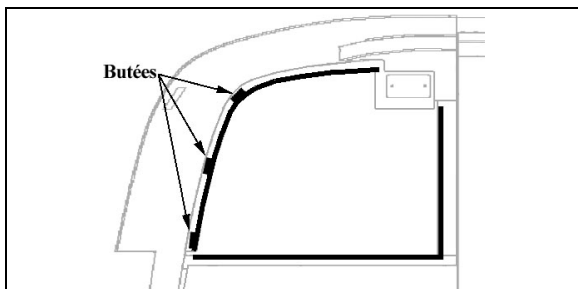
- Apply masking tape onto window.



- Affix 3 spacers #790392 onto fiberglass.
- Apply a double-face self adhesive tape 1/8 by 1/4 inch onto fiberglass perimeter (front face exterior).

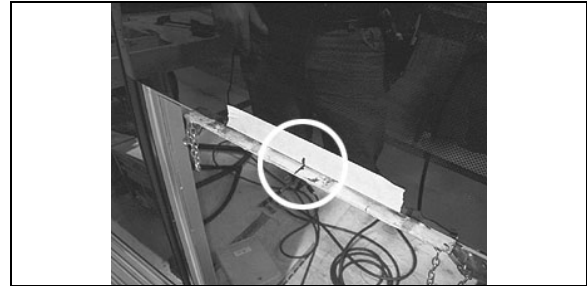
### NOTE

*Do not peel the back from double face self-adhesive tape at this moment.*



- Install window inside the opening to check if window curve and front face are the same.

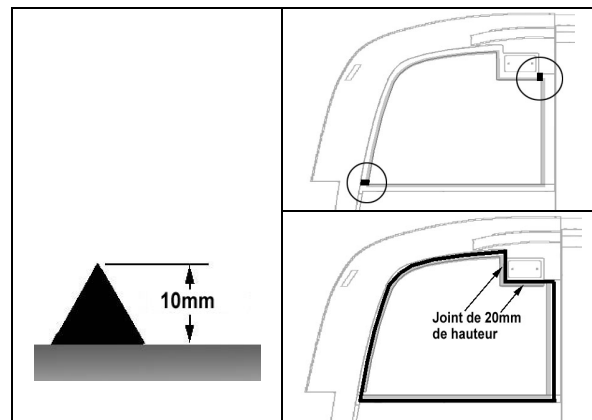
- L.H. side: Front of window must line up with front of driver's window. Use shims to adjust window height if necessary.
- R.H. side: Once the window is centered, apply some masking tape on bottom of window to mark off the position.



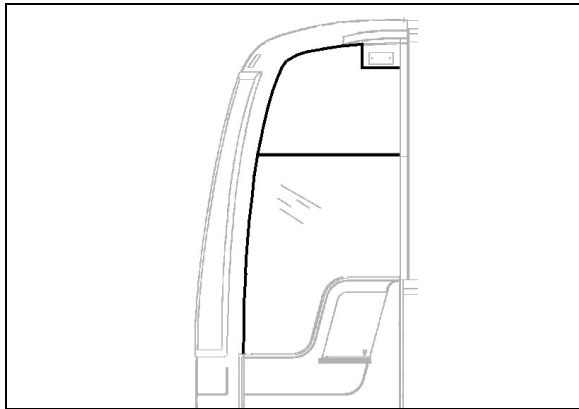
- Peel the back from double face self-adhesive tape.
- Apply some Sika 255 onto fiberglass perimeter (front face exterior).

### NOTE

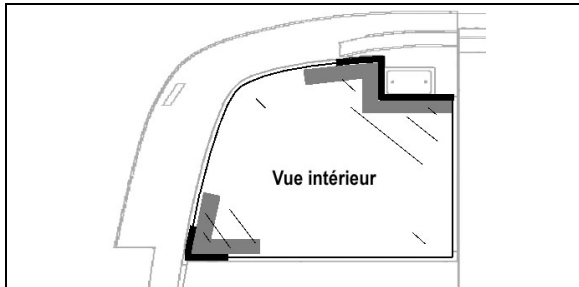
*Make sure the 2 small cavities between fiberglass and structure are filled with Sika.*



- Install and compress all around window perimeter to fix window to self adhesive tape.
- To support the window, position two "Quick Grip" type pliers at the base of the frame.
- Center and align the window base using the two pliers while pressing firmly the window perimeter against the frame.
- Complete a finishing joint and scrape the excess with a plastic scraper.
- Carefully remove masking tape then smooth down finishing joint with your finger. Use soapy water or Sika 208.



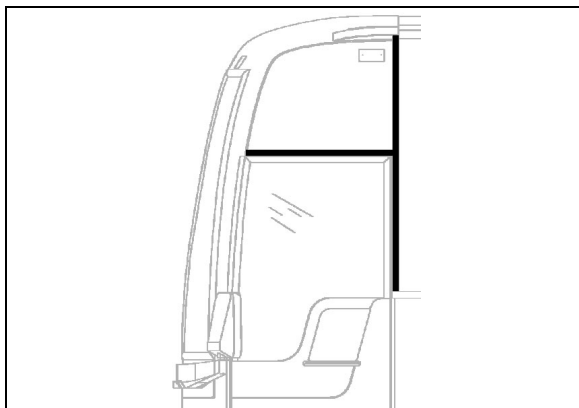
- From vehicle's interior, apply some Sika 255 and make 2 finishing joints. Smooth down the joints and remove masking tape.



- Reinstall clearance lights.
- Discard waste according to applicable environmental regulations, use dangerous waste containers.

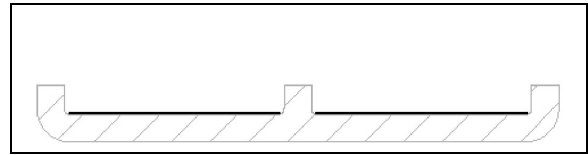
#### Glued Molding Installation

- Clean window gluing area using window cleaner.
- Apply Sika Aktivator onto gluing area making sure to avoid Sika adhesive if it is not cured yet.

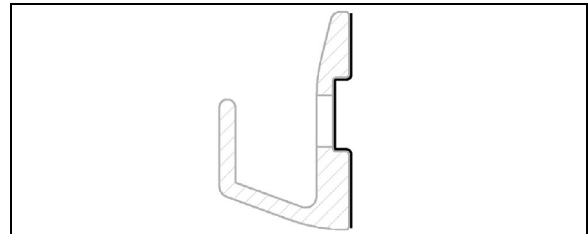


- Apply anti-silicone onto molding.

- Apply Sika 205.



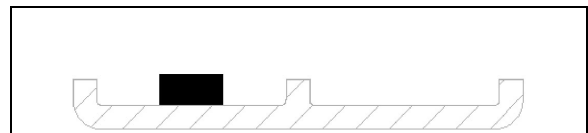
- Clean gutter using anti-silicone.



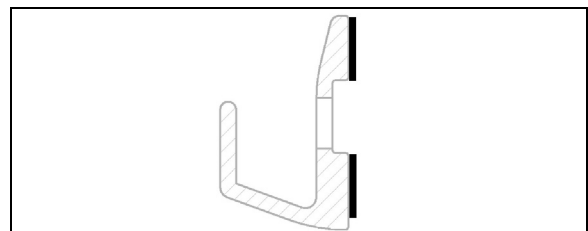
- To seal screw holes, remove screw, apply Sika 205 inside the hole then apply Sika 252.



- Apply a double-face self adhesive tape 1/8 by 1/4 inch inside the molding onto the whole length.

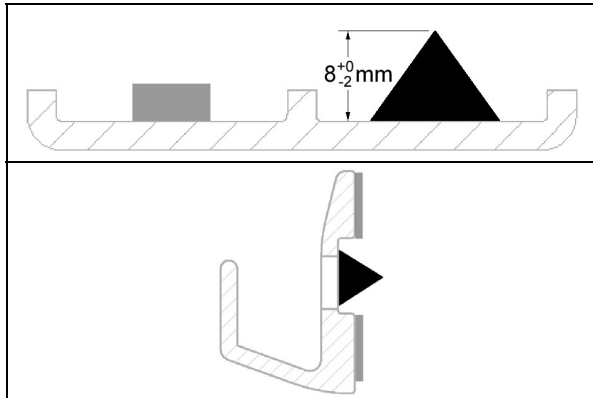


- Apply a double-face self adhesive tape 1/32 by 1/4 inch onto the whole length of the gutter.

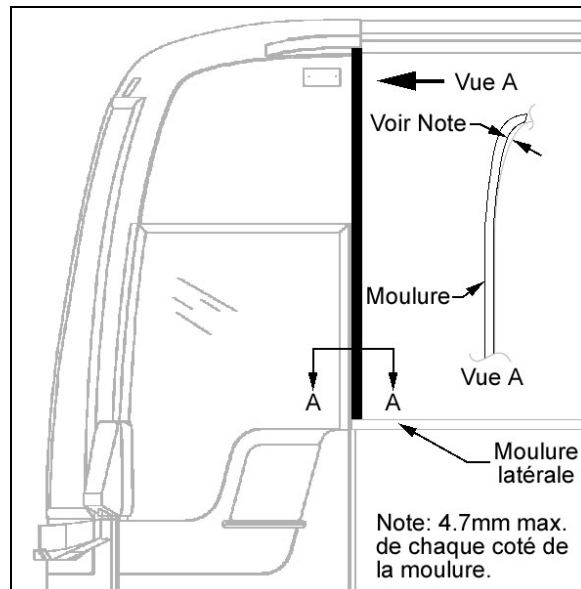


- Apply Sika 252 inside the moldings onto the whole length.

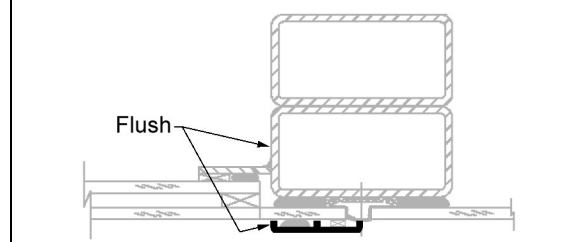
## Section 18: BODY



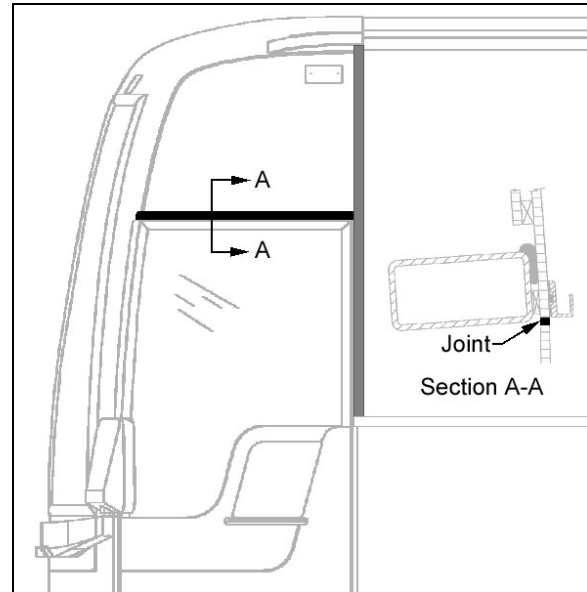
- Position and fix vertical molding. Lean vertical molding against lateral molding. Make sure vertical molding lines up with structural tubing.



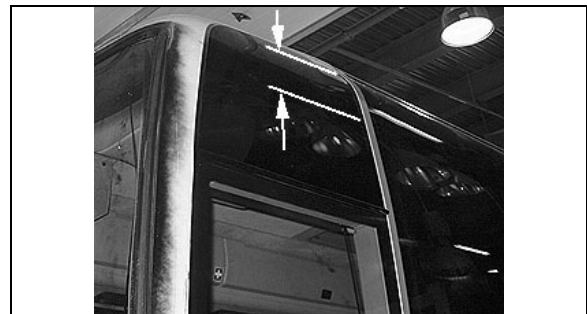
### SECTION VIEW A-A



- Position and fix horizontal molding (gutter). Lean gutter against vertical molding. Position gutter just above Sika finishing joint.



- Apply masking tape on each side of vertical molding. Apply Sika 252 to fill the gap between molding and windows.
- Smooth down the joint with finger.
- If required, clean surfaces using Sika 208.



### 7.7.10 Front Cap

The fiberglass front cap does not need any maintenance except painting as needed. It is held in place with adhesive. If ever it has to be replaced, make an appointment at a Prévost service center near you. For minor damages, refer to section 4 "Fiberglass Repair" and section 5 "Painting".

## 8 ZONE 2

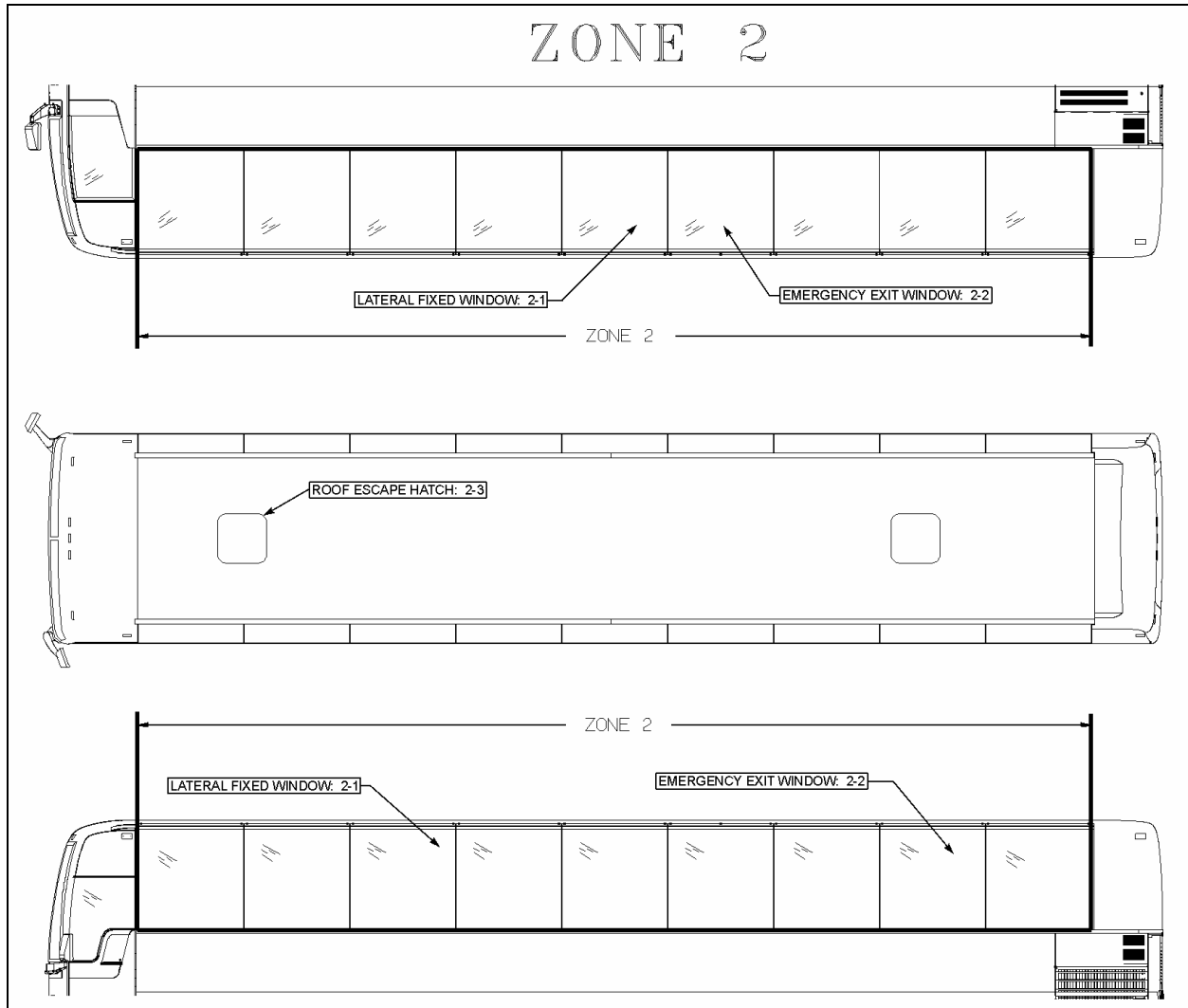


FIGURE 24: ZONE 2

18625

## 8.1 LATERAL FIXED WINDOW

Nine passenger side windows are provided on each side on X3-45. They are made of fixed, single or double-glazed, heat absorbing AS-3 glass. Windows are mounted in painted aluminum extrusions, which hold the glass in place from the top rail of the coach. The extrusion also serves as a hinge to allow the window to swing open when needed. The single-glazed windows are made of tinted tempered safety glass, while the double-glazed windows are made of tinted tempered safety glass outside and clear tempered glass inside.

For fixed side window removal or installation, you will need:

- \* Hammer or;
- \* Drill equipped with a sharp pointed rod into which a small hole was drilled;
- \* Braided windshield wire and a pair of handles;
- \* Gloves, goggles or face shield.

## 8.1.1 Fixed Window Removal

**Method A**

- Apply a sticky plastic film onto window outside surface (thermos) and break window. For single pane, apply a sticky plastic film on both sides of window.

## Section 18: BODY

### Method B

- Using a drill equipped with the special sharp pointed rod, drill through the window seal into one of the bottom corners, from a 30° angle with reference to the vehicle.
- This procedure requires accuracy and it is possible not to succeed on the first attempt. From the inside of vehicle, a second person ensures the rod passes through.
- Remove the rod, thread the wire into the small hole. Reinsert the rod and the wire into the hole far enough so that the person inside the vehicle can pull the rod using a pair of pliers.
- Attach the wire ends to the specially designed handles.
- Pull in turn from the inside and the outside of vehicle to gradually cut the Sika bead on the window perimeter.
- When you reach top corner, detach wire from the outside handle, secure it to a fish wire or rod and thread it underneath the aluminum molding behind the rivets.
- Detach wire from fish wire and continue cutting using the handle.
- Cut Sika bead until you come back to starting point, then you can remove the window by carefully pushing it out from the inside of vehicle.

#### 8.1.2 Preparation of Structure and Installation of Window

##### Preparation of Structure

- Remove old Sika adhesive.
- If primer was removed at the same time than Sika, perform the following steps:
  - Clean using anti-silicone.
  - Remove from structure old primer using a sander (120-150 grit).
  - Clean again using anti-silicone.
  - Apply 206 G+P primer.
- Reactivate 206 G+P primer.

### Installation of Window

- Use window cleaner around window interior perimeter and edges to remove any oily film while inspecting for damages.
- Apply Sika Aktivator.
- Using a triangular nozzle (20mm X 10mm), apply Sika Ultrafast II onto structure.

#### NOTE

*You only have 8 minutes to install window once the SIKA ULTRAFAST II product is applied.*

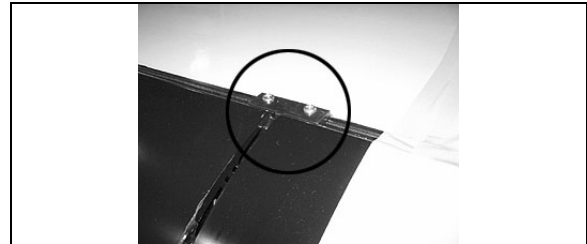
- Install window.



#### CAUTION

To prevent damaging the Sika joint, do not raise the window once it as touched the bead.

- Before compressing window against Sika joint, install two stops into the aluminum extrusion one inch from each window edge.



- Verify window alignment with reference to adjacent surfaces.
- Vehicle must remain stationary for 30 minutes at more than 23°C.

## 8.2 EMERGENCY EXIT WINDOWS

Three of the windows on curb side of the X3-45 serve as emergency exits, while there are four on driver's side. See figure 33. Except for the top window side, the three other glass sides are unprotected, which causes the workers to be exceptionally careful when manipulating or installing such windows.

In addition, when it becomes necessary to lay down the unprotected edges of the glass window, never use a steel or concrete floor support. It is recommended to use a wooden support, even better, a padded surface.

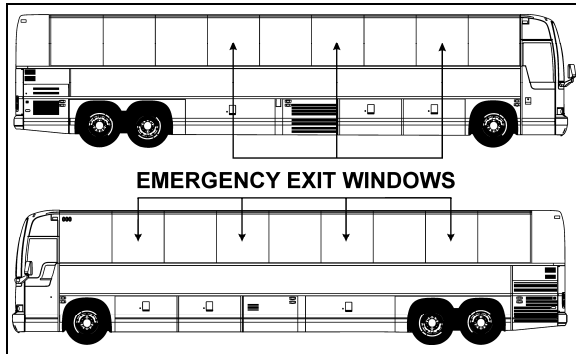


FIGURE 25: X3-45 COACH

18617

An emergency exit window can be opened by pulling the lower part of the release bar to disengage the safety latches, and then by pushing out the window frame (Fig. 32).

Emergency operating instruction decals are affixed under each emergency exit window. To close the window, pull back the window and push down the release bar.

### 8.2.1 Emergency Exit Release Bar

The emergency exit release bar system is generally maintenance free. It has been designed to answer the twenty pound resistance criteria for opening the emergency window. If this handle should be replaced:

1. Remove the screws and bolts securing it to the emergency exit window;
2. Install a new release bar, reverse the procedure.

#### **NOTE**

Check the legal twenty pound maximum resistance to be sure to comply with regulations.

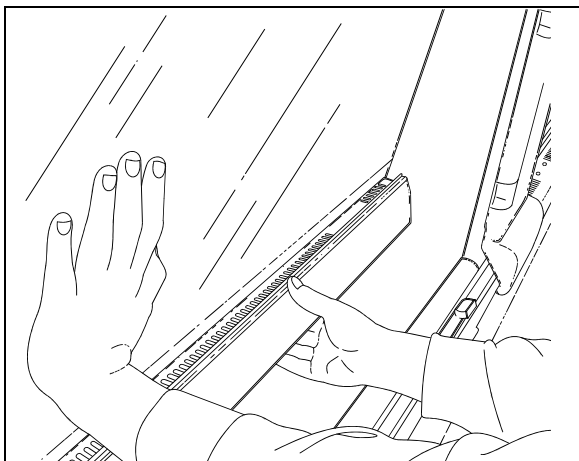


FIGURE 26: EMERGENCY EXIT WINDOW

18008

### 8.2.2 Emergency Exit Window Adjustment

Emergency exit windows should be checked periodically for easy opening and closing. Pulling the lower part of the release bar with both hands placed near the safety latches should disengage both locks on the window simultaneously. The tension required to release the window should not exceed twenty pounds (9 kg) of force.

The release bar mechanism itself has been designed such as no adjustments are necessary.

If too much effort is required to disengage the locks when pulling the release bar or if the window doesn't close tightly or rattles, check for interference by foreign objects or nearby parts into mechanism, such as the microswitch, rubber seal, wires, etc. Correct situation immediately.

#### **NOTE**

Tangs on the lock must be in a horizontal position.

### 8.2.3 Emergency Exit Window Replacement

1. Lift the bar release system;
2. Remove the stop blocks from the top exterior of the window.
3. Push the glass window out ninety degrees (90°).



#### **WARNING**

The window may fall out.

4. The window is free and can be unhooked.

Reverse the procedure to install a new emergency exit window.

### 8.3 ROOF ESCAPE HATCH

The vehicle can be equipped with one or two escape hatches. The escape hatch is designed to provide years of reliable service with a minimum of maintenance. All components are rust proof, and moving parts are Teflon coated to eliminate need for lubrication. Should water infiltrate the vehicle from the escape hatch, refer to the heading "Sealing" in this paragraph for procedures on how to seal this area.



## Section 18: BODY



### CAUTION

Use of lubricants, paints, or other coatings such as graffiti deterring sprays is not recommended.

Suggested maintenance includes periodic inspection of fasteners for evidence of loosening due to tampering, and regular cleaning with mild soap and water.

Although there are other cleaning solutions available, some contain solvents and other chemicals that can attack the high strength materials used in the production of the escape hatch.



### CAUTION

Ensure that cleaning solutions are compatible with the materials used on the escape hatch.

Graffiti removing cleaners often contain acetone, ether, lacquer thinner or other solvents known to destroy the high strength properties of many plastics. Use of these cleaners must be avoided. Graffiti-resisting coatings often leave a sticky residue that interferes with smooth up/down movement of the hatch mechanism. Some of these coatings also contain solvents that will reduce the strength of certain components.



### CAUTION

Use of these coatings is at considerable risk and should be avoided.

#### 8.3.1 Repair

All components used in the production of the escape hatch are available as service parts, except for one hinge that represents a possible hazard when improperly reattached to a hidden tapping plate, itself often damaged whenever the hinge is damaged. The tapping plate is permanently laminated between the inner and outer cover assemblies, and it cannot be inspected or replaced. It is therefore necessary to replace the entire assembly following damage to the hinge. See figure 25.



### CAUTION

Hinge assembly is critical and hinge should never be removed from cover assembly. Fasteners used in this assembly are special

and have critical torque requirements and tamper-resistant heads to discourage tampering.

#### 8.3.2 Sealing

1. Open and tilt up the escape hatch cover.
2. Join the 2 ends of the rubber seal.



### CAUTION

Seal joint should be toward rear of vehicle.

3. Apply rubber adhesive CA-40 (Prévost # 681285) in the gap between the seal ends.
4. Apply Sikaflex 221 sealant (Prévost # 680532) along the outline of the escape hatch on the roof of vehicle.

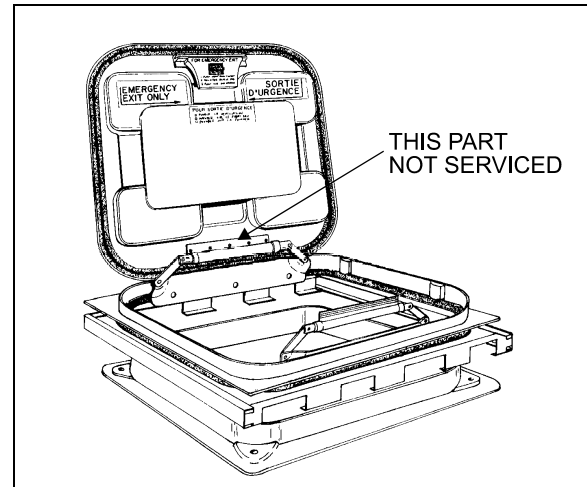


FIGURE 27: ESCAPE HATCH

18104

#### 8.3.3 Escape Hatch Panel Assembly

The frame of the escape hatch is riveted to the roof of the vehicle. The escape hatch panel assembly can be replaced as a unit and a new panel assembly installed in the existing frame. To remove the panel assembly, remove the 4 bolts fastening the 2 hinges to the escape hatch frame and retain the 4 flat washers. Reinstall the panel assembly by fastening the 2 hinges with the 4 bolts and flat washers removed earlier.



### CAUTION

When installing, roof escape hatch's hinge must be toward the front of vehicle, to prevent the hatch from being ripped out if accidentally opened while vehicle is running.

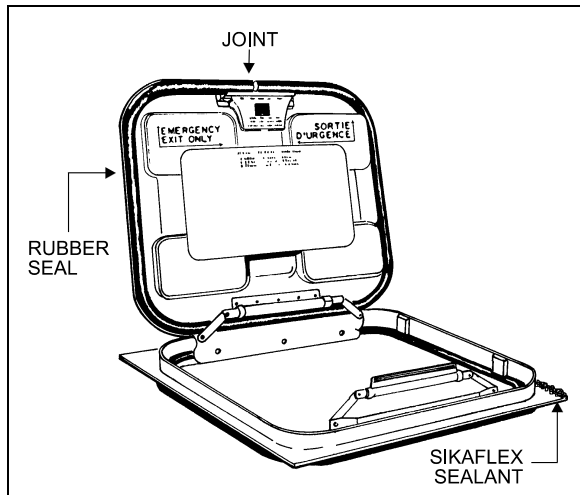


FIGURE 28: ESCAPE HATCH

18105

### 8.3.4 Escape Hatch Frame

When necessary, the escape hatch frame can be removed and replaced in the following way:

## 9 ZONE 3

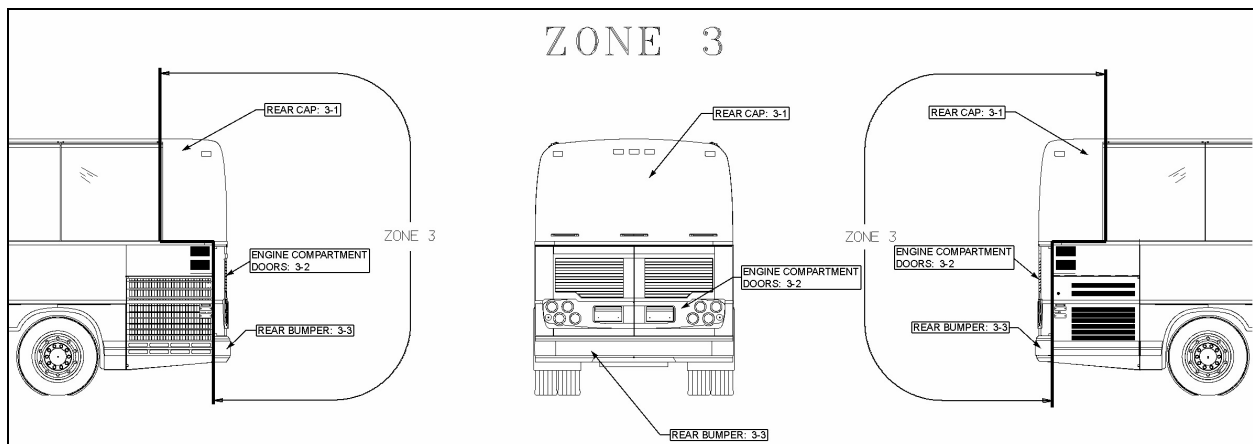


FIGURE 29: ZONE 3

18626

### 9.1 REAR CAP

The fiberglass rear cap does not need any maintenance except painting as needed. It is held in place with adhesive. If ever it has to be replaced, make an appointment at a Prévost service center near you. For minor damages, refer to Paragraph 4 "Common Fiberglass Repair Procedure" and Paragraph 5 "Common Painting Procedure".

### 9.2 ENGINE COMPARTMENT DOORS

Engine compartment doors may be adjusted for proper fit by untightening hinge bolts:

1. Support the frame from inside the vehicle.
2. Remove rivets.
3. Cut the rubber seal with a sharp edge knife and remove the hatch frame.
4. On vehicle top, using the knife, remove as much as possible the remaining rubber seal.
5. Drill holes (if needed) in the new metal frame.
6. Clean both vehicle top and new hatch frame with SIKA 205.
7. Apply rubber adhesive SIKA 221 under the hatch frame surface.
8. Install the frame in place and fix it with rivets.
9. Remove excess adhesive and clean all around.

1. Loosen the bolts, (1, 2 Fig. 30) holding the hinge to the vehicle structure to shift the door "UP or DOWN".
2. Loosening the bolts (3, Fig. 30) allows the door to be shifted "LEFT or RIGHT" and "IN or OUT".
3. Adjust the doors position depending on the gap needed between exterior finishing panels.
4. Tighten the bolts.
5. Check that the doors swing freely and close properly. It may be necessary to adjust the door latch to get proper fit and operation.

## Section 18: BODY

To adjust the latch mechanism (4, Fig. 30) and the striker pin:

1. Open the doors to access the striker pin.
2. Slightly loosen the striker pin.
3. Using a hammer, adjust the striker pin to center it in the door latch mechanism.
4. Tighten the striker pin.
5. Check doors fit and operation.

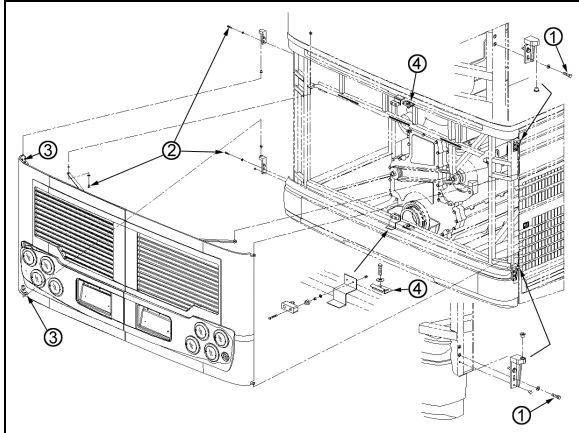


FIGURE 30: ENGINE COMPARTMENT DOORS 18633

### 9.3 REAR BUMPER

Remove three bolts on each side holding bumper to vehicle and remove bumper.

To install bumper, reverse the procedure.

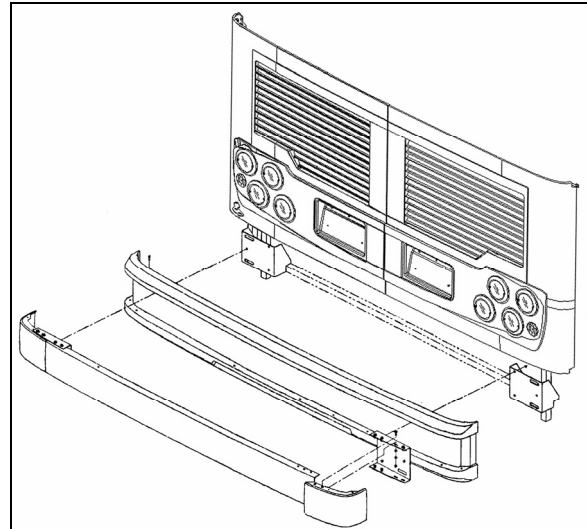


FIGURE 31: REAR BUMPER 18634

## 10 ZONE 4

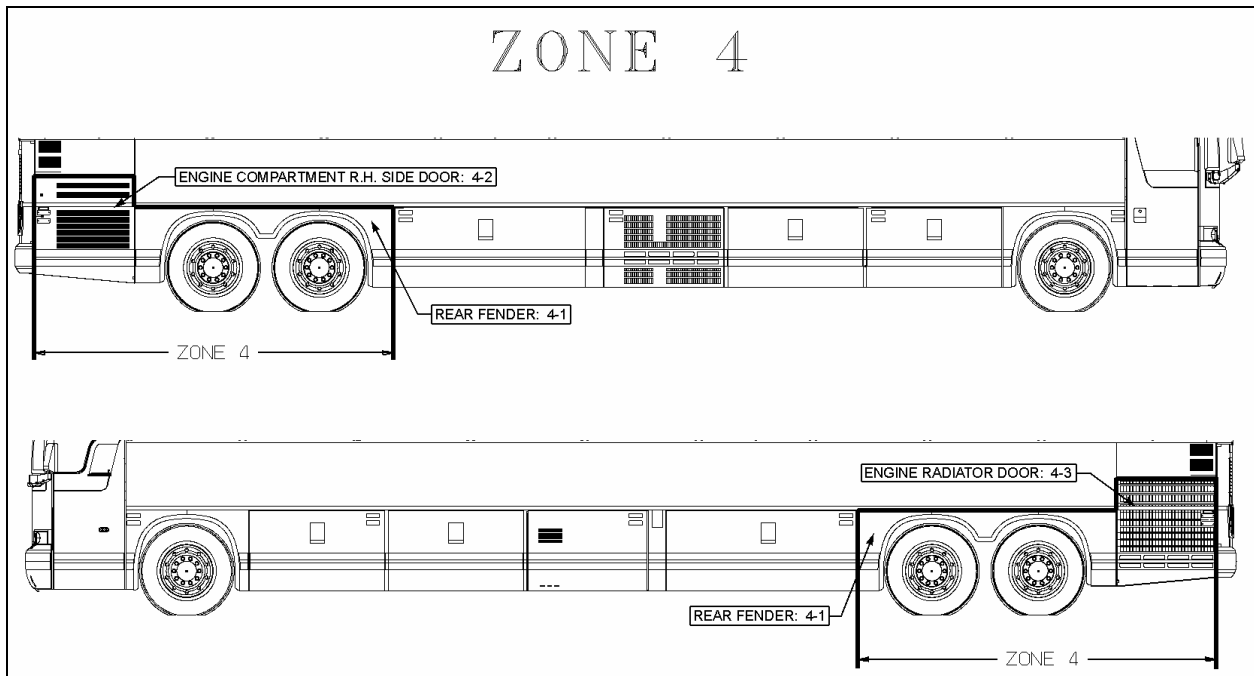


FIGURE 32: ZONE 4 18627

### 10.1 REAR FENDER

On the "X3" series vehicle, rear fenders are hinged for maintenance on brakes and suspension. Each rear fender panel has two mechanical spring loaded holding devices fixing it to the vehicle's structure. Push the spring type rod sideways to disengage the lock.

### 10.2 ENGINE COMPARTMENT R. H. SIDE DOOR

Engine compartment R. H. side door may be adjusted for proper fit by untightening hinge bolts:

1. Loosen the bolts, (1, Fig. 33) holding the hinge to the vehicle structure to shift the door "IN or OUT" and "UP or DOWN".
2. Loosening the bolts (2, Fig. 33) allows the door to be shifted "LEFT or RIGHT" and "UP or DOWN".

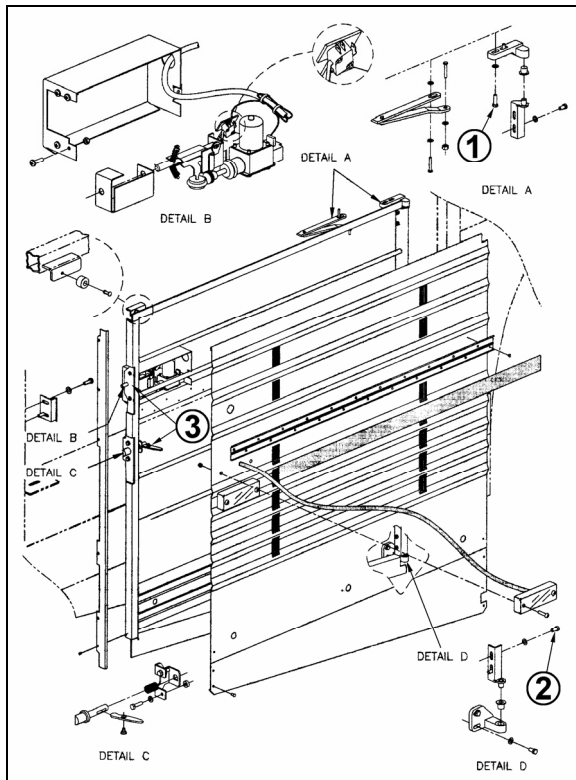


FIGURE 33: ENGINE COMPARTMENT R.H. SIDE DOOR<sup>18635</sup>

3. Adjust the door position depending on the gap needed between exterior finishing panels.
4. Tighten the bolts.

5. Check that the door swings freely and closes properly. It may be necessary to adjust the door latch to get proper fit and operation.

To adjust the latch mechanism (3, Fig. 33) and the striker pin:

1. Open the door to access the striker pin.
2. Slightly loosen the striker pin.
3. Using a hammer, adjust the striker pin to center it in the door latch mechanism.
4. Tighten the striker pin.
5. Check door fit and operation.

### 10.3 ENGINE RADIATOR DOOR

Radiator door may be adjusted for proper fit by untightening hinge bolts:

1. Loosen the bolts, (1, Fig. 34) holding the hinge to the vehicle structure to shift the door "IN or OUT" and "UP or DOWN".
2. Loosening the bolts (2, Fig. 34) allows the door to be shifted "LEFT or RIGHT" and "UP or DOWN".

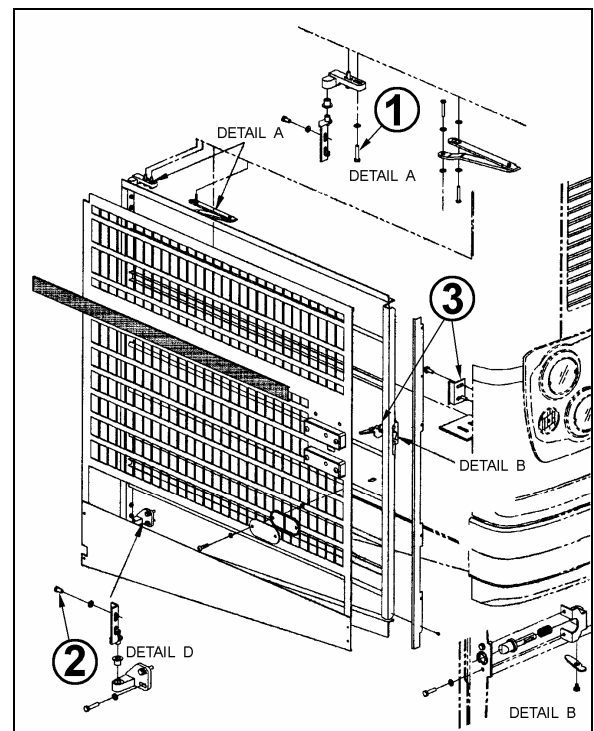


FIGURE 34: RADIATOR DOOR

18636

3. Adjust the door position depending on the gap needed between exterior finishing panels.

## Section 18: BODY

4. Tighten the bolts.
5. Check that the door swings freely and closes properly. It may be necessary to adjust the door latch to get proper fit and operation.

To adjust the latch mechanism (3, Fig. 34) and the striker pin:

1. Open the door to access the striker pin.
2. Slightly loosen the striker pin.
3. Using a hammer, adjust the striker pin to center it in the door latch mechanism.
4. Tighten the striker pin.
5. Check door fit and operation.

### 11 ZONE 5

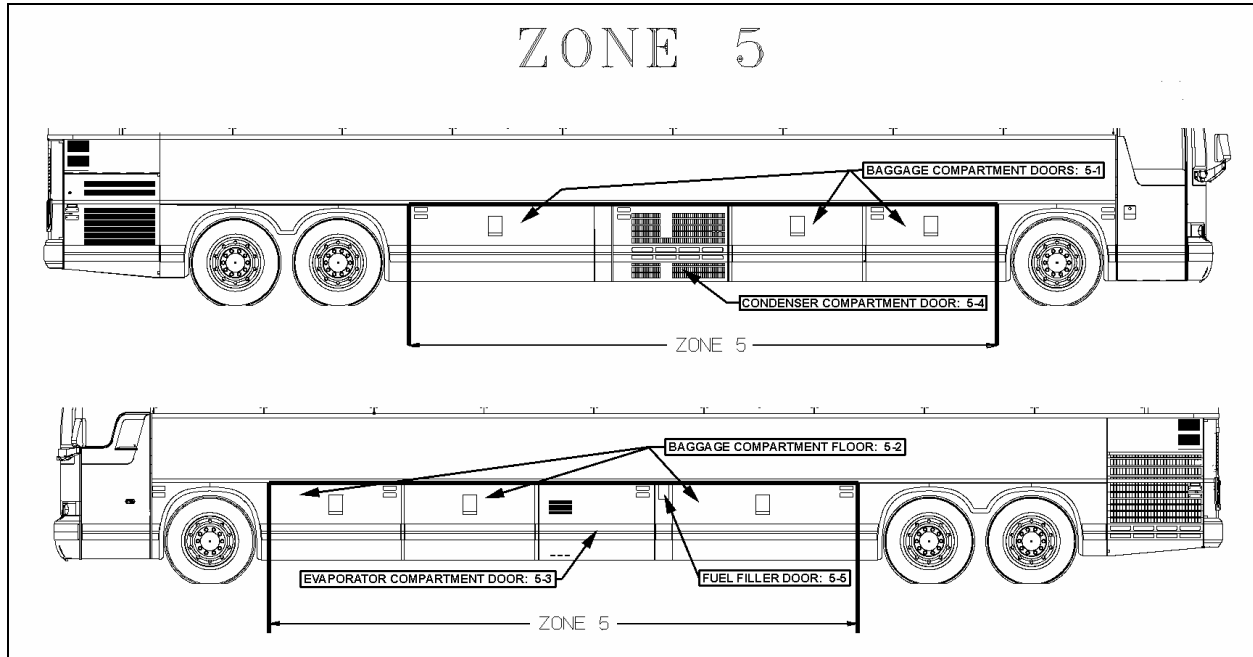


FIGURE 35: ZONE 5

18628

#### 11.1 BAGGAGE COMPARTMENT DOORS

For the removal and installation of baggage compartment door stainless steel body panel, you will need:

A drill with drill bits;

Pneumatic “Zip gun” type tool;

Razor sharp window scraper or putty knife;

- Open damaged compartment door and unfasten rub rail fixing bolts. Remove rub rail.
- Unfasten bolts and disconnect cable if necessary in order to remove door from vehicle.
- Preferably install the door onto a work surface where it can be solidly fixed.

#### 11.1.1 Door Lower Panel

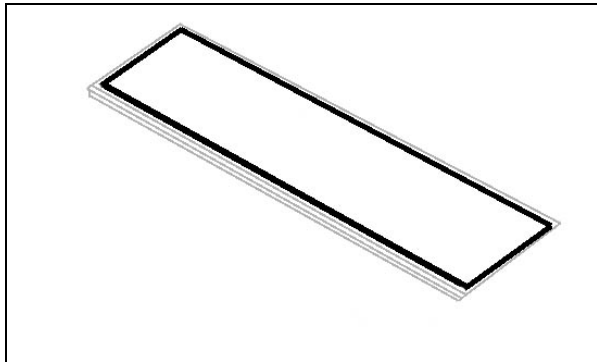
##### Panel Removal

- Using the “Zip Gun”, cut Sika bead located  $\frac{1}{2}$  inch from the door panel perimeter edge.
- Wearing gloves, goggles and ear plugs, pry loose body panel using a “Zip gun” or lever starting from the door lower part.
- Using the window scraper, remove any Sika bead or self adhesive tape residue left on the door frame.

##### Lower Panel Preparation and Installation

- Use a Chix cloth and anti-silicone to remove any dust or residue from door frame.
- Prepare door frame using a scratch pad “Scotch Brite”.
- Clean door frame again using anti-silicone.

- Apply some Sika 206 G+P onto door frame.
- Clean door lower panel using anti-silicone.
- Prepare door lower panel using a scratch pad “Scotch Brite”.
- Clean door lower panel again using anti-silicone.
- Apply some Sika 206 G+P onto door lower panel.
- Using a triangular nozzle (8mm X 9mm), apply some Sika 255 onto door lower panel.



- Position and install door lower panel onto frame.
- Compress and hold for 8 hours.

#### 11.1.2 Door Upper Panel

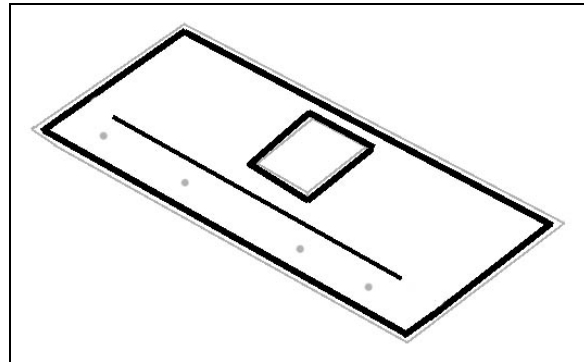
##### Upper Panel Removal

- From the back of the baggage compartment door, remove handle housing fixing screws (6).
- Remove lock access panel
- Wearing gloves, goggles and ear plugs, pry loose body panel using a “Zip gun” or lever starting from the door lower part.
- Cut Sika bead around handle housing.
- Using the window scraper, remove any Sika bead or self adhesive tape residue left on the door frame.

##### Upper Panel Preparation and Installation

- Use a Chix cloth and anti-silicone to remove any dust or residue from door frame.
- Prepare door frame using a scratch pad “Scotch Brite”.
- Clean door frame again using anti-silicone.

- Apply some Sika 206 G+P onto door frame.
- Clean door upper panel using anti-silicone.
- Prepare door upper panel using a scratch pad “Scotch Brite”.
- Clean door upper panel again using anti-silicone.
- Apply some Sika 206 G+P onto door upper panel.
- Using a triangular nozzle (8mm X 9mm), apply some Sika 255 onto door lower panel.



- Position and install door upper panel onto frame.

##### **NOTE**

*Use rub rail fixing holes for upper panel proper positioning.*

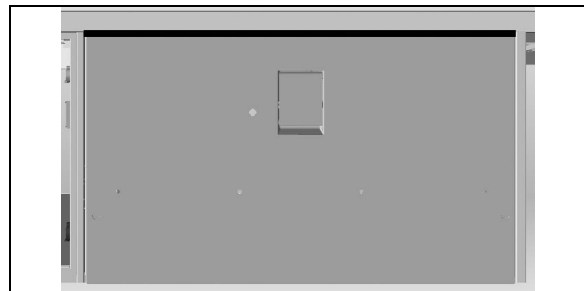
- Compress and hold for 8 hours.

##### Baggage Compartment Door Adjustment

- Adjust door to get a 7mm gap at the top.

##### **NOTE**

*Adjustment is made using the side plates.*

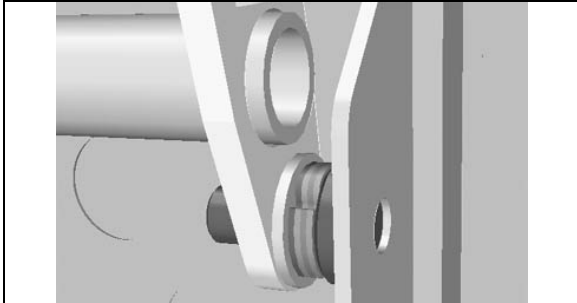


- Center door in the opening using the side plate shims.

## Section 18: BODY

### NOTE

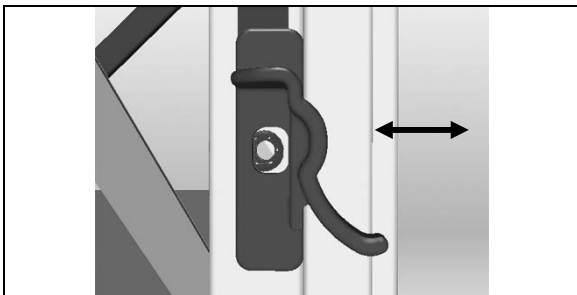
Adjustment is made using shims on the side plates. A total of 8 shims per door must be used e.g. 4 on L.H. side and 4 on R.H. side or 2 on L.H. side and 6 on R.H. side, etc.



- Adjust door position and evenness with reference to adjacent panels and doors.

### NOTE

Adjustment is made by moving IN or OUT the lock plates. Adjust one corner at a time.



- Check handle adjustment. Handle must remain tight against its plastic housing.

### NOTE

Adjustment is made by moving UP or DOWN the lock plates.



- Open baggage compartment door and adjust height using the catch plates.
- Tighten cylinder blocks fixing screws.

## 11.2 BAGGAGE COMPARTMENT FLOOR

### 11.2.1 Repair of Mantex Urethane Covering

#### Minor Repair

Use “Dupont IMRON” paint. Apply using a paint brush or roller depending on gravity.

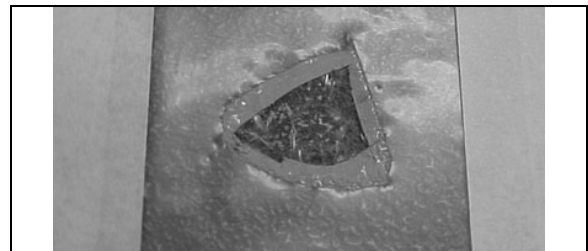
Paint Code: #J4099U

#### Major Repair (Hole)

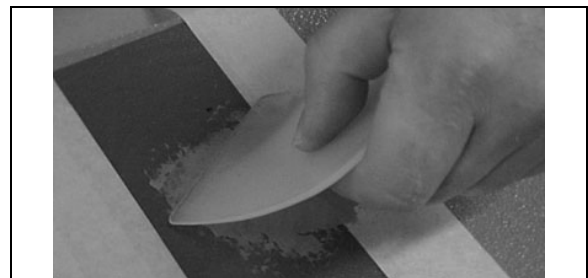
Chamfer the whole perimeter of the damaged area. If applicable, remove loose covering. Remove dust and particles.



Cover and protect damaged area surroundings.



Using a plastic spatula, apply some Sika 221 grey onto the damaged area.



Remove masking tape and protection around damaged area.

Spray pure water onto Sika. Use a floor sample to create some texture onto the adhesive.

If possible spray some more water onto the adhesive to accelerate curing.

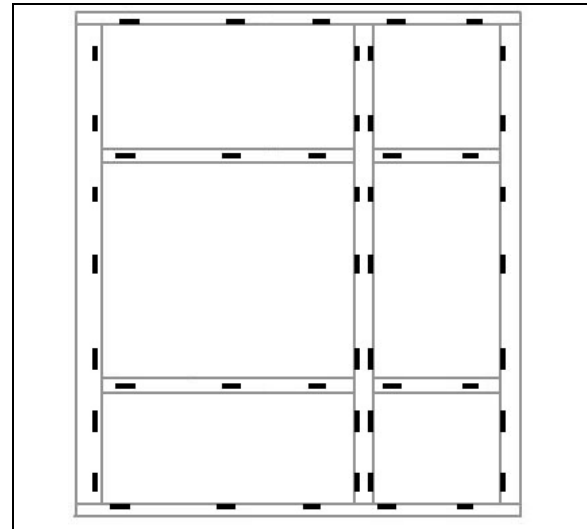


Allow drying for at least **2 hours** then repaint as per paragraph: Minor Repair.

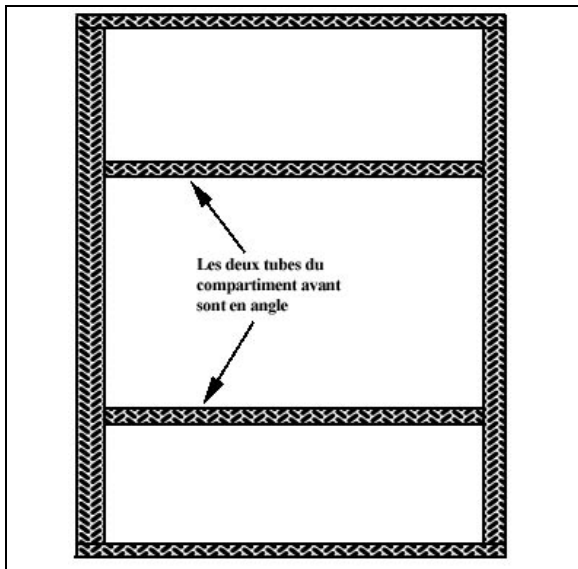
11.2.2 *Baggage Compartment Floor Installation*

**Preparation and Installation**

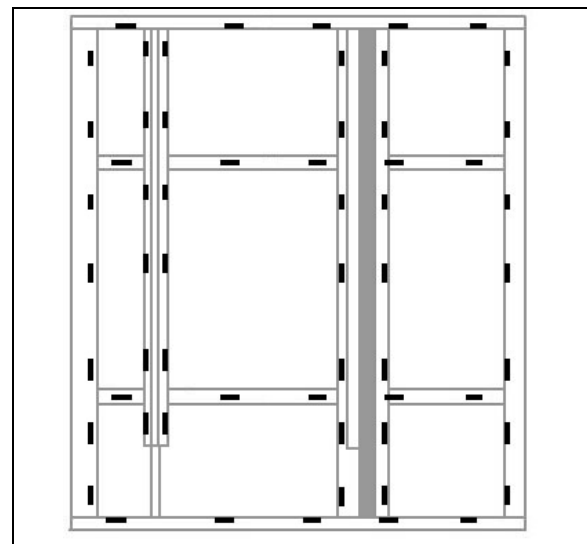
Clean baggage compartment support structure using anti-silicone.



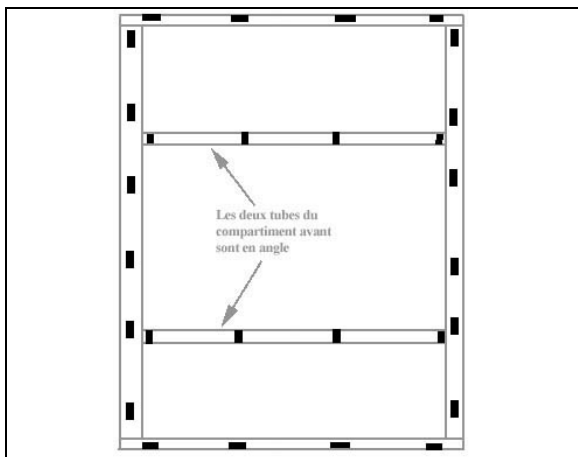
Rear baggage compartment equipped with WCL



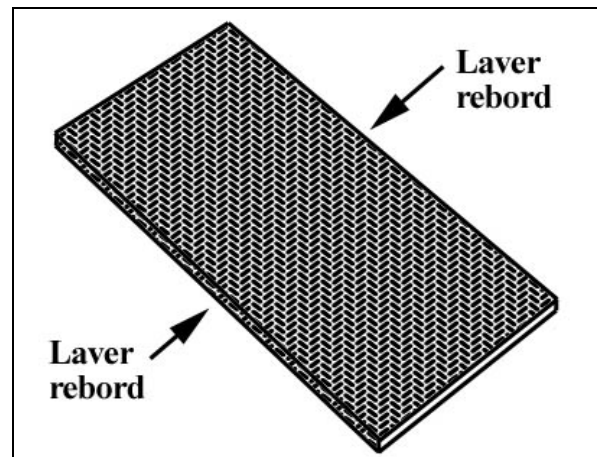
Glue spacers (790392) about 16-inch apart.



Prepare baggage compartment Mantex floor. Clean panel underside and edges.



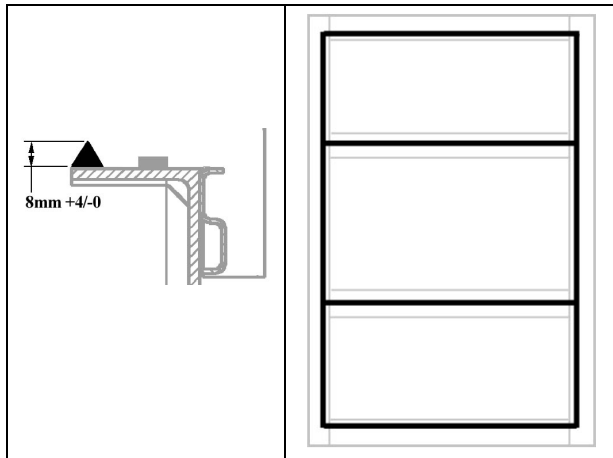
Rear baggage compartment without WCL.



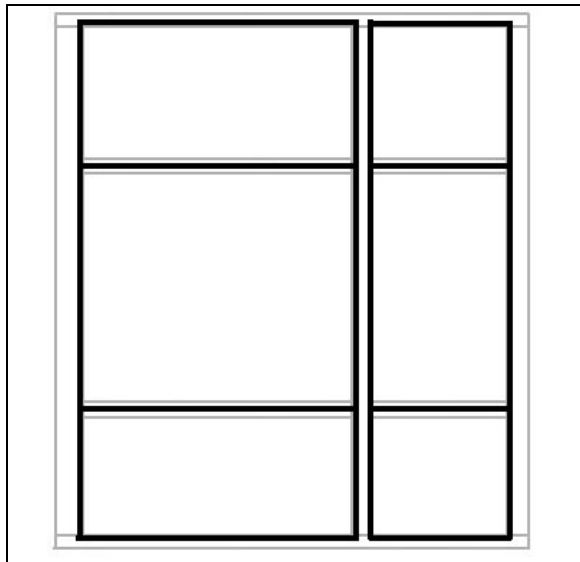


## Section 18: BODY

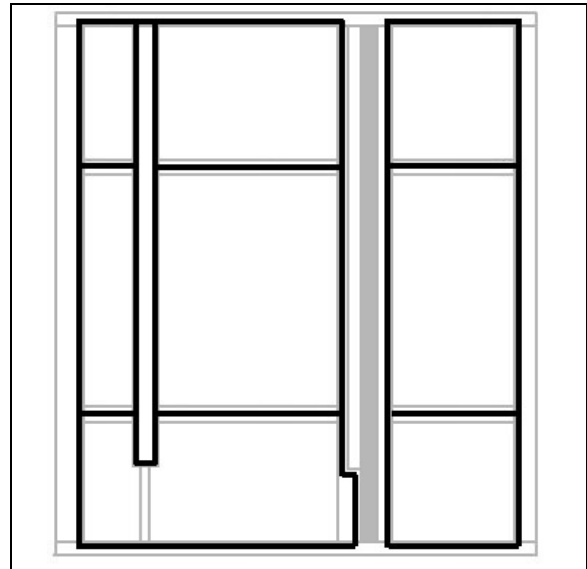
Using a triangular nozzle, apply "Simson" glue (685126) onto support structure.



Rear baggage compartment without WCL.



Rear baggage compartment equipped with WCL

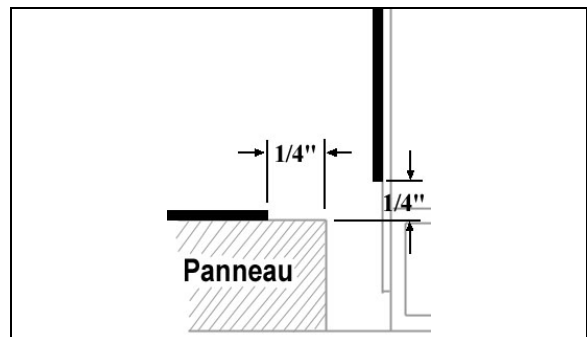


Carefully install panel onto support structure.

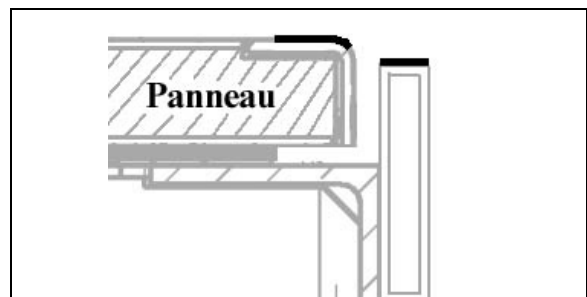
Evenly distribute and install conforming weights (6 to 8) (80 to 100 lbs **total**) onto panel for at least **4 hours**. Make sure panel does not move.

### Finishing Joints

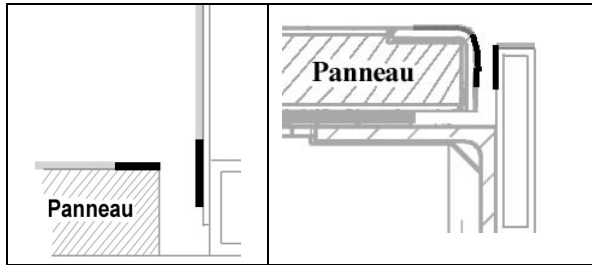
In the case of lateral finishing joint, apply some masking tape  $\frac{1}{4}$ " from panel edge and  $\frac{1}{4}$ " above panel.



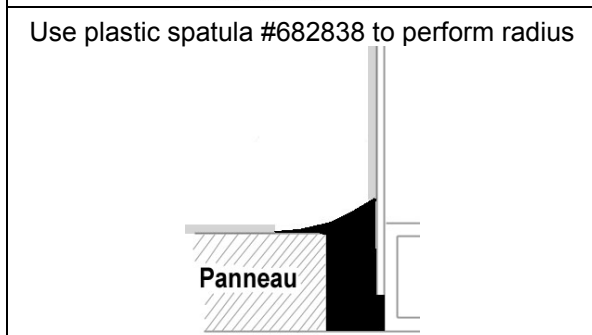
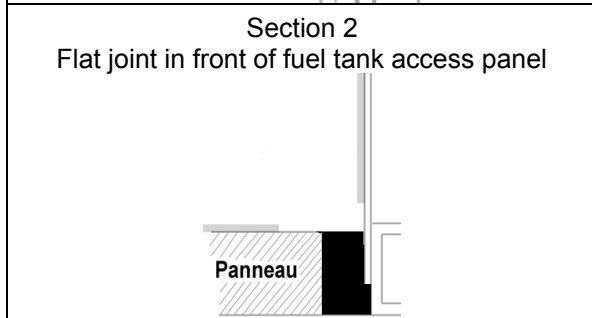
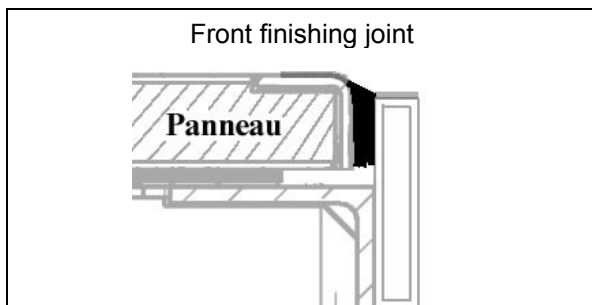
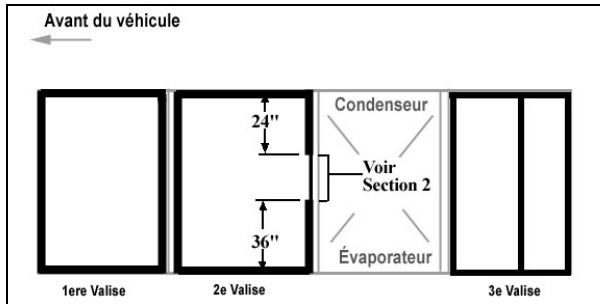
In the case of front finishing joint, apply some masking tape on each side of joint.



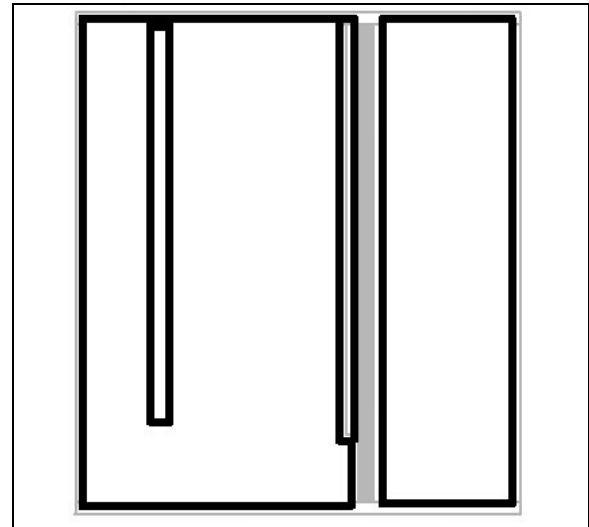
Clean with anti-silicone the area where the Simson glue will be applied.



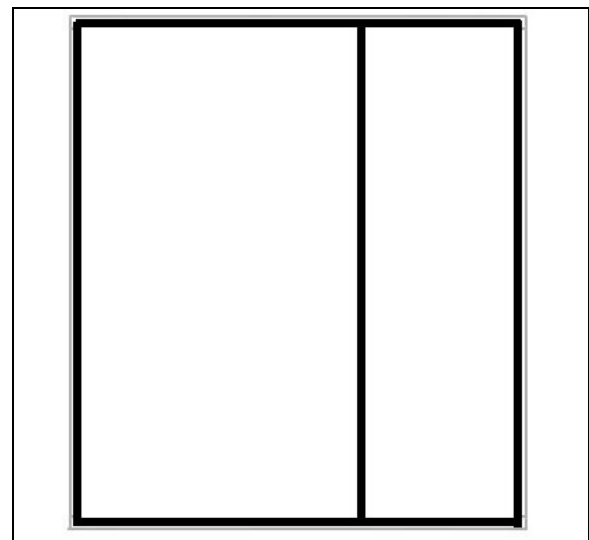
Apply some Simson glue to fill the gap.



Rear baggage compartment equipped with WCL



Rear baggage compartment without WCL.



Remove masking tape.

Smooth down joints using soapy water.

### 11.3 EVAPORATOR COMPARTMENT DOOR

1. Open the evaporator door.
2. Loosen the screws fixing the hinge to hinge attachment or hinge to door assembly. Loosening the screws allows the evaporator door assembly to be shifted "LEFT or RIGHT" and "UP or DOWN" or "IN and OUT".
3. Adjust evaporator door assembly position at the hinge.
4. Tighten the screws.

## Section 18: BODY

5. Respect the required gap between exterior finishing panels.
6. Check that the door swings freely and closes properly. It may be necessary to adjust the door latch to get proper fit and operation.

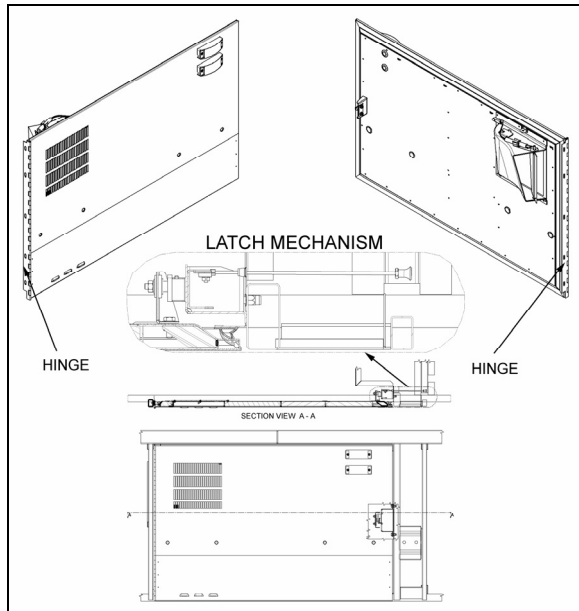


FIGURE 36: EVAPORATOR DOOR

18637

### 11.4 CONDENSER COMPARTMENT DOOR

1. Open the condenser door.
2. Loosen the screws fixing the hinge to hinge attachment or hinge to door assembly. Loosening the screws allows the condenser door assembly to be shifted "LEFT or RIGHT" and "UP or DOWN" or "IN and OUT".
3. Adjust condenser door assembly position at the hinge.
4. Tighten the screws.
5. Respect the required gap between exterior finishing panels.
6. Check that the door swings freely and closes properly. It may be necessary to adjust the door latch to get proper fit and operation.

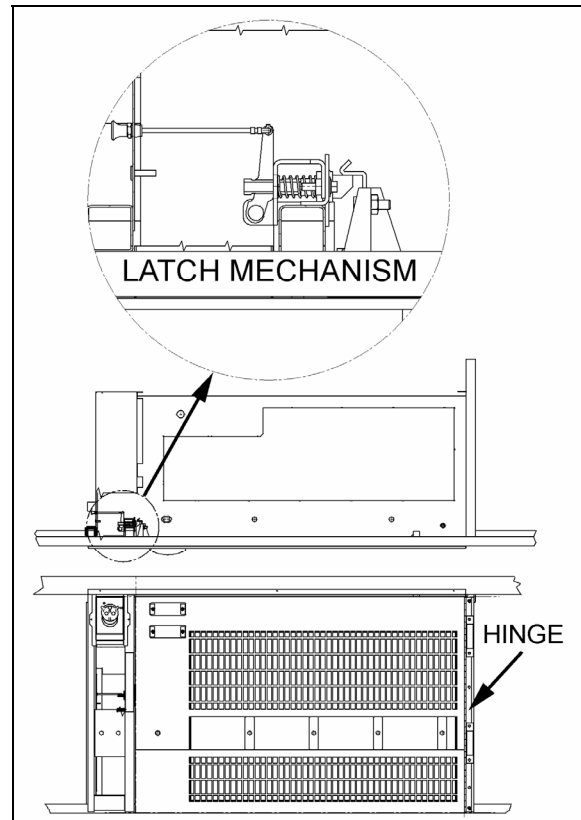


FIGURE 37: CONDENSER DOOR

18638

### 11.5 FUEL FILLER DOOR

1. Open the fuel filler door.
2. Loosen the screws holding the panel to hinge assembly.
3. Adjust the fuel filler door position according to distance required between exterior finishing panels.
4. Tighten the nuts.
5. Check that the door swings freely and closes properly.

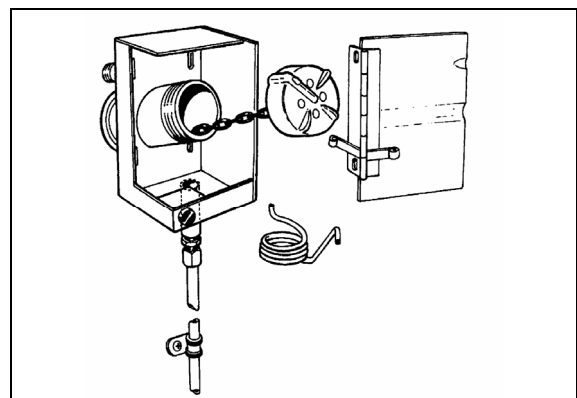


FIGURE 38: FUEL FILLER DOOR

03046

12 ZONE 6

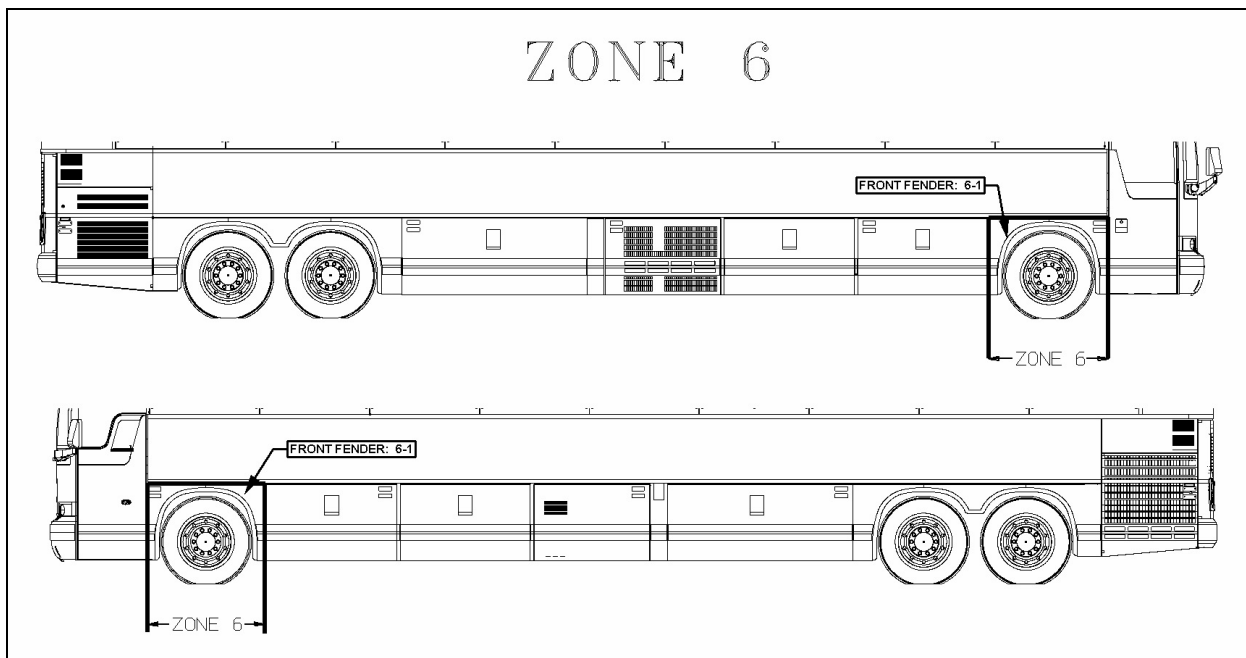


FIGURE 39: ZONE 6

18629

12.1 FRONT FENDER

Front fender may be removed using the following procedure:

Remove the nuts on the inside of the fender. Remove the fender from the vehicle. To reinstall, reverse the procedure.

13 ZONE 7

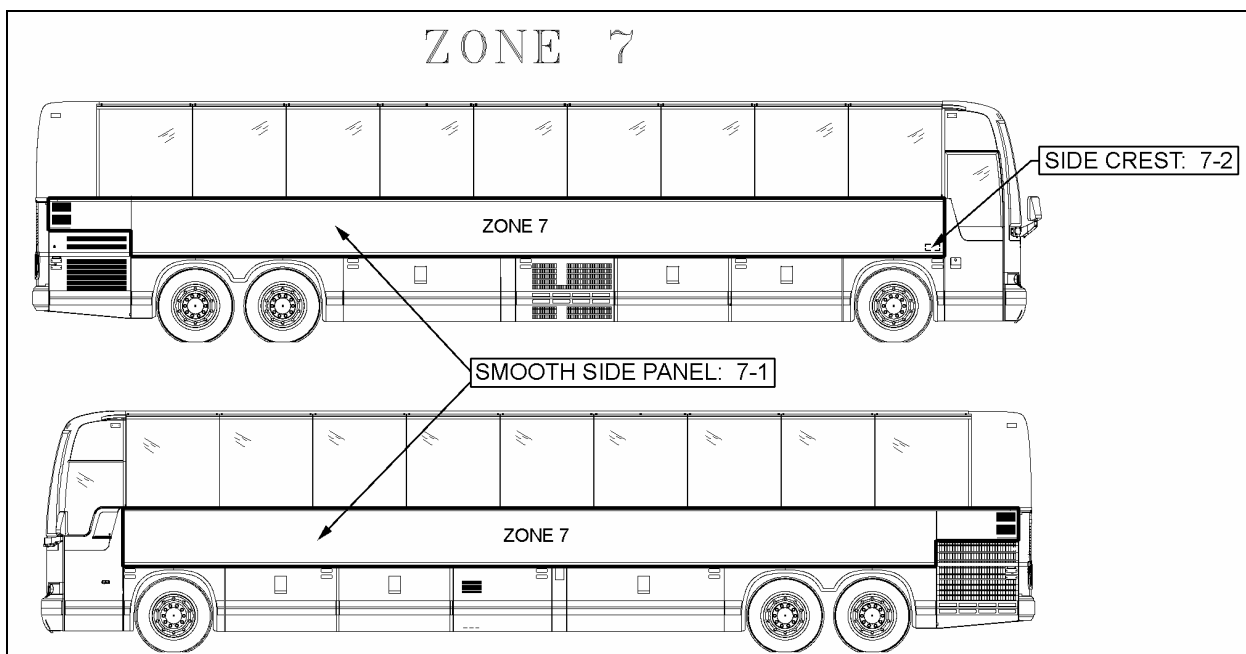


FIGURE 40: ZONE 7

18630

## Section 18: BODY

### 13.1 X3 SMOOTH SIDE PANEL REPLACEMENT PROCEDURE

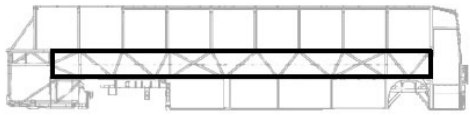
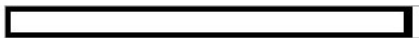
#### Material:

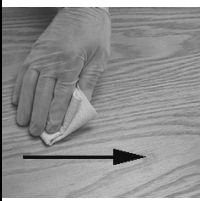
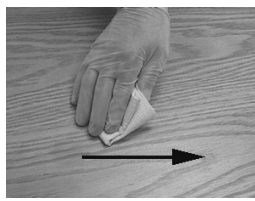
|                        |   |                           |   |                |   |
|------------------------|---|---------------------------|---|----------------|---|
| Anti-silicone (682989) | √ | Scotchbrite gray (680226) | √ | Sika 221 gray  | √ |
| CHIX cloth (682384)    | √ | Sika 205 1liter (683097)  | √ | Sika 252 black | √ |
| Blue cloth (682383)    | √ |                           |   |                |   |

#### Equipment:

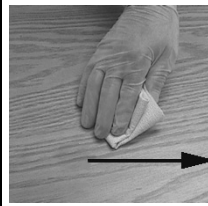
|          |   |  |
|----------|---|--|
| Glue gun | √ |  |
| Pencil   | √ |  |

| SECTION 1 SMOOTH SIDE PANEL REMOVAL |  |  |
|-------------------------------------|--|--|
| 1.00                                | <b>REMOVAL</b>   |  |
| A)                                  | Remove finishing molding. Insert a screwdriver into snap-on finishing molding joint. Bend finishing molding enough to be able to fix a pair of locking pliers. Using the pair of locking pliers, pull the stainless steel molding and at the same time gradually cut Sika bead with a sharp knife. | Be careful not to damage the adjacent surfaces.  |
| B)                                  | Using a hammer and punch, drive out rivet shanks from top and bottom and from front and rear finishing molding supports. Use a #11 titanium drill bit to remove rivet heads.   |  |
| C)                                  | Grind tig weld spots at each end of side panel.  |  |
| D)                                  | Safely support or temporary fix side panel.  | <b>Warning: Panel weights over 200 pounds</b>  |
| E)                                  | Insert a flat screwdriver between the side panel and the vehicle chassis, in the top left and right corners. Make sure to separate side panel from structure.  | Be careful not to damage the adjacent surfaces.  |
| F)                                  | Use the c-clamp to separate the side panel from the back structural panel and at the same time gradually cut Sika bead with a sharp knife.   | Ideally, the hoist or chain block must be fastened to the floor while pulling from a 45° angle so as not to damage the vehicle structure |
| G)                                  | Remove as much glue as possible from the structure using a putty knife or pneumatic knife without damaging 206 G+P primer.   | Never heat SikaFlex adhesive to remove.  |
| H)                                  | Check panel horizontal supports for straightness using a straight edge. Take measurements with a ruler.  | Tolerance : 1mm towards the outside and 1.5mm towards the inside.  |

| SECTION 2 PREPARATION OF SURFACES |   |  |  |
|-----------------------------------|---|--|--|
| 2.00                              | <b>VEHICLE SURFACE PREPARATION</b>          |  |  |
|                                   | A)  | Clean using "anti-silicone" until all clothes come clean.<br>See PR000001 section A. |  |
|                                   | B)  | Use the belt sander (grit coarse)<br>Use a new paper on each vehicle side.           |  |
|                                   | C)  | Clean using "anti-silicone" until all clothes come clean.<br>See PR000001 section A. |  |
| D)                                | Apply – Sika 205<br>See PR000001 section B. |  |  |
| 2.05                              | <b>SIDE PANEL PREPARATION</b>               |  |  |
|                                   | A)  | Clean using "anti-silicone" until all clothes come clean.<br>See PR000001 section A. |  |
|                                   | B)  | Use the belt sander (grit coarse)<br>Use a new paper on each vehicle side panel.     |  |
|                                   | C)  | Clean using "anti-silicone" until all clothes come clean.<br>See PR000001 section A. |  |
| D)                                | Apply – Sika 205<br>See PR000001 section B. |  |  |

| <b>PR000001 Section A Alcohol or Anti-silicone</b>                                   |  |
|--|--|
|   | <p><b>1. Apply</b></p> <p>CHIX cloth</p>   |
|  | <p><b>2. Dry immediately</b></p> <p>Blue cloth</p>                                   |
| <b>3. Allow to dry</b>   |  |
| <b>Mandatory</b>   | <b>Minimum time : Wait for product to evaporate</b>                                  |
|  | <b>After 2 hours: Start cleaning operation again</b>                                 |
| <b>Before applying any other product</b>   | If surface seems dusty, greasy or with finger marks, start cleaning operation again. |

## Section B Sika 205



**1. Apply**

CHIX cloth

**2. Allow drying**

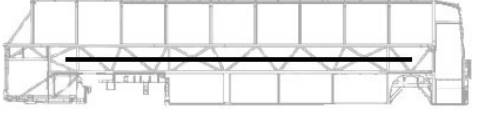
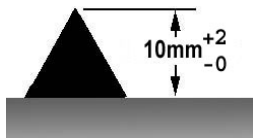
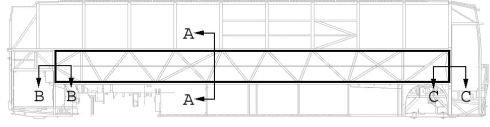
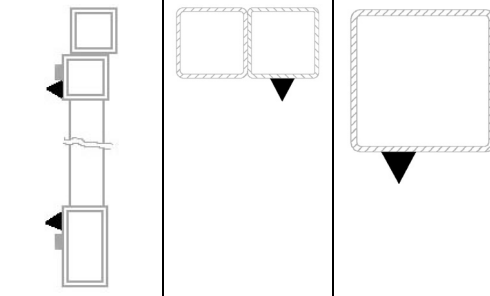
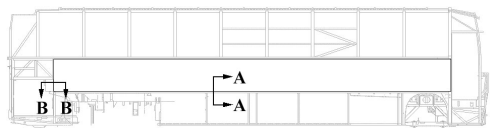
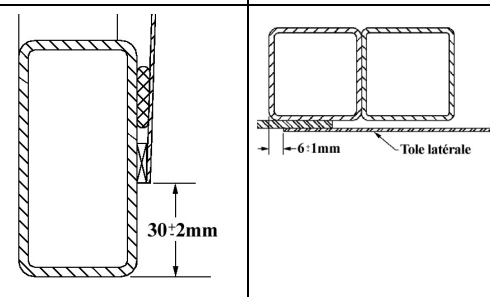
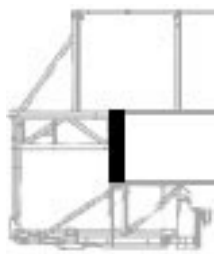
|                  |                     |   |                   |
|------------------|---------------------|---|-------------------|
| <b>Mandatory</b> | <b>Minimum time</b> | - For a smooth surface (aluminum, stainless steel, fiber glass (gelcoat side), etc.): | <b>2 minutes</b>  |
|                  |                     | - Pour a porous surface (fiber glass (non gelcoat side), etc.)                        | <b>10 minutes</b> |

**After 2 hours : Reactivate surface with Sika 205**

**Before applying any other product** If surface seems dusty, greasy or with finger marks, start operation again.




### SECTION 3 SIDE PANEL INSTALLATION

|      |    |   |  |
|------|----|---|--|
| 3.00 | A) | Using a pencil, mark the double-face self adhesive tape position onto vehicle side. |  |
|      | B) | Apply 1/8 X 1/2" double-face tape as per marking.                                   |  |
|      | C) | Compress tape   |  |
|      | D) | Remove protective film from double-face self adhesive tape center section.          |  |

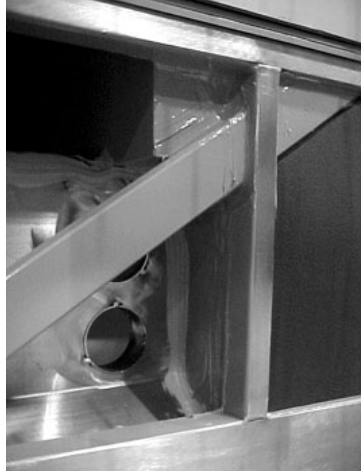
|      |   |  |
|------|---|--|
| 3.05 | Install 1/8 X 1/2" foam tape onto middle reinforcement then compress.   |    |
| 3.10 | <p>Apply Sika 252</p>  <ul style="list-style-type: none"> <li>- Onto vehicle surface</li> <li>- Cut nozzle as per template</li> <li>- Use the guide for the application</li> </ul> <p>Bead must be continuous for the whole perimeter.</p> |  <p>Section A-A    Section B-B    Section C-C</p>    |
| 3.15 | <p>A) Install side panel onto support jig.</p> <p>B) Position side panel in front of vehicle structure</p> <p>C) Perform final adjustment to make sure that side panel is true and square</p> <p>D) Sand rear of side panel 2" wide</p> <p>E) Perform tig spot welding (1" apart)</p>                                       |  <p>Section A-A    Section B-B</p>  <p>30 ± 2mm</p> <p>6 ± 1mm    Tôle latérale</p> <ul style="list-style-type: none"> <li>- 30 mm. ± 2 with reference to bottom tubing</li> <li>- 6 mm ± 1 with reference to vertical tubing</li> </ul>  <p>Quantity of "tig spot": 30 minimum.</p> |

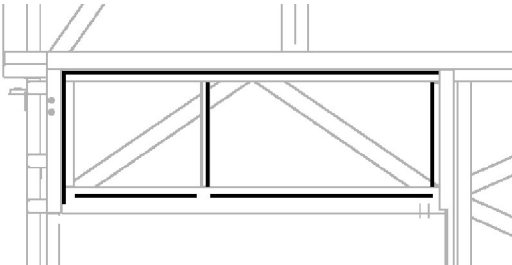

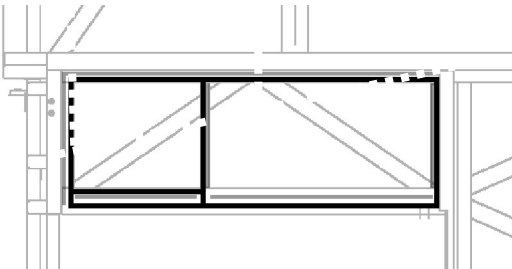


**Section 18: BODY**





|      |  |   |  |
|------|--|---|--|
| 3.20 | A)   | Install pulling equipment at the other end of side panel              |  |
|      | B)   | Make a final adjustment in height                                     |  |
|      | C)   | Sand front of side panel 2" wide                                      |   |
|      | D)   | Pull side panel so that panel moves 1/8"                              | Make sure the equipment pulls along the whole width of side panel                    |
|      | E)   | Perform tig spot welding  | Quantity of "tig spot": 30 minimum.  |
| 3.30 | Remove pulling equipment   |   |  |
| 3.40 | A)   | Remove protective film from double-face self adhesive tape.           |  |
|      | B)   | Compress top and bottom section of side panel                         |   |
| 3.50 | A)   | Cut excess of side panel. Make sure that cut is parallel with tubing. |  |
|      | B)   | Grind side panel end to line up with door tubing.                     |  |
| 3.60 | To seal each panel end, apply masking tape on each side of side panel joint. Use a caulking nozzle and grey Sikaflex 221 adhesive to fill the cavity between the panel and vehicle structure.<br><br>Clean using Sika 205. Allow 5 minutes minimum for drying. |   |  |

|  |  |  |
|--|--|--|
|  | Wear surgical gloves and smooth down the joint with your finger. |  |
|--|--|--|

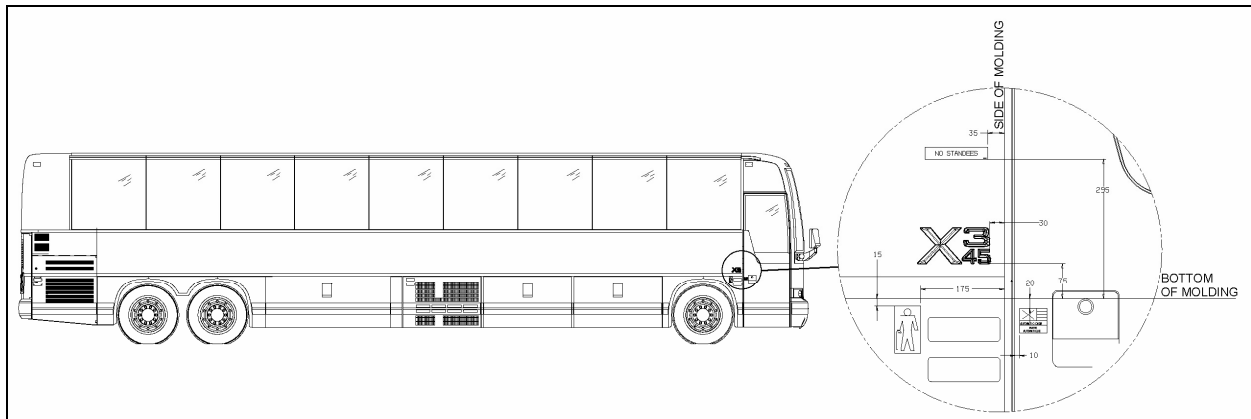
| <b>SECTION 4 ENGINE AIR INTAKE PANEL INSTALLATION</b> |   |   |
|---|---|---|
| 4.00  | Make sure that sealing of structure has been performed properly |  |
| 4.05  | Prepare vehicle surface as for side panel.                      | Refer to step # 2.00  |
| 4.10  | Prepare air intake panel as for side panel                      | Refer to step # 2.05  |

|      |   |  |
|------|---|--|
| 4.15 | Install foam tape 1/8" X 1/4" onto structure, as shown in picture   |  |
| 4.20 | Install foam tape 1/16" X 1/4" onto air intake panel pleat  |  |
| 4.25 | Apply a bead of 252 onto structure as per picture<br>Important: Make sure bead is continuous<br>Triangular bead: 10mm x 8mm |  |
| 4.30 | Install panel onto structure  | Use a jig to make sure that panel is lined up with engine door tubing.               |
| 4.40 | Use a brush to compress Sika bead   |  |

**Section 18: BODY**

|        |                        |  |  |
|--------|------------------------|--|--|
| 5.00 * | <b>Finition Joint</b>  |  |    |
|        | A)                     | Install a protective tape onto the tubing above welding  |   |
|        | B)                     | Apply Sika 205<br>Use a plastic spatula inside a Chix cloth to ensure that Sika 205 reaches as far as the corner.<br>See PR000001 section B. |   |
|        | C)                     | Apply Sika 252 black at the junction of both tubing.<br>Smooth down the joint  |  |
| D)     | Remove protective tape |  |  |

**13.2 SIDE CREST**



**FIGURE 41: SIDE CREST POSITIONING**

18639

- Clean vehicle surface using anti-silicone where the side crest and stickers will be applied.
- Using hands apply and compress side crest.
- Apply required stickers.

14 BODY PANEL AND WINDOW SPACING

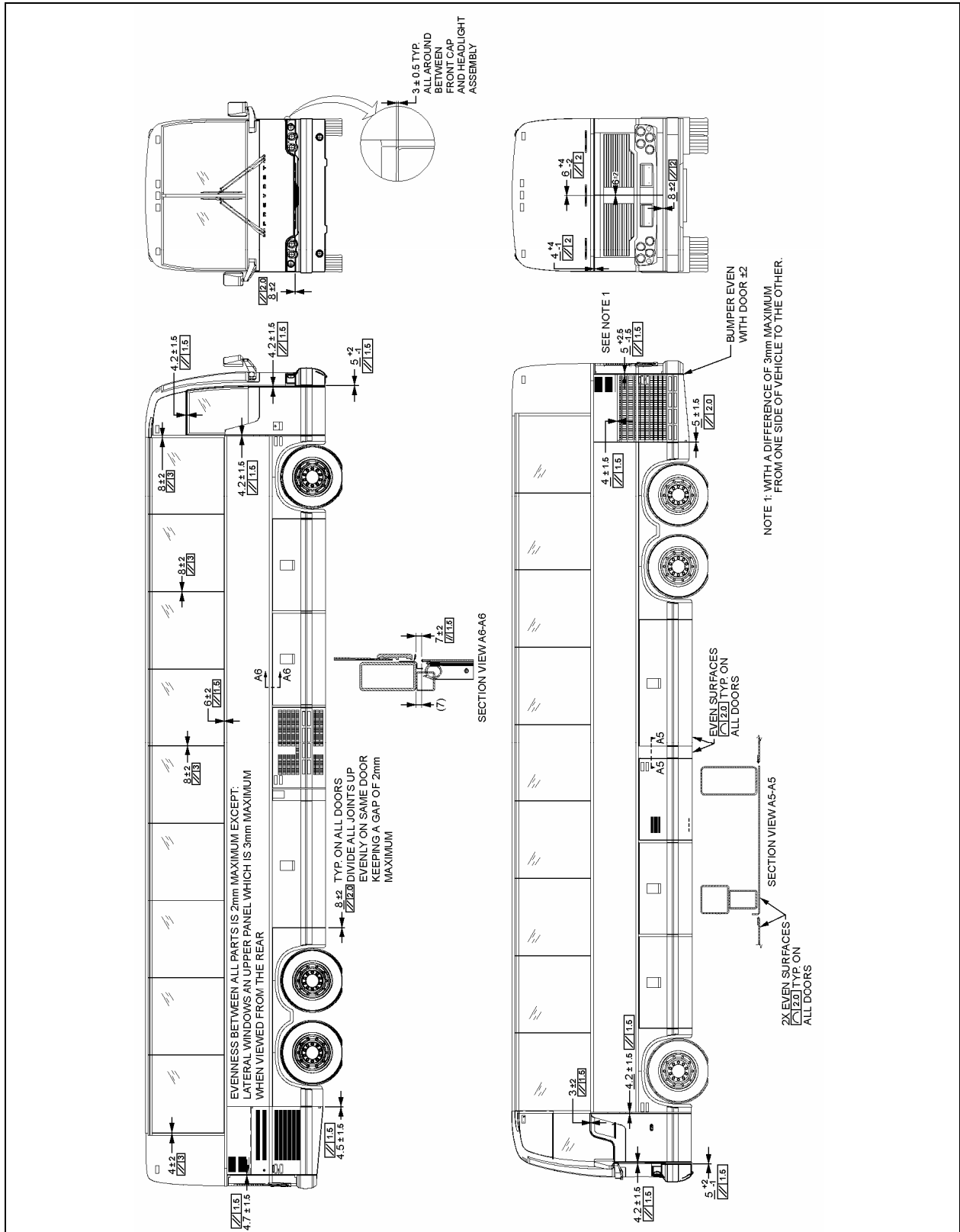


FIGURE 42: BODY PANEL AND WINDOW SPACING

18631

## 15 PASSENGER SEATS

X3 coaches can be equipped with any of 3 basic seat models and installed in a variety of seating arrangements:

1. The "Tourismo 2" seat is the base model and is available in heights of 40" (102 cm) and 42" (107 cm). Seating arrangement includes 2 card tables which can be folded and removed, and pivoting seats ahead of each card table. Each pair of seats is built on a welded steel frame fastened to the side wall and on a track-mounted pedestal.
2. The "Silhouette" seat is an optional model with each pair also built on a welded steel frame and mounted the same way as the "Tourismo 2" seat. Standard seating arrangement with "Silhouette" seat includes 2 card tables and 2 pivoting seats. Seating capacity is the same as with the "Tourismo 2" seat.
3. The "V.I.P." seat model is an optional seat. "V.I.P." seats are mounted on one row of paired seats built on a common frame on one side of the vehicle, and a row of single seats on the other side of the vehicle with an off-center aisle. Each "V.I.P." seat has its own set of armrests.

Each seat has a easily removable bottom cushion. Upholstery is clipped on the cushion frame for cleaning or replacement. To remove the fabric, simply unclip from the frame. The "Tourismo 2" and "Silhouette" seats have 3 armrests. The aisle and center armrests can be folded up and down manually, while the window armrest is fixed.

### 15.1 ROTATING SEATS

1. Remove 1 wing nut holding each seat bottom cushion from under the seat frame.
2. Lift front part of cushions and remove cushions.
3. Remove 4 wing screws fastening seat assembly to seat frame.
4. Pull seat toward aisle and rotate.
5. Align mounting holes and reinstall 4 wing screws.
6. Reinstall seat bottom cushions with wing nuts.

### 15.2 REMOVING FIXED SEATS

**NOTE**

*Seats on one row are not interchangeable with seats of the other row.*

To remove fixed seats, proceed as follows:

1. Remove 1 nut holding each seat bottom cushion from under the front part of the seat frame.
2. Lift front part of cushions and remove cushions.
3. Remove 4 finishing screws holding plastic cover between side wall and seat frame.
4. Remove 2 cap screws, nuts, and washers holding seat frame to side wall and retain the 2 holding brackets. See figure 43.
5. Remove 2 nuts and washers holding seat frame to pedestal rods. See figure 44.

**NOTE**

*Bottom end of rod is coated with Locktite and threaded in a steel block which slides in the floor track. Removal of rod is possible if loosened from block. Otherwise, slide rod and block assembly to the front end of track after removing all seats located in front.*

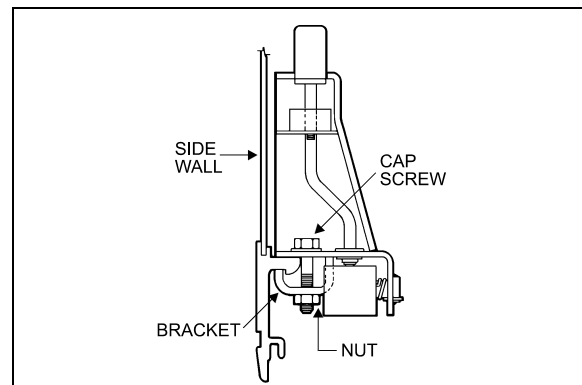


FIGURE 43: ARMREST

18106

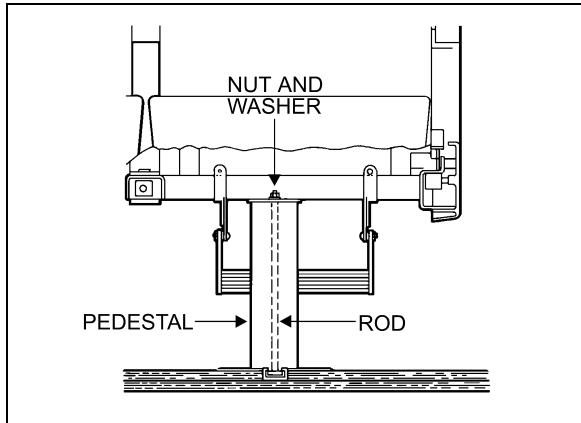


FIGURE 44: SEAT PEDESTAL ASSEMBLY 18107

6. Remove seat assembly.
7. Reverse the above procedure to install seat assembly.

**NOTE**

*On newer vehicles, the rod consists of a carriage bolt inserted in a square plate sliding in the floor track. Removal is possible only by the front or rear end of track.*

### 15.3 UPHOLSTERY MAINTENANCE

Coach seats are lightweight, with foam-padded backs and cushions. For both appearance and wearability, best results are obtained if upholstery is cleaned at regular intervals before dirt, dust and grit have been ground into the fabric. Seat fabric is made of 50% wool, 33% cotton, 9% nylon, and 8% acrylic.

#### 15.3.1 Routine Cleaning

All that is required to remove the dirt is a gentle beating with the hand or the back of a brush. This will bring the dirt to the surface where it is easily removed with a vacuum or brush in the direction of the pile which can easily be recognized by running a hand lightly over the pile. If the fabric becomes excessively dirty, particles of grit will cause gradual wear, reducing the life span of the fabric.

#### 15.3.2 Dry Cleaning

If covers are to be removed for cleaning, dry cleaning is recommended since washing might cause some shrinkage, preventing the covers from being reapplied to the seats without damage. Other than spot cleaning the covers while they are in place, dry cleaning is not

recommended, since the resulting fumes could be hazardous in the confines of the coach and the solvent could be detrimental to the foam padding of the seats.

#### 15.3.3 Cleaning With Covers in Place

The most effective and economical method to clean the fabric seat covers is by washing with either an approved foam upholstery cleaner or with a mild household detergent.

Thoroughly vacuum the upholstery. Remove any spots or stains before the seats are washed to avoid a cleaning ring.

Dilute household detergent or liquid foam cleaner according to directions on the container. Pour a small quantity into a flat pan and work into a thick foam with a sponge or brush.

Apply only the foam to the fabric with a sponge or brush. Clean a small area of the fabric at a time with the foam. **DO NOT SOAK.** Rub vigorously. Sponge the suds from the fabric with a clean sponge or cloth moistened with water. Rinse the sponge or cloth often and change the water when it becomes dirty.

Allow the upholstery to dry completely before the coach goes back into service. To speed up drying, excess moisture can be blown off the fabric with compressed air.



### CAUTION

Oil in the air line will soil the fabric. Blow the line clear and test air discharge against a plain white piece of paper. It is also effective to press the edge of a flat hardwood stick down on the cushion and slowly draw it across the fabric.

Even very soiled areas can be returned to their original appearance by a thorough cleaning, but a regular schedule of cleaning that keeps the upholstery reasonably clean at all times will greatly enhance the life span of upholstery.

**16 TARABUS FLOOR COVERING REPAIR OR REPLACEMENT**

On X3 vehicles equipped with “Tarabus” covering, it is possible to replace or repair this covering. The purpose of this paragraph is to explain the steps to be followed to ensure the best results and adherence.

**MATERIAL**

| Part No | Description                              | Qty   |
|---------|--|-------|
| 680028  | Adhesive, Tarabus Floor Covering (White) | A/R   |
| 684655  | Adhesive, Contact (3M)                   | 3.8L  |
| 684654  | Adhesive, Contact (3M)                   | 18.9L |
| 680532  | Sikaflex 221 Gray                        | A/R   |

**NOTE**

*Material can be obtained through regular channels.*

1. Remove number of passenger seats required to perform repair.
2. Cut and remove damaged section of floor covering.

**NOTE**

*It would be preferable to cut under two rows of seats so that repair is not as noticeable.*

3. Clean plywood using a scraper.

**NOTE**

*Make sure that no staples are sticking out beyond surface. Adjacent plywood sheets must be leveled.*

4. Fill up holes and imperfections using MAPI PRP 110 then sand.
5. Remove dirt and adhesive residue.



**CAUTION**

Do not leave floor covering folded down except temporarily during installation.

6. Apply floor covering adhesive (680028) onto plywood using a serrated spreader with 1/8-inch serration. If required, apply contact adhesive (3M) (684655 or 684654) onto aluminum molding and also onto section of floor covering, which will be in contact with molding (refer to figure 45).

**NOTE**

*Allow adhesive to dry (3 to 5 minutes).*

7. Compress floor covering using a roller so as to remove any trapped air bubble.
8. Apply Sikaflex 221 gray sealant (680532) alongside passenger seat fixing tracks (refer to figure 46).

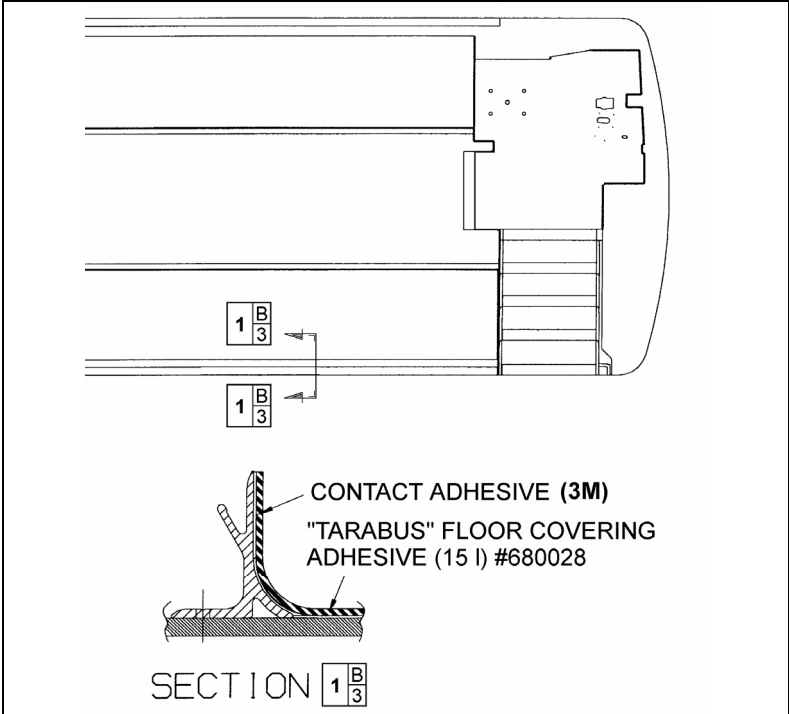


FIGURE 45: TARABUS FLOOR COVERING ADHESIVE APPLICATION 18640

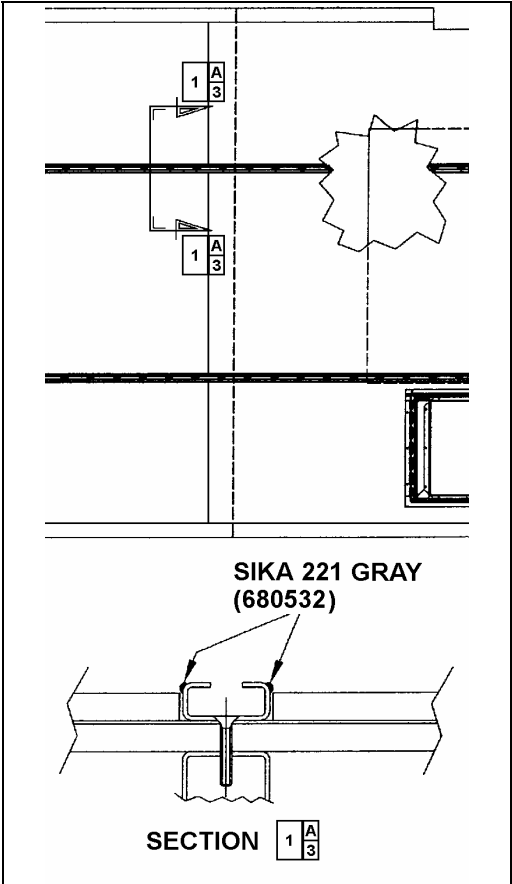


FIGURE 46: APPLICATION OF SIKA 221 GRAY 18641



## Section 18: BODY

### 16.1 FRONT STEPS REPLACEMENT PROCEDURE

#### MATERIAL

| Part No | Description        | Qty |
|---------|--------------------|-----|
| 682989  | Anti-silicone      | A/R |
| 683097  | Sika 205 (1 liter) | A/R |
| 685101  | Sika Remover 208   | A/R |
| 683916  | Sika 215 (1 liter) | A/R |

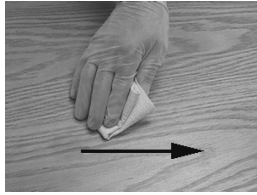
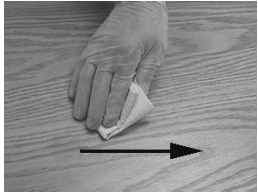
1. Cut and remove damaged step(s).
2. Remove dirt and adhesive residue.

#### *NOTE*

*In wintertime, condensation and cold temperature may greatly influence bonding parameters. Working area must be at a temperature sufficient to prevent reaching condensation point. Mechanically preheat working area (heat lamp or heat gun) or wait until vehicle reaches room temperature.*

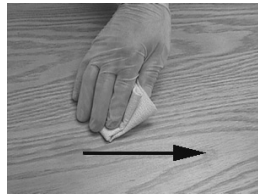
#### PREPARATION OF "TARABUS" FLOOR COVERING

1. Sand under step using "Scotchbrite".
2. Clean using anti-silicone (refer to Section A).

| <b>Section A Alcohol or Anti-silicone</b>  |   |
|--|---|
|   | <b>1. Apply</b><br><div style="border: 1px dashed black; background-color: yellow; padding: 2px; display: inline-block;">CHIX cloth</div>         |
|  | <b>2. Dry immediately</b><br><div style="border: 1px dashed black; background-color: cyan; padding: 2px; display: inline-block;">Blue cloth</div> |
| <b>3. Allow drying</b>   |   |
| <b>Mandatory</b>   | <b>Minimum time : Wait for product to evaporate</b>   |
|  | <b>After 2 hours: Start cleaning operation again</b>  |
| <b>Before applying any other product</b>   | If surface seems dusty, greasy or with finger marks, start cleaning operation again.  |

3. Apply Sika Primer 215 (refer to Section D).

## Section D Sika Primer 215



1. Shake bottle to mix product
2. Apply a thin layer

CHIX cloth

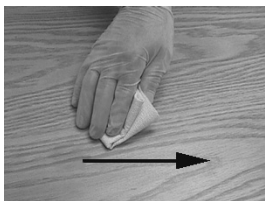
### 3. Allow drying

|  |            |  |
|--|------------|--|
| <b>Mandatory</b>                         | <b>215</b> | <b>Minimum time : 20 minutes</b>   |
|  |            | <b>After 2 hours : Remove dust using damp cloth (pure water)</b>         |
| <b>Before applying any other product</b> |            | If surface seems dusty, dust using damp cloth.                           |
|  |            | If surface seems greasy or with finger marks, reactivate with Aktivator. |

### PREPARATION OF FIBERGLASS

1. Clean using anti-silicone (refer to Section A).
2. Apply Sika 205 (refer to Section B).

## Section D Sika Primer 215



1. Apply

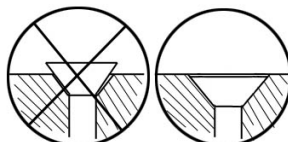
CHIX cloth

### 2. Allow drying

|   |                     |   |                   |
|---|---------------------|---|-------------------|
| <b>Mandatory</b>  | <b>Minimum time</b> | - For a smooth surface (aluminum, stainless, steel, fiberglass (gelcoat side), etc.): | <b>2 minutes</b>  |
|   |                     | - For a porous surface (fiberglass (non gelcoat side), etc.)                          | <b>10 minutes</b> |
| <b>After 2 hours : Reactivate surface with Sika 205</b> |                     |   |                   |
| <b>Before applying any other product</b>                |                     | If surface seems dusty, greasy or with finger marks, start operation again.           |                   |

### X3 VEHICLES FRONT STEPS GLUING

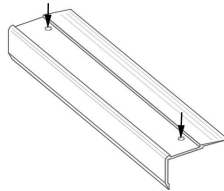
1. Use step nosing to measure and cut necessary length of white safety strip.
2. Use a screw to check depth of countersinking in step nosing. Screw top must not stick out beyond the aluminum surface. Countersink if needed.



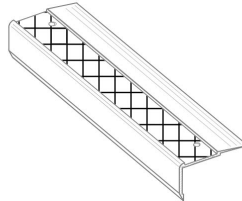
## Section 18: BODY

---

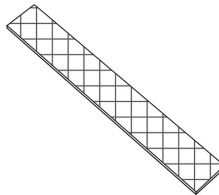
3. Apply some Sika 252 onto the step; make sure to cover the whole surface of the step. Use a serrated spreader with 1/8-inch serration to spread Sika.
4. Apply a bead of Sika 221 onto the perimeter of the step.
5. Install step and press with hands. If Sika overflows, clean with Sika 208. Repeat previous stages for each step if applicable.
6. Remove protective film from double-coated self adhesive tape located underneath step nosing, position step nosing then press. Drill and fix using screws.



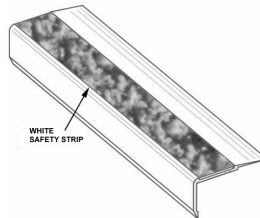
7. Clean top of step nosing using Sika 205 (refer to Section B).



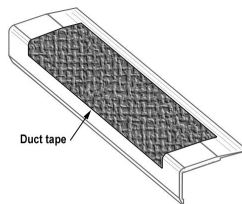
8. Apply some Sika 221 onto white safety strip, spread with a spatula to cover the whole surface.



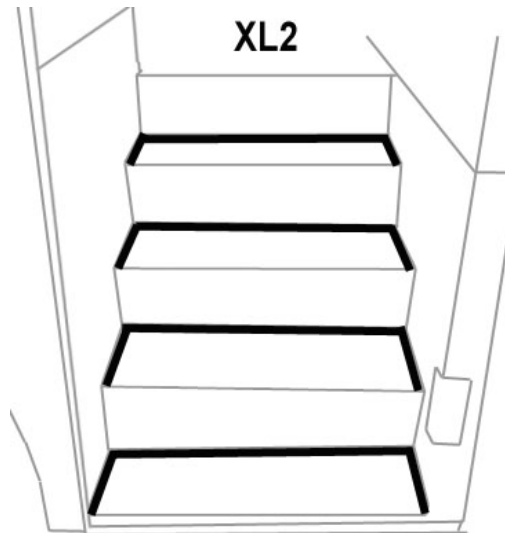
9. Position white safety strip then press using hands. If Sika overflows, clean with Sika 208.



10. Temporarily fix white safety strip with a piece of duct tape, leaving 1 to 2 inches free at each end.



11. Apply some masking tape onto the step perimeter, clean using Sika 205 (refer to Section B) then apply a bead of Sika 252 black. Smooth out the joints then remove masking tape.
12. Install weights onto the steps. Minimum waiting time: 2 hours.

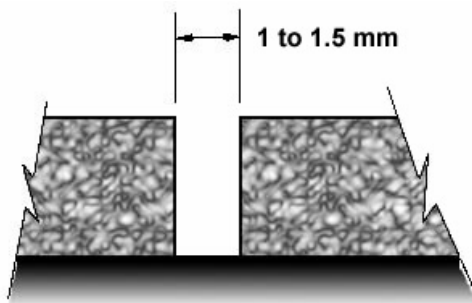


### 16.2 WELDING OF JOINT BETWEEN WHITE SAFETY STRIP AND "TARABUS" FLOOR COVERING

1. Pre-heat welding torch;

Set welding torch to position #4.5 (temperature of 500 °C),  
Heating time: 5 minutes.

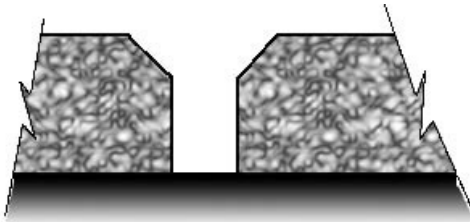
2. Before welding, visually ensure that a 1 to 1.5 mm gap exists between white safety strip and "Tarabus" floor covering. Use a knife if this is not the case.



***NOTE***

There should be no excess of adhesive on top of surfaces, clean if required using "All-Sol".

3. Chamfer the joint.



***NOTE***

The chamfer width must always be less than the filler bead diameter (between 2.5 and 3 mm).

## Section 18: BODY

---

4. Use chamfer knife. **Be careful not to overcut or to cut to the side to prevent damaging “Tarabus” covering.**



5. Add (about 6 inches) some length to the required length of filler bead to make the joint then cut.
6. Take position with welding torch. The proper position is with a slight slope to the rear.



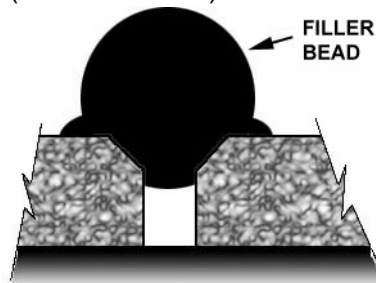
7. Once the welding torch is ready, insert the filler bead into the nozzle and immediately start welding. Move in a regular manner while pressing slightly with torch.



8. The heel of the fast nozzle must not lean against “Tarabus” covering (always parallel to the surface).



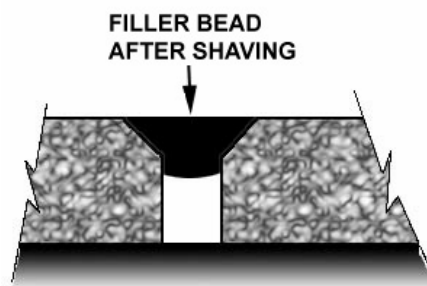
9. Allow cooling down of filler bead (about 5 minutes).



10. Shave filler bead to make it level to the floor. Use supplied knife designed for that purpose.

**NOTE**

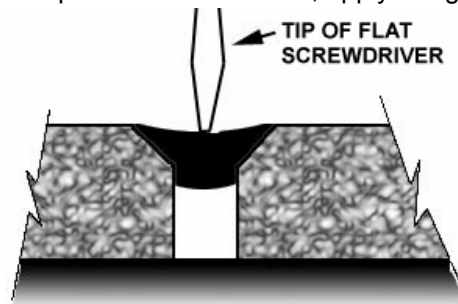
*To facilitate the cut, you can spray some soapy water onto the joint.*



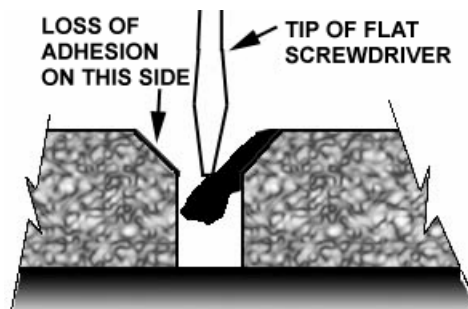
**CAUTION**

The procedure for turning the torch off must absolutely be followed. If this step is not taken, the element may burn.

11. Set temperature potentiometer to "0" position. Fan will evacuate residual heat. Leave the torch in operation as it is for 3 minutes.  
 12. Perform adhesion test using the tip of a flat screwdriver; apply a slight pressure on the joint.



13. If welding was not performed properly, there will a loss of adhesion on one side. If this is the case, repair the joint.



## Section 18: BODY

### 16.3 REPAIR OF A WELDED JOINT

#### **NOTE**

*In wintertime, condensation and cold temperature may greatly influenced bonding parameters. Working area must be at a temperature sufficient to prevent reaching condensation point. Mechanically preheat working area (heat lamp or heat gun) or wait until vehicle reaches room temperature.*

1. Using a knife, remove portion of joint to be repaired.

#### **NOTE**

*Loss of adhesion may be local. If this is the case, repair may also be local.*

2. Chamfer the joint again as indicated in paragraph 12.2, Section: WELDING OF JOINT BETWEEN WHITE SAFETY STRIP AND "TARABUS" FLOOR COVERING.
3. Re-weld the joint as indicated in paragraphs 6, 7 and 8. Use your thumb to hold the filler bead end.



#### **WARNING**

Nozzle is hot.



4. Always add an extra inch of filler bead at the beginning and at the end of repair.
5. Perform steps indicated in paragraphs 9, 10 and 11.

### 17 VEHICLE JACKING POINTS

The vehicle can be lifted by applying pressure under body jacking points or front end and drive axle jacking points. When it is necessary to lift the vehicle, care should be taken to ensure that the pressure is applied only on the specified areas. Equipment for lifting the front of the vehicle must have a combined lifting capacity of at least 20,000 lb. (9 100 kg). Equipment for lifting the rear of the vehicle must have a combined lifting capacity of at least 40,000 lb. (18 200 kg).



#### **WARNING**

DO NOT tow or jack vehicle with people on board.



#### **WARNING**

When it is necessary to raise the vehicle, care should be taken to ensure that pressure is applied only at the points indicated in figures 47 to 53.



#### **WARNING**

Extra lift capacity may be required if luggage or any other type of load are onboard the vehicle.



#### **CAUTION**

The suspension of the vehicle must be in the normal ride position before jacking.

Twelve jacking points are located on the vehicle: three are located on each side of the frame and two are located under each axle. Refer to the following illustrations for the location of jacking points.

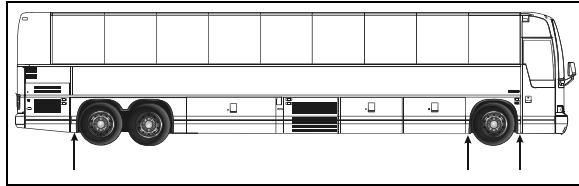


FIGURE 47: JACKING POINTS ON FRAME 18618

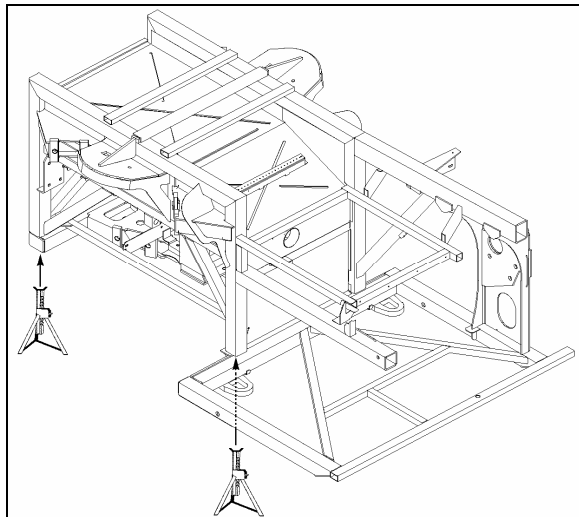


FIGURE 48: FRONT END JACKING POINTS 18592

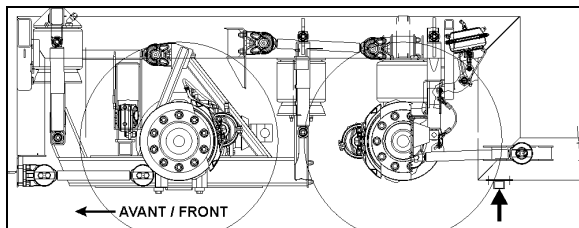


FIGURE 49: REAR END JACKING POINTS 16166

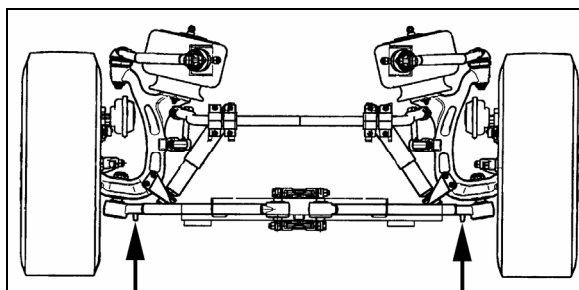


FIGURE 50: JACKING POINTS ON IND. SUSPENSION 16139

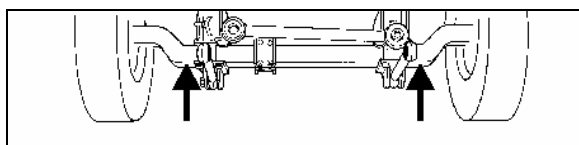


FIGURE 51: JACKING POINT ON FRONT AXLE 10005

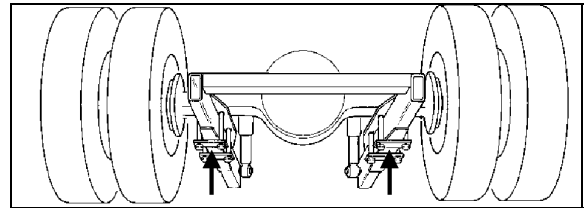


FIGURE 52: JACKING POINTS ON DRIVE AXLE 11005



**CAUTION**

Always unload or retract the tag axle before jacking the vehicle from the front and drive axle jacking points to prevent damage to suspension components.

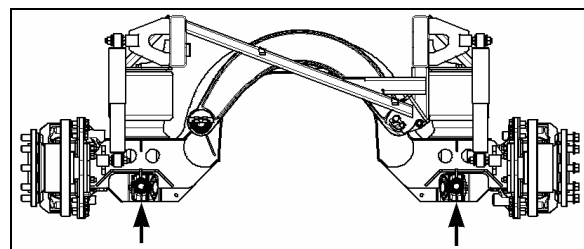


FIGURE 53: JACKING POINTS ON TAG AXLE 11029



**WARNING**

The jacking points on the tag axle must be used for raising the tag axle only.

Several kinds of hydraulic jacks can be used. Only jack at the specified jacking points. Jack must support the following capacities:

- Front end: 20,000 lb. (9 100 kg);
- Drive axle: 40,000 lb. (18 200 kg).

17.1 HYDRAULIC JACK

To raise: turn release valve clockwise. Insert handle in socket and raise by pumping.

To lower: remove handle and turn the release valve slowly counterclockwise.

Always keep ram and extension screw retracted when jack is not in use.

Service: Check oil level when jack fails to raise to full height. Lower ram completely with release valve open and jack in upright position, remove filler plug and refill to level of filler hole with hydraulic jack oil. Never use brake fluid.





**DANGER**

Jack is intended for lifting only. Do not get under the vehicle or load for any reason unless it is properly supported with safety stands and securely blocked.



**DANGER**

Do not overload jack above rated capacity. Prevent "side loading", make sure load is centered on ram. Do not push or tilt load off jack.

**18 TOWING THE VEHICLE**

The vehicle can be transported on a low bed semi-trailer of adequate gross axle weight capacity. When transporting a vehicle, apply parking brake and shut down the engine. Block all wheels and secure vehicle with tie-downs. Check that overall height will clear obstacles on the route to follow, and obtain required permits.

The vehicle can also be towed by lifting the front axle or by towing from the front with all wheels on the ground. These two methods are described below under their respective headings. Whatever the method used, the vehicle should be towed by truck operators authorized and experienced in towing highway coaches.

Observe normal precautions including, but not limited to, the ones listed below when towing the vehicle:

- Make sure the parking brake is released before towing.
- Do not allow passengers to ride onboard the towed vehicle.
- Tow the vehicle at a safe speed as dictated by road and weather conditions.
- Accelerate and decelerate slowly and cautiously.

To prevent damage to the vehicle, use the two tow eyes located under the back bumper and/or fixed to the vehicle's frame between the front axle and the front bumper. Use only a solid link tow bar and a safety chain to tow the vehicle. If required, connect an auxiliary air supply to the vehicle so brakes can be operated while towing.



**CAUTION**

To prevent damage to the vehicle structure, it is not recommended to tow the vehicle from the rear. In case of damage to the drive train components, use a low bed semi-trailer to support the rear end.



**WARNING**

During a towing operation, the driver should be alone inside the vehicle.



**CAUTION**

To prevent damage to the drive train components, disconnect axle shafts or driveshaft before towing. Do not attempt to push or pull-start a vehicle equipped with an automatic transmission.



**CAUTION**

Make sure axle shafts or driveshaft are installed correctly after towing. Tighten axle shaft and driveshaft nuts to the correct torque settings. Do not invert shafts

**18.1 LIFTING AND TOWING**

The towed vehicle must be lifted from under the front axle only. The tow truck must be equipped with the proper lifting equipment to reach under the front axle since no other lifting points are recommended. Lifting and towing from any other point are unauthorized as it may cause serious damage to the structure. Do not unload or raise the tag axle when lifting and towing to prevent overloading the drive axle.

1. Remove both drive axle shafts to prevent damage to the transmission. Plug axle tube to prevent oil loss. Refer to Arvin Meritor "Maintenance Manual no.5" annexed at the end of Section 11, Rear axle, in this manual for correct procedure.



**CAUTION**

Transmission lubrication is inadequate when towing. With automatic, semi-automatic or manual transmission, the drive axle shafts must be removed to avoid serious damage to the transmission.

2. Operate the engine when towing to maintain brake system air pressure. If the engine cannot be operated, connect an external air pressure line from the tow truck to the emergency fill valve in the engine compartment.
3. The emergency fill valve in the front service compartment does not supply air pressure to the brake system. The air pressure must be 75 psi (520 kPa) minimum, and the line should be attached to the air line with a clip-on chuck.

**WARNING**

Do not tow the vehicle without external air pressure applied to the emergency fill valve if the engine does not operate. Without brake system air pressure, the brakes may apply automatically if system air drops below 40 psi (275 kPa). If failure prevents releasing the parking brakes with air pressure, disengage the parking brakes mechanically.

4. Lift the vehicle from under the front axle, and adequately secure the underside to the tow vehicle lifting attachment with chains.
5. Observe safety precautions when towing.

## 18.2 TOWING WITHOUT LIFTING

**WARNING**

When towing vehicle without lifting, use only a tow truck with a solid link tow bar and related equipment. All other means of towing are unauthorized. Tow only from the front of the vehicle.

1. Remove both drive axle shafts to prevent damage to the transmission. Plug axle tube to prevent oil loss. Refer to Arvin Meritor "Maintenance Manual no.5" annexed at the end of Section 11, Rear axle, in this manual for correct procedure.

**CAUTION**

Transmission lubrication is inadequate when towing. With automatic, semi-automatic or manual transmission, the drive axle shafts must be removed to avoid serious damage to the transmission.

2. Operate the engine when towing to maintain brake system air pressure. If the engine cannot be operated, connect an external air pressure line from the tow truck to the emergency fill valve in the engine compartment. The emergency fill valve in the front service compartment does not supply air pressure to the brake system. The air pressure must be 75 psi (520 kPa) minimum, and the line should be attached to the air line with a clip-on chuck.

**WARNING**

Do not tow the vehicle without external air pressure applied to the emergency fill valve if the engine does not operate. Without brake system air pressure, the brakes may apply automatically if system air drops below 40 psi (275 kPa). If failure prevents releasing the parking brakes with air pressure, disengage the parking brakes mechanically.

3. Position the tow truck so that the tow bar contacts the front bumper of the vehicle.
4. Attach the tow truck chains only in the tow eyes of the vehicle under the bumper and take up all the slack.
5. Attach safety chains as applicable.
6. Observe safety precautions when towing.

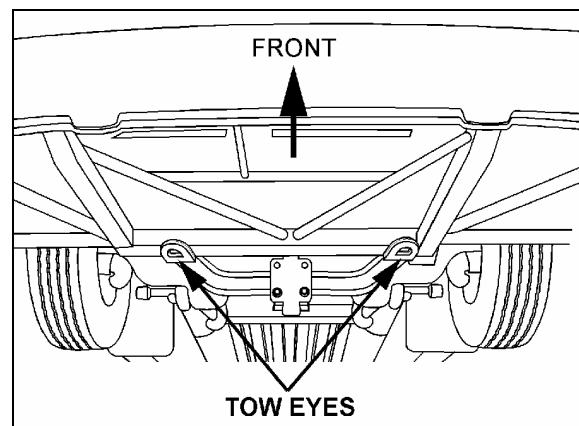


FIGURE 54: TOW EYES

18401

## Section 18: BODY

---

### 19 SPECIFICATIONS

#### Door cylinder

Manufacturer ..... Bimba  
Type ..... Pneumatic  
I.D. .... 1½" ( mm)  
Stroke ..... 8" ( mm)  
Prévost number ..... 780595

#### Damper

Manufacturer ..... Koni  
Prévost number ..... 780565

#### Lock cylinder (upper)

Manufacturer ..... Bimba  
Type ..... Air, single action, 1/8 NPT, hexagonal rod  
I.D. .... 7/8" (22 mm)  
Stroke ..... 1" (25 mm)  
Supplier number ..... D-51127-A  
Prévost number ..... 641392

#### Lock cylinder (central)

Manufacturer ..... Bimba  
Type ..... Air, single action, ¼ NPT  
I.D. .... 1¾" (45 mm)  
Stroke ..... 1" (25 mm)  
Supplier number ..... 241-P  
Prévost number ..... 641209

#### Manifold solenoid

Manufacturer ..... Norgren  
Type ..... 4 ports, 1/8 NPT  
Voltage ..... 24 VDC  
Power consumption ..... 6 watts  
Maximum pressure ..... 150 psi (1035 kPa)  
Prévost number ..... 641448

#### Solenoid valve (Latching valve)

Manufacturer ..... Humphrey  
Model ..... 310  
Operating range ..... 0 to 125 psi (0 to 860 kPa)  
Voltage ..... 24 VDC  
Voltage tolerance ..... +10%, -15% of rated voltage  
Power consumption ..... 4 watts  
Leak rate (max allowed) ..... 0.245 in<sup>3</sup>/min @ 100 psi (4cc/min @ 690 kPa)  
Type of operation ..... Direct solenoid  
Lubrication ..... Not required (factory pre-lubed)  
Filtration ..... 40 micron recommended  
Prévost number ..... 641412

#### Pressure switch assembly

Prévost number ..... 452831

# SECTION 22: HEATING AND AIR CONDITIONING

## CONTENTS

|  |           |
|--|-----------|
| <b>1. HEATING AND AIR CONDITIONING</b> .....                             | <b>5</b>  |
| <b>2. AIR CIRCULATION</b> .....  | <b>5</b>  |
| 2.1 DRIVER'S AREA.....   | 5         |
| 2.2 PASSENGERS' AREA.....  | 5         |
| <b>3. CENTRAL HVAC SYSTEM OPERATION</b> .....                            | <b>6</b>  |
| 3.1 DRIVER'S SECTION OPERATION .....                                     | 6         |
| 3.2 PASSENGERS' SECTION OPERATION .....                                  | 7         |
| 3.3 OVERHEAD COMPARTMENT A/C .....                                       | 8         |
| <b>4. HVAC UNIT MAINTENANCE</b> .....                                    | <b>8</b>  |
| 4.1 COIL CLEANING.....   | 8         |
| 4.2 DRIVER'S SECTION AIR FILTERS .....                                   | 9         |
| 4.3 PASSENGERS' SECTION AIR FILTER .....                                 | 9         |
| 4.4 OVERHEAD COMPARTMENT FAN AIR FILTER.....                             | 10        |
| <b>5. HVAC SYSTEM PARTICULARITIES, TESTING AND TROUBLESHOOTING</b> ..... | <b>10</b> |
| 5.1 HVAC SYSTEM AND TEST MODE FOR SWITCHES AND SENSORS .....             | 10        |
| 5.2 HVAC SYSTEM AND TEST MODE FOR ELECTRIC MOTORS .....                  | 11        |
| 5.3 PARTICULARITIES .....  | 11        |
| 5.4 HVAC SYSTEM TROUBLESHOOTING .....                                    | 12        |
| <b>6. CENTRAL AIR CONDITIONING SYSTEM</b> .....                          | <b>13</b> |
| 6.1 A/C CYCLE .....  | 13        |
| 6.2 REFRIGERANT.....   | 14        |
| 6.2.1 <i>Procurement</i> .....   | 14        |
| 6.2.2 <i>Precautions in Handling Refrigerant</i> .....                   | 14        |
| 6.2.3 <i>Treatment in Case of Injury</i> .....                           | 14        |
| 6.2.4 <i>Precautions in Handling Refrigerant Lines</i> .....             | 16        |
| 6.2.5 <i>Auxiliary System Refrigerant Lines</i> .....                    | 16        |
| 6.3 PUMPING DOWN .....   | 16        |
| 6.4 ADDING REFRIGERANT (VAPOR STATE).....                                | 17        |
| 6.5 EVACUATING SYSTEM .....  | 17        |
| 6.5.1 <i>Double Sweep Evacuation Procedure</i> .....                     | 18        |
| 6.6 CHARGING SYSTEM.....   | 19        |
| 6.7 REFRIGERANT SYSTEM CLEAN-OUT AFTER COMPRESSOR FAILURE.....           | 19        |
| 6.7.1 <i>Determining Severity of Failure</i> .....                       | 20        |
| 6.7.2 <i>Clean-out after Minor Compressor Failure</i> .....              | 20        |
| 6.7.3 <i>Clean-out After Major Compressor Failure</i> .....              | 20        |
| <b>7. CENTRAL A/C SYSTEM COMPONENTS</b> .....                            | <b>20</b> |
| 7.1 COMPRESSOR (CENTRAL SYSTEM) .....                                    | 20        |
| 7.1.1 <i>Belt Replacement</i> .....                                      | 20        |
| 7.1.2 <i>Belt Play</i> .....   | 21        |
| 7.1.3 <i>Pulley Alignment</i> .....                                      | 22        |
| 7.1.4 <i>Longitudinal Compressor Alignment</i> .....                     | 22        |
| 7.1.5 <i>Horizontal Compressor Alignment</i> .....                       | 22        |
| 7.1.6 <i>Vertical Compressor Alignment</i> .....                         | 22        |
| 7.1.7 <i>Compressor Maintenance</i> .....                                | 22        |
| 7.1.8 <i>Troubleshooting Guide</i> .....                                 | 22        |
| 7.2 MAGNETIC CLUTCH .....  | 23        |
| 7.3 EVAPORATOR MOTOR .....   | 23        |

## Section 22: HEATING AND AIR CONDITIONING

---

|           |  |           |
|-----------|--|-----------|
| 7.3.1     | Removal .....  | 23        |
| 7.3.2     | Installation .....   | 24        |
| 7.3.3     | Checking Operation of Brush in Holder .....                          | 24        |
| 7.3.4     | Brush Wear Inspection and Replacement .....                          | 24        |
| 7.3.5     | Seating Brushes .....  | 24        |
| 7.3.6     | Brush Holder Adjustment .....  | 26        |
| 7.3.7     | Checking Commutator .....  | 27        |
| 7.4       | CONDENSER .....  | 27        |
| 7.4.1     | Condenser Fan Motors .....   | 27        |
| 7.4.2     | Condenser Fan Motor Removal .....                                    | 27        |
| 7.5       | RECEIVER TANK .....  | 27        |
| 7.6       | FILTER DRYER .....   | 28        |
| 7.6.1     | Replacement .....  | 28        |
| 7.6.2     | Moisture Indicator .....   | 28        |
| 7.7       | LIQUID REFRIGERANT SOLENOID VALVE .....                              | 29        |
| 7.7.1     | Manual Bypass .....  | 29        |
| 7.7.2     | Coil Replacement .....   | 29        |
| 7.7.3     | Valve Disassembly .....  | 29        |
| 7.7.4     | Valve Reassembly .....   | 29        |
| 7.8       | EXPANSION VALVE .....  | 30        |
| 7.9       | TORCH BRAZING .....  | 32        |
| 7.10      | TROUBLESHOOTING .....  | 33        |
| 7.10.1    | Expansion Valve .....  | 33        |
| 7.10.2    | A/C .....  | 34        |
| 7.11      | TEMPERATURES & PRESSURES .....                                       | 36        |
| 7.12      | LEAK TESTING .....   | 37        |
| <b>8.</b> | <b>AUXILIARY AIR CONDITIONING SYSTEM AND COMPONENTS .....</b>        | <b>37</b> |
| 8.1       | COMPRESSOR .....   | 37        |
| 8.2       | COMPRESSOR REMOVAL .....   | 37        |
| 8.2.1     | When the compressor is operational .....                             | 37        |
| 8.2.2     | When the compressor is inoperable .....                              | 37        |
| 8.2.3     | Evacuating System Before Adding Refrigerant (Auxiliary System) ..... | 38        |
| 8.3       | OIL ADDITION .....   | 38        |
| 8.4       | COMPRESSOR OIL CONTAMINATION .....                                   | 38        |
| 8.5       | OIL RETURN OPERATION .....   | 38        |
| <b>9.</b> | <b>HEATING SYSTEM .....</b>  | <b>40</b> |
| 9.1       | DRAINING HEATING SYSTEM .....  | 40        |
| 9.1.1     | Draining Driver's Heater Core .....                                  | 40        |
| 9.1.2     | Draining Main Heater Core .....                                      | 40        |
| 9.2       | FILLING HEATING SYSTEM .....   | 41        |
| 9.3       | BLEEDING HEATING SYSTEM .....  | 41        |
| 9.4       | SOLDERING .....  | 41        |
| 9.5       | DRIVER'S HOT WATER PNEUMATIC VALVE ASSEMBLY .....                    | 42        |
| 9.5.1     | Description .....  | 42        |
| 9.5.2     | Pneumatic Water Valve Disassembly .....                              | 42        |
| 9.5.3     | Pneumatic Water Valve Reassembly .....                               | 42        |
| 9.5.4     | Pilot Solenoid Valve .....   | 43        |
| 9.5.5     | Valve Troubleshooting .....  | 43        |
| 9.6       | CENTRAL HOT WATER PNEUMATIC VALVE ASSEMBLY .....                     | 43        |
| 9.6.1     | Description .....  | 43        |
| 9.6.2     | Pneumatic Water Valve Disassembly .....                              | 43        |
| 9.6.3     | Pneumatic Water Valve Reassembly .....                               | 44        |
| 9.6.4     | Pilot Solenoid Valve .....   | 44        |
| 9.6.5     | Valve Troubleshooting .....  | 44        |

|            |   |           |
|------------|---|-----------|
| 9.7        | WATER RECIRCULATING PUMP .....                      | 45        |
| 9.7.1      | <i>Removal</i> .....                                | 45        |
| 9.7.2      | <i>Disassembly</i> .....                            | 45        |
| 9.7.3      | <i>Brushes</i> .....                                | 45        |
| 9.7.4      | <i>Assembly</i> .....                               | 47        |
| 9.7.5      | <i>Installation</i> .....                           | 47        |
| 9.8        | PREHEATING SYSTEM (OPTIONAL).....                   | 47        |
| 9.8.1      | <i>Operation</i> .....                              | 48        |
| 9.8.2      | <i>Preheating System Timer</i> .....                | 48        |
| 9.8.3      | <i>Timer Operating Instructions (Webasto)</i> ..... | 49        |
| 9.8.4      | <i>Troubleshooting and Maintenance</i> .....        | 51        |
| <b>10.</b> | <b>SPECIFICATIONS</b> .....                         | <b>52</b> |

## ILLUSTRATIONS

|  |    |
|--|----|
| FIGURE 1: DRIVER'S AIR CIRCULATION .....                             | 5  |
| FIGURE 2: PASSENGERS' AREA RECIRCULATION DAMPER .....                | 5  |
| FIGURE 3: CENTRAL HVAC SYSTEM AIR CIRCULATION .....                  | 6  |
| FIGURE 4: PASSENGERS OVERHEAD COMPARTMENT VENTILATION SYSTEM .....   | 6  |
| FIGURE 5: CENTRAL HVAC SYSTEM CONTROL UNIT .....                     | 7  |
| FIGURE 6: THERMISTOR SENSOR.....                                     | 7  |
| FIGURE 7: EVAPORATOR COMPARTMENT .....                               | 8  |
| FIGURE 8: CONDENSER COMPARTMENT.....                                 | 8  |
| FIGURE 9: EVAPORATOR MOTOR & COIL ACCESS PANEL.....                  | 8  |
| FIGURE 10: EVAPORATOR COIL CLEANING .....                            | 8  |
| FIGURE 11: CONDENSER COIL CLEANING .....                             | 9  |
| FIGURE 12: DRIVER'S SECTION ACCESS GRILL .....                       | 9  |
| FIGURE 13: DRIVER'S SECTION AIR FILTERS .....                        | 9  |
| FIGURE 14: PASSENGERS' SECTION AIR FILTER .....                      | 10 |
| FIGURE 15: OVERHEAD COMPARTMENT FAN AIR FILTER .....                 | 10 |
| FIGURE 16: REFRIGERANT CIRCUIT (CENTRAL AND AUXILIARY SYSTEMS) ..... | 15 |
| FIGURE 17: DOUBLE SWEEP EVACUATION SET-UP .....                      | 18 |
| FIGURE 18: AIR PRESSURE REGULATOR .....                              | 21 |
| FIGURE 19: BELTS ARRANGEMENT (DDC S60 ENGINE).....                   | 21 |
| FIGURE 20: BELTS ARRANGEMENT (VOLVO D13 ENGINE) .....                | 21 |
| FIGURE 21: IDLER PULLEY INSTALLATION ON VOLVO D13 ENGINE.....        | 21 |
| FIGURE 22: BELT PLAY .....   | 21 |
| FIGURE 23: COMPRESSOR ALIGNMENT .....                                | 22 |
| FIGURE 24: COMPRESSOR ALIGNMENT .....                                | 22 |
| FIGURE 25: EVAPORATOR COMPARTMENT.....                               | 23 |
| FIGURE 26: EVAPORATOR MOTOR ASSY FIXING BOLTS.....                   | 24 |
| FIGURE 27: EVAPORATOR MOTOR ASSEMBLY .....                           | 24 |
| FIGURE 28: PROPER GRINDING TECHNIQUE .....                           | 25 |
| FIGURE 29: IMPROPER GRINDING TECHNIQUE.....                          | 25 |
| FIGURE 30: GRINDING WITH THE BRUSH SEATER STONE.....                 | 25 |
| FIGURE 31: SEATING SURFACE OF THE BRUSH.....                         | 26 |
| FIGURE 32: EVAPORATOR MOTOR .....                                    | 26 |
| FIGURE 33: CONDENSER FAN MOTOR .....                                 | 27 |
| FIGURE 34: A/C CONDENSER COMPARTMENT.....                            | 27 |
| FIGURE 35: DRIVER'S EVAPORATOR LIQUID SOLENOID VALVE.....            | 29 |
| FIGURE 36: REFRIGERANT SOLENOID VALVE .....                          | 30 |
| FIGURE 37: EXPANSION VALVE .....                                     | 30 |
| FIGURE 38: SUPERHEAT ADJUSTMENT INSTALLATION .....                   | 31 |
| FIGURE 39: HIGH & LOW SWING TEMPERATURE AT REMOTE BULB .....         | 31 |
| FIGURE 40: COMPRESSOR REMOVAL OR INSTALLATION .....                  | 38 |
| FIGURE 41: CENTRAL HEATING SYSTEM COMPONENTS .....                   | 39 |

## Section 22: HEATING AND AIR CONDITIONING

---

|  |    |
|--|----|
| FIGURE 42: CEILING OF THE SPARE WHEEL COMPARTMENT .....      | 40 |
| FIGURE 43: DRIVER'S HVAC UNIT .....                          | 40 |
| FIGURE 44: HEATER LINE SHUT-OFF VALVES .....                 | 41 |
| FIGURE 45: EVAPORATOR COMPARTMENT .....                      | 41 |
| FIGURE 46: DRIVER'S HOT WATER PNEUMATIC VALVE ASSEMBLY ..... | 42 |
| FIGURE 47: PNEUMATIC WATER VALVE .....                       | 42 |
| FIGURE 48: CENTRAL HOT WATER PNEUMATIC VALVE ASSEMBLY .....  | 43 |
| FIGURE 49: PNEUMATIC WATER VALVE .....                       | 44 |
| FIGURE 50: PUMP LOCATION (CENTRAL A/C) .....                 | 45 |
| FIGURE 51: WATER RECIRCULATING PUMP (CENTRAL A/C) .....      | 46 |
| FIGURE 52: LOCATION OF PREHEATER .....                       | 47 |
| FIGURE 53: WEBASTO PREHEATER (104,000 BTU) .....             | 48 |
| FIGURE 54: WEBASTO .....                                     | 49 |

## 1. HEATING AND AIR CONDITIONING

The coach's interior is pressurized by its Heating, Ventilation, Air Conditioning (HVAC) units. Air flow and controls divide the vehicle in two areas: driver's area and passengers' area. The interior of vehicle should always be slightly pressurized to prevent dust and moisture from entering vehicle. Each section has its own fresh air, returning air and discharge air ducting. The exhaust is mainly done through the lavatory ventilator and through normal air-tightness losses.

## 2. AIR CIRCULATION

### 2.1 DRIVER'S AREA

Fresh air is taken from a plenum underneath the front service compartment and enters the mixing box through an ON/OFF damper. Return air is taken through the base of the dashboard panel utility compartments into the mixing box. Mixed air goes through cooling and heating coils, fans and discharge ducts.

Both right and left discharge ducts defrost one half of the windshield. The driver can also divert some air flow to the console, from which he can direct air to his knees and/or upper body with adjustable HVAC air registers and to his feet with the appropriate button (see Fig. 1 and Operator's manual). The coach is also equipped with a windshield upper section de-icing system.

One additional air register is located in the driver's area but supplied by the passengers' air ducting system. It is installed in the stepwell for step de-icing.

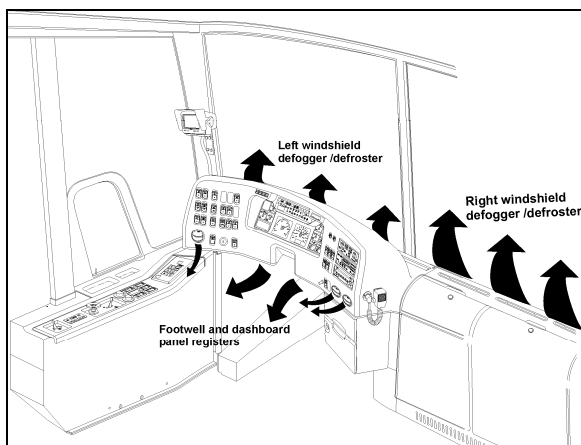


FIGURE 1: DRIVER'S AIR CIRCULATION 22307

### 2.2 PASSENGERS' AREA

Fresh air enters the vehicle on the L.H. side, through the recirculation damper located inside the evaporator compartment door (Fig. 2). The damper can be fully opened for normal operation or closed for extreme weather or highly polluted areas (Refer to the X3 Operator's Manual for more details). The recirculation REC button is located on the HVAC control unit. Press down the button to partially close the fresh air damper. Return air is drawn from inside the vehicle through the register duct located amidships on L.H. side of vehicle (Fig. 3).

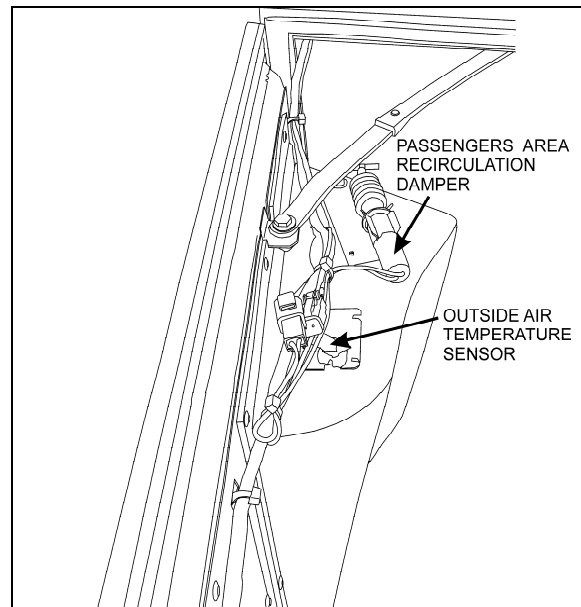


FIGURE 2: PASSENGERS' AREA RECIRCULATION DAMPER 22302

A double blower fan unit, which is activated by the evaporator motor, draws mixed air through an air filter, cooling and heating coils, then forces this air in the ventilation ducts along the walls, and finally exhausts it just below side windows.

X3 coaches are also equipped with an overhead compartment ventilation system, a three-position



rocker switch (OFF - 1<sup>st</sup> speed - 2<sup>nd</sup> speed) located on R.H. dashboard panel controls the speed of both fans. Return air is drawn just below the middle side windows through an air filter into the overhead compartment fan; discharge air is fed to the rotating registers through the ventilation duct (Fig. 4).



## Section 22: HEATING AND AIR CONDITIONING

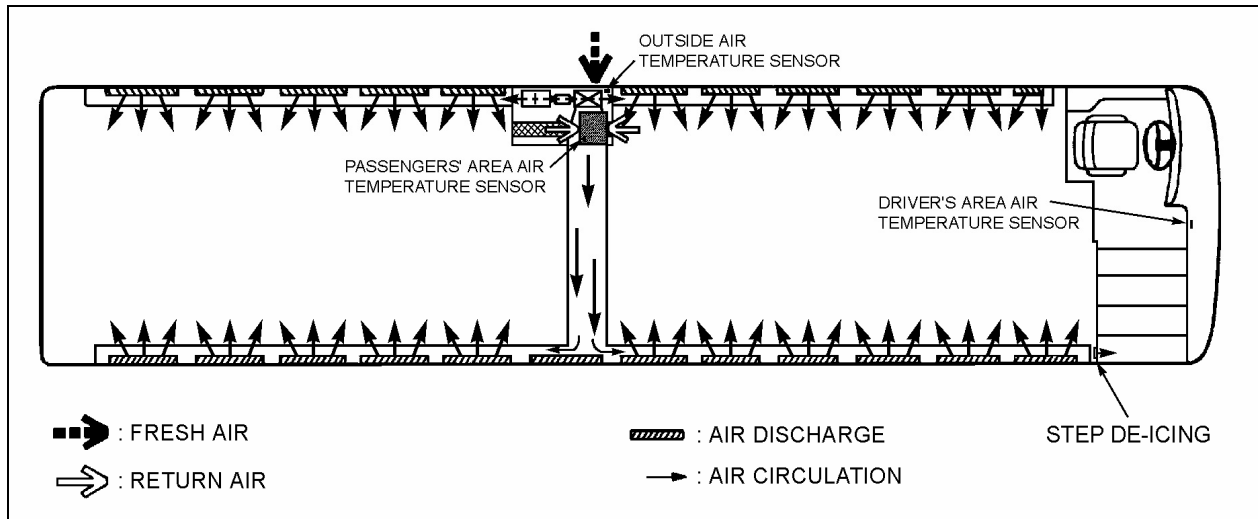


FIGURE 3: CENTRAL HVAC SYSTEM AIR CIRCULATION

22308

The overhead compartment air registers are used to control air flow for the passenger seats. One register per seat direct air flow by pointing or rotating register. Open or close register to adjust air flow.

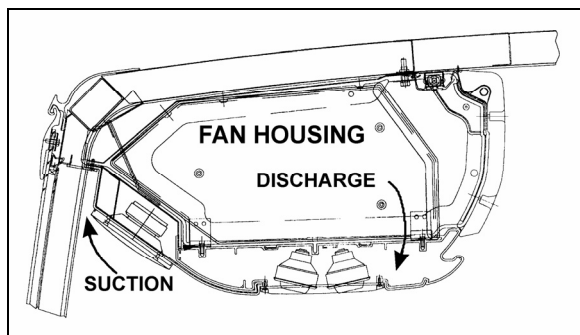


FIGURE 4: PASSENGERS OVERHEAD COMPARTMENT VENTILATION SYSTEM

22211

### 3. CENTRAL HVAC SYSTEM OPERATION

To operate the air conditioning system when coach is stationary, engine should run at fast idle. During operation of the air conditioning system, windows should be kept closed and door not left open longer than necessary. In order to prevent battery discharge, HVAC system will not operate if vehicle charging system is not working properly.

#### 3.1 DRIVER'S SECTION OPERATION

The temperature control in the driver's area is provided directly by the L.H. portion of the HVAC control unit mounted on the R.H. dashboard panel (Fig. 5).


The driver's HVAC section piping is paralleled with the passengers HVAC section piping. Both sections use the same refrigerant and coolant, and are linked to the same condenser and compressor, even if they are individually controlled. It requires the passengers HVAC section to engage the A/C compressor magnetic clutch. Consequently, the driver's section cannot be operated in the A/C mode alone.

#### NOTE

The driver's HVAC section turns on automatically at starting of the engine and uses the settings that were kept in memory before turning off of the system.

The A/C compressor starts automatically when the two following conditions are satisfied:

1. The outside temperature is above 32°F (0°C).
2. The passenger's area temperature has reached 7°F (4°C) under the set point.

Using the Up/Down type switch  sets the fan speed and the speed chosen is illustrated on the window display.

#### NOTE

Upon starting, if the outside temperature is above 32°F (0°C) and then drops below 32°F (0°C), the compressor will keep running up to a temperature of 15°F (-9°C) to prevent condensation from forming on the windows.

## Section 22: HEATING AND AIR CONDITIONING

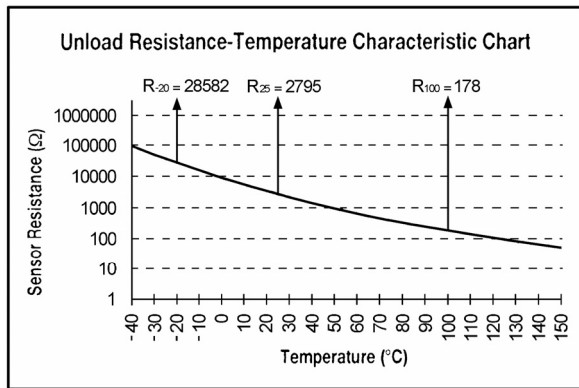
### NOTE

To perform a test of the driver's section windshield defroster, it is possible to run the system without running the engine.

The following 2% error chart and table can be used to troubleshoot the driver's area air temperature sensor and the outside air temperature sensor.

### NOTE

The driver's area air temperature sensor is located behind the grill of the R.H. side console (Refer to fig.12).



| Temp °C | Temp °F | Resistance Ohms |
|---------|---------|-----------------|
| -40     | -40     | 100865          |
| -35     | -31     | 72437           |
| -30     | -22     | 52594           |
| -25     | -13     | 38583           |
| -20     | -4      | 28582           |
| -15     | 5       | 21371           |
| -10     | 14      | 16120           |
| -5      | 23      | 12261           |
| 0       | 32      | 9399            |
| 5       | 41      | 7263            |
| 10      | 50      | 5658            |
| 15      | 59      | 4441            |
| 20      | 68      | 3511            |
| 25      | 77      | 2795            |
| 30      | 86      | 2240            |
| 35      | 95      | 1806            |
| 40      | 104     | 1465            |
| 45      | 113     | 1195            |
| 50      | 122     | 980             |
| 55      | 131     | 808             |
| 60      | 140     | 670             |
| 65      | 149     | 559             |
| 70      | 158     | 468             |
| 75      | 167     | 394             |
| 80      | 176     | 333             |
| 85      | 185     | 283             |
| 90      | 194     | 241             |
| 95      | 203     | 207             |
| 100     | 212     | 178             |
| 105     | 221     | 153             |
| 110     | 230     | 133             |

|     |     |     |
|-----|-----|-----|
| 115 | 239 | 115 |
| 120 | 248 | 100 |
| 125 | 257 | 88  |
| 130 | 266 | 77  |
| 135 | 275 | 68  |
| 140 | 284 | 60  |
| 145 | 293 | 53  |
| 150 | 302 | 47  |

### 3.2 PASSENGERS' SECTION OPERATION

The R.H. portion of the HVAC control unit enables the selection of the temperature in the passenger's area (refer to the Operator's Manual for details).



FIGURE 5: CENTRAL HVAC SYSTEM CONTROL UNIT 22296

Temperature control is provided in conjunction with a thermistor sensor inside register duct, located amidships on L.H. side of vehicle (Figs. 3 & 6).

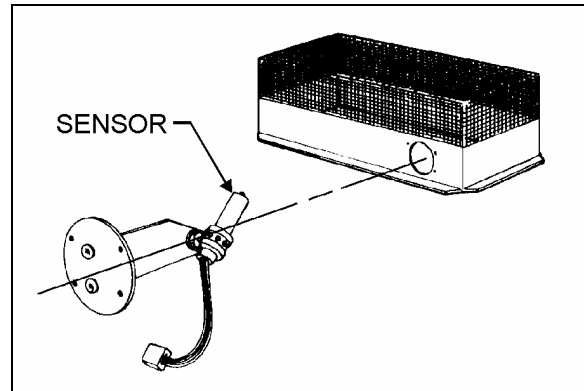


FIGURE 6: THERMISTOR SENSOR

22064

The flow of water to the vehicle's main heater core is controlled by a pneumatic water valve which varies the cycling rate depending on selected temperature. A red LED, located on HVAC control unit, illuminates when heating mode is selected. A green LED illuminates when compressor clutch is in operation.

The evaporator fan motor, located in the evaporator compartment, is protected by a 90 amps, manually-resettable (CB3) circuit breaker located on the rear junction panel of the rear electrical compartment (refer to Section 06, "Electrical System" in this manual for details).

## Section 22: HEATING AND AIR CONDITIONING

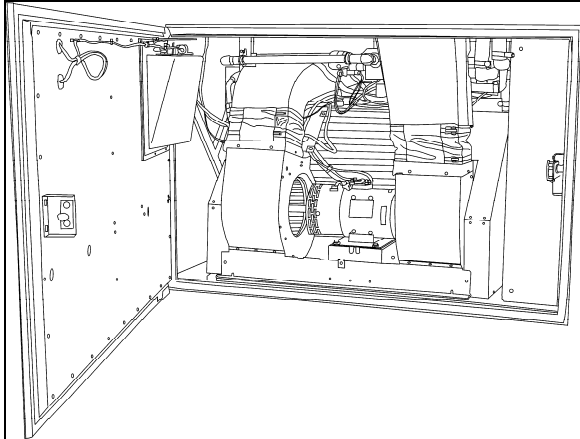


FIGURE 7: EVAPORATOR COMPARTMENT 22301

The condenser coil mounted on the opposite side of the evaporator is ventilated by four axial fans. The fan motors are protected by a manually-resettable 70 amp circuit breaker (CB 7) mounted on the rear junction panel of the rear electrical compartment.

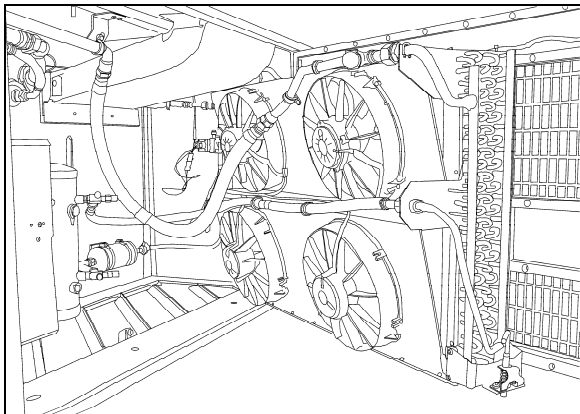


FIGURE 8: CONDENSER COMPARTMENT 22299

### 3.3 OVERHEAD COMPARTMENT A/C

Optional small A/C evaporator coils may be added to both overhead compartments existing air system. These auxiliary A/C system components are separate and completely independent of central system and permit a wider temperature range in the passenger's area. The three-position rocker switch used to control the fans also controls the A/C system.

## 4. HVAC UNIT MAINTENANCE

No special maintenance is required on the passengers, driver's and auxiliary HVAC units, with the exception of cleaning their respective coils and air filters, plus periodic inspection for broken drains, hoses and charging of system.

### NOTE

*Squeeze rubber hose located underneath the appropriate compartment to eliminate the accumulated water and dirt when you make routine maintenance.*

### 4.1 COIL CLEANING

Check the external surface of the coil at regular intervals for dirt or any foreign matter.

For the driver's HVAC unit, remove the grill and the access panels and back flush the coil from inside.

For the passengers' section evaporator coil, remove the access panel and back flush the coil (Fig. 9 & 10) every 12,500 miles (20 000 km) or once a year, whichever comes first.

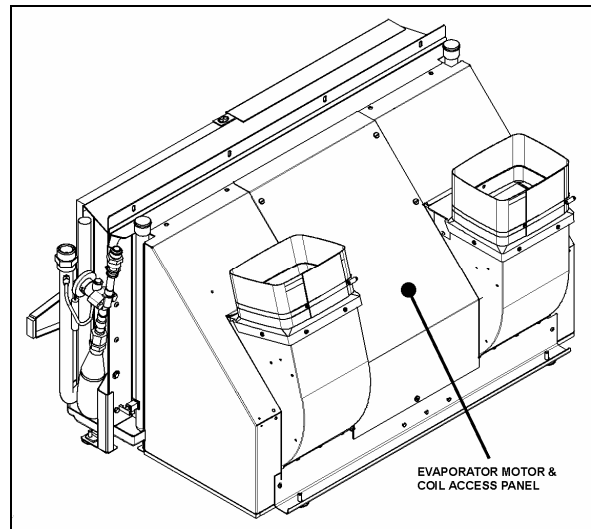


FIGURE 9: EVAPORATOR MOTOR & COIL ACCESS PANEL 22309

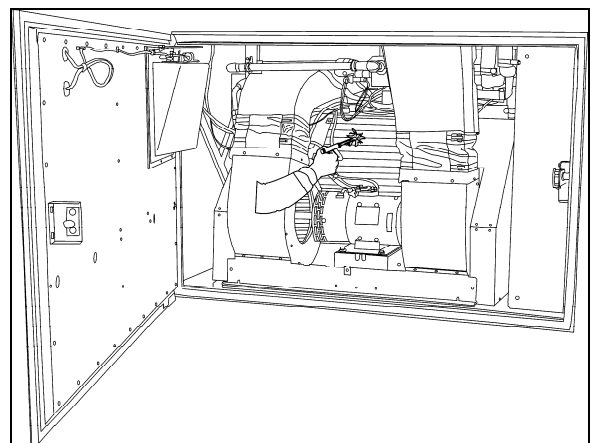




FIGURE 10: EVAPORATOR COIL CLEANING 22310

For the condenser coil, back flush the coil (Fig. 11) every 6,250 miles (10 000 km) or twice a year, whichever comes first.

|   |                |
|---|----------------|
|  | <b>CAUTION</b> |
| Use a water jet or water mixed with low air pressure to clean the coil.           |                |

|   |                |
|---|----------------|
|    | <b>CAUTION</b> |
| Direct the pressure straight through the coil to prevent bending of fins and do not use extremely high pressure. Do not use hot water, steam or caustic soap. |                |

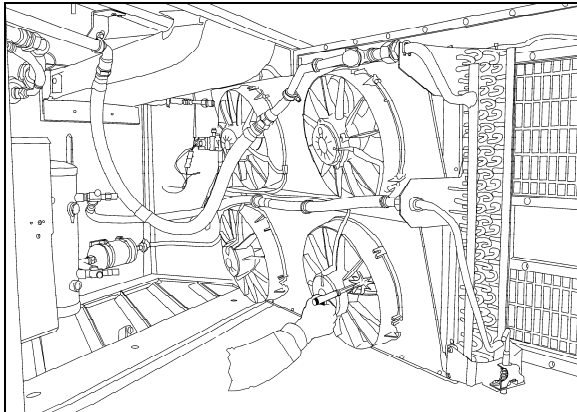


FIGURE 11: CONDENSER COIL CLEANING 22311

#### 4.2 DRIVER'S SECTION AIR FILTERS

The driver HVAC system is located behind the dashboard's R.H. side lateral plastic panel. To gain access to the A/C filters, unscrew the R.H. lateral console's grill located at the top step of the entrance door steps. Slide out the recirculating air and fresh air filters. To clean filters back flush with water, then dry with air, every 12,500 miles (20 000 km) or once a year, which-ever comes first (Fig. 12 & 13).

|   |
|---|
| <p><b>NOTE</b></p> <p><i>If the windshield is continuously fogged, check that the driver's air filter is not clogged.</i></p> |
|---|

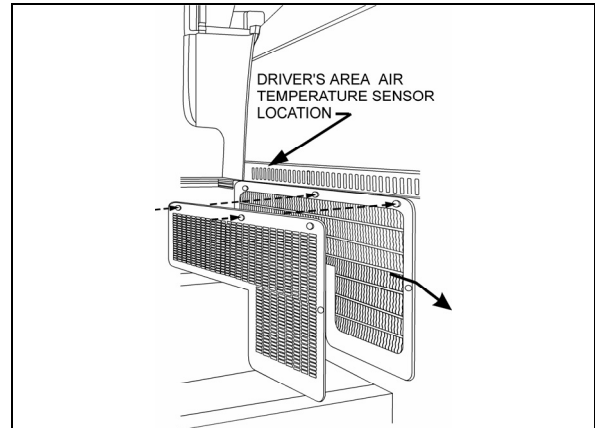


FIGURE 12: DRIVER'S SECTION ACCESS GRILL 22312

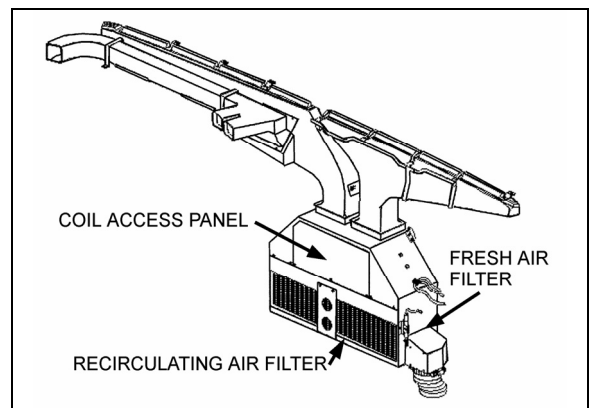


FIGURE 13: DRIVER'S SECTION AIR FILTERS 22171

#### 4.3 PASSENGERS' SECTION AIR FILTER

The passengers' section air filter is located in the evaporator compartment. To access the filter on X3 coaches, open baggage compartment door located in front of the evaporator compartment (L.H. side). Open access panel by turning the three screws of panel 1/4 of a turn, unsnap both fasteners on top of filter, and slide out filter (Fig. 14). To clean filter, back flush with water or soapy water, then dry with air every 12,500 miles (20 000 km) or once a year, whichever comes first.

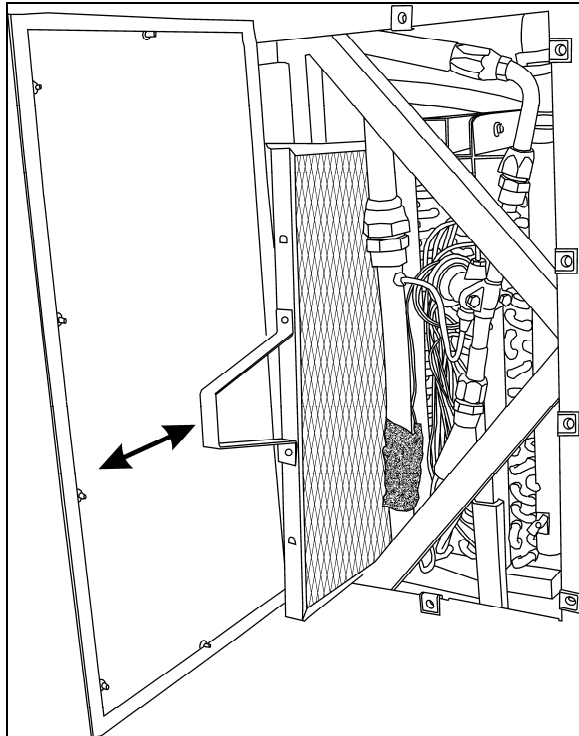


FIGURE 14: PASSENGERS' SECTION AIR FILTER 22306



**CAUTION**

Do not use high pressure water jet to avoid damaging filter.



**CAUTION**

Be sure not to reverse filter upon installation.

4.4 OVERHEAD COMPARTMENT FAN AIR FILTER

A/C evaporator coils may be installed in both overhead compartment air systems. Only the air filters are serviceable. The air filters are accessible from inside the overhead compartments. Slide out the filters, then back flush with water, dry with air and replace. This procedure should be done every 12,500 miles (20,000 km) or once a year, whichever come first.

If A/C units were installed, ball valves are added on supply and return lines in the engine compartment. They have service port to evacuate the A/C overhead compartment circuit. When work has to be done on an evaporator coil unit, it will be easier to remove it and repair it on a bench.

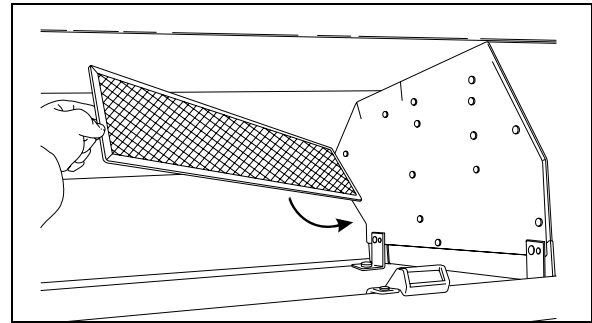


FIGURE 15: OVERHEAD COMPARTMENT FAN AIR FILTER 22201

5. HVAC SYSTEM PARTICULARITIES, TESTING AND TROUBLESHOOTING

Before undertaking any troubleshooting on the HVAC system, study the appropriate wiring diagrams to get a complete understanding of the HVAC components circuitry, read and understand section 06:ELECTRICAL of this manual under "Troubleshooting And Testing The Multiplex Vehicles" and "Test Mode For Switches And Sensors". The information included in these paragraphs is necessary for troubleshooting the HVAC system on Multiplex vehicles.

5.1 HVAC SYSTEM AND TEST MODE FOR SWITCHES AND SENSORS

When in switch/sensor test mode (see Section 06: ELECTRICAL for complete information), the A/C compressor HI and LO pressure values are displayed one after the other instead of the outside temperature in the telltale panel LCD display. This feature can be used when the vehicle is traveling to check the A/C compressor pressure values.

**NOTE**

*When starting the A/C compressor wait 5 seconds before checking pressures in order to give the system a chance to build its pressure. During the first 5 seconds after startup, the compressor is active on 6 cylinders and the A/C valve is open regardless of the pressure readings.*

In test mode, with the parking brake applied and the passenger set point set to a value higher than 64°F (18°C), the hot water circulating pump is not set to OFF as it would normally do when the outside temperature gets above 50°F (10°C). This feature allows verification of the pump when inside a garage. This is also useful

## Section 22: HEATING AND AIR CONDITIONING

when working on the heating system to remove air pockets trapped in the system.

When performing an A/C cooling test and having the water pump shut off in switch/sensor test mode is required, just set the passenger set point temperature to the minimum 64°F (18°C) to shut off the pump.

### 5.2 HVAC SYSTEM AND TEST MODE FOR ELECTRIC MOTORS

The test mode allows testing the motors and electric contactors without the need to have the engine running (see Section 06: ELECTRICAL under "TEST MODE FOR ELECTRICAL MOTORS" for complete information).

Use this test mode for testing of the condenser motors, the A/C compressor clutch activation, left and right unloaders, evaporator motor, water pump, hot water solenoid valve and overhead compartment air register fan.

### 5.3 PARTICULARITIES

|   |  |
|---|--|
| Conditions for engaging the 2 <sup>nd</sup> speed on the evaporator motor (cooling demand).   | The 2 <sup>nd</sup> speed engages if the passenger's area temperature is 1 degree above the set point and it revert to speed 1 if the temperature gets equal or below the set point.   |
| Conditions for hot water recirculating pump activation (heating demand).  | The pump turns to OFF if the outside temperature is above 50°F (10°C), when there is less demand for heating.<br><br>Note: To test a working pump, it is possible to keep it active even if the outside temperature is above 50°F (10°C). See paragraph 5.2 HVAC SYSTEM AND TEST MODE FOR ELECTRIC MOTORS.   |
| The compressor unloaders are working based on pressure and also on the difference between the passenger's area temperature and the set point. | <p><b>2 left compressor cylinders:</b></p> <p>Stop if: Passenger's area temperature is at less than 0.4°C degree above the set point or if the compressor output is above 280 psi, or if the compressor input is below 26 psi.</p> <p>Restart if: Passenger's area temperature is 0.9°C or more above the set point and the compressor pressure output is less than 220 psi and the compressor pressure input is above 34 psi.</p> <p><b>2 right compressor cylinders:</b></p> <p>Stop if: Passenger's area temperature is at less than 0.2°C above the set point or if the compressor input falls below 23 psi.</p> <p>Restart if: Passenger's area temperature is 0.7°C or more above the set point and the compressor input pressure is above 32 psi.</p> |
| The A/C deactivation pressure is 320 psi.   | In case of high pressure, the analog pressure sensor connected to the Multiplex module deactivates the compressor.<br><br>There is also a « Pressure switch » adjusted to 350 PSI that acts to stop the compressor in the instance that the Multiplex module fails.  |

## Section 22: HEATING AND AIR CONDITIONING

### 5.4 HVAC SYSTEM TROUBLESHOOTING

| Problem/Symptom   | Probable Causes   | Actions   |
|---|---|---|
| No temperature control in the passenger area<br>Passenger temperature display indicates two dashes "--" | Problem with the temperature sensor located in the evaporator compartment air intake or the sensor wiring | Instruct the driver to manually control the temperature by playing with the passenger set point. Set above 22°C (72°F) to heat and below 22° C (72°F) to cool   |
| Defroster fan not functioning   | Module A47 is not powered or is faulty  | <ol style="list-style-type: none"> <li>1. Check the SYSTEM DIAGNOSTIC menu of the message center display (MCD). Select FAULT DIAGNOSTIC and ELECTRICAL SYSTEM. The message "Voltage Module A47, Value too Low, Active" confirms a power problem on the module</li> <li>2. Check / reset circuit breaker CB6</li> <li>3. Check / replace fuse F5</li> <li>4. Use the air release valves near the entrance door and in the front service compartment to lock / unlock the door</li> </ol> |
| HVAC condenser fans not functioning in speed 1  | Circuit breaker CB7 was manually tripped and not reset<br>Seized bearing<br>Brush problem<br>Bad wiring   | Check / reset circuit breaker CB7   |
| HVAC condenser fans not functioning in speed 1  | Module A54 is not powered or is faulty  | <ol style="list-style-type: none"> <li>1. Check the SYSTEM DIAGNOSTIC menu of the message center display (MCD). Select FAULT DIAGNOSTIC and ELECTRICAL SYSTEM. The message "Voltage Module A54, Value too Low, Active" confirms a power problem on the module</li> <li>2. Check / reset circuit breaker CB5</li> <li>3. Check / replace fuse F67 , F68</li> </ol>   |
| HVAC condenser fans not functioning in speed 2  | Circuit breaker CB7 was manually tripped and not reset<br>Seized bearing<br>Brush problem<br>Bad wiring   | Check / reset circuit breaker CB7   |
| Defroster fan is functioning but no heat or cooling available in the driver's area                      | Module A46 is not powered or is faulty<br>Faulty speed control<br>Bad wiring                              | <ol style="list-style-type: none"> <li>1. Check the SYSTEM DIAGNOSTIC menu of the message center display (MCD). Select FAULT DIAGNOSTIC and ELECTRICAL SYSTEM. The message "Voltage Module A46, Value too Low, Active" confirms a power problem on the module.</li> </ol>   |

| Problem/Symptom                           | Probable Causes  | Actions   |
|---|--|---|
|   |  | <ol style="list-style-type: none"> <li>2. Check / reset circuit breaker CB1</li> <li>3. Check / replace fuse F12</li> </ol>   |
| The A/C compressor clutch does not engage | Module A52 is not powered or is faulty   | <ol style="list-style-type: none"> <li>1. Check the SYSTEM DIAGNOSTIC menu of the message center display (MCD). Select FAULT DIAGNOSTIC and ELECTRICAL SYSTEM. The message "Voltage Module A52, Value too Low, Active" confirms a power problem on the module</li> <li>2. Check / reset circuit breaker CB5</li> <li>3. Check / replace fuse F65</li> </ol>   |
| Evaporator fan not functioning            | Circuit breaker CB3 tripped<br><br>Module A54 is not powered or is faulty<br><br>Brush problem | <ol style="list-style-type: none"> <li>1. Check / reset circuit breaker CB3</li> <li>2. Check the SYSTEM DIAGNOSTIC menu of the message center display (MCD). Select FAULT DIAGNOSTIC and ELECTRICAL SYSTEM. The message "Voltage Module A54, Value too Low, Active" confirms a power problem on the module</li> <li>3. Check / reset circuit breaker CB5</li> <li>4. Check / replace fuse F67 , F68</li> </ol> |

**6. CENTRAL AIR CONDITIONING SYSTEM**

The schematic of Figure 16 shows the central and auxiliary A/C systems and their components. The central system is equipped with a 6 cylinder, 05G Twin Port Carrier compressor with an air conditioning capacity of 7½ tons. The receiver tank and filter dryer are mounted inside the condenser compartment.

X3 Coaches may be supplied with an auxiliary A/C system (Fig. 16). Auxiliary A/C system comes with a 7 cylinder, Sanden SD7 compressor with an air conditioning capacity of 2 tons.

**6.1 A/C CYCLE**

Refrigeration may be defined as "the transfer of heat from a place where it is not wanted to a place where it is unobjectionable". Components required for a closed circuit refrigeration system are shown in Figure 16.

The air conditioning system used on X3 series coaches is of the "Closed" type using "R-134a".

1. The refrigerant flowing to the compressor is compressed to high pressure and reaches a temperature higher than the surrounding air. It is passed through the air-cooled fins and tubes of the condenser causing the hot,

high pressure gas to be condensed into a liquid form.

2. The liquid refrigerant flows to the receiver tank, then passes through a filter dryer where moisture, acids and dirt are removed and then through a moisture indicator which indicates if any moisture is present in the system.
3. By its own pressure, the liquid refrigerant flows through a thermal expansion valve where the pressure drop causes the refrigerant to vaporize in a vapor-liquid state at a low temperature pressure.
4. The cold low pressure refrigerant passes through the passengers and the driver's evaporator coils which absorbs heat from the air passing over the fins and tubes, and changes into gas. In this form, the refrigerant is drawn into the compressor to repeat the air conditioning cycle.
5. The success of the air conditioning system depends on retaining the conditioned air within the vehicle. All windows and intake vents should be closed. An opening of approximately 8 in<sup>2</sup> (5162 mm<sup>2</sup>) could easily neutralize the total capacity of the system.



## Section 22: HEATING AND AIR CONDITIONING

6. Other causes of inadequate cooling are dirty coils or filter. Dirt acts as insulation and is also serves as a restriction to the air flow.
7. The refrigeration load is not constant and varies. It is also affected by outside temperature, relative humidity, passenger load, compressor speed, the number of stops, etc.
8. The compressor will load or unload depending on operating conditions.

### 6.2 REFRIGERANT

The A/C system of this vehicle has been designed to use Refrigerant 134a as a medium. Regardless of the brand, only R-134a must be used in this system. The chemical name for this refrigerant is Ethane, 1, 1, 1, 2-Tetrafluoro.



#### **DANGER**

Refrigerant in itself is nonflammable, but if it comes in contact with an open flame, it will decompose.

#### 6.2.1 Procurement

Refrigerant is shipped and stored in 30 and 100 pound (13,6 and 45 kg) metal cylinders. Approximately 24 pounds (10,9 kg) are used in the central system. If vehicle is equipped with an auxiliary A/C system, then approximately 5.5 lbs (2,5 kg) will be needed.

It will be impossible to draw the entire refrigerant out of the cylinder. However, the use of warm water when charging the system will assure the extraction of a maximum amount of refrigerant from the cylinder.

#### 6.2.2 Precautions in Handling Refrigerant

1. Do not leave refrigerant cylinder uncapped.
2. Do not subject cylinder to high temperatures, do not weld or steam clean near system or cylinder.
3. Do not fill cylinder completely.
4. Do not discharge vapor into an area where a flame is exposed.
5. Do not expose the eyes to liquid refrigerant.

All refrigerant cylinders are shipped with a heavy metal screw cap. The purpose of the cap is to protect the valve and safety plug from damage. It is a good practice to replace the cap after each use of the cylinder for the same reason. If the cylinder is exposed to the sun's radiant heat pressure increase resulting may cause release of the safety plug or the cylinder may burst.

For the same reason, the refrigerant cylinder should never be subjected to excessive temperature when charging a system. The refrigerant cylinder should be heated for charging purposes by placing it in 125°F (52°C) water. Never heat above 125°F (52°C) or use a blowtorch, radiator, or stove to heat the cylinder. Welding or steam cleaning on or near any refrigerant line or components of the A/C system could build up dangerous and damaging pressures in the system.

If a small cylinder is ever filled from a large one, never fill the cylinder completely. Space should always be allowed above the liquid for expansion. Weighing cylinders before and during the transfer will determine the fullness of the cylinders.



#### **WARNING**

One of the most important precautions when handling refrigerant consists in protecting the eyes. Any liquid refrigerant which may accidentally escape is approximately -40°F (-40°C). If refrigerant comes in contact with the eyes, serious injury could result. Always wear goggles to protect the eyes when opening refrigerant connections.

#### 6.2.3 Treatment in Case of Injury

If liquid refrigerant comes in contact with the skin, treat the injury as if the skin was frost-bitten or frozen. If liquid refrigerant comes in contact with the eyes, consult an eye specialist or doctor immediately. Give the following first aid treatment:

1. Do not rub the eyes. Splash eyes with cold water to gradually bring the temperature above the freezing point.
2. Apply drops of sterile mineral oil (obtainable at any drugstore) in the eyes to reduce the possibility of infection. The mineral oil will also help in absorbing the refrigerant.

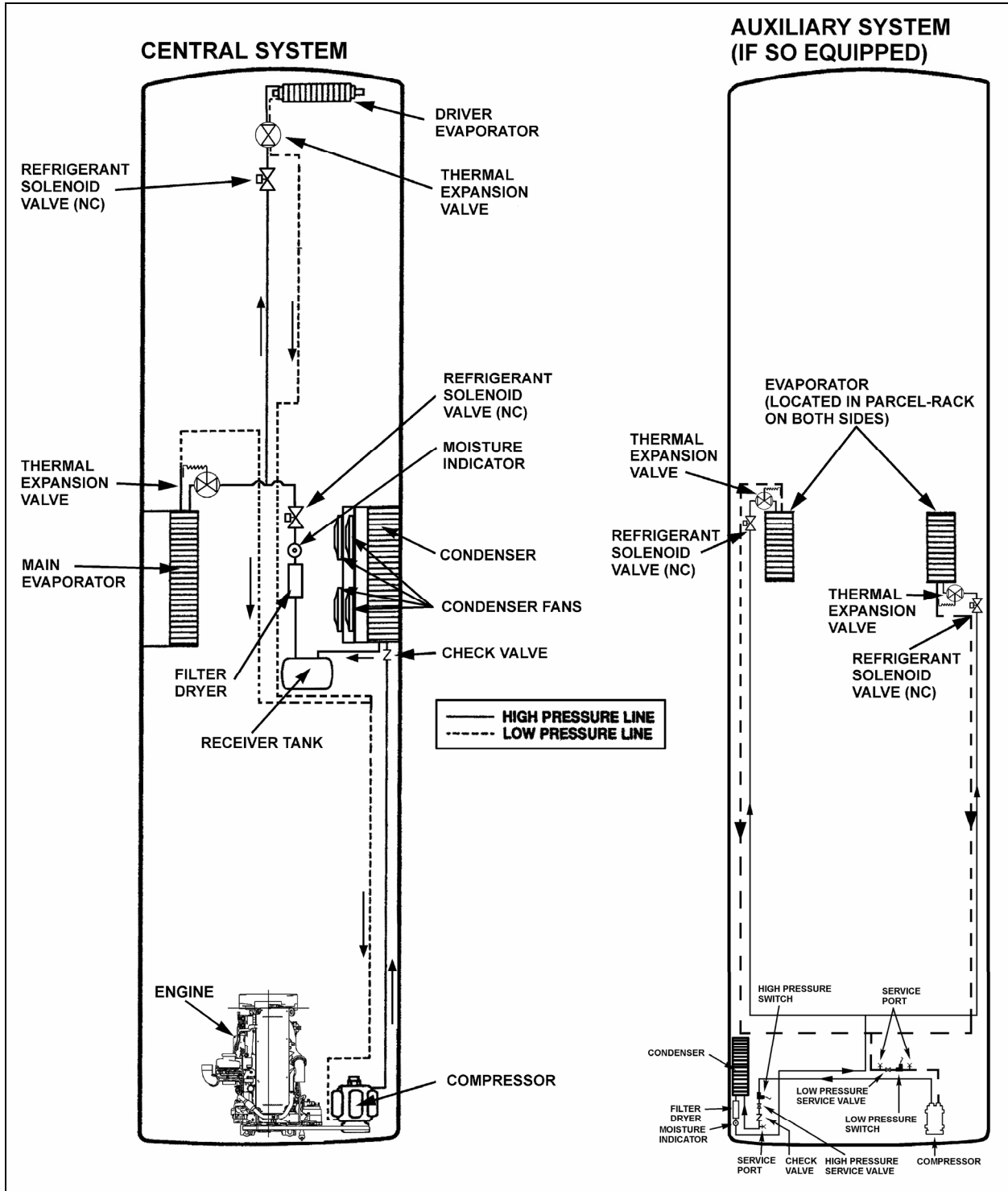


FIGURE 16: REFRIGERANT CIRCUIT (CENTRAL AND AUXILIARY SYSTEMS)

22313\_1

## Section 22: HEATING AND AIR CONDITIONING

### 6.2.4 Precautions in Handling Refrigerant Lines

1. All metal tubing lines should be free of kinks, because of the resulting restrictions on the flow of refrigerant. A single kink can greatly reduce the refrigeration capacity of the entire system.
2. The flexible hose lines should never be allowed to come within a distance of 2-1/2" (6,3 cm) from the exhaust manifold.
3. Use only sealed lines from parts stock.
4. When disconnecting any fitting in the refrigeration system, the system must first be discharged of all refrigerant. However, proceed very cautiously, regardless of gauge readings. If there happens to be liquid refrigerant in the line, disconnect fittings very slowly, keeping face and hands away so that no injury can occur. If pressure is noticed when fitting is loosened, allow it to bleed off very slowly.



#### WARNING

Always wear safety goggles when opening refrigerant lines.

5. In the event that any line is opened to the atmosphere, it should be immediately capped to prevent entrance of moisture and dirt.
6. The use of the proper wrenches when making connections on O-ring fittings is important. The use of improper wrenches may damage the connection. The opposing fitting should always be backed up with a wrench to prevent distortion of connection lines or components. When connecting the flexible hose connections, it is important that the swaged fitting and the flare nut, as well as the coupling to which it is attached, be held at the same time using three different wrenches to prevent turning the fitting and damaging the ground seat.
7. The O-rings and seats must be in perfect condition. The slightest burr or piece of dirt may cause a leak.
8. O-rings should be coated with refrigeration oil and installed on the line before the line is inserted into the fitting to prevent damaging the O-ring. If leaks are encountered at the couplings or connectors, no attempt should

be made to correct the leaks by tightening the connections beyond the recommended torque. The O-rings are designed to seal at the specified torque and overtightening the connection does not result in a satisfactory and permanently sealed connection. The connection must be disassembled and the cause of the leak (damaged O-ring, defective lines, etc.) corrected. Use new O-ring.

### 6.2.5 Auxiliary System Refrigerant Lines

1. From the inside of the coach, remove the mirror located inside the lavatory to access the Y connector separating the system two sides. Also a small access panel located in front of the lavatory entrance door, near the ceiling enables to reach the R.H. side supply and return line fittings.
2. The L.H. side supply and return line fittings are accessible by removing the rearmost overhead storage compartment separator.

### 6.3 PUMPING DOWN

This procedure is intended to reduce refrigerant loss, on central system only, by isolating it in the compressor and the receiver tank, as well as in their connecting line, in order to carry out repairs on other sections of the air conditioning system (lines and components).

#### NOTE

*Before attempting any repair between compressor and receiver tank, use a recovery unit to remove refrigerant from the system.*

#### NOTE

*On vehicles equipped with an auxiliary A/C system, refer to "Sanden SD7 Service Manual".*



#### WARNING

To prevent any injury, when air conditioning system must be opened, refer to previous paragraph "PRECAUTIONS IN HANDLING REFRIGERANT".



**CAUTION**


The filter dryer must be changed each time a line in the system is opened.

**Procedure**

1. Energize passengers 'section liquid solenoid valve.
2. Run the system for 10 minutes, shut it OFF, then close the receiver tank outlet valve by turning it clockwise, backseat the suction service valve on the compressor, install an appropriate pressure gauge set, and turn the valve forward ¼ turn to enable a visual check of the suction pressure.
3. Disconnect the "Low Pressure Switch" connector (mounted near the A/C compressor, and install a jumper wire.

**NOTE**

*This jumper wire will allow the clutch to remain engaged after pressure drops below 15 psi (103,5 kPa).*

4. Start the engine, press the "Passenger ON/OFF" switch then adjust (lower) temperature control  to maximum A/C.
5. Run the compressor until pressure reaches 1-2 psi (7-14 kPa).

**NOTE**

*During this operation, care must be taken not to fill the receiver tank over the upper sight glass. If so, stop process immediately. Always allow refrigerant piping and units to warm up to the ambient air temperature before opening system or sweating will take place inside the lines.*

6. Stop engine, and close compressor outlet valve by turning it clockwise until valve is properly seated.
7. Close compressor suction valve by turning it clockwise until it is properly seated.
8. Wait until pressure gauge reaches 1 to 2 psi (7 to 14 kPa). To accelerate procedure, lightly open compressor suction valve until pressure reaches this value.

**6.4 ADDING REFRIGERANT (VAPOR STATE)**

Use the suction service valve on the compressor to add a small quantity of refrigerant to the system. Backseat the valve and connect a charging line from the refrigerant cylinder to the valve. Tighten connection at level of refrigerant cylinder and open tank end slightly to purge air from the charging line. Tighten the charging line at the compressor. Screw in the stem of suction valve approximately two turns. Start the engine and run at fast idle. Add sufficient refrigerant to bring the level in lower sight glass of receiver tank to mid-point. Always charge the system with the cylinder upright and the valve on top to avoid drawing liquid out of the cylinder.

**6.5 EVACUATING SYSTEM**

1. Open both receiver valves by turning "out" (normal position).
2. Remove the caps from the two 90° adapters on the suction, discharge valves and connect two hoses to the vacuum.
3. Place the two compressor valves, suction and discharge, in neutral position by turning each one 3 to 4 turns "in" from the "out" position.
4. Open the solenoid valve by energizing or manually bypass.
5. Start the vacuum pump. Open the large (suction) shutoff valve and close the small vacuum gauge valve.
6. The pressure will drop to approximately 29 inches vacuum (14.2 psi or 97,9 kPa) (the dial gauge only gives a general idea of the absolute system pressure).
7. Backseat the compressor valves by turning "out" all the way.
8. Shut down the vacuum pump.
9. Remove the hoses.
10. Reinstall the caps at the suction valve take-off points.

## Section 22: HEATING AND AIR CONDITIONING

### 6.5.1 Double Sweep Evacuation Procedure

1. Remove any remaining refrigerant from the system using a refrigerant recovery machine.
2. Connect the evacuation manifold, vacuum pump, hoses and micron gauge to the unit.
3. With the unit service valves closed (back seated) and the vacuum pump and the thermistor valves open, start the pump and draw the manifold and hoses into a very deep vacuum. Shut the vacuum pump off and see if the vacuum holds. This is to check the setup for leaks.
4. Midseat the system service valves.
5. Open the vacuum pump and the thermistor valves. Start the pump and evacuate to a system pressure of 2000 microns.
6. Close the vacuum pump and the thermistor valves, turn off the vacuum pump (closing the thermistor valve protect the valve from damage).
7. Break the vacuum with clean refrigerant (or dry nitrogen) and raise the pressure to approximately 2 PSIG. Monitor the pressure with the compound gauge.
8. Remove the refrigerant with the recovery machine.
9. Repeat steps #5 – 8 one time.

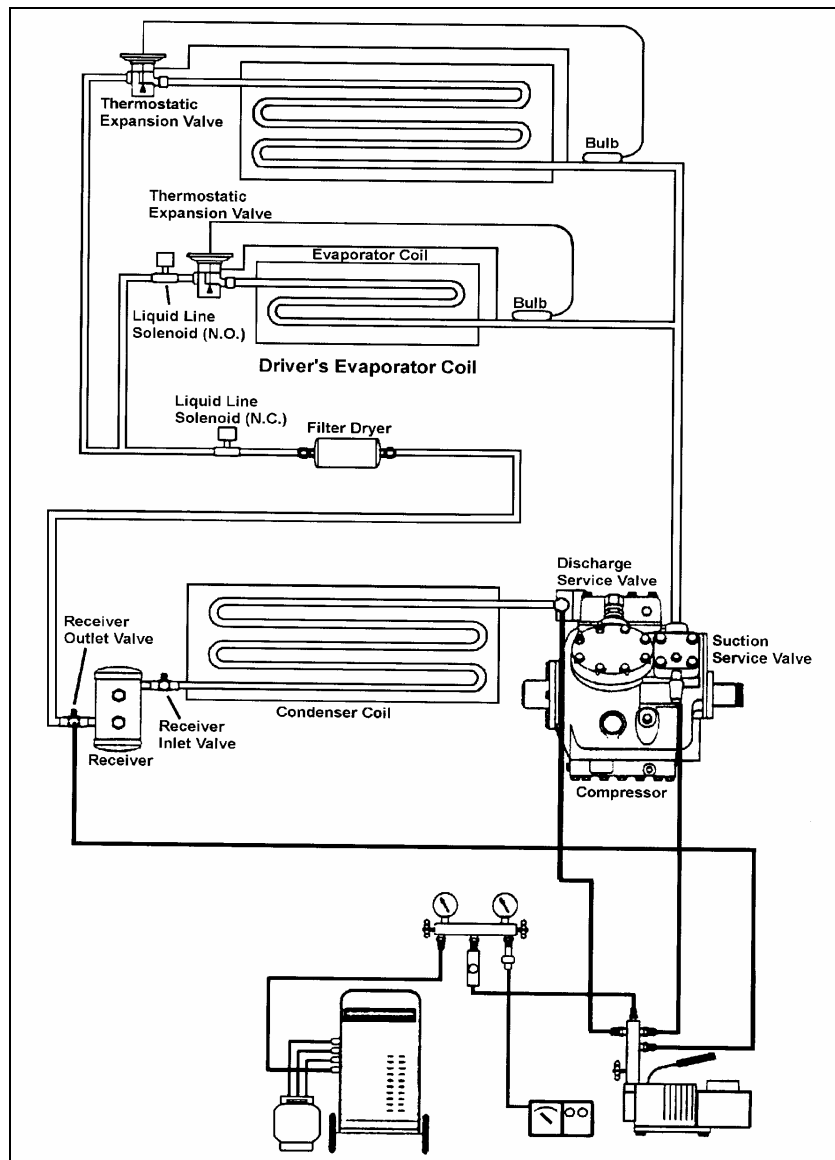


FIGURE 17: DOUBLE SWEEP EVACUATION SET-UP

22298

10. After the second "sweep", change the filter drier (if you have not done so) and evacuate to 500 microns.
11. Evacuating the system below 500 microns on systems using the Carrier 05G compressor may risk drawing air into the system past the carbon shaft seal.
12. Check to insure that vacuum holds. (If the pressure continues to rise, it indicates a leak or moisture in the system).
13. Charge the system with the proper amount of refrigerant using recommended charging procedures.

**NOTE**

*This method will aid in preventing unnecessary system failures by ensuring that the refrigeration system is free of contaminants.*

6.6 CHARGING SYSTEM

When a system has been opened or if there are any questions about the air or moisture in the system, evacuate the system. Charging of an evacuated system may be accomplished by forcing liquid R-134a directly into the receiver tank. This may be accomplished by placing the refrigerant cylinder upside down on a scale with the valves at the bottom. This ensures that only liquid will enter the receiver tank.

When charging an empty system, weigh the amount of refrigerant put into the system. This will eliminate any possibility of overfilling. A nominal charge requires 24 pounds (10,9 kg). If the vehicle is equipped with an auxiliary system, a full charge requires 5.6 lbs (2,6 kg).

1. Backseat the two compressor shutoff valves ("out").
2. Install the test gauges at the shutoff valves noting that the 400 psi (2758 kPa) gauge is connected to the discharge.
3. Turn in the two shutoff valves 3 to 4 turns.
4. Open the lower receiver valve by turning "out" all the way.
5. Backseat the upper receiver valve by turning out all the way.
6. Remove the cover cap from the service fitting in the top receiver valve.

7. Attach a charging hose to the R-134a tank. Open the tank valve slightly permitting R-134a to escape thus purging the hose of air.
8. Connect the charging hose to the service fitting.
9. Open the R-134a tank valve.
10. To build up pressure in the receiver tank, heat the receiver tank with a heating blanket.
11. Turn in the upper receiver valve several turns. The R-134a will now enter the system.
12. The proper charge of R-134a is 24 lbs (10.89 kg). When the scale indicates this amount of charge, backseat the receiver valve and close the R-134a tank valve.
13. Disconnect the charging hose. Replace the cover caps.
14. The system is now ready for operation.



**CAUTION**

The evacuation of the system must be made by authorized and qualified personnel only. Refer to local laws for R-134a recuperation.

6.7 REFRIGERANT SYSTEM CLEAN-OUT AFTER COMPRESSOR FAILURE

Although the vast majority of reciprocating refrigerant compressors manufactured today are extremely reliable, a small percentage do fail. These failures usually result in minor or extensive system contamination depending on the severity of the failure. When an open type compressor becomes damaged internally, this provokes small particles of bearings, steel, brass, copper, and aluminum and, in severe cases, carbonized oil, which could contaminate the system. To prevent repeated failures, the problem which caused the failure should be corrected, and depending upon the severity of the failure, the system should be thoroughly cleaned out using one of the clean-out procedures mentioned.

## Section 22: HEATING AND AIR CONDITIONING

### 6.7.1 Determining Severity of Failure

The severity of compressor failure can be categorized as minor or major. A failure is considered minor when the contamination is limited to the compressor with little or no system contamination. A major failure, or burnout, results in extensive system contamination as well as compressor damage. Extensive system contamination can be determined by withdrawing a small sample of compressor oil and checking its color, odor and acidity. A Virginia Chemical "TKO" one step acid test kit is one of several compressor oil test kits that may be used. A high acid content would indicate a major failure or burnout. A small amount of refrigerant gas may be discharged. A characteristic burned odor would also indicate severe system contamination.

### 6.7.2 Clean-out after Minor Compressor Failure

1. Be sure to correct the problem which caused the failure.
2. Change liquid line filter dryer.
3. Run the unit for 2 hours on high speed cool only.
4. Check compressor oil level to ensure compressor is not overcharged with oil. Sometimes a significant amount of oil is pumped out of the compressor to other parts of the system when a compressor fails. This oil will return to the replacement compressor when it is started, causing an overcharge of oil in the sump of the replacement compressor. In this case, it is important that the oil level be adjusted to the proper level.
5. Withdraw a sample of the compressor oil and check its color, odor, and acidity, using instructions supplied above. If the oil is contaminated, change the oil and filter dryer, and repeat the procedure until the system is clean.

### 6.7.3 Clean-out After Major Compressor Failure


1. Reclaim the refrigerant into a refrigerant bottle through a filter dryer to filter out contaminants.
2. Remove the failed compressor and repair it if possible.

3. Install new or repaired compressor.
4. Change the filter dryer.
5. Circulate clean R-134a or nitrogen with the reclaimer to clean out many of the contaminants collected in the coil valves, TXV (Thermal Expansion Valve), solenoid valves, check valves, and any other mechanical component that may have collected contaminants.
6. Evacuate and charge the system normally.
7. Run the unit for 8 hours and monitor the pressure drop across the filter dryer. Also check the liquid line dryer for signs of restriction. If the pressure drop across the filter dryer exceeds 12 to 14 psig (82,75 to 96,5 kPa) with a 40°F (5°C) evaporator coil temperature, stop the unit and change the liquid line and suction line filter dryer. After 4 or 5 hours of operation, stop the unit and replace the filter dryer.
8. After 8 hours of operation, stop the unit and remove a sample of the compressor oil and check its color, odor, and acidity, using instructions supplied above. If the oil is contaminated, replace the oil and repeat step 7. If the oil is not contaminated, change the filter dryer again and replace the moisture-liquid indicator.
9. After approximately 7 days of operation, recheck the compressor oil for cleanliness and acidity.

## 7. CENTRAL A/C SYSTEM COMPONENTS

### 7.1 COMPRESSOR (CENTRAL SYSTEM)

#### 7.1.1 Belt Replacement

**DANGER**

Set the battery master switch to the "Off" position. For greater safety, set the engine starter selector switch in engine compartment to the "Off" position.

1. Open engine compartment rear doors and locate the belt tensioner pressure releasing valve (Fig. 18), mounted above the engine R.H. side door next to the air pressure regulator, then turn handle clockwise in

order to release pressure and tension on belts.

2. Remove the radiator fan driving mechanism belt (Refer to Section 05: Cooling).
3. Slip the old A/C compressor belts off and the new ones on.
4. Reset belt tensioner pressure releasing valve (Fig. 18) to 50 psi (345 kPa) to apply tension on the new belts as explained in Section 12.

**NOTE**

*Both belts must always be replaced simultaneously to ensure an equal distribution of load on each of them.*

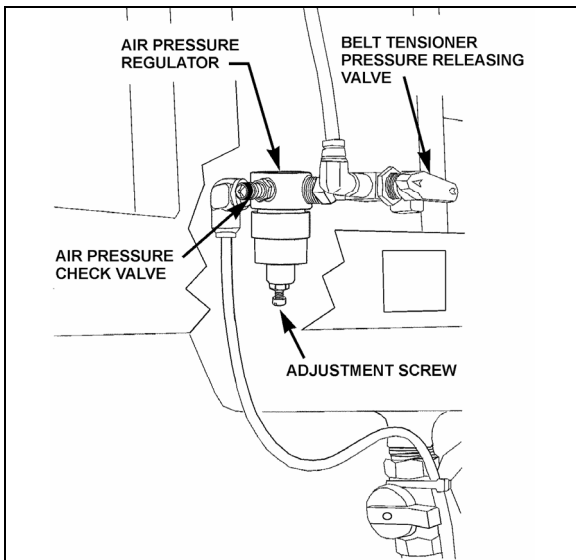


FIGURE 18: AIR PRESSURE REGULATOR 12200

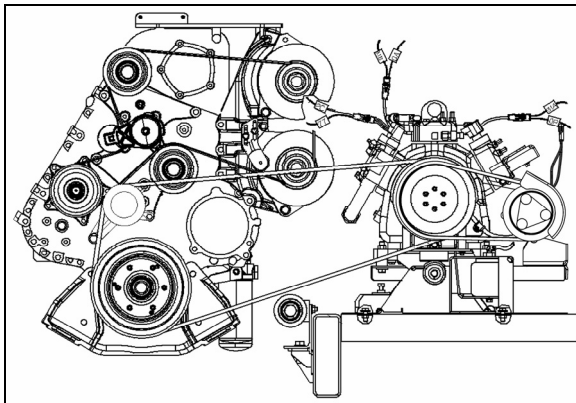


FIGURE 19: BELTS ARRANGEMENT (DDC S60 ENGINE) 22347

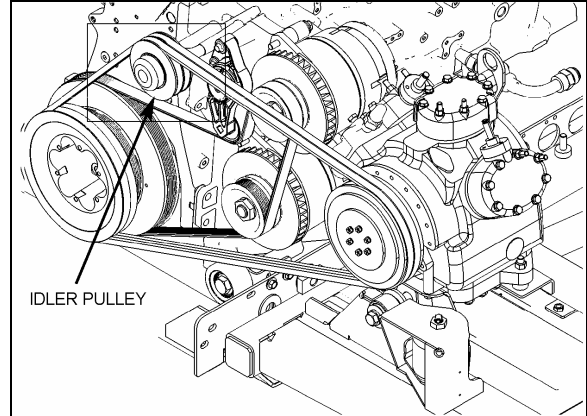


FIGURE 20: BELTS ARRANGEMENT (VOLVO D13 ENGINE)

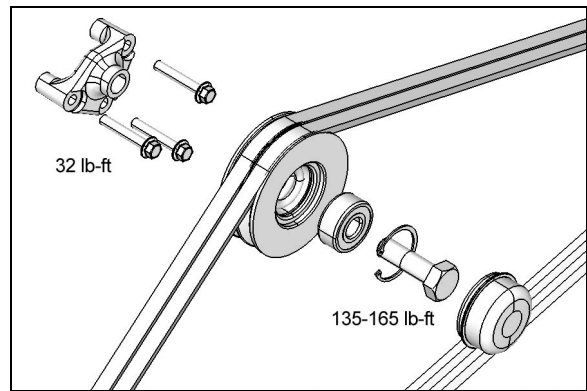


FIGURE 21: IDLER PULLEY INSTALLATION ON VOLVO D13 ENGINE

7.1.2 Belt Play

After belt replacement or during normal maintenance, belt play between pulleys and belt must be checked to ensure proper operation. Refer to figure 22 for proper plays.

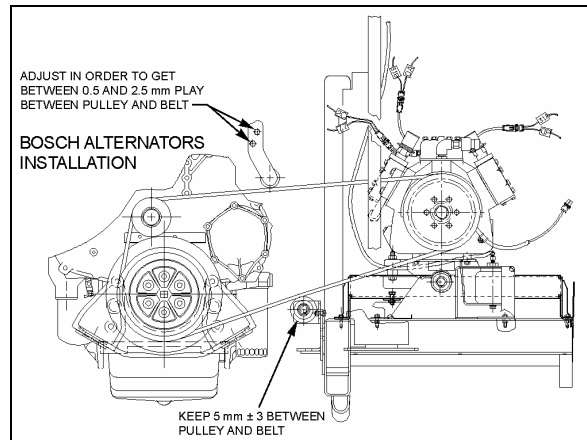


FIGURE 22: BELT PLAY 22288



## Section 22: HEATING AND AIR CONDITIONING

### 7.1.3 Pulley Alignment

In order to avoid skipping, disengagement and a premature wear of compressor belt, it is necessary to align compressor pulley with the crankshaft pulley. Before performing the following procedure, release air from belt tensioner bellows by means of the air pressure releasing valve. After completing these procedures reset belt tensioner air pressure regulator to 50 psi (345 kPa).

### 7.1.4 Longitudinal Compressor Alignment

1. Rest an extremity of a straight edge of approximately 46 inches (117 cm) against the upper part of the outer face of crankshaft pulley, positioning the other end close to the compressor clutch pulley (Figs. 23 & 24).
2. Check the distance between each extremity of straight edge (1. Fig. 23) and the first drive belt. If they are different, loosen the compressor support bolts and with a hammer, knock support to slide it in order to obtain the same distance; then tighten bolts.

### 7.1.5 Horizontal Compressor Alignment

1. Rest an extremity of the straight edge against the upper part of the outer face of compressor pulley, positioning the other end close to the crankshaft pulley.
2. Check the distance between each extremity of straight edge (1, Fig. 24) and drive belt. If they are different, loosen the pillow block compressor bolts and with a hammer, knock compressor pillow block to slide it, in order to obtain the same distance; then tighten bolts.

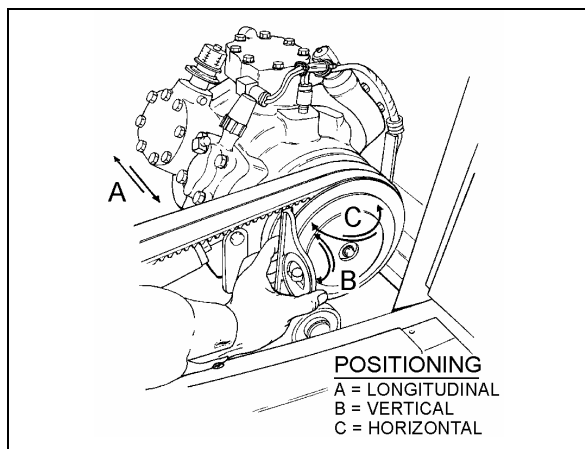


FIGURE 23: COMPRESSOR ALIGNMENT

22072

### 7.1.6 Vertical Compressor Alignment

Rest a short "angle and level indicator" on the outer side face of the crankshaft pulley, adjust the level indicator inclination at  $0^\circ$  and check if the compressor pulley is at same angle (Fig. 23). If it is not the same, shim under the appropriate pillow block in order to obtain the correct angle.

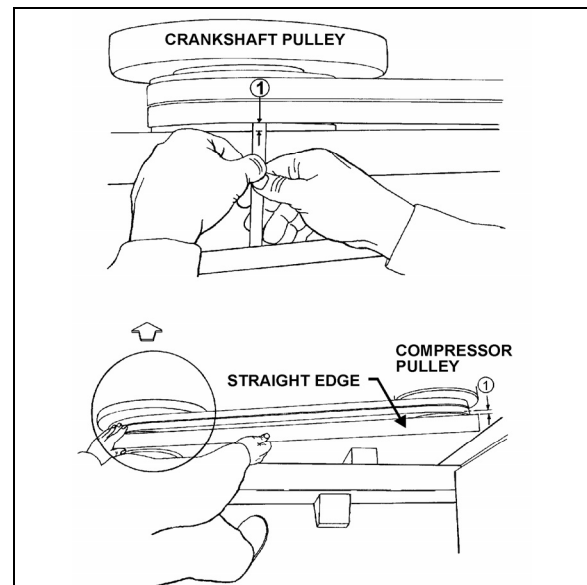


FIGURE 24: COMPRESSOR ALIGNMENT

22040

### 7.1.7 Compressor Maintenance

For the maintenance of the A/C compressor, see the *Carrier Compressor "WORKSHOP MANUAL" for MODEL 05G TWIN PORT COMPRESSOR* included at the end of this section.



## CAUTION

Use only Castrol SW 68 (POE) oils with refrigerant 134a.

### 7.1.8 Troubleshooting Guide

A preliminary check may be made by simply feeling the cylinder heads with the unit in operation at ambient temperatures of  $35^\circ\text{F}$  ( $2^\circ\text{C}$ ) and over. The cylinder heads are internally divided into suction and discharge valves. The lower half of the cylinder head is the suction side, and it should be relatively cool to the touch, as opposed to the hot upper discharge side. If a valve plate or head gasket is blown, or a compressor unloader is stuck open, partially

compressed refrigerant vapor will be circulated between the suction and discharge sides of the head. The affected cylinder head will then have a relatively even temperature across its surface and be neither as hot as the normal discharge temperature nor as cool as the normal suction temperature.

### Blown Head Gaskets

#### Symptom:

- \* Loss of unit capacity at low temperature.
- \* Even cylinder head temperature.

#### Cause:

- \* Improperly torqued cylinder head bolts.
- \* Improperly positioned gasket at assembly.
- \* Warped cylinder head.
- \* Severe liquid refrigerant floodback.

### Blown Valve Plate Gaskets

#### Symptom:

- \* Loss of unit capacity at medium and low temperatures.
- \* Very hot cylinder head surface.
- \* Higher than normal suction pressure.

#### Cause:

- \* Improperly torqued cylinder head bolts.
- \* Severe liquid refrigerant floodback.
- \* Oil slugging caused by an overcharge of oil or flood starts.
- \* Discharge valves not seated properly (liquid drainback during shutdown).

### Broken Suction Valves

#### Symptom:

- \* Loss of unit capacity at all temperatures.
- \* Compressor unable to pull extremely low vacuum with suction service valve frontseated.

#### Cause:

- \* Repeated liquid refrigerant floodback.
- \* Flooded starts.

- \* Overcharge of oil.
- \* Discharge valves not seated properly (liquid drainback during shutdown).
- \* Expansion valve not controlling properly.

### Unloader Valve Stuck Open

#### Symptom:

- \* Loss of unit capacity at all temperatures.
- \* Higher than normal suction pressure.
- \* Even cylinder head temperature.

#### Cause:

- \* Unloader body stem bent.
- \* Foreign material binding unloader piston or plunger.

## 7.2 MAGNETIC CLUTCH

Refer to Carrier service information entitled "Housing-Mounted Electric Clutch" at the end of this section for the description and maintenance of the magnetic clutch.

## 7.3 EVAPORATOR MOTOR

The evaporator motor is installed in the evaporator compartment (L.H. side of vehicle) (Fig. 25). It is a 27.5 volt, 2 HP (1.5 kW) motor which activates a double blower fan unit.

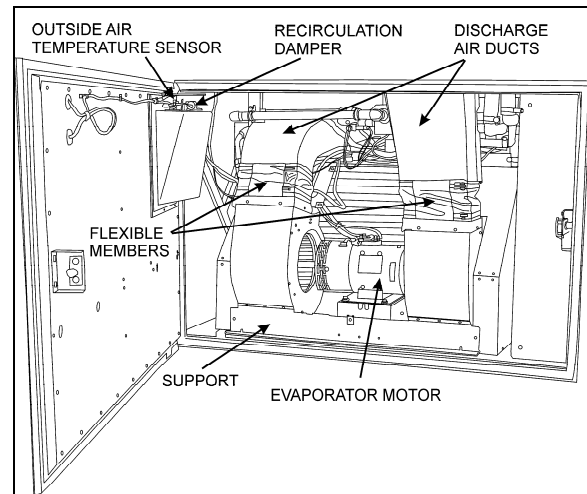


FIGURE 25: EVAPORATOR COMPARTMENT

22314

### 7.3.1 Removal

1. Set the battery master switch (master cut-out) to the "OFF" position.

## Section 22: HEATING AND AIR CONDITIONING

2. Open the last L.H. side baggage compartment door. Pull the black release button located on the L.H. side in order to unlock and open the evaporator compartment door.
3. Remove the evaporator motor and coil access panel.
4. Identify the L.H. side discharge duct inside compartment and remove the Phillips head screws retaining the flexible member to duct.
5. Repeat step 4 for the R.H. side air duct.
6. Disconnect the electrical motor speed control connections on the motor plate.
7. From under the vehicle, remove the eight bolts retaining the evaporator fan motor support. Remove the complete unit from the evaporator compartment (Fig. 26 & 27).

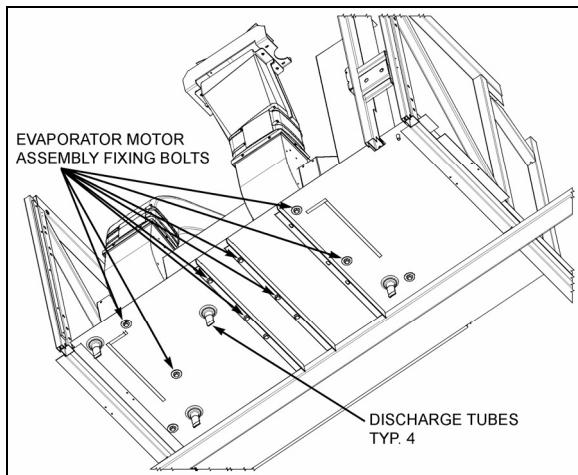


FIGURE 26: EVAPORATOR MOTOR ASSY FIXING BOLTS  
22315



### CAUTION

Never support evaporator motor by its output shafts while moving it.

8. On a work bench, unscrew the fan square head set screws, the Phillips head screws retaining cages to support and slide out the assemblies from the evaporator motor output shaft.

### 7.3.2 Installation

To reinstall the evaporator motor, reverse "Evaporator Motor Removal" procedure.

### 7.3.3 Checking Operation of Brush in Holder

Lift brush slightly 1/8 inch (3 mm) and release it. Brush must produce a dry noise.

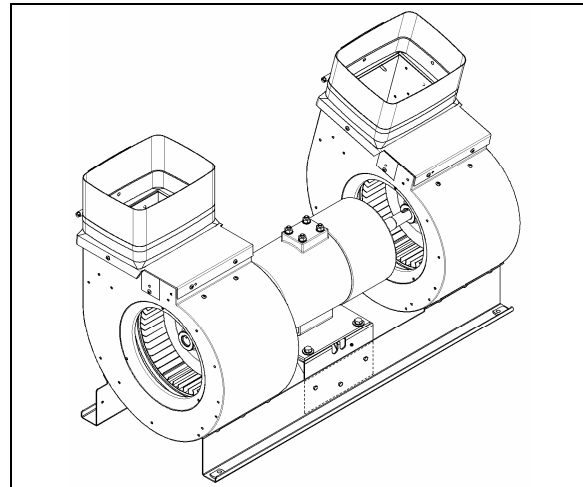


FIGURE 27: EVAPORATOR MOTOR ASSEMBLY  
22316

### 7.3.4 Brush Wear Inspection and Replacement



### CAUTION

Only use replacement brushes recommended by the manufacturer. Not doing so will void warranty.

Replace the brushes if less than 3/4 inch (19 mm). New brush length is 1-1/4 inch.

To replace brushes, proceed as follows:

1. Set battery master switch to the "OFF" position.
2. Remove the protective screen band from the motor housing by pulling down the spring loaded fastener.
3. Lift the spring, remove and replace brushes as per the following procedure: "SEATING BRUSHES".
4. Reverse installation procedure.

### 7.3.5 Seating Brushes

Grinding consists in giving to the seating face of a new brush the exact curve of the commutator or ring so that good mechanical and electric contact of the brush is ensured upon startup.

**For best results, remove oil and grease from commutator before applying brush seater.**

**NOTE**

The new motor brushes are provided with preformed seating face, i.e. with curved face machined with the required radius. This curve is only approximate and does not exempt further grinding. The advantage of preforming is to appreciably shorten the time required for grinding.

Grinding is generally done on the machine itself, in accordance with various processes' and conformably to the importance and the type of machines:

- a) Grinding with abrasive cloth medium grit (sandpaper) (grit 60) applied to a part of the commutator by hand. The new brushes installed in their brush holder and pressing against the cloth, one makes oscillate the rotor until complete grinding of the seating faces (Refer to figure 28). It is necessary to avoid raising the cloth under the brushes otherwise it would result, after grinding, to reduce and badly definite surfaces (Refer to figure 29).

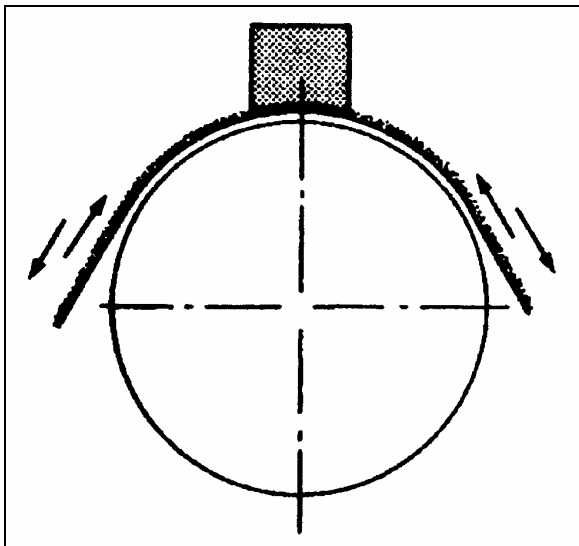


FIGURE 28: PROPER GRINDING TECHNIQUE 22317

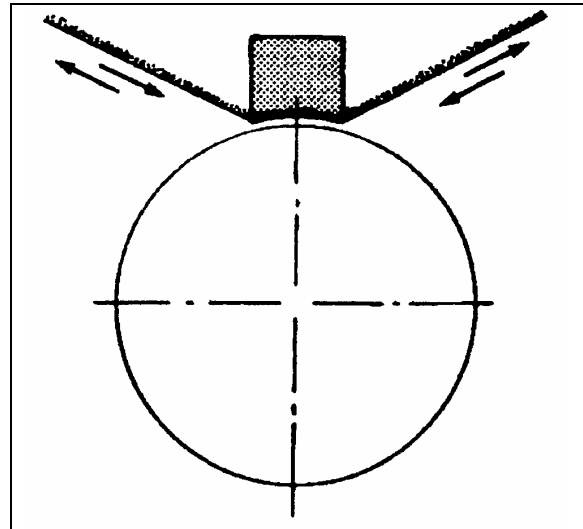


FIGURE 29: IMPROPER GRINDING TECHNIQUE 22318



**CAUTION**

If grinding with a honing stone, you must disconnect the time delay in order to keep the motor in 1<sup>st</sup> speed. If you prefer, you may also install a jumper on the evaporator motor between terminal E2 and A1 to bypass relay R60 and keep the motor in 1<sup>st</sup> speed as well.

- b) Grinding with the honing stone is always done under no or much reduced voltage. Dust particles act like abrasive and wear down the brushes exactly with the profile of the commutator. **Do not misuse this method because grinding removes some metal from the commutator. It is applicable only to grinding requiring only reduced wear of the brushes.**

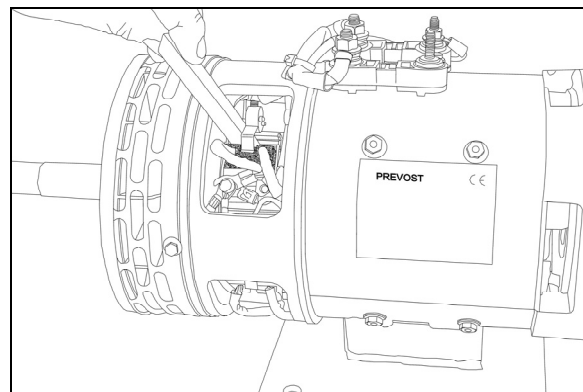


FIGURE 30: GRINDING WITH THE BRUSH SEATER STONE 22319

## Section 22: HEATING AND AIR CONDITIONING

Repeat method a or b until brushes are fully seated. **Seating surface of the brush must be no less than 80% of the face (Refer to figure 31).**



FIGURE 31: SEATING SURFACE OF THE BRUSH 22320



### CAUTION

After grinding with the sandpaper or the honing stone, it is necessary to remove the brushes from the brush holders and vigorously clean with an air gun the commutator and the seating faces of the brushes to eliminate abrasive dust and dust from brushes.



### DANGER

Use a dust mask to prevent inhalation of dust particles. Protect against electrical shock when working on energized equipment. Protect against falling or slipping when working on rotating equipment.



### CAUTION

If grinding is not carried out or is carried out in an incorrect way, the brush may seat against a restricted zone only, which will support the entire load. The consequences risk to be serious for the commutator as for the brush and to seriously damage the motor.

After grinding is completed, it is necessary to check the evaporator motor amperage in 1<sup>st</sup> speed and in 2<sup>nd</sup> speed. **Make sure that the evaporator compartment door is closed and that the reading is 30 A ± 3 in 1<sup>st</sup> speed. Confirm that the reading is 64 A ± 4 (MAX 68 A) in 2<sup>nd</sup> speed.**

### 7.3.6 Brush Holder Adjustment

#### NOTE

*The brush holders are mounted on a support that can rotate. Rotating that rocker ring will move all the brush holders at the same time.*

1. Remove the screws securing the grid and remove the grid. Locate the 2 bolts fixing the mechanism permitting the rotation of the brush rocker ring.
2. Loosen (do not remove) the bolts just enough to release the mechanism.
3. Move gently the exposed brush holder in order to have **30 A ± 3 in 1<sup>st</sup> speed and 64 A ± 4 in 2<sup>nd</sup> speed when the door is closed** and a maximum distance of 10 mm (3/8 inch) between the brush face and a reference line passing through the center of the 2 bolts on the motor housing.



### CAUTION

If rotating the rocker ring is necessary, it is preferable to mark off the angular position of the rocker ring before unfastening the bolts fixing the mechanism in order to get back to the factory setting at the end of the operation.

#### NOTE

*Take a final reading in 1<sup>st</sup> and in 2<sup>nd</sup> speed after tightening the brush holder bolts. The amperage may have changed.*

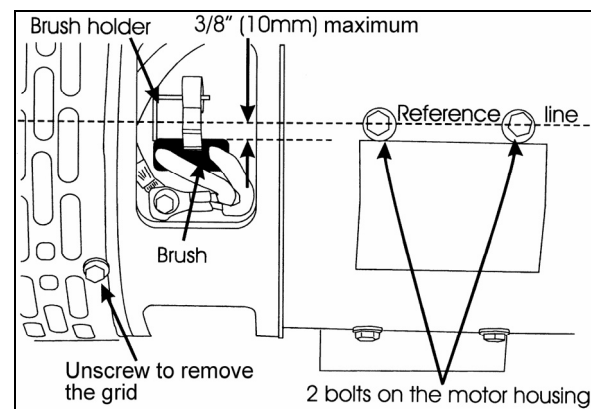


FIGURE 32: EVAPORATOR MOTOR

22321

**CAUTION**

To avoid damaging the motor, make sure all vehicle doors are closed when taking the readings.

### 7.3.7 Checking Commutator

The surface must be polished. A brown-black colored surface is normal and indicates a good switching. Ensure there is no evidence of arcing or metal chips.

## 7.4 CONDENSER

The central A/C system condenser coil is hinge mounted on the R.H. side of the vehicle on the A/C condenser door (Fig. 34). The condenser coil for vehicles equipped with an auxiliary A/C system is mounted on the outer face of engine radiator. Since condenser's purpose is to dissipate heat from the hot refrigerant, it is important to keep the cooling coils and fins clean. A clogged coil will cause high discharge pressure and insufficient cooling.

### 7.4.1 Condenser Fan Motors

Four brushless fan motors (Fig. 33), 28.5 V - (0.6 HP - 0.42 kW) are installed in the condenser compartment on R.H. side of vehicle in order to ventilate the condenser coil. They are mounted on a support, fastened to the door. The fans pull outside air through the condenser coil and discharge it through an opening at bottom of compartment. When temperature drops inside condenser, the pressure in the refrigerant line also drops and it is, therefore, no longer required to cool condenser. Consequently, when pressure drops to 130 psi, the motors will run at low speed and if the pressure continues to drop to 90 psi, a pressure switch stops the motors so that fans do not operate needlessly. When pressure rises to 120 psi, the pressure switch reactivates the motors. If the pressure rises to 170 psi, the motors will switch to high speed.

For details about electrical wiring, refer to "A/C and Heat system" in the master wiring diagram.

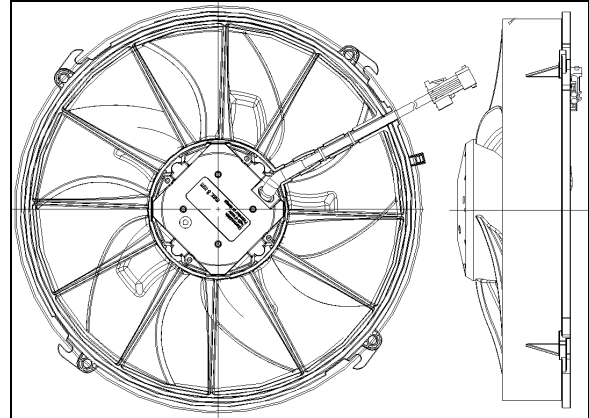


FIGURE 33: CONDENSER FAN MOTOR

22322

### 7.4.2 Condenser Fan Motor Removal

1. Set the battery master switch to the "Off" position.
2. Disconnect wiring from terminals on motor. Tag each wire to aid in identification at time of reconnection.
3. Remove the four "Phillips" head screws retaining the fan motor assembly to the mounting support.
4. Remove the motor.

## 7.5 RECEIVER TANK

The receiver tank is located in the condenser compartment (Fig. 34). The function of the receiver tank is to store the liquid refrigerant. During normal operation, the level of the refrigerant should be approximately at the mid-point of the lower sight glass.

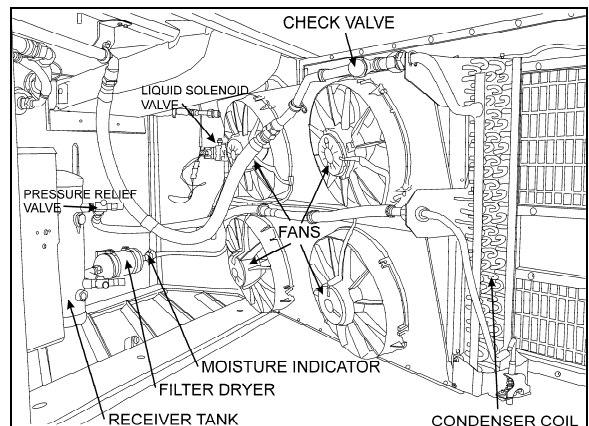


FIGURE 34: A/C CONDENSER COMPARTMENT

22323

In case of extreme pressure there will be a rise in the liquid receiver tank. A pressure relief valve will break at 450 psi (3103 kPa) and relieve the receiver tank pressure.

## Section 22: HEATING AND AIR CONDITIONING

The receiver tank incorporates an inlet valve on the inlet side (upper section) which allows the tank to be isolated or serviced. An outlet valve on the outlet side (lower section) permits complete isolation from the rest of the system.

### 7.6 FILTER DRYER

A filter dryer, also located in the condenser compartment, is installed on the liquid refrigerant line after the receiver tank. It is used to absorb moisture and foreign matter from refrigerant before it reaches the expansion valves.


The filter should be replaced if the system has been opened or after a prolonged exposure, when the moisture indicator sight glass turns to pink.


A filter dryer, located close to the engine compartment L.H. side rear door, is installed on vehicles equipped with an auxiliary A/C system. Its function is similar to that of filter used on main systems. Replace only when system is opened or a problem occurs.

#### 7.6.1 Replacement

The filter is of the disposable type. When replacement is required, remove and discard the complete unit and replace with a new unit of the same type according to this procedure:

1. Isolate the refrigerant in the receiver tank by following the "Pumping Down" procedure explained in this section
2. Change the filter dryer as a unit.
3. Add a small quantity of refrigerant R-134a to the low side of the system. Check for leaks. Return the system to normal operation.

|  |                  |
|--|------------------|
|   | <h3>CAUTION</h3> |
| <p>Do not use carbon tetrachloride or similar solvents to clean parts. Do not use steam guns. Use mineral spirits or naphtha. All parts should be thoroughly cleaned. Use a stiff brush to wash dirt from grooves, holes, etc.</p> |                  |

|   |                 |
|---|-----------------|
|                                        | <h3>DANGER</h3> |
| <p>Cleaning products are flammable and may explode under certain conditions. Always handle in a well ventilated area.</p> |                 |

#### 7.6.2 Moisture Indicator

The moisture sensitive element consists of a color changing ring which is reversible from pink to blue and vice versa as the moisture content in the refrigerant changes. Pink indicates a wet refrigerant, light violet (caution) and blue indicates a dry refrigerant.

Since temperature changes affect the solubility, color change will also vary with the refrigerant temperature. The above table shows the color change for R-134a at various moisture levels and liquid line refrigerant temperatures.

| COLOR INDICATOR                              |               |                          |               |
|--|---------------|--------------------------|---------------|
| TEMPERATURE                                  | BLUE<br>(ppm) | LIGHT<br>VIOLET<br>(ppm) | PINK<br>(ppm) |
| 75°F (24°C)                                  | Below 5       | 5-15                     | Above 15      |
| 100°F (38°C)                                 | Below 10      | 10-30                    | Above 30      |
| 125°F (52°C)                                 | Below 15      | 15-45                    | Above 45      |
| p.p.m.= parts per million (moisture content) |               |                          |               |

A moisture level of less than 15 p.p.m. for R-134a indicated in the blue color range of the above table is generally considered dry and safe. A color indication of light blue to light violet indicates the caution range of moisture level. For positive protection, the drying of the system should be continued until the color of the element turns to deep blue.

The liquid refrigerant is readily visible through the center opening of the moisture element where the presence of bubbles indicates a shortage of refrigerant or restriction in line.

Moisture is one of the main causes of chemical instability or contamination in air conditioning systems. If moisture is present, it can corrode the valves, condenser and evaporator coils, compressor and other components causing a malfunction and eventual failure of the system. Uncontrolled moisture in the system can result in very expensive multiple component replacements if not corrected at an early stage. The moisture indicator permits an early detection of moisture in the system and when corrected by a desiccant charge, system contamination is greatly minimized.

### 7.7 LIQUID REFRIGERANT SOLENOID VALVE

The flow of liquid refrigerant to the driver's and main evaporators is controlled by a normally-closed solenoid valve. The driver's liquid solenoid valve is located on the ceiling of the spare wheel and tire compartment and is accessible through the reclining bumper.

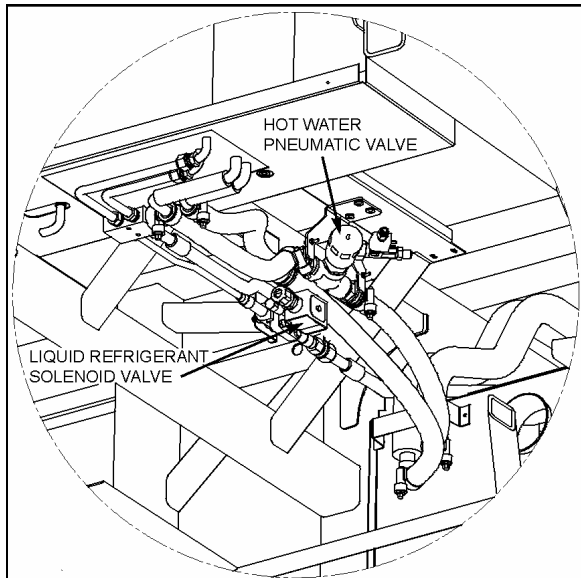


FIGURE 35: DRIVER'S EVAPORATOR LIQUID SOLENOID VALVE 22324

**NOTE**

*An identical refrigerant solenoid valve is used on the auxiliary A/C system and is located near the auxiliary A/C unit.*

#### 7.7.1 Manual Bypass

This type of solenoid valve is equipped with a manual operating stem. The 3/16" square stem located on the bonnet is exposed when the seal cap is removed. To manually open valve, turn stem 1/2 turn counterclockwise. To manually close valve, turn stem clockwise until tight against seat. Manual stem must be in closed position for automatic electric operation.

#### 7.7.2 Coil Replacement

1. Disconnect connector from the coil connector.
2. Take out the retaining screw at the top of the coil housing. The entire coil assembly can then be lifted off the enclosing tube.

3. Place the new coil and yoke assembly on the enclosing tube. Lay data identification plate in place.
4. Insert the coil retaining screw, rotate housing to proper position and tighten screw securely.
5. Connect connector from coil connector.

#### 7.7.3 Valve Disassembly

1. Remove the coil as stated previously.
2. Pump down the system as stated earlier in this section.
3. Remove the four socket head screws which hold the body and bonnet together (Fig. 36).
4. Carefully lift off the bonnet assembly (upper part of the valve) so that plunger will not fall out. The diaphragm can now be lifted out.

**NOTE**

*The above procedure must be followed before brazing solder-type bodies into the line.*



**CAUTION**

Be careful not to damage the machined faces while the valve is apart.

#### 7.7.4 Valve Reassembly

1. Place the diaphragm in the body with the pilot port extension up.
2. Hold the plunger with the synthetic seat against the pilot port.
3. Make sure the bonnet O-rings are in place. Lower the bonnet assembly over the plunger, making sure that the locating sleeve in the bonnet enters the mating hole in the body.



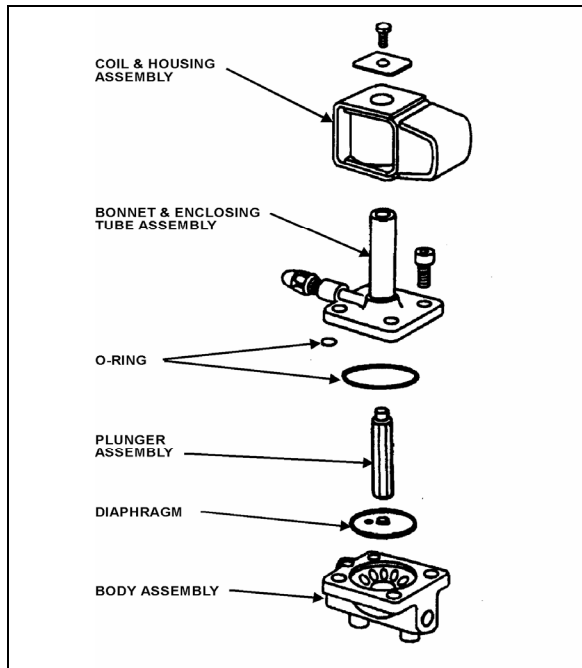


FIGURE 36: REFRIGERANT SOLENOID VALVE 22044

4. Insert the four socket head screws and tighten evenly.
5. Replace the coil as stated previously.
6. Add a small quantity of refrigerant R-134a to the low side of the system. Check for leaks. Return the system to normal operation.

### 7.8 EXPANSION VALVE

The expansion valve for the central system is a thermo-sensitive valve with a remote control bulb head attached to the evaporator outlet line and is accessible by the evaporator coil access door (Fig. 14 & 37). The valve regulates the flow of refrigerant liquid into the evaporator coils and is controlled by the suction gas temperature leaving the evaporator. The bulb head senses the refrigerant gas temperature as it leaves the evaporator. High temperature will cause expansion and pressure on the power head and spring. Such action causes the assembly valve to open, allowing a flow of refrigerant liquid into the evaporator.

The remote bulb and power assembly is a closed system. The pressure within the remote bulb and power assembly corresponds to the saturation pressure of the refrigerant temperature leaving the evaporator and moves the valve pin in the opening direction. Opposed to this force, on the under side of the diaphragm and acting in the closing direction, is the force exerted by the superheat spring. As the

temperature of the refrigerant gas at the evaporator outlet increases above the saturation temperature corresponding to the evaporator pressure, it becomes superheated. The pressure thus generated in the remote bulb and power assembly surpasses the combined pressures of the evaporator pressure and the superheat spring, causing the valve pin to move in the opening direction. Conversely, as the temperature of the **refrigerant** gas leaving the evaporator decreases, the pressure in the remote bulb and power assembly also decreases and the combined evaporator and spring pressures cause the valve pin to move in the closing position.

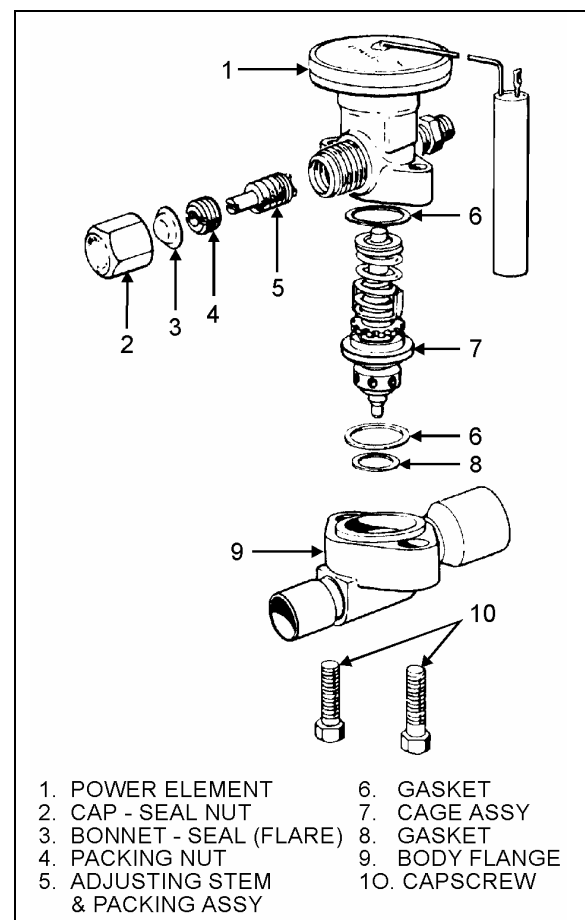


FIGURE 37: EXPANSION VALVE 22045

As the operating superheat is raised, the evaporator capacity decreases, since more of the evaporator surface is required to produce the superheat necessary to open the valve. It is obvious, then, that it is most important to adjust the operating superheat correctly and that a minimum change in superheat to move the valve pin to full open position, is of vital importance because it provides savings in both initial

evaporator cost of operation. Accurate and sensitive control of the refrigerant liquid flowing to the evaporator is necessary to provide maximum evaporator capacity under load conditions. The spring is adjusted to give 12 to 16° F (-11.1 to -8.8° C) of superheat at the evaporator outlet.

This ensures that the refrigerant leaving the evaporator is in a completely gaseous state when drawn into the suction side of the compressor. Liquid would damage the compressor valve, piston and heads if allowed to return in the suction line.

A vapor is said to be superheated when its temperature is higher than the saturation temperature corresponding to its pressure. The amount of the superheat is, of course, the temperature increase above the saturation temperature at the existing pressure.

As the refrigerant moves along in the evaporator, the liquid boils off into a vapor and the amount of liquid decreases until all the liquid has evaporated due to the absorption of a quantity of heat from the surrounding atmosphere equal to the latent heat of vaporization of the refrigerant. The gas continues along in the evaporator and remains at the same pressure. However, its temperature increases due to the continued absorption of heat from the surrounding atmosphere. The degree to which the gas refrigerant is superheated is related to the amount of refrigerant being fed to the evaporator and the load to which the evaporator is exposed.

**Superheat Adjustment**

The starting method of adjusting the superheat is to unscrew completely the main evaporator expansion valve adjusting screw, then screw in 13 turns clockwise for 134A (Fig. 38). Afterwards, the following procedure should be followed:

1. Operate coach for at least one-half hour at fast idle with temperature control set at 82°F (27,7°C), Then set temperature to minimum to keep the compressor on 6 cylinders.
2. Install pressure gauge at the evaporator suction header. You may install the pressure gauge at compressor suction, but then add 3 psi to reading.

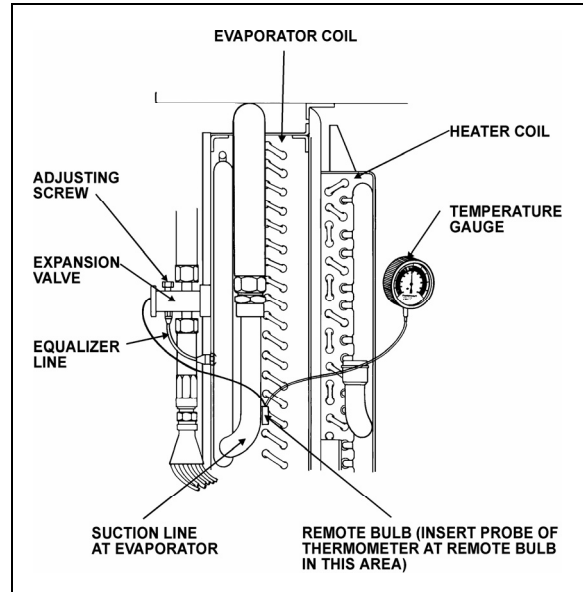


FIGURE 38: SUPERHEAT ADJUSTMENT INSTALLATION<sup>22046</sup>

3. Install a remote reading thermometer to the evaporator outlet line near the existing remote bulb (Fig. 38).
4. Apply thermostatic tape around the bulb and evaporator outlet line to get a true reading of the line temperature.
5. Block condenser if necessary to keep pressure over 150 psi.

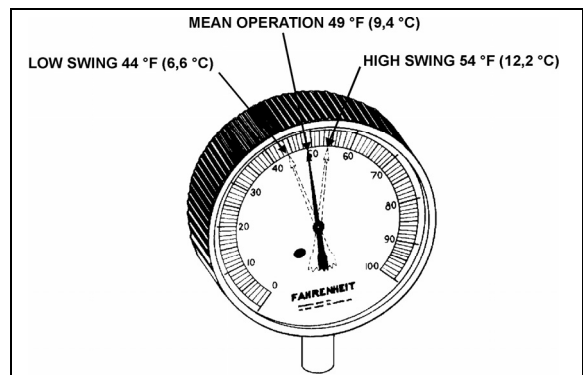


FIGURE 39: HIGH & LOW SWING TEMPERATURE AT REMOTE BULB<sup>22047</sup>

6. Check approximately 5 readings of pressure at 2-minute intervals and convert to temperature using the temperatures & pressures table (page 38). Likewise check the temperature reading at the remote bulb at the same 2-minute intervals and record the low and high swing readings of the needle (refer to Fig. 39).

## Section 22: HEATING AND AIR CONDITIONING

Example of readings taken at fig. 39:

|  |  |                                |
|--|--|--------------------------------|
| A/C pressure gauge converted to temperature at expansion valve fitting | Temperature on remote bulb                       |                                |
| 40°F (4,4°C)   | Low-swing<br>44°F<br>(6,6°C)                     | High swing<br>54°F<br>(12,2°C) |
| Formula for superheat<br>49°F-40°F=9°F<br>(9,4°C-4,4°C = 5°C)          | Average of low and high swing is 49°F<br>(9,4°C) |                                |

### NOTE

The low swing of the superheat should be a minimum of 4°F (2,2°C) higher at the remote bulb and have an average of 8 to 12°F (4 to 6°C) higher range at the bulb than the fitting at the expansion valve.

### NOTE

To reduce the superheat, flow of refrigerant is increased by turning adjusting screw of expansion valve lower evaporator temperature counterclockwise. To increase temperature or increase superheat, flow of refrigerant is reduced by turning adjustment screw of expansion valve clockwise.

- Regulate suction pressure to temperature reading according to temperature chart or to the R-134a temperature scale on the pressure gauge.

**Example:** Suction pressure 30 psi (207 kPa) converted to 32°F (0°C) on chart. If temperature reading is 40°F (4,4°C), subtract 32°F (0°C) and the result will be 8°F (4,4°C) of superheat.



### CAUTION

Before proceeding to the expansion valve adjustment, check for restriction on suction side for plugged filter dryer and partially open valves. These conditions will give a high superheat.

### Maintenance

- Pump down the system as previously indicated in this section.

- Disconnect the external equalizer line from the under side of the power head, and unclamp the remote control bulb from the evaporator coil outlet line.
- Remove the two cap screws holding the power assembly to the valve body flange. Lift off the power assembly and remove the cage assembly.
- When reassembling, replace with the new gaskets in proper location. Make sure the two lugs on the cage assembly fit into grooves provided in the power assembly. Do not force the valves together. The cage must fit properly before tightening the body flange. Tighten bolts evenly.
- Check for leaks.

### Safety Instructions

- Make sure the valve is installed with the flow arrow on the valve body corresponding to the flow direction through the piping system.
- Before opening any system, make sure the pressure in the system is brought to and remains at the atmospheric pressure. Failure to comply may result in system damage and/or personal injury.

### 7.9 TORCH BRAZING

Use an electrode containing 35% silver.



### CAUTION

When using heat near a valve, wrap with a water saturated rag to prevent overheating of vital parts.



### DANGER

Before welding any part of refrigeration system, make sure the area is well ventilated.

7.10 TROUBLESHOOTING

7.10.1 Expansion Valve

| PROBABLE CAUSE  | PROBABLE REMEDY   |
|---|---|
| <b>LOW SUCTION PRESSURE-HIGH SUPERHEAT</b>  |   |
| EXPANSION VALVE LIMITING FLOW:  |   |
| Gas in liquid line due to pressure drop in the line or insufficient refrigerant charge.                                 | Locate cause of line flash and correct by use of any of the following methods. Add R-134a. Replace or clean filter dryer. |
| Inlet pressure too low from excessive low condensing temperature. Resulting pressure difference across valve too small. | Increase head pressure. Verify pressure switch for fan speed control.   |
| Superheat adjustment too high.  | Adjust superheat as outlined under "Superheat Adjustment".  |
| Power assembly failure or partial loss of charge.   | Replace power assembly or replace valve.  |
| Air filter screen clogged.  | Clean or replace air filter screen.   |
| Plugged lines.  | Clean, repair or replace lines.   |
| <b>LOW SUCTION PRESSURE-LOW SUPERHEAT</b>   |   |
| Uneven or inadequate evaporator loading due to poor air distribution or liquid flow.                                    | Balance evaporator load distribution by providing correct air or liquid distribution.                                     |
| <b>HIGH SUCTION PRESSURE-HIGH SUPERHEAT</b>   |   |
| Compressor discharge valve leaking.   | Replace or repair valve.  |
| <b>HIGH SUCTION PRESSURE-LOW SUPERHEAT (DEFECTIVE UNLOADER)</b>   |   |
| Valve superheat setting too low.  | Adjust superheat as outlined under "Superheat Adjustment".  |
| Compressor discharge valves leaking.  | Replace or repair discharge valve.  |
| Incorrect superheat adjustment.   | Superheat adjustment 12 to 16°F.  |
| <b>FLUCTUATING DISCHARGE PRESSURE</b>   |   |
| Insufficient charge.  | Add R-134a to system.   |
|   |   |
|   |   |

## Section 22: HEATING AND AIR CONDITIONING

| PROBABLE CAUSE                             | PROBABLE REMEDY            |
|--|----------------------------|
| <b>HIGH DISCHARGE PRESSURE</b>             |                            |
| Air or non-condensable gases in condenser. | Purge and recharge system. |
| Overcharge or refrigerant.                 | Bleed to proper charge.    |
| Condenser dirty.                           | Clean condenser.           |

### 7.10.2 A/C

| TROUBLE   | CAUSE   |
|---|---|
| Low suction pressure and frosting at dryer outlet.  | Clogged filter.   |
| Low Oil Level.  | Check for oil leaks and for leaking oil seal. Do not attempt to check oil level unless system has been stabilized at least 20 minutes. See oil level verification.                |
| Excessively cold suction line.  | Loss of contact between the expansion valve bulb and the suction line or sticking of the expansion valve.<br><br>Check for foreign matter and clean, repair or replace the valve. |
| Excessively cold suction line and noisy compressor.   | Check superheat adjustment. Check remote bulb contact. Check expansion valve for sticking.  |
| Compressor squeaks or squeals when running.   | Check oil level. Replace oil seal.  |
| Noisy or knocking compressor.   | Check for broken internal parts. Overhaul if required.  |
| Compressor vibrates.  | Check and tighten compressor mounting bolts and belt tension.   |
| Low refrigerant level   | Check for refrigerant leaks and add refrigerant if required.  |
| Suction pressure rises faster than 5 pounds per minute after shutdown.  | Check compressor valve for breakage or damage.  |
| Insufficient cooling.   | Check for refrigerant leaks. Check condition of air filter and motors.  |
| Insufficient air flow.  | Dirty or iced evaporator. Dirty air filter. Blowers inactive. Clogged ducts.  |
| No flow of refrigerant through expansion valve.   | Filter dryer is clogged. Remote bulb has lost charge or expansion valve is defective.   |
| Expansion valve hisses. Bubbles in moisture and liquid indicator.   | Gas in liquid line. Add refrigerant.  |
| Loss of capacity  | Clogged filter. Obstructed or defective expansion valve.  |
| Superheat too high.   | Reset superheat adjustment. Check for clogged external equalizer line, or filter dryer.   |
| Reduced air flow:<br>a. Dirty or clogged air filter;<br>b. Evaporator motor inoperative; or<br>c. Plugged return air ducts. | Dirty or iced evaporator coil. Clean air filter screen. Check return ducts for obstructions. Check blower motor.  |
| Frequent starting and stopping on low pressure control switch.  | Lack of refrigerant. Check for leaks. Recharge.   |

| TROUBLE  | CAUSE   |
|--|---|
| Compressor intermittently starts and stops.  | Intermittent contact in electrical control circuit.<br>Compressor valves not in operating position.   |
| Non-condensable in the refrigeration system.   | <p>Leak on system, system in vacuum in low temp. Specific symptom, pressure in system will not correspond to ambient temperature on shutdown. Only non-condensable will cause this.</p> <p>(Example: Pressure of idle R-134a system in 80°F (26.6°C) room should be 86.4 psi (595.7 kPa). See temperature chart in this section.)</p> <p>An evaporator just does a proper cooling job without sufficient air. Shortage of air can be caused by the following:</p> <ul style="list-style-type: none"> <li>* Dirty filters; or</li> <li>* Dirty coils.</li> </ul> |
| <p>Testing condenser pressure.</p> <p><i>NOTE: R-134A pressure is function of the temperature variation.</i></p> <p>Example, for an exterior temperature of 100°F.<br/>           Exterior temperature (100°F) + 30°F = 130°F. Refer to paragraph "10.11 Temperature &amp; Pressure".<br/>           Note the corresponding pressure for a temperature of 130°F, 199.8 psi.<br/>           Read the condenser pressure, example 171.9 psi.<br/>           171.9 psi &amp; 199.8 psi, the pressure in the condenser is inferior to the pressure corresponding to the exterior temperature, in this case the condenser pressure may be too low. Check for refrigerant leaks and add refrigerant if necessary. If the pressure corresponding to the condenser temperature is superior to the pressure corresponding to the exterior temperature, then the air cooled condenser pressure may be too high. Most frequent causes are:</p> <p>Reduced air quantity. This may be due to:</p> <ul style="list-style-type: none"> <li>* Non-condensable in system;</li> <li>* Dirt on the coil;</li> <li>* Restricted air inlet or outlet;</li> <li>* Dirty fan blades;</li> <li>* Incorrect rotation of fan;</li> <li>* Fan speed too low;</li> <li>* Fan motor going out on overload; or</li> <li>* Prevailing winds.</li> <li>* Too much refrigerant in system. Remove refrigerant if necessary.</li> </ul> |   |

**Section 22: HEATING AND AIR CONDITIONING**

## 7.11 TEMPERATURES &amp; PRESSURES

| VAPOR-PRESSURE |       |          |        |
|----------------|-------|----------|--------|
| TEMPERATURE    |       | PRESSURE |        |
| °F             | °C    | psi      | kPa    |
| -100           | -73.3 | 27.8     | 191.7  |
| -90            | -67.8 | 26.9     | 185.5  |
| -80            | -62.2 | 25.6     | 176.5  |
| -70            | -56.7 | 23.8     | 164.1  |
| -60            | -51.1 | 21.5     | 148.2  |
| -50            | -45.6 | 18.5     | 127.6  |
| -40            | -40.0 | 14.7     | 101.4  |
| -30            | -34.4 | 9.8      | 67.6   |
| -20            | -29   | 3.8      | 26.2   |
| -10            | -23   | 1.8      | 12.4   |
| 0              | -18   | 6.3      | 43.4   |
| 10             | -12   | 11.6     | 80     |
| 20             | -7    | 18.0     | 124.1  |
| 30             | -1    | 25.6     | 176.5  |
| 40             | 4     | 34.5     | 237.9  |
| 50             | 10    | 44.9     | 309.6  |
| 60             | 16    | 56.9     | 392.3  |
| 70             | 21.1  | 70.7     | 487.5  |
| 80             | 27    | 86.4     | 595.7  |
| 90             | 32.2  | 104.2    | 718.5  |
| 100            | 38    | 124.3    | 857.0  |
| 110            | 43.3  | 146.8    | 1012.2 |
| 120            | 49    | 171.9    | 1185.3 |
| 130            | 54.4  | 199.8    | 1377.6 |
| 140            | 60    | 230.5    | 1589.3 |
| 150            | 65.6  | 264.4    | 1823.0 |
| 160            | 71    | 301.5    | 2078.8 |
| 170            | 76.7  | 342.0    | 2358.1 |
| 180            | 82.2  | 385.9    | 2660.8 |

| VAPOR-PRESSURE |      |          |        |
|----------------|------|----------|--------|
| TEMPERATURE    |      | PRESSURE |        |
| °F             | °C   | psi      | kPa    |
| 190            | 87.8 | 433.6    | 2989.7 |
| 200            | 93.3 | 485.0    | 3344.1 |
| 210            | 98.9 | 540.3    | 3725.4 |

7.12 LEAK TESTING

Some methods such as nitrogen pressure, soap and electronic sniffer can be used for leak testing. However, the most common method used is a "Halide" torch consisting of an acetylene tank, a burner and a suction test hose. Proceed as follows:



**DANGER**

Do not inhale fumes from leak detector.

The flow of acetylene to the burner causes suction in the test line. Any gas refrigerant present will be drawn through the hose and into the burner where it decomposes into free acids.

These acids come in contact with the hot copper reaction plate in the burner, causing color reaction in the flame. A small concentration is indicated by a green tint and a large concentration by an intense blue. Do not confuse this change in color with the change caused by shutting off the air supply through the hose by holding the end too close to an object.

The procedure for testing is:

1. Adjust flame so that the top of the cone is approximately level or within one-half inch above the plate.
2. Probe end of suction test tube around all joints, valves, etc. When a leak has been found at a soldered joint, this section of the system must be pumped down. Do not solder as pressure will force hot solder out. If the system is empty, it is more economical to put in just enough R-134a to produce about 15 psi (103 kPa). The pressure can be raised to about 150 psi (1034 kPa) with dry nitrogen.

**NOTE**

*This gas is put into the suction and discharge shutoff valves at the compressor. The receiver valves must be opened. If no leaks are found, dump this mixture, evacuate the system and fill with refrigerant.*

**8. AUXILIARY AIR CONDITIONING SYSTEM AND COMPONENTS**

8.1 COMPRESSOR

Consult the SANDEN SD Compressor Service Manual included at the end of this section.



**WARNING**

Read the cautionary information in the SANDEN SD Compressor Service Manual included at the end of this section.

8.2 COMPRESSOR REMOVAL

8.2.1 When the compressor is operational

- \* Perform the "OIL RETURN OPERATION" (Refer to paragraph 8.9).

8.2.2 When the compressor is inoperable

- \* Perform the "Refrigerant Recovery" operation (Refer to paragraph 8.3.4).
- \* Slacken bolts A (Refer to figure 40).
- \* Remove bolts B & C (Refer to figure 40).
- \* Remove the compressor.



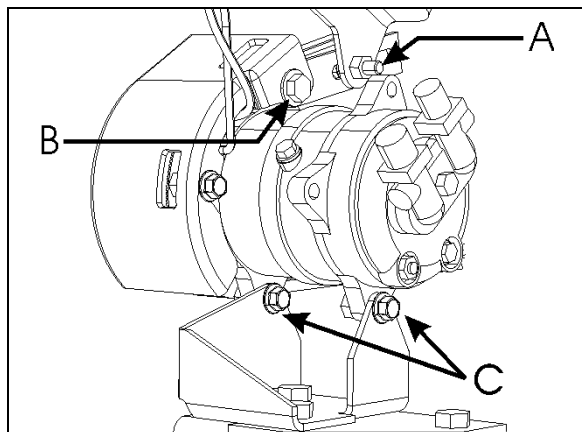


FIGURE 40: COMPRESSOR REMOVAL OR INSTALLATION 22349

### 8.2.3 Evacuating System Before Adding Refrigerant (Auxiliary System)

When a system has been opened for repairs, change the filter dryer and evacuate the system. X3 coaches equipped with an auxiliary system must use high-pressure service port located on the other side of check valve and low-pressure port located alongside rear truss (Fig. 16). It would be good practice to open solenoid valve.

1. Connect two hoses equipped with a micron gauge between the high-pressure service port, the low-pressure service port and the vacuum pump.
2. With the unit service valves open and the vacuum pump valves open, start the pump and draw the manifold and hoses into a very deep vacuum (700 microns).
3. Close manifold valve
4. Shut down the vacuum pump.
5. Check to insure that vacuum holds. (If the pressure continues to rise, it indicates a leak or moisture in the system).
6. Charge the system with the proper amount of refrigerant through the service port near the check valve using recommended charging procedures.
7. Remove the hoses.

### 8.3 OIL ADDITION

The chart below shows the approximate amount of oil to be added to the system when replacing a component.

| Component replaced | Typical amount of oil        |
|--------------------|------------------------------|
| Evaporator         | 50 cm <sup>3</sup> (1.7 ozs) |
| Condenser          | 30 cm <sup>3</sup> (1.0 ozs) |
| Filter-Dryer       | 10 cm <sup>3</sup> (0.3 ozs) |

The amount of oil recovered with the refrigerant recovery should be added at the same time.

### 8.4 COMPRESSOR OIL CONTAMINATION

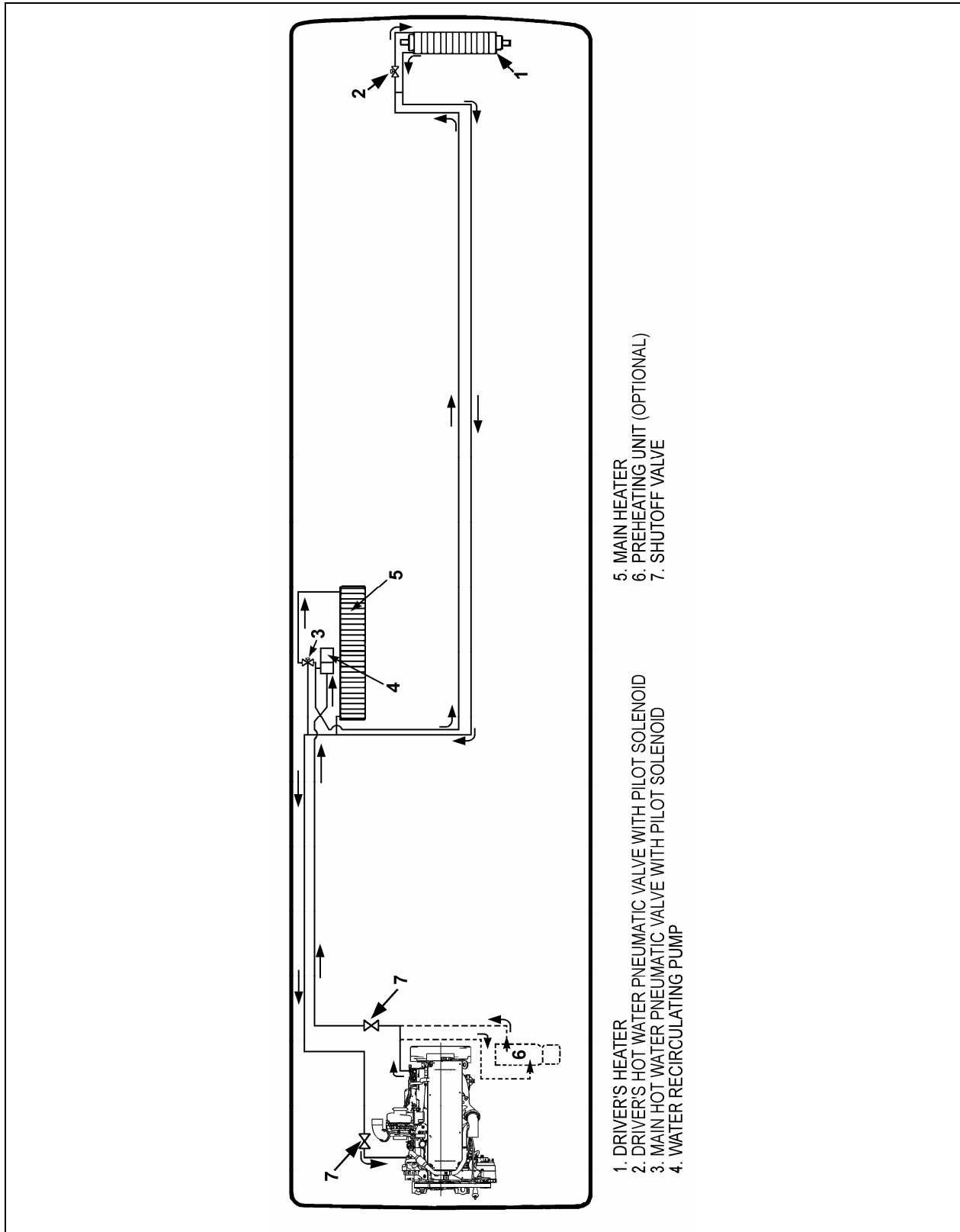
Unlike engine oil, no cleaning agent is added to the compressor oil. Even if the compressor is run for a long time, the oil never becomes turbid as long as there is nothing wrong with the compressor or its method of use. Inspect the extracted oil for any of the following conditions:

- \* Dirt in the oil.
- \* Change to a varnish color.
- \* Presence of foreign substance, metal shavings, etc. in the oil. When the oil extracted from the compressor is as described above, replace the oil as follows:
  1. Clean the interior of the system with approved method.
  2. Replace the filter-dryer.
  3. Supply with new oil as specified in SANDEN SD Compressor Service Manual included at the end of this section.

### 8.5 OIL RETURN OPERATION

There is a close affinity between oil and refrigerant. During normal operation, part of the oil recirculates with the refrigerant in the system. Therefore, when checking the amount of oil in the system or replacing any system component, the compressor must be run in advance to ensure return. This procedure is as follows:

- \* If the amount of refrigerant in the system has decreased, charge to the proper amount.
- \* Start the engine and select fast idle.
- \* Set the fan speed to full air/full A/C and let run for 20 minutes.



- 1. DRIVER'S HEATER
- 2. DRIVER'S HOT WATER PNEUMATIC VALVE WITH PILOT SOLENOID
- 3. MAIN HOT WATER PNEUMATIC VALVE WITH PILOT SOLENOID
- 4. WATER RECIRCULATING PUMP
- 5. MAIN HEATER
- 6. PREHEATING UNIT (OPTIONAL)
- 7. SHUTOFF VALVE

FIGURE 41: CENTRAL HEATING SYSTEM COMPONENTS

22325

## Section 22: HEATING AND AIR CONDITIONING

### 9. HEATING SYSTEM

The schematic of figure 41 shows the central heating system with its components.

In addition to the normal heating provided by the engine, a preheating system (104,000 Btu/hr) (optional) may have been installed in the vehicle.

#### 9.1 DRAINING HEATING SYSTEM

To drain the entire system, refer to Section 05, "Cooling". If only the driver's or main heater core must be drained, refer to the following instructions.

##### 9.1.1 Draining Driver's Heater Core

1. Stop engine and allow engine coolant to cool.
2. Locate the normally open water pneumatic valve on the ceiling of the spare wheel compartment (Fig. 42), move the pilot-solenoid valve red tab to close the valve.



### WARNING

Before proceeding with the following steps, check that coolant has cooled down.

3. Loosen hose clamp, install an appropriate container to recover coolant, and disconnect silicone hose from water solenoid valve.
4. From inside of vehicle, remove the two finishing panels in front of unit. Remove the three screws fixing the unit front panel. Open the manual vent located inside the HVAC unit, on the driver's side (Fig. 43) to ensure an efficient draining.

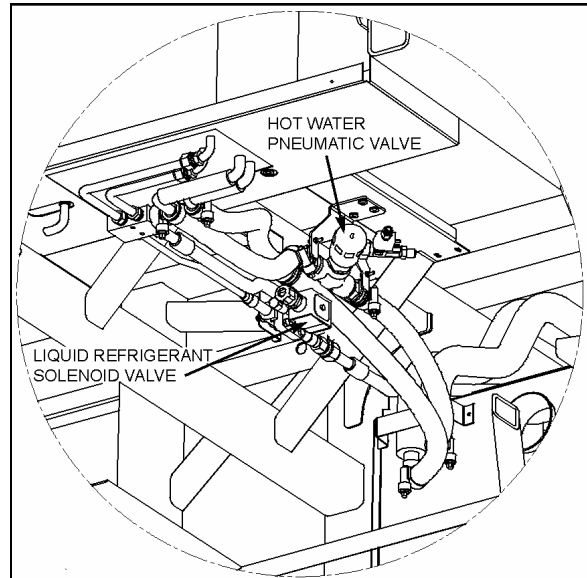


FIGURE 42: CEILING OF THE SPARE WHEEL COMPARTMENT

22324

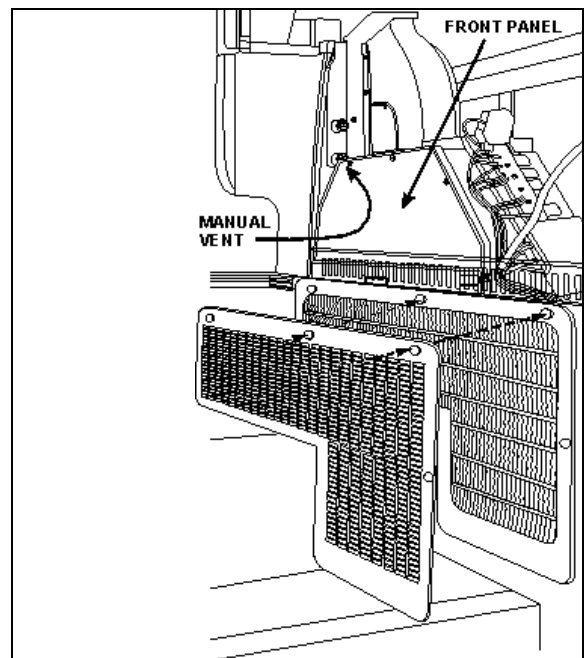


FIGURE 43: DRIVER'S HVAC UNIT

22328

##### 9.1.2 Draining Main Heater Core

1. Stop engine and allow engine coolant to cool.
2. Close both heater line shutoff valves.

**On X3 Coaches**, the valves are located in engine compartment. One is on the L.H. side of compartment in front of the radiator and the other valve is located under the radiator fan gearbox (Fig. 44).

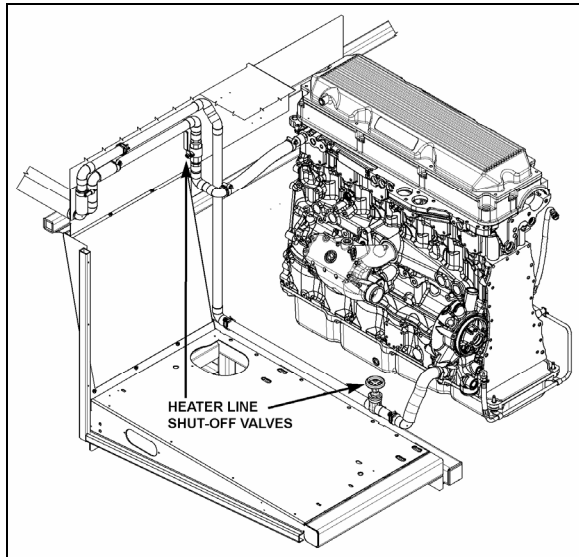


FIGURE 44: HEATER LINE SHUT-OFF VALVES 22326

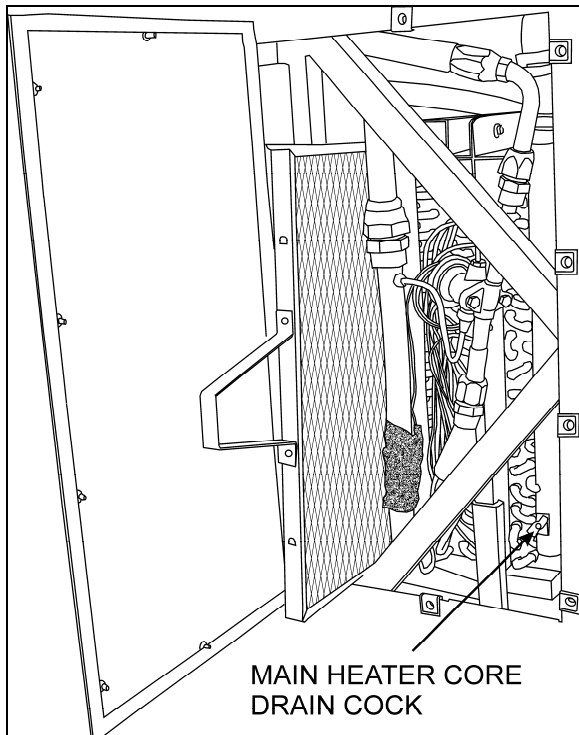


FIGURE 45: EVAPORATOR COMPARTMENT 22327

3. The main heater core drain cock is located in the evaporator compartment. To access the valve on X3 coaches, open baggage compartment door located in front of the evaporator compartment (L.H. side). Open access panel by turning the three screws of panel  $\frac{1}{4}$  of a turn.



## WARNING

Before proceeding with the following steps, check that coolant has cooled down.

4. Open drain cock in bottom of heater core, you can unfasten a hose connection on top of heater core (Fig.45) in order to allow air to enter while draining.

### 9.2 FILLING HEATING SYSTEM

1. Ensure that the drain hose is reconnected and the manual vent and drain cock are closed.
2. Open the surge tank filler cap and slowly fill the system to level of filler neck.
3. After initial filling, the water shut-off valves should be open and the water recirculating pump should be energized to assist in circulating coolant through the heating system. To perform this operation, start the engine, switch on the HVAC control unit, both driver and passenger sections, and set temperature to their maximum positions in order to request the heating mode in each of these sections.
4. When coolant level drops below the surge tank filler neck, slowly fill the system to level of filler neck.
5. Once the level has been stabilized, replace cap.

### 9.3 BLEEDING HEATING SYSTEM

Whenever the heating system has been drained and refilled, or the system has run low on coolant and coolant has been added, it is necessary to bleed air from heating system. Locate the manual vent illustrated in Figure 50, and open momentarily until no air escapes from the line.

### 9.4 SOLDERING

Before soldering any part of the system, make sure the area is well ventilated. Use (stay clean) flux sparingly and apply solder (95-5 round wire 1/8 inch [3,1 mm]). After completing repairs, test for leaks.

When using heat at or near a valve, wrap with a water saturated rag to prevent overheating of vital parts.

## Section 22: HEATING AND AIR CONDITIONING

### 9.5 DRIVER'S HOT WATER PNEUMATIC VALVE ASSEMBLY

#### 9.5.1 Description

The flow of hot water to the driver's heater core is controlled by a pneumatic NO water valve assembly. The valve, located at the ceiling of the spare wheel compartment, is designed so that the pilot solenoid valve, which is part of the assembly, opens and closes a port which directs air pressure to the actuator casing, thereby opening or closing the valve.

When the vehicle is operating with no current to the pilot solenoid valve, no air pressure is admitted to the actuator casing, the cylinder spring pushes up against the cylinder, thereby keeping the water valve open.

The driver's heater water valve requires a minimum amount of maintenance. The valve should be free of dirt sediment that might interfere with its operation. No other maintenance is needed unless a malfunction occurs.

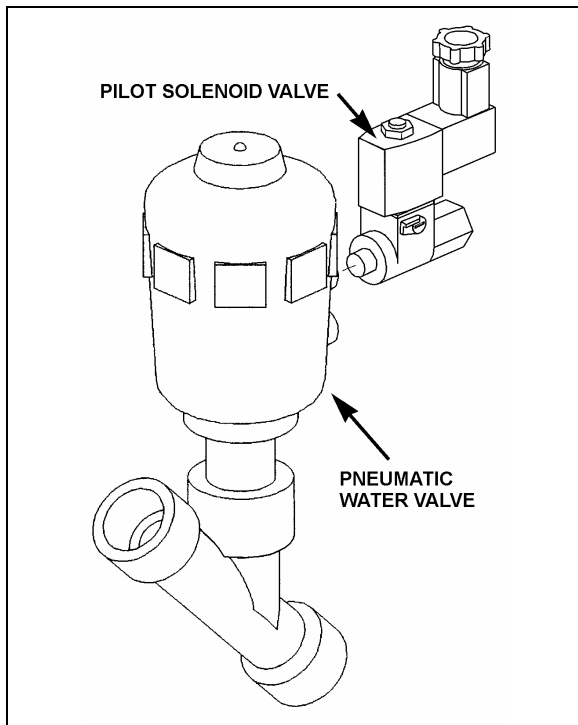


FIGURE 46: DRIVER'S HOT WATER PNEUMATIC VALVE ASSEMBLY 22240

#### 9.5.2 Pneumatic Water Valve Disassembly

1. Shut off air supply pressure and electrical current to the pilot solenoid valve. Disconnect wires.

2. The water valve need not be removed from the line. Unscrew nipple, the actuator casing, tube, spindle and closure member can be removed (Fig. 47).
3. Remove the snap ring using a pair of pliers.
4. You can now access all seals for replacement

Pneumatic water valve replacement seal kits:

- \* Water Side: 871311
- \* Actuator Side: 871312

#### 9.5.3 Pneumatic Water Valve Reassembly

1. Assemble the actuator casing, tube, nipple, spindle and closure member.
2. Tighten the nipple in place in the body cavity as per figure 54. Fasten pilot solenoid valve to the pneumatic water valve. Reconnect air supply pressure and electrical current to the pilot solenoid valve.
3. Check for proper operation.

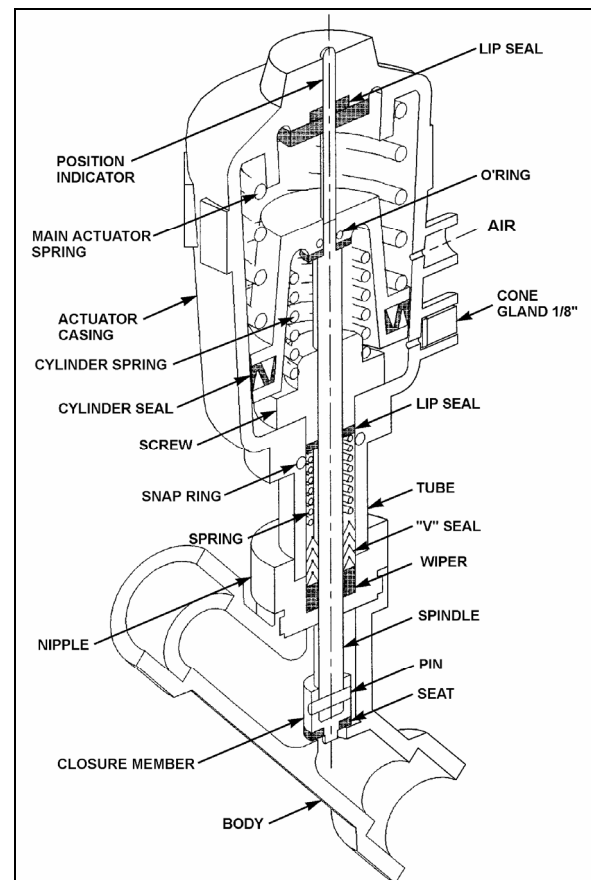


FIGURE 47: PNEUMATIC WATER VALVE 22241

9.5.4 Pilot Solenoid Valve

1. No maintenance is needed unless a malfunction occurs.
2. A pilot solenoid valve replacement seal kit is available: 871313.

9.5.5 Valve Troubleshooting

| PROBLEM               | PROCEDURE  |
|-----------------------|--|
| Valve fails to close. | <ol style="list-style-type: none"> <li>1. Check electrical supply with a voltmeter. It should agree with nameplate rating.</li> <li>2. Check pressure at pilot solenoid valve inlet. It must be at least equal to the minimum pressure stamped on the nameplate. It should not go below minimum while valve is operating.</li> </ol> |
|                       | <ol style="list-style-type: none"> <li>1. Check that the closure member assembly, and that main actuator and cylinder springs are free to travel.</li> <li>2. Check that there is no restriction to the air escaping from the actuator casing.</li> <li>3. Make sure that pilot solenoid valve operates properly.</li> </ol>         |

9.6 CENTRAL HOT WATER PNEUMATIC VALVE ASSEMBLY

9.6.1 Description

The flow of hot water to the vehicle's central heater core is controlled by a 3-way pneumatic water valve assembly. The valve, located in the evaporator compartment, is designed so that the pilot solenoid valve, which is part of the assembly, opens and closes a port which directs air pressure to the actuator casing, thereby allowing the hot water to enter the main heater core or bypassing it.

When the vehicle is operating with no current to the pilot solenoid valve, no air pressure is admitted to the actuator casing, the cylinder spring pushes up against the cylinder, thereby allowing the hot water to enter the main heater core.

The central heater water valve requires a minimum amount of maintenance. The valve should be free of dirt sediment that might interfere with its operation. No other maintenance is needed unless a malfunction occurs.

9.6.2 Pneumatic Water Valve Disassembly

1. Shut off air supply pressure and electrical current to the pilot solenoid valve. Disconnect wires.

2. The water valve need not be removed from the line. Unscrew nipple, the actuator casing, tube, spindle and closure member can be removed (Fig. 49).
3. Remove the snap ring using a pair of pliers.

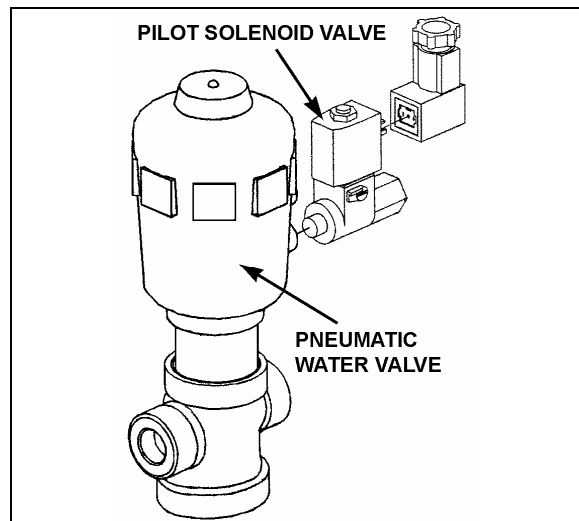


FIGURE 48: CENTRAL HOT WATER PNEUMATIC VALVE ASSEMBLY

22329

4. You can now access all seals for replacement

Pneumatic water valve replacement seal kits:

\* Water Side: 871389

## Section 22: HEATING AND AIR CONDITIONING

\* Actuator Side: 871388

### 9.6.3 Pneumatic Water Valve Reassembly

1. Assemble the actuator casing, tube, nipple, spindle and closure member.
2. Tighten the nipple in place in the body cavity as per figure 49. Fasten pilot solenoid valve to the pneumatic water valve. Reconnect air supply pressure and electrical current to the pilot solenoid valve.
3. Check for proper operation.

### 9.6.4 Pilot Solenoid Valve

1. No maintenance is needed unless a malfunction occurs.
2. A pilot solenoid valve replacement seal kit is available: 871390.

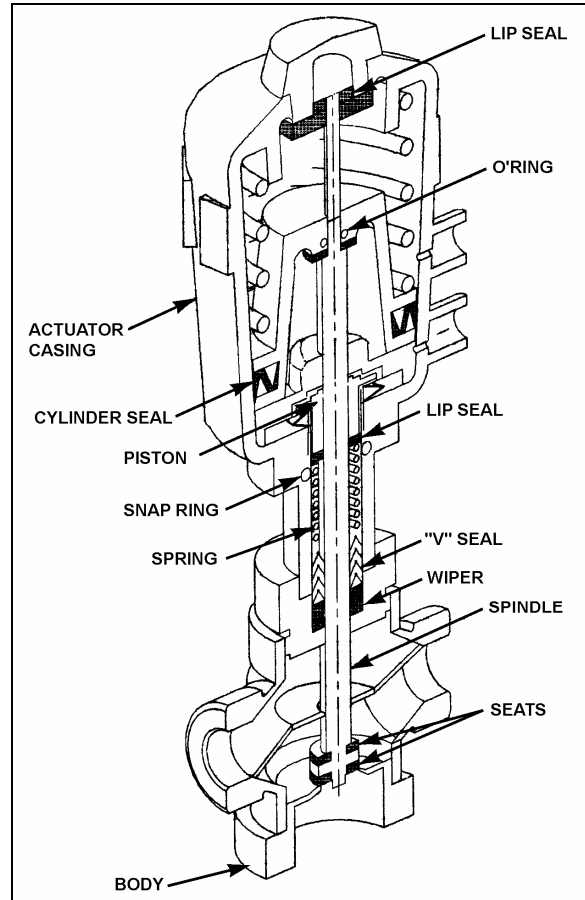


FIGURE 49: PNEUMATIC WATER VALVE

22330

### 9.6.5 Valve Troubleshooting

| PROBLEM               | PROCEDURE  |
|-----------------------|--|
| Valve fails to close. | <ol style="list-style-type: none"> <li>1. Check electrical supply with a voltmeter. It should agree with nameplate rating.</li> <li>2. Check pressure at pilot solenoid valve inlet. It must be at least equal to the minimum pressure stamped on the nameplate. It should not go below minimum while valve is operating.</li> </ol> |
| Valve fails to open.  | <ol style="list-style-type: none"> <li>1. Check that the closure member assembly, and that main actuator and cylinder springs are free to travel.</li> <li>2. Check that there is no restriction to the air escaping from the actuator casing.</li> <li>3. Make sure that pilot solenoid valve operates properly.</li> </ol>         |

9.7 WATER RECIRCULATING PUMP

This vehicle is provided with a water recirculating pump which is located in the evaporator compartment (Fig. 50). The water recirculating pump consists of a centrifugal pump and an electric motor which are mounted in a compact assembly.

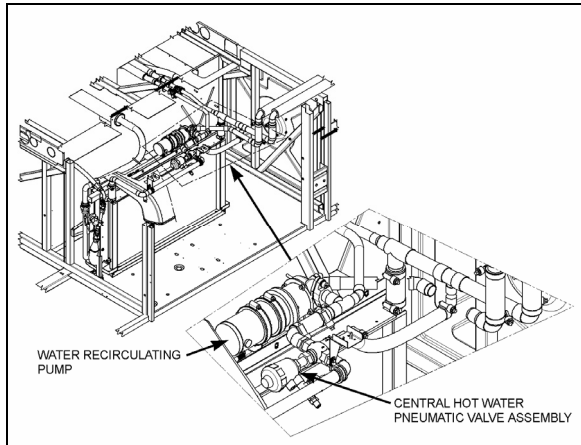



FIGURE 50: PUMP LOCATION (CENTRAL A/C) 22331

The (seal less) pump requires no periodic maintenance other than replacement of motor brushes. Replacement of motor brushes can be performed without removing the pump assembly. Inspection of the pump, to determine if the pump is working properly, should be made while the pump is in operation. If there is evidence that the pump is not operating as per specifications, the unit must be disassembled for corrective measures.

Disassembly of the pump will be necessary only in the case of a rotor failure or motor failure.

9.7.1 Removal

1. Stop engine and allow engine coolant time to cool.
2. Close shutoff valves. Refer to "05 COOLING" under heading "Draining Cooling System" for location of valves.
3. Disconnect the electrical wiring from the motor.

|   |
|---|
|  <p><b>WARNING</b></p> |
| <p>Before proceeding with the following steps, check that coolant has cooled down.</p>                    |

4. Disconnect water lines from pump at flange connections. Place a container to recover the residual coolant in the line.
5. Remove the two clamps holding the pump motor to its mounting bracket. Remove the pump with the motor as an assembly.

9.7.2 Disassembly

1. Separate the housing (1) from the adapter (7) by first removing the 4 capscrews. Remove housing carefully to prevent damaging the O-ring (2).
2. Remove rotor assembly (4), washers (3) and shaft (5) from the adapter.

Inspection

Components removed from the recirculating pump and motor assembly should be compared with new parts to determine the degree of wear.

9.7.3 Brushes

1. When removing brushes, note the position of the brush in the tube. Brush life is shortened if the brushes are not replaced properly.
2. Examine brushes for the following:
  - a. Wear  
Replace the brushes if less than 25% of the usable brush is left (less than 0.300 inch [8 mm]).
  - b. Chipped edges  
Chips can be caused by improper handling or installation. Badly chipped brushes should be replaced regardless of their length.
  - c. Annealed brush spring  
This can be detected by noting the resiliency of the spring. Annealing is caused by failing to tighten the brush caps properly, thus not providing a good low resistance contact between the terminal and the brush tube. Replace brushes showing evidence of annealed springs.
  - d. Frayed or broken pigtail  
An improperly installed brush may have the pigtail (shunt) pinched under the terminal or between the coils of the spring. If the pigtail is badly frayed or broken, replace the brush.



Section 22: HEATING AND AIR CONDITIONING

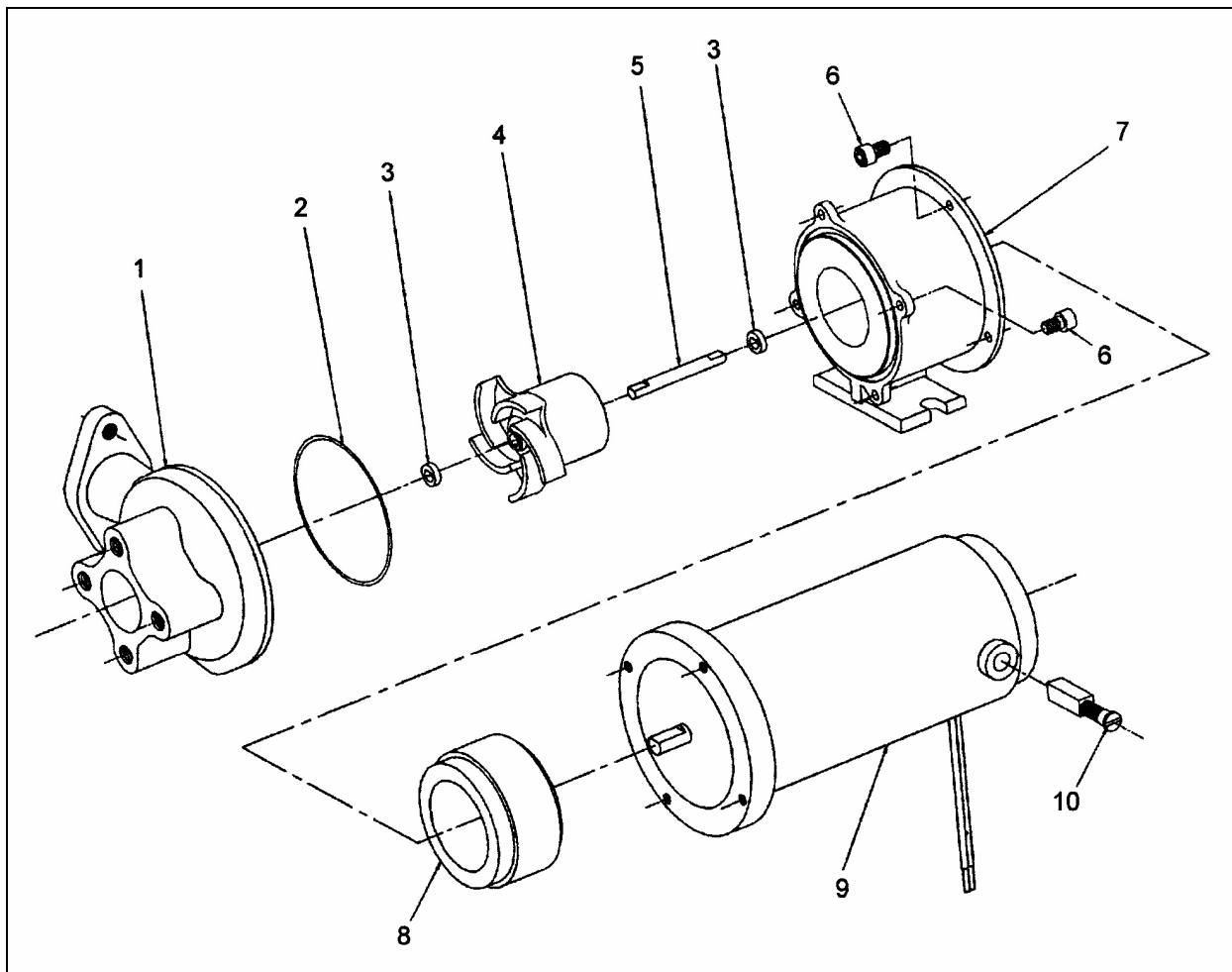


FIGURE 51: WATER RECIRCULATING PUMP (CENTRAL A/C)

22282

| ITEM | DESCRIPTION                         | QTY. |
|------|-------------------------------------|------|
| 1    | Housing                             | 1    |
| 2    | O-Ring                              | 1    |
| 3    | Washer SS                           | 2    |
| 4    | Rotor Assembly                      | 1    |
| 5    | Shaft SS                            | 1    |
| 6    | Screw, Cap Hex Soc. Head 8-32 X 3/8 | 8    |
| 7    | Adaptor                             | 1    |
| 8    | Drive Magnet                        | 1    |
| 9    | Motor Assembly 24V                  | 1    |
| 10   | Brush                               | 2    |

3. Observe the following factors when replacing brushes:
  - a. The face of a new brush is carefully cut to cause proper seating during the "wear-in" period.
  - b. Improper installation can harm both the brush and the commutator.
  - c. Replacement brushes should be of the proper grade.
  - d. Brush performance will be affected if the spring and terminal are not properly placed in the brush tube. The spring should be free over its entire length and the terminal should make good contact with the metal brush tube insert.

### 9.7.4 Assembly

1. Install washer (3), shaft (5) and rotor assembly (4) into adapter (7).
2. Install O-ring (2) into housing (1) and assemble housing to the adapter.
3. Secure housing to adapter using 4 capscrews (6).

### 9.7.5 Installation

1. Apply gasket cement to the line flanges, put the two gaskets in place, and connect water lines to the pump at the flange connections. Position the pump and motor assembly on the mounting bracket. Position the mounting clamps over the motor and secure with mounting bolts.
2. Connect electrical wiring to the pump motor.
3. Open shutoff valve. Refer to "05 COOLING" under heading "Draining Cooling System" for location of valves.
4. Fill the cooling system as previously instructed in this section under "9.2 Filling Heating System", then bleed the system as previously instructed in this section under "9.3 Bleeding Heating System".

### 9.8 PREHEATING SYSTEM (OPTIONAL)

The preheater is located inside engine compartment and is accessible through engine compartment R.H. side door (refer to figure 52).

This Auxiliary Preheating System is used for preheating and retaining the heat of water-cooled engines. It can be used before starting the engine to ease its starting and to provide immediate inside heat upon operation of the heating system. It can also be used with engine running to maintain coolant heat and maintain the set temperature inside vehicle.

The heater operates independently from the vehicle engine. It is connected to the cooling and heating circuits, the fuel system and the electrical system of the vehicle.

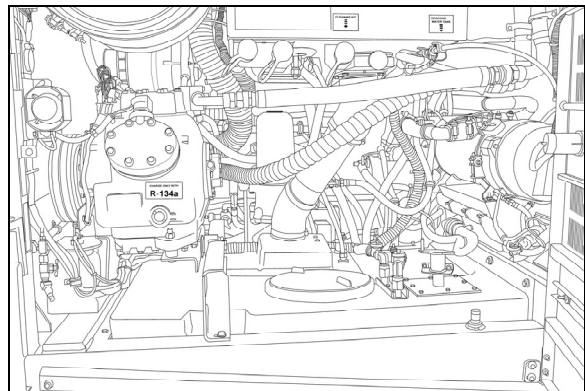


FIGURE 52: LOCATION OF PREHEATER

18607

The pilot lamp turns on when the heater is switched on. Combustion air flows in to flush out the combustion chamber and the water circulation pump is put into operation. The fuel metering pump conveys fuel in precise doses to the combustion chamber where fuel and combustion air form a combustible mixture which is ignited by the glow plug.

Once the flame sensor has signaled to the control unit that combustion has taken place correctly, the glow spark plug and ignition coil are switched off.

The hot combustion gases are diverted at the end of the flame pipe, then pass through the indirect heating surfaces of the heat exchanger and transmit their heat to the water passing through the heat exchanger.

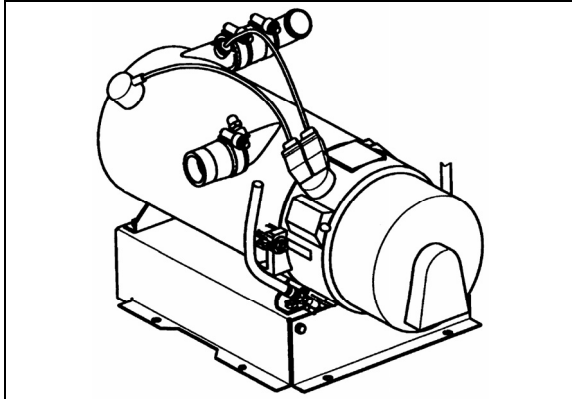


FIGURE 53: WEBASTO PREHEATER (104,000 BTU) 22224

The heat is thermostatically controlled and operates intermittently, i.e. the switched-on times of the burner vary depending on the heat requirement. The water temperature depends on the setting of the built-in thermostat.

The water circulation pump remains in operation as long as the heater is operating, even in the regulation intervals and during the delayed cutout of the switched-off heater. The pump can also be operated independently from the heater by means of an appropriate circuit. The heater can be switched on at any time, even during the delayed cutout period. Ignition takes place once this delay time is over.

When the heater is switched off, the fuel supply is interrupted. The flame goes out, and at the same time a delayed cutout of some 2.5 minutes begins. The combustion air still flowing flushes the remaining combustion gases out of the chamber and cools off the hot parts on the exhaust side of the heat exchanger, while the water circulation pump, still running, transmits the heat present in the heat exchanger, thus preventing local overheats. Once the delayed cutout time is over, both the combustion air blower and the water circulation pump switch off automatically. A cutout will take place in case of any failure of the preheater.

### 9.8.1 Operation

Switch on the heater. The operation indicator lamp comes on and the heater motor and circulating pump begin to run. After about 10-25 seconds the solenoid valve opens and fuel is sprayed into the combustion chamber. At the same time, the electronic ignition unit produces high voltage (8000 V) and the mixture of fuel and air in the combustion chamber is ignited by the spark on the ignition electrodes. The flame is

indicated by the flame detector, then the electronic ignition unit stops producing high voltage and combustion continues by itself (spark on electrodes is required only to ignite the flame). At this moment, the heater is working and producing heat.

If the heater is switched off by the on/off switch, the solenoid valve interrupts fuel supply, combustion stops and indicator lamp turns off. Combustion air fan still blows air, cleaning the combustion chamber of any fumes and cooling down the combustion chamber. Coolant circulation pumps coolant, making a purge cycle for approximately 2-3 minutes, thus protecting the heater against overheating.

If the heater is not switched off by the on/off switch, the control thermostat will switch off the heater when coolant temperature reaches  $165^{\circ} \pm 6^{\circ}\text{F}$  ( $75^{\circ} \pm 3^{\circ}\text{C}$ ) and turns it on at  $154^{\circ} \pm 9^{\circ}\text{F}$  ( $68^{\circ} \pm 5^{\circ}\text{C}$ ). During this time, the heater (combustion) is off and the indication lamp and coolant pump are on. Combustion air fan blows air for 2-3 minutes and then turns off.

### 9.8.2 Preheating System Timer

The timer, located on L.H. lateral console is used to program the starting and stopping time of the preheating system. The system indicator light, located on the timer, illuminates when the system is functional.



### CAUTION

The preheating system should not operate for more than one hour before starting engine as this could discharge batteries.



### DANGER

Preheating system must not operate when vehicle is parked inside or during fuel fill stops.

### NOTE

*Preheating system uses the same fuel as the engine.*

In case of failure:

1. Shut off and turn on again.
2. Check main circuit breaker and overheat fuse.

3. Have system repaired in a specialized shop.

### 9.8.3 Timer Operating Instructions (Webasto)

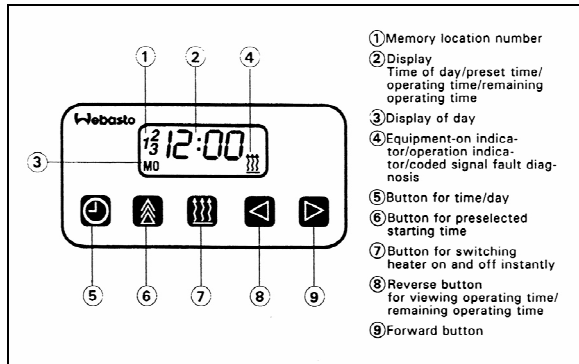


FIGURE 54: WEBASTO 22191

These instructions refer to the timer illustrated in figure 54. They are the same instructions provided in the Webasto instruction booklet, provided with your vehicle.

#### Remaining Operating Time

The remaining operating time refers to the period of time the heater still continues to remain in operation. It may be changed while the heater is in operation.

#### Setting the Digital Timer

After the power has been connected, all symbols on the digital display are flashing. The time of the day and the day of the week must be set.

All flashing symbols of the timer can be set by means of the Forward (9) or Reverse (8) buttons.

When buttons (8) and (9) are pressed for more than 2 seconds, the quick digit advance mode is activated.

#### Setting the Time and Day of the Week

1. Press button (5) for more than 2 seconds (time display flashes).
2. Press (8) or (9) button to set the time of day.
3. Wait 5 seconds. The time of day is stored (time of week flashes).
4. Press (8) or (9) button to set the correct day of week.
5. Wait 5 seconds. The day of week is stored.

#### Viewing the Time (Ignition ON)

Continuous display of current time and day of the week.

#### Viewing the Time (Ignition OFF)

Briefly press button (5) to display current time and day for 5 seconds.

#### SWITCHING HEATER ON (INSTANT HEATING)

##### With Ignition ON:

Press button (7). Heater is switched on (continuous operation) and continues to operate until button (7) is pressed again or ignition is switched off.

#### NOTE

*If the ignition is switched off while heater is in operation, the remaining operating time of 5 minutes flashes on the display and the heater will continue to operate for this period of time.*

##### With Ignition OFF:

Press button (7). Heater is switched on for preset operating time (the factory-set heater operating duration is 60 minutes)

#### SWITCHING HEATER OFF

Press button (7). The heater starts its after-run cycle and switches off thereafter.

#### Presetting Operating Duration

1. Press button (6). Memory location number flashes.

#### NOTE

*By repeatedly pressing button (6), starting time 2 or 3 can be preset.*

2. Press button (8) or (9) until correct startup time is set.
3. Wait 5 seconds. Preset starting time is stored and day of week flashes.
4. Press button (8) or (9) to select the correct startup day of week.
5. Wait 5 seconds. The startup day of week is stored.

## Section 22: HEATING AND AIR CONDITIONING

The number of memory location remains on the display. The timer is now in the programmed mode and will switch the heater in at the preset time.

### **NOTE**

*We recommend that memory locations 1 and 2 be used for presetting times within 24 hours of setting the timer. Memory location 3 can be used for a starting time within the next 7 days of setting the timer.*

### **Recalling Preset Times**

Press (6) repeatedly until the desired memory location number and preset time are displayed.

### **Canceling Preset Time**

Press button (6) repeatedly until no more memory location number is visible on the display.

### **Setting Operating Time**

1. With heater off, press button (8). Operating time flashes.
2. Press button (8) or (9) to set the operating time (between 1 and 120 minutes).

The heater remains in operation for the preset time (except for continuous operation).

### **Setting the Remaining Operating Time**

1. With heater in operation, press button (8). Remaining operating time flashes.
2. Set remaining time with button (8) or (9).
3. Wait 5 seconds. Remaining operating time is stored.

### **Operational Failure Symptoms via Fault/Flash code**

On heaters equipped with a fault diagnosis system using coded light signals, the equipment-on indicator/operation indicator flashes. Refer to the following table.

| <b>Failure Symptom</b>   | <b>Probable Cause</b>   | <b>Check and Correct</b>  |
|--|---|---|
| <b>1X Flash (F 01)</b><br>No combustion after completion of start up sequence.                               | - Fuel system<br><br>- Combustion air<br>- Electronic ignition  | - Fuel level<br>- Type of fuel being used<br>- Fuel filter<br>- Fuel line connections (air bubbles in fuel lines)<br>- Fuel nozzle plugged<br>- Air intake or exhaust, restricted or plugged<br>- Incorrect electrode gap |
| <b>2X Flashes (F 02)</b><br>Flame out during burner operation no restart possible                            | - Fuel supply (shortage of fuel)                                | - Restriction in the fuel system<br>- Fuel filter<br>- Fuel line connections (air bubbles in fuel lines)<br>- Type of fuel being used   |
| <b>3X Flashes (F 03)</b><br>Low voltage for more than 20 seconds   | - Electrical system   | - Load test batteries<br>- Corrosion at connections<br>- Loose connections  |
| <b>4X Flashes (F 04)</b><br>Flame detector recognizes false flame signal during pre-start or shut-down cycle | - Defective flame detector                                      | - Replace flame detector  |
| <b>5X Flashes (F 05)</b><br>Flame detector   | - Wiring<br>- Defective flame detector                          | - Damaged wiring, open or short circuit<br>- Replace flame detector   |
| <b>6X Flashes (F 06)</b><br>Temperature sensor   | - Wiring<br>- Defective temperature sensor                      | - Damaged wiring, open or short circuit<br>- Replace temperature sensor   |
| <b>7X Flashes (F 07)</b><br>Fuel solenoid valve  | - Wiring<br>- Defective solenoid valve                          | - Damaged or corroded wiring, open or short circuit<br>- Replace solenoid valve   |
| <b>8X Flashes (F 08)</b><br>Combustion air fan motor   | - Wiring<br>- Wrong RPM<br>- Defective combustion air fan motor | - Damaged wiring, open or short circuit<br>- Replace combustion air fan<br>- Replace combustion air fan   |

## Section 22: HEATING AND AIR CONDITIONING

|   |   |  |
|---|---|--|
| <b>9X Flashes (F 09)</b><br>Circulation pump motor    | - Wiring<br>- Defective circulation pump motor  | - Damaged wiring, open or short circuit<br>- Replace circulation pump motor  |
| <b>10X Flashes (F 10)</b><br>Temperature limiter      | - Overheat condition<br>- Coolant flow<br><br>- Wiring<br>- Defective temperature limiter | - Reset temperature limiter<br>- Coolant level or flow restriction<br>- Air trapped in coolant circuit<br>- Damaged or corroded wiring, open or short circuit<br>- Replace temperature limiter |
| <b>11X Flashes (F 11)</b><br>Electronic ignition coil | - Wiring<br>- Defective electronic ignition coil  | - Damaged wiring, open or short circuit<br>- Replace electronic ignition coil  |
| <b>12X Flashes (F 12)</b><br>Heater lock out          | - 3 repeated faults/flame-outs or<br>5 repeated start attempts                            | - Reinitialize control unit by switching heater on<br>and disconnecting power.   |

### 9.8.4 Troubleshooting and Maintenance

Refer to the Webasto manual for more information.

**NOTE**

*If there are no heater faults, the heater will go through a normal start cycle and regulate based on thermostat setting.*

**NOTE**

*Switch on the preheating system briefly about once a month, even during the warm season.*



**CAUTION**

When welding on the vehicle, disconnect the preheater module connector in order to protect this system from voltage surges.



**CAUTION**

To avoid running down the batteries, do not turn on the preheating system for more than one hour before starting the engine.



**DANGER**

The preheating system uses the same fuel as the engine. Do not operate in a building or while refueling. Operate only in a well-ventilated area.

**10. SPECIFICATIONS**

**Main evaporator motor**

Make.....US MOTOR  
Type .....T-17  
Voltage ..... 27.5 V DC  
Current draw ..... 68 amps  
Horsepower..... 2  
Revolution ..... 1<sup>st</sup> :1400 rpm, 2<sup>nd</sup> : 1880 rpm nominal  
Insulation .....Class F  
Motor Life .....20 000 hours  
Brush life ..... 10 000 hours  
Motor Prevost number..... 563008  
Brush Prevost number ..... 562951

**Condenser fan motors**

Make..... EBMPAPST  
Type .....AXIAL BRUSHLESS  
Voltage ..... 24 V DC  
Qty..... 4  
Prevost number ..... 563461

**Evaporator air filter (Central system)**

Make..... Permatron Corp.  
Type ..... Polypropylene  
Prevost number ..... 874272

**Driver's unit evaporator motors**

Make.....MCC  
Voltage ..... 24 V DC  
Quantity ..... 1  
Prevost number ..... 871135

**Driver's unit evaporator air filters**

Make.....MCC  
TYPE ..... Recirculating air 6-1/4" x 28" Washable  
Prevost number ..... 871147

Make.....MCC  
 TYPE..... Fresh air 3-5/8" X 5-1/4" Washable  
 Prevost number..... 871144

**Refrigerant**

Type ..... R-134a  
 Quantity (standard) ..... 24 lbs (10.89 Kg)  
 Quantity (A/C Aux. system located in overhead compartments) .....4 lbs (1.8 Kg)

**Compressor (Central system)**

Make..... Carrier Transicold  
 Capacity, option R-134a ..... 41 CFM  
 Capacity, option R-22..... 37 CFM  
 Model, option R-134.....05G-134A  
 Model, option R-22..... 05G-22  
 No. of cylinders ..... 6  
 Bore..... 2" (50,8 mm)  
 Operating speed.....400 to 2200 rpm (1750 rpm. Nominal)  
 Minimum speed (for lubrication).....400 rpm  
 Nominal horsepower ..... 15  
 Oil pressure at 1750 rpm ..... 15 to 30 psi (103-207 kPa)  
 Oil capacity..... 1.13 U.S. gal (4,3 liters)  
 Weight ..... 142 lbs (64,5 kg)  
 Approved oils  
 -Castrol..... SW 68 (POE)  
 Prevost number, option R-134a ..... 950314  
 Prevost number, option R-22 ..... 950207

**A/C Compressor (Auxiliary system)**

Make..... Sanden  
 Model..... SD7H  
 Prevost number ..... 950436  
Approved oil ..... Sanden SP-20 (PAG)  
 Prevost number ..... 950382

**Compressor unloader valve**

Make..... Carrier Transicold



## Section 22: HEATING AND AIR CONDITIONING

---

Type ..... Electric (AMC)  
Voltage ..... 24 V DC  
Watts ..... 15  
Prevost number (without coil) ..... 950095  
Coil Prevost number..... 950096

### **Magnetic clutch**

Make..... Carrier Transicold  
Type ..... Housing mounted 9" dia., 2-B grooves  
Voltage ..... 24 V DC  
Coil resistance at 68 °F (20 °C)..... 5.15 – 5.69 ohms  
Prevost number..... 950204

### **Compressor V belt (Carrier)**

Make..... Dayco  
Model..... BX100  
Prevost number (with two BOSH Alternators) ..... 506864

### **Condenser coil (Auxiliary system)**

Make..... Valeo  
Prevost number .....

### **Condenser coil (Central system)**

Make..... Carrier Transicold  
Aluminum  
Prevost number ..... 870654  
Copper  
Prevost number ..... 870729

### **Evaporator coil (Central system)**

Make..... Carrier Transicold  
Prevost number ..... 871070

### **Receiver tank (with sight glasses)**

Make..... HENRY  
Maximum pressure..... 450 psig  
Prevost number ..... 950261

**Moisture indicator**

Make..... Henry  
 Prevost number..... 950029

**Driver's refrigerant liquid solenoid valve**

Make..... Parker  
 Type ..... Normally closed with manual bypass  
 Voltage ..... 24 V DC  
 Amperage draw ..... 0.67 amps  
 Watts ..... 16  
 Prevost number (without coil) ..... 95-0054  
 Coil Prevost number..... 950055  
 Repair kit Prevost number ..... 950056

**Hot water pneumatic valve (Central system)**

Make..... Burkert  
 Type ..... 3-WAY  
 Voltage ..... 24 V DC  
 Prevost number ..... 871381  
 Seal kit, Water Side..... 871389  
 Seal kit, Actuator Side..... 871388  
 Seal kit, Pilot Solenoid Valve ..... 871390

**Driver's hot water pneumatic valve**

Make..... Burkert  
 Type ..... Normally open  
 Voltage ..... 24 V DC  
 Prevost number ..... 871252  
 Seal kit, Water Side..... 871311  
 Seal kit, Actuator Side..... 871312  
 Seal kit, Pilot Solenoid Valve ..... 871313

**Water recirculating pump**

Make..... M.P. pumps  
 Voltage ..... 24 V DC  
 Prevost number ..... 871342

## Section 22: HEATING AND AIR CONDITIONING

---

### Water filter (small A/C system)

Make..... BRAUKMANN  
Prevost number..... 870807

### Driver's expansion valve

Prevost number, option R-134a ..... 950221  
Prevost number, option R-22 ..... 950282

### Expansion valve (Central system)

Make..... Alco  
Model..... TCLE 5-1/2  
Prevost number..... 950320

### Preheating system

Make..... WEBASTO  
Model..... THERMO 300  
Capacity ..... 104 000 Btu/h (30 kW)  
Heating medium ..... Coolant  
Rated voltage ..... 24 V DC  
Operating voltage ..... 20-28 V DC  
Electric power consumption (without coolant recirc. Pump) ..... 110 watts  
Fuel consumption ..... 1,2 US gallons/hr (4,5 liters/hr)  
Prevost number ..... 871202

# SECTION 23: ACCESSORIES

## CONTENTS

|   |           |
|---|-----------|
| <b>1. AUDIO AND VIDEO SYSTEM DESCRIPTION</b> .....                        | <b>4</b>  |
| 1.1 AM/FM RADIO .....   | 6         |
| 1.1.1 VR300 AM/FM Radio / CD Player.....                                  | 6         |
| 1.1.2 Security Code.....  | 6         |
| 1.1.3 Removal .....   | 6         |
| 1.1.4 DELPHI Premium Satellite Radio AM/FM/MP3 CD stereo (OPTIONAL) ..... | 7         |
| 1.2 VSS-04 SOUND SELECTOR.....  | 7         |
| 1.2.1 Removal .....   | 7         |
| 1.3 VD-404 MOBILE DVD PLAYER.....   | 8         |
| 1.4 MULTICHANNEL POWER AMPLIFIER VA400.8.....                             | 8         |
| 1.5 SPEAKERS.....   | 8         |
| 1.6 VIDEO CASSETTE PLAYER (VCP) .....                                     | 9         |
| 1.6.1 Removal .....   | 9         |
| 1.6.2 Installation .....  | 9         |
| 1.7 BOOM-TYPE MICROPHONE .....  | 9         |
| 1.7.1 Removal .....   | 9         |
| 1.7.2 Installation .....  | 9         |
| 1.8 HANDHELD PRIORITY MICROPHONE .....                                    | 10        |
| 1.9 WIRELESS MICROPHONE.....  | 10        |
| 1.10 TV TUNER.....  | 10        |
| 1.11 KARAOKE .....  | 10        |
| 1.11.1 Karaoke Panasonic Sound System – MOBILE DVD PLAYER DV1500.....     | 10        |
| 1.12 DRIVER'S SPEAKERS.....   | 10        |
| 1.13 MONITOR.....   | 11        |
| 1.14 SCENIC VIEWING SYSTEM.....   | 11        |
| 1.15 ROOF ANTENNA INSTALLATION .....                                      | 11        |
| <b>2. HUBODOMETER</b> .....   | <b>11</b> |
| 2.1 DESCRIPTION.....  | 11        |
| 2.2 OPERATION .....   | 11        |
| 2.3 REMOVAL .....   | 12        |
| 2.4 INSTALLATION .....  | 12        |
| <b>3. BACK-UP CAMERA AND MONITOR</b> .....                                | <b>12</b> |
| <b>4. COLD STARTING AID (ETHER)</b> .....                                 | <b>12</b> |
| 4.1 PREVENTIVE MAINTENANCE.....   | 12        |
| 4.2 TROUBLESHOOTING (IF SYSTEM IS NON-FUNCTIONING) .....                  | 12        |
| 4.3 THERMAL CUTOUT VALVE QUICK TEST .....                                 | 13        |
| <b>5. DESTINATION SIGN</b> .....  | <b>13</b> |
| 5.1 ELECTRONIC DESTINATION SIGN (OPTIONAL) .....                          | 13        |
| <b>6. LAVATORY</b> .....  | <b>14</b> |
| 6.1 DESCRIPTION.....  | 14        |
| 6.2 MAINTENANCE .....   | 15        |
| 6.3 VENTILATION FAN .....   | 15        |
| 6.3.1 Description .....   | 15        |
| 6.3.2 Maintenance.....  | 15        |
| 6.3.3 Removal and Installation .....                                      | 15        |
| 6.4 DOOR LOCK.....  | 15        |

## Section 23: ACCESSORIES

---

|            |   |           |
|------------|---|-----------|
| 6.5        | LAVATORY LIGHT .....                                  | 15        |
| 6.6        | LAVATORY NIGHT-LIGHT.....                             | 16        |
| 6.7        | EMERGENCY BUZZER.....                                 | 16        |
| 6.8        | FRESH WATER TANK.....                                 | 16        |
| 6.8.1      | <i>Fresh Water Tank Draining</i> .....                | 16        |
| 6.8.2      | <i>Fresh Water Tank Filling</i> .....                 | 18        |
| 6.9        | LIQUID SOAP DISPENSER .....                           | 18        |
| 6.10       | FLUSH PUSH-BUTTON .....                               | 18        |
| 6.10.1     | <i>Pneumatic Timer Removal and Installation</i> ..... | 18        |
| 6.10.2     | <i>Timer Adjustment</i> .....                         | 18        |
| 6.11       | FLUSH PUMP .....                                      | 19        |
| 6.11.1     | <i>Flush Pump Removal</i> .....                       | 19        |
| 6.12       | SUMP TANKS .....                                      | 19        |
| 6.12.1     | <i>Main Sump Tank Draining</i> .....                  | 19        |
| 6.12.2     | <i>Main Sump Tank Filling</i> .....                   | 19        |
| 6.12.3     | <i>Auxiliary sump Tank Draining</i> .....             | 19        |
| <b>7.</b>  | <b>AIR HORN VALVE .....</b>                           | <b>20</b> |
| 7.1        | AIR HORN VALVE MAINTENANCE.....                       | 20        |
| <b>8.</b>  | <b>HEADLIGHTS CLEANING SYSTEM.....</b>                | <b>20</b> |
| 8.1        | GENERAL DESCRIPTION .....                             | 20        |
| 8.2        | WASHER FLUID REFILLING.....                           | 20        |
| 8.3        | WASHER NOZZLES ADJUSTMENT .....                       | 20        |
| <b>9.</b>  | <b>WINDSHIELD WIPERS AND WASHERS .....</b>            | <b>21</b> |
| 9.1        | GENERAL DESCRIPTION .....                             | 21        |
| 9.2        | WIPER ARM .....                                       | 22        |
| 9.2.1      | <i>Wiper Arms Positioning</i> .....                   | 22        |
| 9.3        | WINDSHIELD WIPER MOTOR.....                           | 23        |
| 9.3.1      | <i>Windshield Wiper Motor Replacement</i> .....       | 23        |
| 9.4        | TROUBLESHOOTING .....                                 | 24        |
| <b>10.</b> | <b>TIRE PRESSURE MONITORING SYSTEM (TPMS) .....</b>   | <b>25</b> |
| 10.1       | TIRE VALVE INSTALLATION.....                          | 25        |
| 10.2       | BERU SENSORS INSTALLATION .....                       | 26        |
| <b>11.</b> | <b>SPECIFICATIONS .....</b>                           | <b>28</b> |

## ILLUSTRATIONS

|  |    |
|--|----|
| FIGURE 1 : AUDIO-VIDEO PANEL .....               | 4  |
| FIGURE 2: AUDIO & VIDEO CONNECTIONS .....        | 5  |
| FIGURE 3: RACKS ON AUDIO-VIDEO PANEL .....       | 6  |
| FIGURE 4: AUDIO-VIDEO PANEL .....                | 6  |
| FIGURE 5: VR300 CD/AM/FM STEREO RECEIVER .....   | 6  |
| FIGURE 6: DELPHI PREMIUM SATELLITE RADIO .....   | 7  |
| FIGURE 7: VSS-04 SOUND SELECTOR .....            | 7  |
| FIGURE 8: VD-404 MOBILE DVD PLAYER .....         | 8  |
| FIGURE 9: MULTICHANNEL POWER AMPLIFIER .....     | 8  |
| FIGURE 10: CROSSOVER ADJUSTMENT .....            | 8  |
| FIGURE 11: 10CM DUAL CONE SPEAKER .....          | 9  |
| FIGURE 12: V3000 VIDEO CASSETTE PLAYER .....     | 9  |
| FIGURE 13: BOOM-TYPE MICROPHONE .....            | 9  |
| FIGURE 14: HANDHELD PRIORITY MICROPHONE .....    | 10 |
| FIGURE 15: WIRELESS MICROPHONE .....             | 10 |
| FIGURE 16: TUNER CONTROLS DESCRIPTION .....      | 10 |
| FIGURE 17: PANASONIC DV1500 .....                | 10 |
| FIGURE 18: MONITOR MOUNTING .....                | 11 |
| FIGURE 19: SCENIC VIEW CAMERA .....              | 11 |
| FIGURE 20: HUBODOMETER .....                     | 11 |
| FIGURE 21: ENGINE .....                          | 12 |
| FIGURE 22: COLD STARTING AID .....               | 13 |
| FIGURE 23; DESTINATION SIGN – ELECTRONIC .....   | 14 |
| FIGURE 24: LAVATORY .....                        | 14 |
| FIGURE 25: VENTILATION FAN INSTALLATION .....    | 15 |
| FIGURE 26: DOOR LOCK .....                       | 15 |
| FIGURE 27: F/W TANK SERVICE VALVES .....         | 16 |
| FIGURE 28: FUNCTIONING OF LAVATORY .....         | 17 |
| FIGURE 29: LIQUID SOAP DISPENSER .....           | 18 |
| FIGURE 30: AIR HORN VALVE .....                  | 20 |
| FIGURE 31: HEADLIGHTS CLEANING SYSTEM .....      | 20 |
| FIGURE 32: TUBING AND FITTINGS .....             | 21 |
| FIGURE 33: WASHER NOZZLES ADJUSTMENT .....       | 21 |
| FIGURE 34: MULTIFUNCTION LEVER .....             | 21 |
| FIGURE 35: WINDSHIELD WASHER RESERVOIR .....     | 21 |
| FIGURE 36: WINDSHIELD WIPER INSTALLATION .....   | 22 |
| FIGURE 37: WINDSHIELD WIPER (MOTOR SIDE) .....   | 22 |
| FIGURE 38: WINDSHIELD WIPER (DRIVER SIDE) .....  | 22 |
| FIGURE 39: DRIVING MECHANISM (DRIVER SIDE) ..... | 23 |
| FIGURE 40: DRIVING MECHANISM (MOTOR SIDE) .....  | 23 |
| FIGURE 41: WIPER ARMS POSITIONING .....          | 24 |

### 1. AUDIO AND VIDEO SYSTEM DESCRIPTION

The rack mounted components are gathered on the audio-video panel which is located in the first driver's side overhead compartment (Fig. 1). In addition to the power amplifier, options for AM/FM stereo radio and satellite radio, CD changer, karaoke, wireless microphone, DVD and videocassette player, scenic view and back-up camera system and GPS Navigation System module may be featured.

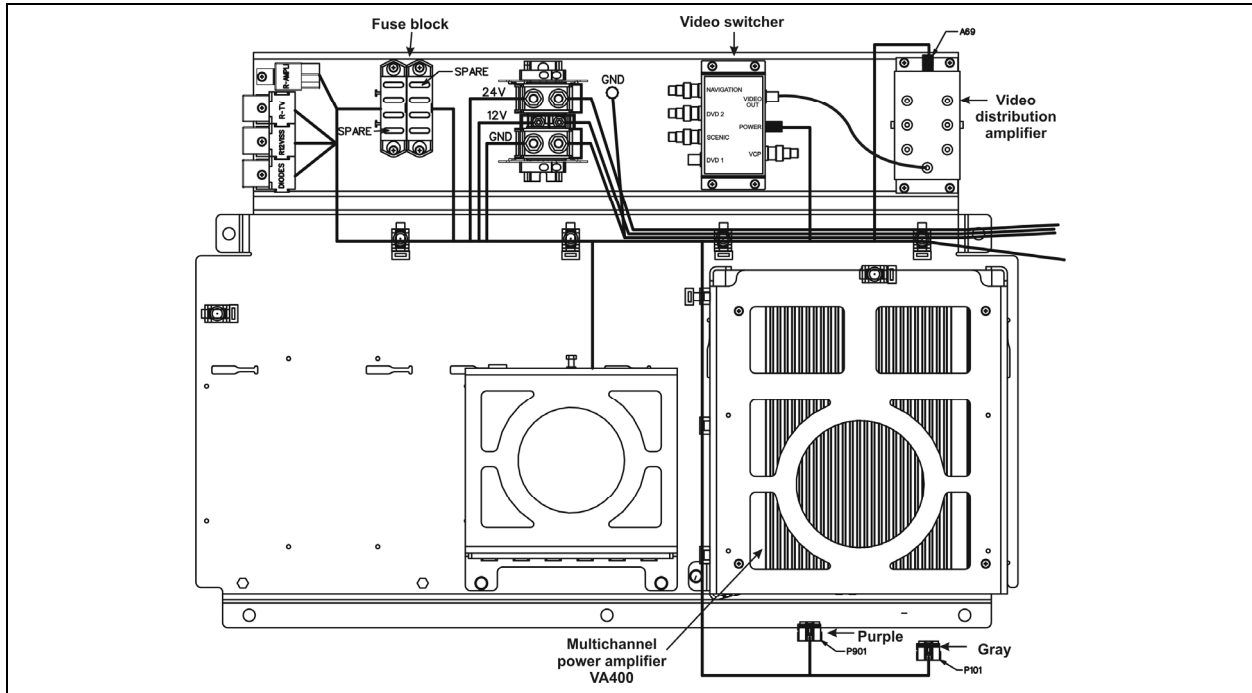


FIGURE 1 : AUDIO-VIDEO PANEL

Each service module mounted to the underside of the parcel racks contains a 40-watt speaker. The speakers in the passenger section are wired in stereo and are powered by the amplifier. A microphone outlet mounted in the driver's area is provided as standard equipment.

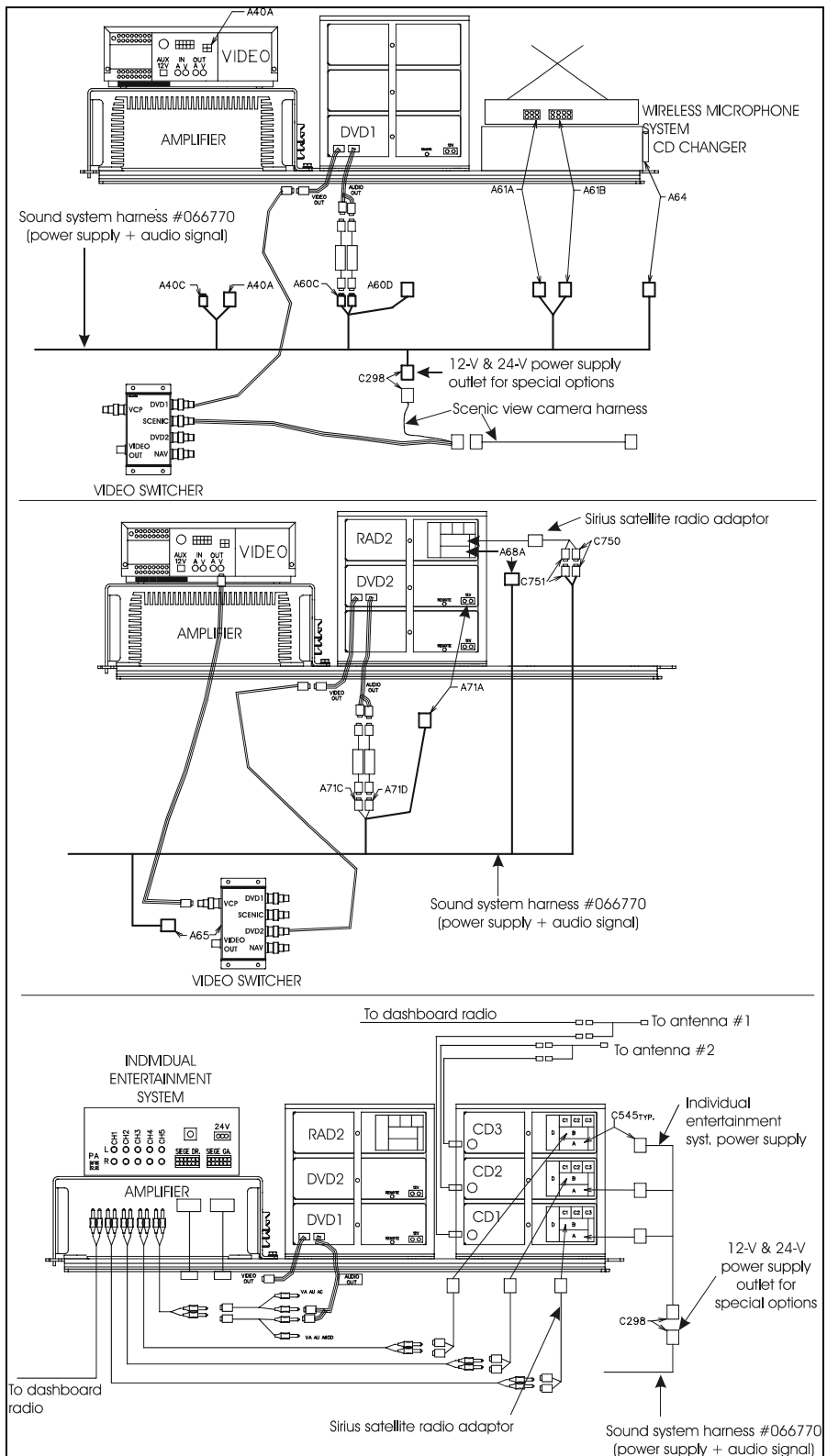


FIGURE 2: AUDIO & VIDEO CONNECTIONS



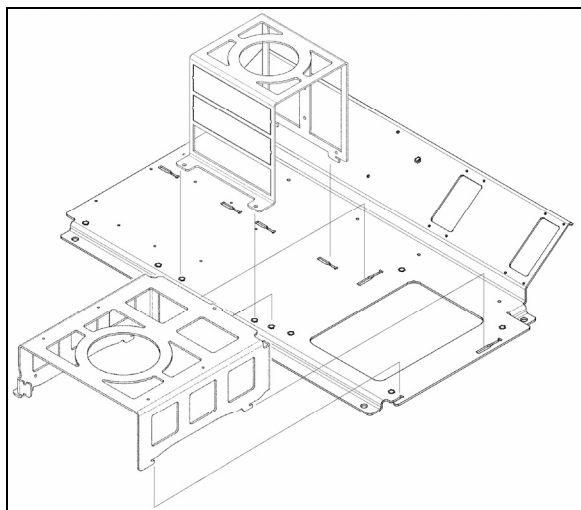


FIGURE 3: RACKS ON AUDIO-VIDEO PANEL 23059

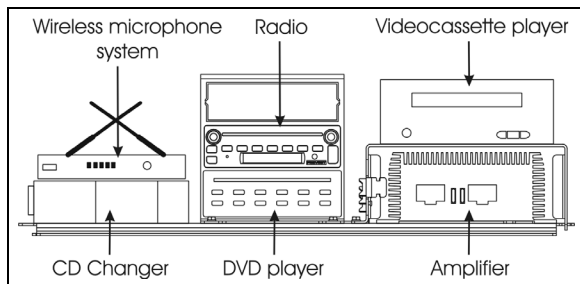


FIGURE 4: AUDIO-VIDEO PANEL

### 1.1 AM/FM RADIO

#### 1.1.1 VR300 AM/FM Radio / CD Player

This AM/FM/WX (weather band) radio CD player model has external CD changer capability (Fig. 4).

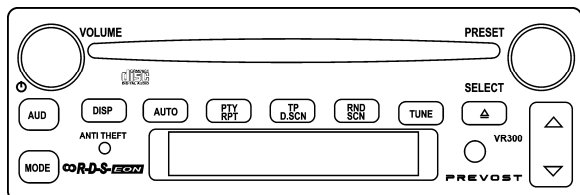


FIGURE 5: VR300 CD/AM/FM STEREO RECEIVER 23351

**NOTE**

*Before attempting to solve an electrical problem on the sound system, refer to the wiring diagrams.*

“VR300 Operating Instruction” manual is included at the end of this section. The radio is a serviceable component and should only be serviced by a qualified electronics technician.

Features:

- CD changer control
- Anti-theft
- Auto preset memory
- LED illumination
- Liquid crystal display
- Amber illumination
- Panel light dimming
- Quartz clock
- Mute function
- Search & repeat
- Track scan
- AUX input
- 4x20W power
- 4 low level outputs

#### 1.1.2 Security Code

Your radio is protected by a security code. The security code can be found on a label delivered with the radio. The security code cannot be changed.

When the radio power is first turned on after power has been interrupted, “ID CHECK” and then “LOCK” is displayed for 3 seconds. Then “0000” is displayed.

To unlock the radio, enter the four-digit security code found on the removable label (refer to “VR300 Operating Instruction” manual).

If the code is entered correctly, the radio will switch to the last active mode (i.e. FM, CD, etc.) and is ready to use. If the code is entered incorrectly, you can try 2 more times. After 3 incorrect entries, the radio will display “LOCK.” You must turn the radio off, while leaving the ignition and battery on, for 1 continuous hour before attempting to unlock the radio again.

#### 1.1.3 Removal

To remove the radio from its location, proceed as follows:

1. Place the ignition switch in the “OFF” position.
2. Remove the dashboard panel cover.
3. Disconnect the electrical cable connectors from radio and unfasten back plate securing nut.
4. To separate the radio from its support, insert the U shaped tool in the two pairs of holes found each side of the radio front panel.
5. Push the unit through the front dashboard panel.
6. Install a new unit by reversing the procedure.

**NOTE**

Remember that because power has been interrupted during removal, the radio must be unlocked by entering the four-digit security code after reinstallation.

### 1.1.4 DELPHI Premium Satellite Radio AM/FM/MP3 CD stereo (OPTIONAL)

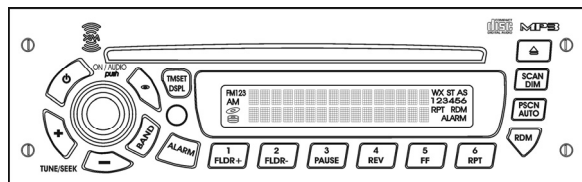


FIGURE 6: DELPHI PREMIUM SATELLITE RADIO 23355

This XM or SIRIUS satellite radio receiver can be located on the dashboard, replacing the standard radio or inside the first driver's side overhead compartment, where many radio can be installed.

#### Features:

- Satellite radio ready with weather band
- 7-channel weather band
- 18 FM & 6 AM presets
- Steering wheel control compatible
- Anti-theft
- Auto preset solutions
- MP3 playback capability
- LED illumination
- Liquid crystal display
- Quartz clock
- Single disc
- Random & repeat play modes
- SDARS receiver compatible
- AUX inputs
- 4x17W power

The complete operating instruction manual is included in your vehicle's *technical publications box*.

## 1.2 VSS-04 SOUND SELECTOR

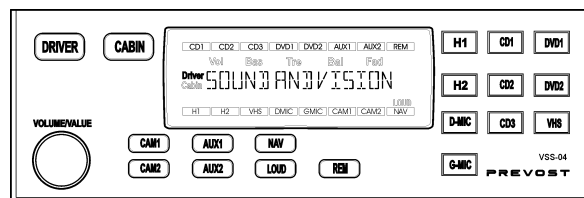


FIGURE 7: VSS-04 SOUND SELECTOR 23350

The VSS-04 Sound Selector enables the driver to select different audio or audio-video entertainment sources for the driver area and the passengers' area. The driver may be listening to the radio and watching the Navigation System route information on the monitor while the passengers may be watching a movie from the DVD player.

With this unit, you can adjust each audio source sound settings (e.g. volume, bass, treble, balance, fade).

#### Features:

##### 7 audio sources

- Radios (2)
- Microphones (2)
- CD players (3)

##### 5 audio-video sources

- DVD players (2)
- VCR (1)
- Auxiliary (2)

##### 3 video sources

- cameras (2)
- GPS Navigation system (1)

### 1.2.1 Removal

To remove the Sound Selector from its location, proceed as follows:

1. Place the battery master switch in the "OFF" position.
2. Remove the dashboard panel cover.
3. Disconnect the electrical cable connectors from unit and unfasten back plate securing nut/screw.
4. To separate the Sound Selector from its support, insert a flat screwdriver each side of the unit front panel.
5. Push the unit through the front dashboard panel.
6. Install a new unit by reversing the procedure.

The operating instructions are included in your Operator's Manual.

## Section 23: ACCESSORIES

### 1.3 VD-404 MOBILE DVD PLAYER



FIGURE 8: VD-404 MOBILE DVD PLAYER

The MOBILE DVD PLAYER is located in the first parcel compartment on the driver's side. Instructions for proper use of this unit are included at the end of this section.

Features:

- **POWER**  
Operating voltage: 12-volt DC
- **COMPATIBILITY**  
This DVD player can play the following disc formats:  
DVD, CD, VCD, DVCD, MP3, CD-R, CD-RW
- **SYSTEM FUNCTIONS**  
Video output system: system MULTI, NTSC or PAL switchable.
  - 1 L/R audio output
  - 1 L/R audio input
  - 1 AUX video output
  - 1 rear camera video input
  - 3 video outputs with one dedicated self switching rear view monitor
- **ADDITIONAL VIDEO FEATURES**  
Multi-angle, multi-view, multi-audio function, multi-level forward and backward motion, play position memory, resume stop and repeat function.

### 1.4 MULTICHANNEL POWER AMPLIFIER VA400.8

This 400-watt, 6-channels brings an added dimension to your stereo equipment and increases the total output of the system.

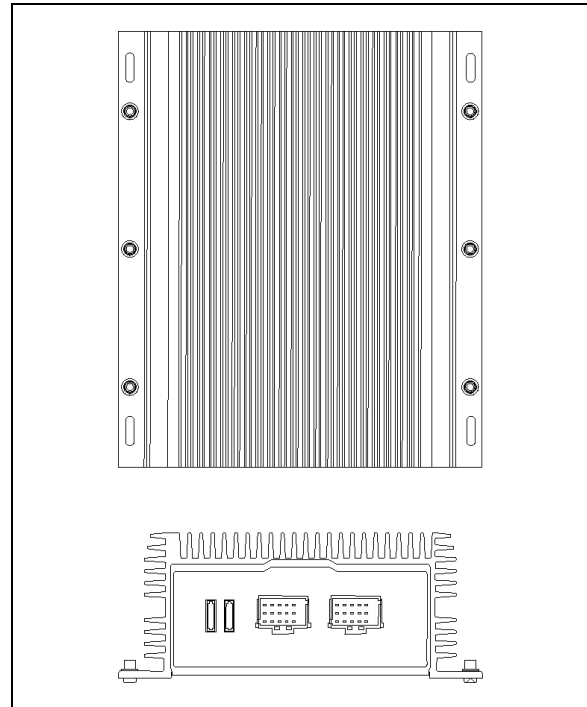


FIGURE 9: MULTICHANNEL POWER AMPLIFIER

For optimum sound quality, adjust the subwoofer crossover filter as shown on figure 10. This adjustment is necessary to balance the subwoofers volume in respect to the other speakers and also to cut high frequencies for a better sound quality.

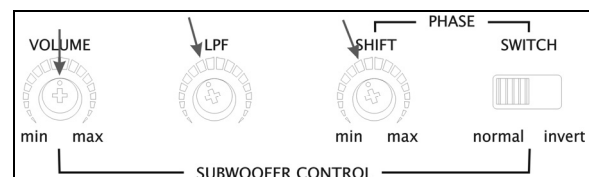


FIGURE 10: CROSSOVER ADJUSTMENT

### 1.5 SPEAKERS

Each passenger's overhead console mounted to the underside of the parcel racks contains a 20-watt Dual Cone 10cm speaker. The speakers in the passenger's section, wired in stereo and arranged in a delta configuration are powered by the amplifier.



FIGURE 11: 10cm DUAL CONE SPEAKER

The vehicle may be equipped with two additional Hi-Fi speakers in the driver's area, mounted one on each side. This arrangement provides the driver with clear stereo sound. Controls for the driver's audio allow selection between the radio and the auxiliary audio (independent of the passenger's speakers) or muting the speakers.

Two specially designed subwoofers may be fixed as an option under a passenger seat with anti-vibration supports.

## 1.6 VIDEO CASSETTE PLAYER (VCP)

The optional VCP is located on the audio-video panel in the first overhead compartment. Instructions for proper use of the VCP are provided in the technical publication box.



FIGURE 12: V3000 VIDEO CASSETTE PLAYER

### 1.6.1 Removal

1. Place the ignition switch in the "OFF" position.
2. Remove the VCP/VCR mounting locknuts from rubber mounts.
3. Disconnect wiring.
4. Remove VCP/VCR unit from parcel compartment.

### 1.6.2 Installation

1. Install VCP/VCR unit into parcel compartment aligning rubber mount studs with mounting holes. Insert mount studs through mounting holes.
2. Install locknuts on mount studs.
3. Reconnect wiring.
5. Place the battery master switch in the "ON" position.

## 1.7 BOOM-TYPE MICROPHONE

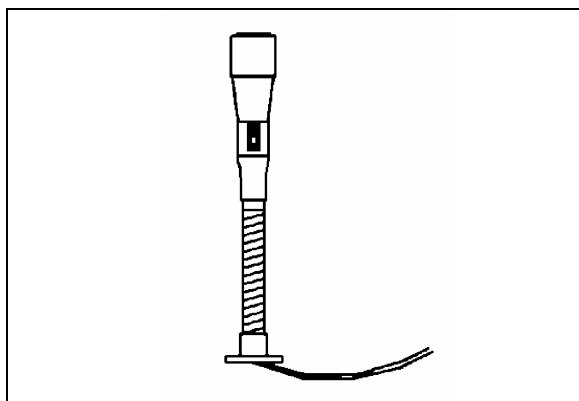


FIGURE 13: BOOM-TYPE MICROPHONE

23083

### 1.7.1 Removal

1. Place the ignition switch in the "OFF" position.
2. Remove the mounting screws at mounting flange.
3. Disconnect wiring.

### 1.7.2 Installation

1. Reconnect wiring.
2. Align mounting flange with holes and install screws.
3. Remove spacer block mounting screws.
4. Insert spacer block and install mounting screws.
5. Place the battery master switch in the "ON" position.

1.8 HANDHELD PRIORITY MICROPHONE

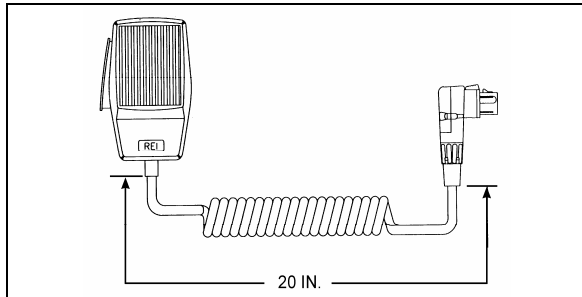


FIGURE 14: HANDHELD PRIORITY MICROPHONE 23216

1.9 WIRELESS MICROPHONE

The system 2000 16 channel wireless microphone, Receiver and Charging Cradle are custom designed units that allow for wireless PA communication from anywhere on the coach. The unit consists of a receiver mounted in the parcel area directly behind the driver, and a rechargeable hand-held microphone and charging unit. Instructions for proper use of the microphone are included in the "REI Operating Manual" which is provided in the technical publications box delivered with the vehicle.

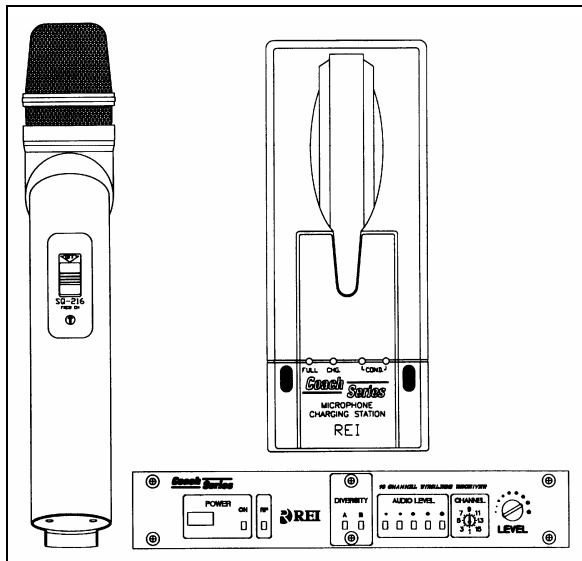


FIGURE 15: WIRELESS MICROPHONE

1.10 TV TUNER

For TV tuner control descriptions, refer to fig. 16.

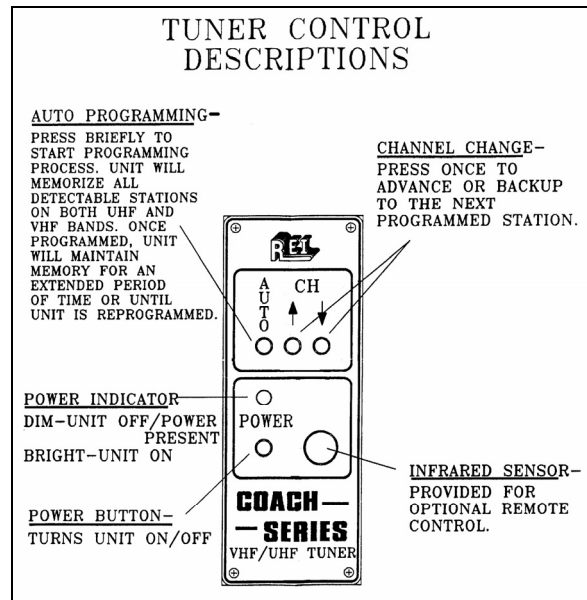


FIGURE 16: TUNER CONTROLS DESCRIPTION

1.11 KARAOKE

The modified Panasonic DVD Player powers up automatically when the video system is activated. The unit can be controlled with the plug-in remote control, or the control head, which has access to the PLAY and STOP commands.

If so equipped, instructions for proper use of the Karaoke system are included in the "Operating Manual" that is provided in the technical publications box delivered with the vehicle.

1.11.1 Karaoke Panasonic Sound System – MOBILE DVD PLAYER DV1500

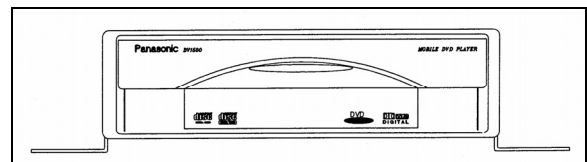


FIGURE 17: PANASONIC DV1500

1.12 DRIVER'S SPEAKERS

The driver's speakers are mounted one on each side. This arrangement provides the driver with clear stereo sound. Controls for the driver's audio allow selection between the radio and the auxiliary audio (independent of the passenger's speakers) or muting the speakers.

1.13 MONITOR

1. Place the ignition switch in the "OFF" position.
2. Unfasten the retaining screw located on the monitor R.H. side.
3. Slide the monitor to the right to release it from the mounting bracket.

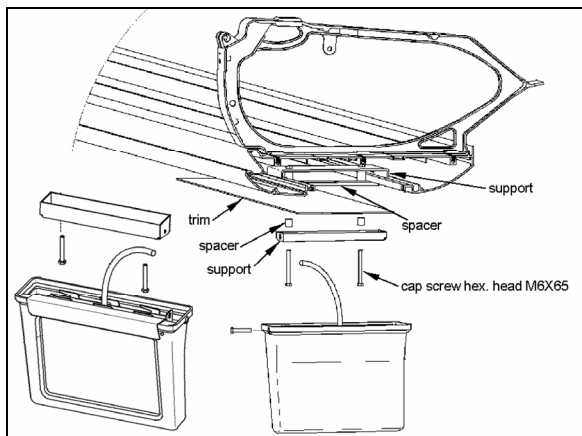


FIGURE 18: MONITOR MOUNTING 23221

1.14 SCENIC VIEWING SYSTEM

The scenic viewing system enables the passengers to view the road ahead of the vehicle. This system is composed of a camera, a dashboard mounted ON/OFF switch and the video switcher located on the audio-video panel (Figs. 1 & 19).



FIGURE 19: SCENIC VIEW CAMERA

1.15 ROOF ANTENNA INSTALLATION

1. Find the desire location and drill a hole according to specification.
2. To remove dirt and grease, wash hole edge with alcohol.

3. If so equipped, remove foam padding ring from antenna to free the metal surface (foam can produce air bulbs in new rubber seal).
4. With SIKA 205, wash the opening edge and the antenna base surface, wait at least two (2) minutes for chemical evaporation.
5. Apply new seal SIKA 221 on both, vehicle hole edge and antenna base.
6. Fix the antenna in place.
7. Remove excess seal and complete a finishing joint all around the antenna base.

2. HUBODOMETER

2.1 DESCRIPTION

An optional wheel hubodometer (Fig. 20) may have been installed on the R.H. side of the drive axle. It indicates the total distance in miles or kilometers covered by the coach since it has left the factory, including road testing.

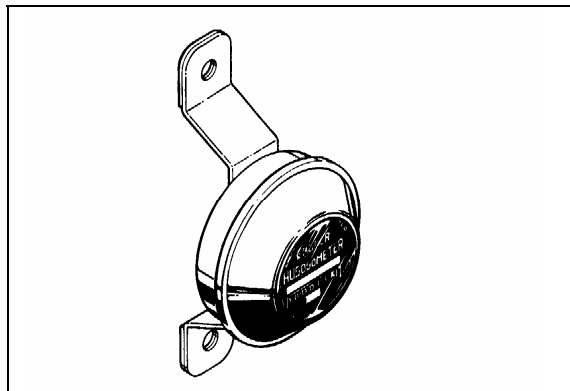


FIGURE 20: HUBODOMETER 23024

2.2 OPERATION

The hubodometer is calibrated for a specific wheel size (diameter). Wheel rotation causes a mechanism inside the hubodometer to record distance after a predetermined number of rotations. The unit should be serviced at a competent speedometer repair facility.

**NOTE**

*Do not use paint, solvent or thinner on hubodometer face or on plastic hubcaps. Do not weld on hubodometer.*

### 2.3 REMOVAL

To remove the unit, remove the two lock nuts and washers securing it to the wheel hub, and pull the unit off the studs.

### 2.4 INSTALLATION

Place the hubodometer unit over the wheel hub studs. Replace the lock washers and nuts. Torque stud nuts to 110-165 Lbf-ft.(150-225 Nm).

## 3. BACK-UP CAMERA AND MONITOR

An optional back-up camera is available which provides the driver with visual assistance when backing-up. The camera is automatically activated when the transmission is put in reverse gear and the ignition switch is "ON". The TV monitor is mounted on top of the dashboard. Refer to the Operator's Manual under "Controls & Instruments".

## 4. COLD STARTING AID (ETHER)

The vehicle can be equipped with an electrically-operated type ether cold starting aid designed to ease engine starting when temperature is low.

On vehicles equipped with cold starting aid, the system consists of the main following parts:

- Ether starting aid switch
- Ether cylinder
- Solenoid valve (24 V)
- Thermal cutout valve
- Atomizer

The control rocker switch is located on the dashboard. This switch is provided with a locking mechanism to avoid accidental use when engine is running. To activate the ether starting aid, proceed as follows:

1. Prior to cranking engine, press down rocker switch for three seconds to fill solenoid valve.
2. Release switch to discharge shot.
3. Allow three seconds for shot to discharge.
4. Start engine, use additional shots if necessary to keep engine running.



### CAUTION

This practice should be performed only when absolutely necessary. Excessive use of fluid could result in serious engine damage.

The ether cylinder and solenoid valve assembly are mounted on the engine compartment wall and are accessible from the engine compartment R.H. side door.

The thermal cutout valve is mounted on the engine (radiator side). Its function is to prevent discharge of ether when engine is warm (over 90°F (32°C)). The atomizer is installed on top of the air intake duct (Fig. 21).

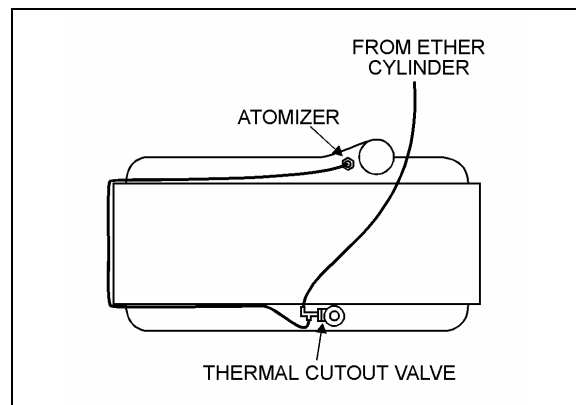


FIGURE 21: ENGINE

23032

### 4.1 PREVENTIVE MAINTENANCE

During the summer months, remove cylinder to avoid high temperature actuation of the cylinder safety relief device. Always screw valve cap into solenoid valve opening to prevent entrance of road dirt. When removing cylinder, be careful to prevent dirt from entering the valve.

### 4.2 TROUBLESHOOTING (IF SYSTEM IS NON-FUNCTIONING)



### DANGER

During the following test, direct free end of tube away from personnel and all sources of ignition as this fuel is extremely flammable. Avoid breathing vapors and contacting fuel with skin. Never smoke during test.

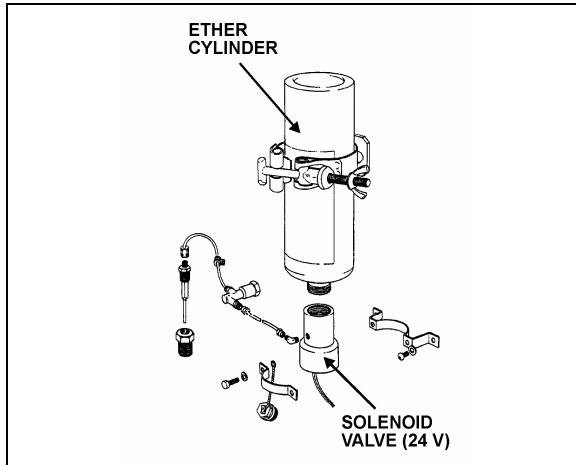


FIGURE 22: COLD STARTING AID

23048

1. Check cylinder for hand tightness and fuel supply (Fig. 22). Empty cylinder weight is approximately 17 oz (480 g); full cylinder weight is approximately 35 oz (990 g). If cylinder is empty, replace it. Before replacing cylinder, install new valve gasket in solenoid valve.
2. If still not functioning, disconnect tubing at solenoid valve fitting. Actuate solenoid valve. (Ask an assistant to actuate solenoid valve using the rocker switch on the dashboard).
  - If solenoid valve is non-functioning, check electric circuit, (refer to wiring diagrams). If sound, remove and replace the solenoid valve. If not, repair electric circuit.
  - If valve is functioning, reassemble valve fitting and connect tube. Disconnect tube at thermal cutout valve from port "Tube from valve".
3. Actuate the solenoid valve.
  - If fuel is not discharged from tube, remove tube and blow out or replace.
  - If fuel is discharged, connect tube to thermal cutout valve, and disconnect other tube.
4. Actuate the solenoid valve.
  - If fuel is not discharged, replace the cut-out valve.

**NOTE**

*If engine coolant temperature is 90°F (32°C) or over, it is normal that fuel is not discharged as the valve is in closed position.*

- If fuel is discharged, connect tube to thermal cutout valve, and disconnect tube from atomizer.

## 5. Actuate the solenoid valve.

- If fuel is not discharged from tube, fuel line is clogged. Remove tube and blow out or replace.
- If fuel is discharged, replace the atomizer.

## 4.3 THERMAL CUTOUT VALVE QUICK TEST

1. Engine coolant temperature must be below 90°F (32°C).
2. Temporarily disconnect tube at thermal cutout valve from port "Tube to atomizer".
3. Actuate solenoid valve (Ask an assistant to actuate solenoid valve by means of the rocker switch on the dashboard). Fuel should be discharged through the thermal cutout valve.

**DANGER**

Avoid breathing vapors and contacting fuel with skin. Never smoke during test.

4. Reconnect tube to thermal cutout valve.
5. Start engine, using cold starting aid if necessary. Stop engine when it reaches operating temperature.
6. Disconnect tube at thermal cutout valve as in step 2, and repeat step 3. No fuel should be discharged.

## 5. DESTINATION SIGN

## 5.1 ELECTRONIC DESTINATION SIGN (OPTIONAL)

The destination sign is located at upper front of the vehicle. To change the destination, depress the selecting switches until the desired destination appears in the LCD display.



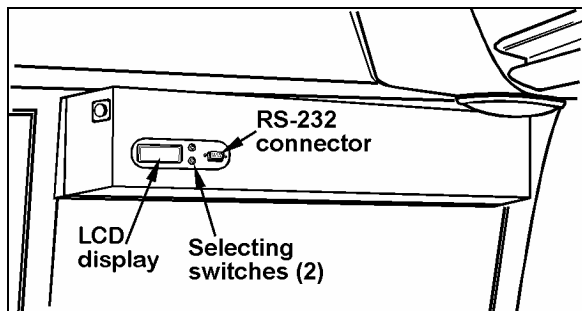


FIGURE 23; DESTINATION SIGN – ELECTRONIC 23123

**NOTE**

The destination sign must be programmed with a computer connected to the RS-232 connector prior to first use. Follow the instructions on the computer disk to install and run the software.

**NOTE**

The destination sign is equipped with lights (bulb light or fluorescent) which illuminates automatically when the headlight or fog light switch is activated.

**6. LAVATORY**

**6.1 DESCRIPTION**

The lavatory is located in the rear R.H. corner of the coach. It is equipped with a chemical flush toilet, bathroom tissue dispenser, washbasin, towel dispenser, waste container, mirror, ashtray, and a cleaning cabinet. A liquid soap dispenser and moist towel dispenser are optional.

Locking the lavatory door from the inside will illuminate a fluorescent light in the lavatory and two outside signs to indicate occupation. One sign is located on the outer wall of the lavatory and another sign is located over the windshield. An indicator light on the dashboard will illuminate to inform the driver when the lavatory is occupied. A night-light is permanently lit in the lavatory when the ignition switch is in the ON position.

If emergency assistance is required, the lavatory occupant can actuate a buzzer that will sound in driver's area. The buzzer's push-button (c/w instruction label) is located on the inner curbside wall of lavatory.

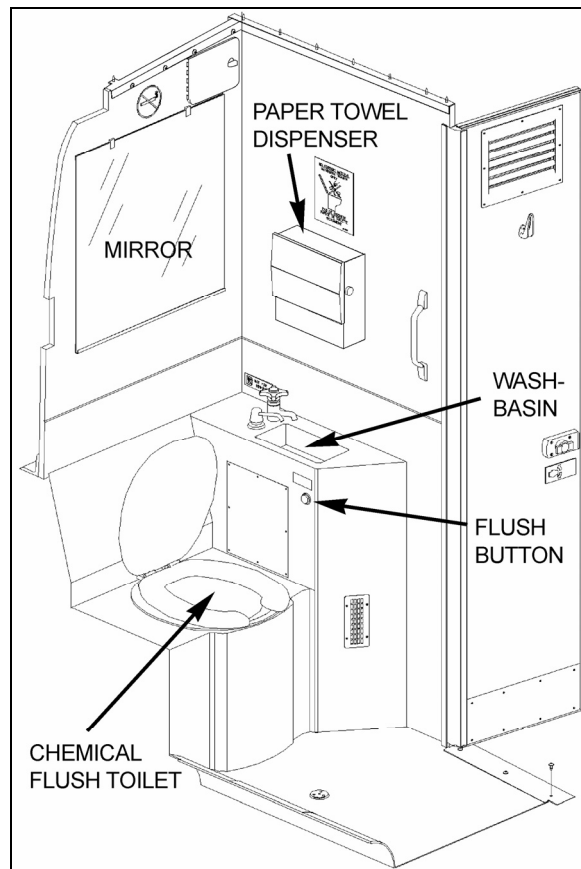


FIGURE 24: LAVATORY 23235

The lavatory has its own ventilation system that operates only when ignition switch is in the "ON" position. An auxiliary sump tank (Fig. 28) (optional) allows main tank to be drained by manually opening an interconnecting tank valve (5, Fig. 27). Lavatory can then be operated for longer periods until coach can be serviced at a facility equipped for disposal.

The fresh water tank, located behind compartment mirror (Fig. 28), is equipped with a thermal drain valve that will drain the tank when water temperature approaches the freezing point preventing damage to the tank (Fig. 28). The fresh water supplies water to the washbasin by gravity. Two tubes are connected on top of the tank. One serves as overflow as well as a vent tube and runs along the curbside wall to the engine compartment R.H. side (6, Fig. 27) while the other tube is connected to the fresh water fill connection which is also located in engine compartment R.H. side (1, Fig. 27). A third tube connected in the bottom of the fresh water tank allows fresh water to flow to the washbasin faucet. Water from washbasin drain tube flows to the main sump tank.

Also, a drain hole located on lavatory floor drain water splashed on the floor to the engine compartment R.H. side.

## 6.2 MAINTENANCE

The servicing procedure for the lavatory is described in the "Operator's Manual" included in the technical publications box delivered with the vehicle.

## 6.3 VENTILATION FAN

### 6.3.1 Description

The lavatory ventilation fan, mounted in engine compartment behind the oil reserve tank (Fig. 25), serves two purposes. It exhausts objectionable odors and provides a constant air circulation in the lavatory compartment by heating or cooling the lavatory with the vehicle ambient air. Air flows in the lavatory compartment through a vent grill located on the lavatory door and exhausts through a grill located next to the toilet.

#### **NOTE**

*This fan runs constantly when the ignition switch located on the dashboard is in the "ON" position.*

### 6.3.2 Maintenance

The frequency of preventive maintenance should be determined according to vehicle mileage and operating conditions. However, it is recommended to check this item every 50,000 miles (80 000 km) or once a year, whichever comes first.

Remove fan and motor assembly. Check for fan housing wheel and motor free operation. When defective motor occurs, new motor must be installed.

### 6.3.3 Removal and Installation

1. With the engine compartment rear doors opened, remove hose clamp securing duct to ventilation fan inlet, and disconnect duct.
2. Disconnect the ventilation motor wiring connector.
3. Remove the support bracket screw. Remove the three bolts fixing the ventilation fan housing support. Remove the ventilation fan assembly from its location.

4. The unit can now be disassembled and motor replaced.
5. Reverse previous steps to reinstall ventilation fan assembly on vehicle.

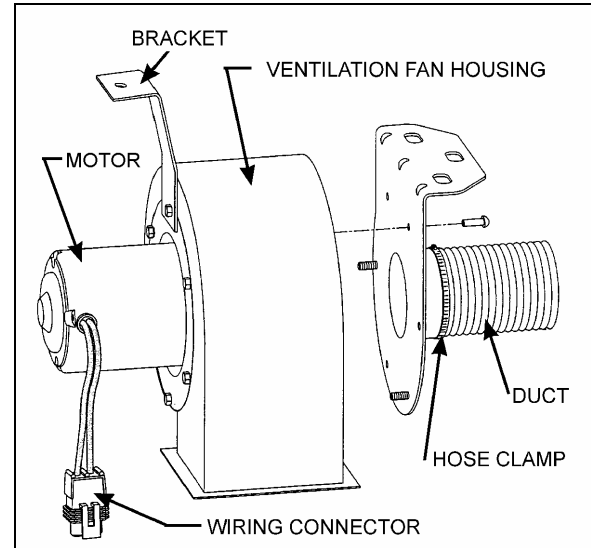


FIGURE 25: VENTILATION FAN INSTALLATION 23222

## 6.4 DOOR LOCK

Lavatory door lock has inside and outside handles, as well as an inside latch to lock door from inside the compartment. If the lock fails to release, the door can be opened from the outside using a special key which is supplied to the driver. Lock assembly can be removed from the door, then readily disassembled and parts replaced, if necessary (Fig. 26). A thin coat of lubricant on all moving parts will ensure trouble-free operation.

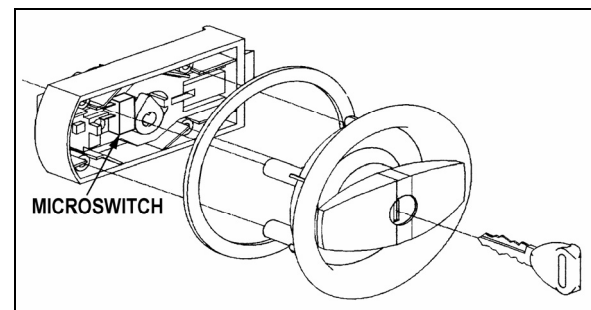


FIGURE 26: DOOR LOCK 23320

## 6.5 LAVATORY LIGHT

The lavatory light is installed on ceiling. A microswitch, which is mounted inside the latch housing, is activated by the door lock mechanism upon locking to energize the circuit. This switch is readily serviced by removing the

## Section 23: ACCESSORIES

four Phillips-head screws securing the housing to the door interior frame.

Proceed as Section 06, Electrical System, *Dome, Rear Roof and Lavatory Lights* for lights replacement.

### 6.6 LAVATORY NIGHT-LIGHT

The lavatory night-light is illuminated as soon as the ignition switch is set to the "ON" position. See Section 06, Electrical System, *Parcel Rack / Lavatory Night Light - "Bulb Removal and Replacement"* for lights replacement.

### 6.7 EMERGENCY BUZZER

The lavatory emergency buzzer is mounted on the inner curb side wall of lavatory and sounds when the emergency call push-button switch in the lavatory compartment is activated. For specific wiring information, refer to wiring diagrams. To remove the emergency call push-button switch, proceed as follows:

1. Remove both Phillips-head screws retaining pushbutton switch plate to wall.
2. Remove steel plate located on L.H. side of pushbutton switch.
3. Remove switch through this opening, taking care to disconnect electric wires.

### 6.8 FRESH WATER TANK

One panel allows access to the fresh water tank. It is located behind the toilet mirror. Remove the tank as follows:

1. Remove the mirror.
2. Remove the fresh water tank tubing, bolts, and different connectors.
3. Remove the tank from the wall.
4. Reverse previous steps to reinstall fresh water tank assembly on vehicle.

#### 6.8.1 Fresh Water Tank Draining

The fresh water tank can be drained by simply opening the fresh water drain cock (Fig. 27). Don't forget to close cock when draining is done.

#### **NOTE**

*The fresh water reservoir is equipped with a thermal valve which is set to open at about 35°F, thereby automatically draining the reservoir in near-freezing temperatures.*

Routine draining and filling of lavatory tanks should be performed by maintenance personnel only. If engine or heating failure occurs in extreme weather conditions, emergency draining of water tanks should be performed under the most suitable conditions and should at all times be supervised by driver.

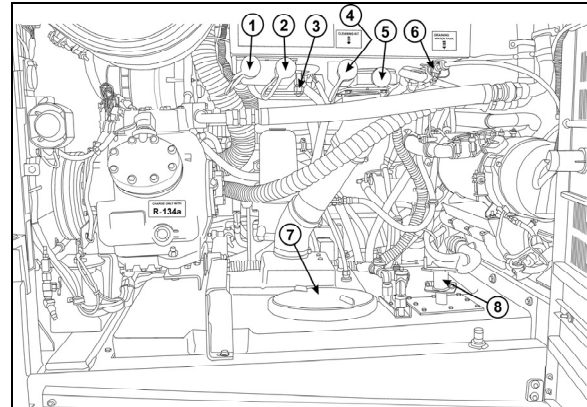


FIGURE 27: F/W TANK SERVICE VALVES

23378

- 1..... Fresh water tank fill connection
- 2..... Main sump tank fill connection
- 3..... Main sump tank overflow cock
- 4..... Cleaning kit hose connector
- 5..... Main sump tank drain valve
- 6..... Fresh water tank drain cock
- 7..... Auxiliary sump tank access cap
- 8..... Auxiliary sump tank drain valve

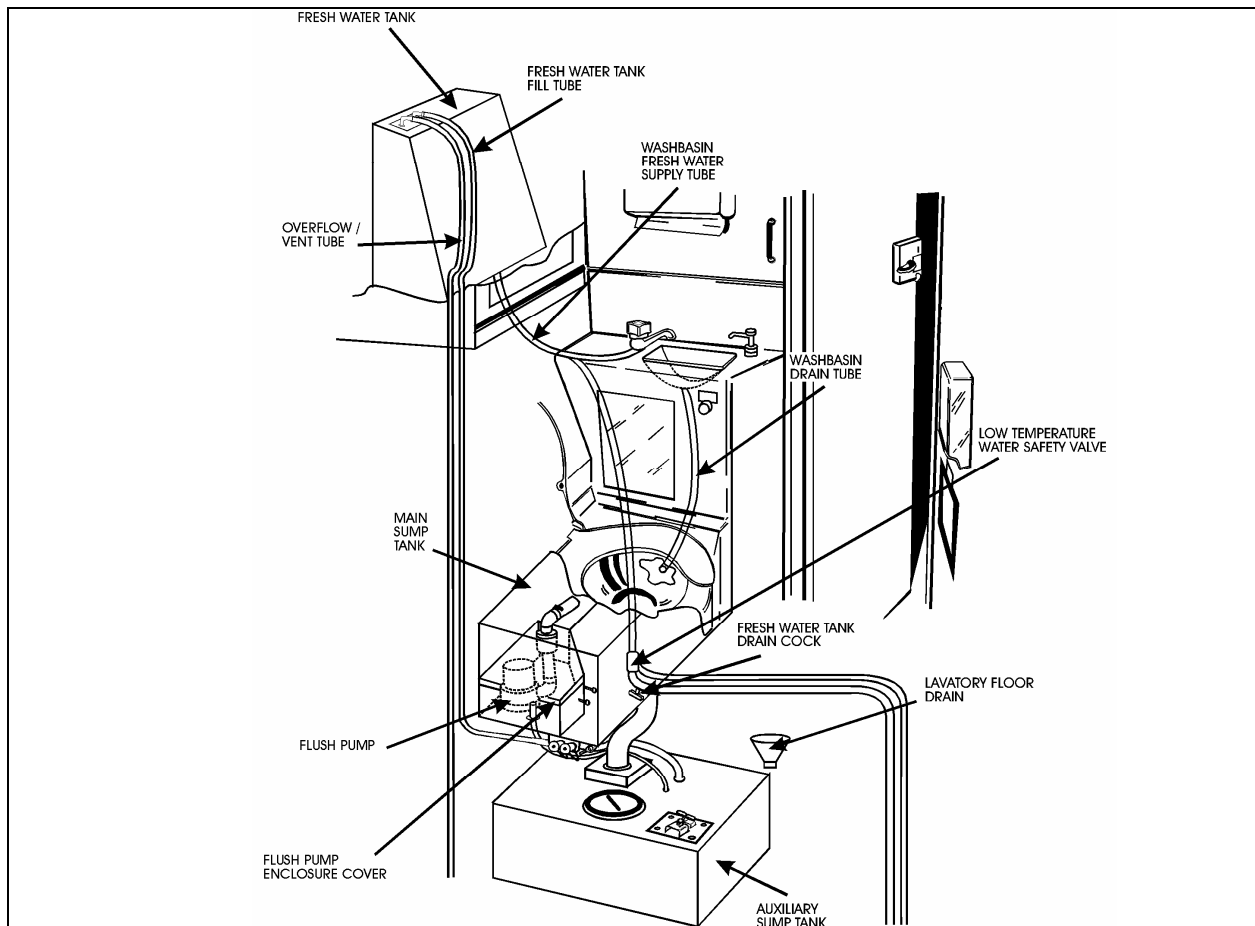


FIGURE 28: FUNCTIONING OF LAVATORY

23051

6.8.2 Fresh Water Tank Filling

Connect the fresh water supply hose to the fresh water reservoir fill connection (Fig. 27) located in the curb-side section of engine compartment. Fill the reservoir until the overflow tube leaks, signaling that the reservoir is full.

**DANGER**

Never put antifreeze in fresh water tank; antifreeze is toxic.

**WARNING**

If tank has not been drained for an extended period of time, draining and filling operations must be repeated three (3) times in order to clean tank and eliminate contaminated water.

6.9 LIQUID SOAP DISPENSER

A liquid soap dispenser may have been installed as optional equipment. To refill dispenser, proceed as follows:

1. Turn cover slightly clockwise until it stops.
2. Lift out piston and spout, cover and supply tube.

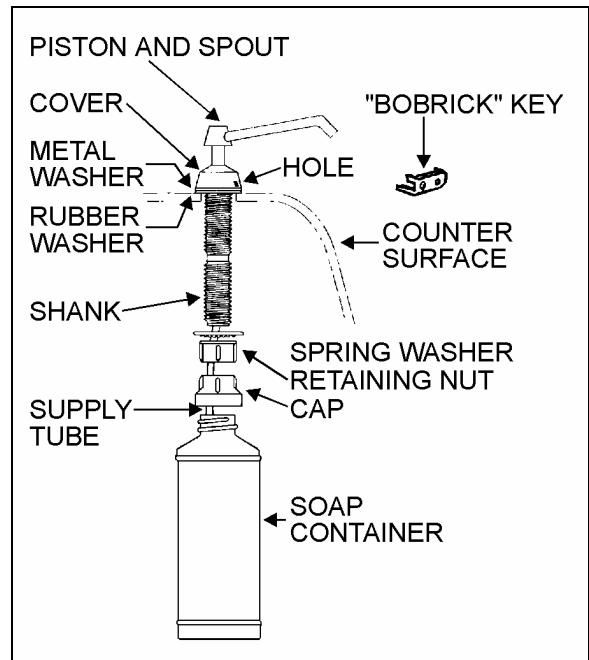


FIGURE 29: LIQUID SOAP DISPENSER 23039

3. Fill dispenser with soap. This model can dispense vegetable oil soaps, synthetic detergents, and lotion soaps.

**CAUTION**

Never use abrasive cleaners.

4. Replace supply tube, piston, and spout mechanism reversing the steps above.
5. Secure the cover by turning clockwise until lock snaps into position.

**NOTE**

The dispenser requires priming when extremely viscous lotion soaps are used. Remove piston and spout, cover and supply tube assembly. Pump water into assembly, then replace into dispenser.

6.10 FLUSH PUSH-BUTTON

The green flush push-button is located near the toilet. Press on push-button to actuate a pneumatic timer located on the other side of wall. This timer allows an electric current flow during a preset time to a pump into the sump tank.

6.10.1 Pneumatic Timer Removal and Installation

1. Unscrew and remove the flush push-button locking ring.
2. Remove steel plate located on L.H. side of pushbutton switch.
3. Remove pneumatic timer through this opening, taking care to disconnect electric wires.

**NOTE**

Care must be taken to avoid losing the spacers installed on the mounting sleeve.

4. Reverse the above procedure to reinstall timer. The recommended torque for the lock nut is 15 Lbf-ft (21 Nm).


6.10.2 Timer Adjustment

Timer can be adjusted from 0.2 second to 3 minutes by turning the time adjustment screw clockwise to increase time, and counterclockwise to decrease time. To gain access to the time adjustment screw, repeat steps 1, 2 and 3 in the previous paragraph "6.10.1 Pneumatic Timer Removal and Installation".

6.11 FLUSH PUMP

The submersible-type flush pump is mounted inside an enclosure in the sump tank (Fig. 28). The enclosure is provided with a screened side which, serves as a strainer to prevent solid matters from entering the pump.

The pump requires no periodic maintenance other than cleaning of the strainer side using a water jet introduced through the circular cap opening, once the sump tank is completely drained. The pump can run dry periodically without damage. However, for maximum seal life, the run dry periods should be kept to a minimum.

|  |
|--|
|  <b>CAUTION</b>   |
| <p>If vehicle is stored for an extended period of time, make sure to clean the strainer as solid matter will tend to pack, and will necessitate replacement of strainer.</p> |

6.11.1 Flush Pump Removal

1. Remove the toilet to gain access to the pump enclosure.
2. Remove the flush pump enclosure cover
3. Unsnap the flush pump.


6.12 SUMP TANKS

6.12.1 Main Sump Tank Draining

When recirculating water in the toilet is soiled, drain main sump tank. If equipped with the optional auxiliary sump tank, drain the main sump tank contents into the auxiliary tank and perform the filling procedure of the main tank.


6.12.2 Main Sump Tank Filling

Open the main sump tank overflow cock and connect a water supply hose to the toilet sump tank fill connection. The main tank is full when water starts flowing through the clear overflow tube. Close main sump tank overflow cock when the tank is full.

|  |
|--|
|  <b>CAUTION</b>                             |
| <p>In cold weather, add 2 gallons (9 liters) of antifreeze (e.g.: ethylene glycol) in the toilet before filling main tank.</p> |


6.12.3 Auxiliary sump Tank Draining


Remove drain cap located under auxiliary sump tank then turn the auxiliary sump tank drain valve lever counterclockwise eight or nine times. Remove the access cap and flush tank with clean water. To close, turn the valve lever several times clockwise until the rubber bladder seals the drain hole. Reinstall access and drain caps.


|  |
|--|
|  <b>CAUTION</b> |
| <p>Lavatory tanks should be serviced only at suitably equipped stations.</p>                     |

|  |
|--|
| <i>NOTE</i>  |
| <p><i>It is unlawful to dump sump tank contents in any location other than those designated as such.</i></p> |

When a full draining is required, clean main tank by repeating the draining and filling operations while leaving the auxiliary sump tank drain cock opened. Close cocks and pour a pack of commercial toilet deodorant (Prévost part #900329) in toilet before adding the antifreeze and starting final filling of main tank.

|  |
|--|
|  <b>WARNING</b>   |
| <p>The toilet deodorant contains products that can be very irritating to skin. Use rubber gloves when handling and then clean toilet seat.</p> |

|  |
|--|
|  <b>WARNING</b> |
| <p>Antifreeze must comply with the effective environmental act.</p>                                |

|   |
|---|
|  <b>CAUTION</b>            |
| <p>When cold weather is expected and there is no antifreeze in the tank, both sump tanks must be drained.</p> |

|  |
|--|
| <i>NOTE</i>  |
| <p><i>If there is no antifreeze solution in the tank, there is less risk of freezing if engine is operating due to the heat it produces.</i></p> |

|   |
|---|
| <i>NOTE</i>   |
| <p><i>New coaches are delivered with the sump and fresh water tanks empty. Fill with water before putting the coach in service.</i></p> |

## 7. AIR HORN VALVE

The air horn valve is located in the front service compartment and the air horn valve button is on the steering wheel center.

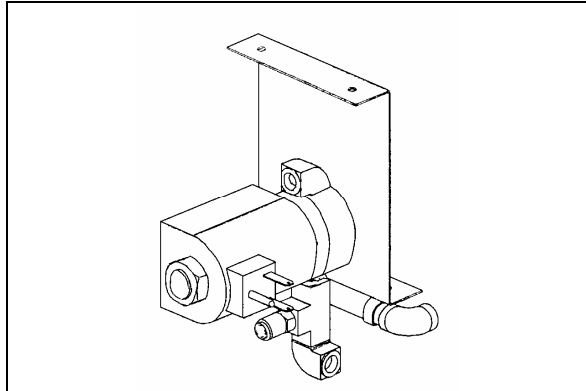


FIGURE 30: AIR HORN VALVE 23230

### 7.1 AIR HORN VALVE MAINTENANCE

When needed, the air horn valve can be serviced or replaced using the following procedure:

1. Unplug the cable connector;
2. Disconnect the air tubes;
3. Loosen the retaining bolts;
4. Service or replace the air horn valve;
5. Reinstall by reversing procedure.

## 8. HEADLIGHTS CLEANING SYSTEM

### 8.1 GENERAL DESCRIPTION

**NOTE**

*When inspecting the headlights cleaning system, check the washer fluid hoses, fittings and connectors to be sure they are properly connected and seal with no restriction to the flow of washer fluid. Check that the washer nozzles are properly aimed.*

The headlights cleaning system is independent from the windshield washer system and has its own washer fluid reservoir located in the front electrical and service compartment. However, this system shares the same telltale light than the windshield washer low level sensor (refer to Operator or Owner's manual for operation). Each pressing of this switch produces 2 successive 0.7 seconds jets.



## CAUTION

Do not operate the headlights washer while the washer fluid reservoir is empty. This may damage the washer fluid pump.

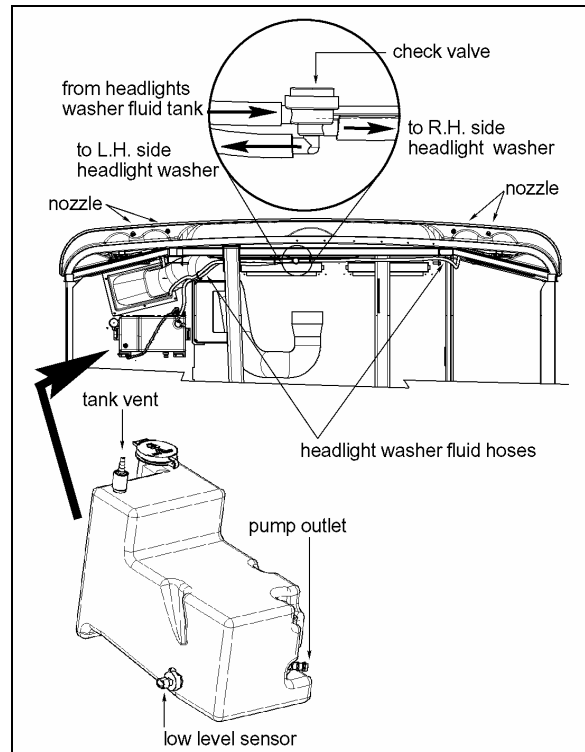


FIGURE 31: HEADLIGHTS CLEANING SYSTEM 23380

### 8.2 WASHER FLUID REFILLING

Open the filler neck cap and add regular windshield washer fluid as required. The tank has a capacity of 10 liters (2.6 US gallons). You may use water or windshield washer fluid as well but, during cold weather days, use windshield washer fluid suitable for freezing temperature only.

### 8.3 WASHER NOZZLES ADJUSTMENT

To avoid waste of washer fluid, assure the fluid jets are properly aimed. Adjust nozzles so they aim as described in figure 33. Align the jet adjustment tool #800377 with the reference line shown on the front view detail. As seen on the side view, position the end of the adjustment tool to a distance of ½" (high beam) and 1" (low beam) from the top of the headlight for proper aiming.



**CAUTION**

Because they are made of plastic, firmly tighten nozzle and bulkhead fittings by hand only.

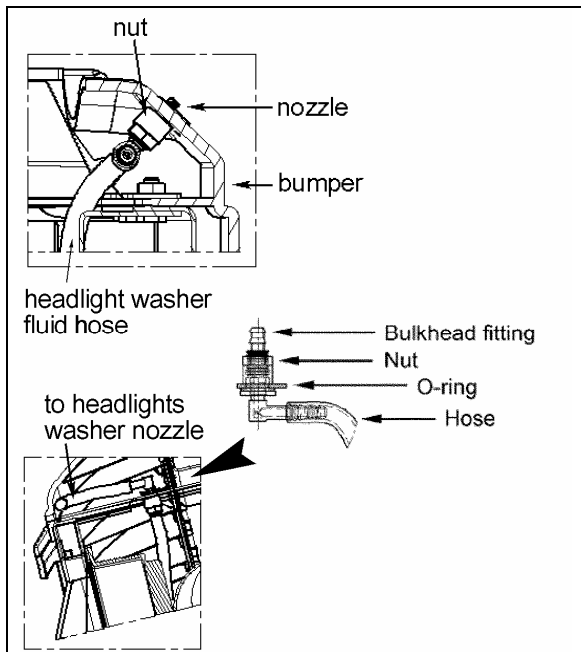


FIGURE 32: TUBING AND FITTINGS

23381

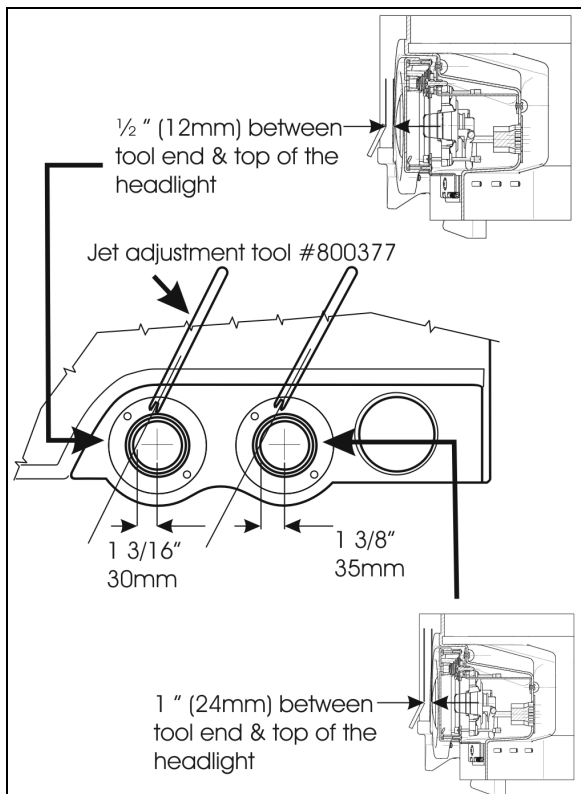


FIGURE 33: WASHER NOZZLES ADJUSTMENT

23382

**9. WINDSHIELD WIPERS AND WASHERS**

**9.1 GENERAL DESCRIPTION**

**NOTE**

When installing a wiper motor, arm or blade, follow recommended procedures to prevent misalignment, binding or malfunction. Check the windshield washer liquid hoses, fittings and connectors to be sure they are properly connected and seal with no restriction to the flow of washer liquid. Check that wiper arms have the proper sweep position and the washer nozzles are aimed so that spray is within the proper wiper pattern.

The windshield wipers are controlled by one electric wiper motor that is accessible for maintenance after removing the appropriate access panel beside the footwell (refer to figure 36). Turn the multifunction lever forward to activate windshield wipers (item 2, fig. 34). The first position operates the wipers at low speed and the second position operates the wipers at high speed. Turning the lever backwards will operate the wipers in the intermittent mode.

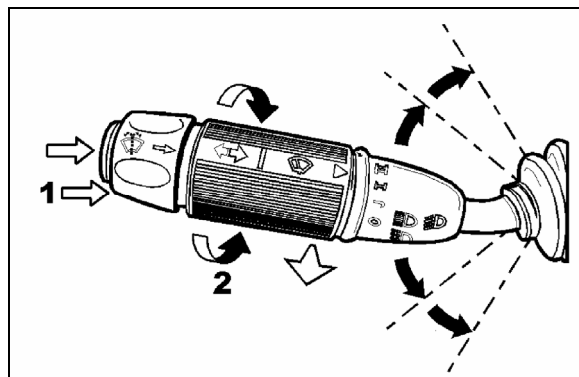


FIGURE 34: MULTIFUNCTION LEVER

23133

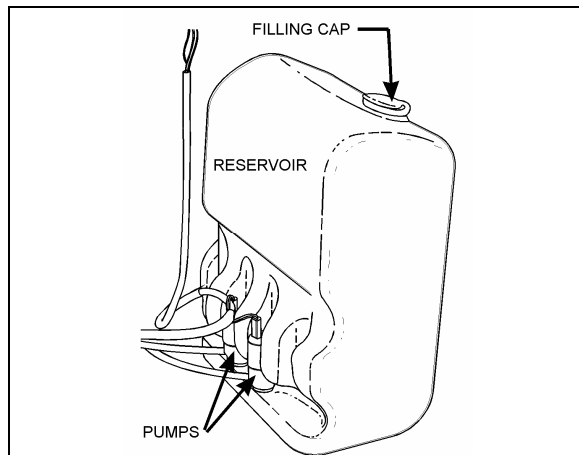


FIGURE 35: WINDSHIELD WASHER RESERVOIR

23220



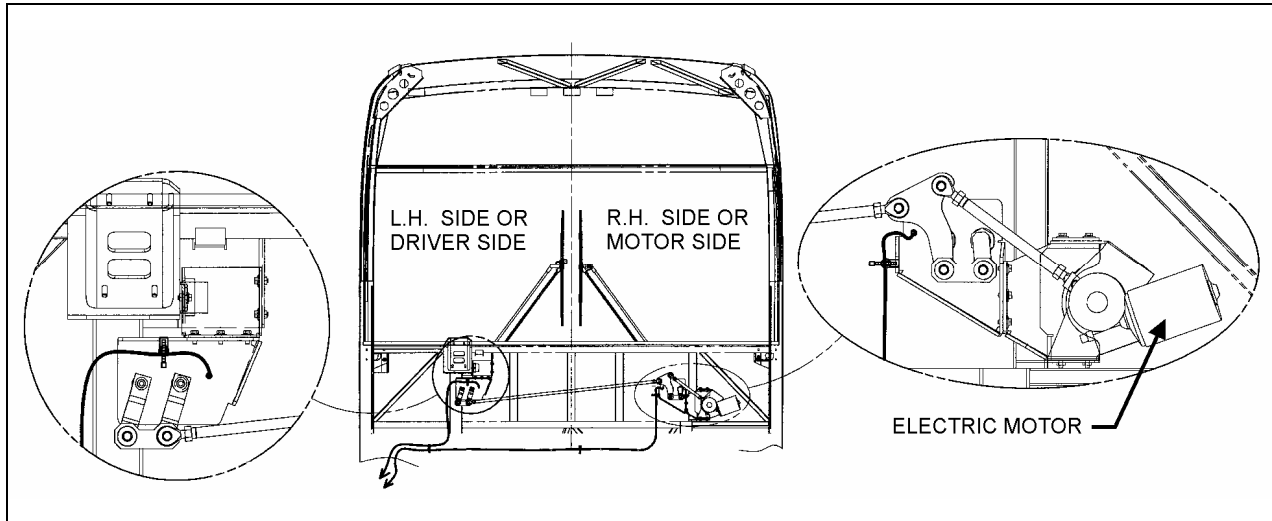


FIGURE 36: WINDSHIELD WIPER INSTALLATION

23287

The windshield washer pumps are electrically operated and are controlled by a washer control ring on the multifunction lever (item 1, fig. 34).

The windshield washer reservoir is located in the front service compartment (Fig. 35). This unit pumps the washer liquid to the spray nozzles where it is dispersed across the windshield.

## 9.2 WIPER ARM

Check operation of the wipers for proper blade sweep and angle.



### CAUTION

Do not attempt to manually move the wiper arms to make wiper blade sweep adjustments as damage to the wiper linkage or motor may occur. If it is necessary to adjust the sweep of blades, remove the arms and make adjustment by positioning the arms using serration on the wiper arm pivot shafts.

### 9.2.1 Wiper Arms Positioning

1. Reinstall the wiper arms and position as shown in figure 41. Before positioning the wipers at their final position, tighten the nuts to 9 Ft-lbs (12 Nm) at first.
2. To find the final position of the wiper arms, lift then release the wiper arm so it falls back on the windshield

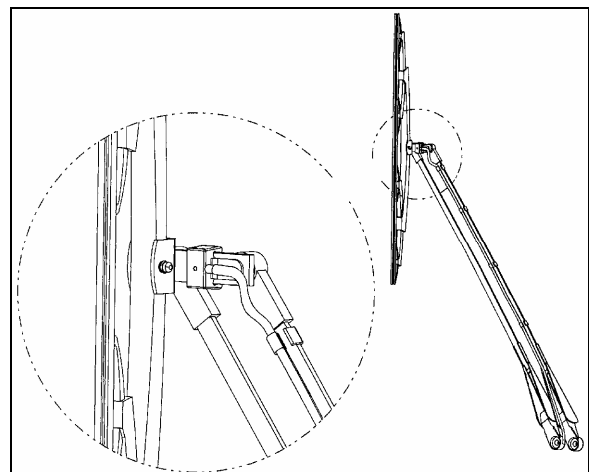


FIGURE 37: WINDSHIELD WIPER (MOTOR SIDE)

23329

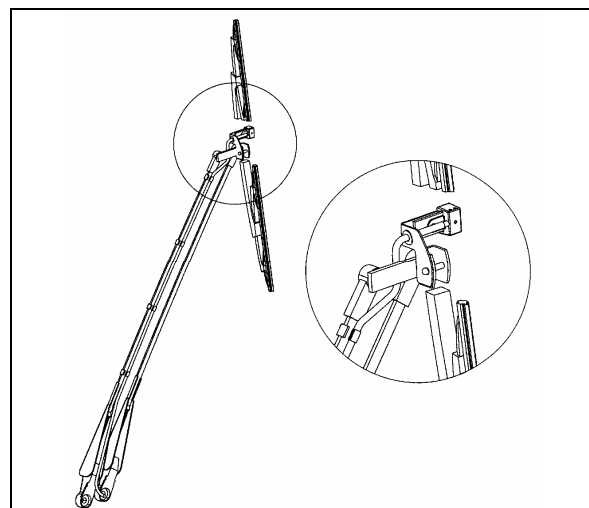


FIGURE 38: WINDSHIELD WIPER (DRIVER SIDE)

23328

3. When the final position is found, tighten the wiper arm nuts to 22 Ft-lbs (30 Nm). Wait 30 minutes and tighten again to 22 Ft-lbs.

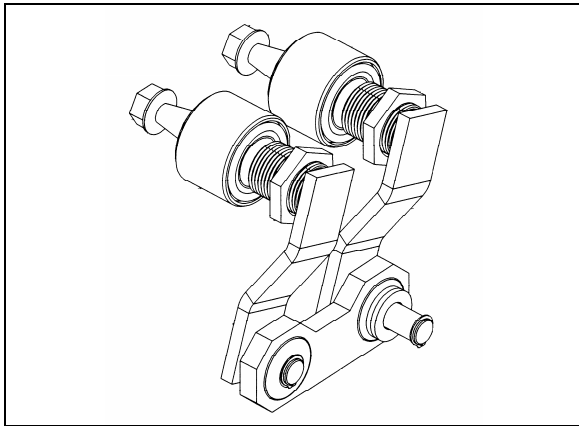


FIGURE 39: DRIVING MECHANISM (DRIVER SIDE) 23284

1. Remove the Phillips-head screws retaining the defroster panels, and remove panels.
2. Disconnect wiring connector from the windshield wiper motor.
3. Loosen clamping screw retaining the lever at the end of the motor driving shaft.
4. Remove the three bolts holding the motor to the steel plate.
5. Remove the windshield wiper motor (Prévost #800328), reverse removal procedure to reinstall.

4. Lower the protective cover.
5. Connect the windshield washer tubing at the base of the wiper arm.
6. Check the adjustment on a wet windshield.

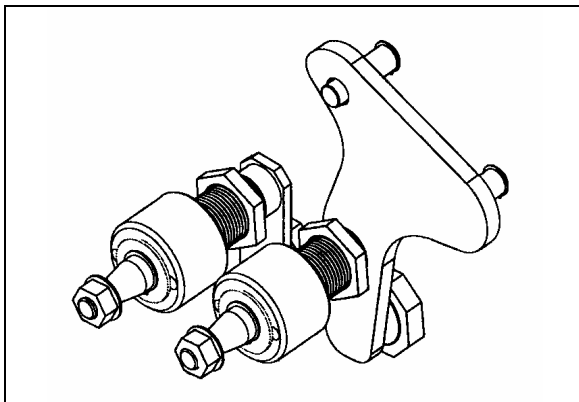


FIGURE 40: DRIVING MECHANISM (MOTOR SIDE) 23285

### 9.3 WINDSHIELD WIPER MOTOR

#### 9.3.1 Windshield Wiper Motor Replacement

The windshield wiper motor is located at lower front of the vehicle, behind the defroster panel. Refer to figure 34 for motor location.



#### **WARNING**

Park vehicle safely, apply parking brake, stop engine and set battery master switch to the "OFF" position prior to working on the vehicle.

## Section 23: ACCESSORIES

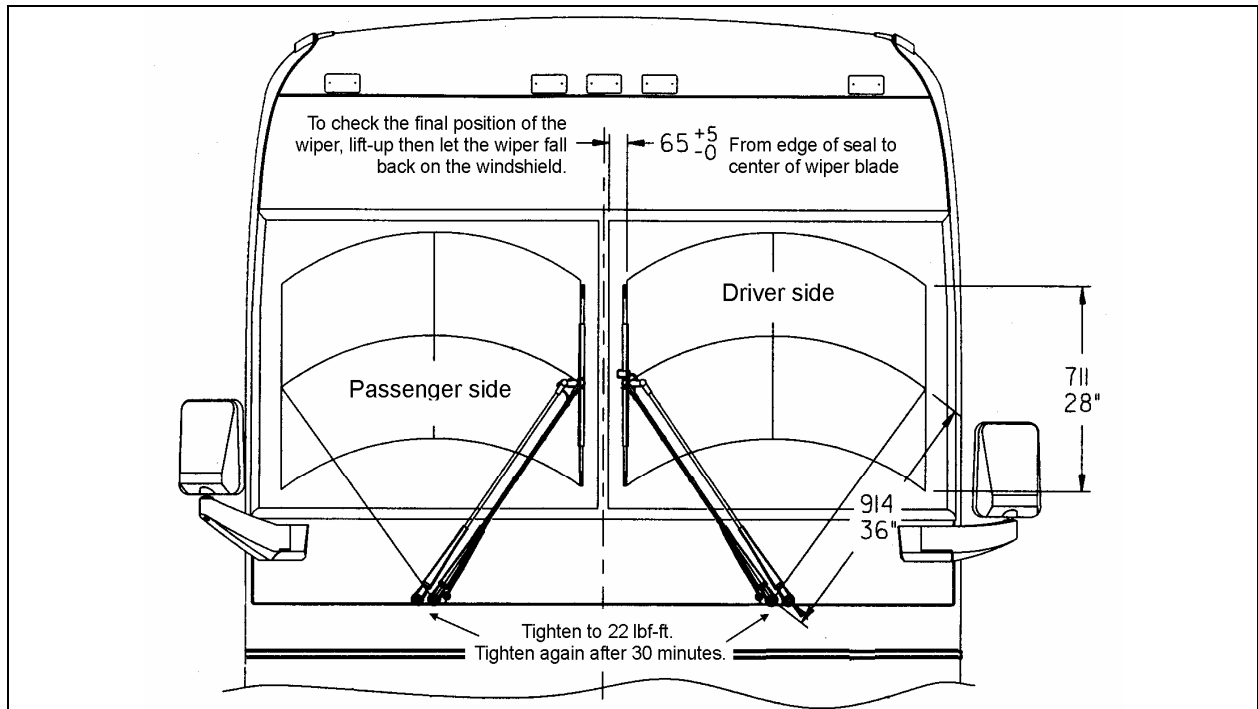


FIGURE 41: WIPER ARMS POSITIONING

23253

### 9.4 TROUBLESHOOTING




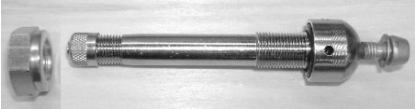

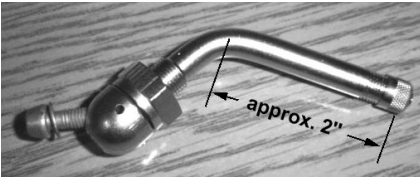

| SYMPTOM                    | PROBABLE CAUSE   | REMEDY   |
|----------------------------|--|--|
| FAIL TO SPRAY WASHER FLUID | <ul style="list-style-type: none"> <li>A. Reservoir empty.</li> <li>B. If below 32°F (0°C), improper washer fluid frozen.</li> <li>C. Contamination in tubing or nozzles.</li> <li>D. Tubing damage.</li> <li>E. Tubing bent (kinked) or off one or more connections.</li> </ul> | <ul style="list-style-type: none"> <li>A. Add proper fluid.</li> <li>B. Store coach or parts in heated area, then purge system with low-temperature solution.</li> <li>C. Remove with compressed air, if severely clogged, replace items.</li> <li>D. Replace section.</li> <li>E. Realign tubing and/or refit. Trim end to ensure proper fit or replace.</li> </ul> |
| INADEQUATE SPRAYING        | <ul style="list-style-type: none"> <li>A. Tubing failure.</li> </ul>   | <ul style="list-style-type: none"> <li>A. Replace tubing.</li> </ul>   |
| SLOW OPERATION             | <ul style="list-style-type: none"> <li>A. Improper solution.</li> <li>B. Jet stream improperly directed.</li> <li>C. Check if valve is stuck in the open position.</li> </ul>  | <ul style="list-style-type: none"> <li>A. Replace with proper type solution.</li> <li>B. Reposition nozzles.</li> <li>C. Remove, clean or replace.</li> </ul>  |

**10. TIRE PRESSURE MONITORING SYSTEM (TPMS)**

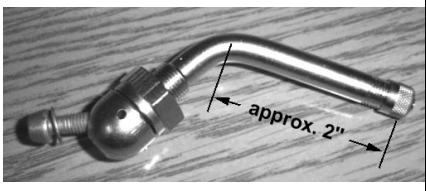
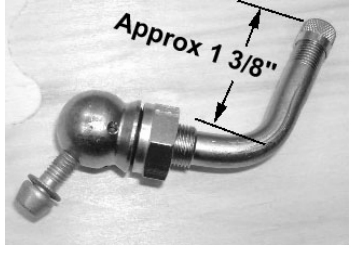



The optional active tire pressure and temperature monitoring system is a sensing device designed to identify and display tire operating data and activate an alert or warning when pressure or temperature irregularities are detected.

For more information on the operation and troubleshooting of the system, refer to the Operator’s Manual, chapters “Controls and Instruments”, “Safety Features and Equipment” and also “Appendix G”.

**10.1 TIRE VALVE INSTALLATION**



|   |   |  |   |
|---|---|--|---|
| <p><b>Use as required a small rod to hold the valve in place when tightening.</b></p> |   |                             |   |
| <p><b>Steel Wheels</b></p>  | <p><b><u>All wheels</u></b><br/>                     a) Install Beru valve<br/>                     Torque valve to 44.5lb-in +/- 9.5<br/>                     b) no extension piece</p>  | <br><p>#Prevost 681083</p>   |   |
|   | <p><b><u>Front axle and tag axle wheels with 365 tires</u></b><br/>                     a) Remove Alcoa valve<br/>                     b) Install Beru valve<br/>                     Torque valve to 102lb-in +/- 22<br/>                     c) No extension piece</p>                  | <br><p>#Prevost 651080</p> |  |
| <p><b>Aluminum Wheels (new CPM wheels)</b></p>  | <p><b><u>Front axle and tag axle wheels with 315 tires</u></b><br/>                     a) Remove Alcoa valve<br/>                     b) Install Beru valve<br/>                     Torque valve to 102lb-po +/- 22<br/>                     c) Small extension piece (approx 50mm)</p> | <br><p>#Prevost 651081</p> |  |

Section 23: ACCESSORIES

|  |   |  |  |
|--|---|--|--|
| <b>Aluminum wheels (new CPM wheels)</b>    | <p><b><u>Drive axle inner and outer wheels with 315 tires—</u></b></p> <p>a) Remove Alco valve<br/>                 b) Install Beru valve<br/>                 Torque valve to 102lb-in +/- 22<br/>                 c) no extension piece</p> |  <p>#Prevost 651081</p>  |   |
|  | <p><b><u>“Super Single” Tires</u></b></p> <p>a) Remove Alcoa valve<br/>                 b) Install Beru valve<br/>                 Torque valve to 102lb-in +/- 22<br/>                 c) no extension piece</p>                             |  <p>#Prevost 651079</p>   |   |
| <b>Aluminum wheels (former CPG wheels)</b> | <p><b><u>All wheels</u></b></p> <p>a) Remove Alcoa valve<br/>                 b) Install Beru valve<br/>                 Torque valve to 102lb-in +/- 22<br/>                 c) no extension piece</p>                                       |  <p>#Prevost 651082</p> |  |

10.2 BERU SENSORS INSTALLATION

|   |
|---|
| <p><b><i>IMPORTANT NOTE</i></b></p> <p><i>Beru sensors have a limited lifespan (5 years on average)</i></p> |
|---|

|  |   |
|--|---|
| <p>Install sensor onto valve. Torx screw T-20. Torque to 35lb-in (4Nm) (supplier specification for the screw).</p> <p>Make sure sensor rests against rim flange.</p> <p><b>IMPORTANT</b></p> <p>Use the screw only once. This screw uses a thread lock. Replacement screw #651084.</p> |   |
| <p>Note bar code and tie it up using wheel holes. Use supplied removable tie-rap.</p>  |  |
| <p><b>Decal</b></p> <p>Glue decal facing the valve.</p>  | <p>#651091 ENGLISH #651090 BILINGUAL</p>  |

## 11. SPECIFICATIONS

### AMPLIFIER

Model..... VA400-8  
Output..... 400 watts, 6 channel RMS at 4 ohm @ 0.5 T.H.D.  
Prevost number..... 901191

### SOUND SELECTOR

Model..... VSS-04  
Power source ..... 12 volts  
Prevost number..... 901192

### AM/FM/CD PLAYER RADIO (standard)

Model..... VR300  
Power source ..... 12 volts  
Prevost number..... 901190

### AM/FM/CD SATELLITE RADIO (optional)

Model..... VR300  
Power source ..... 12 volts  
Prevost number..... 901190

### 6 DISC CD CHANGER

Prevost number..... 901196

### MOBILE DVD PLAYER

Power source ..... 12 volts  
Prevost number..... 901198

### SPEAKER (standard)

Model..... Dual Cone  
Impedance ..... 4 ohms  
Prevost number..... 901194

### SPEAKER (optional)

Model..... Coaxial  
Impedance ..... 4 ohms  
Prevost number..... 901195

### SUBWOOFERS (optional)

Model..... J Drive VB170  
Impedance ..... 4 ohms  
Prevost number..... 901193

### VIDEO CASSETTE PLAYER (VCP)

Model..... V-3000  
Prevost number..... 901030

### VIDEO SWITCHER

Model..... V-3000  
Prevost number..... 901030

### BOOM-TYPE MICROPHONE

Prevost number..... 900763

### HANDHELD PRIORITY MICROPHONE

Prevost number..... 900808

**RUBBER COATED MICROPHONE**

Prevost number ..... 900745

**16 CHANNEL WIRELESS MICROPHONE**

Make ..... R.E.I.

Prevost number ..... 900954

**16 CHANNEL WIRELESS MICROPHONE CHARGING STATION**

Make ..... R.E.I.

Prevost number ..... 900953

**16 CHANNEL WIRELESS MICROPHONE RECEIVER**

Make ..... R.E.I.

Prevost number ..... 900952

**KARAOKE**

Make ..... Panasonic

Model ..... MOBILE DVD PLAYER DV1500

Prevost number ..... 901033

**TV RECEIVER**

Power source ..... 24V

Prevost number ..... 901054

**VIDEO DISTRIBUTION AMPLIFIER**

Power source ..... 24V

Prevost number ..... 901117

**TV MONITOR**

Type ..... 10.4" LCD

Power source ..... 24V

Prevost number ..... 901130

**HUBODOMETER (US model: miles)**

Make ..... Stemco

Prevost number ..... 650002

**HUBODOMETER (Canada model: km)**

Make ..... Stemco

Prevost number ..... 650117

**ELECTRIC DESTINATION SIGN (FLUORESCENT TUBE)**

Make ..... General Electric

Length ..... 30" (76 cm)

Outside diameter ..... 1" (25 mm)

Wattage ..... 20

Color ..... Cool white

Quantity ..... 1

Prevost number ..... 830120

**ELECTRONIC DESTINATION SIGN**

Make ..... Pocatec

Prevost number ..... 940050



**LAVATORY VENTILATION FAN MOTOR**

Make..... Aurora  
Type .....RG500EF  
Voltage ..... 24 volts DC  
Rotation ..... R.H.  
Prevost number ..... 870844

**LAVATORY FLUORESCENT TUBES**

Make..... General Electric  
Model.....F15T8CW  
Length ..... 18" (45 cm)  
Wattage ..... 15  
Quantity ..... 2  
Prevost number ..... 830102

**EMERGENCY BUZZER SWITCH (PUSH BUTTON)**

Make..... Cole Hersee Co.  
Voltage ..... 24 V  
Prevost number ..... 562117

**FRESH WATER TANK**

Make..... Prévost  
Capacity ..... 18 US gal (68 liters)  
Prevost number ..... 401591

**FLUSH PUSH BUTTON PNEUMATIC TIMER**

Make..... Furnas  
Type ..... Resettable  
Time ..... 0,2 to 180 seconds  
Prévost number ..... 900348

**FLUSH PUMP**

Make..... RULE 2000  
Model number ..... 12 - 24 V  
Power source ..... 24 volts DC  
Capacity ..... 1450 GPH  
Prévost number ..... 900960

**AIR HORN**

Make..... Allied Signal Inc.  
Prévost number ..... 640093

**AIR HORN VALVE**

Make..... Allied Signal Inc.  
Prévost number ..... 640128

**WINDSHIELD WIPER MOTOR**

Make..... BOSCH  
Prévost number ..... 800328

**WIPER (BLADE)**

Make..... BOSCH  
Prévost number ..... 800329

**WIPER ARM**

Make..... BOSCH  
Prévost number ..... 800331

# SECTION 24: LUBRICATION

---

## CONTENTS

|  |          |
|--|----------|
| <b>1. LUBRICATION .....</b>                      | <b>2</b> |
| <b>2. LUBRICATION AND SERVICE SCHEDULE .....</b> | <b>2</b> |
| 2.1 FLEXIBLE HOSE MAINTENANCE .....              | 2        |
| 2.1.1 <i>Hose Inspection</i> .....               | 2        |
| 2.1.2 <i>Leaks</i> .....                         | 2        |
| 2.1.3 <i>Service life</i> .....                  | 2        |
| 2.2 LUBRICANT AND COOLANT SPECIFICATIONS .....   | 6        |
| 2.3 PART NUMBER SPECIFICATIONS .....             | 7        |
| 2.4 LUBRICATION AND SERVICING SCHEDULE .....     | 7        |

## ILLUSTRATIONS

|   |   |
|---|---|
| FIGURE 1: LUBRICATION AND SERVICING POINTS ON INDEPENDENT FRONT SUSPENSION VEHICLES ..... | 4 |
| FIGURE 2: LUBRICATION AND SERVICING POINTS ON I-BEAM AXLE FRONT SUSPENSION VEHICLES ..... | 5 |

## Section 24: LUBRICATION

---

### 1. LUBRICATION

The efficiency and life expectancy of mechanical equipment is largely dependent on proper lubrication and servicing. All mechanical components rely on a lubricating film between moving parts to reduce friction, prevent wear and oxidation. Proper lubrication also helps cool the parts and keep dirt particles away from mating surfaces. Efficient lubrication depends upon using the right type of lubricant, at specified intervals and by filling to correct capacities. Past experience shows that many service problems can be traced to an improper lubricant or to incorrect lubrication procedures.

A comprehensive maintenance and lubrication program is important to ensure the long service life this vehicle was designed for and to avoid costly repairs and associated downtime caused by premature part failure.

A lubrication schedule is included in this section to give the location of key service points on the vehicle as well as the lubricant specifications for each component to be serviced. Specific instructions on how to check and service different components are covered in their respective sections in this maintenance manual.

The recommended lubrication intervals are based on normal operating conditions and mileage accumulation.

Shorten the intervals if your vehicle operates in more severe conditions. Severe conditions include heavy towing, high vehicle weight or operation in mountainous areas. Some parts and equipment referred to in this section may not be installed on your vehicle. Check your vehicle's "Coach Final Record" for equipment list.

Dispose of used lubricants and filters in an environmentally safe manner, according to federal and/or local recommendations.

### 2. LUBRICATION AND SERVICE SCHEDULE

Following this service schedule is the most economical and easiest way to ensure your vehicle performs at its best, safest and longest. Also, unscheduled maintenance will be minimized since inspection should expose potential problems before they become major ones.

### 2.1 FLEXIBLE HOSE MAINTENANCE


The performance of engine and equipment are greatly related to the ability of flexible hoses to supply lubricating oil, air, coolant, and fuel oil. Maintenance of hoses is an important step to ensure efficient, economical, and safe operation of the engine and related equipment.

#### 2.1.1 Hose Inspection

Check hoses daily as part of the pre-starting inspection. Examine hose for leaks, and check all fittings, clamps, and ties carefully. Ensure that hoses are not resting on or touching shafts, couplings, heated surfaces including exhaust manifolds, any sharp edges, or other obviously damaging areas. Since all machinery vibrates and moves to a certain extent, clamps and ties can fatigue with time. To ensure proper support, inspect fasteners frequently and tighten or replace them as necessary.

#### 2.1.2 Leaks

Investigate leaks immediately to determine if fittings have loosened or cracked, and also if hoses have ruptured or worn through. Take corrective action immediately. Leaks are not only potentially detrimental to machine operation, but can also result in added expenses caused by the need to replace lost fluids.

|   |
|---|
|  <b>WARNING</b>                            |
| Personal injury and/or property damage may result from fire due to the leakage of flammable fluids, such as fuel or lube oil. |

#### 2.1.3 Service life

The limited service life of a hose is determined by the temperature and pressure of the gas or fluid within it, the time in service, its installation, the ambient temperatures, amount of flexing, and the vibration it is subjected to. With this in mind, it is recommended that all hoses be thoroughly inspected at least every 500 operating hours or after 15,000 miles (24 000 km). Look for surface damage or indications of damaged, twisted, worn, crimped, brittle, cracked, or leaking lines. Hoses having a worn outer surface or hoses with a damaged metal reinforcement should be considered unfit for further service.

It is also recommended that all hoses in this vehicle be replaced during major overhaul and/or after a maximum of five service years. Quality of replacement hose assemblies should always be equal to or superior to those supplied by the Original Equipment Manufacturer.

## Section 24: LUBRICATION

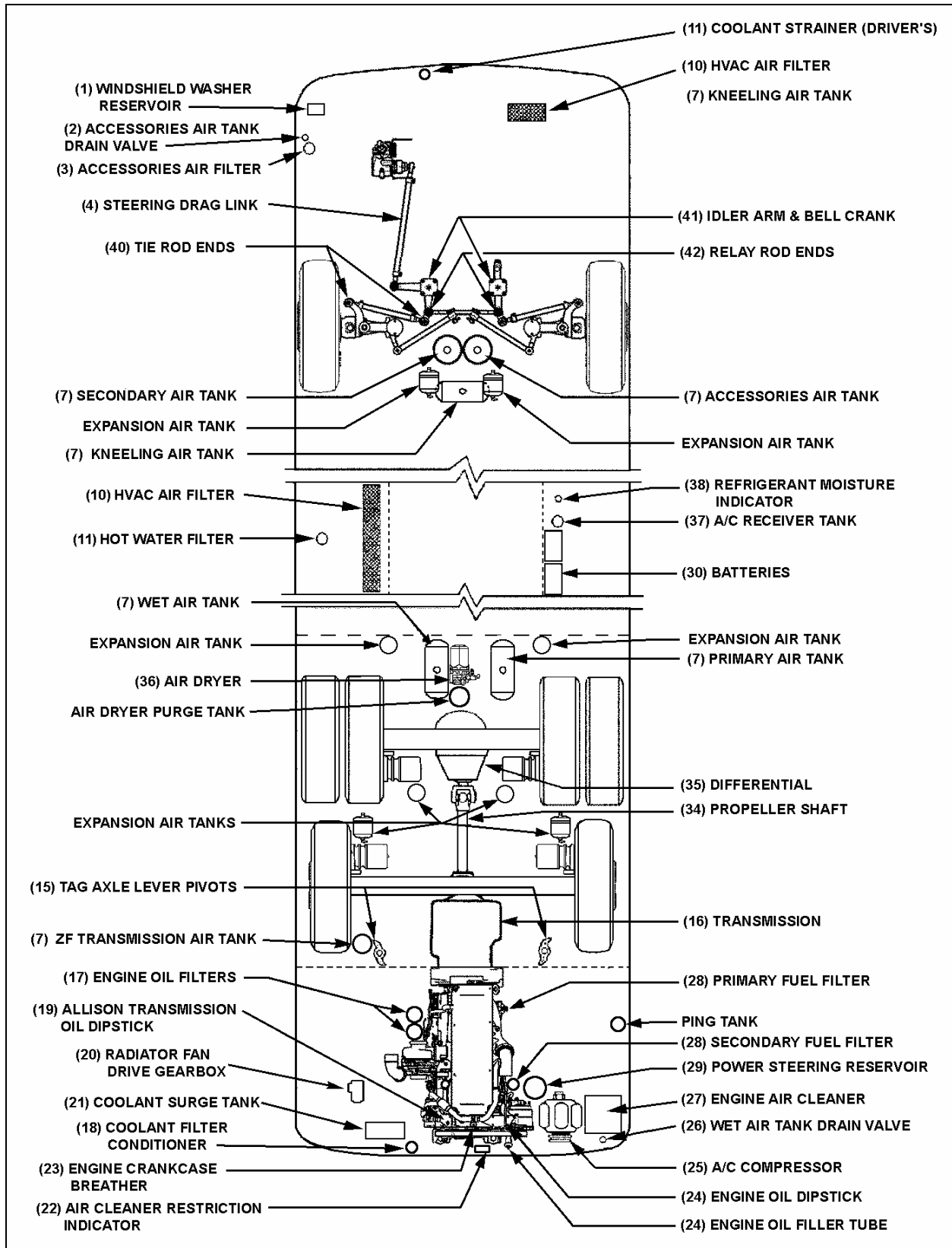


FIGURE 1: LUBRICATION AND SERVICING POINTS ON INDEPENDENT FRONT SUSPENSION VEHICLES

24031\_1

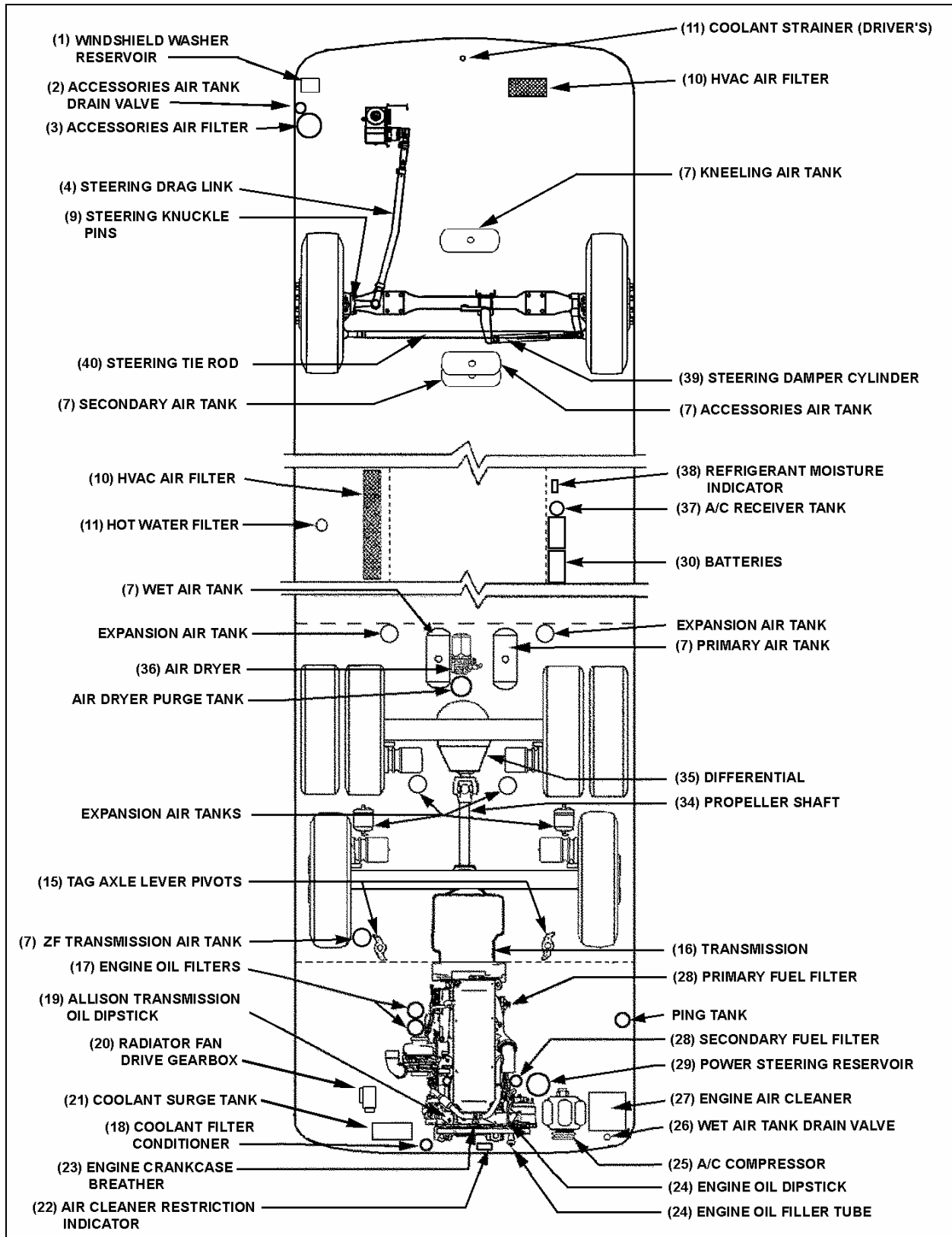


FIGURE 2: LUBRICATION AND SERVICING POINTS ON I-BEAM AXLE FRONT SUSPENSION VEHICLES

24030\_1

## Section 24: LUBRICATION

### 2.2 LUBRICANT AND COOLANT SPECIFICATIONS

| REF | DESCRIPTION                        | SPECIFICATIONS   |
|-----|------------------------------------|--|
| A   | Engine Oil                         | DETROIT DIESEL SERIES 60<br>SAE Viscosity Grade: 15W-40<br>API Classification: CJ-4  |
|     |                                    | VOLVO D13<br>SAE Viscosity Grade: 15W-40<br>API Classification: CJ-4 meeting Volvo specification VDS-4   |
| B   | Power Steering Oil                 | Automatic Transmission Oil, Dexron-III   |
| C   | Engine Coolant                     | DETROIT DIESEL SERIES 60<br>Low silicate, ethylene glycol coolant<br>50% antifreeze/water solution is normally used<br>Antifreeze concentration should be between 30% and 67%  |
|     |                                    | VOLVO D13<br>Texaco or Chevron Extended Life Coolant (ELC)<br>50% antifreeze/water solution is normally used   |
| D   | A/C Compressor Oil                 | Central HVAC system: Polyolester oil, HFC 134a compatible; Castrol SW-68 (POE) or equivalent   |
|     |                                    | Small HVAC system: PAG oil   |
| E   | Differential Oil                   | Multigrade gear oil meeting MIL-L-2105-D: 85W140.<br>If temperature drops below 10°F (-12°C), 80W90 should be used. Below -15°F (-26°C), 75W90 should be used. (In extreme conditions or for better performance, full synthetic gear oil can be used.) |
| F   | Differential Oil (Full Synthetic)  | Multigrade gear oil meeting MIL-L-2105-D: 85W140.<br>If temperature drops below 10°F (-12°C), 80W90 should be used. Below -15°F (-26°C), 75W90 should be used.   |
| G   | Cooling Fan Gearbox Oil            | Synthetic gear lubricant 75W-90  |
| H   | Allison Automatic Transmission Oil | Castrol TranSynd™ Synthetic Transmission Fluid for Allison or TES 295 approved equivalent  |
| I   | Allison Automatic Transmission Oil | Dexron-VI® or approved equivalent 1 Schedule 1 TES-389 fluids;   |
| J   | ZF-ASTronic Transmission Oil       | Castrol Syntrans Grade SAE 75W-85 (Synthetic)  |
| K   | Multi Purpose Grease               | Good quality lithium-base grease:<br>NLGI No.2 Grade is suitable for most temperatures<br>NLGI No.1 Grade is suitable for extremely low temperatures   |
| L   | Multi Purpose Grease               | Molykote longterm 2/78 grease  |

## 2.3 PART NUMBER SPECIFICATIONS

| REF | DESCRIPTION   | PREVOST NO  |
|-----|---|---|
| P1  | Engine oil filters  | #510458   |
| P2  | Engine oil filters – Volvo D13  | #510938 (one by-pass)<br>(Volvo #477556)<br>#478736 (two full-flow) |
| P3  | Power steering oil reservoir filter element                                 | #660987   |
| P4  | Engine air filter   | #530197   |
| P5  | Refrigerant filter dryer unit   | #950332 Central A/C syst.<br>#950370 Small A/C syst.                |
| P6  | Primary fuel filter/water separator – DDC Series 60                         | #032700 #541407   |
| P7  | Racor primary fuel filter and water separator (optional) – DDC Series 60    | #531390   |
| P8  | Secondary fuel filter – DDC Series 60                                       | #510794   |
| P9  | Primary fuel filter cartridge (used with water separation bowl) - Volvo D13 | #20879806   |
| P10 | Secondary fuel filter - Volvo D13   | #20405160   |
| P11 | Engine coolant precharge element filter – DDC Series 60                     | #550629   |
| P12 | Engine coolant maintenance element filter – DDC Series 60                   | #550630   |
| P13 | Engine coolant filter cartridge - Volvo D13                                 | #20458771   |
| P14 | HVAC driver's air filter  | #871147-871144  |
| P15 | HVAC cabin air filter   | #874272   |
| P16 | Allison transmission High Capacity fluid filter kit                         | #571709   |
| P17 | Accessories air filter element  | #641340   |
| P18 | Air dryer cartridge   | #3097369  |
| P19 | Fuel Pro 382 filter element   | #510795   |
| P20 | Overhead compartment fan air filters  | #871159   |
| P21 | Engine coolant  | #685125   |
| P22 | Bosch T1 alternators, voltage regulator                                     | #562981   |
| P23 | Bosch T1 alternators, brush set   | #562983   |
| P24 | Bosch T1 alternators, ball bearing  | #562972   |
| P25 | Bosch T1 alternators, roller bearing  | #562976   |

## 2.4 LUBRICATION AND SERVICING SCHEDULE

For lubrication and servicing schedule, refer to table A.

***IMPORTANT NOTE***

*Refer to the manufacturers documentation included in this maintenance manual for specific manufacturer's maintenance requirements.*





| LUBRICATION AND<br>SERVICING SCHEDULE   |          | Item | Months | DISTANCE TRAVELED <sup>1</sup><br>(miles / km) |                 |                 |                 |                 |                 |                 |                 |                 |                  |                  |                  |                  |                  |                  |                   |                   |                   |                   | LUBRICANT /PART <sup>2</sup> |                   |                   |                   |                   |                   |                   |                   |                   |                   |                   |                   |                   |                     |    |         |         |
|---|----------|------|--------|--|-----------------|-----------------|-----------------|-----------------|-----------------|-----------------|-----------------|-----------------|------------------|------------------|------------------|------------------|------------------|------------------|-------------------|-------------------|-------------------|-------------------|------------------------------|-------------------|-------------------|-------------------|-------------------|-------------------|-------------------|-------------------|-------------------|-------------------|-------------------|-------------------|-------------------|---------------------|----|---------|---------|
|   |          |      |        | 6 250 / 10 000                                 | 12 500 / 20 000 | 18 750 / 30 000 | 25 000 / 40 000 | 31 250 / 50 000 | 37 500 / 60 000 | 43 750 / 70 000 | 50 000 / 80 000 | 56 250 / 90 000 | 62 500 / 100 000 | 68 750 / 110 000 | 75 000 / 120 000 | 81 250 / 130 000 | 87 500 / 140 000 | 93 750 / 150 000 | 100 000 / 160 000 | 106 250 / 170 000 | 112 500 / 180 000 | 118 750 / 190 000 |                              | 125 000 / 200 000 | 131 250 / 210 000 | 137 500 / 220 000 | 143 750 / 230 000 | 150 000 / 240 000 | 185 000 / 300 000 | 200 000 / 320 000 | 225 000 / 360 000 | 250 000 / 400 000 | 275 000 / 440 000 | 300 000 / 500 000 | 500 000 / 800 000 | 600 000 / 1 000 000 |    |         |         |
|   |          |      |        | proceed to maintenance operation at            |                 |                 |                 |                 |                 |                 |                 |                 |                  |                  |                  | each             |                  |                  |                   |                   |                   |                   |                              |                   |                   |                   |                   |                   |                   |                   |                   |                   |                   |                   |                   |                     |    |         |         |
| <b>GENERAL</b>  |          |      |        |  |                 |                 |                 |                 |                 |                 |                 |                 |                  |                  |                  |                  |                  |                  |                   |                   |                   |                   |                              |                   |                   |                   |                   |                   |                   |                   |                   |                   |                   |                   |                   |                     |    |         |         |
| Flexible hoses, thoroughly inspect all hoses  | -        | 12   |        |  |                 |                 |                 |                 |                 |                 |                 |                 |                  |                  |                  |                  |                  |                  |                   |                   |                   |                   |                              |                   |                   |                   |                   |                   |                   |                   |                   |                   |                   |                   |                   |                     |    |         |         |
| Front discharge tube, qty:2, check to see if clogged <sup>3</sup>   | -        | 3    |        |  |                 |                 |                 |                 |                 |                 |                 |                 |                  |                  |                  |                  |                  |                  |                   |                   |                   |                   |                              |                   |                   |                   |                   |                   |                   |                   |                   |                   |                   |                   |                   |                     |    |         |         |
| <b>01 ENGINE</b>  |          |      |        |  |                 |                 |                 |                 |                 |                 |                 |                 |                  |                  |                  |                  |                  |                  |                   |                   |                   |                   |                              |                   |                   |                   |                   |                   |                   |                   |                   |                   |                   |                   |                   |                     |    |         |         |
| Air cleaner, inspect, clean   | 27       |      |        | •  |                 | •               |                 | •               |                 | •               |                 | •               |                  | •                |                  | •                |                  | •                |                   | •                 |                   | •                 |                              | •                 |                   | •                 |                   | •                 |                   | •                 |                   | •                 |                   | •                 |                   | •                   |    | P4      |         |
| Air cleaner, replace element according to restriction indicator   | 27       | 24   |        |  |                 |                 |                 |                 |                 |                 |                 |                 |                  |                  |                  |                  |                  |                  |                   |                   |                   |                   |                              |                   |                   |                   |                   |                   |                   |                   |                   |                   |                   |                   |                   |                     | P4 |         |         |
| Air pre-cleaner, check discharge tube   | -        | 6    | •      | •  | •               | •               | •               | •               | •               | •               | •               | •               | •                | •                | •                | •                | •                | •                | •                 | •                 | •                 | •                 | •                            | •                 | •                 | •                 | •                 | •                 | •                 | •                 | •                 | •                 | •                 | •                 | •                 | •                   |    |         |         |
| Replace crankshaft pulley's rubber damper,<br>See Linnig Repair instruction 142.219 in Section 01   |          |      |        |  |                 |                 |                 |                 |                 |                 |                 |                 |                  |                  |                  |                  |                  |                  |                   |                   |                   |                   |                              |                   |                   |                   |                   |                   |                   |                   |                   |                   |                   |                   |                   |                     | •  |         |         |
| DDC S60 - Engine oil and filter change ( <b>DDC recommends 30K</b> )  | 17       | 12   |        |  |                 |                 |                 |                 |                 |                 |                 |                 |                  |                  |                  |                  |                  |                  |                   |                   |                   |                   |                              |                   |                   |                   |                   |                   |                   |                   |                   |                   |                   |                   |                   |                     |    | A, P1   |         |
| Volvo D13 - Engine oil and filter change, normal <sup>4</sup> operation<br>condition ( <b>Volvo recommends 35,000 miles / 55,000 km</b> ) | 17       |      |        |  |                 |                 |                 |                 |                 |                 |                 |                 |                  |                  |                  |                  |                  |                  |                   |                   |                   |                   |                              |                   |                   |                   |                   |                   |                   |                   |                   |                   |                   |                   |                   |                     |    | A, P2   |         |
| Volvo D13 - Engine oil and filter change, heavy <sup>4</sup> operation<br>condition   | 17       |      |        |  |                 | •               |                 |                 |                 | •               |                 |                 |                  |                  |                  |                  |                  |                  |                   |                   |                   |                   |                              |                   |                   |                   |                   |                   |                   |                   |                   |                   |                   |                   |                   |                     |    | A, P2   |         |
| Volvo D13 - Valves & injectors, initial adjust  | -        | 12   |        |  |                 |                 |                 |                 |                 |                 |                 |                 |                  |                  |                  |                  |                  |                  |                   |                   |                   |                   |                              |                   |                   |                   |                   |                   |                   |                   |                   |                   |                   |                   |                   |                     |    |         |         |
| Volvo D13 - Valves & injectors, check & adjust  | -        | 24   |        |  |                 |                 |                 |                 |                 |                 |                 |                 |                  |                  |                  |                  |                  |                  |                   |                   |                   |                   |                              |                   |                   |                   |                   |                   |                   |                   |                   |                   |                   |                   |                   |                     |    | •       |         |
| Volvo D13 - Drive belts   | -        | 36   |        |  |                 |                 |                 |                 |                 |                 |                 |                 |                  |                  |                  |                  |                  |                  |                   |                   |                   |                   |                              |                   |                   |                   |                   |                   |                   |                   |                   |                   |                   |                   |                   |                     |    | •       |         |
| Volvo D13 - Aftertreatment fuel injector, clean at 4500 hours or...   | -        |      |        |  |                 |                 |                 |                 |                 |                 |                 |                 |                  |                  |                  |                  |                  |                  |                   |                   |                   |                   |                              |                   |                   |                   |                   |                   |                   |                   |                   |                   |                   |                   |                   |                     | •  |         |         |
| Volvo D13 - DPF filter, clean at 4500 hours or as per mileage   | -        |      |        |  |                 |                 |                 |                 |                 |                 |                 |                 |                  |                  |                  |                  |                  |                  |                   |                   |                   |                   |                              |                   |                   |                   |                   |                   |                   |                   |                   |                   |                   |                   |                   |                     |    | •       |         |
| <b>03 FUEL</b>  |          |      |        |  |                 |                 |                 |                 |                 |                 |                 |                 |                  |                  |                  |                  |                  |                  |                   |                   |                   |                   |                              |                   |                   |                   |                   |                   |                   |                   |                   |                   |                   |                   |                   |                     |    |         |         |
| DDC S60 - Change primary & secondary fuel filters   | 28<br>28 | 12   |        | •  |                 | •               |                 | •               |                 | •               |                 | •               |                  | •                |                  | •                |                  | •                |                   | •                 |                   | •                 |                              | •                 |                   | •                 |                   | •                 |                   | •                 |                   | •                 |                   | •                 |                   | •                   |    | P6, P8  |         |
| Volvo D13 - Change primary & secondary fuel filters at every<br>engine oil change ( <b>Volvo recommends 35,000 miles / 55,000 km</b> )    | 28<br>28 |      |        |  |                 |                 |                 |                 |                 |                 |                 |                 |                  |                  |                  |                  |                  |                  |                   |                   |                   |                   |                              |                   |                   |                   |                   |                   |                   |                   |                   |                   |                   |                   |                   |                     |    |         | P9, P10 |
| <b>05 COOLING</b>   |          |      |        |  |                 |                 |                 |                 |                 |                 |                 |                 |                  |                  |                  |                  |                  |                  |                   |                   |                   |                   |                              |                   |                   |                   |                   |                   |                   |                   |                   |                   |                   |                   |                   |                     |    |         |         |
| Cooling fan gearbox, check oil level, add if necessary  | 20       | 6    |        | •  |                 | •               |                 | •               |                 | •               |                 | •               |                  | •                |                  | •                |                  | •                |                   | •                 |                   | •                 |                              | •                 |                   | •                 |                   | •                 |                   | •                 |                   | •                 |                   | •                 |                   | •                   |    | G       |         |
| Cooling fan gearbox, change oil   | 20       | 12   |        |  |                 |                 |                 |                 |                 |                 |                 |                 |                  |                  |                  |                  |                  |                  |                   |                   |                   |                   |                              |                   |                   |                   |                   |                   |                   |                   |                   |                   |                   |                   |                   |                     |    | G       |         |
| DDC S60 - Coolant filter/conditioner, change element <sup>5</sup>   | 18       | 12   |        | •  |                 | •               |                 | •               |                 | •               |                 | •               |                  | •                |                  | •                |                  | •                |                   | •                 |                   | •                 |                              | •                 |                   | •                 |                   | •                 |                   | •                 |                   | •                 |                   | •                 |                   | •                   |    | P11,P12 |         |

<sup>1</sup> Proceed to maintenance operation at distance indicated on odometer or specified number of month, whichever comes first.

<sup>2</sup> See paragraph 2.3 & 2.4 of this section for lubricant specifications and part numbers.

<sup>3</sup> Discharge tubes are rubber tubes located under vehicle

<sup>4</sup> Normal=fuel consumption more than 6 MPG (less than 39 L/100km) ; Heavy= fuel consumption between 4.7 MPG and 6 MPG (between 39 L/100km and 50 L/100km)

**TABLE A**





| LUBRICATION AND<br>SERVICING SCHEDULE  |    | Item | Months | DISTANCE TRAVELED <sup>1</sup><br>(miles / km) |                 |                 |                 |                 |                 |                 |                 |                 |                  |                  |                  |                  |                  |                  |                   |                   |                   | LUBRICANT /PART <sup>2</sup> |                   |                   |                   |                   |                   |                   |                   |                   |                   |                   |                   |                   |                   |                     |  |  |     |         |
|--|----|------|--------|--|-----------------|-----------------|-----------------|-----------------|-----------------|-----------------|-----------------|-----------------|------------------|------------------|------------------|------------------|------------------|------------------|-------------------|-------------------|-------------------|------------------------------|-------------------|-------------------|-------------------|-------------------|-------------------|-------------------|-------------------|-------------------|-------------------|-------------------|-------------------|-------------------|-------------------|---------------------|--|--|-----|---------|
|  |    |      |        | 6 250 / 10 000                                 | 12 500 / 20 000 | 18 750 / 30 000 | 25 000 / 40 000 | 31 250 / 50 000 | 37 500 / 60 000 | 43 750 / 70 000 | 50 000 / 80 000 | 56 250 / 90 000 | 62 500 / 100 000 | 68 750 / 110 000 | 75 000 / 120 000 | 81 250 / 130 000 | 87 500 / 140 000 | 93 750 / 150 000 | 100 000 / 160 000 | 106 250 / 170 000 | 112 500 / 180 000 |                              | 118 750 / 190 000 | 125 000 / 200 000 | 131 250 / 210 000 | 137 500 / 220 000 | 143 750 / 230 000 | 150 000 / 240 000 | 185 000 / 300 000 | 200 000 / 320 000 | 225 000 / 360 000 | 250 000 / 400 000 | 275 000 / 440 000 | 300 000 / 500 000 | 500 000 / 800 000 | 600 000 / 1 000 000 |  |  |     |         |
|  |    |      |        | proceed to maintenance operation at            |                 |                 |                 |                 |                 |                 |                 |                 |                  |                  |                  |                  |                  |                  | each              |                   |                   |                              |                   |                   |                   |                   |                   |                   |                   |                   |                   |                   |                   |                   |                   |                     |  |  |     |         |
| A/C and Heating air filters, clean or replace all elements   | 10 | 6    |        | ●  | ●               | ●               | ●               | ●               | ●               | ●               | ●               | ●               | ●                | ●                | ●                | ●                | ●                | ●                | ●                 | ●                 | ●                 | ●                            | ●                 | ●                 | ●                 |                   |                   |                   |                   |                   |                   |                   |                   |                   |                   |                     |  |  |     | P14,P15 |
| Parcel rack fan air filters, clean or replace  | -  | 6    |        | ●  | ●               | ●               | ●               | ●               | ●               | ●               | ●               | ●               | ●                | ●                | ●                | ●                | ●                | ●                | ●                 | ●                 | ●                 | ●                            | ●                 | ●                 | ●                 |                   |                   |                   |                   |                   |                   |                   |                   |                   |                   |                     |  |  | P20 |         |
| Condenser discharge tube, qty:2, check to see if clogged <sup>9</sup>                                  | -  | 3    |        |  |                 |                 |                 |                 |                 |                 |                 |                 |                  |                  |                  |                  |                  |                  |                   |                   |                   |                              |                   |                   |                   |                   |                   |                   |                   |                   |                   |                   |                   |                   |                   |                     |  |  |     |         |
| Evaporator discharge tube, qty:6, check to see if clogged  | -  | 3    |        |  |                 |                 |                 |                 |                 |                 |                 |                 |                  |                  |                  |                  |                  |                  |                   |                   |                   |                              |                   |                   |                   |                   |                   |                   |                   |                   |                   |                   |                   |                   |                   |                     |  |  |     |         |
| Evaporator motor, condenser motor, recirculating pump drive motor, inspect brush, replace if necessary | -  | 12   |        |  |                 |                 |                 |                 |                 | ●               |                 |                 |                  |                  |                  |                  | ●                |                  |                   |                   |                   |                              |                   |                   |                   |                   |                   |                   |                   |                   |                   |                   |                   |                   |                   |                     |  |  |     |         |

<sup>9</sup> Discharge tubes are rubber tubes located under vehicle

TABLE A