

# PREVOST

## COACH MANUFACTURER

### **MAINTENANCE MANUAL**

LE MIRAGE XLII  
BUS SHELLS



# PA1564

(1<sup>ST</sup> EDITION)

PA1564 1<sup>st</sup> edition  
Date: July, 2007  
Starting from vehicle: 8-9277  
Featuring: DDC S60-2007 engine with Aftertreatment System

# SECTION 00: GENERAL INFORMATION

## CONTENTS

<b>1. FOREWORD</b> .....	<b>2</b>
<b>2. SCHEMATICS</b> .....	<b>2</b>
<b>3. PRECAUTIONS TO BE OBSERVED BEFORE WELDING</b> .....	<b>2</b>
<b>4. SAFETY NOTICE</b> .....	<b>4</b>
4.1 DATA PLATES AND CERTIFICATIONS .....	4
4.1.1 <i>Engine</i> .....	4
4.1.2 <i>Transmission</i> .....	5
4.1.3 <i>Drive Axle</i> .....	5
4.1.4 <i>Front Suspension</i> .....	5
4.1.5 <i>Power Steering Pump</i> .....	5
4.1.6 <i>Coach Final Record</i> .....	5
4.1.7 <i>Safety Certification</i> .....	5
4.1.8 <i>DOT Certification Label</i> .....	6
4.1.9 <i>EPA Engine Label</i> .....	6
4.1.10 <i>Fuel Tank Label</i> .....	6
4.1.11 <i>Vehicle Identification Number (VIN)</i> .....	6
<b>5. FASTENER STRENGTH IDENTIFICATION</b> .....	<b>8</b>
5.1 SELF-LOCKING FASTENERS .....	9
5.2 RECOMMENDATIONS FOR REUSE .....	9
5.3 SIX LOBED SOCKET HEAD .....	9

## ILLUSTRATIONS

FIGURE 1 : DETROIT DIESEL SERIES 60.....	5
FIGURE 2: ALLISON TRANSMISSION .....	5
FIGURE 3: TYPICAL SERIAL & MODEL NUMBERS.....	5
FIGURE 4: ISS TYPICAL SERIAL & MODEL NUMBERS .....	5
FIGURE 5 : POWER STEERING PUMP NAMEPLATE.....	5
FIGURE 6: DOT CERTIFICATION PLATE .....	6
FIGURE 7 : ENGINE COMPARTMENT .....	6
FIGURE 8 : VEHICLE I.D.....	6
FIGURE 9 : VEHICLE IDENTIFICATION NUMBER .....	7
FIGURE 10 : THREAD NOTATION .....	8
FIGURE 11: BOLT STRENGTH MARKINGS .....	8
FIGURE 12 : SELF-LOCKING FASTENERS .....	9
FIGURE 13: METRIC - US STANDARD CONVERSION TABLE.....	10
FIGURE 14: CONVERSION CHART .....	11

## Section 00: GENERAL INFORMATION

### 1. FOREWORD

This manual includes procedures for diagnosis, service, maintenance and repair for components of the XLII series bus shell models as listed on the front cover page. This manual should be kept in a handy place for ready reference by the technician. If properly used, it will meet the needs of the technician and owner.

Information provided in Section 1 through 26 pertains to standard equipment items, systems and components as well as the most commonly used optional equipment and special equipment offered on the bus shell models covered by this manual. At the beginning of each section: a Table of Contents and a list of illustrations give the page number on which each subject begins and where each figure is located. Coach operating information is provided in a separate Owner's Manual. Audio/Video system operator instructions are also included in a separate manual.

More specific information on engine and transmission operating, maintenance, and overhaul information is contained in the applicable engine or transmission service manual published by the engine or transmission manufacturer. Engine and transmission parts information is contained in the applicable engine or transmission parts catalog published by the engine or transmission manufacturer. All information, illustrations and specifications contained in this manual are based on the latest product information available at the time of publication approval. The right is reserved to make product changes at any time without notice.

#### **NOTE**

*Typical illustrations may be used; therefore minor illustration difference may exist when compared to actual parts or other publications.*

Prévost Car occasionally sends Maintenance Information, Warranty Bulletins, Safety Recalls or other literature to update users with the latest service procedures. They are issued, when required, to supplement or supersede information in this manual. Update sheet should be filled out and bulletins should be filed at the end of their respective section for future reference.

### 2. SCHEMATICS

Vehicle AIR SCHEMATICS are provided at the end of Section 12, "Brake". SUSPENSION AIR SCHEMATICS are provided at the end of Section 16, "Suspension". Moreover, ELECTRICAL SCHEMATICS are provided in the technical publications box. Refer to those schematics for detailed circuit information or during diagnosis.

### 3. PRECAUTIONS TO BE OBSERVED BEFORE WELDING



#### **CAUTION**

Precautions are to be observed before welding to minimize the risk of major and costly damage caused to the vehicle electronic components.

#### **NOTE**

*For XLII Multiplex vehicles, also execute procedure no: PR060034 "MULTIPLEX MODULES DISCONNECTION PROCEDURE PRIOR TO WELDING" included at the end of this section.*



#### **CAUTION**

Cover electronic control components and wiring to protect from hot sparks, etc.



#### **CAUTION**

Position welding machine ground clamp as close as possible to the work. Ensure that the welding machine ground return clamp is well secured and makes a good electrical contact with a large metallic area of the chassis located as close as possible to the welding point.



#### **CAUTION**

Do not use TIG welding process on the vehicle. This high frequency current process can seriously damage the electronic components.

**STEEL – STEEL WELDING**



**CAUTION**

Before welding, disconnect electronic modules and battery terminals.

**NOTE**

*Welding surfaces must be free of scale, slag, rust, paint, grease, humidity or other foreign material that would render welding impossible.*



**DANGER**

Only a qualified and experienced person must do welding.

- FCAW (Flux Cored Arc Welding) process ;
- Electrode wire conforms to A5.20 AWS (American Welding Society) specifications ;
- E4801T-9-CH, type electrode wire with 0,045" diameter (1,14 mm) ;

Material Thickness	Voltage	Current	Wire Feed Rate	Shielding Gas
1/8" to 1/2"	26 ± 2 volts	260 Amps	450 ipm. approx.	75% argon – 25% CO2 or 100% CO2

If necessary and with great care to prevent perforating the material, it is possible to use a conventional electric arc welding machine according to the following specifications:

- SMAW (Shielded Metal-Arc Welding) process ;
- Welding rod conforms to A5.1 of AWS (American Welding Society) specifications; E 7018 type welding rod with 1/8" diameter (3,2 mm).
- Current: 100 amperes to 150 amperes; optimum at 120 amps.

It is important to grind weld bead starts and stops and also to grind arc strikes from surfaces.

**STEEL - STAINLESS STEEL OR STAINLESS STEEL - STAINLESS STEEL WELDING**



**CAUTION**

Before welding, disconnect electronic modules and battery terminals.

**NOTE**

*Welding surfaces must be free of scale, slag, rust, paint, grease, humidity or other foreign material that would render welding impossible.*



**DANGER**

Only a qualified and experienced person must do welding.

- GMAW (Gas Metal-Arc Welding) process;
- Welding wire conforms to AWS (American Welding Standards) A5.9 specifications;
- 308LSi type welding wire with 0.035" diameter (0,9 mm);

**STEEL - STAINLESS STEEL WELDING**

Steel Thickness	SS Thickness	Voltage	Current	Wire Feed Rate	Shielding Gas
Less than 1/8"	Any type	20±1.5 volts	130±15 Amps	290 ipm approx.	90% He, 7.5% Ar, 2.5% CO2
1/8" and more	Any type	22±1.5 volts	160±15 Amps	330 ipm approx.	90% He, 7.5% Ar, 2.5% CO2

## Section 00: GENERAL INFORMATION

### STAINLESS STEEL - STAINLESS STEEL WELDING

SS Thickness	Voltage	Current	Wire Feed Rate	Shielding Gas
Any type	20 ± 1.5 volts	130 ± 15 Amps	290 ipm approx.	90% He – 7.5% Ar, 2.5% CO <sub>2</sub>

If necessary and with great care to prevent perforating the material, it is possible to use a conventional electric arc welding machine according to the following specifications :

- SMAW (Shield Metal-Arc Welding) process;
- Welding rod conforms to AWS (American Welding Standards) A5.4 specifications; 308L-17 type welding rod with 3/32" diameter (2,4 mm);
- Current: - 50 amperes to 90 amperes, optimum at 60 amperes.

It is important to grind weld bead starts and stops and also to grind arc strikes from surfaces.

#### 4. SAFETY NOTICE

This maintenance manual has been prepared in order to assist skilled mechanics in the efficient repair and maintenance of PRÉVOST vehicles.

This manual covers only the procedures as of manufacturing date.

Safety features may be impaired if other than genuine PRÉVOST parts are installed.

Torque wrench tightening specifications must be strictly observed. Locking devices must be installed or replaced by new ones, where specified. If the efficiency of a locking device is impaired, It must be replaced.

This manual emphasizes particular information outlined by the wording and symbols:

 <b>DANGER</b>
Directs the operator's attention to unsafe practices which could result in serious personal injury or death.

 <b>WARNING</b>
Directs the operator's attention to unsafe practices which could result in serious personal injury or severe damage to the vehicle.

 <b>CAUTION</b>
Directs the operator's attention to unsafe practices where personal injury is not likely but damage to vehicle components could occur.

#### *NOTE*

*Indicates supplementary information essential to the proper operation of the vehicle. Although, the mere reading of such information does not eliminate the hazard, understanding of the information will promote its correct use.*

#### 4.1 DATA PLATES AND CERTIFICATIONS

Delay and confusion can be avoided by placing the complete vehicle identification number of the coach and the serial numbers of the engine on parts orders and correspondence. Also, the transmission, axles, power steering pump chassis and other major components are identified by serial numbers.

##### 4.1.1 Engine

The engine serial and model numbers are laser etched on the cylinder block (as viewed from the flywheel end) on the left side just below the fire deck and above the cast-in Detroit Diesel logo (Fig. 1).

In addition, option plates made of laminated paper are located on the rocker cover (starter side). The engine serial and model number and a list of the optional engine equipment are written on the option plate. Refer to this information when ordering replacement parts (Fig. 1).

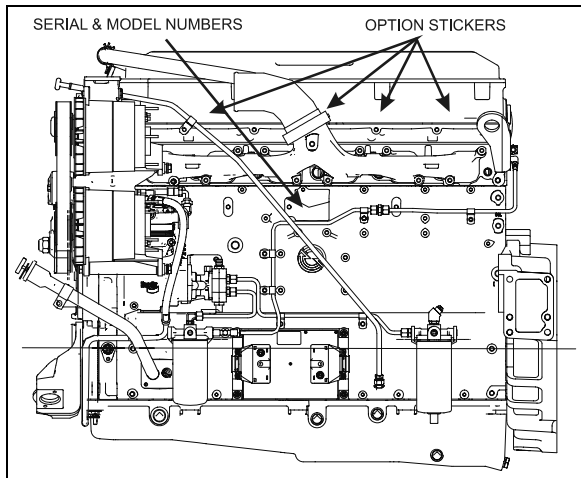

FIGURE 1 : DETROIT DIESEL SERIES 60 00043

4.1.2 Transmission

The transmission identification plate is located on the fluid level dipstick side of the transmission (Fig. 2). The identification plate shows the transmission serial number, part number (assembly number), and model number. Use all three numbers when ordering parts.

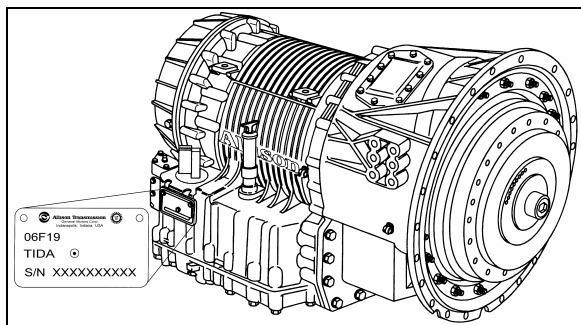

FIGURE 2: ALLISON TRANSMISSION 07139

4.1.3 Drive Axle

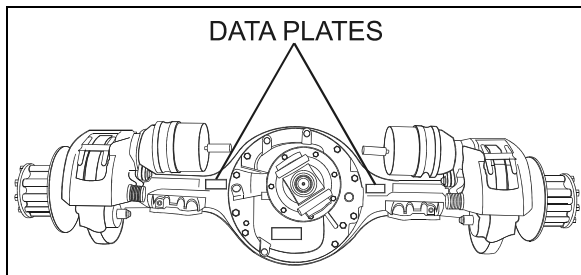

FIGURE 3: TYPICAL SERIAL & MODEL NUMBERS 11019

4.1.4 Front Suspension

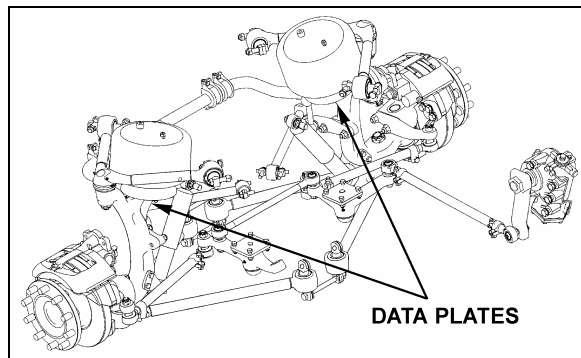

FIGURE 4: ISS TYPICAL SERIAL & MODEL NUMBERS

4.1.5 Power Steering Pump

Power steering pump serial number is located on a tag on the pump (Fig. 5). The pump is mounted on the engine beside the crankshaft pulley.

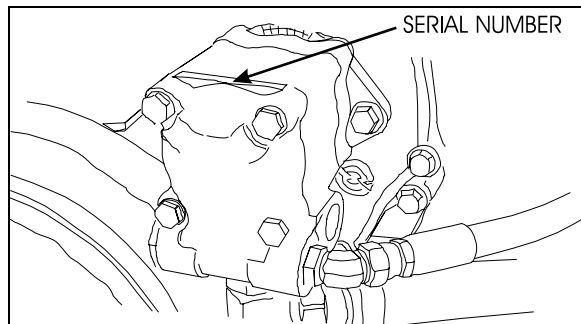

FIGURE 5 : POWER STEERING PUMP NAMEPLATE 00035

4.1.6 Coach Final Record

The Coach Final Record is a record of all data pertaining to the assembly of the coach. This record is included in the technical publication package supplied with the coach. Retain this record in the company records office for reference and safe-keeping.

4.1.7 Safety Certification

Coach components meet specifications and standards as follows:

- Material and parts conform to ASTM and/or SAE standards in effect at the time of manufacture.
- All factory-installed interior materials meet FMVSS 302 for fire resistance.
- Certified according to Provincial, State and Federal Safety standards (Canadian and US) BMCSS, FMVSS, and CMVSS.

## Section 00: GENERAL INFORMATION

Other applicable certification labels are affixed to the component.

### 4.1.8 DOT Certification Label

This certifies that coaches manufactured by Prevost Car Inc., comply with all Federal Motor Vehicle Safety Standards at the time of manufacture. Information such as date of manufacture, model year, gross vehicle weight rating, tire types and inflation pressure is also etched on this plate. The DOT Certification plate is affixed to L.H. control panel.

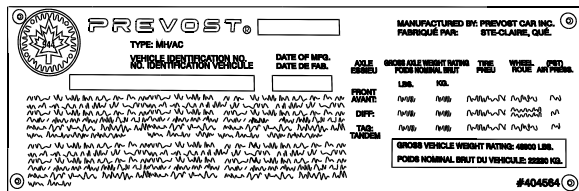

FIGURE 6: DOT CERTIFICATION PLATE 00016

### 4.1.9 EPA Engine Label

The exhaust emission certification label affixed above the engine certifies that the engine conforms to federal and any state exhaust emission regulations (Fig. 7). It gives the operating conditions under which certification was made.

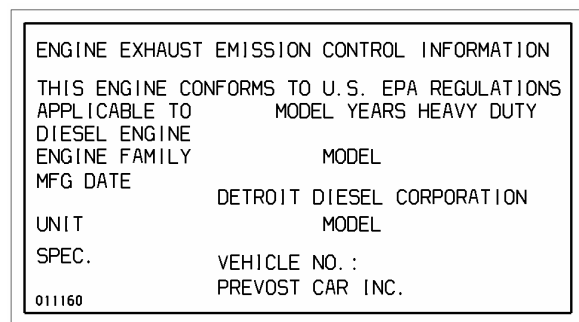

FIGURE 7 : ENGINE COMPARTMENT 00173

### 4.1.10 Fuel Tank Label

The fuel tank label is molded on the side of the fuel tank. To read this label, unscrew the fuel tank access panel nuts located at the left in the condenser compartment.

### 4.1.11 Vehicle Identification Number (VIN)

The seventeen digit vehicle identification number (VIN) is located on a plate (Fig. 8 & 9) located on the windshield frame pillar (driver's side). The VIN is visible from the outside of the coach. Make sure the correct vehicle identification number is given when ordering replacement parts. Using the VIN when ordering parts will facilitate processing.

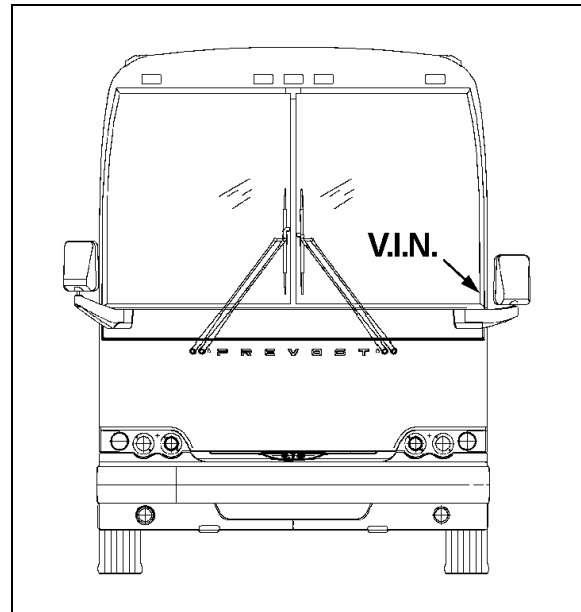

FIGURE 8 : VEHICLE I.D. 00020

#### NOTE

Record the VIN in the coach documentation and keep with company records. The VIN will normally be used for vehicle registration and for obtaining vehicle insurance coverage.



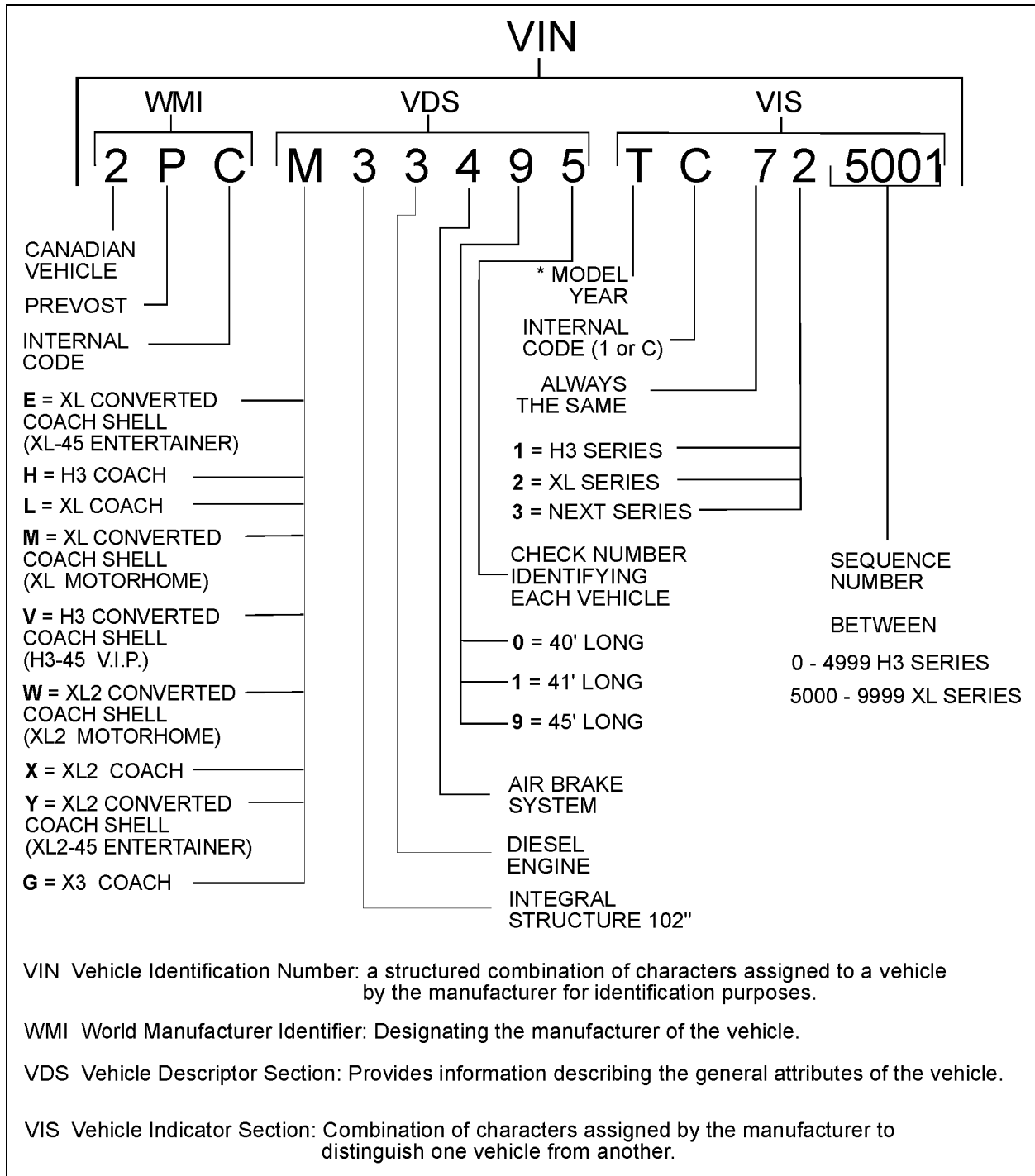

FIGURE 9 : VEHICLE IDENTIFICATION NUMBER

00050

YEAR	CODE	YEAR	CODE
2000	Y	2006	6
2001	1	2007	7
2002	2	2008	8
2003	3	2009	9
2004	4	2010	A
2005	5	2011	B

**Section 00: GENERAL INFORMATION**

**5. FASTENER STRENGTH IDENTIFICATION**

Most commonly used metric fastener strength property classes are 9.8 and 10.9 with the class identification embossed on the head of each bolt. Customary (inch) strength classes range from grade 2 to 8 with radial line identification embossed on each bolt head actual grade (i.e., a grade 7 bolt will have 5 embossed radial lines on the bolt head). Some metric nuts will be marked with single digit strength identification numbers on the nut face. Fig. 11 shows the different strength markings. When replacing

metric fasteners, be careful to use fasteners of the same or greater strength than the original fasteners (the same number marking or higher). It is also important to select replacement fasteners of the correct size. Correct replacement fasteners are available through the parts division. Some metric fasteners available in after-market parts sources were designed to metric standards of countries other the United States and may be of a lower strength, may not have the numbered head marking system, and may be of a different thread pitch.

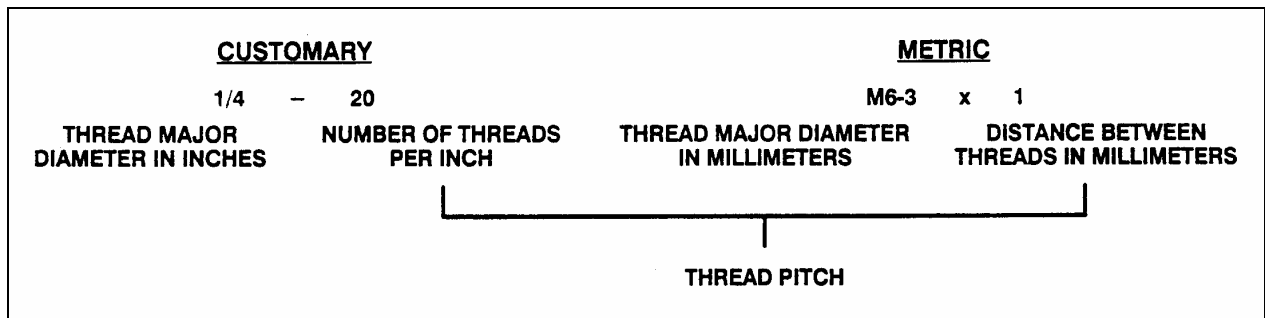

FIGURE 10 : THREAD NOTATION

00002

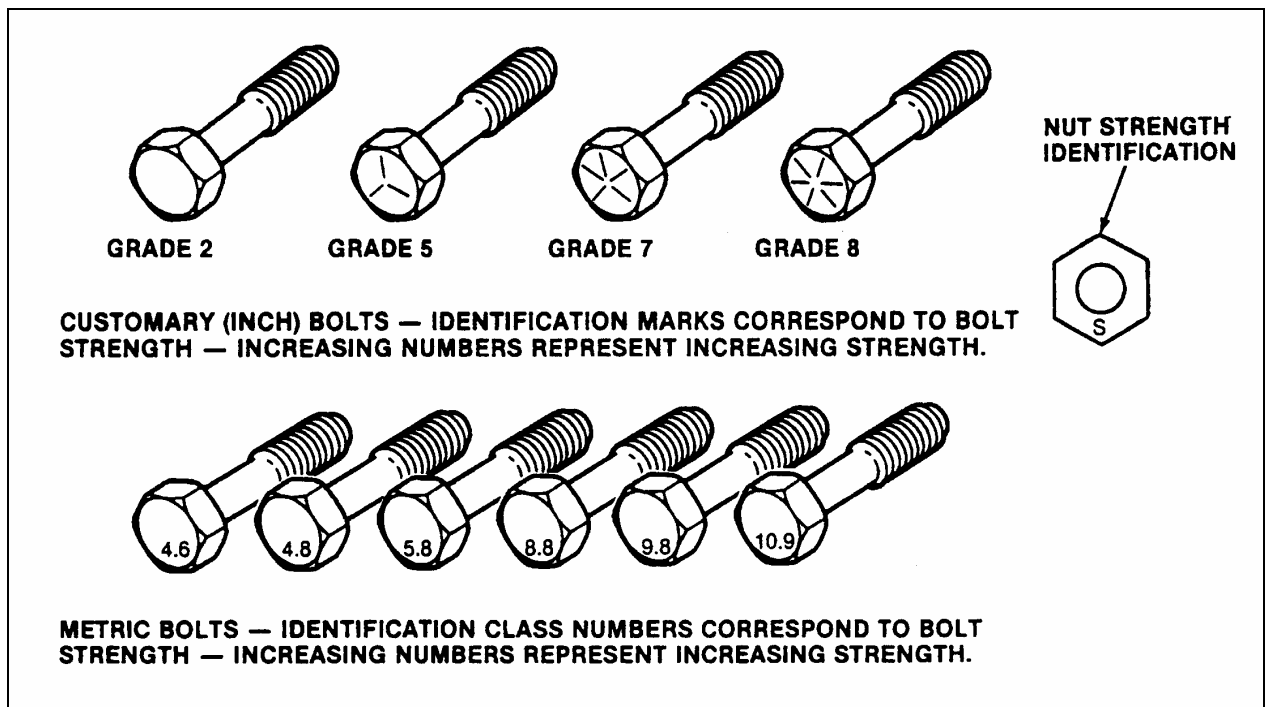

FIGURE 11: BOLT STRENGTH MARKINGS

00003

The metric fasteners used on the coach are designed to new standards and may not yet be manufactured by some non-domestic fastener suppliers. In general, except for special applications, the common sizes and pitches are:

- M 8 X 1.25;
- M 10 X 1.5;
- M 12 X 1.75;
- M 14 X 2;

**5.1 SELF-LOCKING FASTENERS**

A self-locking fastener is designed with an interference fit between the nut and bolt threads. This is most often accomplished by distortion of the top thread of an all-metal nut or bolt or by using a nylon patch on the threads. A nylon insert or the use of adhesives may also be used as a method of interference between nut and bolt threads (Fig. 12).

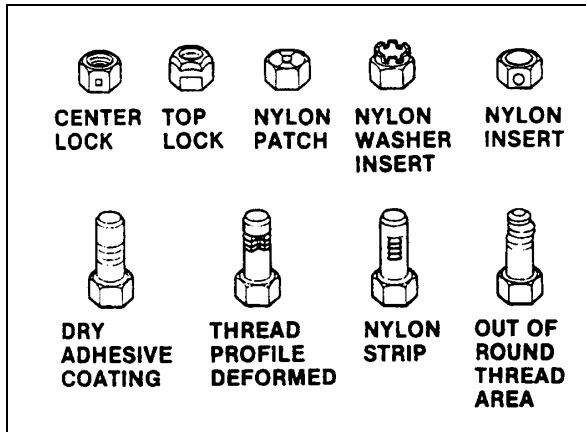

**FIGURE 12 : SELF-LOCKING FASTENERS** 00004

**5.2 RECOMMENDATIONS FOR REUSE**

Clean, unruined self-locking fasteners may be reused as follows:

- a) Clean dirt and other foreign matter from the fastener;
- b) Inspect the fastener to ensure there is no crack, elongation, or other sign of fatigue or overtightening. If there is any doubt, replace with a new self-locking fastener of equal or greater strength;
- c) Assemble parts and hand start fastener;
- d) Observe that, before the fastener seats, it develops torque per the chart in table two. If there is any doubt, replace with a new self-locking fastener of equal or greater strength;
- e) Tighten the fastener to the torque specified in the applicable section of this manual;

Fasteners which are rusty or damaged should be replaced with new ones of equal or greater strength.

<b>SELF-LOCKING FASTENER TORQUE CHART</b>									
<b>METRIC</b>		6 & 6.3	8	10	12	14	16	20	
NUTS AND ALL-METAL BOLTS	Nm	0.4	0.8	1.4	2.2	3.0	4.2	7.0	
	Lbf-in	4.0	7.0	12	18	25	35	57	
ADHESIVE OR NYLON COATED BOLTS	Nm	0.4	0.6	1.2	1.6	2.4	3.4	5.6	
	Lbf-in	4.0	5.0	10	14	20	28	46	
<b>US STANDARD</b>		.250	.312	.375	.437	.500	.562	.625	.750
NUTS AND ALL-METAL BOLTS	Nm	0.4	0.6	1.4	1.8	2.4	3.2	4.2	6.2
	Lbf-in	4.0	5.0	12	15	20	27	35	51
ADHESIVE OR NYLON COATED BOLTS	Nm	0.4	0.6	1.0	1.4	1.8	2.6	3.4	5.2
	Lbf-in	4.0	5.0	9.0	12	15	22	28	43

**5.3 SIX LOBED SOCKET HEAD**

Six lobed socket head (Torx) fasteners are used in some applications on vehicles covered in this manual. The tools designed for these fasteners are available commercially. However, in some cases, if the correct tool is not available, a hex socket head wrench may be used.

Section 00: GENERAL INFORMATION

Multiply	by	to get equivalent number of:	Multiply	by	to get equivalent number of:
	<b>LENGTH</b>			<b>ACCELERATION</b>	
Inch	25.4	millimeters (mm)	Foot/sec <sup>2</sup>	0.305	meter/sec <sup>2</sup> (m/s <sup>2</sup> )
Foot	0.305	meters (m)	Inch/sec <sup>2</sup>	0.026	meter/sec <sup>2</sup>
Yard	0.914	meters			
Mile	1.609	kilometers (km)		<b>TORQUE</b>	
	<b>AREA</b>		Pound-inch	0.113	newton-meters (N·m)
Inch <sup>2</sup>	645.2	millimeters <sup>2</sup> (mm <sup>2</sup> )	Pound-foot	1.35	newton-meters
Foot <sup>2</sup>	6.45	centimeters <sup>2</sup> (cm <sup>2</sup> )			
Yard <sup>2</sup>	0.093	meters <sup>2</sup> (m <sup>2</sup> )		<b>POWER</b>	
	0.836	meters <sup>2</sup>	Horsepower	0.746	kilowatts (kW)
	<b>VOLUME</b>				
Inch <sup>3</sup>	16	mm <sup>3</sup>			
	16.387	cm <sup>3</sup>			
Quart	0.016	liters (l)	Inches of water	0.249	kilopascals (kPa)
Gallon	0.946	liters	Pounds/sq. in.	6.895	kilopascals
Yard <sup>3</sup>	3.785	liters			
	0.765	meters <sup>3</sup> (m <sup>3</sup> )			
	<b>MASS</b>			<b>ENERGY OR WORK</b>	
Pound	0.453	kilograms (kg)	BTU	1 055.0	joules (J)
Ton	907.18	kilograms (kg)	Foot-pound	1.356	joules
Ton	0.907	ton (t)	Kilowatt-hour	3 600 000.0	joules (J = one W's)
				or 3.6 x 10 <sup>6</sup>	
	<b>FORCE</b>				
Kilogram	9.807	newtons (N)		<b>LIGHT</b>	
Ounce	0.278	newtons		1.076	lumens/meter <sup>2</sup> (lm/m <sup>2</sup> )
Pound	4.448	newtons	Foot candle		
	<b>TEMPERATURE</b>			<b>VELOCITY</b>	
Degree Fahrenheit	(°F - 32) ÷ 1.8	Degree Celsius (C)	Miles/hour	1.609	kilometers/hr (km/h)

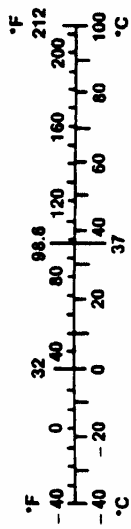

FIGURE 13: METRIC - US STANDARD CONVERSION TABLE

00005

## DECIMAL AND METRIC EQUIVALENTS

FRACTIONS	DECIMAL IN.	METRIC MM	FRACTIONS	DECIMAL IN.	METRIC MM
1/64	.015625	.39688	33/64	.515625	13.09687
1/32	.03125	.79375	17/32	.53125	13.49375
3/64	.046875	1.19062	35/64	.546875	13.89062
1/16	.0625	1.58750	9/16	.5625	14.28750
5/64	.078125	1.98437	37/64	.578125	14.68437
3/32	.09375	2.38125	19/32	.59375	15.08125
7/64	.109375	2.77812	39/64	.609375	15.47812
1/8	.125	3.1750	5/8	.625	15.87500
9/64	.140625	3.57187	41/64	.640625	16.27187
5/32	.15625	3.96875	21/32	.65625	16.66875
11/64	.171875	4.36562	43/64	.671875	17.06562
3/16	.1875	4.76250	11/16	.6875	17.46250
13/64	.203125	5.15937	45/64	.703125	17.85937
7/32	.21875	5.55625	23/32	.71875	18.25625
15/64	.234375	5.95312	47/64	.734375	18.65312
1/4	.250	6.35000	3/4	.750	19.05000
17/64	.265625	6.74687	49/64	.765625	19.44687
9/32	.28125	7.14375	25/32	.78125	19.84375
19/64	.296875	7.54062	51/64	.796875	20.24062
5/16	.3125	7.93750	13/16	.8125	20.63750
21/64	.328125	8.33437	53/64	.828125	21.03437
11/32	.34375	8.73125	27/32	.84375	21.43125
23/64	.359375	9.12812	55/64	.859375	21.82812
3/8	.375	9.52500	7/8	.875	22.22500
25/64	.390625	9.92187	57/64	.890625	22.62187
13/32	.40625	10.31875	29/32	.90625	23.01875
27/64	.421875	10.71562	59/64	.921875	23.41562
7/16	.4375	11.11250	15/16	.9375	23.81250
29/64	.453125	11.50937	61/64	.953125	24.20937
15/32	.46875	11.90625	31/32	.96875	24.60625
31/64	.484375	12.30312	63/64	.984375	25.00312
1/2	.500	12.70000	1	1.00	25.40000

FIGURE 14: CONVERSION CHART

00006

# PREVOST

## MULTIPLEX MODULES DISCONNECTION PROCEDURE PRIOR TO WELDING

**PROCEDURE NO: PR060034**

**REVISION 3  
2007-02-27**

**Material :** N/A

**Equipment(s) :** Phillips-head screwdriver  
Ratchet handle  
3/8" socket  
Electric tape  
Long nose pliers

**Reference schematics:** N/A

**Safety rules :**

- Wear safety goggles
- Set the battery master switch to the OFF position first

**Recommendations:** This procedure should be performed by qualified personnel only.

	Effective
<b>Revision 0 : Issued with multiplex</b>	
<b>Revision 1 : Modified for Fire Protection System and also for VIP with multiplex</b>	
<b>Revision 2 : Step 5 modified for introduction of VIP with multiplex</b>	<b>-0436</b>
<b>Revision 3 : Step 1.15 added C397 Addition of SECTION 2 for X3 Coaches Addition of SECTION 3 for XLII MTH</b>	

SECTION 1 H3 Coaches & VIP

1.00 **Location: Main power compartment and dashboard**  
Set the battery master switch to the OFF position.  
Place the ignition switch to the OFF position.

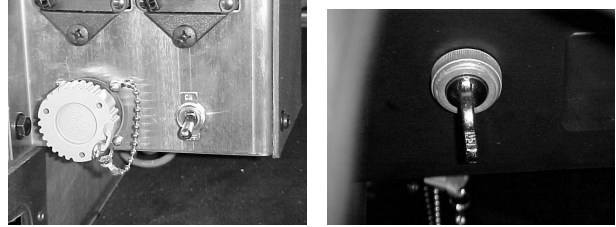

1.05 **Location: Main power compartment**  
Trip circuit breakers CB2, CB4, CB6

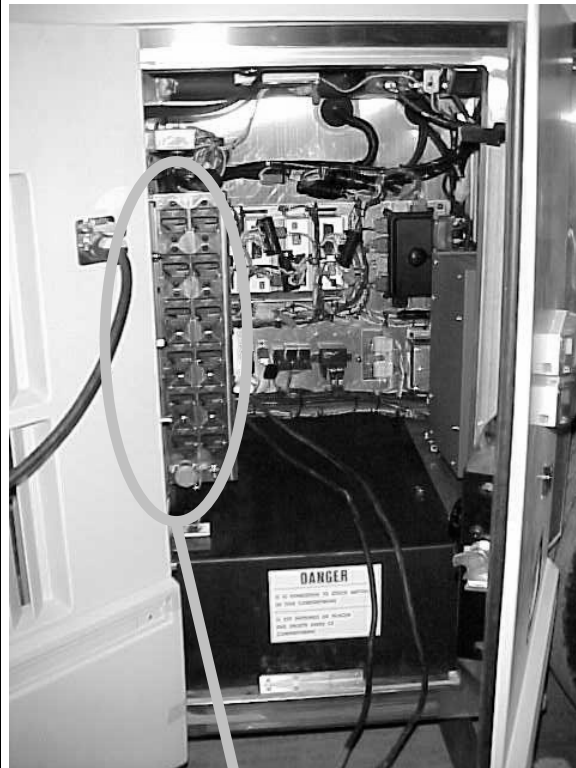

Push the red button to open the circuit



1.10 Location: Main power compartment

Remove the protective cover

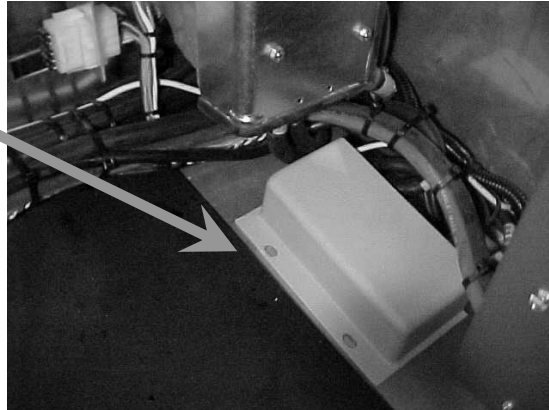

**△ WARNING △**

**LIVE WIRE**

**This 12-volt terminal remains energized**

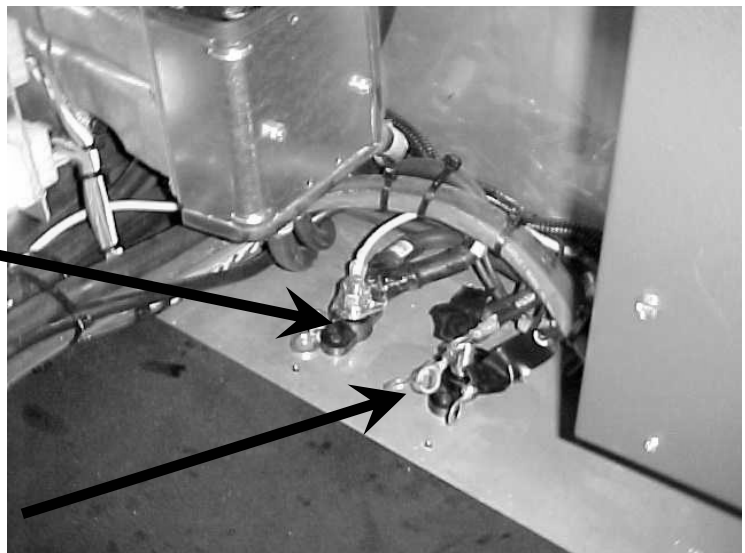

Disconnect the electronic ground terminals from the stud

Using electric tape, insulate the 2 largest gage wires. Make sure the ring terminals do not touch each others and the vehicle body.

*NOTE*

***With disconnection of the electronic ground terminals, disconnecting the engine ECM, transmission TCM and the dashboard electronic components (telltale module, HVAC module, radio, control head, ...) is not required.***

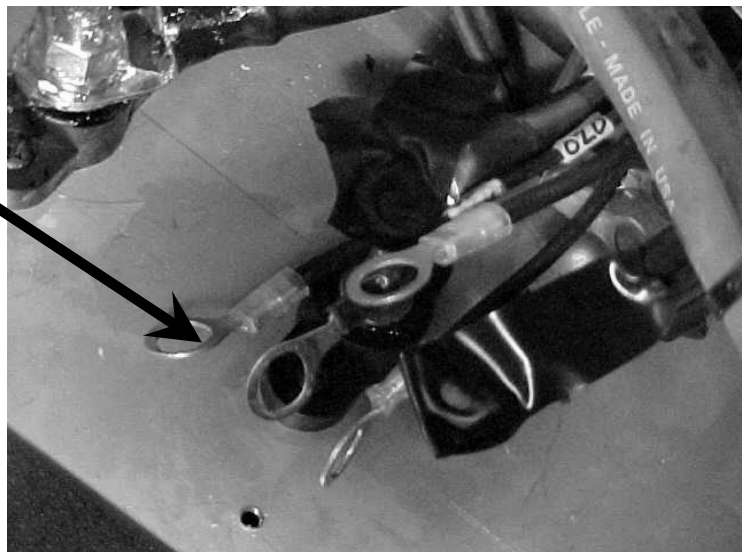



<p>1.15 <b>Location: Main power compartment</b></p> <p>Disconnect the electronic modules :</p> <hr/> <p>Disconnect the I/O A and I/O B modules</p> <p style="padding-left: 40px;">Disconnect C397</p> <p>Disconnect connector C717</p> <p>Unplug 3 connectors per I/O B modules</p> <p>Unplug 3 connectors on the I/O A module</p>	
<p>1.20 <b>Location: Front electrical compartment</b></p> <p><b>VIP + COACH:</b> Disconnect the I/O A, I/O B, ABS, master ID, CECM and CPC modules. Unplug connector C92</p> <p><b>VIP:</b> Disconnect all keyless module connectors.</p> <p>Unplug 3 connectors per I/O B modules and 3 connectors per I/O A modules.</p> <p>Unplug 2 connectors from the ABS module</p>	

Unplug 1 connector from the master ID

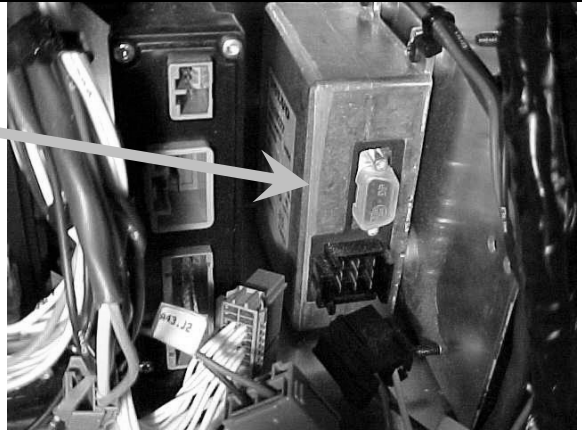

Disconnect CPC connectors



Unplug 3 connectors from the CECM

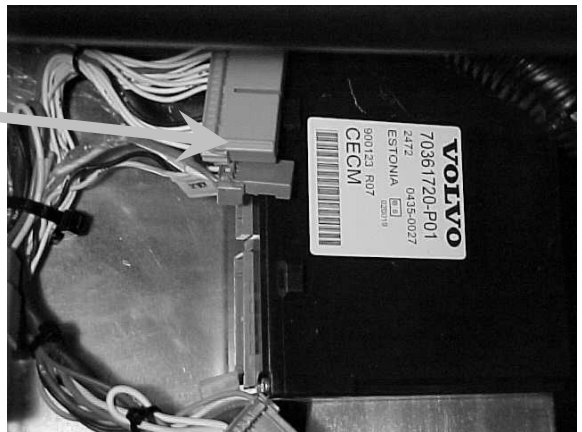

Unplug connector C92



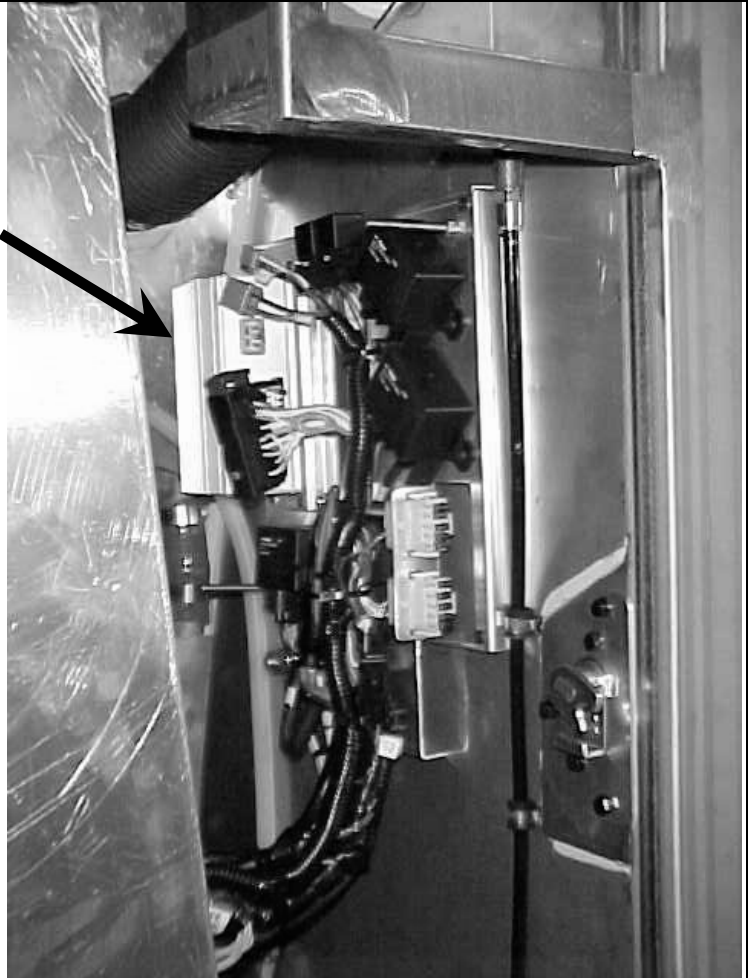

<p>1.25 <b>Location: pneumatic accessory panel inside right console</b></p> <p>Remove the access panel on the right console (R.H. side of dashboard)</p> <p>Disconnect both I/O B modules</p>	
<p>1.30 <b>Location: Evaporator compartment</b></p> <p>Remove the protective cover and disconnect the I/O B module</p>	

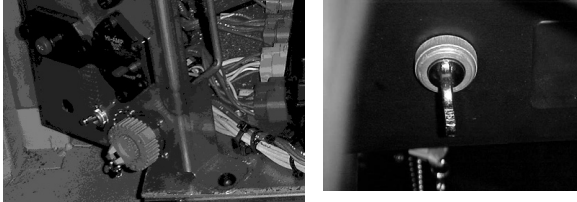
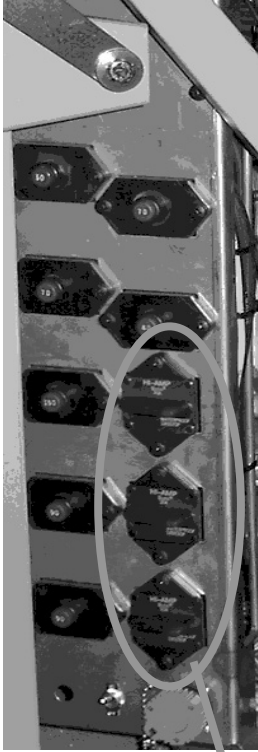
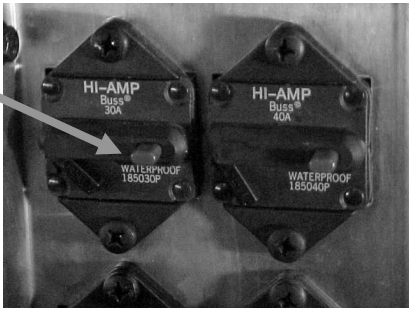

1.40	<p><b>Kidde Automatic Fire Detection and Suppression System (optional)</b></p> <p>Disconnect C466</p> <p>Kidde AFSS module is located on the lateral control panel.</p>	
1.45	<p>When all the previous steps are done, you can do welding on the vehicle</p>	<p><b>ENSURE THAT THE WELDING GROUND RETURN CLAMP IS WELL SECURED AND MAKES A GOOD ELECTRICAL CONTACT WITH A LARGE METALLIC AREA OF THE CHASSIS LOCATED NEAR THE WELDING POINT AS MUCH AS POSSIBLE.</b></p>
1.50	<p><b>When welding is completed, reconnect all the modules.</b></p> <p>Make sure that the connectors locking tab are well engaged</p>	<p><b>BE CAREFUL TO MAKE THE PROPER CONNECTIONS, IF NOT, SOME SYSTEMS OR COMPONENTS MAY NOT BE USABLE</b></p>

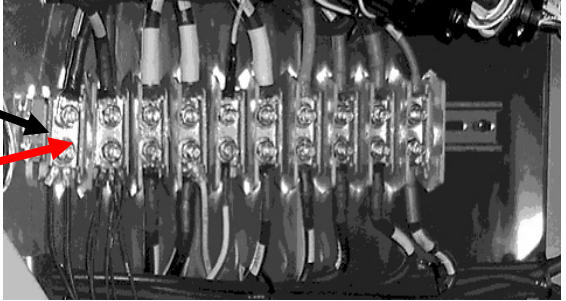
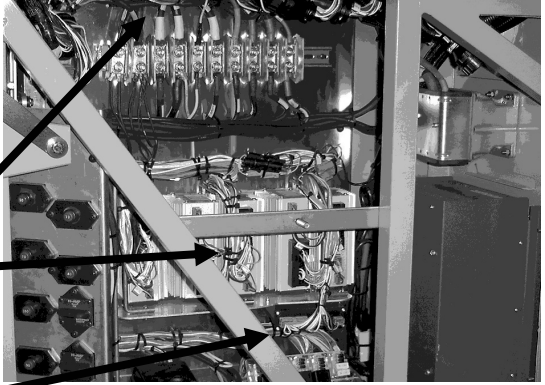
**SECTION 2 X3 Coaches**

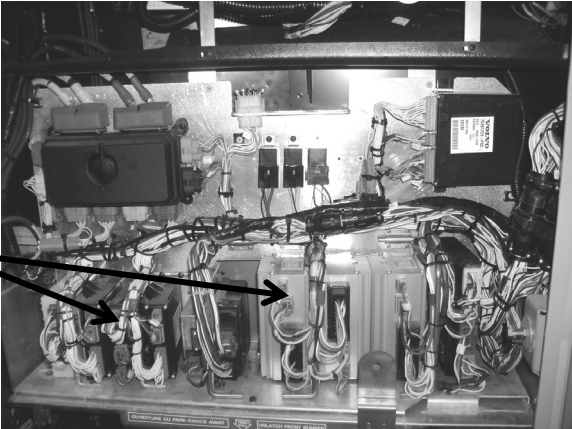
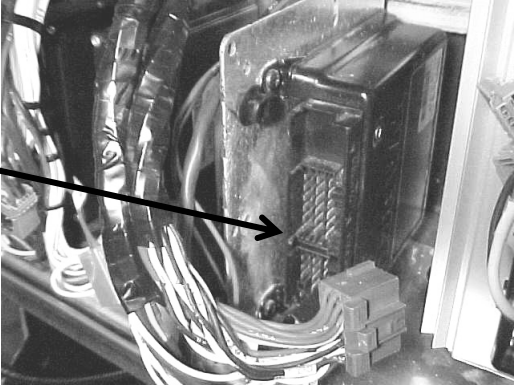
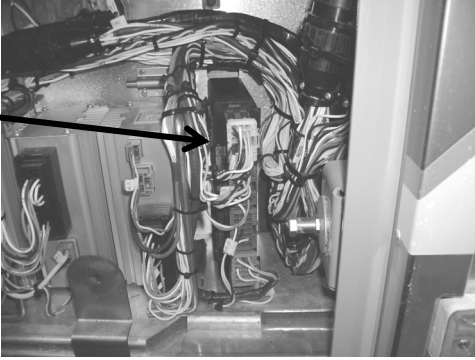
<p>2.00</p>	<p><b>Location: Rear electrical compartment and dashboard</b></p> <p>Set the battery master switch to the OFF position.</p> <p>Place the ignition switch to the OFF position.</p>	
<p>2.05</p>	<p><b>Location: Rear electrical compartment</b></p> <p>Trip circuit breakers CB2-CB4-CB6 located on rear junction panel</p>          <p>Push the red button in to open the circuit</p>	 

<p>2.10</p>	<p><b>Location: Rear electrical compartment</b></p> <p>Disconnect the electronic ground terminals from this stud</p> <div style="border: 2px solid red; padding: 5px; margin: 10px 0;"> <p><b>Warning: The remaining terminals may still be energized</b></p> </div> <p>Use electric tape; make sure that cables do not touch each others and the vehicle body.</p> <p style="text-align: center;"><i>NOTE</i></p> <p><i>With disconnection of the electronic ground terminals, disconnecting the engine ECM, transmission TCM and the dashboard electronic components (telltale module, HVAC module, radio, control head, ...) is not required.</i></p>	
<p>2.15</p>	<p><b>Location: Rear electrical compartment</b></p> <p>Disconnect the electronic modules:</p> <p>Disconnect all I/O A and I/O B modules</p> <p style="padding-left: 40px;">Disconnect C397 and C717</p> <p>Disconnect 3 connectors from each I/O B module</p> <p>Disconnect 3 connectors from each I/O A module</p>	

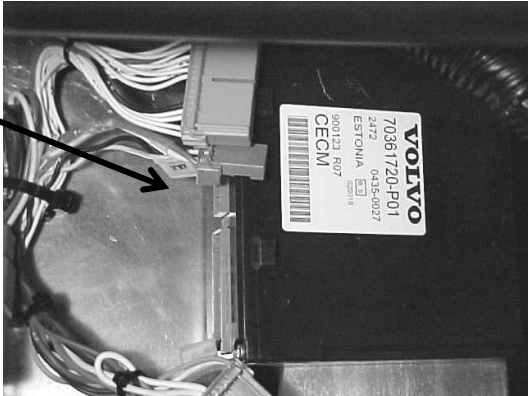
2.20	<p><b>Location: front electrical compartment</b></p> <p>Disconnect I/O A, I/O B, ABS, master ID, CECM and CPC modules and also disconnect connector C92</p>	
	<p>Disconnect the 2 connectors from the ABS module</p>	
	<p>Disconnect CPC connectors</p>	
	<p>Disconnect connector from master ID</p>	

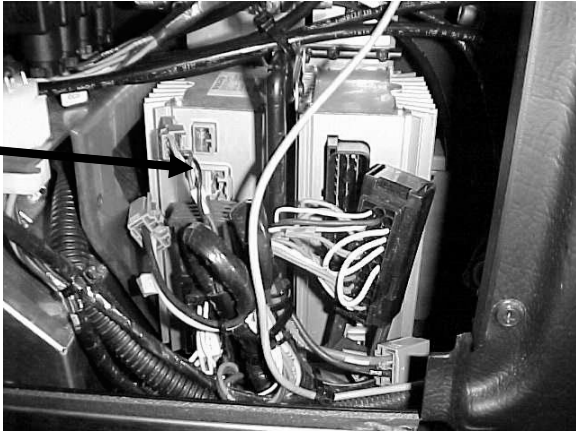
<p>Disconnect the 3 connectors from CECM</p>	
<p>Disconnect connector C92</p>	
<p>2.25 <b>Location: Entrance door &amp; wiper control panel</b> Remove windshield wiper motor access panel and disconnect both I/O B modules</p>	
<p>2.30 When all the previous steps are done, you can do welding on the vehicle</p>	<p><b>ENSURE THAT THE WELDING GROUND RETURN CLAMP IS WELL SECURED AND MAKES A GOOD ELECTRICAL CONTACT WITH A LARGE METALLIC AREA OF THE CHASSIS LOCATED NEAR THE WELDING POINT AS MUCH AS POSSIBLE</b></p>
<p>2.40 <b>When welding is completed, reconnect all the modules.</b> Make sure that the connectors locking tab are well engaged!</p>	<p><b>BE CAREFUL TO MAKE THE PROPER CONNECTIONS, IF NOT, SOME SYSTEMS OR COMPONENTS MAY NOT BE USABLE</b></p>

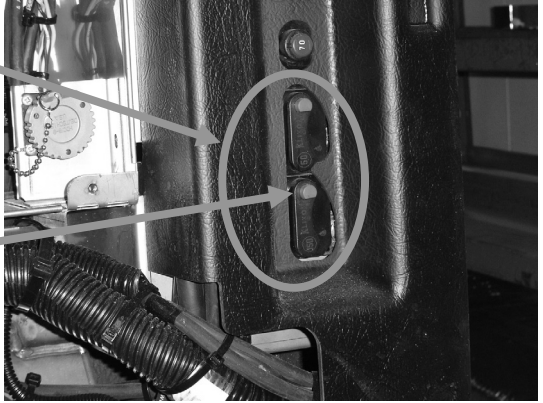
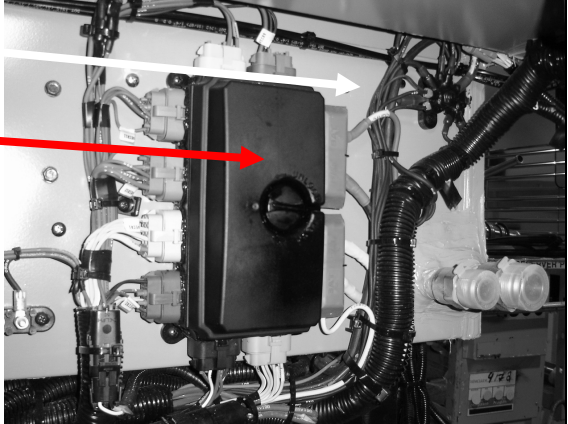

**SECTION 3 XLII MTH**

<p>2.00</p>	<p><b>Location: Dashboard</b></p> <p>Place the ignition switch to the OFF position.</p>	
<p>2.05</p>	<p><b>Location: Engine compartment R. H. side area</b></p> <p>Trip circuit breakers CB1-CB2 located on circuit breaker panel.</p> <p>Push the blue button in to open the circuit</p>	
<p>2.10</p>	<p><b>Location: Rear Junction Box</b></p> <p>Disconnect the electronic ground terminals from this stud.</p> <div style="border: 2px solid red; padding: 5px; margin: 10px 0;"> <p><b>Warning: The remaining terminals may still be energized.</b></p> </div> <p>Use electric tape; make sure that cables do not touch each others and the vehicle body.</p> <p style="text-align: center;"><i>NOTE</i></p> <p><b><i>With disconnection of the electronic ground terminals, disconnecting the engine ECM, transmission TCM and the dashboard electronic components (telltale module, HVAC module, radio, control head, ...) is not required.</i></b></p>	

2.15 **Location: Rear Junction Box**

Disconnect the electronic modules:

Disconnect all I/O A and I/O B modules

Disconnect C397

Disconnect transmission module (A1)

Disconnect 3 connectors from each I/O B

Disconnect 3 connectors from each I/O A

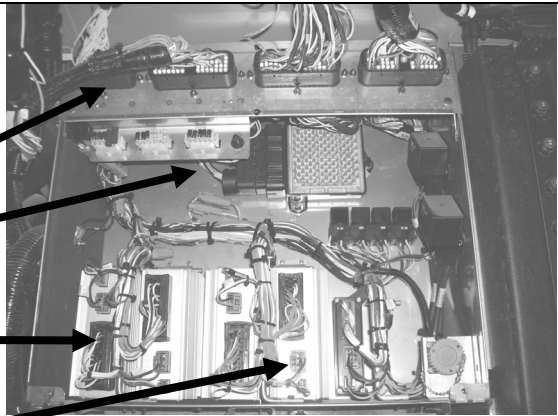

The image shows the rear junction box with several electronic modules. Arrows point from the text to specific components: C397, transmission module (A1), I/O B connectors, and I/O A connectors.

2.20 **Location: Front Electrical Compartment**

Disconnect I/O A, I/O B, ABS, master ID, CECM, CPC, keyless modules and also disconnect connector C92.

Disconnect 3 connectors from the I/O B and I/O A modules

Disconnect connectors from Keyless module

Disconnect 2 connectors from ABS module

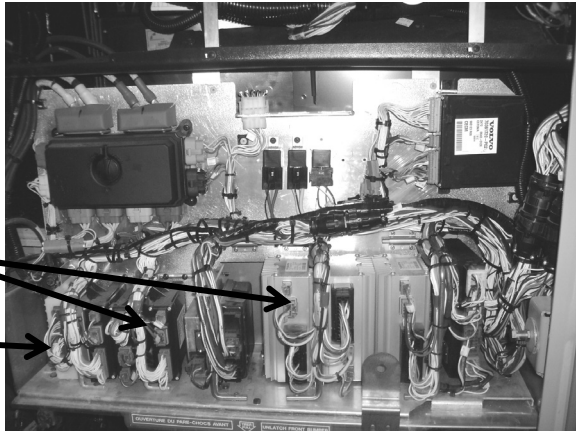
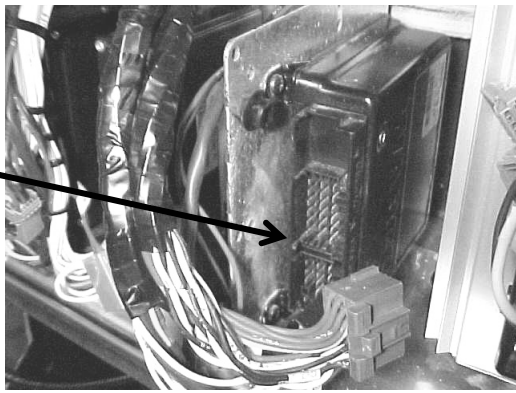



The top image shows the front electrical compartment with various modules. Arrows point to I/O B and I/O A modules, and the Keyless module. The bottom image is a close-up of the ABS module with an arrow pointing to its connectors.

Disconnect connectors from CPC

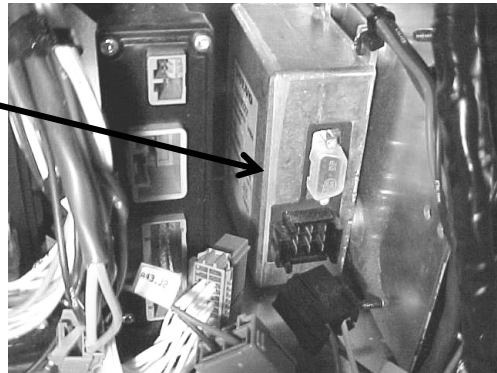

Disconnect connector from master ID



Disconnect 3 connectors from CECM

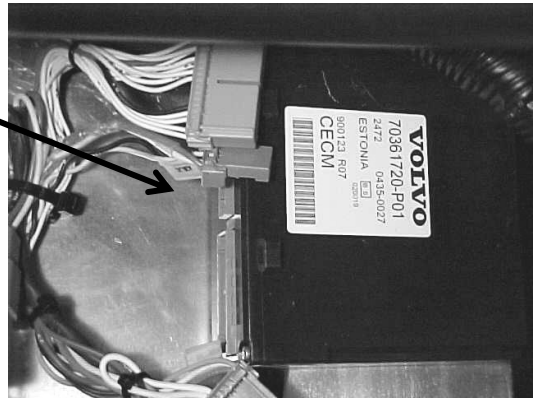

Disconnect connector C92



**Location: Wiper Control Panel**

Remove windshield wiper motor access panel

And disconnect I/O B modules

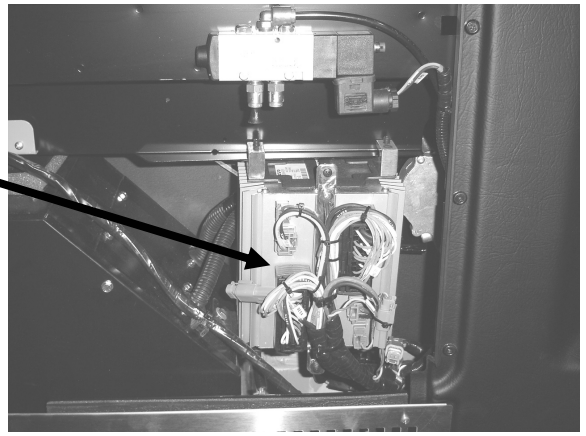

<p>2.30</p>	<p>When all the previous steps are done, you can do welding on the vehicle</p>	<p><b>ENSURE THAT THE WELDING GROUND RETURN CLAMP IS WELL SECURED AND MAKES A GOOD ELECTRICAL CONTACT WITH A LARGE METALLIC AREA OF THE CHASSIS LOCATED NEAR THE WELDING POINT AS MUCH AS POSSIBLE</b></p>
<p>2.35</p>	<p><b>When welding is completed, reconnect all the modules.</b> Make sure that the connectors locking tab are well engaged!</p>	<p><b>BE CAREFUL TO MAKE THE PROPER CONNECTIONS, IF NOT, SOME SYSTEMS OR COMPONENTS MAY NOT BE USABLE</b></p>

## CONTENTS

<b>1. ENGINE</b> .....	<b>3</b>
1.1 DDEC VI SYSTEM .....	3
1.2 HARNESES .....	3
<b>2. ENGINE OVERVIEW</b> .....	<b>4</b>
2.1 DDEC VI SENSORS .....	5
2.2 OTHER SENSORS .....	6
2.3 MOTOR CONTROL MODULE (MCM) .....	6
2.4 COMMON POWERTRAIN CONTROLLER (CPC) .....	6
<b>3. ENGINE-RELATED COMPONENTS</b> .....	<b>6</b>
3.1 ELECTRONIC FOOT PEDAL ASSEMBLY (EFPA) & THROTTLE POSITION SENSOR .....	6
<b>4. DDEC VI DIAGNOSTICS</b> .....	<b>7</b>
4.1 DIAGNOSTIC SYSTEM .....	7
4.1.1 <i>Check Engine Telltale Light (Awl)</i> .....	7
4.1.2 <i>Stop Engine Warning Light (Rsl)</i> .....	8
4.1.3 <i>Stop Engine Override Switch (Seo)</i> .....	8
4.1.4 <i>Diagnostic Data Link (Ddl) Connectors</i> .....	8
4.2 READING DIAGNOSTIC CODES – FLASHING LIGHT METHOD: .....	8
4.3 DDEC VI CPC DIAGNOSTIC CODES LIST .....	9
4.4 DDEC VI MCM DIAGNOSTIC CODES LIST .....	16
<b>5. ENGINE OIL LEVEL</b> .....	<b>27</b>
<b>6. ENGINE OIL AND FILTER CHANGE</b> .....	<b>27</b>
<b>7. RECOMMENDED ENGINE OIL TYPE</b> .....	<b>29</b>
<b>8. POWER PLANT ASSEMBLY REMOVAL</b> .....	<b>29</b>
<b>9. POWER PLANT ASSY. INSTALLATION</b> .....	<b>32</b>
<b>10. VALVE COVER REMOVAL</b> .....	<b>32</b>
<b>11. JAKE BRAKE</b> .....	<b>32</b>
<b>12. ENGINE MOUNTS</b> .....	<b>32</b>
<b>13. ENGINE TROUBLESHOOTING GUIDE</b> .....	<b>34</b>
<b>14. SPECIFICATIONS</b> .....	<b>35</b>

**ILLUSTRATIONS**

FIGURE 1: VEHICLE INTERFACE HARNESS (GENERAL APPLICATION SHOWN) ..... 3  
FIGURE 2: DETROIT DIESEL 2007 SERIES 60 ENGINE (TYPICAL) ..... 5  
FIGURE 3: MOTOR CONTROL MODULE (MCM) ..... 6  
FIGURE 4: CPC ..... 6  
FIGURE 5: THE CPC COMMUNICATES OVER THE J1587 AND J1939 DATA LINKS TO THE VEHICLE..... 6  
FIGURE 6: ELECTRONIC FOOT PEDAL ASSEMBLY ..... 7  
FIGURE 7: FLASHING FAULTS CODES ..... 8  
FIGURE 8: ENGINE OIL LEVEL DIPSTICK..... 27  
FIGURE 9: OIL RESERVE TANK..... 27  
FIGURE 10: ENGINE DRAIN PLUG AND OIL FILTERS..... 28  
FIGURE 11: BELT TENSIONER VALVE ..... 29  
FIGURE 12: ENGINE COMPARTMENT X3 COACHES (TYPICAL)..... 31  
FIGURE 13: POWER PLANT CRADLE INSTALLATION ..... 33

## 1. ENGINE

This vehicle is powered by a 6-cylinder, four-cycle, Detroit Diesel series 60 engine equipped with an electronic control system (DDEC VI).

One engine displacement is used in the XLII MTH Series 60 engines: 14.0 liters. Summary information on the Electronic Control System is given in this section.

Complete maintenance and repair information on the engine will be found in the current DETROIT DIESEL SERIES 60 2007 ON-HIGHWAY SERVICE MANUAL 6SE2007. This essential manual contains complete instructions on operation, adjustment (tune-up), preventive maintenance and lubrication, parts verification, repair or replacement. This manual's sections cover complete systems such as:

- Engine main assembly;
- Fuel system;
- Lubrication system;
- Cooling system;
- Fuel, lubricating oil and coolant;
- Air intake system;
- Exhaust system;
- Exhaust gas recirculation components;
- Electrical equipment;
- Operation and verification;
- Engine tune-up;
- Preventive maintenance;
- Storage;

Refer to Series 60 DDEC VI Troubleshooting Guide published by Detroit Diesel for more complete information on diagnosis of components and system problems.

Procedures for engine removal and installation are given at the end of this section. The DDEC system is self-diagnostic. It can identify faulty components and other engine-related problems by providing the technician with diagnostic codes.

### 1.1 DDEC VI SYSTEM

DDEC VI (Detroit Diesel Electronic Control) is a system that monitors and determines all values required for the operation of the engine. A diagnostic interface is provided to connect to an external diagnosis tester. Besides the engine related sensors and the engine-resident control

unit, the Motor Control Module (MCM), this system has a chassis-mounted control unit for vehicle engine management, the Common Powertrain Controller (CPC). The connection to the vehicle is made via a CAN interface which digitally transmits the nominal values (e.g. torque, engine speed specification, etc.) and the actual values (e.g. engine speed, oil pressure, etc.).

DDEC VI controls the timing and amount of fuel injected by the electronic unit injectors (EUI). The system also monitors several engine functions using electrical sensors, which send electrical signals to the Motor Control Module (MCM). The MCM computes the electrical signals and determines the correct fuel output and timing for optimum power, fuel economy and emissions. The MCM also has the ability to display warnings or shut down the engine completely (depending on option selection) in the event of damaging engine conditions, such as low oil pressure or high engine temperature.

### 1.2 HARNESSSES

There are two major harnesses: the Engine Harness (EH) and the Vehicle Interface Harness (VIH). The Engine Harness is installed at the Detroit Diesel factory and is delivered connected to all engine sensors, the fuel injection system, and the MCM.

The OEM supplied Vehicle Interface Harness connects the CPC to other vehicle systems.

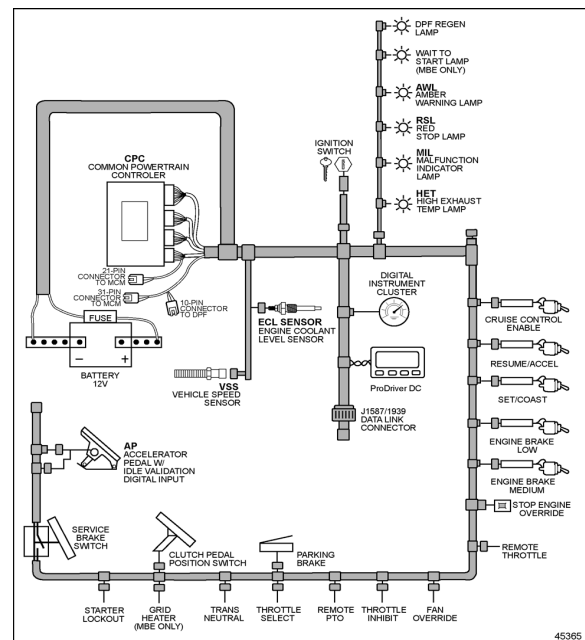
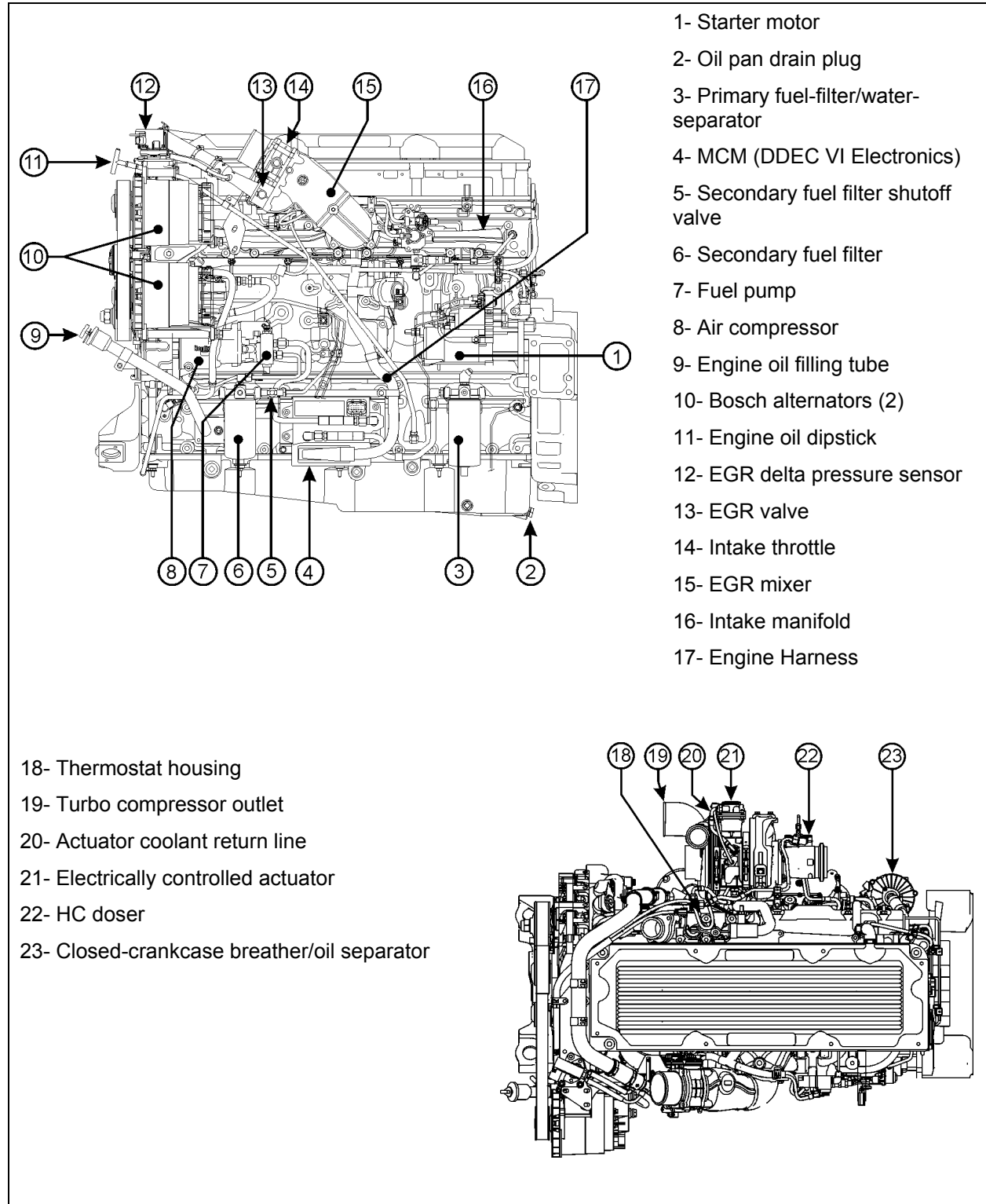

FIGURE 1: VEHICLE INTERFACE HARNESS (GENERAL APPLICATION SHOWN)

2. ENGINE OVERVIEW





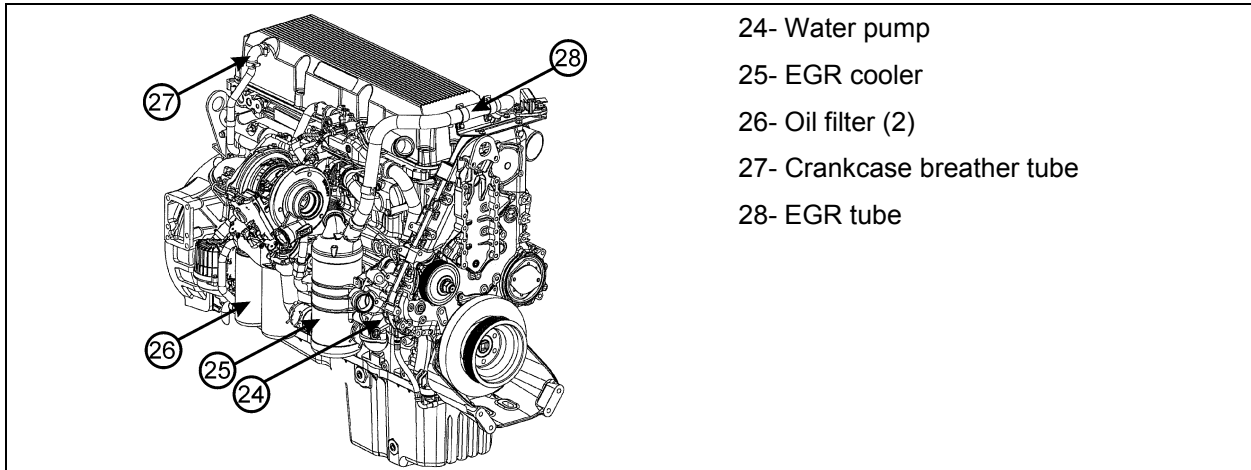

FIGURE 2: DETROIT DIESEL 2007 SERIES 60 ENGINE (TYPICAL)

01150

## 2.1 DDEC VI SENSORS

- **Camshaft Position Sensor (CMP Sensor):** Indicates a specific cylinder in the firing order.
- **Crankshaft Position Sensor (CKP Sensor):** Senses crankshaft position and engine speed for functions such as fuel control strategy.
- **DPF Inlet Pressure Sensor:** Measures pressure between the Diesel Oxidation Catalyst (DOC) and the Diesel Particulate Filter (DPF) in the aftertreatment assembly.
- **DPF Outlet Pressure Sensor:** Measures pressure on the outlet of the aftertreatment device in the exhaust system of the vehicle.
- **DPF Outlet Temperature Sensor:** Temperature measured at the outlet of the after-treatment system that is installed within the exhaust system of the vehicle.
- **DOC Inlet Temperature Sensor:** Temperature measured at the outlet of the after-treatment.
- **DOC Outlet Temperature Sensor:** Temperature measured between the DOC and the DPF in the aftertreatment assembly.
- **EGR Delta Pressure Sensor:** Senses EGR pressure for EGR control.
- **EGR Temperature Sensor:** Senses EGR exhaust temperature after EGR cooler. Used for EGR system diagnosis.
- **Engine Coolant Temperature Sensor (ECT Sensor):** Senses coolant temperature for functions such as engine protection, fan control and engine fueling.
- **Engine Oil Pressure Sensor (EOP Sensor):** Senses gallery oil pressure for functions such as engine protection.
- **Engine Oil Temperature Sensor (EOT Sensor):** Senses oil temperature for functions such as reducing variation in fuel injection and fan control.
- **Fuel Line Pressure Sensor:** Senses fuel line pressure.
- **Fuel Compensation Pressure Sensor:** Compensates fuel line pressure.
- **Intake Manifold Pressure Sensor (IMP Sensor):** Senses turbo boost for functions such as smoke control and engine protection.
- **Intake Manifold Air Temperature Sensor (IMT Sensor):** Senses pressure. The MCM uses this information to compute the amount of air entering the engine.
- **Supply Fuel Temperature Sensor (SFT Sensor):** Senses fuel temperature for functions such as engine fueling.
- **Turbo Compressor Temperature Out Sensor:** Senses turbo out air temperature.
- **Turbo Speed Sensor (TSS):** Monitors turbo speed for overspeed conditions.
- **VGT Position Sensor/EGR Valve Position Sensor.**
- **Intake Air Throttle Valve Sensor.**
- **Exhaust Valve Recirculation Valve (EGR) Sensor.**

## Section 01: ENGINE

### 2.2 OTHER SENSORS

- **Engine Coolant Level Sensor (ECL Sensor):** Senses coolant level for engine protection (mounted on coolant surge tank).
- **Turbo Compressor In Temperature Sensor:** Senses the air temperature at the turbo compressor inlet.

### 2.3 MOTOR CONTROL MODULE (MCM)

The Motor Control Module is mounted, on the starter side of the engine (Fig. 3). Considered the "Brain" of the DDEC VI system, it provides overall monitoring and control of the engine. It does so by comparing input data from the various sensors to a set of calibration data stored in the EEPROM (Electrically Erasable, Programmable, Read-Only Memory) within the Motor Control Module. After comparing the input data with the calibration data, the MCM sends high-current command pulses to the Electronic Unit Injectors (EUI) to initiate fuel injection. The MCM also receives feedback regarding the start and end of injection for a given cylinder. The EEPROM within the Motor Control Module is factory programmed by Detroit Diesel. Reprogramming must be done at a Detroit Diesel authorized service center. However, some changes may be performed to the cruise control and road speed limiter using a diagnostic data reader (see paragraph "DDEC VI Diagnostic Codes" in this section).

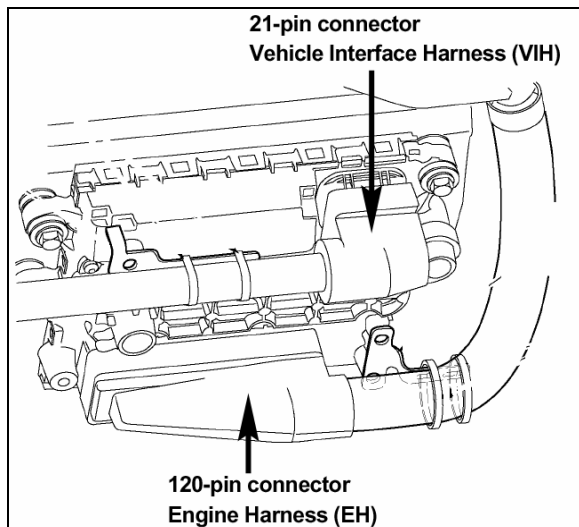

FIGURE 3: MOTOR CONTROL MODULE (MCM) 01145

### 2.4 COMMON POWERTRAIN CONTROLLER (CPC)

The CPC is the interface between the MCM and the vehicle/equipment for engine control and manages other vehicle/equipment functions.

Within the CPC, sets of data for specific applications are stored. These include idle speed, maximum running speed, and speed limitation. Customer programmable parameters are also stored here. The CPC receives data from the operator (accelerator pedal position, switches and various sensors) and other electronic control units. From this data, instructions are computed for controlling the engine and transmitted to the MCM via the proprietary data link.

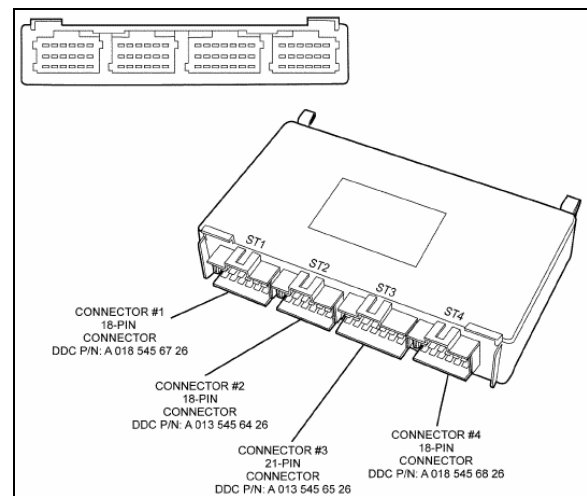

FIGURE 4: CPC

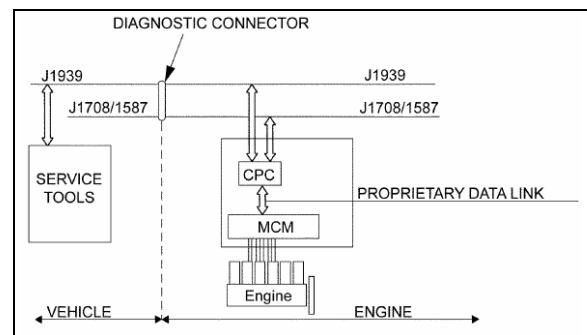

FIGURE 5: THE CPC COMMUNICATES WITH THE VEHICLE OVER THE J1587 AND J1939 DATA LINKS

## 3. ENGINE-RELATED COMPONENTS

### 3.1 ELECTRONIC FOOT PEDAL ASSEMBLY (EFPA) & THROTTLE POSITION SENSOR

The Electronic Foot Pedal Assembly (EFPA) connects the accelerator pedal to a Throttle

Position Sensor (TPS). The (TPS) is a device, which sends an electrical signal to the Motor Control Module (MCM). The TPS varies in voltage depending on how far the pedal is depressed. The system is installed in the space normally occupied by a mechanical foot pedal. The (EFPA) has maximum and minimum stops that are built into the unit during manufacturing (Fig. 6). The (TPS) converts the operator's foot pedal input into a signal for the MCM.

When installed by the equipment manufacturer, the TPS should not require adjustment. If the TPS is suspected of being misadjusted, confirm that the sensor is installed in accordance with the manufacturer's specifications. It is recommended that the idle count be at 50 or higher with a full throttle count of up to 200.

The TPS is self-calibrating and therefore has no optimum closed throttle or wide open throttle count value. If the counts are within the 50 to 200 range, the sensor is properly set.

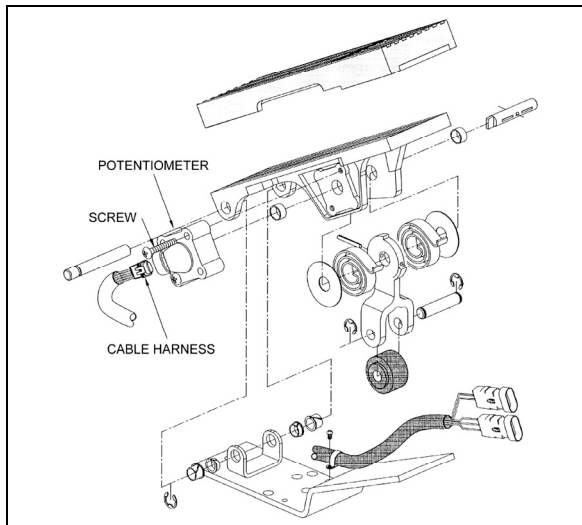

FIGURE 6: ELECTRONIC FOOT PEDAL ASSEMBLY 03035

Monitor the (TPS) at the controls as you move it through its full stroke. Be sure there is no misalignment or obstruction preventing the smooth movement of the TPS through the full stroke. Using a diagnostic data reader, check that the idle and full throttle position counts do not fall within the error zones. The error zones occur when the idle position is less than 14 counts, or when the full throttle position is more than 233 counts. Should these conditions occur, the CPC will signal diagnostic codes of 21-12 for idle error and 21-23 for wide-open throttle error.

## 4. DDEC VI DIAGNOSTICS

### 4.1 DIAGNOSTIC SYSTEM

Diagnostics is a standard feature of DDEC VI. The purpose of this feature is to provide information for problem identification and problem solving in the form of a code. The MCM and CPC continuously perform self diagnostic checks and monitor the other system components. Information for problem identification and problem solving is enhanced by the detection of faults, retention of fault codes and separation of active from inactive codes.

The engine-mounted MCM includes control logic to provide overall engine management. System diagnostic checks are made at ignition on and continue throughout all engine operating modes. Sensors provide information to the MCM and CPC regarding various engine and vehicle performance characteristics. The information is used to regulate engine and vehicle performance, provide diagnostic information, and activate the engine protection system.

The DDEC VI on-board diagnostic system accessories include the following:

- Check Engine telltale light (AWL);
- Stop Engine telltale light (RSL);
- Stop Engine Override switch (SEO);
- Diagnostic Data Link (DDL) connectors.

The AWL is illuminated and a code is stored if an electronic system fault occurs. This indicates the problem should be diagnosed as soon as possible. The CPC illuminates the AWL and RSL and stores a malfunction code if a potentially engine damaging fault is detected. These codes can be accessed in one of four ways:

- Commercially available J1587/J1939 diagnostic tools.
- Detroit Diesel Diagnostic Link® (DDDL 7.0).
- Flashing the AWL and RSL with the SEO/Diagnostic Request Switch.
- Dashboard's Message Center Display (MCD).

#### 4.1.1 Check Engine Telltale Light (AWL)

The CPC illuminates the Check Engine telltale, mounted on the telltale light panel to indicate that a problem has been detected and that a

## Section 01: ENGINE

code has been stored in the MCM memory. This light also has a 5-second bulb check when the ignition is first turned on.

### 4.1.2 Stop Engine Warning Light (RSL)

This light, also mounted on the telltale light panel, illuminates to indicate that a major engine problem is occurring (with the exception of a 5-second bulb check when the ignition is first turned on).

### 4.1.3 Stop Engine Override Switch (SEO)

This switch, mounted on the dashboard, may be used to extend the 30-second delay period before engine shutdown when the Stop engine telltale light is illuminated. This switch can be repeatedly depressed in order to move the vehicle out of traffic.

#### **NOTE**

*The stop engine override switch will be operative only if it has been depressed before the end of the 30 second delay period.*



#### **CAUTION**

The OVERRIDE switch must be used only in emergency cases, such as to move the vehicle out of traffic. Excessive use of this switch can cause serious damage to the engine.

This switch is also used for DDEC diagnostic code requests. Press this switch with the engine at idle or off but with the ignition in the "ON" position and active codes will be flashed on the CHECK ENGINE and STOP ENGINE telltale lights alternately.

### 4.1.4 Diagnostic Data Link (DDL) Connectors

A connector is mounted on the L.H. footwell wall. Another connector is located in the rear electric compartment. They allow the connection of the Diagnostic Data Reader (DDR) to read the codes or to access pertinent data on the condition of the engine. This enables a more complete analysis of any defect found in the DDEC system operation. For more information, see Detroit Diesel Troubleshooting Guide #6SE492.

## 4.2 READING DIAGNOSTIC CODES – FLASHING LIGHT METHOD:

DDEC VI makes use of two types of codes: Active and inactive. The difference between the two types of codes is as follows:

**Active Codes:** Codes that are currently keeping the Check Engine or Stop Engine telltale light illuminated. Active codes are flashed via the Stop Engine Light when checked with the stop-engine-override switch.

**Inactive Codes:** These are all the codes logged in the CPC, which have previously occurred, (whether or not they are currently turning on the Stop or Check Engine Light). Inactive codes are flashed via the Check Engine telltale light when checked with the stop-engine-override switch.

In most instances, only the DDR can provide the information necessary for a quick diagnosis of the problem. If you just need to read out codes, however, and do not have a DDR available, the following procedure will let you read out codes. Make sure the rear-starting switch (located in the engine compartment) is in the normal position. With the ignition ON, the engine idling or engine shut-off, momentarily depress the Stop Engine Override (SEO) switch. Active codes will be flashed on the stop engine telltale, followed by the inactive codes being flashed on the check-engine telltale panel. The cycle repeats itself until the operator depresses the stop engine override switch again.

Flashing codes provide a four digit number. Each fault code is flashed twice in order to help with counting the flashes. If there are no active faults or if there are no inactive faults the number "3" is flashed once followed by an ~3s delay.

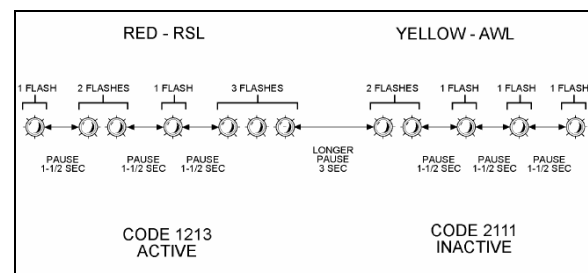

**FIGURE 7: FLASHING FAULTS CODES**

Refer to DDEC Troubleshooting Manual 6SE567 for more information and SAE codes.

**NOTE**

Active codes are flashed in ascending numerical flash code order. Inactive codes are flashed in most recent to least recent order.

**NOTE**

Fault codes can only be cleared using the DDR.

**NOTE**

The listed codes may not be used in all applications. A default value in the normal operating range is used by the MCM to provide for engine operation if a sensor failure is present.

## 4.3 DDEC VI CPC DIAGNOSTIC CODES LIST

SPN	FMI	PID/SID	PID/SID ID	FLASH CODES	FAULT DESCRIPTION
70	2	PID	70	2111	Park Brake Status Not Plausible (Vehicle Moving)
70	19	SID	234	2112	J1939 Park Brake Switch Signal from Source #1 is erratic
70	13	SID	234	2112	J1939 Park Brake Switch Signal from Source #1 is missing
70	19	SID	234	2112	J1939 Park Brake Switch Signal from Source #2 is erratic
70	13	SID	234	2112	J1939 Park Brake Switch Signal from Source #2 is missing
70	19	SID	234	2112	J1939 Park Brake Switch Signal from Source #3 is erratic
70	13	SID	234	2112	J1939 Park Brake Switch Signal from Source #3 is missing
84	21	PID	84	2113	Vehicle Speed Failure
84	3	PID	84	2113	Vehicle Speed Sensor Circuit Failed High
84	4	PID	84	2113	Vehicle Speed Sensor Circuit Failed Low
84	2	PID	84	2113	VSS Anti Tamper Detection via Virtual Gear Ratio
84	8	PID	84	2113	VSS Anti Tamper Detection via Fixed Frequency Device
84	6	PID	84	2113	VSS Anti-Tamper Detection via ABS Vehicle Speed Comparison
84	19	PID	84	2113	J1939 Wheel-Based Vehicle Speed Signal from Source#1 is erratic
84	13	PID	84	2113	J1939 Wheel-Based Vehicle Speed Signal from Source#1 is missing
84	19	SID	84	2113	J1939 Wheel-Based Vehicle Speed Signal from Source#2 is erratic
84	13	PID	84	2113	J1939 Wheel-Based Vehicle Speed Signal from Source#2 is missing
84	19	PID	84	2113	J1939 Wheel-Based Vehicle Speed Signal from Source#3 is erratic

**Section 01: ENGINE**

SPN	FMI	PID/SID	PID/SID ID	FLASH CODES	FAULT DESCRIPTION
84	13	PID	84	2113	J1939 Wheel-Based Vehicle Speed Signal from Source#3 is missing
84	20	PID	84	2113	Vehicle Speed Sensor Drifted High Error (VSS signal not plausible)
91	13	PID	91	2114	Accelerator Pedal Learn Error
91	3	PID	91	2114	Accelerator Pedal Circuit Failed High
91	4	PID	91	2114	Accelerator Pedal Circuit Failed Low
91	8	PID	91	2114	Pwm Accelerator Pedal Signal 1 Frequency Out Of Range
91	14	PID	91	2114	Pwm Accelerator Pedal Not Learned
91	7	PID	91	2114	Pwm Accelerator Pedal Idle Not Recognized
91	31	PID	91	2114	Pwm Accelerator Pedal Learned Range to Large
91	3	PID	91	2114	Accelerator Pedal Signal Circuit Failed High
91	9	SID	231	2615	J1939 EEC2 Message is missing
98	0	PID	98	2115	Oil Level High
98	18	PID	98	2115	Oil Level Low
98	1	PID	98	2115	Oil Level Very Low
100	18	PID	100	2121	Oil Pressure Low
100	1	PID	100	2121	Oil Pressure Very Low
107	0	PID	107	2122	Air Filter Restriction High
107	4	PID	107	2122	Air Filter Signal Circuit Failed Low
107	3	PID	107	2122	Air Filter Signal Circuit Failed High
110	16	PID	110	2123	Coolant Temperature High
110	0	PID	110	2123	Coolant Temperature Very High
111	18	PID	111	2124	Coolant Level Low
111	3	PID	111	2124	Coolant Level Circuit Failed High
111	4	PID	111	2124	Coolant Level Circuit Failed Low
111	1	PID	111	2124	Coolant Level Very Low
168	0	PID	168	2125	Battery Voltage Very Low
168	0	PID	168	2125	Battery Voltage High
168	18	PID	168	2125	Battery Voltage Low
168	14	PID	168	2125	Opt Idle Detected Charging System or Battery Failure
168	14	PID	168	2125	ECU powerdown not completed (Main Battery Terminal Possibly Floating)
171	2	PID	171	2131	Ambient Temperature Sensor Data Erratic
171	14	PID	171	2131	J1587 Ambient Air Temp Sensor Data Not Received This Ign Cycle
171	9	PID	171	2131	J1587 Ambient Air Temp Sensor Data Message Stopped Arriving

**SECTION 01: ENGINE**

SPN	FMI	PID/SID	PID/SID ID	FLASH CODES	FAULT DESCRIPTION
191	9	SID	231	2615	J1939 ETC1 Message is missing
191	19	SID	231	2132	J1939 Transmission Output Shaft Speed Signal is erratic
191	13	SID	231	2132	J1939 Transmission Output Shaft Speed Signal is missing
247	9	PID	247	2615	MCM Engine Hours Data not received or stopped arriving
247	10	PID	247	2615	MCM Engine Hours Data increasing at an implausible rate
247	0	PID	247	2615	MCM Engine Hours Data higher than expected
247	1	PID	247	2615	MCM Engine Hours Data lower than expected
523	19	PID	163	2133	J1939 Transmission Current Gear Signal is erratic
523	13	PID	163	2133	J1939 Transmission Current Gear Signal is missing
524	9	SID	231	2615	J1939 ETC2 Message is missing
527	9	SID	231	2615	J1939 CCVS Message from Source #1 is missing
527	9	SID	231	2615	J1939 CCVS Message from Source #2 is missing
527	9	SID	231	2615	J1939 CCVS Message from Source #3 is missing
558	2	SID	230	2134	Idle Validation Switch Inputs Reversed
558	5	SID	230	2134	Idle Validation Switch 2 Circuit Failed Low
558	6	SID	230	2134	Idle Validation Switch 2 Circuit Failed High
558	4	SID	230	2134	Idle Validation Switch 1 Circuit Failed Low
558	3	SID	230	2134	Idle Validation Switch 1 Circuit Failed High
596	19	SID	244	2135	J1939 Cruise Control Enable Switch Signal from Source #1 is erratic
596	13	SID	244	2135	J1939 Cruise Control Enable Switch Signal from Source #1 is missing
596	19	SID	244	2135	J1939 Cruise Control Enable Switch Signal from Source #2 is erratic
596	13	SID	244	2135	J1939 Cruise Control Enable Switch Signal from Source #2 is missing
596	19	SID	244	2135	J1939 Cruise Control Enable Switch Signal from Source #3 is erratic
596	13	SID	244	2135	J1939 Cruise Control Enable Switch Signal from Source #3 is missing
597	2	SID	246	2141	Service Brake Status Not Plausible
597	19	SID	246	2141	J1939 Service Brake Switch Signal from Source #1 is erratic
597	13	SID	246	2141	J1939 Service Brake Switch Signal from Source #1 is missing

**Section 01: ENGINE**

SPN	FMI	PID/SID	PID/SID ID	FLASH CODES	FAULT DESCRIPTION
597	19	SID	246	2141	J1939 Service Brake Switch Signal from Source #2 is erratic
597	13	SID	246	2141	J1939 Service Brake Switch Signal from Source #2 is missing
597	19	SID	246	2141	J1939 Service Brake Switch Signal from Source #3 is erratic
597	13	SID	246	2141	J1939 Service Brake Switch Signal from Source #3 is missing
599	4	SID	243	2142	Cruise Control SET and RESUME Circuits Failed Low
600	19	SID	243	2143	J1939 Cruise Control Coast Switch Signal from Source #1 is erratic
600	13	SID	243	2143	J1939 Cruise Control Coast Switch Signal from Source #1 is missing
600	19	SID	243	2143	J1939 Cruise Control Coast Switch Signal from Source #2 is erratic
600	13	SID	243	2143	J1939 Cruise Control Coast Switch Signal from Source #2 is missing
600	19	SID	243	2143	J1939 Cruise Control Coast Switch Signal from Source #3 is erratic
600	13	SID	243	2143	J1939 Cruise Control Coast Switch Signal from Source #3 is missing
602	19	SID	242	2144	J1939 Cruise Control Accelerate Switch Signal from Source #1 is erratic
602	13	SID	242	2144	J1939 Cruise Control Accelerate Switch Signal from Source #1 is missing
602	19	SID	242	2144	J1939 Cruise Control Accelerate Switch Signal from Source #2 is erratic
602	13	SID	242	2144	J1939 Cruise Control Accelerate Switch Signal from Source #2 is missing
602	19	SID	242	2144	J1939 Cruise Control Accelerate Switch Signal from Source #3 is erratic
602	13	SID	242	2144	J1939 Cruise Control Accelerate Switch Signal from Source #3 is missing
608	14	SID	250	2145	J1708 Data Link Failure
609	12	SID	233	2145	CPC2 Hardware Failure
615	9	SID	231	2615	J1939 DM1 Message from Transmission is missing
625	13	SID	248	2151	ECAN ID_1629 Diagnostic Message Not Received This Ignition Cycle
625	9	SID	248	2151	ECAN ID_1629 Diagnostic Message No Longer Being Received
625	10	SID	248	2151	ECAN ID_1629 Reporting Inconsistent Number of Frames
625	2	SID	248	2151	ECAN ID_1629 Diagnostic Message Reporting Data Not Available



**SECTION 01: ENGINE**

SPN	FMI	PID/SID	PID/SID ID	FLASH CODES	FAULT DESCRIPTION
625	14	SID	248	2151	ECAN ID_1629 Diagnostic Message Reporting an Unknown MUID
625	9	SID	248	2151	Incorrect MCM System ID Received
625	9	SID	248	2151	MCM System ID Not Received or Stopped Arriving
625	4	SID	248	2151	ECAN Link Circuit Failure
628	14	SID	254	2151	XFLASH Static Fault Code Memory Page Read Write Failure
628	13	SID	155	2615	20ms ECU OS Task Locked in an Endless Loop
628	13	SID	155	2615	20ms ECU OS Task Timed out Prior to Completion
628	13	SID	155	2615	1000ms ECU OS Task Locked in an Endless Loop
628	13	SID	155	2615	1000ms ECU OS Task Timed out Prior to Completion
629	2	SID	254	2151	CPC Hardware/Software Mismatch
629	12	SID	254	2151	DDEC Data Xflash Write Error. Replace CPC2.
630	2	SID	253	2152	EEPROM Checksum Failure
630	2	SID	253	2152	EEPROM Checksum Failure for the SCR Block
630	13	SID	253	2152	SCR Number Out of Range
630	14	SID	155	2615	MCM Fault Codes Unavailable via J1939 and J1587
630	14	SID	155	2615	MCM Fault Code Table Inconsistent - Upgrade MCM Software
630	14	SID	155	2615	Insufficient Static Fault Code Storage Memory - Upgrade CPC Software
630	14	SID	155	2615	MCM Fault Code Table Inconsistent - Upgrade MCM Software
639	14	SID	231	2153	J1939 Data Link Failure
701	3	SID	26	2211	Digital Output 4 09 Circuit Failed High
701	4	SID	26	2211	Digital Output 4 09 Circuit Failed Low
702	3	SID	40	2212	Digital Output 3 17 Circuit Failed High
702	4	SID	40	2212	Digital Output 3 17 Circuit Failed Low
703	3	SID	51	2213	Digital Output 3 09 Circuit Failed High
703	4	SID	51	2213	Digital Output 3 09 Circuit Failed Low
704	3	SID	52	2214	Digital Output 4 07 Circuit Failed High
704	4	SID	52	2214	Digital Output 4 07 Circuit Failed Low
705	3	SID	53	2215	Digital Output 1 13 Circuit Failed High
705	4	SID	53	2215	Digital Output 1 13 Circuit Failed Low
706	3	SID	54	2221	Digital Output 3 10 Circuit Failed High
706	4	SID	54	2221	Digital Output 3 10 Circuit Failed Low

**Section 01: ENGINE**

SPN	FMI	PID/SID	PID/SID ID	FLASH CODES	FAULT DESCRIPTION
707	3	SID	55	2222	Digital Output 2 10 Circuit Failed High (CEL / AWL Lamp)
707	4	SID	55	2222	Digital Output 2 10 Circuit Failed Low (CEL / AWL Lamp)
708	3	SID	56	2223	Digital Output 3 12 Circuit Failed High
708	4	SID	56	2223	Digital Output 3 12 Circuit Failed Low
709	3	SID	257	2224	Digital Output 3 16 Circuit Failed High
709	4	SID	257	2224	Digital Output 3 16 Circuit Failed Low
710	3	SID	258	2225	Digital Output 4 06 Circuit Failed High
710	4	SID	258	2225	Digital Output 4 06 Circuit Failed Low
711	3	SID	259	2231	Digital Output 1 05 Circuit Failed High
711	4	SID	259	2231	Digital Output 1 05 Circuit Failed Low
712	3	SID	260	2232	Digital Output 1 04 Circuit Failed High
712	4	SID	260	2232	Digital Output 1 04 Circuit Failed Low
713	3	SID	261	2234	Digital Output 3 07 Circuit Failed High
713	4	SID	261	2234	Digital Output 3 07 Circuit Failed Low
713	5	SID	261	2234	Digital Output 3 07 Open Circuit
713	7	SID	261	2234	TOP2 Shift Failure
714	3	SID	262	2235	Digital Output 3 08 Circuit Failed High
714	4	SID	262	2235	Digital Output 3 08 Circuit Failed Low
714	5	SID	262	2235	Digital Output 3 08 Open Circuit
715	3	SID	263	2241	Digital Output 4 10 Circuit Failed High
904	9	SID	231	2615	J1939 EBC2 Message from ABS is missing
904	19	SID	231	2242	J1939 Front Axle Speed Signal is erratic
904	13	SID	231	2242	J1939 Front Axle Speed Signal is missing
972	2	SID	203	2243	Throttle inhibit switch signal not plausible due to excess vehicle speed
973	9	SID	231	2615	J1939 EBC1 Message is missing
973	13	SID	231	2244	J1939 Engine Retarder Selection Signal Missing
973	19	SID	231	2244	J1939 Engine Retarder Selection Signal Erratic
974	2	PID	372	2245	Remote Accelerator Pedal Supply Voltage Out of Range
974	3	PID	372	2245	Remote Accelerator Pedal Circuit Failed High
974	4	PID	372	2245	Remote Accelerator Pedal Circuit Failed Low
981	0	SID	155	2311	PTO CC+ and CC- Switches Pressed Simultaneously
986	9	SID	231	2615	J1939 CM1 Message is missing
1267	4	SID	123	2312	Digital Output 4 10 Circuit Failed Low
1267	3	SID	123	2312	Digital Output 4 10 Circuit Failed Open
1321	4	SID	128	2314	Starter Lockout Output Shorted to Ground
1321	3	SID	128	2314	Starter Lockout Output Open Circuit
1590	19	SID	155	2615	Adaptive Cruise Control Message Not Received

**SECTION 01: ENGINE**

SPN	FMI	PID/SID	PID/SID ID	FLASH CODES	FAULT DESCRIPTION
1590	9	SID	231	2615	Adaptive Cruise Control Device Reporting Error
1624	9	SID	231	2615	J1939 TCO1 Message is missing
1624	19	SID	231	2315	J1939 Tachograph Vehicle Speed Signal is erratic
1624	13	SID	231	2315	J1939 Tachograph Vehicle Speed Signal is missing
1663	7	SID	123	2321	Optimized Idle Safety Loop Faulted
1716	9	SID	231	2615	J1939 ERC1 Message is missing
1845	9	SID	231	2615	J1939 TCFG2 Message is missing
2623	14	PID	91	2322	Pwm Accelerator Pedal GAS1 and GAS2 Signal Missing
2623	8	PID	91	2322	Pwm Accelerator Pedal Signal 2 Frequency Out Of Range
2900	9	SID	231	2615	J1939 ETC7 Message is missing
3510	3	SID	211	2333	Accelerator Pedal Supply Voltage Circuit Failed High
3510	4	SID	211	2333	Accelerator Pedal Supply Voltage Circuit Failed Low
3510	4	SID	211	2333	Pwm Accelerator Pedal Supply Voltage Missing
3510	3	SID	211	2333	Accelerator Pedal Supply Voltage Circuit Failed High
3606	9	SID	231	2615	J1939 ESS Message is missing
3695	2	SID	155	2334	Manual DPF Regen and DPF Inhibit Switch Rationality Fault
3695	19	SID	155	2334	DPF Regen Inhibit MUX Switch Message Contains Data Error Indicator
3695	13	SID	155	2334	DPF Regen Inhibit MUX Switch Message Contains SNV Indicator
3695	9	SID	155	2334	DPF Regen Inhibit MUX Switch Message Stopped Arriving
3695	14	SID	155	2334	DPF Regen Inhibit MUX Switch Message Not Received this Ign Cycle
3696	19	SID	155	2335	DPF Regen Force MUX Switch Message Contains Data Error Indicator
3696	13	SID	155	2335	DPF Regen Force MUX Switch Message Contains SNV Indicator
3696	9	SID	155	2335	DPF Regen Force MUX Switch Message Stopped Arriving
3696	14	SID	155	2335	DPF Regen Force MUX Switch Message Not Received this Ign Cycle

## Section 01: ENGINE

### 4.4 DDEC VI MCM DIAGNOSTIC CODES LIST

SPN	FMI	PID/SID	PID/SID ID	FLASH CODE	FAULT DESCRIPTION
27	4	PID	27	1111	EGR Valve Position Circuit Failed Low
27	3	PID	27	1111	EGR Valve Position Circuit Failed High
27	2	PID	27	1111	EGR Valve Position Feedback Failed
27	0	PID	27	1111	EGR Valve Position Feedback Failed (High Box)
27	1	PID	27	1111	EGR Valve Position Feedback Failed (Low Box)
27	14	PID	27	1111	EGR Valve Position Positive Torque Error
27	7	PID	27	1111	EGR Valve Stuck Open
27	19	PID	27	1521	Smart Actuator Indicates EGR Position Error
51	4	SID	51	1112	Intake Air Throttle Circuit Failed Low
51	3	SID	51	1112	Intake Air Throttle Circuit Failed High
51	2	PID	51	1112	Intake Throttle Position Deviation Error
51	0	PID	51	1112	Intake Air Throttle Position High
51	1	PID	51	1112	Intake Air Throttle Position Low
51	7	PID	51	1112	Intake Throttle Auto Calibration Error
94	4	PID	94	1112	Fuel Compensation Pressure Sensor Circuit Failed Low
94	3	PID	94	1112	Fuel Compensation Pressure Sensor Circuit Failed High
94	1	PID	94	1112	Fuel Pressure Too High/Too Low
97	4	PID	97	1615	Water in Fuel Circuit Failed Low
97	3	PID	97	1615	Water in Fuel Circuit Failed High
98	1	PID	98	1114	Oil Level Circuit Failed Low
98	0	PID	98	1114	Oil Level Circuit Failed High
98	13	PID	98	1634	Oil Level Measurement, Configuration Error
98	14	PID	98	1634	Oil Level Measurement, Oil Level Too Low or Too High
100	4	PID	100	1114	Engine Oil Pressure Circuit Failed Low
100	3	PID	100	1114	Engine Oil Pressure Circuit Failed High
100	1	PID	100	1114	Engine Oil Pressure Low
100	2	PID	100	1114	Oil Pressure Plausibility - Engine Running
100	2	PID	100	1114	Oil Pressure Plausibility - Stop
103	2	PID	103	1115	Turbocharger Speed Not Plausible
103	1	PID	103	1115	Turbo Charger Speed Below Threshold (High Box)
103	0	PID	103	1115	Turbo Charger Speed Above Threshold (Low Box)
103	4	PID	103	1115	Turbo Charger Speed Sensor Circuit Failed Low
103	3	PID	103	1115	Turbo Charger Speed Sensor Circuit Failed High
108	4	PID	108	1211	Barometric Pressure Circuit Failed Low
108	3	PID	108	1211	Barometric Pressure Circuit Failed High
108	2	PID	108	1211	Ambient Pressure Plausibility Fault (Low Box)
108	20	PID	108	1211	Ambient Pressure Plausibility Fault (High Box)
110	4	PID	110	1212	Engine Coolant Outlet Temperature Circuit Failed Low
110	3	PID	110	1212	Engine Coolant Outlet Temperature Circuit Failed High
110	0	PID	110	1212	Coolant Temperature High
110	14	PID	110	1212	Coolant Temperature / Engine Oil Temperature Plausibility Fault
110	2	PID	110	1212	Engine Coolant Sensor (OUT), General Temp. Plausibility Error
132	7	PID	132	1213	Intake Air Throttle Valve Closure Detection- Positive Torque
132	14	PID	132	1213	Intake Air Throttle Valve Closure Detection -Braking Condition
132	14	PID	322	1635	HC-Doser Fuel Pressure Not Plausible
132	1	PID	322	1213	Air Mass Flow Too Low
132	13	PID	132	1213	Air Mass Auto Calibration Failed
158	2	PID	43	1214	Ignition Switch Not Plausible
164	4	PID	164	1215	Rail Pressure Governor Sensor Circuit Failed Low
164	3	PID	164	1215	Rail Pressure Governor Sensor Circuit Failed High

**SECTION 01: ENGINE**

SPN	FMI	PID/SID	PID/SID ID	FLASH CODE	FAULT DESCRIPTION
164	0	PID	164	1215	Rail Pressure Governor (High Side) Error
164	0	PID	164	1215	Rail Pressure Governor (Low Side) Error
168	1	PID	168	1221	Battery Voltage Low
168	0	PID	168	1221	Battery Voltage High
171	4	PID	171	1222	Ambient Temperature Circuit Failed Low
171	3	PID	171	1222	Ambient Temperature Circuit Failed High
174	4	PID	174	1223	Fuel Temperature Circuit Failed Low
174	3	PID	174	1223	Fuel Temperature Circuit Failed High
174	2	PID	174	1223	Fuel Temperature Sensor, General Temp. Plausibility
174	0	PID	174	1223	Fuel Temperature Too High
175	4	PID	175	1224	Engine Oil Temperature Circuit Failed Low
175	3	PID	175	1224	Engine Oil Temperature Circuit Failed High
175	14	PID	175	1224	Engine Oil Temperature Sensor Plausibility Fault
175	2	PID	175	1224	Engine Oil Temperature Sensor, General Temp. Plausibility
190	2	PID	190	1225	Engine Speed High
354	4	PID	354	1231	Relative Humidity Circuit Failed Low
354	3	PID	354	1231	Relative Humidity Circuit Failed High
411	4	PID	411	1232	EGR Delta Pressure Sensor Circuit Low
411	3	PID	411	1232	EGR Delta Pressure Sensor Circuit High
411	0	PID	411	1232	EGR Differential Pressure Failed (High Box)
411	1	PID	411	1232	EGR Differential Pressure Failed (Low Box)
411	5	PID	411	1232	EGR Sampling Range Failed
411	13	PID	411	1232	EGR Delta Pressure Sensor Out Of Calibration
411	13	PID	411	1232	EGR Delta Pressure Sensor Out Of Calibration
412	3	PID	412	1233	EGR Temperature Sensor Circuit Failed High
412	4	PID	412	1233	EGR Temperature Sensor Circuit Failed Low
412	20	PID	412	1233	EGR Temperature Drift (High Box)
412	21	PID	412	1233	EGR Temperature Drift (Low Box)
412	2	PID	412	1233	EGR Temperature Sensor, General Temp. Plausibility Error
412	0	PID	412	1512	EGR Temperature Very High
412	16	PID	412	1233	EGR Temperature Sensor / Temperature Too High
615	4	SID	155	1615	Reserved Monitoring Unit For Temperature Diagnostics, Circuit Failed Low MU_ISP_T_TBD4_SRL
615	3	SID	155	1615	Reserved Monitoring Unit For Temperature Diagnostics, Circuit Failed High MU_ISP_T_TBD4_SRH
615	4	SID	155	1615	Reserved Monitoring Unit For Temperature Diagnostics, Circuit Failed Low MU_ISP_T_TBD1_SRL
615	3	SID	155	1615	Reserved Monitoring Unit For Temperature Diagnostics, Circuit Failed High MU_ISP_T_TBD1_SRH
615	4	SID	155	1615	Reserved Monitoring Unit For Temperature Diagnostics, Circuit Failed Low MU_ISP_T_TBD2_SRL
615	3	SID	155	1615	Reserved Monitoring Unit For Temperature Diagnostics, Circuit Failed High MU_ISP_T_TBD2_SRH
615	4	SID	155	1615	Reserved Monitoring Unit For Temperature Diagnostics, Circuit Failed Low MU_ISP_T_TBD3_SRL
615	3	SID	155	1615	Reserved Monitoring Unit For Temperature Diagnostics, Circuit Failed High MU_ISP_T_TBD3_SRH
615	4	SID	155	1615	Catalyst Temperature Sensor Circuit High Input (Bank 1 Sensor 1)
615	3	SID	155	1615	Catalyst Temperature Sensor Circuit Low Input (Bank 1 Sensor 1)
615	4	SID	155	1615	Catalyst Temperature Sensor Circuit High (Bank 1 Sensor 2)
615	3	SID	155	1615	Catalyst Temperature Sensor Circuit Low (Bank 1 Sensor 2)
615	4	SID	51	1322	Water Pump 1 Circuit Failed Low
615	3	SID	51	1322	Water Pump 1 Circuit Failed High

## Section 01: ENGINE

SPN	FMI	PID/SID	PID/SID ID	FLASH CODE	FAULT DESCRIPTION
615	5	SID	51	1322	Water Pump 1 Circuit Failed Open
615	4	SID	55	1331	Turbo Compound Valve Circuit Failed Low
615	3	SID	55	1331	Turbo Compound Valve Circuit Failed High
615	5	SID	55	1331	Turbo Compound Valve Circuit Failed Open
615	4	SID	259	1335	Turbo Brake Sleeve Circuit Failed Low
615	3	SID	259	1335	Turbo Brake Sleeve Circuit Failed High
615	5	SID	259	1335	Turbo Brake Sleeve Circuit Failed Open
615	4	SID	261	1355	Function 20 Circuit Failed Low
615	3	SID	261	1355	Function 20 Circuit Failed High
615	5	SID	261	1355	Function 20 Circuit Failed Open
615	3	SID	155	1451	Service Push Button Circuit Failed High
615	14	SID	155	1615	Turbocharger/Supercharger Boost System Performance
615	14	SID	155	1615	Starter Electronic Fault / ECU internal (Res)
615	14	SID	155	1615	Starter Jammed (Tooth to Tooth Jam)
615	14	SID	155	1615	Rail Pressure Governor, Valve Stays Open
615	14	SID	155	1615	MU_RPG_INT_MON_SRH, I Term Value Too High
615	14	SID	155	1615	Rail Pressure Governor, Leakage in High Pressure Too High
615	14	SID	155	1615	Rail Pressure Governor Sensor, Signal Drift
615	14	SID	155	1615	Rail Pressure Governor Sensor, Sensor Supply Line Broken
615	4	SID	155	1615	Compressor Differential Pressure Outlet Failed Low
615	3	SID	155	1615	Compressor Differential Pressure Outlet Failed High
615	14	SID	155	1615	Doser Metering and Safety Unit Valve Seals Check
615	14	SID	155	1615	High Pressure Pump, Leakage or TDC Position Wrong
615	4	SID	155	1615	Flap In Front of EGR Cooler Circuit Failed Low
615	3	SID	155	1615	Flap In Front of EGR Cooler Circuit Failed High
615	5	SID	155	1615	Flap In Front of EGR Cooler Circuit Failed Open
615	4	SID	155	1615	Water Pump 2 Circuit Failed Low
615	3	SID	155	1615	Water Pump 2 Circuit Failed High
615	5	SID	156	1615	Water Pump 2 Circuit Failed Open
615	4	SID	157	1615	RCP Test Function 1 Circuit Failed Low
615	3	SID	158	1615	RCP Test Function 1 Circuit Failed High
615	5	SID	159	1615	RCP Test Function 1 Circuit Failed Open
615	4	SID	160	1615	RCP Test Function 2 Circuit Failed Low
615	3	SID	161	1615	RCP Test Function 2 Circuit Failed High
615	5	SID	162	1615	RCP Test Function 2 Circuit Failed Open
615	4	SID	163	1615	Volute Control Valve, Shorted to Ground
615	3	SID	164	1615	Volute Control Valve, Shorted to Battery
615	5	SID	165	1615	Volute Control Valve, Open Load
615	4	SID	166	1615	Volute Shut Off Valve, Shorted to Ground
615	3	SID	167	1615	Volute Shut Off Valve, Shorted to Battery
615	5	SID	168	1615	Volute Shut Off Valve, Open Load
615	4	SID	169	1615	Function 30 Circuit Failed Low
615	3	SID	170	1615	Function 30 Circuit Failed High
615	5	SID	171	1615	Function 30 Circuit Failed Open
615	4	SID	172	1615	Function 31 Circuit Failed Low
615	3	SID	173	1615	Function 31 Circuit Failed High
615	5	SID	174	1615	Function 31 Circuit Failed Open
615	14	SID	155	1453	Smart Remote Actuator 2, No Failsafe Mode, Motor Off
615	9	SID	155	1453	Smart Remote Actuator 2, Failsafe Mode, Motor Off

**SECTION 01: ENGINE**

SPN	FMI	PID/SID	PID/SID ID	FLASH CODE	FAULT DESCRIPTION
615	16	SID	155	1453	Smart Remote Actuator 2, Temperature Fault
615	7	SID	155	1453	Smart Remote Actuator 2, Failsafe Mode, Motor On
615	11	SID	155	1453	Smart Remote Actuator 2, Restricted Operability
615	15	SID	155	1453	Smart Remote Actuator 2, Temperature Warning
615	8	SID	155	1453	Smart Remote Actuator 2, Internal Test Running
615	31	SID	155	1453	Smart Remote Actuator 2, Unknown Error Code
615	13	SID	155	1454	Turbocharger Compressor Outlet Differential Pressure Sensor Out Of Calibration
615	13	SID	155	1454	Turbocharger Compressor Outlet Differential Pressure Sensor Out Of Calibration
615	19	SID	155	1637	Smart Actuator Indicates Actuator Position Error
625	2	SID	248	1234	Invalid Data on Engine CAN Link
625	9	SID	248	1234	No Data Received from Engine CAN Link
625	9	SID	248	1234	Engine CAN Low Wire Defect - (wire 1)
625	9	SID	248	1234	Engine CAN High Wire Defect - (wire 2)
630	12	SID	253	1452	EEPROM Read / Write Operation Failed
630	13	SID	253	1455	Calibration Data Not Plausible
630	13	SID	253	1455	Calibration Data Not Plausible (CPLD)
634	4	SID	40	1321	Constant Throttle Valve Circuit Failed Low
634	3	SID	40	1321	Constant Throttle Valve Circuit Failed High
634	5	SID	40	1321	Constant Throttle Valve Circuit Failed Open
636	1	SID	21	1235	Crankshaft Position Sensor Signal Voltage Too Low
636	3	SID	21	1235	Crankshaft Position Sensor Open Circuit
636	4	SID	21	1235	Crankshaft Position Sensor Short to Ground
636	8	SID	21	1235	Crankshaft Position Sensor Time Out
636	14	SID	21	1235	Crankshaft Position Sensor Pins Swapped
636	2	SID	21	1235	No Match of Camshaft and Crankshaft Signals
641	4	SID	27	1542	Turbo Control Circuit Failed Low
641	3	SID	27	1542	Turbo Control Circuit Failed High
641	5	SID	27	1542	Turbo Control Circuit Open
641	14	SID	147	1241	Smart Remote Actuator 5 (VGT), No Failsafe Mode, Motor Off
641	9	SID	147	1241	Smart Remote Actuator 5 (VGT), Failsafe Mode, Motor Off
641	7	SID	147	1241	Smart Remote Actuator 5 (VGT), Failsafe Mode, Motor On
641	11	SID	147	1241	Smart Remote Actuator 5 (VGT), Restricted Operability
641	8	SID	147	1241	Smart Remote Actuator 5 (VGT), Internal Test Running
641	31	SID	147	1241	Smart Remote Actuator 5 (VGT), Unknown Error Code
647	4	SID	33	1334	Fan Stage 1 Circuit Failed Low
647	3	SID	33	1334	Fan Stage 1 Circuit Failed High
647	5	SID	33	1334	Fan Stage 1 Circuit Failed Open
651	14	SID	1	1242	Injector Cylinder #1 Needle Control Valve Abnormal Operation
651	10	SID	1	1242	Injector Cylinder #1 Needle Control Valve Abnormal Rate of Change
651	5	SID	1	1242	Injector Cylinder 1, Nozzle Control Valve or Spill Control Valve, Jammed Closed
651	7	SID	1	1242	Injector Cylinder 1, Nozzle Control Valve or Spill Control Valve, Jammed Open or Leakage
651	6	SID	1	1242	Injector Cylinder #1 Needle Control Valve, Valve Shorted Circuit
651	31	SID	1	1242	Engine Smoothness Control / Cylinder #1 Value Out of Range
652	14	SID	2	1243	Injector Cylinder #2 Needle Control Valve Abnormal Operation

## Section 01: ENGINE

SPN	FMI	PID/SID	PID/SID ID	FLASH CODE	FAULT DESCRIPTION
652	10	SID	2	1243	Injector Cylinder #2 Needle Control Valve Abnormal Rate of Change
652	5	SID	2	1243	Injector Cylinder 2, Nozzle Control Valve or Spill Control Valve, Jammed Closed
652	7	SID	2	1243	Injector Cylinder 2, Nozzle Control Valve or Spill Control Valve, Jammed Open or Leakage
652	6	SID	2	1243	Injector Cylinder #2 Needle Control Valve, Valve Shorted Circuit
652	31	SID	2	1243	Engine Smoothness Control / Cylinder #2 Value Out of Range
653	14	SID	3	1244	Injector Cylinder #3 Needle Control Valve Abnormal Operation
653	10	SID	3	1244	Injector Cylinder #3 Needle Control Valve Abnormal Rate of Change
653	5	SID	3	1244	Injector Cylinder 3, Nozzle Control Valve or Spill Control Valve, Jammed Closed
653	7	SID	3	1244	Injector Cylinder 3, Nozzle Control Valve or Spill Control Valve, Jammed Open or Leakage
653	6	SID	3	1244	Injector Cylinder #3 Needle Control Valve, Valve Shorted Circuit
653	31	SID	3	1244	Engine Smoothness Control / Cylinder #3 Value Out of Range
654	14	SID	4	1245	Injector Cylinder #4 Needle Control Valve Abnormal Operation
654	10	SID	4	1245	Injector Cylinder #4 Needle Control Valve Abnormal Rate of Change
654	5	SID	4	1245	Injector Cylinder 4, Nozzle Control Valve or Spill Control Valve, Jammed Closed
654	7	SID	4	1245	Injector Cylinder 4, Nozzle Control Valve or Spill Control Valve, Jammed Open or Leakage
654	6	SID	4	1245	Injector Cylinder #4 Needle Control Valve, Valve Shorted Circuit
654	31	SID	4	1245	Engine Smoothness Control / Cylinder #4 Value Out of Range
655	14	SID	5	1251	Injector Cylinder #5 Needle Control Valve Abnormal Operation
655	10	SID	5	1251	Injector Cylinder #5 Needle Control Valve Abnormal Rate of Change
655	5	SID	5	1251	Injector Cylinder 5, Nozzle Control Valve or Spill Control Valve, Jammed Closed
655	7	SID	5	1251	Injector Cylinder 5, Nozzle Control Valve or Spill Control Valve, Jammed Open or Leakage
655	6	SID	5	1251	Injector Cylinder #5 Needle Control Valve, Valve Shorted Circuit
655	31	SID	5	1251	Engine Smoothness Control / Cylinder #5 Value Out of Range
656	14	SID	6	1252	Injector Cylinder #6 Needle Control Valve Abnormal Operation
656	10	SID	6	1252	Injector Cylinder #6 Needle Control Valve Abnormal Rate of Change
656	5	SID	6	1252	Injector Cylinder 6, Nozzle Control Valve or Spill Control Valve, Jammed Closed
656	7	SID	6	1252	Injector Cylinder 6, Nozzle Control Valve or Spill Control Valve, Jammed Open or Leakage
656	6	SID	6	1252	Injector Cylinder #6 Needle Control Valve, Valve Shorted Circuit
656	31	SID	6	1252	Engine Smoothness Control / Cylinder #6 Value Out of Range
657	14	SID	7	1253	Injector Cylinder #7 Needle Control Valve Abnormal Operation
657	10	SID	7	1253	Injector Cylinder #7 Needle Control Valve Abnormal Rate of Change
657	6	SID	7	1253	Injector Cylinder #7 Needle Control Valve, Valve Shorted Circuit
657	31	SID	7	1253	Engine Smoothness Control / Cylinder #7 Value Out of Range
658	14	SID	8	1254	Injector Cylinder #8 Needle Control Valve Abnormal Operation
658	10	SID	8	1254	Injector Cylinder #8 Needle Control Valve Abnormal Rate of Change
658	6	SID	8	1254	Injector Cylinder #8 Needle Control Valve, Valve Shorted Circuit
658	31	SID	8	1254	Engine Smoothness Control / Cylinder #8 Value Out of Range
677	2	SID	39	1255	Starter Switch Inconsistent



**SECTION 01: ENGINE**

SPN	FMI	PID/SID	PID/SID ID	FLASH CODE	FAULT DESCRIPTION
677	5	SID	39	1255	Engine Starter Relay Circuit Failed Low
677	4	SID	39	1255	Engine Starter Relay Open Circuit
677	14	SID	39	1255	Starter Electronic Fault / ECU internal (Main)
677	7	SID	39	1255	Engine Starter Relay - Starter Does Not Engage
677	3	SID	39	1255	Engine Starter Relay Shorted to High Source
677	7	SID	39	1255	Engine Starter Relay Jammed
698	4	SID	58	1312	Gridheater Circuit Failed Low
698	3	SID	58	1312	Gridheater Circuit Failed High
698	5	SID	58	1312	Gridheater Circuit Failed Open
715	4	SID	263	1412	High Side Digital Output # 1 Circuit Failed Low
715	3	SID	263	1412	High Side Digital Output # 1 Circuit Failed High
715	5	SID	263	1412	High Side Digital Output # 2 Circuit Failed Open
716	4	SID	264	1413	High Side Digital Output # 2 Circuit Failed Low
723	1	SID	64	1415	Camshaft Position Sensor Signal Voltage Too Low
723	3	SID	64	1415	Camshaft Position Sensor Open Circuit
723	4	SID	64	1415	Camshaft Position Sensor Short to Ground
723	8	SID	64	1415	Camshaft Position Sensor Time Out
723	14	SID	64	1415	Camshaft Position Sensor Pins Swapped
729	4	PID	45	1421	Grid Heater Circuit Failed Low
729	14	PID	45	1421	Grid Heater Special Instructions
729	3	PID	45	1421	Grid Heater Circuit Failed High
729	7	PID	45	1421	Grid Heater Defect
729	0	PID	45	1421	Grid Heater Permanently On
1071	4	SID	60	1314	Fan Stage 2 Circuit Failed Low
1071	3	SID	60	1314	Fan Stage 2 Circuit Failed High
1071	5	SID	60	1314	Fan Stage 2 Circuit Failed Open
1072	4	SID	79	1422	Jake Brake Stage 1 Circuit Failed Low
1072	3	SID	79	1422	Jake Brake Stage 1 Circuit Failed High
1072	5	SID	79	1422	Jake Brake Stage 1 Circuit Failed Open
1073	4	SID	80	1315	Jake Brake Stage 2 Circuit Failed Low
1073	3	SID	80	1315	Jake Brake Stage 2 Circuit Failed High
1073	5	SID	80	1315	Jake Brake Stage 2 Circuit Failed Open
1074	4	SID	81	1345	Exhaust Brake Circuit Failed Low
1074	3	SID	81	1345	Exhaust Brake Circuit Failed High
1074	5	SID	81	1345	Exhaust Brake Circuit Failed Open
1077	14	PID	164	1241	Rail Pressure Governor Error, Open Loop Error
1077	5	PID	164	1423	Rail Pressure Governor Error, Current Governor, Current Too Low
1077	7	PID	164	1423	Rail Pressure Governor Error, Pressure Governor, Pressure Not Plausible
1077	6	SID	155	1423	Rail Pressure Governor Error, Current Too High
1127	4	SID	273	1424	Turbocharger Compressor Outlet Pressure Circuit Failed Low
1127	3	SID	273	1424	Turbocharger Compressor Outlet Pressure Circuit Failed High
1172	4	PID	351	1425	Turbocharger Compressor Inlet Temperature Circuit Failed Low
1172	3	PID	351	1425	Turbocharger Compressor Inlet Temperature Circuit Failed High
1172	2	PID	351	1425	Coolant Temp/Compressor Inlet Temp Plausibility Error
1172	2	PID	351	1425	Turbocharger Compressor Inlet Temp. Sensor, General Temp. Plausibility Error
1176	4	SID	314	1431	Turbocharger Compressor Inlet Pressure Circuit Failed Low
1176	3	SID	314	1431	Turbocharger Compressor Inlet Pressure Circuit Failed High
1176	2	PID	314	1431	Compressor Pressure Plausibility Fault (High Box)
1176	5	PID	314	1431	Compressor Inlet Pressure Plausibility Fault (Delta)
1176	20	SID	314	1431	Compressor Inlet Pressure Plausibility Error, Pressure Too High (High Box)

## Section 01: ENGINE

SPN	FMI	PID/SID	PID/SID ID	FLASH CODE	FAULT DESCRIPTION
1188	4	SID	32	1325	Waste Gate Circuit Failed Low
1188	3	SID	32	1325	Waste Gate Circuit Failed High
1188	5	SID	32	1325	Waste Gate Circuit Failed Open
1188	14	SID	32	1432	Smart Remote Actuator 1 (Wastegate), No Failsafe Mode, Motor Off
1188	9	SID	32	1432	Smart Remote Actuator 1 (Wastegate), Failsafe Mode, Motor Off
1188	16	SID	32	1432	Smart Remote Actuator 1 (Wastegate), Temperature Fault
1188	7	SID	32	1432	Smart Remote Actuator 1 (Wastegate), Failsafe Mode, Motor On
1188	11	SID	32	1432	Smart Remote Actuator 1 (Wastegate), Restricted Operability
1188	15	SID	32	1432	Smart Remote Actuator 1 (Wastegate), Temperature Warning
1188	8	SID	32	1432	Smart Remote Actuator 1 (Wastegate), Internal Test Running
1188	31	SID	32	1432	Smart Remote Actuator 1 (Wastegate), Unknown Error Code
1188	19	SID	32	1432	Smart Actuator Indicates Turbocharger Wastegate Position Error
1213	4	SID	257	1333	MIL Lamp Circuit Failed Low
1213	3	SID	257	1333	MIL Lamp Circuit Failed High
1213	5	SID	257	1333	MIL Lamp Circuit Failed Open
1323	31	SID	155	1433	Cylinder 1 Misfire detected
1323	14	SID	156	1434	Misfire Detected
1324	31	SID	155	1435	Cylinder 2 Misfire detected
1325	31	SID	155	1441	Cylinder 3 Misfire detected
1326	31	SID	155	1442	Cylinder 4 Misfire detected
1327	31	SID	155	1443	Cylinder 5 Misfire detected
1328	31	SID	155	1444	Cylinder 6 Misfire Detected
1329	31	SID	155	1445	Cylinder 7 Misfire Detected
1330	31	SID	155	1446	Cylinder 8 Misfire Detected
1351	4	SID	155	1615	Switchable Air Compressor Circuit Failed Low
1351	3	SID	155	1615	Switchable Air Compressor Circuit Failed High
1351	5	SID	155	1615	Switchable Air Compressor Circuit Failed Open
1636	4	PID	105	1511	Intake Manifold Temperature Circuit Failed Low
1636	3	PID	105	1511	Intake Manifold Temperature Circuit Failed High
1636	2	PID	105	1511	Intake Manifold Temperature Plausibility Error
1636	21	PID	105	1511	Difference Intake Manifold Temperature and EGR Temp. Less Than Threshold (Low Box)
1636	2	PID	105	1511	Difference Intake Manifold and I Cooler Temperature Out Less Than Threshold (Low Box)
1636	2	PID	105	1511	Difference Intake Manifold and I Cooler Temperature Out Less Than Threshold (High Box)
1636	20	PID	105	1511	Intake Manifold Temperature Drift (Low Box)
1636	21	PID	105	1511	Intake Manifold Temperature Drift (High Box)
2629	4	PID	404	1513	Turbocharger Compressor Outlet Temperature Circuit Failed Low
2629	3	PID	404	1513	Turbocharger Compressor Outlet Temperature Circuit Failed High
2629	20	PID	404	1513	Turbocharger Out Temperature, Temperature Too High (Low Box)
2629	21	PID	404	1513	Turbocharger Out Temperature, Temperature Too Low (High Box)
2629	2	PID	404	1513	Turbocharger Compressor Outlet Temp. Sensor, General Temp. Plausibility Error
2630	4	SID	272	1514	Charge Air Cooler Outlet Temperature Circuit Failed Low
2630	3	SID	272	1514	Charge Air Cooler Outlet Temperature Circuit Failed High
2630	2	SID	272	1514	Charge Air Cooler Outlet Temperature Sensor Plausibility Error
2630	20	SID	272	1514	Charge Air Outlet Temperature Drift (Low box)
2630	21	SID	272	1514	Charge Air Outlet Temperature Drift (High box)
2631	4	SID	273	1515	Charge Air Cooler Outlet Pressure Circuit Failed Low

**SECTION 01: ENGINE**

SPN	FMI	PID/SID	PID/SID ID	FLASH CODE	FAULT DESCRIPTION
2631	3	SID	273	1515	Charge Air Cooler Outlet Pressure Circuit Failed High
2659	1	SID	277	1515	EGR Flow Target Error Diagnostic - Low Flow
2659	0	SID	277	1515	EGR Flow Target Error Diagnostic - High Flow
2791	4	PID	146	1521	EGR Valve Circuit Failed Low
2791	3	PID	146	1521	EGR Valve Circuit Failed High
2791	5	PID	146	1521	EGR Valve Circuit Failed Open
2791	7	SID	146	1521	EGR Valve Position Incorrect
2791	14	SID	146	1521	Smart Remote Actuator 3 (EGR), No Failsafe Mode, Motor Off
2791	9	SID	146	1521	Smart Remote Actuator 3 (EGR), Failsafe Mode, Motor Off
2791	16	SID	146	1521	Smart Remote Actuator 3 (EGR), Temperature Fault
2791	7	SID	146	1521	Smart Remote Actuator 3 (EGR), Failsafe Mode, Motor On
2791	11	SID	146	1521	Smart Remote Actuator 3 (EGR), Restricted Operability
2791	15	SID	146	1521	Smart Remote Actuator 3 (EGR), Temperature Warning
2791	8	SID	146	1521	Smart Remote Actuator 3 (EGR), Internal Test Running
2791	31	SID	146	1521	Smart Remote Actuator 3 (EGR), Unknown Error Code
2795	9	SID	269	1241	CAN3 Communication Error
2795	4	SID	269	1522	Position Waste Gate (VNT) Failed Low
2795	3	SID	269	1522	Position Waste Gate (VNT) Failed High
2795	2	SID	269	1522	VNT Valve Position Feedback Failed
2795	0	SID	269	1522	VNT Valve Position Feedback, Position Too Low (High Box)
2795	1	SID	269	1522	VNT Valve Position Feedback, Position Too High (Low Box)
2795	19	SID	147	1522	Smart Actuator Indicates Turbocharger Vane Position Error
2797	4	SID	317	1523	Injector Needle Control Valve Cylinder 1, 2, 3 Shorted to Ground
2797	4	SID	317	1524	Injector Needle Control Valve Cylinder 4, 5, 6 Shorted to Ground
2797	4	SID	317	1615	Injector Needle Control Valve Bank 3, Shorted to Ground
2797	3	SID	317	1523	Injector Needle Control Valve Cylinder 1,2,3 Shorted to Battery
2797	3	SID	317	1524	Injector Needle Control Valve Cylinder 4,5,6, Shorted to Battery
2797	3	SID	317	1615	Injector Needle Control Valve Bank 3, Shorted to Battery
2798	4	SID	317	1615	Injector Spill Control Valve Cylinder 1, 2, 3 Shorted to Ground
2798	4	SID	317	1615	Injector Spill Control Valve Cylinder 4, 5, 6 Shorted to Ground
2798	4	SID	317	1615	Injector Spill Control Valve ("Amplifier") Bank 6, Shorted to Ground
2798	3	SID	317	1615	Injector Spill Control Valve Cylinder 1,2,3, Shorted to Battery
2798	3	SID	317	1615	Injector Spill Control Valve Cylinder 4,5,6, Shorted to Battery
2798	3	SID	317	1615	Injector Spill Control Valve ("Amplifier") Bank 6, Shorted to Battery
2988	4	SID	262	1411	EGR Water Cooling Regulator Circuit Failed Low
988	3	SID	262	1411	EGR Water Cooling Regulator Circuit Failed High
2988	5	SID	262	1411	EGR Water Cooling Regulator Circuit Failed Open
3050	0	SID	155	1525	Engine Air Flow Out of Range Low
3050	1	SID	324	1525	Active Regen Temp Out of Range Low
3058	13	PID	146	1615	EGR System Parametrization Failure
3064	13	SID	155	1615	DPF System Parametrization Failure
3242	4	PID	318	1531	DOC Inlet Temperature Circuit Failed Low
3242	3	PID	318	1531	DOC Inlet Temperature Circuit Failed High
3242	10	SID	318	1531	DOC Inlet Temperature Sensor Stuck
3242	2	SID	318	1531	DOC Inlet Temperature Sensor - Plausibility Error

## Section 01: ENGINE

SPN	FMI	PID/SID	PID/SID ID	FLASH CODE	FAULT DESCRIPTION
3246	4	SID	320	1532	DPF Outlet Temperature Circuit Failed Low
3246	3	SID	320	1532	DPF Outlet Temperature Circuit Failed High
3246	14	SID	320	1532	Abnormal DPF Temperature Rise b)
3246	0	SID	320	1532	DPF Outlet Temperature High
3246	10	SID	320	1532	DPF Outlet Temperature Sensor Stuck
3246	2	SID	320	1532	DPF Outlet Sensor, General Temp. Plausibility
3246	31	SID	323	1532	Abnormal DPF Temperature Rise
3250	4	PID	322	1533	DOC Outlet Temperature Circuit Failed Low
3250	3	PID	322	1533	DOC Outlet Temperature Circuit Failed High
3250	14	PID	322	1533	Abnormal DOC Temperature Rise
3250	10	SID	322	1533	DOC Outlet Temperature Sensor Stuck
3250	2	SID	322	1533	DOC Outlet Temperature Sensor - Plausibility Error
3250	31	PID	322	1533	Abnormal DOC Temperature Rise
3250	0	PID	322	1533	DOC Outlet Temperature High
3251	0	SID	324	1534	DPF Pressure - Out of Range Very High
3251	1	SID	324	1534	DPF Pressure - Out of Range Low
3251	9	SID	324	1534	Abnormal Soot Rate
3251	16	SID	324	1534	DPF Pressure - Out of Range High
3358	4	SID	155	1535	EGR Pressure Failed Low
3358	3	SID	155	1535	EGR Pressure Failed High
3464	4	SID	59	1313	Intake Throttle Valve Circuit Failed Low
3464	3	SID	59	1313	Intake Throttle Valve Circuit Failed High
3464	5	SID	59	1313	Intake Throttle Valve Circuit Failed Open
3464	14	SID	59	1615	Intake Air Throttle Control Electrical Fault
3464	2	PID	51	1541	Intake Throttle Valve, Spring Response Time Not Plausible
3464	7	PID	51	1541	Intake Throttle Valve, Stuck
3464	14	PID	51	1541	Intake Throttle Valve, Integrated Absolute Error Plausibility
3464	8	PID	51	1541	Intake Throttle Valve, Current Deviation Too High
3470	4	SID	57	1311	Actuator Turbo Compound Bypass Circuit Failed Low
3470	3	SID	57	1311	Actuator Turbo Compound Bypass Circuit Failed High
3470	5	SID	57	1311	Actuator Turbo Compound Bypass Circuit Failed Open
3471	4	SID	334	1323	HC Doser Circuit Failed Low
3471	3	SID	334	1323	HC Doser Circuit Failed High
3471	5	SID	334	1323	HC Doser Circuit Failed Open
3471	1	SID	155	1542	EDV Failed Self Test
3480	2	SID	332	1543	Doser Fuel Line Pressure Abnormal
3480	1	SID	332	1543	Doser Fuel Supply Pressure Abnormal
3480	14	SID	332	1543	Doser FLP Sensors Failed Self Test
3482	4	SID	56	1332	Fuel Cut Off Valve Circuit Failed Low
3482	3	SID	56	1332	Fuel Cut Off Valve Circuit Failed High
3482	5	SID	56	1332	Fuel Cut Off Valve Circuit Failed Open
3482	7	SID	155	1544	FCV Failed Self Test
3509	3	SID	212	1631	Multiplexer 1 Channel 1, Shorted High
3509	3	SID	212	1631	Multiplexer 1 Channel 2, Shorted High
3510	3	SID	211	1632	Multiplexer 2 Channel 1, Shorted High
3510	3	SID	211	1632	Multiplexer 2 Channel 2, Shorted High
3511	3	SID	211	1633	Multiplexer 3 Channel 1, Shorted High
3511	3	SID	211	1633	Multiplexer 3 Channel 2, Shorted High
3556	1	SID	155	1545	Regen Temperature - Out of Range Low
3556	0	SID	155	1551	Regen Temperature - Out of Range High
3563	4	PID	106	1551	Intake Manifold Pressure Circuit Failed Low
3563	3	PID	106	1551	Intake Manifold Pressure Circuit Failed High

**SECTION 01: ENGINE**

SPN	FMI	PID/SID	PID/SID ID	FLASH CODE	FAULT DESCRIPTION
3563	20	PID	106	1551	Ambient and Inlet Manifold Pressure Difference (Low Box)
3563	21	PID	106	1551	Ambient and Inlet Manifold Pressure Difference (High Box)
3563	1	PID	106	1551	Inlet Manifold Pressure Failed Low
3563	0	PID	106	1551	Inlet Manifold Pressure Failed High
3563	3	PID	106	1551	Inlet Manifold Pressure Sampling Range Failed
3563	20	PID	106	1551	Intake Manifold Pressure Plausibility (Low Box)
3563	21	PID	106	1551	Intake Manifold Pressure Plausibility Error, Pressure Too Low (High Box)
3588	4	SID	156	1552	Ether Start, Shorted to Ground
3588	3	SID	157	1552	Ether Start, Shorted to Battery
3588	5	SID	158	1552	Ether Start, Open Load
3597	3	SID	155	1553	Proportional Valve Bank 1 Circuit Failed Low
3597	3	SID	155	1615	Proportional Valve Bank 1 Circuit Failed High
3597	6	SID	155	1325	Current Flow on HS1 IM1 Too High
3598	4	SID	155	1615	Proportional Valve Bank 2 Circuit Failed Low
3598	3	SID	155	1615	Proportional Valve Bank 2 Circuit Failed High
3599	4	SID	317	1615	Switching Power Supply Voltage Failed Low
3599	3	SID	317	1615	Switching Power Supply Voltage Failed High
3609	4	PID	370	1554	DPF Inlet Pressure Circuit Failed Low
3609	3	PID	370	1554	DPF Inlet Pressure Circuit Failed High
3609	10	SID	370	1554	DPF Inlet Pressure Sensor Stuck
3609	20	SID	370	1554	DPF Inlet Pressure Sensor Drifted High In Range Fault (Low Box)
3609	2	SID	370	1554	DPF Inlet Pressure Sensor Drifted High In Range Fault (High Box)
3609	21	SID	370	1554	DPF Inlet Pressure Sensor Drifted Low In Range Fault (Low Box)
3609	21	SID	370	1554	DPF Inlet Pressure Sensor Drifted Low In Range Fault (High Box)
3610	3	SID	371	1555	DPF Outlet Pressure Circuit Failed High
3610	4	SID	371	1555	DPF Outlet Pressure Circuit Failed Low
3610	0	SID	371	1334	DPF System Back Pressure Too High
3610	10	SID	371	1555	DPF Outlet Pressure Sensor Stuck
3610	2	SID	371	1555	DPF Pressure Sensors - Plausibility Error
3610	20	SID	371	1555	DPF Outlet Pressure Sensor Drifted High In Range Fault (Low Box)
3610	14	SID	371	1555	DPF Outlet Pressure Sensor Drifted High In Range Fault (High Box)
3610	21	SID	371	1555	DPF Outlet Pressure Sensor Drifted Low In Range Fault (Low Box)
3610	31	SID	371	1555	DPF Outlet Pressure Sensor Drifted Low In Range Fault (High Box)
3659	14	SID	362	1611	Injector Cylinder #1 Spill Control Valve Abnormal Operation
3659	10	SID	362	1611	Injector Cylinder #1 Spill Control Valve ("Amplifier") Abnormal Rate of Change
3659	6	SID	362	1611	Injector Cylinder #1 Spill Control Valve ("Amplifier"), Valve Shorted Circuit
3660	14	SID	363	1612	Injector Cylinder #2 Spill Control Valve Abnormal Operation
3660	10	SID	363	1612	Injector Cylinder #2 Spill Control Valve ("Amplifier") Abnormal Rate of Change
3660	6	SID	363	1612	Injector Cylinder #2 Spill Control Valve ("Amplifier"), Valve Shorted Circuit
3661	14	SID	364	1613	Injector Cylinder #3 Spill Control Valve Abnormal Operation
3661	10	SID	364	1613	Injector Cylinder #3 Spill Control Valve ("Amplifier") Abnormal Rate of Change
3661	6	SID	364	1613	Injector Cylinder #3 Spill Control Valve ("Amplifier"), Valve Shorted Circuit
3662	14	SID	365	1614	Injector Cylinder #4 Spill Control Valve Abnormal Operation
3662	10	SID	365	1614	Injector Cylinder #4 Spill Control Valve ("Amplifier") Abnormal Rate of Change

## Section 01: ENGINE

SPN	FMI	PID/SID	PID/SID ID	FLASH CODE	FAULT DESCRIPTION
3662	6	SID	365	1614	Injector Cylinder #4 Spill Control Valve ("Amplifier"), Valve Shorted Circuit
3663	14	SID	366	1615	Injector Cylinder #5 Spill Control Valve Abnormal Operation
3663	10	SID	366	1615	Injector Cylinder #5 Spill Control Valve ("Amplifier") Abnormal Rate of Change
3663	6	SID	366	1615	Injector Cylinder #5 Spill Control Valve ("Amplifier"), Valve Shorted Circuit
3664	14	SID	367	1621	Injector Cylinder #6 Spill Control Valve Abnormal Operation
3664	10	SID	367	1621	Injector Cylinder #6 Spill Control Valve ("Amplifier") Abnormal Rate of Change
3664	6	SID	367	1621	Injector Cylinder #6 Spill Control Valve ("Amplifier"), Valve Shorted Circuit
3665	14	SID	368	1622	Injector Cylinder #7 Spill Control Valve Abnormal Operation
3665	10	SID	368	1622	Injector Cylinder #7 Spill Control Valve ("Amplifier") Abnormal Rate of Change
3665	6	SID	368	1622	Injector Cylinder #7 Spill Control Valve ("Amplifier"), Valve Shorted Circuit
3666	14	SID	369	1623	Injector Cylinder #8 Spill Control Valve Abnormal Operation
3666	10	SID	369	1623	Injector Cylinder #8 Spill Control Valve ("Amplifier") Abnormal Rate of Change
3666	6	SID	369	1623	Injector Cylinder #8 Spill Control Valve ("Amplifier"), Valve Shorted Circuit
3719	16	SID	155	1624	Soot Level High
3719	0	SID	155	1624	Soot Level Very High
3719	31	SID	155	1635	DPF Zone 2 Condition
3719	15	SID	155	1636	DPF Zone 3 Condition
3720	15	SID	155	1625	DPF Ash Clean Request
3720	16	SID	155	1625	DPF Ash Clean Request - Derate
4076	4	PID	110	1212	Engine Coolant Inlet Temperature Circuit Failed Low
4076	3	PID	110	1212	Engine Coolant Inlet Temperature Circuit Failed High
4076	2	SID	155	1615	Engine Coolant Sensor (IN), General Temp. Plausibility Error
4077	4	SID	332	1543	Doser Fuel Line Pressure Sensor Circuit Failed Low
4077	3	SID	332	1543	Doser Fuel Line Pressure Sensor Circuit Failed High
4077	14	SID	332	1543	Doser Fuel Line Pressure Failed Self Test
4226	4	SID	155	1615	Compressor Differential Pressure Inlet Failed Low
4226	3	SID	155	1615	Compressor Differential Pressure Inlet Failed High
4226	0	SID	155	1615	Turbocharger Compressor Inlet Differential Pressure Too High (Low Box)
4226	1	SID	155	1615	Turbocharger Compressor Inlet Differential Pressure Too Low (High Box)
4226	5	SID	155	1615	Turbocharger Compressor Inlet Differential Pressure Sampling Range Failure
4226	13	SID	155	1454	Turbocharger Compressor Inlet Differential Pressure Sensor Out Of Calibration
4226	13	SID	155	1454	Turbocharger Compressor Inlet Differential Pressure Sensor Out Of Calibration
4227	4	SID	53	1324	Electrostatic Oil Separator Circuit Failed Low
4227	3	SID	53	1324	Electrostatic Oil Separator Circuit Failed High
4227	5	SID	53	1324	Electrostatic Oil Separator Circuit Failed Open
4227	4	SID	155	1615	Oil Separator Circuit Failed Low
4227	3	SID	155	1615	Oil Separator Circuit Failed High
4227	7	SID	155	1615	Oil Separator, Max. Duration Time Reached
4228	16	SID	147	1241	Smart Remote Actuator 5 (VGT), Temperature Fault
4228	15	SID	147	1241	Smart Remote Actuator 5 (VGT), Temperature Warning

## 5. ENGINE OIL LEVEL

 **MAINTENANCE**

Check the oil level daily with the engine stopped. If the engine has just been stopped and is warm, wait at least 10 minutes to allow the oil to drain back to the oil pan before checking. Wipe the dipstick clean then check oil level. The level should always be within the safe range on the dipstick (Fig. 8). Add the proper grade of oil to maintain the correct level on the dipstick. All diesel engines are designed to consume some oil, so a periodic addition of oil is normal.

 **WARNING**

Touching a hot engine can cause serious burns.

 **CAUTION**

Do not overfill. Oil may be blown out through the crankcase breather if the crankcase is overfilled.

 **CAUTION**

Clean end of tube before removing the dipstick to prevent oil contamination.

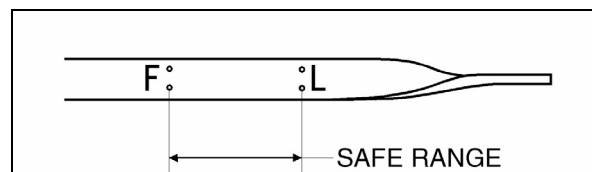



FIGURE 8: ENGINE OIL LEVEL DIPSTICK 01027

 **CAUTION**

If the oil level is constantly above normal and excess lube oil has not been added to the crankcase, consult with an authorized Detroit Diesel service outlet for the cause. Fuel or coolant dilution of lube oil can result in serious engine damage.

The vehicle may be provided with an oil reserve tank in the engine compartment. To adjust oil level, open the oil reserve tank drain valve and allow oil to discharge into the engine until the

"Full" mark on the dipstick is reached then close the valve. Check oil reserve tank level and pour oil in the reserve tank if necessary (Fig. 9).

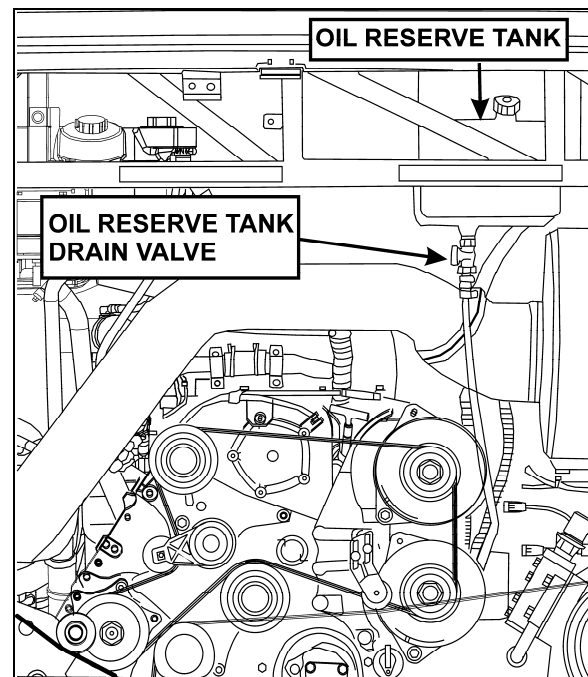



FIGURE 9: OIL RESERVE TANK 01188

## 6. ENGINE OIL AND FILTER CHANGE

 **MAINTENANCE**

Both the engine oil and filter should be changed according to the following maximum interval (based on an oil analysis program).

**Short Haul:** 15,000 miles (24,000km) or once a year, whichever comes first.

**Long Haul:** 30,000 miles (48,000km) or once a year, whichever comes first.

Oil analysis program may be used to determine whether this interval should be shorter, but should not be used to lengthen the interval.

Short haul: 6,000 miles (10,000km) to 60,000 miles (100,000 km) annual.

Long haul: over 60,000 miles (100,000 km) annual.

However, changes that are more frequent may be required when the engine is subject to high

## Section 01: ENGINE

levels of contamination and/or overheating. Change intervals may be decreased or gradually increased with experience on specific lubricants until the most practical service condition has been established. Always refer to the lubricant manufacturer's recommendations (analysis of drained oil can be helpful).



### CAUTION

Do not use solvents to dilute the engine oil when draining. Dilution of fresh oil can occur which may be detrimental to the engine.

Change engine oil with the vehicle on a flat and level surface and with the parking brake applied. It is best to drain the oil when the engine is still warm.

1. From under the vehicle, remove the engine drain plug on the oil pan. Allow oil to drain (Fig. 10).



### WARNING

Hot engine oil can cause serious burns. Wear coveralls with sleeves pulled down and gloves to protect hands.

2. Reinstall the drain plug.
3. Remove the spin-on filter cartridge using a ½" drive socket wrench and extension.
4. Dispose of the used oil and filter in an environmentally responsible manner in accordance with state and/or federal (EPA) recommendations.

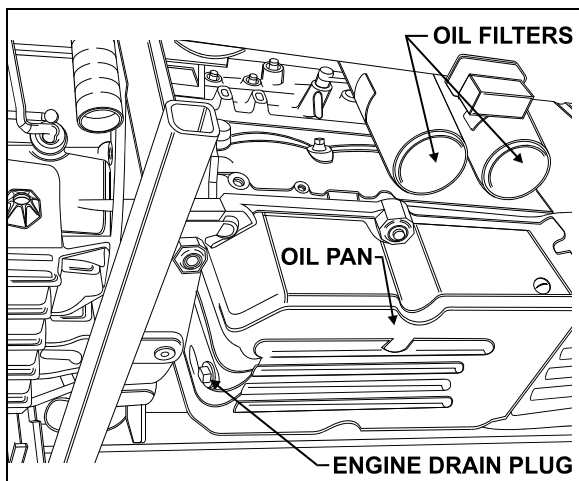

FIGURE 10: ENGINE DRAIN PLUG AND OIL FILTERS  
01029

5. Clean the filter adapter with a clean rag.

6. Lightly coat the filter gasket (seal) with clean engine oil.
7. Install the new filter on the adapter and tighten manually until the gasket touches the mounting adapter head. Tighten full-flow filters an additional two-thirds of a turn manually. Then, manually tighten bypass filter one full turn.



### CAUTION

Overtightening may distort or crack the filter adapter.

8. Remove the engine-oil filler cap and pour oil in the engine until it reaches the "FULL" mark on the dipstick (Fig. 8).
9. Start and run the engine for a short period and check for leaks. After any leaks have been corrected, stop the engine long enough for oil from various parts of the engine to drain back to the crankcase (approximately 20 minutes).
10. Add oil as required to bring the level within the safe range on the dipstick (Fig. 8).



### MAINTENANCE

Engine oil temperature should be checked every 25,000 miles (40 000 km) to determine oil cooler efficiency. This check should be made by inserting a steel jacketed thermometer in the dipstick opening, immediately after stopping a hot, loaded engine. If the oil temperature exceeds the coolant temperature by more than 60 °F (33 °C), the oil cooler may be clogged.

For detailed oil specifications, refer to DETROIT DIESEL SERIES 60 2007 ON-HIGHWAY SERVICE MANUAL 6SE2007 under heading «Lubricating Oil for Detroit Diesel Engines».



## 7. RECOMMENDED ENGINE OIL TYPE

To provide maximum engine life, lubricants shall meet the following specifications: SAE Viscosity Grade: 15W-40 API Classification: CJ-4.



### CAUTION

Low ash oil formulation designated API CJ-4 is required in EPA-07 engines.

CJ-4 contains less than 1% ash which is the key to achieving maximum diesel particulate filter cleaning intervals. Use of high ash engine oils will reduce the cleaning interval on the Diesel Particulate Filter (DPF). DPF regenerates the combustible soot, but the ash (a product of the oil lubricant package) slowly accumulates in the channels of the DPF.

### NOTE

*Monograde oils should not be used in these engines regardless of API Service Classification.*

### NOTE

*The use of supplemental oil additives is discouraged from use in Detroit Diesel Engines.*

**Synthetic oils:** Synthetic oils may be used in Detroit Diesel engines provided they are API-licensed and meet the performance and chemical requirements of non-synthetic oils outlined previously. Synthetic oils do not permit extension of recommended oil drain intervals.

## 8. POWER PLANT ASSEMBLY REMOVAL

To access the engine or engine-related components, the vehicle power plant assembly must be removed as a whole unit by means of a slide-out cradle. The power plant assembly includes the engine, transmission (including retarder if so equipped), air compressor, alternator and transmission oil cooler.

Remove the power plant assembly as follows:



### CAUTION

Tag hoses and cables for identification before disconnecting in order to facilitate reinstallation. Plug all openings to prevent dirt from entering the system.

### NOTE

*No parts within the MCM are serviceable. If found defective, replace the MCM as a unit.*

1. Disconnect the battery or batteries from the starting system by removing one or both of the battery cables from each battery system. With the electrical circuit disrupted, accidental contact with the starter button will not produce an engine start. In addition, the Electronic Unit Injectors (EUI) will be disabled, preventing any fuel delivery to the injector tips.



### WARNING

Due to the heavy load of the rear bumper assembly, it must be adequately supported before attempting to remove it.

2. Remove the rear bumper assembly from the vehicle. Refer to Section 18, BODY, under "REAR BUMPER REMOVAL".
3. Drain the engine cooling system. Refer to Section 05, COOLING under "DRAINING COOLING SYSTEM".

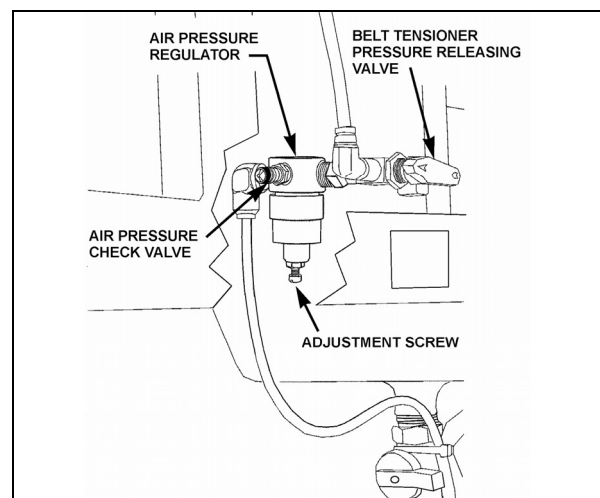

FIGURE 11: BELT TENSIONER VALVE

12200

4. Locate the A/C compressor belt tensioner pressure releasing valve (Fig. 11). Turn pressure releasing valve handle counterclockwise in order to release pressure in belt-tensioner air bellows and loosen belts. Remove the belts.
5. To release all pressure from the air system. Refer to Section 12, BRAKES & AIR SYSTEM for instructions.

## Section 01: ENGINE

---

6. Disconnect and remove the engine-air intake duct mounted between air cleaner housing and turbocharger inlet (Fig.12).



### CAUTION

To avoid damage to turbocharger, cover the turbocharger inlet opening to prevent foreign material from entering.

7. Disconnect and remove the air intake duct mounted between the air cooler outlet and the engine intake (Fig.12).
8. Disconnect and remove section of coolant pipe assembly mounted between the radiator outlet and the water pump inlet (Fig.12).
9. Disconnect the coolant delivery hose located close to the water pump.
10. Disconnect the electric fan-clutch connector located near the cooling fan right angle gearbox (Fig. 12).
11. Disconnect the cooling fan drive shaft.
12. Disconnect and remove the air intake duct mounted between the turbocharger outlet and the air cooler inlet (Fig. 12).
13. Disconnect two vent hoses from the thermostat housing and from the coolant pipe assembly.
14. Disconnect and remove a section of coolant pipe assembly mounted between the thermostat housings and the radiator inlet.
15. Disconnect and remove the small hose connected to the heater line valve and to the water pump.
16. Disconnect the small heater hose located on the cylinder head at the back of the engine.
17. Disconnect and remove the exhaust pipe mounted between the turbocharger outlet and the exhaust bellows. If necessary, refer to Section EXHAUST SYSTEM under MUFFLER REMOVAL AND INSTALLATION".



### CAUTION

To avoid damage to turbocharger, cover the turbocharger outlet opening to prevent foreign material from entering.

18. Disconnect the steel-braided airline from the A/C compressor air bellows.
19. Remove the power steering pump, leaving the supply and discharge hoses connected to it (Fig. 12).
20. Disconnect the oil delivery hose from the valve located at the reserve tank drain (Fig. 12).
21. Disconnect the block heater connector located near the power steering pump if applicable.
22. Close engine fuel supply shutoff valve on primary fuel filter. Disconnect the fuel line connected to inlet port. On vehicles equipped with the optional water-separator-fuel-filter, disconnect the connector and remove cable ties from cradle.
23. Disconnect the air compressor discharge, governor steel-braided airlines and manual filling airlines from compressor. Remove retaining clips.
24. Disconnect the hose connecting the compressor head to the sump tank.
25. Disconnect ground cables from rear subframe ground-stud located close to the starter motor.
26. Disconnect positive cable (red terminal) from starting motor solenoid.
27. Disconnect VIH (vehicle interface harness) connector from MCM.
28. On vehicles equipped with an automatic transmission provided with a hydraulic output retarder, disconnect steel-braided airline from pressure regulator output. The pressure regulator is mounted in the upper section of engine compartment backwall and is accessible through the engine compartment R.H. side door.
29. Disconnect fuel return line from bulkhead fixed on engine cylinder head end.
30. On vehicles equipped with an electrically operated cold-starting aid, disconnect the delivery hose from the starting-aid cylinder solenoid valve. Remove cable ties securing hoses.
31. Disconnect turbo boost pressure gauge airline from engine air intake.
32. Disconnect connectors from transmission. On the left side: four on rear side with one

close to yoke. On right side: close to the solenoid valve of the output retarder.

33. From under the vehicle, disconnect the propeller shaft as detailed in Section 09, under heading "Propeller Shaft Removal".
34. Inspect the power plant assembly to ensure that nothing will interfere when sliding out the cradle. Check for connections or hoses not mentioned in this list as some vehicles are equipped with special or aftermarket components.
35. Remove the six retaining bolts, washers and nuts securing the power plant cradle to the vehicle rear subframe (Fig. 13).

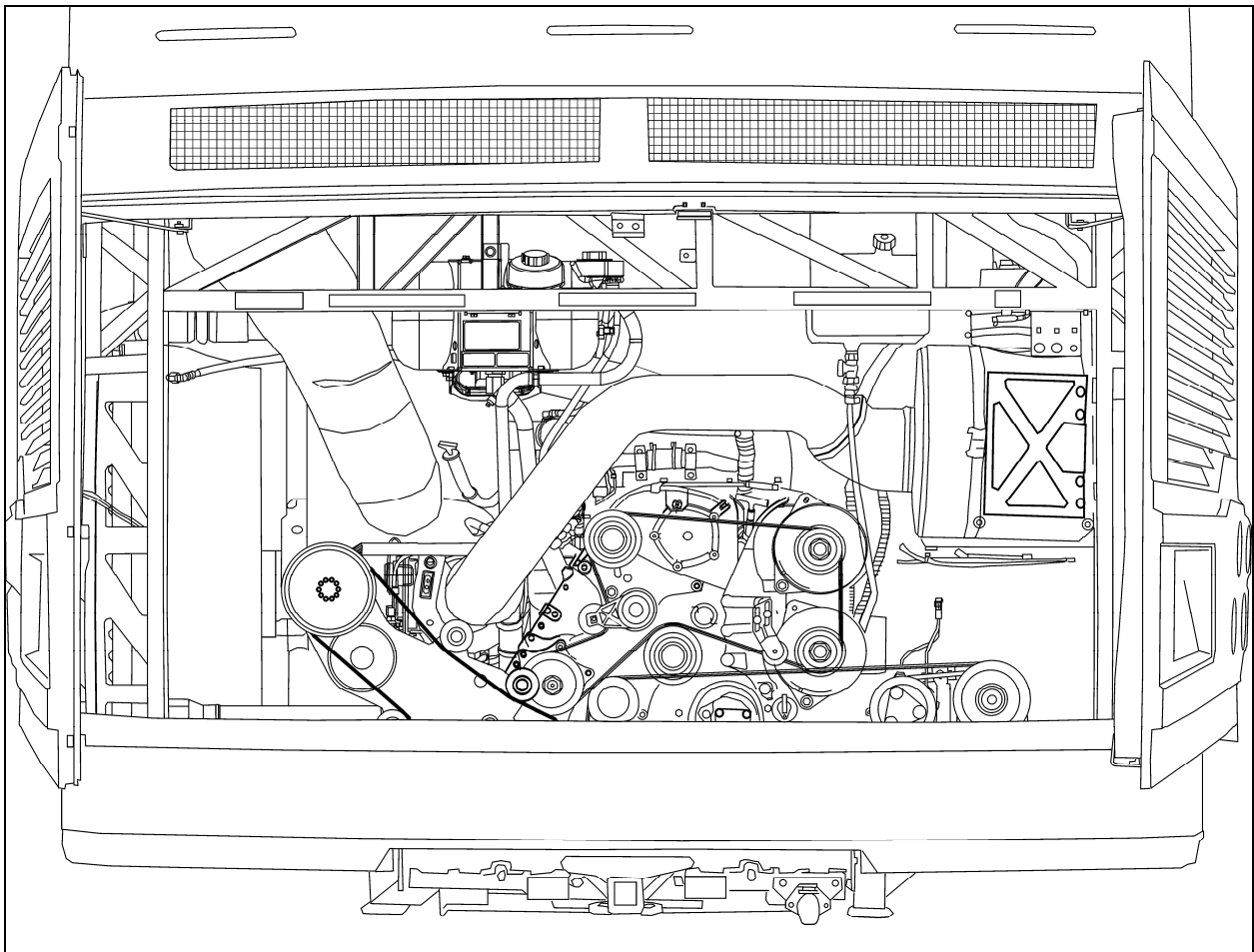

**FIGURE 12: ENGINE COMPARTMENT XLII MTH (TYPICAL)**

01186

## Section 01: ENGINE

### **NOTE**

Check if any spacer(s) have been installed between power plant cradle and vehicle rear subframe, and if so, note position of each washer for reinstallation purposes.

36. Using a forklift, with a minimum capacity of 4,000 lbs (1 800 kg), slightly raise the power plant cradle.
37. Pull engine out slowly from the engine compartment. Make sure all lines, wiring and accessories are disconnected and are not tangled.



### **CAUTION**

Due to the minimum clearance between the power plant equipment and the top of the engine compartment, extreme care should be used to raise the power plant cradle, just enough to free the cradle. Clearance between power plant cradle and mounting rail should range between ¼" and ½" (6-12 mm).

## 9. POWER PLANT ASSY. INSTALLATION

To install a power plant assembly, follow the same procedure as in "Power Plant Assembly Removal" except in reverse order, then proceed with the following:

1. Torque the power plant cradle mounting bolts to 190 lbf-ft (255 Nm).
2. If fan drive has been removed, reinstall and align as per Section 05, COOLING SYSTEM, under "FAN DRIVE ALIGNMENT".
3. Refill cooling system with saved fluid (refer to Section 05, COOLANT SYSTEM).
4. Once engine fuel system has been drained, it will aid restarting if fuel filters are filled with fuel oil (refer to Section 03, FUEL SYSTEM).
5. Start engine for a visual check. Check fuel, oil, cooling, pneumatic and hydraulic system connections for leakage. Test operation of engine controls and accessories.

## 10. VALVE COVER REMOVAL

Refer to the series 60 Detroit diesel service manual for injectors and valves adjustment.

Wait until engine is cold prior to working on vehicle.

1. Remove air intake pipe.
2. Remove the after CAC (Charger-Air-Cooler) air pipe.
3. Disconnect ventilation pipe from valve cover.
4. Remove last seat to access trap door located in the middle rear end of vehicle.
5. Remove engine cover.
6. Adjust Jake brakes (if applicable), injectors and valves using Detroit Diesel service manual for series 60 engines.
7. Verify engine cover gasket and replace if necessary.

### **NOTE**

New gasket must be ordered directly from Detroit Diesel.

8. Reinstall engine cover with a tightening torque of 18-22 Lbf-ft (25-30 Nm).
9. Connect ventilation pipe to engine cover.
10. Reinstall air intake and after CAC air pipes.
11. Reinstall trap door.

## 11. JAKE BRAKE

Refer to both "The Jake Brake Troubleshooting and Maintenance Manual" and "Installation Manual for Model 790 Engine Brakes" for troubleshooting and installation procedures. They are annexed at the end of this section.

## 12. ENGINE MOUNTS

The power plant assembly is mounted to the cradle by means of rubber mounts.

Two rubber mounts are used at the front of the engine while two others are mounted on each side of the flywheel housing (Fig. 13).

It is recommended that new rubber mounts be installed at each major overhaul.

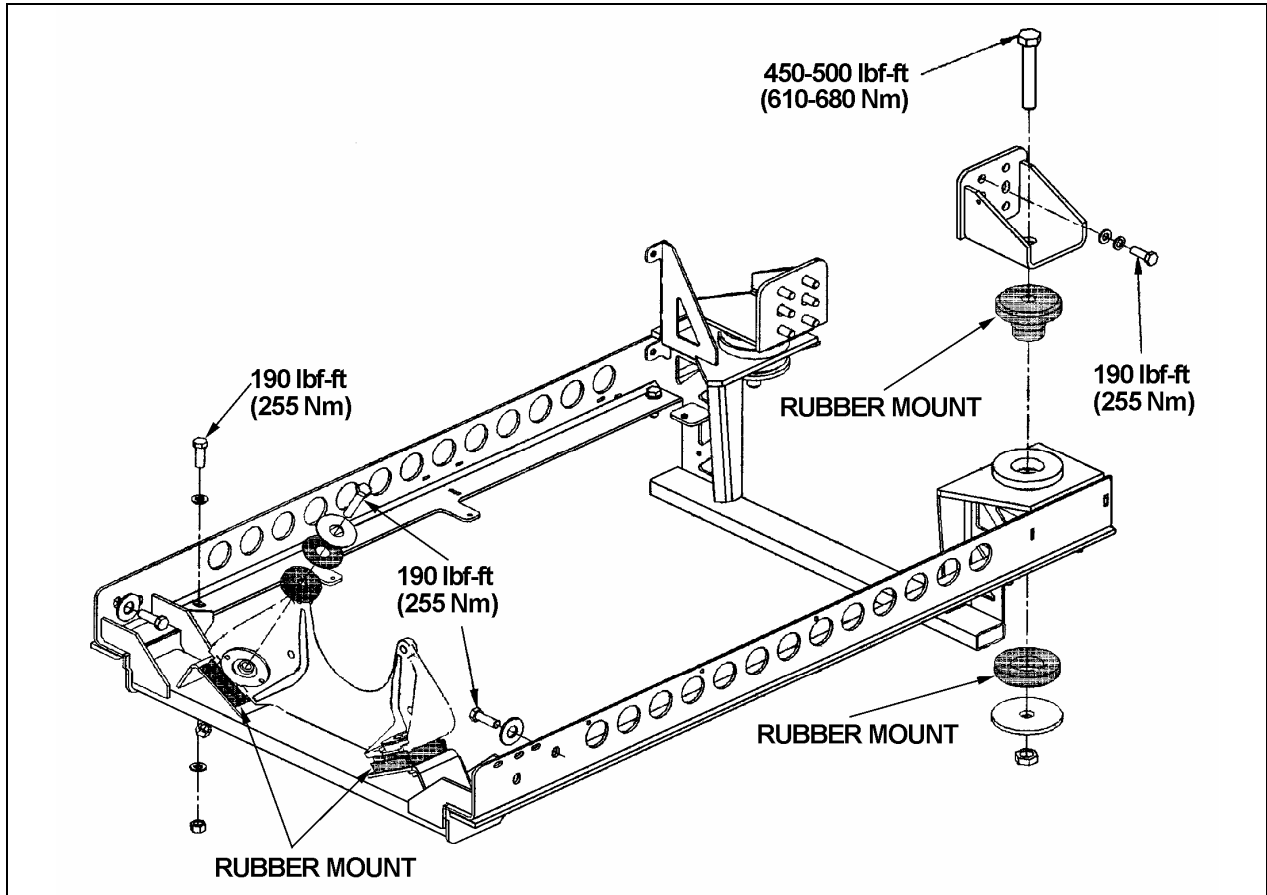
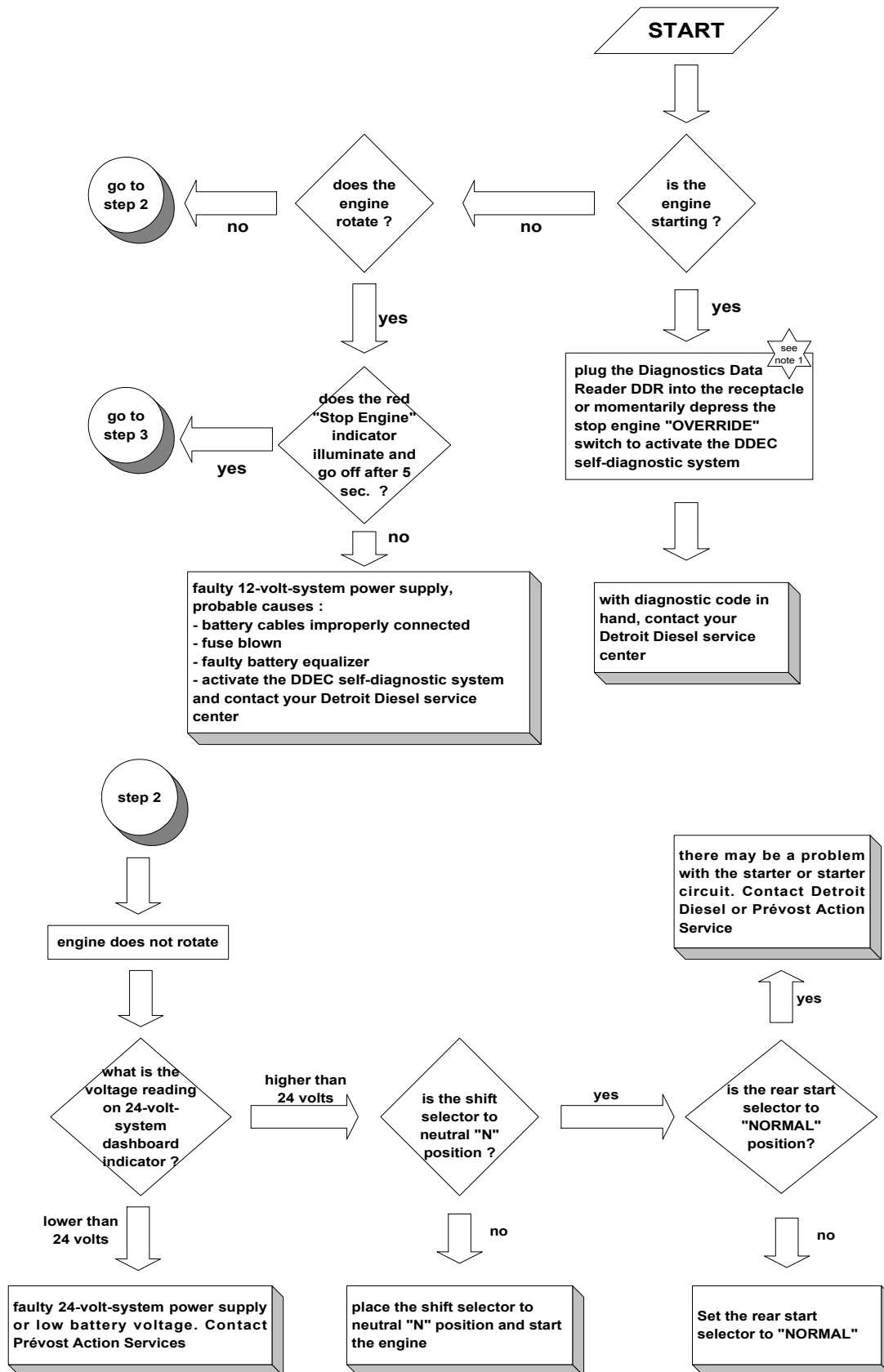
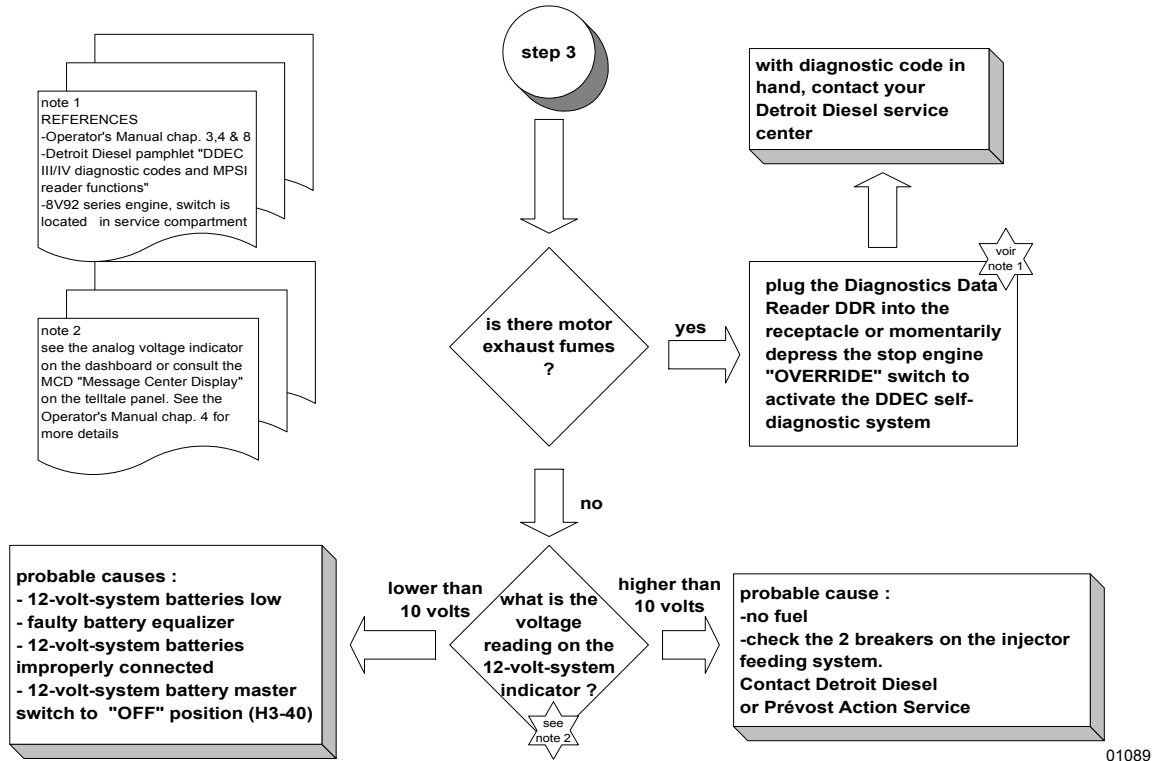

FIGURE 13: POWER PLANT CRADLE INSTALLATION

01140

13. ENGINE TROUBLESHOOTING GUIDE





**14. SPECIFICATIONS**

**Series 60 Engine**

Make ..... Detroit Diesel  
 Type ..... Diesel four cycle/in-line engine  
 Description ..... Turbo/Air to air charge cooled  
 No. of cylinders ..... 6  
 Operating range ..... 1200-2100 RPM  
 Maximum RPM..... 2100

**Lubricant**

Heavy-duty engine oil SAE Viscosity Grade 15W-40, API Classification CJ-4. Synthetic oil may be used if it meets the performance and chemical requirements of non-synthetic oils outlined previously. Some engine operating conditions may require exceptions to this recommendation.

**CAUTION**

To avoid possible engine damage, do not use single grade (Monograde) lubricants in Detroit Diesel four-cycle Series 60 engines, regardless of API classification.

<b>MTH Engine (14.0L)</b>
MTH 45E: 455 HP @1800 rpm; 1550 lb-ft @1200 rpm
MTH 45: 515 HP @1800 rpm; 1650 lb-ft @1200 rpm

## Section 01: ENGINE

---

### Capacity

Oil reserve tank ..... 8.4 US qts (8.0 L)

### Engine oil level quantity

Oil Pan Capacity, Low Limit ..... 26 quarts/25 liters

Oil Pan Capacity, High Limit ..... 32 quarts/30 liters

Total Engine Oil Capacity with Filters ..... 38 quarts/36 liters

### Lubricating oil filter elements

Make ..... AC Rochester Div. GMC # 25014505

Make ..... A/C Filter # PF-2100

Type ..... Full Flow

Prévost number ..... 510458

### Torque specification

Engine oil filter ..... Tighten 2/3 of a turn after gasket contact

### Filters

#### Engine Air Cleaner Filter

Make ..... Nelson # 70337-N

Prévost number ..... 530197

#### Engine Coolant Filter/Conditioner

Make ..... Nalco Chemical Company # DDF3000

Make ..... Detroit Diesel # 23507545

Prévost number ..... 550630

<b><i>NOTE</i></b>
--------------------

<i>For primary and secondary fuel filters, refer to Specifications in section 03</i>
--



## SECTION 03: FUEL SYSTEM

### CONTENTS

<b>1. FUEL SYSTEM DESCRIPTION</b> .....	<b>3</b>
<b>2. FUEL LINES AND FLEXIBLE HOSES</b> .....	<b>4</b>
<b>3. FUEL VALVES</b> .....	<b>4</b>
<b>4. FILTERS AND WATER SEPARATOR</b> .....	<b>5</b>
4.1 FUEL FILTER/WATER SEPARATOR SERVICING .....	5
4.2 FUEL FILTER SERVICING (PRIMARY AND SECONDARY) .....	5
4.3 DAVCO FUEL PRO 382 .....	6
<b>5. FUEL TANK</b> .....	<b>8</b>
5.1 TANK REMOVAL .....	8
5.1.1 <i>Main Fuel Tank</i> .....	8
5.1.2 <i>Auxiliary Fuel Tank (if so equipped)</i> .....	8
5.1.3 <i>Transverse Fuel Tank</i> .....	9
5.2 TANK INSTALLATION .....	9
5.3 FUEL TANK VERIFICATION .....	10
5.4 POLYETHYLENE FUEL TANK REPAIR .....	10
<b>6. PRIMING FUEL SYSTEM</b> .....	<b>11</b>
<b>7. FUEL PUMP INSTALLATION</b> .....	<b>11</b>
<b>8. FUEL SPECIFICATIONS</b> .....	<b>12</b>
8.1 FUEL TYPE .....	12
8.2 BLENDING .....	12
<b>9. AIR CLEANER (DRY TYPE)</b> .....	<b>13</b>
9.1 PRE-CLEANER SERVICING .....	13
9.2 AIR CLEANER SERVICING .....	13
9.3 GENERAL RECOMMENDATIONS .....	13
9.4 AIR CLEANER RESTRICTION INDICATOR .....	13
<b>10. FUEL COOLER</b> .....	<b>14</b>
<b>11. FUEL PEDAL</b> .....	<b>14</b>
11.1 FUEL PEDAL ADJUSTMENT .....	14
11.2 POTENTIOMETER REPLACEMENT .....	14
<b>12. SPECIFICATIONS</b> .....	<b>15</b>

**ILLUTRATIONS**

FIGURE 1: FUEL SYSTEM SCHEMATIC..... 3  
FIGURE 2: FUEL FILTERS ..... 4  
FIGURE 3: MANUAL SHUT-OFF VALVES LOCATION ..... 4  
FIGURE 4: MANUAL SHUT-OFF VALVE WITH DAVCO PRO 382 ..... 4  
FIGURE 5: FUEL FILTER/WATER SEPARATOR ..... 5  
FIGURE 6: DAVCO FUEL PRO 382 FUEL FILTER ..... 7  
FIGURE 7: DAVCO FUEL PRO 382 EXPLODED VIEW ..... 7  
FIGURE 8: 208 US GAL. MAIN FUEL TANK & 90 US GAL. AUXILIARY FUEL TANK (OPTIONAL) (W5) ..... 9  
FIGURE 9: 250 US GALLONS FUEL TANKS (MAIN TANK & TRANSVERSE FUEL TANK) (WE) ..... 10  
FIGURE 10: FUEL TANK REPAIR..... 11  
FIGURE 11: FUEL PUMP LOCATION ..... 11  
FIGURE 12: RESTRICTION INDICATOR ..... 13  
FIGURE 13: FUELRETURN LINE..... 14  
FIGURE 14: FUEL COOLER LOCATION ..... 14  
FIGURE 15: ELECTRONIC FOOT PEDAL ASSEMBLY ..... 15

1. FUEL SYSTEM DESCRIPTION

Figure 1 shows a schematic of the fuel system. Fuel is drawn from the fuel tank through a manual shut-off valve, a primary fuel filter (fuel-filter/water-separator) before it enters the MCM and the fuel pump. If the vehicle is equipped with the optional “Davco Fuel Pro 382”, this one replaces the primary fuel filter. Leaving the pump under pressure, the fuel flows through a secondary fuel filter and a shut-off valve, then to the cylinder head. The fuel reaches the injectors in the cylinder head through passages within the head. Excess fuel exits at the rear of the head just above the inlet, through a restrictive return fitting which maintains fuel pressure in the system. Finally, the fuel flows through the check valve and the fuel cooler before it returns to the fuel tank.

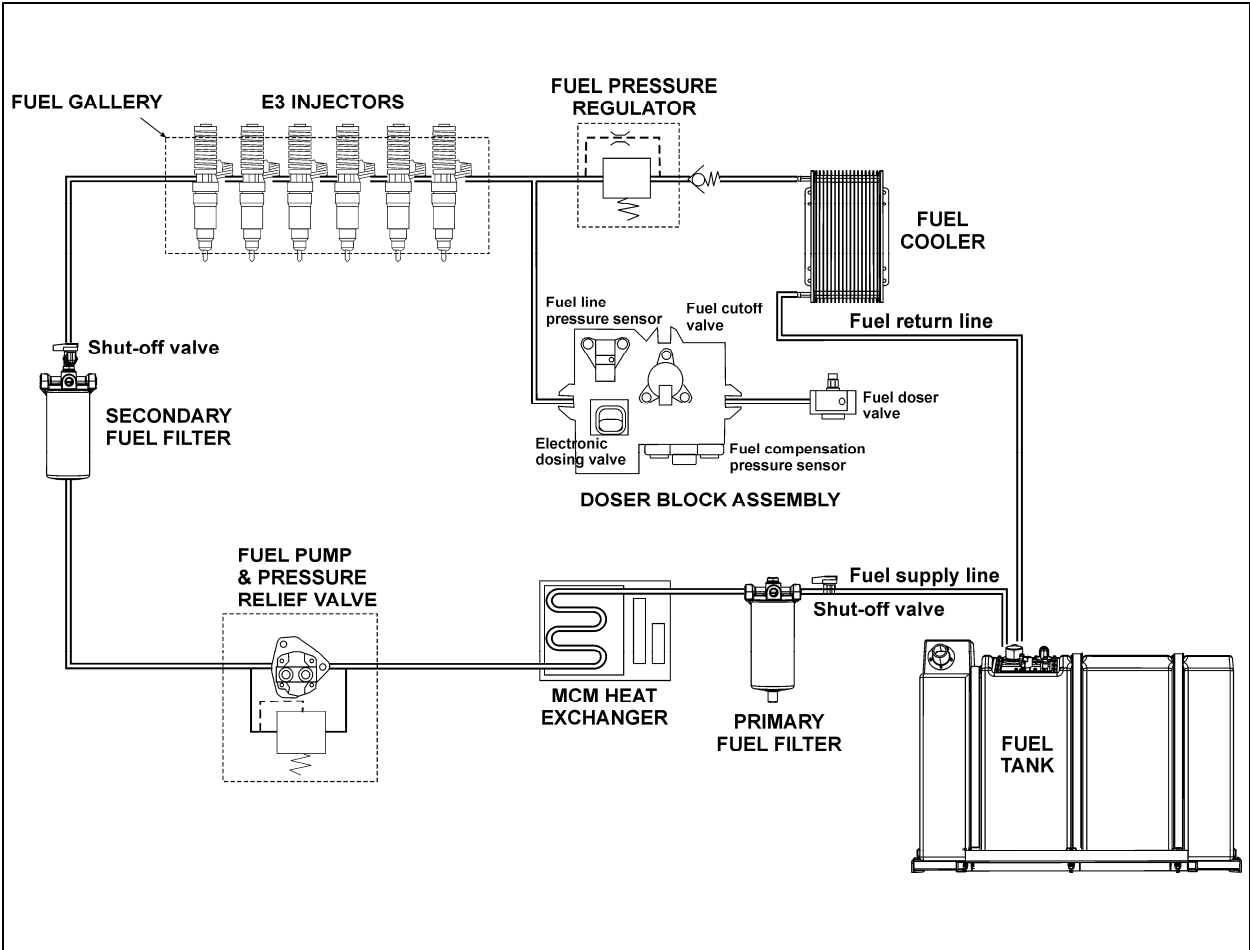

FIGURE 1: FUEL SYSTEM SCHEMATIC

03075

## Section 03: FUEL SYSTEM

### 2. FUEL LINES AND FLEXIBLE HOSES

Make a visual check for fuel leaks at all engine-mounted fuel lines and connections and at the fuel tank suction and return lines. Since fuel tanks are susceptible to road hazards, leaks in this area may best be detected by checking for accumulation of fuel under the tank. Engine performance and auxiliary equipment is greatly dependent on the ability of flexible hoses to transfer lubricating oil, air, coolant and fuel oil. Diligent maintenance of hoses is an important step in ensuring efficient, economical and safe operation of engine and related equipment.



#### MAINTENANCE

Check hoses daily as part of the pre-start-up inspection. Examine hoses for leaks and check all fittings, clamps and ties carefully. Make sure that the hoses are not resting on or touching shafts, couplings, and heated surfaces, including exhaust manifolds, any sharp edges or other obviously hazardous areas.

Since all machinery vibrates and moves to a certain extent, clamps and ties can fatigue with age. To ensure continued proper support, inspect fasteners frequently and tighten or replace them as necessary. Refer to the schematic diagram of the fuel system (Fig. 1).



#### CAUTION

Oil level above the dipstick full mark or a decrease in lube oil consumption may indicate internal fuel leaks. Check oil level frequently.

### 3. FUEL VALVES

Manual shut-off valves on engine fuel-supply line are located on the R.H. side of engine compartment (Fig. 2). A manual shut-off valve is located at the inlet side of the primary fuel filter (fuel filter/water separator, if vehicle is so equipped) under the starter or at the inlet side of the optional Davco Fuel Pro 382 filter. Another manual shut-off valve is located at the outlet side of the secondary fuel filter, under the air compressor. Shut-off valve are designed to prevent loss of fuel prime at time of filter replacement. No manual valve is required on preheater fuel-supply line, since the positive-

displacement fuel pump (located close to the fuel tank) prevents fuel flow when not activated.

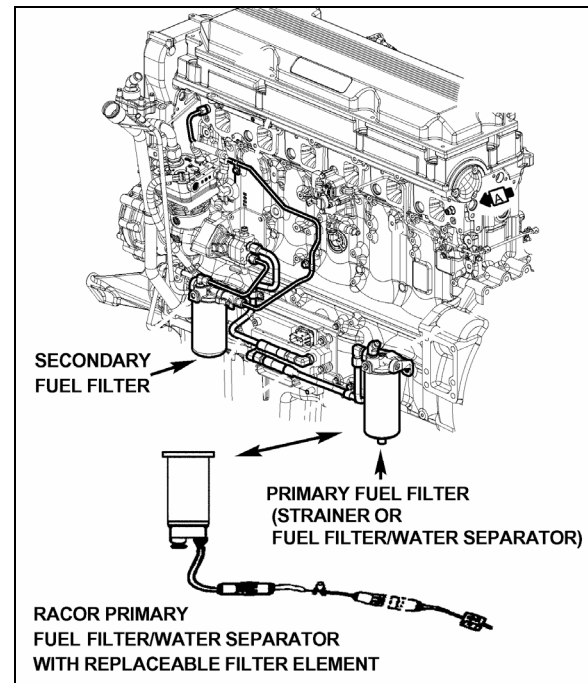

FIGURE 2: FUEL FILTERS

03069

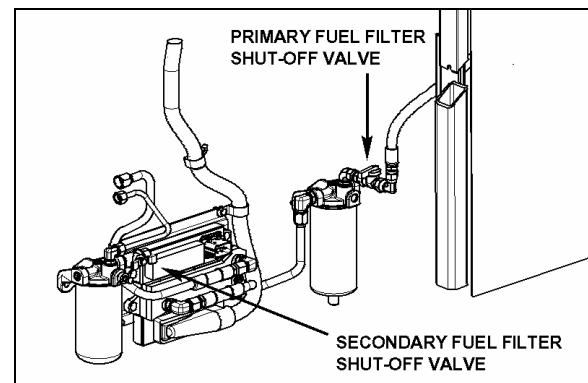

FIGURE 3: MANUAL SHUT-OFF VALVES LOCATION

03072

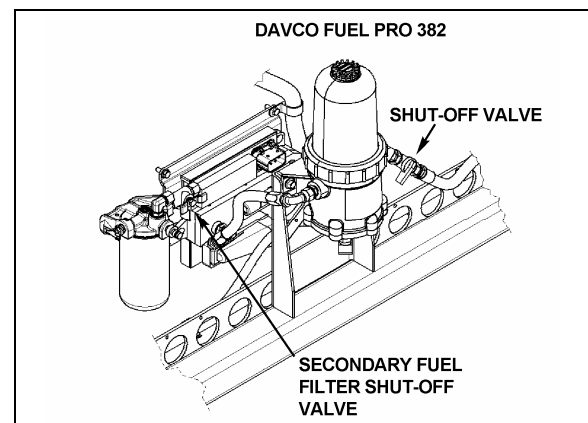

FIGURE 4: MANUAL SHUT-OFF VALVE WITH DAVCO PRO 382

03077

#### 4. FILTERS AND WATER SEPARATOR

The fuel system is equipped with primary and secondary fuel filters for additional protection of the injectors. A fuel-filter/water-separator may be installed in primary fuel-filter location, to prevent water infiltration in engine fuel system (Fig. 2).

**NOTE**

*The operating conditions and cleanliness of type of fuel used determine the service intervals of the filter/water separator element and the secondary fuel filter cartridge.*

##### 4.1 FUEL FILTER/WATER SEPARATOR SERVICING



### MAINTENANCE

The Racor fuel-filter/water-separator should be drained periodically, or when the water separator telltale light on the dashboard illuminates.

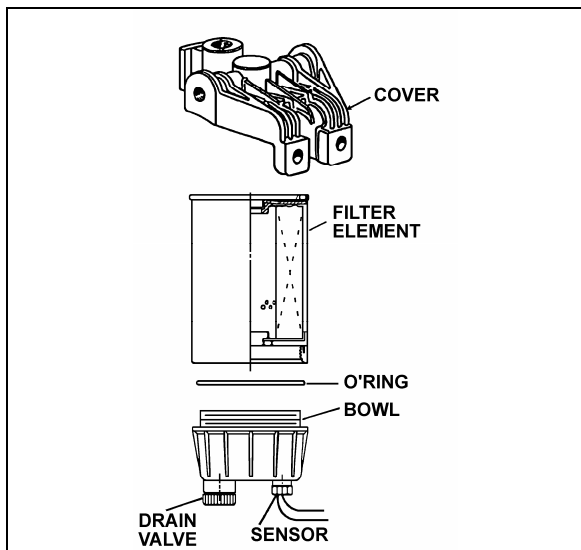

FIGURE 5: FUEL FILTER/WATER SEPARATOR 03025

Replace the water separator element as follows:

1. Drain the fuel filter/water separator as stated previously.
2. With engine "OFF" and engine fuel supply line valves closed; remove the filter element/bowl assembly from cover (for valve location, see "3. FUEL VALVES" in this section).

3. Separate bowl from filter element. Clean bowl and O-ring groove.

**NOTE**

*Bowl is reusable, do not discard.*

4. Lubricate O-ring with clean diesel fuel or motor oil and place it in bowl groove.
5. Screw new filter element onto bowl snugly by hand.



### CAUTION

Do not use tool to tighten. Tighten by hand only.

6. Lubricate filter seal with clean diesel fuel or motor oil.



### CAUTION

If the water separator continuously requires draining, it is possible that water or sediment has accumulated in the fuel tank. To correct this situation, open the drain plug under the tank when the fuel gauge indicates tank is 1/4 full in order to drain any contaminant.

7. Fill filter element/bowl assembly with clean diesel fuel and attach onto cover. Hand tighten an additional 1/3 to 1/2 turn after making full seal contact.
8. Open valves of the engine fuel supply line.
9. Run the engine and check for leaks.

##### 4.2 FUEL FILTER SERVICING (PRIMARY AND SECONDARY)

The primary and secondary fuel filters are located on the R.H. side of the engine. The primary filter is located below the starter, and the secondary fuel filter is below the air compressor. The threaded sleeves that accept the filters body are different sizes to prevent mismatching. Primary filter thread is 1in.X12 while secondary is 13/16in.X12. The word "primary" or "secondary" is cast onto the top of the respective adaptor.

**NOTE**

*The fuel filter adaptors are mounted to the engine block with two bolts each. Torque these bolts to 43-54 lbf-ft (58-73 N•m).*



### MAINTENANCE

The primary and secondary fuel filters are of a spin-on type and must be replaced every 12,500 miles (20 000 km) or once a year, whichever comes first. If the primary fuel filter is a fuel filter/water separator type, it is equipped with a positive seal drain-valve to prevent water infiltration in engine fuel system. To drain, loosen positive seal drain-valve below filter and tighten after water has been flushed out.

A method of determining when filters are clogged to the extent that they should be changed is based on the fuel pressure at the cylinder head fuel inlet fitting and the inlet restriction at the fuel pump. In a clean system, the maximum pump-inlet restriction should not exceed 6 inches of mercury (20.3 kPa) and must not exceed 12 inches of mercury (41 kPa) with a dirty system.

At normal operating speeds and with the standard fuel pressure regulator, the fuel pressure at the cylinder head inlet is 50-75 psi (345-577 kPa). Change the fuel filters whenever the inlet restriction at the fuel pump reaches 12 inches of mercury (42 kPa) at normal operating speeds. Also, change whenever the fuel pressure at the cylinder head inlet fitting falls to the minimum fuel pressure given above.

Change the filter cartridge(s) as follows:

#### **NOTE**

*Use a suitable band wrench or filter wrench, such as J22775, to remove the filters.*

1. Stop engine and place a suitable container under the filter.
2. Close the primary and secondary filter shut-off valves (for valve location, See paragraph "3. FUEL VALVES").
3. Using a band filter wrench, unscrew and discard filters.
4. Fill new filter replacement cartridge(s) with clean fuel oil, about two thirds (2/3). Apply a thin coat of clean fuel oil on gasket.
5. Install new filters. Tighten until filter is snug against the gasket, with no side movement. Rotate an additional 1/2 turn by hand.

6. Open engine fuel supply line shut-off valves.



### CAUTION

Mechanical tightening of the fuel filters is not recommended and may result in seal and/or cartridge damage. Tighten the fuel filters by hand only.

5. Start the engine and check for leaks.

#### **NOTE**

*There is a fuel system shut-off valve on the discharge side of the secondary fuel filter. This check valve is designed to prevent fuel loss at time of filter replacement.*

### 4.3 DAVCO FUEL PRO 382

The optional Fuel Pro 382 diesel fuel filter system consists of a permanently mounted fuel processor, a replaceable filter element, a filter element cover and collar and a fluid filter base assembly. This system is installed between the fuel tank and the fuel pump and is designed to be the only fuel filter in the fuel system. The filter serves as a water separator as well as a fuel filter (refer to figure 6).

The filter fibers used in the Davco Fuel Pro 382 element may cause the fuel level to read artificially high when the filter is first installed. Over the first few days, the filter fibers eventually become fully saturated and the fuel level will drop to normal levels. Do not be concerned about an abnormally high fuel level when a new Davco element is installed.

When new, the fuel level as seen through the clear cover in the 382 filter is very low. It rises as dirt collects on the filter from the bottom up. Restriction remains consistently low because fuel always flows through clean, new media.



### MAINTENANCE

Replace Fuel Pro 382 filter element when the fuel level in the see-thru filter cover reaches the top of the filter element or after one year of service, whichever comes first.

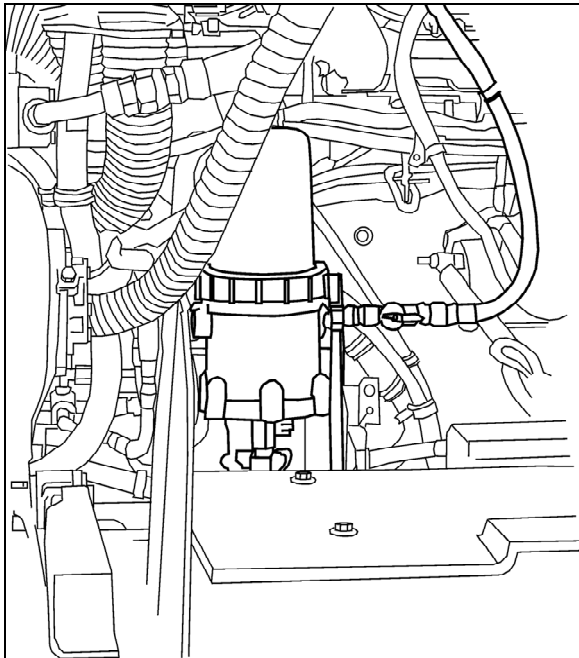

FIGURE 6: DAVCO FUEL PRO 382 FUEL FILTER 03062

Filter renewal:

1. Stop engine;
2. Place a suitable container under the fuel processor;
3. Close the shut-off valve at the inlet side of the fuel filter;
4. Open the drain valve at the base of the fuel processor and drain the fuel until it is below the level of the filter;
5. Untighten upper collar, remove cover, filter hold down spring, filter element and cover seal;
6. Dispose of used filter element;
7. Ensure the filter grommet is included at the base of the new filter element and then install the element onto the center stud;
8. Ensure the filter spring is installed at the top of the cover. If missing, the spring must be replaced to insure proper filter operation.
9. Wipe the cover lid and seal clean. After ensuring the seal is properly positioned at the base of the cover, install the cover and collar onto the fuel processor. Tighten the collar by hand until secure;
10. Fill the cover full of clean fuel through spin off cap located on top of cover. Install vent cap seal and then reinstall the cap and tighten by hand only;

11. Open the shut-off valve;
12. Start engine, raise rpm for 2-3 minutes, hand tighten collar again;
13. After the air is purged and with the engine still running, slowly loosen the vent cap on the filter cover. The fuel level in the cover will start falling. When the fuel level falls to the top of the collar, tighten the vent cap quickly by hand;
14. Shut down the engine and hand-tighten the collar again.

**NOTE**

*Fuel Pro 382 also accepts standard secondary spin-on fuel filters.*

**ENVIRONMENTAL NOTICE**

*Diesel fuel is an environmentally hazardous product. Dispose in an environmentally friendly manner.*

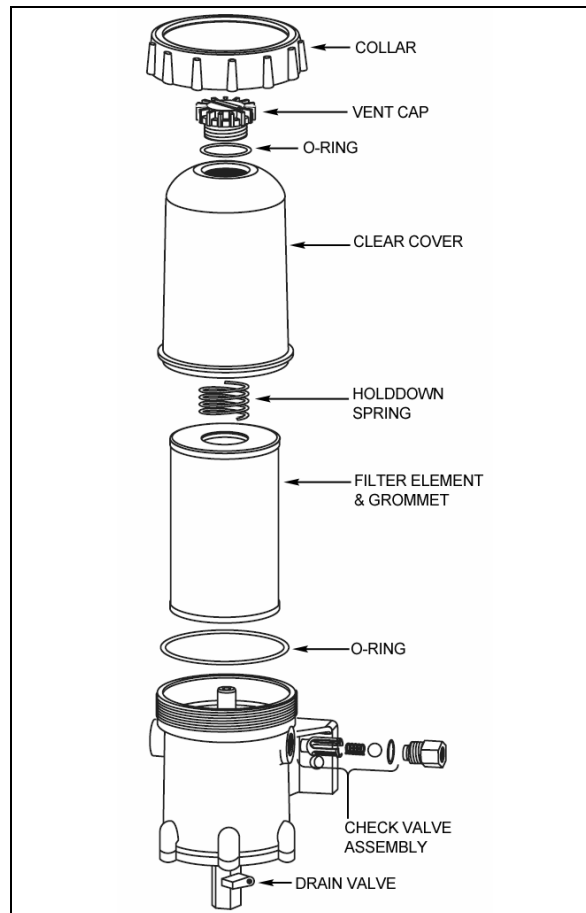

FIGURE 7: DAVCO FUEL PRO 382 EXPLODED VIEW 03034

## Section 03: FUEL SYSTEM

### 5. FUEL TANK

All XLII series motorhomes are equipped with a high-density cross-link polyethylene fuel tank. WE vehicles fuel tanks have a total capacity of 250 US gallons (945 liters) while W5 can be equipped with an optional 90 US gallons (341 Liters) auxiliary stainless steel tank forward of the standard 208 US gallons (787 liters) fuel tank. The main tank is located just forward of the rear baggage compartment, between the A/C condenser and evaporator. The auxiliary tank is located in the baggage compartment just forward of the main tank.

On all vehicles, fuel filling access doors on both sides of vehicle provide direct access to filler necks; offering the added advantage of refueling from either side of vehicle.

A pressure relief valve on the fuel tank connection-panel relieves high-pressure buildup and an overflow tube allows offset air in the tank to escape during filling. For 95% of the tank volume, 5% of tank inside space is kept filled with air with no exit opening, allowing for a fuel expansion safety margin. A drain plug, accessible from under the vehicle, is fitted at the bottom of the tank(s).

#### 5.1 TANK REMOVAL



### DANGER

Park vehicle safely, apply parking brake, stop engine and set battery master switch(es) to the OFF position prior to working on the vehicle.

Before working under an air-suspended vehicle, it is strongly recommended to support the body at the recommended jacking points.

### NOTE

*Before removal, the fuel tank should be completely drained by unscrewing the drain plug. Ensure that the container used has a capacity equal to the amount of fuel remaining in the tank.*

*For vehicles equipped with a transverse tank or an auxiliary tank, drain it as well since it is directly connected to the main tank.*

*It is possible to drain both tanks through only one plug, but the other tank will not drain completely since the connecting hose is not on the bottom.*

#### 5.1.1 Main Fuel Tank

1. Open the condenser door and remove the fuel tank access panel. The rear baggage compartment fuel tank access panel may also be removed to facilitate access to components.
2. If applicable, unscrew clamps retaining L.H. side filler tube to the fuel tank, then disconnect tube and remove it.
3. Unscrew clamps retaining R.H. side filler tube to fuel tank and filler neck. Disconnect tube and remove it.
4. If applicable, unscrew auxiliary return line and/or auxiliary return line from fuel tank connection-panel.
5. Unscrew engine supply and return lines from fuel tank connection-panel, identify them for reinstallation.

### NOTE

*For vehicles equipped with a transverse tank or an auxiliary tank, the two hoses joining the tanks should be disconnected.*

6. Disconnect electrical wiring from tank on connection plate.



### DANGER

Before removing the bolts securing the tank support to the frame, make sure the tank is supported adequately. Failure to do so could result in injury as well as damage to the tank.

7. From under the vehicle, on R.H. side, unscrew the 4 bolts (2 in front, 2 in back) retaining the tank support to the frame.
8. From under the vehicle, on the L.H. side, unscrew the 2 bolts (1 in front, 1 in back) retaining the tank support to the frame.
9. Carefully remove tank from under the vehicle.

#### 5.1.2 Auxiliary Fuel Tank (if so equipped)

1. Open the baggage compartment just forward of condenser compartment, disconnect the (2) hoses previously joining the tanks.
2. From underneath vehicle, unscrew the two (2) bolts retaining the tank strap (one on each side).



- From inside the baggage compartment just forward of condenser compartment, slightly raise the strap and pull out auxiliary fuel tank using the same care as for the main fuel tank.

	<h2>CAUTION</h2>
<p>Protective cushions or rags should be placed on the baggage compartment floor to prevent it from being scratched by the fuel tank during removal.</p>	

- Unscrew clamps retaining L.H. side filler tube to the fuel tank, then disconnect tube and remove it.
- Unscrew clamps retaining R.H. side filler tube to fuel tank and filler neck. Disconnect tube and remove it.
- Remove plastic molded panel from inside baggage compartment located forward of A/C & Heating compartment.
- Slide the tank out carefully.

### 5.1.3 Transverse Fuel Tank

- The transverse fuel tank must be removed from R.H. side. The stainless steel panel must be removed by first removing the adhesive.
- From underneath the vehicle, unscrew the bolt on left and right hand side securing the tank foot. Unscrew the two screws at the center of the tank then disconnect the two hoses previously joining the tanks.

### 5.2 TANK INSTALLATION

To install Main, Auxiliary and Transverse Fuel Tanks, simply reverse the "Tank Removal" procedure.

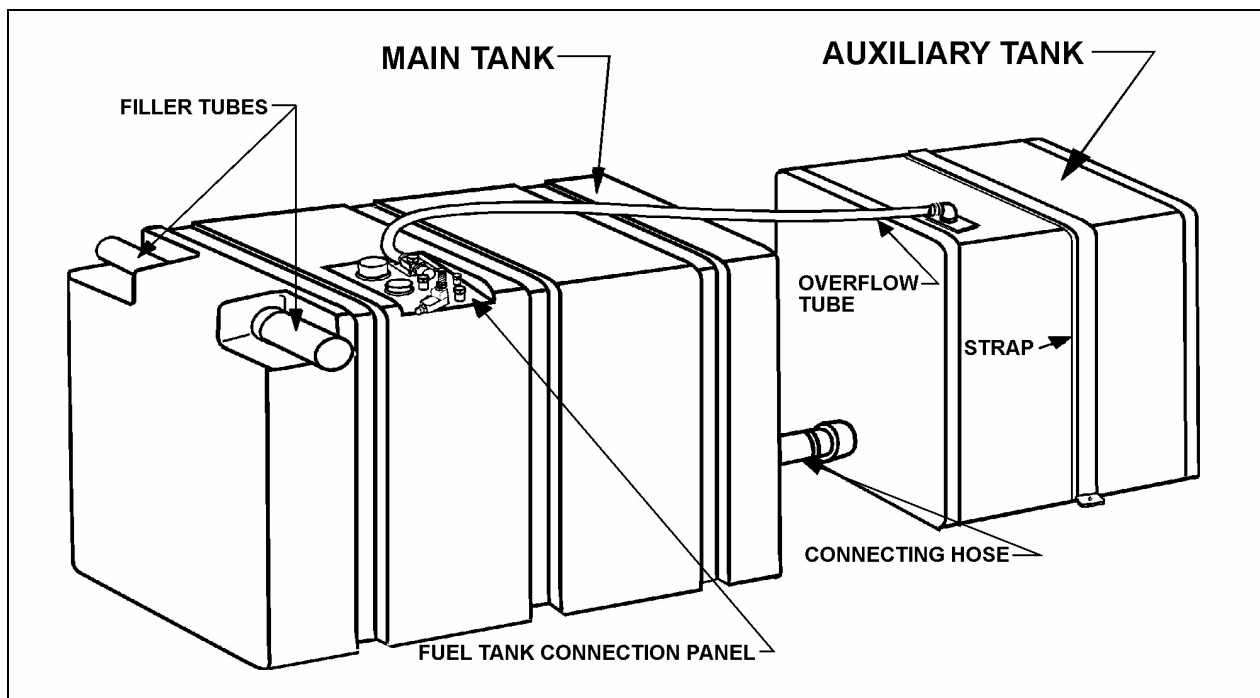

FIGURE 8: 208 US GAL. MAIN FUEL TANK & 90 US GAL. AUXILIARY FUEL TANK (OPTIONAL) (W5)

03063

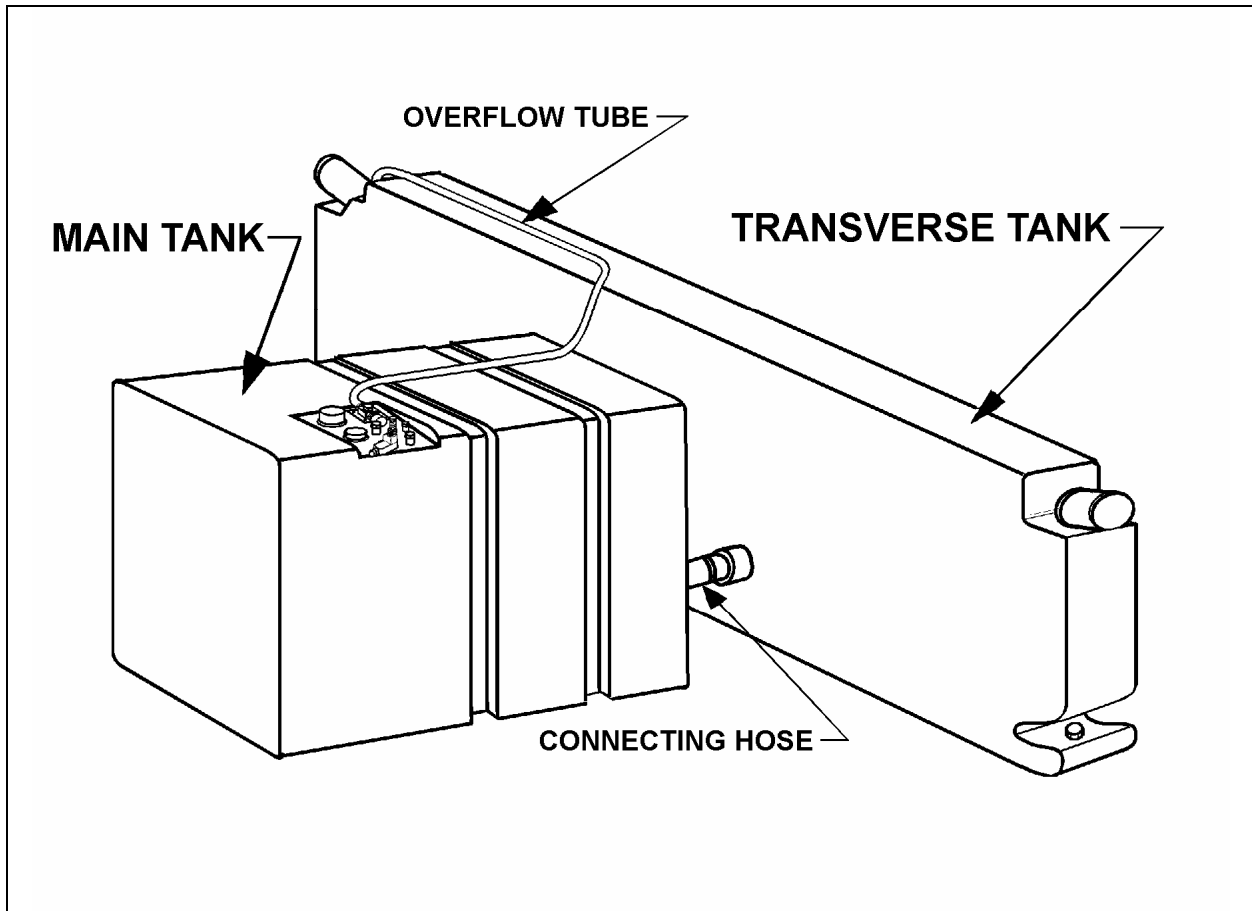

FIGURE 9: 250 US GALLONS FUEL TANKS (MAIN TANK & TRANSVERSE FUEL TANK) (WE)

03029

### 5.3 FUEL TANK VERIFICATION

Inspect fuel tank from under vehicle for leaks or fuel traces. If a leak is detected, repair immediately as per "Polyethylene Fuel Tank Repair" in this section.



#### **DANGER**

Park vehicle safely, apply parking brake, stop engine and set battery master switch(es) to the OFF position prior to working on the vehicle.

Before working under an air-suspended vehicle, it is strongly recommended to support the body at the recommended jacking points.



#### **DANGER**

Park vehicle safely, apply parking brake, stop engine and set battery master switch(es) to the OFF position prior to working on the vehicle.

### 5.4 POLYETHYLENE FUEL TANK REPAIR

#### **NOTE**

*Fuel level must be lower than perforation to carry out this procedure.*

1. Locate perforation on fuel tank.
2. If necessary, remove fuel tank as per instructions in this section.
3. Drill perforation with a 23/64" bit. Make sure drill hole is perfectly round.
4. Insert a screw (Prevost #500196) and a washer (Prevost #5001244) into anchor nut (Prevost #500331).
5. Place assembly in drill hole. Tighten screw by 10 complete turns. Refer to Fig. 10.
6. Apply sealant on head plug (Prevost #507300) and seal hole with the head plug.

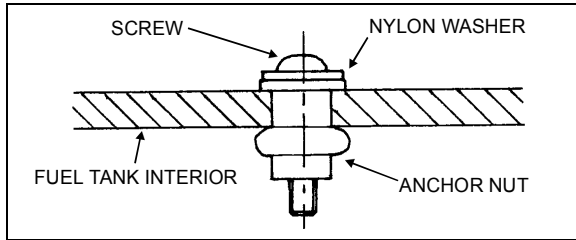

FIGURE 10: FUEL TANK REPAIR 03014

### 6. PRIMING FUEL SYSTEM

The problem with restarting a diesel engine that has run out of fuel, is that after the fuel is exhausted from the tank, it is pumped from the primary fuel filter or the fuel filter/water separator (if vehicle is so equipped), and sometimes partially removed from the secondary filter. This results in an insufficient fuel supply to sustain engine firing. The primary fuel filter or fuel filter/water separator and secondary filter must be free of air in order for the systems to provide adequate fuel for the injectors. When the engine runs out of fuel, the following operations must be performed before restarting:

Fill fuel tank with the recommended fuel oil. If only partial filling is possible, add a minimum of 10 gallons (38 liters) of fuel.

\* If the vehicle is equipped with a Fuel Pro 382 fuel filter/water separation, pour fuel through spin on cap as per "4.3 DAVCO FUEL PRO 382".

#### First method:

1. Close the primary fuel filter shut-off valve. Close the shut-off valve on the secondary filter head and remove the spin-on fuel filters. Fill with clean fuel through the fuel inlet holes (the outer ring of small holes on the element) to insure the fuel is filtered;
2. Thread the elements onto the adaptor inserts until the gaskets make full contact with the adaptor head and no side movement is evident. Tighten filters an additional one-half turn by hand, or as indicated on the filter.
3. Open the fuel shut-off valves, start the engine and check for leaks.

#### Second method:

1. Unscrew the cap on the priming valve located on the secondary filter;
2. Direct fuel under pressure 25 psi (172 kPa) to the priming valve using a quick coupling;

3. Start the engine and check for leaks.

### 7. FUEL PUMP INSTALLATION

The fuel pump is driven off the rear of the air compressor.

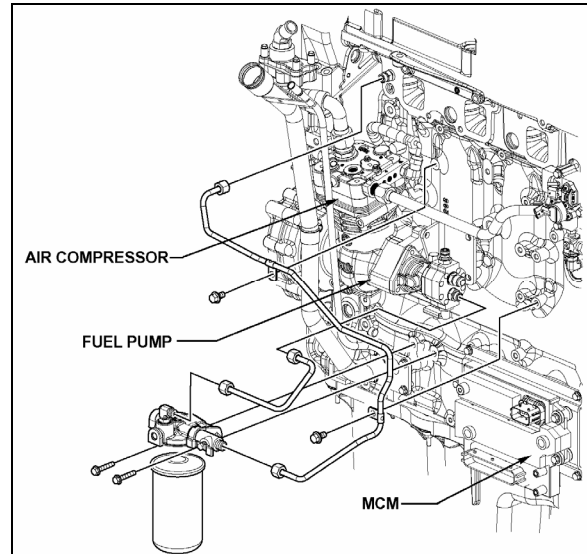

FIGURE 11: FUEL PUMP LOCATION 03070

1. If removed, install inlet and outlet fittings in the cover of the fuel pump.

#### NOTE

*New fittings have sealant already applied. When reusing fittings, coat the threads lightly with Loctite Pipe Sealant, Detroit Diesel number J 26558-92, or equivalent, before installing. To prevent sealant from entering fuel system, do not apply to the first two threads of the fitting. Do not use Teflon tape or paste on the fittings.*

2. Install drive coupling in drive hub of the fuel pump. Install a new gasket to the mounting flange of the pump.
3. Index the drive coupling with the drive hub on the end of the air compressor crankshaft and align the pump mounting bolt holes with those in the air-compressor rear cover.

#### NOTE

*When correctly positioned, the outlet fitting on the pump should be in approximately an 8 o'clock position when viewed from the rear, and the drain opening in the pump body facing down.*

## Section 03: FUEL SYSTEM

4. Seat the fuel pump squarely against the air compressor. Pilot the flange on the pump body, in the opening in the rear cover of the compressor. Install three mounting bolts and tighten them to 22-28 Lbf-ft (30-38 Nm).
5. Connect the fuel inlet and outlet lines to the fuel pump and tighten.
6. Prime engine fuel system before starting engine to ensure pump seal lubrication and prompt engine starting.

### 8. FUEL SPECIFICATIONS

The quality of fuel oil used for high-speed diesel engine operation is a very important factor in obtaining satisfactory engine performance, long engine life and acceptable exhaust emission levels.

The U.S. Environmental Protection Agency (EPA) has issued new standards to improve air quality by significantly reducing emissions through a combination of cleaner-burning diesel engines and vehicles.

To meet EPA standards, the petroleum industry produces **Ultra Low Sulfur Diesel** (ULSD) fuel, also referred to as S15, containing a maximum 15ppm (parts-per-million) sulfur.

On-highway diesel engines meeting 2007 emission regulations are designed to operate **ONLY** with ULSD fuel. ULSD fuel will enable the use of cleaner technology diesel engines and vehicles with advanced emissions control devices, resulting in significantly improved air quality.

#### 8.1 FUEL TYPE

EPA-07 engines like the DDC 2007 Series 60 are designed to run on **Ultra Low Sulfur Diesel** (ULSD) fuel, which can contain no more than 15 ppm sulfur.



### CAUTION

ULSD fuel is necessary to avoid fouling the engine's Aftertreatment Device (ATD). Improper fuel use will reduce the efficiency of the engine's Aftertreatment System and may permanently damage the system.



### CAUTION

Owners of 2007 and later model year on-highway diesel engine must refuel only with ULSD fuel.

#### NOTE

*Burning Low Sulfur Diesel fuel (instead of ULSD fuel) in 2007 and later model year diesel engines is illegal and punishable with civil penalties.*

#### NOTE

*Owners of 2006 and earlier model year on-highway diesel engine may use ULSD or regular Low Sulfur Diesel fuel.*

#### NOTE

*Engine and vehicle manufacturers expect ULSD fuel to be fully compatible with the existing fleet, including 2006 and earlier model year vehicles. In some instances, the introduction of ULSD fuel to older vehicles may affect fuel system components or loosen deposits in fuel tanks. As part of a good maintenance program, owners and operators of existing cars, trucks and buses are encouraged to monitor their diesel-powered vehicles closely for potential fuel system leaks or premature fuel filter plugging during the change-over to ULSD fuel.*

#### NOTE

*Like Low Sulfur Diesel fuel, ULSD fuel requires good lubricity and corrosion inhibitors to prevent unacceptable engine wear. As necessary, additives to increase lubricity and to inhibit corrosion will be added to ULSD fuel prior to its retail sale.*

#### 8.2 BLENDING

Only ultra low sulfur kerosene – No.1 diesel with no more than 15ppm sulfur may be blended with ULSD fuel to improve cold weather performance. With so many kerosene formulations on the market, care must be taken to select kerosene with a maximum of 15ppm sulfur.

Blend rates remain the same as with Low Sulfur Diesel fuel.

## 9. AIR CLEANER (DRY TYPE)

The vehicle is equipped with a dry-type replaceable element air cleaner, located in the engine compartment. Access the air cleaner through the engine R.H. side door. Engine air enters the air cleaner through (2) two intake ducts located just above engine side doors. It then flows through a pre-cleaner and finally through the air cleaner. The pre-cleaner removes dust and moisture by means of a discharge tube at the bottom of the element. It is in series with a replaceable impregnated paper filter element (air cleaner).

### 9.1 PRE-CLEANER SERVICING

 <h2 style="margin: 0;">MAINTENANCE</h2>
<p>The pre-cleaner is designed to be self-cleaning; however, it should be inspected and any accumulated foreign material removed during the periodic replacement of the impregnated paper filter element.</p>

### 9.2 AIR CLEANER SERVICING

Stop the engine, open the R.H. side engine compartment door, and loosen the wing nut retaining the air cleaner element to the air cleaner. Remove the element by pulling on the handle in the center of the air cleaner element.

Install cleaner element as follows:

1. Inspect the gasket-sealing surface inside the air cleaner. It must be smooth, flat and clean;
2. Install the air cleaner element;
3. Make sure that the element seals securely;
4. Inspect element cover gasket and replace if necessary.

Whenever it becomes necessary to remove the air cleaner assembly (dry type) for maintenance or other repair in this area, great care should be taken when installing air cleaner assembly.

The pre-filter should be installed snugly in the air duct and clamped tightly to the air cleaner inlet to prevent any dust infiltration into the air cleaner.

### 9.3 GENERAL RECOMMENDATIONS

The following maintenance procedures will ensure efficient air cleaner operation:

1. Keep the air cleaner housing tight on the air intake pipe;
2. Make sure the correct filters are used for replacement;
3. Keep the air cleaner properly assembled so the joints are air-tight;
4. Immediately repair any damage to the air cleaner or related parts;
5. Inspect, clean or replace the air cleaner or elements as operating conditions warrant. Whenever an element has been removed from the air cleaner housing the inside surface of the housing must be cleaned with a soft clean cloth;
6. Periodically inspect the entire system. Dust-laden air can pass through an almost invisible crack or opening which may eventually cause damage to an engine;
7. Never operate the engine without an element in the air cleaner assembly;

 <h2 style="margin: 0;">CAUTION</h2>
<p>Do not ignore the Warning given by the air restriction indicator. This could result in serious engine damage.</p>

8. Store new elements in a closed area free from dust and possible damage.

### 9.4 AIR CLEANER RESTRICTION INDICATOR

A resettable restriction indicator may be installed on the engine air-intake duct, clearly visible from the rear engine compartment. The indicator monitors the vacuum level between the air filter and the engine. A red marker is displayed when the air filter is clogged and must be replaced. Reset by pressing on the indicator's extremity.

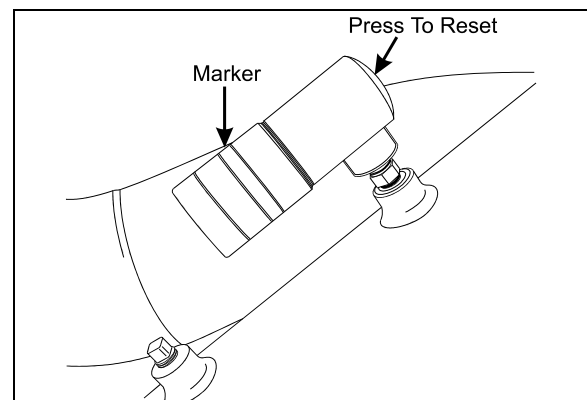

FIGURE 12: RESTRICTION INDICATOR

01052

## Section 03: FUEL SYSTEM

### 10. FUEL COOLER

The fuel cooler serves to cool the surplus diesel fuel after it has exited the cylinder head, on its way back to the fuel tank. It is accessible through the engine radiator door, and is located in front of the charge air cooler (CAC) and the coolant radiator (Fig. 13 & 14).

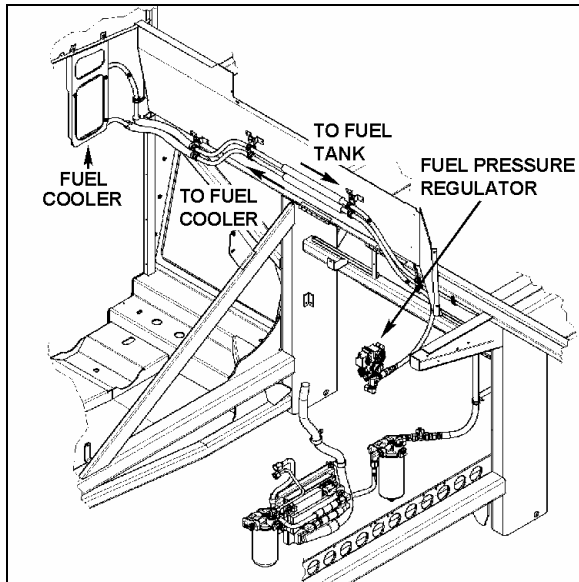

FIGURE 13: FUEL RETURN LINE

03078

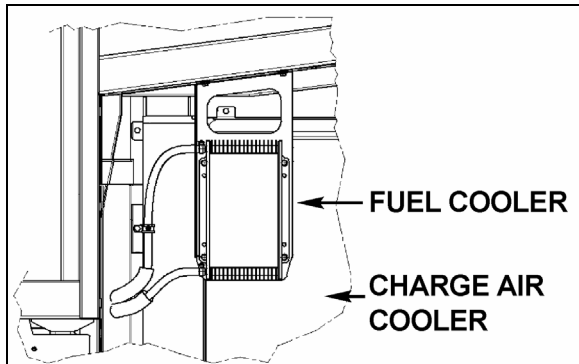

FIGURE 14: FUEL COOLER LOCATION

03079

### 11. FUEL PEDAL

The EFPA (Electronic Foot Pedal Assembly) connects the accelerator pedal to a potentiometer (a device that sends an electrical signal to the ECM, which varies in voltage, depending on how far down the pedal is depressed). The EFPA is installed in the space normally occupied by a mechanical foot pedal. It has maximum and minimum stops that are built into the unit during manufacturing.

#### 11.1 FUEL PEDAL ADJUSTMENT

The EFPA contains a throttle position sensor that varies the electrical signal sent to the ECM. The sensor must be adjusted whenever an EFPA is serviced. In addition, the sensor should be adjusted any time codes 21 and 22 are flashed.

With the ignition "ON" and the proper diagnostic tool (DDR) (for information regarding the DDR, see "01 ENGINE" in this manual), check the throttle counts at idle and full throttle positions. Proper pedal output should be 20/30 counts at idle and 200/235 at full throttle. If adjustment is necessary, remove the potentiometer retaining screws and rotate the potentiometer clockwise to increase counts or counterclockwise to decrease. When correct output is confirmed, tighten retaining screws.

#### 11.2 POTENTIOMETER REPLACEMENT

1. Disconnect cable harness connector.
2. Loosen the two screws and remove potentiometer. Retain for re-assembly.
3. Discard potentiometer (Fig. 15).



### CAUTION

Note the routing and clamping locations of the cable before disassembly. Proper cable routing and fastening is critical to the operation of this system. Marking the foot pedal assembly to record cable routing is recommended.

4. Position new potentiometer. Press potentiometer onto the potentiometer shaft, matching cutouts in shaft to drive tangs of potentiometer. Apply hand pressure until potentiometer has bottomed out in housing. Reinstall screws (Fig. 15) and tighten just enough to secure potentiometer lightly. Tighten screws to 10 - 20 Lbf-in (1.13 - 2.26 Nm).
5. Reconnect electronic foot pedal assembly's cable harness to the ECM connector. If potentiometer calibration is necessary (see "FUEL PEDAL ADJUSTMENT" in this section).

**CAUTION**

Make sure the cable harness is routed correctly, and securely installed so that it does not become pinched, stretched, or otherwise damaged during vehicle operation.

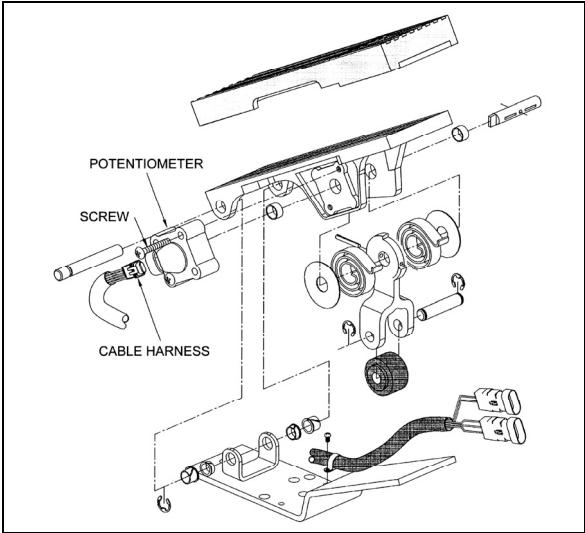

FIGURE 15: ELECTRONIC FOOT PEDAL ASSEMBLY 03035

**12. SPECIFICATIONS**

<b>Davco Fuel Pro 382 Fuel Filter / Water Separator Element</b>	
Prevost number .....	510795
<b>Racor Primary Fuel Filter / Water Separator (optional)</b>	
(May be used instead of regular primary filter (never use with a primary filter).	
Make .....	Racor
Type .....	Replaceable cartridge
<u>ELEMENT</u>	
Prevost number .....	531390
<u>BOWL</u>	
Prevost number .....	531389
<u>DRAIN VALVE AND SEAL</u>	
Prevost number .....	531397
<u>O-RING</u>	
Prevost number .....	531398
<u>PROBE/WATER SENSOR</u>	
Prevost number .....	531391
<b>Primary Fuel Filter</b>	
Make .....	AC
Type .....	Spin-on
Filter No. ....	T-915D
Service Part No. ....	25014274
Prevost number .....	510137

### Section 03: FUEL SYSTEM

---

#### OR

Service Part No (Type with Water Separator) .....23512317  
Prevost number .....032700  
Element torque ..... 1/2 turn after gasket contact

#### **Secondary Fuel Filter**

Make .....AC  
Type ..... Spin-on  
Filter No. .... T-916D  
Prevost number .....510794  
Element torque ..... 1/2 turn after gasket contact

#### **Fuel tank Capacity**

Standard (W5) .....208 US gallons (787 liters)  
Standard (WE) .....250 US gallons (945 liters)  
Optional (W5) .....90 US gallons (341 liters)

#### **Air Cleaner**

Make ..... Nelson  
Prevost Number .....530206  
Service Part No ..... 7182 8N  
Prevost number (element cartridge) .....530197

#### **Air Cleaner Restriction Indicator**

Make ..... Donaldson  
Model ..... RBX00-2220  
Indicates ..... at 20" (508 mm) of water  
Prevost number .....530161

#### **Fuel Cooler**

Make ..... Long Manufacturing  
Prevost number .....531422



# SECTION 04: EXHAUST SYSTEM

---

## CONTENTS

<b>1. EXHAUST AND AFTERTREATMENT SYSTEM OVERVIEW .....</b>	<b>2</b>
1.1 MAINTENANCE .....	2
1.2 FLEXIBLE COUPLING INSTALLATION .....	3
<b>2. AFTERTREATMENT DEVICE (ATD) .....</b>	<b>3</b>
2.1 DIESEL PARTICULATE FILTER (DPF) REMOVAL.....	4
<b>3. DIFFUSER ASSEMBLY .....</b>	<b>5</b>
3.1 DIFFUSER ADJUSTMENT .....	5
3.2 MAINTENANCE .....	6
3.3 DIFFUSER ADAPTER.....	6

## ILLUSTRATIONS

FIGURE 1: EXHAUST SYSTEM.....	2
FIGURE 2: FLEXIBLE COUPLING .....	3
FIGURE 3: AFTERTREATMENT DEVICE (ATD) .....	3
FIGURE 4: OPENING DPF COMPARTMENT ACCESS DOOR .....	4
FIGURE 5: DPF REMOVAL .....	4
FIGURE 6: DIFFUSER ASSEMBLY .....	5
FIGURE 7: DIFFUSER POSITION ADJUSTMENT.....	6
FIGURE 8: DIFFUSER POSITION ADJUSTMENT.....	6
FIGURE 9: DIFFUSER POSITION ADJUSTMENT.....	6
FIGURE 10: DIFFUSER ADAPTER .....	6

## Section 04: EXHAUST SYSTEM

### 1. EXHAUST AND AFTERTREATMENT SYSTEM OVERVIEW

Detroit Diesel's workhorse behind clean emissions technology is an exhaust **Aftertreatment Device (ATD)** which replaces today's muffler. The ATD primary function is to capture and oxidize (regenerate) the particulate matter (soot) in the engine exhaust gases. The ATD is split into two main sections. The exhaust gases first enter the **Diesel Oxidation Catalyst (DOC)** and then flow through the **Diesel Particulate Filter (DPF)**; together they capture and regenerate the soot on a regular or passive basis. Through constant monitoring of the exhaust gas temperature and the system back pressure, DDEC VI is able to manage regeneration.

The ATD is rubber mounted to the vehicle structure. This feature reduces the transmission of vibrations to the ATD thus resulting in extended life of ATD, brackets and also noise reduction.

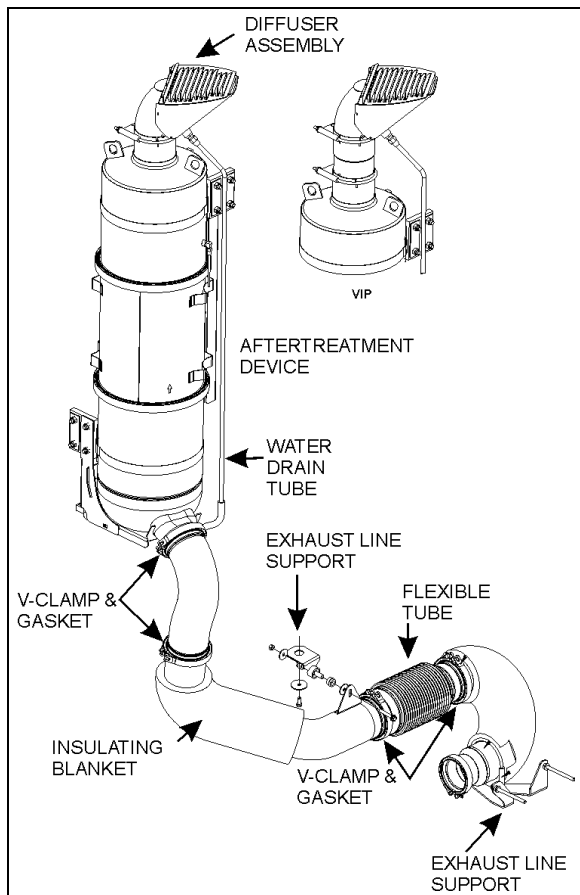

### 1.1 MAINTENANCE

Inspect the exhaust system periodically for restrictions and leaks. Figure 1 presents the major components of the exhaust system. Exhaust leaks are commonly the result of loose clamp bolts, corroded or punctured pipes. In addition to excessive noise, a leaking exhaust system could allow toxic gases to enter the vehicle. Damage to surrounding components from hot gases could result as well. Replace damaged or corroded exhaust components immediately.

Inspect the exhaust system as follows:

- \* At vehicle inspection intervals ;
- \* Whenever a change is noticed in the sound of the exhaust system ; and
- \* Whenever the exhaust system is damaged.

Replace damaged or corroded exhaust system components without delay.

When operating the engine in a service garage or in a closed area, the exhaust must be vented to the outside. Place the shop vent hose over the exhaust outlet pipe.

**DANGER**

Avoid breathing exhaust gases since they contain carbon monoxide which is odorless and colorless but harmful. Carbon monoxide is a dangerous gas that can cause unconsciousness and can be lethal. If, at any time you suspect that exhaust fumes are entering the vehicle, locate and correct the cause(s) as soon as possible.

### NOTE

*The key to successful regeneration is high exhaust temperature for an extended period of time. For this reason, insulating blankets must remain permanently on the exhaust system.*

*If insulating blankets are removed from the system, the exhaust gases temperature may not be high enough to permit efficient particulate oxidation during passive regeneration, resulting in increased fuel consumption due to overuse of active or stationary regeneration.*

1.2 FLEXIBLE COUPLING INSTALLATION

The flexible coupling contains a rigid interior pipe (Fig. 2). To allow appropriate flexibility once installed, be sure interior pipe is concentric to flexible part and that the flexible coupling is straight when installed. This piece of equipment handles vibration and thermal expansion.

**CAUTION**

Adequately support the exhaust system line. The load of the exhaust line **must not** be transferred to the turbocharger.

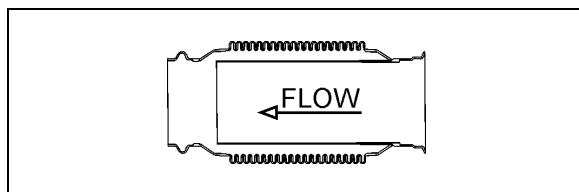

FIGURE 2: FLEXIBLE COUPLING 04022

2. AFTERTREATMENT DEVICE (ATD)

Besides trapping soot, the **DPF (Diesel Particulate Filter)** also traps the ash that has been generated when additives in engine oil are burned. However, unlike soot, ash cannot be oxidized. The ash that accumulates in the filter will eventually cause an increase in exhaust back pressure. DDEC VI will constantly monitor the ash accumulation and forecast the approximate time until DPF ash cleaning is required. This information is stored in DDEC VI and will be accessible by using the Detroit Diesel Diagnostic Link. This allows you the opportunity to plan for the DPF ash cleaning interval. If ash cleaning is not performed proactively, and the back pressure increases beyond the system limit, DDEC VI will flag the amber warning light on the telltale panel, notifying the operator that an ash cleaning is required. Clean remanufactured DPF cartridge will be available through Detroit Diesel on an exchange basis. For most vehicle applications and duty cycle, this will occur after approximately 200,000-400,000 miles (320,000-640,000 km) of operation.

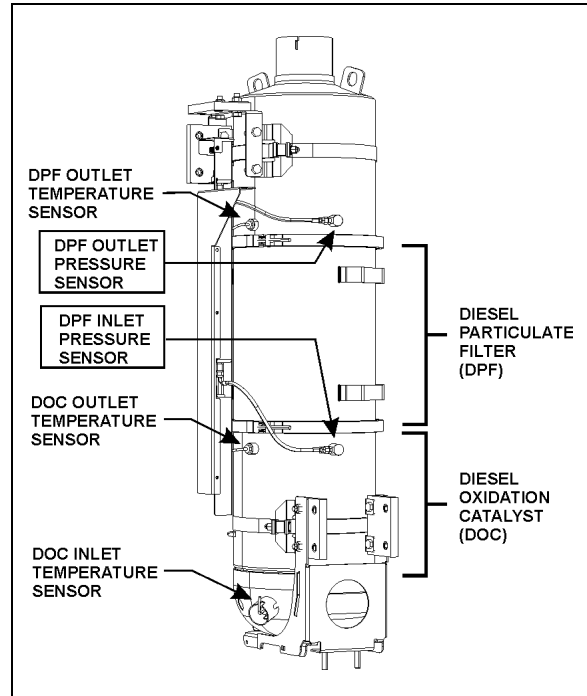

FIGURE 3: AFTERTREATMENT DEVICE (ATD) 04016

**WARNING**

**HOT SURFACES**

Keep yourself clear of hot Aftertreatment Device surfaces, particularly during and after active or stationary regeneration. Hot surfaces can cause serious burns.

Make sure Aftertreatment System components are cold before handling.

**WARNING**

**TOXICITY**

Do not initiate a stationary regeneration in a closed area like a garage. **Stationary regeneration must be undertaken outdoors only.**

## Section 04: EXHAUST SYSTEM



### WARNING

#### HOT EXHAUST

During stationary regeneration, exhaust gases temperature may reach up to 1200°F (650°C) at the DPF outlet. Do not direct at combustible materials. Before initiating stationary regeneration, make sure that the DPF outlet diffuser is clear of objects and that no one is working near the DPF outlet diffuser. Stationary regenerations must be undertaken outdoors only.

### 2.1 DIESEL PARTICULATE FILTER (DPF) REMOVAL

To remove the DPF, proceed as follow:



### CAUTION

External and internal temperatures remain hot long after engine has been shutdown. Allow the Aftertreatment Device and DPF to cool before handling. Wear protective clothing and glove while servicing.

1. First, open the engine compartment door;
2. Under the ATD, on the left wall, pull the catch connecting rod to unlock the DPF compartment access door and lift the door open;
3. Hold the door open by inserting the support rod's free end into the receptacle located on the left side of the DPF;



### CAUTION

After inserting the support rod into the receptacle, make sure the rod supports the door securely from falling down on to your head or body.

4. Loosen the support strap surrounding the upper part of the Aftertreatment Device (ATD);
5. Loosen the upper V-band clamp joining the DPF to the upper part of the ATD. Slide the V-band clamp out of the way;

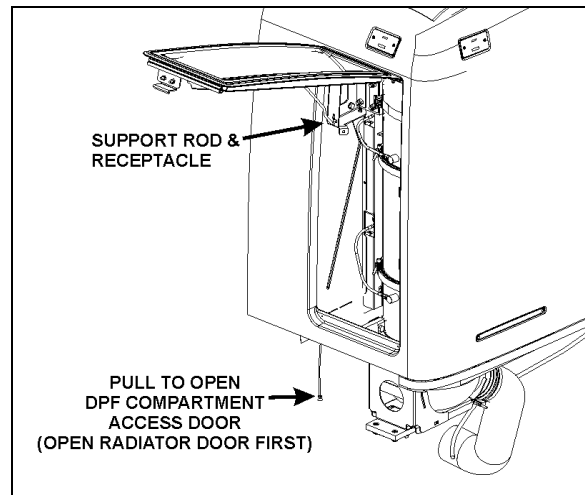

FIGURE 4: OPENING DPF COMPARTMENT ACCESS DOOR

04023

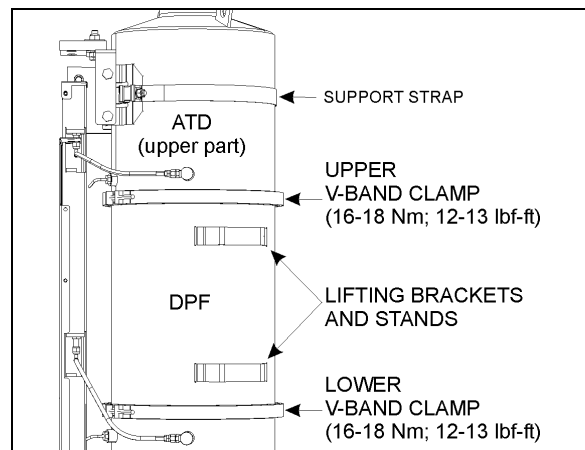

FIGURE 5: DPF REMOVAL

04019

6. Lift up the upper part of the ATD about 1/2" (12mm) and then tighten the strap to maintain it in that raised position;
  7. Loosen the lower V-band clamp and slide it out of the way;
- Pull the DPF section out of the compartment. Use appropriate handling equipment.



### CAUTION

#### HEAVY DEVICE

A suitable lifting or holding device is required. Properly support and attach lifting equipment to prevent the DPF from falling when servicing.

**CAUTION**

**FRAGILE - HANDLE WITH CARE**

Use extreme care when handling DPF cartridge as it could be damaged or destroyed by dropping or sudden impact.

Clean remanufactured DPF cartridge will be available through Detroit Diesel on an exchange basis. For this reason, it is very important to maintain the cartridge in perfect condition. **Damaged cartridge may not be refunded.**

**NOTE**

*When replacing the DPF cartridge, refer to the specifications on the DPF attached tag for proper replacement DPF selection.*

Installation of the DPF is the same as removal, but in reverse order. However, take note of the following points:

1. To prevent exhaust losses, make sure that the DPF section is perfectly aligned with the DOC and the upper part of the ATD before tightening the V-band clamps.
2. Properly tighten all fasteners.
3. Be sure to return the support rod to its clip before closing the door, this prevents rattles.

### 3. DIFFUSER ASSEMBLY

During stationary regeneration, exhaust gases temperature may reach up to 1200°F (650°C) at the DPF outlet. The diffuser decreases the exhaust gasses temperature to 475°F (246°C) approximately, at 6 inches above the diffuser. The diffuser is an important component of the exhaust system and must remain on the vehicle at all times. Operating the vehicle without the diffuser may seriously damage the vehicle.

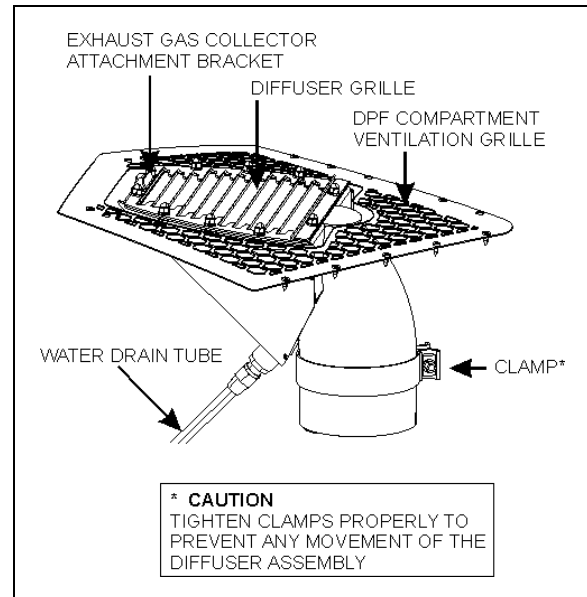

FIGURE 6: DIFFUSER ASSEMBLY

04014

### 3.1 DIFFUSER ADJUSTMENT

Should an adjustment of the diffuser position be necessary, first remove the DPF compartment ventilation grille.

**CAUTION**

To prevent damages caused by hot exhaust gases to the surrounding area, the diffuser grille must be flush with the roof surface or may not exceed the roof surface more than 1/4in (6mm).

**CAUTION**

Tighten clamps properly in order to prevent any movement of the diffuser assembly. An impact wrench is necessary.

1. Loosen the clamp securing the diffuser assembly to the ATD.
2. For proper angular position, make sure that the two edges shown on figure 7 are parallel with each other.
3. Using a straightedge, adjust the diffuser assembly level. The top surface of the tag fixed on the diffuser grille must be flush with the roof surface (fig.8). It may exceed about 1/4in (6mm). Place the straightedge as shown on figure 8.

## Section 04: EXHAUST SYSTEM

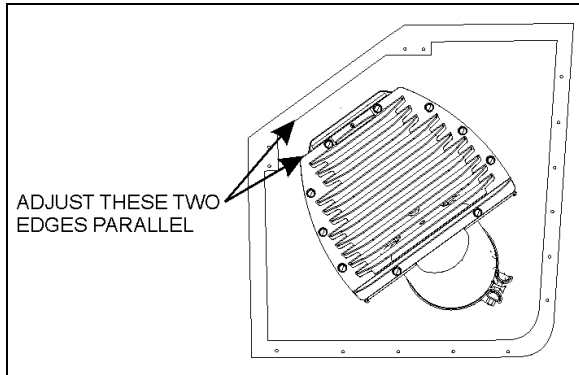

FIGURE 7: DIFFUSER POSITION ADJUSTMENT 04015\_1

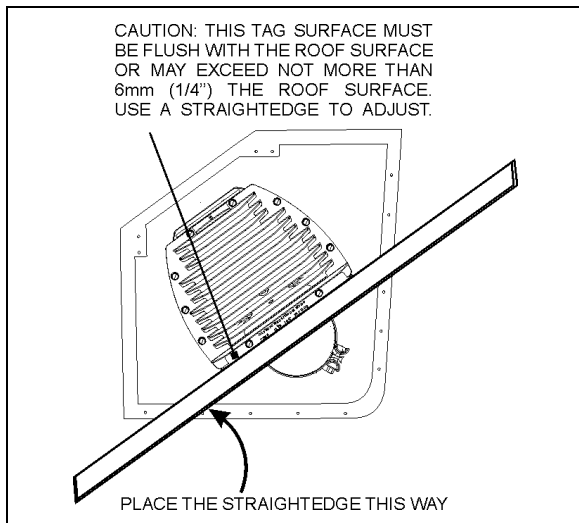

FIGURE 8: DIFFUSER POSITION ADJUSTMENT 04015\_2

4. Tighten the clamp securing the diffuser assembly to the ATD.
5. Reinstall the DPF compartment grille. Put a small quantity of Sika 221 on screws (fig.9).

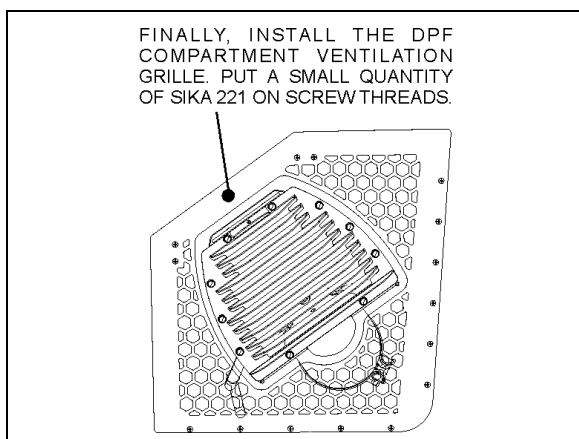

FIGURE 9: DIFFUSER POSITION ADJUSTMENT 04015\_3

### 3.2 MAINTENANCE

Inspect the diffuser assembly as follows:

- At vehicle inspection intervals, inspect diffuser grille for stress cracking;
- Check for proper functioning of the rain cap inside the diffuser housing, make sure that it moves freely;
- Make sure that the water drain tube is not clogged. Pour a cup of water into the diffuser housing and assure that all the water is drained at once at the other end of the drain tube. If tube is clogged, remove tube and blow compressed air inside, in reverse flow.

### 3.3 DIFFUSER ADAPTER

A diffuser adapter (Prevost #040710) is available through Prevost Parts to permit connection with current exhaust gas collecting system.

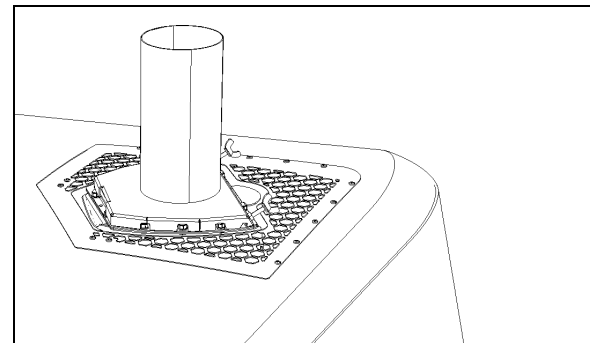

FIGURE 10: DIFFUSER ADAPTER

# SECTION 05: COOLING SYSTEM

## CONTENTS

<b>1. DESCRIPTION</b> .....	<b>3</b>
<b>2. MAINTENANCE</b> .....	<b>4</b>
2.1 VEHICLES WITHOUT COOLANT FILTERS.....	4
2.2 VEHICLES WITH COOLANT FILTERS.....	4
<b>3. HOSES</b> .....	<b>5</b>
3.1 CONSTANT-TORQUE HOSE CLAMPS ON COOLANT LINES .....	5
3.1.1 <i>Installation</i> .....	5
3.1.2 <i>Maintenance</i> .....	6
3.2 CONSTANT-TORQUE HOSE CLAMPS ON CHARGE AIR COOLER (CAC).....	6
3.2.1 <i>Maintenance</i> .....	6
<b>4. THERMOSTAT OPERATION</b> .....	<b>6</b>
<b>5. COOLANT</b> .....	<b>6</b>
5.1 COOLANT LEVEL VERIFICATION.....	6
5.2 COOLANT LEVEL SENSOR.....	7
5.3 THAWING COOLING SYSTEM .....	7
5.4 COOLANT REQUIREMENTS.....	7
5.5 COOLING SYSTEM RECOMMENDATIONS .....	7
5.6 INHIBITORS .....	8
5.6.1 <i>Inhibitor Test Procedures</i> .....	8
5.7 COOLANT RECOMMENDATIONS .....	8
5.7.1 <i>Coolant Not Recommended</i> .....	9
5.7.2 <i>Additives Not Recommended</i> .....	9
5.7.3 <i>Vehicles Without Coolant Filters</i> .....	9
5.7.4 <i>Vehicles With Coolant Filters</i> .....	9
<b>6. DRAINING COOLING SYSTEM</b> .....	<b>9</b>
6.1 VEHICLES EQUIPPED WITH CENTRAL HVAC SYSTEM.....	9
6.2 VEHICLES EQUIPPED WITH SMALL HVAC SYSTEM.....	10
<b>7. FILLING COOLING SYSTEM</b> .....	<b>10</b>
<b>8. FLUSHING</b> .....	<b>11</b>
8.1 COOLING SYSTEM DESCALERS .....	11
8.2 REVERSE FLUSHING.....	11
<b>9. SPIN-ON COOLANT FILTER</b> .....	<b>12</b>
<b>10. RADIATOR</b> .....	<b>13</b>
10.1 MAINTENANCE .....	13
<b>11. CHARGE AIR COOLER LEAKAGE</b> .....	<b>13</b>
<b>12. COOLING FAN DRIVE MECHANISM</b> .....	<b>13</b>
12.1 DRIVE PULLEY AND UNIVERSAL JOINT SHAFT.....	14
12.2 IDLER REPLACEMENT .....	14
<b>13. VARIABLE SPEED COOLING FAN</b> .....	<b>14</b>
13.1 LOCKING RADIATOR FAN FOR EMERGENCY OPERATION.....	15
13.1.1 <i>Electrical Locking</i> .....	15

## Section 05: COOLING SYSTEM

---

13.1.2	Mechanical Locking.....	15
13.2	MAINTENANCE .....	16
13.3	INSPECTION .....	16
13.4	FAN REMOVAL / INSTALLATION.....	16
<b>14.</b>	<b>FAN RIGHT ANGLE GEARBOX.....</b>	<b>17</b>
14.1	MAINTENANCE .....	17
14.2	OIL CHANGE .....	17
14.3	REMOVAL / INSTALLATION.....	17
<b>15.</b>	<b>COOLING FAN DRIVE BELT.....</b>	<b>18</b>
15.1	MOUNTING THE DRIVE BELT.....	18
<b>16.</b>	<b>SPECIFICATIONS .....</b>	<b>19</b>

## ILLUSTRATIONS

FIGURE 1:	COOLANT FLOW SCHEMATIC (IMAGE DDC).....	3
FIGURE 2:	COOLING SYSTEM COMPONENTS .....	3
FIGURE 3:	COOLANT SURGE TANK.....	3
FIGURE 4:	COOLANT SURGE TANK.....	4
FIGURE 5:	COOLANT FLOW TO RADIATOR.....	5
FIGURE 6:	CONSTANT-TORQUE CLAMP .....	5
FIGURE 7:	CHARGE AIR COOLER HOSE CLAMPS.....	6
FIGURE 8:	THERMOSTAT HOUSING (IMAGE DDC) .....	6
FIGURE 9:	SURGE TANK SIGHT GLASS.....	7
FIGURE 10:	HEATER LINE SHUTOFF VALVES (W5).....	9
FIGURE 11:	HEATER LINE SHUTOFF VALVES (WE).....	9
FIGURE 12:	HEATER LINE SHUTOFF VALVES (W5).....	10
FIGURE 13:	HEATER LINE SHUTOFF VALVES (WE).....	10
FIGURE 14:	WATER PUMP DRAIN PLUG .....	10
FIGURE 15:	COOLANT FILTER.....	12
FIGURE 16:	RADIATOR DRAIN PLUG .....	13
FIGURE 17:	COOLING FAN DRIVE MECHANISM .....	13
FIGURE 18:	TIGHTENING SPECIFICATION.....	14
FIGURE 19:	TIGHTENING SPECIFICATION.....	14
FIGURE 20:	IDLER MOUNTED ON THE CAST ALUMINUM SUPPORT .....	14
FIGURE 21:	MECHANICAL LOCKING .....	16
FIGURE 22:	RADIATOR FAN MOUNTING BOLTS .....	17
FIGURE 23:	RIGHT ANGLE GEARBOX.....	17
FIGURE 24:	RIGHT ANGLE GEARBOX MOUNTING .....	17
FIGURE 25:	DRIVE BELT ROUTING .....	18



### 1. DESCRIPTION

A radiator and thermo-modulated fan are used to effectively dissipate the heat generated by the engine. A centrifugal-type water pump is used to circulate the engine coolant (Fig. 1).

Two full blocking-type thermostats are used in the water outlet passage to control the flow of coolant, providing fast engine warm-up and regulating coolant temperature.

The engine coolant is drawn from the lower portion of the radiator by the water pump and is forced through the transmission cooler before going through the oil cooler and into the cylinder block.

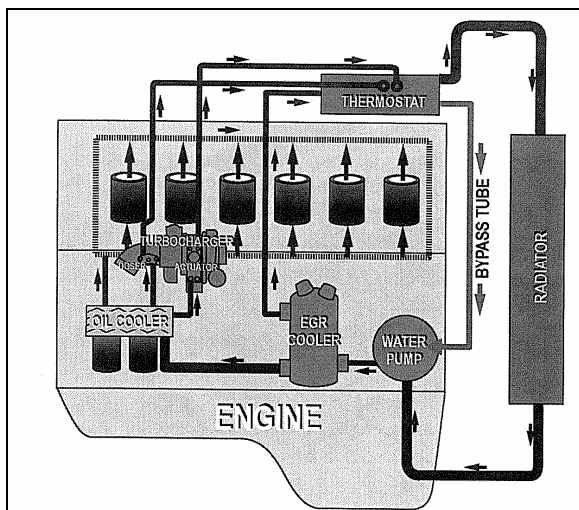

FIGURE 1: COOLANT FLOW SCHEMATIC (IMAGE DDC)

From the cylinder block, the coolant passes up through the cylinder head and, when the engine is at normal operating temperature, it goes through the thermostat housing and into the upper portion of the radiator. The coolant then passes through a series of tubes where its heat is dissipated by air streams created by the revolving fan and the motion of the vehicle.

Upon starting a cold engine or when the coolant is below normal operating temperature, the closed thermostats direct coolant flow from the thermostat housing through the by-pass tube to the water pump. Coolant is recirculated through the engine to aid engine warm up.

When the thermostat opening temperature is reached, coolant flow is divided between the radiator inlet and the by-pass tube. When the thermostats are completely open, all of the coolant flow is to the radiator inlet.

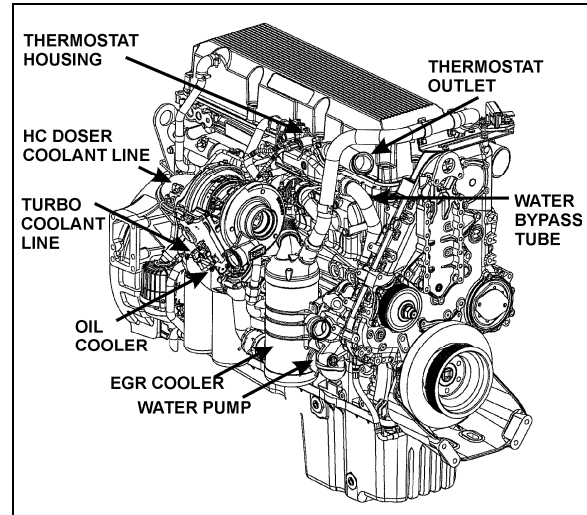

FIGURE 2: COOLING SYSTEM COMPONENTS 05116

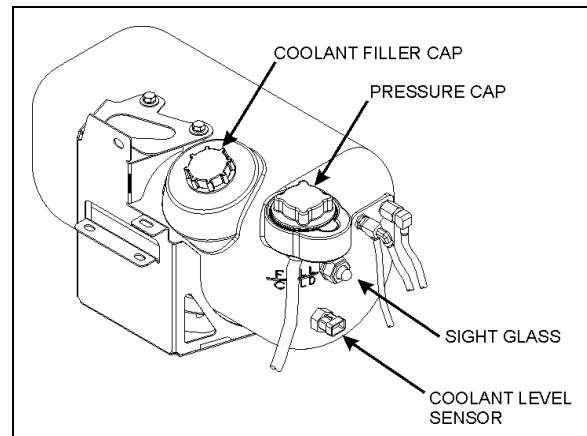

FIGURE 3: COOLANT SURGE TANK 05132

The cooling system is filled through a filler cap on the surge tank (Fig. 3). A pressure cap underneath the surge tank is used to maintain pressure within the system. When system exceeds normal pressure rating (14 psi - 96.53 kPa), the cap releases air and if necessary, coolant through the overflow tube (Fig. 4). Two thermostats are located in the housing attached to the right side of the cylinder head (Fig. 2). Furthermore, a water temperature sensor mounted on the cylinder head (radiator side) is also supplied for engine protection purposes.

The engine cooling system also provides hot coolant fluid for the vehicle heating system. Refer to section 22, "HEATING AND AIR CONDITIONING" in this manual for information relating to heating system water circulation.

## Section 05: COOLING SYSTEM

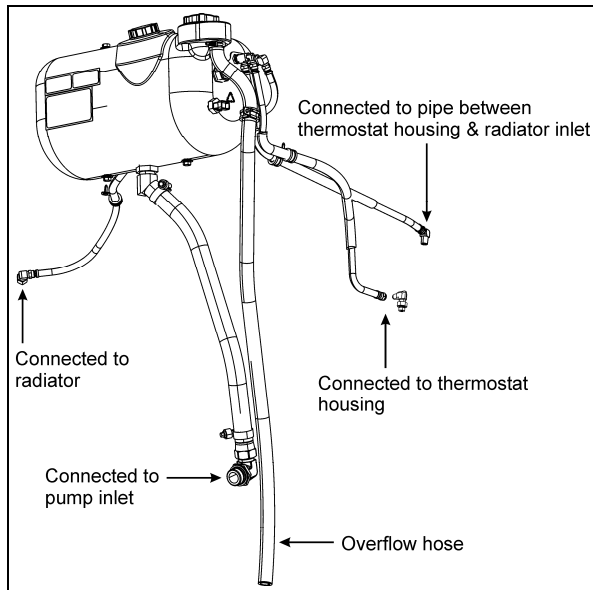



FIGURE 4: COOLANT SURGE TANK

05115

### 2. MAINTENANCE

A systematic routine inspection of cooling system components is essential to ensure maximum engine and heating system efficiency.

- Check coolant level in the surge tank daily, and correct if required. Test antifreeze strength.



### MAINTENANCE

Maintain the prescribed inhibitor strength levels as required. Coolant and inhibitor concentration must be checked at each engine oil change, every 12,500 miles (20 000 km) or once a year, whichever comes first to ensure inhibitor strength. For vehicles equipped with coolant filters replace precharge element filter with a maintenance element filter as per "SPIN-ON COOLANT FILTER" in this section. If the vehicle is not equipped with a filter, add the recommended inhibitor concentration to the antifreeze/water solution.



### MAINTENANCE

Drain, flush, thoroughly clean and refill the system every two years or every 200,000 miles (320 000 km), whichever comes first. For vehicle equipped with coolant filters, change the precharge element filter or the existing maintenance element filter for a new precharge

element filter. If the vehicle is not equipped with filters add the recommended inhibitor concentration to the antifreeze/water solution.

#### NOTE

*Do not add inhibitors to the antifreeze / water solution if vehicle is equipped with a coolant filter.*

Coolant must be discarded in an environmentally safe manner.

#### 2.1 VEHICLES WITHOUT COOLANT FILTERS

Refer to Nalcool 3000 with Stabil-Aid bulletin annexed to the end of this section for preventive maintenance (at each oil change) and initial treatment instructions (each time the cooling system is drained and flushed).

#### 2.2 VEHICLES WITH COOLANT FILTERS

Change the coolant precharge element filter for a maintenance element filter at initial oil change (see "Specifications" at the end of this section) and replace existing maintenance element filter with a new one as per "SPIN-ON COOLANT FILTER" in this section. A precharge element filter must be installed each time the cooling system is drained and flushed prior to installing a maintenance element filter.

- Check belts for proper tension; adjust as necessary and replace any frayed or badly worn belts.
- Check radiator cores for leaks and make sure the cores are not clogged with dirt or insects. To avoid damaging the fins, clean cores with a low-pressure air hose. Steam clean if required.
- Inspect the water pump operation. A leaky pump sucks in air, increasing corrosion.
- Repair all leaks promptly. Unrepaired leaks can lead to trouble. Inspect and tighten radiator mounts periodically. Test and replace thermostats regularly.

#### NOTE

*In order to ensure the integrity of the system, it is recommended that a periodic cooling system pressure check be made. Pressurize the cooling system to 103-138 kPa (15-20 psi) using Radiator and Cooling System Tester, J24460-1. Do not exceed 138 kPa (20 psi).*

**NOTE**

Any measurable drop in pressure may indicate a leak. Whenever the oil pan is removed, the cooling system should be pressure checked as a means of identifying any incipient coolant leaks. Make sure the cause of the internal leak has been corrected before flushing the contaminated system.

Leaks at the thermostat housing hose connections may be caused by deformation of connections or by rough surfaces on the castings of the hose mounting surfaces. It is recommended that "Dow Corning RTV-102 Compound" or any equivalent product be applied on cast surfaces prior to hose installation.



**CAUTION**

Castings should be clean and free of oil and grease before applying compound. No other sealer should be used with RTV-102 compound.

**3. HOSES**

Rotten, swollen, and worn out hoses or loose connections are frequent causes of cooling system problems.

Serious overheating is often caused by an old hose collapsing or from rotten rubber shedding from hoses and clogging the coolant passages.

Connections should be inspected periodically and hose clamps tightened. Replace any hose found to be cracked or swollen.

When installing a new hose, clean pipe connections and apply a thin layer of a non-hardening sealing compound. Replace worn out clamps or clamps that pinch hoses.

**3.1 CONSTANT-TORQUE HOSE CLAMPS ON COOLANT LINES**

All hose clamps of 1 3/8" ID and over, used on the heating and cooling systems, are of the "Constant-torque" type. These clamps are worm-driven, made of stainless steel, and supplied with a series of Belleville spring washers. They also feature an extended integral liner that covers the band slots to protect soft/silicone hoses from damage, and help maintain consistent sealing pressure.

This type of clamp is designed to automatically adjust its diameter to compensate for the normal expansion/contraction of a hose and metal connection that occurs during vehicle operation and shutdown. The constant-torque clamp virtually eliminates coolant losses due to "Cold flow" leakage and greatly minimizes clamp maintenance.

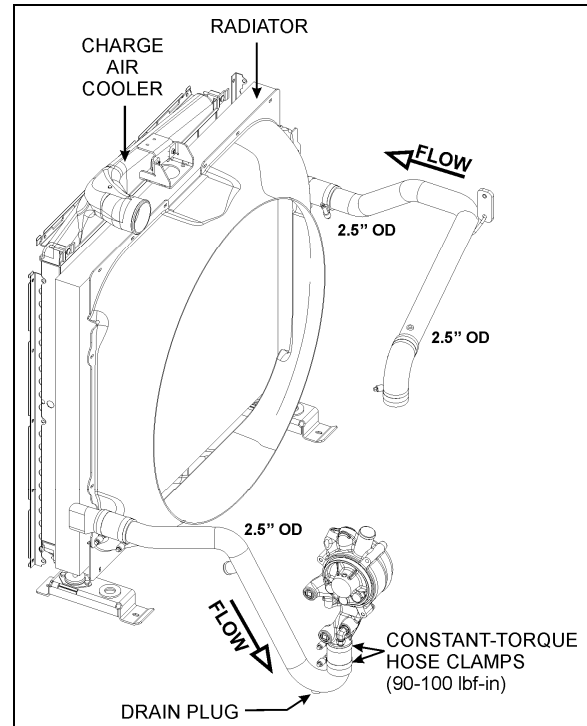

FIGURE 5: COOLANT FLOW TO RADIATOR 05133

**3.1.1 Installation**

A torque wrench should be used for proper installation. The recommended torque is 90 to 100 lbf-in. (10 to 11 Nm). The Belleville spring washer stacks should be nearly collapsed flat and the screw tip should extend 1/4" (6 mm) beyond the housing (Fig. 6).

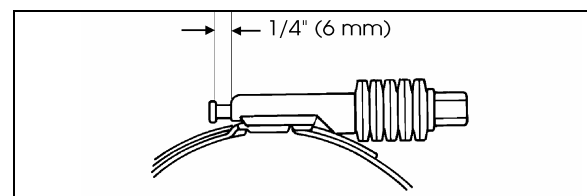

FIGURE 6: CONSTANT-TORQUE CLAMP 05037



**CAUTION**

The hose clamps will break if over-torqued. Do not over-tighten, especially during cold weather when hose has contracted.

## Section 05: COOLING SYSTEM

### 3.1.2 Maintenance

The constant-torque clamps contain a "Visual torque check" feature. When the tip of the screw is extending ¼" (6 mm) out of the housing, the clamp is properly installed and maintains a leak-proof connection. Since the constant-torque clamp automatically adjusts to keep a consistent sealing pressure, there is no need to re-torque hose clamps on a regular basis. During vehicle operation and shutdown, the screw tip will adjust according to the temperature and pressure changes. **Checking for proper torque should be done at room temperature.**

### 3.2 CONSTANT-TORQUE HOSE CLAMPS ON CHARGE AIR COOLER (CAC)

If for any reason such as an accident, hose clamps need to be changed; install and tighten hose clamps to 10±1 lbf-ft (dry) (Fig. 7).

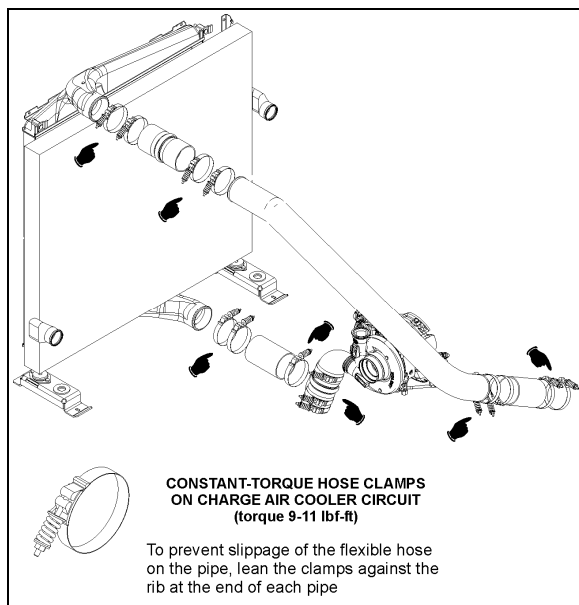

FIGURE 7: CHARGE AIR COOLER HOSE CLAMPS 05134



### CAUTION

The hose clamps will break if over-tighten. Do not over-tighten, especially during cold weather when hose has contracted.

### 3.2.1 Maintenance

Since the constant-torque clamp automatically adjusts to keep a consistent sealing pressure, there is no need to re-torque hose clamps on a regular basis. During vehicle operation and

shutdown, the screw tip will adjust according to the temperature and pressure changes.

**Checking for proper torque should be done at room temperature.**

## 4. THERMOSTAT OPERATION

Coolant temperature is controlled by two blocking-type thermostats located in a housing attached to the cylinder head, on the turbo side of the engine (Fig. 8).

At coolant temperature below approximately 182°F -188°F (83°C-86°C), the thermostat valves remain closed and block the flow of coolant from the engine to the radiator. During this period, all of the coolant in the system is recirculated through the engine and directed back to the suction side of the water pump via a bypass tube. As the coolant temperature rises above 182°F -188°F (83°C-86°C) the thermostat valves start to open, restricting the bypass system, and allowing a portion of the coolant to recirculate through the radiator. When the coolant temperature reaches approximately 202°F (95°C) thermostat valves are fully open, the bypass system is blocked off and the coolant is directed through the radiator.

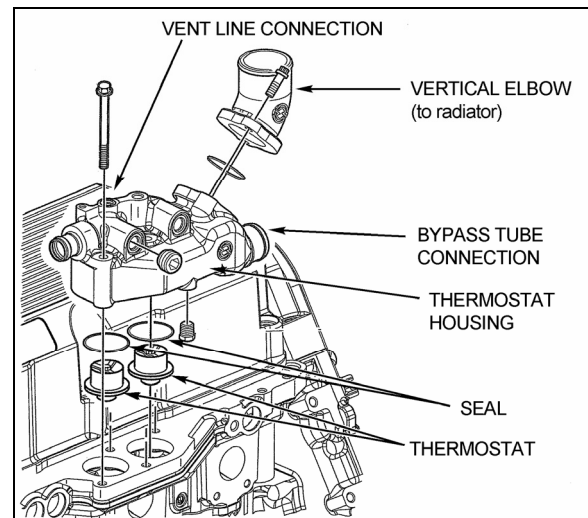

FIGURE 8: THERMOSTAT HOUSING (IMAGE DDC) 05117

## 5. COOLANT

### 5.1 COOLANT LEVEL VERIFICATION

Coolant level is correct when cold coolant is visible through the surge tank sight glass (Fig. 9). If coolant level is low, fill cooling system.

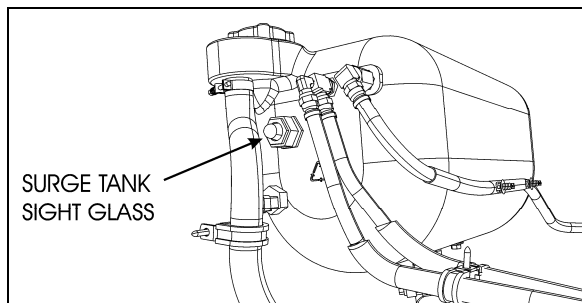



FIGURE 9: SURGE TANK SIGHT GLASS 05114

### 5.2 COOLANT LEVEL SENSOR

This warning device consists of a fluid level probe mounted on the surge tank. The probe sends a signal to the MCM to indicate coolant level. If the coolant level drops below the probe, the "Check Engine" light flashes and a diagnostic code is registered (see section 01 "ENGINE").

	<h2>CAUTION</h2>
<p>Do not run engine with the "Check Engine" light flashing.</p>	

The level probe is mounted on the R.H. side of the surge tank while the electronic module is mounted inside the rear electric junction box.

### 5.3 THAWING COOLING SYSTEM

If the cooling system becomes frozen solid, place the coach in a warm area until the ice is completely thawed. Under no circumstances should the engine be operated when the cooling system is frozen, as it will result in engine overheating due to insufficient coolant.

Once thawed, check engine, radiator and related components for damage caused by expansion of frozen coolant fluid.

### 5.4 COOLANT REQUIREMENTS

The coolant provides a medium for heat transfer and controls the internal temperature of the engine during operation. In an engine having proper coolant flow, some of the combustion heat is conveyed through the cylinder walls and the cylinder head into the coolant. Without adequate coolant, normal heat transfer cannot take place within the engine, and engine temperature rapidly rises. Coolant must therefore be carefully selected and properly maintained.

Select and maintain coolant in order to meet the following basic requirements:

- Provide for adequate heat transfer.
- Provide protection from cavitation damage.
- Provide a corrosion and erosion resistant environment within the cooling system.
- Prevent formation of scale or sludge deposits in the cooling system.
- Be compatible with the cooling system hose and seal materials.
- Provide adequate freeze protection during cold weather operation.

Combining suitable water with reliable inhibitors satisfies the first five requirements. When freeze protection is required, a solution of suitable water and antifreeze containing adequate inhibitors will provide a satisfactory coolant fluid. Ethylene glycol-based antifreeze is recommended for use in Series 60 engines. The cooling system capacity is 24 US gal (91 liters).

<p><b>NOTE</b></p> <p><i>In general, antifreeze does not contain adequate inhibitors. For this reason, supplemental coolant additives are required.</i></p>
---

For a complete overview of engine coolants used with Detroit Diesel Engines, refer to "Coolant Selections" For Engine Cooling Systems Guide at the end of this section (#7se298).

### 5.5 COOLING SYSTEM RECOMMENDATIONS

Always maintain cooling system at the proper coolant level. Check daily.

The cooling system must be pressurized to prevent localized boiling of coolant. The system must be kept clean and leak-free. The filler and pressure caps must be checked periodically for proper operation.

A decal (052635) located on the surge tank provides information on recommended coolants.

<p><b>ANTI GEL</b></p> <p><b>ANTI FREEZE</b></p>	 <p><b>AVERTISSEMENT NE PAS OUVRIR A CHAUD</b> <b>CAUTION NEVER OPEN WHEN HOT</b></p> <p>ANTI GEL RECOMMANDÉ: RECOMMENDED ANTIFREEZE: PREVOST#685125 DETROIT DIESEL POWER COOL 23512138 PRESTONE HEAVY-DUTY 72702, 70119, 70102</p> <p style="font-size: small;">052635 05104</p>
--	--

## Section 05: COOLING SYSTEM

### Recommended phosphate free coolants:

- Prevost #685125;
- Detroit Diesel “DDC Power Cool” (P/N 23512138);
- Prestone AF977 (bulk), 72702 (3.78 L), 70119 (205L), 70102 (4L).

### 5.6 INHIBITORS

A coolant solution, which has insufficient inhibitors or no inhibitors at all, invites the formation of rust, scale, sludge and mineral deposits within the cooling system. These deposits can cause water pump seal wear and coat the interior of coolant system passages. Heat transfer is reduced as deposits build up, leading to an overheating condition. Continued operation with this condition can lead to serious engine damage: liner scuffing, scoring, piston seizure and cylinder head cracking. These damages can occur quickly or over a longer period of time, depending of location and amount of deposits. Improperly inhibited coolants can become corrosive enough to "eat away" coolant passages and seal ring grooves and cause leaks to develop. Hydrostatic lock can occur if leak is internal and accumulates on top of a piston. The result may be a bent connecting rod. Cavitation erosion may occur in improperly inhibited coolants. Cavitation erosion is caused by the implosion of tiny bubbles against localized surfaces of the system. Such implosion causes pinpoint pressures high enough to erode pump impellers, cylinder liners and cylinder blocks. In extreme cases, their surfaces are so deeply pitted that they appear to be spongy, and holes can develop completely through them.

#### 5.6.1 Inhibitor Test Procedures

Test Kits are commercially available to check engine coolant for nitrite concentration. Nitrite concentration is an indication of Supplemental Coolant Additive (SCA) level. Nitrite must be maintained within recommended levels. Coolant must be tested at each oil change to insure that inhibitor levels are maintained within the ranges shown hereafter:

### NOTE

*Above SCA values with Detroit Diesel #7se298 or TMC RP-329 “Type A”. Use Nalco Chemical Company nitrite test kits (CO-318). A factory coolant analysis program is available through Detroit Diesel distributors under part number 23508774.*

### DDC Fully Formulated Glycol Coolant Limits

-30 — 50(°F)	Freeze Point (°F)
125 — 500 ppm	Boron (ppm)
800 — 3200 ppm	Nitrite (ppm)
200 — 750 ppm	Nitrate (ppm)
50 — 250 ppm	Silicon (ppm)
0 ppm MAX	Phosphorus (ppm)
8.0 — 11.0	pH
40 ppm MAX	Chlorides (ppm)
100 ppm MAX	Sulfates (ppm)

### 5.7 COOLANT RECOMMENDATIONS

1. Always use recommended antifreeze, inhibitor and water at proper concentration levels. A 50% coolant/water solution is normally used as factory fill. Antifreeze concentration over 70% is not recommended because of poor heat transfer capability, adverse freeze protection and silicate dropout. Antifreeze concentration below 30% offers little freeze, boilover or corrosion protection.
2. Use only ethylene glycol antifreeze meeting the Detroit Diesel #7se298 or TMC RP-329 “Type A” formulation.
3. Use an antifreeze solution year-round for freeze and boil-over protection. Seasonal changing of coolant from an antifreeze solution to an inhibitor/water solution is recommended.
4. Pre-mix coolant makeup solutions at proper concentrations before adding to the cooling system.
5. Maintain the prescribed inhibitor strength levels as required.
6. Do not mix different base inhibitor packages.
7. Always maintain proper coolant level.



**CAUTION**

Always test the solution before adding water or antifreeze.

8. If cooling system is not at the proper protection level. Mix coolant/water solution to the proper concentration before adding to the cooling system
9. Use only non-chromate inhibitors.
10. Distilled water is recommended.

5.7.1 Coolant Not Recommended

- All antifreeze and coolant containing phosphorous;
- Automotive type coolants;
- Methoxy propanol-base antifreeze;
- Methyl alcohol-base antifreeze;
- Sealer additives or antifreezes containing sealer additives.

5.7.2 Additives Not Recommended

- Soluble Oils;
- Chromates.



**WARNING**

Never remove filler cap while coolant is hot. When coolant is at ambient temperature, release pressure from system by turning the pressure cap counterclockwise 1/4 turn; then remove filler cap slowly. A sudden release of pressure from the heated cooling system can result in severe burns from the expulsion of hot coolant fluid.

5.7.3 Vehicles Without Coolant Filters

Refer to Nalcool 3000 with Stabil-Aid bulletin annexed to the end of this section for preventive maintenance (at each oil change) and initial treatment instructions (each time the cooling system is drained and flushed).

5.7.4 Vehicles With Coolant Filters

Change the coolant precharge element filter for a maintenance element filter at initial oil changes (see Specifications at the end of this section) and replace existing maintenance element filter with a new one as per "SPIN-ON COOLANT FILTER" in this section. A precharge element filter must be installed each time the cooling system is drained and flushed before installing a maintenance element filter.

**NOTE**

The coolant filter contains inhibitors.

**6. DRAINING COOLING SYSTEM**

Use the following procedures to drain the cooling system partially or completely.

6.1 VEHICLES EQUIPPED WITH CENTRAL HVAC SYSTEM

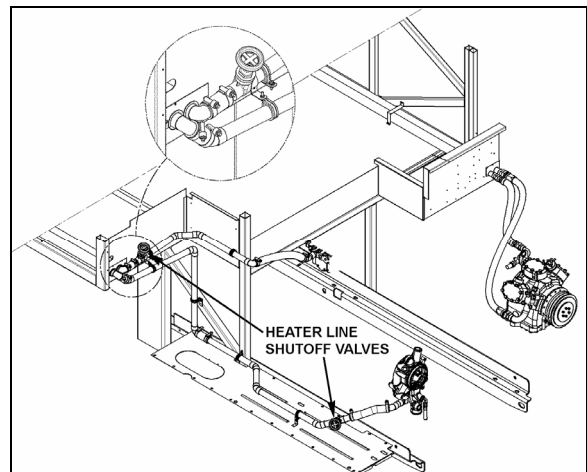

FIGURE 10: HEATER LINE SHUTOFF VALVES (W5)

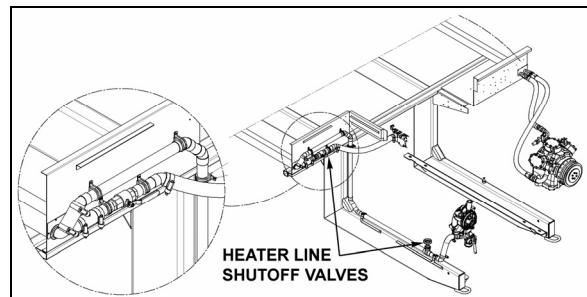

FIGURE 11: HEATER LINE SHUTOFF VALVES (WE)

## Section 05: COOLING SYSTEM

### 6.2 VEHICLES EQUIPPED WITH SMALL HVAC SYSTEM

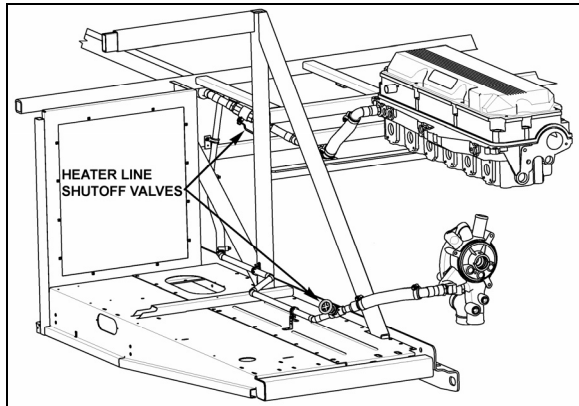

FIGURE 12: HEATER LINE SHUTOFF VALVES (W5)

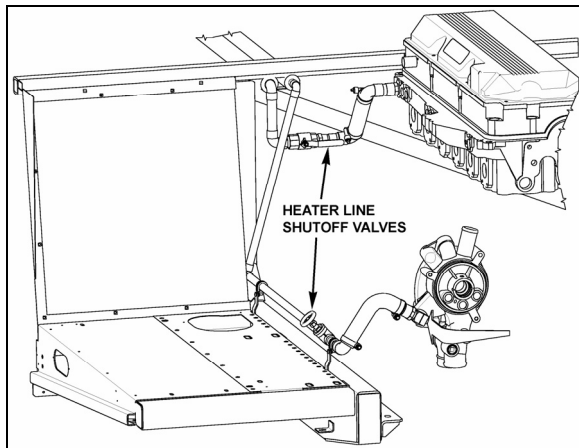

FIGURE 13: HEATER LINE SHUTOFF VALVES (WE)

To drain engine and related components:

1. Stop engine and allow engine to cool. Close both heater line shutoff valves (Refer to figures 10, 11, 12 & 13).



### WARNING

Before proceeding with the following steps, make sure the coolant has cooled down. The sudden release of pressure from a heated cooling system can result in loss of coolant and possible personal injury (scalding) from the hot liquid.

2. Unscrew the surge tank pressure cap counterclockwise,  $\frac{1}{4}$  turn to let air enter the system and permit the coolant to drain completely from system.
3. Unscrew the water pump housing inlet line drain plug (Fig. 14).

4. Open drain cock at bottom of thermostat housing to drain the coolant trapped above the thermostats (Fig. 8).

5. Open the radiator drain cock (Fig. 16).

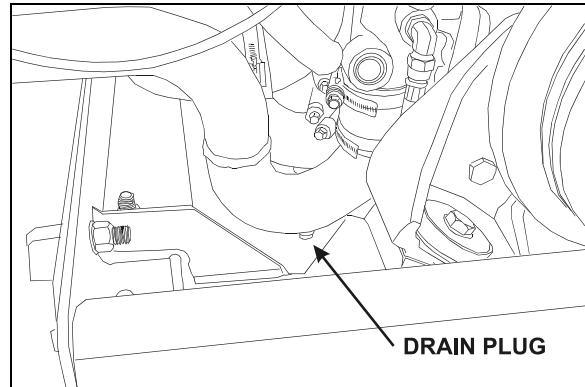

FIGURE 14: WATER PUMP DRAIN PLUG

05093

6. Open engine drain cock.
7. Remove the transmission oil cooler. Drain, flush and inspect. Refer to Section 7, "TRANSMISSION" for oil cooler maintenance or preventive replacement.



### CAUTION

Drain water pump completely before extended storage to avoid possible water pump damage.

If freezing weather is anticipated and the engine is not protected with antifreeze, drain the cooling system completely when vehicle is not in use. Trapped water in the cylinder block, radiator or other components may freeze and expand resulting in damages. Leave the drain plugs open until the cooling system can be filled with coolant fluid. Do not run engine with cooling system empty.

To drain the entire system, do the previous steps while maintaining the shutoff valves in the open position; then follow the procedure under "9.2 Draining Heating System" in Section 22.

### 7. FILLING COOLING SYSTEM

If only the engine and related components were drained, maintain the two heater line shutoff valves in their closed position, then proceed as follows.

1. Close all drain cocks. Refer to draining procedure for the location of draining points.



2. Refill cooling system from the surge tank filler cap inlet with a recommended ethylene glycol-based antifreeze and water solution of the required concentration. Add Detroit Diesel selected product cooling system inhibitors (if required).

**NOTE**

*The coolant level should remain within two inches of the surge tank filler neck.*

**NOTE**

*Make sure the vent line at top of thermostat housing is properly connected and not obstructed. The vent line (thermostat housing dome to radiator top tank) is required to ensure complete engine fill and proper venting of air in the system.*

3. Install the filler and pressure caps, then start the engine and run it at fast idle until reaching normal operating temperature. Check for leaks.

**NOTE**

*If for any reason, the coolant level drops below the surge tank level probe, the Check Engine light will flash.*

4. Stop engine and allow cooling.
5. Open the two heater line shutoff valves, check the coolant level in the surge tank, and then add as required.



**CAUTION**

Never pour cold coolant into a hot engine. The sudden change in temperature may crack the cylinder head or block.

If the entire system has been drained, redo the previous steps while maintaining the two heater line shutoff valves in the "Open" position. With engine running, activate the driver's and central heating systems to permit coolant circulation. Complete the procedure by bleeding the heater cores as explained in Section 22, under "9.4 Bleeding Heating System".

**8. FLUSHING**

If the cooling system is contaminated, flush the cooling system as follows:

1. Drain the coolant from the engine.

2. Refill with clean water.



**CAUTION**

If the engine is hot, fill slowly to prevent rapid cooling and distortion of the engine castings.

3. To thoroughly circulate the water, start and run the engine for 15 minutes after the thermostats have opened.
4. Fully drain system.
5. Refill with clean water and operate for 15 minutes after the thermostats have opened.
6. Stop engine and allow cooling.
7. Fully drain system.

Vehicles without coolant filters:

Fill with a 50/50-antifreeze/water solution and add required inhibitors.

Vehicles with coolant filters:

Replace the coolant filter with a precharge element filter; in this case do not mix inhibitors with antifreeze/water solution.

Dispose of spent fluids in an environmentally responsible manner according to regulations in effect in your area.

**8.1 COOLING SYSTEM DESCALERS**

If the engine overheats and the fan belt tension, coolant level and thermostat operation have been found to be satisfactory, it may be necessary to de-scale and flush the entire cooling system.

Remove scale formation by using a reputable and safe de-scaling solvent. Immediately after using the de-scaling solvent, neutralize with a neutralizing agent. It is important that product directions be thoroughly read and followed.

After using the solvent and neutralizer, fully drain the system, and then reverse flush the engine and radiator (see "Reverse Flushing" in this section) before filling the system with coolant solution.

**8.2 REVERSE FLUSHING**

After the engine and radiator have been thoroughly de-scaled, they should be reverse-flushed. The water pump should be removed and the radiator and engine reverse-flushed separately to prevent dirt and scale deposits from clogging the radiator tubes or being forced

## Section 05: COOLING SYSTEM

through the pump. Reverse flushing is accomplished by hot water, under pressure, being forced through the cooling system in a direction opposite to the normal flow of coolant, loosening and forcing deposits out.

The radiator is reverse flushed as follows:

1. Remove the radiator inlet and outlet hoses and replace existing radiator cap with a new one.
2. Attach a hose to the top of the radiator to lead water away from the engine.
3. Attach a hose at the bottom of the radiator and insert a flushing gun in the hose.
4. Connect the water hose of the gun to the water outlet and the air hose to the compressed air outlet.
5. Turn on the water and when the radiator is full, turn on the air in short blasts, allowing the radiator to fill between blasts.

### NOTE

*Apply air gradually. Do not exert more than 138 kPa (20 psi) air pressure. Too great a pressure may rupture a radiator tube.*

6. Continue flushing until only clean water is expelled from the radiator.

The cylinder block and cylinder head water passages are reverse flushed as follows:

1. Remove the thermostats and the water pump.
2. Attach a hose to the water inlet of oil cooler housing to drain water away from engine.
3. Attach a hose to the water outlet at the top of the cylinder head (thermostat housing) and insert the flushing gun in the hose.
4. Turn on the water until the jackets are filled, and then turn on the air in short blasts. Allow jackets to fill with water between air blasts.
5. Continue flushing until the water from the engine runs clean.

If scale deposits in the radiator cannot be removed by chemical cleaners or reverse flushing as outlined above, it may be necessary to remove the upper tank and rod out the individual radiator tubes with flat steel rods. Circulate the water through the radiator core from the bottom to the top during this operation.

## 9. SPIN-ON COOLANT FILTER

The optional engine cooling system filter is used to filter out impurities such as scale or sand from the coolant and it also eliminates the process of adding inhibitors to the antifreeze/water solution. The filter is mounted onto the cooling fan drive mechanism aluminum casting (Fig. 15).

### NOTE

*If a coolant filter is to be installed on an engine already in service, drain and flush the cooling system before installing the filter.*

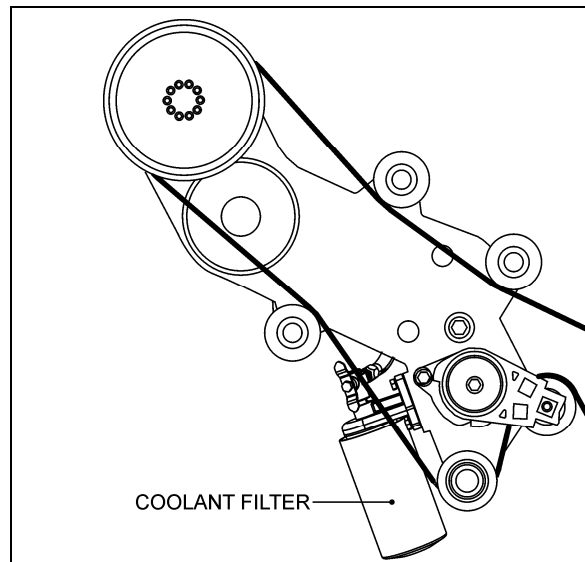

FIGURE 15: COOLANT FILTER

05138

### To replace a filter:

1. Close the two filter shutoff cocks on the filter mounting head and unscrew the old filter from mounting.



### WARNING

Failure to relieve cooling system pressure may result in personal injury.

2. Remove and discard the filter.
3. Clean the filter adapter with a clean, lint-free cloth.
4. Coat surface of gasket with oil, tighten 2/3 to 1 turn after gasket makes contact with head.
5. Open the two filter shutoff cocks.
6. Start engine and check for leaks.

 **CAUTION**  
Do not exceed recommended service intervals.

 **MAINTENANCE**  
The precharge element filter lasts for 12,500 miles (20 000 km) or one year, whichever comes first. Replace the precharge element filter with a maintenance element filter, which lasts for 200,000 miles (320 000 km) or two years, whichever comes first. Each time the coolant is renewed, a precharge element filter must be installed before installing a maintenance element filter.

**PRECHARGE ELEMENT FILTER**  
Prevost number: 550629

**MAINTENANCE ELEMENT FILTER**  
Prevost number: 550630

**CORROSION INHIBITOR & COOLANT STABILIZER**  
Make: Detroit Diesel    Number: 23507857  
Make: Nalco                Number: DD3000-15

**10. RADIATOR**

The radiator is mounted on the L.H. side of engine compartment. It is designed to reduce the temperature of the coolant under all operating conditions. It is essential that the radiator core be kept clean and free from corrosion and scale at all times.

10.1 MAINTENANCE

 **MAINTENANCE**  
Inspect the exterior of the radiator core every 25,000 miles (40 000 km) or once a year, whichever comes first. Clean with a quality grease solvent, such as a mineral spirits and dry with compressed air. Do not use fuel oil, kerosene, gasoline, or any caustic material. It may be necessary to clean the radiator more frequently if the vehicle is operated in extremely dusty or dirty areas. Refer to coolant system flushing and reverse flushing in this section for maintenance of radiator interior.

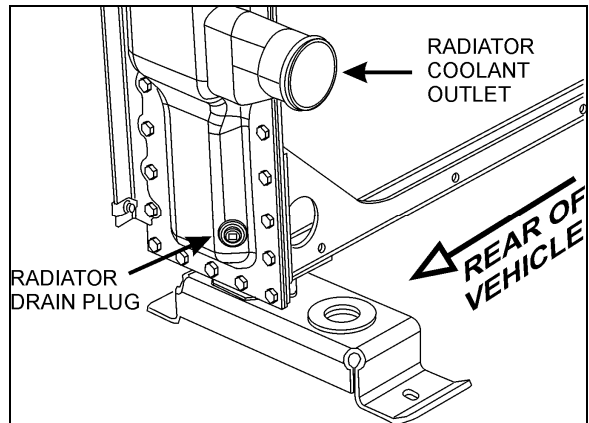

FIGURE 16: RADIATOR DRAIN PLUG 05139

**11. CHARGE AIR COOLER LEAKAGE**

Spec for CAC acceptable leakage:

“The CAC is considered acceptable if it can hold 30 psi (206 kpa) gauge pressure with less than 5 psi (34.5 kpa) loss in 15 seconds after turning off the hand valve.”

**NOTE**  
*This spec does not apply if there is any evidence that the leak was caused by a foreign object impact.*

**12. COOLING FAN DRIVE MECHANISM**

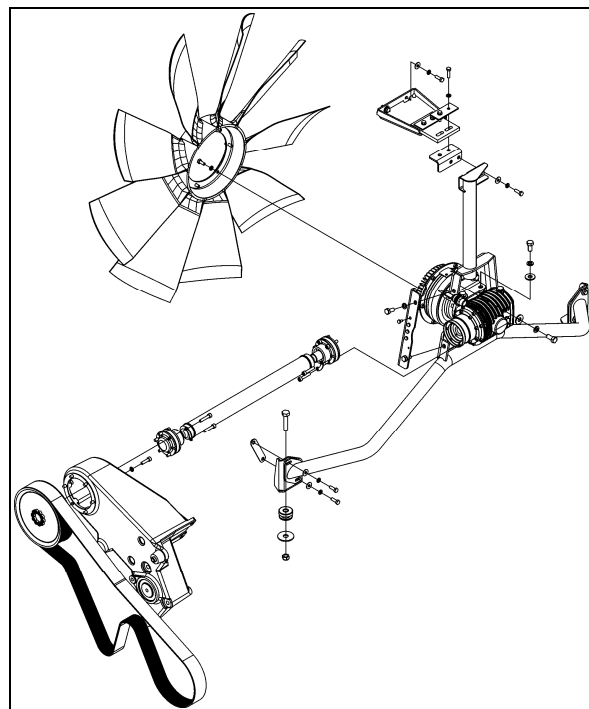

FIGURE 17: COOLING FAN DRIVE MECHANISM

## Section 05: COOLING SYSTEM

### 12.1 DRIVE PULLEY AND UNIVERSAL JOINT SHAFT

To disconnect the universal shaft, proceed as follow:



#### WARNING

Set the ignition to the OFF position and remove the key from the contact switch to prevent accidental starting of the engine.

1. Unwrap the drive belt from around the pulley (see paragraph MOUNTING THE DRIVE BELT).
2. Dismount the drive pulley. Gain access to the 6 mounting bolts from behind the pulley, through the opening in the cast aluminum support (Fig. 18).
3. Unscrew and remove the universal joint shaft mounting bolts (6) at the right angle gearbox.
4. Slowly, move the shaft toward the rear of the vehicle.
5. Finally, dismount the universal joint shaft from the drive pulley (6 bolts).

Installation of the universal joint shaft is the same as removal, but in reverse order.

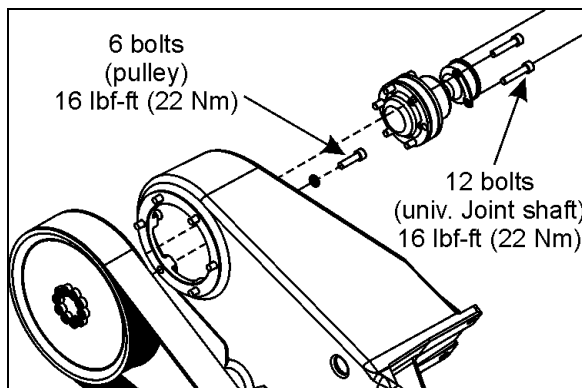

FIGURE 18: TIGHTENING SPECIFICATION

05123A

### 12.2 IDLER REPLACEMENT

If an idler is defective, replace as follow:



#### WARNING

Set the ignition to the OFF position and remove the key from the contact switch to prevent accidental starting of the engine.

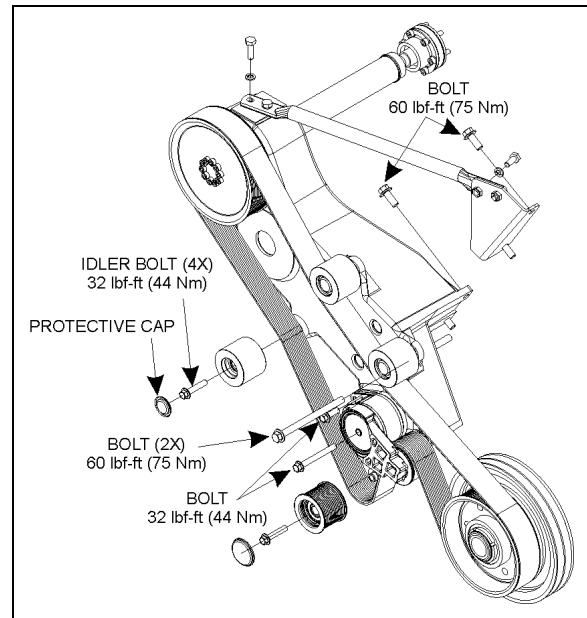

FIGURE 19: TIGHTENING SPECIFICATION

05140

1. Remove the protective cap (replace with a new one).
2. Unscrew the idler mounting bolt.
3. Replace idler with a new one.



#### CAUTION

When installing the idler, make sure it rests perfectly against the bearing surface on the cast aluminum support. If not, the drive belt may slip of the idler. See figure below.

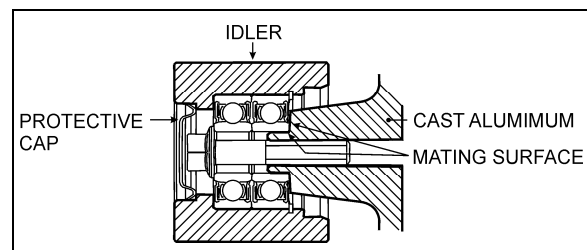

FIGURE 20: IDLER MOUNTED ON THE CAST ALUMINUM SUPPORT



4. Bolt the new idler on the cast aluminum support. Tighten to 32 lbf-ft (44 Nm).
5. Place a new protective cap.



### 13. VARIABLE SPEED COOLING FAN

The cooling fan clutch has two thermostatically controlled speeds, plus a neutral (clutch disengaged). The MCM controls the speed by

comparing data from engine coolant temperature, charge air temperature, Allison transmission oil temperature and small A/C High side pressure to a set of calibration data. The fan drive clutch is electromagnetic; the MCM sends an electric current to regulate speed by activating one magnetic coil for the first speed and two magnetic coils for the second speed.

The settings are:

	Engine coolant temp.	Air intake temp.	Allison trans. oil temp.
temperature rising 	208°F: fan engages in HIGH SPEED	194°F: fan engages in HIGH SPEED	230°F: fan engages in HIGH SPEED
	203°F: fan engages in LOW SPEED	176°F: fan engages in LOW SPEED	216°F: fan engages in LOW SPEED
temperature dropping 	203°F: fan HIGH SPEED disengages	189°F: fan HIGH SPEED disengages	225°F: fan HIGH SPEED disengages
	198°F: fan LOW SPEED disengages	170°F: fan LOW SPEED disengages	210°F: fan LOW SPEED disengages

	Small A/C high side pressure
pressure rising 	170 psi: fan engages in HIGH SPEED
	120 psi: fan engages in LOW SPEED
pressure dropping 	130 psi: fan HIGH SPEED disengages
	90 psi: fan LOW SPEED disengages

 **WARNING**

DO NOT work near the fan with the engine running or the ignition in the ON position. The engine fan can engage at any time without warning. Anyone near the fan when it turns on could be seriously injured.

### 13.1 LOCKING RADIATOR FAN FOR EMERGENCY OPERATION

#### 13.1.1 Electrical Locking

If the cooling fan clutch does not function due to an electrical control system malfunction and the

engine is overheating, execute the following procedure:

1. Set the ignition key to the ON position.
2. Activate the dashboard Telltale Light Test switch 3 times within 4 seconds.
3. In the engine compartment, set the starter selector switch to REAR START and then start the engine from the rear.

 **WARNING**

Potential Accident Risk. Always use extreme caution when working in the vicinity of hot, rotating or moving parts.

While in this mode, the rear start push-button can be used to manually engage the fan clutch. The multiplex system knows when the engine is already running, and it will not activate the starter.

4. Press the push-button one time to engage the clutch to 1<sup>st</sup> speed, press a second time to engage to 2<sup>nd</sup> speed, press a third time to stop the fan, press once again to return to 1<sup>st</sup> speed.

**NOTE**

*If the fan clutch does not engage using this procedure then the clutch is faulty or the wiring between the multiplex module and the clutch is faulty. Mechanically lock the fan as described in section 14.1.2.*

#### 13.1.2 Mechanical Locking

Once mechanically locked, the fan is rigidly connected to the drive mechanism and will rotate continuously, with no considerations for the cooling needs. This is an emergency situation and the vehicle shall not be operated in that situation for an extended period.

In case of a magnetic clutch malfunction:

1. Set the ignition to the OFF position and remove the key from the contact switch to prevent accidental starting of the engine.
2. Disconnect the fan clutch electrical connector.
3. Unscrew and remove the 4 spare bolts screwed to the angle on the fan gearbox mounting support.

## Section 05: COOLING SYSTEM

4. Turn the fan blades in order to position the locking plate bores over the rotor's threaded sockets.
5. Screw in and tighten the spare bolts (Fig. 21).
6. Using the automatic belt tensioner, release tension on the drive belt in order to be able to rotate the fan clutch drive mechanism by hand.
7. Rotate the shaft to get access to the second locking plate and rotor threaded sockets.
8. Screw in and tighten the spare bolts.

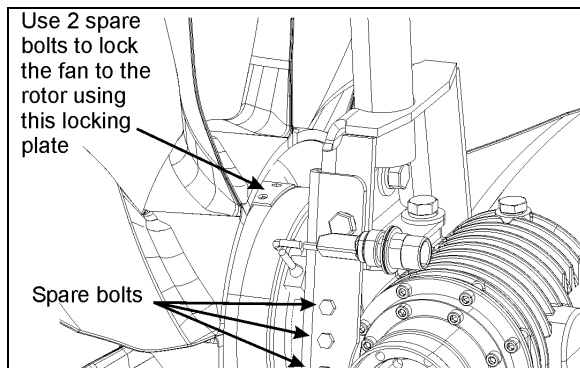

FIGURE 21: MECHANICAL LOCKING

05124

### 13.2 MAINTENANCE

1. Clean the fan and related parts with clean fuel oil and dry them with compressed air. Do not clean with steam or high-pressure jet.
2. Check the fan blades for cracks or other damage. Replace the fan if the blades are cracked or deformed.
3. Remove any rust or rough spots in the grooves of the fan pulley. If the grooves are damaged or severely worn, replace the pulley.
4. Do not restrict fan rotation during engine operation for any reason.
5. Do not operate fan-driving mechanism with a damaged fan assembly. Replace a damaged fan as soon as the fault is noted.
6. Immediately investigate and correct any operator complaint involving driving mechanism or cooling system performance.
7. When questions arise, obtain answers before proceeding. Assistance is available through the authorized Field Sales distributor serving your area.

### 13.3 INSPECTION



## DANGER

Set the starter selector switch in engine compartment to the "Off" position to prevent accidental starting of the engine.

- Check security of fasteners securing fan blade assembly to fan driving mechanism.
- Check coupling installation between fan blade assembly and gearbox.
- Visually inspect fan driving mechanism, fan blade assembly, shroud, radiator, and surrounding area for evidence of contact between rotating and non-rotating parts.
- Check drive belt for fraying, cracking, and proper tension.
- Turn fan through at least 360° of rotation. It should turn smoothly with no resistance.

### 13.4 FAN REMOVAL / INSTALLATION

The fan is bolted to the magnetic clutch. To remove the fan:

1. Unscrew and remove the mounting bolts and washers.

To reinstall the fan:

1. If the fan is still in the radiator fan shroud, place 2 of the mounting bolts on the opposite side of the clutch, in reverse direction, in order to use them as guide pins to position the fan.
2. Once properly positioned, screw the 4 remaining bolts back in and tighten properly (16 lbf-ft; 22 Nm).
3. Finally, take the 2 bolts that were used as guide pins and screw them back in on the proper side of the clutch and tighten properly.

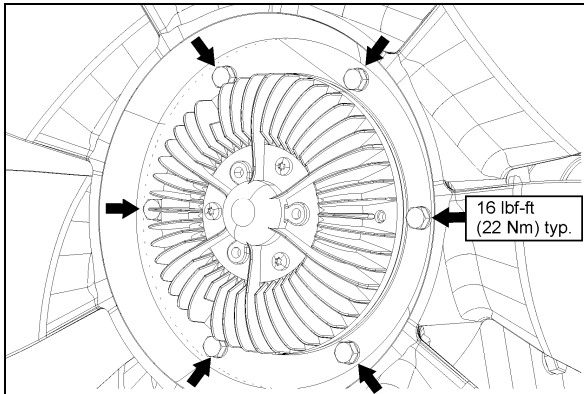

FIGURE 22: RADIATOR FAN MOUNTING BOLTS 05125

### 14. FAN RIGHT ANGLE GEARBOX

The radiator fan is belt driven from the engine crankshaft pulley through a drive belt, a universal joint shaft, a right angle gear and clutch assembly.

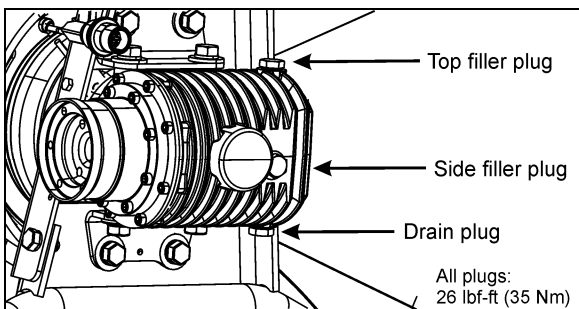

FIGURE 23: RIGHT ANGLE GEARBOX 05118

#### 14.1 MAINTENANCE

### MAINTENANCE

Change the right angle gearbox oil every 50,000 miles (80,000-km) or once a year, whichever comes first.

Use **Synthetic Gear Lubricant SAE 75W-90**.

#### 14.2 OIL CHANGE

1. Stop engine and make sure that all engine safety precautions have been observed.
2. Set the ignition to the OFF position and remove the key from the contact switch to prevent accidental starting of the engine or set the rear start panel selector switch to the OFF position.

3. Remove the drain plug located underneath the right angle gearbox case and allow the oil to drain into a suitable container.
4. Replace the seal and screw the drain plug back in (torque: 26 lbf-ft).
5. Unscrew and remove the side filler plug.
6. Unscrew and remove the top filler plug.
7. Add gear lubricant. The oil level is correct once the top of the oil has reached the bottom of the side filling point.
8. Replace the seals and screw side and top filler plug back in (torque: 26 lbf-ft).
9. Clean gear case carefully.
10. Start the engine and allow running a few minutes. Stop the engine and check for leaks.

#### 14.3 REMOVAL / INSTALLATION

To remove the right angle gearbox, proceed as follow:

1. Set the ignition to the OFF position and remove the key from the contact switch to prevent accidental starting of the engine.
2. Disconnect the fan clutch electrical connector.
3. Dismount the fan and lean it against the radiator (refer to previous paragraph).
4. Disconnect the universal joint shaft.

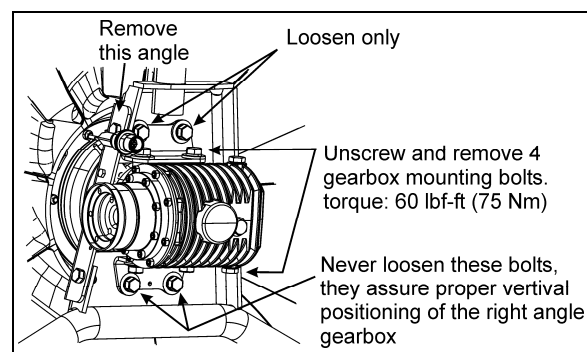

FIGURE 24: RIGHT ANGLE GEARBOX MOUNTING 05126

5. Dismount the angle (see fig. 24).
6. Loosen the gearbox support bracket top bolts.
7. Unscrew and remove 4 gearbox mounting bolts.

## Section 05: COOLING SYSTEM

- Slide the gearbox out of the support assembly.

Installation procedure is the same as removal but in reverse order. Tighten the 4 mounting bolts as specified.

### 15. COOLING FAN DRIVE BELT

#### 15.1 MOUNTING THE DRIVE BELT

To install the cooling fan drive belt, proceed as follow:



#### WARNING

Set the ignition to the OFF position and remove the key from the contact switch to prevent accidental starting of the engine.



#### WARNING

Potential Accident Risk. Always use extreme caution when working in the vicinity of hot, rotating or moving parts.

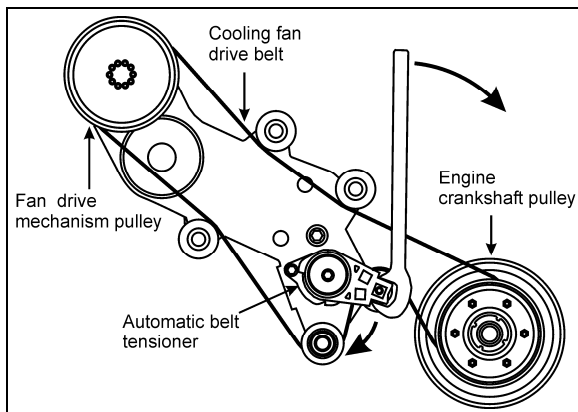

FIGURE 25: DRIVE BELT ROUTING

05137

- Wrap the new drive belt around the fan drive mechanism pulley, the idlers and the automatic tensioner idler as shown on figure 25.
- Using a  $\frac{1}{2}$ " breaker bar or a 1  $\frac{1}{2}$ " open end wrench, rotate the automatic tensioner in clockwise direction to relieve tension on the belt and hold the tensioner in that position (Fig. 25).
- Finally, place the drive belt around the engine crankshaft pulley.

- Release the tensioner slowly and let it return to its natural position.

#### COOLING FAN DRIVE BELT

Make: Dayco

Type: 14PK2605

Prevost number: 550926



**16. SPECIFICATIONS**

**Cooling System Capacity (Approximation)**

Includes heating system..... 24 US gal (91 liters)

**Thermostat**

Number used ..... 2

Start to open ..... 182-188°F (83-86°C)

Fully open ..... 202°F (95°C)

**Cooling Fan Drive Belt**

Make ..... Dayco

Type ..... Poly-Rib 14PK2605

Qty ..... 1

Prevost number ..... 550926

**Coolant**

Prevost Number ..... 685125

DDC (Power Cool) ..... 23512138

Prestone (Heavy Duty)..... AF977 (bulk), 72702 (3.78 L), 70119 (205L), 70102 (4L)

**Corrosion Inhibitor and Coolant Stabilizer**

Supplier number..... Detroit Diesel ..... 23507857

Supplier number..... Nalco ..... DD3000-15

**Coolant Filter**

Number used ..... 1

Make ..... Nalco

Type ..... Spin-on

**MAINTENANCE ELEMENT FILTER**

Supplier number. .... Detroit Diesel ..... 23507545

Supplier number..... Nalco ..... DDF3000

Prevost number ..... 550630

**PRECHARGE ELEMENT FILTER**

Supplier number..... Detroit Diesel ..... 23507189

Supplier number..... Nalco ..... DDF60

Prevost number ..... 550629

# SECTION 06: ELECTRICAL

## CONTENTS

<b>1. GENERAL DESCRIPTION.....</b>	<b>4</b>
1.1 WIRING DIAGRAMS.....	4
1.1.1 <i>Using Wiring Diagram</i> .....	4
1.1.2 <i>Testing Circuits</i> .....	5
1.2 WIRE SIZES AND COLORS.....	5
1.3 SPARE WIRES.....	5
1.4 CLEANING CONNECTORS.....	6
1.5 CIRCUIT BREAKERS.....	6
1.6 MULTIPLEX FUSES .....	6
1.7 RELAYS .....	6
1.8 PRECAUTIONS.....	7
<b>2. XLII MOTORHOMES ELECTRICAL COMPARTMENTS AND JUNCTION BOXES .....</b>	<b>9</b>
2.1 MAINTENANCE .....	10
2.2 REAR JUNCTION BOX .....	10
2.3 CIRCUIT BREAKERS.....	11
2.4 A/C JUNCTION BOX.....	11
2.5 FRONT ELECTRICAL & SERVICE COMPARTMENT .....	12
2.6 ENGINE COMPARTMENT (REAR START PANEL).....	13
2.7 WIPER CONTROL PANEL .....	13
<b>3. BATTERIES.....</b>	<b>13</b>
3.1 BATTERY DISCHARGE PROTECTION .....	14
3.2 MAIN BATTERY RELAYS.....	14
3.3 BATTERY REMOVAL AND INSTALLATION .....	14
3.4 BATTERY RATING .....	15
3.5 BATTERY TESTING .....	16
3.5.1 <i>Visual Inspection</i> .....	16
3.5.2 <i>Removing Surface Charge</i> .....	16
3.5.3 <i>Load Test</i> .....	16
3.5.4 <i>Testing Battery Cables</i> .....	17
3.6 BATTERY CHARGING .....	18
3.6.1 <i>Battery Charging Guide</i> .....	19
3.6.2 <i>Emergency Jump Starting With Auxiliary (Booster) Battery</i> .....	19
3.7 CLEANING AND INSPECTION .....	20
3.8 COMMON CAUSES OF BATTERY FAILURE.....	20
3.9 TROUBLESHOOTING .....	21
3.10 "BAT" BATTERY VOLTAGE INCORRECT TELLTALE LIGHT .....	21
3.10.1 <i>"Bat" Telltale Light Definitions</i> .....	21
<b>4. TROUBLESHOOTING AND TESTING THE MULTIPLEX VEHICLES.....</b>	<b>21</b>
4.1 ELECTRICAL SYSTEM DIAGNOSTIC .....	21
4.2 PROBING VOLTAGE ON THE MULTIPLEX CIRCUITS .....	22
4.3 CAN NETWORK .....	22
4.3.1 <i>Can Connection On The Telltale Panel And The Hvac Control Unit</i> .....	22
4.3.2 <i>Spare Can</i> .....	23
4.4 TEST MODE FOR SWITCHES AND SENSORS .....	23
4.4.1 <i>Information Available And Impact On The Functions In Switch/Sensor Test Mode</i> .....	23
4.5 TEST MODE FOR ELECTRIC MOTORS .....	24
4.5.1 <i>Test Sequence – MTH Equipped With Central HVAC System</i> .....	24
4.5.2 <i>Test Sequence – MTH Equipped With Small HVAC System</i> .....	25
4.6 CAN NETWORK LAYOUT AND TROUBLESHOOTING.....	26
4.7 ROADSIDE TROUBLESHOOTING .....	27

## Section 06: ELECTRICAL

---

4.8	ESSENTIAL FUNCTIONS TO OPERATE THE VEHICLE .....	32
4.8.1	<i>Available Functions</i> .....	32
4.9	LOWER PRIORITY MODULES FOR BREAKDOWN SERVICE.....	32
4.10	MULTIPLEX MODULES.....	32
4.10.1	<i>CECM</i> .....	32
4.10.2	<i>MASTER ID</i> .....	32
4.10.3	<i>IO-A</i> .....	32
4.10.4	<i>IO-B</i> .....	32
4.11	MULTIPLEX MODULES REPLACEMENT .....	32
4.11.1	<i>Replacing IO-A Or IO-B Modules</i> .....	33
4.11.2	<i>Replacing CECM Module</i> .....	33
<b>5.</b>	<b>BOSCH ALTERNATOR</b> .....	<b>33</b>
5.1	TWIN BOSCH ALTERNATORS INSTALLATION .....	35
5.2	ALTERNATORS ARRANGEMENT .....	35
5.3	ALTERNATOR DRIVE BELT .....	36
5.3.1	<i>Adjustment</i> .....	36
<b>6.</b>	<b>BATTERY EQUALIZER</b> .....	<b>36</b>
<b>7.</b>	<b>STARTER</b> .....	<b>36</b>
<b>8.</b>	<b>ENGINE BLOCK HEATER</b> .....	<b>37</b>
8.1	MAINTENANCE .....	37
<b>9.</b>	<b>EXTERIOR LIGHTING</b> .....	<b>37</b>
9.1	HEADLIGHTS.....	37
9.1.1	<i>Headlight Beam Toggle Switch</i> .....	37
9.1.2	<i>Maintenance</i> .....	37
9.1.3	<i>Headlight Adjustment</i> .....	38
9.1.4	<i>Sealed-Beam Unit</i> .....	39
9.1.5	<i>Front Turn Signal</i> .....	40
9.1.6	<i>Optional Xenon Headlamp</i> .....	40
9.2	STOP, TAIL, DIRECTIONAL, BACK-UP, AND HAZARD WARNING LIGHTS .....	41
9.2.1	<i>Lamp Removal and Replacement</i> .....	41
9.2.2	<i>Center Stoplights and Cyclops Light Removal and Replacement</i> .....	42
9.3	LICENSE PLATE LIGHT.....	42
9.4	CLEARANCE, IDENTIFICATION AND MARKER LIGHTS .....	42
9.4.1	<i>Marker Light Removal and Replacement</i> .....	42
9.4.2	<i>Clearance and Identification Light Removal and Replacement</i> .....	42
9.5	DOCKING AND CORNERING LIGHTS .....	43
9.5.1	<i>Lamp Removal and Replacement</i> .....	43
9.6	FOG LIGHTS.....	43
9.6.1	<i>Bulb Removal and Replacement</i> .....	43
<b>10.</b>	<b>INTERIOR LIGHTING EQUIPEMENT</b> .....	<b>43</b>
10.1	CONTROL PANEL LIGHTING.....	43
10.1.1	<i>Switch Lighting</i> .....	43
10.1.2	<i>Telltale Light Replacement</i> .....	44
10.1.3	<i>Gauge Light Bulb Replacement</i> .....	44
10.2	DRIVER'S AREA LIGHTS.....	44
10.2.1	<i>Bulb Removal and Replacement</i> .....	44
10.2.2	<i>Removal and Replacement of In-Station Fluorescent Tubes</i> .....	44
10.2.3	<i>Removal and Replacement of Reading Lamp Bulb</i> .....	44
10.3	ENGINE COMPARTMENT LIGHTING.....	44

<b>11. LIGHT BULB DATA .....</b>	<b>45</b>
<b>12. SPECIFICATIONS .....</b>	<b>46</b>

## ILLUSTRATIONS

FIGURE 1: WIRE IDENTIFICATION .....	5
FIGURE 2: MULTIPLEX MODULE CONNECTORS PIN-OUT .....	7
FIGURE 3: ELECTRICAL COMPARTMENTS (XLII-45E BUS SHELLS) .....	9
FIGURE 4: ELECTRICAL COMPARTMENTS (XLII-45 BUS SHELLS) .....	9
FIGURE 5: REAR JUNCTION BOX .....	10
FIGURE 6: REAR JUNCTION BOX & CIRCUIT BREAKER PANEL .....	11
FIGURE 7: LOCATION OF A/C JUNCTION BOX IN EVAPORATOR COMPARTMENT .....	11
FIGURE 8: A/C JUNCTION BOX .....	11
FIGURE 9: FRONT ELECTRICAL COMPARTMENT .....	12
FIGURE 10: REAR START PANEL .....	13
FIGURE 11: WIPER CONTROL PANEL .....	13
FIGURE 12: ENGINE COMPARTMENT R.H. SIDE .....	14
FIGURE 13: BATTERIES CONNECTIONS .....	15
FIGURE 14: TEST INDICATOR .....	16
FIGURE 15: LOAD TEST .....	17
FIGURE 16: ALLIGATOR CLAMPS AND BATTERY .....	19
FIGURE 17: JUMP STARTING .....	20
FIGURE 18: IO-B MODULE REMOVAL .....	32
FIGURE 19: TWIN BOSCH ALTERNATORS INSTALLATION .....	34
FIGURE 20: ALTERNATORS AND ACCESSORIES MOUNTING TORQUES .....	34
FIGURE 21: BOSCH 24V-140A WITH SMALL HVAC SYSTEM .....	35
FIGURE 22: BOSCH 24V-140A WITH CENTRAL HVAC SYSTEM .....	35
FIGURE 23: DELCO 24V-75A WITH SMALL HVAC SYSTEM .....	36
FIGURE 24: BOSCH 14V-200A WITH CENTRAL HVAC SYSTEM .....	36
FIGURE 25: ALTERNATOR DRIVE BELT .....	36
FIGURE 26: ELECTRIC HEATER PLUG LOCATION .....	37
FIGURE 27: HEADLIGHT ASSEMBLY .....	37
FIGURE 28: OPENING HEADLIGHT ASSEMBLY .....	38
FIGURE 29: ALIGNMENT OF HEADLIGHT AIMING SCREEN .....	39
FIGURE 30: HIGH-INTENSITY ZONE (SHADED AREA) OF A PROPERLY AIMED UPPER BEAM ON THE AIMING SCREEN 7.6 M (25FT) IN FRONT OF VEHICLE .....	39
FIGURE 31: HIGH-INTENSITY ZONE (SHADED AREA) OF A PROPERLY AIMED LOWER BEAM ON THE AIMING SCREEN 7.6 M (25FT) IN FRONT OF VEHICLE .....	39
FIGURE 32: AIM INSPECTION LIMITS FOR UPPER-BEAM HEADLIGHTS .....	39
FIGURE 33: AIM INSPECTION LIMITS FOR LOWER-BEAM HEADLIGHTS .....	39
FIGURE 34: XENON HEADLAMP LOCATION .....	40
FIGURE 35: VARIOUS LIGHTS LOCATION .....	42
FIGURE 36: SWITCH .....	43
FIGURE 37: ENGINE COMPARTMENT LIGHT .....	44

### 1. GENERAL DESCRIPTION

This vehicle uses a dual voltage system to obtain two different voltages (12 and 24 volts) for various electrical controls and accessories. The main power source incorporates four maintenance-free "Volvo" model 20359831 batteries connected in parallel-series. All batteries are kept uniformly charged by means of a 100 amp battery equalizer (standard), giving a maximum possible output supply of 100 amps on the 12 volt system. Both the 12 and 24 volt systems are controlled through individual main battery relays. One or two 24 volt self-rectified alternators are belt driven from the engine, and can be reached through the engine compartment door.

#### 1.1 WIRING DIAGRAMS

A master wiring diagram of the electric circuits, covering standard and optional accessories and systems, is located in the technical publications box. Usually, a separate wiring diagram page is provided for each major function or system. In some cases, more than one circuit may appear on one wiring diagram page; when this occurs, each circuit covered in this page is listed in the wiring diagram index. Moreover, a circuit may appear on several pages; in such case, the number(s) at the extremity of the diagram title will indicate the sheet reference number. Refer to the "*Wiring Diagram Index*" to ensure that the correct diagram is being used to trace the circuit in question. In addition to the major functions page reference, the wiring diagram index contains the following information pages.

- The Multiplexed Device Index,
- The Arrangement-Harness drawing showing the harnesses arrangement and harness number on the vehicle,
- Glossary,
- Circuit number listing,
- Circuit breaker code,
- Connector code,
- Diode number code,
- Resistor number code,
- Fuse code.

##### 1.1.1 Using Wiring Diagram

Three methods are used to "*work*" with electric wiring diagrams.

**Situation:** You have identified the defective part (breaker, diode, relay, etc.), and you wish to locate its corresponding circuit.

**Problem:** Circuit breaker CB6 is released (open circuit) and you don't know which circuit is affected.

- a) Refer to wiring diagram index, and look for "*Circuit breaker code*", pages F.
- b) At item CB6, you will find the location, the Prevost number, the breaker function, the breaker ampere rating and the page on which to find the corresponding diagram.
- c) Refer to page 3.1.
- d) When you have located CB6, follow the wiring up to the end and find the diagram page number and function on which the circuit continues.

**Situation:** You have a problem with a specific system and you want to find the corresponding diagram.

**Problem:** The level low system of the vehicle is inoperative and you must trace the electric circuit.

- a) Refer to wiring diagram index and look for "*Level Low*".
- b) You will find on page 28.1 the components as well as the electric wiring, thus providing you with a complete understanding of this circuit.

**Situation:** Using the message center display (MCD), you check on arrival if there are active errors in the vehicle electrical system. With the SYSTEM DIAGNOSTIC menu, highlight FAULT DIAGNOSTIC, highlight ELECTRICAL SYSTEM to request a diagnostic of the electrical system and then press the enter key. If applicable, the MCD shows the fault messages or fault codes recorded. When more than one fault is recorded, an arrow pointing down appears on the right of the display. Use the down to see all the fault messages.

**Problem:** MCD displays the fault "Low docking lights SW102; shorted to ground" as being active.

- a) Refer to wiring diagram index, and look for "*Multiplexed Device Index*", pages B1-B3.

- b) In first column DEVICE ID, look for device SW102.
- c) At device SW102, find the fault message, the minimum condition to activate, other inputs involved in logic, the multiplex module related to switch 102, the connector and pin number on the module and the page on which to find the corresponding diagram.
- d) Once the problem corrected, the MCD still shows the fault as being active. You have to leave the FAULT DIAGNOSTIC menu, wait approximately 20 to 30 seconds and then return to FAULT DIAGNOSTIC to request a new diagnostic of the ELECTRICAL SYSTEM from the CECM. The MCD should display the fault as being inactive.

1.1.2 Testing Circuits

A careful study of the wiring diagrams should be made to determine the source and flow of current through each circuit. When a circuit is thoroughly understood, a point-to-point check can be made with the aid of the applicable wiring diagrams. Any circuit can be tested for continuity or short circuits with a multimeter or a suitable voltmeter.

All electrical connections must always be kept clean and adequately tight. Loose or corroded connections can result in discharged batteries, difficult starting, dim lights and improper functioning of other electric circuits. Inspect all wiring connections at regular intervals. Make sure knurled nuts on all amphenol-type plugs are securely tightened. Knurled nuts on the plastic amphenol-type connectors will click into a detent when properly tightened. Line connectors, who have the side locking tabs, must have the locks latched in place to ensure a proper electrical connection.

1.2 WIRE SIZES AND COLORS

Each wire in the electrical system has a specific size as designated on the wiring diagram. When replacing a wire, the correct size must be used. Never replace a wire with one of a smaller size. The vehicle electrical system is provided with different voltages. The insulation on each wire is distinctly colored in order to determine visually the wiring voltage and to assist in making connectors. The wires are color coded as follows:

Yellow	Multiplex modules communication CAN-H (twisted with green)
Green	Multiplex modules communication CAN-L (twisted with yellow)
Orange	Connected to multiplex outputs
White	Connected to multiplex inputs
Red	24 volt system
Yellow	12 volt system
Black	grounded wire
Blue	110 V ac system (live)
Green	110 V ac system (ground)
White	110 V ac system (neutral)
Grey	spare wire

**NOTE**  
Wires are identified at each 2-4 inch (5-10 cm) intervals by a printed number.

Each wire on a diagram is patterned to assist in tracing and testing circuits. The wire number identifies the voltage rating, the wire identification number and the basic wire gauge as illustrated in figure 1.

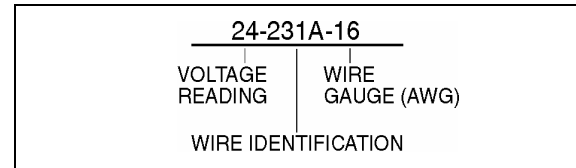

FIGURE 1: WIRE IDENTIFICATION 06048

1.3 SPARE WIRES

When the vehicle leaves the factory, and even in the case of a fully-equipped vehicle, an important number of unconnected spare wires are routed between the junction boxes. Consequently, for any connection of an additional accessory, refer to page D "Spare wires" in master wiring diagram to determine the number, the gauge and location of these wires.

**CAUTION**  
Wire size is calibrated according to the breaker or fuse that protects it. When using a spare wire to replace a damaged wire, assure that the spare wire size is equal or larger than the wire being replaced. Using a wire too small for the breaker or fuse amperage might cause overheating of the wire.

**NOTE**  
Spare wires are identified by a wire identification number and by the letters "SP", to designate "spare".

## Section 06: ELECTRICAL

### 1.4 CLEANING CONNECTORS

When the pins and sockets of connectors become dirty, clean them with a good quality solvent containing HFC 134A refrigerant as its active ingredient. HFC 134A has two qualities that recommend it. First, it does not conduct electricity and therefore, will not cause shorting between connector pins and sockets. Second, it evaporates quickly, eliminating the possibility of condensation within the connectors.

Always shake out or gently blow out any excess HFC 134A before assembling a connector to its mating connector or hardware. HFC 134A trapped in the connector can affect the connector seal.



**DANGER**

HFC 134A is toxic. HFC 134A bases compounds should always be used in a well-ventilated area, never in a confined space. Use outdoor whenever possible.

### 1.5 CIRCUIT BREAKERS

Most electric circuits are protected by circuit breakers of the "Manual Reset" type. The main circuit breakers, as well as those protecting the A/C system, are located in the engine compartment, on R.H. side of the vehicle.

CIRCUIT BREAKERS			
CB1	Distribution	12 VD	150 amps
CB2	Distribution	24 VD	50 amps
CB3	Front distribution	24 VI	70 amps
CB4	HVAC - evaporator	24 VI	90 amps
CB5	HVAC - condenser	24 VI	70 amps
CB6	Slide-Out	24 VI	35 amps
CB7	Distribution	24 VI	60 amps
CB8	HVAC - condenser	12 VI	40 amps
CB9	Distribution	12VI	70 amps

VD= volts direct. The electrical components connected to these circuit breakers are direct-connected to the battery.

VI= volts indirect. Electrical power is supplied via master relay R1 which engages when ignition key is in the ON or ACC position.

This type of circuit breaker deenergizes the circuit without disconnecting any wire. Circuit breakers CB1 & CB2 are different in the fact that you may open the circuit manually, to do so simply press down the blue tab on breaker to trip the circuit breaker, repair defective circuit,

and afterwards toggle yellow lever upwards to reset the circuit breaker and close the circuit.

### 1.6 MULTIPLEX FUSES

The multiplex outputs are protected in current by an internal "soft-fuse". Each output has programmed specific maximum amperage. When an output is shorted, the current gets above the limit and the soft-fuse intervenes to turn the output OFF. The output stays OFF until the "soft-fuse" is reset.

Turn the ignition key to the OFF position and turn to the ON position again. This resets all "soft-fuses".

There is also hardware fuses used to protect the incoming power to the multiplex modules. These fuses are located inside the VECF (Vehicle Electrical Center Front) and VECR (Vehicle Electrical Center Rear).

### 1.7 RELAYS

Relays are used to automatically energize or deenergize a circuit from a remote location. The relay draws a very low current to energize its coil. Once the coil is energized, it develops a magnetic field that pulls a switch arm closed or open, to either energize or deenergize a given component. As the control current required for the coil is very low, the relay allows a remote station to control a high energy circuit without running great lengths of costly high capacity cable, and also eliminates the need for high amperage switches and heavy connectors.

Many systems on this vehicle are provided with control relays, which are all, located in or on the junction boxes, figures 6, 9, 10 and 12.

#### **NOTE**

*Each relay is identified with "12V" or "24V" printed on its casing in order to identify the coil operating voltage.*



#### **CAUTION**

The Multiplex vehicle uses a VF4 relay designed specially for Volvo that has different internal characteristics than the current VF4 relay. It is important to use only the new part marked Volvo as a replacement in Multiplex vehicles. Regular relays have an inadequate lifespan for Multiplex vehicles.

## 1.8 PRECAUTIONS

**DANGER**

Prior to working on a system inside vehicle, make sure to cut electrical power and air supply. A component could be supplied with electricity even if the ignition switch is set to the OFF position and/or a component could be pressurized even if air tanks are emptied. Always refer to the appropriate wiring and pneumatic diagrams prior to working on electrical and/or pneumatic systems.

**NOTE**

When the ignition switch is set to the OFF position, the electrical components are not energized except for the CECM (Chassis Electronic Control Module), engine ECM, transmission TCM, instrument cluster module, the battery equalizer and some Multiplex modules which are energized during 15 minutes after the ignition has been set to the OFF position. If the vehicle will not be operated for a long period (more than 2 weeks), it is recommended, in order to prevent the batteries from discharging, to trip main circuit breakers (1 and 2) located in the rear circuit breakers panel to stop the small current drawn by the radio preset station memory, the CECM memory and the instrument cluster clock. Note that the radio station presets will be erased, same thing for the diagnostic codes history and the instrument cluster clock will have to be reset.

**CAUTION**

Prior to arc welding on the vehicle, refer to "Multiplex Modules Disconnection Procedure Prior To Welding" in section 00 GENERAL of this manual to avoid serious damage to the vehicle components.

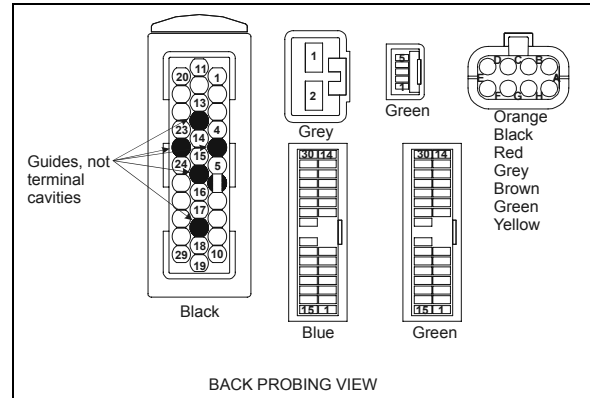
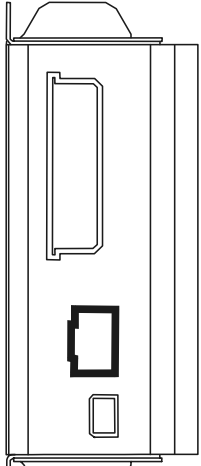
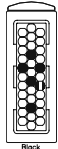
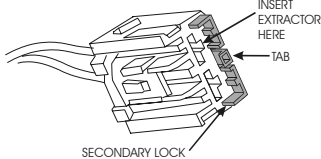
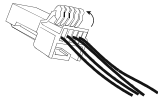
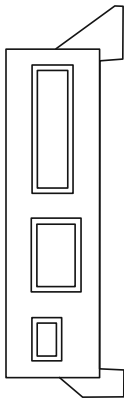
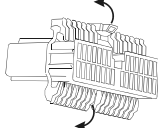
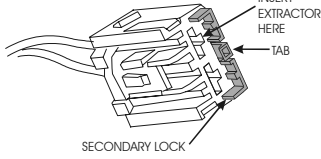
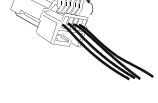
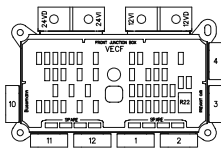
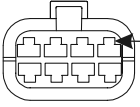

**FIGURE 2: MULTIPLEX MODULE CONNECTORS PIN-OUT**

06624



**Section 06: ELECTRICAL**

Multiplex modules	Connector type	Terminal removal
 <p><b>IO-B</b> 06625</p>	 <p>Back <b>AMP 06628</b></p>	<p>EXTRACTOR/TOOL: Prevost #683594</p> <p>Insert the extractor on the front of the connector. Remove the terminal by disengaging the flexible lock tabs on the terminal. Gently remove the terminal from the connector by pulling on the wire.</p>
	 <p>INSERT EXTRACTOR HERE TAB SECONDARY LOCK <b>grey 06629</b> <b>YAZAKI</b></p>	<p>EXTRACTOR/TOOL: Packard #12094430</p> <p>Using a small flat blade screwdriver, open the hinged secondary lock. Insert the extractor on the front of the connector, over the terminal cavity. Remove the terminal by disengaging the flexible lock tab on the terminal. Gently remove the terminal from the connector by pulling on the wire.</p>
	 <p><b>green 06630</b> <b>JAE</b></p>	<p>EXTRACTOR/TOOL: Prevost #683766</p> <p>Using a small flat blade screwdriver, open the hinged secondary lock. Insert the extractor on the front of the connector, over the terminal cavity. Remove the terminal by disengaging the flexible lock tab on the terminal. Gently remove the terminal from the connector by pulling on the wire.</p>
 <p><b>IO-A</b> 06626</p>	 <p><b>green, blue (CECM)</b> <b>JAE 06631</b></p>	<p>EXTRACTOR/TOOL: Prevost #683766</p> <p>Using a small flat blade screwdriver, open both hinged secondary locks. Insert the extractor on the front of the connector, over the terminal cavity. Remove the terminal by disengaging the flexible lock tab on the terminal. Gently remove the terminal from the connector by pulling on the wire.</p>
	 <p>INSERT EXTRACTOR HERE TAB SECONDARY LOCK <b>grey 06629</b> <b>YAZAKI</b></p>	<p>EXTRACTOR/TOOL: Packard #12094430</p> <p>Using a small flat blade screwdriver, open the hinged secondary lock. Insert the extractor on the front of the connector, over the terminal cavity. Remove the terminal by disengaging the flexible lock tab on the terminal. Gently remove the terminal from the connector by pulling on the wire.</p>
	 <p><b>green 06630</b> <b>JAE</b></p>	<p>EXTRACTOR/TOOL: Prevost #683766</p> <p>Using a small flat blade screwdriver, open the hinged secondary lock. Insert the extractor on the front of the connector, over the terminal cavity. Remove the terminal by disengaging the flexible lock tab on the terminal. Gently remove the terminal from the connector by pulling on the wire.</p>
 <p><b>VECF</b> 06627</p>	 <p>INSERT EXTRACTOR HERE  Orange Black Red Grey Brown Green Yellow <b>BUSSMAN 06632</b></p>	<p>EXTRACTOR/TOOL: Prevost #682256 (Packard 12094429)</p> <p>Remove the terminal by disengaging the flexible lock tab on the terminal. Gently remove the terminal from the connector by pulling on the wire.</p>

2. XLII MOTORHOMES ELECTRICAL COMPARTMENTS AND JUNCTION BOXES

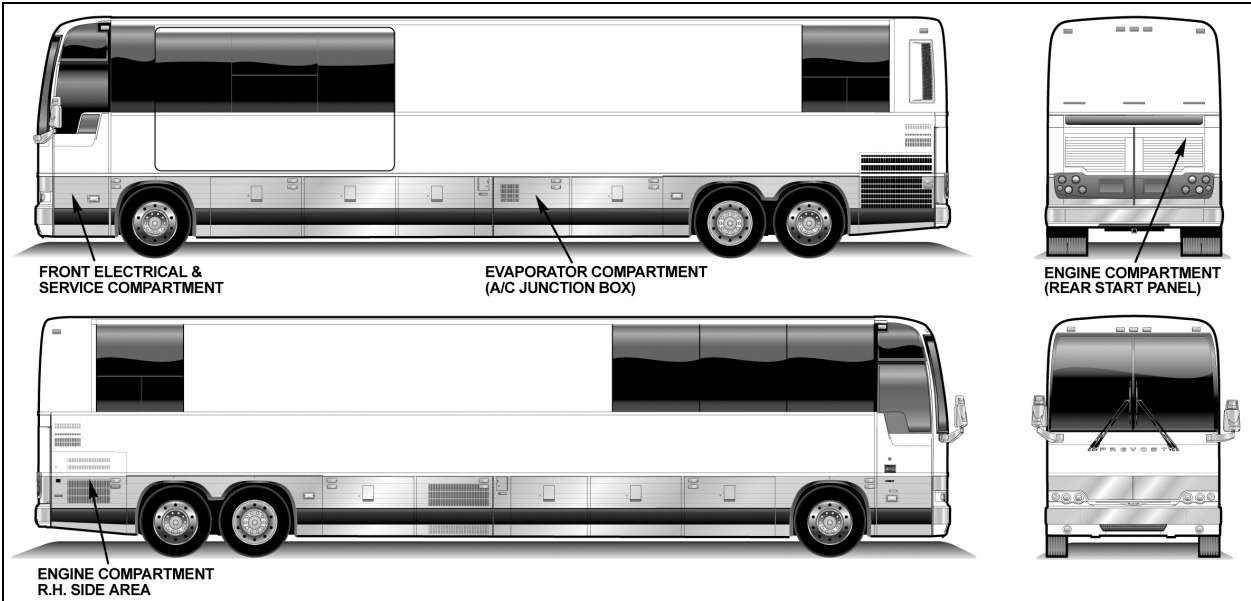

FIGURE 3: ELECTRICAL COMPARTMENTS (XLII-45E BUS SHELLS)

06648

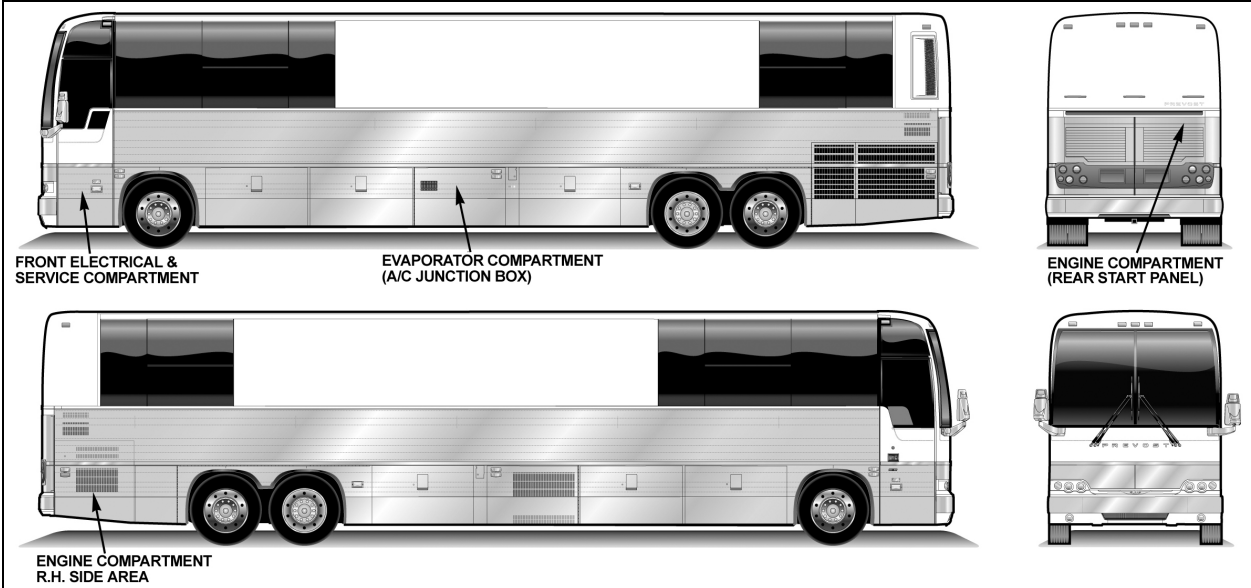



FIGURE 4: ELECTRICAL COMPARTMENTS (XLII-45 BUS SHELLS)

06646

## Section 06: ELECTRICAL

### 2.1 MAINTENANCE

A Cortec VCI-238 corrosion inhibitor has been sprayed in all electrical compartments to protect components from corrosion. The life expectancy of this product is five years, so it is recommended to reapply it every five years. It is also recommended to spray it on new components when added or replaced.



DANGER

Use VIC-238 in a well ventilated area. Do not smoke. Avoid prolonged contact with skin and breathing of spray mist. Harmful or fatal if swallowed. Do not induce vomiting. Call physician immediately.

### 2.2 REAR JUNCTION BOX

The rear junction box is located in the engine compartment, on R.H. side of the vehicle. The rear junction box provides access to the following:

- Multiplex Modules: I/O-A, I/O-B;
- Voltage Regulator;
- Vehicle Electrical Center Rear (VECR);
- Relays and Fuses;
- Transmission ECU;
- Diagnostic Data Reader (DDR Receptacle);
- Electronic Ground Stud;
- Rear Junction Box Temperature Sensor.

Rear Junction Box			
Multiplex Modules			
A49	I/O-A	A52	I/O-B
A50	I/O-B	A53	I/O-B
A51	I/O-B		
Relays			
R1	24V IGN	R30	24V Door lock/Unlock
R3	12V IGN	R31	24V Door lock/Unlock
R8	Service Brake	R32	24V Door lock/Unlock
R11	Not Used	R33	24V Door lock/Unlock
R17	12V wake-up mode		
R21	Emergency		
R25	Engine ECM		
Fuses			
F50	Delco Regulator	F71	Spare
F51	24VD Customer	F72	12VI A50
F52	Lugg. Lock/Unlock	F73	Spare
F53	Cabin area Liq. Valve	F74	12VI ECM Motor
F54	Window ajar & Awning	F75	12VI Trans.
F55	Spare	F76	12VI Customer
F56	Spare	F77	12V Wake-up Transmission

F57	Spare	F78	12V Wake-up ECM
F58	Spare	F79	12V Wake-up ECM
F59	Spare	F80	12V Wake-up A51
F60	Lugg. Lock/Unlock	F81	24V Excitation
F61	Lugg. Lock/Unlock	F85	Not Used
F62	Spare	F86	Spare
F63	Priming Pump	F87	12VI Trailer
F64	Spare	F88	Spare
F65	24VI A49, A52, A53	F89	Spare
F66	Power Fan Clutch	F90	Spare
F67	24VI A54	F91	Spare
F68	24VI A54	F96	Spare
F69	24VI R8	F98	Spare
F70	24 VI Customer	F99	Spare
Resistors			
RES13	Excitation	RES16	Current Reducer
RES14	Excitation	RES17	Current Reducer
Diodes			
D15	Ignition	D46	Service Brakes
D28	Suppression	D67	Upper Rear Light
D29	Suppression	D68	Upper Rear Light
D31	Suppression	D69	Upper Rear Light
D36	Suppression	D70	Upper Rear Light
D37	Suppression		

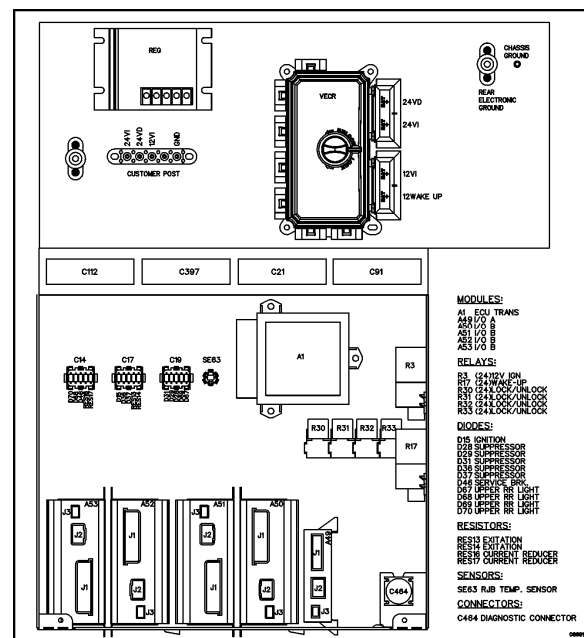



FIGURE 5: REAR JUNCTION BOX

06508



DANGER

During repair or maintenance periods, set ignition key switch to the "OFF" position in order to avoid personal injury. This ensures that power from the batteries is automatically cut off.

**NOTE**

When ignition key switch is set to the "OFF" position, the electrical supply from the batteries is cut off, with the exception of the Fire Detection System, the Engine & Transmission Electronic Controls, the Auxiliary Heating System, the Battery Equalizers and the Digital Clock.

**2.3 CIRCUIT BREAKERS**

All manually-resettable circuit breakers are located in the engine compartment R.H. side area. An identification decal is affixed on the inside face of the door.

MTH WE and W5 may be equipped with nine (9) main breakers; six (5) of which are standard (CB1, CB2, CB3, CB7 & CB9). Three (3) are supplied only on vehicles equipped with central A/C system (CB4, CB5 & CB8); and one (1) is supplied only on vehicles equipped with slide-out (CB6).

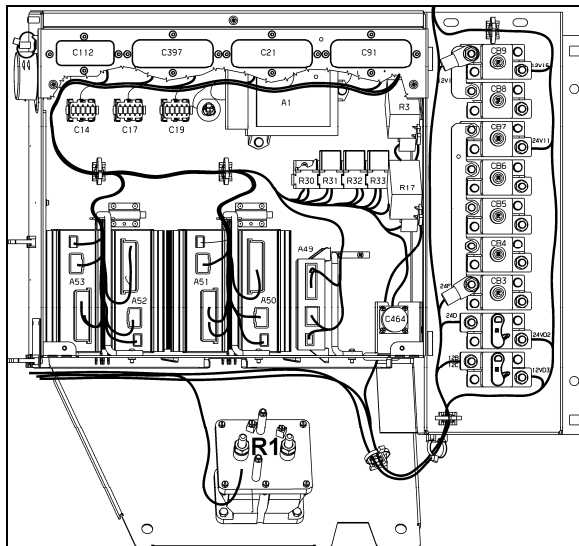

**FIGURE 6: REAR JUNCTION BOX & CIRCUIT BREAKER PANEL**

On all vehicles, breakers CB1 to CB9 are installed on circuit breaker panel in engine compartment R.H. side area (Fig. 6). They are accessible through engine R.H. side door and can be identified as follows:

1. Distribution (CB1) 150 A - 12 volts;
2. Distribution (CB2) 50 A - 24 volts;
3. Front Distribution (CB3) 70 A - 24 volts;
4. Distribution (CB7) 60 A - 24 volts;
5. Distribution (CB9) 70 A - 12 volts;

On all vehicles equipped with central A/C, breakers CB4, CB5 and CB8 are installed on breaker panel in engine compartment R.H. side area (Fig. 6). They are accessible through engine R.H. side door and are identified as follows:

1. HVAC - Evaporator (CB4) 90 A - 24 volts;
2. HVAC - Condenser (CB5) 70 A - 24 volts;
3. HVAC - Condenser (CB8) 40 A - 12 volts.

On all vehicles equipped with one or two slide-outs, breaker CB6 is installed on breaker panel in engine compartment R.H. side area (Fig. 6). It is accessible through engine R.H. side door and is identified as follows:

1. Slide-Out (CB6) 35 A - 24 volts.

**2.4 A/C JUNCTION BOX**

The following components are located in the Evaporator Compartment (HVAC). They are mounted inside the A/C junction box.

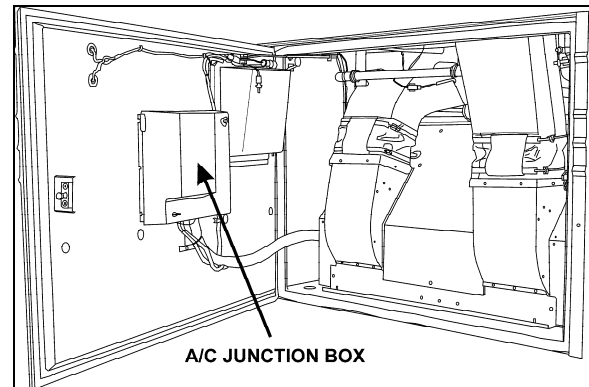

**FIGURE 7: LOCATION OF A/C JUNCTION BOX IN EVAPORATOR COMPARTMENT**

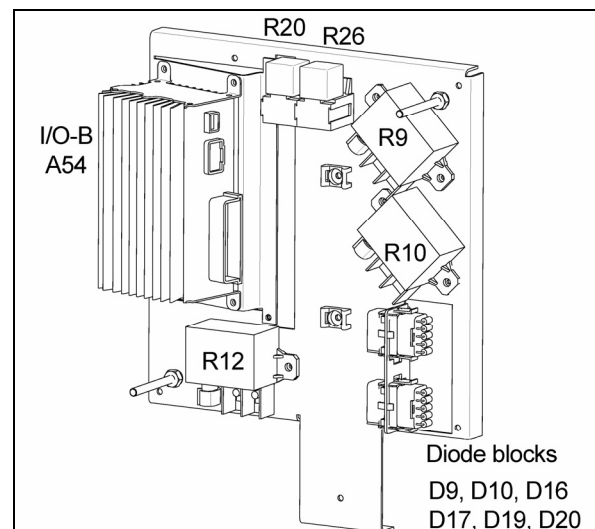

**FIGURE 8: A/C JUNCTION BOX**

## Section 06: ELECTRICAL

Evaporator Compartment			
Multiplex Module			
A54	I/O-B		
Relays			
R9	24V Condenser fan R.H	R20	Water pump
R10	24V Condenser fan L.H	R26	Pre-heating
R12	24V Evaporator fan		
Diodes			
D9	Pre-heating	D19	Baggage compartment -2
D10	Pre-heating	D20	Baggage compartment -1
D16	Baggage compartment -3	DXX	Not used
D17	Baggage compartment -5		

### 2.5 FRONT ELECTRICAL & SERVICE COMPARTMENT

The front electrical & service compartment is located on L.H. side of vehicle, under the driver's window. It contains the following components (Fig. 9):

- Multiplex Modules;
- CECM;
- Common Powertrain Controller (CPC);
- Vehicle Electrical Center Front (VECF);
- Relays and fuses;
- Diodes;
- ABS Electronic control unit (ECU).

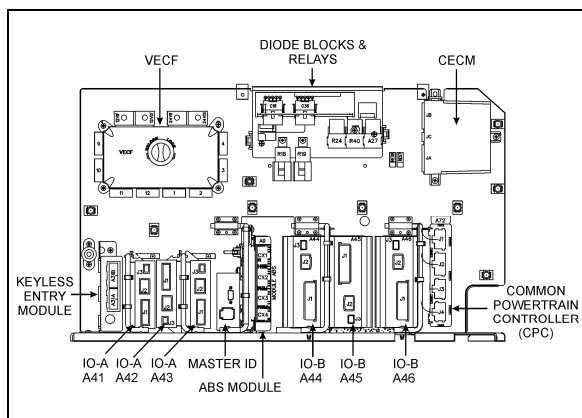

**FIGURE 9: FRONT ELECTRICAL COMPARTMENT** 06319

The light in the front electrical & service compartment turns *ON* automatically when the door is opened.

Front Electrical & Service Compartment			
Multiplex Modules			
VECF	Vehicle Electrical Center Front	A41	I/O-A
A9	ABS-ECU	A42	I/O-A
A13	Master ID	A43	I/O-A
A27	ZF Steering Ctrl	A44	I/O-B
A31	Keyless	A45	I/O-B
A36	CECM	A46	I/O-B
A72	CPC		
Relays			
R18	24V Wake-up mode	R22	Engine ECU Power
R19	12V Wake-up mode		
Fuses			
F1	CECM Power	F24	Mirror
F2	Front start main switch	F25	Spare fuse
F3	Driver liquid solenoid valve	F26	Spare fuse
F4	Spare fuse	F27	12VI Customer
F5	24 volts Wake-up mode	F28	Driver's seat
F6	24VD Customer	F29	Instrument cluster & data reader
F7	Spare fuse	F30	Driver's window
F8	Multi function switch	F31	Keyless module
F9	Spare fuse	F32	Spare fuse
F10	Pneumatic cut-out solenoid	F33	12VD Wake-up mode
F11	Sun visor	F34	12VD Wake-up mode
F12	PWR MUX modules	F35	12-volt accessory outlet
F13	PWR MUX modules	F36	HVAC module & telltale panel
F14	24VI Customer	F37	Spare fuse
F15		F38	PWR A41 multiplex module
F16	Defroster unit	F39	Spare fuse
F17	Level low	F40	Entrance door window
F18		F41	12-volt accessory outlet & lighter
F19		F82	Lower windshield wipers
F20	Witness red LED	F83	Spare fuse
F21	PWR A44 multiplex module	F84	12VD Customer
F22	ZF steering control	F104	Spare fuse
F23	ABS brake system	F105	Spare fuse
Diodes			
D1	Accessories	D13	ABS
D2	Driver unit liquid solenoid valve	D22	Service brake
D12	Engine brake	D44	ignition

### 2.6 ENGINE COMPARTMENT (REAR START PANEL)

The rear start panel is located over the engine in the engine compartment. Switches to start and stop the engine from inside the engine compartment are mounted on that panel. (Fig.10):

- engine compartment light switch;
- starter selector switch;
- Rear start (push button switch);

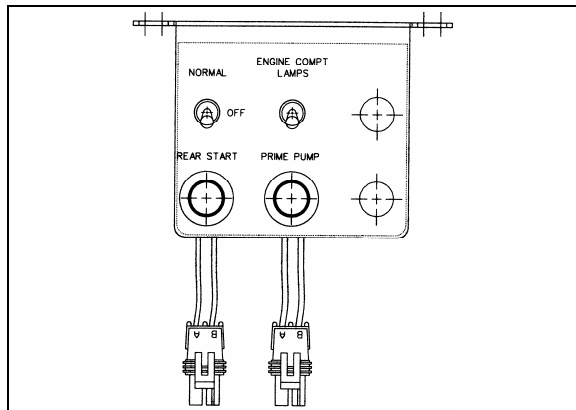

FIGURE 10: REAR START PANEL 06622

### 2.7 WIPER CONTROL PANEL

To access the wiper control panel of the right console, remove the panel under the larger utility compartment at the right of the dashboard.

Wiper Control Panel Inside Right Console			
Multiplex Modules			
A47	I/O-B	A48	I/O-B
Relays			
R23	Lower windshield wipers		
Diodes			
D4	Lower windshield wipers speed 2	DXX	Not Used
D5	Lower windshield wipers speed 1	DXX	Not Used
DX	Not Used		

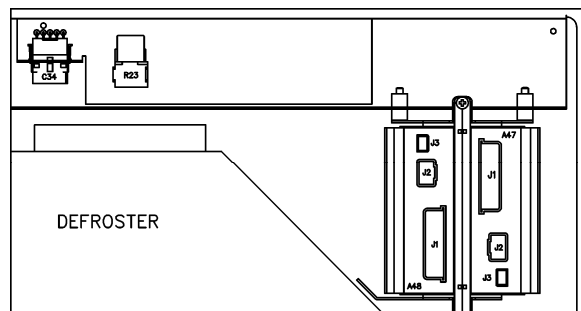

FIGURE 11: WIPER CONTROL PANEL

### 3. BATTERIES

The vehicle is provided with four (4) maintenance-free 12 volt heavy-duty batteries connected in series-parallel (Fig. 13). The top-mounted negative and positive terminals are tightly sealed to prevent leaks. Water never needs to be added to this type of battery. There are no filler caps in the cover. The battery is sealed, except for small vent holes in the cover. The vents must not be restricted as they allow small amounts of gases produced in the battery to escape. The special chemical composition inside the battery reduces gassing to a very small amount at normal charging voltages. Besides reducing gassing, the special chemistry greatly reduces the possibility of overcharge damage.

The vents require keeping the battery in an upright position to prevent electrolyte leakage. Tipping the battery beyond a 45° angle in any direction can allow a small amount of electrolyte to leak out of the vent holes.

**WARNING**

DO NOT tip battery by more than 45° when carrying or installing the battery.

***NOTE***

*Evidence of electrolyte leakage does not necessarily mean the battery is defective.*

With special cables properly attached to the batteries, the metal surfaces that carry the current are completely sealed from the atmosphere. This prevents terminal oxidation and corrosion that may cause starting and charging problems. If new cables are required, sealed terminal cable replacements should be used to retain the reliability of the original maintenance-free connections.

**DANGER**

All lead-acid batteries generate hydrogen gas, which is highly flammable. If ignited by a spark or flame, the gas may explode violently, causing spraying of acid, fragmentation of the battery, which may result in severe personal injuries. Wear safety glasses and do not smoke when working near batteries. In case of contact with acid, flush immediately with water.

## Section 06: ELECTRICAL

The battery has four (4) major functions:

1. Providing a source of current for starting the engine.
2. Stabilizing the voltage in the electrical system.
3. Supplying current for a limited time, when electrical demands of the equipment exceed the power output of the alternator.
4. Providing a limited source of power for connected accessories, when the engine is not running.

The batteries are located in the engine compartment R.H. side (Fig. 13).

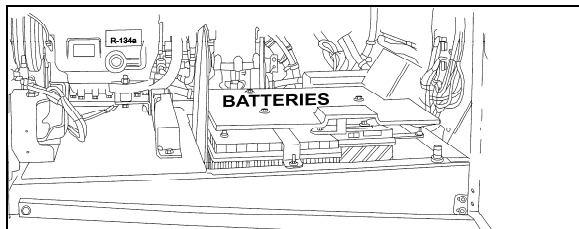

FIGURE 12: ENGINE COMPARTMENT R.H. SIDE 18513

### 3.1 BATTERY DISCHARGE PROTECTION

To prevent discharge of the batteries when the engine is not running, some functions are automatically switched off if the batteries voltage drops below 24.4 volts for more than 30 seconds. The "BAT" telltale light blinks while this protection mode is active. Set the ignition key to the OFF position and then turn the ignition key to the ON position to reactivate the functions for a period of 30 seconds before they switch off again. If a prolonged use of the functions with the engine not running is necessary, connect the battery to a charger.

### 3.2 MAIN BATTERY RELAYS

Main battery relays (24V & 12V) are provided for this vehicle. The relays are located in the rear junction box (R1 & R3). The 24-volt battery relay engages when ignition key is in the ON or ACC position.

When the main battery relays are turned to the OFF position, all electrical supply from the batteries is cut off, with the exception of the following items.

- Battery equalizer check module;
- ECM;
- Transmission Control Module (TCM);
- Preheater electronic timer;

- Preheater and water recirculating pump;
- Radio memory;
- CECM;
- Cluster memory.

### 3.3 BATTERY REMOVAL AND INSTALLATION

The batteries are located in the engine compartment R.H. side area (Fig. 13).

1. Remove the three (3) plastic protective cover retaining bolts. Remove the plastic protective cover.
2. Remove the support retaining bolt.



## DANGER

To prevent possible electric shocks or sparking, trip circuit breakers CB1 & CB2 and turn the ignition key switch in the "Off" position before disconnecting cables from the batteries.

3. Remove the support (if necessary, remove battery cables). To remove battery cables, unscrew terminal nuts and remove cables.
4. Remove battery cables from defective batteries.

### NOTE

When the battery cables have been removed from the batteries, wrap the battery terminals and cable ends with electric tape to prevent accidental grounding. The ground cables should always be disconnected first and replaced last.

5. Remove defective batteries.
6. Installation is the reverse of removal.

### NOTE

In replacing batteries, only batteries of the same specification should be used. Refer to "Specifications" at the end of this section for further details.



## CAUTION

Ensure that connections are not reversed when reinstalling batteries, since damage to electrical system components will result.

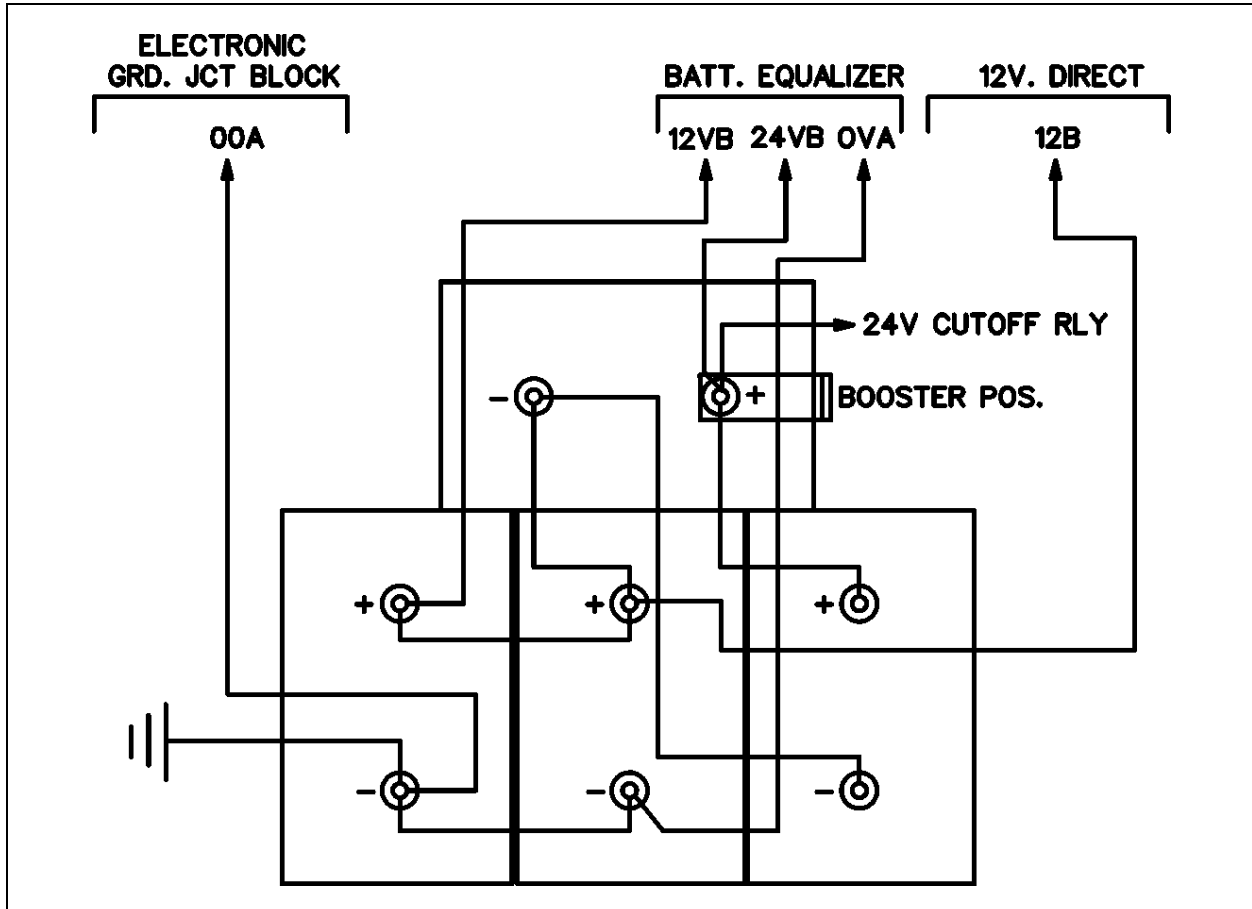

FIGURE 13: BATTERIES CONNECTIONS

06649

**NOTE**

When reinstalling batteries, battery connections must be tightened to 13-15 lbf-ft (18-20 Nm). A torque wrench is required to ensure an accurate tightening torque.

**DANGER**

To prevent possible electric shock or sparking, trip circuit breakers CB1 & CB2 and turn the ignition key switch in the "Off" position before tightening an electrical connection.

**NOTE**

A protective silicone free, coating should be applied on all terminals that have been disconnected. We recommend the use of Cortec VCI-238 (Prévost #682460) on all electrical connections.

**3.4 BATTERY RATING**

Each of the 12 volt batteries used on the vehicle has the following rating:

- Reserve capacity: 195 minutes
- Cold cranking (amps): 950 @ 0°F (-18°C)
- Weight (filled): 59 lb (26,7 kg)

The reserve capacity is defined as the number of minutes a new, fully charged battery at 80°F (26,6°C) can be discharged at 25 amperes and maintain a minimum of 1.75 volts per cell (10.5 volts total for one 12 volts battery). This rating can be used as a basis for determining how long a vehicle might run after an alternator failure. The cold cranking rating is defined as the minimum discharge current a battery will deliver in amperes for 30 seconds at 0°F (-18°C) while maintaining a minimum of 1.2 volts per cell (7.2 volts total for one 12 volts battery). This rating can be used as a basis for comparing starting performance.



## Section 06: ELECTRICAL

### 3.5 BATTERY TESTING

The maintenance-free battery has a strong ability to withstand the damaging effects of overcharge. The test indicator in the cover is used only to determine if the battery can be tested in case of a cranking problem.

The test indicator in the battery cover is to be used with accepted diagnostic procedures only. It must not be used to determine if the battery is good or bad, charged or discharged. The test indicator is a built-in hydrometer in one cell that provides visual information for battery testing (Fig. 15).

It is important when observing the test indicator, that the battery be relatively level and has a clean indicator top to see the correct indication. Some lighting may be required in poorly lit areas. Under normal operation, two indications can be observed.

#### Green Dot Visible

Any green appearance is interpreted as a "green dot", and the battery is ready for testing. On rare occasions, following prolonged cranking, the green dot may still be visible when the battery is obviously discharged. Should this occur, charge the battery as described under "Charging Procedure" in "Battery Charging" later in this section.

#### Dark - Green Dot Not Visible

If there is difficulty cranking the engine, the battery should be tested as described in this section. On rare occasions, the test indicator may turn light yellow. In this case, the integral charging system should be checked. Normally, the battery is capable of further service; however, if difficult start has been reported, replace the battery. **DO NOT CHARGE, TEST, OR JUMP-START.**

#### 3.5.1 Visual Inspection

1. Check the outside of the battery for a broken or cracked cover or case that could permit loss of electrolyte. If obvious physical damage is noted, replace the battery.
2. Check for loose terminal posts, cable connections, damaged cables, and for evidence of corrosion. Correct conditions as required before proceeding with tests.

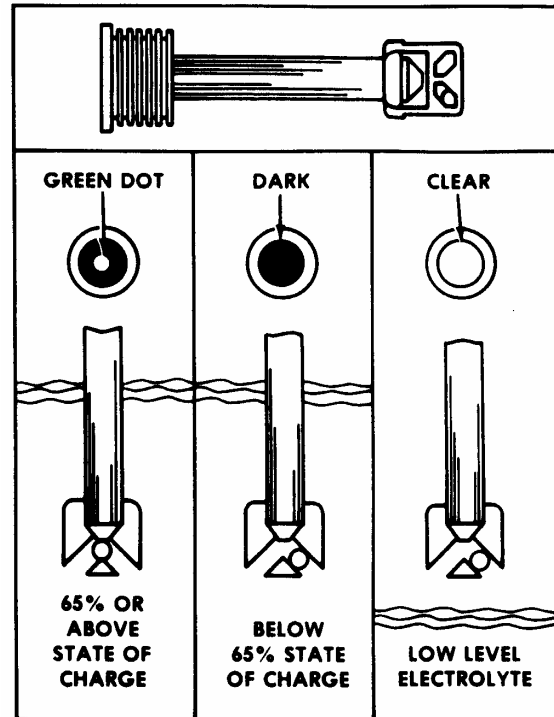

FIGURE 14: TEST INDICATOR

06096

#### 3.5.2 Removing Surface Charge

Disconnect cables from the battery and attach alligator clamps to the contact lead pad on the battery as shown in figure 17. Connect a 300 ampere load across the terminal for 15 seconds to remove surface charge from the battery.

#### 3.5.3 Load Test

This test is one means of checking the battery to determine its ability to function as required in the vehicle.

To make this test, use test equipment that will withstand a heavy electrical load from the battery, such as a carbon pile resistor or other suitable means.

1. Connect a voltmeter, ammeter, and a variable load resistance as illustrated in figure 15.



#### CAUTION

Observe polarity of the meters and the battery when making connections, and select the correct meter range.

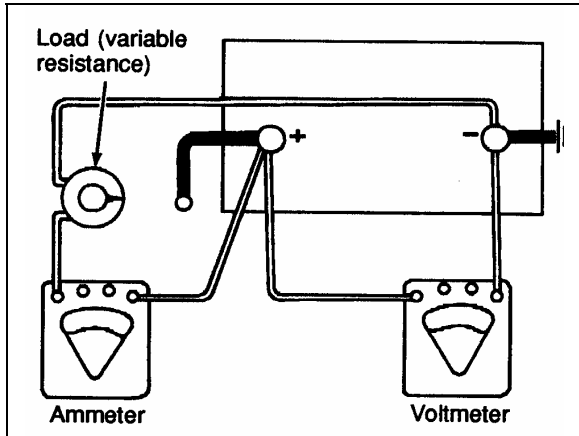

FIGURE 15: LOAD TEST 06064

2. Apply a 290 amperes load to the battery for 15 seconds.
3. With an ammeter reading specified load, read voltage. The voltage should be at least 9.6 volts. Disconnect the load. If the voltmeter indicates 9.6 volts or more, the battery is good. If the voltmeter reading is less than 9.6 volts, replace the battery. This voltage is to be used for battery ambient temperatures of 70°F (21°C) and above. For temperatures below 70°F (21°C), refer to the following "Voltage and Temperature Chart".

**Voltage and Temperature Chart**

Ambient Temperature	Minimum Voltage
70°F (21°C) and above	9.6
60°F (16°C)	9.5
50°F (10°C)	9.4
40°F (4°C)	9.3
30°F (-1°C)	9.1
20°F (-7°C)	8.9
10°F (-12°C)	8.7
0°F (-18°C)	8.5

**NOTE**

*The accuracy of this test procedure is dependent upon close adherence to the proper load, time and temperature specifications.*

**3.5.4 Testing Battery Cables**

Check all cable ring terminals and connections to determine if they are in good condition. Excessive resistance, generally caused by poor connections, produces an abnormal voltage drop which may lower voltage at the starter to such a low value that normal operation of the starter will not be obtained. An abnormal voltage drop can

be detected with a low-reading voltmeter as follows:

DANGER

To prevent the engine from starting, the DDEC engine circuits, which are protected by breakers (CB-1 & CB-2) located in the circuit breaker panel, must be deenergized during these tests; afterward toggle yellow lever upwards to reset the circuit breakers.

1. Check voltage drop between grounded (negative) battery terminal and vehicle frame by placing one prod of the voltmeter on the battery terminal and the other on a good ground (unpainted surface) on the vehicle. With the starter cranking the engine at a temperature of 70°F (21°C), voltage reading should be less than 0.3 volt. If the voltage reading exceeds 0.3 volt, there is excessive resistance in this circuit.
2. Check voltage drop between the positive battery terminal and the starter positive terminal stud while the motor is operated. If the reading is more than 2.5 volts, there is excessive resistance in this circuit.

**NOTE**

*If it is necessary to extend the voltmeter lead for this test, use a #16 (AWG) or larger wire.*

3. Check voltage drop between the starter housing and a good ground on the vehicle. The reading should be less than 0.2 volt.

DANGER

Any procedure other than the following could cause personal injury or damages to the charging system resulting from battery explosion or electrical burns.

Wear adequate eye protection when working on or near the batteries. Ensure that metal tools or jumper cables do not contact the positive battery terminal (or a metal surface in contact with it) as a short circuit will result. Do not attempt to jump start a vehicle suspected of having a frozen battery because the battery may rupture or explode. Both the booster and discharged batteries must be treated carefully when using jumper cables. Follow exactly the procedure outlined later in this section, being careful not to cause sparks.

## Section 06: ELECTRICAL

### 3.6 BATTERY CHARGING

The batteries used on this vehicle can be charged either on or off the vehicle; however, when they are removed from the vehicle, it is recommended that an adapter kit, which is available from any "A/C DELCO" dealer, be used in charging sealed-terminal batteries. Use the booster terminals to charge the batteries when they are left on vehicle and **make sure that the ignition key switch is set to the "On" position.**

The alligator clamps of the tester or charger must be placed between the terminal nuts and the lead pads of the terminal studs (Fig. 17) after the vehicle cables are detached. The alligator clamps should make firm contact with the lead pads.



#### DANGER

During charging of the batteries, an explosive gas mixture forms in each cell. Part of this gas escapes through the vent holes and may form an explosive atmosphere around the battery itself if ventilation is poor. This explosive gas may remain in or around the battery for several hours after it has been charged. Sparks or flames can ignite this gas causing an internal explosion, which may shatter the battery.

1. Do not smoke near a battery which is being charged or which has been recently charged.
2. Do not break live circuits at battery terminals because a spark usually occurs at the point where a live circuit is broken. Care must always be taken when connecting or disconnecting booster leads or cable clamps on chargers. Poor connections are a common cause of electric arcs, which cause explosions.
3. The electrical system on this vehicle is negative ground. Installing the batteries with the positive terminals grounded or incorrect use of the booster battery and jumper cables will result in serious damage to the alternator, batteries and battery cables.

#### NOTE

*If this connection cannot be made because of the alligator clamp design, the load value for testing must be reduced from 290 to 260 amperes.*

On rare occasions, such as those that occur following prolonged cranking, the green dot in the test indicator may still be visible when the battery is obviously discharged. Should this occur, a boost charge of 20 amperes-hour is recommended. Under normal operating conditions, do not charge battery if the green dot is visible. The battery should never be charged if the test indicator (hydrometer) is clear or light yellow. If this occurs, replace the battery.

A charge rate between 3 and 50 amperes is generally satisfactory for any maintenance-free battery as long as spewing of electrolyte does not occur or the battery does not feel excessively hot (over 125°F (52°C)). If spewing or violent gassing of electrolyte occurs or battery temperature exceeds 125°F (52°C), the charging rate must be reduced or temporarily stopped to allow cooling and to avoid damaging the battery. Battery temperature can be estimated by touching or feeling the battery case. The battery is sufficiently charged when the green dot in the built-in hydrometer is visible. No further charging is required. Shake or tilt the battery at hourly intervals during charging to mix the electrolyte and see if the green dot appears.



#### WARNING

Always turn off the charger before connecting or disconnecting to a battery.

#### NOTE

*The charge rate must be doubled when the batteries are charged by the booster terminals, because of the series-parallel circuit.*

Battery charging consists of a charge current in amperes for a period of time in hours. Thus, a 25 ampere charging rate for 2 hours would be a 50 ampere-hour charge to the battery. Most batteries, whose load test values are greater than 200 amperes, will have the green dot visible after at least a 75 ampere-hour charge. In the event that the green dot does not appear, replace the battery.

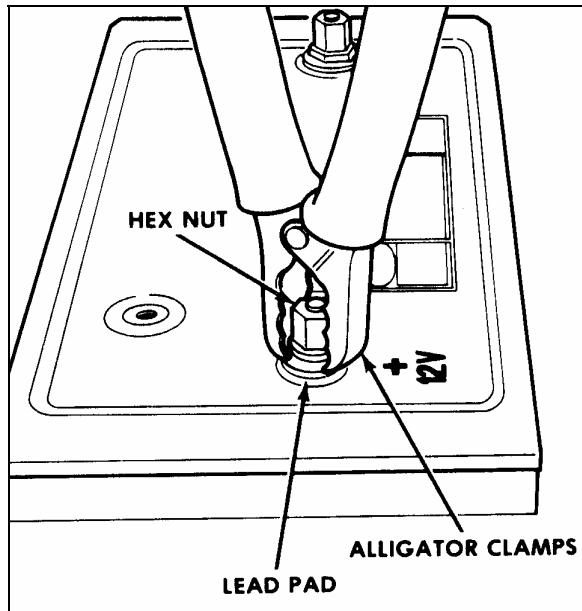

FIGURE 16: ALLIGATOR CLAMPS AND BATTERY 06065

### 3.6.1 Battery Charging Guide

#### Fast Charging Rate

20 amps @ 3-¾ hours  
 30 amps @ 2-½ hours  
 40 amps @ 2 hours  
 50 amps @ 1-½ hours

#### Slow Charging Rate

5 amps @ 15 hours  
 10 amps @ 7-½ hours

The time required for a charge will vary according to the following factors:

#### Size of Battery

For example, a completely discharged large heavy-duty battery requires more than twice the recharging time of a completely discharged small passenger car battery.

#### Temperature

For example, a longer time will be needed to charge any battery at 0°F (-18°C) than at 80°F (27°C). When a fast charger is connected to a cold battery, the current accepted by the battery will be very low at first, and then in time, the battery will accept a higher rate as it warms up.

#### State of Charge

For example, a completely discharged battery requires more than twice as much charge than a half-charged battery. Since the electrolyte is nearly pure water and a poor conductor in a completely discharged battery, the current accepted is very low at first. Later, as the charging current causes the electrolyte acid

content to increase, the charging current will likewise increase.

#### Charger Capacity

For example, a charger which can supply only 5 amperes will require a much longer period of charging than a charger that can supply 30 amperes or more.

### 3.6.2 Emergency Jump Starting With Auxiliary (Booster) Battery.



#### DANGER

Do not jump start vehicles equipped with maintenance-free batteries if the test indicator is light yellow.

Both booster and discharged batteries should be treated carefully when using jumper cables. A vehicle with a discharged battery may be started by using energy from a booster battery or the battery from another vehicle.



#### DANGER

Jump starting may be dangerous and should be attempted only if the following conditions are met:

The booster battery or the battery in the other vehicle must be of the same voltage as the battery in the vehicle being started, and must be negative grounded.

If the booster battery is a sealed-type battery without filler openings or caps, its test indicator must be dark or a green dot must be visible. Do not attempt jump starting if the test indicator of the booster battery or the discharged battery has a light or bright center.



#### DANGER

Follow the procedure exactly as outlined hereafter. Avoid making sparks.

1. Wear eye protection and remove rings, watches with metal bands and other metal jewelry.
2. Apply parking brake and place the transmission shift lever or push-button pads in Neutral (N) position in both vehicles. Turn off lights, heater and other electrical loads. Observe the charge indicator. If the indicator in the discharged battery is illuminated,

## Section 06: ELECTRICAL

replace the battery. **Do not** attempt jump starting when indicator is illuminated. If the test indicator is dark and has a green dot in the center, failure to start is not due to a discharged battery and the cranking system should be checked. If charge indicator is dark but the green dot does not appear in center, proceed as follows:

3. Connect one end of one red jumper cable to the positive (+) terminal of the booster power source and the other end to the positive (+) terminal bar on the battery, located in the engine compartment R.H. side area (refer to fig. 18).
4. Connect one end of the remaining negative jumper cable (black) to the negative (-) terminal of the booster power source and the other end of the black jumper cable to the negative (-) terminal on the structure.
5. Make sure the clips from one cable do not inadvertently touch the clips on the other cable. Do not lean over the battery when making connections. The ground connection must provide good electrical conductivity and current carrying capacity.
6. Start the engine in the vehicle that is providing the jump start. Let the engine run for a few minutes, then start the engine in the vehicle that has the discharged batteries.
7. When removing the jumper cables, perform the above procedure exactly in reverse order.

On all XLII MTH, booster terminals are located in the engine compartment on the R.H. side and are accessible through engine compartment R.H. side door (Fig. 18).

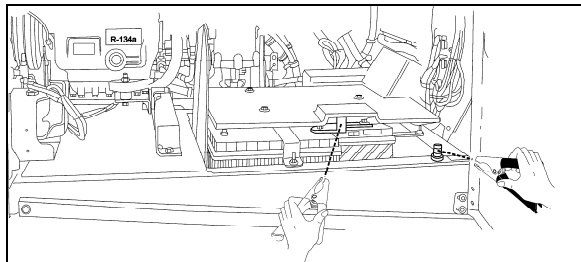

FIGURE 17: JUMP STARTING

06645

**DANGER**

Any procedure other than the above could result in personal injury, property damage due to battery explosion, or damage to the

charging system of the booster vehicle or of the boosted vehicle.

### NOTE

*Jumper cables must withstand 500 cranking amperes. If cable length is 20 feet (6m) or less, use 2/0 (AWG) gauge wires. If cable length is between 20-30 feet (6-9m), use 3/0 (AWG) wires.*

### 3.7 CLEANING AND INSPECTION

The external condition of the battery and the battery cables should be checked periodically. The top of the battery should be kept clean and the battery hold-down clamp bolts should be kept properly tightened. For best results when cleaning the battery, wash first with a diluted solution of ammonia or soda to neutralize any acid present then wash out with clean water. The battery hold-down bolts should be kept tight enough to prevent the batteries from moving, but they should not be tightened to the point that excessive strain is placed on the battery hold-down cover (proper tightening torque: 45-55 lbf-in (5-6 Nm).

To insure good contact, the battery cable ring terminals should be tight on the battery posts. If the posts or cable ring terminals are corroded, the cables should be disconnected and the posts and clamps cleaned separately with a soda solution and a wire brush. Install cable ring terminals on battery posts and tighten to a torque of 10-15 lbf-ft (13-20 Nm). Replace protective caps to prevent corrosion and sparks.

### 3.8 COMMON CAUSES OF BATTERY FAILURE

When a battery fails, the cause of failure may be related to something other than the battery. For this reason, when a battery failure occurs, do not be satisfied with merely recharging or replacing the battery. Locate and correct the cause of the failure to prevent recurrence. Some common external causes of battery failure are as follows:

1. A defect in charging system such as high resistance or a faulty alternator or regulator.
2. A malfunction within the 12 volts system (equalizer).
3. Overloads caused by a defective starter or excessive use of accessories.

4. Dirt and electrolyte on top of the batteries causing a constant drain.
5. Hardened battery plates, due to battery being in a low state of charge over a long period of time.
6. Shorted cells, loss of active material from plates.
7. Driving conditions or requirements under which the vehicle is driven for short periods of time.
8. A constant drain caused by a shorted circuit such as an exposed wire or water infiltration in junction boxes causing ground fault.
9. Extended operation of preheating system with engine not running.
10. Failing to close disconnect switches during the night.

### 3.9 TROUBLESHOOTING

If a battery is known to be good and then has not performed satisfactorily in service for no apparent reason, the following factors may reveal the cause of trouble:

1. Vehicle accessories and disconnect switches inadvertently left on overnight.
2. Defects in the charging system, such as high wiring resistance, faulty alternator, regulator or battery equalizer.
3. A vehicle electrical load exceeding the alternator (or battery equalizer) capacity, with the addition of electrical devices, such as CB radio equipment, a cellular phone or additional lighting systems.
4. Defects in the electrical system, such as shorted or pinched wires.
5. Extended driving at a slow speed while using many accessories.
6. Loose or poor battery cable-to-post connections, previous improper charging of a run-down battery, or loose hold-down clamp bolts.
7. High-resistance connections or defects in the cranking system.

### 3.10 "BAT" BATTERY VOLTAGE INCORRECT TELLTALE LIGHT

If the "BAT" (battery voltage incorrect) telltale light is illuminated, check the 24-volt voltmeter to

determine if the battery voltage is too high or too low.

**NOTE**

*According to the battery charging condition, it is normal that "BAT" telltale light illuminates upon starting the engine and stays illuminated for a few seconds. This is caused by the normal voltage drop of the battery during starting.*

#### 3.10.1 "Bat" Telltale Light Definitions

##### **Voltmeter drops below 24.4 volts dc**

- Check alternator output.
- Check voltage regulator.
- Check battery connections.
- Check battery cells.
- Check battery equalizer connections.

##### **Voltmeter exceeds 30 volts dc**

- Check alternator output.
- Check voltage regulator.
- Check battery connections.

#### **Battery Balance**

**NOTE**

*Allow at least 15 minutes to balance batteries after any corrective measure has been taken.*

1. Batteries out of balance (difference greater than 1.5 volts between the two battery banks).
  - Check battery equalizer connections.
  - Check equalizer cables for proper gauge.
  - Check battery connections.
2. Demand for 12-volt power exceeding rated amperage output of battery equalizers causing batteries to go out of balance.
  - Reduce 12-volt load or install additional battery equalizer(s).

### **4. TROUBLESHOOTING AND TESTING THE MULTIPLEX VEHICLES**

#### 4.1 ELECTRICAL SYSTEM DIAGNOSTIC

Using the message center display (MCD), check if there are active errors in the vehicle electrical

## Section 06: ELECTRICAL

system. With the SYSTEM DIAGNOSTIC menu, highlight FAULT DIAGNOSTIC and then highlight ELECTRICAL SYSTEM to request a diagnostic of the electrical system from the CECM. Press the enter key. If applicable, the MCD shows the multiplex device ID, the fault messages or fault codes recorded. When more than one fault is recorded, an arrow pointing down appears on the right of the display. Use the down arrow to see all the fault messages.

Once the problem corrected, the MCD still shows the fault as being active. You have to leave the FAULT DIAGNOSTIC menu, wait approximately 20 to 30 seconds and then return to FAULT DIAGNOSTIC to request a new diagnostic of the ELECTRICAL SYSTEM from the CECM. The MCD should display the fault as being inactive. The CECM can store up to 20 faults, i.e. the first 10 and the last 10. Middle faults will be erased. If the breakers are tripped, the fault history will be erased from the CECM memory.

### NOTE

*When performing an electrical system diagnostic with the MCD (message center display), the message "No Response ModA41" indicates either module A41 is not responding due to a CAN link problem or module A41 is not powered. Similar messages exist for all modules (A42, A43, A44, etc.).*

*Because it is easier to do, check first if the module is powered by probing on its gray connector. If it is, then you can conclude that there is a CAN link problem. Refer to paragraph 4.6: CAN NETWORK LAYOUT AND TROUBLE-SHOOTING in this section.*

### NOTE

*It is of the utmost importance to have a MCD (message center display) in working condition because it is the most important tool to achieve troubleshooting on a multiplex vehicle.*

### 4.2 PROBING VOLTAGE ON THE MULTIPLEX CIRCUITS

Some Multiplex modules are supplied by 12 volts while others are supplied by 24 volts. The 12-volt or 24-volt information is found on the modules symbol in the wiring diagram. Before taking voltage readings to track the source of a problem, first verify if the module is supplied by 12V or 24V, if not, residual voltage on the

module inputs/outputs can draw an erroneous conclusion.

Inactive Multiplex output = Residual voltage of 18% to 33% of supply voltage.

Inactive Multiplex input = Residual voltage of 50% of supply voltage.

### NOTE

- *Verify on the wiring diagram whether the voltage is 12V or 24V,*
- *For a 12V module: an active voltage would be 12V or 0V but not in between. If you measure the intermediate tensions (ex. 6V, 2V, or 4V) this must be interpreted as if the input or the output is inactive.*
- *For a 24V module: an active voltage would be 24V or 0V but not in between. If you measure the intermediate tensions (ex. 12V, 4V, or 8V) this must be interpreted as if the input or the output is inactive.*

### 4.3 CAN NETWORK

The CAN link wiring is separated in sections and uses connectors that are not shared with other circuits. This allows sections of the network to be isolated to help locate short-circuit on the CAN.

In case of a short-circuit on the CAN link, this affects all the modules and they all show « No Response » in the error messages of the « ELECTRICAL SYSTEM » menu. To locate a short-circuit, proceed by disconnecting one module zone at a time while verifying if this makes inactive the errors in the modules still connected. Connector C1 (front electrical & service compartment) disconnects all the modules at the rear of the vehicle from the network. Connector C5 (front electrical & service compartment) disconnects all the modules from the wiper control panel. Connector C100 disconnects the module from the evaporator compartment. Connector C3 (rear junction box) disconnects the modules from the battery compartment.

Example: Disconnect C5 and C1 and then verify the status of the errors. If the front modules (A41 to A46) now give inactive errors, which means short-circuit is elsewhere than in the front electrical & service compartment.

#### 4.3.1 Can Connection On The Telltale Panel And The Hvac Control Unit

The telltale panel module and HVAC module are linked to the CECM by a CAN connection. In case of a CAN connection default, the telltale panel LCD display shows "CAN", and on the HVAC control unit, the temperature display indicates "---". To confirm a CAN connection default, check that the fan speed on the driver's section HVAC control unit cannot be adjusted.

Moreover, specific error messages from these 2 modules can be read in the ELECTRICAL SYSTEM menu.

**NOTE**

*While downloading a new vehicle program in the CECM from a computer, the CAN network is temporarily interrupted and therefore a CAN reference appears in the telltale panel LCD display.*

4.3.2 Spare Can

A spare CAN network is installed between the front and the rear of the vehicle. It has connectors installed at each end to facilitate swapping from the regular CAN network to the spare CAN network. Refer to the vehicle wiring diagram and paragraph 4.6 for more information.

4.4 TEST MODE FOR SWITCHES AND SENSORS

The switch/sensor test mode provides useful information to diagnose problems complimentary to the electrical system diagnosis.

To enter this mode, activate the dashboard "Telltale Light Test" switch 3 times within 4 seconds. To exit the switch/sensor test mode, reactivate the test switch 1 time or turn OFF the ignition.

4.4.1 Information Available And Impact On The Functions In Switch/Sensor Test Mode

Telltale panel audible alarm emits a *beep* each time an OFF/ON transition is detected on a multiplex input. This allows quick verifying if the switches and sensors are detected or seen by the multiplex modules. When the vehicle is parked, the back-up alarm also emits a sound that allows verification of the sensors at the rear of the vehicle.

Certain inputs are doubled (ex. turn signal switch on multi-function lever) and also other inputs activate at the same time. For these inputs, 2 *beeps* are emitted. If only one *beep* is heard, one of the inputs is defective.

SWITCHES AND SENSORS SUPPORTED BY THE SWITCH/SENSOR TEST MODE
HVAC control unit driver's section ON/OFF
A/C door ajar open sensor
HVAC control unit driver recirculate switch
HVAC control unit cabin area ON/OFF
Engine ether start switch
Radiator fan clutch switch
Engine front start enable switch
Engine rear start enable switch
Engine ignition front switch
Engine ignition rear switch
Entrance door electric window down switch
Entrance door electric window up switch
Electric horn button
Interior lighting switch, 2 positions
Driver's area lighting switch
Reading lights switch
Multi-function lever LH turn signal
Multi-function lever RH turn signal
Fog lights switch
Hazard warning flashers switch
Multi-function lever courtesy blinkers switch
Headlights switch, 2 positions
Multi-function lever headlights beam toggle switch
Baggage compartment door lock/unlock switch
Tag axle signal
Windshield lower wiper
Multi-function lever windshield wipers intermit.
Multi-function lever windshield wipers speed 1,2
Lower windshield wipers backup switch
Lower windshield washer switch

The following inputs, either certain options or sensors which are difficult to activate, are not supported by the switch/sensor test:

- Starter Sensor;
- ABS Warning input;
- Driver's Power Window Switch (up & down);
- Fog Lights Switch;
- Alternator Sensors 1 & 2;
- Retarder Active Signal;
- Radiator fan speed 1 & 2 signals.

When in switch/sensor test mode, the A/C compressor HI and LO pressure values are displayed one after the other instead of the outside temperature in the telltale panel LCD display. This feature can be used when the



## Section 06: ELECTRICAL

vehicle is traveling to check the A/C compressor pressure values, but no *beep* can be heard.

In test mode, with the parking brake applied and the cabin area (passenger) set point set to a value higher than 64°F (18°C), the circulator pump is not set to OFF as it would normally do when the outside temperature gets above 50°F (10°C). This feature allows verification of the pump when inside a garage. This is also useful when working on the heating system to remove air pockets trapped in the system.

When performing an A/C cooling test and having the water pump shut off in switch/sensor test mode is required, just set the cabin (passenger) set point temperature to the minimum 64°F (18°C) to shut off the pump.

### 4.5 TEST MODE FOR ELECTRIC MOTORS

The test mode allows testing the motors and electric contactors without the need to have the engine running. Note that while in test mode, the engine cannot be started.

Prerequisite conditions for the motor test mode:

- A. The battery charger must be connected to a 110-120 volt power supply. If not, the test will be interrupted when the voltage drops below 24.4 volts,
- B. Engine not running,
- C. Parking brake applied,

 <b>DANGER</b>
Before starting the test sequence, make sure nobody is working in the evaporator or condenser compartment.

<b>NOTE</b>
<i>A delay of 15 seconds during which the back-up alarm will sound is introduced prior the test start to advise people that may be working on the vehicle.</i>

#### To enter this mode:

- Activate the dashboard Telltale Light Test switch 3 times within 4 seconds;
- Push the ON/OFF button on the driver's side HVAC control module 5 times (that makes 3 transitions from OFF to ON),

- A *beep* can be heard indicating the motor test mode has started.

#### Using the test mode:

During the entire test, the telltale panel audible alarm gives a signal each second to remind that the motor test mode is underway.

#### 4.5.1 Test Sequence – MTH Equipped With Central HVAC System

- Driver's & cabin units fresh air damper opening. *[20 seconds delay]*
- Go to the condenser compartment and check the fans. The condenser motors start at speed 1 for 3 seconds, then after a short pause, speed 2 activates. *[3 seconds delay]*
- The cabin unit refrigerant solenoid valve activates 3 times. *[10 seconds delay]*

***Then 5 beeps can be heard from the back-up alarm to indicate to go to the engine compartment.***

**In the engine compartment, the sequence is as follows:**

- A/C compressor clutch activates 3 times.
- Left compressor unloader activates 3 times.
- Right compressor unloader activates 3 times. *[5 seconds delay]*
- Radiator fan clutch is disengaged (fan can be turned freely by hand). *[3 seconds delay]*
- Fan clutch engages in speed 1 (fan can be turned by hand but with a certain resistance). *[3 seconds delay]*
- Fan clutch engages in speed 2 (cannot be turned but hand). *[10 seconds delay]*

***5 beeps from the back-up alarm indicate to go to the evaporator compartment.***

**In the evaporator compartment:**

- Evaporator fan motor runs at speed 1 for 3 seconds then runs at speed 2 for 2 seconds.
- Hot water pump starts running for 5 seconds and hot water pneumatic valve cycles 3 times. *[20 seconds delay]*

***5 beeps from the back-up alarm indicate to go to the reclining bumper compartment behind the reclining bumper.***

**Inside the reclining bumper compartment:**

- Driver's unit refrigerant solenoid valve activates 3 times.
- Driver's unit hot water pneumatic valve cycles 3 times.
- Closing of the fresh air dampers.

**This ends the test. Activate the dashboard Telltale Light Test switch one time to leave the motor test mode.**

#### 4.5.2 Test Sequence – MTH Equipped With Small HVAC System

- Driver's unit fresh air damper opening.  
*[20 seconds delay]*

***Then 5 beeps can be heard from the back-up alarm to indicate to go to the engine compartment.***

**In the engine compartment, the sequence is as follows:**

- A/C compressor clutch activated 3 times.  
*[5 seconds delay]*
- Radiator fan clutch is disengaged (fan can be turned freely by hand). *[3 seconds delay]*
- Fan clutch engages in speed 1 (fan can be turned by hand but with a certain resistance).  
*[3 seconds delay]*
- Fan clutch engages in speed 2 (cannot be turned but hand). *[10 seconds delay]*

***5 beeps from the back-up alarm indicate to go to the reclining bumper compartment behind the reclining bumper.***

**Inside the reclining bumper compartment:**

- Hot water pump starts running for 5 seconds.
- Driver's unit refrigerant solenoid valve activates 3 times.
- Driver's unit hot water pneumatic valve cycles 3 times.
- Closing of the fresh air dampers.

**This ends the test. Activate the dashboard Telltale Light Test switch one time to leave the motor test mode.**

## Section 06: ELECTRICAL

### 4.6 CAN NETWORK LAYOUT AND TROUBLESHOOTING

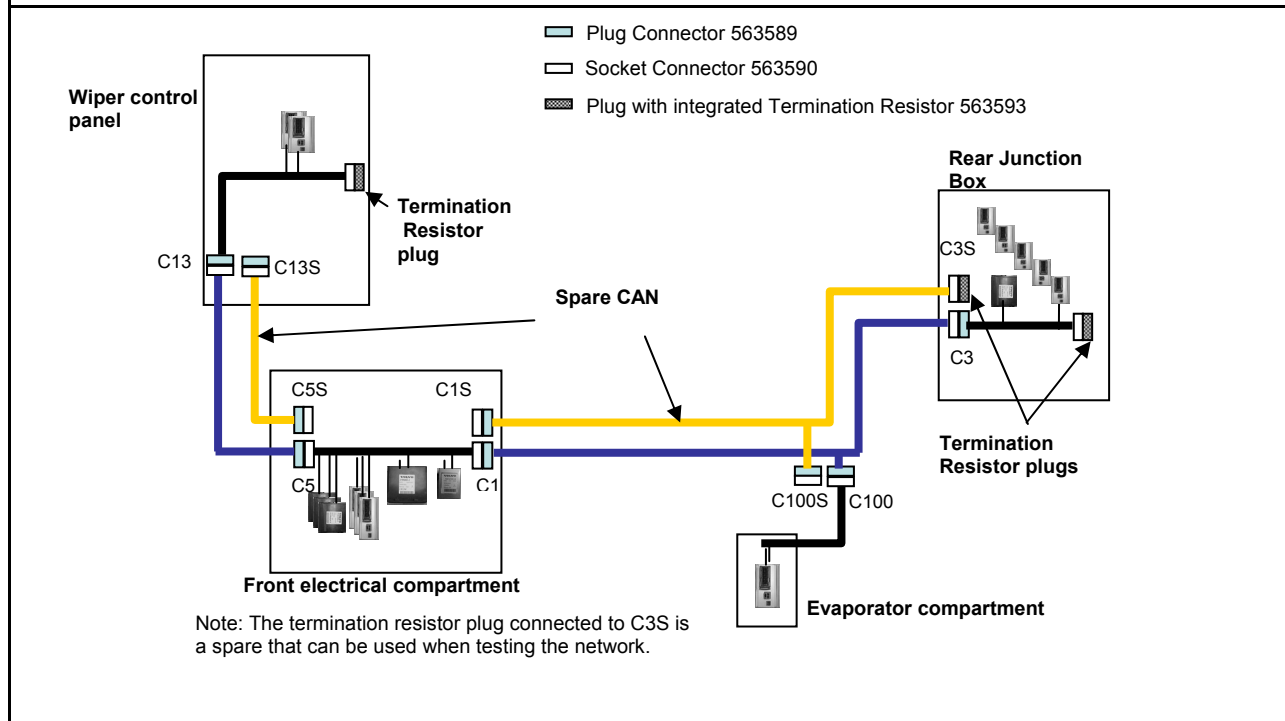
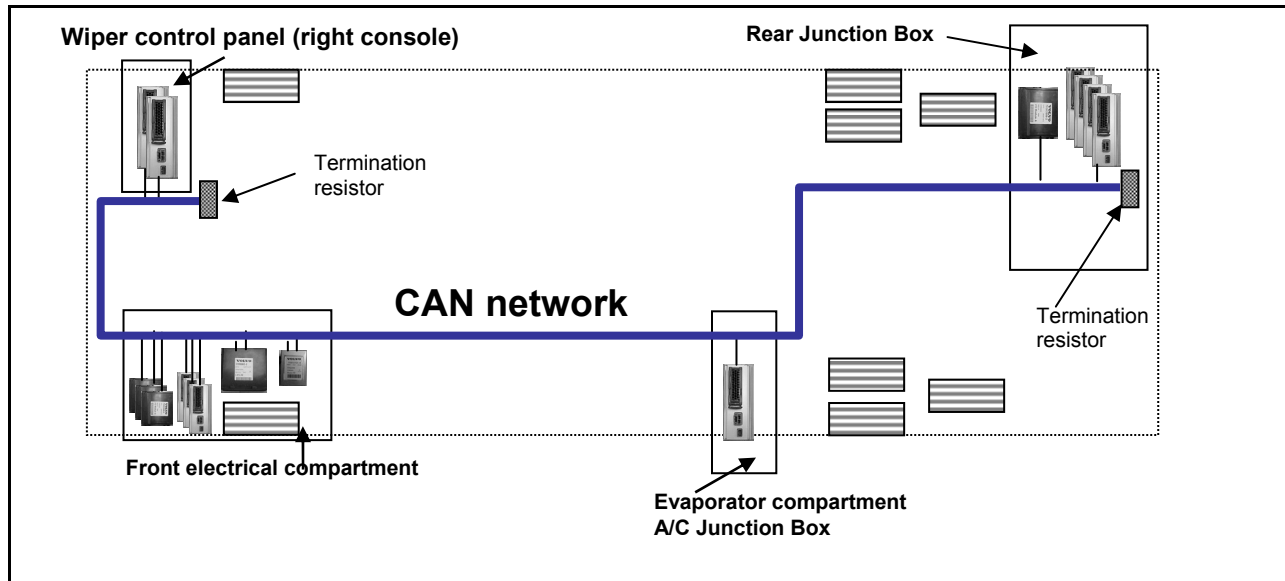

If all 14 modules (A41 to A54) are showed as Not Responding and Active Fault, the problem could be:

- A short circuit somewhere on the CAN network.
- The network is completely open circuit. That means none of the two termination resistors are connected.

Several simple tests can be done to locate the problem.

## 4.7 ROADSIDE TROUBLESHOOTING

Problem/Symptom	Probable Causes	Actions
Vehicle does not Start	Rear Start selector switch is not in the NORMAL position.	<ol style="list-style-type: none"> <li>1. Check that the rear start selector switch is flipped up to NORMAL start position and retry cranking.</li> <li>2. Flip the rear start selector switch to "Rear Start" and start the vehicle from the rear.</li> </ol>
	<p>CAN network problem (Multiplex)</p> <p>Module A53 not powered or is defective</p> <p>Engine MCM does not receive the ignition signal</p> <p>Engine MCM is not powered</p>	<p>If the vehicle does not start from the rear:</p> <ol style="list-style-type: none"> <li>1. Verify that module A53 is powered:               <ol style="list-style-type: none"> <li>a) Check the SYSTEM DIAGNOSTIC menu of the message center display (MCD). Select FAULT DIAGNOSTIC and ELECTRICAL SYSTEM. The message "No Response ModA53, Active", indicates a power problem on the module or a CAN network problem.</li> <li>b) Check / reset circuit breakers CB1 and CB9.</li> <li>c) Check / replace fuse F74 and F80.</li> <li>d) Probe gray connector on module to see if it is powered.</li> </ol> </li> <li>2. Verify that the engine MCM is powered and get the ignition signal. Check / replace fuse F78 and F79.</li> </ol>
	<p>None of the Multiplexed functions are operating, including the basic limp-home functions (door opening, flashers, wipers in speed 1)</p> <p>Three dashes "---" appear in the telltale panel instead of the outside temperature</p> <p><i>Note: The sunshades are still functioning since these are not multiplexed</i></p>	<p>The program version in the CECM is different than the program in the I/O modules and the CECM is forcing all I/O modules to stay inactive</p>

## Section 06: ELECTRICAL

Problem/Symptom	Probable Causes	Actions
<p>Many secondary functions (not essential for driving) not functioning (interior lighting, driver's area lighting, wiper speed 2 and intermittent).</p> <p>Outside temperature display in the telltale LCD panel displays three dashes "---"</p> <p>Marker lights and clearance lights are turned ON when setting ignition to the ON position.</p>	<p>The CECM module does not receive 24 V power.</p> <p>The CAN network is not working. It could be caused by a short on the network, an open circuit, a problem with the CECM or the CECM being disconnected from the network.</p>	<ol style="list-style-type: none"> <li>1. Check / reset circuit breaker CB2 (2<sup>nd</sup> from the bottom). Check / replace fuse F1.</li> <li>2. Operate in limp-home mode by starting the vehicle from the engine compartment (REAR START). All functions essential to drive are available.</li> </ol>
<p>No temperature control in the cabin area.</p> <p>Cabin temperature display indicates two dashes "--"</p>	<p>Problem with the temperature sensor located in the evaporator compartment air intake or the sensor wiring.</p>	<p>Manually control the temperature by playing with the cabin (passenger) set point. Set above 22°C (72°F) to heat and below 22° C (72°F) to cool.</p>
<p>Defroster fan not functioning</p> <p>Windshield wipers not functioning in speed 1 or intermittent</p>	<p>Module A47 is not powered or is faulty</p>	<ol style="list-style-type: none"> <li>1. Check the SYSTEM DIAGNOSTIC menu of the message center display (MCD). Select FAULT DIAGNOSTIC and ELECTRICAL SYSTEM. The message "No Response ModA47, Active" indicates a power problem on the module. (A CAN network problem would show the same message but doesn't produce these symptoms).</li> <li>2. Check / reset circuit breaker CB3.</li> <li>3. Check / replace fuse F5 and F16.</li> <li>4. Probe gray connector on module to see if it is powered.</li> </ol>
<p>Windshield wipers not functioning in speed 1 or intermittent</p>	<p>No power on R23</p>	<p>Check / replace fuse F82</p>
<p>HVAC condenser fans not functioning in speed 1</p>	<p>Circuit breaker CB7 tripped and not reset</p>	<p>Check / reset circuit breaker CB8</p>
<p>HVAC condenser fans not functioning in speed 2</p>	<p>Circuit breaker CB7 tripped and not reset</p>	<p>Check / reset circuit breaker CB5</p>
<p>Windshield washer not functioning</p>	<p>Module A46 is not powered or is faulty</p>	<ol style="list-style-type: none"> <li>1. Check the SYSTEM DIAGNOSTIC menu of the message center display (MCD). Select FAULT DIAGNOSTIC and ELECTRICAL SYSTEM.</li> </ol>

Problem/Symptom	Probable Causes	Actions
Defroster fan is functioning but no heat or cooling available in the driver area.		<p>The message “No Response ModA46, Active” indicates a power problem on the module. (A CAN network problem would show the same message but doesn't produce these symptoms).</p> <ol style="list-style-type: none"> <li>2. Check / reset circuit breaker CB3.</li> <li>3. Check / replace fuse F12 or F13.</li> <li>4. Probe gray connector on module to see if it is powered.</li> </ol>
<p>Low beam headlights and front flasher on left side not functioning</p> <p>Electric horn not functioning</p>	Module A45 is not powered or is faulty	<ol style="list-style-type: none"> <li>1. Check the SYSTEM DIAGNOSTIC menu of the message center display (MCD). Select FAULT DIAGNOSTIC and ELECTRICAL SYSTEM. The message “No Response ModA45, Active” indicates a power problem on the module. (A CAN network problem would show the same message but doesn't produce these symptoms).</li> <li>2. Check / reset circuit breaker CB1.</li> <li>3. Check / replace fuse F33 and F34.</li> <li>4. Probe gray connector on module to see if it is powered.</li> </ol>
Low beam headlights and flasher on right side not functioning	Module A48 is not powered or is faulty	<ol style="list-style-type: none"> <li>1. Check the SYSTEM DIAGNOSTIC menu of the message center display (MCD). Select FAULT DIAGNOSTIC and ELECTRICAL SYSTEM. The message “No Response ModA48, Active” indicates a power problem on the module. (A CAN network problem would show the same message but doesn't produce these symptoms).</li> <li>2. Check / reset circuit breaker CB1.</li> <li>3. Check / replace fuse F33 and F34.</li> <li>4. Probe gray connector on module to see if it is powered.</li> </ol>
<p>Rear flashers not functioning</p> <p>Stoplights and center stoplights not functioning</p>	Module A51 is not powered or is faulty	<ol style="list-style-type: none"> <li>1. Check the SYSTEM DIAGNOSTIC menu of the message center display (MCD). Select FAULT DIAGNOSTIC and ELECTRICAL SYSTEM. The message “No Response ModA51, Active” indicates a power problem on the module. (A CAN network problem would show the same message but doesn't produce this symptom).</li> </ol>

## Section 06: ELECTRICAL

Problem/Symptom	Probable Causes	Actions
		<ol style="list-style-type: none"> <li>2. Check / reset circuit breaker CB1.</li> <li>3. Check / replace fuse F80.</li> <li>4. Probe gray connector on module to see if it is powered.</li> </ol>
<p>Engine is overheating and radiator fan clutch does not engage</p> <p>The A/C compressor clutch does not engage</p>	<p>Module A52 is not powered or is faulty</p>	<ol style="list-style-type: none"> <li>1. Check the SYSTEM DIAGNOSTIC menu of the message center display (MCD). Select FAULT DIAGNOSTIC and ELECTRICAL SYSTEM. The message "No Response ModA52, Active" indicates a power problem on the module. (A CAN network problem would show the same message but doesn't produce this symptom).</li> <li>2. Check / reset circuit breaker CB7.</li> <li>3. Check / replace fuse F65.</li> <li>4. Probe gray connector on module to see if it is powered.</li> </ol>
<p>Evaporator fan not functioning</p>	<p>Circuit breaker CB4 tripped</p> <p>Module A54 is not powered or is faulty</p>	<ol style="list-style-type: none"> <li>1. Check / reset circuit breaker CB4.</li> <li>2. Check the SYSTEM DIAGNOSTIC menu of the message center display (MCD). Select FAULT DIAGNOSTIC and ELECTRICAL SYSTEM. The message "No Response ModA54, Active" indicates a power problem on the module. (A CAN network problem would show the same message but doesn't produce this symptom).</li> <li>3. Check / reset circuit breaker CB7.</li> <li>4. Check / replace fuse F67, F68.</li> <li>5. Probe gray connector on module to see if it is powered.</li> </ol>
<p>HVAC condenser fans not functioning in speed 1</p>	<p>Module A54 is not powered or is faulty</p>	<ol style="list-style-type: none"> <li>1. Check the SYSTEM DIAGNOSTIC menu of the message center display (MCD). Select FAULT DIAGNOSTIC and ELECTRICAL SYSTEM. The message "No Response ModA54, Active" indicates a power problem on the module. (A CAN network problem would show the same message but doesn't produce this symptom).</li> <li>2. Check / reset circuit breaker CB7.</li> <li>3. Check / replace fuse F67, F68.</li> <li>4. Probe gray connector on module to see if it is powered.</li> </ol>

Problem/Symptom	Probable Causes	Actions
Fire alarm telltale light and audible alarm always ON and there is no fire or high temperature in the engine compartment	Short-circuited fire sensor or defective sensor	Prior to start the vehicle, cycle the ignition key to the ON position, OFF position and then ON position again and then start the vehicle. This will deactivate the fire alarm function. This has to be repeated each time the vehicle is re-started.
The vehicle is parked and the electrical horn is activated to indicate a fire in the engine compartment but there is no fire	Short-circuited fire sensor or defective sensor	Cycle the ignition key between the ON and OFF position twice within 3 seconds. This will deactivate the fire alarm function. This has to be repeated each time the vehicle is parked.
A single light, a group of LED lights or another function of the vehicle is not functioning	The multiplex outputs are protected in current by an internal "soft-fuse". When an output is shorted, it turns OFF and stays OFF until the "soft-fuse" is reset	Turn the ignition key to the OFF position and turn to the ON position again. This resets all "soft-fuses".
No backlighting in the instrument cluster	Circuit breaker CB9 is tripped or fuse F21 blown.	Check / reset circuit breaker CB9 Check / replace fuse F21.
The radiator fan clutch does not function and the engine is overheating		<ol style="list-style-type: none"> <li>1. Set the ignition key to the ON position.</li> <li>2. Activate the dashboard Telltale Light Test switch 3 times within 4 seconds.</li> <li>3. In the engine compartment, set the starter selector switch to REAR START and then start the engine from the rear.</li> </ol> <p>While in this mode, the rear start push-button can be used to manually engage the fan clutch. The Multiplex system knows when the engine is already running, and it will not activate the starter.</p> <ol style="list-style-type: none"> <li>4. Press the push-button one time to engage the clutch in 1<sup>st</sup> speed, press a second time to engage in 2<sup>nd</sup> speed, press a third time to stop the fan, press once again to return to 1<sup>st</sup> speed.</li> </ol> <p>If the fan clutch does not engage using this procedure then the clutch is faulty or the wiring between the multiplex module and the clutch is faulty. Mechanically lock the fan clutch as described in section 05: COOLING SYSTEM of the maintenance manual.</p>



## Section 06: ELECTRICAL

### 4.8 ESSENTIAL FUNCTIONS TO OPERATE THE VEHICLE

Even with a defective CECM (Chassis Electronic Control Module) or a CAN network problem, essential base functions are maintained to rear start the vehicle from the engine compartment and drive in a secure manner.

However, many secondary functions are lost. In this case, the following directives must be followed.

- Never connect a battery charger when the ignition is in the ON position on a vehicle with a CAN defective or certain functions will start up by themselves,
- Disconnect the charger before starting the vehicle, if not the default functions will not activate,
- If the default mode does not activate, try to turn the ignition OFF while ensuring that no charger is connected and then restart the vehicle.

#### 4.8.1 Available Functions

- Startup: Turn on the ignition in the driver's area and rear start the vehicle from the engine compartment,
- Windshield wipers: Wipers functions at 1st speed only,
- Windshield washer fluid,
- Headlights: Low beams only,
- Directional signals: Rear and front only,
- Stoplights: 2 upper stoplights + high-mounted stoplight are functional,
- HVAC: Functional with set point fixed at 70°F (22°C), evaporator and condenser fixed at speed 1, defroster fixed at speed 4.

### 4.9 LOWER PRIORITY MODULES FOR BREAKDOWN SERVICE

Modules A43 (IO-A) and A44 (IO-B) affect lower priority functions. These modules can therefore be used as spare parts for breakdown service while on the road.

Functions lost if A43 is removed and used as spare part:

- High beams,
- Ability to turn on the parking lights only,

- Driver's area lighting,
- Tag axle activation,
- Courtesy blinkers.

Functions lost if A44 is removed and used as spare part:

- Fresh air damper mix trap control,
- Driver's area and entrance overhead light,
- Front clearance lights.

### 4.10 MULTIPLEX MODULES

#### 4.10.1 CECM

The CECM plays the role of interface between the engine ECM, the Transmission Control Module TCM, the telltale panel module and other IO-A, IO-B modules. When a multiplex module is being replaced, the CECM will inform the new module of its role and function accordingly to the vehicle options.

#### 4.10.2 MASTER ID

The Master ID works in conjunction with the CECM. It keeps the specific back-up program of the vehicle. So, a specific Master ID cannot be removed from a vehicle and installed on another vehicle.

#### 4.10.3 IO-A

IO-A modules receive inputs and control outputs. IO-A's are used for all outputs of 1 amp or less.

#### 4.10.4 IO-B

IO-B modules receive inputs and control outputs. IO-B's are used for outputs up to 30 amps.

### 4.11 MULTIPLEX MODULES REPLACEMENT

IO-A, IO-B and CECM multiplex modules can be replaced and reprogrammed without having to connect a computer to the vehicle.

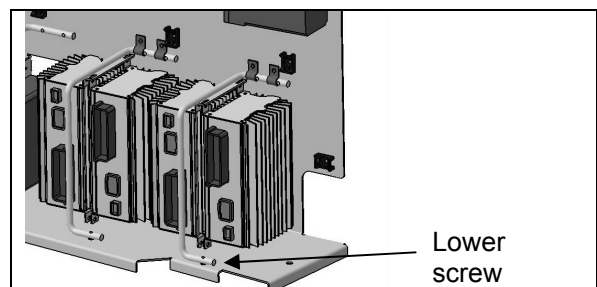

FIGURE 18: IO-B MODULE REMOVAL

4.11.1 Replacing IO-A Or IO-B Modules

- Set the ignition key to the ON position and leave it in that position at all time while performing this procedure.
- Open engine compartment R.H. side door, trip circuit breaker CB2.
- Replace the module (for IO-B modules, disconnect the green connector first, then the grey one and finish with the black connector. To disconnect the black connector, slide downwards the red latch. Remove the lower screw that holds the cable attachment rod onto the floor portion of the panel and flip the rod up, this will relieve the IO-B module, see figure 19).
- Reset circuit breaker CB2. This engages the automatic reprogramming.
- The telltale panel LCD display indicates "CAN" until the reprogramming is complete. Once completed, "CAN" disappears and the temperature reappears.
- Check the SYSTEM DIAGNOSTIC menu of the message center display (MCD). Select FAULT DIAGNOSTIC and ELECTRICAL SYSTEM. Verify the fault message to be certain the module is reprogrammed. If the module is not reprogrammed, the message "Axx Not Responding" appears where Axx is the module number (Ex: A41, A42...etc).

4.11.2 Replacing CECM Module

- Set the ignition key to the ON position and leave it in that position at all time while performing this procedure.
- Open engine compartment R.H. side door, trip circuit breaker CB2.
- Replace the module.
- Reset circuit breaker CB2. This engages the program transfer from the Master ID to the CECM module (the back-up program is inside the Master ID. The Master ID will identify the CECM as being new and will send the correct program to it). The telltale panel LCD display indicates "CAN" during 3 minutes approximately. "CAN" disappears and "----" is displayed alternately with "CAN" (during that sequence, "----" will be displayed up to 6 times and the audible alarm will ring). Wait until "CAN" is replaced by "----" that remains for more than 10 seconds. At

this point the MasterID module has finished loading the program in the CECM.

- Go to the engine compartment R.H. side area and trip circuit breaker CB2 once again. Wait 1 second and reset it. This engages I/O's modules automatic reprogramming.
- The telltale panel LCD display indicates "CAN" until the reprogramming is completed. Once completed, "CAN" disappears and the temperature reappears. Check the SYSTEM DIAGNOSTIC menu of the message center display (MCD). Select FAULT DIAGNOSTIC and ELECTRICAL SYSTEM. Check the error messages. All modules appear in error but are not active. If an active error appears for a module, this one was not reprogrammed. In this case, trip CB2 once again. Wait 1 second and reset CB2. Re-verify the error messages when "CAN" disappears from the telltale panel LCD display.
- Do an error reset to remove all errors (requires Password) from non-active modules, leave the SYSTEM DIAGNOSTIC menu and reopen to verify there are no more errors.

5. BOSCH ALTERNATOR

Two 24 volt 140 amp., self regulated, belt driven, air-cooled BOSCH alternators may be used in the 24 volt electrical system.

An auxiliary BOSCH 12-volt 200 ampere may also be installed.

	<h2>MAINTENANCE</h2>
<p>Change the brushes and voltage regulator as per "Repair and Testing Instructions for T1 Alternator 0120 69 552" every 100,000 miles (160 000 fm) or once every two years, whichever comes first.</p> <p>Replace bearings as per "Repair and Testing Instructions for T1 Alternator 0120 69 552" every 200,000 miles (320 000 fm) or once every four years, whichever comes first.</p> <p>Refer to Bosh T1 Alternator Maintenance Manual Annexed at the end of this section.</p> <p>Refer to Bosh T1 Alternator Maintenance Manual Annexed at the end of this section.</p>	

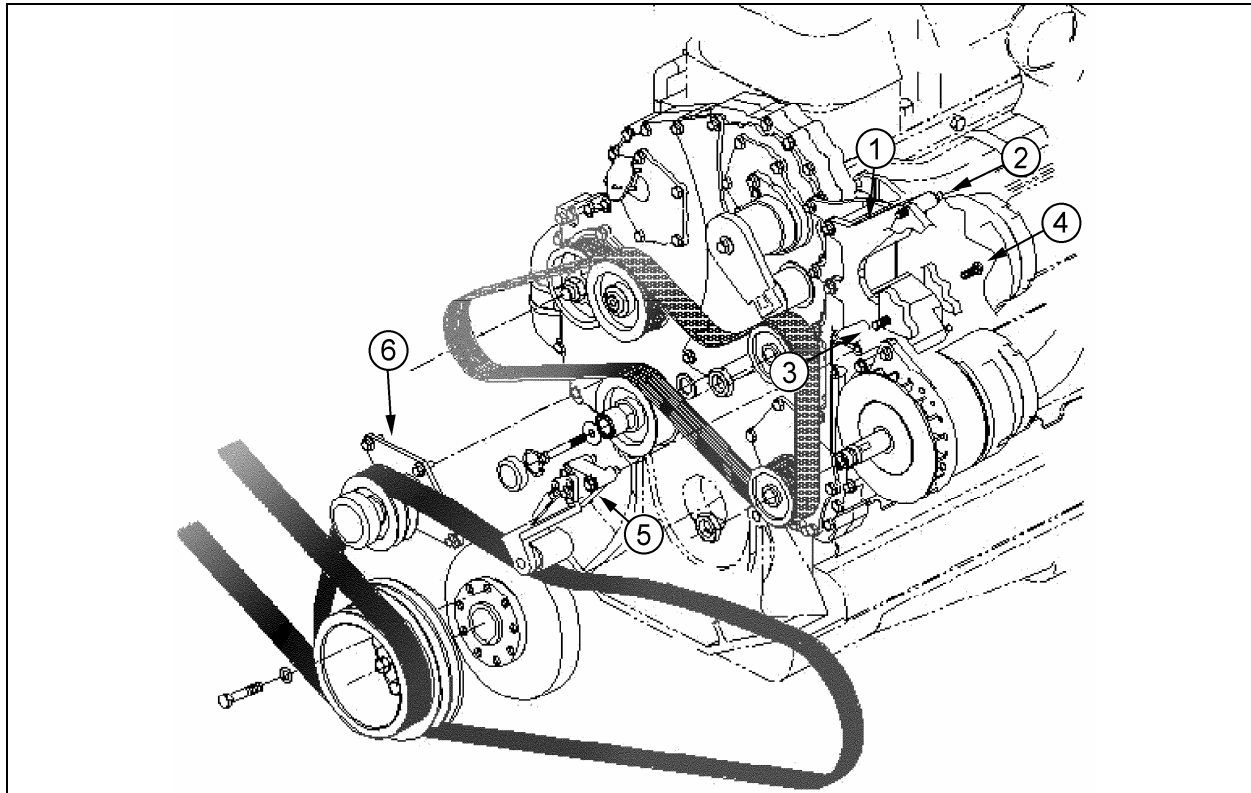

FIGURE 19: TWIN BOSCH ALTERNATORS INSTALLATION

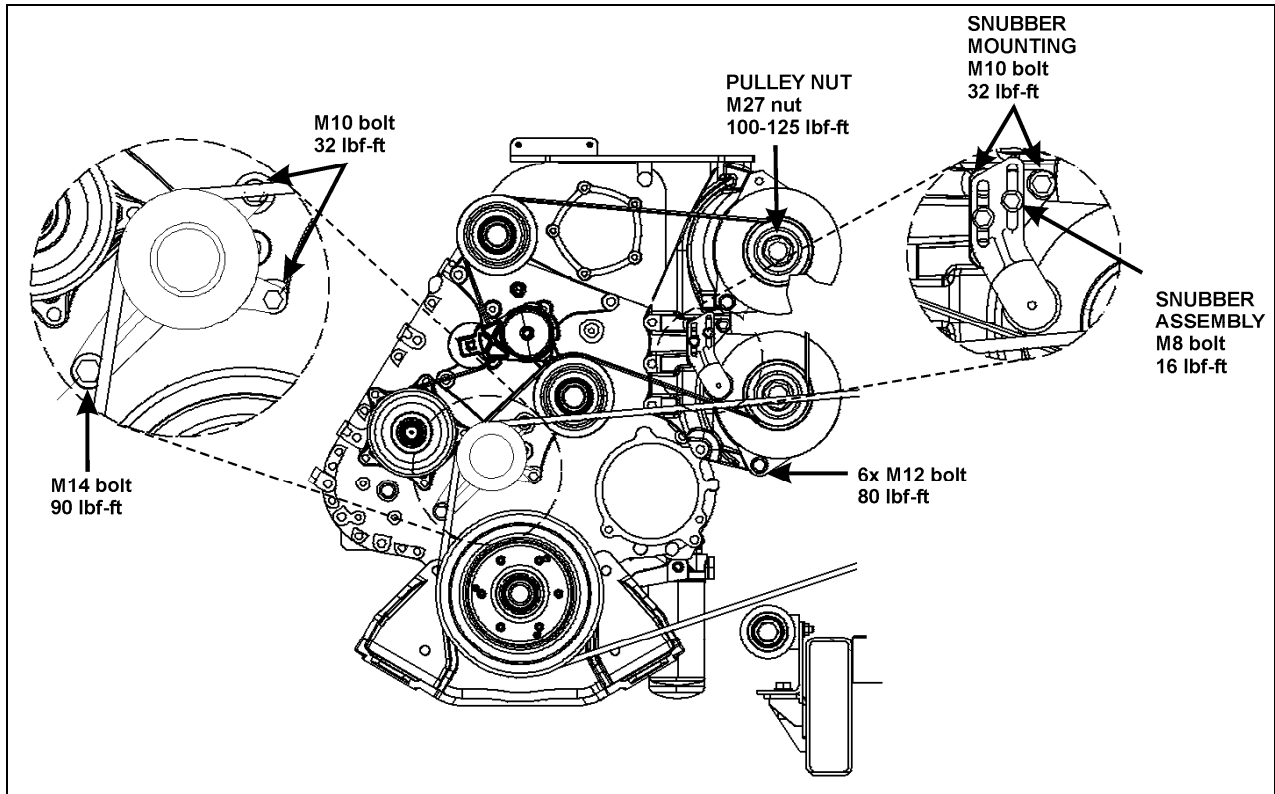

FIGURE 20: ALTERNATORS AND ACCESSORIES MOUNTING TORQUES

**NOTE**

Use Polyrex EM grease (684922) when repacking the bearings. Grease comes in 14.1 oz (400gr) cartridges.

### 5.1 TWIN BOSCH ALTERNATORS INSTALLATION

If the alternators needed to be removed, reinstall as follows. Refer to figure 19 for installation and to figure 20 for tightening specifications:

1. Install alternator mounting bracket (1, figure 19) to the gear case. Use the four flanged phosphor alloy bolts on the pulley end of the bracket and the flanged nuts at the transmission end of the bracket;
2. Bolt the alternators to the bracket using the three inch bolt at the top of the upper alternator (2, fig 19) and flanged bolts at the other mounting bosses (3 and 4, figure 19). Tighten the bolts in the sliding sleeves (4, figure 19) last as they will adjust to prevent breaking the alternator mounting bosses upon final tightening. Repeat for the second alternator;
3. On the drive shafts of both alternators, install key, pulley, spring washer and nut. Tighten to 220 Lbf-ft (300 Nm);

**NOTE**

Final tightening of the pulleys can be performed once the belt is installed. This will help keep the pulley from turning when tightening.

4. Install the snubber bracket (5, fig. 19) using three flanged bolts. Do not tighten the adjustment bolts on the snubber until after final tightening;
5. Install the compressor belt idler pulley (6, fig. 19) as shown. A stud inserts into one of the mounting holes of the pulley assembly. Fasten this one using a nut and bolts for the other two.

### 5.2 ALTERNATORS ARRANGEMENT

An auxiliary BOSCH 24-volt 140 amperes, an auxiliary BOSCH 14-volt 200 ampere or an auxiliary DELCO-REMY 24-volt 75 amperes may also be installed (Refer to figures 21 to 24).

### Possible Alternators Arrangement

W5 with central HVAC system
2x Bosch 24V-140A
2x Bosch 24V-140A + 1 aux. Bosch 24V-140A
2x Bosch 24V-140A + 1 aux. Bosch 14V-200A
W5 with small HVAC system
2x Bosch 24V-140A
2x Bosch 24V-140A + 1 aux. Bosch 24V-140A
2x Bosch 24V-140A + 1 aux. Delco 24V-75A
1x Delco 24V-75A

WE with central HVAC system
2x Bosch 24V-140A
2x Bosch 24V-140A + 1 aux. Bosch 14V-200A
WE with small HVAC system
2x Bosch 24V-140A
1x Delco 24V-75A

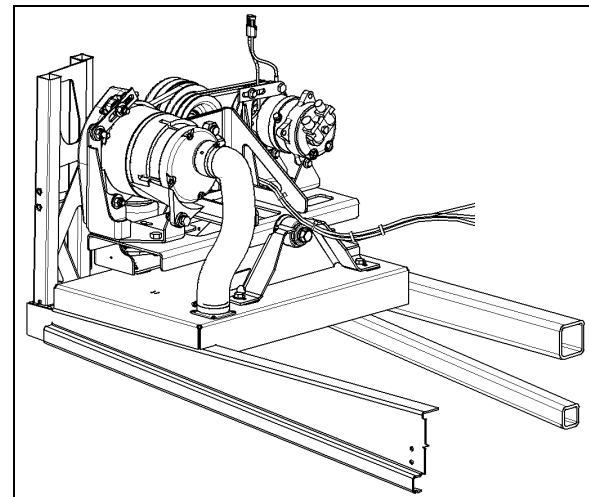

FIGURE 21: BOSCH 24V-140A WITH SMALL HVAC SYSTEM

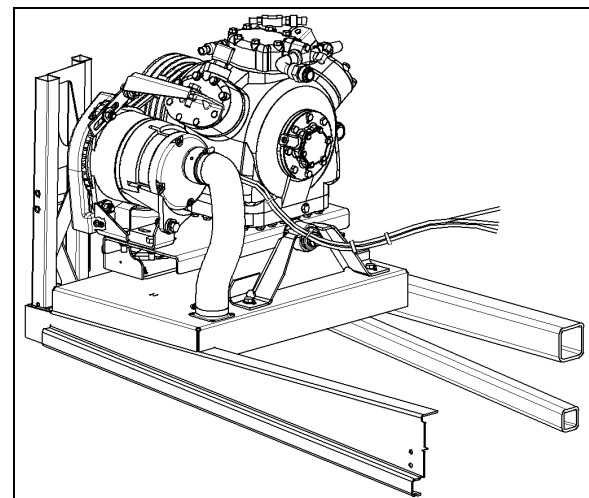

FIGURE 22: BOSCH 24V-140A WITH CENTRAL HVAC SYSTEM

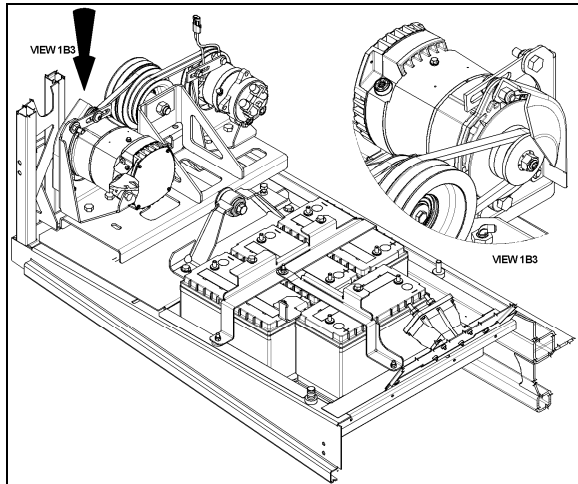

FIGURE 23: DELCO 24V-75A WITH SMALL HVAC SYSTEM

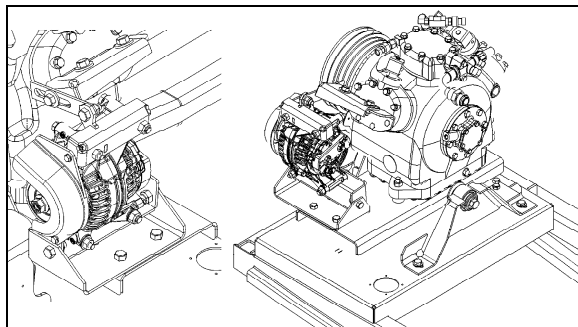

FIGURE 24: BOSCH 14V-200A WITH CENTRAL HVAC SYSTEM

### 5.3 ALTERNATOR DRIVE BELT

#### Removal

1. Insert a 3/4" socket drive into the automatic belt tensioner opening (Fig. 25).
2. Twist the tensioning arm to slacken belt.
3. Remove belt.

#### NOTE

*Belts specifications may vary. For proper belt selection, always consult your vehicle Coach Final Record.*

#### Installation

Installation of the alternator drive belt is the reverse of removal.

#### 5.3.1 Adjustment

Correct belt tension is required to maximize belt life. The tensioning arm maintains proper belt tension, no adjustment is required.



## MAINTENANCE

Check for wear and proper tension every 6,250 miles (10 000 km) or twice a year, whichever comes first.

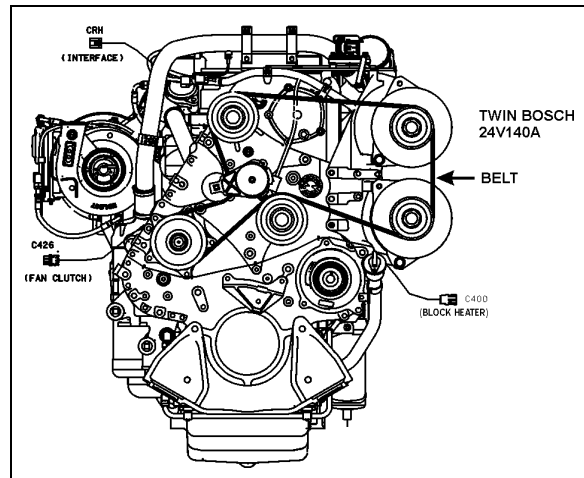

FIGURE 25: ALTERNATOR DRIVE BELT

01180

### 6. BATTERY EQUALIZER

VoltMaster Battery Equalizer Owner's Manual (100 amps) is annexed at the end of this section.

Refer to "Electrical Compartments and Junction Box" in this section, for location.

### 7. STARTER

Refer to Mitsubishi Electric Corporation (MELCO) Service bulletin ME003-P annexed at the end of this section for information and maintenance instruction on MELCO 105P70 starter.



## CAUTION

Prior to the installation of the Mitsubishi starter, the Flywheel Ring Gear must be examined for excess wear or damage. Service Bulletin A1-M1N-1729EN included at the end of Section 06 shows acceptable levels of wear, and illustrates the proper measuring procedure. Maximum wear is 0.5mm. Ring Gears with more than 0.5mm of wear or damage must be replaced before installing the new starter to prevent engagement and/or disengagement problems. Failure to do so will render the Warranty null and void.

**CAUTION**

Do not engage starter for more than 15 seconds at a time. If engine does not start within 15 seconds, release ignition key and let starter cool for one minute before attempting to restart.

**8. ENGINE BLOCK HEATER**

The vehicle may be equipped with an engine immersion-type electric block heater to assist cold weather starting. The heater male electric plug is easily accessible through the engine compartment R.H. side door (Fig. 26). To use it, connect the female plug of an electrical extension cord to the heater plug. The extension cord must be plugged into a 110-120 V AC power source only. The engine block heater should be used whenever the vehicle is parked for an extended period of time in cold weather and a suitable power source is available.

**8.1 MAINTENANCE**

This heater is non-serviceable except for the cord, and if faulty, must be replaced as a unit.

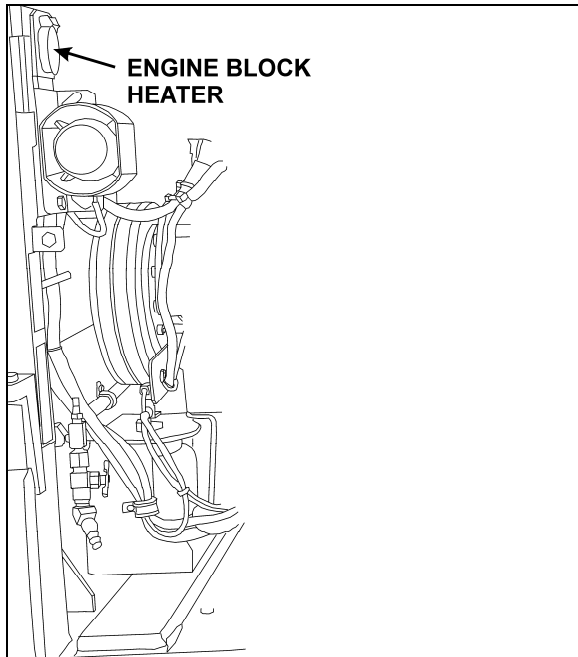

FIGURE 26: ELECTRIC HEATER PLUG LOCATION 18647

**9. EXTERIOR LIGHTING**

The circuit for exterior lights, as well as their control switches, relays and circuit breakers are shown on the applicable wiring diagrams. Wiring

diagrams are located in the technical publication box.

**9.1 HEADLIGHTS**

Each headlight assembly consists of two headlamp module 90 mm (3½ inch) equipped with a 12-volt halogen bulb and one 100 mm (4 inch) 12-volt LED turn/signal lamp. Outer lamps have a double function (both low and high beam). Inner lamps are used for high beam or daytime running light. The inner or outer lamp uses the same single filament halogen bulb part number.

**NOTE**

*If vehicle is equipped with optional Xenon headlamps, refer to paragraph 12.1.6.*

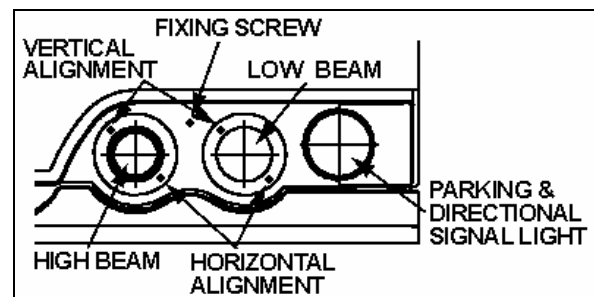

FIGURE 27: HEADLIGHT ASSEMBLY

06546

**9.1.1 Headlight Beam Toggle Switch**

The multifunction lever located on the steering column is used to select proper lighting. High beams or low beams can be selected by pulling the lever rearward. A high beam indicator on the central dashboard panel is illuminated when the high beam circuit is energized.

**NOTE**

*Pulling the lever rearward while the lights are off will flash the headlights.*

**9.1.2 Maintenance**

Clean headlights with soap and water and a good glass cleaner whenever dirty. For maximum illumination, headlight connections must be coated with a dielectric grease to prevent oxidation and proper voltage must be maintained. Low battery voltage, loose or dirty contacts in wiring system and poor ground contribute to a decrease in voltage. Check wiring and connections regularly and keep battery properly charged. When a headlight burns out, a new bulb must be installed. Headlights must be properly aimed to provide

## Section 6: ELECTRICAL

maximum allowable road illumination. When using mechanical aiming devices, follow manufacturer's instructions.

Headlight aim should be checked after installing a new bulb. Aiming can be performed without opening headlight assembly. Horizontal and vertical aiming of each module is provided by two adjusting screws that pivot the module in the housing for proper alignment (fig. 27). There is no adjustment for focus since the module is set for proper focus during manufacturing assembly.

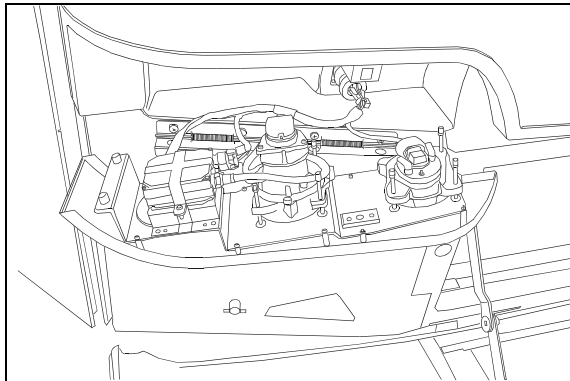

FIGURE 28: OPENING HEADLIGHT ASSEMBLY 06547

### NOTE

*Make sure headlight assembly is properly positioned into its housing before securing using fixing screw.*



### CAUTION

Use a soft cloth to clean the parking and front turn signal lamp.

### 9.1.3 Headlight Adjustment

1. Headlight aiming and inspection can be accomplished by visual means. This is done on a screen located at a distance of 25 feet (7,6 m) of the headlights. It should be of adequate size with a matte-white surface well shaded from extraneous light and properly adjusted to the floor area on which the vehicle stands. Provisions should be made for moving the screen or its vertical centerline so that it can be aligned with the vehicle axis. In addition to the vertical centerline, the screen should be provided with four laterally adjustable vertical tapes and two vertically adjustable horizontal tapes.

2. The four movable vertical tapes should be located on the screen at the left and right limits called for in the specification with reference to centerlines ahead of each headlight assembly.
3. The headlight centerlines shall be spaced either side of the fixed centerline on the screen by  $\frac{1}{2}$  the lateral distance between the light source centers of the pertinent headlights. The horizontal tapes should be located on the screen at the upper and lower limits called for in the specification with reference to the height of beam centers and the plane on which the vehicle rests, not the floor on which the screen rests (Fig. 29).
4. The nominal vertical aim position on lower beam headlights shall be adjusted based on the headlight mounting height, from the ground to the light source center of the headlight, according to table 1.

TABLE 1 – VERTICAL BEAM AIM GUIDELINES

Headlight (centerline) Mounting Height	Nominal Vertical Aim	Aim Inspection Limits for Vertical Aim
56 to 90 cm (22 to 36 inch)	0 Vertical	10 cm (4 inch) up to 10 cm (4 inch) down
90 to 120 cm (36 to 48 inch)	5 cm (2 inch) down	5 cm (2 inch) up to 15 cm (6 inch) down
120 to 140 cm (48 to 54 inch)	6.4 cm (4 inch) down	4 cm (1.5 inch) up to 16.5 cm (6.5 inch) down

5. High beam headlights are aimed so that the center of the high-intensity zone is located at the horizontal and straight ahead vertically (Fig. 30).
6. Low beam headlights are aimed so that the top edge (the cutoff) of the high-intensity zone is at the vertical location as per Table 1 and the left edge of the high-intensity zone is at the vertical centerline of the headlight (Fig. 31).

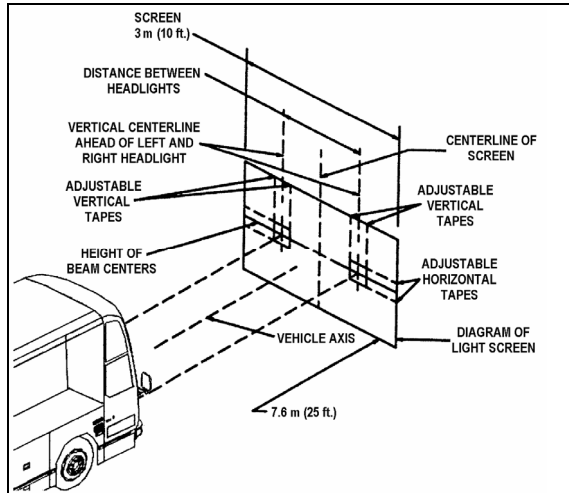

FIGURE 29: ALIGNMENT OF HEADLIGHT AIMING SCREEN 06502

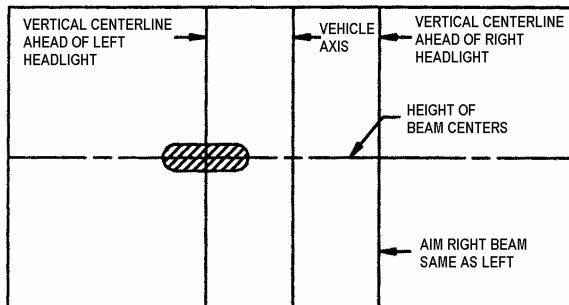

FIGURE 30: HIGH-INTENSITY ZONE (SHADED AREA) OF A PROPERLY AIMED UPPER BEAM ON THE AIMING SCREEN 7.6 M (25FT) IN FRONT OF VEHICLE 06503

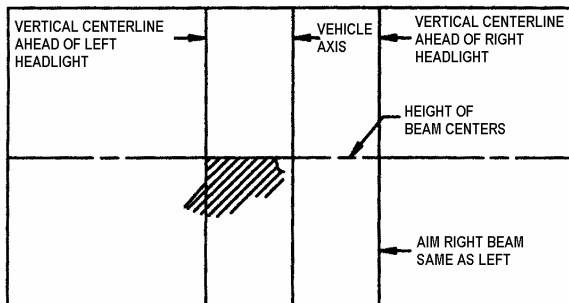
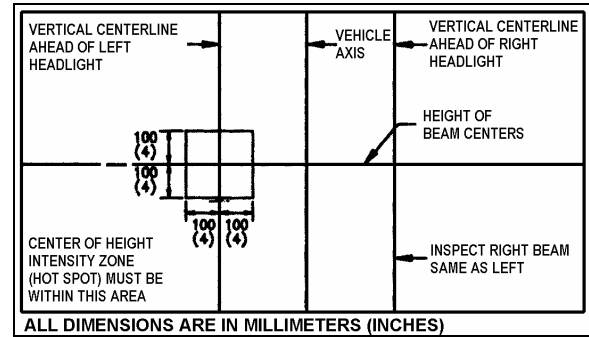

FIGURE 31: HIGH-INTENSITY ZONE (SHADED AREA) OF A PROPERLY AIMED LOWER BEAM ON THE AIMING SCREEN 7.6 M (25FT) IN FRONT OF VEHICLE 06504

7. The inspection limits for high-beam headlights shall be with the center of the high-intensity zone from 10 cm (4 in) up to 10 cm (4 in) down; and, from 10 cm (4 in) left to 10 cm (4 in) right on a screen at 7.6 m (25 ft) (Fig.32).



ALL DIMENSIONS ARE IN MILLIMETERS (INCHES) FIGURE 32: AIM INSPECTION LIMITS FOR UPPER-BEAM HEADLIGHTS 06505

8. The inspection limits in the vertical direction for low-beam headlights or the low beam of a dual-beam headlight, shall be as described in Table 1. In the horizontal direction, the left edge of the high-intensity zone shall be located from 10 cm (4 in) left to 10 cm (4 in) right of the vertical centerline of the beam. The viewing screen shall be located 7.6 m (25 ft) in front of the vehicle (Fig. 33).

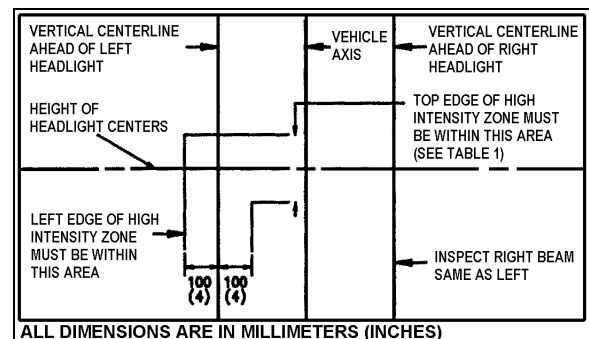

ALL DIMENSIONS ARE IN MILLIMETERS (INCHES) FIGURE 33: AIM INSPECTION LIMITS FOR LOWER-BEAM HEADLIGHTS 06506

#### 9.1.4 Sealed-Beam Unit

#### Bulb Removal and Replacement

1. Pull the release handle located inside the front service compartment to tilt down the entire bumper assembly.
2. Remove the headlight screw fixing the headlight assembly, then tilt headlight assembly down (Fig. 27 and 28).
3. Remove connector from headlight bulb.
4. Remove the bulb by pushing and rotating it out of the socket.
5. Install the new bulb by reversing the previous procedure.



## Section 6: ELECTRICAL



### CAUTION

During this step, avoid contacting the bulb with the fingers not to alter the bulb life.

#### NOTE

Do not disrupt headlight adjustment screws.

### Module Replacement

1. Pull the release handle located inside the front service compartment to tilt down the entire bumper assembly.
2. Remove the headlight screw fixing the headlight assembly, then tilt headlight assembly down (Fig. 27 and 28).
3. Remove connector from headlight bulb.
4. Unfasten three metal clips attaching headlight unit to support.
5. Install new module and fasten metal clips.
6. Install wiring connector on back of new sealed beam unit.
7. Tilt headlight assembly up into its housing then secure using fixing screw.

#### NOTE

Make sure headlight assembly is properly positioned into its housing before securing using fixing screw.

8. Perform alignment procedure.

#### NOTE

The headlight aim must be checked and adjusted even if it was properly adjusted before the sealed beam unit was replaced.

### 9.1.5 Front Turn Signal

The front turn signal is part of the front headlight assembly. The turn signal is a sealed unit (LED) located on each front corner and should be replaced as an assembly. Turn signal is visible from both front and side.

### Removal and Replacement

1. Pull the release handle located inside the front service compartment to tilt down the entire bumper assembly.

2. Remove the headlight screw fixing the headlight assembly, then tilt headlight assembly down (Fig. 27 and 28).
3. Partially unfasten back plate fixing screws, then remove signal lamp.
4. Remove socket from signal lamp.
5. Install wiring connector on back of new signal lamp then install signal lamp.
6. Fasten back plate fixing screws then tilt headlight assembly up into its housing then secure using fixing screw.

#### NOTE

Make sure headlight assembly is properly positioned into its housing before securing using fixing screw.

### 9.1.6 Optional Xenon Headlamp

The outer lamps of each headlight assembly may be equipped with the optional Xenon lamps. These lamps improve visibility and provide better lifespan.

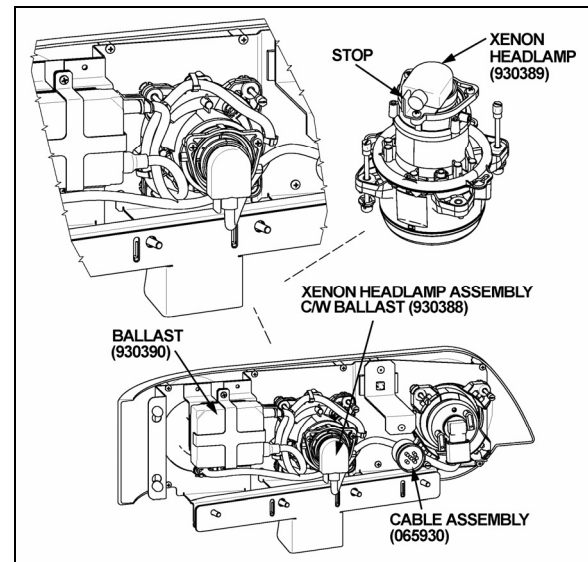

FIGURE 34: XENON HEADLAMP LOCATION

06549

### Bulb Removal and Replacement

1. Pull the release handle located inside the front service compartment to tilt down the entire bumper assembly.
2. Remove the headlight screw fixing the headlight assembly, then tilt headlight assembly down (Fig. 27 and 28).
3. Remove main cable connector (066011).

4. Remove connector from headlamp bulb by turning counterclockwise.
5. Unscrew the three Phillips head screws, pull the retainer and bulb out.

**CAUTION**

To avoid breaking the bulb, make sure the socket is in proper position against the stop.

6. Install the new bulb by reversing the previous procedure.

**CAUTION**

During this step, avoid contacting the bulb with the fingers not to alter the bulb life.

**NOTE**

*Do not disrupt headlight adjustment screws.*

**CAUTION**

Never connect a voltmeter or V.O.M. to measure bulb voltage as instrument will be destroyed.

**Troubleshooting and Safety**

When switching on the Xenon headlamp using the rocker switch, a lamp short-circuit test is performed.

Current is detected in the lamp circuit before the ignition time and ignition prevented. Connection of the "hot" lamp to the body mass also prevents ignition. In both cases, the system is cut off within < 0.2 s and can only be restarted via the rocker switch.

In general, the maximum ignition time is < 0.2 s, which period is followed by cutoff. This would happen if a lamp was defected.

Lamp missing: system is cut off after < 0.2 s.

If lamp components or cables are damaged by force (accident) so that contact with hazardous parts is possible, the current in these lines is earthed by the vehicle body and - as with a defective household appliance - switched off when 30 mA are reached within < 0.2 s. the cutoff time is shortened by a more powerful defect current.

To protect the ballast, a counter in the electronic safety system ensures that a defective lamp can only be switched off 7 times consecutively after a successful ignition, after which the device is cut off. This prevents flutter and flashing. This counter is put out of action when the lamp cutoff time repetition interval is longer than 1.3 s so that temporary non-defect disturbances that result in immediate invisible re-ignition do not cause lamp cutoff.

A warning notice on the lamp plug makes you aware of the fact that the lamp is operated in this system on a higher voltage (you should therefore switch off the lamp before working on this part).

After taking out the lamp, the contact pins are in a practically idle state (< 34 Volt) after < 0.5 seconds so that there is no immediate danger of electric shock even if the warning is disregarded.

With this safety concept there is no danger to check the ballast with a new bulb. There is a very high probability that the ballast is OK if the ballast can ignite the bulb.

One simple test to check the ballast would be to measure the Nominal current of 1.58 A after one minute for the 24V ballast.

**9.2 STOP, TAIL, DIRECTIONAL, BACK-UP, AND HAZARD WARNING LIGHTS**

A combination stoplight, taillight, directional signal light and back-up light assembly is mounted at the rear, on each side of the vehicle. Furthermore, when braking, two center stoplights (LED) and a cyclops light (LED) will illuminate simultaneously with the stoplights on the sides for increased safety. The L.H. and R.H. side center stop lights are also used as directional signal and marker lights.

The stop, tail, directional signal and back-up lights consist of individual LED lights mounted on the engine rear door, and each light is serviced individually as a complete unit. The back-up light uses a regular tungsten bulb.

The hazard warning flashing system uses the front, side and rear directional lights simultaneously. This system is energized by a switch on the L.H. dashboard.

**9.2.1 Lamp Removal and Replacement**

1. Open engine compartment rear door.

## Section 6: ELECTRICAL

- Remove the lamp support retaining screws (2), and then from the outside, remove the lamp and its support.
- From the outside, install the new lamp with its support then fasten the retaining screws.

### 9.2.2 Center Stoplights and Cyclops Light Removal and Replacement

These (LED) lights are sealed unit and should be replaced as an assembly in accordance with the following procedure:

- Unscrew both "Phillips" light screws then remove the light assembly.
- Install new light assembly and secure using screws.

### 9.3 LICENSE PLATE LIGHT

Two LED units are mounted above the rear license plate(s) of vehicle. In case of burn out, the LED unit must be changed according to the following procedure.

- Pry out the rubber seal with a small screwdriver. Pull on the LED unit and disconnect it.
- Reconnect new LED unit, place rubber seal, and press on it until it is seated in position.

### 9.4 CLEARANCE, IDENTIFICATION AND MARKER LIGHTS

The vehicle is equipped with marker, identification and clearance lights (LED). The clearance lights are mounted at each corner of the coach near the top and the identification lights are in the upper center of rear and front sections.

The rear clearance and identification lights are red and the front ones are amber.

The amber marker lights are mounted along the sides of vehicle.

#### 9.4.1 Marker Light Removal and Replacement

The side marker light is a sealed unit (LED) and should be replaced as an assembly in accordance with the following procedure:

- Unscrew both "Phillips" light screws, and then remove the light assembly.
- Position the new light assembly and install the "Phillips" screws.

#### 9.4.2 Clearance and Identification Light Removal and Replacement

The clearance and identification light are sealed units (LED) and can be replaced in accordance with the following procedure:

- Unscrew both "Phillips" light screws, and then remove the light assembly.
- Position the new light assembly, and then install the "Phillips" screws.

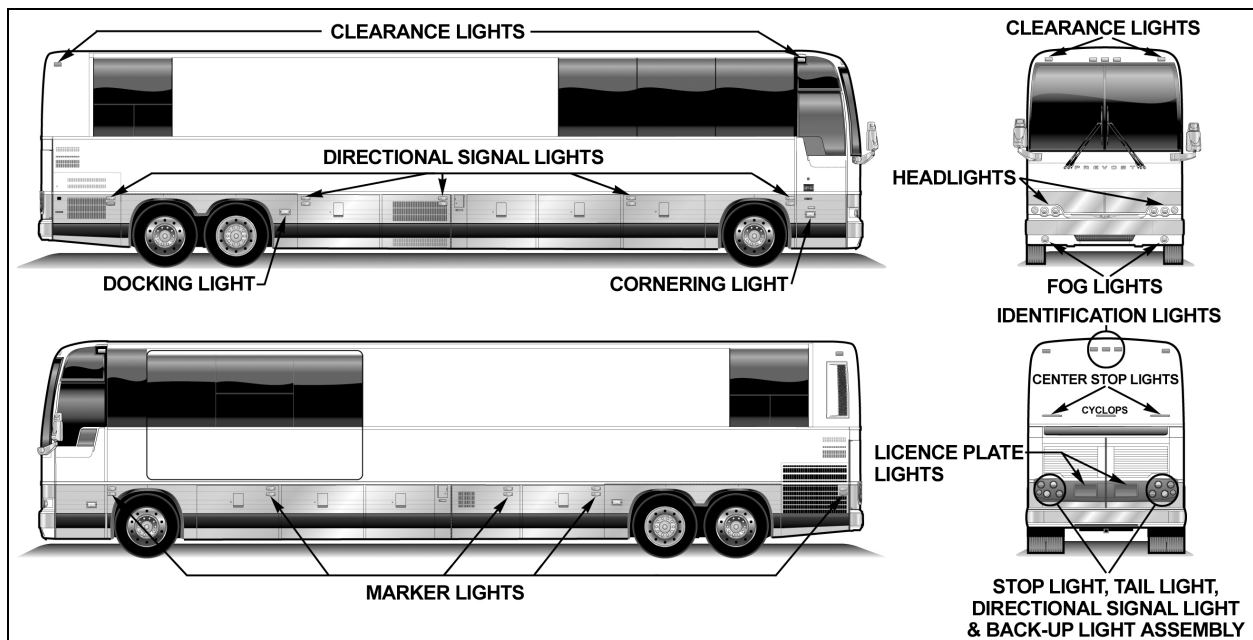

FIGURE 35: VARIOUS LIGHTS LOCATION

06544

### 9.5 DOCKING AND CORNERING LIGHTS

MTH vehicles are provided with two halogen sealed-beam units that serve as cornering lights. They are mounted on the vehicle as follows: one is mounted on the front L.H. side service compartment door, while the other is located on the entrance door on the R.H. side. The main function of these lights is to increase lateral visibility when turning a corner. These lights are energized simultaneously with the directional lights. A dashboard-mounted rocker switch may be actuated to cancel this system in special situations.

Two additional halogen sealed-beam units may be installed aft of the rear baggage compartment. These lights are used as docking lights and both will illuminate automatically when reverse range is selected to facilitate back-up or docking procedure. The cornering lights do not operate automatically when the reverse range is selected, but by means of a dashboard-mounted rocker switch. When the docking position is selected, the docking as well as the cornering lights illuminate.

#### 9.5.1 Lamp Removal and Replacement

Both docking and cornering sealed-beam units can be changed in accordance with the following procedure:

1. Remove the two "Phillips" screws attaching the retaining ring.
2. Disconnect the light unit connection.
3. Remove the lamp.
4. Position new lamp.
5. Connect and position the light unit.
6. Finally, install the retaining ring.

### 9.6 FOG LIGHTS

Optional halogen fog lights can be mounted on this vehicle to give the driver better visibility in foggy weather, or to improve the range of vision just ahead of the coach.

#### 9.6.1 Bulb Removal and Replacement

1. Pull on the release handle located in the front service compartment, near the door lower hinge. The bumper will lower gradually.
2. Unscrew the wing nut and pivot assembly upwards.
3. Unscrew the outer ring. Disconnect the light unit connection and remove the bulb.

4. Install the new bulb, reconnect the light unit and replace in its proper position.



### CAUTION

During this step, avoid contacting the bulb with your fingers. This could alter the bulb life.

5. Reinstall the outer ring, pivot the assembly downwards.
6. Fasten the wing nut and securely close the bumper.

## 10. INTERIOR LIGHTING EQUIPEMENT

### 10.1 CONTROL PANEL LIGHTING

The instrument gauges and switches mounted on all control panels are energized whenever the exterior light switch is pushed to the first position. A control dimmer located on the dashboard is used to vary the brightness of the panel gauges, switches and indicator lights.

The gauge lights, panel lights, switch lights and indicator lights have a different bulb arrangement. Thus, the procedure to change a defective bulb can vary according to the application.

#### 10.1.1 Switch Lighting

1. Slightly pull the switch with a defective LED away from the control panel.
2. Disconnect the electric cable from the switch.
3. To install a new switch, reverse the procedure (Fig. 36).

### NOTE

Switches are lighted by the use of LED. When lighting on a switch fails, replace defective switch as a unit.

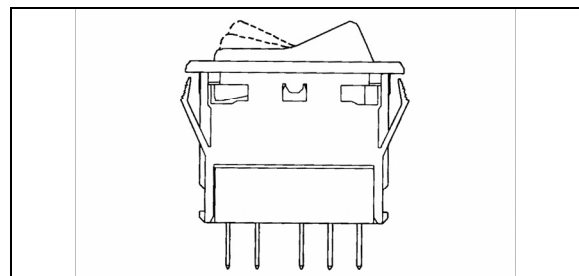

FIGURE 36: SWITCH

06321

## Section 6: ELECTRICAL

### 10.1.2 Telltale Light Replacement

Telltale module is non-serviceable and must be replaced as a unit.

1. Unscrew and remove the top dashboard panel.
2. Remove the telltale back wire electric connectors.
3. Unscrew and remove the telltale module.
4. To replace the telltale module, reverse the procedure.

### 10.1.3 Gauge Light Bulb Replacement

1. For any gauge light bulb replacement, the dashboard panel must be removed in order to have access to the rear of gauges.
2. Remove bulb socket from the gauge, turn the defective bulb counterclockwise and pull it out of the gauge.
3. Push a new bulb and socket ASM and turn clockwise to lock in place.
4. Replace the rear dashboard housing.

## 10.2 DRIVER'S AREA LIGHTS

Two halogen ceiling lights are installed over the stepwell and the driver's area. These lights are frequently used for night-time operation when passengers board or leave coach.

### 10.2.1 Bulb Removal and Replacement

1. Unsnap the lamp with a flat head screwdriver and remove it.
2. Pull the defective bulb out of the socket.
3. Install the new bulb by pushing it in position.
4. Replace the lamp by snapping it back in place.



### CAUTION

Do not touch halogen bulbs with bare hands as natural oils on skin will shorten bulb life span.

### 10.2.2 Removal and Replacement of In-Station Fluorescent Tubes

1. Start by pulling out the corner of the lens then delicately peeling it out of its seat.
2. Rotate and pull the fluorescent tube from its sockets.



### CAUTION

The lens is fragile. Be very careful when removing and handling.

3. Install a new fluorescent tube, rotating the tube to secure it in the sockets.
4. Replace the screen lens by first inserting one side in the seat, then push the other side in and snap it in place by running it in from one corner to the next.

### 10.2.3 Removal and Replacement of Reading Lamp Bulb

1. Engage the tool (#830164) over the lamp and turn one quarter turn counterclockwise. Then, remove the tool slowly.
2. Pull the bulb socket off the reading lamp unit.
3. Push and turn bulb counterclockwise, then pull it out of the socket.
4. Install new bulb in the socket, then push and turn clockwise to lock bulb in position.
5. Push the bulb socket in the reading lamp unit.
6. Position the reading lamp with the tool (#830164), turn one quarter turn clockwise.

## 10.3 ENGINE COMPARTMENT LIGHTING

A switch located in engine compartment on rear start panel, can be used to actuate the two oval engine compartment lights.

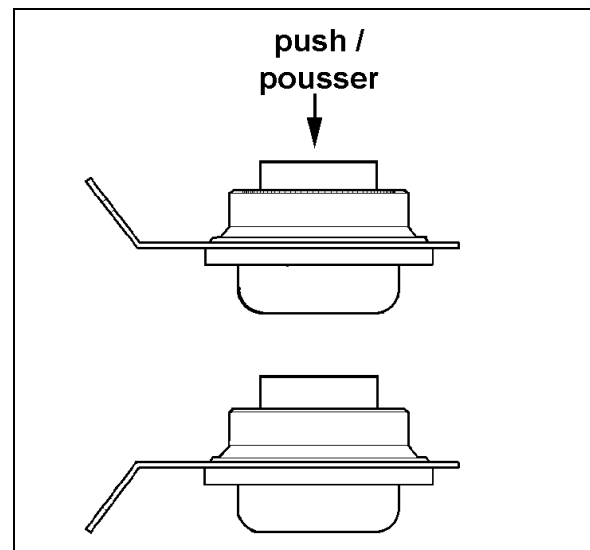

FIGURE 37: ENGINE COMPARTMENT LIGHT

Each light is sealed and can be replaced as follows:

1. Disconnect the light unit connection.
2. Remove the lamp.
3. Position new lamp.
4. Connect the light unit.
5. Make sure the retaining ring is installed properly.

### 11. LIGHT BULB DATA

When replacing a light bulb, special attention must be paid to the voltage rating (refer to light bulb data hereafter).

LIGHT BULB DATA					
APPLICATION	PREVOST PART NO.	TRADE OR SAE NUMBER	WATTS OR CANDLE POWER	VOLTS	QTY
<b>EXTERIOR LIGHTING</b>					
Hi/Lo-beam	930291	9004	65/45 W	12	2
Lo-Beam Xenon (optional)	930388	D2S	35 W	12	2
Docking & cornering	930319	9415	37.5W	12	4
Fog	930361	H3	55 W	12	2
License plate (sealed)	930266	TL 15206	---	12	2
Marker Light (red)	930340	Grote 47072-3	---	12	2
Marker Light (amber)	930341	Grote 47073	---	12	10
Identification (red)	930334	TL 25420R	---	12	3
Clearance (red)	930334	TL 25420R	---	12	4
Identification (amber)	930337	TL 25450Y	---	12	3
Clearance (amber)	930337	TL 25450Y	---	12	4
Front directional (hazard & marker)	562135	3057	32/3W	12	2
Rear directional	560589	1156	32 W	12	4
Stop	560589	1156	32 W	12	8
Back-up	560589	1156	32 W	12	4
Center stop	930330	HELLA 96208	---	12	2
Cyclops	930330	HELLA 96208	---	12	1
Tail	560123	67	4 W	12	4

## Section 6: ELECTRICAL

LIGHT BULB DATA					
APPLICATION	PREVOST PART NO.	TRADE OR SAE NUMBER	WATTS OR CANDLE POWER	VOLTS	QTY
<b>EXTERIOR LIGHTING</b>					
Exterior compartment (except engine)	562278	6429	10 W	24	12
Engine compartment	930383	SEALED	25 W	12	2
<b>INTERIOR LIGHTING</b>					
Instrument cluster lights	562838	2721 MFX (OSRAM)	---	---	---
Telltale panel assy.	562907	---	---	---	1
Step Light	562278	HELLA 78207 (OSRAM 6429)	10 W	24	3

## 12. SPECIFICATIONS

### Battery

Make..... Volvo  
 Model..... 20359831  
 Prévost Number ..... 563030  
 Type ..... Maintenance-free  
 Terminal type ..... Top Stud  
 Group size..... 31  
 Volts ..... 12  
 Load test amperage ..... 290  
 Reserve capacity (minutes) ..... 195  
 Cold cranking (in amps)  
 -At 0°F (-18°C).....950 (each battery)  
 Maximum dimensions (inches/mm)  
 -Length (including flange) ..... 13.0/330,2  
 -Width ..... 6.7/169,3  
 -Height (including top posts) ..... 9.3/237,0  
 -Approximate weight (lbs/kg) ..... 59/26,7  
 \* *Battery tester cable clamps should be between terminal nuts and lead pads of terminals. If not possible, load value should be 210 amperes.*

### Torque specifications

Battery cable to post ..... 10-15 Ft-lbs (13-20 Nm)  
 Battery cover ..... 45-50 Ft-lbs (5-6 Nm)

### Alternator

Make..... BOSCH  
 Model Number..... 0120689552  
 Series ..... T1

Hot output

-Amperes..... 140 at 25°C (AMBIENT)  
-Volts ..... 28  
-Approximate rpm..... 6000  
Ground ..... negative  
Prevost Number ..... 562752

**Battery equalizer**

Make..... Vanner  
Model..... 60-100D  
Amperes ..... 100 amps  
Prevost Number ..... 563334

**Starter**

Make..... Mitsubishi Electric Corporation (MELCO)  
Model Number..... M009T82479  
Type ..... 105P70  
Voltage ..... 24  
Prevost Number ..... 510752

No-load test

-Volts ..... 23.5  
-Max. current draw ..... 125 amperes  
-Min. rpm ..... 3000 rpm

**Starter solenoid**

Make..... Mitsubishi Electric Corporation (MELCO)  
Model Number..... 1115557  
Pull In Voltage ..... 16 volts max.



# SECTION 07: TRANSMISSION

## CONTENTS

<b>1. DESCRIPTION</b>	<b>3</b>
1.1 ALLISON AUTOMATIC TRANSMISSION	3
1.1.1 Retarder (if applicable)	3
<b>2. WELDING PROCEDURES</b>	<b>4</b>
<b>3. ALLISON TRANSMISSION MAINTENANCE</b>	<b>4</b>
3.1 MANUAL FLUID LEVEL CHECK	4
3.2 COLD CHECK	4
3.3 HOT CHECK	5
3.4 FLUID LEVEL CHECK USING THE PUSHBUTTON SHIFT SELECTOR	5
3.5 IMPORTANCE OF PROPER FLUID LEVEL	6
3.6 KEEPING OIL CLEAN	6
3.7 RECOMMENDED AUTOMATIC TRANSMISSION FLUID	6
3.8 OIL CONTAMINATION	7
3.9 METAL PARTICLES	7
3.10 COOLANT LEAKAGE	7
3.11 OIL AND FILTER CHANGE	9
<b>4. INSTALLATION OF ALLISON TRANSMISSION BRACKETS</b>	<b>10</b>
<b>5. ALLISON TRANSMISSION REMOVAL</b>	<b>10</b>
<b>6. TRANSMISSION OIL COOLER REMOVAL</b>	<b>12</b>
6.1 TRANSMISSION WITHOUT RETARDER	12
6.2 TRANSMISSION WITH RETARDER	12
<b>7. CLEANING AND INSPECTION OF THE ALLISON AUTOMATIC TRANSMISSION</b>	<b>12</b>
7.1 BREATHER	13
<b>8. ALLISON TRANSMISSION INSTALLATION</b>	<b>13</b>
<b>9. TROUBLESHOOTING</b>	<b>14</b>
9.1 ALLISON AUTOMATIC TRANSMISSION	14
9.1.1 4 <sup>th</sup> Generation Transmission Control Module	14
9.1.2 Diagnostic Troubleshooting Codes (DTC) — Allison 4 <sup>th</sup> Generation Controls	14
9.1.3 Diagnostic Codes – Allison 4 <sup>th</sup> Generation Controls	15
9.1.4 Diagnostic Code Display And Clearing Procedure – Allison 4 <sup>th</sup> Generation Controls	15
9.1.5 Diagnostic Code Response	16
9.1.6 Diagnostic Troubleshooting Codes (DTC) List - Allison 4 <sup>th</sup> Generation Controls	17
<b>10. SPECIFICATIONS</b>	<b>20</b>

## ILLUSTRATIONS

FIGURE 1: ALLISON TRANSMISSION	3
FIGURE 2: ALLISON TRANSMISSION CONTROL PAD	3
FIGURE 3: OIL LEVEL DIPSTICK (AUTO. TRANS.)	4
FIGURE 4: COLD CHECK	5
FIGURE 5: HOT CHECK	5
FIGURE 6: DRAIN PLUG AND FILTERS	9
FIGURE 7: ALLISON TRANSMISSION BRACKETS	10
FIGURE 8: DETAILS FOR XLII VEHICLES	11

**Section 07: TRANSMISSION**

---

FIGURE 9: ENGINE CRANKING POSITION..... 11  
FIGURE 10: MODINE OIL COOLER ..... 12  
FIGURE 11: COOLER WITH RETARDER ..... 12  
FIGURE 12: AIR PRESSURE REGULATOR (TYPICAL)..... 14  
FIGURE 13: TRANSMISSION CONTROL MODULE ..... 14

## 1. DESCRIPTION

XLII Series Bus Shells are provided with an Allison automatic transmission.

### 1.1 ALLISON AUTOMATIC TRANSMISSION

The B500 or B500R (with retarder) Allison Transmission has 6 speeds with two top range (fifth and sixth) overdrives. Total coverage is determined by dividing the highest gear ratio by the lowest gear ratio. Total coverage expresses the transmission gear ratio versatility. Transmissions with larger total coverage number have a wider variety of available ratios.

An electronic control allows the transmission to shift at exactly the right point on the engine's fuel consumption curve for best economy. Early lockup maintains the highest possible mechanical efficiency through the closely-spaced gear steps, culminating in two overdrive ratios. This combination allows progressive shifting techniques, where engine speeds are reduced for higher efficiency and lower fuel consumption.

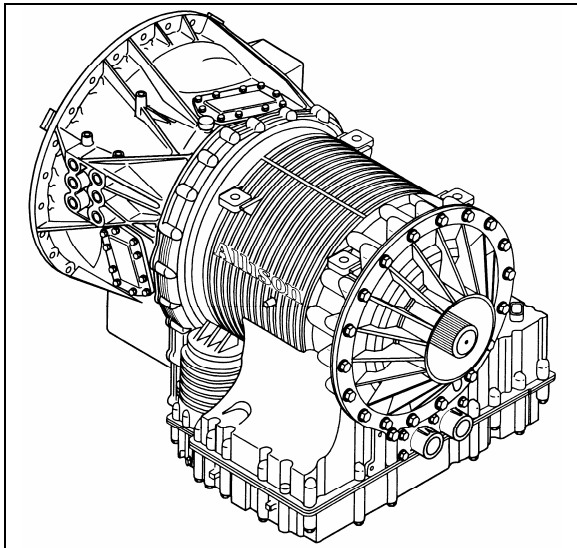

FIGURE 1: ALLISON TRANSMISSION

07075

Gear selection and torque converter modes are controlled by a microcomputer-based electronic transmission management system. It is fed information regarding throttle position, operator range selection, engine speed, turbine speed, transmission output speed and various system pressures from special electronic sensors. With this information, it computes shift points and clutch pressures to meet immediate needs. Using closed loop adaptive logic; the electronic control looks at a number of parameters during the shift, and makes minute adjustments to match the shift to desired profile stored in its

memory. It then looks at these adjustments and resets the parameters, which allow the transmission to quickly compensate for variations in load, terrain or environment and to adjust for clutch wear and engine power changes. A Diagnostic Data Reader can be connected to the electronic control unit to provide a self-check of all systems in the transmission. Four-digit trouble codes greatly reduce the time it takes to pinpoint potential problems. (Refer to heading "10. TROUBLESHOOTING" in this section).

#### 1.1.1 Retarder (if applicable)

This optional auxiliary braking device for the automatic transmission is integrated into the basic envelope of the transmission and transmits its braking force directly to the propeller shaft. It requires no additional length and adds only 75 pounds (34 kg) of weight. Operation of the retarder is controlled electronically by the driver's use of the brake and/or by hand control lever.

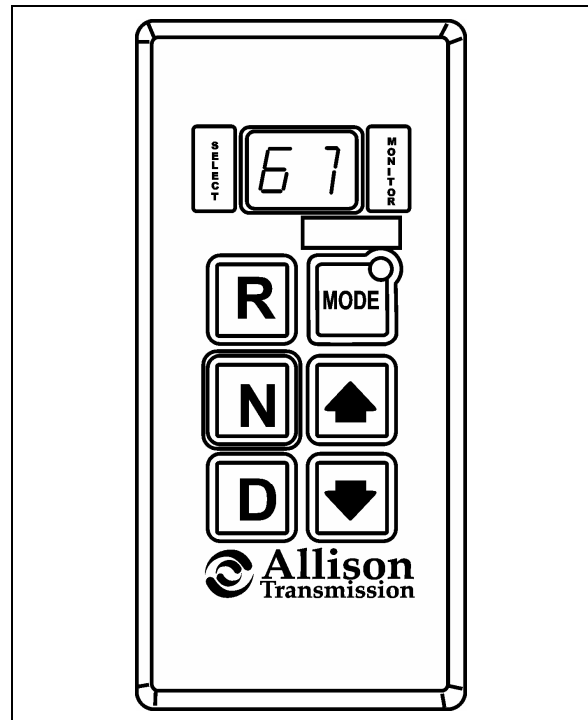

FIGURE 2: ALLISON TRANSMISSION CONTROL PAD 07025

When activated, fluid enters a cavity and provides resistance to the turning of rotor blades revolving with the output shaft. This effectively slows the vehicle to the point where the service brakes are needed only for final stopping. The retarder is fully modulated and is compatible with ABS.

## 2. WELDING PROCEDURES

These procedures are intended only for vehicles equipped with transmission electronic controls. When frame or other welding is required on the vehicle, precautions are to be taken to protect the electronic control components. Refer to section 00: GENERAL INFORMATION, paragraph 3: "Precautions to be observed before welding" for complete procedure.

## 3. ALLISON TRANSMISSION MAINTENANCE

To gain access to the dipstick, open the engine compartment rear doors; dipstick is located on the radiator side of the engine (Fig. 3).

### 3.1 MANUAL FLUID LEVEL CHECK



#### DANGER

When checking the oil level, be sure that the parking brake and/or emergency brakes are set and properly engaged, and the wheels are chocked. Unexpected and possible sudden vehicle movement may occur if these precautions are not taken.

- Special care must be taken not to touch the engine coolant tubing and/or exhaust pipe, since this could cause severe burns.
- Do not wear loose clothing and, stay away from rotating parts during procedure; personal injury could occur.

Clean all dirt from around the end of the oil filler tube before removing the dipstick. Dirt or foreign matter must not be permitted to enter the oil system since it will cause valves to stick, undue wear of transmission parts, and clogged passages. Check the oil level using the procedures in Cold Check and Hot Check. Record any abnormal level on your "Maintenance Records".

Always check the oil level reading at least twice when the engine is running. Consistency is important in maintaining the accuracy of the reading. If inconsistent readings persist, check the transmission breather to ensure it is clean and free of debris.

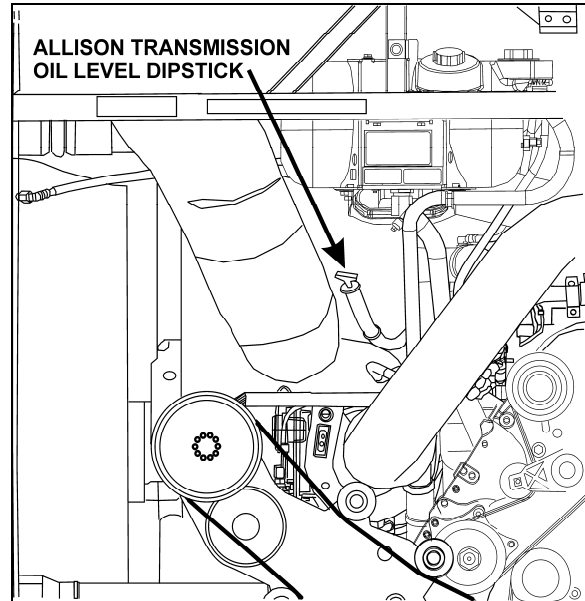

FIGURE 3: OIL LEVEL DIPSTICK (AUTO. TRANS.) 07113

### 3.2 COLD CHECK

The purpose of the **Cold Check** is to determine if the transmission has enough fluid to be operated safely until a **Hot Check** can be made.

1. If the engine has been shut down for an extended period of time, park the vehicle on a level surface and apply the parking brake.



#### CAUTION

The oil level rises as sump temperature increases. DO NOT fill above the "Cold Run" band if the transmission oil is below normal operating temperature. During operation, an overfull transmission can become overheated, leading to transmission damage.

2. Run the engine at idle in «N» (Neutral) for about one minute.
3. Shift to Drive (D) and operate the engine for 30 seconds at 1000-1500 rpm; then shift to Reverse (R) to clear the hydraulic system of air.
4. Move the vehicle to a level surface, put transmission in «N» (Neutral), and set the parking brake.
5. Finally shift to Neutral (N) and allow the engine to idle (500 - 800 rpm).
6. While the engine is running, remove the dipstick from the tube and wipe it clean (Figs. 4 & 5). Insert the dipstick into the fill tube, pushing down until it stops.

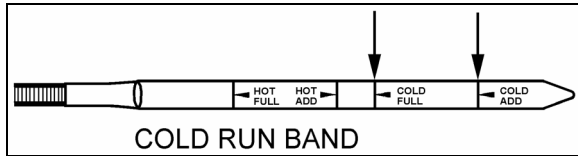

FIGURE 4: COLD CHECK

07050

7. Remove the dipstick and observe the fluid level. Repeat the check procedure to verify the reading. If the fluid on the dipstick is within the COLD CHECK band, the level is satisfactory for operating the transmission until the oil is hot enough to perform a **Hot Check**. If the fluid level is **not** within this band, add or drain fluid as necessary to bring the level within the COLD CHECK band.
8. Perform a **Hot Check** at the first opportunity after the normal operating temperature of 160°F (71°C) to 200°F (93°C) is attained.

**CAUTION**

**DO NOT** operate the transmission for extended periods of time until a **Hot Check** has verified proper fluid level. Transmission damage can result from extended operation at improper fluid level conditions.

**CAUTION**

Obtain an accurate fluid level by imposing the following conditions:

- Engine is idling (500-800 rpm) in «N» (Neutral).
- Transmission fluid is at normal operating temperature.
- The vehicle is on a level surface.

## 3.3 HOT CHECK

**CAUTION**

The oil **must be hot** to ensure an accurate check for this procedure. The oil level rises as temperature increases.

To perform a **Hot Check**, do the following:

1. The **Hot Check** can be performed when the transmission oil reaches the normal operating temperature (160°F to 200°F / 71°C to 93°C). The transmission oil temperature can be checked with the dashboard message center display (MCD)

when selecting the Gauge Mode (refer to the “Operator’s Manual” for added information).

2. Park the vehicle on a level surface and shift to Neutral (N). Apply the parking brake and allow the engine to idle (500 - 800 rpm).
3. Remove the dipstick from the tube and wipe it clean. Insert the dipstick into the fill tube, pushing down until it stops.
4. Remove the dipstick and observe the fluid level. The safe operating level is anywhere within the HOT RUN band on the dipstick. Repeat the check procedure to verify the reading.
5. If the level is **not** within this band, add or drain fluid as necessary to bring the level within the HOT RUN band. (Fig. 5).

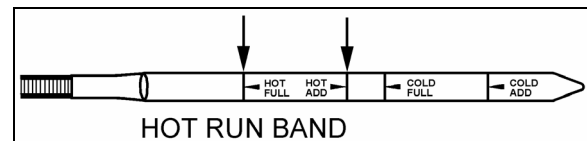

FIGURE 5: HOT CHECK

07049

6. Be sure fluid level checks are consistent. Check level more than once and if readings are not consistent, check to be sure the transmission breather is clean and not clogged. If readings are still not consistent, contact your nearest Allison dealer or distributor.

**NOTE**

*The Cold Check is more appropriate for verifying the oil level after the first fill-up. In case of conflict, the Hot Check has priority over the Cold Check; the fluid level check using the pushbutton shift selector has priority over the Hot Check.*

## 3.4 FLUID LEVEL CHECK USING THE PUSHBUTTON SHIFT SELECTOR

Oil level codes are obtained as follows:

1. Park vehicle on a level surface, select «N» (neutral) on the pushbutton shift selector and apply parking brake.
2. Press simultaneously the ▲ (Up) and ▼ (Down) arrow buttons once.
3. Oil level codes are displayed in 2 minutes (e.g. display will flash and 8, 7, 6, 5, ...; countdown will occur during the 2 minutes) once the following parameters are met:

## Section 07: TRANSMISSION

- **Waiting time, vehicle must be stationary for at least 2 minutes to allow the oil to settle;**
- **Engine at idle;**
- **Oil at normal operating temperature, between 140°F (60°C) and 220°F (104°C);**
- **Transmission in «N» (Neutral);**
- **Transmission output shaft stopped;**
- **Oil level sensor present and working.**

After 2 minutes, the display will flash one of the codes shown hereafter:

CODE	CAUSE OF CODE
O L...O K	Oil level is correct
O L...L O...01	One quart low
O L...L O...02	Two quarts low
O L...H I...01	One quart high
O L...H I...02	Two quarts high

### NOTE

*Failure to meet one of the above parameters will stop the two minute countdown. One of the codes shown hereafter will indicate the cause of the countdown interruption. Once all parameters are met, the countdown will continue from where it left off.*

CODE	CAUSE OF CODE
OL...0X	Waiting time too short
OL...50	Engine speed (rpm) too low
OL...59	Engine speed (rpm) too high
OL...65	Neutral must be selected
OL...70	Sump oil temperature too low
OL...79	Sump oil temperature too high
OL...89	Output shaft rotation
OL...95	Sensor failure

To exit the Oil Level Display Mode, press any range button: «R», «N» or «D».

### 3.5 IMPORTANCE OF PROPER FLUID LEVEL

It is important that the proper fluid level be maintained at all times because the transmission fluid cools, lubricates, and transmits hydraulic power. If the fluid level is too low, the converter and clutches do not receive an adequate supply of fluid. If fluid level is too high, the fluid can aerate, causing the transmission to shift erratically or overheat.

### 3.6 KEEPING OIL CLEAN

Oil must be handled in clean containers, fillers, etc., to prevent foreign material from entering the transmission. Place the dipstick on a clean surface area while filling the transmission.



### CAUTION

Containers or fillers that have been used to handle antifreeze or engine coolant must **NEVER** be used for handling transmission fluid. Antifreeze and coolant solutions contain ethylene glycol that, if introduced into the transmission, can cause the clutch plates to fail.

### 3.7 RECOMMENDED AUTOMATIC TRANSMISSION FLUID

Hydraulic fluids used in the transmission are important influences on transmission performance, reliability and durability. **Castrol TranSynd™ Synthetic Fluid, DEXRON-III®** and **DEXRON-VI®** fluids are recommended for on-highway applications.

- **TranSynd™** is a full synthetic transmission fluid developed by Allison Transmission and Castrol Ltd. This fluid meets Allison specifications for Severe Duty and Extended Drain Intervals. TranSynd™ is fully qualified to the Allison TES295 specifications and is available through Allison distributors and dealerships.

- To be sure a fluid is qualified for use in Allison transmission, check for the **DEXRON-III®** or **DEXRON-VI®** license numbers on the container or consult the lubricant manufacturer. Consult your Allison Transmission dealer or distributor before using other fluid types.

Customers may use TranSynd™/TES 295 equivalent and extend drain intervals. Equivalent TranSynd™ fluid must meet or exceed TES 295 requirements. Customers may choose from a wide variety of approved non-TES 295 like Dexron-III®, Dexron-VI® or approved Schedule 1 TES-389 fluids.

The Transmission Fluid Operating Temperature Requirements table lists the minimum fluid temperatures at which the transmission may be safely operated without preheating. Preheat with auxiliary heating equipment or by running the equipment or vehicle with the transmission in «N» (Neutral) for a minimum of 20 minutes before attempting range operation.

#### Transmission Fluid Operating Temperature Requirements

Fluid type	Minimum operating temperature	
	Celsius	Fahrenheit
TranSynd™	-30	-22
DEXRON-VI®	-25	-13



#### CAUTION

Disregarding minimum fluid temperature limits can result in transmission malfunction or reduced transmission life.

#### NOTE

*The use of an arctic preheat kit is recommended at temperatures below -25°F (-32°C). If a preheat kit is not available, the TCM will restrict full operation until the sump temperature is increased.*

### 3.8 OIL CONTAMINATION

At each oil change, examine the drained oil for evidence of dirt or water. A nominal amount of condensation will emulsify during operation of the transmission. However, if there is evidence of water; check the cooler (heat exchanger) for other signs of leakage. This, however, may also indicate leakage from the engine oil system.

### 3.9 METAL PARTICLES

Metal particles in the oil (except for minute particles normally trapped in the oil filter) indicate damage has occurred in the transmission. When these particles are found in the sump, the transmission must be disassembled and closely inspected to find the source. Metal contamination will require complete disassembly of the transmission and cleaning of all internal and external circuits, coolers, and all other areas where the particles could lodge.



#### CAUTION

If excessive metal contamination has occurred, replacement of the oil cooler and replacement of all bearings within the transmission is recommended.

### 3.10 COOLANT LEAKAGE

If engine coolant leaks into the transmission oil system, immediate action must be taken to prevent malfunction and possible serious damage. The transmission must be completely disassembled, inspected, and cleaned. All traces of the coolant contamination must be removed. Friction clutch plates contaminated with ethylene glycol must be replaced.

**TABLE 1**

Recommended Fluid and Filter Change Intervals Using Dexron-III / Dexron-VI / Non-TranSynd™/Non-TES 295/Mixture							
Severe <sup>3</sup> MTH equipped with retarder				General <sup>4</sup> MTH without retarder			
Fluid	Filters			Fluid	Filters		
	Main	Internal	Lube/ Auxiliary		Main	Internal	Lube/ Auxiliary
12,000 Miles (20 000 km) 6 Months	12,000 Miles (20 000 km) 6 Months	Overhaul	12,000 Miles (20 000 km) 6 Months	25,000 Miles 40 000 km 12 Months	25,000 Miles 40 000 km 12 Months	Overhaul	25,000 Miles (40 000 km) 12 Months

**2 inch Control Module (1.75 approximately) – Requires High-Capacity Filter kit Allison P/N 571709**

**TABLE 2**

Recommended Fluid and Filter Change Intervals <sup>1</sup> Using 100% TranSynd™/TES 295 Approved Fluid <sup>2</sup>							
Severe <sup>3</sup> MTH equipped with retarder				General <sup>4</sup> MTH without retarder			
Fluid	Filters			Fluid	Filters		
	Main	Internal	Lube/ Auxiliary		Main	Internal	Lube/ Auxiliary
150,000 Miles (240 000 km) 48 Months	75,000 Miles (120 000 km) 36 Months	Overhaul	75,000 Miles (120 000 km) 36 Months	300,000 Miles 480 000 km 48 Months	75,000 Miles (120 000 km) 36 Months	Overhaul	75,000 Miles (120 000 km) 36 Months

**TABLE 3**

Recommended Fluid and Filter Change Intervals Using 100% TranSynd™/TES 295 Approved Fluid And Gold Series Filters							
MTH equipped with retarder				MTH without retarder			
Fluid	Filters			Fluid	Filters		
	Main	Internal	Lube/ Auxiliary		Main	Internal	Lube/ Auxiliary
	Initial Break-in 5,000 miles (8,000 km)				Initial Break-in 5,000 miles (8,000 km)		
50,000 Miles (80 000 km) 24 Months	50,000 Miles (80 000 km) 24 Months	Overhaul	50,000 Miles (80 000 km) 24 Months	150,000 Miles 240 000 km 48 Months	50,000 Miles 80 000 km 24 Months	Overhaul	50,000 Miles (80 000 km) 24 Months

<sup>1</sup> Extended TranSynd™/TES 295 fluid and filter change intervals are only allowed with Allison High-Capacity filters.

<sup>2</sup> Less than 100% concentration of TranSynd™/TES 295 approved fluid is considered a mixture and should utilize non-TES 295 change intervals. If the customer replaces non-TranSynd™/non-TES 295 fluid with TranSynd™/TES 295 equivalent, the change interval recommendations of non-TranSynd™/non-TES 295/mixture must be followed. Upon the next oil change, if the customer reinstall TranSynd™/TES 295 equivalent, the fluid & filter change recommendation outlined in 100% TES 295 approved fluids must be followed.

<sup>3</sup> Severe vocation= All retarder, On/Off highway, transit and intercity coach with duty cycle greater than one (1) stop per mile.

<sup>4</sup> General vocation= intercity coach with duty cycle less than or equal to one (1) stop per mile and all other vocations not listed in severe vocation.



## 3.11 OIL AND FILTER CHANGE

Allison transmissions are factory fill with **Castrol TranSynd™** fluid. Oil change must be performed with the vehicle on a flat and level surface and with parking brake applied. Oil and oil filter change frequency is determined by the severity of service and operating conditions of the transmission and by the filter equipment installed. See "TABLE 1, TABLE 2 or TABLE 3" for oil and filter change intervals. More frequent changes may be required when operations are subject to high levels of contamination or overheating. Filters must be changed at or before recommended intervals.

**IMPORTANT NOTE**

Allison Transmission recommends that customers use fluid analysis as the primary method for determining fluid change intervals. Many customers have a systematical annual transmission fluid change while, in many cases, fluid analysis could demonstrate that the transmission fluid is still in good condition and a fluid change is not required. In the absence of a fluid analysis program, the fluid change interval listed in TABLE 1, TABLE 2 & TABLE 3 should be used.

**IMPORTANT NOTE**

Your transmission is equipped with **High Capacity filters**. High Capacity filters allow for increased fluid and filter change intervals in transmissions utilizing TES 295 approved fluid/TranSynd™. High Capacity filters eliminate the requirement of the initial 5000 miles (8000km) main filter change.

Former Gold Series filter kits are completely cancelled and serviced with current High Capacity filter kits. However, if you are using stocked Gold Series filter kits with TES 295 approved fluid/TranSynd™, use TABLE 3 for oil and filter change intervals.

The procedure for changing the transmission oil and oil filters is as follows:

**Drain**

1. The transmission should be at an operating temperature of 160°F (71°C) to 200°F (93°C) when the oil is drained. This will ensure quicker and more complete fluid drainage.

**NOTE**

Remove transmission protective panel located underneath transmission for easier access.

2. Remove the drain plug from under the transmission (Fig. 6) and allow the oil to drain into a suitable container. Check the condition of the oil as described previously.
3. To replace the integral filters, remove twelve bolts (6 on each cover), two filter covers, two O-rings, two square cut seals and the two filters from the bottom of the control module (Fig. 6).
4. To install filters, pre-lube and install the two O-rings, the two square cut seals followed by the filters (lube the O-ring in filter cartridge only) into the filter compartment. Index each filter/cover assembly to holes in channel plate/sump. Push the cover assembly in by hand to seat the seals.

**CAUTION**

Do not use bolts to draw the cover to sump. This can damage the cover, seal, or sump.

5. Install twelve bolts and both covers, and then tighten to 38-45 lbf-ft (51-61 Nm).
6. Inspect the drain plug and O-ring. Replace if necessary. Reinstall the drain plug and tighten to 18-24 lbf-ft (25-32 Nm).
7. Reinstall transmission protective panel

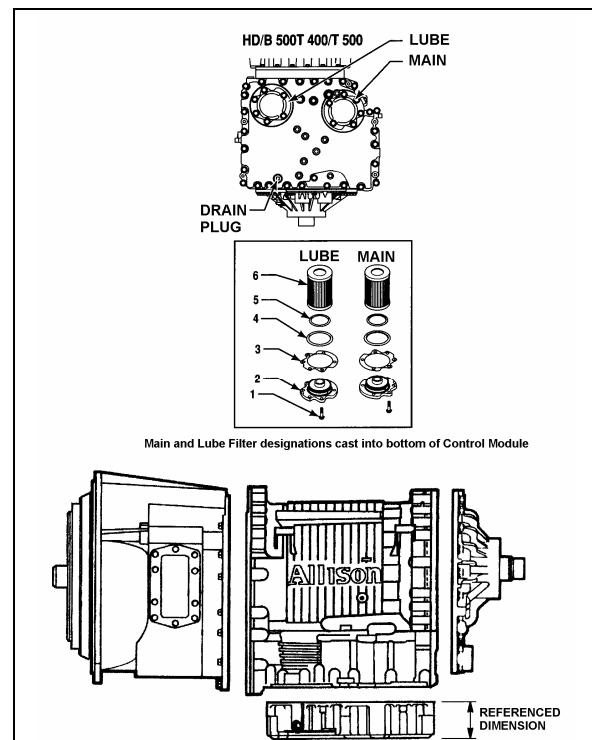

FIGURE 6: DRAIN PLUG AND FILTERS

07074

**Fluid loss with filter change only**

When changing main and lube filters at recommended intervals, approximate fluid loss for each filter as follows:

- Main filter = 2 quarts (1.9 liters)
- Lube filter = 8 quarts (7.6 liters)

**Refilling Transmission**

The amount of refill fluid is less than the amount used for the initial fill. Fluid remains in the external circuits and transmission cavities after draining the transmission.

**NOTE**

*Quantities listed above are approximations and do not include external oil cooler lines.*

Using the oil level dipstick filler tube, refill with 24 US qts (23 liters) [28 US qts (26.5 liters) if equipped with retarder] and check the oil level using the **Fluid Level Check Using Pushbutton Shift Selector** procedure in this section.

**4. INSTALLATION OF ALLISON TRANSMISSION BRACKETS**

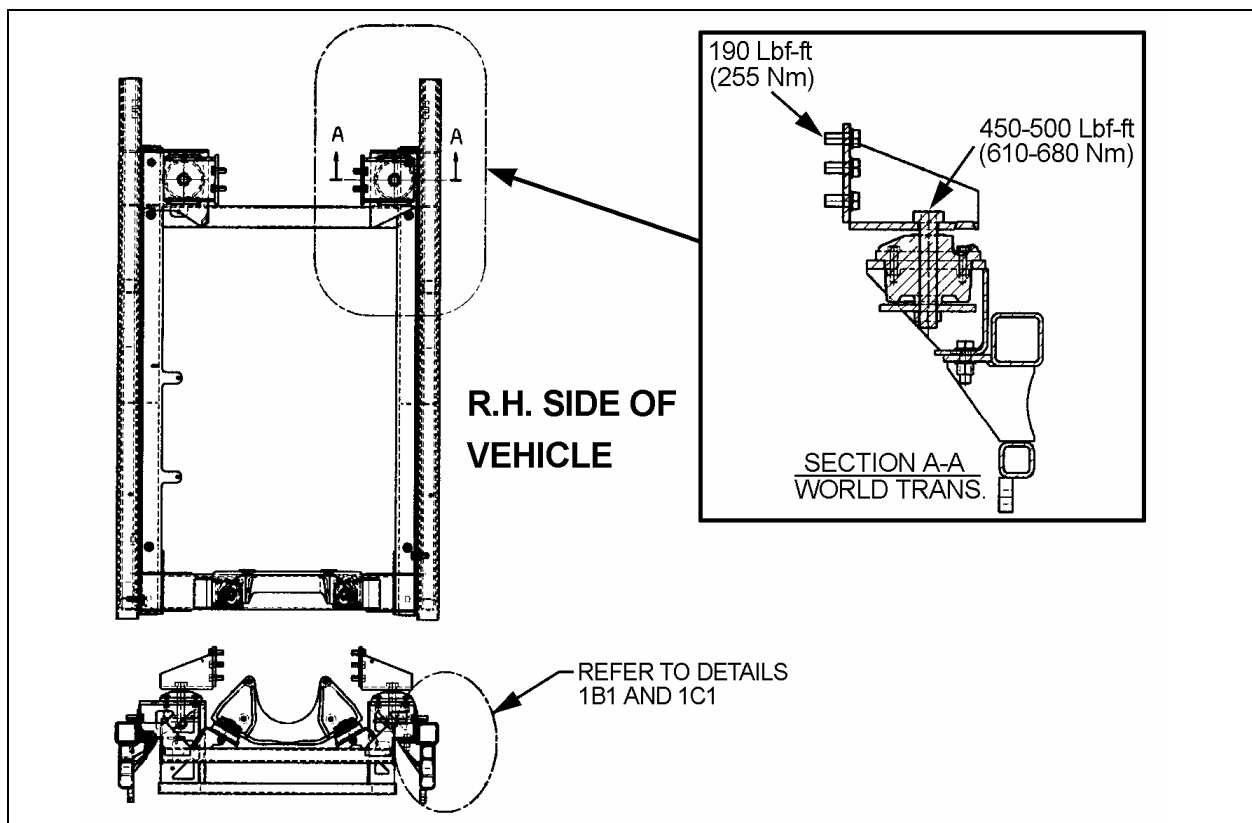

FIGURE 7: ALLISON TRANSMISSION BRACKETS

07133

**5. ALLISON TRANSMISSION REMOVAL**

The following procedure deals with the removal of the Allison transmission without removing the power plant cradle from vehicle. The methods used to support the transmission and engine depend upon conditions and available equipment.

1. Select transmission's "NEUTRAL" position, apply parking brake, then set battery master switch to the "OFF" position.

2. Jack up vehicle, then place safety supports underneath body.



**CAUTION**

Only the recommended jacking points must be used as outlined in Section 18, "BODY".

**NOTE**

For more clearance between the tag axle and transmission, the tag axle may be unloaded and jacked up or retracted (if applicable).

3. Remove engine splash guards and protective panels surrounding transmission.
4. Remove cross member from under transmission.
5. Remove the transmission drain plug and allow oil to drain. Inspect the drain plug washer and replace it if necessary. Reinstall the drain plug and tighten to 33-41 lbf-ft (45-56 Nm) (see "3.11 Oil and Filter Change" in this section).

**WARNING**

It is better to drain oil when it is still warm. Avoid contact with oil since it can be very hot and cause personal injury.

6. Remove transmission dipstick and filler tube.
7. Disconnect propeller shaft from transmission and remove its safety guard. Refer to Section 09, "PROPELLER SHAFT".
8. Disconnect the two oil cooler hoses from transmission. Cover hose ends and fittings to prevent fluid contamination.

**WARNING**

A significant amount of oil may drain from oil lines when they are disconnected.

9. Disconnect all sensors on L.H. side of the transmission.
10. Disconnect main wiring harness.
11. Disconnect the air supply line (steel-braided hose) from retarder control valve (if applicable).
12. Remove any locking tie, clamp and bracket that may interfere with the removal of transmission.
13. Support transmission using a suitable transmission jack.
14. Remove the access plug from the flywheel housing on the R.H. side below starter. From access plug, remove the 12 converter-to-flexible plate attaching screws. Cranking the engine to gain access to the attaching screws may be done by turning the crankshaft pulley using a suitable adapter (fig. 9).

**CAUTION**

Do not rotate alternator shaft clockwise to avoid removing tension on belt.

15. Remove the 12 screws retaining the torque converter housing to the flywheel housing.

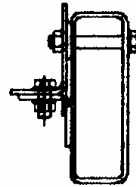

**DETAIL 1C1**  
**XL2-40 & 45E**  
**TYP. 2 SIDES**



**DETAIL 1B1**  
**XL2-45**  
**TYP. 2 SIDES**

FIGURE 8: DETAILS FOR XLII VEHICLES

07116

**CAUTION**

Make sure transmission-to-engine alignment is maintained when removing screws to avoid damaging torque converter housing.

16. Slowly pull transmission straight out to clear the engine.
17. Remove the transmission.

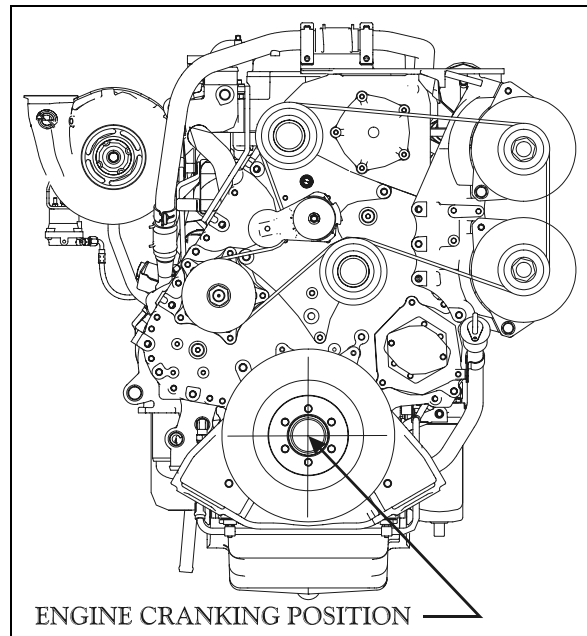

ENGINE CRANKING POSITION

FIGURE 9: ENGINE CRANKING POSITION

01153

## 6. TRANSMISSION OIL COOLER REMOVAL

### 6.1 TRANSMISSION WITHOUT RETARDER

Stop engine and allow engine to cool. Close both heater line shutoff valves (refer to Section 05 "Cooling").

To drain the cooling system, proceed as per Section 05 "Cooling", paragraph 5: Draining. If the cooling system is contaminated, flush system as per Section 05 "Cooling", paragraph 7: Flushing.

1. Disconnect and remove the engine air intake duct mounted between the air cleaner housing and the turbocharger inlet.

	<b>CAUTION</b>
To avoid damage to turbocharger, cover the turbocharger inlet opening to prevent foreign material from entering.	

2. Disconnect the two transmission hoses from oil cooler. Cover hose ends and fittings to prevent fluid contamination.

	<b>WARNING</b>
A significant amount of oil may drain from oil lines when they are disconnected.	

3. Unfasten the constant-torque hose clamps and remove the two hoses.

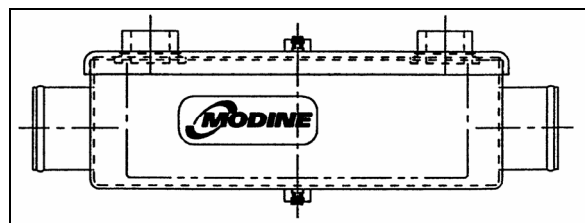



FIGURE 10: MODINE OIL COOLER 07072

4. Unscrew the four holding nuts and remove the U-bolts, remove the oil cooler from engine compartment.
5. Reinstall transmission oil cooler by using reverse procedure.

### 6.2 TRANSMISSION WITH RETARDER

Stop engine and allow engine to cool. Close both heater line shutoff valves (refer to Section 05 "Cooling").

1. To drain the cooling system, proceed as per Section 05 "Cooling", paragraph 5: Draining. If the cooling system is contaminated, flush system as per Section 05 "Cooling", paragraph 7: Flushing.
2. Disconnect and remove the engine air intake duct mounted between the air cleaner housing and the turbocharger inlet.

	<b>CAUTION</b>
To avoid damage to turbocharger, cover the turbocharger inlet opening to prevent foreign material from entering.	

3. Disconnect the transmission hoses from oil cooler. Cover hose ends and fittings to prevent fluid contamination.

	<b>WARNING</b>
A significant amount of oil may drain from oil lines when they are disconnected.	

4. Unfasten the constant-torque hose clamps and remove the two hoses.
5. Unscrew the holding bolts and nuts and remove the oil cooler from engine compartment.

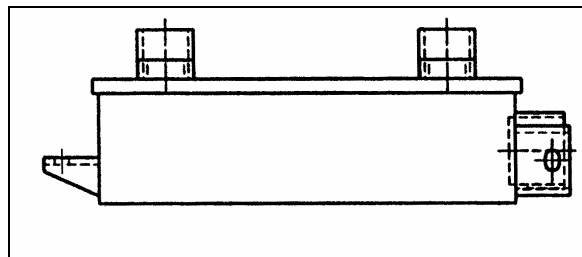

FIGURE 11: COOLER WITH RETARDER 07073

6. Reinstall transmission oil cooler by using reverse procedure.

## 7. CLEANING AND INSPECTION OF THE ALLISON AUTOMATIC TRANSMISSION

The exterior of the transmission should be cleaned and inspected at regular intervals. The length of service and severity of operating conditions will determine the frequency of such inspections. Inspect the transmission for:

1. Loose bolts (transmission and mounting components);
2. Oil leaks (correct immediately);

3. Loose, dirty, or improperly adjusted throttle sensor linkage;
4. Damaged or loose oil lines;
5. Worn or frayed electrical harnesses, improper routing;
6. Worn or out of phase drive line U-joint and slip fittings.

**CAUTION**

DO NOT pressure wash the transmission electrical connectors. Water and detergent will cause the contacts to corrode or become faulty.

## 7.1 BREATHER

The breather is located on the engine, flywheel side near the valve cover. It serves to prevent pressure build-up within the transmission and must be cleaned to keep the passage opened. The prevalence of dust and dirt will determine the frequency at which the breather requires cleaning. Use care when cleaning the engine. Spraying steam, water or cleaning solution directly at the breather can force the water or solution into the transmission. Always use care when removing the hose connector from transmission to prevent the entry of foreign matter.

## 8. ALLISON TRANSMISSION INSTALLATION

**NOTE**

*For more clearance between the tag axle and transmission, the tag axle may be unloaded and jacked up, or retracted (if applicable).*

1. With the access plug removed, align one of the 12 attaching screw holes in the flexible plate with the access opening (starter side).
2. Place the transmission on a transmission jack.
3. Install a headless guide bolt into one of the 12 threaded holes for flexible plate attaching screws in the flywheel.
4. Lubricate the flywheel center pilot boss with molybdenum disulfide grease (Molycote G, or equivalent).
5. Raise transmission and position the flywheel pilot boss into the flexible plate adapter. Align the guide bolt previously installed in the

flywheel with the flexible plate hole facing the access opening in the flywheel housing.

**DANGER**

Severe damages and/or personal injury can occur if transmission is not adequately supported.

6. Seat the transmission against the engine flywheel housing. **NO FORCE IS REQUIRED.** If interference is encountered, move the transmission away from engine, then investigate the cause.

**CAUTION**

The torque converter housing must be seated against the flywheel housing prior to tightening any screws. **DO NOT USE SCREWS TO SEAT THE HOUSING.**

7. Start all torque converter housing screws, and then tighten four of them gradually and in a criss-cross sequence around the housing. Tighten the 12 remaining screws. Recommended torque is between 42-50 lbf-ft (57-68 Nm).
8. Remove the guide bolt through the access opening in the flywheel housing. Replace it with a self-locking screw, finger-tighten then start the remaining screws; tighten to 17-21 lbf-ft (23-28 Nm). Place a wrench on the crankshaft pulley attaching screw to turn the converter to gain access to the threaded holes.
9. Reinstall the access plug.
10. Remove jack from under transmission.
11. Connect all sensors.
12. Connect the main wiring harness.
13. Connect the air supply line (steel-braided hose) to the retarder control valve (if applicable).
14. Connect the two transmission oil cooler hoses as they were previously.
15. Reinstall clamps and brackets, and replace locking ties previously removed during removal procedure.
16. Install propeller shaft and its safety guard. Refer to Section 09, "PROPELLER SHAFT".

## Section 07: TRANSMISSION

17. Install transmission dipstick and filler tube.
18. Install cross member under transmission.
19. Install engine splash guards.
20. Adjust the retarder pressure to  $80 \pm 3$  psi with the air pressure regulator. For more information refer to Section 12, "BRAKE AND AIR SYSTEM", under heading "AIR PRESSURE REGULATOR". The air pressure regulator is located in the engine compartment, above the rear junction box (Fig. 12).

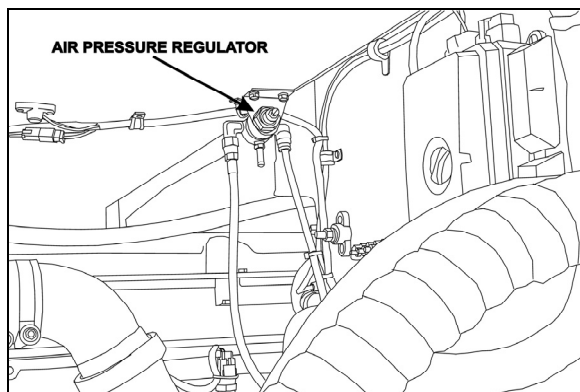

FIGURE 12: AIR PRESSURE REGULATOR (TYPICAL) 07037

23. Make sure that the drain plug is in place, and then remove the transmission dipstick and pour approximately 24 US quarts (23 L) of automatic transmission fluid through the filler tube. Check and adjust oil level.



### CAUTION

Do not overfill the transmission. Overfilling can cause oil aeration (milky appearance) and overheating. If overfilling occurs, drain oil as required to bring it to the proper level.

## 9. TROUBLESHOOTING

### 9.1 ALLISON AUTOMATIC TRANSMISSION

For complete information about Allison transmission troubleshooting, refer to "Allison 4<sup>th</sup> Generation Controls – Troubleshooting Manual: 3000 and 4000 Product families (TS3989)".

#### 9.1.1 4<sup>th</sup> Generation Transmission Control Module

The Allison automatic transmission has a new Transmission Control Module (TCM) which

involves specific diagnostic incident codes. The TCM is located in the coach rear junction box.

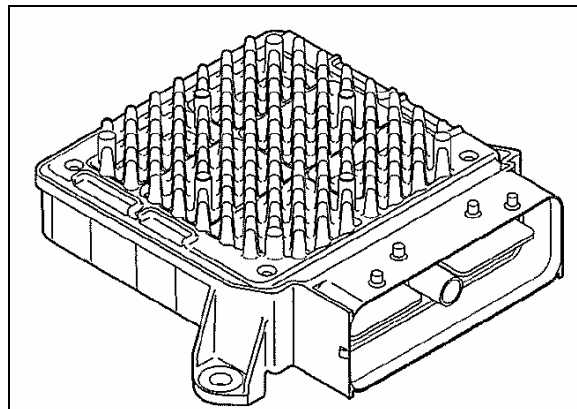

FIGURE 13: TRANSMISSION CONTROL MODULE 07140

### TCM Replacement

The TCM is a non-serviceable electronic device. When it fails, it must be replaced using the following procedure:

- Open the coach engine compartment R.H. side door;
- Open the rear junction box in order to get access to the TCM;
- Remove the electrical cable connectors;
- Unscrew the TCM unit;
- Replace by reversing the procedure.



### CAUTION

Place the ignition key switch to the "OFF" position.

#### 9.1.2 Diagnostic Troubleshooting Codes (DTC) — Allison 4<sup>th</sup> Generation Controls

Diagnostic codes (DTC) are numerical indications relating to a malfunction in transmission operation. These codes are logged in a list in the TCM memory with the most severe or most recent code listed first. A maximum of five codes (numbered d1 to d5) may be listed in memory at one time. As codes are added, the oldest inactive code is dropped from the list. If all codes are active, the code with the lowest priority that is not included on the severity list is dropped from the list.

Diagnostic codes (DTC) and code information may be accessed through the pushbutton shift selector or using an Allison DOC™ diagnostic tool.

The TCM separately stores the active and inactive codes. An active code is any code that is current in the TCM decision-making process. Inactive codes are codes that are retained in the TCM memory and will not necessary affect the TCM decision-making process. Inactive codes are useful in determining if a problem is:

- Isolated ;
- Intermittent ;
- Result from a previous malfunction.



The TCM may automatically delete a code from memory if it has not recurred. If the MODE INDICATOR (LED) is not illuminated, the displayed code is not active. An illuminated MODE INDICATOR (LED) during normal operation signifies secondary shift mode operation.

9.1.3 Diagnostic Codes – Allison 4<sup>th</sup> Generation Controls

When the diagnostic mode is entered, the first code (position d1) is displayed as follows:

Example: Code P0722

Displayed as: **d1...P...07...22**

The code list position is the first item displayed, followed by the DTC. Each item is displayed for about one second. The display cycles continuously until the next code list position is accessed by pressing the **MODE** button. The following example shows how DTC P0722 is displayed on the pushbutton shift selector.

SELECT	d	1	MONITOR
		P	
	0	7	
	2	2	

- d1 (code list position) – The position which a code occupies in the list. Positions are displayed as « d1 » through « d5 » (code list position 1 through code list position 5).
- P0722 (DTC) – The diagnostic troubleshooting code number referring to the general condition or area of fault detected by the TCM.

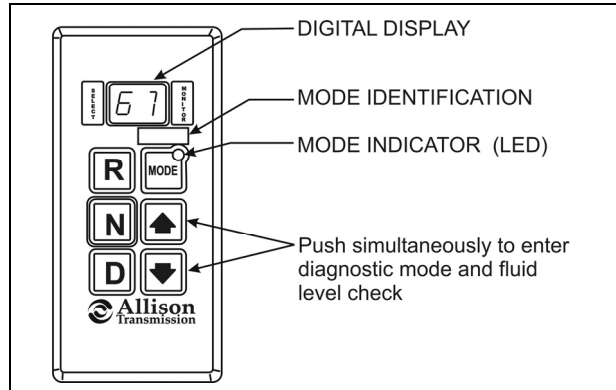

9.1.4 Diagnostic Code Display And Clearing Procedure – Allison 4<sup>th</sup> Generation Controls

Diagnostic codes can be read and cleared by two methods:

- Using an Allison DOC™ diagnostic tool. For specific instructions on how to use an Allison DOC™ diagnostic tool, refer to the User Guide.
- Using the pushbutton shift selector.

**To begin the diagnostic process:**

1. Bring the vehicle to a stop at a safe location.
2. Apply the parking brake.

**To display stored codes:**

1. Simultaneously press the ▲ (Up) and ▼ (Down) arrow buttons twice to access the Diagnostic Display Mode.
2. Observe the digital display for code (d1).

**NOTE**  
 To access the Oil Level Display Mode, simultaneously press the ▲ (Up) and ▼ (Down) arrow buttons once. Consult paragraph: « ALLISON TRANSMISSION OIL LEVEL CHECK USING THE PUSHBUTTON SHIFT SELECTOR » at the end of this section.

3. Press the MODE button to see the next code (d2) – repeat for subsequent codes (d3, d4 & d5).

**NOTE**  
 Be sure to record all codes displayed before they are cleared. This is essential for troubleshooting.

**NOTE**

*The Diagnostic Display Mode can be entered for viewing codes at any speed. Codes can only be cleared when the output speed = 0 and no output speed sensor failure is active*

Active indicators (MODE INDICATOR LED) and inactive codes can be cleared manually, while in the diagnostic display mode, after the condition causing the code is identified.

**To clear active indicators and inactive codes:**

1. While in Diagnostic Display Mode, press and hold the MODE button for 10 seconds to clear both active indicators and inactive codes.
2. Begin operating as normal. Have the transmission checked at the earliest opportunity by an Allison Transmission distributor or dealer.

**NOTE**

*All active indicators are cleared at TCM power down.  
Some codes will clear their active indicator when the condition causing the code is no longer detected by the TCM.*

*The Diagnostic Display Mode can be exited by any of the following methods:*

- Press simultaneously the ▲ (Up) and ▼ (Down) arrow buttons at the same time on the pushbutton shift selector.
- Press any range button «D», «N» or «R» on the pushbutton shift selector (the shift will be commanded if it is not inhibited by an active code).
- Wait until the calibrated time (approximately 10 minutes) has passed. The system will automatically return to the normal operating mode.
- Turn off power to the TCM (shut off the engine using the ignition key).

**NOTE**

*If clearing a code while locked in a «D» (Drive) or «R» (Reverse) position (fail-to-range), the transmission will still be in «D» (Drive) or «R» (Reverse) when the clearing procedure is completed. «N» (Neutral) must be manually selected.*

9.1.5 Diagnostic Code Response

The following responses are used in the "Diagnostic Troubleshooting Code List and Inhibited Operation Description" table to command safe operation when diagnostic codes are sent.

DNS - Do Not Shift Response

Release lock up clutch and inhibit lock up operation.  
Inhibit all shifts.  
Turn ON the CHECK TRANS light.  
Display the range attained.  
Ignore any range selection inputs from the shift selector.

DNA - Do Not Adapt Response

The TCM stops adaptive shift control while the code is active.

SOL OFF - SOLenoid OFF Response

All solenoids are commanded OFF (turning solenoids "A" and "B" off electrically cause them to be on hydraulically).

RPR - Return to Previous Range Response

When the speed sensor ratio or C3 pressure switch test associated with a shift not successful, the TCM commands the same range as commanded before the shift.

NNC - Neutral No Clutches Response

When certain speed sensor ratio or C3 pressure switch tests are not successful, the TCM commands a neutral condition with no clutches applied.



9.1.6 Diagnostic Troubleshooting Codes (DTC) List - Allison 4<sup>th</sup> Generation Controls

DTC	Description	CHECK TRANS Light	Inhibited Operation Description
C1312	Retarder Request Sensor Failed Low	No	May inhibit retarder operation if not using J1939 datalink
C1313	Retarder Request Sensor Failed High	No	May inhibit retarder operation if not using J1939 datalink
P0122	Pedal Position Sensor Low Voltage	No	Use default throttle values. Freezes shift adapts.
P0123	Pedal Position Sensor High Voltage	No	Use default throttle values. Freezes shift adapts.
P0218	Transmission Fluid Over Temperature	No	Use hot mode shift schedule. Holds fourth range. TCC is inhibited. Freezes shift adapts.
P0602	TCM Not Programmed	Yes	Lock in Neutral
P0610	TCM Vehicle Options (Trans ID) Error	Yes	Use TID A calibration
P0613	TCM Processor	No	All solenoids off
P0614	Torque Control Data Mismatch - ECM/TCM	Yes	Allows operation only in reverse and second range.
P0634	TCM Internal Temperature Too High	Yes	SOL OFF (hydraulic default)
P063E	Auto Configuration Throttle Input Not Present	Yes	Use default throttle values
P063F	Auto Configuration Engine Coolant Temp Input Not Present	No	None
P0658	Actuator Supply Voltage 1 (HSD1) Low	Yes	DNS, SOL OFF (hydraulic default)
P0659	Actuator Supply Voltage 1 (HSD1) High	Yes	DNS, SOL OFF (hydraulic default)
P0702	Transmission Control System Electrical (TransID)	Yes	Use TID A calibration
P0703	Brake Switch Circuit Malfunction	No	No Neutral to Drive shifts for refuse packer. TCM inhibits retarder operation if a TPS code is also active.
P0708	Transmission Range Sensor Circuit High Input	Yes	Ignore defective strip selector inputs
P070C	Transmission Fluid Level Sensor Circuit – Low Input	No	None
P070D	Transmission Fluid Level Sensor Circuit – High Input	No	None
P0711	Transmission Fluid Temperature Sensor Circuit Performance	Yes	Use default sump temp
P0712	Transmission Fluid Temperature Sensor Circuit Low Input	Yes	Use default sump temp
P0713	Transmission Fluid Temperature Sensor Circuit High Input	Yes	Use default sump temp
P0716	Turbine Speed Sensor Circuit Performance	Yes	DNS, Lock in current range
P0717	Turbine Speed Sensor Circuit No Signal	Yes	DNS, Lock in current range
P0719	Brake Switch ABS Input Low	No	TCM assumes ABS is OFF
P071A	RELS Input Failed On	Yes	Inhibit RELS operation
P071D	General Purpose Input Fault	Yes	None
P0721	Output Speed Sensor Circuit Performance	Yes	DNS, Lock in current range
P0722	Output Speed Sensor Circuit No Signal	Yes	DNS, Lock in current range
P0726	Engine Speed Sensor Circuit Performance	No	Default to turbine speed
P0727	Engine Speed Sensor Circuit No Signal	No	Default to turbine speed
P0729	Incorrect 6 <sup>th</sup> Gear Ratio	Yes	DNS, Attempt 5 <sup>th</sup> , then 3 <sup>rd</sup>
P0731	Incorrect 1 <sup>st</sup> Gear ratio	Yes	DNS, Attempt 2 <sup>nd</sup> , then 5 <sup>th</sup>

**Section 07: TRANSMISSION**

<b>DTC</b>	<b>Description</b>	<b>CHECK TRANS Light</b>	<b>Inhibited Operation Description</b>
P0732	Incorrect 2 <sup>nd</sup> Gear ratio	Yes	DNS, Attempt 3 <sup>rd</sup> , then 5 <sup>th</sup>
P0733	Incorrect 3 <sup>rd</sup> Gear ratio	Yes	DNS, Attempt 4 <sup>th</sup> , then 6 <sup>th</sup>
P0734	Incorrect 4 <sup>th</sup> Gear ratio	Yes	DNS, Attempt 5 <sup>th</sup> , then 3 <sup>rd</sup>
P0735	Incorrect 5 <sup>th</sup> Gear ratio	Yes	DNS, Attempt 6 <sup>th</sup> , then 3 <sup>rd</sup> , then 2 <sup>nd</sup>
P0736	Incorrect Reverse Gear ratio	Yes	DNS, Lock in Neutral
P0741	Torque Converter Clutch System Stuck Off	Yes	None
P0776	Pressure Control Solenoid 2 Stuck Off	Yes	DNS, RPR
P0777	Pressure Control Solenoid 2 Stuck On	Yes	DNS, RPR
P0796	Pressure Control Solenoid 3 Stuck Off	Yes	DNS, RPR
P0797	Pressure Control Solenoid 3 Stuck On	Yes	DNS, RPR
P0842	Transmission Pressure Switch 1 Circuit Low	Yes	DNS, Lock in current range
P0843	Transmission Pressure Switch 1 Circuit High	Yes	DNS, Lock in current range
P0880	TCM Power Input Signal	No	None
P0881	TCM Power Input Signal Performance	No	None
P0882	TCM Power Input Signal Low	Yes	DNS, SOL OFF (hydraulic default)
P0883	TCM Power Input Signal High	No	None
P0894	Transmission Component Slipping	Yes	DNS, Lock in first
P0960	Pressure Control Solenoid Main Mod Control Circuit Open	Yes	None
P0962	Pressure Control Solenoid Main Mod Control Circuit Low	Yes	DNS, SOL OFF (hydraulic default)
P0963	Pressure Control Solenoid Main Mod Control Circuit High	Yes	None
P0964	Pressure Control Solenoid 2 (PCS2) Control Circuit Open	Yes	DNS, SOL OFF (hydraulic default)
P0966	Pressure Control Solenoid 2 (PCS2) Control Circuit Low	Yes	DNS, SOL OFF (hydraulic default)
P0967	Pressure Control Solenoid 2 (PCS2) Control Circuit High	Yes	DNS, SOL OFF (hydraulic default)
P0968	Pressure Control Solenoid 3 (PCS3) Control Circuit Open	Yes	DNS, SOL OFF (hydraulic default)
P0970	Pressure Control Solenoid 3 (PCS3) Control Circuit Low	Yes	DNS, SOL OFF (hydraulic default)
P0971	Pressure Control Solenoid 3 (PCS3) Control Circuit High	Yes	DNS, SOL OFF (hydraulic default)
P0973	Shift Solenoid 1 (SS1) Control Circuit Low	Yes	DNS, SOL OFF (hydraulic default)
P0974	Shift Solenoid 1 (SS1) Control Circuit High	Yes	DNS, SOL OFF (hydraulic default)
P0975	Shift Solenoid 2 (SS2) Control Circuit Open	Yes	7-speed: Allow 2 through 6, N, R
P0976	Shift Solenoid 2 (SS2) Control Circuit Low	Yes	7-speed: Allow 2 through 6, N, R Inhibit TCC operation
P0977	Shift Solenoid 2 (SS2) Control Circuit High	Yes	7-speed: Allow 2 through 6, N, R
P0989	Retarder Pressure Sensor Failed Low	No	None
P0990	Retarder Pressure Sensor Failed High	No	None
P1739	Incorrect Low Gear Ratio	Yes	Command 2 <sup>nd</sup> and allow shifts 2 through 6, N, R
P1891	Throttle Position Sensor PWM Signal Low Input	No	Use default throttle values
P1892	Throttle Position Sensor PWM Signal High Input	No	Use default throttle values
P2184	Engine Coolant Temperature Sensor Circuit Low Input	No	Use default engine coolant values
P2185	Engine Coolant Temperature Sensor Circuit High Input	No	Use default engine coolant values
P2637	Torque Management Feedback Signal (SEM)	Yes	Inhibit SEM
P2641	Torque Management Feedback Signal (LRTP)	Yes	Inhibit LRTP
P2670	Actuator Supply Voltage 2 (HSD2) Low	Yes	DNS, SOL OFF (hydraulic default)

DTC	Description	CHECK TRANS Light	Inhibited Operation Description
P2671	Actuator Supply Voltage 2 (HSD2) High	Yes	DNS, SOL OFF (hydraulic default)
P2685	Actuator Supply Voltage 3 (HSD3) Low	Yes	DNS, SOL OFF (hydraulic default)
P2686	Actuator Supply Voltage 3 (HSD3) High	Yes	DNS, SOL OFF (hydraulic default)
P2714	Pressure Control Solenoid 4 (PCS4) Stuck Off	Yes	DNS, RPR
P2715	Pressure Control Solenoid 4 (PCS4) Stuck On	Yes	DNS, SOL OFF (hydraulic default)
P2718	Pressure Control Solenoid 4 (PCS4) Control Circuit Open	Yes	DNS, SOL OFF (hydraulic default)
P2720	Pressure Control Solenoid 4 (PCS4) Control Circuit Low	Yes	DNS, SOL OFF (hydraulic default)
P2721	Pressure Control Solenoid 4 (PCS4) Control Circuit High	Yes	DNS, SOL OFF (hydraulic default)
P2723	Pressure Control Solenoid 1 (PCS1) Stuck Off	Yes	DNS, RPR
P2724	Pressure Control Solenoid 1 (PCS1) Stuck On	Yes	DNS, RPR
P2727	Pressure Control Solenoid 1 (PCS1) Control Circuit Open	Yes	DNS, SOL OFF (hydraulic default)
P2729	Pressure Control Solenoid 1 (PCS1) Control Circuit Low	Yes	DNS, SOL OFF (hydraulic default)
P2730	Pressure Control Solenoid 1 (PCS1) Control Circuit High	Yes	DNS, SOL OFF (hydraulic default)
P2736	Pressure Control Solenoid 5 (PCS5) Control Circuit Open	Yes	Inhibit retarder operation
P2738	Pressure Control Solenoid 5 (PCS5) Control Circuit Low	Yes	Allow 2 through 6, N, R. Inhibit retarder and TCC operation
P2739	Pressure Control Solenoid 5 (PCS5) Control Circuit High	Yes	Inhibit retarder operation
P2740	Retarder Oil Temperature Hot	No	None
P2742	Retarder Oil Temperature Sensor Circuit – Low Input	No	Use default retarder temp values
P2743	Retarder Oil Temperature Sensor Circuit – High Input	No	Use default retarder temp values
P2761	TCC PCS Control Circuit Open	Yes	Inhibit TCC operation
P2763	TCC PCS Control Circuit High	Yes	Inhibit TCC operation
P2764	TCC PCS Control Circuit Low	Yes	7-speed: Allow 2 through 6, N, R. Inhibit TCC operation
P278A	Kickdown Input Failed ON	No	Inhibit kickdown operation
P2793	Gear Shift Direction Circuit	Yes	Ignores PWM input from shift selector
P2808	Pressure Control Solenoid 6 (PCS6) Stuck Off	Yes	DNS, RPR
P2809	Pressure Control Solenoid 6 (PCS6) Stuck On	Yes	DNS, RPR
P2812	Pressure Control Solenoid 6 (PCS6) Control Circuit Open	Yes	DNS, SOL OFF (hydraulic default)
P2814	Pressure Control Solenoid 6 (PCS6) Control Circuit Low	Yes	DNS, SOL OFF (hydraulic default)
P2815	Pressure Control Solenoid 6 (PCS6) Control Circuit High	Yes	DNS, SOL OFF (hydraulic default)
U0001	Hi Speed CAN Bus Reset Counter Overrun (IESCAN)	No	Use default values, inhibit SEM
U0010	CAN BUS Reset Counter Overrun	No	Use default values, inhibit SEM
U0100	Lost Communications with ECM/PCM (J1587)	Yes	Use default values
U0103	Lost Communication with Gear Shift Module (Shift Selector) 1	Yes	Maintain range selected, observe gear shift direction circuit
U0115	Lost Communication with ECM	Yes	Use default values
U0291	Lost Communication with Gear Shift Module (Shift Selector) 2	Yes	Maintain range selected, observe gear shift direction circuit
U0304	Incompatible Gear Shift Module 1 (Shift Selector) ID	Yes	Ignore shift selector inputs
U0333	Incompatible Gear Shift Module 2 (Shift Selector) ID	Yes	Ignore shift selector inputs
U0404	Invalid Data Received From Gear Shift Module (Shift Selector) 1	Yes	Maintain range selected, observe gear shift direction circuit
U0592	Invalid Data Received From Gear Shift Module (Shift Selector) 2	Yes	Maintain range selected, observe gear shift direction circuit

## 10. SPECIFICATIONS

### ALLISON AUTOMATIC TRANSMISSION WITH OR WITHOUT RETARDER

#### XLII BUS SHELLS

Gross input power (maximum).....	525 HP (392 kW)
Gross input torque (maximum) .....	1650 Lbf-ft (2237 Nm)
Rated input speed (minimum-maximum) .....	1600-2300 rpm

#### **Mounting:**

Engine..... SAE #1 flywheel housing, flex disk drive

#### **Torque converter:**

Type ..... One stage, three element, polyphase  
Stall torque ratio ..... TC 551-1.8  
Lockup clutch with torsional damper ..... Integral/standard

#### **Gearing:**

Type ..... Patented, constant mesh, helical, planetary

#### Ratio:

First .....	3.51:1
Second.....	1.91:1
Third.....	1.43:1
Fourth.....	1.00:1
Fifth .....	0.74:1
Sixth .....	0.64:1
Reverse .....	4.80:1

#### **Ratio coverage:**

6 speed ..... 5.48:1

**\* Gear ratios do not include torque converter multiplication.**

#### **Oil System:**

Oil type..... TRANSYND, DEXRON-III, DEXRON-VI  
Capacity (excluding external circuits) ..... Initial fill 47 US qts (45 liters)  
Oil change..... 24 US qts (23 liters)  
Oil change (with retarder)..... 27.6 US qts (26 liters)

#### **Oil Filters:**

Make ..... Allison Transmission  
Type ..... Disposable cartridge  
Prévost number (2-filter replacement kit) ..... 571709

# SECTION 09: PROPELLER SHAFT

---

## CONTENTS

<b>1. PROPELLER SHAFT .....</b>	<b>2</b>
1.1 DESCRIPTION.....	2
<b>2. REMOVAL, DISASSEMBLY, REASSEMBLY AND INSTALLATION .....</b>	<b>2</b>
<b>3. CLEANING, INSPECTION AND LUBRICATION .....</b>	<b>3</b>
3.1 CLEANING AND INSPECTION .....	3
3.2 LUBRICATION .....	3
<b>4. EXPLANATION OF COMMON DAMAGES.....</b>	<b>3</b>
<b>5. TROUBLESHOOTING .....</b>	<b>3</b>
<b>6. SPECIFICATIONS.....</b>	<b>4</b>

## ILLUSTRATIONS

FIGURE 1: PROPELLER SHAFT ASSEMBLY .....	2
--	---

## Section 09: PROPELLER SHAFT

### 1. PROPELLER SHAFT

#### 1.1 DESCRIPTION

The propeller shaft transmits power from the transmission to the differential (Fig. 1). Refer to paragraph "6. SPECIFICATIONS" at the end of this section for propeller shaft length. The propeller shaft is "Dana 1810" type with tubular shafts. It is provided with two heavy-duty universal joints (Fig. 1).

The propeller shaft has a full round end yoke at one end and a half round end yoke at the other end. The tube yoke is connected to the differential by a full round end yoke with four needle bearings.

The other extremity (slip yoke assembly) is connected to the transmission by a half round end yoke with two needle bearings.

Furthermore, a slip joint on the propeller shaft compensates for variations in distance between the transmission and the differential, or between the output retarder (optional on the automatic transmission) and differential.

The rise and fall of the drive axle bring about these variations as the vehicle passes over uneven surfaces. The slip joint also eases removal of the transmission or the drive axle.

### 2. REMOVAL, DISASSEMBLY, REASSEMBLY AND INSTALLATION

Refer to "SPICER UNIVERSAL JOINTS AND DRIVESHAFTS" annexed to this section, under headings "Heavy Duty - removal, disassembly, reassembly and installation".

Where applicable:

- Remove or install propeller shaft safety guard.
- Screw bolts to the specified torque (Fig. 1).

#### NOTE

*Disregard the procedure on "Lock straps" mentioned in the "Spicer Universal Joints and Driveshafts Manual".*

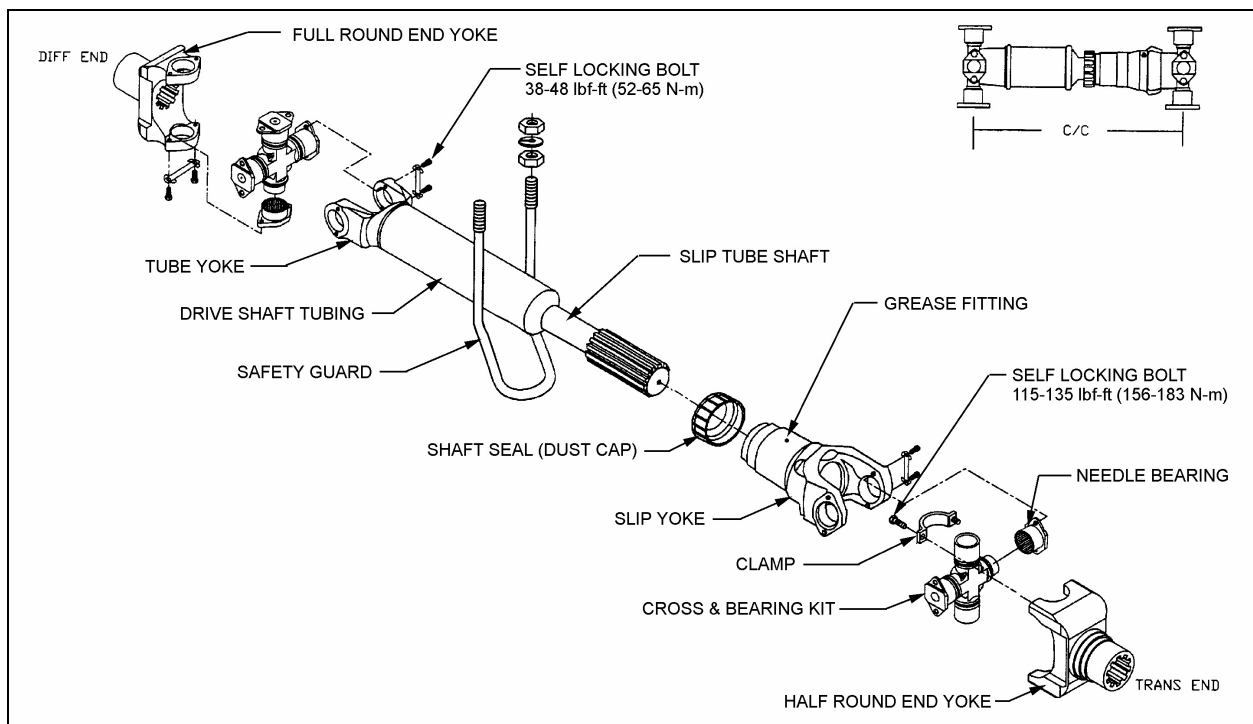

FIGURE 1: PROPELLER SHAFT ASSEMBLY

09002

### 3. CLEANING, INSPECTION AND LUBRICATION

#### 3.1 CLEANING AND INSPECTION

Thoroughly clean grease from bearings, journal, lubricating grease fittings and other parts. Needle bearing assemblies may be soaked in a cleaning solution to soften hard grease particles. It is extremely important that bearing assemblies be absolutely clean and blown out with compressed air, since small particles of dirt or grit can cause rapid bearing wear. Do not attempt to disassemble needle bearings.

Bearing journal areas should be inspected for roughness or grooving. If light honing does not remove roughness, the entire bearing assembly should be replaced. Excessive wear of the needle bearing is indicated if the needles drop out of the retainer, or if marks are present on the journal bearing surface. In such case, replace bearing assembly. Finally, inspect yokes for cracks, wear or distortion.

#### **NOTE**

*Repair kits are available for overhaul of the propeller shaft assembly. Refer to the paragraph "6. Specifications" of this section.*

#### 3.2 LUBRICATION

Lubricate propeller shaft universal joints and slip yoke periodically, every 6,250 miles (10 000 km) or twice a year, whichever comes first. Apply grease gun pressure to the lube fitting. Use a good quality lithium-base grease such as: NLGI No.2 (suitable for most temperatures) or NLGI No.1 (suitable for extremely low temperatures). Refer to "Spicer Universal Joints and Driveshafts, Service Manual", under heading, "Inspection and Lubrication". See lubrication procedures for U-joints and lubrication for slip splines.

#### **NOTE**

*Do not assume that bearing cavities have been filled with new grease unless it has expelled around all seals.*

### 4. EXPLANATION OF COMMON DAMAGES

**1. Cracks:** Stress lines due to metal fatigue. Severe and numerous cracks will weaken the metal until it breaks.

**2. Galling:** Scraping off of metal or metal displacement due to friction between surfaces. This is commonly found on trunnion ends.

**3. Spalling (surface fatigue):** Breaking off of chips, scales, or flakes of metal due to fatigue rather than wear. It is usually found on splines and U-joint bearings.

**4. Pitting:** Small pits or craters in metal surfaces due to corrosion. If excessive, pitting can lead to surface wear and eventual failure.

**5. Brinelling:** Surface wear failure due to the wearing of grooves in metal. It is often caused by improper installation procedures. Do not confuse the polishing of a surface (false brinelling), where no structural damage occurs, with actual brinelling.

**6. Structural Overloading:** Failure caused by a load greater than the component can stand. A structural overload may cause propeller shaft tubing to twist under strain or it may cause cracks or breaks in U-joints and spline plugs.

### 5. TROUBLESHOOTING

Refer to "Spicer Service Manual - Universal Joints and Driveshafts" under heading "Troubleshooting".

**6. SPECIFICATIONS**

**PROPELLER SHAFT**

**VEHICLES EQUIPPED WITH ALLISON WORLD TRANSMISSION**

**W-45 MOTORHOMES**

Make ..... Hayes-Dana Inc.  
Series..... 1810  
Supplier number ..... 819325-2200  
Prevost number .....580070

**Y-45E MOTORHOMES**

Make ..... Hayes-Dana Inc.  
Series..... 1810  
Supplier number ..... 819299-1  
Prevost number .....580075

**Repair kits**

Make ..... Hayes-Dana Inc.  
U-joint kit (tube yoke), Supplier number ..... 5-281X  
U-joint kit (tube yoke), Prevost number .....580043  
U-joint kit (slip yoke), Supplier number ..... 5-510X  
U-joint kit (slip yoke), Prevost number .....580062  
Cap and bolt kit, bolt torque 115-135 lbf•ft (156-183 N•m), Supplier number .....6.5-70-18X  
Cap and bolt kit, bolt torque 115-135 lbf•ft (156-183 N•m), Prevost number .....580063  
Bolts kit, bolt torque 38-48 lbf•ft (52-65 N•m), Supplier number ..... 6-73-209  
Bolts kit, bolt torque 38-48 lbf•ft (52-65 N•m), Prevost number .....580071

**Half Round End Yoke**

Make ..... Covington Detroit Diesel  
Supplier number .....29511516

<b>NOTE</b>
<i>U-joint kits will come equipped with the serrated bolt and lock patch and will no longer contain a lock strap.</i>



# SECTION 11: REAR AXLES

## CONTENTS

<b>1. DRIVE AXLE</b> .....	<b>2</b>
1.1 DESCRIPTION.....	2
1.2 DCDL (DRIVER-CONTROLLED MAIN DIFFERENTIAL LOCK) .....	2
1.3 DRIVE AXLE LUBRICATION .....	2
1.4 MAINTENANCE .....	3
1.4.1 <i>Checking and Adjusting the Oil Level</i> .....	3
1.4.2 <i>Draining and Replacing the Oil</i> .....	3
1.4.3 <i>Speed Sensors (Anti-Lock Brake system, ABS)</i> .....	4
1.5 REMOVAL AND REINSTALLATION .....	4
1.6 DISASSEMBLY AND REASSEMBLY.....	4
1.7 GEAR SET IDENTIFICATION .....	5
1.8 ADJUSTMENTS .....	5
1.9 FASTENER TORQUE CHART .....	5
1.10 TIRE MATCHING .....	5
1.11 DRIVE AXLE ALIGNMENT.....	5
1.11.1 <i>Procedure</i> .....	5
1.12 AXLE SHAFT SEALING METHOD.....	7
<b>2. TAG AXLE</b> .....	<b>7</b>
2.1 RETRACTING TAG AXLE.....	7
2.2 RETRACTING TAG AXLE FOR REPAIR PURPOSES.....	8
2.3 GREASE LUBRICATED WHEEL BEARINGS.....	8
2.4 REMOVAL AND INSTALLATION .....	8
2.4.1 <i>Removing Tag Axle Only</i> .....	8
2.4.2 <i>Removing Tag Axle Along With Suspension Components</i> .....	8
2.5 TAG AXLE ALIGNMENT.....	9
<b>3. SPECIFICATIONS</b> .....	<b>10</b>

## ILLUSTRATIONS

FIGURE 1: DRIVE AXLE .....	2
FIGURE 2: DIFFERENTIAL ASSEMBLY .....	2
FIGURE 3: DRIVER-CONTROLLED DIFFERENTIAL LOCK .....	2
FIGURE 4: DIFFERENTIAL HOUSING BOWL .....	3
FIGURE 5: JACKING POINTS ON FRAME .....	4
FIGURE 6: JACKING POINTS ON DRIVE AXLE .....	4
FIGURE 7: DRIVE AXLE ALIGNMENT.....	6
FIGURE 8: TAG AXLE ALIGNMENT.....	6
FIGURE 9: AXLE SHAFT INSTALLATION .....	7
FIGURE 10: TORQUE SPECIFICATION .....	7
FIGURE 11: JACKING POINTS ON TAG AXLE .....	9

## Section 11: REAR AXLES

### 1. DRIVE AXLE

#### 1.1 DESCRIPTION

The Meritor drive axle is equipped with a single reduction standard carrier mounted in front of the axle housing. The carrier consists of a hypoid drive pinion, a ring gear set and gears in the differential assembly.

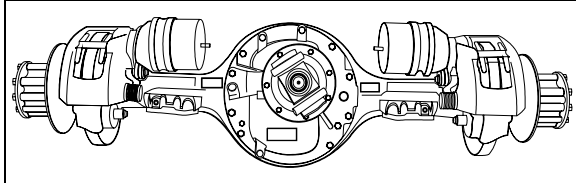

FIGURE 1: DRIVE AXLE

11019

A straight roller bearing (spigot) is mounted on the head of the drive pinion. All other bearings in the carrier are tapered roller bearings. When the carrier operates, there is a normal differential action between the wheels all the time.

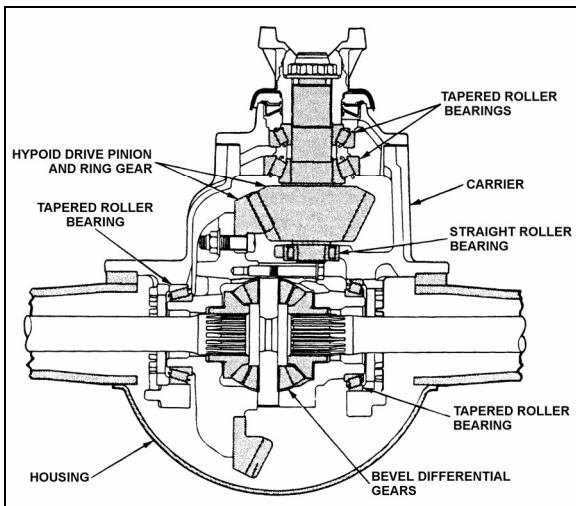

FIGURE 2: DIFFERENTIAL ASSEMBLY

11024

Several speed ratios are available for the drive axle. These ratios depend upon the motor and transmission. Also, special applications may suggest slightly different gear ratios.

#### 1.2 DCDL (DRIVER-CONTROLLED MAIN DIFFERENTIAL LOCK)

Meritor Single-reduction carriers with driver-controlled main differential lock (DCDL) have the same type of gears and bearings as the standard-type carriers. The differential lock is operated by an air actuated shift assembly that is mounted on the carrier.

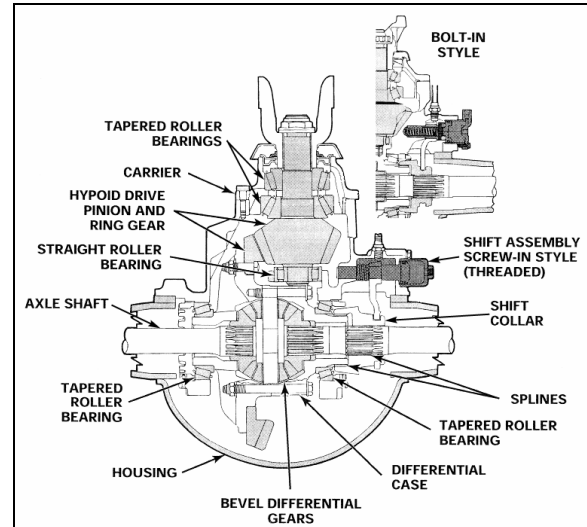

FIGURE 3: DRIVER-CONTROLLED DIFFERENTIAL LOCK

11028

#### 1.3 DRIVE AXLE LUBRICATION

Additional lubrication information is covered in the Meritor Technical Bulletin TP-9539: "Approved Rear Drive Axle Lubricants" annexed to this section. During initial stage of normal operation, tiny metal particles originating from moving parts can be found on mating surfaces. These particles are carried by the lubricant through the assembly and act as lapping compound, which accelerates wear of all parts. To ensure maximum life of the differential and prevent premature failure, the original "factory fill" lubricant should be drained. Change break-in oil before 3,000 miles (4 800 km) of initial operation (drain the unit while it is still warm from operation), in accordance with the lubrication and servicing schedule.

Change differential oil and clean the breathers, magnetic fill and drain plugs, every 100,000 miles (160 000 km) or once every two years, whichever comes first.

Use Multigrade gear oil MIL-L-2105-D. Use the 75W90-gear oil for northern climates and the 80W140 for southern climates. In extreme conditions, or for better performance, fill with synthetic gear oil. Check oil level and add (if necessary) every 6,250 miles (10 000 km) or twice a year, whichever comes first (Fig. 4).

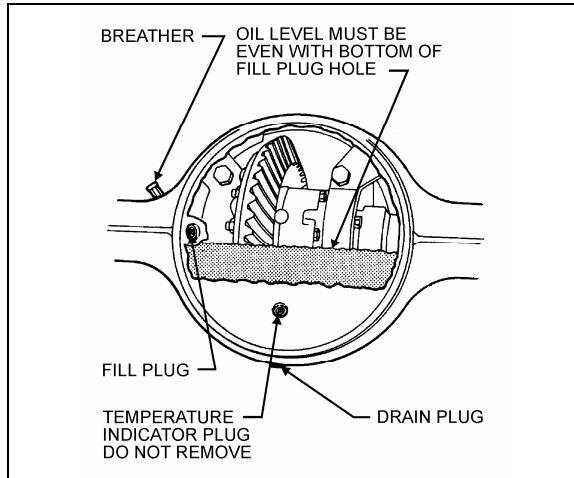



FIGURE 4: DIFFERENTIAL HOUSING BOWL 11007

1.4 MAINTENANCE

Proper vehicle operation begins with preventive maintenance, such as good differential use. The most common types of drive axle carrier failures are spinout, shock, fatigue, overheating and lubrication. Avoid neglecting these points since they would be the first steps to improper maintenance, expensive repairs, and excessive downtime.

Inspect the pinion oil seal, axle shaft flange and carrier housing gaskets for evidence of lubricant leakage. Tighten the bolts and nuts, or replace the gaskets and seals to correct leaks. Maintenance of the axle mountings consists primarily in a regular and systematic inspection of the air suspension units and radius rods, as directed in Section 16, "Suspension".

1.4.1 Checking and Adjusting the Oil Level



DANGER

Before servicing, park safely over a repair pit, apply parking brake, stop engine and set battery master switch to the "OFF" position.

1. Make sure the vehicle is parked on a level surface.



WARNING

Check the oil level when the axle is at room temperature. When hot, the oil temperature may be 190°F (88°C) or more and can cause burns. Also, a correct reading is not obtained when the axle is warm or hot.

2. Make sure the axle is "cold" or at room temperature.
3. Clean the area around the fill plug. Remove the fill plug from the differential axle housing bowl (Fig. 4).
4. The oil level must be even with the bottom of the hole of the fill plug.
  - a. If oil flows from the hole when the plug is loosened, the oil level is high. Drain the oil to the correct level.
  - b. If the oil level is below the bottom of the hole of the fill plug, add the specified oil.
5. Install and tighten the fill plug to 35-50 lbf-ft (48-67 Nm).

1.4.2 Draining and Replacing the Oil



DANGER

Before servicing, park safely over a repair pit, apply parking brake, stop engine and set battery master switch to the "OFF" position.

1. Make sure the vehicle is parked on a level surface. Put a large container under the axle's drain plug.

NOTE

*Drain the oil when the axle is warm.*

2. Remove the drain plug from the bottom of the axle. Drain and discard the oil in an environment friendly manner.
3. Install and tighten the drain plug to 35-50 lbf-ft (48-67 Nm).
4. Clean the area around the fill plug. Remove the fill plug from the differential housing bowl.
5. Add the specified oil until the oil level is even with the bottom of the hole of the fill plug. Allow the oil to flow through the axle and check the oil level again (lube capacity 41 pints [13,3 liters]).



CAUTION

The differential overheats when the oil temperature rises above 250°F (120°C).

6. Install and tighten the fill plug to 35-50 lbf-ft (48-67 Nm).

## Section 11: REAR AXLES

### 1.4.3 Speed Sensors (Anti-Lock Brake system, ABS)

For removing and installing the drive axle speed sensors (for anti-lock brake systems, ABS), refer to Section 12: "Brake and Air System" and to Rockwell WABCO Maintenance Manual: "Anti-Lock Brake Systems For Trucks, Tractors and Buses", annexed at the end of section 12.

### 1.5 REMOVAL AND REINSTALLATION

The following procedure deals with the removal of the drive axle assembly and its attachments as a unit. The method used to support the axle during removal and disassembly depends upon local conditions and available equipment.

1. Raise vehicle by its jacking points on the body (fig. 5 or see Section 18, "Body" under heading "Vehicle Jacking Points"). Place jack stands under frame. Remove drive axle wheels (if required, refer to Section 13, "Wheels, Hubs And Tires".

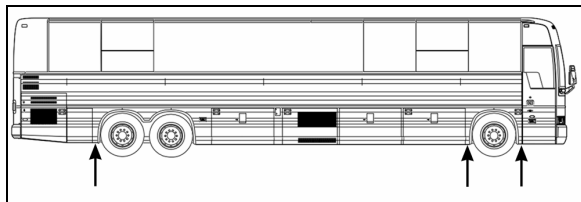

FIGURE 5: JACKING POINTS ON FRAME 11020

2. Exhaust compressed air from the air supply system by opening the drain cock on each air reservoir.
3. Disconnect the propeller shaft as directed in Section 9, "Propeller Shaft", in this manual.
4. On both sides of the vehicle, unscrew fasteners retaining front wheel housing plastic guards, and remove them from vehicle.
5. Disconnect both height control valve links from air spring mounting plate brackets then move the arm down to exhaust air suspension.
6. Remove cable ties securing the ABS cables (if vehicle is so equipped) to service brake chamber hoses. Disconnect the ABS cable plugs from the drive axle wheel hubs.

#### **NOTE**

When removing drive axle, if unfastening cable ties is necessary for ease of operation, remember to replace them afterwards.

7. Disconnect the brake chamber hoses.

#### **NOTE**

Position the hoses so they will not be damaged when removing the axle.

8. Install jacks under the axle jacking points to support the axle weight (refer to figure 6).

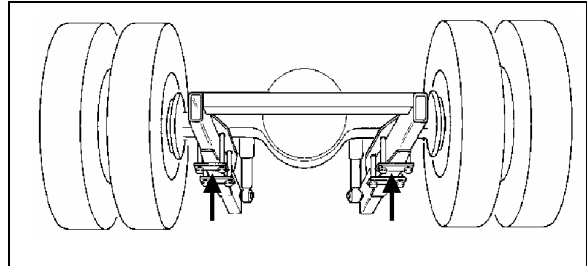

FIGURE 6: JACKING POINTS ON DRIVE AXLE H3B762

9. Remove the four shock absorbers as outlined in Section 16, "Suspension" under heading "Shock Absorber Removal".
10. Remove the sway bar.
11. Remove the lower and upper longitudinal radius rod supports from vehicle sub-frame as outlined in Section 16, "Suspension", under heading "Radius Rod Removal".
12. Remove the transversal radius rod support from the vehicle sub-frame.
13. Remove the two retaining nuts from each of the four air bellows lower mounting supports.
14. Use the jacks to lower axle. Carefully pull away the jacks axle assembly from underneath vehicle.
15. Reverse removal procedure to reinstall drive axle.

#### **NOTE**

Refer to Section 16, "Suspension" for suspension components' proper tightening torques.

#### **NOTE**

Refer to section 13 "Wheels, Hubs And Tires" for correct wheel bearing adjustment procedure.

### 1.6 DISASSEMBLY AND REASSEMBLY

Disassembly and re-assembly procedures are covered under applicable headings in Meritor's "MAINTENANCE MANUAL, NO. 5", annexed to this section.

1.7 GEAR SET IDENTIFICATION

Gear set identification is covered under applicable heading in Meritor's "MAINTENANCE MANUAL NO. 5", annexed to this section.

1.8 ADJUSTMENTS

Adjustments are covered under applicable headings in Meritor's "MAINTENANCE MANUAL NO. 5", annexed to this section.

1.9 FASTENER TORQUE CHART

A differential fastener torque chart is provided in Meritor's "MAINTENANCE MANUAL NO. 5", annexed to this section.

1.10 TIRE MATCHING

Drive axle tire matching is covered under the applicable heading in Section 13, "Wheels, Hubs And Tires" in this manual.

1.11 DRIVE AXLE ALIGNMENT

**NOTE**  
For drive axle alignment specifications, refer to paragraph 3: "Specifications" in this section.

The drive axle alignment consists in aligning the axle according to the frame. The axle must be perpendicular to the frame. The alignment is achieved with the use of shims inserted between the lower longitudinal radius rod supports and the frame.

Drive axle alignment is factory set and is not subject to any change, except if the vehicle has been damaged by an accident or if there are requirements for replacement.

**DRIVE AXLE ALIGNMENT**

- With the system installed as for front end alignment (fig.7), adjust drive axle according to specifications' chart below.

<b>DRIVE AXLE ALL VEHICLES</b>			
Alignment / value	Minimum value	Nominal value	Maximum value
Thrust angle (deg.)	-0.04	0	0.04
Total Toe (deg.)	0.18 Toe-in	0	0.18 Toe-out

If the axle has been removed for repairs or servicing and if all the parts are reinstalled exactly in the same place, the axle alignment is not necessary. However, if the suspension supports have been replaced or altered, proceed with the following instructions to verify or adjust the drive axle alignment.

**NOTE**  
When drive axle alignment is modified, tag axle alignment must be re-verified.

1.11.1 Procedure

1. Park vehicle on a level surface, then chock front vehicle wheels.
2. Using two jacking points (which are at least 30 inches [76 cm] apart) on drive axle, raise the vehicle sufficiently so that wheels can turn freely at about 1/2 inch from ground. Secure in this position with safety stands, and release parking brake.
3. Install wheel mount sensors on front and drive axle wheels (fig. 7). Adjust front wheels according to paragraph: "Front End Alignment" in Section 16: Suspension.

**NOTE**  
See reference numbers on wheel mount sensors (fig.7).

**NOTE**  
Select axle specifications in the appropriate chart

## Section 11: REAR AXLES

### TAG AXLE ALIGNMENT

- Remove and reinstall all wheel mount sensors on the drive and tag axles (fig. 8);

**NOTE**

For an accurate alignment, the tag axle must be aligned with the drive axle.

**NOTE**

Reinstall wheel mount sensors as shown in figure 7. For example, the sensor from the right side of the front wheel is mounted on the right side of the tag axle. For corresponding wheel mount sensor reference numbers, refer to figure 7.

- Adjust tag axle according to specifications' chart below in reference with drive axle.

TAG AXLE ALL VEHICLES			
Alignment / value	Minimum value	Nominal value	Maximum value
Parallelism (deg.)	-0.02	0	0.02
Total Toe (deg.)	0.18 Toe-in	0	0.18 Toe-out

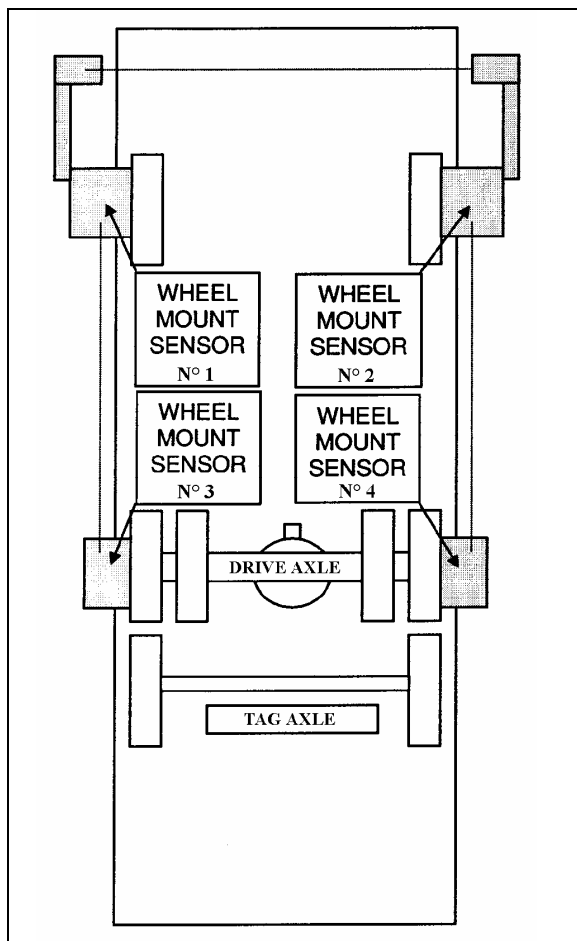

FIGURE 7: DRIVE AXLE ALIGNMENT

11025

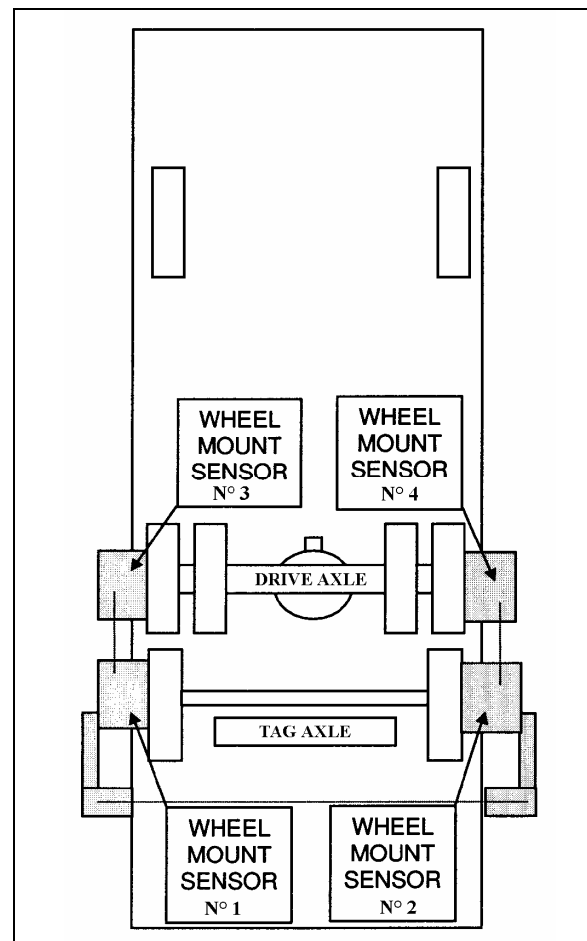

FIGURE 8: TAG AXLE ALIGNMENT

11026

**NOTE**

Refer to Section 16, "Suspension", for proper torque tightening of the longitudinal radius rod support nuts.

**NOTE**

When the drive alignment is changed, the tag alignment must also be adjusted.

1.12 AXLE SHAFT SEALING METHOD

The following method is to be used to ensure that axle shaft installation is fluid-tight:

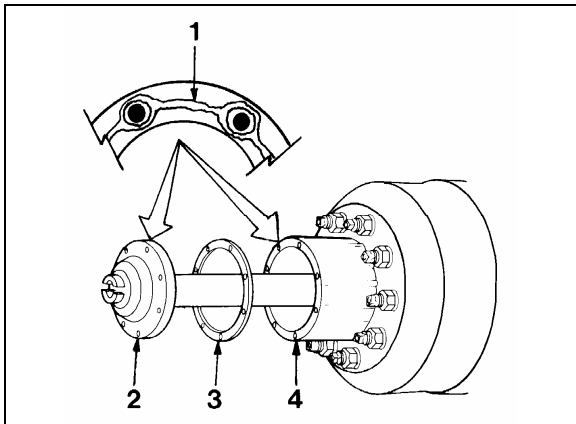

FIGURE 9: AXLE SHAFT INSTALLATION 11003

- 1..... Silicone sealant\*
- 2..... Axle shaft
- 3..... Gasket
- 4..... Wheel hub

1. Clean the mounting surfaces of both the axle shaft flange and wheel hub where silicone sealant will be applied. Remove all old silicone sealant, oil, grease, dirt and moisture. Dry both surfaces.
2. Apply a continuous thin bead of silicone sealant\* (Prévost P/N 680053) on the mounting surfaces and around the edge of all fastener holes of both the axle shaft flange and wheel hub.

\* GENERAL ELECTRIC Silicone Rubber Adhesive Sealant RTV 103 Black.



**WARNING**

Carefully read cautions and instructions on the tube of silicone sealant and its packing.

3. Assemble components immediately to permit the silicone sealant to compress evenly between parts.
  - a. Place a new gasket, then install the axle shaft into the wheel hub and differential carrier. The gasket and flange of the axle shaft must fit flat against the wheel hub.
  - b. Install the tapered dowels at each stud and into the flange of the axle shaft. Use a punch or drift and hammer if needed.
  - c. Install the lock washers and nuts on the studs. Tighten nuts to the correct torque value.

**NOTE**

Torque values are for fasteners that have a light application of oil on the threads (refer to Meritor Maintenance Manual).

9/16-18 plain nut: 110 - 165 lbf-ft (149 - 224 Nm)

5/8-18 plain nut: 150 - 230 lbf-ft (203 - 312 Nm)

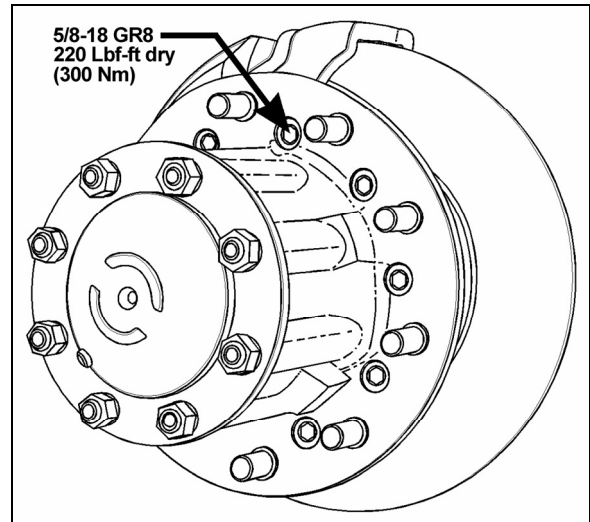

FIGURE 10: TORQUE SPECIFICATION 11030

**2. TAG AXLE**

The tag axle is located behind the drive axle. It carries a single wheel and tire on each side.

2.1 RETRACTING TAG AXLE

The standard tag axle retraction system is controlled by a valve located on the right lateral console and enables unloading and raising the tag axle (refer to the "OWNER'S MANUAL" for location of controls). This system has been designed for the following purposes:

## Section 11: REAR AXLES

1. Shortening of wheelbase, thus allowing tighter turning in tight maneuvering areas such as parking lots or when making a sharp turn.
2. Transferring extra weight and additional traction to the drive wheels on slippery surfaces.



### CAUTION

Do not use tag axle in raised position for an extended period. Raising tag axle increases load on the drive axle, suspension and tires.

Do not drive vehicle with tag axle raised when speed is exceeding 9mph (15 km/h).

In order to prevent damage to the suspension, always raise the tag axle before lifting the coach.

The tag axle service brakes operate only when the axle is in normal driving (loaded) position.

### 2.2 RETRACTING TAG AXLE FOR REPAIR PURPOSES

- Connect an external air pressure line to the emergency fill valve in the engine compartment.
- Lift the axle by pushing the lever forward.



### WARNING

Install a protective cover to prevent unfortunate lever operation while work is being carried out under the vehicle.

- Raise the vehicle using the lifts.



### WARNING

Lift manufacturers recommend lowering the vehicle to the ground or installing some safety stands before activating the suspension to prevent the lifts from becoming unstable.

- For added safety, install nylon slings over tag axle shock absorbers.

### 2.3 GREASE LUBRICATED WHEEL BEARINGS

The unitized hub bearings used on the NDS range of axles, are non-serviceable items. Bearings are pre-adjusted, lubricated and have seals fitted as part of the manufacturing process.

The bearings are greased for life and there is no need or facility for re-lubrication

Front and tag axle wheel hub bearings need to be checked every 30,000 miles (48 000 km).

### NOTE

*For more information on front and tag axle wheel hubs, refer to "DANA SPICER Maintenance Manual Model NDS and Maintenance Manual NDS Axles" annexed at the end of this Section.*

### 2.4 REMOVAL AND INSTALLATION

#### 2.4.1 Removing Tag Axle Only

The following procedure deals with the removal of the tag axle while keeping the air springs installed. The method used to support the axle and suspension components during removal and disassembly depends upon local conditions and available equipment.

- Connect an external air pressure line to the emergency fill valve in the engine compartment.
- Lift the axle by pushing the lever forward.



### WARNING

Install a protective cover to prevent unfortunate lever operation while work is being carried out under the vehicle.

- Disconnect tag axle air springs pneumatic hoses and install valves or plugs.
- Raise the vehicle using the lifts.
- Dismount tag axle components.

Before reinstalling air spring hoses, make sure there is no pressure left inside by opening the valves or unloading tag axle.

#### 2.4.2 Removing Tag Axle Along With Suspension Components

The following procedure deals with the removal of the tag axle assembly along with the suspension components. The method used to support the axle and suspension components during removal and disassembly depends upon local conditions and available equipment.

1. Raise vehicle by its jacking points on the body (fig. 5 or see Section 18, "Body" under heading: "Vehicle Jacking Points"). Place jack



under frame. Remove drive axle wheels (if required, refer to Section 13, "Wheels, Hubs And Tires").

2. Exhaust compressed air from the air supply system by opening the drain cock on each air reservoir and deplete air bags by moving leveling valve arm down.
3. Install jacks under tag axle jacking points to support the axle weight (refer to figure 10).

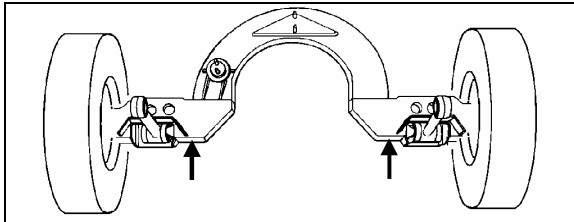

FIGURE 11: JACKING POINTS ON TAG AXLE 11023

4. Disconnect tag axle lifting chain collars from lower longitudinal radius rods.
5. Remove the propeller shaft as directed in Section 9, "Propeller Shaft", in this manual.
6. Disconnect the tag axle brake chamber hoses.



**CAUTION**

Position the hoses so they will not be damaged when removing axle.

7. Disconnect hose from the air spring upper mounting plate.
8. Remove the two shock absorbers as outlined in Section 16, "Suspension", under "Shock Absorber Removal".
9. Disconnect the lower longitudinal radius rods as outlined in Section 16, "Suspension", under "Radius Rod Removal".
10. Disconnect the transversal radius rod.
11. Disconnect the upper longitudinal radius rod.
12. Remove the air bellows retaining nuts from each of the two upper mounting plates.
13. Use the jacks to move the axle forward to clear the axle off the transmission. Lower the axle.



**CAUTION**

On vehicles equipped with an automatic transmission (with or without the output retarder), move tag assembly very carefully. Pay special attention to the U-shaped section, as the transmission end components may be easily damaged through a false maneuver.

14. Reverse removal procedure to reinstall tag axle.

**NOTE**

Refer to Section 16, "Suspension", for proper torque tightening of suspension components.

**NOTE**

Refer to section 13 "Wheels, Hubs And Tires" for correct wheel bearing adjustment procedure.

2.5 TAG AXLE ALIGNMENT

The tag axle alignment consists in aligning the tag axle parallel to the drive axle position. Before aligning the tag axle, proceed with the drive axle alignment (paragraph 1.11). Tag axle alignment is achieved with the use of shims inserted between the lower longitudinal radius rod supports and axle. Tag axle alignment is factory set and is not subject to any change, except if vehicle has been damaged by an accident or if there are requirements for parts replacement.



**CAUTION**

If this setting is altered significantly, it will cause excessive tire wear.

**NOTE**

It may be necessary to adjust the axle TOE as well as its alignment. In this case, insert shims (7 min. - P/N 121203 or 15 min. - P/N 121240) in between mounting plate and spindle, as required.

If axle has been removed for repair or servicing and if all parts are reinstalled exactly in their previous locations, axle alignment is not necessary. However, if the suspension supports have been replaced or have changed position, proceed with the following instructions to verify or adjust the tag axle alignment.

## Section 11: REAR AXLES

---

### 3. SPECIFICATIONS

#### Drive Axle

Make .....Meritor  
Drive track..... 76.7 inches (1 949 mm)  
Gear type .....Hypoid  
Axle type ..... Full floating  
Lube capacity .....41 pints (19,3 liters)

#### Drive axle ratio

##### World Transmission

4.88:1 Standard

4.56:1 Optional

<b><i>NOTE</i></b>
--------------------

<i>The drive axle alignment consists in aligning the axle with reference to the frame. The axle must be perpendicular to the frame.</i>
---

#### Tag Axle

Make .....Prévost  
Rear track ..... 83.6 inches (2 124 mm)  
Axle type ..... Dana Spicer Europe TS8U Hub Unit

<b><i>NOTE</i></b>
--------------------

<i>The tag axle alignment consists in aligning the tag axle parallel to the drive axle.</i>
---

# SECTION 12: BRAKE AND AIR SYSTEM

## CONTENTS

<b>1. AIR SYSTEM .....</b>	<b>5</b>
<b>2. BRAKES .....</b>	<b>5</b>
<b>3. AIR RESERVOIRS.....</b>	<b>5</b>
3.1 MAINTENANCE .....	5
3.1.1 <i>Wet (Main) Air Tank</i> .....	5
3.1.2 <i>Primary Air Tank</i> .....	6
3.1.3 <i>Accessory Air Tank</i> .....	6
3.1.4 <i>Secondary Air Tank</i> .....	6
3.2 PING TANK .....	6
<b>4. AIR SYSTEM EMERGENCY FILL VALVES.....</b>	<b>6</b>
<b>5. ACCESSORY AIR FILTER.....</b>	<b>7</b>
5.1 FILTER ELEMENT REPLACEMENT .....	7
5.2 CLEANING.....	7
<b>6. AIR GAUGES (PRIMARY, SECONDARY AND ACCESSORY) .....</b>	<b>7</b>
<b>7. AIR FILTER/DRYER.....</b>	<b>7</b>
7.1 AIR FILTER/DRYER PURGE TANK .....	8
<b>8. AIR LINES.....</b>	<b>8</b>
8.1 COPPER PIPING .....	8
8.2 FLEXIBLE HOSES .....	8
8.3 NYLON TUBING .....	8
8.4 AIR LINE OPERATING TEST .....	8
8.5 AIR LINE LEAKAGE TEST .....	8
8.6 MAINTENANCE .....	9
<b>9. PRESSURE REGULATING VALVES .....</b>	<b>9</b>
9.1 MAINTENANCE .....	9
9.2 PRESSURE SETTING PROCEDURE .....	9
<b>10. AIR COMPRESSOR (BA-921) .....</b>	<b>10</b>
10.1 COMPRESSOR REMOVAL AND INSTALLATION .....	10
<b>11. EMERGENCY/PARKING BRAKE CONTROL VALVE (PP-1).....</b>	<b>10</b>
<b>12. FLIP-FLOP CONTROL VALVE (TW-1) .....</b>	<b>11</b>
<b>13. DUAL BRAKE APPLICATION VALVE (E-10P) .....</b>	<b>11</b>
13.1 BRAKE PEDAL ADJUSTMENT .....	11
13.1.1 <i>Maintenance</i> .....	11
<b>14. STOPLIGHT SWITCHES.....</b>	<b>11</b>
<b>15. PARKING BRAKE ALARM SWITCH .....</b>	<b>12</b>
<b>16. BRAKE RELAY VALVE (R-12 &amp; R-14) .....</b>	<b>12</b>
<b>17. QUICK RELEASE VALVES (QR-1).....</b>	<b>12</b>

## Section 12: BRAKE AND AIR SYSTEM

---

<b>18.</b>	<b>SPRING BRAKE VALVE (SR-7)</b> .....	<b>12</b>
<b>19.</b>	<b>PRESSURE PROTECTION VALVE (PR-4)</b> .....	<b>13</b>
<b>20.</b>	<b>LOW PRESSURE INDICATOR (LP-3)</b> .....	<b>13</b>
<b>21.</b>	<b>SHUTTLE-TYPE DOUBLE CHECK VALVE (DC-4)</b> .....	<b>13</b>
<b>22.</b>	<b>AIR HORN VALVE</b> .....	<b>13</b>
<b>23.</b>	<b>AIR SYSTEM TROUBLESHOOTING</b> .....	<b>14</b>
<b>24.</b>	<b>BRAKE OPERATION</b> .....	<b>14</b>
<b>25.</b>	<b>AIR BRAKES</b> .....	<b>14</b>
25.1	DISC BRAKES.....	14
25.1.1	<i>Disc Brake Pads</i> .....	14
25.1.2	<i>Caliper Maintenance</i> .....	15
25.1.3	<i>Roadside Inspection for Knorr/Bendix Air Disc Brakes</i> .....	16
25.1.4	<i>Pad Removal</i> .....	16
25.1.5	<i>Checking Pad Wear</i> .....	17
25.1.6	<i>Important Pad and Rotor Measurements</i> .....	17
25.1.7	<i>Checking Caliper Guidance and Seal Condition</i> .....	17
25.1.8	<i>Checking the Tappet Boots</i> .....	18
25.1.9	<i>Pad Installation</i> .....	18
25.1.10	<i>Adjusting the Running Clearance</i> .....	18
25.1.11	<i>Brake Tools</i> .....	19
25.1.12	<i>Checking Brake Pads</i> .....	19
25.1.13	<i>Torque specifications</i> .....	19
<b>26.</b>	<b>SAFE SERVICE PROCEDURES</b> .....	<b>19</b>
<b>27.</b>	<b>AIR BRAKE TROUBLESHOOTING</b> .....	<b>20</b>
<b>28.</b>	<b>BRAKE AIR CHAMBER</b> .....	<b>24</b>
28.1	MAINTENANCE.....	24
28.2	EMERGENCY/PARKING BRAKE MANUAL RELEASE .....	25
28.3	BRAKE CHAMBER REMOVAL.....	25
28.4	BRAKE CHAMBER INSTALLATION.....	25
28.5	BRAKE CHAMBER DISASSEMBLY .....	26
<b>29.</b>	<b>ANTI-LOCK BRAKING SYSTEM (ABS)</b> .....	<b>26</b>
29.1	TROUBLESHOOTING AND TESTING .....	27
29.2	ABS COMPONENTS .....	27
29.2.1	<i>Electronic Control Unit (ECU)</i> .....	27
29.2.2	<i>Bendix® M-32QR™ Pressure Modulator Valves (PMV)</i> .....	27
29.2.3	<i>Sensors</i> .....	28
29.2.4	<i>Sensor Installation</i> .....	28
29.2.5	<i>Spring clip</i> .....	28
<b>30.</b>	<b>AUTOMATIC TRACTION CONTROL (ATC) – ELECTRONIC STABILITY PROGRAM (ESP) ....</b>	<b>30</b>
30.1	COMPONENTS .....	30
30.1.1	<i>The EC-60™ controller's ABS function utilizes the following components:</i> .....	30
30.1.2	<i>The EC-60™ controller's ATC function utilizes the following components:</i> .....	30
30.1.3	<i>The EC-60™ controller's ESP/RSP function utilizes the following components:</i> .....	30

30.1.4	Bendix® M-32QR™ Pressure Modulator Valves (PMV).....	30
30.2	6S/5M CONFIGURATION .....	31
30.3	ADVANCED ABS WITH STABILITY CONTROL.....	31
30.4	BENDIX® SAS-60™ STEERING ANGLE SENSOR.....	31
30.4.1	Removal of the steering angle sensor.....	31
<b>31.</b>	<b>FITTING TIGHTENING TORQUES .....</b>	<b>32</b>
<b>32.</b>	<b>SPECIFICATIONS .....</b>	<b>34</b>

## ILLUSTRATIONS

FIGURE 1:	AIR RESERVOIRS LOCATION .....	5
FIGURE 2:	REAR VALVE LOCATION (TYPICAL) .....	6
FIGURE 3:	FRONT SERVICE COMPARTMENT.....	6
FIGURE 4:	ACCESSORY AIR FILTER.....	7
FIGURE 5:	HALDEX AIR FILTER DRYER.....	7
FIGURE 6:	AIR PRESSURE REGULATING VALVE .....	9
FIGURE 7:	AIR PRESSURE REGULATOR .....	9
FIGURE 8:	AIR COMPRESSOR LOCATION .....	10
FIGURE 9:	PP-1 .....	10
FIGURE 10:	TW-1.....	11
FIGURE 11:	BRAKE PEDAL ADJUSTMENT .....	11
FIGURE 12:	DELCO SWITCH .....	11
FIGURE 13:	BENDIX SWITCH .....	11
FIGURE 14:	R-12 .....	12
FIGURE 15:	R-14 .....	12
FIGURE 16:	QR-1 .....	12
FIGURE 17:	SR-7 .....	12
FIGURE 18:	PR-4 .....	13
FIGURE 19:	LP-3.....	13
FIGURE 20:	DC-4.....	13
FIGURE 21:	BRAKE PAD CHECK.....	15
FIGURE 22:	CLEARANCE INSPECTION .....	15
FIGURE 23:	RUNNING CLEARANCE .....	15
FIGURE 24:	ADJUSTER PINION .....	16
FIGURE 25:	BOX WRENCH ON ADJUSTER PINION .....	16
FIGURE 26:	CALIPER AXIAL MOVEMENT .....	16
FIGURE 27:	BRAKE PAD CHECK.....	16
FIGURE 28:	PAD REMOVAL .....	17
FIGURE 29:	PAD WEAR.....	17
FIGURE 30:	ROTOR AND PAD WEAR LIMITS.....	17
FIGURE 31:	CALIPER GUIDANCE .....	18
FIGURE 32:	RUBBER BOOTS .....	18
FIGURE 33:	PAD INSTALLATION .....	18
FIGURE 34:	RUNNING CLEARANCE .....	19
FIGURE 35:	BRAKE PAD CHECK .....	19
FIGURE 36:	TORQUE SPECIFICATION .....	19
FIGURE 37:	TORQUE SPECIFICATION .....	19
FIGURE 38:	AIR-OPERATED BRAKING SYSTEM (WE) .....	21
FIGURE 39:	AIR-OPERATED BRAKING SYSTEM (W5).....	22
FIGURE 40:	FRONT WHEEL BRAKE AIR CHAMBER.....	24
FIGURE 41:	TAG AXLE BRAKE AIR CHAMBER.....	24
FIGURE 42:	ABS ECU LOCATION .....	27

## Section 12: BRAKE AND AIR SYSTEM

---

FIGURE 43: ABS MODULATOR VALVE .....	27
FIGURE 44: ABS SENSOR LOCATION .....	28
FIGURE 45: SPRING CLIP .....	28
FIGURE 46: ABS 6S/5M CONFIGURATION .....	29
FIGURE 47: HOSE FITTINGS .....	32
FIGURE 48: HOSE FITTING .....	33
FIGURE 49: HOSE FITTING .....	33
FIGURE 50: HOSE FITTING .....	33

**1. AIR SYSTEM**

The basic air system consists of an air compressor, reservoirs, valves, filters and interconnecting lines and hoses. It provides a means for braking; operating controls and accessories, and suspension (refer to Section 16, "Suspension", for complete information on suspension description and maintenance). An air system schematic diagram is annexed in the technical publications box provided with the vehicle for better understanding of the system.

**2. BRAKES**

This vehicle uses both the service brake and emergency/parking brake. The service brake air system is divided into two independent circuits to isolate front brakes from rear brakes, thus providing safe breaking in the event that one circuit fails. Front axle brakes operate from the secondary air system, while brakes on both the drive axle and tag axle operate from the primary air system.

**NOTE**  
*The tag axle service brake operates only when the axle is in normal ride position (loaded and down).*

Furthermore, the brake application or release, which is speed up by a pneumatic relay valve (R-12), will start with the rear axles and will be followed by the front axle, thus providing uniform braking on a slippery road. The vehicle is also equipped with an Anti-Lock Braking System (ABS), which is detailed later in this section.

The drive and tag axles are provided with spring-loaded emergency/parking brakes, which are applied automatically whenever the control valve supply pressure drops below 40 psi (275 kPa).

**3. AIR RESERVOIRS**

The air coming from the air dryer is first forwarded to the wet air tank, then to the primary (for the primary brake system), secondary (for the secondary brake system), and accessory (for the pneumatic accessories) air tanks (Fig. 1).

**3.1 MAINTENANCE**

Ensure that the wet (main) air tank is purged during pre-starting inspection. In addition, it is good practice to purge this reservoir at the end of every driving day. The remaining reservoirs must be purged at every 12,500 miles (or 20 000 km) or once every year, whichever comes first.

**3.1.1 Wet (Main) Air Tank**

This reservoir, located above the L.H. wheel of drive axle in the rear wheelhousing, is provided with a bottom drain valve. A recommended purge using the bottom drain valve should be done at the end of every driving day.

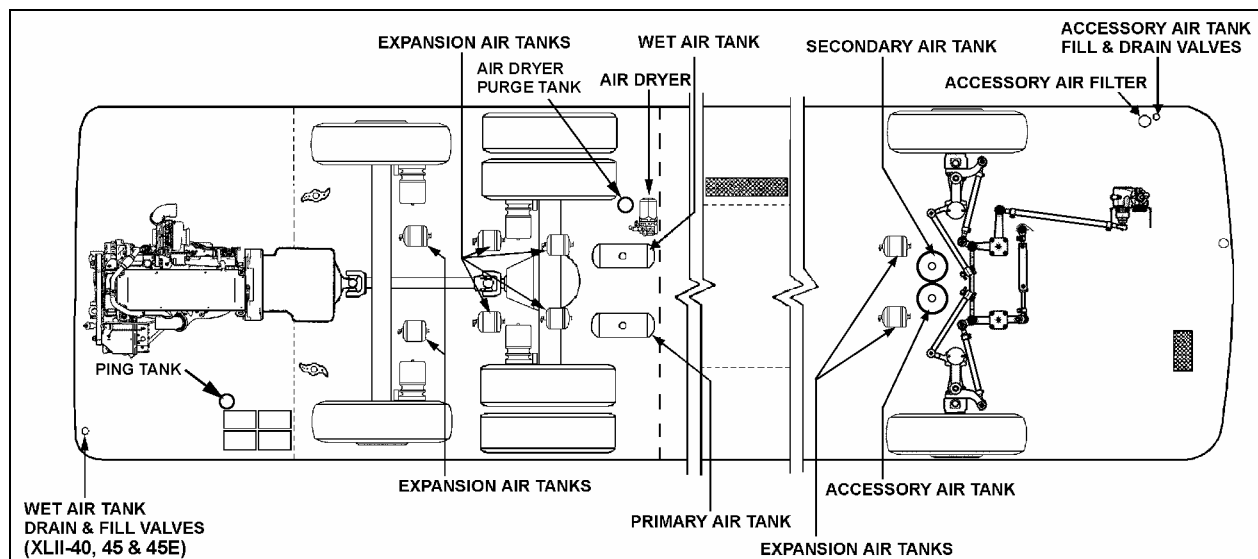

FIGURE 1: AIR RESERVOIRS LOCATION

24037

## Section 12: BRAKE AND AIR SYSTEM

### 3.1.2 Primary Air Tank

This reservoir is located above the R.H. wheel of the drive axle and is provided with a bottom drain valve (Fig. 1). It is recommended to purge the primary air tank every 12,500 miles (20 000 km) or once a year, whichever comes first.

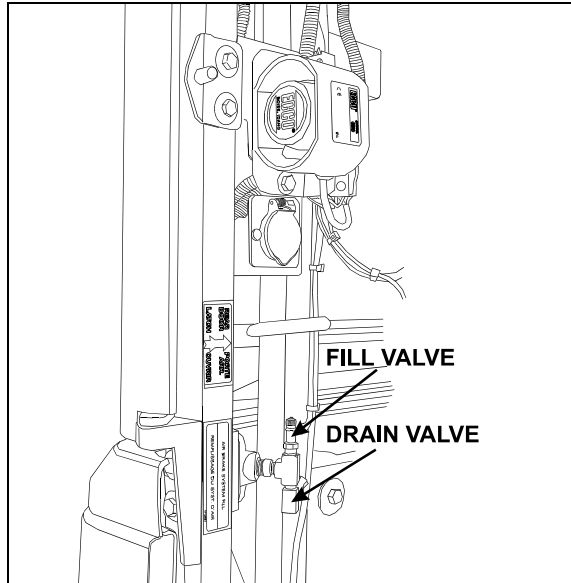

FIGURE 2: REAR VALVE LOCATION (TYPICAL) 12202

### 3.1.3 Accessory Air Tank

The accessory air tank is installed close to the independent front suspension and is provided with a bottom drain valve (Fig. 1).

Purge the reservoir by its drain valve every 12,500 miles (20 000 km) or once a year, whichever comes first.

### 3.1.4 Secondary Air Tank

This tank is located in the front wheelhousing, behind the independent front suspension (Fig. 1). It is provided with a bottom drain valve.

Purge this reservoir every 12,500 miles (20 000 km) or once a year, whichever comes first.

### 3.2 PING TANK

The ping tank is located in the engine compartment and is accessible through the engine compartment R.H. side door. It is used to dissipate heat and to reduce noise produced by the air compressor cycling on and off.

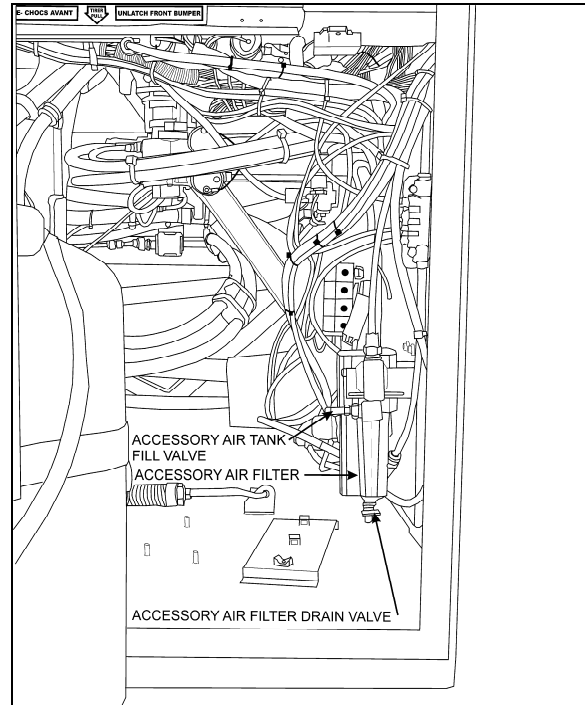

FIGURE 3: FRONT SERVICE COMPARTMENT 12218

## 4. AIR SYSTEM EMERGENCY FILL VALVES

All vehicles come equipped with two emergency fill valves that enable system pressurization by an external source such as an air compressor. The rear valve is located in the engine compartment and is accessible from engine R.H. side door (Fig 2.). It can be positioned close to the door hinge or the door opening.



### CAUTION

Maximum allowable air pressure is 125 psi (860 kPa). Air filled through these two points will pass through the standard air filtering system provided by Prevost. Do not fill system by any point on the system.

The front valve is located in the front service compartment close to R.H. side of door frame (Fig. 3).

These two air system emergency fill valves are fitted with the same valve stems as standard tires, and can be filled by any standard external air supply line.

The rear air system emergency fill valve will supply air for all systems (brakes, suspension and accessories) while the front fill valve will supply air for accessories only.



## 5. ACCESSORY AIR FILTER

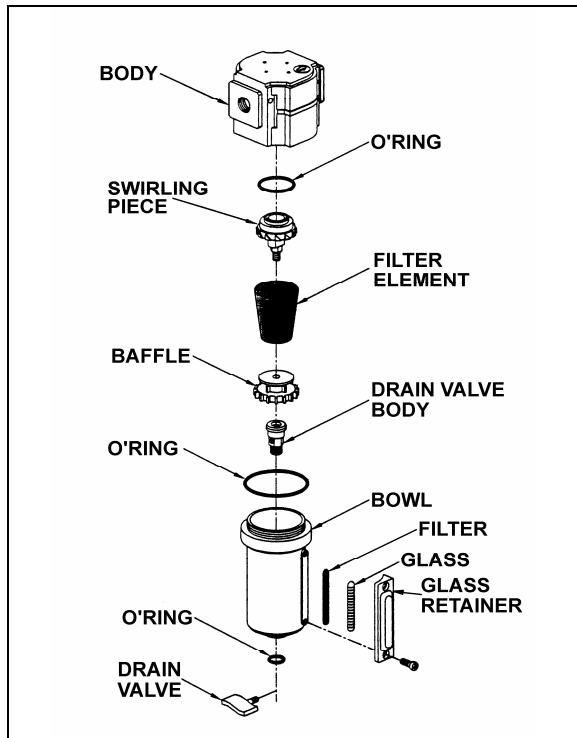

FIGURE 4: ACCESSORY AIR FILTER

12088

This filter is located inside the front service compartment (Fig. 3). Its main function consists in filtering the air supplied to the accessory air system, when connected to an external supply line. Ensure filter is purged whenever supplying the system with an external air line and at least every 12,500 miles (20 000 km). To purge, open drain valve (Fig. 4), let the moisture come out, then close the drain valve.

### 5.1 FILTER ELEMENT REPLACEMENT

Replace filter element whichever of the following occurs first: every 100,000 miles (160 000 km), every two years, or whenever differential pressure exceeds 15 psi (105 kPa) between filter inlet and outlet ports. Check condition of all three O-rings for damage. Replace when necessary (Fig. 4).

### 5.2 CLEANING

Clean filter body and bowl with a warm water and soap solution. Rinse thoroughly with clean water. Blow dry with compressed air making sure the air stream is moisture free and clean. Pay particular attention to the internal passages.

Inspect all parts for damage and replace if necessary.

## 6. AIR GAUGES (PRIMARY, SECONDARY AND ACCESSORY)

The air pressure gauges, located on the dashboard (see "Owner's Manual"), are connected to the DC-4 double check valve, located on the pneumatic accessory panel in the front service compartment.

The latter is connected to the air lines running from the primary and secondary air tanks, as shown on the pneumatic system diagram provided in the technical publications box. The accessory air gauge is connected to the accessory air tank using the drain valve connector. The vehicle should never be set in motion until the buzzer alarm and warning lights turn off, i.e. when air pressure registers at least 66 psi (455 kPa). Moreover, if pressure drops below 66 psi (455 kPa), the "Low air pressure" warning lights will turn on, and the "Low air pressure" buzzer will sound. Stop the vehicle immediately, determine and correct the cause(s) of pressure loss. Check the gauges regularly with an accurate test gauge. Replace the gauge with a new unit if there is a difference of 4 psi (27 kPa) or more in the reading.

## 7. AIR FILTER/DRYER

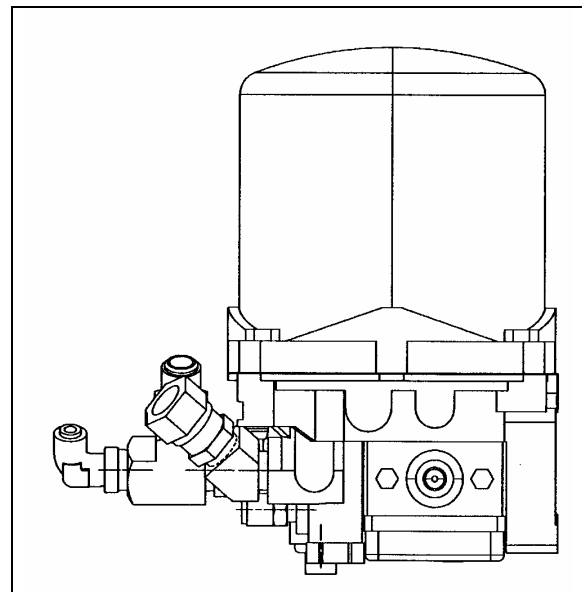

FIGURE 5: HALDEX AIR FILTER DRYER

12194

The air filter/dryer is located in front of rear wheelhousing above drive axle (Fig. 1 & 5). Its purpose is to remove moisture that could damage the air system before the air enters the system reservoir. The air filter/dryer also filters the air to remove dirt, compressor oil, and other contaminants that can damage the system.

## Section 12: BRAKE AND AIR SYSTEM

Change cartridge every 100,000 miles (160 000 km) or once every two years, whichever comes first. The air dryer may be purged for maintenance purposes using the remote drain valve located in the engine compartment and accessible through the engine compartment R.H. side door. The valve is positioned over the battery assembly, close to the door hinge or close to the L.H. side of door opening depending on type of vehicle (Fig. 2). The air filter/dryer has a built-in governor to maintain the system between 108 psig and 123 psig.

Maintenance and repair information is supplied in the maintenance information annexed to this section.

### 7.1 AIR FILTER/DRYER PURGE TANK

A tank is supplied to purge the air filter/dryer to remove moisture and contaminants.

## 8. AIR LINES

Copper piping, nylon-reinforced tubing, and flexible hoses are used to connect the units in the pneumatic system, including air brake system, suspension system and accessory systems such as the entrance door, fresh air damper cylinder, air horns, etc. Furthermore, the nylon tubing is color coded to ease identification. Refer to the following table for the complete color identification code. Service instructions for each type of air line are also provided under the applicable headings.

Color	Circuit
Red	Secondary
Green	Primary and Delivery
Yellow	Parking Brake
Blue	Suspension
Black	Accessory
Brown	Trailer Brake

### 8.1 COPPER PIPING

A heat dissipation copper piping assembly is used to dissipate the heat coming from the compressor before it enters the air filter/dryer. Connections should be checked for leakage at least every 6,250 miles (10 000 km) or twice a year, whichever comes first. Tighten or replace when necessary. When replacing copper piping, the parts must be free of burrs, copper cuttings, and dirt. Blow out piping with compressed air. Any such particles will destroy sealing seats in air control units. Also, new piping must be the same size as the old one.

### 8.2 FLEXIBLE HOSES

A flexible hose is used normally where it is impractical to use copper or nylon tubing due to constant flexing during operation, such as brake chamber hoses. Hose connections should be tested for leakage at least every 6,250 miles (10 000 km) or twice a year, whichever comes first and tightened or replaced if necessary. Any hose which is chafed, worn or kinked should be replaced.

Teflon-braided stainless steel hoses used in the engine compartment must be replaced only with similar hoses.

### 8.3 NYLON TUBING

Nylon tubing is used for air lines in areas where usage of this material is suitable. Nylon tubing is flexible, durable, and weather resistant. When replacing an air line, use nylon tubing only where it has been used previously.

Nylon air lines must never be routed in areas where temperature could exceed 200°F (93°C).



## CAUTION

Nylon air lines should be used to replace existing nylon lines only, and must comply with the color identification code to ease pneumatic system troubleshooting.

### 8.4 AIR LINE OPERATING TEST

If any trouble symptom such as slow brake application or slow brake release indicates a restricted or clogged air line, disconnect the suspected tube or hose at both ends and blow through it to clear the passage.

Inspect tubing and hose for partial restriction that may be caused by dents or kinks. If such a condition is found, the tubing or hose should be replaced.

### 8.5 AIR LINE LEAKAGE TEST

With air system fully charged and the brakes applied, coat all tubing and hose connections with a soapy solution to check for air leakage. No leakage is permitted. Leakage can sometimes be corrected by tightening the connection. If this fails to correct the leakage, new fittings, nylon tubing, copper tubing, teflon-braided stainless steel and flexible hoses must be installed as applicable.

8.6 MAINTENANCE

Inspect all lines for cuts, swelling, kinks or other damage or deterioration. Check for lines being pinched by other components. Retaining clips and ties must be in place.

Any support or bracket should be in good condition and mounted firmly in position. Hose spring guards should be in usable condition and not distorted. Particular attention should be given to long lines. Any supporting component (clips, ties, grommets, etc.) must be secured to prevent against unnecessary vibration and eventual loosening of connection. Any detected leak should be repaired. Be sure nylon lines are not near areas of intense heat. Check for any missing grommets or loose material where chafing or cutting may occur. Replace with new material as required. In general, lines should be securely located in position and free from any binding condition which would hinder air flow.

9. PRESSURE REGULATING VALVES

There is one pressure regulator for the belt tensioners, and an optional one installed on vehicles equipped with the Allison transmission output retarder.

The belt tensioner pressure regulating valve is located in the engine compartment above the doors and is used to limit the air pressure in belt tensioners to 50 ± 2 psi (345 ± 15 kPa) for WE and to 45 ± 2 psi (310 ± 15 kPa) for W5 MTH (Fig. 7).

The optional regulator is located above the rear junction box in the engine compartment (accessible through the engine R.H. side door). It is used for transmission retarder and should be adjusted to 80 ± 3 psi (550 ± 20 kPa).

	Air Pressure (psi)	Air Pressure (kPa)
	<b>Series 60</b>	<b>Series 60</b>
Belt Tensioner	50 (WE) 45 (W5)	345 310
Retarder	80 ± 3	550 ± 20

9.1 MAINTENANCE

Every 100,000 miles (160 000 km) or once every two years, whichever comes first, disassemble the regulating valve and wash all metal parts in a cleaning solvent (Fig. 6). Examine the diaphragm; if cracked, worn or damaged, replace with a new one. If the valve is

excessively grooved or pitted, it should be replaced. Replace any other part that appears worn or damaged. After reassembly, adjust to the specified pressure setting and check for air leakage.

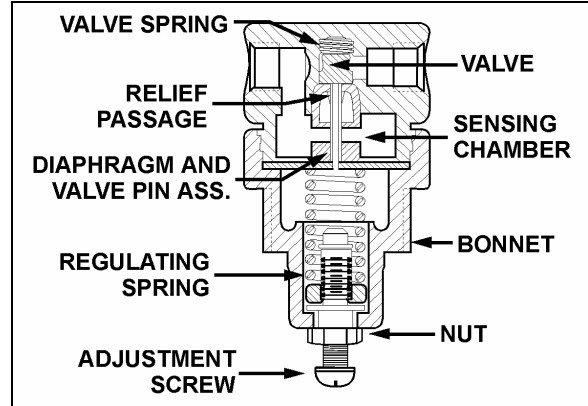

FIGURE 6: AIR PRESSURE REGULATING VALVE 12141B

9.2 PRESSURE SETTING PROCEDURE

Remove the dust cap from the pressure check valve (Fig. 7). Attach a pressure gauge at this port and check the pressure reading. If the pressure reading is incorrect, adjust as follows:

1. Loosen the locking nut, turn the adjustment screw counterclockwise to decrease pressure by approximately 10 psi (70 kPa) below the required pressure.

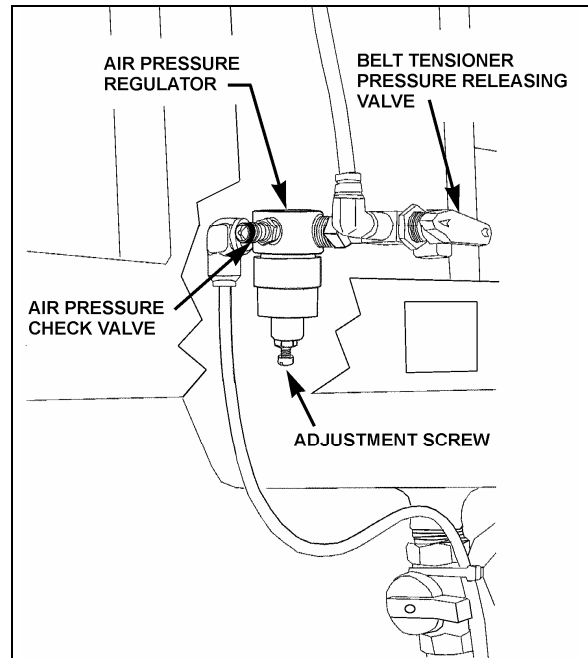

FIGURE 7: AIR PRESSURE REGULATOR 12200

## Section 12: BRAKE AND AIR SYSTEM

2. Turn the adjustment screw clockwise to increase the pressure slowly until the required pressure setting is reached. Tighten the locking nut.
3. Remove pressure gauge and replace dust cap on the air pressure check valve.

### 10. AIR COMPRESSOR (BA-921)

The air compressor is located on starter side of the engine, on the rear of the engine gear case (Fig. 8). Its function is to provide and maintain air under pressure to operate devices in brake and air systems.

This air compressor also drives the engine fuel pump which is bolted to the rear end of the compressor. The compressor crankshaft is designed to accept a drive coupling which is placed between the compressor and fuel pump.

The compressor is driven by the bull gear, and is water cooled. Engine coolant is fed to the compressor through a flexible hose tapped into the block water jacket and connected to the rear of the compressor. Coolant returns from the top of the compressor (governor side) through a flexible hose to the engine pump.

The air is taken from the air intake manifold and entered in the top of the compressor. The compressed air is pushed into the discharge line located on side of the compressor, which sends air to the air dryer. Lubricating oil is supplied to the compressor by a line from the cylinder block oil gallery connected to the air compressor. Lubricating oil returns to the engine crankcase through the air compressor drive assembly.

Maintenance and repair information on the Bendix BA-921 air compressor is supplied in the applicable booklet annexed to this section under reference number SD-01-676.

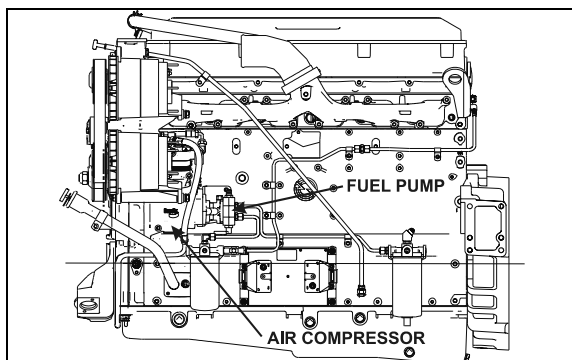

FIGURE 8: AIR COMPRESSOR LOCATION

03061

### 10.1 COMPRESSOR REMOVAL AND INSTALLATION

1. Exhaust compressed air from air system by opening the drain valve of each air tank.
2. Drain the engine cooling system. See Section 5: "Cooling System".
3. Identify and disconnect all air, coolant and oil lines from the compressor assembly.
4. Access the compressor by the engine R.H. side compartment. Remove the four compressor mounting bolts and the two fuel pump support bracket bolts.
5. Slide air compressor rearward to disengage the hub from coupling. Remove the air compressor.

Reverse removal procedure for installation.

### 11. EMERGENCY/PARKING BRAKE CONTROL VALVE (PP-1)

A push-pull control valve mounted on the L.H. lateral console is provided for parking brake application or release. The spring brakes are self-actuated whenever the control valve supply pressure drops below 40 psi (275 kPa). In the UP position, brakes are ON. In the DOWN position, brakes are RELEASED. A protective case around the knob prevents accidentally releasing the brakes.

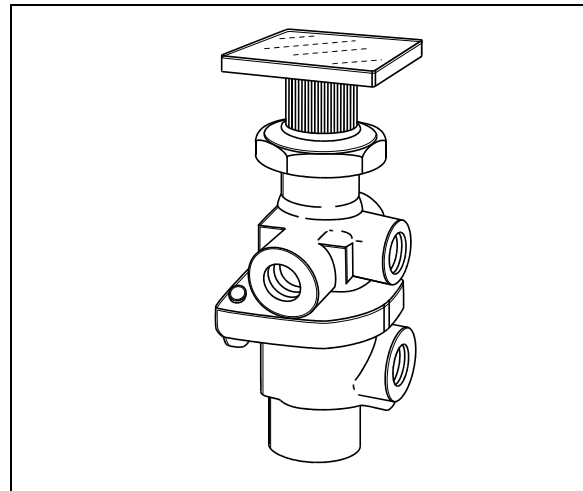

FIGURE 9: PP-1

12142

Maintenance and repair information on this valve is supplied in the applicable booklet annexed to this section under reference number SD-03-3611.

Remove the valve the following way:

1. Drain the air system.

2. Access this valve by tearing out the finishing panel, which holds the controls in place (Fig. 9).
3. Disconnect the air tubes.
4. Remove the retaining screws.
5. Service or replace the valve.
6. Installation is the reverse of removal.

**12. FLIP-FLOP CONTROL VALVE (TW-1)**

A flip-flop control valve mounted on the L.H. lateral console is provided to unload and to lift tag axle air springs. It is a manually operated "on-off" valve. Maintenance and repair information on this valve is supplied in the applicable booklet annexed to this section under reference number SD-03-3602.

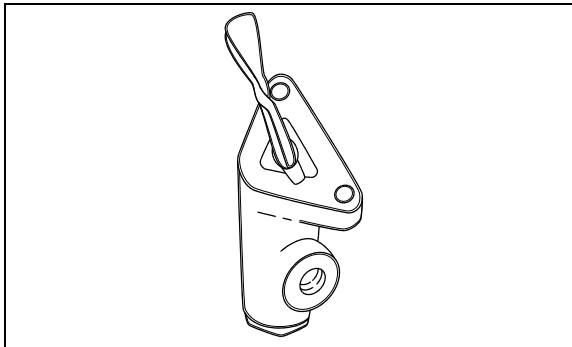

FIGURE 10: TW-1 12138

**13. DUAL BRAKE APPLICATION VALVE (E-10P)**

The E-10P dual brake valve is a floor mounted, foot-operated type brake valve with two separate supply and delivery circuits. This valve is located in the front service compartment (Fig. 11).

**13.1 BRAKE PEDAL ADJUSTMENT**

After brake pedal replacement or repair, adjust the pedal to its proper position according to the following procedure:

1. Replace the linkage, loosen threaded rod lock nuts and screw or unscrew the threaded adjustment rod in order to obtain a 45° brake pedal inclination (Fig. 11).
2. Tighten threaded rod lock nuts.

**13.1.1 Maintenance**

Maintenance and repair information on the E-10P dual brake application valve is supplied in the applicable booklet annexed to this section under reference number SD-03-830.

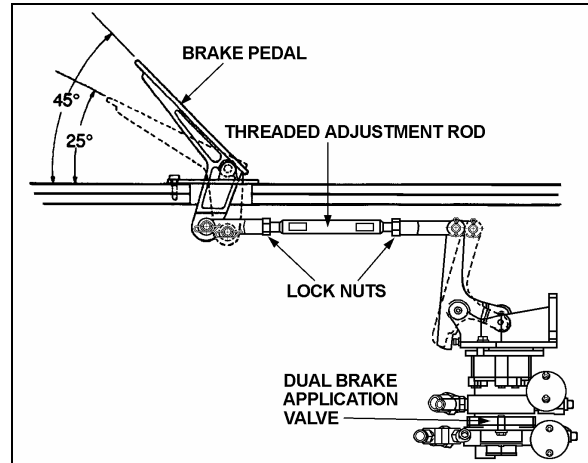

FIGURE 11: BRAKE PEDAL ADJUSTMENT 12208

**14. STOPLIGHT SWITCHES**

Two electro-pneumatic stoplight switches are mounted on the dual brake application valve (E-12). The upper one is used for the primary air circuit while the lower one is used for the secondary air circuit. Both switches are connected in parallel and have the same purpose, i.e. completing the electrical circuit and lighting the stoplights when a brake application is made. The upper switch (AC Delco) is designed to close its contact between 2 psi and 4 psi (14 kPa to 28 kPa) (Fig. 12), while the lower one (Bendix, SL-5) closes its contact at 4 psi (28 kPa) (Fig. 13). The switches are not serviceable items; if found defective, the complete unit must be replaced.

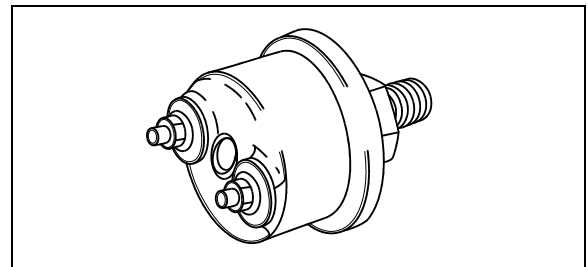

FIGURE 12: DELCO SWITCH 12139

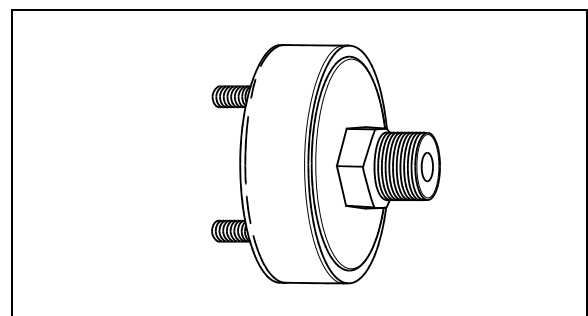

FIGURE 13: BENDIX SWITCH 12140

## Section 12: BRAKE AND AIR SYSTEM

### 15. PARKING BRAKE ALARM SWITCH

Refer to the appropriate annexed booklet (Bendix, SL-5 Stop Light Switch; reference no. SD-06-2501).

The parking brake alarm uses the same switch as the stoplights. It is mounted on the spring brake valve and operates in conjunction with a NC relay to sound a warning alarm by completing the electrical circuit when the ignition key is turned OFF with parking brake released.

### 16. BRAKE RELAY VALVE (R-12 & R-14)

The primary air system includes three brake relay valves being supplied by the dual brake valve, and which function is to speed up the application and release of the service brakes.

One Wabco R-14 valve located in the rear underframe supplies the drive axle service brake air line, while the other two R-12 valves supply independently both the tag axle right and left service brake air line and act as interlock valves. These valves are accessible from under the vehicle at the level of the tag axle. Maintenance and repair information on these valves is supplied in the applicable booklet annexed to this section under reference number SD-03-1064.

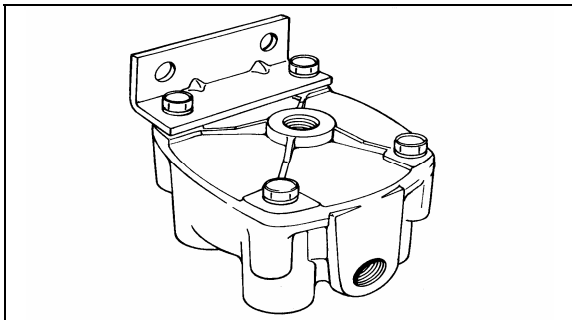

FIGURE 14: R-12

12074

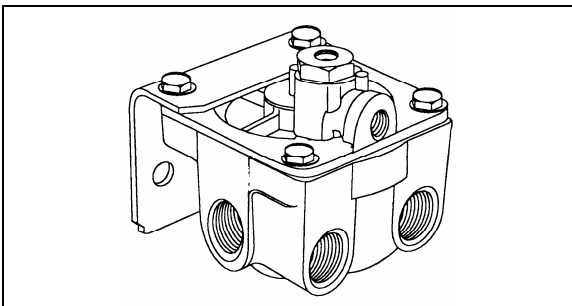

FIGURE 15: R-14

12207

### 17. QUICK RELEASE VALVES (QR-1)

The quick release valve installed on this vehicle is used on Low Buoy rear release system. It permits rapid exhaust of air pressure from brakes, thus decreasing the brake release time.

Maintenance and repair information on this valve is supplied in the applicable booklet annexed to this section under reference number SD-03-901.

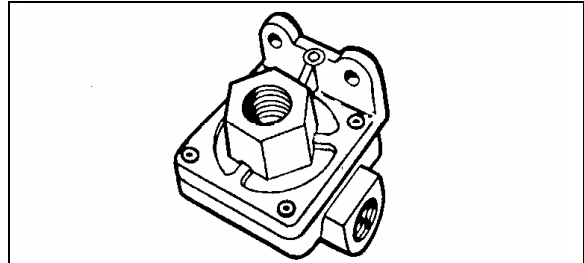

FIGURE 16: QR-1

12075

### 18. SPRING BRAKE VALVE (SR-7)

The spring brake valve is located in the rear underframe. The SR-7 Modulating Valve is used in conjunction with a dual air brake system and spring brake actuator and performs the following functions:

- Provides a rapid application of the spring brake actuator when parking.
- Modulates the spring brake actuator application using the dual brake valve should a primary failure occur in the service brake system.
- Prevents compounding of service and spring forces.

Maintenance and repair information on the spring brake valve is supplied in the applicable booklet annexed to this section under reference number SD-03-9043.

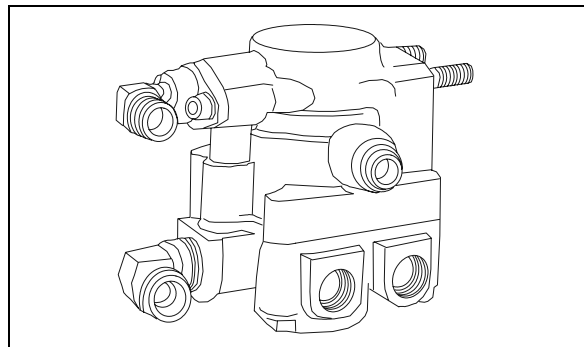

FIGURE 17: SR-7

12206

**19. PRESSURE PROTECTION VALVE (PR-4)**

Maintenance and repair information on the pressure protection valve is supplied in the applicable booklet annexed to this section under reference number SD-03-2010.

The air system includes two pressure protection valves (Fig. 18). One valve is installed on the manifold block, and insures at all times a minimum pressure of 70 psi (482 kPa) in the suspension air system in the event that a pressure drop occurs in either the suspension air system or accessory air system. This valve is located in the front service compartment beside the air filter.

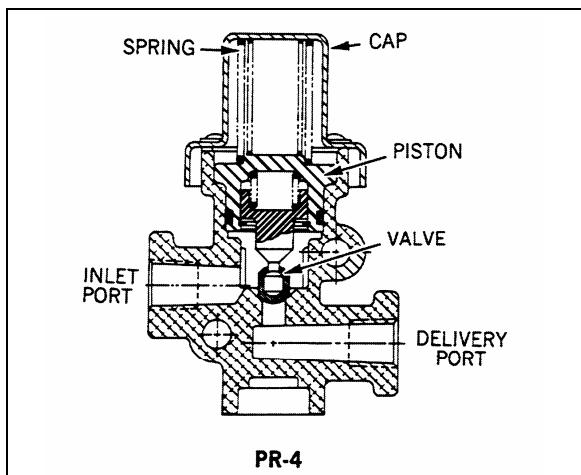

FIGURE 18: PR-4

12174

The other valve is installed on the accessory air tank, and insures a minimum pressure of 70 psi (482 kPa) in the accessory air system in the event that a pressure drop occurs in either the suspension air system or braking air system (refer to Fig. 1 for accessory air tank location).

**20. LOW PRESSURE INDICATOR (LP-3)**

Maintenance and repair information on the low pressure indicators is supplied in the applicable booklet annexed to this section under reference number SD-06-1600.

The air system includes two low pressure switches (Fig. 19), both located on the pneumatic accessory panel in the front service compartment. One serves for the parking brake signal, its pressure setting is  $66 \pm 6$  psi ( $455 \pm 40$  kPa). The remaining pressure switch monitors the parking brake telltale panel indicator; its pressure setting is 30 psi (205 kPa).

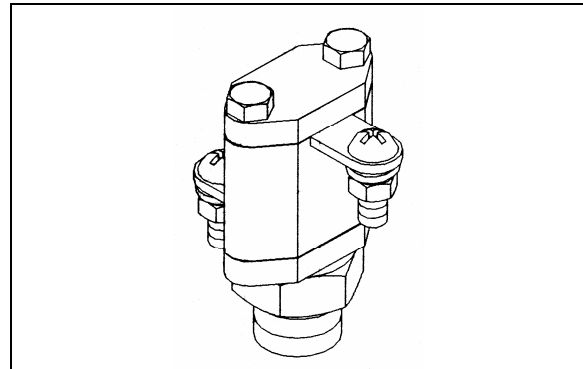

FIGURE 19: LP-3

12078

**21. SHUTTLE-TYPE DOUBLE CHECK VALVE (DC-4)**

Maintenance and repair information on the shuttle-type double check valve is supplied in the applicable booklet annexed to this section under reference number SD-03-2202.

The double check valve is located on the pneumatic accessory panel in the front service compartment. In the event of a pressure drop in either the primary or secondary system, this unit will protect the emergency /parking brake control valve and the intact portion of the air system from pressure loss.

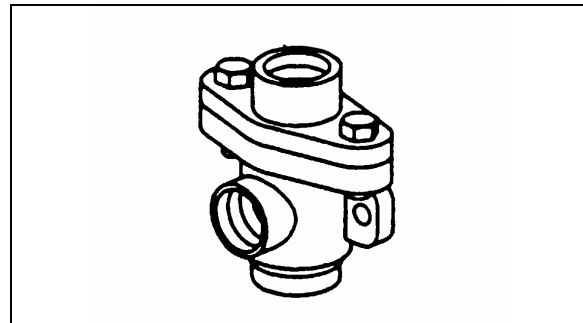

FIGURE 20: DC-4

12134

**22. AIR HORN VALVE**

The air horn valve is located in the L.H. front service compartment. The air horn button is on the center of the steering wheel. Refer to section 23 "ACCESSORIES" for more information.

## Section 12: BRAKE AND AIR SYSTEM

---

### 23. AIR SYSTEM TROUBLESHOOTING

The following list has been designed to help in troubleshooting some of the most common problems in the air system and main causes. For air brakes troubleshooting, refer to “*Air Brakes Troubleshooting*” in this section. For more troubleshooting information, refer to the manufacturer's brochures annexed to this section.

Air pressure doesn't rise to, or doesn't maintain, a normal setting:

- Defective air gauge (registering incorrectly).
- Excessive leaking in air system.
- Reservoir drain cock open.
- Governor poorly adjusted or defective.
- Defective compressor.
- Worn compressor or excessive wear on piston and/or ring.
- Air pressure rises to normal setting too slowly.

Excessive leaking in air system:

- Clogged engine air cleaner.
- Worn compressor or excessive wear on piston and/or ring.
- Engine speed too low.

Air pressure rises above a normal setting:

- Defective air gauge (registering incorrectly).
- Governor poorly adjusted or defective.
- Restriction in line between governor and compressor unloading mechanism.

Air pressure drops quickly when engine is stopped:

- Leaks in compressor discharge valve.
- Leaks in governor.
- Leaks in air lines.
- Leaks in air system valves.

### 24. BRAKE OPERATION

The vehicle braking system uses both service and parking air-operated brakes. The air system is divided into two independent circuits to isolate the front axle brakes and the rear axle brakes (drive and tag), thus providing safe brake

operation in the event that one circuit of the system fails. The primary circuit is connected to the drive and tag axle brakes, while the secondary circuit is connected to the front axle brakes. The tag axle service brakes operate only when the axle is in the normal driving (loaded) position. The spring-type emergency brakes are mounted on the drive and tag axles, and will apply automatically if primary system pressure falls below 40 psi (276 kPa).

Furthermore, brake application or release, which is speed up by a pneumatic relay valve (R-12), will start with the rear axles and be followed by the front axle, thus providing uniform braking on a slippery surface. The vehicle is also equipped with an Anti-lock Brake System (ABS), detailed later in this section.

Brake and air system maintenance consists of periodic inspections. Check all parts for damage and brake adjustment (refer to subsequent headings in this section for more details). Ensure all fasteners are tight (refer to “*Specifications*” for recommended tightening torques).

### 25. AIR BRAKES

#### 25.1 DISC BRAKES

*Knorr-Bremse SN7000* disc brakes are used on all axles. The front and drive axle discs are actuated by 24 square inch effective area air brake chambers, while on tag axle, the brake chambers have a 16 square inch effective area for service brake and a 16 square inch effective area for emergency/parking brakes. The *Knorr-Bremse SN7000* brakes are supplied with automatic clearance (slack) adjusters as standard equipment for easier adjustment. For more information on disc brake components and maintenance, refer to the manufacturer's brochure at the end of this section.

##### 25.1.1 Disc Brake Pads

Brake pads have to be checked on a regular basis depending on the vehicle operation. The remaining thickness of the pads should never be less than 3/32 in (2 mm). To check pad condition without removing the wheel, verify the position of guide bushing (6) relatively to guide sleeve (4) (see Fig. 21). When guide sleeve is in alignment with guide bushing, brake pad thickness has to be checked more precisely with the wheel removed. When replacing brake pads, all four pads on an axle have to be changed at the same time. There is no inner or outer pad,



since all pads are the same. Once removed, worn pads should be replaced in their original position.

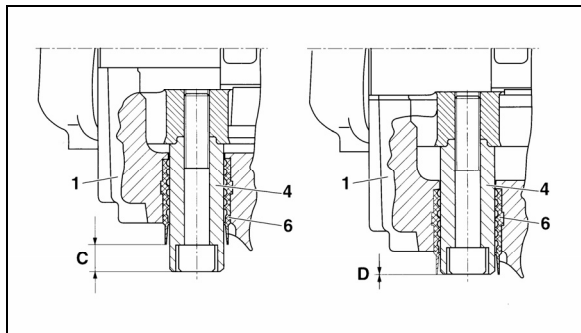

FIGURE 21: BRAKE PAD CHECK

12117

### 25.1.2 Caliper Maintenance

Use the following procedure for brake calipers servicing. The procedure must be followed in proper sequence to ensure that only needed repairs or replacements are performed on calipers. Problems such as hot brakes or cracked rotors may be effects of sticking calipers, too-small clearance between rotor and pad or possible trapped air pressure in the brake chamber. If any of these symptoms occur, perform this procedure before replacing the rotor to ensure the cause of the problem is properly solved.

#### 1. Check for presence of residual pressure:

To check if there is any residual air pressure in the brake chamber, make four or five brake applications, then try to turn the wheel manually, if the wheel does not turn, use a wrench to crack the air line and listen for trapped air in the brake chamber then try to turn the wheel manually again. If you find trapped air in the brake booster, ensure that all pneumatic components in the braking system are functioning properly.

**NOTE**

*A residual pressure of 2-3 PSI in the system is sufficient to prevent the brakes from releasing. Also the stop light switch can operate with as little as 1 PSI, therefore an illuminated brake light does not mean brakes are dragging.*

#### 2. Pad to rotor clearance inspection:

Remove clip and washer (26 & 45, Fig. 22), push down retainer bar (11), pull out pin (44) and remove retainer bar. Push caliper toward actuator (center of vehicle) for maximum clearance.

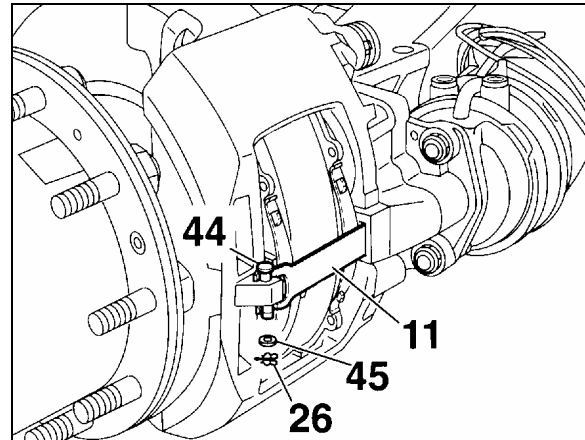

FIGURE 22: CLEARANCE INSPECTION

12119

#### 3. Measure pad to rotor clearance:

Place a long feeler gauge (long enough to measure across entire tappet surface) between the tappet and the backing plate of the pad, measure clearance at both tappets. Clearance should range between 0.020 and 0.035 inch (0.5 mm and 0.9 mm), with a maximum difference between tappet measurements on same brake of 0.008 inch (0.2 mm).

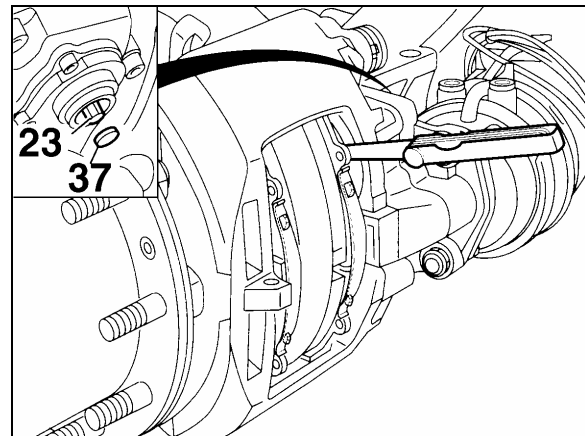

FIGURE 23: RUNNING CLEARANCE

12116

#### 4. Checking the adjuster



**CAUTION**

Use only a standard box wrench on the adjuster hexagonal pinion. Do not overtorque the pinion as overtightening will damage the pinion.

- a) Remove cap (37, Fig. 23).
- b) Using a box wrench (8 mm), turn the adjuster pinion (23, Fig. 23) counterclockwise about 2 - 3 clicks to increase running clearance. By operating the braking system

## Section 12: BRAKE AND AIR SYSTEM

about 5 - 10 times (30 PSI or 2 bar), the wrench should turn clockwise in small increments if the adjuster is functioning correctly (Figs. 24 and 25).

### NOTE

*With increasing number of applications, the incremental adjustment will decrease.*

- c) In case of malfunction, i. e. the pinion or box wrench:
  - i) Does not turn.
  - ii) Turns only with the first application.
  - iii) Turns forwards then backwards with every application.

In any of the above cases, the automatic adjuster has failed and the caliper must be replaced. In such cases the brakes can be adjusted manually to run a short distance.

- d) Take the box wrench off. Replace the cap and check for proper sealing.

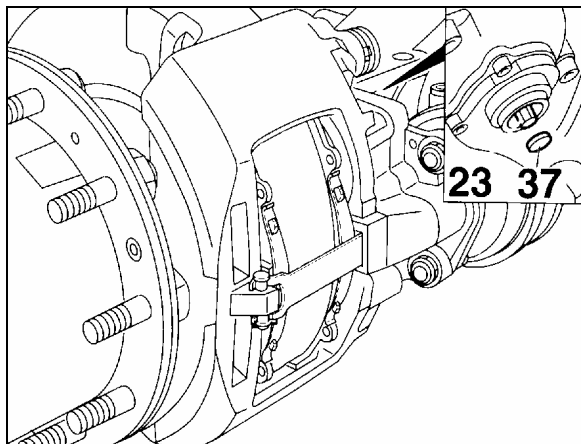

FIGURE 24: ADJUSTER PINION

12120

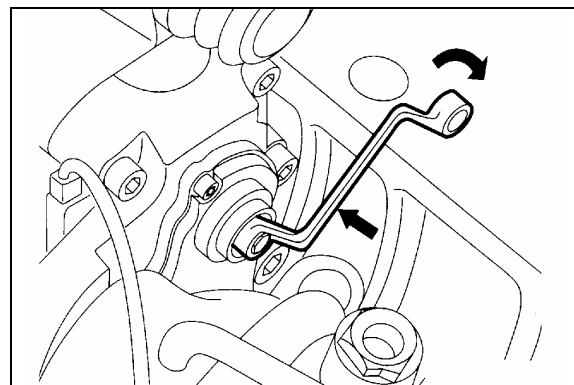

FIGURE 25: BOX WRENCH ON ADJUSTER PINION

12118

### 25.1.3 Roadside Inspection for Knorr/Bendix Air Disc Brakes

The coach is equipped with air disc brakes and therefore, cannot be inspected using the requirements for chamber stroke or visible lining clearance or lining thickness as specified for drum brakes. The roadside inspector should use the following instructions to determine that the air disc brakes are within proper adjustment and have sufficient pad wear thickness.

The Knorr/Bendix air disc brake is designed to move freely, with minimal force, in the axial direction on the two sliding pins as identified in figure 26. The movement in the axial direction should not exceed 2 mm (5/64").

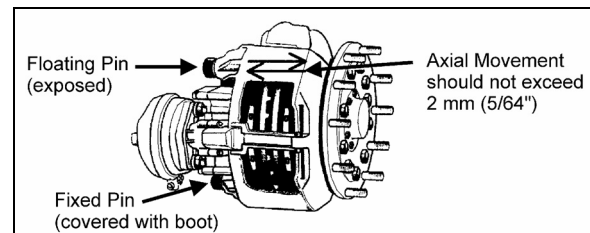

FIGURE 26: CALIPER AXIAL MOVEMENT

12132

The pad thickness can be seen but would require removal of the tire and rim. An indicator of the pad wear condition is available by inspecting the floating pin location in relation to the rubber bushing as shown in figure 27. When pads are in new thickness condition, the pin will be exposed (C) 19 mm (3/4"). When the pads are worn to replacement conditions, the pin will be nearly flush to the bushing (D) or within 1 mm (3/64") of the edge of the rubber bushing.

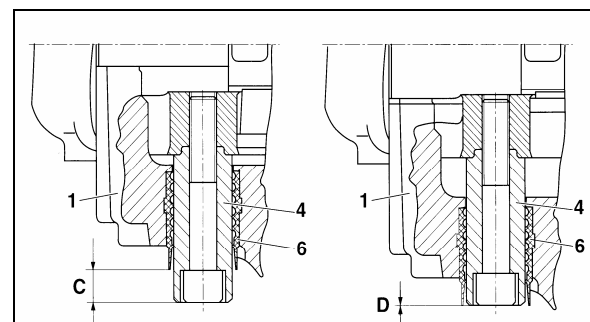

FIGURE 27: BRAKE PAD CHECK

12117

### 25.1.4 Pad Removal

Turn adjuster pinion (23) counterclockwise to increase pad to rotor clearance (a clicking noise will be heard). Push caliper toward actuator and remove pads (12).

**CAUTION**  
Do not apply brakes while pads are removed as this could cause over stroke damage to the adjusting mechanism.

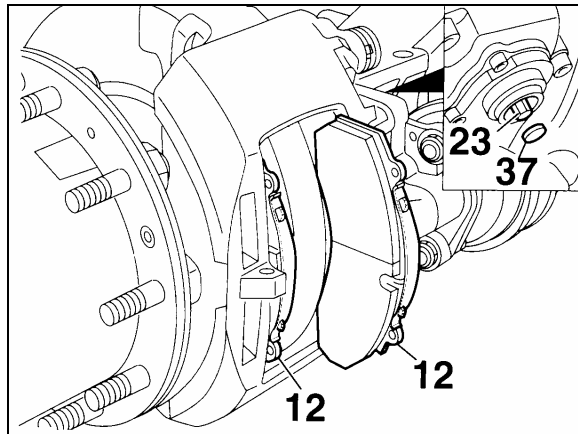

FIGURE 28: PAD REMOVAL 12111

25.1.5 Checking Pad Wear

Minimum friction material thickness is 2 mm (A, Fig. 29)

New friction material has a thickness of 21 mm (B, Fig. 29)

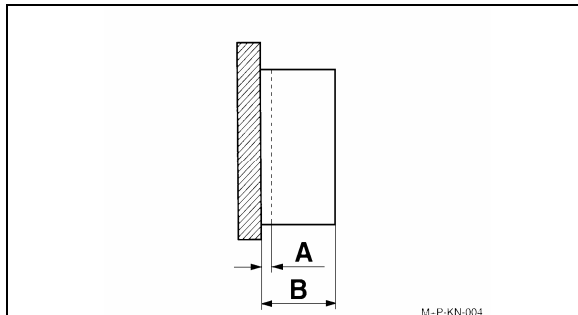

FIGURE 29: PAD WEAR 12112

25.1.6 Important Pad and Rotor Measurements

- A = Rotor thickness (new): 45 mm;
- B = Rotor thickness (worn): 37 mm. Requires replacement;
- C = Overall thickness of pad (new): 30 mm;
- D = Backplate: 9 mm;
- E = Minimum thickness of pad material: 2 mm;
- F = Minimum allowed thickness of overall backplate and friction material: 11 mm.  
**Replacement necessary.**

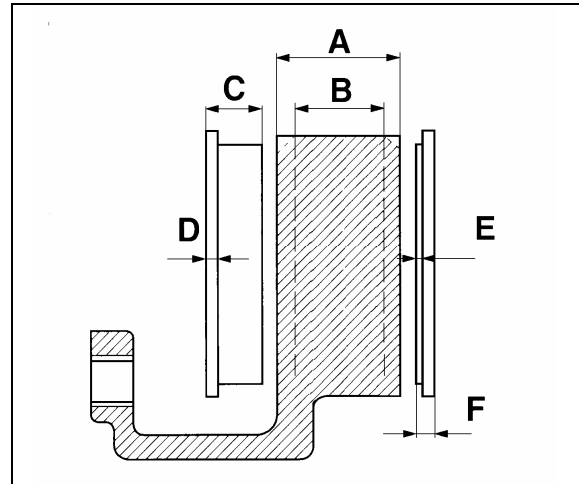

FIGURE 30: ROTOR AND PAD WEAR LIMITS 12113

25.1.7 Checking Caliper Guidance and Seal Condition

Perform sliding test. You must be able to slide the caliper easily at any time. Sliding test should be performed at least every three months or more often depending on the type of operation.

Sliding Test (Refer to Fig. 31):

- a) Using hand pressure only, the caliper (1) must slide freely with its guide pin arrangements (4-7) across a distance of 1 3/16 inch (30 mm) when the pads are removed. The sleeve (5) is sealed using the boot (9) and the cap (10).
- b) The rubber components (9 and 10) should show no damage. The positioning must be checked. If necessary the caliper has to be repaired using the guide kit (part #611168) or with the seal and guide kit (part #611199). When repairing a caliper with the above kits, make sure all parts in the kit are used. Use special green grease (Prévost #683344) to reassemble the slide pin into the bushing, white or yellow grease (Prévost #683345) may be used for all other lubrication needs.
- c) Depending on caliper manufacturing date, black paint may be present on the unsealed pin (short pin). Paint on the slide pin can prevent the caliper from sliding properly especially when the pad starts to wear. If paint is present on the pin, separate the pin from the bushing, clean and reinstall the pin according to procedure.

**NOTE**

Do not attempt to use thinner or alcohol to clean the pin without removing it as it may damage the rubber bushing.

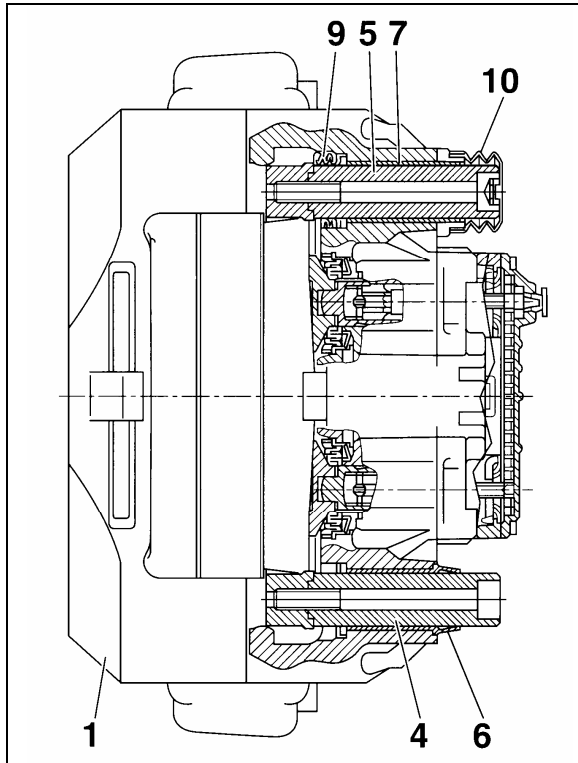

FIGURE 31: CALIPER GUIDANCE

12114

25.1.8 Checking the Tappet Boots

- a) The rubber boots (13, Fig. 32) should show no damage, check the attachment.

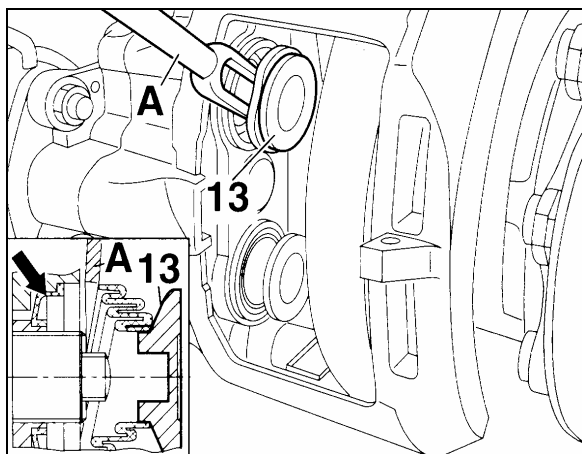

FIGURE 32: RUBBER BOOTS

12115



**CAUTION**

Any ingress of water and dirt will lead to corrosion and may affect the function of the actuation mechanism and adjuster unit.

- b) If boots are damaged but show no corrosion, the boots and tappets should be replaced (Prévost #611177).

25.1.9 Pad Installation

Turn adjuster pinion (23, Fig. 33) counterclockwise until tappets are fully retracted and clean pad seat area. Slide caliper to full outboard position and install outside pad. Slide caliper to full inboard position and install inside pad.



**WARNING**

It is recommended to change all pads on an axle at the same time.

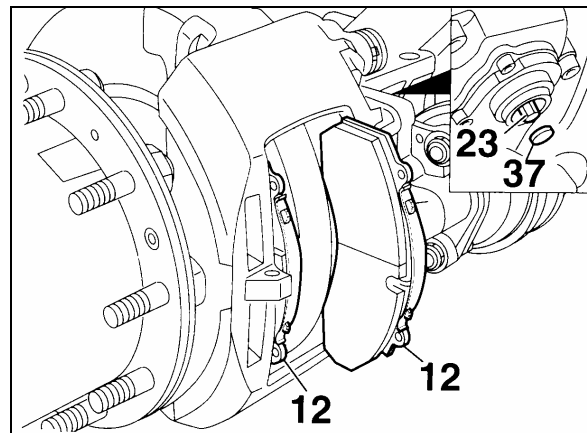

FIGURE 33: PAD INSTALLATION

12111

25.1.10 Adjusting the Running Clearance

- a) Insert a feeler gauge 0.028 inch (0.7 mm thickness) between tappet and pad backplate (Fig. 34). Turn adjuster pinion clockwise until 0.028 inch (0.7 mm) clearance is achieved. Replace cap (37) (Prévost # 641313).
- b) To ensure a constant running clearance between the rotor and pads, the brake is equipped with an automatic adjuster unit. When the pads and rotor wear, the running clearance between the pads and rotor increases. The adjuster (23, Fig. 34) and turning device turn the threaded tubes by the amount necessary to compensate the wear.

Total running clearance should be between 0.020 and 0.035 inch (0.5 and 0.9 mm). Smaller clearances may lead to overheating problems.

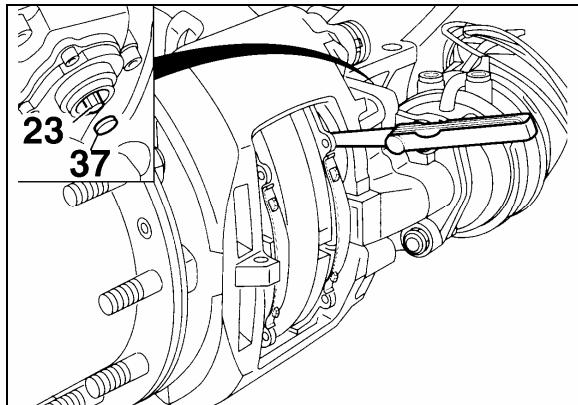

FIGURE 34: RUNNING CLEARANCE 12116

25.1.11 Brake Tools

Four brake tools are available from Prévost to facilitate disc brake maintenance:

- a) #641321, Tappet with boot (item 13).
- b) #641322, Caliper inner boot (item 9).
- c) #641323, Caliper bushing (item 7).
- d) #641435, Fork for boot tappet (item 13).

**Maintenance tip**

Using the following procedure, pad wear can be determined without removing the wheel.

25.1.12 Checking Brake Pads

Brake pads have to be checked on a regular basis depending on the vehicle operation. The remaining thickness of the pads should never be less than 3/32 inch (2 mm). To check pad condition without removing the wheel, verify the position of guide bushing (6) relatively to guide sleeve (4) (Fig. 35). When guide sleeve is in alignment with guide bushing, brake pad thickness must be checked more precisely with wheel removed. When replacing the brake pads, all four pads on an axle have to be changed at the same time. There is no inner or outer pad, since all pads are the same. Worn pads should be replaced in the same position.

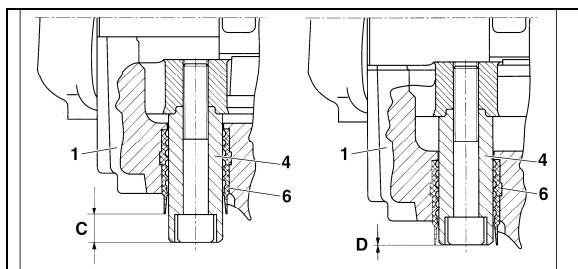

FIGURE 35: BRAKE PAD CHECK 12117

25.1.13 Torque specifications

For proper caliper maintenance, refer to the following figures.

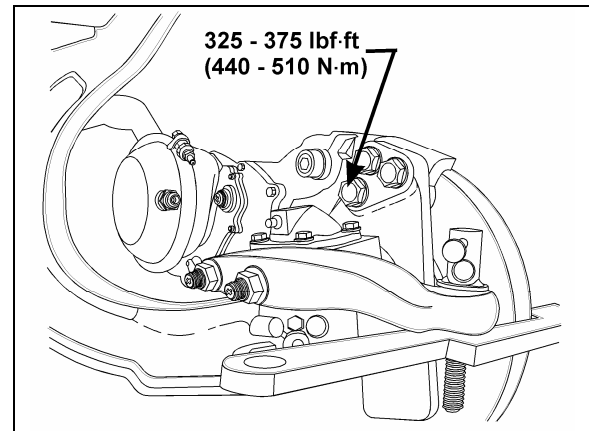

FIGURE 36: TORQUE SPECIFICATION 12145

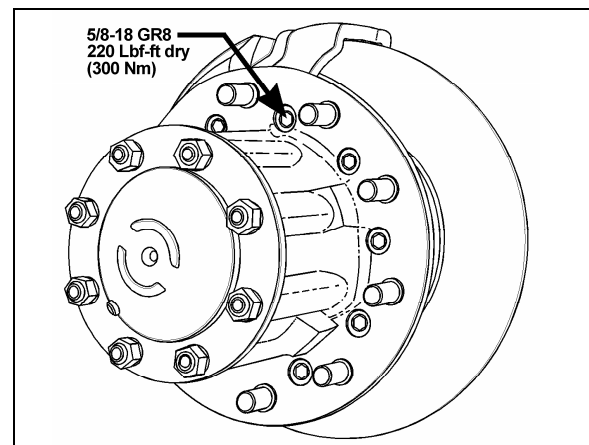

FIGURE 37: TORQUE SPECIFICATION 11030

**26. SAFE SERVICE PROCEDURES**

Most recently manufactured brake linings no longer contain asbestos fibers. Instead of asbestos, these linings contain a variety of ingredients, including glass fibers, mineral wool, aramid fibers, ceramic fibers, and carbon fibers. At present, OSHA (Occupational Safety and Health Administration) does not specifically regulate these non-asbestos fibers, except as nuisance dust. Medical experts do not agree about the potential long-term risks from working with and inhaling non-asbestos fibers. Nonetheless some experts think that long-term exposure to some non-asbestos fibers could cause diseases of the lung, including pneumoconiosis, fibrosis, and cancer. Therefore, lining suppliers recommend that workers use caution to avoid creating and breathing dust when working on brakes that contain non-asbestos fibers.



### WARNING

Whenever possible, work on brakes in a separate area away from other operations.

Always wear a respirator approved by NIOSH (National Institute of Occupational Safety and Health) or MSHA (Mine Safety and Health Administration) during all brake service procedures. Wear the respirator from removal of the wheels through assembly.

NEVER use compressed air or dry brushing to clean brake parts or assemblies. OSHA recommends that you use cylinders that enclose the brake. These cylinders have vacuums with high efficiency (HEPA (Health and Environment Protection Agency)) filters and workmans' arm sleeves. But, if such equipment is not available, carefully clean parts and assemblies in the open air.

Clean brake parts and assemblies in the open air. During disassembly, carefully place all parts on the floor to avoid getting dust into the air. Use an industrial vacuum cleaner with a HEPA filter system to clean dust from the brake drums, backing plates and other brake parts. After using the vacuum, remove any remaining dust with a rag soaked in water and wrung until nearly dry.

If you must grind or machine brake linings, take additional precautions because contact with fiber dust is higher during these operations. In addition to wearing an approved respirator, do such work in an area with exhaust ventilation.

When cleaning the work area, NEVER use compressed air or dry sweeping to clean the work area. Use an industrial vacuum with a HEPA filter and rags soaked in water and wrung until nearly dry. Dispose of used rags with care to avoid getting dust into the air. Use an approved respirator when emptying vacuum cleaners and handling used rags.

Wash your hands before eating, drinking or smoking. Do not wear your work clothes home. Vacuum your work clothes after use and then launder them separately, without shaking, to prevent fiber dust from getting into the air.

Material safety data sheets on this product, as required by OSHA, are available from Rockwell and Knorr-Bremse.

## 27. AIR BRAKE TROUBLESHOOTING

The following tests and check lists have been designed to identify the cause(s) of a sluggish performance and/or leaks in the system. These tests require very little time to perform, and give you a general idea of the system condition. Each test is provided with a corresponding check list which will guide you to the most common causes of problems.

Before performing any test, check all air lines for kinks or dents, and hoses for signs of wear, drying out or overheating.



### WARNING

When working on or around brake system and its related components, the following precautions should be observed:

Always block vehicle wheels. Stop engine when working under a vehicle. Keep hands away from chamber push rods and slack adjusters as they may apply when system pressure drops.

Never connect or disconnect a hose or line containing air pressure. It may whip as air escapes. Never remove a component or pipe plug unless you are sure all system pressure has been depleted.

Never exceed recommended air pressure and always wear safety glasses when working with air pressure. Never look into air jets or direct them at anyone.

Never attempt to disassemble a component until you have read and understood the recommended procedures. Some components contain powerful springs and injury can result if not properly disassembled. Use only proper tools and observe all precautions pertaining to the use of those tools.

Always clean connecting piping and/or fittings, and coat pipe threads with Teflon pipe sealant before installing any air brake system component.

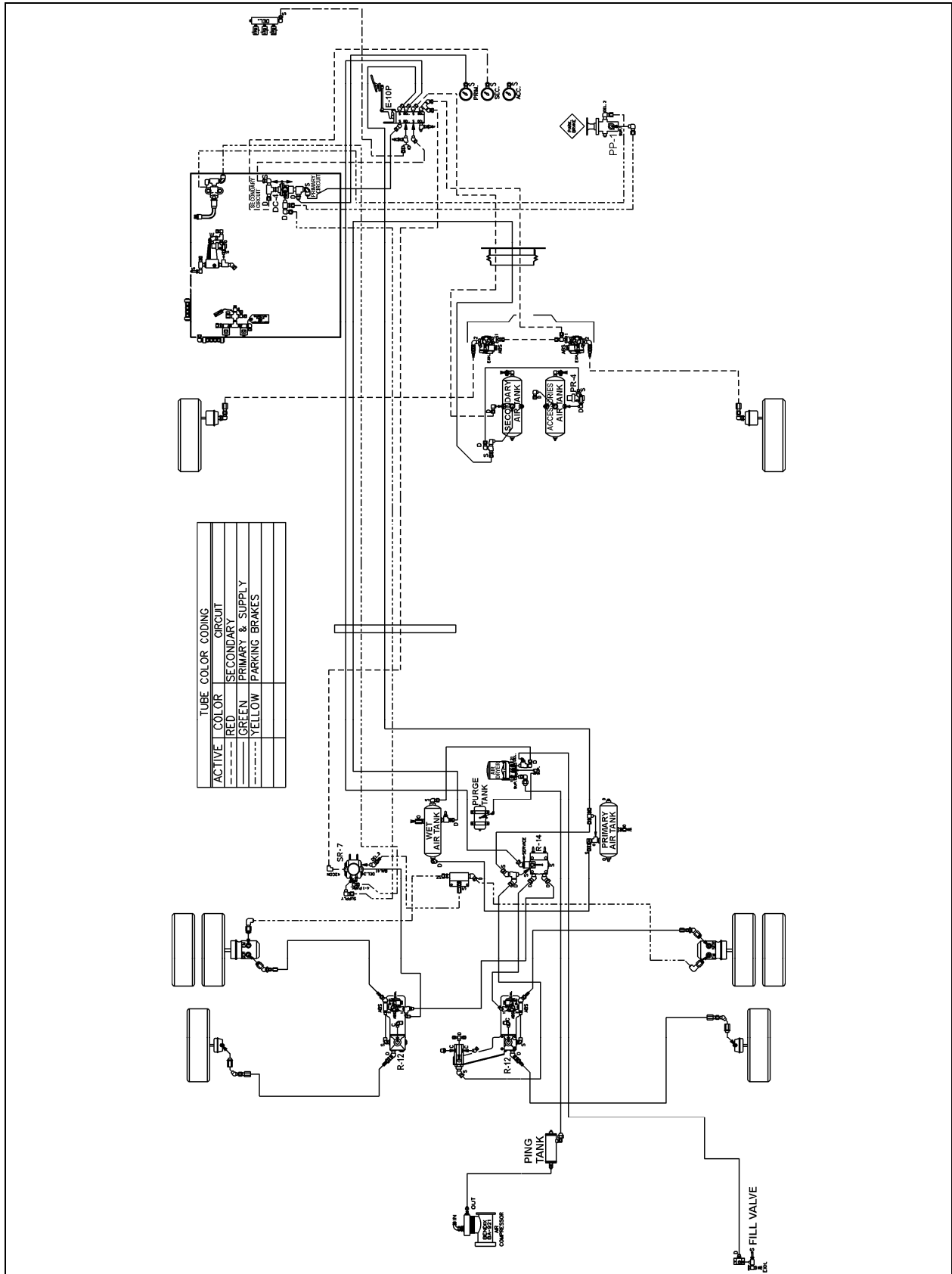

FIGURE 38: AIR-OPERATED BRAKING SYSTEM (WE)

## Section 12: BRAKE AND AIR SYSTEM

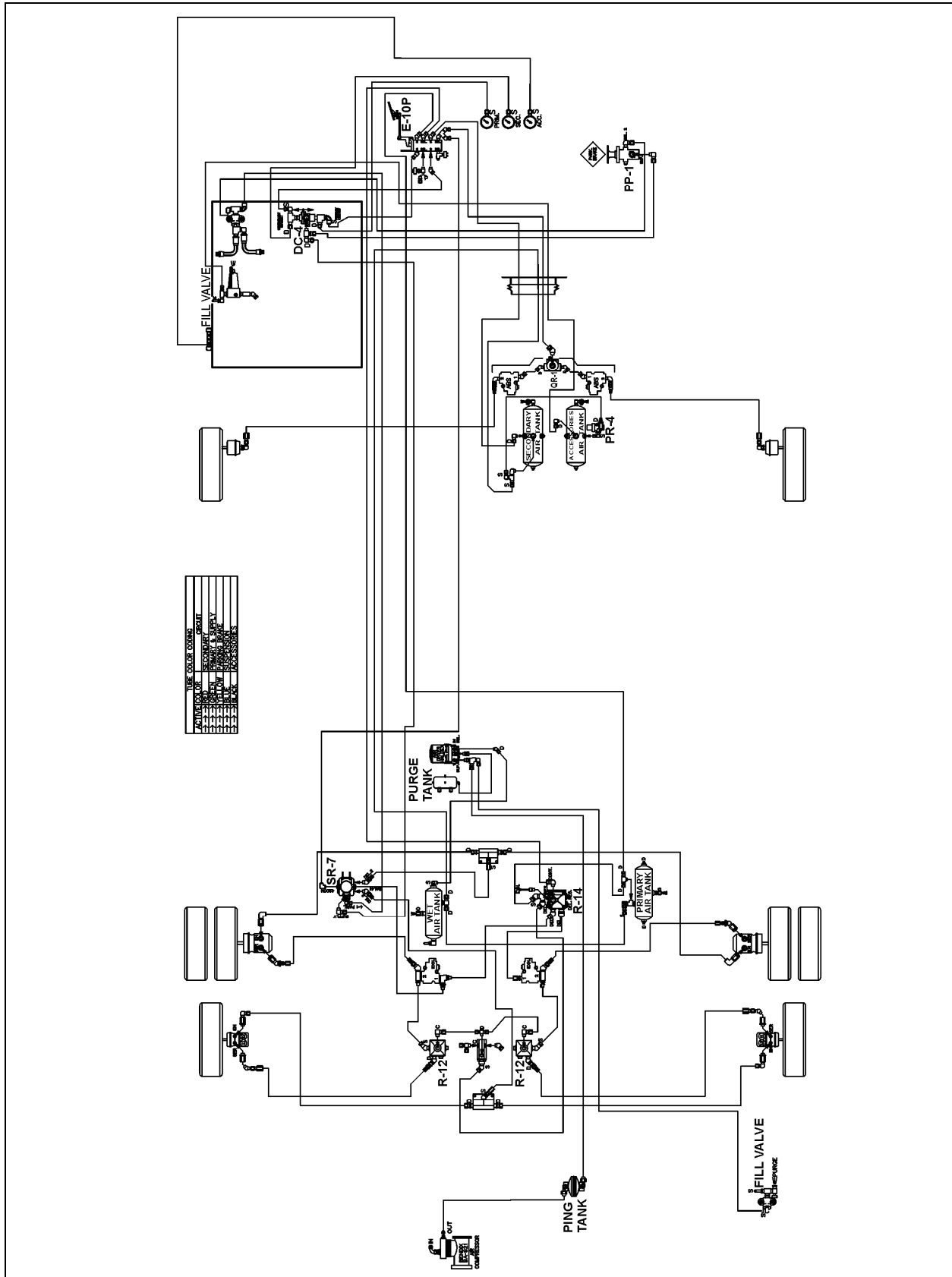

FIGURE 39: AIR-OPERATED BRAKING SYSTEM (W5)



### **Pressure Build-Up / Low Pressure Warning / Cutoff Point / Air Filter/Dryer Built-in Governor Cutout**

CONDITION: Vehicle leveled, parking brake applied.

1. Completely drain wet, primary and secondary air reservoirs only.
2. Start engine and run at fast idle. Low pressure warning lights should be "On".
3. Start checking pressure at 50 psi (344 kPa).
4. Low pressure warning lights and buzzer should go off at or above 60 psi (415 kPa).
5. At 85 psi (586 kPa), run engine at full rpm, then check that build up time to 100 psi (690 kPa) is 30 seconds or less.
6. Air filter/dryer built-in governor cut-out. Cuts out at the correct pressure of 123 psi  $\pm$ 3 (847 $\pm$ 21 kPa).
7. Air filter/dryer built-in governor cut-in. Cuts in around 110 psi (758 kPa).

For common corrections, refer to the following check list:

#### **High or Low Warning Cutoff Point**

- Perform a telltale light and gauge test. Replace entire cluster if found defective.

#### **High or Low Air Filter/Dryer Built-in Governor Cutout Point**

- Perform a telltale light and gauge test. Replace entire cluster if found defective.

OR

- Repair or replace air filter/dryer as necessary after checking that compressor unloader mechanism operates correctly.

#### **More than 30 seconds to build-up pressure from 85 to 100 psi (585 - 690 kPa) at full engine RPM**

- Perform a telltale light and gauge test. Replace entire cluster if found defective.
- Check compressor strainer or inlet line. If restricted, clean or replace element or faulty line.
- Check compressor head or discharge line for carbonization or restriction. Clean or replace as necessary.

- If discharge valves leak, pull head and correct or replace cylinder head.
- If drive is slipping, replace gear.
- If inlet valves are stuck, open or leaking severely, replace unloader kit, inlet valves and/or seats as necessary.
- If drain cock is found open, close it.
- Listen for air leaks and repair.
- Redo list to check all items repaired or replaced.

#### **Air Supply Reservoir Leakage**

CONDITION: Full pressure, engine stopped, parking brake applied

1. Allow at least 1 minute for pressure to stabilize.
2. Stop engine, then check air pressure gauge for 2 minutes. Note any pressure drop.
3. Pressure should not drop by more than 3 psi (20 kPa) per minute.

For common corrections, refer to the following check list:

Excessive air loss:

- With the primary air system at normal operating pressure (95 - 125 psi (655 - 860 kPa)), coat all air line connections and pneumatic components with a water and soap solution. Bubbles will indicate an air leak, and none should be permissible. Repair or replace defective parts.
- Listen for leaks and correct as required.
- Redo test to check all items repaired or replaced.

#### **Brake System Air Leakage**

CONDITION: Full pressure, engine stopped, parking brake released.

1. Apply service (foot) brakes, allow at least 1 minute for pressure to stabilize.
2. Hold down foot valve for 2 minutes while observing air pressure gauge on the dashboard.
3. Pressure drop should not be more than 4 psi (27 kPa) per minute.

For common corrections, refer to the following check list:

## Section 12: BRAKE AND AIR SYSTEM

### Excessive leakage on brake service side:

- With the primary air system at normal operating pressure (95 - 125 psi (655 - 860 kPa)) and foot brake applied, coat all air line connections and brake pneumatic components with a water and soap solution. Bubbles will indicate an air leak, and none should be permissible. Repair or replace defective parts.
- Listen for leaks and correct as required.
- Redo test to check all items repaired or replaced.

#### **IMPORTANT NOTE**

To maintain your vehicle's air disc brakes at their original performance standard, we strongly recommend use of only genuine, approved service replacement parts on Bendix and Knorr-Bremse air disc brake systems. If non-approved friction materials or replacement components are used, neither Prévost Car nor Bendix Spicer Foundation Brake LLC will accept any air disc brake-related warranty returns or claims.

For more information on this policy, refer to Bendix-Prévost product notification annexed at the end of Section 12 of Maintenance Manual.

### 28. BRAKE AIR CHAMBER

Since this vehicle is equipped with *Knorr-Bremse SN7000* disc brakes on all axles, it also uses "Knorr-Bremse" brake chambers. The tag and drive axle chambers consist of two separate air chambers, each having its own diaphragm and push rod. They are used as a service brake chamber, an emergency brake in case of air pressure loss and a spring-applied parking brake. Refer to figures 40 and 41.

The front wheel brake air chambers are used only for service brake duty (Fig. 40).

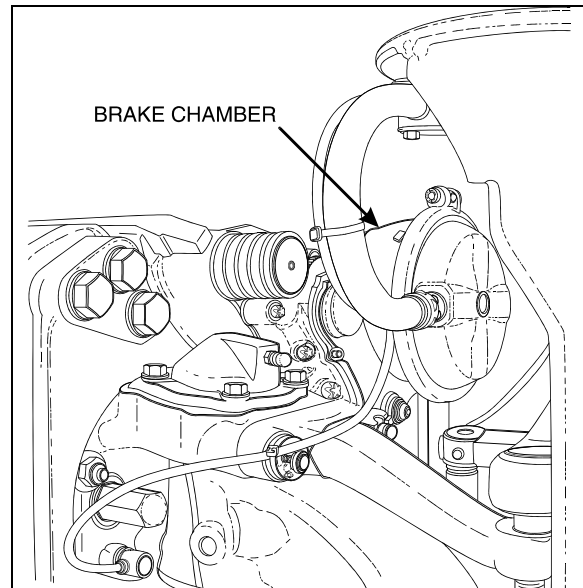

FIGURE 40: FRONT WHEEL BRAKE AIR CHAMBER 12158

#### 28.1 MAINTENANCE

**Every 6,250 Miles (10 000 km) or twice a year, whichever comes first depending on type of operation:**

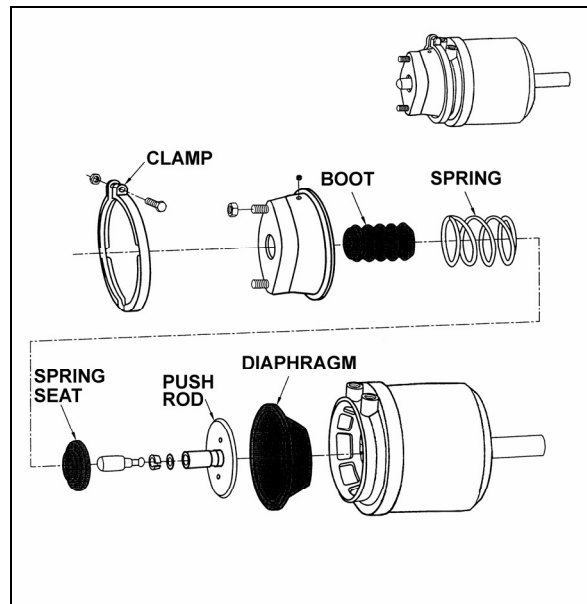

FIGURE 41: TAG AXLE BRAKE AIR CHAMBER 12126

Check all hoses and lines. They should be secure and in good condition.

**Every 100,000 Miles (160 000 km) or once a year, whichever comes first depending on type of operation:**

1. Disassemble and clean all parts.
2. Install new diaphragm or any other part if worn or deteriorated.

**NOTE**

When the diaphragm, spring, or both are replaced, they should be replaced in the corresponding chamber on the same axle.

3. Perform an airtightness test:
  - a) Make and hold a full brake application.
  - b) Coat clamping ring(s) with a soapy solution. If leakage is detected, tighten clamping ring only enough to stop leakage. **Do not overtighten** as this can distort sealing surface or clamping ring. Coat area around push rod hole (loosen boot if necessary). No leakage is permitted. If leakage is detected, the diaphragm must be replaced.

28.2 EMERGENCY/PARKING BRAKE MANUAL RELEASE



**DANGER**

Never stand in the axis line of the spring brake chambers, especially when caging the spring.

**Drive Axle**

1. Block the wheels to prevent the vehicle from moving.
2. Remove the release stud tool from its storage place on drive axle brake air chamber.
3. Remove the access plug from the end of the spring chamber, then insert the release stud through the opening. Turn the release stud ¼ turn (clockwise) to anchor it into the spring plate. Install the flat washer and nut, then turn the nut clockwise to cage the spring. Repeat on the opposite side.



**DANGER**

Make sure the release stud is properly anchored in spring plate receptacle prior to caging the spring.

4. To manually reset the emergency/parking brake, turn the nut counterclockwise. Reinstall access plugs on the spring chambers, and release stud tools in their storage places.

**Tag Axle**

1. Block the wheels to prevent the vehicle from moving.
2. Turn the release bolt counterclockwise to cage the power spring (approx. 2.5 inches (6 cm)). Repeat on the opposite side.
3. To manually reset the emergency/parking brake, turn the bolt clockwise.

28.3 BRAKE CHAMBER REMOVAL



**WARNING**

To prevent personal injuries, brakes should be inoperative prior to working on any of their components.

To prevent personal injuries, brake chambers should be made inoperative by releasing spring tension prior to disposal.

1. Block the wheels to prevent the vehicle from moving.
2. Safely support vehicle at the recommended body jacking points.
3. To gain access to a given brake air chamber, the corresponding wheel can be removed (refer to Section 13: "Wheels, Hubs and Tires").
4. Exhaust compressed air from system by opening the drain valve of each reservoir.
5. For the drive and tag axles brake chambers, manually release spring brakes (refer to "Emergency/Parking Brake, Manual Release" procedure in this section).
6. Disconnect air line(s) from brake chamber.
7. Remove the cotter pin connecting brake chamber and slack adjuster (drive axle).
8. Unbolt and remove the brake chamber from vehicle.

28.4 BRAKE CHAMBER INSTALLATION

Reverse removal procedure, then check brake adjustment.



**CAUTION**

Always clean air lines and fittings, and coat pipe threads with teflon pipe sealant before reconnecting air lines.

## Section 12: BRAKE AND AIR SYSTEM

### 28.5 BRAKE CHAMBER DISASSEMBLY



#### DANGER

Spring brake chambers, on drive and tag axles contain an extremely high compressive force spring, which can possibly cause serious injury if special precautions are not taken when working around this area.

To avoid such injury, the following recommendations must be applied:

- Prévost recommends the installation of a new spring brake chamber if it is found to be defective.
- Spring brake chamber maintenance and/or repair must be performed by trained and qualified personnel only.
- Before manually releasing spring brakes, visually check spring brake for cracks and/or corrosion.
- On “MGM” brake chambers (drive axle), make sure the release stud is properly anchored in spring plate receptacle prior to caging the spring.
- Never stand in the axis line of the spring brake chambers, especially when caging the spring.



#### WARNING

To prevent personal injuries, brakes should be inoperative prior to working on any of their components.

1. Block the wheels to prevent the vehicle from moving.
2. Safely support vehicle at the recommended body jacking points.

#### NOTE

*To gain access to a given brake air chamber, the corresponding wheel can be removed (refer to Section 13: "Wheels, Hubs and Tires").*

3. Exhaust compressed air from air system by opening the drain valve of each reservoir.
4. For the drive and tag axles brake chambers, manually release spring brakes (refer to “Emergency/Parking Brake Manual Release” procedure in this section).

5. Remove clamp ring, remove and discard the existing diaphragm. Install the new diaphragm squarely on body.
6. Reverse the procedure for assembly. Tap clamp ring to ensure proper seating. Check for proper operation before placing vehicle in service.

### 29. ANTI-LOCK BRAKING SYSTEM (ABS)

This device has been designed to ensure stability and permit steering control of vehicle during hard braking, and to minimize its stopping distance whatever the road conditions are. On slippery roads and generally in emergency situations, over-braking frequently induces wheel lock. The anti-lock braking system provides maximum braking performance while maintaining adequate steering control on slippery roads.

The ABS continuously monitors wheel behavior during braking. Sensors on each wheel of front and drive axles (tag axle is slave to drive axle) transmit data to a four channel electronic processor which senses when any wheel is about to lock. Modulator valves quickly adjust the brake pressure (up to 5 times per second) to prevent wheel locking. Each wheel is therefore controlled according to the grip available between its tire and the road.

With this device, the vehicle is brought to a halt in the shortest possible time, while remaining stable and under the driver's control.

Since the braking system has dual circuits, the ABS is also provided with a secondary system should a fault develop in the ABS. Anti-lock systems are a parallel system which does not hinder brake functioning in case of failure. Braking system functions in normal, non anti-lock controlled operation during ABS system failure.

The ABS system consists of two diagonally related circuits, only the half of the system which has sustained damage or other fault is switched off (i.e. wheels return to normal non-ABS braking). The other diagonal half remains under full ABS control.

#### NOTE

*ABS is active on service brake, transmission retarder, Jake brake, but is inactive on emergency/parking brake.*

**NOTE**

The ABS system is inoperative at speeds under 4 mph (6 Km/h). Illumination of ABS telltale indicator at these speeds is normal.



**CAUTION**

Disconnect the ECU or pull the ABS fuse before towing vehicle.

29.1 TROUBLESHOOTING AND TESTING

For troubleshooting and testing of the vehicle's anti-lock braking system, refer to Meritor Wabco Maintenance Manual MM-0112: "Anti-Lock Braking System (ABS) for Trucks, Tractors and Buses" at the end of this section, and to Bendix applicable booklet annexed to this section under reference number SD-13-4869. Use dashboard Message Center Display (MCD) Diagnostic Mode for troubleshooting and repair.

29.2 ABS COMPONENTS

The main components of the ABS system are listed hereafter. Refer to each component for its specific function in the system and for proper maintenance.

29.2.1 Electronic Control Unit (ECU)

This control unit is located in the front service compartment, (refer to figure 42 for location). According to the data transmitted by the sensors (number of pulses/sec is proportional to the speed of each wheel), the electronic control unit determines which wheel is accelerating or decelerating. It then establishes a reference speed (average speed) from each wheel data, and compares the speed of each wheel with this reference speed to determine which wheel is accelerating or decelerating.

As soon as wheel deceleration or wheel slip threshold values are exceeded, the electronic control unit signals a solenoid control valve to limit the excessive brake pressure produced by the driver in the appropriate brake chamber.

**Maintenance**

No specific maintenance is required. The ECU is not serviceable. When found to be defective, replace.

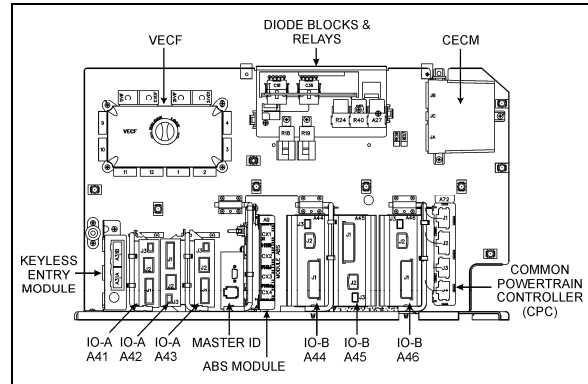

FIGURE 42: ABS ECU LOCATION

12147



**CAUTION**

In order to protect the ABS electronic control unit from voltage surges, always disconnect before performing any welding procedure on vehicle.

29.2.2 Bendix® M-32QR™ Pressure Modulator Valves (PMV)

This ABS system is equipped with four modulator valves, located between the brake chamber and the relay valve (Fig. 43). Note that there is only one solenoid valve controlling the drive and tag axle wheels on the same side (tag axle is slave to drive axle).

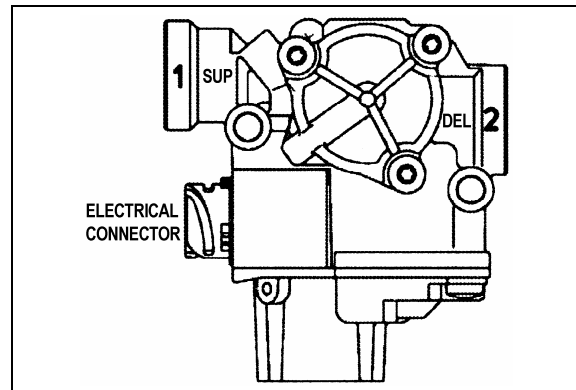

FIGURE 43: ABS MODULATOR VALVE

12221

This is an "On/Off" type valve, i.e., at brake application, the valve exhausts air from the brake chamber when the electronic unit senses that the corresponding wheel speed is decreasing in relation to the other wheels.

**Maintenance**

Maintenance and repair information on this valve is supplied in the applicable booklet annexed to this section under reference number SD-13-4870.

## Section 12: BRAKE AND AIR SYSTEM

### 29.2.3 Sensors

The sensors are mounted on the front and drive axle wheel hubs (Fig. 44). The inductive sensors consist essentially of a permanent magnet with a round pole pin and a coil. The rotation of the toothed wheel alters the magnetic flux picked up by the coil, producing an alternating voltage, the frequency of which is proportional to wheel speed. When wheel speed decreases, magnetic flux decreases proportionately. Consequently, the electronic control unit will command the solenoid control valve to decrease the pressure at the corresponding brake chamber.

#### Maintenance

No specific maintenance is required for sensors, except if the sensors have to be removed for axle servicing. In such a case, sensors should be lubricated with special grease (Prévost #680460) before reinstallation. Refer to paragraph "Sensor Installation" for details.

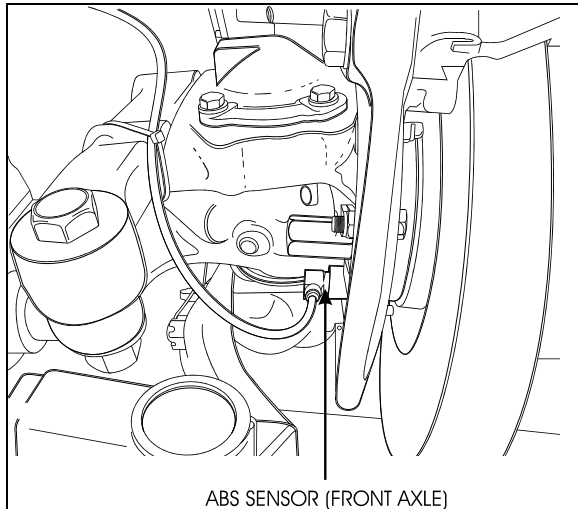

FIGURE 44: ABS SENSOR LOCATION

12153

#### NOTE

*The resistance value, when sensors are checked as a unit, must be equal to 1,75 k ohms. To check the sensors for proper output voltage after the sensors and toothed wheels have been assembled to the axle, connect a suitable AC voltmeter across the output terminals. With the hubs rotating at 30 rpm, the output voltages should read from 50 to 1999 mV to be acceptable.*

### 29.2.4 Sensor Installation

The following procedure deals with sensor installation on the axle wheel hubs. Read

procedure carefully before reinstalling a sensor, as its installation must comply with operational tolerances and specifications.

1. Apply recommended lubricant (Prévost #680460) to spring clip and sensor.



#### CAUTION

Use only this type of grease on the sensors.

2. Insert spring clip in the holder on hub. Make sure the spring clip tabs are on the inboard side of the vehicle. Push in until the clip stops.
3. Push the sensor completely inside the spring clip until it is in contact with the tooth wheel. Ensure mounting is rigid, as it is an important criterion for adequate sensor operation.

#### NOTE

*This installation should be of the "press fit" type.*

### 29.2.5 Spring clip

The spring clip retains the sensor in its mounting bracket close to the toothed pulse wheel. The gap between the sensor end and teeth is set automatically by pushing the sensor in the clip hard up against the tooth wheel, and the latter knocks back the sensor to its adjusted position (Fig. 45).

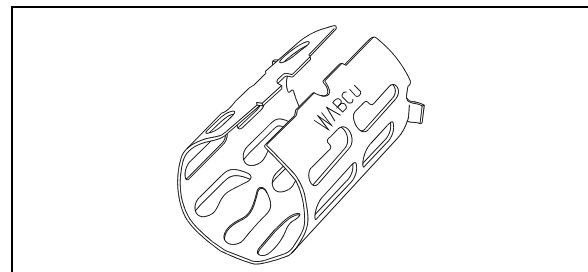

FIGURE 45: SPRING CLIP

12161

#### Maintenance

The spring clip requires no specific maintenance.

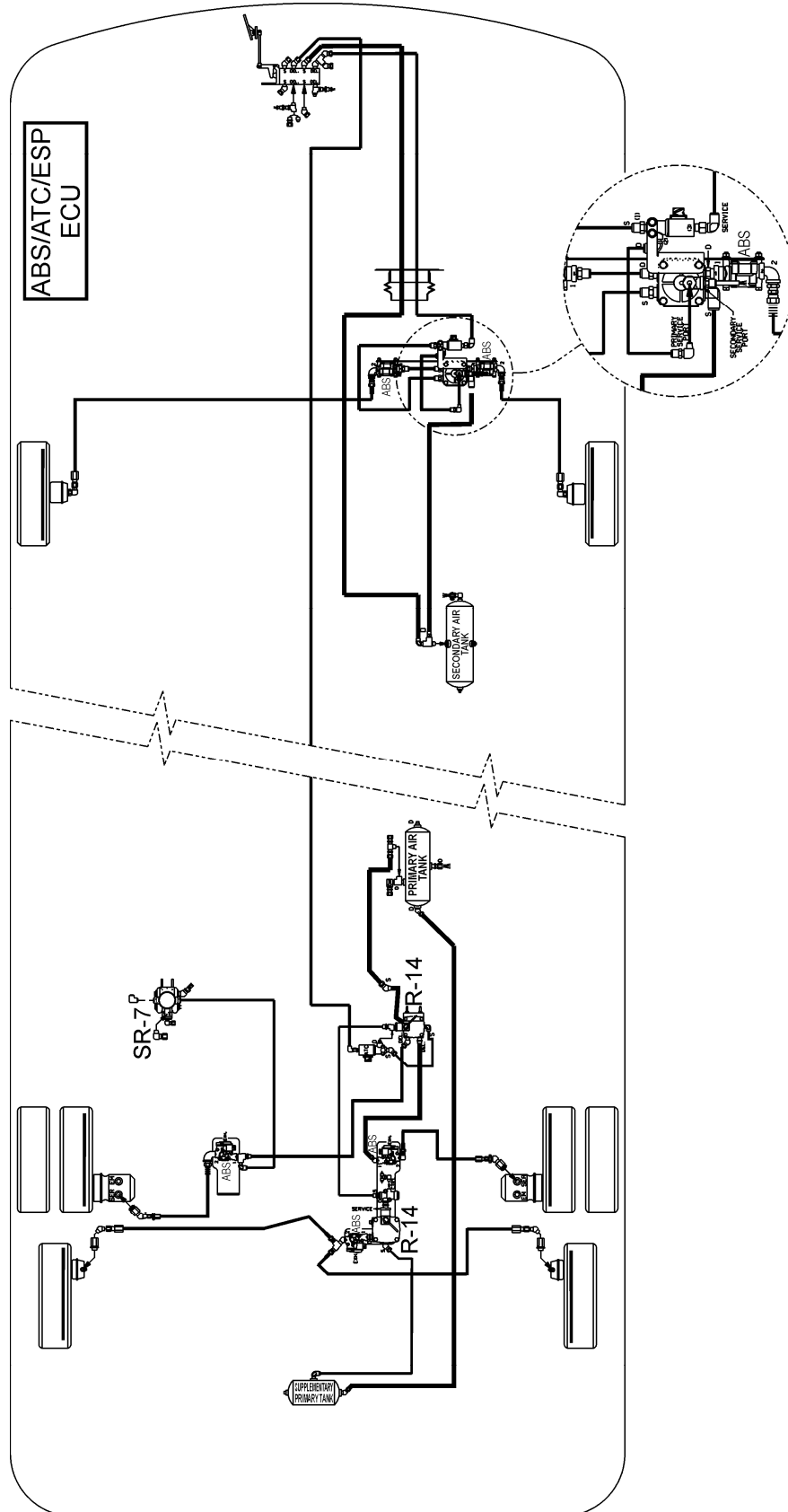

FIGURE 46: ABS 6S/5M CONFIGURATION

## Section 12: BRAKE AND AIR SYSTEM

### 30. AUTOMATIC TRACTION CONTROL (ATC) – ELECTRONIC STABILITY PROGRAM (ESP)

In addition to the ABS function, advanced models of Bendix EC-60 controllers provide an **Automatic Traction Control (ATC)** feature. Bendix ATC can improve vehicle traction during acceleration, and lateral stability while accelerating through curves. ATC utilizes **Engine Torque Limiting (ETL)** where the ECU communicates with the engine's controller and/or **Differential Braking (DB)** where individual wheel brake applications are used to improve vehicle traction.

The EC-60 advanced model controller also provide ABS-based stability features referred to as **ESP® Electronic Stability Program**.

The Bendix ESP system is an ABS-based stability system that enhances vehicle stability by both reducing engine throttle and by applying vehicle braking based on actual vehicle dynamics. Accordingly, the ESP system is available only on specific approved vehicle platforms after vehicle application and development efforts and validation testing. Only certain limited variations of an approved vehicle platform are permitted without further validation of the ESP system application.

ESP stability system consists of Yaw Control (YC) and Roll Stability Program (RSP) features.



#### CAUTION

Even with ESP-equipped vehicles, the driver remains responsible for ensuring vehicle stability during operation.

#### 30.1 COMPONENTS

30.1.1 The EC-60™ controller's ABS function utilizes the following components:

- Six (6) Bendix® WS-24™ wheel speed sensors. Each sensor is installed with a Bendix Sensor Clamping Sleeve;
- Five (5) Bendix® Pressure Modulator Valves (M-32QR™);
- Dash-mounted vehicle ABS Indicator Lamp;
- Service brake relay valve;
- Dash-mounted trailer ABS Indicator Lamp.

30.1.2 The EC-60™ controller's ATC function utilizes the following components:

- Drive axle traction control valve;
- Dash-mounted ATC status/indicator lamp;
- J1939 serial communication to engine control module.

30.1.3 The EC-60™ controller's ESP/RSP function utilizes the following components:

- Front Axle Traction Control Valve integral to the service brake relay valve;
- Dash-mounted ESP status/indicator lamp (also serves as the ATC status/indicator lamp);
- Bendix SAS-60™ Steering Angle Sensor (mounted to the steering column);
- Bendix YAS-60™ Yaw Rate/Lateral Acceleration Sensor (mounted to a cross member forward of the drive axle);
- Brake Demand Sensors (installed in the primary and secondary delivery circuits);
- Load Sensor (installed in the suspension air spring);
- An additional Modulator Valve (Bendix® M-32QR™ Pressure Modulator Valve) that controls pressure apply to the trailer brakes during system intervention.

30.1.4 Bendix® M-32QR™ Pressure Modulator Valves (PMV)

This Bendix® M-32QR™ Pressure Modulator Valves (PMV) is operated by the EC-60™ controller to modify driver applied air pressure to the service brakes during ABS, ATC, RSP or YC activation. The PMV is an electro pneumatic control valve and is the last valve that air passes through on its way to the brake chamber. The modulator hold and release solenoids are activated to “modulate” or “control” the brake pressure during an antilock braking event. The hold solenoid is normally open and the release solenoid is normally closed, such that the PMV nominally allows air to flow through. This design allows for air delivery to brake chambers in the event of electrical trouble.

The Advanced EC-60™ controller also utilizes an additional PMV for control of the trailer service brakes during stability interventions.



### 30.2 6S/5M CONFIGURATION

Prevost vehicles utilize a 6S/5M configuration, with the additional axle (rear tag axle) having two sensors, but only one Pressure Modulator Valve. In this case, the PMV controls both wheels on the additional axle. The additional axle wheels would receive equal brake pressure, based on the wheel that is currently experiencing the most wheel slip.

### 30.3 ADVANCED ABS WITH STABILITY CONTROL

#### Overview

ESP stability system reduces the risk of rollovers, jackknifing and other loss of control. ESP features include Roll Stability Program (RSP) and Yaw Control. During operation, the ECU of the Bendix Advanced ABS system constantly compares performance models to the vehicle's actual movement, using the wheel speed sensors of the ABS system, as well as lateral, yaw, and steering angle sensors. If the vehicle shows a tendency to leave an appropriate travel path, or if critical threshold values are approached, the system will intervene to assist the driver.

#### Roll Stability Program

Bendix RSP, an element of the overall ESP system, addresses rollover conditions. In the case of a potential roll event, the ECU will override the throttle and quickly apply pressure at all wheel ends to slow the vehicle combination. The level of braking application during an RSP event will be proportional to roll risk.

#### Yaw Stability

Yaw stability counteracts the tendency of a vehicle to spin about its vertical axis. During operation, if the friction between the road surface and the tires is not sufficient to oppose lateral (side) forces, one or more of the tires can slide, causing the vehicle to spin. These events are referred to as either an "under-steer" situation (where there is a lack of vehicle response to steering input due to the slide on the front axle) or an "over-steer" (where the vehicle's rear end slides out due to tire slide on the rear axle) situation. Factors that influence yaw stability are: wheelbase, suspension, steering geometry, weight distribution front to rear, and vehicle track width.

#### Yaw Control

Yaw Control corresponds to a wide range of low to high friction surface scenarios including rollover, jackknife and loss of control. It is the recommended system for all power vehicles and especially critical for vehicles pulling trailers. In the case of vehicle slide (over-steer or under-steer situations), the system will reduce the throttle and then brake one or more of the "four corners" of the vehicle (in addition to potentially applying the trailer brakes), thus applying a counter-force to better align the vehicle with an appropriate path of travel.

For example, in an over-steer situation, the system applies the "outside" front brake; while in an under-steer condition, the "inside" rear brake is applied.



#### DANGER

**ESP may reduce the vehicle speed automatically.**

ESP can make the vehicle **decelerate automatically**. ESP can slow the vehicle with or **without the operator applying the brake**, and **even when the throttle is being applied**.

### 30.4 BENDIX® SAS-60™ STEERING ANGLE SENSOR

The Steering Angle Sensor (SAS) is used to provide driver steering input to the controller. It reports the steering wheel position to the controller utilizing a dedicated serial communications link that is shared with the YAS-60™ sensor. The controller supplies the power and ground inputs to the SAS-60™ sensor.

The SAS-60™ sensor installed on Prevost vehicles is the 90° connector.

#### 30.4.1 Removal of the steering angle sensor

##### Service Checks:

1. Check all wiring and connectors. Some installations also include an intermediate connector from the steering angle sensor to the main vehicle wire harness. Make sure all connections are free from visible damage.
2. Examine the sensor. Make sure the sensor, its mounting screws, and the interface between the hub and the steering column are not damaged.

## Section 12: BRAKE AND AIR SYSTEM

### Diagnostics:

The steering angle sensor is only operational in conjunction with an Advanced ECU. No independent diagnostics can be performed on the sensor.

### Removal:

1. Remove steering column upper, middle and lower covers.
2. The steering angle sensor is located near the universal joint.
3. Unplug sensor cable assembly from body of sensor. Squeeze the mounting tabs and pull gently on connector until it disengages.
4. Disconnect steering column upper U-joint.
5. Unscrew all three of the mounting screws that hold the body of the sensor to the steering column body.
6. Slide the sensor over the column to remove. Take note if the sensor label is facing upward or downward.

### Installation:

1. Obtain a new sensor. The sensor is not repairable in the field.
2. Slide the sensor over the column. The center hub of the sensor must be aligned with the corresponding notch in the column. The sensor label should be facing in the same direction as the removed sensor.
3. Reconnect the steering column U-joint.
4. Assemble the column non-moving plate with three self-locking screws.
5. Tighten screws to 48 lbf-ft (65 Nm) to 74 lbf-ft (100 Nm).
6. Reconnect the connector. Ensure that there will be no force applied to the sensor because the connector is pulling on the sensor body.
7. If the wire harness leading to the sensor is being replaced, ensure that it is adequately tie wrapped so that the full motion of the steering column can be achieved without pulling apart the connectors.
8. Reinstall the steering column covers. The sensor is not protected against dirt or water intrusion, so care must be taken not to introduce these elements during installation.

### Steering Angle Sensor Calibration

The steering angle sensor calibration can only be achieved when the sensor is powered by the Advanced ABS ECU. No stand-alone sensor calibration can be carried out. The calibration procedure is performed using Bendix® ACom™ Diagnostic V4.0 or higher. See “Troubleshooting Diagnostic Trouble Codes: Steering Angle Sensor (SAS-60)” for the calibration procedure using this tool.

The sensor **must** be recalibrated after any of these situations:

- Replacement of the steering angle sensor;
- Any opening of the connector hub from the steering angle sensor to the column;
- Any maintenance or repair work on the steering linkage, steering gear or other related mechanism;
- Adjustment of the wheel alignment or wheel track;
- After an accident that may have led to damage of the steering angle sensor or assembly.



### WARNING

If the steering angle sensor is not properly recalibrated as needed, the yaw control system may not function properly, which can result in incidents leading to loss of vehicle control.

### 31. FITTING TIGHTENING TORQUES

**45° Flare and Inverted Flare:** Tighten assembly with a wrench until a solid feeling is encountered. From that point, tighten 1/6 turn (Fig. 47).

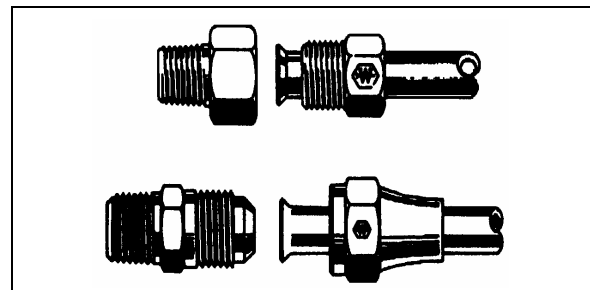

FIGURE 47: HOSE FITTINGS

12053

**Compression:** Tighten nut by hand (Fig. 48). From that point, tighten using a wrench the number of turns indicated in the chart hereafter.

Fitting size	Pipe diameter (inches)	Number of additional turns required following hand tightening
2	1/8	1 ¼
3	3/16	1 ¼
4	1/4	1 ¼
5	5/16	1 ¾
6	3/8	2 ¼
8	1/2	2 ¼
10	5/8	2 ¼
12	3/4	2 ¼
16	1	2 ¼

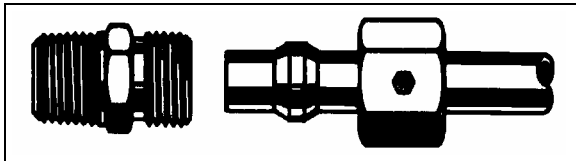

FIGURE 48: HOSE FITTING 12054

**NTA-Type Plastic Tubing:** Hand tighten nut (Fig. 49). From that point, tighten using a wrench the number of turns indicated in the following chart.

Tubing diameter (inches)	Number of additional turns required following hand tightening
1/4	3
3/8 to 1/2	4
5/8 to 3/4	3 ½

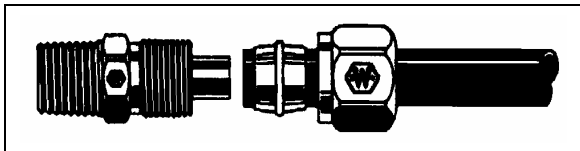

FIGURE 49: HOSE FITTING 12055

**AB-Type Copper Piping:** Hand tighten nut (Fig. 50). From that point, tighten with a wrench the number of turns indicated in the following chart.

Piping diameter (inches)	Number of additional turns required following hand tightening
1/4, 3/8, 1/2	2
5/8, 3/4	3

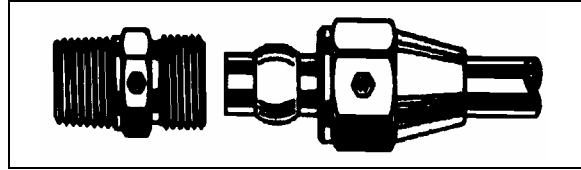

FIGURE 50: HOSE FITTING 12056

**Pipe Tightening:** All connections must be hand tightened. From that point, tighten a minimum of 2 ½ additional turns.

**NOTE**

Use *Loctite* (Prévost number 680098) pipe sealant to seal pipe thread.

**32. SPECIFICATIONS**

**Air Compressor**

Make..... Bendix Westinghouse  
Model..... BA-921  
Capacity (at 1250 rpm) ..... 15.7 cfm (0,445 m<sup>3</sup>/min.)  
Prévost number ..... 641990

**BA-921 Service Kits**

ST-4 Safety Valve  
Prévost number ..... 641989

Series 60 Seal Kit  
Prévost number ..... 641988

Compressor Seal Kit  
Prévost number ..... 641987

Cylinder Head Gasket Kit  
Prévost number ..... 641986

**Air Dryer**

Make..... Haldex  
Model..... AT-87192  
Prévost number ..... 70303498  
Desiccant cartridge Prévost number..... 3097369

**Flip-Flop Control Valve**

Make..... Bendix Westinghouse  
Model..... TW-1  
Type ..... On-Off  
Prévost number ..... 640136

**Emergency/Parking Brake Control Valve**

Make..... Bendix Westinghouse  
Model..... PP-1  
Automatic release pressure ..... 40 psi (275 kPa) nominal  
Prévost number ..... 641128

**Dual Brake Application Valve**

Make..... Bendix Westinghouse  
Model..... E-10P  
Prévost number ..... 641856

**Stoplight Switches**

Make..... Bendix Westinghouse  
Model..... SL-5  
Contact close (ascending pressure) ..... 4 psi and more (28 kPa)  
Prévost number ..... 641462

**Brake Relay Valves**

Make..... Bendix Westinghouse  
Model..... R-12  
Prévost number .....

**Brake Relay Valve**

Make..... Meritor Wabco  
Model..... R-14  
Prévost number .....

**Quick Release Valve**

Make..... Bendix Westinghouse  
 Model..... QR-1  
 Prévost number..... 641429

**Spring Brake Valve**

Make..... Bendix Westinghouse  
 Model..... SR-7  
 Prévost number..... 642015

**Pressure Protection Valve**

Make..... Bendix Westinghouse  
 Model..... PR-4  
 Nominal closing pressure..... 70 psi (482 kPa)  
 Prévost number..... 641137

**Shuttle-Type Double Check Valve**

Make..... Bendix Westinghouse  
 Model..... DC-4  
 Prévost number..... 641015

**Low Pressure Indicators**

Make..... Bendix Westinghouse  
 Model..... LP-3  
 Contact close..... 66 psi (455 kPa)  
 Prévost number..... 640975

**Air Pressure Regulator**

Make..... Norgren  
 Adjustable output range..... 0-80/85 psi (0-552/586 kPa)  
 Recommended pressure setting..... 75 psi (517 kPa)  
 Prévost number..... 641472

**Air Filter Element**

Make..... Norgren  
 Type..... With manual drain  
 Prévost number..... 641338

**Front Wheel Brake Chambers**

Make..... Knorr-Bremse  
 Type..... 24  
 Prévost number (R.H.)..... 641414  
 Prévost number (L.H.)..... 641413

**Drive Axle Brake Chambers**

Make..... Knorr-Bremse  
 Type..... 24 as service -24 as emergency  
 Prévost number..... 641432

**Piggy Back (On Drive Brakes)**

Make..... Knorr-Bremse  
 Type..... 24 as emergency  
 Prévost number..... 641433

## Section 12: BRAKE AND AIR SYSTEM

---

### Tag Axle Brake Chambers

Make..... Knorr-Bremse  
Type ..... 16 as service – 16 as emergency  
Prévost number ..... 641308

### Piggy Back (On Tag Brakes)

Make..... Knorr-Bremse  
Type ..... 16 as emergency  
Prévost number ..... 641431

### Brake Lining (All Axles)

Make..... Knorr-Bremse  
Prévost number ..... 611049  
Prévost number ..... 641226

## ABS (ANTILOCK BRAKING SYSTEM)

### ABS MODULATOR VALVE

Make..... Rockwell Wabco  
Voltage ..... 24 V  
Prévost number ..... 641097

### Sensor, Front Wheel

Prévost number ..... 641288

### Sensor, Drive Axle (In Wheel End)

Prévost number ..... 641095

# SECTION 13: WHEELS, HUBS & TIRES

## CONTENTS

<b>1. WHEELS</b> .....	<b>2</b>
<b>2. WHEEL MAINTENANCE</b> .....	<b>2</b>
2.1 INSPECTION .....	2
2.2 SINGLE WHEEL REMOVAL.....	3
2.3 SINGLE WHEEL INSTALLATION .....	3
<b>3. DUAL WHEELS</b> .....	<b>3</b>
3.1 OUTER WHEEL REMOVAL .....	3
3.2 INNER WHEEL .....	3
3.3 INNER WHEEL INSTALLATION .....	3
3.4 OUTER WHEEL INSTALLATION.....	3
3.5 INSPECTION .....	3
<b>4. ALUMINUM WHEEL ANTI-CORROSION PROTECTION</b> .....	<b>4</b>
<b>5. WHEEL STRAIGHTNESS TEST</b> .....	<b>4</b>
<b>6. WHEEL STUDS</b> .....	<b>5</b>
6.1 DRIVE AXLE STUDS.....	5
6.2 FRONT AND TAG AXLE STUDS.....	5
<b>7. HUB MOUNTED WHEELS</b> .....	<b>6</b>
7.1 CARE OF WHEELS .....	6
<b>8. FRONT AND TAG AXLE WHEEL HUBS</b> .....	<b>6</b>
8.1 HUB BEARING INSPECTION .....	6
<b>9. DRIVE AXLE WHEEL HUBS</b> .....	<b>7</b>
9.1 BEARING ADJUSTMENT .....	7
9.2 DISASSEMBLY AND REPAIR .....	7
<b>10. CHANGING A FLAT TIRE</b> .....	<b>8</b>
<b>11. TIRE MAINTENANCE</b> .....	<b>8</b>
11.1 INFLATION PRESSURE .....	8
11.2 TIRE MATCHING .....	9
11.3 WHEEL BALANCING .....	10
11.4 TIRE ROTATION.....	10
<b>12. SPECIFICATIONS</b> .....	<b>11</b>

## ILLUSTRATIONS

FIGURE 1: WHEEL ARRANGEMENT .....	2
FIGURE 2: TIGHTENING SEQUENCE .....	2
FIGURE 3: DIAL GAUGE INSTALLATION .....	5
FIGURE 4: STUD-MOUNTED WHEELS.....	5
FIGURE 5: HUB-MOUNTED WHEELS .....	6
FIGURE 6: TIRE INFLATION .....	9
FIGURE 7: TIRE LIFE / INFLATION PRESSURE .....	9

## Section 13: WHEELS, HUBS & TIRES

### 1. WHEELS

When the vehicle is provided with stud-mounted wheels, wheel studs and nuts on the left side of the vehicle have left-hand threads whereas those on the right side have right-hand threads. If equipped with hub-mounted wheels, all studs and nuts have right-hand threads. Aluminum-polished wheels are installed on the vehicle and are mounted with radial tubeless tires.

Drive axle wheel dimensions are 22.50 X 9.0 inches (571.5 X 228.6 mm) for 315/80 R 22.5 tires while front and tag axle wheels may either be 22.50 X 9.0 inches (571.5 X 228.6 mm) or 22.50 X 10.5 inches (571.5 X 266.7 mm) for 365/70 R 22.5 tires. Dura-Bright coating on aluminum wheels is optional.

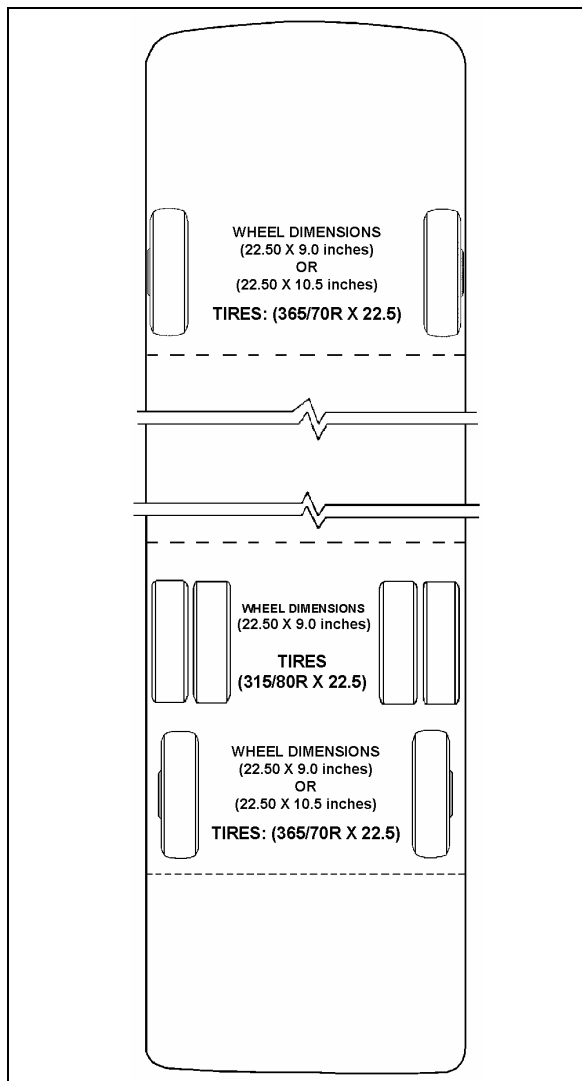

FIGURE 1: WHEEL ARRANGEMENT

13037

### 2. WHEEL MAINTENANCE

Wheel maintenance consists of periodic inspections. Check all parts for damage and make sure that wheel nuts are tightened to the proper torque. In the case of a new vehicle, or after a wheel installation, stud nuts should be tightened every 100 miles (160-km) for the first 500 miles (800-km) to allow setting in of clamping surfaces.

Wheel studs and nuts must be kept free from grease and oil. No lubricant whatsoever should be used. Cleanliness of the wheel and its rotor mating surfaces is important for proper wheel mounting.

However, for hub mounted wheels, it is recommended to add some rust protection lubricant on the pilot diameter of the hub (to facilitate future removal).

It is also important that wheel stud nuts be tightened alternately on opposite sides of the wheel. Refer to Figure 2 for the suggested tightening sequence.

#### 2.1 INSPECTION

Tighten stud nuts progressively as shown in Figure 2. The final tightening should be done with a torque wrench. Tighten stud nuts to 450 - 500 lbf-ft (610 - 680 Nm) for aluminum wheels.

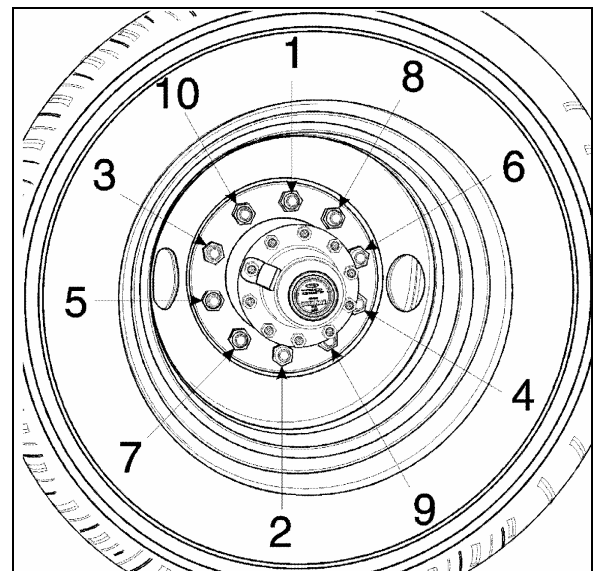

FIGURE 2: TIGHTENING SEQUENCE

13018



## 2.2 SINGLE WHEEL REMOVAL

1. Stop engine and apply parking brake.
2. Loosen wheel nuts about one turn (do not remove the nuts). This is not necessary if equipped with hydraulic powered gun.

### NOTE

*For stud-mounted wheels, turn nuts counterclockwise for R.H. side and clockwise for the L.H. side of vehicle. For hub-mounted wheels, turn nuts counterclockwise on both sides of the vehicle.*

3. Raise the vehicle by its jacking points on the body. See Section 18, "Body", under heading "Vehicle Jacking Points";
4. Unscrew wheel hex stud nuts and remove the wheel;



### CAUTION

Always mark position of the wheel on the axle prior to removal in order to replace wheel at the same location, thus avoiding a new wheel balancing.

## 2.3 SINGLE WHEEL INSTALLATION

1. Mount the wheel over studs, being careful not to damage stud threads;
2. Screw in the hex stud nuts (refer to Figure 2 for sequence) so that wheel will position itself concentrically with hub. This is important, otherwise wheel may be eccentric with hub and will not run straight. In this initial step, slightly tighten the nuts to correctly position the wheel;
3. Tighten stud nuts progressively as shown in Figure 2. The final tightening should be done with a torque wrench. Tighten stud nuts to 450 - 500 lbf-ft (610 - 680 Nm) for aluminum wheel.



### CAUTION

Insufficient mounting-torque can result in damage to parts. Excessive mounting torque can cause studs to break and the wheel to crack in stud hole area.

## 3. DUAL WHEELS

### 3.1 OUTER WHEEL REMOVAL

Same as described in "Single Wheel Removal" procedure described previously.

### 3.2 INNER WHEEL

1. Remove outer wheel;
2. Unscrew inner cap nuts
3. Remove inner wheel.

### 3.3 INNER WHEEL INSTALLATION

1. Mount the wheel over studs, being careful not to damage stud threads;
2. Screw in the inner cap nuts (Fig. 3), so that wheel will position itself concentrically with hub. Refer to Figure 2 for sequence;
3. Tighten inner cap nuts progressively according to sequence shown in Figure 2. Final tightening should be done with a torque wrench. Tighten inner cap nuts to 450 - 500 lbf-ft (610 - 680 Nm) for aluminum wheel.



### CAUTION

Insufficient mounting-torque can result in damage to parts. Excessive mounting torque can cause studs to break and the wheel to crack in stud hole area.

### 3.4 OUTER WHEEL INSTALLATION

With inner wheel installed, tighten the hex stud nuts (Fig. 4) using the single wheel installation procedure described previously.

### NOTE

*On dual wheel assemblies, position the wheels with the tire valves 180° apart in order to have access to both the inner and outer valves.*

### 3.5 INSPECTION

1. Loosen a hex stud nut three turns (Fig. 4);
2. Tighten the inner cap nut to 450 - 500 lbf-ft (610 - 680 Nm);
3. Tighten the hex stud nut to 450 - 500 lbf-ft (610 - 680 Nm).

## Section 13: WHEELS, HUBS & TIRES

Repeat for each of the 10 "hex stud nut - inner cap nut assemblies" according to the tightening sequence in Figure 2.



### CAUTION

Do not attempt to tighten an inner cap nut without having previously loosened the hex stud nut.



### CAUTION

The actual length of thread engagement present in an assembled wheel can not always be determined by visual inspection or measurement of a tightened assembly. The relationship of the wheel cap nut seat to the end of the stud may vary. If there is any doubt that enough thread engagement is present, the number of engaged threads may be counted. Tighten all nuts in the regular manner, then loosen one to hand-tightness. The number of turns to disengage a 1-1/8-inch nut should be at least five full turns. At least seven full turns should be required to disengage a 3/4-inch nut or a M22 nut. Ideally, when torqued to the proper load, the stud should be flush with the face of the nut. The face of the nut may be recessed in nuts that are taller for improved wrenching. With most of the nuts in present use, a few unengaged threads at the outer end will cause no problem provided at least 5-7 full turns are required to disengage the nut depending on thread size.

#### 4. ALUMINUM WHEEL ANTI-CORROSION PROTECTION

Clean wheels often by means of a high pressure water jet. Cleaning may be accelerated with mild soap. Do not use concentrated alkaline cleaning products.

When tire is removed, clean and inspect wheel thoroughly. Remove dirt and corrosion on rim by means of a wire brush. Do not use a wire brush on the outer surface of the wheel.

The following measures should be taken to maintain original appearance of the aluminum wheels:

1. Remove any tar from wheel surface with a good quality tar remover.

2. Spray Alcoa Cleaner (Prévost #683529) evenly on cool outer surface of wheel. Let work 15-20 minutes (keep wet by spraying more Cleaner if necessary).
3. Rinse thoroughly with clean water and let air dry. Heavy oxidation may require a repeat application of cleaner.
4. Apply Alcoa Polish (Prévost #683528) sparingly to a small area using a clean, soft cloth. Work polish into surface as you would a rubbing compound.
5. Buff, turning cloth frequently, until surface is clean and shiny. Let air dry. Use power buffer to improve ease of use and gloss uniformity.
6. On completely dry, clean and polished surface, generously apply Alcoa sealant (Prévost #683527). Rinse thoroughly with water while surface is still wet in appearance (have water source ready as the dry time is very short, usually less than 2 minutes).
7. For best results, finish by wiping the surface with a clean rag to remove excess water, then allow surface to dry.

Clean aluminum wheels as required to maintain original look.



### WARNING

Wheel surfaces may have sharp or cutting edges that may cause injury to the hands. To prevent contact with sharp edges, it is strongly recommended to wear rubber gloves when washing or polishing wheels.

#### 5. WHEEL STRAIGHTNESS TEST

1. Slightly raise axle to be checked and place a safety support underneath;
2. Check wheel lateral runout. Install a dial gauge as shown in Figure 3, then rotate the wheel by hand one full turn. As the wheel turns, note any variation on the dial gauge;



### CAUTION

Damage to the dial gauge could occur if it strikes a wheel balancing weight.

3. If the variation in lateral runout exceeds 0.0625 inch (1,6 mm), the wheel must be replaced.

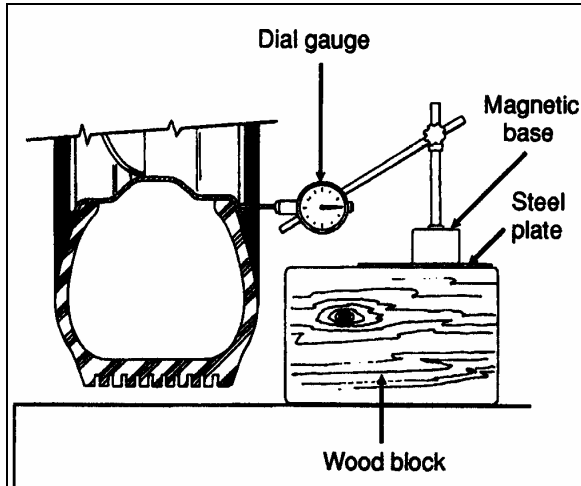

FIGURE 3: DIAL GAUGE INSTALLATION 13008

If doubt exists whether wheel or hub is distorted, hub may be checked as follows:

- Replace the existing wheel with a wheel known to be correct;
- Check wheel lateral runout as outlined in step 2;
- If, within specifications, the hub is correct but the suspected wheel must be replaced.



**WARNING**

NEVER STRAIGHTEN ALUMINUM WHEELS. Never heat aluminum wheels to repair damages incurred after hitting a curb or resulting from other causes. The special alloy in wheels has been heat treated, and any uncontrolled heating could alter wheel structure. Furthermore, never weld aluminum-forged wheels for any reason whatsoever.

**6. WHEEL STUDS**

Stripped threads may be the result of excessive torquing or may have been damaged during wheel installation when placing the wheel over the studs. A stud having damaged threads must be replaced. Broken studs are a direct result of operating with loose stud nuts or improperly seated wheels. When a broken stud is replaced, the adjacent studs, on each side of the broken one must also be replaced since they could have been subjected to excessive strain and may be fatigued.

When installing wheel studs to hubs, check nuts retaining the wheel stud to wheel hub and replace if they are deformed, damaged or severely corroded. Install nut (and washer where applicable) to new stud. Torque to 450 - 500 Ft-lbs (610 - 680 Nm).

**NOTE**

For stud-mounted wheels, turn nuts counterclockwise for R.H. side and clockwise for the L.H. side of vehicle. For hub-mounted wheels, turn nuts counterclockwise on both sides of the vehicle.

**6.1 DRIVE AXLE STUDS**

Stud-mounted wheels are mounted on the drive axle with 3/4"-16 studs with an inner cap nut, and a 1-1/8"-16 nut. Hub-mounted wheels are mounted with M22 x 1.5 studs and an M22 flange nut.

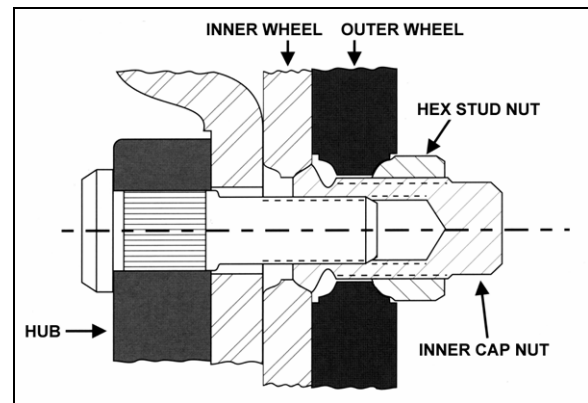

FIGURE 4: STUD-MOUNTED WHEELS 13007

**6.2 FRONT AND TAG AXLE STUDS**

Wheel can be mounted on tag axle with studs (1-1/8"-16 thread) or hub mounted (M22 x 1.5 thread).

**NOTE**

Wheel studs and nuts must be kept free from grease and oil. No lubricant whatsoever should be used.



**WARNING**

The two wheel mounting systems are not interchangeable. They have their specific wheel, nut and stud types. Use only the specific hardware suitable for a mounting type. Always install a wheel to the corresponding mounting type hub.

## 7. HUB MOUNTED WHEELS

Wheel surfaces in contact with hubs, nuts or other wheels should be kept free of all rust, grease and paint (except for initial “E” coat protection, applied to stop rusting and to facilitate wheel removal). The reason for this is to assure that all faces are clamped together without buildup of any coating. The threads of the wheel studs and the wheel nuts should be clean and undamaged.

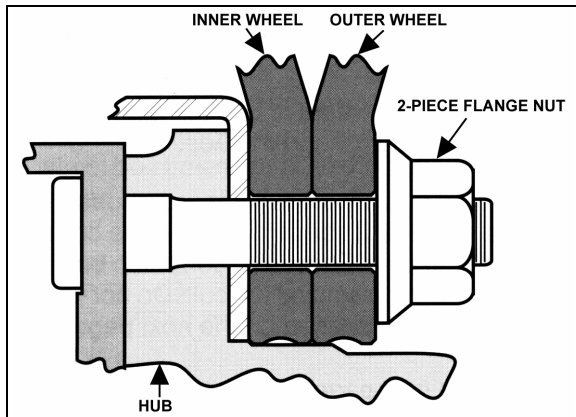

FIGURE 5: HUB-MOUNTED WHEELS

13025

**NOTE**

*When painting wheels, make sure to mask all surfaces identified above.*

Using a calibrated torque wrench, tighten wheel nuts to 450 - 500 lbf-ft (610 - 680 Nm) of torque. Do not use power tools or long bars for tightening. Tighten wheel nuts alternately as shown in figure 2.

**NOTE**

*Tightening should not be done immediately after prolonged braking or when wheel ends are hot.*

Check wheel nut torque at every 100 miles (160 km) for 500 miles (800 km) after fitting wheels. Let cool before checking. If any relaxation of the initial 450 - 500 lbf-ft (610 - 680 Nm) of torque has occurred, retighten. Relaxation of initial torque may occur because of the “bedding down” of the hub and wheel surfaces.

**NOTE**

*Torque relaxation occurs when wheel ends are hot but should revert to original setting when cool. Retightening when hot will produce a higher torque reading than recommended.*

## 7.1 CARE OF WHEELS

Check for cracks in wheels, especially around the fixing holes, studs, nuts and washers. If in doubt, renew.

Do not simply retighten very loose wheel fixings or wheels that are continually becoming loose. Find out why they are loose and whether any damage has been caused.

Use trained personnel and keep records of all attention to wheels and fixings, including which parts were renewed and when.

## 8. FRONT AND TAG AXLE WHEEL HUBS

The unitized hub bearings used on the NDS range of axles, are non-serviceable items. Bearings are pre-adjusted, lubricated and have seals fitted as part of the manufacturing process. The bearings are greased for life and there is no need or facility for re-lubrication

### 8.1 HUB BEARING INSPECTION

An inspection should be made at intervals of 30,000 miles (48 000 km).

- Apply parking brake, raise wheels off the ground and support axle on stands. When the wheels are raised, they should revolve quite freely without roughness.
- Place magnetic base of a dial indicator on brake caliper and position dial indicator stem against a convenient marked spot on face of hub flange.
- With dial indicator in position pull hard but steadily on hub flange and oscillate at same time until a steady reading is achieved.
- Without releasing the pressure, turn bearing so that dial indicator stem contacts marked spot and note reading on indicator.
- Push bearing flange hard and oscillate as before until a steady reading is achieved.
- Without releasing the pressure, turn bearing so that indicator stem again contacts the marked spot and note new reading on indicator.
- The difference between readings is the amount of mounted end play in bearing unit.
- The mounted end play figure should not exceed 0.050 mm for a new bearing.

**NOTE**

If original bearing unit is re-fitted, and end-float is measured at 1 mm, with hub not fully tightened to correct torque, then the retaining clip within the unit is damaged and a new unit must be fitted.

**NOTE**

For more information on front and tag axle wheel hub, refer to "DANA SPICER Maintenance Manual Model NDS and Maintenance Manual NDS Axles" annexed at the end of Section 11 and to Section 16 "Suspension".

**9. DRIVE AXLE WHEEL HUBS**

Drive wheels use a single oil-seal assembly. They are lubricated from the oil supply in the differential housing. Bearings are tapered rollers, adjustable to compensate wear. Maintain differential oil level with general-purpose gear lubricant (refer to Section 24 "Lubrication" for proper oil grade selection) to ensure adequate oil supply to wheel bearings at all times.

**9.1 BEARING ADJUSTMENT**

To adjust drive wheel bearings:

1. Raise vehicle until both dual wheels can be turned freely (approximately 6 inches from the ground). Position jack stands under drive axle, then lower vehicle approximately 2 inches in order to avoid entire weight of the axle being supported by the suspension air bellows and the shock absorber pins.
2. Remove axle shaft as indicated in "Meritor - Maintenance Manual No. 5" under heading "Single Reduction Differential Carriers" annexed to "Section 11" of this manual. Remove gaskets. Unscrew lock nut and remove adjusting nut lock ring.
3. To adjust, tighten adjusting nut until the wheel binds. Rotate the wheel while tightening so that all surfaces are in proper contact. Back off adjusting nut approximately, 1/4 to 1/3 turn to assure 0.001/0.007" (0.0254/0.1778 mm) endplay and to ensure that wheel turns freely. Replace the lock ring, and adjust nut dowel pin in one of the holes. The ring may be turned over if necessary to allow more accurate bearing adjustment.

4. Tighten lock nut and check bearing adjustment. Replace the axle shaft using a new gasket.

**9.2 DISASSEMBLY AND REPAIR**

1. Jack vehicle as per "Bearing Adjustment" and remove axle shaft as indicated in "Meritor - Maintenance Manual No. 5" entitled "Single Reduction Differential Carriers" annexed to Section 11 of this manual.
2. Remove wheels and tires.



**CAUTION**

To replace wheel at the same location, always mark position of the wheel on the axle before removal, thus avoiding a new wheel balancing.

3. Remove lock nut, lock ring and adjusting nut from axle housing to prevent the outer bearing from falling out. Remove outer bearing cone and roller assembly.
4. Remove screws attaching inner oil seal retainer to hub, and remove inner oil seal assembly. Remove inner bearing cone and roller assembly. Bearing cups can be separated from the hub using a hammer and a long brass drift.
5. Thoroughly clean all parts. Bearing cone and roller assemblies can be cleaned in a suitable cleaning solvent using a stiff brush to remove old lubricant.
6. In case that excessive wear, deterioration, cracking or pitting is present on the bearing cups, rollers or cones, the bearings should be replaced. Seals should be replaced each time they are removed from the hub. To install new oil seal, use a suitable adapter and drive the seal into the retainer bore until it bottoms.
7. When installing wheel on spindle, center the wheel hub with spindle to avoid damaging the seal with the end of the spindle. Push wheel straight over the spindle until inside diameter of seal press fits on wiper ring. Fill hub cavity with general-purpose gear lubricant (refer to Section 24 "Lubrication" for proper oil grade selection). Lubricate, then install outer bearing cone. Adjust bearing and lock.

## Section 13: WHEELS, HUBS & TIRES

8. Assemble axle flange to axle using a new gasket. Apply sealant in stud area. After both wheels have been assembled according to above procedure, fill the differential with the recommended lubricant to the proper factory recommended level.

### **NOTE**

*During regular inspection, do not forget to check lubricant level in differential. Clean thoroughly or replace vent as required.*

## 10. CHANGING A FLAT TIRE

In case of a flat tire, turn **ON** the hazard flashers and bring the vehicle to a stop on the side of the road. Apply the parking brake. Make sure the vehicle is parked safely away from traffic. Set up the triangular reflectors in accordance with applicable highway regulations.

We suggest that you **do not** attempt to change a wheel. First, the wheel and tire are very heavy and usually there is no space available to put the removed flat. Second, the wheel nuts, especially those on inner dual, can become very tight after being on for only a short time. Often a heavy air wrench is required to get these nuts loose. We suggest you get help via CB radio or cellular phone. There are tire service trucks all over the country that can bring a wheel and make the change safely.

### **NOTE**

*Bus shell vehicles contain no spare wheel. Access to compartment is obtained by pulling the release handle located in the front service compartment.*



### **WARNING**

The reclining bumper compartment has not been designed for storage. Never leave loose objects in this area since they may interfere with steering linkage mechanism. Make sure bumper is safely locked in place after closing the compartment.

## 11. TIRE MAINTENANCE

The most critical factor in tire maintenance is proper inflation (Fig. 6). No tire is impervious to loss of air pressure. To avoid the hazards of under inflation, always maintain tires at their recommended inflation pressure. Improper inflation decreases tire life.

An under inflated tire builds up heat that can cause sudden tire destruction, resulting in improper vehicle handling and possible loss of vehicle control. At least once a week, before driving (when tires are cold), check inflation pressure on all the tires, including the spare tire. This is especially important in cases when different drivers operate the vehicle.



### **WARNING**

Failure to maintain correct tire inflation pressure may result in sudden tire destruction, improper vehicle handling, and will cause rapid and irregular tire wear. Inflation pressure should be checked weekly and always before long distance trips.

### 11.1 INFLATION PRESSURE

The condition and pressure of the tires can greatly affect both useful tire life and road safety. At regular intervals, verify the tire pressures. Use an accurate tire pressure gauge when checking inflation pressures. Never exceed the maximum inflation pressure specified on each tire.

### **NOTE**

*Inflation pressure should be checked when tires are cold. Cold tire inflation pressure can be measured when a vehicle has not been driven for at least 3 hours or less than 1 mile (1.6 km). Driving, even for a short distance, causes tires to heat up and air pressure to increase. Check inflation pressure on all tires (including the spare tire) using an accurate tire gauge.*

### **NOTE**

*The recommended tire inflation pressures are given in the applicable documents supplied with the vehicle. In addition, cold tire inflation pressures are listed on the Department of Transport's certification plate, affixed on the panel behind the driver's seat. For special tire selection, a "PRÉVOST COACH SPECIAL SPECIFICATION" chart is supplied with the vehicle and is affixed on the left wall near the driver's seat. Remember, tire inflation pressure must be adjusted according to vehicle loading - see table in "Coach Final Record"*

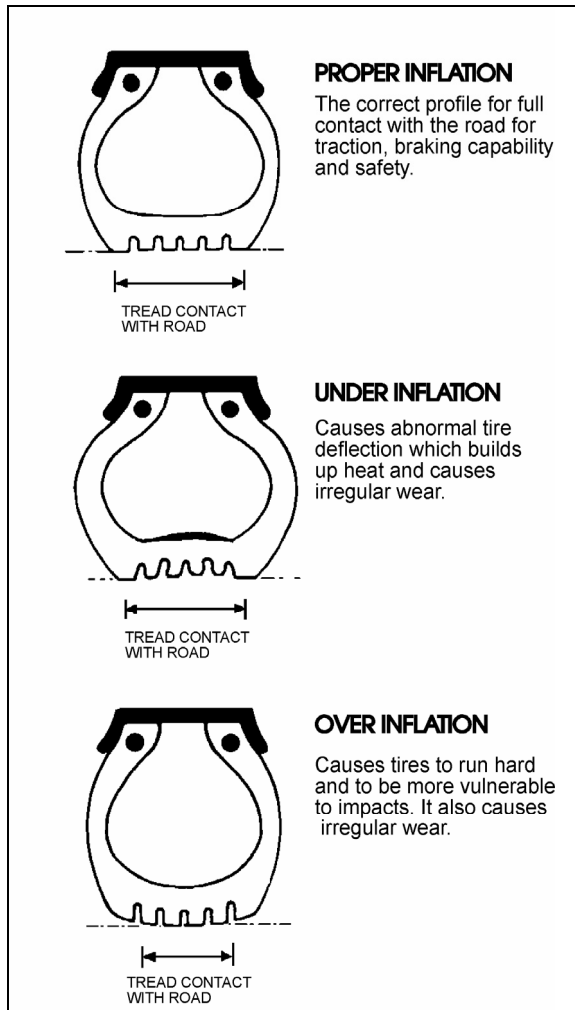

FIGURE 6: TIRE INFLATION 13009

**CAUTION**

Never bleed air from hot tires as tires will then be under inflated. Use an accurate tire gauge to check pressures (Do not kick tires as an inflation check. This is an unreliable method).

**CAUTION**

These tire pressures are established in accordance with the maximum allowable load on each axle. A lower pressure is recommended if the axle load is less than the above specifications. Weigh vehicle fully loaded and pressurize according to tire manufacturer's recommendations. For other tire and wheel specifications, see Prévost tire pressure tabulation in "Coach Final Record".

**WARNING**

Incorrect tire pressures cause increased tire wear and adversely affect road holding of the vehicle, which may lead to loss of vehicle control.

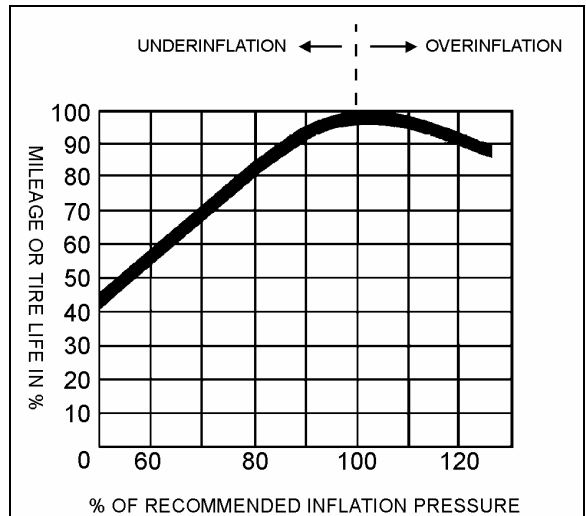

FIGURE 7: TIRE LIFE / INFLATION PRESSURE 13010

**WARNING**

Recommended tire inflation pressures and maximum allowable loads apply to speeds up to 65 mph (105 km/hr). Do not drive vehicle at a higher speed than 65 mph (105 km/h) or above the posted speed limit.

**WARNING**

All tires on the same axle should always be inflated to the same pressure. There should not be a difference in pressure between right and left tires on the same axle. A 5-psi (35-kPa) underinflation in one front tire can not only reduce vehicle maneuverability, but will create steering hazards which can lead to an accident.

11.2 TIRE MATCHING

Unmatched tires on drive axle will cause tire wear and scuffing, as well as possible damage to the drive unit. Consequently, we recommend that tires be matched within 1/8" (3 mm) of the same rolling radius.

## Section 13: WHEELS, HUBS & TIRES

---

***NOTE***

*It is recommended that all tires on coach be of the same type.*

### 11.3 WHEEL BALANCING

Before balancing, wheels must be clean and free from all foreign matter. The tires should be in good condition and properly mounted. An unbalanced wheel can be due to a bent wheel or improper mounting. Before removing the wheel from the vehicle, check for swaying movement and if necessary, check the wheel lateral runout as outlined under heading "*Wheel Straightness Check*".



**WARNING**

When balancing wheel and tire assemblies, it is strongly recommended to closely follow instructions covering the operation of wheel balancer.



**CAUTION**

A maximum of 16-oz (450 g) of balancing weight is recommended. If more weight is necessary, check and correct the cause.

### 11.4 TIRE ROTATION

Radial tires should be rotated only when necessary. If the tires are wearing evenly, there is no need to rotate. If irregular wear becomes apparent or if the wear rate on the tires is perceptively different (from axle to axle), then tires should be rotated in such a manner as to alleviate the condition.

***NOTE***

*There is no restriction on criss-cross rotation.*



**12. SPECIFICATIONS**

**DRIVE AXLE WHEELS**

Wheel size..... 9" X 22.5"  
 Wheel nut torque..... 450 - 500 lbf-ft (610 - 680 Nm)  
 Tire size..... 315/80 R 22.5

**STANDARD FRONT AND TAG AXLE WHEELS**

Wheel size..... 9" X 22.5"  
 Wheel nut torque..... 450 - 500 lbf-ft (610 - 680 Nm)  
 Tire size..... 365/70 R 22.5

**SPECIAL WHEELS FOR FRONT & TAG AXLES**

Wheel size..... 10.5" X 22.5"  
 Wheel nut torque..... 450 - 500 lbf-ft (610 - 680 Nm)  
 Tire size..... 365/70 R 22.5

**RECOMMENDED TIRE INFLATION PRESSURE AT MAXIMUM LOAD (cold)**

<i><b>NOTE</b></i>
<i>Vehicle is delivered with the specific inflation pressure certification plate according to the tire selection.</i>

 <b>WARNING</b>
Special tire selection may lower maximum allowable speed limit, even below posted speed limit. For maximum safety, check with tire manufacturer.

 <b>CAUTION</b>
Bus shell vehicles should be weighed fully loaded and tires pressurized according to tire manufacturer's recommendations.

 <b>WARNING</b>
Recommended tire inflation pressures and maximum allowable loads apply to speeds up to 65 mph (105 km/hr). Do not drive vehicle at a higher speed than 65 mph (105 km/h) or above the posted speed limit.

**ALUMINUM WHEEL CLEANING AND MAINTENANCE PRODUCTS**

Aluminum Wheel Cleaner (22 Oz bottle) .....Prévost #683529  
 Aluminum Wheel Polish (16 Oz bottle) .....Prévost #683528  
 Aluminum Wheel Sealer (13 Oz bottle) .....Prévost #683527

# SECTION 14: STEERING

---

## CONTENTS

<b>1. STEERING SYSTEM</b> .....	<b>3</b>
1.1 DESCRIPTION.....	3
<b>2. POWER STEERING GEAR</b> .....	<b>4</b>
2.1 DESCRIPTION.....	4
2.2 POWER STEERING GEAR REMOVAL .....	5
2.3 POWER STEERING GEAR INSTALLATION .....	5
<b>3. BLEEDING POWER STEERING HYDRAULIC SYSTEM</b> .....	<b>5</b>
<b>4. HYDRAULIC PRESSURE TEST</b> .....	<b>5</b>
<b>5. TROUBLESHOOTING</b> .....	<b>5</b>
<b>6. POWER STEERING HYDRAULIC PUMP</b> .....	<b>5</b>
6.1 DESCRIPTION.....	5
6.2 REMOVAL AND INSTALLATION.....	5
6.3 MAINTENANCE .....	6
<b>7. STEERING WHEEL</b> .....	<b>6</b>
7.1 REMOVAL .....	6
7.2 INSTALLATION .....	6
<b>8. STEERING COLUMN</b> .....	<b>6</b>
8.1 REMOVAL .....	6
<b>9. TURNING ANGLE ADJUSTMENT</b> .....	<b>6</b>
<b>10. STEERING LINKAGE ADJUSTMENT</b> .....	<b>7</b>
<b>11. PITMAN ARM</b> .....	<b>7</b>
11.1 REMOVAL .....	7
11.2 INSTALLATION .....	8
11.3 ADJUSTMENT .....	8
<b>12. MAINTENANCE</b> .....	<b>8</b>
12.1 POWER STEERING RESERVOIR AND FILTER .....	9
12.1.1 <i>Oil Level Check Procedure</i> .....	9
12.1.2 <i>Filter Replacement</i> .....	9
12.2 DRAG LINK .....	10
12.3 POWER STEERING HYDRAULIC PUMP.....	10
<b>13. DRIVING TIPS</b> .....	<b>10</b>
<b>14. TORQUE SPECIFICATIONS</b> .....	<b>11</b>
<b>15. SPECIFICATIONS</b> .....	<b>11</b>

**ILLUSTRATIONS**

FIGURE 1: STEERING SYSTEM AXLE SETUP ..... 3  
FIGURE 2: POWER STEERING GEAR ..... 4  
FIGURE 3: FRONT SERVICE COMPARTMENT..... 4  
FIGURE 4: STEERING COLUMN ..... 6  
FIGURE 5: STEERING STOP SCREW ..... 6  
FIGURE 6: DRAG LINK TO BELL CRANK CONNECTION ..... 7  
FIGURE 7: PITMAN ARM ADJUSTMENT ..... 7  
FIGURE 8: FIXING NUT PUNCH MARK ..... 8  
FIGURE 9: DRAG LINK INSTALLATION ..... 8  
FIGURE 10: HYDRAULIC FLUID RESERVOIR LOCATION ..... 9  
FIGURE 11: POWER STEERING FLUID RESERVOIR..... 10  
FIGURE 12: DRAG LINK COMPONENTS ..... 10

## 1. STEERING SYSTEM

### 1.1 DESCRIPTION

The steering system consists of the steering wheel and column assembly, a vane-type hydraulic pump, reservoir, filter, interconnecting system lines and hoses, integral power steering gear and linkage (Fig. 1). The steering linkage consists of tie rods connected to the bell crank and the steering arm at the left side of the bus shell, and to the idler arm and steering arm at the right side of the bus shell. The bell crank and idler arm are connected by a relay rod. A drag link connected to the bell crank and the pitman arm, which is mounted to the steering gear, transfers the turning motion of the steering wheel to the steering arms.

Hydraulic components are added to transmit, increase and regulate steering control forces.

These elements are:

1. A hydraulic power cylinder;
2. A vane type hydraulic pump; and
3. Hydraulic reservoir and hoses.

The hydraulic power cylinder provides an added source of assistance and being connected to the R.H. wheel, makes it such that the total steering forces are produced with minimal stress on mechanical linkages.

The steering gearbox is self powered and provides movement with power assistance to the left wheel.

Steering stability and tire wear are influenced by wheels, hubs, tires, air suspension, brakes, front suspension and front end alignment which are all covered in their respective sections in this manual.

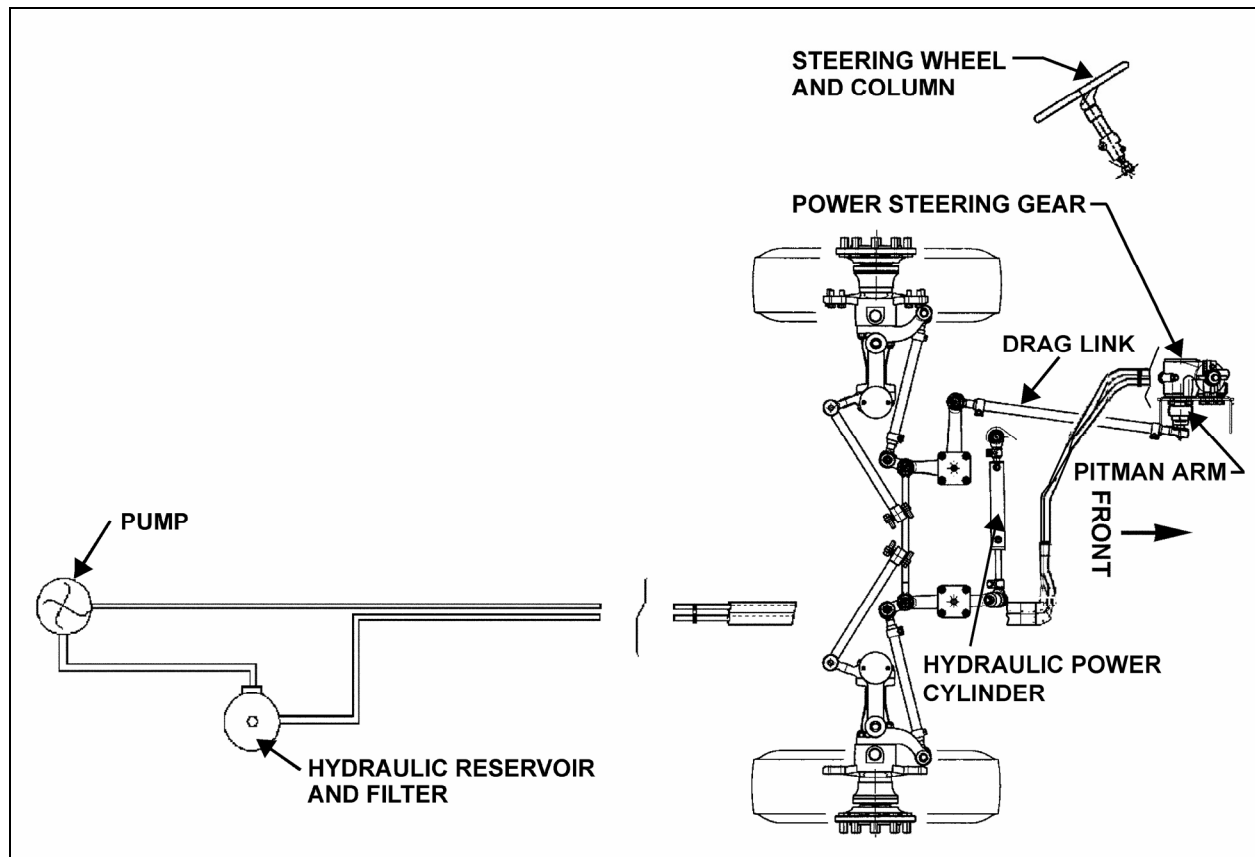

FIGURE 1: STEERING SYSTEM AXLE SETUP

14062

### 2. POWER STEERING GEAR

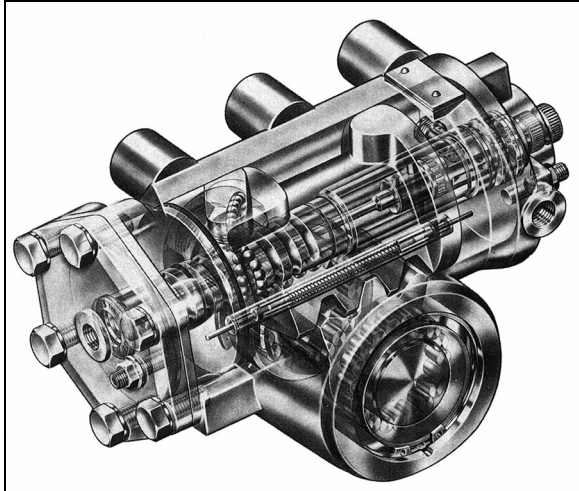

FIGURE 2: POWER STEERING GEAR 14035

#### 2.1 DESCRIPTION

The power steering gear is located in the lower part of front service compartment (Figs. 2 & 3). The housing of the ZF-Servocom contains a control valve, working cylinder and a complete mechanical steering gear. The pressure oil for the steering is delivered by a motor-driven oil pump which is supplied with oil from an oil tank.

The housing is designed as a cylinder for the piston, which converts the rotation of the steering shaft and the worm into an axial movement and transfers this to the steering worm sector shaft. The serration of the sector shaft is straight-cut with a high surface quality in such a way that it is only possible to set a unique setting without play on installation in the straight-ahead driving area by means of the two eccentrically designed lateral housing covers.

The piston and worm are connected via a ball chain. When the worm is turned, the balls are collected by a circulating pipe at one end of the chain and fed in again at the other end, thus producing an endless ball chain.

The control valve consists of the valve slide in a needle bearing in the worm, with six control grooves on the circumference and the control sleeve on the worm, which also has six control grooves. The valve slide, designed with steering shaft connection, turns together with the worm as the steering wheel is turned.

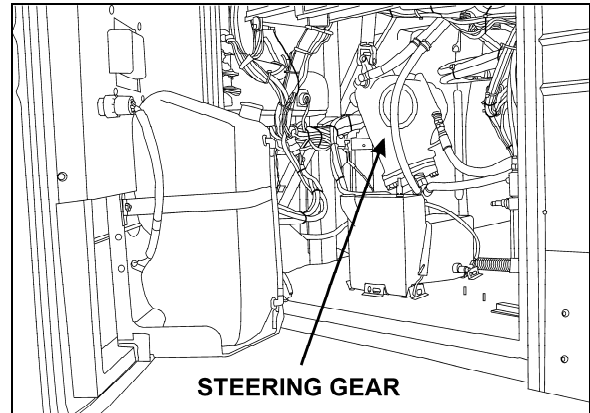

FIGURE 3: FRONT SERVICE COMPARTMENT 14039

A torsion bar, which is pinned with the valve slide and the worm, keeps the control valve in the neutral position as long as no opposing force is applied to the steering wheel. The steering housing contains a pressure relief valve, which limits the discharge pressure of the oil pump to the maximum value required. A replenishing valve can also be used, through which oil is sucked from the return if steering is not hydraulically boosted.

Compared with constant ratio, steering versions with variable ratio are more directly designed in the center area than outside the center area. The resulting smaller steering corrections benefit steering behavior in straight-ahead driving. At the same time, the indirect transmission means that there is a higher hydraulic torque available at the steering arm in parking movement. If the hydraulic assistance fails, the operating forces on the steering wheel are correspondingly lower in this area. This is achieved through a piston/steering worm sector shaft serration with differing modulus and angle of pressure.

Upon transfer of a torque from the steering shaft to the worm, or vice versa, the torsion bar is deformed in the elastic area so that there is torsion between the valve slide and the control sleeve. When the steering wheel is released, the torsion bar ensures that the valve is returned to the neutral position.

Refer to the "ZF-SERVOCOM Repair Manual" and "ZF-SERVOCOM Operating, Servicing /Maintenance and Inspection Instructions" annexed to this section for the functional aspects and maintenance procedure of the steering gear.

#### **NOTE**

*Also available is the ZF-Servocomtronic, which provides variable assistance in function of speed.*

## 2.2 POWER STEERING GEAR REMOVAL

**WARNING**

The steering gearbox weighs approximately 100 lbs (45 kg) dry. Exercise caution when handling.

1. Put a container into place, then disconnect both the inlet and outlet hoses from the power steering gear. Cover fittings to prevent fluid contamination.
2. Mark both the pitman arm and sector shaft with a line, then remove pitman arm. Refer to "11.1 Pitman Arm Removal" procedure.
3. Mark both the steering shaft universal joint yoke and steering gear input shaft with a line, then disconnect universal joint.
4. Unscrew and remove the power steering gear.

## 2.3 POWER STEERING GEAR INSTALLATION

Reverse "Power Steering Gear Removal" procedure paying particular attention to the following:

1. Tighten fasteners as recommended under paragraph 14: "Torque Specifications".
2. Bleed air from the system as per step 3, next.

## 3. BLEEDING POWER STEERING HYDRAULIC SYSTEM

To bleed the power steering hydraulic system, refer to the "ZF-SERVOCOM Repair Manual" annexed to this section, under heading "Setting And Functional Test".

## 4. HYDRAULIC PRESSURE TEST

Perform a pressure test as outlined in the "ZF-SERVOCOM Repair Manual" annexed to this section under heading "Setting And Functional Test".

## 5. TROUBLESHOOTING

Perform troubleshooting of the steering gear as outlined in the "ZF-SERVOCOM Repair Manual", the "ZF-SERVOCOM Operating, Servicing /Maintenance and Inspection Instructions and the "TRW - Power Steering Pump Service Manual".

**NOTE**

For vehicles equipped with ZF-SERVOCOMTRONIC unit, refer to the supplement to the repair manual ZF-SERVOCOM.

## 6. POWER STEERING HYDRAULIC PUMP

## 6.1 DESCRIPTION

The power steering pump is a vane type, gear driven, hydraulic unit which supplies hydraulic pressure for the operation of the steering gear. The pump is mounted on the engine, on the crankshaft pulley's R.H. side.

## 6.2 REMOVAL AND INSTALLATION

The pump is accessible through the engine compartment rear door.

To remove the pump, proceed as follows:

1. Put an empty container directly below pump, then disconnect both the inlet and outlet hoses from the pump. Block fitting cavities to prevent fluid contamination.
2. Remove the two (2) mounting screws, then slowly pry out the pump.
3. Remove and discard gasket.

**CAUTION**

Inspect the drive coupling thoroughly, and replace if necessary (the drive coupling is a fiber component located between the engine and the pump).

For pump installation, reverse the removal procedure paying particular attention to the following:

**CAUTION**

Ensure that drive coupling is correctly positioned before reinstalling the pump.

1. Install a new gasket (Prévost P/N 510488).
2. Bleed air from the system as per step 3, "Bleeding Power Steering Hydraulic System".

## Section 14: STEERING

### 6.3 MAINTENANCE

Refer to the "ZF-SERVOCOM Repair Manual" and the "TRW - Power Steering Pump Service Manual" annexed to this section.

## 7. STEERING WHEEL

### 7.1 REMOVAL

1. Set the battery master switch located in the R.H. side rear service compartment, or the engine compartment to the "OFF" position.
2. Using a tool, such as a small flat head screwdriver, pry off the air horn cap.
3. Loosen the small screw in center of cap and the other retaining the black wire, then disconnect the white terminal. Remove horn cap.
4. Loosen and remove the steering wheel nut.
5. Using a suitable puller, remove the steering wheel.

### 7.2 INSTALLATION

To install, reverse the removal procedure. Torque steering wheel nut to 35-45 lbf-ft (47-60 Nm).

## 8. STEERING COLUMN

### 8.1 REMOVAL

To disassemble the steering column from system, refer to Figure 4. The steering column has no lubrication points. The lower steering column U-joint is easily accessible through the front service compartment. The upper steering column U-joint and the steering slip joint are accessible from the front driver's area. To access these joints, proceed as follows:

1. From the front driver's compartment area, remove the three plastic fasteners on steering column lower cover. Remove the lower cover (Fig. 4).
2. Unscrew the four retaining screws on steering column middle cover.
3. Unscrew the four retaining screws fixing steering column upper cover to middle cover. Remove the steering column middle and upper covers.
4. Position the steering wheel in order to gain access to the joints.

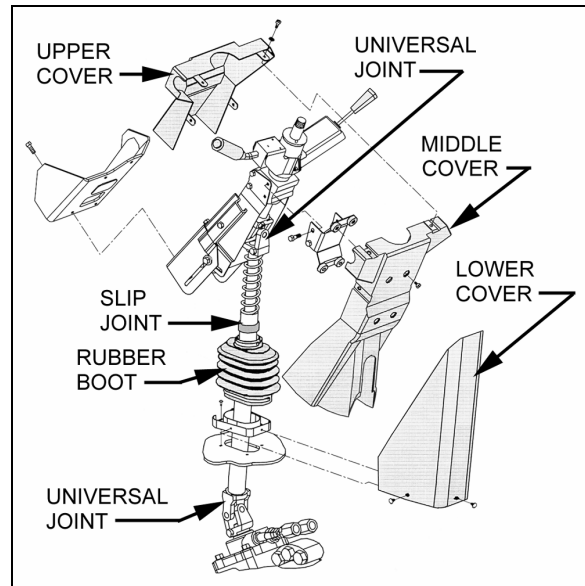

FIGURE 4: STEERING COLUMN

14040

## 9. TURNING ANGLE ADJUSTMENT

The maximum turning angle is set through two (2) steering stop screws installed on the knuckles. Steering stop screws are factory adjusted to accommodate the chassis design, and therefore, do not require adjustment on new vehicles. However, these should be checked and adjusted if necessary, any time a steering system component is repaired, disassembled or adjusted. Refer to section 16 "Suspension" under heading "2.2 "Steering Linkage Adjustment".

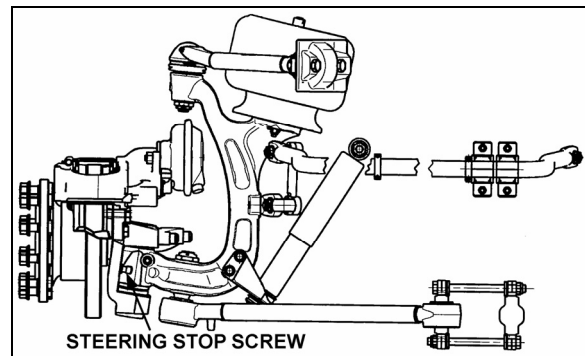

FIGURE 5: STEERING STOP SCREW

14063

### Hydraulic Stop



### CAUTION

Reduce or shut off the power steering hydraulic pressure before the boss on the knuckle touches the stop screw. If not, the components of the front end will be damaged (refer to "ZF-

SERVOCOM Repair Manual" and "ZF-SERVOCOM Operating, Servicing/Maintenance and Inspection Instructions" annexed to this section, under heading "Setting The Steering Limiter").



**CAUTION**

Never maintain the relief pressure for more than 5 seconds, since damage to the power steering pump may occur.

**10. STEERING LINKAGE ADJUSTMENT**

The steering linkage consists of tie rods connected to the bell crank and the steering arm at the left side of the bus shell, and to the idler arm and steering arm at the right side of the bus shell.

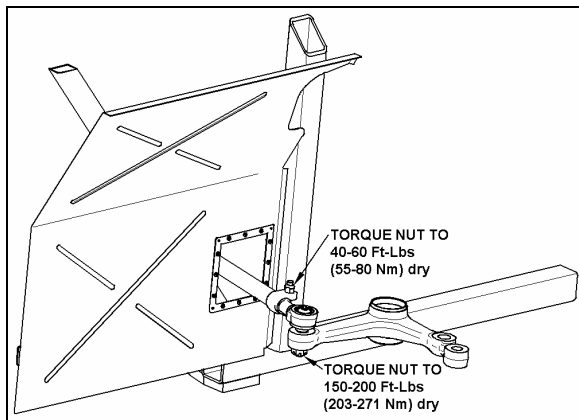

**FIGURE 6: DRAG LINK TO BELL CRANK CONNECTION**

Perform lubrication according to "DANA SPICER NDS Axles Lubrication and Maintenance" annexed to section 11 "Rear Axles".

Drag link ends are provided with grease fittings. Under normal conditions, these should be serviced every 6,250 miles (10 000 km). Refer to section 24 "Lubrication".

Steering linkage pivot points should be checked each time they are lubricated. Looseness can be visually detected while rotating the steering wheel in both directions. Replace defective parts.



**CAUTION**

Front wheel alignment should be checked and adjusted if necessary, any time a component of the steering system is repaired, disassembled or adjusted. Refer to section 16 "Suspension" under heading 7. "Front End Alignment".

**11. PITMAN ARM**

**11.1 REMOVAL**

1. Remove cotter pin, nut and washers from drag link ball stud at pitman arm.
2. Disconnect drag link from pitman arm, using jaw style pullers (pressure screw type).



**WARNING**

Always wear approved eye protection when operating pullers.



**CAUTION**

Do not drive (hammer in) pitman arm on or off pitman shaft as this can damage the steering gear.



**CAUTION**

Heating of components to aid in disassembly is not allowed because it has a detrimental effect on axle components and steering linkages.

3. Using a cold chisel, undo punch mark that locks fixing nut to the pitman arm.
4. Remove pitman arm fixing nut.
5. Check the radial position of the pitman arm in relation to the sector shaft prior to removal of pitman arm.

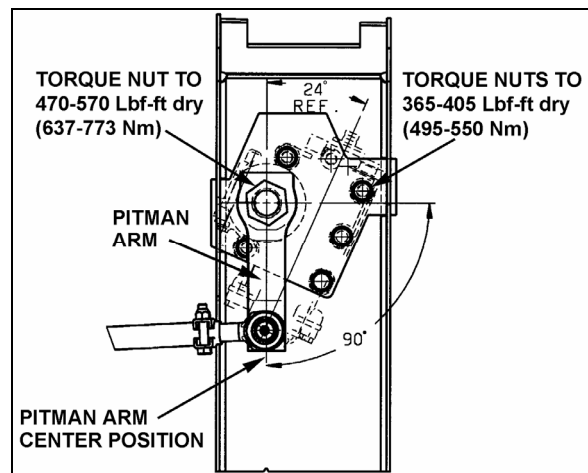

**FIGURE 7: PITMAN ARM ADJUSTMENT**

14057

6. Add reference marks to the arm and shaft if necessary to ensure correct alignment at reassembly.



## Section 14: STEERING

7. You must use a puller to remove pitman arm.

### 11.2 INSTALLATION

1. Position pitman arm on sector gear shaft with reference marks aligned.
2. Install fixing nut (Prévost #661050). Tighten nut to 470-570 lbf-ft (637-773 Nm).

#### NOTE

Use a new nut if the previously removed nut was punched.

3. Lock nut with sector shaft using a punch mark into the groove (Refer to figure 8).

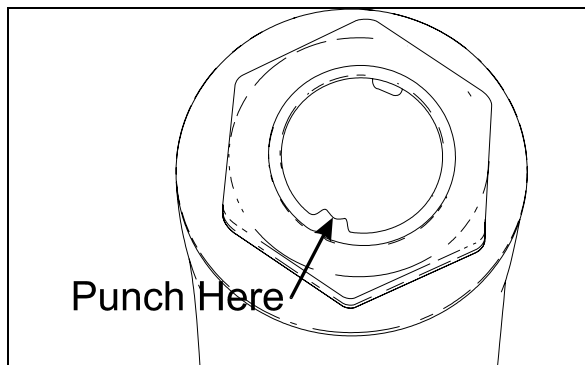

FIGURE 8: FIXING NUT PUNCH MARK

16098

4. Connect drag link to pitman arm while ensuring that rubber stabilizer is in place on the rod end. Install washers. Tighten nut to 150-200 lbf-ft (203-271 Nm). Afterwards, install a new cotter pin.



#### CAUTION

Input shaft marks must be aligned before adjusting pitman arm.

### 11.3 ADJUSTMENT

1. Disconnect the drag link from pitman arm. Center steering wheel by dividing the total number of steering wheel turns in two. Scribe a reference mark on steering gearbox at the center previously determined.
2. Using a protractor, check the angle of the pitman arm (refer to Fig. 7 for details).
3. The pitman arm should be adjusted with reference marks aligned or to an angle of 90° in relation with the vertical axis (towards front of vehicle). If not, unscrew and remove fixing nut. Remove the pitman arm according to the procedure outlined under previous

heading "Pitman arm removal". Adjust to the proper angle.

4. When adjustment is achieved, replace fixing nut and torque to 470-570 lbf-ft (637-773 Nm).

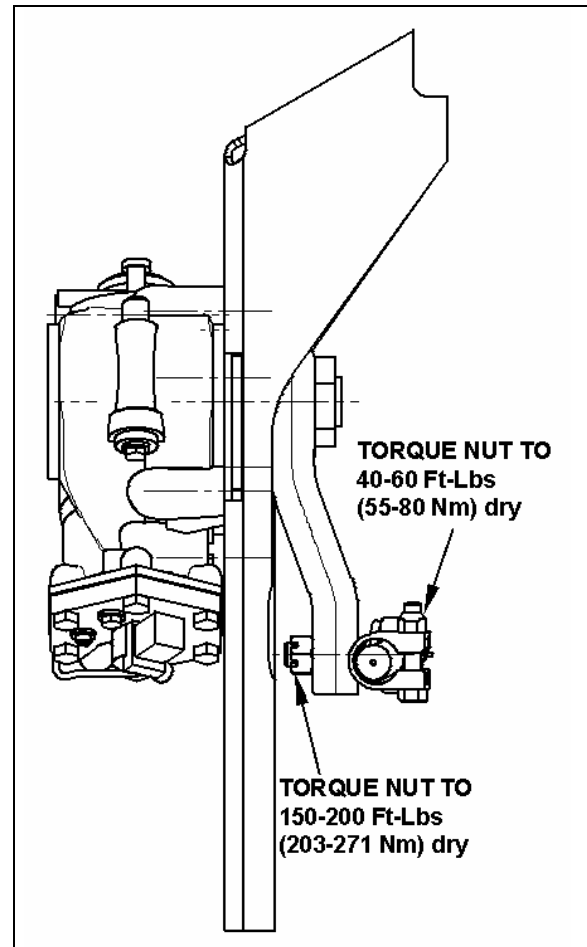

FIGURE 9: DRAG LINK INSTALLATION

14065

## 12. MAINTENANCE

The power steering system requires little maintenance. However, the system should be kept clean to ensure maximum operating performance and troublefree service. Periodic inspections should also be made to check for leakage and all parts for damage or distortion. Insure all fasteners are tight (see "14. Specifications" for recommended tightening torques).

When the slightest evidence of dirt, sludge or water is discovered in the system, disconnect fluid lines at the power steering gear to drain the system. Drain and refill the system with "Dexron-II or Dexron-III" automatic transmission oil.

Air in the hydraulic system will cause spongy action and noisy operation. When a hose has been disconnected or when fluid has been lost for any reason, the system must be bled. Bleed system as outlined under heading 3: "*Bleeding Power Steering Hydraulic System*".



## CAUTION

Do not operate the pump without fluid in the power steering fluid reservoir.

If the steering linkage between the steering gear and the two front wheels is not properly adjusted, or if it is bent, twisted or worn, the steering of the vehicle will be seriously impaired. Whenever a steering linkage part is repaired, replaced or adjusted, steering geometry and front wheel alignment must be checked and necessary corrections made. Refer to section 16 "Suspension" under heading 7. "Front End Alignment".

At regular lubrication intervals, the steering linkage should be thoroughly inspected for worn or loose components.

After the vehicle has been operated continually and high mileage figures have been reached, overhaul of the various steering units will be required. General overhaul procedure normally requires removal of the entire assembly, cleaning and inspection of all parts and final assembly. Careful inspection of all parts during overhaul is very important and must not be neglected.

Lubrication fittings must all be cleaned before applying lubricant. Moreover, always be sure the equipment used in applying lubricant is clean. Every precaution should be taken to prevent entry of dirt, grit, lint or other foreign matter into lubricant containers. Replace fittings that have become broken or damaged. Lubrication intervals, as well as the recommended lubricants for the steering components, are given in the "*Lubrication And Servicing Schedule*" in Section 24 of this manual. The intervals given in the schedule are recommended for normal service. More frequent intervals may be required under severe operating conditions.

### 12.1 POWER STEERING RESERVOIR AND FILTER

The power steering reservoir is located on R.H. side of engine compartment and accessible through the engine compartment doors. (Fig. 10).

At regular intervals, fluid level should be checked in the reservoir and filter assembly. Furthermore, the oil filter cartridge element in the power steering reservoir should be replaced every 50,000 miles (80 000 km) or once a year, whichever comes first.

#### 12.1.1 Oil Level Check Procedure

1. Stop engine. Open engine compartment R.H. side door.
2. Unscrew and remove the dipstick located on top of reservoir and wipe with a clean rag.

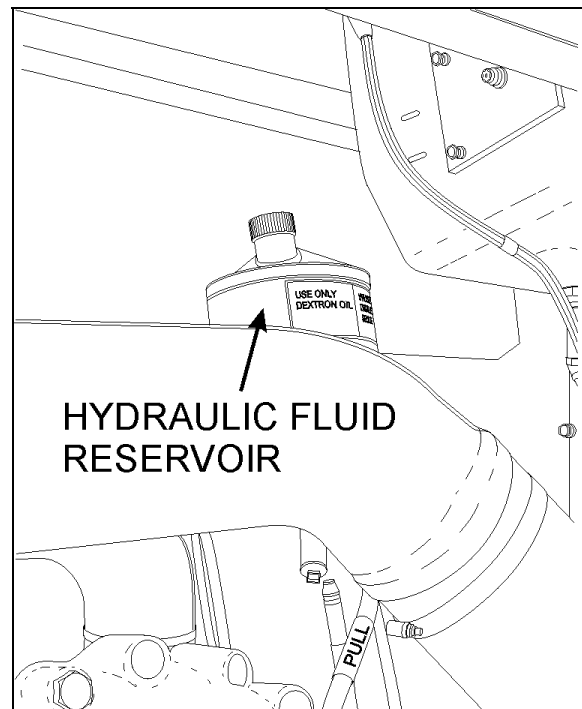

FIGURE 10: HYDRAULIC FLUID RESERVOIR LOCATION  
14044

3. Insert dipstick in reservoir. Remove it again to check fluid level (Fig. 11).
4. Adjust level to "*FULL*" mark using proper dipstick side depending on fluid temperature, use "*Dexron-II* or *Dexron-III*" automatic transmission oil.
5. Reinsert and tighten the dipstick.

#### 12.1.2 Filter Replacement

1. Unscrew and remove the cover nut located on top of the power steering reservoir.
2. Remove the reservoir cover and the gasket.
3. Remove the retaining spring and finally the filter cartridge element.

## Section 14: STEERING

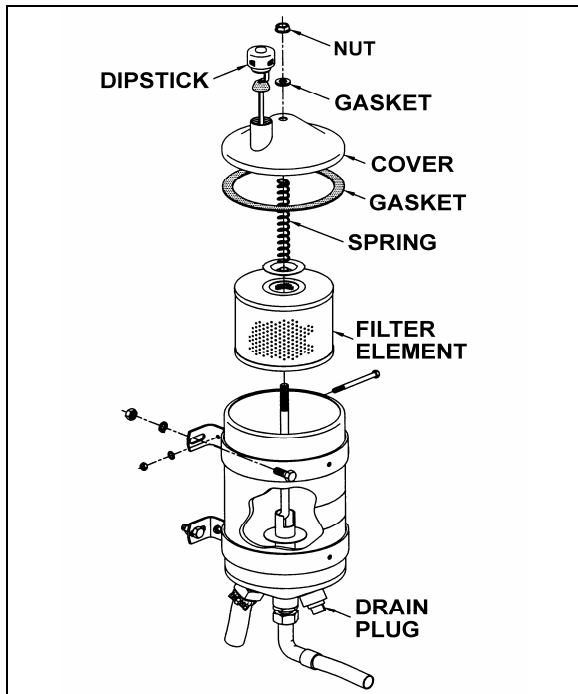

FIGURE 11: POWER STEERING FLUID RESERVOIR  
14018A

### 12.2 DRAG LINK

Lubricate the fittings every 6,250 miles (10 000 km) or twice a year, whichever comes first. Good quality lithium-base grease NLGI No. 1 and 2 are recommended (refer to section 24 "Lubrication").

### 12.3 POWER STEERING HYDRAULIC PUMP

For maintenance of the power steering hydraulic pump, refer to the "TRW - Power Steering Pump Service Manual" annexed to this section.

### 13. DRIVING TIPS

In order to maximize power steering pump service life, do not attempt to turn the steering wheel when the vehicle is stationary, and especially when service brakes are applied (wheel locking will oppose the effect of steering geometry which tends to make the front wheels rotate in opposite directions).

Persisting in turning, or maintaining the steering wheel with an extra effort, could make the hydraulic system work at the relief pressure, and consequently, cause the hydraulic fluid to become overheated.



### CAUTION

Never maintain the hydraulic system at the relief pressure for longer than 5/10 seconds to avoid damaging the power steering pump.

### NOTE

*Unequal or low tire pressure, oversize tires, and vehicle overloading are some of the causes that may increase steering effort.*

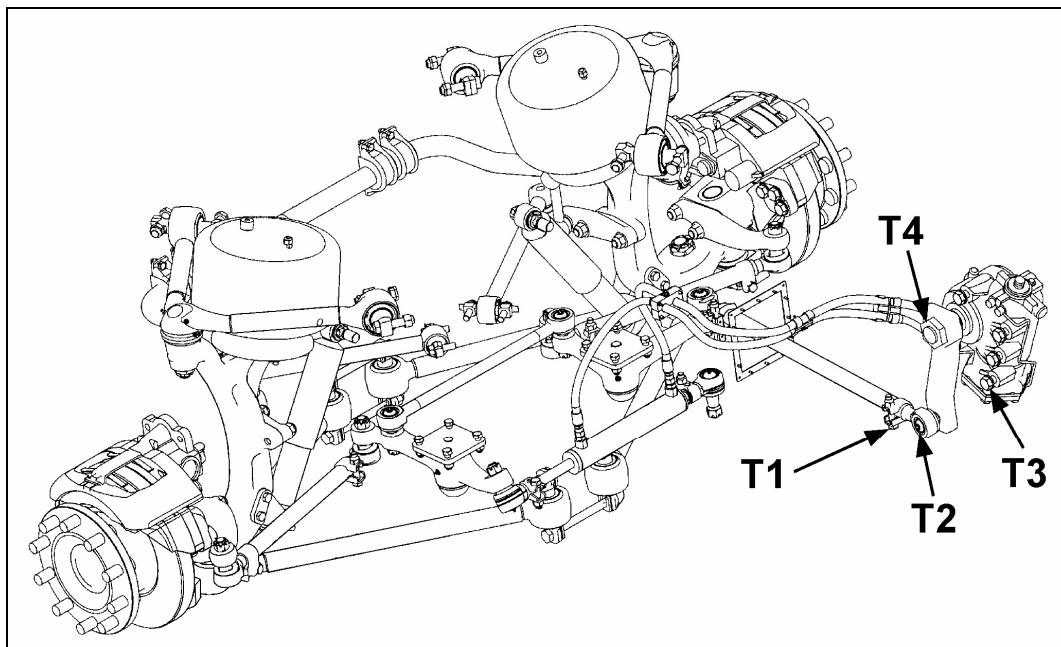

FIGURE 12: DRAG LINK COMPONENTS

16175

**14. TORQUE SPECIFICATIONS**

<b>DRY TORQUES</b>			
<b>Description</b>	<b>Reference</b>	<b>Lbf-ft</b>	<b>Nm</b>
Drag Link Socket End Clamp Bolt Nut (2)	Fig. 12, T1	40-60	55-80
Drag Link End Stud Nut (on steering arm)	Fig. 12, T2	150-200	203-271
Steering Gear Fixing Bolts (5)	Fig. 12, T3	365-405	495-550
Pitman Arm Fixing Nut	Fig. 12, T4	470-570	637-773

**15. SPECIFICATIONS****Power Steering Gear**

Make ..... ZF-SERVOCOMTRONIC  
 Model ..... 8098  
 Supplier number ..... 8098-988-571  
 Prevost number ..... 661044  
 F.E.W. .... 16,600 lbs (7 545 kg)  
 Pressure rating ..... 2,175 psi (150 Bar)  
 Gear ratio (center) ..... 22.2 : 1  
 Gear ratio (extremities) ..... 26.2 : 1  
 Minimum pump flow for 1.5 hwt/sec ..... 4.22 gpm (16 lpm)

**Power Steering Gear**

Make ..... ZF-SERVOCOM  
 Model ..... 8098  
 Supplier number ..... 8098-988-570  
 Prevost number ..... 661045  
 F.E.W. .... 16,600 lbs (7 545 kg)  
 Pressure rating ..... 2,175 psi (150 Bar)  
 Gear ratio (center) ..... 22.2 : 1  
 Gear ratio (extremities) ..... 26.2 : 1  
 Minimum pump flow for 1.5 hwt/sec ..... 4.22 gpm (16 lpm)

**Power Steering Pump**

Make ..... TRW  
 Type ..... PS Series  
 Relief valve setting ..... 2,175 psi (14 990 kPa)  
 Controlled flow rate ..... 4.23 gpm (16 lpm)  
 Inlet port ..... 1 1/4 NPT  
 Outlet port ..... 3/4-16 straight thread SAE O' ring boss conn.  
 Supplier number ..... PS251615L10200  
 Prevost number ..... 661009  
 Gasket - Supplier number ..... 23516100  
 Gasket - Prevost number ..... 510488

**Section 14: STEERING**

---

**Power Steering Reservoir**

Make ..... Nelson Muffler  
Oil capacity ..... 4 US qts (3.7 liters)  
Supplier number ..... 91410A  
Prevost number ..... 660982  
Make ..... Nelson Muffler  
Element filter - Supplier number ..... 83804 E  
Element filter - Prevost number ..... 660987

**Power Steering Hydraulic Cylinder**

Make.....Hyco  
Supplier number..... 007-0300-0  
Prévost number.....661076

# SECTION 16: SUSPENSION

## CONTENTS

<b>1. INTRODUCTION .....</b>	<b>4</b>
<b>2. STEERING LINKAGE .....</b>	<b>4</b>
2.1 POWER STEERING HYDRAULIC PUMP .....	7
2.2 STEERING LINKAGE ADJUSTMENT .....	7
2.3 PITMAN ARM REMOVAL .....	7
2.4 PITMAN ARM INSTALLATION .....	7
2.5 DRAG LINK .....	8
2.5.1 <i>Adjustment</i> .....	8
2.6 BELL CRANK AND IDLER ARM.....	8
2.6.1 <i>Bell Crank and Idler Arm Removal</i> .....	8
2.6.2 <i>Bell crank or Idler Arm Ball Joint Disassembly</i> .....	8
2.6.3 <i>Bell Crank or Idler Arm Ball Joint Reassembly</i> .....	8
2.7 RELAY ROD .....	10
2.7.1 <i>Replacement</i> .....	10
2.8 TIE RODS .....	10
2.8.1 <i>Removal</i> .....	10
2.8.2 <i>Installation</i> .....	11
2.9 STEERING ARMS .....	11
2.9.1 <i>Removal</i> .....	11
2.9.2 <i>Installation</i> .....	11
2.10 LUBRICATION FITTINGS.....	11
<b>3. BALL JOINTS .....</b>	<b>13</b>
3.1 LOWER AND UPPER A-ARM BALL JOINT .....	13
3.1.1 <i>Inspection</i> .....	13
3.1.2 <i>Stripping Down</i> .....	13
3.1.3 <i>Assembly</i> .....	14
3.2 LOWER A- ARM CENTRAL BALL JOINT .....	14
3.2.1 <i>Inspection</i> .....	14
3.2.2 <i>Stripping Down</i> .....	14
3.2.3 <i>Assembly</i> .....	14
3.3 UPPER A-ARM CENTRAL BALL JOINT .....	15
3.3.1 <i>Visual Inspection</i> .....	15
3.3.2 <i>Play Measurement</i> .....	15
<b>4. FRONT END ALIGNMENT .....</b>	<b>15</b>
4.1 ALIGNMENT TERMINOLOGY .....	16
4.2 FRONT END INSPECTION .....	16
4.3 FRONT WHEEL CAMBER .....	17
4.4 FRONT WHEEL TOE-IN .....	17
4.4.1 <i>Toe-In Check</i> .....	17
4.4.2 <i>Toe-In Adjustment</i> .....	17
4.5 FRONT AXLE CASTER.....	17
4.6 MAJOR DAMAGE .....	19
<b>5. FRONT AIR SPRINGS .....</b>	<b>19</b>
5.1 INSPECTION .....	19
5.2 REMOVAL .....	19
5.3 INSTALLATION .....	19
<b>6. SHOCK ABSORBERS.....</b>	<b>20</b>

## Section 16: SUSPENSION

---

6.1	SHOCK ABSORBER REMOVAL .....	21
6.2	SHOCK ABSORBER INSTALLATION .....	21
<b>7.</b>	<b>SWAY BAR .....</b>	<b>21</b>
7.1	REMOVAL .....	21
7.2	INSTALLATION .....	21
<b>8.</b>	<b>REAR SUSPENSION .....</b>	<b>23</b>
8.1	AIR SPRINGS .....	24
8.1.1	<i>Inspection</i> .....	24
8.1.2	<i>Removal</i> .....	24
8.1.3	<i>Installation</i> .....	24
8.2	SHOCK ABSORBERS .....	25
8.2.1	<i>Inspection</i> .....	25
8.2.2	<i>Removal</i> .....	26
8.2.3	<i>Installation</i> .....	26
8.3	RADIUS RODS .....	26
8.3.1	<i>Inspection</i> .....	27
8.3.2	<i>Removal</i> .....	27
8.3.3	<i>Bushing removal</i> .....	27
8.3.4	<i>Bushing installation</i> .....	27
8.3.5	<i>Installation</i> .....	28
<b>9.</b>	<b>SUSPENSION HEIGHT ADJUSTMENT .....</b>	<b>28</b>
<b>10.</b>	<b>HEIGHT CONTROL VALVE .....</b>	<b>29</b>
10.1	LOADING POSITION .....	30
10.2	NEUTRAL POSITION .....	30
10.3	UNLOADING POSITION .....	30
10.4	MAINTENANCE .....	30
10.5	REMOVAL AND INSTALLATION .....	30
<b>11.</b>	<b>"LEVEL-LOW" LEVELING SYSTEM .....</b>	<b>30</b>
11.1	PRINCIPLES OF OPERATION .....	31
11.2	MAINTENANCE .....	31
<b>12.</b>	<b>AIR SYSTEM .....</b>	<b>31</b>
12.1	AIR TANK MAINTENANCE .....	32
12.1.1	<i>Wet Air Tank</i> .....	32
12.1.2	<i>Primary Air Tank</i> .....	32
12.1.3	<i>Secondary Air Tank</i> .....	32
12.1.4	<i>Accessory Air Tank</i> .....	32
12.1.5	<i>Expansion Air Tank</i> .....	33
12.2	EMERGENCY FILL VALVES .....	33
<b>13.</b>	<b>HUB UNIT AND SWIVEL ASSEMBLY .....</b>	<b>33</b>
<b>14.</b>	<b>TORQUE TABLE .....</b>	<b>34</b>
<b>15.</b>	<b>SPECIFICATIONS .....</b>	<b>35</b>

## ILLUSTRATIONS

FIGURE 1: SUSPENSION AND STEERING LINKAGE.....	4
FIGURE 2: LOCATION OF CLAMPS .....	5
FIGURE 3: CLAMP POSITIONING.....	6
FIGURE 4: CLAMP POSITIONING.....	6
FIGURE 5: CLAMP POSITIONING.....	6
FIGURE 6: CLAMP POSITIONING.....	6
FIGURE 7: CLAMP POSITIONING.....	6
FIGURE 8: CLAMP POSITIONING.....	6
FIGURE 9: PITMAN ARM ALIGNMENT.....	7
FIGURE 10: FIXING NUT PUNCH MARK.....	8
FIGURE 11: BELL CRANK AND IDLER ARM.....	9
FIGURE 12: BELL CRANK .....	9
FIGURE 13: BELL CRANK .....	10
FIGURE 14: LUBRICATION FITTINGS' LOCATION DIAGRAM.....	12
FIGURE 15: BALL JOINTS LOCATION.....	13
FIGURE 16: A-ARM BALL JOINTS.....	13
FIGURE 17: LOWER A-ARM BALL JOINT .....	14
FIGURE 18: UPPER A-ARM BALL JOINTS .....	14
FIGURE 19: LOWER A-ARM CENTRAL BALL JOINT .....	15
FIGURE 20: UPPER A-ARM CENTRAL BALL JOINT.....	15
FIGURE 21: STEERING LINKAGE MEASURE .....	16
FIGURE 22: FRONT END ALIGNMENT DIAGRAM.....	18
FIGURE 23: AIR SPRINGS.....	19
FIGURE 24: AIR SPRING AND SHOCK ABSORBER.....	20
FIGURE 25: SHOCK ABSORBER .....	21
FIGURE 26: SWAY BAR (FRONT SUSPENSION) .....	22
FIGURE 27: SWAY BAR (REAR SUSPENSION) .....	22
FIGURE 28: REAR SUSPENSION COMPONENTS .....	23
FIGURE 29: DETAILS OF REAR SUSPENSION .....	23
FIGURE 30: TAG AXLE SUSPENSION .....	23
FIGURE 31: AIR SPRING.....	24
FIGURE 32: SHOCK ABSORBER .....	26
FIGURE 33: TYPICAL SHOCK ABSORBER SETUP .....	26
FIGURE 34: TYPICAL RADIUS ROD SETUP .....	26
FIGURE 35: RADIUS ROD BUSHING REMOVAL.....	27
FIGURE 36: RADIUS ROD BUSHING INSTALLATION .....	27
FIGURE 37: RADIUS ROD INSTALLATION .....	28
FIGURE 38: HEIGHT CONTROL VALVE LOCATION.....	28
FIGURE 39: TYPICAL AIR SPRING CLEARANCE .....	28
FIGURE 40: FRONT HEIGHT CONTROL VALVE.....	29
FIGURE 41: REAR HEIGHT CONTROL VALVE.....	29
FIGURE 42: LOCATION OF AIR TANKS.....	31
FIGURE 43: REAR VALVE LOCATION.....	32
FIGURE 44: FRONT VALVE LOCATION.....	32



**1. INTRODUCTION**

The vehicle is provided with an air suspension system. The system consists of air springs, height control valves, tie rods, radius rods, sway bars, tripod and shock absorbers. The system operation is fully automatic and maintains a constant vehicle height regardless of load, or load distribution.

**2. STEERING LINKAGE**

Turning motion of the steering wheel is transferred by the steering gear and steering linkage to the steering arms at the right and left front wheels. The steering linkage consists of tie rods connected to the bell crank and the steering arm at the left side of the bus shell, and to the idler arm and steering arm at the right side of the bus shell. The bell crank and idler arm are connected by a relay rod. A drag link connected to the bell crank and the pitman arm, which is

mounted to the steering gear, transfers the turning motion of the steering wheel to the steering arms. The hydraulic power cylinder provides an added source of assistance and being connected to the R.H. wheel, makes it such that the total steering forces are produced with minimal stress on mechanical linkages (Fig. 1).

Lower and upper A-arms are widely spaced. They are mounted on ball joints. Torque rods prevent rotation of the uprights around the lower and upper ball joints.

If the steering linkage is bent, twisted or worn, steering action of the vehicle will be seriously affected. Any time steering linkage components are replaced or adjusted, steering geometry and front wheel alignment must be checked as explained in this section.

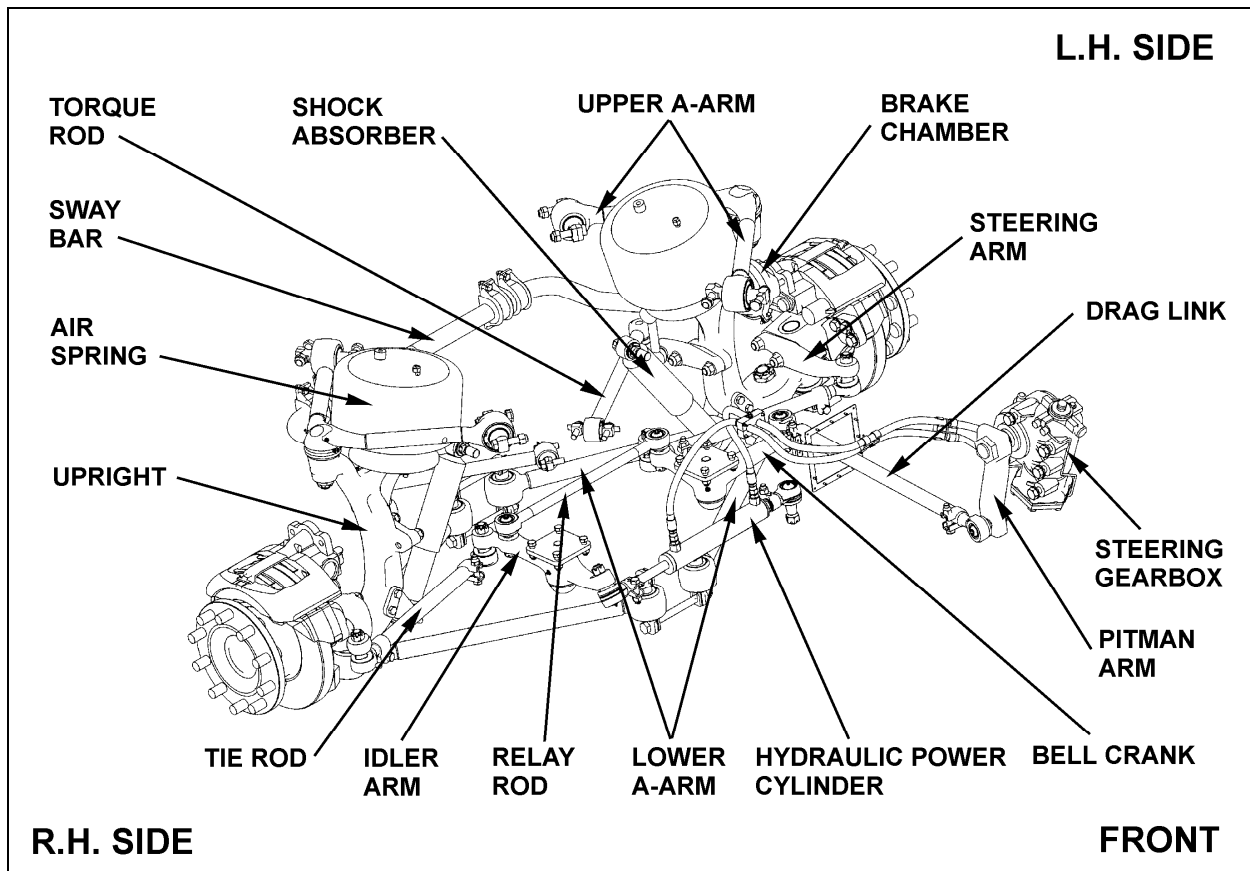

FIGURE 1: SUSPENSION AND STEERING LINKAGE

16124

### Turning Angle

The maximum turning angle is set mechanically through the two steering stop screws installed on the swivel assembly. The turning angle ( $56^\circ + 0^\circ - 1^\circ$ ) mechanical stop is factory adjusted to accommodate the chassis design, and therefore, does not require adjustment on new vehicles.

However, turning angle should be checked and adjusted hydraulically, if necessary, any time a component of the steering system is repaired, disassembled or adjusted.

Before checking the turning angle, be sure the front end is properly aligned as described under paragraph "4. Front End Alignment" in this section.

To check steering maximum turning angle, proceed with the following method:

1. Check if front tires rub against the frame or if the steering gear has been serviced.



### CAUTION

If clamps are not correctly installed, they can interfere with other parts.

2. For a full left and right turn, check clamps' position and for interfering parts. Refer to figures 2 to 7 for location and positioning of clamps. If readjustment is required, make the proper adjustment.

### NOTE

*Prior to steering limiter adjustment, verify vehicle wheel alignment, and ensure that oil level is adequate and that air bleeding is done.*

3. If necessary readjust steering limiter. Refer to "ZF-SERVOCOM Repair Manual" annexed to Maintenance Manual, Section 14, "Steering", under heading: "Setting and Functional Test".

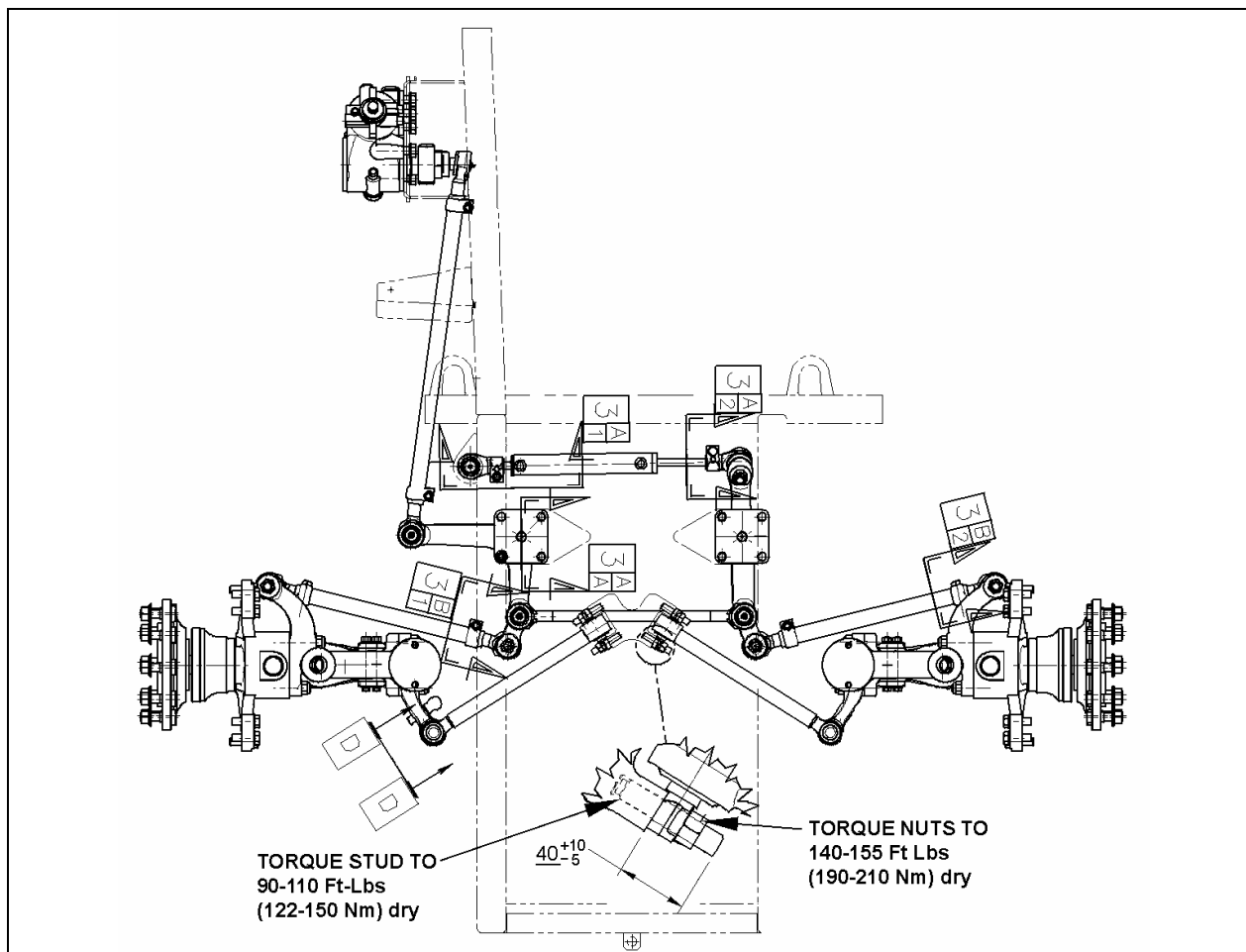

FIGURE 2: LOCATION OF CLAMPS

16177

Section 16: SUSPENSION

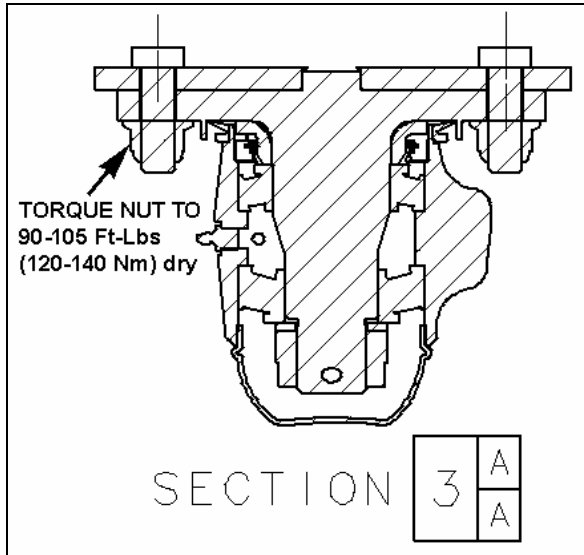

FIGURE 3: CLAMP POSITIONING

16169

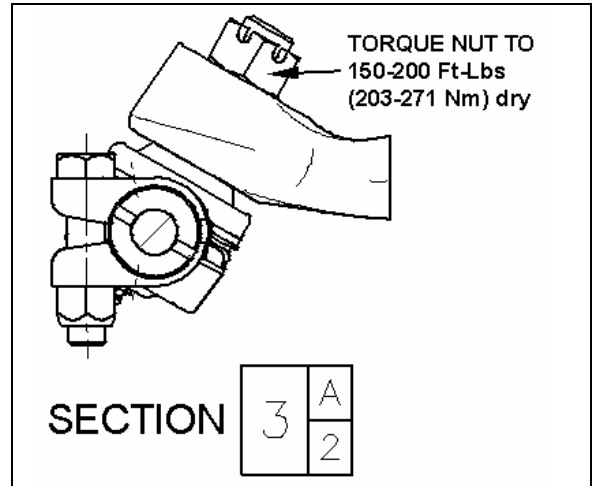

FIGURE 6: CLAMP POSITIONING

16179

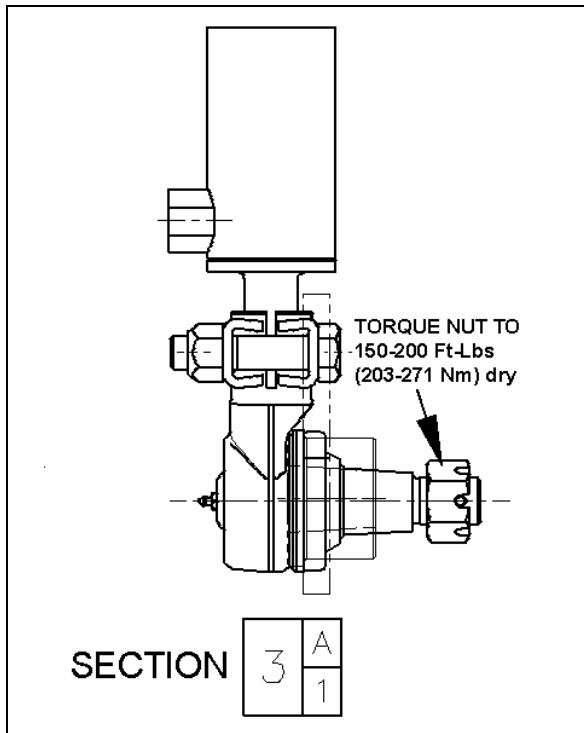

FIGURE 4: CLAMP POSITIONING

16178

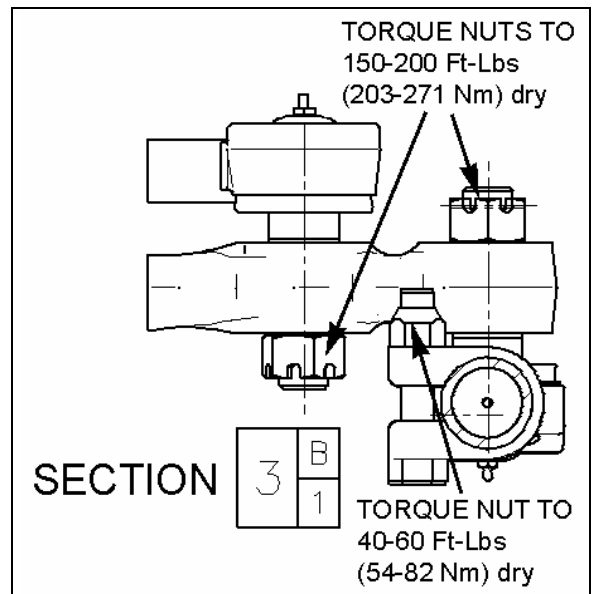

FIGURE 7: CLAMP POSITIONING

16170

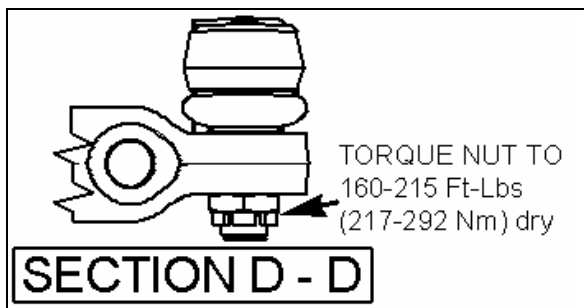

FIGURE 5: CLAMP POSITIONING

16172

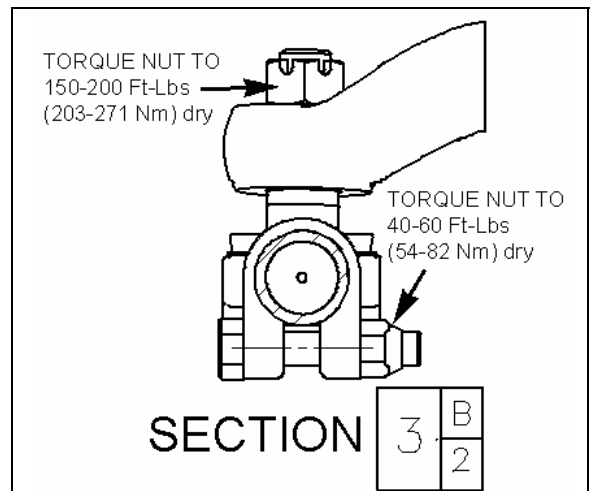

FIGURE 8: CLAMP POSITIONING

16171

2.1 POWER STEERING HYDRAULIC PUMP

Refer to the "TRW Power Steering Pump Service Manual" annexed at the end of Section 14

2.2 STEERING LINKAGE ADJUSTMENT

**NOTE**  
Whenever a steering linkage component has been removed and replaced, check steering geometry and front end alignment as directed in this Section. Check to insure that all stud nuts and mounting bolts and nuts have been tightened to proper torques listed under "14. Torque Table" at the end of this section.

1. First, align the input shafts marks.
2. Afterwards, the pitman arm should be adjusted with reference marks aligned or to an angle of 90° in relation with the horizontal axis (Fig. 9).
3. Locate centerline of vehicle then install relay rod in boss at steering bell crank and idler arm. Align center of relay rod with centerline of vehicle.
4. Install drag link to pitman arm and adjust opposite end of drag link to fit mounting stud hole in bell crank.
5. Install tie rods, and then adjust toe-in as per "Front End Alignment" in this Section.

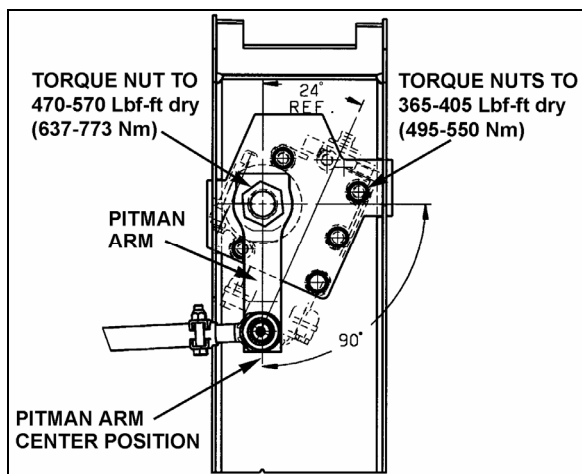





FIGURE 9: PITMAN ARM ALIGNMENT 14057

2.3 PITMAN ARM REMOVAL

1. Remove cotter pin, nut and washer from drag link ball stud at pitman arm.
2. Disconnect drag link from pitman arm, using jaw style pullers (pressure screw type).

 **WARNING**  
Always wear approved eye protection when operating pullers.

 **CAUTION**  
Do not drive pitman arm on or off pitman shaft as this can damage the steering gear.

 **CAUTION**  
Heating of components to aid in disassembly is not allowed because it has a detrimental effect on axle components and steering linkages.

3. Remove pitman arm fixing nut.
4. Check the radial position of the pitman arm in relation to the sector shaft prior to removal of pitman arm.
5. Add reference marks to the arm and shaft if necessary to ensure correct alignment at reassembly.
6. Use a puller to remove pitman arm.

2.4 PITMAN ARM INSTALLATION

1. Position pitman arm on sector gear shaft with reference marks aligned.
2. Install fixing nut. Tighten nut to 470-570 lbf-ft (637-773 Nm).

**NOTE**  
Use a new nut if the previously removed nut was punched.

 **CAUTION**  
Lock nut with sector shaft using a punch mark into the groove (Refer to figure 10).

3. Connect drag link to pitman arm. Install washers. Tighten nut to 150-200 lbf-ft (203-271 Nm). Advance nut to next alignment cotter pin slot and install a new cotter pin.

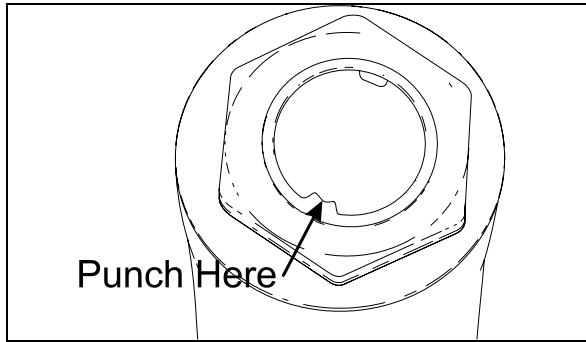

FIGURE 10: FIXING NUT PUNCH MARK 16098

## 2.5 DRAG LINK

Drag link assembly consists of three parts; a drag link and two end assemblies. Both end assemblies are identical and they are retained on the drag link with a clamp bolt and nut.

Stud nuts at the pitman arm and bell crank ends of the drag link must be kept tight or hole at ball stud end of drag link and hole in pitman arm may become enlarged as a result of excessive looseness. Subsequent tightening of stud nuts may draw studs too far into holes and dust cover parts may become damaged which can result in component failure.

Drag link end sockets are equipped with lubrication fittings and should be lubricated as directed in "Lubrication Fittings" in this Section.

### 2.5.1 Adjustment

It should not be necessary to alter the length of the drag link except when a new link is installed or when removable end assembly has been replaced. If drag link adjustment is necessary, proceed as follows:

1. Position front wheels in straight ahead position.
2. Center steering gear as previously explained in paragraph "2.2 Steering Linkage Adjustment".
3. Remove cotter pin, nut and stud from drag link at bell crank. Locate centerline of vehicle and center of relay rod. With center of relay rod aligned with centerline of vehicle, loosen clamp bolt at socket end (bell crank end) of drag link and adjust length of socket end assembly to fit in boss of bell crank.

**NOTE**

Do not change position of pitman arm.

4. Install stud with nut and torque to 150-200 lbf-ft (203-271 Nm). Align nut with cotter pin slot (tighten) and install a new cotter pin.
5. Torque mounting clamp bolt nut to 40-60 lbf-ft (55-80 Nm), then test the adjustment. Front wheels should turn from right to left extremities without noticeable binding at drag link ends.

## 2.6 BELL CRANK AND IDLER ARM

Bell crank and idler arm are equipped with one lubrication fitting and should be lubricated as directed in paragraph "2.10 Lubrication Fittings" at the end of this Section.

### 2.6.1 Bell Crank and Idler Arm Removal

**NOTE**

Use a piece of wire to anchor loosen end of relay rod and tie rod in order to prevent placing an excessive load on opposite socket end.

**Bell crank:** Disconnect drag link, tie rod and relay rod from bell crank by removing cotter pins and nuts from ball studs. Separate socket assemblies from the bell crank.

**Idler arm:** Remove cotter pins and nuts from ball studs connecting relay rod, tie rod and hydraulic power cylinder to idler arm. Separate socket assemblies from idler arm.

Remove nuts from bolts attaching bell crank or idler arm mounting spindle to suspension subframe. Remove bell crank or idler arm mounting spindle.

### 2.6.2 Bell crank or Idler Arm Ball Joint Disassembly

1. Remove adjacent link assemblies from bell crank or idler arm as previously described.
2. Remove the cap (Fig. 11).
3. Remove the cotter pin, nut and thrust washer. Remove bearings, grease retainer, backup ring and the bell crank or idler arm from its mounting spindle (Fig. 11).

### 2.6.3 Bell Crank or Idler Arm Ball Joint Reassembly

**NOTE**

For bearing installation use Prévost tool # 110684.

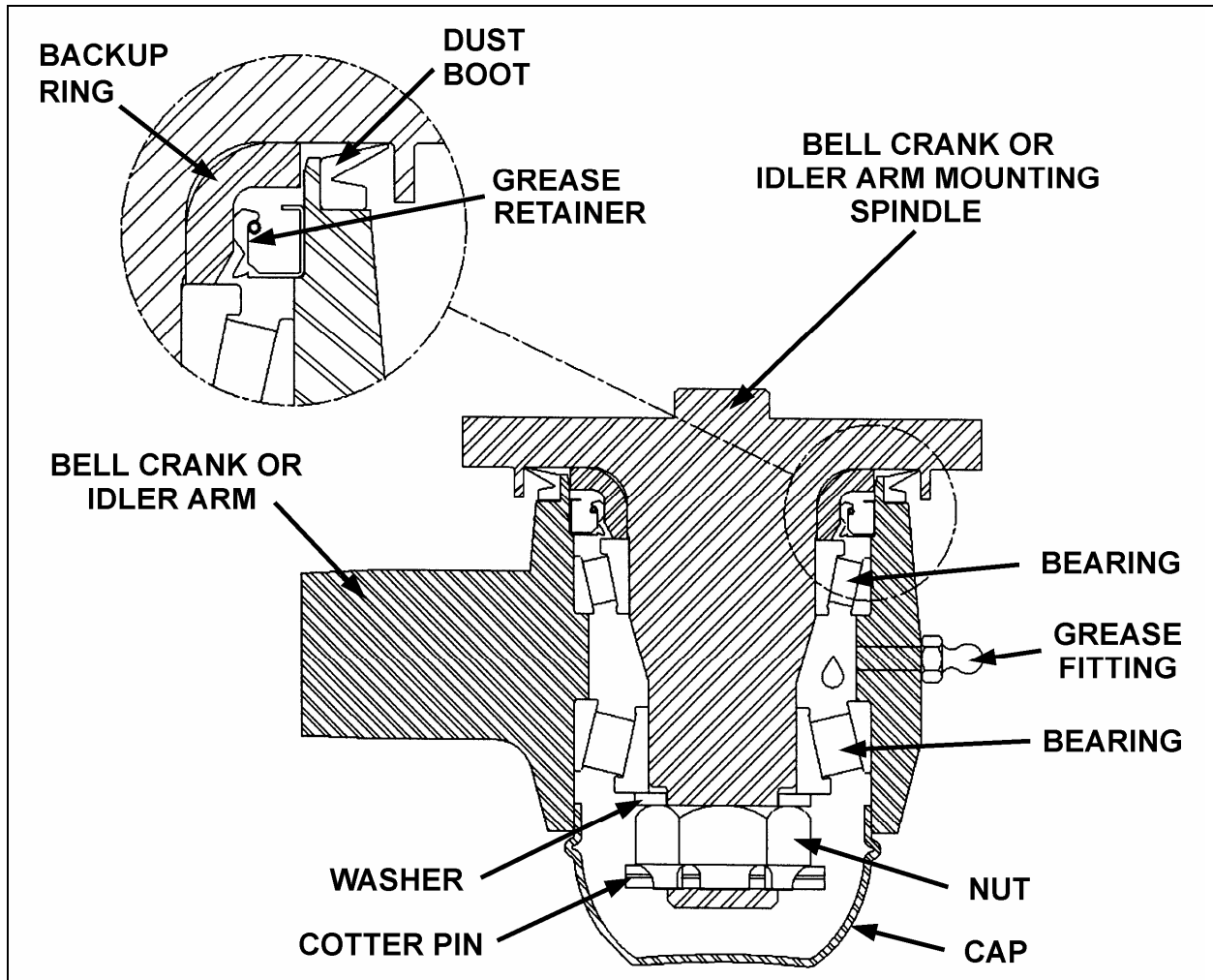

FIGURE 11: BELL CRANK AND IDLER ARM

16109

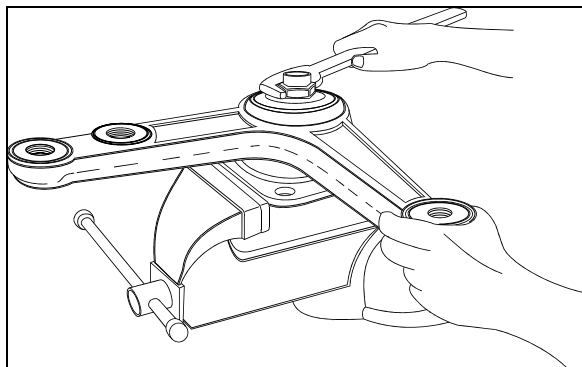

FIGURE 12: BELL CRANK

16044

1. Install backup ring on bell crank or idler arm mounting spindle.
2. Install grease retainer and bearing in bell crank or idler arm eye (Fig. 11).

**NOTE**

Install grease retainer according to figure 11. Grease must be able to exit the bell crank or idler arm mechanism. For grease retainer installation use tool Prévost # 110683.

3. Install bell crank or idler arm onto its mounting spindle, while holding the bell crank or idler arm, slide on the bearing assembly, thrust washer and secure using nut. (Fig. 12).

**NOTE**

Apply grease on bearing before installation.

4. Unscrew nut until bell crank or idler arm starts to turn by the application of 1 to 3 pounds load (Fig. 13).

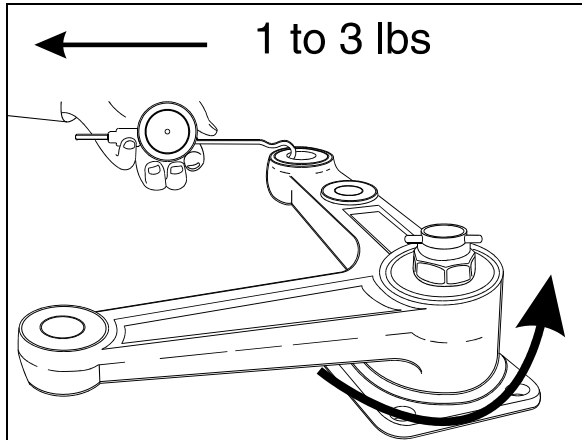

FIGURE 13: BELL CRANK 16045

5. Check for loose bearings by applying an up and down load on bell crank or idler lever. The lever is not supposed to move in the vertical axis direction.
6. Align nut with cotter pin slot (tighten) and install a new cotter pin.

**NOTE**

*Bend cotter pin around the nut (Fig. 11). Do not bend the cotter pin in the direction of the cap, because it may interfere with the cap.*

7. Install the cap.
8. **Bell crank:** Install drag link, tie rod and relay rod as directed herein under each specific subject.
9. **Idler arm:** Install hydraulic power cylinder, tie rod and relay rod as directed herein under each specific subject.
10. Adjust turning angle as previously directed under paragraph "**Turning Angle**" and check front end alignment as specified in paragraph "4. Front End Alignment" of this Section.

2.7 RELAY ROD

Relay rod ends are equipped with lubrication fittings and should be lubricated as directed in paragraph "2.10 Lubrication Fittings" in this Section.

**NOTE**

*The relay rod is crimped in place and it is not possible to remove the ball joints.*

2.7.1 Replacement

1. Remove cotter pins from bell crank and idler arm end of relay rod. Loosen nuts flush with end of studs.
2. Use a puller or place a sledge hammer behind the adjacent part to absorb shocks. Strike the studs with a brass hammer to loosen end assemblies.
3. Remove stud nuts then remove studs.
4. Position new relay rod studs into bell crank and idler arm then tap stud ends with a brass hammer to seat tapered surfaces.
5. Install stud nuts. Tighten nuts to 150-200 lbf-ft (203-271 Nm) torque. Align cotter pin slot (tighten) and install a new cotter pin.

2.8 TIE RODS

Tie rod ends are connected to the bell crank and left steering arm, and to the idler arm and right steering arm. Each tie rod assembly consists of three parts; a tube and two socket end assemblies. The tie rod ends are threaded into the tube and secured with clamp bolts. Right and left hand threads are provided to ease toe-in adjustment. Tie rod assemblies are interchangeable from the right to the left side of the coach.

Tie rod end sockets require no maintenance other than periodic lubrication and inspection to see that ball studs are tight. Replace socket ends when there is excessive up and down motion, lost motion or end play at ball end of stud.

1. Periodically check bolt nut for tightness.
2. Inspect tie rod for bent condition and inspect tube for damaged threads. If tie rod is bent or threads are damaged, replace the assembly.
3. Lubricate tie rod end fittings as directed in paragraph "2.10 Lubrication Fittings" in this section.

2.8.1 Removal

1. Remove cotter pins and stud nuts which attach tie rod socket ends to bell crank and left steering arm (or idler arm) and right steering arm.

- Remove tie rod ball stud by tapping on steering arm and bell crank or idler arm with hammer, while using a sledge hammer to absorb shocks.

**NOTE**

*If tie rod end assemblies are damaged in any way, they must be replaced.*

## 2.8.2 Installation

- Install socket end assemblies on tie rod. Be sure both ends are threaded an equal distance into the tube.
- Make sure threads on stud and in stud nut are clean and not damaged.
- Position ball studs (socket ends of tie rod) in holes in steering arm and bell crank or idler arm. Install a ball stud nut on each stud and tighten firmly.
- Torque stud nuts to 150-200 lbf-ft (203-271 Nm). Align cotter pin slot (tighten) and install a new cotter pin.

**NOTE**

*Adjust toe-in as directed in paragraph "4.4.2 Toe-In Adjustment" of this Section.*

- Make sure tie rod ends are properly aligned with ball studs, then torque tie rod end clamp bolts to 40-60 lbf-ft (55-80 Nm).

**NOTE**

*If tie rod is not properly aligned with stud, binding will result.*

## 2.9 STEERING ARMS

The left and right wheel steering arms are secured to a steering knuckle at one end and to a tie rod at the other end.

## 2.9.1 Removal

- Remove wheel as directed in Section 13, "Wheel, Hubs And Tires" of the maintenance manual.
- Remove cotter pin and nut from stud securing tie rod to steering arm. Remove ball stud from steering arm by tapping on arm with a hammer, placing a sledge hammer underneath steering arm to absorb shocks.

- Remove bolts securing steering arm to steering knuckle assembly. Remove steering arm from steering knuckle.

## 2.9.2 Installation

- Install steering arm onto steering knuckle.
- Torque steering arm to steering knuckle fixing bolts. Torque short bolt (M20 X 65) to 520-575 lbf-ft (705-780 Nm). Torque long bolt (M24 X 100) to 751-830 lbf-ft (1018-1125 Nm).
- Position tie rod ball stud in steering arm and tap with a brass hammer to seat ball stud in steering arm. Install nut on stud. Torque nut to 150-200 lbf-ft dry (203-271 Nm). Tighten nut to nearest cotter pin slot and install a new cotter pin.
- Install wheel as directed in Section 13, "Wheel, Hubs And Tires" under paragraph "3.2 Installation" of the maintenance manual.

## 2.10 LUBRICATION FITTINGS

All lubrication fittings must be clean before applying lubricant. Also, always be sure equipment used in applying lubricant is clean. Every precaution should be taken to prevent entry of dirt, grit, lint or other foreign matter into lubricant containers. Replace fitting when they become broken or damaged.

Intervals of application given in the following paragraphs are recommended for normal service. More frequent intervals may be applied under severe operating conditions. In selecting proper lubricants, supplier reputation must be considered. The supplier must be responsible for product quality. The diagram (Fig. 14) shows approximate location of steering lubrication fittings.

- Drag Link Ends:** Lubricate at two fittings, one at each end of link, every 6,250 miles (10 000 km) with good quality lithium-base grease NLGI No. 2 (Shell Retinax LX or equivalent).
- Relay Rod Ends:** Lubricate at two fittings, one at each end of rod, every 6,250 miles (10 000 km) with good quality lithium-base grease NLGI No. 2 (Shell Retinax LX or equivalent).
- Tie Rod Ends:** Lubricate at four fittings, one at each end of both tie rods, every 6,250 miles (10 000 km) with good quality lithium-



## Section 16: SUSPENSION

base grease NLGI No. 2 (Shell Retinax LX or equivalent).

4. **Swivel Assembly:** Refer to DANA SPICER MAINTENANCE MANUAL NDS AXLES Lubrication and Maintenance" annexed at the end of section 11.
5. **Idler Arm and Crank bell:** Lubricate at two fittings, one on the idler arm and the other on the crank bell, every 6,250 miles (10 000 km) with good quality lithium-base grease NLGI No. 2 (Shell Retinax LX or equivalent). Apply grease gun pressure to the fitting until lubricant appears at the top seal.

6. **Upper A-Arm Central Ball Joint:** Lubricate at fitting until you see some grease on the relief valve nearby, every 6,250 miles (10 000 km) with good quality lithium-base grease NLGI No. 2 (Shell Retinax LX or equivalent).

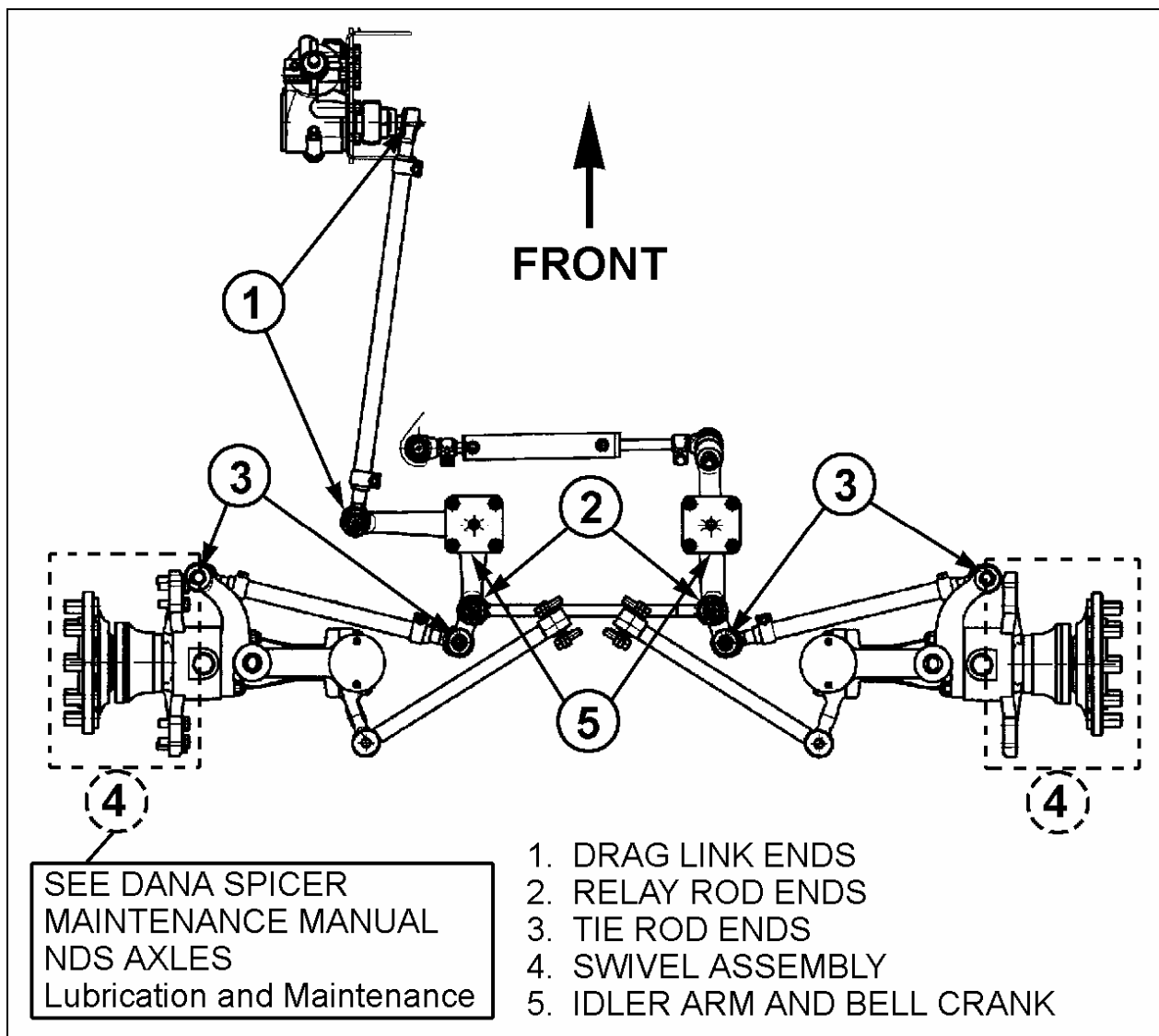

FIGURE 14: LUBRICATION FITTINGS' LOCATION DIAGRAM

16118

### 3. BALL JOINTS

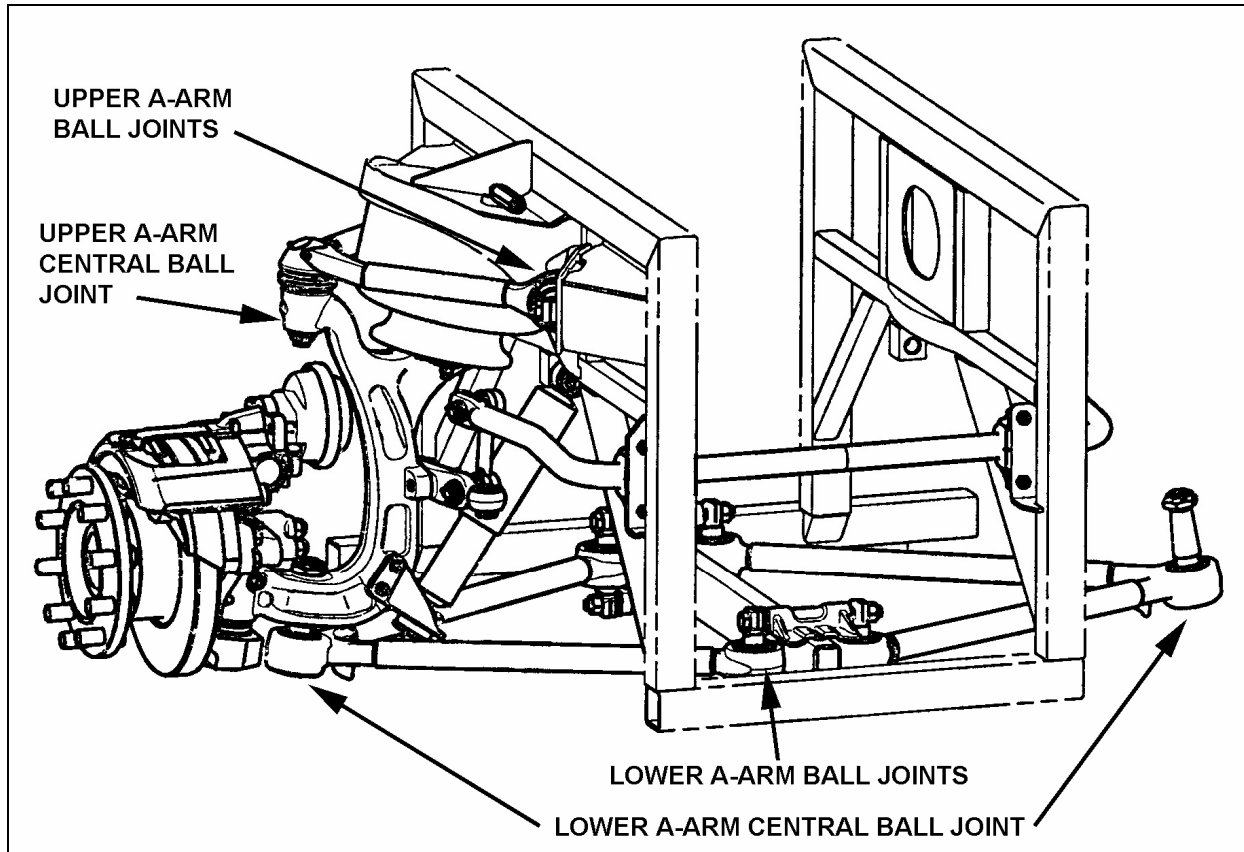

FIGURE 15: BALL JOINTS LOCATION

16137

#### 3.1 LOWER AND UPPER A-ARM BALL JOINT

The assembly work may be done only by a recognized specialized workshop. Ensure that old and new parts do not get mixed up with each other. It is for this reason that all the old parts are to be scrapped immediately after a joint has been stripped down. A complete repair set must be used for each joint repaired, i.e. use of only part of a repair set is not permissible.

##### 3.1.1 Inspection

Take off the load from the ball joint by lifting the front of the vehicle. Apply a load on the joint in all of the degrees of freedom in an axial, radial, etc. sense with a suitable lever tool. After the load is taken off, the joint has to spring back into its starting position. Free play is not acceptable.

Separation of rubber from ball pin or external joint shell is in accordance with "normal wear characteristics".

When the following characteristics are noted, the joint is to be changed:

- Free play;
- Radial cracking of the external sheet-metal race.

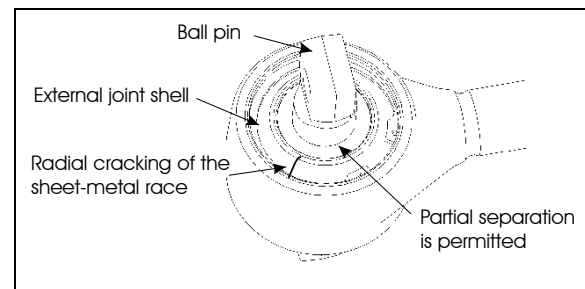

Figure 16: A-ARM BALL JOINTS

##### 3.1.2 Stripping Down

Strip down the defective joint through removal of retaining ring, annular spacer and ball pin/bushing assembly and thereafter clean out housing bore and locking circlips groove.

## Section 16: SUSPENSION

### 3.1.3 Assembly

Execute assembly of the new joint parts in the following sequence:

1. Complete moistening of the contact surface between housing bore and ball pin through application of the grease.

#### **NOTE**

*Apply grease, only in the case of repair kit (Prévost # 611114).*

2. Insert ball pin/bushing assembly. In case of the two-bolt type, ensure that the bolt bores are in the correct position in relation to the axis of the tube.

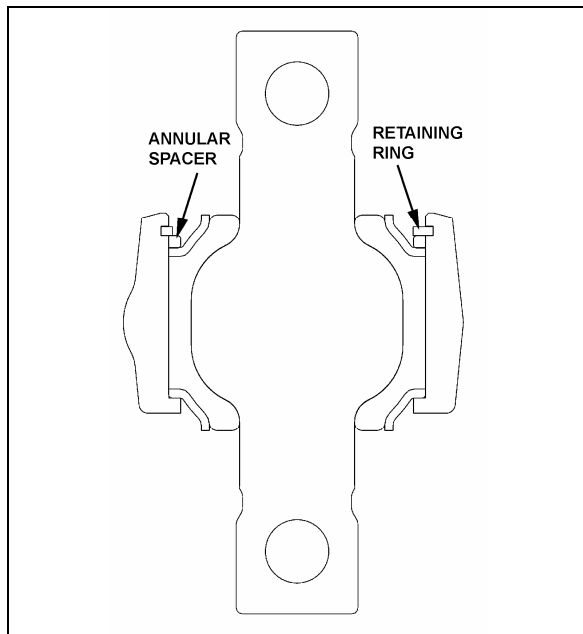

FIGURE 17: LOWER A-ARM BALL JOINT

16114

3. Place joint in receiving fixture and mount annular assembly tool on the housing. Then locate annular spacer and retaining ring in the housing using axial load with the aid of assembly matrix. If the ends of the annular spacer are not in contact with each other, the thus formed opening must be located at 180° to the opening of the retaining ring. Pay attention during assembly to ensure that the retaining ring eyelets are located at each side of the housing shaft axis (retaining ring eyelet lug points to tube), and that retaining ring is properly engaged in the groove of the housing.
4. When repairing defective ball pin assemblies, the necked down-bolt must regularly be replaced with a new one.

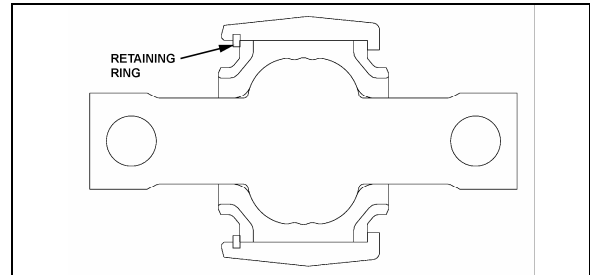

FIGURE 18: UPPER A-ARM BALL JOINTS

16115

### 3.2 LOWER A- ARM CENTRAL BALL JOINT

#### 3.2.1 Inspection

Take off the load from the ball joint by lifting the front of the vehicle. Apply a load on the joint in all of the degrees of freedom in an axial, radial, etc. sense with a suitable lever tool. After the load is taken off, the joint has to spring back into its starting position. Free play is not acceptable.

Separation of rubber from ball pin or external joint bushing shell is in accordance with "normal wear characteristics".

When the following characteristics are noted, the joint is to be changed:

- Free play;
- Radial cracking of the external bushing shell.

#### 3.2.2 Stripping Down

Strip down the defective joint through removal of retaining ring, annular spacer and ball pin/bushing, assembly and thereafter clean out housing bore and locking circlips groove

#### 3.2.3 Assembly

Assemble the new component parts of the joint in the following sequence:

1. Complete moistening of the contact surface between housing bore and ball pin through application of the grease.
2. Place joint in receiving fixture and mount annular assembly tool on the housing. Then locate annular spacer and retaining ring in the housing using axial load with the aid of assembly matrix. If the ends of the annular spacer are not in contact with each other, the thus formed opening must be located at 180° to the opening of the retaining ring. Pay attention during assembly to ensure that the retaining ring eyelets are located at each side of the housing shaft axis (retaining ring eyelet lug points to tube), and that retaining ring is properly engaged in the groove of the housing.

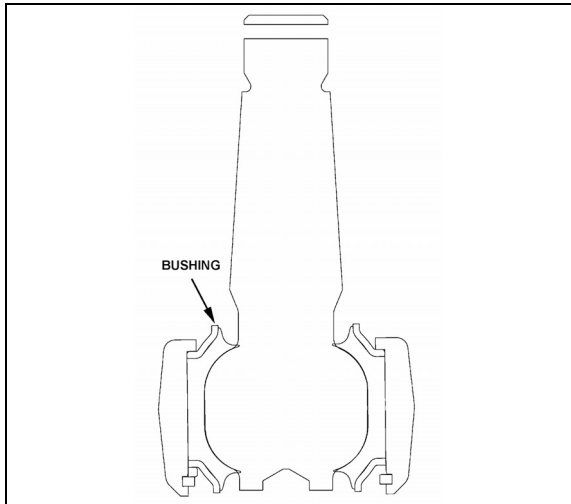

FIGURE 19: LOWER A-ARM CENTRAL BALL JOINT

3. Faultlessly apply grease by mechanical means to bracket-outer core and ball-inner cone. Insert bracket outer cone in fixture with distance ring and then use press tool to apply pressure to press mount with ball-inner cone.

### 3.3 UPPER A-ARM CENTRAL BALL JOINT

#### 3.3.1 Visual Inspection

Check the condition of the sealing boot, in particular:

Check if the retainer ring, which secures the sealing boot at the conical section of the ball stud, is still present.

Check if grease is present on the external surface of the sealing boots. Escaped fluid and accumulations of grease on the sealing boot may be the result of the sealing boot's rupturing. In this case, the ball joint must be systematically replaced.

#### 3.3.2 Play Measurement

1. Raise the vehicle and support through axle jacking points.
2. Using a caliper, measure dimension A on figure 20.
3. With a lever tool, exert sufficient force under the upper A-arm as to separate the upper A-arm from the upright in order to have the ball joint to its maximum extent. Remeasure dimension A. If the difference between the two dimensions is greater than 0.060" (1.5mm), then the ball joint should be replaced.

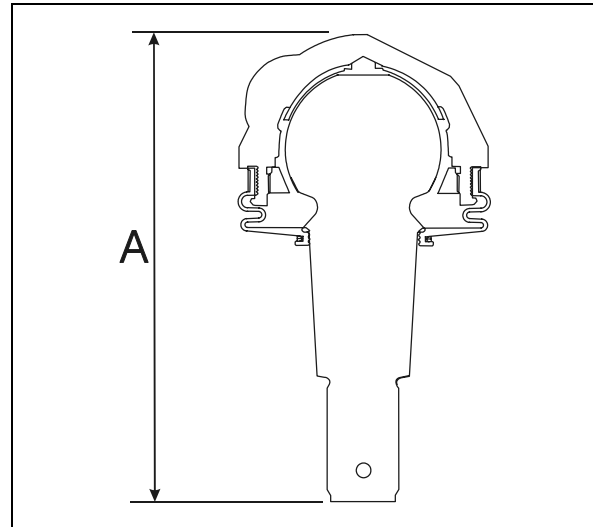

FIGURE 20: UPPER A-ARM CENTRAL BALL JOINT 16116

## 4. FRONT END ALIGNMENT

Proper front end alignment must be maintained to insure ease of steering and provide satisfactory tire life. When making front end alignment inspections, the vehicle must be level and empty with the full weight of the vehicle on the wheels.

Front end alignment inspections fall into two groups: regular service inspections performed at periodic intervals, and inspections to determine the extent of damage after a collision or severe service.

Regular service inspections concern toe-in, camber and caster.

Any variation from the specified alignment will indicate either a need for adjustment or a more thorough inspection to determine if parts replacement is required.



### WARNING

During alignment, both camber and caster among other angles are adjusted. When adjusting these we install or remove shims from the lower "A" arms of the ISS suspension. After performing alignment, make sure that the following is done:

- Installing a new lock nut after all shims are finalized.
- Torque replaced nuts as per figure 24.
- Installing a longer bolt if less the 2 threads are remaining after the nut.
- Using a Torque mark on the nut for future visual inspection.

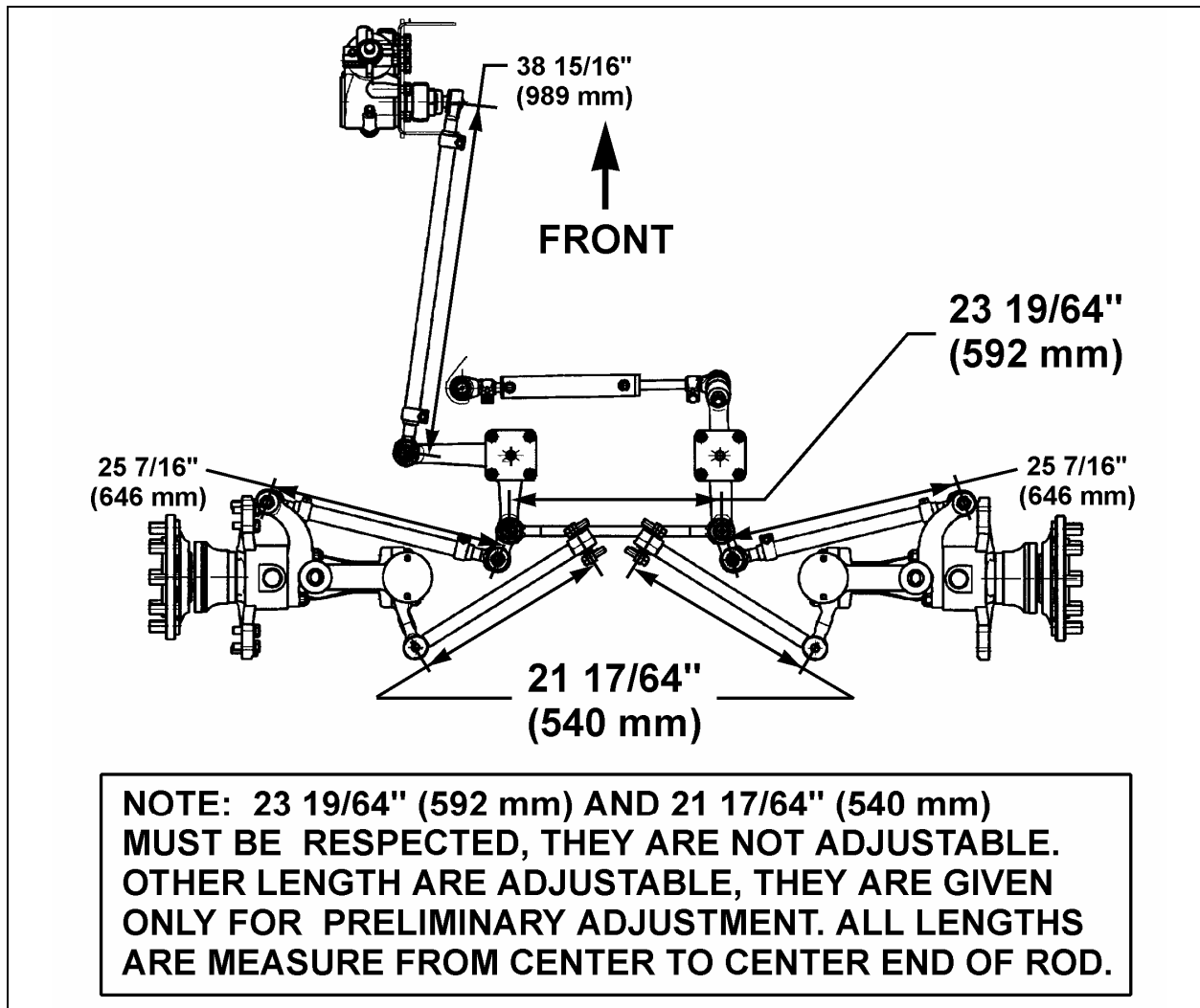

FIGURE 21: STEERING LINKAGE MEASURE

16132

## 4.1 ALIGNMENT TERMINOLOGY

**Wheel Camber**

The amount the wheels are inclined from the vertical plane (A, Fig. 22).

**Wheel Toe-In**

The distance the front wheels are closer together at the front than at the rear of the tires (D minus E, Fig. 22).

**King Pin Inclination**

The inclination of the king pin from vertical toward the center of the vehicle at the top and outward at the bottom (B, Fig. 22).

**Front Axle Caster**

The inclination of the king pin from vertical in the fore and aft direction (C, Fig. 22).

## 4.2 FRONT END INSPECTION

Before checking front end alignment, make the following inspection:

1. Check that the vehicle is at normal ride height (see paragraph "9. Suspension Height Adjustment").
2. Check the tires for proper inflation.
3. Check wheel installation and run-out.
4. Check wheel bearing adjustment.
5. Check tie rods and drag link ends for looseness.
6. Check king pins for looseness.
7. Check if the length of the torque rods is 21 17/64" (540 mm) (Fig. 21). Check if the length of the relay rod is 23 19/64" (592 mm).

### 4.3 FRONT WHEEL CAMBER

Positive camber is the outward inclination of the wheels at the top, negative or reverse camber is the inward inclination of the wheels at the top. Camber variations may be caused by wear at the wheel bearings, wheel spindle bushings, or bent suspension parts.

Check camber, with an accurate gauge. If camber is incorrect, check suspension parts for wear and replace worn parts. If wear is not perceptible, suspension parts may be bent or lower suspension arm may be improperly shimmed.

Check King pin inclination. If King pin inclination is incorrect, readjust the camber and check king pin inclination again.

**NOTE**

*Camber is more important than king pin inclination, so adjust camber and verify king pin inclination.*

Shim the lower suspension arm to adjust camber. If the king pin inclination is incorrect, the wheel king pin assembly may be bent and therefore should be replaced.

Excessive positive camber results in irregular wear of the tires at the outer shoulders. Negative or reverse camber causes wear at the inner shoulders.

**NOTE**

*Shim only the lower suspension arm to adjust the front wheel camber.*



**CAUTION**

Once the perfect shim combination is achieved, always install new stover nuts because the self locking effect is lost after tightening and loosening of the nut. It is recommended to punch marks to detect loosening of the nuts during future visual inspections.

### 4.4 FRONT WHEEL TOE-IN

Toe-in is measured from the center of the tire treads. Measurements at the front and rear of the tires must be made at the same height from the floor. Incorrect toe-in results in excessive tire wear and steering instability with a tendency to wander.

#### 4.4.1 Toe-In Check

1. Check the camber adjustment and adjust if necessary.
2. Hoist the front of the vehicle and spin the wheels marking the centerline of the tire treads.
3. Place the wheels in the straight ahead position and lower the vehicle to rest on the floor.
4. Roll the vehicle ahead several feet. This removes any slack caused by looseness in the wheel bearings or steering connections.
5. Check the distance between the tire centerlines at the front and rear of the front tires. These two measurements must be made at the same height above the floor. The front measurement must be  $3/32 \pm 1/32$  of an inch less than the rear measurement.

#### 4.4.2 Toe-In Adjustment

1. Loosen the tie rod clamp bolts.
2. Using a pipe wrench, turn the tie rod tubes to obtain the toe-in measurement specified in step 5 under paragraph "4.4.1 Toe-in Check" of this Section.
3. Tighten the tie rod clamp bolts and recheck toe-in.
4. Check that the angular relationship of the pitman arm to the steering gear is as shown in figure 9.

**NOTE**

*Use only tie rods to adjust toe-in.*

### 4.5 FRONT AXLE CASTER

Positive caster is the inclination of the top of the king pins toward the rear of the vehicle. Negative or reverse caster is the inclination of the king pins toward the front of the vehicle. This vehicle is designed with positive caster. The purpose of caster is to provide steering stability by keeping the wheels in a straight ahead position.

Caster variations may be caused by bent upper suspension arm, lower suspension arm, or king pin housing. Caster should be adjusted with shims. Precision instruments should be used to measure caster. Shim bell crank and idler arm to adjust caster.

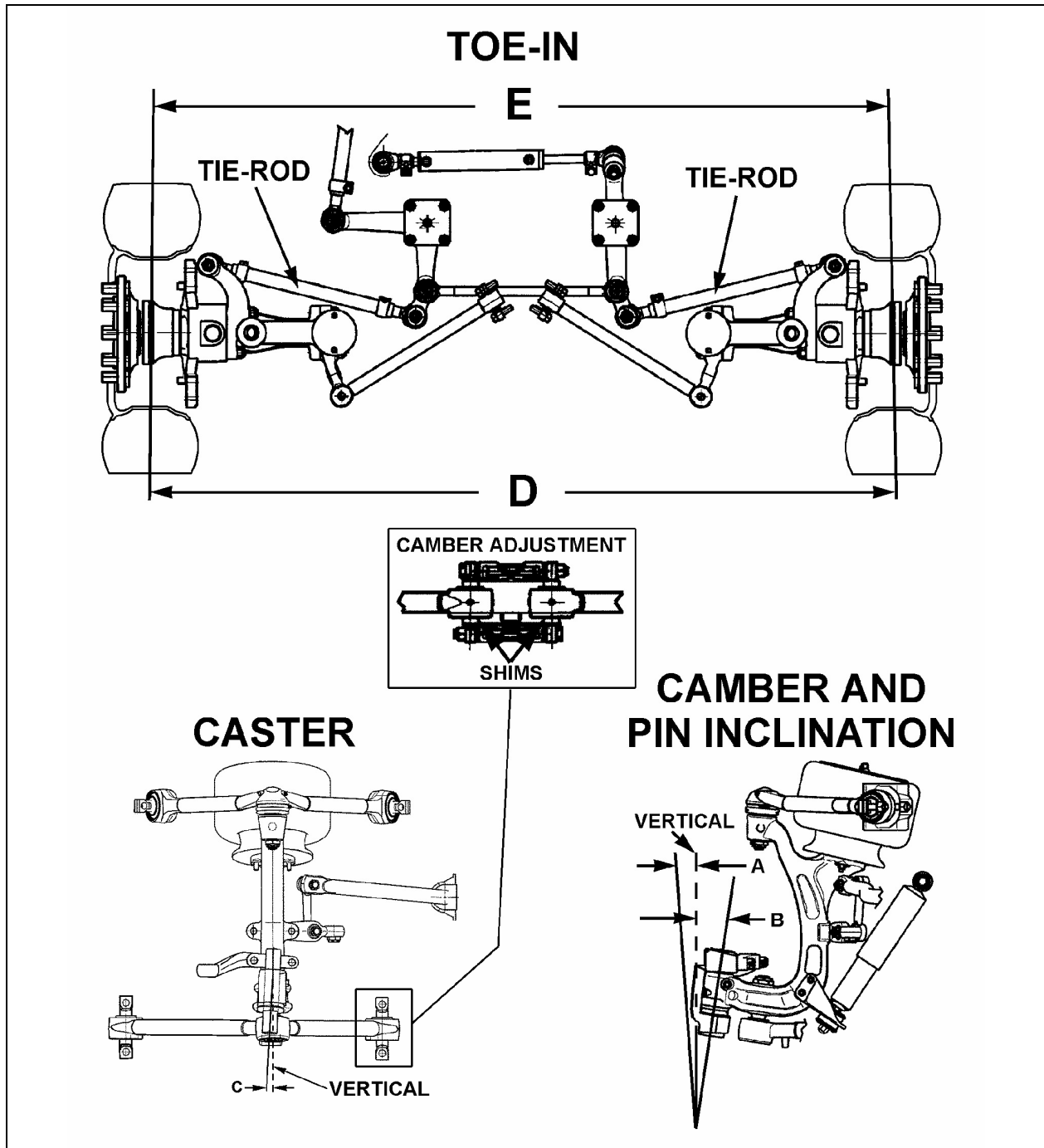

FIGURE 22: FRONT END ALIGNMENT DIAGRAM

16133

ALIGNMENT SPECS (See Figure 22)								
		Minimal		Nominal		Maximal		
Load		Non-converted	Converted	Non-converted	Converted	Non-converted	Converted	
A	WHEEL CAMBER	0.2	-0.150	0.35	0.0	0.55	0.200	
B	KING PIN INCLINATION	8° (not adjustable)						
C	CASTER	2.55		2.8		3.05		
D-E	TOE-IN	0.08		0.10		0.12		

Variations from the specified caster will affect steering stability, cause wandering, wheel shimmy, and reduce returnability when pulling out of curves.

#### 4.6 MAJOR DAMAGE

If the suspension has sustained major damage, it may be necessary to shim the bell crank and the idler arm to avoid the bump steer or roll steer. Moreover refer to paragraph "4. Front End Alignment".

### 5. FRONT AIR SPRINGS

Two "rolling lobe" type air springs are used with the independent front suspension, one at each wheel. These air springs are special and use the complete piston as an extra reservoir to lower the spring stiffness. Front air springs are attached to the subframe and to uprights.

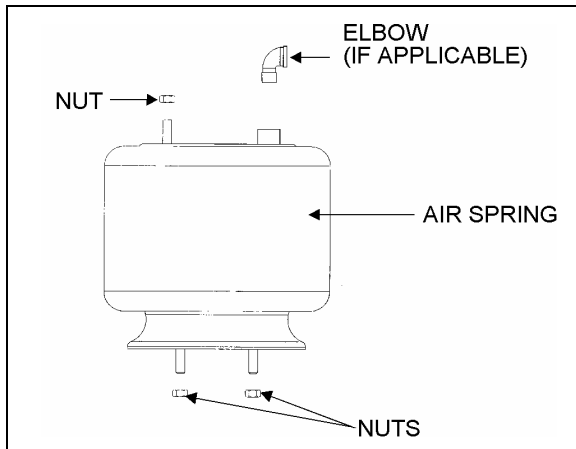

FIGURE 23: AIR SPRINGS

16052

#### 5.1 INSPECTION

1. Check operation of bellows.
2. Visually inspect bellows for evidence of cracks, punctures, deterioration, or chafing. Replace the bellows if damage is evident.
3. With the primary air system at normal operating pressure (95 - 125 psi (655 - 860 kPa)), coat all suspension air line connections and bellow mounting areas with a water and soap solution. Bubbles will indicate an air leak, and none is permissible. Repair or replace defective parts.

#### **NOTE**

If air spring is removed from vehicle, bellows can be lightly inflated and submerged in water to detect any leakage. If leakage is detected, replace bellows.



### **WARNING**

To prevent personal injury, do not apply more than 10 psi (69 kPa) air pressure to the unmounted air spring.

#### 5.2 REMOVAL

#### **NOTE**

Front air springs can be removed without removing the entire suspension assembly.

1. Safely support vehicle at the recommended body jacking points and jack up body understructure.
2. To gain access to a given air spring, the corresponding wheel can be removed.



### **CAUTION**

Only the recommended jacking points must be used as outlined in Section 18, "Body" in the maintenance manual.

3. Support the assembly with a suitable jack.
4. Exhaust compressed air from accessory air tank by opening drain cock under reservoir.
5. Disconnect the height control valve link and pull down the overtravel lever to ensure all air is exhausted from air springs.

#### **NOTE**

While performing this step, do not change the height control valve overtravel lever adjustment.

6. Disconnect air line from air spring, remove elbow (if applicable), and cover both the line end and fitting to prevent the entry of foreign matter.
7. Remove the air spring upper nut, and then the two lower nuts. Remove air spring and remove the back up plate from the top of the air spring.

#### 5.3 INSTALLATION

#### **NOTE**

To facilitate air spring installation, compress it manually then put a piece of tape over the air line threaded fitting. This prevents air from getting back into the bag and keeps it compressed, thus enabling to place the bag in between the mounting plates and greatly easing installation.



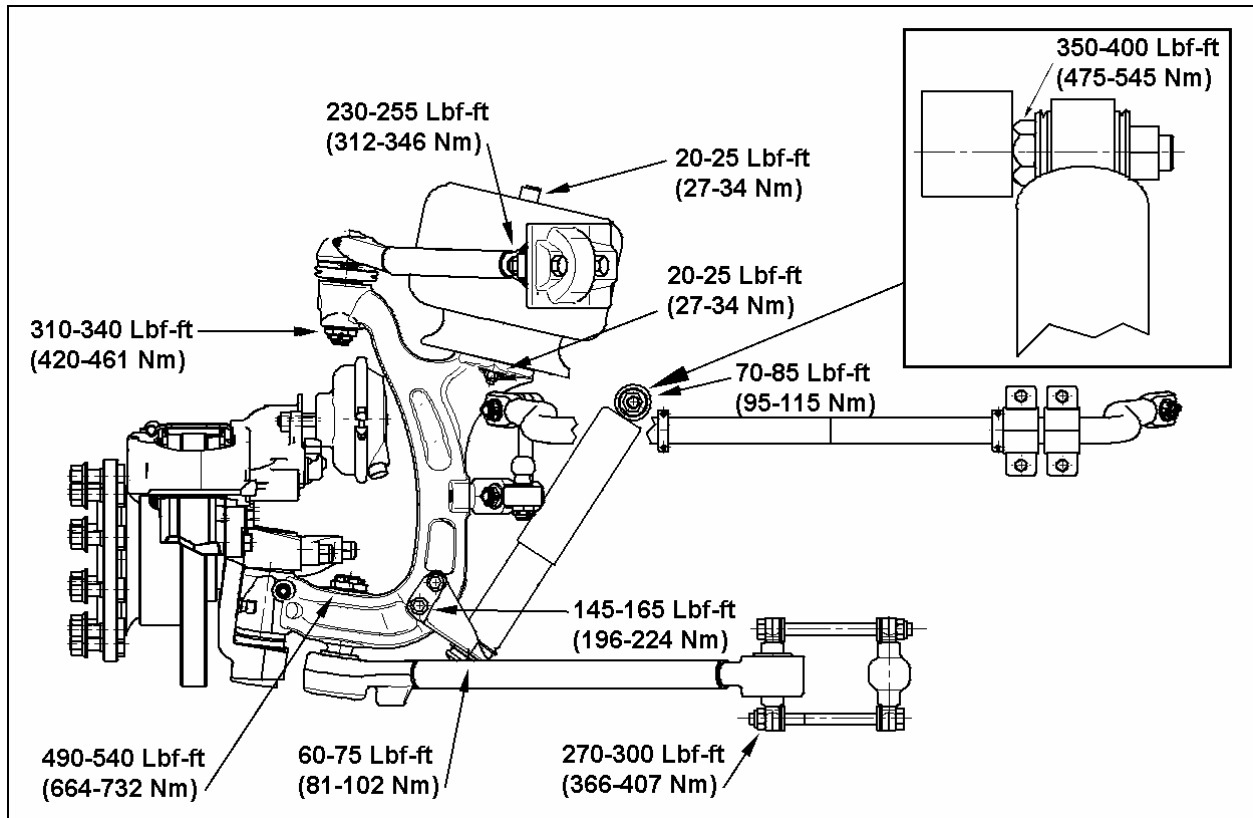

FIGURE 24: AIR SPRING AND SHOCK ABSORBER

16180

1. Compress air spring as necessary, then aligning studs with their holes, position air spring between both the lower and upper supports. Thread the lower nuts and the small upper nut a few turns.
2. Tighten and torque the lower stud nuts, and then the upper nut to 20-25 lbf-ft (27-34 Nm).
3. Install elbow (if applicable), then connect air line.
4. Connect the height control valve link.
5. Build up air pressure in system.

**NOTE**

*To accelerate this operation, air reservoirs can be filled from an exterior air supply connected to the accessory tank fill valve or to the emergency fill valve.*

6. Check operation of bellows, and with the primary air system at normal operating pressure (95 - 125 psi (655 - 860 kPa)), coat the air line connections and air spring mounting areas with a water and soap solution. Bubbles will indicate an air leak,

and none is permissible. Repair or replace defective parts.

7. Remove the hydraulic floor jack from underneath shock absorber bracket.

**6. SHOCK ABSORBERS**

The two front shock absorbers are double-acting and telescopic type. Shock absorbers ensure a smooth ride and enhance vehicle stability on the road. Front shock absorbers have eye-type mountings on the upper side and bayonet type on lower side. Shock absorbers are non-adjustable and non-repairable.



**CAUTION**

When a shock absorber is found defective, always replace with a new set on affected axle, except if there has been a recent replacement of one unit. The following method will help in determining if both shock absorbers on the same axle have to be replaced.

### 6.1 SHOCK ABSORBER REMOVAL

1. Remove the nut, washer and rubber joint from shock absorber mounting stud. Discard the rubber joints.
2. Remove the nut and washer from shock absorber mounting pin (upper side), taking care to identify the inner and outer washers to ease reinstallation. Refer to figure 25 for details.
3. Remove the shock absorber from the vehicle.
4. Remove inner: washers, rubber joint and bushings from the shock absorber. Discard bushings and rubber joint.

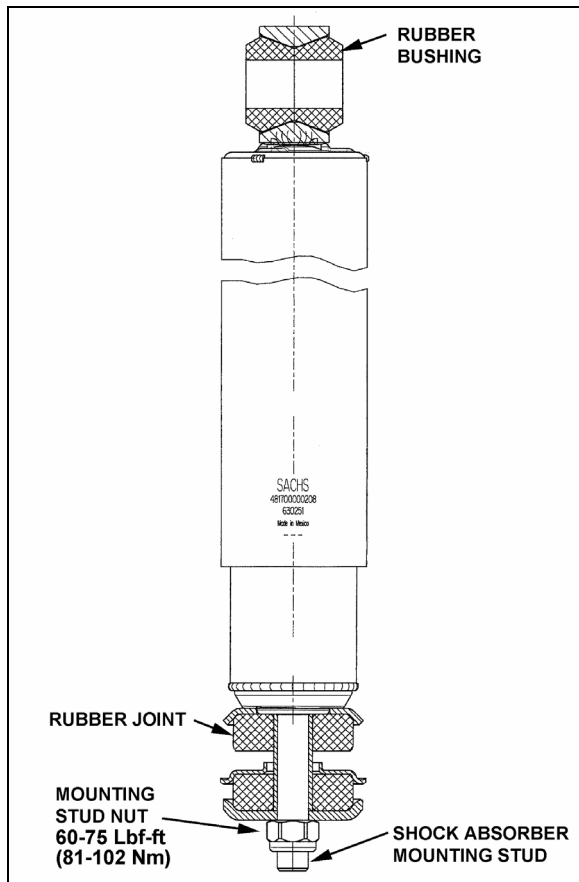

FIGURE 25: SHOCK ABSORBER

16181

### 6.2 SHOCK ABSORBER INSTALLATION

1. Check that the shock absorber mounting pin torque is proper (350-400 lbf-ft (475-545 Nm)). Ensure that the stud is clean and not stripped (upper side).
2. Install new rubber (mounting) bushing on shock absorber (upper side).

3. Place the inner washer on shock absorber pin (Fig. 25).
4. Install washer and rubber joint on shock absorber mounting stud (lower side).
5. Install the shock absorber as shown in figure 24 with the mounting stud protruding through the hole in the mounting bracket and the shock absorber eyes over the mounting pins. Install the outer washer.
6. Place a rubber joint and washer on the shock absorber mounting stud. Place the lower shock absorber mounting stud nut and torque to 60-75 lbf-ft (81-102 Nm).
7. Place the upper mounting pin stud nut and torque to 70-85 lbf-ft (95-116 Nm).

### 7. SWAY BAR

A sway bar is provided on the front and rear suspensions to increase vehicle stability. It controls lateral motion (swaying movement) of vehicle.

#### 7.1 REMOVAL

1. Disconnect the two links from sway bar.
2. Safely support the sway bar. Unbolt bushing collars from subframe.
3. Remove sway bar.

#### **NOTE**

*Sway bar bushings are slit to ease their removal.*

#### 7.2 INSTALLATION

1. Loosely install the sway bar.
2. Torque bushing collar nuts to 80-100 lbf-ft dry (110-135 Nm).
3. Torque sway bar link upper nuts to 165-200 lbf-ft dry (225-270 Nm) on front suspension and to 100-120 lbf-ft dry (135-163 Nm) on rear suspension.
4. Torque sway bar link lower nuts to 165-200 lbf-ft dry (225-270 Nm) on front suspension and to 70-80 lbf-ft dry (95-110 Nm) on rear suspension.

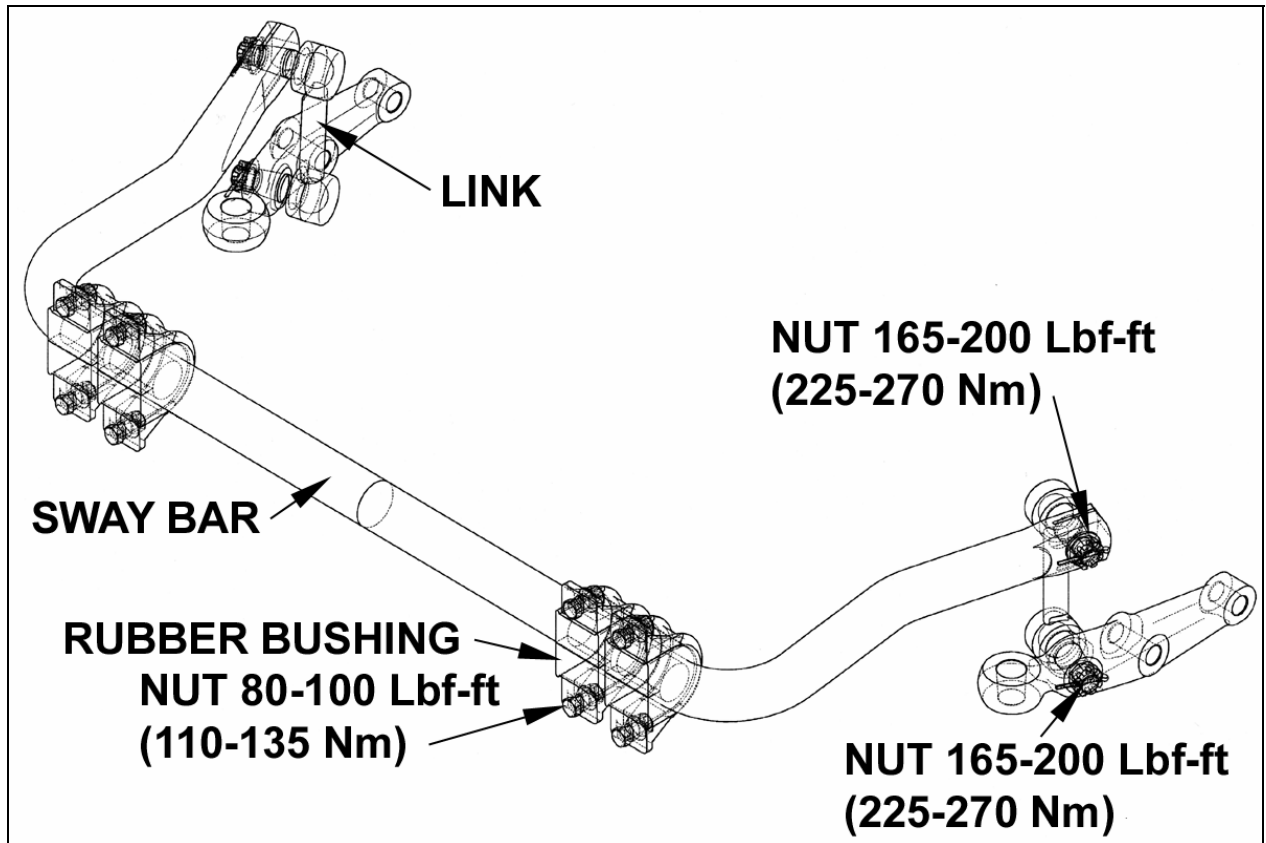

FIGURE 26: SWAY BAR (FRONT SUSPENSION)

16138D

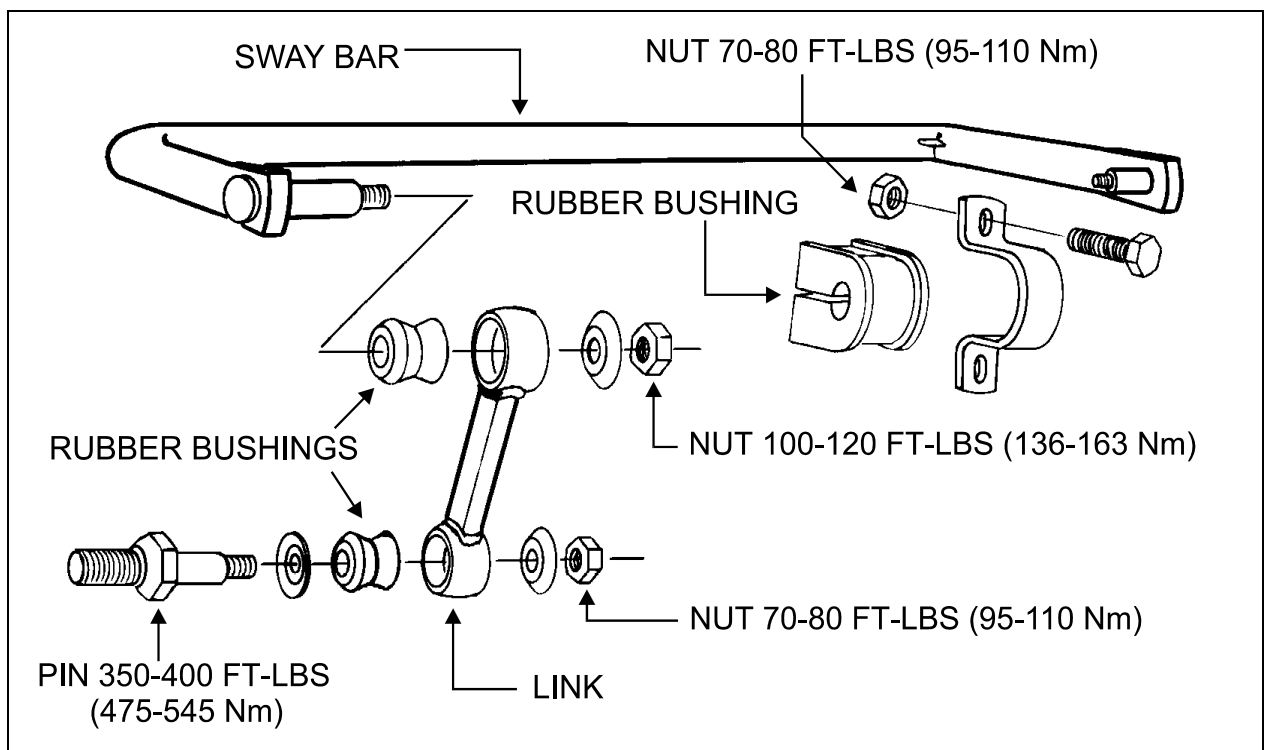

FIGURE 27: SWAY BAR (REAR SUSPENSION)

16014

### 8. REAR SUSPENSION

For a description of all these systems, refer to the appropriate heading in this section.

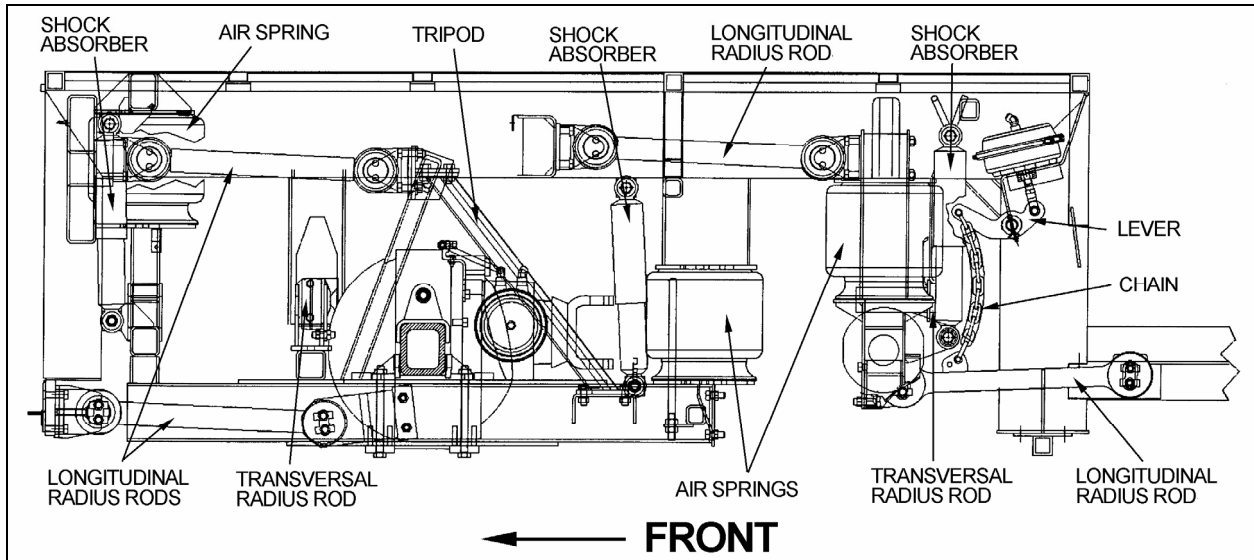

FIGURE 28: REAR SUSPENSION COMPONENTS

16140

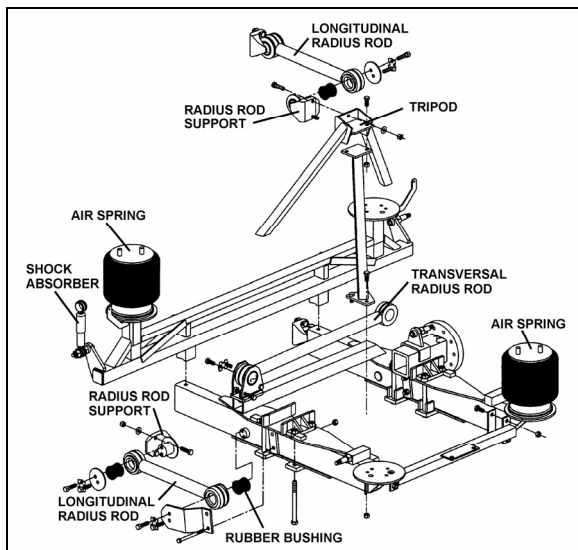

FIGURE 29: DETAILS OF REAR SUSPENSION

16106

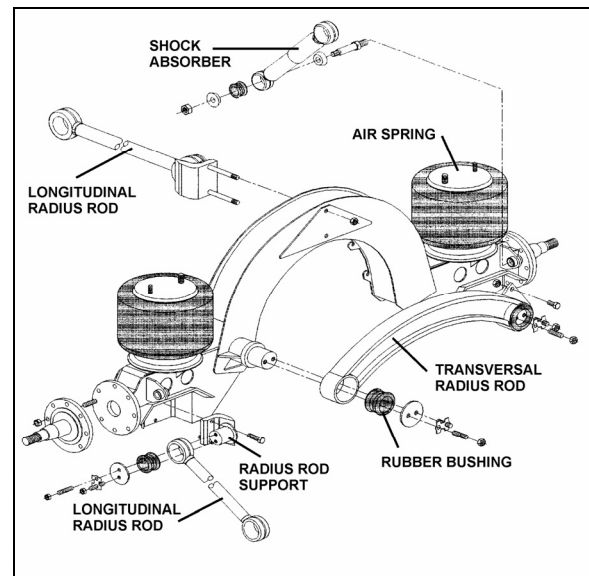

FIGURE 30: TAG AXLE SUSPENSION

16107

### 8.1 AIR SPRINGS

The air springs are made from a special compound rubber molded to the proper contour and dimensions. The entire vertical load of the vehicle is supported by these springs. Each of the two axles is provided with air springs that are attached to the subframe and to the axles (Fig. 31).

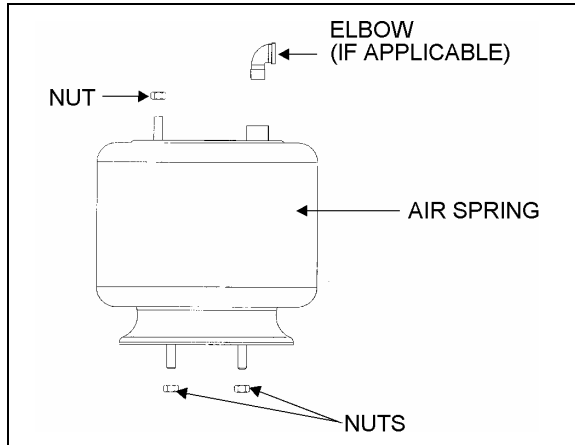

FIGURE 31: AIR SPRING

16052

#### 8.1.1 Inspection

1. Check operation of bellows.
2. Visually inspect bellows for evidence of cracks, punctures, deterioration, or chafing. Replace the bellows if any damage is evident.
3. With the primary air system at normal operating pressure (95 - 125 psi (655 - 860 kPa)), coat all suspension air line connections and bellows mounting areas with a water and soap solution. Bubbles will indicate an air leak, and none is permissible. Repair or replace defective parts.

**NOTE**

*If air spring is removed from vehicle, bellows can be lightly inflated and submerged in water to detect any leakage. If any leakage is detected, replace bellows.*



**WARNING**

To prevent personal injury, do not apply more than 10 psi (69 kPa) of air pressure to the uninstalled air spring.

#### 8.1.2 Removal

**NOTE**

*Suspension air springs (drive and tag axles) can be removed without removing the entire axle assembly.*

1. Safely support vehicle at the recommended body jacking points. To gain access to a given air spring, the corresponding wheel can be removed as follows.
  - a) Jack vehicle until the tire clears the ground, and place safety supports underneath body.



**CAUTION**

Only the recommended jacking points must be used as outlined in Section 18, "Body".

- b) Support the axle with a suitable hydraulic floor jack at the recommended jacking point.
  - c) Remove wheel.
2. Exhaust compressed air from accessory air tank by opening drain cock under reservoir.
3. Disconnect the height control valve link and pull down the overtravel lever to ensure all air is exhausted from air springs.

**NOTE**

*While performing this step, do not change the height control valve overtravel lever adjustment.*

4. Disconnect air line from air spring, remove elbow (if applicable), and cover both the line end and fitting to prevent the entry of foreign matter.
5. Remove the air spring upper nut, and then the two lower nuts. Remove air spring.

#### 8.1.3 Installation

1. Compress air spring as necessary, then aligning studs with their holes, position air spring between both the lower and upper supports. Thread the lower nuts and the small upper nut a few turns.

**NOTE**

*To facilitate air spring installation, compress it manually then put a piece of tape over the air line threaded fitting. This prevents air from getting back into the bag and keeps it compressed, thus enabling to place the bag in between the mounting plates and greatly easing installation.*

2. Tighten and torque the lower stud nuts, and then the upper one to 20 – 25 lbf-ft (27 – 34 Nm).
3. Thread the remaining upper nut (large nut) and tighten to 20 – 25 lbf-ft (27 – 34 Nm).
4. Install elbow (if applicable), then connect air line.
5. Connect the height control valve link.
6. Build up air pressure in system.

**NOTE**

*To accelerate this operation, air reservoirs can be filled from an exterior air supply connected to the accessory tank fill valve or to the emergency fill valve.*

7. Check operation of bellows, and with the primary air system at normal operating pressure (95 – 125 psi (655 – 860 kPa)), coat the air line connections and air spring mounting areas with a water and soap solution. Bubbles will indicate an air leak, and none is permissible. Repair or replace defective parts.
8. Reinstall wheel.
9. Remove the hydraulic floor jack from under the axle, then lower vehicle to ground.

## 8.2 SHOCK ABSORBERS

Double-action, telescoping-type shock absorbers ensure a smooth ride and enhance vehicle stability on the road. All shock absorbers are eye-type mountings. The tag axle is provided with two shock absorbers while the drive axle is provided with four of them (Fig. 28, 29 and 30).

Shock absorbers are non-adjustable and non-repairable. Maintenance requirements involve replacement of the rubber mounting bushings, and tightening of all shock absorber pins at the proper torque of 500 - 550 lbf-ft (680 - 750 Nm) when shock absorber replacement occurs. If a shock absorber becomes inoperative, complete unit must be replaced.

**CAUTION**

When a shock absorber is found defective, always replace with a new set on affected axle, except if there has been a recent replacement of one unit. The following method will help in determining if both shock absorbers on the same axle have to be replaced.

### 8.2.1 Inspection

Loosen lower mounting of both shocks, and then carefully attempt to raise and lower the bottom portion of each shock. Note the rate of effort for distance of travel. Replace both shocks if a definite differential rate is found.

The shock must be bench checked in an upright, vertical position. If checked in any other position, air will enter the cylinder tube and make the shock absorber appear defective.

Proceed as follows to check shock absorbers:

1. With the shock absorber in a vertical position (top end up), clamp the bottom mount in a vise.

**CAUTION**

Do not clamp the reservoir tube or the dust tube.

2. Rotate the dust tube. Notice any binding condition (may be compared with new unit). Binding condition indicates a scored rod. Units with scored rods should be replaced.
3. Fully extend shocks and check for leaks in the seal cover area. Shock fluid is a very thin hydraulic fluid that has a characteristic odor and dark brown tint. A slight trace of shock fluid around the seal cover area is not a cause for replacement. The shock seal is designed to permit a very slight seepage to lubricate the rod. Units that leak should be replaced.
4. Visually check shock for dents that could cause the shock to bind. Also, check for a bent rod.
5. Extend and collapse shock several times to determine that it has control (resistance) in both rebound and compression.
6. Visually inspect the shock mountings and vehicle mounting for:

## Section 16: SUSPENSION

- a) Broken mounts;
- b) Extreme bushing wear;
- c) Shifted bushing or sleeve;
- d) Deep cracks in bushing material (shallow surface cracks are normal);
- e) Loose shock absorber pins;
- f) Presence of convex washers, and their position relative to the rubber bushing.

### 8.2.2 Removal

1. Remove nuts and washers from shock absorbers on upper and lower mounting pins, taking care to identify the inner and outer washers to ease reinstallation. Refer to figure 32 for details.
2. Remove the shock absorber assembly from pins.
3. Remove the two inner bushings from the shock absorber and discard them.

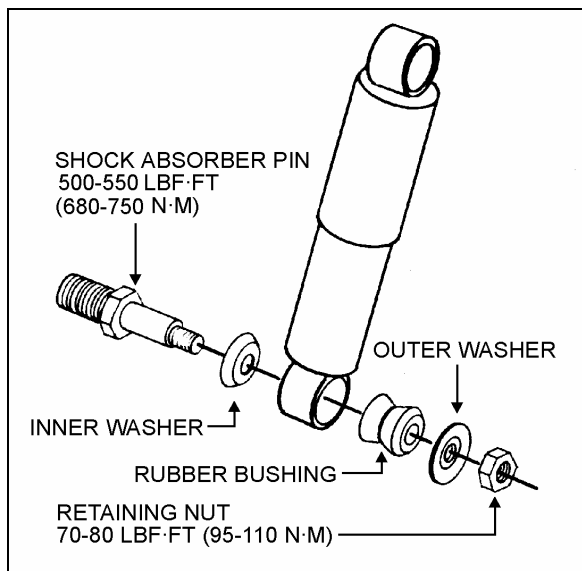

FIGURE 32: SHOCK ABSORBER

16008

### 8.2.3 Installation

1. Ensure that the shock absorber mounting pins are tight and that the threads are not stripped.
2. Install new rubber mounting bushings on shock absorbers (upper and lower).
3. Place the inner washers (with washer convex side facing the shock absorber rubber bushing) on each shock absorber pin (Fig. 33).

4. Install the shock absorber eyes over the mounting pins, then the outer washers (with washer convex side facing the shock absorber rubber bushing) on each shock extremity.

#### NOTE

If shock absorber pins are removed, they must be reinstalled using "loctite" (see "Parts Specifications" in this section).

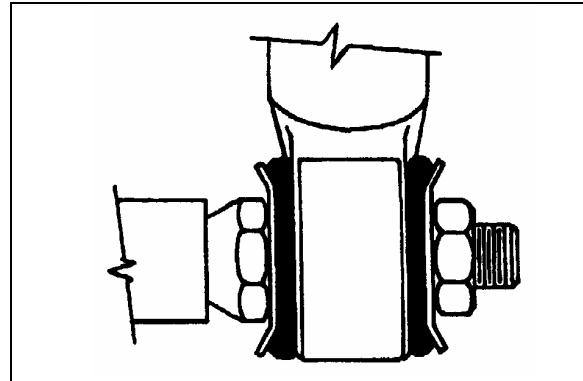

FIGURE 33: TYPICAL SHOCK ABSORBER SETUP

16009

5. Place the lower and upper mounting pin stud nuts and torque to 70 - 80 lbf-ft (95 - 110 Nm).

### 8.3 RADIUS RODS

Radius rods are used to secure the axles in the proper transversal and longitudinal positions. Four radius rods are provided on the drive axle suspension (three longitudinal and one transversal) and also four on the tag axle with a layout similar to the drive axle. Refer to figures 28, 29 and 30 for details. These rods transmit both braking and driving forces from the axles to the vehicle body.

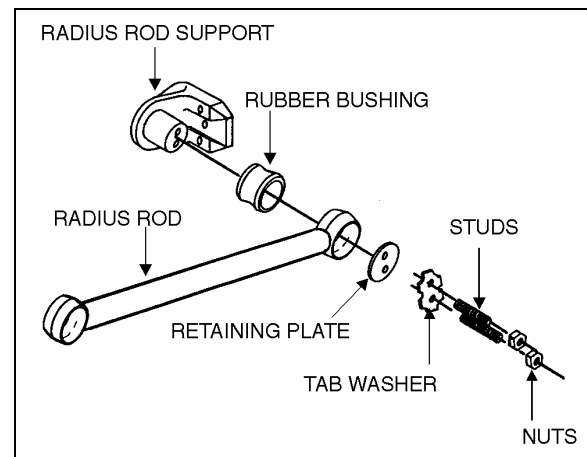

FIGURE 34: TYPICAL RADIUS ROD SETUP

16010

### 8.3.1 Inspection

The following instructions apply to all radius rods used on this vehicle:

1. Clean all parts thoroughly.
2. Inspect radius rods for distortion and cracks. We recommend the "Magnaflux" process to detect cracks in the radius rod. Any damaged part should be replaced with a new one.

#### NOTE

*New bushings should be used when rods are replaced.*

3. The radius rod bushings should be checked periodically for signs of shearing, deterioration, or damage. Any defective part should be replaced with a new one.

### 8.3.2 Removal

1. Flatten the tab washer which secures the two retaining nuts (or bolts), then unscrew the nuts (or bolts) at each extremity of the radius rod (Fig. 34).
2. Remove the tab washer and the retaining plates and radius rod ends from anchor pins, and then remove the radius rod.

### 8.3.3 Bushing removal

1. Safely support the radius rod as shown in figure 35.

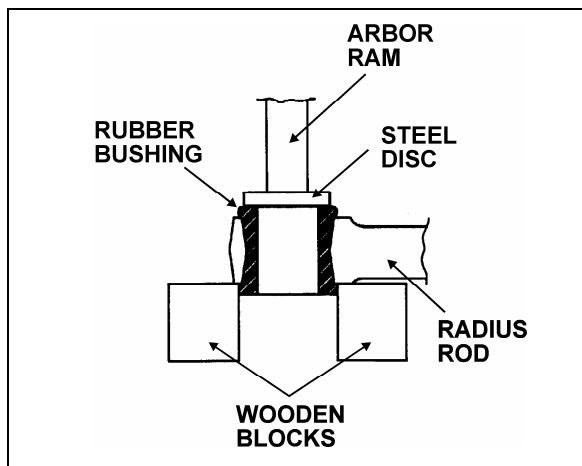

FIGURE 35: RADIUS ROD BUSHING REMOVAL 16011

2. Place a flat steel disc, slightly smaller than the outside diameter of the bushing (Fig. 35).

3. Using an arbor press or a suitable driving tool, press or drive the old bushing out of the rod and discard the bushing.



#### CAUTION

Make sure to prevent the steel disc from contacting the radius rod end.

### 8.3.4 Bushing installation

1. Lightly spray the inner and outer surfaces of radius rod bushing with water.



#### CAUTION

No lubricant whatsoever is to be used on the rubber bushing.

2. Safely support the radius rod, and place new bushing on top of the radius rod end (Fig. 36).
3. Place a block of wood on top of bushing and press on it manually.
4. If necessary, use an arbor press or a suitable driving tool. Press or drive the bushing into the radius rod end until it extends equally on both sides of the rod.
5. It is also possible to proceed differently. Place radius rod bushing on a plane surface. Spray a light coat of water on the inner and outer surfaces of radius rod bushing.
6. Take radius rod, align the bushing. Tap radius rod on bushing until latter is positioned correctly.

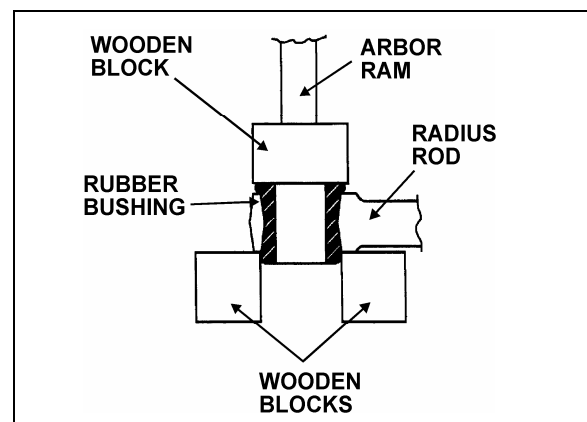

FIGURE 36: RADIUS ROD BUSHING INSTALLATION 16012



### 8.3.5 Installation

1. Lightly spray the radius rod support with water. Place the radius rod end over the radius rod support (Fig. 36).
2. Position the retaining plate. Install the tab washer and nuts (or bolts).

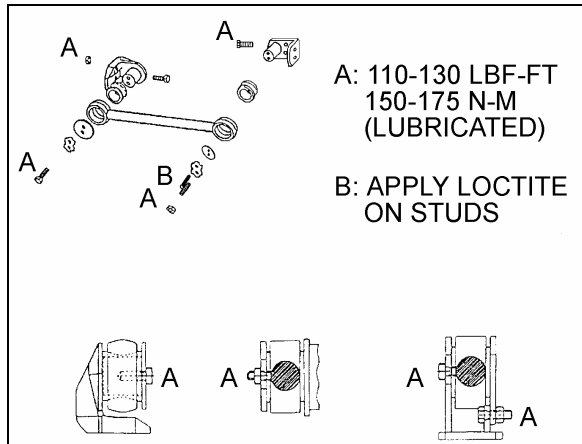

FIGURE 37: RADIUS ROD INSTALLATION 16028

**CAUTION**  
Always use new tab washers at installation.

3. Tighten the nuts (or bolts) lightly, and repeat at the other end.
4. Refer to heading "Suspension Height Adjustment" later in this section, and set the vehicle to normal ride height.
5. With the vehicle at normal ride height, apply oil on threads and tighten all radius rod anchor pin nuts or bolts to 110 – 130 lbf-ft (150 – 175 Nm).

**CAUTION**  
It is extremely important upon reconnection of the rods that the proper clearance height between the axle and body be maintained. Otherwise, the rubber bushings in radius rod ends will become preloaded, thus reducing their life span.

## 9. SUSPENSION HEIGHT ADJUSTMENT

The flow of pressurized air from the accessory air tank to the air springs is controlled by three height control valves. The two rear valves are mounted to the subframe, one on each inner side of rear wheelhousing and connected to the rear axles through an arm and link connection.

The front valve is mounted to the subframe **at center of front sway bar** and connected to the front air tank support (Fig. 38). The front height control valve regulates air to front suspension air springs in order to maintain the vehicle at the required height. These connections allow the valves to apportion air pressure in the springs to the vehicle load, maintaining normal ride height.

Immediate response height control valves increase or decrease the air pressure in the suspension system as required.

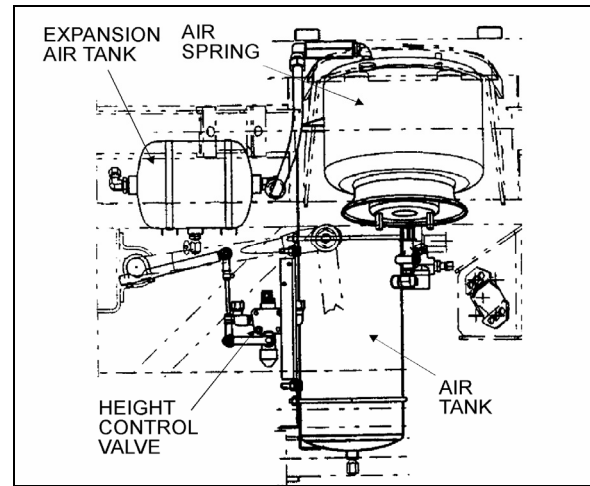

FIGURE 38: HEIGHT CONTROL VALVE LOCATION 16057

The appropriate vehicle body height is obtained by measuring the clearance of all the air springs installed on the vehicle. The two front air springs clearance should be  $11 \pm \frac{1}{4}$ " (279  $\pm$  6 mm). Refer to figure 39 to identify the correct area to take measurement. The rear air springs clearance should be  $11 \frac{1}{2} \pm \frac{1}{4}$ " (292  $\pm$  6 mm).

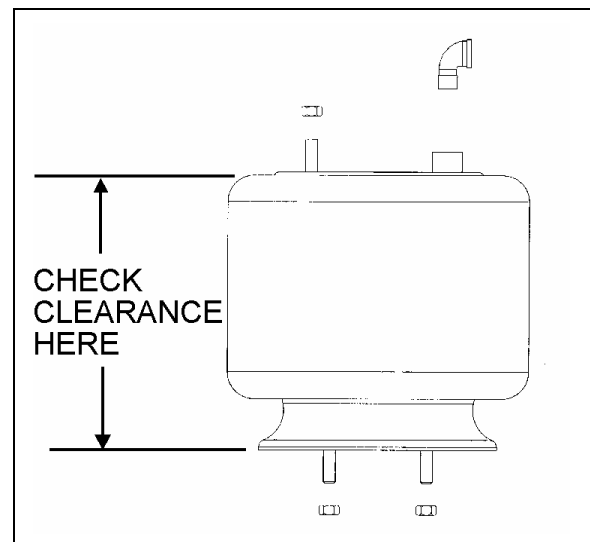

FIGURE 39: TYPICAL AIR SPRING CLEARANCE 16058

At this point, it should not be necessary to make an adjustment under normal service conditions. However, if an adjustment is required, change the position of the overtravel lever in relation to the overtravel control body. The lever should be moved up to raise vehicle height, and down to lower it. Check that main air pressure is at normal operating pressure and raise the vehicle to the specified height.



## CAUTION

Always adjust on "fill cycle". If it is necessary to lower vehicle height, release sufficient air to be well below height, and adjust to height or fill cycle.

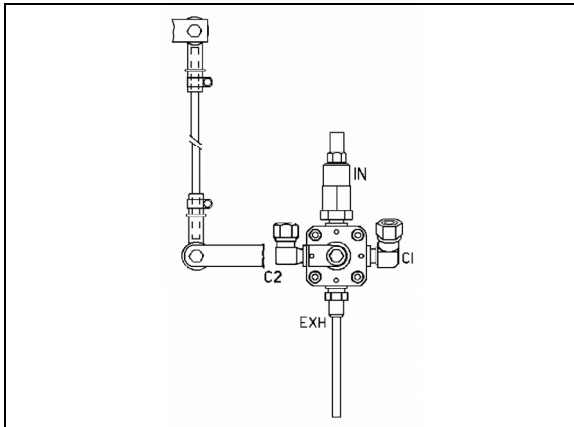

FIGURE 40: FRONT HEIGHT CONTROL VALVE 16100

The normal ride height is obtained by adjusting air spring clearance of both front and rear suspension as follows:

### Front air spring clearance

1. With the vehicle at normal operating air pressure (100 - 125 psi (689 - 860 kPa)), measure air spring clearance. This clearance should be  $11 \pm \frac{1}{4}$ " (279  $\pm$  6 mm).

#### NOTE

The measurement should be taken from underneath the upper air spring support on subframe to top of the lower air spring support on axle (refer to figure 39 for more details). If adjustment is required, begin with the drive axle.

2. Loosen the clamp on the height control valve rubber coupling and bring it up or down (Fig. 40).

#### NOTE

Allow suspension to stabilize before taking reading.

When the desired height is obtained, tighten clamp.

### Rear air springs clearance

1. With the vehicle at normal operating air pressure [100 - 125 psi (689 - 860 kPa)], measure air spring clearance. This clearance should be  $11 \frac{1}{2} \pm \frac{1}{4}$ " (292  $\pm$  6 mm).

#### NOTE

The measurement should be taken from underneath the upper air spring support on subframe to top of the lower air spring support on axle (refer to figure 39 for more details).

2. Loosen the clamp on the height control valve rubber coupling and bring it up or down (Fig. 41).

#### NOTE

Allow suspension to stabilize before taking reading.

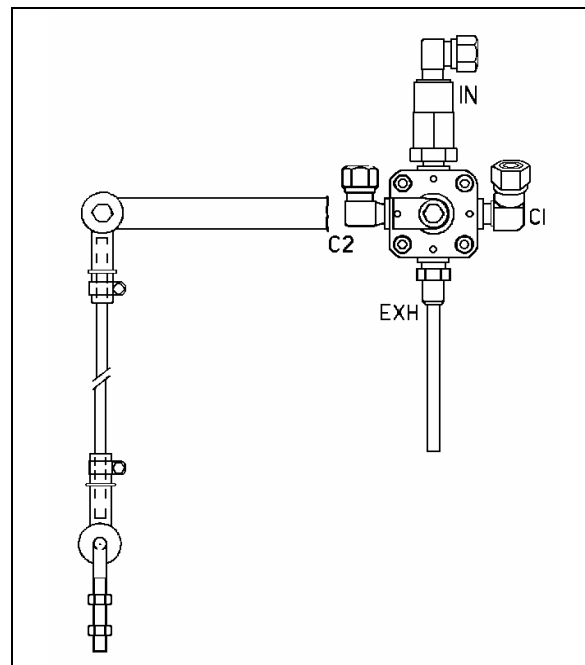

FIGURE 41: REAR HEIGHT CONTROL VALVE 16093

When the desired height is obtained, tighten clamp.

## 10. HEIGHT CONTROL VALVE

The height control valves automatically add air to, or release air from air springs to maintain constant suspension height regardless of load, or load distribution. Each valve adjusts independently according to the following conditions:

### 10.1 LOADING POSITION

As the load increases and lowers the vehicle body, the overtravel lever commands the height control valve to add air to air springs.

### 10.2 NEUTRAL POSITION

When vehicle body reaches the normal ride height, the height control valve overtravel lever reaches the "neutral" position and keeps both the supply and exhaust ports closed to ensure normal ride height is maintained. This condition remains static until the vehicle load is altered.

### 10.3 UNLOADING POSITION

As the load decreases and raises the vehicle body, the overtravel lever commands the height control valve to release air from air springs.

### 10.4 MAINTENANCE

The height control valve requires no periodic maintenance. Height control valve linkage operates on rubber bushings and no lubrication should be attempted at this location. Inspect the valve for loose joints, air leaks and worn bushings.

### 10.5 REMOVAL AND INSTALLATION

Before disconnecting a height control valve air line, securely support the vehicle by its jacking points on the body, and place safety supports underneath body. Refer to paragraph "16. Vehicle Jacking Points" in Section 18, "Body".

1. Exhaust air from air system by opening all air tank drain cocks. Remove height control valves.
2. Disconnect overtravel lever from link and pull down lever to exhaust remaining air from air springs.
3. Disconnect air supply and delivery lines from the height control valve. Cover line ends with tape to prevent entry of foreign matter.
4. Remove the nuts retaining the height control valve to the mounting bracket, then remove valve assembly.

Reverse removal procedure to replace height control valve. After installation, check for leakage using a soap and water solution.

## 11. "LEVEL-LOW" LEVELING SYSTEM

Bus shells are equipped with "LEVEL-LOW" leveling system. The purpose of the "LEVEL-LOW" is to adjust suspension in three separate points (front, rear right and rear left air springs) in order to level vehicle body. Three height control valves, automatically control air pressure in the three separate points (air springs) and maintains a constant vehicle height regardless of load, or load distribution. The control solenoid valve supplies air to the five way three-position air control valve, which bypasses the height control valve, and opens a passage to allow the air control and exhaust valve to release/supply air from air springs. To improve road comfort, an expansion air tank is installed in series with each air spring.

In addition to the above suspension components the system also includes: sway bar, upper and lower A-arms, rods and shock absorbers (Fig. 1).

#### **NOTE**

*Only for preliminary adjustment, refer to figure 21. Torque rod length must be fixed to 21 17/64" (540 mm) and relay rod to 23 19/64" (592 mm).*



#### **CAUTION**

Parts must be replaced by ones with the same part numbers or with equivalent parts, if replacement becomes necessary. Do not use parts of lesser quality or substitute design. Torque values must be used as specified during reassembly to assure proper retention of these parts.

The purpose of the "level-low" leveling system is to adjust suspension in three separate points (front, rear right and rear left) in order to level vehicle body. This system can be put into service when the ignition key is turned to the "ON" position, and must be used only when the parking brake is applied. The "level-low" warning light on the dashboard indicates that the selector switch is not in the "OFF" position. Level low system controls are located on L.H. side control panel.

## 11.1 PRINCIPLES OF OPERATION

## DOWN:

The (front/rear right/rear left) control solenoid valve supplies air to the (front/rear right/rear left) five-way three-position air control valve, which bypasses the (front/rear right/rear left) height control valve, and opens a passage to allow the air control and exhaust valve to release air from (front/rear right/rear left) air springs.

## UP:

The (front/rear right/rear left) control solenoid valve supplies air to the (front/rear right/rear left) five-way three-position air control valve, which bypasses the (front/rear right/rear left) height control valve, and opens a passage to allow the air control and exhaust valve to supply air to (front/rear right/rear left) air springs.

## DRIVE:

When the ignition key is turned to the "ON" position with selector knob in the "DRIVE" position, the drive control solenoid valve supplies air to all five-way three-position air control valves, each one opening a passage to allow height control valves to accomplish their function.

When the ignition key is turned to the "OFF" position and selector knob to the "DRIVE" position, the air is entrapped between air springs and five-way three-position air control valves to ensure the adjusted level will be kept.

**WARNING**

Never move vehicle with selector knob in any other position than the "DRIVE" position.

## 11.2 MAINTENANCE

Since the kneeling action is issued from both the air system and electrical system, refer to Section: 12, "Brake and Air System" and Section 06, "Electrical System".

For diagnosis and understanding of the system, refer to wiring diagrams, and to the appropriate air system schematic diagram annexed to Section 12, "Brake and Air System".

**12. AIR SYSTEM**

The basic air system consists of an air compressor, tanks, valves, filters and interconnecting lines and hoses (refer to Section 12, "Brake and Air System" for complete information). It provides a means for braking, operating controls and accessories, and suspension. An air system schematic diagram is annexed at the end of this Section for better understanding of the system.

The air coming from the air dryer is first directed to the wet air tank, then to the primary (for the primary brake system), secondary (for the secondary brake system), and accessory (for the pneumatic accessories) air tanks (Fig. 42).

In addition, an expansion air tank is installed in series with each air spring.

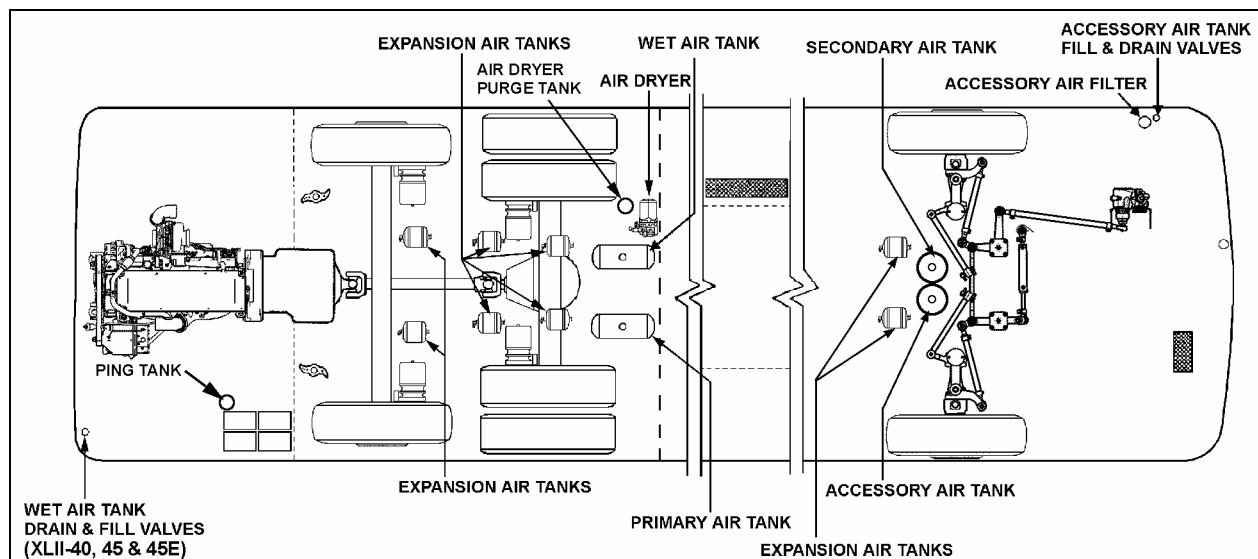

FIGURE 42: LOCATION OF AIR TANKS

24037

## Section 16: SUSPENSION

### 12.1 AIR TANK MAINTENANCE

Ensure that the accessory air tank is purged during pre-starting inspection. A good practice is to purge this tank at the end of every driving day by the remote air tank drain valve located in the steering compartment (Fig. 42).

Moreover, purge all tanks by their bottom drain valves at specified intervals.

#### 12.1.1 Wet Air Tank

This tank is installed above L.H. wheel of drive axle, and is provided with a bottom drain valve. It is recommended to **purge** the wet air tank by its bottom drain valve every 12,500 miles (20 000 km), or once a year, whichever comes first.

A remote valve located in engine compartment and accessible through engine R.H. side door is used to **drain** the air dryer (Fig. 43).

#### 12.1.2 Primary Air Tank

The primary air tank is located above R.H. wheel of drive axle.

This tank is provided with a bottom drain valve (Fig. 42). It is recommended to purge the primary air tank by its bottom drain valve every 12,500 miles (20 000 km) or once a year, whichever comes first.

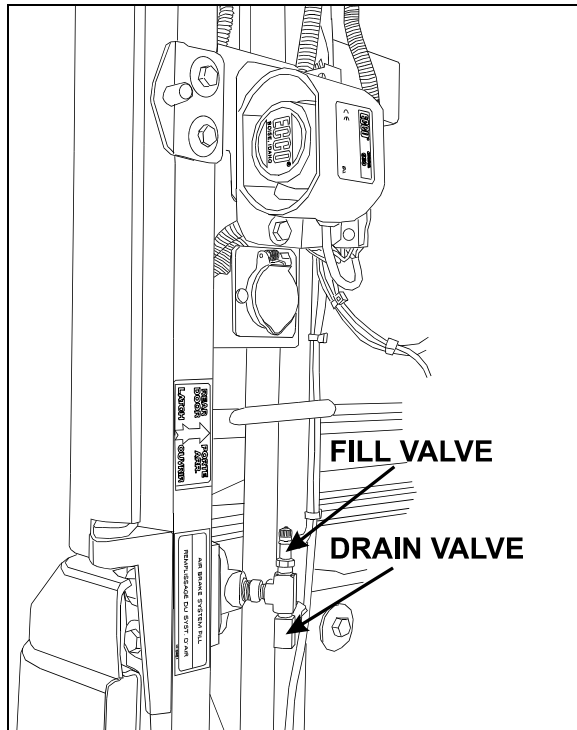

FIGURE 43: REAR VALVE LOCATION

12202

#### 12.1.3 Secondary Air Tank

This tank is located in front wheelhousing, between air springs. The tank is installed vertically and is provided with a bottom drain valve (Fig. 42).

It is recommended to purge the tank by its bottom drain valve, every 12,500 miles (20 000 km) or once a year, whichever comes first.

#### 12.1.4 Accessory Air Tank

The accessory air tank is installed next to the secondary air tank. The tank is installed vertically and is provided with a bottom drain valve (Fig. 42).

It is recommended to purge the tank by its bottom drain valve, every 12,500 miles (20 000 km) or once a year, whichever comes first.

A remote drain valve is located in front service compartment (Fig. 44) underneath the accessory air filter. Refer to Section 12, paragraph "5. Accessory Air Filter" of the maintenance manual for daily purge procedure.

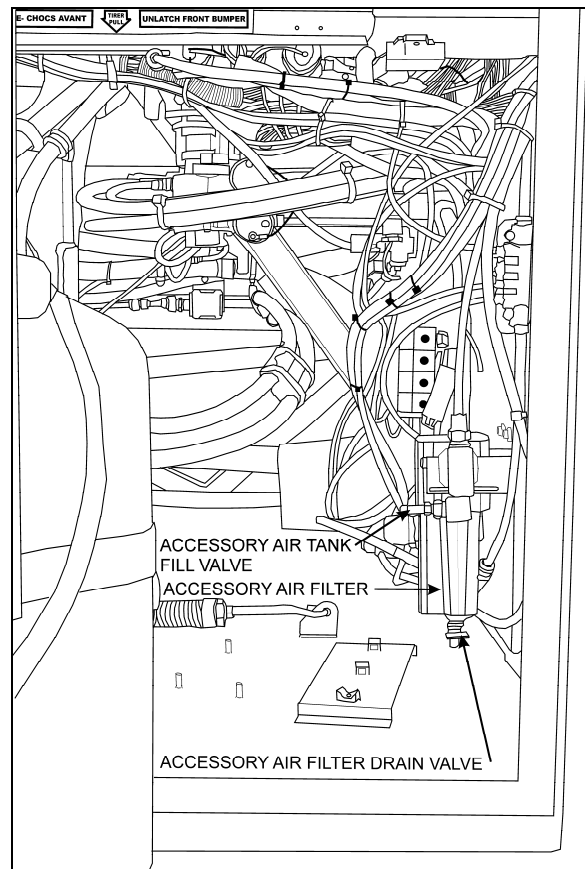

FIGURE 44: FRONT VALVE LOCATION

12218

### 12.1.5 Expansion Air Tank

Two expansion tanks are located in front wheelhousing. These air tanks are located behind secondary and accessory air tank. Also, six expansion tanks are located near rear air springs (Fig. 42). Expansion tanks are connected in series with air springs. Expansion tanks are used to lower the stiffness of the air spring. They are provided with a bottom drain valve.

It is recommended to purge them, with all other tanks, every 12,500 miles (20 000 km) or once a year, whichever comes first.

### 12.2 EMERGENCY FILL VALVES

The vehicle is equipped with two air system emergency fill valves to supplement the air system when air pressure is low and engine cannot be operated.

**The rear valve** is located in engine compartment and accessible from engine R.H. side door (Fig. 43).



#### CAUTION

No other point should be used to supply air system. The maximum allowable air pressure is 125 psi (860 kPa).

The front valve is located in the front service compartment close to accessory air filter (Fig. 44).

These two air valves are fitted with the same valve stems as standard tires, and can be filled by any standard external air supply line.

The rear valve will supply air for all systems (brakes, suspension and accessories) while the front valve will supply air for accessories only.



#### CAUTION

Air filled through these two points will pass through the standard air filtering system provided by Prévost. Do not fill air through any other points.

## 13. HUB UNIT AND SWIVEL ASSEMBLY

Refer to "DANA SPICER Service Manual General Information, Maintenance Manual Model NDS and Maintenance Manual NDS Axles" annexed to section 11 "*Rear Axles*".

**Section 16: SUSPENSION**

**14. TORQUE TABLE**

DESCRIPTION	QTY	TORQUE (DRY)	
		Lbf-ft	Nm
Pitman Arm to Steering Gear Fixing Nut	1	470-570	637-773
Steering Gear to Mounting Bracket Bolts	5	365-405	495-550
Drag Link to Pitman Arm Stud Nut *	1	150-200	203-271
Drag Link to Bell crank Stud Nut *	1	150-200	203-271
Drag Link Socket End Clamp Bolt Nut	2	40-60	55-80
Relay Rod to Bell crank Stud Nut *	1	150-200	203-271
Relay Rod to Idler Arm Stud Nut *	1	150-200	203-271
Tie Rod to Bell crank Stud Nut *	1	150-200	203-271
Tie Rod to Idler Arm Stud Nut*	1	150-200	203-271
Tie Rod to Steering Arm Stud Nut *	2	150-200	203-271
Tie Rod End Clamp Bolt Nut	4	40-60	55-80
Steering Arm to Steering Knuckle Bolt (M20 X 65)	2	520-575	705-780
Steering Arm to Steering Knuckle bolt (M24 X 100)	2	751-830	1018-1125
Torque Rod Stud Nut	2	160-215	217-292
Torque Rod Mounting Bracket Stud	4	90-110	122-150
Torque Rod Mounting Bracket Nut	4	140-155	190-210
Idler Arm and Bell Crank Mounting Spindle Nut	8	90-105	122-142
Jacking Point Bracket Nut	8	70-80	95-110
Sway Bar Bushing Collar Nuts	8	80-100	110-135
Sway Bar Link Upper and Lower Nuts (Front Suspension)	2	165-200	225-270
Sway Bar Link Upper Nuts (Rear Suspension)	2	100-120	135-160
Sway Bar Link Lower Nuts (Rear Suspension)	2	70-80	95-110
Shock Absorber Pin	2	350-400	475-545
Shock Absorber Support	4	145-165	196-224
Shock Absorber Upper Mounting Pin Stud Nut	2	70-85	95-115
Shock Absorber Lower Mounting Pin Nut	2	60-75	81-102
Air Spring Lower Nut	4	20-25	27-34
Air Spring Upper Nut	2	20-25	27-34
Upper A-Arm Central Ball Joint (Hex Castle Nut)*	2	310-340	420-461
Upper A-Arm Ball Joint	8	230-255	312-346
Lower A-Arm Central Ball Joint (Hex Castle Nut)*	2	490-540	664-732
Lower A-Arm Ball Joint	8	270-300	366-407

\* Tighten nut to specified torque, then advance to next aligning cotter pin slot and install a new cotter pin.

**15. SPECIFICATIONS****Front Axle Air Springs**

Make..... Goodyear Tire and Rubber  
 Model..... 1400  
 Type ..... Mae West  
 Diameter..... 14.5 inches  
 Air Inlet ..... 1/2" - 14 NPTF  
 Prévost number..... 630239

**Tag Axle Air Springs (WE)**

Make..... Goodyear Tire and Rubber  
 Model..... 1200  
 Type ..... Mae West  
 Nominal diameter ..... 12" (304 mm)  
 Prévost number..... 630151

**Tag Axle Air Springs (W0 & W5)**

Make..... Goodyear Tire and Rubber  
 Model..... 1100  
 Type ..... Mae West  
 Nominal diameter ..... 11.5" (304 mm)  
 Prévost number..... 630259

**Drive axle air springs**

Make..... Goodyear Tire and Rubber  
 Model..... 1100  
 Type ..... Double Flare  
 Nominal diameter ..... 11.5" (292 mm)  
 Prévost number..... 630105

**Front axle shock absorbers**

Make..... Arvin  
 Color..... Black  
 Piston Diam. .... 1 5/8 inch  
 Collapsed length ..... 14.16 inches  
 Extended length ..... 22.44 inches  
 Prévost number..... 630136

**Drive and tag axle shock absorbers**

Make..... Sachs  
 Color..... Black  
 Type ..... N45X225HA  
 Ext. Diam. .... 75 mm  
 Collapsed length ..... 15.51" (394 mm)  
 Extended length ..... 24.37" (619 mm)  
 Prévost number..... 630253

**Height control valve (Front)**

Make..... Barksdale  
 Quantity used ..... 1  
 Prévost number..... 630157



## Section 16: SUSPENSION

---

### Height control valve (Rear)

Make..... Barksdale  
Quantity ..... 2  
Prévost number ..... 630156

### Radius rod bushing

Make..... Prévost  
Prévost number ..... 630021

### Loctite

Make..... Loctite  
Prévost number ..... 680039

### Sway bar bushing (Front Suspension)

Make..... Prévost  
Prévost number ..... 630020

### Sway bar bushing (Drive Axle)

Make..... Prévost  
Prévost number ..... 130953

### Sway bar link

Make..... Tennaco Automotive  
Prévost number ..... 630230

### Shock absorber bushings

Make..... Monroe  
Prévost number ..... 630062

### Air regulator

Make..... Norgren  
Recommended pressure sett..... 90 psi (621 kPa)  
Prévost number ..... 641352

### Shim (Camber Adjustment)

Thickness ..... 3.175 mm  
Prévost number ..... 160993  
Thickness ..... 6.35 mm  
Prévost number ..... 160992

# SECTION 22: HEATING AND AIR CONDITIONING

## CONTENTS

<b>1. HEATING AND AIR CONDITIONING</b> .....	<b>4</b>
<b>2. AIR CIRCULATION WITH CENTRAL HVAC SYSTEM</b> .....	<b>4</b>
2.1 DRIVER'S AREA.....	4
2.2 CABIN AREA .....	4
<b>3. AIR CIRCULATION WITH SMALL HVAC SYSTEM</b> .....	<b>4</b>
<b>4. SMALL HVAC SYSTEM OPERATION</b> .....	<b>5</b>
<b>5. CENTRAL HVAC SYSTEM OPERATION</b> .....	<b>5</b>
5.1 DRIVER'S UNIT OPERATION .....	5
5.2 CABIN UNIT OPERATION .....	6
<b>6. HVAC UNIT MAINTENANCE</b> .....	<b>7</b>
6.1 COIL CLEANING.....	7
6.2 DRIVER'S HVAC UNIT & CABIN HVAC UNIT AIR FILTERS .....	8
<b>7. HVAC SYSTEM PARTICULARITIES, TESTING AND TROUBLESHOOTING</b> .....	<b>9</b>
7.1 HVAC SYSTEM AND TEST MODE FOR SWITCHES AND SENSORS .....	9
7.2 HVAC SYSTEM AND TEST MODE FOR ELECTRIC MOTORS .....	10
7.3 PARTICULARITIES.....	10
7.4 HVAC SYSTEM TROUBLESHOOTING.....	11
<b>8. CENTRAL HVAC SYSTEM - AIR CONDITIONING</b> .....	<b>12</b>
8.1 A/C CYCLE .....	12
8.2 REFRIGERANT.....	13
8.2.1 <i>Procurement</i> .....	13
8.2.2 <i>Precautions in Handling Refrigerant</i> .....	13
8.2.3 <i>Treatment in Case of Injury</i> .....	13
8.2.4 <i>Precautions in Handling Refrigerant Lines</i> .....	14
8.3 PUMPING DOWN .....	16
8.4 ADDING REFRIGERANT (VAPOR STATE).....	17
8.5 EVACUATING SYSTEM .....	17
8.5.1 <i>Double Sweep Evacuation Procedure</i> .....	17
8.6 CHARGING SYSTEM.....	19
8.7 REFRIGERANT SYSTEM CLEAN-OUT AFTER COMPRESSOR FAILURE.....	19
8.7.1 <i>Determining Severity of Failure</i> .....	19
8.7.2 <i>Clean-out after Minor Compressor Failure</i> .....	19
8.7.3 <i>Clean-out After Major Compressor Failure</i> .....	20
<b>9. CENTRAL HVAC SYSTEM – AIR CONDITIONING COMPONENTS</b> .....	<b>20</b>
9.1 COMPRESSOR (CENTRAL SYSTEM).....	20
9.1.1 <i>Belt Replacement</i> .....	20
9.1.2 <i>Belt Play</i> .....	21
9.1.3 <i>Pulley Alignment</i> .....	21
9.1.4 <i>Longitudinal Compressor Alignment</i> .....	21
9.1.5 <i>Horizontal Compressor Alignment</i> .....	21
9.1.6 <i>Vertical Compressor Alignment</i> .....	21
9.1.7 <i>Compressor Maintenance</i> .....	22
9.1.8 <i>Troubleshooting Guide</i> .....	22
9.2 MAGNETIC CLUTCH .....	23
9.3 EVAPORATOR MOTOR .....	23

## Section 22: HEATING AND AIR CONDITIONING

---

9.3.1	Removal .....	23
9.3.2	Installation .....	23
9.3.3	Checking Operation of Brush in Holder .....	23
9.3.4	Brush Wear Inspection and Replacement .....	24
9.3.5	Seating Brushes .....	24
9.3.6	Brush Holder Adjustment .....	25
9.3.7	Checking Commutator.....	26
9.4	CONDENSER .....	26
9.4.1	Condenser Fan Motors.....	26
9.4.2	Condenser Fan Motor Removal.....	26
9.4.3	Preliminary Disassembly.....	26
9.4.4	Disassembly.....	27
9.5	RECEIVER TANK.....	27
9.6	FILTER DRYER .....	27
9.6.1	Replacement .....	27
9.6.2	Moisture Indicator.....	27
9.7	LIQUID REFRIGERANT SOLENOID VALVE .....	28
9.7.1	Manual Bypass.....	28
9.7.2	Coil Replacement.....	28
9.7.3	Valve Disassembly.....	28
9.7.4	Valve Reassembly.....	29
9.8	EXPANSION VALVE .....	29
9.8.1	Cabin HVAC Unit.....	29
9.8.2	Driver's HVAC Unit.....	31
9.9	TROUBLESHOOTING .....	32
9.9.1	Expansion Valve.....	32
9.9.2	A/C.....	33
9.10	TEMPERATURES & PRESSURES .....	35
9.11	TORCH BRAZING .....	36
9.12	LEAK TESTING .....	36
<b>10.</b>	<b>SMALL HVAC SYSTEM - AIR CONDITIONING COMPONENTS.....</b>	<b>36</b>
10.1	COMPRESSOR .....	36
10.2	COMPRESSOR REMOVAL .....	36
10.2.1	When the compressor is operational.....	36
10.2.2	When the compressor is inoperable.....	37
10.2.3	Evacuating System Before Adding Refrigerant (Auxiliary System) .....	37
10.3	OIL ADDITION.....	37
10.4	COMPRESSOR OIL CONTAMINATION .....	37
10.5	OIL RETURN OPERATION .....	37
<b>11.</b>	<b>HEATING SYSTEM .....</b>	<b>39</b>
11.1	CENTRAL HEATING SYSTEM.....	39
11.1.1	Draining Heating System.....	39
11.1.2	Filling Heating System.....	41
11.1.3	Bleeding Heating System.....	41
11.1.4	Soldering .....	42
11.1.5	Driver's Hot Water Pneumatic valve Assembly.....	42
11.1.6	Central Hot Water Pneumatic Valve Assembly.....	43
11.1.7	Water Recirculating Pump.....	45
11.2	SMALL HEATING SYSTEM.....	48
11.2.1	Draining Heating System.....	48
11.2.2	Filling Heating System.....	48
11.2.3	Driver's Hot Water Pneumatic Valve Assembly .....	48
11.2.4	Water Recirculating Pump.....	48

12. SPECIFICATIONS ..... 52

ILLUSTRATIONS

FIGURE 1: DRIVER’S AIR CIRCULATION .....4  
 FIGURE 2: CABIN AREA RECIRCULATION DAMPER .....4  
 FIGURE 3: CENTRAL HVAC SYSTEM AIR CIRCULATION .....5  
 FIGURE 4: SMALL HVAC SYSTEM CONTROL MODULE.....5  
 FIGURE 5: CENTRAL HVAC SYSTEM CONTROL MODULE.....5  
 FIGURE 6: EVAPORATOR COMPARTMENT.....6  
 FIGURE 7: CONDENSER COMPARTMENT .....7  
 FIGURE 8: A/C JUNCTION BOX .....7  
 FIGURE 9: DRIVER’S HVAC UNIT COIL ACCESS PANEL .....7  
 FIGURE 10: EVAPORATOR COIL ACCESS PANEL.....8  
 FIGURE 11: EVAPORATOR COIL CLEANING .....8  
 FIGURE 12: CONDENSER COIL CLEANING .....8  
 FIGURE 13: ACCESS TO DRIVER’S HVAC UNIT AIR FILTERS .....9  
 FIGURE 14: DRIVER’S HVAC UNIT AIR FILTERS .....9  
 FIGURE 15: CABIN HVAC UNIT AIR FILTERS.....9  
 FIGURE 16: REFRIGERANT CIRCUIT (CENTRAL SYSTEM) .....15  
 FIGURE 17: DOUBLE SWEEP EVACUATION SET-UP .....18  
 FIGURE 18: AIR PRESSURE REGULATOR.....20  
 FIGURE 19: BELT TENSIONER .....21  
 FIGURE 20: BELT PLAY.....21  
 FIGURE 21: COMPRESSOR ALIGNMENT.....21  
 FIGURE 22: COMPRESSOR ALIGNMENT.....22  
 FIGURE 23: EVAPORATOR COMPARTMENT .....23  
 FIGURE 24: EVAPORATOR MOTOR ASSY FIXING BOLTS.....23  
 FIGURE 25: EVAPORATOR MOTOR ASSEMBLY .....24  
 FIGURE 26: PROPER GRINDING TECHNIQUE .....24  
 FIGURE 27: IMPROPER GRINDING TECHNIQUE .....24  
 FIGURE 28: GRINDING WITH THE BRUSH SEATER STONE .....25  
 FIGURE 29: SEATING SURFACE OF THE BRUSH.....25  
 FIGURE 30: EVAPORATOR MOTOR .....26  
 FIGURE 31: CONDENSER FAN MOTOR .....26  
 FIGURE 32: A/C CONDENSER COMPARTMENT.....27  
 FIGURE 33: DRIVER’S LIQUID REFRIGERANT SOLENOID VALVE .....28  
 FIGURE 34: REFRIGERANT SOLENOID VALVE.....29  
 FIGURE 35: EXPANSION VALVE .....30  
 FIGURE 36: SUPERHEAT ADJUSTMENT INSTALLATION .....30  
 FIGURE 37: HIGH & LOW SWING TEMPERATURE AT REMOTE BULB .....31  
 FIGURE 38: COMPRESSOR REMOVAL OR INSTALLATION .....37  
 FIGURE 39: REFRIGERANT CIRCUIT (SMALL SYSTEM) .....38  
 FIGURE 40: CEILING OF THE SPARE WHEEL COMPARTMENT .....39  
 FIGURE 41: DRIVER’S HVAC UNIT .....39  
 FIGURE 42: CENTRAL HEATING SYSTEM COMPONENTS .....40  
 FIGURE 43: HEATER LINE SHUTOFF VALVES .....41  
 FIGURE 44: HEATER LINE SHUT-OFF VALVES .....41  
 FIGURE 45: CABIN HVAC UNIT DRAIN COCK .....41  
 FIGURE 46: DRIVER’S HOT WATER PNEUMATIC VALVE ASSEMBLY .....42  
 FIGURE 47: PNEUMATIC WATER VALVE .....43  
 FIGURE 48: CENTRAL HOT WATER PNEUMATIC VALVE ASSEMBLY .....43  
 FIGURE 49: PNEUMATIC WATER VALVE .....44  
 FIGURE 50: PUMP LOCATION .....45  
 FIGURE 51: WATER RECIRCULATING PUMP (CENTRAL HVAC SYSTEM) .....47  
 FIGURE 52: CEILING OF THE SPARE WHEEL COMPARTMENT .....49  
 FIGURE 53: HEATER LINE SHUTOFF VALVES (W5) .....49  
 FIGURE 54: HEATER LINE SHUTOFF VALVES (WE) .....50  
 FIGURE 55: SMALL HEATING SYSTEM COMPONENTS .....51

## Section 22: HEATING AND AIR CONDITIONING

### 1. HEATING AND AIR CONDITIONING

The vehicle interior is pressurized by its Heating, Ventilation and Air Conditioning (HVAC) system. Two HVAC systems are available: Small HVAC System and Central HVAC System. The vehicle interior should always be slightly pressurized to prevent dust and moisture from entering. If the vehicle is equipped with a Central HVAC System; air flow and controls divide the vehicle into two areas: driver's area and cabin area. Each area has its own fresh air, returning air and discharge air ducting; exhaust is mainly done through normal air-tightness losses.

### 2. AIR CIRCULATION WITH CENTRAL HVAC SYSTEM

#### 2.1 DRIVER'S AREA

Fresh air is taken from a plenum behind the front bumper and enters the mixing box through an ON/OFF damper. Returning air is taken through the right console into the mixing box. Mixed air goes through cooling and heating coils, fans and discharge ducts.

Both right and left discharge ducts defrost one half of the windshield. The driver can also divert his air flow to the dashboard, from which he can direct vent to his upper body with adjustable HVAC register and to his feet with the appropriate button (see figure 1 and Owner's manual)

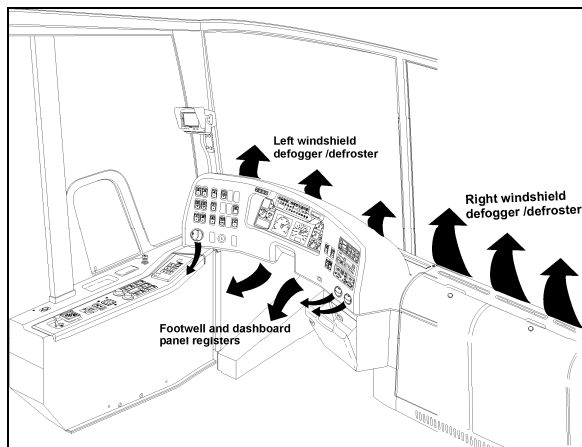

FIGURE 1: DRIVER'S AIR CIRCULATION

22171

#### 2.2 CABIN AREA

Fresh air enters the vehicle on the L.H. side, through the recirculation damper located inside the evaporator compartment door (Fig. 2). The damper can be fully opened for normal operation or closed for extreme weather or highly polluted

areas (Refer to the Owner's Manual for more details). The recirculation REC button is located on the HVAC control module. Press down the button to partially close the fresh air damper. Return air is drawn from inside the vehicle through a wire mesh opening in the floor located amidships on L.H. side of vehicle (Fig. 3).

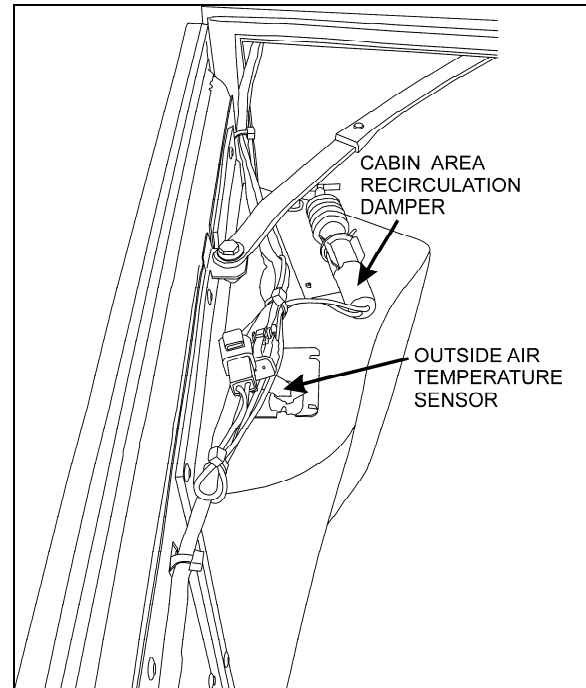

FIGURE 2: CABIN AREA RECIRCULATION DAMPER<sup>22339</sup>

A double blower fan unit, which is activated by the evaporator motor, draws mixed air through an air filter, cooling and heating coils, then forces this air in the ventilation ducts along the walls, and finally exhausts it just below side windows.

### 3. AIR CIRCULATION WITH SMALL HVAC SYSTEM

Fresh air is taken from a plenum behind the front bumper and enters the mixing box through an adjustable damper. Returning air is taken through the right console into the mixing box. The recirculation REC button is located on the HVAC control module (Figure 4). Mixed air goes through cooling and heating coils, fans and discharge ducts.

Both right and left discharge ducts defrost/defog one half of the windshield. The driver can divert his air flow to the dashboard, from which he can direct vent to his upper body with adjustable HVAC register and to his feet with the appropriate button (see figure 1 and Owner's manual).

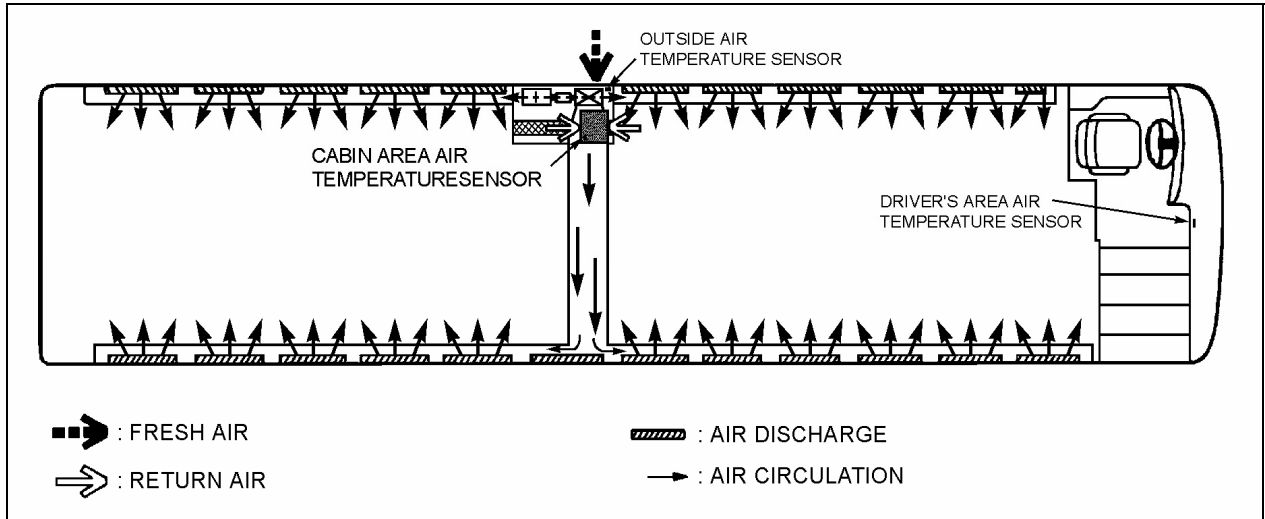

FIGURE 3: CENTRAL HVAC SYSTEM AIR CIRCULATION

22334

#### 4. SMALL HVAC SYSTEM OPERATION

Only the temperature in the driver's area is controlled by the HVAC control module mounted on the R.H. dashboard panel (Fig. 4).

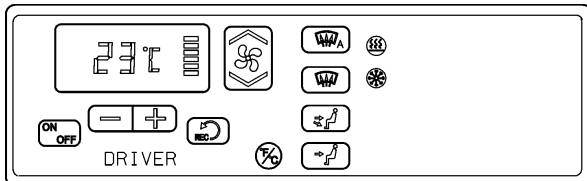

FIGURE 4: SMALL HVAC SYSTEM CONTROL MODULE<sup>22184</sup>

Using the Up/Down type switch sets the fan speed and the speed chosen is displayed on the HVAC control module.

**NOTE**

The driver's area air temperature sensor is located behind the grill of the R.H. side console.

**NOTE**

The outside air temperature sensor is located behind the front bumper on the L.H. side.

#### 5. CENTRAL HVAC SYSTEM OPERATION

To operate the air conditioning system when coach is stationary, engine should run at fast idle. During operation of the air conditioning system, windows should be kept closed and door not left open longer than necessary. In order to prevent battery discharge, HVAC system will not operate if vehicle charging system is not working properly.

#### 5.1 DRIVER'S UNIT OPERATION

The temperature control in the driver's area is provided directly by the L.H. portion of the HVAC control module mounted on the R.H. dashboard panel (Fig. 5).



FIGURE 5: CENTRAL HVAC SYSTEM CONTROL MODULE

The driver's HVAC unit piping is paralleled with the cabin HVAC unit piping. Both units use the same refrigerant and coolant, and are linked to the same condenser and compressor, even if they are individually controlled. It requires the cabin HVAC unit to engage the A/C compressor magnetic clutch. Consequently, the driver's unit cannot be operated in the A/C mode alone.

**NOTE**

The driver's HVAC unit turns on automatically at starting of the engine and uses the settings that were kept in memory before turning off of the system.

The A/C compressor starts automatically when the two following conditions are satisfied:

1. The outside temperature is above 32°F (0°C).
2. The cabin area air temperature has reached 7°F (4°C) under the set point.

## Section 22: HEATING AND AIR CONDITIONING

Using the Up/Down type switch  sets the fan speed and the speed chosen is illustrated on the window display.

### NOTE

Upon starting, if the outside temperature is above 32°F (0°C) and then drops below 32°F (0°C), the compressor will keep running up to a temperature of 15°F (-9°C) to prevent condensation from forming on the windows.

### NOTE

To perform a test of the driver's unit windshield defroster, it is possible to run the system without running the engine.

The following 2% error chart and table can be used to troubleshoot the driver's area air temperature sensor and the outside air temperature sensor.

### NOTE

The driver's area air temperature sensor is located behind the grill of the R.H. side console (Refer to fig.12).

Temp °C	Temp °F	Resistance Ohms
-40	-40	100865
-35	-31	72437
-30	-22	52594
-25	-13	38583
-20	-4	28582
-15	5	21371
-10	14	16120
-5	23	12261
0	32	9399
5	41	7263
10	50	5658
15	59	4441
20	68	3511
25	77	2795
30	86	2240
35	95	1806
40	104	1465
45	113	1195
50	122	980
55	131	808
60	140	670
65	149	559
70	158	468
75	167	394
80	176	333
85	185	283
90	194	241
95	203	207
100	212	178
105	221	153
110	230	133
115	239	115

120	248	100
125	257	88
130	266	77
135	275	68
140	284	60
145	293	53
150	302	47

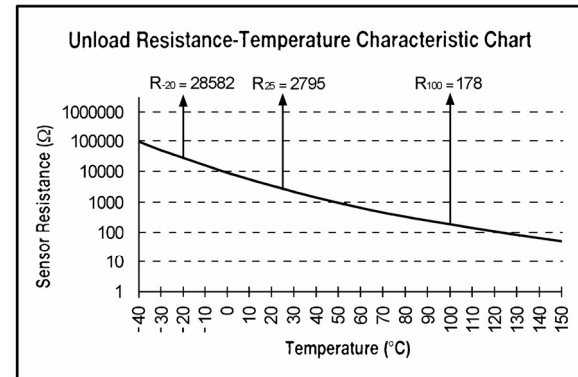

## 5.2 CABIN UNIT OPERATION

The HVAC control module located on the R.H. dashboard panel (Fig. 5), enables the selection of the temperature in the cabin area (refer to the Owner's Manual for details).

Temperature control is provided in conjunction with a thermistor air temperature sensor located amidships on L.H. side of vehicle, underneath the wire mesh opening in the floor (Figs. 3 & 6).

The flow of water to the vehicle's main heater core is controlled by an electric water valve which varies the cycling rate depending on selected temperature. A red LED, located on HVAC control module illuminates when heating mode is selected. A green LED illuminates when compressor clutch is in operation.

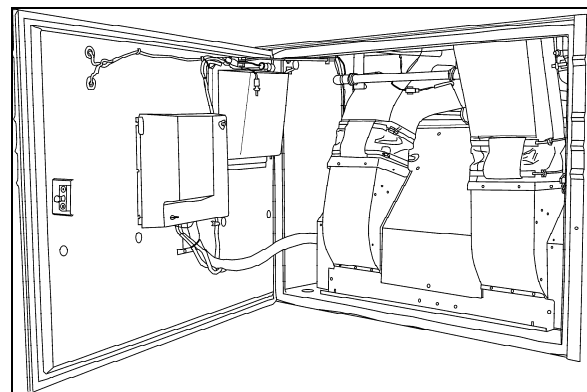

FIGURE 6: EVAPORATOR COMPARTMENT

22178F

The evaporator fan motor, located in the evaporator compartment, is protected by a 90 amps, manually-resettable (CB4) circuit breaker mounted in the engine compartment, on the

circuit breakers panel (refer to Section 06, "Electrical System" in this manual for details).

The condenser coil mounted on the opposite side of the evaporator is ventilated by two axial fans. The fan motors are protected by a manually-resettable 70 amp circuit breaker (CB 5) and a 40 amp circuit breaker (CB 8) also mounted in the engine compartment, on the circuit breakers panel (Fig. 7).

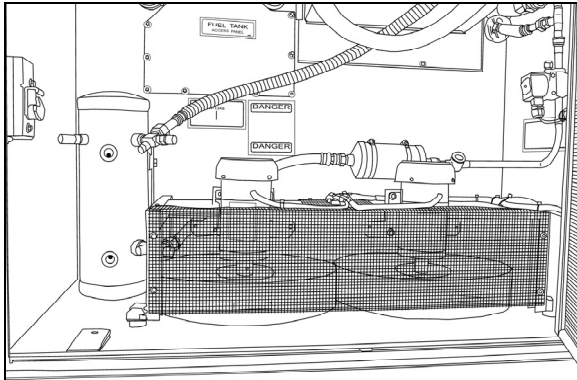

FIGURE 7: CONDENSER COMPARTMENT

Furthermore, the following relays, diodes and multiplex module are located in the evaporator compartment (Fig. 8). They are mounted in the HVAC junction box located inside the evaporator compartment door.

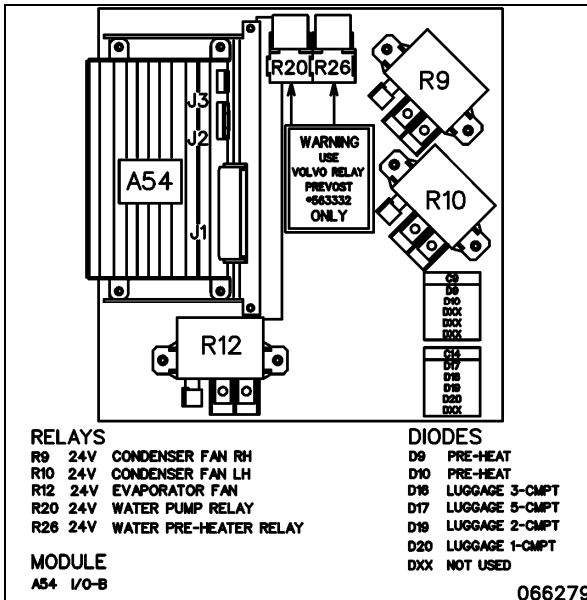

FIGURE 8: A/C JUNCTION BOX

Multiplex Module (evaporator compartment)	
A54	I/O-B
Relays (evaporator compartment)	
R9	24V Condenser fan R.H.
R10	24V Condenser fan L.H.
R12	24V Evaporator fan
R20	Water pump
R26	Pre-heating
Diodes (evaporator compartment)	
D9	Pre-heating
D10	Pre-heating
D16	Baggage compartment -3
D17	Baggage compartment -5
D19	Baggage compartment -2
D20	Baggage compartment -1
DXX	Not used

6. HVAC UNIT MAINTENANCE

No special maintenance is required on the cabin and driver's HVAC units, with the exception of cleaning their respective coils and air filters, plus periodic inspection for broken drains, hoses and charging of system.

NOTE

Squeeze rubber discharge tubes located underneath the appropriate compartment to eliminate the accumulated water and dirt when you make routine maintenance.

6.1 COIL CLEANING

Check the external surface of the coil at regular intervals for dirt or any foreign matter.

For the driver's HVAC unit, remove the grill and the access panels and back flush the coil from inside.

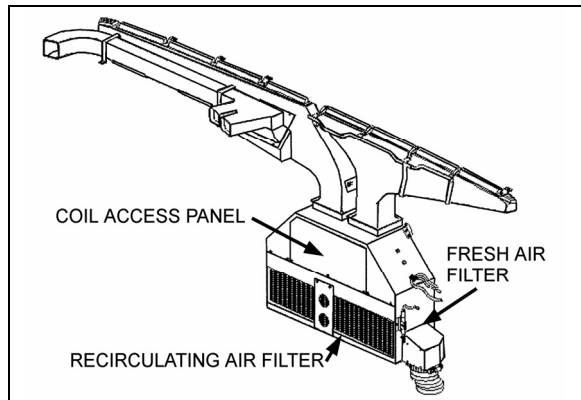

FIGURE 9: DRIVER'S HVAC UNIT COIL ACCESS PANEL



## Section 22: HEATING AND AIR CONDITIONING

For the cabin HVAC unit evaporator, remove the evaporator motor & coil access panel. Back flush the coil (Fig. 10 & 11) every 12,500 miles (20 000 km) or once a year, whichever comes first.

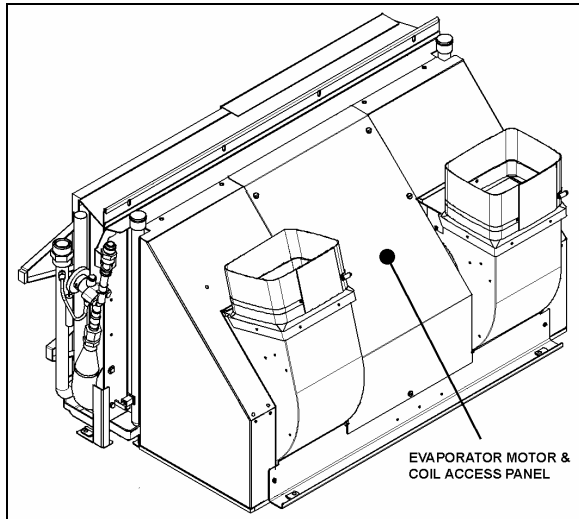

FIGURE 10: EVAPORATOR COIL ACCESS PANEL 22244

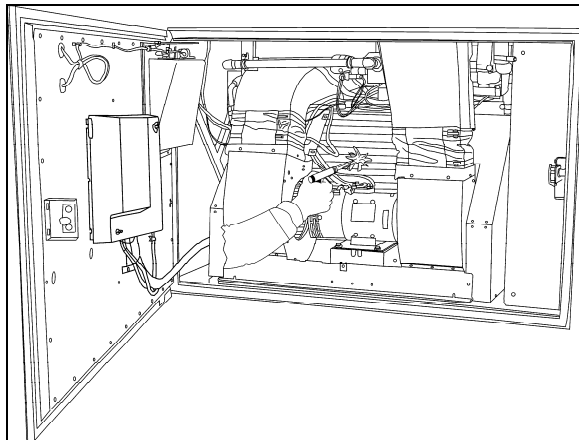

FIGURE 11: EVAPORATOR COIL CLEANING

For the condenser coil, back flush the coil (Fig. 12) every 6,250 miles (10 000 km) or twice a year, whichever comes first.



### CAUTION

Use a water jet or water mixed with low air pressure to clean the coil.

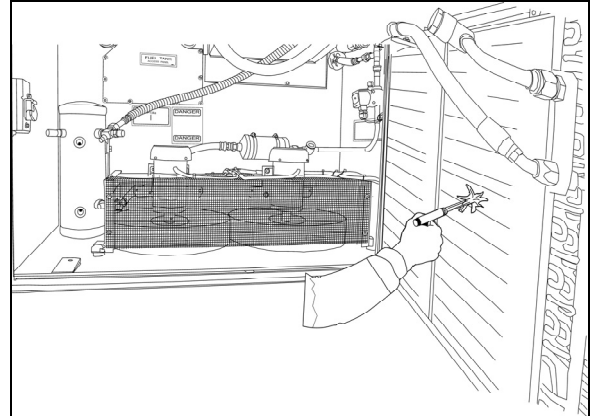

FIGURE 12: CONDENSER COIL CLEANING

22243A



### CAUTION

Direct the pressure straight through the coil to prevent bending of fins and do not use extremely high pressure. Do not use hot water, steam or caustic soap.

### 6.2 DRIVER'S HVAC UNIT & CABIN HVAC UNIT AIR FILTERS

The driver's HVAC unit is located behind the dashboard's R.H. side lateral plastic panel. To gain access to the A/C filters, unscrew the R.H. lateral console's grill located at the top step of the entrance door steps. Slide out the R/A and F/A filters. To clean filters back flush with water, then dry with air, every 12,000 miles (20 000 km) or once a year, which-ever comes first (Fig. 13 & 14).

### NOTE

*If the windshield is continuously fogged, check that the driver's air filter is not clogged.*

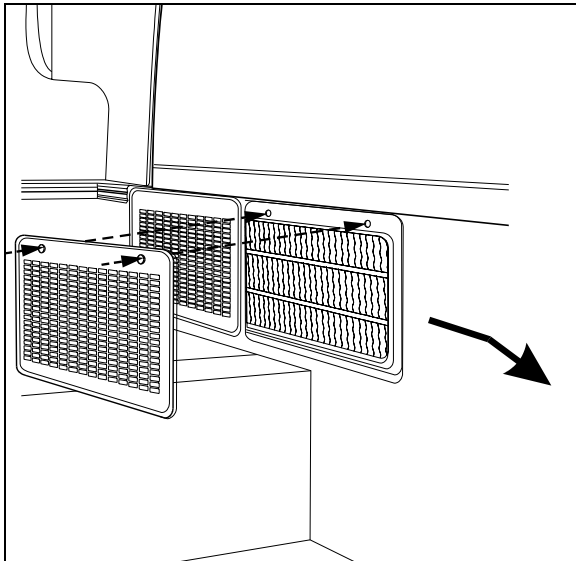

FIGURE 13: ACCESS TO DRIVER'S HVAC UNIT AIR FILTERS 22172

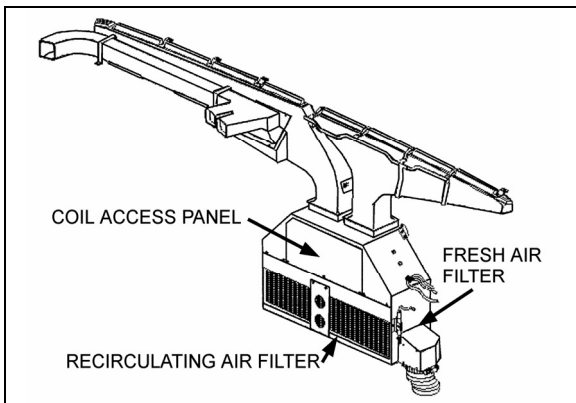

FIGURE 14: DRIVER'S HVAC UNIT AIR FILTERS

The cabin HVAC unit air filters are located in the evaporator compartment on driver's side of the vehicle. To access, open the baggage compartment forward of the evaporator compartment. An access door held shut by three retaining tabs is located in the wall separating the baggage compartment and the evaporator compartment. Remove the access door, slide out the top then bottom filter for maintenance purposes. (Fig. 15). To clean filters, back flush with water or soapy water, then dry with air every 12,000 miles (20 000 km) or once a year, whichever comes first.

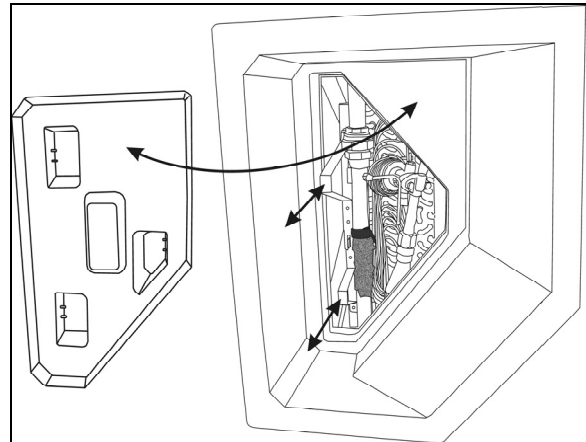

FIGURE 15: CABIN HVAC UNIT AIR FILTERS 22179

**CAUTION**

Do not use high pressure water jet to avoid damaging filter.

**CAUTION**

Be sure not to reverse filter upon installation.

**7. HVAC SYSTEM PARTICULARITIES, TESTING AND TROUBLESHOOTING**

Before undertaking any troubleshooting on the HVAC system, study the appropriate wiring diagrams to get a complete understanding of the HVAC components circuitry, read and understand section 06: ELECTRICAL of this manual under "Troubleshooting And Testing The Multiplex Vehicles" and "Test Mode For Switches And Sensors". The information included in these paragraphs is necessary for troubleshooting the HVAC system on Multiplex vehicles.

**7.1 HVAC SYSTEM AND TEST MODE FOR SWITCHES AND SENSORS**

When in switch/sensor test mode (see Section 06: ELECTRICAL for complete information), the A/C compressor HI and LO pressure values are displayed one after the other instead of the outside temperature in the telltale panel LCD display. This feature can be used when the vehicle is traveling to check the A/C compressor pressure values.

## Section 22: HEATING AND AIR CONDITIONING

### **NOTE**

*When starting the A/C compressor wait 5 seconds before checking pressures in order to give the system a chance to build its pressure. During the first 5 seconds after startup, the compressor is active on 6 cylinders and the A/C valve is open regardless of the pressure readings.*

In test mode, with the parking brake applied and the passenger set point set to a value higher than 64°F (18°C), the hot water circulating pump is not set to OFF as it would normally do when the outside temperature gets above 50°F (10°C). This feature allows verification of the pump when inside a garage. This is also useful when working on the heating system to remove air pockets trapped in the system.

When performing an A/C cooling test and having the water pump shut off in switch/sensor test mode is required, just set the passenger set point temperature to the minimum 64°F (18°C) to shut off the pump.

### 7.2 HVAC SYSTEM AND TEST MODE FOR ELECTRIC MOTORS

The test mode allows testing the motors and electric contactors without the need to have the engine running (see Section 06: ELECTRICAL under "TEST MODE FOR ELECTRICAL MOTORS" for complete information).

Use this test mode for testing of the condenser motors, the A/C compressor clutch activation, left and right unloaders, evaporator motor, water pump, and hot water solenoid valve.

### 7.3 PARTICULARITIES

Conditions for engaging the 2 <sup>nd</sup> speed on the evaporator motor (cooling demand).	The 2 <sup>nd</sup> speed engages if the cabin area air temperature is 1 degree above the set point and it revert to speed 1 if the temperature gets equal or below the set point.
Conditions for hot water recirculating pump activation (heating demand).	The pump turns to OFF if the outside temperature is above 50°F (10°C), when there is less demand for heating.  Note: To test a working pump, it is possible to keep it active even if the outside temperature is above 50°F (10°C). See paragraph 7.2 HVAC SYSTEM AND TEST MODE FOR ELECTRIC MOTORS.
The compressor unloaders are working based on pressure and also on the difference between the cabin area air temperature and the set point.	<b>2 left compressor cylinders:</b>  Stop if: Cabin area air temperature is at less than 0.4°C degree above the set point or if the compressor output is above 280 psi, or if the compressor input is below 26 psi.  Restart if: Cabin area air temperature is 0.9°C or more above the set point and the compressor pressure output is less than 220 psi and the compressor pressure input is above 34 psi.  <b>2 right compressor cylinders:</b>  Stop if: Cabin area air temperature is at less than 0.2°C above the set point or if the compressor input falls below 23 psi.  Restart if: Cabin area air temperature is 0.7°C or more above the set point and the compressor input pressure is above 32 psi.
The A/C deactivation pressure is 320 psi.	In case of high pressure, the analog pressure sensor connected to the Multiplex module deactivates the compressor.  There is also a « Pressure switch » adjusted to 350 PSI that acts to stop the compressor in the instance that the Multiplex module fails.

## Section 22: HEATING AND AIR CONDITIONING

### 7.4 HVAC SYSTEM TROUBLESHOOTING

Problem/Symptom	Probable Causes	Actions
No temperature control in the cabin area Cabin temperature display indicates two dashes "--"	Problem with the temperature sensor located on L.H. side of vehicle, underneath the wire mesh opening in the floor or the sensor wiring	Driver must manually control the temperature by playing with the cabin set point. Set above 22°C (72°F) to heat and below 22° C (72°F) to cool
Defroster fan not functioning	Module A47 is not powered or is faulty	<ol style="list-style-type: none"> <li>1. Check the SYSTEM DIAGNOSTIC menu of the message center display (MCD). Select FAULT DIAGNOSTIC and ELECTRICAL SYSTEM. The message "Voltage Module A47, Value too Low, Active" confirms a power problem on the module</li> <li>2. Check / reset circuit breaker CB2</li> <li>3. Check / replace fuse F5</li> </ol>
HVAC condenser fans not functioning in speed 1	Circuit breaker CB5 was manually tripped and not reset  Seized bearing  Faulty brushes  Bad wiring	Check / reset circuit breaker CB9
HVAC condenser fans not functioning in speed 1	Module A54 is not powered or is faulty	<ol style="list-style-type: none"> <li>1. Check the SYSTEM DIAGNOSTIC menu of the message center display (MCD). Select FAULT DIAGNOSTIC and ELECTRICAL SYSTEM. The message "Voltage Module A54, Value too Low, Active" confirms a power problem on the module</li> <li>2. Check / reset circuit breaker CB7</li> <li>3. Check / replace fuse F67 , F68</li> </ol>
HVAC condenser fans not functioning in speed 2	Circuit breaker CB5 was manually tripped and not reset  Seized bearing  Faulty brushes  Bad wiring	Check / reset circuit breaker CB5
Defroster fan is functioning but no heat or cooling available in the driver's area	Module A46 is not powered or is faulty  Faulty speed control  Bad wiring	<ol style="list-style-type: none"> <li>1. Check the SYSTEM DIAGNOSTIC menu of the message center display (MCD). Select FAULT DIAGNOSTIC and ELECTRICAL SYSTEM. The message "Voltage Module A46, Value too Low, Active" confirms a power problem on the module.</li> <li>2. Check / reset circuit breaker CB7</li> <li>3. Check / replace fuse F12</li> </ol>
The A/C compressor clutch does not engage	Module A52 is not powered or is faulty	<ol style="list-style-type: none"> <li>1. Check the SYSTEM DIAGNOSTIC menu of the message center display (MCD).</li> </ol>

## Section 22: HEATING AND AIR CONDITIONING

Problem/Symptom	Probable Causes	Actions
		<p>Select FAULT DIAGNOSTIC and ELECTRICAL SYSTEM. The message "Voltage Module A52, Value too Low, Active" confirms a power problem on the module</p> <p>2. Check / reset circuit breaker CB7</p> <p>3. Check / replace fuse F65</p>
Evaporator fan not functioning	<p>Circuit breaker CB4 tripped</p> <p>Module A54 is not powered or is faulty</p> <p>Faulty brushes</p>	<p>1. Check / reset circuit breaker CB4</p> <p>2. Check the SYSTEM DIAGNOSTIC menu of the message center display (MCD). Select FAULT DIAGNOSTIC and ELECTRICAL SYSTEM. The message "Voltage Module A54, Value too Low, Active" confirms a power problem on the module</p> <p>3. Check / reset circuit breaker CB4</p> <p>4. Check / replace fuse F67 , F68</p>

### 8. CENTRAL HVAC SYSTEM - AIR CONDITIONING

The schematic of Figure 16 shows the central A/C system and its components. The central system is equipped with a 6 cylinder, 05G-134A Carrier compressor with an air conditioning capacity of 7½ tons. The receiver tank and filter dryer are mounted inside the condenser compartment.

XLII Converted vehicles may be supplied with a central or small A/C system (Fig. 16 and 40). For vehicles equipped with a small A/C system, refer to paragraph 10: SMALL HVAC SYSTEM – AIR CONDITIONING COMPONENTS further in this section.

#### 8.1 A/C CYCLE

Refrigeration may be defined as "the transfer of heat from a place where it is not wanted to a place where it is unobjectionable". Components required for a closed circuit refrigeration system are shown in Figures 16 and 41.

The air conditioning system used on XLII series vehicle is of the "Closed" type using "R-134a".

1. The refrigerant flowing to the compressor is compressed to high pressure and reaches a temperature higher than the surrounding air. It is passed through the air-cooled fins and tubes of the condenser causing the hot, high pressure gas to be condensed into a liquid form.

2. The liquid refrigerant flows to the receiver tank, then back to the condenser sub-cooler. It leaves the condenser and passes through a filter dryer where moisture, acids and dirt are removed and then through a moisture indicator which indicates if any moisture is present in the system.
3. By its own pressure, the liquid refrigerant flows through a thermal expansion valve where the pressure drop causes the refrigerant to vaporize in a vapor-liquid state at a low temperature pressure.
4. The cold low pressure refrigerant passes through the main and the driver's evaporator coils which absorbs heat from the air passing over the fins and tubes, and changes into gas. In this form, the refrigerant is drawn into the compressor to repeat the air conditioning cycle.
5. The success of the air conditioning system depends on retaining the conditioned air within the vehicle. All windows and intake vents should be closed. An opening of approximately 8 in<sup>2</sup> (5162 mm<sup>2</sup>) could easily neutralize the total capacity of the system.
6. Other causes of inadequate cooling are dirty coils or filter. Dirt acts as insulation and is also serves as a restriction to the air flow.

7. The refrigeration load is not constant and varies. It is also affected by outside temperature, relative humidity, passenger load, compressor speed, the number of stops, etc.
8. The compressor will load or unload depending on operating conditions.

## 8.2 REFRIGERANT

The A/C system of this vehicle has been designed to use Refrigerant 134a as a medium. Regardless of the brand, only R-134a must be used in this system. The chemical name for this refrigerant is Ethane, 1, 1, 1, 2-Tetrafluoro.



### DANGER

Refrigerant in itself is nonflammable, but if it comes in contact with an open flame, it will decompose.

### 8.2.1 Procurement

Refrigerant is shipped and stored in metal cylinders. It is serviced in 30 and 100 pound (13,6 and 45 kg) cylinders. Approximately 24 pounds (10,9 kg) are used in the system.

It will be impossible to draw the entire refrigerant out of the cylinder. However, the use of warm water when charging the system will assure the extraction of a maximum amount of refrigerant from the cylinder.

### 8.2.2 Precautions in Handling Refrigerant

1. Do not leave refrigerant cylinder uncapped.
2. Do not subject cylinder to high temperatures, do not weld or steam clean near system or cylinder.
3. Do not fill cylinder completely.
4. Do not discharge vapor into an area where a flame is exposed.
5. Do not expose the eyes to liquid refrigerant.



### WARNING

One of the most important precautions when handling refrigerant consists in protecting the eyes. Any liquid refrigerant which may accidentally escape is approximately -40°F (-40°C). If refrigerant comes in contact with the eyes, serious injury could result. Always wear goggles to protect the eyes when opening refrigerant connections.

All refrigerant cylinders are shipped with a heavy metal screw cap. The purpose of the cap is to protect the valve and safety plug from damage. It is a good practice to replace the cap after each use of the cylinder for the same reason. If the cylinder is exposed to the sun's radiant heat pressure increase resulting may cause release of the safety plug or the cylinder may burst.

For the same reason, the refrigerant cylinder should never be subjected to excessive temperature when charging a system. The refrigerant cylinder should be heated for charging purposes by placing it in 125°F (52°C) water. Never heat above 125°F (52°C) or use a blowtorch, radiator, or stove to heat the cylinder. Welding or steam cleaning on or near any refrigerant line or components of the A/C system could build up dangerous and damaging pressures in the system.

If a small cylinder is ever filled from a large one, never fill the cylinder completely. Space should always be allowed above the liquid for expansion. Weighing cylinders before and during the transfer will determine the fullness of the cylinders.

### 8.2.3 Treatment in Case of Injury

If liquid refrigerant comes in contact with the skin, treat the injury as if the skin was frost-bitten or frozen. If liquid refrigerant comes in contact with the eyes, consult an eye specialist or doctor immediately. Give the following first aid treatment:

1. Do not rub the eyes. Splash eyes with cold water to gradually bring the temperature above the freezing point.
2. Apply drops of sterile mineral oil (obtainable at any drugstore) in the eyes to reduce the possibility of infection. The mineral oil will also help in absorbing the refrigerant.

## Section 22: HEATING AND AIR CONDITIONING

---

### 8.2.4 Precautions in Handling Refrigerant Lines

1. All metal tubing lines should be free of kinks, because of the resulting restrictions on the flow of refrigerant. A single kink can greatly reduced the refrigeration capacity of the entire system.
2. The flexible hose lines should never be allowed to come within a distance of 2-½" (6,3 cm) from the exhaust manifold.
3. Use only sealed lines from parts stock.
4. When disconnecting any fitting in the refrigeration system, the system must first be discharged of all refrigerant. However, proceed very cautiously, regardless of gauge readings. If there happens to be liquid refrigerant in the line, disconnect fittings very slowly, keeping face and hands away so that no injury can occur. If pressure is noticed when fitting is loosened, allow it to bleed off very slowly.



#### **WARNING**

Always wear safety goggles when opening refrigerant lines.

5. In the event that any line is opened to the atmosphere, it should be immediately capped to prevent entrance of moisture and dirt.

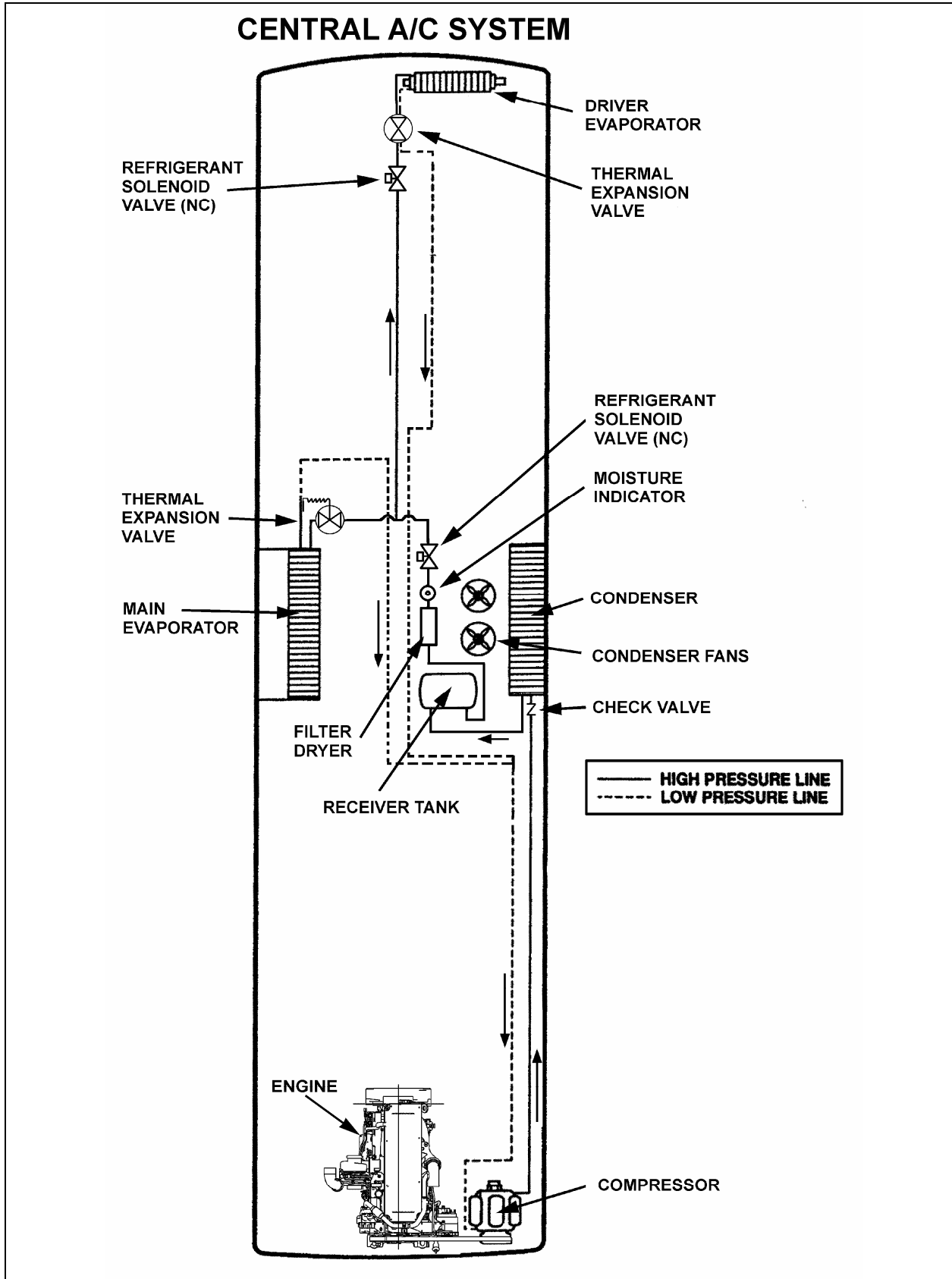

FIGURE 16: REFRIGERANT CIRCUIT (CENTRAL SYSTEM)

22247



## Section 22: HEATING AND AIR CONDITIONING

6. The use of the proper wrenches when making connections on O-ring fittings is important. The use of improper wrenches may damage the connection. The opposing fitting should always be backed up with a wrench to prevent distortion of connection lines or components. When connecting the flexible hose connections, it is important that the swaged fitting and the flare nut, as well as the coupling to which it is attached, be held at the same time using three different wrenches to prevent turning the fitting and damaging the ground seat.
7. The O-rings and seats must be in perfect condition. The slightest burr or piece of dirt may cause a leak.
8. O-rings should be coated with refrigeration oil and installed on the line before the line is inserted into the fitting to prevent damaging the O-ring. If leaks are encountered at the couplings or connectors, no attempt should be made to correct the leaks by tightening the connections beyond the recommended torque. The O-rings are designed to seal at the specified torque and overtightening the connection does not result in a satisfactory and permanently sealed connection. The connection must be disassembled and the cause of the leak (damaged O-ring, defective lines, etc.) corrected. Use new O-ring.

### 8.3 PUMPING DOWN

This procedure is intended to reduce refrigerant loss, on central system only, by isolating it in the compressor and the receiver tank, as well as in their connecting line, in order to carry out repairs on other sections of the air conditioning system (lines and components).

#### **NOTE**

*Before attempting any repair between compressor and receiver tank, use a recovery unit to remove refrigerant from the system.*

#### **NOTE**

*On vehicles equipped with a small A/C system only, refer to "Small HVAC System - Air Conditioning Components": paragraph 10.9 "OIL RETURN OPERATION" and 10.3.4 "Refrigerant Recovery", further in this section.*



### **WARNING**

To prevent any injury, when air conditioning system must be opened, refer to previous paragraph "Precautions in Handling Refrigerant Lines".



### **CAUTION**

The filter dryer must be changed each time a line in the system is opened.

### **Procedure**

1. Energize cabin side liquid solenoid valve.
2. Run the system for 10 minutes, shut it OFF, then close the receiver tank outlet valve by turning it clockwise, backseat the suction service valve on the compressor, install an appropriate pressure gauge set, and turn the valve forward ¼ turn to enable a visual check of the suction pressure.
3. Disconnect the "Low Pressure Switch" connector (mounted near the A/C compressor, and install a jumper wire.

#### **NOTE**

*This jumper wire will allow the clutch to remain engaged after pressure drops below 15 psi (103,5 kPa).*

4. Start the engine, press the "Passenger ON/OFF" switch then the A/C switch, adjust "A/C Temperature" control to maximum A/C.
5. Run the compressor until pressure reaches 1-2 psi (7-14 kPa).

#### **NOTE**

*During this operation, care must be taken not to fill the receiver tank over the upper sight glass. If so, stop process immediately. Always allow refrigerant piping and units to warm up to the ambient air temperature before opening system or sweating will take place inside the lines.*

6. Stop engine, and close compressor outlet valve by turning it clockwise until valve is properly seated.
7. Close compressor suction valve by turning it clockwise until it is properly seated.

8. Wait until pressure gauge reaches 1 to 2 psi (7 to 14 kPa). To accelerate procedure, lightly open compressor suction valve until pressure reaches this value.

#### 8.4 ADDING REFRIGERANT (VAPOR STATE)

Use the suction service valve on the compressor to add a small quantity of refrigerant to the system. Backseat the valve and connect a charging line from the refrigerant cylinder to the valve. Tighten connection at level of refrigerant cylinder and open tank end slightly to purge air from the charging line. Tighten the charging line at the compressor. Screw in the stem of suction valve approximately two turns. Start the engine and run at fast idle. Add sufficient refrigerant to bring the level in lower sight glass of receiver tank to mid-point. Always charge the system with the cylinder upright and the valve on top to avoid drawing liquid out of the cylinder.

#### 8.5 EVACUATING SYSTEM

1. Open both receiver valves by turning "out" (normal position).
2. Remove the caps from the two 90° adapters on the suction, discharge valves and connect two hoses to the vacuum.
3. Place the two compressor valves, suction and discharge, in neutral position by turning each one 3 to 4 turns "in" from the "out" position.
4. Open the solenoid valve by energizing or manually bypass.
5. Start the vacuum pump. Open the large (suction) shutoff valve and close the small vacuum gauge valve.
6. The pressure will drop to approximately 29 inches vacuum (14.2 psi or 97,9 kPa) (the dial gauge only gives a general idea of the absolute system pressure).
7. Backseat the compressor valves by turning "out" all the way.
8. Shut down the vacuum pump.
9. Remove the hoses.
10. Reinstall the caps at the suction valve take-off points.

#### 8.5.1 Double Sweep Evacuation Procedure

1. Remove any remaining refrigerant from the system using a refrigerant recovery machine.
2. Connect the evacuation manifold, vacuum pump, hoses and micron gauge to the unit.
3. With the unit service valves closed (back seated) and the vacuum pump and the thermistor valves open, start the pump and draw the manifold and hoses into a very deep vacuum. Shut the vacuum pump off and see if the vacuum holds. This is to check the setup for leaks.
4. Midseat the system service valves.
5. Open the vacuum pump and the thermistor valves. Start the pump and evacuate to a system pressure of 2000 microns.
6. Close the vacuum pump and the thermistor valves, turn off the vacuum pump (closing the thermistor valve protect the valve from damage).
7. Break the vacuum with clean refrigerant (or dry nitrogen) and raise the pressure to approximately 2 PSIG. Monitor the pressure with the compound gauge.
8. Remove the refrigerant with the recovery machine.
9. Repeat steps #5 – 8 one time.
10. After the second "sweep", change the filter drier (if you have not done so) and evacuate to 500 microns.
11. Evacuating the system below 500 microns on systems using the Carrier 05G compressor may risk drawing air into the system past the carbon shaft seal.
12. Check to insure that vacuum holds. (If the pressure continues to rise, it indicates a leak or moisture in the system).
13. Charge the system with the proper amount of refrigerant using recommended charging procedures.

**NOTE**

*This method will aid in preventing unnecessary system failures by ensuring that the refrigeration system is free of contaminants.*

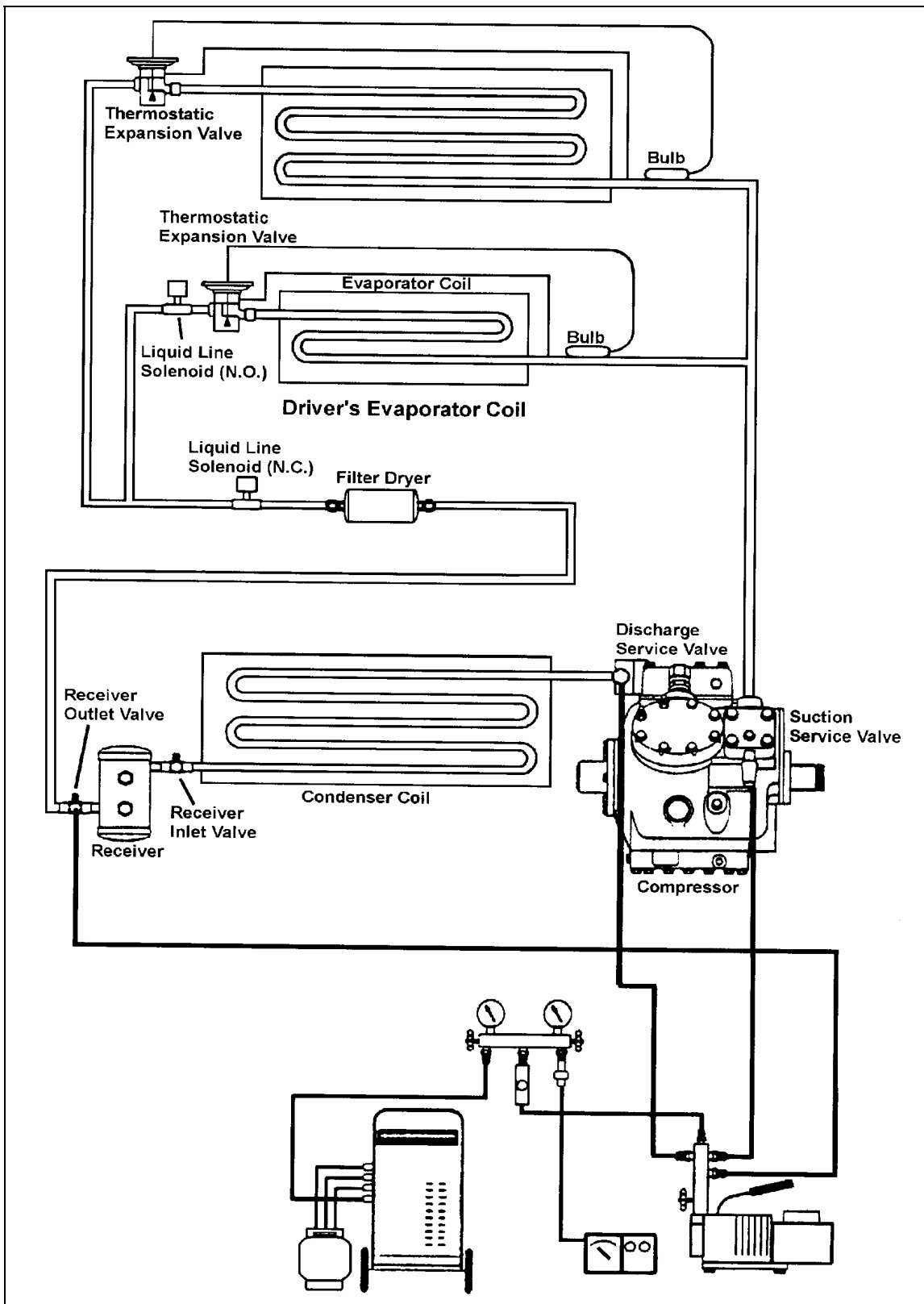

FIGURE 17: DOUBLE SWEEP EVACUATION SET-UP

## 8.6 CHARGING SYSTEM

When a system has been opened or if there are any questions about the air or moisture in the system, evacuate the system. Charging of an evacuated system may be accomplished by forcing liquid R-134a directly into the receiver tank. This may be accomplished by placing the refrigerant cylinder upside down on a scale with the valves at the bottom. This ensures that only liquid will enter the receiver tank.

When charging an empty system, weigh the amount of refrigerant put into the system. This will eliminate any possibility of overfilling. A nominal charge requires 24 pounds (10,9 kg).

1. Backseat the two compressor shutoff valves ("out").
2. Install the test gauges at the shutoff valves noting that the 400 psi (2758 kPa) gauge is connected to the discharge.
3. Turn in the two shutoff valves 3 to 4 turns.
4. Open the lower receiver valve by turning "out" all the way.
5. Backseat the upper receiver valve by turning out all the way.
6. Remove the cover cap from the service fitting in the top receiver valve.
7. Attach a charging hose to the R-134a tank. Open the tank valve slightly permitting R-134a to escape thus purging the hose of air.
8. Connect the charging hose to the service fitting.
9. Open the R-134a tank valve.
10. To build up pressure in the receiver tank, heat the receiver tank with a heating blanket.
11. Turn in the upper receiver valve several turns. The R-134a will now enter the system.
12. The proper charge of R-134a is 24 lbs (10.89 kg). When the scale indicates this amount of charge, backseat the receiver valve and close the R-134a tank valve.
13. Disconnect the charging hose. Replace the cover caps.
14. The system is now ready for operation.



## CAUTION

The evacuation of the system must be made by authorized and qualified personnel only. Refer to local laws for R-134a recuperation.

## 8.7 REFRIGERANT SYSTEM CLEAN-OUT AFTER COMPRESSOR FAILURE

Although the vast majority of reciprocating refrigerant compressors manufactured today are extremely reliable, a small percentage do fail. These failures usually result in minor or extensive system contamination depending on the severity of the failure. When an open type compressor becomes damaged internally, this provokes small particles of bearings, steel, brass, copper, and aluminum and, in severe cases, carbonized oil, which could contaminate the system. To prevent repeated failures, the problem which caused the failure should be corrected, and depending upon the severity of the failure, the system should be thoroughly cleaned out using one of the clean-out procedures mentioned.

### 8.7.1 Determining Severity of Failure

The severity of compressor failure can be categorized as minor or major. A failure is considered minor when the contamination is limited to the compressor with little or no system contamination. A major failure, or burnout, results in extensive system contamination as well as compressor damage. Extensive system contamination can be determined by withdrawing a small sample of compressor oil and checking its color, odor and acidity. A Virginia Chemical "TKO" one step acid test kit is one of several compressor oil test kits that may be used. A high acid content would indicate a major failure or burnout. A small amount of refrigerant gas may be discharged. A characteristic burned odor would also indicate severe system contamination.

### 8.7.2 Clean-out after Minor Compressor Failure

1. Be sure to correct the problem which caused the failure.
2. Change liquid line filter dryer
3. Run the unit for 2 hours on high speed cool only.

## Section 22: HEATING AND AIR CONDITIONING

4. Check compressor oil level to ensure compressor is not overcharged with oil. Sometimes a significant amount of oil is pumped out of the compressor to other parts of the system when a compressor fails. This oil will return to the replacement compressor when it is started, causing an overcharge of oil in the sump of the replacement compressor. In this case, it is important that the oil level be adjusted to the proper level.
5. Withdraw a sample of the compressor oil and check its color, odor, and acidity, using instructions supplied above. If the oil is contaminated, change the oil and filter dryer, and repeat the procedure until the system is clean.

### 8.7.3 Clean-out After Major Compressor Failure

1. Reclaim the refrigerant into a refrigerant bottle through a filter dryer to filter out contaminants.
2. Remove the failed compressor and repair it if possible.
3. Install new or repaired compressor.
4. Change the filter dryer.
5. Circulate clean R-134a or nitrogen with the reclaiming to clean out many of the contaminants collected in the coil valves, TXV (Thermal Expansion Valve), solenoid valves, check valves, and any other mechanical component that may have collected contaminants.
6. Evacuate and charge the system normally.
7. Run the unit for 8 hours and monitor the pressure drop across the filter dryer. Also check the liquid line dryer for signs of restriction. If the pressure drop across the filter dryer exceeds 12 to 14 psig (82,75 to 96,5 kPa) with a 40°F (5°C) evaporator coil temperature, stop the unit and change the liquid line and suction line filter dryer. After 4 or 5 hours of operation, stop the unit and replace the filter dryer.
8. After 8 hours of operation, stop the unit and remove a sample of the compressor oil and check its color, odor, and acidity, using instructions supplied above. If the oil is contaminated, replace the oil and repeat step 7. If the oil is not contaminated, change the

filter dryer again and replace the moisture-liquid indicator.

9. After approximately 7 days of operation, recheck the compressor oil for cleanliness and acidity.

## 9. CENTRAL HVAC SYSTEM – AIR CONDITIONING COMPONENTS

### 9.1 COMPRESSOR (CENTRAL SYSTEM)

#### 9.1.1 Belt Replacement



### DANGER

Turn the ignition key switch to the “Off” position. For greater safety, trip circuit breakers CB1 & CB2 and set the engine starter selector switch in engine compartment to the “Off” position.

1. Open engine compartment rear doors and locate the belt tensioner pressure releasing valve (Fig. 18), mounted above the engine R.H. side door next to the air pressure regulator, then turn handle clockwise in order to release pressure and tension on belts.
2. Slip the old belts off and the new ones on.
3. Reset belt tensioner pressure releasing valve (Fig. 18) to 45 psi (310 kPa) to apply tension on the new belts as explained in Section 12.

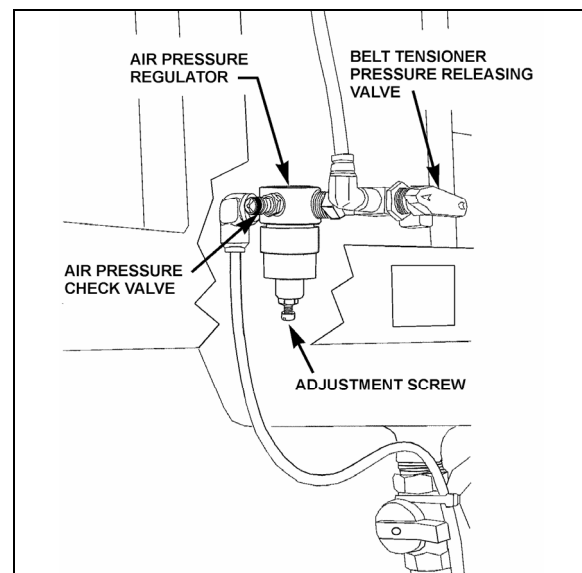

FIGURE 18: AIR PRESSURE REGULATOR

12200

**NOTE**

*Both belts must always be replaced simultaneously to ensure an equal distribution of load on each of them.*

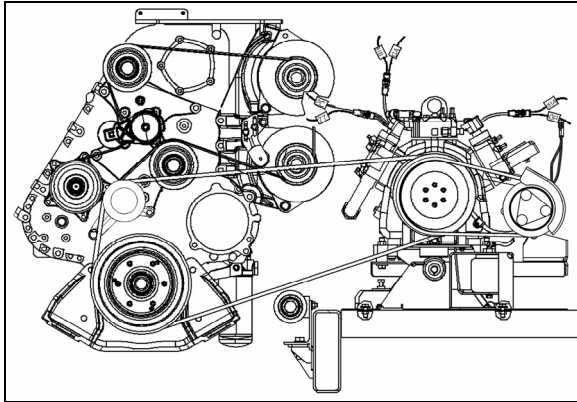

FIGURE 19: BELT TENSIONER

01059

9.1.2 Belt Play

After belt replacement or during normal maintenance, belt play between pulleys and belt must be checked to ensure proper operation. Refer to figure 20 for proper plays.

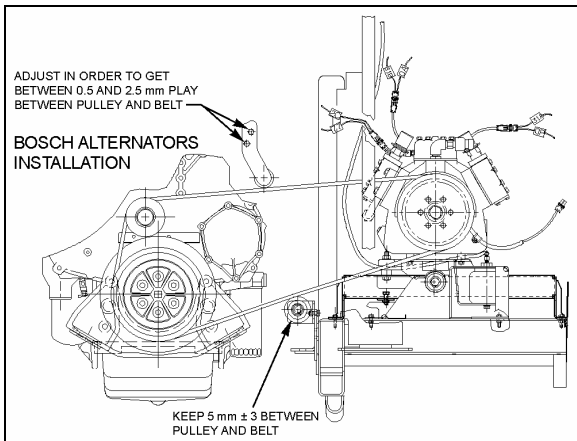

FIGURE 20: BELT PLAY

22288

9.1.3 Pulley Alignment

In order to avoid skipping, disengagement and a premature wear of compressor belt, it is necessary to align compressor pulley with the crankshaft pulley. Before performing the following procedure, release air from belt tensioners by means of the air pressure releasing valve. After completing these procedures reset belt tensioner air pressure regulator to 45 psi (310 kPa).

9.1.4 Longitudinal Compressor Alignment

1. Rest an extremity of a straight edge of approximately 46 inches (117 cm) against the upper part of the outer face of crankshaft pulley, positioning the other end close to the compressor clutch pulley (Figs. 21 & 22).
2. Check the distance between each extremity of straight edge (1. Fig. 22) and the first drive belt. If they are different, loosen the compressor support bolts and with a hammer, knock support to slide it in order to obtain the same distance; then tighten bolts.

9.1.5 Horizontal Compressor Alignment

1. Rest an extremity of the straight edge against the upper part of the outer face of compressor pulley, positioning the other end close to the crankshaft pulley.
2. Check the distance between each extremity of straight edge (1, Fig. 22) and drive belt. If they are different, loosen the pillow block compressor bolts and with a hammer, knock compressor pillow block to slide it, in order to obtain the same distance; then tighten bolts.

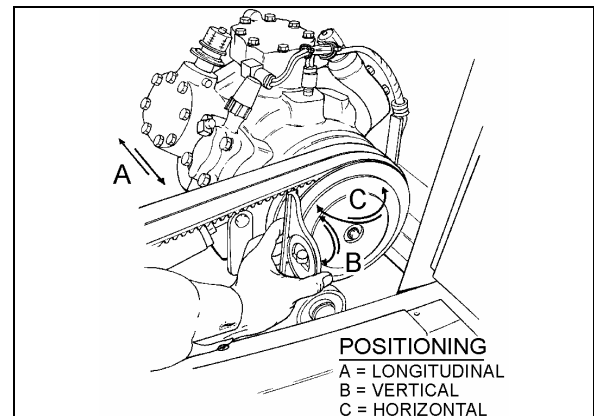

FIGURE 21: COMPRESSOR ALIGNMENT

22072

9.1.6 Vertical Compressor Alignment

Rest a short "angle and level indicator" on the outer side face of the crankshaft pulley, adjust the level indicator inclination at 0° and check if the compressor pulley is at same angle (Figs. 21 & 22). If it is not the same, shim under the appropriate pillow block in order to obtain the correct angle.

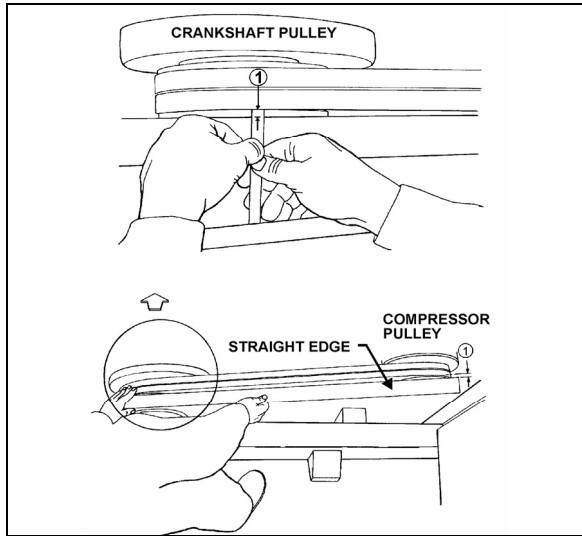

FIGURE 22: COMPRESSOR ALIGNMENT

22040

### 9.1.7 Compressor Maintenance

For the maintenance of the A/C compressor, see the *Carrier Compressor "WORKSHOP MANUAL"* for MODEL 05G TWIN PORT COMPRESSOR" included at the end of this section.



### CAUTION

Use only Castrol SW 68 (POE) oils with refrigerant 134a.

### 9.1.8 Troubleshooting Guide

A preliminary check may be made by simply feeling the cylinder heads with the unit in operation at ambient temperatures of 35°F (2°C) and over. The cylinder heads are internally divided into suction and discharge valves. The lower half of the cylinder head is the suction side, and it should be relatively cool to the touch, as opposed to the hot upper discharge side. If a valve plate or head gasket is blown, or a compressor unloader is stuck open, partially compressed refrigerant vapor will be circulated between the suction and discharge sides of the head. The affected cylinder head will then have a relatively even temperature across its surface and be neither as hot as the normal discharge temperature nor as cool as the normal suction temperature.

#### Blown Head Gaskets

##### Symptom:

- \* Loss of unit capacity at low temperature.

- \* Even cylinder head temperature.

##### Cause:

- \* Improperly torqued cylinder head bolts.
- \* Improperly positioned gasket at assembly.
- \* Warped cylinder head.
- \* Severe liquid refrigerant floodback.

#### Blown Valve Plate Gaskets

##### Symptom:

- \* Loss of unit capacity at medium and low temperatures.
- \* Very hot cylinder head surface.
- \* Higher than normal suction pressure.

##### Cause:

- \* Improperly torqued cylinder head bolts.
- \* Severe liquid refrigerant floodback.
- \* Oil slugging caused by an overcharge of oil or flood starts.
- \* Discharge valves not seated properly (liquid drainback during shutdown).

#### Broken Suction Valves

##### Symptom:

- \* Loss of unit capacity at all temperatures.
- \* Compressor unable to pull extremely low vacuum with suction service valve frontseated.

##### Cause:

- \* Repeated liquid refrigerant floodback.
- \* Flooded starts.
- \* Overcharge of oil.
- \* Discharge valves not seated properly (liquid drainback during shutdown).
- \* Expansion valve not controlling properly.

#### Unloader Valve Stuck Open

##### Symptom:

- \* Loss of unit capacity at all temperatures.
- \* Higher than normal suction pressure.
- \* Even cylinder head temperature.

Cause:

- \* Unloader body stem bent.
- \* Foreign material binding unloader piston or plunger.

9.2 MAGNETIC CLUTCH

Refer to Carrier service information entitled "Housing-Mounted Electric Clutch" at the end of this section for the description and maintenance of the magnetic clutch.

9.3 EVAPORATOR MOTOR

(Central HVAC system only)

The evaporator motor is installed in the evaporator compartment (L.H. side of vehicle) (Fig. 16). It is a 27.5 volt, 2 HP (1.5 kW) motor which activates a double blower fan unit.

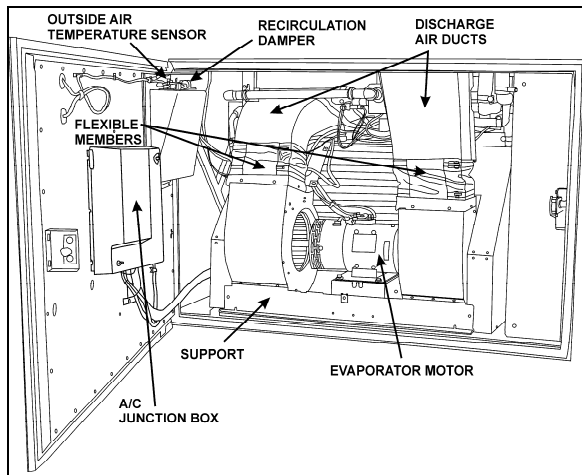

FIGURE 23: EVAPORATOR COMPARTMENT 22314

9.3.1 Removal

1. Set the ignition key switch to the "OFF" position and trip circuit breakers CB1 & CB2.
2. Open the last L.H. side baggage compartment door. Pull the black release button located on the L.H. side in order to unlock and open the evaporator compartment door.
3. Remove the evaporator motor and coil access panel.
4. Identify the L.H. side discharge duct inside compartment and remove the Phillips head screws retaining the flexible member to duct.

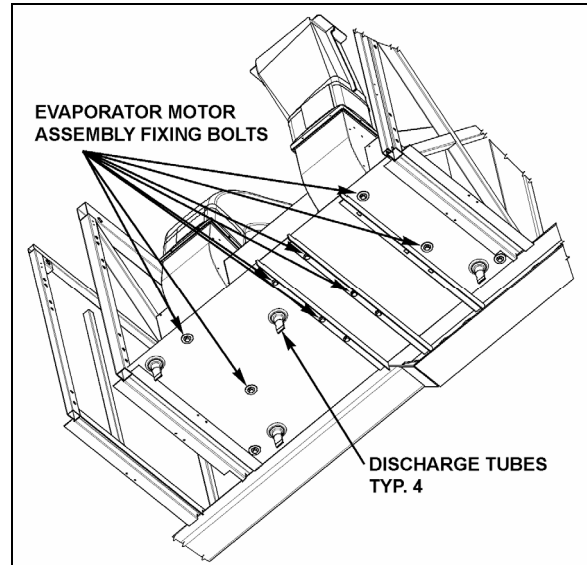

FIGURE 24: EVAPORATOR MOTOR ASSY FIXING BOLTS

5. Repeat step 4 for the R.H. side air duct.
6. Disconnect the electrical motor speed control connections on the motor plate.
7. From under the vehicle, remove the eight bolts retaining the evaporator fan motor support. Remove the complete unit from the evaporator compartment (Fig. 24 & 25).



**CAUTION**

Never support evaporator motor by its output shafts while moving it.

8. On a work bench, unscrew the fan square head set screws, the Phillips head screws retaining cages to support and slide out the assemblies from the evaporator motor output shaft.

9.3.2 Installation

To reinstall the evaporator motor, reverse "Evaporator Motor Removal" procedure.

9.3.3 Checking Operation of Brush in Holder

Lift brush slightly 1/8 inch (3 mm) and release it. The spring should push the brush freely back into the holder securing it against the commutator.



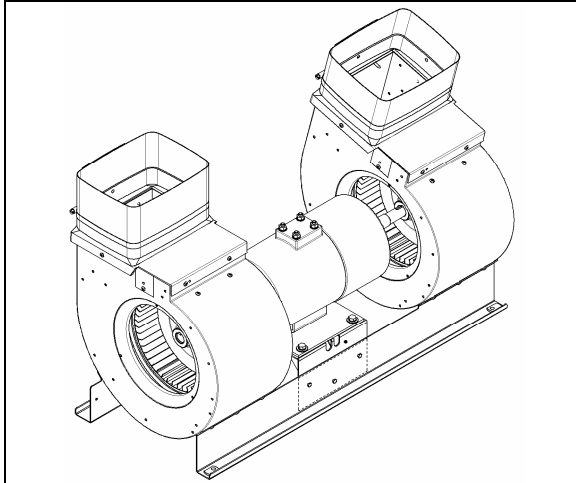

FIGURE 25: EVAPORATOR MOTOR ASSEMBLY 22316

9.3.4 Brush Wear Inspection and Replacement

	<p><b>CAUTION</b></p>
<p>Only use replacement brushes recommended by the manufacturer. Not doing so will void warranty.</p>	

Replace the brushes if less than 3/4 inch (19 mm). New brush length is 1-1/4 inch.

To replace brushes, proceed as follows:

1. Set ignition key switch to the "OFF" position.
2. Remove the protective screen band from the motor housing by pulling down the spring loaded fastener.
3. Lift the spring, remove and replace brushes as per the following procedure: "SEATING BRUSHES".
4. Reverse installation procedure.

9.3.5 Seating Brushes

Grinding consists in giving to the seating face of a new brush the exact same curvature of the commutator so that good mechanical and electric contact of the brush is made.

<p><b>NOTE</b></p> <p><i>The new motor brushes are provided with a preformed seating face which is approximately the same curvature as the commutator. Grinding/honing will give an exact match in curvature. The advantage of preforming is to appreciably shorten the time required for grinding.</i></p>
---

**For best results, remove oil and grease from commutator before applying brush seater.**

Grinding is generally done on the machine itself, in accordance with various processes' and conformably to the importance and the type of machines:

- a) Grinding with abrasive cloth (60 grit sandpaper) applied to the commutator must be done by hand. With the new brushes installed in brush holders and pressing against the abrasive cloth, rotate the armature (by hand) until satisfactory seating of each brush is achieved (Refer to figure 26). It is necessary to avoid raising the cloth under the brushes otherwise it would result, after grinding, to reduce and badly definite surfaces (Refer to figure 27).

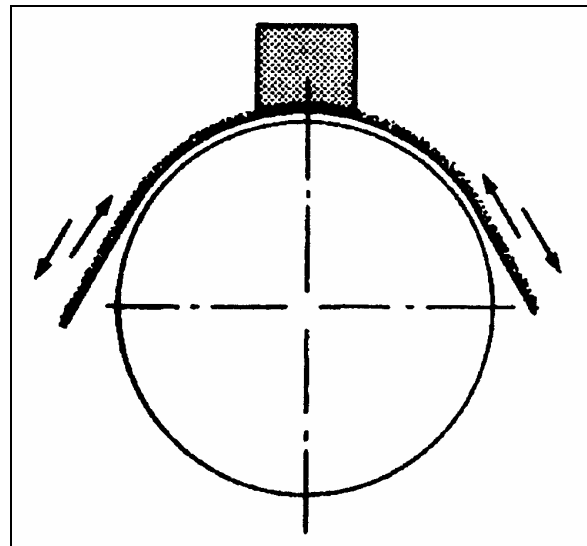

FIGURE 26: PROPER GRINDING TECHNIQUE 22317

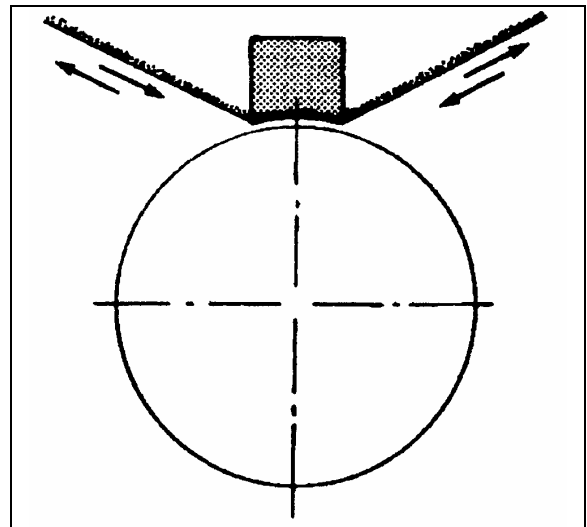

FIGURE 27: IMPROPER GRINDING TECHNIQUE 22318

**CAUTION**

If grinding with a honing stone, you must disconnect the time delay in order to keep the motor in 1<sup>st</sup> speed. If you prefer, you may also install a jumper on the evaporator motor between terminal E2 and A1 to bypass relay R60 and keep the motor in 1<sup>st</sup> speed as well.

- b) Grinding with the honing stone is always done under reduced voltage. Dust particles act like abrasive and wear down the brushes exactly with the profile of the commutator. **Caution is advised here as prolonged honing could wear the brushes and commutator prematurely.**

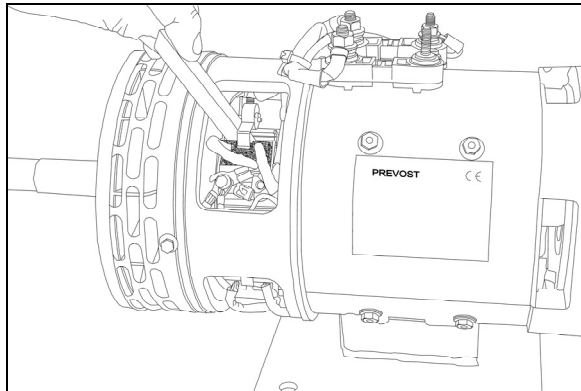

FIGURE 28: GRINDING WITH THE BRUSH SEATER STONE 22319

Repeat method a or b until brushes are fully seated. **Seating surface of the brush must be no less than 80% of the face (Refer to figure 29).**

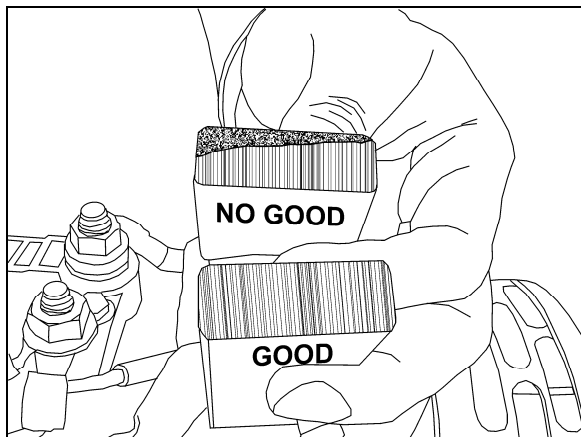

FIGURE 29: SEATING SURFACE OF THE BRUSH 22320

**CAUTION**

After grinding with the sandpaper or the honing stone, it is necessary to remove the brushes from the brush holders and vigorously clean with an air gun the commutator and the seating faces of the brushes to eliminate abrasive dust and dust from brushes.

**DANGER**

Use a dust mask to prevent inhalation of dust particles. Protect against electrical shock when working on energized equipment. Protect against falling or slipping when working on rotating equipment.

**CAUTION**

If grinding is not carried out or is carried out in an incorrect way, the brush may seat against a restricted zone only, which will create a high amperage situation for the commutator as for the brushes and could seriously damage the motor.

After grinding is completed, it is necessary to check the evaporator motor amperage in 1<sup>st</sup> speed and in 2<sup>nd</sup> speed. **Make sure that the evaporator compartment door is closed and that the reading is 30 A ± 3 in 1<sup>st</sup> speed.**

**Confirm that the reading is 64 A ± 4 (MAX 68 A) in 2<sup>nd</sup> speed.**

#### 9.3.6 Brush Holder Adjustment

**NOTE**

*The brush holders are mounted on a support that can rotate. Rotating that rocker ring will move all the brush holders at the same time.*

1. Remove the screws securing the grid and remove the grid. Locate the 2 bolts fixing the mechanism permitting the rotation of the brush rocker ring.
2. Loosen (do not remove) the bolts just enough to release the mechanism.
3. Move gently the exposed brush holder in order to have **30 A ± 3 in 1<sup>st</sup> speed and 64 A ± 4 in 2<sup>nd</sup> speed when the door is closed** and a maximum distance of 10 mm

## Section 22: HEATING AND AIR CONDITIONING

(3/8 inch) between the brush face and a reference line passing through the center of the 2 bolts on the motor housing.



### CAUTION

If rotating the rocker ring is necessary, it is preferable to mark off the angular position of the rocker ring before unfastening the bolts fixing the mechanism in order to get back to the factory setting at the end of the operation.

### NOTE

Take a final reading in 1<sup>st</sup> and in 2<sup>nd</sup> speed after tightening the brush holder bolts. The amperage may have changed.

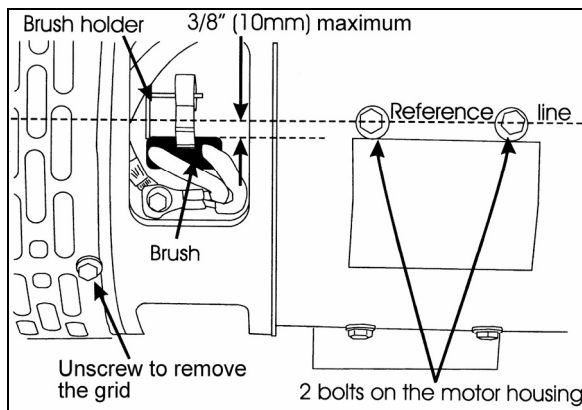

FIGURE 30: EVAPORATOR MOTOR

22321



### CAUTION

To avoid damaging the motor, make sure all vehicle doors are closed when taking the readings.

### 9.3.7 Checking Commutator

The surface must be polished. A brown-black colored surface is normal and indicates a good switching. Ensure there is no evidence of arcing or metal chips.

## 9.4 CONDENSER

The central A/C system condenser coil is hinge mounted on the R.H. side of the vehicle on the A/C condenser door (Fig. 32). Since condenser's purpose is to dissipate heat from the hot refrigerant, it is important to keep the cooling coils and fins clean. A clogged coil will cause high discharge pressure and insufficient cooling.

### 9.4.1 Condenser Fan Motors

Two fan motors (Fig. 31), 28.5 V - (0.6 HP - 0.42 kW) and cages are installed in the condenser compartment on R.H. side of vehicle in order to ventilate the condenser coil. They are mounted on a support, fastened to the floor. The fans pull outside air through the condenser coil and discharge it through an opening at bottom of compartment. When temperature drops inside condenser, the pressure in the refrigerant line also drops and it is, therefore, no longer required to cool condenser. Consequently, when pressure drops to 130 psi, the motors will run at low speed and if the pressure continues to drop to 90 psi, a pressure switch stops the motors so that fans do not operate needlessly. When pressure rises to 120 psi, the pressure switch reactivates the motors. If the pressure rises to 170 psi, the motors will switch to high speed.

For details about electrical wiring, refer to "A/C and Heat system" in the master wiring diagram.

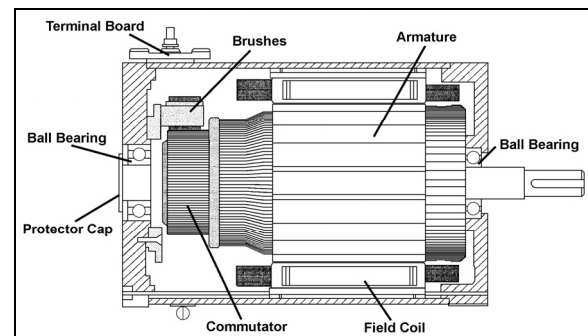

FIGURE 31: CONDENSER FAN MOTOR

22234

### 9.4.2 Condenser Fan Motor Removal

1. Set the ignition key switch to the "Off" position.
2. Remove the two "Phillips" head screws retaining the fan motor protective cover to the square tubing. Remove the protective grill from mounting support.
3. Disconnect wiring from terminals on motor. Tag each wire to aid in identification at time of reconnection.
4. Support motor, and remove bolts which attach motor to mounting bracket. Remove the motor.

### 9.4.3 Preliminary Disassembly

1. Remove the brushes.

2. Unscrew the flange retaining screws on the shaft end side (opposite to the commutator end frame), and separate flange from frame (Fig. 31).
3. Remove flange and armature assembly by pushing bearing shaft toward the commutator end frame.
4. Separate flange from armature.

#### 9.4.4 Disassembly

1. Perform preliminary disassembly.
2. Carefully note the position of the brush holder ring and the connections on the flange support.
3. Unscrew and remove the flange on the commutator end frame.
4. Remove the brush holder ring.
5. Finally, separate the following parts: brush holders, brush boxes, terminal board, bearings, etc.

#### 9.5 RECEIVER TANK

The receiver tank is located in the condenser compartment (Fig. 32). The function of the receiver tank is to store the liquid refrigerant. During normal operation, the level of the refrigerant should be approximately at the mid-point of the lower sight glass.

In case of extreme pressure there will be a rise in the liquid receiver tank. A pressure relief valve will break at 450 psi (3103 kPa) and relieve the receiver tank pressure.

The receiver tank incorporates an inlet valve on the inlet side (upper section) which allows the tank to be isolated or serviced. An outlet valve on the outlet side (lower section) permits complete isolation from the rest of the system.

#### 9.6 FILTER DRYER

A filter dryer, also located in the condenser compartment, is installed on the liquid refrigerant line after the receiver tank. It is used to absorb moisture and foreign matter from refrigerant before it reaches the expansion valves.

The filter should be replaced if the system has been opened or after a prolonged exposure, when the moisture indicator sight glass turns to pink.

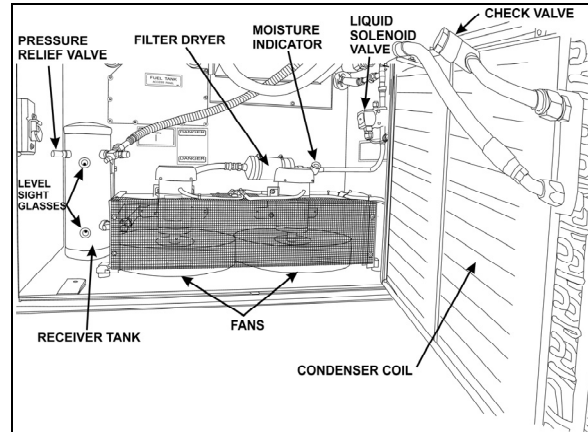

FIGURE 32: A/C CONDENSER COMPARTMENT 22243B

#### 9.6.1 Replacement

The filter is of the disposable type. When replacement is required, remove and discard the complete unit and replace with a new unit of the same type according to this procedure:

1. Isolate the refrigerant in the receiver tank by following the "Pumping Down" procedure explained in this section
2. Change the filter dryer as a unit.
3. Add a small quantity of refrigerant R-134a to the low side of the system. Check for leaks. Return the system to normal operation.



### CAUTION

Do not use carbon tetrachloride or similar solvents to clean parts. Do not use steam guns. Use mineral spirits or naphtha. All parts should be thoroughly cleaned. Use a stiff brush to wash dirt from grooves, holes, etc.



### DANGER

Cleaning products are flammable and may explode under certain conditions. Always handle in a well ventilated area.

#### 9.6.2 Moisture Indicator

The moisture sensitive element consists of a color changing ring which is reversible from pink to blue and vice versa as the moisture content in the refrigerant changes. Pink indicates a wet refrigerant, light violet (caution) and blue indicates a dry refrigerant.

## Section 22: HEATING AND AIR CONDITIONING

COLOR INDICATOR			
TEMPERATURE	BLUE (ppm)	LIGHT VIOLET (ppm)	PINK (ppm)
75°F (24°C)	Below 5	5-15	Above 15
100°F (38°C)	Below 10	10-30	Above 30
125°F (52°C)	Below 15	15-45	Above 45
p.p.m.= parts per million (moisture content)			

Since temperature changes affect the solubility, color change will also vary with the refrigerant temperature. The above table shows the color change for R-134a at various moisture levels and liquid line refrigerant temperatures.

A moisture level of less than 15 p.p.m. for R-134a indicated in the blue color range of the above table is generally considered dry and safe. A color indication of light blue to light violet indicates the caution range of moisture level. For positive protection, the drying of the system should be continued until the color of the element turns to deep blue.

The liquid refrigerant is readily visible through the center opening of the moisture element where the presence of bubbles indicates a shortage of refrigerant or restriction in line.

Moisture is one of the main causes of chemical instability or contamination in air conditioning systems. If moisture is present, it can corrode the valves, condenser and evaporator coils, compressor and other components causing a malfunction and eventual failure of the system. Uncontrolled moisture in the system can result in very expensive multiple component replacements if not corrected at an early stage. The moisture indicator permits an early detection of moisture in the system and when corrected by a desiccant charge, system contamination is greatly minimized.

### 9.7 LIQUID REFRIGERANT SOLENOID VALVE

The flow of liquid refrigerant to the driver's and main evaporators is controlled by a normally-closed solenoid valve (Refer to fig. 32 & 33). The driver's liquid refrigerant solenoid valve is located on the ceiling of the spare wheel and tire compartment and is accessible through the reclining bumper.

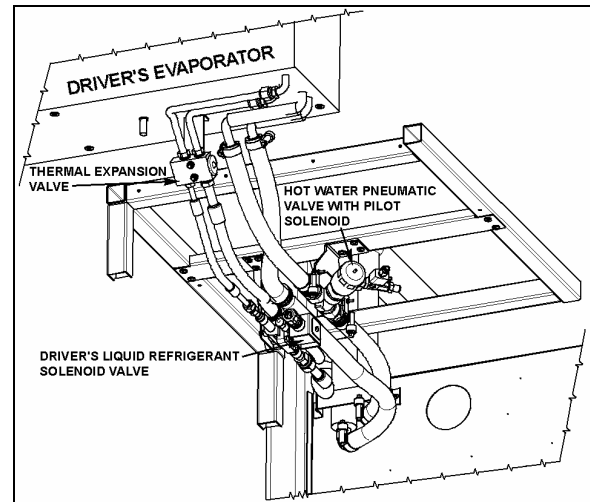

FIGURE 33: DRIVER'S LIQUID REFRIGERANT SOLENOID VALVE

22181

#### 9.7.1 Manual Bypass

This type of solenoid valve is equipped with a manual operating stem. The 3/16" square stem located on the bonnet is exposed when the seal cap is removed. To manually open valve, turn stem 1/2 turn counterclockwise. To manually close valve, turn stem clockwise until tight against seat. Manual stem must be in closed position for automatic electric operation.

#### 9.7.2 Coil Replacement

1. Disconnect connector from the coil connector.
2. Take out the retaining screw at the top of the coil housing. The entire coil assembly can then be lifted off the enclosing tube.
3. Place the new coil and yoke assembly on the enclosing tube. Lay data identification plate in place.
4. Insert the coil retaining screw, rotate housing to proper position and tighten screw securely.
5. Connect connector from coil connector.

#### 9.7.3 Valve Disassembly

1. Remove the coil as stated previously.
2. Pump down the system as stated earlier in this section.
3. Remove the four socket head screws which hold the body and bonnet together (Fig. 34).

- Carefully lift the bonnet assembly off (upper part of the valve) so that plunger will not fall out. The diaphragm can now be lifted out.

**NOTE**

*The above procedure must be followed before brazing solder-type bodies into the line.*



**CAUTION**

Be careful not to damage the machined faces while the valve is apart.

9.7.4 Valve Reassembly

- Place the diaphragm in the body with the pilot port extension up.
- Hold the plunger with the synthetic seat against the pilot port.
- Make sure the bonnet O-rings are in place. Lower the bonnet assembly over the plunger, making sure that the locating sleeve in the bonnet enters the mating hole in the body.
- Insert the four socket head screws and tighten evenly.
- Replace the coil as stated previously.
- Add a small quantity of refrigerant R-134a to the low side of the system. Check for leaks. Return the system to normal operation.

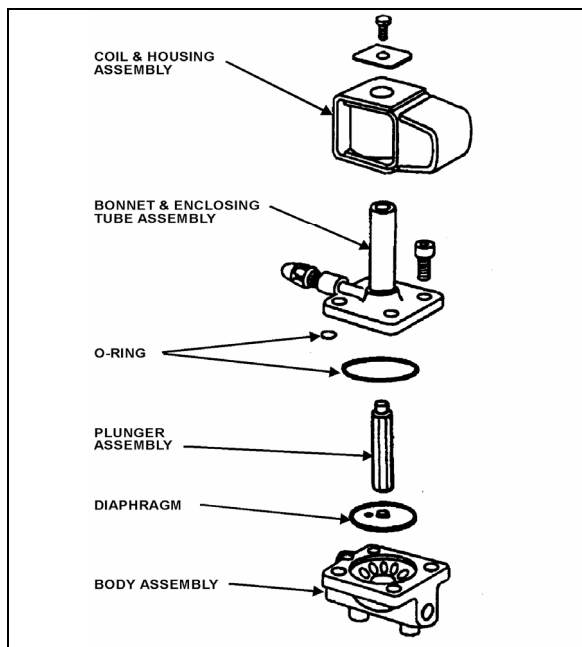

FIGURE 34: REFRIGERANT SOLENOID VALVE 22044

9.8 EXPANSION VALVE

9.8.1 Cabin HVAC Unit

The expansion valve for the cabin HVAC unit is a thermo-sensitive valve with a remote control bulb head attached to the evaporator outlet line and is accessible by the cabin air filters access door (Fig. 15). The valve regulates the flow of refrigerant liquid into the evaporator coils and is controlled by the suction gas temperature leaving the evaporator. The bulb head senses the refrigerant gas temperature as it leaves the evaporator. High temperature will cause expansion and pressure on the power head and spring. Such action causes the assembly valve to open, allowing a flow of refrigerant liquid into the evaporator.

The remote bulb and power assembly is a closed system. The pressure within the remote bulb and power assembly corresponds to the saturation pressure of the refrigerant temperature leaving the evaporator and moves the valve pin in the opening direction. Opposed to this force, on the under side of the diaphragm and acting in the closing direction, is the force exerted by the superheat spring. As the temperature of the refrigerant gas at the evaporator outlet increases above the saturation temperature corresponding to the evaporator pressure, it becomes superheated. The pressure thus generated in the remote bulb and power assembly surpasses the combined pressures of the evaporator pressure and the superheat spring, causing the valve pin to move in the opening direction. Conversely, as the temperature of the refrigerant gas leaving the evaporator decreases, the pressure in the remote bulb and power assembly also decreases and the combined evaporator and spring pressures cause the valve pin to move in the closing position.

As the operating superheat is raised, the evaporator capacity decreases, since more of the evaporator surface is required to produce the superheat necessary to open the valve. It is obvious, then, that it is most important to adjust the operating superheat correctly and that a minimum change in superheat to move the valve pin to full open position, is of vital importance because it provides savings in both initial evaporator cost of operation. Accurate and sensitive control of the refrigerant liquid flowing to the evaporator is necessary to provide maximum evaporator capacity under load conditions. The spring is adjusted to give 12 to

## Section 22: HEATING AND AIR CONDITIONING

16° F (-11.1 to -8.8 ° C) of superheat at the evaporator outlet.

This ensures that the refrigerant leaving the evaporator is in a completely gaseous state when drawn into the suction side of the compressor. Liquid would damage the compressor valve, piston and heads if allowed to return in the suction line.

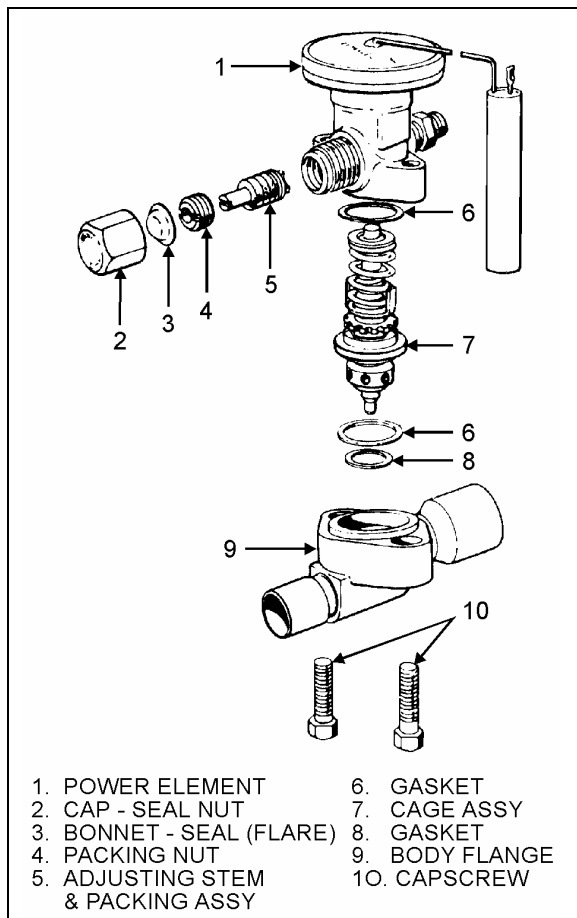

FIGURE 35: EXPANSION VALVE

22045

A vapor is said to be superheated when its temperature is higher than the saturation temperature corresponding to its pressure. The amount of the superheat is, of course, the temperature increase above the saturation temperature at the existing pressure.

As the refrigerant moves along in the evaporator, the liquid boils off into a vapor and the amount of liquid decreases until all the liquid has evaporated due to the absorption of a quantity of heat from the surrounding atmosphere equal to the latent heat of vaporization of the refrigerant. The gas continues along in the evaporator and remains at the same pressure. However, its temperature

increases due to the continued absorption of heat from the surrounding atmosphere. The degree to which the gas refrigerant is superheated is related to the amount of refrigerant being fed to the evaporator and the load to which the evaporator is exposed.

### Superheat Adjustment

The starting method of adjusting the superheat is to unscrew completely the main evaporator expansion valve adjusting screw, then screw in 13 turns clockwise for 134A (Fig. 36). Afterwards, the following procedure should be followed:

1. Operate vehicle for at least one-half hour at fast idle with temperature control set at 82°F (27,7°C), Then set temperature to minimum to keep the compressor on 6 cylinders.

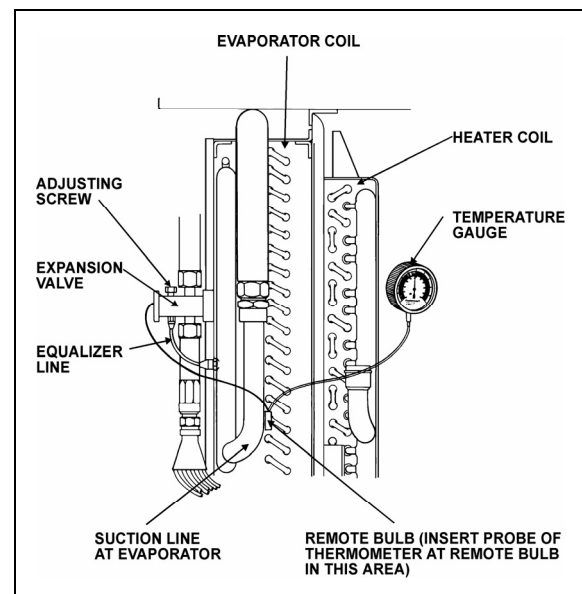

FIGURE 36: SUPERHEAT ADJUSTMENT INSTALLATION

22046

2. Install pressure gauge at the evaporator suction header. You may install the pressure gauge at compressor suction, but then add 3 psi to reading.
3. Install a remote reading thermometer to the evaporator outlet line near the existing remote bulb (Fig. 36).
4. Apply thermostatic tape around the bulb and evaporator outlet line to get a true reading of the line temperature.
5. Block condenser if necessary to keep pressure over 150 psi.
6. Check approximately 5 readings of pressure at 2-minute intervals and convert to temperature using the temperatures &

pressures table (page 35). Likewise check the temperature reading at the remote bulb at the same 2-minute intervals and record the low and high swing readings of the needle (refer to Fig. 37).

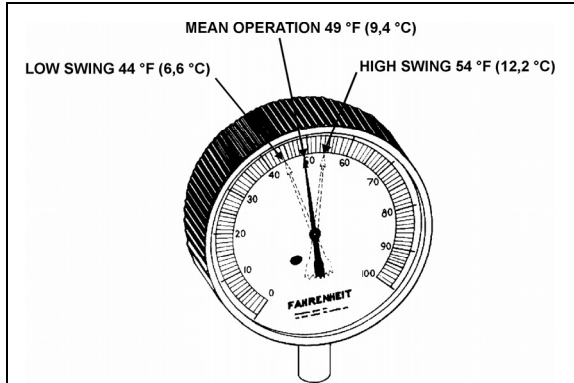

FIGURE 37: HIGH & LOW SWING TEMPERATURE AT REMOTE BULB 22047

Example of readings taken at fig. 37:

A/C pressure gauge converted to temperature at expansion valve fitting	Temperature on remote bulb	
40°F (4,4°C)	Low-swing 44°F (6,6°C)	High swing 54°F (12,2°C)
Formula for superheat 49°F-40°F=9°F (9,4°C-4,4°C = 5°C)	Average of low and high swing is 49°F (9,4°C)	

**NOTE**

The low swing of the superheat should be a minimum of 4°F (2,2°C) higher at the remote bulb and have an average of 8 to 12°F (4 to 6°C) higher range at the bulb than the fitting at the expansion valve.

**NOTE**

To reduce the superheat, flow of refrigerant is increased by turning adjusting screw of expansion valve lower evaporator temperature counterclockwise. To increase temperature or increase superheat, flow of refrigerant is reduced by turning adjustment screw of expansion valve clockwise.

6. Regulate suction pressure to temperature reading according to temperature chart or to the R-134a temperature scale on the pressure gauge.

**Example:** Suction pressure 30 psi (207 kPa) converted to 32°F (0°C) on chart. If temperature reading is 40°F (4,4°C), subtract 32°F (0°C) and the result will be 8°F (4,4°C) of superheat.



**CAUTION**

Before proceeding to the expansion valve adjustment, check for restriction on suction side for clogged up filter dryer and partially open valves. These conditions will give a high superheat.

**Maintenance**

1. Pump down the system as previously indicated in this section.
2. Disconnect the external equalizer line from the under side of the power head, and unclamp the remote control bulb from the evaporator coil outlet line.
3. Remove the two cap screws holding the power assembly to the valve body flange. Lift off the power assembly and remove the cage assembly.
4. When reassembling, replace with the new gaskets in proper location. Make sure the two lugs on the cage assembly fit into grooves provided in the power assembly. Do not force the valves together. The cage must fit properly before tightening the body flange. Tighten bolts evenly.
5. Check for leaks.

**Safety Instructions**

1. Make sure the valve is installed with the flow arrow on the valve body corresponding to the flow direction through the piping system.
2. Before opening any system, make sure the pressure in the system is brought to and remains at the atmospheric pressure. Failure to comply may result in system damage and/or personal injury.

9.8.2 Driver's HVAC Unit

The function and operation of the expansion valve for the driver's HVAC unit are similar to the cabin HVAC unit but no superheat adjustment is required (see figures 16 and 33).



## Section 22: HEATING AND AIR CONDITIONING

### 9.9 TROUBLESHOOTING

#### 9.9.1 Expansion Valve

PROBABLE CAUSE	PROBABLE REMEDY
<b>LOW SUCTION PRESSURE-HIGH SUPERHEAT</b>	
EXPANSION VALVE LIMITING FLOW:	
Gas in liquid line due to pressure drop in the line or insufficient refrigerant charge.	Locate cause of line flash and correct by use of any of the following methods. Add R-134a. Replace or clean filter dryer.
Inlet pressure too low from excessive low condensing temperature. Resulting pressure difference across valve too small.	Increase head pressure. Verify pressure switch for fan speed control.
Superheat adjustment too high.	Adjust superheat as outlined under "Superheat Adjustment".
Power assembly failure or partial loss of charge.	Replace power assembly or replace valve.
Air filter screens clogged.	Clean or replace air filter screens.
Clogged lines.	Clean, repair or replace lines.
<b>LOW SUCTION PRESSURE-LOW SUPERHEAT</b>	
Uneven or inadequate evaporator loading due to poor air distribution or liquid flow.	Balance evaporator load distribution by providing correct air or liquid distribution.
<b>HIGH SUCTION PRESSURE-HIGH SUPERHEAT</b>	
Compressor discharge valve leaking.	Replace or repair valve.
<b>HIGH SUCTION PRESSURE-LOW SUPERHEAT (DEFECTIVE UNLOADER)</b>	
Valve superheat setting too low.	Adjust superheat as outlined under "Superheat Adjustment".
Compressor discharge valves leaking.	Replace or repair discharge valve.
Incorrect superheat adjustment.	Superheat adjustment 12 to 16°F.
<b>FLUCTUATING DISCHARGE PRESSURE</b>	
Insufficient charge.	Add R-134a to system.
<b>HIGH DISCHARGE PRESSURE</b>	
Air or non-condensable gases in condenser.	Purge and recharge system.
Overcharge or refrigerant.	Bleed to proper charge.
Condenser coil dirty.	Clean condenser coil.

9.9.2 A/C

TROUBLE	CAUSE
Low suction pressure and frosting at dryer outlet.	Clogged filter.
Low Oil Level.	Check for oil leaks and for leaking oil seal. Do not attempt to check oil level unless system has been stabilized at least 20 minutes. See oil level verification.
Excessively cold suction line.	Loss of contact between the expansion valve bulb and the suction line or sticking of the expansion valve.  Check for foreign matter and clean, repair or replace the valve.
Excessively cold suction line and noisy compressor.	Check superheat adjustment. Check remote bulb contact. Check expansion valve for sticking.
Compressor squeaks or squeals when running.	Check oil level. Replace oil seal.
Noisy or knocking compressor.	Check for broken internal parts. Overhaul if required.
Compressor vibrates.	Check and tighten compressor mounting bolts and belt tension.
Low refrigerant level	Check for refrigerant leaks and add refrigerant if required.
Suction pressure rises faster than 5 pounds per minute after shutdown.	Check compressor valve for breakage or damage.
Insufficient cooling.	Check for refrigerant leaks. Check condition of air filter and motors.
Insufficient air flow.	Dirty or iced evaporator. Dirty air filter. Blowers inactive. Clogged ducts.
No flow of refrigerant through expansion valve.	Filter dryer is clogged. Remote bulb has lost charge or expansion valve is defective.
Expansion valve hisses. Bubbles in moisture and liquid indicator.	Gas in liquid line. Add refrigerant.
Loss of capacity	Clogged filter. Obstructed or defective expansion valve.
Superheat too high.	Reset superheat adjustment. Check for clogged external equalizer line, or filter dryer.
Reduced air flow: a. Dirty or clogged air filter; b. Evaporator motor inoperative; or c. Clogged return air ducts.	Dirty or iced evaporator coil. Clean air filter screens. Check return ducts for obstructions. Check blower motor.
Frequent starting and stopping on low pressure control switch.	Lack of refrigerant. Check for leaks. Recharge.
Compressor intermittently starts and stops.	Intermittent contact in electrical control circuit. Compressor valves not in operating position.
Non-condensable in the refrigeration system.	Leak on system, system in vacuum in low temp. Specific symptom, pressure in system will not correspond to ambient temperature on shutdown. Only non-condensable will cause this.  (Example: Pressure of idle R-134a system in 80°F (26.6°C) room should be 86.4 psi (595.7 kPa). See temperature chart in this section.)

## Section 22: HEATING AND AIR CONDITIONING

TROUBLE	CAUSE
	<p>An evaporator just does a proper cooling job without sufficient air. Shortage of air can be caused by the following:</p> <ul style="list-style-type: none"> <li>* Dirty filters; or</li> <li>* Dirty coils.</li> </ul>
<p>Testing condenser pressure.</p> <p>Note: R-134A pressure is function of the temperature variation.</p> <p>Example, for an exterior temperature of 100°F.            Exterior temperature (100°F) + 30°F = 130°F. Refer to paragraph "10.11 Temperature &amp; Pressure".            Note the corresponding pressure for a temperature of 130°F, 199.8 psi.            Read the condenser pressure, example 171.9 psi.            171.9 psi &amp; 199.8 psi, the pressure in the condenser is inferior to the pressure corresponding to the exterior temperature, in this case the condenser pressure may be too low. Check for refrigerant leaks and add refrigerant if necessary. If the pressure corresponding to the condenser temperature is superior to the pressure corresponding to the exterior temperature, then the air cooled condenser pressure may be too high. Most frequent causes are:</p> <p>Reduced air quantity. This may be due to:</p> <ul style="list-style-type: none"> <li>* Non-condensable in system;</li> <li>* Dirt on the coil;</li> <li>* Restricted air inlet or outlet;</li> <li>* Dirty fan blades;</li> <li>* Incorrect rotation of fan;</li> <li>* Fan speed too low;</li> <li>* Fan motor going out on overload; or</li> <li>* Prevailing winds.</li> <li>* Too much refrigerant in system. Remove refrigerant if necessary.</li> </ul>	

## 9.10 TEMPERATURES &amp; PRESSURES

VAPOR-PRESSURE			
TEMPERATURE		PRESSURE	
°F	°C	psi	kPa
-100	-73.3	27.8	191.7
-90	-67.8	26.9	185.5
-80	-62.2	25.6	176.5
-70	-56.7	23.8	164.1
-60	-51.1	21.5	148.2
-50	-45.6	18.5	127.6
-40	-40.0	14.7	101.4
-30	-34.4	9.8	67.6
-20	-29	3.8	26.2
-10	-23	1.8	12.4
0	-18	6.3	43.4
10	-12	11.6	80
20	-7	18.0	124.1
30	-1	25.6	176.5
40	4	34.5	237.9
50	10	44.9	309.6
60	16	56.9	392.3
70	21.1	70.7	487.5
80	27	86.4	595.7
90	32.2	104.2	718.5
100	38	124.3	857.0
110	43.3	146.8	1012.2
120	49	171.9	1185.3
130	54.4	199.8	1377.6
140	60	230.5	1589.3
150	65.6	264.4	1823.0
160	71	301.5	2078.8
170	76.7	342.0	2358.1
180	82.2	385.9	2660.8

## Section 22: HEATING AND AIR CONDITIONING

VAPOR-PRESSURE			
TEMPERATURE		PRESSURE	
°F	°C	psi	kPa
190	87.8	433.6	2989.7
200	93.3	485.0	3344.1
210	98.9	540.3	3725.4

### 9.11 TORCH BRAZING

Use an electrode containing 35% silver.



#### CAUTION

When using heat near a valve, wrap with a rag saturated with water to prevent overheating of vital parts.



#### DANGER

Before welding any part of refrigeration system, make sure the area is well ventilated.

### 9.12 LEAK TESTING

Some methods such as nitrogen pressure and soap, and electronic sniffer can be used for leak testing. However, the most common method used is a "Halide" torch consisting of an acetylene tank, a burner and a suction test hose. Proceed as follows:



#### DANGER

Do not inhale fumes from leak detector.

The flow of acetylene to the burner causes suction in the test line. Any gas refrigerant present will be drawn through the hose and into the burner where it decomposes into free acids.

These acids come in contact with the hot copper reaction plate in the burner, causing color reaction in the flame. A small concentration is indicated by a green tint and a large concentration by an intense blue. Do not confuse this change in color with the change caused by shutting off the air supply through the hose by holding the end too close to an object.

The procedure for testing is:

1. Adjust flame so that the top of the cone is approximately level or within one-half inch above the plate.
2. Probe end of suction test tube around all joints, valves, etc. When a leak has been found at a soldered joint, this section of the system must be pumped down. Do not solder as pressure will force hot solder out. If the system is empty, it is more economical to put in just enough R-134a to produce about 15 psi (103 kPa). The pressure can be raised to about 150 psi (1034 kPa) with dry nitrogen.

#### NOTE

*This gas is put into the suction and discharge shutoff valves at the compressor. The receiver valves must be opened. If no leaks are found, dump this mixture, evacuate the system and fill with refrigerant.*

## 10. SMALL HVAC SYSTEM - AIR CONDITIONING COMPONENTS

### 10.1 COMPRESSOR

Consult the SANDEN SD Compressor Service Manual included at the end of this section.



#### WARNING

Read the cautionary information in the SANDEN SD Compressor Service Manual included at the end of this section.

### 10.2 COMPRESSOR REMOVAL

10.2.1 When the compressor is operational

- \* Perform the "OIL RETURN OPERATION" (Refer to paragraph 10.5).

10.2.2 When the compressor is inoperable

- \* Evacuate the system (Refer to paragraph 10.2.3).
- \* Slacken bolts A (Refer to figure 38).
- \* Remove bolts B & C (Refer to figure 38).
- \* Remove the compressor.

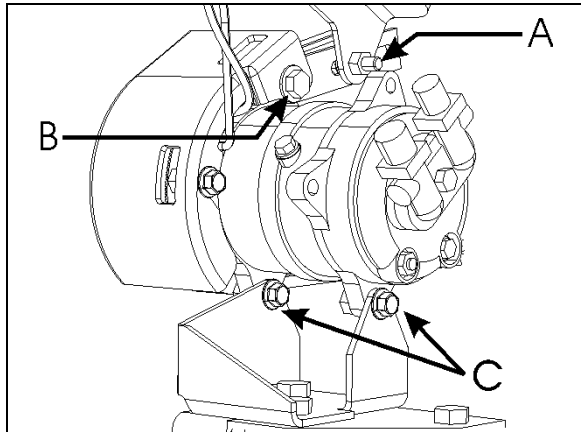

FIGURE 38: COMPRESSOR REMOVAL OR INSTALLATION 22349

10.2.3 Evacuating System Before Adding Refrigerant (Small HVAC System)

When a system has been opened for repairs, change the filter dryer and evacuate the system. XLII vehicles equipped with a small HVAC system must use high-pressure service port located on the other side of check valve and low-pressure port located alongside rear truss (Fig. 39). It would be good practice to open solenoid valve.

1. Connect two hoses equipped with a micron gauge between the high-pressure service port, the low-pressure service port and the vacuum pump.
2. With the unit service valves open and the vacuum pump valves open, start the pump and draw the manifold and hoses into a very deep vacuum (700 microns).
3. Close manifold valve
4. Shut down the vacuum pump.
5. Check to insure that vacuum holds. (If the pressure continues to rise, it indicates a leak or moisture in the system).
6. Charge the system with the proper amount of refrigerant through the service port near the check valve using recommended charging procedures.

7. Remove the hoses.

10.3 OIL ADDITION

The chart below shows the approximate amount of oil to be added to the system when replacing a component.

Component replaced	Typical amount of oil
Evaporator	50 cm <sup>3</sup> (1.7 ozs)
Condenser	30 cm <sup>3</sup> (1.0 ozs)
Filter-Dryer	10 cm <sup>3</sup> (0.3 ozs)

The amount of oil recovered with the refrigerant recovery should be added at the same time.

10.4 COMPRESSOR OIL CONTAMINATION

Unlike engine oil, no cleaning agent is added to the compressor oil. Even if the compressor is run for a long time, the oil never becomes turbid as long as there is nothing wrong with the compressor or its method of use. Inspect the extracted oil for any of the following conditions:

- \* Dirt in the oil.
- \* Change to a varnish color.
- \* Presence of foreign substance, metal shavings, etc. in the oil. When the oil extracted from the compressor is as described above, replace the oil as follows:
  1. Clean the interior of the system with approved method.
  2. Replace the filter-dryer.
  3. Supply with new oil as specified in SANDEN SD Compressor Service Manual included at the end of this section.

10.5 OIL RETURN OPERATION

There is a close affinity between oil and refrigerant. During normal operation, part of the oil recirculates with the refrigerant in the system. Therefore, when checking the amount of oil in the system or replacing any system component, the compressor must be run in advance to ensure return. This procedure is as follows:

- \* If the amount of refrigerant in the system has decreased, charge to the proper amount.
- \* Start the engine and select fast idle.
- \* Set the fan speed to full air/full A/C and let run for 20 minutes.

# SMALL A/C SYSTEM

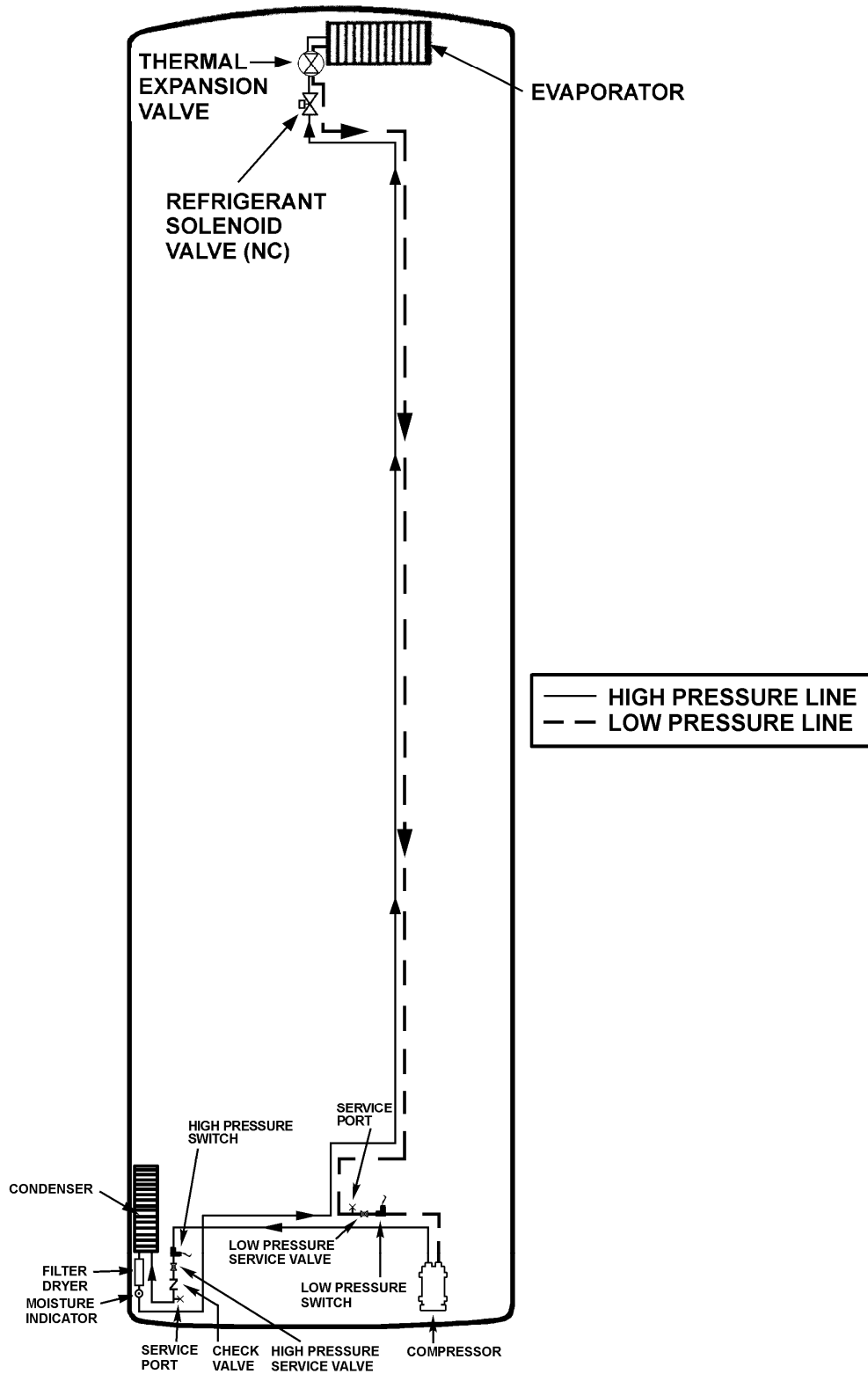

FIGURE 39: REFRIGERANT CIRCUIT (SMALL SYSTEM)

22350

## 11. HEATING SYSTEM

As seen earlier in this section, the vehicle interior is pressurized by its Heating, Ventilation and Air Conditioning (HVAC) system. Two heating systems are available: Central Heating System and Small Heating System. The vehicle interior should always be slightly pressurized to prevent cold and moisture from entering. If the vehicle is equipped with a Central Heating System; air flow and controls divide the vehicle into two areas: driver's area and cabin area.

The schematic of Figure 42 shows the central heating system with its components.

### 11.1 CENTRAL HEATING SYSTEM

#### 11.1.1 Draining Heating System

To drain the entire system, refer to Section 05, "Cooling". If only the driver's HVAC unit or cabin HVAC unit heater core must be drained, refer to the following instructions.

- **Draining Driver's HVAC Unit Heater Core**
  - a) Stop engine and allow engine coolant to cool.
  - b) Locate the normally open hot water pneumatic valve on the ceiling of the spare wheel compartment (Fig. 40), move the pilot-solenoid valve red tab to close the valve.



### WARNING

Before proceeding with the following steps, check that coolant has cooled down.

- c) Loosen hose clamp, install an appropriate container to recover coolant, and disconnect silicone hose from hot water pneumatic valve.
- d) From inside of vehicle, remove the two finishing panels in front of unit. Remove the three screws fixing the unit front panel. Open the manual vent located inside the HVAC unit, on the driver's side (Fig. 41) to ensure an efficient draining.

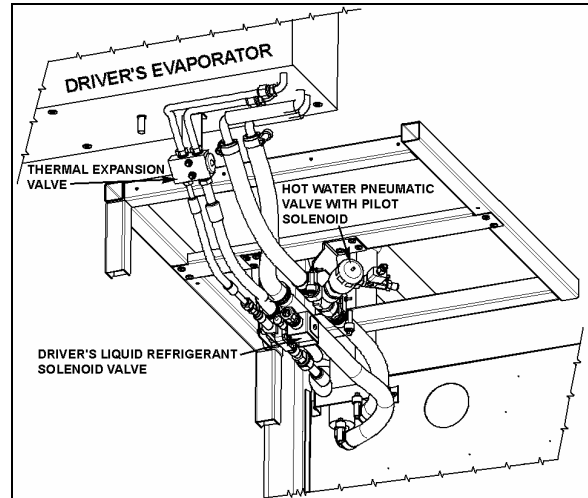

FIGURE 40: CEILING OF THE SPARE WHEEL COMPARTMENT

22181

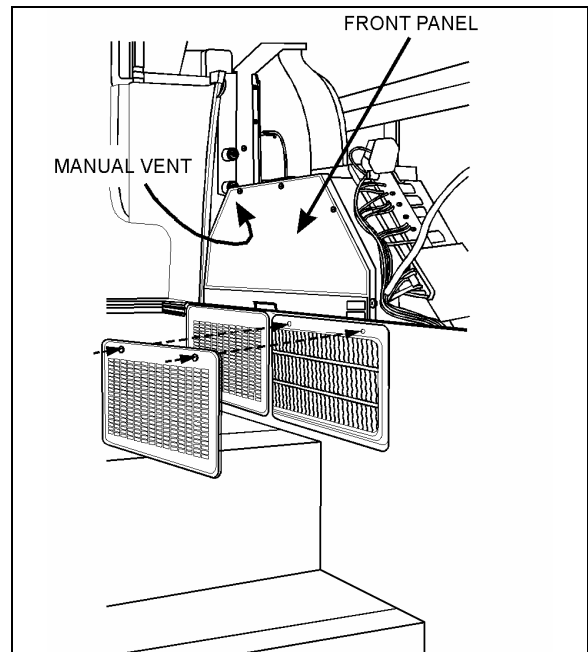

FIGURE 41: DRIVER'S HVAC UNIT

22172

- **Draining Cabin HVAC Unit Heater Core**
  - a) Stop engine and allow engine coolant to cool.
  - b) Close both heater line shutoff valves.

**On XLII-45E vehicles**, the valves are located in engine compartment. One is on the L.H. side of compartment in front of the radiator and the other valve is located under the radiator fan gear box (Fig. 43).



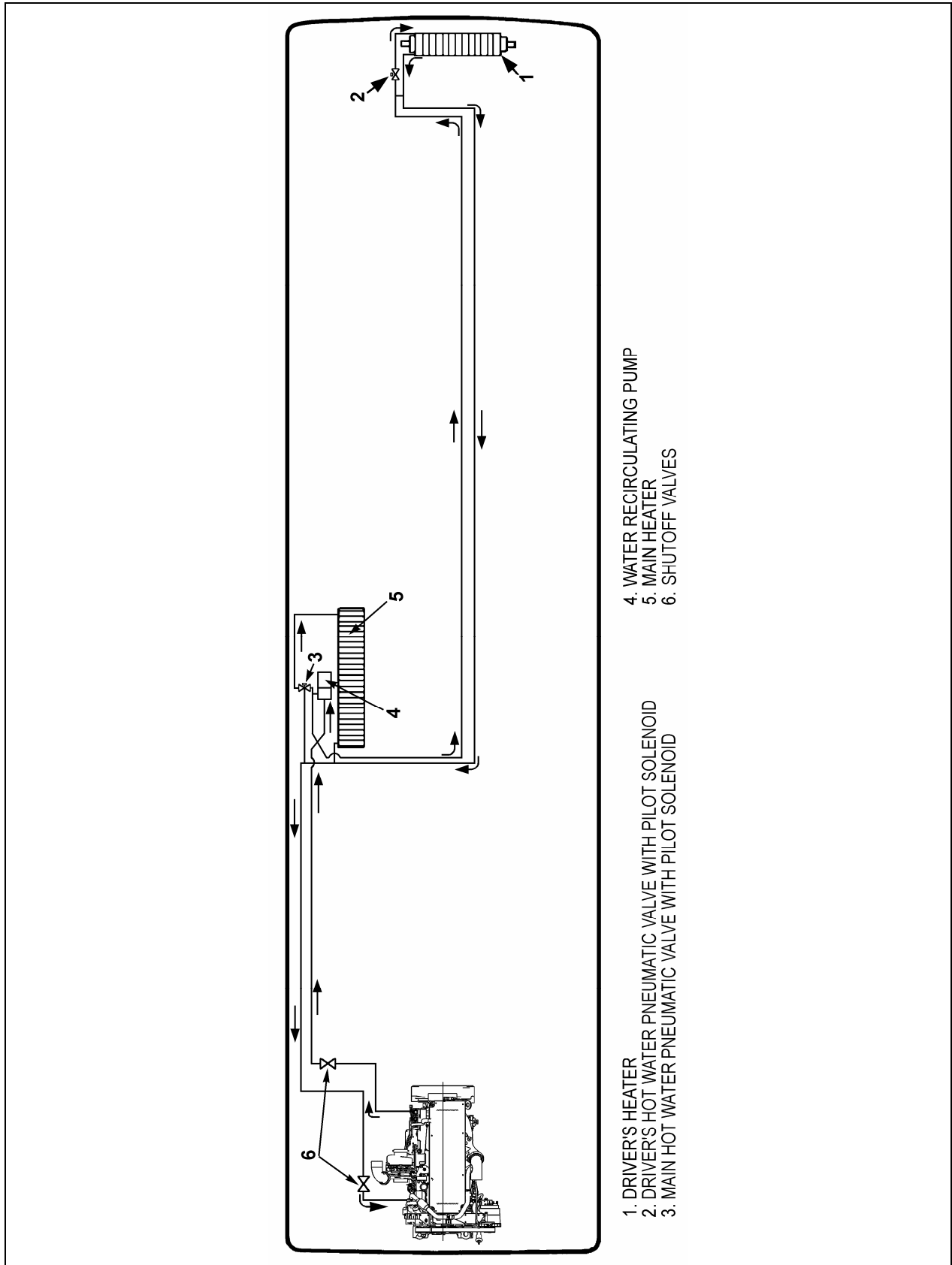

FIGURE 42: CENTRAL HEATING SYSTEM COMPONENTS

22338

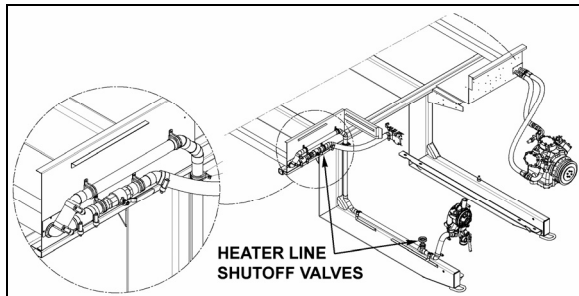

FIGURE 43: HEATER LINE SHUTOFF VALVES 05070

On XLII-45 vehicles, the valves are located in engine compartment. One is on the L.H. side of compartment in front of the radiator and the other valve is located under the radiator fan gearbox (Fig. 44).

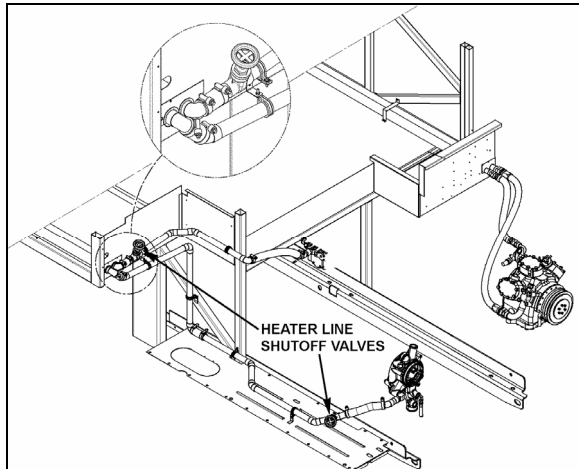



FIGURE 44: HEATER LINE SHUT-OFF VALVES 05067

- c) The main heater core drain cock is located in the evaporator compartment. To access, open the baggage compartment forward of the evaporator compartment. An access door held shut by three retaining tabs is located in the wall separating the baggage compartment and the evaporator compartment (Fig. 15).



**WARNING**

Before proceeding with the following step, check that coolant has cooled down.

- d) Open drain cock in bottom of heater core, you can unfasten a hose connection on top of heater core (Fig. 45) in order to allow air to enter while draining.

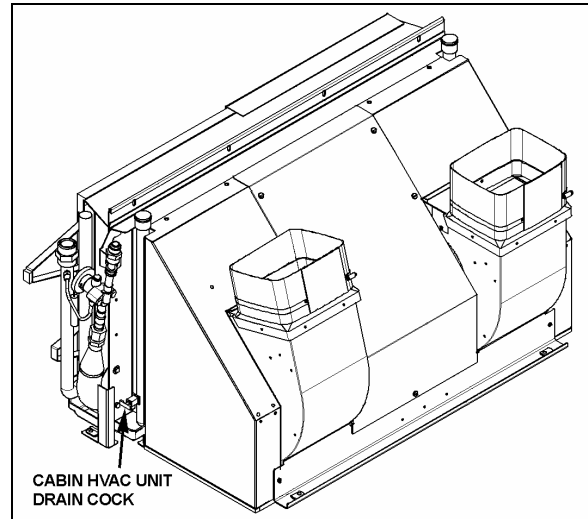

FIGURE 45: CABIN HVAC UNIT DRAIN COCK 22128

### 11.1.2 Filling Heating System

1. Ensure that the drain hose is reconnected and the manual vent and drain cock are closed.
2. Open the surge tank filler cap and slowly fill the system to level of filler neck.
3. After initial filling, the water valves should be open and the water recirculating pump should be energized to assist in circulating coolant through the heating system. To perform this operation, start the engine, switch on the HVAC control module, both driver's and cabin (passenger) areas, and set temperature to their maximum positions in order to request the heating mode in each of these areas.
4. When coolant level drops below the surge tank filler neck, slowly fill the system to level of filler neck.
5. Once the level has been stabilized, replace cap.

### 11.1.3 Bleeding Heating System

Whenever the heating system has been drained and refilled, or the system has run low on coolant and coolant has been added, it is necessary to bleed air from heating system. Locate the manual vent illustrated in Figure 41 and open momentarily until no air escapes from the line.

## Section 22: HEATING AND AIR CONDITIONING

### 11.1.4 Soldering

Before soldering any part of the system, make sure the area is well ventilated. Use (stay clean) flux sparingly and apply solder (95-5 round wire 1/8 inch [3,1 mm]). After completing repairs, test for leaks.

When using heat at or near a valve, wrap with a water saturated rag to prevent overheating of vital parts.

### 11.1.5 Driver's Hot Water Pneumatic valve Assembly

#### o Description

The flow of hot water to the driver's heater core is controlled by a pneumatic NO water valve assembly. The valve, located at the ceiling of the spare wheel compartment, is designed so that the pilot solenoid valve, which is part of the assembly, opens and closes a port which directs air pressure to the actuator casing, thereby opening or closing the valve.

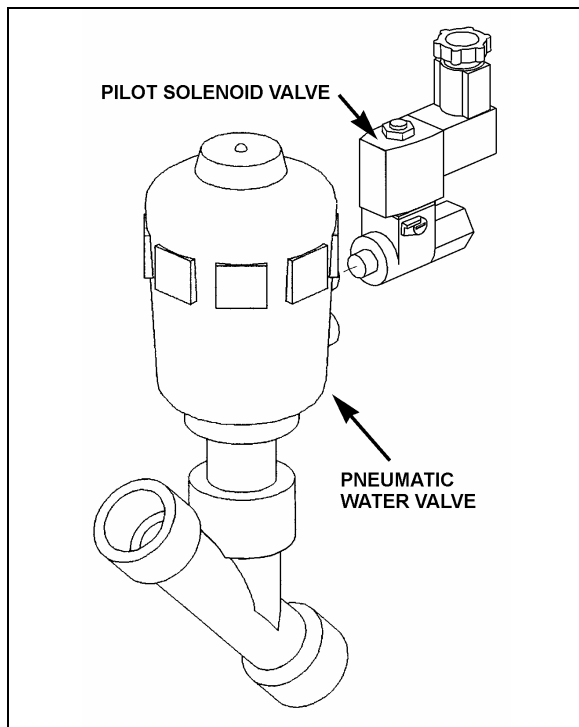

FIGURE 46: DRIVER'S HOT WATER PNEUMATIC VALVE ASSEMBLY  
22240

When the vehicle is operating with no current to the pilot solenoid valve, no air pressure is admitted to the actuator casing, the cylinder spring pushes up against the cylinder, thereby keeping the water valve open.

The driver's heater water valve requires a minimum amount of maintenance. The valve should be free of dirt sediment that might interfere with its operation. No other maintenance is needed unless a malfunction occurs.

#### o Pneumatic Water Valve Disassembly

- Shut off air supply pressure and electrical current to the pilot solenoid valve. Disconnect wires.
- The water valve need not be removed from the line. Unscrew nipple, the actuator casing, tube, spindle and closure member can be removed (Fig. 47).
- Remove the snap ring using a pair of pliers.
- You can now access all seals for replacement

Pneumatic water valve replacement seal kits:

❖ Water Side: 871311

❖ Actuator Side: 871312

#### o Pneumatic Water Valve Reassembly

- Assemble the actuator casing, tube, nipple, spindle and closure member.
- Tighten the nipple in place in the body cavity as per figure 47. Fasten pilot solenoid valve to the pneumatic water valve. Reconnect air supply pressure and electrical current to the pilot solenoid valve.
- Check for proper operation.

#### o Pilot Solenoid Valve

- No maintenance is needed unless a malfunction occurs.
- A pilot solenoid valve replacement seal kit is available: 871313.

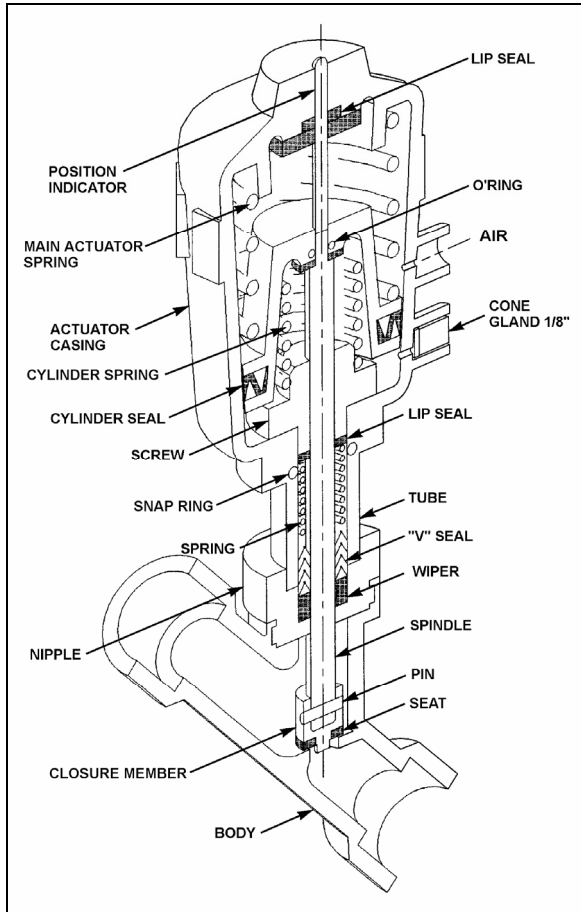

FIGURE 47: PNEUMATIC WATER VALVE 22241

o Valve Troubleshooting

PROBLEM	PROCEDURE
Valve fails to close.	<ol style="list-style-type: none"> <li>1. Check electrical supply with a voltmeter. It should agree with nameplate rating.</li> <li>2. Check pressure at pilot solenoid valve inlet. It must be at least equal to the minimum pressure stamped on the nameplate. It should not go below minimum while valve is operating.</li> </ol>
Valve fails to open.	<ol style="list-style-type: none"> <li>1. Check that the closure member assembly, and that main actuator and cylinder springs are free to travel.</li> </ol>

2. Check that there is no restriction to the air escaping from the actuator casing.
3. Make sure that pilot solenoid valve operates properly.

11.1.6 Central Hot Water Pneumatic Valve Assembly

o Description

The flow of hot water to the vehicle's central heater core is controlled by a 3-way pneumatic water valve assembly. The valve, located in the evaporator compartment, is designed so that the pilot solenoid valve, which is part of the assembly, opens and closes a port which directs air pressure to the actuator casing, thereby allowing the hot water to enter the main heater core or bypassing it.

When the vehicle is operating with no current to the pilot solenoid valve, no air pressure is admitted to the actuator casing, the cylinder spring pushes up against the cylinder, thereby allowing the hot water to enter the main heater core.

The central heater water valve requires a minimum amount of maintenance. The valve should be free of dirt sediment that might interfere with its operation. No other maintenance is needed unless a malfunction occurs.

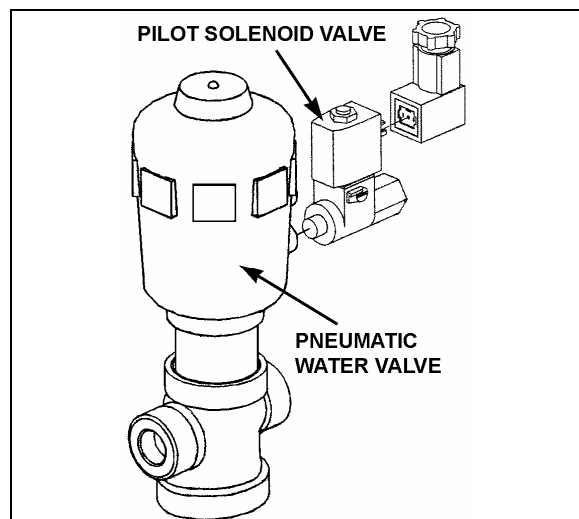

FIGURE 48: CENTRAL HOT WATER PNEUMATIC VALVE ASSEMBLY 22240

## Section 22: HEATING AND AIR CONDITIONING

### ○ Pneumatic Water Valve Disassembly

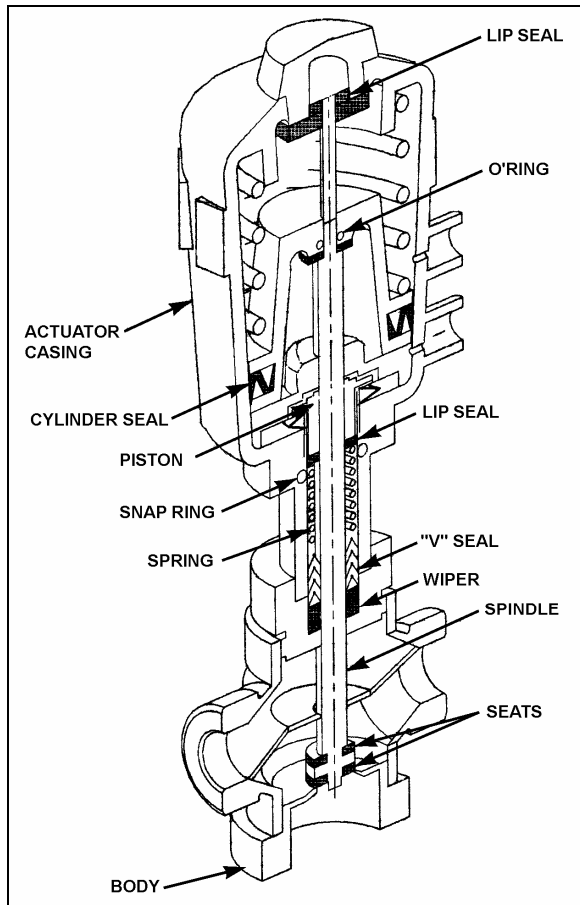

FIGURE 49: PNEUMATIC WATER VALVE

22241

- a) Shut off air supply pressure and electrical current to the pilot solenoid valve. Disconnect wires.
- b) The water valve need not be removed from the line. Unscrew nipple, the actuator casing, tube, spindle and closure member can be removed (Fig. 49).
- c) Remove the snap ring using a pair of pliers.
- d) You can now access all seals for replacement.

Pneumatic water valve replacement seal kits:

❖ Water Side: 871389

❖ Actuator Side: 871388

### ○ Pneumatic Water Valve Reassembly

- a) Assemble the actuator casing, tube, nipple, spindle and closure member.
- b) Tighten the nipple in place in the body cavity as per figure 49. Fasten pilot solenoid valve to the pneumatic water valve. Reconnect air supply pressure and electrical current to the pilot solenoid valve.
- c) Check for proper operation.

### ○ Pilot Solenoid Valve

- a) No maintenance is needed unless a malfunction occurs.
- b) A pilot solenoid valve replacement seal kit is available: 871390.

### ○ Valve Troubleshooting

PROBLEM	PROCEDURE
Valve fails to close.	<ol style="list-style-type: none"> <li>1. Check electrical supply with a voltmeter. It should agree with nameplate rating.</li> <li>2. Check pressure at pilot solenoid valve inlet. It must be at least equal to the minimum pressure stamped on the nameplate. It should not go below minimum while valve is operating.</li> </ol>
Valve fails to open.	<ol style="list-style-type: none"> <li>1. Check that the closure member assembly, and that main actuator and cylinder springs are free to travel.</li> <li>2. Check that there is no restriction to the air escaping from the actuator casing.</li> <li>3. Make sure that pilot solenoid valve operates properly.</li> </ol>

11.1.7 Water Recirculating Pump

This vehicle is provided with a water recirculating pump which is located in the evaporator compartment (Fig. 50). The water recirculating pump consists of a centrifugal pump and an electric motor which are mounted on a common shaft in a compact assembly.

The (seal less) pump requires no periodic maintenance other than replacement of motor brushes. Replacement of motor brushes can be performed without removing the pump assembly. Inspection of the pump, to determine if the pump is working properly, should be made while the pump is in operation. If there is evidence that the pump is not operating as per specifications, the unit must be disassembled for corrective measures.

Disassembly of the pump will be necessary only in the case of a rotor failure or motor failure.

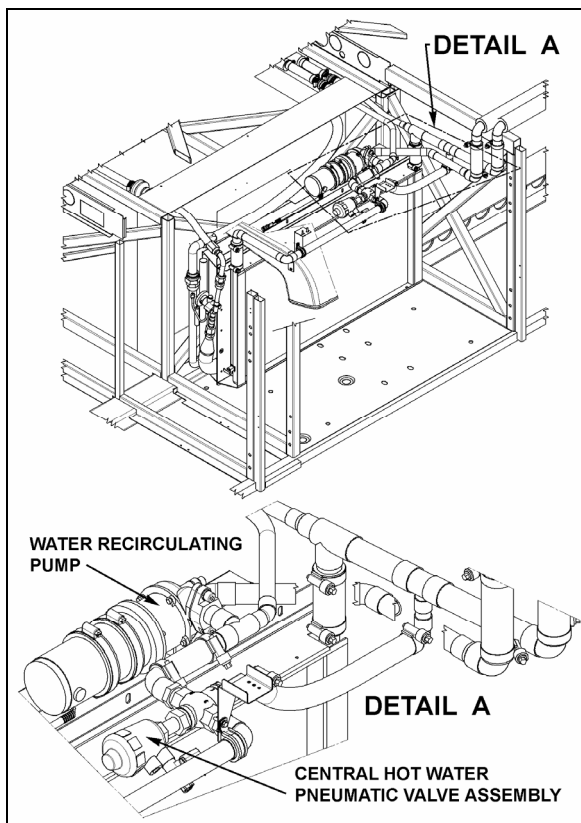

FIGURE 50: PUMP LOCATION

22178G

o **Removal**

- a) Stop engine and allow engine coolant time to cool.

- b) Close shutoff valves. Refer to "05 COOLING" under heading "Draining Cooling System" for location of valves.

- c) Disconnect the electrical wiring from the motor.

	WARNING
Before proceeding with the following steps, check that coolant has cooled down.	

- d) Disconnect water lines from pump at flange connections. Place a container to recover the residual coolant in the line.
- e) Remove the two clamps holding the pump motor to its mounting bracket. Remove the pump with the motor as an assembly.

o **Disassembly**

- a) Separate the housing (1) from the adapter (7) by first removing the 4 capscrews. Remove housing carefully to prevent damaging the O-ring (2).
- b) Remove rotor assembly (4), washers (3) and shaft (5) from the adapter.

**Inspection**

Components removed from the recirculating pump and motor assembly should be compared with new parts to determine the degree of wear.

o **Brushes**

1. When removing brushes, note the position of the brush in the tube. Brush life is shortened if the brushes are not replaced properly.
2. Examine brushes for the following:

a. Wear

Replace the brushes if less than 25% of the usable brush is left (less than 0.300 inch [8 mm]).

b. Chipped edges

Chips can be caused by improper handling or installation. Badly chipped brushes should be replaced regardless of their length.

c. Annealed brush spring

This can be detected by noting the resiliency of the spring. Annealing is caused by failing to tighten the brush

## Section 22: HEATING AND AIR CONDITIONING

---

caps properly, thus not providing a good low resistance contact between the terminal and the brush tube. Replace brushes showing evidence of annealed springs.

### d. Frayed or broken pigtail

An improperly installed brush may have the pigtail (shunt) pinched under the terminal or between the coils of the spring. If the pigtail is badly frayed or broken, replace the brush.

3. Observe the following factors when replacing brushes:
  - a. The face of a new brush is carefully cut to cause proper seating during the "wear-in" period.
  - b. Improper installation can harm both the brush and the commutator.
  - c. Replacement brushes should be of the proper grade.
  - d. Brush performance will be affected if the spring and terminal are not properly placed in the brush tube. The spring should be free over its entire length and the terminal should make good contact with the metal brush tube insert.
- **Assembly**
  - a) Install washer (3), shaft (5) and rotor assembly (4) into adapter (7).
  - b) Install O-ring (2) into housing (1) and assemble housing to the adapter.
  - c) Secure housing to adapter using 4 capscrews (6).

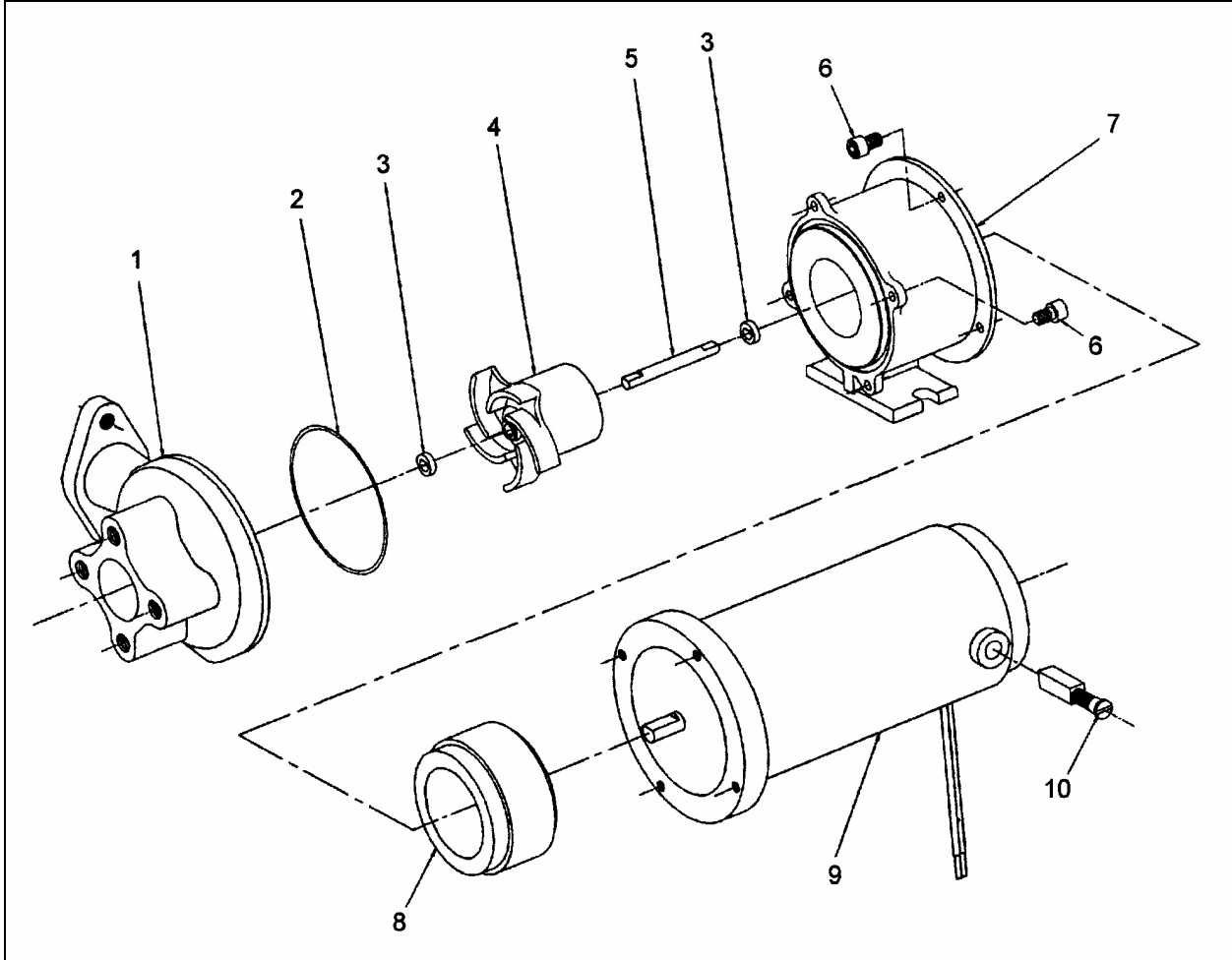

FIGURE 51: WATER RECIRCULATING PUMP (CENTRAL HVAC SYSTEM)

22091

ITEM	DESCRIPTION	QTY.
1	Housing	1
2	O-Ring	1
3	Washer SS	2
4	Rotor Assembly	1
5	Shaft SS	1
6	Screw, Cap Hex Soc. Head 8-32 X 3/8	8
7	Adaptor	1
8	Drive Magnet	1
9	Motor Assembly 24V	1
10	Brush	2



## Section 22: HEATING AND AIR CONDITIONING

---

### ○ Installation

- a) Apply gasket cement to the line flanges, put the two gaskets in place, and connect water lines to the pump at the flange connections. Position the pump and motor assembly on the mounting bracket. Position the mounting clamps over the motor and secure with mounting bolts.
- b) Connect electrical wiring to the pump motor.
- c) Open shutoff valve. Refer to "05 COOLING" under heading "Draining Cooling System" for location of valves.
- d) Fill the cooling system as previously instructed in this section under "11.1.2 Filling Heating System", then bleed the system as previously instructed in this section under "11.1.3 Bleeding Heating System".

## 11.2 SMALL HEATING SYSTEM

### 11.2.1 Draining Heating System

To drain the entire system, refer to Section 05, "Cooling". If only the driver's HVAC unit heater core must be drained, refer to the following instructions.

#### ○ Draining Driver's HVAC Unit Heater Core

- a) Stop engine and allow engine coolant to cool.
- b) Locate the normally open hot water pneumatic valve on the ceiling of the spare wheel compartment (Fig. 52), move the pilot-solenoid valve red tab to close the valve.



### **WARNING**

Before proceeding with the following steps, check that coolant has cooled down.

- c) Loosen hose clamp, install an appropriate container to recover coolant, and disconnect silicone hose from hot water pneumatic valve.
- d) From inside of vehicle, remove the two finishing panels in front of unit. Remove the three screws fixing the unit front panel. Open the manual vent located inside the HVAC unit, on the driver's side (Fig. 41) to ensure an efficient draining.

### 11.2.2 Filling Heating System

- a) Ensure that the drain hose is reconnected and the manual vent is closed.
- b) Open the surge tank filler cap and slowly fill the system to level of filler neck.
- c) After initial filling, the water valve should be open and the water recirculating pump should be energized to assist in circulating coolant through the heating system. To perform this operation, start the engine, switch on the HVAC control module and set temperature to the maximum position in order to request the heating mode.
- d) When coolant level drops below the surge tank filler neck, slowly fill the system to level of filler neck.
- e) Once the level has been stabilized, replace cap.

### 11.2.3 Driver's Hot Water Pneumatic Valve Assembly

The small system driver's hot water pneumatic valve assembly is similar to the one installed in a central heating system.

Refer to figure 52 for hot water pneumatic valve location and to paragraph 11.1.5 for more information.

### 11.2.4 Water Recirculating Pump

The small system water recirculating pump is similar to the one installed in a central heating system.

Refer to figure 52 for pump location and to paragraph 11.1.7 for more information.

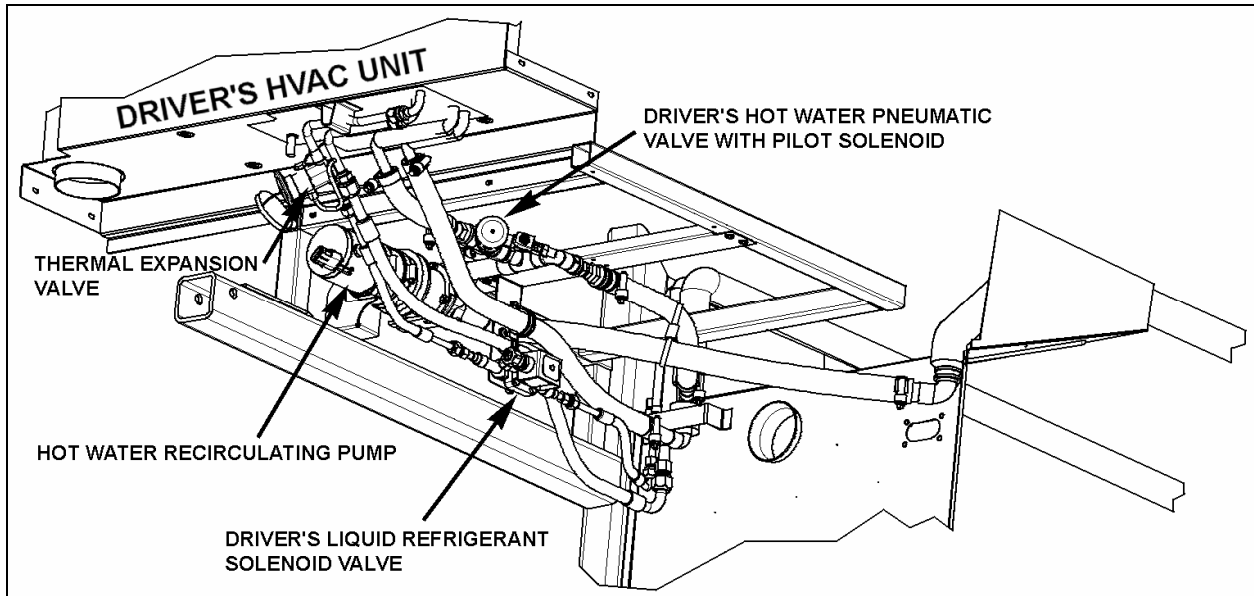

FIGURE 52: CEILING OF THE SPARE WHEEL COMPARTMENT

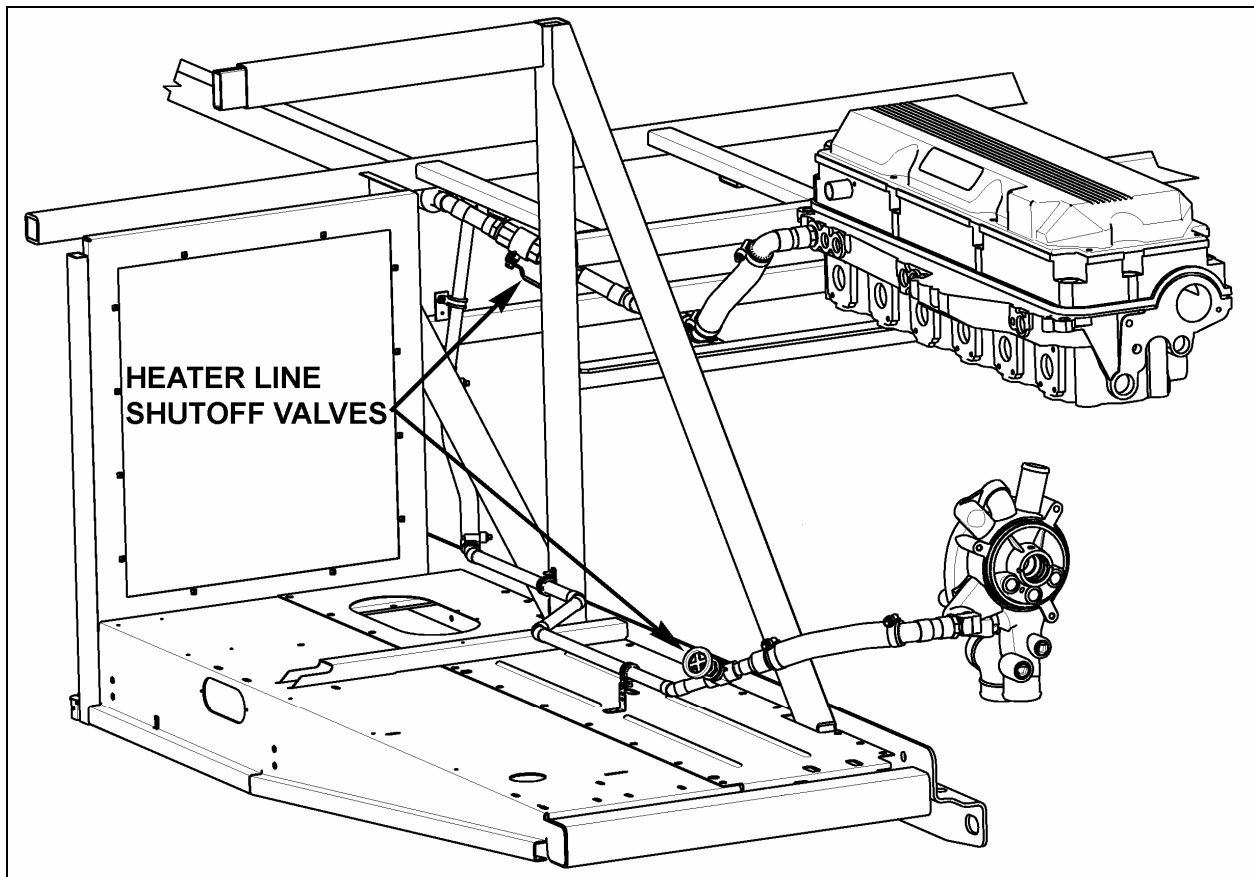

FIGURE 53: HEATER LINE SHUTOFF VALVES (W5)

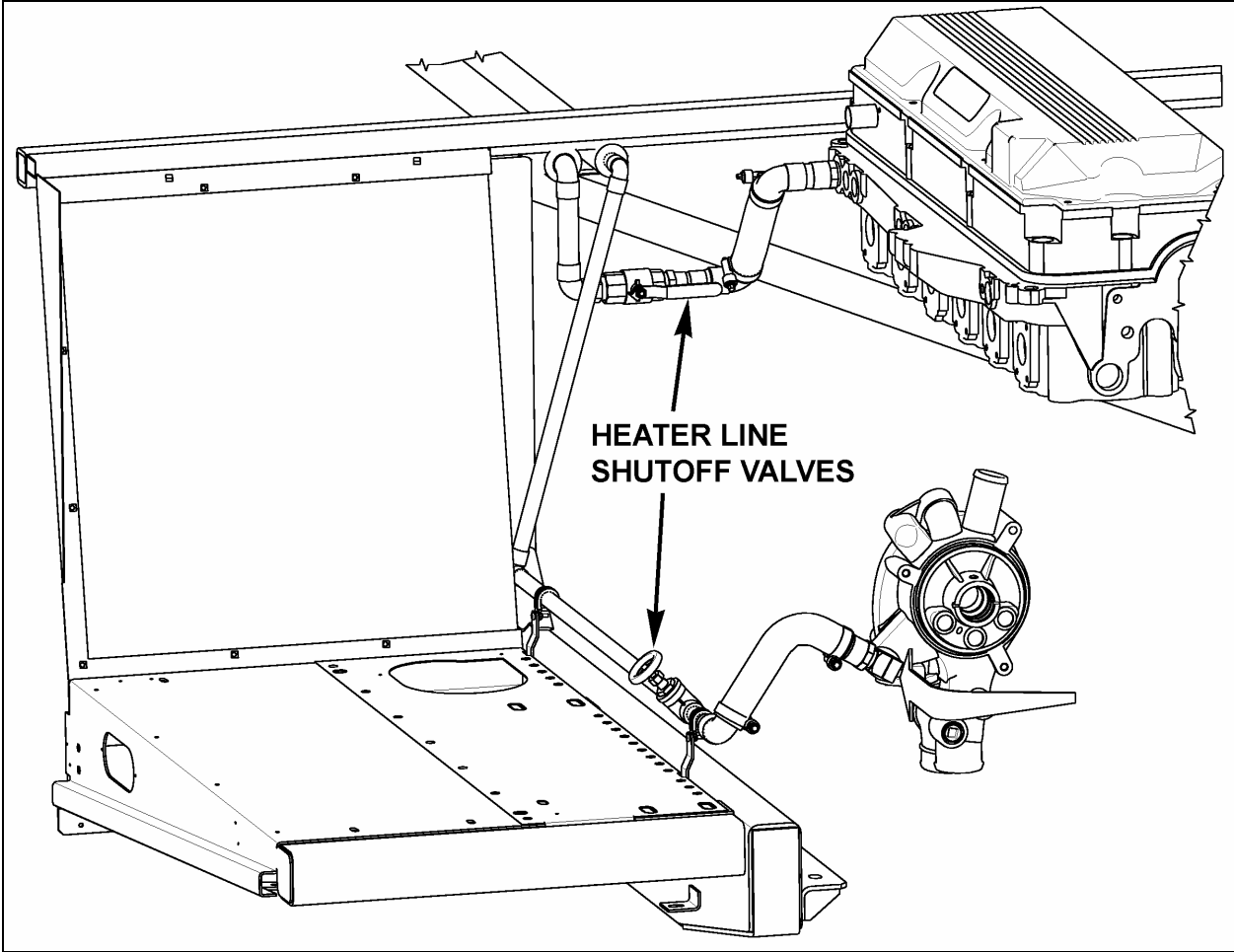
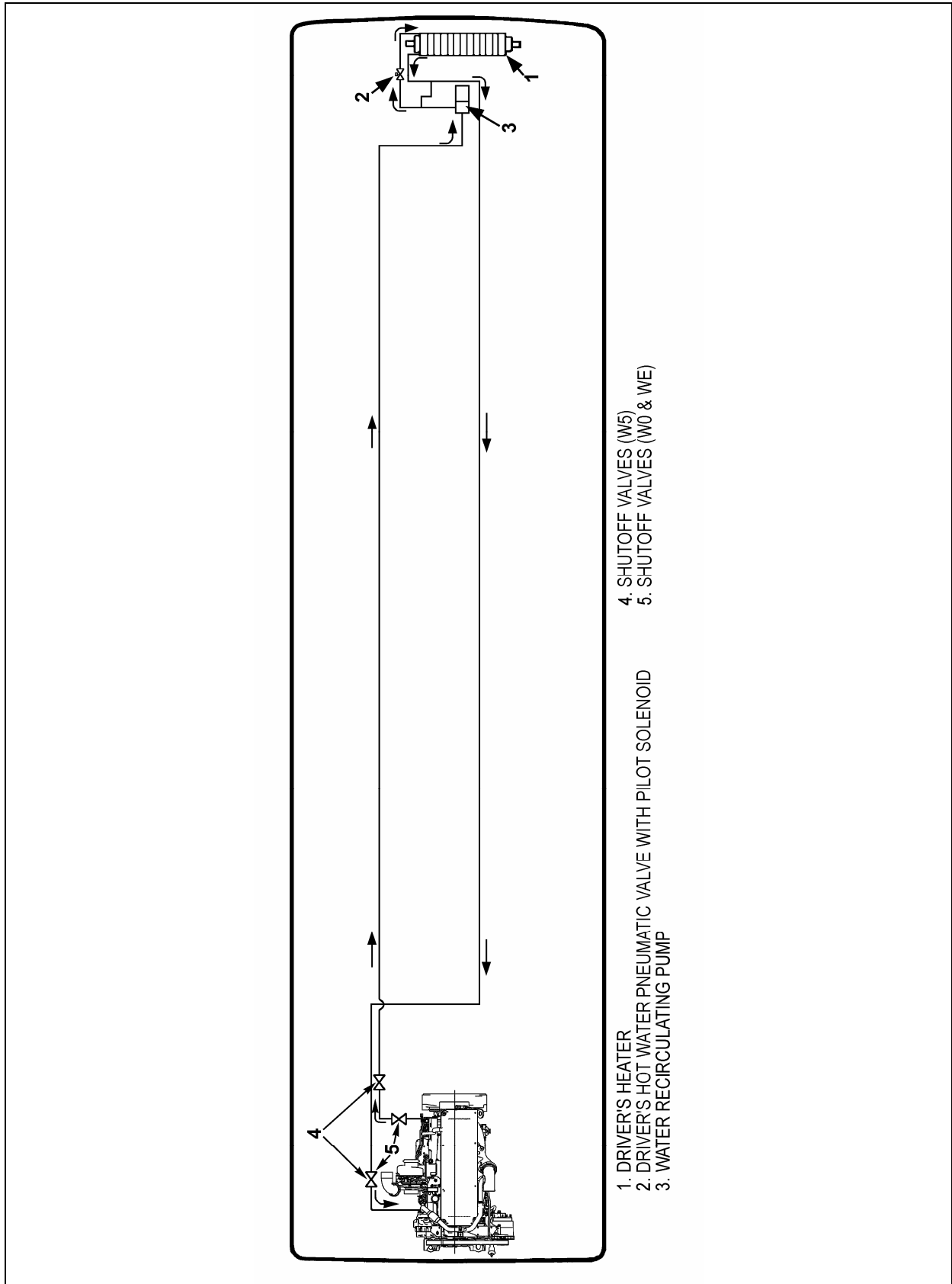

FIGURE 54: HEATER LINE SHUTOFF VALVES (WE)



- 1. DRIVER'S HEATER
- 2. DRIVER'S HOT WATER PNEUMATIC VALVE WITH PILOT SOLENOID
- 3. WATER RECIRCULATING PUMP
- 4. SHUTOFF VALVES (W5)
- 5. SHUTOFF VALVES (W0 & WE)

FIGURE 55: SMALL HEATING SYSTEM COMPONENTS

22337

## Section 22: HEATING AND AIR CONDITIONING

---

### 12. SPECIFICATIONS

#### Main evaporator motor

Make.....US MOTOR  
Type .....T-17  
Voltage ..... 27.5 V DC  
Current draw ..... 68 amps  
Horsepower..... 2  
Revolution ..... 1<sup>st</sup> :1400 rpm, 2<sup>nd</sup> : 1880 rpm nominal  
Insulation .....Class F  
Motor Life .....20 000 hours  
Brush life ..... 10 000 hours  
Motor Prevost number.....563008  
Brush Prevost number .....562951

#### Condenser fan motors

Make.....US MOTOR  
Type ..... TF-12  
Voltage ..... 28.5 V DC  
Current draw ..... 20 amps  
Horsepower..... 0.57  
Revolution ..... 1950 rpm  
Insulation .....Class F  
Motor .....20 000 hours  
Brush life ..... 10 000 hours  
Qty..... 2  
Prevost number ..... 562579  
Brush Prevost number ..... 561914

#### Evaporator air filters (Central system)

Make..... Permatron Corp.  
Type ..... Polypropylene  
Prevost number ..... 871383

#### Driver's HVAC unit evaporator motors

Make.....MCC  
Voltage ..... 24 V DC  
Quantity ..... 1  
Prevost number ..... 871135

**Driver's HVAC unit evaporator air filter**

Make.....MCC  
 TYPE..... Recirculating air 6-1/4" x 28" Washable  
 Prevost number..... 871147

Make.....MCC  
 TYPE..... Fresh air 3-5/8" X 5-1/4" Washable  
 Prevost number..... 871144

**Refrigerant**

Type..... R-134a  
 Quantity (standard)..... 24 lbs (10.89 Kg)  
 Quantity (A/C Aux. system located in overhead compartments).....4 lbs (1.8 Kg)

**Compressor (Central system)**

Make..... Carrier Transicold  
 Capacity..... 41 CFM  
 Model.....05G-134A  
 No. of cylinders..... 6  
 Bore..... 2" (50,8 mm)  
 Operating speed.....400 to 2200 rpm (1750 rpm. Nominal)  
 Minimum speed (for lubrication)..... 400 rpm  
 Nominal horsepower..... 15  
 Oil pressure at 1750 rpm..... 15 to 30 psi (103-207 kPa)  
 Oil capacity..... 1.13 U.S. gal (4,3 liters)  
 Weight..... 142 lbs (64,5 kg)  
 Approved oils  
 -Castrol..... SW 68 (POE)  
 Prevost number, option R-134a..... 950314

**A/C Compressor (Small system)**

Make..... Sanden  
 Model..... SD7H  
 Prevost number..... 950436  
Approved oil..... Sanden SP-20 (PAG)  
 Prevost number..... 950382

**Compressor unloader valve**

Make..... Carrier Transicold  
 Type..... Electric (AMC)  
 Voltage..... 24 V DC

## Section 22: HEATING AND AIR CONDITIONING

---

Watts ..... 15  
Prevost number (without coil) ..... 950095  
Coil Prevost number..... 950096

### **Magnetic clutch**

Make..... Carrier Transicold  
Type ..... Housing mounted 9" dia., 2-B grooves  
Voltage ..... 24 V DC  
Coil resistance at 68 °F (20 °C)..... 5.15 – 5.69 ohms  
Prevost number ..... 950204

### **Compressor V belts**

Make..... Dayco  
Model (matching set of 2) ..... BX97  
Prevost number (with Delco 270/300 Amp Alternator) ..... 506664

### **Compressor V belt**

Make..... Dayco  
Model..... BX100  
Prevost number (with two BOSH Alternators) ..... 506681

### **Condenser coil (Central system)**

Make..... Carrier Transicold  
Aluminum

Prevost number ..... 870654

#### Copper

Prevost number ..... 870729

### **Evaporator coil (Central system)**

Make..... Carrier Transicold  
Prevost number ..... 871070

### **Receiver tank (with sight glasses)**

Make..... HENRY  
Maximum pressure..... 450 psig  
Prevost number ..... 950261

### **Filter Dryer assembly**

Make..... AC&R HENRY  
Prevost number ..... 950262

### **Moisture indicator**

Make..... Henry  
Prevost number ..... 950029

**Driver's refrigerant liquid solenoid valve**

Make.....	Parker
Type .....	Normally closed with manual bypass
Voltage .....	24 V DC
Amperage draw .....	0.67 amps
Watts .....	16
Prevost number (without coil) .....	95-0054
Coil Prevost number.....	950055
Repair kit Prevost number .....	950056

**Driver's hot water pneumatic valve**

Make.....	Burkert
Type .....	Normally open
Voltage .....	24 V DC
Prevost number .....	871252
Seal kit, Water Side.....	871311
Seal kit, Actuator Side.....	871312
Seal kit, Pilot Solenoid Valve .....	871313

**Hot water pneumatic valve (Central system)**

Make.....	Burkert
Type .....	3-WAY
Voltage .....	24 V DC
Prevost number .....	871381
Seal kit, Water Side.....	871389
Seal kit, Actuator Side.....	871388
Seal kit, Pilot Solenoid Valve .....	871390

**Water recirculating pump**

Make.....	M.P. pumps
Voltage .....	24 V DC
Prevost number .....	871342

**Driver's expansion valve**

Prevost number .....	950221
----------------------	--------

**Expansion valve (Central system)**

Make.....	Alco
Model.....	TCLE 5-1/2
Prevost number .....	950320



# SECTION 23: ACCESSORIES

## CONTENTS

<b>1. ROOF ANTENNA INSTALLATION .....</b>	<b>3</b>
<b>2. HUBODOMETER .....</b>	<b>3</b>
2.1 DESCRIPTION.....	3
2.2 OPERATION .....	3
2.3 REMOVAL .....	3
2.4 INSTALLATION .....	3
<b>3. BACK-UP CAMERA AND MONITOR .....</b>	<b>3</b>
<b>4. COLD STARTING AID (ETHER) .....</b>	<b>3</b>
4.1 PREVENTIVE MAINTENANCE.....	4
4.2 TROUBLESHOOTING (IF SYSTEM IS NON-FUNCTIONING) .....	4
5.3 THERMAL CUTOUT VALVE QUICK TEST .....	5
<b>5. AIR HORN VALVE .....</b>	<b>5</b>
5.1 AIR HORN VALVE MAINTENANCE.....	5
<b>6. HEADLIGHTS CLEANING SYSTEM.....</b>	<b>5</b>
6.1 GENERAL DESCRIPTION .....	5
6.2 WASHER FLUID REFILLING.....	6
6.3 WASHER NOZZLES ADJUSTMENT .....	6
<b>7. WINDSHIELD WIPERS AND WASHERS .....</b>	<b>6</b>
7.1 GENERAL DESCRIPTION .....	6
7.2 WIPER ARM .....	7
7.2.1 <i>Wiper Arms Positioning</i> .....	7
7.3 WINDSHIELD WIPER MOTOR.....	8
7.3.1 <i>Windshield Wiper Motor Replacement</i> .....	8
7.4 TROUBLESHOOTING .....	9
<b>8. TIRE PRESSURE MONITORING SYSTEM (TPMS).....</b>	<b>9</b>
8.1 TIRE VALVE INSTALLATION.....	10
8.2 BERU SENSORS INSTALLATION .....	11
<b>9. SPECIFICATIONS.....</b>	<b>12</b>

## ILLUSTRATIONS

FIGURE 1: HUBODOMETER.....	3
FIGURE 2: ENGINE .....	4
FIGURE 3: COLD STARTING AID .....	4
FIGURE 4: AIR HORN VALVE .....	5
FIGURE 5: HEADLIGHTS CLEANING SYSTEM.....	5
FIGURE 6: TUBING AND FITTINGS.....	6
FIGURE 7: WASHER NOZZLES ADJUSTMENT .....	6
FIGURE 8: WINDSHIELD WIPER INSTALLATION.....	7
FIGURE 9: MULTIFUNCTION LEVER.....	7
FIGURE 10: WINDSHIELD WASHER RESERVOIR .....	7
FIGURE 11: WINDSHIELD WIPER (MOTOR SIDE) .....	8
FIGURE 12: WINDSHIELD WIPER ( DRIVER SIDE) .....	8
FIGURE 13: DRIVING MECHANISM (DRIVER SIDE) .....	8
FIGURE 14: DRIVING MECHANISM (MOTOR SIDE) .....	8
FIGURE 15: WIPER ARMS POSITIONING .....	9

## 1. ROOF ANTENNA INSTALLATION

- Find the desire location and drill a hole according to specification.
- To remove dirt and grease, wash hole edge with alcohol.
- If so equipped, remove foam padding ring from antenna to free the metal surface (foam can produce air bulbs in new rubber seal).
- With SIKA 205, wash the edge of the hole and the antenna base surface, wait at least two (2) minutes for chemical evaporation.
- Apply new seal SIKA 221 on both, edge of the hole and antenna base.
- Fix the antenna in place.
- Remove excess seal and complete a finishing joint all around the antenna base.

## 2. HUBODOMETER

### 2.1 DESCRIPTION

An optional wheel hubodometer (Fig. 1) may have been installed on the R.H. side of the drive axle. It indicates the total distance in miles or kilometers covered by the coach since it has left the factory, including road testing.

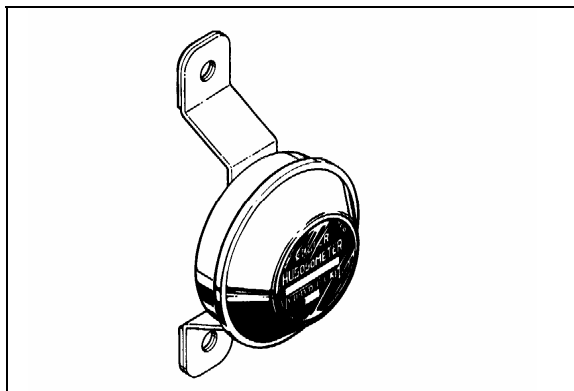

FIGURE 1: HUBODOMETER

23024

### 2.2 OPERATION

The hubodometer is calibrated for a specific wheel size (diameter). Wheel rotation causes a mechanism inside the hubodometer to record distance after a predetermined number of rotations. The unit should be serviced at a competent speedometer repair facility.

### NOTE

*Do not use paint, solvent or thinner on hubodometer face or on plastic hubcaps. Do not weld on hubodometer.*

### 2.3 REMOVAL

To remove the unit, remove the two lock nuts and washers securing it to the wheel hub, and pull the unit off the studs.

### 2.4 INSTALLATION

Place the hubodometer unit over the wheel hub studs. Replace the lock washers and nuts. Torque stud nuts to 110-165 Lbf-ft (150-225 Nm).

## 3. BACK-UP CAMERA AND MONITOR

An optional back-up camera is available which provides the driver with visual assistance when backing-up. The camera is automatically activated when the transmission is put in reverse gear and the ignition switch is "ON". The TV monitor is mounted on top of the dashboard. Refer to the Owner's Manual under "Controls & Instruments".

## 4. COLD STARTING AID (ETHER)

The vehicle can be equipped with an electrically-operated type ether cold starting aid designed to ease engine starting when temperature is low.

On vehicles equipped with cold starting aid, the system consists of the main following parts:

- Ether starting aid switch
- Ether cylinder
- Solenoid valve (24 V)
- Thermal cutout valve
- Atomizer

The control rocker switch is located on the dashboard. This switch is provided with a locking mechanism to avoid accidental use when engine is running. To activate the ether starting aid, proceed as follows:

1. Prior to cranking engine, press down rocker switch for three seconds to fill solenoid valve.
2. Release switch to discharge shot.

## Section 23: ACCESSORIES

3. Allow three seconds for shot to discharge.
4. Start engine, use additional shots if necessary to keep engine running.



### CAUTION

This practice should be performed only when absolutely necessary. Excessive use of fluid could result in serious engine damage.

The ether cylinder and solenoid valve assembly are mounted on the engine compartment wall and are accessible from the engine compartment R.H. side door.

The thermal cutout valve is mounted on the engine (radiator side). Its function is to prevent discharge of ether when engine is warm (over 90 F (32 C)). The atomizer is installed on top of the air intake duct (Fig. 2).

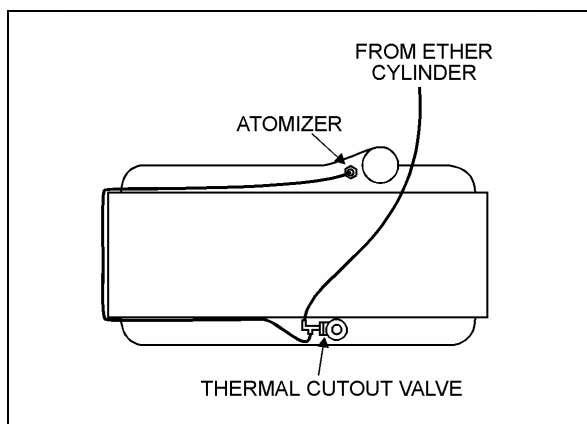

FIGURE 2: ENGINE

23032

### 4.1 PREVENTIVE MAINTENANCE

During the summer months, remove cylinder to avoid high temperature actuation of the cylinder safety relief device. Always screw valve cap into solenoid valve opening to prevent entrance of road dirt. When removing cylinder, be careful to prevent dirt from entering the valve.

### 4.2 TROUBLESHOOTING (IF SYSTEM IS NON-FUNCTIONING)



### DANGER

During the following test, direct free end of tube away from personnel and all sources of ignition as this fuel is extremely flammable. Avoid breathing vapors and contacting fuel with skin. Never smoke during test.

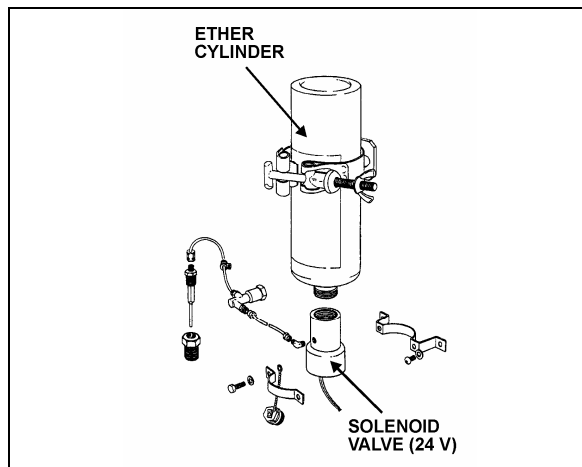

FIGURE 3: COLD STARTING AID

23048

1. Check cylinder for hand tightness and fuel supply (Fig. 3). Empty cylinder weight is approximately 17 oz (480 g); full cylinder weight is approximately 35 oz (990 g). If cylinder is empty, replace it. Before replacing cylinder, install new valve gasket in solenoid valve.
2. If still not functioning, disconnect tubing at solenoid valve fitting. Actuate solenoid valve. (Ask an assistant to actuate solenoid valve using the rocker switch on the dashboard).
  - If solenoid valve is non-functioning, check electric circuit, (refer to wiring diagrams). If sound, remove and replace the solenoid valve. If not, repair electric circuit.
  - If valve is functioning, reassemble valve fitting and connect tube. Disconnect tube at thermal cutout valve from port "Tube from valve".
3. Actuate the solenoid valve.
  - If fuel is not discharged from tube, remove tube and blow out or replace.
  - If fuel is discharged, connect tube to thermal cutout valve, and disconnect other tube.
4. Actuate the solenoid valve.
  - If fuel is not discharged, replace the cut-out valve.

### NOTE

If engine coolant temperature is 90°F (32°C) or over, it is normal that fuel is not discharged as the valve is in closed position.

- If fuel is discharged, connect tube to thermal cutout valve, and disconnect tube from atomizer.
5. Actuate the solenoid valve.
    - If fuel is not discharged from tube, fuel line is clogged. Remove tube and blow out or replace.
    - If fuel is discharged, replace the atomizer.

### 5.3 THERMAL CUTOUT VALVE QUICK TEST

1. Engine coolant temperature must be below 90 F (32 C).
2. Temporarily disconnect tube at thermal cutout valve from port "Tube to atomizer".
3. Actuate solenoid valve (Ask an assistant to actuate solenoid valve by means of the rocker switch on the dashboard). Fuel should be discharged through the thermal cutout valve.



## DANGER

Avoid breathing vapors and contacting fuel with skin. Never smoke during test.

4. Reconnect tube to thermal cutout valve.
5. Start engine, using cold starting aid if necessary. Stop engine when it reaches operating temperature.
6. Disconnect tube at thermal cutout valve as in step 2, and repeat step 3. No fuel should be discharged.

## 5. AIR HORN VALVE

The air horn valve is located in the front service compartment and the air horn valve button is on the steering wheel center.

### 5.1 AIR HORN VALVE MAINTENANCE

When needed, the air horn valve can be serviced or replaced using the following procedure:

1. Unplug the cable connector;
2. Disconnect the air tubes;
3. Loosen the retaining bolts;
4. Service or replace the air horn valve;
5. Reinstall by reversing procedure.

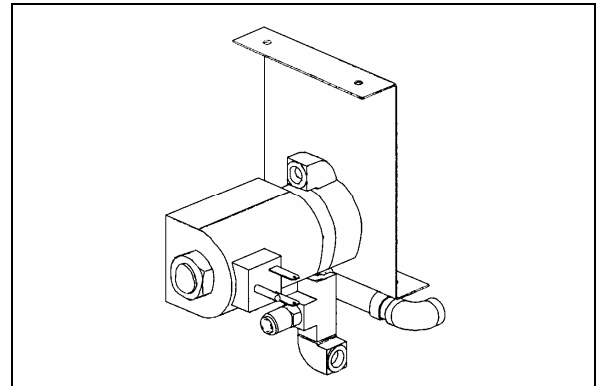

FIGURE 4: AIR HORN VALVE

23230

## 6. HEADLIGHTS CLEANING SYSTEM

### 6.1 GENERAL DESCRIPTION

#### NOTE

*When inspecting the headlights cleaning system, check the washer fluid hoses, fittings and connectors to be sure they are properly connected and seal with no restriction to the flow of washer fluid. Check that the washer nozzles are properly aimed.*

The headlights cleaning system is independent from the windshield washer system and has its own washer fluid reservoir located in the front electrical and service compartment.

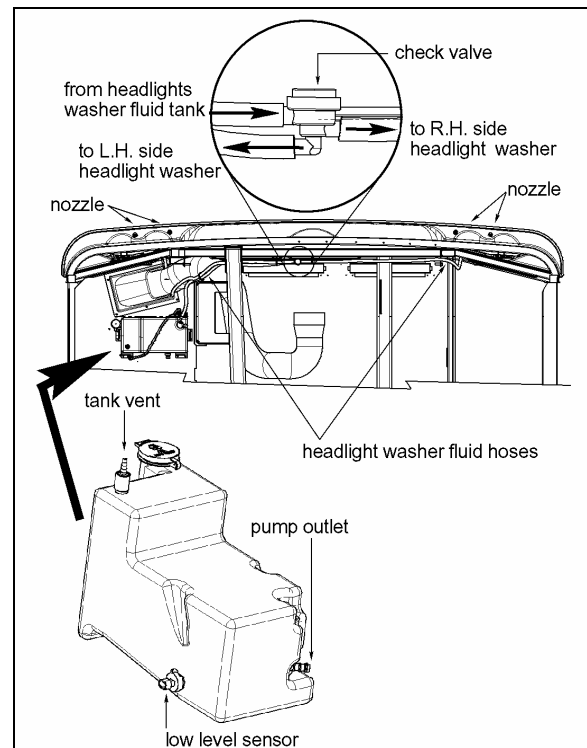

FIGURE 5: HEADLIGHTS CLEANING SYSTEM

23380

## Section 23: ACCESSORIES

However, this system shares the same telltale light than the windshield washer low level sensor (refer to Owner's manual for operation). Each pressing of this switch produces 2 successive 0.7 seconds jets.



### CAUTION

Do not operate the headlights washer while the washer fluid reservoir is empty. This may damage the washer fluid pump.

### 6.2 WASHER FLUID REFILLING

Open the filler neck cap and add regular windshield washer fluid as required. The tank has a capacity of 10 liters (2.6 US gallons). You may use water or windshield washer fluid as well but, during cold weather days, use windshield washer fluid suitable for freezing temperature only.

### 6.3 WASHER NOZZLES ADJUSTMENT

To avoid waste of washer fluid, assure the fluid jets are properly aimed. Adjust nozzles so they aim as described in figure 7. Align the jet adjustment tool #800377 with the reference line shown on the front view detail. As seen on the side view, position the end of the adjustment tool to a distance of 1/2" (high beam) and 1" (low beam) from the top of the headlight for proper aiming.

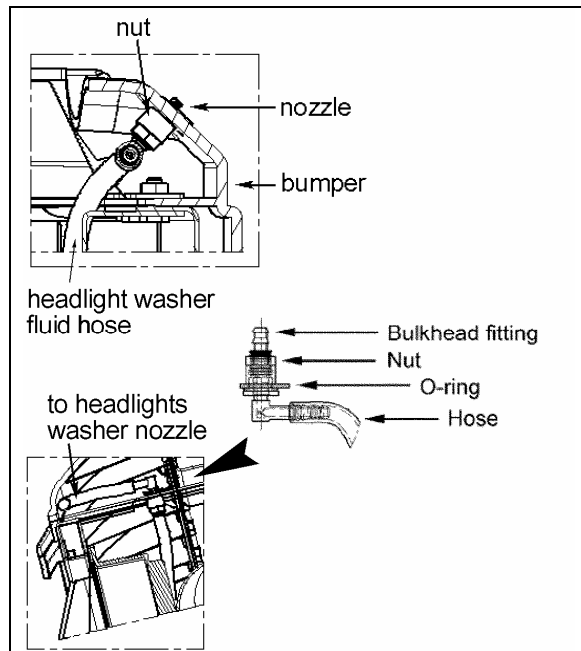

FIGURE 6: TUBING AND FITTINGS

23381



### CAUTION

Because they are made of plastic, firmly tighten nozzle and bulkhead fittings by hand only.

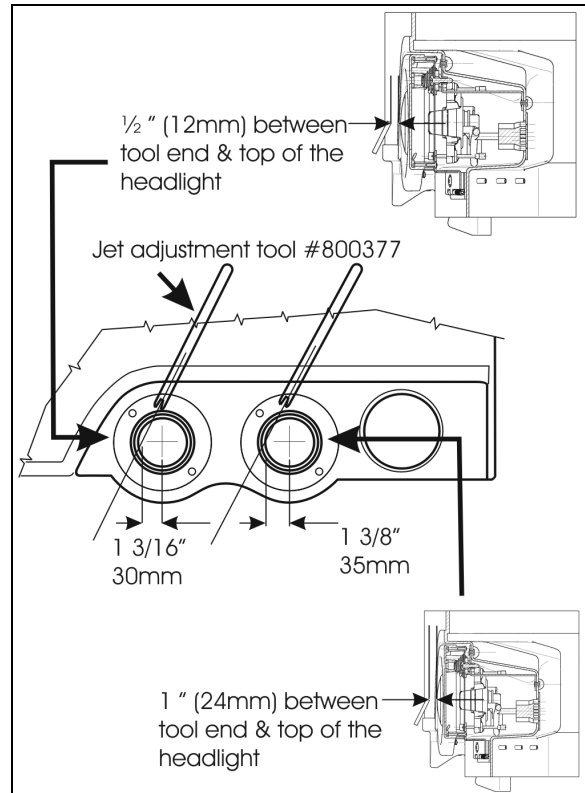

FIGURE 7: WASHER NOZZLES ADJUSTMENT

23382

## 7. WINDSHIELD WIPERS AND WASHERS

### 7.1 GENERAL DESCRIPTION

#### NOTE

When installing a wiper motor, arm or blade, follow recommended procedures to prevent misalignment, binding or malfunction. Check the windshield washer liquid hoses, fittings and connectors to be sure they are properly connected and seal with no restriction to the flow of washer liquid. Check that wiper arms have the proper sweep position and the washer nozzles are aimed so that spray is within the proper wiper pattern.

The windshield wipers are controlled by one electric wiper motor that is accessible for maintenance after removing the appropriate access panel beside the footwell (refer to figure 8).

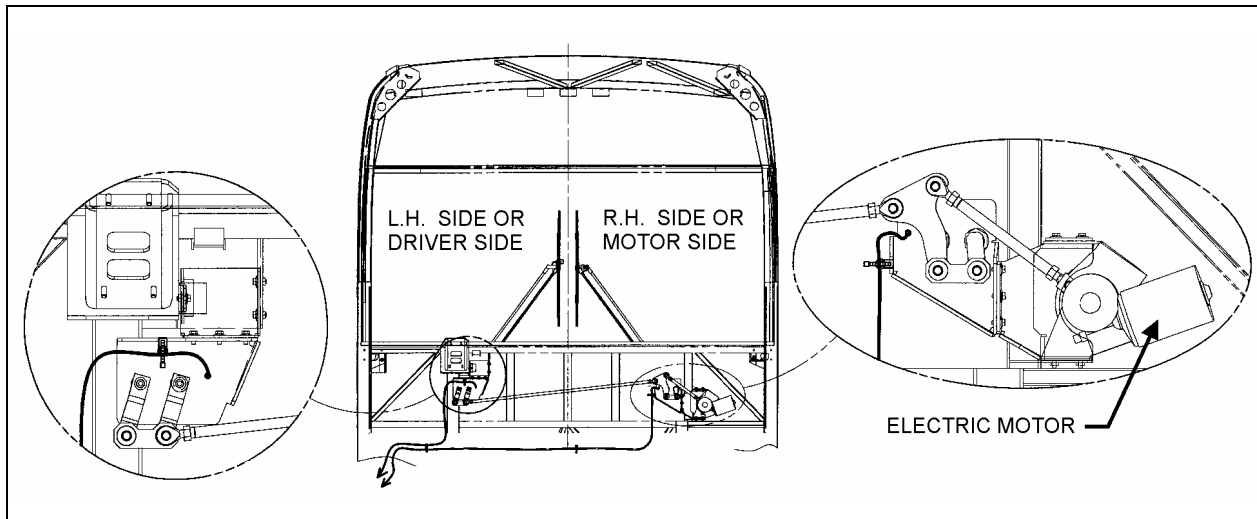

FIGURE 8: WINDSHIELD WIPER INSTALLATION

23287

Turn the multifunction lever forward to activate windshield wipers (item 2, fig. 9). The first position operates the wipers at low speed and the second position operates the wipers at high speed. Turning the lever backwards will operate the wipers in the intermittent mode.

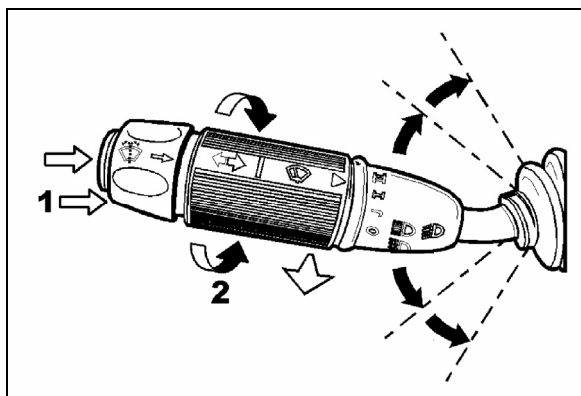

FIGURE 9: MULTIFUNCTION LEVER

23133

The windshield washer pumps are electrically operated and are controlled by a washer control ring on the multifunction lever (item 1, fig. 9).

The windshield washer reservoir is located in the front service compartment (fig. 10). This unit pumps the washer liquid to the spray nozzles where it is dispersed across the windshield.

7.2 WIPER ARM

Check operation of the wipers for proper blade sweep and angle.

	<p><b>CAUTION</b></p>
<p>Do not attempt to manually move the wiper arms to make wiper blade sweep adjustments as damage to the wiper linkage or motor may occur. If it is necessary to adjust the sweep of blades, remove the arms and make adjustment by positioning the arms using serration on the wiper arm pivot shafts.</p>	

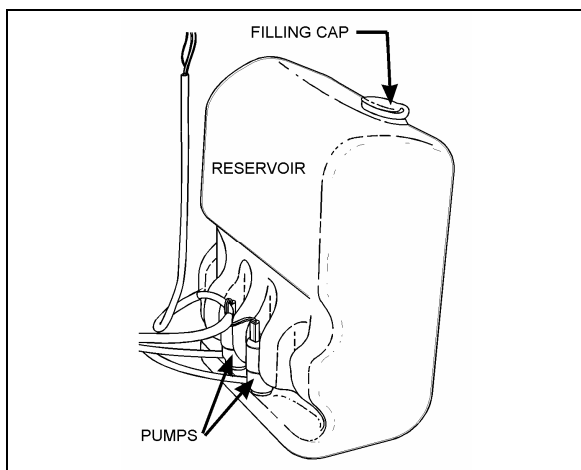

FIGURE 10: WINDSHIELD WASHER RESERVOIR

23220

7.2.1 Wiper Arms Positioning

1. Reinstall the wiper arms and position as shown in figure 15. Before positioning the wipers at their final position, tighten the nuts to 9 Ft-lbs (12 Nm) at first.
2. To find the final position of the wiper arms, lift then release the wiper arm so it falls back on the windshield

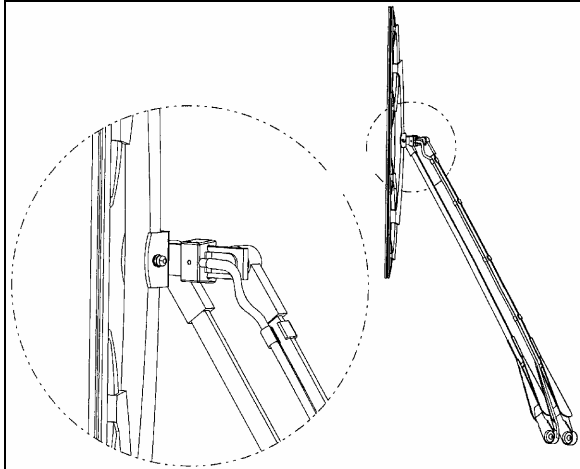

FIGURE 11: WINDSHIELD WIPER (MOTOR SIDE) 23335

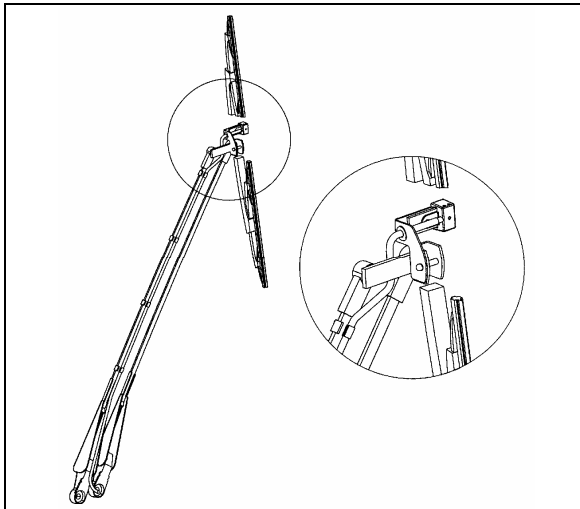

FIGURE 12: WINDSHIELD WIPER ( DRIVER SIDE) 23334

3. When the final position is found, tighten the wiper arm nuts to 22 Ft-lbs (30 Nm). Wait 30 minutes and tighten again to 22 Ft-lbs.

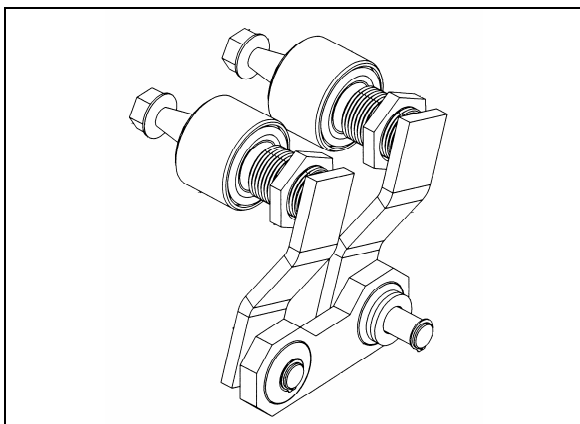

FIGURE 13: DRIVING MECHANISM (DRIVER SIDE) 23334

4. Lower the protective cover.

5. Connect the windshield washer tubing at the base of the wiper arm.
6. Check the adjustment on a wet windshield.

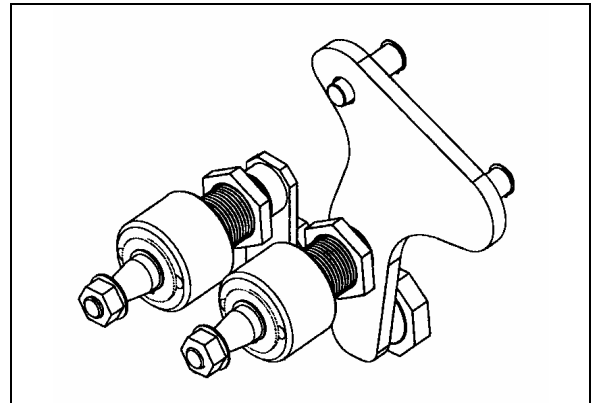

FIGURE 14: DRIVING MECHANISM (MOTOR SIDE) 23254

### 7.3 WINDSHIELD WIPER MOTOR

#### 7.3.1 Windshield Wiper Motor Replacement

The windshield wiper motor is located at lower front of the vehicle, behind the defroster panel. Refer to figure 8 for motor location.



### WARNING

Park vehicle safely, apply parking brake, stop engine and set battery master switch to the "OFF" position prior to working on the vehicle.

1. Remove the Phillips-head screws retaining the defroster panels, and remove panels.
2. Disconnect wiring connector from the windshield wiper motor.
3. Loosen clamping screw retaining the lever at the end of the motor driving shaft.
4. Remove the three bolts holding the motor to the steel plate.
5. Remove the windshield wiper motor (Prevost #800328), reverse removal procedure to reinstall.



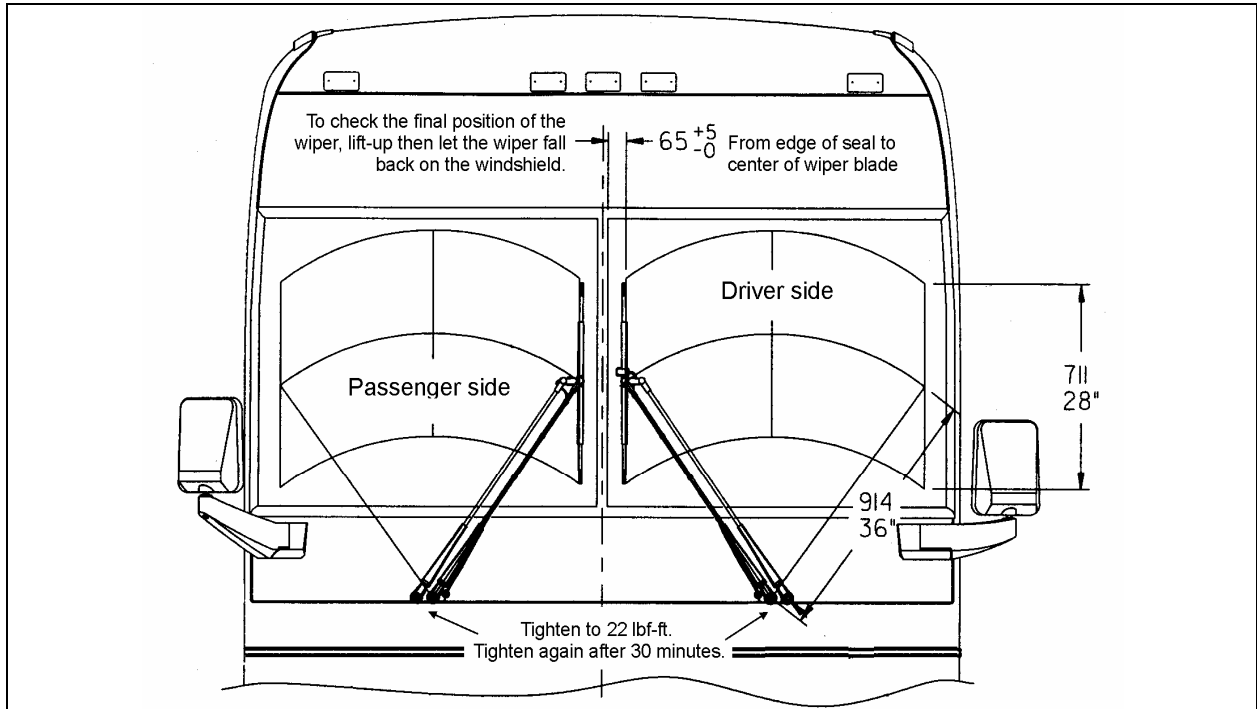

FIGURE 15: WIPER ARMS POSITIONING

23253

7.4 TROUBLESHOOTING

SYMPTOM	PROBABLE CAUSE	REMEDY
FAIL TO SPRAY WASHER FLUID	A. Reservoir empty. B. If below 32°F (0°C), improper washer fluid frozen. C. Contamination in tubing or nozzles. D. Tubing damage. E. Tubing bent (kinked) or off one or more connections.	A. Add proper fluid. B. Store coach or parts in heated area, then purge system with low-temperature solution. C. Remove with compressed air, if severely clogged, replace items. D. Replace section. E. Realign tubing and/or refit. Trim end to ensure proper fit or replace.
INADEQUATE SPRAYING	A. Tubing failure.	A. Replace tubing.
SLOW OPERATION	A. Improper solution. B. Jet stream improperly directed. C. Check if valve is stuck in the open position.	A. Replace with proper type solution. B. Reposition nozzles. C. Remove, clean or replace.









8. TIRE PRESSURE MONITORING SYSTEM (TPMS)

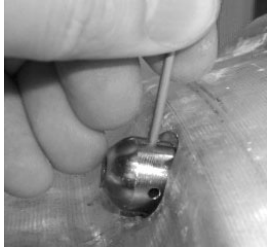

The optional active tire pressure and temperature monitoring system is a sensing device designed to identify and display tire operating data and activate an alert or warning when pressure or temperature irregularities are detected.

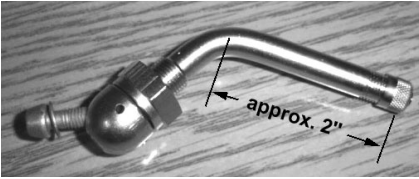
Section 23: ACCESSORIES

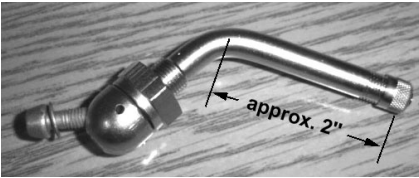
For more information on the operation and troubleshooting of the system, refer to the Owner's Manual, chapters "Controls and Instruments", "Safety Features and Equipment" and also "Appendix E".

8.1 TIRE VALVE INSTALLATION

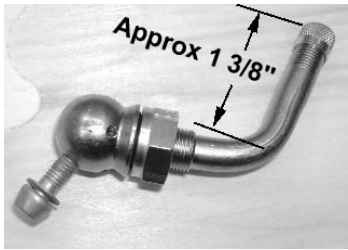
<p><b>Use as required a small rod to hold the valve in place when tightening.</b></p>			
<p><b>Steel Wheels</b></p>	<p><u>All wheels</u> a) Install Beru valve Torque valve to 44.5lb-in +/- 9.5 b) no extension piece</p>	 <p>#Prevost 681083</p>	
	<p><u>Front axle and tag axle wheels with 365 tires</u> a) Remove Alcoa valve b) Install Beru valve Torque valve to 102lb-in +/- 22 c) no extension piece</p>	 <p>#Prevost 651080</p>	
<p><b>Aluminum Wheels (new CPM wheels)</b></p>	<p><u>Front axle and tag axle wheels with 315 tires</u> a) Remove Alcoa valve b) Install Beru valve Torque valve to 102lb-po +/- 22 c) Small extension piece (approx 50mm)</p>	 <p>#Prevost 651081</p>	
	<p><u>Drive axle inner and outer wheels with 315 tires</u> a) Remove Alcoa valve b) Install Beru valve Torque valve to 102lb-in +/- 22 c) no extension piece</p>	 <p>#Prevost 651081</p>	

	<p><b><u>"Super Single" Tires</u></b>                  a) Remove Alcoa valve                  b) Install Beru valve                  Torque valve to 102lb-in +/- 22                  c) no extension piece</p>	 <p>Approx 1 3/8"</p> <p>#Prevost 651079</p>	
--	---	---	---

<p><b>Aluminum wheels (former CPG wheels)</b></p>	<p><b><u>All wheels</u></b>                  a) Remove Alcoa valve                  b) Install Beru valve                  Torque valve to 102lb-in +/- 22                  c) no extension piece</p>	 <p>#Prevost 651082</p>	
---	---	---	---

8.2 BERU SENSORS INSTALLATION

<p><b><i>IMPORTANT NOTE</i></b></p>
<p><i>Beru sensors have a limited lifespan (5 years on average)</i></p>

<p>Install sensor onto valve. Torx screw T-20. Torque to 35lb-in (4Nm) (supplier specification for the screw).                  Make sure sensor rests against rim flange.  <b>IMPORTANT</b>                  Use the screw only once. This screw uses a thread lock. Replacement screw #651084.</p>	
--	--

**Section 23: ACCESSORIES**

<p>Note bar code and tie it up using wheel holes. Use supplied removable tie-rap.</p>	
<p><b>Decal</b>  <b>Glue decal facing the valve.</b></p>	<p><b>#651091 ENGLISH #651090 BILINGUAL</b></p>

**9. SPECIFICATIONS**

**HUBODOMETER (US model: miles)**

Make..... Stemco  
 Prevost number..... 650002

**HUBODOMETER (Canada model: km)**

Make..... Stemco  
 Prevost number..... 650117

**AIR HORN**

Make..... Allied Signal Inc.  
 Prevost number..... 640093

**AIR HORN VALVE**

Make..... Allied Signal Inc.  
 Prevost number..... 640128

**WINDSHIELD WIPER MOTOR**

Make..... BOSCH  
 Prevost number..... 800328

**WIPER (BLADE)**

Make..... BOSCH  
 Prevost number..... 800329

**WIPER ARM**

Make..... BOSCH  
 Prevost number..... 800331

# SECTION 24: LUBRICATION

---

## CONTENTS

<b>1. LUBRICATION .....</b>	<b>2</b>
1.1 FIRST SERVICE ON NEW VEHICLE.....	2
1.1.1 <i>Differential</i> .....	2
1.1.2 <i>Hot Water Filter</i> .....	2
1.1.3 <i>Allison Transmission</i> .....	2
1.1.4 <i>Engine</i> .....	2
<b>2. LUBRICATION AND SERVICE SCHEDULE .....</b>	<b>2</b>
2.1 FLEXIBLE HOSE MAINTENANCE.....	3
2.1.1 <i>Pre-Starting Inspection</i> .....	3
2.1.2 <i>Leaks</i> .....	3
2.1.3 <i>Service life</i> .....	3
2.2 WALK-AROUND INSPECTION .....	4
2.3 LUBRICANT AND COOLANT SPECIFICATIONS .....	6
2.4 PART NUMBER SPECIFICATIONS .....	7
2.5 LUBRICATION AND SERVICING SCHEDULE .....	8

## ILLUSTRATIONS

FIGURE 1: LUBRICATION AND SERVICING POINTS ON INDEPENDENT FRONT SUSPENSION VEHICLES .....	5
---	---

## Section 24: LUBRICATION

---

### 1. LUBRICATION

The efficiency and life expectancy of mechanical equipment is largely dependent upon proper lubrication and servicing. All mechanical components rely on a lubricating film between moving parts to reduce friction, prevent wear and oxidation. Proper lubrication also helps cool the parts and keep dirt particles away from mating surfaces. Efficient lubrication depends upon using the right type of lubricant, at specified intervals and by filling to correct capacities. Past experience shows that many service problems can be traced to an improper lubricant or to incorrect lubrication procedures.

A comprehensive maintenance and lubrication program is important to ensure the long service life this vehicle was designed for and to avoid costly repairs and associated downtime caused by premature part failure.

A lubrication schedule is included in this section to give the location of key service points on the vehicle as well as the lubricant specifications for each component to be serviced. Specific instructions on how to check and service different components are covered in their respective sections in this maintenance manual.

The recommended lubrication intervals are based on normal operating conditions and mileage accumulation.

Shorten the intervals if your vehicle operates in more severe conditions. Severe conditions include heavy towing, high vehicle weight or operation in mountainous areas. Some parts and equipment referred to in this section may not be installed on your vehicle. Check your vehicle's "Coach Final Record" for equipment list.

Dispose of used lubricants and filters in an environmentally safe manner, according to federal and/or local recommendations.

#### 1.1 FIRST SERVICE ON NEW VEHICLE

Perform the following maintenance procedures after the first 3,000 miles (4 800 km) of operation (unless otherwise specified). Once initial maintenance is performed, refer to recommended intervals in the lubrication schedule.

Repeat a component's initial maintenance procedure when it has undergone a major repair.

#### 1.1.1 Differential

No initial oil or filter change necessary. Refer to regular lubrication and servicing schedule.

#### 1.1.2 Hot Water Filter

The hot water filter is designed to recover the soldering residues trapped inside the coolant lines during their initial assembly; perform initial cleaning once vehicle has run approximately 3,000 miles (4 800 km), then according to the lubrication and servicing schedule.

<b>NOTE</b>
-------------

<i>If additional soldering has been performed on any point of coolant piping, clean coolant system strainer as outlined for a new vehicle at 3,000 miles (4 800 km).</i>
--

#### 1.1.3 Allison Transmission

Your Allison transmission is equipped with High Capacity filters, eliminating the requirement of an initial fluid and filter change. Refer to regular lubrication and servicing schedule.

#### 1.1.4 Engine

Since engine break-in has been done in factory, there is no special break-in, so oil should be changed according to the lubrication and servicing schedule intervals. Since some oil consumption by engine is normal, check oil level daily with engine stopped and add to FULL mark on dipstick if necessary (refer to Section 01: Engine of this manual for complete procedure). Furthermore, the engine oil filter should be replaced each time the engine oil is changed.

### 2. LUBRICATION AND SERVICE SCHEDULE

Following this service schedule is the most economical and easiest way to ensure your vehicle performs at its best, safest and longest. Also, unscheduled maintenance will be minimized since inspection should expose potential problems before they become major ones.

## 2.1 FLEXIBLE HOSE MAINTENANCE

The performance of engine and equipment are greatly related to the ability of flexible hoses to supply lubricating oil, air, coolant, and fuel oil. Maintenance of hoses is an important step to ensure efficient, economical, and safe operation of the engine and related equipment.

### 2.1.1 Pre-Starting Inspection

Check hoses daily as part of the pre-starting inspection. Examine hose for leaks, and check all fittings, clamps, and ties carefully. Ensure that hoses are not resting on or touching shafts, couplings, heated surfaces including exhaust manifolds, any sharp edges, or other obviously damaging areas. Since all machinery vibrates and moves to a certain extent, clamps and ties can fatigue with time. To ensure proper support, inspect fasteners frequently and tighten or replace them as necessary.

### 2.1.2 Leaks

Investigate leaks immediately to determine if fittings have loosened or cracked, and also if hoses have ruptured or worn through. Take corrective action immediately. Leaks are not only potentially detrimental to machine operation, but can also result in added expenses caused by the need to replace lost fluids.

	<b>WARNING</b>
Personal injury and/or property damage may result from fire due to the leakage of flammable fluids, such as fuel or lube oil.	

### 2.1.3 Service life

The limited service life of a hose is determined by the temperature and pressure of the gas or fluid within it, the time in service, its installation, the ambient temperatures, amount of flexing, and the vibration it is subjected to. With this in mind, it is recommended that all hoses be thoroughly inspected at least every 500 operating hours or after 15,000 miles (24 000 km). Look for surface damage or indications of damaged, twisted, worn, crimped, brittle, cracked, or leaking lines. Hoses having a worn outer surface or hoses with a damaged metal reinforcement should be considered unfit for further service.

It is also recommended that all hoses in this vehicle be replaced during major overhaul and/or after a maximum of five service years. Quality of replacement hose assemblies should always be equal to or superior to those supplied by the Original Equipment Manufacturer.

## Section 24: LUBRICATION

### 2.2 WALK-AROUND INSPECTION

It is good practice to make a basic visual inspection of key areas on the vehicle every day and to correct any problem found.

OUTSIDE THE VEHICLE	
ITEM <sup>1</sup>	DESCRIPTION
---	Check for leaks under vehicle and in engine compartment.
---	Check that baggage and service compartment doors close properly.
---	Inspect tires and wheels for correct tire pressure, wear or damage and for missing wheel studs and nuts.
1	Check windshield washer fluid level and add if necessary.
---	Check condition of windshield wiper blades.
---	Verify proper operation of all road lights, signal lights, brake lights, marker lights and back-up lights; Replace light bulbs as required.
2, 26	Drain accumulated water in accessory and wet air tanks.

ENGINE COMPARTMENT	
ITEM <sup>1</sup>	DESCRIPTION
24	Check engine crankcase oil level; Add if necessary.
19	Check Allison transmission oil level (can be checked from push-button shift selector); Add if necessary.
29	Check power steering reservoir fluid level; Add if necessary.
21	Check coolant surge tank fluid level; Add if necessary.
28	Drain accumulated water in primary fuel filter/water separator (if equipped). Visually check fuel filter cartridge (Fuel-Pro 382 equipped vehicles only).
22, 27	Check air cleaner restriction indicator; Replace air cleaner when red signals locks in full view.

INSIDE THE VEHICLE	
ITEM <sup>1</sup>	DESCRIPTION
---	Check for proper operation of the entrance door.
---	Check that emergency exit windows and roof escape hatches can be opened then close all windows and hatches securely.
---	Verify proper operation of windshield wiper/washer.
---	Adjust and clean mirrors as needed for adequate rear-view vision.
---	Start engine and check for proper operation of all gauges and indicator lights.
---	Check for proper operation of electric and air horns and back-up alarm.
---	Perform a brake test. Check both primary and secondary pressure gauges.

<sup>1</sup> Item numbers refer to figures 1



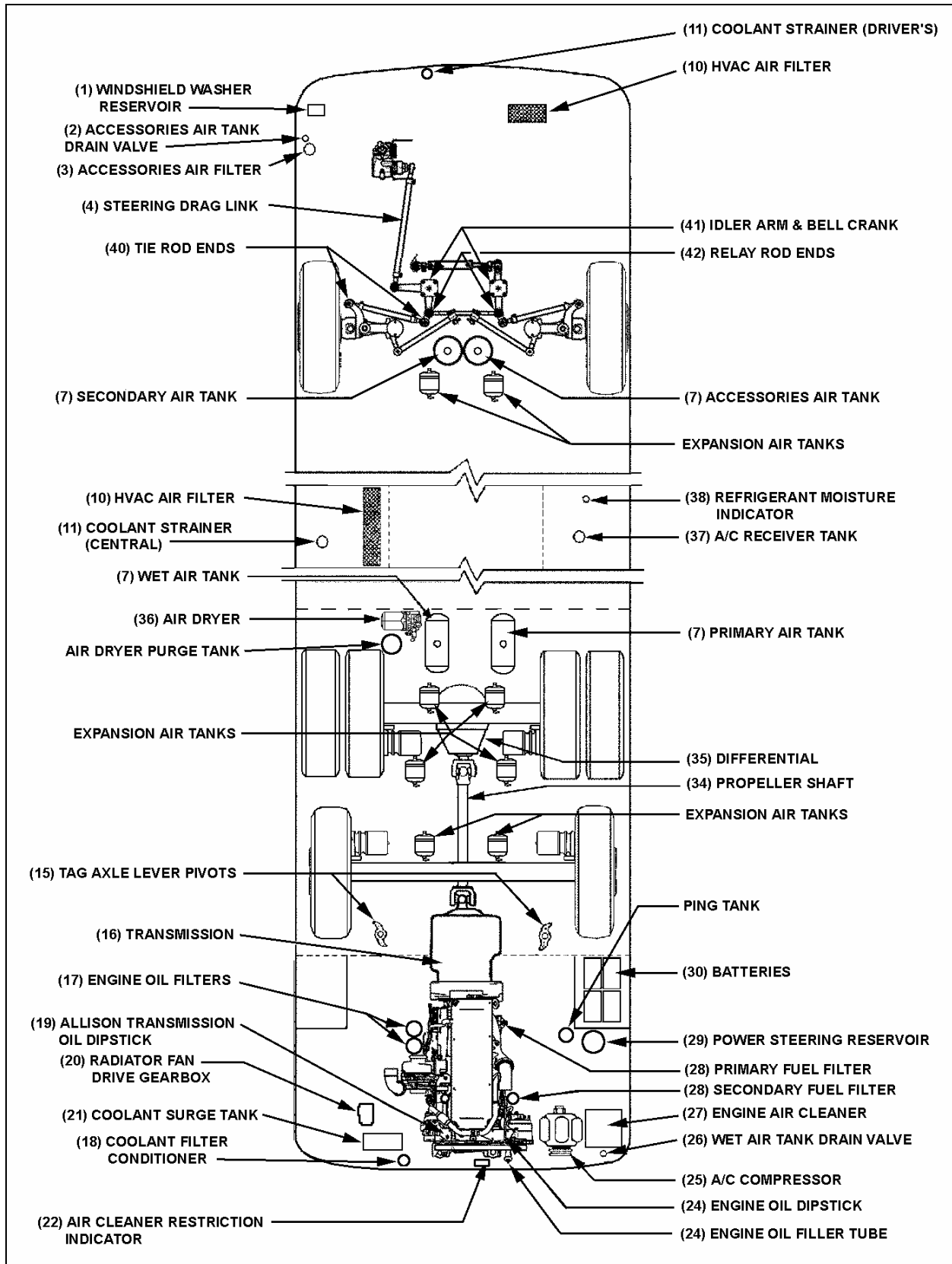

FIGURE 1: LUBRICATION AND SERVICING POINTS ON INDEPENDENT FRONT SUSPENSION VEHICLES

24036\_1

## Section 24: LUBRICATION

### 2.3 LUBRICANT AND COOLANT SPECIFICATIONS

REF	DESCRIPTION	SPECIFICATIONS
A	Engine Oil	SAE Viscosity Grade: 15W-40 API Classification: CJ-4
B	Power Steering Oil	Automatic Transmission Oil, Dexron-III
C	Engine Coolant	Low silicate, ethylene glycol coolant 50% antifreeze/water solution is normally used Antifreeze concentration should be between 30% and 67%
D	A/C Compressor Oil	Central HVAC system: Polyolester oil, HFC 134a compatible; Castrol SW-68 (POE) or equivalent  Small HVAC system: PAG oil
E	Differential Oil	Multigrade gear oil meeting MIL-L-2105-D: 85W140. If temperature drops below 10°F (-12°C), 80W90 should be used. Below -15°F (-26°C), 75W90 should be used. (In extreme conditions or for better performance, full synthetic gear oil can be used.)
F	Differential Oil (Full Synthetic)	Multigrade gear oil meeting MIL-L-2105-D: 85W140. If temperature drops below 10°F (-12°C), 80W90 should be used. Below -15°F (-26°C), 75W90 should be used.
G	Cooling Fan Gearbox Oil	Synthetic gear lubricant 75W-90
H	Allison Automatic Transmission Oil	Castrol TranSynd™ Synthetic Transmission Fluid for Allison or TES 295 approved equivalent
I	Allison Automatic Transmission Oil	Dexron-VI® or approved equivalent 1 Schedule 1 TES-389 fluids;
K	Multi Purpose Grease	Good quality lithium-base grease: NLGI No.2 Grade is suitable for most temperatures NLGI No.1 Grade is suitable for extremely low temperatures
L	Multi Purpose Grease	Molykote longterm 2/78 grease

## 2.4 PART NUMBER SPECIFICATIONS

REF	DESCRIPTION	PREVOST NO
P1	Engine oil filters	#510458
P2	Power steering oil reservoir filter element	#660987
P3	Engine air filter	#530197
P4	Refrigerant filter dryer unit	#950332 Central A/C syst. #950370 Small A/C syst.
P5	Primary fuel filter/water separator	#032700 #541407
P6	Racor primary fuel filter and water separator (optional)	#531390
P7	Secondary fuel filter	#510794
P8	Engine coolant precharge element filter	#550629
P9	Engine coolant maintenance element filter	#550630
P10	HVAC driver's air filter	#871147-871144
P11	HVAC cabin air filter	#871383
P12	Allison transmission High Capacity fluid filter kit	#571709
P13	Hot water filter	#871029
P14	Accessories air filter element	#641340
P15	Air dryer cartridge	#3097369
P16	Fuel Pro 382 filter element	#510795
P18	Engine coolant	#685125
P19	Bosch T1 alternators, voltage regulator	#562981
P20	Bosch T1 alternators, brush set	#562983
P21	Bosch T1 alternators, ball bearing	#562972
P22	Bosch T1 alternators, roller bearing	#562976

## Section 24: LUBRICATION

---

### 2.5 LUBRICATION AND SERVICING SCHEDULE

For lubrication and servicing schedule, refer to table A.

<b><i>IMPORTANT NOTE</i></b>
------------------------------

<i>Refer to the manufacturers documentation included in this maintenance manual for specific manufacturer's maintenance requirements.</i>
---







# SECTION 26: XLII SLIDE-OUT

## CONTENTS

<b>1 SLIDE-OUT</b> .....	<b>5</b>
1.1 INNER STOPPER.....	5
1.1.1 Maintenance.....	5
1.1.2 Adjustment.....	5
1.2 "IN LIMIT" STOPPER.....	6
1.2.1 Maintenance.....	6
1.2.2 Adjustment.....	6
1.3 EXTERIOR EXTRUSION.....	6
<b>2 SECURITY PIN</b> .....	<b>7</b>
2.1 MAINTENANCE.....	7
2.2 AIR CYLINDER REPLACEMENT.....	7
<b>3 ROOF REINFORCING ROD</b> .....	<b>7</b>
<b>4 RACK</b> .....	<b>8</b>
4.1 MAINTENANCE.....	8
4.2 FRONT SLIDE-OUT RACK REPLACEMENT.....	8
4.3 REAR SLIDE-OUT RACK REPLACEMENT.....	8
<b>5 PINION</b> .....	<b>9</b>
5.1 PINION AND KEYLESS BUSHING POSITIONING.....	9
5.2 FRONT SLIDE-OUT SHAFT PINION REPLACEMENT.....	9
5.3 REAR SLIDE-OUT SHAFT PINION REPLACEMENT.....	10
5.4 KEYLESS BUSHING.....	10
5.4.1 Installation.....	10
<b>6 ELECTRIC MOTOR</b> .....	<b>13</b>
6.1 MAINTENANCE.....	13
6.2 REPLACEMENT.....	13
<b>7 SPEED REDUCTION GEARBOX</b> .....	<b>13</b>
7.1 MAINTENANCE.....	13
7.2 GEARBOX REPLACEMENT.....	13
<b>8 JAW COUPLING</b> .....	<b>13</b>
8.1 MAINTENANCE.....	13
8.2 REPLACEMENT & ADJUSTMENT.....	14
<b>9 FLANGE BEARING</b> .....	<b>14</b>
<b>10 LOCKING COLLAR</b> .....	<b>14</b>
10.1 INSTALLATION.....	14
<b>11 LINEAR BEARING</b> .....	<b>15</b>
11.1 MAINTENANCE.....	15
11.2 REPLACEMENT & ADJUSTMENT.....	15
11.3 LEVEL & TILT ADJUSTMENT.....	15
11.3.1 Procedure.....	15
<b>12 RAIL</b> .....	<b>16</b>



## Section 26: XLII SLIDE-OUT

---

12.1	MAINTENANCE.....	17
12.2	REPLACEMENT.....	17
<b>13</b>	<b>ACETAL PLASTIC BLOCKS.....</b>	<b>17</b>
13.1	REMOVAL / INSTALLATION.....	17
<b>14</b>	<b>SLIDE-OUT PNEUMATIC SYSTEM.....</b>	<b>18</b>
14.1	DESCRIPTION.....	18
14.2	MAINTENANCE.....	19
14.3	SEAL.....	20
14.3.1	Maintenance.....	21
14.3.2	Seal assembly removal.....	21
14.3.3	Seal assembly installation.....	21
14.3.4	Slide-out 2" inside retraction.....	22
<b>15</b>	<b>SLIDE-OUT ELECTRICAL SYSTEM.....</b>	<b>22</b>
15.1	ELECTRICAL INTERCONNECTION WITH PREVOST VEHICLE.....	23
15.2	SLIDE-OUT BREAKERS / FUSES.....	23
15.2.1	Multiplex fuses.....	24
15.3	PROBING VOLTAGE ON THE MULTIPLEX CIRCUITS.....	24
15.4	MODULE REPLACEMENT.....	24
15.4.1	I/O-B replacement.....	24
15.4.2	CECM module replacement.....	24
15.5	SLIDE-OUT LIMIT SENSORS.....	25
15.5.1	Maintenance and adjustment.....	25
<b>16</b>	<b>SLIDE-OUT EXTERIOR FINISHING PANELS &amp; WINDOWS.....</b>	<b>26</b>
16.1	FACE PANEL REMOVAL.....	26
16.2	FACE PANEL INSTALLATION.....	26
16.3	SIDE PANELS REMOVAL.....	26
16.4	SIDE PANELS INSTALLATION.....	27
16.5	TOP AND BOTTOM PANEL REMOVAL.....	28
16.6	TOP AND BOTTOM PANEL INSTALLATION.....	28
16.7	WINDOWS REMOVAL.....	29
16.8	FIXED WINDOWS INSTALLATION.....	29
16.9	AWNING WINDOW INSTALLATION.....	31
16.10	SLIDING WINDOW INSTALLATION.....	33
16.11	FINISHING JOINT.....	34
16.11.1	Slide-out face.....	35
16.11.2	Slide-out side.....	35
16.11.3	Slide-out bottom.....	36
16.11.4	Top of Slide-out.....	36
<b>17</b>	<b>WELDING PRECAUTION.....</b>	<b>36</b>
<b>18</b>	<b>SLIDE-OUT MANUAL OVERRIDE PROCEDURES.....</b>	<b>36</b>
18.1	PRELIMINARY CONDITIONS FOR MANUAL OVERRIDE PROCEDURE.....	37
18.1.1	Manual retracting procedure – Front and rear slide-out.....	37
18.1.2	Manual extending procedure – Front and rear slide-out.....	38

<b>19 SLIDE-OUT MAXIMUM LOAD</b> .....	<b>39</b>
<b>20 CONVERSION CHECKLIST</b> .....	<b>40</b>
20.1 ERROR CONDITION OR MISSING OPERATION CONDITION .....	41
20.2 TROUBLESHOOTING – OPERATING CONDITIONS & CONTROL .....	41
20.3 TROUBLESHOOTING - MECHANICAL COMPONENTS .....	43
20.4 SLIDE-OUT FAULT MESSAGE ON MESSAGE CENTER DISPLAY (MCD) .....	46

## ILLUSTRATIONS

FIGURE 1 : FRONT SLIDE-OUT .....	5
FIGURE 2 : REAR SLIDE-OUT .....	5
FIGURE 3 : SIDE INNER STOPPER ADJUSTMENT .....	5
FIGURE 4: UPPER INNER STOPPERS ADJUSTMENT .....	5
FIGURE 5: LOWER "IN LIMIT" STOPPER .....	6
FIGURE 6: UPPER "IN LIMIT" STOPPER .....	6
FIGURE 7 : EXTERIOR EXTRUSION .....	6
FIGURE 8: SECURITY PIN AIR CYLINDER REMOVAL .....	7
FIGURE 9 : FRONT SLIDE-OUT ROOF REINFORCING ROD .....	7
FIGURE 10 : RACK .....	8
FIGURE 11: PINION AND KEYLESS BUSHING POSITIONING .....	9
FIGURE 12: PINION AND KEYLESS BUSHING AS SEEN FROM EVAPORATOR COMPARTMENT .....	9
FIGURE 13: MECHANICAL COMPONENTS (TYPICAL) .....	9
FIGURE 14 : KEYLESS BUSHING TIGHTENING .....	10
FIGURE 15 : TORQUE WRENCH FORMULA .....	10
FIGURE 16 : KEYLESS BUSHING INSTALLATION INSTRUCTION .....	12
FIGURE 17: ELECTRIC MOTOR AND SPEED REDUCTION GEARBOX .....	13
FIGURE 18: DRIVE MOTOR/GEARBOX ASSEMBLY MOUNTING BOLTS .....	13
FIGURE 19: CLAMPING HUB POSITION ON GEARBOX SHAFT .....	14
FIGURE 20: JAW COUPLING .....	14
FIGURE 21: SLIDE-OUT LEVEL ADJUSTEMENT .....	15
FIGURE 22 : SLIDE-OUT LEVELING .....	16
FIGURE 23: TILT ADJUSTMENT .....	16
FIGURE 24 : RAIL POSITIONING .....	17
FIGURE 25: ACETAL PLASTIC BLOCKS .....	17
FIGURE 26: REMOVE THE UPPER ACETAL PLASTIC BLOCKS WITH A PICKING TOOL .....	17
FIGURE 27: LOWER ACETAL PLASTIC BLOCK INSERTION .....	18
FIGURE 28 : FRONT SERVICE COMPARTMENT .....	19
FIGURE 29: PNEUMATIC COMPONENT PANEL .....	20
FIGURE 30 : SEAL ASSEMBLY .....	20
FIGURE 31: REAR SLIDE-OUT INFLATABLE SEAL AIR INLET .....	21
FIGURE 32: SLIDE-OUT 2" INSIDE – UPPER PART .....	22
FIGURE 33 : DASHBOARD SLIDE-OUT TELLTALE LIGHT .....	23
FIGURE 34: MAIN BREAKER IN ENGINE R.H. SIDE ACCESS COMPARTMENT .....	23
FIGURE 35 : SLIDE-OUT CONTROL PANEL .....	23
FIGURE 36 : VEC CIRCUIT BREAKERS & FUSES .....	24
FIGURE 37 : FRONT SLIDE-OUT SENSORS .....	25
FIGURE 38: REAR SLIDE-OUT SENSORS .....	25
FIGURE 39 : MAGNETS ON SLIDE-OUT UNDERBODY .....	25
FIGURE 40 : SLIDE-OUT PANELS AND WINDOWS .....	26
FIGURE 41 : SIDE PANEL INSTALLATION – DOUBLE FACE ADHESIVE TAPE APPLICATION ON THE SLIDE-OUT STRUCTURE .....	27
FIGURE 42 : SIDE PANEL INSTALLATION – SIKA 206 G+P APPLICATION .....	27
FIGURE 43 : SIDE PANEL INSTALLATION – SIKA TACK+BOOSTER APPLICATION .....	27
FIGURE 44 : SIDE PANEL INSTALLATION .....	28

## Section 26: XLII SLIDE-OUT

---

FIGURE 45 : TOP AND BOTTOM PANEL INSTALLATION - DOUBLE FACE ADHESIVE TAPE APPLICATION.....	28
FIGURE 46 TOP AND BOTTOM PANEL INSTALLATION - SIKA 206 G+P APPLICATION.....	29
FIGURE 47 : TOP AND BOTTOM PANEL INSTALLATION - SIKA TACK+BOOSTER APPLICATION.....	29
FIGURE 48 : TOP PANEL INSTALLATION.....	29
FIGURE 49 : BOTTOM PANEL INSTALLATION.....	29
FIGURE 50 : FACE FIXED WINDOWS - RUBBER SEAL INSTALLATION .....	30
FIGURE 51 : FACE FIXED WINDOWS - RUBBER SEAL INSTALLATION .....	30
FIGURE 52 : FACE FIXED WINDOWS – 3/16 X 1/2 DOUBLE FACE ADHESIVE TAPE INSTALLATION .	30
FIGURE 53 : SIDE FIXED WINDOW – ¼ X ½ DOUBLE FACE ADHESIVE TAPE INSTALLATION .....	30
FIGURE 54 : FACE FIXED WINDOW AND HALF-WINDOW – SIKA AKTIVATOR.....	30
FIGURE 55 : SIDE FIXED WINDOW – SIKA AKTIVATOR.....	30
FIGURE 56 : FACE FIXED WINDOW INSTALLATION – SIKA TACK+BOOSTER.....	30
FIGURE 57 : FACE FIXED HALF-WINDOW INSTALLATION – SIKA TACK+BOOSTER .....	31
FIGURE 58 : SIDE FIXED WINDOW – SIKA TACK + BOOSTER.....	31
FIGURE 59 : FACE FIXED WINDOW INSTALLATION.....	31
FIGURE 60 : SIDE FIXED WINDOW.....	31
FIGURE 61: AWNING WINDOW - RUBBER BUMPER INSTALLATION.....	31
FIGURE 62: SIDE BUMPERS.....	32
FIGURE 63: MASKING TAPE APPLICATION .....	32
FIGURE 64: SIKA 255 APPLICATION .....	32
FIGURE 65 : AWNING WINDOW – SIKA AKTIVATOR.....	32
FIGURE 66: AWNING WINDOW – SIKA 255 APPLICATION .....	32
FIGURE 67 : CORRECT TIGHTENING SEQUENCE .....	32
FIGURE 68 : SMOOTH DOWN THE JOINT.....	33
FIGURE 69 : AWNING WINDOW – SEAL THE UPPER CORNERS.....	33
FIGURE 70 : AWNING WINDOW – SEAL THE CHINK.....	33
FIGURE 71 : SLIDING WINDOW - SIKA AKTIVATOR.....	34
FIGURE 72 : SLIDING WINDOW - SIKA AKTIVATOR.....	34
FIGURE 73: AWNING WINDOW – SIKA 252 APPLICATION .....	34
FIGURE 74 : CORRECT TIGHTENING SEQUENCE .....	34
FIGURE 75 : SLIDING WINDOW – SEAL THE UPPER CORNERS .....	34
FIGURE 76 : SEAL .....	34
FIGURE 77 .....	35
FIGURE 78.....	35
FIGURE 79.....	35
FIGURE 80.....	35
FIGURE 81.....	35
FIGURE 82.....	36
FIGURE 83.....	36
FIGURE 84.....	36
FIGURE 85.....	36
FIGURE 86.....	36
FIGURE 87: COMPARTMENTS LOCATION .....	37
FIGURE 88: VEC CIRCUIT BREAKERS ON SLIDE-OUT CONTROL PANEL.....	37
FIGURE 89: MAIN SLIDE-OUT BREAKER IN ENGINE R.H. SIDE ACCESS COMPARTMENT .....	37
FIGURE 90: SLIDE-OUT CONTROL PANEL.....	37
FIGURE 91: INFLATABLE SEAL RELIEVING SHUT-OFF VALVE.....	38
FIGURE 92: SLIDE-OUT MOTOR ROTATION.....	38
FIGURE 93: INFLATABLE SEAL PRESSURE GAGE .....	38
FIGURE 94: SLIDE-OUT MOTOR ROTATION.....	39
FIGURE 95 : FRONT SLIDE-OUT DEFLECTION .....	39

# 1 SLIDE-OUT

## 1.1 INNER STOPPER

The front slide-out is equipped with six inner stoppers laid out in the following way: two stoppers on the top horizontal member of the slide-out, and two stoppers on each vertical upright, while the rear slide-out is equipped with only three stoppers (figure 1 and figure 2). The upper inner stoppers are used to provide a support to position perpendicularly the slide-out with the vehicle structure.

The side inner stoppers are used to block the extension of the slide-out. They act as ultimate physical limits but take note that when the “out limit” sensors are properly adjusted, the slide-out extension stops before the side inner stoppers reach the side structure keys (figure 1 & 2).

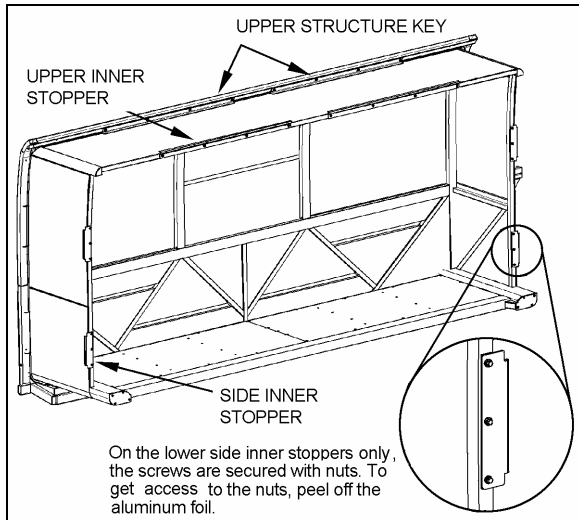

FIGURE 1 : FRONT SLIDE-OUT

### 1.1.1 Maintenance

Check that the inner stopper screws are tight and that no damage or deformation has taken place for both the side and the upper stoppers.

### 1.1.2 Adjustment

- Adjust the side inner stoppers at 1/8" from the vehicle side structure keys, and tighten the screws. Make sure there is a minimum gap of 2mm (0.079") between the side inner stopper and the side window pane (figure 3). Use shim as required.
- Adjust the upper structure key and the upper inner stoppers according to FIGURE 4 with the seal deflated. When inflating, the seal presses the roof structure upward and at

that moment, the upper inner stopper comes into contact with the upper structure key

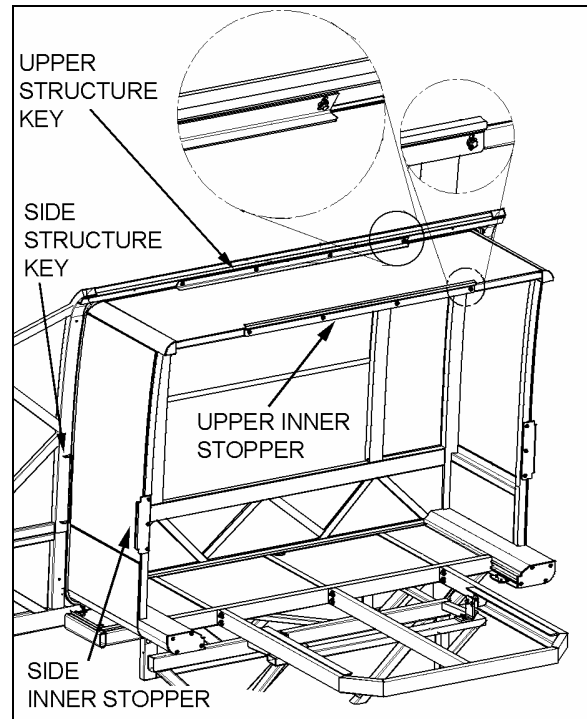

FIGURE 2 : REAR SLIDE-OUT

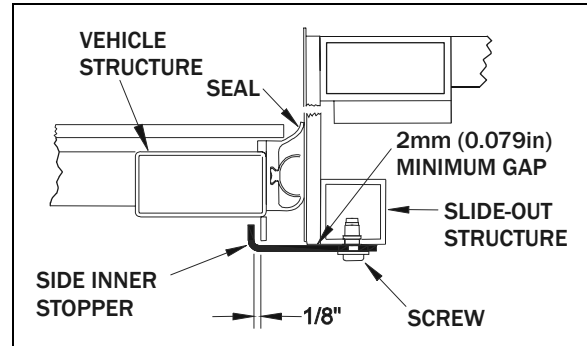

FIGURE 3 : SIDE INNER STOPPER ADJUSTMENT

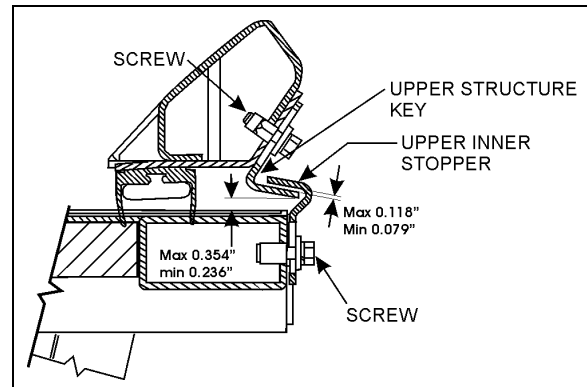

FIGURE 4 : UPPER INNER STOPPERS ADJUSTMENT

## 1.2 "IN LIMIT" STOPPER

Each slide-out has four "in limit" stoppers. Two "in limit" stoppers are mounted on the exterior extrusion at the top of the slide-out (FIGURE 6) and two other "in limit" stoppers are mounted under the slide-out, next to the rail (Figure 5). These stoppers are used to position the outer face of the slide-out flush with the vehicle body when retracted.

### 1.2.1 Maintenance

Check that the "in limit" stoppers are clean and that there is no foreign matter accumulated between the stopper and their bearing surface. Check that the screws and set screws (where applicable) locking the stoppers in proper position are tight.

### 1.2.2 Adjustment

**NOTE**

*To properly adjust the "in limit" stoppers, the slide-out system must be turned off to prevent the "in limit" sensors from stopping the slide-out movement before having the "in limit" stoppers contacting their bearing surface.*

1. Extend the slide-out partially.
2. Set the ignition switch to the OFF position.
3. To adjust the lower "in limit" stoppers, loosen the set screw and then rotate the stopper CW or CCW to move it back or forward depending on the required adjustment. To adjust the upper plastic "in limit" stoppers, add or remove shims as required between the stopper and the extrusion.
4. Using the manual override procedure (section 18), move the slide-out up to its full "in" position.
5. Using a straight edge, check if the outer face of the slide-out is flush with the vehicle body with the stoppers contacting their bearing surface. Readjust the stoppers if necessary.
6. Readjust the "in limit" sensor.

**NOTE**

*To make sure that the lower "in limit" stoppers are contacting their bearing surface (the acetal plastic blocks) when the slide-out is closed, put white paint on the "in limit" stopper before and check if the acetal plastic blocks are marked with paint.*

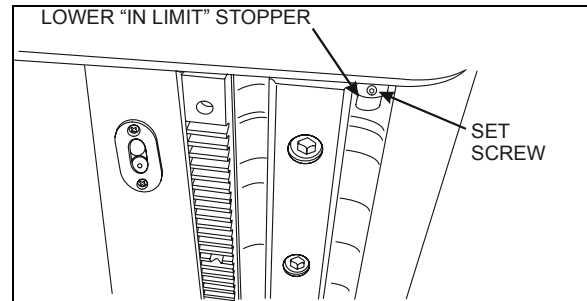

FIGURE 5: LOWER "IN LIMIT" STOPPER

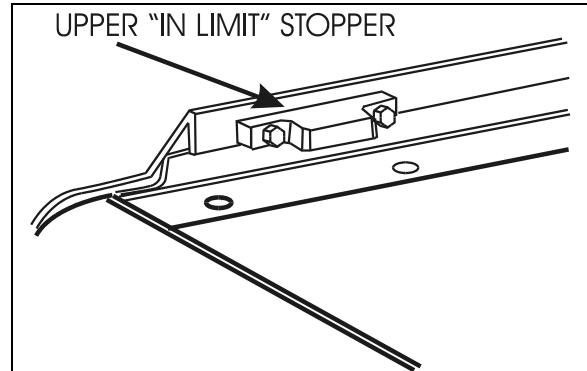

FIGURE 6: UPPER "IN LIMIT" STOPPER

## 1.3 EXTERIOR EXTRUSION

The exterior extrusion function is to provide a leaning surface for the inflatable seal. When inflating, the seal leans against the extrusion and presses the roof structure upward until it rests on the inner side of the extrusion.

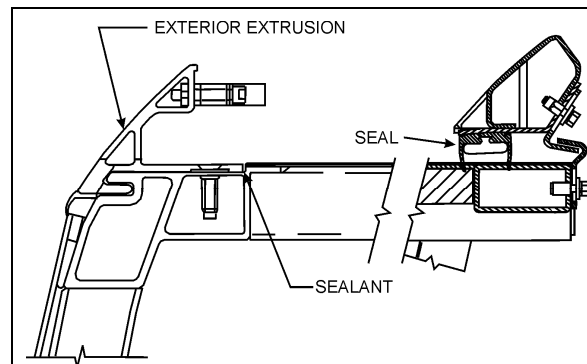

FIGURE 7 : EXTERIOR EXTRUSION

### Maintenance

Inspect the exterior extrusion for any deformation or deterioration. Check that the screws are tight. Inspect the sealant condition on screw head and between the extrusion and the vehicle structure, and also at both ends of the extrusion. If needed, clean old sealant and replace with Sika 221 sealant or equivalent product.

## 2 SECURITY PIN

During normal ride, the slide-out cannot extend by itself because the 740:1 ratio speed reduction worm gear type gearbox system is not reversible, the output shafts are self-locking. The security pin purpose is to lock the slide-out in retracted position if an accident occurs. It is built to stand a great lateral acceleration of the slide-out.

The system consists of a stainless steel pin connected to a single action/spring return pneumatic cylinder (FIGURE 8). The pin engages in the slide-out receptacle with releasing of the parking brake. A knocking sound may be heard at this moment. An O-ring is located at the base of the pin housing to reduce knocking when the pin retracts. The lower hole on the pin housing permits water to drain. The upper hole permits to insert a small screwdriver to prevent the pin from rotating when the air cylinder has to be removed.

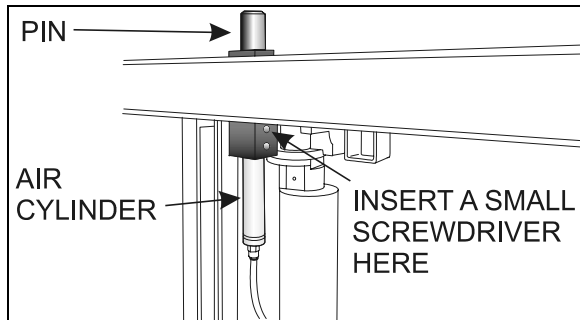

FIGURE 8: SECURITY PIN AIR CYLINDER REMOVAL

### 2.1 MAINTENANCE

Inspect air cylinder and fitting for air leaks. Periodically, check that the pin retracts and engages in the receptacle as it should when the parking brake is applied or released. To do slide-out, the slide-out must be in its full "IN" position with the engine running. If the pin produces excessive knocking when it engages with releasing of the parking brake, reduce air cylinder speed by adjusting the air flow regulator on the pneumatic control panel (FIGURE 29, item 11).

### 2.2 AIR CYLINDER REPLACEMENT

1. Assure the parking brake is applied.
2. Disconnect the cylinder air tubing from the 2<sup>nd</sup> baggage compartment (front slide-out) or under the bed structure (rear slide-out).

3. Using a wrench at its lower end, unscrew the air cylinder from the pin housing.
4. Insert a small screwdriver through the pin and housing to prevent rotation of the pin and then, unscrew the cylinder rod from the pin.
5. Transfer the fitting on the new cylinder. Place Teflon on threads.
6. Cylinder installation is like removal but in reverse order.

## 3 ROOF REINFORCING ROD



### CAUTION

The front slide-out roof reinforcing rod may have to be adjusted after a load variation inside the vehicle or on the top of the vehicle.



### CAUTION

Always lock the turnbuckle using the jam nut to prevent loosening.

The roof reinforcing rod is located on the upper horizontal member of the front slide-out opening and is welded on the roof arches (figure 9).

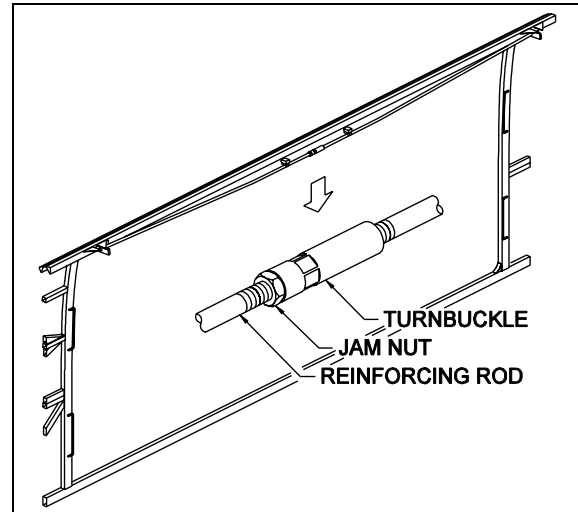

FIGURE 9 : FRONT SLIDE-OUT ROOF REINFORCING ROD

This rod allows an adjustment between the slide-out horizontal member and the roof. When screwing the turnbuckle, the roof is moved upward, and vice versa. Use this rod to adjust the horizontal member parallel to the slide-out. A member not parallel with the slide-out may

## Section 26: XLII SLIDE-OUT

cause the inflatable seal to leave the wiper seal or may reduce the inflatable seal and wiper seal efficiency.

### 4 RACK

Slide-out movement is made by a system of racks and pinions. There are two racks on each slide-out.

#### 4.1 MAINTENANCE

Once a year, check the racks for broken or worn tooth, especially the front slide-out racks. Also, check the rack fastening hole teeth that are weaker and might break (figure 10). Replace the racks if excessive wear is present. Clean racks from sand or other debris. Check that the racks are properly secured. Check the backlash between the gear and the rack. Excessive backlash indicates rack wear.

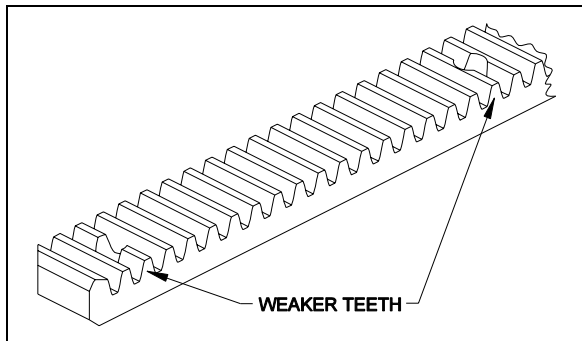

FIGURE 10 : RACK

#### 4.2 FRONT SLIDE-OUT RACK REPLACEMENT

1. Remove the slide-out from the vehicle (removal must be performed according to the Slide-Out Removal Procedure. Ask to your Prevest service representative).
2. From under the slide-out, unscrew all the rack screws and remove the rack.
3. Install a new rack. Tighten the screws to a maximum torque of 2 ft-lbs. Use Loctite™ 242 or equivalent product on threads.
4. Reinstall the front slide-out inside the vehicle.



### CAUTION

The counterboring required for recessed screw heads reduce plastic thickness. Do not torque higher than specified.

#### 4.3 REAR SLIDE-OUT RACK REPLACEMENT

1. Using the slide-out handheld control or the manual override procedure (section 18, if using the manual override procedure, do not forget to deflate the inflatable seal completely), extend the slide-out about one foot.
2. From outside, unscrew and remove only the first two screws of the rack to be changed.
3. Using the manual override procedure (section 18) only, retract the slide-out to its fully closed position.
4. Loosen the pinion keyless bushing of the rack to be changed.
5. From under the slide-out, unscrew all the rack screws and remove the rack.
6. Install a new rack between the slide out structural rack seat and the pinion. Tighten the screws to a maximum torque of 2 ft-lbs. Use Loctite™ 242 or equivalent product.



### CAUTION

The counterboring required for recessed screw heads reduce plastic thickness. Do not torque higher than specified.

7. Tighten the pinion keyless bushing as described in section 5.4.
8. Using the slide-out manual override procedure only, extend the slide-out about one foot.
9. Tighten the two remaining screws to a maximum torque of 2 ft-lbs. Use Loctite™ 242 or equivalent product.
10. Using the slide-out handheld control switch or the manual override procedure, retract the slide-out to its fully closed position.
11. Re-inflate the air seal at 10 psi.

## 5 PINION



### CAUTION

Make sure all keyless bushings are tightened to 125 lb-ft before moving the slide-out. Refer to section 5.4 for torque wrench settings. A lower torque value may cause the bushing to slip on the shaft, and a higher torque value may break the bushing.

### 5.1 PINION AND KEYLESS BUSHING POSITIONING

For proper functioning, respect the positioning shown on the following figure.

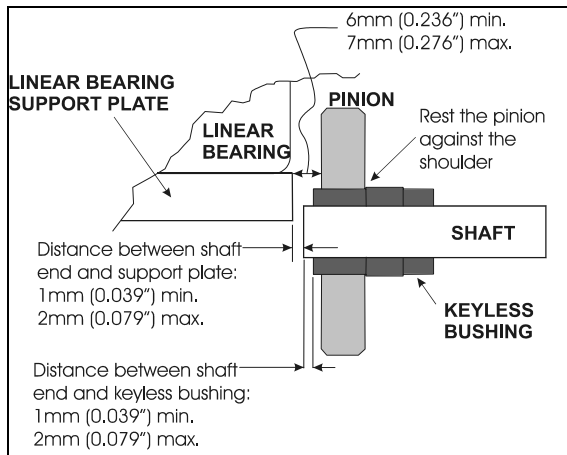

FIGURE 11: PINION AND KEYLESS BUSHING POSITIONING

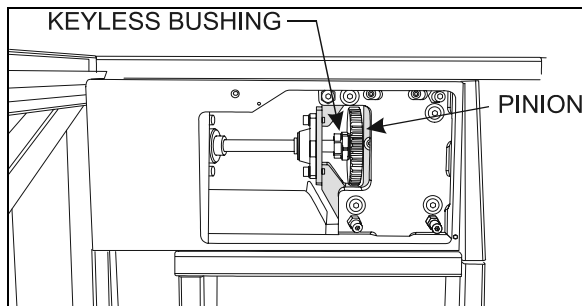

FIGURE 12: PINION AND KEYLESS BUSHING AS SEEN FROM EVAPORATOR COMPARTMENT

### 5.2 FRONT SLIDE-OUT SHAFT PINION REPLACEMENT



### CAUTION

Before reinstalling the pinion, clean the following surfaces with alcohol to prevent slippage.

- Pinion bore;
- Keyless bushing I.D. and O.D.;
- Shaft.

Before proceeding with the front slide-out shaft pinion replacement, check the following conditions:

- The locking collars located on the side of the pinion being replaced are disengaged;
- The drive motor/gearbox assembly is removed (see section 7.2);

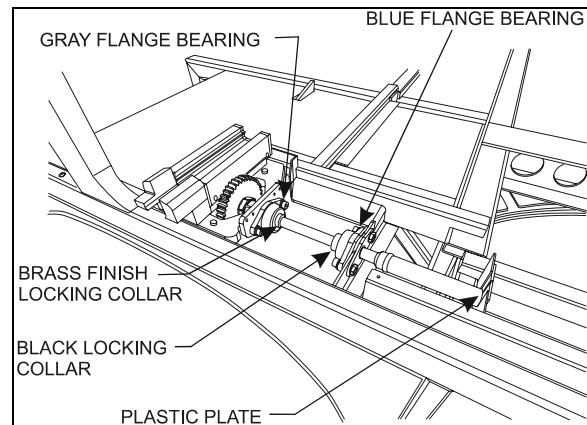

FIGURE 13: MECHANICAL COMPONENTS (TYPICAL)

1. Loosen the keyless bushing (see section 5.4) of the pinion to be replaced. Slide the pinion and its bushing out of the shaft. Check the keyless bushing condition and replace if needed.

#### NOTE

*If necessary, loosen the blue and gray flange bearing to move the pinion away from the rack.*

2. Assemble new pinion on the keyless bushing and then slide on the shaft. Do not tighten the bushing at this moment.
3. Properly position the shaft end in relation to the linear bearing support plate (see FIGURE 11) and then tighten the locking collars to maintain the shaft in that position.
4. Position pinion and keyless bushing as shown on FIGURE 11 and tighten the keyless bushing as described in section 5.4.
5. Reinstall the drive motor/gearbox assembly.





**CAUTION**

Make sure the keyless bushing is tightened to 125 lb-ft before moving the slide-out. Refer to section 5.4.1 for torque wrench settings.

**5.3 REAR SLIDE-OUT SHAFT PINION REPLACEMENT**

The procedure is similar to the front slide-out shaft pinion replacement. Gain access to the mechanism from under the bed structure. Refer to section 5.2.

**5.4 KEYLESS BUSHING**

The keyless bushings need a specific tightening torque value to ensure proper pinion transmitting torque. They also need specific tools to be tightened.

To tighten or loosen the keyless bushing, use those specific tools:

- crowfoot wrench 1 ½";
- torque wrench;
- combination wrench 1 ¾";
- pipe wrench;
- drive extension 5";
- socket 1 ½".

**5.4.1 Installation**

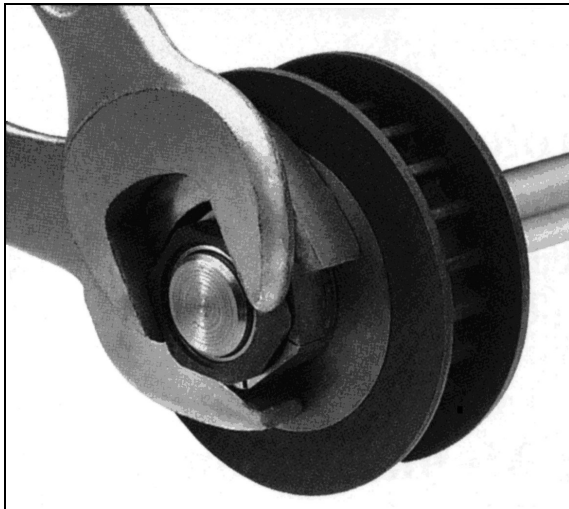

FIGURE 14 : KEYLESS BUSHING TIGHTENING

To tighten the keyless bushing, use a special open-end wrench to retain the yellow part and another wrench to tighten the black part. Figure 20 shows how to tighten the keyless bushing. When tightening, make sure the pinion does not move or rotate.

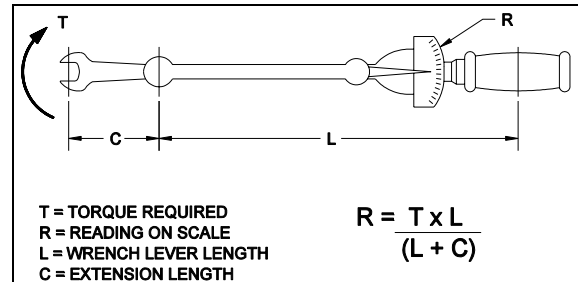

FIGURE 15 : TORQUE WRENCH FORMULA



**CAUTION**

Make sure all keyless bushings are tightened to 125 lb-ft before moving the slide-out. A lower torque value may cause the bushing to slip on the shaft, and a higher torque value may break the bushing. The torque may need to be recalculated depending of the wrench size. Refer to figure 15 for wrench size compensation.

Take note that when the keyless bushing nut is tightened, the pinion moves about 1/16" to 3/32" toward the slide-out center.

**NOTE**

*On the front slide-out, the driver side keyless bushing is not accessible for tightening or removal unless you remove the front left wheel. If the slide-out has been removed, this keyless bushing should be tightened before reinstalling the slide-out.*

**WRENCHES FOR INSTALLATION**

Fenner Drives offers a complete line of high-quality crowfoot wrenches for installation and to provide counter-torque. These wrenches are much narrower than earlier designs and are specifically for use with Trantorque GT units. It is recommended that both wrenches be used when installing a Trantorque GT unit.

**1/2" SQUARE DRIVE**

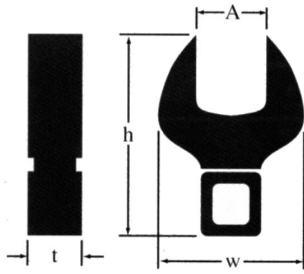

**Style C  
Installation Nut**

Shaft Size	Part Number	Wrench Style	Dimensions (inches)			
			A	h	w	t
13/16 to 1	6202990024	C	1-1/2	3.44	2.75	0.75

## INSTALLATION INSTRUCTIONS

A Trantorque GT Keyless Bushing offers flexible and easy installation while providing exceptional holding power. To ensure a Trantorque GT unit performs as specified, it must be installed properly.

**Warning: Use no lubricants in this installation.**

1. Shaft and component bore must be within  $\pm 0.003"$  ( $\pm 0.08\text{mm}$ ) [ $\pm 0.0015"$  ( $\pm 0.04\text{mm}$ ) Mini Series] of stated bore diameter and must have a surface finish of 32-125 Ra (roughness average). If the surface finish is outside these specified values, consult Fenner Drives.

2. Both shaft and component bore must be completely free of paint, grease, oil, and dirt. If necessary, clean the surfaces with a non-petroleum based solvent, such as isopropyl alcohol.

**Warning: Do not lubricate the Trantorque GT bushing or shaft. The use of any lubricant on the contact surfaces could result in bushing failure and will void all warranties.**

3. Insert the Trantorque GT unit into the component to be mounted, making sure the mating hub is flush against the shoulder at the hex flats.

4. Position the assembly at the desired location on the shaft and hand-tighten the nut (clockwise) until the assembly becomes snug on the shaft.

**Warning: Do not hammer or use any type of impact to force the Trantorque GT assembly along the shaft.**

**Warning: The shaft must fully engage the shaft gripping area (Figure 1) of the Trantorque GT unit. Figure 2 illustrates minimum shaft engagement.**

5. Using a torque wrench, tighten the nut to the proper installation torque. See table for torque value. (Note: Fenner Drives has available crowfoot wrenches for square drives in sizes from 1/2" to 3-1/2".) The hex flats on the outer ring are provided for counter-torque, eliminating the need to hold the component or shaft while applying installation torque.

Note: At full installation torque, the assembly will have moved approximately  $\pm 0.075"$  ( $\pm 1.9\text{mm}$ ) [ $\pm 0.045"$  ( $\pm 1.1\text{mm}$ ) Mini Series] axially along the shaft away from the nut. If axial position is critical it may be necessary to loosen the nut and reposition the assembly.

**Warning: Over-tightening the nut could damage the Trantorque GT unit and/or the mounted component.**

**Do not use an impact wrench in the installation.**

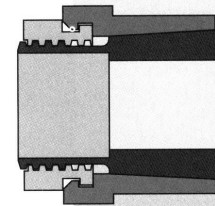

Figure 1

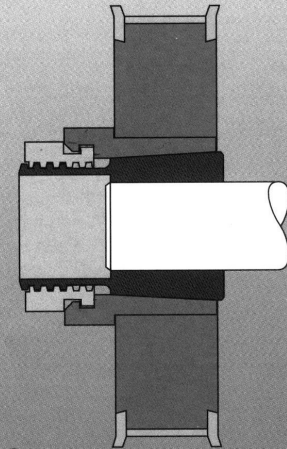
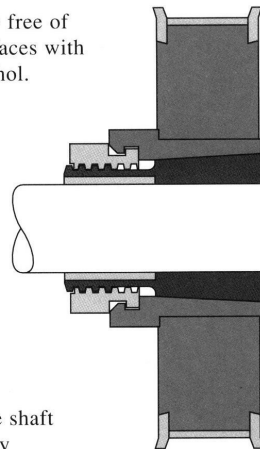

Figure 2

### Installation Torque on Nut

	<u>Inch Pound System</u>		<u>Metric System</u>	
	Shaft Size	In. Lbs.	Shaft size	N-m
<b>MINI SERIES</b>	3/16-1/4	125	5-6mm	14.1
	5/16-3/8	150	7-9mm	17.0
	7/16-1/2	175	10-12mm	19.8
	9/16-5/8	200	14-16mm	22.6
	3/4	700	17mm	80.0
<b>STANDARD SERIES</b>	5/8-3/4	1200	15-19mm	136
	<b>13/16-1</b>	<b>1500</b>	20-25mm	170
	1-1/16-1-1/4	2000	28-32mm	225
	1-5/16-1-1/2	2300	34-38mm	260
	1-9/16-1-3/4	2800	40-42mm	316
<b>LARGE SERIES</b>	1-13/16-2	4900	45-50mm	554
	2-1/16-2-1/4	5300	55mm	600
	2-5/16-2-1/2	5600	60mm	635
	2-9/16-2-3/4	6000	65-70mm	680
	2-13/16-3	6600	75mm	750

FIGURE 16 : KEYLESS BUSHING INSTALLATION INSTRUCTION

## 6 ELECTRIC MOTOR

The power is supplied by a 24V 1/3 HP electric motor coupled with a speed reduction gearbox. Opposite to the gearbox, the motor is equipped with a 3/8 hexagonal socket shaft extension permitting to move the slide-out without using the handheld control. This is very useful when moving the slide-out very slowly is required like during the inner stoppers adjustment, the tilt adjustment or the 2" inside retraction. See section 18 for the manual override procedures.



### CAUTION

When moving the slide-out with a cordless power drill as described in the manual override procedure, be careful as the slide-out approaches its opened or closed position, in order not to overload the mechanism.

### 6.1 MAINTENANCE

Inspect the electrical connections and their watertightness. Check that the mounting bolts are tight (FIGURE 18).

### 6.2 REPLACEMENT

1. The slide-out must be retracted.
2. Unplug the electric cable connector.

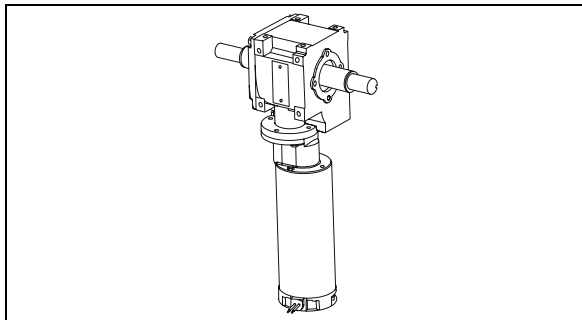

FIGURE 17: ELECTRIC MOTOR AND SPEED REDUCTION GEARBOX

3. Remove the motor from the gearbox.
4. Fasten the new motor to the gearbox using screws.
5. Re-connect the electric cable connector.

## 7 SPEED REDUCTION GEARBOX

The speed reduction gearbox used is a helical worm gear type. This gearbox has a 2-stage

740:1 ratio and the output shafts are self-locking. Keys on output shafts are glued into keyseats.

### 7.1 MAINTENANCE

Inspect the gearbox to check if there is any leakage or backlash in the box. Replace the gearbox if excessive wear is present. Check that all bolts are tight.

The gearbox is lubricated for life and the oil should not have to be changed.

### 7.2 GEARBOX REPLACEMENT

1. The slide-out must be retracted.
2. Disengage the shafts jaw couplings (refer to section 8: JAW COUPLING).
3. Remove the 4 cap screws securing the drive motor/gearbox assembly and dismount the assembly (see FIGURE 18).
4. Remove the gearbox from the motor and install the new one.
5. Reinstall the drive motor/gearbox assembly on the vehicle mounting bracket. Tighten mounting bolts to a torque of 18 lbf-ft in a criss-cross pattern.



### CAUTION

To prevent damaging threads, use your fingers to drive the bolts into the aluminum gearbox housing mounting holes.

6. Reinstall the jaw couplings.

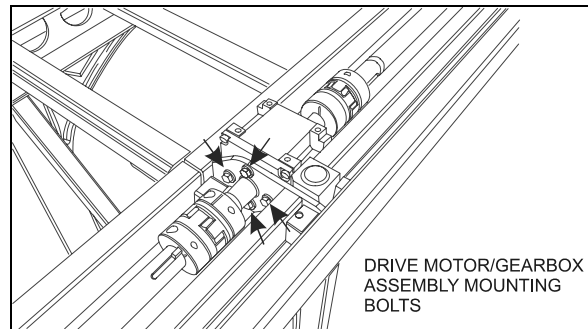

FIGURE 18: DRIVE MOTOR/GEARBOX ASSEMBLY MOUNTING BOLTS

## 8 JAW COUPLING

### 8.1 MAINTENANCE

Inspect the jaw couplings to check if there is any backlash between the key and the keyway. Also,

## Section 26: XLII SLIDE-OUT

check the spider condition. Check that the clamping screws are tight.

### 8.2 REPLACEMENT & ADJUSTMENT

1. The slide-out must be retracted.
2. Disengage the jaw coupling: loosen the clamping screw on each clamping hub. If required, rotate the motor shaft extension as described in the manual override procedure (section 18) to get to the clamping screws.
3. Separate both clamping hubs.

#### NOTE

*It may be necessary to loosen the blue flange bearings to move the shaft out of the way.*

4. Clean and degrease the hub bore and the shaft.
5. Push the new clamping hubs onto the shaft (pinion side).
6. Install a clamping hub on one of the gearbox shaft (opposite side of gearbox mounting bolts) flush with the shaft extremity (FIGURE 19). Tighten the clamping screw to a torque of 18 lbf-ft.
7. Install the second clamping hub on the gearbox shaft. Position the clamping hubs so that they are flush with the shafts extremity (see FIGURE 19).

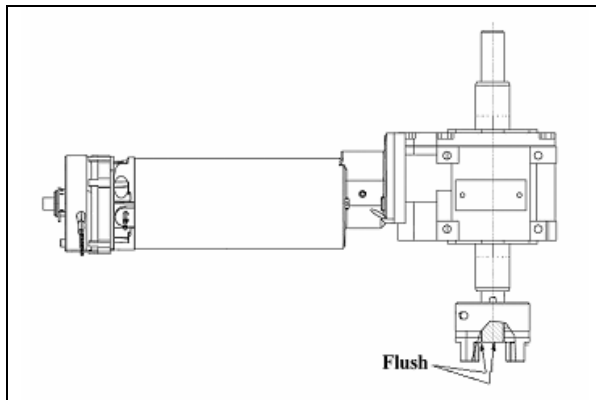

FIGURE 19: CLAMPING HUB POSITION ON GEARBOX SHAFT

8. Reconnect the clamping hubs with the spider. Leave a gap of 20mm (0.787inch) between each clamping hubs as shown on FIGURE 20. Use the motor hexagonal socket output shaft to align the keyways.
9. Tighten clamping screws to a torque of 18 lbf-ft.

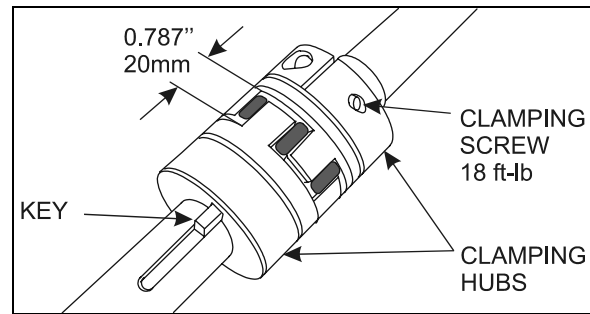

FIGURE 20: JAW COUPLING

### 9 FLANGE BEARING

There are two different types of flange bearing on the slide-out mechanism (FIGURE 13). Their purpose is to maintain the shaft in position while permitting rotation. The gray flange bearings are fixed to the linear bearing support plate and are not adjustable. The blue flange bearings are fixed to a support with oblong holes permitting to raise or lower the flange bearing as the linear bearing support plate level is being adjusted.

The flange bearings are pre-lubricated and no subsequent lubrication is required due to the very low extending and retracting speed of the slide-out system.

### 10 LOCKING COLLAR

The locking collar locks the shaft and the flange bearing together using friction. Once locked, it permits no axial translation of the shaft and prevents rotation of the shaft into the flange bearing bore.

#### 10.1 INSTALLATION

Slide the locking collar along the shaft up to the flange bearing (FIGURE 13). Turn the locking collar clockwise while maintaining it pressed against the flange bearing. Knock the collar with a punch to lock it in place, there is a cavity on the collar made for that purpose. Tighten the set screw.

To remove, loosen the set screw and release the locking collar using channellock pliers or a small pipe wrench.

## 11 LINEAR BEARING

### 11.1 MAINTENANCE

Make every effort not to allow dust and foreign objects to enter inside the linear bearing.

The linear bearings are pre-lubricated and no subsequent lubrication is required due to the very low demanding use of the slide-out system.

### 11.2 REPLACEMENT & ADJUSTMENT

1. Remove the slide-out from the vehicle (removal must be performed according to the Slide-Out Removal Procedure. Ask to your Prevost service representative).
2. Disconnect the jaw coupling on the side of the linear bearing being replaced (refer to section 8).
3. Dismount the blue flange bearing.
4. From the mechanism access panel, remove the retaining screws A, B, C & D (see figure 22).
5. Now, you have access to the linear bearing mounting bolts if you turn its support up side down. Dismount the linear bearing and install the new one.
6. Tighten the mounting bolts in a criss-cross pattern to a torque of 60 ft-lb.
7. Reinstall the support plate, retaining screws, blue flange bearing and reengage the jaw coupling. Refer to the specific procedures.

### 11.3 LEVEL & TILT ADJUSTMENT

Leveling of the slide-out is done by changing the linear bearing support plate height using the leveling screws 1, 2, 3, 4 (figure 22). When proper level is attained, the retaining screws A, B, C & D maintain the support plate seated on the leveling screws. Also, the retaining screws prevent the slide-out from tipping inside the vehicle when it is retracted.

The slide-out is slightly tilted. When retracting, the upper "in limit" stoppers touch first the vehicle structure, followed by the lower "in limit" stoppers. Tilt adjustment is done by changing the linear bearing support plate inclination using the leveling screws 1 & 2 as pivot and 3 to adjust the angle (figure 22).

#### 11.3.1 Procedure

##### *NOTE*

For the **front slide-out**, the front linear bearing leveling screws are accessible from the access panel located over the front wheel while the rear linear bearing leveling screws are accessible from the access panel in the evaporator compartment. For the **rear slide-out**, access the linear bearing from under the bed structure or the radiator compartment.



##### **WARNING**

The slide-out must be retracted when the level and tilt adjustment is performed.

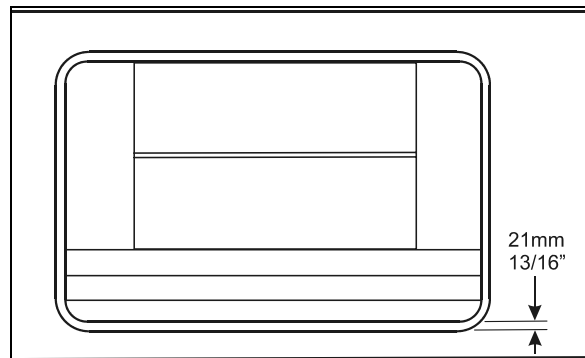

**FIGURE 21: SLIDE-OUT LEVEL ADJUSTMENT**

Before proceeding with the level and tilt adjustment, check the following conditions:

- The slide-out is retracted;
  - The 2 lower "in limit" stoppers are perfectly adjusted, that means that the lower edge of the slide-out outer panel is flush with the vehicle body when retracted;
  - The 2 upper "in limit" stoppers are removed from the slide-out (see section 1.2).
1. Loosen the blue flange bearings mounting screws (FIGURE 13).
  2. For front slide-out only, loosen the two plastic plates mounting screws along the shafts (FIGURE 13).
  3. With the lower edge of the slide-out outer panel flush with the vehicle body, adjust the slide-out level. The distance between the top of the horizontal member under the slide-out and the slide-out under panel must be 21mm (13/16" approximately).

## Section 26: XLII SLIDE-OUT



### WARNING

Never unscrew completely retaining screw A, B, C, D or the slide-out may tip inside.

**To raise the linear bearing support plate**, turn levelling screw 1 & 2 clockwise. Slightly and gradually, loosen the retaining screws A & B as the support plate elevates, but keep the retaining screws tighten.

**To lower the linear bearing support plate**, turn screw 1 & 2 counterclockwise. As the support plate goes down, maintain the retaining screw A & B tighten.

- Loosen retaining screws C & D. Unscrew leveling screw 4. Now, the support plate should be resting on levelling screw 1, 2 & 3.
- Using levelling screw 3, adjust the tilt in order to have the top of the slide-out recessed between 5mm and 10mm ( $7/32$ " and  $3/8$ "") (see FIGURE 23).
- When proper tilt is attained, tighten leveling screw 4 so that it comes into contact with the support plate.
- Loosen slightly levelling screw 3 and then tighten it so it is perfectly in contact with the support plate. Make sure screws 1, 2, 3 & 4 are in contact with the support plate.
- Loosen retaining screw A & B.
- Using a crisscross pattern, tighten progressively (3 rounds) the retaining screw A, B, C & D to a torque of 50 ft-lb.
- Assure that the levelling screw 1, 2, 3 & 4 are firmly leaning on the support plate and then firmly tighten the jam nuts.
- Verify that the tilt is still properly adjusted (between  $7/32$ " and  $3/8$ "").

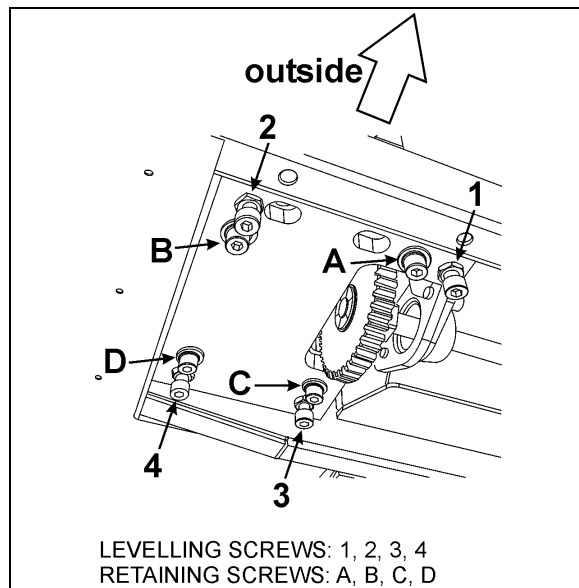

FIGURE 22 : SLIDE-OUT LEVELING

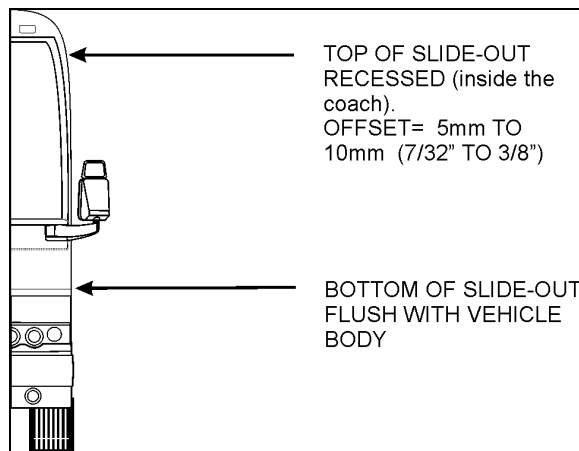

FIGURE 23: TILT ADJUSTMENT

## 12 RAIL

Rail and linear bearing system provide precise frictionless linear movement together with high load carrying capacity and high stiffness. These standardized equipments are fully interchangeable.

To prevent corrosion, an electrolytic black film treatment is performed to the rail. Do not strike the rail with metal tools, this could damage the treatment.

After the rail is mounted to the slide-out base, a cap is used to cover the bolt hole to prevent foreign matters from clogging up the hole or from entering into the ball slide. The cap for the bolt hole is made of synthetic resin which is superb in its resistance to oil and wear.

## 12.1 MAINTENANCE

Check that all the caps for the bolt hole are present. Missing caps must be replaced. To insert a cap into the rail bolt hole, use a flat tool. Pound the cap gradually until its height becomes flush with the rail top face.

Clean accumulated dirt from the rails with a soft cloth.

## 12.2 REPLACEMENT

1. Remove the slide-out from the vehicle (removal must be performed according to the Slide-Out Removal Procedure. Ask to your Prevest service representative).
2. Remove the bolt hole cap covers. To do so, pierce a hole in the center and hook them out. They will not be reusable.
3. Remove the rail mounting bolts.
4. Wipe off the rust preventive oil applied to the new rail. Remove burrs and small bumps on the slide-out mounting face with an oilstone.
5. Carefully place the rail on the bed on its mounting face.

### NOTE

The rail is bolted to a flat bar on which weldnuts are mounted. The flat bar is inserted in the slide-out lower body extrusion and can be removed through the end cap (FIGURE 24).

6. Adjust the flat bar position to align the weldnuts with the rail mounting holes.
7. Temporarily tighten the bolts.
8. Adjust the rail position with as per FIGURE 24. For each rail, make sure the gap is the same both side of the rail.
9. For final tightening of the bolts, tighten on either end of the rail and then start to the other end. Tighten to a torque of 95 ft-lbf. Use blue Loctite™ on threads.
10. Cap the bolt holes.

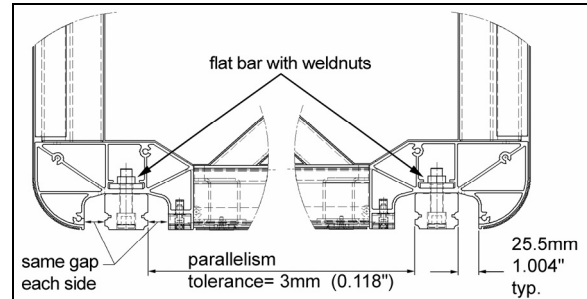

FIGURE 24 : RAIL POSITIONING

## 13 ACETAL PLASTIC BLOCKS

Three different acetal plastic blocks are installed next to each linear bearing to prevent dirt and foreign matter from entering inside the vehicle. They also serve as bearing surface for:

1. The inflatable seal each side of the rail.
2. The "in limit" stoppers.

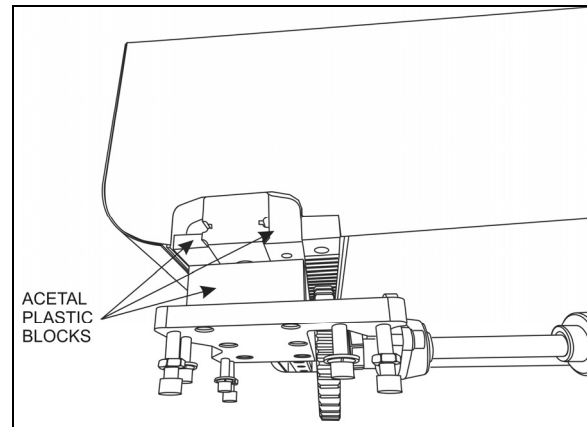

FIGURE 25: ACETAL PLASTIC BLOCKS

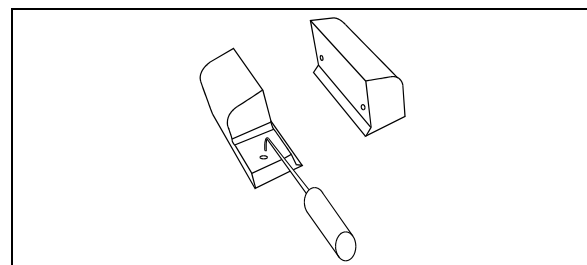

FIGURE 26: REMOVE THE UPPER ACETAL PLASTIC BLOCKS WITH A PICKING TOOL

## 13.1 REMOVAL / INSTALLATION

1. Gain access to the linear bearing support plate.
2. From under the support plate, remove the acetal plastic block mounting screws (see the oblong holes on figure 22).
3. Remove the 2 upper acetal plastic blocks. They have holes so they can be removed



with a picking tool (FIGURE 26) from outside the vehicle. If the acetal plastic blocks are too hard to reach, slightly extend the slide-out, the movement of the slide-out should bring them out.

4. To remove the lower acetal plastic block, gain access to the compartment under it. Slide the acetal plastic block toward the center of the slide-out. Proceed the same way to reinstall it.
5. Reinstalling the upper acetal plastic blocks. Fold the wiper seal toward the outside with a flat tool to ease installation (FIGURE 27). Tighten the mounting screws to a torque of 7 ft-lb. Leave no gap between the blocks and the rail.

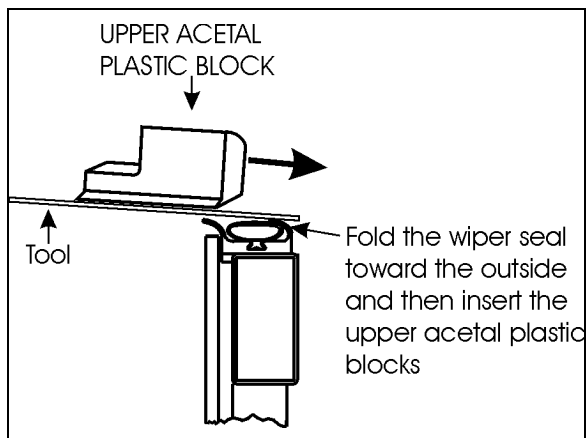

FIGURE 27: LOWER ACETAL PLASTIC BLOCK INSERTION

## 14 SLIDE-OUT PNEUMATIC SYSTEM

The slide-out is controlled by a pneumatic and electrical system. Mainly, the pneumatic system consists of electrically operated valves that control slide-out components and safety operations.

### 14.1 DESCRIPTION

#### AIR PRESSURE INLET VALVE

The slide-out air pressure comes from the air pressure inlet valve on the pneumatic panel in the front service compartment (figure 28).

#### INFLATABLE SEAL VALVE

The inflation and the deflation of a seal are done using a 5-port 2-position manifold valve with two solenoids. One solenoid is used for inflating of the seal and the other for deflating of the seal. When one of the solenoids is activated (seal deflating valve for example), the valve will keep its state even if the solenoid is deactivated. The inflating valve solenoid is activated to re-inflate the seal when the slide-out reaches its inner or outer limit. The inflatable seal pressure is set to 10 psi and in full "IN" or full "OUT" position, this pressure is continuously applied to the seal as long as the accessory air tank (which supply the slide-out) is not empty.

#### VACUUM GENERATOR

A vacuum generator using Venturi principle is controlled by a 5-port 2-position manifold valve and is used to evacuate the air faster from the seal and to ensure that the seal surface does not stay in contact with the slide-out.

The vacuum generator valve is activated simultaneously with seal deflating valve solenoid for 10 seconds. A pressure transducer will detect a seal, vacuum valve or generator failure if -5 psig is not reached after the 10 seconds delay. In that situation, an error code will be stored in the MCD (message center display). In normal operating condition, -5 psig is a necessary condition to consider the seal as deflated.

#### NOTE

*When air pressure is relieved using the shut-off valve, the normal extending and retracting operation cycle is disabled, because the pressure transducer reads 0 psig and that is higher than -5 psig (vacuum). For that reason the slide-out cannot be moved with the handheld control.*

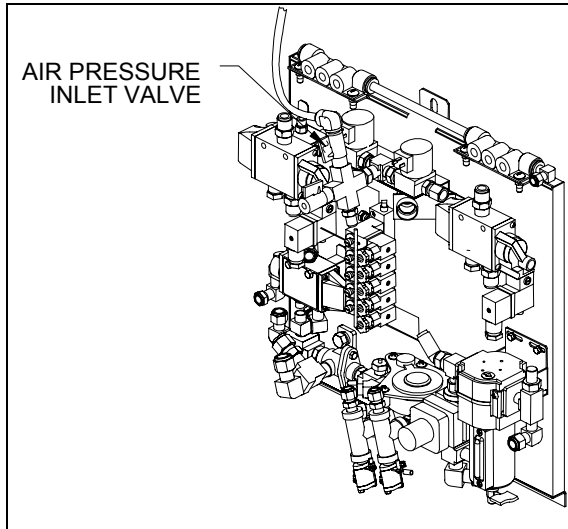

FIGURE 28 : FRONT SERVICE COMPARTMENT

### INFLATABLE SEAL CIRCUIT

The efficiency of the seal could be affected by impurities, such as white powder in the pneumatic control valve. It is recommended to inspect the inflatable seal control components once a year to prevent malfunction. In this case, remove the seal valves and clean the interior valve components using a compressed air nozzle. Do the same thing with the vacuum generators.

The inflatable seal pressure must be set from 7 to 10 psi maximum. It is recommended to check the inflatable seal pressure once a month to ensure sealing efficiency and prevent any infiltration from outside.

## 14.2 MAINTENANCE

### COMPRESSED AIR LINE

Inspect all compressed air line tubing for cut, swelling, kink or other damage or deterioration. Inspect the pneumatic fittings and components for any leak. The slide-out air supply is connected to the accessory air tank and the maintenance is specified in the "brake and air system" section from the Prevest maintenance manual.

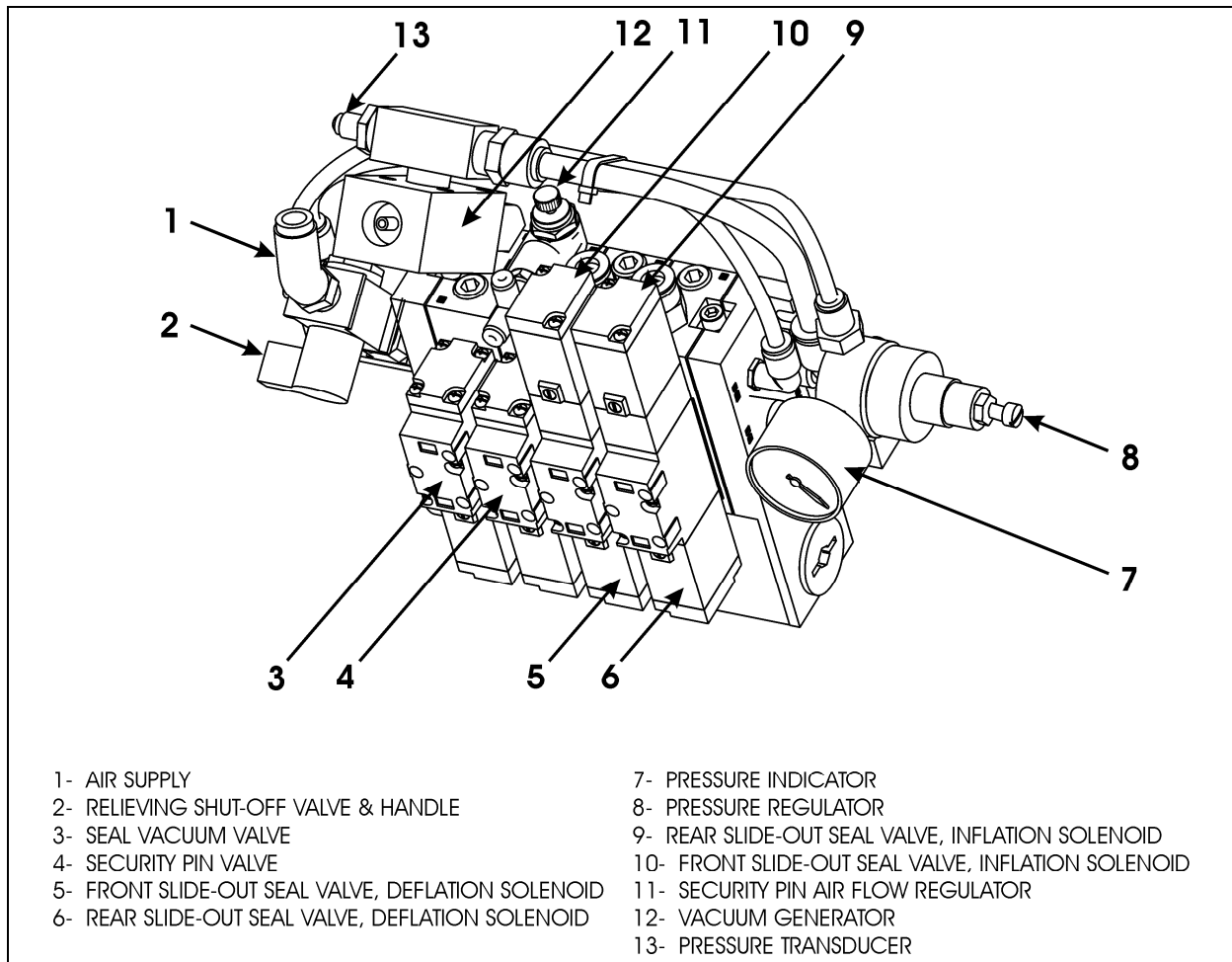

FIGURE 29: PNEUMATIC COMPONENT PANEL

### 14.3 SEAL

**NOTE**

Refer to the Prevest parts manual for descriptions of the sealant and adhesives used.

The slide-out sealing device is used to prevent any type of infiltration that may occur between the structure body and the slide-out itself. It is composed of an inflatable seal which is used as a primary sealing device for both retracted and extended slide-out position and a wiper seal as a secondary sealing device which is used to wipe water out and to ensure sealing during slide-out movement.

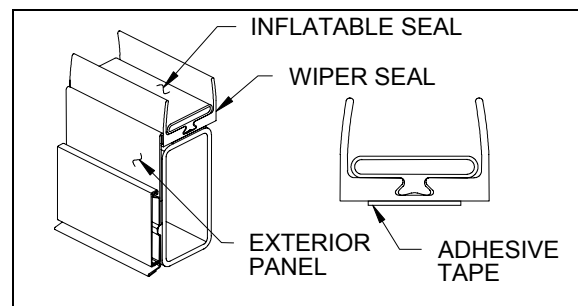

FIGURE 30 : SEAL ASSEMBLY

The seal deflation is done each time the slide-out moves. The deflating valve solenoid is activated before and during the slide-out movement. When the slide-out reaches its retracted or extended position, the deflating solenoid is deactivated before activation of the inflating solenoid to re-inflate the seal.

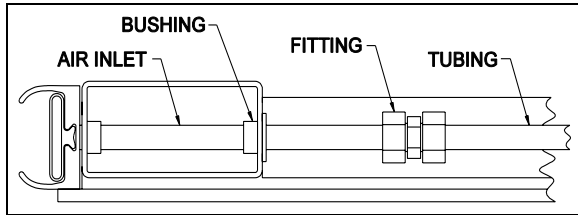

FIGURE 31: REAR SLIDE-OUT INFLATABLE SEAL AIR INLET



**CAUTION**

Make sure the inflatable seal is deflated when manually moving the slide-out during service maintenance. Deflate both inflatable seals completely by turning the relief shut-off valve handle clockwise (see FIGURE 29).



**CAUTION**

Check before using any cleaning or adhesive product on seal, panel or glass to prevent alteration or damage.

14.3.1 Maintenance

The inflatable seal pressure must be set to 10 psi maximum with the pressure regulator. It is recommended to check the inflatable seal pressure once a month to ensure sealing efficiency and prevent any infiltration from outside. Check both seals for air leaks or cracks. Check the sealant between the inflatable seal and the exterior panels and glasses. Add sealant if necessary.

14.3.2 Seal assembly removal



**DANGER**

Always wear the appropriate safety equipment. Maintain adequate ventilation at all time.

1. Retract the slide-out 2" inside the vehicle (section 14.3.4).
2. Unplug the tubing from the inflatable seal air inlet (FIGURE 31). Keep the bushing.
3. Unstick and remove the wiper seal from the structure.
4. Scrape remaining tape from the structure. Remove old sealant that was between the wiper seal and the exterior panels and glasses.

14.3.3 Seal assembly installation

*NOTE*

*This procedure is to install the inflatable seal assembly on the structure.*



**CAUTION**

Always apply product in the same direction to prevent dirt from being brought back.



**CAUTION**

Check before using any cleaning or adhesive product on seal, panel or glass to prevent alteration or damage.

*NOTE*

*Refer to the slide-out parts manual for descriptions of primer, cleaner, sealant and adhesives used.*

*NOTE*

*Refer to the product specification for drying time.*

1. Retract the slide-out 2" inside the vehicle (section 14.3.4).
2. Clean the part of the structure that will receive the inflatable seal and also the back of the exterior panel and glasses with a chix cloth and thinner. Use another cloth to dry the surfaces. Wait at least 2 minutes for drying.
3. Rub the structure and also the back of the exterior panel and glasses with a Scotch Brite (or equivalent product).
4. Clean another times the structure and the back of the exterior panel and glasses with a chix cloth and thinner. Use another cloth to dry the surfaces. Wait at least 2 minutes for drying.
5. Clean the structure and the back of the exterior panel and glasses with appropriate cleaner. Wait until the product is dry before proceeding.
6. Seal the gap between the structure and the exterior panels and the gap between the glasses and the fiberglass panels with appropriate sealant. Make sure not to put

## Section 26: XLII SLIDE-OUT

sealant on the structure surface where the inflatable seal will be placed. Wait until the product is dry before proceeding.

7. Install the inflatable seal on the structure, placing it as close as possible from the exterior side of the structure. Position the air inlet first. Then remove locally the inflatable seal adhesive tape protection, and press the upper corners on the structure and hold them in place for 90 to 120 seconds. Install the lower corners next, then the straight section. Press the straight inflatable seal sections on the structure for at least 15 seconds. Use a small roller to ensure a good adhesive contact on the structure.
8. Seal the gap between the inflatable seal and the exterior panels and the gap between the glasses and the fiberglass panels with appropriate sealant. Wait until the product is dry before proceeding. Remove excess sealant with appropriate cleaner.
9. Replace the bushing and plug the pneumatic tubing on the inflatable seal air inlet (FIGURE 31).

### 14.3.4 Slide-out 2" inside retraction

1. For both sides of the slide-out, remove the 2 upper acetal plastic blocks shown on FIGURE 26 (refer to section 13).
2. Manually deflate the seal completely by turning the relieving shut-off valve clockwise (FIGURE 29). Make sure the pressure indicator reading is "0 psi".
3. Turn the ignition to the off position. Using the manual override procedure (section 18), extend the slide-out a few inches so the exterior extrusion screws located on the top of the slide-out are accessible from outside (figure 7).
4. Using a knife cut the sealant between the extrusion and the roof (figure 7). Unscrew and remove the central exterior extrusion screws and the two end extrusion screws.



### CAUTION

Do not use the slide-out handheld control to move the slide-out 2" inside the vehicle, because the limits are not recognized over the closed position. The slide-out will not stop and damage may occur.

5. Using the manual override procedure, move the slide-out 2" inside the vehicle, so the seal is accessible from outside (FIGURE 32).

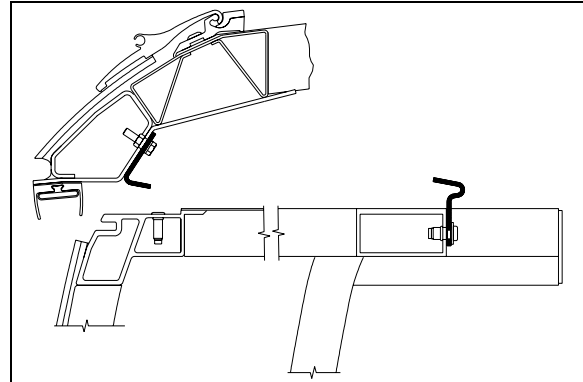

FIGURE 32: SLIDE-OUT 2" INSIDE – UPPER PART

6. Once completed, use the manual override procedure to extend the slide-out to reinstall the exterior extrusion. Apply appropriate sealant on the exterior extrusion screws and between the extrusion, the roof and the edges to prevent water infiltration (FIGURE 32).
7. Reinstall the acetal plastics blocks.
8. Using the manual override procedure, retract the slide-out to its closed position.
9. Finally, the seal can be re-inflated by turning the shut-off valve handle counterclockwise. Check the pressure gage on the inflatable seal regulator to see if the pressure is increasing to 10 psi.

## 15 SLIDE-OUT ELECTRICAL SYSTEM



### DANGER

Never modify the slide-out electrical wiring without the Prevest Car approval. Any modifications may cause an unexpected slide-out action and could result in personal injuries.

The multiplexed slide-out electrical system is mainly composed of the Master ID module, the CECM module, the VEC module and two I/O-B modules.

Each slide-out has its own I/O-B module and two power relays. The I/O-B modules analyze the input signal conditions and activate outputs like the pneumatic valves, the retracting or extending

programmed sequence, etc. The power relays are used to supply power coming from the I/O-B module to the electric motor and to change polarity to reverse motor rotation.

The I/O-B modules input signals are:

- Handheld control switch IN;
- Handheld control switch OUT;

Also, the following input signals are required for a safe operation of the slide-out:

- Pressure transducer;
- Parking brake;
- “in limit” sensor;
- “out limit” sensor;

The I/O-B modules output signals are:

- Handheld control green indicator light;
- Power relay current reversing;
- Seal valve inflating solenoid;
- Seal valve deflating solenoid;
- Vacuum generator valve solenoid;
- Security pin valve solenoid;
- Electric motor, first power output 15 amps;
- Electric motor, second power output 15 amps;

The CECM module output signals are:

- Dashboard telltale light;
- Transmission inhibit;



DANGER

Before working on the slide-out electrical system, turn the ignition key to the “OFF” position.

### 15.1 ELECTRICAL INTERCONNECTION WITH PREVOST VEHICLE

The slide-out power supply comes from the 24-volts circuit breaker (FIGURE 34) in the engine R.H. side access compartment. The other interconnections are located on the pneumatic panel and the electrical panel in the front service compartment. All the interconnections are shown on the electrical diagrams of your vehicle.

A blinking signal is added on the dashboard telltale panel (figure 33) to indicate that an error condition or a missing operation condition is present on a slide-out. The slide-out telltale light also illuminates to indicate that at least one of the slide-outs is extended.

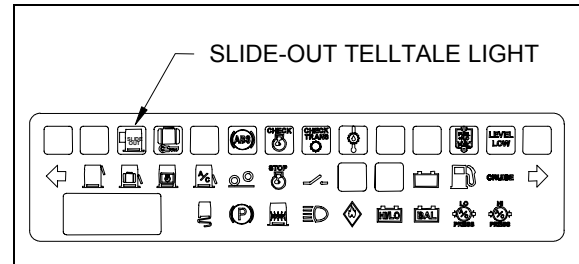

FIGURE 33 : DASHBOARD SLIDE-OUT TELLTALE LIGHT

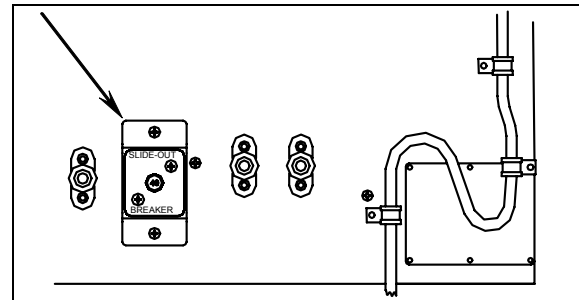

FIGURE 34: MAIN BREAKER IN ENGINE R.H. SIDE ACCESS COMPARTMENT

### 15.2 SLIDE-OUT BREAKERS / FUSES

The main breaker (for both slide-outs) is located in the engine R.H. side access compartment. All other slide-out breakers and hardware fuses are located inside the VEC, on the slide-out electrical component panel located in the third baggage compartment on the driver side (figure 35 and figure 36).

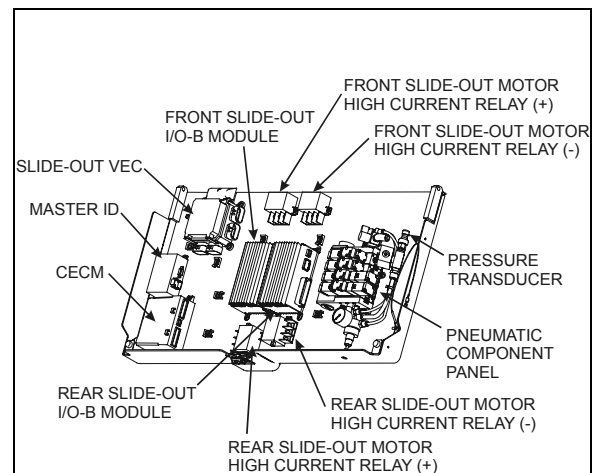

FIGURE 35 : SLIDE-OUT CONTROL PANEL

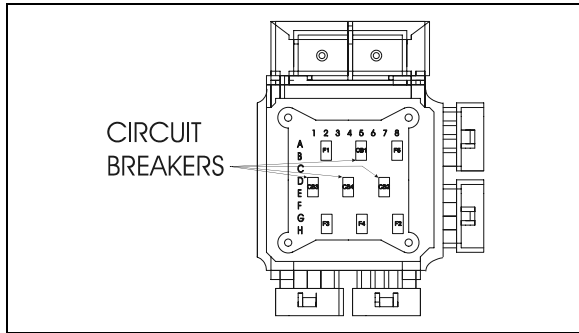

FIGURE 36 : VEC CIRCUIT BREAKERS & FUSES

### 15.2.1 Multiplex fuses

The multiplex module outputs are protected in current by an internal "soft-fuse". Each output is programmed to specific maximum amperage. When an output is shorted, the current gets above the limit and the soft-fuse intervenes to turn the output OFF. The output stays OFF until the "soft-fuse" is reset.

Turn the ignition key to the OFF position and turn to the ON position again. This resets all "soft-fuses".



### CAUTION

Never put grease, Cortec VCI-238 or other product on the multiplex modules connector terminals.

## 15.3 PROBING VOLTAGE ON THE MULTIPLEX CIRCUITS

Multiplex modules are supplied by 24 volts.

Inactive Multiplex output = Residual voltage of 18% to 33% of supply voltage.

Inactive Multiplex input = Residual voltage of 50% of supply voltage.

### NOTE

*For a 24V module: an active voltage would be 24V or 0V but not in between. If you measure the intermediate tensions (ex. 12V, 4V, or 8V) this must be interpreted as if the input or the output is inactive.*

## 15.4 MODULE REPLACEMENT

I/O-B and CECM multiplex modules can be replaced and reprogrammed without having to connect a computer to the vehicle.

### 15.4.1 I/O-B replacement

- Turn the ignition key to OFF.
- Replace the module (disconnect the green connector first, then the grey one and finish with the black connector. To disconnect the black connector, slide downwards the red latch).
- Turn the ignition key to the ON position. This engages the automatic reprogramming,
- The slide-out telltale light will turn on and stay on until the reprogramming is complete. Once completed, the slide-out telltale light will turn off or stay on (not blinking) if at least, one slide-out is extended.
- Check the SYSTEM DIAGNOSTIC menu of the message center display (MCD). Select FAULT DIAGNOSTIC and ELECTRICAL SYSTEM. Verify the fault message to be certain the module is reprogrammed. If the module is not reprogrammed, the message « Axx Not Responding » appears where Axx is the module number (A56 or A57).

### 15.4.2 CECM module replacement

- Turn the ignition key to OFF.
- Replace the module.
- Turn the ignition key to the ON position. This engages the program transfer from the Master ID to the CECM module (the back-up program is inside the Master ID. The Master ID will identify the CECM as being new and will send the correct program to it). The slide-out telltale light will turn on and stay on for a while, and then will turn off. Wait until the slide-out telltale starts blinking each second. At this point, the MasterID module has finished loading the program in the CECM.
- Turn the ignition key to the OFF position and then turn it back to the ON position. This engages I/O's modules automatic reprogramming.
- The slide-out telltale light will turn on. Once completed, the slide-out telltale light will turn off or stay on (not blinking) if at least, one slide-out is extended.

- Check the SYSTEM DIAGNOSTIC menu of the message center display (MCD). Select FAULT DIAGNOSTIC and ELECTRICAL SYSTEM. You should read “no errors”. If an active error appears for a module, this one was not reprogrammed. In this case, repeat the procedure.

## 15.5 SLIDE-OUT LIMIT SENSORS

Two Hall-Effect sensors are used on each slide-out to define end limit positions. The “in limit” and “out limit” sensor detect two pairs of permanent magnets fixed on the slide-out underbody.

### 15.5.1 Maintenance and adjustment

The rear slide-out sensors are accessible from inside of the vehicle, under the bed structure while the front slide-out sensors can be reached from the 3<sup>rd</sup> baggage compartment access panel. To remove the sensors, unsnap them from the mounting bracket.

#### To adjust the “in limit” sensors:

Prior to adjust the “in limit” sensors, assure that the “in limit” stoppers are perfectly adjusted (see section 1.2.2).

1. Retract the slide-out to its full “IN” position with the “in limit” stoppers in contact with their bearing surface.
2. Loosen the “in limit” sensor mounting bracket screws and move back the sensor completely (toward the inside of the vehicle).
3. Bring slowly the sensor toward the outside of the vehicle until the light emitting diode (LED) turns on. When it does, move it 0.079” (2mm) further in the same direction and tighten the mounting bracket screws.
4. Check if the “in limit” sensor is properly adjusted. At the moment when the slide-out stops during normal retraction, the “in limit” stoppers must contact their bearing surface (lower acetal plastic block). Put white paint on the “in limit” stopper before and check if the acetal plastic blocks are marked with paint.

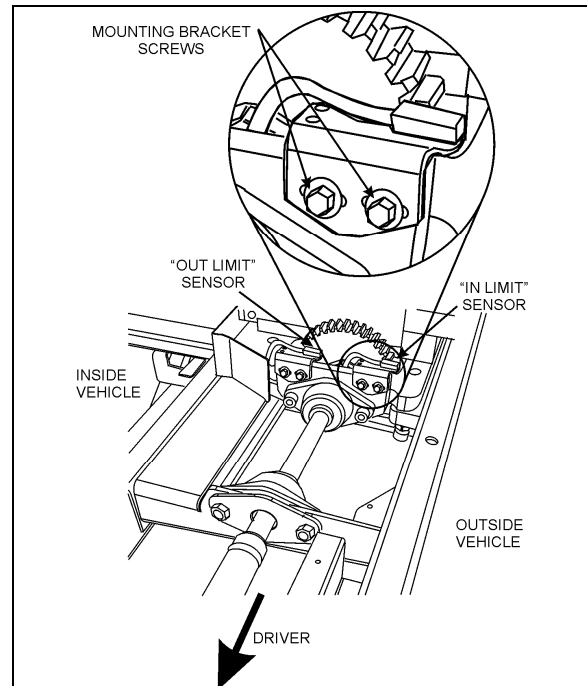

FIGURE 37 : FRONT SLIDE-OUT SENSORS

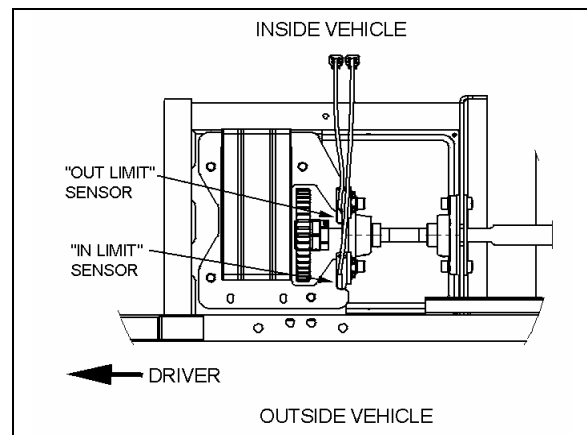

FIGURE 38: REAR SLIDE-OUT SENSORS

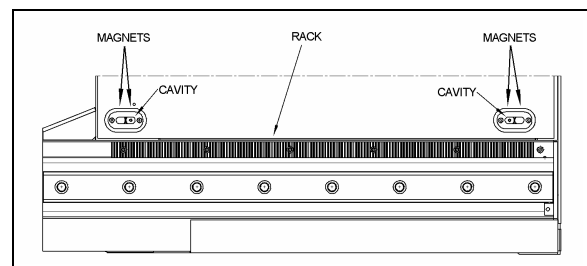

FIGURE 39 : MAGNETS ON SLIDE-OUT UNDERBODY

#### To adjust the “out limit” sensors:

Prior to adjust the “out limit” sensors, assure that the inner stoppers are perfectly adjusted (see section 1.1).



## Section 26: XLII SLIDE-OUT

1. The slide-out is slightly tilted except when it is in its full "IN" or "OUT" position. Extend the slide-out near its full "OUT" position. When the slide-out straightens up and that it is perpendicular with the vehicle body, stop the slide-out.
2. Loosen the "out limit" sensor mounting bracket screws and move back the sensor completely (toward the inside of the vehicle).
3. Bring slowly the sensor toward the outside of the vehicle until the light emitting diode (LED) turns on. When it does, tighten the mounting bracket screws.

### NOTE

When the "out limit" sensors are properly adjusted, the slide-out extension stops before the side inner stoppers reach the vehicle structure.

## 16 SLIDE-OUT EXTERIOR FINISHING PANELS & WINDOWS

### NOTE

The removal and installation procedures are all based on standard service methods described in section 18: BODY. Refer to this manual for procedures, tools, cleaner, adhesives and other product needed.

### 16.1 FACE PANEL REMOVAL

Use the same procedure as described in section 18: BODY for MTH side panel removal, and:

- Keep the slide-out retracted;
- Make sure not to damage the finishing molding supports to be able to re-use them;
- Remove the old adhesive on the finishing molding supports and clean them before re-using;
- Check where adhesive, sealant and double face adhesive tape are on the structure and the panel back side, in order to be able to stick the new panel in the same way;
- Check the tape width and use same width tape when installing new panels.

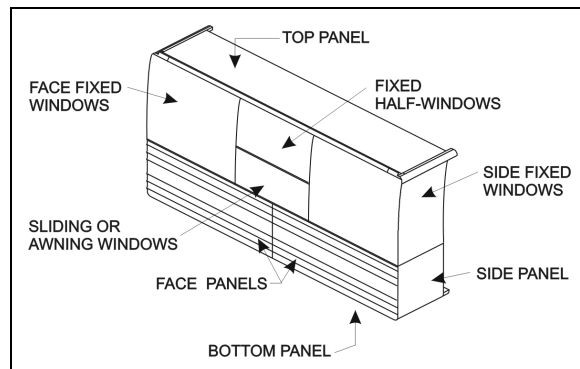

FIGURE 40 : SLIDE-OUT PANELS AND WINDOWS

### 16.2 FACE PANEL INSTALLATION

For surface cleaning, and preparation, panel installation and products needed, use the same procedure as the MTH side panel installation described in section 18: BODY.

- Keep the slide-out retracted for panel alignment;
- Make sure to apply sealant between the face panels and the side panels, and also between face panels and bottom and top panels. Apply sealant both inside and outside the slide-out panels.

### 16.3 SIDE PANELS REMOVAL

#### NOTE

The side panels are made of aluminum, or of stainless steel in option.



### CAUTION

Be careful not to damage the adjacent surfaces.

1. Remove the slide-out (according to the Slide-Out Removal Procedure. Ask to your Prevost service representative).
2. Remove the side fixed windows from the slide-out first, as described in section 16.7.
3. Insert a flat screwdriver between the panel and the slide-out structure, in the top left and right corners of the panel, and unstick the panel from the structure.
4. Use C-clamp to peel the panel from the slide-out structure.
5. Check where adhesive, sealant and double face adhesive tape are on the structure and

the panel back side, in order to be able to stick the new panel in the same way.

6. Check the tape width and use same width tape when installing new panels.

	<h3>CAUTION</h3>
<p>Make sure the heat gun nozzle tip is at least 4" from surface.</p>	

7. Use a heat gun and putty knife to remove the dried off adhesive and tape residue from the structure.

	<h3>DANGER</h3>
<p>Because of the adhesive toxicity, never use a buffer or other sanding method to remove it.</p>	

## 16.4 SIDE PANELS INSTALLATION

<p><i><b>NOTE</b></i></p> <p><i>The side panels are made of aluminum, or of stainless steel in option. Use rivet of same material as the panels.</i></p>
--

For surface cleaning and preparation, panel installation and products needed, refer to the MTH side panel installation procedure described in section 18: BODY.

1. Protect adjacent surfaces with appropriate material;
2. Refer to figure 41 for 1/16x1/4 double face adhesive tape location on structure;
3. Apply Sika 206 G+P on the side panel as shown in figure 42 ;
4. Apply Sika Tack+Booster (triangular bead: 9mm width X 6mm high) as shown in Figure 43 and glue panel in place as shown in FIGURE 44;
5. Exert pressure and let dry for at least 90 minutes;
6. Smooth down the joint and remove glue in excess;
7. After drying, apply Sika 252 as a finishing joint;
8. Smooth down the joint.
9. Refer to section 16.11 for the finishing joint application procedure.

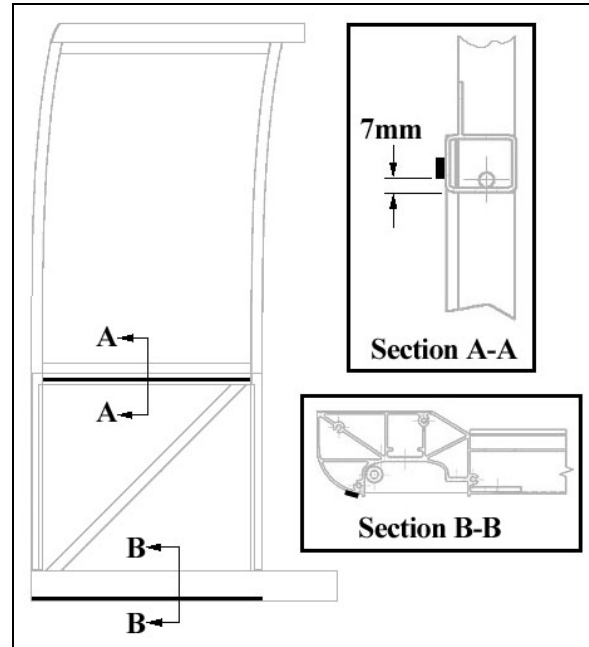

FIGURE 41 : SIDE PANEL INSTALLATION – DOUBLE FACE ADHESIVE TAPE APPLICATION ON THE SLIDE-OUT STRUCTURE

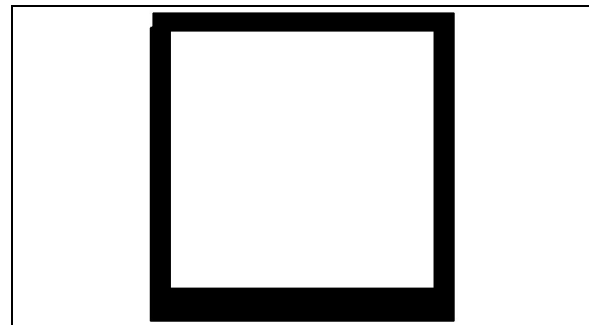

FIGURE 42 : SIDE PANEL INSTALLATION – SIKA 206 G+P APPLICATION

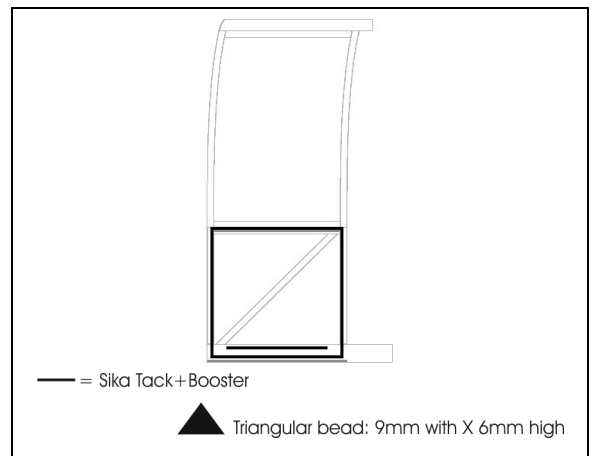

FIGURE 43 : SIDE PANEL INSTALLATION – SIKA TACK+BOOSTER APPLICATION

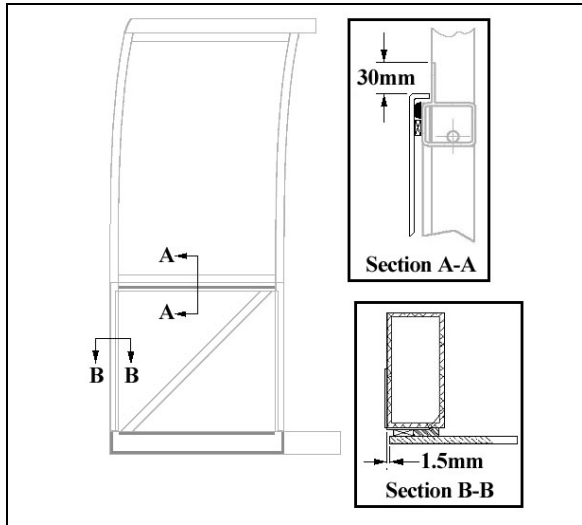

FIGURE 44 : SIDE PANEL INSTALLATION

### 16.5 TOP AND BOTTOM PANEL REMOVAL

**NOTE**

*The top and bottom panels are made of aluminum sheets.*

1. Remove the slide-out (according to the Slide-Out Removal Procedure. Ask to your Prevost service representative).
2. Insert a flat screwdriver between the panel and the slide-out structure, and unstick the panel from the structure.
3. Use C-clamp to peel the panel from the slide-out structure.
4. Check where adhesive, sealant and double face adhesive tape are on the structure and the panel back side, in order to be able to stick the new panel in the same way.
5. Check the tape width and use same width tape when installing new panels.
6. Use a heat gun and putty knife to remove the dried off adhesive and tape residue from the structure.



DANGER

Because of the adhesive toxicity, never use a buffer or other sanding method to remove it.

### 16.6 TOP AND BOTTOM PANEL INSTALLATION

**NOTE**

*The top and bottom panels are made of aluminum sheets and need aluminum rivet.*

For surface cleaning, preparation, panel installation and products needed, refer to the MTH side panel installation procedure described in section 18: BODY.

1. Protect adjacent surfaces with appropriate material.
2. Refer to FIGURE 45 for 1/16x1/4 double face adhesive tape location on structure;
3. Apply Sika 206 G+P on panel as shown in FIGURE 46;
4. Apply Sika Tack+Booster (triangular bead: 9mm width X 6mm high) has shown in FIGURE 47 and glue panel in place as shown in figure 48 & figure 49 ;
5. Exert pressure and let dry for at least 90 minutes;
6. Smooth down the joint and remove glue in excess;
7. After drying, apply Sika 252 as a finishing joint;
8. Smooth down the joint.
9. Refer to section 16.11 for the finishing joint application procedure.

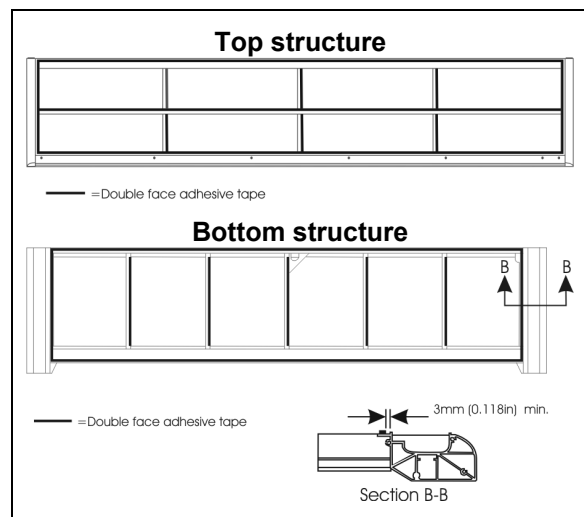

FIGURE 45 : TOP AND BOTTOM PANEL INSTALLATION - DOUBLE FACE ADHESIVE TAPE APPLICATION

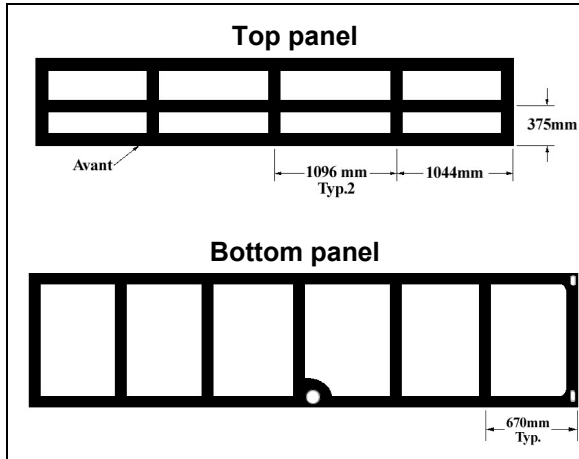

FIGURE 46 TOP AND BOTTOM PANEL INSTALLATION - SIKA 206 G+P APPLICATION

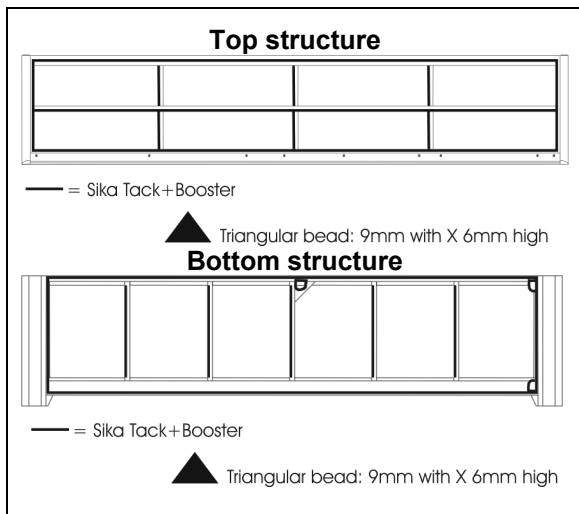

FIGURE 47 : TOP AND BOTTOM PANEL INSTALLATION - SIKA TACK+BOOSTER APPLICATION

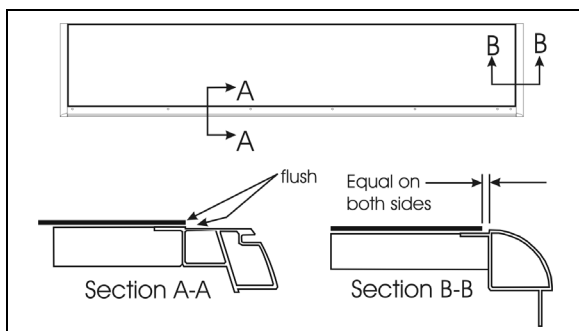

FIGURE 48 : TOP PANEL INSTALLATION

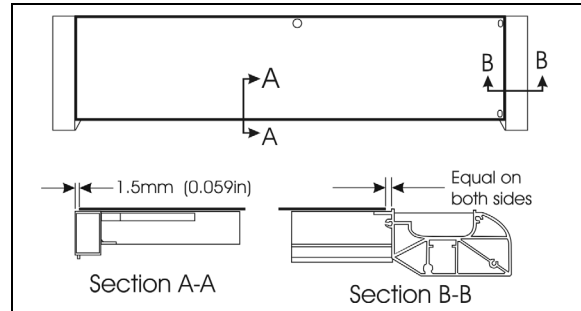

FIGURE 49 : BOTTOM PANEL INSTALLATION

**NOTE**

The removal and installation procedures are based on standard service methods described in section 18: BODY. Refer to these procedures for tools and adhesives specifications.



**DANGER**

Always wear safety equipment when working with glass and chemical adhesives.

**16.7 WINDOWS REMOVAL**

1. Remove the slide-out.
2. If needed, remove the exterior extrusion as described in section 1.3.



**CAUTION**

Be careful not to damage the adjacent surfaces.

3. With a knife or a wire, cut the sealant and the adhesive between the windows and the structure. Make sure not to damage the rubber seal between the windows.
4. With a helper, remove the window from the slide-out.

**16.8 FIXED WINDOWS INSTALLATION**

Refer to procedures described in section 18: BODY of the maintenance manual for details.

1. Clean and prepare the windows and the slide-out structure surfaces with appropriate cleaner, abrasives and primers.
2. If necessary, install the rubber seals as per FIGURE 50 & FIGURE 51 . Press the seal against the structure with a roller.

**Section 26: XLII SLIDE-OUT**

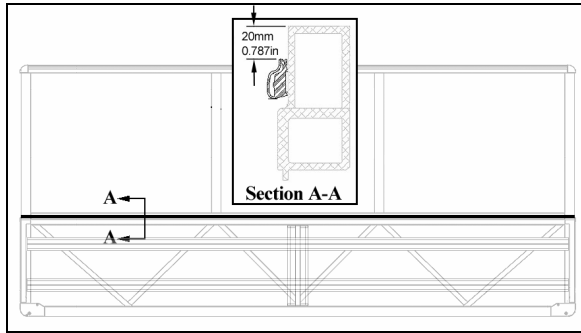

**FIGURE 50 : FACE FIXED WINDOWS - RUBBER SEAL INSTALLATION**

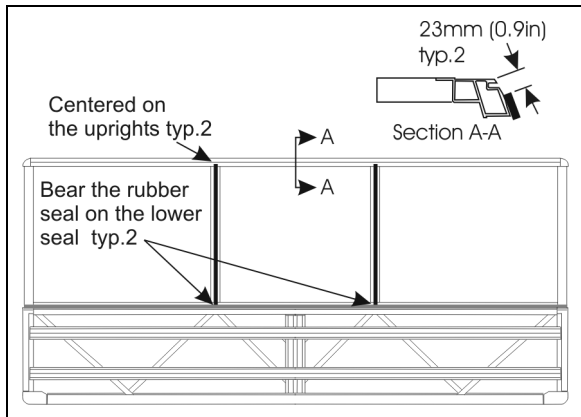

**FIGURE 51 : FACE FIXED WINDOWS - RUBBER SEAL INSTALLATION**

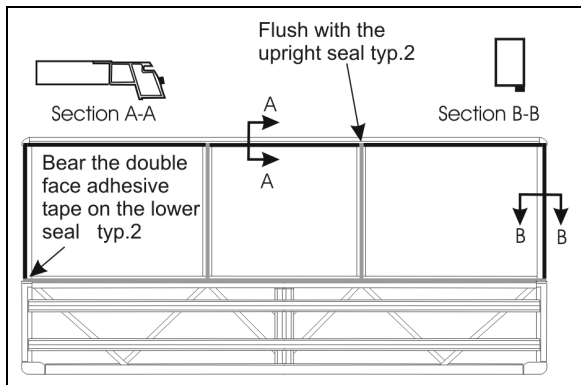

**FIGURE 52 : FACE FIXED WINDOWS - 3/16 X 1/2 DOUBLE FACE ADHESIVE TAPE INSTALLATION**

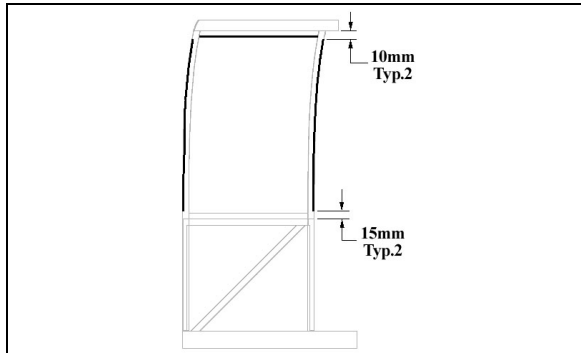

**FIGURE 53 : SIDE FIXED WINDOW - 1/4 X 1/2 DOUBLE FACE ADHESIVE TAPE INSTALLATION**

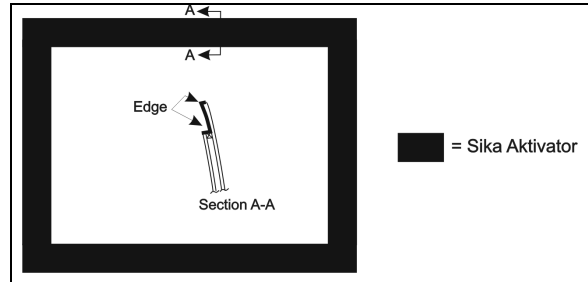

**FIGURE 54 : FACE FIXED WINDOW AND HALF-WINDOW - SIKA AKTIVATOR**

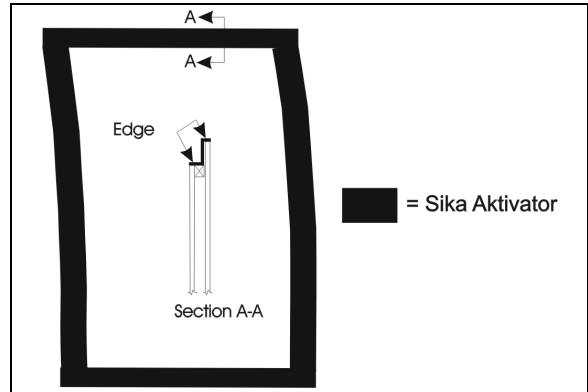

**FIGURE 55 : SIDE FIXED WINDOW - SIKA AKTIVATOR**

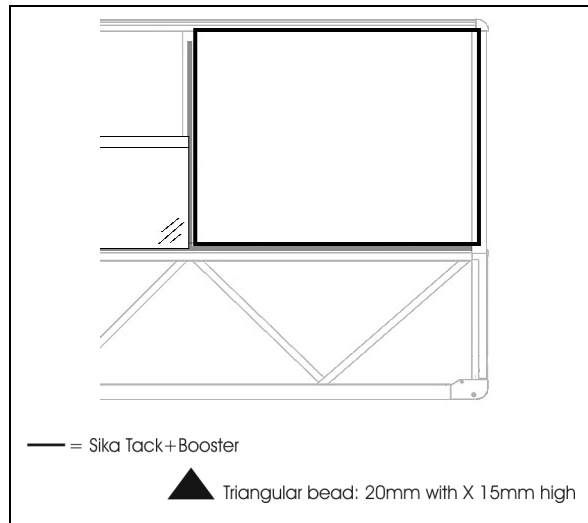

**FIGURE 56 : FACE FIXED WINDOW INSTALLATION - SIKA TACK+BOOSTER**

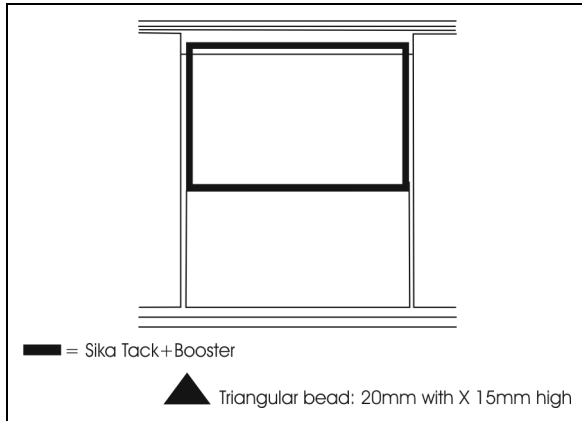

**FIGURE 57 : FACE FIXED HALF-WINDOW INSTALLATION – SIKA TACK+BOOSTER**

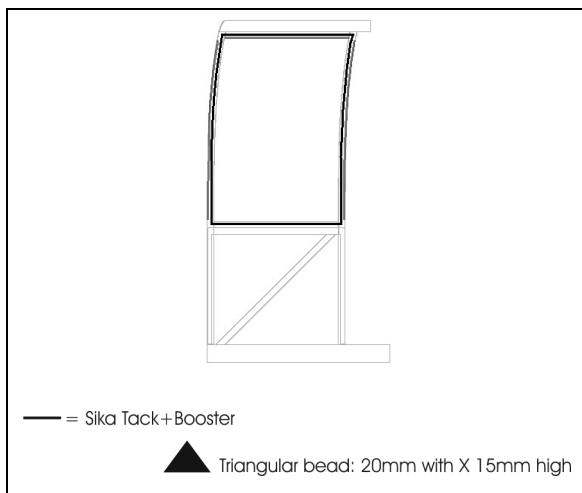

**FIGURE 58 : SIDE FIXED WINDOW – SIKA TACK + BOOSTER**

3. Apply appropriate double face self adhesive tape on the slide-out structure (see FIGURE 52 for face fixed windows or FIGURE 53 for side fixed window).
4. Clean window with appropriate window cleaner.
5. Apply Sika Aktivator on the window pane as per FIGURE 54 or FIGURE 55.
6. Apply Sika Tack+Booster as per FIGURE 56 FIGURE 57 or FIGURE 58 (triangular bead: 20mm width X 15mm high).
7. Install the windows on the slide-out structure (see FIGURE 59 or FIGURE 60).
8. Press the jigs on the windows and wait for the adhesive to dry (90 minutes minimum).
9. After drying, apply Sika 221 as a finishing joint. Clean excess with Sika 208.

10. Refer to section 16.11 for the finishing joint application procedure.

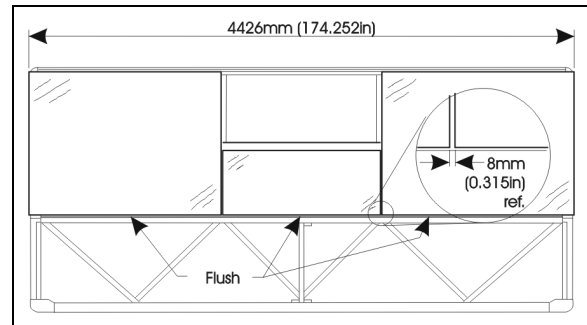

**FIGURE 59 : FACE FIXED WINDOW INSTALLATION**

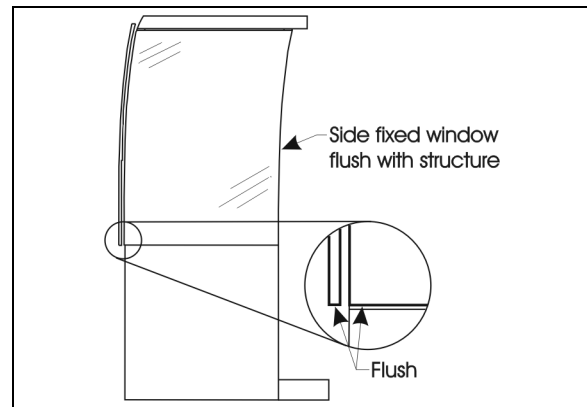

**FIGURE 60 : SIDE FIXED WINDOW**

### 16.9 AWNING WINDOW INSTALLATION

1. Clean and prepare the windows and the slide-out structure surfaces with appropriate cleaner, abrasives and primers.
2. Glue on the structure horizontal member, 4 rubber bumpers (#5061020), placing them 2 by 2 to have a total thickness of 1/16" (FIGURE 61).

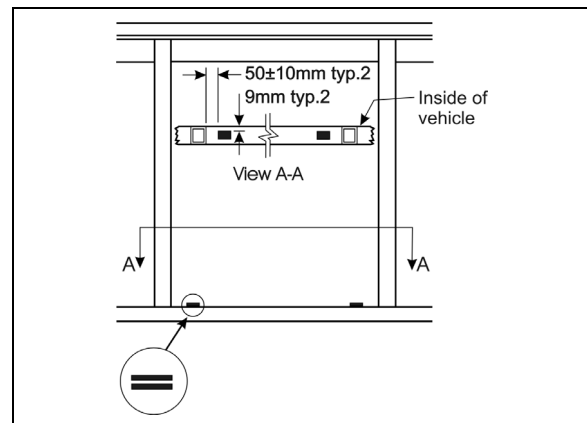

**FIGURE 61: AWNING WINDOW - RUBBER BUMPER INSTALLATION**

## Section 26: XLII SLIDE-OUT

3. Glue 4 rubber bumpers (#790610) on the awning window frame as per FIGURE 62.

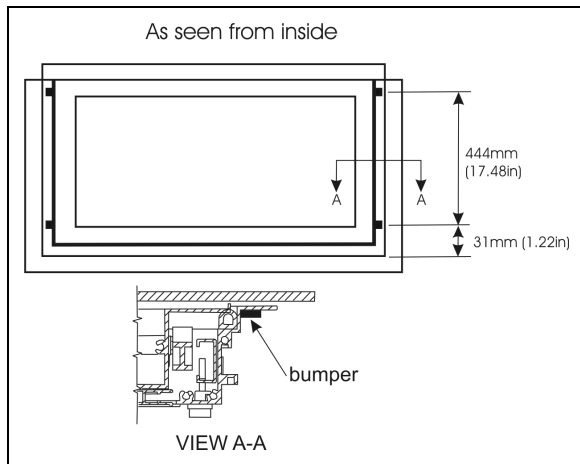

FIGURE 62: SIDE BUMPERS

4. Place masking tape on the inside of the frame as per FIGURE 63.

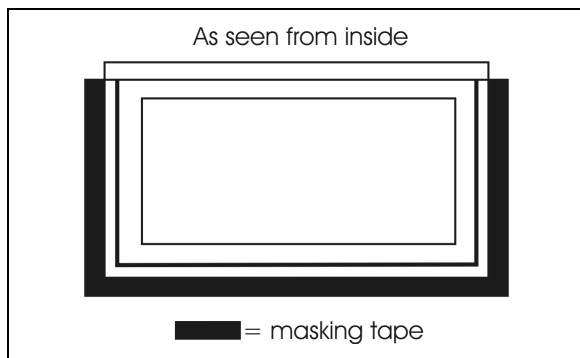

FIGURE 63: MASKING TAPE APPLICATION

5. Apply Sika 255 in the upper and lower frame corner as per FIGURE 64.

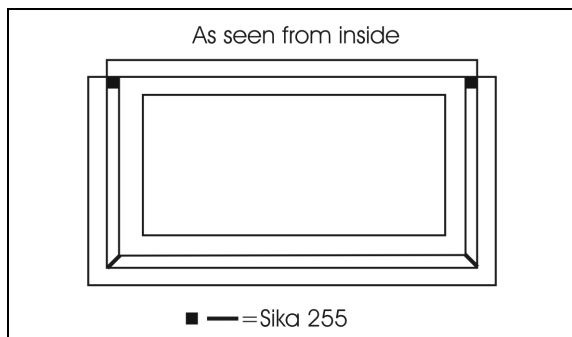

FIGURE 64: SIKA 255 APPLICATION

6. Apply Sika Aktivator as per FIGURE 65.
7. Apply Sika 255 as per FIGURE 66 (triangular bead: 10mm width X 10mm high).

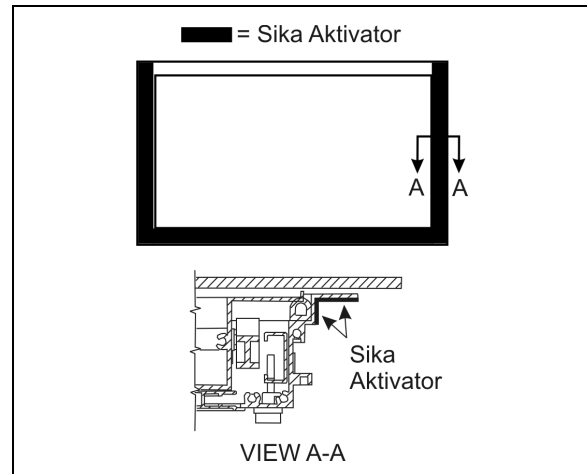

FIGURE 65 : AWNING WINDOW – SIKA AKTIVATOR

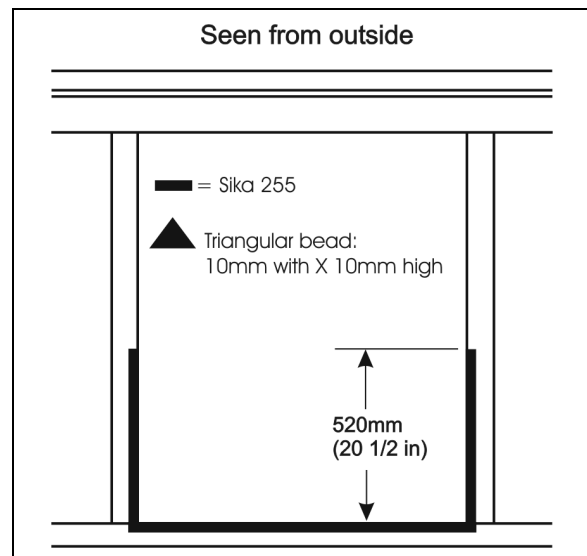

FIGURE 66: AWNING WINDOW – SIKA 255 APPLICATION

8. Install the awning window centered in the opening. Press the window slightly. The awning window must be kept closed.
9. While a helper is pressing on the window from outside, install the awning window clamping frame and tighten screws according to the sequence shown in FIGURE 67.

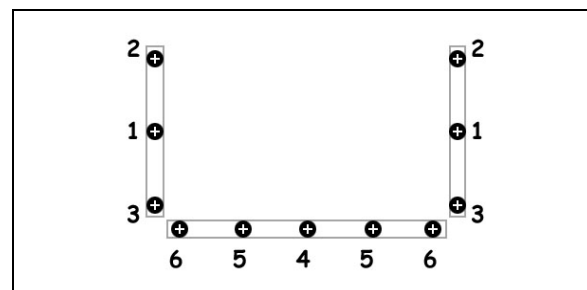

FIGURE 67 : CORRECT TIGHTENING SEQUENCE

10. Open the awning window manually and smooth down the joint (FIGURE 68) and remove glue in excess with Sika 208.

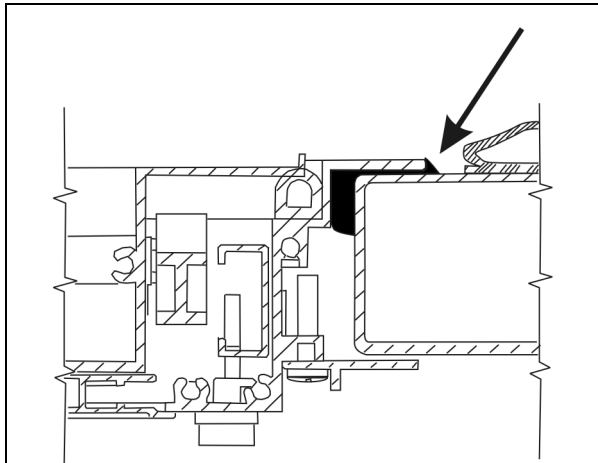

FIGURE 68 : SMOOTH DOWN THE JOINT

11. Using Sika 252 or 255, seal the upper corner of the awning window, both side (FIGURE 69).
12. Using Sika 252 or 255, seal the chink between the structure vertical member and the awning window, both side (FIGURE 70).

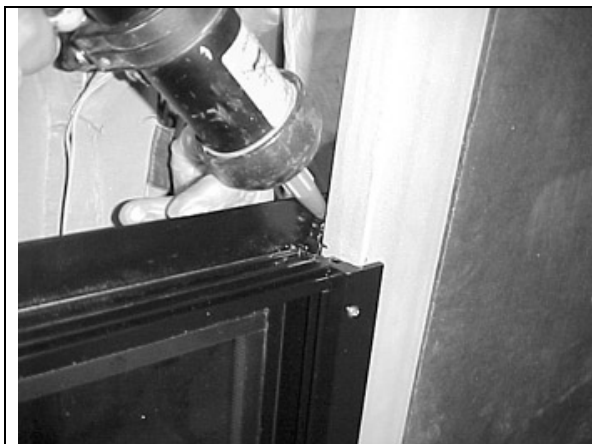

FIGURE 69 : AWNING WINDOW – SEAL THE UPPER CORNERS

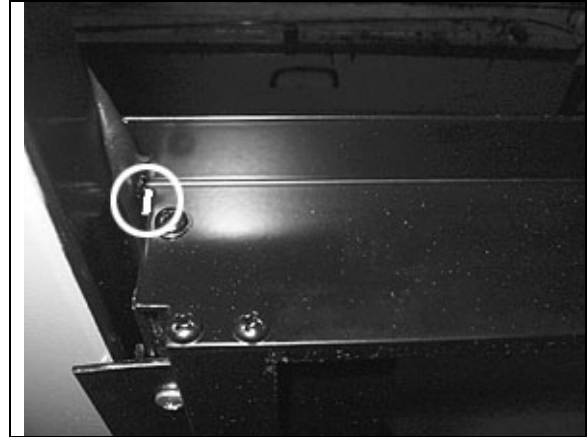

FIGURE 70 : AWNING WINDOW – SEAL THE CHINK

### 16.10 SLIDING WINDOW INSTALLATION

1. Clean and prepare the windows and the slide-out structure surfaces with appropriate cleaner, abrasives and primers. Clean surfaces with anti-silicone.
2. Apply Sika Aktivator on sliding window as per FIGURE 71.
3. Apply Sika Aktivator on the structure as per FIGURE 72.
4. Apply Sika 252 as per FIGURE 73 (triangular bead: 20mm width X 10mm high).
5. Install the sliding window centered in the opening. Press the window slightly. The window must be kept closed.
6. While a helper is pressing on the window from outside, install the awning window clamping frame and tighten screws according to the sequence shown in FIGURE 74.
7. Remove glue in excess with Sika 208.
8. Using Sika 252 or 255, seal the inside upper corner of the sliding window, both side (FIGURE 75).
9. Using Sika 252 or 255, seal the chink between the structure vertical rubber seal and the sliding window, both side (FIGURE 76).



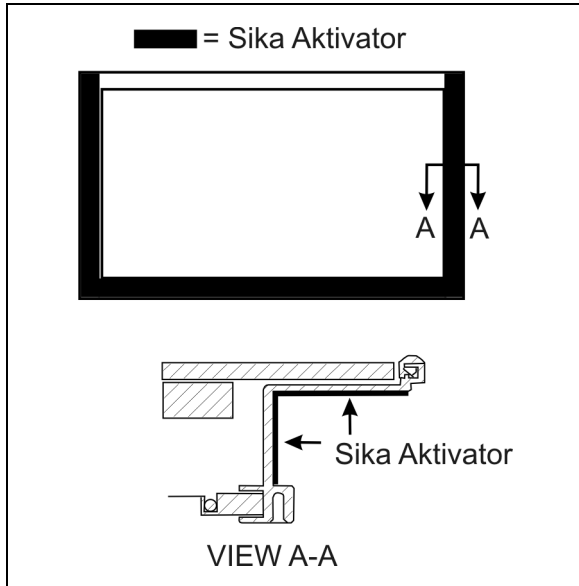

FIGURE 71 : SLIDING WINDOW - SIKa AKTIVATOR



FIGURE 72 : SLIDING WINDOW - SIKa AKTIVATOR

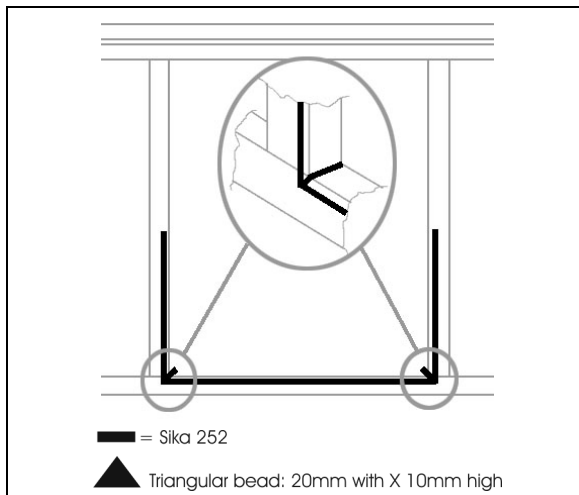

FIGURE 73 : AWNING WINDOW – SIKa 252 APPLICATION

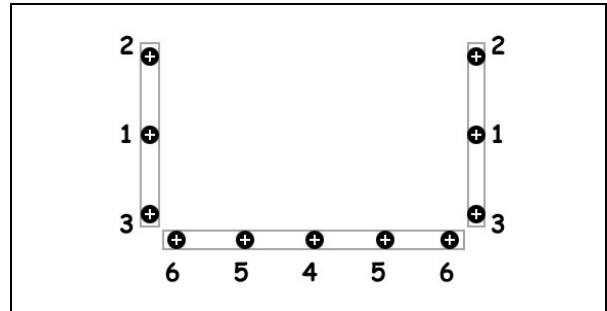

FIGURE 74 : CORRECT TIGHTENING SEQUENCE

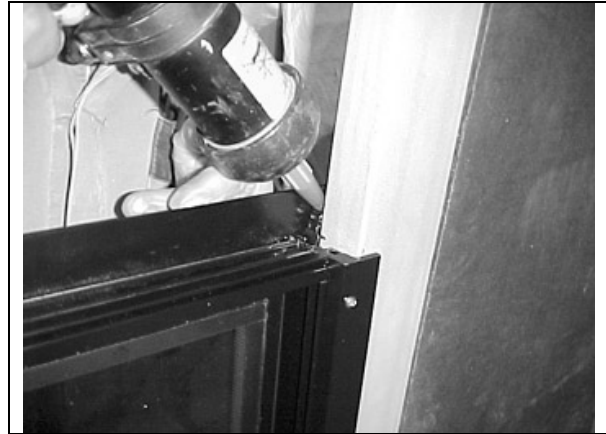

FIGURE 75 : SLIDING WINDOW – SEAL THE UPPER CORNERS



FIGURE 76 : SEAL

### 16.11 FINISHING JOINT

The following procedure applies to section 16.11.1 up to 16.11.4.

For surface cleaning and preparation, tools, cleaner, adhesives and other product needed, refer to the MTH side panel installation procedure described in section 18: BODY.

1. Place masking tape to protect surfaces from smudge.
2. Apply Sika 221.

- 3. Using soapy water, smooth down the joint with your finger (wear vinyl gloves).

16.11.1 Slide-out face

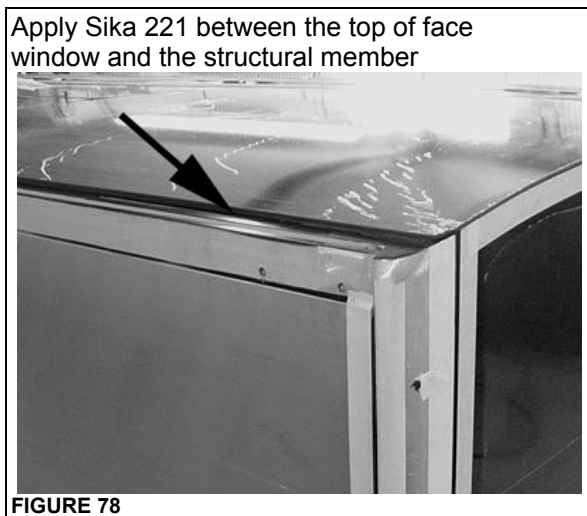
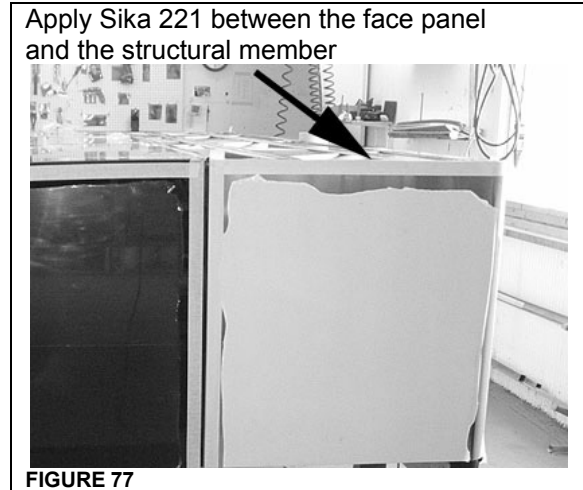

16.11.2 Slide-out side

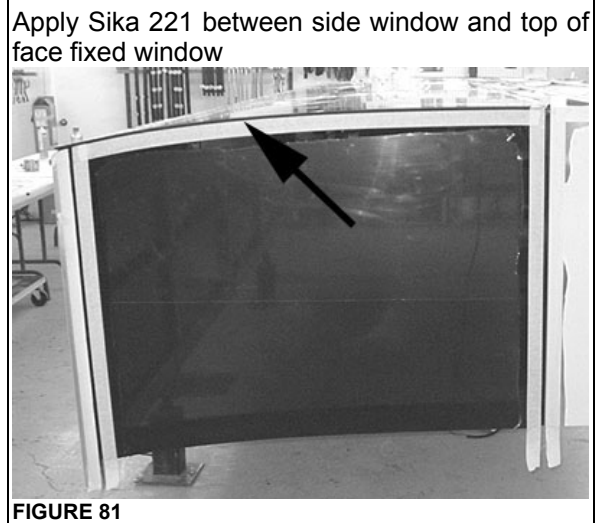
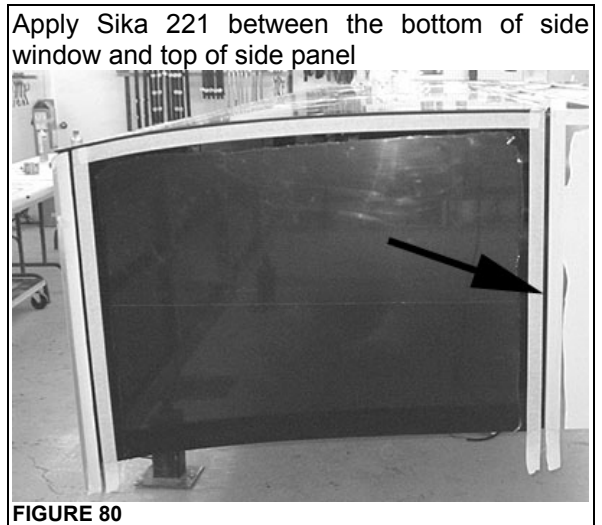
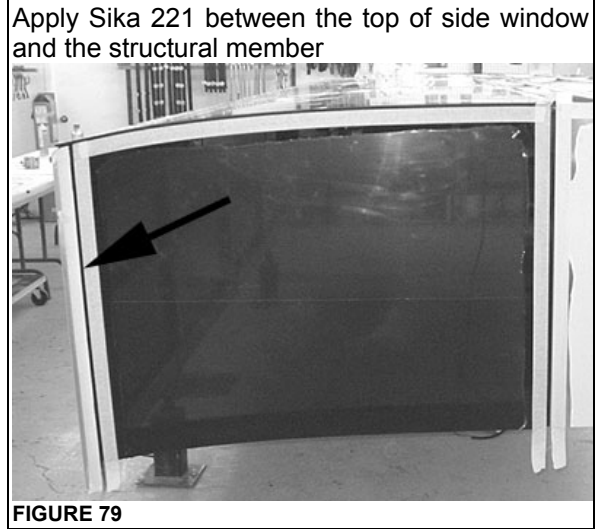

## Section 26: XLII SLIDE-OUT

### 16.11.3 Slide-out bottom

Apply Sika 221 between bottom edge of side panel and structural member

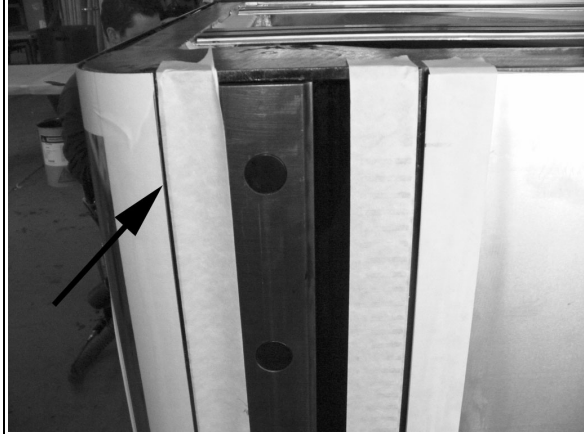

FIGURE 82

Apply Sika 221 between edge of bottom panel and structural member

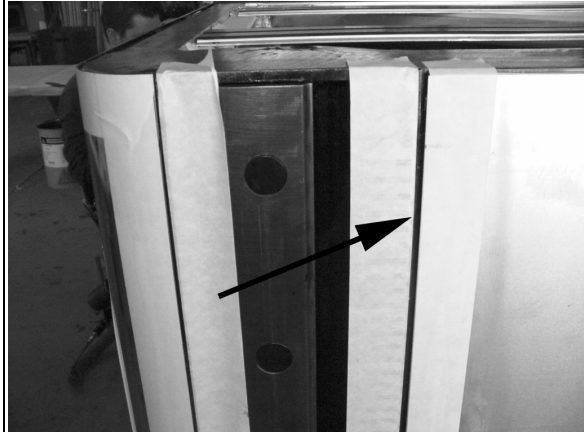

FIGURE 83

Apply Sika 221 between the bottom panel and the magnets

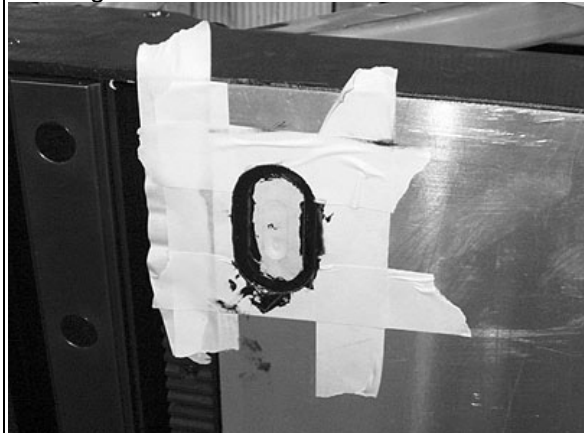

FIGURE 84

Apply Sika 221 around the security pin cavity



FIGURE 85

### 16.11.4 Top of Slide-out

Apply Sika 221 between edge of top panel and structural member

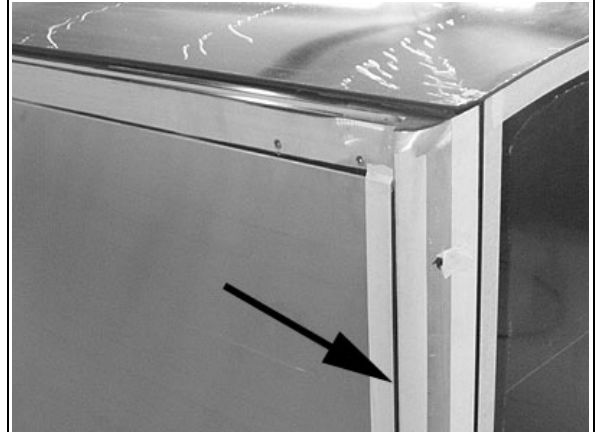

FIGURE 86

## 17 WELDING PRECAUTION



### CAUTION

Prior to arc welding on the vehicle, refer to the "Welding Precautions Procedure Prior To Welding" in section 00 GENERAL of this manual to avoid serious damage to the vehicle components.

## 18 SLIDE-OUT MANUAL OVERRIDE PROCEDURES

In case of power retracting system failure, it is possible to use the manual override procedure to retract or extend the slide-out.

The manual override procedures consist in rotating the slide-out motor shaft extension using a cordless power drill with a 3/8" hexagonal bit. However, it is very important to follow all the instructions very carefully to assure that the inflatable seal or the retraction mechanisms are not damaged.

### 18.1 PRELIMINARY CONDITIONS FOR MANUAL OVERRIDE PROCEDURE

Before using the slide-out manual override procedures, make sure that the problem cannot be solved by one of the following simple checks:

- Make sure that none of the breakers are tripped (the breakers are located inside the VEC on the slide-out control panel (FIGURE 88) and the main slide-out breaker is located in the engine R.H. side access compartment (FIGURE 89)).
- Make sure the barking brake is applied and that transmission is in the "NEUTRAL" position.
- Make sure the voltage is high enough by running the engine at fast idle or having the battery charger connected.

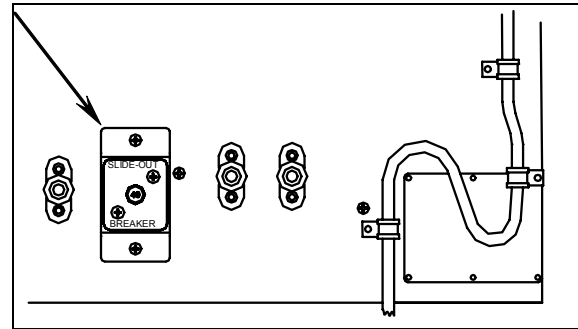

FIGURE 89: MAIN SLIDE-OUT BREAKER IN ENGINE R.H. SIDE ACCESS COMPARTMENT

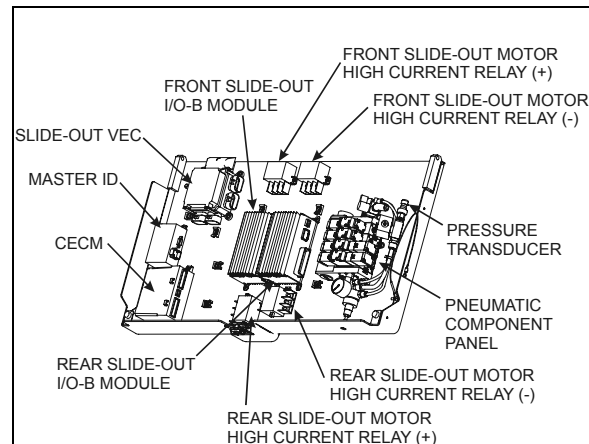

FIGURE 90: SLIDE-OUT CONTROL PANEL

**CAUTION**

Before extending or retracting the slide-out, always open a window to avoid movement restriction and to prevent the motor from stopping in overcurrent because of a vacuum or pressure build up inside the vehicle.

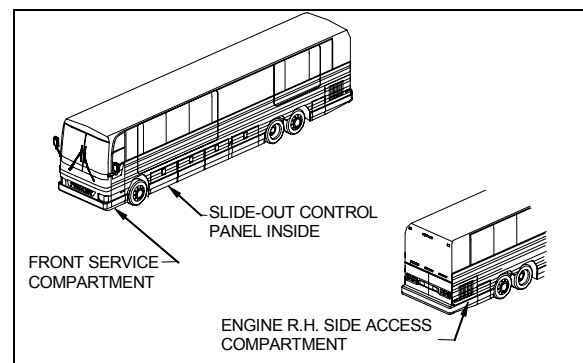

FIGURE 87: COMPARTMENTS LOCATION

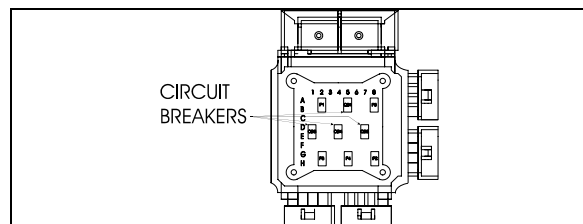

FIGURE 88: VEC CIRCUIT BREAKERS ON SLIDE-OUT CONTROL PANEL

#### 18.1.1 Manual retracting procedure – Front and rear slide-out

1. Turn the ignition switch to the "OFF" position, and remove the ignition key for more safety.
2. Deflate the inflatable seal by using the relieving shut-off valve located on the pneumatic component panel (FIGURE 91).
3. Turn the handle clockwise to deflate the seal. Make sure the pressure indicator reading is "0 psi".

**CAUTION**

The pressure in the inflatable seal must be completely relieved to prevent any damage to the seal.

**NOTE**

*When air pressure is relieved using the shut-off valve, the normal extending and retracting operation cycle is disabled, for that reason the slide-out cannot be moved using the handheld control.*

## Section 26: XLII SLIDE-OUT

- To move the slide-out, use a cordless power drill with a 3/8" hexagonal bit on the shaft extension of the slide-out motor.
- Rotate the slide-out motor shaft extension with the power drill until the slide-out comes to its closed position (FIGURE 92).
- Once the slide-out room is lined up to its closed position, remove the tool from the motor.

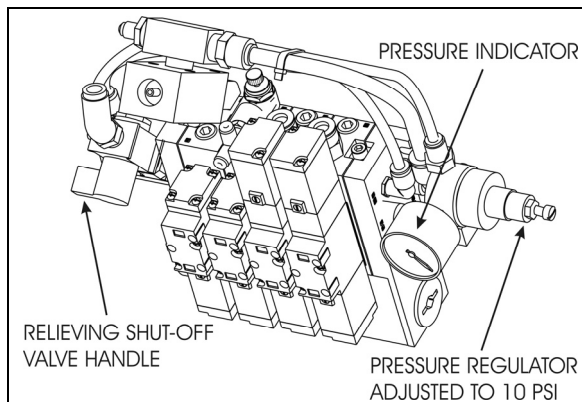

FIGURE 91: INFLATABLE SEAL RELIEVING SHUT-OFF VALVE

### NOTE

The **front slide-out motor** is located inside the 2<sup>nd</sup> baggage compartment while the **rear slide-out motor** is accessible from inside the vehicle, under the bed structure.

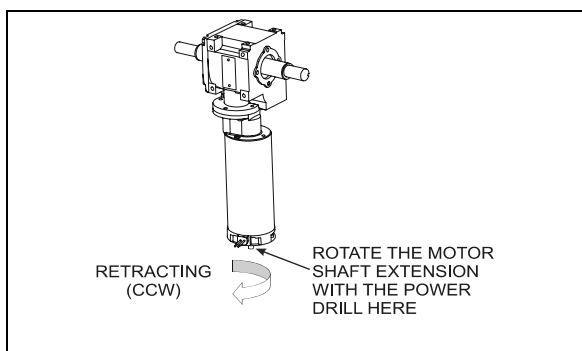

FIGURE 92: SLIDE-OUT MOTOR ROTATION



### CAUTION

Slow down on the closing speed as the slide-out approaches its closed position. As soon as the "in limit" stoppers come in contact with their bearing surface, stop immediately the power drill rotating movement. Not doing so could overload the drive mechanism and cause damage to the reduction gearbox.

- Finally, the inflatable seal can be re-inflated by turning the shut-off valve handle counterclockwise. Check the pressure gage on the inflatable seal regulator to see if the pressure is increasing to 10 psi (FIGURE 93).

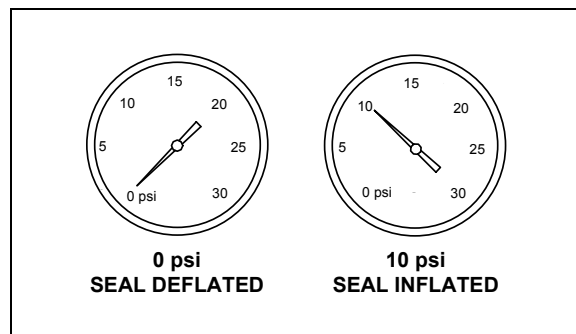

FIGURE 93: INFLATABLE SEAL PRESSURE GAGE

### NOTE

The slide-out control system inhibits transmission range selection to prevent the vehicle from moving if the slide-out is not in its full "IN" position.

### 18.1.2 Manual extending procedure – Front and rear slide-out

- Apply parking brake to disengage the security pin from the receptacle.
- Turn the ignition switch to the "OFF" position, and remove the ignition key for more safety.
- Deflate the inflatable seal by using the relieving shut-off valve located on the pneumatic component panel (FIGURE 91). Turn the handle clockwise to deflate the seal. Make sure the pressure indicator reading is "0 psi".



### CAUTION

The pressure in the inflatable seal must be completely relieved to prevent any damage to the seal.

### NOTE

When air pressure is relieved using the shut-off valve, the normal extending and retracting operation cycle is disabled, for that reason the slide-out cannot be moved with the handheld control.

4. To move the slide-out, use a cordless power drill with a 3/8" hexagonal bit on the shaft extension of the slide-out motor.
5. Rotate the slide-out motor shaft extension with the power drill until the slide-out comes to its opened position (FIGURE 94).
6. Once the slide-out is lined up to its opened position, remove the tool from the motor.

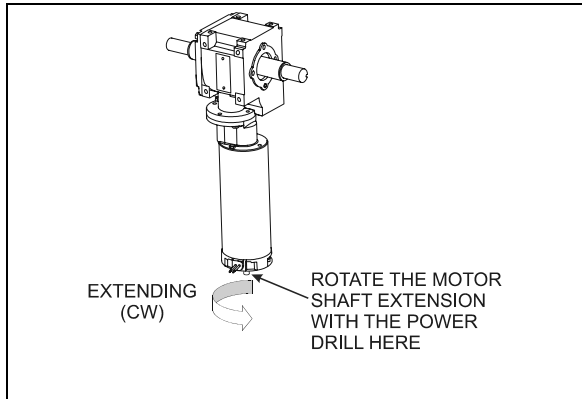

FIGURE 94: SLIDE-OUT MOTOR ROTATION

**NOTE**

The **front slide-out motor** is located inside the 2<sup>nd</sup> baggage compartment while the **rear slide-out motor** is accessible from inside the vehicle, under the bed structure.



**CAUTION**

Slow down on the closing speed as the slide-out approaches its extended position. As soon as the "out limit" stoppers come in contact with their bearing surface, stop immediately the power drill rotating movement. Not doing so could overload the drive mechanism and cause damage to the reduction gearbox.

7. Finally, the inflatable seal can be re-inflated by turning the shut-off valve handle counterclockwise. Check the pressure gage on the inflatable seal regulator to see if the pressure is increasing to 10 psi (FIGURE 94).

**NOTE**

The slide-out control system inhibits transmission range selection to prevent the vehicle from moving if the slide-out is not in its full "IN" position.

## 19 SLIDE-OUT MAXIMUM LOAD

**Front slide-out:**

Maximum load with vehicle at stand still (retracted or extended) .....1500 lb  
 Maximum load with vehicle moving or slide-out moving .....1200 lb<sup>1</sup>

**Rear slide-out:**

Maximum load with vehicle at stand still (retracted or extended) .....1500 lb  
 Maximum load with vehicle moving or slide-out moving .....1000 lb<sup>1</sup>

**NOTE**

Maximum load includes people weight and equipment added by the converters in the slide-out

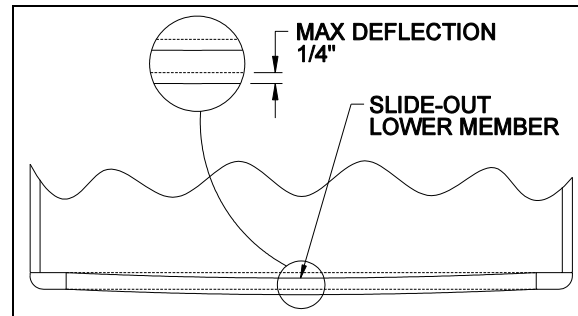

FIGURE 95 : FRONT SLIDE-OUT DEFLECTION

<sup>1</sup> When the load is distributed in the slide-out to prevent a deflection of the inside lower member over 1/4" that could damage the seal.



## CAUTION

Never remove the structural reinforcement angle brackets inside the baggage compartments. Doing so could lead to termination of the warranty coverage concerning the structural integrity.

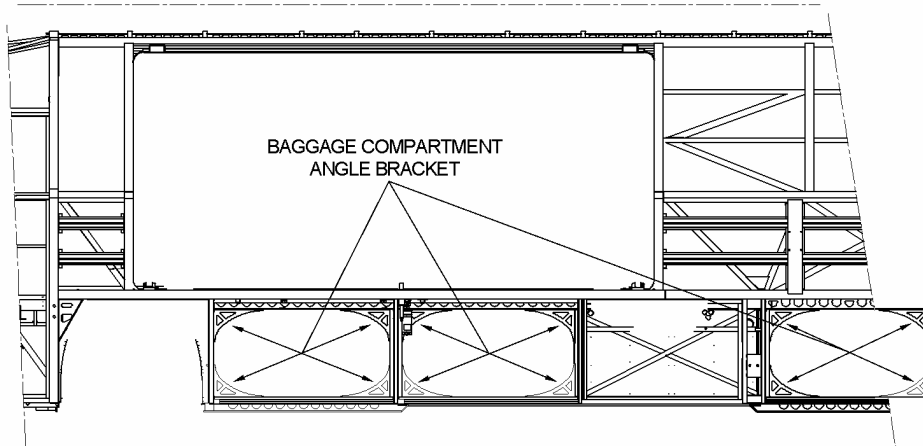

## 20 CONVERSION CHECKLIST

The converter should check these points before closing the walls covering the roof reinforcing rod and the pinions:

1. Check that the front slide-out exterior panels are parallel with the vehicle panels when retracted. If not, readjust the tilt.
2. Check that the slide-out is straight when completely extended, and that it leans against all inner stoppers.
3. Make sure the vehicle upper member is parallel with the front slide-out structure. If not, readjust the roof reinforcing rod. This may be affected by the loading on the roof.
4. Make sure the front slide-out lower member deflection is within 1/4". If not, redistribute the slide-out load.
5. Check the whole slide-out mechanism good functioning. The slide-out should retract and extend smoothly without vibration.

Final check:

- Make sure the slide-out air pressure inlet valve is completely opened.
- Check the inflatable seal air pressure on the pressure regulator. The pressure should be 10 psi.

## TROUBLESHOOTING

### 20.1 ERROR CONDITION OR MISSING OPERATION CONDITION

When an error condition or a missing operation condition is present on a slide-out, the green indicator light on its respective handheld control starts blinking upon releasing of the IN/OUT rocker switch.

Turning the ignition OFF and ON again, will stop the blinking and reset the fault. If the error condition or a missing operation condition is still present, the blinking will start again the next time that the slide-out is operated. So, to get a fault diagnostic, use the MCD right after operating the slide-out without cycling the ignition switch.

#### **NOTE**

*It is of the utmost importance to have a MCD (message center display) in working condition because it is the most important tool to achieve troubleshooting on a multiplex vehicle.*

#### **Fault diagnostic**

To get more specific information about the error condition or the missing operation condition, request a diagnostic from the slide-out CECM using the dashboard message center display (MCD). Check if there are active errors in the slide-out electrical system. With the SYSTEM DIAGNOSTIC menu, highlight FAULT DIAGNOSTIC and then highlight ELECTRICAL SYSTEM to request a diagnostic of the electrical system from the CECM. Press the enter key. If applicable, the MCD shows the device ID, the fault messages or fault codes recorded. When more than one fault is recorded, an arrow pointing down appears on the right of the display. Use the down arrow to see all the fault messages.

Once the problem corrected, the MCD still shows the fault as being active. You have to leave the FAULT DIAGNOSTIC menu, wait approximately 20 to 30 seconds and then return to FAULT DIAGNOSTIC to request a new diagnostic of the ELECTRICAL SYSTEM from the CECM. The MCD should display the fault as being inactive.

### 20.2 TROUBLESHOOTING – OPERATING CONDITIONS & CONTROL

PROBLEM	CAUSE	CORRECTIVE ACTION
The slide-out functions normally but the handheld control green indicator light blinks	<p>Something is defective and may eventually create an issue if not repaired. The problem may be:</p> <p>A. Faulty limit sensor causing the slide-out to stop in overcurrent;</p> <p>B. CAN network problem causing the transmission inhibit safety to be non-operational;</p> <p>C. Vacuum pressure transducer disconnected or damaged (vacuum is applied for a fixed time of 7 seconds);</p> <p>D. Seal inflating valve solenoid open circuit (the seal is not re-inflated and water can penetrate in the vehicle);</p> <p>E. Security pin valve solenoid open circuit (the security pin is not extended while vehicle is riding).</p>	Request a diagnostic from the electrical system using the MCD SYSTEM DIAGNOSTIC menu and refer to the Fault Message list in section 20.4.



## Section 26: XLII SLIDE-OUT

PROBLEM	CAUSE	CORRECTIVE ACTION
The slide-out does not extend	<p>A. The parking brake is not seen by the controller as being applied;</p> <p>B. Not enough air pressure in the accessory air tank to permit proper operation of the vacuum generator;</p> <p>C. Faulty vacuum generator, connection to the vacuum generator open, seal deflating valve solenoid open circuit;</p> <p>D. I/O-B module output defective, regulated 5-volt supply to sensors shorted to ground, "out limit" sensor shorted to ground, connection to the motor negative relay solenoid open circuit;</p>	<p>A. Make sure the parking brake is applied. Confirm parking brake application with the parking brake light on the telltale panel.</p> <p>B. Run the engine at fast idle a few minutes to increase air pressure in the accessory air tank and try again.</p> <p>C. Turn the relieving shut-off valve handle clockwise to deflate the inflatable seal, disconnect the pressure transducer. Do not forget to reconnect the pressure transducer and to close the relieving shut-off valve. Failure to do so could damage the seal and lead to water infiltration;</p> <p>D. Operate the slide-out with the manual override procedures.</p>
The slide-out does not retract	<p>A. Not enough air pressure in the accessory air tank to permit proper operation of the vacuum generator;</p> <p>B. Faulty vacuum generator, connection to the vacuum generator open, seal deflating valve solenoid open circuit;</p> <p>C. I/O-B module output defective, "in limit" sensor shorted to ground, connection to the motor positive relay solenoid open circuit;</p>	<p>A. Run the engine at fast idle a few minutes to increase air pressure in the accessory air tank and try again.</p> <p>B. Turn the relieving shut-off valve handle clockwise to deflate the inflatable seal, disconnect the pressure transducer. CAUTION, do not forget to reconnect the pressure transducer and to close the relieving shut-off valve. Failure to do so could damage the seal and lead to water infiltration;</p> <p>C. Operate the slide-out with the manual override procedures.</p>
When extending, the slide-out stops after having extended by 1 inch	<p>A. The security pin valve solenoid circuit is shorted to (+) 24-volt and the pin remains engaged;</p>	<p>A. Disconnect air supply from the safety pin cylinder;</p>
Transmission DRIVE range or REVERSE cannot be selected (the slide-out telltale light is illuminating).	<p>A. Slide-out not in full "in" position;</p> <p>B. Faulty "in limit" sensor. The slide-out is retracted but the controller doesn't see it as retracted.</p>	<p>A. Retract slide-out.</p> <p>B. Confirm that all slide-out are retracted. On the slide-out control panel, disconnect the 5 pins green connector on the I/O-B module to disable the transmission inhibit. CAUTION, this is a temporary measure, the vehicle must be serviced as soon as possible.</p>

## 20.3 TROUBLESHOOTING - MECHANICAL COMPONENTS

PROBLEM	CAUSE	CORRECTIVE ACTION
Slide-out does not retract or extend when depressing the control switch.	<ul style="list-style-type: none"> <li>A. Electrical motor failure;</li> <li>B. Speed reduction gearbox failure;</li> <li>C. Security pin still engaged in receptacle;</li> </ul>	<ul style="list-style-type: none"> <li>A. Replace motor.</li> <li>B. Inspect gearbox components, particularly: bronze wheel or first reduction stage output shaft. Replace damaged components.</li> <li>C. Disengage pin and check if air cylinder is damaged.</li> </ul>
Slide-out is not straight once retracted or during retracting or extending operation.	<ul style="list-style-type: none"> <li>A. Broken rack tooth;</li> <li>B. Faulty rack attachment;</li> <li>C. Faulty shaft key at speed reduction gearbox or jaw coupling;</li> <li>D. Pinion keyless bushing slipping;</li> <li>E. Shaft breaking;</li> <li>F. Flange bearing attachment loosen;</li> </ul>	<ul style="list-style-type: none"> <li>A. Replace rack.</li> <li>B. Tighten mounting bolts, apply proper torque and use Loctite threadlocker (replace rack if necessary).</li> <li>C. Replace key or component having a damaged keyway.</li> <li>D. Realign slide-out and apply proper torque to keyless bushing.</li> <li>E. Replace shaft.</li> <li>F. Reposition shaft and tighten flange bearing mounting bolts.</li> </ul>
Slide-out moves out slightly when vehicle is traveling.	<ul style="list-style-type: none"> <li>A. Lower "in limit" stoppers are not leaning against the structure at the moment when the "in limit" sensor detects the magnet;</li> </ul>	<ul style="list-style-type: none"> <li>A. Adjust the sensor position in order to have contact of the stoppers against the structure at the time when the system stops the slide-out retraction.</li> </ul>
Slide-out moves when vehicle is moving.	<ul style="list-style-type: none"> <li>A. Inflatable seal not inflated</li> </ul>	<ul style="list-style-type: none"> <li>A. Check seal condition and seal air supply system.</li> </ul>
Slide-out retracts or extends difficultly.	<ul style="list-style-type: none"> <li>A. Foreign matters accumulated in the linear bearing;</li> </ul>	<ul style="list-style-type: none"> <li>A. Inspect the linear bearing end seals to see if they are in good condition. If not, replace the end seals and clean the inside of linear bearing.</li> </ul>
Slide-out oscillates vertically when retracting or extending	<ul style="list-style-type: none"> <li>A. Linear bearing balls hardened due to a too heavy load;</li> <li>B. Linear bearing mounting bolts loosen;</li> </ul>	<ul style="list-style-type: none"> <li>A. If balls clearance is excessive, replace linear bearing.</li> <li>B. Tighten mounting bolts.</li> </ul>
Slide-out vibrating or noisy when extending or retracting	<ul style="list-style-type: none"> <li>A. Acetal plastic block rubbing against the slide-out structure;</li> <li>B. Worn-out anti-friction coating on wiper seal around slide-out;</li> <li>C. Lower acetal plastic block rubbing against rail;</li> </ul>	<ul style="list-style-type: none"> <li>A. Realign acetal plastic block.</li> <li>B. Replace wiper seal.</li> <li>C. Remove lower acetal plastic block and machine down 1mm (0.039").</li> </ul>

## Section 26: XLII SLIDE-OUT

PROBLEM	CAUSE	CORRECTIVE ACTION
Top of slide-out moves sideways when vehicle is moving	A. Roof reinforcing rod misadjusted;	A. Readjust as per procedure.
Slide-out does not retract up to its full "in" position	A. Interference between the exterior extrusion and the vehicle upper horizontal member above the slide-out;	A. Check for straightness of horizontal member and adjust the roof reinforcing rod. B. Check for outer wiper seal lip straightness on the slide-out roof.
Bottom of slide-out not flush with vehicle body	A. Broken or misadjusted lower "in limit" stopper; B. Lower "in limit" stoppers are not leaning against the structure at the moment when the "in limit" sensor detects the magnet; C. Acetal plastic block serving as leaning surface for lower "in limit" stopper broken or moved;	A. Replace or adjust lower "in limit" stopper. B. Adjust the sensor position in order to have contact of the stoppers against the structure when slide-out is stopped. C. Replace or adjust acetal plastic block proper position.
Top of slide-out not flush with vehicle body	A. Broken or misadjusted leveling or retaining screw; B. Faulty upper "in limit" stopper;	A. Check and replace screw. B. Replace upper "in limit" stopper.
Lower edge of slide-out not parallel with vehicle body opening	A. Faulty leveling and retaining screw (8 screws each side).	A. Inspect screw, replace and adjust slide-out level.
Watertightness problem	A. Inflatable seal and/or wiper seal damaged or unstuck; B. Insufficient air pressure in the seal; C. No air pressure in the slide-out pneumatic system; D. Sealant missing; E. Wiper seal draining hole clogged; F. Faulty water recovery pan; G. Faulty internal gutter;	A. Check both seals condition. B. Check the pressure regulator, the relieving shut-off valve and the seal valve condition. C. Check the slide-out air pressure inlet valve condition and the accessory air tank pressure. D. Check the exterior extrusion screws, the windows and the exterior panels sealant condition. E. Unclog draining hole. F. Check the recovery pan. G. Check internal gutter.
Knocking sound at end of travel when extending slide-out	A. Inner stoppers misadjusted;	A. Readjust the inner stoppers.

PROBLEM	CAUSE	CORRECTIVE ACTION
Knocking sound when parking brake is released	A. Security pin retracts too rapidly;	A. Adjust security pin air flow regulator.
Inflatable seal damaged or removed, or wiper seal unstuck from the structure.	A. Slide-out has been retracted or extended with the manual procedure with the inflatable seal not deflated; B. Pressure transducer malfunction; C. Faulty roof reinforcing rod adjustment; D. Seal valve malfunction; E. Excessive load in the slide-out; F. Slide-out not centered in the structure opening;	A. Always deflate the seal when manually retracting or extending the slide-out. B. Check the pressure transducer condition, replace if necessary. C. Readjust the roof reinforcing rod. D. Check the seal valve condition. E. Reduce load or distribute load evenly in order to respect the deflection criterion and slide-out load capacity. F. Readjust the slide-out height and center horizontally in opening.
Friction at end of travel when in full OUT position or at beginning of retraction	A. Interference between upper structure key and upper inner stopper;	A. Readjust the upper inner stopper.

## 20.4 SLIDE-OUT FAULT MESSAGE ON MESSAGE CENTER DISPLAY (MCD)

SID #	FAULT MESSAGE	TEXT	PROBABLE CAUSE	CORRECTIVE ACTION
1	Voltage Module A56	Value Too Low	Module A56 sees a Voltage less than 18 V on its power supply connector. Breaker, fuse or wiring harness open.	Check/ reset circuit breaker CBSo and CBSo1. Check/ replace fuse FSo5 Fix wiring harness
2	No Response Mod A56	Data Error	CECM module does not receive CAN communication from module A56. CAN connector A56 J3 Disconnected or CAN wiring harness open, or module A56 is defective.	Check connection A56 J3 Fix CAN wiring harness Replace module A56
3	Voltage Module A57	Value Too Low	Module A57 sees a voltage less than 18 V on its power supply connector. Breaker, fuse or wiring harness open.	Check/ reset circuit breaker CBSo and CBSo2. Check/ replace fuse FSo2 Fix wiring harness
4	No Response Mod A57	Data Error	CECM module does not receive CAN communication from module A57. CAN connector A57 J3 disconnected or CAN wiring harness open or module A57 is defective.	Check connection A57 J3 Fix CAN wiring harness Replace module
5	SlidO Vacuum Sensor	Open Circuit	Pressure transducer disconnected. Faulty pressure transducer. Connection or wiring harness open.	Check/ replace vacuum transducer Check/ reconnect the connector SESo1 Fix wiring harness
		Shorted High	Pressure transducer is faulty Wiring harness shorted to 12v or 24v	Check/ replace vacuum transducer Fix wiring harness
6	SlidO Seal Deaf Vac	Mechanical Fault	Does not reach vacuum level (-5 PSIG). Slide-out seal damaged or air leak in the seal deflating pneumatic circuit.	Check the seals and the pneumatic circuit.
7	SlidO Motor/Limit se	Mechanical Or Electrical Fault	Slide-Out motor is activated for more than 5 seconds and the limit sensor from the departing end is still seen as active. Either the motor is defective and the slide-out is not moving or the limit sensor from the departing end is broken active.	If the slide-Out is not moving, then check the motor and its wiring.  If the slide-out is moving, then check the limit sensor from the departing end. (If problem occurs when extending, check the in-limit sensor. If the problem occurred when retracting, then check the out-limit sensor).
8	SlidO Park Br Signal	Mechanical Or Electrical Fault	Parking brake is not applied. Wire between parking brake switch and CECM is open.	Make sure the parking brake is applied and the parking brake telltale illuminates. Check / replace parking brake switch. Fix wiring harness.

SID #	FAULT MESSAGE	TEXT	PROBABLE CAUSE	CORRECTIVE ACTION
		Shorted High	Wire between parking brake switch and CECM is shorted to 12v or 24v.	Fix wiring harness.
9	SldO Mot SpeedA Ctr	Shorted High	Wiring harness shorted to 12v or 24v	Fix wiring harness
		Current Above normal	Security pin or object stop the movement of a slide-out	Check / fix security pin functionality. Check / remove any object around the slide-out.
10	SldO Mot SpeedB Ctr	Shorted High	Wiring harness shorted to 12v or 24v	Fix wiring harness
		Current Above normal	Security pin or object stop the movement of a slide-out	Check / fix security pin functionality. Check / remove any object around the slide-out.
11	SldO Remote Led	Shorted High	LED or wiring harness shorted to 12v or 24v	Fix LED or wiring harness
		Shorted Low	Led or wiring harness shorted to ground	Fix LED or wiring harness
		Open Circuit	LED is broken. Bad connection on handheld control. Wiring harness is cut.	Check / fix remote LED or connection Check /fix wiring harness
		Current Above normal	Led or wiring harness shorted to 12v or 24v	Fix Led or wiring harness
12	SldO Seal Inf Sol	Shorted High	Solenoid or wiring harness shorted to 12v or 24v	Fix solenoid or wiring harness
		Shorted Low	Solenoid or wiring harness shorted to ground	Fix solenoid or wiring harness
		Open Circuit	Solenoid is broken or open. Bad connection on solenoid or bloc valve. Wiring harness is cut.	Check / fix solenoid or connection Check /fix wiring harness
		Current Above normal	Solenoid or wiring harness shorted to 12v or 24v	Fix solenoid or wiring harness
13	SldO Seal Def Sol	Shorted High	Solenoid or wiring harness shorted to 12v or 24v	Fix solenoid or wiring harness
		Shorted Low	Solenoid or wiring harness shorted to ground	Fix solenoid or wiring harness
		Open Circuit	Solenoid is broken or open. Bad connection on solenoid or bloc valve. Wiring harness is cut.	Check / fix solenoid or connection. Check /fix wiring harness
		Current Above normal	Solenoid or wiring harness shorted to 12v or 24v	Fix solenoid or wiring harness
14	SldO Vacc Gen Sol	Shorted High	Solenoid or wiring harness shorted to 12v or 24v	Fix solenoid or wiring harness
		Shorted Low	Solenoid or wiring harness Shorted to ground	Fix solenoid or wiring harness
		Open Circuit	Solenoid is broken or open. Bad connection on solenoid or bloc valve. Wiring harness is cut.	Check / fix solenoid or connection Check / fix wiring harness
		Current Above normal	Solenoid or wiring harness shorted to 12v or 24v	Fix Solenoid or wiring harness
15	SldO Mot Neg Rly	Shorted High	Relay coil or wiring harness shorted to 12v or 24v	Fix relay coil or wiring harness

**Section 26: XLII SLIDE-OUT**

<b>SID #</b>	<b>FAULT MESSAGE</b>	<b>TEXT</b>	<b>PROBABLE CAUSE</b>	<b>CORRECTIVE ACTION</b>
		Shorted Low	Relay coil or wiring harness shorted to ground	Fix relay coil or wiring harness
		Open Circuit	Relay coil is broken or open. Bad connection on relay. Wiring harness is cut.	Check / fix relay coil or connection Check / fix wiring harness
		Current Above normal	Relay coil or wiring harness shorted to 12v or 24v	Fix relay coil or wiring harness
16	SldO Mot Pos Rly	Shorted High	Relay coil or wiring harness shorted to 12v or 24v	Fix relay coil or wiring harness
		Shorted Low	Relay coil or wiring harness shorted to ground	Fix relay coil or wiring harness
		Open Circuit	Relay coil is broken or open. Bad connection on relay. Wiring harness is cut.	Check / fix relay coil or connection Check / fix wiring harness
		Current Above normal	Relay coil or wiring harness shorted to 12v or 24v	Fix relay coil or wiring harness
17	SldO Open Sw	Shorted High	Switch or wiring harness shorted to 12v or 24v	Fix switch or wiring harness
18	SldO Close Sw	Shorted High	Switch or wiring harness shorted to 12v or 24v	Fix switch or wiring harness
19	SldO Limit In Se	Shorted High	Sensor or wiring harness shorted to 12v or 24v	Fix sensor or wiring harness
20	SldO Limit Out Se	Shorted High	Sensor or wiring harness shorted to 12v or 24v	Fix sensor or wiring harness
21	SldO Secu Pin Sol	Shorted High	Solenoid or wiring harness shorted to 12v or 24v	Fix solenoid or wiring harness
		Shorted Low	Solenoid or wiring Harness shorted to ground	Fix solenoid or wiring harness
		Open Circuit	Solenoid is broken or open. Bad connection on solenoid or bloc valve. Wiring harness is cut.	Check / fix solenoid or connection. Check / fix wiring harness
		Current Above normal	Solenoid or wiring harness shorted to 12v or 24v	Fix solenoid or wiring harness
22	SldO Limit In Out	Mechanical Or Electrical Fault	In Limit and Out Limit are seen at the same time. In Limit or Out Limit problem.	Check / replace in limit or out limit sensors Fix wiring harness.
23	Limit Sensor 5 V supply	Shorted Low	5v IO-B output is less than 2v. Wiring harness is open or shorted to ground.	Check 5v output on IO-B / replace IO-B module. Fix wiring harness.

# SECTION 18: BODY

## CONTENTS

<b>1. VEHICLE EXTERIOR</b> .....	<b>5</b>
<b>2. VEHICLE STRUCTURE</b> .....	<b>7</b>
<b>3. VEHICLE EXTERIOR MAINTENANCE</b> .....	<b>7</b>
3.1 CORROSION PREVENTION .....	7
3.2 PREVENTIVE MAINTENANCE SCHEDULE .....	8
3.3 RUST INHIBITOR APPLICATION .....	8
<b>4. COMMON FIBERGLASS REPAIR PROCEDURE</b> .....	<b>13</b>
4.1 REPAIR USING FIBERGLASS CLOTH .....	13
4.2 REPAIR USING FIBERGLASS PASTE.....	13
4.3 TYPICAL FIBERGLASS REPAIR PROCEDURE .....	14
<b>5. COMMON PAINTING PROCEDURE</b> .....	<b>15</b>
5.1 NEW PAINT CARE .....	15
5.2 PAINT TOUCHUP .....	15
5.3 PAINTING.....	16
5.3.1 <i>Safety</i> .....	16
5.3.2 <i>Surface Preparation And Paint Application</i> .....	16
<b>6. W5 MTH EXTERIOR FINISHING AND BODY REPAIR</b> .....	<b>17</b>
6.1 ZONE 1 .....	18
6.1.1 <i>Front Bumper</i> .....	18
6.1.2 <i>Front Crest</i> .....	18
6.1.3 <i>Headlights</i> .....	19
6.1.4 <i>Rear View Mirrors</i> .....	19
6.1.5 <i>Windshield Wipers</i> .....	20
6.1.6 <i>Windshield</i> .....	20
6.1.7 <i>Front face Body Panel</i> .....	22
6.1.8 <i>Entrance Door</i> .....	22
6.1.9 <i>Front Electrical &amp; Service Compartment Door</i> .....	23
6.1.10 <i>Upper Lateral Window</i> .....	23
6.1.11 <i>Front Cap</i> .....	24
6.2 ZONE 2 .....	24
6.2.1 <i>Upper Side Panel</i> .....	24
6.2.2 <i>Fixed Windows</i> .....	24
6.2.3 <i>Electric Awning Windows</i> .....	25
6.2.4 <i>Electric Sliding Windows</i> .....	28
6.3 ZONE 3 .....	31
6.3.1 <i>Rear Cap</i> .....	31
6.3.2 <i>Engine Compartment Doors</i> .....	31
6.3.3 <i>Rear Bumper</i> .....	32
6.4 ZONE 4 .....	33
6.4.1 <i>Rear Fender</i> .....	33
6.4.2 <i>Engine Compartment R.H. Side Door</i> .....	33
6.4.3 <i>Engine Radiator Door</i> .....	34
6.4.4 <i>R.H. Side Rear Service Compartment Door</i> .....	35
6.5 ZONE 5 .....	35
6.5.1 <i>Baggage Compartment Doors</i> .....	36
6.5.2 <i>Condenser Compartment Door</i> .....	37
6.5.3 <i>Evaporator Compartment Door</i> .....	37



## Section 18: BODY

---

6.5.4	Fuel Filler Door.....	38
6.6	ZONE 6.....	38
6.6.1	Front Fender.....	38
6.7	ZONE 7.....	39
6.7.1	Side Panel for Vehicles Not Fitted With Slide-Out.....	39
6.7.2	Side Panel for Vehicles Fitted With Slide-Out.....	40
6.7.3	Side Crest.....	40
6.8	ZONE 8.....	40
6.8.1	Slide-Out Exterior Finishing Panels & Windows.....	41
6.9	ZONE 9.....	41
6.9.1	Slide-Out Exterior Finishing Panels & Windows.....	41
6.10	BODY PANEL AND WINDOW SPACING FOR W5 MTH NOT FITTED WITH SLIDE-OUT.....	42
6.11	BODY PANEL AND WINDOW SPACING FOR W5 MTH FITTED WITH SLIDE-OUT.....	43
<b>7.</b>	<b>WE MTH EXTERIOR FINISHING AND BODY REPAIR.....</b>	<b>44</b>
7.1	ZONE 1.....	44
7.1.1	Front Bumper.....	44
7.1.2	Front Crest.....	45
7.1.3	Headlights.....	46
7.1.4	Rear View Mirrors.....	46
7.1.5	Windshield Wipers.....	47
7.1.6	Windshield.....	47
7.1.7	Front face Body Panel.....	48
7.1.8	Entrance Door.....	49
7.1.9	Front Electrical & Service Compartment Door.....	49
7.1.10	Upper Lateral Window.....	50
7.1.11	Front Cap.....	50
7.2	ZONE 2.....	51
7.2.1	Upper Side Panel.....	51
7.2.2	Fixed Windows.....	51
7.2.3	Electric Awning Windows.....	52
7.2.4	Electric Sliding Windows.....	52
7.3	ZONE 3.....	52
7.3.1	Rear Cap.....	52
7.3.2	Engine Compartment Doors.....	52
7.3.3	Rear Bumper.....	53
7.4	ZONE 4.....	54
7.4.1	Rear Fender.....	54
7.4.2	Engine Compartment R.H. Side Door.....	54
7.4.3	Engine Radiator Door.....	55
7.5	ZONE 5.....	55
7.5.1	Baggage Compartment Doors.....	56
7.5.2	Condenser Compartment Door.....	57
7.5.3	Evaporator Compartment Door.....	57
7.5.4	Fuel Filler Door.....	58
7.6	ZONE 6.....	58
7.6.1	Front Fender.....	58
7.7	ZONE 7.....	59
7.7.1	Smooth Side Panel.....	59
7.7.2	Side Crest.....	60
7.8	ZONE 8.....	60
7.8.1	Slide-Out Exterior Finishing Panels & Windows.....	60
7.9	BODY PANEL AND WINDOW SPACING FOR WE MTH FITTED WITH SLIDE-OUT.....	61
<b>8.</b>	<b>VEHICLE JACKING POINTS.....</b>	<b>62</b>
8.1	HYDRAULIC JACK.....	63

<b>9. TOWING THE VEHICLE</b> .....	<b>63</b>
9.1 LIFTING AND TOWING .....	64
9.2 TOWING WITHOUT LIFTING .....	64

## ILLUSTRATIONS

FIGURE 1: XLII-45 CONVERTED VEHICLE EXTERIOR VIEW (TYPICAL) .....	5
FIGURE 2: XLII-45E CONVERTED VEHICLE EXTERIOR VIEW (TYPICAL) .....	6
FIGURE 3: FIBERGLASS REPAIR .....	14
FIGURE 4: FIBERGLASS REPAIR .....	14
FIGURE 5: FIBERGLASS REPAIR .....	14
FIGURE 6: FIBERGLASS REPAIR .....	15
FIGURE 7: FIBERGLASS REPAIR .....	15
FIGURE 8: W5 MTH ZONING .....	17
FIGURE 9: W5 MTH FITTED WITH SLIDE-OUT .....	17
FIGURE 10: ZONE 1 .....	18
FIGURE 11: FRONT BUMPER REMOVAL .....	18
FIGURE 12: FRONT BUMPER RELEASE HANDLE .....	18
FIGURE 13: REAR VIEW MIRROR (RAMCO) .....	19
FIGURE 14: WINDSHIELD INSTALLATION USING ROPE .....	21
FIGURE 15: APPLICATION OF SIKA 221 BLACK .....	22
FIGURE 16: VIEW OF FRONT FACE .....	22
FIGURE 17: ZONE 2 .....	24
FIGURE 18: ELECTRIC AWNING WINDOW EXPLODED VIEW (FRAME) .....	26
FIGURE 19: ELECTRIC AWNING WINDOW EXPLODED VIEW (SASH) .....	26
FIGURE 20: ELECTRIC SLIDING WINDOW EXPLODED VIEW .....	28
FIGURE 21: REMOVING THE SASH .....	29
FIGURE 22: DISENGAGING THE BOTTOM OF THE SASH .....	29
FIGURE 23: PROPER ALIGNMENT .....	30
FIGURE 24: POSITIONING THE LOWER LEFT CORNER OF THE SASH .....	30
FIGURE 25: RELEASE LATCH PROPER POSITION .....	31
FIGURE 26: ZONE 3 .....	31
FIGURE 27: ENGINE COMPARTMENT DOORS .....	32
FIGURE 28: REAR BUMPER .....	32
FIGURE 29: ZONE 4 .....	33
FIGURE 30: ENGINE COMPARTMENT R.H. SIDE DOOR .....	33
FIGURE 31: RADIATOR DOOR .....	34
FIGURE 32: SMALL RADIATOR DOOR .....	34
FIGURE 33: R.H. SIDE REAR SERVICE COMPARTMENT DOOR .....	35
FIGURE 34: ZONE 5 .....	35
FIGURE 35: BAGGAGE COMPARTMENT DOOR .....	36
FIGURE 36: BAGGAGE DOOR CATCH STRIKER .....	37
FIGURE 37: CONDENSER DOOR .....	37
FIGURE 38: EVAPORATOR DOOR .....	37
FIGURE 39: FUEL FILLER DOOR .....	38
FIGURE 40: ZONE 6 .....	38
FIGURE 41: ZONE 7 .....	39
FIGURE 42: ZONE 8 .....	40
FIGURE 43: ZONE 9 .....	41
FIGURE 44: BODY PANEL & WINDOW SPACING FOR W5 MTH NOT FITTED WITH SLIDE-OUT .....	42
FIGURE 45: BODY PANEL & WINDOW SPACING FOR W5 MTH FITTED WITH SLIDE-OUT .....	43
FIGURE 46: WE MTH ZONING .....	44
FIGURE 47: ZONE 1 .....	44

## Section 18: BODY

---

FIGURE 48: FRONT BUMPER RELEASE HANDLE.....	45
FIGURE 49: FRONT BUMPER REMOVAL .....	45
FIGURE 50: REAR VIEW MIRROR (RAMCO).....	46
FIGURE 51: WINDSHIELD INSTALLATION USING ROPE .....	48
FIGURE 52: APPLICATION OF SIKA 221 BLACK .....	48
FIGURE 53: VIEW OF FRONT FACE .....	49
FIGURE 54: ZONE 2.....	51
FIGURE 55: ZONE 3.....	52
FIGURE 56: ENGINE COMPARTMENT DOORS .....	53
FIGURE 57: REAR BUMPER .....	53
FIGURE 58: ZONE 4.....	54
FIGURE 59: ENGINE COMPARTMENT R.H. SIDE DOOR .....	54
FIGURE 60: RADIATOR DOOR .....	55
FIGURE 61: ZONE 5.....	55
FIGURE 62: BAGGAGE COMPARTMENT DOOR .....	56
FIGURE 63: BAGGAGE DOOR CATCH STRIKER .....	57
FIGURE 64: CONDENSER DOOR .....	57
FIGURE 65: EVAPORATOR DOOR.....	57
FIGURE 66: FUEL FILLER DOOR.....	58
FIGURE 67: ZONE 6.....	58
FIGURE 68: ZONE 7.....	59
FIGURE 69: ZONE 8.....	60
FIGURE 70: BODY PANEL & WINDOW SPACING FOR WE MTH FITTED WITH SLIDE-OUT .....	61
FIGURE 71: JACKING POINTS ON FRAME .....	62
FIGURE 72: FRONT SUBFRAME JACKING POINTS.....	62
FIGURE 73: REAR SUBFRAME JACKING POINTS.....	62
FIGURE 74: JACKING POINTS ON IND. SUSPENSION .....	62
FIGURE 75: JACKING POINTS ON DRIVE AXLE .....	62
FIGURE 76: JACKING POINTS ON TAG AXLE .....	63

1. VEHICLE EXTERIOR

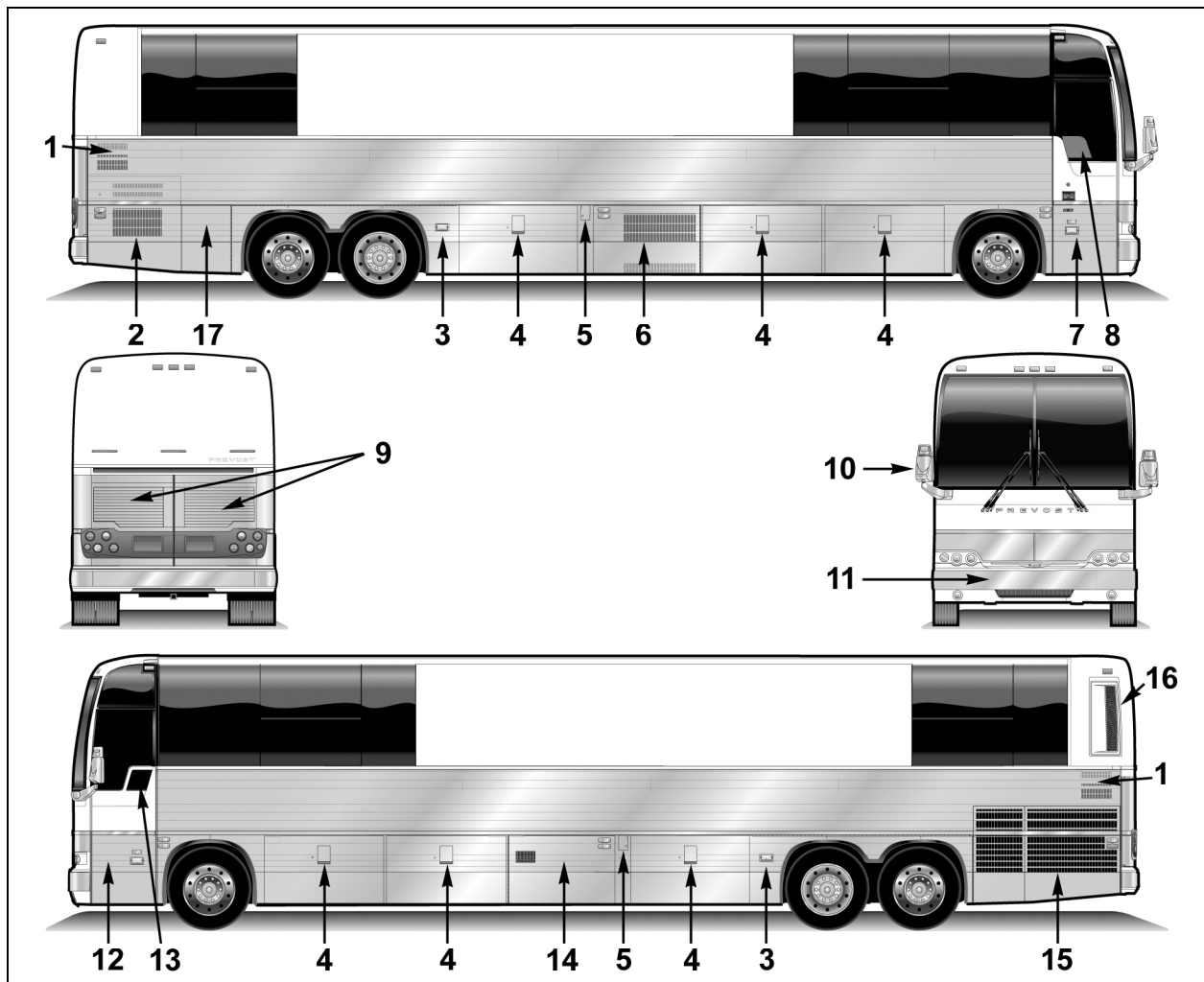

FIGURE 1: XLII-45 CONVERTED VEHICLE EXTERIOR VIEW (TYPICAL)

- |   |   |
|---|---|
| 1. Engine air intake                            | 11. Reclining bumper  |
| 2. Engine compartment R.H. side door            | 12. Front electrical & service compartment                  |
| 3. Hinged rear fender                           | 13. Driver's power window                                   |
| 4. Baggage compartment                          | 14. Evaporator compartment or Baggage compartment           |
| 5. Fuel filler door                             | 15. Radiator door   |
| 6. Condenser compartment or Baggage compartment | 16. Diesel Particulate Filter (DPF) compartment access door |
| 7. Entrance door                                |   |
| 8. Entrance door power window                   |   |
| 9. Engine compartment rear doors                |   |
| 10. Rear-view mirror                            |   |
|   | Front Slide-Out (Optional)                                  |
|   | Rear Slide-Out (Optional)                                   |

Section 18: BODY

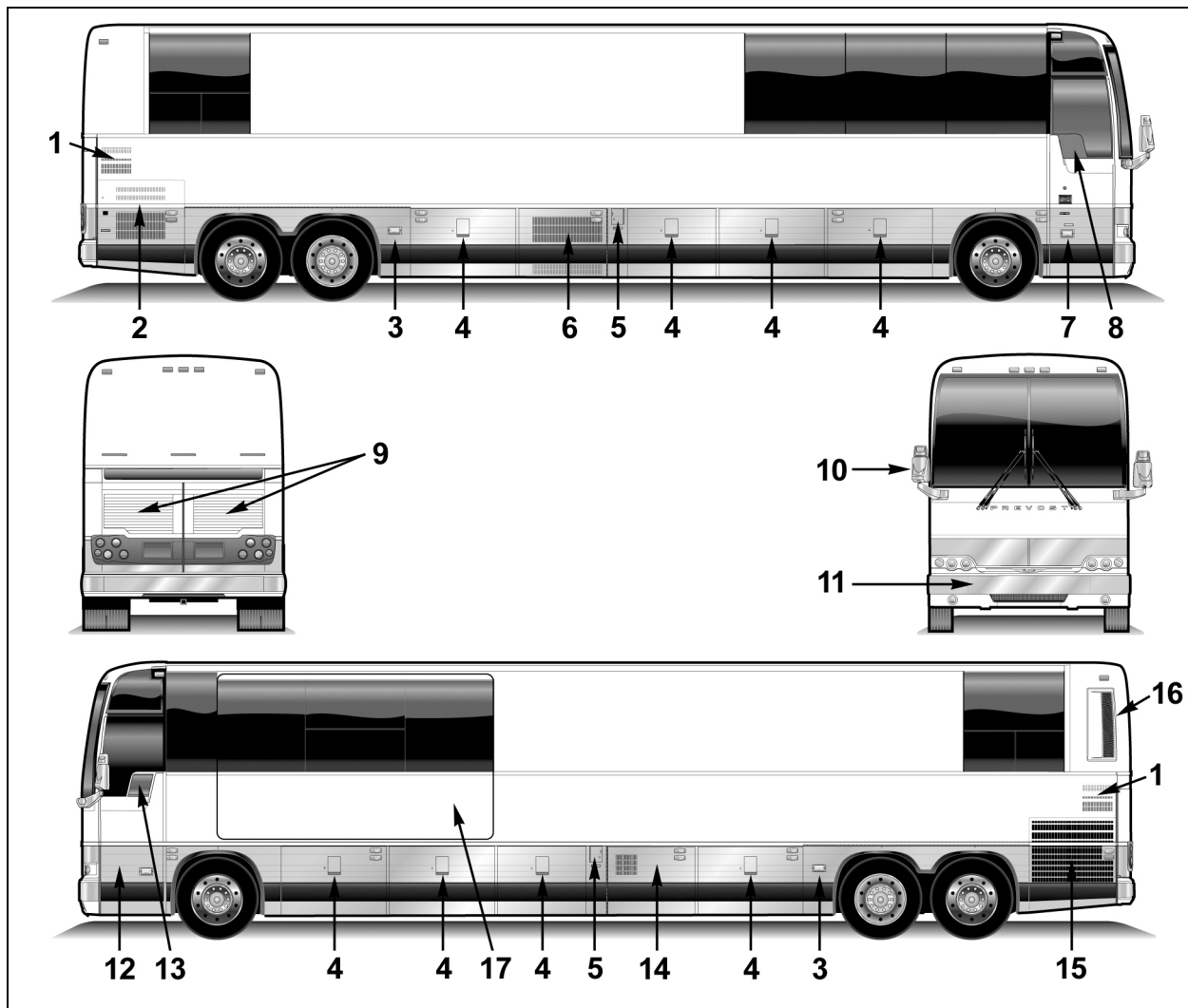

FIGURE 2: XLII-45E CONVERTED VEHICLE EXTERIOR VIEW (TYPICAL)

18369

- |   |   |
|---|---|
| 1. Engine air intake                            | 10. Rear-view mirror  |
| 2. Engine compartment R.H. side door            | 11. Reclining bumper  |
| 3. Hinged rear fender                           | 12. Front electrical & service compartment                  |
| 4. Baggage compartment                          | 13. Driver's power window                                   |
| 5. Fuel filler door                             | 14. Evaporator compartment or Baggage compartment           |
| 6. Condenser compartment or Baggage compartment | 15. Radiator door   |
| 7. Entrance door                                | 16. Diesel Particulate Filter (DPF) compartment access door |
| 8. Entrance door power window                   | 17. Front Slide-Out (Optional)                              |
| 9. Engine compartment rear doors                |   |

## 2. VEHICLE STRUCTURE

The body of the XLII vehicles is an integral structure made of 14, 16 and 18 gauge welded and braced high tensile steel and stainless steel members. All stainless exterior panels are glued to anti-corrosion coated members. The complete structure is protected against corrosion prior to assembly. The front and rear caps are made of molded fiberglass. The main roof is made of high tensile aluminum panels riveted to the roof structure. The floor is made of 2 layers of ½" (13 mm) thick plywood separated by a 1/8" (3 mm) insulation to reduce power train and road noises.

### Welding

Since welding is a procedure that may be carried out either as specific instructions from Prévost or by an independent decision of the owner, the following information pertaining to welding should be read before beginning any welding procedure. The prohibitions and requirements outlined below must be followed during welding procedure:

1. Welding must be done only by a qualified and experienced person.
2. Adequate ground contacts and shields must be positioned as required to protect components from damage due to heat, contact by weld splatter, arcing, or other potentially damaging events associated with welding.
3. The following precautions are to be taken to protect the electronic control components. Refer to section 00, paragraph 3: "PRECAUTIONS TO BE OBSERVED BEFORE WELDING" in this manual.
4. Always wear the appropriate safety equipment.
5. Weld in clean and well ventilated area, and always have an appropriate fire extinguisher within your reach.

## 3. VEHICLE EXTERIOR MAINTENANCE

Regular washing to remove dust and dirt is recommended. See *"Owner's Manual"* for more details on washing and cleaning your vehicle.

### 3.1 CORROSION PREVENTION

Preventive maintenance is a key factor in avoiding corrosion and must be considered as part of the regular service intervals. The entire underside of the vehicle is sprayed with a heavy application of asphalt base undercoating.

The operating environment the vehicle is subjected to will largely influence the amount of dirt and corrosion that will accumulate over a given period. Corrosion is one of the most costly factors of part failure and shortened part life. It is, however, an item that can be controlled when it is conscientiously looked after and the proper steps are taken in a timely manner.

Certain areas of the coach are more vulnerable to corrosion than others, and it is these areas that should be addressed. For example, the rear baggage compartment bulkhead in the rear wheelhousing area contains many key components and should be examined regularly for corrosion. Other areas include the front wheelhousing area and the engine compartment.

Road splash will affect undercarriage, condenser coil and engine compartment. These areas must be thoroughly cleaned to remove dirt accumulations from flanges, channels and ledges. These places accumulate dirt and salt and hold it in direct contact with steel and aluminum surfaces. Use an understructure high pressure spray as part of a regular wash. Damaged undercoating or paint should be promptly repaired before corrosion can start.

Frequency of wash periods depends on operating conditions. During periods of exposure to salt, daily washing as described above is recommended. If underbody parts show evidence of rust or corrosion, treat as follows:

1. Remove dirt, grease and oil by solvent washing.
2. Remove corrosion as well as all loose coating by cleaning with a wire brush or sandblasting.



### CAUTION

Sandblasting can be used for cleaning bulkheads, brackets and other structural members. It should not be used for exterior side paneling. Extreme care should be taken not to sandblast excessively.

3. Apply correct primer, paint and undercoating after removing all corrosion to prevent further damage.

## Section 18: BODY

### 3.2 PREVENTIVE MAINTENANCE SCHEDULE

**NOTE**

*TECTYL 185 GW rust inhibitor may have been applied on your vehicle underbody as an option, if this is the case, follow this procedure thoroughly. For future application of product, refer to paragraph 3.3 in this section.*

DESCRIPTION	INTERVALS		MAINTENANCE	CORRECTIVE ACTION	REFERENCE
	MONTHS	KM MILES			
BODY, EXTERNAL WINDOW FRAME	6	40 000 25 000	VISUALLY INSPECT SEALING BEADS CONDITION	REPAIR OR REPLACE SEALING BEADS IF NECESSARY	
VEHICLE UNDERBODY	12	100 000 60 000	USE A LOW PRESSURE SPRAY TO CLEAN UNDERSTRUCTURE AND VISUALLY INSPECT FOR CALCIUM DEPOSIT, CORROSION OR ANY DIRT ACCUMULATED ONTO EXPOSED SURFACES. VISUALLY INSPECT SEALING BEADS CONDITION.  VISUALLY INSPECT IF UNDERFLOOR IS PEELING. VISUALLY INSPECT WHEELHOUSING COATING.  MAKE SURE DISCHARGE TUBES ARE FREE FROM OBSTRUCTIONS	APPLY UNDERCOATING LOCALLY AS NECESSARY.  APPLY UNDERCOATING LOCALLY AS NECESSARY  REMOVE ANY OBSTRUCTION OR REPLACE DEFECTIVE TUBE	
SUSPENSION AND UNDERSTRUCTURE	12	100 000 60 000	VERIFY THE CONDITION OF ALL SUSPENSION AND UNDERSTRUCTURE FASTENERS AND CLAMPS	TIGHTEN OR REPLACE DEFECTIVE OR MISSING FASTENERS	
FLOOR COVERING	3	20 000 12 500	VISUALLY INSPECT IF FLOOR COVERING IS SHOWING SIGNS OF DETERIORATION SUCH AS CUTS, BURNS, ETC. ALSO, VISUALLY INSPECT SEALANT ALONGSIDE TRACKS. INSPECT WALL PANELS FROM BOTTOM TO WINDOWS	REPAIR OR REPLACE DEFECTIVE COVERING. MAKE SURE PROPER SEALANT IS USED.	
FLOOR CLEANING			CLEAN FLOOR COVERING AS NECESSARY		



### WARNING

Failure to follow this preventive maintenance schedule will result in warranty void.



### 3.3 RUST INHIBITOR APPLICATION

Material: Tectyl 185 GW R1KG21

Safety Rules: Use safety glasses

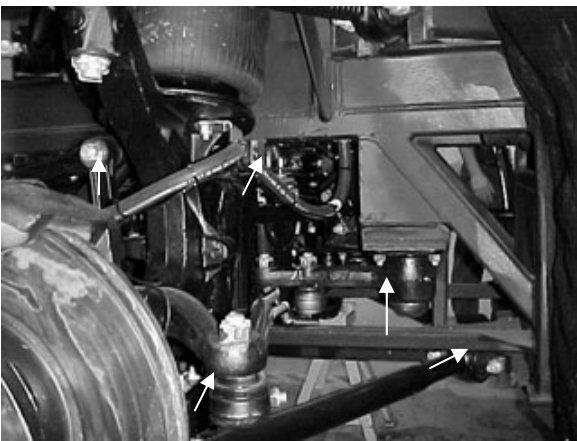

Supplied air hood

Solvent-resistant rubber gloves

<p>1.0 Wash both wheelhousing mechanical parts before masking.</p>	<p>A water-hose nozzle is recommended. Water may be hot to reduce washing time especially during winter. If parts are soiled with oil, clean using R1KG21. Avoid rubber parts.</p>
<p>2.0 Dry all water sprayed parts. Surface temperature and dew point must be respected before applying rust inhibitor.</p>	<p>Air pressure system may be used, refer to annex 1 for surface temperature and dew point.</p>
<p><b>3.0 Front wheelhousing</b>  a) Mask all rubber joints. Braking system must also be protected (refer to arrows). Commercial aluminum foil may be used for masking.</p>	
<p><b>3.1 Front wheelhousing</b>  Front view</p>	
<p><b>3.2 Front wheelhousing</b></p>	

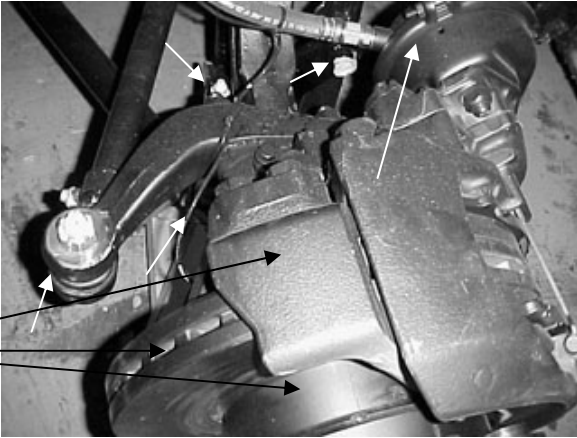

**Section 18: BODY**

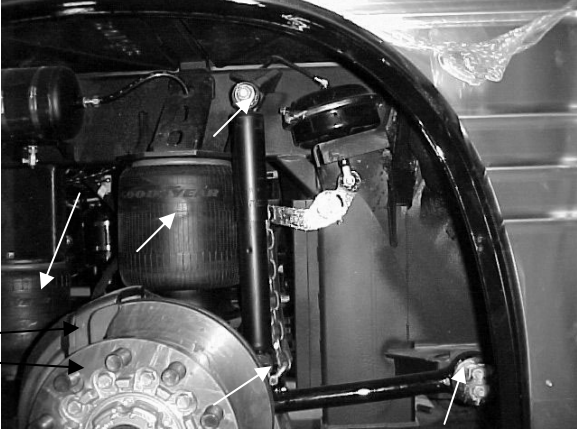
<p><b>3.3 Front wheelhousing</b></p> <p>(Entire braking system)</p>	
<p><b>4.0 Rear wheelhousing</b></p> <p>a) Mask all rubber joints. Braking system must also be protected (refer to arrows). Commercial aluminum foil may be used for masking</p> <p>(Entire braking system)</p>	
<p><b>4.1 Rear wheelhousing</b></p> <p>(Entire braking system)</p>	

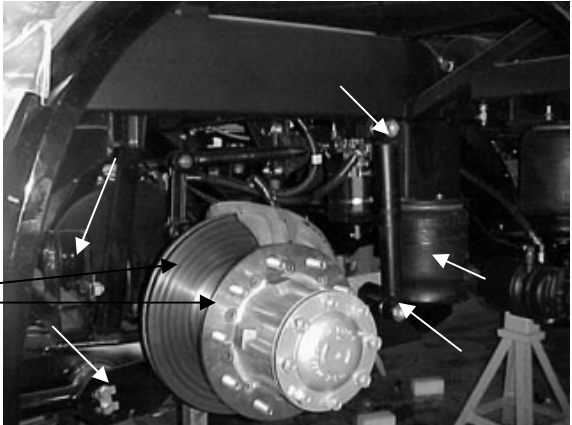
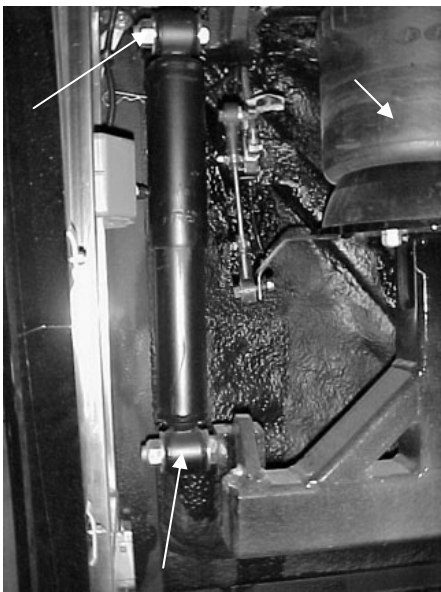
<p>4.2 Rear wheelhousing</p> <p>(Entire braking system)</p>	
<p>4.3 Rear wheelhousing</p>	
<p>5.0 Close off wheelhousing using masking paper.</p>	<p>Prevent rust inhibitor from coming in contact with paint. To close off wheelhousing, a polythene sheet may be used.</p>
<p>6.0 Apply TECTYL 185 GW black rust inhibitor onto wheelhousing mechanical parts.</p>	<p>A spray gun and pumping system are required to apply the rust inhibitor. If the application is done inside a paint room, select high speed ventilation. <b>Minimum required thickness is 10 mils wet or 5 mils dry.</b></p>
<p>7.0 Remove all masking material 30 minutes after application.</p>	

**ANNEX 1**

1. Check and confirm that dew point and surface temperature are in accordance with to the following criteria:
  - Surface temperature > 10°C
  - Surface temperature > or = to dew point + 3°C

**NOTE**  
Use the following table to determine dew point.

2. Check and confirm that TECTYL temperature is between 10°C and 35°C.

**Section 18: BODY**

**DEW POINT**

	Relative Humidity (%)									
	10	20	30	40	50	60	70	80	90	100
Temp (c)										
0	---	-16	-11	-8	-5	-3	-1	0	1	3
1	---	-15	-10	-7	-5	-3	-1	1	2	4
2	---	-14	-10	-6	-4	-1	0	2	3	5
3	---	-13	-9	-5	-3	-1	1	2	4	6
4	---	-13	-8	-5	-2	0	2	4	5	7
5	---	-11	-7	-4	-1	1	3	5	6	8
6	---	-11	-8	-3	0	2	4	6	7	9
7	-18	-10	-6	-2	0	2	5	6	8	10
8	-17	-9	-5	-1	1	4	6	7	9	11
9	-16	-9	-4	-1	2	4	6	9	10	12
10	-16	-8	-3	0	3	5	7	10	11	13
11	-15	-7	-3	1	4	6	9	10	12	14
12	-14	-6	-1	2	5	7	10	11	13	15
13	-14	-6	-1	2	6	8	10	12	14	16
14	-13	-5	0	4	6	9	11	14	15	17
15	-12	-4	1	4	7	10	12	14	16	18
16	-11	-4	1	5	9	11	13	15	17	19
17	-10	-3	2	6	9	12	14	16	18	20
18	-10	-2	3	7	10	13	15	17	19	21
19	-9	-1	4	8	11	14	16	18	20	22
20	-9	0		5	9	12	15	17	19	21 23
21	-8	0		5	10	13	16	18	20	22 24
22	-7	1		6	11	14	16	19	21	23 25
23	-6	2		7	11	15	17	20	22	24 26
24	-6	2		8	12	16	19	21	23	25 27
25	-5	3		9	13	16	20	22	24	26 28
26	-4	4		10	14	17	20	23	25	27 29
27	-4	5		11	15	19	21	24	26	28 30
28	-3	6		11	16	19	22	25	27	29 31
29	-2	6		12	17	20	23	26	28	30 32
30	-1	7		13	17	21	24	27	29	31 33
31	-1	8		14	19	22	25	27	30	32 34
32	0	9		15	20	23	26	29	31	33 35

#### 4. COMMON FIBERGLASS REPAIR PROCEDURE

All repairs to fiberglass parts consist of filling the damaged area with fiberglass cloth and resin or strand fiberglass and resin. The repair is allowed to harden, and then finishing operations may be performed. Use of the various materials is determined by the type of repair to be made. Large holes, torn sections and separate joints require the adhesive qualities of the resin and the reinforcing qualities of the fiberglass. Small dents, scratches or pits can be repaired using resin and strand fiberglass and filler mixed into paste. Instructions for either mix are explained under their respective headings in this section. For best results when making repairs, temperature should be between 70 and 75 °F (21-24 °C). Some people experience a skin reaction to resins. In such cases, wipe resin off with denatured alcohol or a good thinner. Use of protective hand cream is recommended.

	<b>WARNING</b>
Always wear a respirator and goggles when grinding or sanding.	

Extreme care must be taken if the sander is electrically operated, as dust from some resins is combustible when subjected to sparks or open flames. The proper tool for sanding resin is a low speed, air driven disc sander with a water attachment or a dry sander having a vacuum bag. Either will eliminate flying glass and resin dust.

The following additional tools and materials will assist in making repairs: hacksaw blade, assorted files, emery paper or cloth (150 or finer), scissors or tin snips, wax paper or cellophane sheets, a 3" (75 mm) paint roller, paint brush, putty knife, acetone and one or more heat lamps.

##### 4.1 REPAIR USING FIBERGLASS CLOTH

Where necessary, sand paint away around damaged area and scrape away undercoating, if any, and wipe clean with solvent. Grind or file the damaged area to form a "V" at the broken or cracked portion. Sides of "V" should have a shallow pitch for maximum bonding area.

<b>NOTE</b>
<i>Roughening the surface improves adhesion of resin.</i>

If part is warped from original shape, use clamping equipment to straighten the surface. Preheat area to be repaired with one or two heat lamps placed 18 to 24 inches (450-610 mm) from repair.

	<b>CAUTION</b>
Temperature should not exceed 140 °F (60 °C) during 30 minutes in order to avoid distortion.	

Cut fiberglass cloth with scissors or tin snips, 1 to 3 inches (25-75 mm) larger than area to be repaired. Build area to desired height.

Mix resin and hardener following instructions on their containers. Saturate layers of fiberglass with mixture and place laminates over damaged area. Smooth out wrinkles and make sure general contour of area is maintained. Bubbles and wrinkles can be eliminated with a roller.

	<b>CAUTION</b>
The pot life of the mix is approximately 15 minutes. Any accidental contamination to the skin, clothing, tools, etc. must be removed within this period. Use acetone to remove uncured resin.	

Heat resin material again by placing heat lamps 18 to 24 inches (450-610 mm) from repaired area. Allow 12 to 15 minutes for repair to cure. After repair is cured, grind, file or sand to contour. Files other than body files may be more suitable. Featheredge and finish sanding.

If small pits or irregularities appear after making repair, correct by using a liberal amount of chopped strand or filler mixed with resin to form a paste. Refer to heading "*Repair using Fiberglass Paste*" in this section.

##### 4.2 REPAIR USING FIBERGLASS PASTE

Fiberglass paste is used for repairing small dents, scratches, and pits. Paste is made by mixing resin, hardener and fiberglass strand or filler to the consistency of putty. Where it may be necessary, sand paint away around damaged area. On underside of coach, scrape away undercoating from damaged area, and wipe clean with solvent.

Preheat the area to be repaired using heat lamps. Mix desired quantities of resin and hardener according to manufacturer's

## Section 18: BODY

instructions. Add powdered fiberglass strand into mixture to thicken it into a putty state.

### **NOTE**

*If repair is made on a vertical surface, adding powdered filler material to mixture will reduce tendency of hot resin to flow or run.*

Apply the material with a putty knife or similar object, building material up to the desired contour. For deep filling and on vertical surfaces, several layers of material may be used.

A hacksaw blade, held flat to adjacent contour and then moved in a sawing action across the repair when the resin is in a gel state, will remove excess resin from repair. Finish repair with the same procedure as when using fiberglass cloth.

### **4.3 TYPICAL FIBERGLASS REPAIR PROCEDURE**

Remove all loose particles or damaged material using a power sander or rasp. Clean area, overlapping hole approximately 1" to 1-½" (25-40 mm) all around. Remove all dirt, grease and paint from area to ensure good bonding surface. Feather the cleaned area all around (Fig. 3).

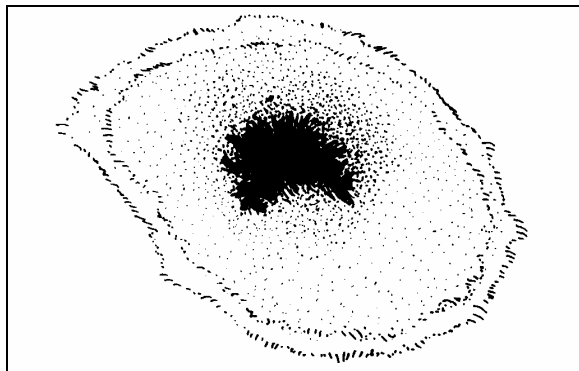

**FIGURE 3: FIBERGLASS REPAIR**

18089

Cut a piece of fiberglass mat slightly larger than area being repaired. Impregnate mat with general purpose polyester resin catalyzed normally. Use a clean paint brush to apply the polyester resin. Apply impregnated mat over hole and press onto surface with brush to obtain good adherence. Another coat of general purpose polyester resin can be applied at this time (Fig. 4).

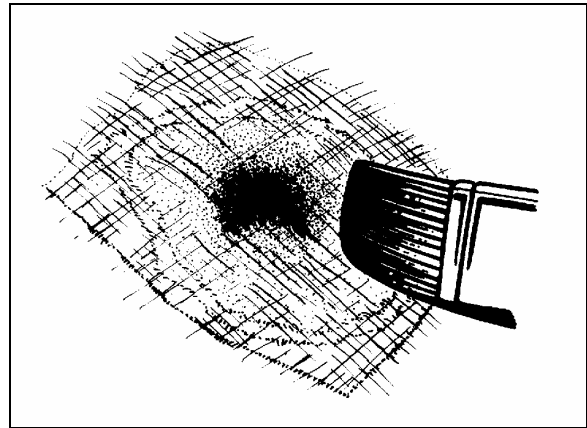

**FIGURE 4: FIBERGLASS REPAIR**

18090

### **NOTE**

*Remove all air between surfaces being joined. Allow area to harden and sand surface to remove any wax.*

Apply another mat, followed by a cloth patch, and another mat. All layers must be thoroughly impregnated with polyester resin, brushed well and free of air. Apply more layers of mat and cloth as required until the desired strength and thickness is obtained, minimum two 1-½ oz (43 g) mats and one 9 oz (255 g) cloth (Fig. 5).

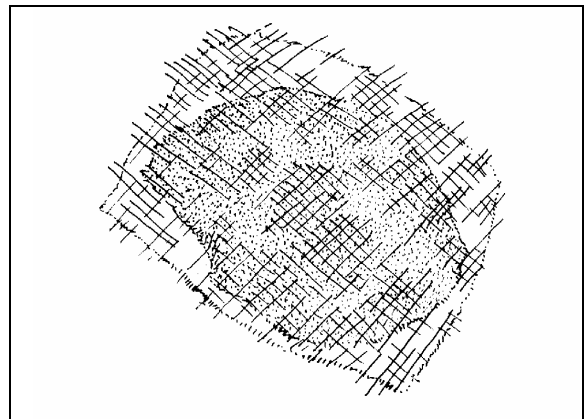

**FIGURE 5: FIBERGLASS REPAIR**

18091

Allow area to harden and contour the area with coarse sandpaper #100 (Fig. 6).

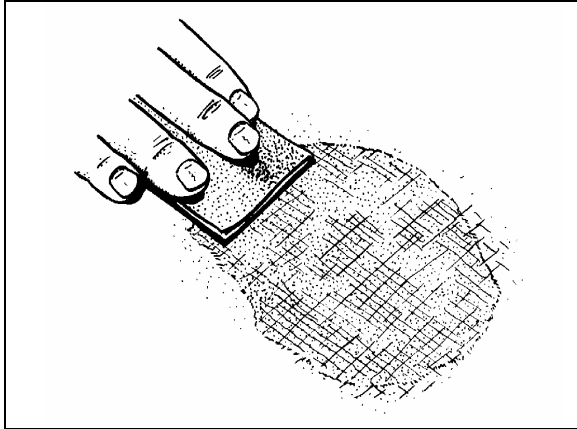

FIGURE 6: FIBERGLASS REPAIR

18092

Cover the area with a layer of resin putty and allow drying for approximately 15 to 20 minutes (Fig. 7).

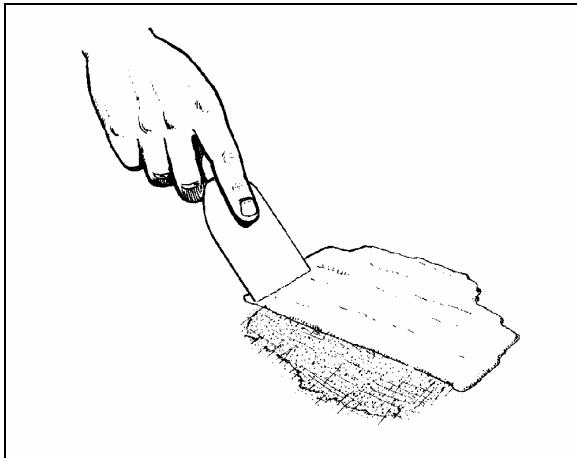

FIGURE 7: FIBERGLASS REPAIR

18093

Smooth off surface with coarse sandpaper #100 to desired shape. Further smooth surface with fine sandpaper #120 until repaired surface matches surrounding area paneling. Prime and paint the area to match surrounding paintwork.

## 5. COMMON PAINTING PROCEDURE

### 5.1 NEW PAINT CARE

Our paint supplier recommends that you follow these simple precautions the first months of your new vehicle's life.



### CAUTION

Apply these recommendations after repainting vehicle.

#### During the first 30 days:

- Do not use a commercial bus wash. Stiff brushes or sponges could mar the finish and damage the surface. Wash the vehicle by hand only and with cool water and a very mild bus wash solution. Be careful to use only a soft cloth or sponge;
- Wash vehicle in the shade, never in direct sunlight;
- Do not "dry wipe" vehicle –always use clean water. Dry wiping could scratch the finish;
- Avoid extreme heat and cold. Park vehicle in the shade whenever possible;
- Do not park under trees which drop sap or near factories with heavy smoke fallout. Tree sap and industrial fallout may mar or spot a freshly painted surface;
- Trees are also likely to attract birds. Bird droppings are highly acidic and will damage a freshly painted surface. Bird droppings, tree sap and industrial fallout should be washed off as soon as possible;
- Do not spill oil, gasoline, antifreeze, transmission fluid or windshield solvent on new finish. IMMEDIATELY rinse off any such spill with clean water, DO NOT WIPE;
- Do not drive on gravel roads. Paint finish easily chips during the first 30 days;
- Do not scrape ice or snow from the surface. A snow scraper can act like a paint scraper if the finish is new. Brush off loose material with a soft snow brush.

#### During the first 90 days:

- Do not wax or polish the vehicle. This will allow the finish to dry and harden completely.

### 5.2 PAINT TOUCHUP

When paint touchup or partial repainting is necessary, refer to the vehicle's paint scheme for color codes and paint brand.

Prévost recommends using the original paint brand to ease color matching.

In the event you sand through to the gelcoat surface you should prime the area with Standox "Non Stop Fill Primer (ST-11000)".

## Section 18: BODY

If you sand through to metal surface, first prime with Standox "Etch Primer (ST-11858)" then with Standox "Non Stop Fill Primer (ST-11000)".

 <b>CAUTION</b>
<p>Be sure to heed all paint manufacturer's recommendations, especially concerning paint dilution and application.</p>

### 5.3 PAINTING

The standard paint used on the exterior of the vehicle is Standox Basislack. It is a high gloss polyurethane enamel finish designed for exposure to extreme conditions. Other types of paint may be called for as options by owner but are not dealt with in this section.

#### 5.3.1 Safety

Care should be exercised in storing, handling, mixing, and applying paint and chemicals listed in this manual. The topcoat, primer, solvent, catalysts, accelerators, and cleaners are highly volatile and/or toxic if not properly used. Observe all safety instructions marked on the different packaging, as well as the following:

1. Do not smoke in the paint room or in adjacent area exposed to residue fumes.
2. Wear respirators approved by the governing safety and health regulations.
3. Maintain adequate ventilation at all times.
4. Dispose of any leftover paint mix properly.
5. Wear rubber gloves, rubber apron, and face shield during all phases of paint and chemical handling

#### 5.3.2 Surface Preparation And Paint Application

	Aluminum and / or Stainless Steel	Fiberglass	Comments
<b>Surface Preparation</b>	Sand using P-150 grit sandpaper. It is recommended to sandblast rivets and panel edges with OLIMAG 35-70 blast media.	Sand using P-180 or P-240 sandpaper.	Do not use paint remover over aluminum or fiberglass.
<b>Cleaning</b>	STANDOX silicone remover ST-11654 (68-2989)		
<b>Priming</b>	STANDOX Reactive Etch Primer ST-13908 * Wait 30 minutes then apply STANDOX Non-Stop Füllprimer ST-11000 (68-2973)	STANDOX Non-Stop Füllprimer ST-11000 (68-2973)	Refer to product Technical Data sheet for proper mixing
<b>Basecoat</b>	Refer to paint scheme or coach record for proper color code and paint brand. We recommend using the same paint brand to ease color matching.		Refer to product Technical Data sheet for proper mixing
<b>Clearcoat</b>	STANDOX 2K MS Rapid Clear ST-11760 (68-2979) Allow 16 hours for drying		Refer to product Technical Data sheet for proper mixing

If assistance or technical information on STANDOX products is needed, please dial: 1 (800) 551-9296

**6. W5 MTH EXTERIOR FINISHING AND BODY REPAIR**

The following procedures explain the steps to be followed for proper repair, installation and replacement for various doors, panels and windows pertaining to W5 MTH. The paragraph divides the vehicle into zones to facilitate the search; each zone is then sub-divided into components.

Refer to the appropriate zone then component for complete procedure.

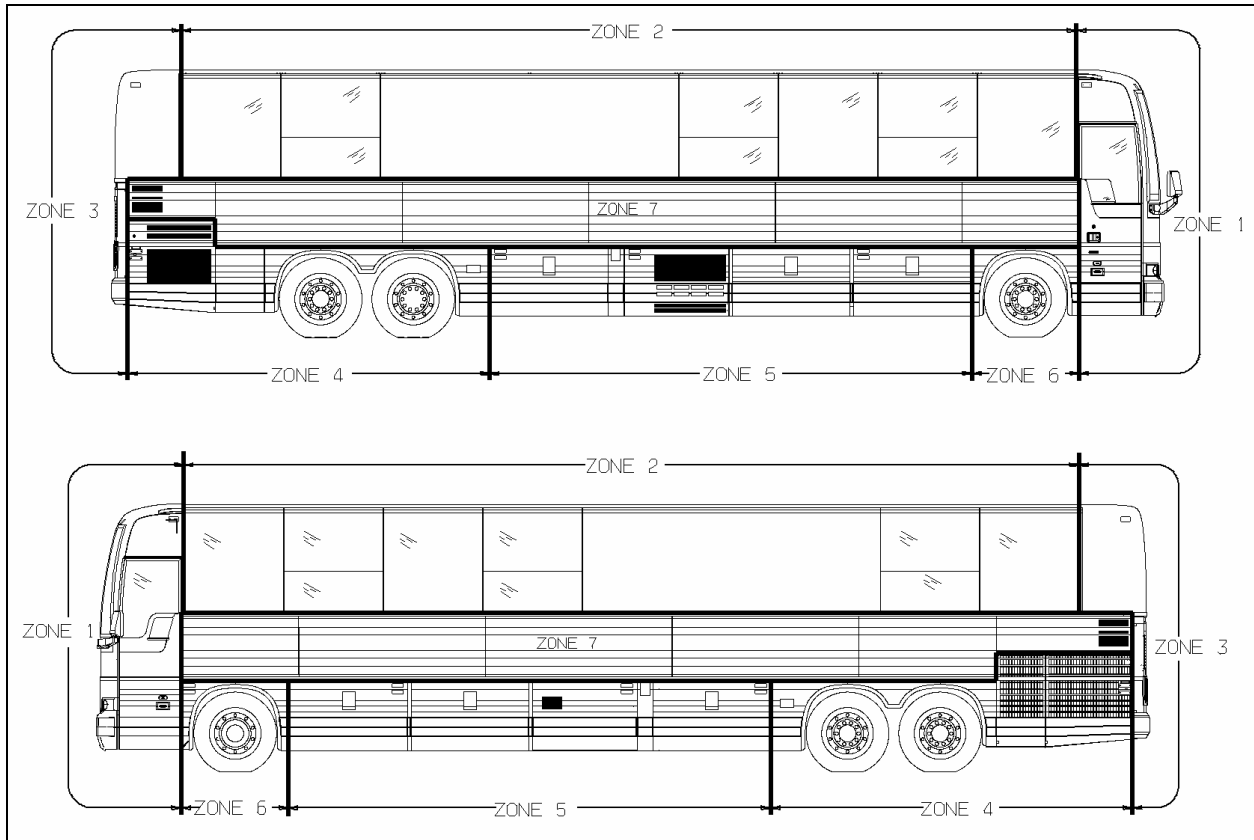

**FIGURE 8: W5 MTH ZONING**

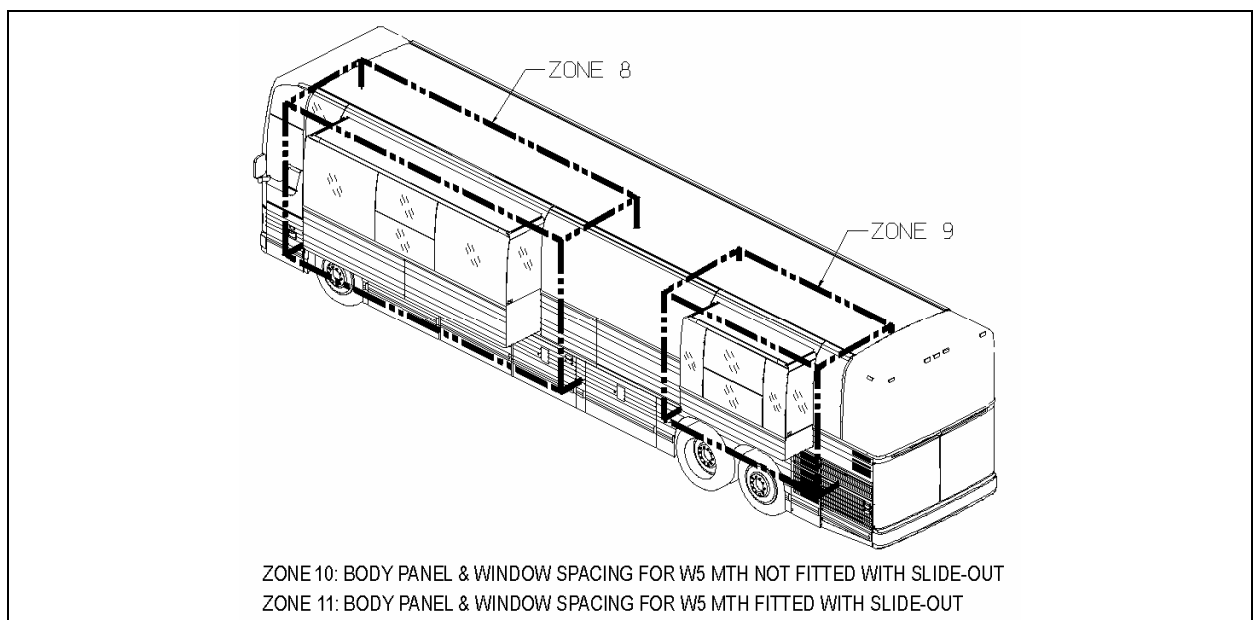

**FIGURE 9: W5 MTH FITTED WITH SLIDE-OUT**



## Section 18: BODY

### 6.1 ZONE 1

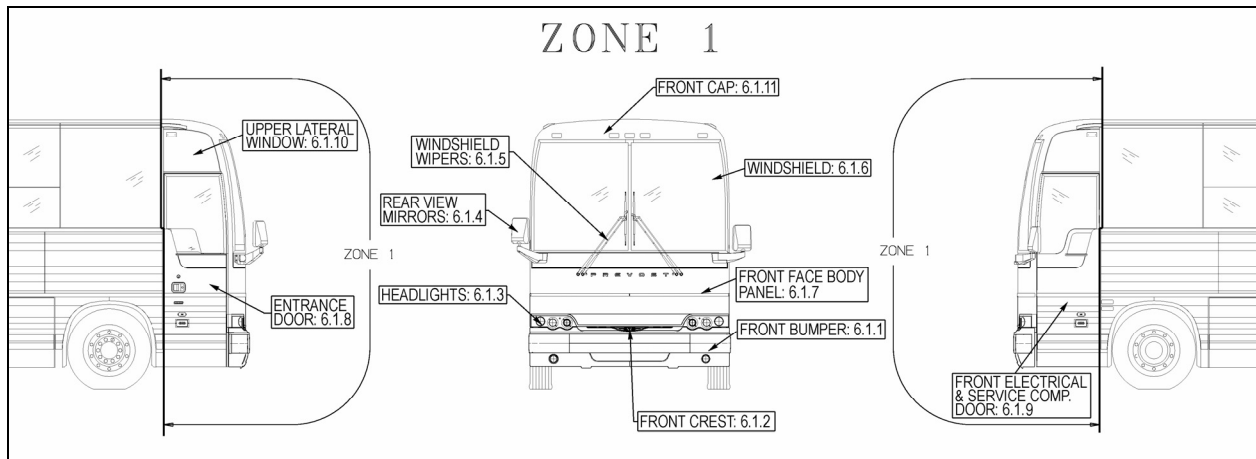

FIGURE 10: ZONE 1

#### 6.1.1 Front Bumper

The front bumper can be tilted downward to give access to the bumper compartment. Pull the release handle located inside front service compartment to unlock. Tilt down the entire bumper assembly to access the compartment. Push the bumper back up firmly in place to lock in position.

Two people are required to remove and install the front bumper. Safely support the bumper and remove the two bolts on each bumper side to separate the bumper from the spare wheel compartment door. To install bumper, reverse the removal procedure.



#### WARNING

Front bumper is heavy. Use proper lifting equipment to support the bumper during the removal and installation operations to avoid personal injury.

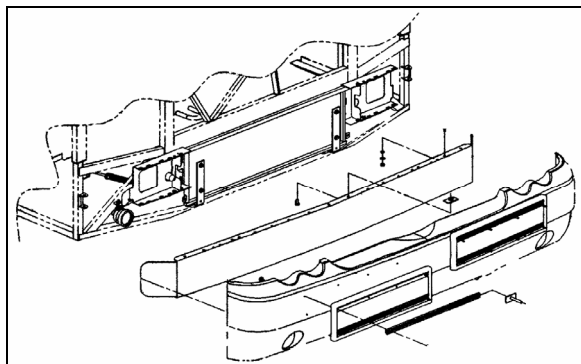

FIGURE 11: FRONT BUMPER REMOVAL



#### WARNING

The compartment behind the bumper is not designed for storage. Never store loose objects in this compartment since they can interfere with the steering linkage mechanism.

Use care when opening or closing the reclining bumper compartment to prevent personal injury.

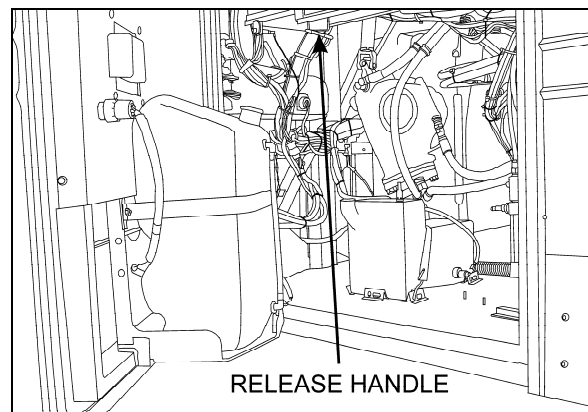

FIGURE 12: FRONT BUMPER RELEASE HANDLE 18613

For gluing of front bumper panel refer to procedure **SAV00198** included at the end of this section.

#### 6.1.2 Front Crest

- Use a Chix cloth and anti-silicone to clean the surface where the crest will be applied.

**CAUTION**

Do not exceed the crest dedicated surface.

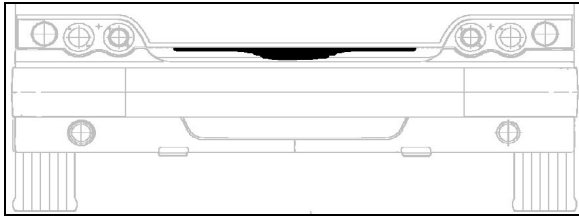

- Peel the back from the self adhesive crest side pieces.

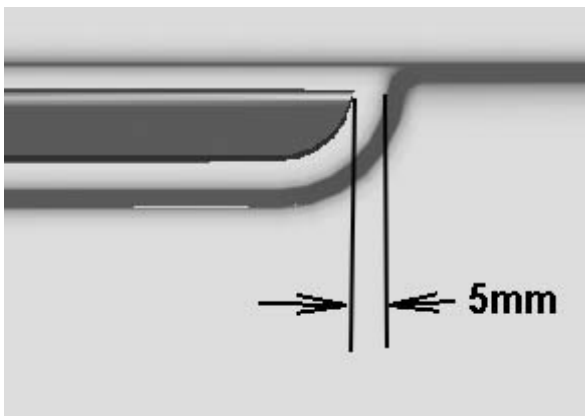

- Peel the back from the self adhesive crest center piece. Center crest and apply.
- Compress the crest three pieces using your hands.

**6.1.3 Headlights**

Refer to Paragraph 9.1 Headlights, included in Section 06: Electrical of the Maintenance Manual for complete information on headlights.

**6.1.4 Rear View Mirrors**

Your vehicle is equipped with two exterior mirrors.

The mirrors may be equipped with an optional electric heating system which serves to minimize ice and condensation on the mirror glass in extreme weather conditions. Integral thermostats are installed in both mirrors to avoid continuous heating. Use the appropriate switch on the dashboard to activate the defroster system on both mirrors simultaneously. The mirrors can easily be adjusted by using the remote controls located on the L.H. side control panel. The mirrors have easy to replace glass in case of breakage. Remote control motors can also be replaced.

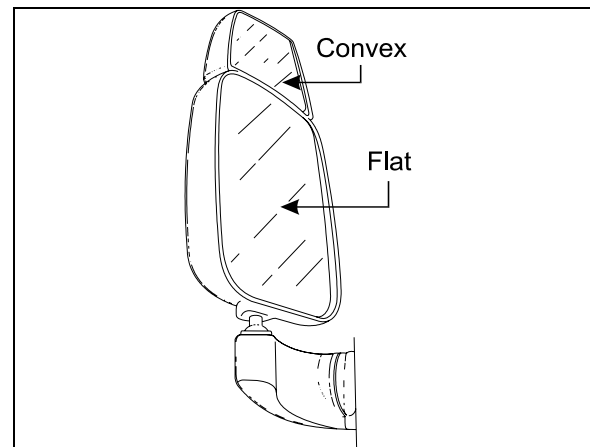

FIGURE 13: REAR VIEW MIRROR (RAMCO)

18398A

❖ **Adjustment**

At the base of the mirror arm, loosen the mounting bolt to swing arm in or out.

To pivot the mirror head, loosen the setscrews on each side of the ball stub at the base of the mirror head to facilitate the adjustment.

❖ **Disassembly**

At end of mirror arm, loosen the setscrews to relieve tension on the ball stem. Remove the ball stem from the arm.

Remove the four screws fastening the mirror arm base to the coach.

❖ **Assembly**

Mount the mirror arm base to the coach. Insert the ball stem into the mirror arm and tighten the socket setscrews.

## Section 18: BODY

### **NOTE**

*Position the ball cup halves so the joint between them lies on the centerline of the arm. Ensure that the setscrews are not on the joint between the cup halves.*

### ❖ Replacement of Mirror Glass

Remove the broken glass.

Position new glass in mirror head and press to lock the Velcro in place.

### ❖ Heated / Remote Controlled Rear View Mirrors

Heated/remote controlled external rear view mirrors may be provided to prevent the mirrors from frosting up in cold weather.

The remote controlled external rear view mirrors attach to support arms using a pivot collar secured by setscrews. Loosening the setscrews allows the whole head assembly to turn on the support arm for initial adjustment. A mounting bolt and washer hold the arm support to the mounting bracket. The arm support can be moved to position the mirror head into or away from the coach body.

The mirror heat switch is located to the left of the driver on the dashboard. This switch must be activated before the mirror heating element will energize. Once energized, the mirror heating element is kept at a sustained temperature (between 60-80°F) by a thermostat. Refer to wiring diagram annexed in the technical publication box.



### **CAUTION**

Do not attach stick-on type convex mirror accessories to the heated mirror glass. This could impede uniform heat distribution on the mirror surface which could break the mirror.

#### ▪ Mirror Control

The remote control pointer knob(s) for the mirrors is (are) mounted on the L.H. side control panel. The harness to the mirror head runs through the arm support. The remote motor is mounted to the mirror head behind the mirror glass.

Turn pointer knob to the left for mirror head adjustments and to the right for convex mirror

adjustment, then push down on either of the button's (4) sides to adjust the selected mirror viewing angle.

#### ▪ Disassembly

At end of mirror arm, loosen the setscrews to relieve tension on the ball stud. Remove the ball stud. Remove the ball stud from the arm and gently pull the harness out until the connector is exposed.

Remove the four screws fastening the mirror arm base to the coach. Slide the harness free of the mirror arm base.

#### ▪ Assembly

Attach a stiff wire (snake) to the end of the harness and insert the wire through the mirror arm base and arm, gently pull the harness through the arm and disconnect the "snake". Connect the mirror head harness. Insert the harness connector back into the mirror arm. Insert the ball stud into the mirror arm and tighten the socket setscrews.

### **NOTE**

*Position the ball cup halves so the joint between them lies on the centerline of the arm. Ensure that the setscrews are not on the joint between the cup halves.*

#### ▪ Convex & Flat Mirror Removal

The mirror glass assembly is mounted to the control mechanism or to mirror base with Velcro strips. Remove the mirror glass by gently pulling the lens to release the Velcro. Disconnect the heater grid at the two connectors.

Connect the connectors of the new mirror's grid to the harness. Install the lens by positioning the lens in the mirror frame and pressing to lock the Velcro in place.

#### 6.1.5 Windshield Wipers

Refer to Paragraph 23.7 Windshield Wipers and Washers, included in Section 23: Accessories of the Maintenance Manual for complete information on windshield wipers.

#### 6.1.6 Windshield

For the removal or installation of windshield, you will need:

- A rope,
- A plastic spatula to lift the rubber seal lip,

- A metal rod or screwdriver to clean the seal groove,
  - A filler insertion tool,
  - Goggles and protective gloves.
- From inside of vehicle, remove center post and interior finishing panels surrounding the windshield. In this case, we are replacing the R.H. side windshield.
  - From outside of vehicle, remove filler located inside rubber seal to ease damaged windshield removal.
  - From inside of vehicle, push against the top L.H. side corner of windshield for the removal of a R.H. side windshield. If the L.H. side windshield had to be removed, you would have to push against the top R.H. side corner.

**NOTE**

*We are referring to the L.H and R.H. side as viewed from the inside of the vehicle.*

- At the same time, another person gradually lifts the rubber lip from the vehicle exterior using a plastic spatula from top to bottom.
- Remove the entire damaged windshield and broken glass if applicable.
- If applicable, using a screwdriver or metal rod, remove black butyl sealant residue from rubber seal then clean with Sika 205.

❖ **Windshield Installation****NOTE**

*Rubber seal may have to be replaced if it was used on several windshield replacements.*

- Spray rubber seal with soapy water to ease windshield insertion.
- Insert rope into rubber extrusion leaving enough length at each corner to make a loop. Spray soapy water onto rope and rubber extrusion (Fig. 14).
- Slide windshield into rubber seal groove starting with the bottom curved side edge. Using a plastic spatula, move the rubber seal lip aside to gradually insert the windshield into the groove.

- Spray soapy water on a regular basis to ease this operation.
- Using the same type of plastic spatula, repeat the same operation from inside of vehicle, gradually inserting the windshield into the groove.

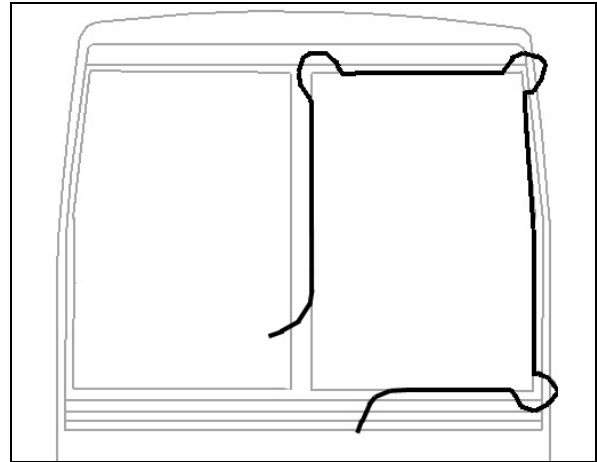

**FIGURE 14: WINDSHIELD INSTALLATION USING ROPE**

**NOTE**

*Make sure windshield bottom edge is well inserted into the rubber seal groove before proceeding with the sides.*

- Then, working from both sides of windshield bottom to top, gradually move the rubber seal lip aside to insert the windshield into the groove. Use also soapy water on the inside of vehicle to insert the windshield into the rubber seal groove.
- Insert the top curved corner then finish with the top of windshield.
- At the top of windshield, clean surface between fiberglass and rubber extrusion using Sika 205 (Fig. 15).
- Apply Sika 221 black between fiberglass and rubber extrusion
- Spray filler and rubber seal groove generously with soapy water.
- Using the special filler insertion tool, insert the filler into the rubber seal groove.
- Gradually insert filler into the rubber seal groove ensuring to leave a 2 inch excess length at the filler extremity.
- Every 6 inches or so, it is important to compress the filler due to its tendency to contract during drying process.

## Section 18: BODY

- When filler insertion is almost complete, cut filler leaving ¼" of excess length to thwart filler contraction over time then insert filler into groove.

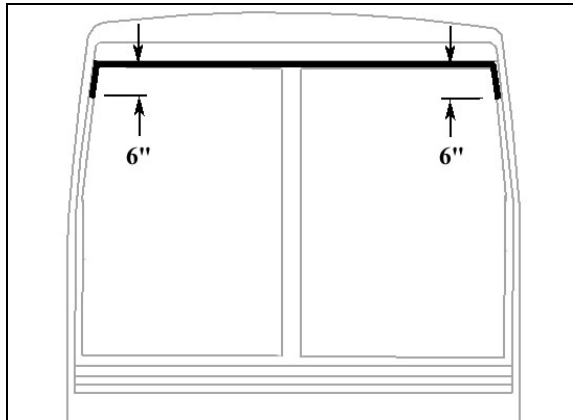

FIGURE 15: APPLICATION OF SIKA 221 BLACK

- Reinstall center post and interior finishing panels.
- Clean windshield surface of butyl residue.

### 6.1.7 Front face Body Panel

For removal of front face body panel and molding, you will need:

Drill with drill bits,  
Lever or similar tool,  
Olfa knife,  
“C”-clamp,  
Razor sharp window scraper.

#### ❖ Front Face Molding Removal

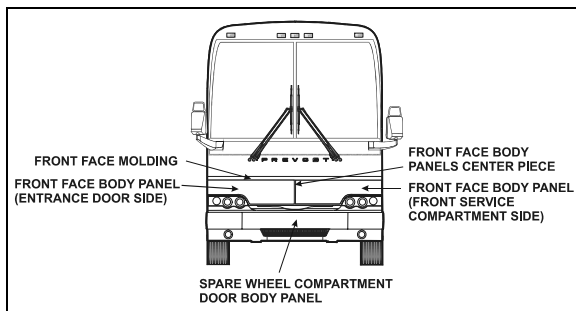

FIGURE 16: VIEW OF FRONT FACE

- First of all, pry loose the front face molding using the lever. Save molding if only the body panel needs to be changed.
- Using the Olfa knife, cut the Sika bead and the double-face self adhesive tape. Remove the Sika bead and self adhesive tape residue with the scraper.

#### ❖ Front Face Body Panel Removal

- Using a drill and a 1/8" drill bit remove the rivets fixing the vertical molding. The stainless steel molding is located on the entrance door or service door frame side depending on body panel to be removed.
- Using the Olfa knife, cut the Sika bead and the double-face self adhesive tape. Remove the Sika bead and self adhesive tape residue with the scraper.
- Pry loose the front face body panel using the lever.
- While somebody cuts the Sika bead and double-face self adhesive tape, another person pulls the body panel using the “C”-clamp to exert tension.
- Using the window scraper, remove any Sika bead or self adhesive tape residue left on fiber glass surface.

#### ❖ Front Face Molding Installation

For gluing of front face molding, refer to procedure **SAV00212** included at the end of this section.

#### ❖ Front face Body Panel Installation

For gluing of front face body panels, refer to procedure **SAV470047** included at the end of this section.

### 6.1.8 Entrance Door

For the removal of entrance door body panel, you will need:

Pneumatic “Zip gun” type tool;  
Razor sharp window scraper;

- Before removing body panel, you can to ease repair uninstal entrance door from vehicle. If applicable, remove reflector, keyless system keyboard and cornering light.
- You must also remove horizontal finishing molding located underneath the window. This molding is glued and will have to be replaced because it will be damaged at removal.
- Remove interior finishing panel to access rub rail fixing bolts, then remove rub rail.
- Using the “Zip Gun”, cut Sika bead located ¼ inch (7-8 mm) from each body panel edge and around cornering light.

- Separate body panel from door.
- Remove from door surface Sika bead and double-face self adhesive tape residue using a razor sharp window scraper.
- Use a Chix cloth and anti-silicone to remove any dust or residue.

For assembly, gluing or finishing joints of entrance door, refer to procedure **SAV280020** included at the end of this section.

For gluing of entrance door horizontal finishing molding, refer to procedure **SAV00213** included at the end of this section.

For the installation of entrance door, refer to procedure **SAV280022** included at the end of this section.

#### 6.1.9 Front Electrical & Service Compartment Door

For the removal of front electrical & service door body panel, you will need:

Pneumatic «Zip gun» type tool;  
Razor sharp window scraper;

- Before removing body panel, you can to ease repair uninstall front electrical & service door from vehicle. If applicable, remove reflector and cornering light.
- You must also remove horizontal finishing molding located underneath the window. This molding is glued and will have to be replaced because it will be damaged at removal.
- Remove interior finishing panel to access rub rail fixing bolts, then remove rub rail.
- Using the «**Zip Gun**», cut Sika bead located ¼ inch (7-8 mm) from each body panel edge and around cornering light.
- Separate body panel from door.
- Remove from door surface Sika bead and double-face self adhesive tape residue using a razor sharp window scraper.
- Use a Chix cloth and anti-silicone to remove any dust or residue.

For assembly, gluing or finishing joints of front electrical & service compartment door, refer to procedure **SAV280021** included at the end of this section.

For gluing of driver's window, refer to procedure **SAV290013** included at the end of this section.

For gluing of front electrical & service compartment door horizontal finishing molding, refer to procedure **SAV00213** included at the end of this section.

For the installation of front electrical & service compartment door, refer to procedure **SAV280022** included at the end of this section.

#### 6.1.10 Upper Lateral Window

For the removal of driver's window or upper lateral window, you will need:

Pneumatic «Zip gun» type tool;  
Razor sharp window scraper;  
«Olfa» knife;  
Face shield.

- In the case of driver's window only, open front service compartment door.
- Mark the position of the driver's window for future reference.
- From inside of vehicle, cut Sika bead around window perimeter using a «Zip gun» while another person hold the window from the outside.

#### **NOTE**

*Wear ear plugs during this operation.*

- Then, move outside of vehicle and cut Sika bead to free window while somebody else hold the window from the inside.
- Carefully remove window from frame, ask for help if needed.
- Using a razor sharp window scraper, remove from window frame Sika bead and double-face self adhesive tape residue.
- First of all, check Sika 205 cleaner expiration date.
- Before applying Sika cleaner, fold «Chix» cloth twice for proper width.
- Apply an even coat onto the inside of window frame and allow drying for 2 minutes (maximum 2 hours).
- Discard waste according to applicable environmental regulations, use dangerous waste containers.
- Apply masking tape before applying Sika glue to protect paint and adjacent window during surface treatment.

## Section 18: BODY

For gluing of upper lateral window, refer to procedure **SAV290016** included at the end of this section.

### 6.1.11 Front Cap

The fiberglass front cap does not need any maintenance except painting as needed. It is held in place with adhesive. If ever it has to be replaced, make an appointment at a Prevost service center near you. For minor damages, refer to paragraph 4 "Common Fiberglass Repair procedure" and paragraph 5 "Common Painting Procedure".

## 6.2 ZONE 2

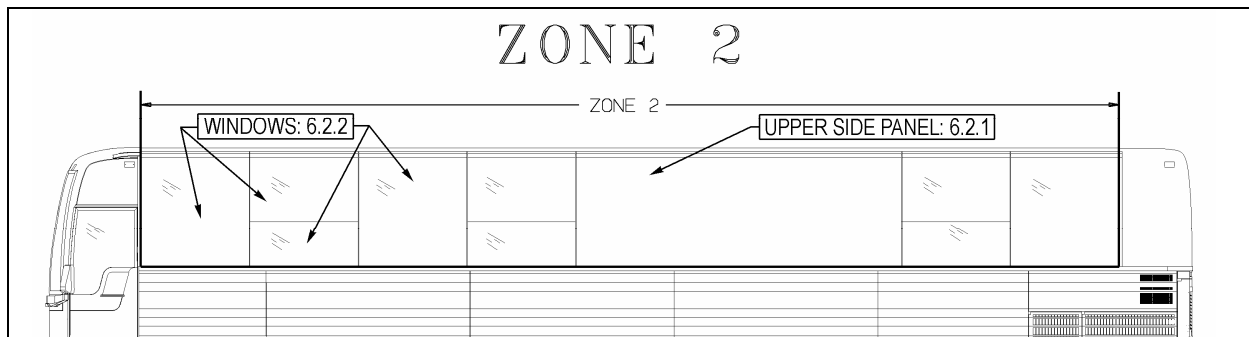

FIGURE 17: ZONE 2

### 6.2.1 Upper Side Panel

For structure preparation, refer to procedure **SAV00035** included at the end of this section.

For installation of upper side panel neoprene foam tapes, refer to procedure **SAV00036** included at the end of this section.

For installation of upper side panel, refer to procedure **SAV00041** included at the end of this section.

### 6.2.2 Fixed Windows

Depending on the method chosen for fixed side window removal or installation, you may need:

- \* Drill equipped with a sharp pointed rod into which a small hole was drilled;
- \* Razor sharp window scraper;
- \* Braided windshield wire and a pair of handles;
- \* Gloves, goggles or face shield.

#### Fixed Window Removal

##### 1<sup>st</sup> Method

#### **NOTE**

*This method is used only in the case of a regular fixed side window. For the fixed upper portion of awning or sliding windows, you must use method number 2.*

- Apply a sticky plastic film onto all of window outside surface for safety reason.
- Using a drill equipped with the special sharp pointed rod, drill through the window seal into one of the bottom corners, from a 30° angle with reference to the vehicle.
- This procedure requires accuracy and it is possible not to succeed on the first attempt. From the inside of vehicle, a second person ensures the rod passes through.
- Remove the rod; thread the wire into the small hole. Reinsert the rod and the wire into the hole far enough so that the person inside the vehicle can pull the rod using a pair of pliers.
- Attach the wire ends to the specially designed handles.
- Pull in turn from the inside and the outside of vehicle to gradually cut the Sika bead on the window perimeter.
- When you reach top corner, detach wire from the outside handle, secure it to a fish wire or rod and thread it underneath the aluminum molding behind the rivets.
- Detach wire from fish wire and continue cutting using the handle.

- Cut Sika bead until you come back to starting point, then you can remove the window by carefully pushing it out from the inside of vehicle.

## 2<sup>nd</sup> Method

- Apply a sticky plastic film onto all of window outside surface.
- To limit as much damage as possible, remove any interior molding in the way. Install a plastic film on the window interior surface and secure using masking tape onto all of window perimeter.

### **NOTE**

*Do not stretch plastic film and leave enough play to be able to push window out without tearing the plastic film.*

- Using a ball peen hammer, hit one of the window bottom corners from the **outside**.
- Carefully push window out and lift it up sufficiently to separate it from the aluminum molding.
- Attach the windshield wire to a fish wire and thread it underneath the aluminum molding behind the rivets.
- Detach wire from fish wire and continue cutting using the handle.
- Make a notch at each window top corner to make sure you pass underneath the remaining pieces of glass.
- Remove the aluminum molding and clean up the frame using the window scraper.

For gluing of lateral fixed window behind driver, refer to procedure **SAV00046** included at the end of this section.

For gluing of lateral fixed half-window, refer to procedure **SAV00045** included at the end of this section.

For the installation of awning or sliding window, refer to procedure **SAV00038** included at the end of this section.

For gluing of lateral fixed window, refer to various procedures: **SAV00037** for gluing vertical and bottom rubber seals; **SAV00043** for the installation of lateral fixed window and **SAV00044** for making the Simson joint around fixed windows.

All these procedures are included at the end of this section.

### 6.2.3 Electric Awning Windows

The electric awning windows are connected directly on the batteries 24 V DC terminal block. As a result, they can be operated regardless of the state open or close of the master switch.

### Window Removal

Replacement awning window does not include a new motor. If in working order, transfer the motor of the replaced window to the replacement window. If not, the motor can be bought separately. When replacing the window, keep the components in working order as spare parts.

1. Push the vertical latch handle downwards to release the track and then open the window using the horizontal latch handle.
2. Take out the screw at the lower end of the track to let free the swiveling arm roller.
3. Unplug connectors. Dismount the gas spring from the window.
4. Loosen the set screws #5 (figure 19) (rotate the arm to get to the second set screw) and disengage the swiveling arm from the motor shaft extension.
5. Push the glass window out ninety degrees (90°).



### **CAUTION**

The window may fall out.

6. The window is free and can be unhooked.
7. Reverse procedure to install a new one.



Section 18: BODY

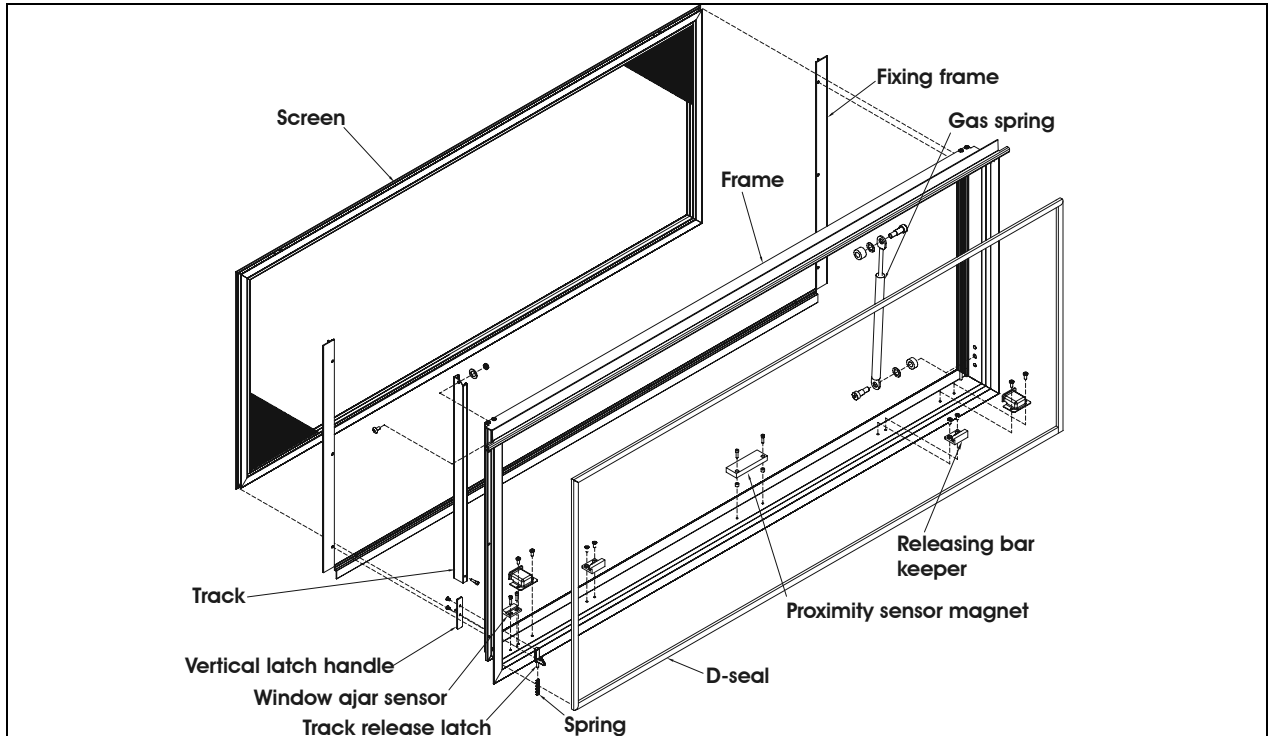

FIGURE 18: ELECTRIC AWNING WINDOW EXPLODED VIEW (FRAME) 18586

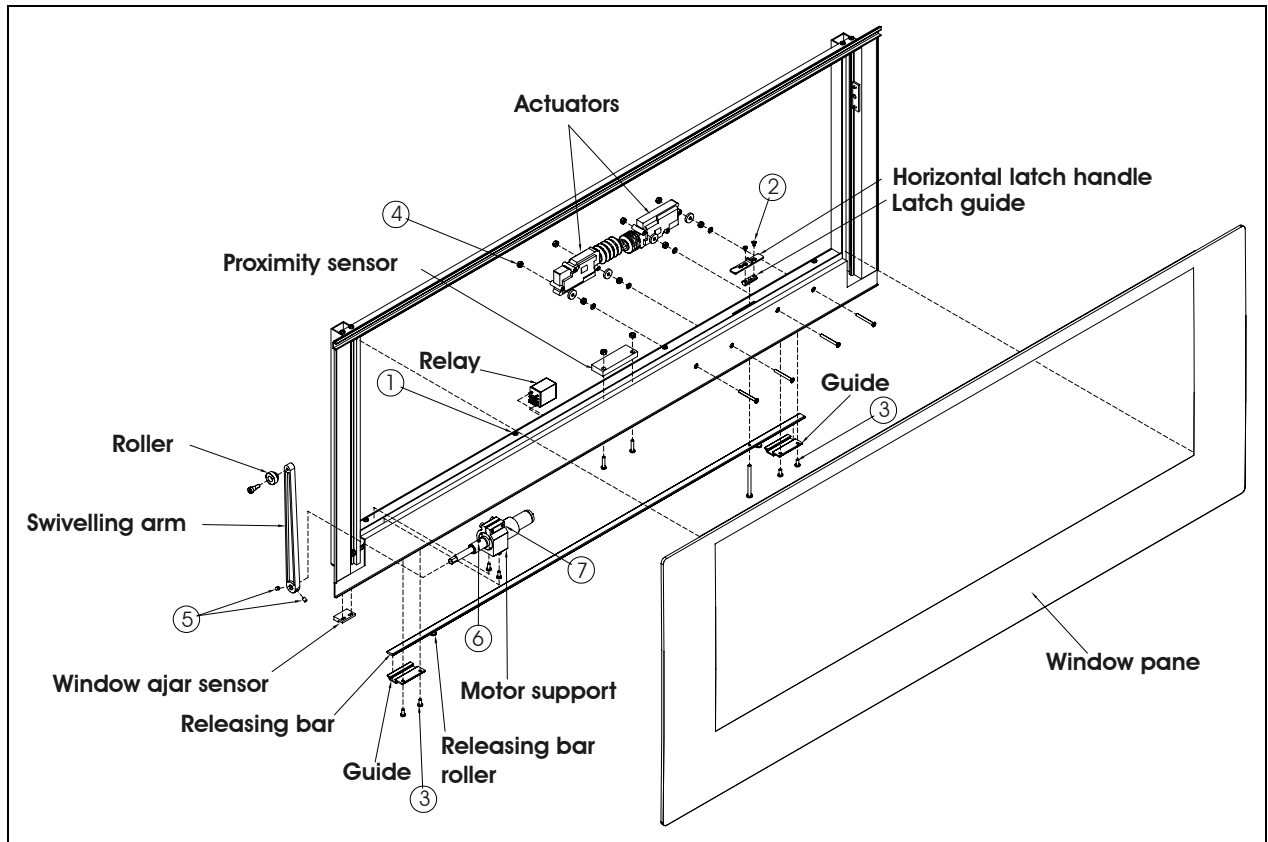

FIGURE 19: ELECTRIC AWNING WINDOW EXPLODED VIEW (SASH)

18583

**Actuator Replacement**

1. Push the vertical latch handle downwards to release the track and then unlatch the window using the horizontal latch handle.
2. Remove actuator access cover by taking out screws #1 (8x).
3. Take out screws #2 (2x) and remove horizontal latch handle and guide.
4. Take out the guide screws #3 (4x) and remove releasing bar.
5. Unplug connectors from defective actuator, unscrew nuts #4 (2x) and remove the actuator.
6. Reverse operations for reinstallation.

**Motor Replacement**

1. Push the vertical latch handle downwards to release the track and then unlatch the window using the horizontal latch handle
2. Take out the screw at the lower end of the track to let free the swiveling arm roller.
3. Remove actuator access cover by taking out screws #1 (8x).
4. Loosen the set screws #5 (rotate the arm to get to the second set screw) and disengage the swiveling arm from the motor shaft extension.
5. Unplug motor connector and dismount motor and support assembly.
6. The shaft extension is glued to the motor shaft. It has to be heated to break the binding to permit removal. Loosen set screw #6 and remove the shaft extension. Also loosen screw #7 and remove motor from the support.

Reverse operations for reinstallation.

ELECTRIC AWNING WINDOW – CONVERTER CHECKLIST	
Check the electrical circuit & proximity sensor	<p>A: The latching system will not operate without power.</p> <p>Is there electrical power to the latching circuit? The horizontal latch handle, on the sill sash will be seen to move if there is power on this circuit, or it can be checked with an electrical tester. If there is no power to this circuit when the window is closed and either rocker switch are switched "ON", there is a problem with the electrical system.</p> <p>B: The Proximity Sensor on the sash may not be switching power to the latching circuit if the magnet is not getting close enough to the switch OR the Proximity Sensor may be broken (or stuck in one position).</p> <p>Is the proximity sensor switching when the window is closed?</p>
Check the release force required to operate the horizontal latch handle	<p>A: If the pull force required to move the latch is more than 20lbs the window will not latch properly. Average pull force during testing by manufacturer is 12lbs -15lbs.</p> <p>What is the force required to release the handle? Check using a force gauge (same test done by manufacturer).</p>
Check Installation	<p>A: If the window is too tightly installed OR if the sequence for tightening the clamping frame screws is incorrect the window may not close properly.</p> <p>Was the window installed correctly?</p> <p>Was the correct sequence (see below) used when tightening the clamping frame screws?</p> <div style="text-align: center;"> </div> <p>B: Removing the shipping blocks before the window is installed can create major problems.</p>

## Section 18: BODY

	<p>Were the shipping blocks in place during installation?</p> <p>C: Failure to remove the shipping blocks after installation can create interference between sash and frame.</p> <p>Have the shipping blocks been removed after installation?</p> <p>D: The window is misaligned or not installed squarely.</p> <p>Is there interference with any coach parts?</p> <p>Is there proper clearance between the bottom of the outer glass and the belt-line trim / seal?</p>
<p>Check for missing parts or misaligned parts</p>	<p>A: The frame and sash are misaligned.</p> <p>Is there any interference between the sash and frame?</p> <p>Is there clearance between the sash and the rocker switch covers?</p> <p>B: Releasing bar guides are missing.</p> <p>Check that the releasing bar guides are installed. There should be 4 installed on H windows, and 3 installed on XL2 windows.</p>

### 6.2.4 Electric Sliding Windows

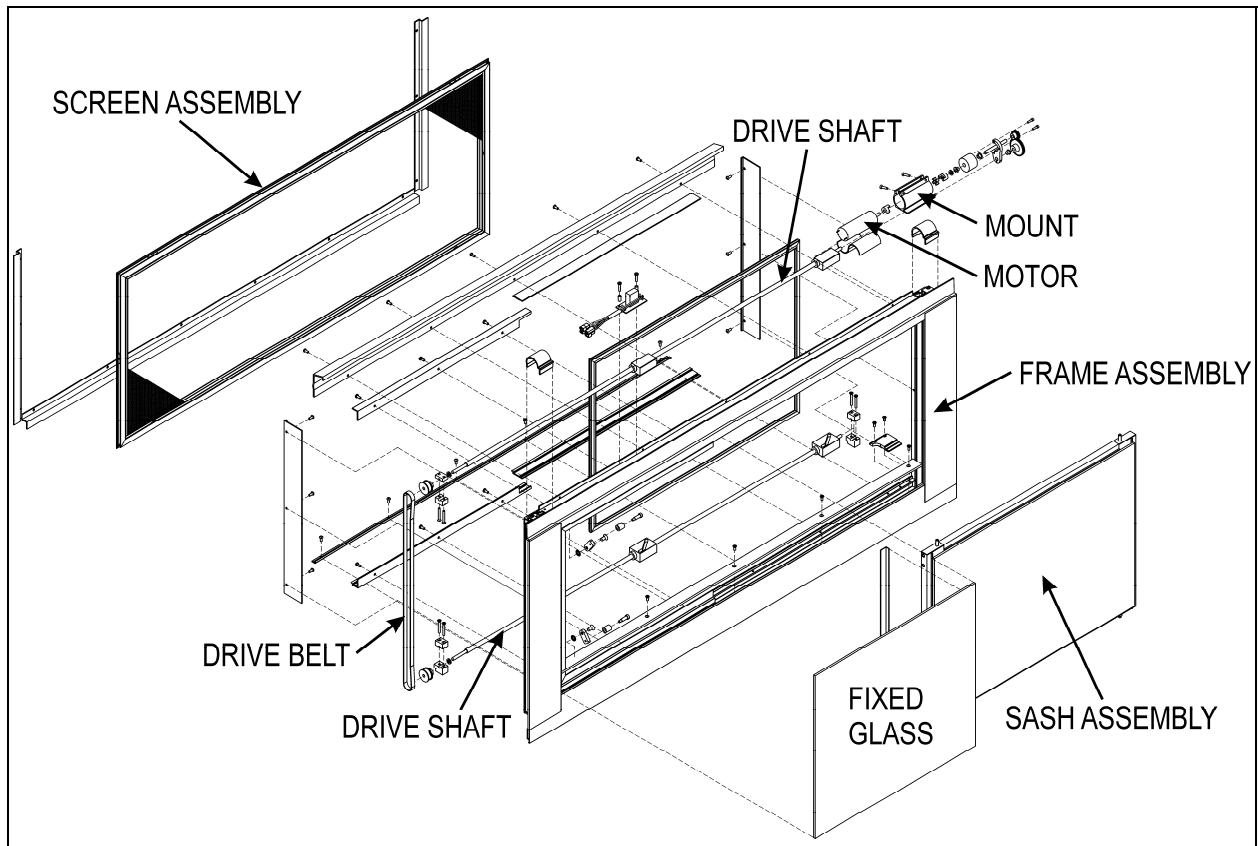

FIGURE 20: ELECTRIC SLIDING WINDOW EXPLODED VIEW

#### Sash Removal

1. Remove the Screen Assembly
2. Pull down on both release latches simultaneously and rotate the sash inwards approximately 10 degrees.(Figure 21)



FIGURE 21: REMOVING THE SASH

3. Lift the sash up and out to disengage the bottom of the sash from the window frame. (Figure 22)



FIGURE 22: DISENGAGING THE BOTTOM OF THE SASH

### Installation

1. Align the leading edge of the slot on the lower cam follower block with the sash stop. Use the power toggle switch to obtain the correct alignment. (Figure 23)

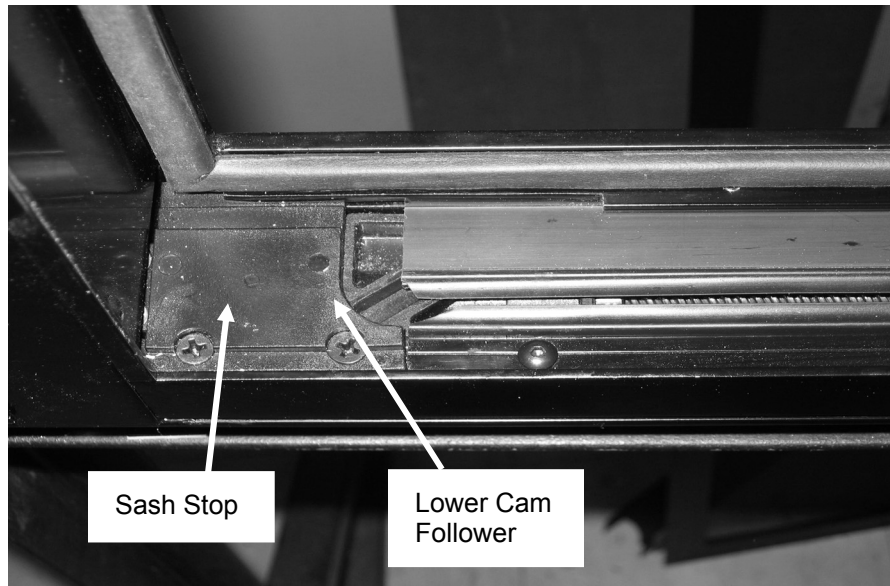

FIGURE 23: PROPER ALIGNMENT

2. Position the left hand lower corner of the sash over the front cam follower block (Figure 24)

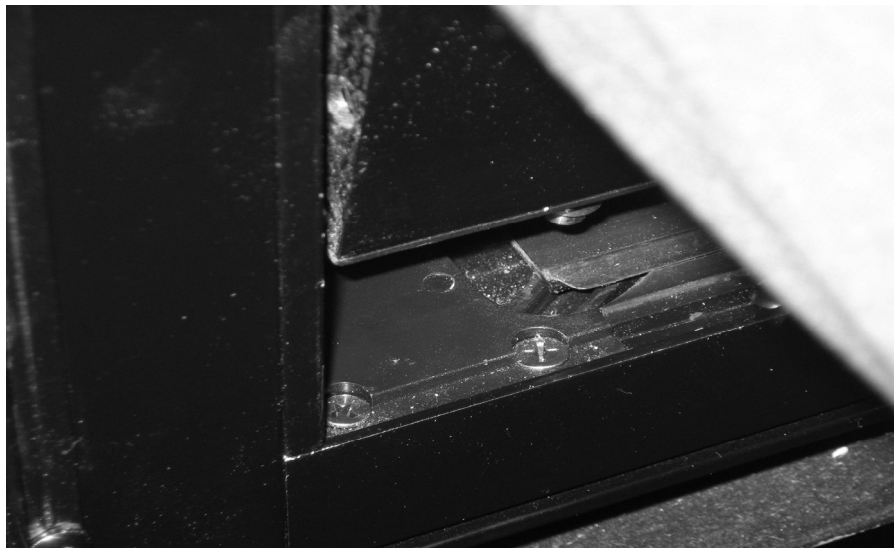

FIGURE 24: POSITIONING THE LOWER LEFT CORNER OF THE SASH

3. Engage the sash pin with the leading edge of the slot of the cam follower block. Do the same at the rear of the sash.
4. Pull down on the release latches and rotate the sash inwards until it is parallel with the window frame.
5. Release the latches to engage the latch pins with the upper cam follower blocks.
6. Confirm that both latches are in the closed (latched) position. The upper edge of the latch opening must be aligned with upper edge of the sash opening (Figure 25)

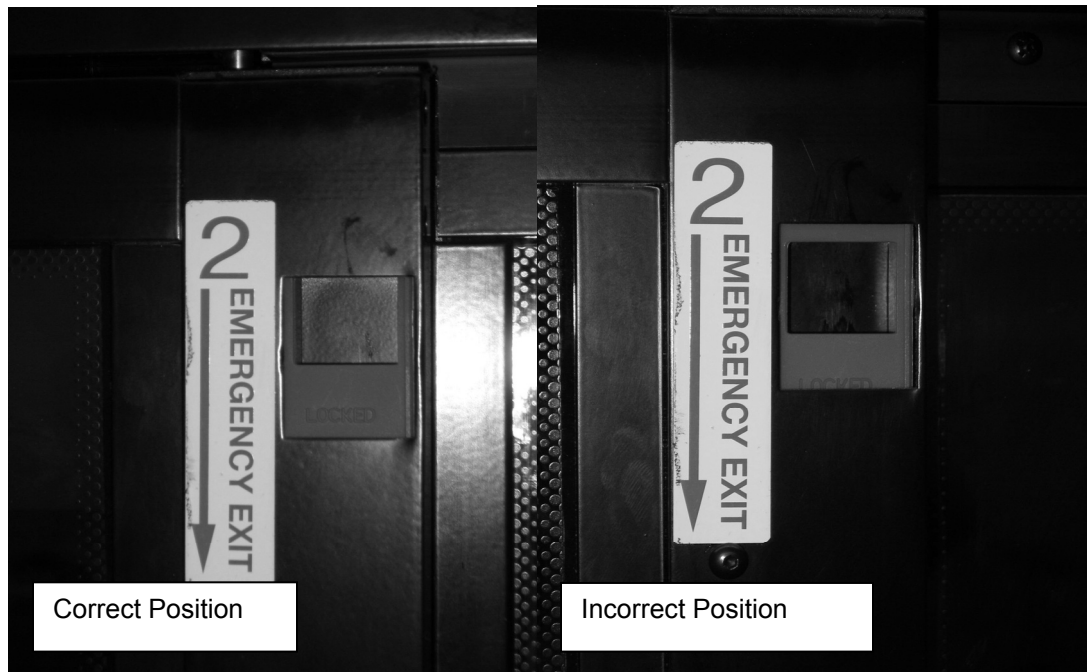

FIGURE 25: RELEASE LATCH PROPER POSITION

7. \* Failure to confirm this step may lead to the sash becoming disengaged with the frame and could result in personal injury.
8. Operate the window to confirm that it opens and closes properly.

Install the screen assembly.

### 6.3 ZONE 3

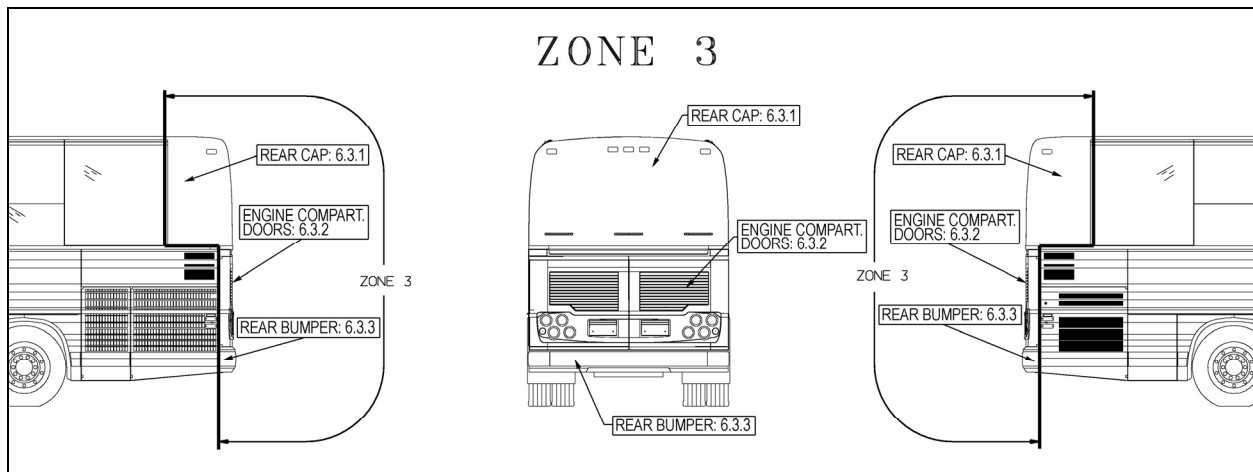

FIGURE 26: ZONE 3

#### 6.3.1 Rear Cap

The fiberglass rear cap does not need any maintenance except painting as needed. It is held in place with adhesive. If ever it has to be replaced, make an appointment at a Prévost service center near you.

For minor damages, refer to Paragraph 4 "Common Fiberglass Repair Procedure" and Paragraph 5 "Common Painting Procedure".

#### 6.3.2 Engine Compartment Doors

##### ❖ Engine Compartment Doors Adjustment

## Section 18: BODY

Engine compartment doors may be adjusted for proper fit by untightening hinge bolts:

1. Loosen the bolts, (1, 2 Fig. 27) holding the hinge to the vehicle structure to shift the door "UP or DOWN".
2. Loosening the bolts (3, Fig. 27) allows the door to be shifted "LEFT or RIGHT" and "IN or OUT".
3. Adjust the doors position depending on the gap needed between exterior finishing panels.
4. Tighten the bolts.
5. Check that the doors swing freely and close properly. It may be necessary to adjust the door latch to get proper fit and operation.

To adjust the latch mechanism (4, Fig. 27) and the striker pin:

1. Open the doors to access the striker pin.
2. Slightly loosen the striker pin.
3. Using a hammer, adjust the striker pin to center it in the door latch mechanism.
4. Tighten the striker pin.
5. Check doors fit and operation.

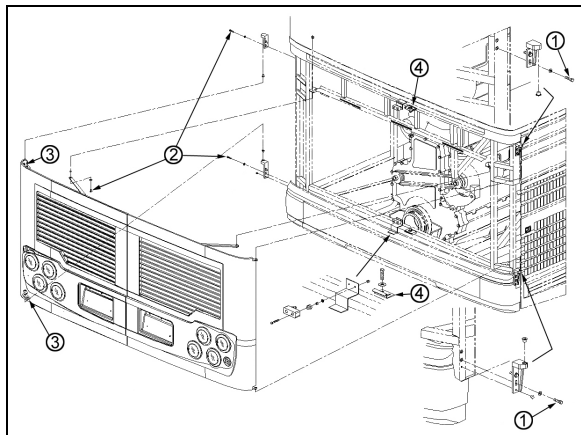

FIGURE 27: ENGINE COMPARTMENT DOORS 18633

### ❖ Engine Compartment Door Body Panel Removal

For the removal of engine compartment door body panel, you will need:

Pneumatic "Zip gun" type tool;  
Razor sharp window scraper;  
A pair of locking pliers;  
Isopropyl alcohol.

- Remove damaged engine compartment door from vehicle.
- Install the damaged door onto an appropriate support.
- Wearing gloves, goggles and ear plugs, pry loose body panel using a "Zip gun" or lever starting from the edge opposite the curved side.
- Use the "Zip gun" to detach completely the stainless steel body panel from door frame.



### CAUTION

Do not damage painted surface.

- Use a second person equipped with a pair of locking pliers to pull the body panel as you cut the Sika bead.



### WARNING

Be very careful when pulling the body panel, somebody could get hurt if the body panel suddenly detach from the door surface without notice.

- Using the window scraper, remove any Sika bead or self adhesive tape residue left on the fiber glass surface.

For gluing of engine compartment doors molding, refer to procedure **SAV00211** included at the end of this section.

For engine compartment door body panel installation, refer to procedure **SAV280032** included at the end of this section.

### 6.3.3 Rear Bumper

Remove three bolts on each side holding bumper to vehicle and remove bumper.

To install bumper, reverse the procedure.

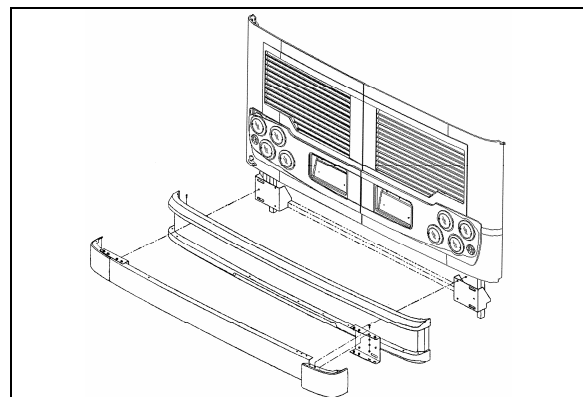

FIGURE 28: REAR BUMPER

## 6.4 ZONE 4

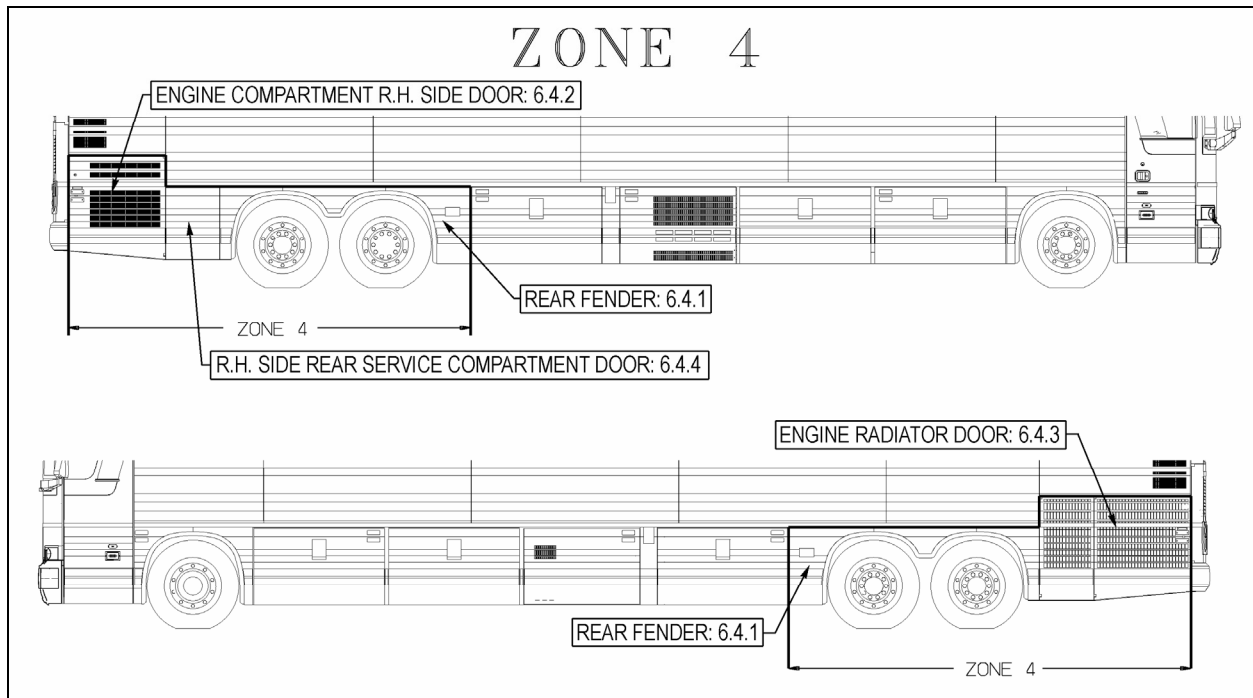

FIGURE 29: ZONE 4

## 6.4.1 Rear Fender

On the "XLII MTH" series vehicles, rear fenders are hinged for maintenance on brakes and suspension. Each rear fender panel has two mechanical spring loaded holding devices fixing it to the vehicle's structure. Push the spring type rod sideways to disengage the lock.

For the installation of rear fender body panel, refer to procedure **SAV470046** included at the end of this section.

## 6.4.2 Engine Compartment R.H. Side Door

Engine compartment R. H. side door may be adjusted for proper fit by untightening hinge bolts:

1. Loosen the bolts, (1, Fig. 30) holding the hinge to the vehicle structure to shift the door "IN or OUT" and "UP or DOWN".
2. Loosening the bolts (2, Fig. 30) allows the door to be shifted "LEFT or RIGHT" and "UP or DOWN".
3. Adjust the door position depending on the gap needed between exterior finishing panels.
4. Tighten the bolts.

5. Check that the door swings freely and closes properly. It may be necessary to adjust the door latch to get proper fit and operation.

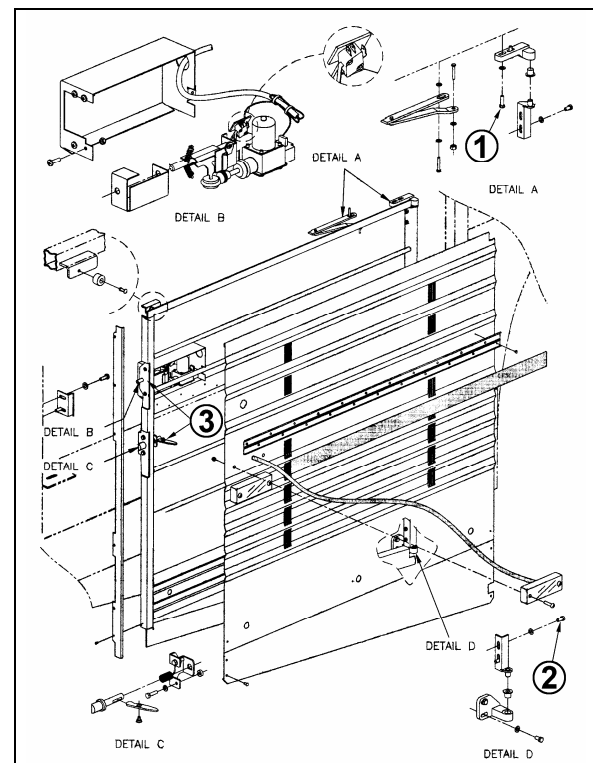
FIGURE 30: ENGINE COMPARTMENT R.H. SIDE DOOR<sup>18635</sup>



## Section 18: BODY

To adjust the latch mechanism (3, Fig. 30) and the striker pin:

1. Open the door to access the striker pin.
2. Slightly loosen the striker pin.
3. Using a hammer, adjust the striker pin to center it in the door latch mechanism.
4. Tighten the striker pin.
5. Check door fit and operation.

For gluing of engine compartment R.H. side door finishing molding, refer to procedure **SAV00210** included at the end of this section.

### 6.4.3 Engine Radiator Door

Radiator door may be adjusted for proper fit by untightening hinge bolts:

1. Loosen the bolts, (1, Fig. 31) holding the hinge to the vehicle structure to shift the door "IN or OUT" and "UP or DOWN".
2. Loosening the bolts (2, Fig. 31) allows the door to be shifted "LEFT or RIGHT" and "UP or DOWN".

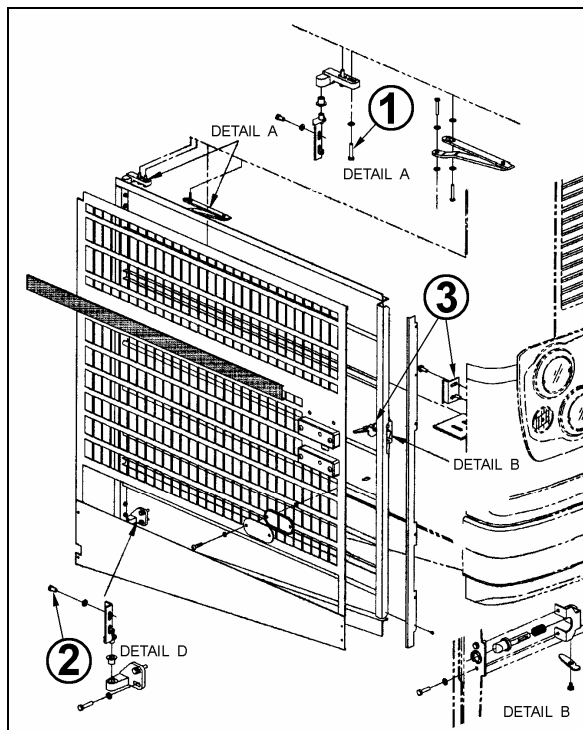

FIGURE 31: RADIATOR DOOR

18636

3. Adjust the door position depending on the gap needed between exterior finishing panels.
4. Tighten the bolts.

5. Check that the door swings freely and closes properly. It may be necessary to adjust the door latch to get proper fit and operation.

To adjust the latch mechanism (3, Fig. 31) and the striker pin:

1. Open the door to access the striker pin.
2. Slightly loosen the striker pin.
3. Using a hammer, adjust the striker pin to center it in the door latch mechanism.
4. Tighten the striker pin.
5. Check door fit and operation.

### ❖ Engine Small Radiator Door

Small radiator door may be adjusted for proper fit by untightening hinge bolts:

1. Loosen the bolts, (1, Fig. 32) holding the hinge to the vehicle structure to shift the door "IN or OUT" and "UP or DOWN".
2. Loosening the bolts (2, Fig. 32) allows the door to be shifted "LEFT or RIGHT" and "UP or DOWN".

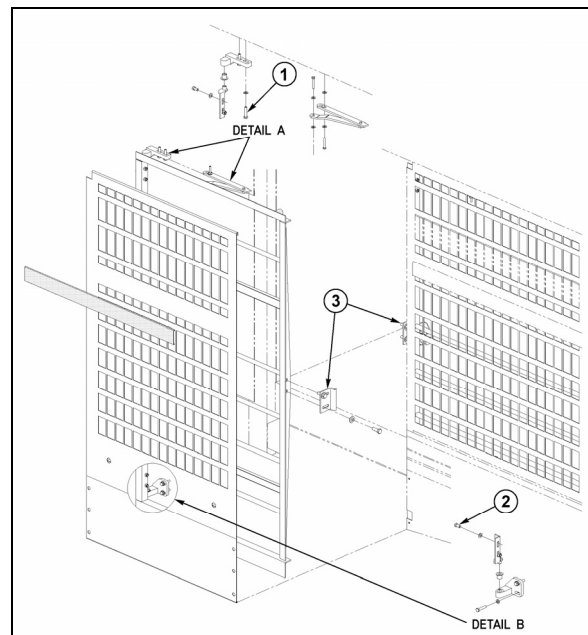

FIGURE 32: SMALL RADIATOR DOOR

18636

3. Adjust the door position depending on the gap needed between exterior finishing panels.
4. Tighten the bolts.
5. Check that the door swings freely and closes properly. It may be necessary to

adjust the door latch to get proper fit and operation.

To adjust the latch mechanism (3, Fig. 32) and the striker pin:

1. Open the radiator door to access the striker pin.
2. Slightly loosen the striker pin.
3. Using a hammer, adjust the striker pin to center it in the door latch mechanism.
4. Tighten the striker pin.
5. Check door fit and operation.

For gluing of engine radiator door finishing molding, refer to procedure **SAV00210** included at the end of this section.

#### 6.4.4 R.H. Side Rear Service Compartment Door

To adjust the R. H. side rear service compartment door:

1. Open the compartment door.
2. Loosen the screws fixing the hinge to hinge attachment or hinge to door assembly. Loosening the screws allows the compartment door assembly to be shifted "LEFT or RIGHT" and "UP or DOWN" or "IN and OUT".
3. Adjust compartment door assembly position at the hinge.
4. Tighten the screws.

5. Respect the required gap between exterior finishing panels.
6. Check that the door swings freely and closes properly. It may be necessary to adjust the door latch to get proper fit and operation.

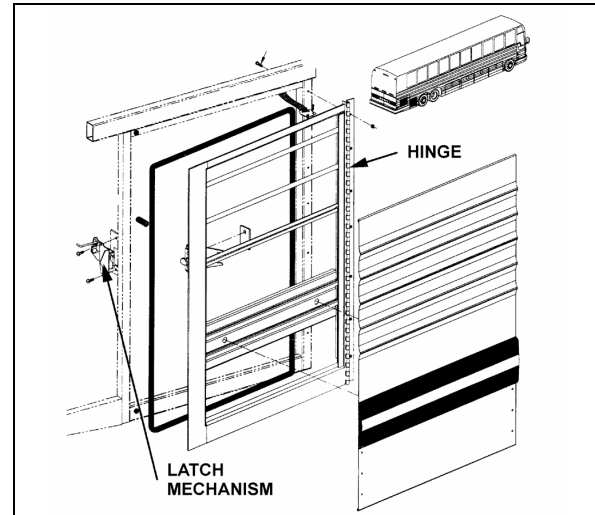

FIGURE 33: R.H. SIDE REAR SERVICE COMPARTMENT DOOR

To adjust the latch mechanism and the striker pin:

1. Open the door to access the striker pin.
2. Loosen slightly the striker pin.
3. Using a hammer, adjust the striker pin to center it in the door latch mechanism.
4. Tighten the striker pin.
5. Check door fit and operation.

### 6.5 ZONE 5

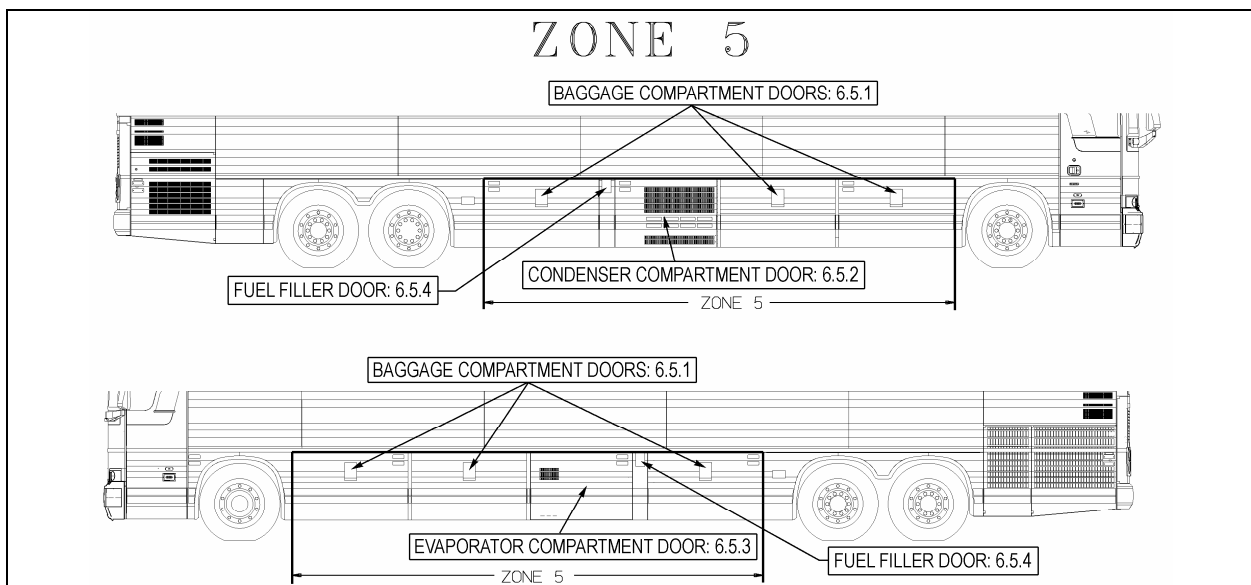

FIGURE 34: ZONE 5

## Section 18: BODY

### 6.5.1 Baggage Compartment Doors

The baggage compartment doors on the vehicle are of identical design. The doors are pantograph, vertical-lift type and are fully sealed. Each door has a flush-mounted latch handle. To open, lift latch handle, then pull door outward and up. The door is held open by 2 gas-charged cylinders. To close, leave latch handle in the open position, pull downward on door and push down on latch to secure door. The door lower arm is spring loaded to secure effort required to close the door (Fig. 35).

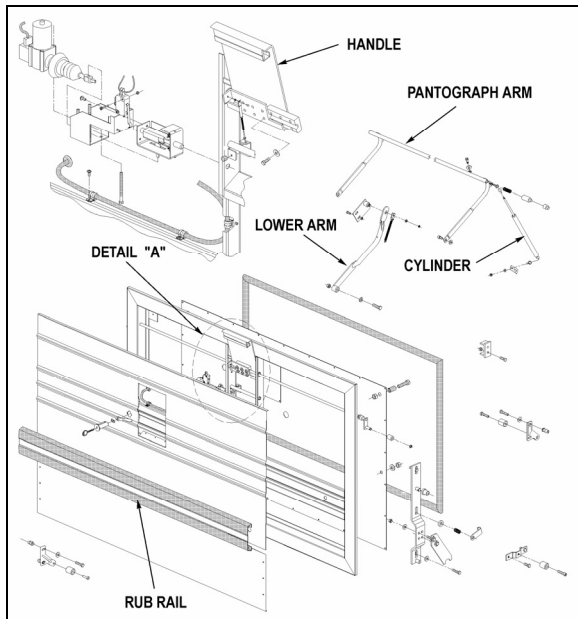

FIGURE 35: BAGGAGE COMPARTMENT DOOR 18145

If a door does not remain in the fully open position, one or both cylinders on that door is (are) defective. To test the cylinders, first support the door in the open position with proper equipment. Disconnect the rod end of one cylinder and retract the rod. If strong resistance is felt, the cylinder is in good condition and can be reinstalled. If the rod retracts with little effort, the cylinder is defective and should be replaced at once. Use the same procedure to test the other cylinder on that door.

#### ❖ Door Removal



### CAUTION

Two people are required to remove the baggage compartment doors.

1. Maintain the door halfway open by placing a wooden block between one of the pantograph arms and the upper frame.
2. Remove cap screw, lock washer and flat washer retaining lower arm to door
3. Remove spring pins and lock washers fastening the pantograph arms to the door.



### WARNING

Support the door properly to prevent it from falling.

4. Spread the pantograph arms away from the door and remove door.
5. Inspect all pivot points and bushings for wear and damage. Check tension of gas-charged cylinders and replace if necessary.

#### ❖ Pantograph Arms Removal and Installation

1. Disconnect rod end of gas-charged cylinders from the pantograph arms.
2. Loosen jam nut and cap screw locking the horizontal member of the pantograph to the pivot pin.
3. Slide pantograph assembly to the right and remove assembly from the vehicle.
4. To install, perform the removal instructions in reverse.

#### ❖ Door Installation

1. Use a wooden block to support the pantograph arms horizontally.
2. Support the door and insert each pantograph arm into the pivot pins on the side of the door.
3. Install washer and spring pin to fasten each arm to its pivot pin.
4. Fasten lower arm to the door with flat washer, lock washer and cap screw.
5. Remove wooden block and close baggage compartment door.

Door should be adjusted to leave a gap of 3/16" (5 cm) above the top edge of the door. To adjust, loosen the bolts retaining lock plate support and position the door correctly. Tighten the bolts after the adjustment.

If the baggage door locks too tightly or too loosely, the position of the catch striker is misadjusted. To adjust, loosen the catch striker retaining bolts, position the striker correctly and tighten the retaining bolts.

If the lower part of the baggage door does not close evenly with the side of the vehicle, adjust the lock plates by loosening their retaining bolts and positioning the locking plates correctly (Fig. 36).

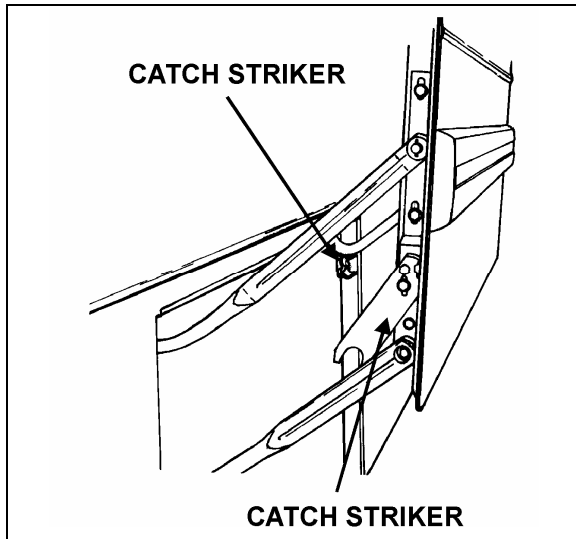

FIGURE 36: BAGGAGE DOOR CATCH STRIKER 18146

For the removal and installation of baggage compartment door body panels, refer to procedure **SAV00177** included at the end of this section.

### 6.5.2 Condenser Compartment Door

1. Open the condenser door.
2. Loosen the screws fixing the hinge to hinge attachment or hinge to door assembly. Loosening the screws allows the condenser door assembly to be shifted "LEFT or RIGHT" and "UP or DOWN" or "IN and OUT".
3. Adjust condenser door assembly position at the hinge.
4. Tighten the screws.
5. Respect the required gap between exterior finishing panels.
6. Check that the door swings freely and closes properly. It may be necessary to adjust the door latch to get proper fit and operation.

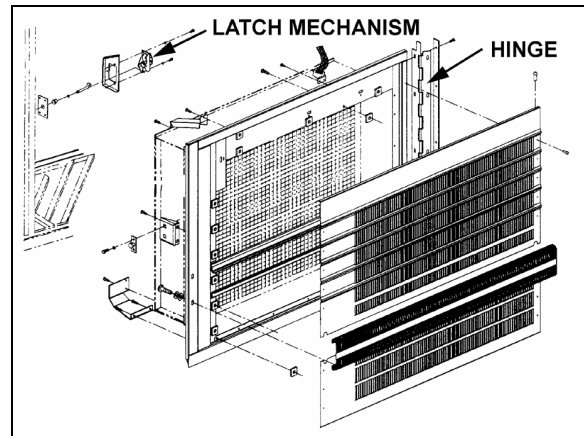

FIGURE 37: CONDENSER DOOR

For the installation of condenser compartment door body panel, refer to procedure **SAV00131** included at the end of this section.

### 6.5.3 Evaporator Compartment Door

1. Open the evaporator door.
2. Loosen the screws fixing the hinge to hinge attachment or hinge to door assembly. Loosening the screws allows the evaporator door assembly to be shifted "LEFT or RIGHT" and "UP or DOWN" or "IN and OUT".
3. Adjust evaporator door assembly position at the hinge.
4. Tighten the screws.
5. Respect the required gap between exterior finishing panels.
6. Check that the door swings freely and closes properly. It may be necessary to adjust the door latch to get proper fit and operation.

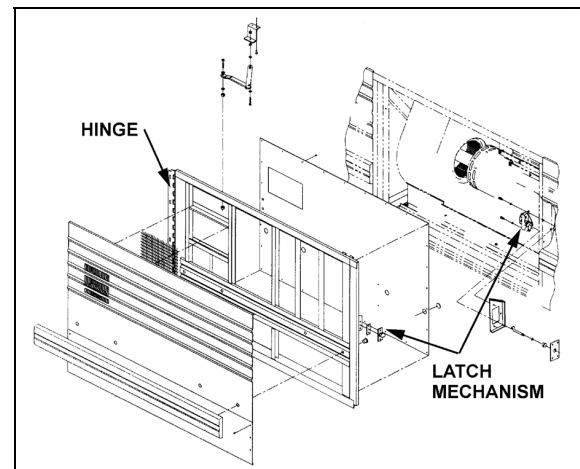

FIGURE 38: EVAPORATOR DOOR

## Section 18: BODY

For the installation of evaporator compartment door body panel, refer to procedure **SAV00133** included at the end of this section.

### 6.5.4 Fuel Filler Door

- Open the fuel filler door.
- Loosen the screws holding the panel to hinge assembly.
- Adjust the fuel filler door position according to distance required between exterior finishing panels.
- Tighten the nuts.

- Check that the door swings freely and closes properly.

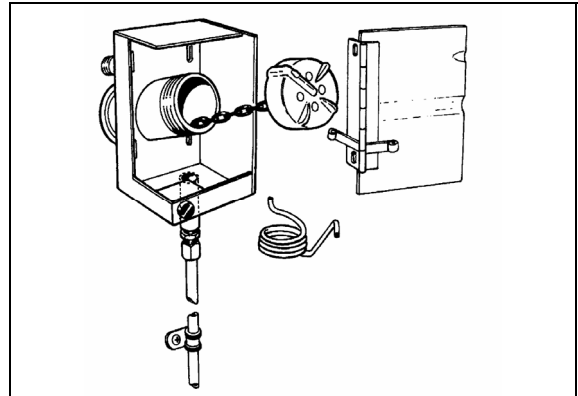

FIGURE 39: FUEL FILLER DOOR

03046

## 6.6 ZONE 6

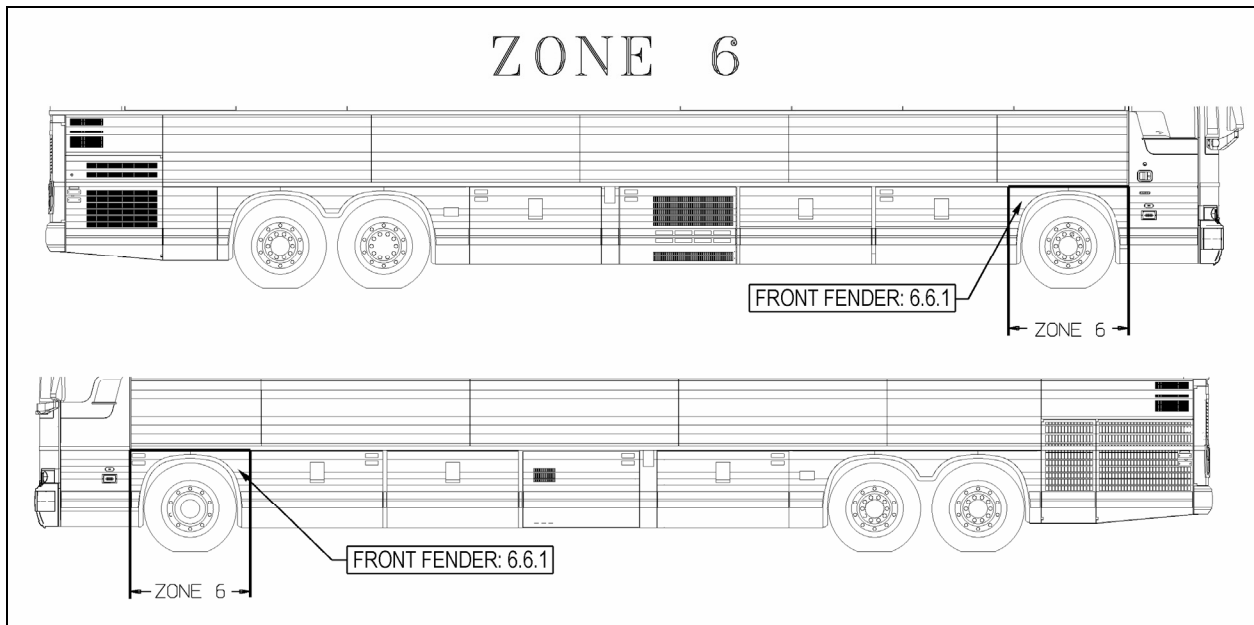

FIGURE 40: ZONE 6

### 6.6.1 Front Fender

Front fender may be removed using the following procedure:

Remove the nuts on the inside of the fender. Remove the fender from the vehicle. To reinstall, reverse the procedure.

For the installation of front fender body panel, refer to procedure **SAV470024** included at the end of this section.

## 6.7 ZONE 7

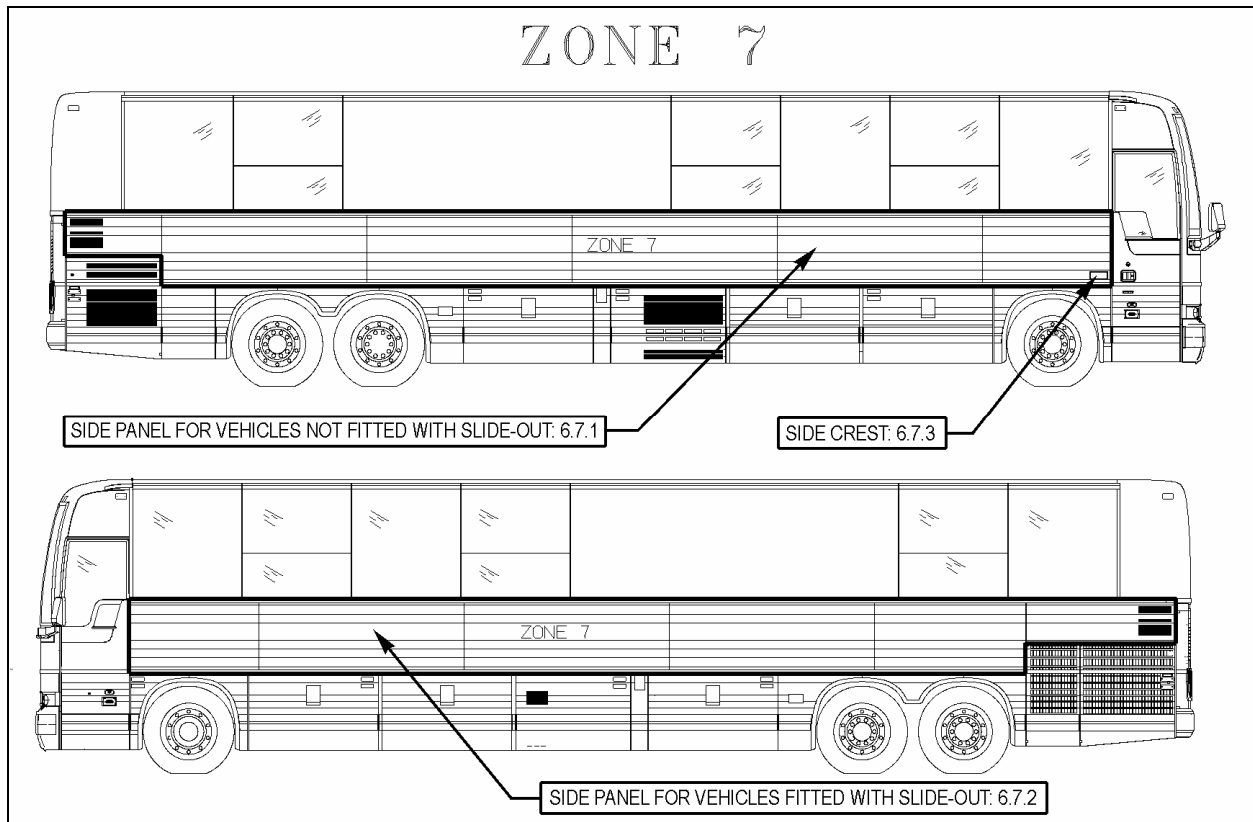

FIGURE 41: ZONE 7

## 6.7.1 Side Panel for Vehicles Not Fitted With Slide-Out

## ❖ Removal

Remove top and bottom finishing moldings. Insert a screwdriver into snap-on finishing molding joint. Bend finishing molding enough to be able to fix a pair of locking pliers. Using the pair of locking pliers, pull the stainless steel molding and at the same time gradually cut Sika bead with a sharp knife.	Be careful not to damage the adjacent surfaces You need to remove the finishing molding support and rivets in the case of engine air intake panel.
Insert a flat screwdriver between the side panel and the vehicle chassis, in the top left and right corners.	
Use the c-clamp to peel the side panel from the back structural panel as far as the middle and at the same time gradually cut Sika bead with a sharp knife. Do the same for the other corner.	Ideally, the hoist or chain block must be fastened to the floor while pulling from a 45° angle so as not to damage the vehicle structure
Remove as much glue as possible from the structure using a putty knife or pneumatic knife without damaging 206 G+P primer.	Never heat SikaFlex adhesive to remove.
Check panel horizontal supports for straightness using a straight edge. Take measurements with a ruler.	Tolerance: 1mm towards the outside and 1.5mm towards the inside.

## Section 18: BODY

For the structure preparation before the installation of a ridged side panel, refer to procedure **SAV00027** included at the end of this section.

For gluing of ridged side panels, refer to procedure **SAV00028** included at the end of this section.

For sealing the side panels' upper portion, refer to procedure **SAV00030** included at the end of this section.

For gluing of horizontal finishing molding, refer to procedure **SAV00208** included at the end of this section.

### 6.7.2 Side Panel for Vehicles Fitted With Slide-Out

#### ❖ Removal

Refer to paragraph 6.7.1 for procedure.



## CAUTION

Because most junction panels are only riveted and not spot welded, be careful when removing a side panel not to damage adjacent panels.

For the slide-out junction panel preparation before the installation of a ridged side panel, refer to procedure **SAV00031** included at the end of this section.

For gluing of ridged side panels on vehicles fitted with slide-out, refer to procedure **SAV00029** included at the end of this section.

### 6.7.3 Side Crest

- Clean vehicle surface using anti-silicone where the side crest and stickers will be applied.
- Using hands apply and compress side crest.
- Apply required stickers.

## 6.8 ZONE 8

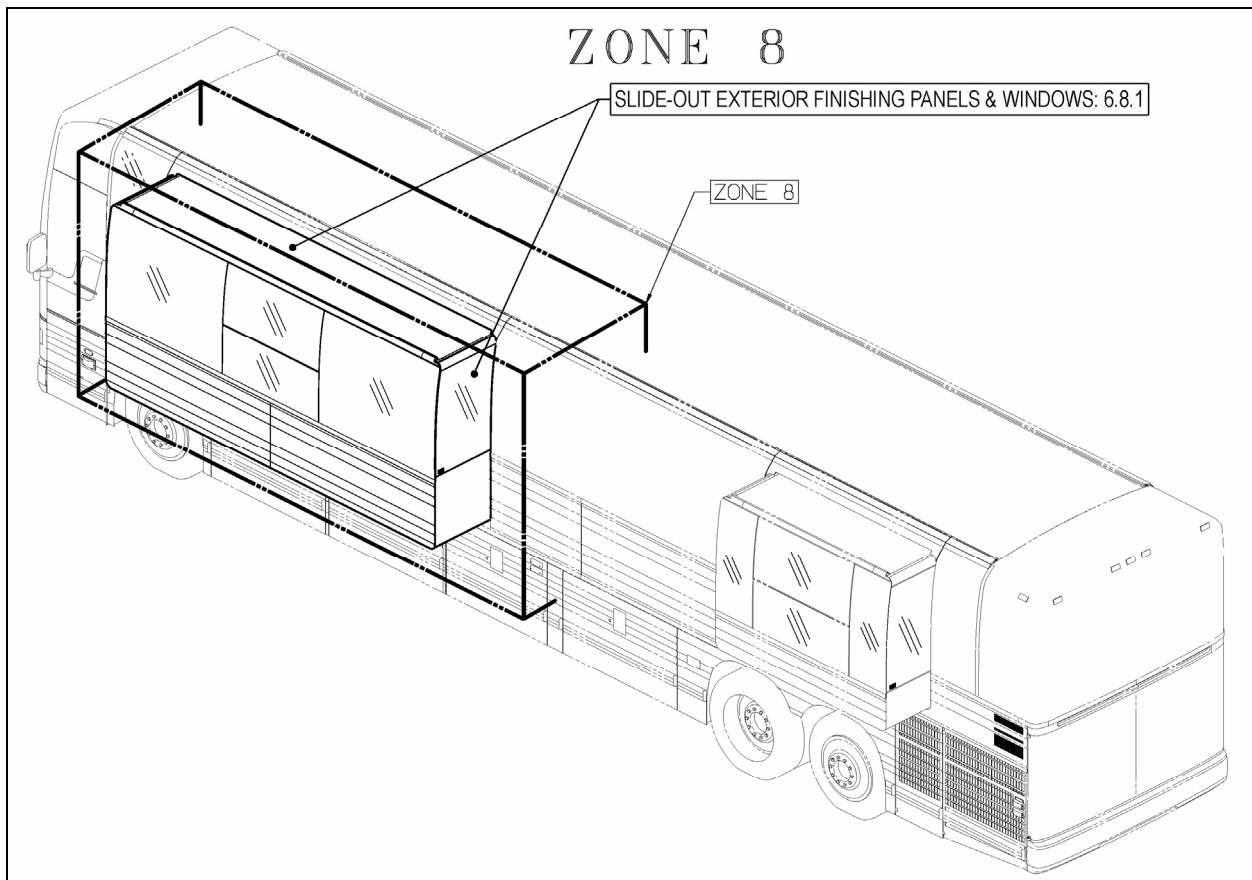

FIGURE 42: ZONE 8

6.8.1 *Slide-Out Exterior Finishing Panels & Windows*

Refer to Maintenance Manual, Section 26: Paragraph 16 for the procedure on slide-out exterior finishing panels & windows.

6.9 ZONE 9

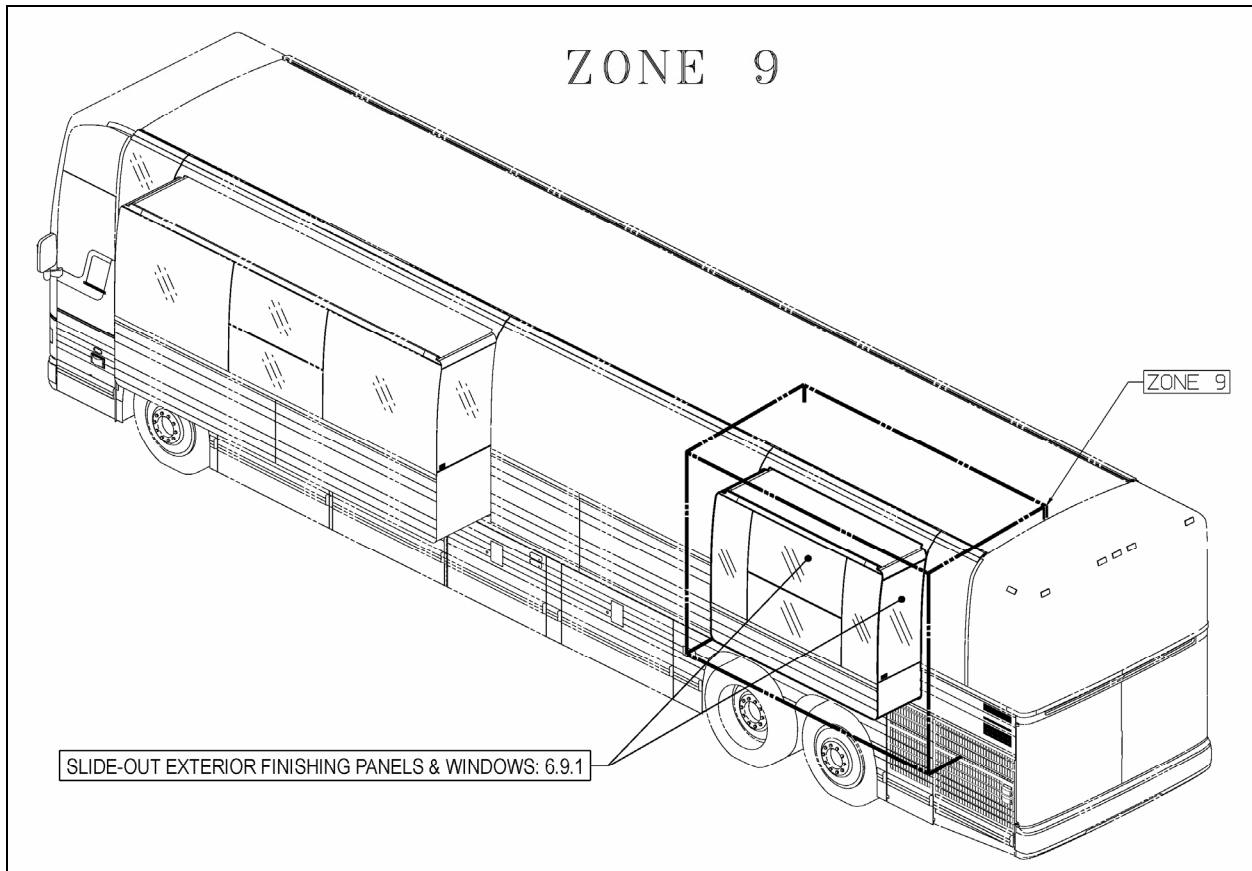

FIGURE 43: ZONE 9

6.9.1 *Slide-Out Exterior Finishing Panels & Windows*

Refer to Maintenance Manual, Section 26: Paragraph 16 for the procedure on slide-out exterior finishing panels & windows.



6.10 BODY PANEL AND WINDOW SPACING FOR W5 MTH NOT FITTED WITH SLIDE-OUT

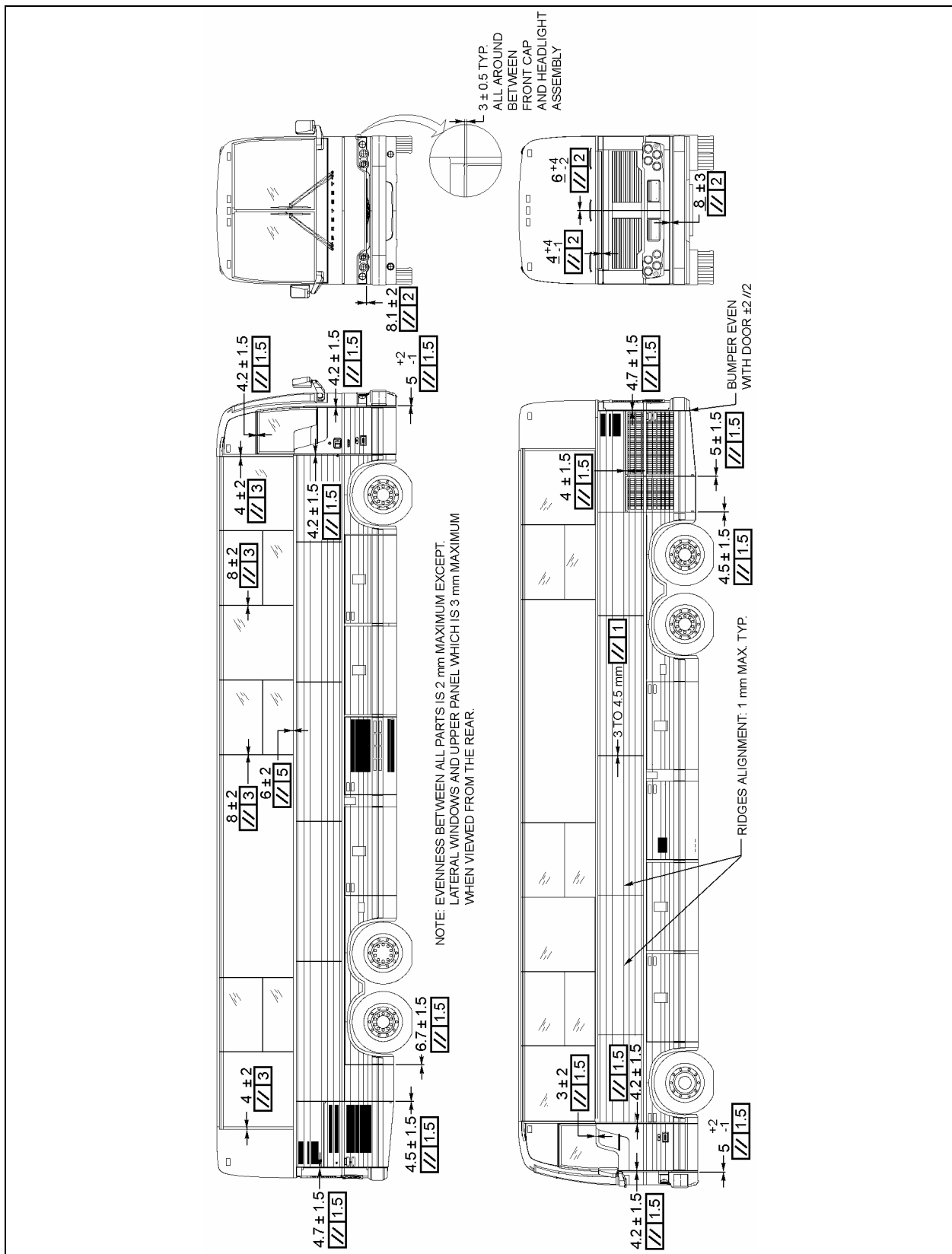

FIGURE 44: BODY PANEL & WINDOW SPACING FOR W5 MTH NOT FITTED WITH SLIDE-OUT



## Section 18: BODY

### 7. WE MTH EXTERIOR FINISHING AND BODY REPAIR

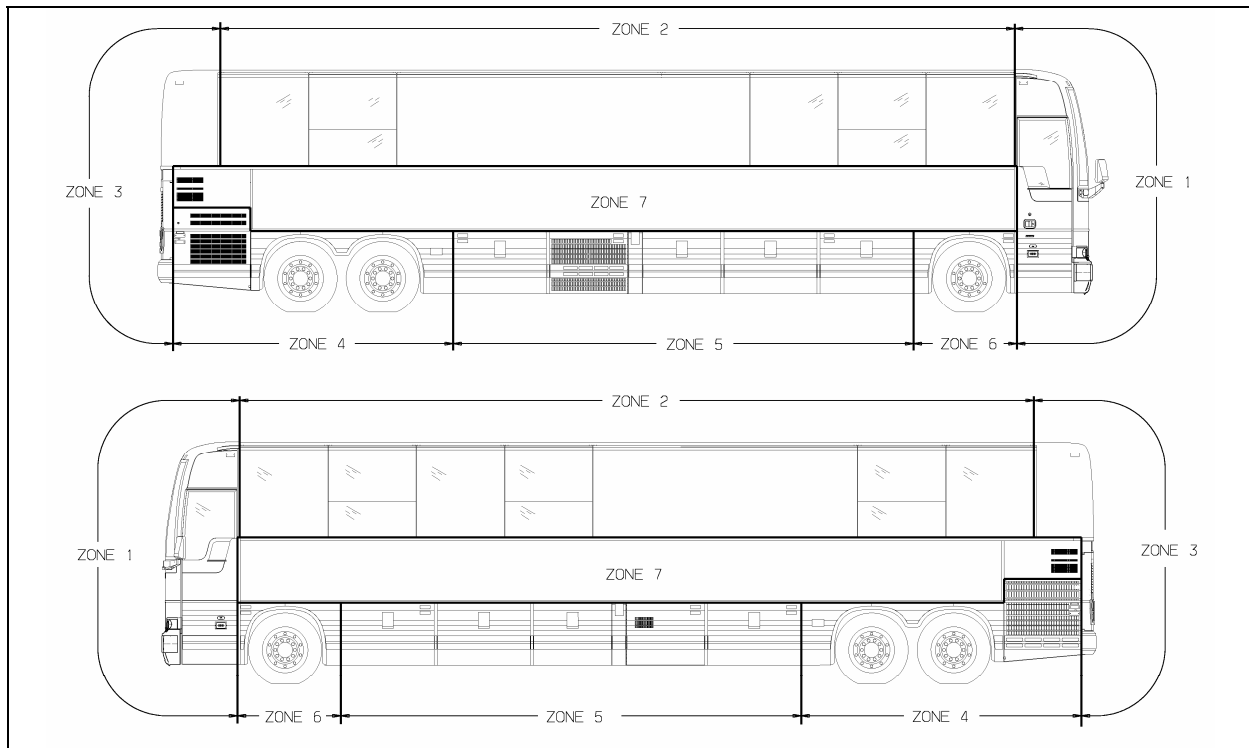

FIGURE 46: WE MTH ZONING

#### 7.1 ZONE 1

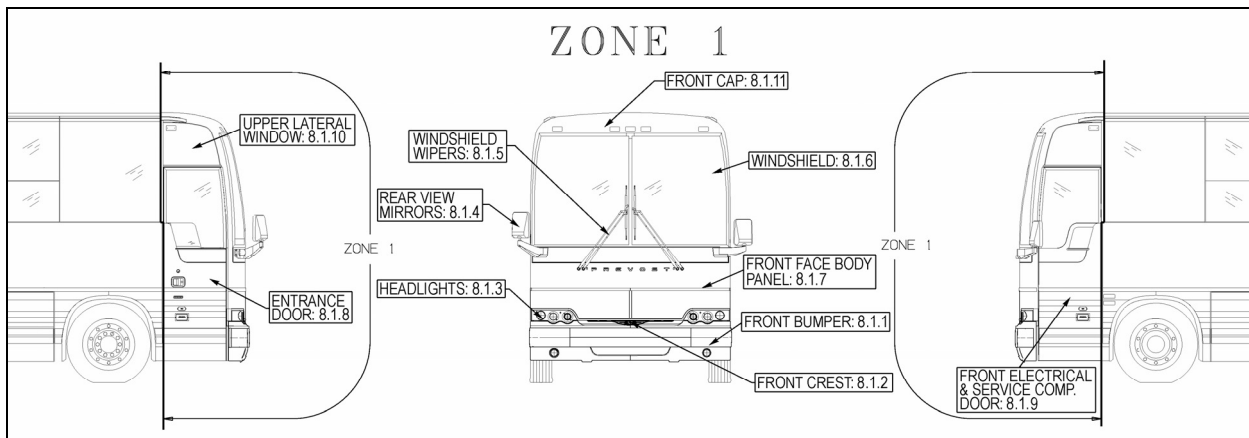

FIGURE 47: ZONE 1

##### 7.1.1 Front Bumper

The front bumper can be tilted downward to give access to the bumper compartment. Pull the release handle located inside front service compartment to unlock. Tilt down the entire bumper assembly to access the compartment.

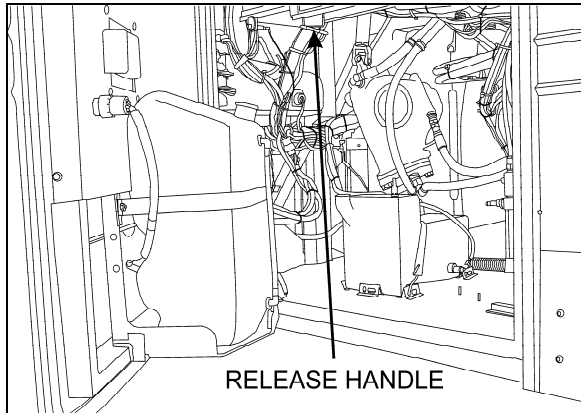

FIGURE 48: FRONT BUMPER RELEASE HANDLE 18613

Push the bumper back up firmly in place to lock in position.

Two people are required to remove and install the front bumper. Safely support the bumper and remove the two bolts on each bumper side to separate the bumper from the spare wheel compartment door. To install bumper, reverse the removal procedure.

**WARNING**

Front bumper is heavy. Use proper lifting equipment to support the bumper during the removal and installation operations to avoid personal injury.

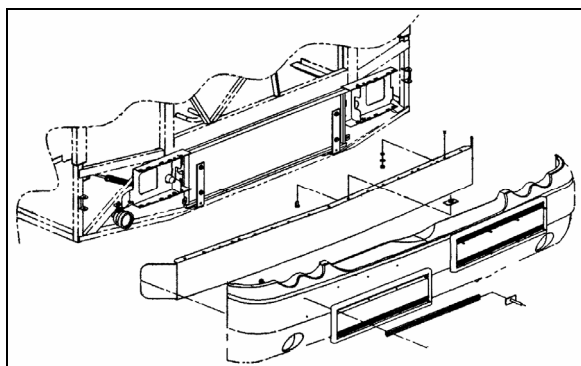

FIGURE 49: FRONT BUMPER REMOVAL

**WARNING**

The compartment behind the bumper is not designed for storage. Never store loose objects in this compartment since they can interfere with the steering linkage mechanism. Use care when opening or closing the reclining bumper compartment to prevent personal injury.

For gluing of front bumper panel refer to procedure **SAV00198** included at the end of this section.

7.1.2 Front Crest

- Use a Chix cloth and anti-silicone to clean the surface where the crest will be applied.

**CAUTION**

Do not exceed the crest dedicated surface.

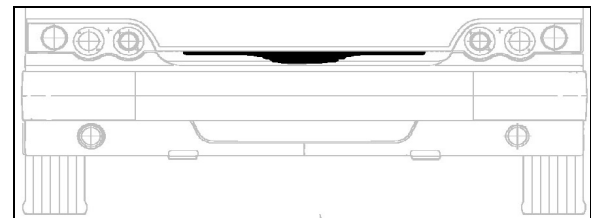

- Peel the back from the self adhesive crest side pieces.

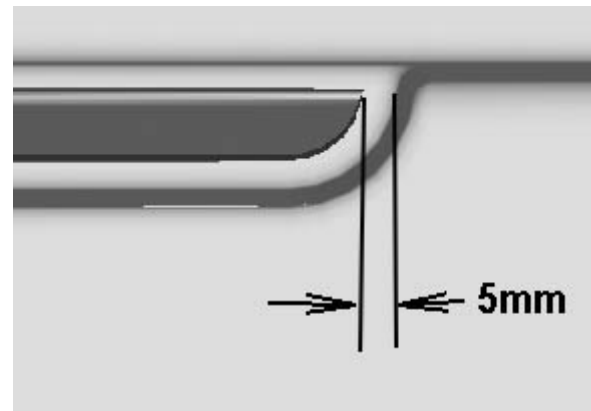

- Peel the back from the self adhesive crest center piece. Center crest and apply.
- Compress the crest three pieces using your hands.



## Section 18: BODY

### 7.1.3 Headlights

Refer to Paragraph 9.1 Headlights, included in Section 06: Electrical of the Maintenance Manual for complete information on headlights.

### 7.1.4 Rear View Mirrors

Your vehicle is equipped with two exterior mirrors.

The mirrors may be equipped with an optional electric heating system which serves to minimize ice and condensation on the mirror glass in extreme weather conditions. Integral thermostats are installed in both mirrors to avoid continuous heating. Use the appropriate switch on the dashboard to activate the defroster system on both mirrors simultaneously. The mirrors can easily be adjusted by using the remote controls located on the L.H. side control panel. The mirrors have easy to replace glass in case of breakage. Remote control motors can also be replaced.

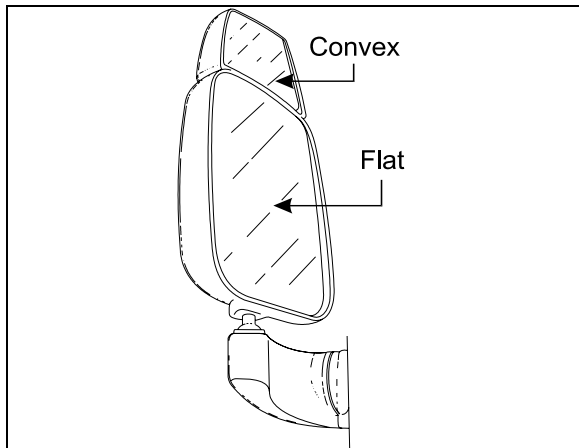

FIGURE 50: REAR VIEW MIRROR (RAMCO) 18398A

#### ❖ Adjustment

At the base of the mirror arm, loosen the mounting bolt to swing arm in or out. To pivot the mirror head, loosen the setscrews on each side of the ball stub at the base of the mirror head to facilitate the adjustment.

#### ❖ Disassembly

At end of mirror arm, loosen the setscrews to relieve tension on the ball stem. Remove the ball stem from the arm.

Remove the four screws fastening the mirror arm base to the coach.

#### ❖ Assembly

Mount the mirror arm base to the coach. Insert the ball stem into the mirror arm and tighten the socket setscrews.

#### **NOTE**

*Position the ball cup halves so the joint between them lies on the centerline of the arm. Ensure that the setscrews are not on the joint between the cup halves.*

#### ❖ Replacement of Mirror Glass

Remove the broken glass.

Position new glass in mirror head and press to lock the Velcro in place.

#### ❖ Heated / Remote Controlled Rear View Mirrors

Heated/remote controlled external rear view mirrors may be provided to prevent the mirrors from frosting up in cold weather.

The remote controlled external rear view mirrors attach to support arms using a pivot collar secured by setscrews. Loosening the setscrews allows the whole head assembly to turn on the support arm for initial adjustment. A mounting bolt and washer hold the arm support to the mounting bracket. The arm support can be moved to position the mirror head into or away from the coach body.

The mirror heat switch is located to the left of the driver on the dashboard. This switch must be activated before the mirror heating element will energize. Once energized, the mirror heating element is kept at a sustained temperature (between 60-80°F) by a thermostat. Refer to wiring diagram annexed in the technical publication box.



#### **CAUTION**

Do not attach stick-on type convex mirror accessories to the heated mirror glass. This could impede uniform heat distribution on the mirror surface which could break the mirror.

- Mirror Control

The remote control pointer knob(s) for the mirrors is (are) mounted on the L.H. side control panel. The harness to the mirror head runs through the arm support. The remote motor is mounted to the mirror head behind the mirror glass.

Turn pointer knob to the left for mirror head adjustments and to the right for convex mirror adjustment, then push down on either of the button's (4) sides to adjust the selected mirror viewing angle.

- Disassembly

At end of mirror arm, loosen the setscrews to relieve tension on the ball stud. Remove the ball stud. Remove the ball stud from the arm and gently pull the harness out until the connector is exposed.

Remove the four screws fastening the mirror arm base to the coach. Slide the harness free of the mirror arm base.

- Assembly

Attach a stiff wire (snake) to the end of the harness and insert the wire through the mirror arm base and arm, gently pull the harness through the arm and disconnect the "snake". Connect the mirror head harness. Insert the harness connector back into the mirror arm. Insert the ball stud into the mirror arm and tighten the socket setscrews.

**NOTE**

*Position the ball cup halves so the joint between them lies on the centerline of the arm. Ensure that the setscrews are not on the joint between the cup halves.*

- Convex & Flat Mirror Removal

The mirror glass assembly is mounted to the control mechanism or to mirror base with Velcro strips. Remove the mirror glass by gently pulling the lens to release the Velcro. Disconnect the heater grid at the two connectors.

Connect the connectors of the new mirror's grid to the harness. Install the lens by positioning the lens in the mirror frame and pressing to lock the Velcro in place.

### 7.1.5 Windshield Wipers

Refer to Paragraph 23.7 Windshield Wipers and Washers, included in Section 23: Accessories of the Maintenance Manual for complete information on windshield wipers.

### 7.1.6 Windshield

For the removal or installation of windshield, you will need:

- A rope,
- A plastic spatula to lift the rubber seal lip,
- A metal rod or screwdriver to clean the seal groove,
- A filler insertion tool,
- Goggles and protective gloves.
  - From inside of vehicle, remove center post and interior finishing panels surrounding the windshield. In this case, we are replacing the R.H. side windshield.
  - From outside of vehicle, remove filler located inside rubber seal to ease damaged windshield removal.
  - From inside of vehicle, push against the top L.H. side corner of windshield for the removal of a R.H. side windshield. If the L.H. side windshield had to be removed, you would have to push against the top R. H. side corner.

**NOTE**

*We are referring to the L.H and R.H. side as viewed from the inside of the vehicle.*

- At the same time, another person gradually lifts the rubber lip from the vehicle exterior using a plastic spatula from top to bottom.
- Remove the entire damaged windshield and broken glass if applicable.
- If applicable, using a screwdriver or metal rod, remove black butyl sealant residue from rubber seal then clean with Sika 205.

### ❖ Windshield Installation

**NOTE**

*Rubber seal may have to be replaced if it was used on several windshield replacements.*

## Section 18: BODY

- Spray rubber seal with soapy water to ease windshield insertion.
- Insert rope into rubber extrusion leaving enough length at each corner to make a loop. Spray soapy water onto rope and rubber extrusion (Fig. 51).
- Slide windshield into rubber seal groove starting with the bottom curved side edge. Using a plastic spatula, move the rubber seal lip aside to gradually insert the windshield into the groove.
- Spray soapy water on a regular basis to ease this operation.
- Using the same type of plastic spatula, repeat the same operation from inside of vehicle, gradually inserting the windshield into the groove.

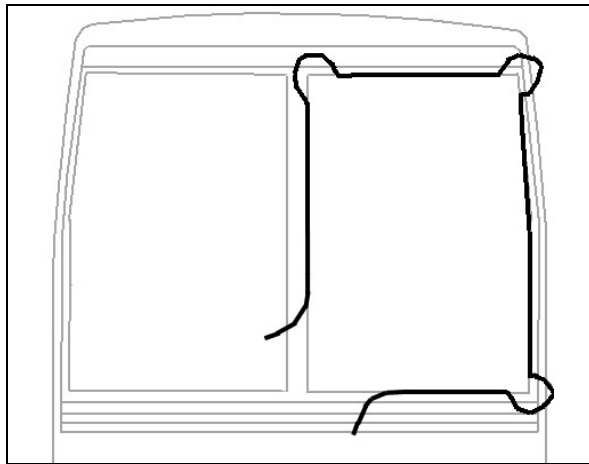

FIGURE 51: WINDSHIELD INSTALLATION USING ROPE

### NOTE

*Make sure windshield bottom edge is well inserted into the rubber seal groove before proceeding with the sides.*

- Then, working from both sides of windshield bottom to top, gradually move the rubber seal lip aside to insert the windshield into the groove. Use also soapy water on the inside of vehicle to insert the windshield into the rubber seal groove.
- Insert the top curved corner then finish with the top of windshield.
- At the top of windshield, clean surface between fiberglass and rubber extrusion using Sika 205 (Fig.52).
- Apply Sika 221 black between fiberglass and rubber extrusion

- Spray filler and rubber seal groove generously with soapy water.
- Using the special filler insertion tool, insert the filler into the rubber seal groove.
- Gradually insert filler into the rubber seal groove ensuring to leave a 2 inch excess length at the filler extremity.
- Every 6 inches or so, it is important to compress the filler due to its tendency to contract during drying process.
- When filler insertion is almost complete, cut filler leaving 1/4" of excess length to thwart filler contraction over time then insert filler into groove.

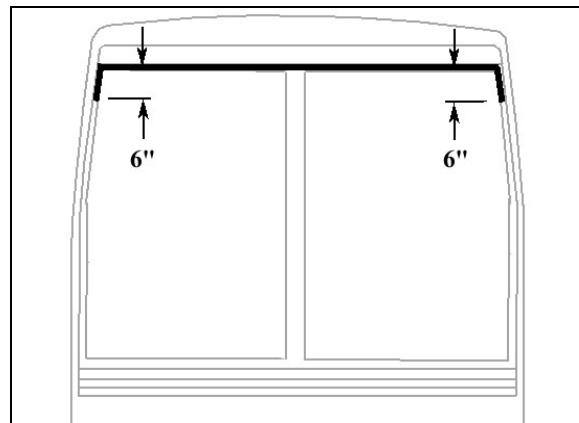

FIGURE 52: APPLICATION OF SIKA 221 BLACK

- Reinstall center post and interior finishing panels.
- Clean windshield surface of butyl residue.

### 7.1.7 Front face Body Panel

For removal of front face body panel and molding, you will need:

Drill with drill bits,  
Lever or similar tool,  
Olfa knife,  
"C"-clamp,  
Razor sharp window scraper.

❖ **Front Face Molding Removal**

FIGURE 53: VIEW OF FRONT FACE

- First of all, pry loose the front face molding using the lever. Save molding if only the body panel needs to be changed.
- Using the Olfa knife, cut the Sika bead and the double-face self adhesive tape. Remove the Sika bead and self adhesive tape residue with the scraper.

❖ **Front Face Body Panel Removal**

- Using a drill and a 1/8" drill bit remove the rivets fixing the vertical molding. The stainless steel molding is located on the entrance door or service door frame side depending on body panel to be removed.
- Using the Olfa knife, cut the Sika bead and the double-face self adhesive tape. Remove the Sika bead and self adhesive tape residue with the scraper.
- Pry loose the front face body panel using the lever.
- While somebody cuts the Sika bead and double-face self adhesive tape, another person pulls the body panel using the "C"-clamp to exert tension.
- Using the window scraper, remove any Sika bead or self adhesive tape residue left on fiber glass surface.

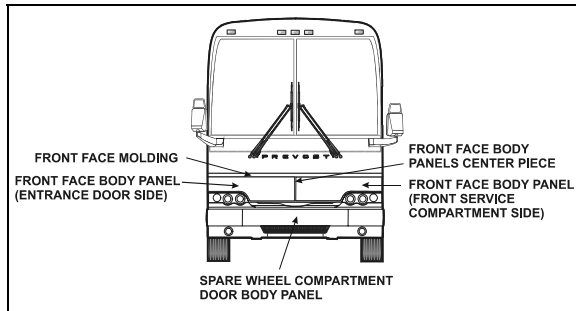
❖ **Front Face Molding Installation**

For gluing of front face molding, refer to procedure **SAV00212** included at the end of this section.

❖ **Front face Body Panel Installation**

For gluing of front face body panels, refer to procedure **SAV470047** included at the end of this section.

7.1.8 *Entrance Door*

For the removal of entrance door body panel, you will need:

Pneumatic "Zip gun" type tool;  
Razor sharp window scraper;

- Before removing body panel, you can to ease repair uninstall entrance door from vehicle. If applicable, remove reflector, keyless system keyboard and cornering light.
- You must also remove horizontal finishing molding located underneath the window. This molding is glued and will have to be replaced because it will be damaged at removal.
- Remove interior finishing panel to access rub rail fixing bolts, then remove rub rail.
- Using the "Zip Gun", cut Sika bead located 1/4 inch (7-8 mm) from each body panel edge and around cornering light.
- Separate body panel from door.
- Remove from door surface Sika bead and double-face self adhesive tape residue using a razor sharp window scraper.
- Use a Chix cloth and anti-silicone to remove any dust or residue.

For assembly, gluing or finishing joints of entrance door, refer to procedure **SAV280020** included at the end of this section.

For gluing of entrance door horizontal finishing molding, refer to procedure **SAV00213** included at the end of this section.

For the installation of entrance door, refer to procedure **SAV280022** included at the end of this section.

7.1.9 *Front Electrical & Service Compartment Door*

For the removal of front electrical & service door body panel, you will need:

Pneumatic "Zip gun" type tool;  
Razor sharp window scraper;

- Before removing body panel, you can to ease repair uninstall front electrical & service door from vehicle. If applicable, remove reflector and cornering light.



## Section 18: BODY

---

- You must also remove horizontal finishing molding located underneath the window. This molding is glued and will have to be replaced because it will be damaged at removal.
- Remove interior finishing panel to access rub rail fixing bolts, then remove rub rail.
- Using the “**Zip Gun**”, cut Sika bead located ¼ inch (7-8 mm) from each body panel edge and around cornering light.
- Separate body panel from door.
- Remove from door surface Sika bead and double-face self adhesive tape residue using a razor sharp window scraper.
- Use a Chix cloth and anti-silicone to remove any dust or residue.

For assembly, gluing or finishing joints of front electrical & service compartment door, refer to procedure **SAV280021** included at the end of this section.

For gluing of driver’s window, refer to procedure **SAV290013** included at the end of this section.

For gluing of front electrical & service compartment door horizontal finishing molding, refer to procedure **SAV00213** included at the end of this section.

For the installation of front electrical & service compartment door, refer to procedure **SAV280022** included at the end of this section.

### 7.1.10 Upper Lateral Window

For the removal of driver’s window or upper lateral window, you will need:

Pneumatic «Zip gun» type tool;  
Razor sharp window scraper;  
“Olfa” knife;  
Face shield.

- In the case of driver’s window only, open front service compartment door.
- Mark the position of the driver’s window for future reference.
- From inside of vehicle, cut Sika bead around window perimeter using a “Zip gun” while another person hold the window from the outside.

<b>NOTE</b>
Wear ear plugs during this operation.

- Then, move outside of vehicle and cut Sika bead to free window while somebody else hold the window from the inside.
- Carefully remove window from frame, ask for help if needed.
- Using a razor sharp window scraper, remove from window frame Sika bead and double-face self adhesive tape residue.
- First of all, check Sika 205 cleaner expiration date.
- Before applying Sika cleaner, fold “Chix” cloth twice for proper width.
- Apply an even coat onto the inside of window frame and allow drying for 2 minutes (maximum 2 hours).
- Discard waste according to applicable environmental regulations, use dangerous waste containers.
- Apply masking tape before applying Sika glue to protect paint and adjacent window during surface treatment.

For gluing of upper lateral window, refer to procedure **SAV290016** included at the end of this section.

### 7.1.11 Front Cap

The fiberglass front cap does not need any maintenance except painting as needed. It is held in place with adhesive. If ever it has to be replaced, make an appointment at a Prevost service center near you. For minor damages, refer to paragraph 4 "Common Fiberglass Repair procedure" and paragraph 5 "Common Painting Procedure".

## 7.2 ZONE 2

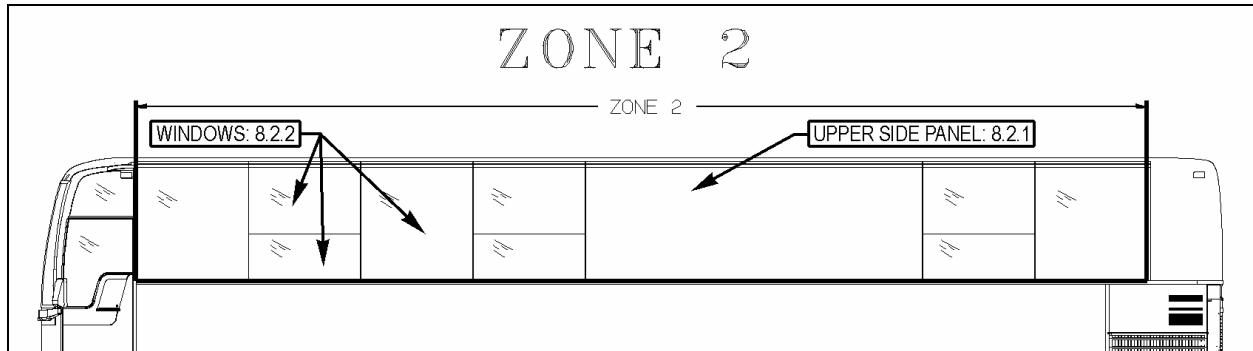

FIGURE 54: ZONE 2

### 7.2.1 Upper Side Panel

For structure preparation, refer to procedure **SAV00035** included at the end of this section.

For installation of upper side panel neoprene foam tapes, refer to procedure **SAV00036** included at the end of this section.

For installation of upper side panel, refer to procedure **SAV00041** included at the end of this section.

### 7.2.2 Fixed Windows

Depending on the method chosen for fixed side window removal or installation, you may need:

- \* Drill equipped with a sharp pointed rod into which a small hole was drilled;
- \* Razor sharp window scraper;
- \* Braided windshield wire and a pair of handles;
- \* Gloves, goggles or face shield.

#### Fixed Window Removal

##### 1<sup>st</sup> Method

###### **NOTE**

*This method is used only in the case of a regular fixed side window. For the fixed upper portion of awning or sliding windows, you must use method number 2.*

- Apply a sticky plastic film onto all of window outside surface for safety reason.
- Using a drill equipped with the special sharp pointed rod, drill through the window seal into one of the bottom corners, from a 30° angle with reference to the vehicle.

- This procedure requires accuracy and it is possible not to succeed on the first attempt. From the inside of vehicle, a second person ensures the rod passes through.
- Remove the rod; thread the wire into the small hole. Reinsert the rod and the wire into the hole far enough so that the person inside the vehicle can pull the rod using a pair of pliers.
- Attach the wire ends to the specially designed handles.
- Pull in turn from the inside and the outside of vehicle to gradually cut the Sika bead on the window perimeter.
- When you reach top corner, detach wire from the outside handle, secure it to a fish wire or rod and thread it underneath the aluminum molding behind the rivets.
- Detach wire from fish wire and continue cutting using the handle.
- Cut Sika bead until you come back to starting point, then you can remove the window by carefully pushing it out from the inside of vehicle.

##### 2<sup>nd</sup> Method

- Apply a sticky plastic film onto all of window outside surface.
- To limit as much damage as possible, remove any interior molding in the way. Install a plastic film on the window interior surface and secure using masking tape onto all of window perimeter.

###### **NOTE**

*Do not stretch plastic film and leave enough play to be able to push window out without tearing the plastic film.*

## Section 18: BODY

- Using a ball peen hammer, hit one of the window bottom corners from the **outside**.
- Carefully push window out and lift it up sufficiently to separate it from the aluminum molding.
- Attach the windshield wire to a fish wire and thread it underneath the aluminum molding behind the rivets.
- Detach wire from fish wire and continue cutting using the handle.
- Make a notch at each window top corner to make sure you pass underneath the remaining pieces of glass.
- Remove the aluminum molding and clean up the frame using the window scraper.

For gluing of lateral fixed half-window, refer to procedure **SAV00045** included at the end of this section.

For the installation of awning or sliding window, refer to procedure **SAV00038** included at the end of this section.

For gluing of lateral fixed window, refer to various procedures: **SAV00037** for gluing vertical and bottom rubber seals; **SAV00043** for the installation of lateral fixed window and **SAV00044** for making the Simson joint around fixed windows.

All these procedures are included at the end of this section.

### 7.2.3 Electric Awning Windows

For window or components replacement, refer to paragraph 6.2.3.

### 7.2.4 Electric Sliding Windows

For sash removal or replacement, refer to paragraph 6.2.4.

## 7.3 ZONE 3

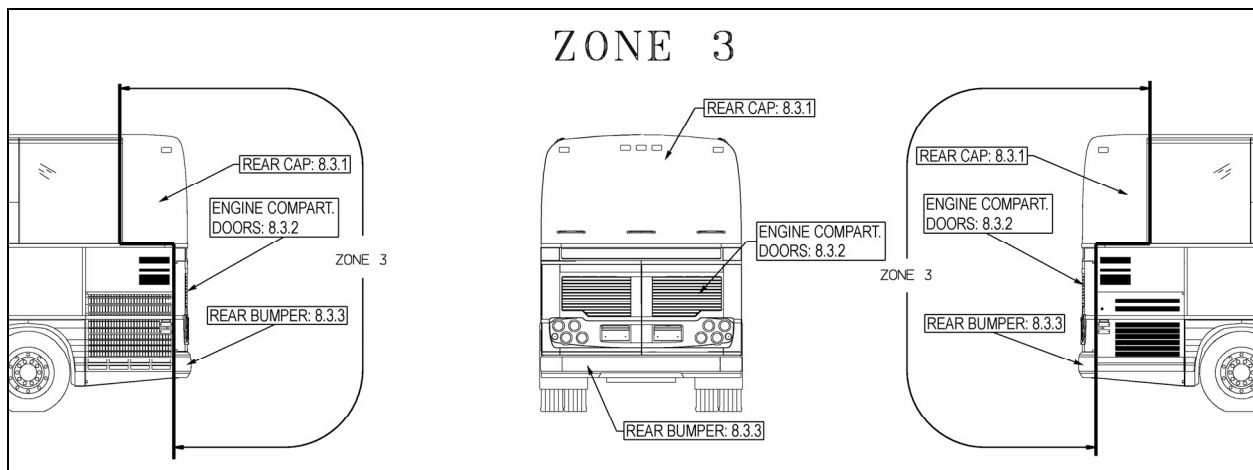

FIGURE 55: ZONE 3

### 7.3.1 Rear Cap

The fiberglass rear cap does not need any maintenance except painting as needed. It is held in place with adhesive. If ever it has to be replaced, make an appointment at a Prévost service center near you.

For minor damages, refer to Paragraph 4 "Common Fiberglass Repair Procedure" and Paragraph 5 "Common Painting Procedure".

### 7.3.2 Engine Compartment Doors

#### ❖ Engine Compartment Doors Adjustment

Engine compartment doors may be adjusted for proper fit by untightening hinge bolts:

1. Loosen the bolts, (1, 2 Fig. 56) holding the hinge to the vehicle structure to shift the door "UP or DOWN".
2. Loosening the bolts (3, Fig. 56) allows the door to be shifted "LEFT or RIGHT" and "IN or OUT".
3. Adjust the doors position depending on the gap needed between exterior finishing panels.
4. Tighten the bolts.

5. Check that the doors swing freely and close properly. It may be necessary to adjust the door latch to get proper fit and operation.

To adjust the latch mechanism (4, Fig. 56) and the striker pin:

1. Open the doors to access the striker pin.
2. Slightly loosen the striker pin.
3. Using a hammer, adjust the striker pin to center it in the door latch mechanism.
4. Tighten the striker pin.
5. Check doors fit and operation.

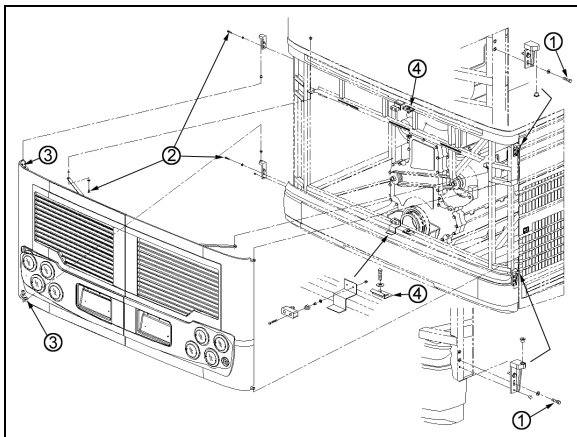

FIGURE 56: ENGINE COMPARTMENT DOORS 18633

#### ❖ Engine Compartment Door Body Panel Removal

For the removal of engine compartment door body panel, you will need:

Pneumatic “Zip gun” type tool;  
Razor sharp window scraper;  
A pair of locking pliers;  
Isopropyl alcohol.

- Remove damaged engine compartment door from vehicle.
- Install the damaged door onto an appropriate support.
- Wearing gloves, goggles and ear plugs, pry loose body panel using a “Zip gun” or lever starting from the edge opposite the curved side.
- Use the “Zip gun” to detach completely the stainless steel body panel from door frame.



### CAUTION

Do not damage painted surface.

- Use a second person equipped with a pair of locking pliers to pull the body panel as you cut the Sika bead.



### WARNING

Be very careful when pulling the body panel, somebody could get hurt if the body panel suddenly detach from the door surface without notice.

- Using the window scraper, remove any Sika bead or self adhesive tape residue left on the fiber glass surface.

For gluing of engine compartment doors molding, refer to procedure **SAV00211** included at the end of this section.

For engine compartment door body panel installation, refer to procedure **SAV280032** included at the end of this section.

#### 7.3.3 Rear Bumper

Remove three bolts on each side holding bumper to vehicle and remove bumper.

To install bumper, reverse the procedure.

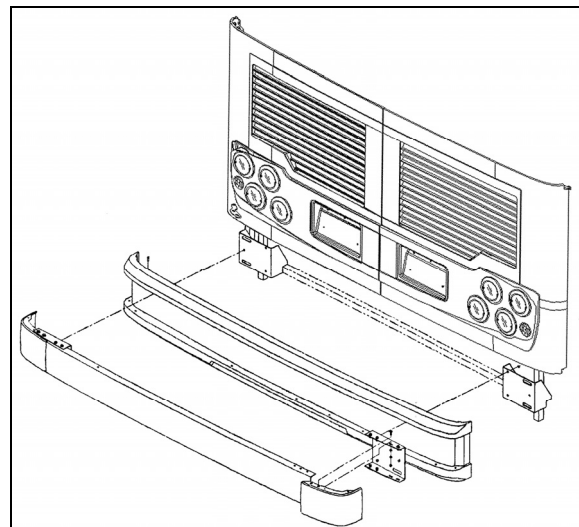

FIGURE 57: REAR BUMPER

7.4 ZONE 4

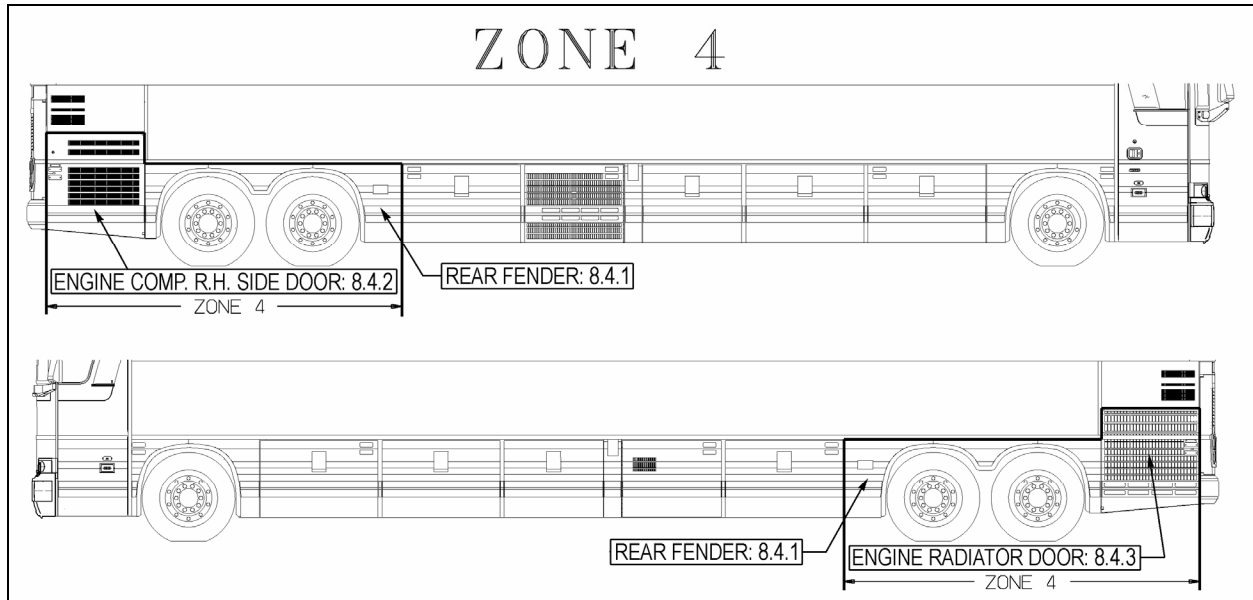

FIGURE 58: ZONE 4

7.4.1 Rear Fender

On the "XLII MTH" series vehicles, rear fenders are hinged for maintenance on brakes and suspension. Each rear fender panel has two mechanical spring loaded holding devices fixing it to the vehicle's structure. Push the spring type rod sideways to disengage the lock.

For the installation of rear fender body panel, refer to procedure **SAV470046** included at the end of this section.

7.4.2 Engine Compartment R.H. Side Door

Engine compartment R. H. side door may be adjusted for proper fit by untightening hinge bolts:

1. Loosen the bolts, (1, Fig. 59) holding the hinge to the vehicle structure to shift the door "IN or OUT" and "UP or DOWN".
2. Loosening the bolts (2, Fig. 59) allows the door to be shifted "LEFT or RIGHT" and "UP or DOWN".
3. Adjust the door position depending on the gap needed between exterior finishing panels.
4. Tighten the bolts.
5. Check that the door swings freely and closes properly. It may be necessary to adjust the door latch to get proper fit and operation.

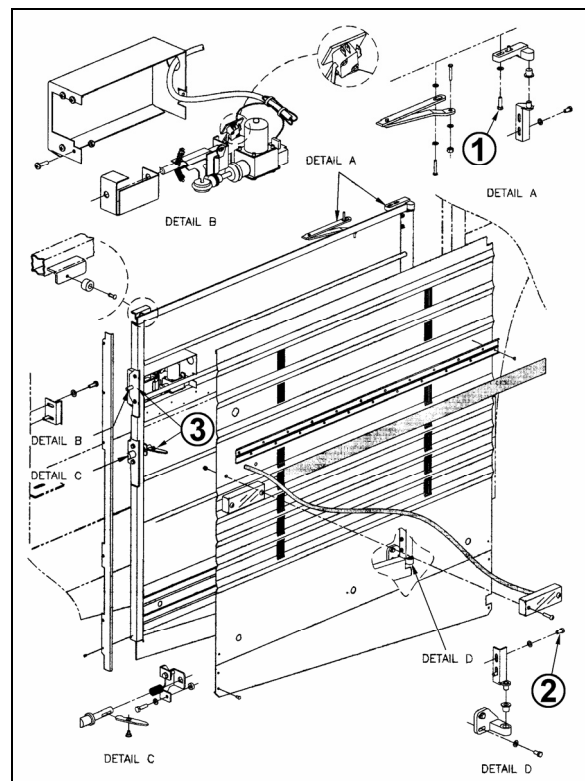

FIGURE 59: ENGINE COMPARTMENT R.H. SIDE DOOR<sup>18635</sup>

To adjust the latch mechanism (3, Fig. 59) and the striker pin:

1. Open the door to access the striker pin.
2. Slightly loosen the striker pin.

3. Using a hammer, adjust the striker pin to center it in the door latch mechanism.
4. Tighten the striker pin.
5. Check door fit and operation.

For gluing of engine compartment R.H. side door finishing molding, refer to procedure **SAV00210** included at the end of this section.

#### 7.4.3 Engine Radiator Door

Radiator door may be adjusted for proper fit by untightening hinge bolts:

1. Loosen the bolts, (1, Fig. 60) holding the hinge to the vehicle structure to shift the door "IN or OUT" and "UP or DOWN".
2. Loosening the bolts (2, Fig. 60) allows the door to be shifted "LEFT or RIGHT" and "UP or DOWN".
3. Adjust the door position depending on the gap needed between exterior finishing panels.
4. Tighten the bolts.
5. Check that the door swings freely and closes properly. It may be necessary to adjust the door latch to get proper fit and operation.

To adjust the latch mechanism (3, Fig. 60) and the striker pin:

1. Open the door to access the striker pin.

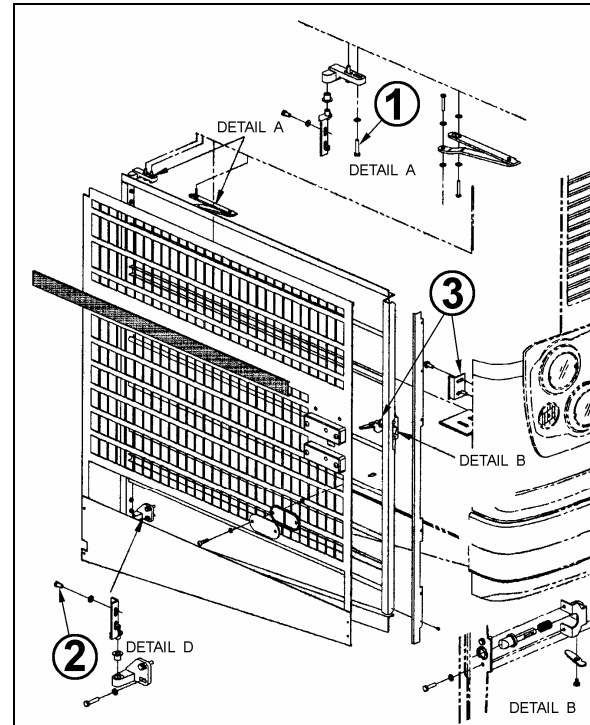

FIGURE 60: RADIATOR DOOR

18636

2. Slightly loosen the striker pin.
3. Using a hammer, adjust the striker pin to center it in the door latch mechanism.
4. Tighten the striker pin.
5. Check door fit and operation.

For gluing of engine radiator door finishing molding, refer to procedure **SAV00210** included at the end of this section.

#### 7.5 ZONE 5

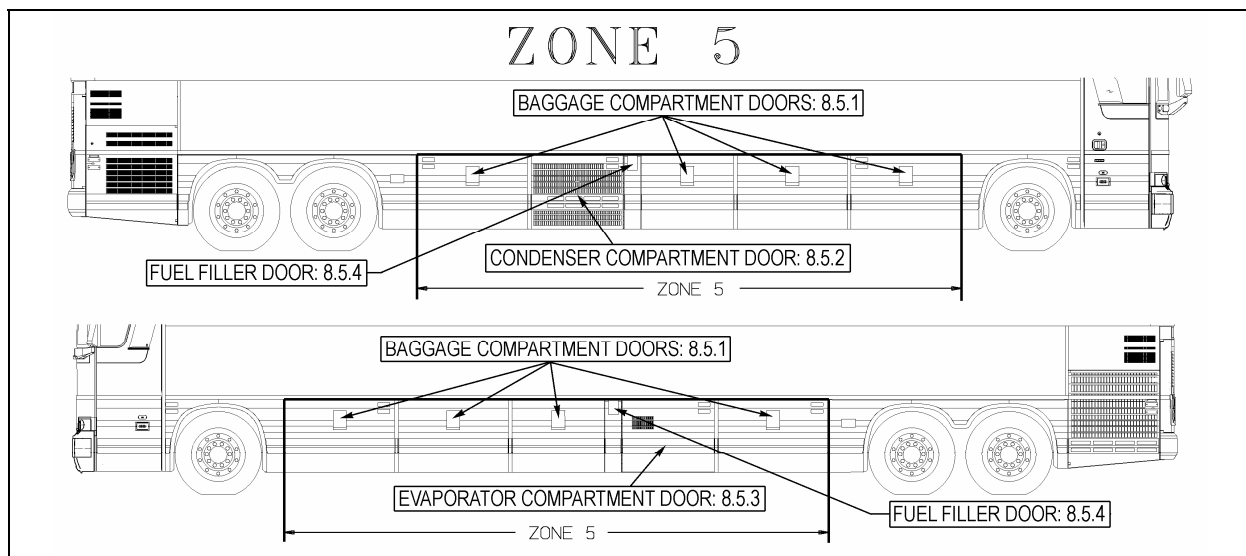

FIGURE 61: ZONE 5

## Section 18: BODY

### 7.5.1 Baggage Compartment Doors

The baggage compartment doors on the vehicle are of identical design. The doors are pantograph, vertical-lift type and are fully sealed. Each door has a flush-mounted latch handle. To open, lift latch handle, then pull door outward and up. The door is held open by 2 gas-charged cylinders. To close, leave latch handle in the open position, pull downward on door and push down on latch to secure door. The door lower arm is spring loaded to secure effort required to close the door (Fig. 62).

If a door does not remain in the fully open position, one or both cylinders on that door is (are) defective. To test the cylinders, first support the door in the open position with proper equipment. Disconnect the rod end of one cylinder and retract the rod. If strong resistance is felt, the cylinder is in good condition and can be reinstalled. If the rod retracts with little effort, the cylinder is defective and should be replaced at once. Use the same procedure to test the other cylinder on that door.

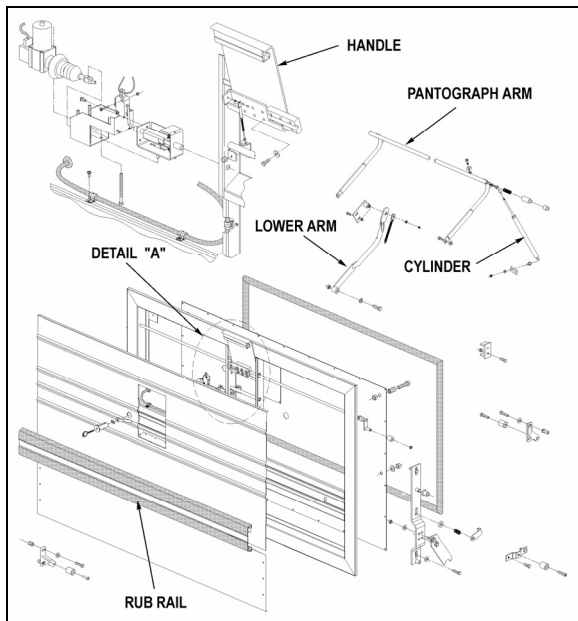

FIGURE 62: BAGGAGE COMPARTMENT DOOR 18145

#### ❖ Door Removal



### CAUTION

Two people are required to remove the baggage compartment doors.

1. Maintain the door halfway open by placing a wooden block between one of the pantograph arms and the upper frame.
2. Remove cap screw, lock washer and flat washer retaining lower arm to door
3. Remove spring pins and lock washers fastening the pantograph arms to the door.



### WARNING

Support the door properly to prevent it from falling.

4. Spread the pantograph arms away from the door and remove door.
5. Inspect all pivot points and bushings for wear and damage. Check tension of gas-charged cylinders and replace if necessary.

#### ❖ Pantograph Arms Removal and Installation

1. Disconnect rod end of gas-charged cylinders from the pantograph arms.
2. Loosen jam nut and cap screw locking the horizontal member of the pantograph to the pivot pin.
3. Slide pantograph assembly to the right and remove assembly from the vehicle.
4. To install, perform the removal instructions in reverse.

#### ❖ Door Installation

1. Use a wooden block to support the pantograph arms horizontally.
2. Support the door and insert each pantograph arm into the pivot pins on the side of the door.
3. Install washer and spring pin to fasten each arm to its pivot pin.
4. Fasten lower arm to the door with flat washer, lock washer and cap screw.
5. Remove wooden block and close baggage compartment door.

Door should be adjusted to leave a gap of 3/16" (5 cm) above the top edge of the door. To adjust, loosen the bolts retaining lock plate support and position the door correctly. Tighten the bolts after the adjustment.

If the baggage door locks too tightly or too loosely, the position of the catch striker is misadjusted. To adjust, loosen the catch striker retaining bolts, position the striker correctly and tighten the retaining bolts.

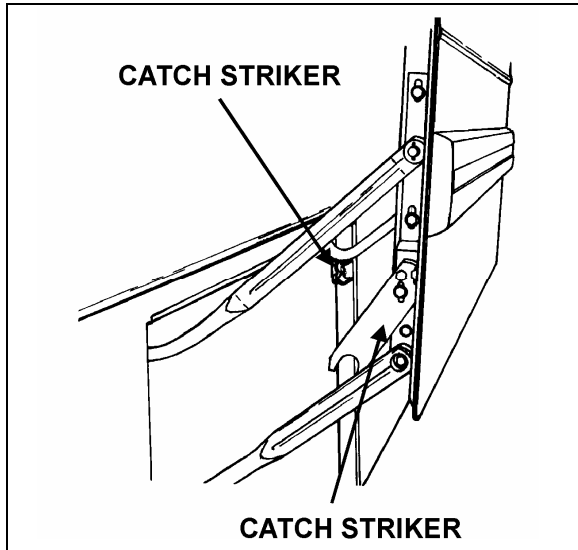

FIGURE 63: BAGGAGE DOOR CATCH STRIKER 18146

If the lower part of the baggage door does not close evenly with the side of the vehicle, adjust the lock plates by loosening their retaining bolts and positioning the locking plates correctly (Fig. 63).

For the removal and installation of baggage compartment door body panels, refer to procedure **SAV00177** included at the end of this section.

#### 7.5.2 Condenser Compartment Door

1. Open the condenser door.
2. Loosen the screws fixing the hinge to hinge attachment or hinge to door assembly. Loosening the screws allows the condenser door assembly to be shifted "LEFT or RIGHT" and "UP or DOWN" or "IN and OUT".
3. Adjust condenser door assembly position at the hinge.
4. Tighten the screws.
5. Respect the required gap between exterior finishing panels.
6. Check that the door swings freely and closes properly. It may be necessary to adjust the door latch to get proper fit and operation.

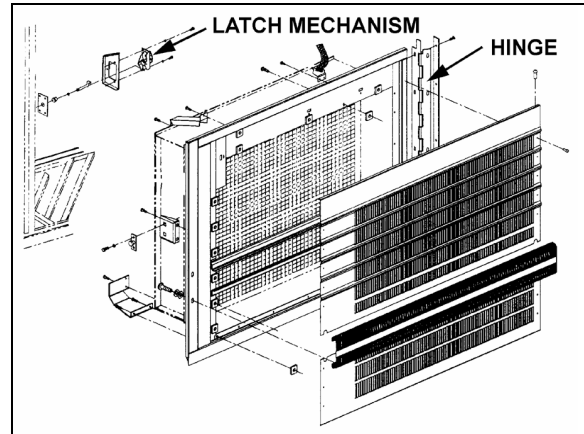

FIGURE 64: CONDENSER DOOR

For the installation of condenser compartment door body panel, refer to procedure **SAV00131** included at the end of this section.

#### 7.5.3 Evaporator Compartment Door

1. Open the evaporator door.
2. Loosen the screws fixing the hinge to hinge attachment or hinge to door assembly. Loosening the screws allows the evaporator door assembly to be shifted "LEFT or RIGHT" and "UP or DOWN" or "IN and OUT".
3. Adjust evaporator door assembly position at the hinge.
4. Tighten the screws.
5. Respect the required gap between exterior finishing panels.
6. Check that the door swings freely and closes properly. It may be necessary to adjust the door latch to get proper fit and operation.

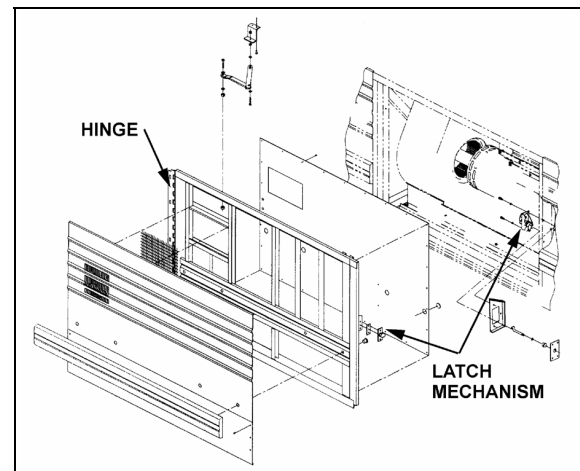

FIGURE 65: EVAPORATOR DOOR



## Section 18: BODY

For the installation of evaporator compartment door body panel, refer to procedure **SAV00133** included at the end of this section.

### 7.5.4 Fuel Filler Door

- Open the fuel filler door.
- Loosen the screws holding the panel to hinge assembly.
- Adjust the fuel filler door position according to distance required between exterior finishing panels.
- Tighten the nuts.

- Check that the door swings freely and closes properly.

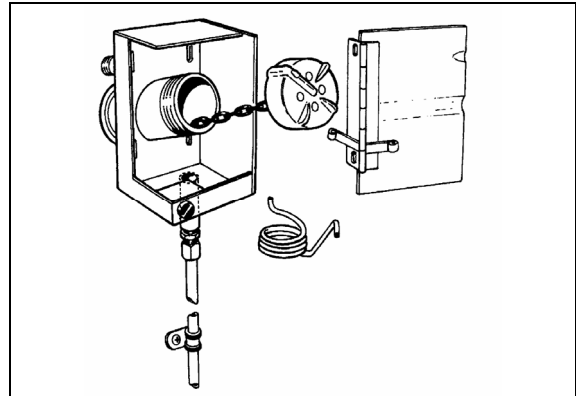

FIGURE 66: FUEL FILLER DOOR

03046

## 7.6 ZONE 6

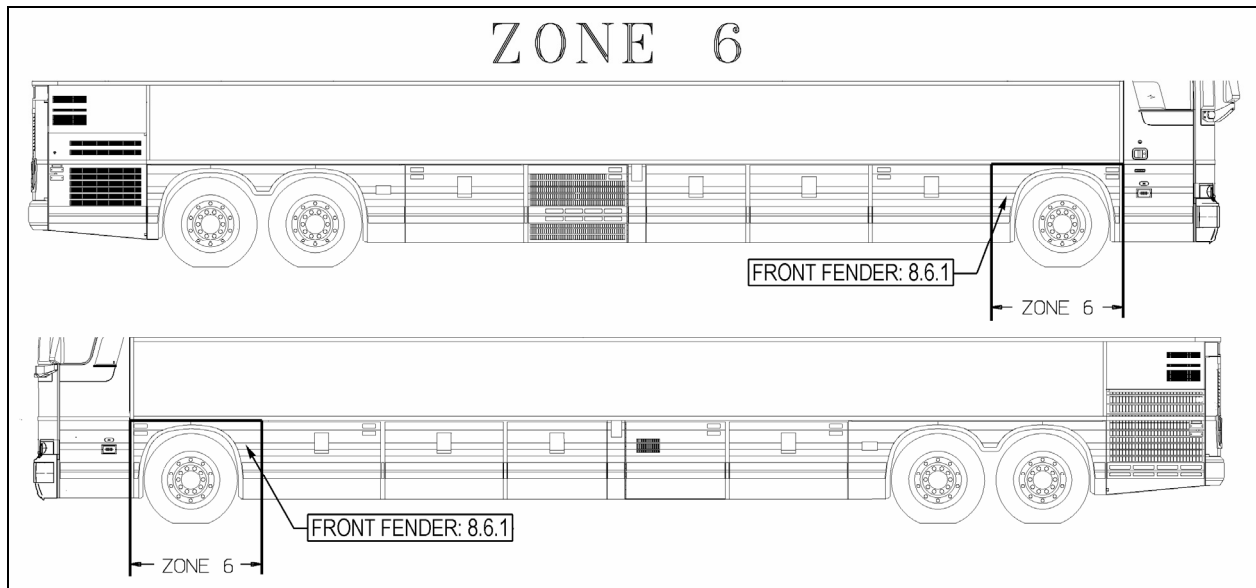

FIGURE 67: ZONE 6

### 7.6.1 Front Fender

Front fender may be removed using the following procedure:

Remove the nuts on the inside of the fender. Remove the fender from the vehicle. To reinstall, reverse the procedure.

For the installation of front fender body panel, refer to procedure **SAV470024** included at the end of this section.

## 7.7 ZONE 7

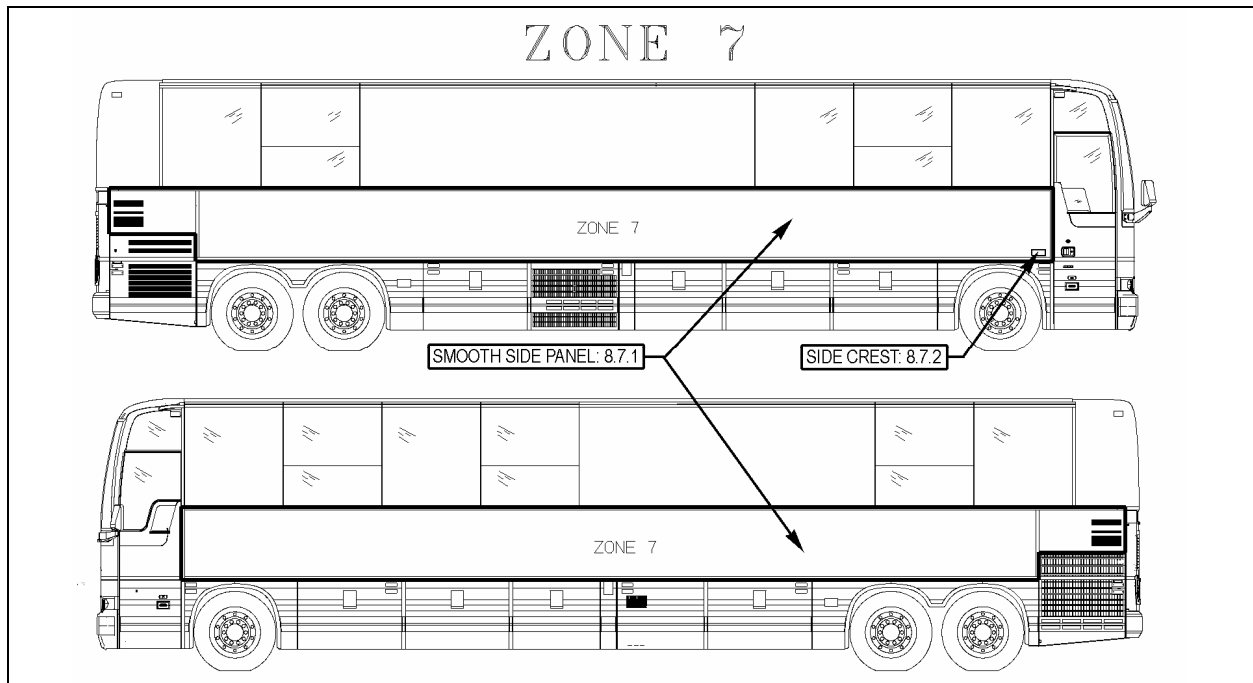

FIGURE 68: ZONE 7

## 7.7.1 Smooth Side Panel

## ❖ Removal

A)	Remove finishing molding. Insert a screwdriver into snap-on finishing molding joint. Bend finishing molding enough to be able to fix a pair of locking pliers. Using the pair of locking pliers, pull the stainless steel molding and at the same time gradually cut Sika bead with a sharp knife.	Be careful not to damage the adjacent surfaces.
B)	Using a hammer and punch, drive out rivet shanks from top and bottom and from front and rear finishing molding supports. Use a #11 titanium drill bit to remove rivet heads.	
C)	Grind tig weld spots at each end of side panel.	
D)	Safely support or temporary fix side panel.	<b>Warning: Panel weights over 200 pounds</b>
E)	Insert a flat screwdriver between the side panel and the vehicle chassis, in the top left and right corners. Make sure to separate side panel from structure.	Be careful not to damage the adjacent surfaces.
F)	Use the c-clamp to separate the side panel from the back structural panel and at the same time gradually cut Sika bead with a sharp knife.	Ideally, the hoist or chain block must be fastened to the floor while pulling from a 45° angle so as not to damage the vehicle structure
G)	Remove as much glue as possible from the structure using a putty knife or pneumatic knife without damaging 206 G+P primer.	Never heat SikaFlex adhesive to remove.
H)	Check panel horizontal supports for straightness using a straight edge. Take measurements with a ruler.	Tolerance: 1 mm towards the outside and 1.5 mm towards the inside.

## Section 18: BODY

### ❖ Installation Procedures

SMOOTH SIDE PANEL – STRUCTURE PREPARATION	SAV00072
SMOOTH SIDE PANEL – INSTALLATION	SAV00073
ENGINE AIR INTAKE PANEL - GLUING	SAV00074
SMOOTH SIDE PANEL – FINISHING JOINT	SAV00075
SMOOTH SIDE PANEL – GLUING MOLDINGS	SAV00214
SMOOTH SIDE PANEL – REAR MOLDING GLUING	SAV00215
SMOOTH SIDE PANEL – PROTECTION OF UNPRIMED TIG WELDING SPOTS	SAV00216
SMOOTH SIDE PANEL – GLUING SLIDE-OUT VERTICAL MOLDING	SAV00217
SMOOTH SIDE PANEL – CUTTING HORIZONTAL FINISHING MOLDING AT SLIDE-OUT LEVEL	SAV00220

#### 7.7.2 Side Crest

- Clean vehicle surface using anti-silicone where the side crest and stickers will be applied.
- Using hands apply and compress side crest.
- Apply required stickers.

#### 7.8 ZONE 8

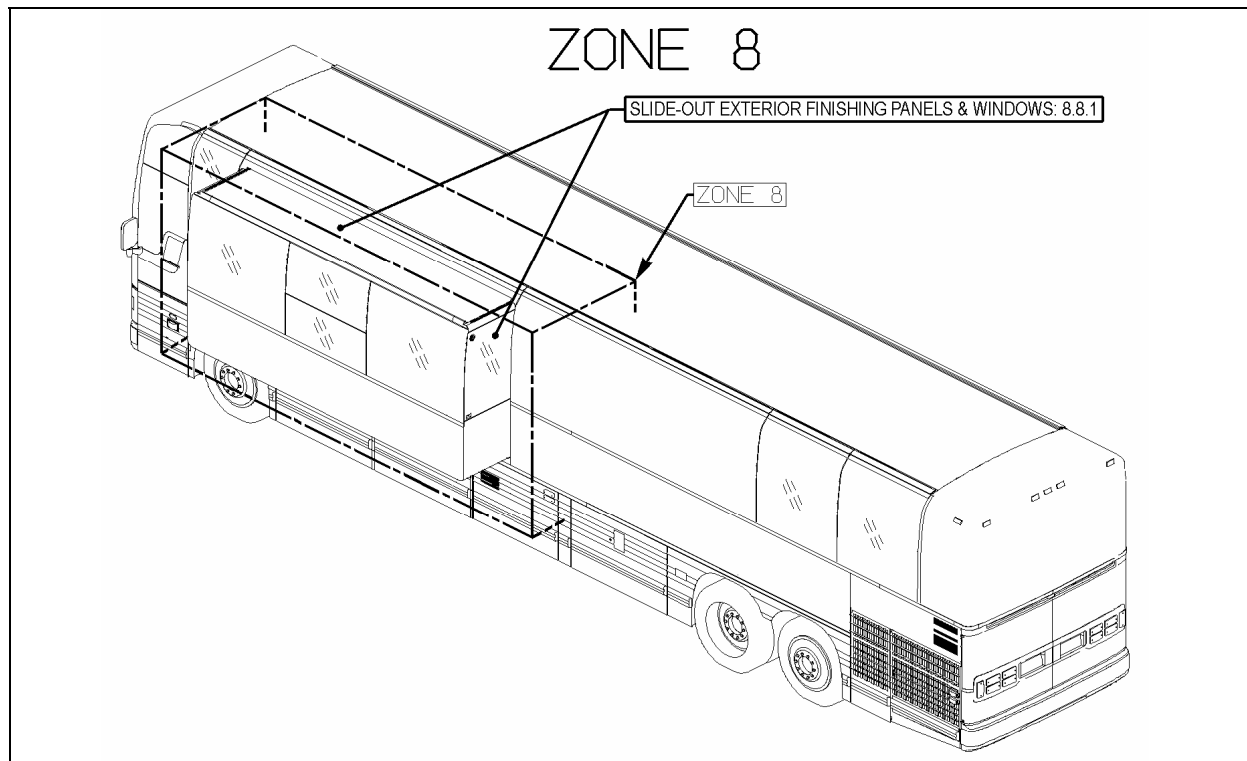

FIGURE 69: ZONE 8

#### 7.8.1 Slide-Out Exterior Finishing Panels & Windows

Refer to Maintenance Manual, Section 26: Paragraph 16 for the procedure on slide-out exterior finishing panels & windows.



### 8. VEHICLE JACKING POINTS

The vehicle can be lifted by applying pressure under body jacking points or front and drive axle jacking points. When it is necessary to lift the vehicle, care should be taken to ensure that the pressure is applied only on the specified areas. Equipment for lifting the front of the vehicle must have a combined lifting capacity of at least 20,000 lb. (9 100 kg). Equipment for lifting the rear of the vehicle must have a combined lifting capacity of at least 40,000 lb. (18 200 kg).



#### WARNING

DO NOT tow or jack vehicle with people on board.



#### WARNING

When it is necessary to raise the vehicle, care should be taken to ensure that pressure is applied only at the points indicated in figures 71 to 76.



#### WARNING

Extra lift capacity may be required if luggage or any other type of load (e.g. conversion equipment) are onboard the vehicle.



#### CAUTION

The suspension of the vehicle must be in the normal ride position before jacking. The "Level Low" system on a motorcoach must be in the "DRIVE" position prior to turning the ignition key "OFF".

Twelve jacking points are located on the vehicle: three are located on each side of the frame and two are located under each axle. Refer to the following illustrations for the location of jacking points.

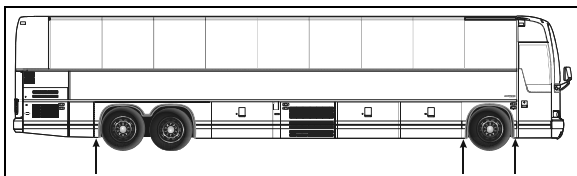

FIGURE 71: JACKING POINTS ON FRAME

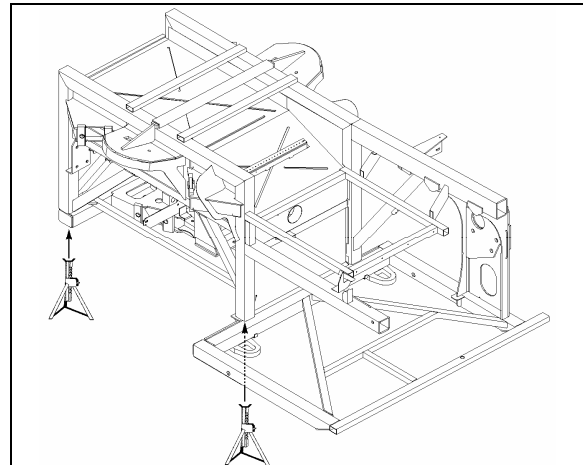

FIGURE 72: FRONT SUBFRAME JACKING POINTS 18592

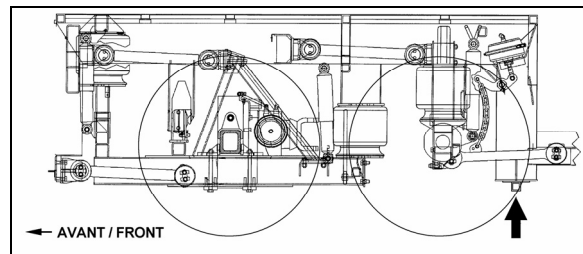

FIGURE 73: REAR SUBFRAME JACKING POINTS

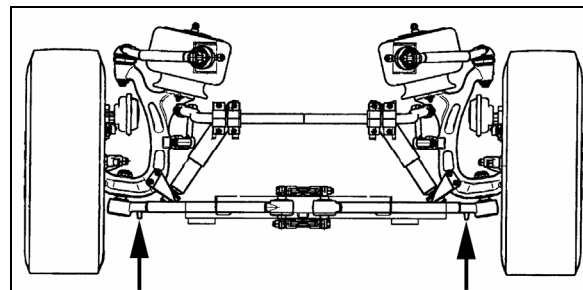

FIGURE 74: JACKING POINTS ON IND. SUSPENSION 16095

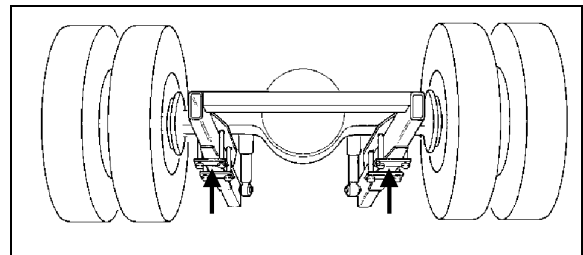

FIGURE 75: JACKING POINTS ON DRIVE AXLE OEH3B762



#### CAUTION

Always unload or retract the tag axle before jacking the vehicle from the front and drive axle jacking points to prevent damage to suspension components.

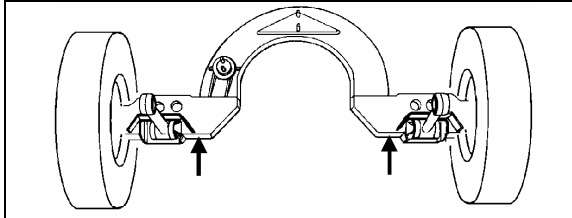

FIGURE 76: JACKING POINTS ON TAG AXLE OEH3B764

**WARNING**

The jacking points on the tag axle must be used for raising the tag axle only.

Several kinds of hydraulic jacks can be used. Only jack at the specified jacking points. Jack must support the following capacities:

Front axle: 20,000 lb. (9 100 kg);

Drive axle: 40,000 lb. (18 200 kg).

**8.1 HYDRAULIC JACK**

To raise: turn release valve clockwise. Insert handle in socket and raise vehicle by pumping.

To lower: remove handle and turn the release valve slowly counterclockwise.

Always keep ram and extension screw retracted when jack is not in use.

Service: Check oil level when jack fails to raise to full height. Lower ram completely with release valve open and jack in upright position, remove filler plug and refill to level of filler hole with hydraulic jack oil. Never use brake fluid.

**DANGER**

Jack is intended for lifting only. Do not get under the vehicle or load for any reason unless it is properly supported with safety stands and securely blocked.

**DANGER**

Do not overload jack above rated capacity. Prevent "side loading", make sure load is centered on ram. Do not push or tilt load off jack.

**9. TOWING THE VEHICLE**

The vehicle can be transported on a low bed semi-trailer of adequate gross axle weight

capacity. When transporting a vehicle, apply parking brake and shut down the engine. Block all wheels and secure vehicle with tie-downs. Check that overall height will clear obstacles on the route to follow, and obtain required permits.

The vehicle can also be towed by lifting the front axle or by towing from the front with all wheels on the ground. These two methods are described below under their respective headings. Whatever the method used, the vehicle should be towed by truck operators authorized and experienced in towing highway coaches.

Observe normal precautions including, but not limited to, the ones listed below when towing the vehicle:

- Make sure the parking brake is released before towing.
- Do not allow passengers to ride onboard the towed vehicle.
- Tow the vehicle at a safe speed as dictated by road and weather conditions.
- Accelerate and decelerate slowly and cautiously.

To prevent damage to the vehicle, use the two tow eyes located under the back bumper and/or fixed to the vehicle's frame between the front axle and the front bumper. Use only a solid link tow bar and a safety chain to tow the vehicle. If required, connect an auxiliary air supply to the vehicle so brakes can be operated while towing.

**WARNING**

During a towing operation, the driver should be alone inside the vehicle.

**CAUTION**

To prevent damage to the drive train components, disconnect axle shafts or driveshaft before towing. Do not attempt to push or pull-start a vehicle equipped with an automatic transmission.

**NOTE**

*Make sure axle shafts or driveshaft are installed correctly after towing. Tighten axle shaft and driveshaft nuts to the correct torque settings. Do not invert shafts*

### 9.1 LIFTING AND TOWING

The towed vehicle must be lifted from under the front axle only. The tow truck must be equipped with the proper lifting equipment to reach under the front axle since no other lifting points are recommended. Lifting and towing from any other point are unauthorized as it may cause serious damage to the structure. Do not unload or raise the tag axle when lifting and towing to prevent overloading the drive axle.

1. Remove both drive axle shafts to prevent damage to the transmission. Plug axle tube to prevent oil loss. Refer to Rockwell's "Maintenance manual no.5" annexed at the end of Section 11, Rear axle, in this manual for correct procedure.



#### CAUTION

Transmission lubrication is inadequate when towing. The drive axle shafts must be removed to avoid serious damage to the transmission.

2. Operate the engine when towing to maintain brake system air pressure. If the engine cannot be operated, connect an external air pressure line from the tow truck to the emergency fill valve in the engine compartment.
3. The emergency fill valve in the front service compartment does not supply air pressure to the brake system. The air pressure must be a minimum of 75 psi (520 kPa), and the line should be attached to the air line with a clip-on chuck.



#### WARNING

Do not tow the vehicle without external air pressure applied to the emergency fill valve if the engine does not operate. Without brake system air pressure, the brakes may apply automatically if system air drops below 40 psi (275 kPa). If failure prevents releasing the parking brakes with air pressure, disengage the parking brakes mechanically.

4. Lift the vehicle from under the front axle, and adequately secure the underside to the tow vehicle lifting attachment with chains.
5. Observe safety precautions when towing.

### 9.2 TOWING WITHOUT LIFTING



#### WARNING

When towing vehicle without lifting, use only a tow truck with a solid link tow bar and related equipment. All other means of towing are unauthorized. Tow only from the front of the vehicle.

1. Remove both drive axle shafts to prevent damage to the transmission. Plug axle tube to prevent oil loss. Refer to Rockwell's "Maintenance manual no.5" annexed at the end of Section 11, Rear axle, in this manual for correct procedure.



#### CAUTION

Transmission lubrication is inadequate when towing. The drive axle shafts must be removed to avoid serious damage to the transmission.

2. Operate the engine when towing to maintain brake system air pressure. If the engine cannot be operated, connect an external air pressure line from the tow truck to the emergency fill valve in the engine compartment. The emergency fill valve in the front service compartment does not supply air pressure to the brake system. The air pressure must be a minimum of 75 psi (520 kPa), and the line should be attached to the air line with a clip-on chuck.



#### WARNING

Do not tow the vehicle without external air pressure applied to the emergency fill valve if the engine does not operate. Without brake system air pressure, the brakes may apply automatically if system air drops below 40 psi (275 kPa). If failure prevents releasing the parking brakes with air pressure, disengage the parking brakes mechanically.

3. Position the tow truck so that the tow bar contacts the front bumper of the vehicle.
4. Attach the tow truck chains only in the tow eyes of the vehicle under the bumper and take up all the slack.
5. Attach safety chains as applicable.
6. Observe safety precautions when towing.