

| | | | | | |
|----------------------------------|----------|--------------------|--------------------------|---------|--|
| Engineering Release Notice (ERN) | Location | Change Description | A = Added D = Deleted | W = Was | Document Release Status RELEASED |
| | | See DCN | | | Date Modification Count |

WIRING DIAGRAM INDEX

VOLUME 1

| NAME | PAGE |
|-------------------|------|
| INSTRUCTIONS | 2 |
| ABBREVIATION LIST | 6 |

VOLUME 2

| NAME | DESCRIPTION | PAGE |
|------|-------------------------------|------|
| AA | IGNITION AND STARTING SYSTEM | 1 |
| AB | POWER SUPPLY | 2 |
| AB2 | NVPDUF & NVPDUR | 3 |
| AB3 | STARTER BATTERY | 4 |
| AB4 | CONSUMER BATTERY | 5 |
| AB5 | PRE HEATER | 6 |
| AC | I-START SYSTEM | 7 |
| AF | STARTER MOTOR AND ALTERNATORS | 8 |
| BA | VECU | 9 |
| BB | BBM | 10 |
| BC | BBM | 11 |
| BE | AEBS, LDWS, ACC | 12 |
| CL | BIO | 13 |
| CS | ENGINE INTERFACE D13 | 14 |
| CU | DNOX2 FOR EURO 5 | 15 |
| CX | ACM 2.0 | 16 |
| CZ | RETARDER I-SHIFT | 17 |
| DN | I-SHIFT | 18 |
| DN2 | I-SHIFT | 19 |
| DN3 | I-SHIFT | 20 |
| DN4 | I-SHIFT AND RETARDER | 21 |
| DN5 | ALLISON | 22 |
| DN6 | I-SHIFT | 23 |
| EO | EBS | 24 |
| EP | EBS | 25 |
| FA | AIR SUSPENSION ECS | 26 |
| FB | AIR SUSPENSION ECS | 27 |
| FB2 | AIR SUSPENSION ECS | 28 |
| FC1 | VDS, Volvo Dynamic Steering | 29 |

The copying, distribution and utilization of this document as well as the communication of its contents to others without expressed authorization is prohibited. Offenders will be held liable for payment of damages. All rights reserved in the event of the grant of a patent, utility model or ornamental design registration.

VOLVO

Volvo Bus Corporation

Document title
**WIRING DIAGRAM
 B13R
 US/CAN**

Document type
PRODUCT SCHEMATICS

Owner domain: Document prefix

| | | | |
|--------------------------------|--------------------|-------------------------|-------------------------|
| Document No 22610880 | Issue 11 | Volume 01(03) | Sheet No 1(9) |
|--------------------------------|--------------------|-------------------------|-------------------------|

WIRING DIAGRAM INDEX

VOLUME 2

| NAME | DESCRIPTION | PAGE |
|-------|--------------------------------|------|
| FC2 | VDS GATEWAY | 30 |
| GA | LCM | 31 |
| GB | LCM | 32 |
| GE | LCM | 33 |
| GM | WIPER, WASHER | 34 |
| IS | HORN, SWM | 35 |
| IU | AUDIO | 36 |
| NA | BUS INSTRUMENT CLUSTER BIC2 | 37 |
| NA2 | OBD, ON BOARD DIAGNOSTICS | 38 |
| NB | TACHOGRAPH | 39 |
| NC | TGW II | 40 |
| ND | ALCOLOCK | 41 |
| NE | FMS GATEWAY | 42 |
| NF | ELD (ELETRONIC LOGGING DEVICE) | 43 |
| TL | AIC POWER SUPPLY | 44 |
| TT | I-COACH | 45 |
| XC | CAN SAE 1939 | 46 |
| XD | CAN SAE1587 | 47 |
| XE | DBUS | 48 |
| XF | CAN 1939_7 | 49 |
| XG | CAN J2284 | 50 |
| XH1-1 | CAN ENGINE_SUBNET | 51 |
| XH1-2 | CAN ENGINE_SUBNET | 52 |
| XJ | CAN J1939 2/3 | 53 |
| XJ2 | CAN J1939 2/3 | 54 |
| XK | FMS-CAN | 55 |
| XN | ACTIVE SAFETY BACKBONE 2 | 56 |
| XO | CAN VDS | 57 |
| ZC | GROUND | 58 |

VOLVO

Volvo Bus Corporation

Document title

WIRING DIAGRAM

Document type

PRODUCT SCHEMATICS

Document No

22610880

Issue

11

Volume

01(03)

Sheet No

2(9)

Example of Wiring Diagram

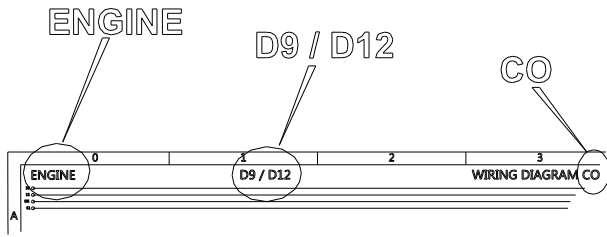

Component wiring diagram title, variant/subtitle and sheet number.

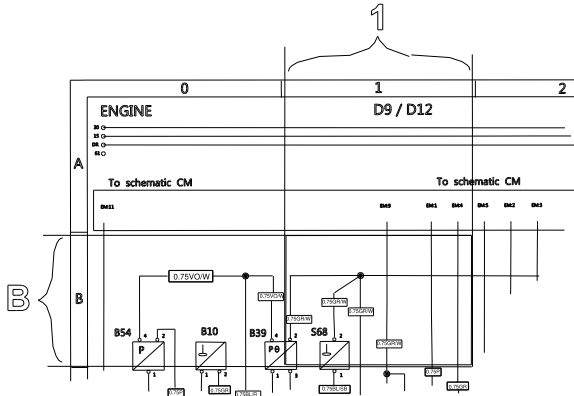

Coordinates (B 1).

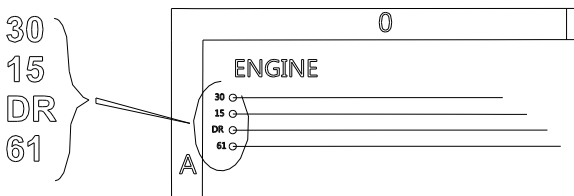

B+ Voltage battery with switch in ON position.
30 Voltage battery with main switch on, kl.30.
15 Voltage with starter key in drive position, kl.15.
DR Voltage with starter key in drive position, preheat position and start position, kl.DR.

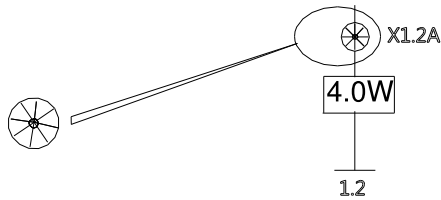

Splice.

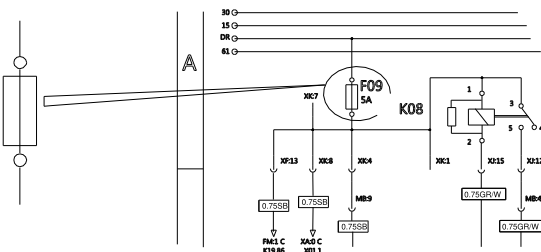

Fuse.

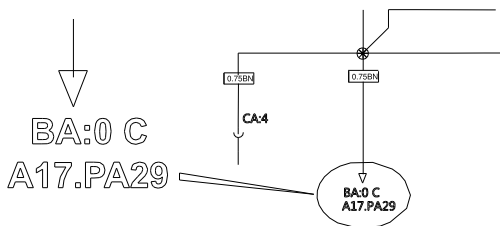

Reference arrow, for Diagram BA, coordinates 0 C, component A17, connector PA pin 29.

VOLVO

Volvo Bus Corporation

Document title
WIRING DIAGRAM

Document type
PRODUCT SCHEMATICS

Document No

22610880

Issue

11

Volume

01(03)

Sheet No

3(9)

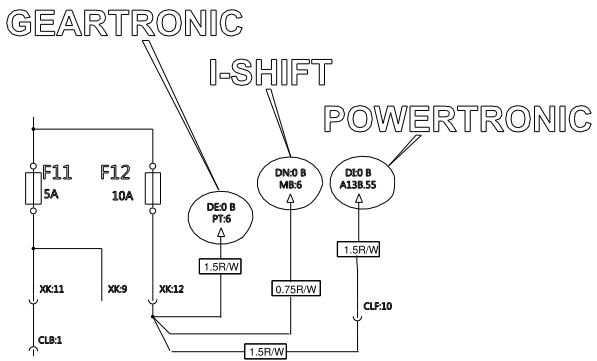

The maximum of variants are drawn, think about that all wires and components are not standard for all markets or vehicle models.

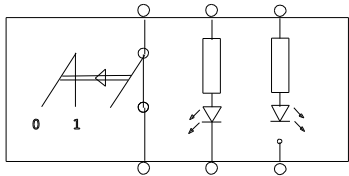

Switch.

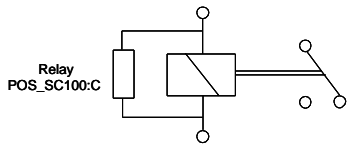

Relay with position.

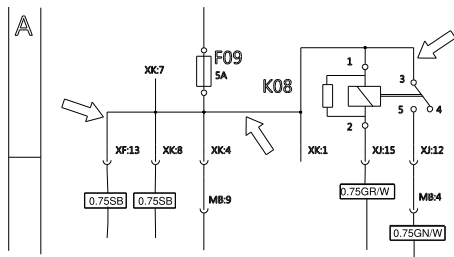

Conductor on circuit card.

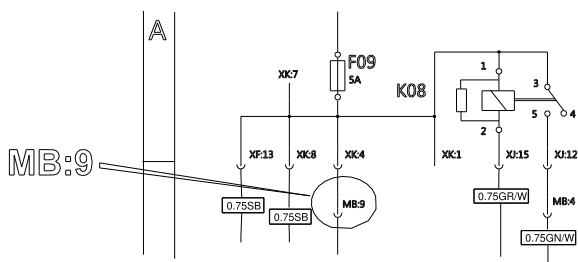

Connector MB terminal 9.

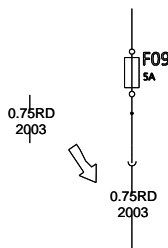

Wire area, colour and equipotential.

VOLVO

Volvo Bus Corporation

Document title
WIRING DIAGRAM

Document type
PRODUCT SCHEMATICS

Document No
22610880

Issue
11

Volume
01(03)

Sheet No
4(9)

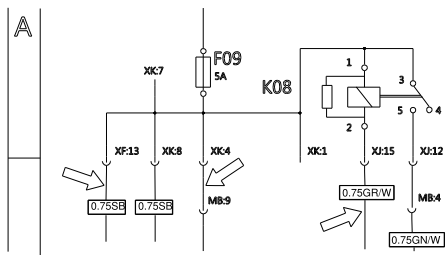

Thin lines, wires.

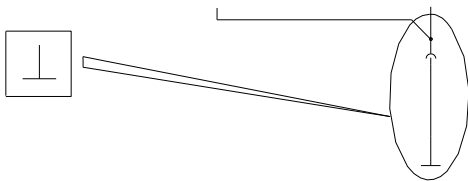

Earth connection to circuit card.

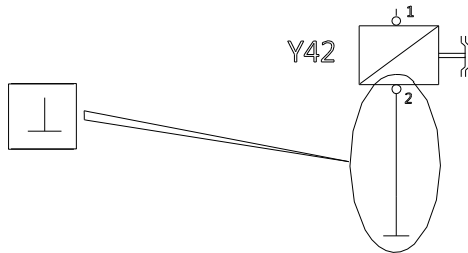

Earth connection without wire.

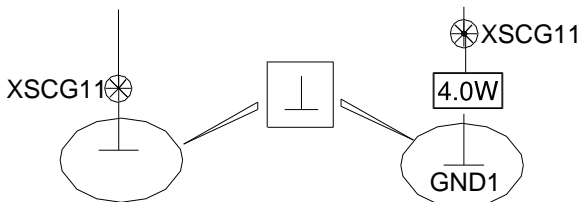

Same splice can be drawn on several diagrams. The wire from the splice to the earth connection point will only be drawn and coded on one diagram. On the other diagrams will only the earth connection point be written besides the splice.

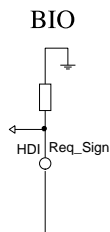

An ECU symbol with a dashed box describes that the ECU exists in several different sheets.

VOLVO

Volvo Bus Corporation

Document title
WIRING DIAGRAM

Document type
PRODUCT SCHEMATICS

Document No
22610880

Issue
11

Volume
01(03)

Sheet No
5(9)

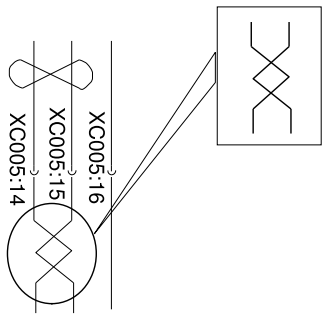

Twisted wires.

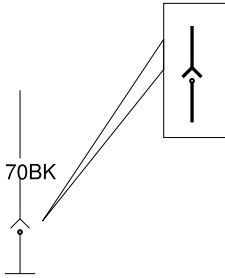

inline connector symbol for power cable ring terminal.

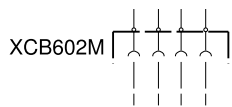

Interface symbol.

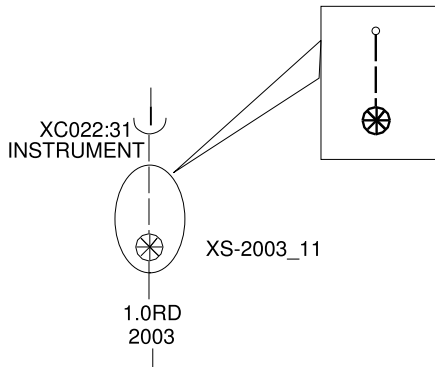

Splice with dotted line indicates that wire already exists in some other sheet and splice is shared.

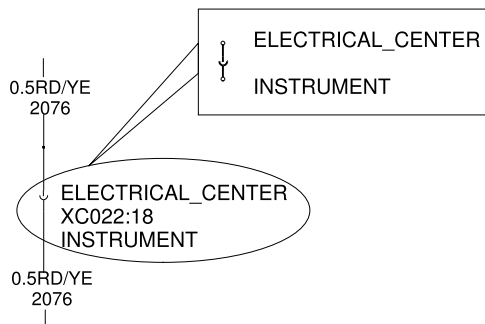

The text on either side of the inline incates that wire belongs to stated harness.

VOLVO

Volvo Bus Corporation

Document title
WIRING DIAGRAM

Document type
PRODUCT SCHEMATICS

Document No
22610880

Issue
11

Volume
01(03)

Sheet No
6(9)

ABBREVIATION LIST

| ABBREVIATION | DESCRIPTION |
|--------------|--|
| +15 | VOLTAGE WITH STARTER KEY IN DRIVE POSITION |
| +30 | VOLTAGE BATTERY WITH MAIN SWITCH ON |
| +30C | VOLTAGE BATTERY WITH MAIN SWITCH ON |
| AC | AIR CONDITION |
| Acp | ACCELERATOR PEDAL |
| AI | ANALOG INPUT |
| AIC | ADVANCED INFORMATION CENTER |
| Amb | AMBIENT |
| An.IN | ANALOGUE INPUT |
| AO | ANALOG OUTPUT |
| APBE | AUTOMATIC PARKING BRAKE EVACUATION |
| ARC | AIR REGENERATION CONTROL |
| ARMS | AUTOMATIC RESET MAIN SWITCH |
| B+ | VOLTAGE BATTERY WITH SWITCH IN ON POSITION |
| BB | BODY BUILDER |
| BBM | BODY BUILDER MODULE |
| BHSA | BRAKE HILL START AID |
| Bpole | BATTERY POSITIVE BEFORE MAIN SWITCH |
| Brk | BRAKE |
| Buf | BUFFERED |
| C | CLOSING |
| CampL | CAMPIGN LIGHTS |
| Cent | CENTERING |
| CICU | Charging |
| Ctrl | CONTROL |
| Cyl | CYLINDER |
| Dash | DASHBOARD |
| Deliv | DELIVERY |
| DI | DIGITAL INPUT |
| Diag | DIAGNOSTIC |
| Dig.OUT | DIGITAL OUTPUT |
| Dir | DIRECTION |
| Dis | DISABLE |
| DO | DIGITAL OUTPUT |
| DRL_RMC | DAYTIME RUNNING LIGTH/REDUCED MODE CONTROL |
| EACC | ELECTRIC AIR COMPRESSOR CONTROL |
| EBS | ELECTRONIC BRAKE SYSTEM |
| ECB | VBC ENGINE COMPRESSOR BRAKE |
| ECU | ELECTRONIC CONTROL UNIT |
| ECU_GND | EXTERNAL GROUND |
| EGR | EXHAUST REDIRECTION VALVE |
| ELC | ELECTRICAL CENTER |
| EMT | EXHAUST MANIFOLD TEMPERATURE |
| Eng | ENGINE |
| EPG | EXHAUST PRESSURE GOVERNOR |
| ES | ENGINE SYNCHRONIZATION |
| ESS | ENERGY STORAGE SYSTEM |
| ETCC | EXHAUST TEMPERATURE CATALYTIC CONVERTER |
| Ext | EXTERNAL |
| FRC | FRONT RELAY CENTER |
| GECU | GEAR SELECTOR ELECTRONIC CONTROL UNIT |
| GND | SIGNAL GROUND |
| H | HIGH |
| Haz | HAZARD |

VOLVO

Volvo Bus Corporation

Document title
WIRING DIAGRAM

Document type
PRODUCT SCHEMATICS

| | | | |
|-----------------|-----------|---------------|-------------|
| Document No | Issue | Volume | Sheet No |
| 22610880 | 11 | 01(03) | 7(9) |

| ABBREVIATION | DESCRIPTION |
|--------------|--|
| HDI | HIGH_DIGITAL_INPUT |
| HDO | HIGH_DIGITAL_OUTPUT |
| HLa | HEADLAMPS |
| HPCU | HYBRID_POWER_TRAIN_CONTROL_UNIT |
| HS | HIGH_SIDE |
| HSA | HILL_START_AID |
| HSD | HIGH_SIDE_DRIVER |
| HVAC | HEATING_VENTILATION_AIR_CONDITION_SYSTEM |
| Hyd | HYDRAULIC |
| IJ | INLET_JET |
| Ind | INDICATOR |
| Inj | INJECTION |
| JK | JACK_KNIFE |
| KL | KEY_LINE |
| L | LOW |
| LCM | LIGHT_CONTROL_MODULE |
| LCP | LIGHT_CONTROL_PANEL |
| LDI | LOW_DIGITAL_INPUT |
| LDO | LOW_DIGITAL_OUTPUT |
| LS | LOW_SIDE |
| Nd | NEEDLE |
| O | OUTPUT |
| OBD | ON_BOARD_DIAGNOSTIC |
| OLS | OIL_LEVEL_SENSOR |
| OP | OPENING |
| OV | OVERFLOW |
| PCM | POWER_TRAIN_CONTROL_MODULE |
| PCS | PRESSURE_CONTROL_SOLENOID |
| PCV | PRESSURE_CONTROL_VALVE |
| Plo | PLOUGH |
| Pos | POSITION |
| PR | PRESSURE_REGULATOR |
| Pres | PRESSURE |
| PS | PRESSURE |
| PWM | PULSE_WIDTH_MODULATION |
| Rad | RADIATOR |
| RAI | RESISTANCE_ANALOGUE_INPUT |
| Red | REDUCTOR |
| Rel | RELAY |
| Req | REQUEST |
| RES | INPUT_FOR_SENSORS_WITH_VARIABLE_RESISTANCE |
| Ret | RETARDER |
| RX | SIGNAL_RECEIVER |
| Sen | SENSOR |
| Sign | SIGNAL |
| Sno | SNOW |
| Sp | SPEED |
| SS | SENSOR_SUPPLY |
| St | START |
| Stp | STOP |
| SV | SUPPLY_VOLTAGE |
| Sw | SWITCH |
| TCC | TORQUE_CONVERTER_CLUTCH |
| Temp | TEMPERATURE |

VOLVO

Volvo Bus Corporation

Document title
WIRING DIAGRAM

Document type
PRODUCT SCHEMATICS

| | | | |
|--------------------------------|--------------------|-------------------------|-------------------------|
| Document No 22610880 | Issue 11 | Volume 01(03) | Sheet No 8(9) |
|--------------------------------|--------------------|-------------------------|-------------------------|

| ABBREVIATION | DESCRIPTION |
|--------------|----------------------------|
| Tor | TORQUE |
| TX | SIGNAL_TRANSMITTER |
| UBat | FEED_DIRECTLY_FROM_BATTERY |
| VEB | VOLVO_ENGINE_BRAKE |
| Veh | VEHICLE |

VOLVO

Volvo Bus Corporation

Document title
WIRING DIAGRAM

Document type
PRODUCT SCHEMATICS

| Document No | Issue | Volume | Sheet No |
|-------------|-------|--------|----------|
| 22610880 | 11 | 01(03) | 9(9) |

IGNITION AND STARTING SYSTEM

WIRING DIAGRAM AA

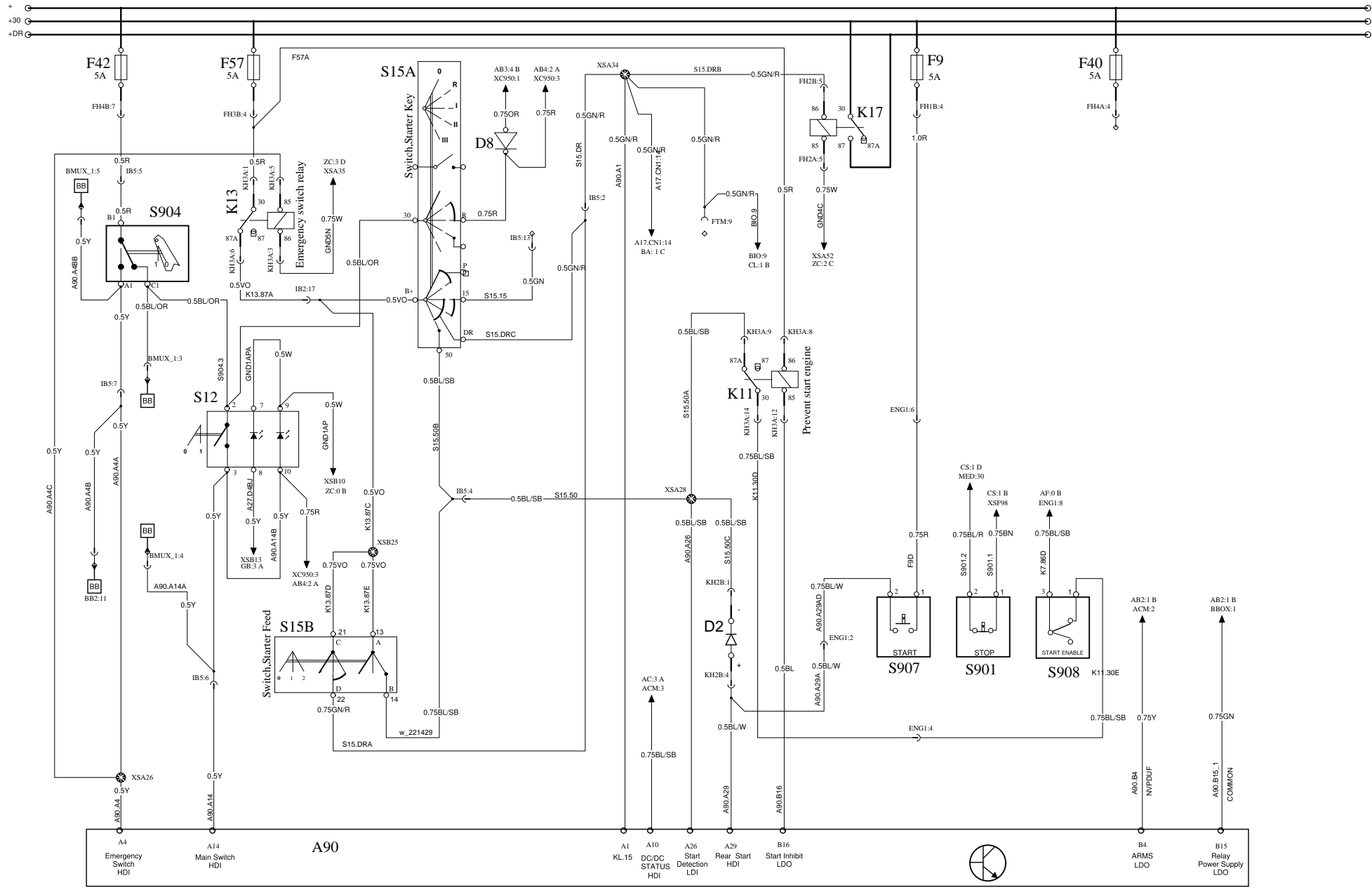

POWER SUPPLY

US/CAN

WIRING DIAGRAM AB

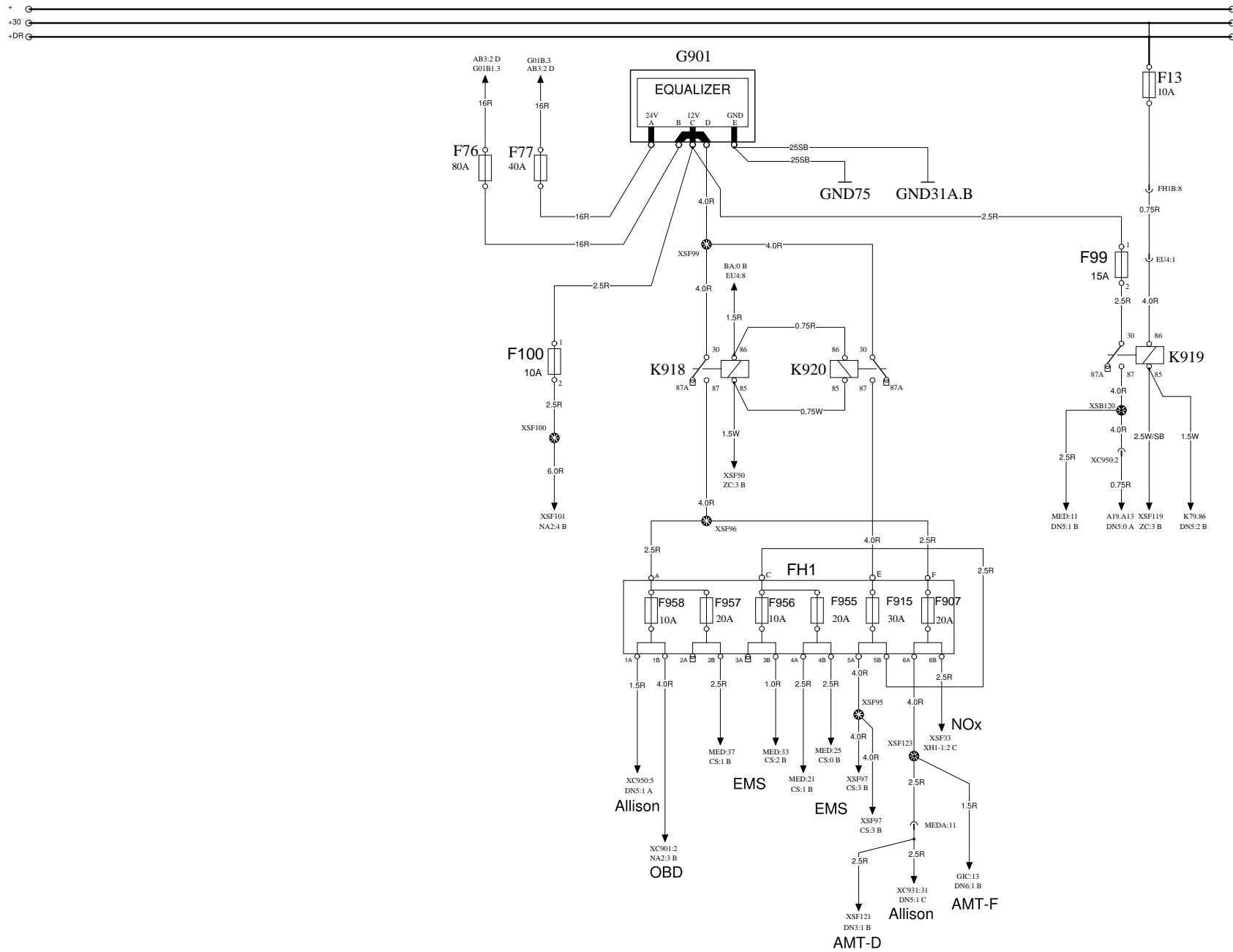

NVPDUF & NVPDUR

FOR EURO 5 (MEXICO)

WIRING DIAGRAM AB2

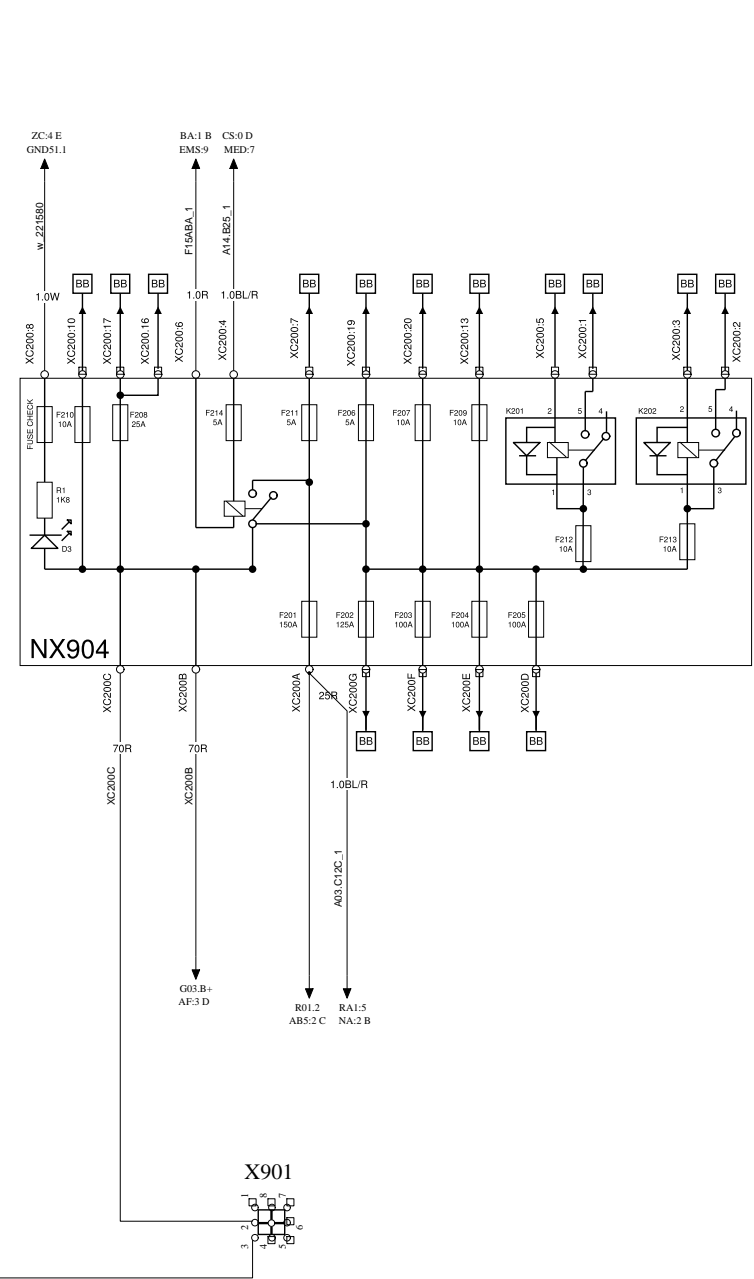
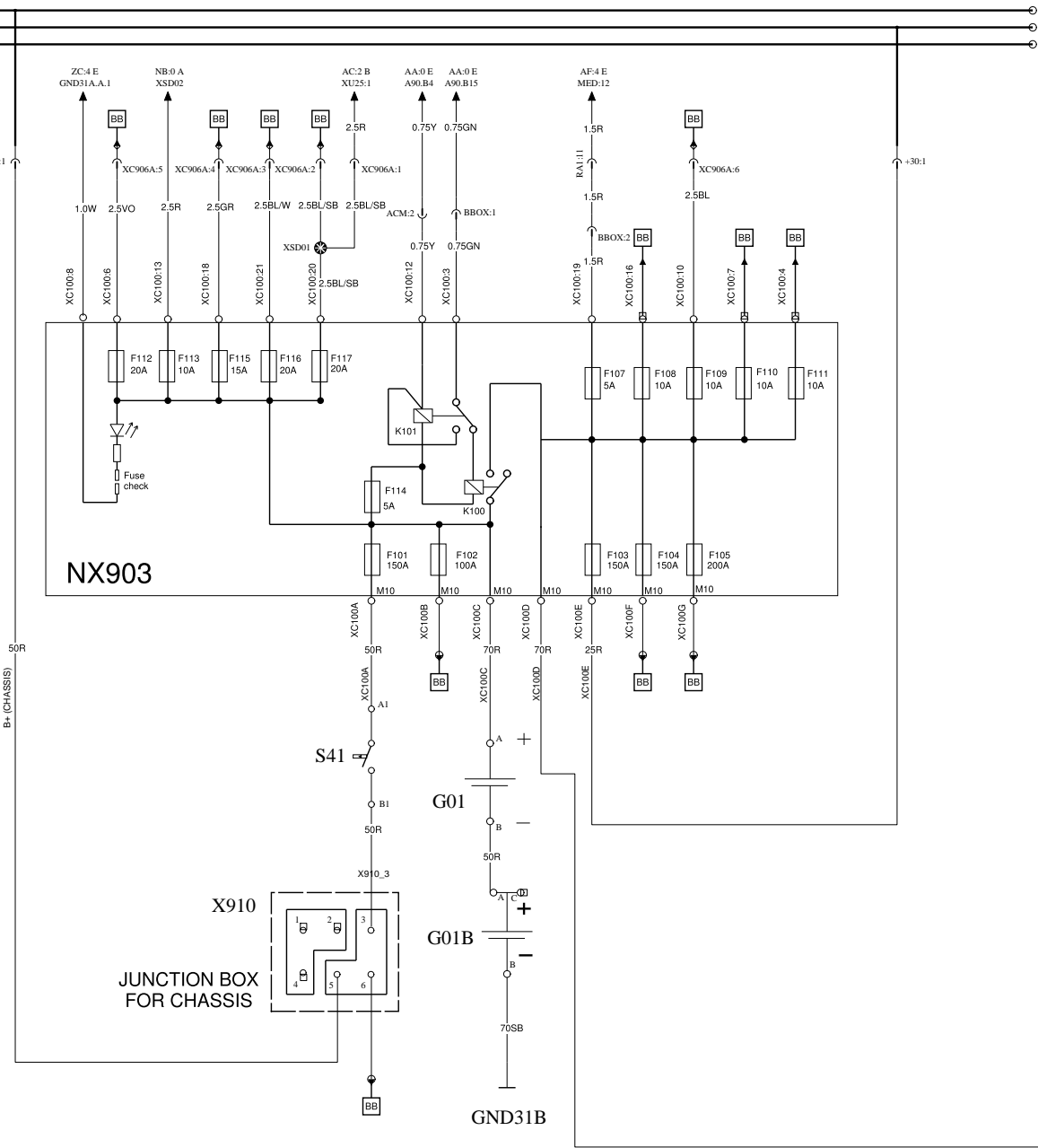

STARTER BATTERY

US/CAN

WIRING DIAGRAM AB3

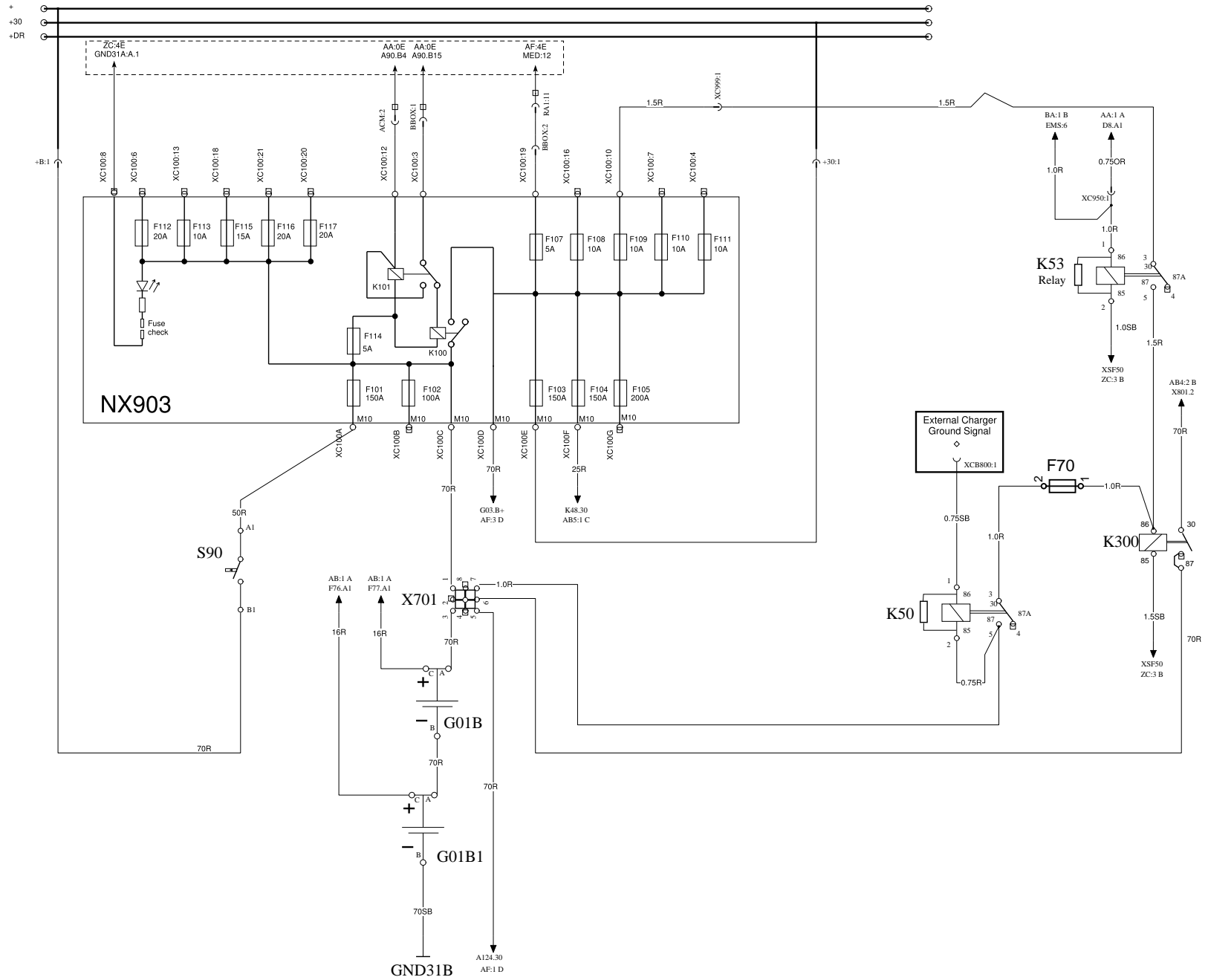

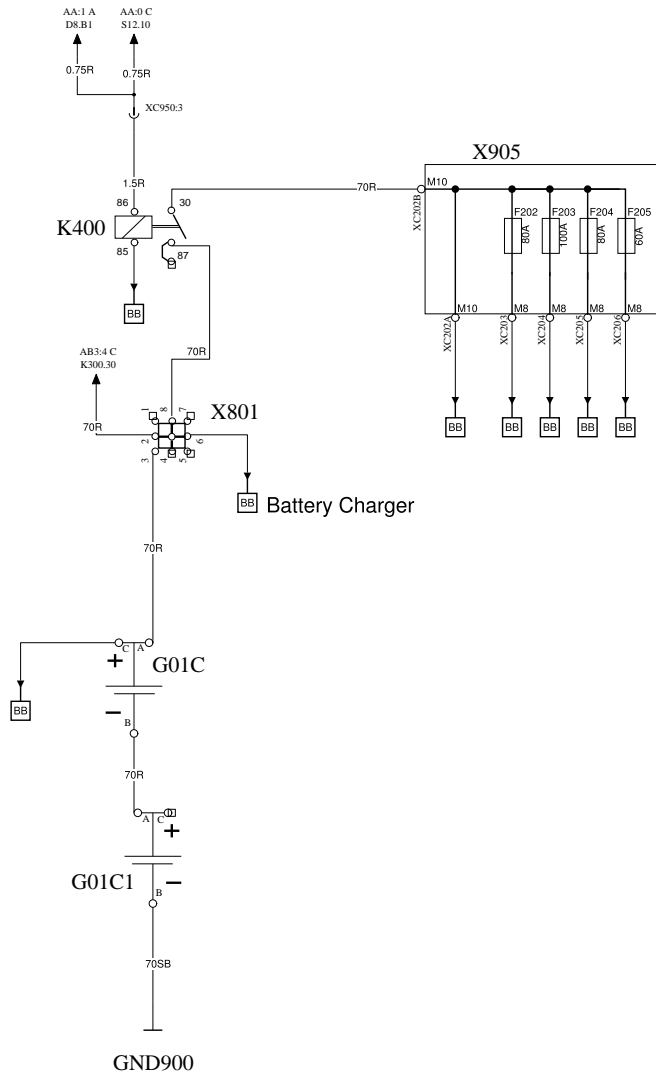

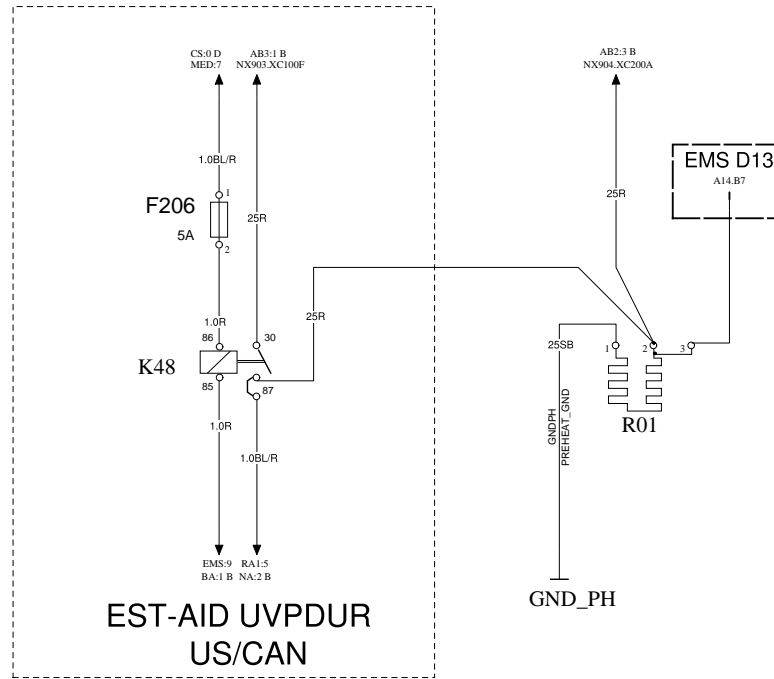

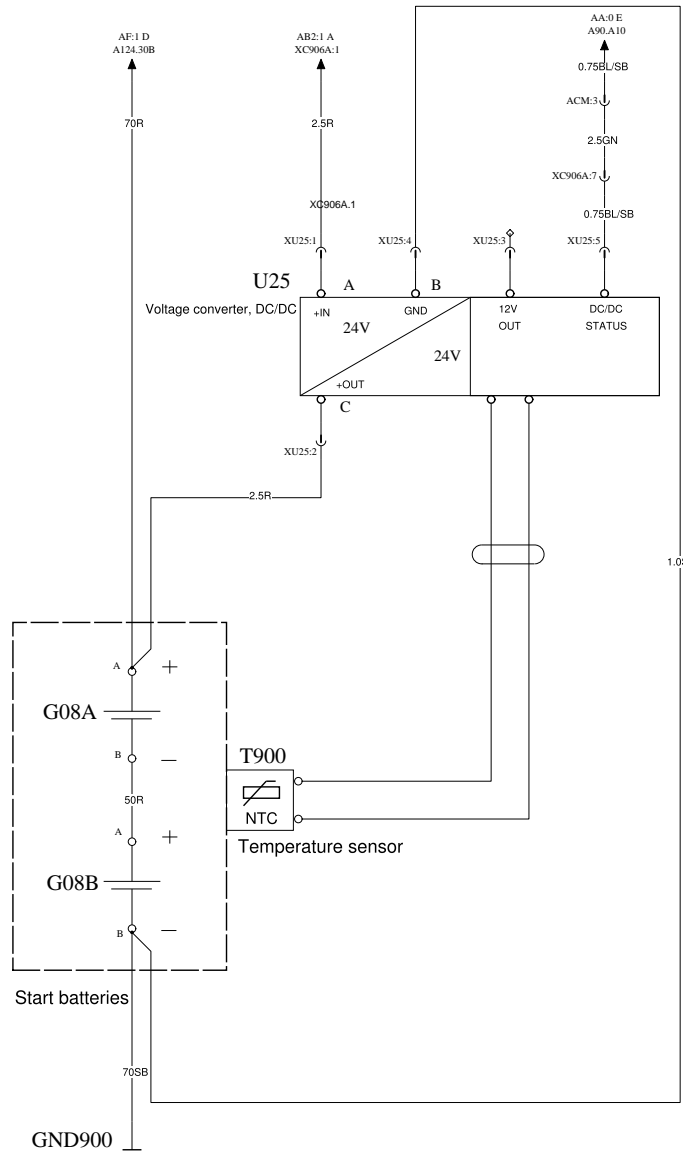

STARTER MOTOR AND ALTERNATORS

WIRING DIAGRAM AF

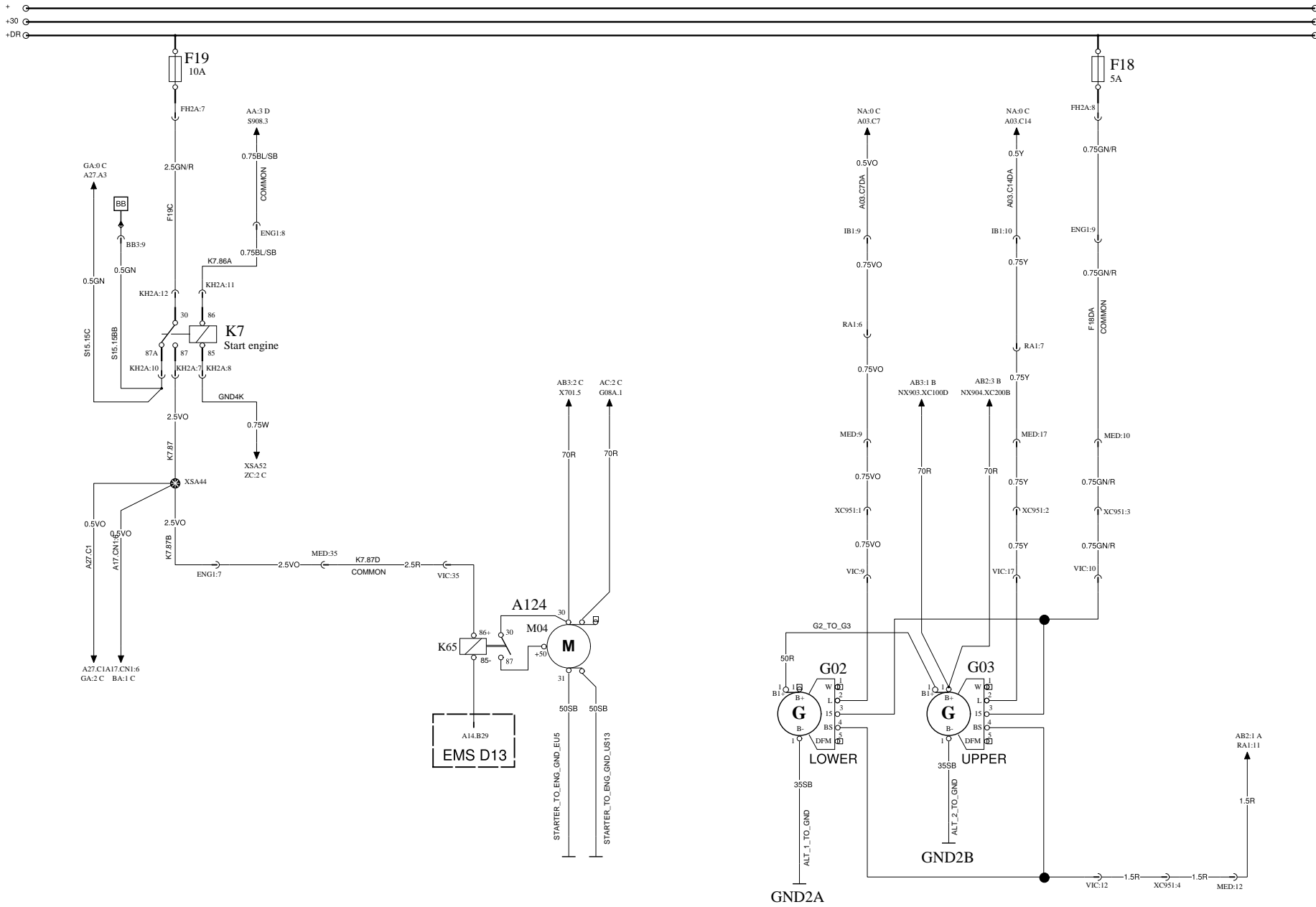

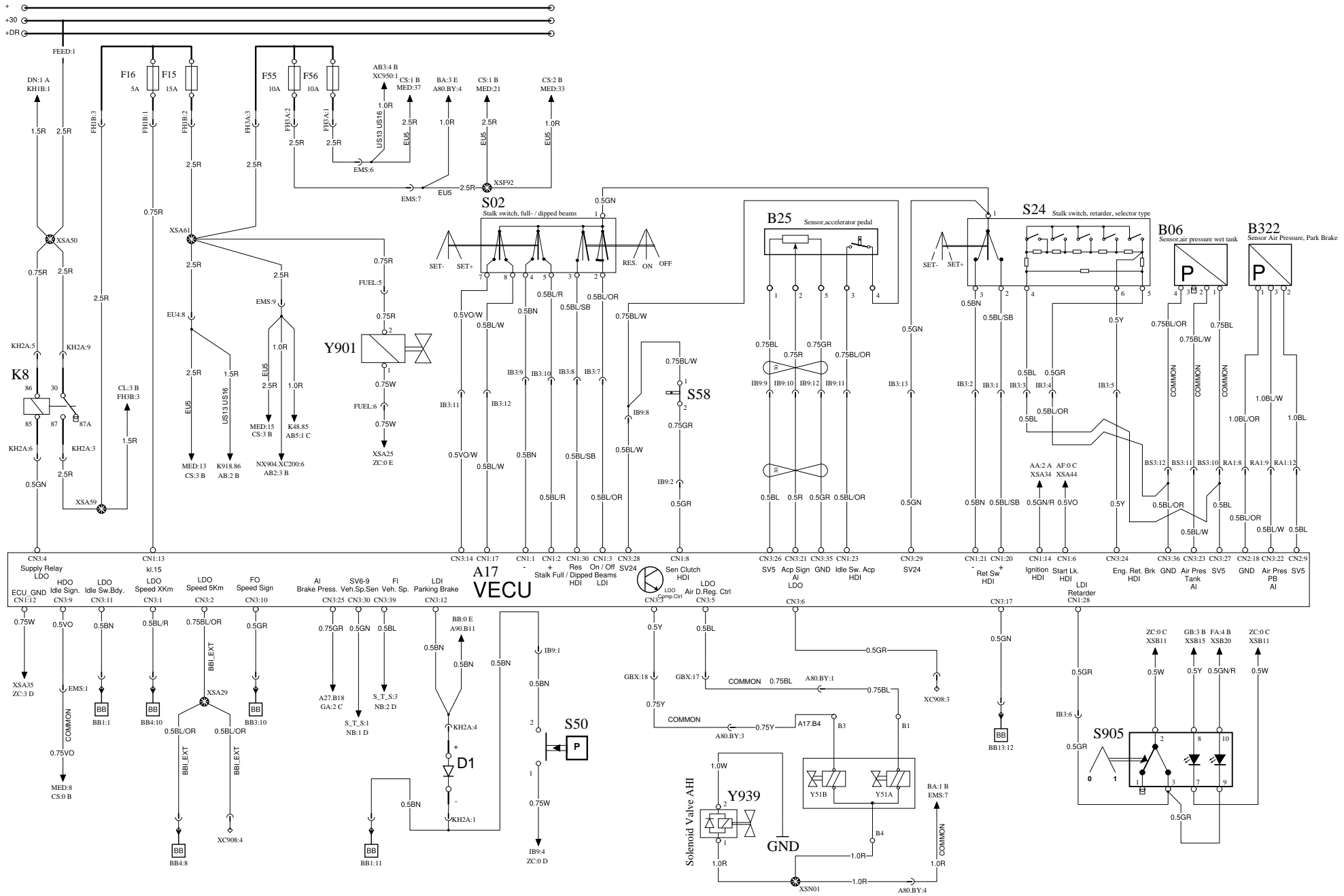

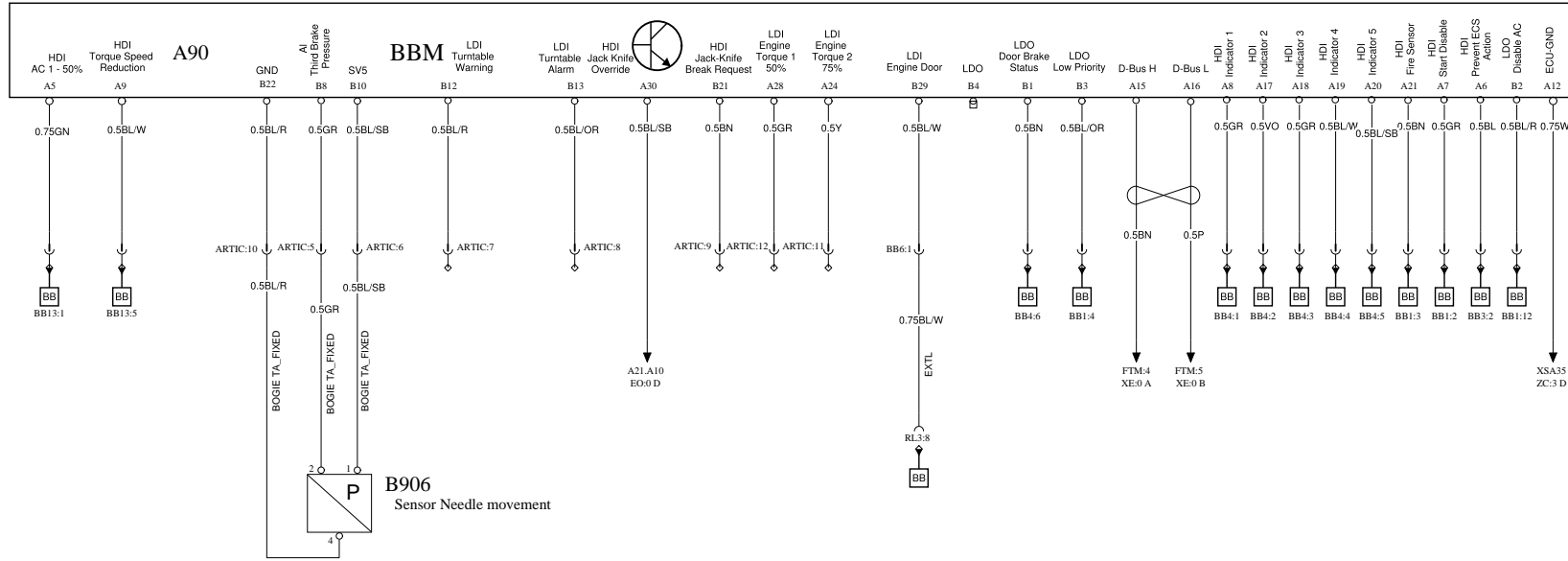

| | | | | | |
|---------------------------|------------------------------------|------------------------------------|-------|--------|--------|
| Volvo Bus Corporation | Document title WIRING DIAGRAM | Document No 22610880 | Issue | Volume | Page |
| | Document type PRODUCT SCHEMATIC | | 11 | 02(03) | 11(58) |

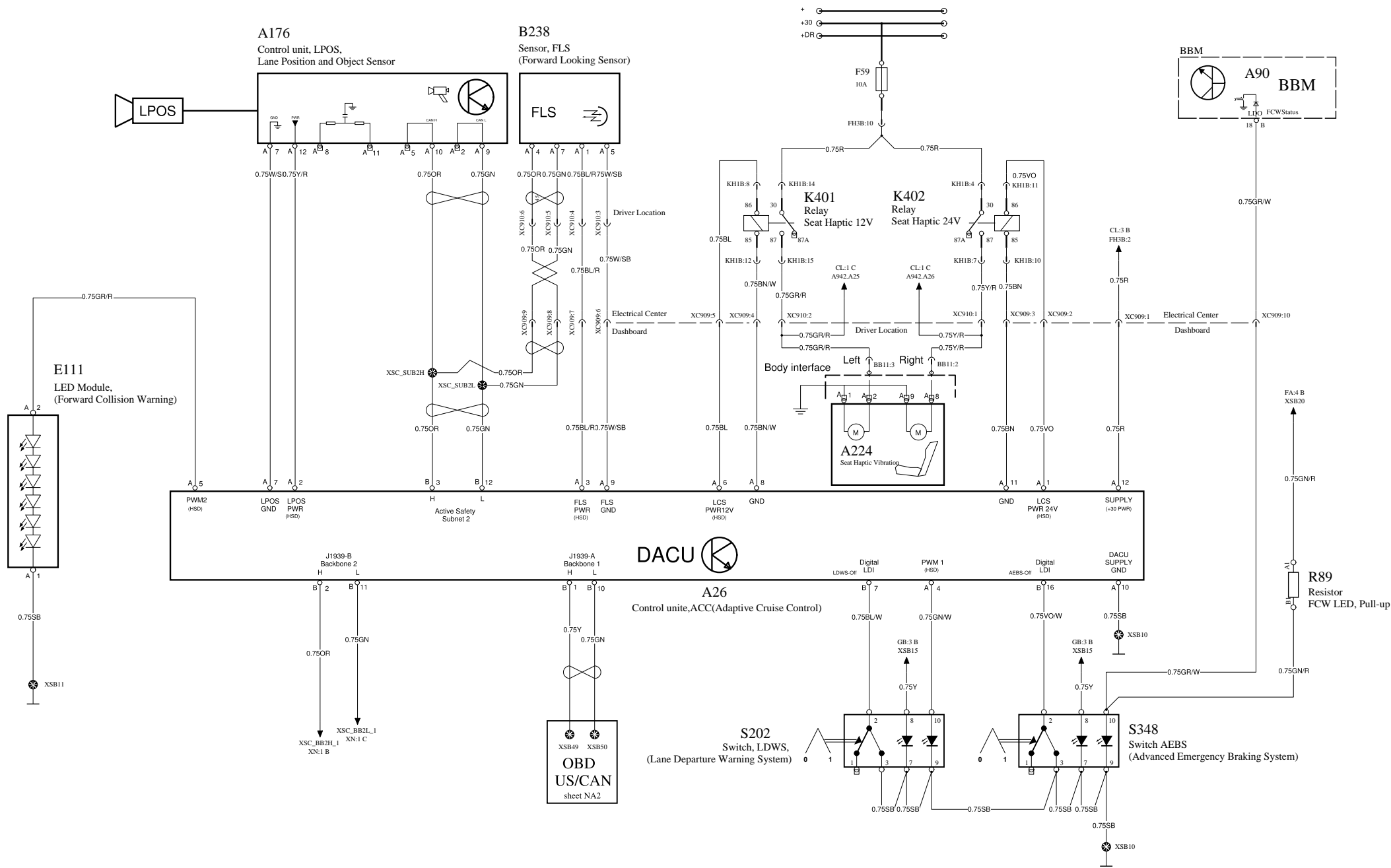

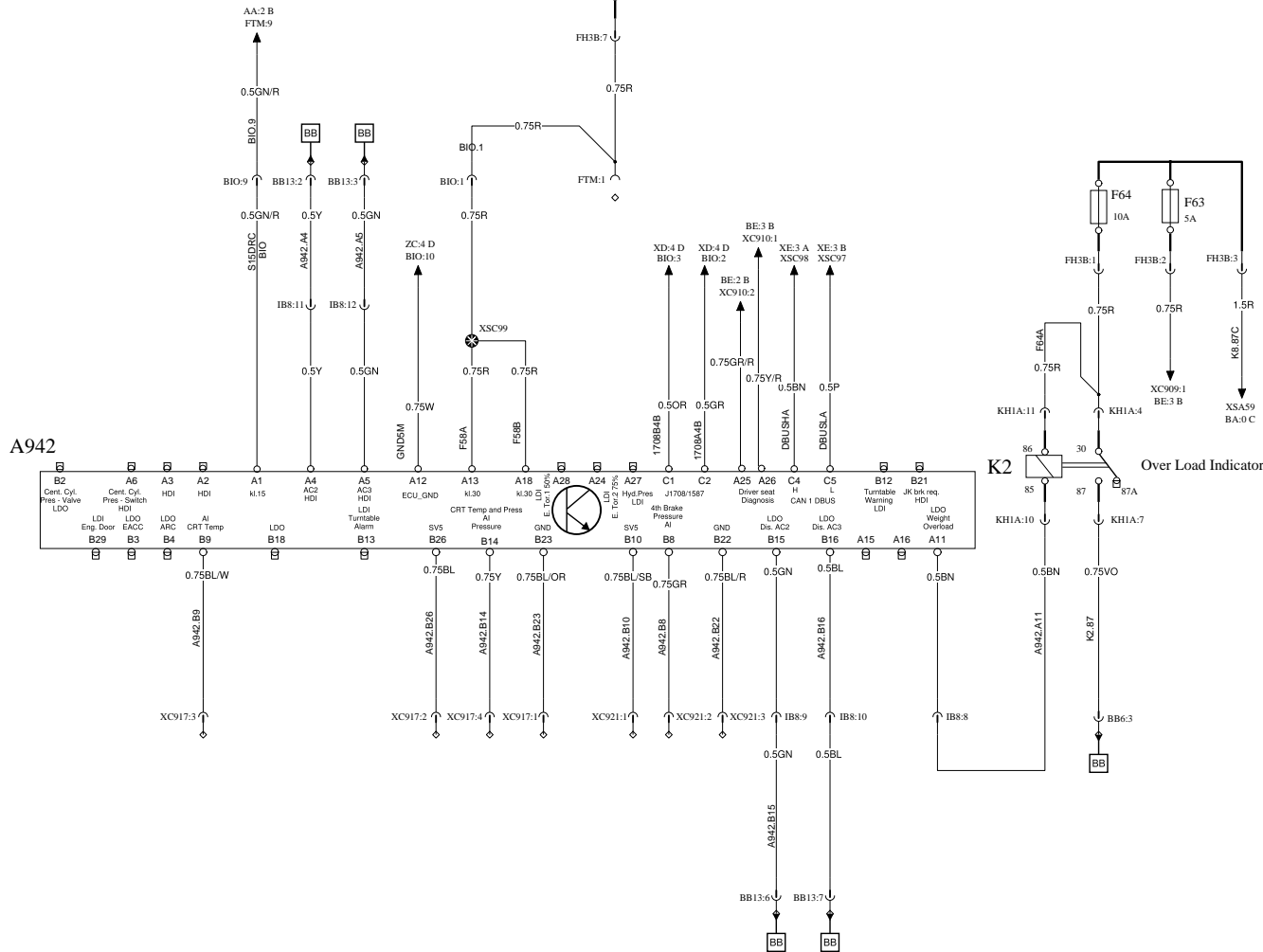
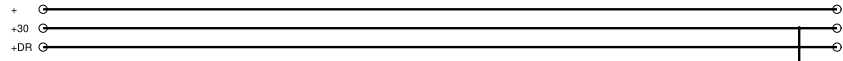

ENGINE INTERFACE D13

WIRING DIAGRAM CS

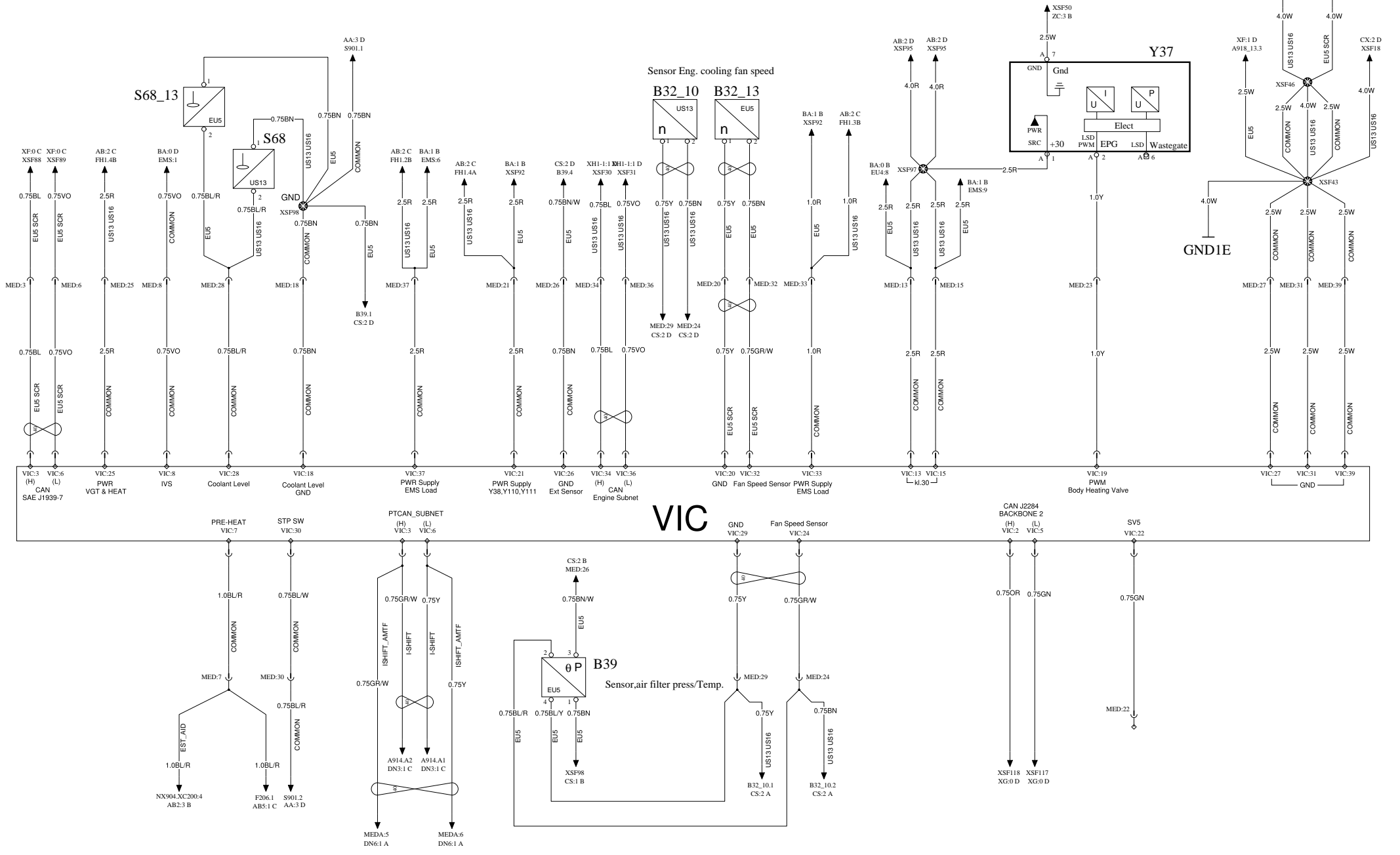

DNOX2 FOR EURO 5

WIRING DIAGRAM CU

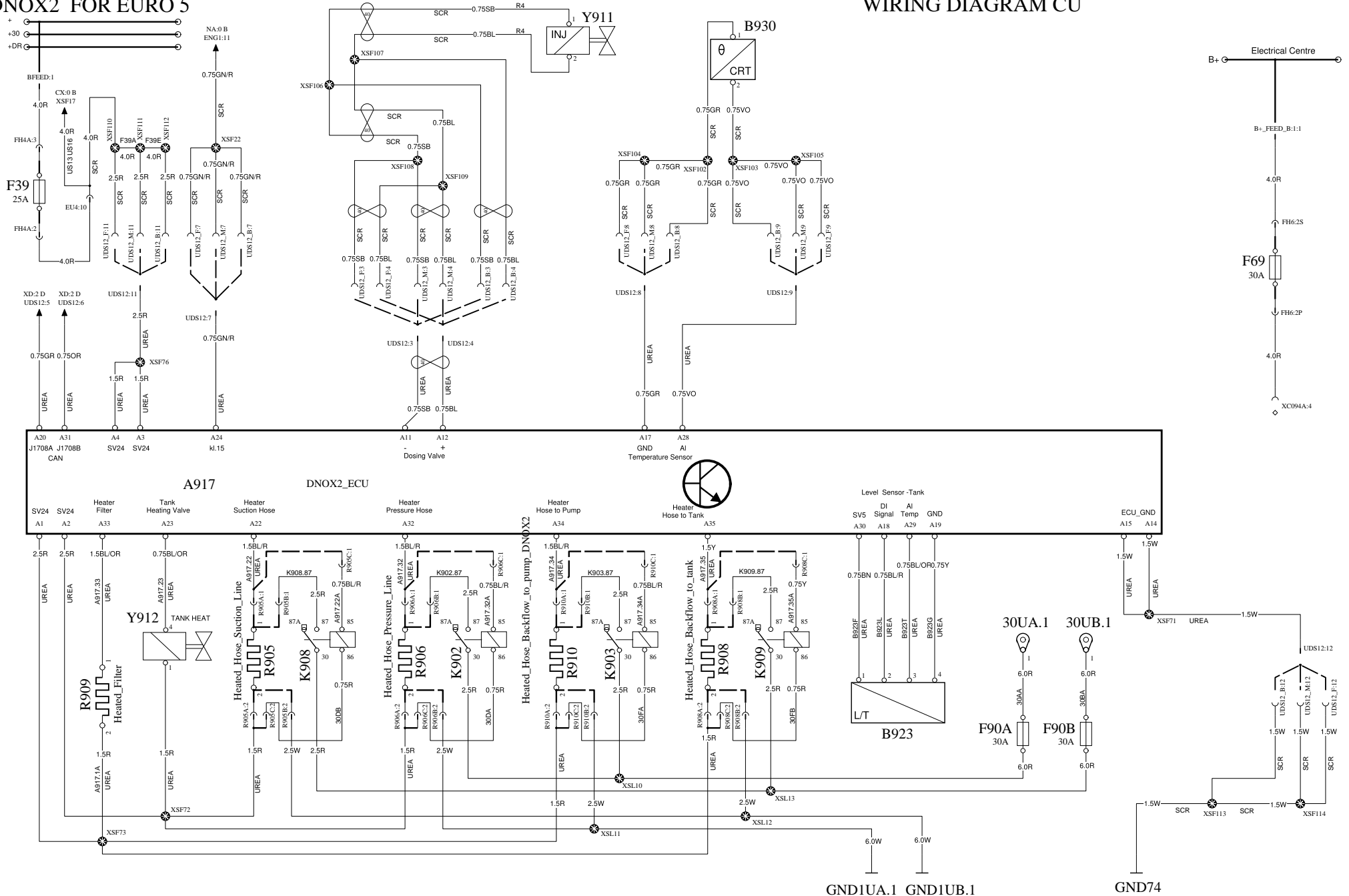

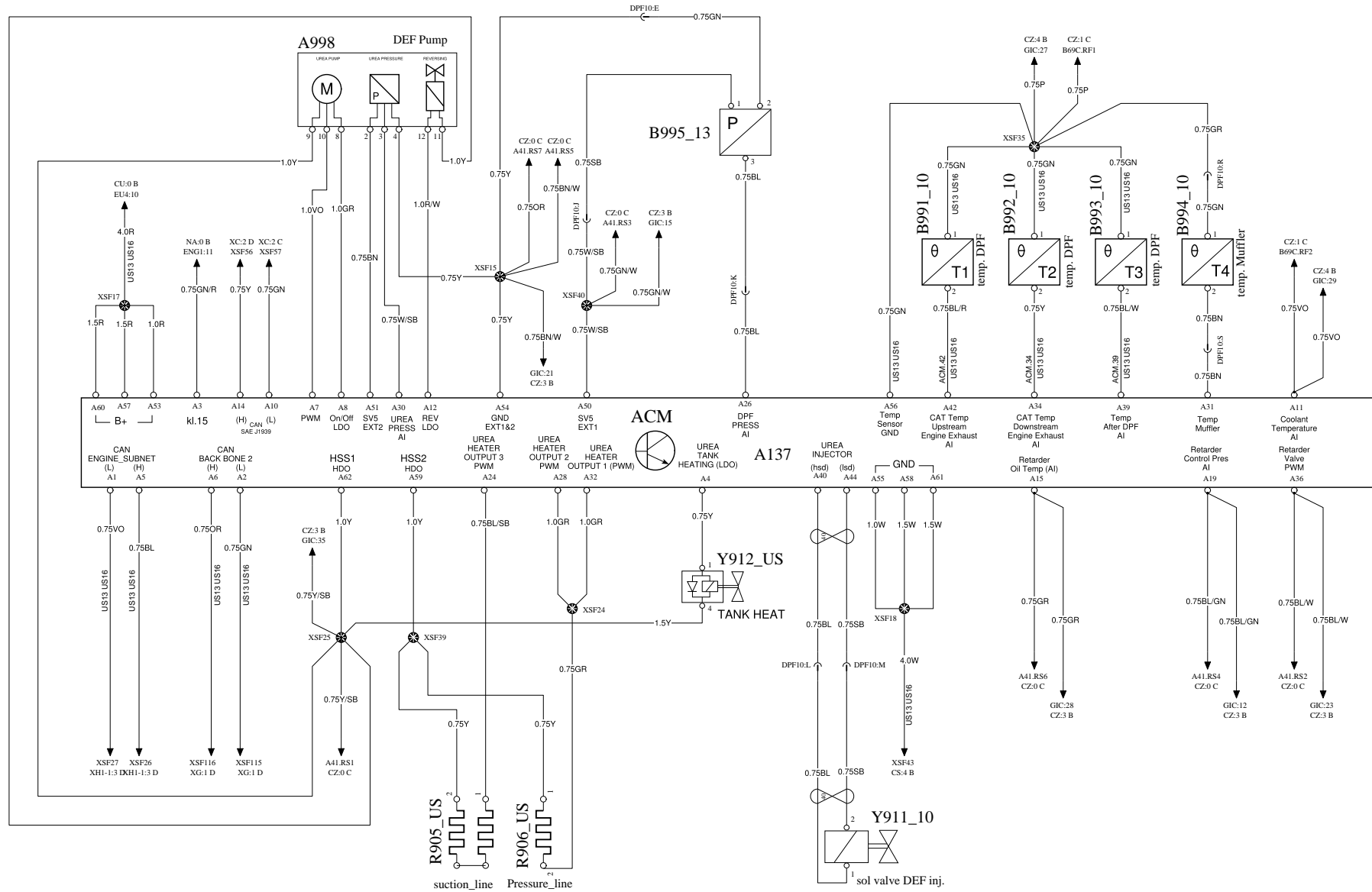

CONNECTIONS FOR AMT-D

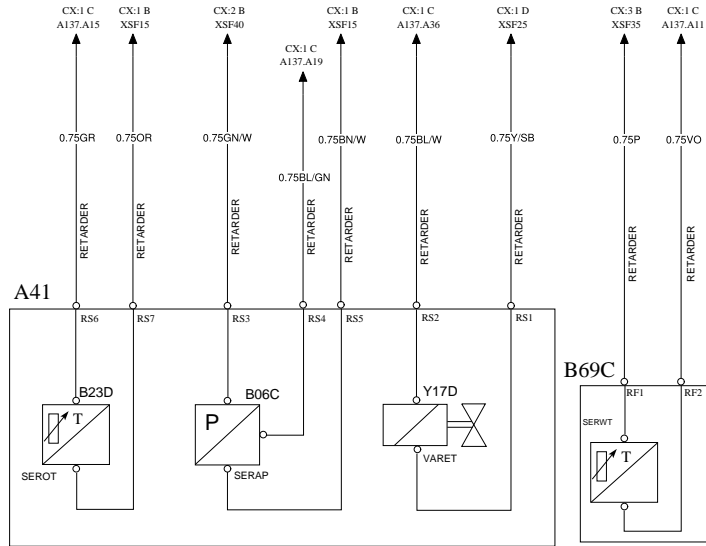

CONNECTIONS FOR AMT-F

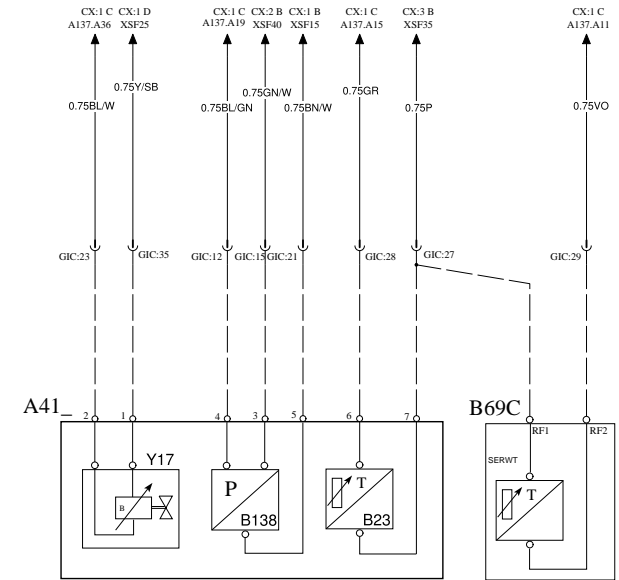

I-SHIFT

GECU

WIRING DIAGRAM DN

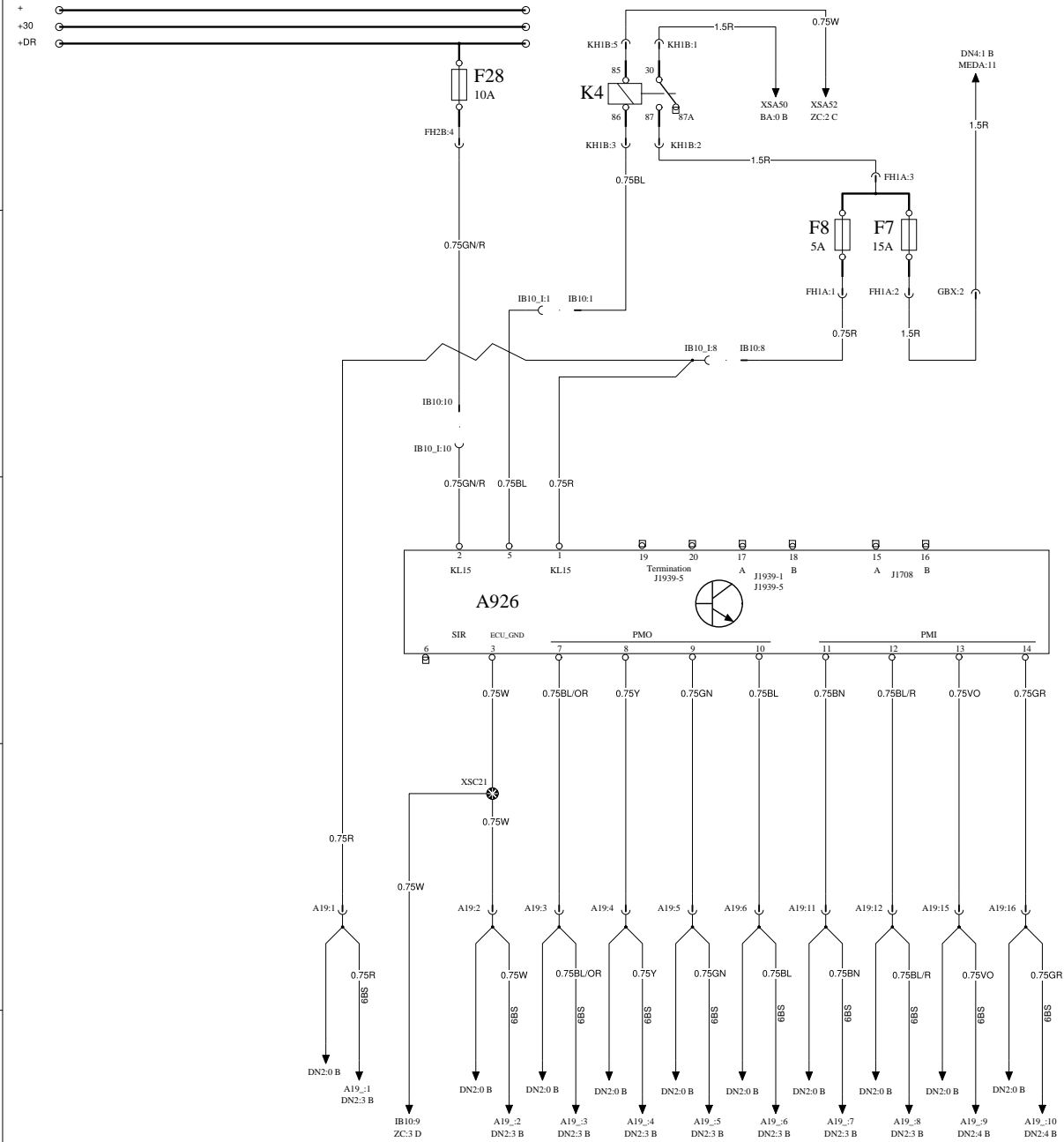

I-SHIFT

GEAR LEVER

GEAR LEVER GSS-STD, GSS-PRO AND GSS-4BS

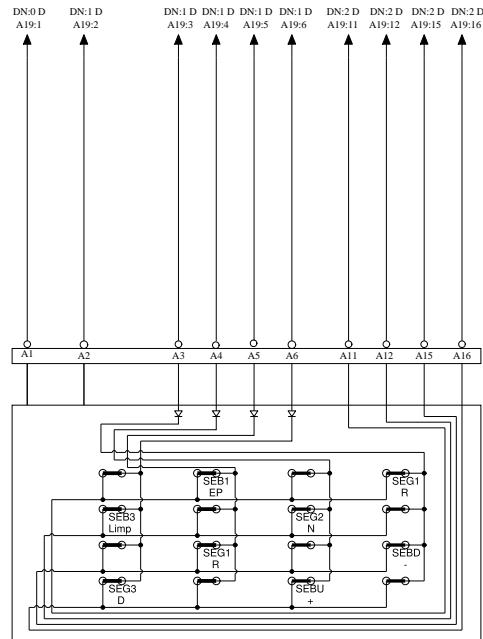

CONNECTIONS

| PIN | SIGNAL NAME | ASSIGNMENT |
|-----|-------------|-----------------|
| 1 | UBATT | MAIN SUPPLY |
| 2 | GND | MAIN GROUND |
| 3 | INP1 | MATRIX INPUT 1 |
| 4 | INP2 | MATRIX INPUT 2 |
| 5 | INP3 | MATRIX INPUT 3 |
| 6 | INP4 | MATRIX INPUT 4 |
| 11 | OUP1 | MATRIX OUTPUT 1 |
| 12 | OUP2 | MATRIX OUTPUT 2 |
| 15 | OUP3 | MATRIX OUTPUT 3 |
| 16 | OUP4 | MATRIX OUTPUT 4 |

WIRING DIAGRAM DN2

GEAR LEVER GSS-6BS

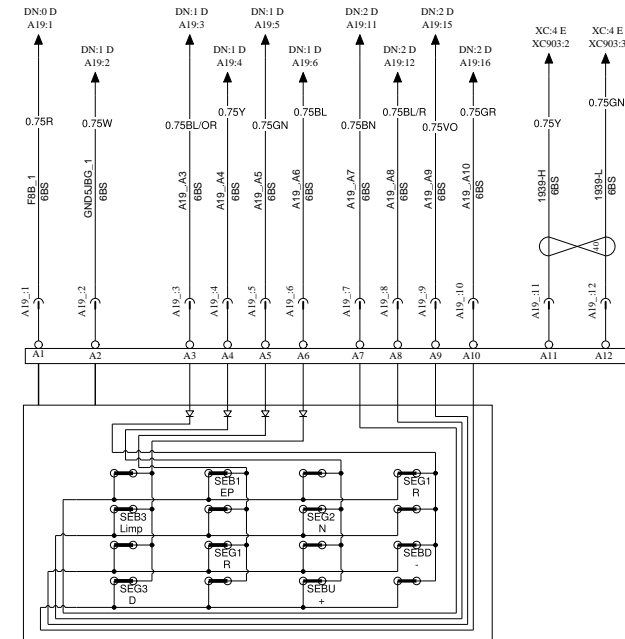

CONNECTIONS

| PIN | SIGNAL NAME | ASSIGNMENT | PIN | SIGNAL NAME |
|-----|-------------|-----------------|-----|-------------|
| 1 | UBATT | MAIN SUPPLY | 11 | J1939-H |
| 2 | GND | MAIN GROUND | 12 | J1939-L |
| 3 | INP1 | MATRIX INPUT 1 | | |
| 4 | INP2 | MATRIX INPUT 2 | | |
| 5 | INP3 | MATRIX INPUT 3 | | |
| 6 | INP4 | MATRIX INPUT 4 | | |
| 7 | OUP1 | MATRIX OUTPUT 1 | | |
| 8 | OUP2 | MATRIX OUTPUT 2 | | |
| 9 | OUP3 | MATRIX OUTPUT 3 | | |
| 10 | OUP4 | MATRIX OUTPUT 4 | | |

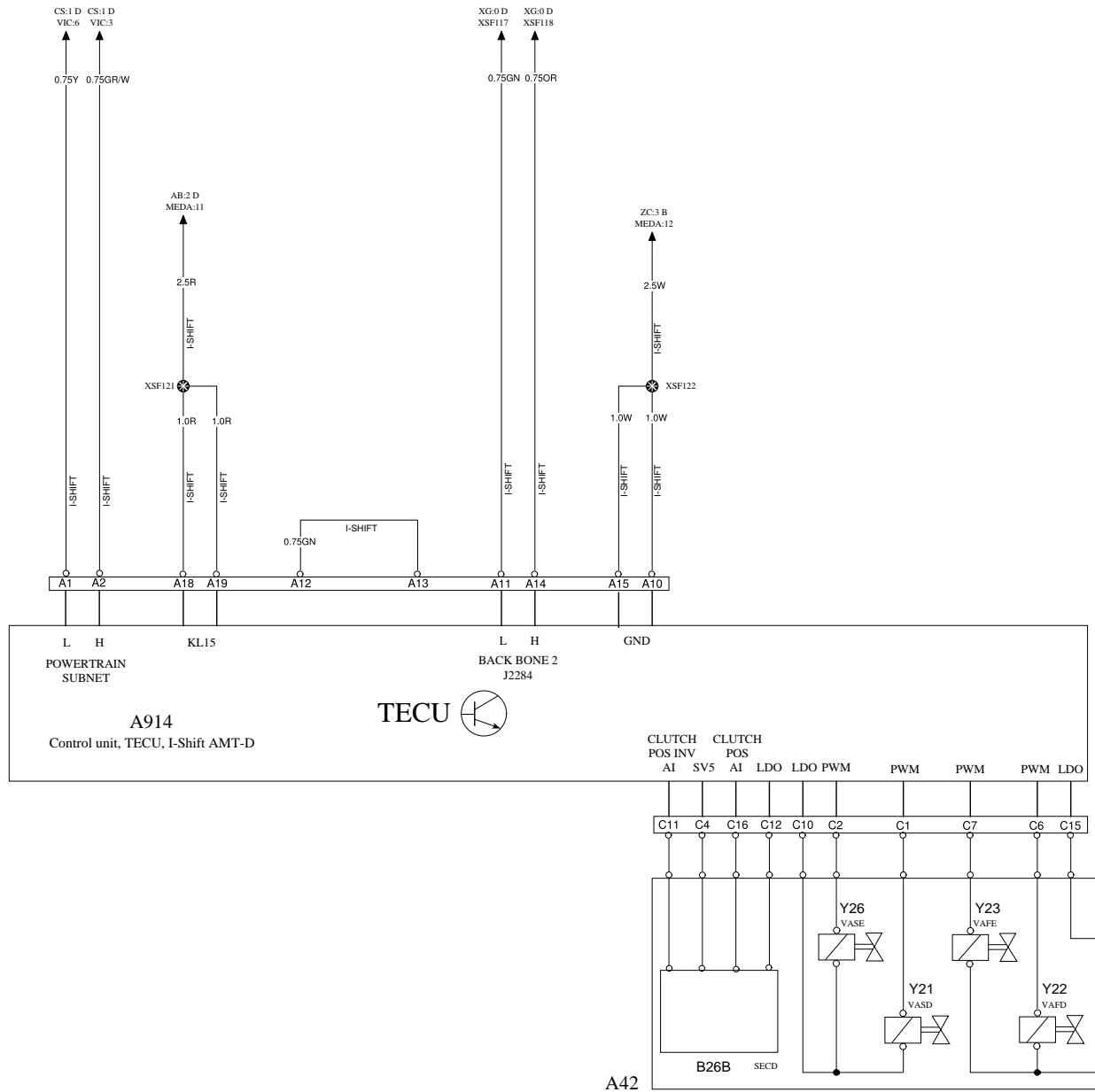

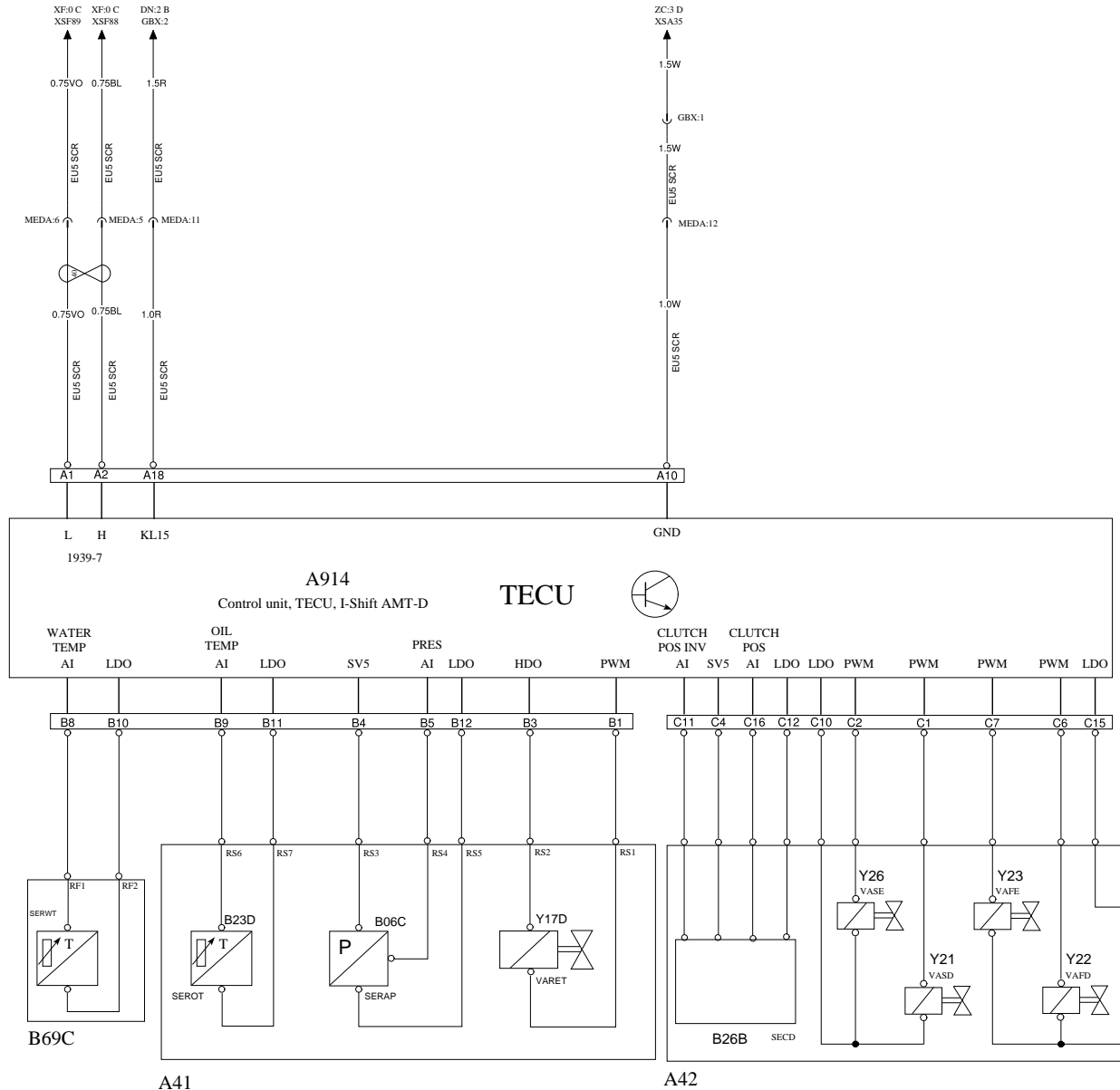

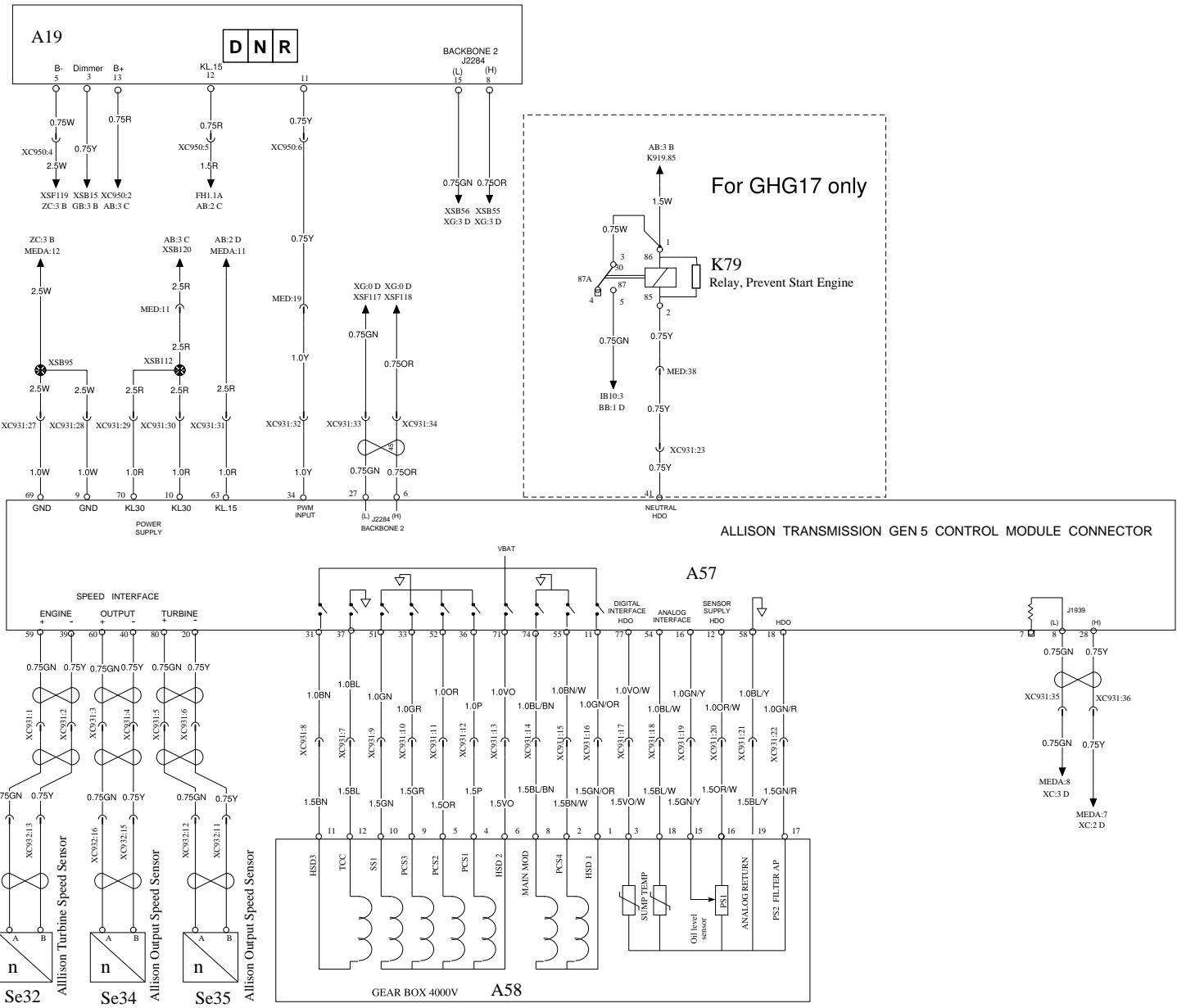

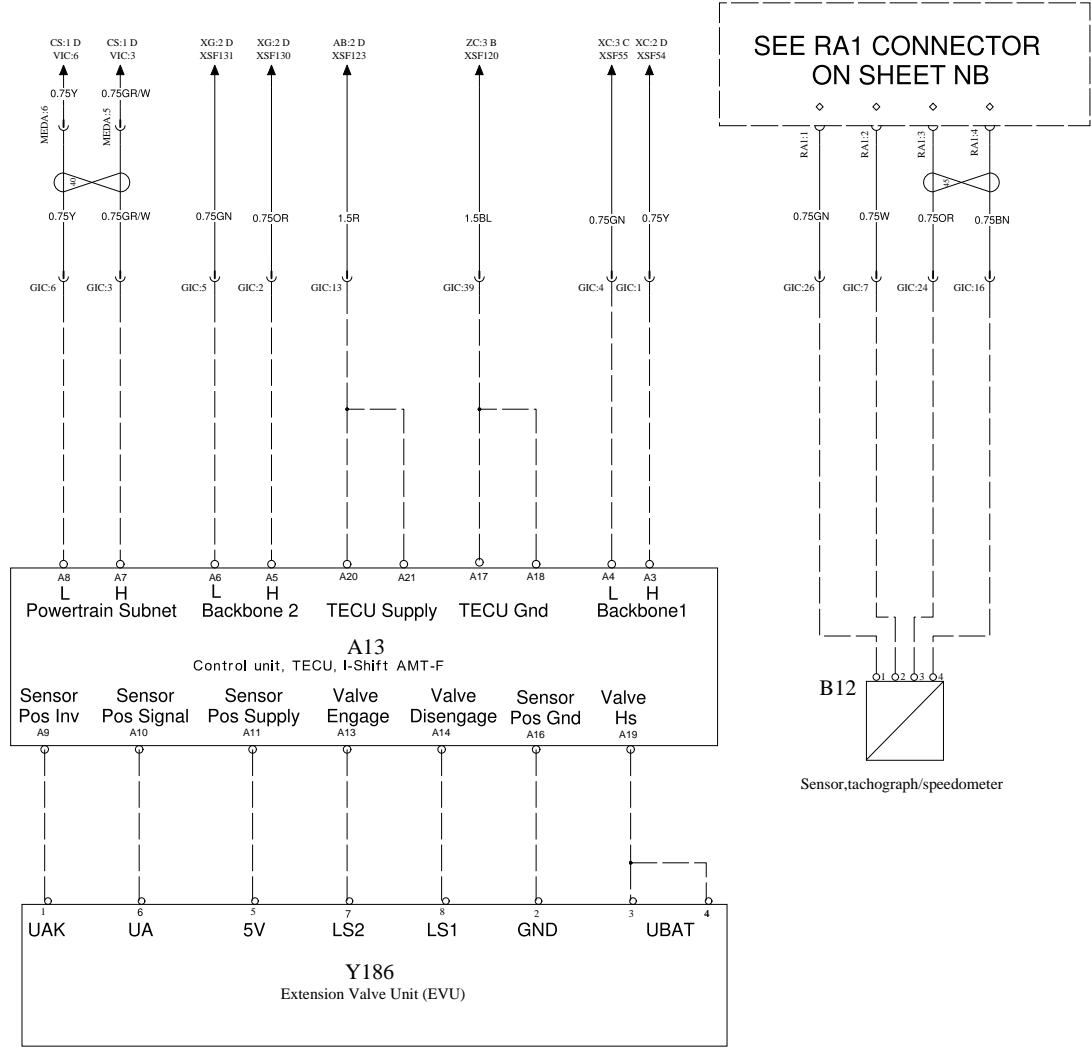

EBS

WIRING DIAGRAM EO

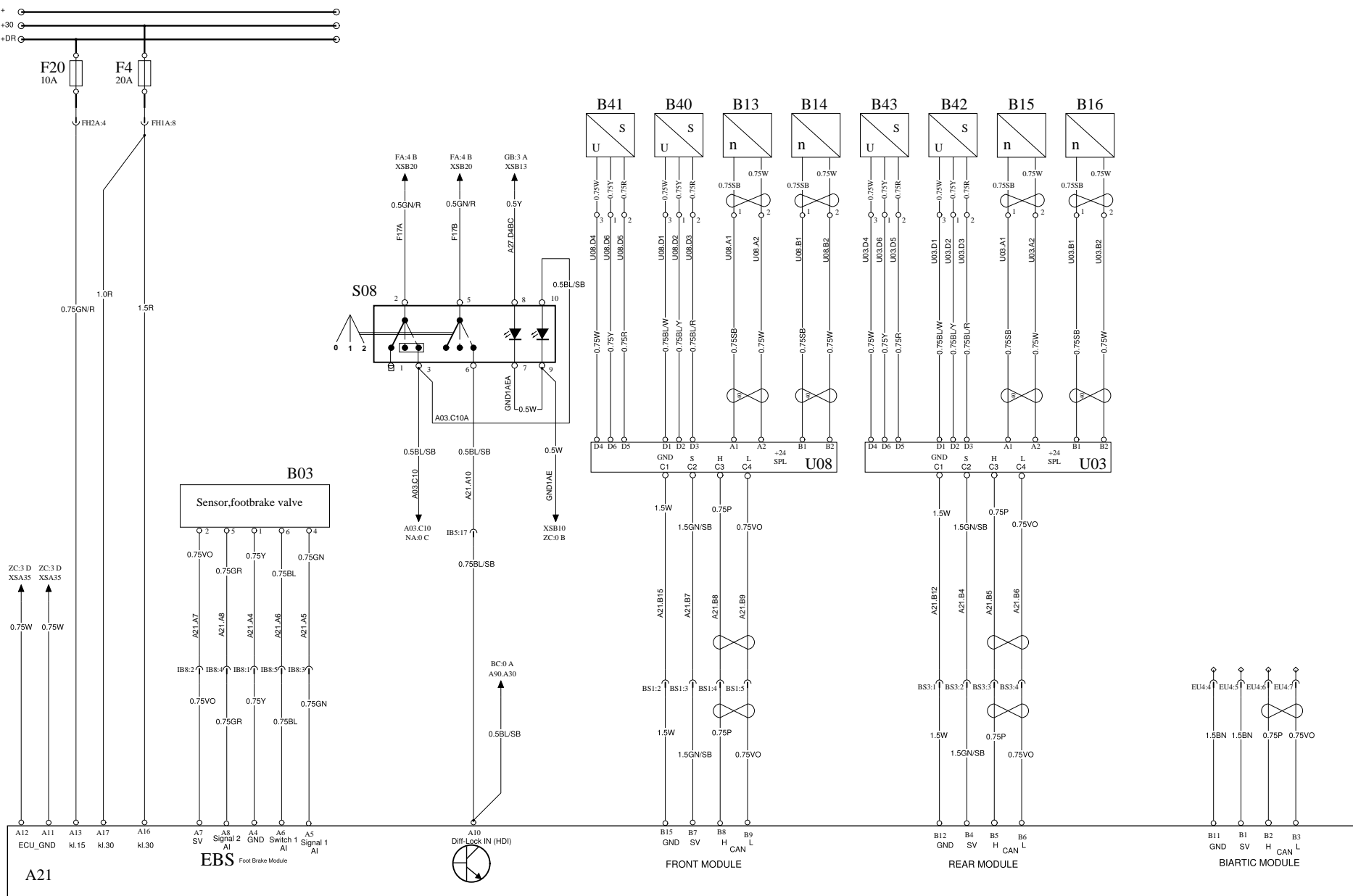

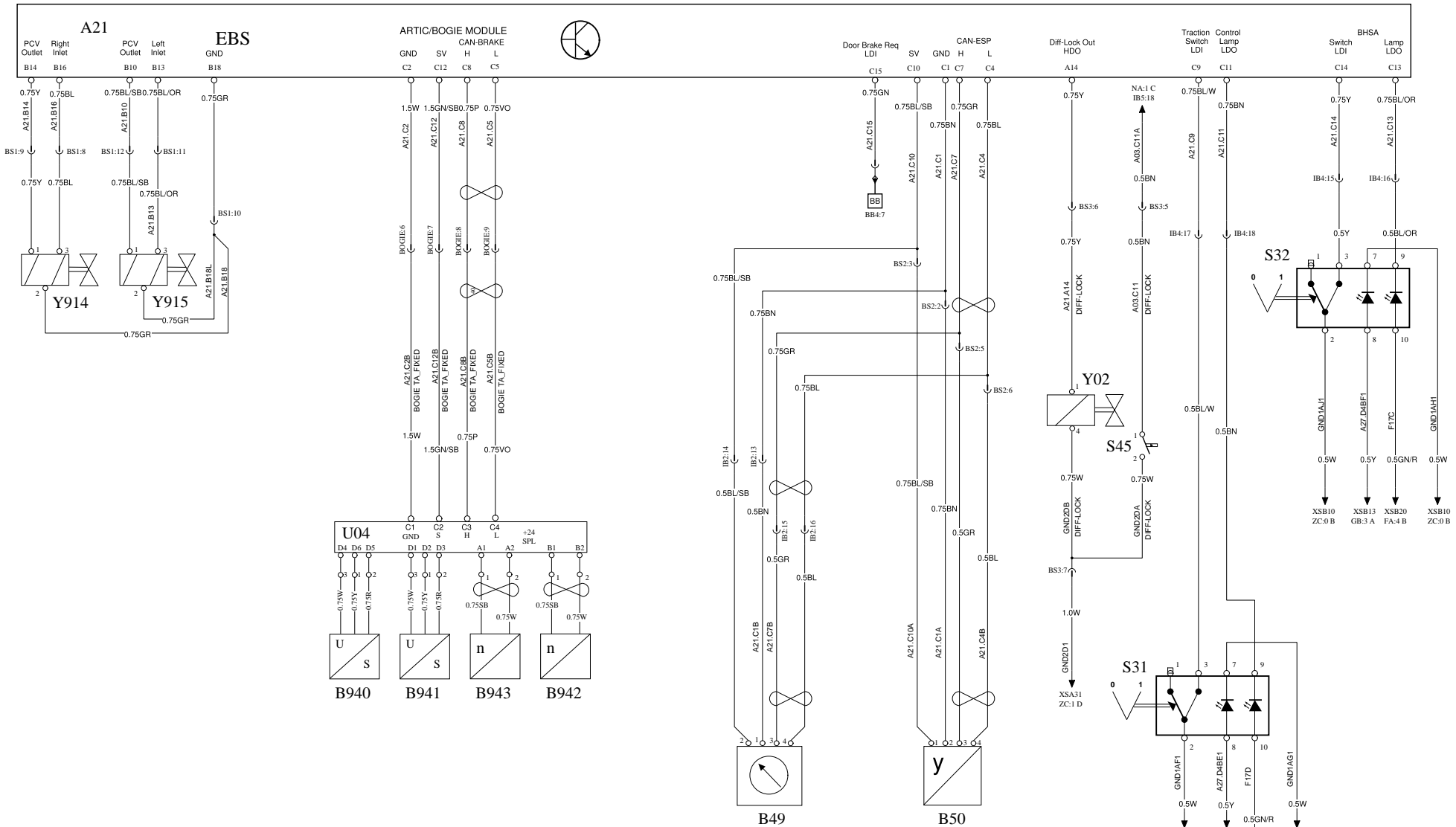

AIR SUSPENSION ECS

WIRING DIAGRAM FA

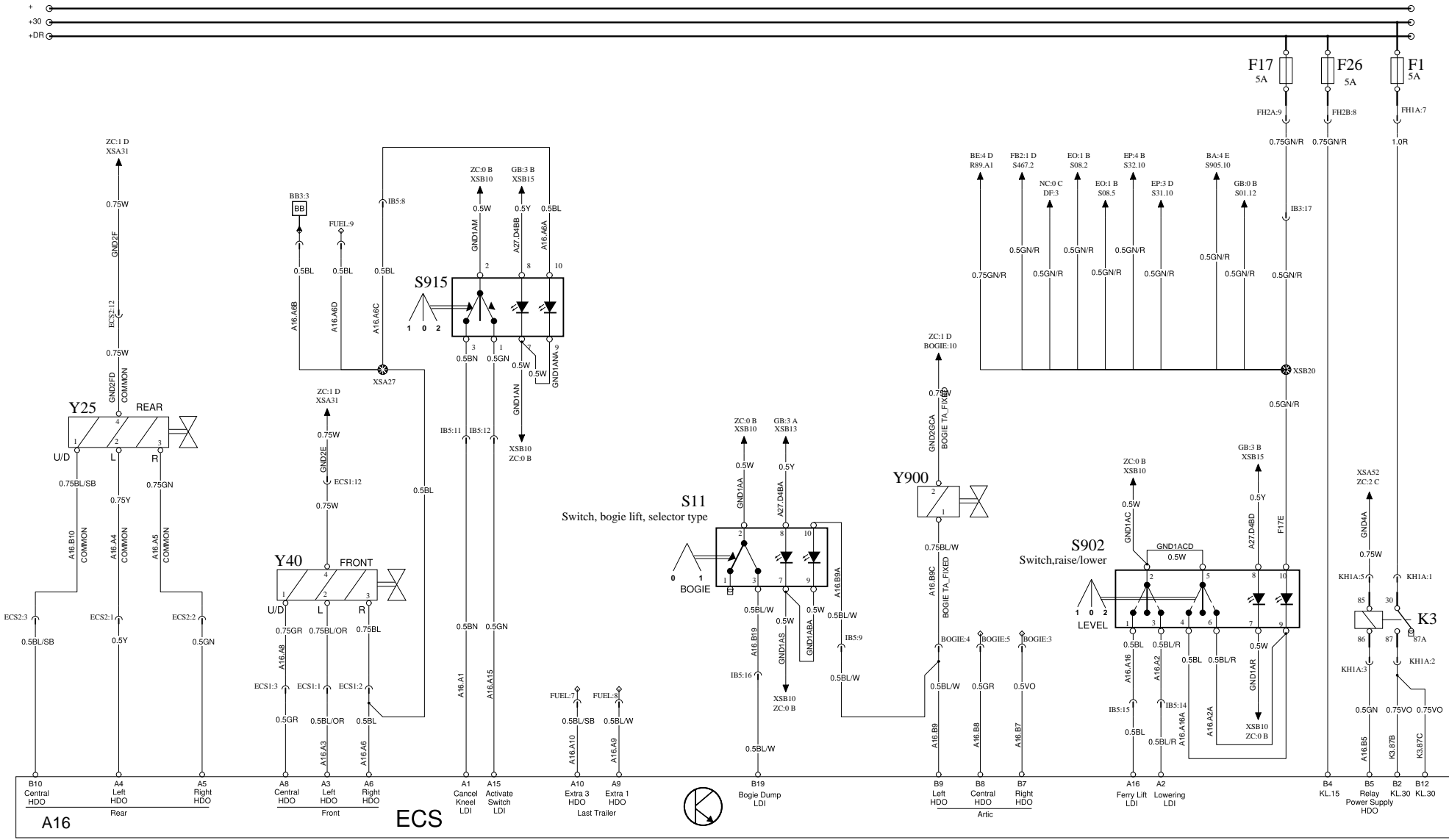

| | | | | | |
|---|--|--|----------------------------|---------------------------------|-------------------------------|
| <p>VOLVO Volvo Bus Corporation</p> | <p>Document title WIRING DIAGRAM</p> | <p>Document No 22610880</p> | <p>Issue 11</p> | <p>Volume 02(03)</p> | <p>Page 26(58)</p> |
| | <p>Document type PRODUCT SCHEMATIC</p> | | | | |

AIR SUSPENSION ECS

WIRING DIAGRAM FB

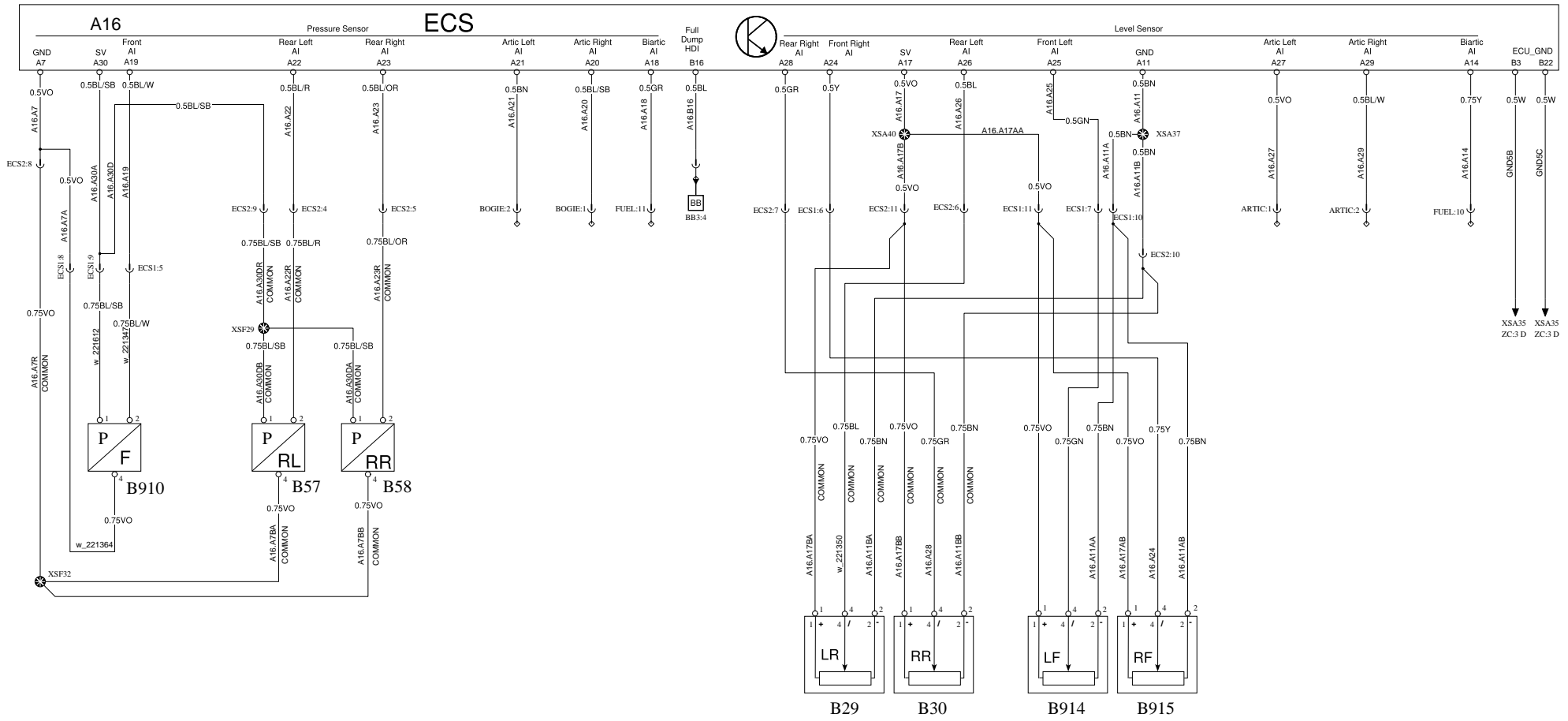

B13R - Switch Speed Dependent Ride Height

B13R - Pinch Protection

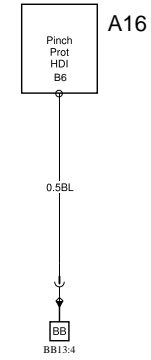
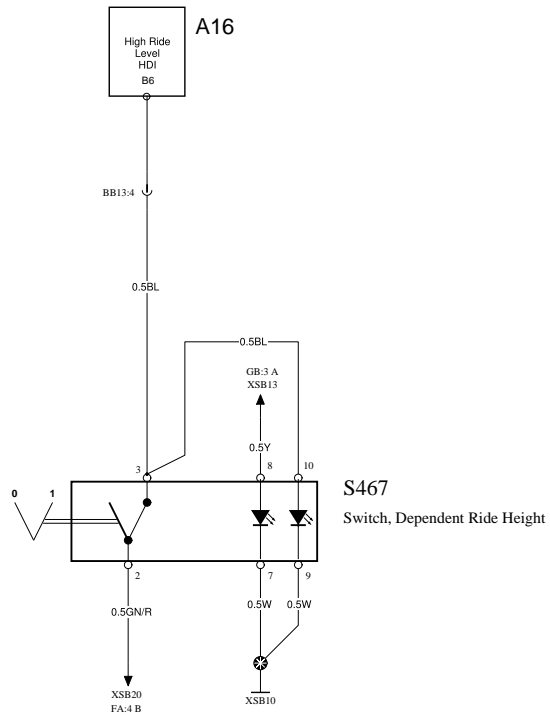

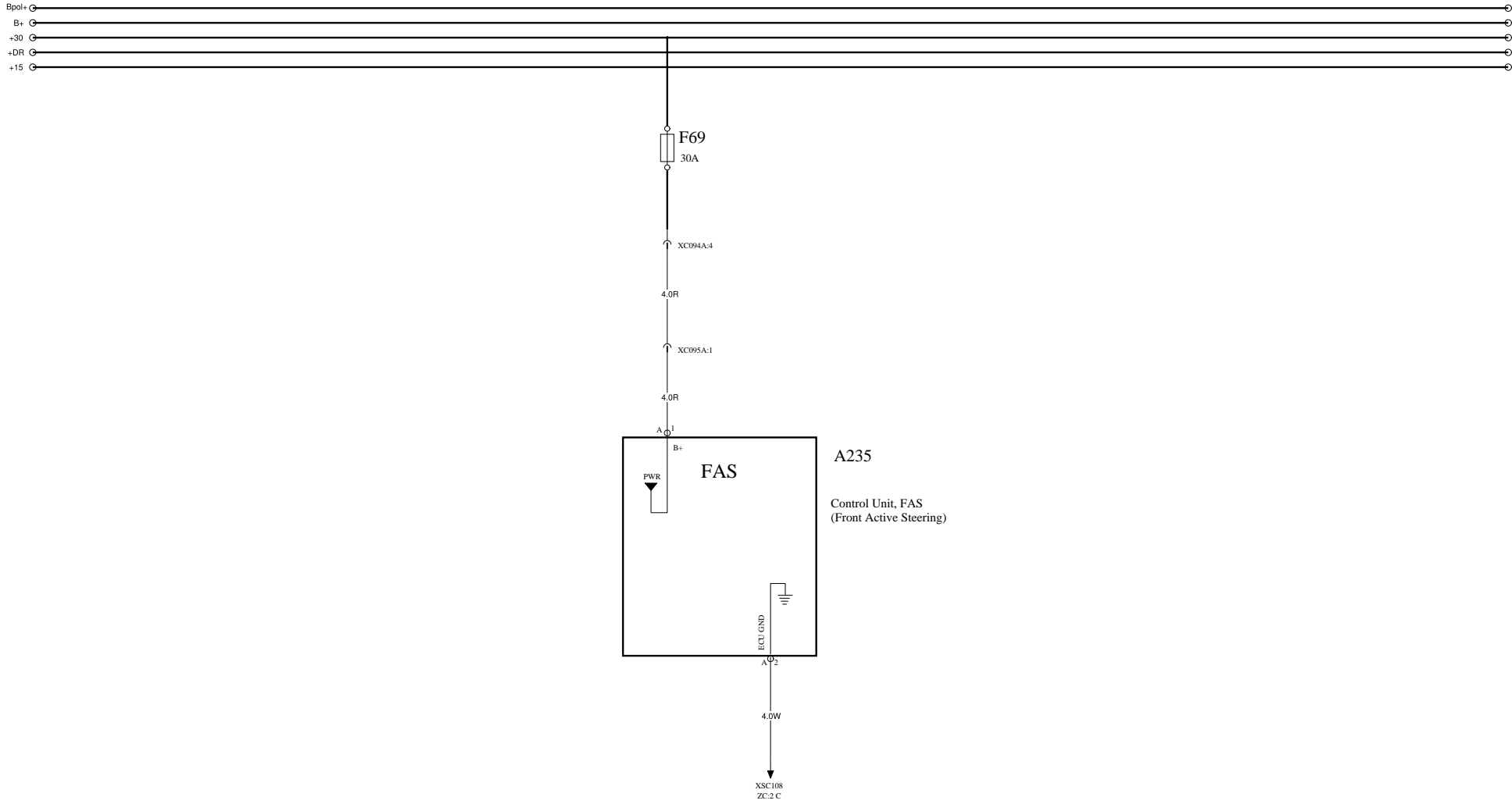

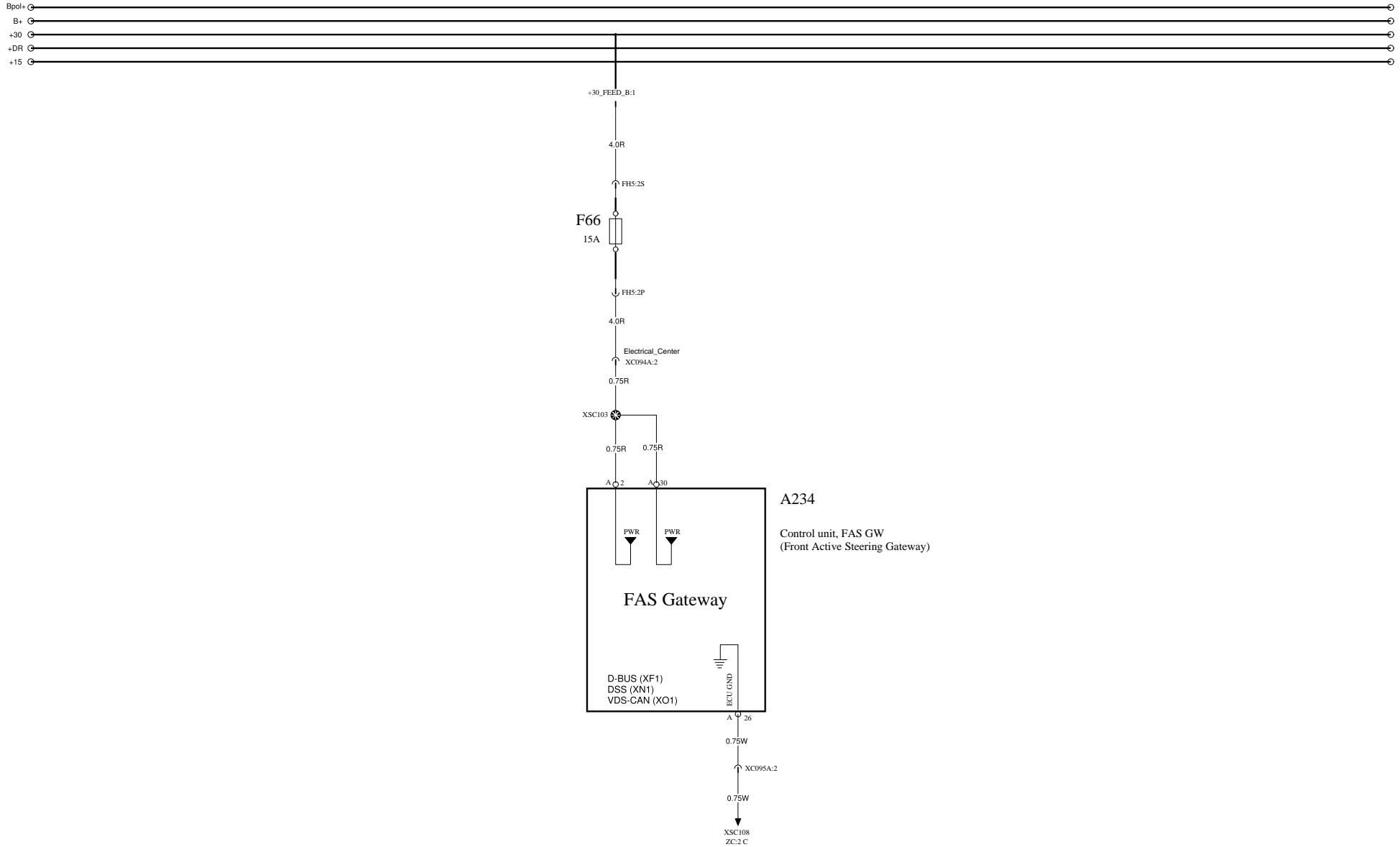

LCM

REAR LIGHTS

WIRING DIAGRAM GA

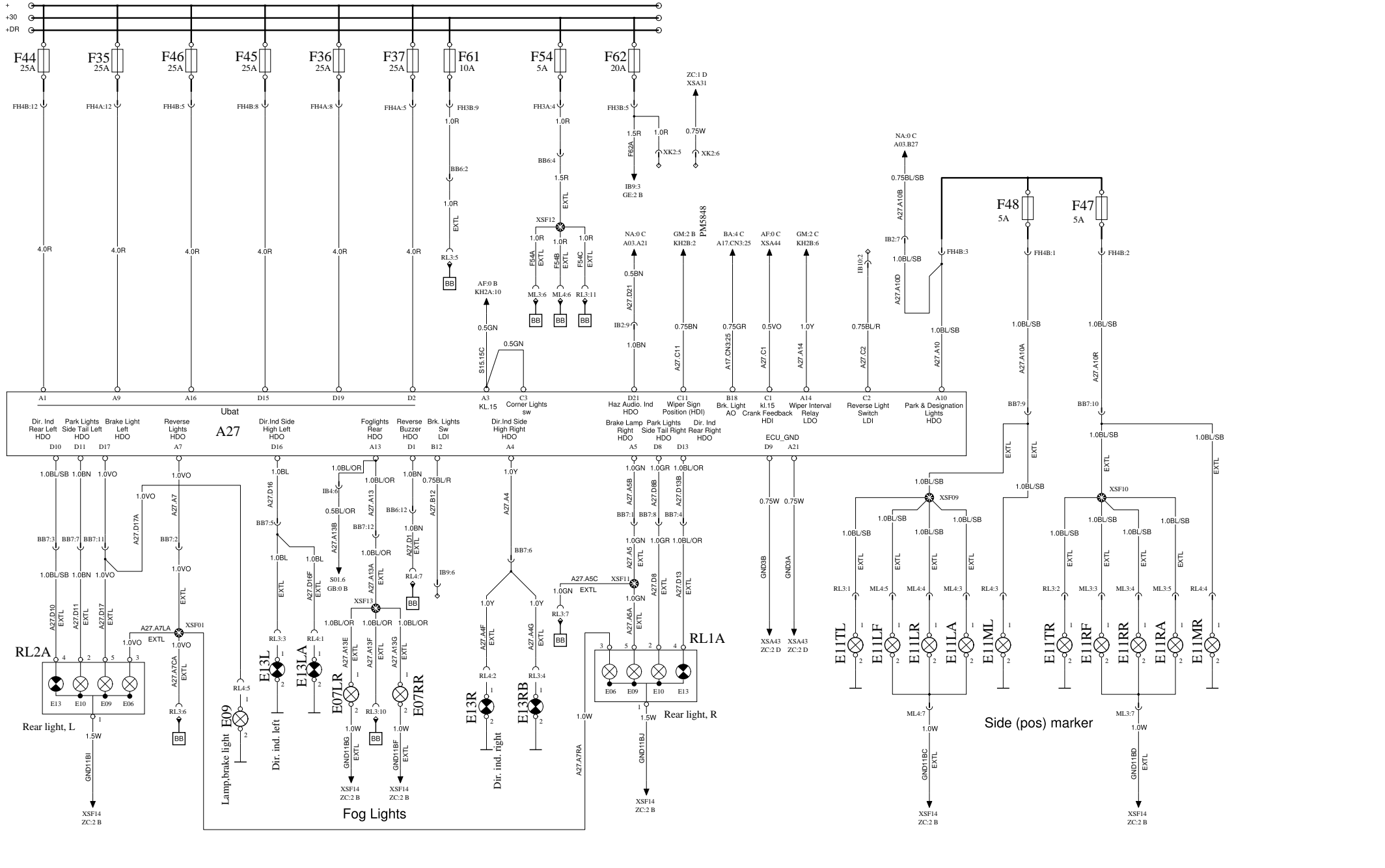

| | | | | |
|------------------------------------|-------------------------|-------------|------------------|----------------|
| Document title WIRING DIAGRAM | Document No 22610880 | Issue 11 | Volume 02(03) | Page 31(58) |
| Document type PRODUCT SCHEMATIC | | | | |

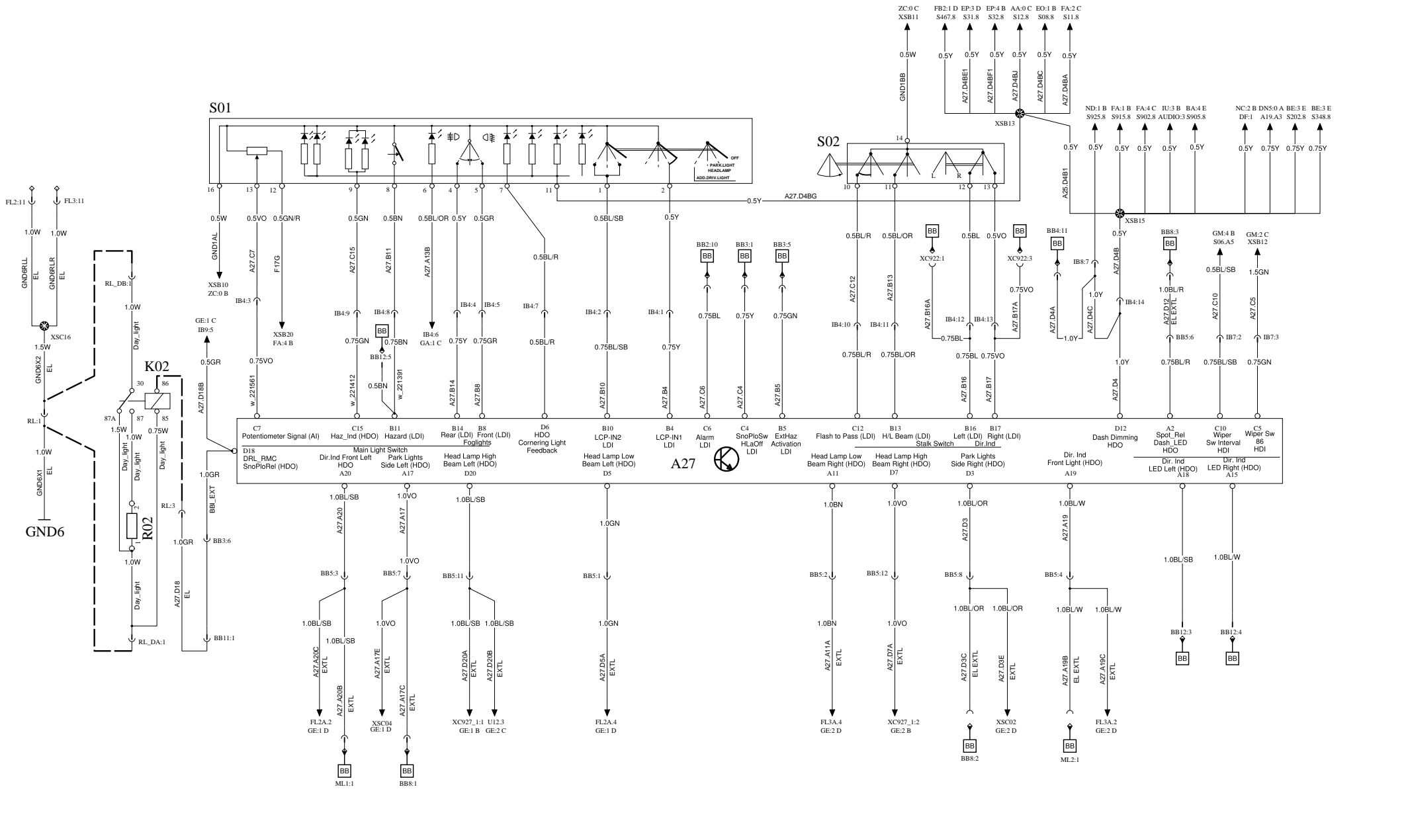

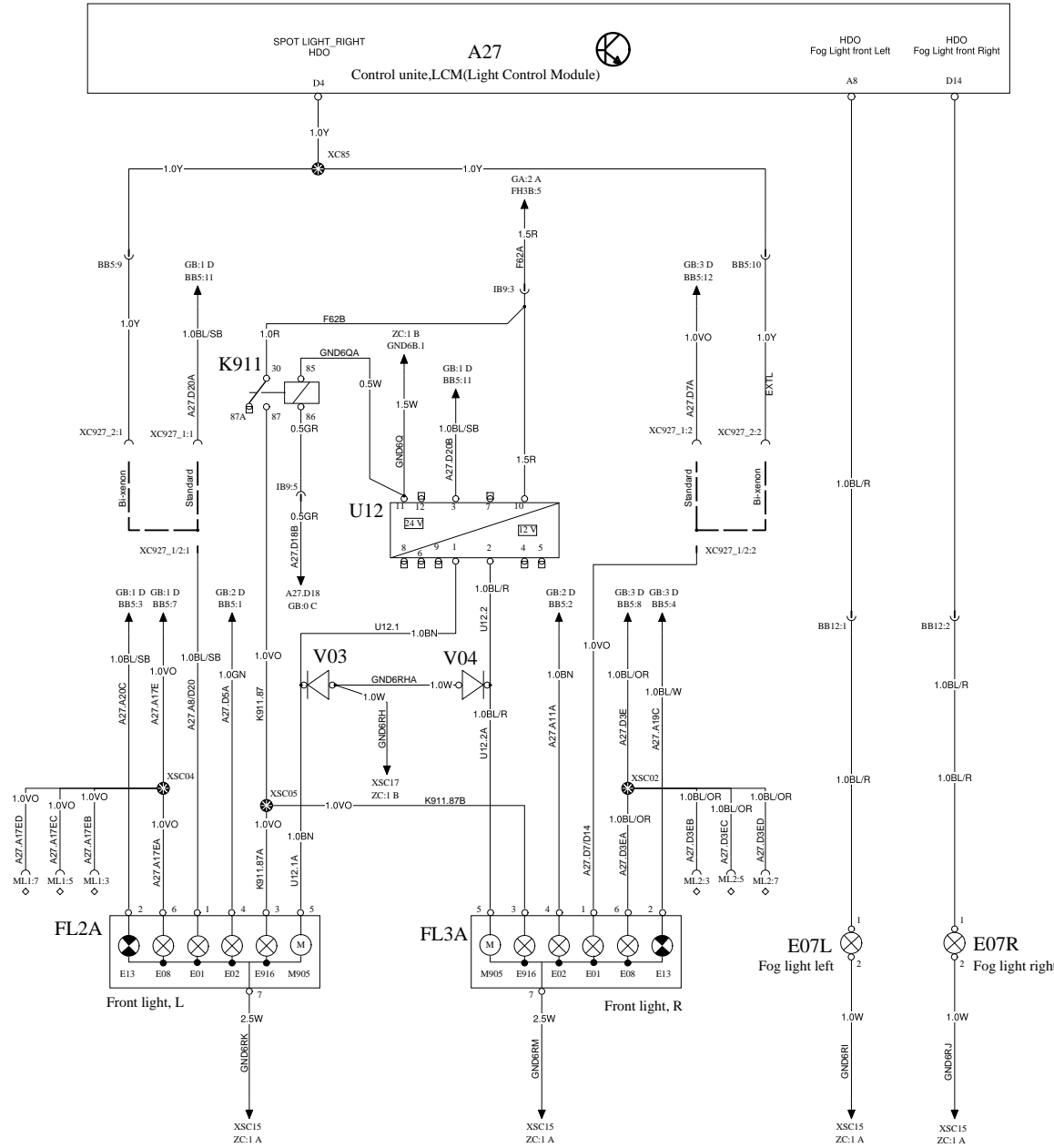

WIPER, WASHER

WIRING DIAGRAM GM

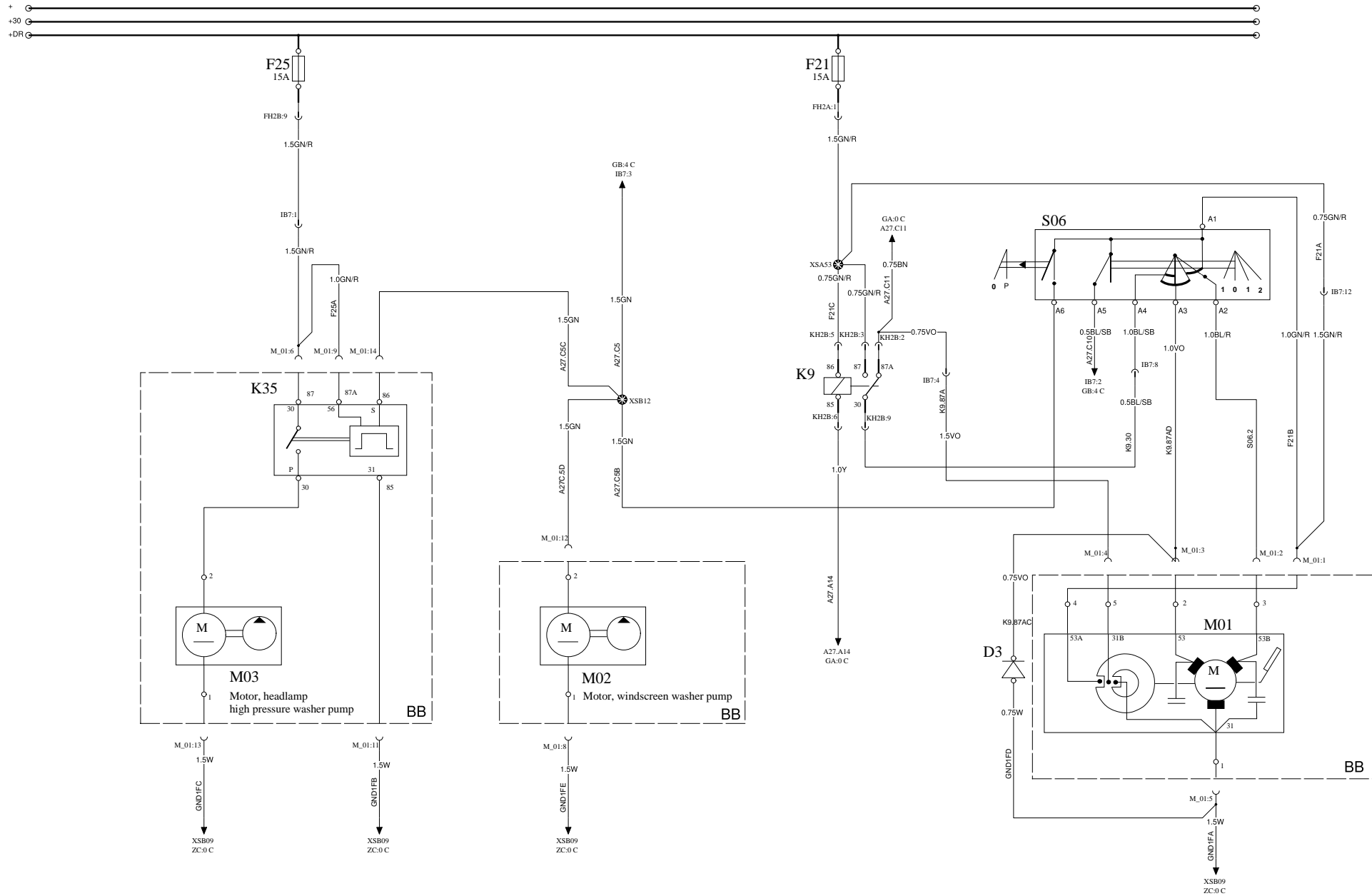

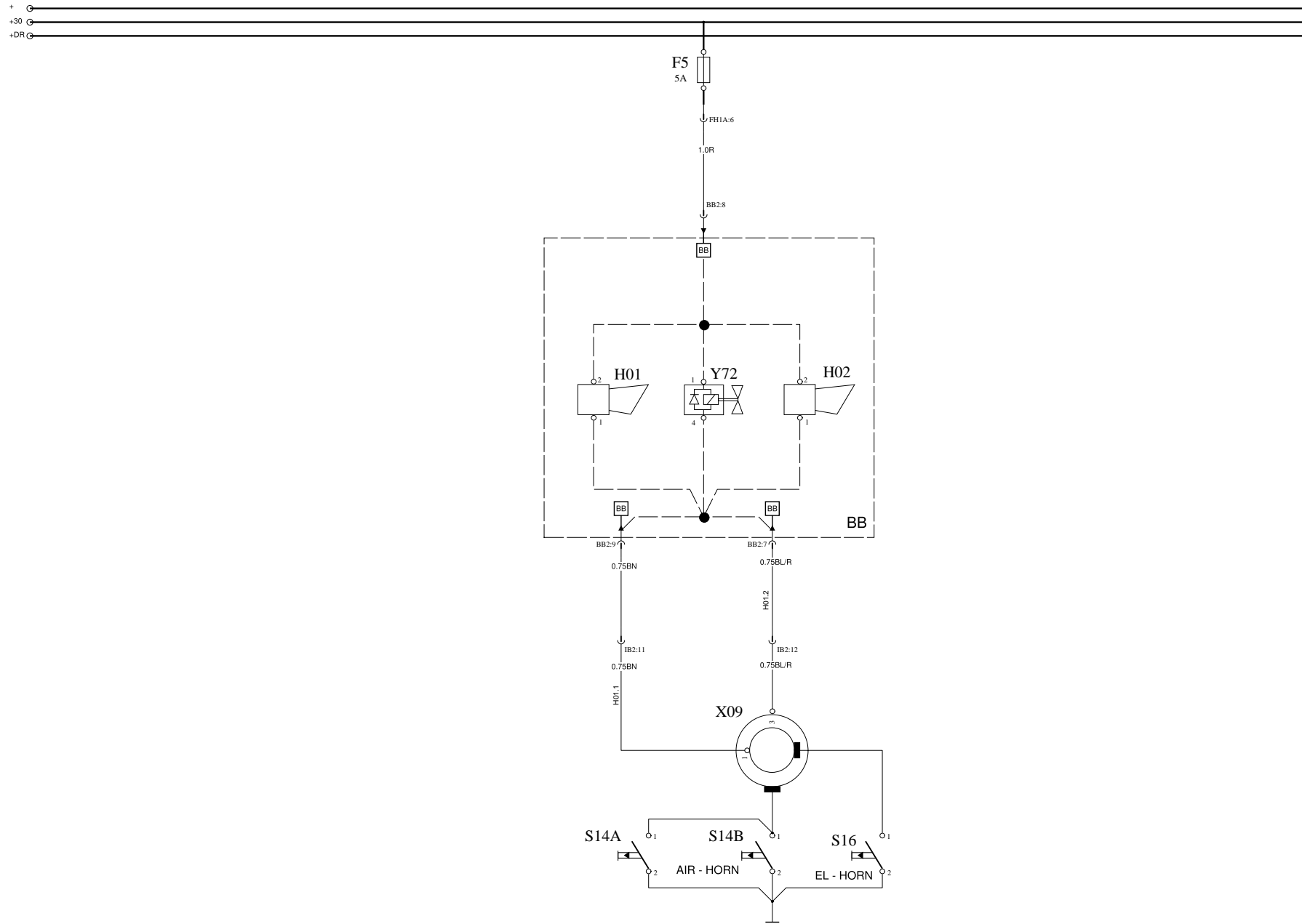

AUDIO

WIRING DIAGRAM IU

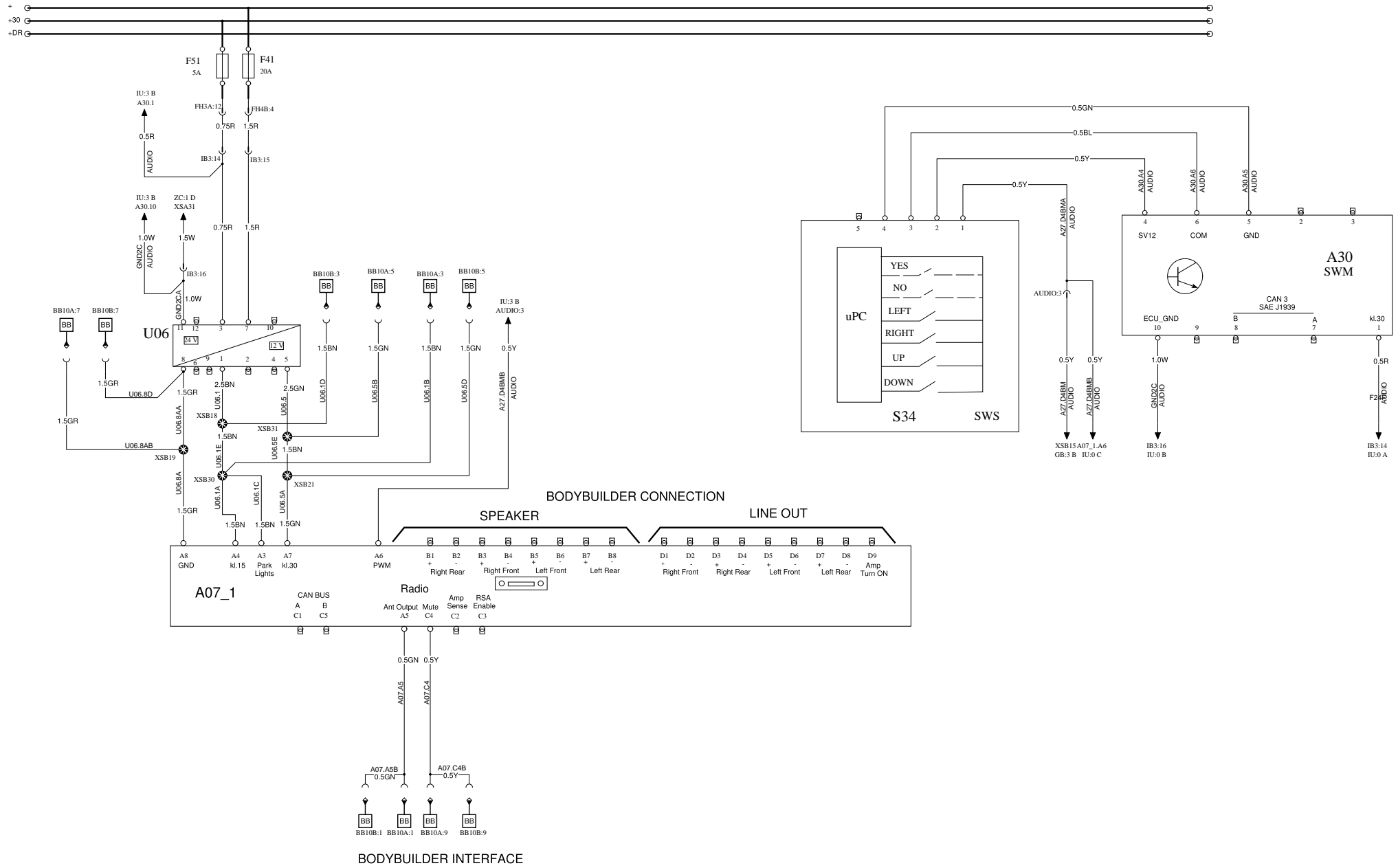

BUS INSTRUMENT CLUSTER BIC2

WIRING DIAGRAM NA

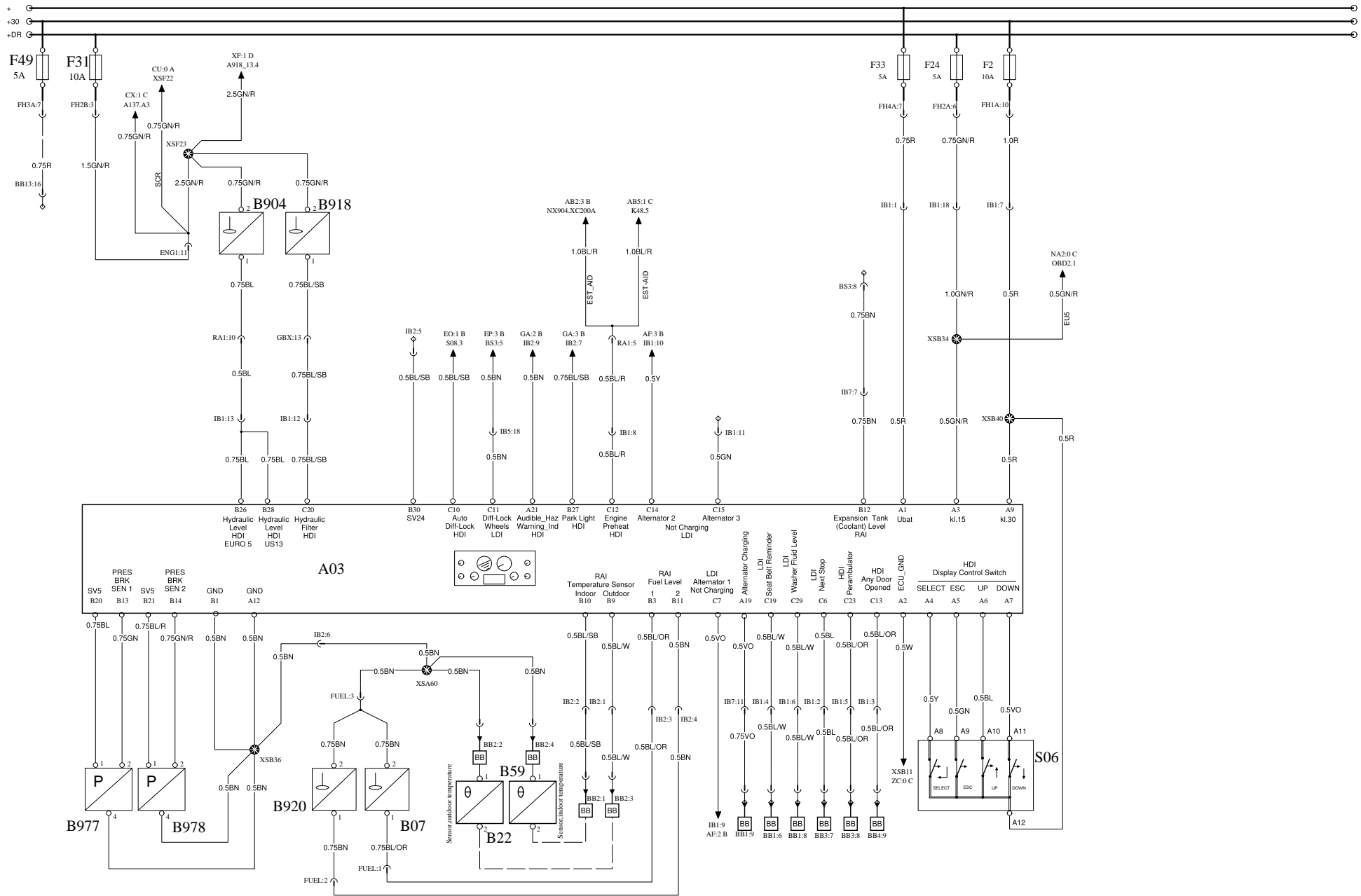

CONNECTIONS FOR EURO 5

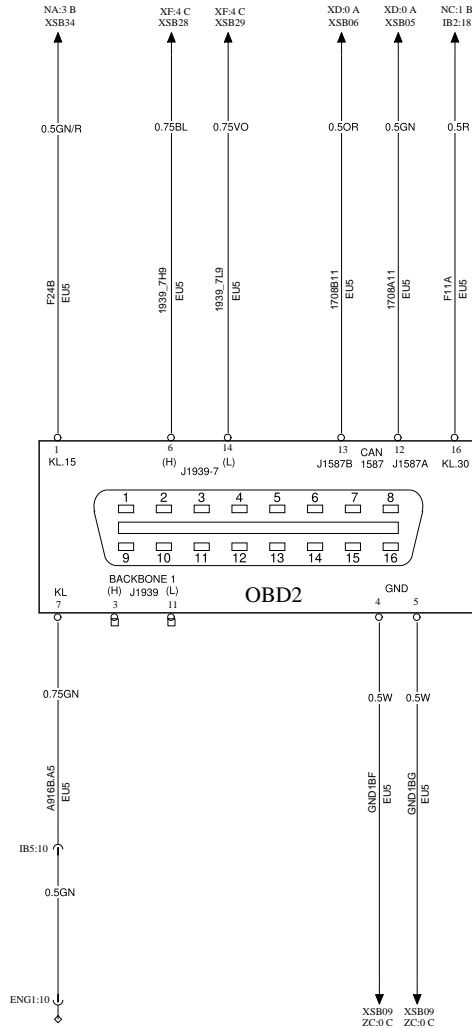

CONNECTIONS FOR US/CAN

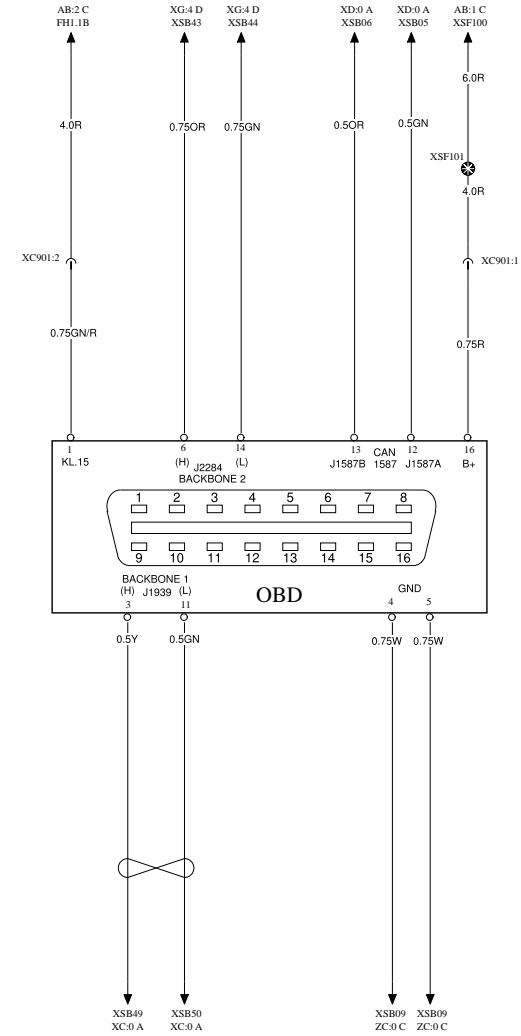

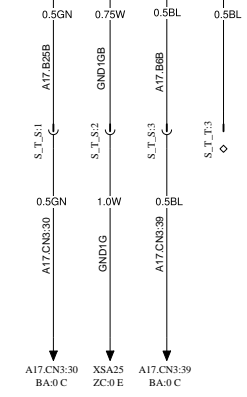
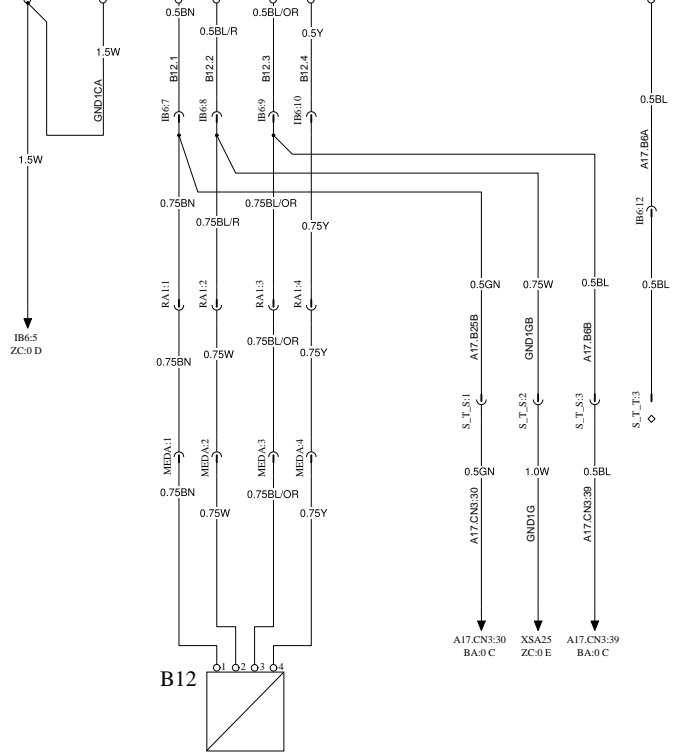
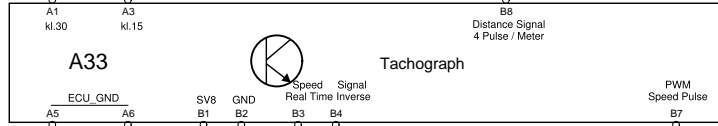
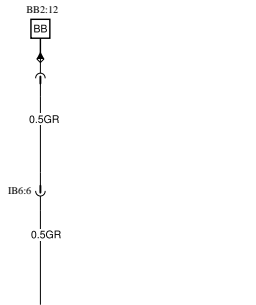
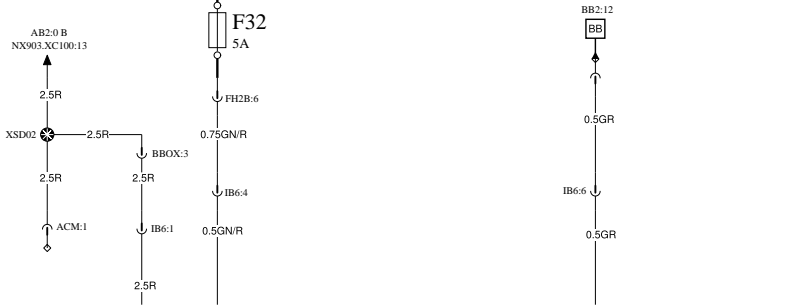
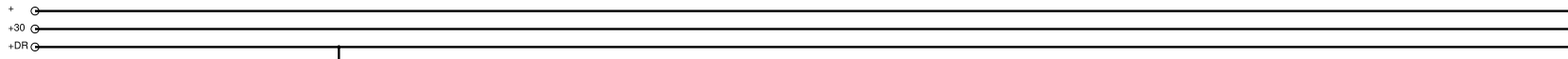

Sensor, tachograph/speedometer

| | | | | | |
|---------------------------------------|------------------------------------|--------------------------------|-------------|------------------|----------------|
| VOLVO Volvo Bus Corporation | Document title WIRING DIAGRAM | Document No 22610880 | Issue 11 | Volume 02(03) | Page 39(58) |
| | Document type PRODUCT SCHEMATIC | | | | |

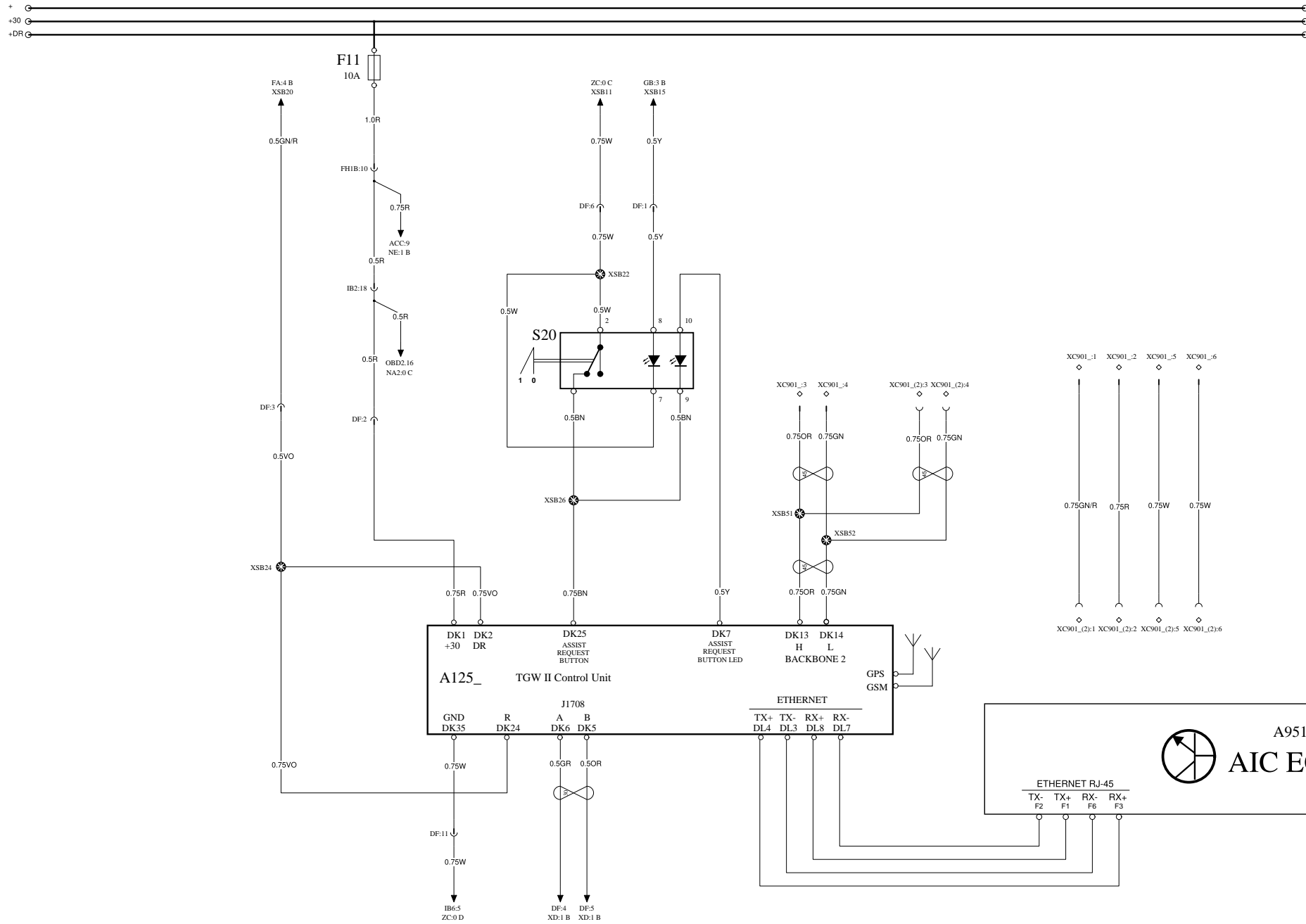

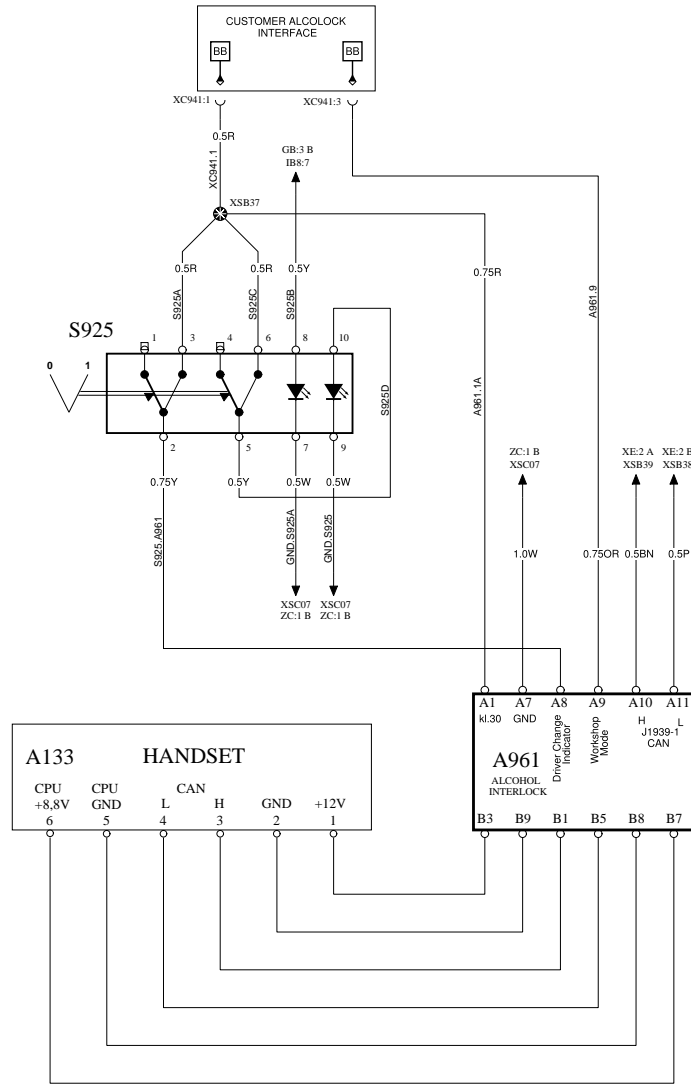

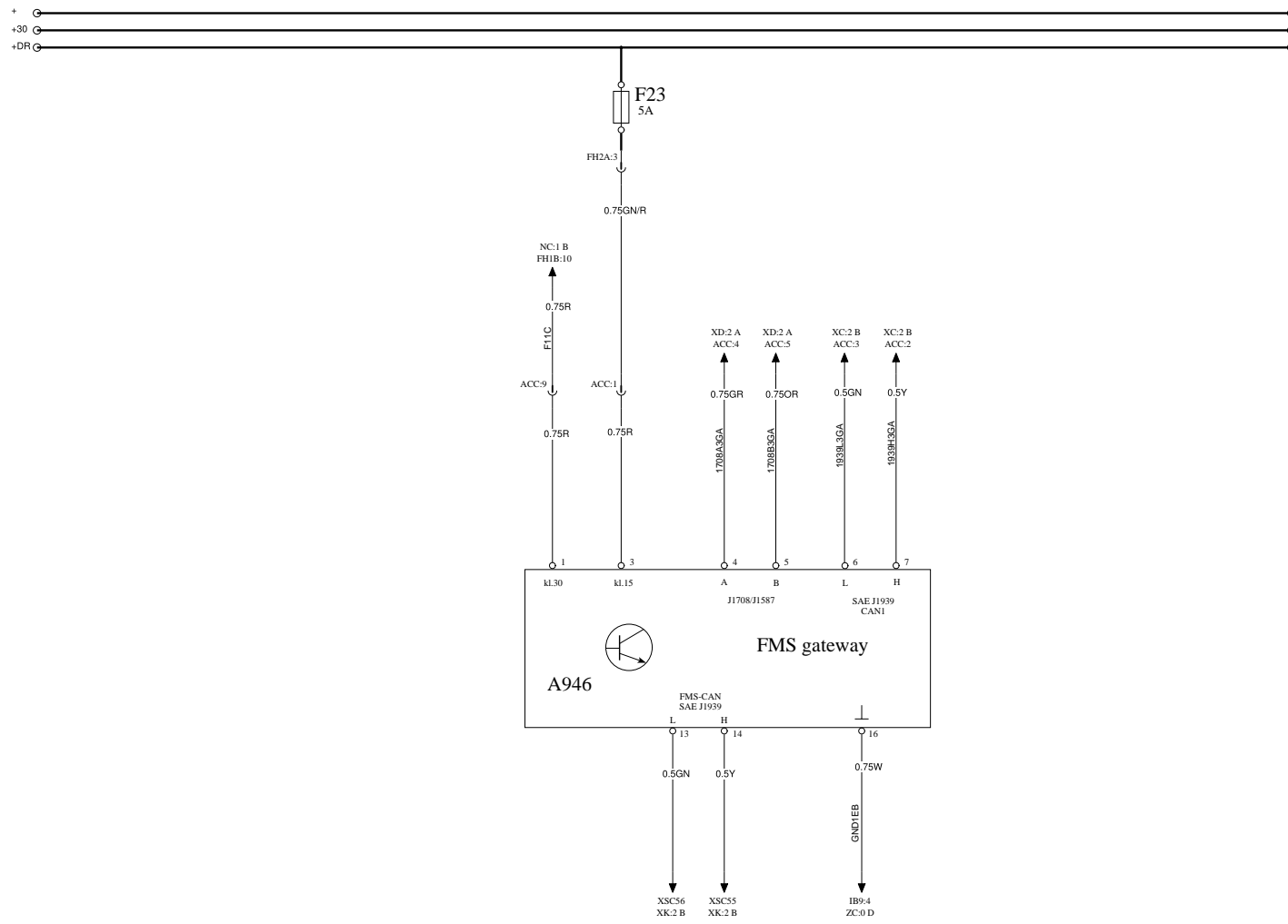

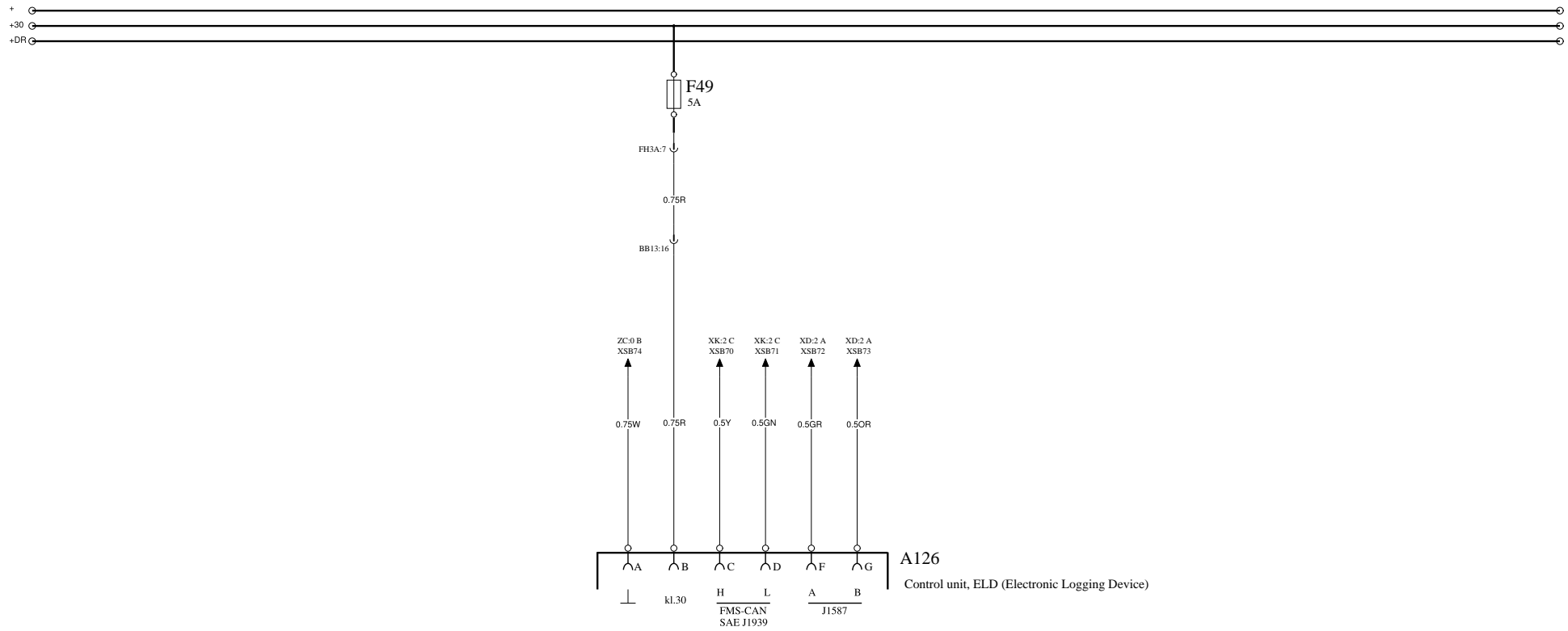

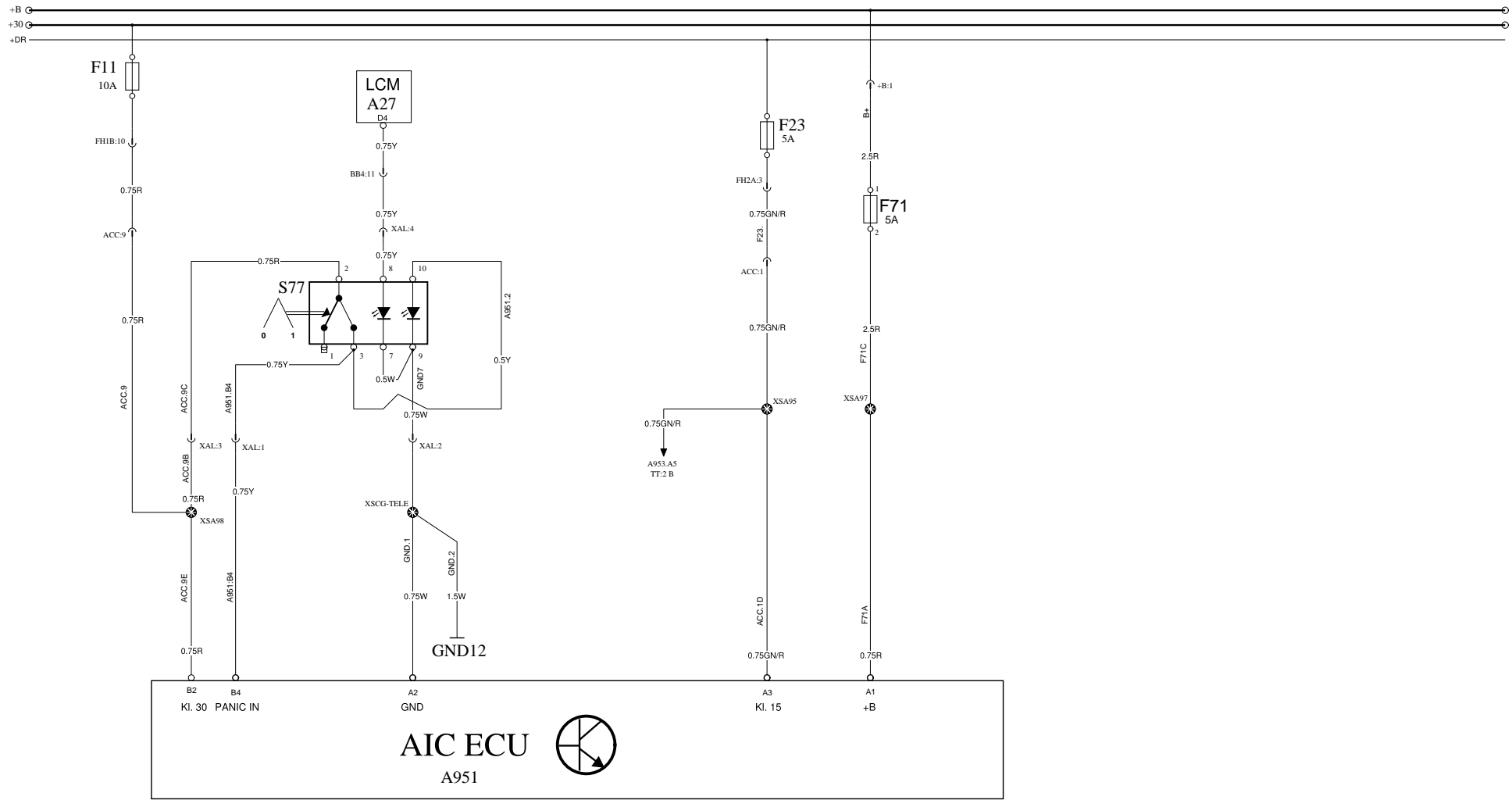

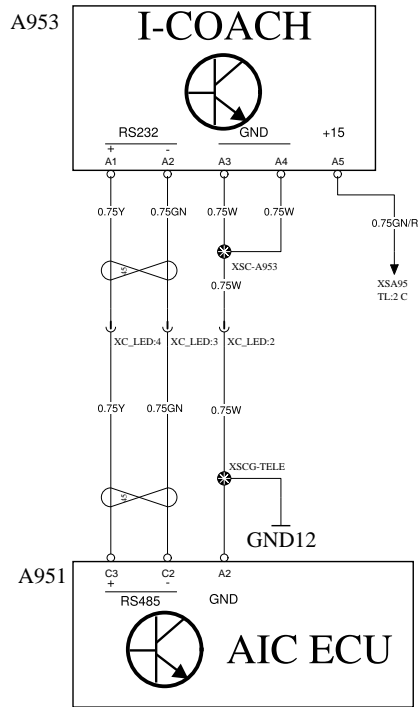

CAN SAE 1939

BACKBONE 1

WIRING DIAGRAM XC

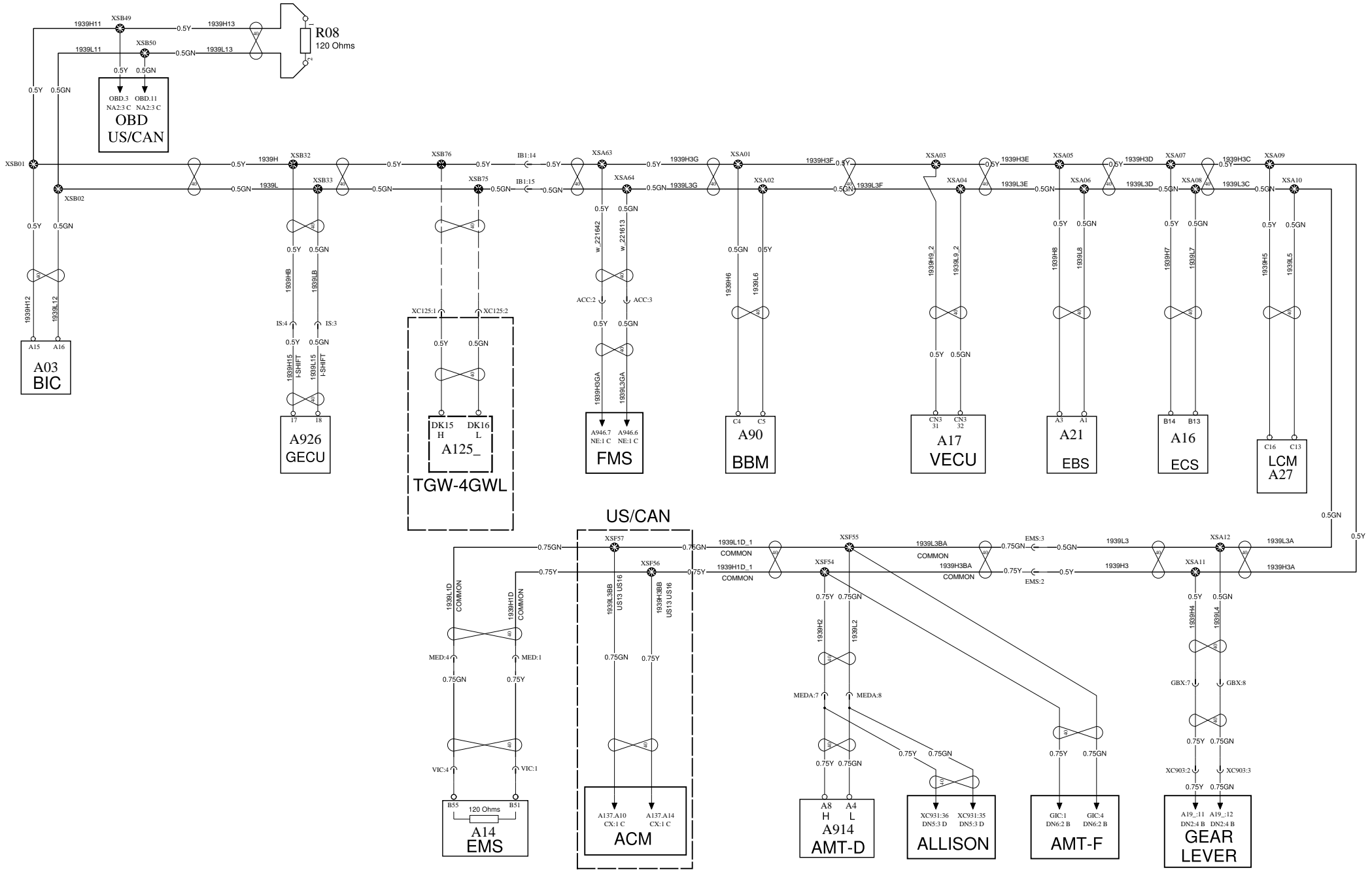

CAN SAE1587

WIRING DIAGRAM XD

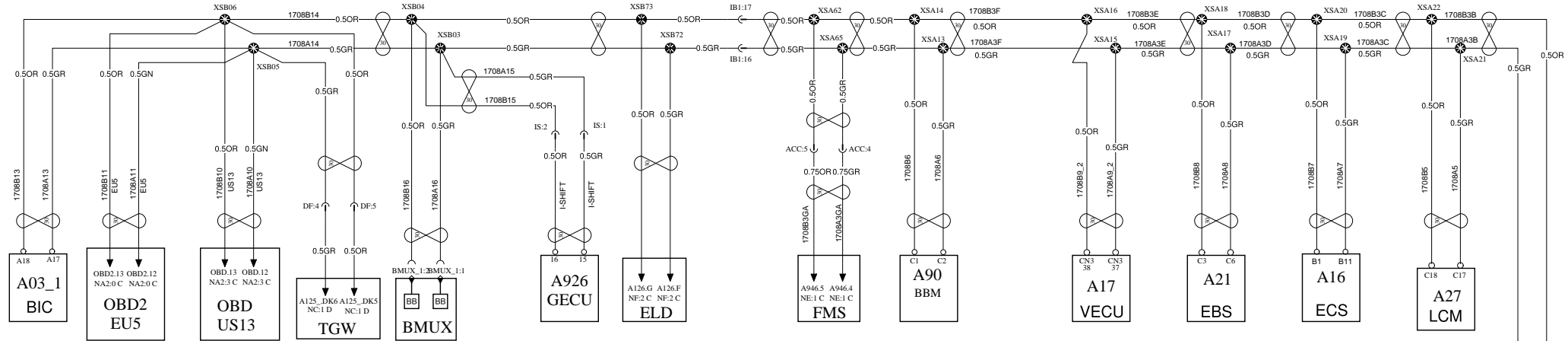

EURO 5

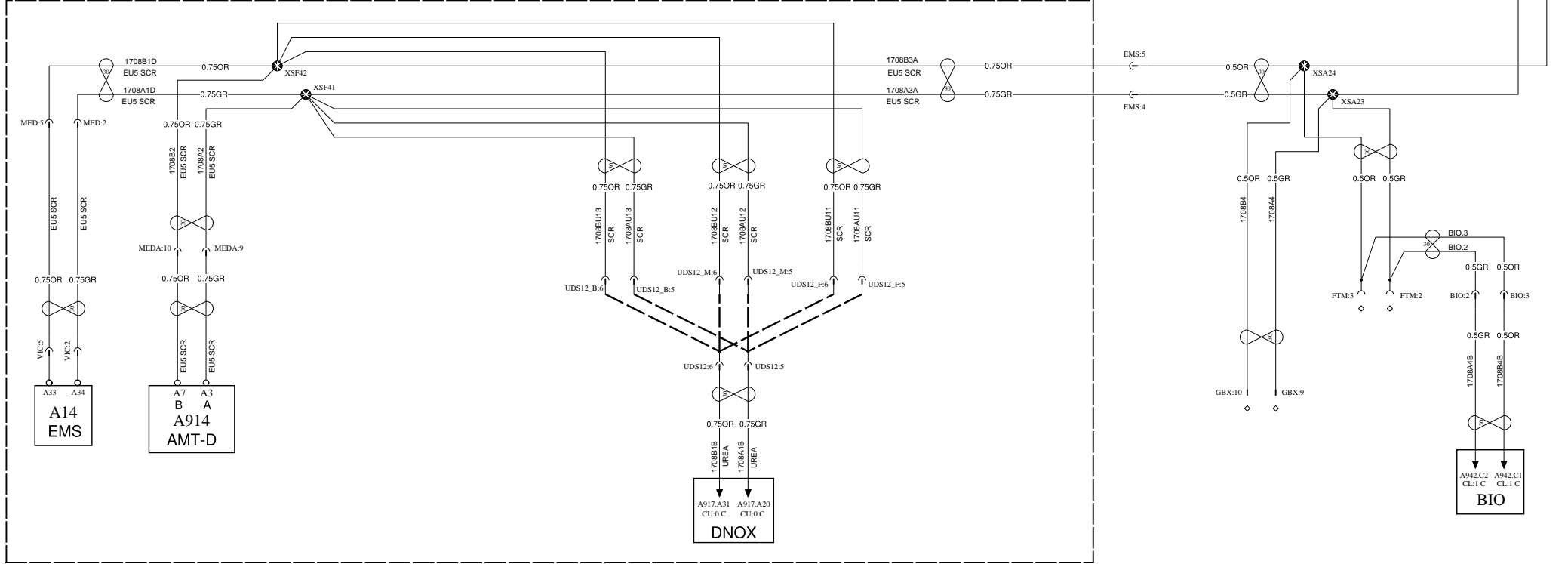

DBUS WIRING DIAGRAM XE

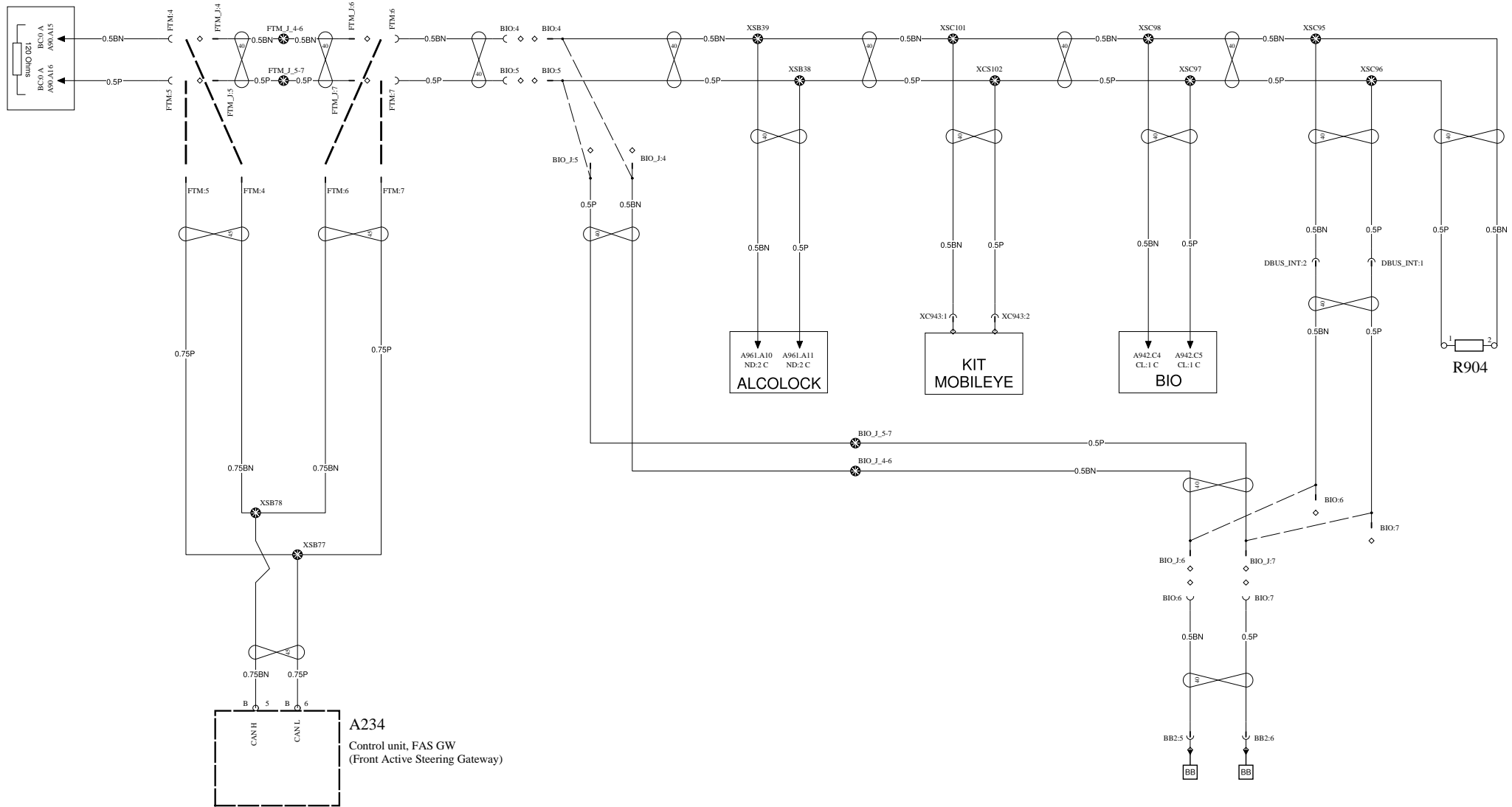

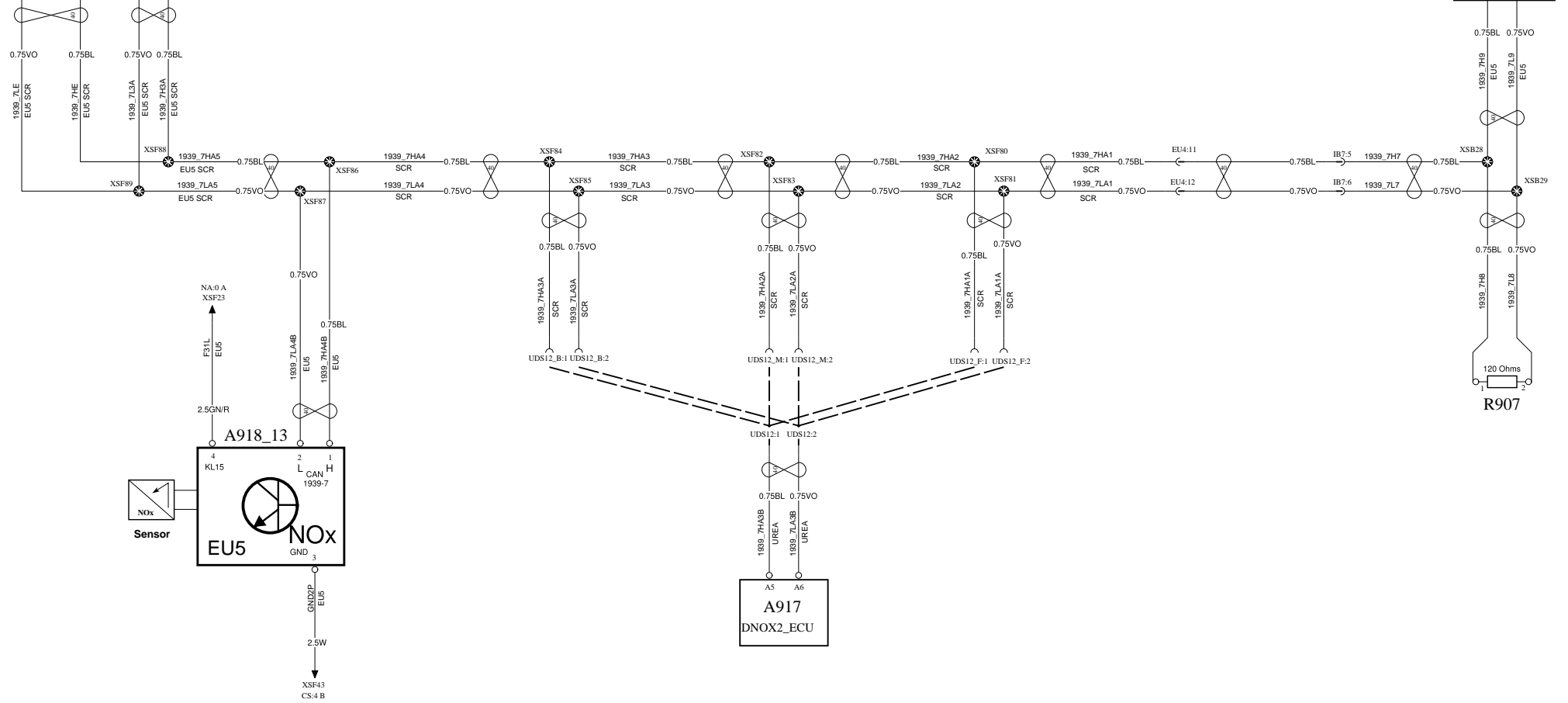
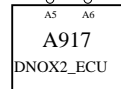
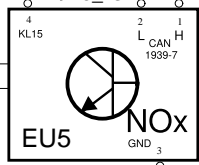
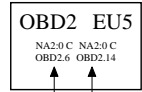
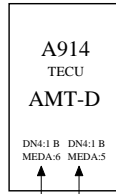
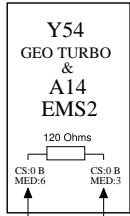

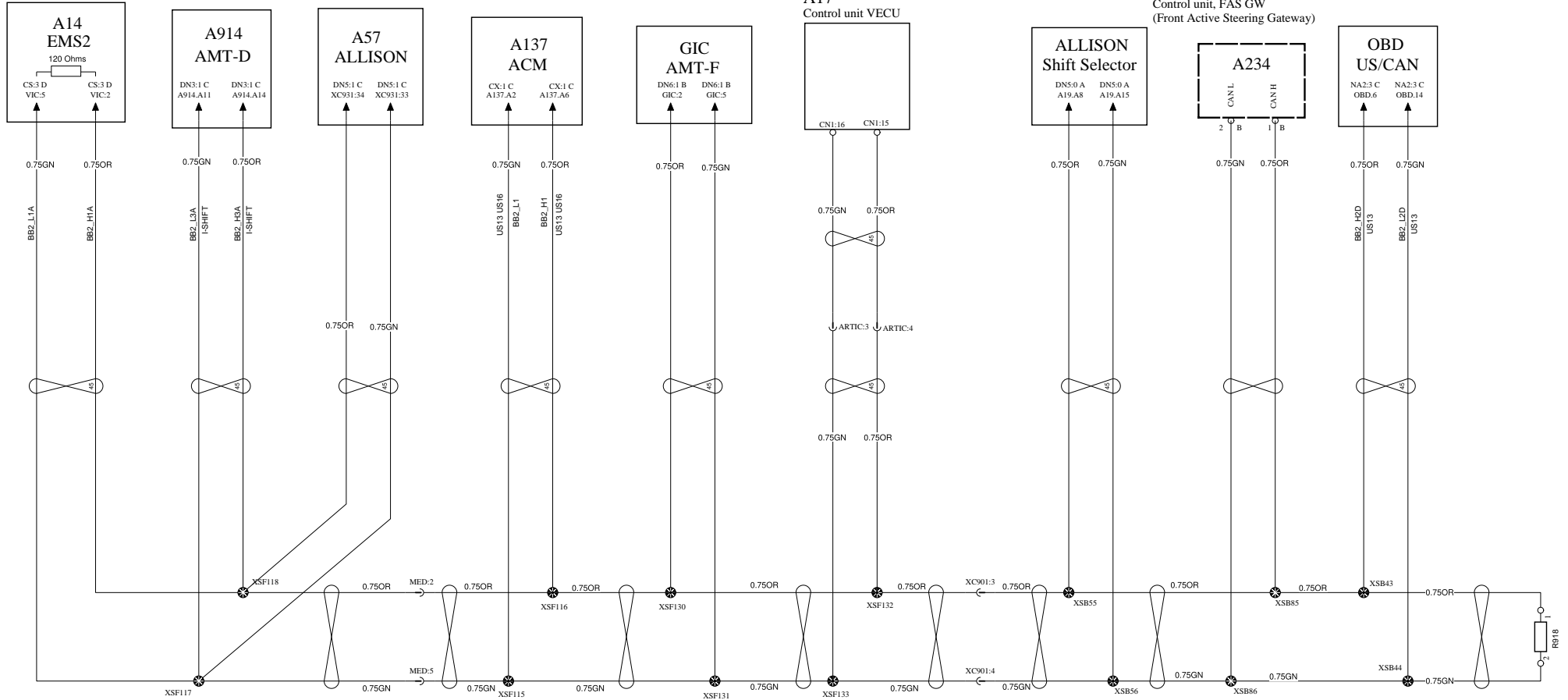

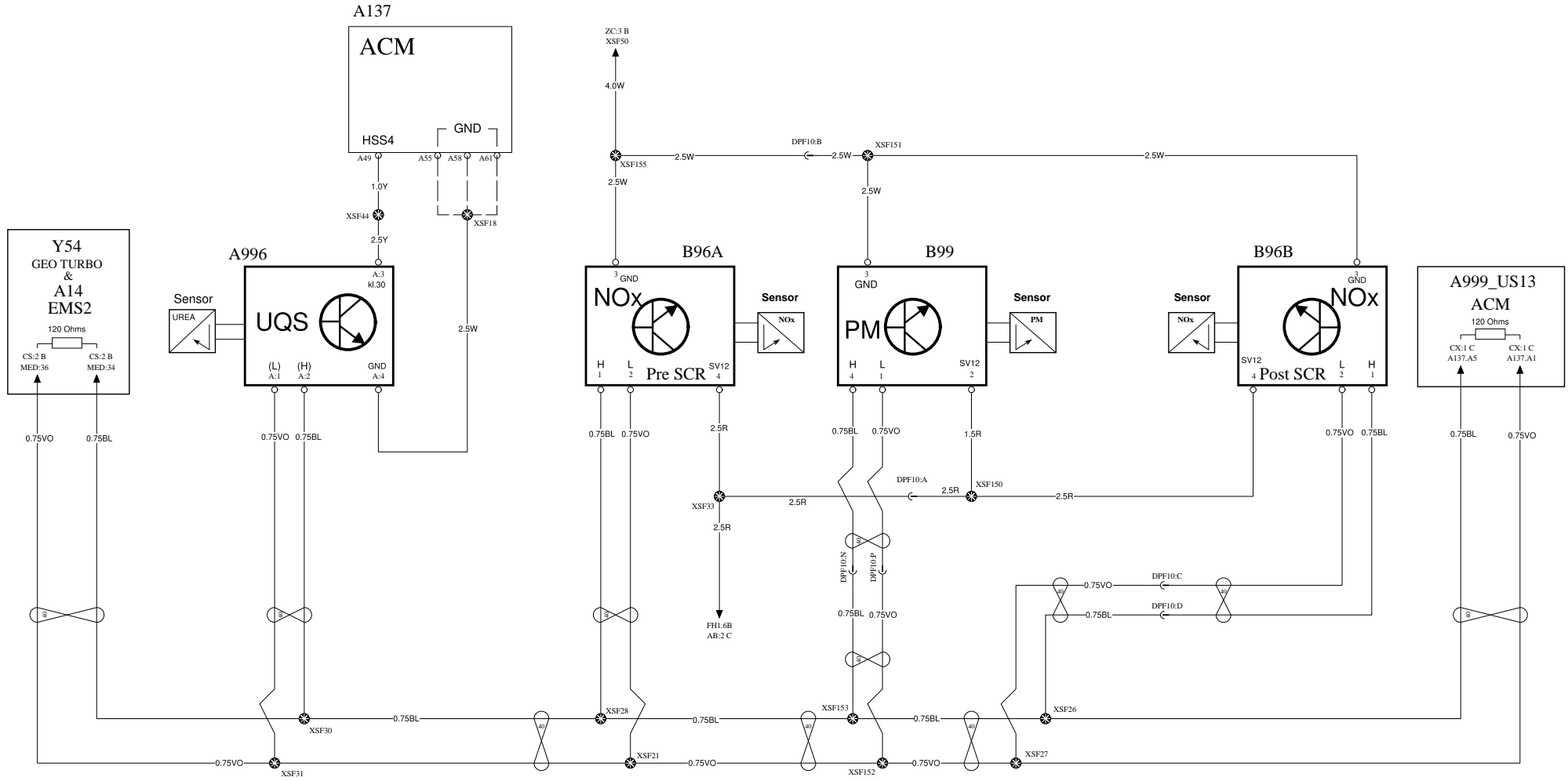

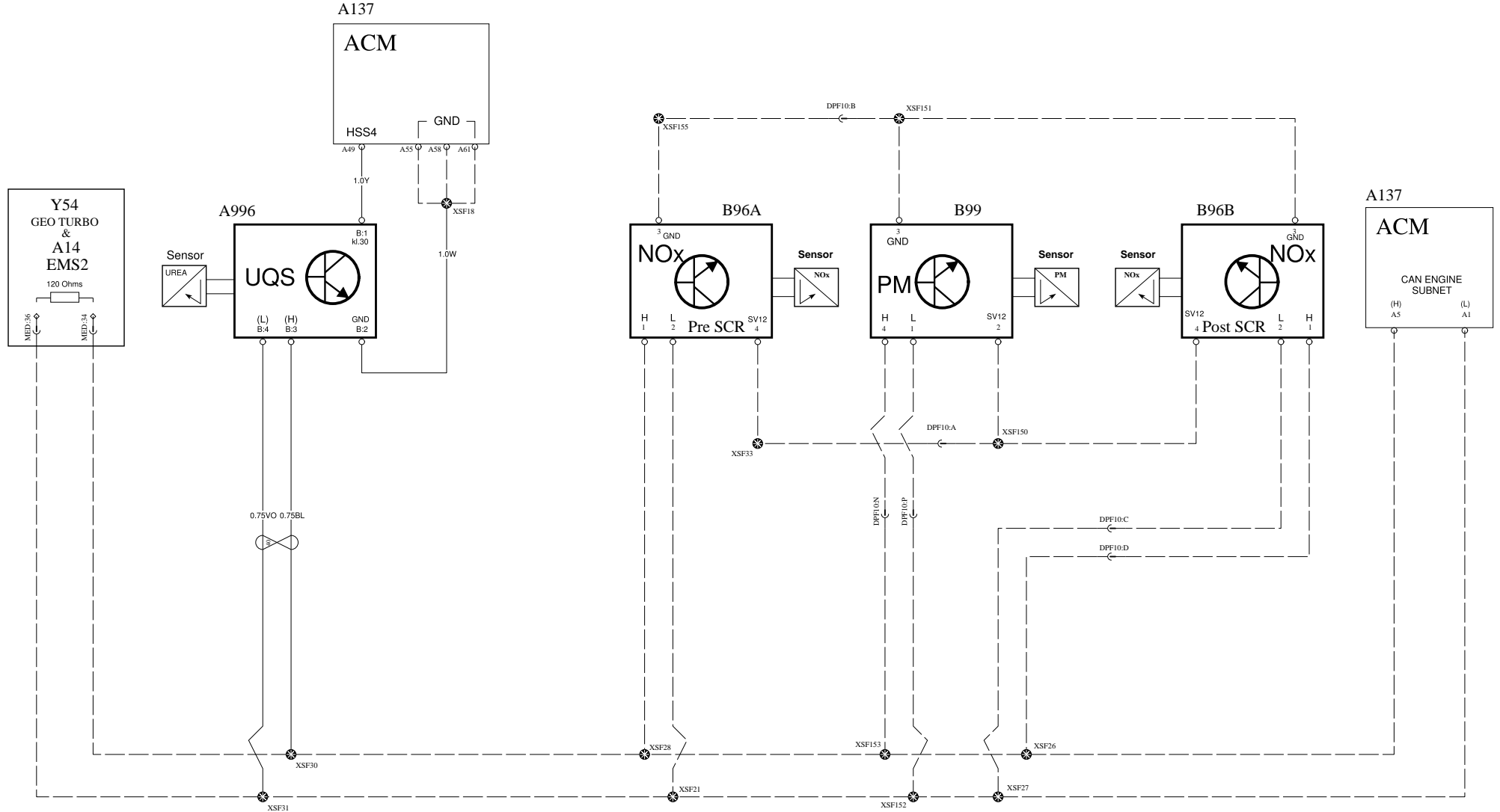

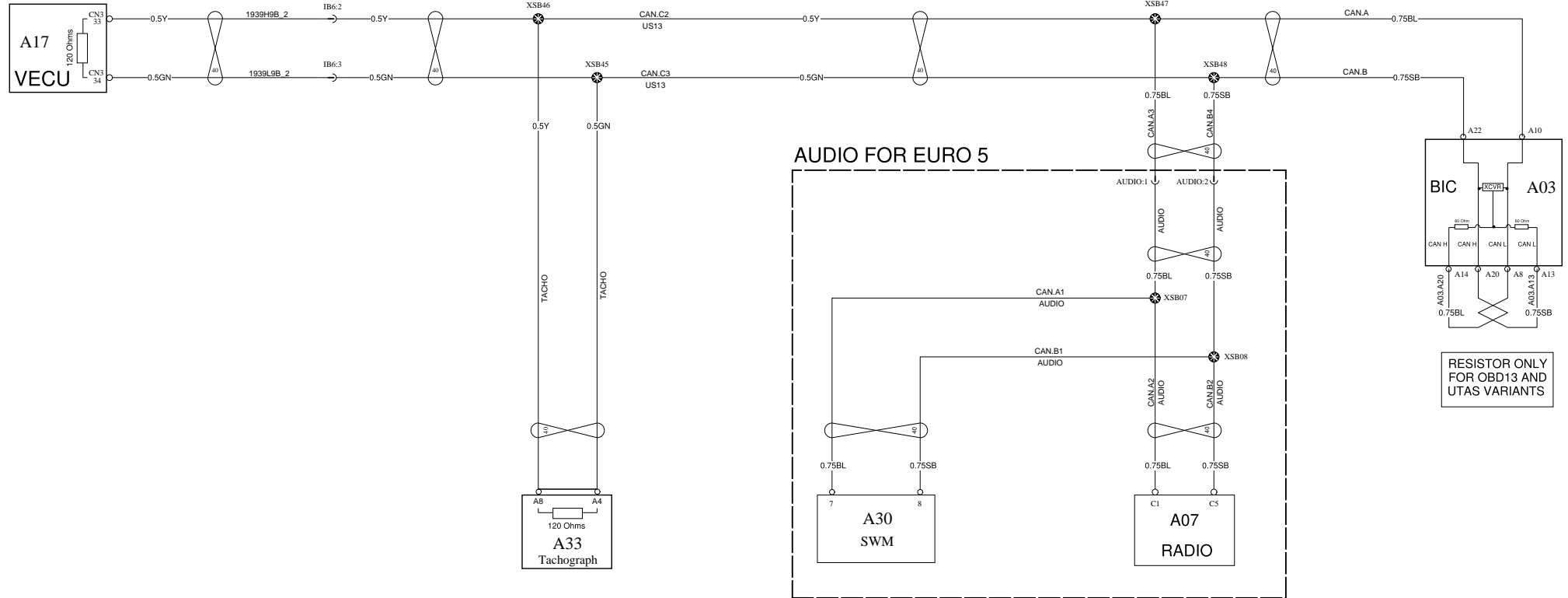

RESISTOR ONLY FOR OBD13 AND UTAS VARIANTS

WITHOUT VBC TELEMATICS

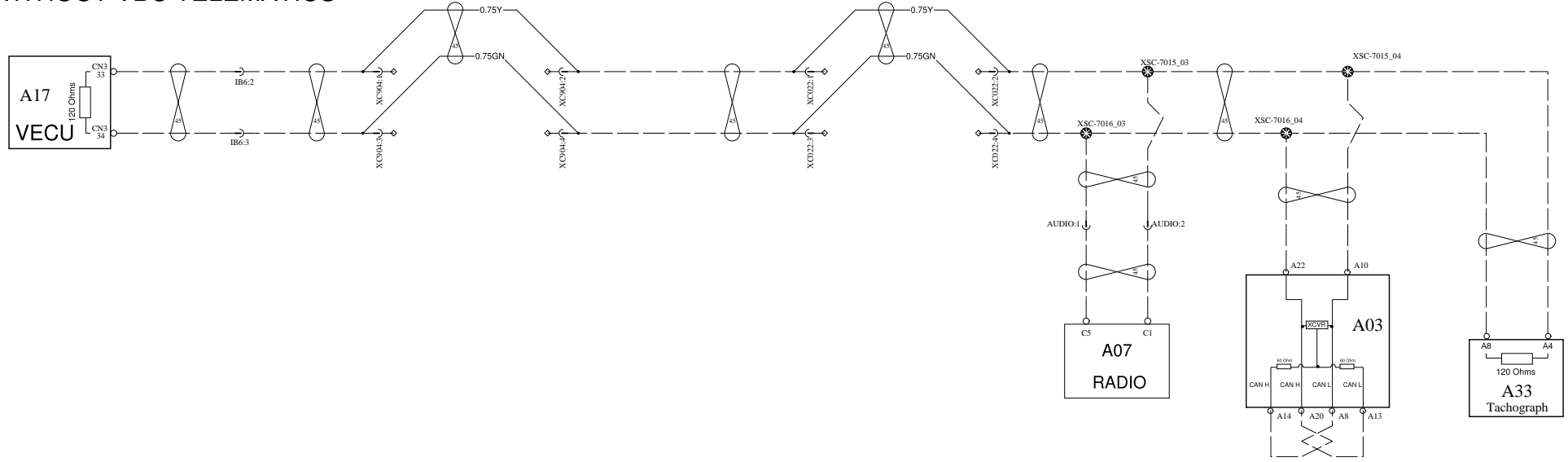

WITH VBC TELEMATICS

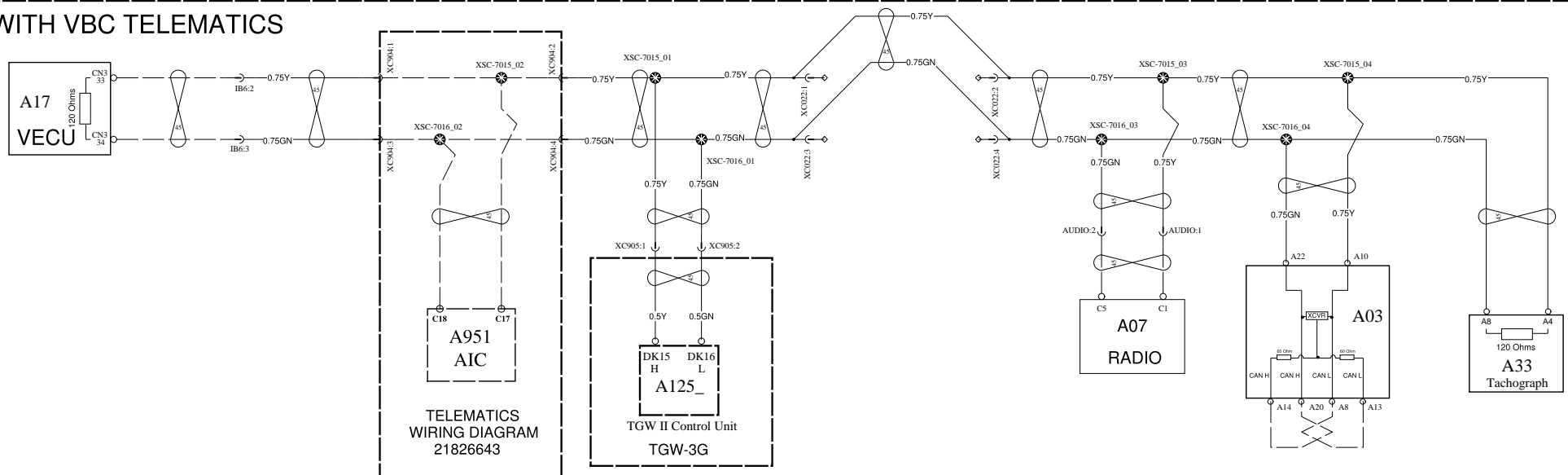

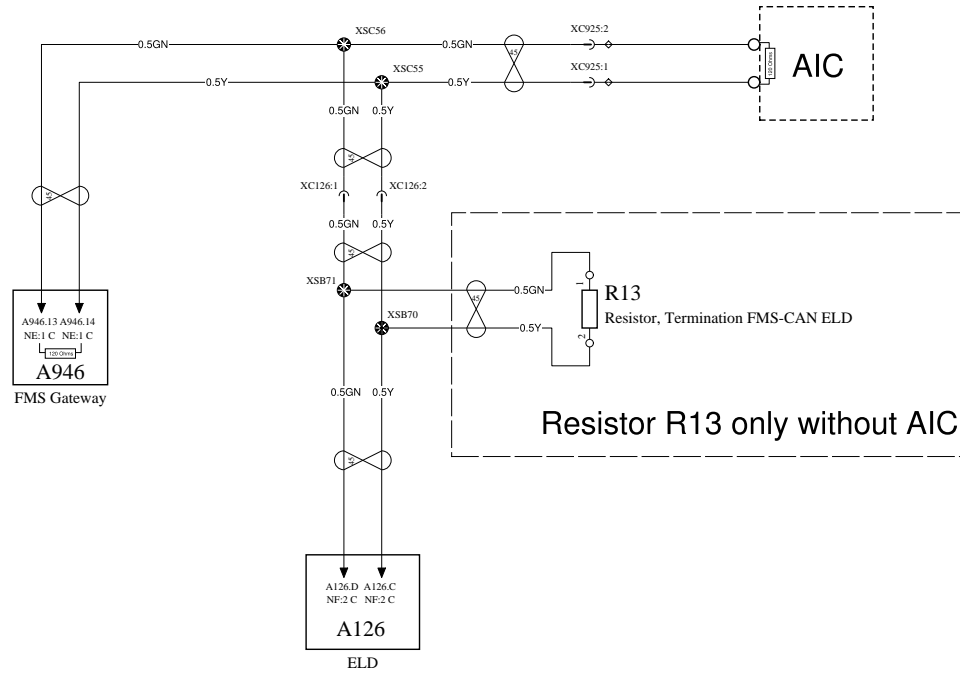

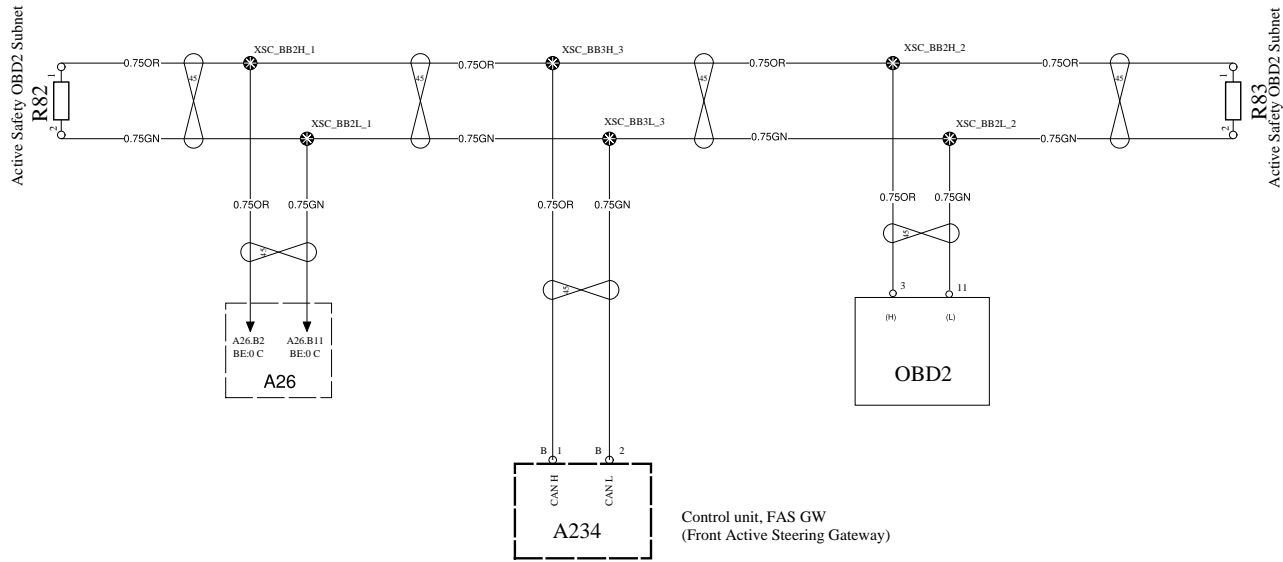

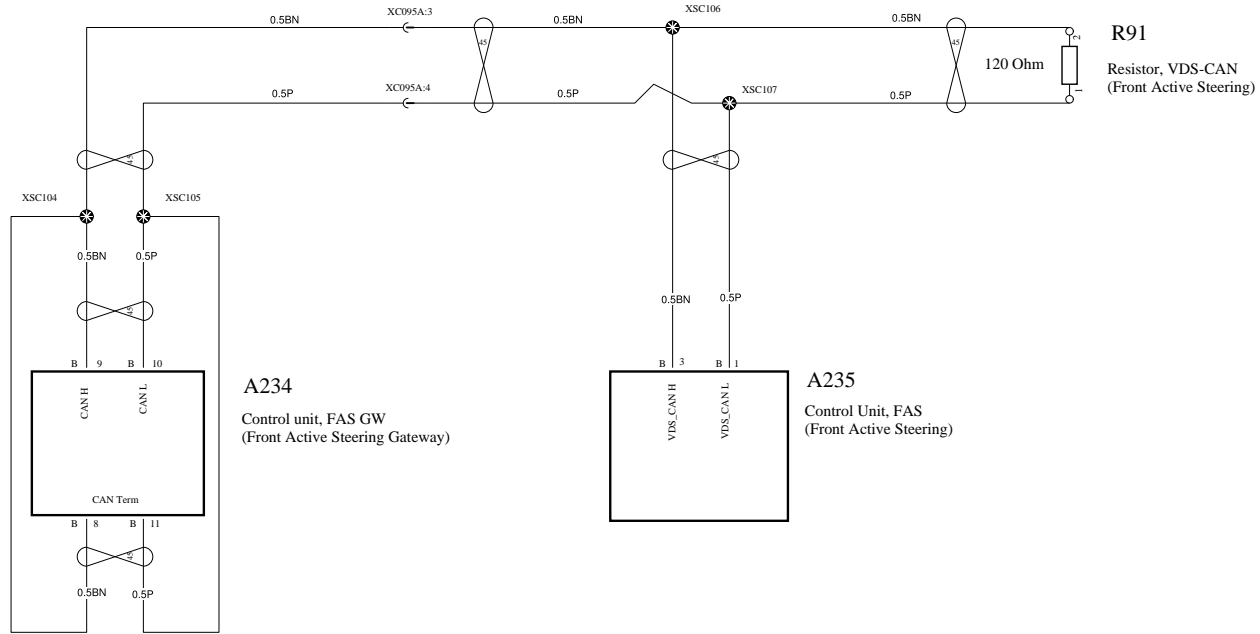

GROUND

WIRING DIAGRAM ZC

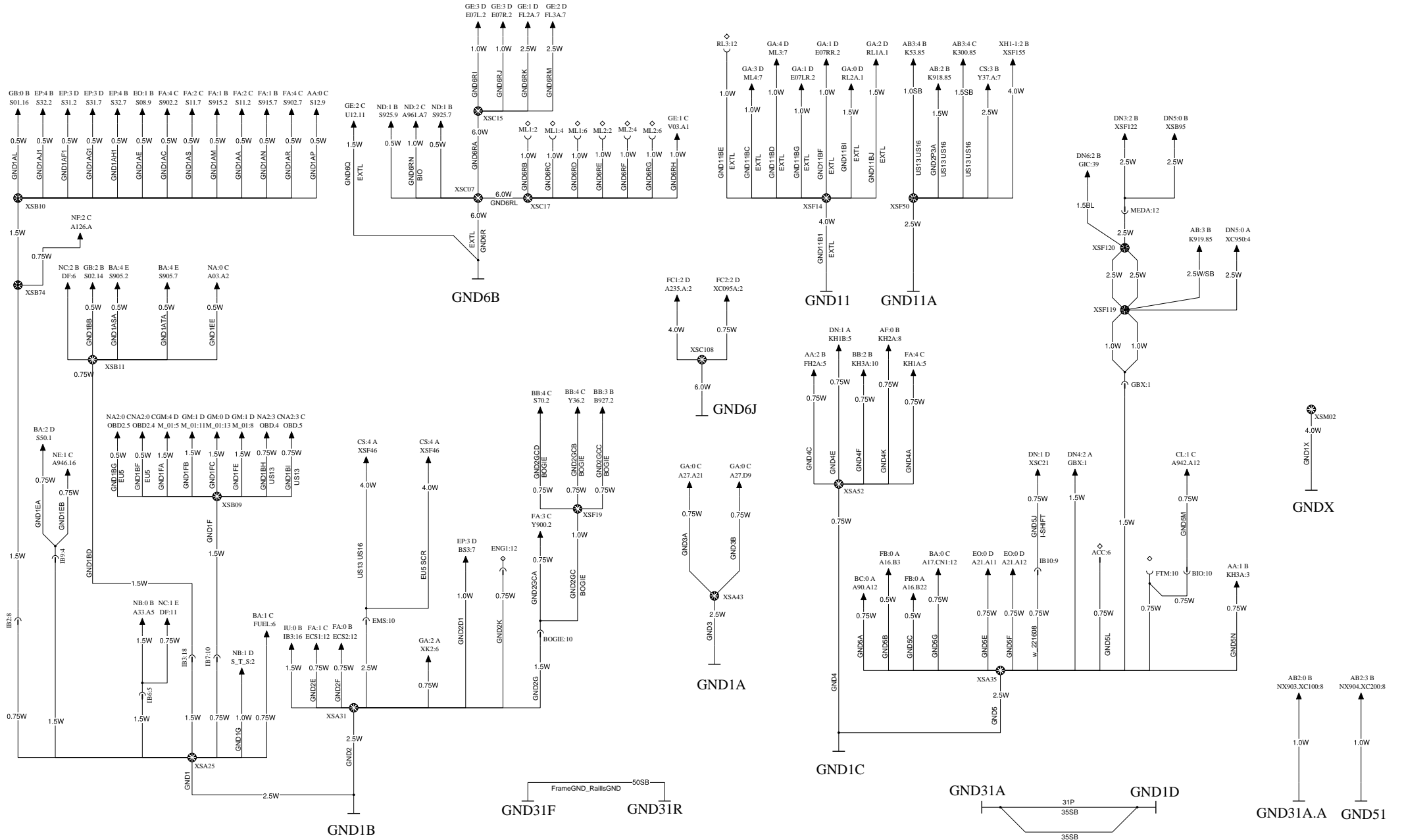

| | | | | | |
|---|------------------------------------|--------------------------------------|--------------------------|-------------------------------|-----------------------------|
| <p>VOLVO Volvo Bus Corporation</p> | Document title WIRING DIAGRAM | Document No <h2>22610880</h2> | Issue <h2>11</h2> | Volume <h2>02(03)</h2> | Page <h2>58(58)</h2> |
| | Document type PRODUCT SCHEMATIC | | | | |

REFERENCE INDEX

| NAME | PAGE |
|----------------------------|------|
| GROUNDS | 2 |
| FUSES AND CIRCUIT BREAKERS | 3 |
| COMPONENTS | 5 |
| INLINES | 13 |
| SPLICES | 33 |

VOLVO

Volvo Bus Corporation

| | | | |
|--|--------------------|-------------------------|--------------------------|
| Document title WIRING DIAGRAM | | | |
| Document type PRODUCT SCHEMATICS | | | |
| Document No 22610880 | Issue 11 | Volume 03(03) | Sheet No 1(38) |

GROUNDS

| NAME | PAGE |
|----------|---------|
| GND | BA 2 E |
| GND1A | ZC 2 D |
| GND1B | ZC 1 E |
| GND1C | ZC 2 D |
| GND1D | ZC 4 E |
| GND1E | CS 4 B |
| GND1UA.1 | CU 3 E |
| GND1UB.1 | CU 3 E |
| GND2A | AF 2 E |
| GND2B | AF 3 E |
| GND6 | GB 0 C |
| GND6B | ZC 1 B |
| GND6J | ZC 2 C |
| GND11 | ZC 2 B |
| GND11A | ZC 3 B |
| GND12 | TL 1 D |
| GND12 | TT 2 C |
| GND31A | ZC 3 E |
| GND31A.A | ZC 4 E |
| GND31A.B | AB 2 A |
| GND31B | AB2 1 E |
| GND31B | AB3 2 E |
| GND31F | ZC 1 E |
| GND31R | ZC 2 E |
| GND40 | AF 1 E |
| GND41 | AF 2 E |
| GND51 | ZC 4 E |
| GND74 | CU 4 E |
| GND75 | AB 2 A |
| GND900 | AB4 2 D |
| GND900 | AC 2 E |
| GND_PH | AB5 2 D |
| GNDX | ZC 4 C |

VOLVO

Volvo Bus Corporation

Document title
WIRING DIAGRAM

Document type
PRODUCT SCHEMATICS

Document No
22610880

Issue
11

Volume
03(03)

Sheet No
2(38)

FUSES AND CIRCUIT BREAKERS

| FUSE | DESCRIPTION | PAGE |
|-----------|---|--------|
| F1 (5A) | ECS, 5A | FA 4 A |
| F2 (10A) | BIC2, 10A | NA 3 A |
| F4 (20A) | EBS, 20A | EO 0 A |
| F5 (5A) | Horn, 5A | IS 2 A |
| F7 (15A) | Gearbox ECU I-shift, 15A | DN 2 B |
| F8 (5A) | Gear selector I-shift, 5A | DN 2 B |
| F9 (5A) | Switchbox start/stop rear, 5A | AA 3 A |
| F10 (5A) | Fire Alarm, 5A | BB 0 A |
| F11 (10A) | Dynafleet, 10A | NC 1 A |
| F11 (10A) | Dynafleet, 10A | TL 0 A |
| F12 (5A) | Body +30, 5A | BB 1 A |
| F13 (10A) | Spare | AB 3 A |
| F14 (5A) | BBM, 5A | BB 0 A |
| F15 (15A) | +15 signal for K918, K920, Y901, K48 & K5 | BA 0 A |
| F16 (5A) | VECU, 5A | BA 0 A |
| F17 (5A) | Switch feed, 5A | FA 4 A |
| F18 (5A) | Alternator, 5A | AF 3 A |
| F19 (10A) | Hymer, 10A | AF 0 A |
| F20 (10A) | EBS, 10A | EO 0 A |
| F21 (15A) | Wiper washer, 15A | GM 2 A |
| F23 (5A) | ACC, 5A | NE 1 A |
| F23 (5A) | ACC, 5A | TL 2 A |
| F24 (5A) | BIC2, 5A | NA 3 A |
| F25 (15A) | Washer motor, 15A | GM 1 A |
| F26 (5A) | ECS, 5A | FA 4 A |
| F28 (10A) | Retarder, 10A | DN 1 A |
| F29 (5A) | Body +DR, 5A | BB 1 A |
| F31 (10A) | Hydraulic oil, DNOX2, 10A | NA 0 A |
| F32 (5A) | Tachograph, 5A | NB 0 A |
| F33 (5A) | BIC2, 5A | NA 3 A |
| F35 (25A) | LCM, 25A | GA 0 A |
| F36 (25A) | LCM, 25A | GA 1 A |
| F37 (25A) | LCM, 25A | GA 1 A |
| F39 (25A) | DNOX2, 25A | CU 0 A |
| F40 (5A) | Voltage guard, 5A | AA 3 A |
| F41 (20A) | Radio, 20A | IU 0 A |
| F42 (5A) | Main switch, 5A | AA 0 A |
| F44 (25A) | LCM, 25A | GA 0 A |
| F45 (25A) | LCM, 25A | GA 1 A |
| F46 (25A) | LCM, 25A | GA 0 A |
| F47 (5A) | Side marker L, 5A | GA 3 B |
| F48 (5A) | Side marker R, 5A | GA 3 B |
| F49 (5A) | Fuel cut off valve, 5A | NA 0 A |
| F49 (5A) | Fuel cut off valve, 5A | NF 2 A |
| F51 (5A) | Radio, 5A | IU 0 A |
| F52 (10A) | Luggage light, 10A | BB 2 A |
| F53 (10A) | Bogie valve, Heater waterseparator, 10A | BB 4 A |
| F54 (5A) | Engine/Luggage hatch, 5A | GA 2 A |
| F55 (10A) | Engine brake valve, Preheat relay, Fan sp | BA 1 A |
| F56 (10A) | Engine brake, 10A | BA 1 A |
| F57 (5A) | Key switch, 5A | AA 0 A |
| F58 (5A) | FTM, 5A | CL 1 A |
| F59 (10A) | Fuse, Active Safety Seat Haptic | BE 3 A |
| F61 (10A) | Light luggage room, 10A | GA 1 A |

VOLVO

Volvo Bus Corporation

Document title
WIRING DIAGRAM

Document type
PRODUCT SCHEMATICS

| | | | |
|-----------------|-----------|---------------|--------------|
| Document No | Issue | Volume | Sheet No |
| 22610880 | 11 | 03(03) | 3(38) |

| FUSE | DESCRIPTION | PAGE |
|------------|---|---------|
| F62 (20A) | Light sleeping compartment, 20A | GA 2 A |
| F63 (5A) | Starter motor control, 5A | CL 3 B |
| F64 (10A) | Spare | CL 3 B |
| F66 (15A) | Fuse, Extra Fan | FC2 2 B |
| F69 (30A) | Fuse, VDS (Volvo Dynamic Steering) | CU 4 B |
| F69 (30A) | Fuse, VDS (Volvo Dynamic Steering) | FC1 2 A |
| F70 (3A) | Fuse, External Charger Starter Battery | AB3 4 C |
| F71 (5A) | Telematics extra fuse | TL 2 B |
| F76 (80A) | FUSE, 12V Equalizer | AB 1 A |
| F77 (40A) | FUSE, 24V Equalizer | AB 1 A |
| F90A (30A) | FUSE - DNOX2RA | CU 3 D |
| F90B (30A) | FUSE - DNOX2RB | CU 3 D |
| F99 (15A) | Fuse, Allison +30 power supply | AB 3 B |
| F100 (10A) | 10A Fuse, OBD connection to B+ | AB 1 B |
| F206 (5A) | External Pre-Heater, 5A | AB5 1 C |
| F907 (20A) | Fuse 12V I-shift, Allison and AMT-F power | AB 2 C |
| F915 (30A) | Fuse 12V EMS power supply | AB 2 C |
| F955 (20A) | Fuse 12V EMS power supply for Y109, Y110, | AB 2 C |
| F956 (10A) | Fuse 12V EMS load power supply | AB 2 C |
| F957 (20A) | Fuse 12V EMS loads power supply | AB 2 C |
| F958 (10A) | FUSE 12V Allison GBX and OBD connector | AB 2 C |

VOLVO

Volvo Bus Corporation

Document title

WIRING DIAGRAM

Document type

PRODUCT SCHEMATICS

Document No

22610880

Issue

11

Volume

03(03)

Sheet No

4(38)

COMPONENTS

| COMPONENT | DESCRIPTION | PAGE |
|-----------|---|---------|
| 30UA.1 | Terminal - Power for heated hose | CU 3 D |
| 30UB.1 | Terminal - Power for heated hose | CU 3 D |
| A03 | Instrument cluster | NA 0 C |
| A03 | Instrument cluster | XC 0 B |
| A03 | Instrument cluster | XJ 4 B |
| A03 | Instrument cluster | XJ2 3 B |
| A03_1 | Instrument cluster | XD 0 B |
| A07 | Radio | XJ 3 D |
| A07 | Radio | XJ2 2 C |
| A07_1 | Radio | IU 0 C |
| A13 | Control unit, TECU, I-Shift AMT-F | DN6 1 C |
| A14 | Control unit EMS | XC 1 E |
| A14 | Control unit EMS | XD 0 D |
| A16 | Control unit,ECS(Electronic Controlled ai | FA 0 D |
| A16 | Control unit,ECS(Electronic Controlled ai | FB 0 A |
| A16 | Control unit,ECS(Electronic Controlled ai | FB2 3 B |
| A16 | Control unit,ECS(Electronic Controlled ai | XC 4 C |
| A16 | Control unit,ECS(Electronic Controlled ai | XD 4 B |
| A17 | Control unit VECU | BA 0 C |
| A17 | Control unit VECU | XC 3 C |
| A17 | Control unit VECU | XD 3 B |
| A17 | Control unit VECU | XG 2 B |
| A17 | Control unit VECU | XJ 0 B |
| A17 | Control unit VECU | XJ2 0 A |
| A19 | Control unit,GECU(gear selector ECU) | DN5 0 A |
| A19_1 | Control unit,GECU(gear selector ECU) | DN2 0 B |
| A19_2 | Control unit,GECU(gear selector ECU) | DN2 3 B |
| A21 | Control unit,EBS(Electronic Brake System) | EO 0 D |
| A21 | Control unit,EBS(Electronic Brake System) | EP 0 A |
| A21 | Control unit,EBS(Electronic Brake System) | XC 3 C |
| A21 | Control unit,EBS(Electronic Brake System) | XD 3 B |
| A26 | Control unite,ACC(Adaptive Cruise Control | BE 0 C |
| A27 | Control unite,LCM(Light Control Module) | GA 0 C |
| A27 | Control unite,LCM(Light Control Module) | GB 0 C |
| A27 | Control unite,LCM(Light Control Module) | GE 2 A |
| A27 | Control unite,LCM(Light Control Module) | TL 1 B |
| A27 | Control unite,LCM(Light Control Module) | XC 4 C |
| A27 | Control unite,LCM(Light Control Module) | XD 3 B |
| A30 | Control unite,SWM(Steering Wheel Module) | IU 3 B |
| A30 | Control unite,SWM(Steering Wheel Module) | XJ 3 D |
| A33 | Tachograph | NB 0 B |
| A33 | Tachograph | XJ 1 D |
| A33 | Tachograph | XJ2 4 B |
| A41 | Body I/O Module 41 | CZ 0 C |
| A41 | Body I/O Module 41 | DN4 1 D |
| A41 | Body I/O Module 41 | CZ 3 C |
| A42 | Body I/O Module 42 | DN3 2 D |
| A42 | Body I/O Module 42 | DN4 2 D |
| A57 | Control unit, Body | DN5 0 C |
| A58 | Control unit, Body | DN5 1 D |
| A80 | Air Dryer | BA 2 E |
| A90 | BBM | AA 0 E |
| A90 | BBM | BB 0 E |
| A90 | BBM | BC 0 A |

VOLVO

Volvo Bus Corporation

Document title
WIRING DIAGRAM

Document type
PRODUCT SCHEMATICS

| | | | |
|--------------------------------|--------------------|-------------------------|--------------------------|
| Document No 22610880 | Issue 11 | Volume 03(03) | Sheet No 5(38) |
|--------------------------------|--------------------|-------------------------|--------------------------|

| COMPONENT | DESCRIPTION | PAGE |
|-----------|---|-----------|
| A90 | BBM | BE 4 A |
| A90 | BBM | XC 2 C |
| A90 | BBM | XD 2 B |
| A124 | Starter motor with relay | AF 1 D |
| A125 | TGW II Control Unit | NC 1 D |
| A125 | TGW II Control Unit | XC 1 C |
| A125 | TGW II Control Unit | XJ2 2 D |
| A126 | Control unit, ELD (Electronic Logging Dev | NF 2 C |
| A133 | Handset | ND 1 D |
| A137 | DEF CONTROL MODULE | CX 1 C |
| A137 | DEF CONTROL MODULE | XH1-1 1 A |
| A137 | DEF CONTROL MODULE | XH1-2 1 A |
| A176 | Control unit, LPOS, Lane Position and Obj | BE 1 A |
| A224 | Seat Haptic Vibration | BE 3 C |
| A234 | Control unit, FAS GW (Front Active Steeri | FC2 2 D |
| A234 | Control unit, FAS GW (Front Active Steeri | XE 0 E |
| A234 | Control unit, FAS GW (Front Active Steeri | XG 3 B |
| A234 | Control unit, FAS GW (Front Active Steeri | XN 2 D |
| A234 | Control unit, FAS GW (Front Active Steeri | XO 1 D |
| A235 | Control Unit, FAS (Front Active Steering) | FC1 2 D |
| A235 | Control Unit, FAS (Front Active Steering) | XO 2 D |
| A914 | Control unit, TECU, I-Shift AMT-D | DN3 1 C |
| A914 | Control unit, TECU, I-Shift AMT-D | DN4 1 C |
| A914 | Control unit, TECU, I-Shift AMT-D | XC 2 E |
| A914 | Control unit, TECU, I-Shift AMT-D | XD 0 D |
| A917 | DNOX2_ECU | CU 0 C |
| A917 | DNOX2_ECU | XF 2 D |
| A918_13 | NOx-sensor | XF 1 D |
| A926 | GearShift_ECU | DN 1 C |
| A926 | GearShift_ECU | XC 1 C |
| A926 | GearShift_ECU | XD 1 B |
| A942 | BIO - Bus I/O | CL 1 C |
| A946 | FMS GATEWAY | NE 1 C |
| A951 | Control unit, AIC ECU | NC 4 E |
| A951 | Control unit, AIC ECU | TL 0 D |
| A951 | Control unit, AIC ECU | TT 2 D |
| A953 | I-COACH | TT 2 B |
| A961 | Control unit, Alcolock Interlock | ND 2 C |
| A996 | UQS | XH1-1 1 B |
| A996 | UQS | XH1-2 0 B |
| A998 | DEF Pump | CX 1 B |
| B03 | Sensor,footbrake valve | EO 0 C |
| B06 | Sensor,air pressure wet tank | BA 4 B |
| B07 | Sensor,fuel level | NA 1 E |
| B12 | Sensor,tachograph/speedometer | DN6 3 C |
| B12 | Sensor,tachograph/speedometer | NB 1 E |
| B13 | Sensor,wheel speed, lhs. 1:st front axle | EO 2 B |
| B14 | Sensor,wheel speed, rhs. 1:st front axle | EO 2 B |
| B15 | Sensor,wheel speed, lhs. 1st rear axle | EO 3 B |
| B16 | Sensor,wheel speed, rhs. 1:st rear axle | EO 3 B |
| B22 | Sensor,outdoor temperature | NA 1 D |
| B25 | Sensor,accelerator pedal | BA 2 B |
| B29 | Sensor,chassis level, lhs.rear axle | FB 2 D |
| B30 | Sensor,chassis level, rhs.rear axle | FB 2 D |

VOLVO

Volvo Bus Corporation

Document title
WIRING DIAGRAM

Document type
PRODUCT SCHEMATICS

Document No
22610880

Issue
11

Volume
03(03)

Sheet No
6(38)

| COMPONENT | DESCRIPTION | PAGE |
|-----------|---|-----------|
| B32_10 | Sensor Eng. cooling fan Speed | CS 2 A |
| B32_13 | Sensor Eng. cooling fan speed | CS 2 A |
| B39 | Sensor,air filter press/Temp. | CS 2 D |
| B40 | Sensor,brake lining wear indicator, lhs.1 | EO 2 B |
| B41 | Seonsor,brake lining wear indicator, rhs. | EO 1 B |
| B42 | Sensor,brake lining wear indicator,lhs. 1 | EO 3 B |
| B43 | Sensor,brake lining wear indicator,rhs. 1 | EO 2 B |
| B49 | Sensor,steering angle | EP 2 D |
| B50 | Sensor,yaw-rate | EP 2 D |
| B57 | Sensor,air pressure,suspension bellows,ih | FB 0 C |
| B58 | Sensor,air pressur,suspension bellows,rhs | FB 1 C |
| B59 | Sensor,indoor temperature | NA 1 D |
| B69C | Sensor,coolant temperature, retarder | CZ 1 C |
| B69C | Sensor,coolant temperature, retarder | DN4 1 D |
| B96A | Pre-Sensor, NOx | XH1-1 2 C |
| B96A | Pre-Sensor, NOx | XH1-2 2 B |
| B96B | Pos Sensor, NOx | XH1-1 4 C |
| B96B | Pos Sensor, NOx | XH1-2 4 B |
| B99 | Sensor, PM soot sensor | XH1-1 2 C |
| B99 | Sensor, PM soot sensor | XH1-2 2 B |
| B238 | Sensor, FLS (Forward Looking Sensor) | BE 1 A |
| B322 | Sensor Air Pressure, Park Brake | BA 4 B |
| B904 | Hydraulic oil level sensor | NA 1 B |
| B906 | Sensor Needle movement | BC 1 C |
| B910 | Sensor airpressure ECS frot LHS | FB 0 C |
| B914 | Sensor chassis level front axle LHS | FB 3 D |
| B915 | Sensor chassis level front axle RHS | FB 3 D |
| B918 | Hydraulic oil level sensor_2 | NA 1 B |
| B920 | Sensor fuel level 2, | NA 1 E |
| B923 | Sensor temp/level adblue SCRT | CU 3 D |
| B927 | Sensor Hydr.oil press | BB 3 B |
| B930 | Sensor_temp_uppstream_scrt_DNOX2 | CU 2 A |
| B940 | Sensor brake lining wear indicator,A/B R | EP 1 D |
| B941 | Sensor brake lining wear indicator,A/B L | EP 1 D |
| B942 | Sensor wheel speed,A/B R | EP 1 D |
| B943 | Sensor wheel speed,A/B L | EP 1 D |
| B973 | Fire Sensor, 150°C | BB 0 C |
| B974 | Fire sensor | BB 0 C |
| B975 | Fire sensor | BB 0 C |
| B977 | Sensor, brake pressure | NA 0 D |
| B978 | Sensor, brake pressure | NA 0 D |
| B979 | Parking brake pressure | BB 1 C |
| B980 | Auxilliary pressure | BB 1 C |
| B985 | Fire sensor 4, D13 | BB 0 B |
| B986 | Fire sensor 5, D13 | BB 0 B |
| B991_10 | temp. DPF | CX 3 B |
| B992_10 | temp. DPF | CX 3 B |
| B993_10 | temp. DPF | CX 3 B |
| B994_10 | temp. Muffler | CX 3 B |
| B995_13 | SENSOR, DPF PRESSURE | CX 2 B |
| BBI | BodyBuilder Interface Connector | AA 0 C |
| BBI | BodyBuilder Interface Connector | AB2 1 C |
| BBI | BodyBuilder Interface Connector | AB4 2 B |
| BBI | BodyBuilder Interface Connector | AF 0 B |

VOLVO

Volvo Bus Corporation

Document title
WIRING DIAGRAM

Document type
PRODUCT SCHEMATICS

Document No
22610880

Issue
11

Volume
03(03)

Sheet No
7(38)

| COMPONENT | DESCRIPTION | PAGE |
|-----------|---|---------|
| BBI | BodyBuilder Interface Connector | BA 0 D |
| BBI | BodyBuilder Interface Connector | BB 2 C |
| BBI | BodyBuilder Interface Connector | BC 3 B |
| BBI | BodyBuilder Interface Connector | CL 1 B |
| BBI | BodyBuilder Interface Connector | EP 2 B |
| BBI | BodyBuilder Interface Connector | FA 1 B |
| BBI | BodyBuilder Interface Connector | FB 2 B |
| BBI | BodyBuilder Interface Connector | FB2 3 C |
| BBI | BodyBuilder Interface Connector | GA 1 B |
| BBI | BodyBuilder Interface Connector | GB 3 B |
| BBI | BodyBuilder Interface Connector | IS 2 C |
| BBI | BodyBuilder Interface Connector | IU 1 E |
| BBI | BodyBuilder Interface Connector | NA 2 D |
| BBI | BodyBuilder Interface Connector | NB 1 A |
| BBI | BodyBuilder Interface Connector | ND 1 A |
| BBI | BodyBuilder Interface Connector | XD 1 B |
| BBI | BodyBuilder Interface Connector | XE 3 E |
| D1 | Diode | BA 1 E |
| D2 | Diode | AA 2 D |
| D3 | Diode - Wiper motor | GM 3 D |
| D8 | Diode for UMAIN module | AA 1 A |
| E07L | Fog light left | GE 3 D |
| E07LR | Fog light left rear | GA 1 D |
| E07R | Fog light right | GE 3 D |
| E07RR | Fog light right rear | GA 1 D |
| E09 | Lamp,brake light | GA 0 D |
| E11LA | Side marker light left | GA 3 D |
| E11LF | Side marker light left front | GA 3 D |
| E11LR | Side marker light left rear | GA 3 D |
| E11ML | Side marker light middle left | GA 3 D |
| E11MR | Side marker light middle right | GA 4 D |
| E11RA | Side marker light right | GA 4 D |
| E11RF | Side marker light right front | GA 3 D |
| E11RR | Side marker light right rear | GA 4 D |
| E11TL | Position Light,Left(Trailer) | GA 3 D |
| E11TR | Position Light,Right(Trailer) | GA 3 D |
| E13L | Dir. ind. left | GA 1 D |
| E13LA | Dir.indicator left | GA 1 D |
| E13R | Dir. ind. right | GA 1 D |
| E13RB | Dir.indicator right | GA 1 D |
| E111 | LED Module, (Forward Collision Warning) | BE 0 C |
| FH1 | FuseHolder 12V | AB 2 C |
| FL2A | Front light, L | GE 1 D |
| FL3A | Front light, R | GE 2 D |
| G01 | Battery | AB2 1 C |
| G01B | Battery | AB2 1 D |
| G01B | Battery | AB3 2 D |
| G01B1 | I-Start Starter Battery | AB3 2 D |
| G01C | I-Start Consumer Battery | AB4 2 C |
| G01C1 | I-Start Consumer Battery | AB4 2 D |
| G02 | Alternator 1 | AF 2 D |
| G03 | Alternator 2 | AF 3 D |
| G08A | Battery | AC 2 C |
| G08B | Battery | AC 2 D |

VOLVO

Volvo Bus Corporation

Document title
WIRING DIAGRAM

Document type
PRODUCT SCHEMATICS

Document No
22610880

Issue
11

Volume
03(03)

Sheet No
8(38)

| COMPONENT | DESCRIPTION | PAGE |
|-----------|---|---------|
| G901 | Battery Equalizer | AB 2 A |
| GND | GDN - Adapter_AHI | BA 2 E |
| GND1A | GND - Electrical Center | ZC 2 D |
| GND1B | GND - Electrical Center | ZC 1 E |
| GND1C | GND4/GND5 - Electrical Center | ZC 2 D |
| GND1D | GND - Batt_Box_NVPDUF | ZC 4 E |
| GND1E | GND - US13 | CS 4 B |
| GND1UA.1 | GND - DNOX2RA | CU 3 E |
| GND1UB.1 | GND - DNOX2RB | CU 3 E |
| GND2A | GND - ALT_1 | AF 2 E |
| GND2B | GND - ALT_2 | AF 3 E |
| GND6 | GND - Driver Location | GB 0 C |
| GND6B | GND6Q/GND6R - Driver Location | ZC 1 B |
| GND6J | GND, VDS | ZC 2 C |
| GND11 | GND - Rear Axle | ZC 2 B |
| GND11A | GND - Rear Axle | ZC 3 B |
| GND12 | AIC ECU Ground | TL 1 D |
| GND12 | AIC ECU Ground | TT 2 C |
| GND31A | GND - Batt_Box_NVPDUF | ZC 3 E |
| GND31A.A | GND - Batt_Boxx_NVPDUF | ZC 4 E |
| GND31A.B | Ground | AB 2 A |
| GND31B | GND - Battery | AB2 1 E |
| GND31B | GND - Battery | AB3 2 E |
| GND31F | GND - Frame | ZC 1 E |
| GND31R | GND - Rails | ZC 2 E |
| GND40 | GND - STARTER_ENG | AF 1 E |
| GND41 | GND - STARTER_ENG_US | AF 2 E |
| GND51 | GND - Adapter_NVPDUR | ZC 4 E |
| GND74 | GND - SCR | CU 4 E |
| GND75 | GND - Equalizer | AB 2 A |
| GND900 | GND - Starter Batteries | AB4 2 D |
| GND900 | GND - Starter Batteries | AC 2 E |
| GND_PH | GND - Pre heater | AB5 2 D |
| GNDX | GND - Xenon Lights | ZC 4 C |
| H01 | Horn, air-operated | IS 1 B |
| H02 | Diaphragm horn | IS 2 B |
| K2 | Over Load Indicator | CL 3 C |
| K02 | Relay - Day Light | GB 0 C |
| K3 | ECS | FA 4 C |
| K4 | I-Shift/Voith | DN 1 A |
| K7 | Start engine | AF 0 B |
| K8 | VECU,EMS | BA 0 C |
| K9 | Wiper/Washer | GM 2 C |
| K11 | Prevent start engine | AA 2 C |
| K12 | Luggage Light | BB 2 B |
| K13 | Emergency switch relay | AA 0 B |
| K14 | Bogie | BB 4 B |
| K17 | Ignition +15 | AA 2 A |
| K35 | relay_disconn_headlight_wash | GM 1 C |
| K48 | Relay Engine Preheating | AB5 1 C |
| K50 | Relay, External Charger Starter Battery | AB3 4 C |
| K53 | Relay | AB3 4 B |
| K79 | Relay, Prevent Start Engine | DN5 2 B |
| K300 | I-Start Main Relay | AB3 4 C |

VOLVO

Volvo Bus Corporation

Document title
WIRING DIAGRAM

Document type
PRODUCT SCHEMATICS

Document No
22610880

Issue
11

Volume
03(03)

Sheet No
9(38)

| COMPONENT | DESCRIPTION | PAGE |
|-----------|---|---------|
| K400 | I-Start +30 Relay (Body) | AB4 2 B |
| K401 | Relay Seat Haptic 12V | BE 2 B |
| K402 | Relay Seat Haptic 24V | BE 3 B |
| K902 | Relay heated hose pressure line | CU 1 D |
| K903 | Relay heated hose backflow to pump line | CU 2 D |
| K908 | Relay heated hose suction line | CU 1 D |
| K909 | Relay heated hose backflow to tank line | CU 2 D |
| K911 | Relay, DRL Light | GE 1 B |
| K918 | Relay, 12V Gearbox, OBD and NOx sensor | AB 2 B |
| K919 | Relay, 12V Allison | AB 3 B |
| K920 | Relay, 12V EMS Main Fuse | AB 2 B |
| M01 | Motor, windscreen wiper | GM 3 D |
| M02 | Motor, windscreen washer pump | GM 1 C |
| M03 | Motor, headlamp high pressure washer pum | GM 0 C |
| NX903 | I-Start Front Fuse Box | AB2 0 B |
| NX903 | I-Start Front Fuse Box | AB3 1 B |
| NX904 | I-Start Rear Fuse BOX | AB2 3 B |
| OBD | ON BOARD DIAGNOSTIC CONNECTOR | NA2 3 C |
| OBD2 | On Board Diagnostic | NA2 0 C |
| OBD2 | On Board Diagnostic | XN 2 C |
| R01 | Heater, engine preheat | AB5 2 C |
| R02 | Heater, rear view mirror | GB 0 C |
| R08 | Termination resistor, CAN-bus | XC 1 A |
| R13 | Resistor, Termination FMS-CAN ELD | XK 2 C |
| R82 | Active Safety OBD2 Subnet | XN 1 C |
| R83 | Active Safety OBD2 Subnet | XN 3 C |
| R89 | Resistor FCW LED, Pull-up | BE 4 D |
| R91 | Resistor, VDS-CAN (Front Active Steering) | XO 3 B |
| R904 | Resistor DBUS | XE 4 C |
| R905 | Heated Hose Suction Line | CU 1 D |
| R905_US | suction_line | CX 1 E |
| R906 | Heated Hose Pressure Line | CU 1 D |
| R906_US | Pressure_line | CX 1 E |
| R907 | 1939-7 resistor | XF 4 D |
| R908 | Heated Hose Backflow to tank | CU 2 D |
| R909 | Heated Filter | CU 0 D |
| R910 | Heated Hose Backflow to pump_DNOX2 | CU 2 D |
| R918 | Termination resistor 120ohm | XG 4 D |
| RL1A | Rear light, R | GA 2 D |
| RL2A | Rear light, L | GA 0 D |
| S01 | Switch, main lighting, selector type | GB 0 B |
| S02 | Stalk switch, full- / dipped beams | BA 2 B |
| S02 | Stalk switch, full- / dipped beams | GB 2 B |
| S06 | Stalk switch, windscreen wiper, selector | GM 4 B |
| S06 | Stalk switch, windscreen wiper, selector | NA 2 D |
| S08 | Switch, differential gear lock, rear whee | EO 1 B |
| S11 | Switch, bogie lift, selector type | FA 2 C |
| S12 | Switch, battery main switch | AA 0 C |
| S14A | Switch, push button, horn | IS 2 E |
| S14B | Switch, push button, horn | IS 2 E |
| S15A | Switch, Starter Key | AA 1 B |
| S15B | Switch, Starter Feed | AA 1 D |
| S16 | Switch, push button, air horn | IS 2 E |
| S20 | Dynafleet Switch | NC 1 C |

VOLVO

Volvo Bus Corporation

Document title
WIRING DIAGRAM

Document type
PRODUCT SCHEMATICS

| | | | |
|-----------------|-----------|---------------|---------------|
| Document No | Issue | Volume | Sheet No |
| 22610880 | 11 | 03(03) | 10(38) |

| COMPONENT | DESCRIPTION | PAGE |
|-----------|---|---------|
| S24 | Stalk switch, retarder, selector type | BA 3 B |
| S31 | Switch, TCS (Traction Control System) | EP 3 D |
| S32 | Switch, brake hold | EP 4 B |
| S34 | Switch unit, steering wheel push buttons | IU 3 B |
| S41 | Switch, battery main switch control | AB2 1 C |
| S45 | Position switch, differential gear lock i | EP 3 C |
| S50 | Switch, pressure parking brake indicator, | BA 2 D |
| S58 | Position switch, clutch pedal, NO. | BA 2 C |
| S68 | Sensor coolant level | CS 0 A |
| S68_13 | Sensor Coolant level | CS 0 A |
| S70 | Position switch, flow sensor, power-steer | BB 4 C |
| S77 | Switch, emergency call | TL 1 B |
| S90 | Battery Switch | AB3 1 C |
| S202 | Switch, LDWS, (Lane Departure Warning Sy | BE 3 E |
| S348 | Switch AEBS (Advanced Emergency Braking S | BE 3 E |
| S467 | Switch, Dependent Ride Height | FB2 1 D |
| S901 | eng_stop_rear | AA 3 D |
| S902 | Switch,raise/lower | FA 4 C |
| S904 | Switch,emergency cut-out | AA 0 B |
| S905 | Switch,Retarder | BA 4 E |
| S907 | eng_start_rear | AA 3 D |
| S908 | eng_start_enable_rear | AA 3 D |
| S915 | Switch,kneeling | FA 1 B |
| S925 | Switch, Alcolock | ND 1 B |
| Se32 | Allison Turbine Speed Sensor | DN5 0 E |
| Se34 | Allison Output Speed Sensor | DN5 1 E |
| Se35 | Allison Output Speed Sensor | DN5 1 E |
| T900 | DC converter temperature sensor | AC 2 D |
| U03 | Modulator, EBS, rear axle | EO 3 C |
| U04 | Modulator, EBS, 3:rd axle | EP 1 C |
| U06 | Voltage converter | IU 0 B |
| U08 | Modulator,EBS,front | EO 2 C |
| U12 | Voltage converter, Bi-xenon | GE 2 C |
| U25 | Voltage converter, DC/DC | AC 2 B |
| V03 | Diod, Light | GE 1 C |
| V04 | Diod, Light | GE 2 C |
| X701 | I-Start Media Bracket (Chassis) | AB3 2 C |
| X801 | I-Start Media Bracket (Body) | AB4 2 B |
| X901 | Connector Battery + | AB2 3 E |
| X905 | VPDU Rear without preheat relay | AB4 2 B |
| X910 | Junction Box for Chassis | AB2 0 D |
| Y02 | Solenoid valve, diff. lock, rear wheels | EP 3 C |
| Y25 | Solenoid valve unit, level control, air s | FA 0 C |
| Y36 | Solenoid valve, steerable axle | BB 4 C |
| Y37 | Solenoid valve AVU, engine brake / EPG (E | CS 3 B |
| Y40 | Solenoid valve unit, front axle, air susp | FA 1 C |
| Y72 | Valve, Horn | IS 2 B |
| Y186 | Extension Valve Unit (EVU) | DN6 1 D |
| Y900 | solenoid valve unit, ECS, Bogie axle | FA 3 C |
| Y901 | Fuel cut off valve front axle | BA 1 C |
| Y911 | Sol-valve-inj-SCRT | CU 2 A |
| Y911_10 | sol valve DEF inj. | CX 2 E |
| Y912 | Sol-valve-water-heating-SCRT | CU 0 D |
| Y912_US | Sol_Valve_Heating_Urea_Tank | CX 2 D |

VOLVO

Volvo Bus Corporation

Document title
WIRING DIAGRAM

Document type
PRODUCT SCHEMATICS

| | | | |
|-----------------|-----------|---------------|---------------|
| Document No | Issue | Volume | Sheet No |
| 22610880 | 11 | 03(03) | 11(38) |

| COMPONENT | DESCRIPTION | PAGE |
|-----------|-------------------------------|--------|
| Y914 | Pressure control valve(PCU/R) | EP 0 B |
| Y915 | Pressure control valve(PCU/L) | EP 0 B |
| Y939 | Solenoid Valve AHI | BA 2 E |

VOLVO

Volvo Bus Corporation

Document title
WIRING DIAGRAM

Document type
PRODUCT SCHEMATICS

| Document No | Issue | Volume | Sheet No |
|-----------------|-----------|---------------|---------------|
| 22610880 | 11 | 03(03) | 12(38) |

INLINES

| INLINE | PAGE |
|--------------|---------|
| +30:1 | AB2 2 A |
| +30:1 | AB3 3 A |
| +30_FEED_B:1 | FC2 2 A |
| +B:1 | AB2 0 A |
| +B:1 | AB3 1 A |
| +B:1 | TL 2 A |
| A19:1 | DN 0 D |
| A19:2 | DN 1 D |
| A19:3 | DN 1 D |
| A19:4 | DN 1 D |
| A19:5 | DN 1 D |
| A19:6 | DN 1 D |
| A19:11 | DN 2 D |
| A19:12 | DN 2 D |
| A19:15 | DN 2 D |
| A19:16 | DN 2 D |
| A19_:1 | DN2 3 B |
| A19_:2 | DN2 3 B |
| A19_:3 | DN2 3 B |
| A19_:4 | DN2 3 B |
| A19_:5 | DN2 3 B |
| A19_:6 | DN2 3 B |
| A19_:7 | DN2 3 B |
| A19_:8 | DN2 3 B |
| A19_:9 | DN2 4 B |
| A19_:10 | DN2 4 B |
| A19_:11 | DN2 4 B |
| A19_:12 | DN2 4 B |
| A80.BY:1 | BA 2 D |
| A80.BY:3 | BA 2 D |
| A80.BY:4 | BA 3 E |
| ACC:1 | NE 1 B |
| ACC:1 | TL 2 B |
| ACC:2 | XC 2 B |
| ACC:3 | XC 2 B |
| ACC:4 | XD 2 A |
| ACC:5 | XD 2 A |
| ACC:6 | ZC 3 D |
| ACC:9 | NE 1 B |
| ACC:9 | TL 0 B |
| ACM:1 | NB 0 B |
| ACM:2 | AB2 1 B |
| ACM:3 | AC 3 A |
| ARTIC:1 | FB 3 B |
| ARTIC:2 | FB 4 B |
| ARTIC:3 | XG 2 C |
| ARTIC:4 | XG 2 C |
| ARTIC:5 | BC 1 B |
| ARTIC:6 | BC 1 B |
| ARTIC:7 | BC 1 B |
| ARTIC:8 | BC 1 B |
| ARTIC:9 | BC 2 B |
| ARTIC:10 | BC 0 B |
| ARTIC:11 | BC 2 B |

VOLVO

Volvo Bus Corporation

Document title
WIRING DIAGRAM

Document type
PRODUCT SCHEMATICS

| | | | |
|--------------------------------|--------------------|-------------------------|---------------------------|
| Document No 22610880 | Issue 11 | Volume 03(03) | Sheet No 13(38) |
|--------------------------------|--------------------|-------------------------|---------------------------|

| INLINE | PAGE |
|---------------|---------|
| ARTIC:12 | BC 2 B |
| AUDIO:1 | XJ 3 B |
| AUDIO:1 | XJ2 3 B |
| AUDIO:1 | XJ2 3 D |
| AUDIO:2 | XJ 3 B |
| AUDIO:2 | XJ2 3 B |
| AUDIO:2 | XJ2 3 D |
| AUDIO:3 | IU 3 B |
| B+ FEED_B:1:1 | CU 4 A |
| BB1:1 | BA 0 D |
| BB1:2 | BC 3 B |
| BB1:3 | BC 3 B |
| BB1:4 | BC 2 B |
| BB1:5 | BB 2 C |
| BB1:6 | NA 2 D |
| BB1:8 | NA 2 D |
| BB1:9 | NA 2 D |
| BB1:10 | BB 3 B |
| BB1:11 | BA 1 E |
| BB1:12 | BC 3 B |
| BB2:1 | NA 2 D |
| BB2:2 | NA 1 D |
| BB2:3 | NA 2 D |
| BB2:4 | NA 1 D |
| BB2:5 | XE 3 E |
| BB2:6 | XE 4 E |
| BB2:7 | IS 2 C |
| BB2:8 | IS 2 B |
| BB2:9 | IS 2 C |
| BB2:10 | GB 2 B |
| BB2:11 | AA 0 C |
| BB2:12 | NB 1 A |
| BB3:1 | GB 2 B |
| BB3:2 | BC 3 B |
| BB3:3 | FA 1 B |
| BB3:4 | FB 2 B |
| BB3:5 | GB 2 B |
| BB3:6 | GB 0 D |
| BB3:7 | NA 2 D |
| BB3:8 | NA 3 D |
| BB3:9 | AF 0 B |
| BB3:10 | BA 1 D |
| BB3:11 | BB 1 B |
| BB3:12 | BB 1 B |
| BB4:1 | BC 3 B |
| BB4:2 | BC 3 B |
| BB4:3 | BC 3 B |
| BB4:4 | BC 3 B |
| BB4:5 | BC 3 B |
| BB4:6 | BC 2 B |
| BB4:7 | EP 2 B |
| BB4:8 | BA 0 E |
| BB4:9 | NA 3 D |
| BB4:10 | BA 0 D |

VOLVO

Volvo Bus Corporation

Document title

WIRING DIAGRAM

Document type

PRODUCT SCHEMATICS

Document No

22610880

Issue

11

Volume

03(03)

Sheet No

14(38)

| INLINE | PAGE |
|---------|--------|
| BB4:11 | GB 3 B |
| BB4:11 | TL 1 B |
| BB5:1 | GB 2 D |
| BB5:2 | GB 2 D |
| BB5:3 | GB 1 D |
| BB5:4 | GB 3 D |
| BB5:6 | GB 4 C |
| BB5:7 | GB 1 D |
| BB5:8 | GB 3 D |
| BB5:9 | GE 1 B |
| BB5:10 | GE 2 B |
| BB5:11 | GB 1 D |
| BB5:12 | GB 3 D |
| BB6:1 | BC 2 B |
| BB6:2 | GA 1 B |
| BB6:3 | CL 3 D |
| BB6:4 | GA 2 A |
| BB6:5 | BB 2 C |
| BB6:6 | BB 2 C |
| BB6:12 | GA 1 C |
| BB7:1 | GA 2 C |
| BB7:2 | GA 0 C |
| BB7:3 | GA 0 C |
| BB7:4 | GA 2 C |
| BB7:5 | GA 1 C |
| BB7:6 | GA 1 D |
| BB7:7 | GA 0 C |
| BB7:8 | GA 2 C |
| BB7:9 | GA 3 C |
| BB7:10 | GA 3 C |
| BB7:11 | GA 0 C |
| BB7:12 | GA 1 C |
| BB8:1 | GB 1 E |
| BB8:2 | GB 3 D |
| BB8:3 | GB 4 B |
| BB10A:1 | IU 1 E |
| BB10A:3 | IU 1 B |
| BB10A:5 | IU 1 B |
| BB10A:7 | IU 0 B |
| BB10A:9 | IU 1 E |
| BB10B:1 | IU 1 E |
| BB10B:3 | IU 1 B |
| BB10B:5 | IU 1 B |
| BB10B:7 | IU 0 B |
| BB10B:9 | IU 1 E |
| BB11:1 | GB 0 D |
| BB11:2 | BE 3 C |
| BB11:3 | BE 3 C |
| BB12:1 | GE 3 C |
| BB12:2 | GE 3 C |
| BB12:3 | GB 4 D |
| BB12:4 | GB 4 D |
| BB12:5 | GB 1 C |
| BB13:1 | BC 0 B |

VOLVO

Volvo Bus Corporation

Document title
WIRING DIAGRAM

Document type
PRODUCT SCHEMATICS

Document No
22610880

Issue
11

Volume
03(03)

Sheet No
15(38)

| INLINE | PAGE |
|----------|---------|
| BB13:2 | CL 1 B |
| BB13:3 | CL 1 B |
| BB13:4 | FB2 1 C |
| BB13:4 | FB2 3 C |
| BB13:5 | BC 0 B |
| BB13:6 | CL 2 D |
| BB13:7 | CL 2 D |
| BB13:12 | BA 3 D |
| BB13:16 | NA 0 B |
| BB13:16 | NF 2 B |
| BBOX:1 | AB2 1 B |
| BBOX:2 | AB2 1 B |
| BBOX:3 | NB 0 A |
| BFEED:1 | CU 0 A |
| BIO:1 | CL 1 B |
| BIO:2 | XD 4 D |
| BIO:3 | XD 4 D |
| BIO:4 | XE 1 A |
| BIO:4 | XE 1 A |
| BIO:5 | XE 1 B |
| BIO:5 | XE 1 B |
| BIO:6 | XE 3 D |
| BIO:6 | XE 4 C |
| BIO:7 | XE 4 D |
| BIO:7 | XE 4 D |
| BIO:9 | CL 1 B |
| BIO:10 | ZC 4 D |
| BIO_J:4 | XE 2 B |
| BIO_J:5 | XE 1 B |
| BIO_J:6 | XE 3 D |
| BIO_J:7 | XE 4 D |
| BMUX_1:1 | XD 1 B |
| BMUX_1:2 | XD 1 B |
| BMUX_1:3 | AA 0 B |
| BMUX_1:4 | AA 0 C |
| BMUX_1:5 | AA 0 B |
| BOGIE:1 | FB 1 B |
| BOGIE:2 | FB 1 B |
| BOGIE:3 | FA 3 D |
| BOGIE:4 | FA 3 D |
| BOGIE:5 | FA 3 D |
| BOGIE:6 | EP 1 B |
| BOGIE:7 | EP 1 B |
| BOGIE:8 | EP 1 B |
| BOGIE:9 | EP 1 B |
| BOGIE:10 | ZC 1 D |
| BOGIE:11 | BB 4 C |
| BOGIE:12 | BB 4 C |
| BS1:2 | EO 2 D |
| BS1:3 | EO 2 D |
| BS1:4 | EO 2 D |
| BS1:5 | EO 2 D |
| BS1:8 | EP 0 B |
| BS1:9 | EP 0 B |

VOLVO

Volvo Bus Corporation

Document title
WIRING DIAGRAM

Document type
PRODUCT SCHEMATICS

| | | | |
|--------------------------------|--------------------|-------------------------|---------------------------|
| Document No 22610880 | Issue 11 | Volume 03(03) | Sheet No 16(38) |
|--------------------------------|--------------------|-------------------------|---------------------------|

| INLINE | PAGE |
|------------|-----------|
| BS1:10 | EP 0 B |
| BS1:11 | EP 0 B |
| BS1:12 | EP 0 B |
| BS2:2 | EP 3 B |
| BS2:3 | EP 2 B |
| BS2:5 | EP 3 C |
| BS2:6 | EP 3 C |
| BS3:1 | EO 3 D |
| BS3:2 | EO 3 D |
| BS3:3 | EO 3 D |
| BS3:4 | EO 3 D |
| BS3:5 | EP 3 B |
| BS3:6 | EP 3 B |
| BS3:7 | EP 3 D |
| BS3:8 | NA 3 B |
| BS3:9 | BB 3 D |
| BS3:10 | BA 4 C |
| BS3:11 | BA 4 C |
| BS3:12 | BA 4 C |
| DBUS_INT:1 | XE 4 B |
| DBUS_INT:2 | XE 4 B |
| DF:1 | NC 2 B |
| DF:2 | NC 1 C |
| DF:3 | NC 0 C |
| DF:4 | XD 1 B |
| DF:5 | XD 1 B |
| DF:6 | NC 2 B |
| DF:11 | NC 1 E |
| DPF10:A | XH1-1 2 C |
| DPF10:A | XH1-2 3 C |
| DPF10:B | XH1-1 2 B |
| DPF10:B | XH1-2 2 A |
| DPF10:C | XH1-1 3 C |
| DPF10:C | XH1-2 3 C |
| DPF10:D | XH1-1 3 D |
| DPF10:D | XH1-2 3 C |
| DPF10:E | CX 2 A |
| DPF10:F | BB 0 B |
| DPF10:G | BB 0 B |
| DPF10:J | CX 2 B |
| DPF10:K | CX 2 B |
| DPF10:L | CX 2 D |
| DPF10:M | CX 2 D |
| DPF10:N | XH1-1 2 C |
| DPF10:N | XH1-2 2 C |
| DPF10:P | XH1-1 2 C |
| DPF10:P | XH1-2 2 C |
| DPF10:R | CX 3 B |
| DPF10:S | CX 3 C |
| ECS1:1 | FA 1 D |
| ECS1:2 | FA 1 D |
| ECS1:3 | FA 0 D |
| ECS1:5 | FB 0 B |
| ECS1:6 | FB 2 B |

VOLVO

Volvo Bus Corporation

Document title
WIRING DIAGRAM

Document type
PRODUCT SCHEMATICS

| | | | |
|--------------------------------|--------------------|-------------------------|---------------------------|
| Document No 22610880 | Issue 11 | Volume 03(03) | Sheet No 17(38) |
|--------------------------------|--------------------|-------------------------|---------------------------|

| INLINE | PAGE |
|---------|---------|
| ECS1:7 | FB 3 B |
| ECS1:8 | FB 0 B |
| ECS1:9 | FB 0 B |
| ECS1:10 | FB 3 B |
| ECS1:11 | FB 3 B |
| ECS1:12 | FA 1 C |
| ECS2:1 | FA 0 D |
| ECS2:2 | FA 0 D |
| ECS2:3 | FA 0 D |
| ECS2:4 | FB 0 B |
| ECS2:5 | FB 1 B |
| ECS2:6 | FB 2 B |
| ECS2:7 | FB 2 B |
| ECS2:8 | FB 0 B |
| ECS2:9 | FB 0 B |
| ECS2:10 | FB 3 B |
| ECS2:11 | FB 2 B |
| ECS2:12 | FA 0 B |
| EMS:1 | BA 0 D |
| EMS:2 | XC 3 D |
| EMS:3 | XC 3 C |
| EMS:4 | XD 3 C |
| EMS:5 | XD 3 C |
| EMS:6 | BA 1 B |
| EMS:7 | BA 1 B |
| EMS:9 | BA 1 B |
| EMS:10 | ZC 1 D |
| EMS:11 | BB 3 C |
| ENG1:2 | AA 2 D |
| ENG1:3 | BB 0 D |
| ENG1:4 | AA 3 D |
| ENG1:5 | BB 0 B |
| ENG1:6 | AA 3 C |
| ENG1:7 | AF 0 C |
| ENG1:8 | AF 0 B |
| ENG1:9 | AF 3 B |
| ENG1:10 | NA2 0 E |
| ENG1:11 | NA 0 B |
| ENG1:12 | ZC 1 D |
| EU4:1 | AB 3 B |
| EU4:4 | EO 3 D |
| EU4:5 | EO 4 D |
| EU4:6 | EO 4 D |
| EU4:7 | EO 4 D |
| EU4:8 | BA 0 B |
| EU4:10 | CU 0 B |
| EU4:11 | XF 3 C |
| EU4:12 | XF 3 C |
| FEED:1 | BA 0 A |
| FH1A:1 | DN 2 B |
| FH1A:2 | DN 2 B |
| FH1A:3 | DN 2 A |
| FH1A:6 | IS 2 A |
| FH1A:7 | FA 4 A |

VOLVO

Volvo Bus Corporation

Document title
WIRING DIAGRAM

Document type
PRODUCT SCHEMATICS

| | | | |
|--------------------------------|--------------------|-------------------------|---------------------------|
| Document No 22610880 | Issue 11 | Volume 03(03) | Sheet No 18(38) |
|--------------------------------|--------------------|-------------------------|---------------------------|

| INLINE | PAGE |
|---------|--------|
| FH1A:8 | EO 0 A |
| FH1A:10 | NA 3 A |
| FH1B:1 | BA 0 A |
| FH1B:2 | BA 0 A |
| FH1B:3 | BA 0 A |
| FH1B:4 | AA 3 A |
| FH1B:6 | BB 0 A |
| FH1B:7 | BB 0 A |
| FH1B:8 | AB 3 B |
| FH1B:10 | NC 1 B |
| FH1B:10 | TL 0 B |
| FH1B:11 | BB 1 A |
| FH2A:1 | GM 2 A |
| FH2A:3 | NE 1 A |
| FH2A:3 | TL 2 B |
| FH2A:4 | EO 0 A |
| FH2A:5 | AA 2 B |
| FH2A:6 | NA 3 A |
| FH2A:7 | AF 0 A |
| FH2A:8 | AF 3 A |
| FH2A:9 | FA 4 A |
| FH2B:1 | BB 1 A |
| FH2B:3 | NA 0 A |
| FH2B:4 | DN 1 A |
| FH2B:5 | AA 2 A |
| FH2B:6 | NB 0 A |
| FH2B:8 | FA 4 A |
| FH2B:9 | GM 1 A |
| FH3A:1 | BA 1 A |
| FH3A:2 | BA 1 A |
| FH3A:3 | BA 1 A |
| FH3A:4 | GA 2 A |
| FH3A:5 | BB 4 A |
| FH3A:7 | NA 0 A |
| FH3A:7 | NF 2 B |
| FH3A:8 | BB 2 A |
| FH3A:12 | IU 0 A |
| FH3B:1 | CL 3 B |
| FH3B:2 | CL 3 B |
| FH3B:3 | CL 3 B |
| FH3B:4 | AA 0 A |
| FH3B:5 | GA 2 A |
| FH3B:7 | CL 1 A |
| FH3B:9 | GA 1 A |
| FH3B:10 | BE 3 A |
| FH4A:2 | CU 0 B |
| FH4A:3 | CU 0 A |
| FH4A:4 | AA 3 A |
| FH4A:5 | GA 1 A |
| FH4A:7 | NA 3 A |
| FH4A:8 | GA 1 A |
| FH4A:12 | GA 0 A |
| FH4B:1 | GA 3 B |
| FH4B:2 | GA 3 B |

VOLVO

Volvo Bus Corporation

Document title
WIRING DIAGRAM

Document type
PRODUCT SCHEMATICS

| | | | |
|--------------------------------|--------------------|-------------------------|---------------------------|
| Document No 22610880 | Issue 11 | Volume 03(03) | Sheet No 19(38) |
|--------------------------------|--------------------|-------------------------|---------------------------|

| INLINE | PAGE |
|---------------|-------------|
| FH4B:3 | GA 3 B |
| FH4B:4 | IU 0 A |
| FH4B:5 | GA 0 A |
| FH4B:7 | AA 0 A |
| FH4B:8 | GA 1 A |
| FH4B:12 | GA 0 A |
| FH5:2P | FC2 2 B |
| FH5:2S | FC2 2 B |
| FH6:2P | CU 4 B |
| FH6:2S | CU 4 B |
| FL2:11 | GB 0 B |
| FL3:11 | GB 0 B |
| FTM:1 | CL 1 B |
| FTM:2 | XD 4 D |
| FTM:3 | XD 4 D |
| FTM:4 | XE 0 A |
| FTM:4 | XE 0 B |
| FTM:5 | XE 0 B |
| FTM:5 | XE 0 B |
| FTM:6 | XE 1 A |
| FTM:6 | XE 1 B |
| FTM:7 | XE 1 B |
| FTM:7 | XE 1 B |
| FTM:9 | AA 2 B |
| FTM:10 | ZC 4 D |
| FTM_J:4 | XE 0 A |
| FTM_J:5 | XE 0 B |
| FTM_J:6 | XE 1 A |
| FTM_J:7 | XE 1 B |
| FUEL:1 | NA 1 E |
| FUEL:2 | NA 1 E |
| FUEL:3 | NA 1 D |
| FUEL:5 | BA 1 B |
| FUEL:6 | BA 1 C |
| FUEL:7 | FA 1 D |
| FUEL:8 | FA 2 D |
| FUEL:9 | FA 1 B |
| FUEL:10 | FB 4 B |
| FUEL:11 | FB 2 B |
| GBX:1 | DN4 2 A |
| GBX:1 | ZC 3 C |
| GBX:2 | DN 2 B |
| GBX:7 | XC 4 D |
| GBX:8 | XC 4 D |
| GBX:9 | XD 3 D |
| GBX:10 | XD 3 D |
| GBX:13 | NA 1 B |
| GBX:17 | BA 2 D |
| GBX:18 | BA 2 D |
| GIC:1 | DN6 2 B |
| GIC:2 | DN6 1 B |
| GIC:3 | DN6 1 B |
| GIC:4 | DN6 2 B |
| GIC:5 | DN6 1 B |

VOLVO

Volvo Bus Corporation

Document title
WIRING DIAGRAM

Document type
PRODUCT SCHEMATICS

| | | | |
|--------------------------------|--------------------|-------------------------|---------------------------|
| Document No 22610880 | Issue 11 | Volume 03(03) | Sheet No 20(38) |
|--------------------------------|--------------------|-------------------------|---------------------------|

| INLINE | PAGE |
|---------------|-------------|
| GIC:6 | DN6 1 B |
| GIC:7 | DN6 3 B |
| GIC:12 | CZ 3 B |
| GIC:13 | DN6 1 B |
| GIC:15 | CZ 3 B |
| GIC:16 | DN6 3 B |
| GIC:21 | CZ 3 B |
| GIC:23 | CZ 3 B |
| GIC:24 | DN6 3 B |
| GIC:26 | DN6 3 B |
| GIC:27 | CZ 4 B |
| GIC:28 | CZ 3 B |
| GIC:29 | CZ 4 B |
| GIC:35 | CZ 3 B |
| GIC:39 | DN6 2 B |
| IB1:1 | NA 3 B |
| IB1:2 | NA 2 D |
| IB1:3 | NA 3 D |
| IB1:4 | NA 2 D |
| IB1:5 | NA 3 D |
| IB1:6 | NA 2 D |
| IB1:7 | NA 3 B |
| IB1:8 | NA 2 C |
| IB1:9 | AF 2 B |
| IB1:10 | AF 3 B |
| IB1:11 | NA 2 C |
| IB1:12 | NA 1 C |
| IB1:13 | NA 1 C |
| IB1:14 | XC 1 B |
| IB1:15 | XC 1 B |
| IB1:16 | XD 2 A |
| IB1:17 | XD 2 A |
| IB1:18 | NA 3 B |
| IB2:1 | NA 2 D |
| IB2:2 | NA 2 D |
| IB2:3 | NA 2 D |
| IB2:4 | NA 2 D |
| IB2:5 | NA 1 B |
| IB2:6 | NA 1 D |
| IB2:7 | GA 3 B |
| IB2:8 | ZC 0 D |
| IB2:9 | GA 2 B |
| IB2:11 | IS 2 D |
| IB2:12 | IS 2 D |
| IB2:13 | EP 2 C |
| IB2:14 | EP 2 C |
| IB2:15 | EP 2 C |
| IB2:16 | EP 2 C |
| IB2:17 | AA 1 B |
| IB2:18 | NC 1 B |
| IB3:1 | BA 3 C |
| IB3:2 | BA 3 C |
| IB3:3 | BA 3 C |
| IB3:4 | BA 3 C |

VOLVO

Volvo Bus Corporation

Document title
WIRING DIAGRAM

Document type
PRODUCT SCHEMATICS

| | | | |
|--------------------------------|--------------------|-------------------------|---------------------------|
| Document No 22610880 | Issue 11 | Volume 03(03) | Sheet No 21(38) |
|--------------------------------|--------------------|-------------------------|---------------------------|

| INLINE | PAGE |
|--------|---------|
| IB3:5 | BA 3 C |
| IB3:6 | BA 3 D |
| IB3:7 | BA 2 C |
| IB3:8 | BA 2 C |
| IB3:9 | BA 1 C |
| IB3:10 | BA 2 C |
| IB3:11 | BA 1 C |
| IB3:12 | BA 1 C |
| IB3:13 | BA 3 C |
| IB3:14 | IU 0 A |
| IB3:15 | IU 0 A |
| IB3:16 | IU 0 B |
| IB3:17 | FA 4 B |
| IB3:18 | ZC 0 D |
| IB4:1 | GB 2 B |
| IB4:2 | GB 2 B |
| IB4:3 | GB 0 B |
| IB4:4 | GB 1 B |
| IB4:5 | GB 1 B |
| IB4:6 | GA 1 C |
| IB4:7 | GB 1 B |
| IB4:8 | GB 1 B |
| IB4:9 | GB 1 B |
| IB4:10 | GB 3 C |
| IB4:11 | GB 3 C |
| IB4:12 | GB 3 C |
| IB4:13 | GB 3 C |
| IB4:14 | GB 3 B |
| IB4:15 | EP 4 B |
| IB4:16 | EP 4 B |
| IB4:17 | EP 3 B |
| IB4:18 | EP 3 B |
| IB5:2 | AA 2 B |
| IB5:4 | AA 1 C |
| IB5:5 | AA 0 B |
| IB5:6 | AA 0 D |
| IB5:7 | AA 0 C |
| IB5:8 | FA 1 B |
| IB5:9 | FA 2 D |
| IB5:10 | NA2 0 D |
| IB5:11 | FA 1 C |
| IB5:12 | FA 1 C |
| IB5:13 | AA 1 B |
| IB5:14 | FA 3 D |
| IB5:15 | FA 3 D |
| IB5:16 | FA 2 D |
| IB5:17 | EO 1 C |
| IB5:18 | NA 1 C |
| IB6:1 | NB 0 B |
| IB6:2 | XJ 1 B |
| IB6:2 | XJ2 0 A |
| IB6:2 | XJ2 0 C |
| IB6:3 | XJ 1 B |
| IB6:3 | XJ2 0 D |

VOLVO

Volvo Bus Corporation

Document title
WIRING DIAGRAM

Document type
PRODUCT SCHEMATICS

| | | | |
|--------------------------------|--------------------|-------------------------|---------------------------|
| Document No 22610880 | Issue 11 | Volume 03(03) | Sheet No 22(38) |
|--------------------------------|--------------------|-------------------------|---------------------------|

| INLINE | PAGE |
|-----------|---------|
| IB6:3 | XJ2 0 A |
| IB6:4 | NB 0 B |
| IB6:5 | ZC 0 D |
| IB6:6 | NB 1 B |
| IB6:7 | NB 1 C |
| IB6:8 | NB 1 C |
| IB6:9 | NB 1 C |
| IB6:10 | NB 1 C |
| IB6:12 | NB 2 C |
| IB7:1 | GM 1 B |
| IB7:2 | GB 4 C |
| IB7:3 | GB 4 C |
| IB7:4 | GM 3 B |
| IB7:5 | XF 4 C |
| IB7:6 | XF 4 C |
| IB7:7 | NA 3 C |
| IB7:8 | GM 3 B |
| IB7:10 | ZC 0 D |
| IB7:11 | NA 2 D |
| IB7:12 | GM 4 B |
| IB8:1 | EO 0 D |
| IB8:2 | EO 0 D |
| IB8:3 | EO 1 D |
| IB8:4 | EO 0 D |
| IB8:5 | EO 0 D |
| IB8:7 | GB 3 B |
| IB8:8 | CL 2 D |
| IB8:9 | CL 2 D |
| IB8:10 | CL 2 D |
| IB8:11 | CL 1 B |
| IB8:12 | CL 1 B |
| IB9:1 | BA 2 D |
| IB9:2 | BA 2 C |
| IB9:3 | GE 2 B |
| IB9:4 | ZC 0 D |
| IB9:5 | GE 1 C |
| IB9:6 | GA 1 D |
| IB9:8 | BA 2 C |
| IB9:9 | BA 2 C |
| IB9:10 | BA 2 C |
| IB9:11 | BA 3 C |
| IB9:12 | BA 2 C |
| IB10:1 | DN 1 B |
| IB10:2 | GA 3 B |
| IB10:3 | BB 1 D |
| IB10:8 | DN 1 B |
| IB10:9 | ZC 3 D |
| IB10:10 | DN 1 B |
| IB10_I:1 | DN 1 B |
| IB10_I:8 | DN 1 B |
| IB10_I:10 | DN 1 B |
| IS:1 | XD 1 A |
| IS:2 | XD 1 A |
| IS:3 | XC 1 B |

VOLVO

Volvo Bus Corporation

Document title
WIRING DIAGRAM

Document type
PRODUCT SCHEMATICS

| | | | |
|--------------------------------|--------------------|-------------------------|---------------------------|
| Document No 22610880 | Issue 11 | Volume 03(03) | Sheet No 23(38) |
|--------------------------------|--------------------|-------------------------|---------------------------|

| INLINE | PAGE |
|---------|--------|
| IS:4 | XC 1 B |
| KH1A:1 | FA 4 C |
| KH1A:2 | FA 4 D |
| KH1A:3 | FA 4 D |
| KH1A:4 | CL 3 C |
| KH1A:5 | FA 4 C |
| KH1A:7 | CL 3 C |
| KH1A:10 | CL 2 C |
| KH1A:11 | CL 2 C |
| KH1B:1 | DN 1 A |
| KH1B:2 | DN 1 A |
| KH1B:3 | DN 1 A |
| KH1B:4 | BE 3 B |
| KH1B:5 | DN 1 A |
| KH1B:7 | BE 3 B |
| KH1B:8 | BE 2 B |
| KH1B:10 | BE 3 B |
| KH1B:11 | BE 3 B |
| KH1B:12 | BE 2 B |
| KH1B:14 | BE 2 B |
| KH1B:15 | BE 2 B |
| KH2A:1 | BA 1 E |
| KH2A:3 | BA 0 C |
| KH2A:4 | BA 1 D |
| KH2A:5 | BA 0 B |
| KH2A:6 | BA 0 C |
| KH2A:7 | AF 0 B |
| KH2A:8 | AF 0 B |
| KH2A:9 | BA 0 B |
| KH2A:10 | AF 0 B |
| KH2A:11 | AF 0 B |
| KH2A:12 | AF 0 B |
| KH2B:1 | AA 2 D |
| KH2B:2 | GM 2 B |
| KH2B:3 | GM 2 B |
| KH2B:4 | AA 2 D |
| KH2B:5 | GM 2 B |
| KH2B:6 | GM 2 C |
| KH2B:9 | GM 2 C |
| KH3A:1 | AA 0 B |
| KH3A:3 | AA 1 B |
| KH3A:4 | BB 2 B |
| KH3A:5 | AA 1 B |
| KH3A:6 | AA 0 B |
| KH3A:7 | BB 2 B |
| KH3A:8 | AA 2 B |
| KH3A:9 | AA 2 B |
| KH3A:10 | BB 2 B |
| KH3A:11 | BB 2 B |
| KH3A:12 | AA 2 C |
| KH3A:14 | AA 2 C |
| KH3B:1 | BB 4 B |
| KH3B:2 | BB 4 B |
| KH3B:3 | BB 4 B |

VOLVO

Volvo Bus Corporation

Document title
WIRING DIAGRAM

Document type
PRODUCT SCHEMATICS

| | | | |
|--------------------------------|--------------------|-------------------------|---------------------------|
| Document No 22610880 | Issue 11 | Volume 03(03) | Sheet No 24(38) |
|--------------------------------|--------------------|-------------------------|---------------------------|

| INLINE | PAGE |
|---------------|-------------|
| KH3B:5 | BB 4 B |
| M_01:1 | GM 4 C |
| M_01:2 | GM 4 C |
| M_01:3 | GM 3 C |
| M_01:4 | GM 3 C |
| M_01:5 | GM 4 D |
| M_01:6 | GM 1 B |
| M_01:8 | GM 1 D |
| M_01:9 | GM 1 B |
| M_01:11 | GM 1 D |
| M_01:12 | GM 1 C |
| M_01:13 | GM 0 D |
| M_01:14 | GM 1 B |
| MED:1 | XC 1 D |
| MED:2 | XD 0 C |
| MED:2 | XG 1 D |
| MED:3 | CS 0 B |
| MED:4 | XC 1 D |
| MED:5 | XD 0 C |
| MED:5 | XG 1 D |
| MED:6 | CS 0 B |
| MED:7 | CS 0 D |
| MED:8 | CS 0 B |
| MED:9 | AF 2 C |
| MED:10 | AF 3 C |
| MED:11 | DN5 1 B |
| MED:12 | AF 4 E |
| MED:13 | CS 3 B |
| MED:14 | BB 0 C |
| MED:15 | CS 3 B |
| MED:16 | BB 0 D |
| MED:17 | AF 3 C |
| MED:18 | CS 1 B |
| MED:19 | DN5 1 B |
| MED:20 | CS 2 B |
| MED:21 | CS 1 B |
| MED:22 | CS 4 D |
| MED:23 | CS 3 B |
| MED:24 | CS 2 D |
| MED:25 | CS 0 B |
| MED:26 | CS 2 B |
| MED:27 | CS 4 B |
| MED:28 | CS 0 B |
| MED:29 | CS 2 D |
| MED:30 | CS 1 D |
| MED:31 | CS 4 B |
| MED:32 | CS 2 B |
| MED:33 | CS 2 B |
| MED:34 | CS 2 B |
| MED:34 | XH1-2 0 B |
| MED:35 | AF 1 C |
| MED:36 | CS 2 B |
| MED:36 | XH1-2 0 B |
| MED:37 | CS 1 B |

VOLVO

Volvo Bus Corporation

Document title
WIRING DIAGRAM

Document type
PRODUCT SCHEMATICS

| | | | |
|--------------------------------|--------------------|-------------------------|---------------------------|
| Document No 22610880 | Issue 11 | Volume 03(03) | Sheet No 25(38) |
|--------------------------------|--------------------|-------------------------|---------------------------|

| INLINE | PAGE |
|---------|---------|
| MED:38 | DN5 2 B |
| MED:39 | CS 4 B |
| MEDA:1 | NB 1 D |
| MEDA:2 | NB 1 D |
| MEDA:3 | NB 1 D |
| MEDA:4 | NB 1 D |
| MEDA:5 | DN4 1 B |
| MEDA:5 | DN6 1 A |
| MEDA:6 | DN4 1 B |
| MEDA:6 | DN6 1 A |
| MEDA:7 | XC 2 D |
| MEDA:8 | XC 3 D |
| MEDA:9 | XD 0 D |
| MEDA:10 | XD 0 D |
| MEDA:11 | AB 2 D |
| MEDA:11 | DN4 1 B |
| MEDA:12 | DN4 2 B |
| MEDA:12 | ZC 3 B |
| ML1:1 | GB 1 E |
| ML1:2 | ZC 1 A |
| ML1:3 | GE 1 D |
| ML1:4 | ZC 1 A |
| ML1:5 | GE 1 D |
| ML1:6 | ZC 2 A |
| ML1:7 | GE 1 D |
| ML2:1 | GB 3 D |
| ML2:2 | ZC 2 A |
| ML2:3 | GE 2 D |
| ML2:4 | ZC 2 A |
| ML2:5 | GE 2 D |
| ML2:6 | ZC 2 A |
| ML2:7 | GE 2 D |
| ML3:1 | BB 3 C |
| ML3:2 | BB 2 B |
| ML3:3 | GA 3 D |
| ML3:4 | GA 4 D |
| ML3:5 | GA 4 D |
| ML3:6 | GA 1 B |
| ML3:7 | GA 4 D |
| ML4:1 | BB 2 C |
| ML4:2 | BB 2 B |
| ML4:3 | GA 3 D |
| ML4:4 | GA 3 D |
| ML4:5 | GA 3 D |
| ML4:6 | GA 2 B |
| ML4:7 | GA 3 D |
| R905A:1 | CU 1 D |
| R905A:2 | CU 1 D |
| R905B:1 | CU 1 D |
| R905B:2 | CU 1 D |
| R905C:1 | CU 1 C |
| R905C:2 | CU 1 D |
| R906A:1 | CU 1 D |
| R906A:2 | CU 1 D |

VOLVO

Volvo Bus Corporation

Document title
WIRING DIAGRAM

Document type
PRODUCT SCHEMATICS

| | | | |
|-----------------|-----------|---------------|---------------|
| Document No | Issue | Volume | Sheet No |
| 22610880 | 11 | 03(03) | 26(38) |

| INLINE | PAGE |
|---------|---------|
| R906B:1 | CU 1 D |
| R906B:2 | CU 1 D |
| R906C:1 | CU 1 C |
| R906C:2 | CU 1 D |
| R908A:1 | CU 2 D |
| R908A:2 | CU 2 D |
| R908B:1 | CU 2 D |
| R908B:2 | CU 2 D |
| R908C:1 | CU 2 C |
| R908C:2 | CU 2 D |
| R910A:1 | CU 2 D |
| R910A:2 | CU 2 D |
| R910B:1 | CU 2 D |
| R910B:2 | CU 2 D |
| R910C:1 | CU 2 C |
| R910C:2 | CU 2 D |
| RA1:1 | DN6 3 A |
| RA1:1 | NB 1 C |
| RA1:2 | DN6 3 A |
| RA1:2 | NB 1 C |
| RA1:3 | DN6 3 A |
| RA1:3 | NB 1 C |
| RA1:4 | DN6 3 A |
| RA1:4 | NB 1 C |
| RA1:5 | NA 2 B |
| RA1:6 | AF 2 B |
| RA1:7 | AF 3 B |
| RA1:8 | BA 4 C |
| RA1:9 | BA 4 C |
| RA1:10 | NA 1 B |
| RA1:11 | AB2 1 A |
| RA1:12 | BA 4 C |
| RL3:1 | GA 3 D |
| RL3:2 | GA 3 D |
| RL3:3 | GA 1 D |
| RL3:4 | GA 1 D |
| RL3:5 | GA 1 B |
| RL3:6 | GA 0 D |
| RL3:7 | GA 2 D |
| RL3:8 | BC 2 C |
| RL3:10 | GA 1 D |
| RL3:11 | GA 2 B |
| RL3:12 | ZC 2 A |
| RL4:1 | GA 1 D |
| RL4:2 | GA 1 D |
| RL4:3 | GA 3 D |
| RL4:4 | GA 4 D |
| RL4:5 | GA 0 D |
| RL4:7 | GA 1 D |
| RL:1 | GB 0 C |
| RL:3 | GB 0 C |
| RL_DA:1 | GB 0 D |
| RL_DB:1 | GB 0 B |
| S_T_S:1 | NB 1 D |

VOLVO

Volvo Bus Corporation

Document title
WIRING DIAGRAM

Document type
PRODUCT SCHEMATICS

| | | | |
|--------------------------------|--------------------|-------------------------|---------------------------|
| Document No 22610880 | Issue 11 | Volume 03(03) | Sheet No 27(38) |
|--------------------------------|--------------------|-------------------------|---------------------------|

| INLINE | PAGE |
|------------|--------|
| S_T_S:2 | NB 1 D |
| S_T_S:3 | NB 2 D |
| S_T_T:3 | NB 2 D |
| UDS12:1 | XF 2 D |
| UDS12:2 | XF 2 D |
| UDS12:3 | CU 1 B |
| UDS12:4 | CU 1 B |
| UDS12:5 | XD 2 D |
| UDS12:6 | XD 2 D |
| UDS12:7 | CU 0 B |
| UDS12:8 | CU 2 B |
| UDS12:9 | CU 2 B |
| UDS12:11 | CU 0 B |
| UDS12:12 | CU 4 D |
| UDS12_B:1 | XF 1 D |
| UDS12_B:2 | XF 1 D |
| UDS12_B:3 | CU 1 B |
| UDS12_B:4 | CU 1 B |
| UDS12_B:5 | XD 1 D |
| UDS12_B:6 | XD 1 D |
| UDS12_B:7 | CU 0 B |
| UDS12_B:8 | CU 2 B |
| UDS12_B:9 | CU 2 B |
| UDS12_B:11 | CU 0 B |
| UDS12_B:12 | CU 4 D |
| UDS12_F:1 | XF 3 D |
| UDS12_F:2 | XF 3 D |
| UDS12_F:3 | CU 1 B |
| UDS12_F:4 | CU 1 B |
| UDS12_F:5 | XD 2 D |
| UDS12_F:6 | XD 2 D |
| UDS12_F:7 | CU 0 B |
| UDS12_F:8 | CU 2 B |
| UDS12_F:9 | CU 2 B |
| UDS12_F:11 | CU 0 B |
| UDS12_F:12 | CU 4 D |
| UDS12_M:1 | XF 2 D |
| UDS12_M:2 | XF 2 D |
| UDS12_M:3 | CU 1 B |
| UDS12_M:4 | CU 1 B |
| UDS12_M:5 | XD 2 D |
| UDS12_M:6 | XD 2 D |
| UDS12_M:7 | CU 0 B |
| UDS12_M:8 | CU 2 B |
| UDS12_M:9 | CU 2 B |
| UDS12_M:11 | CU 0 B |
| UDS12_M:12 | CU 4 D |
| VIC:1 | XC 1 E |
| VIC:2 | CS 3 D |
| VIC:2 | XD 0 D |
| VIC:3 | CS 0 C |
| VIC:3 | CS 1 D |
| VIC:4 | XC 1 E |
| VIC:5 | CS 3 D |

VOLVO

Volvo Bus Corporation

Document title
WIRING DIAGRAM

Document type
PRODUCT SCHEMATICS

| | | | |
|--------------------------------|--------------------|-------------------------|---------------------------|
| Document No 22610880 | Issue 11 | Volume 03(03) | Sheet No 28(38) |
|--------------------------------|--------------------|-------------------------|---------------------------|

| INLINE | PAGE |
|----------|---------|
| VIC:5 | XD 0 D |
| VIC:6 | CS 0 C |
| VIC:6 | CS 1 D |
| VIC:7 | CS 0 D |
| VIC:8 | CS 0 C |
| VIC:9 | AF 2 C |
| VIC:10 | AF 3 C |
| VIC:12 | AF 3 E |
| VIC:13 | CS 3 C |
| VIC:14 | BB 0 C |
| VIC:15 | CS 3 C |
| VIC:16 | BB 0 D |
| VIC:17 | AF 3 C |
| VIC:18 | CS 1 C |
| VIC:19 | CS 3 C |
| VIC:20 | CS 2 C |
| VIC:21 | CS 1 C |
| VIC:22 | CS 4 D |
| VIC:24 | CS 2 D |
| VIC:25 | CS 0 C |
| VIC:26 | CS 2 C |
| VIC:27 | CS 4 C |
| VIC:28 | CS 0 C |
| VIC:29 | CS 2 D |
| VIC:30 | CS 1 D |
| VIC:31 | CS 4 C |
| VIC:32 | CS 2 C |
| VIC:33 | CS 2 C |
| VIC:34 | CS 2 C |
| VIC:35 | AF 1 C |
| VIC:36 | CS 2 C |
| VIC:37 | CS 1 C |
| VIC:39 | CS 4 C |
| XAL:1 | TL 0 C |
| XAL:2 | TL 1 C |
| XAL:3 | TL 0 C |
| XAL:4 | TL 1 B |
| XC022:1 | XJ2 2 A |
| XC022:1 | XJ2 2 C |
| XC022:2 | XJ2 2 C |
| XC022:2 | XJ2 2 A |
| XC022:3 | XJ2 2 A |
| XC022:3 | XJ2 2 D |
| XC022:4 | XJ2 2 A |
| XC022:4 | XJ2 2 D |
| XC094A:2 | FC2 2 C |
| XC094A:4 | CU 4 C |
| XC094A:4 | FC1 2 B |
| XC095A:1 | FC1 2 B |
| XC095A:2 | FC2 2 D |
| XC095A:3 | XO 2 B |
| XC095A:4 | XO 2 B |
| XC125:1 | XC 1 B |
| XC125:2 | XC 1 B |

VOLVO

Volvo Bus Corporation

Document title
WIRING DIAGRAM

Document type
PRODUCT SCHEMATICS

Document No
22610880

Issue
11

Volume
03(03)

Sheet No
29(38)

| INLINE | PAGE |
|-------------|---------|
| XC126:1 | XK 2 C |
| XC126:2 | XK 2 C |
| XC901:1 | NA2 4 B |
| XC901:2 | NA2 3 B |
| XC901:3 | XG 3 D |
| XC901:4 | XG 3 D |
| XC901_(2):1 | NC 3 D |
| XC901_(2):2 | NC 3 D |
| XC901_(2):3 | NC 3 C |
| XC901_(2):4 | NC 3 C |
| XC901_(2):5 | NC 3 D |
| XC901_(2):6 | NC 3 D |
| XC901_:1 | NC 3 C |
| XC901_:2 | NC 3 C |
| XC901_:3 | NC 2 C |
| XC901_:4 | NC 2 C |
| XC901_:5 | NC 3 C |
| XC901_:6 | NC 3 C |
| XC903:2 | XC 4 E |
| XC903:3 | XC 4 E |
| XC904:1 | XJ2 1 C |
| XC904:1 | XJ2 1 A |
| XC904:2 | XJ2 1 C |
| XC904:2 | XJ2 1 A |
| XC904:3 | XJ2 1 D |
| XC904:3 | XJ2 1 A |
| XC904:4 | XJ2 1 A |
| XC904:4 | XJ2 1 D |
| XC905:1 | XJ2 2 D |
| XC905:2 | XJ2 2 D |
| XC906A:1 | AB2 1 A |
| XC906A:2 | AB2 1 A |
| XC906A:3 | AB2 0 A |
| XC906A:4 | AB2 0 A |
| XC906A:5 | AB2 0 A |
| XC906A:6 | AB2 1 A |
| XC906A:7 | AC 3 B |
| XC908:3 | BA 3 D |
| XC908:4 | BA 0 E |
| XC909:1 | BE 3 B |
| XC909:2 | BE 3 B |
| XC909:3 | BE 3 B |
| XC909:4 | BE 2 B |
| XC909:5 | BE 2 B |
| XC909:6 | BE 2 B |
| XC909:7 | BE 2 B |
| XC909:8 | BE 2 B |
| XC909:9 | BE 1 B |
| XC909:10 | BE 4 B |
| XC910:1 | BE 3 B |
| XC910:2 | BE 2 B |
| XC910:3 | BE 2 B |
| XC910:4 | BE 2 B |
| XC910:5 | BE 2 B |

VOLVO

Volvo Bus Corporation

Document title
WIRING DIAGRAM

Document type
PRODUCT SCHEMATICS

| | | | |
|-----------------|-----------|---------------|---------------|
| Document No | Issue | Volume | Sheet No |
| 22610880 | 11 | 03(03) | 30(38) |

| INLINE | PAGE |
|-------------|---------|
| XC910:6 | BE 1 B |
| XC917:1 | CL 1 D |
| XC917:2 | CL 1 D |
| XC917:3 | CL 0 D |
| XC917:4 | CL 1 D |
| XC921:1 | CL 1 D |
| XC921:2 | CL 2 D |
| XC921:3 | CL 2 D |
| XC922:1 | GB 3 B |
| XC922:3 | GB 3 B |
| XC925:1 | XK 2 B |
| XC925:2 | XK 2 B |
| XC926:1 | BB 1 D |
| XC926:2 | BB 1 D |
| XC926:3 | BB 2 D |
| XC926:4 | BB 2 D |
| XC927_1/2:1 | GE 1 C |
| XC927_1/2:2 | GE 2 C |
| XC927_1:1 | GE 1 B |
| XC927_1:2 | GE 2 B |
| XC927_2:1 | GE 1 B |
| XC927_2:2 | GE 2 B |
| XC931:1 | DN5 0 D |
| XC931:2 | DN5 1 D |
| XC931:3 | DN5 1 D |
| XC931:4 | DN5 1 D |
| XC931:5 | DN5 1 D |
| XC931:6 | DN5 1 D |
| XC931:7 | DN5 1 D |
| XC931:8 | DN5 1 D |
| XC931:9 | DN5 1 D |
| XC931:10 | DN5 1 D |
| XC931:11 | DN5 2 D |
| XC931:12 | DN5 2 D |
| XC931:13 | DN5 2 D |
| XC931:14 | DN5 2 D |
| XC931:15 | DN5 2 D |
| XC931:16 | DN5 2 D |
| XC931:17 | DN5 2 D |
| XC931:18 | DN5 2 D |
| XC931:19 | DN5 2 D |
| XC931:20 | DN5 2 D |
| XC931:21 | DN5 2 D |
| XC931:22 | DN5 3 D |
| XC931:23 | DN5 2 C |
| XC931:27 | DN5 0 C |
| XC931:28 | DN5 1 C |
| XC931:29 | DN5 1 C |
| XC931:30 | DN5 1 C |
| XC931:31 | DN5 1 C |
| XC931:32 | DN5 1 C |
| XC931:33 | DN5 1 C |
| XC931:34 | DN5 1 C |
| XC931:35 | DN5 3 D |

VOLVO

Volvo Bus Corporation

Document title
WIRING DIAGRAM

Document type
PRODUCT SCHEMATICS

| | | | |
|--------------------------------|--------------------|-------------------------|---------------------------|
| Document No 22610880 | Issue 11 | Volume 03(03) | Sheet No 31(38) |
|--------------------------------|--------------------|-------------------------|---------------------------|

| INLINE | PAGE |
|---------------|-------------|
| XC931:36 | DN5 3 D |
| XC932:11 | DN5 1 D |
| XC932:12 | DN5 1 D |
| XC932:13 | DN5 0 D |
| XC932:14 | DN5 0 D |
| XC932:15 | DN5 1 D |
| XC932:16 | DN5 1 D |
| XC941:1 | ND 1 B |
| XC941:3 | ND 2 B |
| XC943:1 | XE 3 C |
| XC943:2 | XE 3 C |
| XC950:1 | AB3 4 B |
| XC950:2 | AB 3 C |
| XC950:3 | AB4 2 A |
| XC950:4 | DN5 0 A |
| XC950:5 | DN5 1 A |
| XC950:6 | DN5 1 A |
| XC951:1 | AF 2 C |
| XC951:2 | AF 3 C |
| XC951:3 | AF 3 C |
| XC951:4 | AF 3 E |
| XC999:1 | AB3 3 A |
| XC_LED:2 | TT 2 C |
| XC_LED:3 | TT 2 C |
| XC_LED:4 | TT 2 C |
| XCB604M:1 | BB 0 D |
| XCB800:1 | AB3 3 C |
| XK2:5 | GA 2 A |
| XK2:6 | GA 2 A |
| XU25:1 | AC 2 B |
| XU25:2 | AC 2 B |
| XU25:3 | AC 2 B |
| XU25:4 | AC 2 B |
| XU25:5 | AC 3 B |

VOLVO

Volvo Bus Corporation

Document title

WIRING DIAGRAM

Document type

PRODUCT SCHEMATICS

Document No

22610880

Issue

11

Volume

03(03)

Sheet No

32(38)

SPLICES

| SPLICE | PAGE |
|---------------|--------|
| BIO_J_4-6 () | XE 2 C |
| BIO_J_5-7 () | XE 2 C |
| FTM_J_4-6 () | XE 1 A |
| FTM_J_5-7 () | XE 1 B |
| XC85 () | GE 1 A |
| XCS102 () | XE 3 B |
| XSA01 () | XC 2 B |
| XSA02 () | XC 2 B |
| XSA03 () | XC 3 B |
| XSA04 () | XC 3 B |
| XSA05 () | XC 3 B |
| XSA06 () | XC 3 B |
| XSA07 () | XC 4 B |
| XSA08 () | XC 4 B |
| XSA09 () | XC 4 B |
| XSA10 () | XC 4 B |
| XSA11 () | XC 4 D |
| XSA12 () | XC 4 C |
| XSA13 () | XD 2 A |
| XSA14 () | XD 2 A |
| XSA15 () | XD 3 A |
| XSA16 () | XD 3 A |
| XSA17 () | XD 3 A |
| XSA18 () | XD 3 A |
| XSA19 () | XD 4 A |
| XSA20 () | XD 4 A |
| XSA21 () | XD 4 A |
| XSA22 () | XD 4 A |
| XSA23 () | XD 4 C |
| XSA24 () | XD 4 C |
| XSA25 () | ZC 0 E |
| XSA26 () | AA 0 D |
| XSA27 () | FA 1 B |
| XSA28 () | AA 2 C |
| XSA29 () | BA 0 D |
| XSA31 () | ZC 1 D |
| XSA34 () | AA 2 A |
| XSA35 () | ZC 3 D |
| XSA37 () | FB 3 B |
| XSA40 () | FB 2 B |
| XSA43 () | ZC 2 D |
| XSA44 () | AF 0 C |
| XSA46 () | BB 2 D |
| XSA50 () | BA 0 B |
| XSA52 () | ZC 2 C |
| XSA53 () | GM 2 B |
| XSA59 () | BA 0 C |
| XSA60 () | NA 1 D |
| XSA61 () | BA 0 B |
| XSA62 () | XD 2 A |
| XSA63 () | XC 2 B |
| XSA64 () | XC 2 B |
| XSA65 () | XD 2 A |
| XSA95 (K115) | TL 2 C |

VOLVO

Volvo Bus Corporation

Document title
WIRING DIAGRAM

Document type
PRODUCT SCHEMATICS

Document No
22610880

Issue
11

Volume
03(03)

Sheet No
33(38)

| SPLICE | PAGE |
|---------------|-------------|
| XSA97 (+B) | TL 2 C |
| XSA98 (K130) | TL 0 C |
| XSB01 () | XC 0 B |
| XSB02 () | XC 0 B |
| XSB03 () | XD 1 A |
| XSB04 () | XD 1 A |
| XSB05 () | XD 0 A |
| XSB06 () | XD 0 A |
| XSB07 () | XJ 3 C |
| XSB08 () | XJ 3 C |
| XSB09 () | ZC 0 C |
| XSB10 () | BE 3 D |
| XSB10 () | FB2 1 D |
| XSB10 () | ZC 0 B |
| XSB11 () | BE 0 D |
| XSB11 () | ZC 0 C |
| XSB12 () | GM 2 C |
| XSB13 () | GB 3 A |
| XSB15 () | GB 3 B |
| XSB18 () | IU 0 C |
| XSB19 () | IU 0 C |
| XSB20 () | FA 4 B |
| XSB21 () | IU 1 C |
| XSB22 () | NC 2 B |
| XSB24 () | NC 0 C |
| XSB25 () | AA 1 C |
| XSB26 () | NC 1 C |
| XSB28 () | XF 4 C |
| XSB29 () | XF 4 C |
| XSB30 () | IU 0 C |
| XSB31 () | IU 1 C |
| XSB32 () | XC 1 B |
| XSB33 () | XC 1 B |
| XSB34 () | NA 3 B |
| XSB36 () | NA 1 D |
| XSB37 () | ND 1 B |
| XSB38 () | XE 2 B |
| XSB39 () | XE 2 A |
| XSB40 () | NA 3 C |
| XSB43 () | XG 4 D |
| XSB44 () | XG 4 D |
| XSB45 () | XJ 1 B |
| XSB46 () | XJ 1 B |
| XSB47 () | XJ 3 B |
| XSB48 () | XJ 3 B |
| XSB49 () | BE 2 D |
| XSB49 () | XC 0 A |
| XSB50 () | BE 2 D |
| XSB50 () | XC 0 A |
| XSB51 () | NC 2 C |
| XSB52 () | NC 2 C |
| XSB55 () | XG 3 D |
| XSB56 () | XG 3 D |
| XSB70 () | XK 2 C |

VOLVO

Volvo Bus Corporation

Document title
WIRING DIAGRAM

Document type
PRODUCT SCHEMATICS

Document No
22610880

Issue
11

Volume
03(03)

Sheet No
34(38)

| SPLICE | PAGE |
|-----------------|---------|
| XSB71 () | XK 2 C |
| XSB72 () | XD 2 A |
| XSB73 () | XD 2 A |
| XSB74 () | ZC 0 B |
| XSB75 () | XC 1 B |
| XSB76 () | XC 1 B |
| XSB77 () | XE 1 D |
| XSB78 () | XE 0 D |
| XSB85 () | XG 3 D |
| XSB86 () | XG 3 D |
| XSB95 () | DN5 0 B |
| XSB112 () | DN5 1 B |
| XSB120 () | AB 3 C |
| XSC-7015_01 () | XJ2 2 C |
| XSC-7015_02 () | XJ2 1 C |
| XSC-7015_03 () | XJ2 3 A |
| XSC-7015_04 () | XJ2 3 A |
| XSC-7016_01 () | XJ2 2 D |
| XSC-7016_02 () | XJ2 1 D |
| XSC-7016_03 () | XJ2 3 A |
| XSC-7016_04 () | XJ2 3 D |
| XSC-A953 (GND) | TT 2 C |
| XSC02 () | GE 2 D |
| XSC04 () | GE 1 D |
| XSC05 () | GE 1 D |
| XSC07 () | ZC 1 B |
| XSC15 () | ZC 1 A |
| XSC16 () | GB 0 C |
| XSC17 () | ZC 1 B |
| XSC21 () | DN 1 D |
| XSC55 () | XK 2 B |
| XSC56 () | XK 2 B |
| XSC95 () | XE 4 A |
| XSC96 () | XE 4 B |
| XSC97 () | XE 3 B |
| XSC98 () | XE 3 A |
| XSC99 () | CL 1 C |
| XSC101 () | XE 3 A |
| XSC103 () | FC2 2 C |
| XSC104 () | XO 1 C |
| XSC105 () | XO 1 C |
| XSC106 () | XO 2 B |
| XSC107 () | XO 2 B |
| XSC108 () | ZC 2 C |
| XSC_BB2H_1 () | XN 1 B |
| XSC_BB2H_2 () | XN 2 B |
| XSC_BB2L_1 () | XN 1 C |
| XSC_BB2L_2 () | XN 3 C |
| XSC_BB3H_3 () | XN 2 B |
| XSC_BB3L_3 () | XN 2 C |
| XSC_SUB2H () | BE 1 C |
| XSC_SUB2L () | BE 1 C |
| XSCG-TELE (GND) | TL 1 C |
| XSCG-TELE (GND) | TT 2 C |

VOLVO

Volvo Bus Corporation

Document title
WIRING DIAGRAM

Document type
PRODUCT SCHEMATICS

| | | | |
|--------------------------------|--------------------|-------------------------|---------------------------|
| Document No 22610880 | Issue 11 | Volume 03(03) | Sheet No 35(38) |
|--------------------------------|--------------------|-------------------------|---------------------------|

| SPLICE | PAGE |
|---------------|-------------|
| XSD01 () | AB2 1 B |
| XSD02 () | NB 0 A |
| XSF01 () | GA 0 D |
| XSF09 () | GA 3 C |
| XSF10 () | GA 3 C |
| XSF11 () | GA 2 D |
| XSF12 () | GA 2 B |
| XSF13 () | GA 1 D |
| XSF14 () | ZC 2 B |
| XSF15 () | CX 1 B |
| XSF17 () | CX 0 B |
| XSF18 () | CX 2 D |
| XSF18 () | XH1-1 1 B |
| XSF18 () | XH1-2 1 B |
| XSF19 () | ZC 2 C |
| XSF21 () | XH1-1 2 D |
| XSF21 () | XH1-2 2 D |
| XSF22 () | CU 0 A |
| XSF23 () | NA 0 A |
| XSF24 () | CX 1 D |
| XSF25 () | CX 1 D |
| XSF26 () | XH1-1 3 D |
| XSF26 () | XH1-2 3 D |
| XSF27 () | XH1-1 3 D |
| XSF27 () | XH1-2 3 D |
| XSF28 () | XH1-1 2 D |
| XSF28 () | XH1-2 2 D |
| XSF29 () | FB 0 B |
| XSF30 () | XH1-1 1 D |
| XSF30 () | XH1-2 1 D |
| XSF31 () | XH1-1 1 D |
| XSF31 () | XH1-2 1 D |
| XSF32 () | FB 0 C |
| XSF33 () | XH1-1 2 C |
| XSF33 () | XH1-2 2 C |
| XSF35 () | CX 3 B |
| XSF39 () | CX 1 D |
| XSF40 () | CX 2 B |
| XSF41 () | XD 0 C |
| XSF42 () | XD 0 C |
| XSF43 () | CS 4 B |
| XSF44 () | XH1-1 1 B |
| XSF46 () | CS 4 A |
| XSF50 () | ZC 3 B |
| XSF54 () | XC 2 D |
| XSF55 () | XC 3 C |
| XSF56 () | XC 2 D |
| XSF57 () | XC 2 C |
| XSF71 () | CU 4 D |
| XSF72 () | CU 0 E |
| XSF73 () | CU 0 E |
| XSF76 () | CU 0 B |
| XSF80 () | XF 3 C |
| XSF81 () | XF 3 C |

VOLVO

Volvo Bus Corporation

Document title

WIRING DIAGRAM

Document type

PRODUCT SCHEMATICS

Document No

22610880

Issue

11

Volume

03(03)

Sheet No

36(38)

| SPLICE | PAGE |
|---------------|-------------|
| XSF82 () | XF 2 C |
| XSF83 () | XF 2 C |
| XSF84 () | XF 1 C |
| XSF85 () | XF 1 C |
| XSF86 () | XF 1 C |
| XSF87 () | XF 1 C |
| XSF88 () | XF 0 C |
| XSF89 () | XF 0 C |
| XSF92 () | BA 1 B |
| XSF93 () | BB 1 C |
| XSF94 () | BB 1 D |
| XSF95 () | AB 2 D |
| XSF96 () | AB 2 C |
| XSF97 () | CS 3 B |
| XSF98 () | CS 1 B |
| XSF99 () | AB 2 B |
| XSF100 () | AB 1 C |
| XSF101 () | NA2 4 B |
| XSF102 () | CU 2 A |
| XSF103 () | CU 2 A |
| XSF104 () | CU 2 A |
| XSF105 () | CU 2 A |
| XSF106 () | CU 1 A |
| XSF107 () | CU 1 A |
| XSF108 () | CU 1 A |
| XSF109 () | CU 1 B |
| XSF110 () | CU 0 A |
| XSF111 () | CU 0 A |
| XSF112 () | CU 0 A |
| XSF113 () | CU 4 E |
| XSF114 () | CU 4 E |
| XSF115 () | XG 1 D |
| XSF116 () | XG 1 D |
| XSF117 () | XG 0 D |
| XSF118 () | XG 0 D |
| XSF119 () | ZC 3 B |
| XSF120 () | ZC 3 B |
| XSF121 () | DN3 1 B |
| XSF122 () | DN3 2 B |
| XSF123 () | AB 2 D |
| XSF130 () | XG 2 D |
| XSF131 () | XG 2 D |
| XSF132 () | XG 2 D |
| XSF133 () | XG 2 D |
| XSF150 () | XH1-1 3 C |
| XSF150 () | XH1-2 3 C |
| XSF151 () | XH1-1 2 B |
| XSF151 () | XH1-2 2 A |
| XSF152 () | XH1-1 2 D |
| XSF152 () | XH1-2 2 D |
| XSF153 () | XH1-1 2 D |
| XSF153 () | XH1-2 2 D |
| XSF155 () | XH1-1 2 B |
| XSF155 () | XH1-2 2 A |

VOLVO

Volvo Bus Corporation

Document title
WIRING DIAGRAM

Document type
PRODUCT SCHEMATICS

| | | | |
|-----------------|-----------|---------------|---------------|
| Document No | Issue | Volume | Sheet No |
| 22610880 | 11 | 03(03) | 37(38) |

| SPLICE | PAGE |
|---------------|-------------|
| XSL10 () | CU 2 D |
| XSL11 () | CU 2 E |
| XSL12 () | CU 2 E |
| XSL13 () | CU 2 E |
| XSM02 () | ZC 4 C |
| XSN01 () | BA 2 E |

VOLVO

Volvo Bus Corporation

Document title
WIRING DIAGRAM

Document type
PRODUCT SCHEMATICS

| | | | |
|--------------------------------|--------------------|-------------------------|---------------------------|
| Document No 22610880 | Issue 11 | Volume 03(03) | Sheet No 38(38) |
|--------------------------------|--------------------|-------------------------|---------------------------|