

---

## TABLE OF CONTENTS

---

### STARTING AND STOPPING

#### PROCEDURES 4 - 1

General information.....	4 - 1
Detroit Diesel Electronic Control (DDEC).....	4 - 3
World Transmission WT Electronic Control System.....	4 - 4
Manual transmission.....	4 - 8
Cold weather starting.....	4 - 8
Daily inspection.....	4 - 9
Recommendations.....	4 - 10
Heating and air conditioning.....	4 - 11
Preheating systems.....	4 - 14
Windshield washer reservoir.....	4 - 15
Jump starting.....	4 - 16
Electric circuit protection.....	4 - 17
Tires.....	4 - 18
Towing.....	4 - 20
Jacking points.....	4 - 21
Retractable tag axle.....	4 - 21
Tag axle unloaded.....	4 - 21

#### TECHNICAL INFORMATION 5 - 1

Dimensions.....	5 - 1
Weights.....	5 - 2
Capacities.....	5 - 2
Fuel type.....	5 - 2
Wheels and tires.....	5 - 2
Belts.....	5 - 3
Engines.....	5 - 3
Transmissions.....	5 - 3
Drive axle ratio.....	5 - 3
Brakes.....	5 - 4
Steering.....	5 - 4
Electrical system.....	5 - 4
Sound system.....	5 - 4
Video system.....	5 - 4
Suspension.....	5 - 4

Alignment.....	5 - 5
Heating and air conditioning.....	5 - 5
Oil specifications.....	5 - 5
Antilock braking system (ABS).....	5 - 6
Preheating systems.....	5 - 6
Storage volume.....	5 - 6
Seats.....	5 - 7
DDEC III diagnostic codes.....	5 - 7
World transmission WT diagnostic codes.....	5 - 10
Light bulb data.....	5 - 25
Data plate and certification.....	5 - 27

#### CARE AND MAINTENANCE 6 - 1

Interior cleaning.....	6 - 1
Exterior cleaning.....	6 - 3
Oil verification.....	6 - 4
Air tanks.....	6 - 7
Coolant level verification.....	6 - 8
Water separator.....	6 - 8
Belt tensioners.....	6 - 8
A/C and heating air filters.....	6 - 10
Flexible hose maintenance.....	6 - 10
Lubrication.....	6 - 11
Fire extinguishers.....	6 - 11
110-120 volt in-station lighting.....	6 - 11
110-120 volt in-station connectors.....	6 - 11
Back-up camera.....	6 - 12
Filter restriction indicator.....	6 - 12
Lavatory maintenance.....	6 - 12
First service on new vehicle.....	6 - 14
Lubrication and servicing schedule.....	6 - 15

#### SERVICE LITERATURE 7 - 1

# PREVOST

## XL Series Motorcoach STARTING AND STOPPING PROCEDURES

### GENERAL INFORMATION

**CAUTION:** Read this section of manual before driving vehicle.

#### Starting engine from driver's compartment

The following procedure is used to start and stop the engine from the driver's compartment.

##### Starting engine

1. Make sure the starter selector switch in engine compartment is set to the "NORMAL" position and that main battery disconnect switch (see page 2-2) is set to the "ON" position.
2. Make sure the parking brake control valve knob, located on R.H. lateral console, is pulled all the way up, so that the spring-loaded parking brakes are applied.
3. Make sure transmission is in neutral.
4. Turn ignition key to "START" position, then release it as soon as engine starts.

**NOTE:** If engine does not start, ignition key must be returned to the "OFF" position prior to restarting.

**CAUTION:** Special precautions are necessary with turbocharged engines to avoid possible turbine damage. After starting, run the engine at low idle for two minutes to allow flowing of lubricant to the turbocharger. Afterwards, run at fast idle and check oil pressure before attempting to drive the vehicle.

*Do not engage starter for more than 15 seconds at a time. If engine does not start within 15 seconds, release ignition key and allow starter to cool for one (1) minute before engaging starter again. Continuous use of the starter without allowing a cooling period may damage the starter motor.*

*With DDEC engines, pressure must not be applied on accelerator pedal before starting. An application on pedal will induce a fault information to the Electronic Control Unit, thus affecting the fuel system control.*

*If accelerator pedal is depressed inadvertently, release it and wait approximately 30 seconds before resuming starting procedure.*

##### Stopping engine

1. Apply parking brake then set transmission to the neutral position.
2. Allow engine to run at slow idle for at least two minutes, then shut off engine. This will ensure that the turbine speed has dropped, and the engine exhaust gas temperature is down to approximately 300°F. If engine is equipped with pyrometers, temperature can be observed.

**CAUTION:** Do not shut the engine down directly from high rpm.

*If vehicle is parked and left unattended for an extended period of time, main battery disconnect switch (see page 2-2) should be set to the "OFF" position.*

## STARTING AND STOPPING PROCEDURES

### Starting engine from engine compartment

The following procedure is used to start and stop the engine from the engine compartment.

#### Starting engine

Switches for starting and stopping the engine from the engine compartment are mounted on the R.H. side of rear junction box.

**WARNING:** Before attempting to start engine from engine compartment, make sure parking brake is applied and transmission is in neutral.

1. Make sure the starter selector switch in engine compartment is set to the "REAR START" position and the main battery disconnect switch (see page 2-2) is set to the "ON" position.

2. Press starter push button switch and release as soon as engine starts.

**WARNING:** Stay away from moving parts, and do not wear loose clothes (no neckties, open jackets, shirttails, etc.).

**CAUTION:** Steps previously explained with respect to starter use also apply in this situation.

#### Stopping engine

Stop only by turning the starter selector switch to the "OFF" position.

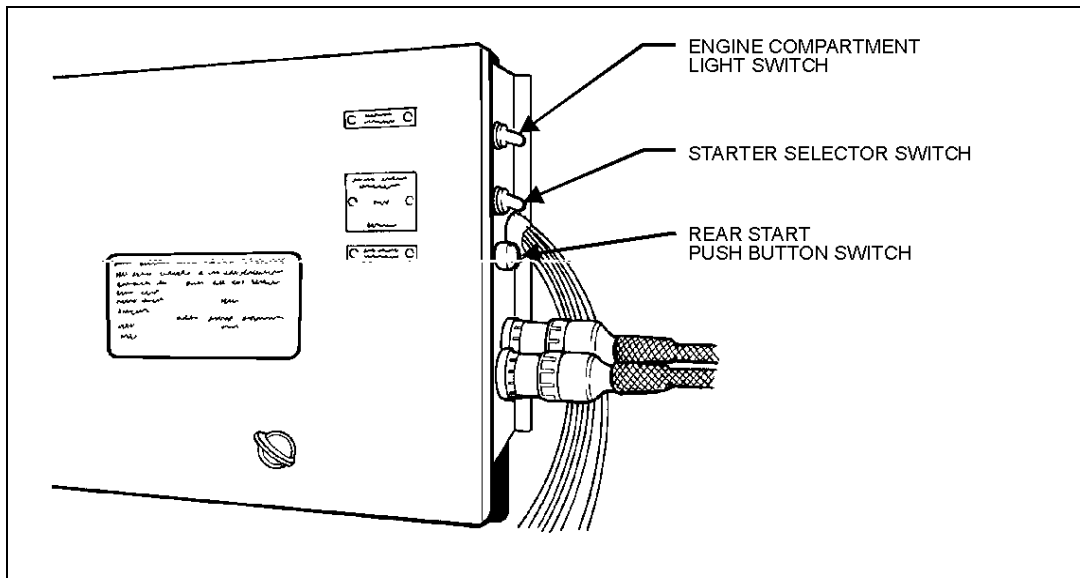

01017

## DETROIT DIESEL ELECTRONIC CONTROL (DDEC)

The major components of DDEC are as follows:

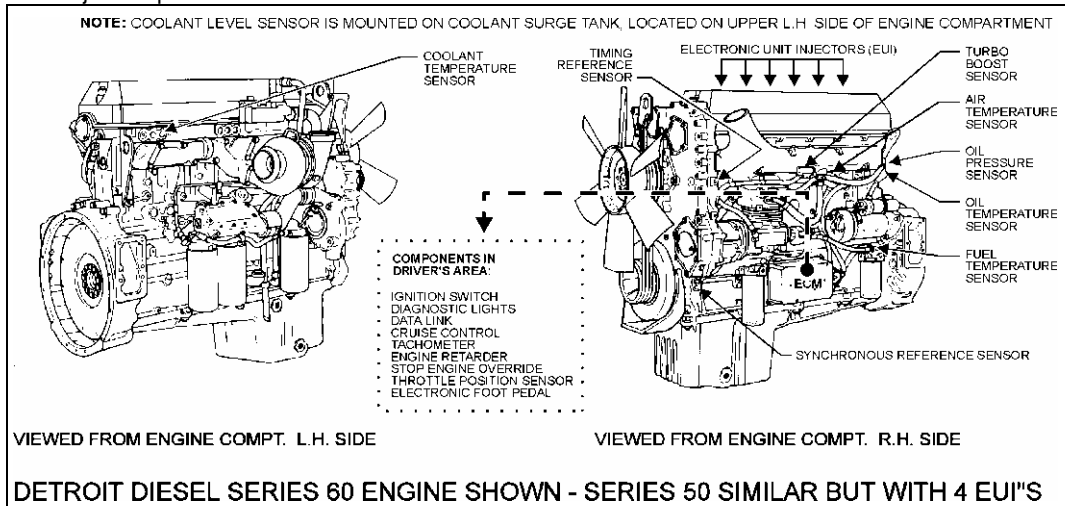

01015

DDEC is an advanced technology electronic fuel injection and control system for Detroit Diesel engines. As an integral part of the engine, the DDEC system provides a number of performance features and driver benefits, including improved fuel economy and performance, reduced cold smoke, reduced maintenance and repair cost. These advantages are obtained by optimizing control of the critical engine functions which affect fuel economy, engine reliability and the performance of the injectors.

Its major components include an Electronic Control Module (ECM), Electronic Unit Injectors (EUI) and sensors. The ECM is the brain of the DDEC system and is located over the engine between both cylinder heads. Within the ECM is the Electrically Erasable, Programmable, Read Only Memory (EEPROM) that provides instructions for basic engine control functions such as rated speed and power, engine governing, cold start logic and diagnostics, plus an engine protection system.

The ECM continuously monitors and analyzes the DDEC system during engine operation with electronic sensors. The Electronic Unit Injectors (EUI) operate a similar principle to the mechanical unit injector system. However, a solenoid-operated control valve performs the injection timing and metering functions which make injector timing much simpler and more precise.

DDEC provides the capability to quickly diagnose system malfunctions by a self-diagnostic system; the self-diagnostic system monitors all engine sensors and electronic components and recognizes system faults and other engine-related problems by providing the technician with a diagnostic code. Diagnostic codes are logged into the ECM memory and can be read by performing procedure outlined on page 5-7.

### ENGINE RETARDER SYSTEM (JACOBS)

The "Jacobs brake" is a diesel engine retarder that uses the engine itself to aid in slowing and

---

## STARTING AND STOPPING PROCEDURES

controlling the vehicle. When activated, the "Jacobs brake" alters the operation of the engine's exhaust valves so that the engine works as a power-absorbing air compressor. This provides a retarding action to the wheels.

The engine brake is a vehicle-slowng device, not a vehicle-stopping device. It is not a substitute for the service braking system. The vehicle's service brakes must be used to bring the vehicle to a complete stop.

Effectiveness of the engine brake system will vary according to transmission gear in use. The engine brake system is more effective in lower gears and at higher engine speeds.

**WARNING:** *When descending significant grades, use service brakes as little as possible. If engine does not slow vehicle to a safe speed, apply service brakes and shift to a lower gear. Let the engine (and engine brake) retard the vehicle. Keep brakes cool and ready for emergency stopping.*

**NOTE:** *Engine brake is operative only when accelerator pedal is released, and when engine speed is over 900 rpm.*

*Each time the engine brake system is in operation, the stoplights will automatically light up.*

## WORLD TRANSMISSION WT ELECTRONIC CONTROL SYSTEM

The WT Electronic Control System consists of five (5) major components connected by wiring harnesses - Electronic Control Unit (ECU), engine throttle position sensor (or direct electronic communication), three (3) speed sensors, pushbutton shifter, and control module (which contains solenoid valves and a pressure switch). The throttle position sensor, speed sensors pressure switch, and pushbutton shifter transmit information to the ECU. The ECU processes this information and sends signals to actuate specific solenoids located on the control module in the

transmission. These solenoids control both the oncoming and offgoing clutch pressure during a shift.

Another feature of the World Transmission is its ability to adapt or "learn" as it operates. Each shift is electronically measured, stored and used by the ECU to adapt and "learn" the optimum conditions for future clutch apply and release. It is important to note that if the shift quality of low mileage vehicles or vehicles with new or recalibrated ECU's is unacceptable, simply drive the vehicle through its shift ranges for awhile. After this "learning" period any rough shifting will be corrected and shift quality will be restored.

In addition to controlling the operation of the transmission, the ECU monitors the system for conditions that could result in damage to the transmission or improper vehicle operation. When one of these conditions is detected, the ECU is programmed to respond automatically in a manner which will ensure safe operation of the vehicle and the transmission.

### Torque converter

The torque converter consists of three (3) elements - pump, turbine, and stator. The pump is the input element and is driven directly by the engine. The turbine is the output element and is hydraulically driven by the pump. The stator is the reaction (torque multiplying) element. When the pump turns faster than the turbine, the torque converter is multiplying torque. When the turbine approaches the speed of the pump, the stator starts to rotate with the pump and turbine. When this occurs, torque multiplication stops and the torque converter functions as a fluid coupling.

The lockup clutch is located inside the torque converter and consists of three (3) elements - piston, clutch plate/damper, and backplate. The piston and backplate are driven by the engine. The clutch plate/damper, located between the piston and backplate, is splined to the converter turbine. The lockup clutch is engaged and released in response to electronic signals from the ECU. Engagement of the lockup clutch provides a direct

## STARTING AND STOPPING PROCEDURES

drive from the engine to the transmission gearing. This eliminates converter slippage to provide maximum fuel economy. The torsional damper absorbs engine torsional vibration.

The lockup clutch releases at lower speeds and when ECU detects conditions requiring it to be released.

### Planetary gears and clutches

A series of three (3) helical planetary gear sets and shafts provides the gear ratios and direction of travel for the vehicle. The planetary gear sets are controlled by five (5) multiplate clutches that work in pairs to produce six (6) speeds. The clutches are applied and released hydraulically in response to electronic signals from the ECU to the appropriate combination of solenoids.

### Cooler circuit

The transmission oil is cooled by a remote-mounted oil cooler. Connections to the cooling circuit are located at the rear of the transmission to facilitate installation of remote cooler lines. Oil ports are internal requiring only coolant to be routed to and from the cooler.



Steering Compartment

07005

To enhance troubleshooting and to allow interrogation of the ECU for valuable service information, a DDR (diagnostic data reader) can be used. To use it, plug the appropriate connector (not furnished by the manufacturer) in the terminal located in the steering compartment or the DDR connector located on L.H. side control

panel. You can also use your pushbutton shifter to perform certain maintenance operations (see page 4-6 under "Diagnostic codes").

### Output retarder (Optional)

The purpose of the retarder is to assist in stopping the vehicle during stop and go driving and to control the downhill speed of the vehicle on a grade. For both of these uses, the retarder serves to extend the life of the service brakes and to enhance vehicle control.

The retarder system is activated by turning "ON" the retarder enable switch (L.H. side control panel-item #4 on page 2-4).

The retarder controls are broken down into two (2) types:

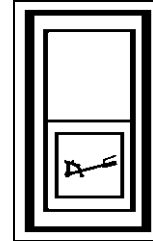

18017

**BRAKE APPLY** - actuated by brake pressure; applies the retarder at three (3) distinct retardation levels (low = 1/3 - 2 psi, medium = 2/3 - 4 psi, and "full on" - 7 psi) when increasing pressures are detected in the brake system.

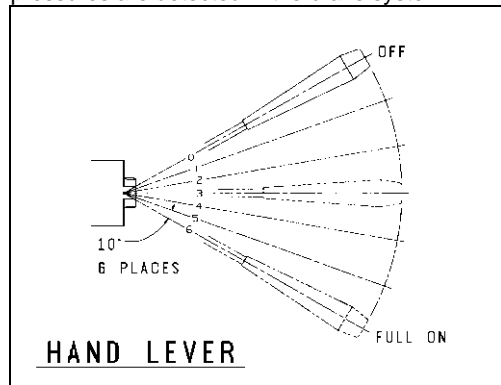

18018

**AUTOMATIC APPLY** - actuated by hand lever located on R.H. side of steering column; retarder capacity is determined by hand lever which permits the operator to select "OFF", or one of six (6) levels of automatically-commanded retardation, the highest of which is maximum retarder capacity "full on".

---

## STARTING AND STOPPING PROCEDURES

The controls may be used in combinations such that the retarder can be activated when either of the two (2) controls are actuated. (If both are actuated simultaneously, the level of retardation will correspond to higher input signal).

The optimum retarder control will depend on the vehicle type and retarder use. In general maximum brake savings occur with increased retarder use. In stop and go driving, retarder use can be maximized by using the "BRAKE APPLY". For downhill speed control, the "AUTOMATIC APPLY" may provide the best operator control.

When the vehicle is equipped with the anti-lock braking system (ABS) and the system is activated, the transmission controls "ABS input" is used to disengage the retarder and the transmission lockup clutch, thus enhancing performance of the ABS system.

### Diagnostic telltales

Two (2) diagnostic features are available with the transmission control system to assist in troubleshooting of malfunctions and/or the monitoring of specific operating parameters. These features include a "DO NOT SHIFT" light on the dashboard, and the Diagnostic Data Reader (DDR). When a malfunction is detected in the control system, a series of "diagnostic codes" are used to identify and clarify the nature of the malfunction.

#### Do not shift - light

The "DO NOT SHIFT" light is located on dashboard.

Illumination of this light, accompanied by eight (8) seconds of short beeps from the shifter, indicates that shifts are being restricted. The *SELECT* digit on the display will be blank. Operation may continue in order to reach service assistance. The ECU may not respond to shifter requests, since operating limitations are being placed on the transmission,



i.e. upshifts and downshifts may be restricted. Direction changes will not occur. The ECU will not respond to operator requests while *DO NOT SHIFT* is indicated.

Any time this light has been illuminated, the ECU will register a diagnostic code. It may be identified on the digital display and/or the Diagnostic Data Reader (DDR).

#### Diagnostic Data Reader (DDR) (Optional)

The purpose of the DDR is to assist in the installation checkout and the troubleshooting of malfunctions as detected by the ECU. The DDR is a portable microcomputerbased receiver/transmitter/display unit. The DDR transmits and receives data to/from the ECU, processes the data and displays appropriate information to the servicer. Operating instructions are supplied with each DDR.

#### Diagnostic codes

Illumination of the *DO NOT SHIFT* light during vehicle operation (start-up), indicates that the ECU has registered a diagnostic code. A summary of diagnostic codes with each associated transmission response is shown on pages 5-10 through 5-24.

Diagnostic codes can be displayed either by the DDR or on the digital display of the shifter. The following information describes use of the diagnostic capabilities of the system without the DDR.

Up to five (5) diagnostic codes can be registered in the ECU at one time. In addition to the code itself, additional information for each code is available: whether or not any inhibits resulting from the code are active; ignition cycle counts to indicate the frequency of the code occurrence. After a fixed number of ignition cycles, any code will automatically disappear from memory if it has not reoccurred.

The general procedure to display the codes is to first enter the diagnostic mode. This is

---

## STARTING AND STOPPING PROCEDURES

---

accomplished by pressing the upshift and downshift arrow buttons simultaneously on the pushbutton shifter. Diagnostic mode will be entered only with the vehicle stopped. (The transmission should be shifted to *NEUTRAL* and the vehicle parking brake applied.) For each code stored in memory, beginning with any code that is presently inhibiting the transmission, the four (4) digits of the code and the pertinent parameters are continuously flashed on the display. Pressing the mode button once will cause the next code with pertinent information to be displayed. Dashes indicate all stored codes have been displayed.

To clear any active inhibits, the mode button must be depressed and held for an extended length of time. To clear the code from memory, The mode button must be pressed and held for a longer period of time. All active inhibits will also be cleared during a normal powerdown (ignition switched off followed by zero output and zero engine speeds).

### Importance of proper oil level

1. Maintaining the proper oil level is very important. The transmission oil is used to apply clutches and to lubricate and cool the components. If the oil level is too low, the result can be poor performance because clutches will not receive adequate oil supply. If the oil level is too high, overheating results from the oil being churned and aerated.
2. Always check the oil level at least twice to ensure that an accurate check is obtained.
3. Transmission input speed and oil temperature significantly affect the oil level. An increase in input speed lowers the oil level; an increase in oil temperature raises the oil level. Thus, the oil level must always be checked with the engine running at idle (approximately 500 rpm), the parking brake applied, and the transmission in neutral. A final check of the oil level must be made when the transmission reaches normal operating temperature (160 - 250°F; 70 - 120°C).

### Fill pipe protection

When adding oil or checking oil level, dirt or foreign material must not be allowed to enter the filler tube. Before removing the dipstick, clean around the end of the filler tube. Refer to "*Care & maintenance*" section for manual oil level check procedure.

### Readout of the oil level sensor

The oil level sensor (OLS) is designed to measure transmission oil level only when a specific combination of operating conditions exist:

- engine must be at idle
- **NEUTRAL** must be selected
- zero output speed
- transmission oil must be within a "normal" temperature band
- once the first four (4) conditions are met, a "waiting" period must pass (approx. 2 min., to facilitate consistent oil drainback) before oil level measurement may begin.

To enter OLS readout mode (after meeting the conditions noted above), simultaneously press the *UPSHIFT* and *DOWNSHIFT* arrows on the shifter. If the five (5) conditions noted above are present, the display will immediately enter the reading mode. If the "waiting" period has not elapsed, the left digit of the display will become a "chasing" digit and the right digit will count down from (8) to (1) until the waiting period is complete.

After attaining the reading mode, the display will flash "*OL-OK*", "*LO-01*", "*HI-02*", etc., where the suffix "*01*" or "*02*" indicate the volume of oil (in quarts) low or high.

At any time in this sequence, simultaneously pressing the **UPSHIFT** and **DOWNSHIFT** arrows directs the ECU to enter the transmission diagnostic mode as described under "*Diagnostic Codes*" on page 4-6. D, N, or R may also be selected on the shifter at any time - the OLS mode will abort and normal transmission will commence. Shifts are not inhibited.



---

## STARTING AND STOPPING PROCEDURES

---

### Oil level sensor (OLS) codes

<u>CODE</u>	<u>CAUSE OF CODE</u>
OL-OK	oil level is correct
LO-01	one quart low
LO-02	two quarts low
HI-01	one quart high
HI-02	two quarts high
OL-50	engine speed (rpm) too low
OL-59	engine speed (rpm) too high
OL-65	neutral must be selected
OL-70	sump oil temperature too low
OL-79	sump oil temperature too high
OL-89	output shaft rotation
OL-95	sensor failure

## MANUAL TRANSMISSION

Do not overfill the transmission. Overfilling usually results in oil breakdown due to excessive heat and aeration from the churning action of the gears. Early breakdown of the oil will result in heavy varnish and sludge deposits that plug up oil ports and build up on splines and bearings. Overflow of oil escapes onto clutch or parking brakes causing additional trouble. However, if oil level is too low, gears will be insufficiently lubricated.

**CAUTION:** Do not tow vehicles equipped with manual transmissions without first pulling the axles or disconnecting the drive shaft. Lubrication of the internal gear train is inadequate when the vehicle is towed.

## COLD WEATHER STARTING

### Cold starting aid (Ether) (Optional)

The vehicle may be equipped with an electrically-operated ether cold starting aid designed to ease engine starting when temperature is below 35°F (2°C). The control rocker switch, located on the L.H. lower switch panel (see page 2-15), is provided with a locking mechanism to avoid accidental use when engine is running. To activate the ether starting aid, proceed as follows:

1. Prior to cranking engine, slide down lock tab while pressing rocker switch for three (3) seconds to fill solenoid valve.

2. Release switch to discharge shot.

3. Allow three (3) seconds for shot to discharge.

4. Start engine, use additional shots if necessary to keep engine running.

**CAUTION:** This practice should be performed only when absolutely necessary. Excessive use of fluid could result in serious engine damage.

### Engine block heater

The vehicle is equipped with an engine immersion-type electric block heater to assist cold weather starting. The heater male electric plug is easily accessible through the engine oil reserve tank access door. To use it, connect the female plug of an electrical extension cord to the heater plug. Some converted vehicles may have the heater connected to the coach AC power system. The extension cord must be plugged into a 110-120 V AC power source only. The engine block heater should be used whenever the vehicle is parked for an extended period of time in cold weather and a suitable power source is available.

**CAUTION:** Use only a 110-120 V AC power source. Extension cord must be of the grounded type (three prongs) and have a minimum rated capacity of 15 amps. Be sure to disconnect cord before starting and/or moving the vehicle.

### Engine warm-up

After starting the engine, run it at low idle for two (2) minutes to allow flowing of lubricant to the turbocharger, then increase speed to fast idle for warm-up period by using "FAST IDLE" switch

---

## STARTING AND STOPPING PROCEDURES

---

located on L.H. lower switch panel (see page 2-15). Run the engine at fast idle and no load for about five (5) minutes to allow it to warm-up before applying a load. Parking brakes should be kept applied throughout warm-up. Gauges and indicator lights should be monitored to check that all conditions are normal. If an abnormal condition should develop, stop engine immediately and have condition corrected.

**WARNING:** *Never let the engine run in an enclosed, non-ventilated area. Exhaust fumes from the engine contain dangerous gases which can be fatal if inhaled.*

**NOTE:** *The engine will come up to normal operating temperature shortly after you start driving; if possible, avoid going to full throttle until engine coolant temperature reaches 140°F (60°C).*

### Transmission warm-up

When temperature is below -20°F (-29°C), the "DO NOT SHIFT" and "CHECK TRANS" will stay "ON" after the engine is started. The transmission will stay in neutral, regardless of the gear range selected until it warms past -20°F (-29°C). At that point, the "DO NOT SHIFT" light will turn off and the transmission will operate only in first gear or reverse. When the "CHECK TRANS" light goes out at 20°F (-7°C), the transmission is warm enough to safely operate in all gear ranges.

## DAILY INSPECTION

### With engine stopped

#### General

Check general vehicle condition and verify all exterior lighting. Also check for loose nuts and bolts.

#### Extinguishers

Ensure that fire extinguishers are in working order and easily accessible.

#### Emergency exits

Check that emergency exits can be easily opened.

#### Driver's area

Adjust mirrors and seat.

#### Doors

Make sure that all exterior doors and windows are closed.

#### Tools and spares

Check for wheel nut wrench and jack, door keys, spare belts and emergency reflectors.

#### Washer reservoir

Check that it is full. To prevent the windshield washer fluid from freezing during the winter, use antifreeze windshield washer.

#### Tires

All tires, including the spare, should be inspected for cuts and correct inflation. On both aluminum alloy and steel wheels, nuts should be checked using a torque wrench. Torque to 450-500 lbf•ft (610-680 N•m).

#### Wheel bearings

Check oil level in sight glass (see page 6-6).

**CAUTION:** *During a fuel stop, especially if a brake job has been performed recently, apply hand on wheel bearing cover and check for overheating.*

#### Leaks

Check thoroughly under vehicle and in compartments. Report all leaks to maintenance personnel.

---

## STARTING AND STOPPING PROCEDURES

---

### Coolant level

The cooling system is completely filled when the coolant (cold) is visible in the sight glass on the right side of the surge tank. If topping-up is necessary, fill the system with the same mixture ratio already used (50-50), as instructed in the "Maintenance Manual".

**WARNING:** Hot engine coolant is under pressure. Never remove cap until coolant has cooled.

### Engine oil

Check oil level; refill directly into engine or from reserve tank (see page 6-4).

### Air system

Purge accessories and wet tanks by opening drain valve (see page 6-7).

### Power steering oil tank

Check oil level (see page 6-6).

### Belts

Check for worn belts.

### Belt tensioners

Visually check belt tension and the space between tensioning bellows' brackets (see page 6-8).

### Seats

Make sure all seats and seat cushions are firmly attached.

### Lavatory

Inspect for cleanliness and paper, towels & water supply.

### With engine running

**NOTE:** Vehicle must be on level ground.

### Gauges and buzzers

Gauges should be in normal position, warning lights and buzzers off.

### Fuel level

Be sure level is sufficient.

### Transmission

Check oil level (see page 6-4).

### Leaks

Inspect around vehicle and listen for any air leak.

### Water separator

Purge drain valve (see page 6-8).

### Turbocharger

Look for any leaks or unusual sounds coming from the turbo compressor.

### Service brakes

Check for pressure build-up. With engine stopped and no brake applied, loss should not exceed 3 psi/min. (21 kPa/min). Make a full brake application; loss should not exceed 7 psi (48 kPa).

### Parking and emergency brakes

With air pressure above 65 psi (448 kPa), lower pressure with brake pedal applications, check that buzzer works and that control button lifts up. Wait until air pressure exceeds 95 psi (655 kPa) before releasing parking brakes.

## RECOMMENDATIONS

- Make sure the basic principles of operation of the vehicle are understood.
- Maintain the vehicle in good running condition.

- Do not drive your vehicle with an extremely low fuel level. This advice is very important, especially if your vehicle is equipped with an auxiliary fuel tank. Unlike a gasoline engine, if a diesel engine runs out of fuel it will not simply restart after fuel is added to the tank. The engine must be "primed" (see procedure in the Maintenance Manual).

- Allow engine to run at slow idle for at least 2 minutes before turning it off.

- Engine should always be at idle speed when shifting from neutral to reverse or forward range.

- Automatic transmission shift pattern does not include a park position. Parking brake must therefore be applied to hold vehicle when it is unattended. Gearshift should then be in neutral position. If engine is stopped without applying the parking brake, a warning buzzer will sound until the parking brake is applied and your foot is removed from the brake pedal.

- Perform procedures as detailed in this manual.

- Unless otherwise specified, engine should be turned off for all lubrication and maintenance procedures.

- Do not attempt to push-start or pull-start the vehicle.

- Do not tow vehicle without first removing the drive axle shafts or disconnecting the drive shaft. Internal lubrication of the transmission is inadequate when the vehicle is towed.

- Fire extinguishers are stored underneath the front L.H. passenger seat. In case of fire, get everyone out of the vehicle, then think of your own safety before attempting to fight the fire.

- When driving on ice or snow, accelerations or decelerations should be done gradually.

**NOTE:** Normal operation as well as some emergencies or abnormal conditions are covered in this booklet. Any malfunction interfering with satisfactory operation should be corrected immediately, particularly when safety may be involved.

## HEATING AND AIR CONDITIONING

### Ventilation

Driver should always try to introduce as much circulation of outside fresh air as possible without hampering heating and air conditioning systems. Under extreme temperature conditions however, when maximum capacity is required, the adjustable intake dampers (see following pages) should be closed.

It should be remembered that the inside of vehicle should always be slightly pressurized to minimize the entrance of dust and moisture.

Vehicle heating and air conditioning systems have been designed to allow circulation of some outside fresh air, so windows should be kept closed at all times.

In case of air conditioning system failure, substitute ventilation may be provided by opening roof-mounted emergency vent(s).

**NOTE:** The driver's area A/C & heating and defrost systems are independant from the central system.

### Central A/C & heating system

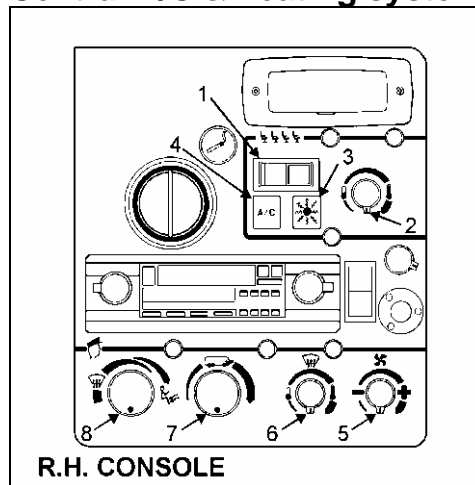

18123

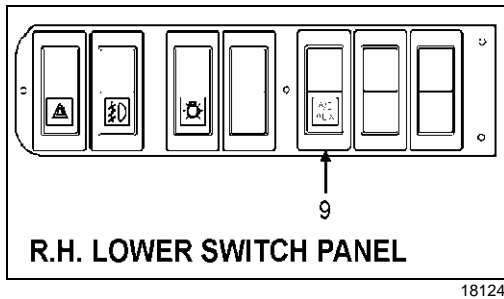

**1. "A/C heat" switch**

This switch has three positions: "A/C - OFF - HEAT". Set the switch to:

- "A/C" position (L.H. side) when vehicle's interior needs to be cooled or dehumidified.
- "HEAT" position (R.H. side) when vehicle's interior needs to be warmed or ventilated.
- "OFF" position (center) before stopping the vehicle.

**NOTE:** Fuel economy is slightly reduced when "A/C" position is used.

*To operate air conditioning system when vehicle is stationary, run engine at fast idle. During operation of air conditioning system, windows should be kept closed and door not left open longer than necessary.*

*In order to prevent battery discharge, A/C & heating system will not operate if battery charging system is not working properly.*

**CAUTION:** "A/C" position should not be used when outside temperature is below 40°F (5°C).

*While the A/C system is running, make sure the vehicle is parked at least four (4) feet (1,2m) from other vehicles and/or buildings to allow a sufficient air flow through the condenser core.*

**2. "Temperature" control**

Once the A/C clutch switch is set to the proper position and fans are on, select the desired temperature by turning the temperature control knob clockwise to raise or counterclockwise to lower temperature. Only a slight movement of knob is generally sufficient to change temperature setting.

Temperature control knob is used to select interior temperature within the range of 65 to 78°F (18 to 26° C). Once temperature is selected, system will automatically maintain it within close limits.

At extreme clockwise position, full heat will be maintained.

**3. "Heat" indicator light**

This indicator will be illuminated when hot water is circulating through the water valve, no matter which mode has been selected (A/C or heating).

**4. "A/C" warning light**

This light is designed to light up when the "A/C" system is not working properly. If this happens, first stop "A/C" system, then perform the following checks:

- Check the condenser for obstruction. Clean if necessary. (Refer to "Maintenance Manual").
- Check that the evaporator and condenser motors are operating.
- Check evaporator filter for cleanliness. Clean or replace as required. (Refer to "Care and Maintenance" section, page 6-9).
- Check the air return duct(s) for obstruction. Ducts are located on the left side or on both sides of the vehicle floor, approximately in the center. Clean if necessary.

After these checks, test the system. If the "A/C" warning light does not turn off, set the "A/C - heat" switch to "OFF" position, and seek qualified service assistance.

## Driver's compartment A/C & heating system

### 5. "Fan" speed control

Turn knob clockwise at the first position to obtain minimum air flow and to start "Driver's system" to circulate warm, cool, or outside air, according to settings of temperature control knob (driver's), "A/C-heat" switch and "Recirc.-fresh air" control. Turn clockwise again to obtain the desired ventilation speed.

### 6. "Temperature" control

Once the A/C clutch switch is set to the proper position and fans are on, select the desired temperature by turning the temperature control knob clockwise to raise or counterclockwise to lower temperature. Only a slight movement of knob is generally sufficient to change temperature setting.

Temperature control knob is used to select interior temperature within the range of 65 to 78°F (18 to 26° C). Once temperature is selected, system will automatically maintain it within close limits.

At extreme clockwise position, full heat will be maintained.

**WARNING:** Excessive high temperature in driver's area could induce drowsiness, affecting driver's ability to operate the coach safely.

**NOTE:** Driver's air conditioning system will only operate simultaneously with main air conditioning system, but heating and defrost systems are independant from main system.

Driver's A/C & heating system also affects the two (2) front rows of passenger seats, and should be used in concert with main system, not in opposition.

### 7. "Recirc.-fresh air" control

This knob should normally be rotated clockwise to allow maximum fresh air admission. When outside temperature is extremely high and maximum cooling is required or when outside temperature is extremely low and maximum heating is required, the knob should be rotated counterclockwise to shut off the fresh air admission, thus recirculating the air inside vehicle. This position should also be selected when driving vehicle on dusty roads and in air polluted areas to avoid admission of contaminated air inside vehicle.

**WARNING:** Keep in mind that the "Recirc.-fresh air" control must be reset to the "fresh air" position following these special road conditions in order to prevent contamination of air in driver's area.

**NOTE:** In order to improve air circulation when A/C system is inoperative, open the roof escape(s) and position the "Recirc.-fresh air" control to the extreme right position (fresh-air).

### 8. "Feet air outlet" control

This control is used to control the air flow delivered under the dash on the driver's side. Turn control knob clockwise to increase air flow and counterclockwise to decrease.

### 9. "A/C auxiliary" switch

Push down rocker switch to actuate the optional auxiliary A/C system located at rear of coach to supplement the central A/C system. This system will operate only if central A/C system is operating.

#### How to use the controls

- To ventilate

Turn the "temperature" control knobs to the maximum counterclockwise position (cool), turn the "recirc.-fresh air" control knob to the maximum clockwise position (fresh air), then set the "A/C heat" switch to the "heat" position and turn the fan speed control knob to the desired position.

- To heat

## STARTING AND STOPPING PROCEDURES

To ensure maximum efficiency of heating system, set the "A/C - heat" switch to the "heat" position, switch the fan speed control to the highest speed position, then adjust the temperature control knobs to a comfortable setting.

- To defrost

To obtain the maximum defrosting efficiency, switch the "fan" speed control to the highest position, set the "hot water pump" switch to the "ON" position, turn the "recirc.-fresh air" control knob to the maximum clockwise position (fresh air), turn the "feet air outlet" control knob to the maximum counterclockwise position (defrost position), then turn the "temperature" control to the maximum clockwise position (warm).

- To dehumidify

Because an air conditioner dehumidifies as it cools, you can use it in cool weather to help in drying air. Set the "A/C - heat" switch to the "A/C" position, then adjust the "temperature" control to a comfortable setting. With this set-up, the A\C and heating will run simultaneously, thus drying air as it flows through the evaporator and then heating it as it flows through the heater radiator.

**CAUTION:** The air conditioning system should not be used when outside temperature is below 40° F (5°C).

- To turn everything OFF

Set the "A/C heat" switch and "fan speed" control knob to the "OFF" position and turn the "temperature" control knobs to the maximum counterclockwise position (cool).

An adjustable air intake damper is located in the evaporator compartment (third compartment on the L.H. side of vehicle). The damper should normally be left open. However, under extreme temperature conditions, it can be closed or partially closed to block the addition of ambient air and heat or cool air inside of coach as desired. As soon as extreme heating or cooling is no longer required, the damper should be reopened.

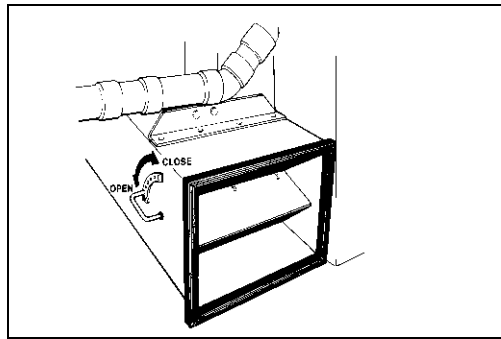

22004

## PREHEATING SYSTEMS

(Optional)

### ESPAR (EBERSPÄCHER):

#### Description of operations

This Auxiliary Preheating System is used for preheating and retaining the heat of water-cooled engines. It can be used before starting the engine to ease its starting and to provide immediate inside heat upon operation of the heating system. It can also be used with engine running to maintain coolant heat and maintain the set temperature inside vehicle.

The heater operates independently of the vehicle engine. It is connected to the cooling and heating circuits, the fuel system and the electrical system of the vehicle.

The pilot lamp turns on when the heater is switched on. Combustion air flows in to flush out the combustion chamber, and the water circulation pump is put into operation. The fuel metering pump conveys fuel in precise doses to the combustion chamber, where fuel and combustion air form a combustible mixture which is ignited by the glow plug.

Once the flame sensor has signalled to the control unit that combustion has taken place correctly, the glow-spark plug and ignition coil are switched off.

The hot combustion gases are diverted at the end of the flame pipe, then pass through the indirect heating surfaces of the heat exchanger and

## STARTING AND STOPPING PROCEDURES

transmit their heat to the water passing through the heat exchanger.

The heat is thermostatically controlled, and operates intermittently, i.e. the switched-on times of the burner vary depending on the heat requirement. The water temperature depends on the setting of the built-in water thermostat.

The water circulation pump remains in operation as long as the heater is operating - even in the regulation intervals and during the delayed cutout of the switched-off heater. The pump can also be operated independently of the heater by means of an appropriate circuit. The heater can be switched on at any time, i.e. during the delayed cutout period too. Ignition takes place once this delay time is over.

When the heater is switched off, the fuel supply is interrupted. The flame goes out, and at the same time a delayed cutout of some 2.5 minutes begins. The combustion air still flowing flushes the remaining combustion gases out of the chamber and cools off the hot parts on the exhaust side of the heat exchanger, while the water circulation pump still running transmits the heat present in the heat exchanger, thus preventing local overheats. Once the delayed cutout time is over, both the combustion air blower and the water circulation pump switch off automatically. A cutout will take place in case of any failure of the preheater.

### WEBASTO:

#### Description of operations

Switch on the heater, the operation indicator lamp comes on and the heater motor & circulating pump begin to run. After about 10-25 seconds the solenoid valve opens and fuel is sprayed into the combustion chamber. At the same time the electronic ignition unit produces high voltage (8000V) and the mixture of fuel and air in the combustion chamber is ignited by the spark on the ignition electrodes. The flame is indicated by the flame detector, then the electronic ignition unit stops producing high voltage and combustion continues by itself (spark on electrodes is required only to ignite the flame). At this moment the heater is working and produces heat.

If the heater is switched off by the on/off switch, the solenoid valve interrupts fuel supply, combustion stops and indicator lamp turns off. Combustion air fan still blows air, cleaning the combustion chamber of any fumes and cooling down the combustion chamber. Coolant circulation pump pumps coolant, making a purge cycle for approximately 2-3 minutes, thus protecting the heater against overheating.

If the heater is not switched off by the on/off switch, the control thermostat will switch off the heater when coolant temperature reaches  $165^{\circ} \pm 6^{\circ} \text{ F}$  ( $75^{\circ} \pm 3^{\circ} \text{ C}$ ) and turns it on at  $154^{\circ} \pm 9^{\circ} \text{ F}$  ( $68^{\circ} \pm 5^{\circ} \text{ C}$ ). During this time the heater (combustion) is off, the indication lamp and coolant pump are on. Combustion air fan blows air for 2-3 minutes and then turns off.

## WINDSHIELD WASHER RESERVOIR

Windshield washer reservoir is located in front left compartment (steering compartment) below driver's floor. This reservoir has a capacity of approximately 5 U.S. gallons (18,9 litres). Its spin-on type cover is provided with a removable cap to ease windshield washer reservoir filling. Reservoir supply should be checked regularly.

Spray jets are mounted under windshield wiper arms. The reservoir's fluid is forced by air pressure through rubber tubes into spray jets and onto windshield.



23011



## STARTING AND STOPPING PROCEDURES

### JUMP STARTING

Whenever it becomes necessary to start the engine while batteries are discharged, use another power source of the same voltage (24 volt DC), negative grounded and proper jumper cables.

**WARNING:** Procedures other than the one outlined could cause injury or damage from battery acid spray, explosion, or charging system overload.

- Never connect to the negative post of the discharged battery.
- Never allow the two vehicles or the jumper cable clamps to touch each other.
- Never attempt to jump start a vehicle if the discharged battery fluid is frozen or if the battery fluid level is low, as the battery may rupture or explode.
- Do not jump start vehicles equipped with maintenance-free batteries if the test indicator is light yellow.
- Turn off all lights, heaters and other electrical accessories. Make sure the parking brake is applied and the transmission is set to "NEUTRAL" before attempting to jump start the engine.

Wear eye protection and remove rings, watches with metal bands and other metal jewelry.

1. Connect one end of the red jumper cable to the positive (+) post of the booster power source.
2. Remove the red protective cap from Booster Block's Positive Stud, then connect the other end of the red jumper cable to this stud.
3. Connect one end of the black jumper cable to the negative (-) post of the booster power source.
4. Remove the black protective cap from Booster Block's Negative Stud, then connect the other end of the black jumper cable to this stud.
5. Start the engine in the vehicle that is providing the jump start. Let the engine run for a few minutes, then start the engine in the vehicle that has the discharged batteries.

**WARNING:** Do not engage starter for more than 15 seconds. Allow starter time to cool before engaging again. This will prevent starter from overheating and will allow time delay relay time to cool.

6. To remove the cables, perform the above procedure in reverse order, then replace the protective sealant, if possible.

**NOTE:** Jumper cables must withstand 500 cranking amperes. If cable length is 20 feet (6 m) or less, use 2/0 (AWG) gage wires. If cable length is between 20-30 feet (6-9 m), use 3/0 (AWG) gauge wires.

**NOTE:** If, after doing this procedure, Starter turns but Engine still doesn't run; (with Jumper Cables in place) wait approximately 15 minutes (to give battery equalizers time to balance 12V and 24V charges), then try again. If engine still doesn't run, repeat procedure once again.

On **XL-40** vehicles, booster block is located in the engine compartment and is accessible through engine R.H. side door.

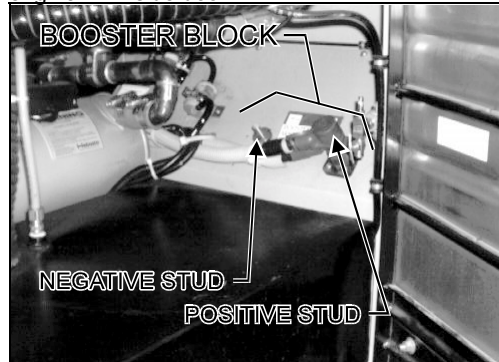

On **XL-45** vehicles, booster block is located in main power compartment.

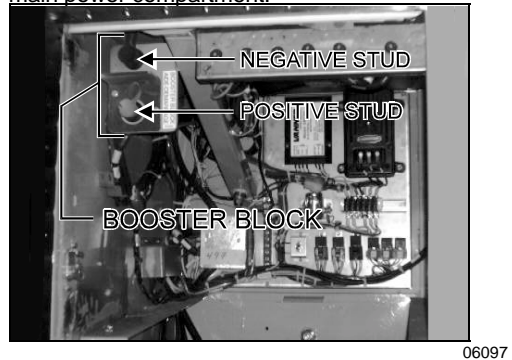

## ELECTRIC CIRCUIT PROTECTION

Two types of cutoff mechanisms are installed to protect the vehicle's electrical system; fuses and manually-resettable circuit breakers. If an electrical device is inoperative, check the corresponding cutoff mechanism.

**CAUTION:** Never replace a fuse with a higher rated one because it will cause severe damage to the electrical system.

### Main breakers

Most of the manually-resettable circuit breakers are located in the front & rear junction boxes and in the rear baggage compartment (XL-40) or the main power compartment (XL-45). An identification decal is affixed on the inside face of each door.

**XL-40** vehicles are equipped with six (6) main breakers; they are installed just below R.H. side baggage compartment's ceiling and can be identified as follows:

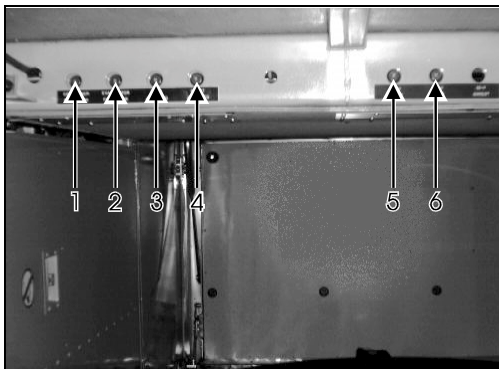

06099

- |                               |                   |
|-------------------------------|-------------------|
| 1. Condenser fan motor (CB8)  | 105 amps-24 volts |
| 2. Evaporator fan motor (CB9) | 105 amps-24 volts |
| 3. Rear junction box (CB7)    | 90 amps-24 volts  |
| 4. Front junction box (CB6)   | 90 amps-24 volts  |
| 5. Front junction box (CB4)   | 90 amps-12 volts  |
| 6. Rear junction box (CB3)    | 70 amps-12 volts  |

**XL-45** vehicles are equipped with eleven (11) main breakers; five (5) are installed on A/C junction box located in condenser compartment and the other six (6) are installed in main power compartment and can be identified as follows:

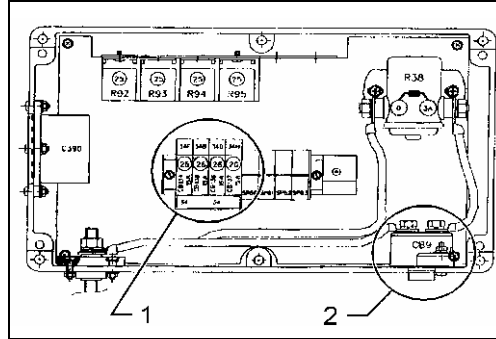

A/C junction box

06100

1. (From left to right)

- |                            |                  |
|----------------------------|------------------|
| CB134: Condenser fan motor | 15 amps-24 volts |
| CB135: Condenser fan motor | 15 amps-24 volts |
| CB136: Condenser fan motor | 15 amps-24 volts |
| CB137: Condenser fan motor | 15 amps-24 volts |

2. CB9: Evaporator fan motor 105 amps-24 volts

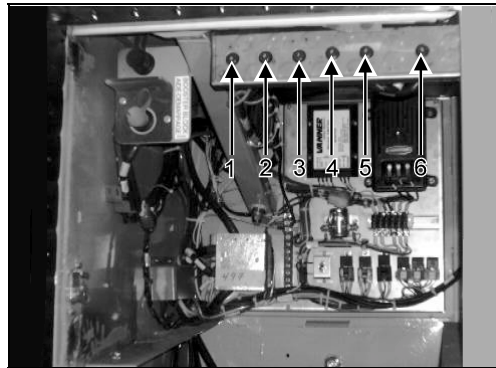

06101

- |                                |                   |
|--------------------------------|-------------------|
| 1. Rear junction box (CB3)     | 70 amps-12 volts  |
| 2. Front junction box (CB4)    | 90 amps-12 volts  |
| 3. Video system (Opt.) (CB131) | 40 amps-12 volts  |
| 4. Rear junction box (CB6)     | 90 amps-24 volts  |
| 5. Front junction box (CB7)    | 90 amps-24 volts  |
| 6. A/C main (CB1)              | 200 amps-24 volts |

**Locate burned fuses as follows:**

**R.H. console** (at back of temperature control buttons)

Temperature control.....1.5 amps (qty=2)

**Rear L.H. side baggage compartment ceiling**  
(for vehicles equipped with video system)

Video inverter .....2 amps (qty=2)

To gain access to the fuses, simply remove the inverter's front protective screen.



06104

**Steering compartment**

Kneeling module.....3 amps (qty=1)

Speed limit switch.....3 amps (qty=2)

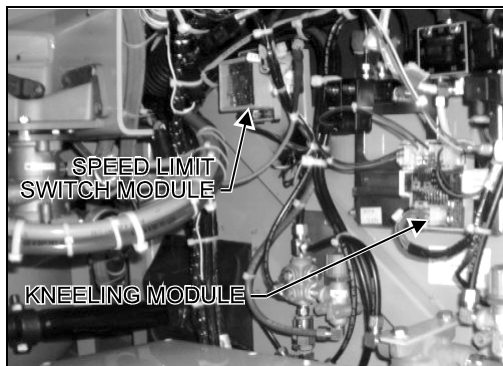

06105

**Battery equalizers**

On **XL-40** vehicles the two (2) battery equalizers ("VANNER"-50 amps-12 & 24 volts) are installed just below L.H. side baggage compartment's ceiling. The reset buttons are located on the end of equalizers facing the center of the coach.

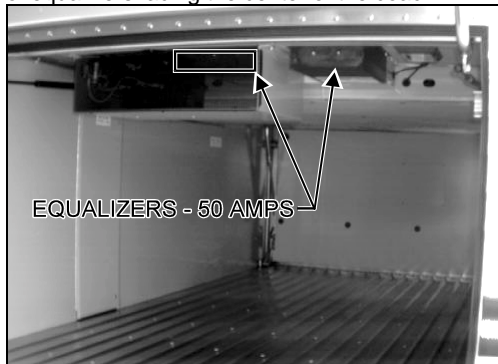

06106

**XL-45** vehicles have one (1) equalizer ("VANNER"-100 amps-12 & 24 volts). It is located inside Main power compartment and is equipped with auto reset, therefore there is no reset button.

**TIRES**

**Tire pressure**

The condition and pressure of the tires can greatly affect both useful tire life and road safety.

**NOTE:** The recommended tire inflation pressures are given in the "Technical Information" section, page 5-2. Also, cold tire inflation pressures are listed on the Department of Transport's certification plate, affixed below L.H. side control panel in driver's area. Tire pressure must be adjusted according to vehicle loading - see table in "Coach Final Record" (NOT NECESSARILY THE V.I.N. PLATE).

At regular intervals, verify the tire pressures. Use an accurate tire pressure gauge when checking inflation pressures. Never exceed the maximum tire inflation pressure specified on each tire.

Cold tire inflation pressure means: When a vehicle has not been driven for at least 3 hours or less than 1 mile (1.6 km).

## STARTING AND STOPPING PROCEDURES

**WARNING:** Incorrect tire pressures cause increased tire wear and adversely affect road holding of the vehicle, leading to loss of vehicle control.

**NOTE:** Always include the spare tire during a pressure verification.

### Changing wheels

Tire failure is a rare event these days, if tires are properly cared for. In case of a flat tire, move vehicle a safe distance away from traffic and apply the parking brake. Remember to switch "ON" the hazard flashers and according to the highway code regulations, set up the triangular reflectors (see "Emergency warning reflectors" on page 3-6) at an adequate distance to warn incoming motorists.

Spare wheel and tire are stored in the Spare wheel and tire compartment and are accessible by lowering the reclining front bumper. Use the wheel nut wrench to unscrew the two (2) bumper retaining bolts.

**WARNING:** It is recommended that two (2) people do this operation since bumper weighs 100lbs (45kg).

**CAUTION:** This compartment has not been designed for storage. Never leave any loose objects in this area since they may interfere with steering linkage mechanism.

### Removing spare wheel and tire from compartment

To pull out spare wheel and tire, open reclining bumper according to the previous instructions, unscrew the wing nut retaining the support and rail extension assembly (stored on R.H. side of wheel), then take out the assembly. Install assembly by matching its two (2) holes to the corresponding mounting pins located in front center of spare tire compartment. Unscrew the retaining bracket's T-handle to release the wheel and dolly assembly and pull out bracket. Pull out wheel using strap then remove tire covering.

Separate wheel and tire from dolly by unscrewing the two (2) mounting nuts.

**CAUTION:** After reclining bumper has been secured, the two (2) retaining bolts should be checked to make sure that they are tightly fastened.

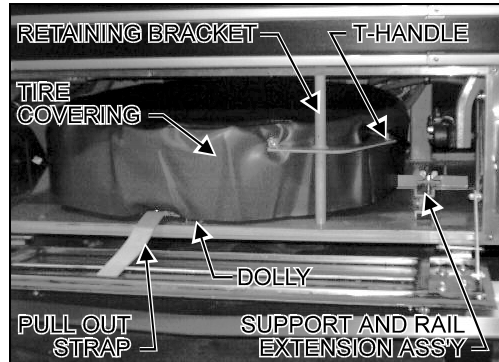

13005

**NOTE:** Reinstall support and rail extension assembly, then secure tire with retaining bracket before moving vehicle.

Jack and wheel nut wrench are stored at right in forward R.H. side baggage compartment.

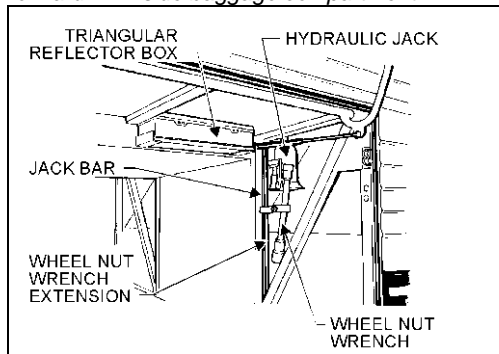

23012

Check the spare tire's inflation pressure periodically to keep it ready for use. Inflate spare tire to the pressure of the tire which has the highest pressure on the vehicle. Also, make sure that retaining bracket is securely fastened in order to prevent it from moving around inside compartment.

19

## STARTING AND STOPPING PROCEDURES

### Procedure

#### Step 1

Stop engine, apply parking brake, take out jack and wrench, then remove spare wheel and tire from their compartment.

#### Step 2

Remove hub cap (with appropriate wrench) or cover from wheel.

#### Step 3

With supplied wrench, loosen all wheel nuts to about one (1) full turn.

**NOTE:** For stud-mounted wheels, turn nuts counterclockwise on R.H. side of vehicle and clockwise on L.H. side. For hub-mounted wheels, turn nuts counterclockwise on both sides of vehicle.

#### Step 4

Use the hydraulic jack to raise the vehicle. Raise vehicle to the height required to remove wheel.

**NOTE:** For hydraulic jack placement, refer to "Jacking points", next in this section.

**WARNING:** Place jack on stable and level ground; if necessary, place a board under the jack.

Do not raise the vehicle until you are sure the jack is securely engaged.

**WARNING:** To prevent personal injury and/or equipment damage, use only the recommended jacking points.

Passengers must not remain inside vehicle while wheel is being replaced.

#### Step 5

Fully unscrew the wheel nuts, then remove nuts and wheel. Install spare wheel with existing nuts,

then slightly tighten nuts in a crisscross pattern before lowering the vehicle.

#### Step 6

Lower vehicle (until tire touches ground) by slowly unscrewing the jack's hydraulic valve.

#### Step 7

Torque all nuts, in a crisscross pattern, to 450-500 ft•lbs (610-680 N•m).

#### Step 8

Completely lower the coach and remove jack. Adjust tire pressure according to the cold tire inflation pressures.

#### Step 9

Store damaged wheel in spare tire compartment. Repair and balance the flat tire as soon as possible.

## TOWING

Two tow eyes are provided at front and rear under vehicle. Towing should be done from these points only. A solid link tow bar and safety chain must be used. This recommended method prevents damaging the vehicle. If required, connect an auxiliary air supply to the vehicle to actuate the vehicle brakes. The engine cannot be started by pushing or towing.

**WARNING:** Never allow passengers to ride in a towed vehicle for any reason whatsoever.

**CAUTION:** Internal lubrication of the transmission is inadequate when the vehicle is towed. The propeller shaft or the axle shafts should be removed when being towed to avoid the possibility of damaging transmission.

**NOTE:** When the propeller or axle shafts are reinstalled, ensure the nuts are tightened to the appropriate torques and the axle shafts are properly installed (R.H. & L.H.) and/or the propeller shaft is properly phased. Refer to the "Maintenance Manual" for torque values.

## STARTING AND STOPPING PROCEDURES

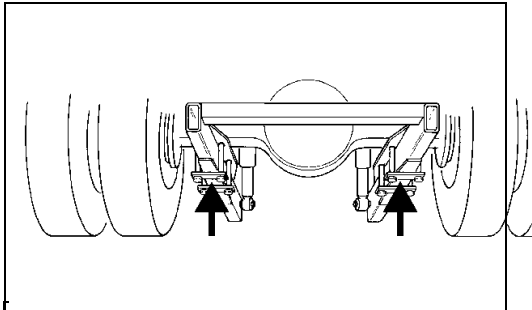

Drive Axle Jacking Points 11005

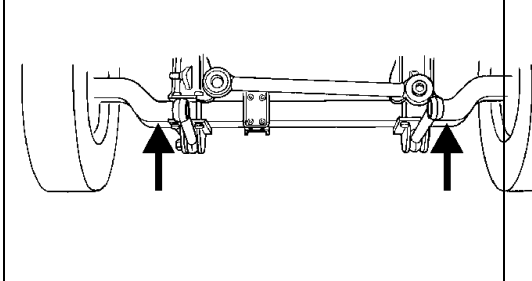

Front Axle Jacking Points 10005

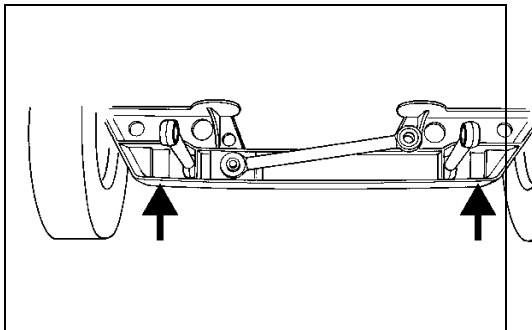

Tag Axle Jacking Points 11006

### JACKING POINTS

One (1) jacking point on each side of each axle is provided on vehicle. Refer to the following illustrations for details.

**CAUTION:** Remember that only these jacking points can be used.

**CAUTION:** The jacking points on tag axle must be used only to lift this axle.

**CAUTION:** To prevent damage to suspension components, always raise or unload tag axle before jacking coach.

Several kinds of hydraulic jacks can be used but must all support the following capacities:

Front axle - 13,000 lbs (5 900 kg)

Drive axle - 25,000 lbs (11 365 kg)

### RETRACTABLE TAG AXLE

Operation of the tag axle is controlled by a valve located on the L.H. Lateral Console. The valve can be flipped to either one of two positions, "Wheels up" or "Wheels down". Axle will automatically be raised or lowered by air pressure according to valve position (see page 2-20).

Tag axle service brakes operate only when axle is down. Never lower tag axle while vehicle is moving. When tag axle is up, the corresponding indicator light will illuminate, and a beep will sound to remind you that axle is up. Tag axle can be raised in tight maneuvering areas as in parking lots or to help in turning a short corner, thus shortening the wheelbase and allowing tighter turning. Raising tag axle transfers extra weight and additional traction to the drive wheels on a slippery surface.

**CAUTION:** Always raise tag axle before lifting vehicle to prevent damage to suspension components.

After either of the above uses, vehicle must be stopped, then tag axle must be lowered before resuming normal driving.

### TAG AXLE UNLOADED

This standard system allows unloading of the tag axle air springs, without raising the axle. This system is controlled by the same valve that applies to the retractable tag axle, and is used in the same situations described in "RETRACTABLE TAG AXLE" section. Follow the same recommendations that apply to the retractable axle.