

SECTION 23: ACCESSORIES

CONTENTS

1. AUDIO AND VIDEO EQUIPMENT DESCRIPTION	23-4
1.1 AMP-2000 (HIGH POWER AMPLIFIER)	23-5
1.1.1 Removal	23-6
1.2 AM/FM RADIO	23-6
1.2.1 AM/FM Radio Cassette and Disc CD Changer	23-6
1.2.2 AM/FM Radio / CD 1 Disc	23-6
1.2.3 Removal	23-6
1.3 CONTROL HEAD	23-7
1.3.1 Removal	23-7
1.4 VIDEO.....	23-7
1.4.1 Removal	23-8
1.4.2 Installation	23-8
1.5 BOOM-TYPE MICROPHONE	23-8
1.5.1 Removal	23-8
1.5.2 Installation	23-8
1.6 WIRELESS MICROPHONE	23-8
1.7 TV TUNER	23-9
1.8 KARAOKE	23-9
1.8.1 Karaoke Sound System - REI	23-9
1.8.2 Karaoke Panasonic Sound System – DVD-A300	23-9
1.9 DRIVER'S SPEAKERS.....	23-9
1.10 MONITOR.....	23-9
1.10.1 Removal	23-9
1.10.2 Installation	23-9
1.11 SCENIC VIEWING SYSTEM.....	23-10
1.12 ROOF ANTENNA INSTALLATION.....	23-10
2. HUBODOMETER	23-10
2.1 DESCRIPTION	23-10
2.2 OPERATION.....	23-10
2.3 REMOVAL	23-11
2.4 INSTALLATION	23-11
3. REMOTE KEYLESS ENTRY SYSTEM.....	23-11
4. BACK-UP CAMERA AND MONITOR	23-11
5. COLD STARTING AID (ETHER)	23-11
5.1 PREVENTIVE MAINTENANCE.....	23-12
5.2 TROUBLESHOOTING (IF SYSTEM IS NON-FUNCTIONING).....	23-12
5.3 THERMAL CUTOUT VALVE QUICK TEST.....	23-13
6. DESTINATION SIGN.....	23-13
6.1 DESCRIPTION	23-13
6.2 MAINTENANCE.....	23-13
6.3 DESTINATION SIGN LIGHT REPLACEMENT	23-13
6.4 ELECTRIC MOTOR REMOVAL AND INSTALLATION	23-13
6.5 SIGN CURTAIN REPAIR.....	23-14

Section 23: ACCESSORIES

7. LAVATORY	23-14
7.1 DESCRIPTION	23-14
7.2 MAINTENANCE.....	23-14
7.3 VENTILATION FAN	23-14
7.3.1 <i>Description</i>	23-14
7.3.2 <i>Maintenance</i>	23-15
7.3.3 <i>Removal and Installation</i>	23-15
7.4 DOOR LOCK	23-15
7.5 LAVATORY LIGHT	23-15
7.6 LAVATORY NIGHT-LIGHT.....	23-15
7.7 EMERGENCY BUZZER	23-16
7.8 FRESH WATER TANK	23-16
7.8.1 <i>Fresh Water Tank Heater (Optional)</i>	23-16
7.8.2 <i>Fresh Water Tank Draining</i>	23-17
7.8.3 <i>Fresh Water tank Filling</i>	23-17
7.9 LIQUID SOAP DISPENSER	23-17
7.10 FLUSH PUSH-BUTTON.....	23-18
7.10.1 <i>Pneumatic Timer Removal and Installation</i>	23-18
7.10.2 <i>Timer Adjustment</i>	23-18
7.11 FLUSH PUMP.....	23-18
7.11.1 <i>Flush Pump Pressure Adjustment</i>	23-18
7.12 SUMP TANK.....	23-18
7.12.1 <i>Sump Tank Draining</i>	23-18
7.12.2 <i>Sump Tank Filling</i>	23-18
7.13 CLEANING CABINET	23-19
8. AIR HORN VALVE	23-19
8.1 AIR HORN VALVE MAINTENANCE.....	23-19
9. WINDSHIELD WIPERS AND WASHERS	23-19
9.1 GENERAL DESCRIPTION	23-19
9.2 WIPER ARM	23-20
9.2.1 <i>Sweep Adjustment</i>	23-20
9.2.2 <i>Removal</i>	23-21
9.2.3 <i>Installation</i>	23-21
9.3 LOWER LINKAGE ADJUSTMENT	23-21
9.4 UPPER LINKAGE ADJUSTMENT.....	23-22
9.5 WINDSHIELD WIPER MOTORS.....	23-23
9.5.1 <i>Lower Windshield Wiper Motor Replacement</i>	23-23
9.5.2 <i>Upper Windshield Wiper Motor Replacement</i>	23-24
9.6 TROUBLESHOOTING	23-24
10. SPECIFICATIONS	23-33

ILLUSTRATIONS

FIGURE 1: SOUND SYSTEM JUNCTION PLATE	23-4
FIGURE 2: AMP-2000 AMPLIFIER	23-5
FIGURE 3: PANASONIC CQ-R115SEUC.....	23-6
FIGURE 4: PANASONIC CQ-DP930-EUC.....	23-6
FIGURE 5: CONTROL HEAD	23-7

FIGURE 6: INSTALLATION IN PARCEL COMPARTMENT	23-7
FIGURE 7: VIDEO	23-7
FIGURE 8: BOOM-TYPE MICROPHONE	23-8
FIGURE 9: WIRELESS MICROPHONE	23-8
FIGURE 10: TUNER CONTROLS DESCRIPTION	23-9
FIGURE 11: KARAOKE (FRONT VIEW)	23-9
FIGURE 12: KARAOKE (REAR VIEW)	23-9
FIGURE 13: KARAOKE PANASONIC DVD-A300	23-9
FIGURE 14: MONITOR HOUSING REAR PANEL.....	23-0
FIGURE 15: INSTALLATION IN PARCEL COMPARTMENT	23-10
FIGURE 16: CAMERA INSTALLATION ON WINDSHIELD	23-10
FIGURE 17: HUBODOMETER	23-10
FIGURE 18: ENGINE.....	23-12
FIGURE 19: COLD STARTING AID	23-12
FIGURE 20: DESTINATION SIGN - ELECTRICAL.....	23-13
FIGURE 21: DESTINATION SIGN - ELECTRIC MOTOR.....	23-14
FIGURE 22: DESTINATION SIGN – ELECTRONIC	23-14
FIGURE 23: LAVATORY	23-14
FIGURE 24: VENTILATION FAN INSTALLATION.....	23-15
FIGURE 25: DOOR LOCK.....	23-15
FIGURE 26: FUNCTIONING OF LAVATORY	23-16
FIGURE 27: FRESH WATER TANK SERVICE VALVES.....	23-17
FIGURE 28: LIQUID SOAP DISPENSER.....	23-17
FIGURE 29: SUMP TANK.....	23-18
FIGURE 30: AIR HORN VALVE	23-19
FIGURE 31: WIPER MOTORS LOCVAATION.....	23-19
FIGURE 32: DASHBOARD.....	23-19
FIGURE 33: MULTIFUNCTION LEVER	23-20
FIGURE 34: WINDSHIELD WASHER RESERVOIR.....	23-20
FIGURE 35: LOWER WINDSHIELD WIPER.....	23-20
FIGURE 36: UPPER WINDSHIELD WIPER	23-21
FIGURE 37: LOWER WINDSHIELD WIPER INSTALLATION.....	23-22
FIGURE 38: UPPER WINDSHIELD WIPER INSTALLATION.....	23-23
FIGURE 39: TROUBLESHOOTING	23-25
FIGURE 40: TROUBLESHOOTING	23-26
FIGURE 41: TROUBLESHOOTING	23-27
FIGURE 42: TROUBLESHOOTING	23-28
FIGURE 43: TROUBLESHOOTING	23-29
FIGURE 44: TROUBLESHOOTING	23-30
FIGURE 45: TROUBLESHOOTING	23-31
FIGURE 46: TROUBLESHOOTING	23-32

1. AUDIO AND VIDEO EQUIPMENT DESCRIPTION

The power amplifier is mounted on a sound system junction plate which is located over the front wheel housing (Fig. 1), to access, open the first baggage compartment. In addition to the public address (PA) systems, options for AM/FM stereo radio and cassette player, CD changer, karaoke, wireless microphone, video system with monitors, scenic viewer and digital processor controller may be featured.

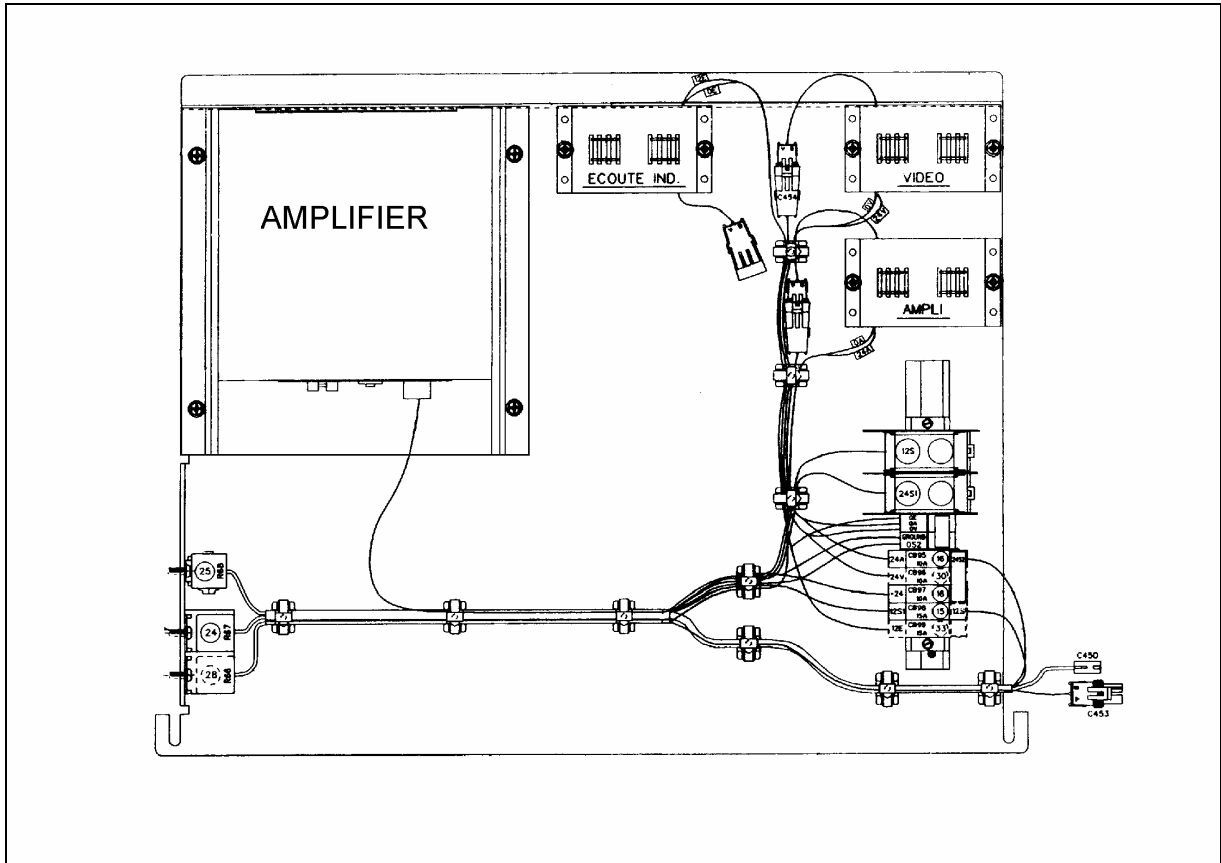

FIGURE 1: SOUND SYSTEM JUNCTION PLATE

Each service module mounted to the underside of the parcel racks contains a 40-watt speaker. The speakers in the passenger section (twelve in H3-41 or sixteen in H3-45) are wired in stereo and are powered by the amplifier. A microphone outlet mounted in the driver's area is provided as standard equipment.

1.1 AMP-2000 (HIGH POWER AMPLIFIER)

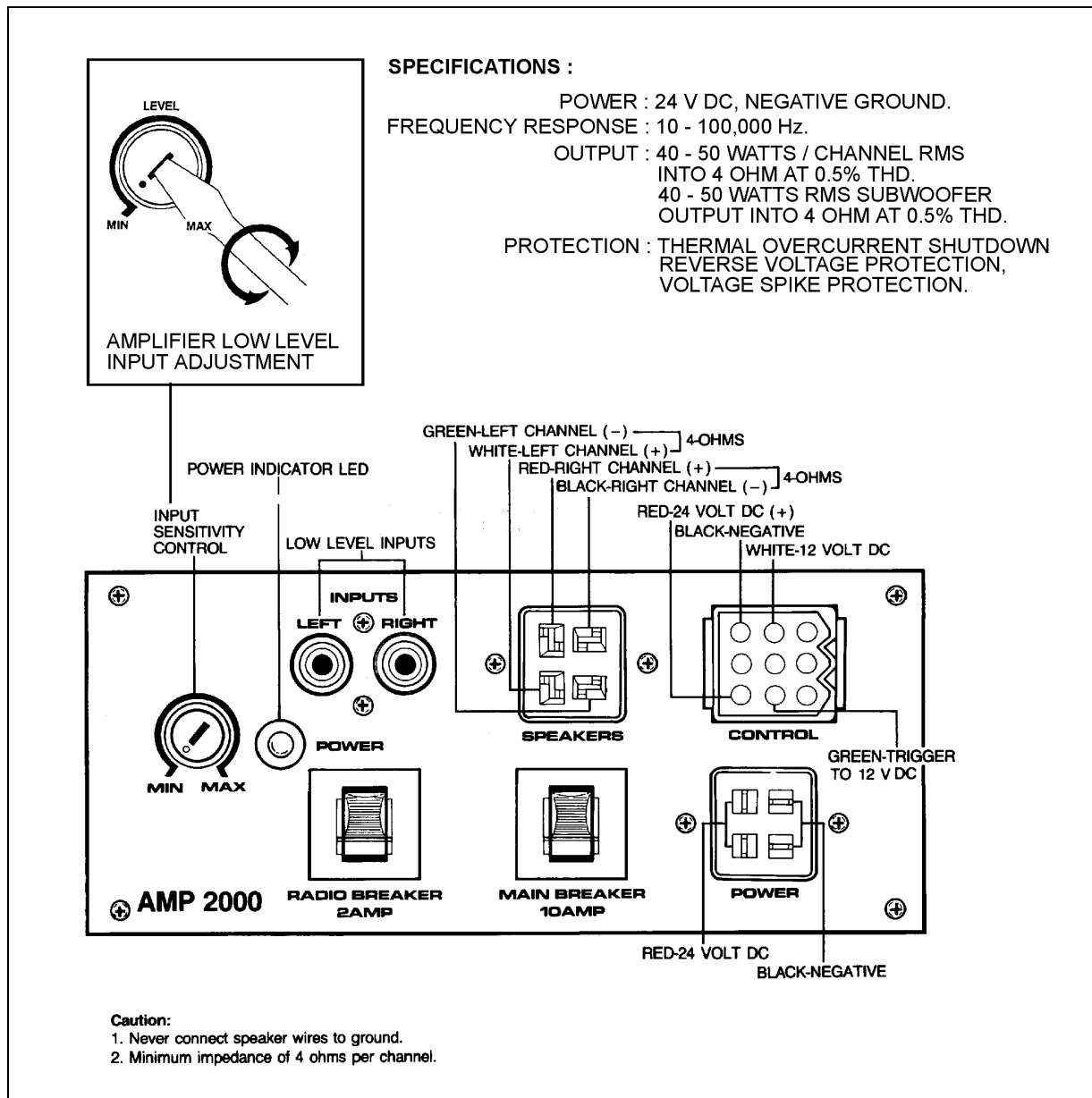

FIGURE 2: AMP-2000 AMPLIFIER

The AMP-2000 brings an added dimension to your stereo equipment and increases the total output of the system. The amplifier will perform with any unit operating in a 24-volt with negative ground electric system. The AMP-2000 is located over the front wheel housing. To access, open the first baggage compartment door.

The input sensitivity is adjustable from 100mV to 1V to match the output of the radio or tape deck. Set the volume control on the radio, then adjust the input control on the amplifier for an average listening level. This gives the best balance between radio output and system signal-to-noise ratio (Fig. 2).

Section 23: ACCESSORIES

Caution: The low level input adjustment for this amplifier has been preset according to system specifications.

1.1.1 Removal

Remove the amplifier as follows:

1. Set the battery master switch to the "OFF" position. Refer to Section 6: "Electrical System" for switch location.
2. Remove the sound system junction plate from its location. To perform this step, disconnect wiring connectors, remove cable ties and remove the bolts retaining the sound system junction plate.
3. Remove the four screws retaining the amplifier to its sound system junction plate.
4. Reverse the removal procedure to install the amplifier.

1.2 AM/FM RADIO

1.2.1 AM/FM Radio Cassette and Disc CD Changer

The audio system is composed of an AM/FM radio cassette player "Panasonic, model CQ-R115SEUC (Fig. 3). Also, the vehicle may be equipped with a 6 or 12 disc CD changer and two additional Hi-Fi speakers in the driver's area. A roof antenna as well as different microphone outlets, can be installed as optional equipment.



FIGURE 3: PANASONIC CQ-R115SEUC

1.2.2 AM/FM Radio / CD 1 Disc

This audio system is composed of an AM/FM radio CD player "Panasonic, model CQ-DP930-

EUC (Fig. 4). Also, the vehicle may be equipped with two additional Hi-Fi speakers in the driver's area. A roof antenna as well as different microphone outlets, can be installed as optional equipment.



FIGURE 4: PANASONIC CQ-DP930-EUC

Note: Before attempting to solve an electrical problem on the sound system, refer to the master wiring diagrams.

Instructions for proper use of the radio are included in the "Panasonic Owner's Manual" which is provided in the technical publication box delivered with the vehicle. The radio is a serviceable component and should only be serviced by a qualified electronics technician. Refer to "Panasonic Service Centers" guide included in the technical publication box.

1.2.3 Removal

To remove the radio from its location, proceed as follows:

1. Place the battery master switch in the "OFF" position.
2. Remove the dashboard panel cover.
3. Disconnect the electrical cable connectors from radio and unfasten back plate securing screw.
4. To separate the radio from its support, push in the dismounting pins included with the Panasonic Owner's Manual.
5. Push the unit through the front instrumentation panel.
6. Install a new unit by reversing the procedure.

1.3 CONTROL HEAD

The system 2000 (Fig. 5) is designed exclusively for coach operations. A complete system will control the following equipment:

- A specially designed 70 watt per channel RMS amplifier, capable of driving up to twenty-six, four ohm speakers.
- Six, custom designed ten-inch color monitors that incorporate a unique anti-theft locking slide mount. This makes installation and removal very easy.
- A specially modified VHS video cassette player that allows the operator convenient control over its functions.
- A digital audio processor that incorporates a centralized system control. The system 2000 microprocessor allows the operator to control up to three audio selections, permitting custom tailoring of each channel's sound quality. There are three microphone inputs for the PUBLIC ADDRESS SYSTEM (PAS), which are switchable between internal and external speakers. The unit contains a separate video section for the VCP that allows the driver to control his own separate audio selections.

Instructions for proper use of the control head are included in the "REI Operator's Manual" which is provided in the technical publication box delivered with the vehicle.

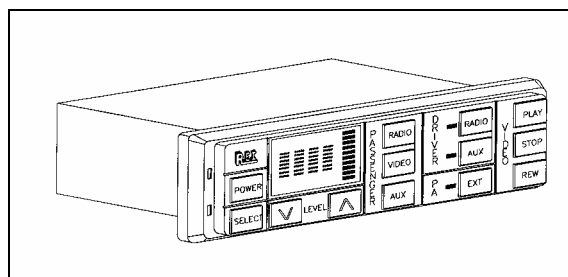

FIGURE 5: CONTROL HEAD

1.3.1 Removal

To remove the control head from its location, proceed as follows:

1. Place the battery master switch in the "OFF" position.
2. Remove the dashboard panel cover.
3. Disconnect the electrical cable connectors from radio and unfasten back plate securing nut.
4. To separate the control head from its support, push in the dismantling pins included with the REI Operator's Manual.
5. Push the unit through the front instrumentation panel.
6. Install a new unit by reversing the procedure.

1.4 VIDEO

The video is located in the first parcel compartment on the driver's side (Fig 6 & 7). Instructions for proper use of the video are included in the "Operator's Manual" which is provided in the technical publication box.

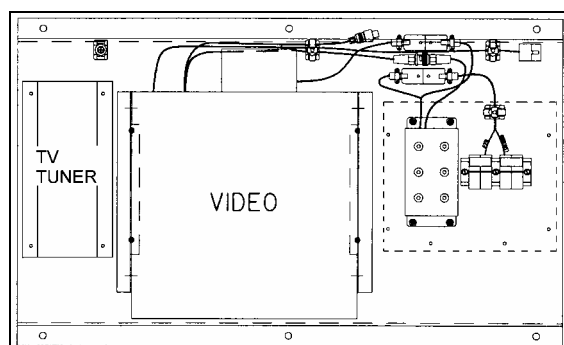

FIGURE 6: INSTALLATION IN PARCEL COMPARTMENT

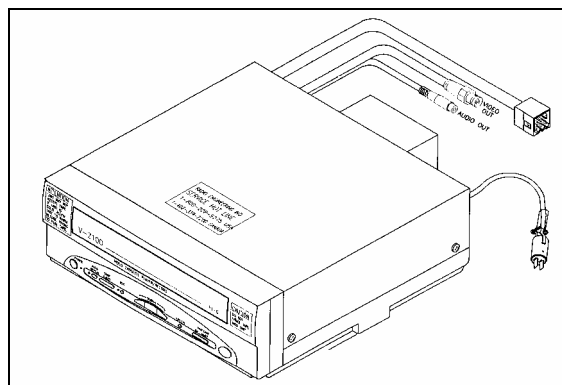

FIGURE 7: VIDEO

Section 23: ACCESSORIES

1.4.1 Removal

1. Place the battery master switch in the "OFF" position.
2. Remove the VCP/VCR mounting locknuts from rubber mounts.
3. Disconnect wiring.
4. Remove VCP/VCR unit from parcel compartment.

1.4.2 Installation

1. Install VCP/VCR unit into parcel compartment aligning rubber mount studs with mounting holes. Insert mount studs through mounting holes.
2. Install locknuts on mount studs.
3. Reconnect wiring.
4. Place the battery master switch in the "ON" position.

1.5 BOOM-TYPE MICROPHONE

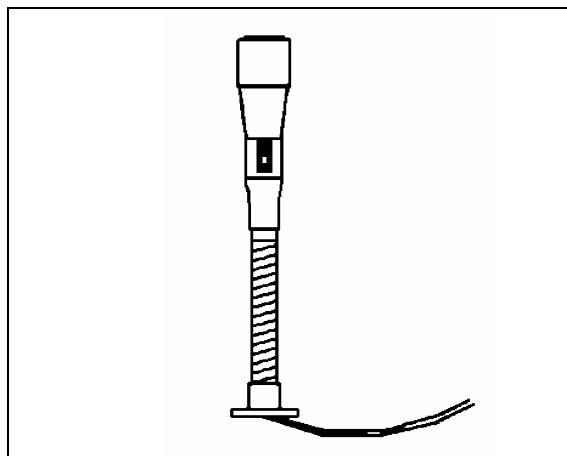

FIGURE 8: BOOM-TYPE MICROPHONE

23083

1.5.1 Removal

1. Place the battery master switch in the "OFF" position.
2. Remove the mounting screws at mounting flange.

3. Disconnect wiring.

1.5.2 Installation

1. Reconnect wiring.
2. Align mounting flange with holes and install screws.
3. Remove spacer block mounting screws.
4. Insert spacer block and install mounting screws.
5. Place the battery master switch in the "ON" position.

1.6 WIRELESS MICROPHONE

The R-505 is a VHF high-band system with quartz controlled fixed frequency and tone squelch design (fig. 9). The R-505 must be combined with Q series wireless microphones, and can be used as an individual or a multi-channel system with 2 or more sets together. Instructions for proper use of the R-505 are included in the "REI Operating Manual" which is provided in the technical publications box delivered with the vehicle.

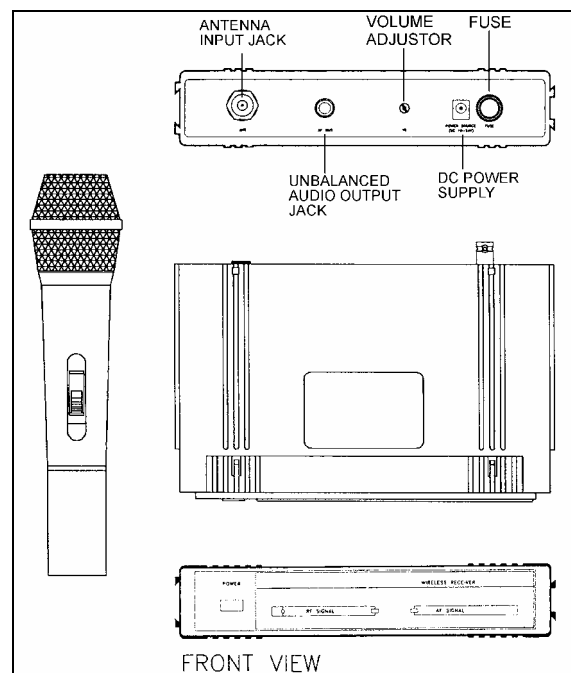

FIGURE 9: WIRELESS MICROPHONE

1.7 TV TUNER

For TV tuner control descriptions, refer to fig. 10.

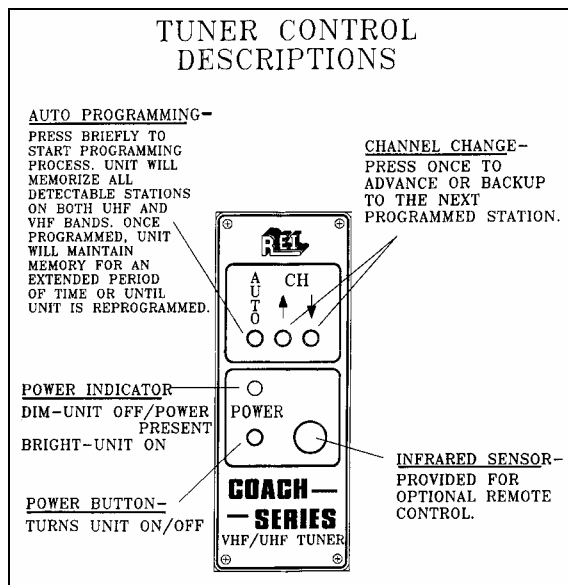

FIGURE 10: TUNER CONTROLS DESCRIPTION

1.8 KARAOKE

Instructions for proper use of the relevant Karaoke system are included in the "Operating Manual" that is provided in the technical publications box delivered with the vehicle.

1.8.1 Karaoke Sound System - REI

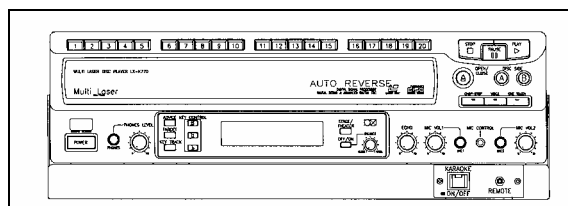

FIGURE 11: KARAOKE (FRONT VIEW) 23078

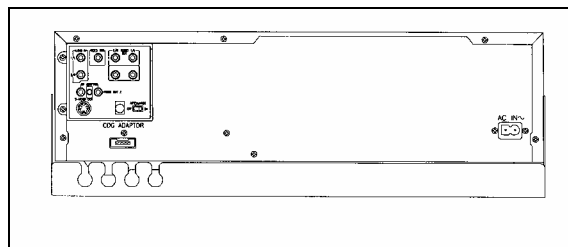

FIGURE 12: KARAOKE (REAR VIEW) 23079

1.8.2 Karaoke Panasonic Sound System – DVD-A300



FIGURE 13: KARAOKE PANASONIC DVD-A300

1.9 DRIVER'S SPEAKERS

The driver's speakers are mounted one on each side. This arrangement provides the driver with clear stereo sound. Controls for the driver's audio allow selection between the radio and the auxiliary audio (independent of the passenger's speakers) or muting the speakers.

1.10 MONITOR

For monitor adjustment, refer to figure 14.

1.10.1 Removal

The front and side, ten-inch color monitors are slide mounted and retained by key locks. A LED indicator is provided on the back to indicate when the unit is "ON". The red button is the monitor ON/OFF switch and the pin style button is the circuit breaker reset button.

1. Place the battery master switch in the "OFF" position.
2. Unlock the monitor slide and pull towards the front of the monitor.
3. After removal, cover mount location using the monitor cover assembly and lock.

1.10.2 Installation

1. Remove monitor cover assembly located over mounting bracket if needed.
2. Align the monitor mount with the slide and slide monitor into place.
3. Lock the monitor or cover to prevent removal.

Note: Make sure connections are not bent or damaged. If monitor is not being replaced, immediately install the mounting cover.

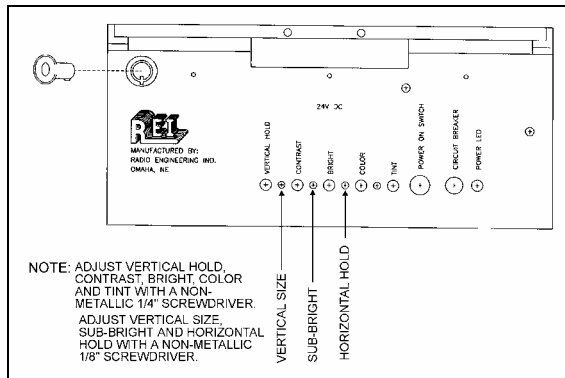

FIGURE 14: MONITOR HOUSING REAR PANEL

1.11 SCENIC VIEWING SYSTEM

The scenic viewing system enables the passengers to view the road ahead of the vehicle. This system is composed of a camera, a dashboard mounted ON/OFF switch and the audio – video switching box located in the first parcel compartment on the driver's side (Figs. 15 & 16).

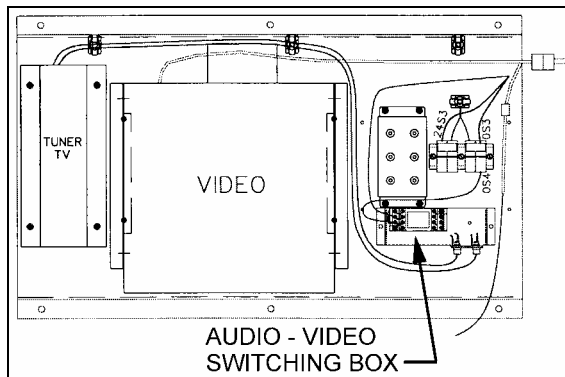

FIGURE 15: INSTALLATION IN PARCEL COMPARTMENT

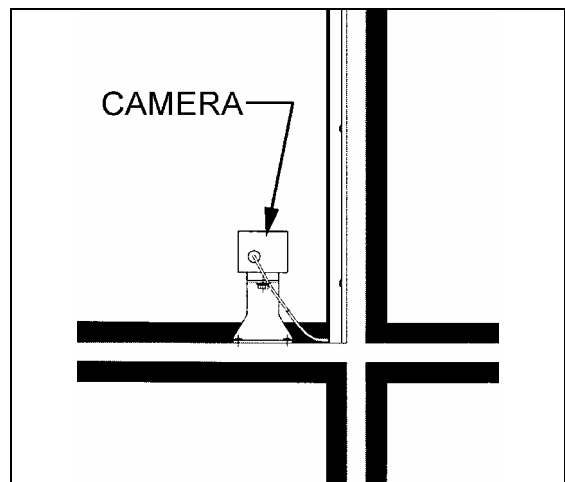

FIGURE 16: CAMERA INSTALLATION ON WINDSHIELD

1.12 ROOF ANTENNA INSTALLATION

1. Find the desired location and drill a hole according to specification.
2. To remove dirt and grease, wash hole edge with alcohol.
3. If so equipped, remove foam padding ring from antenna to free the metal surface (foam can produce air bulbs in new rubber seal).
4. With SIKA 205, wash the vehicle hole edge and the antenna base surface, wait at least two (2) minutes for chemical evaporation.
5. Apply new seal SIKA 221 on both, vehicle hole edge and antenna base.
6. Fix the antenna in place.
7. Remove excess seal and complete a finishing joint all around the antenna base.

2. HUBODOMETER

2.1 DESCRIPTION

An optional wheel hubodometer (Fig. 17) may have been installed on the R.H. side of the drive axle. It indicates the total distance in miles or kilometers covered by the coach since it has left the factory, including road testing.

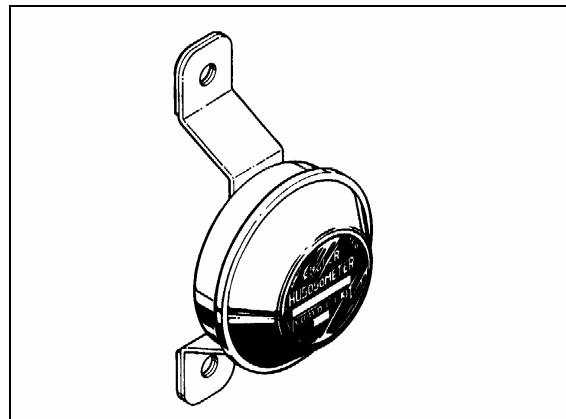

FIGURE 17: HUBODOMETER

23027

2.2 OPERATION

The hubodometer is calibrated for a specific wheel size (diameter). Wheel rotation causes a mechanism inside the hubodometer to record distance after a predetermined number of rotations. The unit should be serviced at a competent speedometer repair facility.

Note: Do not use paint, solvent or thinner on hubodometer face or on plastic hubcaps. Do not weld on hubodometer.

2.3 REMOVAL

To remove the unit, remove the two lock nuts and washers securing it to the wheel hub, and pull the unit off the studs.

2.4 INSTALLATION

Place the hubodometer unit over the wheel hub studs. Replace the lock washers and nuts. Torque stud nuts to 110-165 ft•lb (150-225 N•m).

3. REMOTE KEYLESS ENTRY SYSTEM (VIP ONLY)

The remote keyless entry and anti-theft alarm system has two main components:

1. A five-button keypad on the entrance door outside panel.
2. An electronic microprocessor/relay module mounted on top of the defroster unit.

The factory-programmed code is permanently recorded on a plastic card (credit card size) which is supplied to the owner, and on a decal, which is affixed on the electronic microprocessor/relay module mounted on defroster unit. Owner can also select and program his own personal code by pressing a specified sequence of keypad buttons. Refer to "Owner's Manual" and "Remote Keyless Entry and Anti-Theft Alarm System" Instruction Guide for instructions on how to program a new code and for any operation information relating to the keyless door entry system.

Caution: Never press on the keypad buttons with a key, a pencil or any sharp object. Such objects could damage the buttons. Although each button is provided with two digits separated by a vertical line, there is only one contact per button. Press in center of button, i.e. between the two digits where the vertical line is.

Before attempting to solve an electrical problem on the remote keyless entry system, refer to the wiring diagrams (VIP model).

Caution: Do not tamper the electronic microprocessor/relay module seal during the warranty period, as this will void the warranty.

4. BACK-UP CAMERA AND MONITOR

An optional back-up camera is available which provides the driver with visual assistance when backing-up. The back-up camera is mounted in a retractable housing. The camera is automatically activated when the transmission is put in reverse gear and the ignition switch is "ON". The TV monitor is mounted on top of the dashboard. Refer to the Operator's Manual under "Controls & Instruments".

Note: A switch located in the rear electric compartment is used to retract the back-up camera for cleaning or maintenance.

5. COLD STARTING AID (ETHER)

The vehicle can be equipped with an electrically-operated type ether cold starting aid designed to ease engine starting when temperature is below 35°F (2°C).

On vehicles equipped with cold starting aid, the system consists of the main following parts:

- Ether starting aid switch
- Ether cylinder
- Solenoid valve (24 V)
- Thermal cutout valve
- Atomizer

The control rocker switch is located on the dashboard. This switch is provided with a locking mechanism to avoid accidental use when engine is running. To activate the ether starting aid, proceed as follows:

1. Prior to cranking engine, press down rocker switch for three seconds to fill solenoid valve.
2. Release switch to discharge shot.

Section 23: ACCESSORIES

3. Allow three seconds for shot to discharge.
4. Start engine, use additional shots if necessary to keep engine running.

Caution: This practice should be performed only when absolutely necessary. Excessive use of fluid could result in serious engine damage.

The ether cylinder and solenoid valve assembly are mounted on the engine compartment wall and are accessible from the engine compartment R.H. side door.

The thermal cutout valve is mounted on the engine (radiator side). Its function is to prevent discharge of ether when engine is warm (over 90 F (32 C)). An atomizer is installed on top of the air intake duct (Fig. 18).

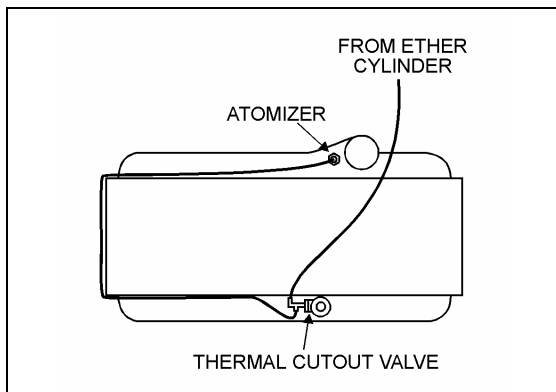

FIGURE 18: ENGINE

23032

5.1 PREVENTIVE MAINTENANCE

During the summer months, remove cylinder to avoid high temperature actuation of the cylinder safety relief device. Always screw valve cap into solenoid valve opening to prevent entrance of road dirt. When removing cylinder, be careful to prevent dirt from entering the valve.

5.2 TROUBLESHOOTING (IF SYSTEM IS NON-FUNCTIONING)

Warning: During the following test, direct free end of tube away from personnel and all sources of ignition as this fuel is extremely flammable. Avoid breathing vapors and contacting fuel with skin. Never smoke during test.

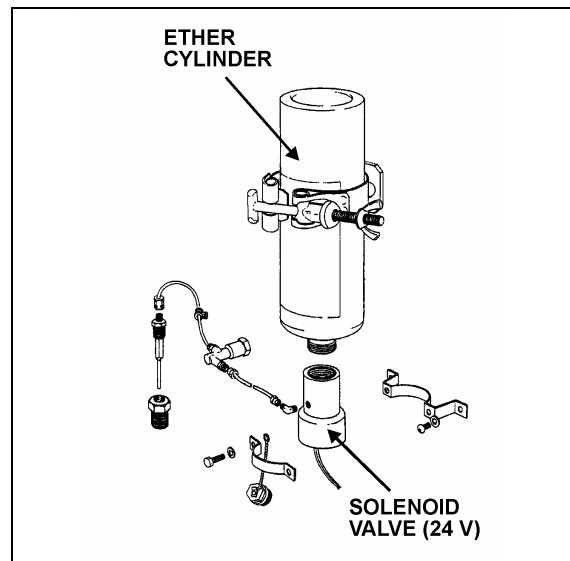

FIGURE 19: COLD STARTING AID

23048

1. Check cylinder for hand tightness and fuel supply (Fig. 19). Empty cylinder weight is approximately 17 oz (480 g); full cylinder weight is approximately 35 oz (990 g). If cylinder is empty, replace it. Before replacing cylinder, install new valve gasket in solenoid valve.
2. If still not functioning, disconnect tubing at solenoid valve fitting. Actuate solenoid valve. (Ask an assistant to actuate solenoid valve using the rocker switch on the dashboard).
 - If solenoid valve is non-functioning, check electric circuit, (refer to wiring diagrams). If sound, remove and replace the solenoid valve. If not, repair electric circuit.
 - If valve is functioning, reassemble valve fitting and connect tube. Disconnect tube at thermal cutout valve from port "Tube from valve".
3. Actuate the solenoid valve.
 - If fuel is not discharged from tube, remove tube and blow out or replace.
 - If fuel is discharged, connect tube to thermal cutout valve, and disconnect other tube.
4. Actuate the solenoid valve.
 - If fuel is not discharged, replace the cutout valve.

Note: If engine coolant temperature is 90°F (32°C) or over, it is normal that fuel is not discharged as the valve is in closed position.

- If fuel is discharged, connect tube to thermal cutout valve, and disconnect tube from atomizer.

5. Actuate the solenoid valve.

- If fuel is not discharged from tube, fuel line is clogged. Remove tube and blow out or replace.
- If fuel is discharged, replace the atomizer.

5.3 THERMAL CUTOUT VALVE QUICK TEST

1. Engine coolant temperature must be below 90 F (32 C).
2. Temporarily disconnect tube at thermal cutout valve from port "Tube to atomizer".
3. Actuate solenoid valve (Ask an assistant to actuate solenoid valve by means of the rocker switch on the dashboard). Fuel should be discharged through the thermal cutout valve.

Warning: Avoid breathing vapors and contacting fuel with skin. Never smoke during test.

4. Reconnect tube to thermal cutout valve.
5. Start engine, using cold starting aid if necessary. Stop engine when it reaches operating temperature.
6. Disconnect tube at thermal cutout valve as in step 2, and repeat step 3. No fuel should be discharged.

6. DESTINATION SIGN

6.1 DESCRIPTION

The destination sign is located at upper front of the vehicle. Two models are available.

ELECTRICAL DESTINATION SIGN (Optional)

The lighting is provided with a fluorescent tube, which is activated by means of a rocker switch

located on the dashboard. The destination sign is electrically operated, two rocker switches mounted side by side on the destination sign control its motor. The unwinding speed control switch determines the rolling speed without actuating it. The selecting switch (momentary type) controls and actuates the rolling direction (fig. 20).

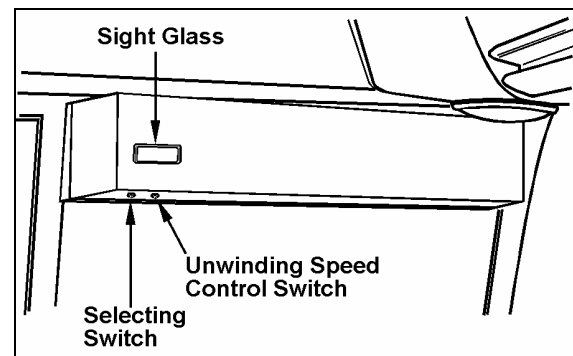

FIGURE 20: DESTINATION SIGN - ELECTRICAL 23122

6.2 MAINTENANCE

Inspect the following items regularly:

1. Check for free and easy mechanism movement.
2. Check for loose items on the sign mechanism, such as wire, loose clips, hanging tape, etc.
3. Check tension and condition of the two drive belts and replace as required.
4. Periodic lubrication is **NOT** recommended.

6.3 DESTINATION SIGN LIGHT REPLACEMENT

Refer to Section 06, Electrical System, paragraph "13.4.7 Destination Sign Light - Bulb Removal and Replacement" and "13.4.8 Destination Sign - Fluorescent Removal and Replacement".

6.4 ELECTRIC MOTOR REMOVAL AND INSTALLATION

To remove the electric motor:

1. Remove the six Phillips-head screws and washers retaining the destination sign cover, then carefully remove the cover from its location.
2. Disconnect wires from electrical motor.

Section 23: ACCESSORIES

3. Remove both screws retaining motor to destination sign frame (Fig. 21).
4. Slide motor upwards, then remove the drive belt.
5. Remove motor through the opening intended for this purpose.

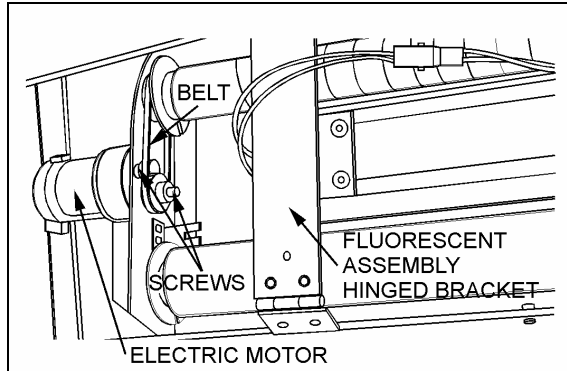

FIGURE 21: DESTINATION SIGN-ELECTRIC MOTOR 23034

6. Install the motor by reversing the above procedure.

6.5 SIGN CURTAIN REPAIR

In the event a destination sign curtain is torn, it can be repaired with 3M polyester tape or any equivalent cellophane tape. When repairing a tear, the tape should be used on both sides of the curtain.

ELECTRONIC DESTINATION SIGN (Optional)

To change the destination, depress the selecting switches until the desired destination appears in the LCD display.

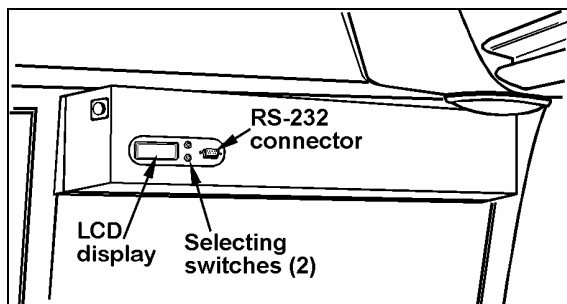

FIGURE 22: DESTINATION SIGN – ELECTRONIC 23123

Note: The destination sign must be programmed with a computer connected to the RS-232 connector prior to first use. Follow the instructions on the computer disk to install and run the software.

Note: All destination sign models are equipped with lights (bulb light or fluorescent) which illuminates automatically when the headlight or fog light switch is activated.

7. LAVATORY

7.1 DESCRIPTION

The lavatory is located in the rear R.H. corner of the coach. It is equipped with a chemical flush toilet, bathroom tissue dispenser, washbasin, towel dispenser, waste container, mirror, ashtray, and a cleaning cabinet. A liquid soap dispenser and moist towel dispenser are optional.

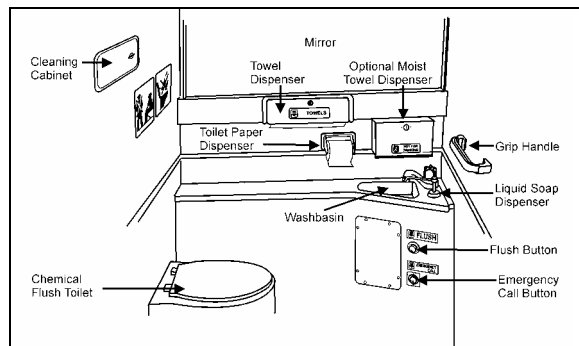

FIGURE 23: LAVATORY

Locking the lavatory door from the inside will illuminate a fluorescent light in the lavatory and two outside signs to indicate occupation. One sign is located on the outer wall of the lavatory and another sign is located over the windshield. An indicator light on the dashboard will illuminate to inform the driver when the lavatory is occupied. A night-light is permanently lit in the lavatory when the ignition switch is in the ON position.

7.2 MAINTENANCE

The servicing procedure for the lavatory is described in the "Operator's Manual" included in the technical publications box delivered with the vehicle.

7.3 VENTILATION FAN

7.3.1 Description

The lavatory ventilation fan, mounted in engine compartment over the oil reserve tank (Fig. 24), serves two purposes. It exhausts objectionable odors and provides a constant air circulation in the lavatory compartment by heating or cooling the lavatory with the vehicle ambient air. Air

flows in the lavatory compartment through a vent grill located in the upper section of the lavatory door and exhausts through a grill located next to the toilet.

Note: This fan runs constantly when the ignition switch located on the dashboard is in the "ON" position.

7.3.2 Maintenance

The frequency of preventive maintenance should be determined according to vehicle mileage and operating conditions. However, it is recommended to check this item every 50,000 miles (80 000 km) or once a year, whichever comes first.

Remove fan and motor assembly. Check for fan housing wheel and motor free operation. When defective motor occurs, new motor must be installed.

7.3.3 Removal and Installation

1. With the engine compartment rear door opened, remove hose clamp securing duct to ventilation fan inlet, and disconnect duct.
2. Disconnect the ventilation motor wiring connector.
3. Remove the two bolts retaining the ventilation fan housing support to the square tubing. Remove the ventilation fan assembly from its location.
4. The unit can now be disassembled and motor replaced.
5. Reverse previous steps to reinstall ventilation fan assembly on vehicle.

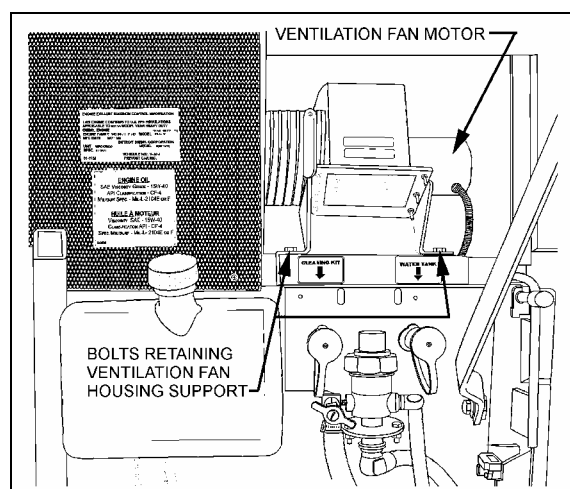

FIGURE 24: VENTILATION FAN INSTALLATION

7.4 DOOR LOCK

Lavatory door lock has inside and outside handles, as well as an inside latch to lock door from inside the compartment. If the lock fails to release, the door can be opened from the outside using a special key which is supplied to the driver. Lock assembly can be removed from the door, then readily disassembled and parts replaced, if necessary (Fig. 25). A thin coat of lubricant on all moving parts will ensure trouble-free operation.

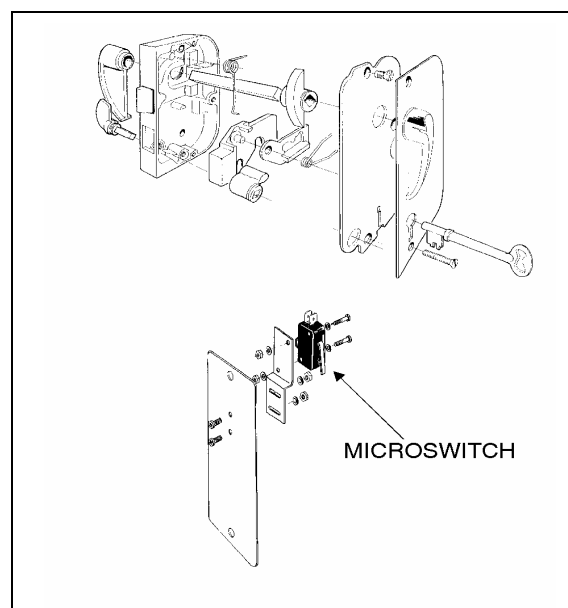

FIGURE 25: DOOR LOCK

23037

7.5 LAVATORY LIGHT

The lavatory light is installed on ceiling. A microswitch, which is mounted in the door exterior frame, is activated by the door lock mechanism upon locking to energize the circuit. This switch is readily serviced by removing the two Phillips-head screws securing the mounting plate to the door exterior frame.

Proceed as Section 06, Electrical System, paragraph "13.3 Dome, Rear Roof and Lavatory Lights" for lights replacement.

7.6 LAVATORY NIGHT-LIGHT

The lavatory night-light is illuminated as soon as the ignition switch is set to the "ON" position. See Section 06, Electrical System, paragraph "13.4.4 Parcel Rack / Lavatory Night Light - Bulb Removal and Replacement" for lights replacement.

Section 23: ACCESSORIES

7.7 EMERGENCY BUZZER

The lavatory emergency buzzer is mounted on the alarm junction box in the front service compartment and sounds when the emergency call push-button switch in the lavatory compartment is activated. For specific wiring information, refer to wiring diagrams. To remove the emergency call push-button switch, proceed as follows:

1. Remove both phillips-head screws retaining pushbutton switch plate to wall.
2. Remove steel plate located on L.H. side of pushbutton switch.
3. Remove switch through this opening, taking care to disconnect electric wires.

7.8 FRESH WATER TANK

The fresh water tank located at rear of lavatory wall (over cleaning cabinet), supplies water to the washbasin by gravity. Two tubes are connected in the upper section of tank (Fig. 26). One serves as overflow as well as vent tube and runs along the wall to the underside of the lavatory close to the engine air filter housing,

while the other tube is connected to the fresh water fill valve which is mounted besides the engine oil reserve tank.

A third tube connected in the lower section of fresh water tank is provided with a T-connector and allows fresh water to flow to the washbasin faucet and to the low temperature water safety valve for automatic or manual draining. An access panel, located at rear of last R.H. side row of seats and secured in place using 6 Phillips-head screws, allow access to the cleaning cabinet and fresh water tank tubing, fresh water tank heater and different wiring connectors.

7.8.1 Fresh Water Tank Heater (Optional)

A 75 watts, 110 volts AC immersion-type water heater may have been installed in the bottom of the fresh water tank. The heated portion of element must be immersed at all times to ensure proper heater life. The 110-120 volts in-station connector mounted on the engine compartment rear door provides the water heater power source.

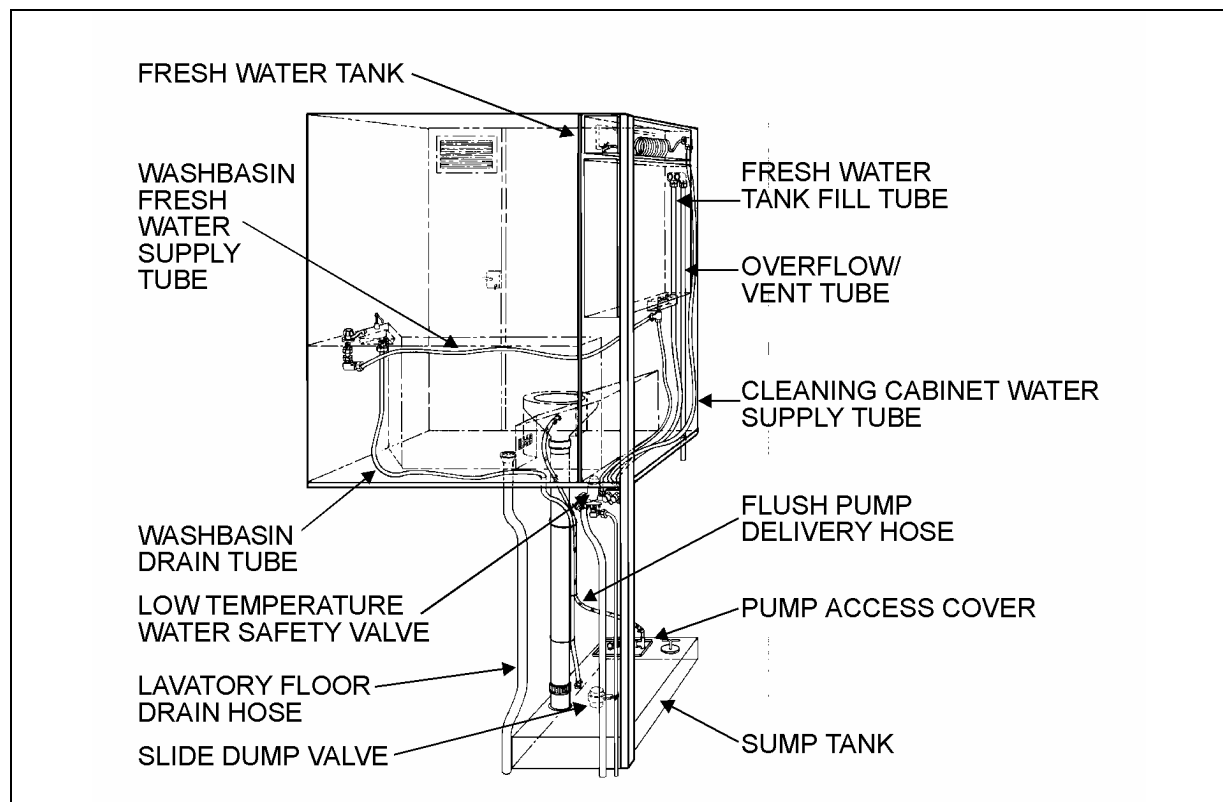

FIGURE 26: FUNCTIONING OF LAVATORY

23038

7.8.2 Fresh Water Tank Draining

The fresh water tank can be drained by simply opening the fresh water drain cock (Fig. 27). Don't forget to close cock when draining is done.

Caution: If fresh water tank heater is inoperative or not installed on your vehicle, water should be drained from reservoir under cold weather conditions since it might freeze and damage both reservoir and connecting links.

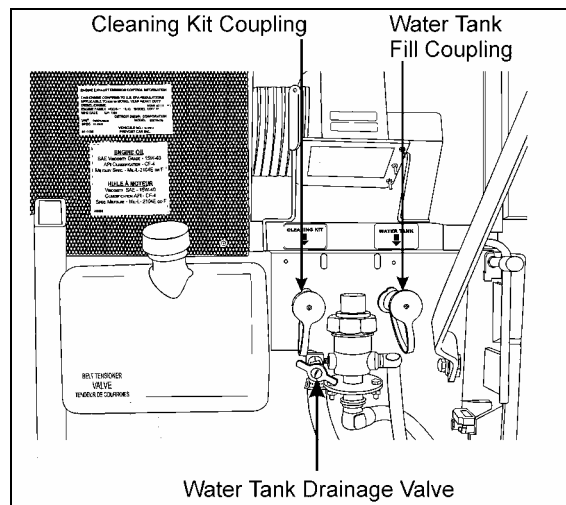

FIGURE 27: FRESH WATER TANK SERVICE VALVES

7.8.3 Fresh Water tank Filling

Plug the fresh water supply hose to the fresh water tank fill connection (Fig. 27); fill the tank until the overflow tube leaks, signaling that tank is full.

Warning: Never put antifreeze in fresh water tank; antifreeze is toxic.

Warning: If tank has not been drained for an extended period of time, draining and filling operations must be repeated three (3) times in order to clean tank and eliminate contaminated water.

7.9 LIQUID SOAP DISPENSER

A liquid soap dispenser may have been installed as optional equipment. To refill dispenser, proceed as follows:

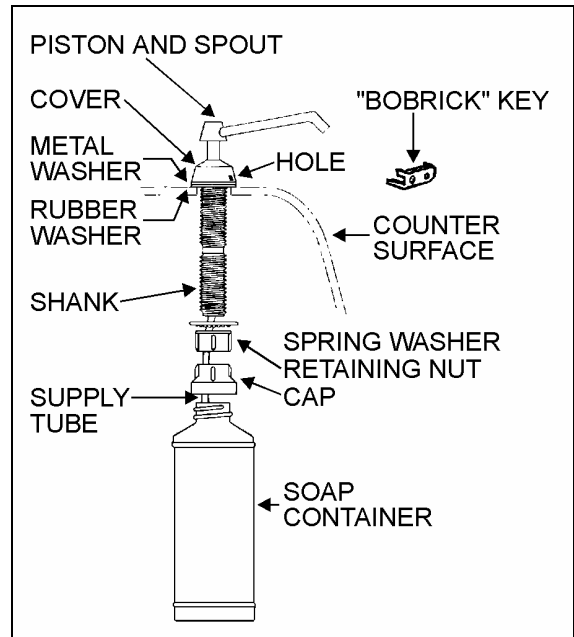

FIGURE 28: LIQUID SOAP DISPENSER

23039

1. Turn cover slightly clockwise until it stops.
2. Insert projection at end of "BOBRICK" key into rectangular hole in cover (Fig. 20). Push straight in. While holding "BOBRICK" key in, turn cover counterclockwise about 1/8 turn.

Caution: Do not use "BOBRICK" key to turn cover.

3. Lift out piston and spout, cover and supply tube.
4. Fill dispenser with soap. This model can dispense vegetable oil soaps, synthetic detergents, and lotion soaps.

Caution: Never use abrasive cleaners.

5. Replace supply tube, piston, and spout mechanism reversing the steps above.
6. Secure the cover by turning clockwise until lock snaps into position.

Note: The dispenser requires priming when extremely viscous lotion soaps are used. Remove piston and spout, cover and supply tube assembly. Pump water into assembly, then replace into dispenser.

Section 23: ACCESSORIES

7.10 FLUSH PUSH-BUTTON

The green flush push-button is located near the toilet. Press on push-button to actuate a pneumatic timer located on the other side of wall. This timer allows an electric current flow during a preset time to a pump into the sump tank.

7.10.1 Pneumatic Timer Removal and Installation

1. Unscrew and remove the flush push-button locking ring.
2. Remove steel plate located on L.H. side of pushbutton switch.
3. Remove pneumatic timer through this opening, taking care to disconnect electric wires.

Note: Care must be taken to avoid losing the spacers installed on the mounting sleeve.

4. Reverse the above procedure to reinstall timer. The recommended torque for the lock nut is 15 ft-lbf (21 N•m).

7.10.2 Timer Adjustment

Timer can be adjusted from 0.2 second to 3 minutes by turning the time adjustment screw clockwise to increase time, and counterclockwise to decrease time. To gain access to the time adjustment screw, repeat steps 1, 2 and 3 in the previous paragraph "7.10.1 Pneumatic Timer Removal and Installation".

7.11 FLUSH PUMP

The submersible-type flush pump is mounted inside an enclosure in the sump tank (Fig. 29). The enclosure is provided with a screened side which, serves as a strainer to prevent solid matters from entering the pump.

The pump requires no periodic maintenance other than cleaning of the strainer side using a water jet introduced through the circular cap opening, once the sump tank is completely drained. The pump can run dry periodically without damage. However, for maximum seal life, the run dry periods should be kept to a minimum.

Caution: If vehicle is stored for an extended period of time, make sure to clean the strainer as solid matter will tend to pack, and will necessitate replacement of strainer.

7.11.1 Flush Pump Pressure Adjustment

The flush pump is provided with a manually-adjustable control valve mounted on the flush pump enclosure cover and serves to limit the flush pump output pressure. To adjust, ask an assistant to activate the flush pushbutton and check the liquid projection while you manually adjust the control valve

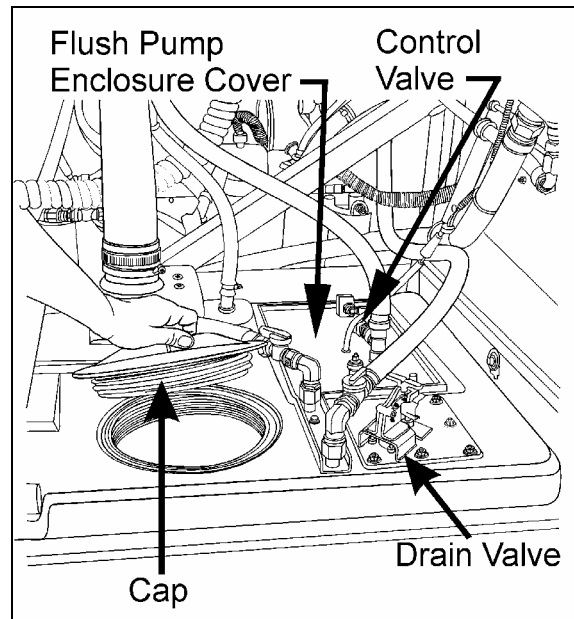

FIGURE 29: SUMP TANK

7.12 SUMP TANK

7.12.1 Sump Tank Draining

To drain sump tank, unscrew cap a few turns and pull on the drain valve T-handle. Flush tank and pump cage with clean water. Close drain valve using T-handle.

Caution: The lavatory should be serviced by maintenance personnel after emergency draining. Lavatory tanks should be serviced only at suitably equipped stations.

7.12.2 Sump Tank Filling

Remove cap on sump tank. Fill Tank with 2 gallons (9 liters) of antifreeze and two gallons of water.

Caution: Do not overfill sump tank.

Note: The antifreeze solution in the sump tank will be diluted by fresh water coming from the lavatory sink. Regular maintenance of the sump tank is required to prevent freezing.

7.13 CLEANING CABINET

A coiled hose located in the cleaning cabinet above the toilet can be used during lavatory cleaning. To use, connect a fresh water supply to the "Hansen" quick-release coupling, identified as "Cleaning Kit", located besides the engine oil reserve tank (Fig. 27). To prevent freezing during cold weather, drain the hose after every use. To drain the hose, uncoil and open the nozzle near the lavatory floor drain. Have an assistant push on the spring ball of the quick-release coupling to allow air into the system.

8. AIR HORN VALVE

The air horn valve is located in the front service compartment and the air horn valve button is on the steering wheel center.

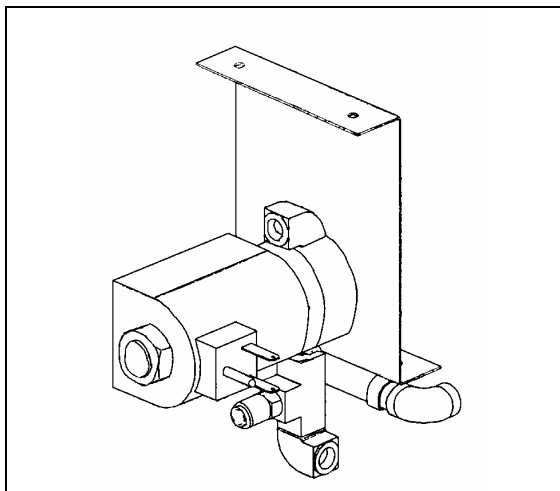

FIGURE 30: AIR HORN VALVE

8.1 AIR HORN VALVE MAINTENANCE

When needed, the air horn valve can be serviced or replaced using the following procedure:

1. Unplug the cable connector;
2. Disconnect the air tubes;
3. Loosen the retaining bolts;
4. Service or replace the air horn valve;
5. Reinstall by reversing procedure.

9. WINDSHIELD WIPERS AND WASHERS

9.1 GENERAL DESCRIPTION

Note: When installing a wiper motor, arm or blade, follow recommended procedures to prevent misalignment, binding or malfunction. Check the windshield washer liquid hoses, fittings and connectors to be sure they are properly connected and seal with no restriction to the flow of washer liquid. Check that wiper arms have the proper sweep position and the washer nozzles are aimed so that spray is within the proper wiper pattern.

The windshield wipers are controlled by two electric wiper motors that are accessible for maintenance after raising the appropriate access panel at the front of the coach (refer to figure 31).

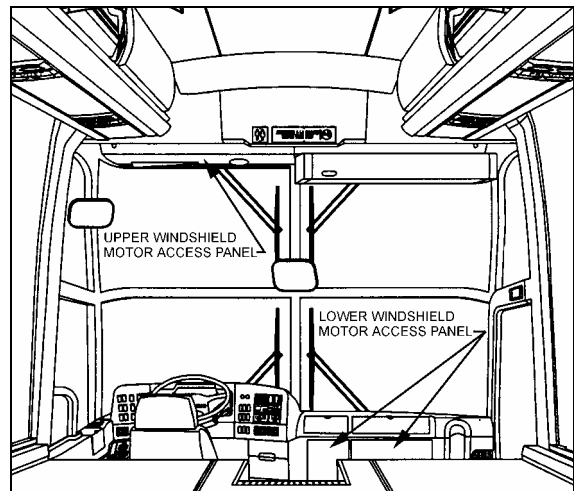

FIGURE 31: WIPER MOTORS LOCATION

Each wiper motor is independently operated:

Depress the upper windshield wiper switch located on the dashboard L.H. side to the first position for intermittent wiping, and to the second position for continuous wiping (item 1, fig. 32).

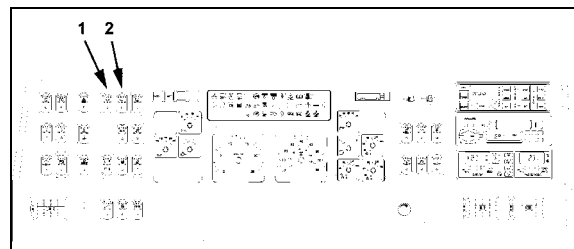

FIGURE 32: DASHBOARD

Turn the multifunction lever forward to activate lower windshield wipers (item 2, fig. 33). The first position operates the wipers at low speed and the second position operates the wipers at high speed. Turning the lever backwards will operate the wipers in the intermittent mode.

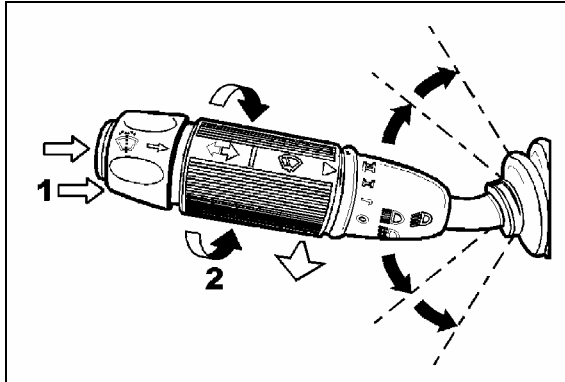

FIGURE 33: MULTIFUNCTION LEVER

Each windshield washer pump is independently operated:

To activate the upper windshield washer pump, depress and hold the rocker switch on dashboard L.H. side (item 2, fig. 32). The upper wipers will come on automatically and will shut off a few seconds after releasing the rocker switch. The lower windshield washer pump is electrically operated and is controlled by a washer control ring on the multifunction lever (item 1, fig. 33).

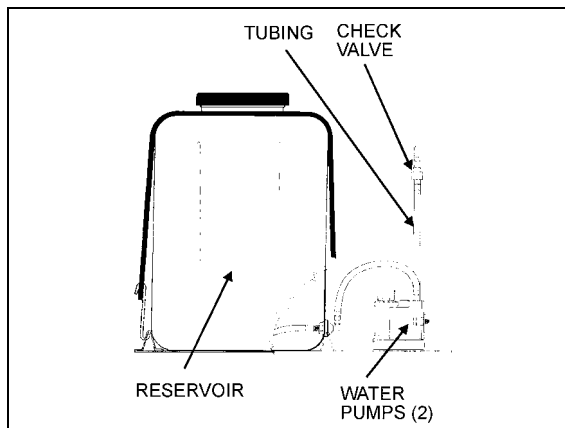

FIGURE 34: WINDSHIELD WASHER RESERVOIR 23085

The windshield washer reservoir is located in the front service compartment (Fig. 34). This unit pumps the washer liquid to the spray nozzles where it is dispersed across the windshield. Adjust nozzles with a flat tip screwdriver as needed to get proper spray coverage.

9.2 WIPER ARM

Check operation of the wipers for proper blade sweep and angle.

Caution: Do not attempt to manually move the wiper arms to make wiper blade sweep adjustments as damage to the wiper linkage or motor may occur. If it is necessary to adjust the sweep of blades, remove the arms and make adjustment by positioning the arms using serration on the wiper arm pivot shafts.

9.2.1 Sweep Adjustment

On a dry windshield, to avoid possible damage to the arm assembly or wiper motors, hold the wiper arms away from the windshield by inserting a small nail, or other such object, through the holes at the base of each wiper arm specially drilled for this purpose.

Sweep adjustment is a rough adjustment. It must be followed by lower and upper linkage adjustment. See paragraph "9.3 and 9.4".

In order to obtain the sweep adjustment, it may be necessary to remove and reposition the wiper arms, proceed as follows:

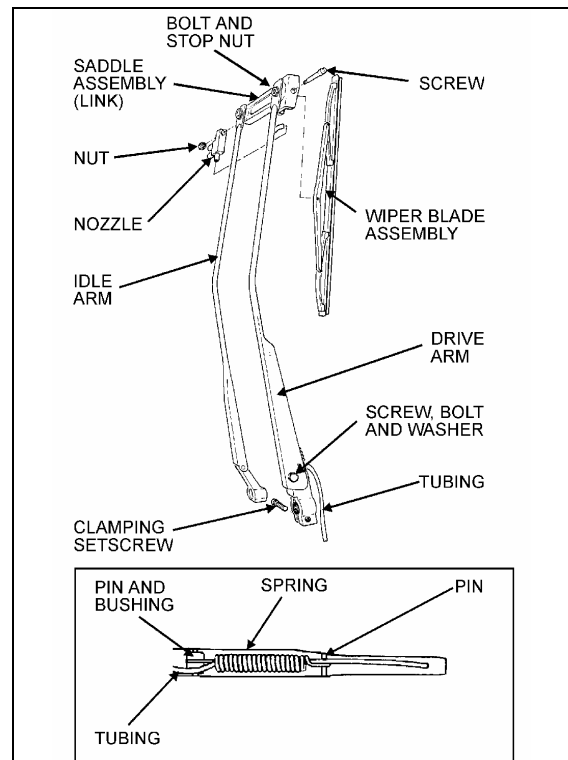

FIGURE 35: LOWER WINDSHIELD WIPER 23086

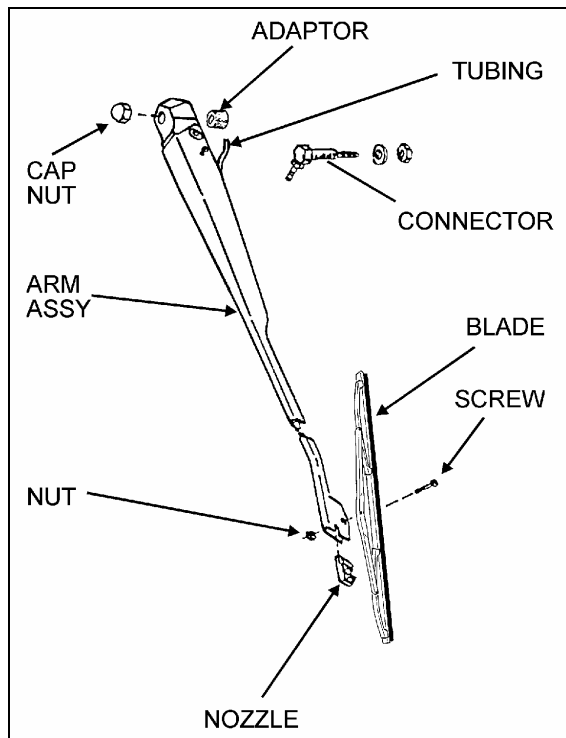

FIGURE 36: UPPER WINDSHIELD WIPER

23087

1. Remove the cap nuts from the wiper arm pivot shafts (Fig. 35 and 36);
2. Disconnect the windshield washer tubing at the base of the wiper arm (Fig 35 and 36);
3. Lower windshield wiper (Fig. 35): loosen the clamping set screw securing the drive arm to the knurled arm pivot shaft;
4. Remove the drive and idler arms (Fig. 35) or arm assembly (Fig. 36);
5. Relocate the drive arm (Fig. 35) or arm assembly (Fig. 36) on its knurled pivot shaft to obtain the desired position;
6. Lower windshield wiper (Fig. 35). Tighten the clamping set screw to secure the drive arm to the knurled shaft. Fit the idler arm onto the idler pivot shaft.
7. Install the cap nut pivot shafts.
8. Connect the windshield washer tubing at the base of the wiper arm (Fig. 35 and 36);
9. Check the adjustment on a wet windshield (Fig. 35 and 36).

9.2.2 Removal

1. Remove the cap nuts from arms (Fig. 35 and 36);
2. Disconnect the windshield washer tubing at the base of the wiper arm (Fig. 35 and 36);
3. Mark the relationship of the arm head to the end of the knurled drive shaft to ensure the original position if the arm is to be reinstalled;
4. Lower windshield wiper (Fig. 35): loosen the clamping set screw on the base of the drive arm;
5. Remove the wiper arm assembly (Fig. 35 and 36).

9.2.3 Installation

1. Make sure the wiper motor is in the stop position. Lower windshield wiper (Fig. 35): position the wiper arm on the knurled drive shaft and idler arm on the pivot shaft. Upper windshield wiper (Fig. 36): position the wiper arm assembly on the knurled drive shaft;
2. If the original arm is reinstalled, align the marks made during removal;
3. Operate the wipers on a wet windshield to check the wiper blade sweep and angle. Re-adjust as necessary;
4. Lower windshield wiper (Fig. 35): Tighten clamping nut onto the drive arm. Install cap nuts onto the arm shafts (Fig. 35 and 36);
5. Connect the windshield washer tubing at the base of the wiper arm (Fig. 35 and 36);
6. Check the adjustment on a wet windshield (Fig. 35 and 36).

9.3 LOWER LINKAGE ADJUSTMENT

1. Make sure the wiper motor is in the stop position prior to working on the linkage.
2. Adjust the two pivot shafts vertically.
3. Adjust the rod length of the connecting pivot shafts. During rod length adjustment, maintain the pivot shafts in the vertical position.
4. Adjust the rod located between right pivot shaft and motor to a 40.5° angle (Fig. 37). The motor lever must be on the same axis as the rod.

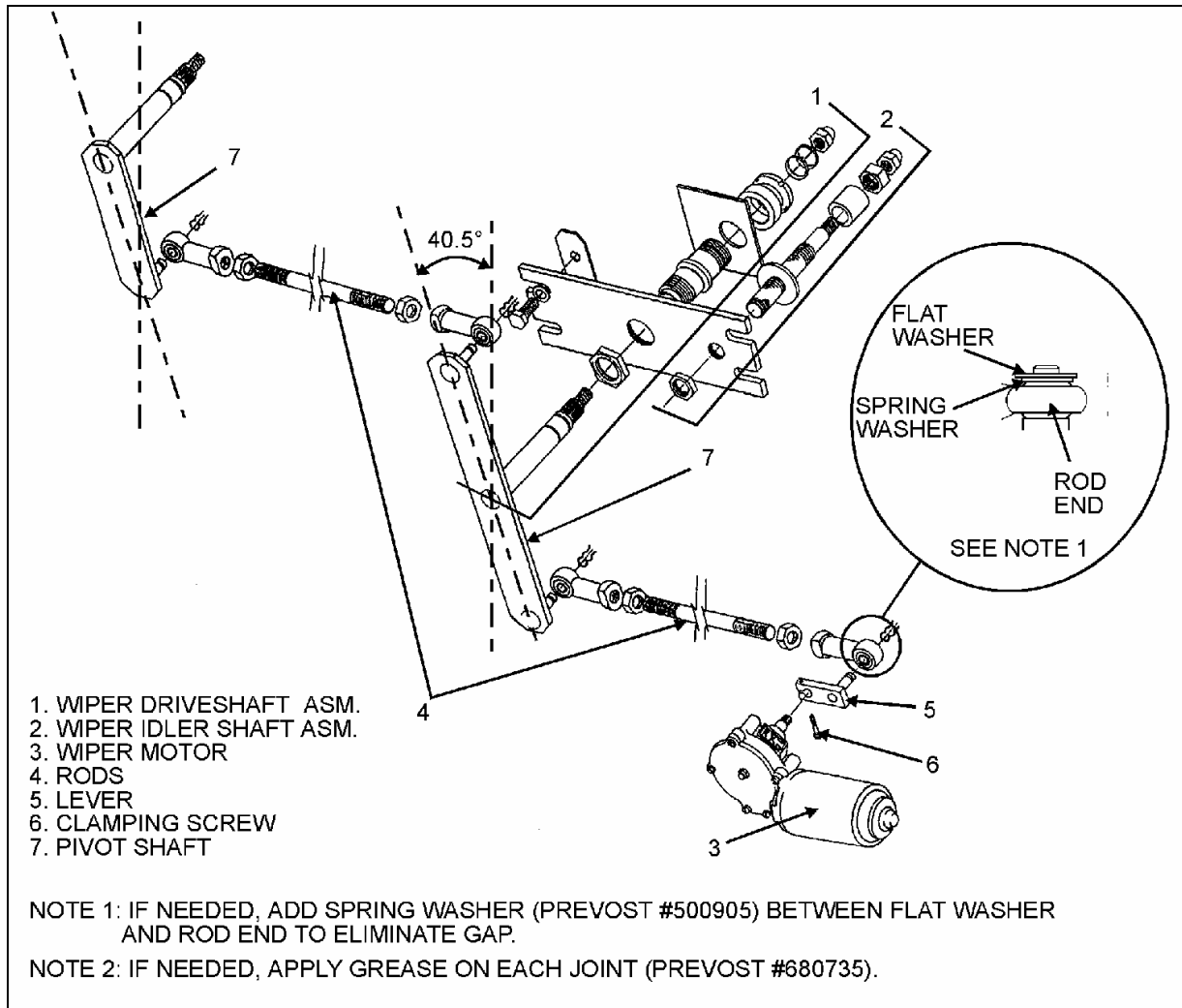

FIGURE 37: LOWER WINDSHIELD WIPER INSTALLATION

23088

5. Install the right wiper arm in its normal position (in the middle of the windshield (Fig. 31)). Refer to paragraph "9.2.1 Sweep Adjustment".
6. The right wiper arm final adjustment is made by adjusting the smallest rod length.
7. Install the left wiper arm in its normal position (in the middle of the windshield (Fig. 31)). Refer to paragraph "9.2.1 Sweep Adjustment".
8. The left wiper arm final adjustment is made by adjusting the longest rod length.
9. Check the adjustment on a wet windshield.

9.4 UPPER LINKAGE ADJUSTMENT

1. Make sure the wiper motor is in the stop position prior to working on the linkage.
2. Adjust rods length (Fig. 38).
3. Install the left wiper arm in its normal position (in the middle of the windshield (Fig. 31)). Refer to paragraph "9.2.1 Sweep Adjustment".
4. The left wiper arm final adjustment is made by adjusting the rod length to 8.46 inches (215 mm).

5. Install the right wiper arm in its normal position (in the middle of the windshield (Fig. 31)). Refer to paragraph "9.2.1 Sweep Adjustment".
6. The right wiper arm final adjustment is made by adjusting the rod length to 23.54 inches (598 mm).
7. Check the adjustment on a wet windshield.

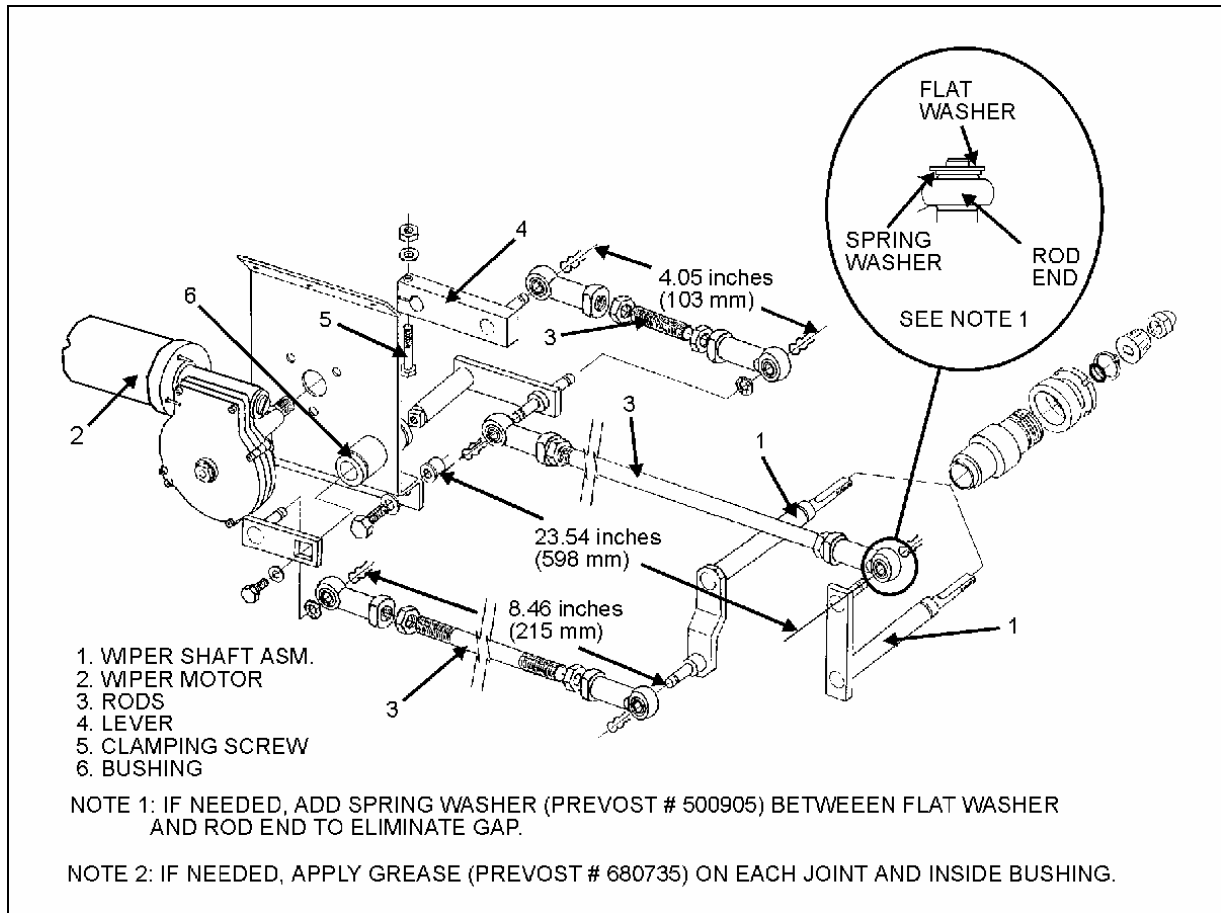

FIGURE 38: UPPER WINDSHIELD WIPER INSTALLATION

23089

9.5 WINDSHIELD WIPER MOTORS

9.5.1 Lower Windshield Wiper Motor Replacement

The lower windshield wiper motor is located at lower front of the vehicle, behind the defroster panel. Refer to figure 31 for motor location.

Warning: Park vehicle safely, apply parking brake, stop engine and set battery master switch to the "OFF" position prior to working on the vehicle.

1. Remove the two Phillips-head screws retaining the defroster panel, and remove panel.
2. Disconnect wiring connector from the windshield wiper motor.
3. Loosen clamping screw retaining the lever at the end of the motor driving shaft (Fig. 37).
4. Remove the three bolts holding the motor to the steel plate.
5. Remove the windshield wiper motor (Prévost #800304), reverse removal procedure to reinstall.

Section 23: ACCESSORIES

9.5.2 Upper Windshield Wiper Motor Replacement

The upper windshield wiper motor is located above L.H. upper windshield panel, refer to figure 31 for motor location. To remove the motor, it is necessary to remove left sun visor and upper windshield panel.

Warning: Park vehicle safely, apply parking brake, stop engine and set battery master switch to the "OFF" position prior to working on the vehicle.

1. Pull out the wiring connector (black and red wires) located on sun visor L.H. side and disconnect.
2. Remove the two Phillips-head screws at the bottom end of the sun visor arms.

3. Remove the two Phillips-head screws on each roller side, pull out the sun visor.
4. Remove the Phillips-head screws retaining the upper windshield panel.
5. If equipped with blower defroster, loosen hose clamp to remove air duct from hose.
6. Disconnect wiring connector from the windshield wiper motor.
7. Loosen the bolt retaining the lever at the end of the motor driving shaft (Fig. 38).
8. Remove the three bolts holding the motor to the steel plate.
9. Remove the windshield wiper motor (Prévost #800304), reverse removal procedure to reinstall.

9.6 TROUBLESHOOTING

SYMPTOM	PROBABLE CAUSE	REMEDY
FAIL TO SPRAY WASHER FLUID	<ol style="list-style-type: none"> A. Reservoir empty. B. If below 32°F (0°C), improper washer fluid frozen. C. Contamination in tubing or nozzles. D. Tubing damage. E. Tubing bent (kinked) or off one or more connections. 	<ol style="list-style-type: none"> A. Add proper fluid. B. Store coach or parts in heated area, then purge system with low-temperature solution. C. Remove with compressed air, if severely clogged, replace items. D. Replace section. E. Realign tubing and/or refit. Trim end to ensure proper fit or replace.
INADEQUATE SPRAYING	<ol style="list-style-type: none"> A. Tubing failure. 	<ol style="list-style-type: none"> A. Replace tubing.
SLOW OPERATION	<ol style="list-style-type: none"> A. Improper solution. B. Jet stream improperly directed. C. Check if valve is stuck in the open position. 	<ol style="list-style-type: none"> A. Replace with proper type solution. B. Reposition nozzles. C. Remove, clean or replace.

SYMPTOM: LOWER WIPER MOTOR DOES NOT FUNCTION

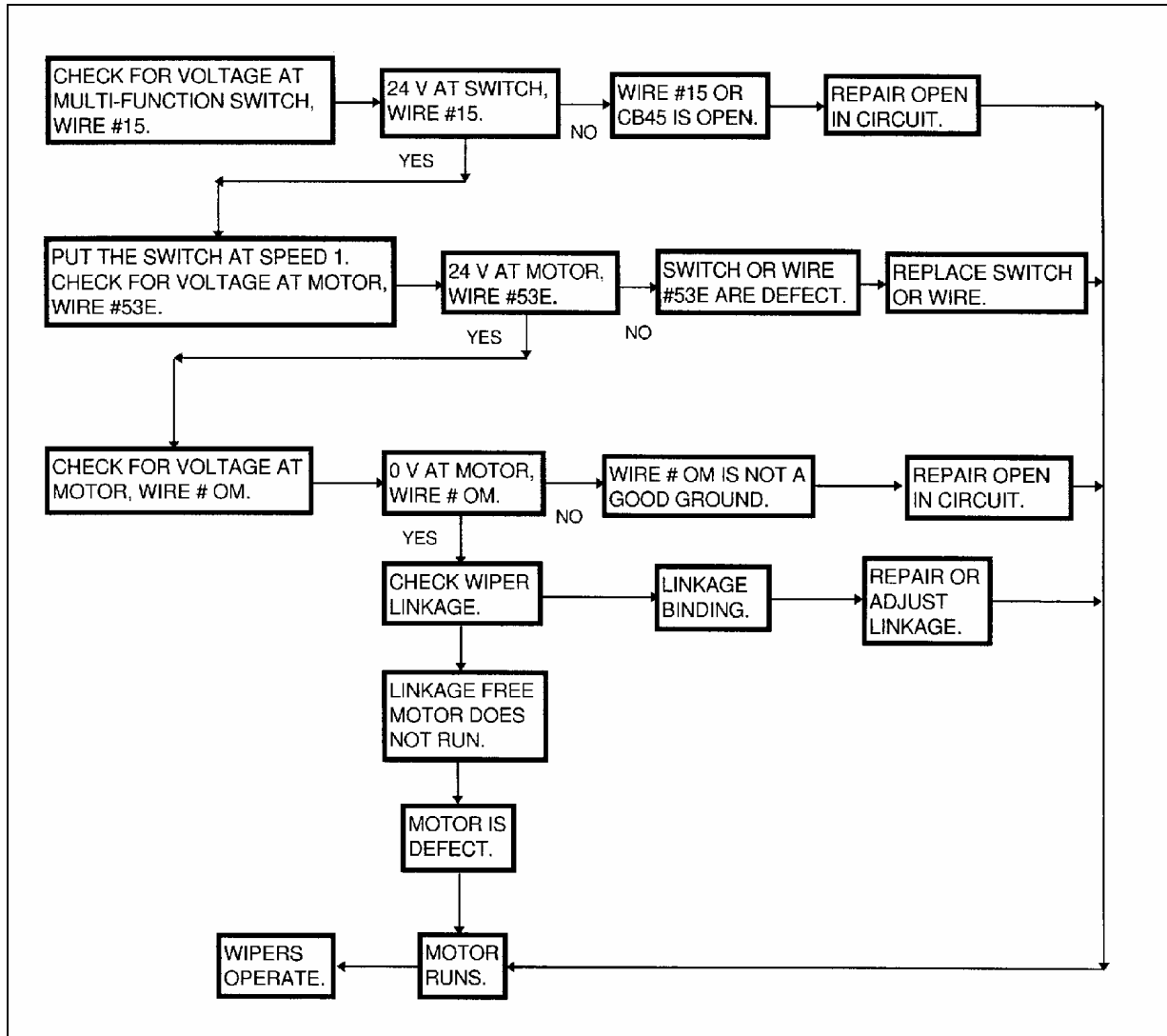

FIGURE 39: TROUBLESHOOTING

23062

SYMPTOM: UPPER WIPER MOTOR DOES NOT FUNCTION

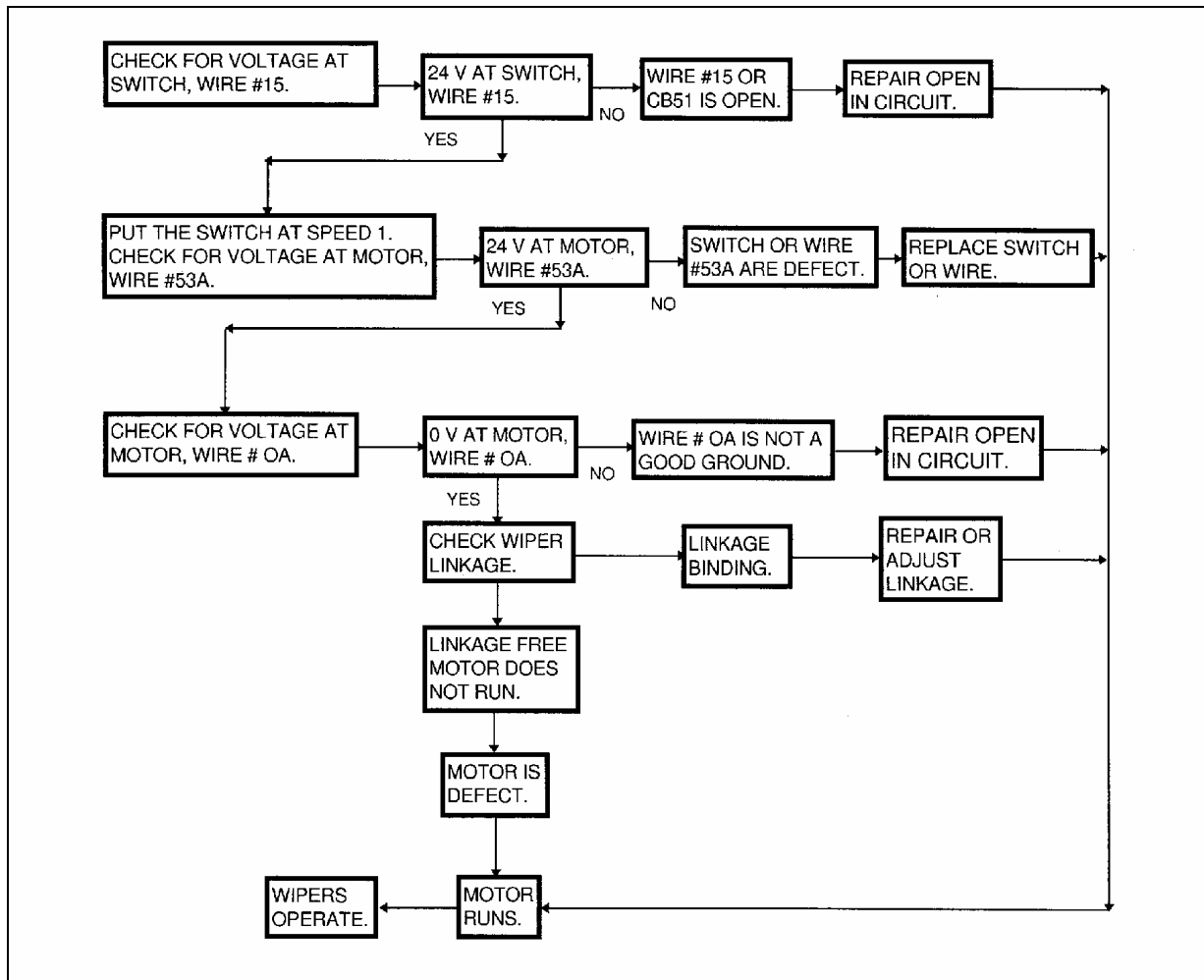

FIGURE 40: TROUBLESHOOTING

23063

SYMPTOM: LOWER WIPER DOES NOT RETURN TO INITIAL POSITION

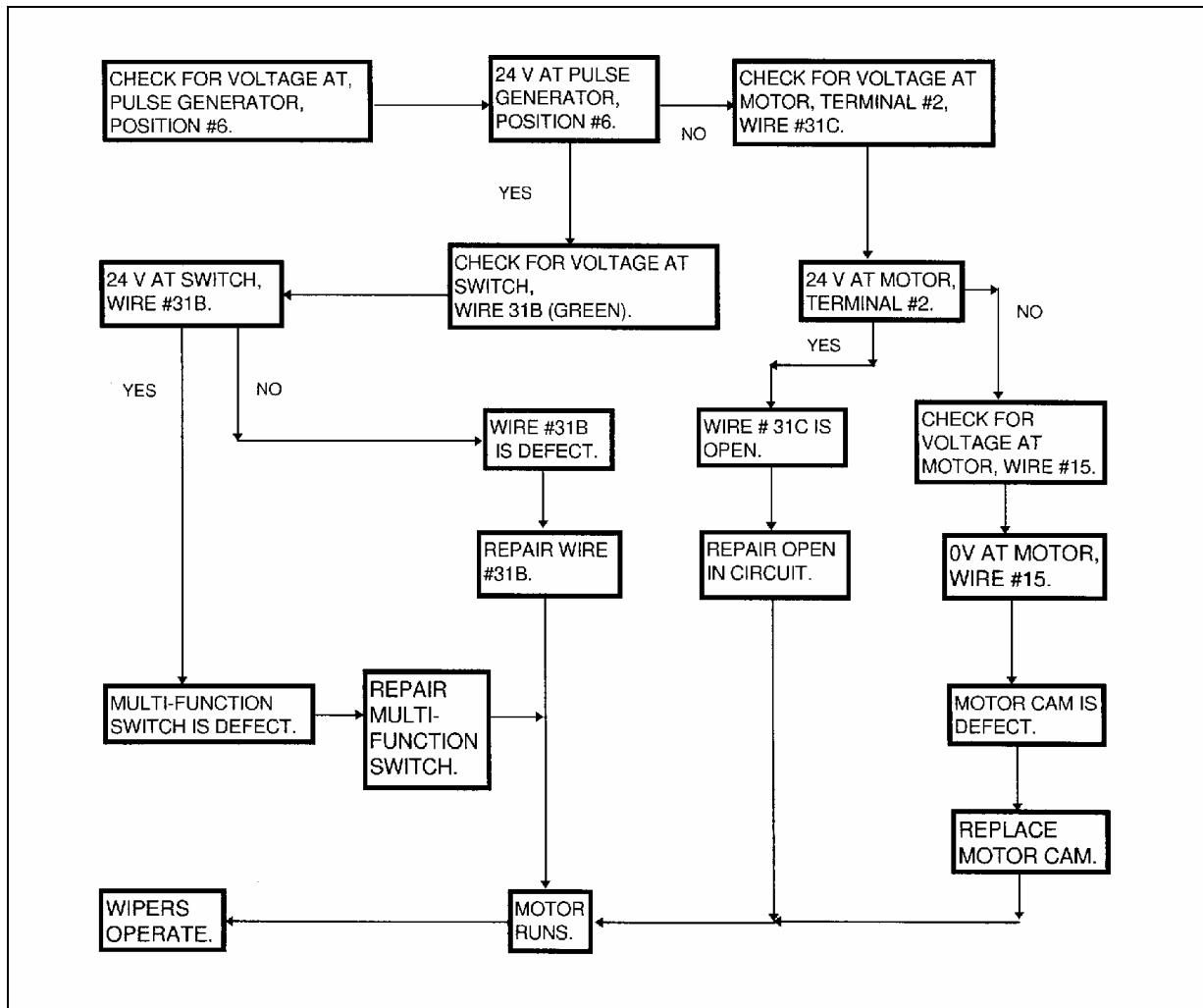

FIGURE 41: TROUBLESHOOTING

23064

SYMPTOM: UPPER WIPER DOES NOT RETURN TO INITIAL POSITION

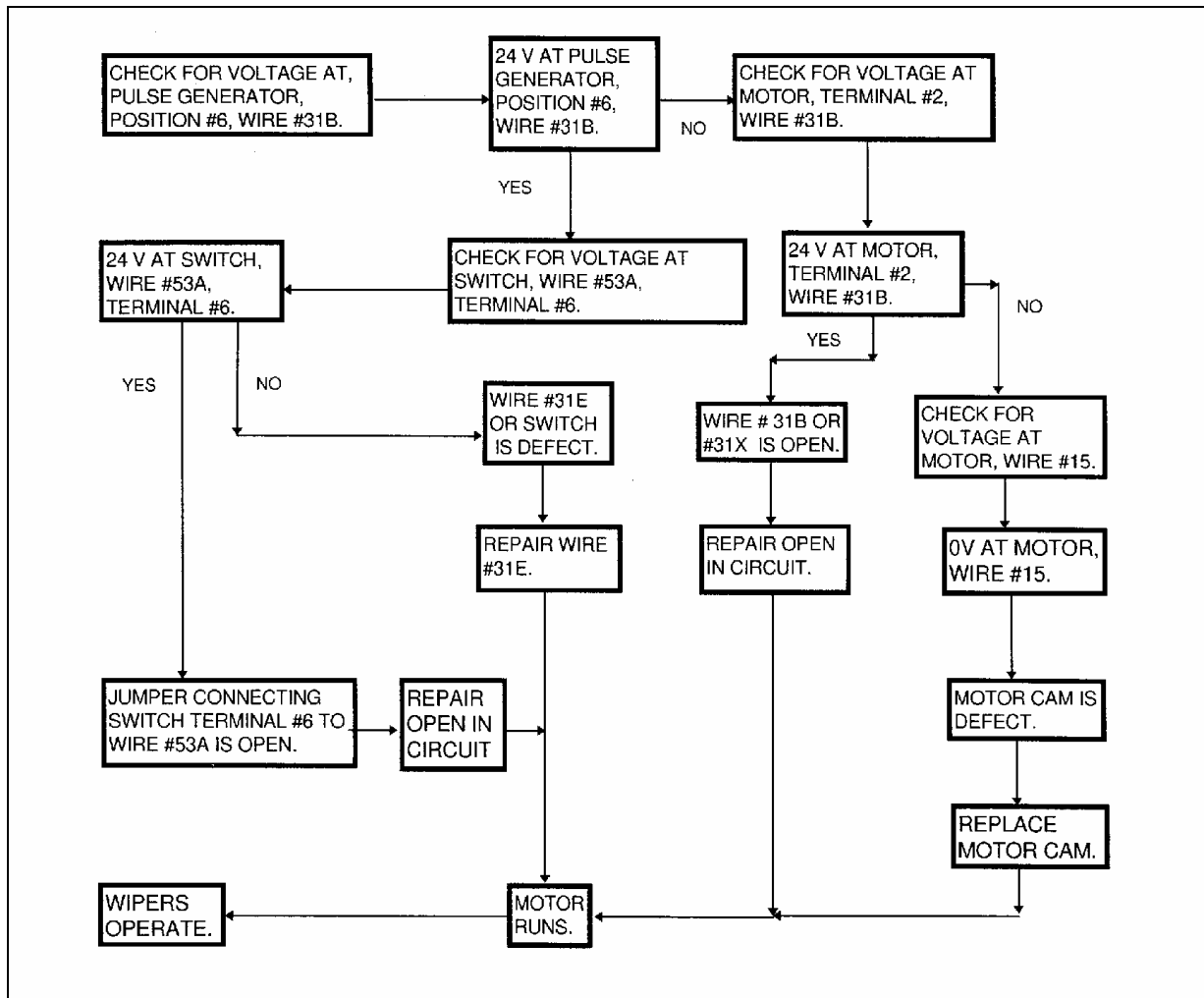

FIGURE 42: TROUBLESHOOTING

23065

SYMPTOM: LOWER WIPER MOTOR DOES NOT FUNCTION IN INTERMITTENT MODE

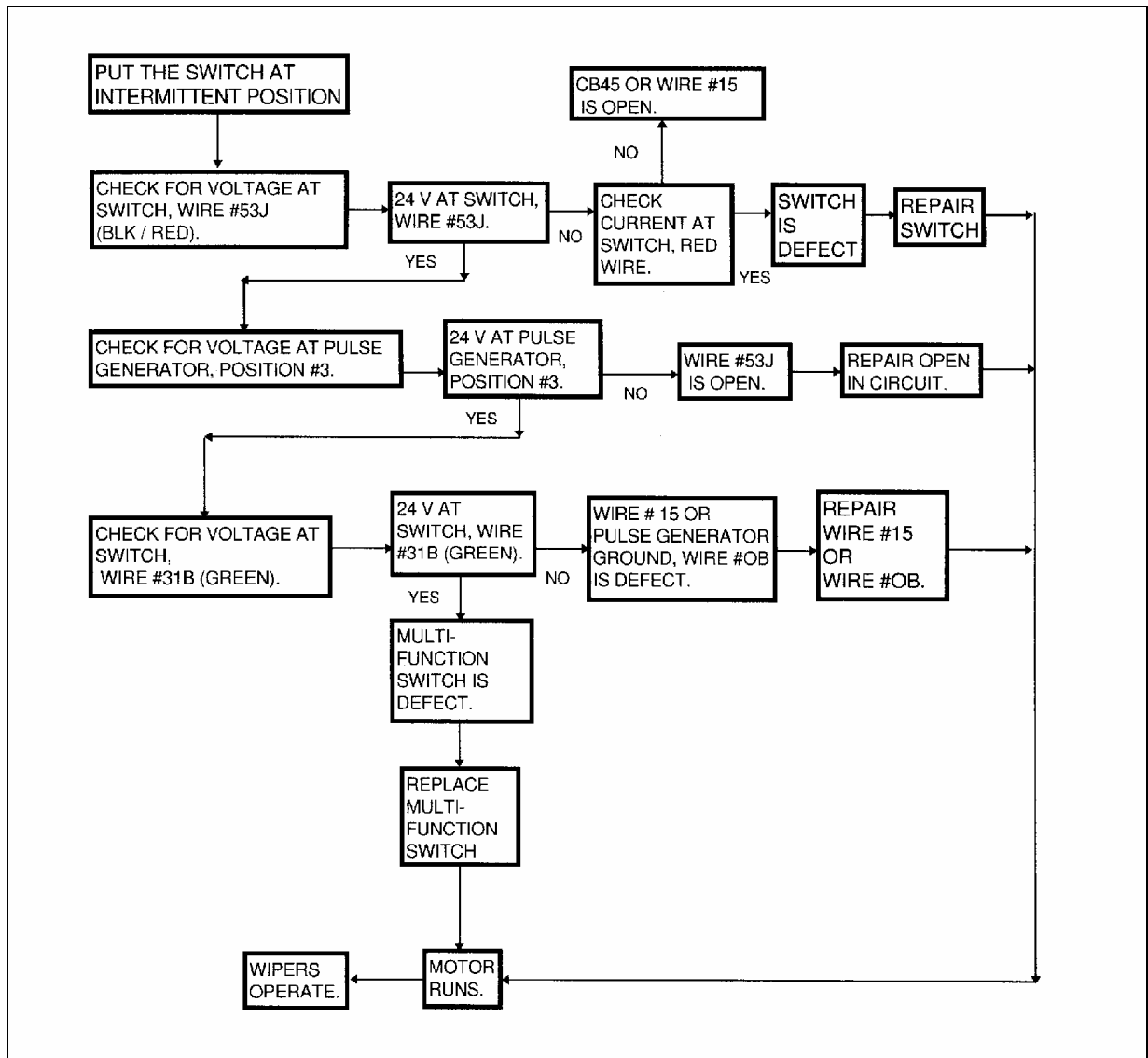

FIGURE 43: TROUBLESHOOTING

23066

SYMPTOM: UPPER WIPER MOTOR DOES NOT FUNCTION IN INTERMITTENT MODE

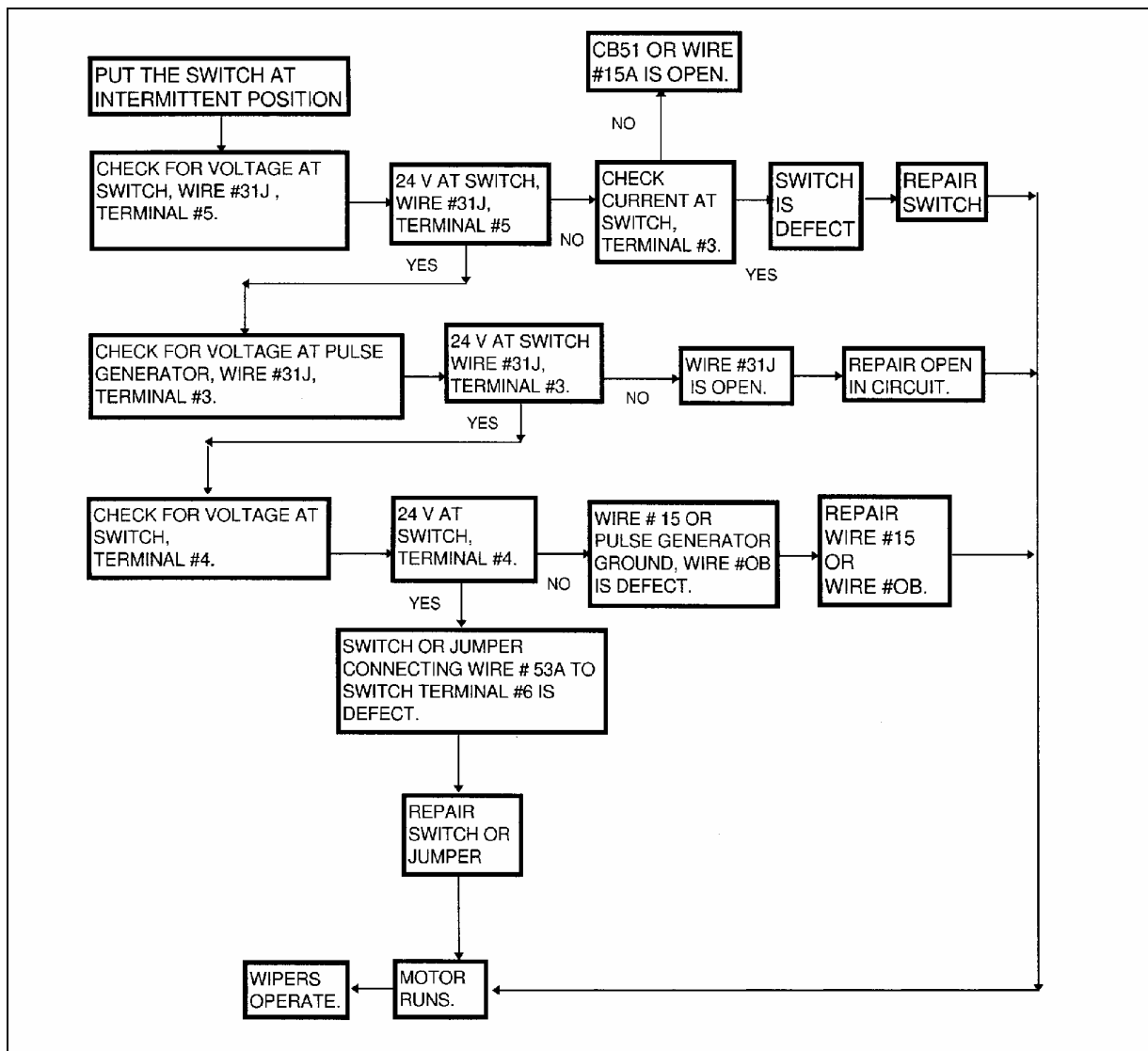

FIGURE 44: TROUBLESHOOTING

23067

SYMPTOM: LOWER WIPER MOTOR DOES NOT FUNCTION WHILE WINDSHIELD WASHER MOTOR IS ACTIVATED

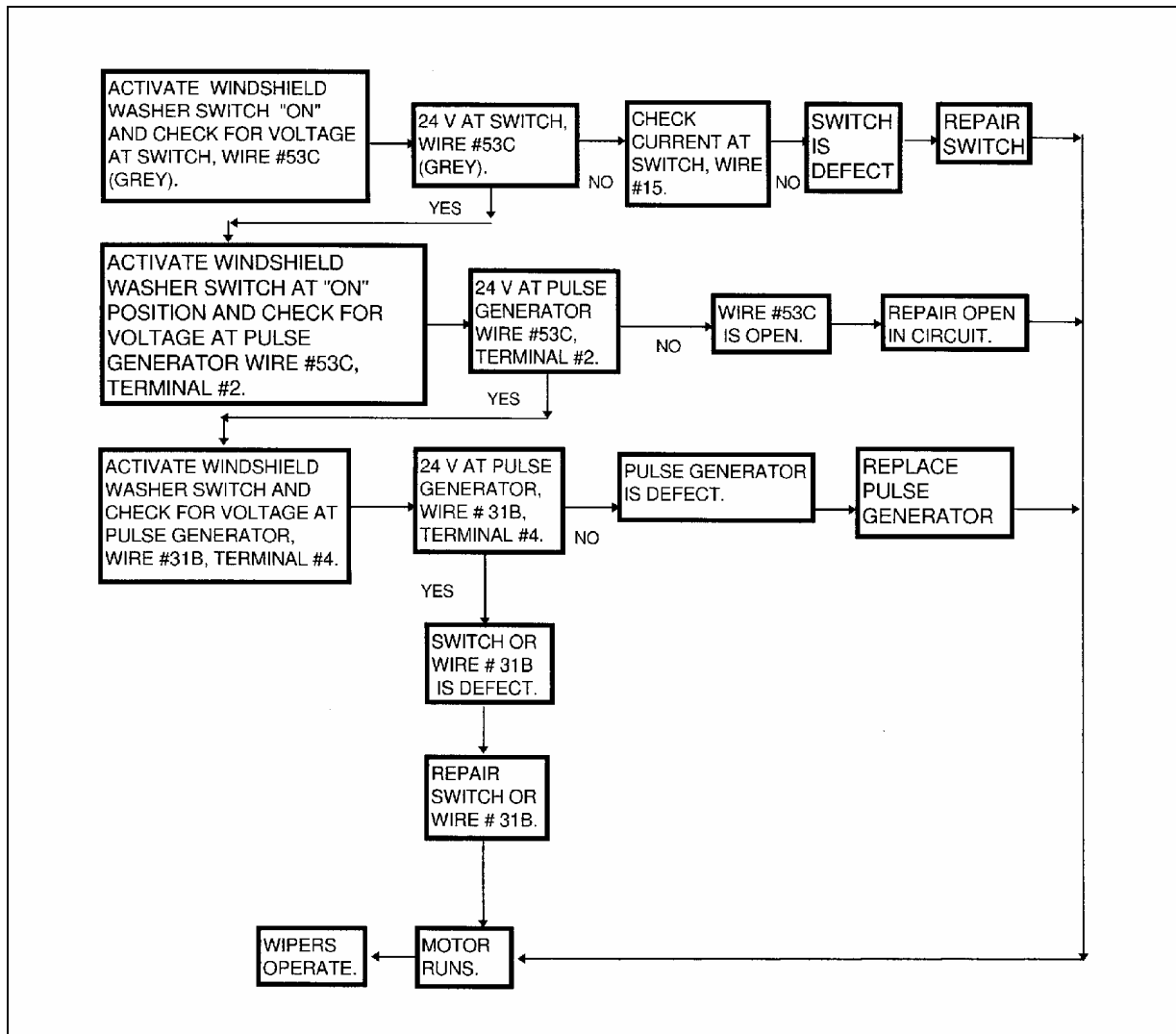

FIGURE 45: TROUBLESHOOTING

23068

SYMPTOM: UPPER WIPER MOTOR DOES NOT FUNCTION WHILE WINDSHIELD WASHER MOTOR IS ACTIVATED

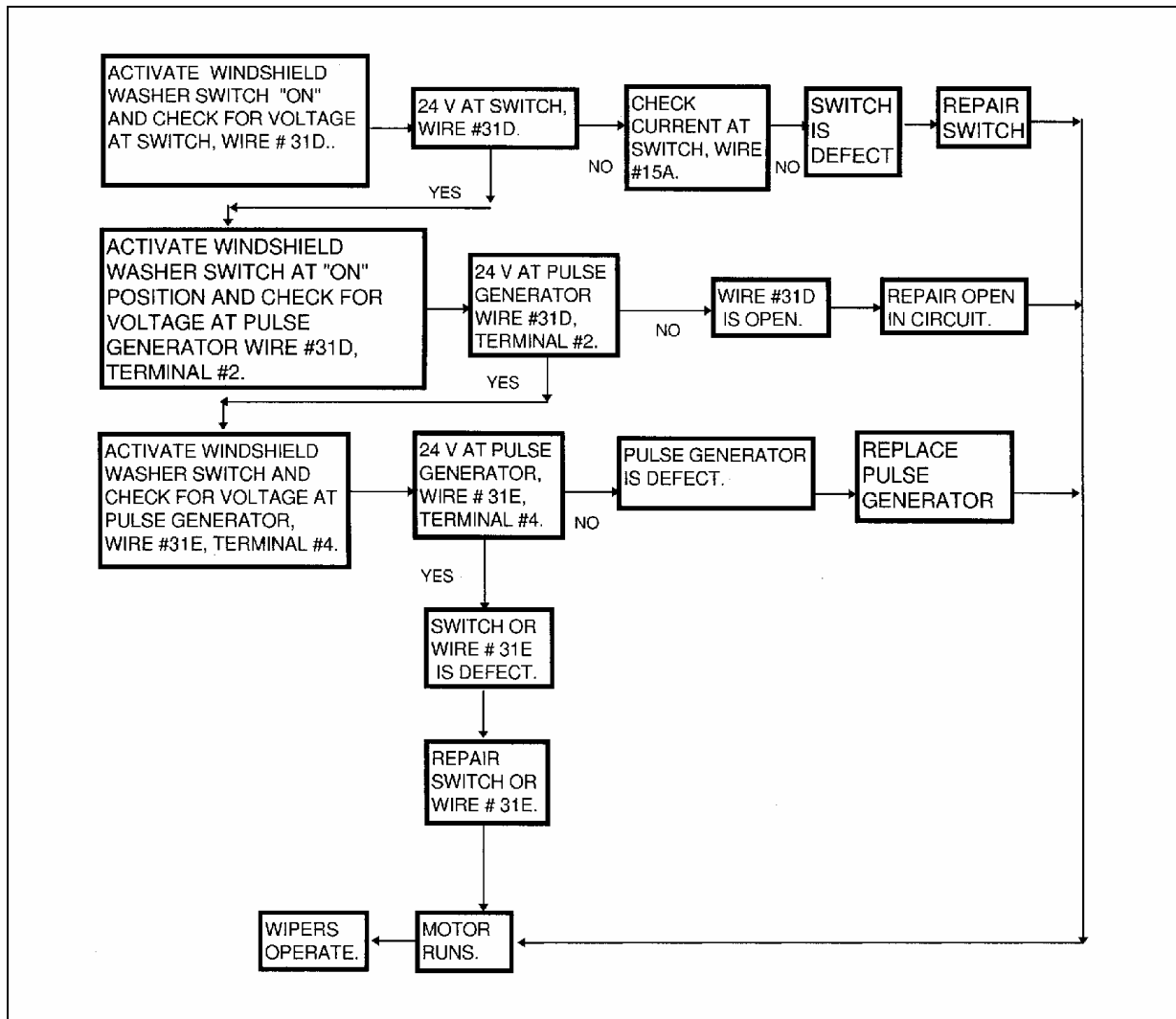

FIGURE 46: TROUBLESHOOTING

23069

10. SPECIFICATIONS**AMPLIFIER**

Make..... R.E.I.
 Model..... AMP-2000
 Power source 24 volts DC Negative ground
 Current 8 Amps maximum
 Frequency Response..... 10-30,000 Hz
 Output..... 90 watts/channel maximum power
 65 watts/channel RMS at 4 ohm @ 0.5 T.H.D.
 Signal to noise ratio.....86 dB
 Supplier number..... 700189
 Prévost number..... 900802

AM/FM RADIO CASSETTE PLAYER

Make..... Panasonic
 Model..... CQ-R115SEUC
 Power source 12 volts
 Supplier number..... 700590
 Prévost number..... 900917

AM/FM RADIO CD PLAYER

Make..... Panasonic
 Model..... CQ-DP930-EUC
 Power source 12 volts
 Supplier number..... 700574
 Prévost number..... 900891

6 DISC CD CHANGER

Make..... R.E.I.
 Supplier number..... 700467
 Prévost number..... 900822

12 DISC CD CHANGER

Make..... R.E.I.
 Supplier number..... 700473

SPEAKER

Make..... Robert Bosch
 Max. power..... 90 watts
 RMS power 40 watts
 Freq. response 45 Hz - 24 kHz
 Sensitivity 92 dB
 Impedance 4 ohms
 Supplier number..... RPSPKR54
 Prévost number..... 900765

CONTROL HEAD

Make..... R.E.I.
 Model..... C-2000
 Supplier number..... 700227
 Prévost number..... 900803

Section 23: ACCESSORIES

VIDEO TAPE RECORDER

Make..... R.E.I.
Model.....SYS-2000
Supplier number..... 700454
Prévost number..... 900806

BOOM-TYPE MICROPHONE

Make..... R.E.I.
Supplier number..... 480076BK
Prévost number..... 900763

WIRELESS MICROPHONE

Make..... R.E.I.
Supplier number..... 480066
Prévost number..... 900812

WIRELESS MICROPHONE RECEIVER

Make..... R.E.I.
Supplier number..... 480067M
Prévost number..... 900813

TV TUNER

Make..... R.E.I.
Power source24V
Supplier number..... 700471
Prévost number..... 900814

KARAOKE

Make..... R.E.I.
Supplier number..... 700470
Prévost number..... 900815

KARAOKE

Make..... Panasonic
Model.....DVD-A300
Supplier number..... 700565
Prévost number..... 900883

TV MONITOR

Make..... R.E.I.
Power source24V
Supplier number..... 700182
Prévost number..... 900809

HUBODOMETER (US model: miles)

Make..... Stemco
Supplier number..... 650-0593
Prévost number..... 650002

HUBODOMETER (Canada model: km)

Make..... Stemco
Supplier number..... 650-0025
Prévost number..... 650117

ELECTRIC DESTINATION SIGN (FLUORESCENT TUBE)

Make..... General Electric
 Length 30" (76 cm)
 Outside diameter 1" (25 mm)
 Wattage 20
 Color Cool white
 Quantity 1
 Supplier number F30T8 CW4
 Prévost number 830120

ELECTRONIC DESTINATION SIGN

Make..... Pocatec
 Supplier number 9000230
 Prévost number 940050

LAVATORY VENTILATION FAN MOTOR

Make..... Aurora
 Type RG500EF
 Voltage 24 volts DC
 Rotation R.H.
 Supplier number 131.40.50
 Prévost number 870844

LAVATORY FLUORESCENT TUBES

Make..... General Electric
 Model F15T8CW
 Length 18" (45 cm)
 Wattage 15
 Quantity 2
 Prévost number 830102

EMERGENCY BUZZER SWITCH (PUSH BUTTON)

Make..... Cole Hersee Co.
 Voltage 24 V
 Supplier number 40224
 Prévost number 562117

FRESH WATER TANK

Make..... Prévost
 Capacity 18 US gal (68 liters)
 Prévost number 403030

FRESH WATER TANK HEATER

Make..... Hot Watt
 Wattage 75 watts
 Voltage 115 volts AC
 Supplier number EM 37-5
 Prévost number 562018

Section 23: ACCESSORIES

FLUSH PUSH BUTTON PNEUMATIC TIMER

Make..... Furnas
Type Resettable
Time 0,2 to 180 seconds
Supplier number 55-AA
Prévost number 900348

FLUSH PUMP

Make..... Jabsco
Model number 30240-1024 24 V
Power source 24 volts DC
Capacity 1452 GPH
Prévost number 900496

AIR HORN

Make..... Allied Signal Inc.
Supplier number 101493
Prévost number 640093

AIR HORN VALVE

Make..... Allied Signal Inc.
Supplier number 228672
Prévost number 640128

WINDSHIELD WIPER MOTOR

Make..... SWF
Supplier number 403.195
Prévost number 800304

LOWER WIPER (BLADE)

Make..... Sprague device inc.
Supplier number S-1147-2-22
Prévost number 800284

UPPER WIPER (BLADE)

Make..... Sprague device inc.
Supplier number C-1140-2-20
Prévost number 800234