

# SECTION 12: BRAKE AND AIR SYSTEM

## CONTENTS

<b>1. AIR SYSTEM</b>	<b>12-5</b>
<b>2. BRAKES</b>	<b>12-5</b>
<b>3. AIR RESERVOIRS</b>	<b>12-5</b>
3.1 MAINTENANCE	12-6
3.1.1 <i>Wet (Main) Air Tank</i>	12-6
3.1.2 <i>Primary Air Tank</i>	12-6
3.1.3 <i>Accessory Air Tank</i>	12-6
3.1.4 <i>Emergency/Parking Brake Override Air Tank</i>	12-6
3.1.5 <i>Secondary Air Tank</i>	12-6
3.1.6 <i>Kneeling Air Tank</i>	12-6
3.2 PING TANK	12-6
<b>4. AIR SYSTEM EMERGENCY FILL VALVES</b>	<b>12-7</b>
<b>5. ACCESSORY AIR FILTER</b>	<b>12-7</b>
5.1 FILTER ELEMENT REPLACEMENT	12-7
5.2 CLEANING	12-7
<b>6. AIR GAUGES (PRIMARY AND SECONDARY)</b>	<b>12-7</b>
<b>7. AIR FILTER/DRYER</b>	<b>12-8</b>
7.1 AIR FILTER/DRYER PURGE TANK	12-8
<b>8. AIR LINES</b>	<b>12-8</b>
8.1 COPPER PIPING	12-8
8.2 FLEXIBLE HOSES	12-8
8.3 NYLON TUBING	12-8
8.4 AIR LINE OPERATING TEST	12-9
8.5 AIR LINE LEAKAGE TEST	12-9
8.6 MAINTENANCE	12-9
<b>9. PRESSURE REGULATING VALVES</b>	<b>12-9</b>
9.1 MAINTENANCE	12-9
9.2 PRESSURE SETTING PROCEDURE	12-9
<b>10. AIR COMPRESSOR (TU-FLO 750)</b>	<b>12-10</b>
10.1 COMPRESSOR REMOVAL AND INSTALLATION	12-10
<b>11. EMERGENCY / PARKING BRAKE CONTROL VALVE (PP-1)</b>	<b>12-11</b>
<b>12. EMERGENCY / PARKING BRAKE OVERRULE CONTROL VALVE (RD-3)</b>	<b>12-11</b>
<b>13. FLIP-FLOP CONTROL VALVE (TW-1)</b>	<b>12-11</b>
<b>14. DUAL BRAKE APPLICATION VALVE (E-10P)</b>	<b>12-11</b>
14.1 BRAKE PEDAL ADJUSTMENT	12-12

## Section 12: BRAKE AND AIR SYSTEM

---

14.1.1	Maintenance .....	12-12
15.	<b>STOPLIGHT SWITCHES</b> .....	<b>12-12</b>
16.	<b>PARKING BRAKE ALARM SWITCH</b> .....	<b>12-12</b>
17.	<b>BRAKE RELAY VALVE (R-12 &amp; R-12DC)</b> .....	<b>12-12</b>
18.	<b>QUICK RELEASE VALVES (QR-1)</b> .....	<b>12-13</b>
19.	<b>SPRING BRAKE VALVE (SR-1)</b> .....	<b>12-13</b>
20.	<b>PRESSURE PROTECTION VALVE (PR-2)</b> .....	<b>12-13</b>
21.	<b>LOW PRESSURE INDICATORS (LP-3)</b> .....	<b>12-14</b>
22.	<b>SHUTTLE-TYPE DOUBLE CHECK VALVE (DC-4)</b> .....	<b>12-14</b>
23.	<b>EMERGENCY DOOR OPENING VALVES</b> .....	<b>12-14</b>
23.1	INTERIOR VALVE MAINTENANCE .....	12-14
24.	<b>AIR HORN VALVE</b> .....	<b>12-14</b>
25.	<b>AIR SYSTEM TROUBLESHOOTING</b> .....	<b>12-14</b>
26.	<b>BRAKE OPERATION</b> .....	<b>12-15</b>
27.	<b>AIR BRAKES</b> .....	<b>12-15</b>
27.1	DISC BRAKE PADS .....	12-15
27.2	CALIPER MAINTENANCE .....	12-16
27.3	ROADSIDE INSPECTION FOR KNORR /BENDIX AIR DISC BRAKES .....	12-17
27.4	PAD REMOVAL .....	12-18
27.5	CHECKING PAD WEAR .....	12-18
27.6	IMPORTANT PAD AND ROTOR MEASUREMENTS .....	12-18
27.7	CHECKING CALIPER GUIDANCE AND SEAL CONDITION .....	12-18
27.8	CHECKING THE TAPPET BOOTS .....	12-19
27.9	PAD INSTALLATION .....	12-19
27.10	ADJUSTING THE RUNNING CLEARANCE .....	12-20
27.11	BRAKE TOOLS .....	12-20
27.12	TORQUE SPECIFICATIONS .....	12-20
28.	<b>SAFE SERVICE PROCEDURES</b> .....	<b>12-20</b>
29.	<b>AIR BRAKE TROUBLESHOOTING</b> .....	<b>12-21</b>
30.	<b>BRAKE AIR CHAMBER</b> .....	<b>12-24</b>
30.1	MAINTENANCE .....	12-24
30.2	EMERGENCY/PARKING BRAKE MANUAL RELEASE .....	12-25
30.3	BRAKE CHAMBER REMOVAL .....	12-25
30.4	BRAKE CHAMBER INSTALLATION .....	12-25
30.5	BRAKE CHAMBER DISASSEMBLY .....	12-25

<b>31. ANTI-LOCK BRAKING SYSTEM (ABS)</b> .....	<b>12-26</b>
31.1 TROUBLESHOOTING AND TESTING.....	12-26
31.2 ABS COMPONENTS .....	12-28
31.2.1 <i>Electronic Control Unit (ECU)</i> .....	12-28
31.2.2 <i>Maintenance</i> .....	12-28
31.3 ABS MODULATOR VALVE .....	12-28
31.3.1 <i>Maintenance</i> .....	12-28
31.4 SENSORS.....	12-28
31.4.1 <i>Maintenance</i> .....	12-29
31.4.2 <i>Sensor Installation</i> .....	12-29
31.5 SPRING CLIP .....	12-29
31.5.1 <i>Maintenance</i> .....	12-29
<b>32. FITTING TIGHTENING TORQUES</b> .....	<b>12-29</b>
<b>33. SPECIFICATIONS</b> .....	<b>12-31</b>

## ILLUSTRATIONS

FIGURE 1: AIR RESERVOIRS LOCATION .....	12-5
FIGURE 2: REAR VALVE LOCATION .....	12-6
FIGURE 3: FRONT SERVICE COMPARTMENT .....	12-6
FIGURE 4: ACCESSORY AIR FILTER .....	12-7
FIGURE 5: HALDEX AIR FILTER DRYER.....	12-8
FIGURE 6: AIR PRESSURE REGULATING VALVE .....	12-9
FIGURE 7: AIR PRESSURE REGULATOR.....	12-10
FIGURE 8: AIR COMPRESSOR INSTALLATION .....	12-10
FIGURE 9: PP-1 .....	12-11
FIGURE 10: RD-3.....	12-11
FIGURE 11: TW-1 .....	12-11
FIGURE 12: BRAKE PEDAL ADJUSTMENT .....	12-12
FIGURE 13: DELCO SWITCH .....	12-12
FIGURE 14: BENDIX SWITCH .....	12-12
FIGURE 15: R-12 .....	12-13
FIGURE 16: QR-1 .....	12-13
FIGURE 17: SR-1 .....	12-13
FIGURE 18: PR-2.....	12-13
FIGURE 19: LP-3.....	12-14
FIGURE 20: DC-4.....	12-14
FIGURE 21: THREE WAY VALVE.....	12-14
FIGURE 22: BRAKE PAD CHECK.....	12-16
FIGURE 23: CLEARANCE INSPECTION .....	12-16
FIGURE 24: RUNNING CLEARANCE .....	12-16
FIGURE 25: ADJUSTER PINION.....	12-17
FIGURE 26: BOX WRENCH ON ADJUSTER PINION .....	12-17
FIGURE 27: CALIPER AXIAL MOVEMENT .....	12-17
FIGURE 28: RADIAL MOVEMENT INSPECTION .....	12-17
FIGURE 29: BRAKE PAD CHECK.....	12-18
FIGURE 30: PAD REMOVAL .....	12-18
FIGURE 31: PAD WEAR.....	12-18
FIGURE 32: ROTOR AND PAD WEAR LIMITS.....	12-18
FIGURE 33: CALIPER GUIDANCE.....	12-19
FIGURE 34: RUBBER BOOTS .....	12-19

## Section 12: BRAKE AND AIR SYSTEM

---

FIGURE 35: PAD INSTALLATION .....	12-19
FIGURE 36: RUNNING CLEARANCE .....	12-20
FIGURE 37: TORQUE SPECIFICATION .....	12-20
FIGURE 38: TORQUE SPECIFICATION .....	12-20
FIGURE 39: AIR-OPERATED BRAKING SYSTEM H3 .....	12-22
FIGURE 40: RIGID SUSPENSION FRONT AXLE BRAKE AIR CHAMBER.....	12-24
FIGURE 41: TAG AXLE OR DRIVE AXLE BRAKE AIR CHAMBER.....	12-24
FIGURE 42: ABS 4S/4M CONFIGURATION .....	12-27
FIGURE 43: FIRST L.H. BAGGAGE COMPARTMENT.....	12-28
FIGURE 44: ABS MODULATOR VALVE .....	12-28
FIGURE 45: ABS SENSOR LOCATION .....	12-29
FIGURE 46: SPRING CLIP .....	12-29
FIGURE 47: HOSE FITTINGS .....	12-29
FIGURE 48: HOSE FITTING.....	12-30
FIGURE 49: HOSE FITTING.....	12-30

### 1. AIR SYSTEM

The basic air system consists of an air compressor, reservoirs, valves, filters and interconnecting lines and hoses. It provides a means for braking, operating controls and accessories, and suspension (refer to Section 16, "Suspension", for complete information on suspension description and maintenance). An air system schematic diagram is annexed in the technical publications box provided with the vehicle for better understanding of the system.

### 2. BRAKES

This vehicle uses both the service brake and emergency/parking brake. The service brake air system is divided into two independent circuits to isolate front brakes from rear brakes, thus providing safe breaking in the event that one circuit fails. Front axle brakes operate from the secondary air system, while brakes on both the drive axle and tag axle operate from the primary air system.

**Note:** The tag axle service brake operates only when the axle is in normal ride position (loaded and down).

Furthermore, the brake application or release, which is speed up by pneumatic relay valves (R-12 & R-12DC), will start with the rear axles and will be followed by the front axle, thus providing uniform braking on a slippery road. The vehicle is also equipped with an Anti-Lock Braking System (ABS), which is detailed later in this section.

The drive and tag axles are provided with spring-loaded emergency/parking brakes, which are applied automatically whenever the control valve supply pressure drops below 40 psi (275 kPa). The optional emergency/parking brake overrule system allows the driver to release spring brakes, and to move the vehicle to a safe parking place, such as in the case of a self-application of these brakes due to a drop in air pressure.

### 3. AIR RESERVOIRS

The air coming from the air dryer is first forwarded to the wet air tank, then to the primary (for the primary brake system), secondary (for the secondary brake system), and accessory (for the pneumatic accessories) air tanks (Fig. 1).

Two additional air reservoirs may be installed on the vehicle: the kneeling air tank and emergency/parking brake overrule air tank.

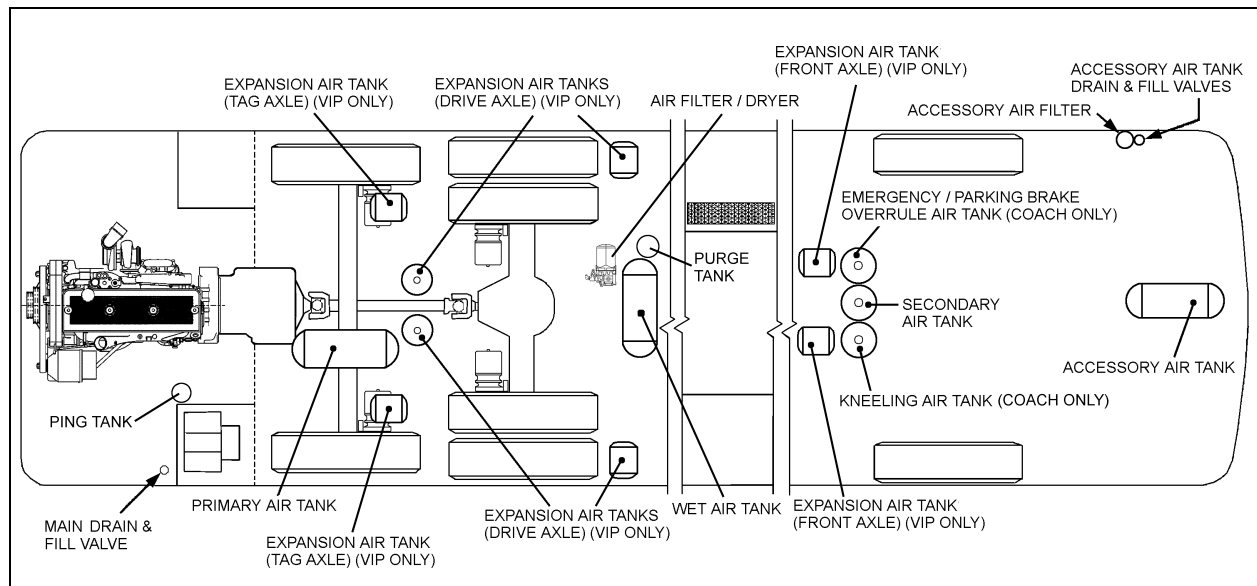

FIGURE 1: AIR RESERVOIRS LOCATION

12196

## Section 12: BRAKE AND AIR SYSTEM

### 3.1 MAINTENANCE

Ensure that both the accessories and the wet (main) air tanks are purged during pre-starting inspection. In addition, it is good practice to purge these reservoirs at the end of every working day. The remaining reservoirs must be purged at every 12,000 miles (or 20 000 km) or once every year, whichever comes first.

#### 3.1.1 Wet (Main) Air Tank

This reservoir, located in front and above the drive axle in the rear wheelhousing, is provided with a bottom drain valve. A recommended purge using the bottom drain valve should be done every 12,000 miles (20 000 km), or once a year, whichever comes first. Purge daily using the drain valve located in the engine compartment R.H. side (Fig. 2).

#### 3.1.2 Primary Air Tank

This reservoir is located above the tag axle, and is provided with a bottom drain valve (Fig. 1). It is recommended to purge the primary air tank every 12,500 miles (20 000 km) or once a year, whichever comes first.

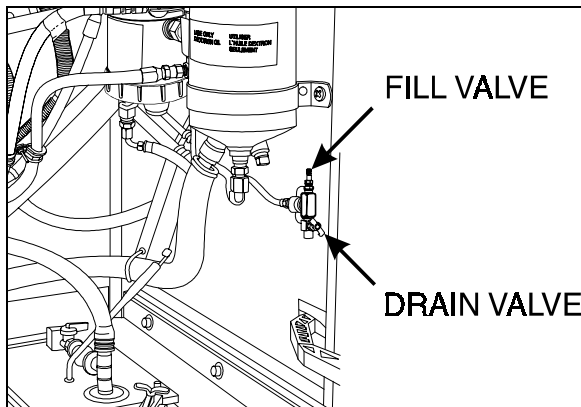

FIGURE 2: REAR VALVE LOCATION

12148

#### 3.1.3 Accessory Air Tank

The accessory air tank is installed at the ceiling of spare wheel compartment and is provided with a bottom drain valve (Fig. 1). Purge daily using the remote drain valve located in the front service compartment (Fig. 3). Purge the reservoir by it's drain valve every 12,500 miles (20 000 km) or once a year, whichever comes first.

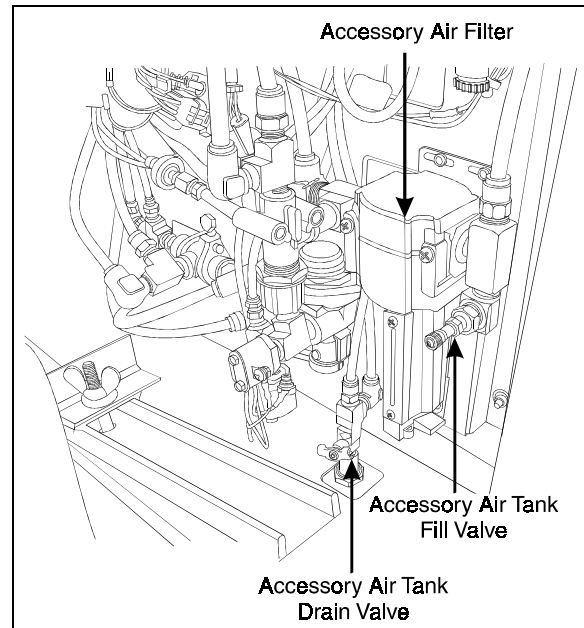

FIGURE 3: FRONT SERVICE COMPARTMENT

12130

#### 3.1.4 Emergency/Parking Brake Override Air Tank

Installed on vehicles equipped with this option, this reservoir is located in the front wheelhousing (Fig. 1). It is provided with a bottom drain valve.

Purge this reservoir every 12,500 miles (20 000 km) or once a year, whichever comes first.

#### 3.1.5 Secondary Air Tank

Located in the front wheelhousing, this tank is set between the optional Emergency/Parking Brake override air tank and the Kneeling air tank (Fig. 1). It is provided with a bottom drain valve.

Purge this reservoir every 12,500 miles (20 000 km) or once a year, whichever comes first.

#### 3.1.6 Kneeling Air Tank

The kneeling air tank is installed on vehicles equipped with the Kneeling or Hi/Low-Buoy options. It is located in the front wheelhousing (Fig. 1), and is provided with a bottom drain valve. Purge this reservoir every 12,500 miles (20 000 km) or once a year, whichever comes first.

### 3.2 PING TANK

The ping tank is located in the engine compartment and is accessible through the engine compartment R.H. side door. It is used to dissipate heat and to reduce noise produced by the air compressor cycling on and off.

#### 4. AIR SYSTEM EMERGENCY FILL VALVES

All vehicles come equipped with two emergency fill valves that enable system pressurization by an external source such as an air compressor. The rear valve is located in the engine compartment and is accessible from engine compartment R.H. side door (Fig 2.).

**Caution:** Maximum allowable air pressure is 140 psi (965 kPa). Air filled through these two points will pass through the standard air filtering system provided by Prevost. Do not fill system by any other point on the system.

The front valve is located in the front electrical and service compartment close to R.H. side of doorframe (Fig. 3).

These two air system emergency fill valves are fitted with the same valve stems as standard tires, and can be filled by any standard external air supply line.

The rear air system emergency fill valve will supply air for all systems (brakes, suspension and accessories) while the front fill valve will supply air to accessories only.

whenever supplying the system with an external air line and at least every 12,500 miles (20 000 km).

To purge, open drain valve (Fig. 4) let the moisture come out, then close the drain valve.

#### 5.1 FILTER ELEMENT REPLACEMENT

Replace filter element whichever of the following occurs first: every 100,000 miles (160 000 km), every two years, or whenever differential pressure exceeds 15 psi (105 kPa) between filter inlet and outlet ports. Check condition of all three O'rings for damage. Replace when necessary (Fig. 4).

#### 5.2 CLEANING

Clean filter body and bowl with a warm water and soap solution. Rinse thoroughly with clean water.

Blow dry with compressed air making sure the air stream is moisture free and clean. Pay particular attention to the internal passages. Inspect all parts for damage and replace if necessary.

#### 5. ACCESSORY AIR FILTER

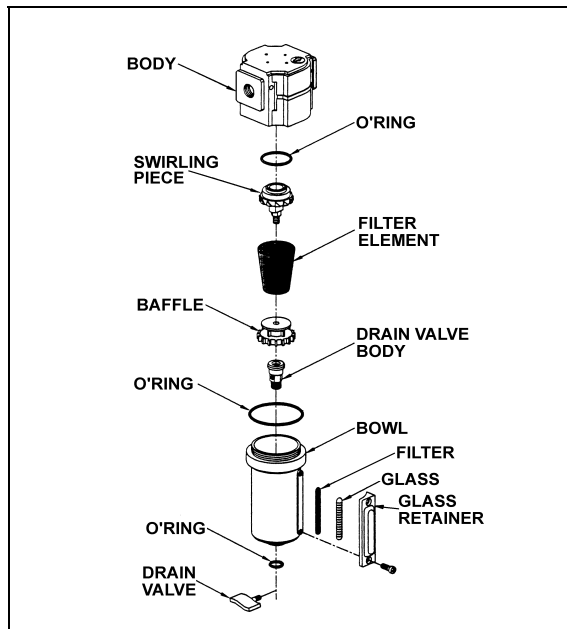

**FIGURE 4: ACCESSORY AIR FILTER** 12088  
This filter is located inside the front electrical and service compartment (Fig. 3). Its main function consists in filtering the air supplied to the accessory air system, when connected to an external supply line. Ensure filter is purged

#### 6. AIR GAUGES (PRIMARY AND SECONDARY)

The air pressure gauges, located on the dashboard (see "Operator's Manual" or "Owner's Manual"), are connected to the DC-4 double check valve, located on the pneumatic accessories panel in the front service compartment.

The latter is connected to the air lines running from the primary and secondary air tanks, as shown on the pneumatic system diagram provided in the technical publication box. The vehicle should never be set in motion until the buzzer alarm and warning lights turn off, i.e. when air pressure registers at least 66 psi (455 kPa). Moreover, if pressure drops below 66 psi (455 kPa), the "Low air pressure" warning lights will turn on, and the "Low air pressure" buzzer will sound. Stop the vehicle immediately, determine and correct the cause(s) of pressure loss. Check the gauges regularly with an accurate test gauge. Replace the gauge with a new unit if there is a difference of 4 psi (27 kPa) or more in the reading.

## Section 12: BRAKE AND AIR SYSTEM

### 7. AIR FILTER/DRYER

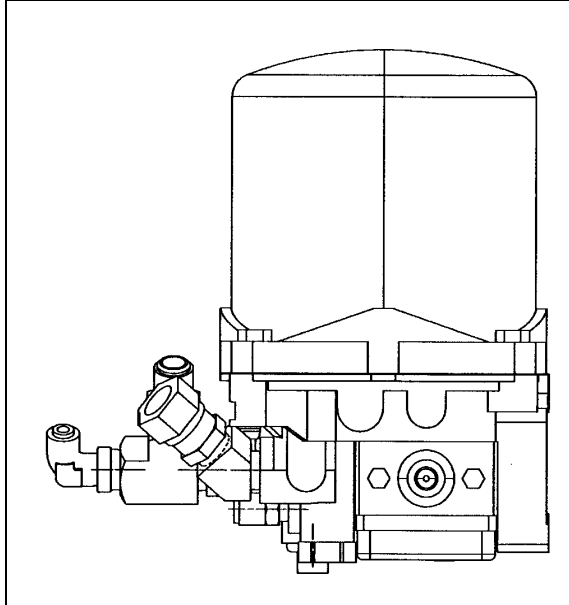

FIGURE 5: HALDEX AIR FILTER DRYER 12194

The air filter/dryer is located in front of rear wheelhousing above drive axle (Fig. 1 & 5). Its purpose is to remove moisture that could damage the air system before the air enters the system reservoir. The air filter/dryer also filters the air to remove dirt, compressor oil, and other contaminants that can damage the system. Change cartridge every 100,000 miles (160 000 km) or once every two years, whichever comes first. The air dryer may be purged for maintenance purposes using the remote drain valve located in the engine compartment and accessible through the engine compartment R.H. side door. The valve is positioned close to the door hinge (Fig. 2). The air filter/dryer has a built-in governor to maintain the system between a minimum and a maximum value.

Maintenance and repair information is supplied in the applicable booklet annexed to this section.

#### 7.1 AIR FILTER/DRYER PURGE TANK

A tank is supplied to purge the air filter/dryer to remove moisture and contaminants.

### 8. AIR LINES

Copper piping, nylon-reinforced tubing, and flexible hoses are used to connect the units in the pneumatic system, including air brake system, suspension system and accessory

systems such as the entrance door, air horns, etc. Furthermore, the nylon tubing is color coded to ease identification. Refer to the following table for the complete color identification code. Service instructions for each type of air line are also provided under the applicable headings.

Color	Circuit
Red	Secondary
Green	Primary and Delivery
Yellow	Parking Brake
Blue	Suspension
Black	Accessory
Brown	Trailer Brake

#### 8.1 COPPER PIPING

A heat dissipation copper piping assembly is used to dissipate the heat coming from the compressor before it enters the air filter/dryer. Connections should be checked for leakage at least every 6,250 miles (10 000 km) or twice a year, whichever comes first. Tighten or replace when necessary. When replacing copper piping, the parts must be free of burrs, copper cuttings, and dirt. Blow out piping with compressed air. Any such particles will destroy sealing seats in air control units. Also, new piping must be the same size as the old one.

#### 8.2 FLEXIBLE HOSES

A flexible hose is used normally where it is impractical to use copper or nylon tubing due to constant flexing during operation, such as brake chamber hoses or belt tensioner air cylinder hoses. Hose connections should be tested for leakage at least every 6,250 miles (10 000 km) or twice a year, whichever comes first and tightened or replaced if necessary. Any hose, which is chafed, worn or kinked, should be replaced.

Teflon-braided stainless steel hoses used in the engine compartment must be replaced only with similar hoses.

#### 8.3 NYLON TUBING

Nylon tubing is used for air lines in areas where usage of this material is suitable. Nylon tubing is flexible, durable, and weather resistant. When



replacing an air line, use nylon tubing only where it has been used previously.

Nylon air lines must never be routed in areas where temperature could exceed 200°F (93°C).

**Caution:** Nylon air lines should be used to replace existing nylon lines only, and must comply with the color identification code to ease pneumatic system troubleshooting.

#### 8.4 AIR LINE OPERATING TEST

If any trouble symptom such as slow brake application or slow brake release indicates a restricted or clogged air line, disconnect the suspected tube or hose at both ends and blow through it to clear the passage.

Inspect tubing and hose for partial restriction that may be caused by dents or kinks. If such a condition is found, the tubing or hose should be replaced.

#### 8.5 AIR LINE LEAKAGE TEST

With air system fully charged and the brakes applied, coat all tubing and hose connections with a soapy solution to check for air leakage. No leakage is permitted. Leakage can sometimes be corrected by tightening the connection. If this fails to correct the leakage, new fittings, nylon tubing, copper tubing, teflon-braided stainless steel and flexible hoses must be installed as applicable.

#### 8.6 MAINTENANCE

Inspect all lines for cuts, swelling, kinks or other damage or deterioration. Check for lines being pinched by other components. Retaining clips and ties must be in place.

Any support or bracket should be in good condition and mounted firmly in position. Hose spring guards should be in usable condition and not distorted. Particular attention should be given to long lines. Any supporting component (clips, ties, grommets, etc.) must be secured to prevent against unnecessary vibration and eventual loosening of connection. Any detected leak should be repaired. Be sure nylon lines are not near areas of intense heat. Check for any missing grommets or loose material where chafing or cutting may occur. Replace with new material as required. In general, lines should be securely located in position and free from any binding condition, which would hinder air flow.

### 9. PRESSURE REGULATING VALVES

There is one pressure regulator for the belt tensioners, and an optional one installed on vehicles equipped with the world transmission output retarder.

The belt tensioner pressure regulating valve is located in the engine compartment at the back of the engine starting control panel. It is used to limit the air pressure in belt tensioners to 50 ± 2 psi (345 ± 15 kPa) (Fig. 7).

The optional regulator is located in the engine compartment and is accessible through the engine R.H. side door. It is used for transmission retarder and should be adjusted to 80 ± 3 psi (550 ± 20 kPa).

	Air Pressure (psi)	Air Pressure (kPa)
Belt Tensioner	50 ± 2	345 ± 15
Retarder	80 ± 3	550 ± 20

#### 9.1 MAINTENANCE

Every 100,000 miles (160 000 km) or once every two years, whichever comes first, disassemble the pressure regulating valve and wash all metal parts in a cleaning solvent (Fig. 6). Examine the diaphragm; if cracked, worn or damaged, replace with a new one. If the valve is excessively grooved or pitted, it should be replaced. Replace any other part that appears worn or damaged. After reassembly, adjust to the specified pressure setting and check for air leakage.

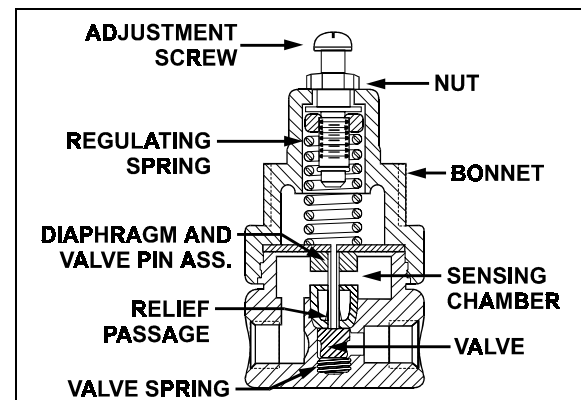

FIGURE 6: AIR PRESSURE REGULATING VALVE 12141A

#### 9.2 PRESSURE SETTING PROCEDURE

Remove the dust cap from the pressure check port (Fig. 7). Attach a pressure gauge at this

## Section 12: BRAKE AND AIR SYSTEM

port and check the pressure reading. If the pressure reading is incorrect, adjust as follows:

1. Loosen the locking nut, turn the adjustment screw counterclockwise to decrease pressure by approximately 10 psi (70 kPa) below the required pressure.
2. Turn the adjustment screw clockwise to increase the pressure slowly until the required pressure setting is reached. Tighten the locking nut.
3. Remove pressure gauge and replace dust cap on the pressure check port.

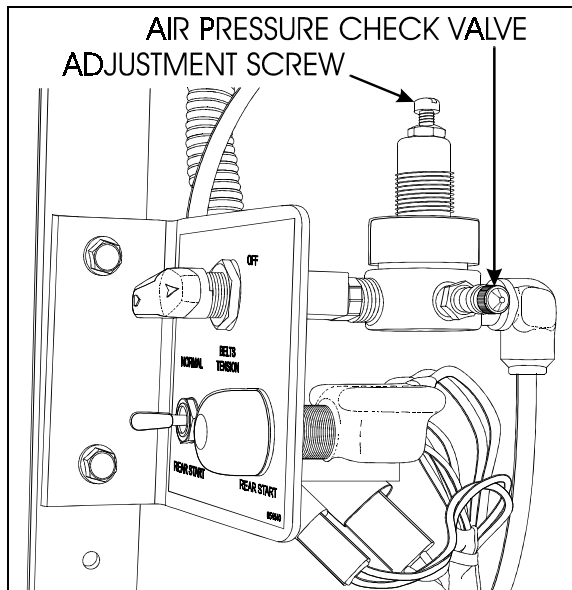

FIGURE 7: AIR PRESSURE REGULATOR

12143

### 10. AIR COMPRESSOR (TU-FLO 750)

The air compressor is located on starter side of the engine, on the rear of the engine gear case (Fig. 8). Its function is to provide and maintain air under pressure to operate devices in brake and air systems.

This air compressor also drives the engine fuel pump, which is bolted to the rear end of the compressor. The compressor crankshaft is designed to accept a drive coupling which is placed between the compressor and fuel pump.

The compressor is driven by the bull gear, and is water cooled. Engine coolant is fed to the compressor through a flexible hose tapped into the block water jacket and connected to the rear of the compressor. Coolant returns from the right of the compressor (fuel pump side) through a flexible hose to the engine cylinder head.

The air is taken from the air intake manifold and entered in the back of the compressor. The compressed air is pushed into the discharge line located on top of the compressor, which sends air to the air dryer. Lubricating oil is supplied to the compressor by a line from the cylinder block oil gallery connected to the air compressor. Lubricating oil returns to the engine crankcase through the air compressor drive assembly.

Maintenance and repair information on the TU-FLO 750 air compressor is supplied in the applicable booklet annexed to this section under reference number SD-01-344.

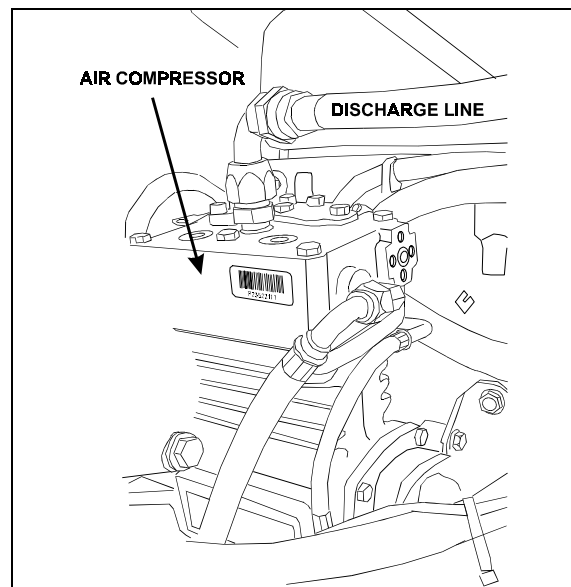

FIGURE 8: AIR COMPRESSOR INSTALLATION

12199

#### 10.1 COMPRESSOR REMOVAL AND INSTALLATION

1. Exhaust compressed air from air system by opening the drain valve of each air tank.
2. Drain the engine cooling system. See Section 5: "Cooling System".
3. Identify and disconnect all air, coolant and oil lines from the compressor assembly.
4. Access the compressor by the engine R.H. side compartment. Remove the four compressor mounting bolts and the two fuel pump support bracket bolts.
5. Slide air compressor rearward to disengage the hub from coupling. Remove the air compressor.

Reverse removal procedure for installation.

**11. EMERGENCY / PARKING BRAKE CONTROL VALVE (PP-1)**

A push-pull control valve mounted on the L.H. lateral console is provided for parking brake application or release. The spring brakes are self-actuated whenever the control valve supply pressure drops below 40 psi (275 kPa). In the UP position, brakes are ON. In the DOWN position, brakes are RELEASED. A protective case around the knob prevents accidentally releasing the brakes.

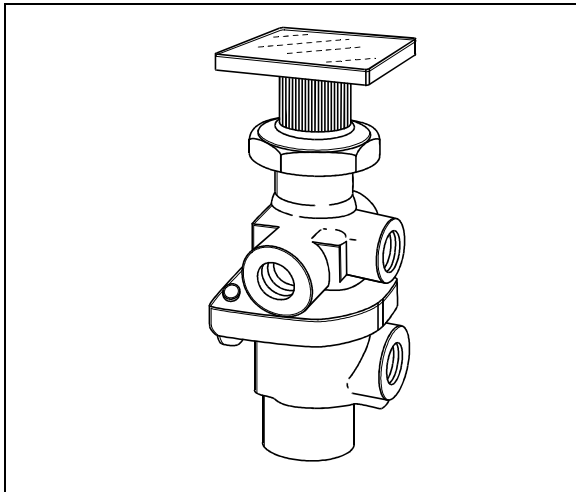

FIGURE 9: PP-1 12142

Maintenance and repair information on this valve is supplied in the applicable booklet annexed to this section under reference number SD-03-3611.

Remove the valve the following way:

1. Drain the air system.
2. Access this valve by tearing out the finishing panel, which holds the controls in place (Fig. 9).
3. Disconnect the air tubes.
4. Remove the retaining screws.
5. Service or replace the valve.
6. Installation is the reverse of removal.

**12. EMERGENCY / PARKING BRAKE OVERRULE CONTROL VALVE (RD-3)**

A RD-3 control valve is used with the optional parking brake overrule system. In the case of self-application of spring brakes due to a pressure drop, the brakes can be released by

holding down this control valve. Maintenance and repair information on this valve is supplied in the applicable booklet annexed to this section under reference number SD-03-3611.

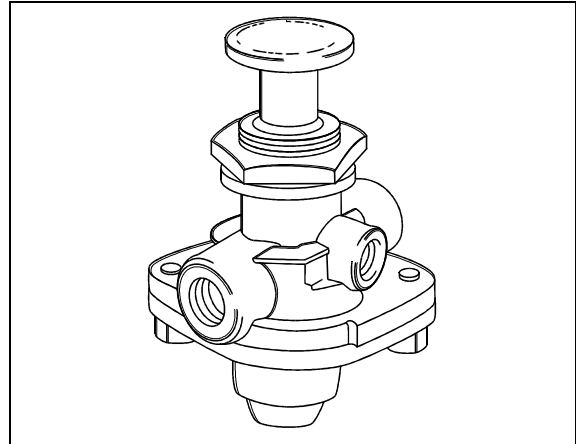

FIGURE 10: RD-3 12136

**13. FLIP-FLOP CONTROL VALVE (TW-1)**

A flip-flop control valve mounted on the L.H. lateral console is provided to unload tag axle air springs (and to lift tag axle if vehicle is so equipped). Another one controls the low-buoy system (coaches only). It is a manually operated "on-off" valve. Maintenance and repair information on this valve is supplied in the applicable booklet annexed to this section under reference number SD-03-3602.

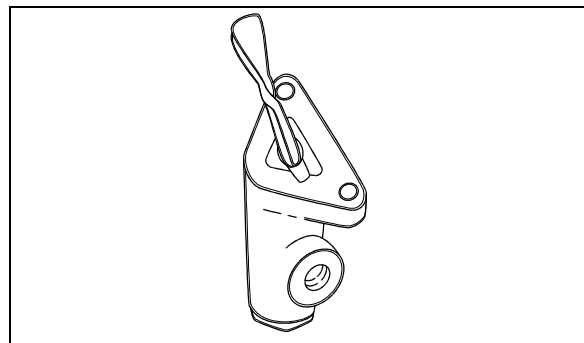

FIGURE 11: TW-1 12138

**14. DUAL BRAKE APPLICATION VALVE (E-10P)**

The E-10P dual brake valve is a floor mounted, foot-operated type brake valve with two separate supply and delivery circuits. This valve is located in the front service compartment (Fig. 12).

## Section 12: BRAKE AND AIR SYSTEM

### 14.1 BRAKE PEDAL ADJUSTMENT

After brake pedal replacement or repair, adjust the pedal to its proper position according to the following procedure:

1. Replace the linkage, loosen threaded rod lock nuts and screw or unscrew the threaded adjustment rod in order to obtain a 45° brake pedal inclination (Fig. 12).
2. Tighten threaded rod lock nuts.

#### 14.1.1 Maintenance

Maintenance and repair information on the E-10P dual brake application valve is supplied in the applicable booklet annexed to this section under reference number SD-03-830.

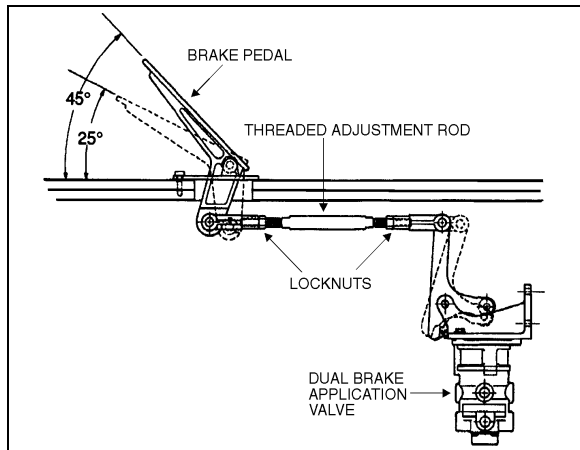

FIGURE 12: BRAKE PEDAL ADJUSTMENT 12040

### 15. STOPLIGHT SWITCHES

Two Electro-pneumatic stoplight switches are mounted on the dual brake application valve (E-10P). The upper one is used for the primary air circuit while the lower one is used for the secondary air circuit. Both switches are connected in parallel and have the same purpose, i.e. completing the electrical circuit and lighting the stoplights when a brake application is made. The upper switch (AC Delco) is designed to close its contact between 2 psi and 4 psi (14 kPa to 28 kPa) (Fig. 13), while the lower one (Bendix, SL-5) closes its contact at 4 psi (28 kPa) (Fig. 14). The switches are not a serviceable items; if found defective, the complete unit must be replaced.

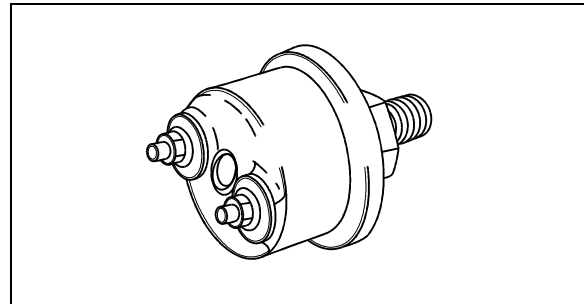

FIGURE 13: DELCO SWITCH 12139

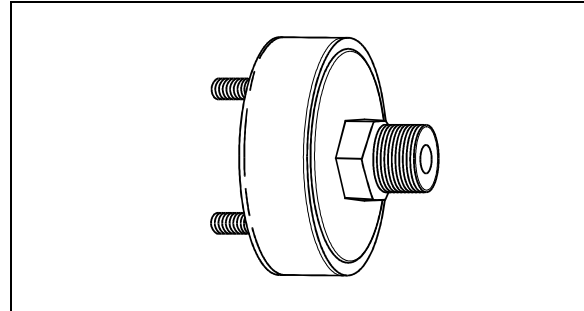

FIGURE 14: BENDIX SWITCH 12140

### 16. PARKING BRAKE ALARM SWITCH

Refer to the appropriate annexed booklet (Bendix, SL-5 Stop Light Switch; reference no. SD-06-2501).

The parking brake alarm uses the same switch as the stoplights. It is mounted on the spring brake valve and operates in conjunction with a NC relay to sound a warning alarm by completing the electrical circuit when the ignition key is turned OFF with parking brake released.

### 17. BRAKE RELAY VALVE (R-12 & R-12DC)

The primary air system includes three brake relay valves being supplied by the dual brake valve, and which function is to speed up the application and release of the service brakes.

One R-12DC valve supplies the drive axle service brake air line, while the other two valves supply independently both the tag axle right and left service brake air line and act as interlock valves. These valves are accessible from under the vehicle at the level of the tag axle. Maintenance and repair information on these valves is supplied in the applicable booklet annexed to this section under reference number SD-03-1064 and SD-03-1068.

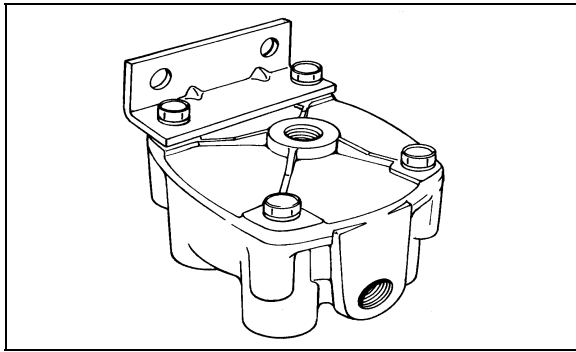

FIGURE 15: R-12

12074

### 18. QUICK RELEASE VALVES (QR-1)

One quick release valve is installed on this vehicle and is located on the front axle service brakes air line. It is also used on Low Buoy rear release system. It permits rapid exhaust of air pressure from brakes, thus decreasing the brake release time.

Maintenance and repair information on these valves is supplied in the applicable booklet annexed to this section under reference number SD-03-901.

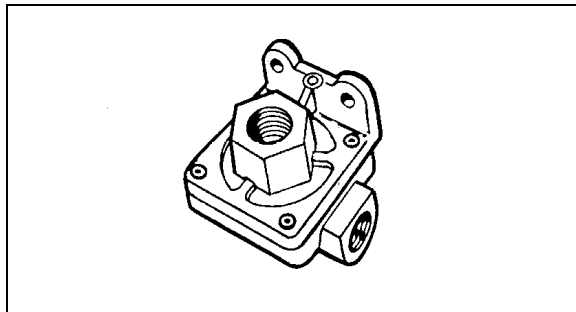

FIGURE 16: QR-1

12075

### 19. SPRING BRAKE VALVE (SR-1)

The spring brake valve is located at ceiling of front bumper compartment. The function of the SR-1 is to modulate the spring brakes during the application of the foot brake valve in the event of loss of service brake pressure. Maintenance and repair information on the spring brake valve is supplied in the applicable booklet annexed to this section under reference number SD-03-4508.

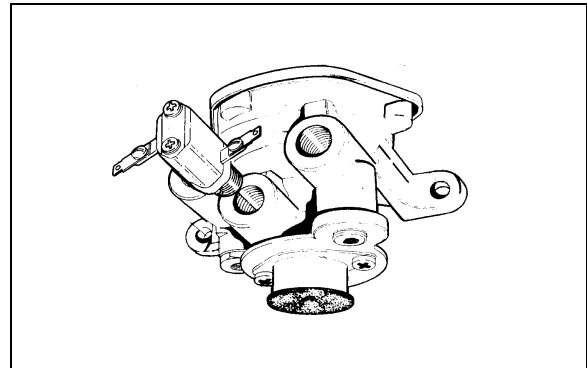

FIGURE 17: SR-1

12076

### 20. PRESSURE PROTECTION VALVE (PR-2)

Maintenance and repair information on the pressure protection valve is supplied in the applicable booklet annexed to this section under reference number SD-03-2010.

The air system includes two pressure protection valves (Fig. 18). One valve is installed on the manifold block, and insures at all times a minimum pressure of 75 psi (517 kPa) in the suspension air system in the event that a pressure drop occurs in either the suspension air system or accessory air system. This valve is located in the steering compartment besides the air filter.

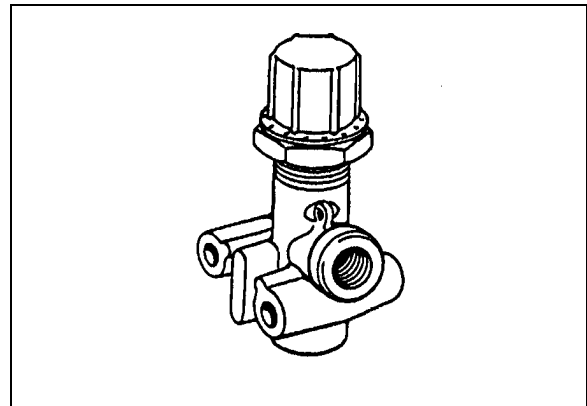

FIGURE 18: PR-2

12077

The other valve is installed on the accessory air tank, and insures a minimum pressure of 75 psi (517 kPa) in the accessory air system in the event that a pressure drop occurs in either the suspension air system or braking air system (refer to Fig. 1 for accessory air tank location).

## Section 12: BRAKE AND AIR SYSTEM

### 21. LOW PRESSURE INDICATORS (LP-3)

Maintenance and repair information on the low pressure indicators is supplied in the applicable booklet annexed to this section under reference number SD-06-1600.

The air system includes two low pressure switches. One is located on the pneumatic accessories panel in the front service compartment. The remaining pressure switch is mounted on the spring brake valve, and monitors the parking brake pilot lamp. Its pressure setting is 30 psi (205 kPa).

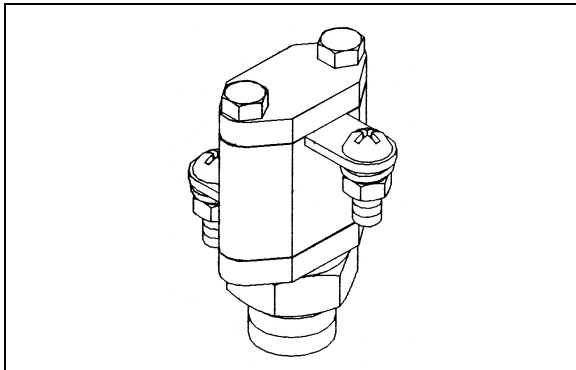

FIGURE 19: LP-3

12078

### 22. SHUTTLE-TYPE DOUBLE CHECK VALVE (DC-4)

Maintenance and repair information on the shuttle-type double check valve is supplied in the applicable booklet annexed to this section under reference number SD-03-2202.

The double check valve is located on the pneumatic accessories panel in the front service compartment. In the event of a pressure drop in either the primary or secondary system, this unit will protect the emergency /parking brake control valve and the intact portion of the air system from pressure loss.

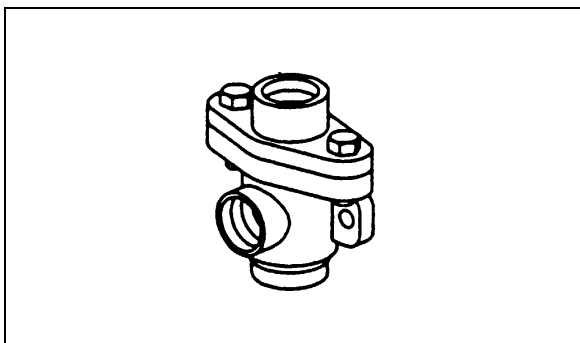

FIGURE 20: DC-4

12134

### 23. EMERGENCY DOOR OPENING VALVES

Two emergency door opening three-way valves are installed on coaches. One is in the front service compartment, readily accessible. The other one is on the R.H. side lateral console, close to the entrance door. When used, the valve releases pressure in the door locking cylinder, thus allowing the door to be manually opened.

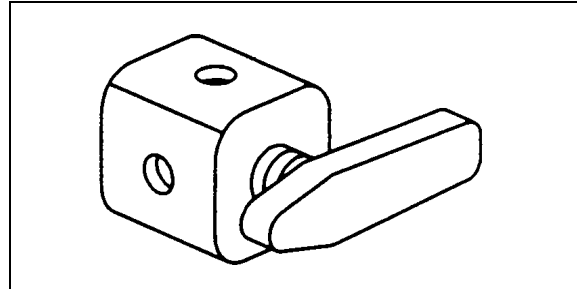

FIGURE 21: THREE WAY VALVE

12186

#### 23.1 INTERIOR VALVE MAINTENANCE

When needed, this valve can be changed according to the following procedure:

1. Unscrew the front R.H. decorative panel in order to access the valve.
2. Unscrew and remove the valve handle.
3. Unscrew and remove the valve retaining ring.
4. Push the valve inside the console.
5. Disconnect the air tubes.
6. Reverse the procedure to install a new valve.

### 24. AIR HORN VALVE

The air horn solenoid valve is located in the front service compartment. The air horn activating button is on the center of the steering wheel. Refer to section 23 "ACCESSORIES" for more information.

### 25. AIR SYSTEM TROUBLESHOOTING

The following list has been designed to help in troubleshooting some of the most common problems in the air system and main causes. For air brakes troubleshooting, refer to "Air Brakes Troubleshooting" in this section. For more troubleshooting information, refer to the manufacturer's brochures annexed to this section.

**Air pressure doesn't rise to, or doesn't maintain, a normal setting:**

- Defective air gauge (registering incorrectly).
- Excessive leaking in air system.
- Reservoir drain cock open.
- Air filter/dryer built-in governor poorly adjusted or defective.
- Defective compressor.
- Worn compressor or excessive wear on piston and/or ring.

**Air pressure rises to normal setting too slowly:**

- Excessive leaking in air system.
- Clogged engine air cleaner.
- Worn compressor or excessive wear on piston and/or ring.
- Engine speed too low.

**Air pressure rises above a normal setting:**

- Defective air gauge (registering incorrectly).
- Air filter/dryer built-in governor poorly adjusted or defective.

**Air pressure drops quickly when engine is stopped:**

- Leaks in compressor discharge valve.
- Leaks in air lines.
- Leaks in air system valves.

**26. BRAKE OPERATION**

The vehicle braking system uses both service and parking air-operated brakes. The air system is divided into two independent circuits to isolate the front axle brakes and the rear axle brakes (drive and tag), thus providing safe brake operation in the event that one circuit of the system fails. The primary circuit is connected to the drive and tag axle brakes, while the secondary circuit is connected to the front axle brakes. The tag axle service brakes operate only when the axle is in the normal driving (loaded) position. The spring-type emergency brakes are mounted on the drive and tag axles, and will apply automatically if primary system pressure falls below 40 psi (276 kPa). The optional parking brake override system can cancel the parking brakes, enabling the driver to move the vehicle to a safe parking place. To operate this system, push down and hold the control knob

located on the R.H. side of the driver's seat (see "Operator's Manual" for more details).

Furthermore, brake application or release, which is sped up by a pneumatic relay valve (R-12 & R-12DC), will start with the rear axles and be followed by the front axle, thus providing uniform braking on a slippery surface. The vehicle is also equipped with an Anti-lock Brake System (ABS), detailed later in this section.

Brake and air system maintenance consists of periodic inspections. Check all parts for damage and brake adjustment (refer to subsequent headings in this section for more details). Ensure all fasteners are tight (refer to "Specifications" for recommended tightening torques).

**27. AIR BRAKES**

*Knorr-Bremse SB7000* disc brakes are used on all axles. The front and drive axle discs are actuated by 24 inch<sup>2</sup> effective area air brake chambers (22 inch<sup>2</sup> for front solid beam axle), while on tag axle, the brake chambers have a 16 inch<sup>2</sup> effective area for service brake and a 16 inch<sup>2</sup> effective area for emergency/parking brakes. The *Knorr-Bremse SB7000* brakes are supplied with automatic clearance (slack) adjusters as standard equipment for easier adjustment. For more information on disc brake components and maintenance, refer to the manufacturer's brochure at the end of this section.

**27.1 DISC BRAKE PADS**

Brake pads have to be checked on a regular basis depending on the vehicle operation. The remaining thickness of the pads should never be less than 3/32 in (2 mm). To check pad condition without removing the wheel, verify the position of guide bushing (6) relatively to guide sleeve (4) (see Fig. 23). When guide sleeve is in alignment with guide bushing, brake pad thickness has to be checked more precisely with the wheel removed. When replacing brake pads, all four pads on an axle have to be changed at the same time. There is no inner or outer pad, since all pads are the same. Once removed, worn pads should be replaced in their original position.

## Section 12: BRAKE AND AIR SYSTEM

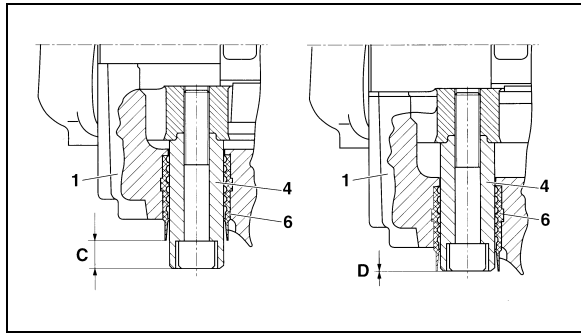

FIGURE 22: BRAKE PAD CHECK

12117

### 27.2 CALIPER MAINTENANCE

Use the following procedure for brake calipers servicing. The procedure must be followed in proper sequence to ensure that only needed repairs or replacements are performed on calipers. Problems such as hot brakes or cracked rotors may be effects of sticking calipers, too-small clearance between rotor and pad or possible trapped air pressure in the brake chamber. If any of these symptoms occur, perform this procedure before replacing the rotor to ensure the cause of the problem is properly solved.

#### 1. Check for presence of residual pressure:

To check if there is any residual air pressure in the brake chamber, make four or five brake applications, then try to turn the wheel manually. If the wheel does not turn, use a wrench to crack the air line and listen for trapped air in the brake chamber then try to turn the wheel manually again. If you find trapped air in the brake booster, ensure that all pneumatic components in the braking system are functioning properly.

**Note:** A residual pressure of 2-3 PSI in the system is sufficient to prevent the brakes from releasing. Also the stop light switch can operate with as little as 1 PSI, therefore an illuminated brake light does not mean brakes are dragging.

#### 2. Pad to rotor clearance inspection:

Remove clip and washer (26 & 45, Fig. 23), push down retainer bar (11), pull out pin (44) and remove retainer bar. Push caliper toward actuator (center of vehicle) for maximum clearance.

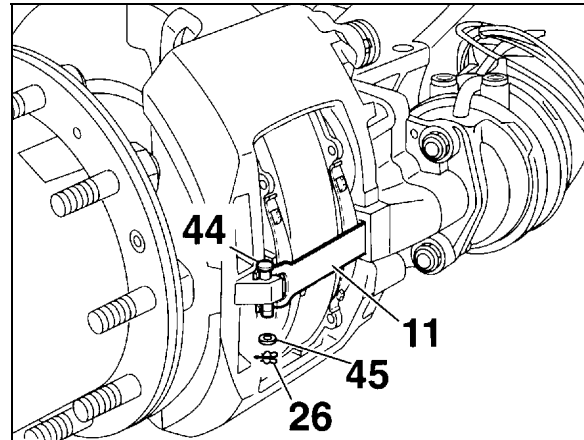

FIGURE 23: CLEARANCE INSPECTION

12119

#### 3. Measure pad to rotor clearance:

Place a long feeler gauge (long enough to measure across entire tappet surface) between the tappet and the backing plate of the pad, measure clearance at both tappets. Clearance should range between 0.020 and 0.035 inch (0.5 mm and 0.9 mm), with a maximum difference between tappet measurements on same brake of 0.008 inch (0.2 mm).

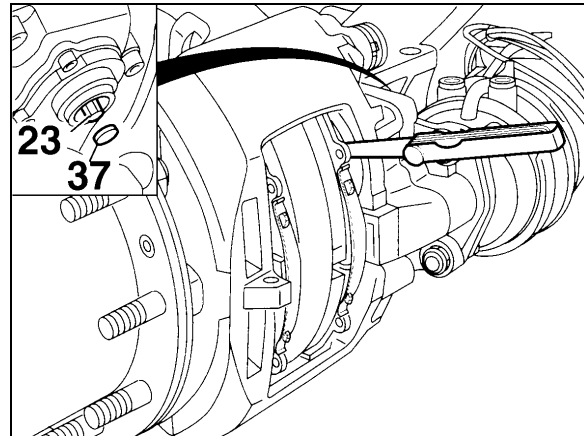

FIGURE 24: RUNNING CLEARANCE

12116

#### 4. Checking the adjuster

**Warning:** Use only a standard box wrench on the adjuster hexagonal pinion. Do not overtorque the pinion as overtightening will damage the pinion.

- Remove cap (37, Fig. 25).
- Using a box wrench (8 mm), turn the adjuster pinion (23, Fig. 25) counterclockwise about 2-3 clicks to increase running clearance. By operating the braking system about 5-10 times (30 PSI or 2 bar), the



wrench should turn clockwise in small increments if the adjuster is functioning correctly (Figs. 25 and 26).

**Note:** With increasing number of applications, the incremental adjustment will decrease.

- c) In case of malfunction, i. e. the pinion or box wrench:
  - i) Does not turn.
  - ii) Turns only with the first application.
  - iii) Turns forwards then backwards with every application.

In any of the above cases, the automatic adjuster has failed and the caliper must be replaced. In such cases the brakes can be adjusted manually to run a short distance.

- d) Take the box wrench off. Replace the cap and check for proper sealing.

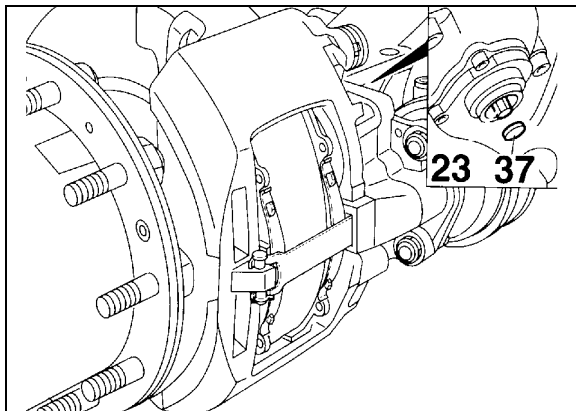

FIGURE 25: ADJUSTER PINION 12120

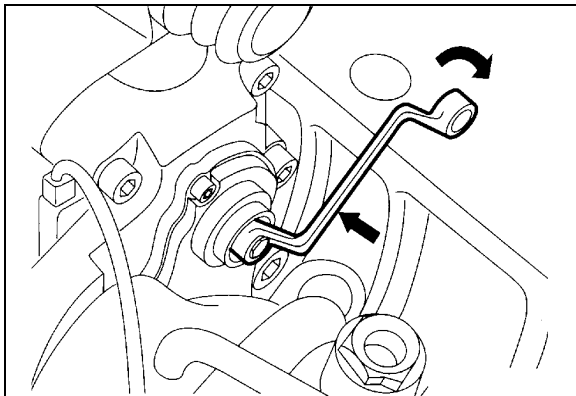

FIGURE 26: BOX WRENCH ON ADJUSTER PINION 12118

### 27.3 ROADSIDE INSPECTION FOR KNORR /BENDIX AIR DISC BRAKES

The coach is equipped with air disc brakes and therefore, cannot be inspected using the requirements for chamber stroke or visible lining clearance or lining thickness as specified for drum brakes. The roadside inspector should use the following instructions to determine that the air disc brakes are within proper adjustment and have sufficient pad wear thickness.

The Knorr/Bendix air disc brake is designed to move freely, with minimal force, in the axial direction on the two sliding pins as identified in figure 27. The movement in the axial direction should not exceed 2 mm (5/64”).

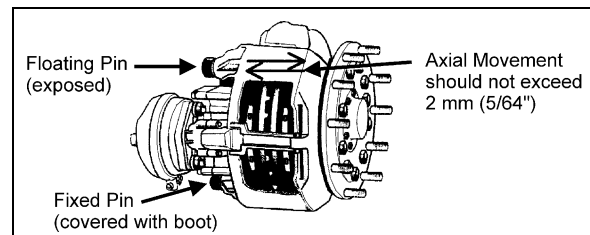

FIGURE 27: CALIPER AXIAL MOVEMENT 12132

The caliper flotation consists of two pins. One pin (fixed pin) floats and should have minimal movement in the radial direction. The other pin is floating in a rubber bushing. The maximum radial movement should not exceed 2.0 mm (0.080”). To check the radial movement, insert a pry tool between the caliper and carrier near the middle and then measure the relative movement as shown in figure 28.

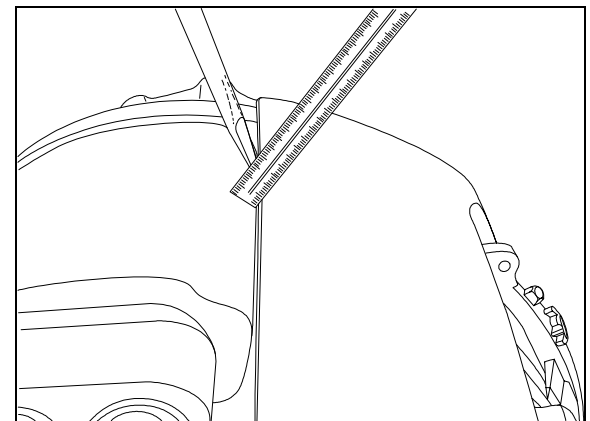

FIGURE 28: RADIAL MOVEMENT INSPECTION 12187

The pad thickness can be seen but would require removal of the tire and rim. An indicator of the pad wear condition is available by inspecting the floating pin location in relation to the rubber bushing as shown in figure 29. When

## Section 12: BRAKE AND AIR SYSTEM

pads are in new thickness condition, the pin will be exposed (C) 19 mm ( $\frac{3}{4}$ ""). When the pads are worn to replacement conditions, the pin will be nearly flush to the bushing (D) or within 1 mm ( $\frac{3}{64}$ "") of the edge of the rubber bushing.

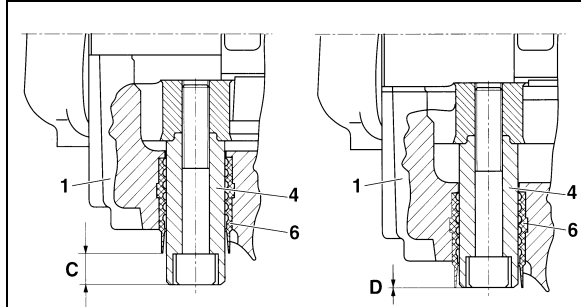

FIGURE 29: BRAKE PAD CHECK

12117

### 27.4 PAD REMOVAL

Turn adjuster pinion (23) counterclockwise to increase pad to rotor clearance (a clicking noise will be heard). Push caliper toward actuator and remove pads (12).

**Caution:** Do not apply brakes while pads are removed as this could cause over stroke damage to the adjusting mechanism.

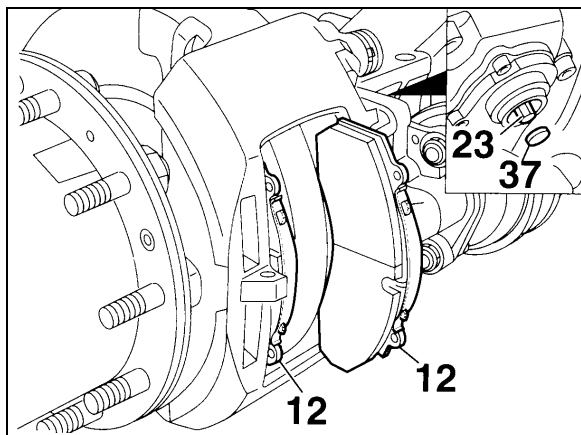

FIGURE 30: PAD REMOVAL

12111

### 27.5 CHECKING PAD WEAR

Minimum friction material thickness is 2 mm (A, Fig. 31)

New friction material has a thickness of 21 mm (B, Fig. 31)

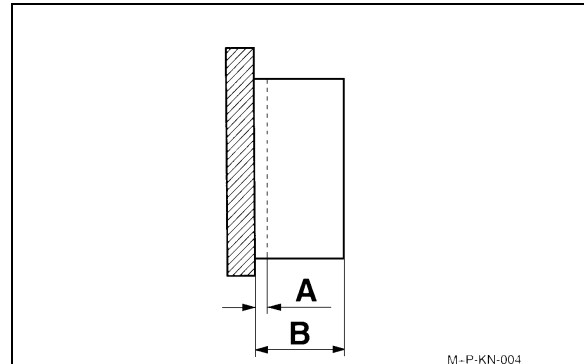

FIGURE 31: PAD WEAR

M-P-KN-004

12112

### 27.6 IMPORTANT PAD AND ROTOR MEASUREMENTS

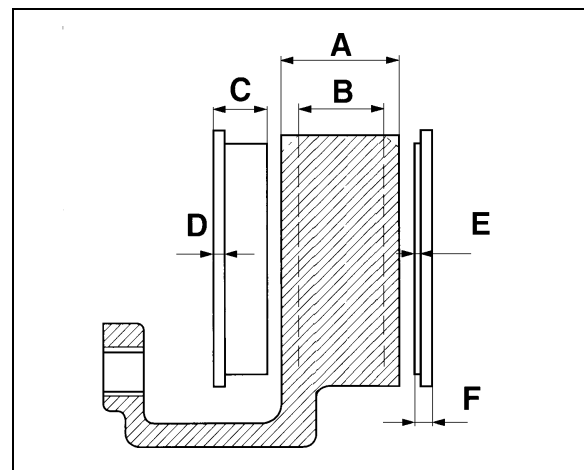

FIGURE 32: ROTOR AND PAD WEAR LIMITS

12113

A = Rotor thickness (new): 45 mm;

B = Rotor thickness (worn): 37 mm. Requires replacement;

C = Overall thickness of pad (new): 30 mm;

D = Backplate: 9 mm;

E = Minimum thickness of pad material: 2 mm;

F = Minimum allowed thickness of overall backplate and friction material: 11 mm.

**Replacement necessary.**

### 27.7 CHECKING CALIPER GUIDANCE AND SEAL CONDITION

Perform sliding test. You must be able to slide the caliper easily at any time. Sliding test should be performed at least every three months or more often depending on the type of operation.

Sliding Test (Refer to Fig. 33):

- a) Using hand pressure only, the caliper (1) must slide freely with its guide pin arrangements (4-7) across a distance of 1 3/16 inch (30 mm) when the pads are removed. The sleeve (5) is sealed using the boot (9) and the cap (10).
- b) The rubber components (9 and 10) should show no damage. The positioning must be checked. If necessary the caliper has to be repaired using the guide kit (part #611168) or with the seal and guide kit (part #611199). When repairing a caliper with the above kits, make sure all parts in the kit are used. Use special green grease (Prévost #683344) to reassemble the slide pin into the bushing, white or yellow grease (Prévost #683345) may be used for all other lubrication needs.
- c) Depending on caliper manufacturing date, black paint may be present on the unsealed pin (short pin). Paint on the slide pin can prevent the caliper from sliding properly especially when the pad starts to wear. If paint is present on the pin, separate the pin from the bushing, clean and reinstall the pin according to procedure.

**Note:** Do not attempt to use thinner or alcohol to clean the pin without removing it as it may damage the rubber bushing.

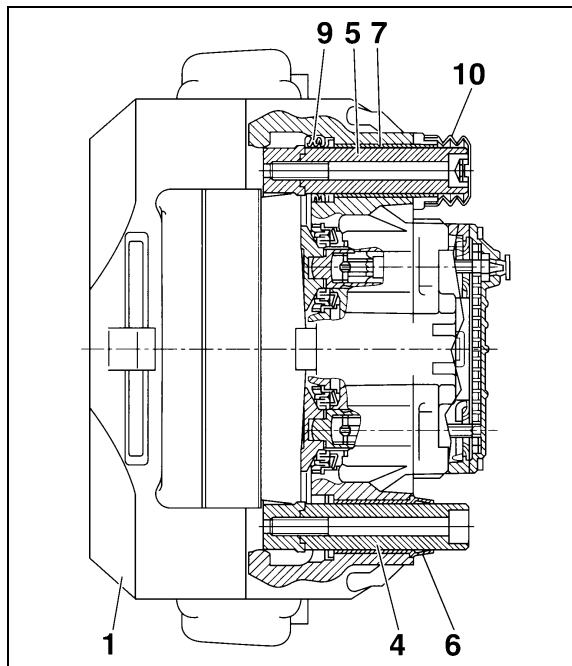

FIGURE 33: CALIPER GUIDANCE

12114

### 27.8 CHECKING THE TAPPET BOOTS

- a) The rubber boots (13, Fig. 34) should show no damage, check the attachment.

**Caution:** Any ingress of water and dirt will lead to corrosion and may affect the function of the actuation mechanism and adjuster unit.

- b) If boots are damaged but show no corrosion, the boots and tappets should be replaced (Prévost #611177).

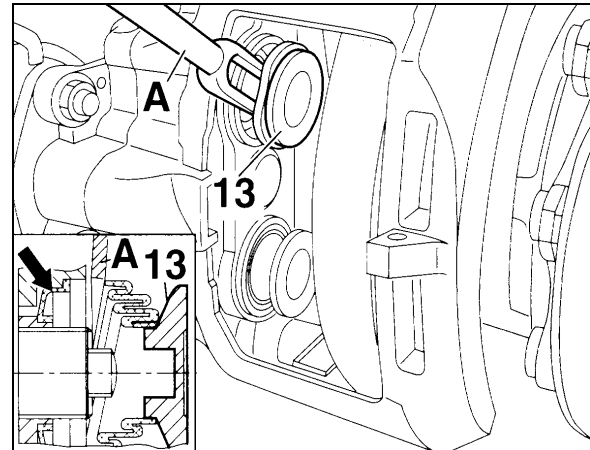

FIGURE 34: RUBBER BOOTS

12115

### 27.9 PAD INSTALLATION

Turn adjuster pinion (23, Fig. 35) counterclockwise until tappets are fully retracted and clean pad seat area. Slide caliper to full outboard position and install outside pad. Slide caliper to full inboard position and install inside pad.

**Warning:** It is recommended to change all pads on an axle at the same time.

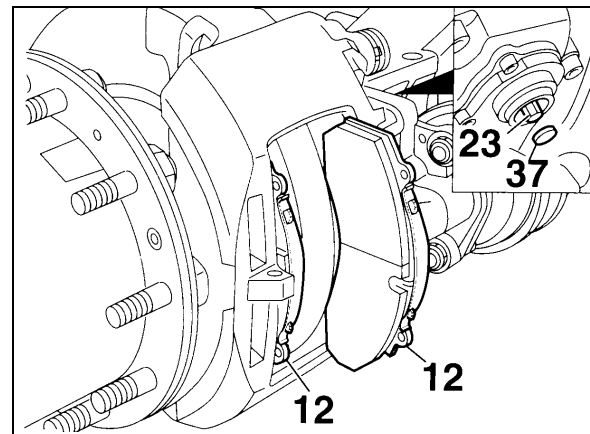

FIGURE 35: PAD INSTALLATION

12111

## Section 12: BRAKE AND AIR SYSTEM

### 27.10 ADJUSTING THE RUNNING CLEARANCE

- a) Insert a feeler gauge 0.028 inch (0.7 mm thickness) between tappet and pad back-plate (Fig. 36). Turn adjuster pinion clockwise until 0.028 inch (0.7 mm) clearance is achieved. Replace cap (37) (Prévost # 641313).
- b) To ensure a constant running clearance between the rotor and pads, the brake is equipped with an automatic adjuster unit. When the pads and rotor wear, the running clearance between the pads and rotor increases. The adjuster (23, Fig. 36) and turning device turn the threaded tubes by the amount necessary to compensate the wear.

Total running clearance should be between 0.020 and 0.035 inch (0.5 and 0.9 mm). Smaller clearances may lead to overheating problems.

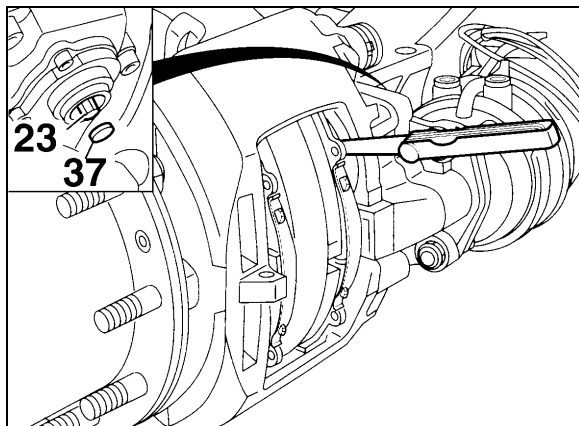

FIGURE 36: RUNNING CLEARANCE

12116

### 27.11 BRAKE TOOLS

Four brake tools are available from Prévost to facilitate disc brake maintenance:

- a) #641321, Tappet with boot (item 13).
- b) #641322, Caliper inner boot (item 9).
- c) #641323, Caliper bushing (item 7).
- d) #641435, Fork for boot tappet (item 13).

#### Maintenance tip

Using the following procedure, pad wear can be determined without removing the wheel.

### 27.12 TORQUE SPECIFICATIONS

For proper caliper maintenance, refer to the following figures.

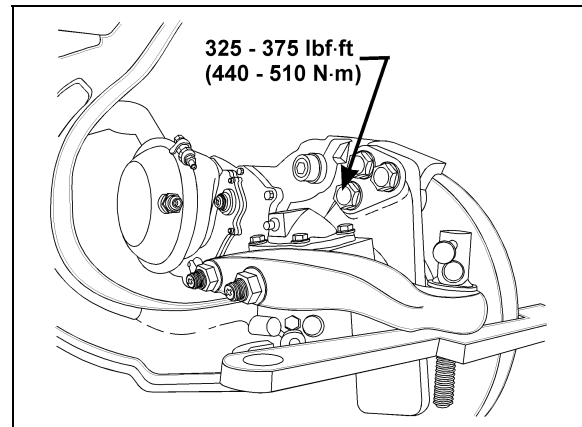

FIGURE 37: TORQUE SPECIFICATION

12145

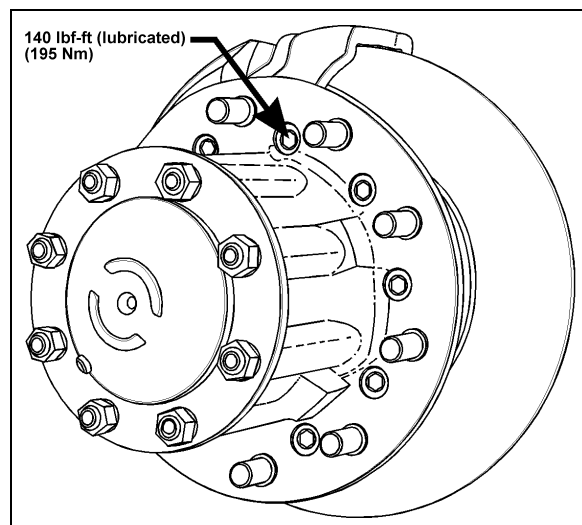

FIGURE 38: TORQUE SPECIFICATION

12149

## 28. SAFE SERVICE PROCEDURES

Most recently manufactured brake linings no longer contain asbestos fibers. Instead of asbestos, these linings contain a variety of ingredients, including glass fibers, mineral wool, aramid fibers, ceramic fibers, and carbon fibers. At present, OSHA (Occupational Safety and Health Administration) does not specifically regulate these non-asbestos fibers, except as nuisance dust. Medical experts do not agree about the potential long-term risks from working with and inhaling non-asbestos fibers. Nonetheless some experts think that long-term exposure to some non-asbestos fibers could cause diseases of the lung, including pneumoconiosis, fibrosis, and cancer. Therefore, lining suppliers recommend that workers use caution to avoid creating and breathing dust when working on brakes that contain non-asbestos fibers.

**Warning:**

Whenever possible, work on brakes in a separate area away from other operations.

Always wear a respirator approved by NIOSH (National Institute of Occupational Safety and Health) or MSHA (Mine Safety and Health Administration) during all brake service procedures. Wear the respirator from removal of the wheels through assembly.

NEVER use compressed air or dry brushing to clean brake parts or assemblies. OSHA recommends that you use cylinders that enclose the brake. These cylinders have vacuums with high efficiency (HEPA (Health and Environment Protection Agency)) filters and workmans' arm sleeves. But, if such equipment is not available, carefully clean parts and assemblies in the open air.

Clean brake parts and assemblies in the open air. During disassembly, carefully place all parts on the floor to avoid getting dust into the air. Use an industrial vacuum cleaner with a HEPA filter system to clean dust from the brake drums, backing plates and other brake parts. After using the vacuum, remove any remaining dust with a rag soaked in water and wrung until nearly dry.

If you must grind or machine brake linings, take additional precautions because contact with fiber dust is higher during these operations. In addition to wearing an approved respirator, do such work in an area with exhaust ventilation.

When cleaning the work area, NEVER use compressed air or dry sweeping to clean the work area. Use an industrial vacuum with a HEPA filter and rags soaked in water and wrung until nearly dry. Dispose of used rags with care to avoid getting dust into the air. Use an approved respirator when emptying vacuum cleaners and handling used rags.

Wash your hands before eating, drinking or smoking. Do not wear your work clothes home. Vacuum your work clothes after use and then launder them separately, without shaking, to prevent fiber dust from getting into the air.

Material safety data sheets on this product, as required by OSHA, are available from Knorr-Bremse.

**29. AIR BRAKE TROUBLESHOOTING**

The following tests and check lists have been designed to identify the cause(s) of a sluggish performance and/or leaks in the system. These tests require very little time to perform, and give you a general idea of the system condition. Each test is provided with a corresponding check list which will guide you to the most common causes of problems.

Before performing any test, check all air lines for kinks or dents, and hoses for signs of wear, drying out or overheating.

**Warning:** When working on or around brake system and its related components, the following precautions should be observed:

Always block vehicle wheels. Stop engine when working under a vehicle. Keep hands away from chamber push rods and slack adjusters as they may apply when system pressure drops.

Never connect or disconnect a hose or line containing air pressure. It may whip as air escapes. Never remove a component or pipe plug unless you are sure all system pressure has been depleted.

Never exceed recommended air pressure and always wear safety glasses when working with air pressure. Never look into air jets or direct them at anyone.

Never attempt to disassemble a component until you have read and understood the recommended procedures. Some components contain powerful springs and injury can result if not properly disassembled. Use only proper tools and observe all precautions pertaining to the use of those tools.

Always clean connecting piping and/or fittings, and coat pipe threads with Teflon pipe sealant before installing any air brake system component.

Section 12: BRAKE AND AIR SYSTEM

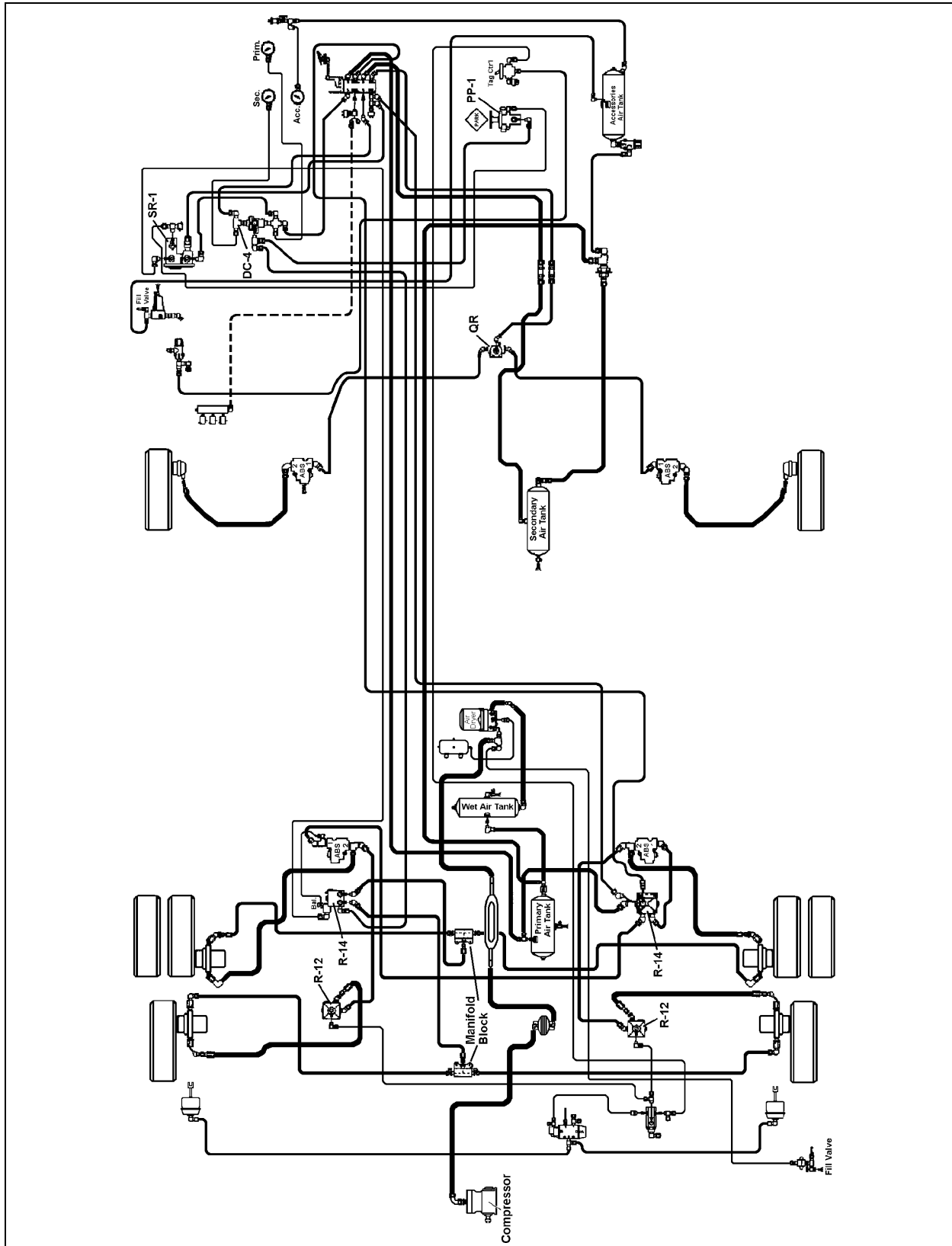

FIGURE 39: AIR-OPERATED BRAKING SYSTEM H3

12197

**Pressure Build-Up / Low Pressure Warning / Cutoff Point / Air Filter/Dryer Built-in Governor Cutout**

CONDITION: Vehicle leveled, parking brake applied.

1. Completely drain wet, primary and secondary air reservoirs only.
2. Start engine and run at fast idle. Low pressure warning lights should be "On".
3. Start checking pressure at 50 psi (344 kPa).
4. Low pressure warning lights and buzzer should go off at or above 60 psi (415 kPa).
5. At 85 psi (586 kPa), run engine at full rpm, then check that build up time to 100 psi (690 kPa) is 30 seconds or less.
6. Air filter/dryer built-in governor cut-out. Cuts out at the correct pressure of 123 psi  $\pm$ 3 (847 $\pm$ 21 kPa).
7. Air filter/dryer built-in governor cut-in. Cuts in around 110 psi (758 kPa).

For common corrections, refer to the following check list:

**High or Low Warning Cutoff Point**

- ✓ Perform a telltale light and gauge test. Replace entire cluster if found defective.

**High or Low Air Filter/Dryer Built-in Governor Cutout Point**

- ✓ Perform a telltale light and gauge test. Replace entire cluster if found defective.

OR

- ✓ Repair or replace air filter/dryer as necessary after checking that compressor unloader mechanism operates correctly.

**More than 30 seconds to build-up pressure from 85 to 100 psi (585 - 690 kPa) at full engine RPM**

- ✓ Perform a telltale light and gauge test. Replace entire cluster if found defective.
- ✓ Check compressor strainer or inlet line. If restricted, clean or replace element or faulty line.
- ✓ Check compressor head or discharge line for carbonization or restriction. Clean or replace as necessary.

- ✓ If discharge valves leak, pull head and correct or replace cylinder head.
- ✓ If drive is slipping, replace gear.
- ✓ If inlet valves are stuck, open or leaking severely, replace unloader kit, inlet valves and/or seats as necessary.
- ✓ If drain cock is found open, close it.
- ✓ Listen for air leaks and repair.
- ✓ Redo list to check all items repaired or replaced.

**Air Supply Reservoir Leakage**

CONDITION: Full pressure, engine stopped, parking brake applied

1. Allow at least 1 minute for pressure to stabilize.
2. Stop engine, then check air pressure gauge for 2 minutes. Note any pressure drop.
3. Pressure should not drop by more than 3 psi (20 kPa) per minute.

For common corrections, refer to the following check list:

Excessive air loss:

- ✓ With the primary air system at normal operating pressure (95 - 125 psi (655 - 860 kPa)), coat all air line connections and pneumatic components with a water and soap solution. Bubbles will indicate an air leak, and none should be permissible. Repair or replace defective parts.
- ✓ Listen for leaks and correct as required.
- ✓ Redo test to check all items repaired or replaced.

**Brake System Air Leakage**

CONDITION: Full pressure, engine stopped, parking brake released.

1. Apply service (foot) brakes, allow at least 1 minute for pressure to stabilize.
2. Hold down foot valve for 2 minutes while observing air pressure gauge on the dashboard.
3. Pressure drop should not be more than 4 psi (27 kPa) per minute.

For common corrections, refer to the following check list:

## Section 12: BRAKE AND AIR SYSTEM

### Excessive leakage on brake service side:

- ✓ With the primary air system at normal operating pressure (95 - 125 psi (655 - 860 kPa)) and foot brake applied, coat all air line connections and brake pneumatic components with a water and soap solution. Bubbles will indicate an air leak, and none should be permissible. Repair or replace defective parts.
- ✓ Listen for leaks and correct as required.
- ✓ Redo test to check all items repaired or replaced.

### 30. BRAKE AIR CHAMBER

This vehicle uses “Knorr-Bremse” brake chambers on all axles. The tag and drive axle chambers consist of two separate air chambers, each having its own diaphragm and push rod. They are used as a service brake chamber, an emergency brake in case of air pressure loss and a spring-applied parking brake. Refer to figures 40 and 41.

The front axle brake air chambers are used only for service brake duty (Fig. 40).

#### 30.1 MAINTENANCE

Every 6,250 Miles (10 000 km) or twice a year, whichever comes first depending on type of operation:

1. Insert a box wrench (8 mm) onto the adjuster pinion.
2. Apply brakes 5 – 10 times and observe that the pads move out promptly without binding and that box wrench turns clockwise in small increments.
3. Check tightness of mounting nuts. Check that cotter pins are in place.
4. Check all hoses and lines. They should be secure and in good condition.

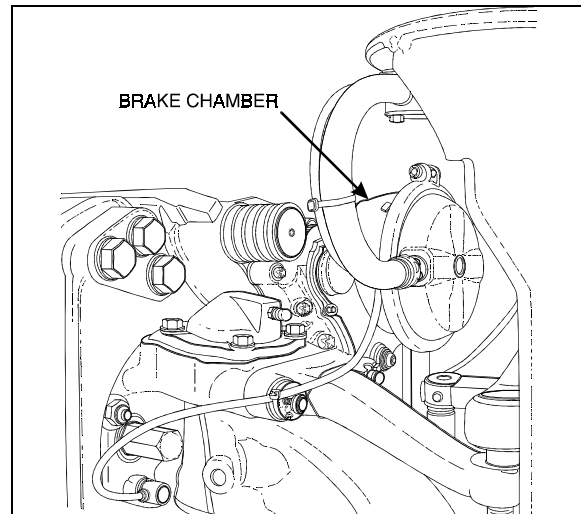

FIGURE 40: RIGID SUSPENSION FRONT AXLE BRAKE AIR CHAMBER  
12158

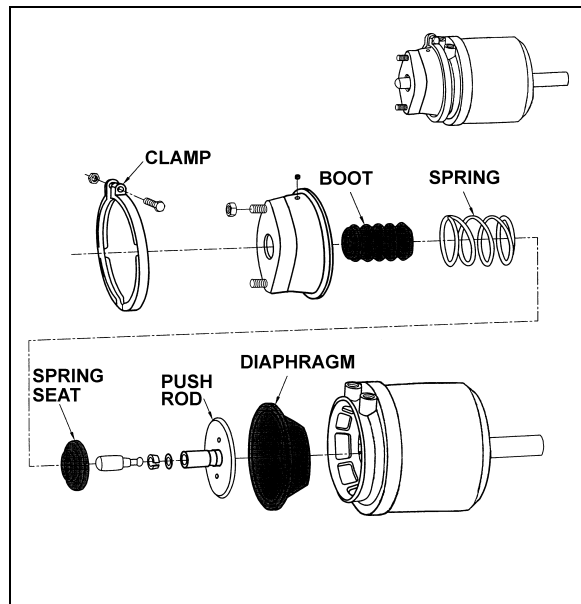

FIGURE 41: TAG AXLE OR DRIVE AXLE BRAKE AIR CHAMBER  
12126

Every 100,000 Miles (160 000 km) or once a year, whichever comes first depending on type of operation

1. Disassemble and clean all parts.
2. Install new diaphragm or any other part if worn or deteriorated.

**Note:** When the diaphragm, spring, or both are replaced, they should be replaced in the corresponding chamber on the same axle.

3. Perform an airtightness test:



- a) Make and hold a full brake application.
- b) Coat clamping ring(s) with a soapy solution. If leakage is detected, tighten clamping ring only enough to stop leakage. **Do not over-tighten** as this can distort sealing surface or clamping ring. Coat area around push rod hole (loosen boot if necessary). No leakage is permitted. If leakage is detected, the diaphragm must be replaced.

### 30.2 EMERGENCY/PARKING BRAKE MANUAL RELEASE

**Warning:** Never stand in the axis line of the spring brake chambers, especially when caging the spring.

#### Drive Axle

1. Block the wheels to prevent the vehicle from moving.
2. Remove the release stud tool from its storage place on drive axle brake air chamber.
3. Remove the access plug from the end of the spring chamber, then insert the release stud through the opening. Turn the release stud 1/4 turn (clockwise) to anchor it into the spring plate. Install the flat washer and nut, then turn the nut clockwise to cage the spring. Repeat on the opposite side.

**Warning:** Make sure the release stud is properly anchored in spring plate receptacle prior to caging the spring.

4. To manually reset the emergency/parking brake, turn the nut counterclockwise. Reinstall access plugs on the spring chambers, and release stud tools in their storage places.

#### Tag Axle

1. Block the wheels to prevent the vehicle from moving.
2. Turn the release bolt counterclockwise to cage the power spring (approx. 2.5 inches (6 cm)). Repeat on the opposite side.
3. To manually reset the emergency/parking brake, turn the bolt clockwise.

### 30.3 BRAKE CHAMBER REMOVAL

**Warning:** To prevent personal injuries, brakes should be inoperative prior to working on any of their components.

**Warning:** To prevent personal injuries, brake chambers should be made inoperative by releasing spring tension prior to disposal.

1. Block the wheels to prevent the vehicle from moving.
2. Safely support vehicle at the recommended body jacking points.
3. To gain access to a given brake air chamber, the corresponding wheel can be removed (refer to Section 13: "Wheels, Hubs and Tires").
4. Exhaust compressed air from system by opening the drain valve of each reservoir.
5. For the drive and tag axles brake chambers, manually release spring brakes (refer to "Emergency/Parking Brake, Manual Release" procedure in this section).
6. Disconnect air line(s) from brake chamber.
7. Remove the cotter pin connecting brake chamber and slack adjuster (drive axle).
8. Unbolt and remove the brake chamber from vehicle.

### 30.4 BRAKE CHAMBER INSTALLATION

Reverse removal procedure, then check brake adjustment.

**Caution:** Always clean air lines and fittings, and coat pipe threads with teflon pipe sealant before reconnecting air lines.

### 30.5 BRAKE CHAMBER DISASSEMBLY

**Warning:** Spring brake chambers, on drive and tag axles contain an extremely high compressive force spring, which can possibly cause serious injury if special precautions are not taken when working around this area.

To avoid such injury, the following recommendations must be applied:

1. Prévost recommends the installation of a new spring brake chamber if it is found to be defective.

## Section 12: BRAKE AND AIR SYSTEM

---

2. Spring brake chamber maintenance and/or repair must be performed by trained and qualified personnel only.

3. Before manually releasing spring brakes, visually check spring brake for cracks and/or corrosion.

4. Make sure the release stud is properly anchored in spring plate receptacle prior to caging the spring.

5. Never stand in the axis line of the spring brake chambers, especially when caging the spring.

**Warning:** To prevent personal injury, brakes should be inoperative before working on any components.

1. Block the wheels to prevent the vehicle from moving.
2. Safely support vehicle at the recommended body jacking points.

**Note:** To gain access to a given brake air chamber, the corresponding wheel can be removed (refer to Section 13: "Wheels, Hubs and Tires").

3. Exhaust compressed air from air system by opening the drain valve of each reservoir.
4. For the drive and tag axles brake chambers, manually release spring brakes (refer to "Emergency/Parking Brake Manual Release" procedure in this section).
5. Remove clamp ring, remove and discard the existing diaphragm. Install the new diaphragm squarely on body.
6. Reverse the procedure for assembly. Tap clamp ring to ensure proper seating. Check for proper operation before placing vehicle in service.

### 31. ANTI-LOCK BRAKING SYSTEM (ABS)

This device has been designed to ensure stability and permit steering control of vehicle during hard braking, and to minimize its stopping distance whatever the road conditions are. On slippery roads and generally in emergency situations, over-braking frequently induces wheel lock. The anti-lock braking system provides

maximum braking performance while maintaining adequate steering control on slippery roads.

The ABS continuously monitors wheel behavior during braking. Sensors on each wheel of front and drive axles (tag axle is slave to drive axle) transmit data to a four channel electronic processor which senses when any wheel is about to lock. Modulator valves quickly adjust the brake pressure (up to 5 times per second) to prevent wheel locking. Each wheel is therefore controlled according to the grip available between its tire and the road.

With this device, the vehicle is brought to a halt in the shortest possible time, while remaining stable and under the driver's control.

Since the braking system has dual circuits, the ABS is also provided with a secondary system should a fault develop in the ABS. Anti-lock systems are a parallel system which does not hinder brake functioning in case of failure. Braking system functions in normal, non anti-lock controlled operation during ABS system failure.

The ABS system consists of two diagonally related circuits, only the half of the system which has sustained damage or other fault is switched off (i.e. wheels return to normal non-ABS braking). The other diagonal half remains under full ABS control.

**Note:** ABS is active on service brake, transmission retarder, Jake brake, but is inactive on emergency/parking brake.

**Note:** The ABS system is inoperative at speeds under 4 mph (7 Km/h). Illumination of ABS telltale indicator at these speeds is normal.

**Caution:** Disconnect the ECU or pull the ABS fuse before towing vehicle.

#### 31.1 TROUBLESHOOTING AND TESTING

For troubleshooting and testing of the vehicle's anti-lock braking system, refer to Rockwell WABCO Maintenance Manual: "Anti-Lock Brake Systems For Trucks, Tractors and Buses", at the end of this section. Use dashboard Message Center Display (MCD) Diagnostic Mode for troubleshooting and repair.

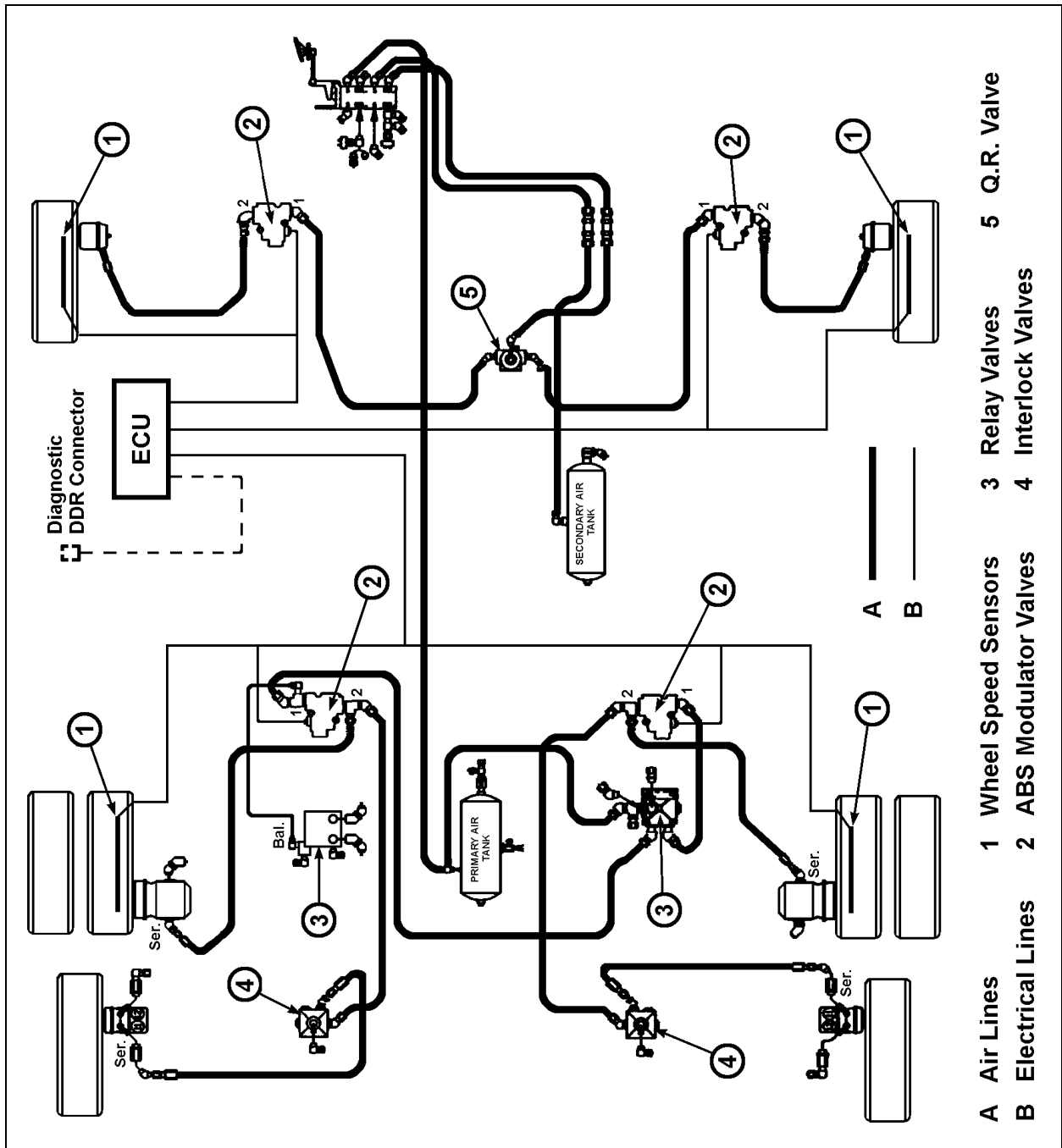

FIGURE 42: ABS 4S/4M CONFIGURATION

12190

## Section 12: BRAKE AND AIR SYSTEM

### 31.2 ABS COMPONENTS

The main components of the ABS system are listed hereafter. Refer to each component for its specific function in the system and for proper maintenance.

#### 31.2.1 Electronic Control Unit (ECU)

This control unit is located in the first baggage compartment, on the driver's side of the vehicle (refer to figure 43 for location) or in the front electrical and service compartment. According to the data transmitted by the sensors (number of pulses/sec is proportional to the speed of each wheel), the electronic control unit determines which wheel is accelerating or decelerating. It then establishes a reference speed (average speed) from each wheel data, and compares the speed of each wheel with this reference speed to determine which wheel is accelerating or decelerating.

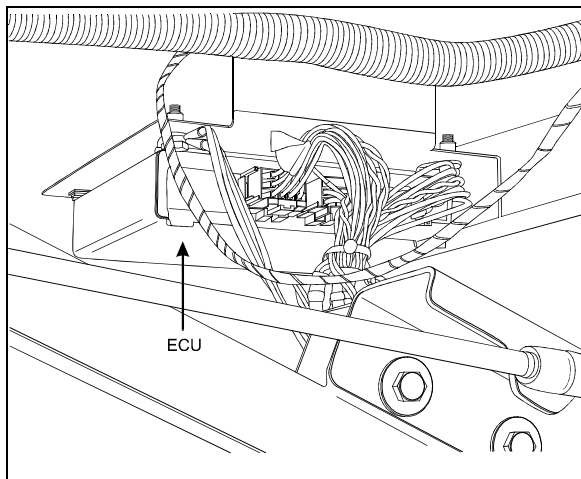

FIGURE 43: FIRST L.H. BAGGAGE COMPARTMENT 12198

As soon as wheel deceleration or wheel slip threshold values are exceeded, the electronic control unit signals a solenoid control valve to limit the excessive brake pressure produced by the driver in the appropriate brake chamber.

#### 31.2.2 Maintenance

No specific maintenance is required. The ECU is not serviceable. When found to be defective, replace.

**Caution:** In order to protect the ABS electronic control unit from voltage surges, always disconnect before performing any welding procedure on vehicle.

### 31.3 ABS MODULATOR VALVE

This ABS system is equipped with four modulator valves, located between the brake chamber and the relay valve or quick release valve (Fig. 44). Note that there is only one solenoid valve controlling the drive and tag axle wheels on the same side (tag axle is slave to drive axle).

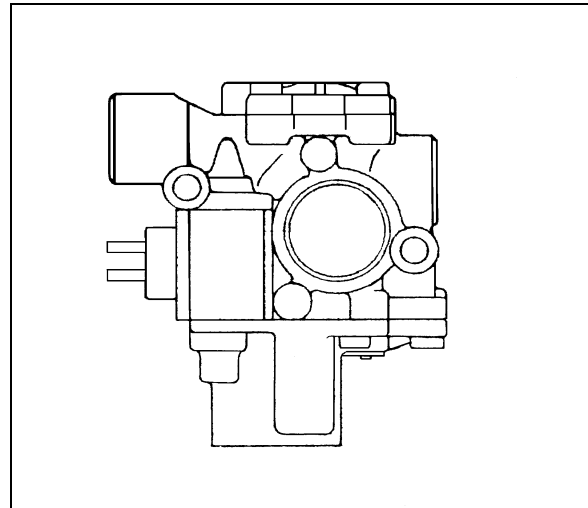

FIGURE 44: ABS MODULATOR VALVE

12084

This is an "On/Off" type valve, i.e., at brake application, the valve exhausts air from the brake chamber when the electronic unit senses that the corresponding wheel speed is decreasing in relation to the other wheels.

#### 31.3.1 Maintenance

No specific maintenance is required for the solenoid control valve.

### 31.4 SENSORS

The sensors are mounted on the front and drive axle wheel hubs (Fig. 45). The inductive sensors consist essentially of a permanent magnet with a round pole pin and a coil. The rotation of the toothed wheel alters the magnetic flux picked up by the coil, producing an alternating voltage, the frequency of which is proportional to wheel speed. When wheel speed decreases, magnetic flux decreases proportionately. Consequently, the electronic control unit will command the solenoid control valve to decrease the pressure at the corresponding brake chamber.

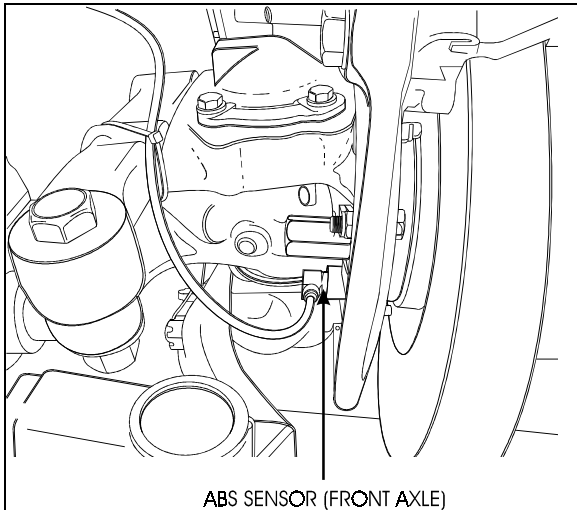

FIGURE 45: ABS SENSOR LOCATION

12153

### 31.4.1 Maintenance

No specific maintenance is required for sensors, except if the sensors have to be removed for axle servicing. In such a case, sensors should be lubricated with a special grease (Prévost #680460) before reinstallation. Refer to paragraph "Sensor Installation" for details.

**Note:** The resistance value, when sensors are checked as a unit, must be equal to 1,75 k ohms. To check the sensors for proper output voltage after the sensors and toothed wheels have been assembled to the axle, connect a suitable AC voltmeter across the output terminals. With the hubs rotating at 30 rpm, the output voltages should read from 50 to 1999 mV to be acceptable.

### 31.4.2 Sensor Installation

The following procedure deals with sensor installation on the axle wheel hubs. Read procedure carefully before reinstalling a sensor, as its installation must comply with operational tolerances and specifications.

1. Apply recommended lubricant (Prévost #680460) to spring clip and sensor.

**Caution:** Use only this type of grease on the sensors.

2. Insert spring clip in the holder on hub. Make sure the spring clip tabs are on the inboard side of the vehicle. Push in until the clip stops.

3. Push the sensor completely inside the spring clip until it is in contact with the tooth wheel. Ensure mounting is rigid, as it is an important criterion for adequate sensor operation.

**Note:** This installation should be of the "press fit" type.

### 31.5 SPRING CLIP

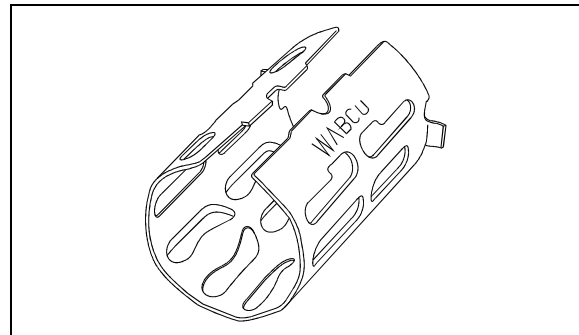

FIGURE 46: SPRING CLIP

12161

The spring clip retains the sensor in its mounting bracket close to the toothed pulse wheel. The gap between the sensor end and teeth is set automatically by pushing the sensor in the clip hard up against the tooth wheel, and the latter knocks back the sensor to its adjusted position (Fig. 46).

### 31.5.1 Maintenance

The spring clip requires no specific maintenance.

## 32. FITTING TIGHTENING TORQUES

**45° Flare and Inverted Flare:** Tighten assembly with a wrench until a solid feeling is encountered. From that point, tighten 1/6 turn (Fig. 47).

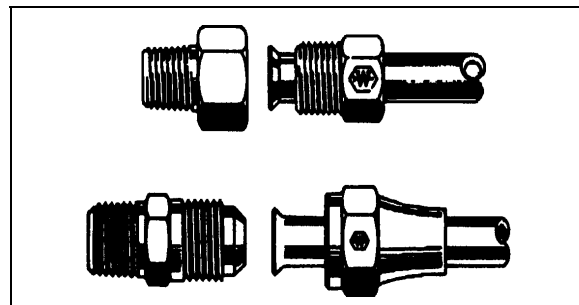
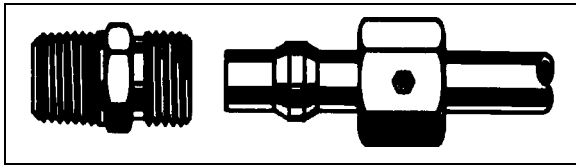

FIGURE 47: HOSE FITTINGS

12053

**Compression:** Tighten nut by hand (Fig. 48). From that point, tighten using a wrench the number of turns indicated in the chart hereafter.

**Section 12: BRAKE AND AIR SYSTEM**



**FIGURE 48: HOSE FITTING** 12054

Fitting size	Pipe diameter (inches)	Number of additional turns required following manual tightening
2	1/8	1 ¼
3	3/16	1 ¼
4	1/4	1 ¼
5	5/16	1 ¾
6	3/8	2 ¼
8	1/2	2 ¼
10	5/8	2 ¼
12	3/4	2 ¼
16	1	2 ¼

**NTA-Type Plastic Tubing:** Hand tighten nut (Fig. 49). From that point, tighten using a wrench the number of turns indicated in the following chart.

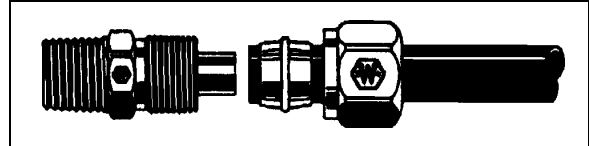

**FIGURE 49: HOSE FITTING** 12055

Tubing diameter (inch)	Number of additional turns required following manual tightening
1/4	3
3/8 to 1/2	4
5/8 to 3/4	3 ½

**33. SPECIFICATIONS**

**Air Compressor**

Make ..... Bendix Westinghouse  
 Model ..... Tu-Flo 750  
 Capacity (at 1250 rpm) ..... 16.5 cfm (0,467 m<sup>3</sup>/min.)  
 Supplier number ..... 109426  
 Prévost number ..... 641392

**Air Dryer**

Make ..... Haldex  
 Model ..... AT-87192  
 Prévost number ..... 70303498  
 Desiccant cartridge Prévost number ..... 3097369

**Flip-Flop Control Valve**

Make ..... Bendix Westinghouse  
 Model ..... TW-1  
 Type ..... On-Off  
 Supplier number ..... 229635  
 Prévost number ..... 640136

**Emergency/Parking Brake Control Valve**

Make ..... Bendix Westinghouse  
 Model ..... PP-1  
 Automatic release pressure ..... 40 psi (275 kPa) nominal  
 Supplier number ..... 287325  
 Prévost number ..... 641128

**Emergency/Parking Brake Overrule Control Valve**

Make ..... Bendix Westinghouse  
 Model ..... RD-3  
 Supplier number ..... 281481  
 Prévost number ..... 640472

**Dual Brake Application Valve**

Make ..... Bendix Westinghouse  
 Model ..... E-10P  
 Supplier number ..... 5006280  
 Prévost number ..... 641856

**Stoplight Switches**

Make ..... Bendix Westinghouse  
 Model ..... SL-5  
 Contact close (ascending pressure) ..... 4 psi and more (28 kPa)  
 Supplier number ..... 286404  
 Prévost number ..... 641462

**Brake Relay Valves**

Make ..... Bendix Westinghouse  
 Model ..... R-12 & R-12DC  
 Supplier number ..... 102852  
 Prévost number ..... 641088

## Section 12: BRAKE AND AIR SYSTEM

---

### Quick Release Valve

Make ..... Bendix Westinghouse  
Model ..... QR-1  
Supplier number ..... 5001496  
Prévost number ..... 641429

### Spring Brake Valve

Make ..... Bendix Westinghouse  
Model ..... SR-1  
Supplier number ..... 286364  
Prévost number ..... 640870

### Pressure Protection Valve

Make ..... Bendix Westinghouse  
Model ..... PR-2  
Nominal closing pressure ..... 75 psi (517 kPa)  
Supplier number ..... 277226  
Prévost number ..... 640439

### Shuttle-Type Double Check Valve

Make ..... Bendix Westinghouse  
Model ..... DC-4  
Supplier number ..... 277988  
Prévost number ..... 641015

### Low Pressure Indicators

Make ..... Bendix Westinghouse  
Model ..... LP-3  
Contact close ..... 66 psi (455 kPa)  
Supplier number ..... 277227  
Prévost number ..... 640975  
Make ..... Bendix Westinghouse  
Model ..... LP-3  
Contact close ..... 30 psi (207 kPa)  
Supplier number ..... 276599  
Prévost number ..... 641174

### Air Pressure Regulator

Make ..... Norgren  
Adjustable output range ..... 0-80/85 psi (0-552/586 kPa)  
Recommended pressure setting ..... 75 psi (517 kPa)  
Supplier number ..... R06-2G7 RNKA  
Prévost number ..... 641472

### Air Filter Element

Make ..... Norgren  
Type ..... With manual drain  
Supplier number ..... F74G-345-004  
Prévost number ..... 641338



**Front Axle Brake Chambers**

Make ..... Knorr-Bremse  
 Type ..... 22  
 Supplier number (R.H.) ..... BS-3457 II 34671  
 Prévost number (R.H.) ..... 641414  
 Supplier number (L.H.) ..... BS-3457 II 34670  
 Prévost number (L.H.) ..... 641413

**Drive Axle Brake Chambers**

Make ..... Knorr-Bremse  
 Type ..... 24 as service -24 as emergency  
 Supplier number ..... II/35699/BS-9524  
 Prévost number ..... 641432

**Tag Axle Brake Chambers**

Make ..... Knorr-Bremse  
 Type ..... 16 as service – 16 as emergency  
 Supplier number ..... II/18224/V1-BS9396  
 Prévost number ..... 641308

**Brake Lining (All Axles)**

Make ..... Knorr-Bremse  
 Supplier number ..... II 33976  
 Prévost number ..... 611049

**ABS ANTILOCK BRAKING SYSTEM (if applicable)**

**ABS Modulator Valve**

Make ..... Rockwell Wabco  
 Voltage ..... 24 V  
 Supplier number ..... 472 195 006 0  
 Prévost number ..... 641097

**Sensor, Front Axle**

Supplier number ..... 441 032-572-0  
 Prévost number ..... 641288

**Sensor, Drive Axle (In Carrier)**

Supplier number ..... SA13280X9150  
 Prévost number ..... 641341

**Sensor, Drive Axle (In Wheel End)**

Supplier number ..... 441 032-576-0  
 Prévost number ..... 641095

# MAINTENANCE INFORMATION

## HALDEX AT-87192 AIR DRYER

### Service Information

**Important !!!** Before servicing the dryer, block the wheels to prevent the vehicle from rolling. Test the vehicle for air leaks. Drain all reservoirs and air lines to 0 psi. The Haldex dryer does not have to be removed from the vehicle for servicing. The following kits are available for dryer servicing:

#### 1 Desiccant cartridge, #471-77430

Loosen the four 15mm mounting bolts. Lift the canister about 1/2" and remove it. Place the assembly upside-down on the foam pad that is included in the desiccant kit. Press the cartridge down and rotate it counterclockwise to release the cartridge. The cartridge itself contains no hazardous material, but there may be a small amount of oil from the compressor. Clean the canister and aluminum housing. Attach the cartridge spring to the top of the new cartridge. A plastic sleeve is attached to the spring. When assembling, the plastic sleeve must contact the metal canister. Put the new cartridge and spring into the canister. Align the slots on the cartridge with the projections on the canister. Press the cartridge into the canister and rotate clockwise to engage the cartridge. Change the two cartridge "O" rings.

**Important...**Place the "O" rings on the aluminum housing, not the cartridge.

Place the cartridge assembly on the housing and tighten the 15mm mounting bolts to 35-40 ft.lbs.

#### 2 Safety Valve, #471-78275

When mounting the new valve, check the placement of the "O" ring. The valve is set to open at 155 psi. Tighten the valve to 10 ft.lbs.

#### 3 Heating Element, 12 Volt #471-77432, 24 Volt #471-78250,

If heater has a "Packard" style connector order:

#### 12 Volt #471-78223, 24 Volt #471-78199

The heater is thermostatically controlled and is designed to heat when the temperature is below freezing. Check heater function with amp meter when temperature is below freezing. If defective, loosen the screw on the heater housing. Remove the heater assembly and replace. Insure that the "O" ring is seated against the aluminum housing.

#### 4 Check valve, #471-78275

Remove the check valve plug and clean the valve seat. Replace the spring and seal and reassemble. Tighten to 20 ft.lbs.

#### 5 Regeneration Valve #471-77434 ( Optional )

Before mounting the new valve, check that the "O" rings and check valve are in the proper position. Tighten to 20 ft.lbs. If the vehicle uses an external purge tank, the regeneration valve will be replaced with a plug with "O" rings. A plastic cap is supplied with the valve to protect the breather hole on the valve.

#### 6 Valve Pack

#471-77442 Standard dryer application or

#471-77343 With integrated governor

Repair of the valve pack is not possible. If valve pack fails, the valve should be replaced. Loosen the 6 bolts with a 6 mm hex key. Remove the valve. Clean the mounting surface. Mount the new valve and tighten the 6 bolts to 5 ft.lbs., starting with the two center bolts.

#### 7 Turbo protection valve #471-78106 ( Optional )

Replace the valve and tighten in the correct position.

#### 8 Electrical Connection #471-76284, For "Packard" style order #471-10015

Assemble connection, as shown. Use 14 gauge wire.

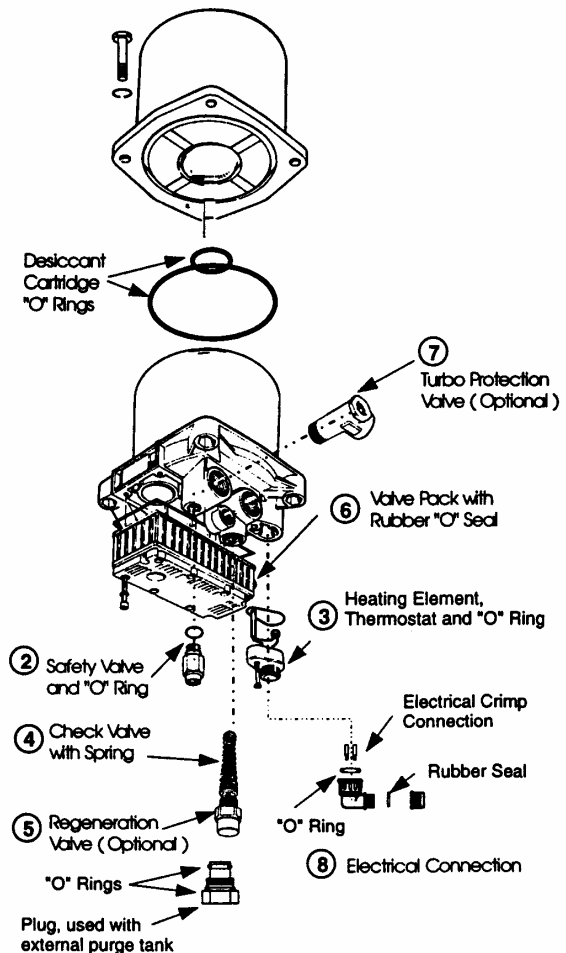
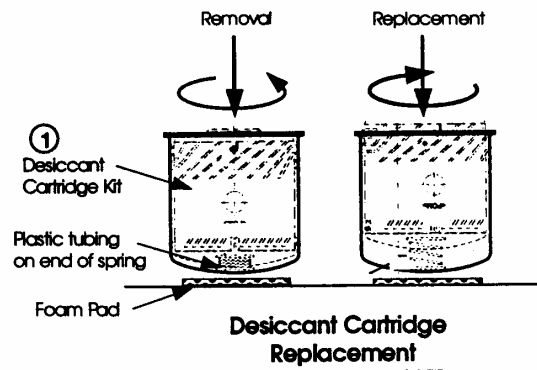

## Troubleshooting

- **Block wheels to prevent vehicle from rolling.**
- **Wear eye protection to prevent eye injury.**
- **Drain all reservoirs and supply lines to 0 psi.**
- **Test truck for air leaks**

<b>Problem</b>	<b>Cause</b>	<b>Repair</b>
<b>Water In air system</b>	1. Contaminants in desiccant.	1. Change desiccant cartridge. Check compressor for excessive oil passage.
	2. Regeneration valve not working properly.	2. At compressor cut-out there <b>must</b> be a slight blow of regeneration air for 20 to 30 seconds from the dryer valve pack. If not, replace regeneration valve.
	3. Leaks in air system.	3. Tighten air connections, soap connection and re-check for leaks. System pressure drop should not exceed 2 PSI per minute with the brake released and 3 PSI per minute with the brake applied. Leaks in the system will shorten the desiccant and compressor life.
<b>Constant exhaust of air at dryer</b>	1. Defective dryer outlet check valve.	1. Clean valve seat and replace check valve.
	2. Dryer purge valve not closing.	2. Replace valve pack.
<b>Excessive compressor cycling</b>	1. Excessive leaks in air system.	1. Tighten air connections, soap connection and re-check for leaks.
	2. Excessive drop in system pressure during purge cycle.	2. During compressor unloading the air system pressure gauge will drop approximately 6 psi to purge the desiccant cartridge, which is normal. If pressure drop is greater than 10 PSI a second pressure controlled check valve can be used on the secondary reservoir. This is normally required on a vehicle with a single drive axle. The system pressure will not drop when an external purge tank is used.
	3. Defective pressure controlled check valve.	3. If defective the pressure in the wet tank will quickly drop causing the compressor to cycle. Check installation or replace valve.
	4. Defective dryer outlet check valve.	4. Clean valve seat and replace check valve.
<b>Safety valve is open</b>	1. Desiccant cartridge is plugged.	1. Excessive oil passage from compressor. Replace desiccant cartridge.
	2. Ice block in dryer.	2. Check heater function.
	3. Excessive system pressure.	3. Repair or replace governor
<b>Short life of dryer or desiccant cartridge</b>	1. Air at inlet of dryer exceeds 150°F.	1. Extend length of compressor discharge line, see installation instructions. The 150 °F dryer inlet temperature can usually be accomplished with 12' to 15' of compressor discharge line.
	2. Duty cycle of compressor does not allow for sufficient time for desiccant regeneration.	2. During normal operation the compressor must remain unloaded for a minimum of 30 seconds to allow for sufficient purge. Lengthy loading times must be avoided. Air Dryer must be "by-passed" in applications with high air use such as bulk unloading.

# S e r v i c e M a n u a l

RA-SB0002-EN

## Pneumatic Disc Brake

SB 6... / SB 7...  
Axial- and Radial Disc  
Brake

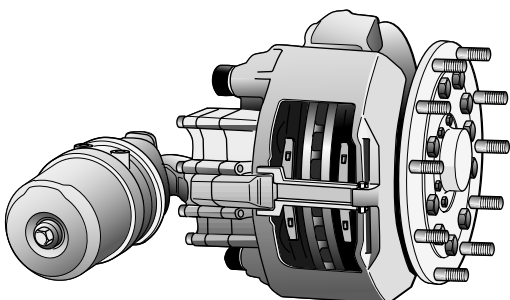
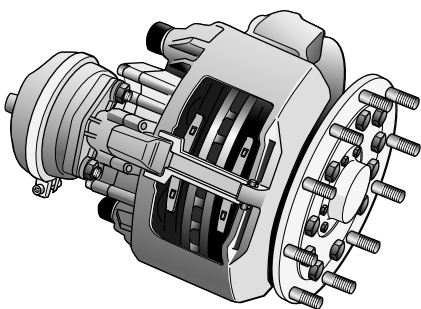

**KNORR-BREMSE**  
Systems for Commercial Vehicles



## Index

	Page	
<b>1</b>	<b>Exploded view of brake</b>	
1.1	Axial Disc Brake Components	4
1.2	Axial Disc Brake Repair Kits	5
1.2.1	Axial Disc Brake Wear Indicator Kits	5
1.3	Radial Disc Brake Components	6
1.4	Radial Disc Brake Repair Kits	7
1.4.1	Radial Disc Brake Wear Indicator Kits	7
1.5	Brake Discs	8
<b>2</b>	<b>General information</b> (for "Axial- and Radial Disc Brake")	
2.1	Service Tools	9
2.2	Diagnostic Equipment	9
2.3	Lubrication	9
2.4	Torque requirements	9
<b>3</b>	<b>Description and Function</b>	
3.1	Axial Disc Brake Sectioned View	10
3.2	Description of operation	11
3.2.1	Brake actuation	11
3.2.2	Brake release	11
3.2.3	Brake adjustment (automatic)	11
3.3	Radial Disc Brake Sectioned View	12
3.4	Description of operation	13
3.4.1	Brake actuation	13
3.4.2	Brake release	13
3.4.3	Brake adjustment (automatic)	13
<b>4</b>	<b>Safety instructions for service work</b> (for "Axial- and Radial Disc Brake")	13
<b>5</b>	<b>Brake testing</b> (for "Axial- and Radial Disc Brake")	
5.1	Fault finding procedure	14
5.2	Adjuster check	15
5.3	Wear limits of Brake Pads and Discs	16
5.3.1	Brake wear check using Guide Pin (for Calipers with standard Guide Pins)	18
5.3.2	Brake wear check using Guide Pin (for Calipers with long Guide Pins)	19
5.3.3	Wear Indicators	20
5.4	Diagnostic-Equipment - Hand held device ZB9031	21
5.5	Diagnostic-Equipment - Vehicle mounted device ZB9033	21
<b>6</b>	<b>Pad replacement</b> (for "Axial- and Radial Disc Brake")	
6.1	Pad removal	22
6.1.1	Tappet Boot check	22
6.1.2	Caliper guidance check	23
6.2	Pad fitting	23
<b>7</b>	<b>Tappet with Boot replacement</b> (for "Axial- and Radial Disc Brake")	
7.1	Tappet with Boot removal	24
7.1.1	Adjuster thread inspection	25
7.2	Tappet with Boot fitting	25
<b>8</b>	<b>Caliper Suspension Sealing</b> (for "Axial- and Radial Disc Brake")	27

<b>9</b>	<b>Guide Pin Bush replacement</b> (for "Axial- and Radial Disc Brake")	28
9.1	Brass Bush replacement	28
9.2	Rubber Bush replacement	28
<b>10</b>	<b>Caliper replacement</b> (for "Axial- and Radial Disc Brake")	
10.1	Caliper removal	29
10.2	Caliper fitting	30
10.2.1	Caliper with Outer Boot (10)	30
10.2.2	Caliper with Steel Cap (10a)	31
<b>11</b>	<b>Carrier replacement</b> (for "Axial- and Radial Disc Brake")	32
<b>12</b>	<b>Actuation cylinder replacement</b> (for "Axial- and Radial Disc Brake")	
12.1	Brake Chamber removal	33
12.2	Brake Chamber fitting	33
12.3	Spring Brake removal	34
12.4	Spring Brake fitting	34
<b>13</b>	<b>Additional Information</b>	
13.1	Service Video	35
13.2	Service Tool Kit	35
13.3	Diagnostic Equipment	35

## Personal Notes

# 1 Overall view

## 1.1 Axial Disc Brake Components

(for Wear Indicators Kits see 1.2.1)

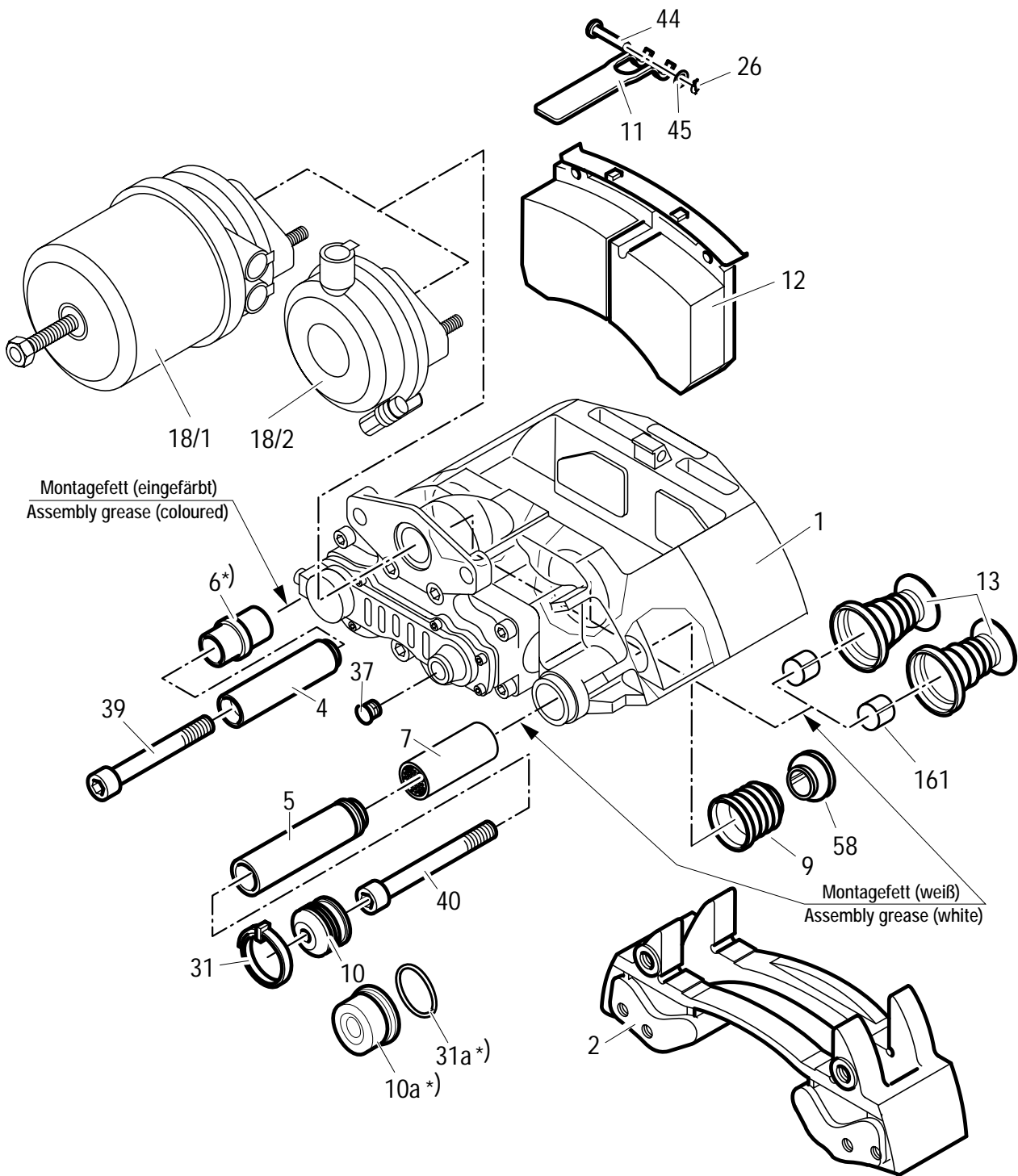

- |      |                  |      |                  |
|------|------------------|------|------------------|
| 1    | Caliper          | 18/2 | Brake Chamber    |
| 2    | Carrier          | 26   | Spring Clip      |
| 4    | Sleeve           | 31   | Outer Boot Clip  |
| 5    | Sleeve           | 31a  | O-Ring           |
| 6    | Rubber Bush      | 37   | Adjuster Cap     |
| 7    | Brass Bush       | 39   | Caliper Bolt     |
| 9    | Inner Boot       | 40   | Caliper Bolt     |
| 10   | Outer Boot       | 44   | Pad Retainer Pin |
| 10a  | Steel Cap        | 45   | Washer           |
| 11   | Pad Retainer     | 58   | Ring             |
| 12   | Pad              | 161  | Tappet Bush      |
| 13   | Tappet with Boot |      |                  |
| 18/1 | Spring Brake     |      |                  |

→ possible variants by items 10a & 31a

If short rubber bush (6) (sleeve ring is placed centrally), Caliper bolts (39) & (40) are identically

VF 00127/12-AIO1

## 1.2 Axial Disc Brake Repair Kits

**ATTENTION!**  
Use only **KNORR-BREMSE** parts

The following Repair Kits are available

Description	Contents	Association of Repair Kits to the Disc Brakes and Repair Kit's Order no.
Carrier Guide Kit	2, 4, 5, 31, 39, 40	see Disc Brake Product Catalogue (Part Number Y000875), also available as an electronic form (CD-ROM, <a href="http://www.Knorr-BremseSfN.com">http://www.Knorr-BremseSfN.com</a> )
Carrier Guide Kit (Steel Cap)	2, 4, 5, 10a, 31a, 39, 40	
Wear Indicator Kit (per axle)	for variants see 1.2.1 <b>with</b> or <b>without</b> 104	
Guide Pins Kit	4-7, 9, 10, 31, 39, 40, 58	
Guide Pins Kit (Steel Cap)	4, 5, 6, 7, 9, 10a, 31a, 39, 40, 58	
Seal Kit for Guide Pins	9, 10, 31, 37, 58	
Tappet and Boot Kit (2 pcs)	13, 161	
Pad Set (per axle)	12, 26, 37, 44, 45	
Adjuster Cap (4 pcs)	37	
Pad Retainer Kit (per axle)	11, 26, 44, 45	
Pad Retainer Kit (per axle)	11, 26, 44, 45, 104, 115, 116	
Kit for Rubber Sleeve	4, 6, 39	
Outer Guide Seal Kit (10 pcs)	10, 31	
Repair Kit	5, 7, 9, 10a, 31a, 40, 58	
Kit for Steel Cap	10a, 31a	
Screw Kit for Steel Cap	10a, 31a, 39, 40	
Screw Kit for Outer Boot	10, 31, 39, 40	
Exchange Caliper r.h.	only in assembled condition	see Type plate on the Caliper
Exchange Caliper l.h.		

### 1.2.1 Axial Disc Brake Wear Indicator Kits

(Typical kits are shown below)

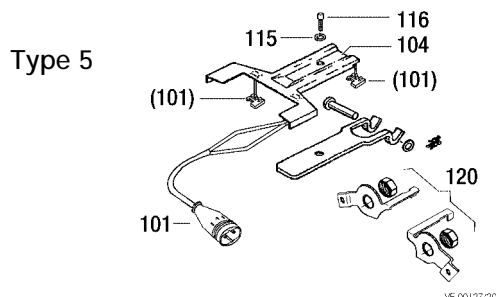
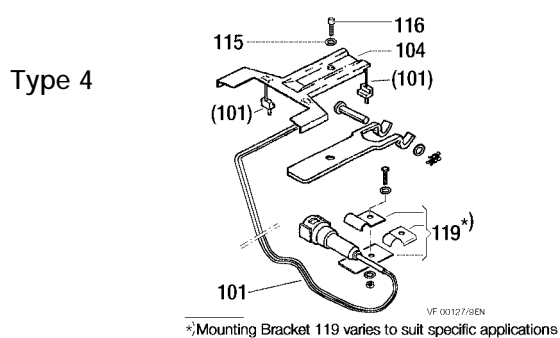
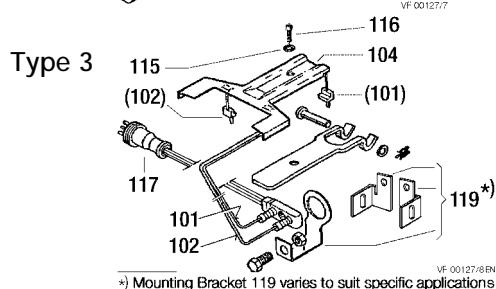
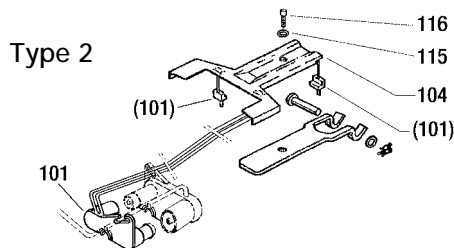
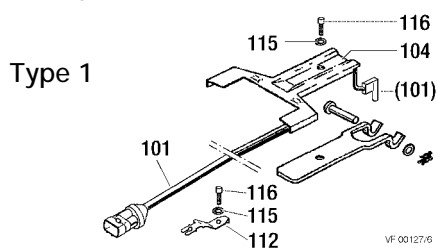

- |     |                        |     |                      |
|-----|------------------------|-----|----------------------|
| 101 | Sensor                 | 115 | Spring Washer        |
| 102 | Sensor                 | 116 | Screw                |
| 104 | Cable Protection Plate | 117 | Wear Indicator Cable |
| 112 | Clip                   | 119 | Bracket              |
|     |                        | 120 | Bracket              |



1.3 Radial Disc Brake Components  
(for Wear Indicator Kits see 1.4.1)

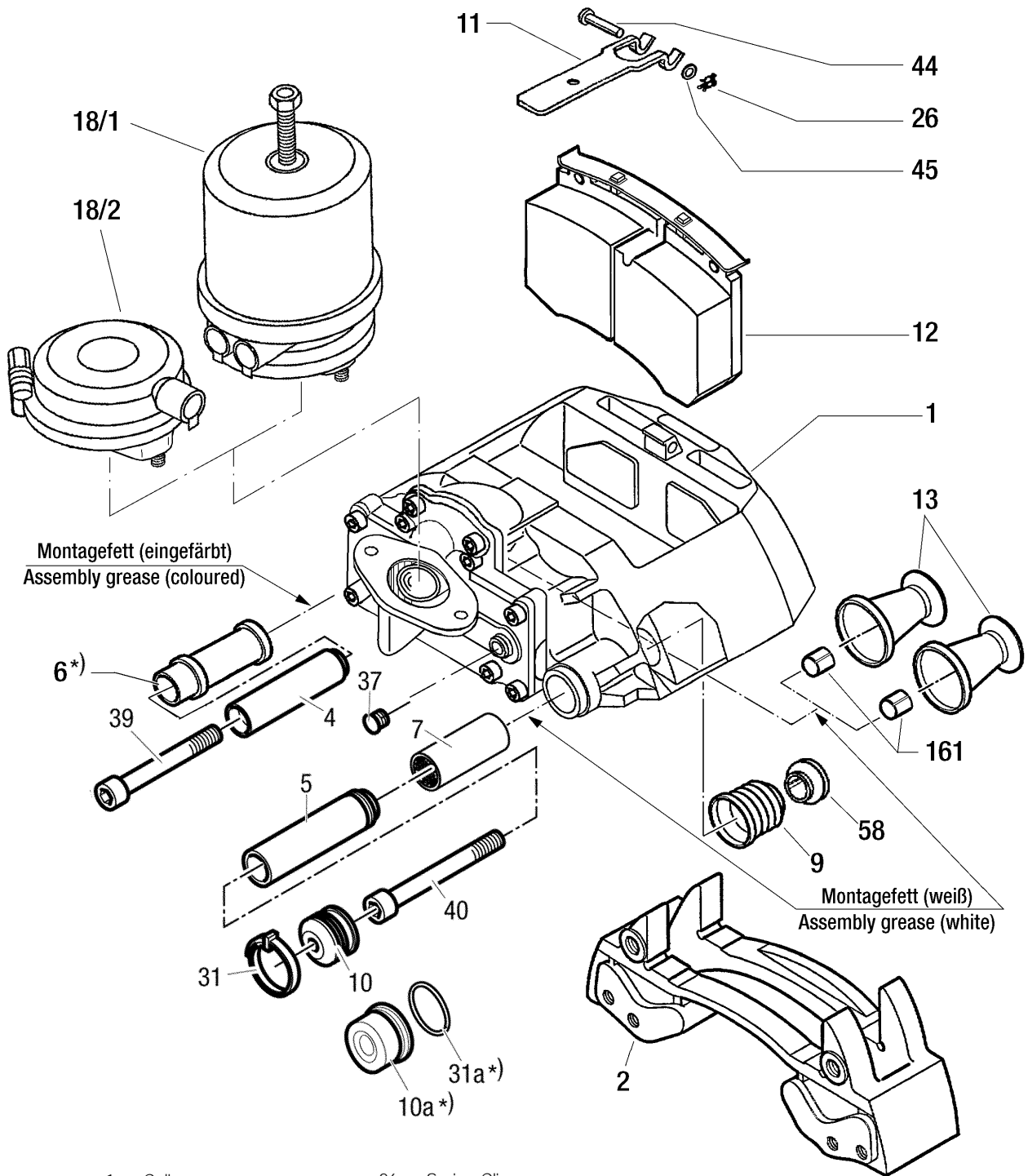

- |      |                  |     |                  |
|------|------------------|-----|------------------|
| 1    | Caliper          | 26  | Spring Clip      |
| 2    | Carrier          | 31  | Outer Boot Clip  |
| 4    | Sleeve           | 31a | O-Ring           |
| 5    | Sleeve           | 37  | Adjuster Cap     |
| 6    | Rubber Bush      | 39  | Caliper Bolt     |
| 7    | Brass Bush       | 40  | Caliper Bolt     |
| 9    | Inner Boot       | 44  | Pad Retainer Pin |
| 10   | Outer Boot       | 45  | Washer           |
| 10a  | Steel Cap        | 58  | Ring             |
| 11   | Pad Retainer     | 161 | Tappet Bush      |
| 12   | Pad              |     |                  |
| 13   | Tappet with Boot |     |                  |
| 18/1 | Spring Brake     |     |                  |
| 18/2 | Brake Chamber    |     |                  |

VF00113/2-Äi01

\*) possible variants by items 10a & 31a

If short rubber bush (6) (sleeve ring is placed centrally), Caliper bolts (39) & (40) are identically

## 1.4 Radial Disc Brake Repair Kits

**ATTENTION!**  
Use only **KNORR-BREMSE** parts

The following Repair Kits are available

Description	Contents	Association of Repair Kits to the Disc Brakes and Repair Kit's Order no.
Carrier Guide Kit	2, 4, 5, 31, 39, 40	see Disc Brake Product Catalogue (Part Number Y000875), also available as an electronic form (CD-ROM, <a href="http://www.Knorr-BremseSfN.com">http://www.Knorr-BremseSfN.com</a> )
Carrier Guide Kit (Steel Cap)	2, 4, 5, 10a, 31a, 39, 40	
Wear Indicator Kit (per axle)	for variants see 1.2.1 <b>with</b> or <b>without</b> 104	
Guide Pins Kit	4-7, 9, 10, 31, 39, 40, 58	
Guide Pins Kit (Steel Cap)	4, 5, 6, 7, 9, 10a, 31a, 39, 40, 58	
Seal Kit for Guide Pins	9, 10, 31, 37, 58	
Tappet and Boot Kit (2 pcs)	13, 161	
Pad Set (per axle)	12, 26, 37, 44, 45	
Adjuster Cap (4 pcs)	37	
Pad Retainer Kit (per axle)	11, 26, 44, 45	
Pad Retainer Kit (per axle)	11, 26, 44, 45, 104, 115, 116	
Kit for Rubber Sleeve	4, 6, 39	
Outer Guide Seal Kit (10 pcs)	10, 31	
Repair Kit	5, 7, 9, 10a, 31a, 40, 58	
Kit for Steel Cap	10a, 31a	
Screw Kit for Steel Cap	10a, 31a, 39, 40	
Screw Kit for Outer Boot	10, 31, 39, 40	
Exchange Caliper r.h.	only in assembled condition	see Type plate on the Caliper
Exchange Caliper l.h.		

### 1.4.1 Radial Disc Brake Wear Indicator Kits

(Typical kits are shown below)

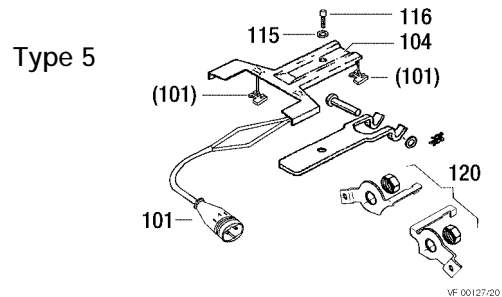
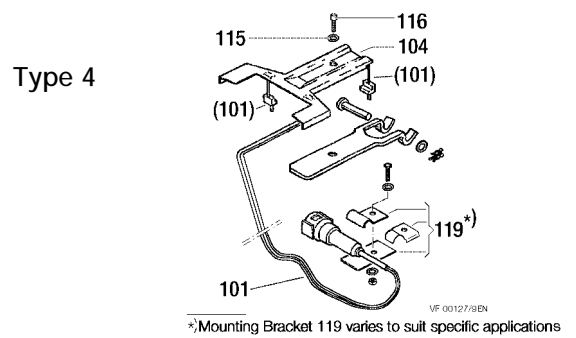
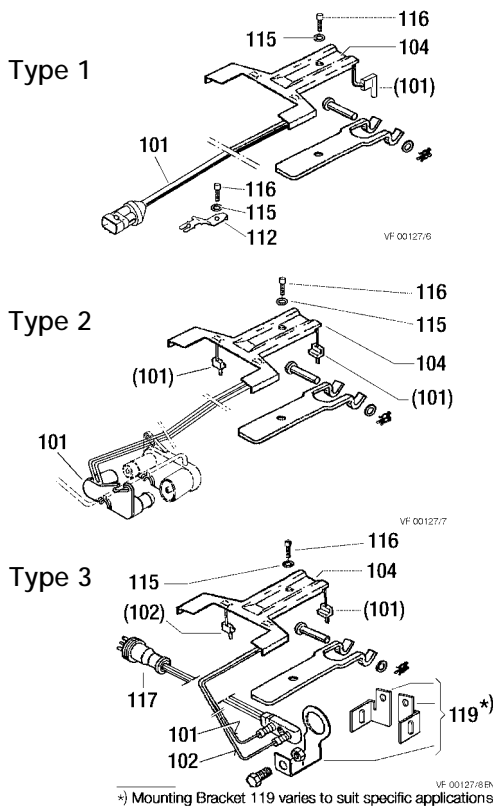

- |     |                        |     |                      |
|-----|------------------------|-----|----------------------|
| 101 | Sensor                 | 115 | Spring Washer        |
| 102 | Sensor                 | 116 | Screw                |
| 104 | Cable Protection Plate | 117 | Wear Indicator Cable |
| 112 | Clip                   | 119 | Bracket              |
|     |                        | 120 | Bracket              |

## **1.5 Brake Discs**

(for "Axial- and Radial Disc Brake")

When replacing the Discs, please also refer to the instructions of the Vehicle Manufacturer.

This should also be done when fitting KNORR-Brake Discs.

When replacing Discs, please adhere to the recommended bolt tightening torques.

The use of non-approved Brake Discs will reduce levels of safety and invalidate warranty.

Brake Discs can be ordered through the Knorr-Aftermarket Organisation.

Detailed informations can be taken out from our Product Catalogue "Disc Brake" (Part Number Y000875). This is also available as an electronic form (CD-ROM, <http://www.Knorr-BremseSfN.com>).

## 2 General Information (for "Axial- and Radial Disc Brake")

### 2.1 Service Tools

Part Number	Description
II 19252	Press-In Tool for Tappet and Boot (13)
II 19253	Pull-In Tool for Inner Boot (9)
II 19254	Pull-In/Out Tool for Brass Bush (7)
II 32202	Wedged Fork for removal of Tappet and Boot (13)
II 36797	Grooving Tool for Brass Bush (7)
Z001105	Press in Tool for Steel Cap (10a)

*Service tool kit ZB 9032 II 37951/004EX contains the above listed tools as well as this Service manual. The service video in English is available separately in the UK as Part No. KBP2060/1 and in other territories as RA-SB0002 EN.*

### 2.2 Diagnostic Equipment

Part Number	Description
II 36695	<b>ZB 9031</b> Hand held device for checking Potentiometer function. ( Also Pad + Disc wear when 13 pin chassis plug installed ).
II 38691F	<b>ZB 9033</b> Chassis mounted device for measuring Pad + Disc wear

### 2.3 Lubrication

Part Number	Description	Colour	Application
II 14525	Renolit HLT2	White <sup>2)</sup>	Brass Bush (7)
II 32793	Syntheso GL EP1	Green <sup>2)</sup>	Rubber Bush (6)

<sup>2)</sup> **Important Note:** The correct Grease MUST be used for each Bush!

### 2.4 Torque requirements

Item Number		Torque [Nm]	spanner size (mm)
39 + 40	Caliper Bolts M16x1,5 - 10.9	285 <sup>±25</sup>	14
	Actuator Mounting Nuts M16x1,5	180 <sup>+30</sup>	24

### 3 Description and function

#### 3.1 Axial Disc Brake Sectioned View

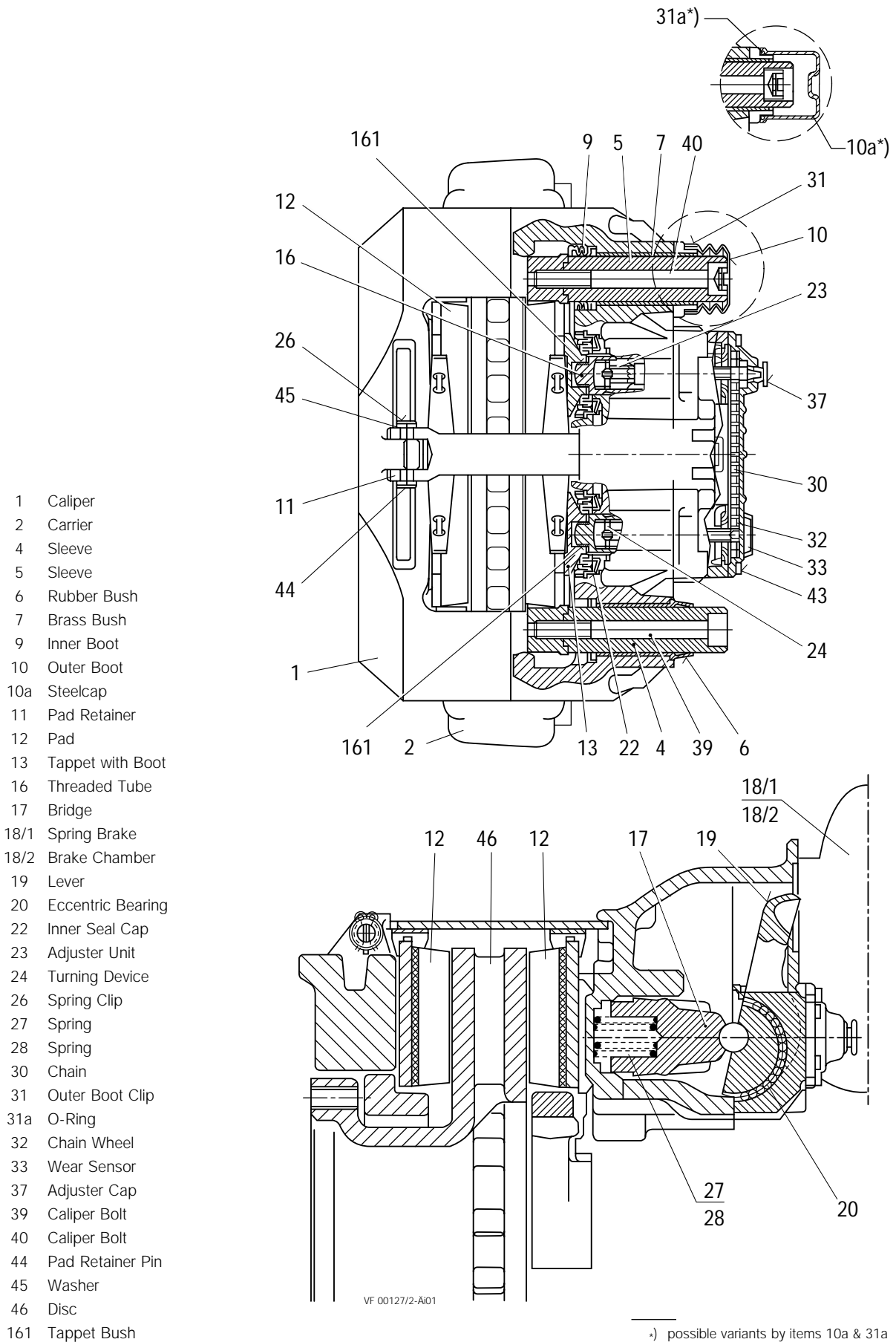

## **3.2 Description of operation**

(Floating Caliper principle)

### **3.2.1 Brake actuation**

During actuation, the Push Rod of the Actuator (18/1 or 18/2) moves the Lever (19). The input forces are transferred via the Eccentric Bearing (20) to the Bridge (17). The force is then distributed by the Bridge (17) and the two Threaded Tubes (16) to the Tappets (13) and finally to the inboard Pad (12).

After overcoming the running clearance between the Pads and the Disc, the reaction forces are transmitted to the outboard Pad (12). The clamping forces on the Pads (12) and the Disc (46) generate the braking force for the wheel.

### **3.2.2. Brake release**

After releasing the air pressure, the two Return Springs (27/28) push the Bridge (17) and Lever (19) back to the start position; this ensures a running clearance between Pads and Disc is maintained.

### **3.2.3 Brake adjustment (automatic)**

To ensure a constant running clearance between Disc and Pads, the brake is equipped with a low wearing, automatic adjuster mechanism. The Adjuster (23) operates with every cycle of actuation due to the mechanical connection with Lever (19). As the Pads and Disc wear, the running clearance increases. The Adjuster (23) and Turning Device (24) turn the Threaded Tubes (16) by an amount necessary to compensate for this wear. The total running clearance (sum of clearance both sides of Disc) should be between 0.6 and 0.9 mm.; smaller clearances may lead to overheating problems.

### 3.3 Radial Disc Brake Sectioned View

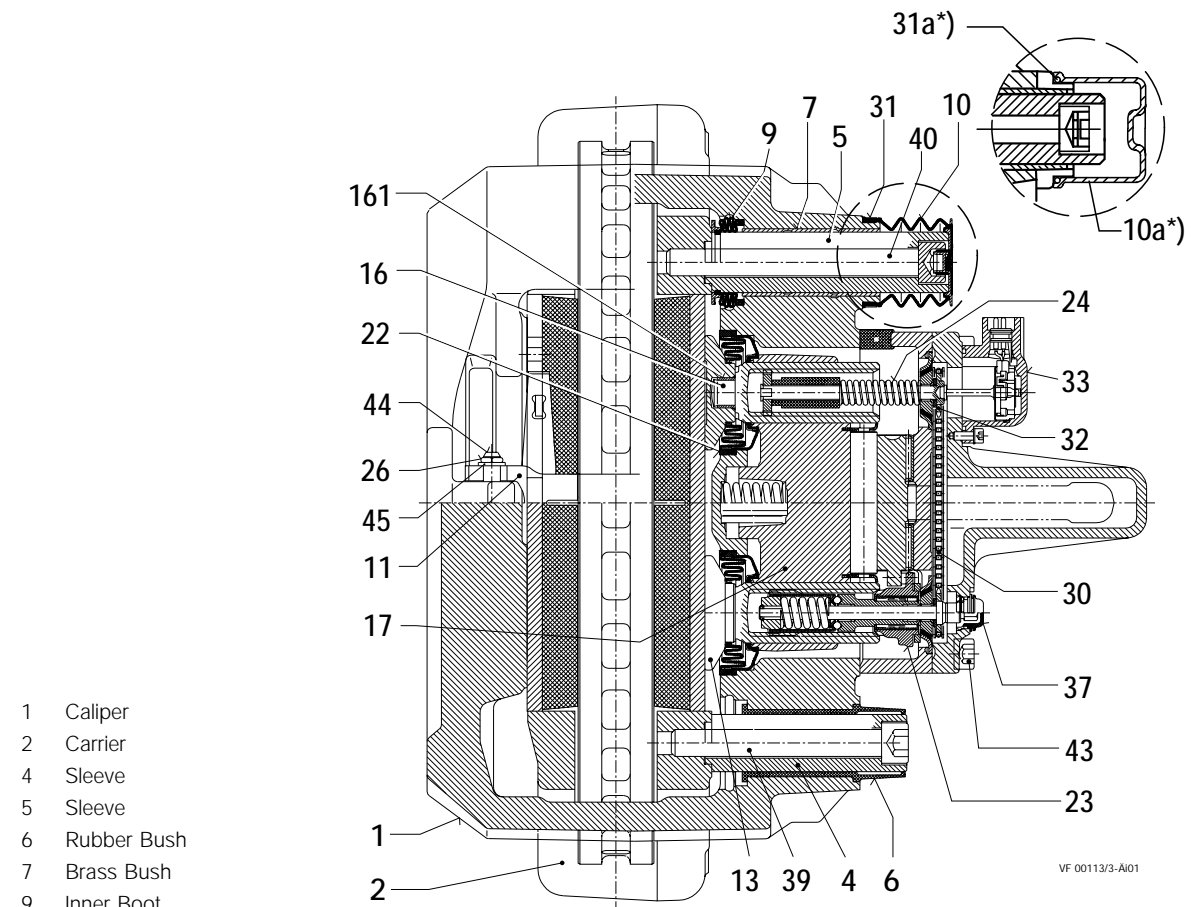

- 1 Caliper
- 2 Carrier
- 4 Sleeve
- 5 Sleeve
- 6 Rubber Bush
- 7 Brass Bush
- 9 Inner Boot
- 10 Outer Boot
- 10a Steelcap
- 11 Pad Retainer
- 12 Pad
- 13 Tappet with Boot
- 16 Threaded Tube
- 17 Bridge
- 18/1 Spring Brake
- 18/2 Brake Chamber
- 19 Lever
- 20 Eccentric Bearing
- 22 Inner Seal Cap
- 23 Adjuster Unit
- 24 Turning Device
- 26 Spring Clip
- 27 Spring
- 28 Spring
- 30 Chain
- 31 Outer Boot Clip
- 31a O-Ring
- 32 Chain Wheel
- 33 Wear Sensor
- 37 Adjuster Cap
- 39 Caliper Bolt
- 40 Caliper Bolt
- 44 Pad Retainer Pin
- 45 Washer
- 46 Disc
- 161 Tappet Bush

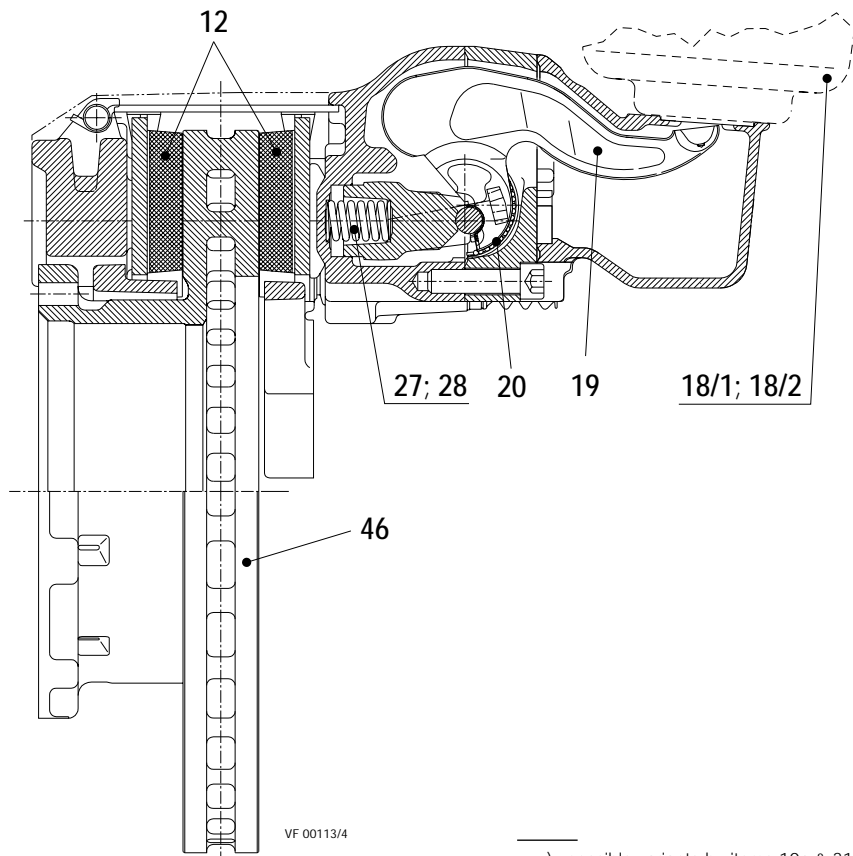

-) possible variants by items 10a & 31a

### 3.4 Description of operation (Floating Caliper principle)

#### 3.4.1. Brake Actuation

During actuation, the Push Rod of the Actuator (18/1 or 18/2) moves the Lever (19). The input forces are transferred via the Eccentric Bearing (20) to the Bridge (17). The force is then distributed by the Bridge (17) and the two Threaded Tubes (16) to the Tappets (13) and finally to the inboard Pad (12).

After overcoming the running clearance between the Pads and Disc, the reaction forces are transmitted to the outboard Pad (12). The clamping forces on the Pads (12) and the Disc (46) generate the braking force for the wheel.

#### 3.4.2. Brake release

After releasing the air pressure, the two Return Springs (27/28) push the Bridge (17) and Lever (19) back to the start position; this ensures a running clearance between Pads and Disc is maintained.

#### 3.4.3 Brake adjustment (automatic)

To ensure a constant running clearance between Disc and Pads, the brake is equipped with a low wearing, automatic adjuster mechanism. The Adjuster (23) operates with every cycle of actuation due to the mechanical connection with Lever (19). As the Pads and Disc wear, the running clearance increases. The Adjuster (23) and Turning Device (24) turn the Threaded Tubes (16) by an amount necessary to compensate for this wear. The total running clearance (sum of clearance both sides of Disc) should be between 0.6 and 0.9 mm.; smaller clearances may lead to overheating problems.

## 4 Safety Instructions for service work (for "Axial- and Radial Disc Brake")

Please also refer to the relevant safety instructions for repair work on commercial vehicles, especially for jacking up and securing the vehicle.

Use only original KNORR-BREMSE parts.

### ***WARNING!***

*Before starting repair work, ensure the service brake and parking brake are not applied and that the vehicle cannot roll away.*

Please follow repair manual instructions and adhere to the wear limits of the Pads and the Discs - see Section 5.3.

Use only recommended tools - see Section 2.1.

Tighten bolts and nuts to the recommended torque values - see Section 2.4.

After re-fitting the wheel according to the Vehicle Manufacturer's recommendations, please ensure that there is sufficient clearance between the Tyre Inflation Valve, the Caliper and the wheel rim, to avoid damage to the Valve.

After service work:

Check the brake performance and the system behaviour on a rolling road or by actual road test.



## 5 Brake Testing

(for Axial- and Radial Disc Brake)

### 5.1 Fault finding procedure

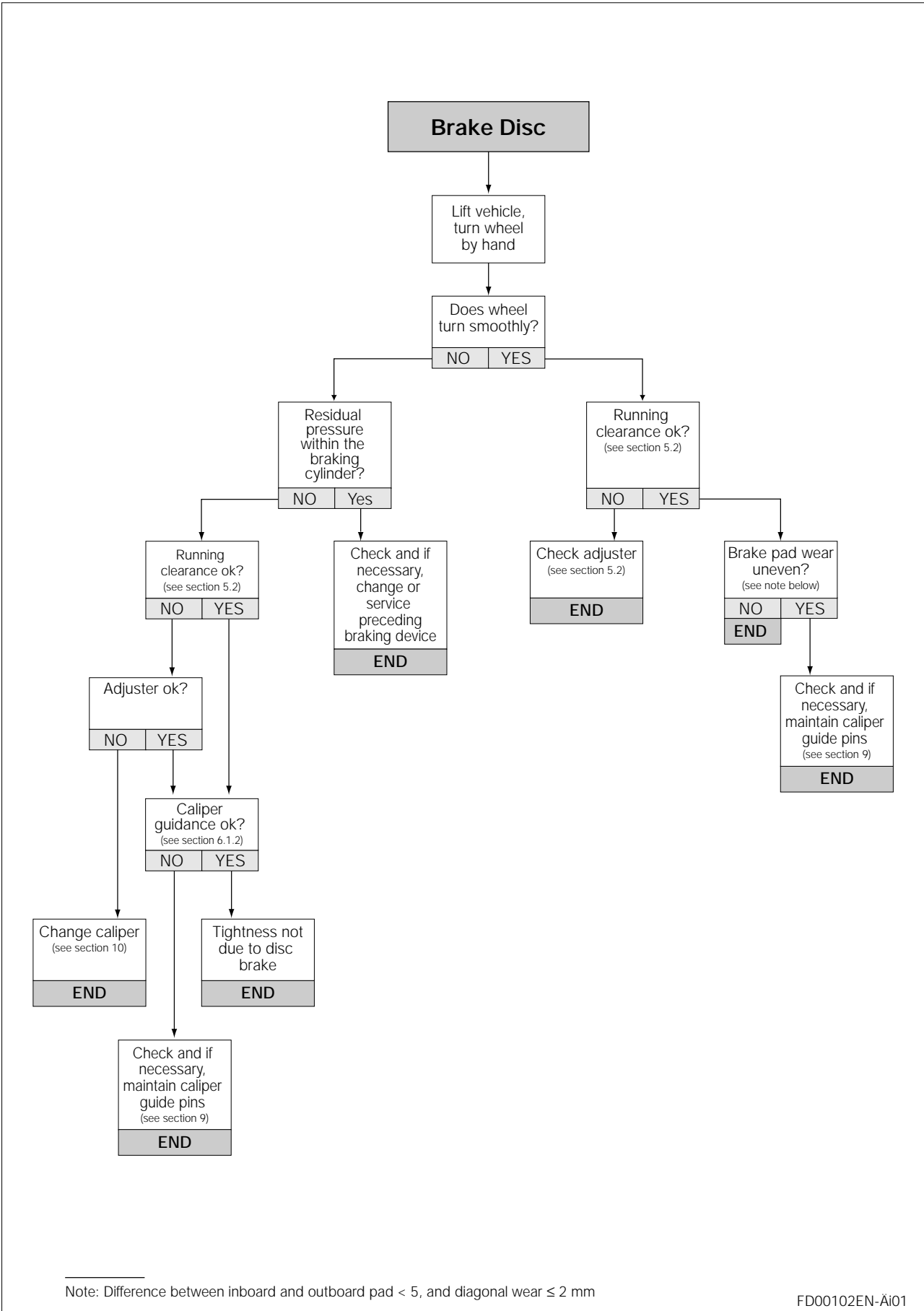

## 5.2 Adjuster check

### **WARNING!**

*Before starting repair work, ensure the service brake and parking brake are not applied and that the vehicle cannot roll away.*

Remove wheel.

The caliper assembly should be pushed inboard on its guide pins. Using a suitable tool, press the inboard pad (12) away from the Tappets and check Tappet and inboard pad backplate - it should be between 0.5mm & 1.0mm. If the running clearance is too small or large, the adjuster may not be functioning correctly and should be checked as follows.

Remove Cap (37).

### **WARNING!**

*Do not overload or damage the Adjuster (23). Use only 8mm Ring Spanner or 1/4" drive Socket with a lever length no greater than 100mm.*

**DO NOT** use an Open Ended Spanner since this may damage the Adjuster shaft.

The Adjuster should be turned counter-clockwise for 2 or 3 clicks (increasing running clearance).

### **Attention!**

*Make sure that the Ring Spanner or Socket can turn freely during following procedure.*

By applying the brake 5 - 10 times (about 2 Bar) the Spanner or Socket should turn clockwise in small increments if the Adjuster is functioning correctly (see notes below).

If Pads are not being changed, Cap (37) should be replaced having lightly greased it with Renolit HLT2 (available as part number II14525).

#### **NOTE:**

As the number of applications increases, incremental adjustment will decrease.

#### **NOTE:**

If the Spanner or Socket does not turn, turns only with the first application or turns forward and backward with every application, the automatic Adjuster has failed and the Caliper must be replaced.

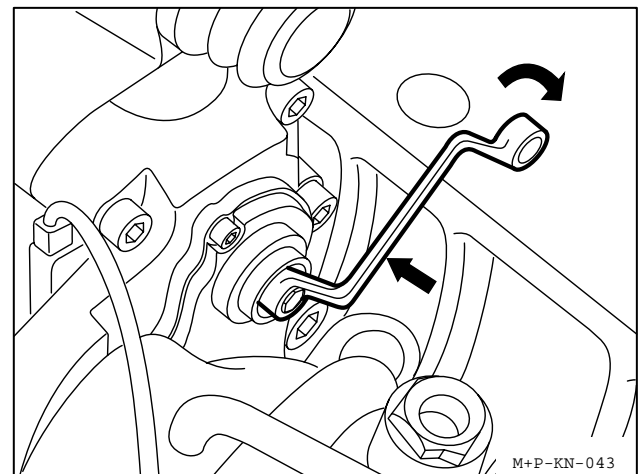
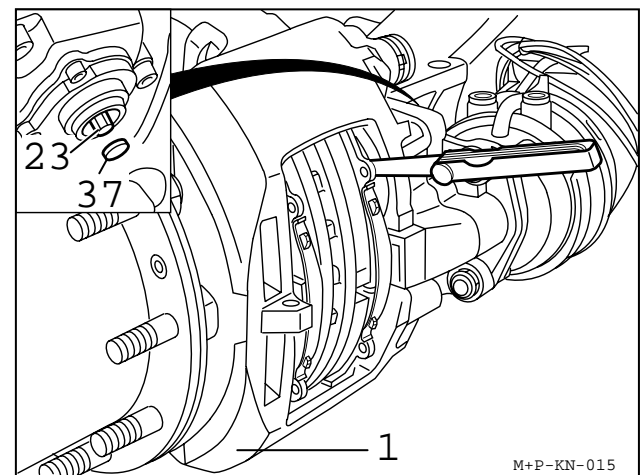
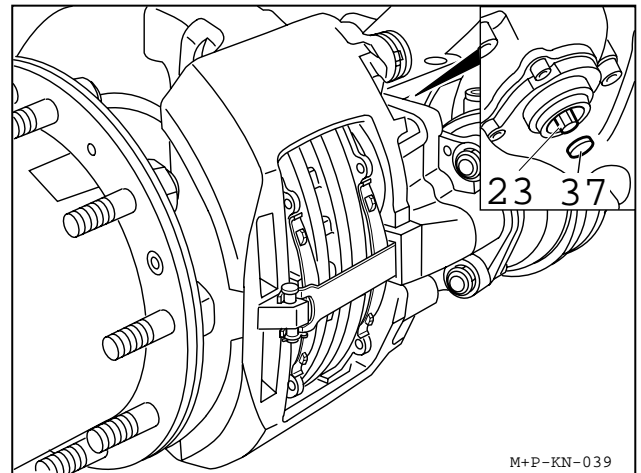

### 5.3 Wear Limits of Pads and Discs

#### **WARNING!**

*For optimum safety, stay within the Disc and Pad Wear Limits*

#### **Pads**

The thickness of the Pads must be checked regularly dependent on the usage of the vehicle.  
The Pads should be checked corresponding to any legal requirements that may apply.  
If no Wear Indicator has been connected this should be at least every 3 month.  
If friction material is less than 2mm (see E), the Pads must be replaced.

#### **Discs**

Measure thickness at thinnest point. Avoid measuring near the edge of the disc as a burr may be present.

- A = Disc thickness (new condition) 45mm
- B = Disc thickness (worn) 37 mm, Disc must be replaced
- C = Overall thickness of Pad (new condition) 30mm
- D = Backplate 9mm
- E = Minimum thickness of friction material 2mm
- F = Minimum allowed thickness in worn condition for backplate and friction material 11mm (replacement of Pads necessary).

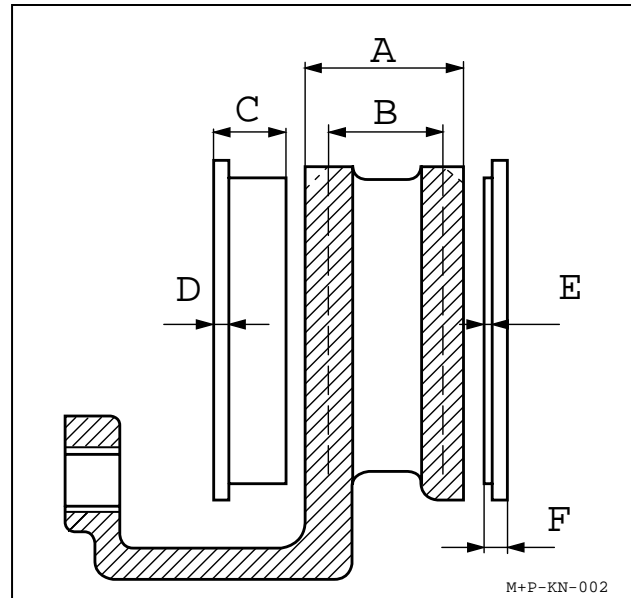

If wear dimension  $B \leq 39$  mm Disc should be renewed together with Pads.

Wear dimension  $B = 37$ mm must not decrease.

#### **WARNING!**

*If these recommendation are ignored, there is a danger of brake failure*

Check Disc at each change of Pads for grooves and cracks.

The diagram shows possible conditions of the surface.

**A<sub>1</sub>** = Small cracks spread over the surface  
**are allowed**

**B<sub>1</sub>** = Cracks less than 1.5mm deep or wide, running  
in a Radial direction, **are allowed**

**C<sub>1</sub>** = Grooves (circumferencial) less than 1.5mm wide  
**are allowed**

**D<sub>1</sub>** = Cracks in the vanes **are not allowed** and the  
Disc **MUST BE REPLACED**.

**a** = Pad contact area

#### Note

In case of surface conditions A<sub>1</sub>,-C<sub>1</sub>, the Disc can  
continue to be used until the minimum thickness  
of 37mm is reached.

Knorr-Bremse Discs are normally service-free and  
grinding when changing Pads is not necessary.  
However, grinding could be useful, e.g. to increase  
the load-bearing surface of the Pads after severe  
grooving on the entire friction surface has occurred.  
To meet safety requirements, the minimum thickness  
after regrinding is > 39 mm.

In addition, the recommendation of the Vehicle  
Manufacturer **MUST** be followed.

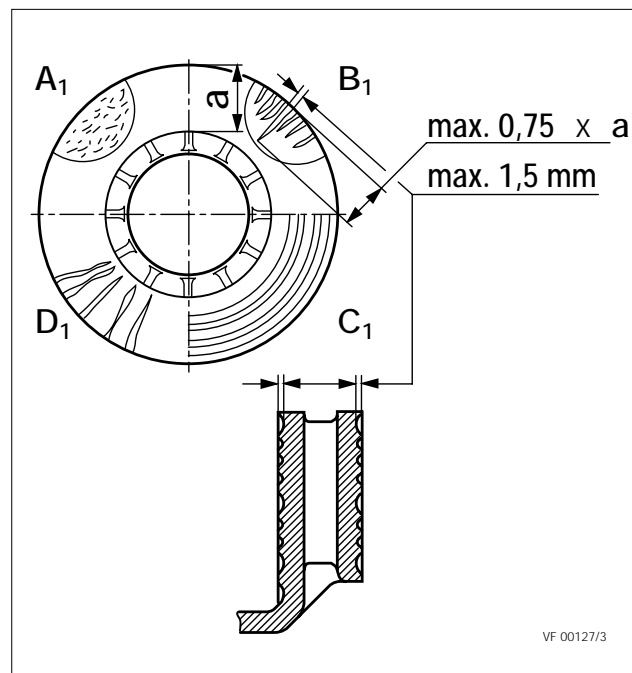

### **WARNING!**

*If these recommendations are ignored, there is a danger of brake failure. If the Pads are worn down to the backplate or if Disc wear is excessive, brake performance will be severely affected and may be lost completely.*

**5.3.1 Brake Wear Check using Guide Pin** (For all Axial and Radial Disc Brakes except those listed in Section 5.3.2 - These Callipers do **not** have the rib in position B (see also Section 5.3.2))

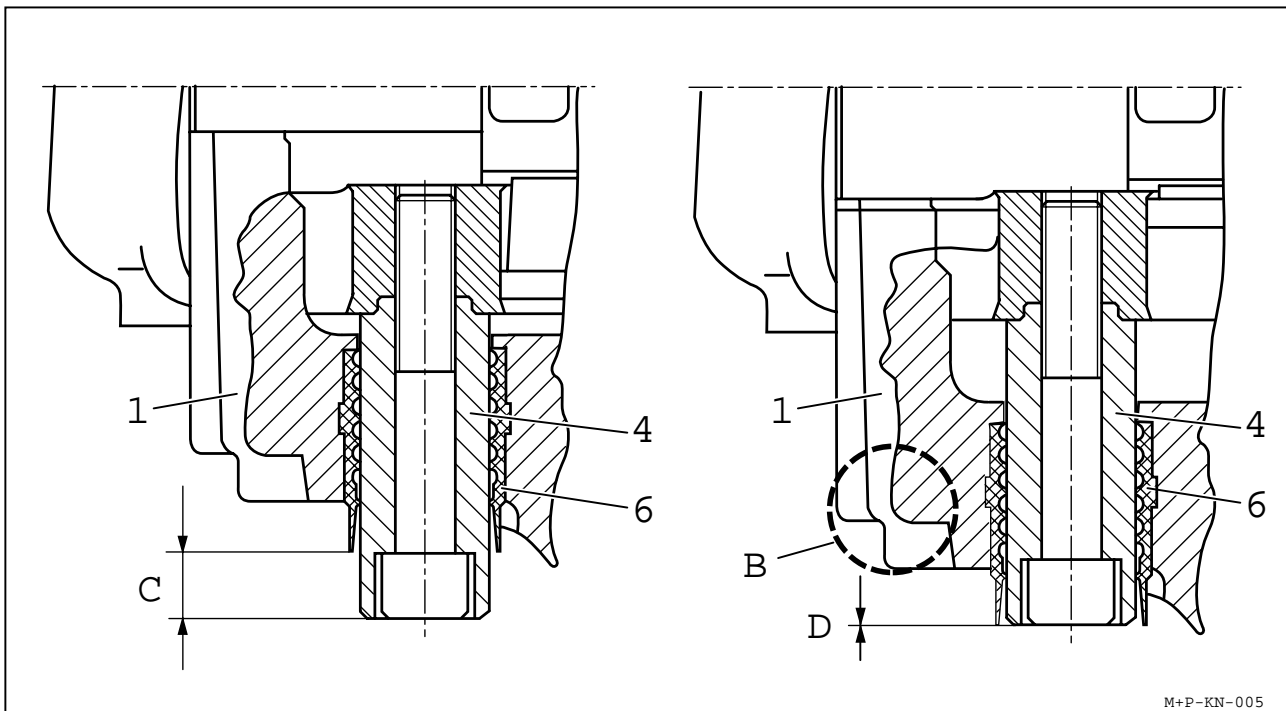

The condition of the Pads can be visually determined without removing the road wheel by noting the position of the Fixed Sleeve (4) in the Floating Caliper (1).

If dimension 'C' is less than 1mm, a more accurate check of the Pads and Disc must be made.

If necessary change the Pads - see Section 6

B = without rib (see also Section 5.3.2)

C = pin protrusion - shown in new condition

D = minimal pin protrusion - Pads and Disc must be checked with road wheel removed

**5.3.2 Brake Wear Check using Guide Pin (Only for Axial Disc Brakes SB 7541, SB 7551 to SB 7629, SB 7639 and Radial Disc Brakes SB 7102, SB 7112, SB 7103, SB 7113, SB 7104, SB 7114, SB 7105, SB 7115, SB 7108, SB7118, SB 7109, SB 7119, SB 7120, SB 7130 - These Callipers do have the rib in position B (see also Section 5.3.1)**

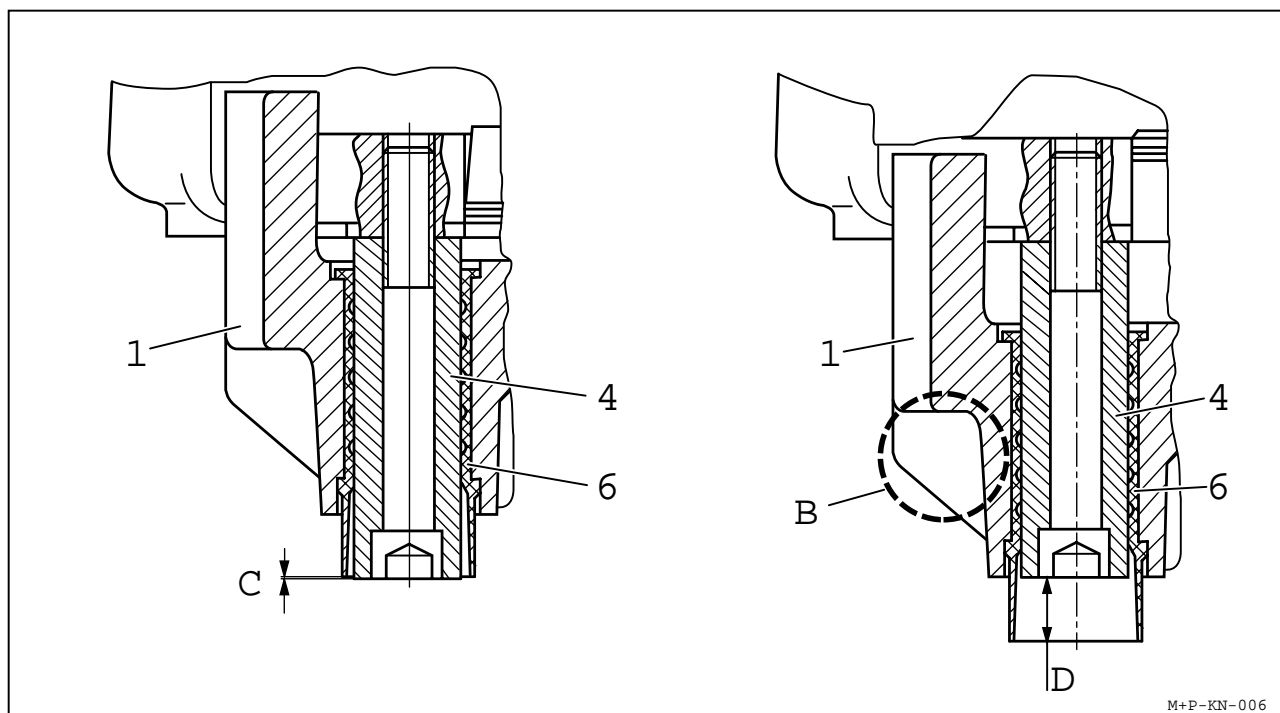

The condition of the Pads can be visually determined without removing the road wheel by noting the position of the Fixed Sleeve (4) in the Floating Caliper (1).

If the head of the Fixed Sleeve (4) is inside the Rubber Bush (6) by a dimension D greater than 18mm, then a more accurate check of the Pads and Disc must be made.

If necessary change the Pads - see Section 6.

B = with rib (see also Section 5.3.1)

C = new condition

D = 18 mm or more, Pads and Disc must be checked with road wheel removed

### 5.3.3 Wear Indicators

Due to different Vehicle Manufacturer and vehicle types there are several types of Pad Wear Indicator used.

- a) In - Pad Normally Closed Indicator - Circuit is broken when Pad Wear reaches limit.
- b) In - Pad Normally Open Indicator - Circuit is made when Pad Wear reaches limit.

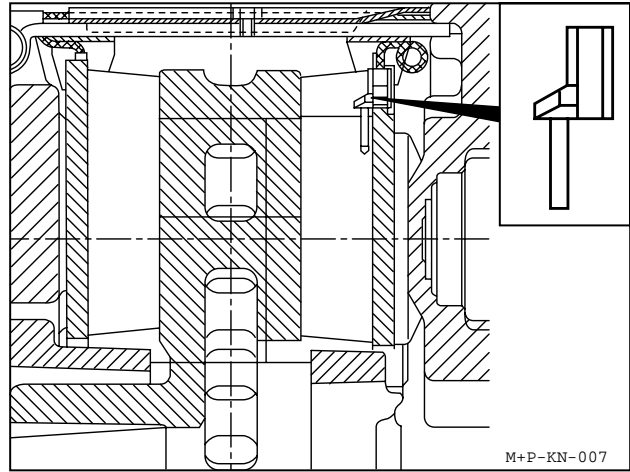

- c) Wear Indicator using built in Potentiometer. This is available either as an on/off version or as a continuous signal version which can be linked to the vehicle's electronic monitoring systems.

An optical or acoustic device may be linked to any of the above.

#### **Important**

Please also refer to specifications provided by the Vehicle Manufacturer

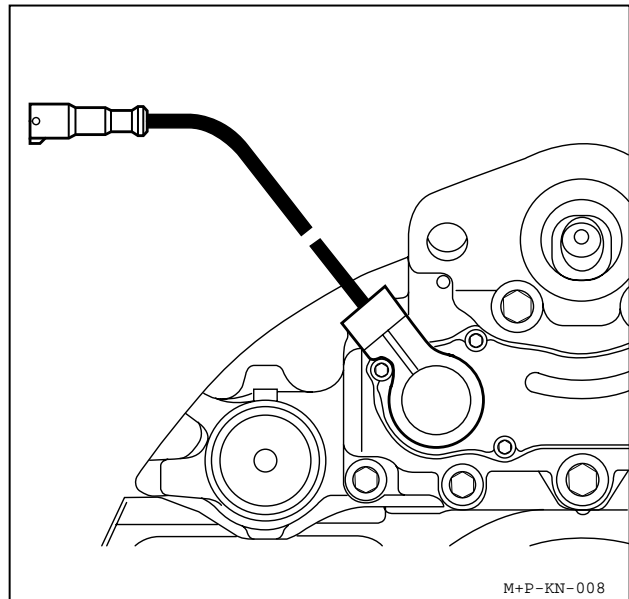

### 5.4 Knorr-Bremse Diagnostic Equipment

The Knorr-Bremse Diagnostic Unit ZB 9031 is a hand held device suitable for vehicles that are fitted with Knorr-Bremse Disc Brakes using a continuous signal type of Wear Potentiometer.

The wear condition of each brake can be measured by connecting the device to a suitable 13 pin socket (DIN 72570) where fitted. This socket will have been connected to each sensor by the vehicle manufacturer.

The Diagnostic unit allows:

- Quick and simple wear check.
- A check of the potentiometer function.

*A detailed instruction manual is included with each unit.*

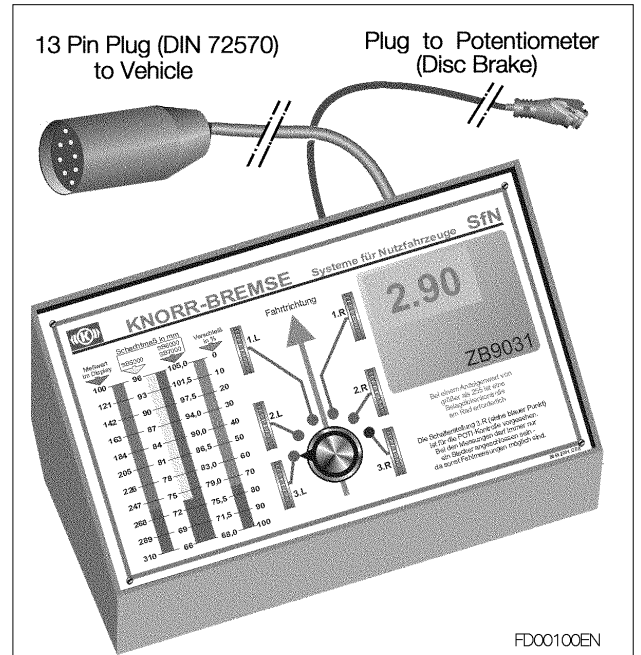

### 5.5 Knorr-Bremse Diagnostic Equipment

The Knorr-Bremse Wear Check Module ZB 9033 is a chassis mounted device suitable for vehicles that are fitted with Knorr-Bremse Disc Brakes using a continuous signal type of Wear Potentiometer.

The module continuously monitors and displays the wear at each brake.

For vehicles without an automatic brake control system, particularly Trailer applications, the module allows for a quick and simple wear check.

The Wear Check Module allows:

- Up to 6 Brakes to be checked together.
- LED monitoring of each Brake condition.

*A detailed instruction manual is included with each unit.*

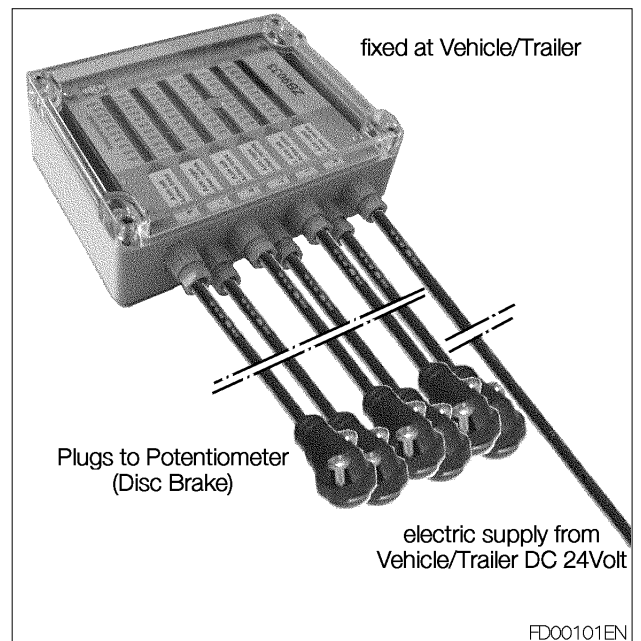



## 6 Pad replacement

(for "Axial- and Radial Disc Brake")

### **WARNING!**

*Before starting repair work, ensure the service brake and parking brake are not applied and that the vehicle cannot roll away.*

### 6.1 Pad removal

Take the wheel off (refer to Vehicle Manufacturer's recommendations).

Remove Clip (26) and Washer (45), push down the Pad Retainer (11) and remove Pin (44).

If the Pad Retainer (11) is corroded, it should be replaced.

#### **Important**

Before removing Pads it is strongly recommended that the Adjuster mechanism is checked for correct operation. See Section (5.2)

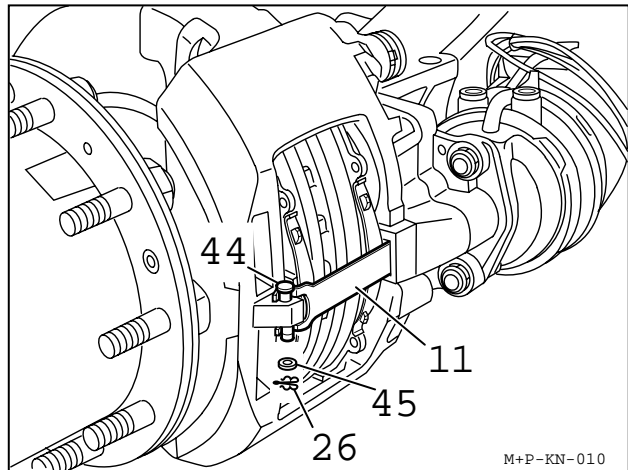

### **WARNING!**

*Do not overload or damage the Adjuster (23). Use only 8mm Ring Spanner or 1/4" drive Socket with a lever length no greater than 100mm.*

**DO NOT** use an Open Ended Spanner since this may damage the Adjuster shaft.

Remove Cap (37).

Turn the Adjuster counter-clockwise until Pads can be removed. A clicking noise will be heard during this procedure.

Push inboard Pad (12) toward Actuator.

Pull out both Pads (12).

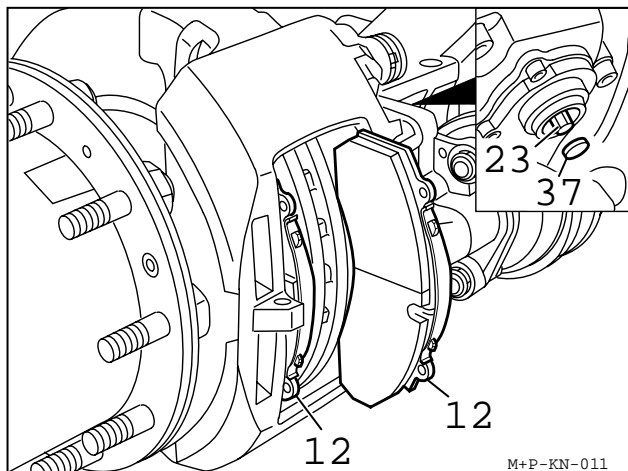

### 6.1.1 Tappet Boot Check

The Adjuster (23) should be screwed clockwise until the boots are clearly visible.

The Boots should not show any damage.

Check the attachment of the Boots into the Caliper housing.

#### **Important**

Any ingress of water or dirt past the Tappet Boot will lead to corrosion and affect the function of the Actuation Mechanism and Adjuster Unit.

If damaged, the Boot and Tappet must be replaced (see Section 7).

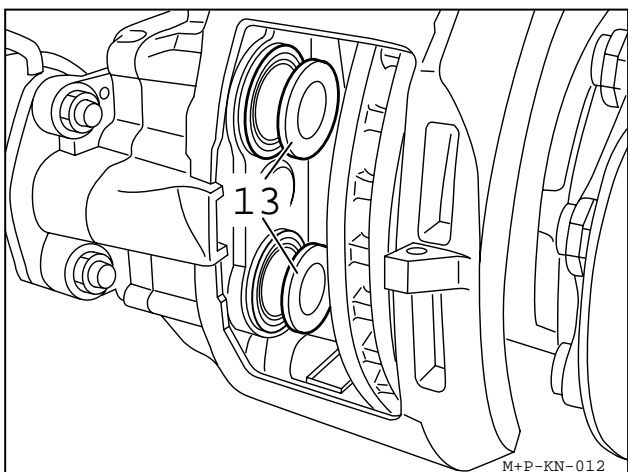

### 6.1.2 Caliper guidance check

Following Pad removal (Section 6.1)

Using hand pressure only (no tools), the Caliper (1) must slide freely over the whole length of the Guide Pin arrangement >30mm.

During this operation the Sleeve (5) is sealed by the Boot (9) and Cap (10) or Steel Cap (10a) and O-Ring (31a). These must show no signs of damage. Check that these are correctly seated.

The Caliper may have to be re-sealed by using a suitable Kit (see page 5 or page 7).

### 6.2 Pad fitting

#### **WARNING!**

*Pads must be changed as an axle set and NOT individually.  
Use only Pads which are permitted by the vehicle manufacturer, axle manufacturer and brake manufacturer.  
Failure to comply with this may invalidate the vehicle manufacturer's warranty*

#### **Note:**

Before placing the Pads into the Carrier, the Adjuster (23) must be further de-adjusted by rotating it counter clockwise.

Clean the Pad abutments.

Push Caliper (1) outboard and fit the outboard Pad (12).

For fitting the inboard Pad (12) push Caliper (1) in the opposite direction.

If fitted, replace Wear Indicators and fittings / brackets etc. See page 5 or 7.

#### **WARNING!**

*Do not overload or damage the Adjuster (23). Use only 8mm Ring Spanner or 1/4" drive Socket with a lever length no greater than 100mm.*

**DO NOT** use an Open Ended Spanner since this may damage the Adjuster shaft.

Rotate the Adjuster clockwise until the Pads come into contact with the Disc. Then turn back the Adjuster 2 clicks.

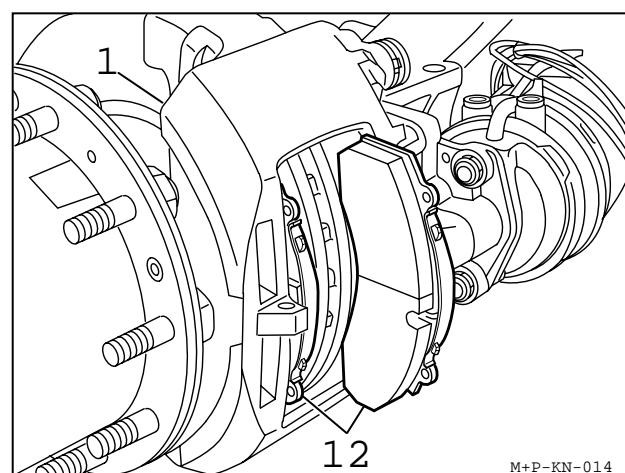
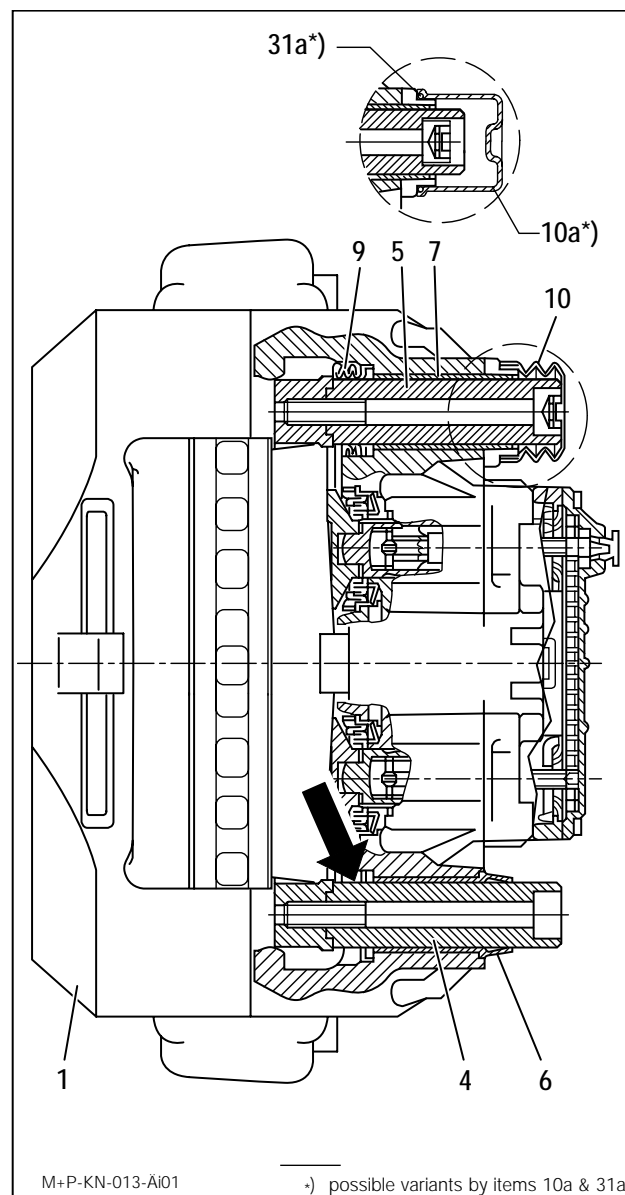

The hub should turn easily by hand after having applied and released the brake.

The Cap (37) must then be replaced having lightly greased it with Renolit HLT2 (available as part number II14525).

After setting the Pad Retainer (11) into the groove of the Caliper (1), it must be pushed in to enable the positioning of Pad Retainer Pin (44).

Fit washer (45) and Spring Clip (26) to the Pad Retainer Pin (44) (use only new parts).

Our recommendation is fitting Washer (45) and Spring Clip (26) pointing downwards (see diagram).

Wheel mounting (refer to Vehicle Manufacturer's recommendations).

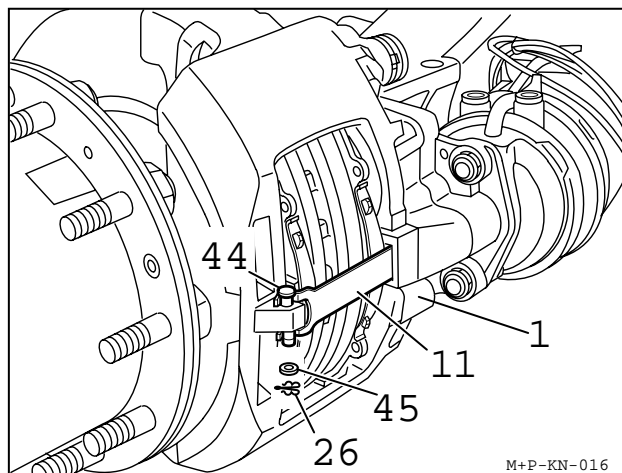

### ***IMPORTANT!***

*New Pads need bedding in. Heavy or long duration braking should initially be avoided.*

## **7 Tappet with Boot replacement**

(for "Axial- and Radial Disc Brake")

### **7.1 Tappet with Boot removal**

#### **Note:**

It may be easier to remove the Caliper from the axle to replace the Tappets of the Caliper (see Section 10.1).

The Adjuster (23) must be screwed clockwise until the Boots can be reached.

If the Caliper has been removed from the vehicle care must be taken not to overrun the threads (see section 7.1.1).

To remove the Tappet Boot from the Caliper bore, a Screwdriver should be used to deform the Boot location ring - see diagram.

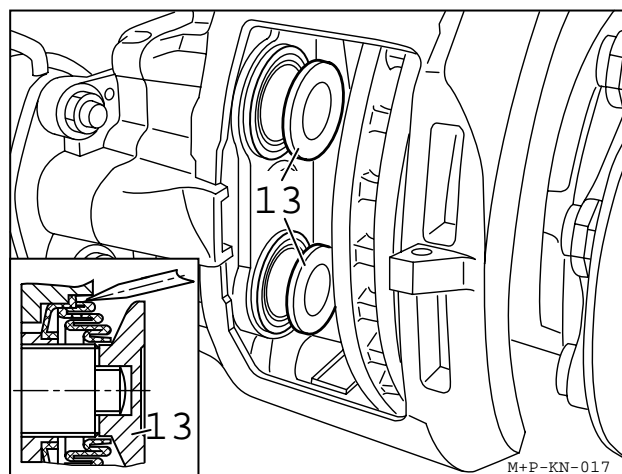

### ***Warning!***

*Great care must be taken not to damage the Inner Seal since it is not a replacement item.*

The Tappets (13) can be removed from the Threaded Tubes by using Wedge Fork A. (Order No. II32202).

Remove the old Tappet Bush (116).

Check Inner Seal (arrow) and if damaged, the Caliper must be replaced .

### 7.1.1 Adjuster thread inspection

Place an unworn Pad (12) into the outboard gap to avoid overrunning of the Threaded Tubes.

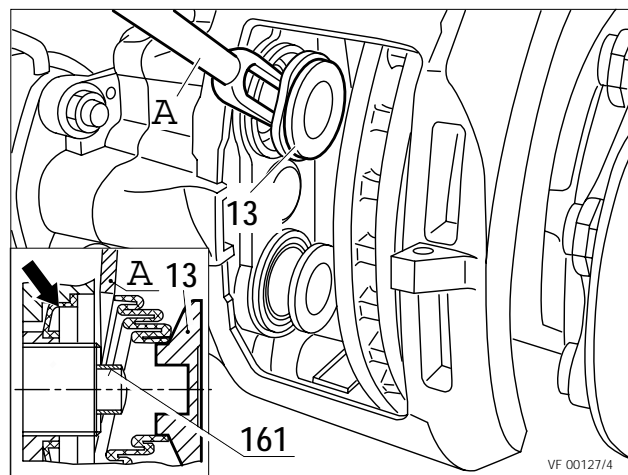

### **IMPORTANT!**

*Threaded Tubes should not overrun the inner thread of the Bridge.  
The Caliper must be changed if synchronisation is lost.*

For the inspection of the threads, the tubes must be screwed out (max. 30mm) by turning the Adjuster (23) clockwise.

If Caliper is not installed on axle, put a spacer E (length = 70mm) into the Caliper (1) to avoid overrunning of the Threaded Tubes (16) when screwing them out (see illustration opposite). During screwing, the threads can be checked for corrosion damage. In case of water ingress or corrosion, the Caliper must be replaced.

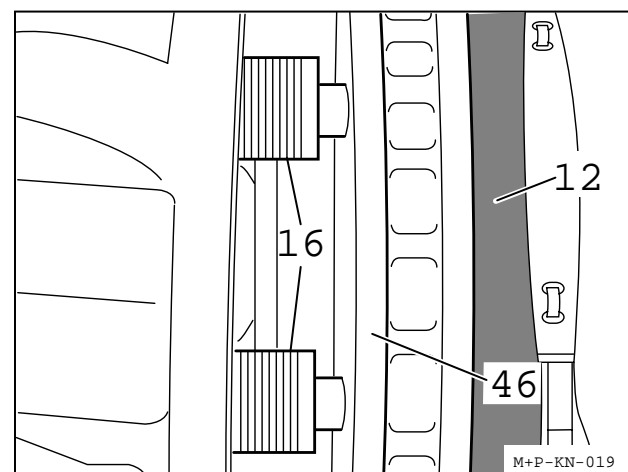

### 7.2 Tappet with Boot fitting

#### With Caliper fixed to axle:

Grease threads with RENOLIT HLT2 (Order No. II14525).

Screw back Threaded Tubes (16), by turning the Adjuster (23) counter-clockwise.

Place new Tappet Bush (161) onto the head of the Tube (16).

Sealing seat in the caliper for Tappet with Boot (13) must be clean and free of grease.

Place Tappet with Boot (13) onto the head of the Tube.

Use Push-In Tool with the short strut (B) (Order No II19252) for positioning and pressing-in the Boot (13).

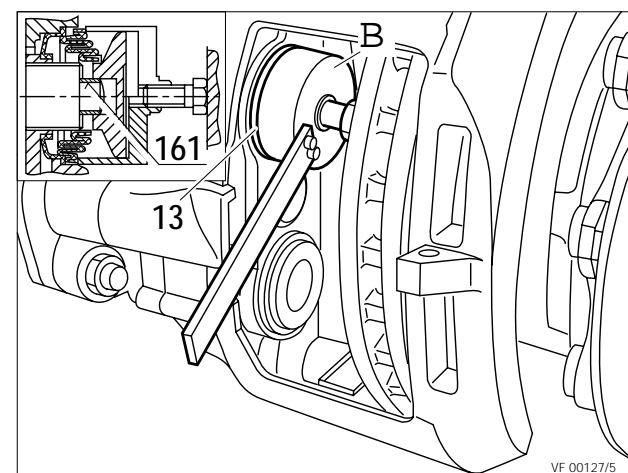
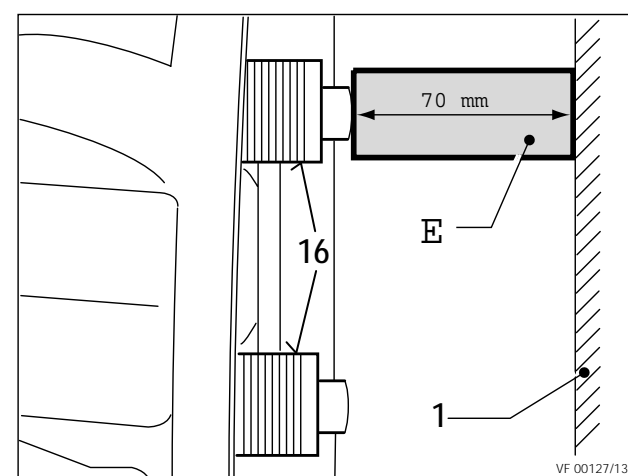

Using Tool B in reverse, the Tappet can be pressed on.

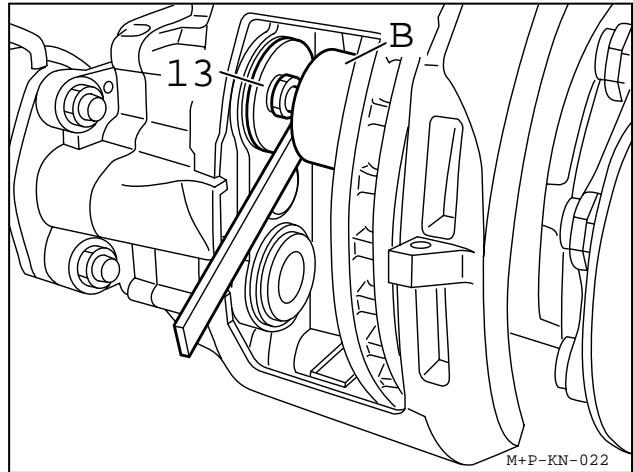

**With Caliper not installed on axle**

Grease threads with RENOLIT HLT2 (Order No. I114525).

Screw back Threaded Tubes (16), by turning the Adjuster (23) counter-clockwise.

Sealing seat in the caliper for Tappet with Boot (13) must be clean and free of grease.

Place new Tappet Bush (161) onto the head of the Tube (16).

Place Tappet with Boot (13) onto the head of the Tube.

Use Push-In Tool with the long strut (B) (Order No I119252) for positioning and pressing-in the Boot (13).

Using the Tool (B) in reverse, the Tappet can be pressed on.

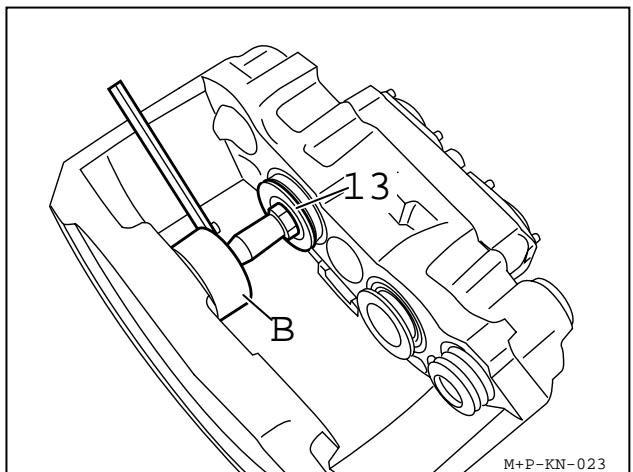
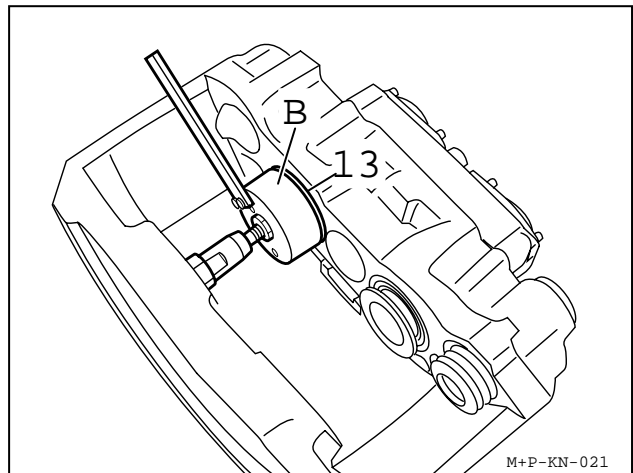

## 8 Caliper Suspension sealing (Replacement of inner Boot (9) ) (for the Axial and Radial Disc Brake)

Remove Caliper (see Section 10.1)

Remove Ring (58)

Pull out Sleeve (5)

Push out Boot (9) with screw driver.

Inspect and clean contact area of Boot (9)

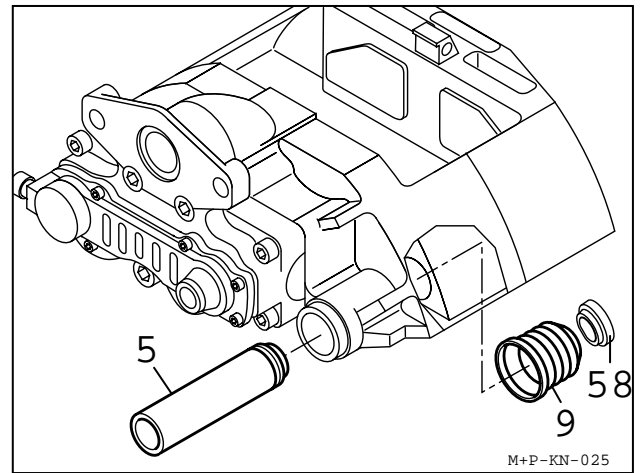

Put new Boot (9) into the Sleeve (arrow) of the Tool C (Order No II19253).

Position Sleeve with Boot (9) into the Caliper bore and pull in.

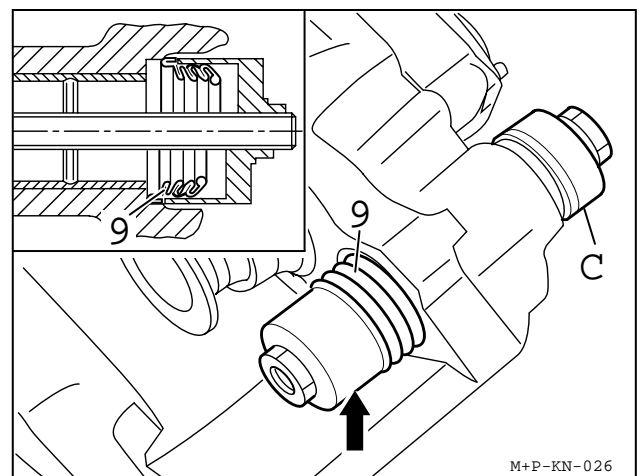

Fit the Sleeve (5)

The Boot end must engage in the groove of the Sleeve (5) (arrow). Lock with Ring (58) by pushing until it engages.

### Important:

Before fitting the Caliper the unsealed Sleeve with the Rubber Bush should be checked for its ability to slide.

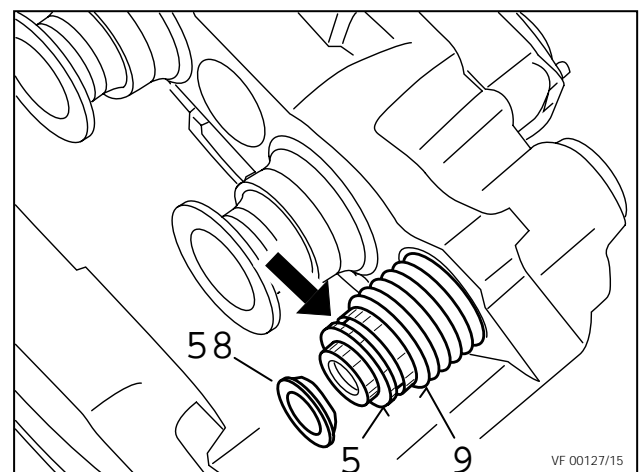

Fit Caliper (see Section 10.2).

## 9 Guide Pin Bush replacement

(for "Axial- and Radial Disc Brake")

Remove Caliper (see Section 10.1)

Remove Sleeve (5) and inner Boot (9) (see Section 8).

### 9.1 Brass Bush (7) replacement

Remove old Sleeve (5).

Pull out Bush (7) with Tool (D) (Order No. II19254).

#### If Caliper has no groove (see arrow)

(Note: Groove is always located on the inboard side)

Pull in new Brass Bush (7) with Tool (D).

#### If Caliper has a groove:

Pull in new Brass Bush (7) with Tool (D).  
To prevent longitudinal displacement use Tool (F) (Order No II36797) to create new groove.

Check contact area of Brass Bush (7) for burrs.  
Remove burrs.

Grease Bush with white Grease RENOLIT HLT2 (Order No II14525).

Insert new Sleeve (5).

#### Note:

The Guide Pins Kit contains new Sleeves (4) & (5) and new Caliper Bolts (39) & (40) (see Section 1.2 and 1.4).

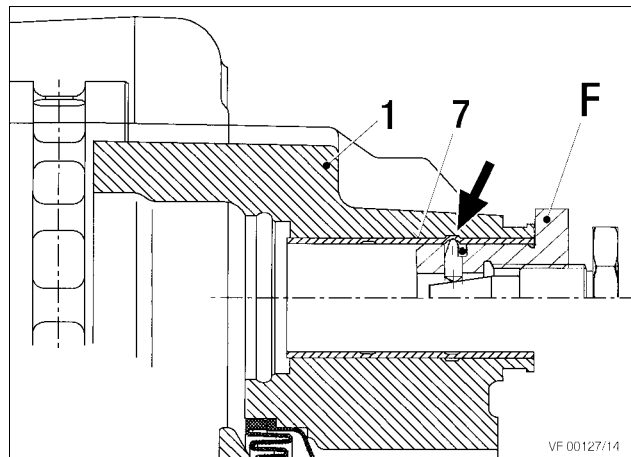
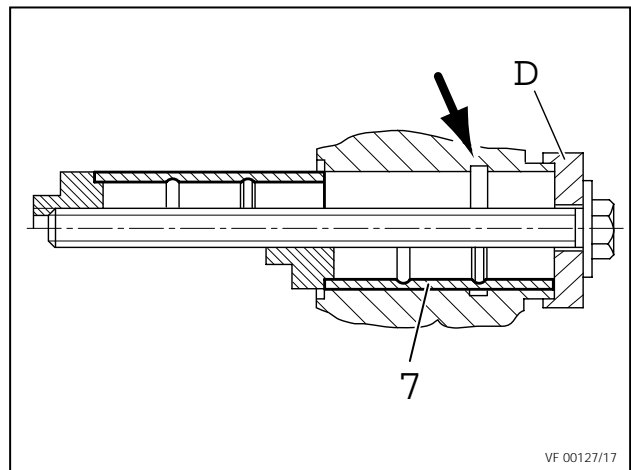
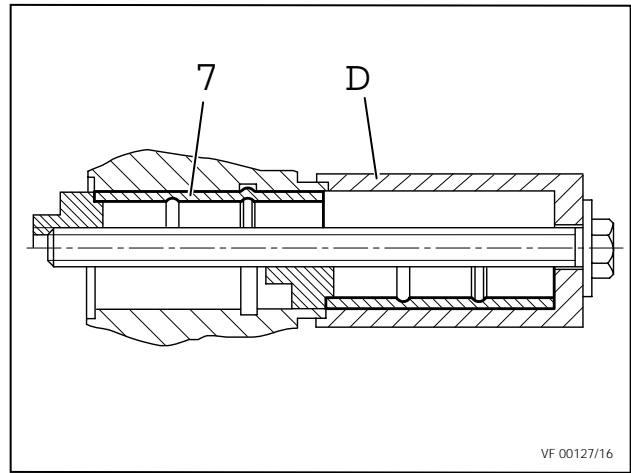

### 9.2 Rubber Bush (6) replacement

Remove old Sleeve (4)

Pull Rubber Bush (6) out of bore.

Check bore for corrosion, clean if necessary with Corrosion protection paint (e.g. Zinc spray).

#### Note:

Grease new Rubber Bush (6) inside and outside with green Grease SYNTHESO GL EP 1 (Order No II32793).

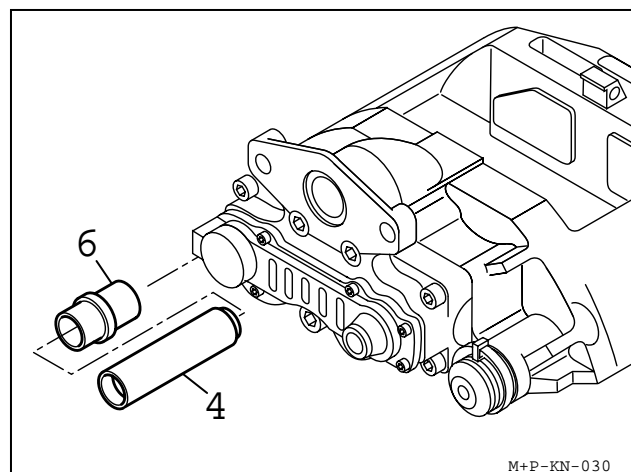

Deform new Rubber Bush (6) and push from the inner side of the Caliper into the bore.  
Push Rubber Bush (6) so that the outer positioning ring locates in the groove (see arrows).

**IMPORTANT!**

*Under no circumstances must the white Grease (containing mineral oil) be used for lubricating the Bush or Sleeve. Use only synthetic based green Grease (Part Number I132793).*

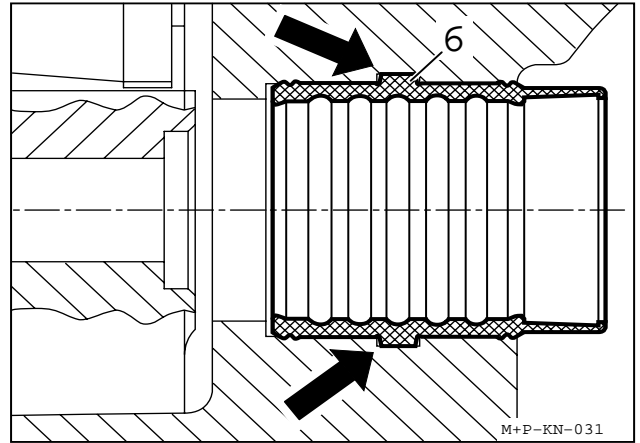

**Note:**

The Guide Pins Kit contains new Sleeves (4) & (5) and new Caliper Bolts (39) & (40).

Assemble Sleeve (4)

Re-fit Caliper (see Section 10.2)

**Important:**

Torque Caliper Bolts to 285<sup>+25</sup> Nm and check that the Caliper slides easily.

**10 Caliper replacement**

(for Axial- and Radial Disc Brake)

**10.1 Caliper removal**

Remove Pads (see Section 6.1)

Remove Actuator (see Section 12.1 and 12.3).

Remove Outer Boot Clip (31) and take off Outer Boot (10)

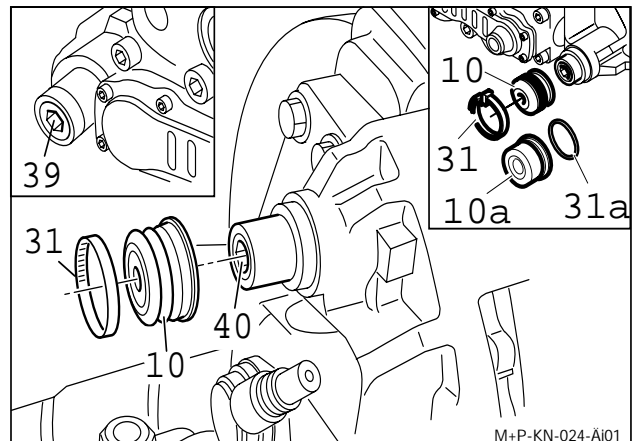

**Note:**

As well as Calipers with Outer Boot (10) and Outer Boot Clip (31) there are versions with Steel Cap (10a) and O-Ring (31a) available.

On models with Steel Caps (10a) and O-Rings (31a), place tool (G) (Part Number Z001105) onto the Steel Cap and tighten the threaded pin by a hexagon socket spanner. Then use hammer as shown.

Remove Cylinder Bolts (39 and 40).

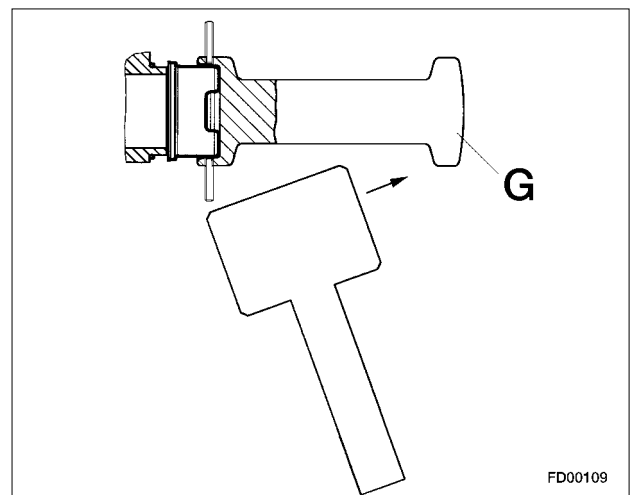



### **WARNING!**

*Hold Caliper only at its outer side.  
Never get your fingers between  
Caliper and Carrier!*

Remove Caliper from Carrier.

### **IMPORTANT!**

*The opening or dismantling of the  
Caliper has not been authorized.  
Use only Genuine Knorr-Bremse  
Service Exchange Calipers.*

## 10.2 Caliper fitting

The correct choice of Caliper must be ensured by checking the Part No. on the label (arrow, picture above)

### **Note:**

Service Exchange Calipers have a blue label.

The Service Exchange Caliper has a plastic cap or an adhesive tape in the area of the Actuator attachment. Remove the cap tape after installing the Caliper (see arrow).

### **Note:**

The service exchange Caliper includes sealing and guiding elements. The Pads are not included.

### **WARNING!**

*Hold Caliper only at its outer side.  
Never get your fingers between  
Caliper and Carrier!*

### 10.2.1 Caliper with Outer Boot (10)

Locate the Caliper to the Carrier.

Screw-in Caliper Bolts (39 and 40) and tighten to 285<sup>+25</sup> Nm (use only new parts).

Check that the Caliper slides easily.

Check the position of the Inner Boot (9) on the Sleeve (5).

Check Adjuster function (see Section 5.2)

If necessary use new Outer Boot (10).

Check grease-free seating of the Outer Boot (10) on the Caliper (1)

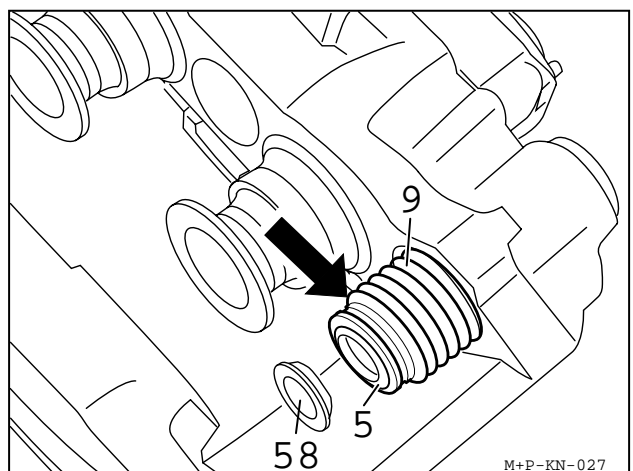
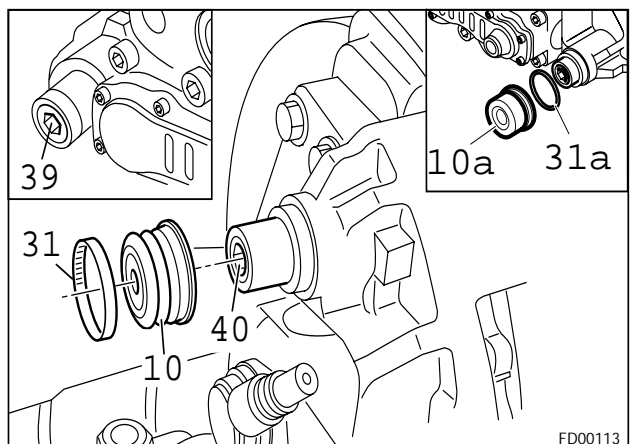
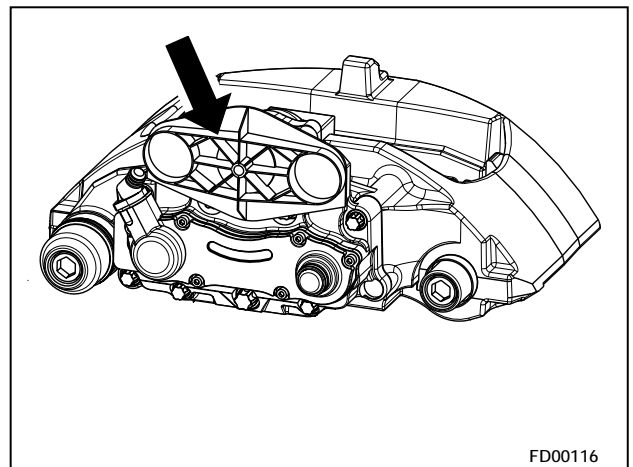
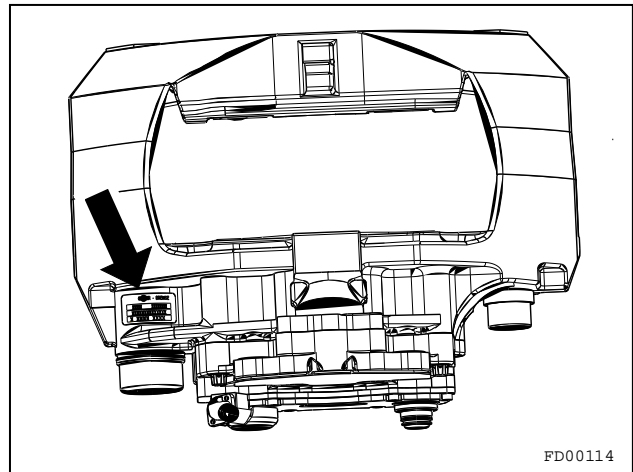

Tighten Outer Boot Clip (31)

Fit the Pads (see Section 6.2)

Attach Brake Chamber or Spring Brake (see Section 12.2 or 12.4)

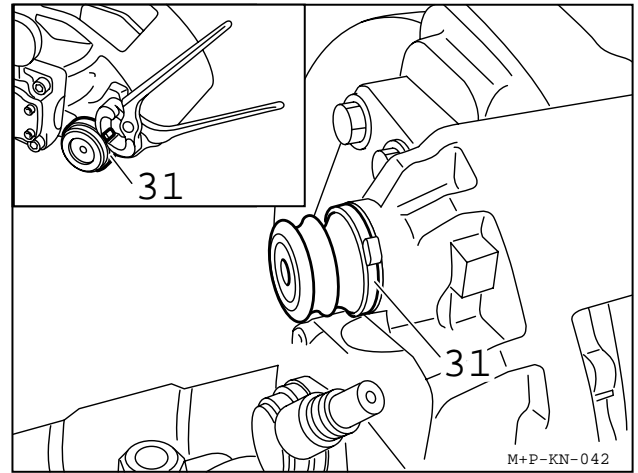

### 10.2.2 Caliper with Steelcap (10a)

#### **IMPORTANT!**

*It is only allowed to replace the Outer Boot (10) by the Steel Cap (10a) when replacing the Sleeve (5), the O-Ring (31a) and the Screw (40) at the same time. Replace only after permission by Axle- or Vehicle-manufacturer. On SB 6... (19,5") only permissible after manufacturing date A0026. (see type plate).*

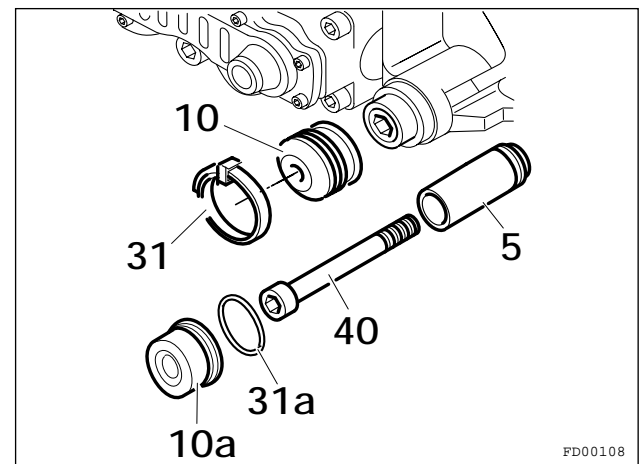

It may be easier to remove the Caliper and the Carrier from the axle to replace the Steel Cap.

#### **Assembly at the Vehicle :**

The fitting must be carried out with Pads still installed.

- Clean area.
  - Using the Grease supplied (II14525), lightly lubricate the O-Ring and place it over the cast spigot (see Sketch).
  - Remove Threaded Pins from assembly tool (G) to avoid damage of the Steel Cap.
  - Hold the new Steel Cap on the end of the Spigot. By using a suitable press or special assembly tool (Part Number Z001105) and a hammer, press the Steel Cap fully on the spigot making sure not to deform the Cap.
- After removal the Steel Cap and the O-Ring must not be refitted.

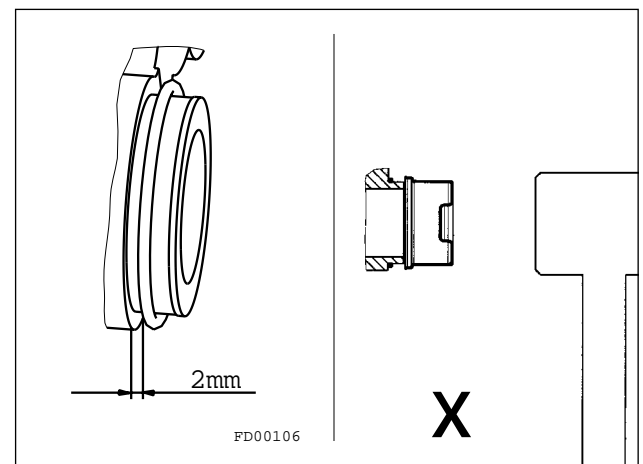

#### **IMPORTANT!**

*The Steel Cap (10a) and the O-Ring must only be used once.*

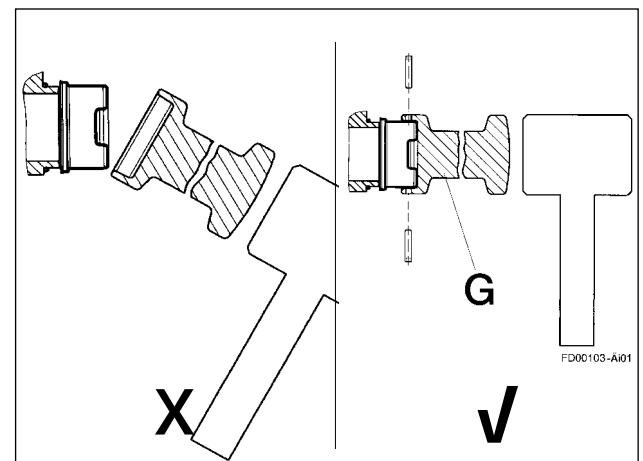

Assembly on the Caliper and Carrier removed from the axle:

**IMPORTANT!**

*It is only allowed to replace the Outer Boot (10) by the Steel Cap (10a) when replacing the Sleeve (5), the O-Ring (31a) and the Screw (40) at the same time. Replace only after permission by Axle- or Vehicle-manufacturer. On SB 6... (19,5") only permissible after manufacturing date A0026. (see type plate).*

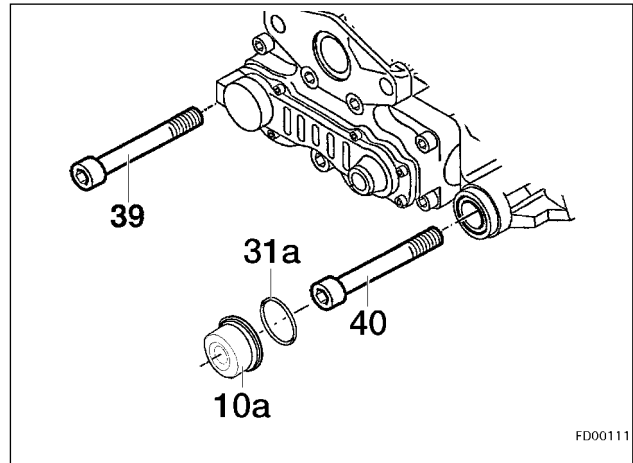

Put the Caliper on the Carrier.

**IMPORTANT!**

*Special threaded Screw (40) and Steel Cap (10a) as well as the O-Ring (31a) must be renewed whenever Screw (40) has been removed.*

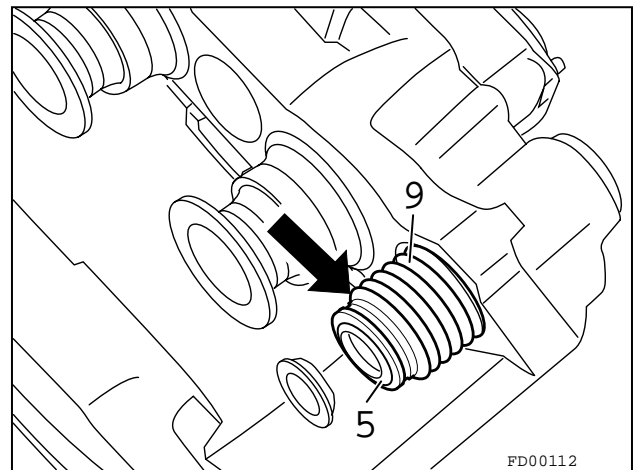

Screw-in Caliper Bolts (39 and 40) and tighten to 285<sup>+25</sup> Nm.

Check the position of the Inner Boot (9) on the Sleeve (5).

Check that the Caliper slides easily.

In the shown clamping (e.g. vice) press the Caliper against the Carrier as far as possible. The inner Boot (9) must be in compressed condition, this to prevent air being trapped inside of the Cap.

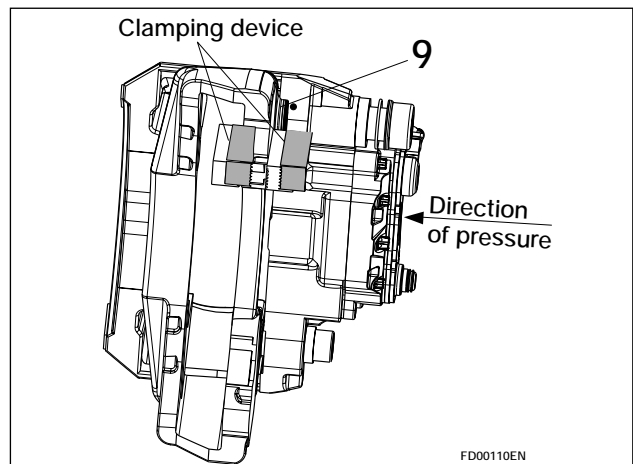

The assembly of the Steel Cap (10a) can now be carried out as in Section " Assembly at the Vehicle".

Check Adjuster (Section 5.2).

**11 Carrier replacement**

(for Axial- and Radial Disc Brake)

Remove Caliper (see Section 10.1).

Remove Carrier (2) from axle.

Clean axle contact area.

Attach new Carrier with new bolts from the relevant truck manufacturer. Bolts are not supplied by Knorr-Bremse.

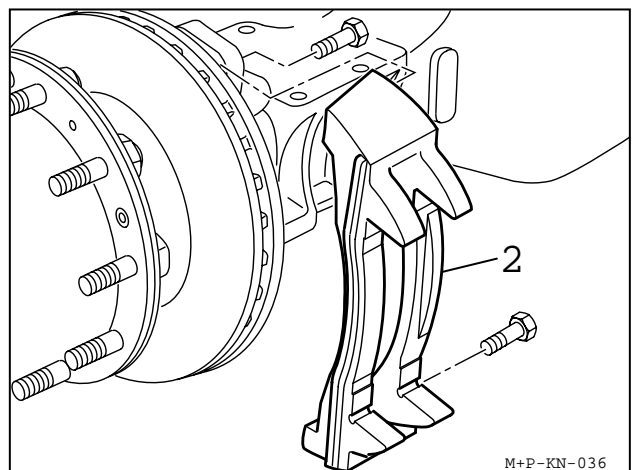

Attach Caliper (see Section 10.2)

## 12 Actuation cylinder replacement (for "Axial- and Radial Disc Brake")

### 12.1 Brake Chamber removal

Disconnect air line from Brake Chamber (18/2)

Unscrew Brake Chamber Mounting Nuts (do not re-use them).

Remove Brake Chamber

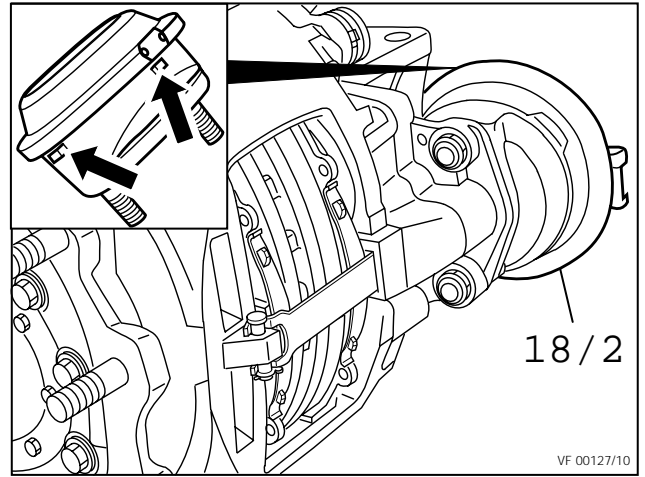

### 12.2 Brake Chamber fitting

#### IMPORTANT:

New Brake Chambers (18/2) have drain plugs installed. Remove bottom plug (see arrows). All other drain holes should be plugged.

Before fitting the new Brake Actuator, the sealing surface (see arrow) must be cleaned, and the Spherical Cup (19) in the Lever must be greased with white Grease RENOLIT HLT2 (Order no II14525).

Surface area of the flange must be plain and clean.

#### **IMPORTANT!**

*Do not use Grease containing molybdenum disulphate. Use only KORR-Actuators which are recommended by the Vehicle Manufacturer.*

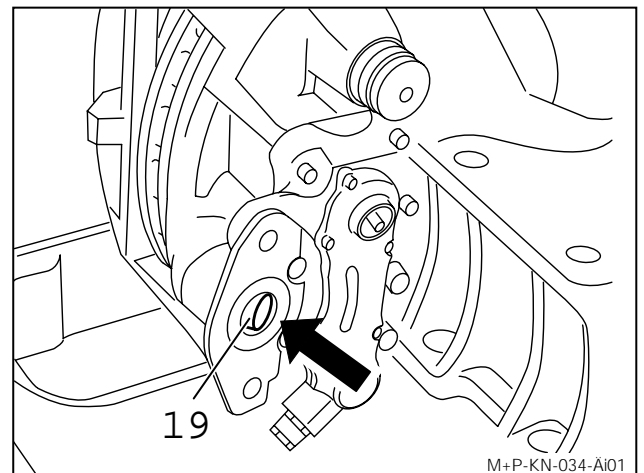

Attach Actuator with new Nuts (self-locking EN ISO 7042) and torque tighten to 180<sup>+30</sup> Nm.

Connect air hose and check for leakage.

Make sure that hose is not twisted and that chafing is not possible.

#### **IMPORTANT!**

*Check function and effectiveness of the brake.*

### 12.3 Spring Brake removal

#### **CAUTION!**

*Chock wheels before releasing  
Spring Brake*

Release parking brake, move Hand Control Valve to 'run' position.

Screw-out Release Bolt (arrow) with a maximum torque of 35Nm.

Release air from brake, move Hand Control Valve to 'park' position.

Disconnect air hoses from Spring Brake Actuator (18/1)

Unscrew Spring Brake Actuator Mounting Nuts (do not re-use).

Remove Spring Brake Actuator.

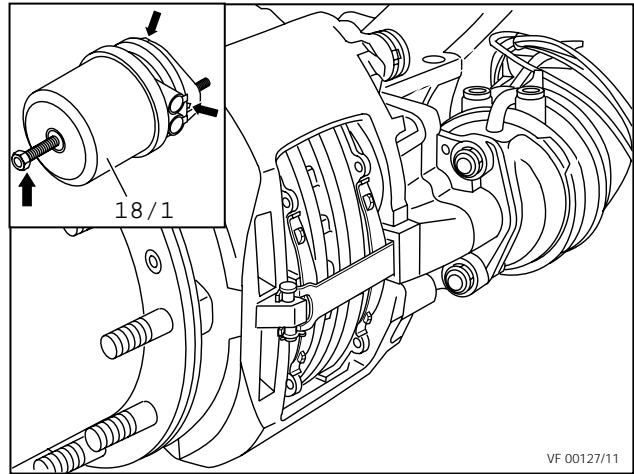

### 12.4 Spring Brake fitting

#### **IMPORTANT!**

New Spring Brake Actuators (18/1) have drain plugs installed. Remove bottom plug (see arrows). All other drain holes should be plugged.

Before fitting the new Brake Actuator, the sealing surfaces have to be cleaned, and the Spherical Cup (19) in the Lever must be greased with white Grease RENOLIT HLT2 (Order no II14525)

Surface area of the flange must be plain and clean.

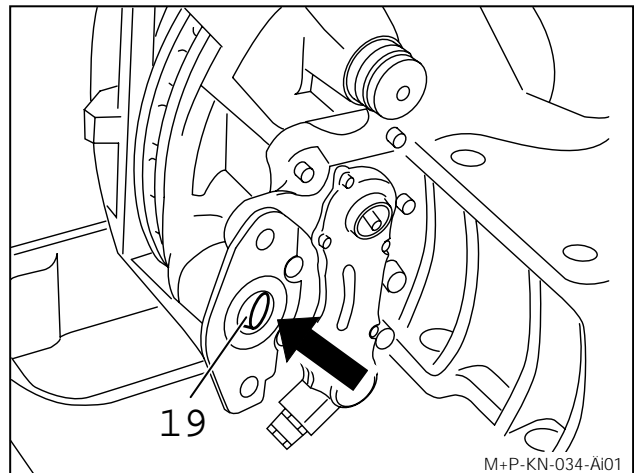

#### **IMPORTANT!**

*Do not use grease containing  
molybdenum disulphate.  
Use only KNORR-BREMSE Actuators  
which are recommended by the  
Vehicle Manufacturer.*

#### **IMPORTANT!**

*On Radial Disc Brake the Train Plugs in  
the bottom of the Cylinderflange must  
be open.*

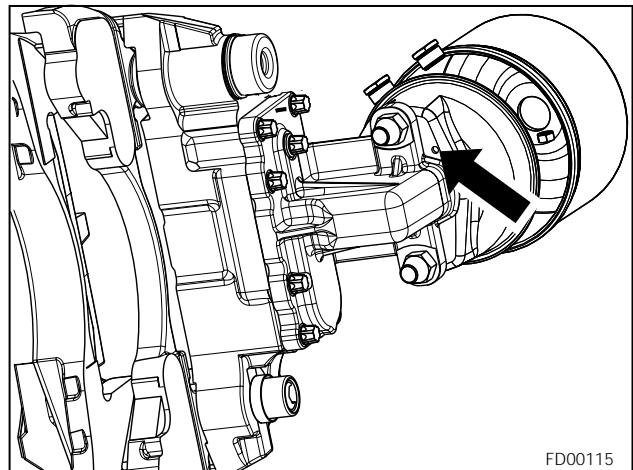

Attach Actuator with new Nuts (self-locking EN ISO 7042) and torque tighten to 180<sup>+30</sup> Nm.

Connect air hose, ensuring that hoses are not mixed up.

Make sure that hoses are not twisted and that chafing is not possible.

Release parking brake, move Hand Control Valve to 'run' position, and check for leakage.

Screw in Spring Brake Release bolt to maximum 70 Nm.

### ***IMPORTANT!***

*Check function and effectiveness of the brake.*

## **13 Additional information**

### **13.1 Service Video**

A Video is available for additional information.

Order number: RA-SB0002.DE Video (German)  
RA-SB0002.EN Video (English)  
(in UK. order KBP2060/1)  
RA-SB0002.IT Video (Italian)  
RA-SB0002.SP Video (Spanish)  
RA-SB0002.PO Video (Portugese)  
RA-SB0002.DA Video (Danish)  
RA-SB0002.HU Video (Hungarian)  
RA-SB0002.FR Video (French)

### **13.2 Service Tool Kit ZB 9032**

For service and repair work we recommend our Tool Kit ZB 9032 II 37951/004EX, which contains all necessary special tools.

### **13.3 Diagnostic Equipment**

For vehicles fitted with continuous potentiometer type wear sensors, Knorr-Bremse Diagnostic Equipment may be used to ensure quick and simple measurement of wear at each caliper. See sections 5.4 and 5.5.

►  
Knorr-Bremse  
Systeme für Nutzfahrzeuge GmbH  
Moosacher Straße 80  
D-80809 Munich  
Germany  
Phone: +49 89 35 47-0  
Fax: +49 89 35 47-27 67

►  
Knorr-Bremse  
Sistemi per Autoveicoli  
Commerciali S.p.A.  
Via C. Battisti, 68  
I-20043 Arcore (MI)  
Italy  
Phone: +390 39 60 75-1  
Fax: +390 39 60 75-4 35

►  
Knorr-Bremse  
Systèmes pour Véhicules  
Utilitaires France S.A.  
BP 34178  
La Briqueterie, RN 13  
Glos  
F-14104 Lisieux Cedex  
France  
Phone: +33 2 31 32 12 00  
Fax: +33 2 31 32 13 03

►  
Knorr-Bremse  
Systems for Commercial Vehicles Ltd.  
Douglas Road  
Kingswood  
GB-Bristol BS 15 8NL  
Great Britain  
Phone: +44 117 9 84 61 00  
Fax: +44 117 9 84 61 01

►  
Knorr-Bremse  
Benelux B.V.B.A.  
Overijsselhaven 79  
NL-3433 PH Nieuwegein  
Netherlands  
Phone: +31 30 6 08 10 90  
Fax: +31 30 6 08 08 75

►  
Knorr-Bremse  
Benelux B.V.B.A.  
Industriepark 39 - Zone A  
B-2220 Heist-op-den-Berg  
Belgium  
Phone: +32 15 25 02 83  
Fax: +32 15 24 92 40

►  
Knorr-Bremse  
System för Tunga Fordon AB  
Hemsögatan 20  
S-21124 Malmö  
Sweden  
Phone: +46 40 6 80 58 80  
Fax: +46 40 93 74 90

►  
Knorr-Bremse  
Systeme für Nutzfahrzeuge GmbH,  
Moscow  
Kazachy per, 5/2  
RF-109017 Moscow  
Russian Federation  
Phone: +7 503 2 34 49 95  
Fax: +7 503 2 34 49 96

►  
Knorr-Bremse  
Systémy pro užitková vozidla, CR,  
s.r.o.  
Petra Bezruce 399  
CZ-46362 Hejnice  
Czech Republic  
Phone: +420 427 36 36 11  
Fax: +420 427 36 37 11

►  
Knorr-Bremse  
Fékkendzszerek Kft.  
Szegedi út 49  
H-6000 Kecskemét  
Hungary  
Phone: +36 76 51 11 00  
Fax: +36 76 48 13 63

►  
Knorr-Orsan  
Ticari Araç Sistemleri Ltd. Sti.  
Türkgücü Köyü Yolu Üstü, 5 km  
TR-Çorlu/Tekirdag  
Turkey  
Phone: +90 282 6 81 84 00  
Fax: +90 282 6 81 84 15

►  
Knorr-Bremse  
Systems for Commercial Vehicles India  
Ltd.  
14/6 Mathura Road  
IND-Faridabad-121003 Haryana  
India  
Phone: +91 129 5 27 64 09  
Fax: +91 129 5 27 59 35

►  
Knorr-Bremse Far East Ltd.  
Truck Brake Systems Division  
1301 CRC Protective Tower  
38 Gloucester Road  
Wanchai  
Hong Kong  
China  
Phone: +852 25 20 61 19  
Fax: +852 25 20 62 59

►  
JKC Truck Brake Systems Co. Ltd.  
Zexel Building 6/F  
3-6-7 Shibuya, Shibuya-Ku  
J-Tokyo 150-0002  
Japan  
Phone: +81 3 34 98 84 41  
Fax: +81 3 34 98 84 43

►  
Bendix Commercial Vehicle Systems  
901 Cleveland Street  
USA-Elyria/OH 44036  
USA  
Phone: +1 440 3 29 90 00  
Fax: +1 440 3 29 95 77

►  
Knorr-Bremse  
Sistemas para Veículos Comerciais  
Brasil Ltda.  
Av. Eng.º Eusébio Stevaux, 873,  
Bloco B  
BR-04696-902 São Paulo/S.P.  
Brasil  
Phone: +55 11 56 81 11 04  
Fax: +55 11 2 46 39 05



**KNORR-BREMSE**  
Systeme für Nutzfahrzeuge GmbH

Moosacher Straße 80 · D-80809 München · Germany · Phone +49 89 35 47-0  
Fax +49 89 35 47-27 67 · Homepage <http://www.knorr-bremse.com>

## TU-FLO 750 COMPRESSOR

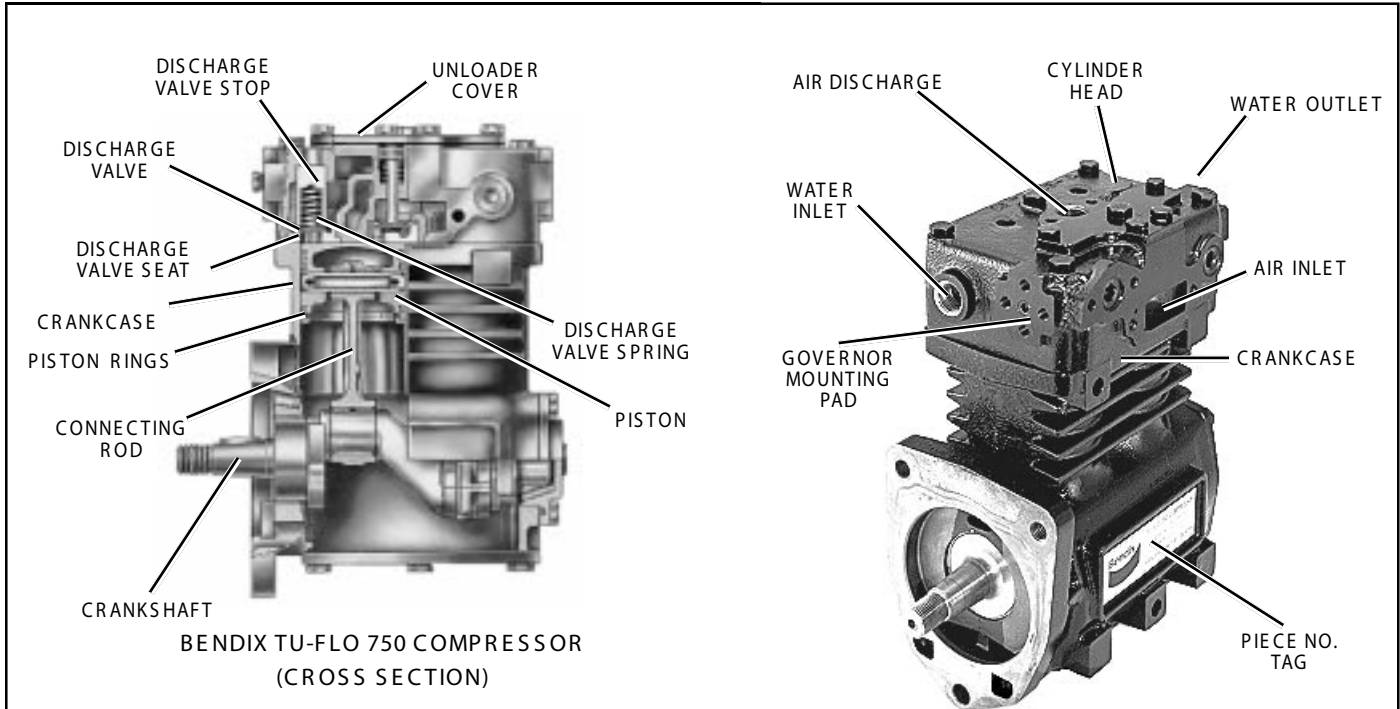

### DESCRIPTION

The function of the air compressor is to provide and maintain air under pressure to operate devices in the air brake and/or auxiliary air systems. The Tu-Flo 650 compressor is a two cylinder single stage, reciprocating compressor with a rated displacement of 16.5 cubic feet per minute at 1250 RPM.

The compressor assembly consists of two major subassemblies, the cylinder head and the crankcase. The cylinder head is an iron casting which houses the inlet, discharge, and unloader valving. (See Figure 1.) The cylinder head contains the air inlet port and is designed with both top and side air discharge ports. Three water coolant ports provide a choice of coolant line connections. Governor mounting surfaces are provided at both the front and the rear of the cylinder head. The head is mounted on the crankcase and is secured by six cap screws. The Tu-Flo 750 compressor is designed such that the cylinder head can be installed in one of two positions which are 180 degrees apart. The crankcase houses the cylinder bores, pistons, crankshaft and main bearings, and provides the flange or base mounting surface.

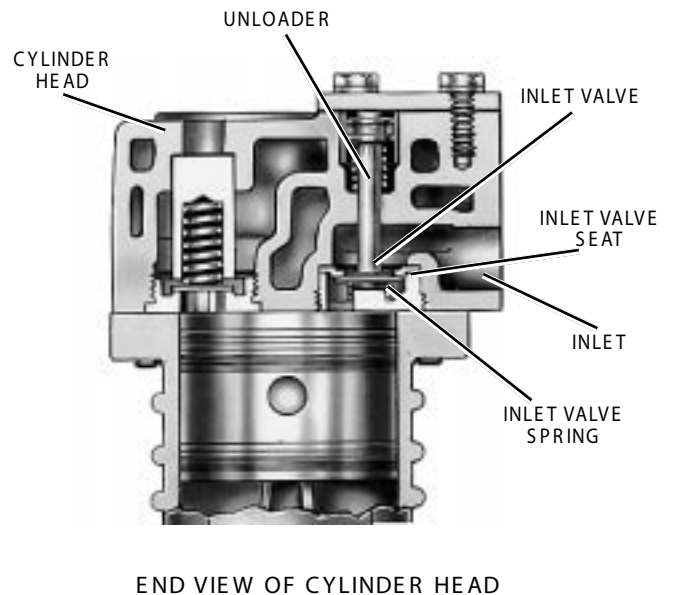



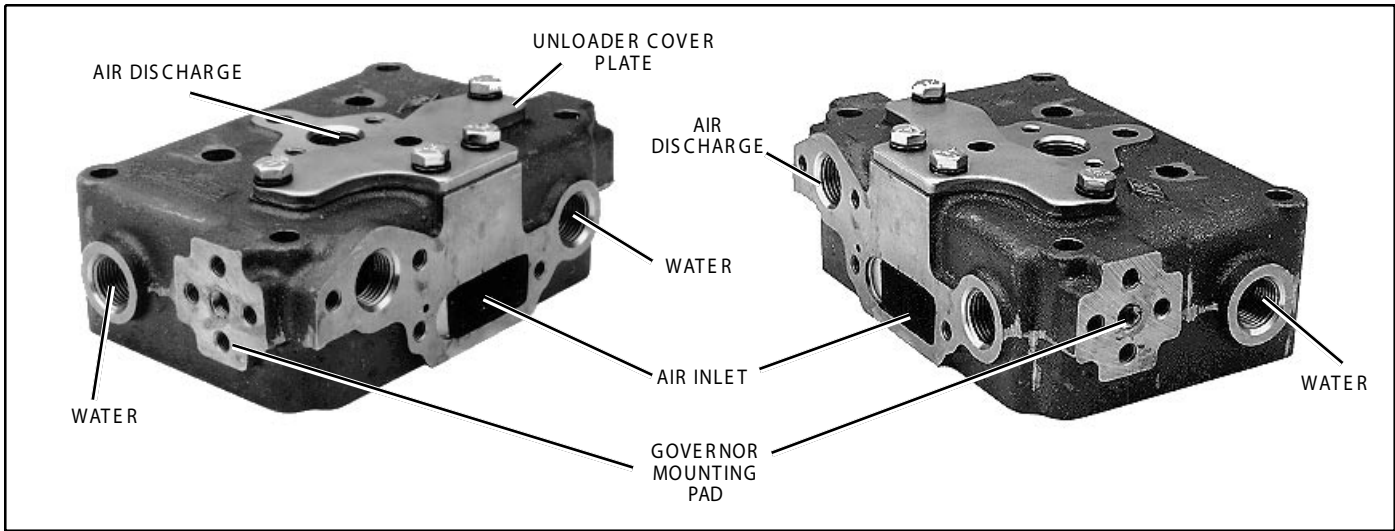

FIGURE 1 - CYLINDER HEAD

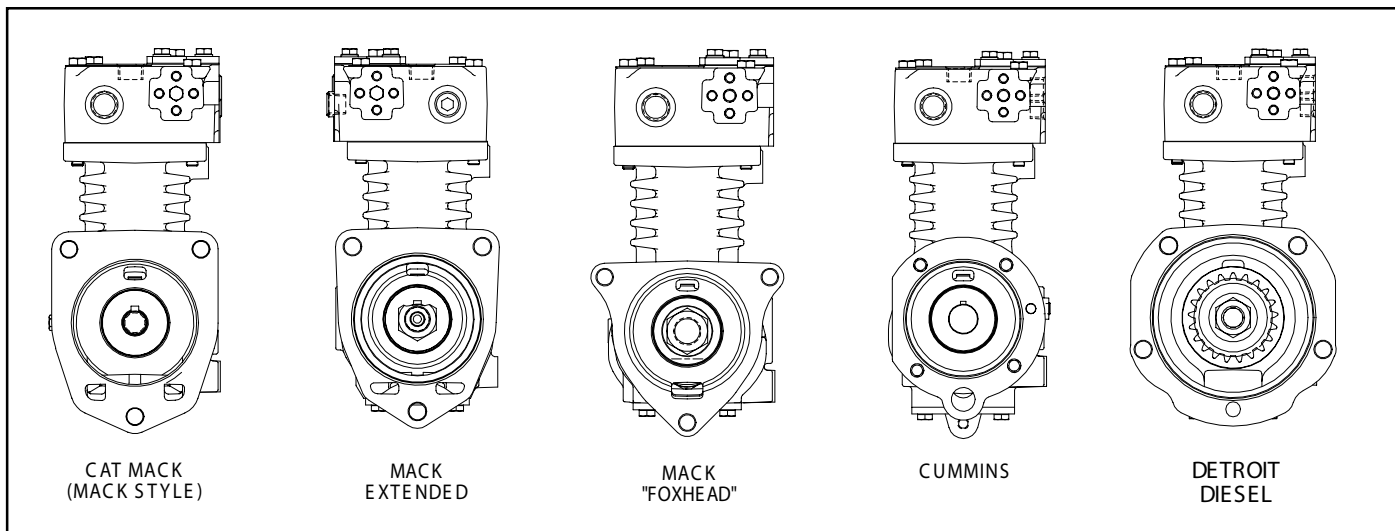

FIGURE 2 - MOUNTING CONFIGURATIONS

Various mounting and drive configurations, as shown in Figure 2, are supplied as required by the vehicle engine designs. A nameplate identifying the compressor piece number and serial number is attached to the side of the crankcase. (Reference Figure 3.)

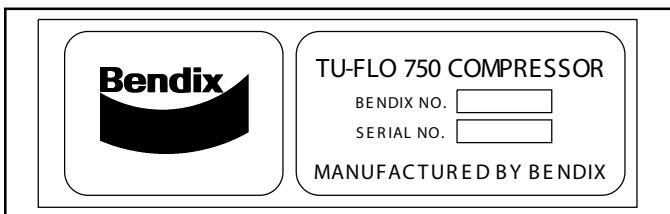

FIGURE 3 - NAMEPLATE

## OPERATION

The compressor is driven by the vehicle engine and is operating continuously while the engine is running. Actual compression of air is controlled by the compressor unloading mechanism and the governor. The governor which is generally mounted on the compressor maintains the brake

system air pressure to a preset maximum and minimum pressure level.

### INTAKE AND COMPRESSION OF AIR (LOADED)

During the down stroke of the piston, a slight vacuum is created between the top of the piston and the cylinder head, causing the inlet valve to move off its seat and open. (Note: The discharge valve remains on its seat.) Atmospheric air is drawn through the air strainer and the open inlet valve into the cylinder (see Figure 4). As the piston begins its upward stroke, the air that was drawn into the cylinder on the down stroke is being compressed. Air pressure on the inlet valve plus the force of the inlet spring, returns the inlet valve to its seat and closes. The piston continues the upward stroke and compressed air pushes the discharge valve off its seat and air flows by the open discharge valve, into the discharge line and to the reservoirs (see Figure 5). As the piston reaches the top of its stroke and starts down, the discharge valve spring and air pressure in the discharge line returns the discharge valve to its seat. This prevents the compressed

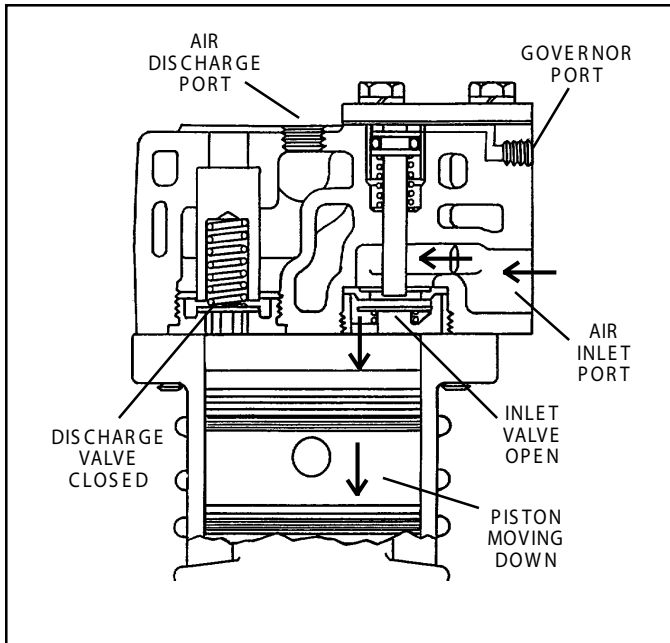

FIGURE 4 - OPERATIONAL-LOADED (INTAKE)

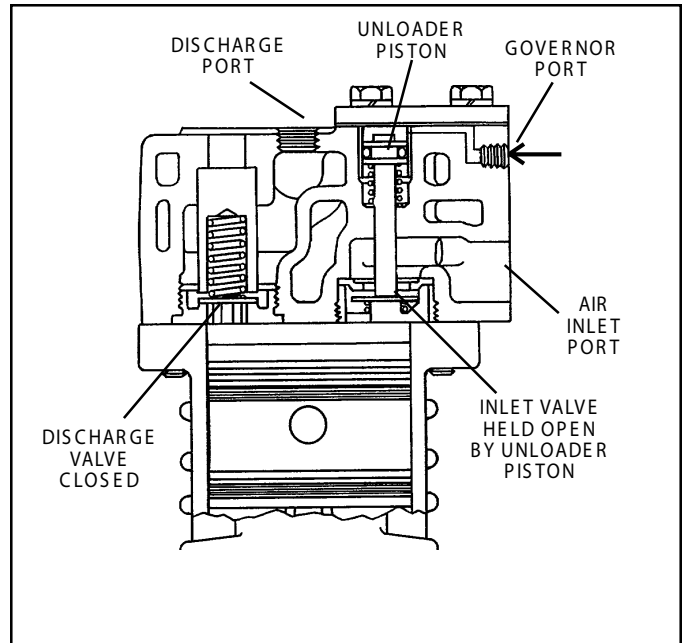

FIGURE 6 - OPERATIONAL-UNLOADED

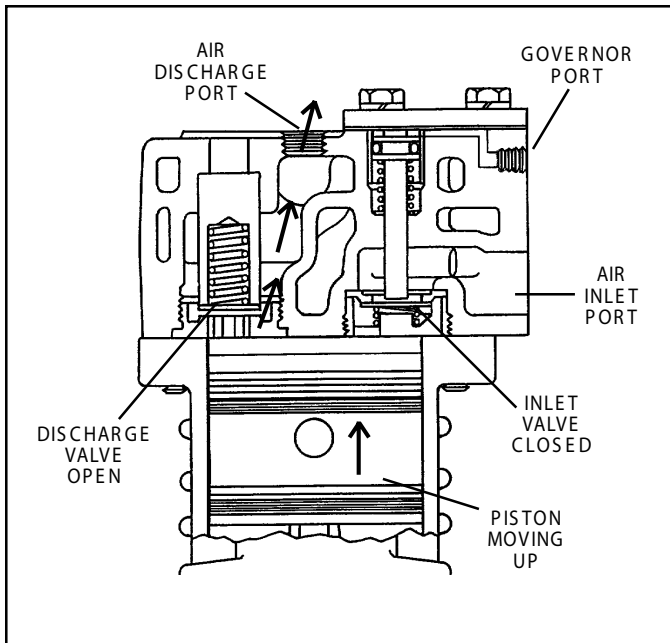

FIGURE 5 - OPERATIONAL-LOADED (COMPRESSION)

air in the discharge line from returning to the cylinder bore as the intake and compression cycle is repeated.

### NON-COMPRESSON OF AIR (UNLOADED)

When air pressure in the reservoir reaches the cut-out setting of the governor, the governor allows air to pass from the reservoir, through the governor and into the cavity above the unloader pistons. The unloader pistons move down holding the inlet pistons. The unloader pistons move down holding the inlet valves off their seats (see Figure 6.) With the inlet valves held off their seats by the unloader pistons, air is pumped back and forth between the two cylinders, and the discharge valves remain closed. When air pressure from the reservoir drops to the cut-in setting of the governor, the gov-

ernor closes and exhausts the air from above the unloader pistons. The unloader springs force the pistons upward and the inlet valves return to their seats. Compression is then resumed.

### LUBRICATION

The vehicle's engine provides a continuous supply of oil to the compressor. Oil is routed from the engine to the compressor oil inlet. An oil passage in the compressor crankshaft allows oil to lubricate the connecting rod crankshaft bearings. Connecting rod wrist pin bushings and crankshaft ball bearings are spray lubricated. An oil return line connected from the compressor drain outlet to the vehicle engine crankcase allows for oil return. On flange mounted models the oil drains back directly to the engine through the mounting flange.

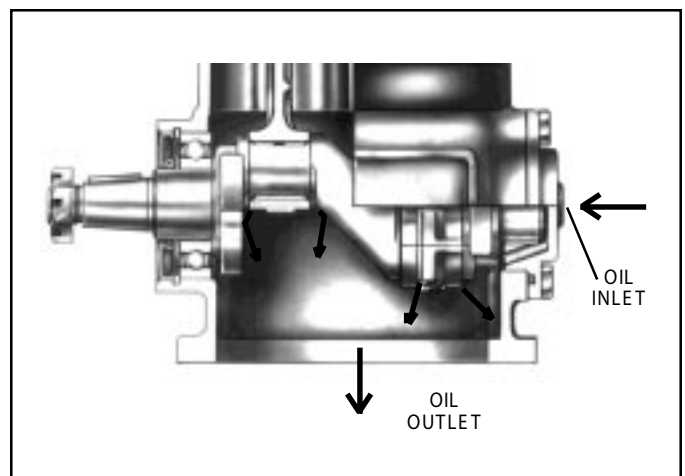

FIGURE 7 - LUBRICATION (BASE MOUNT MODEL SHOWN)

## COOLING

Air flowing through the engine compartment from the action of the engine's fan and the movement of the vehicle assists in cooling the compressor. Coolant flowing from the engine's cooling system through connecting lines enters the head and passes through internal passages in the cylinder head and is returned to the engine. Proper cooling is important in maintaining discharge air temperatures below the maximum recommended 400 degrees Fahrenheit.

Figure 8 illustrates the various approved coolant flow connections. See the tabulated technical data in the back of this manual for specific requirements.

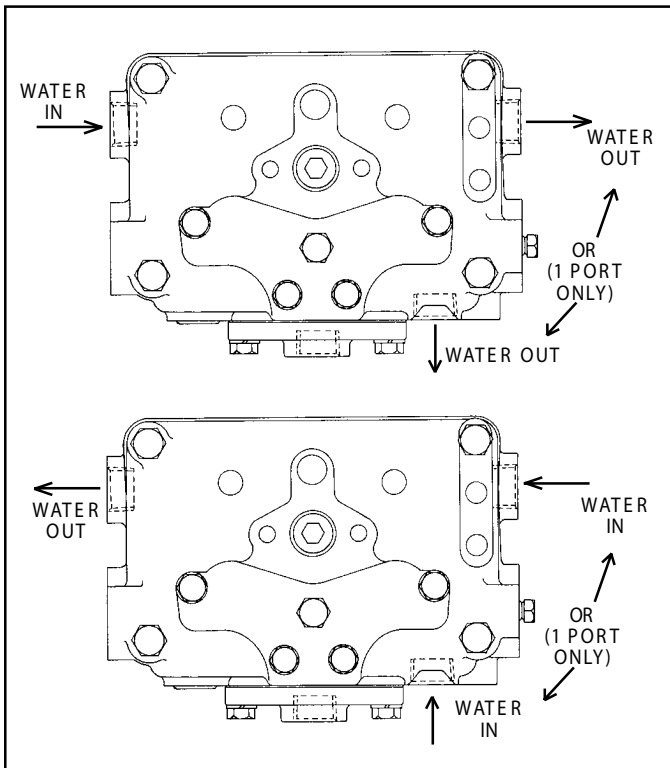

FIGURE 8 - COOLING

## AIR INDUCTION

There are three methods of providing clean air to the Tu-Flo 750 compressor:

1. Naturally aspirated - Compressor utilizes its own attached air strainer (polyurethane sponge or pleated paper dry element).
2. Naturally aspirated - Compressor inlet is connected to the engine air cleaner or the vacuum side (engine air cleaner) of the supercharger or turbocharger.
3. Pressurized induction - Compressor inlet is connected to the pressure side of the supercharger or turbocharger.

See the tabulated technical data in the back of this manual for specific requirements for numbers 2 and 3 above.

If a previously unturbocharged compressor is being turbocharged, it is recommended that the inlet cavity screen (238948) be installed with an inlet gasket (291909) on both sides of the screen.

## COMPRESSOR TURBOCHARGING PARAMETERS

Air entering the compressor inlet during the loaded cycle must not exceed 250 degrees Fahrenheit (121 degrees Celsius). A metal inlet line is suggested to help meet this parameter.

The following compressor crankshaft rotative speed and inlet pressure relationships may not be exceeded.

Crankshaft	Maximum Compressor R.P.M. Inlet Pressure
1900 RPM	30.0 psi (207 kPa)
2000 RPM	27.5 psi (190 kPa)
2100 RPM	24.0 psi (165 kPa)
2200 RPM	21.0 psi (145 kPa)
2300 RPM	19.0 psi (131 kPa)
2400 RPM	16.0 psi (110 kPa)

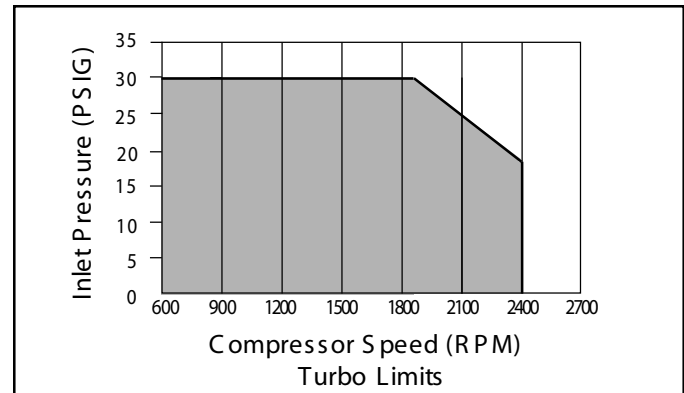

FIGURE 9 - TURBO LIMITS CURVE

## PREVENTATIVE MAINTENANCE

**Important Note:** Review the warranty policy before performing any intrusive maintenance procedures. An extended warranty may be voided if intrusive maintenance is performed during this period.

## AIR INDUCTION

One of the single most important aspects of compressor preventive maintenance is the induction of clean air. The type and interval of maintenance required will vary depending upon the air induction system used.

The intervals listed under the headings below pertain to typical highway and street operation. More frequent maintenance will be required for operation in dusty or dirty environments.



POLYURETHANE SPONGE STRAINER



PAPER AIR STRAINER DRY ELEMENT-PLEATED

FIGURE 10 - STRAINERS

### POLYURETHANE SPONGE STRAINER

Every month, 150 operating hours or 5,000 miles, whichever occurs first, remove and wash all of the parts. The strainer element should be cleaned or replaced. If the element is cleaned, it should be washed in a commercial solvent or a detergent and water solution. The element should be saturated in clean engine oil, then squeezed dry before replacing it in the strainer. Be sure to replace the air strainer gasket if the entire strainer is removed from the compressor intake.

### DRY ELEMENT - PLEATED PAPER STRAINER

Every two months, 800 operating hours or 20,000 miles whichever occurs first, loosen the spring clip from the unhinged side of the mounting baffle and open the cover. Replace the pleated paper filter and secure the cleaned cover, making sure the filter is in position. Be sure to replace the air strainer gasket if the entire air strainer is removed from the compressor intake.

### INTAKE ADAPTER

When the engine air cleaner is replaced: Some compressors are fitted with compressor intake adapters, which allow the compressor intake to be connected to the engine air induction system. In this case, the compressor receives a supply of clean air from the engine air cleaner. When the engine air filter is changed, the compressor intake adapter should be checked. If it is loose, remove the intake adapter, clean the strainer plate, if applicable, and replace the intake adapter gasket, and reinstall the adapter securely. Check line connections both at the compressor intake adapter and at the engine. Inspect the connecting line for ruptures and replace it if necessary.

### COMPRESSOR COOLING

Every 6 months, 1800 operating hours or after each 50,000 miles whichever occurs first, inspect the compressor discharge port, inlet cavity and discharge line for evidence of restrictions and carboning. If excessive buildup is noted, thoroughly clean or replace the affected parts and closely inspect the compressor cooling system. Check all compressor coolant lines for kinks and restrictions to flow. Minimum coolant line size is 3/8" I.D. Check coolant lines for internal clogging from rust scale. If coolant lines appear suspicious, check the coolant flow and compare to the tabulated technical data present in the back of this manual. Carefully inspect the air induction system for restrictions.

### LUBRICATION

Every six months, 1800 operating hours or 50,000 miles which ever occurs first, check external oil supply and return lines, if applicable, for kinks, bends, or restrictions to flow. Supply lines must be a minimum of 3/16" I.D. and return lines must be a minimum of 1/2" I.D. Oil return lines should slope as sharply as possible back to the engine crankcase and should have as few fittings and bends as possible. Refer to the tabulated technical data in the back of this manual for oil pressure minimum values

### COMPRESSOR DRIVE

Every six months, 1800 operating hours or 50,000 miles, whichever occurs first, check for noisy compressor operation, which could indicate a worn drive gear coupling, a loose pulley or excessive internal wear. Adjust and/or replace as necessary.

If the compressor is belt driven, check for proper belt and pulley alignment and belt tension. Check all compressor mounting bolts and retighten evenly if necessary. Check for leakage and proper unloader mechanism operation. Repair or replace parts as necessary.

Every 24 months, 7200 operating hours, or after each 200,000 MILES, perform a thorough inspection, and depend-

ing upon the results of this inspection or experience, disassemble the compressor, clean and inspect all parts thoroughly, replace all worn or damaged parts using only genuine Bendix replacements or replace the compressor with a genuine Bendix remanufactured unit.

## GENERAL SERVICE CHECKS

### OPERATING TESTS

Vehicles manufactured after the effective date of FMVSS 121, with the minimum required reservoir volume, must have a compressor capable of raising air system pressure from 85-100 psi in 25 seconds or less. This test is performed with the engine operating at maximum recommended governed speed. The vehicle manufacturer must certify this performance on new vehicles with appropriate allowances for air systems with greater than the minimum required reservoir volume.

### AIR LEAKAGE TESTS

Compressor leakage tests need not be performed on a regular basis. These tests should be performed when; it is suspected that discharge valve leakage is substantially affecting compressor build-up performance, or when it is suspected that the compressor is "cycling" between the load and unloaded modes due to unloader piston leakage.

These tests must be performed with the vehicle parked on a level surface, the engine not running, the entire air system completely drained to 0 P.S.I., and the inlet check valve detail parts removed, if applicable.

### UNLOADER PISTON LEAKAGE

The unloader pistons can be checked for leakage as follows: with the cylinder head removed from the compressor and the inlet flange securely covered, apply 120 psi of air pressure to the governor port. Listen for an escape of air at the inlet valve area. An audible escape of air should not be detected.

### DISCHARGE VALVE LEAKAGE

Unloader piston leakage must be repaired before this test is performed. Leakage past the discharge valves can be detected as follows: Remove the discharge line and apply shop air back through the discharge port. Listen for an escape of air at the compressor inlet cavity. A barely audible escape of air is generally acceptable.

If the compressor does not function as described above or if the leakage is excessive, it is recommended that it be returned to the nearest authorized Bendix distributor for a factory remanufactured compressor. If it is not possible, the compressor can be repaired using a genuine Bendix cylin-

der head maintenance kit. Retest the cylinder head after installation of the kit.

## REMOVAL AND DISASSEMBLY

### GENERAL

The following disassembly and assembly procedure is presented for reference purposes and presupposes that a major rebuild of the compressor is being undertaken. Several maintenance kits are available which do not require full disassembly. The instructions provided with these parts and kits should be followed in lieu of the instructions presented here.

### REMOVAL

These instructions are general and are intended to be a guide, in some cases additional preparations and precautions are necessary.

1. Block the wheels of the vehicle and drain the air pressure from all the reservoirs in the system.
2. Drain the engine cooling system and the cylinder head of the compressor. Identify and disconnect all air, water and oil lines leading to the compressor.
3. Remove the governor and any supporting bracketry attached to the compressor and note their positions on the compressor to aid in reassembly.
4. Remove the discharge and inlet fittings, if applicable, and note their position on the compressor to aid in reassembly.
5. Remove the flange or base mounting bolts and remove the compressor from the vehicle.
6. Remove the drive gear(s) or pulley from the compressor crankshaft using a gear puller. Inspect the pulley or gear and associated parts for visible wear or damage. Since these parts are precision fitted, they must be replaced if they are worn or damaged.

### PREPARATION FOR DISASSEMBLY

Remove road dirt and grease from the exterior of the compressor with a cleaning solvent. Before the compressor is disassembled, the following items should be marked to show their relationship when the compressor is assembled. Mark the rear end cover in relation to the crankcase. Mark the base plate or base adapter in relation to the crankcase.

A convenient method to indicate the above relationships is to use a metal scribe to mark the parts with numbers or lines. Do not use marking methods such as chalk that can be wiped off or obliterated during rebuilding.

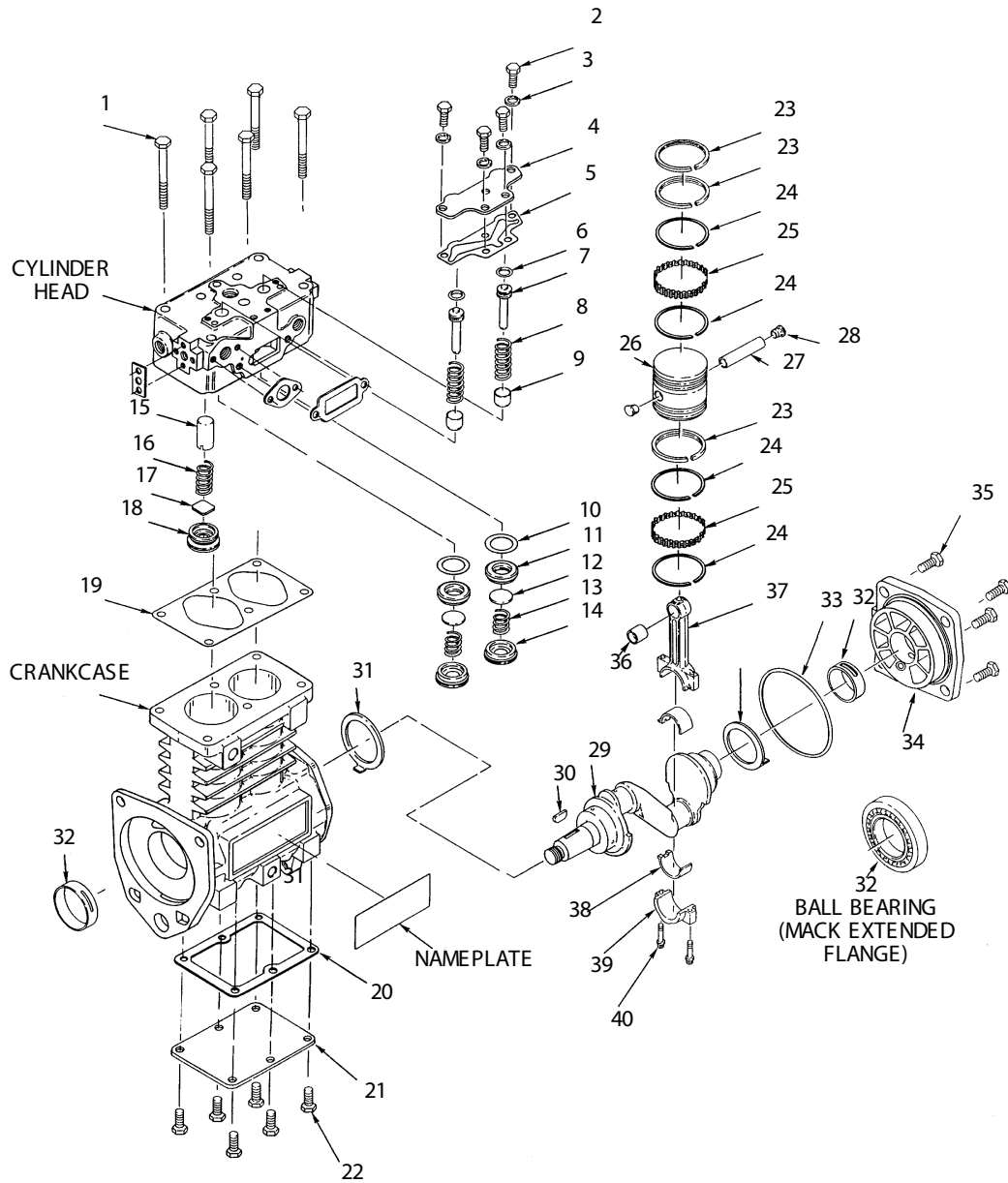

FIGURE 11 - EXPLODED VIEW

ITEM	QTY	DESCRIPTION	ITEM	QTY	DESCRIPTION	ITEM	QTY	DESCRIPTION
1	6	Cylinder Head Cap Screws	15	2	Discharge Valve Stop	29	1	Crankshaft
2	4	Unloader Plate Cap Screws	16	2	Discharge Valve Spring	30	1	Crankshaft Key
3	4	Unloader Plate Lock Washers	17	2	Discharge Valve	31	2	Thrust Washer
4	1	Unloader Plate	18	2	Discharge Valve Stop	32	2	Sleeve (or Ball) Bearing
5	1	Unloader Plate Gasket	19	1	Cylinder Head Gasket	33	1	End Cover Seal
6	2	O-ring	20	1	Base Gasket	34	1	End Cover
7	2	Unloader	21	1	Base Plate	35	4	End Cover Cap Screws
8	2	Spring	22	6	Base Plate Cap Screws	36	2	Wrist Pin Bushing
9	2	Unloader Bushing	23	6	Standard Piston Rings	37	2	Connecting Rod
10	2	Gasket	24	8	Oil Ring	38	2	Conn. Rod Inserts (Sets)
11	2	Inlet Valve Seat	25	4	Expander Ring	39	2	Connecting Rod Caps
12	2	Inlet Valve	26	2	Piston	40	4	Connecting Rod Bolts
13	2	Inlet Valve Spring	27	2	Wrist Pin			
14	2	Inlet Valve Stop	28	4	Wrist Pin Button			

## CYLINDER HEAD

Remove the six cylinder head cap screws (1) and tap the head with a soft mallet to break the gasket seal. Remove the unloader cover plate cap screws (2), lockwashers (3) and the unloader cover plate (4). Scrape off any gasket material (5) from the cover plate, cylinder head and crankcase.

1. Remove the unloader pistons (7), o-rings (6) and springs (8).
2. Inspect the unloader piston bushings (9) for nicks, wear, corrosion and scoring. It is recommended that the compressor be replaced if it is determined that the unloader bushing is damaged or worn excessively.

Before disassembling the discharge valve mechanism, measure and record the discharge valve travel (from closed to completely open).

3. If the measured discharge valve travel exceeds .046 inches, the compressor should be replaced. If the discharge valve travel does not exceed .046, using a 9/16" Allen wrench, remove the discharge valve seats (18), valves (17) and valve springs (16).
4. Remove the inlet valve stops (14), valves (17), valve seats (11), valve springs (12) and gaskets (10). It is recommended that a tool such as a J-25447-B, produced by Kent Moore Tool Division Roseville, Michigan phone 1-800-328-6657, be used to remove the inlet valve stop.

## CRANKCASE BOTTOM COVER OR ADAPTER DISASSEMBLY

1. Remove the cap screws (22) securing the bottom cover or adapter (21). Tap with a soft mallet to break the gasket seal. Scrape off any gasket material (20) from the crankcase and bottom cover or adapter.

## CONNECTING ROD DISASSEMBLY

Before removing the connecting rod, mark the connecting rods (37) and their caps (39) to ensure correct reassembly. The connecting rod and cap are a matched set therefore the caps must not be switched or rotated end for end.

1. Remove the connecting rod bolts (40) and bearing caps (39).
2. Push the pistons (26) with the connecting rods (37) attached out the top of the cylinder bore of the crankcase. Replace the bearing caps on the connecting rods.
3. Remove the piston rings (23-25) from the piston. If the piston is to be removed from the connecting rod, remove the wrist pin teflon plugs (28) and press the wrist pin (27) from the piston and connecting rod.
4. If the piston is removed from the rod, inspect the wrist pin bore in the piston and bronze wrist pin bushing (36)

in the connecting rod. If excessive wear is noted or suspected, replace the connecting rod and piston.

## COMPRESSOR CRANKCASE DISASSEMBLY

1. Remove the key or keys (30) from the crankshaft (29) and any burrs from the crankshaft where the key or keys were removed. (Note: Through drive compressors may have a crankshaft key at both ends.)
2. Remove the four cap screws (35) and lockwashers or nuts and lockwashers that secure the rear end cover (34) to the crankcase.
3. Remove the rear end cover (34), thrust washer (31) and end cover oil seal ring (33), taking care not to damage the bearing if present in the end cover.
4. If the compressor has ball type main bearings, press the crankshaft (29) and ball bearings from the crankcase, then press the ball bearings from the crankshaft.
5. Press the oil seal out of the compressor crankcase, if so equipped.

## CLEANING OF PARTS GENERAL

All parts should be cleaned in a good commercial grade of solvent and dried prior to inspection.

## CYLINDER HEAD

Remove carbon deposits from the discharge cavity and rust and scale from the cooling cavities of the cylinder head body. Scrape all foreign matter from the body surfaces and use shop air pressure to blow the dirt particles from the cavities. Clean carbon and dirt from the inlet and unloader passages. Use shop air to blow the carbon and dirt deposits from the unloader passages.

## OIL PASSAGES

Thoroughly clean all oil passages through the crankshaft, crankcase, end covers, base plate or base adapter. Inspect the passages with a wire to be sure. Blow the loosened foreign matter out with air pressure.

## INSPECTION OF PARTS

### CYLINDER HEAD BODY

Inspect the cylinder head for cracks or damage. With the cylinder head and head gasket secured to a flat surface or crankcase, apply shop air pressure to one of the coolant ports with all others plugged, and check for leakage by applying a soap solution to the exterior of the body. If leakage is detected, replace the compressor.

### END COVERS

Check for cracks and external damage. If the crankshaft main bearing (32) is installed in the end cover (34), check for excessive wear and flat spots and replace if necessary.

## CRANKCASE

Check all crankcase surfaces for cracks and damage. On compressors where ball bearing main bearings are used the difference between the O.D. of the outer race and the I.D. of the crankcase hole should be .0003 in. tight to .0023 in. loose. This is to maintain the correct fit. The compressor must be replaced if the fit is too loose.

On compressors fitted with precision, sleeve main bearings, the difference between the O.D. of the crankshaft journal and the main bearing I.D. must not exceed .005 in. If the clearance is greater than .005 in. the bearing must be replaced.

The cylinder bores should be checked with inside micrometers or calipers. Cylinder bores which are scored or out of round by more than .0005 in. or tapered more than .0005 in. should be rebored or honed oversize. Oversized pistons and piston rings are available in .010 in., .020 in. and .030 in. oversizes. Cylinder bores must be smooth, straight and round. Clearance between the cast iron pistons and cylinder bores should be between .002 in. minimum and .004 in. maximum.

## PISTON RINGS

Check the pistons for scores, cracks or enlarged ring grooves; replace the pistons if any of these conditions are found. Measure each piston with a micrometer in relation to the cylinder bore diameter to be sure the diametrical clearance is between .002 in. minimum and .004 in. maximum.

Check the fit of the wrist pins to the pistons and connecting rod bushings. The wrist pin should be a light press fit in the piston. If the wrist pin is a loose fit, the piston and pin assembly should be replaced. Check the fit of the wrist pin in the connecting rod bushing by rocking the piston. This clearance should not exceed .0007 in. Replace the connecting rod and cap assembly which includes the wrist pin bushings if excessive clearance is found. Check the fit of the rings in the piston ring grooves. Check the ring gap with the rings installed in the cylinder bores. Refer to Figure 12 for correct gap and groove clearances.

## CRANKSHAFT

Check the crankshaft threads, keyways, tapered ends and all machined and ground surfaces for wear, scores, or damage. Standard crankshaft journals are 1.1242 in. - 1.1250 in. in diameter. If the crankshaft journals are excessively scored or worn or out of round and cannot be reground, the compressor must be replaced. Connecting rod bearing inserts are available in .010 in., .020 in. and .030 in. undersizes for compressors with reground crankshafts. Main bearing journals must be maintained so the ball bearings are a snug fit or so that no more than .005 in. clearance exists between the precision sleeve main bearing and the main bearing jour-

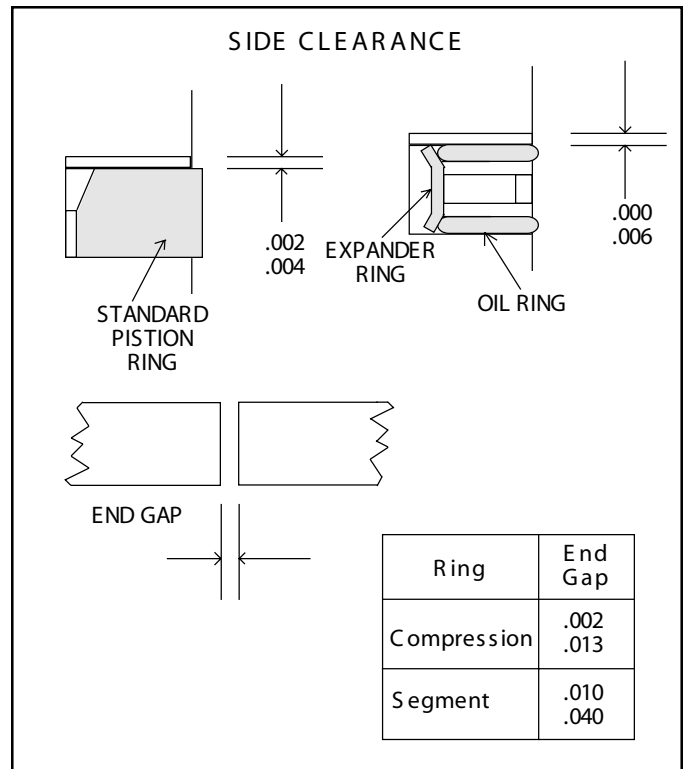

FIGURE 12 - RING CONFIGURATION

nals on the crankshaft. Check to be sure the oil passages are open through the crankshaft.

## CONNECTING ROD BEARINGS

Used bearing inserts must be replaced. The connecting rod and cap are a matched set and therefore the caps must not be switched or rotated end for end. Make sure the locating tangs on the inserts engage with the locating notches in the rod and cap. Clearance between the connecting rod journal and the connecting rod bearing must not be less than .0003 in. or more than .0021 in. after rebuilding.

## REPAIRS

### UNLOADER

A new cylinder head maintenance kit should be used when rebuilding. Note: The entire contents of this kit must be used. Failure to do so may result in compressor failure. The unloader pistons in the kit are prelubricated with a special lubricant piece number 239379 and need no additional lubrication. Install the springs and unloader pistons in their bores being careful not to cut the o-rings. Install the unloader cover gasket and unloader cover and secure the cover cap screws. Tighten the cap screws to 175-225 in. lbs. in a crossing pattern after first snugging all screws.



## DISCHARGE VALVES, VALVE STOPS AND SEATS

If the discharge valve seats merely show signs of slight wear, they can be dressed by using a lapping stone, grinding compound and grinding tool however it is recommended that a cylinder head maintenance be used. Install new discharge valve springs and valves. Screw in the discharge valve seats, and tighten to 70-90 ft.-lbs. Discharge valve travel should be between .030 in. to .046 in. To test for leakage by the discharge valves, apply 100 psi to the cylinder head discharge port and apply a soap solution to the discharge valve and seats. Leakage in the form of soap bubbles is permissible. If excessive leakage is found, leave the air pressure applied and with the use of a fiber or hardwood dowel and a hammer, tap the discharge valves off their seats several times. This will help the valves to seat and should reduce the leakage. With the air pressure still applied at the discharge port of the cylinder head, check for leakage around the discharge valve stop on the top of the cylinder head casting. No leakage is permitted.

## INLET VALVES AND SEATS

Inlet valves and springs should be replaced. However, if the inlet valve seats show signs of slight nicks or scratches, they can be redressed with a fine piece of emery cloth or by lapping with a lapping stone, grinding compound and grinding tool. If the seats are damaged to the extent that they cannot be reclaimed, they must be replaced.

## ASSEMBLY

General Note: All torques specified in this manual are assembly torques and typically can be expected to fall off after assembly is accomplished. Do not retorquer after initial assembly torques fall unless instructed otherwise. A compiled listing of torque specifications is presented at the end of this manual.

To convert inch pounds of torque to foot pounds of torque, divide in pounds by 12.

inch pounds  $\div$  12 = foot pounds

To convert foot pounds of torque to inch pounds of torque, multiply foot pounds by 12.

foot pounds  $\times$  12 = inch pounds

## INSTALLING CRANKSHAFT

Press new sleeve bearings in the end cover and crankcase. Ensure that the slot in the bearings line up with the oil passages in the end cover or crankcase. If you have a model with no oil passage present in the crankcase, press the sleeve bearing into the crankcase with the slot located 90 degrees from vertical.

Install the front thrust washer with the tang inserted in the slot toward the flange. Insert the crankshaft and the rear thrust washer with the tang toward the rear of the compressor.

Place the oil seal ring on the boss of the rear end cover and install the end cover making sure not to pinch the seal ring. Ensure the tang of the thrust washer is inserted in the slot of the end cover. Fasten the end cover to the crankcase with the four cover cap screws. Torque the cap screws to 175-225 inch pounds in a cross pattern.

## PISTONS AND CONNECTING RODS

If the pistons are to be replaced ensure that the correct pistons are being installed. Note that the pistons for the Tu-Flo 750 compressor are similar to those of other Bendix compressor models but may be identified by the piston diameter and the distance to the center of the wrist pin from the top of the piston as shown in Figure 13.

## PISTON RINGS

Check each ring end gap in a cylinder bore before installation. Place the ring in the top of the cylinder bore and using the piston, push the ring to the midpoint of the cylinder bore and check the ring gap. If the end gaps are incorrect either the wrong repair size has been purchased or the compressor is worn beyond specification and should be replaced.



FIGURE 13 - PISTON COMPARISON

Install the rings on the pistons per the following instructions starting at the center of the piston and moving outward.

1. Install the spacer and segment rings as follows. Place the spacer ring (25) in the piston groove, the ends of the spacer must butt and not overlap. Install the top segment (24) by inserting one end above the spacer in the ring groove, 120 degrees from the spacer ends and wind the segment into position. Install the bottom segment in the same manner beneath the spacer making sure the gap is staggered 120 degrees from both the top ring segment and the spacer end gaps. Before using be sure

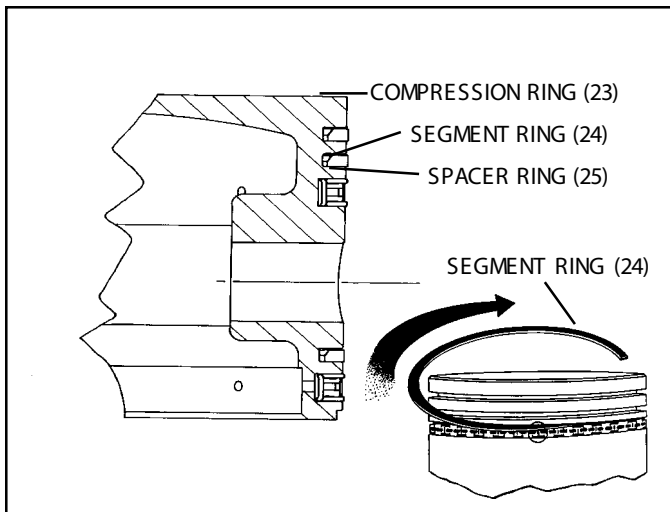

FIGURE 14 - PISTON & RINGS

both painted ends of the spacer are visible and butted. (Refer to Figure 14.)

2. Install the compression rings (23) in the proper grooves with the bevel or "pip" mark (if any) toward the top of the piston. (Refer to Figure 14.)

Check the ring side clearance of each ring in the piston ring groove. (Refer to Figure 12.) If the side clearance is too large, the piston ring groove is worn beyond specifications and the piston must be replaced.

Rotate the piston rings in their respective groove so that each end gap is at least 90 degrees from the previous ring's end gap.

Lubricate the wrist pin (22) and wrist pin bushing in the connecting rod with engine oil. Assemble the upper portion of the connecting rods and the pistons with the wrist pins. Insert the wrist pin buttons (28) in the ends of the wrist pin. Lubricate the pistons and rings with engine oil. Using a ring compression tool return the piston to the cylinder bore.

Turn the crankshaft so that one of its connecting rod journals is in the downward, center position. Install the crankshaft journal bearing segments (38) on the connecting rod (37) and connecting rod cap (39). Tighten the connecting rod bolts (40) evenly and torque to 150 - 170 inch pounds. Install the other connecting rod and piston in the same manner. It is recommended that new connecting rod cap screws be used.

Before replacing the cylinder head on the crankcase ensure the correct pistons have been used by turning the crankshaft one complete revolution such that each piston moves to its maximum upward stroke. At the maximum upward stroke position each piston should move to the top of the crankcase. If the piston does not approach the top of the crankcase the piston is incorrect and if not replaced could result in compressor damage.

## BASE PLATE OR BASE ADAPTER

Position the base plate or base adapter gasket (20) on the crankcase and install the base plate or base adapter (21) as marked before disassembly. Tighten the six cap screws (22), securing the cast iron base adapter evenly to a torque of 175-225 inch pounds for base plate or cover in a crossing pattern after first snugging all 6 screws.

## CYLINDER HEAD

Place the cylinder head gasket (19) and cylinder head on the compressor crankcase and install the six cylinder head cap screws. If the cylinder head gasket has a bead on one side, install the gasket on the crankcase with the beaded side up. Snug the cylinder head cap screws prior to torquing the cap screws to 440-500 in. lbs. in a cross pattern. Retorque the unloader cover cap screws to 170-225 in. lbs.

## FINAL COMPRESSOR ASSEMBLY

Install all crankshaft keys making certain to support the crankshaft to avoid bearing damage. Install the crankshaft nut where applicable. When installing drive couplings or gears, do not exceed 120 foot pounds torque on the crankshaft nut.

Use covers, plugs, or masking tape to protect all ports if compressor is not to be installed immediately. Protect the ends of the crankshaft against damage by wrapping with masking tape or friction tape.

## TESTING REBUILT COMPRESSOR

In order to properly test a compressor under operating conditions, a test rack for correct mounting, cooling, lubricating, and driving the compressor is necessary. Such tests are not compulsory if the unit has been carefully rebuilt by an experienced person. A compressor efficiency or build up test can be run which is not too difficult. An engine lubricated compressor must be connected to an oil supply line of at least 15 P.S.I. pressure during the test and an oil return line must be installed to keep the crankcase drained.

Connect to the compressor discharge port, a reservoir with a volume of 1500 cubic inches, including the volume of the connecting line. With the compressor operating at 2100 R.P.M., the time required to raise the reservoir(s) pressure from 85 psi to 100 psi should not exceed 5 seconds. During this test, the compressor should be checked for gasket leakage and noisy operation, as well as unloader operation and leakage.

If the compressor functions as indicated reinstall on the vehicle connecting all lines as marked in the disassembly procedure.

## TU-FLO 750 SPECIFICATIONS

Average weight .....	53
Number of cylinders .....	2
Bore size .....	2.78 In.
Stroke .....	1.87 In.
Displacement at 1250 RPM .....	16.5 CFM
CFM Maximum recommended RPM .....	2400 RPM
Minimum coolant flow (water cooled) at Maximum RPM .....	2.5 GPM
Minimum RPM .....	5 GPM
Approximate horsepower required at 1250 RPM at 120 PSIG (naturally aspirated) .....	3.2
Turbocharge limits See Compressor Turbocharging Parameters	
Maximum inlet air temperature .....	250°F
Maximum discharge air temperature .....	400°F
Minimum pressure required to unload (naturally aspirated) .....	60 PSIG
Minimum oil pressure required at engine idling speed .....	15 PSIG
Minimum oil pressure required at maximum governed engine speed .....	15 PSIG
Minimum discharge-line size .....	1/2" I.D.
Minimum coolant-line size .....	3/8" I.D.
Minimum oil-supply line size .....	3/16" I.D.
Minimum oil-return line size .....	1/2" I.D.
Minimum air-inlet line size .....	5/8" I.D.
Minimum unloader-line size .....	3/16" I.D.

## TORQUE SPECIFICATIONS

Bolt, Nut or Screw .....	Assembly Torque (in. lbs.)
Cylinder Head .....	440 - 500
Unloader Cover Plate .....	175 - 225
Discharge Valve Seat .....	840 - 1080 (70-90 ft. lbs.)
Inlet Valve Stop .....	840 - 1080 (70-90 ft. lbs.)
End Cover .....	175 - 225
Connecting Rod .....	150 - 170
Bottom Cover .....	175 - 225
Air Strainer .....	125 - 150
Inlet Fitting .....	175 - 225
Discharge Fitting .....	175 - 225
Governor or Governor Adapter .....	175 - 225
Pipe Plugs	
1/16 .....	35 - 50
1/8 .....	85 - 105
1/4 .....	130 - 170
3/8 .....	160 - 200
1/2 .....	200 - 270
Pipe Bushing	
1/2 .....	175 - 225
Crankshaft Nut	
Marsden or Castle .....	1200 - 1400 (100-120 ft. lbs.)
P/N 298125	

(Metric Thread) ..... 2640 - 3048 (220-254 ft. lbs.)

## DIMENSIONAL DATA

Port Sizes	
Water inlet .....	1/2 - 14 NPT
Water outlet .....	1/2 - 14 NPT
Air discharge .....	1/2 - 14 NPT
Governor .....	1/8 - 27 NPT
Oil inlet (end cover) .....	1/8 - 27 NPT
Piston	
(standard) .....	2.77825 in.
(.010 oversize) .....	2.78825 in.
(.020 oversize) .....	2.79825 in.
(.030 oversize) .....	2.80825 in.
Cylinder bore	
(standard) .....	2.7810 in.
(.010 oversize) .....	2.7910 in.
(.020 oversize) .....	2.8010 in.
(.030 oversize) .....	2.8110 in.

## MAINTENANCE KITS AND AVAILABLE SERVICE PARTS

- Cylinder Maintenance Kit.
- Piston Ring Kit (standard and oversizes.)
- Piston and Rod Kit (standard and oversizes.)
- Crankshaft Bearing Kit.

IMPORTANT! PLEASE READ:

When working on or around a vehicle, the following general precautions should be observed:

1. Park the vehicle on a level surface, apply the parking brakes, and always block the wheels.
2. Stop the engine when working around the vehicle.
3. If the vehicle is equipped with air brakes, make certain to drain the air pressure from all reservoirs before beginning any work on the vehicle.
4. Following the vehicle manufacturer's recommended procedures, deactivate the electrical system in a manner that removes all electrical power from the vehicle.
5. When working in the engine compartment the engine should be shut off. Where circumstances require that the engine be in operation, extreme caution should be used to prevent personal injury resulting from contact with moving, rotating, leaking, heated, or electrically charged components.
6. Never connect or disconnect a hose or line containing pressure; it may whip. Never remove a component or plug unless you are certain all system pressure has been depleted.
7. Never exceed recommended pressures and always wear safety glasses.
8. Do not attempt to install, remove, disassemble or assemble a component until you have read and thoroughly understand the recommended procedures. Use only the proper tools and observe all precautions pertaining to use of those tools.
9. Use only genuine Bendix replacement parts, components, and kits. Replacement hardware, tubing, hose, fittings, etc. should be of equivalent size, type, and strength as original equipment and be designed specifically for such applications and systems.
10. Components with stripped threads or damaged parts should be replaced rather than repaired. Repairs requiring machining or welding should not be attempted unless specifically approved and stated by the vehicle or component manufacturer.
11. Prior to returning the vehicle to service, make certain all components and systems are restored to their proper operating condition.

## COMPRESSOR TROUBLESHOOTING CHART

SYMPTOMS	CAUSE	REMEDY
<p>1. Compressor passes excessive oil as evidenced by presence of oil at exhaust ports of valving or seeping from air strainer.</p>	A. Restricted air intake.	A. Check engine or compressor air cleaner and replace if necessary. Check compressor air inlet for kinks, excessive bends and be certain inlet lines have the minimum specified inside diameter. Recommended minimum inlet line inside diameter is 5/8". Recommended maximum air inlet restriction is 25" of water.
	B. Restricted oil return (to engine)	B. Oil return to the engine should not be in any way restricted. Check for excessive bends, kinks and restrictions in the oil return line. Minimum recommended oil return line size is 5/8" O.D. tubing or equivalent I.D. (1/2" minimum). <u>Return line must constantly descend</u> from the compressor to the engine crankcase. Make certain oil drain passages in the compressor and mating engine surfaces are unobstructed and aligned. Special care must be taken when sealants are used with, or instead of, gaskets.
	C. Poorly filtered inlet air.	C. Check for damaged, defective or dirty air filter on engine or compressor. Check for leaking, damaged or defective compressor air intake components (e.g. induction line, fittings, gaskets, filter bodies, etc.). The compressor intake should not be connected to any part of the exhaust gas recirculation (E.G.R.) system on the engine.
	D. Insufficient compressor cooling (compressor runs hot).	<p>D. For air-cooled portions of the compressor:</p> <ol style="list-style-type: none"> <li>1. Remove accumulated grease, grime or dirt from the cooling fins. Replace components found damaged.</li> <li>2. Check for damaged cooling fins. Replace components found damaged.</li> </ol> <p>For water-cooled compressor or water-cooled portions of the compressor:</p> <ol style="list-style-type: none"> <li>1. Check for proper coolant line sizes. Minimum recommended size is 1/2" O.D. tubing.</li> <li>2. Check the coolant flow through the compressor. Minimum allowable flow is 2.5 gallons per minute at engine governed speed. If low coolant flow is detected, inspect the coolant lines and fittings for accumulated rust scale, kinks and restrictions.</li> <li>3. Water temperature should not exceed 200 degrees Fahrenheit.</li> <li>4. Optimum cooling is achieved when engine coolant flows, as shown in Figure 8 of this manual.</li> </ol>

## COMPRESSOR TROUBLESHOOTING CHART (Continued)

SYMPTOMS	CAUSE	REMEDY
1. (Continued.)	E. Contaminants not being regularly drained from system reservoirs.	E. Check reservoir drain valves to insure that they are functioning properly. It is recommended that the vehicle should be equipped with functioning automatic drain valves, or have all reservoirs drained to zero (0) psi daily, or optimally to be equipped with a desiccant-type air dryer prior to the reservoir system.
	F. Compressor runs loaded an excessive amount of time.	F. Vehicle system leakage should not exceed industry standards of 1 psi pressure drop per minute without brakes applied and 3 psi pressure drop per minute with brakes applied. If leakage is excessive, check for system leaks and repair.
	G. Excessive engine crankcase pressure.	G. Test for excessive engine crankcase pressure & replace or repair ventilation components as necessary. (An indication of crankcase pressure is a loose or partially lifted dipstick.)
	H. Excessive engine oil pressure.	H. Check the engine oil pressure with a test gauge and compare the reading to the engine specifications. Bendix does not recommend restricting the compressor oil supply line because of the possibility of plugging the restriction with oil contaminants. Minimum oil supply line size is 3/16" I.D. tubing.
	I. Faulty compressor.	I. Replace or repair the compressor only after making certain none of the preceding installation defects exist.
2. Noisy compressor operations.	A. Loose drive gear or pulley.	A. Inspect the fit of the drive gear on pulley on the compressor crankshaft. The pulley on gear must be completely seated and the crankshaft nut must be tight. If the compressor crankshaft surface or its keyway are damaged, it is an indication of loose drive components. If damage to the compressor crankshaft is detected, replace the compressor. When installing the drive gear or pulley, torque the crankshaft nut to the appropriate torque specifications. <u>Do not back off the crankshaft nut to align the cotter pin and castellated nut.</u> (Some compressors do not use castellated nuts.) <u>Do not use impact wrenches.</u>

## COMPRESSOR TROUBLESHOOTING CHART (Continued)

SYMPTOMS	CAUSE	REMEDY
2. (Continued.)	B. Excessively worn drive couplings or gears.	B. Inspect drive gear and couplings and engine for excessive wear. Replace as necessary. (Nonmetallic gears should be replaced when the compressor is changed.)
	C. Compressor cylinder head or discharge line restrictions.	C. Inspect the compressor discharge port and discharge line for carbon build-up. If carbon is detected, check for proper cooling to the compressor. (See Cause and Remedy (D) under Symptom #1.) Inspect the discharge line for kinks and restrictions. Replace discharge line as necessary.
	D. Worn or burned out bearings.	D. Check for proper oil pressure in the compressor. Minimum required oil pressure; 15 psi engine idling, 15 psi maximum governed engine rpm. Check for excessive oil temperature—should not exceed 240 degrees Fahrenheit.
	E. Faulty compressor.	E. Replace or repair the compressor after determining none of the preceding installation defects exist.
3. Excessive build-up and recover time. Compressor should be capable of building air system from 85-100 psi in 40 seconds with engine at full governed rpm. Minimum compressor performance is certified to meet Federal requirements by the vehicle manufacturer. Do not downsize the original equipment compressor.	A. Dirty induction air filter.	A. Inspect engine or compressor air filter and replace if necessary.
	B. Restricted induction line.	B. Inspect the compressor air induction line for kinks and restrictions and replace as necessary.
	C. Restricted discharge line or compressor discharge cavity.	C. Inspect the compressor discharge port and line for restrictions and carbon build-up. If a carbon build-up is found, check for proper compressor cooling. Replace faulty sections of the discharge line.
	D. Slipping drive components.	D. Check for faulty drive gears and couplings and replace as necessary. Check the condition of drive belts and replace or tighten, whichever is appropriate.
	E. Excessive air system leakage.	E. Test for excessive system leakage and repair as necessary. Use the following as a guide: Build system pressure to governor cutout and allow the pressure to stabilize for one minute. Using the dash gauge, note the system pressure and the pressure drop after two minutes.  The pressure drops should not exceed:  1. 2 psi in each reservoir for a single vehicle. 2. 6 psi in each reservoir for a tractor and trailer. 3. 8 psi in each reservoir for a tractor and 2 trailers.

## COMPRESSOR TROUBLESHOOTING CHART (Continued)

SYMPTOMS	CAUSE	REMEDY
3. (Continued.)	F. Sticking unloader pistons.	F. Check the operation of the unloading mechanism. Check the proper operation of the compressor air governor. If the governor is operating properly, replace the unloader mechanism. Inspect for bent, linked or blocked tubing leading to or from the governor.
	G. Faulty compressor.	G. Replace or repair the compressor after determining none of the preceding installation defects exist.
4. Compressor fails to unload.	A. Faulty governor or governor installation.	A. Test the governor for proper operation and inspect air lines to and from the governor for kinks or restrictions. Replace or repair the governor or its connecting air lines
	B. Faulty or worn unloader pistons or bores.	B. Inspect for worn, dirty or corroded unloader pistons and their bores. Replace as necessary.
5. Compressor leaks oil.	A. Damaged mounting gasket.	A. Check the compressor mounting bolt torque. If the mounting bolt torque is low, replace the compressor mounting gasket before retorquing the mounting bolts.
	B. Cracked crankcase or end cover.	B. Visually inspect the compressor exterior for cracked or broken components. Cracked or broken crankcases or mounting flanges can be caused by loose mounting bolts. The end cover can be cracked by overtorquing fitting or plugs installed in the end cover. Replace or repair the compressor as necessary.
	C. Loose end cover cap cover.	C. Check the cap screw torques and tighten as necessary.
	D. Loose oil supply or return line fittings.	D. Check the torque of external oil line fittings and tighten as necessary.
	E. Porous compressor casting.	E. Replace the compressor if porosity is found.
	F. Mounting flange or end cover, o-ring or gasket - missing, cut or damaged	F. Replace as necessary.
6. Compressor constantly cycles (compressor remains unloaded for a very short time).	A. Leaking compressor unloader pistons.	A. Remove the compressor inlet air strainer or fitting. With the compressor unloaded (not compressing air), check for air leakage. Replace as necessary.
	B. Faulty Governor.	B. Test the governor for proper operation and repair or replace as necessary.



## COMPRESSOR TROUBLESHOOTING CHART (Continued)

SYMPTOMS	CAUSE	REMEDY
6. (Continued.)	C. Excessive system leakage.	C. Test for excessive system leakage as instructed in Symptom #3 Remedy E. Reduce leakage wherever possible.
	D. Excessive reservoir contaminants.	D. Drain reservoirs.
7. Compressor leaks coolant.	A. Improperly installed plugs and coolant line fittings.	A. Check torque of fittings and plugs and tighten as necessary. Overtorqued fittings and plugs can crack the head or block casting.
	B. Freeze cracks due to improper antifreeze strength.	B. Test antifreeze and strengthen as necessary. Check coolant flow through compressor to assure the proper antifreeze mixture reaches the compressor.
	C. Faulty compressor (porous castings).	C. If casting porosity is detected, replace the compressor.
8. Compressor head gasket failure.	A. Restricted discharge line.	A. Clear restriction or replace line.
	B. Loose head bolts	B. Tighten evenly to a torque of 25-30 foot pounds.
	C. Faulty compressor or head gasket.	C. Check for rough or poorly machined head or block surfaces. Replace compressor as necessary.

## R-12 & R-14 RELAY VALVES

\*FORMERLY SD-03-31

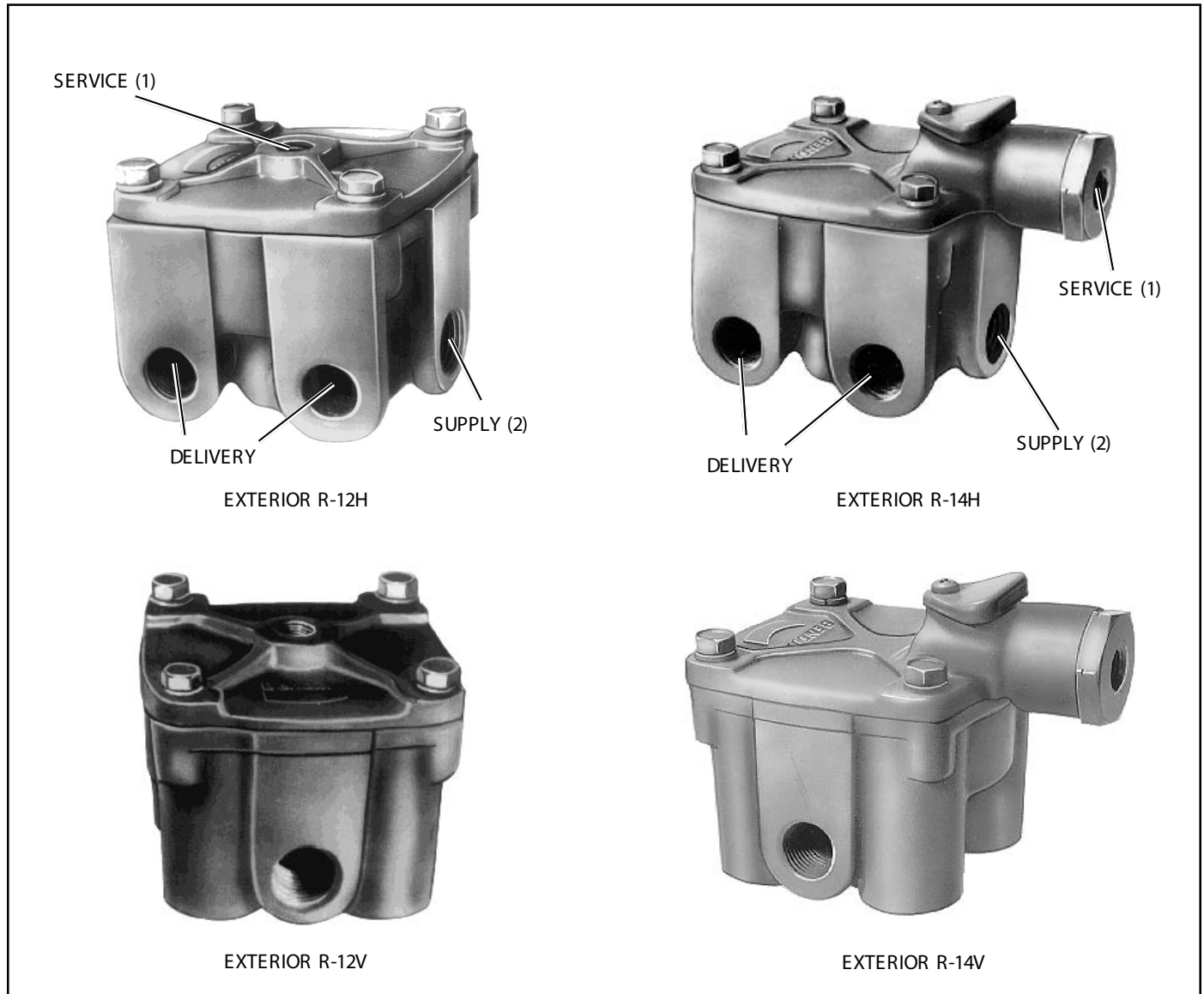

FIGURE 1 - EXTERIOR VIEWS  
DESCRIPTION

The Relay Valve in an air brake system functions as a relay station to speed up the application and release of the brakes. The valve is normally mounted at the rear of the vehicle in proximity to the chambers it serves. The valve operates as a remote controlled brake valve that delivers or releases air to the chambers in response to the control air delivered to it from the foot brake valve or other source.

The R-12 and R-14 Relay Valves are designed for either reservoir or frame mounting. A universal mounting bracket is furnished that permits easy interchange with other Bendix relay valves. Both valves are available in the two body styles illustrated in Figure 1. The R-14 differs from the R-12 in that it incorporates a quick release and anti-compounding feature located above its horizontal service port. The R-14's anti-compound feature allows it

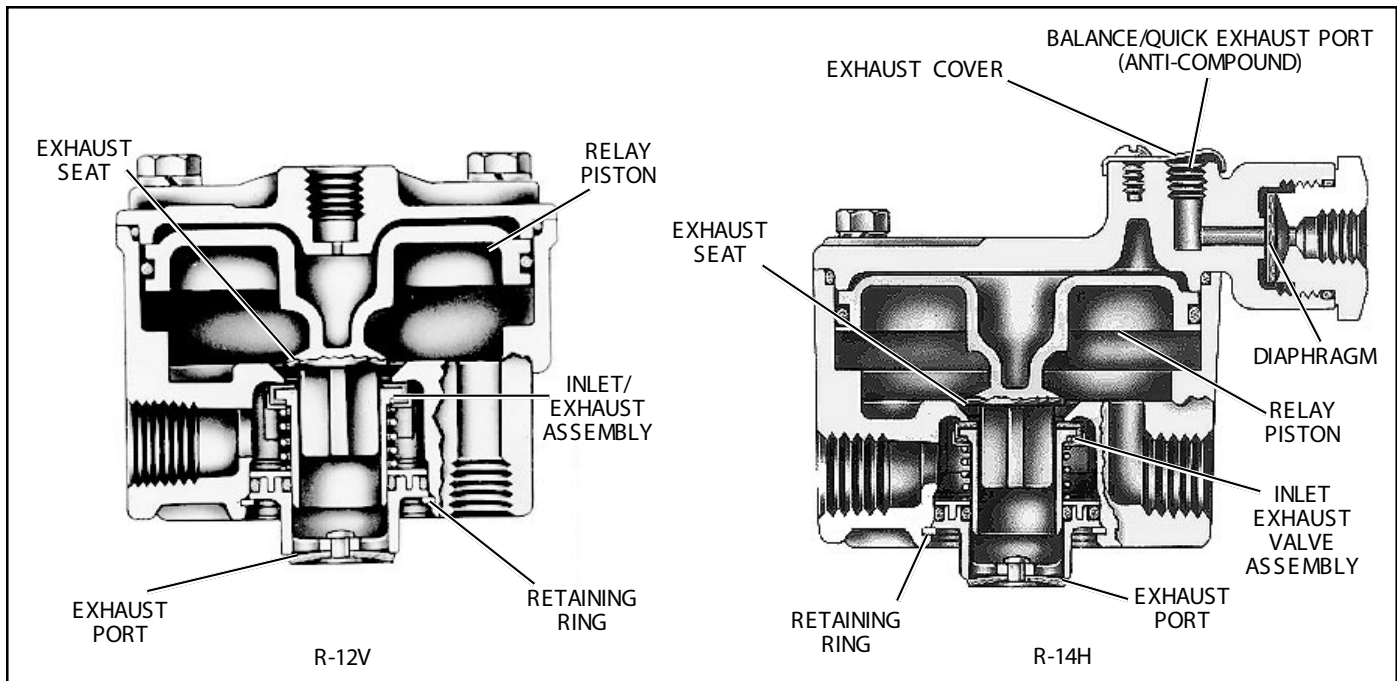

FIGURE 2 - SECTIONAL VIEWS

to be conveniently used as either a service or spring brake relay valve. An exhaust cover is installed that protects the 1/8" balance port when the R-14 anti-compound feature is not in use.

All parts are interchangeable between the R-12 and R-14 with the exception of the detail components of the R-14 cover. Both valves make extensive use of non-metallic internal components. For ease of servicing, the inlet/exhaust valve can be replaced without the need for line removal.

## OPERATION

### APPLICATION

Air pressure delivered to the service port enters the small cavity above the piston and moves the piston down. The exhaust seat moves down with the piston and seats on the inner or exhaust portion of the inlet/exhaust valve, sealing off the exhaust passage. At the same time, the outer or inlet portion of the inlet/exhaust valve moves off its seat, permitting supply air to flow from the reservoir, past the open inlet valve and into the brake chambers.

### BALANCE

The air pressure being delivered by the open inlet valve also is effective on the bottom area of the relay piston. When air pressure beneath the piston equals the service air pressure above, the piston lifts slightly and the inlet spring returns the inlet valve to its seat. The exhaust remains closed as the service line pressure balances the

delivery pressure. As delivered air pressure is changed, the valve reacts instantly to the change, holding the brake application at that level.

### EXHAUST OR RELEASE

When air pressure is released from the service port and air pressure in the cavity above the relay piston is exhausted, air pressure beneath the piston lifts the relay piston and the exhaust seat moves away from the exhaust valve, opening the exhaust passage. With the exhaust passage open, the air pressure in the brake chambers is then permitted to exhaust through the exhaust port, releasing the brakes.

### ANTI-COMPOUNDING (SIMULTANEOUS SERVICE AND PARK APPLICATION)

In those applications where the R-14 Relay Valve is used to control spring brake chambers, the anti-compound feature may be utilized. With the anti-compound feature of the R-14 connected, a service application made while the vehicle is parked is countered by a release of the parking brakes. To utilize this feature, the exhaust cover of the quick release portion of the R-14 is removed and a line is installed which is connected to the delivery of the service brake valve or relay valve. With no air pressure at the service port of the R-14, the parking brakes are applied. If a service brake application is made, air from the service brake valve enters the exhaust port of the quick release of the R-14 and moves the diaphragm, blocking the service port. Air then proceeds into the cavity above the relay piston, forces the piston down, closing the exhaust and

opening the inlet to deliver air to the spring brake cavity as described under the section of this manual entitled Application.

## PREVENTIVE MAINTENANCE

**Important:** Review the warranty policy before performing any intrusive maintenance procedures. An extended warranty may be voided if intrusive maintenance is performed during this period.

Because no two vehicles operate under identical conditions, maintenance and maintenance intervals will vary. Experience is a valuable guide in determining the best maintenance interval for any one particular operation.

1. Every three months or 25,000 miles or 900 operating hours check for proper operation.
2. Every twelve months or 100,000 miles or 3600 operating hours: disassemble valve, clean parts with mineral spirits. Replace all rubber parts and any part worn or damaged. Check for proper operation before placing vehicle in service.

## OPERATIONAL AND LEAKAGE TEST

1. Chock the wheels, fully charge air brake system and adjust the brakes.
2. Make several brake applications and check for prompt application and release at each wheel.
3. Check for inlet valve and o-ring leakage.
  - A. Make this check with the service brakes released when the R-12 or R-14 is used to control the service brakes.
  - B. Make the check with the spring brakes applied (PARK) when the R-14 is used to control the spring brakes. Coat the exhaust port and the area around the retaining ring with a soap solution; a 1 inch bubble in 3 seconds leakage is permitted.
4. Check for exhaust valve leakage.
  - A. Make this check with the service brakes fully applied if the R-12 or R-14 control the service brakes.
  - B. Make this check with the spring brakes fully released if the R-14 is used to control the spring brakes. Coat the exhaust port with a soap solution; a 1 inch bubble in 3 seconds leakage is permitted. Coat the outside of the valve where the cover joins the body to check for seal ring leakage; no leakage is permitted.
5. If the R-14 is used to control the spring brakes, place the park control in the released position and coat the balance port with a soap solution to check the diaphragm and its seat. Leakage equivalent to a 1 inch bubble in 3 seconds is permitted.

Note: If the anti-compound feature is in use, the line attached to the balance port must be disconnected to perform this test.

If the valves do not function as described above, or if leakage is excessive, it is recommended that the valves be replaced with new or remanufactured units or repaired with genuine Bendix parts, available at any authorized Bendix parts outlet.

## REMOVAL AND INSTALLATION

### REMOVAL

1. Block and hold vehicle by means other than air brakes.
2. Drain air brake system reservoirs.
3. If entire valve is to be removed, identify air lines to facilitate installation.
4. Disconnect air lines from valve.\*
5. Remove valve from reservoir or if remotely mounted, remove mounting bolts and then valve.

\*It is generally not necessary to remove entire valve to service the inlet/exhaust valve. The inlet/exhaust valve insert can be removed by removing the snap ring, exhaust cover assembly and then inlet/exhaust valve.

Caution: Drain all reservoirs before attempting to remove the inlet exhaust valve.

### DISASSEMBLY

Note: Prior to disassembly, mark the location of the mounting bracket to the cover and the cover to the body.

1. Remove the four (4) cap screws and lockwashers securing the cover to the body.
2. Remove the cover, sealing ring, and mounting bracket.
3. Remove the piston and o-ring from the body.
4. While depressing the exhaust cover, remove the retaining ring and slowly relax the spring beneath the exhaust cover.
5. Remove the exhaust cover assembly and o-rings.
6. Remove the inlet/exhaust valve return spring from the body.
7. Remove the inlet/exhaust valve from the body.
8. Remove the valve retainer from the inlet/exhaust valve.
9. Remove the Phillips head screw and exhaust cover from the R-14 cover.
10. Remove the service port cap nut and o-ring from the R-14.
11. Remove the diaphragm from the R-14 cover.

opening the inlet to deliver air to the spring brake cavity as described under the section of this manual entitled Application.

## PREVENTIVE MAINTENANCE

**Important:** Review the warranty policy before performing any intrusive maintenance procedures. An extended warranty may be voided if intrusive maintenance is performed during this period.

Because no two vehicles operate under identical conditions, maintenance and maintenance intervals will vary. Experience is a valuable guide in determining the best maintenance interval for any one particular operation.

1. Every three months or 25,000 miles or 900 operating hours check for proper operation.
2. Every twelve months or 100,000 miles or 3600 operating hours: disassemble valve, clean parts with mineral spirits. Replace all rubber parts and any part worn or damaged. Check for proper operation before placing vehicle in service.

## OPERATIONAL AND LEAKAGE TEST

1. Chock the wheels, fully charge air brake system and adjust the brakes.
2. Make several brake applications and check for prompt application and release at each wheel.
3. Check for inlet valve and o-ring leakage.
  - A. Make this check with the service brakes released when the R-12 or R-14 is used to control the service brakes.
  - B. Make the check with the spring brakes applied (PARK) when the R-14 is used to control the spring brakes. Coat the exhaust port and the area around the retaining ring with a soap solution; a 1 inch bubble in 3 seconds leakage is permitted.
4. Check for exhaust valve leakage.
  - A. Make this check with the service brakes fully applied if the R-12 or R-14 control the service brakes.
  - B. Make this check with the spring brakes fully released if the R-14 is used to control the spring brakes. Coat the exhaust port with a soap solution; a 1 inch bubble in 3 seconds leakage is permitted. Coat the outside of the valve where the cover joins the body to check for seal ring leakage; no leakage is permitted.
5. If the R-14 is used to control the spring brakes, place the park control in the released position and coat the balance port with a soap solution to check the diaphragm and its seat. Leakage equivalent to a 1 inch bubble in 3 seconds is permitted.

Note: If the anti-compound feature is in use, the line attached to the balance port must be disconnected to perform this test.

If the valves do not function as described above, or if leakage is excessive, it is recommended that the valves be replaced with new or remanufactured units or repaired with genuine Bendix parts, available at any authorized Bendix parts outlet.

## REMOVAL AND INSTALLATION

### REMOVAL

1. Block and hold vehicle by means other than air brakes.
2. Drain air brake system reservoirs.
3. If entire valve is to be removed, identify air lines to facilitate installation.
4. Disconnect air lines from valve.\*
5. Remove valve from reservoir or if remotely mounted, remove mounting bolts and then valve.

\*It is generally not necessary to remove entire valve to service the inlet/exhaust valve. The inlet/exhaust valve insert can be removed by removing the snap ring, exhaust cover assembly and then inlet/exhaust valve.

Caution: Drain all reservoirs before attempting to remove the inlet exhaust valve.

### DISASSEMBLY

Note: Prior to disassembly, mark the location of the mounting bracket to the cover and the cover to the body.

1. Remove the four (4) cap screws and lockwashers securing the cover to the body.
2. Remove the cover, sealing ring, and mounting bracket.
3. Remove the piston and o-ring from the body.
4. While depressing the exhaust cover, remove the retaining ring and slowly relax the spring beneath the exhaust cover.
5. Remove the exhaust cover assembly and o-rings.
6. Remove the inlet/exhaust valve return spring from the body.
7. Remove the inlet/exhaust valve from the body.
8. Remove the valve retainer from the inlet/exhaust valve.
9. Remove the Phillips head screw and exhaust cover from the R-14 cover.
10. Remove the service port cap nut and o-ring from the R-14.
11. Remove the diaphragm from the R-14 cover.

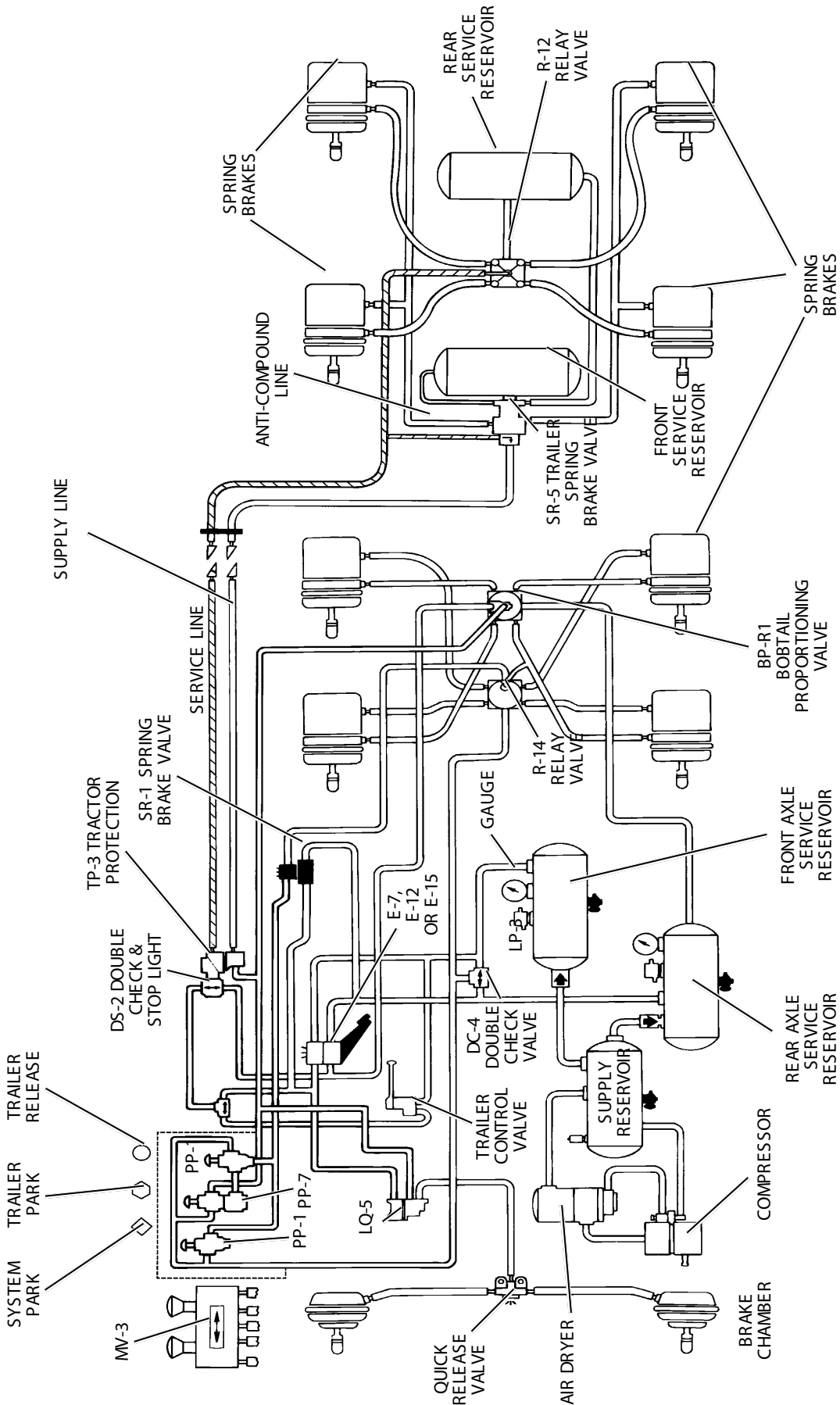

FIGURE 3 - TYPICAL PIPING SCHEMATIC

## CLEANING AND INSPECTION

1. Wash all metal parts in mineral spirits and dry them thoroughly.  
(Note: When rebuilding, all springs and all rubber parts should be replaced.)
2. Inspect all metal parts for deterioration and wear, as evidenced by scratches, scoring and corrosion.
3. Inspect the exhaust valve seat on the relay piston for nicks and scratches which could cause excessive leakage.
4. Inspect the inlet valve seat in the body for scratches and nicks, which could cause excessive leakage.
5. Inspect the exhaust seat of the quick release diaphragm in the R-14 cover and make sure all internal air passages in this area are open and clean and free of nicks and scratches.
6. Replace all parts not considered serviceable during these inspections and all springs and rubber parts. Use only genuine Bendix replacement parts, available from any authorized Bendix parts outlet.

## ASSEMBLY

Note: All torque specified in this manual are assembly torque and can be expected to fall off slightly after assembly. Do not re-torque after initial assembly torque fall. For assembly, hand wrenches are recommended.

Prior to assembly, lubricate all o-rings, o-ring bores and any sliding surface with a silicone lubricant equivalent to Dow Corning #10.

1. Install large piston o-ring on piston.
2. Install inner and outer o-rings in the exhaust cover assembly.
3. Install the sealing ring on the cover.
4. Install piston in body, taking care not to damage the piston o-ring.
5. Noting the reference marks made during disassembly, install the cover on the valve body and the mounting bracket on the cover.
6. Secure the mounting bracket and cover to the body using the four (4) cap screws and lock washers. Torque to 80-120 inch pounds.
7. Install the valve retainer on the inlet/exhaust valve and install in the body.
8. Install the inlet/exhaust valve return spring in the body.
9. Install the exhaust cover assembly in the body, taking care not to damage the o-ring.
10. While depressing the exhaust cover, install the retaining ring. Make certain the retainer is completely seated in its groove in the body.

11. Install the R-14 service port cap nut o-ring on the cap nut. Install the diaphragm in the R-14 cover making certain it is positioned between the guide ribs in the cover.
13. Install the service port cap nut and torque to 150 inch pounds.
14. If the quick release exhaust port was protected with an exhaust cover, install the cover using the #10-24 Phillips head screw. Torque to approx. 15-25 inch pounds.
15. Test the valves as outlined in the Operational and Leakage Test section before returning the valve to service.

## INSTALLATION

1. Clean air lines.
2. Inspect all lines and/or hoses for damage and replace as necessary.
3. Install valve and tighten mounting bolts.
4. Connect air lines to valve (plug any unused ports).
5. Test valve as outlined in Operational and Leakage Tests.

## IMPORTANT! PLEASE READ

When working on or around a vehicle, the following general precautions should be observed:

1. Park the vehicle on a level surface, apply the parking brakes, and always block the wheels.
2. Stop the engine when working around the vehicle.
3. If the vehicle is equipped with air brakes, make certain to drain the air pressure from all reservoirs before beginning ANY work on the vehicle.
4. Following the vehicle manufacturer's recommended procedures, deactivate the electrical system in a manner that removes all electrical power from the vehicle.
5. When working in the engine compartment the engine should be shut off. Where circumstances require that the engine be in operation, EXTREME CAUTION should be used to prevent personal injury resulting from contact with moving, rotating, leaking, heated, or electrically charged components.
6. Never connect or disconnect a hose or line containing pressure; it may whip. Never remove a component or plug unless you are certain all system pressure has been depleted.
7. Never exceed recommended pressures and always wear safety glasses.



8. Do not attempt to install, remove, disassemble or assemble a component until you have read and thoroughly understand the recommended procedures. Use only the proper tools and observe all precautions pertaining to use of those tools.
9. Use only genuine Bendix replacement parts, components, and kits. Replacement hardware, tubing, hose, fittings, etc. should be of equivalent size, type, and strength as original equipment and be designed specifically for such applications and systems.
10. Components with stripped threads or damaged parts should be replaced rather than repaired. Repairs requiring machining or welding should not be attempted unless specifically approved and stated by the vehicle or component manufacturer.
11. Prior to returning the vehicle to service, make certain all components and systems are restored to their proper operating condition.







# Service Data

SD-03-1068

## R-12DC RELAY VALVE WITH BIASED DOUBLE CHECK

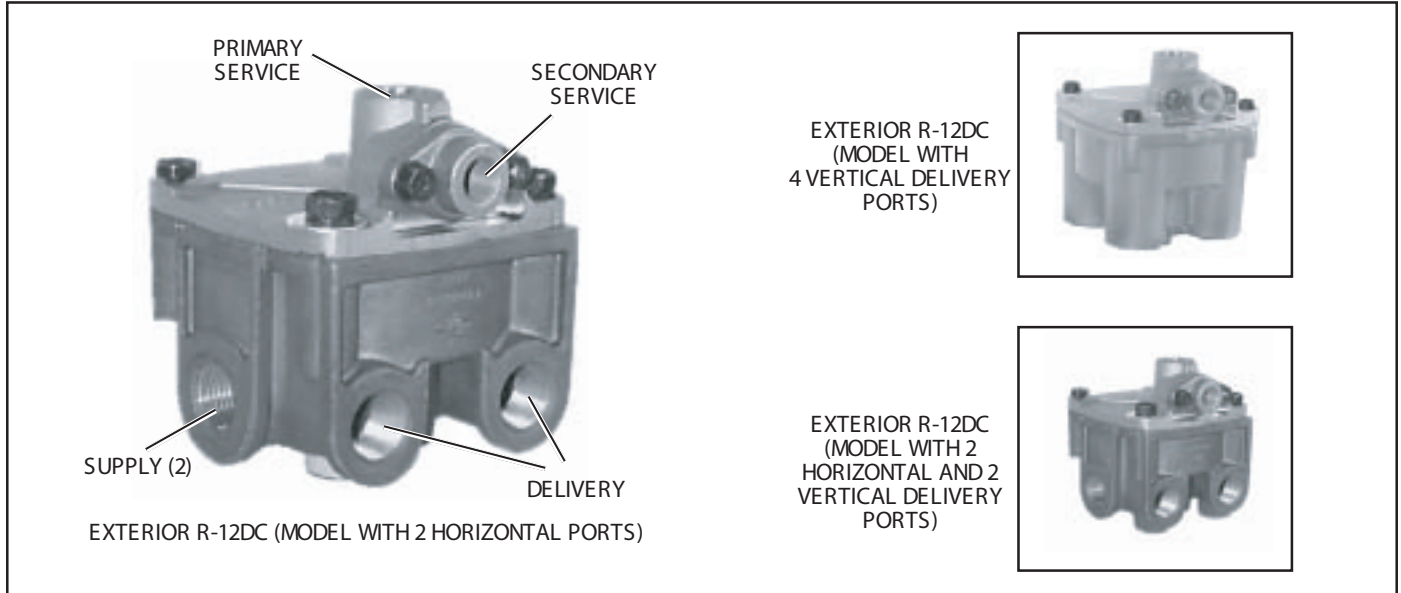

FIGURE 1 - EXTERIOR VIEWS.

### DESCRIPTION

The Relay Valve in an air brake system functions as a relay station to speed up the application and release of the brakes. The valve is normally mounted at the rear of the vehicle in proximity to the chambers it serves. The valve operates as a remote controlled brake valve that delivers

or releases air to the chambers in response to the control air delivered to it from the foot brake valve.

The R-12DC Relay Valves are designed for either reservoir or frame mounting. (See Figure 1). For ease of servicing, the inlet/exhaust valve can be replaced without the need for line removal.

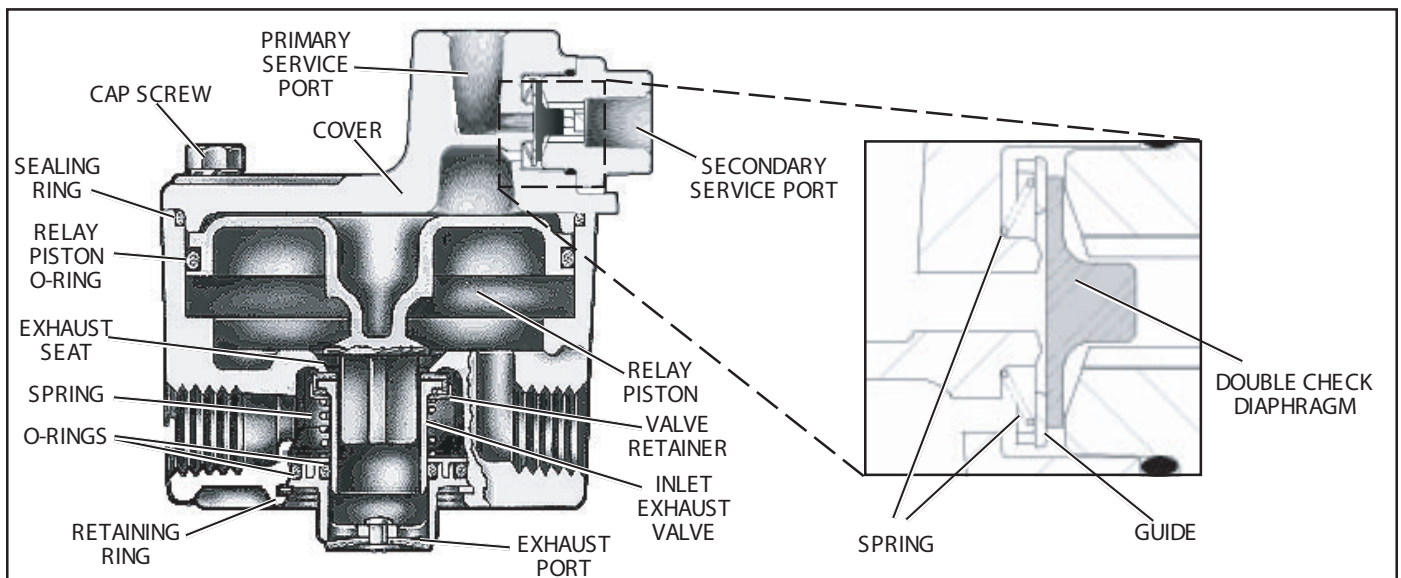

FIGURE 2 - R-12DC SECTIONAL VIEW

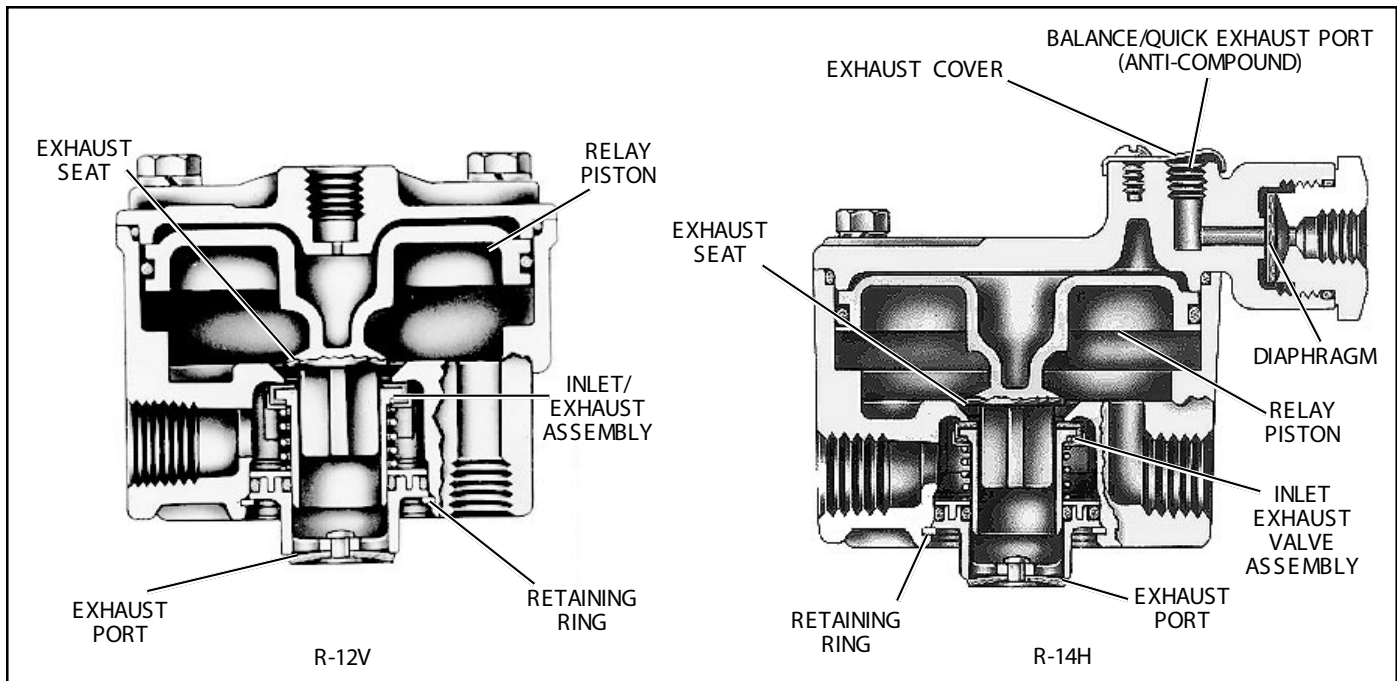

FIGURE 2 - SECTIONAL VIEWS

to be conveniently used as either a service or spring brake relay valve. An exhaust cover is installed that protects the 1/8" balance port when the R-14 anti-compound feature is not in use.

All parts are interchangeable between the R-12 and R-14 with the exception of the detail components of the R-14 cover. Both valves make extensive use of non-metallic internal components. For ease of servicing, the inlet/exhaust valve can be replaced without the need for line removal.

## OPERATION

### APPLICATION

Air pressure delivered to the service port enters the small cavity above the piston and moves the piston down. The exhaust seat moves down with the piston and seats on the inner or exhaust portion of the inlet/exhaust valve, sealing off the exhaust passage. At the same time, the outer or inlet portion of the inlet/exhaust valve moves off its seat, permitting supply air to flow from the reservoir, past the open inlet valve and into the brake chambers.

### BALANCE

The air pressure being delivered by the open inlet valve also is effective on the bottom area of the relay piston. When air pressure beneath the piston equals the service air pressure above, the piston lifts slightly and the inlet spring returns the inlet valve to its seat. The exhaust remains closed as the service line pressure balances the

delivery pressure. As delivered air pressure is changed, the valve reacts instantly to the change, holding the brake application at that level.

### EXHAUST OR RELEASE

When air pressure is released from the service port and air pressure in the cavity above the relay piston is exhausted, air pressure beneath the piston lifts the relay piston and the exhaust seat moves away from the exhaust valve, opening the exhaust passage. With the exhaust passage open, the air pressure in the brake chambers is then permitted to exhaust through the exhaust port, releasing the brakes.

### ANTI-COMPOUNDING (SIMULTANEOUS SERVICE AND PARK APPLICATION)

In those applications where the R-14 Relay Valve is used to control spring brake chambers, the anti-compound feature may be utilized. With the anti-compound feature of the R-14 connected, a service application made while the vehicle is parked is countered by a release of the parking brakes. To utilize this feature, the exhaust cover of the quick release portion of the R-14 is removed and a line is installed which is connected to the delivery of the service brake valve or relay valve. With no air pressure at the service port of the R-14, the parking brakes are applied. If a service brake application is made, air from the service brake valve enters the exhaust port of the quick release of the R-14 and moves the diaphragm, blocking the service port. Air then proceeds into the cavity above the relay piston, forces the piston down, closing the exhaust and

opening the inlet to deliver air to the spring brake cavity as described under the section of this manual entitled Application.

## PREVENTIVE MAINTENANCE

**Important:** Review the warranty policy before performing any intrusive maintenance procedures. An extended warranty may be voided if intrusive maintenance is performed during this period.

Because no two vehicles operate under identical conditions, maintenance and maintenance intervals will vary. Experience is a valuable guide in determining the best maintenance interval for any one particular operation.

1. Every three months or 25,000 miles or 900 operating hours check for proper operation.
2. Every twelve months or 100,000 miles or 3600 operating hours: disassemble valve, clean parts with mineral spirits. Replace all rubber parts and any part worn or damaged. Check for proper operation before placing vehicle in service.

## OPERATIONAL AND LEAKAGE TEST

1. Chock the wheels, fully charge air brake system and adjust the brakes.
2. Make several brake applications and check for prompt application and release at each wheel.
3. Check for inlet valve and o-ring leakage.
  - A. Make this check with the service brakes released when the R-12 or R-14 is used to control the service brakes.
  - B. Make the check with the spring brakes applied (PARK) when the R-14 is used to control the spring brakes. Coat the exhaust port and the area around the retaining ring with a soap solution; a 1 inch bubble in 3 seconds leakage is permitted.
4. Check for exhaust valve leakage.
  - A. Make this check with the service brakes fully applied if the R-12 or R-14 control the service brakes.
  - B. Make this check with the spring brakes fully released if the R-14 is used to control the spring brakes. Coat the exhaust port with a soap solution; a 1 inch bubble in 3 seconds leakage is permitted. Coat the outside of the valve where the cover joins the body to check for seal ring leakage; no leakage is permitted.
5. If the R-14 is used to control the spring brakes, place the park control in the released position and coat the balance port with a soap solution to check the diaphragm and its seat. Leakage equivalent to a 1 inch bubble in 3 seconds is permitted.

Note: If the anti-compound feature is in use, the line attached to the balance port must be disconnected to perform this test.

If the valves do not function as described above, or if leakage is excessive, it is recommended that the valves be replaced with new or remanufactured units or repaired with genuine Bendix parts, available at any authorized Bendix parts outlet.

## REMOVAL AND INSTALLATION

### REMOVAL

1. Block and hold vehicle by means other than air brakes.
2. Drain air brake system reservoirs.
3. If entire valve is to be removed, identify air lines to facilitate installation.
4. Disconnect air lines from valve.\*
5. Remove valve from reservoir or if remotely mounted, remove mounting bolts and then valve.

\*It is generally not necessary to remove entire valve to service the inlet/exhaust valve. The inlet/exhaust valve insert can be removed by removing the snap ring, exhaust cover assembly and then inlet/exhaust valve.

Caution: Drain all reservoirs before attempting to remove the inlet exhaust valve.

### DISASSEMBLY

Note: Prior to disassembly, mark the location of the mounting bracket to the cover and the cover to the body.

1. Remove the four (4) cap screws and lockwashers securing the cover to the body.
2. Remove the cover, sealing ring, and mounting bracket.
3. Remove the piston and o-ring from the body.
4. While depressing the exhaust cover, remove the retaining ring and slowly relax the spring beneath the exhaust cover.
5. Remove the exhaust cover assembly and o-rings.
6. Remove the inlet/exhaust valve return spring from the body.
7. Remove the inlet/exhaust valve from the body.
8. Remove the valve retainer from the inlet/exhaust valve.
9. Remove the Phillips head screw and exhaust cover from the R-14 cover.
10. Remove the service port cap nut and o-ring from the R-14.
11. Remove the diaphragm from the R-14 cover.

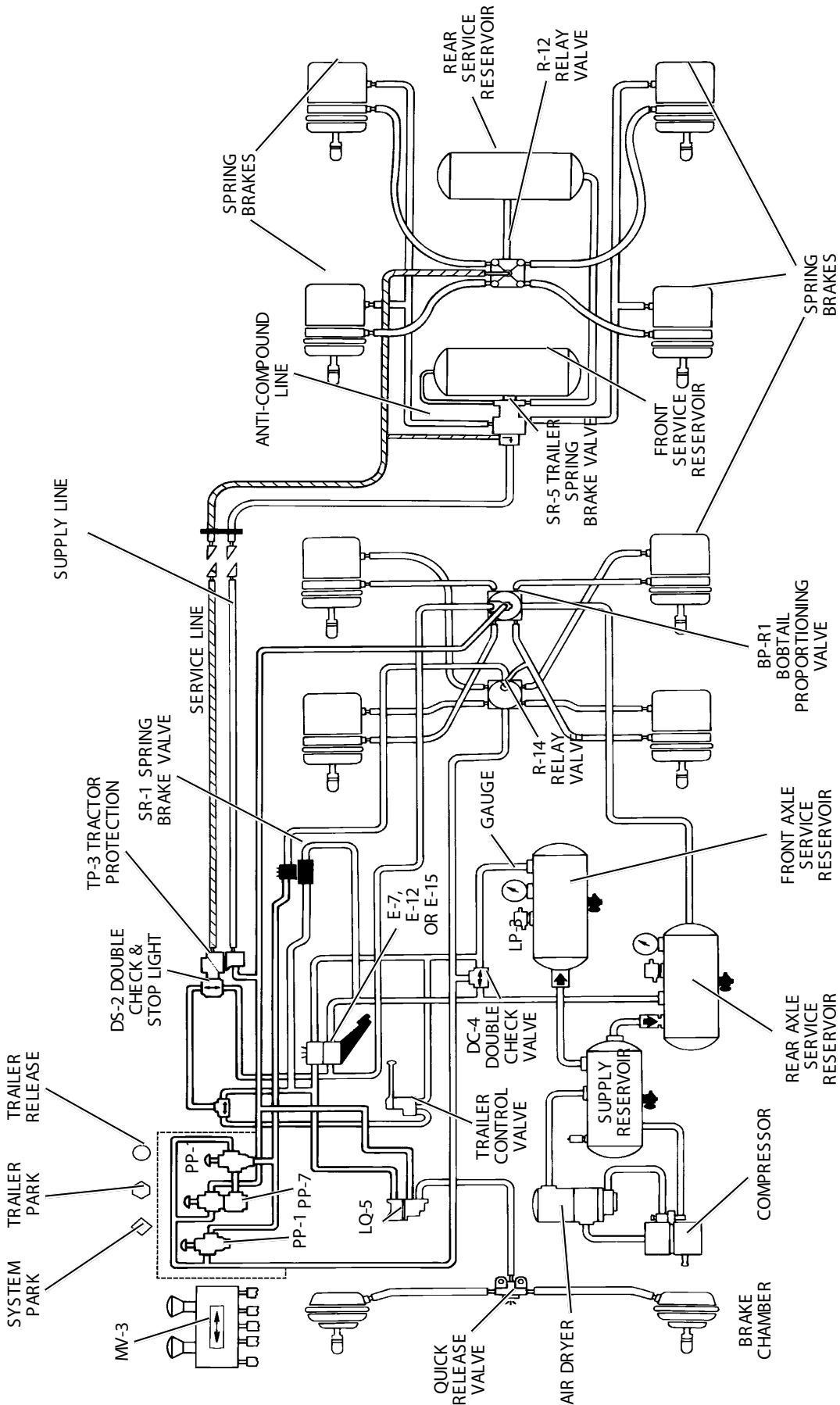

FIGURE 3 - TYPICAL PIPING SCHEMATIC

## CLEANING AND INSPECTION

1. Wash all metal parts in mineral spirits and dry them thoroughly.  
(Note: When rebuilding, all springs and all rubber parts should be replaced.)
2. Inspect all metal parts for deterioration and wear, as evidenced by scratches, scoring and corrosion.
3. Inspect the exhaust valve seat on the relay piston for nicks and scratches which could cause excessive leakage.
4. Inspect the inlet valve seat in the body for scratches and nicks, which could cause excessive leakage.
5. Inspect the exhaust seat of the quick release diaphragm in the R-14 cover and make sure all internal air passages in this area are open and clean and free of nicks and scratches.
6. Replace all parts not considered serviceable during these inspections and all springs and rubber parts. Use only genuine Bendix replacement parts, available from any authorized Bendix parts outlet.

## ASSEMBLY

Note: All torque specified in this manual are assembly torque and can be expected to fall off slightly after assembly. Do not re-torque after initial assembly torque fall. For assembly, hand wrenches are recommended.

Prior to assembly, lubricate all o-rings, o-ring bores and any sliding surface with a silicone lubricant equivalent to Dow Corning #10.

1. Install large piston o-ring on piston.
2. Install inner and outer o-rings in the exhaust cover assembly.
3. Install the sealing ring on the cover.
4. Install piston in body, taking care not to damage the piston o-ring.
5. Noting the reference marks made during disassembly, install the cover on the valve body and the mounting bracket on the cover.
6. Secure the mounting bracket and cover to the body using the four (4) cap screws and lock washers. Torque to 80-120 inch pounds.
7. Install the valve retainer on the inlet/exhaust valve and install in the body.
8. Install the inlet/exhaust valve return spring in the body.
9. Install the exhaust cover assembly in the body, taking care not to damage the o-ring.
10. While depressing the exhaust cover, install the retaining ring. Make certain the retainer is completely seated in its groove in the body.

11. Install the R-14 service port cap nut o-ring on the cap nut. Install the diaphragm in the R-14 cover making certain it is positioned between the guide ribs in the cover.
13. Install the service port cap nut and torque to 150 inch pounds.
14. If the quick release exhaust port was protected with an exhaust cover, install the cover using the #10-24 Phillips head screw. Torque to approx. 15-25 inch pounds.
15. Test the valves as outlined in the Operational and Leakage Test section before returning the valve to service.

## INSTALLATION

1. Clean air lines.
2. Inspect all lines and/or hoses for damage and replace as necessary.
3. Install valve and tighten mounting bolts.
4. Connect air lines to valve (plug any unused ports).
5. Test valve as outlined in Operational and Leakage Tests.

## IMPORTANT! PLEASE READ

When working on or around a vehicle, the following general precautions should be observed:

1. Park the vehicle on a level surface, apply the parking brakes, and always block the wheels.
2. Stop the engine when working around the vehicle.
3. If the vehicle is equipped with air brakes, make certain to drain the air pressure from all reservoirs before beginning ANY work on the vehicle.
4. Following the vehicle manufacturer's recommended procedures, deactivate the electrical system in a manner that removes all electrical power from the vehicle.
5. When working in the engine compartment the engine should be shut off. Where circumstances require that the engine be in operation, EXTREME CAUTION should be used to prevent personal injury resulting from contact with moving, rotating, leaking, heated, or electrically charged components.
6. Never connect or disconnect a hose or line containing pressure; it may whip. Never remove a component or plug unless you are certain all system pressure has been depleted.
7. Never exceed recommended pressures and always wear safety glasses.



8. Do not attempt to install, remove, disassemble or assemble a component until you have read and thoroughly understand the recommended procedures. Use only the proper tools and observe all precautions pertaining to use of those tools.
9. Use only genuine Bendix replacement parts, components, and kits. Replacement hardware, tubing, hose, fittings, etc. should be of equivalent size, type, and strength as original equipment and be designed specifically for such applications and systems.
10. Components with stripped threads or damaged parts should be replaced rather than repaired. Repairs requiring machining or welding should not be attempted unless specifically approved and stated by the vehicle or component manufacturer.
11. Prior to returning the vehicle to service, make certain all components and systems are restored to their proper operating condition.







# Service Data

SD-03-2010\*

## PRESSURE PROTECTION VALVES

\*Formerly SD-03-55

### DESCRIPTION

The pressure protection valve is a normally closed, pressure control valve which can be referred to as a non-exhausting sequence valve. These valves are used in many different applications. An example would be in an air brake system to protect one reservoir, or reservoir system from another, by closing automatically at a preset pressure should a reservoir system failure occur. The valves can also be used

to delay filling of auxiliary reservoirs to insure a quick build-up of brake system pressure.

The PR-2 and PR-4 pressure protection valves have one 1/4" N.P.T.F. supply port and one 1/4" N.P.T.F. delivery port which are identified. Both valves are provided with two 9/32" mounting holes through the body. The closing pressure of the PR-2 is externally adjustable while the PR-4 has a fixed setting.

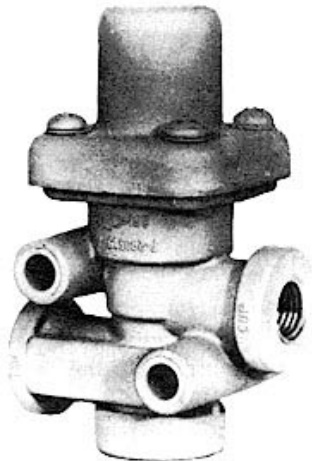

PR-3 OR PR-4

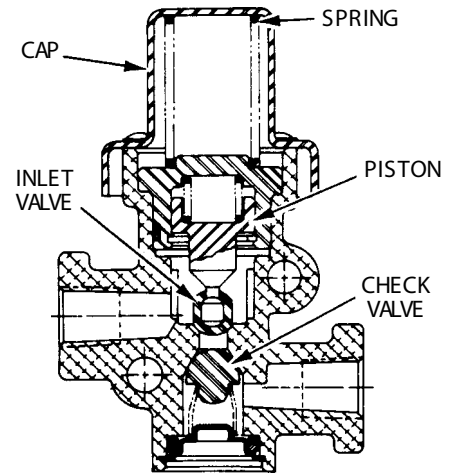

PR-3

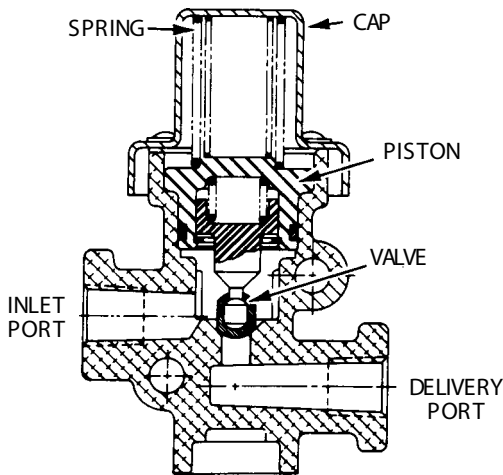

PR-4

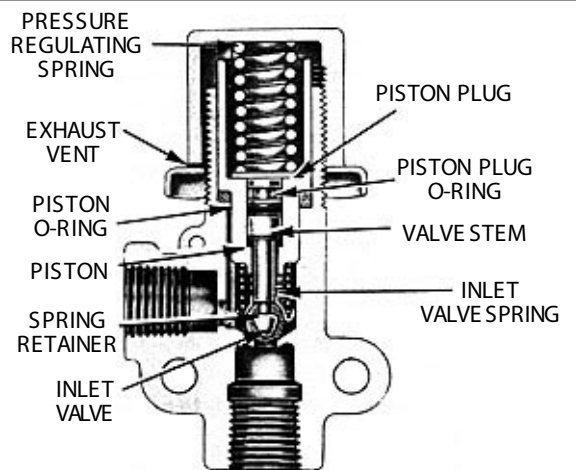

PR-2

## OPERATION

Air entering the supply port is initially prevented from flowing out the delivery port by the inlet valve which is held closed by the pressure regulating spring above the piston. When sufficient air pressure builds beneath the piston to overcome the setting of the regulating spring, the piston will move, causing the inlet valve to unseat (open), and allow air to flow out the delivery port. As long as air pressure at the supply port and beneath the piston remains above the specified closing pressure, the inlet valve will remain open.

NOTE: The PR-2 and PR-4 closing pressure is noted on the label affixed to the valve. Opening pressures of the valves are higher than closing pressures. The pressure ranges are noted below:

PR-2-Opening pressure 15-20 psi higher than closing pressure.

PR-3 & PR-4-Opening pressure approx. 10 psi higher than closing pressure.

PR-3-Check valve will retain maximum pressure in downstream reservoir.

If for any reason system air pressure is decreased below the specified closing pressure, the regulating spring will move the piston closing the inlet valve. The remaining air pressure at either the supply or delivery side, (depending upon where the pressure drop has occurred) will be retained.

## PREVENTIVE MAINTENANCE

Every three months, 900 operating hours or 25,000 miles, whichever is first, it is recommended that the operation and leakage checks described in this manual be performed.

## OPERATING AND LEAKAGE CHECKS

### OPERATING CHECKS

1. Provide a pressure gauge and drain valve at the supply side and delivery side of the pressure protection valve being checked.
2. Build up the air system to full pressure and shut off the engine.
3. While watching the gauges on the supply and delivery sides of the valve, slowly begin to exhaust pressure from the delivery side. Note that both gauges will show pressure loss until the closing pressure of the pressure protection valve is reached.

The pressure protection valve should close at approximately ( $\pm 5$  psi) the pressure indicated on the valve's label or in the vehicle handbook. The gauge on the delivery side of the valve should continue to show loss of pressure while the gauge on the supply side should stop at the same pressure as the setting of the valve.

4. (PR-3 only) Build pressure up again and shut off engine. Slowly exhaust air from the supply side of the PR-3. The gauge on the delivery side of the valve should remain at the highest pressure previously attained.

### LEAKAGE CHECKS

1. Build up the air system to full pressure and shut off the engine.
2. Apply a soap solution around the cap of the pressure protection valve. A one-inch bubble in three seconds or longer is acceptable. PR-3 - No leakage permissible at bottom of valve.
3. Drain the air pressure from the delivery side of the pressure protection valve and disconnect the air line to it.
4. Apply a soap solution to the delivery port. A one inch bubble in five seconds or more is acceptable.

### GENERAL

If the pressure protection valve does not operate as described or leakage is excessive, it is recommended that a replacement be obtained at the nearest authorized AlliedSignal Truck Brake Systems Co. distributor.

## REMOVING AND INSTALLING

### REMOVING

1. Block or hold the vehicle by means other than air brakes.
2. Drain all system reservoirs individually, to 0 psi.
3. Disconnect and identify (supply and delivery) the air lines leading to and from the pressure protection valve.
4. Remove the mounting bolts, if any, that secure the valve.

### INSTALLING

1. Re-install the mounting bolts and secure the replacement valve to the vehicle.
2. Reconnect the supply delivery air lines to the proper ports of the replacement valve.

### GENERAL

After installing a replacement valve, it is recommended that the operating and leakage checks be performed as outlined in this manual. If the closing pressure does not conform to that shown on the valve label or in the vehicle or a different setting is desired, the PR-2 may be adjusted by loosening the locknut and tightening or loosening the adjusting cap as required; however, if the proper setting cannot be attained by moderate adjustment of the cap, the valve may have the wrong spring and will have to be exchanged for the correct valve. The PR-3 and PR-4 are not adjustable.

## IMPORTANT! PLEASE READ

When working on or around a vehicle, the following general precautions should be observed:

1. Park the vehicle on a level surface, apply the parking brakes, and always block the wheels.
2. Stop the engine when working around the vehicle.
3. If the vehicle is equipped with air brakes, make certain to drain the air pressure from all reservoirs before beginning **ANY** work on the vehicle.
4. Following the vehicle manufacturer's recommended procedures, deactivate the electrical system in a manner that removes all electrical power from the vehicle.
5. When working in the engine compartment the engine should be shut off. Where circumstances require that the engine be in operation, **EXTREME CAUTION** should be used to prevent personal injury resulting from contact with moving, rotating, leaking, heated, or electrically charged components.
6. Never connect or disconnect a hose or line containing pressure; it may whip. Never remove a component or plug unless you are certain all system pressure has been depleted.
7. Never exceed recommended pressures and always wear safety glasses.
8. Do not attempt to install, remove, disassemble or assemble a component until you have read and thoroughly understand the recommended procedures. Use only the proper tools and observe all precautions pertaining to use of those tools.
9. Use only genuine Bendix replacement parts, components, and kits. Replacement hardware, tubing, hose, fittings, etc. should be of equivalent size, type, and strength as original equipment and be designed specifically for such applications and systems.
10. Components with stripped threads or damaged parts should be replaced rather than repaired. Repairs requiring machining or welding should not be attempted unless specifically approved and stated by the vehicle or component manufacturer.
11. Prior to returning the vehicle to service, make certain all components and systems are restored to their proper operating condition.



## DOUBLE CHECK VALVES

\*FORMERLY SD-03-67

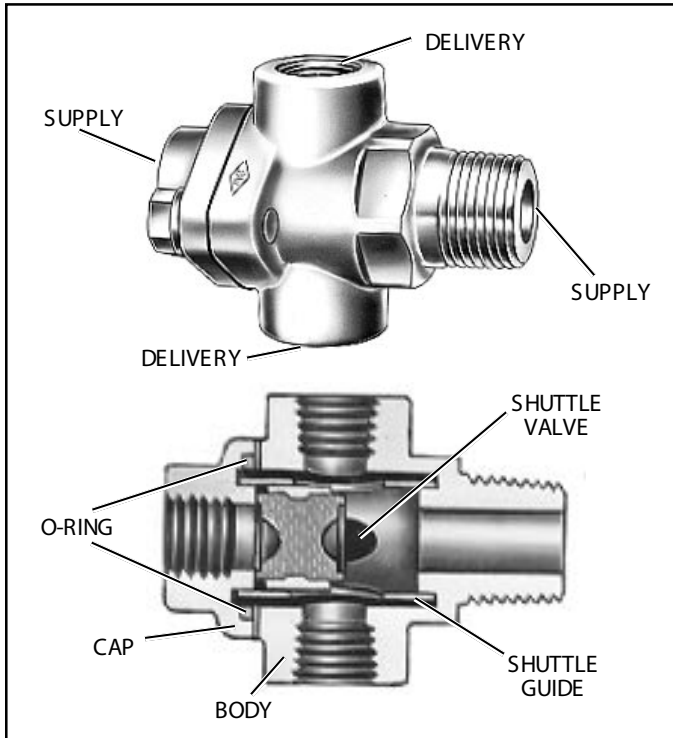

FIGURE 1 - DOUBLE CHECK VALVE (SHUTTLE TYPE)

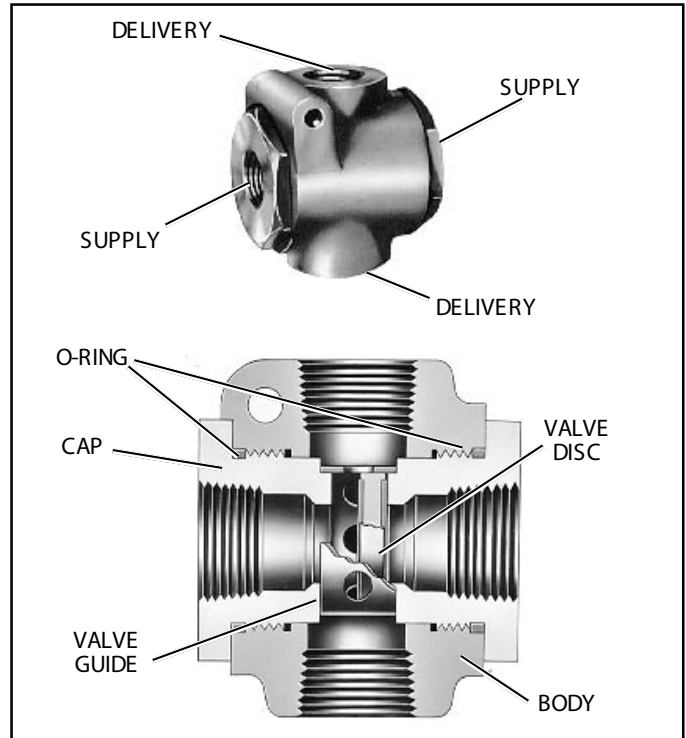

FIGURE 2 - DOUBLE CHECK VALVE (DISC TYPE)

### DESCRIPTION

Double Check Valves are used in an air brake system to direct a flow of air into a common line from either of two sources, whichever is at the higher pressure. They may be used for directing air flow for specific functions or to select the higher pressure of either of two sources of air as a supply source.

AlliedSignal manufactures two types of Bendix Double Check Valves: shuttle and disc. Although the valves are somewhat different physically, the same function is performed by both types. The difference in the design of the two valves is that the shuttle type has a movable shuttle to seal off the lower pressure source, whereas the disc type has a movable disc.

### OPERATION

As air under pressure enters either end of the Double Check Valve (inlet port) the moving shuttle or disc responds to the pressure and seals the opposite port, assuming it is at a lower pressure level than the other. The air flow continues out the delivery port of the Double Check Valve. The position

of the shuttle or disc will reverse if the pressure levels are reversed. Double Check Valves are designed so that the shuttle or disc can never impede the backflow of air in the exhaust mode.

Figure 3 (see page 2) illustrates a typical use of a Double Check Valve to control a given device, such as trailer brakes, from either of two control sources.

Figure 4 (see page 2) illustrates a typical use of a Double Check Valve to supply air to a system or systems from either of two separate sources, whichever is at the greater pressure level. In this type of installation the pressure differential to which the valve is subjected may under certain conditions be minimal. It is therefore suggested that performance of the Double Check Valve will be optimized if it is mounted in the horizontal position.

### PREVENTIVE MAINTENANCE

Every 3600 operating hours, 100,000 miles, or yearly, disassemble, clean and inspect all parts. Install new parts if they show signs of wear or deterioration.

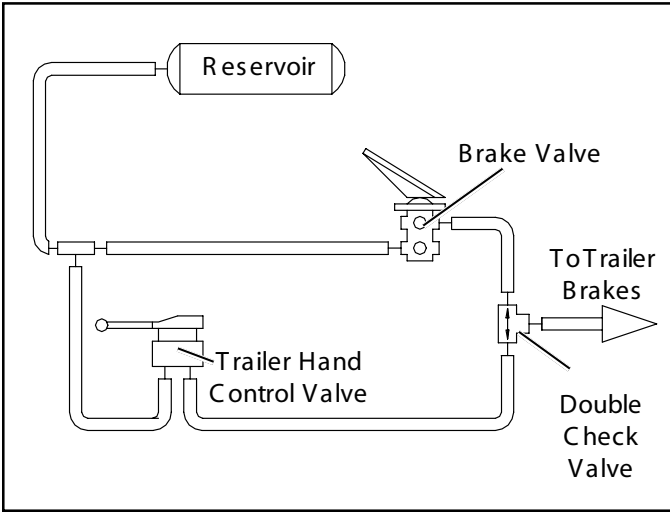

FIGURE 3 - DOUBLE CHECK VALVE: CONTROL OF SYSTEM FROM EITHER OF TWO CONTROL SOURCES

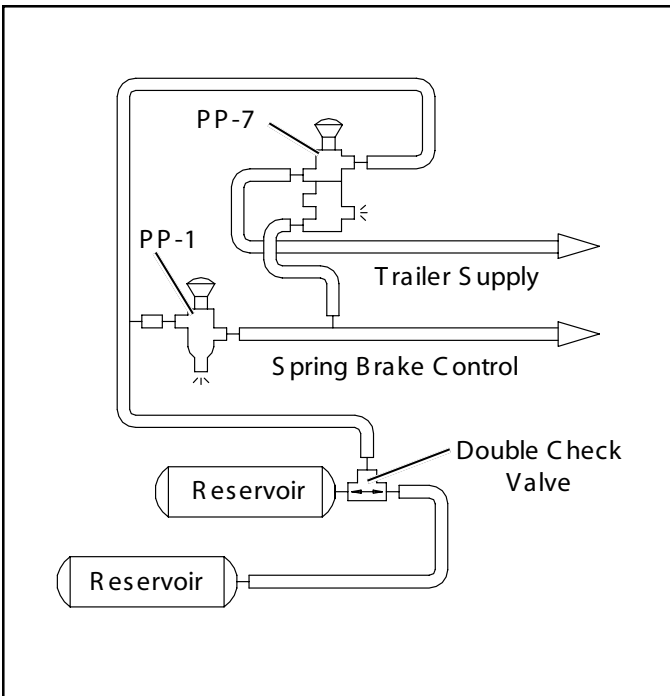

FIGURE 4 - DOUBLE CHECK VALVE: SYSTEM WITH TWO SUPPLY SOURCES

## SERVICE CHECKS

### OPERATING AND LEAKAGE TEST

- A. When the Double Check Valve is used in conjunction with a Trailer Control Valve, the following operating and leakage test can be made:
1. Apply and release foot brake valve and note that the brakes apply and release on both tractor and trailer.
  2. Apply and release the Trailer Control Valve and note that only the trailer brakes apply and release. With trailer control valve applied check exhaust port of foot brake valve for leakage with soap solution. Permissible leakage is a one inch bubble in five seconds (100 sccm).

3. Apply and hold a full foot brake valve application. Check exhaust port of Trailer Control Valve for leakage with soap solution. Permissible leakage is a one inch bubble in five seconds (100 sccm). (Note: On some vehicles, an exhaust line is connected to the exhaust port and piped outside the cab in which case it may be necessary to disconnect this line to make leakage check.)
- B. If Double Check Valve is to be bench tested or tested on the vehicle, two separately controlled air supplies must be connected to the inlet ports.
1. Install an accurate test gauge in the outlet port or in a line from outlet port.
  2. Apply and release air to one inlet port and note that gauge registers application and release.
  3. Repeat by applying and releasing air to other inlet port.
  4. Leakage check should be performed at inlet ports of valve in the following manner:
    - a. Disconnect line from one inlet port.
    - b. Apply air to other inlet port and coat opposite inlet port with soap solution. Permissible leakage is a one inch bubble in five seconds (100 sccm).
    - c. Repeat Step "b" applying air to other inlet port while checking opposite inlet port for leakage.

If the Double Check Valve does not function as described or if leakage is excessive, it is recommended that the valve be repaired or replaced with genuine Bendix parts. The following instructions should prove helpful:

### DISASSEMBLY

1. Remove end cap(s) from valve.
2. Remove grommets (if applicable).
3. Remove shuttle and/or shuttle guide, disc and/or disc guide (depending upon type of valve).

### CLEANING AND INSPECTION

1. Clean all metal parts in a cleaning solvent.
2. Inspect all metal parts for signs of cracks, wear or deterioration. Replace all parts not considered serviceable.
3. Replace all rubber parts.

### ASSEMBLY

1. Install disc guide, disc and/or shuttle and shuttle guide.
2. Coat all static seals such as o-rings, grommets, etc. with BW 650M Silicone lubricant (BW 291126). It is not necessary to lubricate shuttles or discs.
3. Install grommets.
4. Install end cap(s).

### TESTING OF REBUILT DOUBLE CHECK VALVE

Perform operating and leakage tests as described in “Service Checks” section.

### IMPORTANT! PLEASE READ:

When working on or around a vehicle, the following general precautions should be observed:

1. Park the vehicle on a level surface, apply the parking brakes, and always block the wheels.
2. Stop the engine when working around the vehicle.
3. If the vehicle is equipped with air brakes, make certain to drain the air pressure from all reservoirs before beginning ANY work on the vehicle.
4. Following the vehicle manufacturer’s recommended procedures, deactivate the electrical system in a manner that removes all electrical power from the vehicle.
5. When working in the engine compartment the engine should be shut off. Where circumstances require that the engine be in operation, EXTREME CAUTION should be used to prevent personal injury resulting from contact with moving, rotating, leaking, heated, or electrically charged components.
6. Never connect or disconnect a hose or line containing pressure; it may whip. Never remove a component or plug unless you are certain all system pressure has been depleted.
7. Never exceed recommended pressures and always wear safety glasses.
8. Do not attempt to install, remove, disassemble or assemble a component until you have read and thoroughly understand the recommended procedures. Use only the proper tools and observe all precautions pertaining to use of those tools.
9. Use only genuine Bendix replacement parts, components, and kits. Replacement hardware, tubing, hose, fittings, etc. should be of equivalent size, type, and strength as original equipment and be designed specifically for such applications and systems.
10. Components with stripped threads or damaged parts should be replaced rather than repaired. Repairs requiring machining or welding should not be attempted unless specifically approved and stated by the vehicle or component manufacturer.
11. Prior to returning the vehicle to service, make certain all components and systems are restored to their proper operating condition.



## TW-1, TW-3, TW-4, TW-5 & TW-6 CONTROL VALVES

\*Formerly SD-03-64

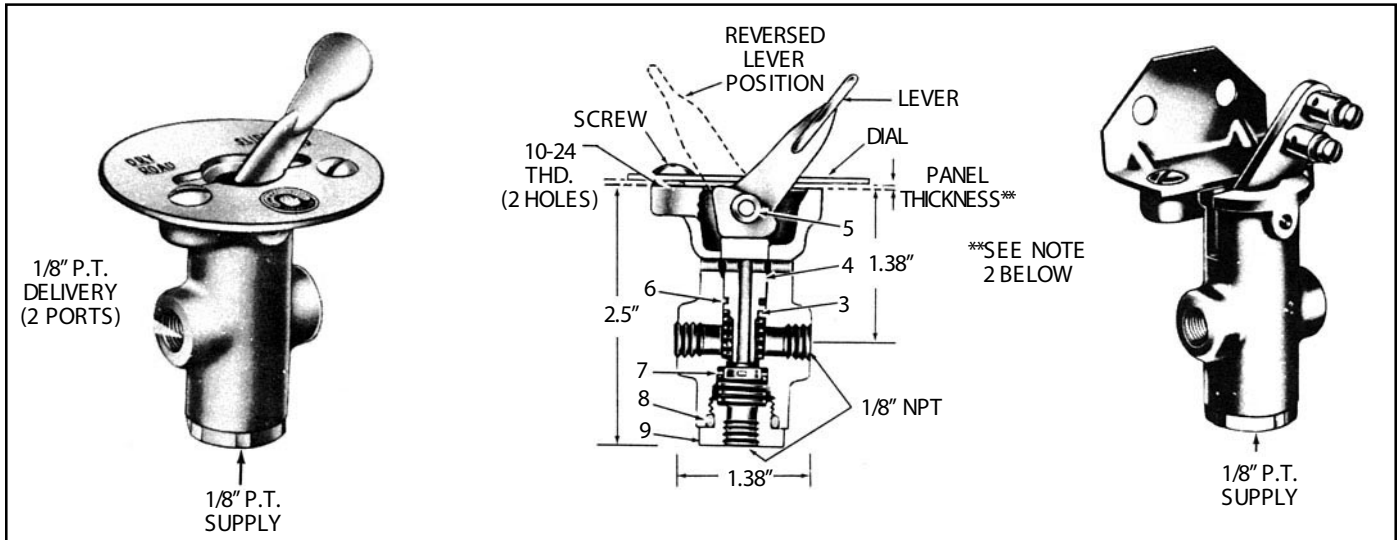

FIGURE 1 - TW-1

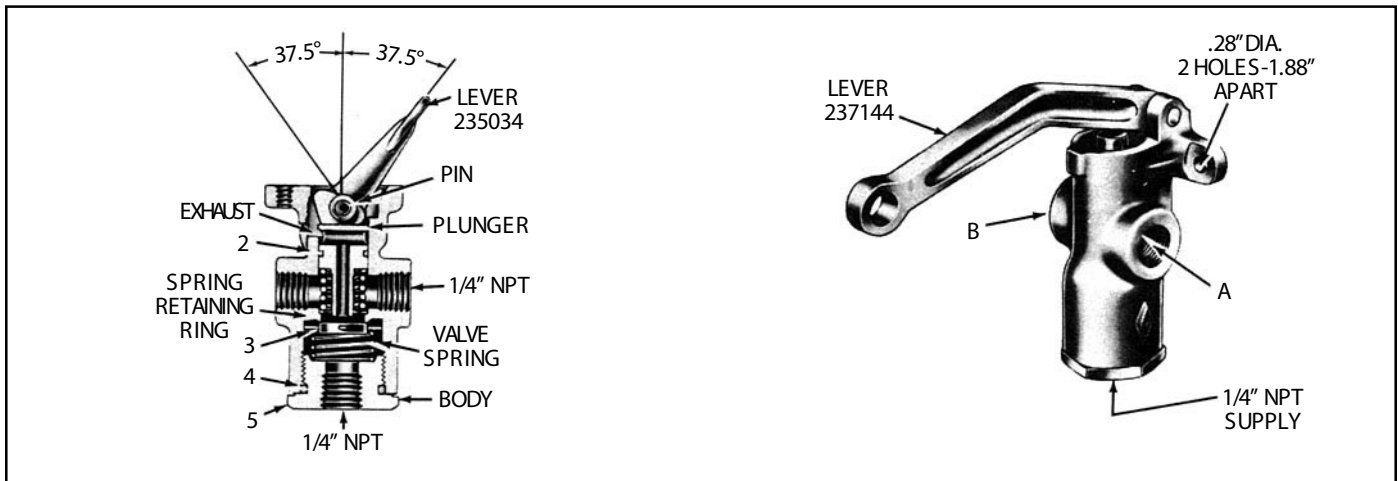

FIGURE 2 - TW-3

### DESCRIPTION

The TW series valves are manually operated on-off valves. They are extensively used in air systems to control nonmodulating air controlled devices. They may be lever or button operated, direct or remote control.

The TW-1 (Figure 1) is normally panel mounted with a steel, zinc or nylon manually operated lever. Some are equipped with a steel lever with connectors for Bowden cable control. All TW-1's have 1/8" NPT ports.

The TW-3 (Figure 2) is lever operated, either direct or remote and differs from the TW-1 in having 1/4" NPT ports and larger capacity. Some versions have a heavy inlet valve spring making them suitable for vacuum control.

TW-4's and TW-5's (Figure 3) are similar to the TW-1 except the plunger is designed for a push button, giving momentary application whenever the button is depressed.

The TW-6 (Figure 4) is a TW-1 with a grounding switch included. In the exhaust position the switch is open. When the valve is applied the switch is closed.



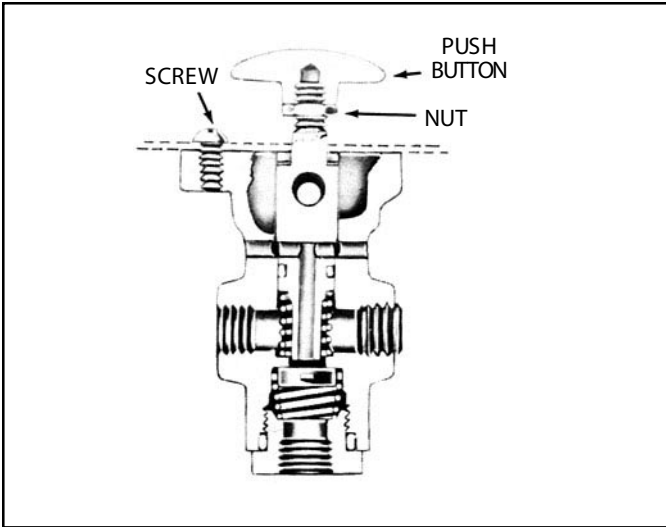

FIGURE 3 - TW-4

## OPERATION

With air pressure at the supply port (Figure 1) and the plunger in the upward position the valve is in the exhaust position. The delivery ports are open to atmosphere through the exhaust passage in the center of the plunger.

When the plunger is depressed by the cam action of the lever (Figure 1) or by a direct force on a push button (Figure 3) the plunger contacts the inlet valve, closing the exhaust passage and pushes the inlet valve off the inlet seat in the body, allowing supply air to flow through the delivery ports to the controlled device.

## PREVENTIVE MAINTENANCE

Every year, 100,000 miles or 1800 operating hours disassemble, clean and check all parts and replace if necessary.

## SERVICE CHECKS

### OPERATING AND LEAKAGE TESTS

Connect a 100 psi air pressure source to the supply port and connect delivery to an air gauge. (if there are two delivery ports, plug one.) With the valve in the released position, check for leakage at the exhaust holes with a soap solution. No leakage permitted. Place the valve in the applied position. Supply air pressure should show on the gauge. Check for leakage at the exhaust holes. No leakage permitted.

If the TW valve does not function as described or if leakage occurs, it is recommended that it be replaced with a new unit or repaired with genuine Bendix parts.

## REMOVING

Secure the vehicle with other means than brakes and drain the reservoirs.

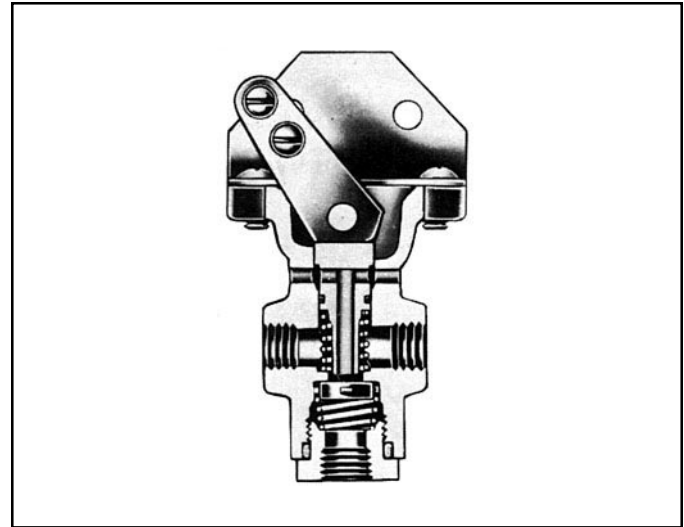

FIGURE 4 - TW-6

Disconnect all air lines and remove the valve.

## INSTALLING

Place valve handle through appropriate hole in panel, place dial (if used) over handle and install mtg. screws. Connect air lines.

## DISASSEMBLY

Remove operating handle or lever by driving the pin out of the body (Figure 1) and remove the lever, plunger and plunger spring. Remove the O-Ring from the plunger.

Remove the supply cap nut, inlet valve and spring. Remove the O-Ring from the supply cap nut.

## CLEANING AND INSPECTION OF PARTS

Wipe rubber parts clean. Clean plastic and metal parts in mineral spirits and dry thoroughly. Inspect all rubber parts for wear or deterioration and replace where necessary. Polish the inlet seat in the body if nicked or corroded. Inspect all springs for cracks, distortion or corrosion and replace if necessary.

## ASSEMBLY

Prior to assembly lubricate body bore, plunger, O-Rings, and cap nut threads with Bendix silicone lubricant BW 650M Pc. No. 291126.

Place inlet valve in body.

Place inlet valve spring on inlet valve.

Place O-Ring on cap nut and install cap nut.

Install plunger spring from top of body.

Install O-Ring on plunger and install plunger.

### TW-1 TW-3 & TW-6

Depress plunger, place lever cam in slot in body, line up holes in body with hole in lever and insert pin.

### TW-4 & TW-5

Depress plunger with button until hole in plunger lines up with holes in body. Insert pin.

### LEAKAGE TEST

Test valve per instructions in paragraph on “Service Checks.”

### IMPORTANT! PLEASE READ

When working on or around a vehicle, the following general precautions should be observed:

1. Park the vehicle on a level surface, apply the parking brakes, and always block the wheels.
2. Stop the engine when working around the vehicle.
3. If the vehicle is equipped with air brakes, make certain to drain the air pressure from all reservoirs before beginning ANY work on the vehicle.
4. Following the vehicle manufacturer’s recommended procedures, deactivate the electrical system in a manner that removes all electrical power from the vehicle.
5. When working in the engine compartment the engine should be shut off. Where circumstances require that the engine be in operation, EXTREME CAUTION should be used to prevent personal injury resulting from contact

with moving, rotating, leaking, heated, or electrically charged components.

6. Never connect or disconnect a hose or line containing pressure; it may whip. Never remove a component or plug unless you are certain all system pressure has been depleted.
7. Never exceed recommended pressures and always wear safety glasses.
8. Do not attempt to install, remove, disassemble or assemble a component until you have read and thoroughly understand the recommended procedures. Use only the proper tools and observe all precautions pertaining to use of those tools.
9. Use only genuine Bendix replacement parts, components, and kits. Replacement hardware, tubing, hose, fittings, etc. should be of equivalent size, type, and strength as original equipment and be designed specifically for such applications and systems.
10. Components with stripped threads or damaged parts should be replaced rather than repaired. Repairs requiring machining or welding should not be attempted unless specifically approved and stated by the vehicle or component manufacturer.
11. Prior to returning the vehicle to service, make certain all components and systems are restored to their proper operating condition.



## PUSH-PULL TYPE CONTROL VALVES: PP-1, PP-2, PP-5, PP-8, & RD-3

\*FORMERLY SD-03-61

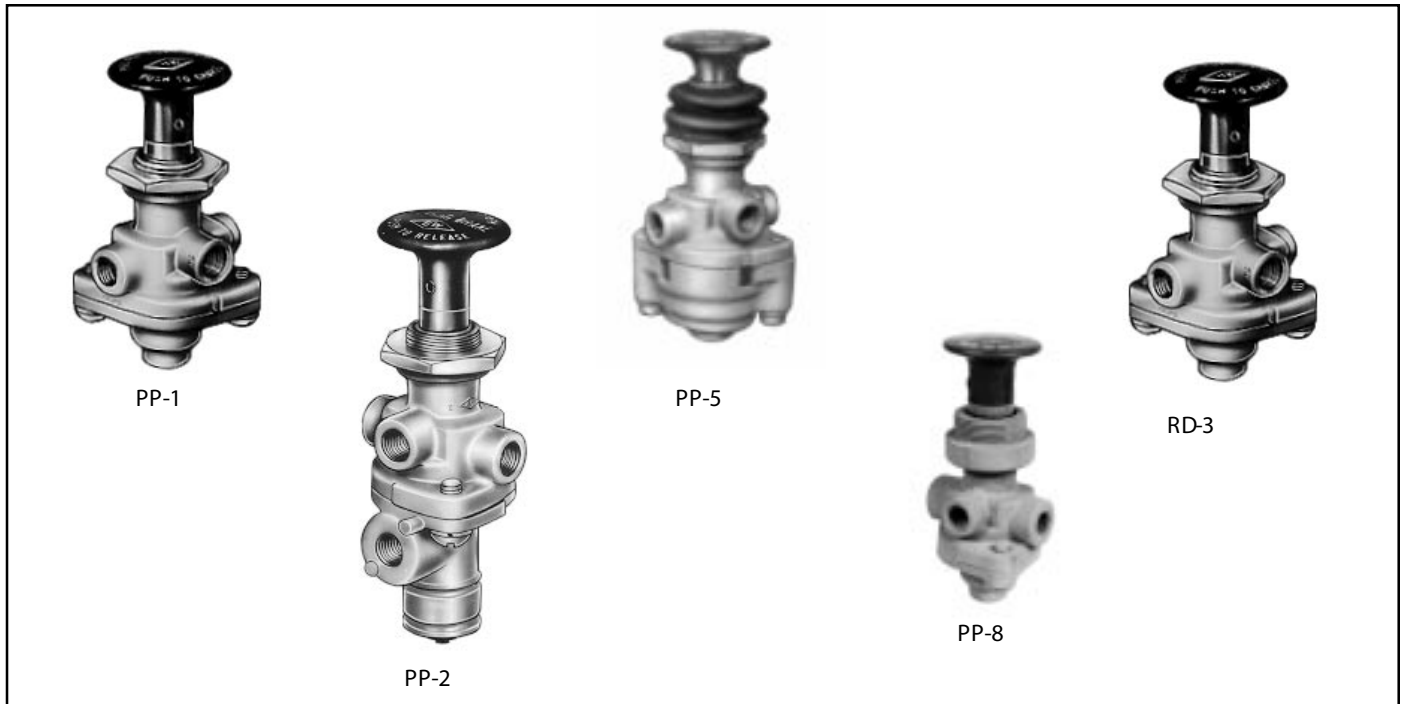

FIGURE 1 - PUSH-PULL TYPE CONTROL VALVES

### DESCRIPTION

The PP valves are push-pull manually operable on-off air control valves with an exhaust function. Most are pressure sensitive, so that they will automatically move from the applied to the exhaust position as supply pressure is reduced to a certain minimum, depending on the spring installed. The exception to this is the PP-8 valve and some PP-1 valves which have no spring. The PP-8 valve also has a larger diameter shaft for button mounting so that when installed on the same panel with other PP valves the buttons cannot be inadvertently mixed. The PP-8 is normally used to operate tractor spring brakes independently from the trailer.

The PP-5 is unique in having an auxiliary piston in the lower cover which, upon receiving a pneumatic signal of 18 psi or more, will cause the valve to move from the applied to the exhaust position from a 100 psi application.

The RD-3 differs slightly in that it normally remains in the exhaust position and requires a constant manual force to hold it in the applied position.

The PP-2 has an auxiliary port which may be plumbed into a service brake line to release the spring brakes if a service application is made, preventing compounding of forces on the foundation brakes.

### PREVENTIVE MAINTENANCE

Every six months, 50,000 miles or 1800 operating hours, disassemble, clean and replace parts if necessary.

### REMOVAL

Block and/or hold the vehicle by a means other than air brakes and drain all reservoirs.

1. Drive the Button Roll-Pin out with a punch and remove the button.
2. Mark each air supply line and its port for easy reinstallation, then disconnect them. Remove the valve from the panel by removing the Panel Mounting Nut.

	AUTOMATIC EXHAUST	MOMENTARY APPLY	PILOT TRIP FEATURE	NON-AUTOMATIC
PP-1	20,30,40 or 60 psi			
PP-2	40 psi			
PP-5	40 psi		18 psi	
RD-3		Must be held manually		
PP-8				Will remain in either position

## INSTALLING

1. Install valve in panel, securing with the Panel Mounting Nut.
2. Reconnect the air lines using marks made during removal as a guide.
3. Install the operating button. Secure the operating button by installing the Button Roll Pin.

### DISASSEMBLY: PP-1, PP-8 AND RD-3

1. Remove the two cap screws (3) which retain the lower cover and remove cover. Remove the sealing ring (4).
2. Insert a small punch through the roll pin hole in the stem and remove the lock nut (5).
3. Remove inlet-exhaust valve (6) and plunger (7) and spring (8) (if any).
4. Remove o-ring (9) from plunger.

### DISASSEMBLY: PP-5

1. Perform same operations as for PP-1.
2. Remove inlet seal (10) in Figure 4 from lower cover. Remove the ring diaphragm (4) from the inlet seat.
3. Remove piston (11) Figure 4 and o-ring (2).

### DISASSEMBLY: PP-2

1. Insert a small punch through the roll pin hole in the plunger and remove the lock nut (1) from the plunger.
2. Withdraw the plunger and remove the spring (9) and o-ring (8).
3. Remove the two machine screws (2) and remove the lower cover (3).
4. Remove the inlet-exhaust valve (4), and piston (5).
5. Remove o-rings (6 & 7) from piston.

## OPERATING AND LEAKAGE TESTS

### PP-1, PP-8, RD-3

1. An accurate test gauge should be tee'd into the supply line and a means of controlling the supply pressure provided. Apply a 120 psi air source to the supply port. A small volume reservoir (e.g. 90 cu. in.) with a gauge should be connected to the delivery port.

2. With 120 psi supply pressure, and the button pulled out (exhaust position), leakage at the exhaust port should not exceed a 1" bubble in five seconds; at the plunger stem a 1" bubble in five seconds. There should be no leakage between upper and lower body.
3. Push the button in (applied position). Leakage at the exhaust port should not exceed a 1" bubble in 3 seconds; at the plunger a 1" bubble in three seconds. (The RD-3 will have to be manually held in this position.)
4. Reduce the supply pressure. At a pressure from 60 to 20 psi depending on the spring installed the button should pop out automatically, exhausting the delivery volume. (This does not apply to the RD-3, PP-8 or some PP-1's).

### PP-5

1. Proceed as for PP-1 through Step 3.
2. Connect a modulated source of air pressure to the pilot air inlet. With the button pushed in (applied position) with 125 psi supply pressure and a gradually increasing pressure applied at the pilot air port the valve should move to the release position with a pilot pressure of not more than 18 psi. Leakage in this mode should not exceed a 1" bubble in three seconds at the exhaust port and a 1" bubble in five seconds at the plunger stem.

### PP-2

1. Proceed as for PP-1 through Step 1.
2. With the button pulled out (exhaust position), leakage at the brake valve port or at the plunger stem should not exceed a 1" bubble in five seconds.
3. Push the button in. Supply pressure should be present in the delivery volume. Leakage at the exhaust port or around the plunger stem should not exceed a 1" bubble in five seconds.
4. Pull the button out and apply supply pressure at the brake valve port. Supply pressure should be present in the delivery volume and leakage at the exhaust port should not exceed a 1" bubble in five seconds.

Note: If any of the above push-pull valves do not function as described or if leakage is excessive, it is recommended they be returned to our nearest authorized distributor for a factory rebuilt or new valve.

### IMPORTANT! PLEASE READ:

When working on or around a vehicle, the following general precautions should be observed:

1. Park the vehicle on a level surface, apply the parking brakes, and always block the wheels.
2. Stop the engine when working around the vehicle.

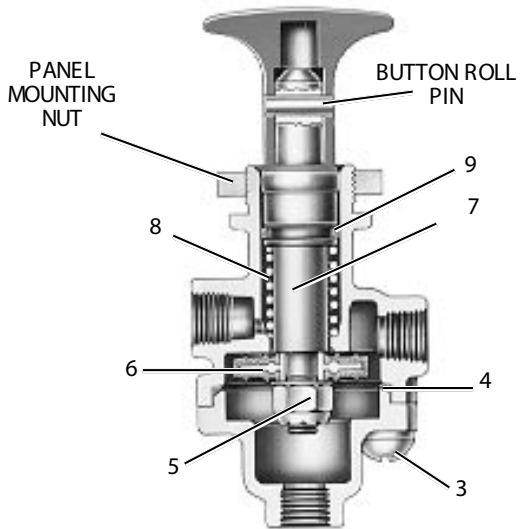

FIGURE 2 PP-1

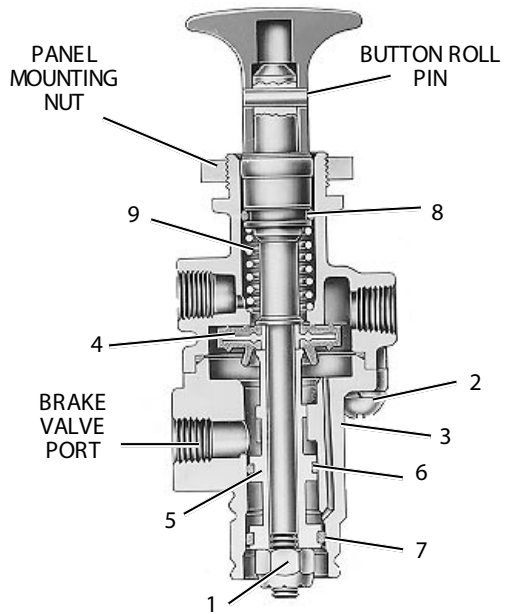

FIGURE 3 PP-2

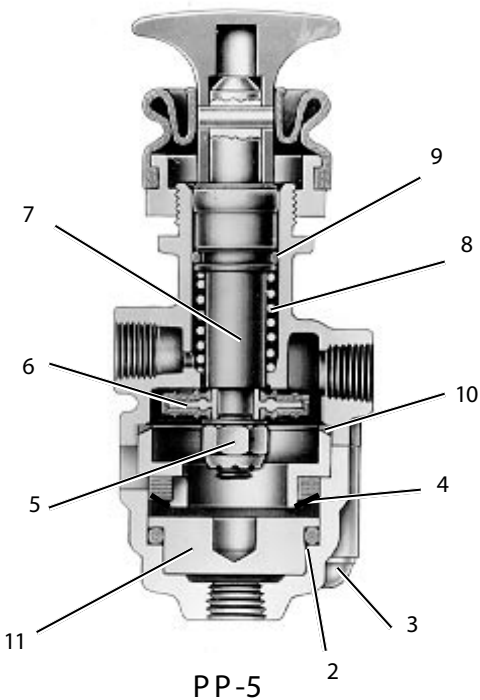

FIGURE 4

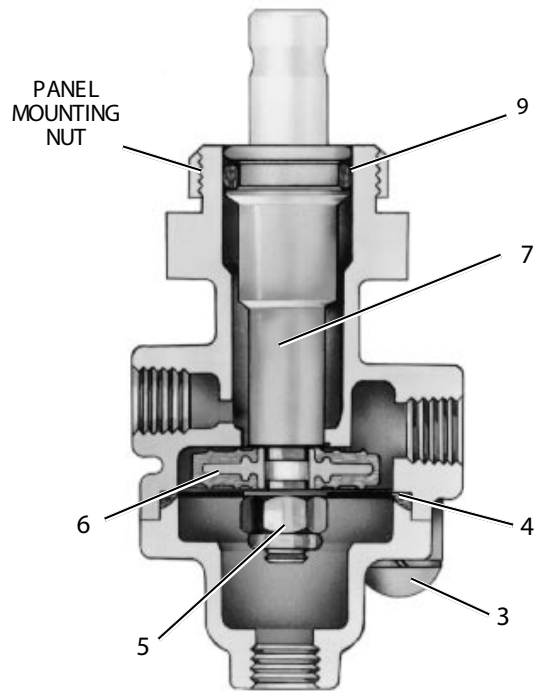

FIGURE 5

3. If the vehicle is equipped with air brakes, make certain to drain the air pressure from all reservoirs before beginning any work on the vehicle.
4. Following the vehicle manufacturer's recommended procedures, deactivate the electrical system in a manner that removes all electrical power from the vehicle.
5. When working in the engine compartment the engine should be shut off. Where circumstances require that the engine be in operation, extreme caution should be used to prevent personal injury resulting from contact with moving, rotating, leaking, heated, or electrically charged components.

6. Never connect or disconnect a hose or line containing pressure; it may whip. Never remove a component or plug unless you are certain all system pressure has been depleted.
7. Never exceed recommended pressures and always wear safety glasses.
8. Do not attempt to install, remove, disassemble or assemble a component until you have read and thoroughly understand the recommended procedures. Use only the proper tools and observe all precautions pertaining to use of those tools.
9. Use only genuine Bendix replacement parts, components, and kits. Replacement hardware, tubing, hose, fittings, etc. should be of equivalent size, type, and strength as original equipment and be designed specifically for such applications and systems.
10. Components with stripped threads or damaged parts should be replaced rather than repaired. Repairs requiring machining or welding should not be attempted unless specifically approved and stated by the vehicle or component manufacturer.
11. Prior to returning the vehicle to service, make certain all components and systems are restored to their proper operating condition.

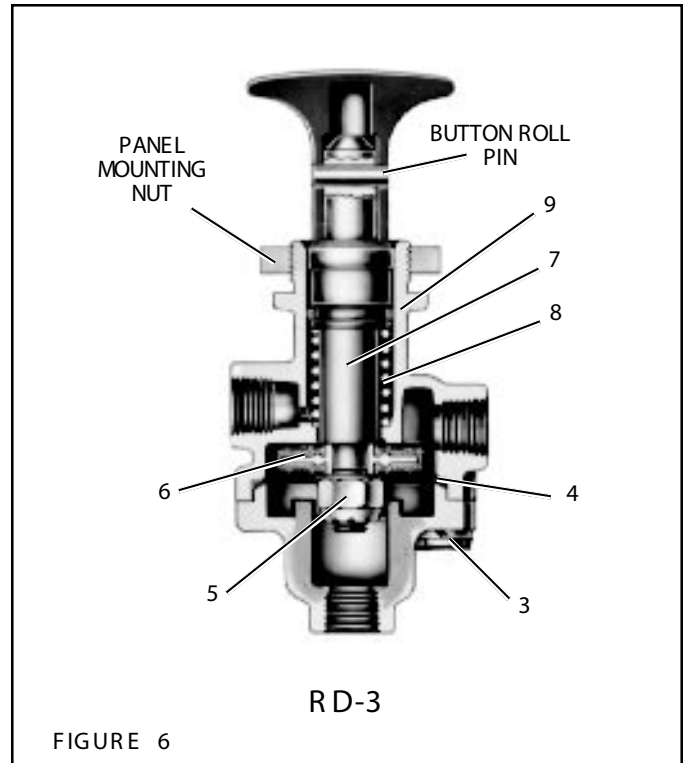

FIGURE 6



## SR-1 SPRING BRAKE VALVE

\*Formerly SD-03-87

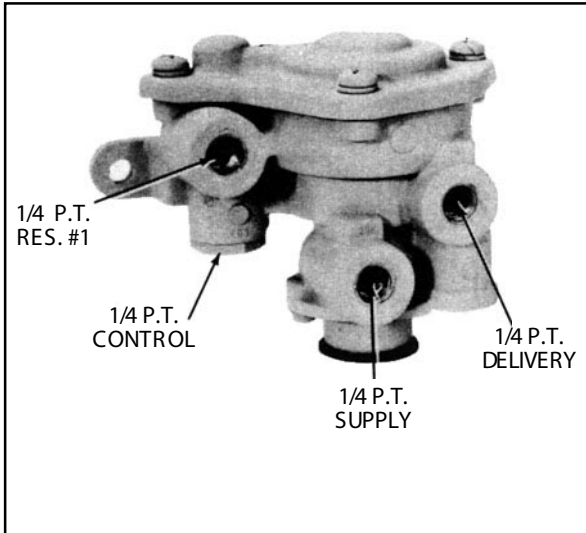

FIGURE 1 - EXTERIOR VIEW

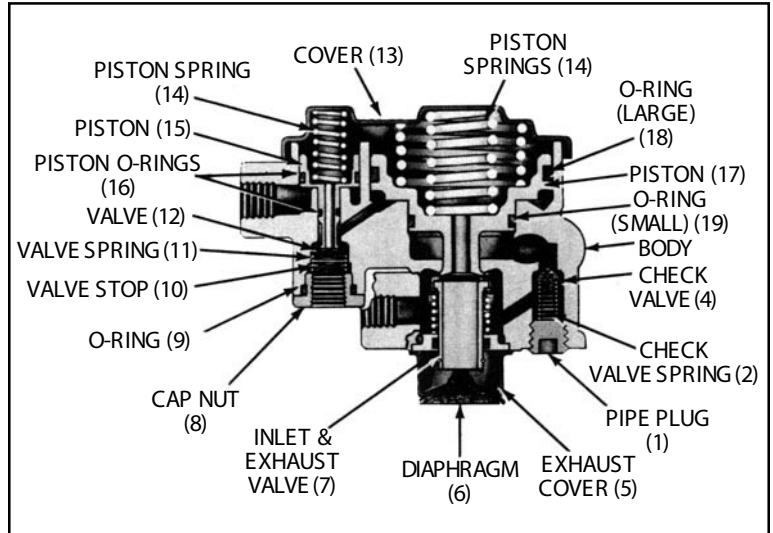

FIGURE 2 - SECTIONAL VIEW

### DESCRIPTION:

The SR-1 Spring Brake Valve is used in dual or "split" air brake systems equipped with spring brake actuators. The function of the SR-1 is to supply a specific, limited hold-off pressure to the spring brakes, and in the event of loss of No. 1 service air pressure, to modulate the spring brakes through the use of the service brake valve.

The valve has four identified 1/4" N.P.T.F. ports and a diaphragm protected exhaust port. Two 5/16" diameter holes are provided in the integral mounting bracket of the valve body. The SR-1 must be mounted with the exhaust port down toward the road surface.

### OPERATION - INITIAL AIR SYSTEM CHARGE

Upon initial charge, air from #1 & #2 service reservoirs flows through the park control valve and enters the SR-1 supply port. Air entering the supply port flows past inlet and exhaust valve B to the underside of piston B and out the delivery port of the SR-1 to the emergency air connection at the spring brake actuator. Note that the springs above piston B force it into contact with inlet and exhaust valve B. In the position shown the exhaust is closed and the inlet is open.

Air flowing from the No. 1 reservoir only enters the reservoir port of the SR-1. This air remains under piston A as system pressure builds. With No. 1 reservoir pressure below approximately 55 P.S.I. the spring above piston A forces it into contact with inlet and exhaust valve A causing the exhaust to seal and the inlet to open.

With air system pressure above approximately 55 P.S.I. in No. 1 & 2 service reservoirs, piston A has moved against the force of the spring above it, allowing the inlet of valve A to close and opening the hollow exhaust passage through piston A.

### OPERATION - AIR BRAKE SYSTEM FULLY CHARGED

When air pressure beneath piston B is approximately 95\*\* P.S.I., piston B rises slightly, against the force of the springs above it, allowing the inlet of valve B to close. The exhaust through valve B remains closed. The closing of the inlet portion of valve B retains approximately 95\* P.S.I. in the hold-off cavity of the spring brake actuators while allowing full air system pressure to build elsewhere.

\*\*Note: Other spring brake hold-off pressures are supplied according to the vehicle manufacturer's specifications. 95 P.S.I. was chosen only for the purpose of explanation.

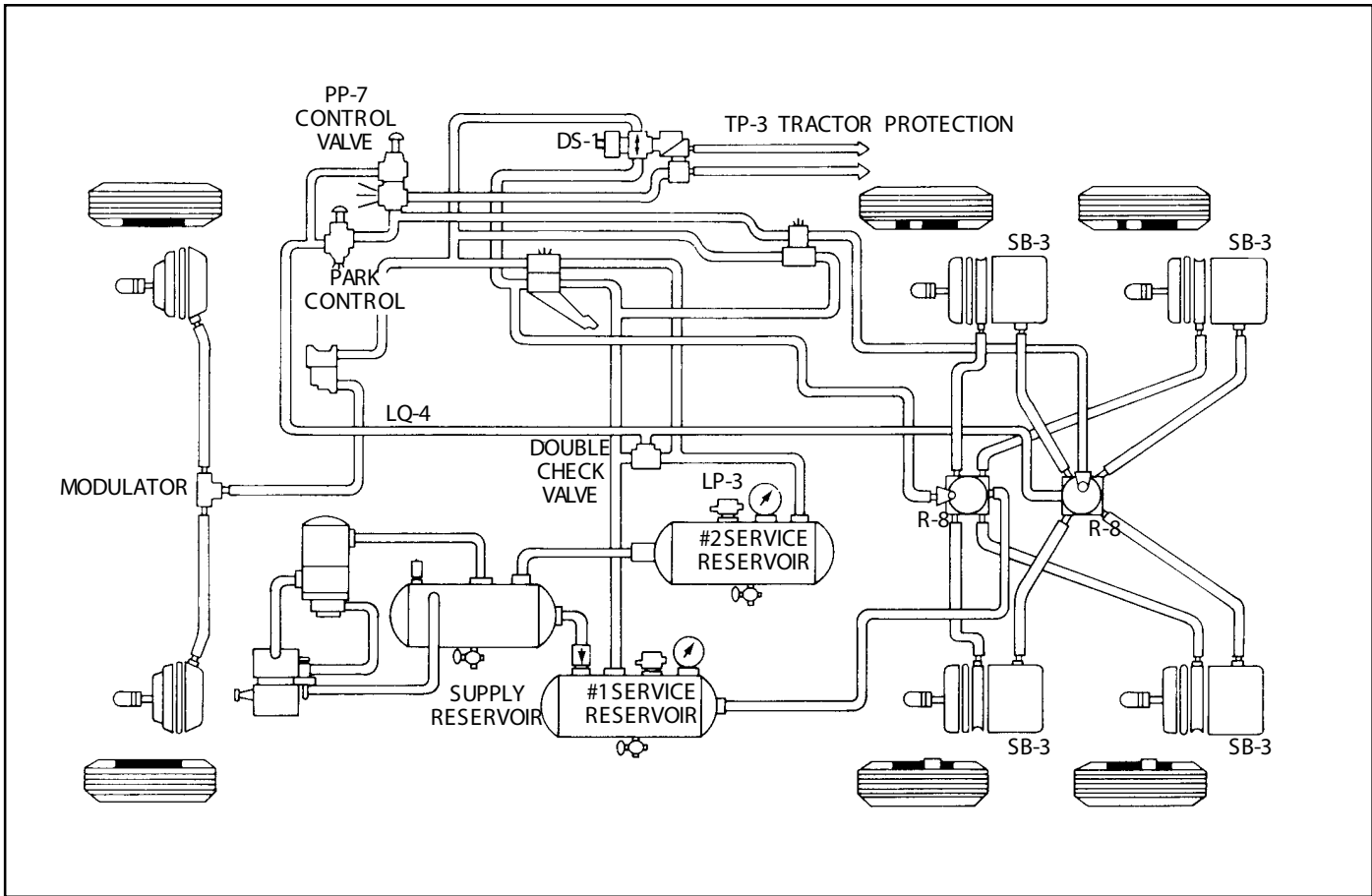

FIGURE 3 - PIPING DIAGRAM

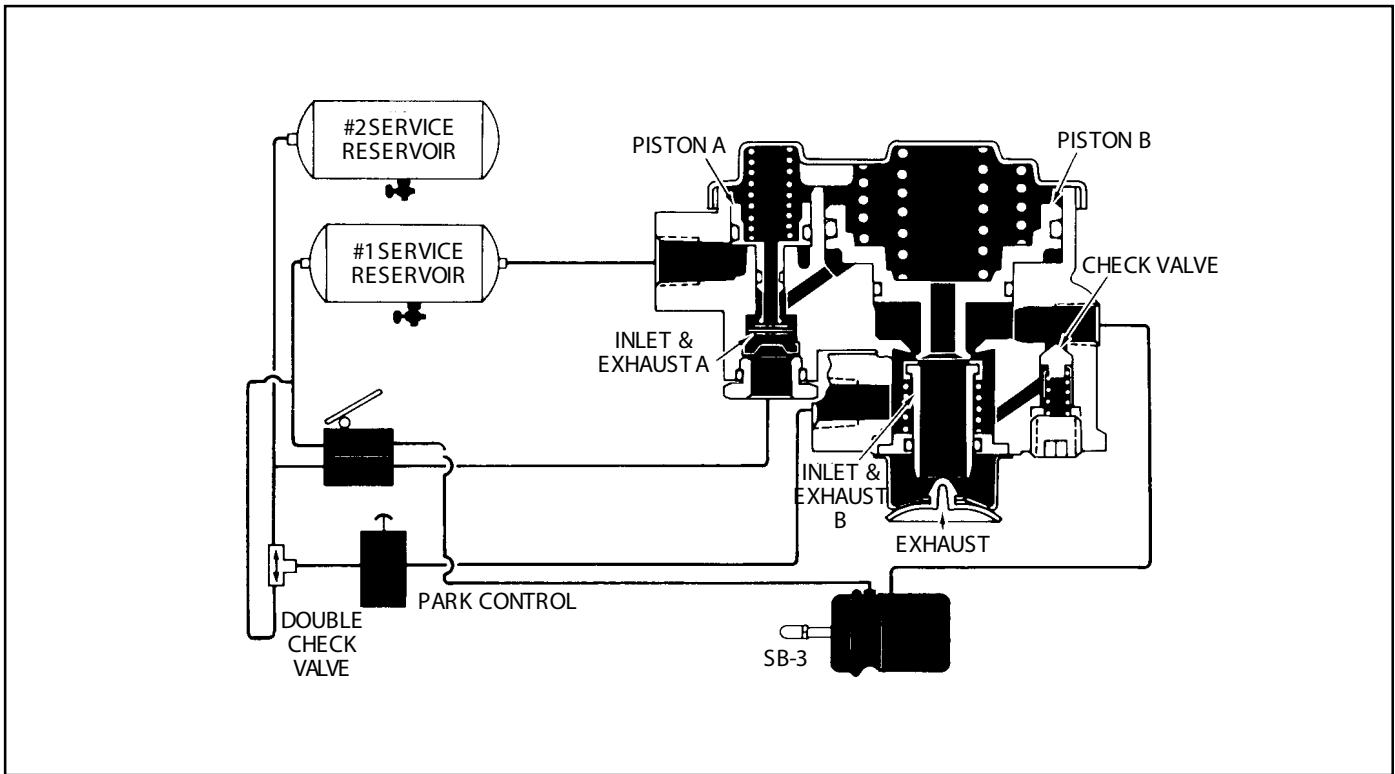

FIGURE 4 - CHARGING - BELOW 55 P.S.I.





Use only the proper tools and observe all precautions pertaining to use of those tools.

9. Use only genuine Bendix replacement parts, components, and kits. Replacement hardware, tubing, hose, fittings, etc. should be of equivalent size, type, and strength as original equipment and be designed specifically for such applications and systems.
10. Components with stripped threads or damaged parts should be replaced rather than repaired. Repairs requiring machining or welding should not be attempted unless specifically approved and stated by the vehicle or component manufacturer.
11. Prior to returning the vehicle to service, make certain all components and systems are restored to their proper operating condition.

## DISASSEMBLY (REFER TO FIGURE 2)

1. Remove the socket head pipe plug (1).
2. Remove the check valve spring (2) and the check valve (4).
3. Remove the two phillips head screws and remove the exhaust cover (5).
4. Separate the exhaust diaphragm (6) from the cover.
5. Remove the inlet and exhaust valve assembly (7).
6. Remove the inlet and exhaust valve cap nut (8) and separate the cap nut o-ring (9).
7. Remove the valve stop (10) valve spring (11) and inlet and exhaust valve (12).
8. Remove the four phillips head screws and lockwashers that secure the cover to the body. Caution: the cover is under a spring load, and should be held while removing the screws.
9. Remove the cover (13) and the three piston springs (14). Note: Some SR-1 piece numbers have one large piston spring.
10. Remove the small piston (15) and the small and large o-rings (16).
11. Remove the large piston (17). Remove piston o-rings (18) & (19).

## CLEANING & INSPECTION

Wash all metal parts in mineral spirits and dry.

Inspect all parts for excessive wear or deterioration.

Inspect the valve seats for nicks or burrs.

Check the springs for cracks or corrosion.

Replace all rubber parts and any part not found to be serviceable during inspection. Use only genuine Bendix replacement parts.

## ASSEMBLY (REFER TO FIGURE 2)

Prior to assembly of the SR-1 Spring Brake Valve, lubricate all o-rings, o-ring grooves, and piston bores with Dow Corning 55-M Pneumatic Grease (Bendix No. 291126).

Note: All torques specified in this manual are assembly torques and can be expected to fall off, after assembly is accomplished. Do not retorque after initial assembly torques fall.

1. Assemble the check valve (4), and valve spring (2) and install in body.
2. Apply pipe sealant to the socket head pipe plug (1) and install in the body. Tighten to 130-170 inch pounds torque.
3. Install inlet and exhaust valve assembly (7) in valve body.

4. Secure the exhaust cover (5) with two 10-24 phillips screws and lockwashers. Tighten to 20-30 inch pounds torque.
5. Install exhaust diaphragm (6) into the exhaust cover.
6. Place inlet exhaust valve (12) in the body. Install the valve spring (11) and valve stop (10).
7. Install o-ring (9) on cap nut and install cap nut (8) in body. Tighten to 100- 125 inch pounds torque.
8. Install the small and large o-rings (16) on the small diameter piston (15) and install piston in the body.
9. Install large o-ring (18) and small o-ring (19) on the large diameter piston and install piston in the body.
10. Install the piston springs (14) in their respective pistons.
11. Secure the cover to body using four 1/4"-20 phillips head screws and lockwashers. Tighten to 50-80 inch pounds torque.

## TESTING THE REBUILT SR-1 SPRING BRAKE VALVE

Test the rebuilt SR-1 Spring Brake Valve by performing the operation and leakage test outlined in the "Service Checks" section of this manual.

## IMPORTANT! PLEASE READ

When working on or around a vehicle, the following general precautions should be observed:

1. Park the vehicle on a level surface, apply the parking brakes, and always block the wheels.
2. Stop the engine when working around the vehicle.
3. If the vehicle is equipped with air brakes, make certain to drain the air pressure from all reservoirs before beginning ANY work on the vehicle.
4. Following the vehicle manufacturer's recommended procedures, deactivate the electrical system in a manner that removes all electrical power from the vehicle.
5. When working in the engine compartment the engine should be shut off. Where circumstances require that the engine be in operation, EXTREME CAUTION should be used to prevent personal injury resulting from contact with moving, rotating, leaking, heated, or electrically charged components.
6. Never connect or disconnect a hose or line containing pressure; it may whip. Never remove a component or plug unless you are certain all system pressure has been depleted.
7. Never exceed recommended pressures and always wear safety glasses.
8. Do not attempt to install, remove, disassemble or assemble a component until you have read and thoroughly understand the recommended procedures.

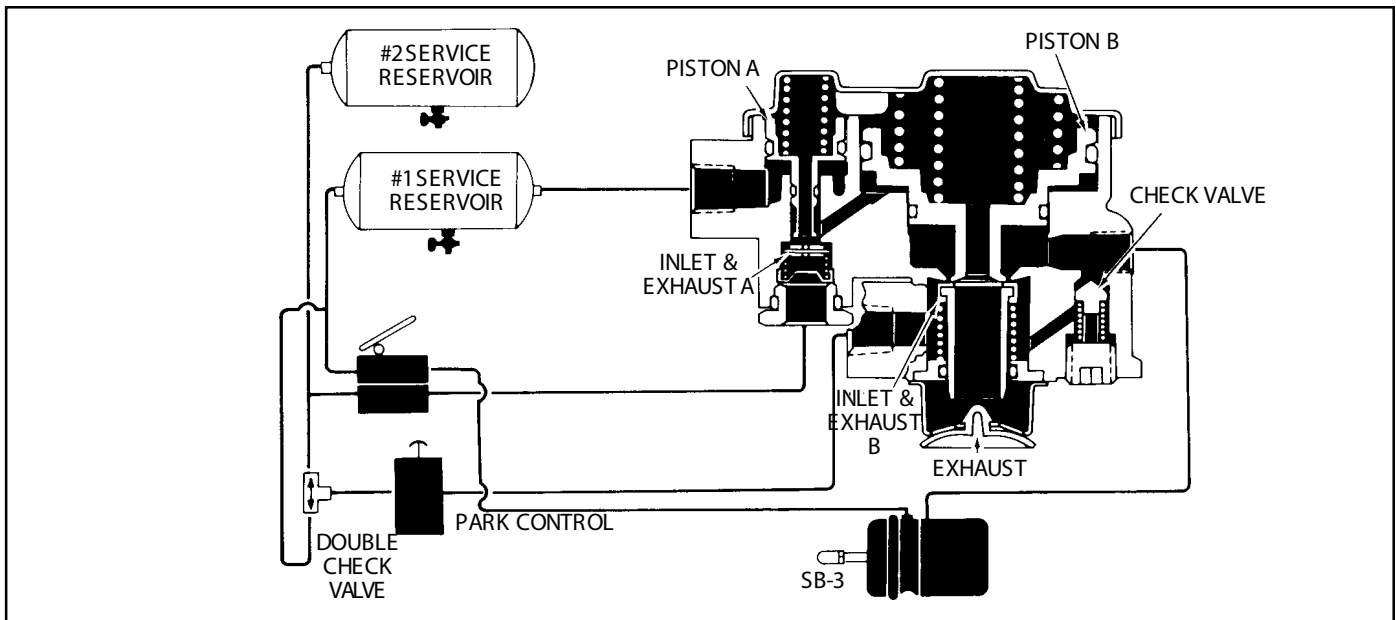

FIGURE 9 - PARK APPLICATION

## OPERATION - PARKING

If both systems #1 and #2 are intact and the park control valve is placed in the “park” or exhaust position, the SR-1 supply of air pressure and the air pressure in the spring brake actuator cavities is exhausted. The single check valve in the SR-1 assists this exhaust of air pressure from the spring brake by allowing the air below piston B to flow back out the open exhaust of the park control valve. When air pressure below piston B has dropped sufficiently, piston B moves down opening the inlet of valve B thus providing an additional exhaust passage for air exhausting through the SR-1 from the spring brakes.

## PREVENTIVE MAINTENANCE

Every 3600 operating hours, 100,000 miles or yearly, disassemble valve, clean all parts in mineral spirits. Replace all rubber parts, and any part worn or damaged with genuine Bendix parts.

## SERVICE CHECKS

### OPERATING CHECKS

Block vehicle and hold by means other than vehicle brakes. Charge air brake system to governor cut-out pressure.

1. Place parking control valve in the “park” position. Observe that the spring brake actuators apply promptly. In the delivery port of the valve install a test gauge known to be accurate. Place the parking control valve in the “release” position. Observe that the spring brake actuators release fully.
2. With the parking control valve in the “release” position, note the gauge pressure reading. (Check the vehicle manual for the correct spring brake actuator hold-off pressure.) If the pressure reading is incorrect, the valve must be repaired or replaced.

3. Place the parking control valve in the “park” position, the gauge reading should drop to zero promptly. A slow release of pressure may indicate faulty operation of the single check valve (within the Modulating Valve.)

4. Place the parking control valve in the “release” position. Locate the number one service reservoir and drain it completely.

Apply the foot brake valve several times and note that the pressure reading on the gauge decreases each time the foot brake valve is applied. After several applications, pressure on the gauge will drop to the point where release of the spring brake actuators will no longer occur.

## LEAKAGE CHECK

With the air system fully charged and the parking control valve in the “release” position, coat the exhaust port and around the valve corner with a soap solution. Slight leakage is permitted.

If the SR-1 Spring Brake Valve does not function as described above, or leakage is excessive, it is recommended that it be returned to the nearest Bendix authorized distributor for a new or remanufactured valve. If this is not possible, the valve can be repaired with genuine Bendix parts in which case the following should prove helpful.

Note: A maintenance kit for the SR-1 Spring Brake Valve is available from any authorized Bendix outlet. All parts necessary for minor repair are included.

## REMOVAL

1. Prior to removing the SR-1 apply the parking brakes and drain all the vehicle reservoirs.
2. Identify all air lines before disconnecting.
3. Remove the two mounting bolts from the SR-1 and remove the valve.

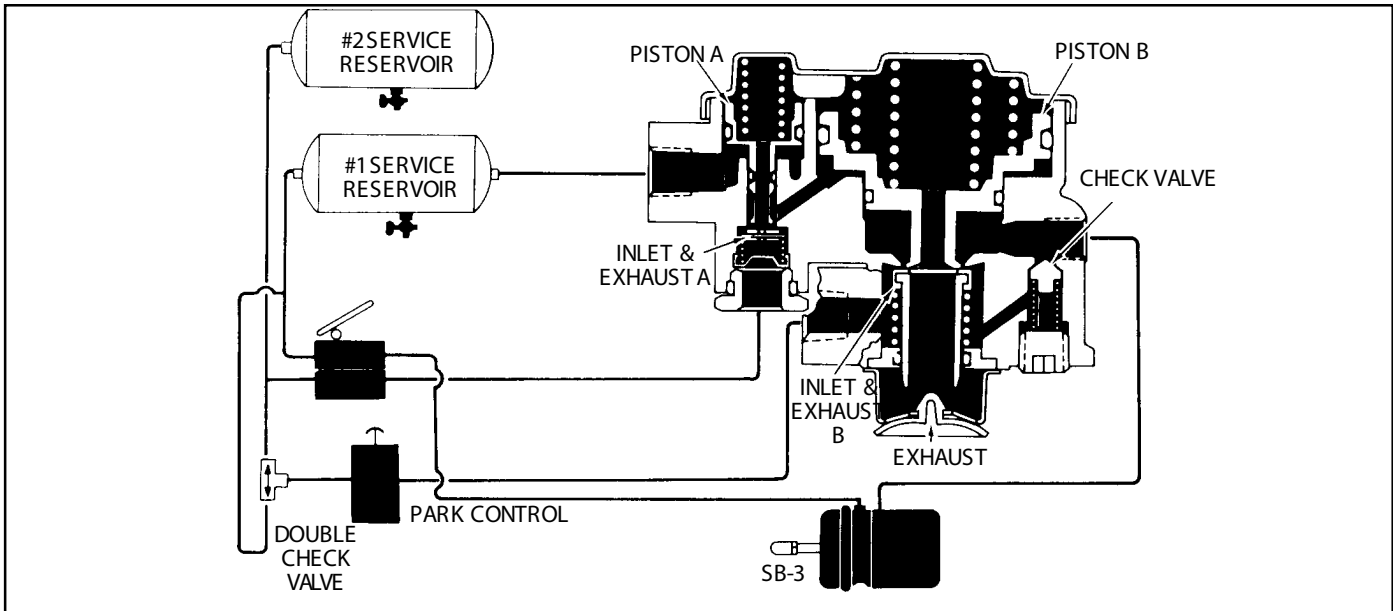

FIGURE 7 - SERVICE APPLICATION - LOSS OF #2 RESERVOIR

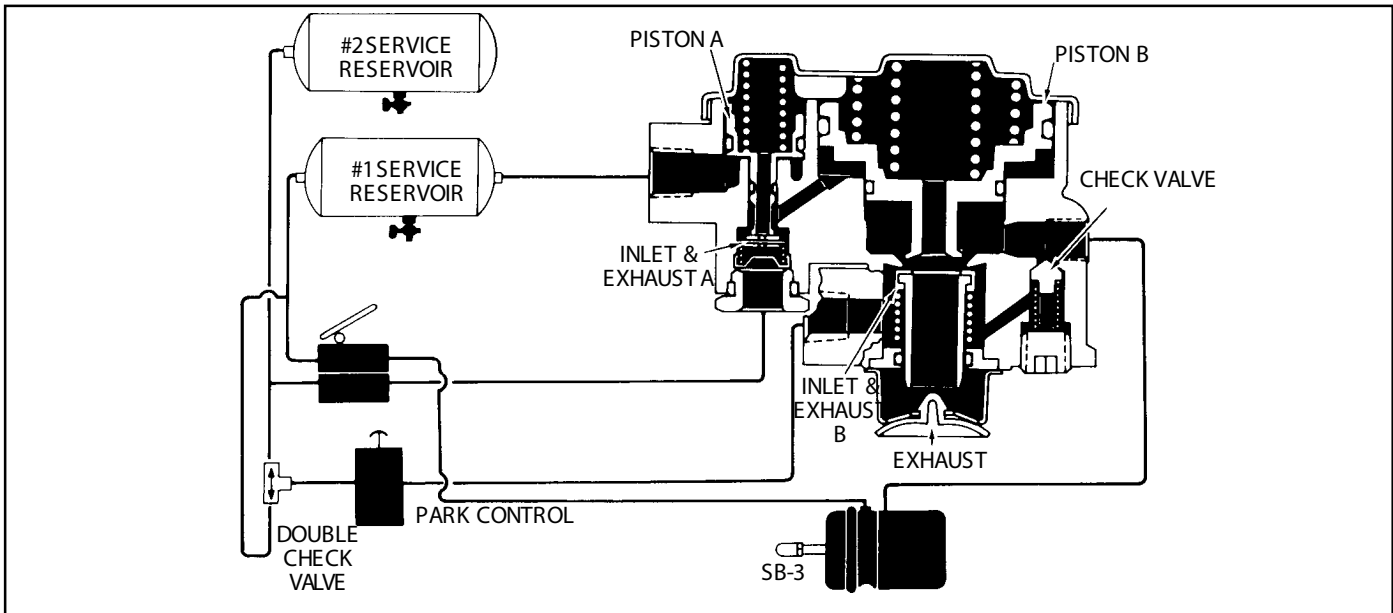

FIGURE 8 - SERVICE APPLICATION - LOSS OF #1 RESERVOIR

circuit of the dual brake valve will apply the service section of the spring brake actuators.

**OPERATION - SERVICE APPLICATION WITH LOSS OF NO. 1 RESERVOIR PRESSURE**

If air pressure in the No. 1 service reservoir falls below approximately 55 P.S.I., the pressure beneath piston A is insufficient to resist the spring force above and piston A moves into contact with valve A. Initial contact between piston A and valve A closes the hollow exhaust passage of piston A. Continued movement of the piston opens the inlet of valve A.

The No. 2 service reservoir and the park control valve are protected from pressure loss by the action of the Double Check Valve.

When a service application of the dual brake valve is made, air delivered from the No. 2 delivery circuit of the dual brake valve enters the SR-1 control port. Air entering the control port, now moves past the inlet of valve A and is conducted through a passage in the body to the underside of piston B. The added force of air pressure beneath piston B, moves up, opening the exhaust of valve B. When the exhaust of valve B opens, air pressure trapped in the emergency section of the spring brake actuator is allowed to escape resulting in a brake application by the emergency section. The amount of air pressure released from the spring brake is in proportion to the amount of air pressure delivered to the control port of the SR-1 by the No. 2 delivery of the dual brake valve.

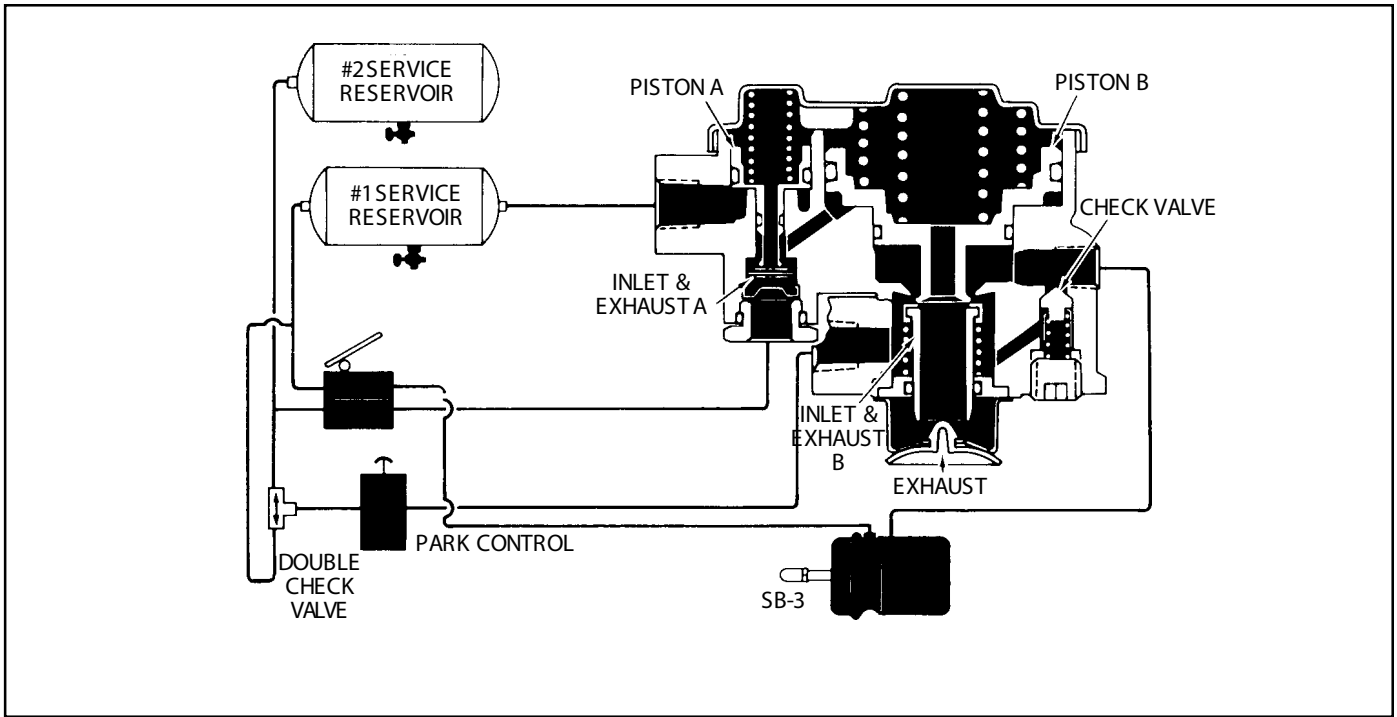

FIGURE 5 - SYSTEM FULLY CHARGED

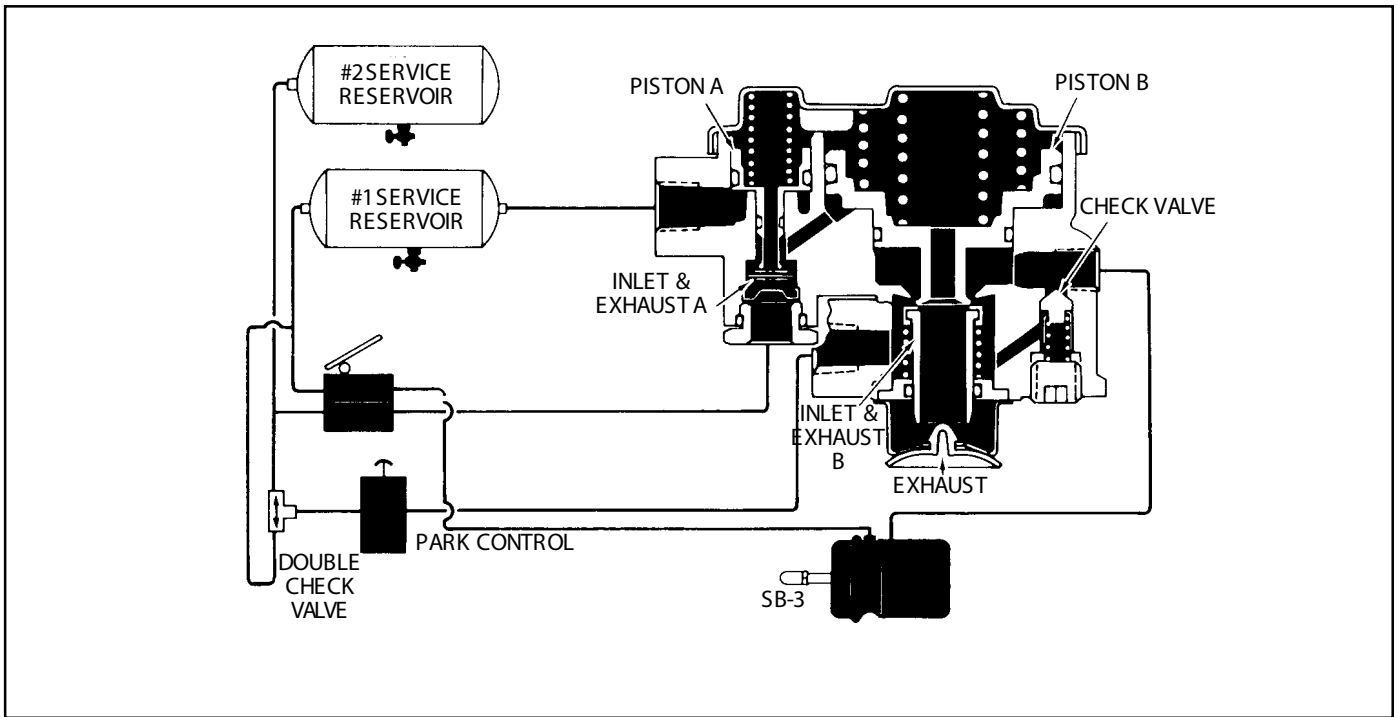

FIGURE 6 - NORMAL SERVICE APPLICATION

**OPERATION - NORMAL SERVICE RESERVOIRS 1 & 2 CHARGED**

When a service application is made by actuating the dual brake valve; air, from the No. 2 delivery circuit is delivered from the brake valve to the control port, and is stopped at the closed inlet of valve A. No movement of the internal components of the SR-1 takes place. Air from the No. 1 delivery circuit of the dual brake valve actuates the service section of the spring brake actuators.

**OPERATION - SERVICE APPLICATION WITH LOSS OF NO. 2 RESERVOIR PRESSURE**

In the event air pressure is lost in No. 2 reservoir, the No. 1 reservoir as well as the parking control valve will be protected through the action of the double and single check valves in the air system. A service application of the dual air brake valve in this situation results in little or no air being delivered from the No. 2 delivery circuit to the control port of the SR-1. No movement of the SR-1 internal components takes place. Braking is assured because the No. 1 service reservoir is protected by a check valve and the No. 1 delivery



## E-8P & E-10P DUAL BRAKE VALVES

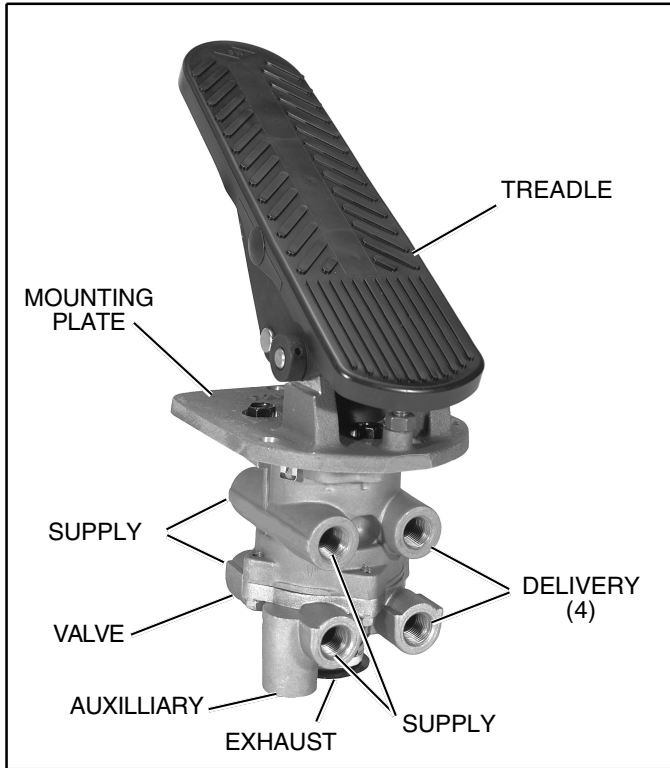

FIGURE 1 - E-8P

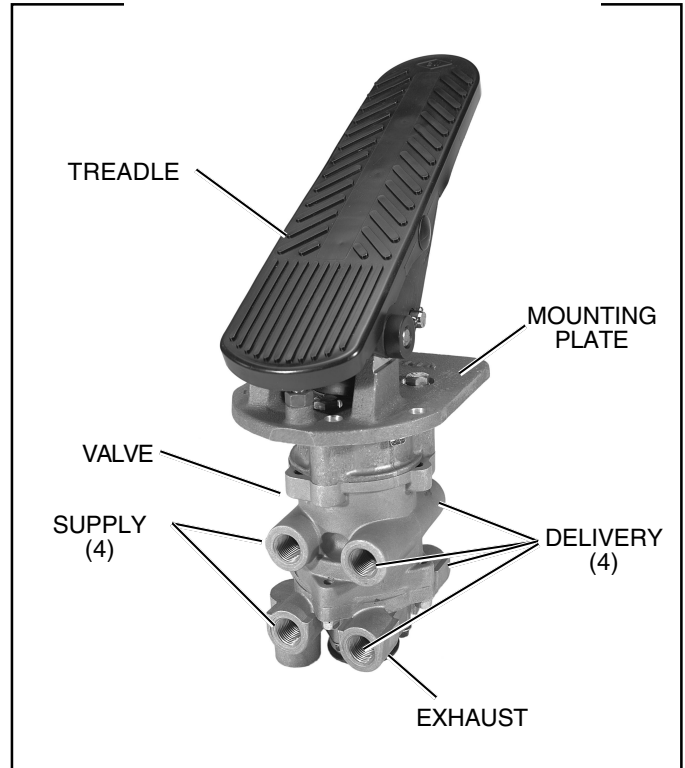

FIGURE 2 - E-10P

### DESCRIPTION

Refer to Figures 4, 5 and 6 for item numbers referenced in parenthesis.

The E-8P (Figure 1) and E-10P (Figure 2) Dual Brake Valves are floor mounted, treadle operated type brake valves with two separate supply and delivery circuits for service (primary and secondary) braking, which provides the driver with a graduated control for applying and releasing the vehicle brakes.

The E-10P Dual Brake Valve (Figure 2) is similar to the E-8P Dual Brake Valve except that a metal coil spring (5) housed in an upper body assembly replaces the rubber spring (27) used in the E-8P valve. The use of a metal coil spring (and the upper body assembly) provides greater treadle travel and, therefore, provides the driver with a less sensitive "feel" when making a brake application. The E-10P Dual Brake

Valve is generally used on busses, where smooth brake applications contribute to passenger comfort.

The circuits in the E-8P/E-10P Dual Brake Valves are identified as follows: The No. 1 or primary circuit is that portion of the valve between the spring seat which contacts the plunger and the relay piston; the No. 2 or secondary circuit is that portion between the relay piston and the exhaust cavity.

The primary circuit of the valve is similar in operation to a standard single circuit air brake valve and under normal operating conditions the secondary circuit is similar in operation to a relay valve.

Both primary and secondary circuits of the brake valve use a common exhaust protected by an exhaust diaphragm.

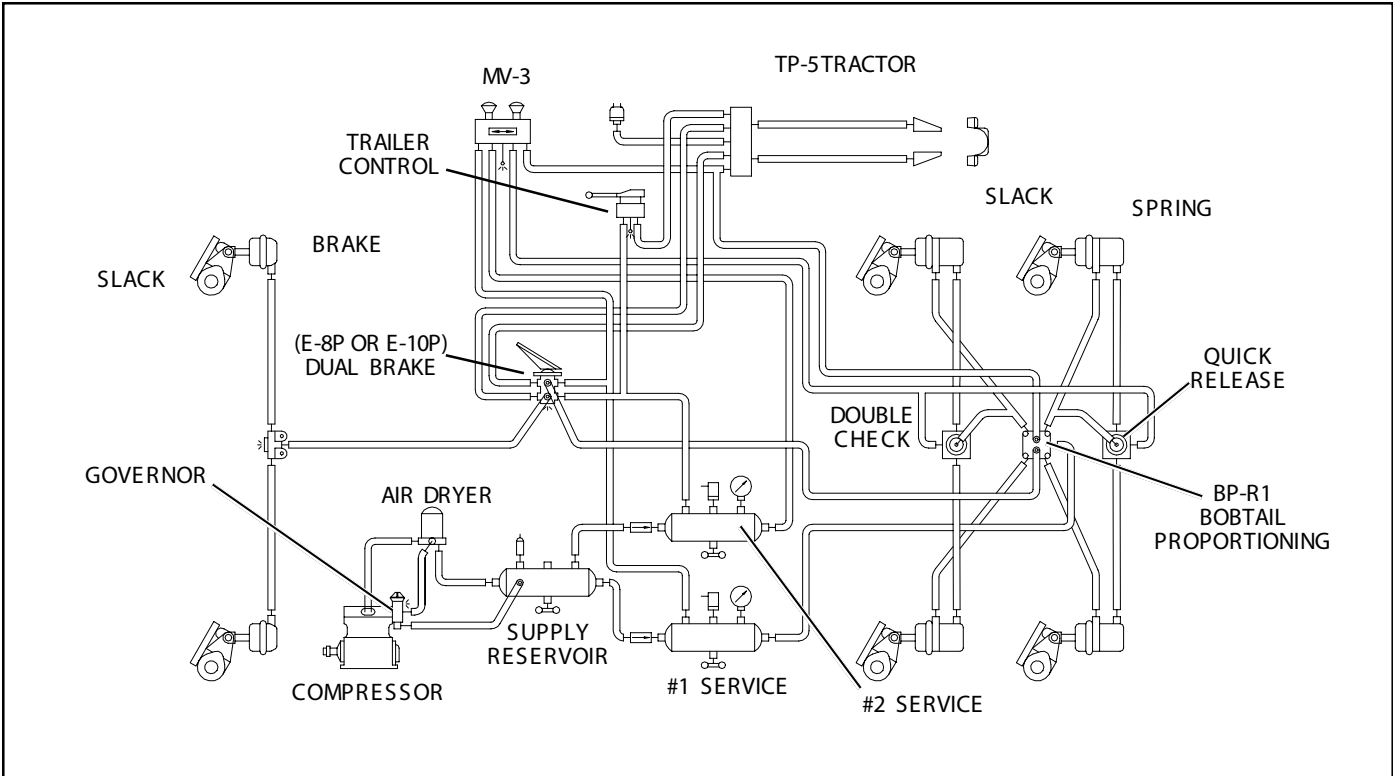

FIGURE 3 - TYPICAL PIPING SCHEMATIC

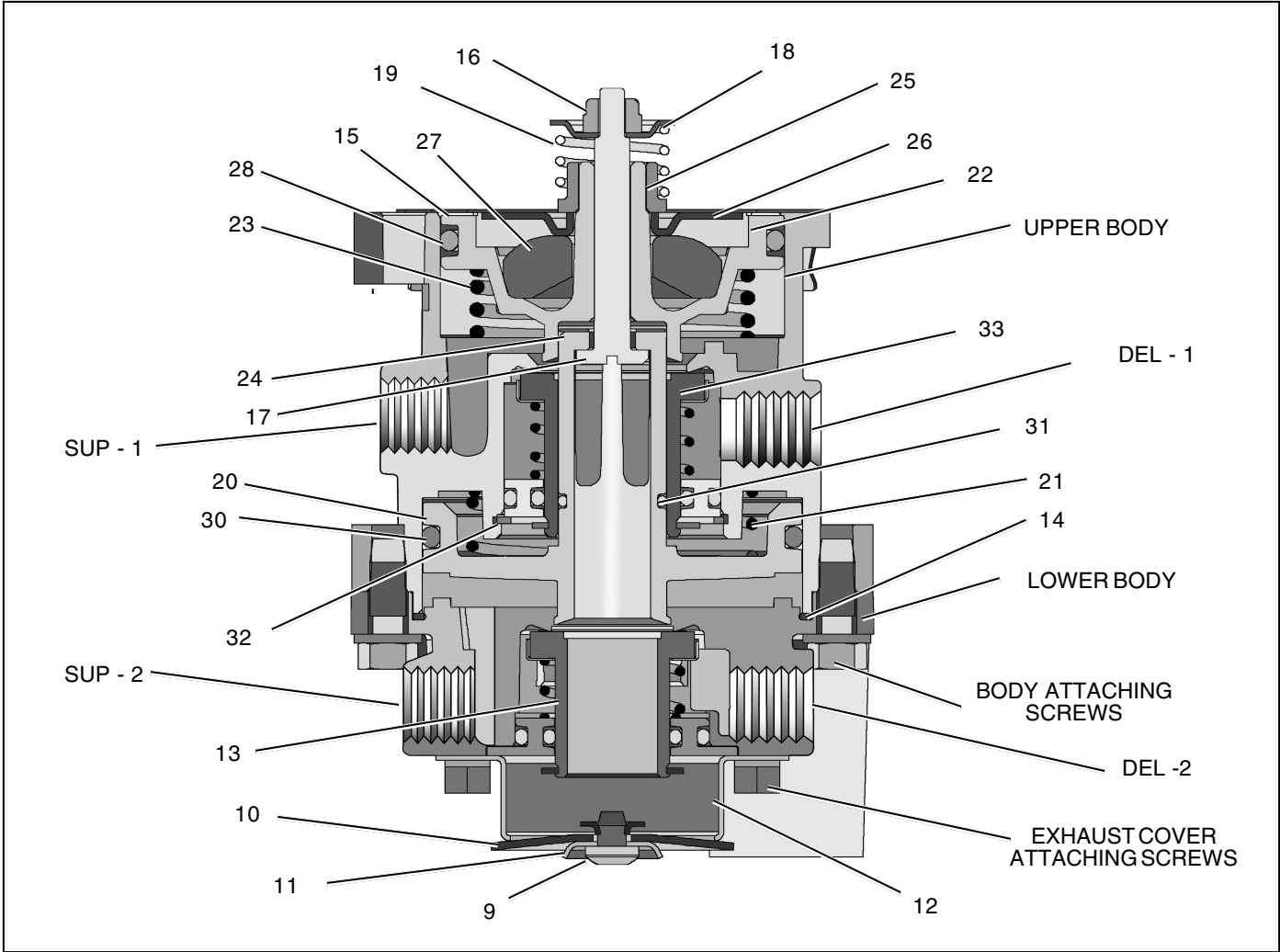

FIGURE 4 - E-8P SECTIONAL VIEW



2. Reconnect all air lines to the valve using the identification made during VALVE REMOVAL step 1.
3. After installing the brake valve assembly, perform the “OPERATION AND LEAKAGE CHECKS” before placing the vehicle in service.

### **IMPORTANT: MAINTENANCE PRECAUTIONS**

When working on or around a vehicle, the following general precautions should be observed:

1. Park the vehicle on a level surface, apply the parking brakes, and always block the wheels.
2. Stop the engine when working around the vehicle.
3. Drain the air pressure from all reservoirs before beginning ANY work on the vehicle.
4. Following the vehicle manufacturer’s recommended procedures, deactivate the electrical system in a manner that removes all electrical power from the vehicle.
5. When working in the engine compartment the engine should be shut off. Where circumstances require that the engine be in operation, **EXTREME CAUTION** should be used to prevent personal injury resulting from contact with moving, rotating, leaking, heated, or electrically charged components.
6. Never connect or disconnect a hose or line containing pressure; it may whip. Never remove a component or plug unless you are certain all system pressure has been depleted.
7. Never exceed recommended pressures and always wear safety glasses.
8. Do not attempt to install, remove, disassemble, or assemble a component until you have read and thoroughly understand the recommended procedures. Use only the proper tools and observe all precautions pertaining to use of those tools.
9. Use only genuine Bendix replacement parts, components, and kits. Replacement hardware, tubing, hose, fittings, etc. should be of equivalent size, type, and strength as original equipment and be designed specifically for such applications and systems.
10. Components with stripped threads or damaged parts should be replaced rather than repaired. Repairs requiring machining or welding should not be attempted unless specifically approved and stated by the vehicle or component manufacturer.
11. Prior to returning the vehicle to service, make certain all components and systems are restored to their proper operating condition.

11. Remove the relay piston (20), relay piston spring (21), primary piston (**E-8P**: 22, **E-10P**: 2) and primary piston return spring (**E-8P**: 23, **E-10P**: 6) from the upper body. Use care so as not to nick seats.
12. A small washer (24) will be found in the cavity of the lower side of the primary piston (**for E-8P**: 22, **for E-10P**: 2).
13. **For E-8P only**: Disassemble the primary piston by rotating the spring seat nut (25) counterclockwise. Separate the spring seat nut, spring seat (26), and rubber spring (27) and remove the piston o-ring (28).
14. Remove the large and small o-rings (30 & 31) from the relay piston (20).
15. Remove the retaining ring (32) securing the primary inlet and exhaust valve assembly (33) in the upper body and remove the valve assembly.
6. Place relay piston spring (21) in concave portion of relay piston (20) and install relay piston through primary inlet/exhaust assembly (33) into under side of upper body.
7. **For E-10P only**: Install o-ring (4) on adapter (1) and install adapter on upper body. Install o-ring (34) on primary piston (2).
8. Place screwdriver, blade up, in vise. Insert stem (17) through the relay piston upper body sub assembly, slide this assembly over the blade of the secured screwdriver, engage the screwdriver blade in the slot in the head of the stem.
9. Place the washer (24) over the stem (17) and on top of the relay piston (20).
10. Install primary return spring (**E-8P**: 23, **E-10P**: 6) in upper body piston bore.
11. **For E-8P only**: Install the primary piston rubber spring sub assembly (steps 4 & 5) over the stem, into the upper body piston bore. **For E-10P**: Install primary piston sub-assembly (reference step 7).

## CLEANING AND INSPECTION

1. Wash all metal parts in mineral spirits and dry.
2. Inspect all parts for excessive wear or deterioration.
3. Inspect the valve seats for nicks or burrs.
4. Check the springs for cracks or corrosion.
5. Replace all rubber parts and any part not found to be serviceable during inspection, use only genuine Bendix replacement parts.

## ASSEMBLY

Prior to reassembling, lubricate all o-rings, o-ring grooves, piston bores, and metal to metal moving surfaces with Dow Corning 55 o-ring lubricant (Bendix piece number 291126).

**Note:** All torques specified in this manual are **assembly** torques and can be expected to fall off, after assembly is accomplished. **Do not retorque** after initial assembly torques fall.

1. Install the primary inlet and exhaust assembly (33) in the upper body and replace the retaining ring (32) to secure it. Be sure the retaining ring is seated completely in its groove.
2. Install the large and small o-rings (30 & 31) on the relay piston (20).
3. **For E-8P only**: Install o-ring (28) in the primary piston (22) o-ring groove.
4. **For E-8P only**: Install the rubber spring (do not lubricate) (27), concave side down in the primary piston (22) and place the spring seat (26), flat side up, over the rubber spring.
5. **For E-8P only**: Install the primary piston spring seat nut (25), with its hex closest to the spring seat, and rotate clockwise until the top surface of the spring seat is even with the top surface of the piston. Set aside.
12. Compress piston(s) (**For E-8P**: the relay piston (20), **for E-10P**: the primary and relay pistons (2 & 20)) and retaining ring into the upper body from either side and hold compressed, either manually or mechanically. **See the cautionary note under step 8 in the Disassembly section of this manual.**
13. Place the stem spring (19) (**E-8P**: place over the spring seat nut (25)), the spring seat (18) (concave side up) and lock nut (16) on the stem (17). Torque to 20 - 30 inch pounds.
14. **For E-8P only**: Install the primary piston retainer (15) over the piston, making certain all three lock tabs have engaged the outer lip of the body.
15. **For E-10P only**: Install coil spring (5), spring seat (7), and retaining ring (8) .
16. Replace the rubber seal ring (14) on the lower body.
17. Install the 4 hex head cap screws securing the lower body to the upper body. Torque to 30 - 60 inch pounds.
18. Install the secondary inlet and exhaust valve assembly (13) on the lower body.
19. Install the screws that secure the exhaust cover (12) to the lower body. Torque to 20 - 40 inch pounds.
20. Secure the screw (9) holding the exhaust diaphragm (10) and the diaphragm washer (11) to the exhaust cover (12). Torque to 5 - 10 inch pounds.
21. Install all air line fittings and plugs making certain thread sealant material does not enter valve.

## VALVE INSTALLATION

1. Install the assembled brake valve on the vehicle.

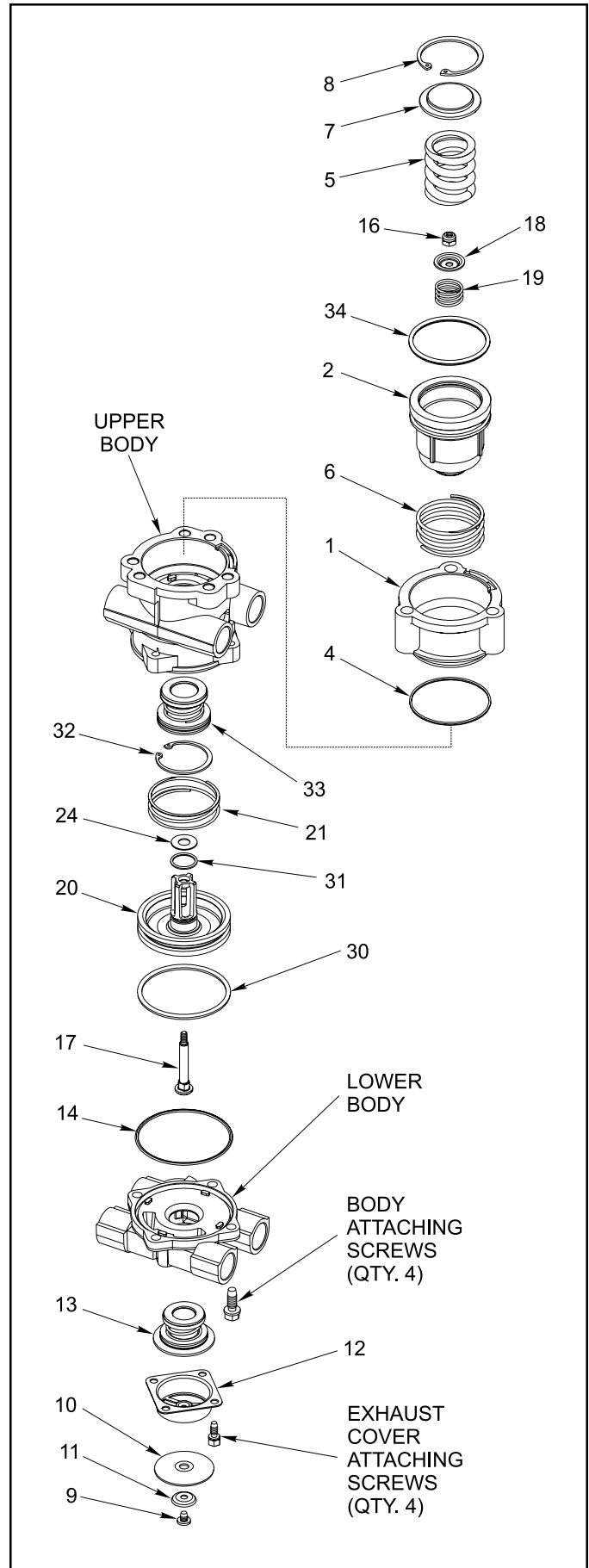
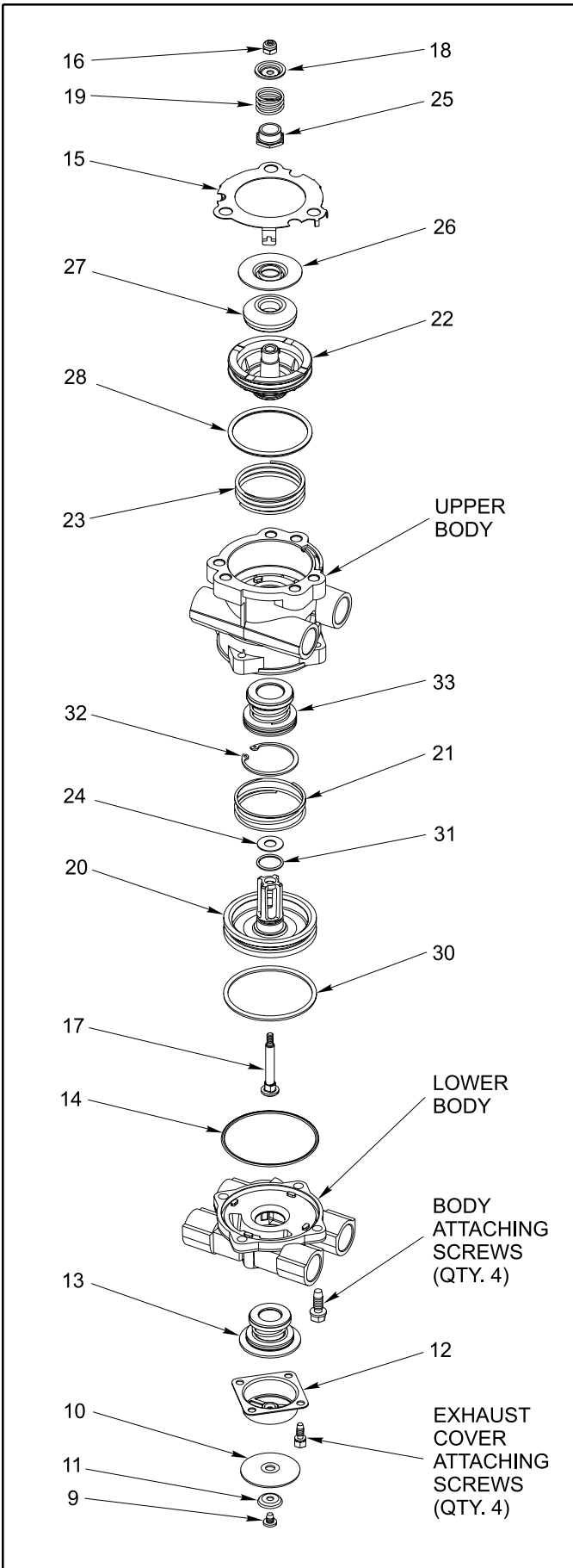

FIGURE 5 E-8P BRAKE VALVE EXPLODED VIEW

FIGURE 6 E-10R BRAKE VALVE EXPLODED VIEW

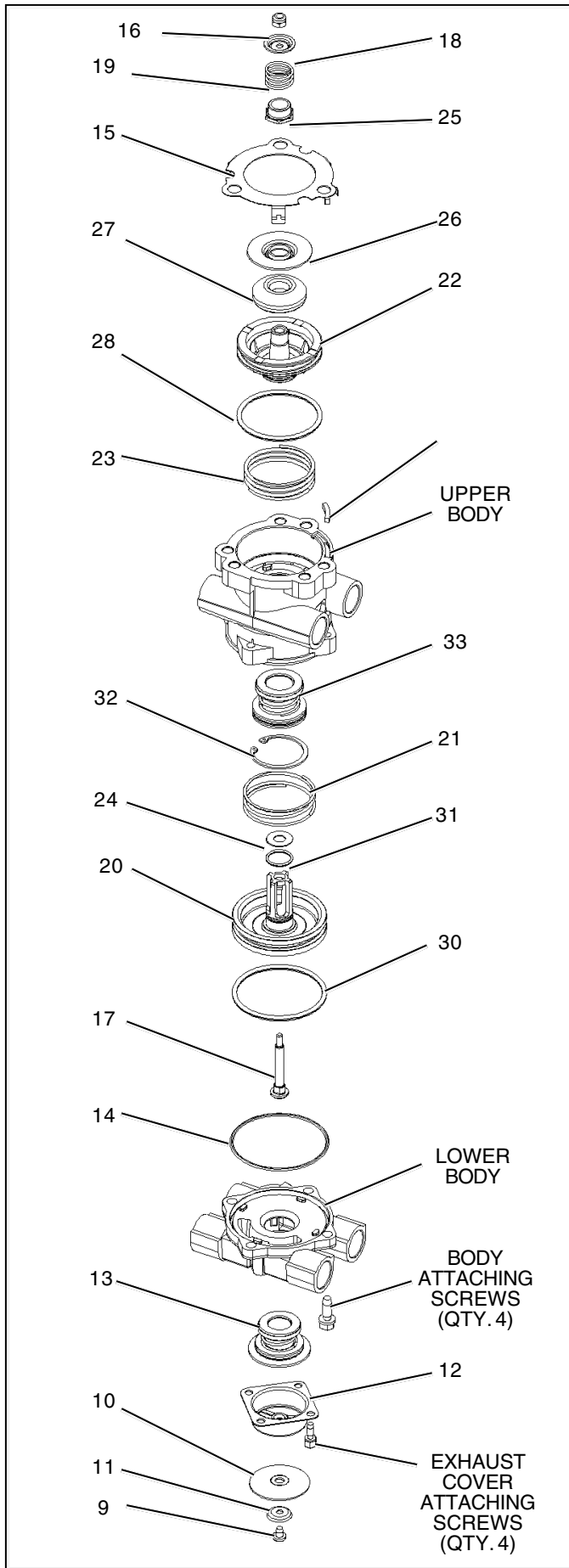

FIGURE 5 - E-8P BRAKE VALVE - EXPLODED VIEW

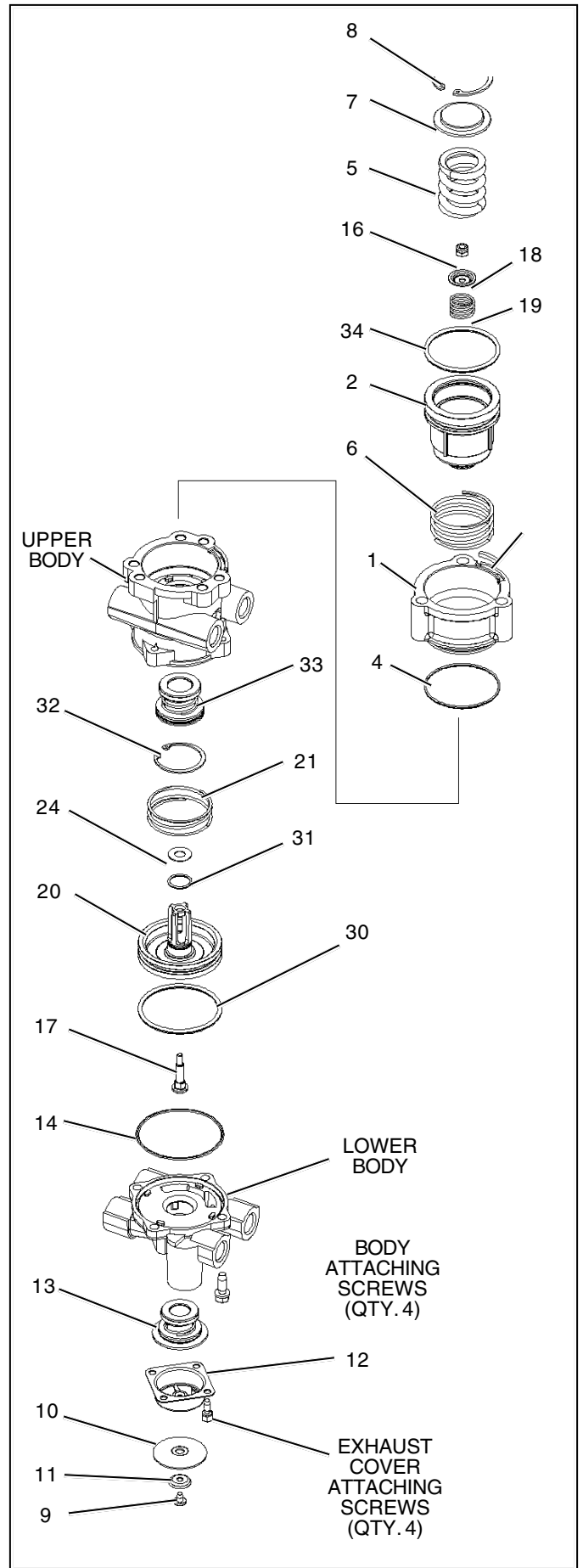

FIGURE 6 - E-10P BRAKE VALVE - EXPLODED VIEW

Using light oil, lubricate the treadle roller, roller pin, and hinge pin.

Check the rubber plunger boot for cracks, holes or deterioration and replace if necessary. Also, check mounting plate and treadle for integrity.

Apply 2 to 4 drops of oil between plunger and mounting plate - **do not over oil!**

**Every year, or 100,000 miles, or 3,600 operating hours:**

Disassemble, clean parts with mineral spirits, replace all rubber parts, or any part worn or damaged. Check for proper operation before placing vehicle in service.

## SERVICE CHECKS

### OPERATING CHECK

Check the delivery pressure of both primary and secondary circuits using accurate test gauges. Depress the treadle to several positions between the fully released and fully applied positions, and check the delivered pressure on the test gauges to see that it varies equally and proportionately with the movement of the brake pedal.

After a full application is released, the reading on the test gauges should fall off to zero promptly. It should be noted that the primary circuit delivery pressure will be about 2 PSI greater than the secondary circuit delivery pressure with both supply reservoirs at the same pressure. This is normal for this valve.

**Important:** A change in vehicle braking characteristics or a low pressure warning may indicate a malfunction in one or the other brake circuit, and although the vehicle air brake system may continue to function, the vehicle should not be operated until the necessary repairs have been made and both braking circuits, including the pneumatic and mechanical devices, are operating normally. Always check the vehicle brake system for proper operation after performing brake work and before returning the vehicle to service.

### LEAKAGE CHECK

1. Make and hold a high pressure (80 psi) application.
2. Coat the exhaust port and body of the brake valve with a soap solution.
3. Leakage permitted is a one inch bubble in 3 seconds. If the brake valve does not function as described above or leakage is excessive, it is recommended that it be replaced with a new or remanufactured unit, or repaired with genuine Bendix parts available at authorized Bendix parts outlets.

Refer to figures 4, 5 and 6 for item numbers referenced in parenthesis.

### REMOVAL

1. Chock the vehicle wheels or park the vehicle by mechanical means. (Block and hold vehicle by means other than air brakes.) Drain all air system reservoirs.
2. Identify and disconnect all supply and delivery lines at the brake valve.
3. Remove the brake valve and treadle assembly from the vehicle by removing the three cap screws on the outer bolt circle of the mounting plate. The basic brake valve alone can be removed by removing the three cap screws on the inner bolt circle.

### DISASSEMBLY (Figures 4, 5 and 6)

1. If the entire brake valve and treadle assembly was removed from the vehicle, remove the three cap screws securing the treadle assembly to the basic brake valve.
2. Remove the screw (9) securing the exhaust diaphragm (10) and washer (11) to the exhaust cover (12).
3. Remove the four screws that secure the exhaust cover (12) to the lower body.
4. Remove the secondary inlet and exhaust valve assembly (13) from the lower body.
5. Remove the four hex head cap screws securing the lower body to the upper body and separate the body halves.
6. Remove the rubber seal ring (14) from the lower body.
7. **For E-8P only:** While applying thumb pressure to the primary piston (22), lift out and up on the three lock tabs of the primary piston retainer (15).
8. **For E-10P only:** While depressing spring seat (7), remove retaining ring (8). Remove spring seat (7) and coil spring (5).

**Caution:** Before proceeding with the disassembly, refer to Figures 3 and 4 and note that the lock nut (16) and stem (17) are used to contain the primary piston return spring (**for E-8P:** 23, **for E-10P:** 6), stem spring (19), and the relay piston spring (21). The combined force of these springs is approximately 50 pounds and care must be taken when removing the lock nut as the spring forces will be released. It is recommended that the primary piston and relay piston be manually or mechanically contained while the nut and stem are being removed.

9. Using a 3/8" wrench, hold the lock nut (16) on the threaded end of the stem (17). Insert a screwdriver to restrain the stem, remove the lock nut (16), spring seat, (18) and stem spring (19).
10. **For E-10P only:** Remove adapter (1) and o-ring (4). Remove the primary piston (2) from adapter (1) and o-ring (34) from the primary piston (2).

## **OPERATION** - Refer to Figure 3

### **APPLYING: NORMAL OPERATION - NO. 1 OR PRIMARY CIRCUIT PORTION**

When the brake treadle is depressed, the plunger exerts force on the spring seat (26), graduating spring (23), and primary piston (22). The primary piston, which contains the exhaust valve seat, closes the primary exhaust valve. As the exhaust valve closes, the primary inlet valve is moved off its seat allowing primary air to flow out the No. 1 or primary delivery port.

### **APPLYING: NORMAL OPERATION - NO. 2 OR SECONDARY CIRCUIT**

When the primary inlet valve (33) is moved off its seat, air is permitted to pass through the bleed passage and enters the relay piston cavity. The air pressure moves the relay piston (20), which contains the exhaust seat, and closes the secondary exhaust valve. As the secondary exhaust valve closes, the inlet valve (13) is moved off its seat allowing the secondary air to flow out the delivery of the same circuit. Because of the small volume of air required to move the relay piston (20), action of the secondary circuit of the valve is almost simultaneous with the primary circuit portion.

### **APPLYING: LOSS OF AIR IN THE NO. 2 OR SECONDARY CIRCUIT**

Should air be lost in the No. 2 or secondary circuit, the No. 1 or primary circuit will continue to function as described above under *Normal Operation: No. 1 or Primary Circuit Portion*.

### **APPLYING: LOSS OF AIR IN THE NO. 1 OR PRIMARY CIRCUIT**

Should air be lost in the primary circuit, the function will be as follows: As the brake treadle is depressed and no air pressure is present in the primary circuit supply and delivery ports, the primary piston (22) will mechanically move the relay piston (20), allowing the piston to close the secondary exhaust valve and open the secondary inlet valve and allow air to flow out the secondary delivery port.

### **BALANCED: NO. 1 OR PRIMARY CIRCUIT**

When the primary delivery pressure acting on the primary piston (22) equals the mechanical force of the brake pedal application, the primary piston (22) will move and the primary inlet valve (33) will close, stopping further flow of air from the primary supply line through the valve. The exhaust valve remains closed preventing any escape of air through the exhaust port.

### **BALANCED: NO. 2 OR SECONDARY CIRCUIT**

When the air pressure on the delivery side of the relay piston (20) approaches that being delivered on the primary side of the relay piston, the relay piston moves closing the secondary inlet valve and stopping further flow of air from the supply line through the valve. The exhaust remains closed as the secondary delivery pressure balances the primary delivery pressure.

When applications in the graduating range are made, a balanced position in the primary circuit is reached as the air pressure on the delivery side of the primary piston (22) equals the effort exerted by the driver's foot on the treadle. A balanced position in the secondary portion is reached when air pressure on the secondary side of the relay piston (20) closely approaches the air pressure on the primary side of the relay piston.

When the brake treadle is fully depressed, both the primary and secondary inlet valves remain open and full reservoir pressure is delivered to the actuators.

### **RELEASING: NO. 1 OR PRIMARY CIRCUIT**

With the brake treadle released, mechanical force is removed from the spring seat (26), graduating spring (23), and primary piston (22). Air pressure and spring load moves the primary piston, opening the primary exhaust valve, allowing air pressure in the primary delivery line to exhaust out the exhaust port.

### **RELEASING: NO. 2 OR SECONDARY CIRCUIT**

With the brake treadle released, air is exhausted from the primary circuit side of the relay piston (20). Air pressure and spring load move the relay piston, opening the secondary exhaust valve, allowing air pressure in the secondary delivery line to exhaust out the exhaust port.

## **PREVENTIVE MAINTENANCE**

**Important:** Review the warranty policy before performing any intrusive maintenance procedures. An extended warranty may be voided if intrusive maintenance is performed during this period.

Because no two vehicles operate under identical conditions, maintenance and maintenance intervals will vary. Experience is a valuable guide in determining the best maintenance interval for any one particular operation.

Visually check for physical damage to the brake valve such as broken air lines and broken or missing parts.

### **Every 3 months, or 25,000 miles or 900 operating hours:**

Clean any accumulated dirt, gravel, or foreign material away from the heel of the treadle, plunger boot, and mounting plate.



## QR AND QR-1 QUICK RELEASE VALVES

\*Formerly SD-03-69

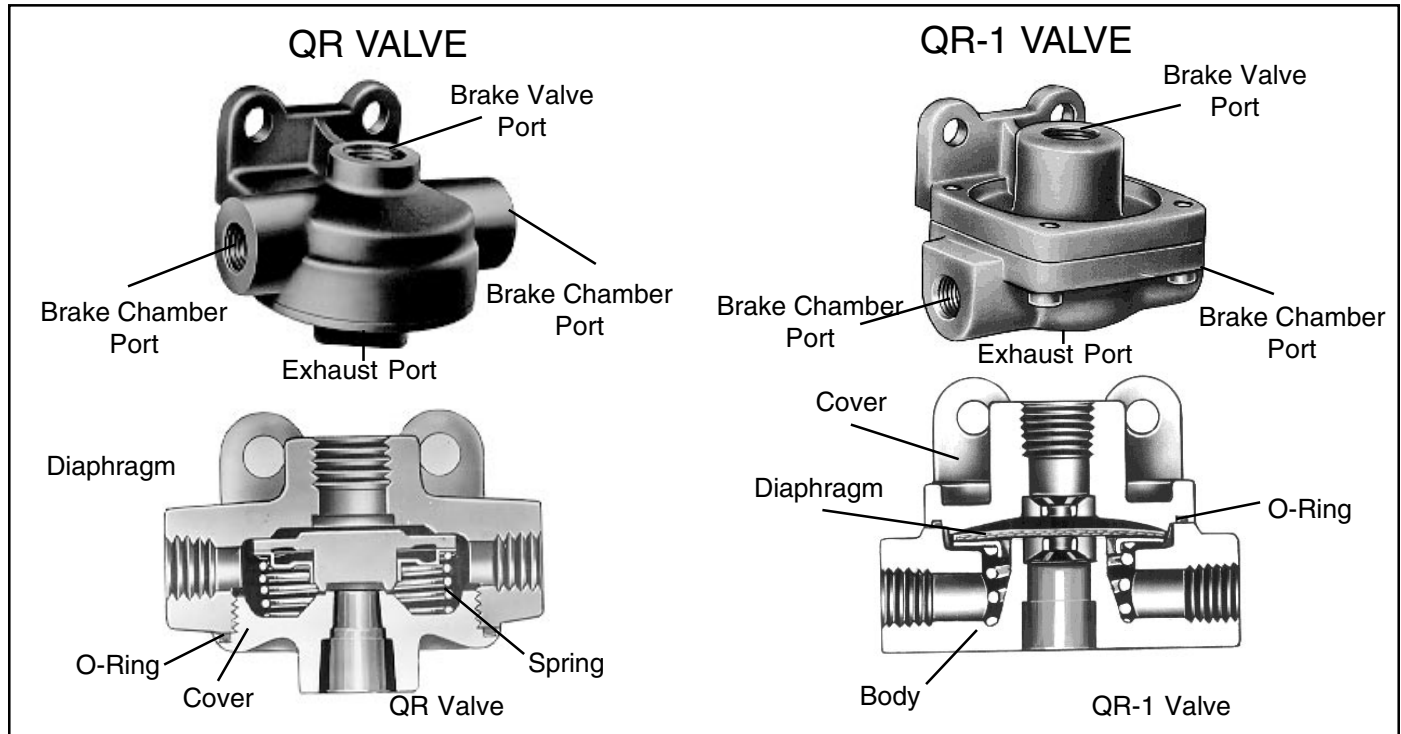

FIGURE 1

### DESCRIPTION

The function of the Quick Release Valve is to speed up the exhaust of air from the air chambers. It is mounted close to the chambers it serves. In its standard configuration the valve is designed to deliver within one (1) psi of control pressure to the controlled device; however, for special applications the valve is available with greater differential pressure designed into the valve.

Reference Figure 1, two styles of Quick Release Valves are available and are functionally the same; the QR valve, which is of older design and utilizes a spring and spring seat, and the QR-1 valve, which in its standard configuration does not employ a spring or spring seat.

(Note: AR-1 Valves with a pressure differential employ a spring and spring seat.)

Porting consists of one (1) brake valve port, two (2) delivery ports and one (1) exhaust port.

### OPERATION

When a brake application is made, air pressure enters the brake valve port; the diaphragm moves down, sealing the

exhaust. At the same time, air pressure forces the edges of the diaphragm down and air flows out the delivery port.

When air pressure being delivered (beneath the diaphragm) equals the pressure being delivered by the brake valve (above the diaphragm), the outer edge of the diaphragm will seal against the body seat. The exhaust port is still sealed by the center portion of the diaphragm when the brake valve application is released; the air pressure above the diaphragm is released back through the brake valve exhaust; air pressure beneath the diaphragm forces the diaphragm to rise, opening the exhaust, allowing air in the chambers to exhaust.

### PREVENTIVE MAINTENANCE

Every 12 months, 100,000 miles or 3600 operating hours; disassemble valve, wash metal parts in mineral spirits, wipe rubber parts dry. It is recommended that all rubber parts be replaced. Inspect all parts and replace any part showing signs of wear or deterioration.

### OPERATING AND LEAKAGE TESTS

While holding a foot brake valve application:



1. Coat exhaust port with soap solution; leakage of a one (1) inch bubble in three (3) seconds is permitted.
2. Coat body and cover with soap solution. No leakage permitted between body and cover.

If the valve does not function as described, or if leakage is excessive, it is recommended that it be replaced with a new or remanufactured unit, or repaired with genuine Bendix parts.

## REMOVING AND INSTALLING

### REMOVING

Block vehicle wheels and/or hold vehicle by means other than air brakes.

Drain all air brake system reservoirs.

Disconnect air lines from valve.

Remove mounting bolts, then valve.

### INSTALLING

Mount valve with exhaust port pointing down; securely tighten mounting bolts.

Connect air lines to valve (brake valve application line to top port; brake chamber line to side ports.)

## DISASSEMBLY

### QR VALVE

1. Using wrench on square portion of exhaust port, remove cover.
2. Remove spring, spring seat and diaphragm. Remove cover O-Ring.

### QR-1 VALVE

1. Remove four screws.
2. Remove spring and spring seat (if so equipped).
3. Remove diaphragm.
4. Remove cover O-Ring.

## CLEANING AND INSPECTION

Clean all metal parts in mineral spirits. Wipe all rubber parts clean.

It is recommended that all rubber parts and any other part showing signs of wear or deterioration be replaced with genuine Bendix parts.

## ASSEMBLY

### QR VALVE

1. Position spring seat over the diaphragm and then install into body.
2. Install spring and cover O-Ring.
3. Install cover; tighten securely. (Torque to 150-400 inch pounds.)

### QR-1 VALVE

1. If valve is equipped within spring and spring seat:
  - a. Position spring in body.
  - b. Position diaphragm over spring seat.

- a. Install O-Ring in cover groove; install cover and tighten screws evenly and securely. (Torque to 30-60 inch pounds.)
2. If valve is not equipped with spring and spring seat:
  - a. Install diaphragm.
  - b. Install O-Ring in cover groove; install cover and tighten screws evenly and securely. (Torque to 30-60 inch pounds.)
3. Perform tests as outlined in "Operating and Leakage Tests" section.

## IMPORTANT! PLEASE READ

When working on or around a vehicle, the following general precautions should be observed:

1. Park the vehicle on a level surface, apply the parking brakes, and always block the wheels.
2. Stop the engine when working around the vehicle.
3. If the vehicle is equipped with air brakes, make certain to drain the air pressure from all reservoirs before beginning ANY work on the vehicle.
4. Following the vehicle manufacturer's recommended procedures, deactivate the electrical system in a manner that removes all electrical power from the vehicle.
5. When working in the engine compartment the engine should be shut off. Where circumstances require that the engine be in operation, EXTREME CAUTION should be used to prevent personal injury resulting from contact with moving, rotating, leaking, heated, or electrically charged components.
6. Never connect or disconnect a hose or line containing pressure; it may whip. Never remove a component or plug unless you are certain all system pressure has been depleted.
7. Never exceed recommended pressures and always wear safety glasses.
8. Do not attempt to install, remove, disassemble or assemble a component until you have read and thoroughly understand the recommended procedures. Use only the proper tools and observe all precautions pertaining to use of those tools.
9. Use only genuine Bendix replacement parts, components, and kits. Replacement hardware, tubing, hose, fittings, etc. should be of equivalent size, type, and strength as original equipment and be designed specifically for such applications and systems.
10. Components with stripped threads or damaged parts should be replaced rather than repaired. Repairs requiring machining or welding should not be attempted unless specifically approved and stated by the vehicle or component manufacturer.
11. Prior to returning the vehicle to service, make certain all components and systems are restored to their proper operating condition.

## LOW PRESSURE INDICATORS

\*Formerly SD-06-2

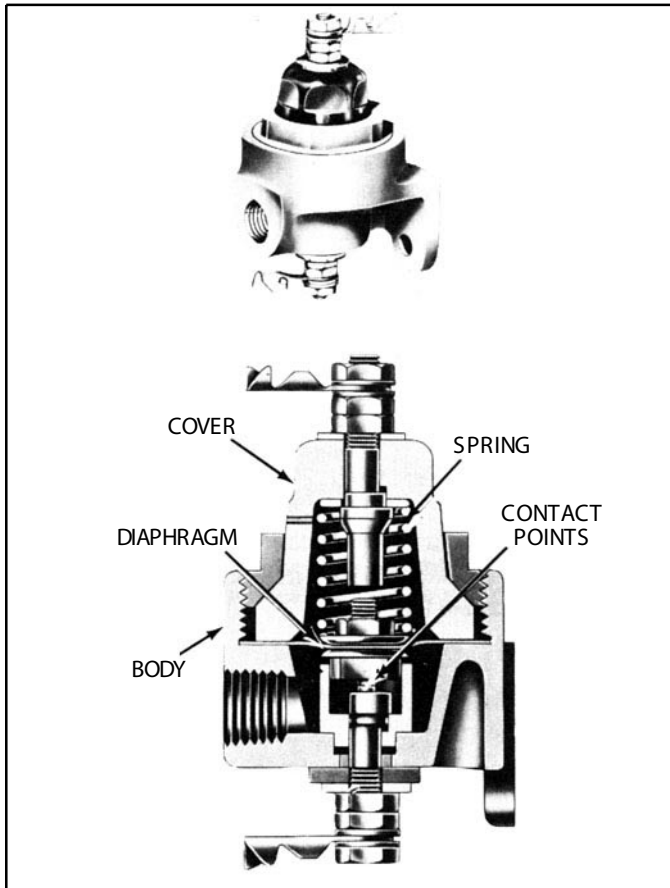

FIGURE 1 - LP-2

### DESCRIPTION

The Low Pressure Indicator is a safety device designed to give an automatic warning to the driver whenever air pressure in the air brake system is below the safe minimum for normal vehicle operation. It is usually used to operate an electrical buzzer or warning light, or both, which are audible or visible to the driver.

Two styles of Low Pressure Indicators are currently manufactured.

The LP-2 Low Pressure Indicator, which is the older style and consists of a die cast body with a spring loaded diaphragm clamped between the body and the Bakelite cover.

The LP-3 Low Pressure Indicator is the newer style, consisting of a die cast body, nylon cover and employs a spring loaded O-Ring diaphragm and piston. The LP-3 is

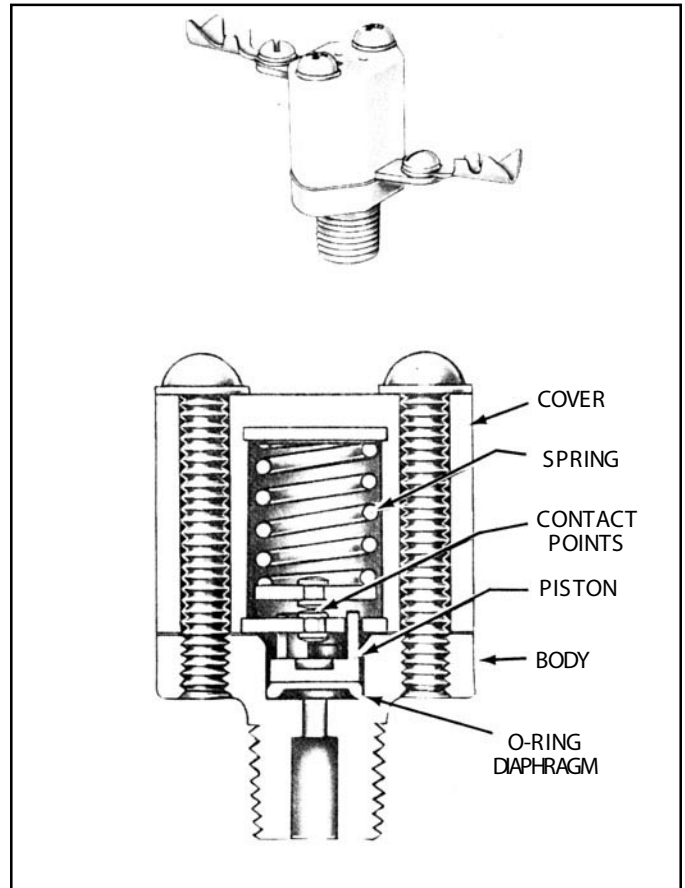

FIGURE 2 - LP-3

available with either one terminal or two. The single terminal unit utilizes a metallic gasket between body and case to ground the lower contact strip. The two terminal unit utilizes a phenolic insulating gasket to isolate both terminals from the vehicle frame.

The electrical contacts provided in both the LP-2 and LP-3 indicators remain closed by spring force until the air brake system pressure below the diaphragm is above the setting (force) of the Low Pressure Indicator spring. The setting of the indicator and piece number is marked on a label on the valve body. If a label is not present, then the vehicle manual should be consulted for the proper setting. The nominal setting of the indicator is 60 psi; however, pressure settings may vary depending upon the vehicle.

### OPERATION

To describe the operation, we shall assume that the Low

Pressure Indicator is set for 60 psi. When air pressure at the supply port and under the diaphragm is above 60 psi, the electrical contacts remain open because the force exerted by air pressure underneath the diaphragm overcomes the force exerted by the spring above the diaphragm.

When air pressure below the diaphragm drops below 60 psi, the spring exerts a force which is greater than the force exerted by the air pressure below the diaphragm. This causes the diaphragm (and the piston in the LP-3) to move and allow the electrical contacts to close. This completes or closes the electrical circuit to the warning device, warning the driver of low air pressure in the system.

## PREVENTIVE MAINTENANCE

Every six months, 1800 operating hours or 50,000 miles, check electrical connections. Low Pressure Indicator should be checked for proper operation by performing "Operating Test" as described elsewhere in this sheet.

## TESTING FOR SERVICEABILITY

### OPERATING TEST

1. If possible, determine the setting of the Low Pressure Indicator by referring to the label on the valve or the vehicle manual.
2. Operation of the Low Pressure Indicator may be checked with ignition switch "on" by reducing the system pressure and observing that low pressure warning occurs when system pressure drops below the setting of the Low Pressure Indicator. The contacts will be closed when the warning device operates. If the setting of the indicator is unknown, the contacts should close between approximately 70 psi and 50 psi.

### LEAKAGE TEST

1. With air pressure present at the supply port, coat the indicator with soap solution. No leakage permitted.

## REMOVING

1. Block the wheels. Otherwise, secure the vehicle with other than service brakes.
2. The ignition switch should be in the "off" position.
3. Drain the air from the system.
4. Disconnect the electrical connections at the Low Pressure Indicator.
5. Disconnect the air line and mounting bolts or unscrew the Indicator from the fitting and remove.

## INSTALLING

1. Install in a convenient location for servicing.
2. Connect to a reservoir pressure line at a high point in the system for adequate drainage.

3. If installing an LP-2G Indicator, use a supply line of 1/4 O.D. minimum.
4. Connect the Indicator terminals in series with the ignition switch and the warning device.

## DISASSEMBLY

NOTE: It is generally recommended that the Low Pressure Indicator, if faulty, be replaced with a new unit; however, service parts are available; and if repairs are necessary, the following will apply:

LP-2 Unscrew the cover retainer from the body. Remove cover and remove spring and diaphragm assembly.

LP-3. Remove cover screws, lockwashers. Remove cover, contact disc, spring, and shim(s). (Note: Shims may or may not be present.) Remove contact plate, gasket, piston, and O-Ring diaphragm.

## CLEANING AND INSPECTION

Clean all metal parts in mineral spirits.

Inspect all parts for wear, cracks, or deterioration and replace all parts not considered serviceable with genuine Bendix parts.

If contact points are not pitted severely, they can be dressed with a fine file.

## ASSEMBLY

### LP-2

1. Place and position the diaphragm assembly in the body. Position the spring so that it rests on the upper diaphragm follower.
2. Place cover over the diaphragm and screw cover retainer to the body and tighten securely. (Torque to 110-130 inch pounds.)

### LP-3

1. Lubricate bore of body and both sides of the O-Ring diaphragm with silicone lubricant BW-650-M (Bendix piece no. 291126).
2. Install O-Ring diaphragm in body. (Note: O-Ring portion of diaphragm should face supply port.)
3. Install piston in body. Flat side of piston should face O-Ring diaphragm.
4. Install gasket. (Always use a phenolic gasket in a two terminal switch and a metallic gasket in the single terminal.)
5. Position contact plate over fingers of piston. Contact plate should rest on face of gasket.
6. If shim(s) are used, place shim(s) in cover.
7. Place spring in cover.
8. Place contact point so that it rests on spring.

9. Install cover on body, using machine screws, making certain that the contact plate is in position over fingers of piston, and arm of contact plate is positioned so that it will fit in groove of cover.
10. Tighten screws securely. (Torque to 20-30 inch pounds).

#### TEST OF REBUILT LOW PRESSURE INDICATOR

After rebuilding, perform the leakage and operating tests as outlined in section "Testing for Serviceability."

#### IMPORTANT! PLEASE READ

When working on or around a vehicle, the following general precautions should be observed:

1. Park the vehicle on a level surface, apply the parking brakes, and always block the wheels.
2. Stop the engine when working around the vehicle.
3. If the vehicle is equipped with air brakes, make certain to drain the air pressure from all reservoirs before beginning ANY work on the vehicle.
4. Following the vehicle manufacturer's recommended procedures, deactivate the electrical system in a manner that removes all electrical power from the vehicle.
5. When working in the engine compartment the engine should be shut off. Where circumstances require that the engine be in operation, EXTREME CAUTION should be used to prevent personal injury resulting from contact

- with moving, rotating, leaking, heated, or electrically charged components.
6. Never connect or disconnect a hose or line containing pressure; it may whip. Never remove a component or plug unless you are certain all system pressure has been depleted.
  7. Never exceed recommended pressures and always wear safety glasses.
  8. Do not attempt to install, remove, disassemble or assemble a component until you have read and thoroughly understand the recommended procedures. Use only the proper tools and observe all precautions pertaining to use of those tools.
  9. Use only genuine Bendix replacement parts, components, and kits. Replacement hardware, tubing, hose, fittings, etc. should be of equivalent size, type, and strength as original equipment and be designed specifically for such applications and systems.
  10. Components with stripped threads or damaged parts should be replaced rather than repaired. Repairs requiring machining or welding should not be attempted unless specifically approved and stated by the vehicle or component manufacturer.
  11. Prior to returning the vehicle to service, make certain all components and systems are restored to their proper operating condition.

## SL-5 STOP LIGHT SWITCH & DS-2 COMBINED STOP LIGHT SWITCH & DOUBLE CHECK VALVE

\*Formerly SD-06-7

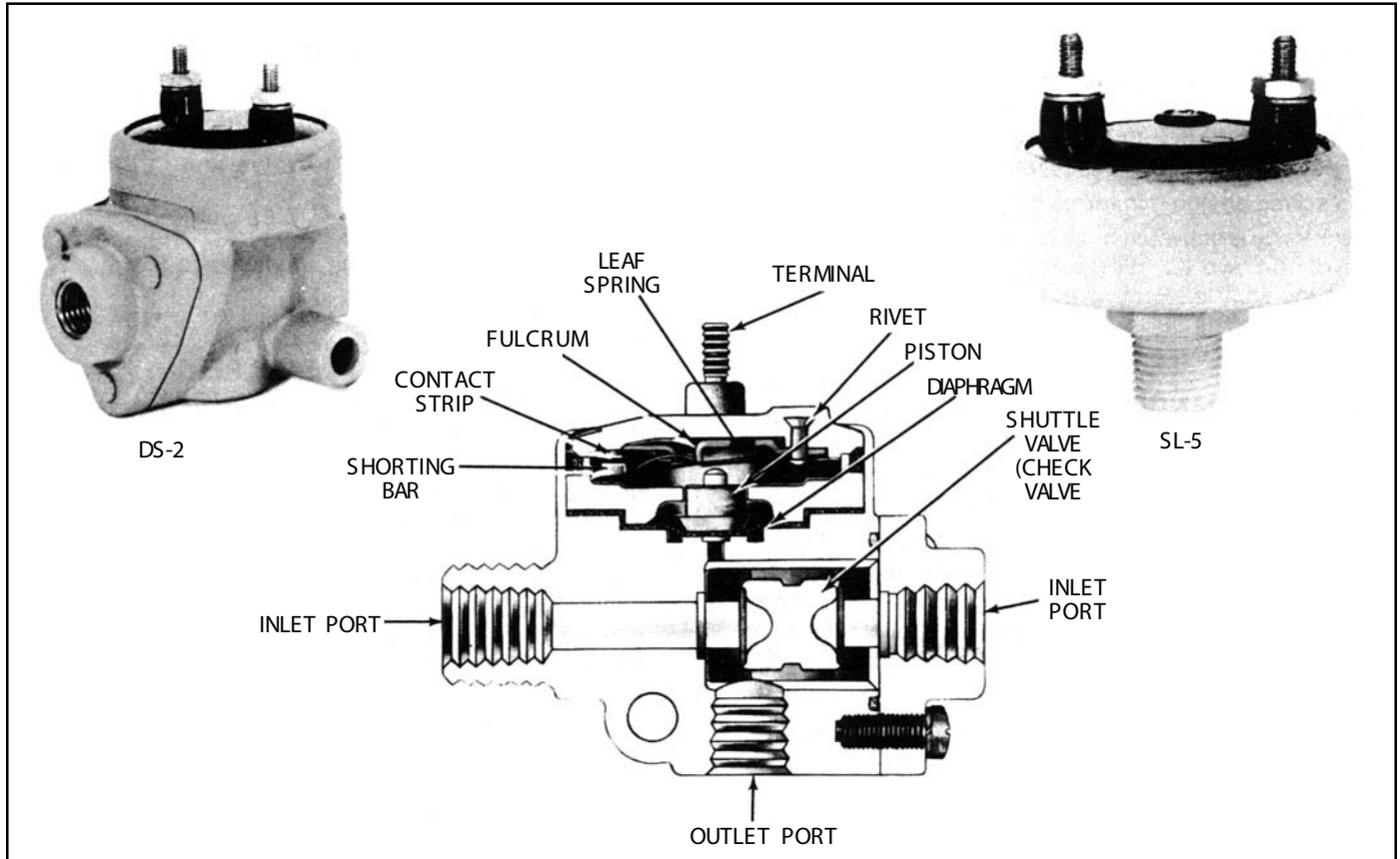

FIGURE 1 - DS-2 SECTIONAL

### DESCRIPTION

The stop light switch (SL-5) is an electro-pneumatic 5 psi non-grounded switch that operates in conjunction with the brake valve and stop lights by completing the electrical circuit and lighting the stop lights when a brake application is made.

The combined stop light switch and double check valve (DS-2), as the name implies, combines a stop light switch (SL-5) with a double check valve to perform the function of both. It operates in conjunction with the brake valve and hand control valve by directing the flow of air from whichever delivers the higher pressure into a common delivery line and to the stop light switch, closing the electrical circuit to the stop lamps.

The stop light switch can be used with either 12 or 24 volt systems.

The stoplight switch is not a serviceable item; and if found defective in either device, the complete unit must be replaced.

The shuttle valve in the DS-2 is serviceable and may be replaced.

Both the SL-5 and DS-2 have been tested and meet the requirements of FMVSS-121.

### OPERATION

The stop switch mechanism is identical in the SL-5 and DS-2.

When a brake application is made, air pressure from the brake valve enters the cavity below the diaphragm. The air pressure below the diaphragm moves the piston until it contacts the leaf spring. The leaf spring travels past a

fulcrum at which point the leaf springs snaps a shorting bar which mates with the contact strips. The stop light electrical circuit is completed, lighting the stop lights before the brake application pressures reach 6 psi.

The snap action spring design minimizes arcing.

The Double Check Valve is activated by air being introduced through either of the two (2) inlet ports. The greater pressure pushes the shuttle along its guides and closes the opposite inlet port. The air is then directed out the common delivery line and to the stop light switch.

## PREVENTIVE MAINTENANCE

Every six months, 1800 operating hours or 50,000 miles check the electrical connections and determine that stop lamps operate properly.

## OPERATING AND LEAKAGE TEST

1. Install an accurate air gauge in the service line (or brake chamber). Apply brake valve gradually. Stop lamps should light at 6 psi or less and go out after the brake application is released. This checks the electrical function of the stop light switch in either the SL-5 or DS-2.
2. (DS-2 only) Apply the foot valve and coat the exhaust port of the hand valve (or other alternate source). Reverse the above, applying the hand valve or other alternate source and coat the exhaust port of the foot valve. In either mode a leakage of not more than a 1" bubble in 5 seconds is permissible.
3. (SL-5 or DS-2) When pressurized, no leakage is permitted from the body of the valve or switch.

If the SL-5 or DS-2 does not function as described above or if leakage is excessive, the valve or switch should be replaced with a new unit or in the case of the double check portion of the DS-2 repaired with genuine Bendix parts.

## REMOVING AND INSTALLING

### REMOVING

1. Block vehicle wheels or hold by means other than vehicle service brakes.
2. Disconnect electrical connections from terminal screws.
3. (SL-5) Remove the switch using a wrench on the hex portion of the body.
4. (DS-2) Disconnect air lines and remove the DS-2.

### INSTALLING

1. Replace the SL-5 or DS-2 in the port from which it was removed. Do not install with the terminals pointing down.
2. Secure electrical connections.
3. Reinstall air line connections to DS-2 valve.

## DISASSEMBLY (Double Check Valve)

1. Remove three cap screws and cap.
2. Remove O-Ring seal from cap.
3. Remove shuttle valve.

## CLEANING AND INSPECTION

1. Blow dust or other foreign material out of body. Do not immerse in cleaning fluid.
2. Inspect shuttle valve and O-Ring and replace if deteriorated.

## TEST

Repeat "Operating and Leakage Test."

## IMPORTANT! PLEASE READ

When working on or around a vehicle, the following general precautions should be observed:

1. Park the vehicle on a level surface, apply the parking brakes, and always block the wheels.
2. Stop the engine when working around the vehicle.
3. If the vehicle is equipped with air brakes, make certain to drain the air pressure from all reservoirs before beginning ANY work on the vehicle.
4. Following the vehicle manufacturer's recommended procedures, deactivate the electrical system in a manner that removes all electrical power from the vehicle.
5. When working in the engine compartment the engine should be shut off. Where circumstances require that the engine be in operation, EXTREME CAUTION should be used to prevent personal injury resulting from contact with moving, rotating, leaking, heated, or electrically charged components.
6. Never connect or disconnect a hose or line containing pressure; it may whip. Never remove a component or plug unless you are certain all system pressure has been depleted.
7. Never exceed recommended pressures and always wear safety glasses.
8. Do not attempt to install, remove, disassemble or assemble a component until you have read and thoroughly understand the recommended procedures. Use only the proper tools and observe all precautions pertaining to use of those tools.
9. Use only genuine Bendix replacement parts, components, and kits. Replacement hardware, tubing, hose, fittings, etc. should be of equivalent size, type, and strength as original equipment and be designed specifically for such applications and systems.
10. Components with stripped threads or damaged parts should be replaced rather than repaired. Repairs requiring machining or welding should not be attempted unless specifically approved and stated by the vehicle or component manufacturer.
11. Prior to returning the vehicle to service, make certain all components and systems are restored to their proper operating condition.