

# SECTION 16: SUSPENSION

## CONTENTS

<b>1. DESCRIPTION .....</b>	<b>16-3</b>
<b>2. AIR SPRINGS.....</b>	<b>16-4</b>
2.1 INSPECTION .....	16-4
2.2 REMOVAL .....	16-4
2.3 INSTALLATION .....	16-5
<b>3. SHOCK ABSORBERS.....</b>	<b>16-5</b>
3.1 INSPECTION .....	16-6
3.2 REMOVAL .....	16-6
3.3 INSTALLATION .....	16-6
<b>4. RADIUS RODS.....</b>	<b>16-7</b>
4.1 INSPECTION .....	16-7
4.2 REMOVAL .....	16-7
4.3 BUSHING REMOVAL.....	16-7
4.4 BUSHING INSTALLATION.....	16-8
4.5 INSTALLATION .....	16-8
<b>5. SWAY BAR .....</b>	<b>16-9</b>
5.1 REMOVAL .....	16-9
5.2 INSTALLATION .....	16-9
<b>6. SUSPENSION AIR SYSTEM .....</b>	<b>16-9</b>
6.1 INSPECTION .....	16-9
6.2 AIR LINE TEST .....	16-10
6.3 AIR TANK MAINTENANCE .....	16-10
<b>7. SUSPENSION HEIGHT ADJUSTMENT.....</b>	<b>16-10</b>
<b>8. HEIGHT CONTROL VALVES.....</b>	<b>16-11</b>
8.1 MAINTENANCE .....	16-11
8.1.1 <i>Removal and installation</i> .....	16-11
8.1.2 <i>Air leakage test</i> .....	16-11
<b>9. FRONT KNEELING SYSTEM.....</b>	<b>16-12</b>
9.1 PRINCIPLE OF OPERATION .....	16-12
9.2 MAINTENANCE .....	16-12
9.3 BELLOWS CONTROL SOLENOID VALVES .....	16-12
9.3.1 <i>Removal and installation</i> .....	16-12
<b>10. HIGH-BUOY SYSTEM.....</b>	<b>16-13</b>
10.1 PRINCIPLES OF OPERATION .....	16-13
10.2 MAINTENANCE .....	16-13
10.3 HIGH-BUOY – PRESSURE REGULATING VALVE.....	16-13
10.3.1 <i>Adjustment</i> .....	16-13
10.3.2 <i>Disassembly</i> .....	16-14
10.3.3 <i>Cleaning</i> .....	16-14
10.3.4 <i>Reassembly</i> .....	16-14

## Section 16: SUSPENSION

---

<b>11. LOW-BUOY SYSTEM .....</b>	<b>16-14</b>
11.1 PRINCIPLES OF OPERATION .....	16-14
11.2 MAINTENANCE .....	16-14
<b>12. TROUBLESHOOTING.....</b>	<b>16-15</b>
<b>13. PARTS SPECIFICATIONS.....</b>	<b>16-15</b>
<b>14. TORQUE SPECIFICATIONS.....</b>	<b>16-17</b>

## ILLUSTRATIONS

FIGURE 1: FRONT SUSPENSION COMPONENTS .....	16-3
FIGURE 2: DETAILS OF FRONT SUSPENSION .....	16-3
FIGURE 3: REAR SUSPENSION COMPONENTS .....	16-3
FIGURE 4: DETAILS OF REAR SUSPENSION .....	16-4
FIGURE 5: TAG AXLE SUSPENSION .....	16-4
FIGURE 6: AIR SPRING.....	16-4
FIGURE 7: SHOCK ABSORBER .....	16-6
FIGURE 8: TYPICAL SHOCK ABSORBER SETUP .....	16-7
FIGURE 9: TYPICAL RADIUS ROD SETUP .....	16-7
FIGURE 10: RADIUS ROD BUSHING REMOVAL.....	16-7
FIGURE 11: RADIUS ROD BUSHING INSTALLATION .....	16-8
FIGURE 12: RADIUS ROD INSTALLATION .....	16-8
FIGURE 13: I-BEAM FRONT AXLE SWAY BAR .....	16-9
FIGURE 14: TYPICAL AIR SPRING CLEARANCE.....	16-10
FIGURE 15: HEIGHT CONTROL VALVE.....	16-11
FIGURE 16: REGULATING VALVE.....	16-13

1. DESCRIPTION

The vehicle is provided with an air suspension system. The system consists of air springs, height control valves, radius rods, sway bars, tripod and shock absorbers (Fig. 1, 2, 3, 4 and 5). The system operation is fully automatic and maintains a constant vehicle height regardless of load, or load distribution.

The vehicle can also be equipped with systems such as:

- Front Kneeling (w/ Front High-Buoy);
- Front Kneeling (w/ Full High-Buoy);
- Front Kneeling (w/ Front High-Buoy) and Low-Buoy Combination;
- Front Kneeling (w/ Full High-Buoy) and Low-Buoy Combination;

For a description of all these systems, refer to the appropriate heading in this section.

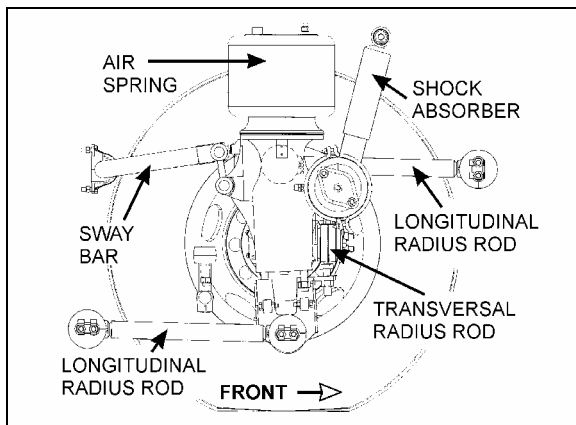

FIGURE 1: FRONT SUSPENSION COMPONENTS 16096

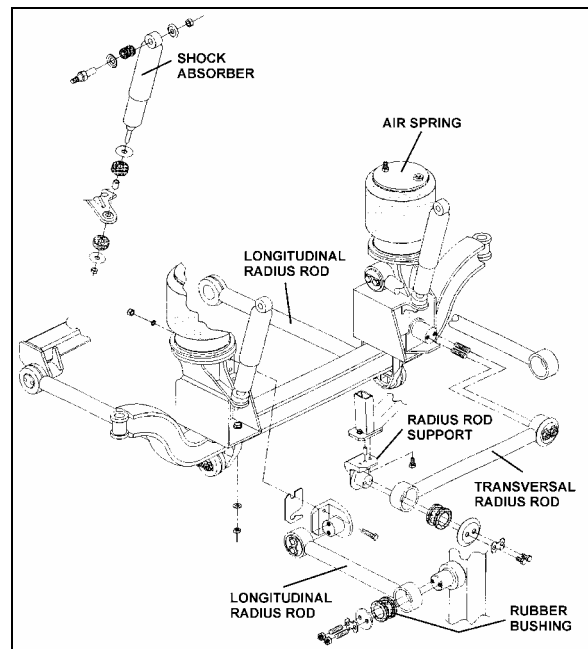

FIGURE 2: DETAILS OF FRONT SUSPENSION 16110

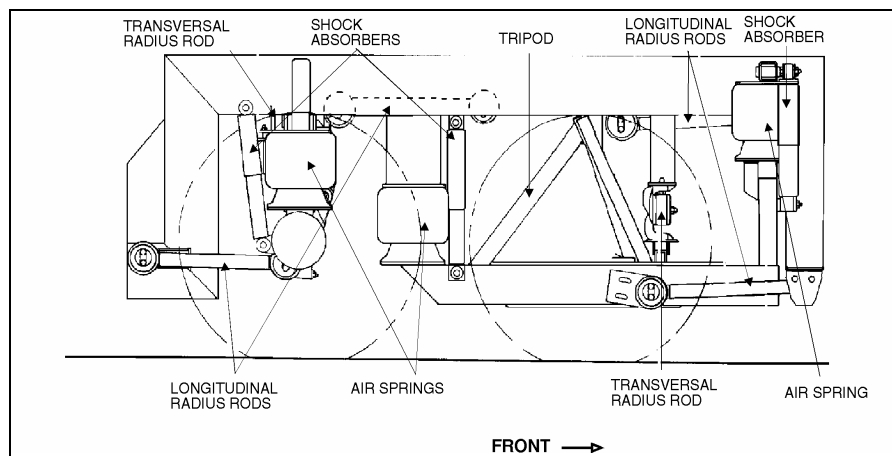

FIGURE 3: REAR SUSPENSION COMPONENTS 16027

## Section 16: SUSPENSION

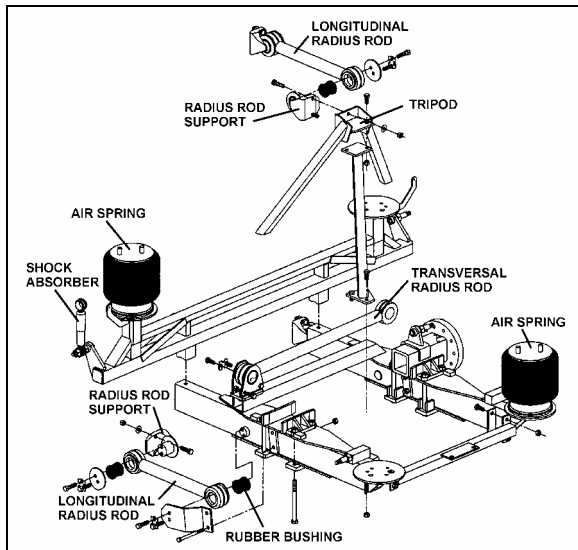

FIGURE 4: DETAILS OF REAR SUSPENSION 16106

### 2. AIR SPRINGS

The air springs are made from a special compound rubber molded to the proper contour and dimensions. The entire vertical load of the vehicle is supported by these springs. Each of the three axles is provided with air springs that are attached to the subframe and to the axles (Fig. 6).

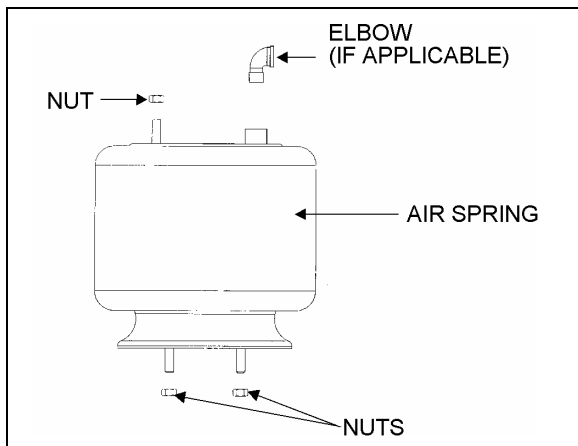

FIGURE 6: AIR SPRING 16052

#### 2.1 INSPECTION

1. Check operation of bellows.
2. Visually inspect bellows for evidence of cracks, punctures, deterioration, or chafing. Replace the bellows if any damage is evident.

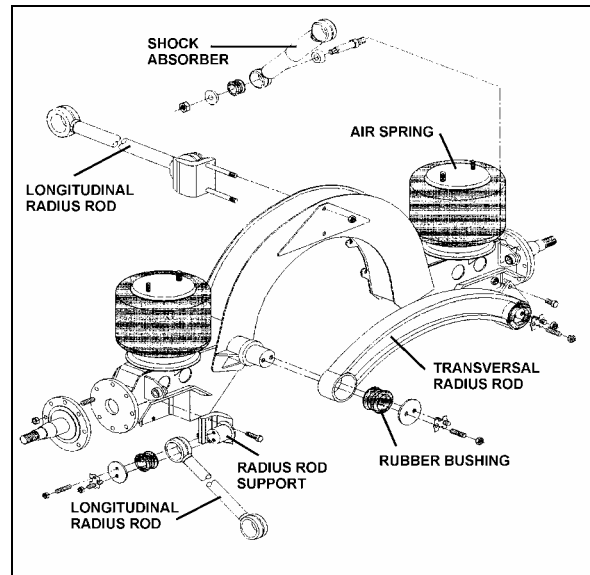

FIGURE 5: TAG AXLE SUSPENSION 16107

3. With the primary air system at normal operating pressure (95 - 125 psi (655 - 860 kPa)), coat all suspension air line connections and bellows mounting areas with a water and soap solution. Bubbles will indicate an air leak, and none is permissible. Repair or replace defective parts.

#### NOTE

If air spring is removed from vehicle, bellows can be lightly inflated and submerged in water to detect any leakage. If any leakage is detected, replace bellows.

#### WARNING

To prevent personal injury, do not apply more than 10 psi (69 kPa) of air pressure to the uninstalled air spring.

#### 2.2 REMOVAL

#### NOTE

Suspension air springs (front, drive, and tag axles) can be removed without removing the entire axle assembly.

1. Safely support vehicle at the recommended body jacking points. To gain access to a given air spring, the corresponding wheel can be removed as follows.

- a) Jack vehicle until the tire clears the ground, and place safety supports underneath body.

**⚠ CAUTION ⚠**

**Only the recommended jacking points must be used as outlined in Section 18, "Body".**

- b) Support the axle with a suitable hydraulic floor jack at the recommended jacking point.
  - c) Remove wheel.
2. Exhaust compressed air from accessory air tank by opening drain cock under reservoir.
  3. Disconnect the height control valve link and pull down the overtravel lever to ensure all air is exhausted from air springs.

**NOTE**

*While performing this step, do not change the height control valve overtravel lever adjustment.*

4. Disconnect air line from air spring, remove elbow (if applicable), and cover both the line end and fitting to prevent the entry of foreign matter.
5. Remove the air spring upper nut, and then the two lower nuts. Remove air spring.

### 2.3 INSTALLATION

1. Compress air spring as necessary, then aligning studs with their holes, position air spring between both the lower and upper supports. Thread the lower nuts and the small upper nut a few turns.

**NOTE**

*To facilitate air spring installation, compress it manually then put a piece of tape over the air line threaded fitting. This prevents air from getting back into the bag and keeps it compressed, thus enabling to place the bag in between the mounting plates and greatly easing installation.*

2. Tighten and torque the lower stud nuts, and then the upper one to 20 – 25 lbf-ft (27 – 34 Nm).
3. Thread the remaining upper nut (large nut) and tighten to 20 – 25 lbf-ft (27 – 34 Nm).

4. Install elbow (if applicable), then connect air line.
5. Connect the height control valve link.
6. Build up air pressure in system.

**NOTE**

*To accelerate this operation, air reservoirs can be filled from an exterior air supply connected to the accessory tank fill valve or to the emergency fill valve.*

7. Check operation of bellows, and with the primary air system at normal operating pressure (95 – 125 psi (655 – 860 kPa)), coat the air line connections and air spring mounting areas with a water and soap solution. Bubbles will indicate an air leak, and none is permissible. Repair or replace defective parts.
8. Reinstall wheel.
9. Remove the hydraulic floor jack from under the axle, then lower vehicle to ground.

### 3. SHOCK ABSORBERS

Double-action, telescoping-type shock absorbers ensure a smooth ride and enhance vehicle stability on the road. All shock absorbers are eye-type mountings. The front and tag axles are each provided with two shock absorbers while the drive axle is provided with four of them (Fig. 1, 2, 3, 4 and 5).

Shock absorbers are non-adjustable and non-repairable. Maintenance requirements involve replacement of the rubber mounting bushings, and tightening of all shock absorber pins at the proper torque of 500 - 550 lbf-ft (680 - 750 Nm) when shock absorber replacement occurs. If a shock absorber becomes inoperative, complete unit must be replaced.

**⚠ CAUTION ⚠**

**When a shock absorber is found defective, always replace with a new set on affected axle, except if there has been a recent replacement of one unit. The following method will help in determining if both shock absorbers on the same axle have to be replaced.**

## Section 16: SUSPENSION

### 3.1 INSPECTION

Loosen lower mounting of both shocks, and then carefully attempt to raise and lower the bottom portion of each shock. Note the rate of effort for distance of travel. Replace both shocks if a definite differential rate is found.

The shock must be bench checked in an upright, vertical position. If checked in any other position, air will enter the cylinder tube and make the shock absorber appear defective.

Proceed as follows to check shock absorbers:

1. With the shock absorber in a vertical position (top end up), clamp the bottom mount in a vise.



**Do not clamp the reservoir tube or the dust tube.**

2. Rotate the dust tube. Notice any binding condition (may be compared with new unit). Binding condition indicates a scored rod. Units with scored rods should be replaced.
3. Fully extend shocks and check for leaks in the seal cover area. Shock fluid is a very thin hydraulic fluid that has a characteristic odor and dark brown tint. A slight trace of shock fluid around the seal cover area is not a cause for replacement. The shock seal is designed to permit a very slight seepage to lubricate the rod. Units that leak should be replaced.
4. Visually check shock for dents that could cause the shock to bind. Also, check for a bent rod.
5. Extend and collapse shock several times to determine that it has control (resistance) in both rebound and compression.
6. Visually inspect the shock mountings and vehicle mounting for:
  - a. Broken mounts;
  - b. Extreme bushing wear;
  - c. Shifted bushing or sleeve;
  - d. Deep cracks in bushing material (shallow surface cracks are normal);
  - e. Loose shock absorber pins;
  - f. Presence of convex washers, and their position relative to the rubber bushing.

### 3.2 REMOVAL

1. Remove nuts and washers from shock absorbers on upper and lower mounting pins, taking care to identify the inner and outer washers to ease reinstallation. Refer to figure 7 for details.
2. Remove the shock absorber assembly from pins.
3. Remove the two inner bushings from the shock absorber and discard them.

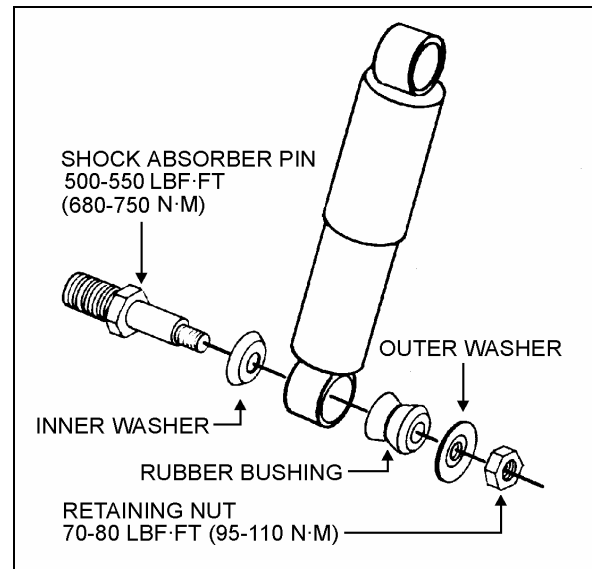

FIGURE 7: SHOCK ABSORBER

16008

### 3.3 INSTALLATION

1. Ensure that the shock absorber mounting pins are tight and that the threads are not stripped.
2. Install new rubber mounting bushings on shock absorbers (upper and lower).
3. Place the inner washers (with washer convex side facing the shock absorber rubber bushing) on each shock absorber pin (Fig. 8).
4. Install the shock absorber eyes over the mounting pins, then the outer washers (with washer convex side facing the shock absorber rubber bushing) on each shock absorber extremity.

#### NOTE

*If shock absorber pins are removed, they must be reinstalled using "loctite" (see "Parts Specifications" in this section).*

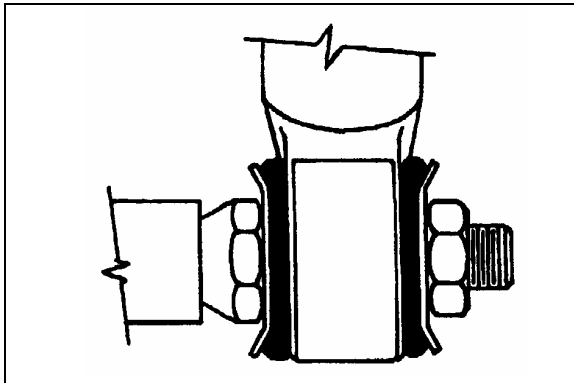

FIGURE 8: TYPICAL SHOCK ABSORBER SETUP 16009

- Place the lower and upper mounting pin stud nuts and torque to 70 - 80 lbf-ft (95 - 110 Nm).

#### 4. RADIUS RODS

Radius rods are used to secure the axles in the proper transversal and longitudinal positions. Four radius rods are provided on the front axle suspension (three longitudinal and one transversal), four on the drive axle suspension (three longitudinal and one transversal) and also four on the tag axle with a layout similar to the drive axle. Refer to figures 1, 2, 3, 4 and 5 for details. These rods transmit both braking and driving forces from the axles to the vehicle body.

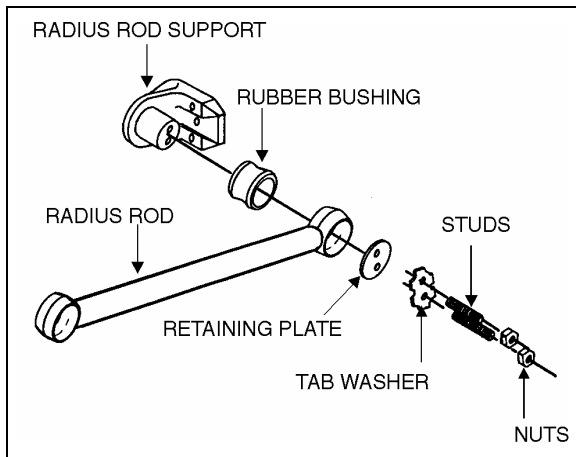

FIGURE 9: TYPICAL RADIUS ROD SETUP 16010

##### 4.1 INSPECTION

The following instructions apply to all radius rods used on this vehicle:

- Clean all parts thoroughly.

- Inspect radius rods for distortion and cracks. We recommend the "Magnaflux" process to detect cracks in the radius rod. Any damaged part should be replaced with a new one.

*NOTE*

*New bushings should be used when rods are replaced.*

- The radius rod bushings should be checked periodically for signs of shearing, deterioration, or damage. Any defective part should be replaced with a new one.

##### 4.2 REMOVAL

- Flatten the tab washer which secures the two retaining nuts (or bolts), then unscrew the nuts (or bolts) at each extremity of the radius rod (Fig. 9).
- Remove the tab washer and the retaining plates and radius rod ends from anchor pins, and then remove the radius rod.

##### 4.3 BUSHING REMOVAL

- Safely support the radius rod as shown in figure 10.

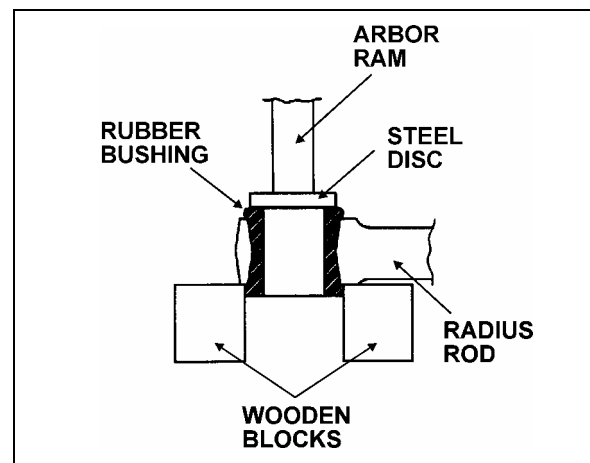

FIGURE 10: RADIUS ROD BUSHING REMOVAL 16011

- Place a flat steel disc, slightly smaller than the outside diameter of the bushing (Fig. 10).
- Using an arbor press or a suitable driving tool, press or drive the old bushing out of the rod and discard the bushing.

## Section 16: SUSPENSION



**Make sure to prevent the steel disc from contacting the radius rod end.**

### 4.4 BUSHING INSTALLATION

1. Lightly spray the inner and outer surfaces of radius rod bushing with water.



**No lubricant whatsoever is to be used on the rubber bushing.**

2. Safely support the radius rod, and place new bushing on top of the radius rod end (Fig. 11).
3. Place a block of wood on top of bushing and press on it manually.
4. If necessary, use an arbor press or a suitable driving tool. Press or drive the bushing into the radius rod end until it extends equally on both sides of the rod.
5. It is also possible to proceed differently. Place radius rod bushing on a plane surface. Spray a light coat of water on the inner and outer surfaces of radius rod bushing.
6. Take radius rod, align the bushing. Tap radius rod on bushing until latter is positioned correctly.

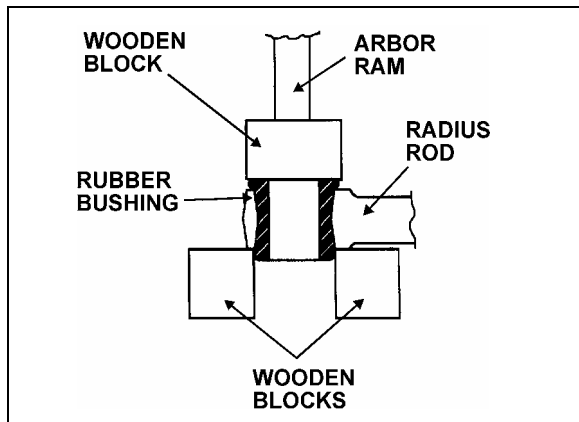

FIGURE 11: RADIUS ROD BUSHING INSTALLATION 16012

### 4.5 INSTALLATION

1. Lightly spray the radius rod support with water. Place the radius rod end over the radius rod support (Fig. 12).

2. Position the retaining plate. Install the tab washer and nuts (or bolts).

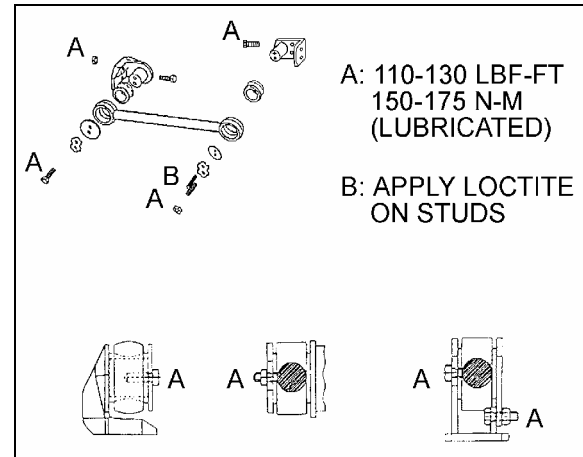

FIGURE 12: RADIUS ROD INSTALLATION

16028



**Always use new tab washers at installation.**

3. Tighten the nuts (or bolts) lightly, and repeat at the other end.
4. Refer to heading "*Suspension Height Adjustment*" later in this section, and set the vehicle to normal ride height.
5. With the vehicle at normal ride height, apply oil on threads and tighten all radius rod anchor pin nuts or bolts to 110 – 130 lbf-ft (150 – 175 Nm).



**It is extremely important upon reconnection of the rods that the proper clearance height between the axle and body be maintained. Otherwise, the rubber bushings in radius rod ends will become preloaded, thus reducing their life span.**



## 5. SWAY BAR

A sway bar is provided on the front axle to increase vehicle stability. It controls lateral motion (swaying movement) of the vehicle (Fig. 13). Vehicles equipped with an independent front suspension (IFS) are provided with two sway bars. Refer to supplement information on independent front suspension for more details.

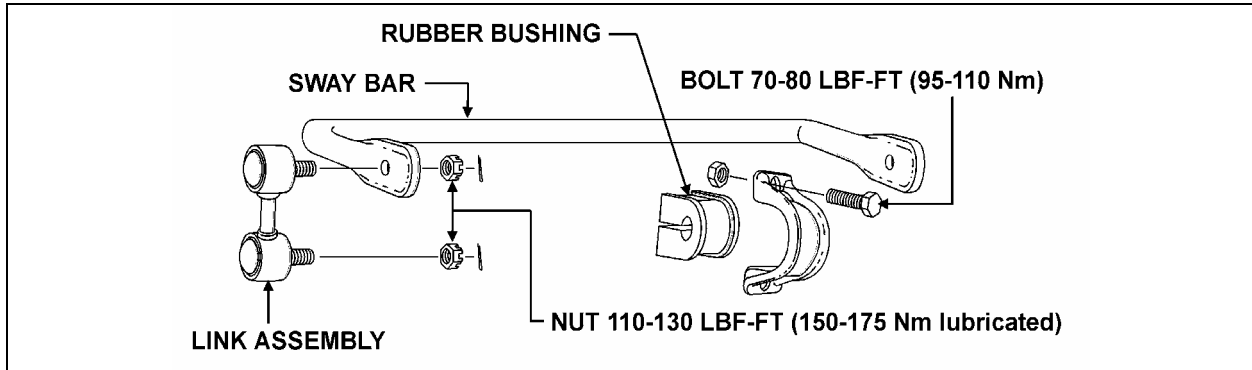

FIGURE 13: I-BEAM FRONT AXLE SWAY BAR

16099

### 5.1 REMOVAL

1. Disconnect the two links from sway bar.
2. Safely support the sway bar. Unbolt the four bushing collars from subframe.
3. Remove sway bar.

#### **NOTE**

*Sway bar bushings are slitted to ease their removal.*

### 5.2 INSTALLATION

1. Loosely install the sway bar.
2. Tighten the eight bushing collar nuts to 70 - 80 lbf-ft (95 - 110 Nm) (Fig. 13).
3. Install two sway bar link upper and lower nuts and tighten to 100 - 130 lbf-ft (150 - 175 Nm) (Fig. 13).
4. Install a cotter pin on each nut and bend.

## 6. SUSPENSION AIR SYSTEM

The suspension air system has its own air reservoir (accessory tank) which is located behind the front axle. Pressurized air from the main tank (wet tank) flows through a pressure protection valve (PR-2), installed on the accessory air tank then flows to the accessory air tank.

The pressure protection valve (PR-2) controls the pressure at which compressed air is delivered to the accessory air tank. The valve remains closed until a preset pressure is reached (approximately 70 psi (485 kPa)). It then opens and passes air out the delivery port.

The main use for this valve is to protect the main air system by ensuring at all times a sufficient air pressure in the main system (i.e. air delivered to the accessories will be shut off in case of a decrease in pressure). Maintenance and repair information on the pressure protection valve is supplied in the applicable booklet, annexed to Section 12, "Brakes and Air System" under reference number SD-03-2010.

#### **WARNING**

**Depressurize parts prior to removal.**

### 6.1 INSPECTION

The following inspection should be performed at established service inspection periods. Performing these procedures will allow substandard performance to be discovered before the condition becomes bad enough to cause operator complaints and failure on a run.

1. Visually inspect the suspension air lines for evidence of chafing on metal parts or other damage.
2. Visually inspect the air springs for cracks, abrasion or other damage.

## Section 16: SUSPENSION

3. Replace any parts found to be damaged.

### 6.2 AIR LINE TEST

With the main air system at normal operating pressure [95 – 125 psi (655 – 860 kPa)], coat all suspension air line connections and air spring mountings with a solution of soap and water. Air leakage will produce soap bubbles. Any leak found must be corrected as no air leakage is permissible.

### 6.3 AIR TANK MAINTENANCE

Refer to Section 12, “Brakes and Air System” under “Maintenance” for complete instructions on air tank maintenance.

## 7. SUSPENSION HEIGHT ADJUSTMENT

The flow of pressurized air from the accessory air tank to the air springs is controlled by three height control valves. These valves are mounted to the subframe and connected to the axles through an arm and link connection. This connection allows the valves to apportion air pressure in the springs to the vehicle load, maintaining normal ride height.

Immediate response height control valves increase or decrease the air pressure in the suspension system as required. One height control valve is located at center of front axle, and regulates air to front axle air springs in order to maintain the vehicle at the required height. Two are located at the drive axle, one on each inner side of rear wheelhousing. Refer to figure 15.

The appropriate vehicle body height is obtained by measuring the clearance of all the air springs installed on the front and drive axles. The clearance should be 11 11/16” (297 mm) for the air springs installed on the front axle and 11 1/2” ± 1/4” (292 ± 6 mm) for those installed on the drive axle. Refer to figure 14 to identify the correct location where the measure has to be taken. At this point, it should not be necessary to make an adjustment under normal service conditions. However, if an adjustment is required, change the position of the overtravel lever in relation to the overtravel control body. The lever should be moved up to raise the height of vehicle and down to lower it. Check that main air pressure is at normal operating

pressure and raise the vehicle to the specified height.

### ⚠ CAUTION ⚠

**Because of the “deadband”, always adjust on “fill cycle”. If it is necessary to lower vehicle height, release sufficient air to be well below height, and adjust to height through fill cycle.**

To adjust suspension height, proceed as follows:

1. With the vehicle at normal operating air pressure, check the air spring clearance as illustrated in figure 14. This clearance should be 11 11/16” (297 mm) for the front axle air springs and 11 1/2” ± 1/4” (292 ± 6 mm) for those on the drive axle.

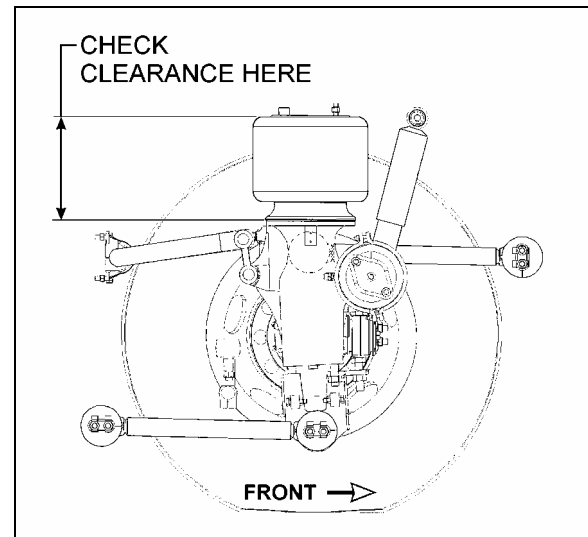

FIGURE 14: TYPICAL AIR SPRING CLEARANCE 16097

### NOTE

*The measure should be taken from under the upper air spring support on subframe to top of the lower air spring support on axle (refer to fig. 14 for more details). If adjustment is required, begin with the drive axle.*

2. Loosen the adjusting nuts on the connecting rod of height control valve to raise or lower the overtravel lever until the desired clearance is reached.
3. If there is not enough play on adjusting nuts, it is possible to make further adjustments by loosening the clamp on the rubber coupling and bringing it up or down.

**NOTE**

*Allow suspension to stabilize before taking reading.*

4. When the desired height is obtained, tighten adjusting nuts and clamp.

**8. HEIGHT CONTROL VALVES**

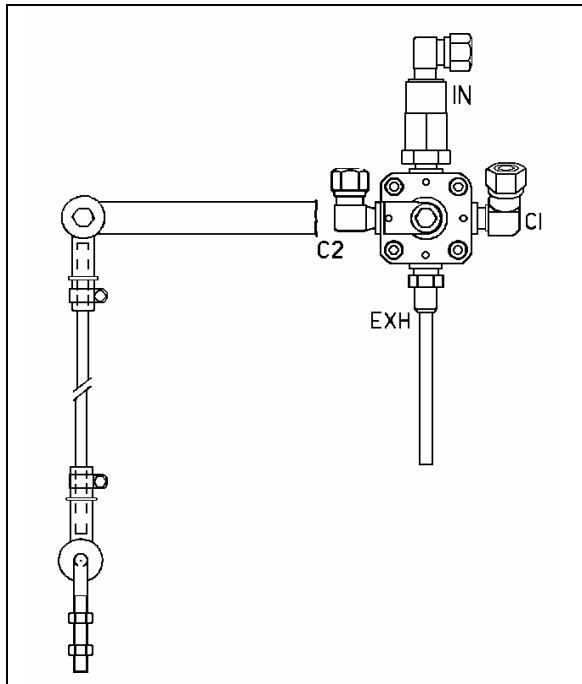

**FIGURE 15: HEIGHT CONTROL VALVE** 16093

The height control valves automatically add air to, or release air from air springs to maintain constant suspension height regardless of load, or load distribution. Each valve adjusts independently according to the following conditions:

**Loading position**

As the load increases and lowers the vehicle body, the overtravel lever commands the height control valve to add air to air springs.

**Neutral position**

When vehicle body reaches the normal ride height, the height control valve overtravel lever reaches the "neutral" position and keeps both the supply and exhaust ports closed to ensure normal ride height is maintained. This condition remains static until the vehicle load is altered.

**Unloading position**

As the load decreases and raises the vehicle body, the overtravel lever commands the height control valve to release air from air springs.

**8.1 MAINTENANCE**

The height control valve requires no periodic maintenance. Height control valve linkage operates on rubber bushings and no lubrication should be attempted at this point.

**8.1.1 Removal and installation**

Before disconnecting any height control valve air lines, securely support the vehicle by its jacking points on the body, and place safety support underneath body. Refer to "Vehicle Jacking Points" in Section 18, "Body".

1. Exhaust air from air system by opening the drain cock on accessory air reservoir.
2. Disconnect overtravel lever from link and pull down lever to exhaust remaining air from air springs.
3. Disconnect air supply and delivery lines from the height control valve. Cover ends of the lines with tape.
4. Remove the two nuts retaining the height control valve to the mounting bracket, then remove valve assembly.

Reverse removal procedure to replace height control valve. After installation, check for leakage using a soap and water solution.

**8.1.2 Air leakage test**

**NOTE**

*The following procedure applies when valve assembly has been removed from vehicle.*

1. Clean the exterior of valve assembly.
2. Connect air pressure line to air inlet port, then allow air pressure build-up (70- 100 psi (480 - 690 kPa)).
3. Dip the valve assembly in a container of water, and watch for air bubbles when the overtravel lever is in the center position. No air should escape from any point of the valve assembly.

## Section 16: SUSPENSION

---

4. If bubbles appear from the air spring port, this is an indication that the air inlet valve assembly is defective and must be replaced.
5. Remove air pressure line from air inlet fitting and connect it to the air spring port. If bubbles appear at the air inlet check valve port, this is an indication that the check valve unit is defective and must be replaced.
6. If bubbles appear at the exhaust port, this is an indication that the exhaust valve assembly is defective and must be replaced.
7. If bubbles appear around edge of valve cover plate, the cover plate gasket must be replaced.
8. If no leaks are found, remove valve assembly from water, then with air pressure still connected to the air spring port, actuate overtravel lever to remove any excess water which may have entered exhaust valve chamber. Remove air line, connect it to the air inlet port, and repeat operation to remove water from the air inlet valve chamber.

### 9. FRONT KNEELING SYSTEM

The kneeling system is used to lower front of vehicle. This allows passengers to board the vehicle with greater ease. The kneeling action is achieved by exhausting air from the front air springs (bellows). This system bypasses the height control valve to provide a fast up and down movement of the front suspension. Only seven seconds are required to lower vehicle from normal level to the lowered position, and approximately the same time to raise the vehicle back to normal level. The quick response is achieved by an auxiliary air tank installed beside the secondary air reservoir (for exact position, refer to Section 12, *"Brake and Air System"*). This tank provides sufficient air supply to the kneeling system for some successive operations.

The system is provided with two safety features; first, a speed switch will enable the kneeling system to work only at less than 5 mph (8 km/h). Secondly, the parking brake is automatically applied, and a limit switch will keep it applied as long as the vehicle has not returned to a certain height where the driver will be able to manually remove the parking brake.

The purpose of the hi-buoy function in this system is to raise the front end of the vehicle to allow an extra ground clearance for particular situations. In driving condition, the height control valve is in operation and only the hi-buoy can be operated.

#### 9.1 PRINCIPLE OF OPERATION

Refer to the air system schematic diagram annexed at the end of Section 12, *"Brake and Air System"*.

##### DOWN (FRONT KNEELING):

Both the bellows control and bellows exhaust solenoid valves are energized, so the air control valves release air from front air springs. The height control valve is bypassed to ensure no air is forwarded to air springs while lowering the front suspension.

##### UP (FRONT HIGH-BUOY):

Only the bellows control solenoid valve is energized, so the air coming from the kneeling air tank is routed through air control valves, and up to front air springs.

The height control valve is bypassed until the kneeling proximity switch signals the kneeling module to cut off the bellows control solenoid valve, about 1" (25 mm) below normal ride height. The final height adjustment is achieved by the height control valve.

#### 9.2 MAINTENANCE

Since the kneeling action is issued from both the air system and electrical system, refer to Section: 12, *"Brake and Air System"* and Section 06, *"Electrical System"*.

For diagnosis and understanding of the system, refer to wiring diagrams, and to the appropriate air system schematic diagram annexed to Section 12, *"Brake and Air System"*.

#### 9.3 BELLOWS CONTROL SOLENOID VALVES

##### 9.3.1 Removal and installation

1. On the rear side of steering compartment, locate both the bellows control and bellows exhaust solenoid valves.

2. Identify hoses and wires to ease reinstallation. Disconnect solenoid wires and the three flexible black hoses from solenoid valves.
3. Unscrew and remove the control solenoid valve and exhaust solenoid valve assembly. Place on a clean working place.

Reverse removal procedure to reinstall.

<b>CAUTION</b>
<p><b>Any cable tie that has been cut during removal procedure should be replaced with a new one.</b></p>

## 10. HIGH-BUOY SYSTEM

The purpose of the rear high-buoy system is to raise the entire vehicle body about 4" (100 mm) in order to increase ground clearance to board a ferryboat, to jump a curb, etc. This system can be put into service during normal vehicle operation.

### 10.1 PRINCIPLES OF OPERATION

The rear high-buoy system is added over the front kneeling (with front high-buoy). The front end uses the same valves as the front kneeling (with front high-buoy). A solenoid valve is added to send air to the double shuttle valves for the rear end. It uses the same dash switch as the kneeling (with front high-buoy).

#### UP:

The air coming from the control valve, flows through double shuttle valves, to supply air springs. The double shuttle valves prevent height control valves from releasing air from air springs.

#### DOWN:

The control valve, on the dashboard, cuts off air supply, so the double shuttle valves allow height control valves to accomplish their function. Height control valves release air from air springs until suspension returns to its normal position.

### 10.2 MAINTENANCE

Refer to the air system schematic diagram "Opt. Front Kneeling With Rear High-Buoy Combination" annexed at the end of this Section.

### 10.3 HIGH-BUOY – PRESSURE REGULATING VALVE

The regulating valve is located in the front service compartment. This valve should be adjusted to 90 psi (621 kPa).

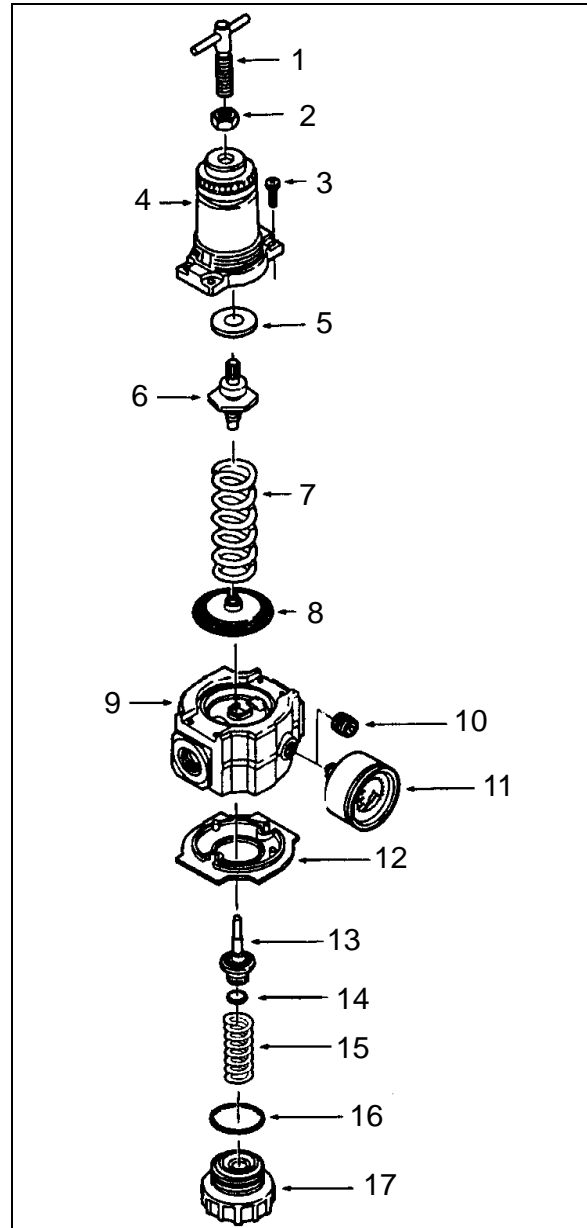

FIGURE 16: REGULATING VALVE

16035

#### 10.3.1 Adjustment

1. Before turning on system air pressure, release jam nut (2, Fig. 16) then turn regulator adjustment counterclockwise until all load is removed from the regulating spring.

## Section 16: SUSPENSION

---

2. Turn on system pressure.
3. Turn regulator adjustment clockwise until the desired outlet pressure is reached.
4. To avoid minor readjustment after making a change in pressure setting, always approach the desired pressure from a lower pressure. When reducing from a higher to a lower setting, first reduce the pressure at a lower pressure, and then increase it to the desired level of pressure.
5. Tighten jam nut (2, Fig. 16) to lock pressure setting.

### 10.3.2 Disassembly

1. Shut off inlet pressure and reduce pressure in inlet and outlet lines to zero. Turn regulator adjustment (1, Fig. 16) counterclockwise until all load is removed from regulating spring. Regulator can be disassembled without removal from air line.
2. Disassemble regulator in accordance with the item numbers on the exploded view.

### 10.3.3 Cleaning

1. Clean parts with warm water and soap. Dry parts and blow out internal passages in body using clean, dry compressed air.
2. Inspect parts. Replace those found to be damaged.

### 10.3.4 Reassembly

1. Lubricate O-ring (14 and 16, Fig. 16), valve stem (13, Fig. 16), tip of adjusting screw (1, Fig. 16), and the outer circumference and both sides of the thrust washer (9, Fig. 16) with a light coat of good quality O-ring grease.
2. Assemble the regulator as shown on the exploded view.

Torque Table	
Item	Torque in lbf-inch (Nm)
3 (Screw)	25-35 (2.8-3.9)
17 (Bottom plug)	20-25 (2.3-2.8)

## 11. LOW-BUOY SYSTEM

The purpose of the low-buoy system is to lower the whole suspension by about 4" (100 mm) in order to reduce the overall height for low clearances. This system can be put into service during normal vehicle operation.

### 11.1 PRINCIPLES OF OPERATION

On XL2 coaches, the rear low-buoy is added over the front kneeling system. The control valve on the left console panel sends an electric signal from its pressure switch to control the front suspension as if kneeling. It also removes air from a relay valve that exhausts air supply to all leveling valves and the quick release in the rear section. Air from the rear suspension can then be depleted through the check valve-quick release assembly.

#### DOWN:

The control valve, on the L.H. control panel, cuts off air supply, so air is released from air springs. A relay valve prevents height control valves from supplying air springs.

#### UP:

The control valve, on the L.H. control panel, supplies air to close the passage between both the delivery and supply ports. A relay valve opens and provides air springs until the suspension reaches the normal ride height.

### 11.2 MAINTENANCE

Refer to the air system schematic diagram "Opt. Front Kneeling With Rear Low-Buoy Combination" annexed at the end of this Section.

**12. TROUBLESHOOTING**

Condition	Cause	Correction
Bellows deflate over time	<ol style="list-style-type: none"> <li>1. Defective check valve assembly.</li> <li>2. Defective exhaust valve assembly.</li> <li>3. Leak in air line and/or bellows.</li> <li>4. Defective valve cover, rubber O-rings or gasket.</li> </ol>	<ol style="list-style-type: none"> <li>1. Replace check valve assembly.</li> <li>2. Replace exhaust valve assembly.</li> <li>3. Replace air line or bellows.</li> <li>4. Replace valve cover, O-rings or gasket.</li> </ol>
Bellows raise to full height and fail to exhaust air pressure	<ol style="list-style-type: none"> <li>1. A clogged exhaust screen in height control valve assembly.</li> <li>2. A combination clogged exhaust screen and defective air inlet valve assembly.</li> </ol>	<ol style="list-style-type: none"> <li>1. Remove and clean screen.</li> <li>2. Clean exhaust screen and replace air inlet valve assembly.</li> </ol>
Erratic valve action	<ol style="list-style-type: none"> <li>1. Dirt or foreign matter in the air valve lever chamber.</li> <li>2. Defectives valves.</li> </ol>	<ol style="list-style-type: none"> <li>1. Remove valve cover and blow out dirt. Install cover using new gasket.</li> <li>2. Overhaul height control valve assembly</li> </ol>
Vehicle body fails to level to satisfactory ride height	<ol style="list-style-type: none"> <li>1. Improper height control valve overtravel lever adjustment</li> </ol>	<ol style="list-style-type: none"> <li>1. Adjust lever as directed.</li> </ol>

**13. PARTS SPECIFICATIONS**

**Front and tag axle air springs**

Make..... Goodyear Tire and Rubber  
 Model.....1200  
 Type ..... Mae West  
 Nominal diameter .....12" (304 mm)  
 Supplier number .....1R12-319  
 Prévost number .....630125

**Drive axle air springs**

Make..... Goodyear Tire and Rubber  
 Model.....1100  
 Type ..... Double Flare  
 Nominal diameter ..... 11.5" (292 mm)  
 Supplier number .....1R11-088  
 Prévost number .....630104

**Front axle shock absorbers**

Make ..... Sachs  
 Color ..... Black  
 Type .....N45X225HA  
 Ext. Diam. .... 75 mm  
 Collapsed length ..... 15.51" (394 mm)  
 Extended length ..... 24.37" (619 mm)  
 Supplier number .....481700000207  
 Prévost number ..... 630252

**Drive and tag axle shock absorbers**

Make ..... Sachs  
 Color ..... Black  
 Type .....N45X225HA  
 Ext. Diam. .... 75 mm  
 Collapsed length ..... 15.51" (394 mm)  
 Extended length ..... 24.37" (619 mm)  
 Supplier number .....481700000209  
 Prévost number ..... 630253

## Section 16: SUSPENSION

---

### Height control valve (MTH, front only)

Make..... Barksdale  
Quantity used .....1  
Supplier number.....52321POAQ3-Q62  
Prévost number.....630157

### Height control valve (coach, all axles & MTH, rear only)

Make..... Barksdale  
Quantity .....2  
Supplier number.....52321POAQ3-Q26  
Prévost number.....630156

### Bellows control and exhaust solenoid valve assembly

Make..... Norgren

### Solenoid valve manifold

Supplier number.....D0043B  
Prévost number.....641130

### Coil

Voltage .....24 V DC  
Current draw ..... 29 amperes  
Supplier number.....54932-27  
Prévost number.....641144

### Valve (3 way, 2 positions)

Type ..... N/C  
Supplier number.....411-C-456235W  
Prévost number.....641357  
Type ..... N/O  
Supplier number.....411-D-456236X  
Prévost number.....641356

### Radius rod bushing

Make..... Prévost  
Prévost number.....630021

### Loctite

Make ..... Loctite  
Prévost number .....680039

### Sway bar bushing (Front Axle)

Make .....Prévost  
Prévost number .....630020

### Sway bar link

Make .....Tennaco Automotive  
Supplier number .....934400  
Prévost number .....630230

### Shock absorber bushings

Make .....Monroe  
Supplier number .....45380  
Prévost number .....630062

### Air regulator

Make .....Norgren  
Recommended pressure sett. . 90 psi (621 kPa)  
Supplier number .....R74G-4AT-RMN  
Prévost number .....641352



**14. TORQUE SPECIFICATIONS**

- 1- Shock absorber pin ..... 500-550 lbf-ft (680-750 Nm)
- 2- Shock absorber pin nut ..... 70-80 lbf-ft (95-110 Nm)
- 3- Radius rod stud ..... 20-40 lbf-ft (27-54 Nm)
- 4- Radius rod retaining nut or bolt ..... 110-130 lbf-ft lubricated (150-175 Nm lubricated)
- 5- Radius rod support nut ..... 110-130 lbf-ft lubricated (150-175 Nm lubricated)
- 6- Axle attachment nut..... 425-475 lbf-ft (580-645 Nm)
- 7- Air spring stud nut ..... 20-25 lbf-ft (27-34 Nm)
- 8- Sway bar link nuts ..... 110-130 lbf-ft lubricated (150-175 Nm lubricated)
- 9- Sway bar bushing collar bolts ..... 70-80 lbf-ft (95-110 Nm)

***NOTE***

*During assembly, use "Loctite 242" (Prévost No 680038) with item 1 and 3. After assembly, apply "anti-seize compound" (Prévost No 680064) on all threads nuts.*

# SECTION 16: MTH EQUIPPED WITH INDEPENDENT FRONT SUSPENSION (IFS)

## CONTENTS

<b>1. INTRODUCTION</b> .....	<b>16(MTH)-4</b>
<b>2. STEERING LINKAGE</b> .....	<b>16(MTH)-4</b>
2.1 POWER STEERING HYDRAULIC PUMP .....	16(MTH)-7
2.2 STEERING LINKAGE ADJUSTMENT .....	16(MTH)-7
2.3 PITMAN ARM REMOVAL.....	16(MTH)-7
2.4 PITMAN ARM INSTALLATION.....	16(MTH)-7
2.5 DRAG LINK.....	16(MTH)-8
2.5.1 <i>adjustment</i> .....	16(MTH)-8
2.6 BELL CRANK AND IDLER ARM.....	16(MTH)-8
2.6.1 <i>bell crank and idler arm removal</i> .....	16(MTH)-8
2.6.2 <i>bell crank or idler arm ball joint disassembly</i> .....	16(MTH)-8
2.6.3 <i>bell crank or idler arm ball joint reassembly</i> .....	16(MTH)-8
2.7 RELAY ROD.....	16(MTH)-10
2.7.1 <i>replacement</i> .....	16(MTH)-10
2.8 TIE RODS.....	16(MTH)-10
2.8.1 <i>removal</i> .....	16(MTH)-10
2.8.2 <i>installation</i> .....	16(MTH)-11
2.9 STEERING ARMS.....	16(MTH)-11
2.9.1 <i>removal</i> .....	16(MTH)-11
2.9.2 <i>installation</i> .....	16(MTH)-11
2.10 LUBRICATION FITTINGS .....	16(MTH)-11
<b>3. BALL JOINTS</b> .....	<b>16(MTH)-13</b>
<b>4. LOWER AND UPPER A-ARM BALL JOINT</b> .....	<b>16(MTH)-13</b>
4.1 INSPECTION.....	16(MTH)-13
4.2 STRIPPING DOWN .....	16(MTH)-13
4.3 ASSEMBLY .....	16(MTH)-13
<b>5. LOWER A- ARM CENTRAL BALL JOINT</b> .....	<b>16(MTH)-14</b>
5.1 INSPECTION.....	16(MTH)-14
5.2 STRIPPING DOWN .....	16(MTH)-14
5.3 ASSEMBLY .....	16(MTH)-14
<b>6. UPPER A-ARM CENTRAL BALL JOINT</b> .....	<b>16(MTH)-15</b>
6.1 VISUAL INSPECTION .....	16(MTH)-15
6.2 PLAY MEASUREMENT.....	16(MTH)-15
<b>7. FRONT END ALIGNMENT</b> .....	<b>16(MTH)-15</b>
7.1 ALIGNMENT TERMINOLOGY.....	16(MTH)-16
7.2 FRONT END INSPECTION .....	16(MTH)-16
7.3 FRONT WHEEL CAMBER.....	16(MTH)-17
7.4 FRONT WHEEL TOE-IN.....	16(MTH)-17
7.4.1 <i>toe-in check</i> .....	16(MTH)-17
7.4.2 <i>toe-in adjustment</i> .....	16(MTH)-17
7.5 FRONT AXLE CASTER .....	16(MTH)-17
7.6 MAJOR DAMAGE .....	16(MTH)-19
<b>8. FRONT AIR SPRINGS</b> .....	<b>16(MTH)-19</b>

**Section 16: MTH EQUIPPED WITH INDEPENDENT FRONT SUSPENSION (IFS)**

---

8.1	INSPECTION.....	16(MTH)-19
8.2	REMOVAL.....	16(MTH)-19
8.3	INSTALLATION.....	16(MTH)-19
<b>9.</b>	<b>SHOCK ABSORBERS .....</b>	<b>16(MTH)-20</b>
9.1	SHOCK ABSORBER REMOVAL.....	16(MTH)-21
9.2	SHOCK ABSORBER INSTALLATION.....	16(MTH)-21
<b>10.</b>	<b>SWAY BAR .....</b>	<b>16(MTH)-21</b>
10.1	REMOVAL.....	16(MTH)-21
10.2	INSTALLATION.....	16(MTH)-21
<b>11.</b>	<b>INDEPENDENT FRONT SUSPENSION ADJUSTMENT .....</b>	<b>16(MTH)-23</b>
<b>12.</b>	<b>SUSPENSION HEIGHT ADJUSTMENT .....</b>	<b>16(MTH)-23</b>
<b>13.</b>	<b>HEIGHT CONTROL VALVE .....</b>	<b>16(MTH)-24</b>
13.1	LOADING POSITION .....	16(MTH)-24
13.2	NEUTRAL POSITION .....	16(MTH)-24
13.3	UNLOADING POSITION.....	16(MTH)-24
13.4	MAINTENANCE.....	16(MTH)-24
13.5	REMOVAL AND INSTALLATION.....	16(MTH)-25
<b>14.</b>	<b>"LEVEL-LOW" LEVELING SYSTEM .....</b>	<b>16(MTH)-25</b>
14.1	PRINCIPLES OF OPERATION .....	16(MTH)-25
14.2	MAINTENANCE.....	16(MTH)-25
<b>15.</b>	<b>AIR SYSTEM .....</b>	<b>16(MTH)-25</b>
15.1	AIR TANK MAINTENANCE.....	16(MTH)-26
15.1.1	<i>wet air tank</i> .....	16(MTH)-26
15.1.2	<i>primary air tank</i> .....	16(MTH)-26
15.1.3	<i>secondary air tank</i> .....	16(MTH)-26
15.1.4	<i>accessory air tank</i> .....	16(MTH)-27
15.1.5	<i>expansion air tank</i> .....	16(MTH)-27
15.2	EMERGENCY FILL VALVES.....	16(MTH)-27
<b>16.</b>	<b>HUB UNIT AND SWIVEL ASSEMBLY .....</b>	<b>16(MTH)-27</b>
<b>17.</b>	<b>TORQUE TABLE .....</b>	<b>16(MTH)-28</b>
<b>18.</b>	<b>SPECIFICATIONS.....</b>	<b>16(MTH)-29</b>

**ILLUSTRATIONS**

FIGURE 1: SUSPENSION AND STEERING LINKAGE ..... 16(MTH)-4  
FIGURE 2: LOCATION OF CLAMPS..... 16(MTH)-5  
FIGURE 3: CLAMP POSITIONING ..... 16(MTH)-6  
FIGURE 4: CLAMP POSITIONING ..... 16(MTH)-6  
FIGURE 5: CLAMP POSITIONING ..... 16(MTH)-6  
FIGURE 6: CLAMP POSITIONING ..... 16(MTH)-6  
FIGURE 7: CLAMP POSITIONING ..... 16(MTH)-6  
FIGURE 8: PITMAN ARM ALIGNMENT ..... 16(MTH)-7  
FIGURE 9: FIXING NUT PUNCH MARK ..... 16(MTH)-8  
FIGURE 10: BELL CRANK AND IDLER ARM ..... 16(MTH)-9  
FIGURE 11: BELL CRANK ..... 16(MTH)-9  
FIGURE 12: BELL CRANK ..... 16(MTH)-10  
FIGURE 13: LUBRICATION FITTINGS' LOCATION DIAGRAM ..... 16(MTH)-12  
FIGURE 14: BALL JOINTS LOCATION ..... 16(MTH)-13  
FIGURE 15: A-ARM BALL JOINTS ..... 16(MTH)-13  
FIGURE 16: UPPER A-ARM BALL JOINT..... 16(MTH)-14  
FIGURE 17: LOWER A-ARM BALL JOINTS ..... 16(MTH)-14  
FIGURE 18: LOWER A-ARM CENTRAL BALL JOINT..... 16(MTH)-14  
FIGURE 19: UPPER A-ARM CENTRAL BALL JOINT ..... 16(MTH)-15  
FIGURE 20: STEERING LINKAGE MEASURE..... 16(MTH)-16  
FIGURE 21: FRONT END ALIGNMENT DIAGRAM ..... 16(MTH)-18  
FIGURE 22: AIR SPRINGS ..... 16(MTH)-19  
FIGURE 23: AIR SPRING AND SHOCK ABSORBER ..... 16(MTH)-20  
FIGURE 24: SHOCK ABSORBER..... 16(MTH)-21  
FIGURE 25: SWAY BAR (FRONT SUSPENSION)..... 16(MTH)-22  
FIGURE 26: SWAY BAR (REAR SUSPENSION)..... 16(MTH)-22  
FIGURE 27: HEIGHT CONTROL VALVE LOCATION ..... 16(MTH)-23  
FIGURE 28: TYPICAL AIR SPRING CLEARANCE ..... 16(MTH)-24  
FIGURE 29: FRONT HEIGHT CONTROL VALVE ..... 16(MTH)-24  
FIGURE 30: LOCATION OF AIR TANKS ..... 16(MTH)-26  
FIGURE 31: REAR VALVE LOCATION ..... 16(MTH)-26  
FIGURE 32: FRONT VALVE LOCATION ..... 16(MTH)-27

**1. INTRODUCTION**

This supplement contains service procedures and specifications that apply to the PREVOST converted coach shell vehicles equipped with an independent front suspension.

This text contains information unique to the independent suspension system. In the case you cannot find information on a subject in this supplement section, the information given in the regular sections of the Maintenance Manual will apply.

**2. STEERING LINKAGE**

Turning motion of the steering wheel is transferred by the steering gear and steering linkage to the steering arms at the right and left front wheels. The steering linkage consists of tie rods connected to the bell crank and the steering arm at the left side of the coach, and to the idler arm and steering arm at the right side of the coach. The bell crank and idler arm are

connected by a relay rod. A drag link connected to the bell crank and the pitman arm, which is mounted to the steering gear, transfers the turning motion of the steering wheel to the steering arms. The hydraulic power cylinder provides an added source of assistance and being connected to the R.H. wheel, makes it such that the total steering forces are produced with minimal stress on mechanical linkages (Fig. 1).

Lower and upper A-arms are widely spaced. They are mounted on ball joints. Torque rods prevent rotation of the uprights around the lower and upper ball joints.

If the steering linkage is bent, twisted or worn, steering action of the coach will be seriously affected. Any time steering linkage components are replaced or adjusted, steering geometry and front wheel alignment must be checked as explained in this section of supplement.

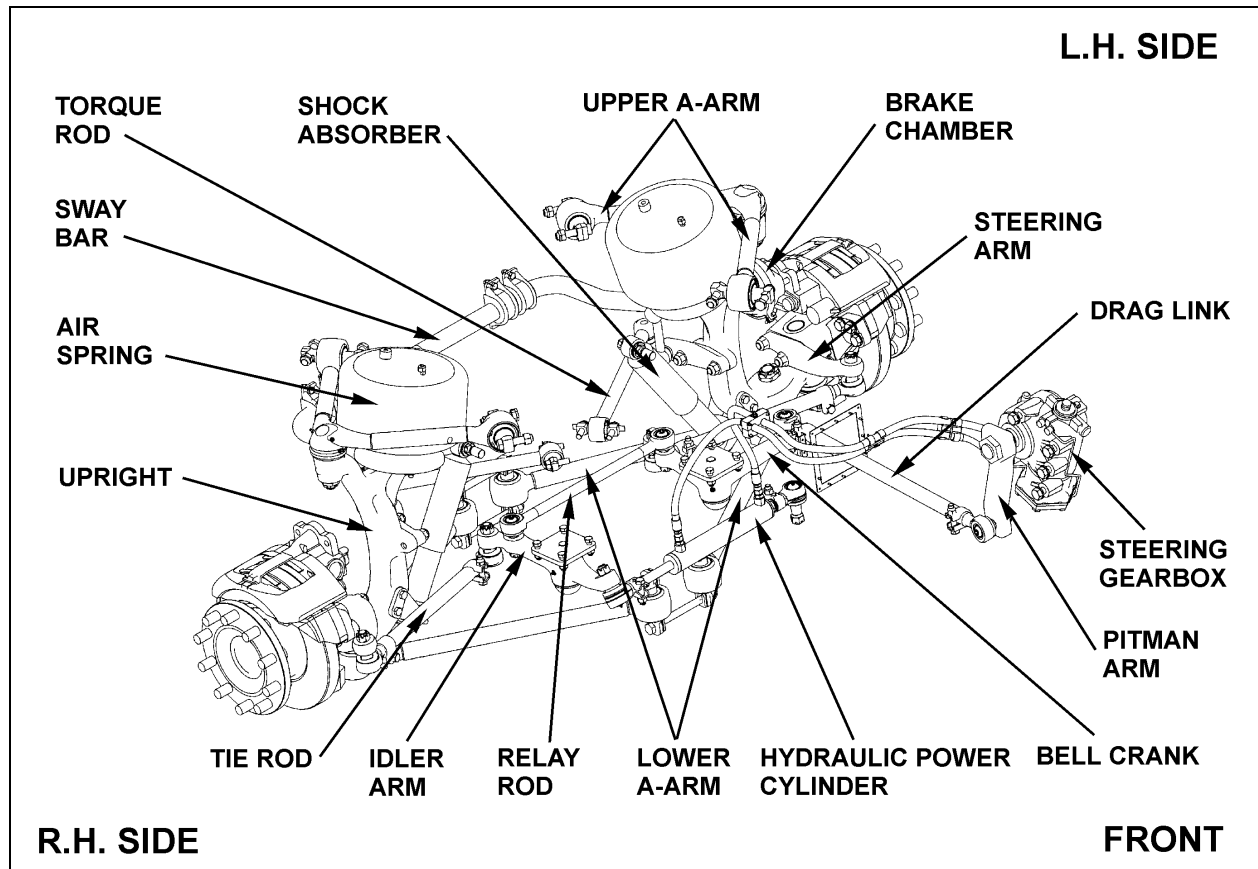

**FIGURE 1: SUSPENSION AND STEERING LINKAGE**

16124

### Turning Angle

The maximum turning angle is set mechanically through the two steering stop screws installed on the swivel assembly. The turning angle ( $56^{\circ} + 0^{\circ} - 1^{\circ}$ ) mechanical stop is factory adjusted to accommodate the chassis design, and therefore, does not require adjustment on new vehicles.

However, turning angle should be checked and adjusted hydraulically, if necessary, any time a component of the steering system is repaired, disassembled or adjusted.

Before checking the turning angle, be sure the front end is properly aligned as described under paragraph "4. Front End Alignment" in this supplement.

To check steering maximum turning angle, proceed with the following method:

1. Check if front tires rub against the frame or if the steering gear has been serviced.

**CAUTION**

**If clamps are not correctly installed, they can interfere with other parts.**

2. For a full left and right turn, check clamps' position and for interfering parts. Refer to figures 2 to 7 for location and positioning of clamps. If readjustment is required, make the proper adjustment.

**NOTE**

*Prior to steering limiter adjustment, verify vehicle wheel alignment, and ensure that oil level is adequate and that air bleeding is done.*

3. If necessary readjust steering limiter. Refer to "ZF-SERVOCOM Repair Manual" annexed to XL2 Maintenance Manual, Section 14, "Steering", under heading: "Setting and Functional Test".

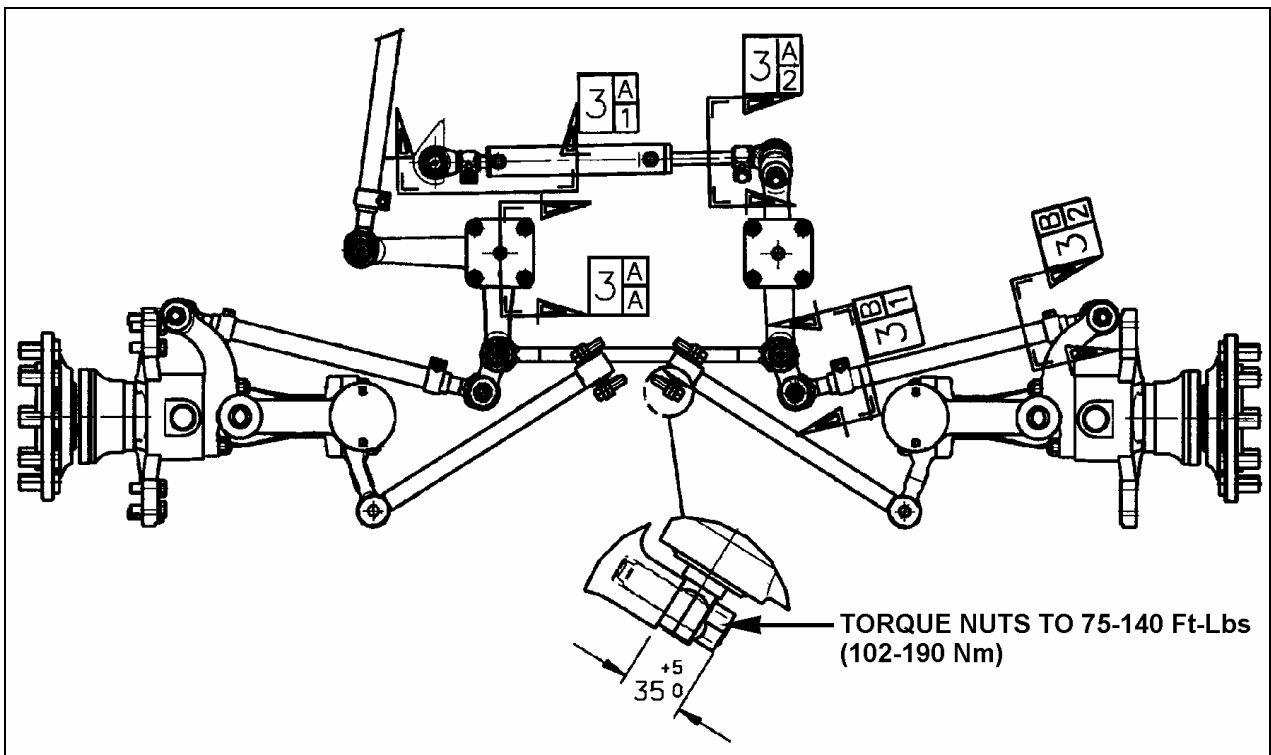

FIGURE 2: LOCATION OF CLAMPS

16126

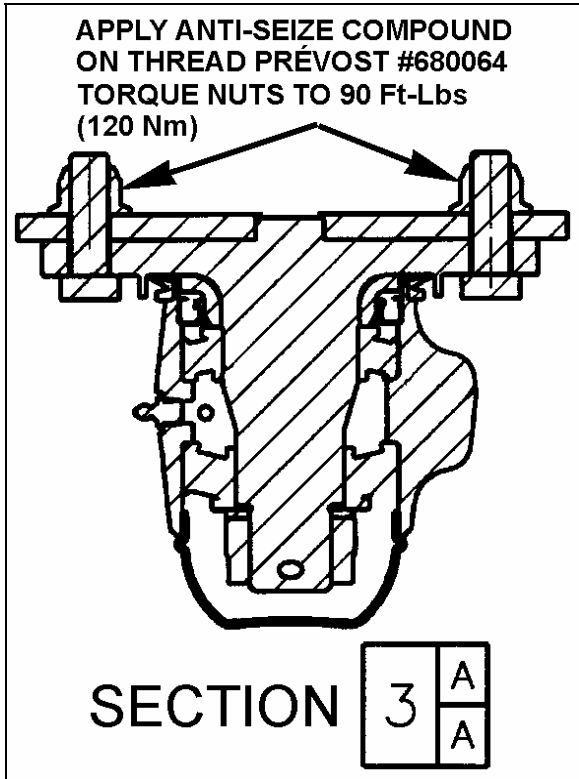

FIGURE 3: CLAMP POSITIONING 16128

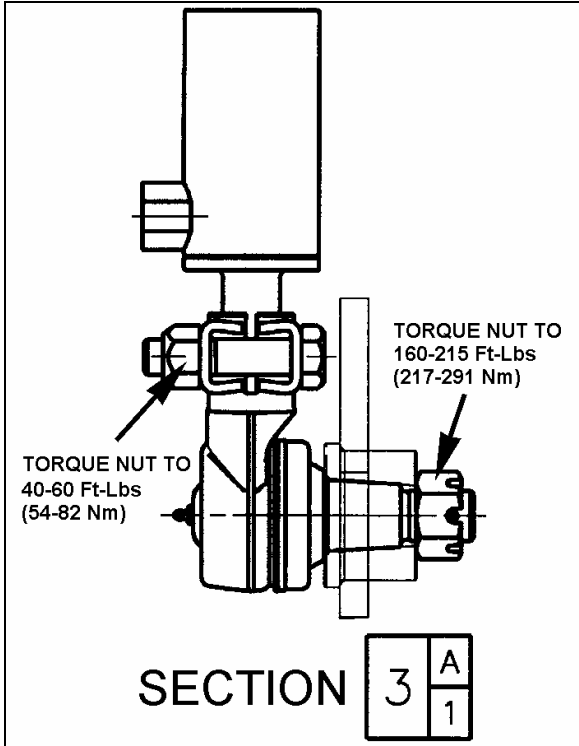

FIGURE 4: CLAMP POSITIONING 16121

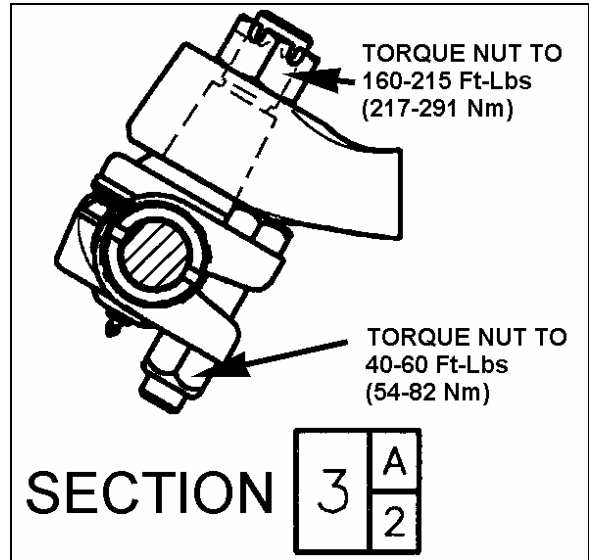

FIGURE 5: CLAMP POSITIONING 16122

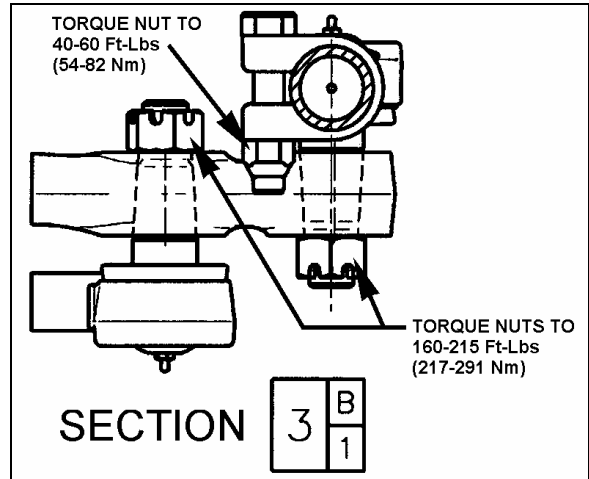

FIGURE 6: CLAMP POSITIONING 16120

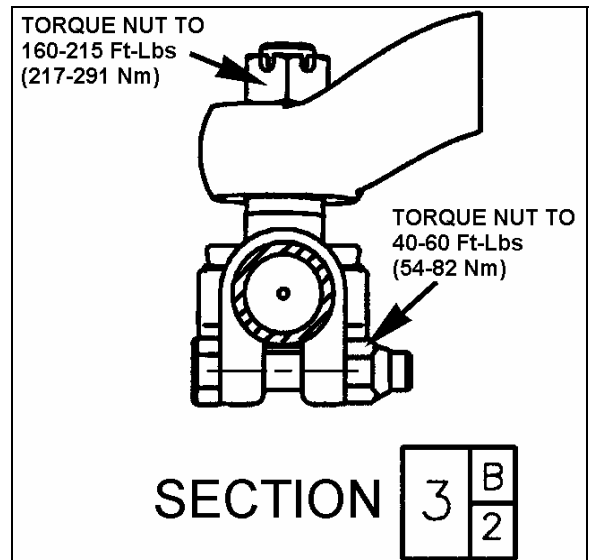

FIGURE 7: CLAMP POSITIONING 16123

2.1 POWER STEERING HYDRAULIC PUMP

Refer to the "TRW Power Steering Pump Service Manual" annexed at the end of Section 14

2.2 STEERING LINKAGE ADJUSTMENT

**NOTE**  
Whenever a steering linkage component has been removed and replaced, check steering geometry and front end alignment as directed in this Supplement. Check to insure that all stud nuts and mounting bolts and nuts have been tightened to proper torques listed under "16. Torque Table" at the end of this supplement.

1. First, align the input shafts marks.
2. Afterwards, the pitman arm should be adjusted with reference marks aligned or to an angle of 90° in relation with the horizontal axis (Fig. 8).
3. Locate centerline of vehicle then install relay rod in boss at steering bell crank and idler arm. Align center of relay rod with centerline of vehicle.
4. Install drag link to pitman arm and adjust opposite end of drag link to fit mounting stud hole in bell crank.
5. Install tie rods, and then adjust toe-in as per "Front End Alignment" in this Supplement.

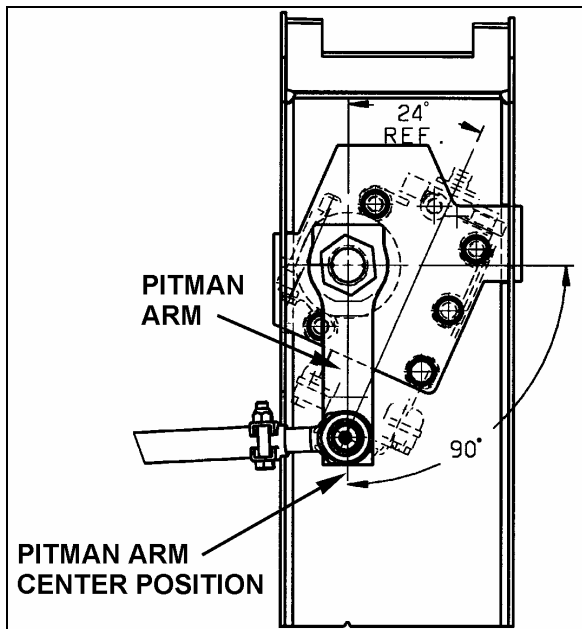

FIGURE 8: PITMAN ARM ALIGNMENT

14037

2.3 PITMAN ARM REMOVAL

1. Remove cotter pin, nut and washer from drag link ball stud at pitman arm.
2. Disconnect drag link from pitman arm, using jaw style pullers (pressure screw type).

**WARNING**  
Always wear approved eye protection when operating pullers.

**CAUTION**  
Do not drive pitman arm on or off pitman shaft as this can damage the steering gear.

**CAUTION**  
Heating of components to aid in disassembly is not allowed because it has a detrimental effect on axle components and steering linkages.

3. Remove pitman arm fixing nut.
4. Check the radial position of the pitman arm in relation to the sector shaft prior to removal of pitman arm.
5. Add reference marks to the arm and shaft if necessary to ensure correct alignment at reassembly.
6. Use a puller to remove pitman arm.

2.4 PITMAN ARM INSTALLATION

1. Position pitman arm on sector gear shaft with reference marks aligned.
2. Install fixing nut. Tighten nut to 400-450 lbf-ft (545-612 Nm).

**NOTE**  
Use a new nut if the previously removed nut was punched.

**CAUTION**  
Lock nut with sector shaft using a punch mark into the groove (Refer to figure 9).

3. Connect drag link to pitman arm. Install washers. Tighten nut to 160-215 lbf-ft (218-292 Nm). Advance nut to next alignment cotter pin slot and install a new cotter pin.



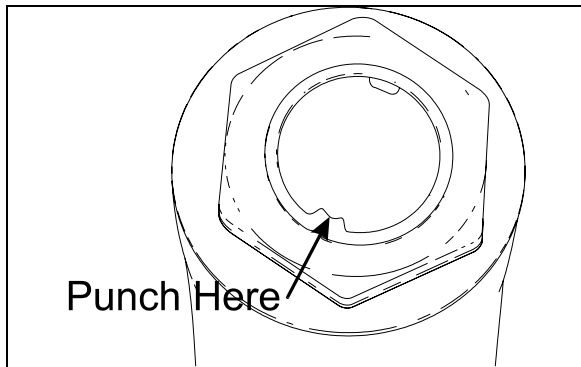

FIGURE 9: FIXING NUT PUNCH MARK 16098

## 2.5 DRAG LINK

Drag link assembly consists of three parts; a drag link and two end assemblies. Both end assemblies are identical and they are retained on the drag link with a clamp bolt and nut.

Stud nuts at the pitman arm and bell crank ends of the drag link must be kept tight or hole at ball stud end of drag link and hole in pitman arm may become enlarged as a result of excessive looseness. Subsequent tightening of stud nuts may draw studs too far into holes and dust cover parts may become damaged which can result in component failure.

Drag link end sockets are equipped with lubrication fittings and should be lubricated as directed in "Lubrication Fittings" in this supplement.

### 2.5.1 Adjustment

It should not be necessary to alter the length of the drag link except when a new link is installed or when removable end assembly has been replaced. If drag link adjustment is necessary, proceed as follows:

1. Position front wheels in straight ahead position.
2. Center steering gear as previously explained in paragraph "2.1 Steering Linkage Adjustment".
3. Remove cotter pin and stud from drag link at bell crank. Locate centerline of vehicle and center of relay rod. With center of relay rod aligned with centerline of vehicle, loosen clamp bolt at socket end (bell crank end) of drag link and adjust length of socket end assembly to fit in boss of bell crank.

**NOTE**

Do not change position of pitman arm.

4. Install stud nut and torque to 160 lbf-ft (220 Nm). Align nut with cotter pin slot (tighten) and install a new cotter pin.
5. Torque mounting clamp bolt nut to 40-60 lbf-ft (54-82 Nm), then test the adjustment. Front wheels should turn from right to left extremities without noticeable binding at drag link ends.

## 2.6 BELL CRANK AND IDLER ARM

Bell crank and idler arm are equipped with one lubrication fitting and should be lubricated as directed in paragraph "2.9 Lubrication Fittings" at the end of this Supplement.

### 2.6.1 Bell Crank and Idler Arm Removal

**NOTE**

Use a piece of wire to anchor loosen end of relay rod and tie rod in order to prevent placing an excessive load on opposite socket end.

**Bell crank:** Disconnect drag link, tie rod and relay rod from bell crank by removing cotter pins, stud nuts and washers from ball studs. Separate socket assemblies from the bell crank.

**Idler arm:** Remove cotter pins, nuts and washers from ball studs connecting relay rod and tie rod to idler arm. Separate socket assemblies from idler arm.

Remove nuts and washers from bolt attaching bell crank or idler arm mounting bracket to vehicle understructure. Remove bell crank or idler arm mounting bracket.

### 2.6.2 Bell crank or Idler Arm Ball Joint Disassembly

1. Remove adjacent link assemblies from bell crank or idler arm as previously described.
2. Remove the cap (Fig. 10).
3. Remove the cotter pin, nut and tongue washer. Remove bearings, grease seal, bearing bushing and the bell crank or idler arm from its mounting bracket stud (Fig. 10).

### 2.6.3 Bell Crank or Idler Arm Ball Joint Reassembly

**NOTE**

For bearing installation use tool Prévost # 110684.

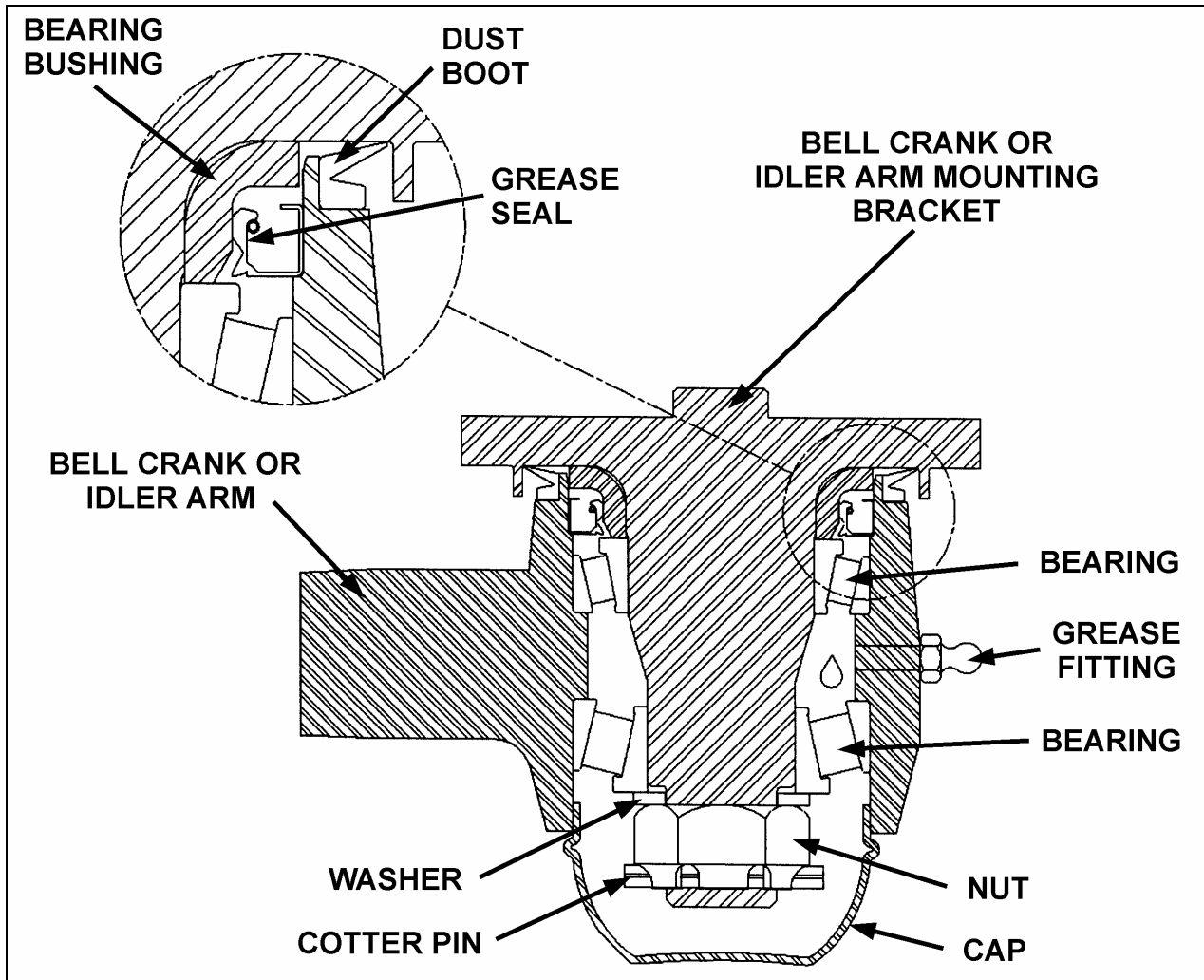

FIGURE 10: BELL CRANK AND IDLER ARM 16109

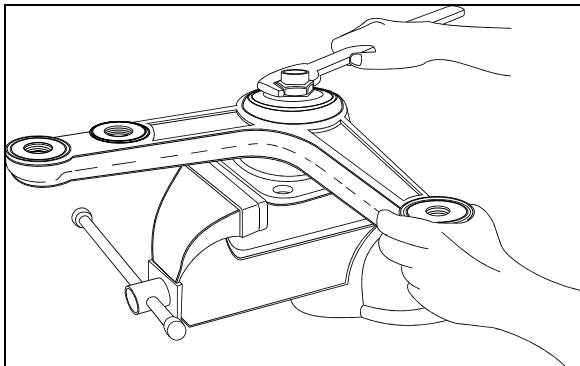

FIGURE 11: BELL CRANK 16044

1. Install bearing bushing on bell crank or idler arm mounting bracket stud.
2. Install bearing and grease seal in bell crank or idler arm eye (Fig. 10).

**NOTE**

Install grease seal according to figure 8. Grease must be able to exit the bell crank or idler arm mechanism. For grease seal installation use tool Prévost # 110683.

3. Install bell crank or idler arm on its mounting bracket stud (Fig. 10).
4. Install bearing and nut.

**NOTE**

Apply grease on bearing before installation.

5. Firmly tighten nut (Fig. 11).
6. Unscrew nut until bell crank or idler arm starts to turn by the application of 1 to 3 pounds load (Fig. 12).

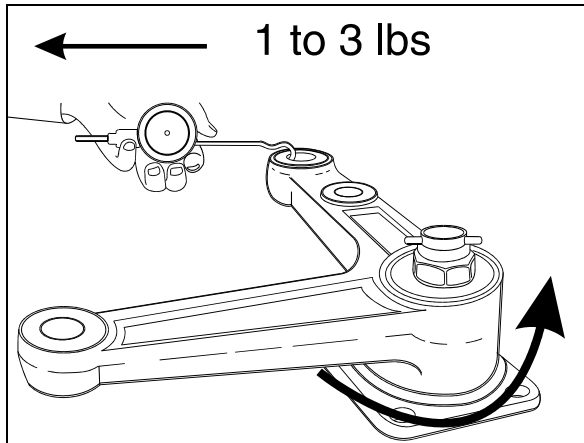

FIGURE 12: BELL CRANK

16045

7. Check for loose bearings by applying an up and down load on bell crank or idler lever (Fig. 12). The lever is not supposed to move in the vertical axis direction.
8. Align nut with cotter pin slot (tighten) and install a new cotter pin.

**NOTE**

*Bend cotter pin around the nut (Fig. 10). Do not bend the cotter pin in the direction of the cap, because it may interfere with the cap.*

9. Install the cap.
10. **Bell crank:** Install drag link, tie rod and relay rod as directed herein under each specific subject.
11. **Idler arm:** Install tie rod and relay rod as directed herein under each specific subject.
12. Adjust turning angle as previously directed under paragraph "**Turning Angle**" and check front end alignment as specified in paragraph "6. Front End Alignment" of this supplement.

2.7 RELAY ROD

Relay rod ends are equipped with lubrication fittings and should be lubricated as directed in paragraph "2.9 Lubrication Fittings" in this supplement.

**NOTE**

*The relay rod is crimped in place and it is not possible to remove the ball joints.*

2.7.1 Replacement

1. Remove cotter pins from bell crank and idler arm end of relay rod. Loosen nuts flush with end of studs.

2. Use a puller or place a sledge hammer behind the adjacent part to absorb shocks. Strike the studs with a brass hammer to loosen end assemblies.
3. Remove stud nuts and washers then remove studs.
4. Position relay rod studs into bell crank and idler arm then tap stud ends with a brass hammer to seat tapered surfaces.
5. Install washers and stud nuts. Tighten nuts to 160 lbf-ft (220 Nm) torque. Align cotter pin slot (tighten) and install a new cotter pin.

2.8 TIE RODS

Tie rod ends are connected to the bell crank and left steering arm, and to the idler arm and right steering arm. Each tie rod assembly consists of three parts; a tube and two socket end assemblies. The tie rod ends are threaded into the tube and secured with clamp bolts. Right and left hand threads are provided to ease toe-in adjustment. Tie rod assemblies are interchangeable from the right to the left side of the coach.

Tie rod end sockets require no maintenance other than periodic lubrication and inspection to see that ball studs are tight. Replace socket ends when there is excessive up and down motion, lost motion or end play at ball end of stud.

1. Periodically check bolt nut for tightness.
2. Inspect tie rod for bent condition and inspect tube for damaged threads. If tie rod is bent or threads are damaged, replace the assembly.
3. Lubricate tie rod end fittings as directed in paragraph "2.9 Lubrication Fittings" at the end of this section.

2.8.1 Removal

1. Remove cotter pins and stud nuts which attach tie rod socket ends to bell crank and left steering arm (or idler arm) and right steering arm.
2. Remove tie rod ball stud by tapping on steering arm and bell crank or idler arm with hammer, while using a sledge hammer to absorb shocks.

**NOTE**

*If tie rod end assemblies are damaged in any way, they must be replaced.*

2.8.2 Installation

1. Install socket end assemblies on tie rod. Be sure both ends are threaded an equal distance into the tube.
2. Make sure threads on stud and in stud nut are clean and not damaged.
3. Position ball studs (socket ends of tie rod) in holes in steering arm and bell crank or idler arm. Install a ball stud nut on each stud and tighten firmly.
4. Torque stud nuts to 160 lbf-ft (220 Nm). Align cotter pin slot (tighten) and install a new cotter pin.

<b>NOTE</b>
<i>Adjust toe-in as directed in paragraph "6.4.2 Toe-In Adjustment" of this supplement.</i>

5. Make sure tie rod ends are properly aligned with ball studs, then torque tie rod end clamp bolts to 40-60 lbf-ft (54-82 Nm).

<b>NOTE</b>
<i>If tie rod is not properly aligned with stud, binding will result.</i>

2.9 STEERING ARMS

The left and right wheel steering arms are secured to a swivel at one end and to a tie rod at the other end.

2.9.1 Removal

1. Remove wheel as directed in Section 13, "Wheel, Hubs And Tires" of the maintenance manual.
2. Remove cotter pin, washer and nut from stud securing tie rod to steering arm. Remove ball stud from steering arm by tapping on arm with a hammer, placing a sledge hammer underneath steering arm to absorb shocks.
3. Remove cotter pin and nut securing steering arm to swivel assembly. Remove steering arm from swivel.

2.9.2 Installation

1. Insert steering arm in swivel.
2. Torque steering arm to swivel nut to 190 lbf-ft (260 Nm). Align cotter pin slot (tighten) and install a new cotter pin.

3. Position tie rod ball stud in steering arm and tap with a brass hammer to seat ball stud in steering arm. Install washer and nut on stud. Torque nut to 160-215 lbf-ft (217-291 Nm). Tighten nut to nearest cotter pin slot and install a new cotter pin.
4. Install wheel as directed in Section 13, "Wheel, Hubs And Tires" under paragraph "3.2 Installation" of the maintenance manual.

2.10 LUBRICATION FITTINGS

All lubrication fittings must be clean before applying lubricant. Also, always be sure equipment used in applying lubricant is clean. Every precaution should be taken to prevent entry of dirt, grit, lint or other foreign matter into lubricant containers. Replace fitting when they become broken or damaged.

Intervals of application given in the following paragraphs are recommended for normal service. More frequent intervals may be applied under severe operating conditions. In selecting proper lubricants, supplier reputation must be considered. The supplier must be responsible for product quality. The diagram (Fig. 13) shows approximate location of steering lubrication fittings.

1. **Drag Link Ends:** Lubricate at two fittings, one at each end of link, every 6,250 miles (10 000 km) with good quality lithium-base grease NLGI No. 2 (Shell Retinax LX or equivalent).
2. **Relay Rod Ends:** Lubricate at two fittings, one at each end of rod, every 6,250 miles (10 000 km) with good quality lithium-base grease NLGI No. 2 (Shell Retinax LX or equivalent).
3. **Tie Rod Ends:** Lubricate at four fittings, one at each end of both tie rods, every 6,250 miles (10 000 km) with good quality lithium-base grease NLGI No. 2 (Shell Retinax LX or equivalent).
4. **Swivel Assembly:** Refer to DANA SPICER MAINTENANCE MANUAL NDS AXLES Lubrication and Maintenance" annexed at the end of section 10.
5. **Idler Arm and Crank bell:** Lubricate at two fittings, one on the idler arm and the other on the crank bell, every 6,250 miles (10 000 km) with good quality lithium-base grease NLGI No. 2 (Shell Retinax LX or equivalent). Apply grease gun pressure to the fitting until lubricant appears at the top seal.

6. **Upper V-Link Outer Ball Joint:** Lubricate at fitting until you see some grease on the relief valve nearby, every 6,250 miles (10 000 km) with good quality lithium-base grease NLGI No. 2 (Shell Retinax LX or equivalent).

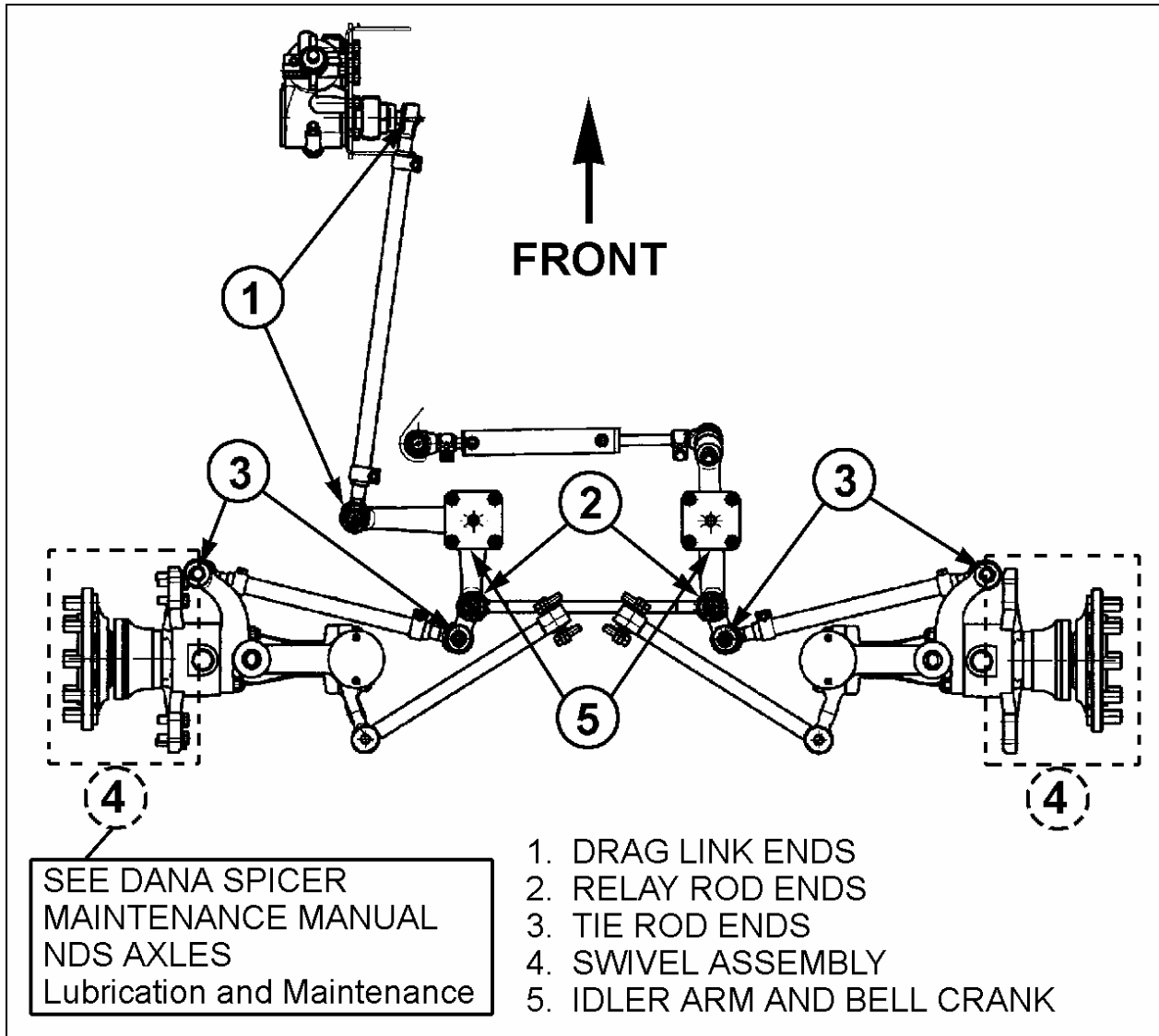

FIGURE 13: LUBRICATION FITTINGS' LOCATION DIAGRAM

16118

### 3. BALL JOINTS

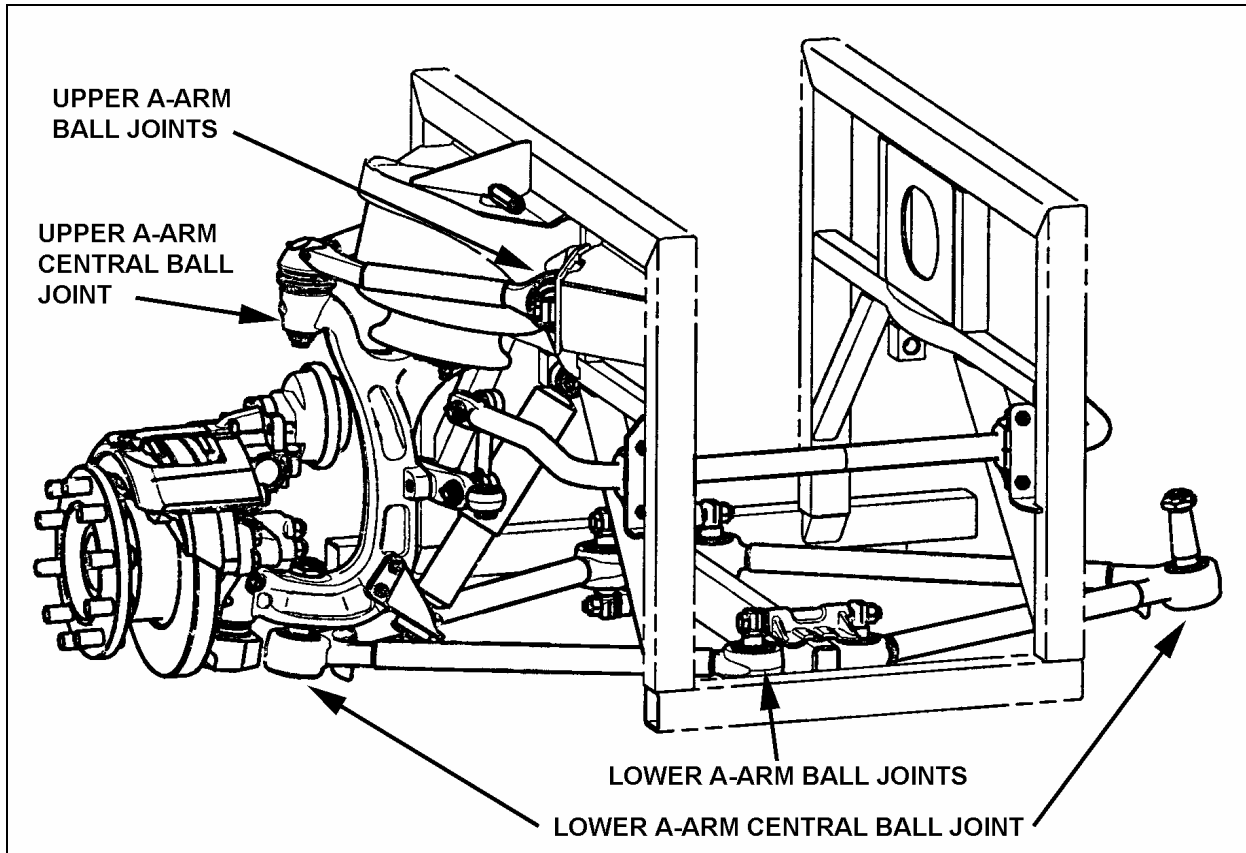

FIGURE 14: BALL JOINTS LOCATION

16137

### 4. LOWER AND UPPER A-ARM BALL JOINT

The assembly work may be done only by a recognized specialized workshop. Ensure that old and new parts do not get mixed up with each other. It is for this reason that all the old parts are to be scrapped immediately after a joint has been stripped down. A complete repair set must be used for each joint repaired, i.e. use of only part of a repair set is not permissible.

#### 4.1 INSPECTION

Take off the load from the ball joint by lifting the front of the vehicle. Apply a load on the joint in all of the degrees of freedom in an axial, radial, etc. sense with a suitable lever tool. After the load is taken off, the joint has to spring back into its starting position. Free play is not acceptable.

Separation of rubber from ball pin or external joint shell is in accordance with "normal wear characteristics".

When the following characteristics are noted, the joint is to be changed:

- Free play;
- Radial cracking of the external sheet-metal race.

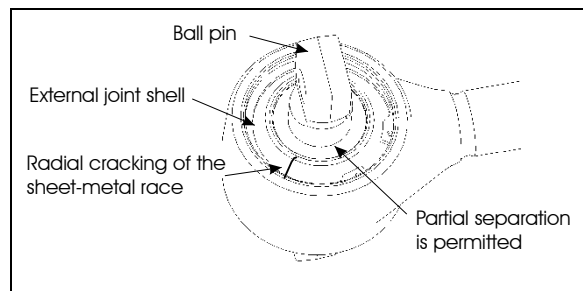

Figure 15: A-ARM BALL JOINTS

#### 4.2 STRIPPING DOWN

Strip down the defective joint through removal of retaining ring, annular spacer and ball pin/bushing assembly and thereafter clean out housing bore and locking circlips groove.

#### 4.3 ASSEMBLY

Execute assembly of the new joint parts in the following sequence:

1. Complete moistening of the contact surface between housing bore and ball pin through application of the grease.

**NOTE**

*Apply grease, only in the case of repair kit (Prévost # 611114).*

2. Insert ball pin/bushing assembly. In case of the two-bolt type, ensure that the bolt bores are in the correct position in relation to the axis of the tube.

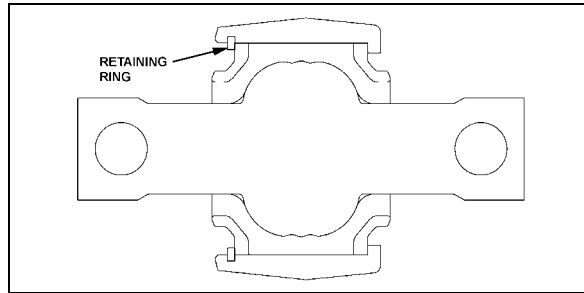

FIGURE 16: UPPER A-ARM BALL JOINT

3. Place joint in receiving fixture and mount annular assembly tool on the housing. Then locate annular spacer and retaining ring in the housing using axial load with the aid of assembly matrix. If the ends of the annular spacer are not in contact with each other, the thus formed opening must be located at 180° to the opening of the retaining ring. Pay attention during assembly to ensure that the retaining ring eyelets are located at each side of the housing shaft axis (retaining ring eyelet lug points to tube), and that retaining ring is properly engaged in the groove of the housing.
4. When repairing defective ball pin assemblies, the necked down-bolt must regularly be replaced with a new one.

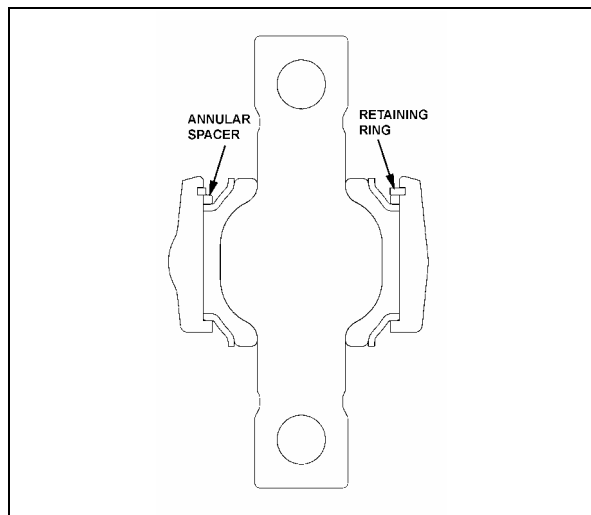

FIGURE 17: LOWER A-ARM BALL JOINTS

16047

## 5. LOWER A- ARM CENTRAL BALL JOINT

### 5.1 INSPECTION

Take off the load from the ball joint by lifting the front of the vehicle. Apply a load on the joint in all of the degrees of freedom in an axial, radial, etc. sense with a suitable lever tool. After the load is taken off, the joint has to spring back into its starting position. Free play is not acceptable.

Separation of rubber from ball pin or external joint bushing shell is in accordance with "normal wear characteristics".

When the following characteristics are noted, the joint is to be changed:

- Free play;
- Radial cracking of the external bushing shell.

### 5.2 STRIPPING DOWN

Strip down the defective joint through removal of retaining ring, annular spacer and ball pin/bushing, assembly and thereafter clean out housing bore and locking circlips groove

### 5.3 ASSEMBLY

Assemble the new component parts of the joint in the following sequence:

1. Complete moistening of the contact surface between housing bore and ball pin through application of the grease.

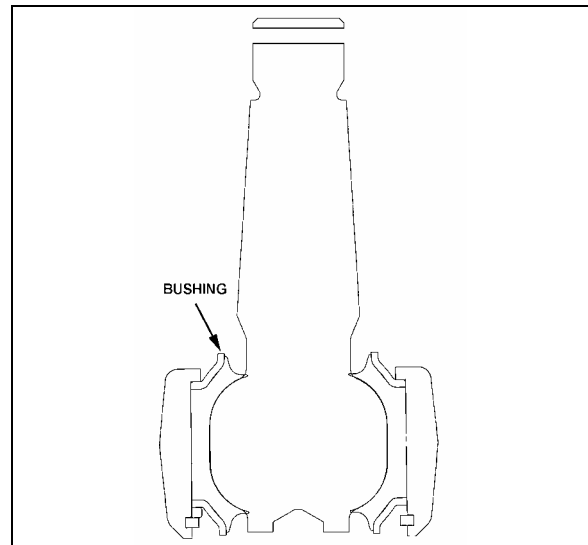

FIGURE 18: LOWER A-ARM CENTRAL BALL JOINT

2. Place joint in receiving fixture and mount annular assembly tool on the housing. Then locate annular spacer and retaining ring in the housing using axial load with the aid of

assembly matrix. If the ends of the annular spacer are not in contact with each other, the thus formed opening must be located at 180° to the opening of the retaining ring. Pay attention during assembly to ensure that the retaining ring eyelets are located at each side of the housing shaft axis (retaining ring eyelet lug points to tube), and that retaining ring is properly engaged in the groove of the housing.

3. Faultlessly apply grease by mechanical means to bracket-outer core and ball-inner cone. Insert bracket outer cone in fixture with distance ring and then use press tool to apply pressure to press mount with ball-inner cone.

## 6. UPPER A-ARM CENTRAL BALL JOINT

### 6.1 VISUAL INSPECTION

Check the condition of the sealing boot, in particular:

Check if the retainer ring, which secures the sealing boot at the conical section of the ball stud, is still present.

Check if grease is present on the external surface of the sealing boots. Escaped fluid and accumulations of grease on the sealing boot may be the result of the sealing boot's rupturing. In this case, the ball joint must be systematically replaced.

### 6.2 PLAY MEASUREMENT

1. Raise the vehicle and support through axle jacking points.

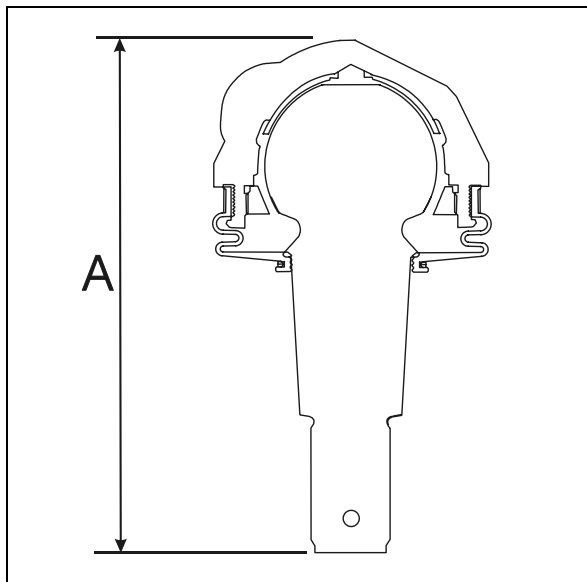

FIGURE 19: UPPER A-ARM CENTRAL BALL JOINT 16116

2. Using a caliper, measure dimension A on figure 19.
3. With a lever tool, exert sufficient force under the upper A-arm as to separate the upper A-arm from the upright in order to have the ball joint to its maximum extent. Remeasure the dimension A. If the difference between the two dimensions is greater than 0.060" (1.5mm), then the ball joint should be replaced.

## 7. FRONT END ALIGNMENT

Proper front end alignment must be maintained to insure ease of steering and provide satisfactory tire life. When making front end alignment inspections, the vehicle must be level and empty with the full weight of the vehicle on the wheels.

Front end alignment inspections fall into two groups: regular service inspections performed at periodic intervals, and inspections to determine the extent of damage after a collision or severe service.

Regular service inspections concern toe-in, camber and caster.

Any variation from the specified alignment will indicate either a need for adjustment or a more thorough inspection to determine if parts replacement is required.

### ⚠ WARNING ⚠

**During alignment, both camber and caster among other angles are adjusted. When adjusting these we install or remove shims from the lower "A" arms of the ISS suspension. After performing alignment, make sure that the following is done:**

- **Installing a new lock nut after all shims are finalized.**
- **Torque replaced nuts as per figure 23.**
- **Installing a longer bolt if less the 2 threads are remaining after the nut.**
- **Using a Torque mark on the nut for future visual inspection.**



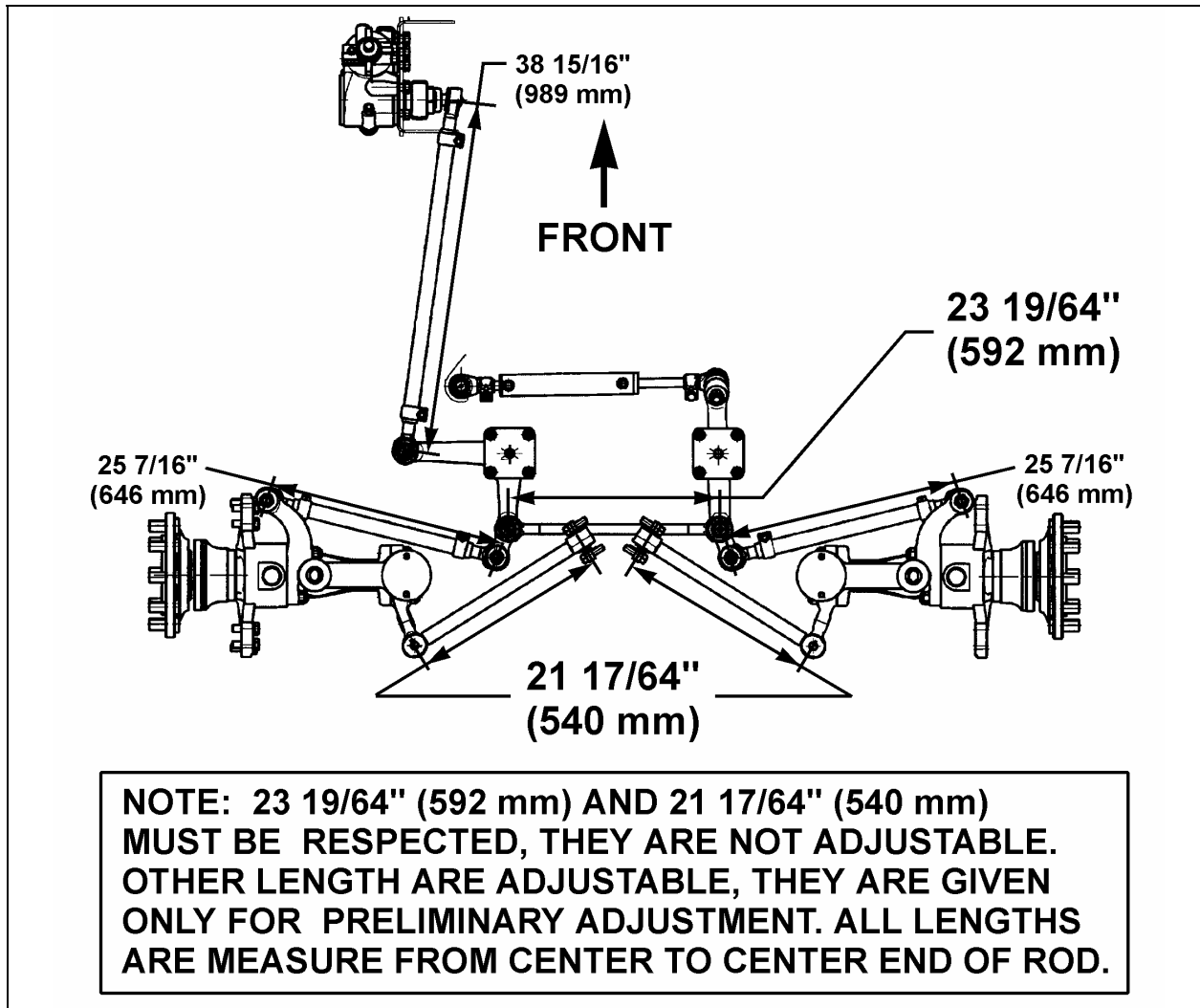

FIGURE 20: STEERING LINKAGE MEASURE

16132

### 7.1 ALIGNMENT TERMINOLOGY

#### Wheel Camber

The amount the wheels are inclined from the vertical plane (A, Fig. 21).

#### Wheel Toe-In

The distance the front wheels are closer together at the front than at the rear of the tires (D minus E, Fig. 21).

#### King Pin Inclination

The inclination of the king pin from vertical toward the center of the vehicle at the top and outward at the bottom (B, Fig. 21).

#### Front Axle Caster

The inclination of the king pin from vertical in the fore and aft direction (C, Fig. 21).

### 7.2 FRONT END INSPECTION

Before checking front end alignment, make the following inspection:

1. Check that the vehicle is at normal ride height (see paragraph "11. Suspension Height Adjustment").
2. Check the tires for proper inflation.
3. Check wheel installation and run-out.
4. Check wheel bearing adjustment.
5. Check tie rods and drag link ends for looseness.
6. Check king pins for looseness.
7. Check if the length of the torque rod is 21 17/64" (540 mm) (Fig. 20). Check if the length of the relay rod is 23 19/64" (592 mm).

### 7.3 FRONT WHEEL CAMBER

Positive camber is the outward inclination of the wheels at the top, negative or reverse camber is the inward inclination of the wheels at the top. Camber variations may be caused by wear at the wheel bearings, wheel spindle bushings, or bent suspension parts.

Check camber, with an accurate gauge. If camber is incorrect, check suspension parts for wear and replace worn parts. If wear is not perceptible, suspension parts may be bent or lower suspension arm may be improperly shimmed.

Check King pin inclination. If King pin inclination is incorrect, readjust the camber and check king pin inclination again.

<b>NOTE</b>
<i>Camber is more important than king pin inclination, so adjust camber and verify king pin inclination.</i>

Shim the lower suspension arm to adjust camber. If the king pin inclination is incorrect, the wheel king pin assembly may be bent and therefore should be replaced.

Excessive positive camber results in irregular wear of the tires at the outer shoulders. Negative or reverse camber causes wear at the inner shoulders.

<b>NOTE</b>
<i>Shim only the lower suspension arm to adjust the front wheel camber.</i>

<b>⚠ CAUTION ⚠</b>
<b>Once the perfect shim combination is achieved, always install new stover nuts because the self looking effect is lost after tightening and loosening of the nut. It is recommended to punch marks to detect loosening of the nuts during future visual inspections.</b>

### 7.4 FRONT WHEEL TOE-IN

Toe-in is measured from the center of the tire treads. Measurements at the front and rear of the tires must be made at the same height from the floor. Incorrect toe-in results in excessive tire wear and steering instability with a tendency to wander.

#### 7.4.1 Toe-In Check

1. Check the camber adjustment and adjust if necessary.
2. Hoist the front of the vehicle and spin the wheels marking the centerline of the tire treads.
3. Place the wheels in the straight ahead position and lower the vehicle to rest on the floor.
4. Roll the vehicle ahead several feet. This removes any slack caused by looseness in the wheel bearings or steering connections.
5. Check the distance between the tire centerlines at the front and rear of the front tires. These two measurements must be made at the same height above the floor. The front measurement must be  $3/32 \pm 1/32$  of an inch less than the rear measurement.

#### 7.4.2 Toe-In Adjustment

1. Loosen the tie rod clamp bolts.
2. Using a pipe wrench, turn the tie rod tubes to obtain the toe-in measurement specified in step 5 under paragraph "6.4.1 Toe-in Check" of this Supplement.
3. Tighten the tie rod clamp bolts and recheck toe-in.
4. Check that the angular relationship of the pitman arm to the steering gear is as shown in figure 8.

<b>NOTE</b>
<i>Use only tie rods to adjust toe-in.</i>

### 7.5 FRONT AXLE CASTER

Positive caster is the inclination of the top of the king pins toward the rear of the vehicle. Negative or reverse caster is the inclination of the king pins toward the front of the vehicle. This vehicle is designed with positive caster. The purpose of caster is to provide steering stability by keeping the wheels in a straight ahead position.

Caster variations may be caused by bent upper suspension arm, lower suspension arm, or king pin housing. Caster should be adjusted with shims. Precision instruments should be used to measure caster. Shim bell crank and idler arm to adjust caster.

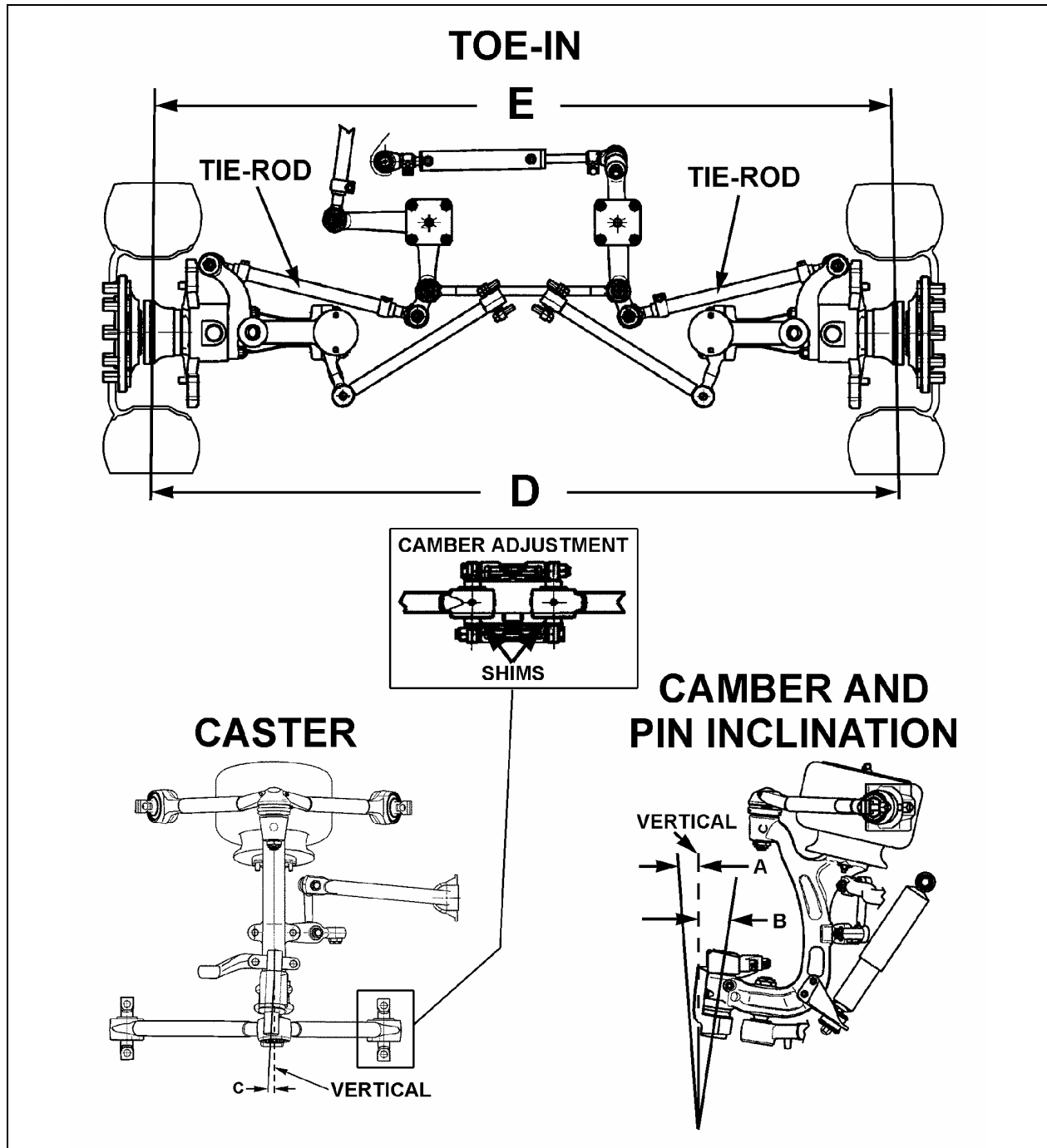

FIGURE 21: FRONT END ALIGNMENT DIAGRAM

16133

ALIGNMENT SPECS (See Figure 21)							
		Minimal		Nominal		Maximal	
Load		Non-converted	Converted	Non-converted	Converted	Non-converted	Converted
A	WHEEL CAMBER	0.2	-0.150	0.35	0.0	0.55	0.200
B	KING PIN INCLINATION	8° (not adjustable)					
C	CASTER	2.55		2.8		3.05	
D-E	TOE-IN	0.08		0.13		0.17	

Variations from the specified caster will affect steering stability, cause wandering, wheel shimmy, and reduce returnability when pulling out of curves.

### 7.6 MAJOR DAMAGE

If the suspension has sustained major damage, it may be necessary to shim the bell crank and the idler arm to avoid the bump steer or roll steer. Moreover refer to paragraph "7. Front End Alignment".

## 8. FRONT AIR SPRINGS

Two "rolling lobe" type air springs are used with the independent front suspension, one at each wheel. These air springs are special and use the complete piston as an extra reservoir to lower the spring stiffness. Front air springs are attached to the subframe and to uprights.

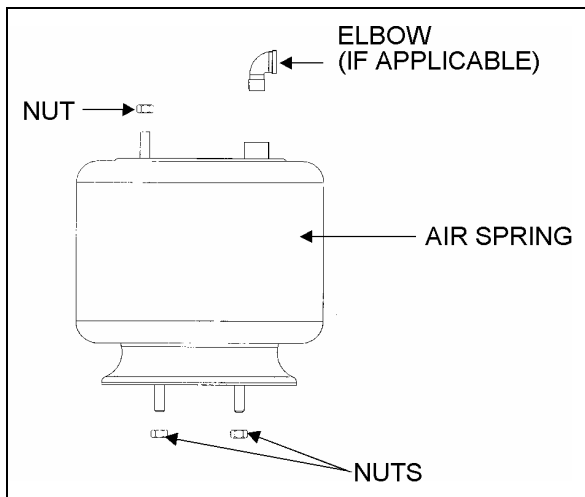

FIGURE 22: AIR SPRINGS

16052

### 8.1 INSPECTION

1. Check operation of bellows.
2. Visually inspect bellows for evidence of cracks, punctures, deterioration, or chafing. Replace the bellows if damage is evident.
3. With the primary air system at normal operating pressure (95 - 125 psi (655 - 860 kPa)), coat all suspension air line connections and bellow mounting areas with a water and soap solution. Bubbles will indicate an air leak, and none is permissible. Repair or replace defective parts.

#### **NOTE**

*If air spring is removed from vehicle, bellows can be lightly inflated and submerged in water to detect any leakage. If leakage is detected, replace bellows.*

#### **WARNING**

**To prevent personal injury, do not apply more than 10 psi (69 kPa) air pressure to the unmounted air spring.**

### 8.2 REMOVAL

#### **NOTE**

*Front air springs can be removed without removing the entire suspension assembly.*

1. Safely support vehicle at the recommended body jacking points and jack up body understructure.
2. To gain access to a given air spring, the corresponding wheel can be removed.

#### **CAUTION**

**Only the recommended jacking points must be used as outlined in Section 18, "Body" in the maintenance manual.**

3. Support the assembly with a suitable jack.
4. Exhaust compressed air from accessory air tank by opening drain cock under reservoir.
5. Disconnect the height control valve link and pull down the overtravel lever to ensure all air is exhausted from air springs.

#### **NOTE**

*While performing this step, do not change the height control valve overtravel lever adjustment.*

6. Disconnect air line from air spring, remove elbow (if applicable), and cover both the line end and fitting to prevent the entry of foreign matter.
7. Remove the air spring upper nut, and then the two lower nuts. Remove air spring and remove the back up plate from the top of the air spring.

### 8.3 INSTALLATION

#### **NOTE**

*To facilitate air spring installation, compress it manually then put a piece of tape over the air line threaded fitting. This prevents air from getting back into the bag and keeps it compressed, thus enabling to place the bag in between the mounting plates and greatly easing installation.*

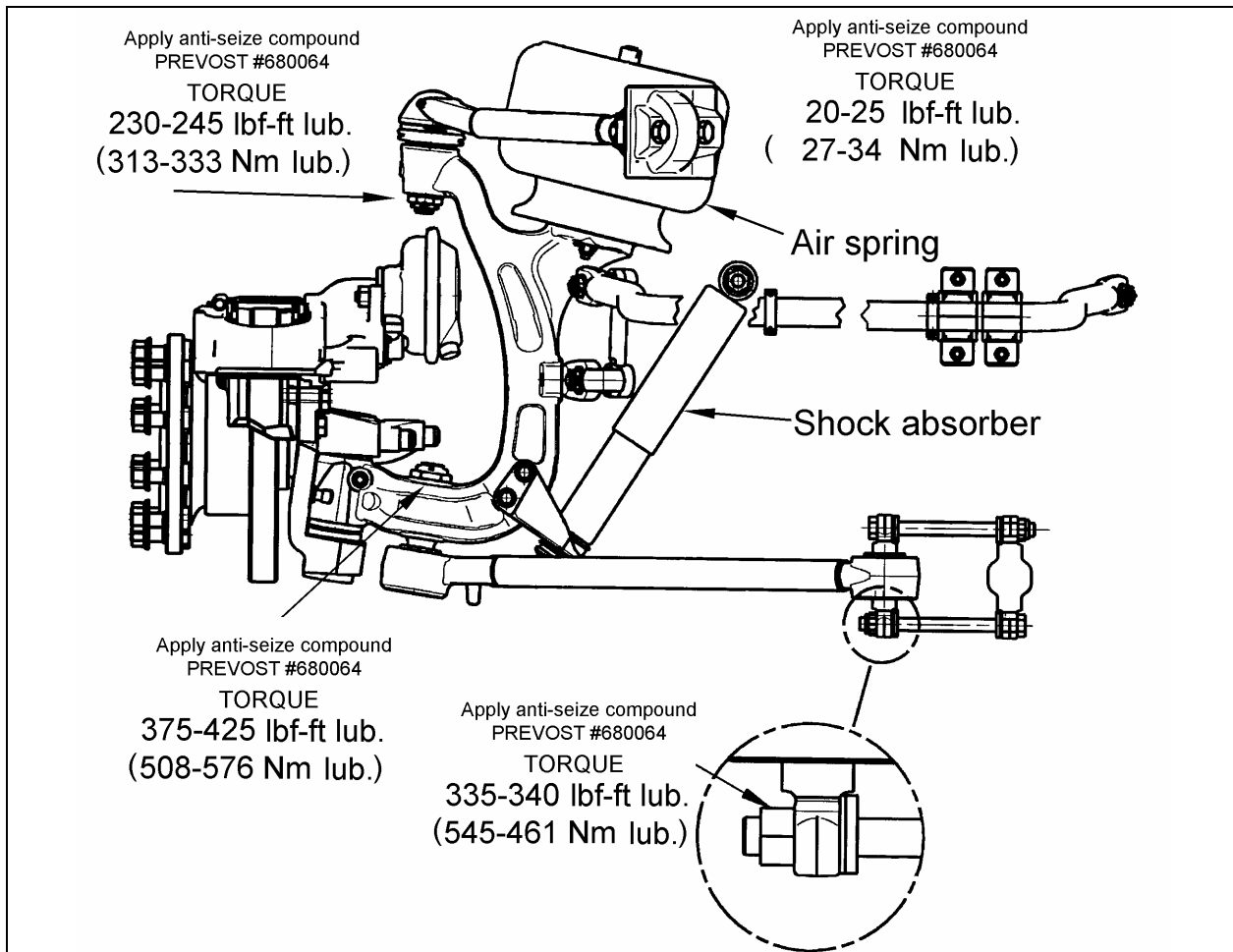

FIGURE 23: AIR SPRING AND SHOCK ABSORBER

16145

1. Compress air spring as necessary, then aligning studs with their holes, position air spring between both the lower and upper supports. Thread the lower nuts and the small upper nut a few turns.
2. Tighten and torque the lower stud nuts, and then the upper nut to 20-25 lbf-ft (27-34 Nm).
3. Install elbow (if applicable), then connect air line.
4. Connect the height control valve link.
5. Build up air pressure in system.
6. Check operation of bellows, and with the primary air system at normal operating pressure (95 - 125 psi (655 - 860 kPa)), coat the air line connections and air spring mounting areas with a water and soap solution. Bubbles will indicate an air leak, and none is permissible. Repair or replace defective parts.
7. Remove the hydraulic floor jack from underneath shock absorber bracket.

## 9. SHOCK ABSORBERS

The two front shock absorbers are double-acting and telescopic type. Shock absorbers ensure a smooth ride and enhance vehicle stability on the road. Front shock absorbers have eye-type mountings on the upper side and bayonet type on lower side. Shock absorbers are non-adjustable and non-repairable.

### NOTE

*To accelerate this operation, air reservoirs can be filled from an exterior air supply connected to the accessory tank fill valve or to the emergency fill valve.*

**⚠ CAUTION ⚠**

**When a shock absorber is found defective, always replace with a new set on affected axle, except if there has been a recent replacement of one unit. The following method will help in determining if both shock absorbers on the same axle have to be replaced.**

### 9.1 SHOCK ABSORBER REMOVAL

1. Remove the nut, washer and rubber joint from shock absorber mounting stud. Discard the rubber joints.
2. Remove the nut and washer from shock absorber mounting pin (upper side), taking care to identify the inner and outer washers to ease reinstallation. Refer to figure 24 for details.
3. Remove the shock absorber from the vehicle.
4. Remove inner: washers, rubber joint and bushings from the shock absorber. Discard bushings and rubber joint.

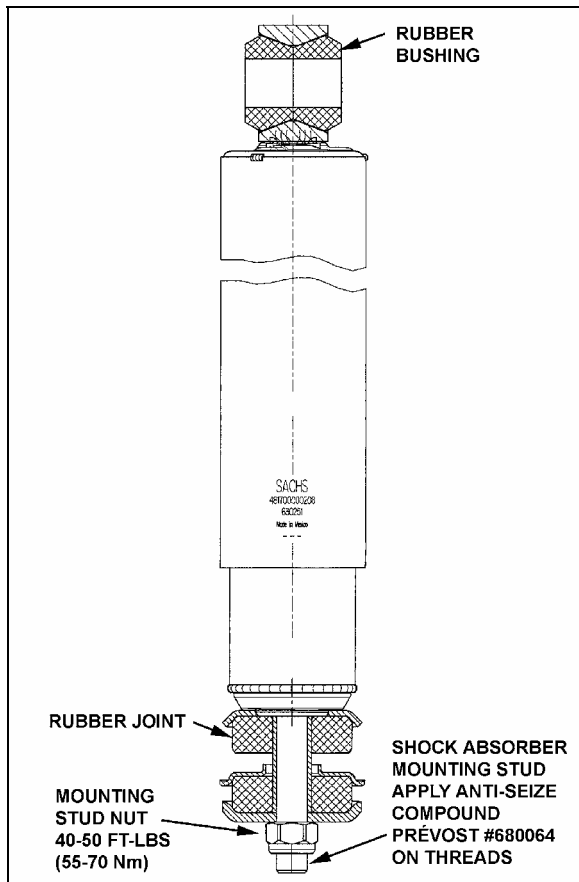

FIGURE 24: SHOCK ABSORBER

16112

### 9.2 SHOCK ABSORBER INSTALLATION

1. Check that the shock absorber mounting pin torque is proper (350-400 lbf-ft (475-545 Nm)). Ensure that the stud is clean and not stripped (upper side).
2. Install new rubber (mounting) bushing on shock absorber (upper side).
3. Place the inner washer on shock absorber pin (Fig. 24).
4. Install washer and rubber joint on shock absorber mounting stud (lower side).
5. Install the shock absorber as shown in figure 18 with the mounting stud protruding through the hole in the mounting bracket and the shock absorber eyes over the mounting pins. Install the outer washer.
6. Place a rubber joint and washer on the shock absorber mounting stud. Place the lower shock absorber mounting stud nut and torque to 40-50 lbf-ft (54-68 Nm).
7. Place the upper mounting pin stud nut and torque to 70-85 lbf-ft (95-116 Nm).

## 10. SWAY BAR

A sway bar is provided on the front and drive axles to increase vehicle stability. It controls lateral motion (swaying movement) of vehicle.

### 10.1 REMOVAL

1. Disconnect the two links from sway bar.
2. Safely support the sway bar. Unbolt bushing collars from subframe.
3. Remove sway bar.

**NOTE**

*Sway bar bushings are slit to ease their removal.*

### 10.2 INSTALLATION

1. Loosely install the sway bar.
2. Torque bushing collar nuts to 60 lbf-ft (82 Nm).
3. Torque sway bar link upper nuts to 120-140 lbf-ft (163-190 Nm) on front suspension and to 100-120 lbf-ft (136-163 Nm) on rear suspension.
4. Torque sway bar link lower nuts to 120-140 lbf-ft (163-190 Nm) on front suspension and to 70-80 lbf-ft (95-110 Nm) on rear suspension.

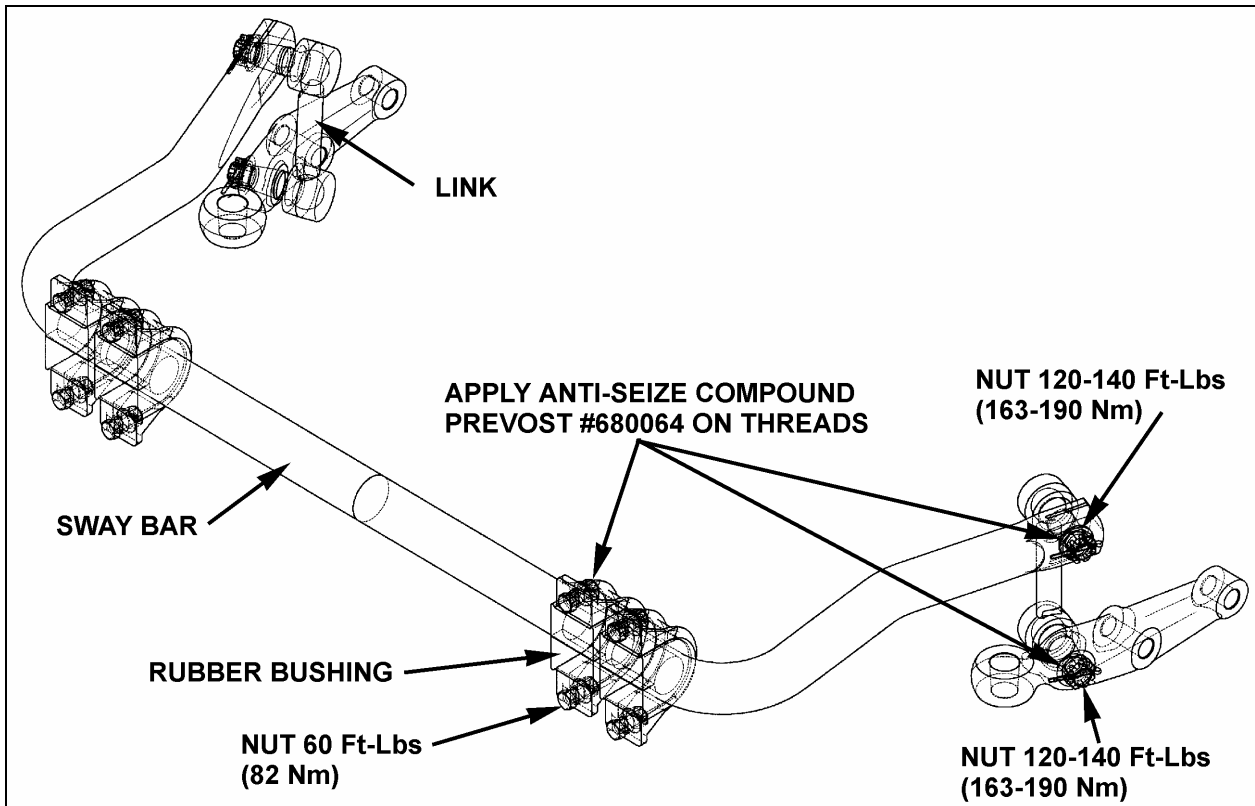

FIGURE 25: SWAY BAR (FRONT SUSPENSION)

16055

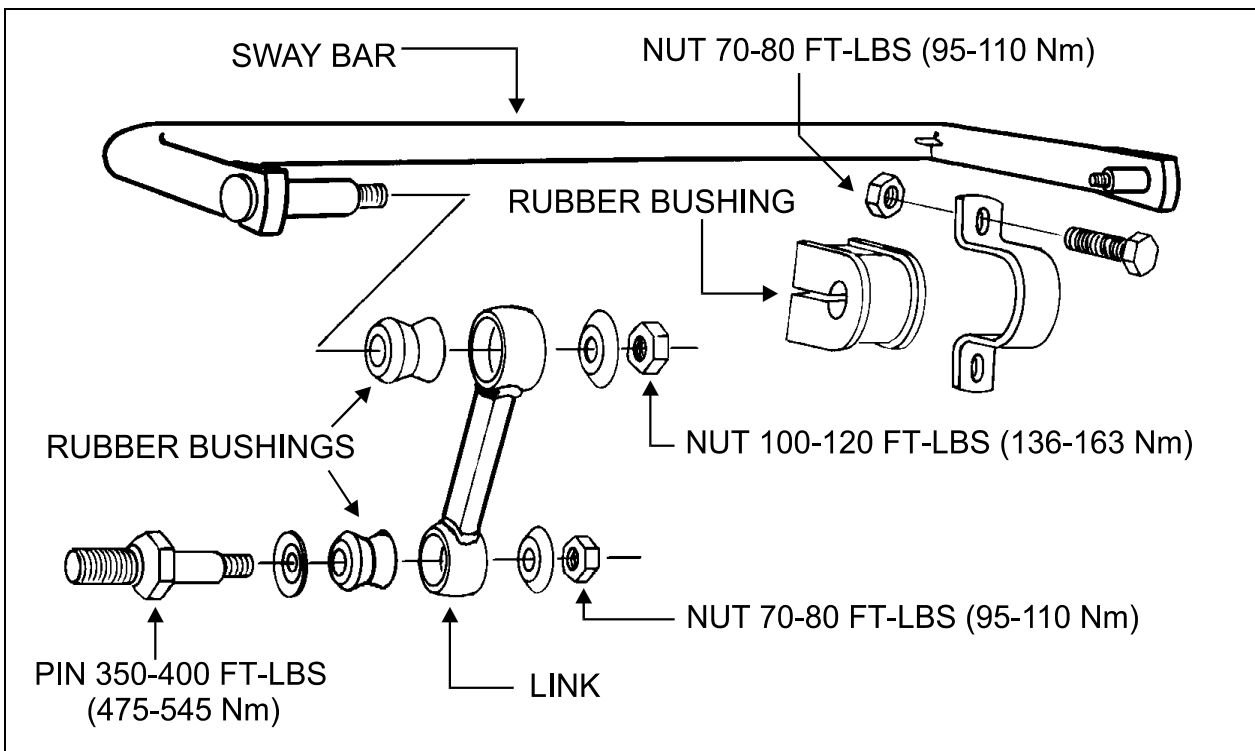

FIGURE 26: SWAY BAR (REAR SUSPENSION)

16014

## 11. INDEPENDENT FRONT SUSPENSION ADJUSTMENT

Converted coach shells are equipped with "LEVEL-LOW" leveling system. The purpose of the "LEVEL-LOW" is to adjust suspension in three separate points (front, rear right and rear left air springs) in order to level vehicle body. Three height control valves, automatically control air pressure in the three separate points (air springs) and maintains a constant vehicle height regardless of load, or load distribution. The control solenoid valve supplies air to the five way three-position air control valve, which bypasses the height control valve, and opens a passage to allow the air control and exhaust valve to release/supply air from air springs. To improve road comfort, an expansion air tank is installed in series with each air springs.

In addition to the above suspension components the system also includes: sway bar, upper and lower suspensions, bars and shock absorbers (Fig. 1).

### NOTE

Only for preliminary adjustment, refer to figure 20. Torque rod length must be fixed to 21 17/64" (540 mm) and relay rod to 23 19/64" (592 mm).

### CAUTION

Parts must be replaced by ones with the same part numbers or with equivalent parts, if replacement becomes necessary. Do not use parts of lesser quality or substitute design. Torque values must be used as specified during reassembly to assure proper retention of these parts.

## 12. SUSPENSION HEIGHT ADJUSTMENT

The flow of pressurized air from the accessory air tank to the air springs is controlled by three height control valves. The two rear valves are mounted to the subframe and connected to the rear axles through an arm and link connection. The front valve is mounted to the subframe and connected to the front air tank support (Fig. 27). These connections allow the valves to apportion air pressure in the springs to the vehicle load, maintaining normal ride height.

Immediate response height control valves increase or decrease the air pressure in the suspension system as required. One height control valve is located **at center of front sway bar**, and regulates air to front suspension air springs in order to maintain the vehicle at the required height. Two are located at the drive axle, one on each inner side of rear wheelhousing.

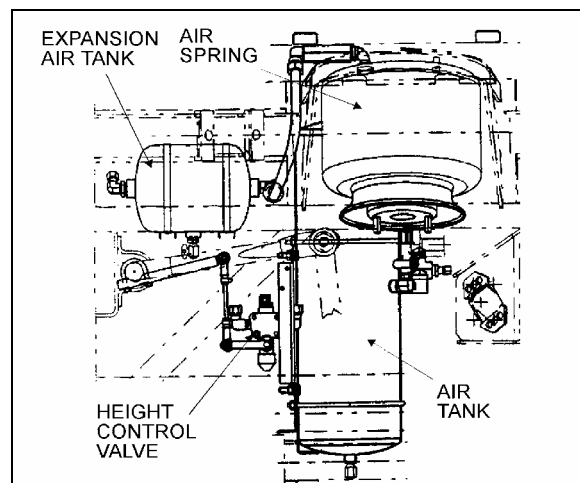

FIGURE 27: HEIGHT CONTROL VALVE LOCATION 16057

The appropriate vehicle body height is obtained by measuring the clearance of all the air springs installed on the vehicle. The two front air springs clearance should be  $11 \pm \frac{1}{4}$ " ( $279 \pm 6$  mm). Refer to figure 28 to identify the correct area to take measurement. The rear air springs clearance should be  $11 \frac{1}{2} \pm \frac{1}{4}$ " ( $292 \pm 6$  mm) (refer to Maintenance Manual, Section 16, under "Suspension Height Adjustment" for rear height control valves' adjustment). At this point, it should not be necessary to make an adjustment under normal service conditions. However, if an adjustment is required, change the position of the overtravel lever in relation to the overtravel control body. The lever should be moved up to raise vehicle height, and down to lower it. Check that main air pressure is at normal operating pressure and raise the vehicle to the specified height.



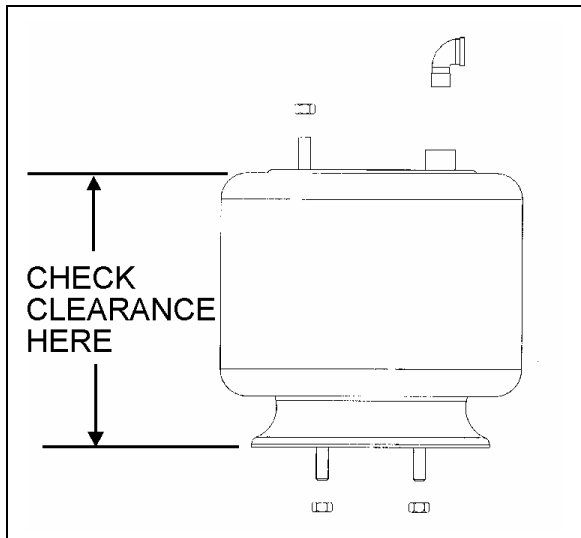

FIGURE 28: TYPICAL AIR SPRING CLEARANCE 16058

**⚠ CAUTION ⚠**

**Always adjust on "fill cycle". If it is necessary to lower vehicle height, release sufficient air to be well below height, and adjust to height or fill cycle.**

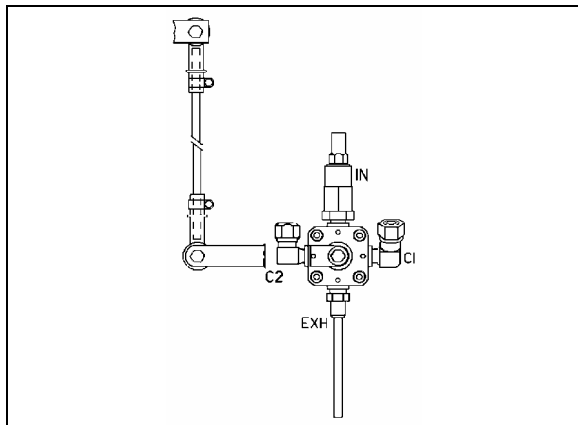

FIGURE 29: FRONT HEIGHT CONTROL VALVE 16100

The normal ride height is obtained by adjusting air spring clearance of both front and rear suspension as follows:

**Front air spring clearance**

1. With the vehicle at normal operating air pressure (100 - 125 psi (689 - 860 kPa)), measure air spring clearance. This clearance should be  $11 \pm \frac{1}{4}$ " (279  $\pm$  6 mm).

**NOTE**

*The measurement should be taken from underneath the upper air spring support on subframe to top of the lower air spring support on axle (refer to figure 28 for more details). If adjustment is required, begin with the drive axle.*

2. Loosen the clamp on the height control valve rubber coupling and bring it up or down (Fig. 29).

**NOTE**

*Allow suspension to stabilize before taking reading.*

When the desired height is obtained, tighten clamp.

**Rear air springs clearance**

Refer to XL2 Maintenance Manual, Section 16, under "Suspension Height Adjustment".

**13. HEIGHT CONTROL VALVE**

The height control valves automatically add air to, or release air from air springs to maintain constant suspension height regardless of load, or load distribution. Each valve adjusts independently according to the following conditions:

**13.1 LOADING POSITION**

As the load increases and lowers the vehicle body, the overtravel lever commands the height control valve to add air to air springs.

**13.2 NEUTRAL POSITION**

When vehicle body reaches the normal ride height, the height control valve overtravel lever reaches the "neutral" position and keeps both the supply and exhaust ports closed to ensure normal ride height is maintained. This condition remains static until the vehicle load is altered.

**13.3 UNLOADING POSITION**

As the load decreases and raises the vehicle body, the overtravel lever commands the height control valve to release air from air springs.

**13.4 MAINTENANCE**

The height control valve requires no periodic maintenance. Height control valve linkage operates on rubber bushings and no lubrication should be attempted at this location. Inspect the valve for loose joints, air leaks and worn bushings.

### 13.5 REMOVAL AND INSTALLATION

Before disconnecting a height control valve air line, securely support the vehicle by its jacking points on the body, and place safety supports underneath body. Refer to paragraph "16. Vehicle Jacking Points" in Section 18, "Body".

1. Exhaust air from air system by opening all air tank drain cocks. Remove height control valves.
2. Disconnect overtravel lever from link and pull down lever to exhaust remaining air from air springs.
3. Disconnect air supply and delivery lines from the height control valve. Cover line ends with tape to prevent entry of foreign matter.
4. Remove the nuts retaining the height control valve to the mounting bracket, then remove valve assembly.

Reverse removal procedure to replace height control valve. After installation, check for leakage using a soap and water solution.

### 14. "LEVEL-LOW" LEVELING SYSTEM

The purpose of the "level-low" leveling system is to adjust suspension in three separate points (front, rear right and rear left) in order to level vehicle body. This system can be put into service when the ignition key is turned to the "ON" position, and must be used only when the parking brake is applied. The "level-low" warning light on the dashboard indicates that the selector switch is not in the "OFF" position. Level low system controls are located on L.H. side control panel.

#### 14.1 PRINCIPLES OF OPERATION

##### DOWN:

The (front/rear right/rear left) control solenoid valve supplies air to the (front/rear right/rear left) five-way three-position air control valve, which bypasses the (front/rear right/rear left) height control valve, and opens a passage to allow the air control and exhaust valve to release air from (front/rear right/rear left) air springs.

##### UP:

The (front/rear right/rear left) control solenoid valve supplies air to the (front/rear right/rear left) five-way three-position air control valve, which

bypasses the (front/rear right/rear left) height control valve, and opens a passage to allow the air control and exhaust valve to supply air to (front/rear right/rear left) air springs.

##### DRIVE:

When the ignition key is turned to the "ON" position with selector knob in the "DRIVE" position, the drive control solenoid valve supplies air to all five-way three-position air control valves, each one opening a passage to allow height control valves to accomplish their function.

When the ignition key is turned to the "OFF" position and selector knob to the "DRIVE" position, the air is entrapped between air springs and five-way three-position air control valves to ensure the adjusted level will be kept.

#### △ WARNING △

**Never move vehicle with selector knob in any other position than the "DRIVE" position.**

### 14.2 MAINTENANCE

Since the kneeling action is issued from both the air system and electrical system, refer to Section: 12, "Brake and Air System" and Section 06, "Electrical System".

For diagnosis and understanding of the system, refer to wiring diagrams, and to the appropriate air system schematic diagram annexed to Section 12, "Brake and Air System".

### 15. AIR SYSTEM

The basic air system consists of an air compressor, tanks, valves, filters and interconnecting lines and hoses (refer to Section 12, "Brake and Air System" for complete information). It provides a means for braking, operating controls and accessories, and suspension. An air system schematic diagram is annexed at the end of this supplement for better understanding of the system.

The air coming from the air dryer is first directed to the wet air tank, then to the primary (for the primary brake system), secondary (for the secondary brake system), and accessory (for the pneumatic accessories) air tanks (Fig. 30).

In addition, an expansion air tank is installed in series with each air spring.

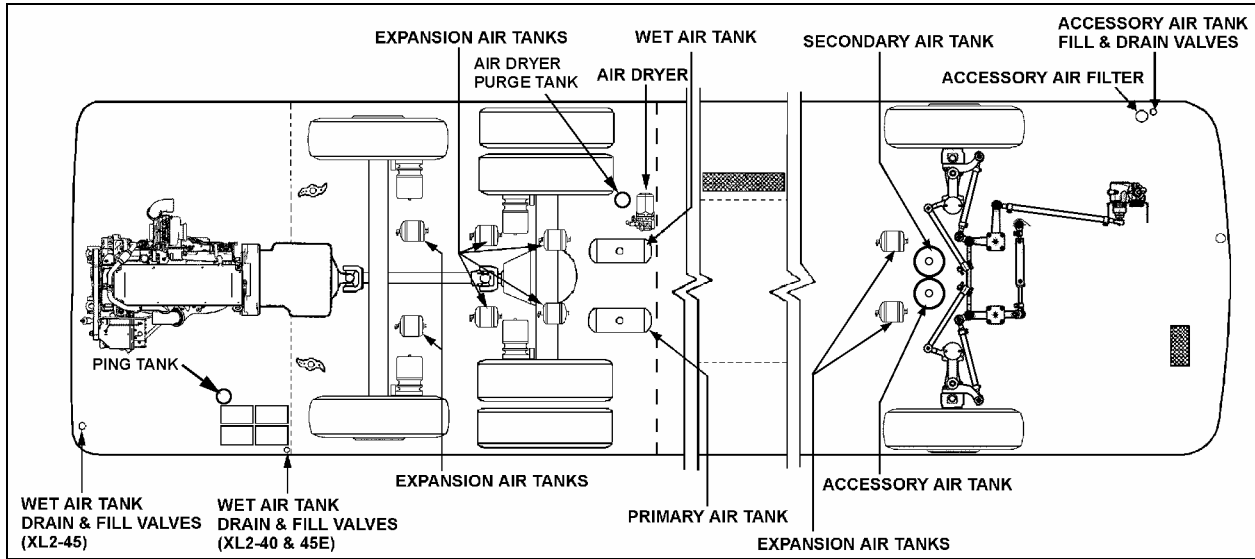

FIGURE 30: LOCATION OF AIR TANKS

24007

### 15.1 AIR TANK MAINTENANCE

Ensure that the accessory air tank is purged during pre-starting inspection. A good practice is to purge this tank at the end of every driving day by the remote air tank drain valve located in the steering compartment (Fig. 30).

Moreover, purge all tanks by their bottom drain valves at specified intervals.

#### 15.1.1 Wet Air Tank

This tank is installed above L.H. wheel of drive axle, and is provided with a bottom drain valve. It is recommended to **purge** the wet air tank by its bottom drain valve every 12,500 miles (20 000 km), or once a year, whichever comes first.

A remote valve located in engine compartment and accessible through engine R.H. side door is used to **drain** the air dryer (Fig. 31).

#### 15.1.2 Primary Air Tank

The primary air tank is located above R.H. wheel of drive axle.

This tank is provided with a bottom drain valve (Fig. 30). It is recommended to purge the primary air tank by its bottom drain valve every 12,500 miles (20 000 km) or once a year, whichever comes first.

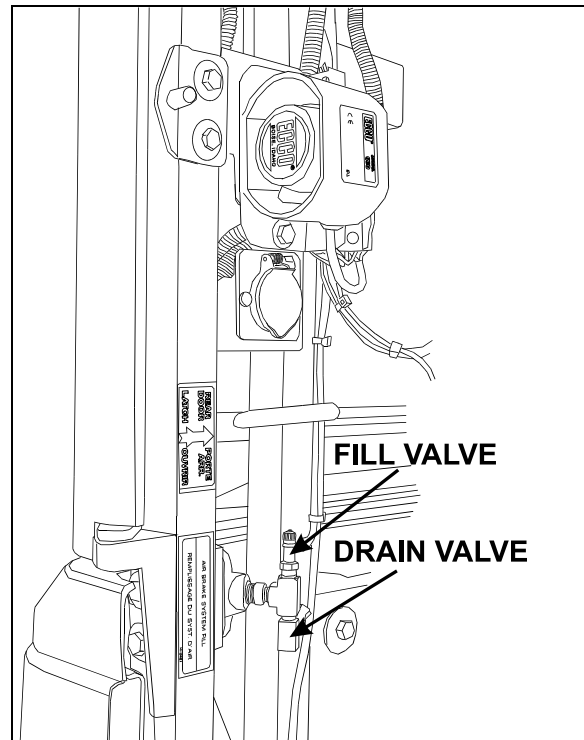

FIGURE 31: REAR VALVE LOCATION

12202

#### 15.1.3 Secondary Air Tank

This tank is located in front wheelhousing, between air springs. The tank is installed vertically and is provided with a bottom drain valve (Fig. 30).

It is recommended to purge the tank by its bottom drain valve, every 12,500 miles (20 000 km) or once a year, whichever comes first.

#### 15.1.4 Accessory Air Tank

The accessory air tank is installed next to the secondary air tank. The tank is installed vertically and is provided with a bottom drain valve (Fig. 30).

It is recommended to purge the tank by its bottom drain valve, every 12,500 miles (20 000 km) or once a year, whichever comes first.

A remote drain valve is located in front service compartment (Fig. 32) underneath the accessory air filter. Refer to Section 12, paragraph "4. Accessory Air Filter" of the maintenance manual for daily purge procedure.

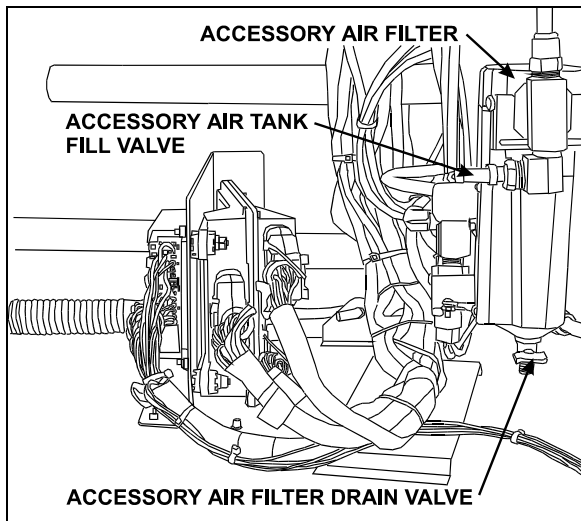

FIGURE 32: FRONT VALVE LOCATION

12201

#### 15.1.5 Expansion Air Tank

Two expansion tanks are located in front wheelhousing. These air tanks are located behind secondary and accessory air tank. Also, six expansion tanks are located near rear air springs (Fig. 30). Expansion tanks are connected in series with air springs. Expansion tanks are used to lower the stiffness of the air spring. They are provided with a bottom drain valve.

It is recommended to purge them, with all other tanks, every 12,500 miles (20 000 km) or once a year, whichever comes first.

### 15.2 EMERGENCY FILL VALVES

The vehicle is equipped with two air system emergency fill valves to supplement the air system when air pressure is low and engine cannot be operated.

The rear valve is located in engine compartment and accessible from engine R.H. side door (Fig. 31).



**No other point should be used to supply air system. The maximum allowable air pressure is 125 psi (860 kPa).**

The front valve is located in the front service compartment close to accessory air filter (Fig. 32).

These two air valves are fitted with the same valve stems as standard tires, and can be filled by any standard external air supply line.

The rear valve will supply air for all systems (brakes, suspension and accessories) while the front valve will supply air for accessories only.



**Air filled through these two points will pass through the standard air filtering system provided by Prévost. Do not fill air through any other points.**

### 16. HUB UNIT AND SWIVEL ASSEMBLY

Refer to "DANA SPICER Service Manual General Information, Maintenance Manual Model NDS and Maintenance Manual NDS Axles" annexed to section 10 "Front Axle".

**Section 16: MTH EQUIPPED WITH INDEPENDENT FRONT SUSPENSION (IFS)**

**17. TORQUE TABLE**

<b>DESCRIPTION</b>	<b>QTY</b>	<b>REFERENCE</b>	<b>TORQUE (DRY) Lbf-ft / Nm</b>	
<i>Pitman Arm to Steering Gear Fixing Nut</i>	1	8	400-450	545-610
<i>Drag Link to Pitman Arm Stud Nut*</i>	1	---	160-215	220-290
<i>Drag Link to Bell crank Stud Nut*</i>	1	---	160-215	220-290
<i>Drag Link Socket End Clamp Bolt Nut</i>	2	---	40-60	55-80
<i>Relay Rod to Bell crank Stud Nut*</i>	1	---	160-215	220-290
<i>Relay Rod to Idler Arm Stud Nut*</i>	1	5	160-215	220-290
<i>Tie Rod to Bell crank Stud Nut*</i>	1	---	160-215	220-290
<i>Tie Rod to Idler Arm Stud Nut*</i>	1	5	160-215	220-290
<i>Tie Rod to Steering Arm Stud Nut*</i>	2	3	160-215	220-290
<i>Tie Rod End Clamp Bolt Nut</i>	4	3	40-60	55-80
<i>Steering Arm to Swivel Nut*</i>	4	---	190	260
<i>Torque Rod Stud Nut</i>	2	4	160-215	220-290
<i>Idler Arm and Bell Crank Cap Screws</i>	8	9	8	11
<i>Torque Rod Mounting Bracket Nut</i>	4	6	75-140	100-190
<i>Torque Rod Clamp Nut</i>	4	4	53-59	72-80
<i>Jacking Point Bracket Nut</i>	8	19	70-80	95-110
<i>Bushing Collar Nut</i>	8	20	72-88	98-120
<i>Sway Bar Link Upper Nuts (Rear Suspension)</i>	2	20	100-120	135-160
<i>Sway Bar Link Lower Nuts (Rear Suspension)</i>	2	20	70-80	95-110

<b>DESCRIPTION</b>	<b>QTY</b>	<b>REFERENCE</b>	<b>TORQUE (Lubricated) (Anti-Seize #680064) Lbf-ft / Nm</b>	
<i>Idler Arm and Bell Crank Mounting Bracket Nut</i>	8	5	90-120	120-160
<i>Shock Absorber Mounting Stud Nut</i>	2	19	40-50	55-70
<i>Shock Absorber Pin Nut</i>	2	19	70-85	95-115
<i>Air Spring Nut</i>	3	18	20-25	27-34
<i>Sway Bar Link Upper and Lower Nuts (Front Suspension)</i>	2	20	120-140	160-190
<i>Upper A-Arm Stud Nut*</i>	2	18	230-245	315-335
<i>Lower A-Arm Bracket Nut</i>	8	18	375-425	510-580

<b>DESCRIPTION</b>	<b>QTY</b>	<b>REFERENCE</b>	<b>TORQUE (Lubricated) (Loctite #242 Blue) Lbf-ft / Nm</b>	
<i>Shock Absorber Pin</i>	2	19	350-400	475-545
<i>Steering Gear to Mounting Bracket Bolt</i>	5	8	355	485

☛ Tighten nut to specified torque, then advance to next aligning cotter pin slot and install a new cotter pin.

**18. SPECIFICATIONS**

**Front Axle Air Springs**

Make ..... Goodyear Tire and Rubber  
Diameter ..... 14.5 inches  
Air Inlet..... 1/2"- 14 NPTF  
Supplier number ..... 1R14-167  
Prévost number ..... 630239

**Shock Absorbers**

Collapsed length ..... 350 mm  
Extended Length ..... 560 mm  
Supplier number ..... 481700000208  
Prévost number ..... 630251

**Height Control Valve**

Make ..... Barksdale  
Supplier number ..... 52321POAQ3-Q26 and 52321POAQ3-Q62  
Prévost number ..... 630156 and 630157

**Steering Gear Box**

Make ..... ZF-Servocom  
Supplier number ..... 8098-988-570  
Prévost number ..... 661045

**Steering Gear Box (Optional)**

Make ..... ZF-Servocomtronic  
Supplier number ..... 8098-988-571  
Prévost number ..... 661044

**Power Steering Hydraulic Pump**

Make ..... TRW  
Supplier number ..... PS251616L10200  
Prévost number ..... 661070

**Power Steering Hydraulic Cylinder**

Make ..... Hyco  
Supplier number ..... 007-0300-0  
Prévost number ..... 661076

**Shim (Camber Adjustment)**

Thickness ..... 3.175 mm  
Prévost number ..... 160993  
Thickness ..... 6.35 mm  
Prévost number ..... 160992

**Sway bar bushing (Drive Axle)**

Make ..... Prévost  
Prévost number ..... 130953

# SECTION 16: COACHES EQUIPPED WITH INDEPENDENT FRONT SUSPENSION (IFS)

## CONTENTS

<b>1. INTRODUCTION</b> .....	<b>16(COACH)-4</b>
<b>2. STEERING LINKAGE</b> .....	<b>16(COACH)-4</b>
2.1 POWER STEERING HYDRAULIC PUMP .....	16(COACH)-6
2.2 STEERING LINKAGE ADJUSTMENT .....	16(COACH)-6
2.3 PITMAN ARM REMOVAL .....	16(COACH)-7
2.4 PITMAN ARM INSTALLATION .....	16(COACH)-7
2.5 DRAG LINK .....	16(COACH)-7
2.5.1 <i>Adjustment</i> .....	16(coach)-7
2.6 BELL CRANK AND IDLER ARM .....	16(COACH)-8
2.6.1 <i>Bell Crank and Idler Arm Removal</i> .....	16(coach)-8
2.6.2 <i>Bell crank or Idler Arm Ball Joint Disassembly</i> .....	16(coach)-8
2.6.3 <i>Bell Crank or Idler Arm Ball Joint Reassembly</i> .....	16(coach)-8
2.7 RELAY ROD .....	16(COACH)-9
2.7.1 <i>Replacement</i> .....	16(coach)-9
2.8 TIE RODS .....	16(COACH)-10
2.8.1 <i>Removal</i> .....	16(coach)-10
2.8.2 <i>Installation</i> .....	16(coach)-10
2.9 STEERING ARMS .....	16(COACH)-10
2.9.1 <i>Removal</i> .....	16(coach)-10
2.9.2 <i>Installation</i> .....	16(coach)-10
2.10 LUBRICATION FITTINGS .....	16(COACH)-11
<b>3. BALL JOINTS</b> .....	<b>16(COACH)-12</b>
<b>4. LOWER AND UPPER A-ARM BALL JOINT</b> .....	<b>16(COACH)-12</b>
4.1 STRIPPING DOWN .....	16(COACH)-12
4.2 ASSEMBLY .....	16(COACH)-12
<b>5. LOWER A- ARM CENTRAL BALL JOINT</b> .....	<b>16(COACH)-13</b>
5.1 STRIPPING DOWN .....	16(COACH)-13
5.2 ASSEMBLY .....	16(COACH)-13
<b>6. UPPER A-ARM CENTRAL BALL JOINT</b> .....	<b>16(COACH)-14</b>
<b>7. FRONT END ALIGNMENT</b> .....	<b>16(COACH)-14</b>
7.1 ALIGNMENT TERMINOLOGY .....	16(COACH)-15
7.2 FRONT END INSPECTION .....	16(COACH)-15
7.3 FRONT WHEEL CAMBER .....	16(COACH)-16
7.4 FRONT WHEEL TOE-IN .....	16(COACH)-16
7.4.1 <i>Toe-In Check</i> .....	16(coach)-16
7.4.2 <i>Toe-In Adjustment</i> .....	16(coach)-16
7.5 FRONT AXLE CASTER .....	16(COACH)-16
7.6 MAJOR DAMAGE .....	16(COACH)-16
<b>8. FRONT AIR SPRINGS</b> .....	<b>16(COACH)-18</b>
8.1 INSPECTION .....	16(COACH)-18
8.2 REMOVAL .....	16(COACH)-18
8.3 INSTALLATION .....	16(COACH)-18
<b>9. SHOCK ABSORBERS</b> .....	<b>16(COACH)-19</b>

**Section 16: COACHES EQUIPPED WITH INDEPENDENT FRONT SUSPENSION (IFS)**

---

9.1	SHOCK ABSORBER REMOVAL.....	16(COACH)-20
9.2	SHOCK ABSORBER INSTALLATION.....	16(COACH)-20
<b>10.</b>	<b>SWAY BAR .....</b>	<b>16(COACH)-20</b>
10.1	REMOVAL.....	16(COACH)-20
10.2	INSTALLATION.....	16(COACH)-20
<b>11.</b>	<b>SUSPENSION HEIGHT ADJUSTMENT .....</b>	<b>16(COACH)-22</b>
<b>12.</b>	<b>HEIGHT CONTROL VALVE .....</b>	<b>16(COACH)-23</b>
12.1	LOADING POSITION .....	16(COACH)-23
12.2	NEUTRAL POSITION .....	16(COACH)-23
12.3	UNLOADING POSITION.....	16(COACH)-23
12.4	MAINTENANCE.....	16(COACH)-23
12.5	REMOVAL AND INSTALLATION .....	16(COACH)-23
<b>13.</b>	<b>AIR SYSTEM.....</b>	<b>16(COACH)-23</b>
13.1	AIR TANK MAINTENANCE.....	16(COACH)-23
13.1.1	<i>Wet Air Tank .....</i>	<i>16(coach)-23</i>
13.1.2	<i>Primary Air Tank .....</i>	<i>16(coach)-24</i>
13.1.3	<i>Secondary Air Tank .....</i>	<i>16(coach)-24</i>
13.1.4	<i>Accessory Air Tank.....</i>	<i>16(coach)-24</i>
13.1.5	<i>Expansion Air Tank.....</i>	<i>16(coach)-25</i>
13.2	EMERGENCY FILL VALVES.....	16(COACH)-25
<b>14.</b>	<b>HUB UNIT AND SWIVEL ASSEMBLY .....</b>	<b>16(COACH)-25</b>
<b>15.</b>	<b>TORQUE TABLE .....</b>	<b>16(COACH)-26</b>
<b>16.</b>	<b>SPECIFICATIONS.....</b>	<b>16(COACH)-27</b>



**ILLUSTRATIONS**

FIGURE 1: SUSPENSION AND STEERING LINKAGE ..... 16(COACH)-4  
FIGURE 2: LOCATION OF CLAMPS..... 16(COACH)-5  
FIGURE 3: CLAMP POSITIONING ..... 16(COACH)-6  
FIGURE 4: CLAMP POSITIONING ..... 16(COACH)-6  
FIGURE 5: CLAMP POSITIONING ..... 16(COACH)-6  
FIGURE 6: PITMAN ARM ALIGNMENT ..... 16(COACH)-6  
FIGURE 7: FIXING NUT PUNCH MARK ..... 16(COACH)-7  
FIGURE 8: BELL CRANK ..... 16(COACH)-8  
FIGURE 9: BELL CRANK ..... 16(COACH)-8  
FIGURE 10: BELL CRANK AND IDLER ARM BALL JOINT ..... 16(COACH)-9  
FIGURE 11: LUBRICATION FITTINGS' LOCATION DIAGRAM ..... 16(COACH)-11  
FIGURE 12: BALL JOINTS LOCATION ..... 16(COACH)-12  
FIGURE 13: A-ARM BALL JOINTS ..... 16(COACH)-12  
FIGURE 14: LOWER A-ARM BALL JOINTS ..... 16(COACH)-13  
FIGURE 15: UPPER A-ARM BALL JOINTS..... 16(COACH)-13  
FIGURE 16: LOWER A-ARM CENTRAL BALL JOINT..... 16(COACH)-14  
FIGURE 17: UPPER A-ARM CENTRAL BALL JOINT ..... 16(COACH)-14  
FIGURE 18: STEERING LINKAGE MEASURE ..... 16(COACH)-15  
FIGURE 19: FRONT END ALIGNMENT DIAGRAM ..... 16(COACH)-17  
FIGURE 20: AIR SPRINGS ..... 16(COACH)-18  
FIGURE 21: AIR SPRING AND SHOCK ABSORBER ..... 16(COACH)-19  
FIGURE 22: SHOCK ABSORBER..... 16(COACH)-20  
FIGURE 23: SWAY BAR (FRONT SUSPENSION)..... 16(COACH)-21  
FIGURE 24: SWAY BAR (REAR SUSPENSION)..... 16(COACH)-21  
FIGURE 25: TYPICAL AIR SPRING CLEARANCE ..... 16(COACH)-22  
FIGURE 26: FRONT HEIGHT CONTROL VALVE ..... 16(COACH)-22  
FIGURE 27: LOCATION OF AIR TANKS ..... 16(COACH)-24  
FIGURE 28: REAR VALVE LOCATION ..... 16(COACH)-24  
FIGURE 29: FRONT VALVE LOCATION ..... 16(COACH)-25

## 1. INTRODUCTION

This supplement contains service procedures and specifications that apply to the PREVOST coaches equipped with an independent front suspension.

This text contains information unique to the independent suspension system. In the case you cannot find information on a subject in this supplement section, the information given in the regular sections of the Maintenance Manual will apply.

## 2. STEERING LINKAGE

Turning motion of the steering wheel is transferred by the steering gear and steering linkage to the steering arms at the right and left front wheels. The steering linkage consists of tie rods connected to the bell crank and the steering arm at the left side of the coach, and to the idler

arm and steering arm at the right side of the coach. The bell crank and idler arm are connected by a relay rod. A drag link connected to the bell crank and the pitman arm, which is mounted to the steering gear, transfers the turning motion of the steering wheel to the steering arms (Fig. 1).

Lower and upper A-arms are widely spaced. They are mounted on ball joints. Torque rods prevent rotation of the uprights around the lower and upper ball joints.

If the steering linkage is bent, twisted or worn, steering action of the coach will be seriously affected. Any time steering linkage components are replaced or adjusted, steering geometry and front wheel alignment must be checked as explained in this section of supplement.

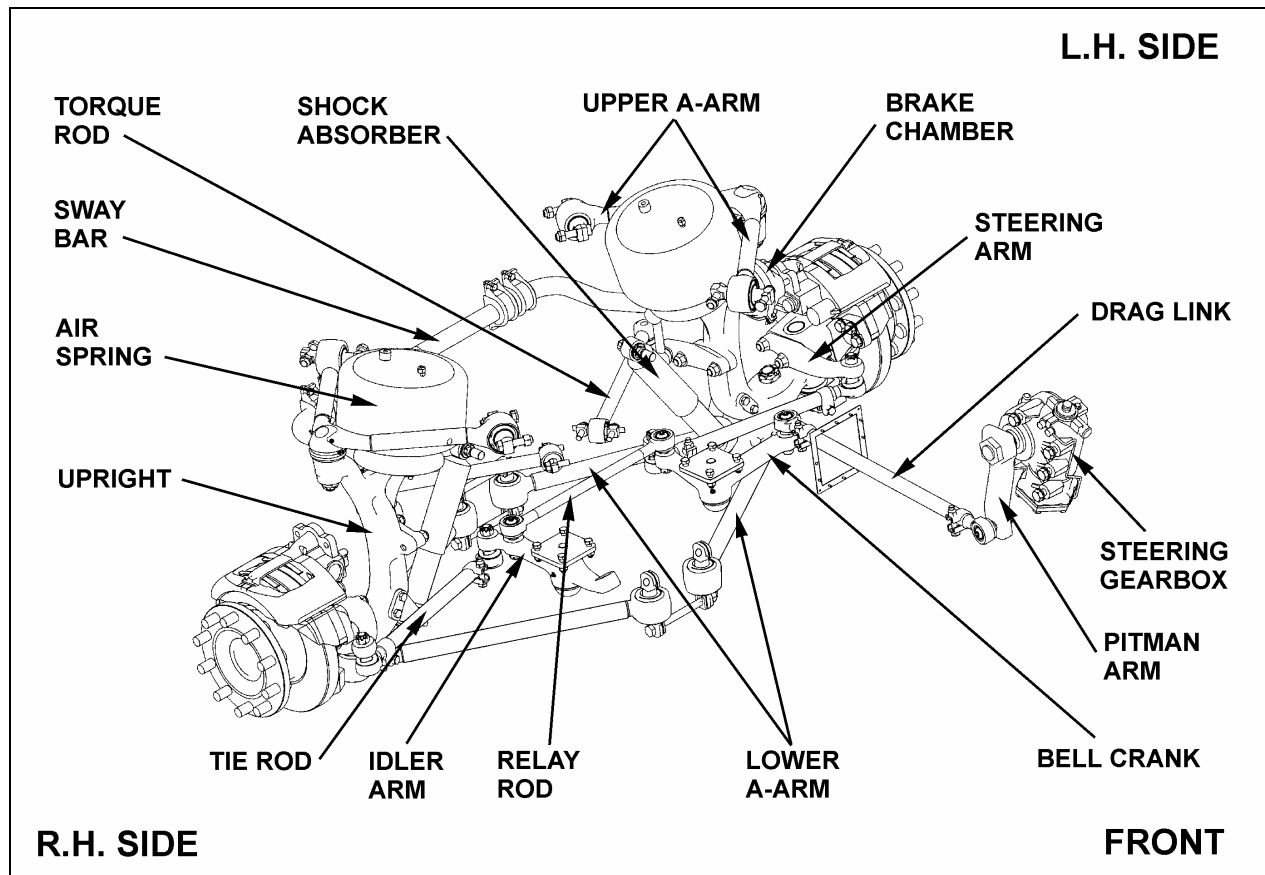

FIGURE 1: SUSPENSION AND STEERING LINKAGE

16125

**Turning Angle**

The maximum turning angle is set mechanically through the two steering stop screws installed on the swivel assembly. The turning angle ( $56^{\circ} + 0^{\circ} - 1^{\circ}$ ) mechanical stop is factory adjusted to accommodate the chassis design, and therefore, does not require adjustment on new vehicles.

However, turning angle should be checked and adjusted hydraulically, if necessary, any time a component of the steering system is repaired, disassembled or adjusted.

Before checking the turning angle, be sure the front end is properly aligned as described under paragraph "4. Front End Alignment" in this supplement.

To check steering maximum turning angle, proceed with the following method:

1. Check if front tires rub against the frame or if the steering gear has been serviced.

**⚠ CAUTION ⚠**

**If clamps are not correctly installed, they can interfere with other parts.**

2. For a full left and right turn, check clamps' position and for interfering parts. Refer to figures 2 to 5 for location and positioning of clamps. If readjustment is required, make the proper adjustment.

*NOTE*

*Prior to steering limiter adjustment, verify vehicle wheel alignment, and ensure that oil level is adequate and that air bleeding is done.*

3. If necessary readjust steering limiter. Refer to "ZF-SERVOCOM Repair Manual" annexed to XL2 Maintenance Manual, Section 14, "Steering", under heading: "Setting and Functional Test".

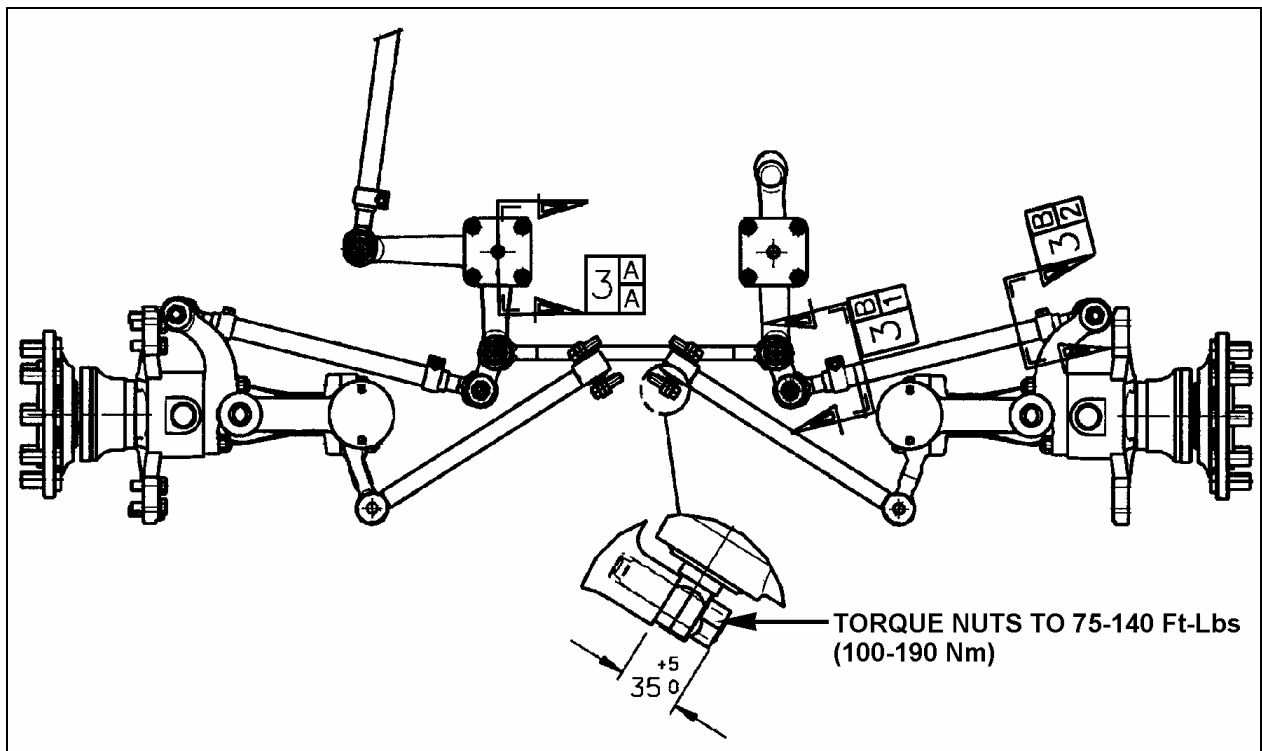

FIGURE 2: LOCATION OF CLAMPS

16127

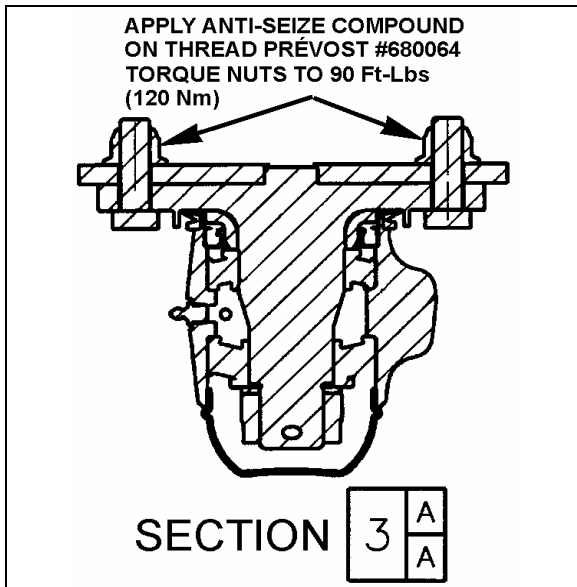

FIGURE 3: CLAMP POSITIONING 16128

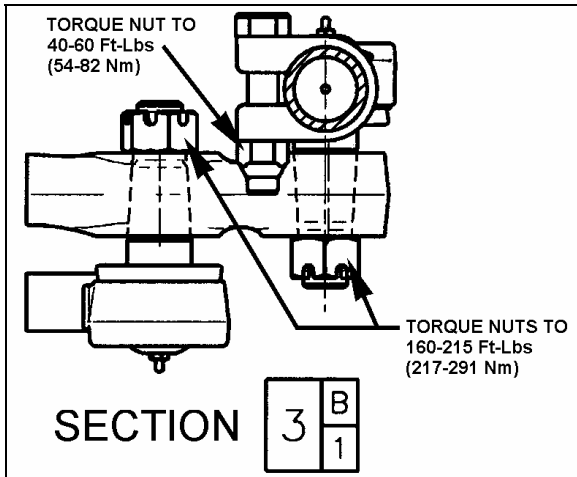

FIGURE 4: CLAMP POSITIONING 16120

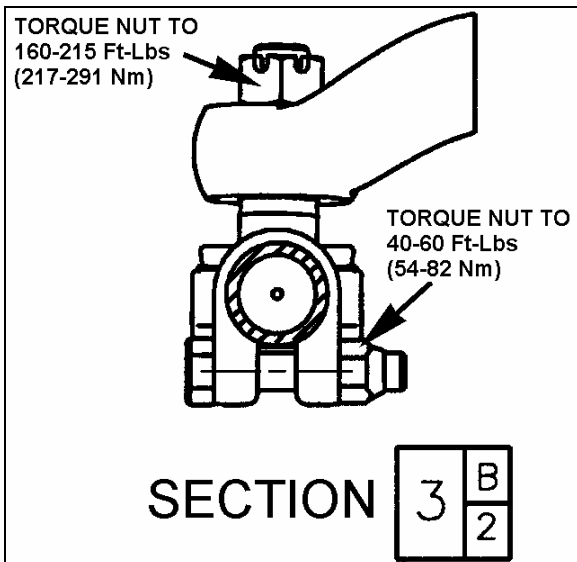

FIGURE 5: CLAMP POSITIONING 16123

## 2.1 POWER STEERING HYDRAULIC PUMP

Refer to the "TRW Power Steering Pump Service Manual" annexed at the end of Section 14.

## 2.2 STEERING LINKAGE ADJUSTMENT

### NOTE

Whenever a steering linkage component has been removed and replaced, check steering geometry and front end alignment as directed in this Supplement. Check to insure that all stud nuts and mounting bolts and nuts have been tightened to proper torques listed under "16. Torque Table" at the end of this supplement.

1. First, align input shaft marks.
2. Afterwards, the pitman arm should be adjusted with reference mark aligned or to an angle of 90° in relation with the horizontal axis (Fig. 6).
3. Locate centerline of vehicle then install relay rod in boss at steering bell crank and idler arm. Align center of relay rod with centerline of vehicle.
4. Install drag link to pitman arm and adjust opposite end of drag link to fit mounting stud hole in bell crank.
5. Install tie rods, and then adjust toe-in as per "Front End Alignment" in this Supplement.

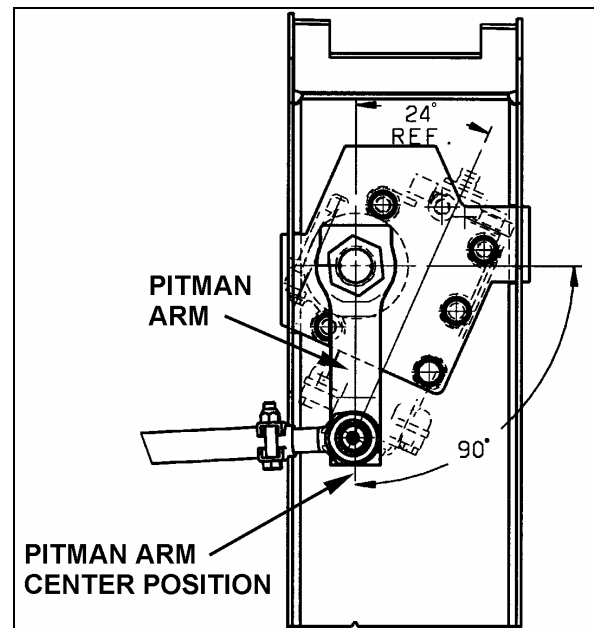

FIGURE 6: PITMAN ARM ALIGNMENT 14037

## Section 16: COACHES EQUIPPED WITH INDEPENDENT FRONT SUSPENSION (IFS)

### 2.3 PITMAN ARM REMOVAL

1. Remove cotter pin, nut and washer from drag link ball stud at pitman arm.
2. Disconnect drag link from pitman arm, using jaw style pullers (pressure screw type).

#### **⚠ WARNING ⚠**

**Always wear approved eye protection when operating pullers.**

#### **⚠ CAUTION ⚠**

**Do not drive pitman arm on or off pitman shaft as this can damage the steering gear.**

#### **⚠ CAUTION ⚠**

**Heating of components to aid in disassembly is not allowed because it has a detrimental effect on axle components and steering linkages.**

3. Remove pitman arm fixing nut.
4. Check the radial position of the pitman arm in relation to the sector shaft prior to removal of pitman arm.
5. Add reference marks to the arm and shaft if necessary to ensure correct alignment at reassembly.
6. Use a puller to remove pitman arm.

### 2.4 PITMAN ARM INSTALLATION

1. Position pitman arm on sector gear shaft with reference marks aligned.
2. Install fixing nut. Tighten nut to 400-450 lbf-ft (545-610 Nm).

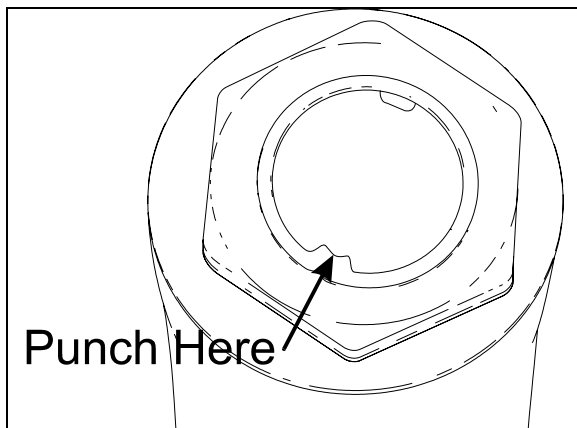

FIGURE 7: FIXING NUT PUNCH MARK

16098

#### **NOTE**

*Use a new nut if the previously removed nut was punched.*

#### **⚠ CAUTION ⚠**

**Lock nut with sector shaft using a punch mark into the groove (Refer to figure 7).**

3. Connect drag link to pitman arm. Install washers. Tighten nut to 160-215 lbf-ft (220-290 Nm). Advance nut to next alignment cotter pin slot and install a new cotter pin.

### 2.5 DRAG LINK

Drag link assembly consists of three parts; a drag link and two end assemblies. Both end assemblies are identical and they are retained on the drag link with a clamp bolt and nut.

Stud nuts at the pitman arm and bell crank ends of the drag link must be kept tight or hole at ball stud end of drag link and hole in pitman arm may become enlarged as a result of excessive looseness. Subsequent tightening of stud nuts may draw studs too far into holes and dust cover parts may become damaged which can result in component failure.

Drag link end sockets are equipped with lubrication fittings and should be lubricated as directed in "Lubrication Fittings" in this supplement.

#### 2.5.1 Adjustment

It should not be necessary to alter the length of the drag link except when a new link is installed or when removable end assembly has been replaced. If drag link adjustment is necessary, proceed as follows:

1. Position front wheels in straight ahead position.
2. Center steering gear as previously explained in paragraph "2.1 Steering Linkage Adjustment".
3. Remove cotter pin and stud from drag link at bell crank. Locate centerline of vehicle and center of relay rod. With center of relay rod aligned with centerline of vehicle, loosen clamp bolt at socket end (bell crank end) of drag link and adjust length of socket end assembly to fit in boss of bell crank.

#### **NOTE**

*Do not change position of pitman arm.*

## Section 16: COACHES EQUIPPED WITH INDEPENDENT FRONT SUSPENSION (IFS)

4. Install stud nut and torque to 160 lbf-ft (220 Nm). Align nut with cotter pin slot (tighten) and install a new cotter pin.
5. Torque mounting clamp bolt nut to 40-60 lbf-ft (55-80 Nm), then test the adjustment. Front wheels should turn from right to left extremities without noticeable binding at drag link ends.

### 2.6 BELL CRANK AND IDLER ARM

Bell crank and idler arm are equipped with one lubrication fitting and should be lubricated as directed in paragraph "2.9 Lubrication Fittings" at the end of this Supplement.

#### 2.6.1 Bell Crank and Idler Arm Removal

##### **NOTE**

Use a piece of wire to anchor loosen end of relay rod and tie rod in order to prevent placing an excessive load on opposite socket end.

**Bell crank:** Disconnect drag link, tie rod and relay rod from bell crank by removing cotter pins, stud nuts and washers from ball studs. Separate socket assemblies from the bell crank.

**Idler arm:** Remove cotter pins, nuts and washers from ball studs connecting relay rod and tie rod to idler arm. Separate socket assemblies from idler arm.

Remove nuts and washers from bolt attaching bell crank or idler arm mounting bracket to vehicle understructure. Remove bell crank or idler arm mounting bracket.

#### 2.6.2 Bell crank or Idler Arm Ball Joint Disassembly

1. Remove adjacent link assemblies from bell crank or idler arm as previously described.
2. Remove the cap (Fig.10).
3. Remove the cotter pin, nut and tongue washer. Remove bearings, grease seal, bearing bushing and the bell crank or idler arm from its mounting bracket stud (Fig. 10).

#### 2.6.3 Bell Crank or Idler Arm Ball Joint Reassembly

##### **NOTE**

For bearing installation use tool Prévost # 110684.

1. Install bearing bushing on bell crank or idler arm mounting bracket stud.
2. Install bearing and grease seal in bell crank or idler arm eye (Fig. 10).

##### **NOTE**

Install grease seal according to figure 9. Grease must be able to exit the bell crank or idler arm mechanism. For grease seal installation use tool Prévost # 110683.

3. Install bell crank or idler arm on its mounting bracket stud (Fig. 10).
4. Install bearing and nut.

##### **NOTE**

Apply grease on bearing before installation.

5. Firmly tighten nut (Fig. 8).

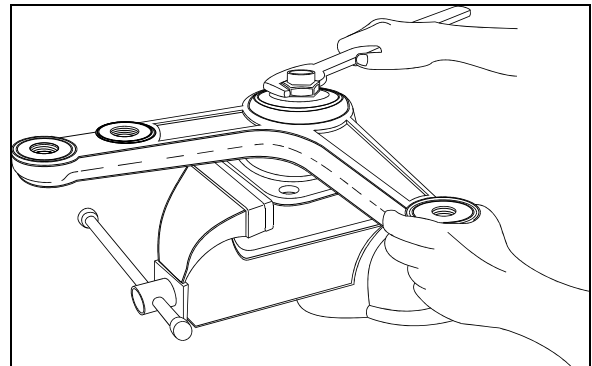

FIGURE 8: BELL CRANK

16044

6. Unscrew nut until bell crank or idler arm starts to turn by the application of 1 to 3 pounds load (Fig. 9).

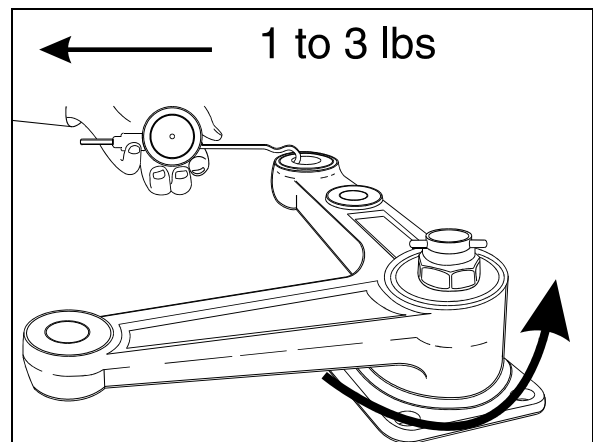

FIGURE 9: BELL CRANK

16045

7. Check for loose bearings by applying an up and down load on bell crank or idler lever (Fig. 10). The lever is not supposed to move in the vertical axis direction.

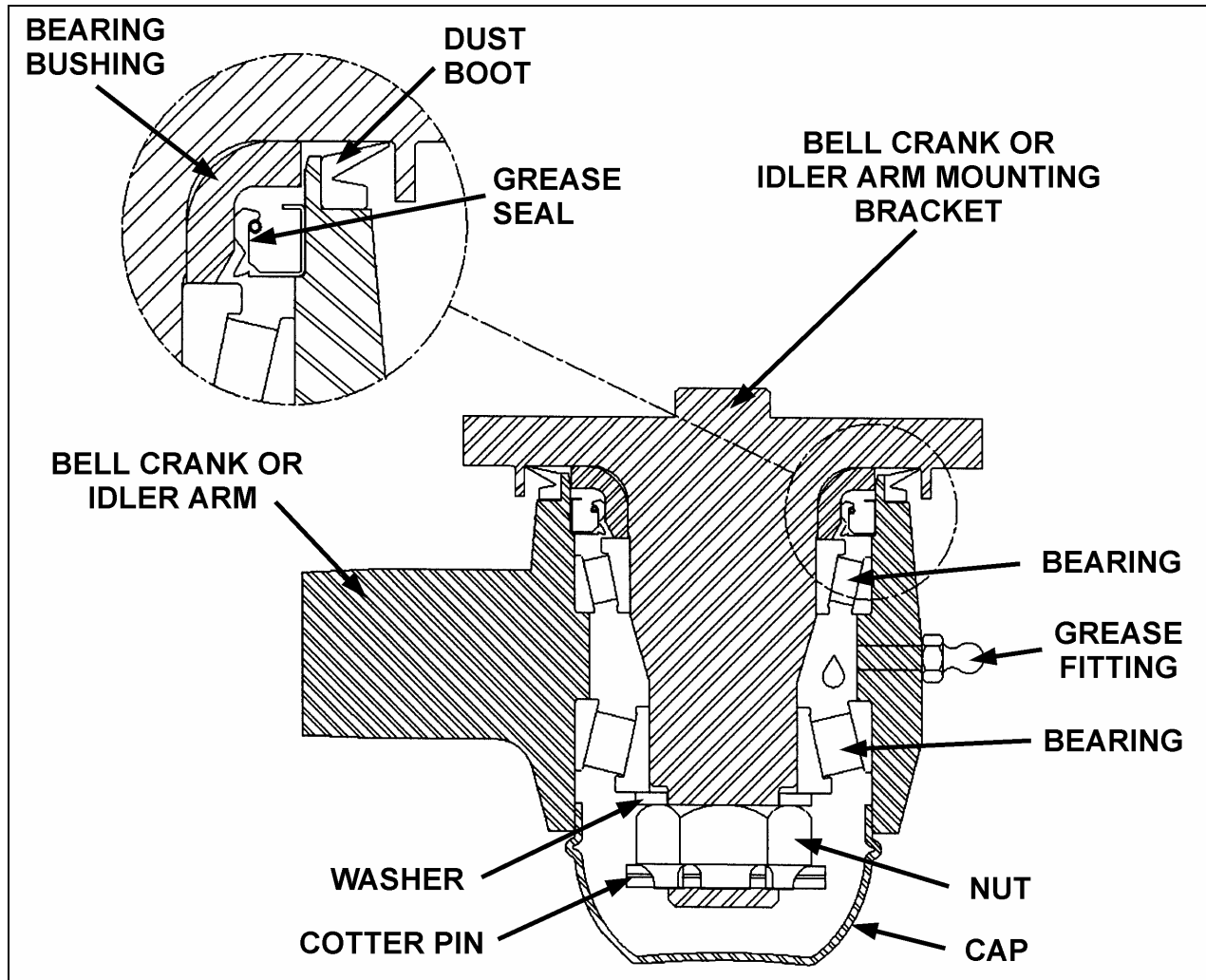

FIGURE 10: BELL CRANK AND IDLER ARM BALL JOINT

16109

8. Align nut with cotter pin slot (tighten) and install a new cotter pin.

**NOTE**

*Bend cotter pin around the nut (Fig. 10). Do not bend the cotter pin in the direction of the cap, because it may interfere with the cap.*

9. Install the cap.
10. **Bell crank:** Install drag link, tie rod and relay rod as directed herein under each specific subject.
11. **Idler arm:** Install tie rod and relay rod as directed herein under each specific subject.
12. Adjust turning angle as previously directed under paragraph "**Turning Angle**" and check front end alignment as specified in paragraph "6. Front End Alignment" of this supplement.

2.7 RELAY ROD

Relay rod ends are equipped with lubrication fittings and should be lubricated as directed in paragraph "2.9 Lubrication Fittings" in this supplement.

**NOTE**

*The relay rod is crimped in place and it is not possible to remove the ball joints.*

2.7.1 Replacement

1. Remove cotter pins from bell crank and idler arm end of relay rod. Loosen nuts flush with end of studs.
2. Use a puller or place a sledge hammer behind the adjacent part to absorb shocks. Strike the studs with a brass hammer to loosen end assemblies.

## Section 16: COACHES EQUIPPED WITH INDEPENDENT FRONT SUSPENSION (IFS)

3. Remove stud nuts and washers then remove studs.
4. Position relay rod studs into bell crank and idler arm then tap stud ends with a brass hammer to seat tapered surfaces.
5. Install washers and stud nuts. Tighten nuts to 160 lbf-ft (220 Nm) torque. Align cotter pin slot (tighten) and install a new cotter pin.

### 2.8 TIE RODS

Tie rod ends are connected to the bell crank and left steering arm, and to the idler arm and right steering arm. Each tie rod assembly consists of three parts; a tube and two socket end assemblies. The tie rod ends are threaded into the tube and secured with clamp bolts. Right and left hand threads are provided to ease toe-in adjustment. Tie rod assemblies are interchangeable from the right to the left side of the coach.

Tie rod end sockets require no maintenance other than periodic lubrication and inspection to see that ball studs are tight. Replace socket ends when there is excessive up and down motion, lost motion or end play at ball end of stud.

1. Periodically check bolt nut for tightness.
2. Inspect tie rod for bent condition and inspect tube for damaged threads. If tie rod is bent or threads are damaged, replace the assembly.
3. Lubricate tie rod end fittings as directed in paragraph "2.9 Lubrication Fittings" at the end of this section.

#### 2.8.1 Removal

1. Remove cotter pins and stud nuts which attach tie rod socket ends to bell crank and left steering arm (or idler arm) and right steering arm.
2. Remove tie rod ball stud by tapping on steering arm and bell crank or idler arm with hammer, while using a sledge hammer to absorb shocks.

#### **NOTE**

*If tie rod end assemblies are damaged in any way, they must be replaced*

#### 2.8.2 Installation

1. Install socket end assemblies on tie rod. Be sure both ends are threaded an equal distance into the tube.
2. Make sure threads on stud and in stud nut are clean and not damaged.

3. Position ball studs (socket ends of tie rod) in holes in steering arm and bell crank or idler arm. Install a ball stud nut on each stud and tighten firmly.
4. Torque stud nuts to 160 lbf-ft (220 Nm). Align cotter pin slot (tighten) and install a new cotter pin.

#### **NOTE**

*Adjust toe-in as directed in paragraph "6.4.2 Toe-In Adjustment" of this supplement.*

5. Make sure tie rod ends are properly aligned with ball studs, then torque tie rod end clamp bolts to 40-60 lbf-ft (55-80 Nm).

#### **NOTE**

*If tie rod is not properly aligned with stud, binding will result.*

### 2.9 STEERING ARMS

The left and right wheel steering arms are secured to a swivel at one end and to a tie rod at the other end.

#### 2.9.1 Removal

1. Remove wheel as directed in Section 13, "Wheel, Hubs And Tires" of the maintenance manual.
2. Remove cotter pin, washer and nut from stud securing tie rod to steering arm. Remove ball stud from steering arm by tapping on arm with a hammer, placing a sledge hammer underneath steering arm to absorb shocks.
3. Remove cotter pin and nut securing steering arm to swivel assembly. Remove steering arm from swivel.

#### 2.9.2 Installation

1. Insert steering arm in swivel.
2. Torque steering arm to swivel nut to 190 lbf-ft (260 Nm). Align cotter pin slot (tighten) and install a new cotter pin.
3. Position tie rod ball stud in steering arm and tap with a brass hammer to seat ball stud in steering arm. Install washer and nut on stud. Torque nut to 160 lbf-ft (220 Nm). Tighten nut to nearest cotter pin slot and install a new cotter pin.
4. Install wheel as directed in Section 13, "Wheel, Hubs And Tires" under paragraph "3.2 Installation" of the maintenance manual.



2.10 LUBRICATION FITTINGS

All lubrication fittings must be clean before applying lubricant. Also, always be sure equipment used in applying lubricant is clean. Every precaution should be taken to prevent entry of dirt, grit, lint or other foreign matter into lubricant containers. Replace fitting when they become broken or damaged.

Intervals of application given in the following paragraphs are recommended for normal service. More frequent intervals may be applied under severe operating conditions. In selecting proper lubricants, supplier reputation must be considered. The supplier must be responsible for product quality. The diagram (Fig. 11) shows approximate location of steering lubrication fittings.

1. **Drag Link Ends:** Lubricate at two fittings, one at each end of link, every 6,250 miles (10 000 km) with good quality lithium-base grease NLGI No. 2 (Shell Retinax LX or equivalent).
2. **Relay Rod Ends:** Lubricate at two fittings, one at each end of rod, every 6,250 miles

(10 000 km) with good quality lithium-base grease NLGI No. 2 (Shell Retinax LX or equivalent).

3. **Tie Rod Ends:** Lubricate at four fittings, one at each end of both tie rods, every 6,250 miles (10 000 km) with good quality lithium-base grease NLGI No. 2 (Shell Retinax LX or equivalent).
4. **Swivel Assembly:** Refer to DANA SPICER MAINTENANCE MANUAL NDS AXLES Lubrication and Maintenance" annexed at the end of section 10.
5. **Idler Arm and Crank bell:** Lubricate at two fittings, one on the idler arm and the other on the crank bell, every 6,250 miles (10 000 km) with good quality lithium-base grease NLGI No. 2 (Shell Retinax LX or equivalent). Apply grease gun pressure to the fitting until lubricant appears at the top seal.
6. **Upper V-Link Outer Ball Joint:** Lubricate at fitting until you see some grease on the relief valve nearby, every 6,250 miles (10 000 km) with good quality lithium-base grease NLGI No. 2 (Shell Retinax LX or equivalent).

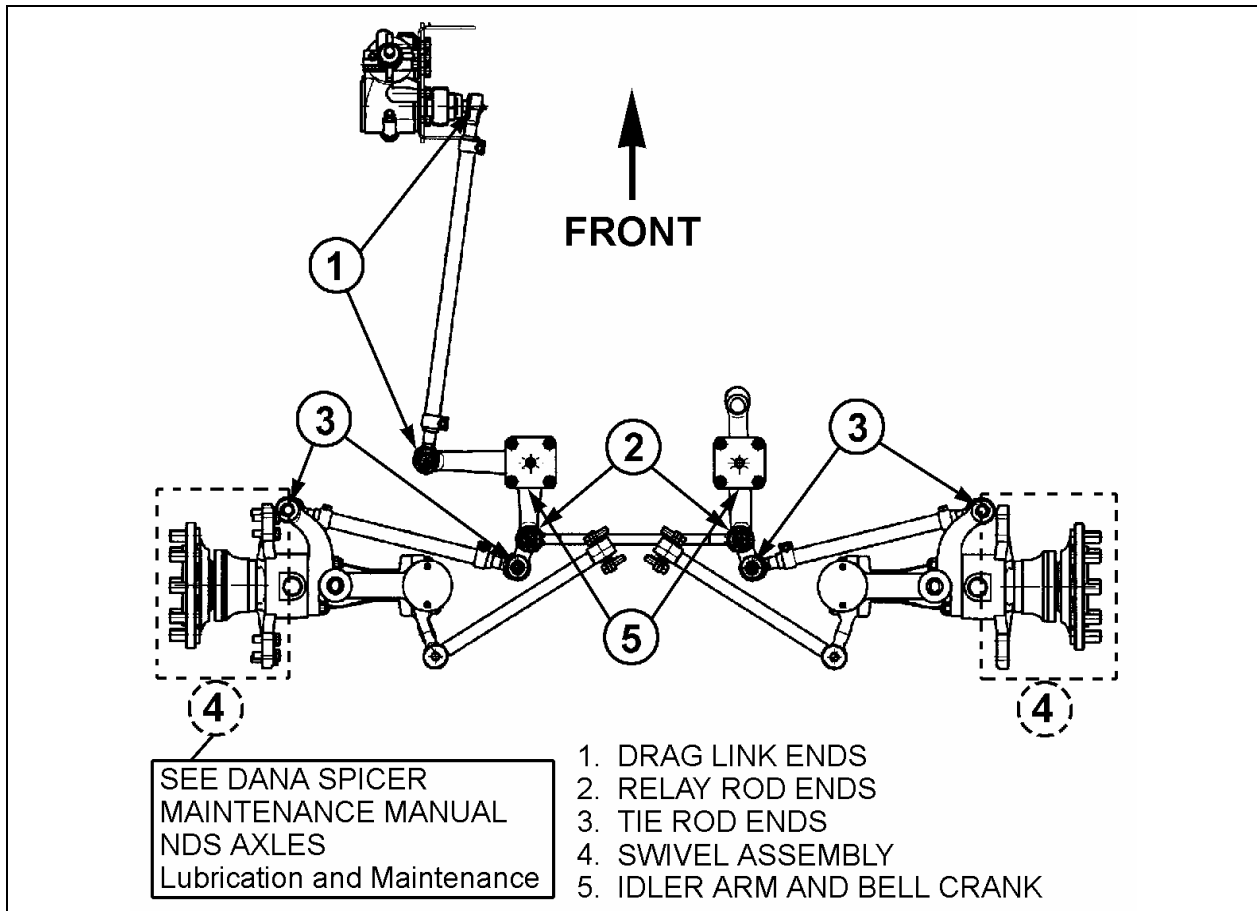

FIGURE 11: LUBRICATION FITTINGS' LOCATION DIAGRAM

16119

### 3. BALL JOINTS

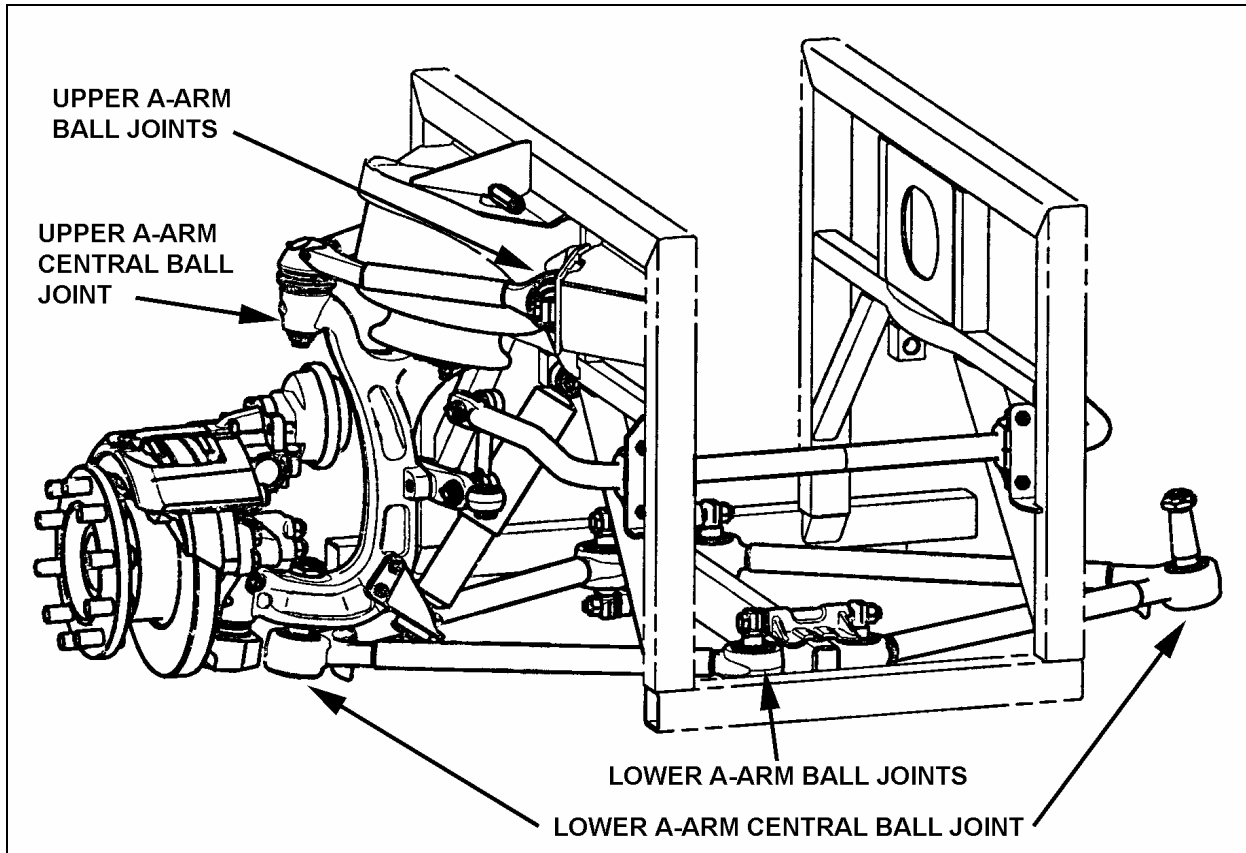

FIGURE 12: BALL JOINTS LOCATION

16137

### 4. LOWER AND UPPER A-ARM BALL JOINT

The assembly work may be done only by a recognized specialized workshop. Ensure that old and new parts do not get mixed up with each other. It is for this reason that all the old parts are to be scrapped immediately after a joint has been stripped down. A complete repair set must be used for each joint repaired, i.e. use of only part of a repair set is not permissible.

#### 4.1 INSPECTION

Take off the load from the ball joint by lifting the front of the vehicle. Apply a load on the joint in all of the degrees of freedom in an axial, radial, etc. sense with a suitable lever tool. After the load is taken off, the joint has to spring back into its starting position. Free play is not acceptable.

Separation of rubber from ball pin or external joint shell is in accordance with "normal wear characteristics".

When the following characteristics are noted, the joint is to be changed:

- Free play;
- Radial cracking of the external sheet-metal race.

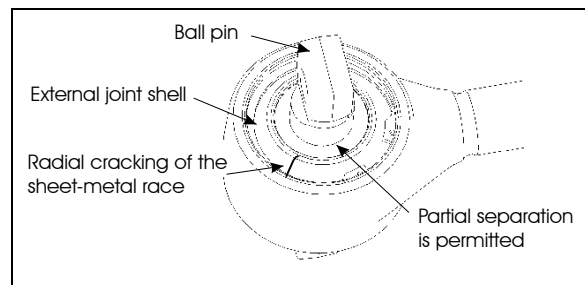

FIGURE 13: A-ARM BALL JOINTS

#### 4.2 STRIPPING DOWN

Strip down the defective joint through removal of retaining ring, annular spacer and ball pin/bushing, assembly and thereafter clean out housing bore and locking circlips groove.

#### 4.3 ASSEMBLY

Execute assembly of the new joint parts in the following sequence:

1. Complete moistening of the contact surface between housing bore and ball pin through application of the grease.

**NOTE**

*Apply grease, only in the case of repair kit (Prévost # 611114).*

2. Insert ball pin/bushing, assembly. In case of the two-bolt type, ensure that the bolt bores are in the correct position in relation to the axis of the tube.
3. Place joint in receiving fixture and mount annular assembly tool on the housing. Then locate annular spacer and retaining ring in the housing using axial load with the aid of assembly matrix. If the ends of the annular spacer are not in contact with each other, the thus formed opening must be located at 180° to the opening of the retaining ring. Pay attention during assembly to ensure that the retaining ring eyelets are located at each side of the housing shaft axis (retaining ring eyelet lug points to tube), and that retaining ring is properly engaged in the groove of the housing.
4. When repairing defective ball pin assemblies, the necked down-bolt must regularly be replaced with a new one.

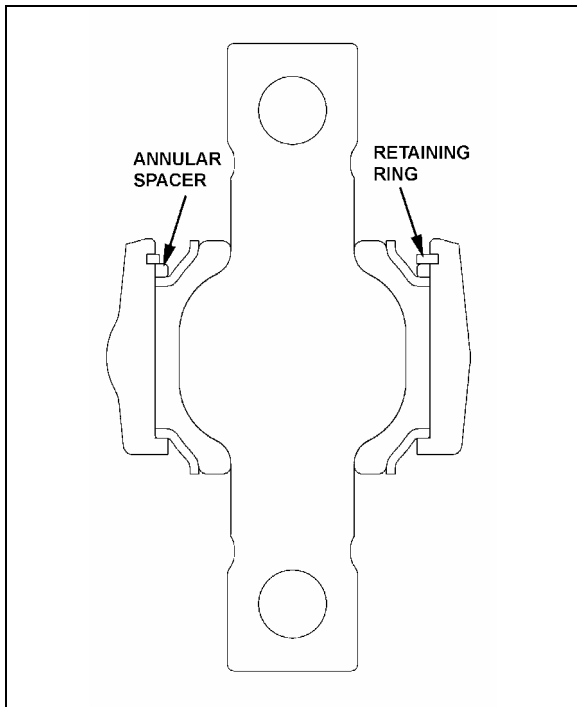

FIGURE 14: LOWER A-ARM BALL JOINTS 16114

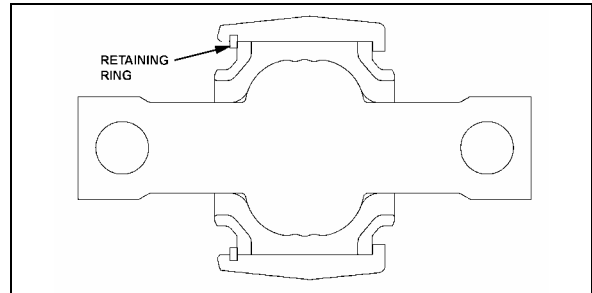

FIGURE 15: UPPER A-ARM BALL JOINTS 16115

**5. LOWER A- ARM CENTRAL BALL JOINT**

**5.1 INSPECTION**

Take off the load from the ball joint by lifting the front of the vehicle. Apply a load on the joint in all of the degrees of freedom in an axial, radial, etc. sense with a suitable lever tool. After the load is taken off, the joint has to spring back into its starting position. Free play is not acceptable.

Separation of rubber from ball pin or external joint bushing shell is in accordance with "normal wear characteristics".

When the following characteristics are noted, the joint is to be changed:

- Free play;
- Radial cracking of the external bushing shell.

**5.2 STRIPPING DOWN**

Strip down the defective joint through removal of retaining ring, annular spacer and ball pin/bushing, assembly and thereafter clean out housing bore and locking circlips groove.

**5.3 ASSEMBLY**

Assemble the new component parts of the joint in the following sequence:

1. Complete moistening of the contact surface between housing bore and ball pin through application of the grease.
2. Place joint in receiving fixture and mount annular assembly tool on the housing. Then locate annular spacer and retaining ring in the housing using axial load with the aid of assembly matrix. If the ends of the annular spacer are not in contact with each other, the thus formed opening must be located at 180° to the opening of the retaining ring. Pay attention during assembly to ensure that the retaining ring eyelets are located at each side of the housing shaft axis (retaining ring eyelet lug points to tube), and that retaining ring is properly engaged in the groove of the housing.

- Faultlessly apply grease by mechanical means to bracket-outer core and ball-inner cone. Insert bracket outer cone in fixture with distance ring and then use press tool to apply pressure to press mount with ball-inner cone.

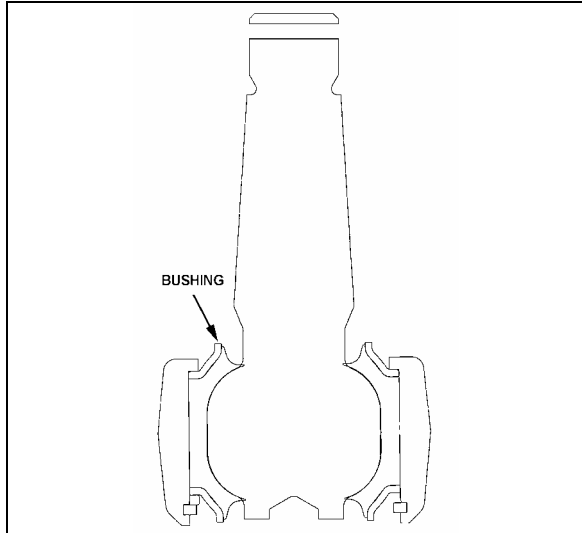

FIGURE 16: LOWER A-ARM CENTRAL BALL JOINT 16113

## 6. UPPER A-ARM CENTRAL BALL JOINT

### 6.1 VISUAL INSPECTION

Check the condition of the sealing boot, in particular:

Check if the retainer ring, which secures the sealing boot at the conical section of the ball stud, is still present.

Check if grease is present on the external surface of the sealing boots. Escaped fluid and accumulations of grease on the sealing boot may be the result of the sealing boot's rupturing. In this case, the ball joint must be systematically replaced.

### 6.2 PLAY MEASUREMENT

- Raise the vehicle and support through axle jacking points.
- Using a caliper, measure dimension A on figure 17.
- With a lever tool, exert sufficient force under the upper A-arm as to separate the upper A-arm from the upright in order to have the ball joint to its maximum extent. Remeasure the dimension A. If the difference between the two dimensions is greater than 0.060" (1.5mm), then the ball joint should be replaced.

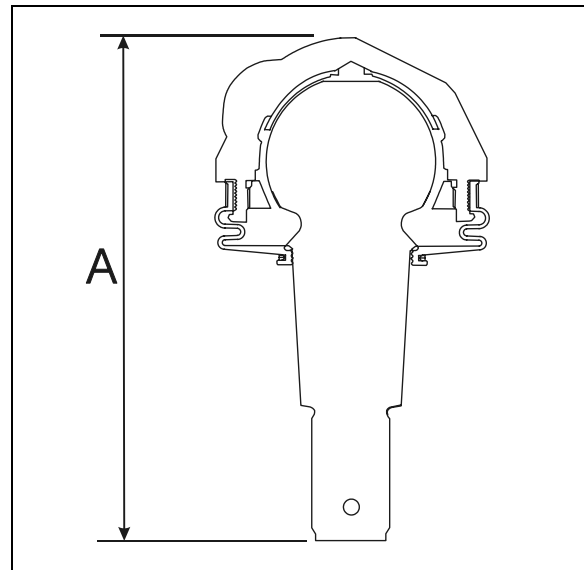

FIGURE 17: UPPER A-ARM CENTRAL BALL JOINT 16116

## 7. FRONT END ALIGNMENT

Proper front end alignment must be maintained to insure ease of steering and provide satisfactory tire life. When making front end alignment inspections, the vehicle must be level and empty with the full weight of the vehicle on the wheels.

Front end alignment inspections fall into two groups: regular service inspections performed at periodic intervals, and inspections to determine the extent of damage after a collision or severe service.

Regular service inspections concern toe-in, camber and caster.

Any variation from the specified alignment will indicate either a need for adjustment or a more thorough inspection to determine if parts replacement is required.

### ⚠ WARNING ⚠

**During alignment, both camber and caster among other angles are adjusted. When adjusting these we install or remove shims from the lower "A" arms of the ISS suspension. After performing alignment, make sure that the following is done:**

- **Installing a new lock nut after all shims are finalized.**
- **Torque replaced nuts as per figure 21.**
- **Installing a longer bolt if less the 2 threads are remaining after the nut.**
- **Using a Torque mark on the nut for future visual inspection.**

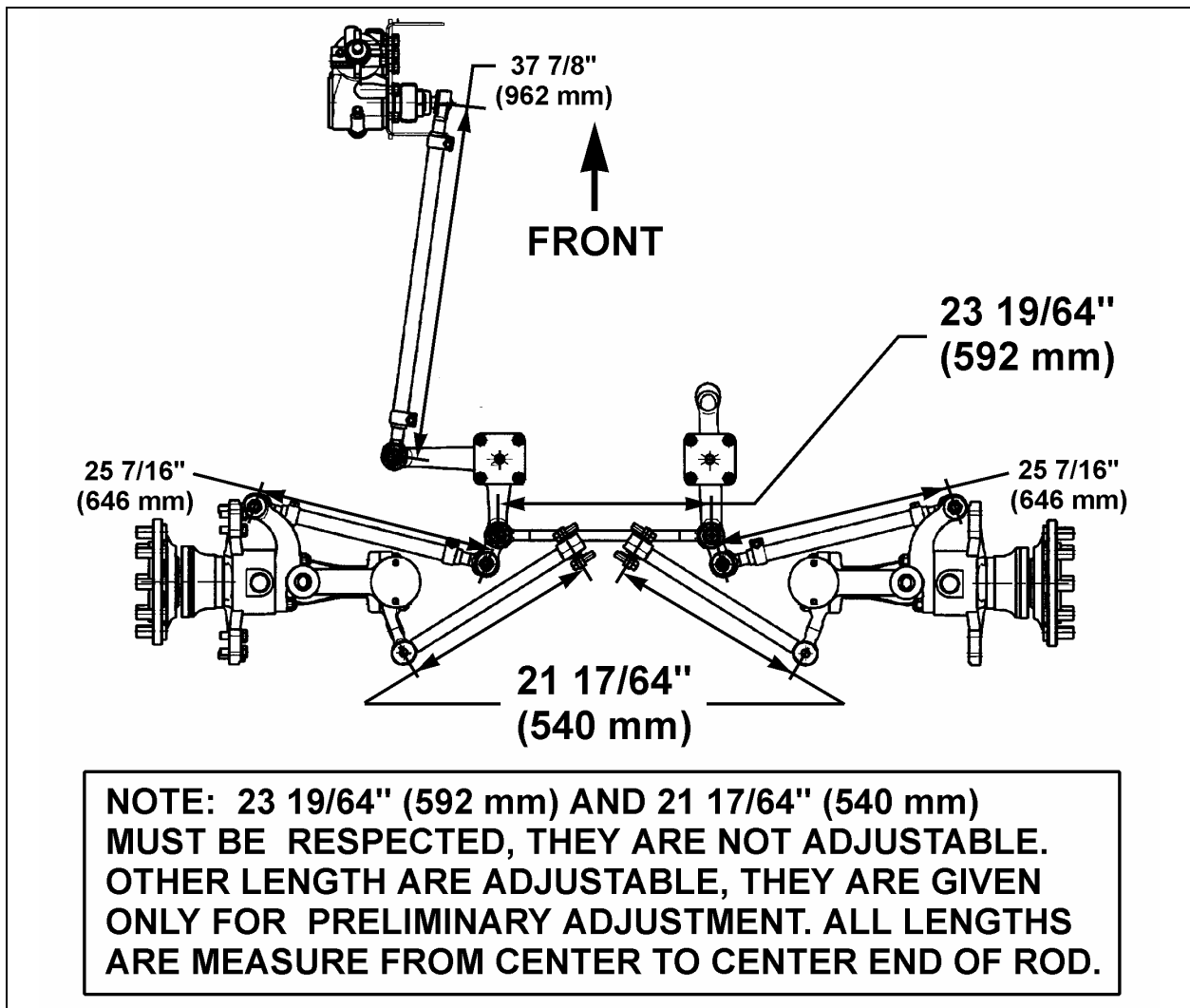

FIGURE 18: STEERING LINKAGE MEASURE

16130

### 7.1 ALIGNMENT TERMINOLOGY

#### Wheel Camber

The amount the wheels are inclined from the vertical plane (A, Fig. 18).

#### Wheel Toe-In

The distance the front wheels are closer together at the front than at the rear of the tires (D minus E, Fig. 18).

#### King Pin Inclination

The inclination of the king pin from vertical toward the center of the vehicle at the top and outward at the bottom (B, Fig. 18).

#### Front Axle Caster

The inclination of the king pin from vertical in the fore and aft direction (C, Fig. 18).

### 7.2 FRONT END INSPECTION

Before checking front end alignment, make the following inspection:

1. Check that the vehicle is at normal ride height (see paragraph "11. Suspension Height Adjustment").
2. Check the tires for proper inflation.
3. Check wheel installation and run-out.
4. Check wheel bearing adjustment.
5. Check tie rods and drag link ends for looseness.
6. Check king pins for looseness.
7. Check if the length of the torque rod is 21 17/64" (540 mm) (Fig. 18). Check if the length of the relay rod is 23 19/64" (592 mm).

### 7.3 FRONT WHEEL CAMBER

Positive camber is the outward inclination of the wheels at the top, negative or reverse camber is the inward inclination of the wheels at the top. Camber variations may be caused by wear at the wheel bearings, wheel spindle bushings, or bent suspension parts.

Check camber, with an accurate gauge. If camber is incorrect, check suspension parts for wear and replace worn parts. If wear is not perceptible, suspension parts may be bent or lower suspension arm may be improperly shimmed.

Check King pin inclination. If King pin inclination is incorrect, readjust the camber and check king pin inclination again.

<b>NOTE</b>
<i>Camber is more important than king pin inclination, so adjust camber and verify king pin inclination.</i>

Shim the lower suspension arm to adjust camber. If the king pin inclination is incorrect, the wheel king pin assembly may be bent and therefore should be replaced.

Excessive positive camber results in irregular wear of the tires at the outer shoulders. Negative or reverse camber causes wear at the inner shoulders.

<b>NOTE</b>
<i>Shim only the lower suspension arm to adjust the front wheel camber.</i>

<b>⚠ CAUTION ⚠</b>
<b>Once the perfect shim combination is achieved, always install new stover nuts because the self looking effect is lost after tightening and loosening of the nut. It is recommended to punch marks to detect loosening of the nuts during future visual inspections.</b>

### 7.4 FRONT WHEEL TOE-IN

Toe-in is measured from the center of the tire treads. Measurements at the front and rear of the tires must be made at the same height from the floor. Incorrect toe-in results in excessive tire wear and steering instability with a tendency to wander.

#### 7.4.1 Toe-In Check

1. Check the camber adjustment and adjust if necessary.
2. Hoist the front of the vehicle and spin the wheels marking the centerline of the tire treads.

3. Place the wheels in the straight ahead position and lower the vehicle to rest on the floor.
4. Roll the vehicle ahead several feet. This removes any slack caused by looseness in the wheel bearings or steering connections.
5. Check the distance between the tire centerlines at the front and rear of the front tires. These two measurements must be made at the same height above the floor. The front measurement must be  $3/32 \pm 1/32$  of an inch less than the rear measurement.

#### 7.4.2 Toe-In Adjustment

1. Loosen the tie rod clamp bolts.
2. Using a pipe wrench, turn the tie rod tubes to obtain the toe-in measurement specified in step 5 under paragraph "6.4.1 Toe-in Check" of this Supplement.
3. Tighten the tie rod clamp bolts and recheck toe-in.
4. Check that the angular relationship of the pitman arm to the steering gear is as shown in figure 6.

<b>NOTE</b>
<i>Use only tie rods to adjust toe-in.</i>

### 7.5 FRONT AXLE CASTER

Positive caster is the inclination of the top of the king pins toward the rear of the vehicle. Negative or reverse caster is the inclination of the king pins toward the front of the vehicle. This vehicle is designed with positive caster. The purpose of caster is to provide steering stability by keeping the wheels in a straight ahead position.

Caster variations may be caused by bent upper suspension arm, lower suspension arm, or king pin housing. Caster should be adjusted with shims. Precision instruments should be used to measure caster. Shim bell crank and idler arm to adjust caster.

Variations from the specified caster will affect steering stability, cause wandering, wheel shimmy, and reduce returnability when pulling out of curves.

### 7.6 MAJOR DAMAGE

If the suspension has sustained major damage, it may be necessary to shim the bell crank and the idler arm to avoid the bump steer or roll steer. Moreover refer to paragraph "7: Front End Alignment".

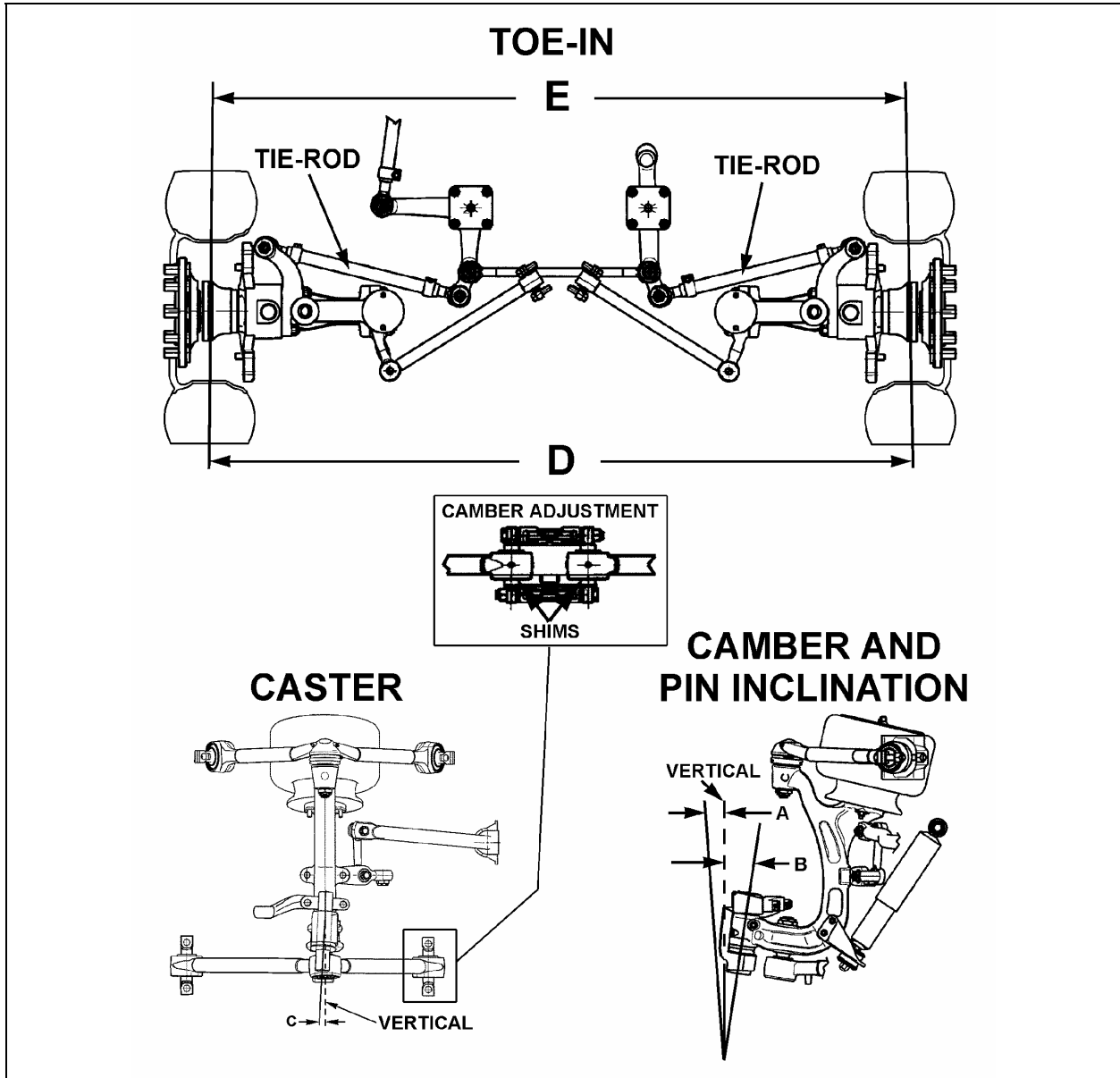

FIGURE 19: FRONT END ALIGNMENT DIAGRAM

16134

ALIGNMENT SPECS (See Figure 19)				
		Minimal	Nominal	Maximal
A	WHEEL CAMBER	0.0	0.150	0.35
B	KING PIN INCLINATION	8° (not adjustable)		
C	CASTER	2.35	2.6	2.85
D-E	TOE-IN	0.08	0.13	0.17

## 8. FRONT AIR SPRINGS

Two "rolling lobe" type air springs are used with the independent front suspension, one at each wheel. These air springs are special and use the complete piston as an extra reservoir to lower the spring stiffness. Front air springs are attached to the subframe and to uprights.

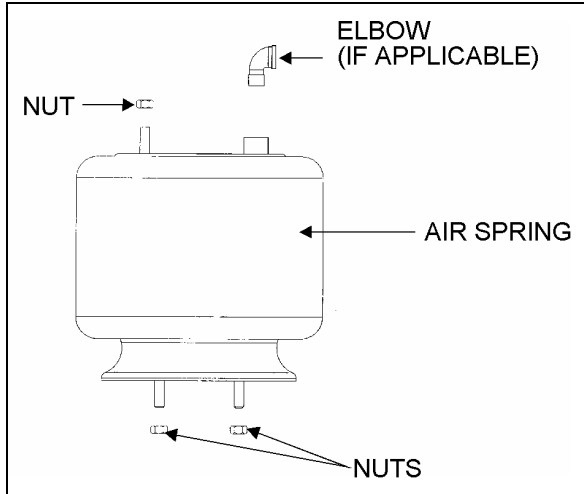

FIGURE 20: AIR SPRINGS

16052

### 8.1 INSPECTION

1. Check operation of bellows.
2. Visually inspect bellows for evidence of cracks, punctures, deterioration, or chafing. Replace the bellows if damage is evident.
3. With the primary air system at normal operating pressure (95 - 125 psi (655 - 860 kPa)), coat all suspension air line connections and bellow mounting areas with a water and soap solution. Bubbles will indicate an air leak, and none is permissible. Repair or replace defective parts.

#### NOTE

*If air spring is removed from vehicle, bellows can be lightly inflated and submerged in water to detect any leakage. If leakage is detected, replace bellows.*

#### WARNING

**To prevent personal injury, do not apply more than 10 psi (69 kPa) air pressure to the unmounted air spring.**

### 8.2 REMOVAL

#### NOTE

*Front air springs can be removed without removing the entire suspension assembly.*

1. Safely support vehicle at the recommended body jacking points and jack up body understructure.
2. To gain access to a given air spring, the corresponding wheel can be removed.

#### CAUTION

**Only the recommended jacking points must be used as outlined in Section 18, "Body" in the maintenance manual.**

3. Support the assembly with a suitable jack.
4. Exhaust compressed air from accessory air tank by opening drain cock under reservoir.
5. Disconnect the height control valve link and pull down the overtravel lever to ensure all air is exhausted from air springs.

#### NOTE

*While performing this step, do not change the height control valve overtravel lever adjustment.*

6. Disconnect air line from air spring, remove elbow (if applicable), and cover both the line end and fitting to prevent the entry of foreign matter.
7. Remove the air spring upper nut, and then the two lower nuts. Remove air spring and remove the back up plate from the top of the air spring.

### 8.3 INSTALLATION

#### NOTE

*To facilitate air spring installation, compress it manually then put a piece of tape over the air line threaded fitting. This prevents air from getting back into the bag and keeps it compressed, thus enabling to place the bag in between the mounting plates and greatly easing installation.*



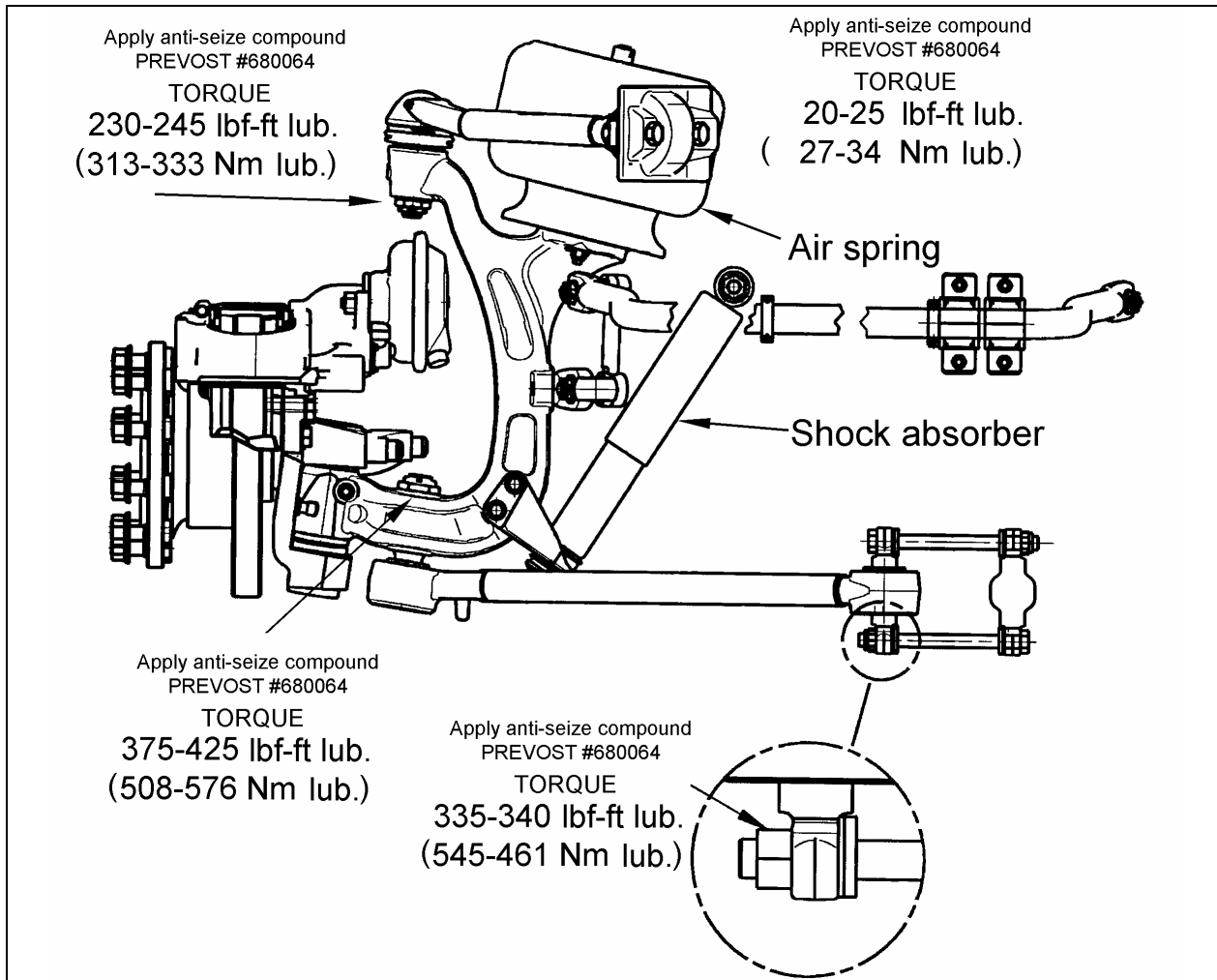

FIGURE 21: AIR SPRING AND SHOCK ABSORBER

16145

1. Compress air spring as necessary, then aligning studs with their holes, position air spring between both the lower and upper supports. Thread the lower nuts and the small upper nut a few turns.
2. Tighten and torque the lower stud nuts, and then the upper nut to 20-25 lbf-ft (27-34 Nm).
3. Install elbow (if applicable), then connect air line.
4. Connect the height control valve link.
5. Build up air pressure in system.

6. Check operation of bellows and with the primary air system at normal operating pressure (95 - 125 psi (655 - 860 kPa), coat the air line connections and air spring mounting areas with a water and soap solution. Bubbles will indicate an air leak, and none is permissible. Repair or replace defective parts.
7. Remove the hydraulic floor jack from underneath shock absorber bracket.

## 9. SHOCK ABSORBERS

The two front shock absorbers are double-acting and telescopic type. Shock absorbers ensure a smooth ride and enhance vehicle stability on the road. Front shock absorbers have eye-type mountings on the upper side and bayonet type on lower side. Shock absorbers are non-adjustable and non-repairable.

### NOTE

To accelerate this operation, air reservoirs can be filled from an exterior air supply connected to the accessory tank fill valve or to the emergency fill valve.

**⚠ CAUTION ⚠**

**When a shock absorber is found defective, always replace with a new set on affected axle, except if there has been a recent replacement of one unit. The following method will help in determining if both shock absorbers on the same axle have to be replaced.**

### 9.1 SHOCK ABSORBER REMOVAL

1. Remove the nut, washer and rubber joint from shock absorber mounting stud. Discard the rubber joints.
2. Remove the nut and washer from shock absorber mounting pin (upper side), taking care to identify the inner and outer washers to ease reinstallation. Refer to figure 22 for details.
3. Remove the shock absorber from the vehicle.
4. Remove inner: washers, rubber joint and bushings from the shock absorber. Discard bushings and rubber joint.

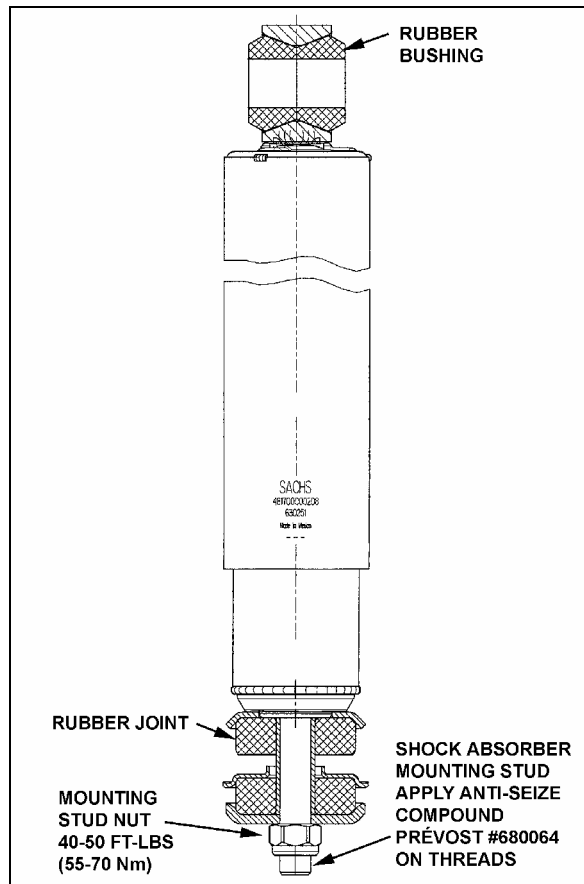

FIGURE 22: SHOCK ABSORBER

16112

### 9.2 SHOCK ABSORBER INSTALLATION

1. Check that the shock absorber mounting pin torque is proper (350-400 lbf-ft (475-545 Nm)). Ensure that the stud is clean and not stripped (upper side).
2. Install new rubber (mounting) bushing on shock absorber (upper side).
3. Place the inner washer on shock absorber pin (Fig. 22).
4. Install washer and rubber joint on shock absorber mounting stud (lower side).
5. Install the shock absorber as shown in figure 18 with the mounting stud protruding through the hole in the mounting bracket and the shock absorber eyes over the mounting pins. Install the outer washer.
6. Place a rubber joint and washer on the shock absorber mounting stud. Place the lower shock absorber mounting stud nut and torque to 40-50 lbf-ft (55-70 Nm).
7. Place the upper mounting pin stud nut and torque to 70-85 lbf-ft (95-115 Nm).

### 10. SWAY BAR

A sway bar is provided on the front and drive axles to increase vehicle stability. It controls lateral motion (swaying movement) of vehicle.

#### 10.1 REMOVAL

1. Disconnect the two links from sway bar.
2. Safely support the sway bar. Unbolt bushing collars from subframe.
3. Remove sway bar.

**NOTE**

*Sway bar bushings are slit to ease their removal.*

#### 10.2 INSTALLATION

1. Loosely install the sway bar.
2. Torque bushing collar nuts to 60 lbf-ft (82 Nm).
3. Torque sway bar link upper nuts to 120-140 lbf-ft (163-190 Nm) on front suspension and to 100-120 lbf-ft (136-163 Nm) on rear suspension.
4. Torque sway bar link lower nuts to 120-140 lbf-ft (163-190 Nm) on front suspension and to 70-80 lbf-ft (95-110 Nm) on rear suspension.

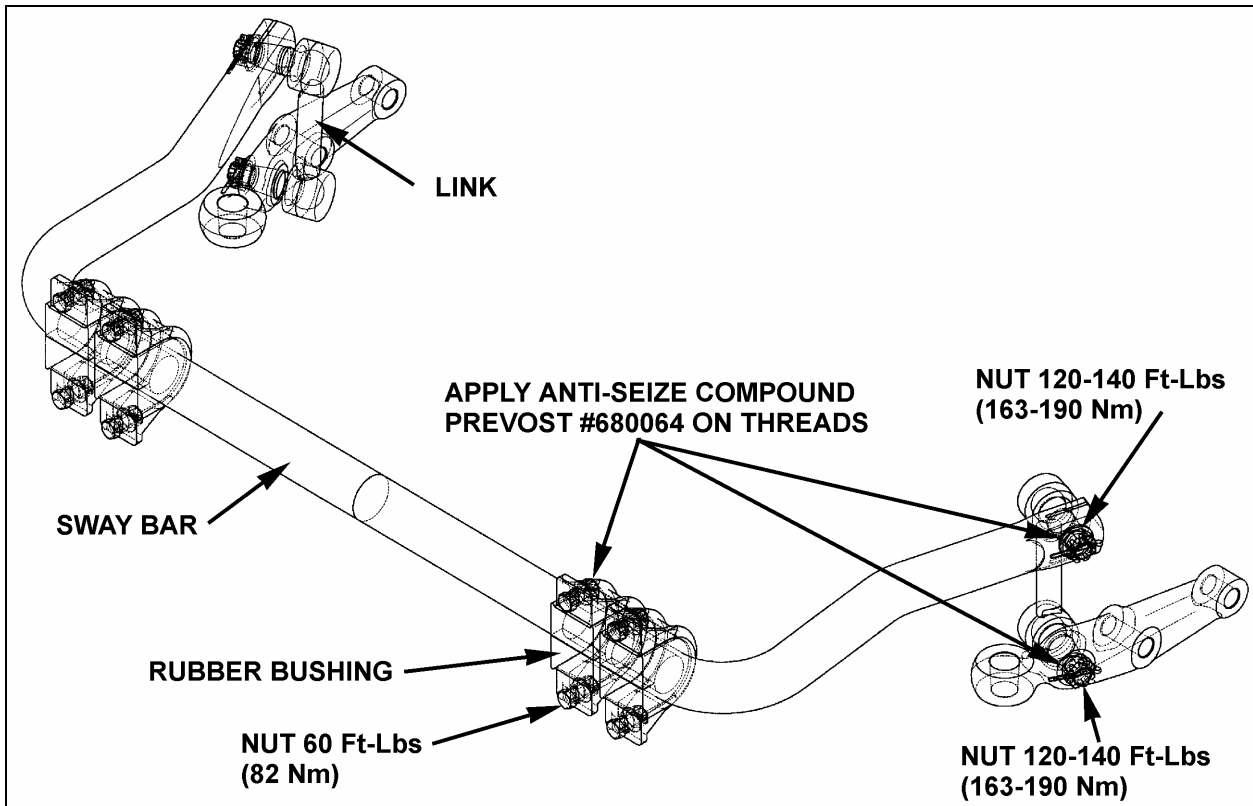

FIGURE 23: SWAY BAR (FRONT SUSPENSION)

16055

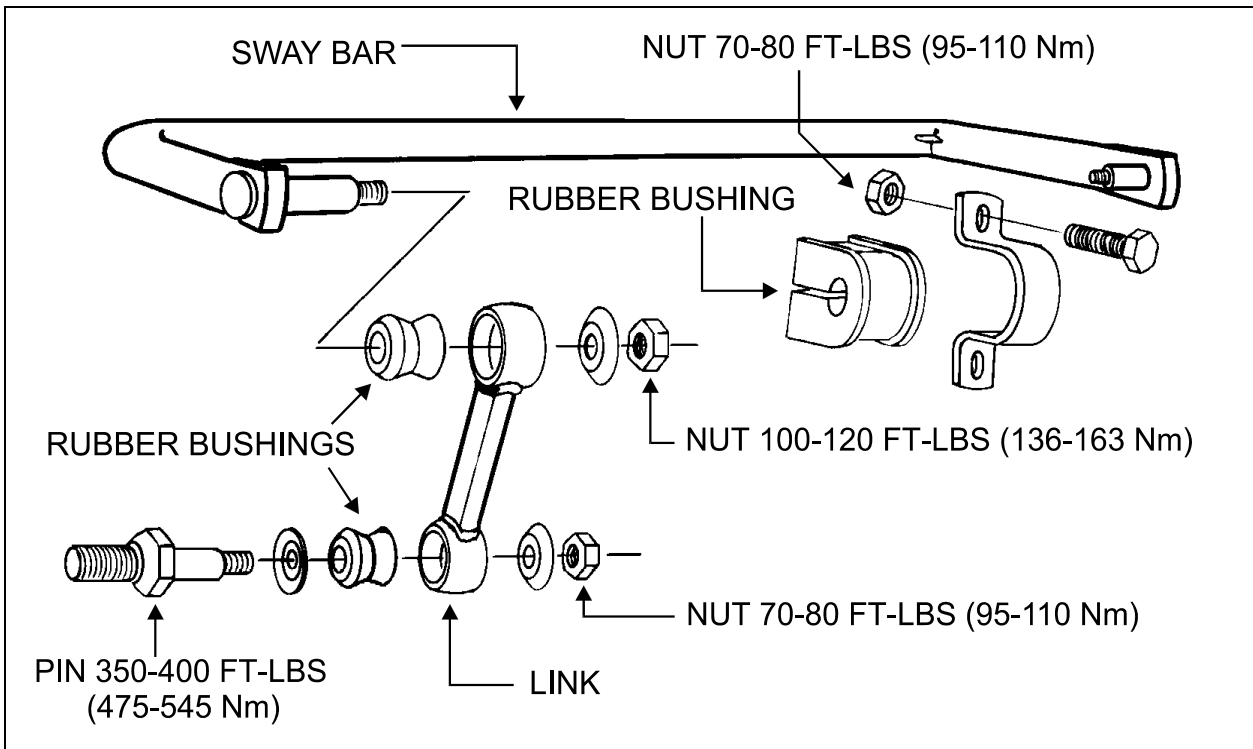

FIGURE 24: SWAY BAR (REAR SUSPENSION)

16014

### 11. SUSPENSION HEIGHT ADJUSTMENT

The flow of pressurized air from the accessory air tank to the air springs is controlled by three height control valves. The two rear valves are mounted to the subframe and connected to the rear axles through an arm and link connection. The front valve is mounted to the subframe and connected to the front air tank support. These connections allow the valves to apportion air pressure in the springs to the vehicle load, maintaining normal ride height.

Immediate response height control valves increase or decrease the air pressure in the suspension system as required. One height control valve is located **at center of front sway bar**, and regulates air to front suspension air springs in order to maintain the vehicle at the required height. Two are located at the drive axle, one on each inner side of rear wheelhousing.

The appropriate vehicle body height is obtained by measuring the clearance of all the air springs installed on the vehicle. The two front air springs clearance should be  $11 \pm \frac{1}{4}$ " (279 ± 6 mm). Refer to figure 25 to identify the correct area to take measurement. The rear air springs clearance should be  $11 \frac{1}{2} \pm \frac{1}{4}$ " (292 ± 6 mm) (refer to Maintenance Manual, Section 16, under "Suspension Height Adjustment" for rear height control valves' adjustment).

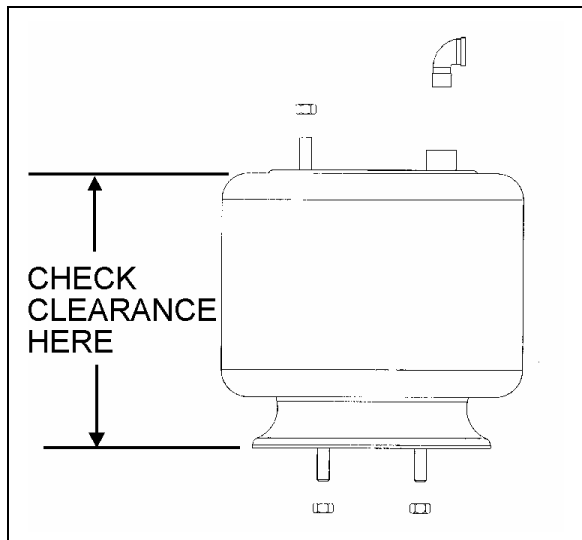

FIGURE 25: TYPICAL AIR SPRING CLEARANCE 16058

At this point, it should not be necessary to make an adjustment under normal service conditions. However, if an adjustment is required, change the position of the overtravel lever in relation to the overtravel control body. The lever should be

moved up to raise vehicle height, and down to lower it. Check that main air pressure is at normal operating pressure and raise the vehicle to the specified height.

**CAUTION**

**Always adjust on "fill cycle". If it is necessary to lower vehicle height, release sufficient air to be well below height, and adjust to height or fill cycle.**

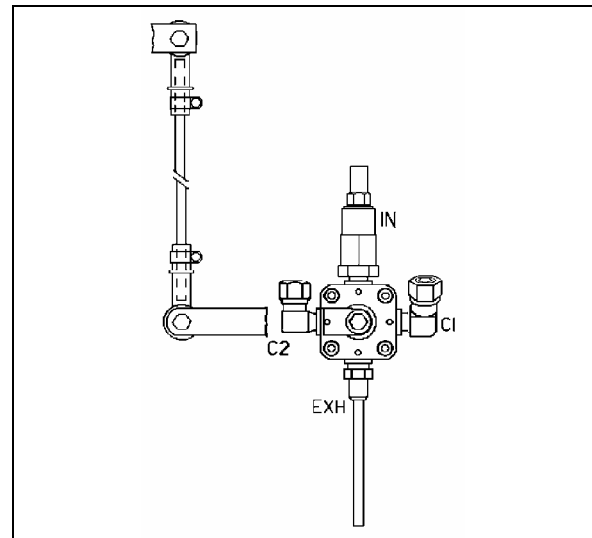

FIGURE 26: FRONT HEIGHT CONTROL VALVE 16100

The normal ride height is obtained by adjusting air spring clearance of both front and rear suspension as follows:

#### Front air spring clearance

1. With the vehicle at normal operating air pressure [100 - 125 psi (689 - 860 kPa)], measure air spring clearance. This clearance should be  $11 \pm \frac{1}{4}$ " (279 ± 6 mm).

**NOTE**

*The measurement should be taken from underneath the upper air spring support on subframe to top of the lower air spring support on axle (refer to figure 25 for more details). If adjustment is required, begin with the drive axle.*

2. Loosen the clamp on the height control valve rubber coupling and bring it up or down (Fig. 26).

**NOTE**

*Allow suspension to stabilize before taking reading.*

When the desired height is obtained, tighten clamp.

### Rear air springs clearance

Refer to XL2 Maintenance Manual, Section 16, under "Suspension Height Adjustment".

## 12. HEIGHT CONTROL VALVE

The height control valves automatically add air to, or release air from air springs to maintain constant suspension height regardless of load, or load distribution. Each valve adjusts independently according to the following conditions:

### 12.1 LOADING POSITION

As the load increases and lowers the vehicle body, the overtravel lever commands the height control valve to add air to air springs.

### 12.2 NEUTRAL POSITION

When vehicle body reaches the normal ride height, the height control valve overtravel lever reaches the "neutral" position and keeps both the supply and exhaust ports closed to ensure normal ride height is maintained. This condition remains static until the vehicle load is altered.

### 12.3 UNLOADING POSITION

As the load decreases and raises the vehicle body, the overtravel lever commands the height control valve to release air from air springs.

### 12.4 MAINTENANCE

The height control valve requires no periodic maintenance. Height control valve linkage operates on rubber bushings and no lubrication should be attempted at this location. Inspect the valve for loose joints, air leaks and worn bushings.

### 12.5 REMOVAL AND INSTALLATION

Before disconnecting a height control valve air line, securely support the vehicle by its jacking points on the body, and place safety supports underneath body. Refer to paragraph "16. Vehicle Jacking Points" in Section 18, "Body".

1. Exhaust air from air system by opening all air tank drain cocks. Remove height control valves.
2. Disconnect overtravel lever from link and pull down lever to exhaust remaining air from air springs.

3. Disconnect air supply and delivery lines from the height control valve. Cover line ends with tape to prevent entry of foreign matter.

4. Remove the nuts retaining the height control valve to the mounting bracket, then remove valve assembly.

Reverse removal procedure to replace height control valve. After installation, check for leakage using a soap and water solution.

## 13. AIR SYSTEM

The basic air system consists of an air compressor, tanks, valves, filters and interconnecting lines and hoses (refer to Section 12, "Brake and Air System" for complete information). It provides a means for braking, operating controls and accessories, and suspension. An air system schematic diagram is annexed at the end of this supplement for better understanding of the system.

The air coming from the air dryer is first directed to the wet air tank, then to the primary (for the primary brake system), secondary (for the secondary brake system), and accessory (for the pneumatic accessories) air tanks (Fig. 27).

In addition, an expansion air tank is installed in series with each air spring.

### 13.1 AIR TANK MAINTENANCE

Ensure that the accessory air tank is purged during pre-starting inspection. A good practice is to purge this tank at the end of every driving day by the remote air tank drain valve located in the steering compartment (Fig. 29).

Moreover, purge all tanks by their bottom drain valves at specified intervals.

#### 13.1.1 Wet Air Tank

This tank is installed above L.H. wheel of drive axle, and is provided with a bottom drain valve. It is recommended to **purge** the wet air tank by its bottom drain valve every 12,500 miles (20 000 km), or once a year, whichever comes first.

A remote valve located in engine compartment and accessible through engine R.H. side door is used to **drain** the air dryer (Fig. 28).

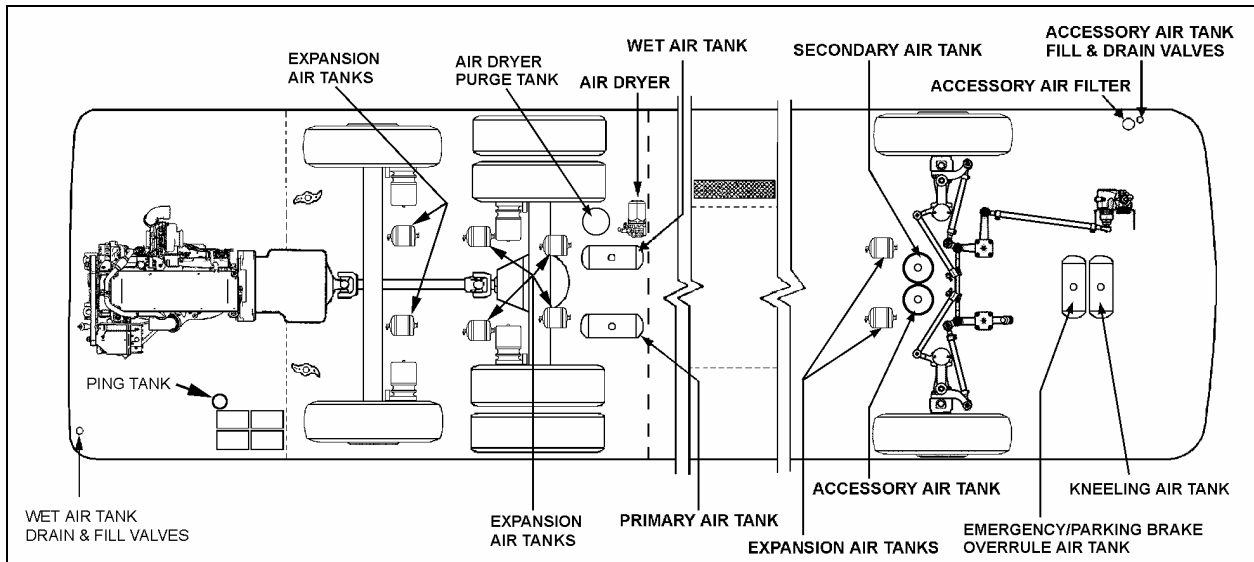

FIGURE 27: LOCATION OF AIR TANKS

24007C

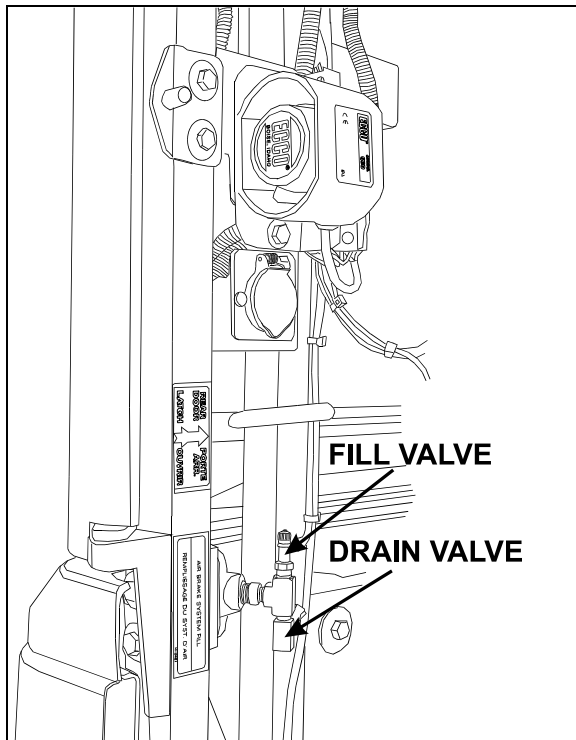

FIGURE 28: REAR VALVE LOCATION

12202

### 13.1.3 Secondary Air Tank

This tank is located in front wheelhousing, between air springs. The tank is installed vertically and is provided with a bottom drain valve (Fig. 27).

It is recommended to purge the tank by its bottom drain valve, every 12,500 miles (20 000 km) or once a year, whichever comes first.

### 13.1.4 Accessory Air Tank

The accessory air tank is installed next to the secondary air tank. The tank is installed vertically and is provided with a bottom drain valve (Fig. 27).

It is recommended to purge the tank by its bottom drain valve, every 12,500 miles (20 000 km) or once a year, whichever comes first.

A remote drain valve is located in front service compartment (Fig. 28) underneath the accessory air filter. Refer to Section 12, paragraph "4. Accessory Air Filter" of the maintenance manual for daily purge procedure.

### 13.1.2 Primary Air Tank

The primary air tank is located above R.H. wheel of drive axle.

This tank is provided with a bottom drain valve (Fig. 27). It is recommended to purge the primary air tank by its bottom drain valve every 12,500 miles (20 000 km) or once a year, whichever comes first.

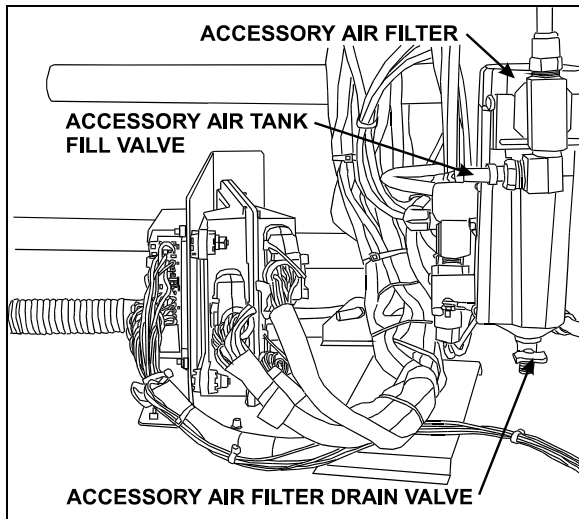

FIGURE 29: FRONT VALVE LOCATION 12201

### 13.1.5 Expansion Air Tank

Two expansion tanks are located in front wheelhousing. These air tanks are located behind secondary and accessory air tank. Also, six expansion tanks are located near rear air springs (Fig. 27). Expansion tanks are connected in series with air springs. Expansion tanks are used to lower the stiffness of the air spring. They are provided with a bottom drain valve.

It is recommended to purge them, with all other tanks, every 12,500 miles (20 000 km) or once a year, whichever comes first.

### 13.2 EMERGENCY FILL VALVES

The vehicle is equipped with two air system emergency fill valves to supplement the air system when air pressure is low and engine cannot be operated.

**The rear valve** is located in engine compartment and accessible from engine R.H. side door (Fig. 28).

<p><b>⚠ CAUTION ⚠</b></p>
<p><b>No other point should be used to supply air system. The maximum allowable air pressure is 125 psi (860 kPa).</b></p>

The front valve is located in the front service compartment close to accessory air filter (Fig. 29).

These two air valves are fitted with the same valve stems as standard tires, and can be filled by any standard external air supply line.

The rear valve will supply air for all systems (brakes, suspension and accessories) while the front valve will supply air for accessories only.

<p><b>⚠ CAUTION ⚠</b></p>
<p><b>Air filled through these two points will pass through the standard air filtering system provided by Prévost. Do not fill air through any other points.</b></p>

### 14. HUB UNIT AND SWIVEL ASSEMBLY

Refer to “DANA SPICER Service Manual General Information, Maintenance Manual Model NDS and Maintenance Manual NDS Axles” annexed to section 10 “Front Axle”.

**Section 16: COACHES EQUIPPED WITH INDEPENDENT FRONT SUSPENSION (IFS)**

**15. TORQUE TABLE**

<b>DESCRIPTION</b>	<b>QTY</b>	<b>REFERENCE</b>	<b>TORQUE (DRY) Lbf-ft / Nm</b>	
<i>Pitman Arm to Steering Gear Fixing Nut</i>	1	8	400-450	545-610
<i>Drag Link to Pitman Arm Stud Nut*</i>	1	---	160-215	220-290
<i>Drag Link to Bell crank Stud Nut*</i>	1	---	160-215	220-290
<i>Drag Link Socket End Clamp Bolt Nut</i>	2	---	40-60	55-80
<i>Relay Rod to Bell crank Stud Nut*</i>	1	---	160-215	220-290
<i>Relay Rod to Idler Arm Stud Nut*</i>	1	5	160-215	220-290
<i>Tie Rod to Bell crank Stud Nut*</i>	1	---	160-215	220-290
<i>Tie Rod to Idler Arm Stud Nut*</i>	1	5	160-215	220-290
<i>Tie Rod to Steering Arm Stud Nut*</i>	2	3	160-215	220-290
<i>Tie Rod End Clamp Bolt Nut</i>	4	3	40-60	55-80
<i>Steering Arm to Swivel Nut*</i>	4	---	190	260
<i>Torque Rod Stud Nut</i>	2	4	160-215	220-290
<i>Idler Arm and Bell Crank Cap Screws</i>	8	9	8	11
<i>Torque Rod Mounting Bracket Nut</i>	4	6	75-140	100-190
<i>Torque Rod Clamp Nut</i>	4	4	53-59	72-80
<i>Jacking Point Bracket Nut</i>	8	19	70-80	95-110
<i>Bushing Collar Nut</i>	8	20	72-88	98-120
<i>Sway Bar Link Upper Nuts (Rear Suspension)</i>	2	20	100-120	135-160
<i>Sway Bar Link Lower Nuts (Rear Suspension)</i>	2	20	70-80	95-110

<b>DESCRIPTION</b>	<b>QTY</b>	<b>REFERENCE</b>	<b>TORQUE (Lubricated) (Anti-Seize #680064) Lbf-ft / Nm</b>	
<i>Idler Arm and Bell Crank Mounting Bracket Nut</i>	8	5	90-120	120-160
<i>Shock Absorber Mounting Stud Nut</i>	2	19	40-50	55-70
<i>Shock Absorber Pin Nut</i>	2	19	70-85	95-115
<i>Air Spring Nut</i>	3	18	20-25	27-34
<i>Sway Bar Link Upper and Lower Nuts (Front Suspension)</i>	2	20	120-140	160-190
<i>Upper A-Arm Stud Nut*</i>	2	18	230-245	315-335
<i>Lower A-Arm Bracket Nut</i>	8	18	375-425	510-580

<b>DESCRIPTION</b>	<b>QTY</b>	<b>REFERENCE</b>	<b>TORQUE (Lubricated) (Loctite #242 Blue) Lbf-ft / Nm</b>	
<i>Shock Absorber Pin</i>	2	19	350-400	475-545
<i>Steering Gear to Mounting Bracket Bolt</i>	5	8	355	485

● Tighten nut to specified torque, then advance to next aligning cotter pin slot and install a new cotter pin.



**16. SPECIFICATIONS**

**Front Axle Air Springs**

Make ..... Goodyear Tire and Rubber  
Diameter ..... 14.5 inches  
Air Inlet..... 1/2"- 14 NPTF  
Supplier number ..... 1R14-167  
Prévost number ..... 630239

**Shock Absorbers**

Collapsed length ..... 350 mm  
Extended Length ..... 560 mm  
Supplier number ..... 481700000208  
Prévost number ..... 630251

**Height Control Valve**

Make ..... Barksdale  
Supplier number ..... 52321POAQ3-Q26 and 52321POAQ3-Q62  
Prévost number ..... 630156 and 630157

**Steering Gear Box**

Make ..... ZF-Servocom  
Supplier number ..... 8098-988-570  
Prévost number ..... 661045

**Steering Gear Box (Optional)**

Make ..... ZF-Servocomtronic  
Supplier number ..... 8098-988-571  
Prévost number ..... 661044

**Power Steering Hydraulic Pump**

Make ..... TRW  
Supplier number ..... PS251616L10200  
Prévost number ..... 661070

**Shim (Camber Adjustment)**

Thickness ..... 3.175 mm  
Prévost number ..... 160993  
Thickness ..... 6.35 mm  
Prévost number ..... 160992

**Sway bar bushing (Drive Axle)**

Make ..... Prévost  
Prévost number ..... 130953