

SECTION 03: FUEL SYSTEM

CONTENTS

1. FUEL SYSTEM DESCRIPTION	03-3
2. FUEL LINES AND FLEXIBLE HOSES.....	03-4
3. FUEL VALVES.....	03-4
4. FILTERS AND WATER SEPARATOR.....	03-4
4.1 FUEL FILTER/WATER SEPARATOR SERVICING.....	03-4
4.2 FUEL FILTER SERVICING (PRIMARY AND SECONDARY).....	03-5
4.3 DAVCO FUEL PRO 382.....	03-6
4.4 PREHEATER FUEL FILTER	03-7
5. FUEL TANK.....	03-7
5.1 TANK REMOVAL	03-7
5.2 TANK INSTALLATION	03-8
5.3 FUEL TANK VERIFICATION	03-9
5.4 POLYETHYLENE FUEL TANK REPAIR.....	03-9
6. PRIMING FUEL SYSTEM	03-9
7. FUEL PUMP INSTALLATION.....	03-10
8. FUEL OIL SPECIFICATIONS	03-10
9. AIR CLEANER (DRY TYPE)	03-10
9.1 PRE-CLEANER SERVICING.....	03-11
9.2 AIR CLEANER SERVICING	03-11
9.3 GENERAL RECOMMENDATIONS	03-11
9.4 AIR CLEANER RESTRICTION INDICATOR	03-11
10. FUEL COOLER	03-12
11. FUEL PEDAL	03-12
11.1 FUEL PEDAL ADJUSTMENT	03-12
11.2 POTENTIOMETER REPLACEMENT.....	03-12
12. SPECIFICATIONS.....	03-13

Section 03: FUEL SYSTEM

ILLUTRATIONS

FIGURE 1: FUEL SYSTEM SCHEMATIC	03-3
FIGURE 2: MANUAL SHUT-OFF VALVES.....	03-4
FIGURE 3: FUEL FILTER/WATER SEPARATOR	03-5
FIGURE 4: DAVCO FUEL PRO 382 INSTALLATION	03-6
FIGURE 5: DAVCO FUEL PRO 382 EXPLODED VIEW	03-7
FIGURE 6: FUEL TANK ARRANGEMENT	03-8
FIGURE 7: FUEL TANK INSTALLATION.....	03-8
FIGURE 8: FUEL TANK RETENTION	03-9
FIGURE 9: FUEL TANK REPAIR	03-9
FIGURE 10: PRIME PUMP SWITCH LOCATION	03-10
FIGURE 11: FUEL PUMP LOCATION.....	03-10
FIGURE 12: RESTRICTION INDICATOR.....	03-11
FIGURE 13: FUEL COOLER LOCATION	03-12
FIGURE 14: ELECTRONIC FOOT PEDAL ASSEMBLY	03-12

1. FUEL SYSTEM DESCRIPTION

Figure 1 shows a schematic of the fuel system. Fuel is drawn from the fuel tank through a manual shut-off valve, a primary fuel filter or a fuel filter/water separator (optional) before it enters the fuel pump. If the vehicle is equipped with the optional “Davco Fuel Pro 382”, it is designed to be the only fuel filter in the system, no secondary fuel filter is necessary. Leaving the pump under pressure, the fuel flows through a secondary fuel filter and a shut-off valve, then to the cylinder head. The fuel reaches the injectors in the cylinder head through passages within the head. Excess fuel exits at the rear of the head just above the inlet, through a restrictive return fitting which maintains fuel pressure in the system. Finally, the fuel flows through the check valve and the fuel cooler before it returns to the fuel tank. One preheater is available: 104 000 BTU. If the vehicle is equipped with the 104 000 BTU preheater, the fuel is drawn from the fuel tank through the fuel filter to the preheater. Excess fuel returns to the fuel tank.

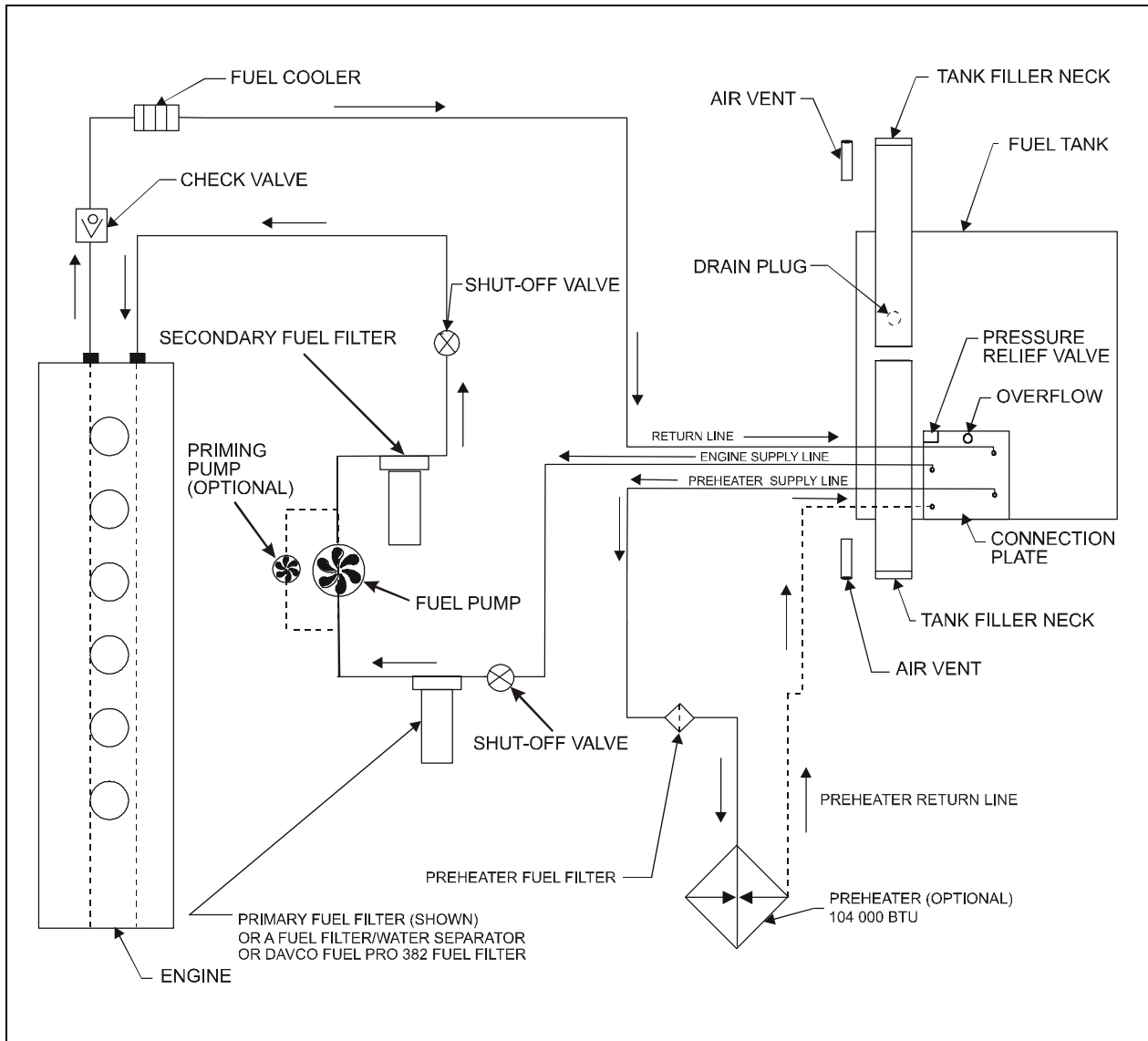

FIGURE 1: FUEL SYSTEM SCHEMATIC

03056

Section 03: FUEL SYSTEM

2. FUEL LINES AND FLEXIBLE HOSES

Make a visual check for fuel leaks at all engine-mounted fuel lines and connections and at the fuel tank suction and return lines. Since fuel tanks are susceptible to road hazards, leaks in this area may best be detected by checking for accumulation of fuel under the tank. Engine performance and auxiliary equipment is greatly dependent on the ability of flexible hoses to transfer lubricating oil, air, coolant and fuel oil. Diligent maintenance of hoses is an important step in ensuring efficient, economical and safe operation of engine and related equipment.

Check hoses daily as part of the pre-start-up inspection. Examine hoses for leaks and check all fittings, clamps and ties carefully. Make sure that the hoses are not resting on or touching shafts, couplings, and heated surfaces, including exhaust manifolds, any sharp edges or other obviously hazardous areas. Since all machinery vibrates and moves to a certain extent, clamps and ties can fatigue with age. To ensure continued proper support, inspect fasteners frequently and tighten or replace them as necessary. Refer to the schematic diagram of the fuel system (Fig. 1).

Caution: Oil level above the dipstick full mark or a decrease in lube oil consumption may indicate internal fuel leaks. Check oil level frequently.

3. FUEL VALVES

Manual shut-off valves on engine fuel-supply line are located on the R.H. side of engine compartment (Fig. 2). A manual shut-off valve is located at the inlet side of the primary fuel filter (fuel filter/water separator, if vehicle is so equipped) under the starter or at the inlet side of Davco Fuel Pro 282 fuel filter. Another manual shut-off valve is located at the outlet side of the secondary fuel filter, under the air compressor or at the outlet side of the pump in the case of Davco. No manual valve is required on preheater fuel-supply line, since the positive-displacement fuel pump (located close to the fuel tank) prevents fuel flow when not activated.

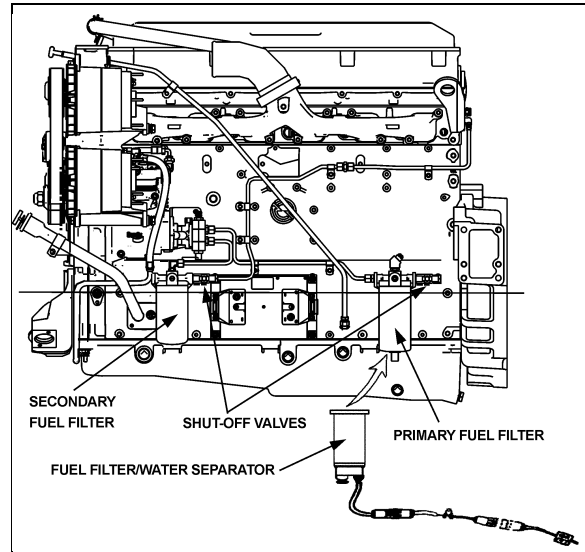

FIGURE 2: MANUAL SHUT-OFF VALVES

03060

4. FILTERS AND WATER SEPARATOR

The fuel system is equipped with primary and secondary fuel filters for additional protection of the injectors. A fuel-filter/water-separator may be installed in primary fuel-filter location, to prevent water infiltration in engine fuel system (Fig. 2). It should be drained periodically, or when the water separator telltale light on the dashboard illuminates. To drain, loosen positive seal drain valve below separator, and tighten after water has been flushed out.

Note: The operating conditions and cleanliness of type of fuel used determine the service intervals of the filter/water separator element and the secondary fuel filter cartridge.

Note: For more information on the Davco Fuel Pro 382 fuel filter, refer to paragraph 4.3.

4.1 FUEL FILTER/WATER SEPARATOR SERVICING

The fuel filter/water separator is located on the starter side of the engine, below the starter. The water separator must be drained periodically or when the telltale light on the dashboard illuminates (Fig. 3).

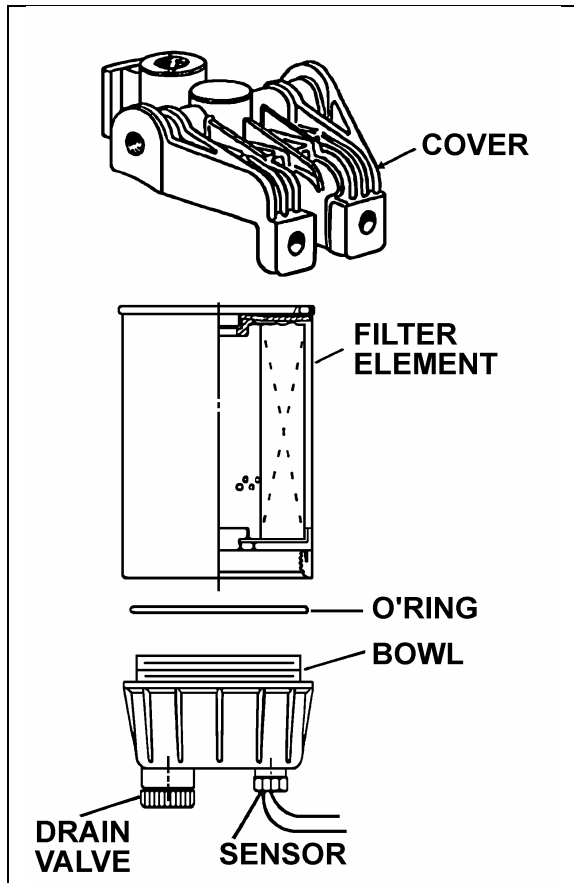

FIGURE 3: FUEL FILTER/WATER SEPARATOR 03025

Replace the water separator element as follows:

1. Drain the fuel filter/water separator as stated previously.
2. With engine "OFF" and engine fuel supply line valves closed; remove the filter element/bowl assembly from cover (for valve location, see "3. FUEL VALVES" in this section).
3. Separate bowl from filter element. Clean bowl and O-ring groove.

Note: Bowl is reusable, do not discard.

4. Lubricate O-ring with clean diesel fuel or motor oil and place it in bowl groove.
5. Screw new filter element onto bowl snugly by hand.

Caution: Do not use tool to tighten. Tighten by hand only.

6. Lubricate filter seal with clean diesel fuel or motor oil.
7. Fill filter element/bowl assembly with clean diesel fuel and attach onto cover. Handtighten an additional 1/3 to 1/2 turn after making full seal contact.
8. Open valves of the engine fuel supply line.
9. Run the engine and check for leaks.

Caution: If the water separator continuously requires draining, it is possible that water or sediment has accumulated in the fuel tank. To correct this situation, open the drain plug under the tank when the fuel gauge indicates tank is 1/4 full in order to drain any contaminant.

4.2 FUEL FILTER SERVICING (PRIMARY AND SECONDARY)

The primary and secondary fuel filters are located on the R.H. side of the engine. The primary filter is located below the starter, and the secondary fuel filter is below the air compressor. They are of a spin-on type and must be replaced every 12,500 miles (20 000 km) or once a year, whichever comes first. The primary fuel filter is equipped with a positive seal drain-valve to prevent water infiltration in engine fuel system. To drain, loosen positive seal drain-valve below filter and tighten after water has been flushed out.

A method of determining when filters are clogged to the extent that they should be changed is based on the fuel pressure at the cylinder head fuel inlet fitting and the inlet restriction at the fuel pump. In a clean system, the maximum pump-inlet restriction should not exceed 6 inches of mercury (20.3 kPa) and must not exceed 12 inches of mercury (41 kPa) with a dirty system.

At normal operating speeds and with the standard "0.080" restriction fittings, the fuel pressure at the cylinder head inlet is 50-75 psi (345-577 kPa). Change the fuel filters whenever the inlet restriction at the fuel pump reaches 12 inches of mercury (42 kPa) at normal operating speeds. Also, change whenever the fuel pressure at the cylinder head inlet fitting falls to the minimum fuel pressure given above.

Change the filter cartridge(s) as follows:

Section 03: FUEL SYSTEM

Note: Use a suitable band wrench or filter wrench, such as J22775, to remove the filters.

1. Stop engine, shut off the engine fuel supply line valves (for valve location, See "3. FUEL VALVES"). Unscrew and discard filters.
2. Fill new filter replacement cartridge(s) with clean fuel oil, about two thirds (2/3). Apply a thin coat of clean fuel oil on gasket.
3. Install new filters. Tighten until filter is snug against the gasket, with no side movement. Rotate an additional 1/2 turn by hand.
4. Open engine fuel supply line valves.

Caution: Mechanical tightening of the fuel filters is not recommended and may result in seal and/or cartridge damage. Tighten the fuel filters by hand only.

5. Start the engine and check for leaks.

Note: There is a fuel system shut-off valve on the discharge side of the secondary fuel filter. This check valve is designed to prevent fuel loss at time of filter replacement.

4.3 DAVCO FUEL PRO 382

The optional Fuel Pro 382 diesel fuel filter system consists of a permanently mounted fuel processor, a replaceable filter element, a filter element cover and collar and a fluid filter base assembly. This system is installed between the fuel tank and the fuel pump and is designed to be the only fuel filter in the fuel system. The filter serves as a water separator as well as a fuel filter (Fig. 4).

When new, the fuel level as seen through the clear cover in the 382 filter is very low. It rises as dirt collects on the filter from the bottom up. Restriction remains consistently low because fuel always flows through clean, new media. Change filter when fuel level reaches the top of filter element (Refer to figure 5).

Filter renewal:

1. Stop engine;
2. Drain fuel by opening the drain valve;

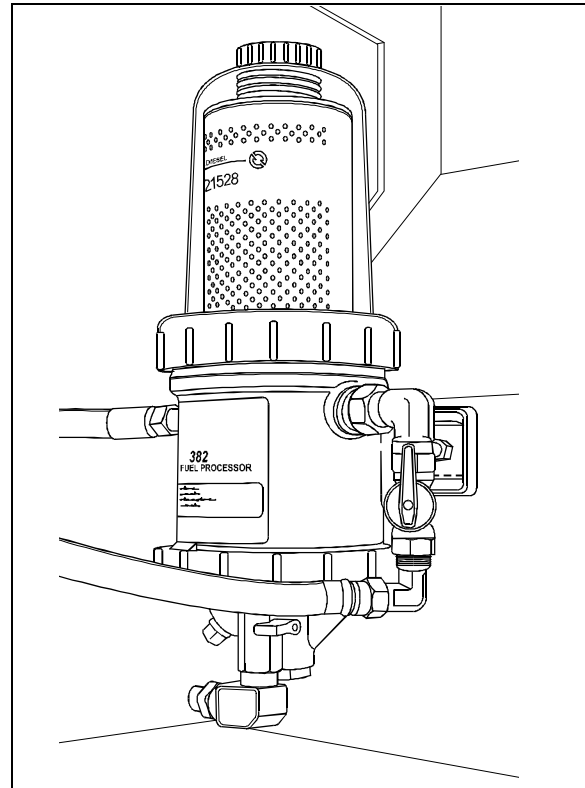

FIGURE 4: DAVCO FUEL PRO 382 INSTALLATION 03032

3. Untighten upper collar, remove cover;
4. Replace filter element;
5. Check O-Rings and components for wear;
6. Replace cover, hand tighten collar;
7. Pour fuel up to bottom of filter element through spin off cap located on top of cover.
8. Start engine, raise rpm for 2-3 minutes, hand tighten collar again.

Note: Fuel Pro 382 also accepts standard secondary spin-on fuel filters.

Environmental Notice: Diesel fuel is an environmentally hazardous product. Dispose in an environmentally friendly manner.

4.4 PREHEATER FUEL FILTER

The preheater fuel filter is located beside the preheater in the dedicated compartment above the rear wheelhousing, on the L.H. side of vehicle. Replace the filter every 50,000 miles (80 000 km) or once a year, whichever comes first.

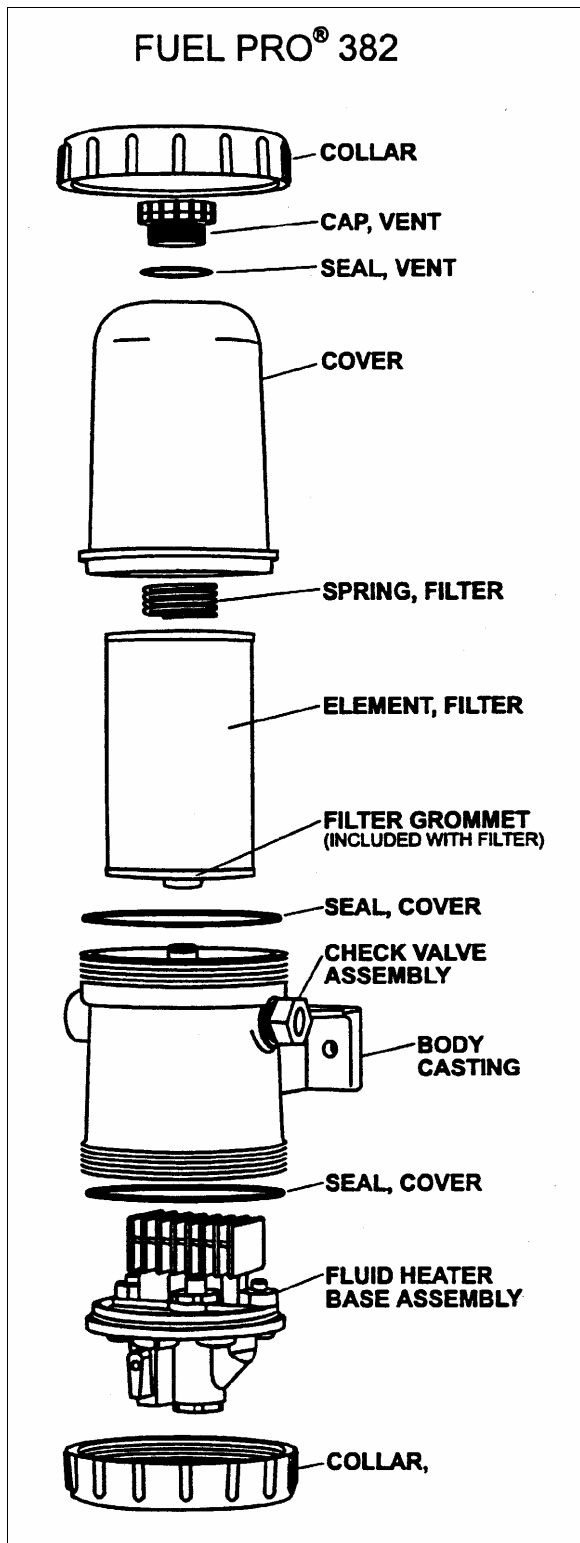

FIGURE 5: DAVCO FUEL PRO 382 EXPLODED VIEW 03034

5. FUEL TANK

All H3 series vehicles are equipped with a high-density cross-link polyethylene fuel tank with a capacity of 235 US gallons (890 liters). The tank is located just forward of the last baggage compartment, between the A/C condenser and evaporator.

Fuel filling access doors on both sides of vehicle provide direct access to filler necks; offering the added advantage of refueling from either side of vehicle.

A pressure relief valve on the fuel tank connection-panel relieves high-pressure buildup and an overflow tube allows offset air in the tank to escape during filling. For 95% of the tank volume, 5% of tank inside space is kept filled with air with no exit opening, allowing for a fuel expansion safety margin. A drain plug, accessible from under the vehicle, is fitted at the bottom of the tank.

5.1 TANK REMOVAL

Warning: Park vehicle safely, apply parking brake, stop engine and set battery master switch (es) to the OFF position before working on the vehicle.

Before working under an air-suspended vehicle, it is strongly recommended to support the body at the recommended jacking points.

Note: Before removal, the fuel tank should be completely drained by unscrewing the drain plug. Ensure that the container used has a capacity equal to the amount of fuel remaining in the tank.

Open the condenser door and remove the fuel tank access panel. The rear baggage compartment fuel tank access panel may also be removed to facilitate access to components.

1. Unscrew clamps retaining L.H. side filler tube to the fuel tank, then disconnect tube and remove it.
2. Unscrew clamps retaining R.H. side filler tube to fuel tank and filler neck. Disconnect tube and remove it.

Section 03: FUEL SYSTEM

3. If applicable, unscrew preheater supply line, preheater return line, auxiliary return line and/or auxiliary return line from fuel tank connection-panel.
4. Unscrew engine supply and return lines from fuel tank connection-panel, identify them for reinstallation.
5. Disconnect electrical wiring from tank on connection plate.

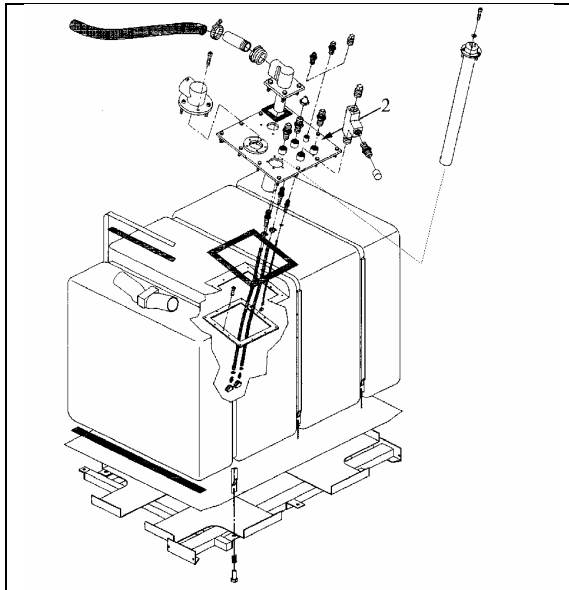

FIGURE 6: FUEL TANK ARRANGEMENT

03048

Warning: Before removing the bolts securing the tank support to the frame, make sure the tank is supported adequately. Failure to do so could result in injury as well as damage to the tank.

6. From under the vehicle, on R.H. side, unscrew the 4 bolts (2 in front, 2 in back) retaining the tank support to the frame.
 7. From under the vehicle, on the L.H. side, unscrew the 2 bolts (1 in front, 1 in back) retaining the tank support to the frame.
 8. Carefully remove tank from under the vehicle.
- ### 9. TANK INSTALLATION

Tank installation is the reverse of removal.

Note: Fastening of rubber flap must always be on top, in line with clamp screw (Fig.6).

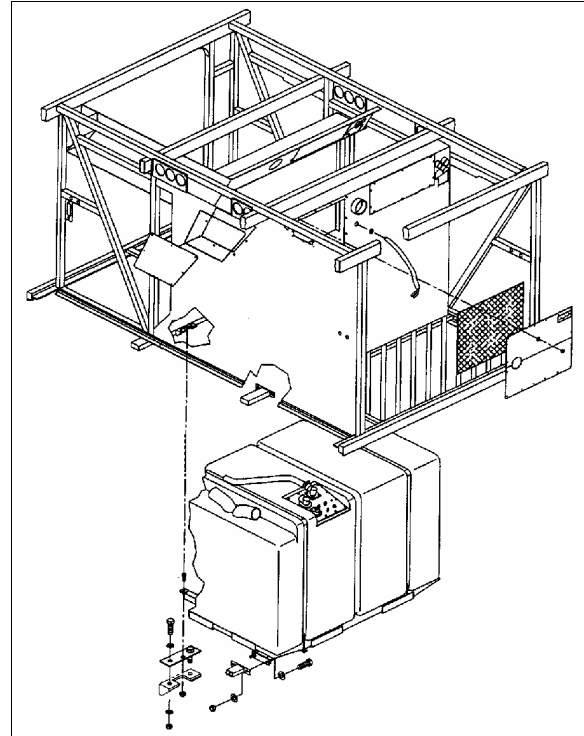

FIGURE 7: FUEL TANK INSTALLATION

03049

Note: Insert check valve assembly in right-side filler hose (Fig. 6), use hose clamp to fix it. Repeat with left side filler hose.

Note: When reinstalling lines, use Loctite 567 type thread sealant on line fittings.

Warning: For proper assembly, check connections and fasteners for tightness.

Note: Under vehicle, locate fuel tank and the four nuts retaining the two fuel-tank-retaining straps.

For each of the four nuts (Fig. 7):

1. Clean nuts and stud threads.
2. Apply a Loctite 242 type thread adhesive on stud threads.

When installing an old fuel tank, screw nuts so coils touch. When installing a new fuel tank, screw nuts so coils touch, then unscrew nuts 3.5 turns.

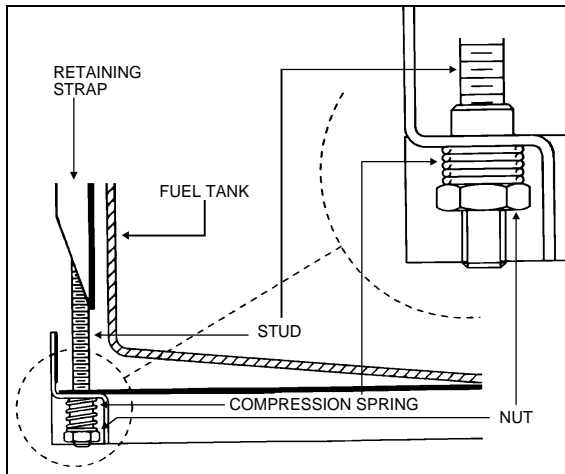

FIGURE 8: FUEL TANK RETENTION 03019

5.2 FUEL TANK VERIFICATION

Inspect fuel tank from under vehicle for leaks or fuel traces. If a leak is detected, repair immediately as per "Polyethylene Fuel Tank Repair" in this section.

Warning: Park vehicle safely, apply parking brake, stop engine and set battery master switch(es) to the OFF position before working on the vehicle.

Before working under an air-suspended vehicle, it is strongly recommended to support the body at the recommended jacking points.

5.3 POLYETHYLENE FUEL TANK REPAIR

Note: Fuel level must be lower than perforation to carry out this procedure.

Warning: Park vehicle safely, apply parking brake, stop engine and set battery master switches to the OFF position before working on the vehicle.

1. Locate perforation on fuel tank.
2. If necessary, remove fuel tank as per instructions in this section.
3. Drill perforation with a 23/64" bit. Make sure drill hole is perfectly round.
4. Insert a screw (Prevost #500196) and a washer (Prevost #5001244) into anchor nut (Prevost #500331).
5. Place assembly in drill hole. tighten screw by 10 complete turns. Refer to Fig. 9.

6. Apply sealant on head plug (Prevost #507300) and seal hole with the head plug.

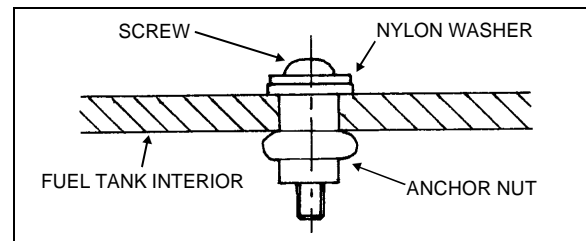

FIGURE 9: FUEL TANK REPAIR 03014

6. PRIMING FUEL SYSTEM

The problem with restarting a diesel engine that has run out of fuel, is that after the fuel is exhausted from the tank, it is pumped from the primary fuel filter or the fuel filter/water separator (if vehicle is so equipped), and sometimes partially removed from the secondary filter. This results in an insufficient fuel supply to sustain engine firing. The primary fuel filter or fuel filter/water separator and secondary filter must be free of air in order for the systems to provide adequate fuel for the injectors. When the engine runs out of fuel, the following operations must be performed before restarting:

Fill fuel tank with the recommended fuel oil. If only partial filling is possible, add a minimum of 10 gallons (38 liters) of fuel.

- If the vehicle is equipped with a Fuel Pro 382 fuel filter/water separation, pour fuel through spin on cap as per "4.3 DAVCO FUEL PRO 382".
- If the vehicle is equipped with the optional priming pump see Figure 10.

Press the priming switch, located under the rear start panel. Start the engine and check for leaks.

Section 03: FUEL SYSTEM

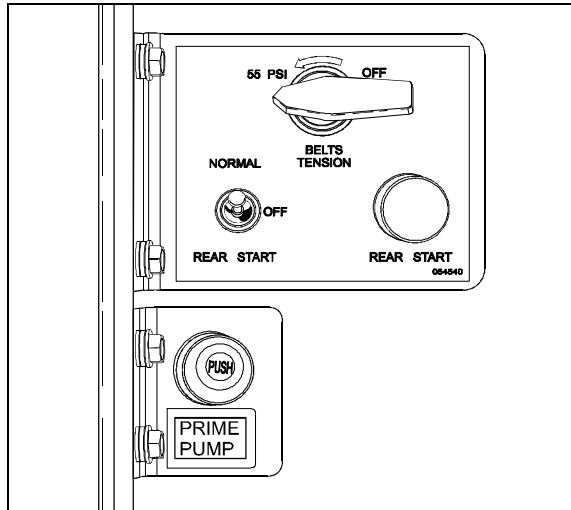

FIGURE 10: PRIME PUMP SWITCH LOCATION 03033

If the vehicle is not equipped with a priming pump:

1. Unscrew the cap on the priming valve located on the secondary filter;
2. Direct fuel under pressure 25 psi (172 kPa) to the priming valve using a quick coupling;
3. Start the engine and check for leaks.

7. FUEL PUMP INSTALLATION

The fuel pump is driven off the rear of the air compressor.

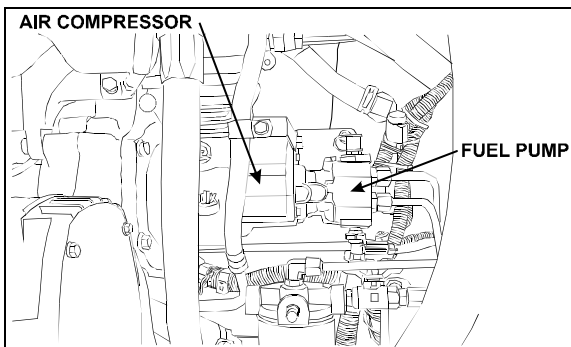

FIGURE 11: FUEL PUMP LOCATION 03026

1. If removed, install inlet and outlet fittings in the cover of the fuel pump.

Note: New fittings have sealant already applied. When reusing fittings, coat the threads lightly with Loctite Pipe Sealant, Detroit Diesel number J 26558-92, or equivalent, before installing. To prevent sealant from entering fuel

system, do not apply to the first two threads of the fitting. Do not use Teflon tape or paste on the fittings.

2. Install drive coupling in drive hub of the fuel pump. Install a new gasket to the mounting flange of the pump.
3. Index the drive coupling with the drive hub on the end of the air compressor crankshaft and align the pump mounting bolt holes with those in the air-compressor rear cover.

Note: When correctly positioned, the outlet fitting on the pump should be in approximately an 8 o'clock position when viewed from the rear, and the drain opening in the pump body facing down.

4. Seat the fuel pump squarely against the air compressor. Pilot the flange on the pump body, in the opening in the rear cover of the compressor. Install three mounting bolts and tighten them to 22-28 lbf-ft (30-38 Nm).
5. Connect the fuel inlet and outlet lines to the fuel pump and tighten.
6. Prime engine fuel system before starting engine to ensure pump seal lubrication and prompt engine starting.

8. FUEL OIL SPECIFICATIONS

The quality of fuel oil used for high-speed diesel engine operation is a very important factor in obtaining satisfactory engine performance, long engine life and acceptable exhaust emission levels. The fuel oil should meet ASTM designation D 975. Grade 1-D is recommended, however grade 2-D is acceptable.

Note: These fuel grades are very similar to grade DF-1 or DF-2 of Federal Specifications VV-F-800. For detailed fuel recommendations, refer to publication "Engine Requirements-Lubricating Oil, Fuel, and Filters" #7SE270 available from Detroit Diesel Distributors.

9. AIR CLEANER (DRY TYPE)

The vehicle is equipped with a dry-type replaceable element air cleaner, located in the engine compartment. Access the air cleaner through the engine R.H. side door. Engine air

enters the air cleaner through an intake duct on the R.H. side of the rear cap, next to the last window. It then flows through a pre-cleaner and finally through the air cleaner. The pre-cleaner removes dust and moisture by means of a discharge tube at the bottom of the element. It is in series with a replaceable impregnated paper filter element (air cleaner).

9.1 PRE-CLEANER SERVICING

The pre-cleaner is designed to be self-cleaning; however, it should be inspected and any accumulated foreign material removed during the periodic replacement of the impregnated paper filter element.

9.2 AIR CLEANER SERVICING

Stop the engine, open the R.H. side engine compartment door, and loosen the wing nut retaining the air cleaner element to the air cleaner. Remove the element by pulling on the handle in the center of the air cleaner element.

Install cleaner element as follows:

1. Inspect the gasket-sealing surface inside the air cleaner. It must be smooth, flat and clean;
2. Install the air cleaner element;
3. Make sure that the element seals securely;
4. Inspect element cover gasket and replace if necessary.

Whenever it becomes necessary to remove the air cleaner assembly (dry type) for maintenance or other repair in this area, great care should be taken when installing air cleaner assembly.

The pre-filter should be installed snugly in the air duct and clamped tightly to the air cleaner inlet to prevent any dust infiltration into the air cleaner.

9.3 GENERAL RECOMMENDATIONS

The following maintenance procedures will ensure efficient air cleaner operation:

1. Keep the air cleaner housing tight on the air intake pipe;
2. Make sure the correct filters are used for replacement;

3. Keep the air cleaner properly assembled so the joints are air-tight;
4. Immediately repair any damage to the air cleaner or related parts;
5. Inspect, clean or replace the air cleaner or elements as operating conditions warrant. Whenever an element has been removed from the air cleaner housing the inside surface of the housing must be cleaned with a soft clean cloth;
6. Periodically inspect the entire system. Dust-laden air can pass through an almost invisible crack or opening which may eventually cause damage to an engine;
7. Never operate the engine without an element in the air cleaner assembly;

Caution: Do not ignore the Warning given by the air restriction indicator. This could result in serious engine damage.

8. Store new elements in a closed area free from dust and possible damage.

9.4 AIR CLEANER RESTRICTION INDICATOR

A resettable restriction indicator may be installed on the engine air-intake duct, clearly visible from the rear engine compartment. The indicator monitors the vacuum level between the air filter and the engine. A red marker is displayed when the air filter is clogged and must be replaced. Reset by pressing on the indicator's extremity.

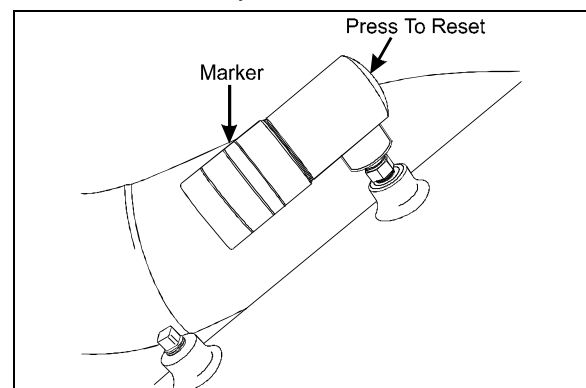

FIGURE 12: RESTRICTION INDICATOR

01052

Section 03: FUEL SYSTEM

10. FUEL COOLER

The fuel cooler serves to cool the surplus diesel fuel after it has exited the cylinder head, on its way back to the fuel tank. It is accessible through the engine radiator door and is located just in front of the coolant radiator (Fig.13).

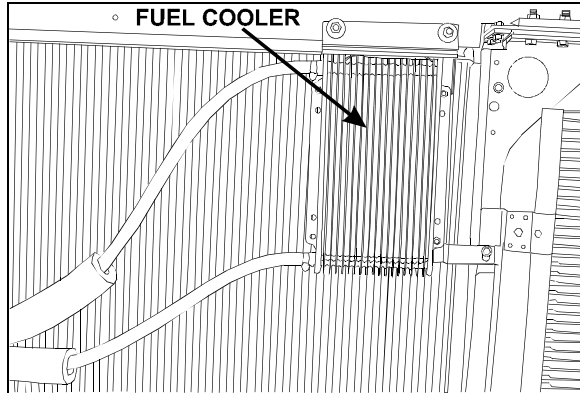

FIGURE 13: FUEL COOLER LOCATION

03047

11. FUEL PEDAL

The EFPA (Electronic Foot Pedal Assembly) connects the accelerator pedal to a potentiometer (a device that sends an electrical signal to the ECM, which varies in voltage, depending on how far down the pedal is depressed). The EFPA is installed in the space normally occupied by a mechanical foot pedal. It has maximum and minimum stops that are built into the unit during manufacturing.

11.1 FUEL PEDAL ADJUSTMENT

The EFPA contains a throttle position sensor that varies the electrical signal sent to the ECM. The sensor must be adjusted whenever an EFPA is serviced. In addition, the sensor should be adjusted any time codes 21 and 22 are flashed.

With the ignition "ON" and the proper diagnostic tool (DDR) (for information regarding the DDR, see "01 ENGINE" in this manual), check the throttle counts at idle and full throttle positions. Proper pedal output should be 20/30 counts at idle and 200/235 at full throttle. If adjustment is necessary, remove the potentiometer retaining screws and rotate the potentiometer clockwise to increase counts or counterclockwise to decrease. When correct output is confirmed, tighten retaining screws.

11.2 POTENTIOMETER REPLACEMENT

1. Disconnect cable harness connector.

Caution: Note the routing and clamping locations of the cable before disassembly. Proper cable routing and fastening is critical to the operation of this system. Marking the foot pedal assembly to record cable routing is recommended.

2. Loosen the two screws and remove potentiometer. Retain for re-assembly.
3. Discard potentiometer (Fig. 14).
4. Position new potentiometer. Press potentiometer onto the potentiometer shaft, matching cutouts in shaft to drive tangs of potentiometer. Apply hand pressure until potentiometer has bottomed out in housing. Reinstall screws (Fig. 14) and tighten just enough to secure potentiometer lightly. Tighten screws to 10 - 20 lbf-in (1.5 - .2 Nm).
5. Reconnect electronic foot pedal assembly's cable harness to the ECM connector. If potentiometer calibration is necessary (see "FUEL PEDAL ADJUSTMENT" in this section).

Caution: Make sure the cable harness is routed correctly, and securely installed so that it does not become pinched, stretched, or otherwise damaged during vehicle operation.

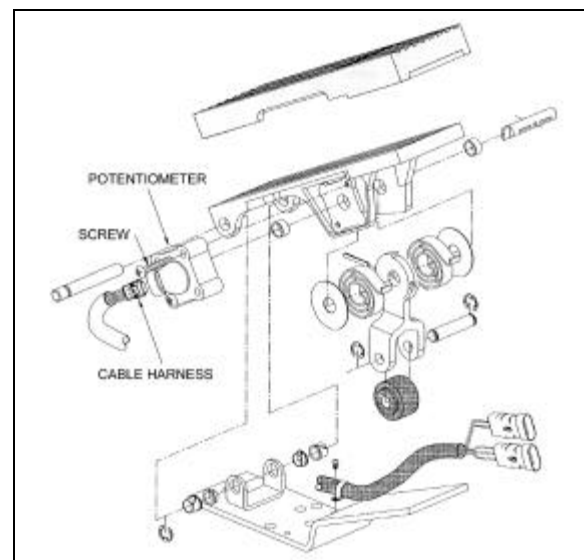

FIGURE 14: ELECTRONIC FOOT PEDAL ASSEMBLY

03035

12. SPECIFICATIONS

Davco FuelPro 382 Fuel Filter / Water Separator Element

Supplier number 23521528
 Prévost number 531437

Primary Fuel Filter / Water Separator (optional)

(May be used instead of primary filter (never use with a primary filter).

Make Racor
 Type Spin-on

ELEMENT

Supplier number S 3202
 Prévost number 531390

BOWL

Supplier number RK30051
 Prévost number 531389

DRAIN VALVE AND SEAL

Supplier number RK30058
 Prévost number 531397

O-RING

Supplier number RK30076
 Prévost number 531398

PROBE/WATER SENSOR

Supplier number RK21069
 Prévost number 531391

Primary Fuel Filter

Make AC
 Type Spin-on
 Filter No. T-915D
 Service Part No. 25014274
 Prévost number 510137

OR

Service Part No (Type with Water Separator) 23512317
 Prévost number 531407
 Element torque 1/2 turn after gasket contact

Section 03: FUEL SYSTEM

Secondary Fuel Filter

Make AC
Type Spin-on
Filter No. T-916D
Service Part No. 25014342
Prévost number 510128
Element torque 1/2 turn after gasket contact

Fuel tank

Capacity 235 US gal (890 liters)

Air Cleaner

Make Nelson
Prevost Number 530206
Service Part No 7182 8N
Supplier number (element cartridge)..... 70337N
Prévost number (element cartridge)..... 530197

Air Cleaner Restriction Indicator

Make Donaldson
Model RBX00-2220
Indicates at 20" (508 mm) of water
Prévost number 530161

Preheater Fuel Filter

Make Webasto
Supplier number 603.359
Prévost number 871037

Fuel Cooler

Make Berendsen
Supplier number DB-1240
Prévost number 950109