

## CONTENTS

<b>1. ENGINE</b> .....	<b>01-3</b>
<b>2. ENGINE-MOUNTED COMPONENTS</b> .....	<b>01-3</b>
2.1 ELECTRONIC CONTROL MODULE .....	01-4
2.2 N3 ELECTRONIC UNIT INJECTOR .....	01-4
2.3 VPOD .....	01-4
2.3.1 VPOD Removal.....	01-5
2.3.2 VPOD Installation.....	01-5
2.4 EGR HYDRAULIC VALVE.....	01-5
2.5 SYNCHRONOUS REFERENCE SENSOR .....	01-5
2.6 TIMING REFERENCE SENSOR.....	01-5
2.7 TURBO BOOST PRESSURE SENSOR .....	01-5
2.8 COOLANT TEMPERATURE SENSOR .....	01-6
2.9 FUEL TEMPERATURE SENSOR.....	01-6
2.10 AIR TEMPERATURE SENSOR .....	01-6
2.11 TURBO COMPRESSOR IN TEMPERATURE SENSOR.....	01-6
2.12 ABSOLUTE OIL PRESSURE SENSOR .....	01-6
2.13 OIL TEMPERATURE SENSOR .....	01-6
<b>3. ENGINE-RELATED COMPONENTS</b> .....	<b>01-7</b>
3.1 COOLANT LEVEL SYSTEM (CLS) .....	01-7
3.2 ELECTRONIC FOOT PEDAL ASSEMBLY (EFPA) & THROTTLE POSITION SENSOR.....	01-7
3.3 CRUISE CONTROL SWITCHES (CCS).....	01-7
3.4 DIAGNOSTIC SYSTEM ACCESSORIES (DSA).....	01-8
3.4.1 Check Engine Telltale Light .....	01-8
3.4.2 Stop Engine Telltale Light .....	01-8
3.4.3 Stop Engine Override Switch .....	01-8
3.4.4 Diagnostic Data Link (DDL) Connectors .....	01-8
<b>4. DDEC V DIAGNOSTIC CODES</b> .....	<b>01-8</b>
4.1 READING DIAGNOSTIC CODES - FLASHING LIGHT METHOD: .....	01-8
<b>5. ENGINE OIL LEVEL</b> .....	<b>01-19</b>
<b>6. ENGINE OIL AND FILTER CHANGE</b> .....	<b>01-20</b>
<b>7. RECOMMENDED ENGINE OIL TYPE</b> .....	<b>01-20</b>
<b>8. POWER PLANT ASSEMBLY REMOVAL</b> .....	<b>01-21</b>
<b>9. POWER PLANT ASSY. INSTALLATION</b> .....	<b>01-24</b>
<b>10. VALVE COVER REMOVAL</b> .....	<b>01-24</b>
10.1 XL2-45 COACHES AND MOTORHOMES .....	01-24
<b>11. JAKE BRAKE</b> .....	<b>01-25</b>
<b>12. ENGINE MOUNTS</b> .....	<b>01-25</b>
<b>13. ENGINE TROUBLESHOOTING GUIDE</b> .....	<b>01-27</b>
<b>14. SPECIFICATIONS</b> .....	<b>01-28</b>

**ILLUSTRATIONS**

FIGURE 1: DETROIT DIESEL SERIES 60 ENGINE (TYPICAL) ..... 01-3  
FIGURE 2: ELECTRONIC CONTROL MODULE (ECM) ..... 01-4  
FIGURE 3: UNIT INJECTOR CROSS SECTION ..... 01-4  
FIGURE 4: VPOD LOCATION ..... 01-4  
FIGURE 5: VPOD INSTALLATION ..... 01-5  
FIGURE 6: EGR VALVE & ACTUATOR ASSEMBLY ..... 01-5  
FIGURE 7: TURBO BOOST PRESSURE SENSOR ..... 01-6  
FIGURE 8: FUEL TEMPERATURE SENSOR ..... 01-6  
FIGURE 9: TURBO COMPRESSOR IN TEMPERATURE SENSOR LOCATION ..... 01-6  
FIGURE 10: ENGINE OPS ..... 01-6  
FIGURE 11: ELECTRONIC FOOT PEDAL ASSEMBLY ..... 01-7  
FIGURE 12: ENGINE OIL LEVEL DIPSTICK ..... 01-19  
FIGURE 13: OIL RESERVE TANK ..... 01-19  
FIGURE 14: ENGINE DRAIN PLUG AND OIL FILTERS ..... 01-20  
FIGURE 15: BELT TENSIONER VALVE ..... 01-21  
FIGURE 16: ELECTRIC FAN-CLUTCH CONNECTOR ..... 01-22  
FIGURE 17: ENGINE COMPARTMENT XL2 COACHES (TYPICAL) ..... 01-23  
FIGURE 18: ENGINE COMPARTMENT XL2 MTH (TYPICAL) ..... 01-23  
FIGURE 19: RUBBER DAMPER TOLERANCE ..... 01-24  
FIGURE 20: POWER PLANT CRADLE INSTALLATION ..... 01-26

## 1. ENGINE

This vehicle is powered by a 6-cylinder, four-cycle, Detroit Diesel series 60 engine equipped with an electronic control system (DDEC V).

Two engine displacements are used in the Series 60 engines: 12.7 and 14.0 liters. Summary information on the Electronic Control System is given in this section.

Complete maintenance and repair information on the engine will be found in the current DDEC V Service Manual. This maintenance manual covers engine accessories, controls and related components.

Procedures for engine removal and installation are given at the end of this section. The DDEC system is self-diagnostic. It can identify faulty components and other engine-related problems by providing the technician with a diagnostic code.

Refer to DDEC Troubleshooting Guide published by Detroit Diesel for more complete information on diagnosis of components and system problems.

DDEC V (Detroit Diesel Electronic Control) controls the timing and quantity of fuel injected by the electronic unit injectors (EUI). The system also monitors several engine functions using electrical sensors, which send electrical signals to the Electronic Control Module (ECM). The ECM computes the electrical signals and determines the correct fuel output and timing for optimum power, fuel economy and emissions. The ECM also has the ability to display warnings or shut down the engine completely (depending on option selection) in the event of damaging engine conditions, such as low oil pressure, low coolant level, or high oil temperature.

Two categories divide system components: engine-mounted components and engine-related components.

## 2. ENGINE-MOUNTED COMPONENTS

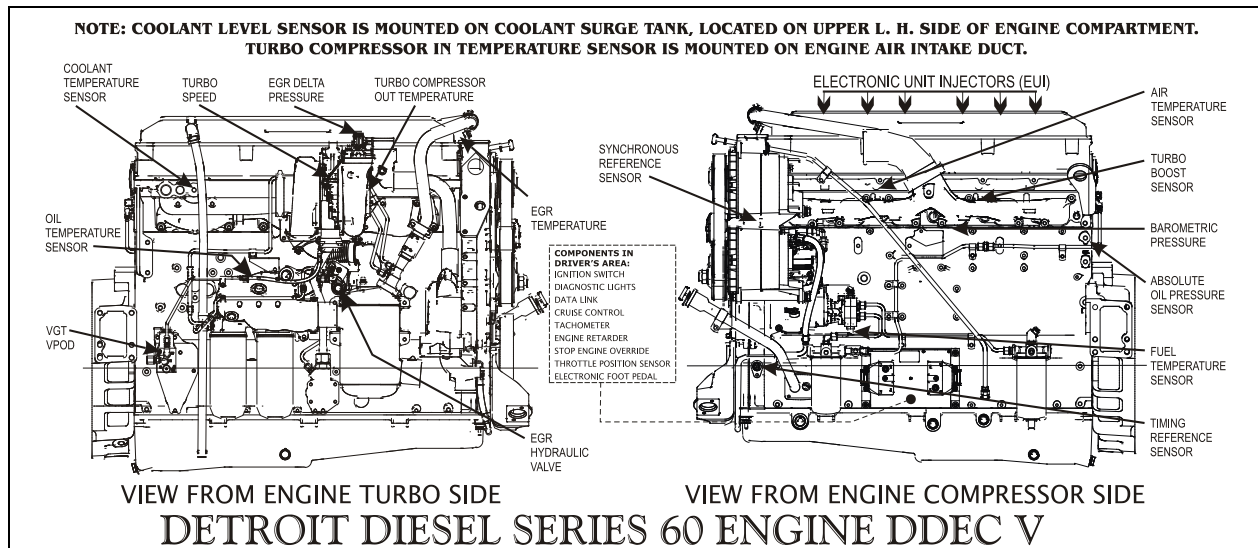

FIGURE 1: DETROIT DIESEL SERIES 60 ENGINE (TYPICAL)

01113

Engine-mounted components are as follows:

- Electronic Control Module
- Electronic Unit Injector
- Synchronous Reference Sensor
- Timing Reference Sensor
- Turbo Boost Pressure Sensor
- Coolant Temperature Sensor
- Fuel Temperature Sensor
- Air Temperature Sensor
- Absolute Oil Pressure Sensor
- Oil Temperature Sensor
- Barometric Pressure
- EGR Delta Pressure
- EGR Temperature
- Turbo Speed
- Turbo Compressor Out Temperature
- Turbo Compressor In Temperature

## Section 01: ENGINE

### 2.1 ELECTRONIC CONTROL MODULE

The Electronic Control Module is mounted, on the starter side of the engine (Fig. 2). Considered the "Brain" of the DDEC V system, it provides overall monitoring and control of the engine. It does so by comparing input data from the various sensors to a set of calibration data stored in the EEPROM (Electrically Erasable, Programmable, Read-Only Memory) within the Electronic Control Module. After comparing the input data with the calibration data, the ECM sends high-current command pulses to the Electronic Unit Injectors (EUI) to initiate fuel injection. The ECM also receives feedback regarding the start and end of injection for a given cylinder. The EEPROM within the Electronic Control Module is factory programmed by Detroit Diesel. Reprogramming must be done at a Detroit Diesel authorized service center. However, some changes may be performed to the cruise control and road speed limiter using a diagnostic data reader (see paragraph "DDEC V Diagnostic Codes" in this section).

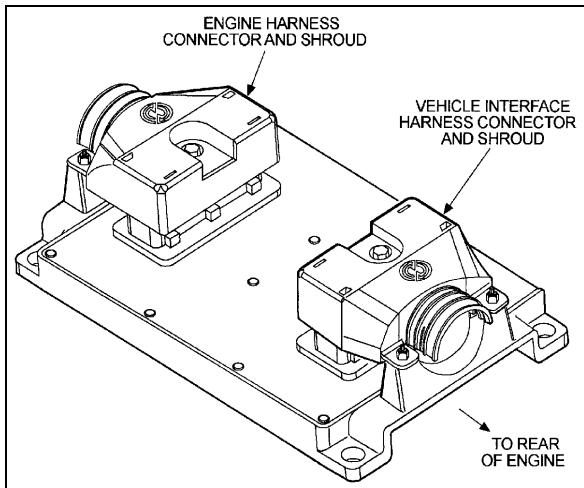

FIGURE 2: ELECTRONIC CONTROL MODULE (ECM)  
01145

### 2.2 N3 ELECTRONIC UNIT INJECTOR

The N3 Electronic Unit Injector (EUI) is a compact device that injects diesel fuel directly into the combustion chamber (Fig. 3). The amount of fuel injected and injection timing is determined by the Electronic Control Module (ECM). The ECM sends a command pulse, which activates the injector solenoid. The EUI performs four functions:

- Creates the high-fuel pressure required for efficient injection;
- Meters and injects the exact amount of fuel required to handle the load;

- Atomizes the fuel for mixing with the air in the combustion chamber;
- Permits continuous fuel flow for component cooling.

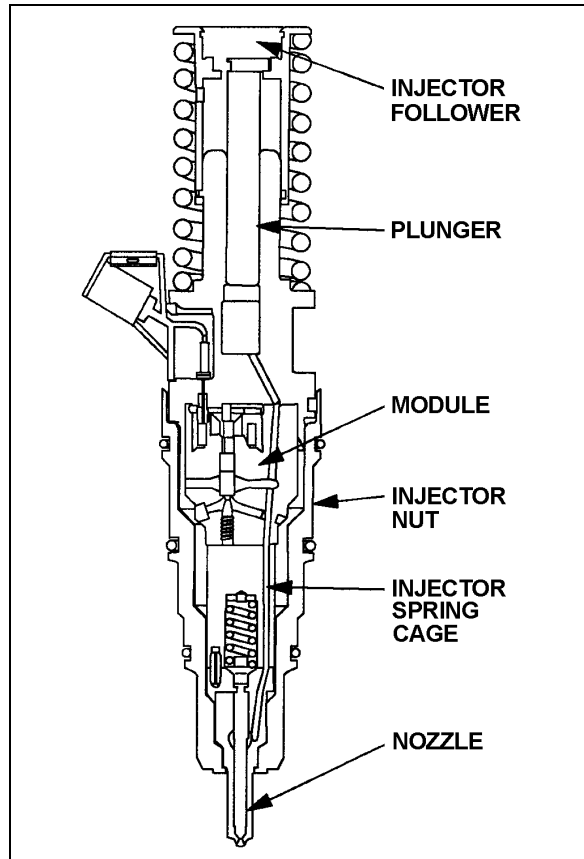

FIGURE 3: UNIT INJECTOR CROSS SECTION  
01146

### 2.3 VPOD

There is one air-operated Variable Pressure Output Device (VPOD) that controls the Variable Geometry Turbo (VGT). The location of the VPOD is to the left of the engine oil filters (Fig. 4). Pneumatic system supplies air pressure.

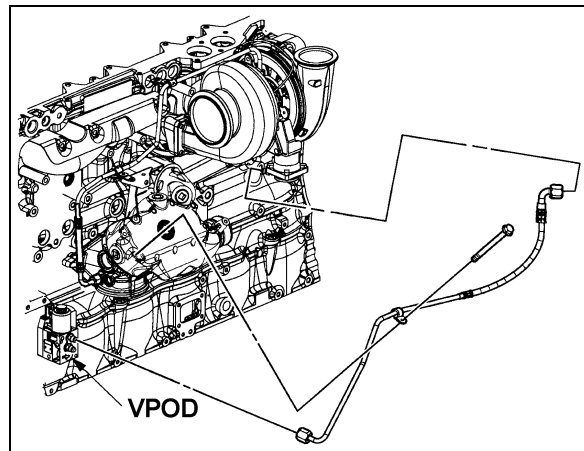

FIGURE 4: VPOD LOCATION  
01149

### 2.3.1 VPOD Removal

1. Remove airline from VPOD.
2. Unplug harness connection.
3. Remove two bolts and one stud holding VPOD assembly and bracket to engine block.

### 2.3.2 VPOD Installation

1. Align VPOD assembly and bracket to threaded holes in engine block; install two bolts and one stud. Torque the M10 bolts and M10 stud to 43-54 Lbf-ft (58-73 Nm). Torque the M8 bolt to 22-28 Lbf-ft (30-38 Nm).
2. Connect airline to VPOD and tighten.
3. Plug harness connection into VPOD assembly.

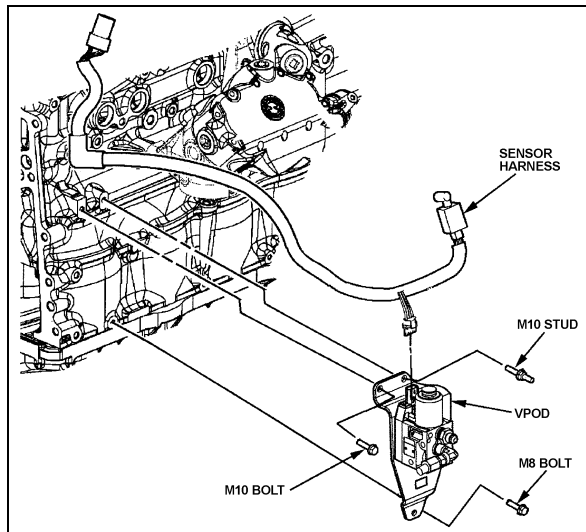

FIGURE 5: VPOD INSTALLATION

01147

#### **NOTE**

*VPOD assembly is not serviceable, remove and replace only.*

### 2.4 EGR HYDRAULIC VALVE

The hydraulic valve that controls the Exhaust Gas Recirculation (EGR) system is located on the same side as the VPOD but near the EGR cooler (Fig. 1 & 6).

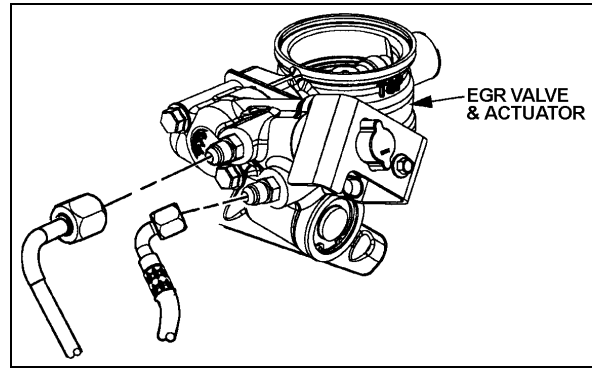

FIGURE 6: EGR VALVE & ACTUATOR ASSEMBLY 01148

### 2.5 SYNCHRONOUS REFERENCE SENSOR

The Synchronous Reference Sensor (SRS) is an electronic component, mounted to the rear of the gear case (Fig. 1). The SRS senses a raised metal pin on the rear of the camshaft idler gear and sends a signal to the ECM via a black connector wire. The SRS sensor extends through a hole in the gear case. It is positioned near the rear of the idler gear. A bolt, inserted through a hole in the SRS bracket, secures the SRS assembly to the gear case.

The idler gear pin passes by the SRS as piston number one crank pin reaches 45° before Top-Dead-Center. The ECM uses this information to determine engine speed.

The SRS is non-serviceable and must be replaced as a unit. No adjustment is required.

### 2.6 TIMING REFERENCE SENSOR

The Timing Reference Sensor (TRS) is an electronic component mounted on the left side of the gear case (right side of coach), near the crankshaft centerline. The TRS is positioned near the timing wheel gear teeth and extends through an opening in the gear case. A bolt, inserted through a hole in the TRS bracket, secures the TRS assembly to the gear case. The TRS connector is gray. The TRS sends a signal to the ECM, this signal is generated by a series of evenly spaced special teeth on the timing wheel. A tooth passes by the TRS as each cylinder crank pin reaches 10° before Top-Dead-Center.

The ECM uses these signals to determine injector solenoid operation time. The TRS is non-serviceable and must be replaced as a unit. No adjustment is required.

### 2.7 TURBO BOOST PRESSURE SENSOR

The Turbo Boost Pressure Sensor is located on the intake manifold. This device is a pressure

## Section 01: ENGINE

sensor that sends an electrical signal to the ECM. The ECM uses this information to compute the volume of air entering the engine. Turbo boost sensor information regulates fuel supply to control engine exhaust.

The turbo boost pressure sensor is non-serviceable and must be replaced as an assembly. No adjustment is required.

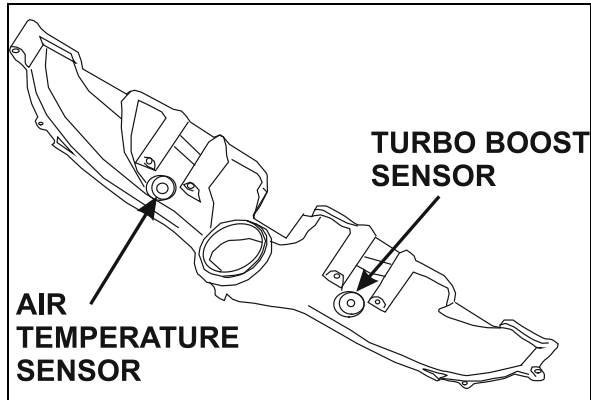

FIGURE 7: TURBO BOOST PRESSURE SENSOR 01023

### 2.8 COOLANT TEMPERATURE SENSOR

The coolant temperature sensor (Fig. 1) is mounted on the engine's radiator side (turbo side). The sensor helps protect the engine against overheating by sensing coolant temperature.

### 2.9 FUEL TEMPERATURE SENSOR

The Fuel Temperature Sensor (FTS) is installed underneath the fuel pump (Fig. 8).

The FTS sends an electrical signal to the ECM indicating fuel inlet temperature. The ECM uses this information to calculate fuel consumption.

The FTS is non-serviceable and must be replaced as a unit. No adjustment is required.

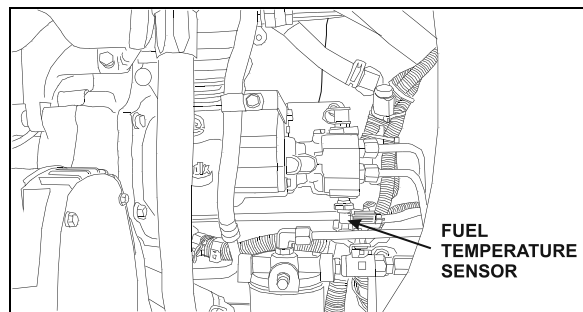

FIGURE 8: FUEL TEMPERATURE SENSOR 01024

### 2.10 AIR TEMPERATURE SENSOR

The Air Temperature Sensor (Fig. 1 & 7) located on the intake manifold provides input data to vary hot idle speed and injection timing. This helps to

improve cold starts and reduces white exhaust smoke.

### 2.11 TURBO COMPRESSOR IN TEMPERATURE SENSOR

The Turbo Compressor In Temperature Sensor is located on the engine air intake pipe (Fig. 9).

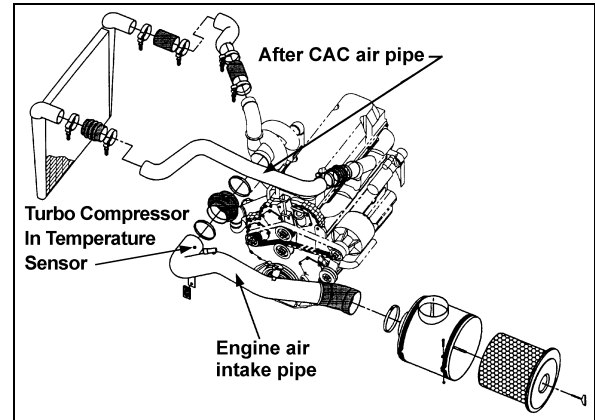

FIGURE 9: TURBO COMPRESSOR IN TEMPERATURE SENSOR LOCATION

### 2.12 ABSOLUTE OIL PRESSURE SENSOR

The Absolute Oil Pressure Sensor (OPS) is installed in the main engine-oil gallery. A typical location is the left rear corner of the cylinder block (Fig. 10). The OPS sends an electrical signal to the ECM indicating the engine oil pressure at any given speed. A low oil pressure signal exceeding seven seconds is used by the ECM to begin the stop engine or warning function. The OPS is non-serviceable and must be replaced as a unit. No adjustment is required.

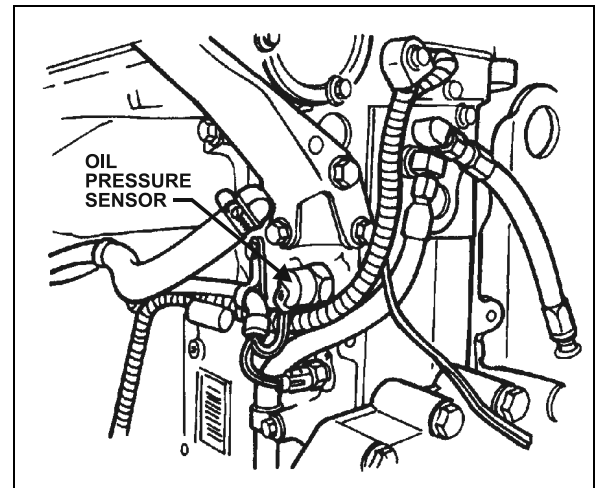

FIGURE 10: ENGINE OPS 01025B

### 2.13 OIL TEMPERATURE SENSOR

The Oil Temperature Sensor (OTS) is installed behind the engine oil filters manifold (Fig. 1). The

OTS sends an electrical signal to the ECM indicating engine oil temperature. The ECM uses this information to modify engine speed for better cold weather starts and faster warm-ups. Oil temperatures exceeding engine specifications for two seconds or more will illuminate the Check Engine Light.

The OTS is non-serviceable and must be replaced as a unit. No adjustment is required.

### 3. ENGINE-RELATED COMPONENTS

Engine-related components include:

- Coolant Level System (CLS)
- Electronic Foot Pedal Assembly (EFPA) and Throttle Position Sensor
- Cruise Control Switch (CCS)
- Diagnostic System Accessories (DSA)

#### 3.1 COOLANT LEVEL SYSTEM (CLS)

The coolant level system consists of a conductivity probe mounted in the surge tank and an electronic interface module located inside the rear junction box. Coolant level is determined by the change in impedance of the probe and its brass mount when immersed in coolant. The electronic device in the module conditions the signal to levels compatible with DDEC. A low coolant level will trigger the engine warning functions.

The probe and electronic interface module are non-serviceable items and should be replaced as units, if found defective. No adjustment is required.

#### 3.2 ELECTRONIC FOOT PEDAL ASSEMBLY (EFPA) & THROTTLE POSITION SENSOR

The Electronic Foot Pedal Assembly (EFPA) connects the accelerator pedal to a Throttle Position Sensor (TPS). The (TPS) is a device, which sends an electrical signal to the Electronic Control Module (ECM). The TPS signal varies in voltage depending on how far the pedal is depressed. The system is installed in the space normally occupied by a mechanical foot pedal. The (EFPA) has maximum and minimum stops that are built into the unit during manufacturing (Fig. 11). The (TPS) converts the operator's foot pedal input into a signal for the ECM. The (EFPA) is shown in Figure 11.

When installed by the equipment manufacturer, the TPS should not require adjustment. If the TPS is suspected of being misadjusted, confirm that the sensor is installed in accordance with the

manufacturer's specifications. It is recommended that the idle count be at 50 or higher with a full throttle count of up to 200.

The TPS is self-calibrating and therefore has no optimum closed throttle or wide open throttle count value. If the counts are within the 50 to 200 range, the sensor is properly set.

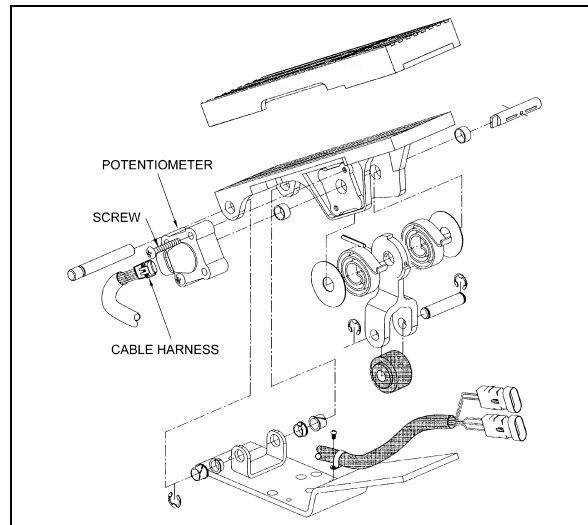

FIGURE 11: ELECTRONIC FOOT PEDAL ASSEMBLY<sup>03035</sup>

Monitor the (TPS) at the controls as you move it through its full stroke. Be sure there is no misalignment or obstruction preventing the smooth movement of the TPS through the full stroke. Using a diagnostic data reader, check that the idle and full throttle position counts do not fall within the error zones. The error zones occur when the idle position is less than 14 counts, or when the full throttle position is more than 233 counts. Should these conditions occur, the ECM will signal diagnostic codes of 21-12 for idle error and 21-23 for wide-open throttle error.

#### 3.3 CRUISE CONTROL SWITCHES (CCS)

The four cruise control switches are located in the driver's area on the L.H. side control panel.

1. **Cruise:** This is the main switch that actuates the ECM memory in order to use the speed-regulating mode.
2. **Set:** This switch is used to set the cruise control speed or to decrease the set speed by 2 MPH at each application.

#### **NOTE**

*Cruise control system will not accept speed settings, nor will the "Resume" switch operate below 20 mph (32 km/h) and the engine speed must be above 1100 RPM.*

## Section 01: ENGINE

3. **Resume:** Each time this switch is actuated, the speed will be increased by 2 mph (3,5 km/h). This switch allows the driver return to the last regulated speed following a brake or "DECEL" switch application.

### NOTE

*On-off switch must be in the "ON" position in order to return to the last regulated speed.*

4. **Decel:** Will cancel the cruise temporarily and let the vehicle coast. Set speed is still in memory for resume.

For additional information, see the "Operator's Manual" or the "Owner's Manual".

### 3.4 DIAGNOSTIC SYSTEM ACCESSORIES (DSA)

The DDEC V engine Diagnostic System Accessories includes the following:

- ◆ Check Engine telltale light;
- ◆ Stop Engine telltale light;
- ◆ Stop Engine Override switch;
- ◆ Diagnostic Data Link (DDL) connectors.

#### 3.4.1 Check Engine Telltale Light

The Check Engine telltale, mounted on the telltale light panel indicates that a problem has been detected and that a code has been stored in the ECM memory. This light also has a 5-second bulb check when the ignition is first turned on. The Check Engine telltale illuminates when the temperature at coolant sensors exceeds 217°F (103°C) and the temperature at oil sensors exceeds 260°F (127°C). When sensors reach those temperatures, DDEC starts to decrease engine power linearly.

#### 3.4.2 Stop Engine Telltale Light

This light, also mounted on the telltale light panel, illuminates to indicate that a major engine problem is occurring (with the exception of a 5-second bulb check when the ignition is first turned on). The Stop Engine Light illuminates when the temperature at coolant sensors exceeds 222°F (106°C) and the temperature at oil sensors exceeds 239°F (115°C). When sensors detect such temperatures, DDEC shuts the engine down after a 30 seconds grace period. This 30-second delay may be extended another 30 seconds (if absolutely necessary) by using the STOP ENGINE OVERRIDE switch.

### NOTE

*Once engine is stopped, it can not be restarted until the malfunction is corrected.*

#### 3.4.3 Stop Engine Override Switch

This switch, mounted on the dashboard, may be used to extend the 30-second delay period before engine shutdown when the Stop engine telltale light is illuminated. This switch can be repeatedly depressed in order to move the vehicle out of traffic.

### NOTE

*The stop engine override switch will be operative only if it has been depressed before the end of the 30 second delay period.*



**The OVERRIDE switch must be used only in emergency cases, such as to move the vehicle out of traffic. Excessive use of this switch can cause serious damage to the engine.**

This switch is also used for DDEC diagnostic code requests. Press this switch with the engine at idle or off but with the ignition in the "ON" position and active codes will be flashed on the CHECK ENGINE and STOP ENGINE telltale lights alternately. Refer to "DDEC V DIAGNOSTIC CODES" in this section for more information.

#### 3.4.4 Diagnostic Data Link (DDL) Connectors

A connector is mounted on the L.H. footwell wall. Another connector is located in the rear electric compartment. They allow the connection of the Diagnostic Data Reader (DDR) to read the codes or to access pertinent data on the condition of the engine. This enables a more complete analysis of any defect found in the DDEC system operation. For more information, see Detroit Diesel Troubleshooting Guide.

## 4. DDEC V DIAGNOSTIC CODES

### 4.1 READING DIAGNOSTIC CODES - FLASHING LIGHT METHOD:

DDEC V makes use of two types of codes: Active and inactive. The difference between the two types of codes is as follows:

**Active Codes:** Codes that are currently keeping the Check Engine or Stop Engine telltale



light illuminated. Active codes are flashed via the Stop Engine Light when checked with the stop-engine-override switch.

**Inactive Codes:** These are all the codes logged in the ECM (whether or not they are currently turning on the Stop or Check Engine Light). Inactive codes are flashed via the Check Engine telltale light when checked with the stop-engine-override switch. In most instances, only the DDR can provide the information necessary for a quick diagnosis of the problem.

If you just need to read out codes, however, and do not have a DDR available, the following procedure will let you read out codes. Make sure the rear-starting switch (located in the engine compartment) is in the normal position. With the ignition ON, the engine idling or engine shut-off, momentarily depress the Stop Engine Override switch. Active codes will be flashed on the stop engine telltale, followed by the inactive codes being flashed on the check-engine telltale panel. The cycle repeats itself until the operator depresses the stop engine override switch again.

A code "43" consists of four flashes, followed by a short pause, then three flashes in quick succession.

Refer to DDEC Troubleshooting Manual for more information and SAE codes.

**NOTE**

*Active codes are flashed in ascending numerical flash code order. Inactive codes are flashed in most recent to least recent order.*

**NOTE**

*Fault codes can only be cleared using the DDR.*

**NOTE**

*The listed codes may not be used in all applications. A default value in the normal operating range is used by the ECM to provide for engine operation if a sensor failure is present.*

DDEC V Code	PID	SID	FMI	DESCRIPTION
11	187	--	4	Variable Speed Governor Sensor Voltage Low
11	187	--	7	Variable Speed Governor Switch System Not Responding
12	187	--	3	Variable Speed Governor Sensor Voltage High
13	111	--	4	Coolant Level Sensor Input Voltage Low
13	111	--	6	Add Coolant Level Sensor Input Voltage Low
13		146	6	EGR Valve Current too High
14	52	--	3	Intercooler Coolant Temperature Sensor Input Voltage High
14	110	--	3	Coolant Temperature Sensor Input Voltage High
14	175	--	3	Oil Temperature Sensor Input Voltage High
15	52	--	4	Intercooler Coolant Temperature Sensor Input Voltage Low
15	110	--	4	Coolant Temperature Sensor Input Voltage Low
15	175	--	4	Oil Temperature Sensor Input Voltage Low
16	111	--	3	Coolant Level Sensor Input Voltage High
16	111	--	5	Add Coolant Level Sensor Input Voltage High
16		146	5	EGR Valve Current too Low
17	51	--	3	Throttle Plate Position Sensor Input Voltage High
17	72	--	3	Blower Bypass Position Input Voltage High
17	354	--	3	Relative Humidity Sensor Circuit Failed High

**Section 01: ENGINE**

<b>DDEC V Code</b>	<b>PID</b>	<b>SID</b>	<b>FMI</b>	<b>DESCRIPTION</b>
18	51	--	4	Throttle Plate Position Sensor Input Voltage Low
18	72	--	4	Blower Bypass Position Input Voltage Low
18	354	--	4	Relative Humidity Sensor Circuit Failed Low
21	91	--	3	Throttle Position Sensor Input Voltage High
22	91	--	4	Throttle Position Sensor Input Voltage Low
23	174	--	3	Fuel Temperature Sensor Input Voltage High
23	--	65	3	Oxygen Content Circuit Input Voltage High
24	174	--	4	Fuel Temperature Sensor Input Voltage Low
24	--	65	4	Oxygen Content Circuit Input Voltage Low
25	--	--	--	Reserved for "No Codes"
26	--	25	11	Aux. Shutdown #1 Active
26	--	61	11	Aux. Shutdown #2 Active
27	105	--	3	Intake Manifold Temperature Sensor Input Voltage High
27	171	--	3	Ambient Air Temperature Sensor Input Voltage High
27	172	--	3	Air Temperature Sensor Input Voltage High
28	105	--	4	Intake Manifold Temperature Sensor Input Voltage Low
28	171	--	4	Ambient Air Temperature Sensor Input Voltage Low
28	172	--	4	Air Temperature Sensor Input Voltage Low
29	351	—	4	TCI Temperature Circuit Failed Low
29	404	—	4	Turbo Compressor Temperature Out Sensor Input Voltage Low
31	--	51	3	Aux. Output #3 Open Circuit (High Side) – Pin E-49
31	--	51	4	Aux. Output #3 Short To Ground (High Side) – Pin E-49
31	--	51	7	Aux. Output #3 Mechanical System Fail - Pin E-49
31	--	52	3	Aux. Output #4 Open Circuit (High Side) - Pin E-48
31	--	52	4	Aux. Output #4 Short to Ground (High Side) - Pin E-48
31	--	52	7	Aux. Output #4 Mechanical System Failure - Pin E-48
31	--	260	3	Aux. Output #12 Open Circuit (High Side) - Pin E-46
31	--	260	4	Aux. Output #12 Short to Ground (High Side) - Pin E-46
31	--	260	7	Aux. Output #12 Mechanical System Failure - Pin E-46
31	--	261	3	Aux. Output #13 Open Circuit (High Side) - Pin E-47
31	--	261	4	Aux. Output #13 Short to Ground (High Side) - Pin E-47
31	--	261	7	Aux. Output #13 Mechanical System Failure - Pin E-47
31	--	262	3	Aux. Output #14 Open Circuit (High Side) - Pin E-50
31	--	262	4	Aux. Output #14 Short to Ground (High Side) - Pin E-50
31	--	262	7	Aux. Output #14 Mechanical System Failure - Pin E-50
31	--	263	3	Aux. Output #15 Open Circuit (High Side) - Pin E-51

**SECTION 01: ENGINE**

<b>DDEC V Code</b>	<b>PID</b>	<b>SID</b>	<b>FMI</b>	<b>DESCRIPTION</b>
31	--	263	4	Aux. Output #15 Short to Ground (High Side) - Pin E-51
31	--	263	7	Aux. Output #15 Mechanical System Failure - Pin E-51
31	--	264	3	Aux. Output #16 Open Circuit (High Side) - Pin E-52
31	--	264	4	Aux. Output #16 Short to Ground (High Side) - Pin E-52
31	--	264	7	Aux. Output #16 Mechanical System Failure - Pin E-52
31	--	265	3	Aux. Output #17 Open Circuit (High Side) - Pin E-53
31	--	265	4	Aux. Output #17 Short to Ground (High Side) - Pin E-53
31	--	265	7	Aux. Output #17 Mechanical System Failure - Pin E-53
32	--	238	3	RSL Short to Battery (+)
32	--	238	4	RSL Open Circuit
32	--	239	3	AWL Short to Battery (+)
32	--	239	4	AWL Open Circuit
33	102	--	3	Turbo Boost Pressure Sensor Input Voltage High
34	102	--	4	Turbo Boost Pressure Sensor Input Voltage Low
35	19	--	3	High Range Oil Pressure Sensor Input Voltage High
35	100	--	3	Oil Pressure Sensor Input Voltage High
36	19	--	4	High Range Oil Pressure Sensor Input Voltage Low
36	100	--	4	Oil Pressure Sensor Input Voltage Low
37	18	--	3	High Range Fuel Pressure Sensor Input Voltage High
37	94	--	3	Fuel Pressure Sensor Input Voltage High
37	95	--	3	Fuel Restriction Sensor Input Voltage High
38	18	--	4	High Range Fuel Pressure Sensor Input Voltage Low
38	94	--	4	Fuel Pressure Sensor Input Voltage Low
38	95	--	4	Fuel Restriction Sensor Input Voltage Low
39	—	146	2	EGR Leak- Boost Power
39	—	146	12	EGR Leak- Boost Jake
39	—	146	7	EGR Valve Not Responding
39	—	147	2	VNT Vanes Not Responding – Boost Power
39	—	147	11	VNT Vanes at Max – Jake
39	—	147	12	VNT Vanes Not Responding – Boost Jake
39	—	147	14	EGR Flow too low
39	—	147	7	VNT Vanes Not Responding – EGR
41	--	21	0	Too Many CKP Sensor (missing CMP Sensor)
42	--	21	1	Too few CKP Sensor (missing CKP Sensor)
43	111	--	1	Coolant Level Low
44	52	--	0	Intercooler Coolant Temperature High
44	105	--	0	Intake Manifold Temperature High
44	105	--	14	Engine Power Derate Due to Intake Manifold Temperature

**Section 01: ENGINE**

<b>DDEC V Code</b>	<b>PID</b>	<b>SID</b>	<b>FMI</b>	<b>DESCRIPTION</b>
44	110	--	0	Coolant Temperature High
44	110	--	14	Engine Power Derate Due to Coolant Temperature
44	172	--	0	Air Inlet Temperature High
44	175	--	0	Oil Temperature High
45	19	--	1	High Range Oil Pressure Low
45	100	--	1	Oil Pressure Low
46	168	--	1	ECM Battery Voltage Low
46	--	155		Injector V (reg) Voltage Failed Low
46	--	211	1	Sensor Supply Pins V-11/V-12 Low
46	--	212	4	Injector V (slope) Voltage Failed Low
46	--	214	1	RTC Backup Battery Voltage Low, Pin E-59
46	--	221	4	Injector I (pull-in) Voltage Failed Low
46	--	232	1	Sensor Supply Voltage Low, Pin E-12/E-26
47	18	--	0	High Range Fuel Pressure High
47	94	--	0	Fuel Pressure High
47	102	--	0	Turbo Boost Pressure High
47	102	--	14	Engine Power Derate Due to Turbo Boost Pressure
47	106	--	0	Air Inlet Pressure High
47	164	--	0	Injection Control Pressure High
48	18	--	1	High Range Fuel Pressure Low
48	94	--	1	Fuel Pressure Low
48	106	--	1	Air Inlet Pressure Low
48	164	--	1	Injection Control Pressure Low
48	351	--	1	TCI Temperature Low
48	404	--	1	Turbo Compressor Temperature Out Low
48	404	--	14	Engine Power Derate Due to Turbo Compressor Out Temperature
48	411	--	1	EGR Differential Pressure Low
48	412	--	1	EGR Temperature Low
49	351	--	0	TCI Temperature High
49	404	--	0	Turbo Compressor Out Temperature High
51	351	--	3	TCI Temperature Circuit Failed High
51	404	--	3	Turbo Compressor Out Temperature Sensor Input Voltage High
52	--	254	12	A/D Conversion Fail
53	--	253	2	Nonvolatile Checksum Incorrect
53	--	253	12	EEPROM Write Error
53	--	253	13	Out of Calibration
54	84	--	12	Vehicle Speed Sensor Fault

**SECTION 01: ENGINE**

<b>DDEC V Code</b>	<b>PID</b>	<b>SID</b>	<b>FMI</b>	<b>DESCRIPTION</b>
55	--	216	14	Other ECU Fault (This fault is logged in conjunction with another fault to indicate missing information from another ECU.)
55	--	231	12	J1939 Data Link Fault
55	--	248	8	Proprietary Data Link Fault (Master)
55	--	248	9	Proprietary Data Link Fault (Receiver)
56	--	250	12	J1587 Data Link Fault
57	--	249	12	J1922 Data Link Fault
58	92	--	0	Torque Overload
61	--	xxx	0	Injector xxx Response Time Long
62	--	26	3	Aux. Output #1 Short to Battery (+) – Pin V-4
62	--	26	4	Aux. Output #1 Open Circuit - Pin V-4
62	—	26	7	Aux. Output #1 Mechanical System Not Responding Properly - Pin V-4
62	--	40	3	Aux. Output #2 Short to Battery (+) - Pin V-5
62	--	40	4	Aux. Output #2 Open Circuit - Pin V-5
62	—	40	7	Aux. Output #2 Mechanical System Not Responding Properly – Pin V-5
62	--	53	3	Aux. Output #5 Short to Battery (+) - Pin V-6
62	--	53	4	Aux. Output #5 Open Circuit - Pin V-6
62	—	53	7	Aux. Output #5 Mechanical System Not Responding Properly - Pin V-6
62	--	54	3	Aux. Output #6 Short to Battery (+) - Pin V-7
62	--	54	4	Aux. Output #6 Open Circuit - Pin V-7
62	--	54	7	Aux. Output #6 Mechanical System Not Responding Properly - Pin V-7
62	--	55	3	Aux. Output #7 Short to Battery (+) - Pin V-40
62	--	55	4	Aux. Output #7 Open Circuit - Pin V-40
62	—	55	7	Aux. Output #7 Mechanical System Not Responding Properly - Pin V-40
62	--	56	3	Aux. Output #8 Short to Battery (+) – Pin V-53
62	--	56	4	Aux. Output #8 Open Circuit - Pin V-53
62	--	56	7	Aux. Output #8 Mechanical System Not Responding Properly - Pin V-53
62	--	257	3	Aux. Output #9 Open Circuit – Pin V-54
62	--	257	4	Aux. Output #9 Short to Gnd – Pin V-54
62	--	257	7	Aux. Output #9 Mechanical System Failure – Pin V-54
62	--	258	3	Aux. Output #10 Open Circuit – Pin V-55
62	--	258	4	Aux. Output #10 Short to Gnd – Pin V-55
62	--	258	7	Aux. Output #10 Mechanical System Failure – Pin V-55
62	--	259	3	Aux. Output #11 Open Circuit – Pin E-13

**Section 01: ENGINE**

<b>DDEC V Code</b>	<b>PID</b>	<b>SID</b>	<b>FMI</b>	<b>DESCRIPTION</b>
62	--	259	4	Aux. Output #11 Short to Gnd – Pin E-13
62	--	259	7	Aux. Output #11 Mechanical System Failure – Pin E-13
63	--	57	0	PWM #1 Above Normal Range, Pin V-53
63	--	57	1	PWM #1 Below Normal Range, Pin V-53
63	--	57	3	PWM #1 Short to Battery (+), Pin V-53
63	--	57	4	PWM #1 Open Circuit, Pin V-53
63	--	58	0	PWM #2 Above Normal Range, Pin V-46
63	--	58	1	PWM #2 Below Normal Range, Pin V-46
63	--	58	3	PWM #2 Short to Battery (+), Pin V-46
63	--	58	4	PWM #2 Open Circuit, Pin V-46
63	--	59	0	PWM #3 Above Normal Range, Pin E-3
63	--	59	1	PWM #3 Below Normal Range, Pin E-3
63	--	59	3	PWM #3 Short to Battery (+), Pin E-3
63	--	59	4	PWM #3 Open Circuit, Pin E-3
63	--	60	0	PWM #4 Above Normal Range, Pin E-4
63	--	60	1	PWM #4 Below Normal Range, Pin E-4
63	--	60	3	PWM #4 Short to Battery (+), Pin E-4
63	--	60	4	PWM #4 Open Circuit, Pin E-4
63	--	267	0	PWM #5 Above Normal Range - Pin E-8
63	--	267	1	PWM #5 Below Normal Range - Pin E-8
63	--	267	3	PWM #5 Short to Battery (+) - Pin E-8
63	--	267	4	PWM #5 Open Circuit - Pin E-8
63	--	267	7	PWM #5 Mechanical System Failed - Pin E-8
63	--	268	0	PWM #6 Above Normal Range - Pin E-11
63	--	268	1	PWM #6 Below Normal Range - Pin E-11
63	--	268	3	PWM #6 Short to Battery (+) - Pin E-11
63	--	268	4	PWM #6 Open Circuit - Pin E-11
63	--	268	7	PWM #6 Mechanical System Failed - Pin E-11
64	103	--	0	Turbo Overspeed
64	103	--	8	Turbo Speed Sensor Input Failure – Abnormal Period
65	51	--	0	Throttle Plate Position Above Normal Range
65	51	--	1	Throttle Plate Position Below Normal Range
65	51	--	2	Throttle Plate Position Erratic
65	51	--	7	Throttle Plate Not Responding
65	107	--	3	Air Filter Restriction Sensor Voltage High
65	107	--	4	Air Filter Restriction Sensor Voltage Low
66	99	--	3	Oil Filter Restriction Sensor Voltage High
66	99	--	4	Oil Filter Restriction Sensor Voltage Low

**SECTION 01: ENGINE**

<b>DDEC V Code</b>	<b>PID</b>	<b>SID</b>	<b>FMI</b>	<b>DESCRIPTION</b>
66	--	76	0	Engine Knock Level Above Normal Range
66	--	76	3	Engine Knock Level Sensor Input Voltage High
66	--	76	4	Engine Knock Level Sensor Input Voltage Low
66	--	76	7	Engine Knock Level Sensor Not Responding
67	20	--	3	High Range Coolant Pressure Sensor Input Voltage High
67	20	--	4	High Range Coolant Pressure Sensor Input Voltage Low
67	106	--	3	Air Inlet Pressure Sensor Input Voltage High
67	106	--	4	Air Inlet Pressure Sensor Input Voltage Low
67	109	--	3	Coolant Pressure Sensor Input Voltage High
67	109	--	4	Coolant Pressure Sensor Input Voltage Low
68	--	230	5	TPS Idle Validation Circuit Fault (open circuit)
68	--	230	6	TPS Idle Validation Circuit Fault (short to ground)
71	--	xxx	1	Injector xxx Response Time Short
72	84	--	0	Vehicle Overspeed
72	84	--	11	Vehicle Overspeed (Absolute)
72	--	65	0	Oxygen Content Too High
72	--	65	1	Oxygen Content Too Low
73	107	--	0	Air Filter Restriction High
73	--	77	0	Gas Valve Position Above Normal Range
73	--	77	1	Gas Valve Position Below Normal Range
73	--	77	3	Gas Valve Position Input Voltage High
73	--	77	4	Gas Valve Position Input Voltage Low
73	--	77	7	Gas Metering Valve Not Responding
74	70	--	4	Optimized Idle Safety Loop Short to Ground
74	99	--	0	Oil Filter Restriction High
75	168	--	0	ECM Battery Voltage High
75	--	155	3	Injector V (reg) Voltage Failed High
75	--	211	0	Sensor Supply Pins V-11/V-12 Voltage High
75	--	212	3	Injector V (slope) Voltage Failed High
75	--	221	3	Injector V (pull-in) Voltage Failed High
75	--	214	0	RTC Backup Battery Voltage High
75	--	232	0	Sensor Supply Voltage High, Pin E-26
76	121	--	0	Engine Overspeed With Engine Brake
77	19	—	0	High Range Oil Pressure High
77	20	—	0	High Range Coolant Pressure High
77	21	—	0	ECU Temperature Above Range
77	21	—	1	ECU Temperature Below Range
77	21	—	3	ECU Temperature Above Failed High

**Section 01: ENGINE**

<b>DDEC V Code</b>	<b>PID</b>	<b>SID</b>	<b>FMI</b>	<b>DESCRIPTION</b>
77	21	—	4	ECU Temperature Above Failed Low
77	72	—	0	Blower Bypass Door Position High
77	72	—	1	Blower Bypass Door Position Low
77	73	—	1	Fire Pump Pressure Low
77	81	—	0	Exhaust Back Pressure High
77	81	—	1	Exhaust Back Pressure Low
77	81	—	3	Exhaust Back Pressure Sensor Voltage High
77	81	—	4	Exhaust Back Pressure Sensor Voltage Low
77	81	—	12	Exhaust Back Pressure at Rampdown Threshold
77	95	—	1	Fuel Filter Differential Pressure Low
77	99	—	1	Oil Filter Differential Pressure Low
77	100	—	0	Engine Oil Pressure High
77	102	—	1	Turbo Boost Pressure Low
77	105	—	1	Inlet Manifold Temperature Low
77	107	—	1	Air filter Restriction Pressure Low
77	108	—	0	Barometric Pressure High
77	108	—	1	Barometric Pressure Low
77	109	—	0	Coolant Pressure High
77	110	—	1	Coolant Temperature Low
77	111	—	0	Coolant Level High
77	171	—	0	Ambient Air Temperature High
77	171	—	1	Ambient Air Temperature Low
77	172	—	1	Air Inlet Temperature Low
77	174	—	0	Fuel Temperature High
77	174	—	1	Fuel Temperature Low
77	175	—	1	Engine Oil Temperature Low
77	222	—	14	Anti-Theft Fault Present
77	251	—	10	Clock Module Abnormal Rate of Change
77	251	—	13	Clock Module Failure
77	252	—	10	Clock Module Abnormal Rate of Change
77	252	—	13	Clock Module Failure
77	354	—	0	Relative Humidity Above Range
77	354	—	1	Relative Humidity Below Range
77	446	—	0	Cylinder Head Temperature Above Range
77	—	151	11	Service Now Lamp Fault Expiration
78	86	--	14	Cruise Control/Adaptive Cruise Control Fault
81	98	--	3	Oil Level Sensor Input Voltage High
81	101	--	3	Crankcase Pressure Sensor Input Voltage High



**SECTION 01: ENGINE**

<b>DDEC V Code</b>	<b>PID</b>	<b>SID</b>	<b>FMI</b>	<b>DESCRIPTION</b>
81	153	--	3	Extended Crankcase Pressure Input Voltage High
81	164	--	3	Injection Control Pressure Sensor Input Voltage High
81	173	--	3	Exhaust Temperature Sensor Input Voltage High
81	411	—	3	EGR Delta Pressure Sensor Circuit Failed High
81	412	—	3	EGR Temperature Circuit Failed High
81	412	—	9	EGR Temperature Network Sensor Not Responding
81		20	3	Timing Actuator Failed High
81		20	4	Timing Actuator Failed Low
81	--	129	3	Exhaust Port Temperature #1 Sensor Voltage High
81	--	130	3	Exhaust Port Temperature #2 Sensor Voltage High
81	--	131	3	Exhaust Port Temperature #3 Sensor Voltage High
81	--	132	3	Exhaust Port Temperature #4 Sensor Voltage High
81	--	133	3	Exhaust Port Temperature #5 Sensor Voltage High
81	--	134	3	Exhaust Port Temperature #6 Sensor Voltage High
81	--	135	3	Exhaust Port Temperature #7 Sensor Voltage High
81	--	136	3	Exhaust Port Temperature #8 Sensor Voltage High
81	--	137	3	Exhaust Port Temperature #9 Sensor Voltage High
81	--	138	3	Exhaust Port Temperature #10 Sensor Voltage High
81	--	139	3	Exhaust Port Temperature #11 Sensor Voltage High
81	--	140	3	Exhaust Port Temperature #12 Sensor Voltage High
81	--	141	3	Exhaust Port Temperature #13 Sensor Voltage High
81	--	142	3	Exhaust Port Temperature #14 Sensor Voltage High
81	--	143	3	Exhaust Port Temperature #15 Sensor Voltage High
81	--	144	3	Exhaust Port Temperature #16 Sensor Voltage High
81	—	277	9	EGR Rate Sensor not Responding
81	—	277	12	EGR Rate Sensor Failed
82	98	--	4	Oil Level Sensor Input Voltage Low
82	101	--	4	Crankcase Pressure Sensor Input Voltage Low
82	153	--	4	Extended Crankcase Pressure Input Voltage Low
82	164	--	4	Injection Control Pressure Sensor Input Voltage Low
82	173	--	4	Exhaust Temperature Sensor Input Voltage Low
82	411	—	4	EGR Delta Pressure Sensor Circuit Failed Low
82	412	—	4	EGR Temperature Circuit Failed Low
82	412	—	12	EGR Temperature Network Sensor Failed
82	--	129	4	Exhaust Port Temperature #1 Sensor Voltage Low
82	--	130	4	Exhaust Port Temperature #2 Sensor Voltage Low
82	--	131	4	Exhaust Port Temperature #3 Sensor Voltage Low
82	--	132	4	Exhaust Port Temperature #4 Sensor Voltage Low

**Section 01: ENGINE**

<b>DDEC V Code</b>	<b>PID</b>	<b>SID</b>	<b>FMI</b>	<b>DESCRIPTION</b>
82	--	133	4	Exhaust Port Temperature #5 Sensor Voltage Low
82	--	134	4	Exhaust Port Temperature #6 Sensor Voltage Low
82	--	135	4	Exhaust Port Temperature #7 Sensor Voltage Low
82	--	136	4	Exhaust Port Temperature #8 Sensor Voltage Low
82	--	137	4	Exhaust Port Temperature #9 Sensor Voltage Low
82	--	138	4	Exhaust Port Temperature #10 Sensor Voltage Low
82	--	139	4	Exhaust Port Temperature #11 Sensor Voltage Low
82	--	140	4	Exhaust Port Temperature #12 Sensor Voltage Low
82	--	141	4	Exhaust Port Temperature #13 Sensor Voltage Low
82	--	142	4	Exhaust Port Temperature #14 Sensor Voltage Low
82	--	143	4	Exhaust Port Temperature #15 Sensor Voltage Low
82	--	144	4	Exhaust Port Temperature #16 Sensor Voltage Low
82	—	277	12	EGR Rate Sensor Failed
82	412	—	9	EGR Temperature Smart Sensor not Responding
82	412	—	12	EGR Temperature Smart Sensor failed
83	73	—	0	Pump Pressure High
83	98	--	0	Oil Level High
83	101	--	0	Crankcase Pressure High
83	153	--	0	Extended Crankcase Pressure High
83	173	--	0	Exhaust Temperature High
83	411	—	0	EGR Delta Pressure High
83	412	—	0	EGR Temperature High
83	--	129	0	Exhaust Port Temperature #1 High
83	--	130	0	Exhaust Port Temperature #2 High
83	--	131	0	Exhaust Port Temperature #3 High
83	--	132	0	Exhaust Port Temperature #4 High
83	--	133	0	Exhaust Port Temperature #5 High
83	--	134	0	Exhaust Port Temperature #6 High
83	--	135	0	Exhaust Port Temperature #7 High
83	--	136	0	Exhaust Port Temperature #8 High
83	--	137	0	Exhaust Port Temperature #9 High
83	--	138	0	Exhaust Port Temperature #10 High
83	--	139	0	Exhaust Port Temperature #11 High
83	--	140	0	Exhaust Port Temperature #12 High
83	--	141	0	Exhaust Port Temperature #13 High
83	--	142	0	Exhaust Port Temperature #14 High
83	--	143	0	Exhaust Port Temperature #15 High
83	--	144	0	Exhaust Port Temperature #16 High

DDEC V Code	PID	SID	FMI	DESCRIPTION
84	98	--	1	Oil Level Low
84	101	--	1	Crankcase Pressure Low
84	153	--	1	Extended Crankcase Pressure Low
85	190	--	0	Engine Overspeed
85	190	--	14	Engine Overspeed Signal
86	73	--	3	Pump Pressure Sensor Input Voltage High
86	108	--	3	Barometric Pressure Sensor Input Voltage High
87	73	--	4	Pump Pressure Sensor Input Voltage Low
87	108	--	4	Barometric Pressure Sensor Input Voltage Low
88	20	--	1	High Range Coolant Pressure Low
88	109	--	1	Coolant Pressure Low
89	95	--	0	Fuel Restriction High
89	111	--	12	Maintenance Alert Coolant Level Fault

**5. ENGINE OIL LEVEL**

Check the oil level daily with the engine stopped. If the engine has just been stopped and is warm, wait at least 10 minutes to allow the oil to drain back to the oil pan before checking. Wipe the dipstick clean then check oil level. The level should always be within the safe range on the dipstick (Fig. 12). Add the proper grade of oil to maintain the correct level on the dipstick. All diesel engines are designed to consume some oil, so a periodic addition of oil is normal.

**If the oil level is constantly above normal and excess lube oil has not been added to the crankcase, consult with an authorized Detroit Diesel service outlet for the cause. Fuel or coolant dilution of lube oil can result in serious engine damage.**

The vehicle may be provided with an oil reserve tank in the engine compartment. To adjust oil level, open the oil reserve tank drain valve and allow oil to discharge into the engine until the "Full" mark on the dipstick is reached then close the valve. Check oil reserve tank level and pour oil in the reserve tank if necessary (Fig. 13).

**⚠ WARNING ⚠**

**Touching a hot engine can cause serious burns.**

**⚠ CAUTION ⚠**

**Do not overfill. Oil may be blown out through the crankcase breather if the crankcase is overfilled.**

**⚠ CAUTION ⚠**

**Clean end of tube before removing the dipstick to prevent oil contamination.**

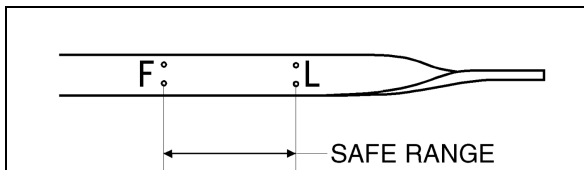

FIGURE 12: ENGINE OIL LEVEL DIPSTICK 01027

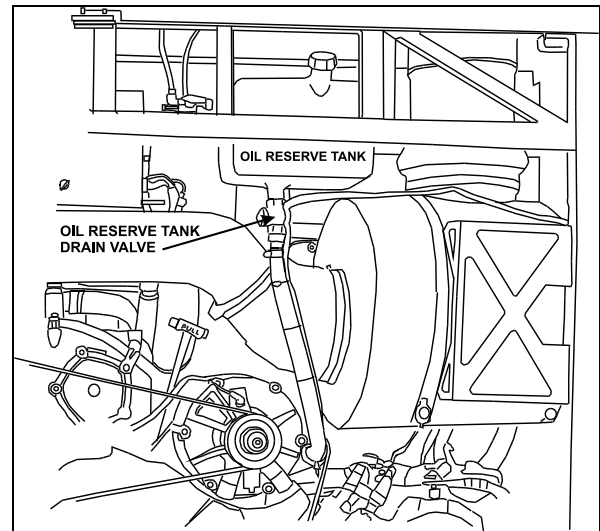

FIGURE 13: OIL RESERVE TANK 01063

**⚠ CAUTION ⚠**

## 6. ENGINE OIL AND FILTER CHANGE

Both the oil and filter should be changed every 12,500 miles (20,000 km) or once a year, whichever comes first. However, changes that are more frequent may be required when the engine is subject to high levels of contamination and/or overheating. Change intervals may be decreased or gradually increased with experience on specific lubricants until the most practical service condition has been established. Always refer to the lubricant manufacturer's recommendations (analysis of drained oil can be helpful).

**⚠ CAUTION ⚠**

**Do not use solvents to dilute the engine oil when draining. Dilution of fresh oil can occur which may be detrimental to the engine.**

Change engine oil with the vehicle on a flat and level surface and with the parking brake applied. It is best to drain the oil when the engine is still warm.

1. From under the vehicle, remove the engine drain plug on the oil pan. Allow oil to drain (Fig. 14).

**⚠ WARNING ⚠**

**Hot engine oil can cause serious burns. Wear coveralls with sleeves pulled down and gloves to protect hands.**

2. Reinstall the drain plug.
3. Remove the spin-on filter cartridge using a ½" drive socket wrench and extension.
4. Dispose of the used oil and filter in an environmentally responsible manner in accordance with state and/or federal (EPA) recommendations.

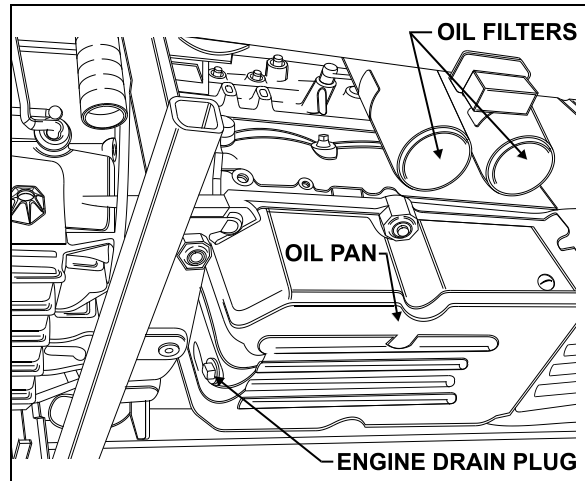

FIGURE 14: ENGINE DRAIN PLUG AND OIL FILTERS  
01029

5. Clean the filter adapter with a clean rag.
6. Lightly coat the filter gasket (seal) with clean engine oil.
7. Install the new filter on the adapter and tighten manually until the gasket touches the mounting adapter head. Tighten full-flow filters an additional two-thirds of a turn manually. Then, manually tighten bypass filter one full turn.

**⚠ CAUTION ⚠**

**Overtightening may distort or crack the filter adapter.**

8. Remove the engine-oil filler cap and pour oil in the engine until it reaches the "FULL" mark on the dipstick (Fig. 12).
9. Start and run the engine for a short period and check for leaks. After any leaks have been corrected, stop the engine long enough for oil from various parts of the engine to drain back to the crankcase (approximately 20 minutes).
10. Add oil as required to bring the level within the safe range on the dipstick (Fig. 12).

## 7. RECOMMENDED ENGINE OIL TYPE

To provide maximum engine life, lubricants shall meet the following specifications: SAE Viscosity Grade: 15W-40 API Classification: CI-4.

**NOTE**

*Monograde oils should not be used in these engines regardless of API Service Classification.*

**NOTE**

*The use of supplemental oil additives is discouraged from use in Detroit Diesel Engines.*

**Synthetic oils:** Synthetic oils may be used in Detroit Diesel engines provided they are API-licensed and meet the performance and chemical requirements of non-synthetic oils outlined previously. Synthetic oils do not permit extension of recommended oil drain intervals.

**Lubricant Selection World Wide:** Oils meeting API CD or CC specifications may be used if they also meet military specification MIL-L-2104 D or E. Oils which meet European CCMC D4 specifications may also be used.

Modification of drain interval may be necessary, depending on fuel quality. Contact Detroit Diesel Corporation for further guidance.

**8. POWER PLANT ASSEMBLY REMOVAL**

To access the engine or engine-related components, the vehicle power plant assembly must be removed as a whole unit by means of a slide-out cradle. The power plant assembly includes the engine, transmission (including retarder if so equipped), air compressor, alternator and transmission oil cooler.

Remove the power plant assembly as follows:

<b>⚠ CAUTION ⚠</b>
<b>Tag hoses and cables for identification before disconnecting in order to facilitate reinstallation. Plug all openings to prevent dirt from entering the system.</b>

<i>NOTE</i>
<i>No parts within the ECM are serviceable. If found defective, replace the complete ECM unit.</i>

1. Disconnect the battery or batteries from the starting system by removing one or both of the battery cables from each battery system. With the electrical circuit disrupted, accidental contact with the starter button will not produce an engine start. In addition, the Electronic Unit Injectors (EUI) will be disabled, preventing any fuel delivery to the injector tips.

<b>⚠ WARNING ⚠</b>
<b>Due to the heavy load of the rear bumper assembly, it must be adequately supported before attempting to remove it.</b>

2. Remove the rear bumper assembly from the vehicle. Refer to Section 18, BODY, under "REAR BUMPER REMOVAL".

3. Drain the engine cooling system. Refer to Section 05, COOLING under "DRAINING COOLING SYSTEM".

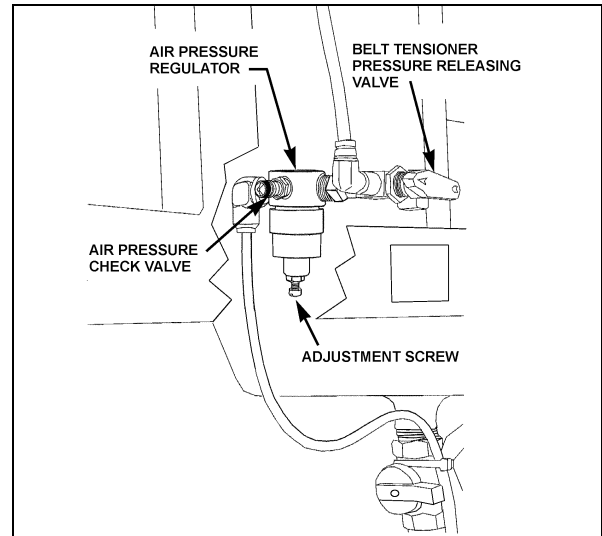

**FIGURE 15: BELT TENSORER VALVE**  
12200

4. Locate the belt tensioner pressure releasing valve (Fig. 15). Turn pressure releasing valve handle counterclockwise in order to release pressure in belt-tensioner air bellows and loosen belts. Remove the belts.
5. To release all pressure from the air system. Refer to Section 12, BRAKES & AIR SYSTEM for instructions.
6. Disconnect and remove the engine-air intake duct mounted between air cleaner housing and turbocharger inlet (1, Fig.17, 18).

<b>⚠ CAUTION ⚠</b>
<b>To avoid damage to turbocharger, cover the turbocharger inlet opening to prevent foreign material from entering.</b>

7. Disconnect and remove the air intake duct mounted between the air cooler outlet and the engine intake (2, Fig.17, 18).
8. Disconnect and remove section of coolant pipe assembly mounted between the radiator outlet and the water pump inlet (3, Fig.17, 18).
9. Disconnect the coolant delivery hose located close to the water pump.
10. Disconnect the electric fan-clutch connector, close to the water pump (Fig. 17, 18).
11. Dismantle the air bellows from the upper bracket of the fan-drive assembly tensioner. Remove the upper bracket (4, Fig.17, 18).

## Section 01: ENGINE

- 12.If necessary, remove the fan drive from the engine compartment by removing the four retaining bolts, washers and nuts securing the fan drive to the floor.

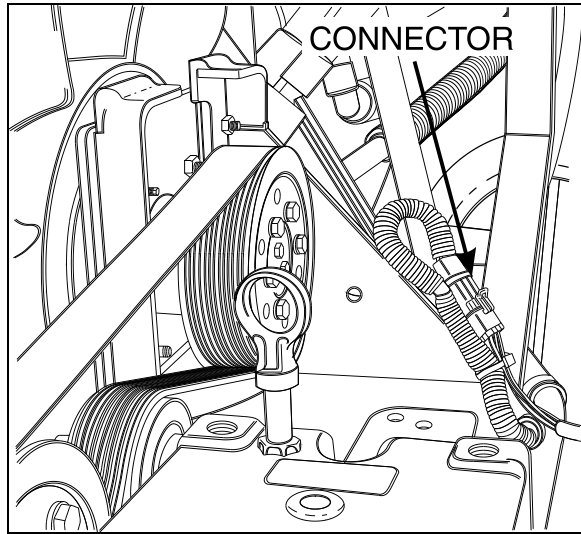

FIGURE 16: ELECTRIC FAN-CLUTCH CONNECTOR 010XX

- 13.Disconnect and remove the air intake duct mounted between the turbocharger outlet and the air cooler inlet (5, Fig. 17, 18).
- 14.Disconnect two vent hoses from the thermostat housing and from the coolant pipe assembly.
- 15.Disconnect and remove a section of coolant pipe assembly mounted between the thermostat housings and the radiator inlet.
- 16.Disconnect and remove the small hose connected to the heater line valve and to the water pump.
- 17.Disconnect the small heater hose located on the cylinder head at the back of the engine.
- 18.Disconnect and remove the exhaust pipe mounted between the turbocharger outlet and the exhaust bellows. If necessary, refer to Section EXHAUST SYSTEM under MUFFLER REMOVAL AND INSTALLATION".
- 19.Disconnect the steel-braided airline from the A/C compressor air bellows.
- 20.Disconnect the power steering pump supply and discharge hoses. Cap hose openings immediately to limit fluid loss. Remove retaining clips from cradle (6, Fig. 17, 18).
- 21.Disconnect the oil delivery hose from the valve located at the reserve tank drain (7, Fig. 17, 18).
- 22.Disconnect the block heater connector from the power steering pump if applicable.
- 23.Close engine fuel supply shutoff valve on primary fuel filter. Disconnect the fuel line connected to inlet port. On vehicles equipped with the optional water-separator-fuel-filter, disconnect the connector and remove cable ties from cradle.
- 24.Disconnect the air compressor discharge, governor steel-braided airlines and manual filling airlines from compressor. Remove retaining clips.
- 25.Disconnect the hose connecting the compressor head to the sump tank.
- 26.Disconnect ground cables from rear subframe ground-stud located close to the starter motor.
- 27.Disconnect positive cable (red terminal) from starting motor solenoid.
- 28.Disconnect the power plant wiring-harness main connectors from ECM and remove retaining clips from engine compartment backwall.
- 29.On vehicles equipped with an automatic transmission provided with a hydraulic output retarder, disconnect steel-braided airline from pressure regulator output. The pressure regulator is mounted in the upper section of engine compartment backwall and is accessible through the engine compartment R.H. side door.
- 30.Disconnect fuel return line from bulkhead fixed on engine cylinder head end.
- 31.On vehicles equipped with an electrically operated cold-starting aid, disconnect the delivery hose from the starting-aid cylinder solenoid valve. Remove cable ties securing hoses.
- 32.Disconnect turbo boost pressure gauge airline from engine air intake.
- 33.Only if the vehicle is equipped with a retarder, remove the transmission rubber-damper assembly above transmission by removing: nut, bushing, rubber damper, rubber damper guide, bolt and washer. Remove the rubber damper bracket from transmission.

**⚠ CAUTION ⚠**

**To avoid damage to turbocharger, cover the turbocharger outlet opening to prevent foreign material from entering.**



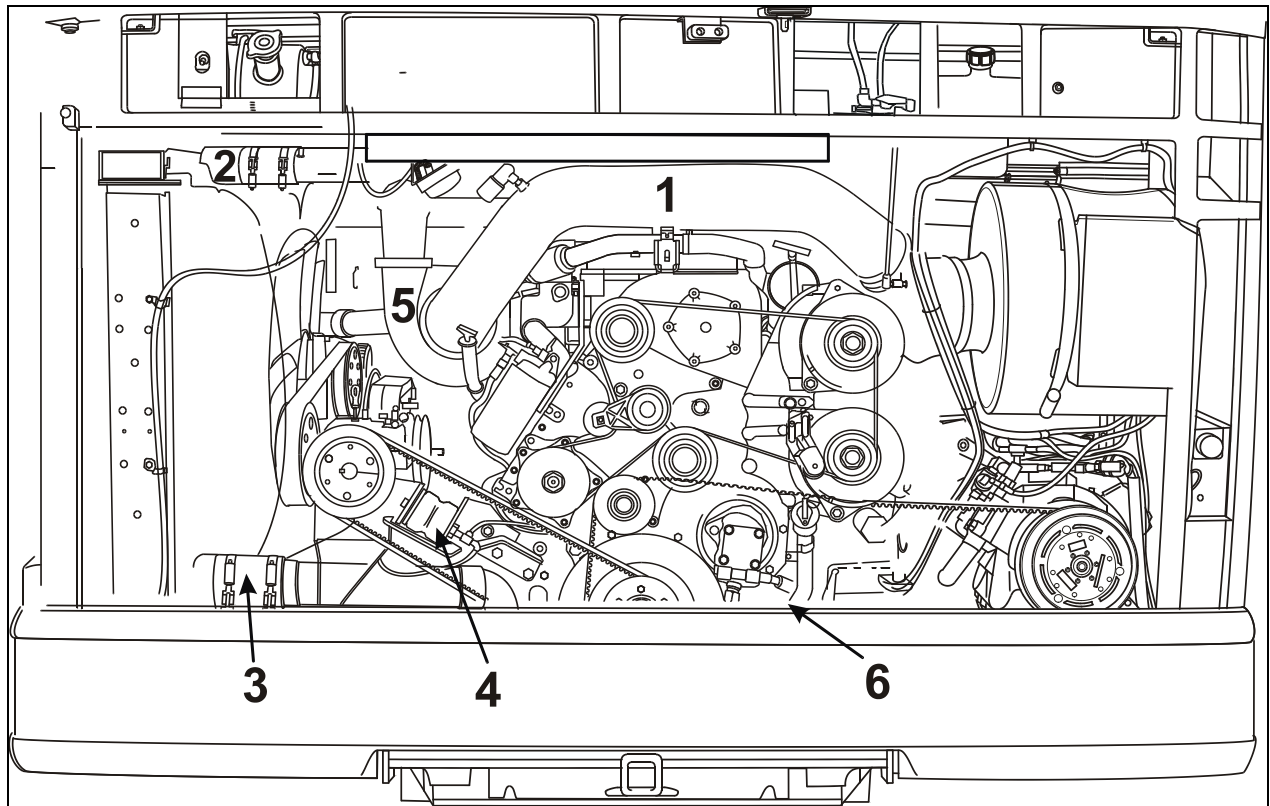

FIGURE 17: ENGINE COMPARTMENT XL2 COACHES (TYPICAL)

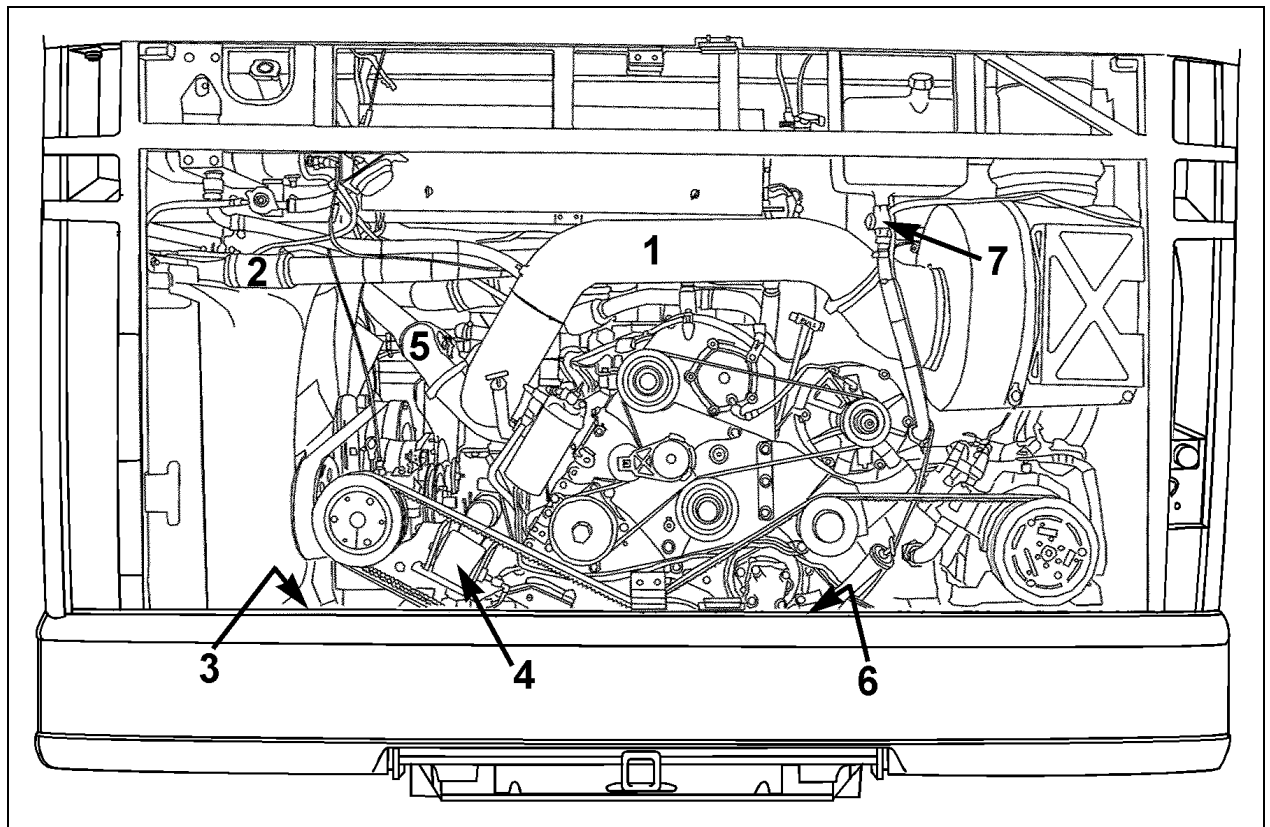

FIGURE 18: ENGINE COMPARTMENT XL2 MTH (TYPICAL)

01112

## Section 01: ENGINE

34. Disconnect connectors from transmission.  
On the left side: four on rear side with one close to yoke. On right side: close to the solenoid valve of the output retarder.
35. From under the vehicle, disconnect the propeller shaft as detailed in Section 09, under heading "Propeller Shaft Removal".
36. Inspect the power plant assembly to ensure that nothing will interfere when sliding out the cradle. Check for connections or hoses not mentioned in this list as some vehicles are equipped with special or aftermarket components.
37. Remove the six retaining bolts, washers and nuts securing the power plant cradle to the vehicle rear subframe (Fig. 20).

### NOTE

Check if any spacer(s) have been installed between power plant cradle and vehicle rear subframe, and if so, note position of each washer for reinstallation purposes.

38. Using a forklift, with a minimum capacity of 4,000 lbs (1 800 kg), slightly raise the power plant cradle.
39. Pull engine out slowly from the engine compartment. Make sure all lines, wiring and accessories are disconnected and are not tangled.

### CAUTION

Due to the minimum clearance between the power plant equipment and the top of the engine compartment, extreme care should be used to raise the power plant cradle, just enough to free the cradle. Clearance between power plant cradle and mounting rail should range between  $\frac{1}{4}$ " and  $\frac{1}{2}$ " (6-12 mm).

## 9. POWER PLANT ASSY. INSTALLATION

To install a power plant assembly, follow the same procedure as in "Power Plant Assembly Removal" except in reverse order, then proceed with the following:

1. Torque the power plant cradle mounting bolts to 190 lbf-ft (255 Nm).
- \* For vehicles equipped with an Allison automatic transmission and a retarder:
- a) Install transmission bracket (Fig. 19), tighten to 71-81 lbf-ft (96-110 Nm).

- b) Install the transmission's rubber damper assembly above transmission by assembling: bolt, washer, rubber damper guide, rubber damper, bushing nut.

- c) Respect damper tolerance of 58 mm (Fig. 19)

2. If fan drive has been removed, reinstall and align as per Section 05, COOLING SYSTEM, under "FAN DRIVE ALIGNMENT".
3. Refill cooling system with saved fluid (refer to Section 05, COOLANT SYSTEM).
4. Once engine fuel system has been drained, it will aid restarting if fuel filters are filled with fuel oil (refer to Section 03, FUEL SYSTEM).

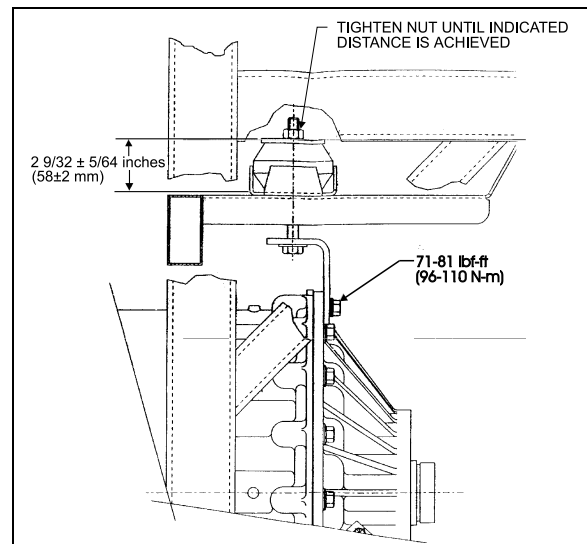

FIGURE 19: RUBBER DAMPER TOLERANCE

07014

5. Start engine for a visual check. Check fuel, oil, cooling, pneumatic and hydraulic system connections for leakage. Test operation of engine controls and accessories.

## 10. VALVE COVER REMOVAL

Refer to the series 60 Detroit diesel service manual for injectors and valves adjustment. Access to engine cover differs depending on vehicle model.

Wait until engine is cold prior to working on vehicle.

### 10.1 XL2-45 COACHES AND MOTORHOMES

1. Remove air intake pipe.
2. Remove the after CAC (Charger-Air-Cooler) air pipe.
3. Disconnect ventilation pipe from valve cover.



4. Remove trap door located in the middle rear end of vehicle.

***NOTE***

*On coaches, last seat has to be removed to access trap door. On motorhomes, it will depend on interior design*

5. Remove engine cover.
6. Adjust Jake brakes (if applicable), injectors and valves using Detroit Diesel service manual for series 60 engines.
7. Verify engine cover gasket and replace if necessary.

***NOTE***

*New gasket must be ordered directly from Detroit Diesel.*

8. Reinstal engine cover with a tightening torque of 18-22 Lbf-ft (25-30 Nm).
9. Connect ventilation pipe to engine cover.
10. Reinstall air intake and after CAC air pipes.
11. Reinstall trap door, seats or interior finish for motorhomes.

## **11. JAKE BRAKE**

Refer to both "The Jake Brake Troubleshooting and Maintenance Manual" and "Installation Manual for Model 790 Engine Brakes" for troubleshooting and installation procedures. They are annexed at the end of this section.

## **12. ENGINE MOUNTS**

The power plant assembly is mounted to the cradle by means of rubber mounts.

Two rubber mounts are used at the front of the engine while two others are mounted on each side of the flywheel housing (Fig. 20).

It is recommended that new rubber mounts be installed at each major overhaul.

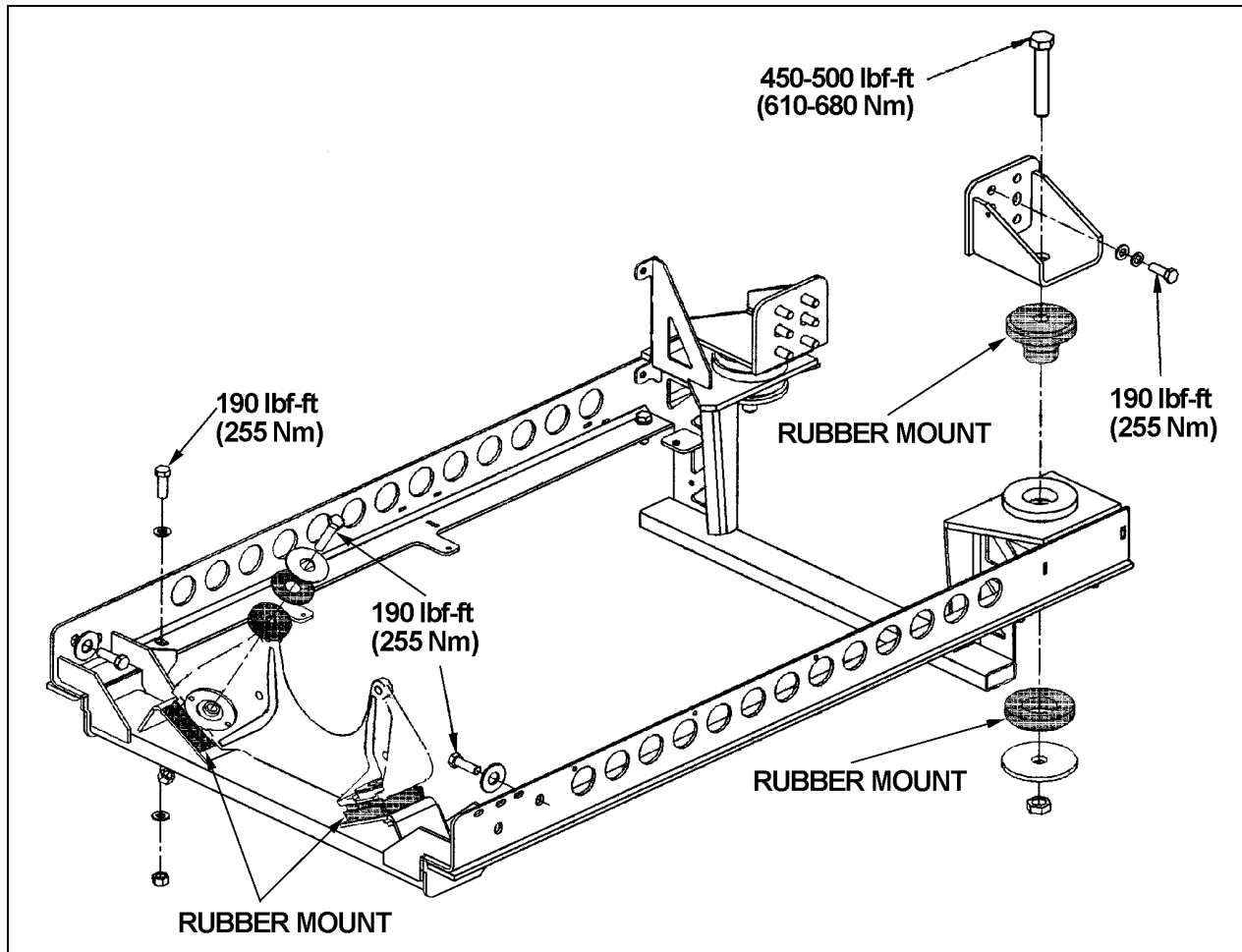
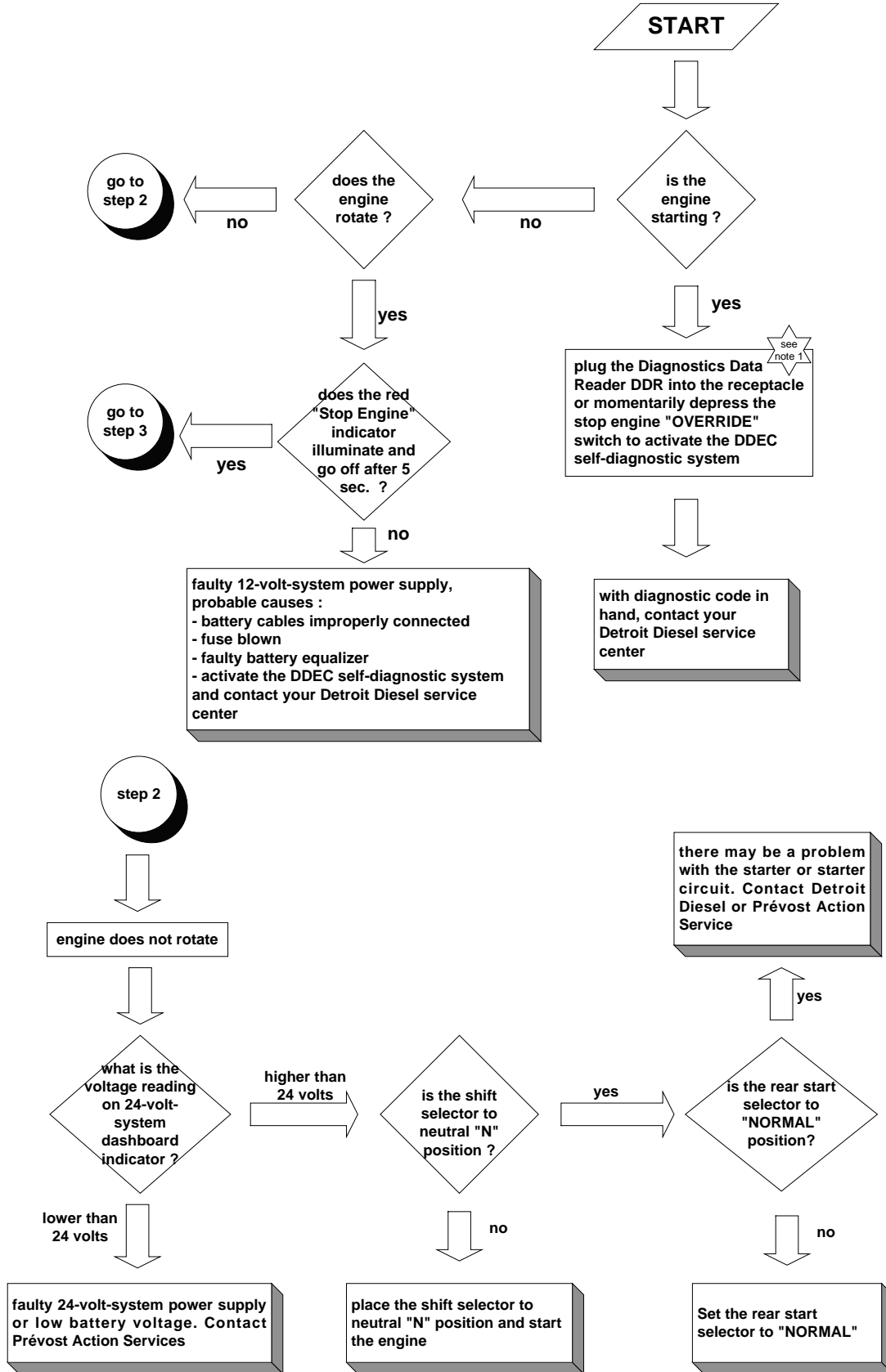
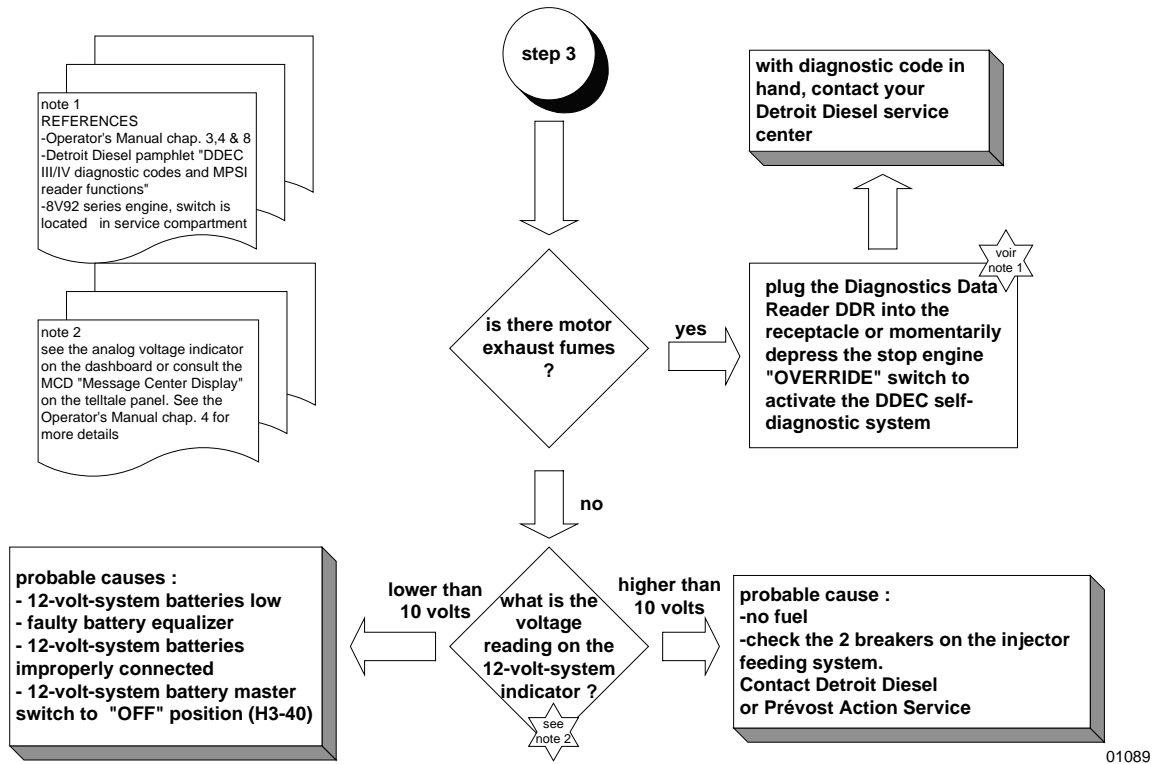

FIGURE 20: POWER PLANT CRADLE INSTALLATION

01140

13. ENGINE TROUBLESHOOTING GUIDE





**14. SPECIFICATIONS**

**Series 60 Engine**

Make ..... Detroit Diesel  
 Type ..... Diesel four cycle/in-line engine  
 Description ..... Turbo/Air to air charge cooled  
 No. of cylinders ..... 6  
 Operating range ..... 1200-2100 RPM  
 Maximum RPM ..... 2100

**Lubricant**

Heavy-duty engine oil SAE Viscosity Grade 15W-40, API Classification CI-4. Synthetic oil may be used if it meets the performance and chemical requirements of non-synthetic oils outlined previously. Some engine operating conditions may require exceptions to this recommendation.

**⚠ CAUTION ⚠**

**To avoid possible engine damage, do not use single grade (Monograde) lubricants in Detroit Diesel four-cycle Series 60 engines, regardless of API classification.**

**Detroit Diesel Series 60 engine ratings**

Series 60 engine ratings used in Prevost Car Models are listed in the following tables. The standard engine ratings are written in bold, customer may easily switch from one rating to another within the same table by having the DDEC V system reprogrammed.

<b>Coach Base Engine (12.7L)</b>	
<b>380 HP</b>	<b>@1800 rpm; 1350 lb-ft @1200 rpm</b>

<b>Coach Standard Engine (12.7L)</b>	
425 HP	@1800 rpm; 1450 lb-ft @1200 rpm
<b>435 HP</b>	<b>@1800 rpm; 1450 lb-ft @1200 rpm</b>
445 HP	@1800 rpm; 1450 lb-ft @1200 rpm
425/445 HP	@1800 rpm; 1450 lb-ft @1200 rpm

<b>XL2 Entertainer &amp; 40' MTH Engine (12.7L)</b>	
445 HP	@1800 rpm; 1550 lb-ft @1200 rpm
450 HP	@1800 rpm; 1550 lb-ft @1200 rpm
<b>455 HP</b>	<b>@1800 rpm; 1550 lb-ft @1200 rpm</b>
445/455 HP	@1800 rpm; 1550 lb-ft @1200 rpm

<b>XL2 45' MTH Engine (14.0L)</b>	
470 HP	@1800 rpm; 1650 lb-ft @1200 rpm
490 HP	@1800 rpm; 1650 lb-ft @1200 rpm
<b>515 HP</b>	<b>@1800 rpm; 1650 lb-ft @1200 rpm</b>
470/515 HP	@1800 rpm; 1650 lb-ft @1200 rpm

**Capacity**

Oil reserve tank.....8.4 US qts (8.0 L)

**Engine oil level quantity**

Oil Pan Capacity, Low Limit..... 26 quarts/25 liters

Oil Pan Capacity, High Limit..... 32 quarts/30 liters

Total Engine Oil Capacity with Filters..... 38 quarts/36 liters

**Lubricating oil filter elements**

Make..... AC Rochester Div. GMC # 25014505

Make..... A/C Filter # PF-2100

Type..... Full Flow

Prévost number..... 510458

**Torque specification**

Engine oil filter..... Tighten 2/3 of a turn after gasket contact

**Filters**

**Engine Air Cleaner Filter**

Make..... Nelson # 70337-N

Prévost number..... 530197

**Engine Coolant Filter/Conditioner**

Make..... Nalco Chemical Company # DDF3000

Make..... Detroit Diesel # 23507545

Prévost number..... 550630

<b>NOTE</b>
<i>For primary and secondary fuel filters, refer to Specifications in section 03</i>