

SECTION 07: TRANSMISSION

CONTENTS

1. DESCRIPTION	07-3
1.1 ALLISON AUTOMATIC TRANSMISSION	07-3
1.1.1 Retarder (if applicable)	07-3
1.2 ZF-ASTRONIC TRANSMISSION	07-4
2. WELDING PROCEDURES	07-4
3. MAINTENANCE	07-4
3.1 ALLISON TRANSMISSION	07-4
3.1.1 Cold Check	07-5
3.1.2 Hot Check	07-5
3.1.3 Fluid Level Check Using the Pushbutton Shift Selector	07-6
3.1.4 Importance of Proper Fluid Level	07-6
3.1.5 Keeping Oil Clean	07-7
3.1.6 Oil Recommendations	07-7
3.1.7 Oil Contamination	07-8
3.1.8 Metal Particles	07-8
3.1.9 Coolant Leakage	07-8
3.1.10 Oil and Filter Change	07-9
3.2 ZF AS-TRONIC TRANSMISSION	07-9
3.2.1 Oil Change	07-9
3.2.2 ZF AS-TRONIC / SACHS Clutch Installation Procedure	07-10
4. INSTALLATION OF ZF OR ALLISON TRANSMISSION BRACKETS	07-12
5. ALLISON TRANSMISSION REMOVAL	07-13
6. TRANSMISSION OIL COOLER REMOVAL	07-14
6.1 TRANSMISSION WITHOUT RETARDER	07-14
6.2 TRANSMISSION WITH RETARDER	07-14
7. CLEANING AND INSPECTION OF THE TRANSMISSION	07-14
7.1 ALLISON AUTOMATIC TRANSMISSION	07-14
7.1.1 Breather	07-15
8. ALLISON TRANSMISSION INSTALLATION	07-15
9. ALLISON TRANSMISSION PRINCIPLES OF OPERATION	07-16
10. TROUBLESHOOTING	07-16
10.1 ALLISON AUTOMATIC TRANSMISSION	07-16
10.1.1 4 th Generation Transmission Control Module	07-16
10.1.2 Diagnostic Troubleshooting Codes (DTC) — Allison 4 th Generation Controls	07-16
10.1.3 Diagnostic Codes – Allison 4 th Generation Controls	07-17
10.1.4 Diagnostic Code Display And Clearing Procedure – Allison 4 th Generation Controls	07-17
10.1.5 Diagnostic Code Response	07-18
10.1.6 Diagnostic Troubleshooting Codes (DTC) List - Allison 4 th Generation Controls	07-19
11. ZF-ASTRONIC TRANSMISSION SYSTEM FAULTS AND ERROR MESSAGES	07-23

Section 07: TRANSMISSION

11.1 SYSTEM FAULTS (ERROR MESSAGES)07-23

12. SPECIFICATIONS07-29

ILLUSTRATIONS

FIGURE 1: ALLISON TRANSMISSION 3

FIGURE 2: ALLISON TRANSMISSION CONTROL PAD..... 3

FIGURE 3: ZF-ASTRONIC TRANSMISSION 4

FIGURE 4: OIL LEVEL DIPSTICK (AUTO. TRANS.) 4

FIGURE 5: COLD CHECK 5

FIGURE 6: HOT CHECK 5

FIGURE 7: DRAIN PLUG AND FILTERS 9

FIGURE 8: RELEASE BEARING RETAINING CLIP 11

FIGURE 9: ZF OR ALLISON TRANSMISSION BRACKETS..... 12

FIGURE 10: ENGINE CRANKING POSITION..... 13

FIGURE 11: MODINE OIL COOLER 14

FIGURE 12: COOLER WITH RETARDER 14

FIGURE 13: AIR PRESSURE REGULATOR (TYPICAL)..... 16

FIGURE 14: TRANSMISSION CONTROL MODULE 16

1. DESCRIPTION

X3 Series coaches may be provided with either an Allison automatic transmission or a ZF-AsTronic transmission.

1.1 ALLISON AUTOMATIC TRANSMISSION

The B500 and B500R (with retarder) Allison Transmissions have 6 speeds with two top range (fifth and sixth) overdrives. Total coverage is determined by dividing the highest gear ratio by the lowest gear ratio. Total coverage expresses the transmission gear ratio versatility. Transmissions with larger total coverage number have a wider variety of available ratios.

An electronic control allows the transmission to shift at exactly the right point on the engine's fuel consumption curve for best economy. Early lockup maintains the highest possible mechanical efficiency through the closely-spaced gear steps, culminating in two overdrive ratios. This combination allows progressive shifting techniques, where engine speeds are reduced for higher efficiency and lower fuel consumption.

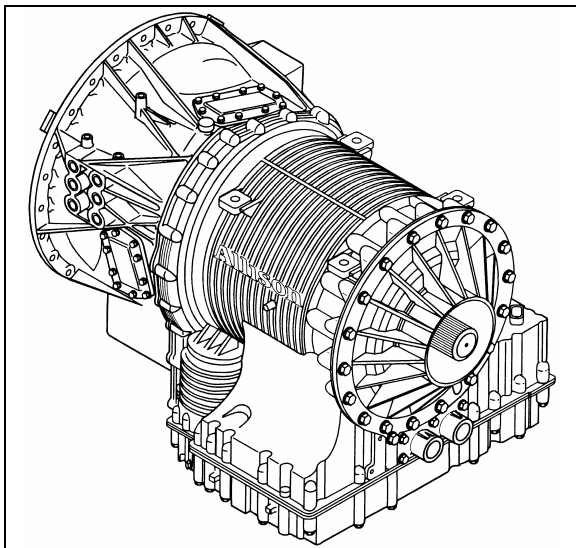

FIGURE 1: ALLISON TRANSMISSION 07136

Gear selection and torque converter modes are controlled by a microcomputer-based electronic transmission management system. It is fed information regarding throttle position, operator range selection, engine speed, turbine speed, transmission output speed and various system pressures from special electronic sensors. With this information, it computes shift points and clutch pressures to meet immediate needs.

Using closed loop adaptive logic; the electronic control looks at a number of parameters during the shift, and makes minute adjustments to match the shift to desired profile stored in its memory. It then looks at these adjustments and resets the parameters, which allow the transmission to quickly compensate for variations in load, terrain or environment and to adjust for clutch wear and engine power changes. A Diagnostic Data Reader can be connected to the electronic control unit to provide a self-check of all systems in the transmission. Five-digit trouble codes greatly reduce the time it takes to pinpoint potential problems. (Refer to paragraph "10. TROUBLESHOOTING" in this section).

1.1.1 Retarder (if applicable)

This optional auxiliary braking device for the automatic transmission is integrated into the basic envelope of the transmission and transmits its braking force directly to the propeller shaft. It requires no additional length and adds only 75 pounds (34 kg) of weight. Operation of the retarder is controlled electronically by the driver's use of the brake and/or by hand control lever.

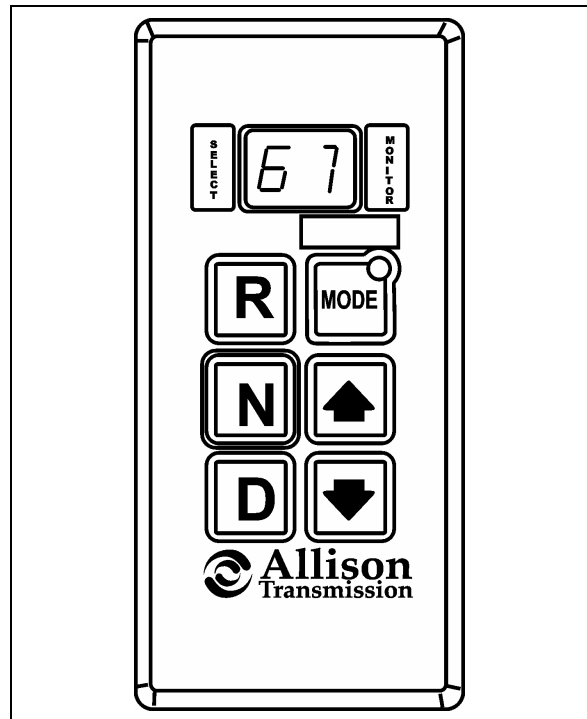

FIGURE 2: ALLISON TRANSMISSION CONTROL PAD 07025

When activated, fluid enters a cavity and provides resistance to the turning of rotor blades revolving

Section 07: TRANSMISSION

with the output shaft. This effectively slows the vehicle to the point where the service brakes are needed only for final stopping. The retarder is fully modulated and is compatible with ABS.

1.2 ZF-ASTRONIC TRANSMISSION

The AS TRONIC gear shift system is a combination of an electro-pneumatically shifted constant-mesh gearbox and an automated dry clutch.

If the AS TRONIC transmission system is to be used, the vehicle must have an electronic engine control unit as well as CAN communication. Since the clutch is automated (clutch pedal no longer fitted), the driver no longer has to activate the clutch.

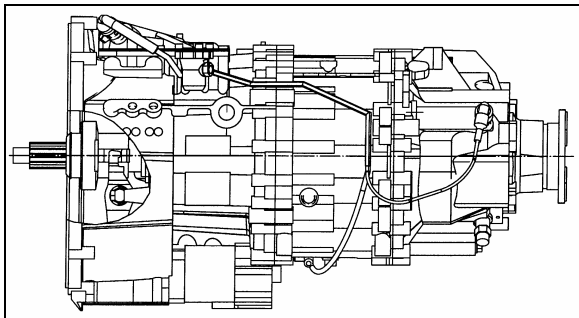

FIGURE 3: ZF-ASTRONIC TRANSMISSION 07078

The actual shift procedure is performed by the electronic transmission control unit. The driver has the option of driving the vehicle in both semi-automatic mode as well as fully automatically. When in semi-automatic mode, manual shifting with the range selector is made easier.

When in fully automatic mode, gears are selected and shifts made by the electronic control unit. The driver can still intervene if he wishes to. All system functions required are shown on the display, e.g. neutral, gear change, clutch overload and diagnosis information.

2. WELDING PROCEDURES

These procedures are intended only for vehicles equipped with transmission electronic controls. When frame or other welding is required on the vehicle, precautions are to be taken to protect the electronic control components. Refer to section 00: GENERAL INFORMATION, paragraph 3: "Precautions to be observed before welding" for complete procedure.

3. MAINTENANCE

3.1 ALLISON TRANSMISSION

To gain access to the dipstick, open the engine compartment rear doors; dipstick is located on the radiator side of the engine (Fig. 4).

To check the transmission oil level, a cold check and a hot check must be performed. A cold check must be made between 60°F (16°C) and 140°F (60°C). The transmission oil temperature gauge indicates the operating temperature; it is located in the MCD dashboard integrated Liquid Crystal Display and can be viewed when selecting the Gauge Mode (refer to "Operator's Manual" for added information).

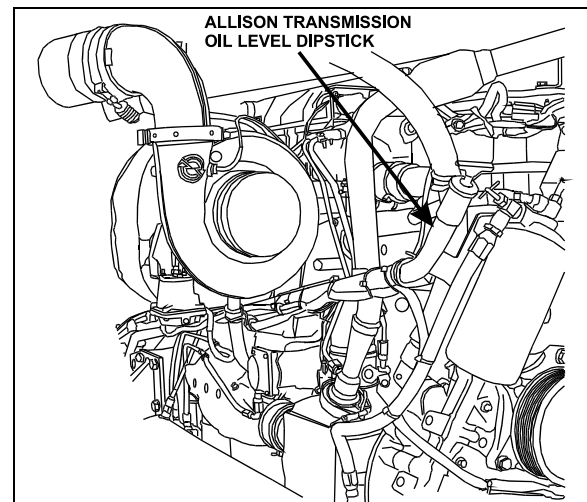

FIGURE 4: OIL LEVEL DIPSTICK (AUTO. TRANS.) 07113

NOTE

Perform the cold check first to verify the transmission oil level before performing the hot check.

The hot check can be performed when the transmission oil reaches the normal operating temperature of 160°F (71°C) to 200°F (93°C).

Clean all dirt from around the end of the oil filler tube before removing the dipstick. Dirt or foreign matter must not be permitted to enter the oil system since it will cause valves to stick, undue wear of transmission parts, and clogged passages. Check the oil level in accordance with the following procedures and record any abnormal level on your "Maintenance Records".

⚠ WARNING ⚠

When checking the oil level, be sure that the parking brake and/or emergency brakes are set and properly engaged, and the wheels are chocked. Unexpected and possible sudden vehicle movement may occur if these precautions are not taken.

- **Special care must be taken not to touch the engine coolant tubing and/or exhaust pipe, since this could cause severe burns.**
- **Do not wear loose clothing and, stay away from rotating parts during procedure; personal injury could occur.**

Always check the oil level reading at least twice when the engine is running. Consistency is important in maintaining the accuracy of the reading. If inconsistent readings persist, check the transmission breather to ensure it is clean and free of debris.

3.1.1 Cold Check

The purpose of the **Cold Check** is to determine if the transmission has enough fluid to be operated safely until a **Hot Check** can be made.

1. If the engine has been shut down for an extended period of time, park the vehicle on a level surface and apply the parking brake.

⚠ CAUTION ⚠

The oil level rises as sump temperature increases. DO NOT fill above the "Cold Run" band if the transmission oil is below normal operating temperature.

2. Run the engine for at least one minute. Shift to Drive (D) and operate the engine for 30 seconds at 1000-1500 rpm; then shift to Reverse (R) to clear the hydraulic system of air. Finally shift to Neutral (N) and allow the engine to idle (500 - 800 rpm).
3. While the engine is running, remove the dipstick from the tube and wipe it clean (Figs. 4 & 5).

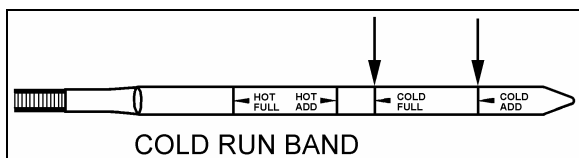

FIGURE 5: COLD CHECK

07050

4. Insert the dipstick into the tube and then remove, checking the oil level reading (Fig. 4). Repeat the check procedure to verify the reading. If the oil reading is within the "Cold Run" band, the level is satisfactory for operating the transmission until the oil is hot enough to perform a "Hot Run" check. If the oil reading is not within the "Cold Run" band, add or drain oil as necessary to bring the level within the "Cold Run" band.
5. Perform a **Hot Check** at the first opportunity after the normal operating temperature of 160°F (71°C) to 200°F (93°C) is attained.

⚠ CAUTION ⚠

An accurate fluid level check cannot be made unless the engine is idling (500-800 rpm) in Neutral, the transmission fluid is at the proper temperature, and the vehicle is on a level surface.

3.1.2 Hot Check

⚠ CAUTION ⚠

The oil must be hot to ensure an accurate check for this procedure. The oil level rises as temperature increases.

1. Operate the transmission in Drive (D) range until normal operating temperature is reached 160°F (71°C) to 200°F (93°C).
2. Park the vehicle on a level surface and shift to Neutral (N). Apply the parking brake and allow the engine to idle (500 - 800 rpm).
3. While the engine is running, remove the dipstick from the tube and wipe it clean.
4. Insert the dipstick into the tube and then remove, checking the oil level reading. Repeat the check procedure to verify the reading.

The safe operating level is anywhere within the "Hot Run" band on the dipstick (Fig. 5).

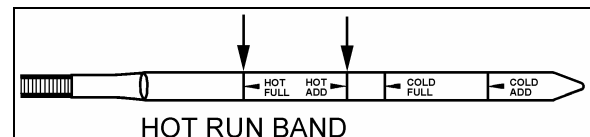

FIGURE 6: HOT CHECK

07049

If the oil level is not within the "Hot Run" band, add or drain oil as necessary to bring the oil level within the band.

Section 07: TRANSMISSION

<i>NOTE</i>
<i>The Cold Check is more appropriate for verifying the oil level after the first fill-up. In case of conflict, the Hot Check has priority over the Cold Check; the automatic system of verification via the shift selector has priority over the Hot Check.</i>

3.1.3 Fluid Level Check Using the Pushbutton Shift Selector

Oil level codes are obtained as follows:

1. Park vehicle on a level surface, select «N» (neutral) on the pushbutton shift selector and apply parking brake.
2. Press simultaneously the ▲ (Up) and ▼ (Down) arrow buttons once.
3. Oil level codes are displayed in 2 minutes (e.g. display will flash and 8, 7, 6, 5, ...; countdown will occur during the 2 minutes) once the following parameters are met:
 - **Waiting time, vehicle must be stationary for at least 2 minutes to allow the oil to settle;**
 - **Engine at idle;**
 - **Oil at normal operating temperature, between 140°F (60°C) and 220°F (104°C);**
 - **Transmission in «N» (Neutral);**
 - **Transmission output shaft stopped;**
 - **Oil level sensor present and working.**

After 2 minutes, the display will flash one of the codes shown below:

CODE	CAUSE OF CODE
O L...O K	Oil level is correct
O L...L O...01	One quart low
O L...L O...02	Two quarts low
O L...H I...01	One quart high
O L...H I...02	Two quarts high

<i>NOTE</i>
<i>Failure to meet one of the above parameters will stop the two minute countdown. One of the codes shown hereafter will indicate the cause of the countdown interruption. Once all parameters are met, the countdown will continue from where it left off.</i>

CODE	CAUSE OF CODE
OL...0X	Waiting time too short
OL...50	Engine speed (rpm) too low
OL...59	Engine speed (rpm) too high
OL...65	Neutral must be selected
OL...70	Sump oil temperature too low
OL...79	Sump oil temperature too high
OL...89	Output shaft rotation
OL...95	Sensor failure

To exit the Oil Level Display Mode, press any range button: «R», «N» or «D».

3.1.4 Importance of Proper Fluid Level

It is important that the proper fluid level be maintained at all times because the transmission fluid cools, lubricates, and transmits hydraulic power. If the fluid level is too low, the converter and clutches do not receive an adequate supply of fluid. If fluid level is too high, the fluid can aerate, causing the transmission to shift erratically or overheat.

3.1.5 Keeping Oil Clean

Oil must be handled in clean containers, fillers, etc., to prevent foreign material from entering the transmission. Place the dipstick on a clean surface area while filling the transmission.

 **CAUTION** 

Containers or fillers that have been used to handle antifreeze or engine coolant must NEVER be used for handling transmission fluid. Antifreeze and coolant solutions contain ethylene glycol that, if introduced into the transmission, can cause the clutch plates to fail.

3.1.6 Oil Recommendations

Hydraulic fluids used in the transmission are important influences on transmission performance, reliability and durability. **Castrol TranSynd™ Synthetic Fluid** and **DEXRON-III®** fluids are recommended for on-highway applications.

- **TranSynd™** is a full synthetic transmission fluid developed by Allison Transmission and Castrol Ltd. This fluid meets Allison specifications for Severe Duty and Extended Drain Intervals. TranSynd™ is fully qualified to the Allison TES295 specifications and is available through Allison distributors and dealerships.
- To be sure a fluid is qualified for use in Allison transmission, check for the **DEXRON-III®** license numbers on the container or consult the lubricant manufacturer. Consult your Allison Transmission dealer or distributor before using other fluid types.

The Transmission Fluid Operating Temperature Requirements table lists the minimum fluid temperatures at which the transmission may be safely operated without preheating. Preheat with auxiliary heating equipment or by running the equipment or vehicle with the transmission in «N» (Neutral) for a minimum of 20 minutes before attempting range operation.

Transmission Fluid Operating Temperature Requirements

Fluid type	Minimum operating temperature	
	Celsius	Fahrenheit
TranSynd™	-30	-22
DEXRON-III®	-25	-13

 **CAUTION** 

Disregarding minimum fluid temperature limits can result in transmission malfunction or reduced transmission life.

NOTE

The use of an arctic preheat kit is recommended at temperatures below -25°F (-32°C). If a preheat kit is not available, the TCM will restrict full operation until the sump temperature is increased.

Section 07: TRANSMISSION

3.1.7 Oil Contamination

At each oil change, examine the drained oil for evidence of dirt or water. A nominal amount of condensation will emulsify during operation of the transmission. However, if there is evidence of water, check the cooler (heat exchanger) for other signs of leakage. This, however, may also indicate leakage from the engine oil system.

3.1.8 Metal Particles

Metal particles in the oil (except for minute particles normally trapped in the oil filter) indicate damage has occurred in the transmission. When these particles are found in the sump, the transmission must be disassembled and closely inspected to find the source. Metal contamination will require complete disassembly of the transmission and cleaning of all internal and external circuits, coolers, and all other areas where the particles could lodge.



If excessive metal contamination has occurred, replacement of the oil cooler and replacement of all bearings within the transmission is recommended.

3.1.9 Coolant Leakage

If engine coolant leaks into the transmission oil system, immediate action must be taken to prevent malfunction and possible serious damage. The transmission must be completely disassembled, inspected, and cleaned. All traces of the coolant contamination must be removed. Friction clutch plates contaminated with ethylene glycol must be replaced.

TABLE 1: Recommended Fluid and Filter Change Intervals (Non-TranSynd™/Non-TES 295/Mixture)

Coaches equipped with retarder				Coaches without retarder			
Fluid	Filters			Fluid	Filters		
	Main	Internal	Lube/ Auxiliary		Main	Internal	Lube/ Auxiliary
	Initial Break-in 5,000 miles (8,000 km)				Initial Break-in 5,000 miles (8,000 km)		
12,000 Miles (20 000 km) 6 Months	12,000 Miles (20 000 km) 6 Months	Overhaul	12,000 Miles (20 000 km) 6 Months	25,000 Miles 40 000 km 12 Months	25,000 Miles 40 000 km 12 Months	Overhaul	25,000 Miles (40 000 km) 12 Months

TABLE 2: Recommended Fluid and Filter Change Intervals (TranSynd™/TES 295 Approved Fluid)
2 inch Control Module (1.75 approximately) – Requires filter kit P/N 29540493

Coaches equipped with retarder				Coaches without retarder			
Fluid	Filters			Fluid	Filters		
	Main	Internal	Lube/ Auxiliary		Main	Internal	Lube/ Auxiliary
	Initial Break-in 5,000 miles (8,000 km)				Initial Break-in 5,000 miles (8,000 km)		
50,000 Miles (80 000 km) 24 Months	50,000 Miles (80 000 km) 24 Months	Overhaul	50,000 Miles (80 000 km) 24 Months	150,000 Miles 240 000 km 48 Months	50,000 Miles 80 000 km 24 Months	Overhaul	50,000 Miles (80 000 km) 24 Months

3.1.10 Oil and Filter Change

Allison transmissions are now factory fill with TranSynd fluid. Oil change must be performed with the vehicle on a flat and level surface and with parking brake applied. Oil and oil filter change frequency is determined by the severity of service and operating conditions of the transmission and by the filter equipment installed. See "Table 1 and 2" for oil and filter change intervals. More frequent changes may be required when operations are subject to high levels of contamination or overheating.

The procedure for changing the transmission oil and oil filters is as follows:

Drain

1. The transmission should be at an operating temperature of 160°F (71°C) to 200°F (93°C) when the oil is drained. This will ensure quicker and more complete fluid drainage.

NOTE

Remove transmission protective panel located underneath transmission for easier access.

2. Remove the drain plug from under the transmission (Fig. 7) and allow the oil to drain into a suitable container. Check the condition of the oil as described previously.
3. To replace the integral filters, remove twelve bolts (6 on each cover), two filter covers, two O-rings, two square cut seals and the two filters from the bottom of the control module (Fig. 7).
4. To install filters, pre-lube and install the two O-rings, the two square cut seals followed by the filters (lube the O-ring in filter cartridge only) into the filter compartment. Index each filter/cover assembly to holes in channel plate/sump. Push the cover assembly in by hand to seat the seals.

CAUTION

Do not use bolts to draw the cover to sump. This can damage the cover, seal, or sump.

5. Install twelve bolts and both covers, and then tighten to 38-45 lbf-ft (51-61 Nm).
6. Inspect the drain plug and O-ring. Replace if necessary. Reinstall the drain plug and tighten to 18-24 lbf-ft (25-32 Nm).
7. Reinstall transmission protective panel

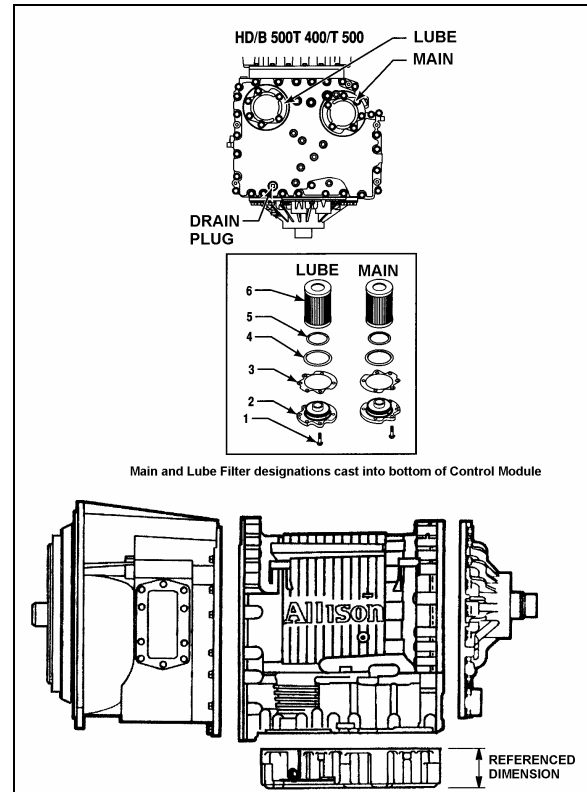

FIGURE 7: DRAIN PLUG AND FILTERS

07074

Refill

Using the oil level dipstick filler tube, refill with 24 US qts (23 liters) [28 US qts (26.5 liters) if equipped with retarder] and check the oil level using the previously described procedure. The refill amount is less than the initial filling because some of the oil remains in the external circuits and transmission cavities.

NOTE

Quantities listed above are approximations and do not include external oil cooler lines.

3.2 ZF AS-TRONIC TRANSMISSION

All information needed for the removal /installation or maintenance of the ZF transmission is included in the documents annexed at the end of this section.

3.2.1 Oil Change

Approximately 11 liters is needed for a complete oil change.

Section 07: TRANSMISSION

3.2.2 ZF AS-TRONIC / SACHS Clutch Installation Procedure

Important Note:

The clutch hub splines, input shaft, release bearing, clutch fork, and clutch push rod ends all come pre-lubed from the factory.

- Clean the flywheel, clutch disc, and pressure plate surfaces, removing any grease prior to assembly.
- Slide the clutch disk onto the transmission input shaft to check for smooth engagement. Remove clutch disk.
- Apply a very thin coating of Optimol Olista Longtime synthetic grease to the transmission input shaft. Slide the clutch disk along the full length of the input shaft to transfer grease to the clutch hub splines. Remove clutch disc, and remove any excess grease from the exterior of the clutch disc hub. **It is very important that no excess grease is left on the exterior of the clutch hub or clutch disk!**
- Install two temporary pilot studs (7/16-14, 3" long), placing them on the same diameter, 180° apart. These are used to aid in the alignment of the clutch pressure plate.
- Verify that the pilot bearing is seated properly in the flywheel. Insert a clutch alignment tool (SAE 2" DIA, 10 Spline) through the clutch disc and into the pilot bearing. PLEASE NOTE: the direction matters – the large side of the hub should face the clutch pressure plate. The clutch disc hub should be marked "flywheel side" – this side should face the flywheel.
- Use the clutch alignment tool to keep the clutch disc in the proper position and align the clutch cover with the two studs. Push the cover in place in the direction of the flywheel and start installing the clutch bolts. Use Lock-Tite for each bolt. Install, but do not torque, the 10 bolts. Remove the two pilot studs and in their place install the remaining 2 bolts.
- When the bolts are hand tight, be sure that the clutch cover fits into the flywheel centering ring. Tighten each bolt a little at a time, in a crisscross pattern, until the pressure plate cover contacts the flywheel

face. Once the cover has touched the face of the flywheel, torque the clutch bolts to 55 ft-lbs, again in a crisscross fashion.

- Remove the clutch alignment tool. If the installation was successful, it should slide out smoothly.
- Ensure that the release bearing retaining clip (located on the "fingers" of the pressure plate) is closed. Refer to figure 8.
- Remove the Clutch Inspection Cover from the bottom of the transmission.
- The transmission should have been shipped in gear. This will allow the installer to rotate the output shaft in order to align the input shaft with the clutch disc hub. If the transmission is in neutral, a "strap wrench" (with a rubber or leather strap) can be used to align the input shaft. Do not use a wrench of the "chain" variety, as damage to the input shaft may result. When aligned, push the transmission towards the engine. Be sure that the bell housing contacts the flywheel housing.

Warning!

- Insure that the transmission moves in a straight line. It can very easily go off center relative to the clutch disc and pilot bearing.
- Insure that the bell housing interfaces evenly with the flywheel housing. Even surface contact should be attained before tightening bolts.
- Do not try to correct relative position of the bell housing and flywheel housing by pulling the transmission into place with the bell housing bolts. The transmission bell housing should seat into the flywheel housing freely.
- When the bell housing and flywheel housing surfaces and bolt holes are aligned, install the transmission bolts. Only hardened steel flat washers should be used, **SERRATED LOCK WASHERS ARE NOT ALLOWED**. Torque the transmission bolts to 55 ft-lbs. in a crisscross fashion.
- From underneath, push the clutch release bearing forward (in the direction of flywheel) using the release fork. Use force to snap the bearing into the retaining clip located on the "fingers" of the pressure plate. The installer

should be able to both hear and feel the bearing seat into place. Refer to figure 8.

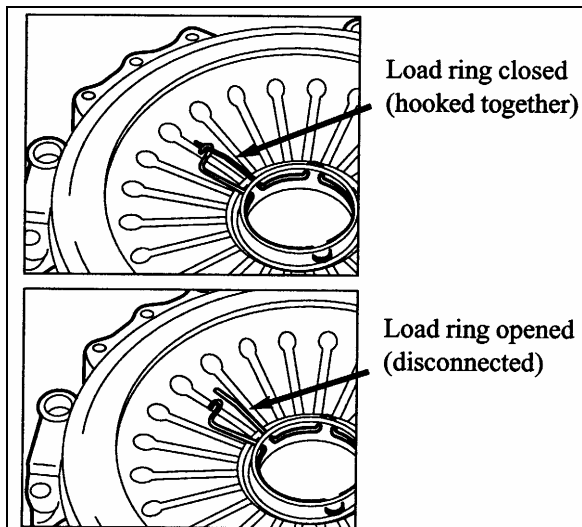

FIGURE 8: RELEASE BEARING RETAINING CLIP 07112

- Install the Clutch Actuator inspection cover.
- The clutch/transmission installation is now complete.

4. INSTALLATION OF ZF OR ALLISON TRANSMISSION BRACKETS

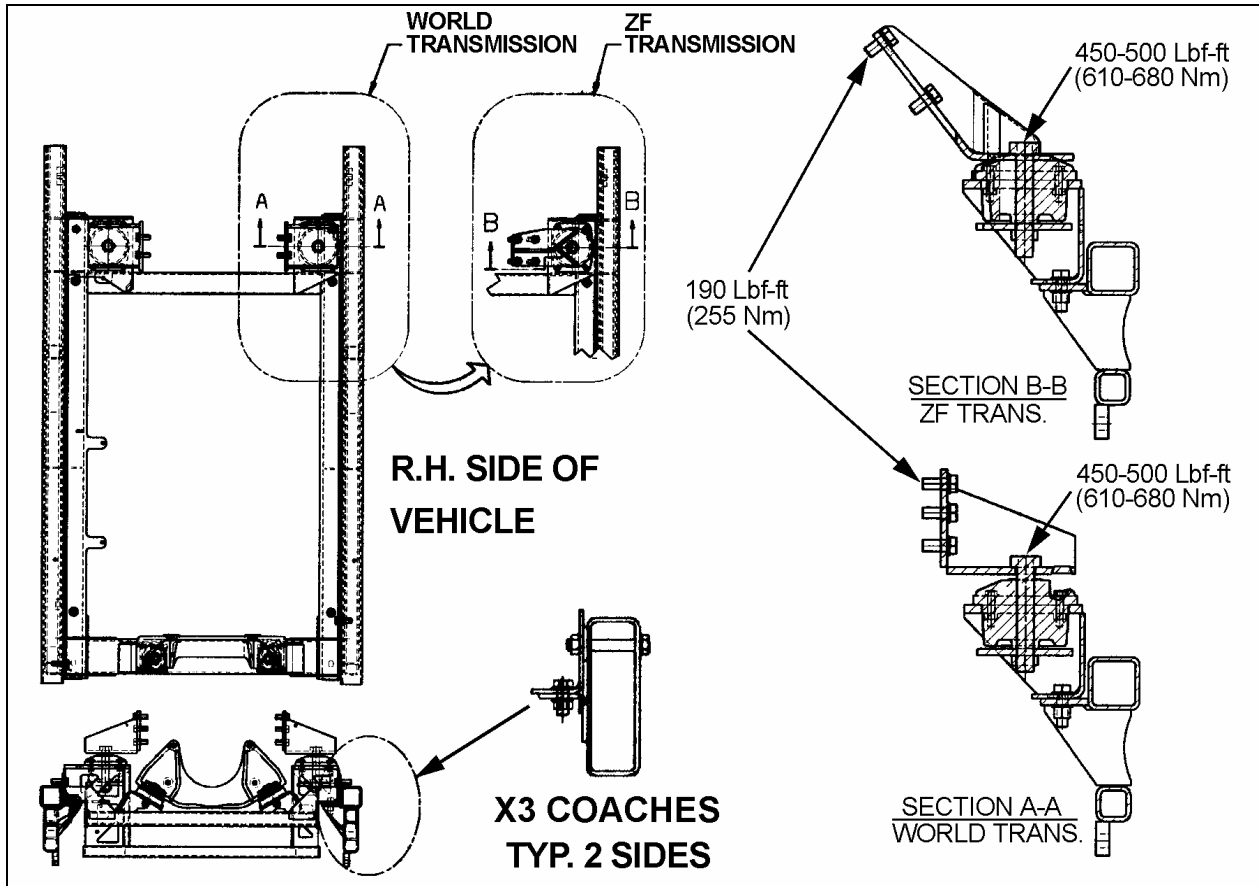

FIGURE 9: ZF OR ALLISON TRANSMISSION BRACKETS

07131

5. ALLISON TRANSMISSION REMOVAL

The following procedure deals with the removal of the Allison transmission without removing the power plant cradle from vehicle. The methods used to support the transmission and engine depend upon conditions and available equipment.

1. Select transmission's "NEUTRAL" position, apply parking brake, then set battery master switch to the "OFF" position.
2. Jack up vehicle, then place safety supports underneath body.

⚠ CAUTION ⚠

Only the recommended jacking points must be used as outlined in Section 18, "BODY".

NOTE

For more clearance between the tag axle and transmission, the tag axle may be unloaded and jacked up or retracted (if applicable).

3. Remove engine splash guards and protective panels surrounding transmission.
4. Remove cross member from under transmission.
5. Remove the transmission drain plug and allow oil to drain. Inspect the drain plug washer and replace it if necessary. Reinstall the drain plug and tighten to 33-41 lbf-ft (45-56 Nm) (see "3.2.9 Oil and Filter Change" in this section).

⚠ WARNING ⚠

It is better to drain oil when it is still warm. Avoid contact with oil since it can be very hot and cause personal injury.

6. Remove transmission dipstick and filler tube.
7. Disconnect propeller shaft from transmission and remove its safety guard. Refer to Section 09, "PROPELLER SHAFT".
8. Disconnect the two oil cooler hoses from transmission. Cover hose ends and fittings to prevent fluid contamination.

⚠ WARNING ⚠

A significant amount of oil may drain from oil lines when they are disconnected.

9. Disconnect all sensors on L.H. side of the transmission.

10. Disconnect main wiring harness.
11. Disconnect the air supply line (steel-braided hose) from retarder control valve (if applicable).
12. Remove any locking tie, clamp and bracket that may interfere with the removal of transmission.
13. Support transmission using a suitable transmission jack.
14. Remove the access plug from the flywheel housing on the R.H. side below starter. From access plug, remove the 12 converter-to-flexible plate attaching screws. Cranking the engine to gain access to the attaching screws may be done by turning the crankshaft pulley using a suitable adapter (fig. 10).

⚠ CAUTION ⚠

Do not rotate alternator shaft clockwise to avoid removing tension on belt.

15. Remove the 12 screws retaining the torque converter housing to the flywheel housing.

⚠ CAUTION ⚠

Make sure transmission-to-engine alignment is maintained when removing screws to avoid damaging torque converter housing.

16. Slowly pull transmission straight out to clear the engine.
17. Remove the transmission.

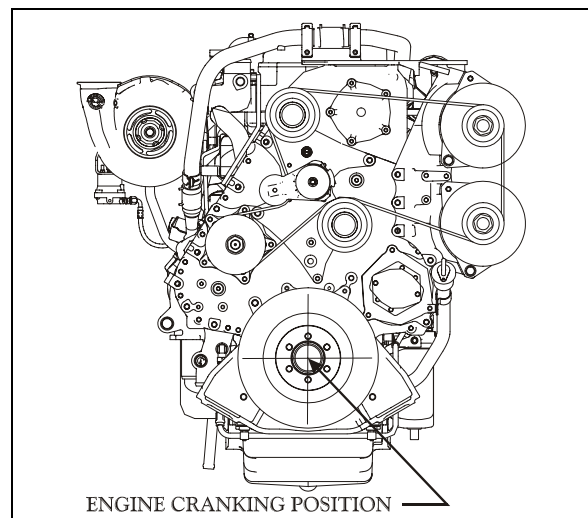

FIGURE 10: ENGINE CRANKING POSITION

01153

6. TRANSMISSION OIL COOLER REMOVAL

6.1 TRANSMISSION WITHOUT RETARDER

Stop engine and allow engine to cool. Close both heater line shutoff valves (refer to Section 05 "Cooling").

To drain the cooling system, proceed as per Section 05 "Cooling", paragraph 5: Draining. If the cooling system is contaminated, flush system as per Section 05 "Cooling", paragraph 7: Flushing.

1. Disconnect and remove the engine air intake duct mounted between the air cleaner housing and the turbocharger inlet.

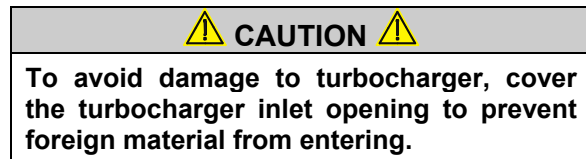

2. Disconnect the two transmission hoses from oil cooler. Cover hose ends and fittings to prevent fluid contamination.

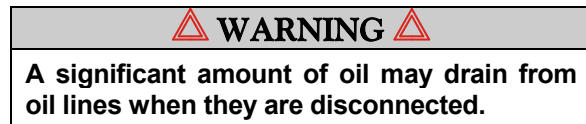

3. Unfasten the constant-torque hose clamps and remove the two hoses.

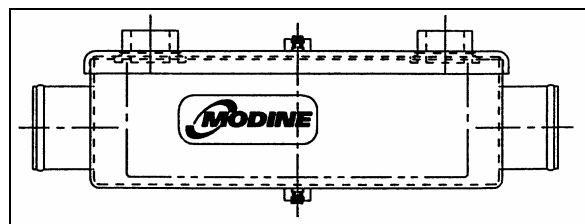

FIGURE 11: MODINE OIL COOLER 07072

4. Unscrew the four holding nuts and remove the U-bolts, remove the oil cooler from engine compartment.
5. Reinstall transmission oil cooler by using reverse procedure.

6.2 TRANSMISSION WITH RETARDER

Stop engine and allow engine to cool. Close both heater line shutoff valves (refer to Section 05 "Cooling").

1. To drain the cooling system, proceed as per Section 05 "Cooling", paragraph 5: Draining. If the cooling system is contaminated, flush system as per Section 05 "Cooling", paragraph 7: Flushing.
2. Disconnect and remove the engine air intake duct mounted between the air cleaner housing and the turbocharger inlet.

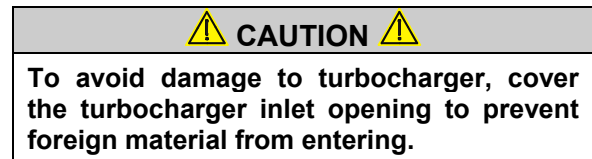

3. Disconnect the transmission hoses from oil cooler. Cover hose ends and fittings to prevent fluid contamination.



4. Unfasten the constant-torque hose clamps and remove the two hoses.
5. Unscrew the holding bolts and nuts and remove the oil cooler from engine compartment.

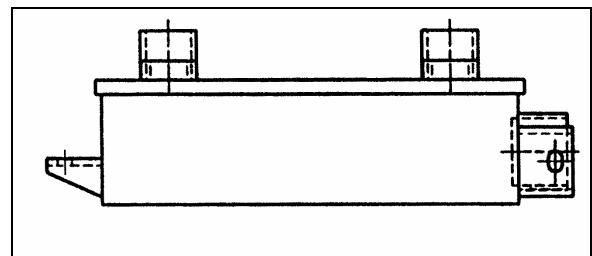

FIGURE 12: COOLER WITH RETARDER 07073

6. Reinstall transmission oil cooler by using reverse procedure.

7. CLEANING AND INSPECTION OF THE TRANSMISSION

7.1 ALLISON AUTOMATIC TRANSMISSION

The exterior of the transmission should be cleaned and inspected at regular intervals. The length of service and severity of operating conditions will determine the frequency of such inspections. Inspect the transmission for:

1. Loose bolts (transmission and mounting components);

2. Oil leaks (correct immediately);
3. Loose, dirty, or improperly adjusted throttle sensor linkage;
4. Damaged or loose oil lines;
5. Worn or frayed electrical harnesses, improper routing;
6. Worn or out of phase drive line U-joint and slip fittings.

⚠ CAUTION ⚠

DO NOT pressure wash the transmission electrical connectors. Water and detergent will cause the contacts to corrode or become faulty.

7.1.1 Breather

The breather is located on the engine, flywheel side near the valve cover. It serves to prevent pressure build-up within the transmission and must be cleaned to keep the passage opened. The prevalence of dust and dirt will determine the frequency at which the breather requires cleaning. Use care when cleaning the engine. Spraying steam, water or cleaning solution directly at the breather can force the water or solution into the transmission. Always use care when removing the hose connector from transmission to prevent the entry of foreign matter.

8. ALLISON TRANSMISSION INSTALLATION

NOTE

For more clearance between the tag axle and transmission, the tag axle may be unloaded and jacked up, or retracted (if applicable).

1. With the access plug removed, align one of the 12 attaching screw holes in the flexible plate with the access opening (starter side).
2. Place the transmission on a transmission jack.
3. Install a headless guide bolt into one of the 12 threaded holes for flexible plate attaching screws in the flywheel.
4. Lubricate the flywheel center pilot boss with molybdenum disulfide grease (Molycote G, or equivalent).

5. Raise transmission and position the flywheel pilot boss into the flexible plate adapter. Align the guide bolt previously installed in the flywheel with the flexible plate hole facing the access opening in the flywheel housing.

⚠ WARNING ⚠

Severe damages and/or personal injury can occur if transmission is not adequately supported.

6. Seat the transmission against the engine flywheel housing. **NO FORCE IS REQUIRED.** If interference is encountered, move the transmission away from engine, then investigate the cause.

⚠ CAUTION ⚠

The torque converter housing must be seated against the flywheel housing prior to tightening any screws. DO NOT USE SCREWS TO SEAT THE HOUSING.

7. Start all torque converter housing screws, and then tighten four of them gradually and in a criss-cross sequence around the housing. Tighten the 12 remaining screws. Recommended torque is between 42-50 lbf-ft (57-68 Nm).
8. Remove the guide bolt through the access opening in the flywheel housing. Replace it with a self-locking screw, finger-tighten then start the remaining screws; tighten to 17-21 lbf-ft (23-28 Nm). Place a wrench on the crankshaft pulley attaching screw to turn the converter to gain access to the threaded holes.
9. Reinstall the access plug.
10. Remove jack from under transmission.
11. Connect all sensors.
12. Connect the main wiring harness.
13. Connect the air supply line (steel-braided hose) to the retarder control valve (if applicable).
14. Connect the two transmission oil cooler hoses as they were previously.
15. Reinstall clamps and brackets, and replace locking ties previously removed during removal procedure.

Section 07: TRANSMISSION

16. Install propeller shaft and its safety guard.
Refer to Section 09, "PROPELLER SHAFT".
17. Install transmission dipstick and filler tube.
18. Install cross member under transmission.
19. Install engine splash guards.
20. Adjust the retarder pressure to 80 ± 3 psi with the air pressure regulator. For more information refer to Section 12, "BRAKE AND AIR SYSTEM", under heading "AIR PRESSURE REGULATOR". The air pressure regulator is located near the Webasto in engine compartment, on R.H. side (Fig. 13).
21. Make sure that the drain plug is in place, and then remove the transmission dipstick and pour approximately 24 US quarts (23 L) of automatic transmission fluid through the filler tube. Check and adjust oil level.

⚠ CAUTION ⚠

Do not overfill the transmission. Overfilling can cause oil aeration (milky appearance) and overheating. If overfilling occurs, drain oil as required to bring it to the proper level.

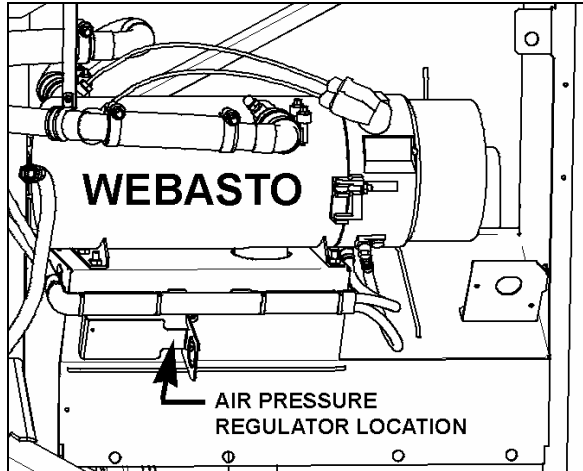

FIGURE 13: AIR PRESSURE REGULATOR (TYPICAL) 07130

9. ALLISON TRANSMISSION PRINCIPLES OF OPERATION

Refer to "Allison Transmission, MD Series, Principles of Operation, SA 2454".

10. TROUBLESHOOTING

10.1 ALLISON AUTOMATIC TRANSMISSION

For complete information about Allison transmission troubleshooting, refer to "Allison 4th Generation Controls – Troubleshooting Manual: 3000 and 4000 Product families (TS3989)".

10.1.1 4th Generation Transmission Control Module

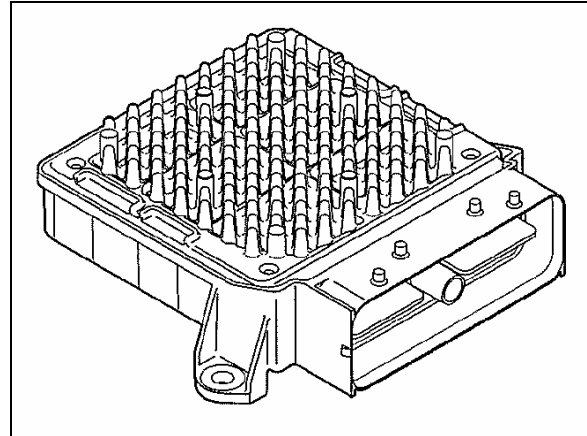

FIGURE 14: TRANSMISSION CONTROL MODULE 07140

The Allison transmission has a new Transmission Control Module (TCM) which involves specific diagnostic incident codes. The TCM unit is located in the coach rear electrical compartment.

TCM Replacement

The TCM is a non-serviceable electronic device. When it fails, it must be replaced using the following procedure:

- Open the coach rear baggage compartment then remove the rear electrical compartment door in order to get access to the TCM;
- Remove the electrical cable connectors;
- Unscrew the TCM unit;
- Replace by reversing the procedure.

⚠ CAUTION ⚠

Place the battery master switch to the "OFF" position.

10.1.2 Diagnostic Troubleshooting Codes (DTC) — Allison 4th Generation Controls

Diagnostic codes (DTC) are numerical indications relating to a malfunction in transmission operation. These codes are logged in a list in the TCM memory with the most severe or most recent code listed first. A

maximum of five codes (numbered d1 to d5) may be listed in memory at one time. As codes are added, the oldest inactive code is dropped from the list. If all codes are active, the code with the lowest priority that is not included on the severity list is dropped from the list.

Diagnostic codes (DTC) and code information may be accessed through the pushbutton shift selector or using an Allison DOC™ diagnostic tool.

The TCM separately stores the active and inactive codes. An active code is any code that is current in the TCM decision-making process. Inactive codes are codes that are retained in the TCM memory and will not necessary affect the TCM decision-making process. Inactive codes are useful in determining if a problem is:

- Isolated ;
- Intermittent ;
- Result from a previous malfunction.



The TCM may automatically delete a code from memory if it has not recurred. If the MODE INDICATOR (LED) is not illuminated, the displayed code is not active. An illuminated MODE INDICATOR (LED) during normal operation signifies secondary shift mode operation.

10.1.3 Diagnostic Codes – Allison 4th Generation Controls

When the diagnostic mode is entered, the first code (position d1) is displayed as follows:

Example: Code P0722

Displayed as: **d1...P...07...22**

The code list position is the first item displayed, followed by the DTC. Each item is displayed for about one second. The display cycles continuously until the next code list position is accessed by pressing the **MODE** button. The following example shows how DTC P0722 is displayed on the pushbutton shift selector.

SELECT	d	1	MONITOR
		P	
	0	7	
	2	2	

- d1 (code list position) – The position which a code occupies in the list. Positions are displayed as « d1 » through « d5 » (code list position 1 through code list position 5).
- P0722 (DTC) – The diagnostic troubleshooting code number referring to the general condition or area of fault detected by the TCM.

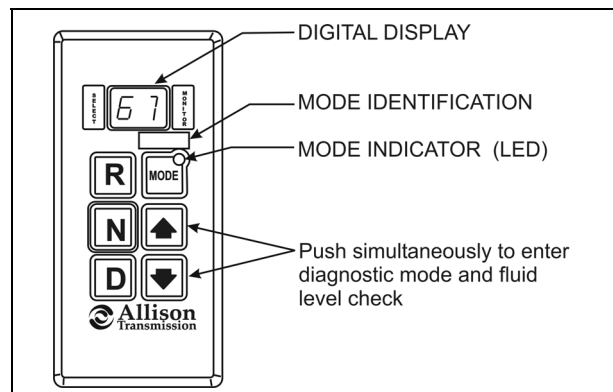

10.1.4 Diagnostic Code Display And Clearing Procedure – Allison 4th Generation Controls

Diagnostic codes can be read and cleared by two methods:

- Using an Allison DOC™ diagnostic tool. For specific instructions on how to use an Allison DOC™ diagnostic tool, refer to the User Guide.
- Using the pushbutton shift selector.

To begin the diagnostic process:

1. Bring the vehicle to a stop at a safe location.
2. Apply the parking brake.

To display stored codes:

1. Simultaneously press the ▲ (Up) and ▼ (Down) arrow buttons twice to access the Diagnostic Display Mode.

Section 07: TRANSMISSION

NOTE

To access the Oil Level Display Mode, simultaneously press the ▲ (Up) and ▼ (Down) arrow buttons once. Consult paragraph: « ALLISON TRANSMISSION OIL LEVEL CHECK USING THE PUSHBUTTON SHIFT SELECTOR » at the end of this section.

2. Observe the digital display for code (d1).
3. Press the MODE button to see the next code (d2) – repeat for subsequent codes (d3, d4 & d5).

NOTE

Be sure to record all codes displayed before they are cleared. This is essential for troubleshooting.

NOTE

The Diagnostic Display Mode can be entered for viewing codes at any speed. Codes can only be cleared when the output speed = 0 and no output speed sensor failure is active

Active indicators (MODE INDICATOR LED) and inactive codes can be cleared manually, while in the diagnostic display mode, after the condition causing the code is identified.

To clear active indicators and inactive codes:

1. While in Diagnostic Display Mode, press and hold the MODE button for 10 seconds to clear both active indicators and inactive codes.
2. Begin operating as normal. Have the transmission checked at the earliest opportunity by an Allison Transmission distributor or dealer.

NOTE

All active indicators are cleared at TCM power down.

Some codes will clear their active indicator when the condition causing the code is no longer detected by the TCM.

The Diagnostic Display Mode can be exited by any of the following methods:

- Press simultaneously the ▲ (Up) and ▼ (Down) arrow buttons at the same time on the pushbutton shift selector.
- Press any range button «D», «N» or «R» on the pushbutton shift selector (the shift will be commanded if it is not inhibited by an active code).
- Wait until the calibrated time (approximately 10 minutes) has passed. The system will automatically return to the normal operating mode.
- Turn off power to the TCM (shut off the engine using the ignition key).

NOTE

If clearing a code while locked in a «D» (Drive) or «R» (Reverse) position (fail-to-range), the transmission will still be in «D» (Drive) or «R» (Reverse) when the clearing procedure is completed. «N» (Neutral) must be manually selected.

10.1.5 Diagnostic Code Response

The following responses are used in the "Diagnostic Troubleshooting Code List and Inhibited Operation Description" table to command safe operation when diagnostic codes are sent.

DNS - Do Not Shift Response

Release lock up clutch and inhibit lock up operation.

Inhibit all shifts.

Turn ON the CHECK TRANS light.

Display the range attained.

Ignore any range selection inputs from the shift selector.

DNA - Do Not Adapt Response

The TCM stops adaptive shift control while the code is active.

SOL OFF - SOLenoid OFF Response

All solenoids are commanded *OFF* (turning solenoids “A” and “B” off electrically cause them to be on hydraulically).

RPR - Return to Previous Range Response

When the speed sensor ratio or C3 pressure switch test associated with a shift not successful, the TCM commands the same range as commanded before the shift.

NNC - Neutral No Clutches Response

When certain speed sensor ratio or C3 pressure switch tests are not successful, the TCM commands a neutral condition with no clutches applied.

10.1.6 Diagnostic Troubleshooting Codes (DTC) List - Allison 4th Generation Controls

DTC	Description	CHECK TRANS Light	Inhibited Operation Description
C1312	Retarder Request Sensor Failed Low	No	May inhibit retarder operation if not using J1939 datalink
C1313	Retarder Request Sensor Failed High	No	May inhibit retarder operation if not using J1939 datalink
P0122	Pedal Position Sensor Low Voltage	No	Use default throttle values. Freezes shift adapts.
P0123	Pedal Position Sensor High Voltage	No	Use default throttle values. Freezes shift adapts.
P0218	Transmission Fluid Over Temperature	No	Use hot mode shift schedule. Holds fourth range. TCC is inhibited. Freezes shift adapts.
P0602	TCM Not Programmed	Yes	Lock in Neutral
P0610	TCM Vehicle Options (Trans ID) Error	Yes	Use TID A calibration
P0613	TCM Processor	No	All solenoids off
P0614	Torque Control Data Mismatch - ECM/TCM	Yes	Allows operation only in reverse and second range.
P0634	TCM Internal Temperature Too High	Yes	SOL OFF (hydraulic default)
P063E	Auto Configuration Throttle Input Not Present	Yes	Use default throttle values
P063F	Auto Configuration Engine Coolant Temp Input Not Present	No	None
P0658	Actuator Supply Voltage 1 (HSD1) Low	Yes	DNS, SOL OFF (hydraulic default)
P0659	Actuator Supply Voltage 1 (HSD1) High	Yes	DNS, SOL OFF (hydraulic default)
P0702	Transmission Control System Electrical (TransID)	Yes	Use TID A calibration
P0703	Brake Switch Circuit Malfunction	No	No Neutral to Drive shifts for refuse packer. TCM inhibits retarder operation if a TPS code is also active.

Section 07: TRANSMISSION

DTC	Description	CHECK TRANS Light	Inhibited Operation Description
P0708	Transmission Range Sensor Circuit High Input	Yes	Ignore defective strip selector inputs
P070C	Transmission Fluid Level Sensor Circuit – Low Input	No	None
P070D	Transmission Fluid Level Sensor Circuit – High Input	No	None
P0711	Transmission Fluid Temperature Sensor Circuit Performance	Yes	Use default sump temp
P0712	Transmission Fluid Temperature Sensor Circuit Low Input	Yes	Use default sump temp
P0713	Transmission Fluid Temperature Sensor Circuit High Input	Yes	Use default sump temp
P0716	Turbine Speed Sensor Circuit Performance	Yes	DNS, Lock in current range
P0717	Turbine Speed Sensor Circuit No Signal	Yes	DNS, Lock in current range
P0719	Brake Switch ABS Input Low	No	TCM assumes ABS is OFF
P071A	RELS Input Failed On	Yes	Inhibit RELS operation
P071D	General Purpose Input Fault	Yes	None
P0721	Output Speed Sensor Circuit Performance	Yes	DNS, Lock in current range
P0722	Output Speed Sensor Circuit No Signal	Yes	DNS, Lock in current range
P0726	Engine Speed Sensor Circuit Performance	No	Default to turbine speed
P0727	Engine Speed Sensor Circuit No Signal	No	Default to turbine speed
P0729	Incorrect 6 th Gear Ratio	Yes	DNS, Attempt 5 th , then 3 rd
P0731	Incorrect 1 st Gear ratio	Yes	DNS, Attempt 2 nd , then 5 th
P0732	Incorrect 2 nd Gear ratio	Yes	DNS, Attempt 3 rd , then 5 th
P0733	Incorrect 3 rd Gear ratio	Yes	DNS, Attempt 4 th , then 6 th
P0734	Incorrect 4 th Gear ratio	Yes	DNS, Attempt 5 th , then 3 rd
P0735	Incorrect 5 th Gear ratio	Yes	DNS, Attempt 6 th , then 3 rd , then 2 nd
P0736	Incorrect Reverse Gear ratio	Yes	DNS, Lock in Neutral
P0741	Torque Converter Clutch System Stuck Off	Yes	None
P0776	Pressure Control Solenoid 2 Stuck Off	Yes	DNS, RPR
P0777	Pressure Control Solenoid 2 Stuck On	Yes	DNS, RPR
P0796	Pressure Control Solenoid 3 Stuck Off	Yes	DNS, RPR
P0797	Pressure Control Solenoid 3 Stuck On	Yes	DNS, RPR
P0842	Transmission Pressure Switch 1 Circuit Low	Yes	DNS, Lock in current range
P0843	Transmission Pressure Switch 1 Circuit High	Yes	DNS, Lock in current range
P0880	TCM Power Input Signal	No	None
P0881	TCM Power Input Signal Performance	No	None
P0882	TCM Power Input Signal Low	Yes	DNS, SOL OFF (hydraulic default)
P0883	TCM Power Input Signal High	No	None
P0894	Transmission Component Slipping	Yes	DNS, Lock in first
P0960	Pressure Control Solenoid Main Mod Control Circuit Open	Yes	None
P0962	Pressure Control Solenoid Main Mod Control Circuit Low	Yes	DNS, SOL OFF (hydraulic default)
P0963	Pressure Control Solenoid Main Mod Control Circuit High	Yes	None
P0964	Pressure Control Solenoid 2 (PCS2) Control Circuit Open	Yes	DNS, SOL OFF (hydraulic default)
P0966	Pressure Control Solenoid 2 (PCS2) Control Circuit Low	Yes	DNS, SOL OFF (hydraulic default)
P0967	Pressure Control Solenoid 2 (PCS2) Control Circuit High	Yes	DNS, SOL OFF (hydraulic default)
P0968	Pressure Control Solenoid 3 (PCS3) Control Circuit Open	Yes	DNS, SOL OFF (hydraulic default)

Section 07: TRANSMISSION

DTC	Description	CHECK TRANS Light	Inhibited Operation Description
P0970	Pressure Control Solenoid 3 (PCS3) Control Circuit Low	Yes	DNS, SOL OFF (hydraulic default)
P0971	Pressure Control Solenoid 3 (PCS3) Control Circuit High	Yes	DNS, SOL OFF (hydraulic default)
P0973	Shift Solenoid 1 (SS1) Control Circuit Low	Yes	DNS, SOL OFF (hydraulic default)
P0974	Shift Solenoid 1 (SS1) Control Circuit High	Yes	DNS, SOL OFF (hydraulic default)
P0975	Shift Solenoid 2 (SS2) Control Circuit Open	Yes	7-speed: Allow 2 through 6, N, R
P0976	Shift Solenoid 2 (SS2) Control Circuit Low	Yes	7-speed: Allow 2 through 6, N, R Inhibit TCC operation
P0977	Shift Solenoid 2 (SS2) Control Circuit High	Yes	7-speed: Allow 2 through 6, N, R
P0989	Retarder Pressure Sensor Failed Low	No	None
P0990	Retarder Pressure Sensor Failed High	No	None
P1739	Incorrect Low Gear Ratio	Yes	Command 2 nd and allow shifts 2 through 6, N, R
P1891	Throttle Position Sensor PWM Signal Low Input	No	Use default throttle values
P1892	Throttle Position Sensor PWM Signal High Input	No	Use default throttle values
P2184	Engine Coolant Temperature Sensor Circuit Low Input	No	Use default engine coolant values
P2185	Engine Coolant Temperature Sensor Circuit High Input	No	Use default engine coolant values
P2637	Torque Management Feedback Signal (SEM)	Yes	Inhibit SEM
P2641	Torque Management Feedback Signal (LRTP)	Yes	Inhibit LRTP
P2670	Actuator Supply Voltage 2 (HSD2) Low	Yes	DNS, SOL OFF (hydraulic default)
P2671	Actuator Supply Voltage 2 (HSD2) High	Yes	DNS, SOL OFF (hydraulic default)
P2685	Actuator Supply Voltage 3 (HSD3) Low	Yes	DNS, SOL OFF (hydraulic default)
P2686	Actuator Supply Voltage 3 (HSD3) High	Yes	DNS, SOL OFF (hydraulic default)
P2714	Pressure Control Solenoid 4 (PCS4) Stuck Off	Yes	DNS, RPR
P2715	Pressure Control Solenoid 4 (PCS4) Stuck On	Yes	DNS, SOL OFF (hydraulic default)
P2718	Pressure Control Solenoid 4 (PCS4) Control Circuit Open	Yes	DNS, SOL OFF (hydraulic default)
P2720	Pressure Control Solenoid 4 (PCS4) Control Circuit Low	Yes	DNS, SOL OFF (hydraulic default)
P2721	Pressure Control Solenoid 4 (PCS4) Control Circuit High	Yes	DNS, SOL OFF (hydraulic default)
P2723	Pressure Control Solenoid 1 (PCS1) Stuck Off	Yes	DNS, RPR
P2724	Pressure Control Solenoid 1 (PCS1) Stuck On	Yes	DNS, RPR
P2727	Pressure Control Solenoid 1 (PCS1) Control Circuit Open	Yes	DNS, SOL OFF (hydraulic default)
P2729	Pressure Control Solenoid 1 (PCS1) Control Circuit Low	Yes	DNS, SOL OFF (hydraulic default)
P2730	Pressure Control Solenoid 1 (PCS1) Control Circuit High	Yes	DNS, SOL OFF (hydraulic default)
P2736	Pressure Control Solenoid 5 (PCS5) Control Circuit Open	Yes	Inhibit retarder operation
P2738	Pressure Control Solenoid 5 (PCS5) Control Circuit Low	Yes	Allow 2 through 6, N, R. Inhibit retarder and TCC operation
P2739	Pressure Control Solenoid 5 (PCS5) Control Circuit High	Yes	Inhibit retarder operation
P2740	Retarder Oil Temperature Hot	No	None
P2742	Retarder Oil Temperature Sensor Circuit – Low Input	No	Use default retarder temp values
P2743	Retarder Oil Temperature Sensor Circuit – High Input	No	Use default retarder temp values
P2761	TCC PCS Control Circuit Open	Yes	Inhibit TCC operation
P2763	TCC PCS Control Circuit High	Yes	Inhibit TCC operation
P2764	TCC PCS Control Circuit Low	Yes	7-speed: Allow 2 through 6, N, R. Inhibit TCC operation

Section 07: TRANSMISSION

DTC	Description	CHECK TRANS Light	Inhibited Operation Description
P278A	Kickdown Input Failed ON	No	Inhibit kickdown operation
P2793	Gear Shift Direction Circuit	Yes	Ignores PWM input from shift selector
P2808	Pressure Control Solenoid 6 (PCS6) Stuck Off	Yes	DNS, RPR
P2809	Pressure Control Solenoid 6 (PCS6) Stuck On	Yes	DNS, RPR
P2812	Pressure Control Solenoid 6 (PCS6) Control Circuit Open	Yes	DNS, SOL OFF (hydraulic default)
P2814	Pressure Control Solenoid 6 (PCS6) Control Circuit Low	Yes	DNS, SOL OFF (hydraulic default)
P2815	Pressure Control Solenoid 6 (PCS6) Control Circuit High	Yes	DNS, SOL OFF (hydraulic default)
U0001	Hi Speed CAN Bus Reset Counter Overrun (IESCAN)	No	Use default values, inhibit SEM
U0010	CAN BUS Reset Counter Overrun	No	Use default values, inhibit SEM
U0100	Lost Communications with ECM/PCM (J1587)	Yes	Use default values
U0103	Lost Communication with Gear Shift Module (Shift Selector) 1	Yes	Maintain range selected, observe gear shift direction circuit
U0115	Lost Communication with ECM	Yes	Use default values
U0291	Lost Communication with Gear Shift Module (Shift Selector) 2	Yes	Maintain range selected, observe gear shift direction circuit
U0304	Incompatible Gear Shift Module 1 (Shift Selector) ID	Yes	Ignore shift selector inputs
U0333	Incompatible Gear Shift Module 2 (Shift Selector) ID	Yes	Ignore shift selector inputs
U0404	Invalid Data Received From Gear Shift Module (Shift Selector) 1	Yes	Maintain range selected, observe gear shift direction circuit
U0592	Invalid Data Received From Gear Shift Module (Shift Selector) 2	Yes	Maintain range selected, observe gear shift direction circuit

11. ZF-ASTRONIC TRANSMISSION SYSTEM FAULTS AND ERROR MESSAGES

11.1 SYSTEM FAULTS (ERROR MESSAGES)

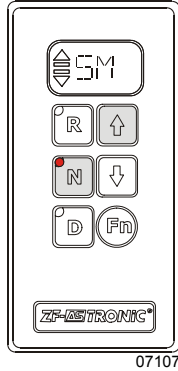

If the “SM” symbol appears in the display, a system error has occurred.

- Stop the vehicle
- Vehicle may no longer be driven

Error messages and the reactions resulting from these errors can be deleted with the vehicle at a standstill and the “Ignition OFF”. (Wait until the display goes out). If the display does not go out once the ignition has been turned “OFF”, set the battery master switch to the **OFF** position. Switch the ignition back on. If the error message is still in place, the transmission has to be repaired. The transmission is inoperative. The vehicle will have to be taken to a service point. The error number(s) must be specified when the service point is contacted.

ERROR CODES

Remark to titles in table:

ZF fault number: defined by ZF.

Display SM-Symbol : (0=NO, 1=YES) Display shows “SM”(severe failure)

Warning lamp : (0=NO, 1=YES) Telltale panel warning lamp “check trans”(less severe failure)

Shift schemes of transmissions:

- Y2 Splitter K2
- Y3 Splitter K1
- Y8 Range (GP) low
- Y9 Range (GP)

10/12-Gear Scheme

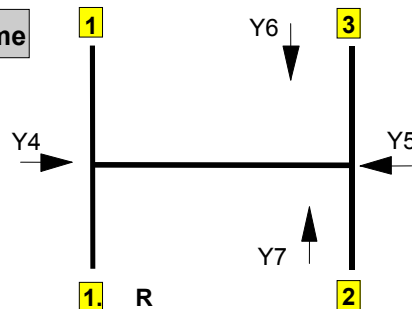

Calling up error numbers

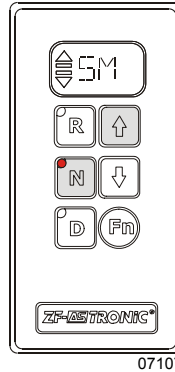

- Switch on ignition
- Depress “N” key
- Hold down “↑” key
- * One or more error numbers appear on the display. These correspond to the errors presently active in the system.

Calling up error numbers from the error memory:

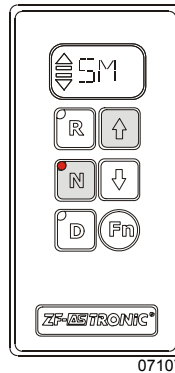

- Switch on ignition
- Press “N” key and at the same time depress the foot-operated brake
- Hold down the foot-operated brake and depress and hold down “↑” key
- * The errors stored in the transmission ECU are shown on the display one after another.

Section 07: TRANSMISSION

ON MESSAGES CENTER DISPLAY (MCD) SAE-J1587 Codes	ON SHIFT SELECTOR DISPLAY	ISO CODES WITH TESTMAN TOOL	DESCRIPTION
8, 7	8	161	Easy Start, Brake doesn't open completely
8, 14	8	162	Easy Start, Not Available
20,6	14	22	Short circuit to ground at output ACC (wakeup control signal for ZMTEC, keep alive signal for voltage doubler, and power signal for speed sensor #2)
20,5	14	54	Interruption at output ACC (wakeup control signal for ZMTEC, keep alive signal for voltage doubler, and power signal for speed sensor #2)
20,3	14	86	Short circuit to positive at output ACC (wakeup control signal for ZMTEC, keep alive signal for voltage doubler, and power signal for speed sensor #2)
21,2	15	127	Error on ECU temperature sensor signal
21,0	15	193	ECU temperature too high
31,3	1F	137	No range change group (GP) sensor signal (Short circuit to positive)
31,6	1F	138	No range change group (GP) sensor signal (Short circuit to ground)
31,5	1F	139	No range change group (GP) sensor signal (Interruption)
31,13	1F	140	Self adjustment error of range change group sensor in position fast
31,7	1F	159	Range-change group sensor signal leaves engaged position during driving
32,3	20	141	No splitter group (GV) sensor signal (Short circuit to positive)
32,6	20	142	No splitter group (GV) sensor signal (Short circuit to ground)
32,5	20	143	No splitter group (GV) sensor signal (Interruption)
32,13	20	144	Splitter group (GV) sensor self adjustment error
32,7	20	160	Splitter sensor signal leaves engaged position during driving
33,14	21	107	Stabilised voltage supply at output AU (clutch sensor supply) too high or too low
33,13	21	117	Error in clutch self-adjustment process
33,2	21	124	Error on clutch travel signal
34,7	22	120	Mechanical failure of small clutch disengagement valve
34,7	22	121	Mechanical failure of large clutch disengagement valve
34,7	22	122	Mechanical failure of small clutch engagement valve
34,7	22	123	Mechanical failure of large clutch engagement valve
34,6	22	18	Short circuit to ground at output stage to small disengagement clutch valve
34,6	22	19	Short circuit to ground at output stage to small engagement clutch valve
34,6	22	20	Short circuit to ground at output stage to large disengagement clutch valve
34,6	22	21	Short circuit to ground at output stage to large engagement clutch valve
34,5	22	50	Interruption at output stage to small disengagement clutch valve
34,5	22	51	Interruption at output stage to small engagement clutch valve

ON MESSAGES CENTER DISPLAY (MCD) SAE-J1587 Codes	ON SHIFT SELECTOR DISPLAY	ISO CODES WITH TESTMAN TOOL	DESCRIPTION
34,5	22	52	Interruption at output stage to large disengagement clutch valve
34,5	22	53	Interruption at output stage to large engagement clutch valve
34,3	22	82	Short circuit to positive at output stage to small disengagement clutch valve
34,3	22	83	Short circuit to positive at output stage to small engagement clutch valve
34,3	22	84	Short circuit to positive at output stage to large disengagement clutch valve
34,3	22	85	Short circuit to positive at output stage to large engagement clutch valve
35,5	23	41	Interruption at output stage to Y9 (Valve Range)
35,3	23	73	Short circuit to positive at output stage to Y9 (Valve range)
35,6	23	9	Short circuit to ground at output stage to Y9 (Valve Range)
36,5	24	40	Interruption at output stage to Y8 (Valve Range)
36,3	24	72	Short circuit to positive at output stage to Y8 (Valve range)
36,6	24	8	Short circuit to ground at output stage to Y8 (Valve Range)
37,6	25	2	Short circuit to ground at output stage to Y2 (Valve Splitter)
37,5	25	34	Interruption at output stage to Y2 (Valve Splitter)
37,3	25	66	Short circuit to positive at output stage to Y2 (Valve Splitter)
38,6	26	3	Short circuit to ground at output stage to Y3 (Valve Splitter)
38,5	26	35	Interruption at output stage to Y3 (Valve Splitter)
38,3	26	67	Short circuit to positive at output stage to Y3 (Valve Splitter)
39,5	27	36	Interruption at output stage to Y4 (Valve Select)
39,6	27	4	Short circuit to ground at output stage to Y4 (Valve Select)
39,3	27	68	Short circuit to positive at output stage to Y4 (Valve Select)
40,5	28	38	Interruption at output stage to Y6 (Valve Shift)
40,6	28	6	Short circuit to ground at output stage to Y6 (Valve Shift)
40,3	28	70	Short circuit to positive at output stage to Y6 (Valve Shift)
43,2	2B	175	Error on "Ignition lock" signal (terminal 15)
48,3	30	129	No shift sensor signal (Short circuit to positive)
48,6	30	130	No shift sensor signal (Short circuit to ground)
48,5	30	131	No shift sensor signal (Interruption)
48,13	30	132	Self adjustment error of shift sensor
48,7	30	157	Selector sensor signal leaves position during driving
48,7	30	158	Engage sensor signal leaves engaged position during driving
50,5	32	37	Interruption at output stage to Y5 (Valve Select)

Section 07: TRANSMISSION

ON MESSAGES CENTER DISPLAY (MCD) SAE-J1587 Codes	ON SHIFT SELECTOR DISPLAY	ISO CODES WITH TESTMAN TOOL	DESCRIPTION
50,6	32	5	Short circuit to ground at output stage to Y5 (Valve Select)
50,3	32	69	Short circuit to positive at output stage to Y5 (Valve Select)
51,5	33	39	Interruption at output stage to Y7 (Valve Shift)
51,6	33	7	Short circuit to ground at output stage to Y7 (Valve Shift)
51,3	33	71	Short circuit to positive at output stage to Y7 (Valve Shift)
54,6	36	17	Short circuit to ground at output stage to Y1 (inertia brake valve)
54,5	36	49	Interruption at output stage to Y1 (inertia brake valve)
54,3	36	81	Short circuit to positive at output stage to Y1 (inertia brake valve)
55,7	37	114	Clutch engaged unintentionally at standstill, gear engaged
55,7	37	118	Clutch does not disengage
55,7	37	119	Clutch does not engage / does not transmit engine torque
56,7	38	145	Range change group (GP) disengagement error
56,7	38	146	Changeover error during range change group (GP) shifting
56,7	38	147	Range change group (GP) does not engage
57,2	39	108	Error in shift lever
57,14	39	110	ZF CAN timeout (can also means shift lever error through ZMP06400.hex)
58,7	3A	154	Main transmission gear does not disengage
58,7	3A	155	Main transmission gear does not engage
58,7	3A	156	Wrong gear shifting
59,7	3B	151	Selector cylinder does not disengage
59,7	3B	152	Change over error during gate selection procedure
59,7	3B	153	Selector cylinder does not engage
60,3	3C	133	No gate select sensor signal (Short circuit to positive)
60,6	3C	134	No gate select sensor signal (Short circuit to ground)
60,5	3C	135	No gate select sensor signal (Interruption)
60,13	3C	136	Gate select sensor self adjustment error
61,7	3D	148	Splitter (GV) does not disengage
61,7	3D	149	Change over error during splitter shifting
61,7	3D	150	Splitter (GV) does not engage
63,14	3F	100	Error on output speed signal 2
106,0	6A	125	Error on pressure reduction valve
106,14	6A	126	Error on pressure sensor signal

ON MESSAGES CENTER DISPLAY (MCD) SAE-J1587 Codes	ON SHIFT SELECTOR DISPLAY	ISO CODES WITH TESTMAN TOOL	DESCRIPTION
150,14	96	59	Acknowledge fault of PTO 1
150,14	96	60	Acknowledge fault of PTO 2
150,7	96	61	Disengagement fault of PTO 1
150,7	96	62	Disengagement fault of PTO 2
150,7	96	63	Engagement fault of PTO1
150,7	96	64	Engagement fault of PTO2
151,14	97	102	Plausibility error between transmission input speed and output speed
152,6	98	10	Short circuit to ground at output stage to Y10 (Main valve)
152,5	98	42	Interruption at output stage to Y10 (Main valve)
152,3	98	74	Short circuit to positive at output stage to Y10 (Main valve)
153,14	99	-	Error on ISO 14320 communications line
154,14	9A	101	Error on both output speed signals
161,14	A1	98	Error on transmission input speed signal
177,2	B1	128	Error on oil temperature sensor signal
191,14	BF	194	Both sources of vehicle speed are faulty
191,14	BF	99	Error on output speed signal 1
230,14	E6	166	Permanent idle signal
230,14	E6	168	No idle signal or error on "idle signal switch" signal (EEC2)
230,14	E7	103	Error on "Wheel-based vehicle speed" signal (CCV
231,7	E7	163	Engine does not react on torque intervention
231,14	E7	164	Error on "Drivers demand engine percent torque" (EEC1)
231,14	E7	165	Error on "Accelerator pedal position" (EEC2)
231,14	E7	167	Error on "Percent load at current speed" signal (EEC2)
231,14	E7	171	Error on "Actual engine percent torque" signal (EEC1)
231,14	E7	172	Permanent engine brake request signal
231,14	E7	173	Error on "Brake switch" signal (CCVS)
231,14	E7	177	System-CAN Busoff error
231,11	E7	178	CAN error frames
231,11	E7	179	CAN queue overrun
231,14	E7	180	CAN EEC1 timeout
231,14	E7	181	CAN EEC2 timeout
231,14	E7	182	CAN CCVS timeout

Section 07: TRANSMISSION

ON MESSAGES CENTER DISPLAY (MCD) SAE-J1587 Codes	ON SHIFT SELECTOR DISPLAY	ISO CODES WITH TESTMAN TOOL	DESCRIPTION
231,14	E7	183	CAN ERC1_ER timeout
231,14	E7	197	Error on "Front axle speed" (WSI)
231,14	E7	198	Error on "Relative wheel speeds" (WSI)
231,14	E7	199	CAN WSI timeout
231,14	E7	26	CAN engine configuration timeout
231,14	E7	27	Error on "engine configuration message" (engine configuration)
231,14	E7	31	Error on "Actual engine retarder - percent torque" signal (ERC1_ER)
231,14	E7	32	Error on "Engine retarder configuration message" (Engine retarder configuration)
231,14	E7	33	CAN "Engine retarder configuration" timeout
231,14	E7	91	CAN EBC1 timeout
231,14	E7	92	Error on "ABS active" signal (EBC1)
231,14	E7	93	Error on "ASR engine control active" signal (EBC1)
231,14	E7	94	Error on "ASR brake control active" signal (EBC1)
231,14	E7	95	Error on "Cruise control active" signal (CCVS)
231,14	E7	96	Error on "Cruise control set speed" (CCVS)
231,14	E7	97	Error on "Engine speed" signal (EEC1)
-	EE	-	Communication error between GS3 and ZMTEC on display line
248,6	F8	25	Short circuit to ground at output SD to display
248,3	F8	89	Short circuit to positive at output SD to display

12. SPECIFICATIONS

ALLISON AUTOMATIC TRANSMISSION WITH OR WITHOUT RETARDER

X3 Coaches

Gross input power (maximum).....500 HP (373 kW)
 Gross input torque (maximum)1525 Lbf-ft- (2068 Nm)
 Rated input speed (minimum-maximum) 1600-2300 rpm

Mounting:

Engine.....SAE #1 flywheel housing, flex disk drive

Torque converter:

Type One stage, three element, polyphase
 Stall torque ratioTC 551-1.8
 Lockup clutch with torsional damper Integral/standard

Gearing:

Type Patented, constant mesh, helical, planetary

Ratio:

First3.51:1
 Second..... 1.91:1
 Third..... 1.43:1
 Fourth..... 1.00:1
 Fifth0.74:1
 Sixth0.64:1
 Reverse 4.80:1

Ratio coverage:

6 speed5.48:1

*** Gear ratios do not include torque converter multiplication.**

Oil System:

Oil type.....TRANSYND, DEXRON III
 Capacity (excluding external circuits)Initial fill 47 US qts (45 liters)
 Oil change..... 24 US qts (23 liters)
 Oil change (with retarder)..... 27.6 US qts (26 liters)

Oil Filters:

Make Allison Transmission
 Type Disposable cartridge
 Supplier number29503829
 Prévost number 57-1687