

CONTROLS AND INSTRUMENTS

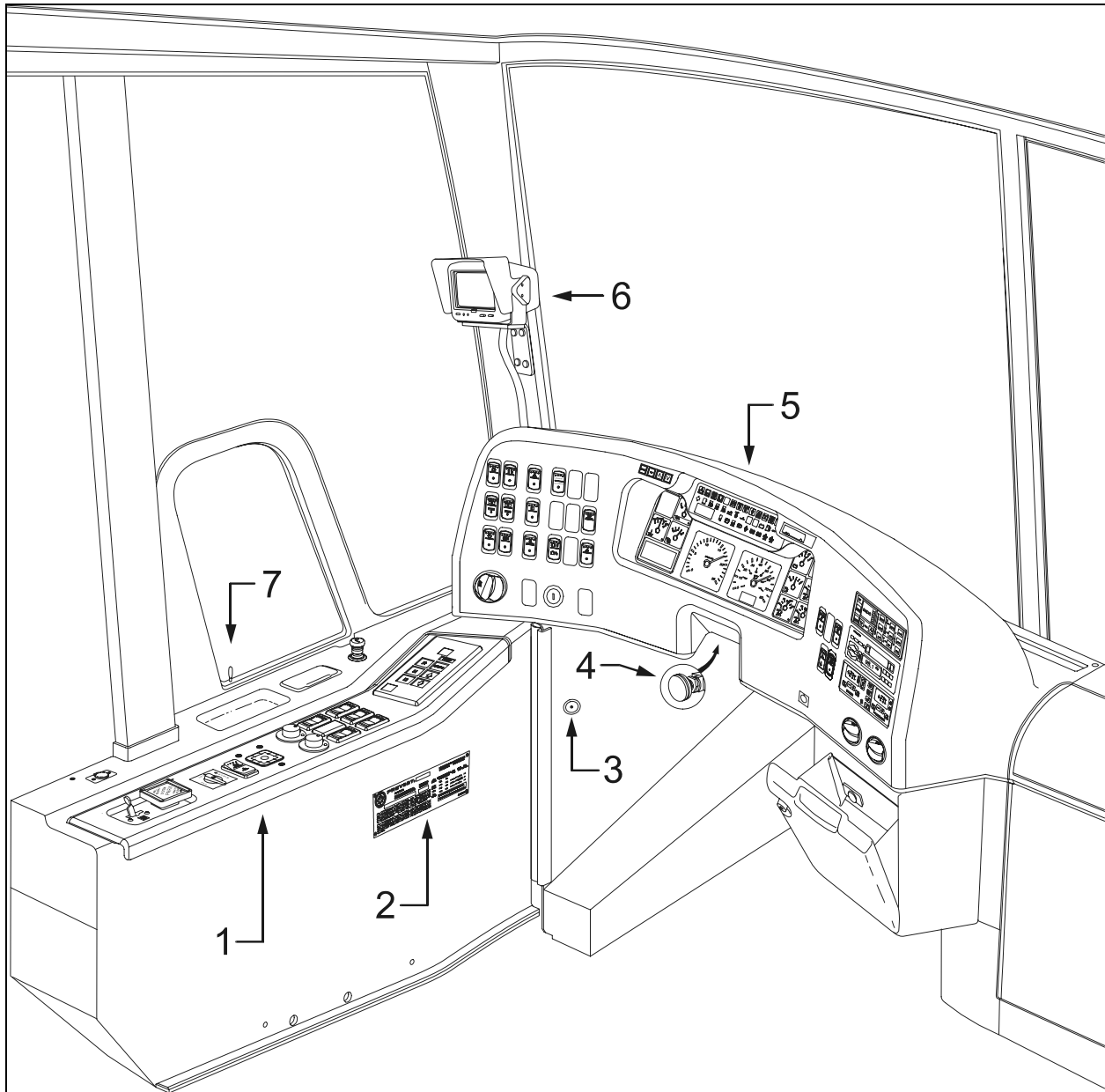

DRIVER'S AREA

18563

- | | |
|---|--|
| 1. Lateral control panel | 5. Dashboard |
| 2. DOT certification plate | 6. Rear view TV monitor (optional) |
| 3. Diagnostic Data Reader (DDR) receptacle | 7. Front service door unlocking pull-rod |
| 4. Foot operated steering wheel adjustment unlock air valve | |

KEYS

Four different key models are provided with the vehicle:

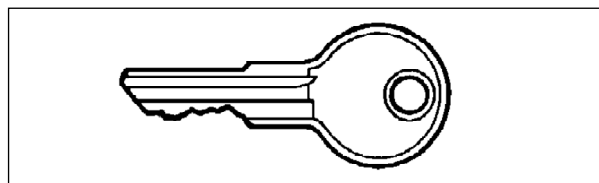

IGNITION KEY

23056

CONTROLS AND INSTRUMENTS

The ignition switch doubles as the battery master switch. Any position other than OFF activates the battery electrical circuit. The battery electrical circuit is also activated when the hazard switch is depressed.

Use the ignition key to activate the battery electrical circuit by turning it counterclockwise to the ACC position.

To start the engine, turn the key clockwise to the START position, and then release it. The key will set to ON position.

⚠ CAUTION ⚠

When the vehicle is parked overnight or for an extended period of time, the battery master switch (ignition switch) should be set to the OFF position.

NOTE

When the battery master switch (ignition switch) is set to the OFF position, all electrical supply from the batteries is cut off, with the exception of battery equalizer check module, ECM ignition and power supply, ECU power (World Transmission), coolant heater electronic timer, coolant heater and water recirculating pump, pro-driver, power-verter, keyless entry system and fire alarm.

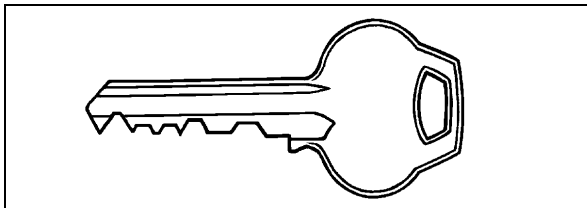

ENTRANCE DOOR KEY

23057

Use the entrance door key to lock or unlock the door from the outside. It is also possible to lock or unlock the entrance door using the exterior compartment door lock, the entrance door unlocking switch or using the keyless entry system.

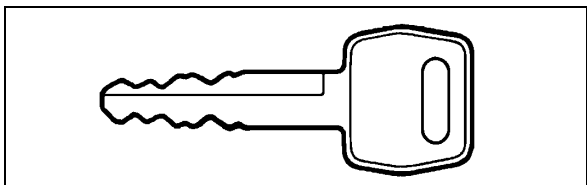

EXTERIOR COMPARTMENTS KEY

23244

Use one of the two exterior compartment keys provided to lock or unlock any exterior compartment door, including the electrical or

service compartment doors, but excluding the fuel tank filling access doors. It is also possible to lock or unlock the baggage compartments and service compartments from the inside by means of a switch located on the dashboard.

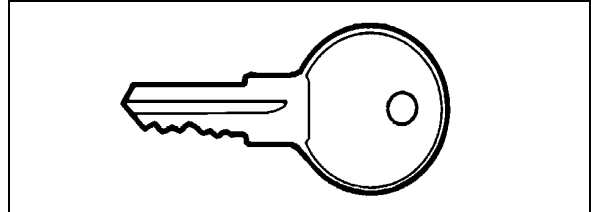

FUEL FILLER DOOR KEY

23014C

Use this key to unlock the fuel filler doors on either side of the vehicle.

NOTE

For your protection against theft, record the key numbers and keep this information in a safe place. Do not keep these records inside vehicle. It is also advisable to deposit a duplicate of each key in a safe place, so they can be obtained without difficulty in case of an emergency or loss.

REMOTE ENTRY TRANSMITTER

Up to four hand held (electronic key) transmitters can control electronic door lock system.

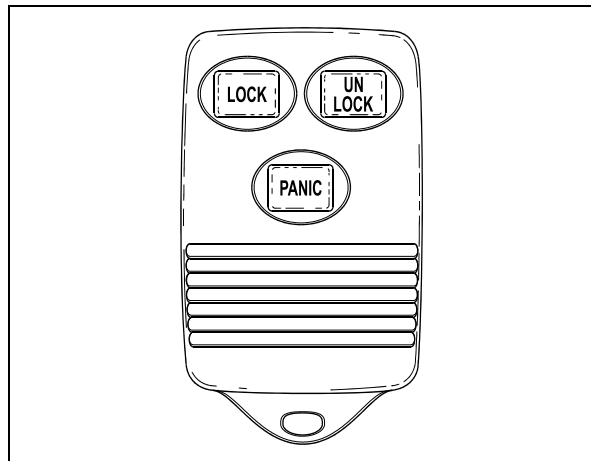

REMOTE ENTRY TRANSMITTER

23208

To unlock the entry door:

- Press the UNLOCK button on the transmitter. This will unlock the door and disarm the anti-theft system.

To unlock all compartments:

- Press UNLOCK a second time within five seconds of the first unlock. If more than five seconds pass pressing UNLOCK will only unlock the entry door.

To lock all doors and arm the anti-theft system:

- Press LOCK on the transmitter once.

To confirm that the door and compartments have been locked and that the anti-theft system is armed:

- Press LOCK again within five seconds of the first lock. The horn will chirp once if the door and compartments have locked. If the door or one of the compartments is open, a door ajar signal prevents arming of the system.

To set off the personal security alarm:

- Press the red PANIC button on any transmitter. The horn will sound and the headlamps will flash for a maximum of three minutes.

To deactivate the personal security alarm:

- Press the red PANIC button again on any transmitter or turn the ignition key ON.

NOTE

The remote entry features will not function when the ignition is in the ON or ACC position.

IGNITION SWITCH

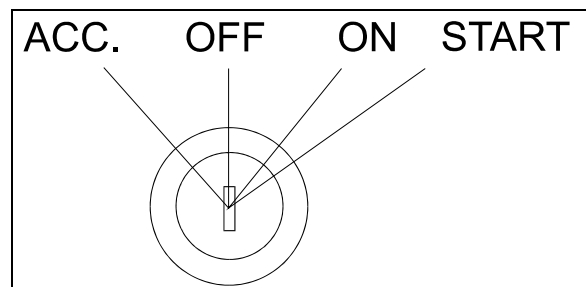

06354

The ignition switch is located on the lower left side of the dashboard. It has four positions:

Off

In the *OFF* position, ignition cannot take place. The key can be removed in this position.

The electrical circuits are not activated when the switch is in this position. Only the accessories connected directly to the batteries can be activated. These are: the coolant heater and water pump, the keyless entry system and anti-theft alarm, the central locking system, entry lights electric horn and Message Center Display (MCD). Maintain the switch in this position when parked overnight or for an extended period.

Accessories

To operate the accessories only, turn the ignition key counterclockwise. The key cannot be removed in this position.

The battery electrical circuits are activated when the switch is in this position or when the hazard flashers are activated.

The features enabled when the key is in the ACC position are all those linked directly to the battery plus the exterior temperature display, the radio or entertainment system, exterior and interior lighting.

On

To place ignition switch to *ON*, turn the key clockwise to the first position. The key cannot be removed in this position.

The electrical circuits activated are the same than when the switch is in the *ACC* position plus the transmission, engine and accessories, ABS system, wipers, level low system, dashboard cluster gauges and buzzers, air horn and air dryer heater are activated when the key is in this position. Do not leave the key in this position unless the engine is running.

Start

Turn the key clockwise to the second position and release as soon as the engine starts. The key will return to the *ON* position. If the engine did not start, return the ignition key to the *OFF* position before trying to restart the engine.

CAUTION

To avoid overheating the starter, do not engage the starter for more than 15 seconds at a time. Allow the starter to cool before trying to restart the engine.

The features activated when the engine is running are all those described above plus the HVAC system and day time running lights. The optional ether cold-start system is automatically deactivated once the engine runs.

LATERAL CONTROL PANEL

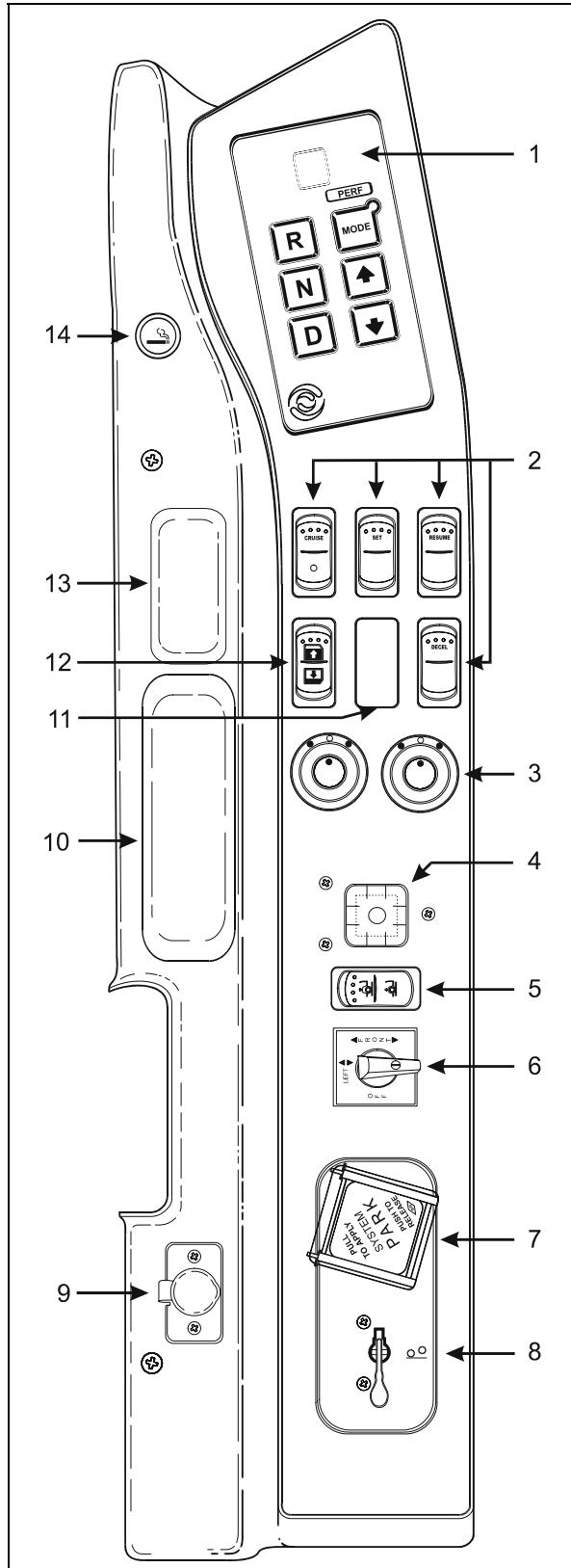

L.H. CONTROL PANEL

06514

1. Transmission Control Pad
2. Cruise Control Switches
3. Mirror Controls
4. Level Indicator
5. Height Control Switch
6. Level Low Control Valve
7. Parking Brakes Control Valve
8. Tag Axle Control Valve
9. 12 Volt DC Power Outlet
10. Accessory Pocket
11. Blank
12. Driver's Power Window Switch
13. Accessory Pocket or Ashtray (Optional)
14. Cigarette Lighter (Optional)

TRANSMISSION CONTROL PAD (1)

The control pad for the transmission is located as shown. Refer to "Automatic Transmission" in this chapter for operating instructions and more information.

CRUISE CONTROL SWITCHES (2)

The cruise control is part of the DDEC V electronic engine control that will maintain a set speed when the vehicle is traveling above 20 mph (32 km/h).

⚠ WARNING ⚠

Do not use the cruise control when driving speed must be constantly adjusted, such as in heavy traffic or on winding, icy, snow-covered or slippery roads, or on gravel roads.

⚠ WARNING ⚠

Do not put the transmission in the neutral (N) position while driving with cruise control. This will cause the engine to over-speed and may result in a loss of driving control.

Setting Coach Speed

Depress the CRUISE rocker switch to activate the cruise control. A LED on the switch illuminates when the cruise control is activated. Accelerate the vehicle to the desired cruising speed using the accelerator pedal. Depress and release the **SET** switch then remove foot from the accelerator pedal. This will set the vehicle cruise speed and store it in memory.

NOTE
 The CRUISE CONTROL and RESUME switch do not operate at speeds below 20 mph (32 km/h).

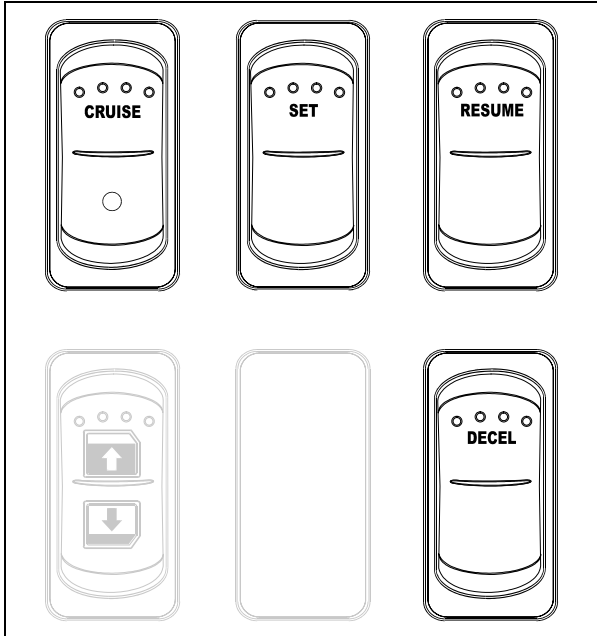

CRUISE CONTROL SWITCHES 06233

Increasing Set Speed

The vehicle cruise speed setting can be increased by one of the following methods:

- Accelerate using the accelerator pedal until the desired cruising speed is reached. Depress and release the SET switch.
- Depress and hold the RESUME switch until the desired cruising speed is reached. When the RESUME switch is released, the new cruising speed will be stored in the cruise control memory. The RESUME switch does not operate at speeds below 20 mph (32 km/h).

When driving with cruise control ON, each time either the RESUME switch is momentarily depressed, the cruising set speed is raised by 0.6 mph (1.0 km/h).

NOTE
 When driving with cruise control, the vehicle can still be accelerated by depressing the accelerator pedal in the usual manner. Once the accelerator pedal is released, the vehicle will return to the previously set cruising speed.

Decreasing Set Speed

The cruise speed setting can be decreased by one of the following methods:

- Depress and hold the SET switch until the desired cruising speed is reached. When the SET switch is released, the new cruising speed will be stored in the cruise control memory.
- Depressing momentarily the SET switch will decrease set cruising speed by 0.6 mph (1.0 km/h).
- Slightly apply the service brake.
- Depress and release the DECEL switch.

After disengaging the cruise control, you can return to the preset cruising speed by pressing and releasing the RESUME switch providing that your speed is above 20 mph (32 km/h).

NOTE
 To avoid sudden vehicle hesitation, slightly depress the accelerator pedal before disengaging the cruise control.

NOTE
 When the CRUISE rocker switch is turned off, the cruise control is completely shut off and the cruise speed setting is erased from the cruise control memory.

IMPORTANT NOTE
 If the engine was stopped and the CRUISE rocker switch was in the ON position, the rocker switch must be reset by turning it OFF then ON again in order for the cruise control to be reactivated.

WARNING
 Every time the SET or the RESUME switch is depressed results in a decrease or increase (respectively) in cruising set speed of 0.6 mph (1.0 km/h).

MIRROR CONTROLS (3)

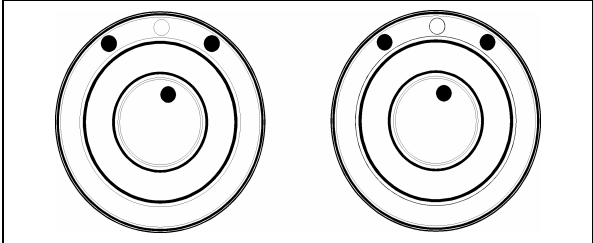

MIRROR CONTROLS 06374

CONTROLS AND INSTRUMENTS

Turn left pointer knob counterclockwise for outside flat mirror adjustments and to the right for convex mirror adjustments, then use the joystick control to adjust the selected mirror's viewing angle. Adjust the right outside mirror similarly but by using the right side control.

NOTE

If the mirror assemblies on your vehicle do not include convex mirrors, only one (1) mirror control knob will be installed for both mirrors. To operate, turn pointer knob to the left for L.H. mirror adjustments and to the right for R.H. mirror adjustments, then use the joystick control to adjust the selected mirror's viewing angle.

LEVEL LOW SYSTEM (4, 5, 6)

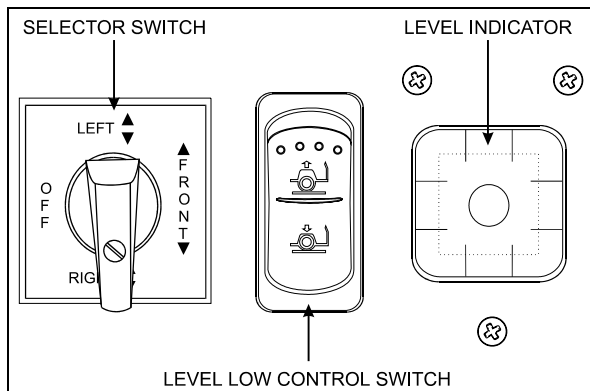

LEVEL LOW SYSTEM CONTROLS

16094

During driving, the conventional air leveling system of the vehicle controls the height at three points: the front, the left rear and the right rear. Your vehicle is equipped with a suspension system that consists of air springs (pressurized air bellows) located near each wheel. The amount of air in each air spring (and thus the vehicle height) is controlled by automatic leveling valves that operate between the chassis and the axles of the vehicle.

The three leveling valves are located as follows: one at the front which controls the amount of air in both front air springs, one at the left rear which controls the left rear corner of the vehicle and one at the right rear which controls the right rear corner of the vehicle. During normal driving, these valves work automatically to maintain the chassis at the proper level above the axles, indifferent of road conditions or vehicle weight.

NOTE

Prévost Car vehicles are designed to operate within specific weight load/ranges for each axle (GAW) and for total vehicle weight (GVW). If the coach is heavier than the design limits, Level Low System (LLS) components damage and problems can occur.

When parked, and **ONLY** when parked, the level of the vehicle can be manually adjusted within the range of travel of the air springs. Thus, if the vehicle is parked on uneven ground, the manual override leveling system can be used to level the chassis of the vehicle. With the ignition ON (engine running or not), turn the selector switch located on L.H. side control panel to the area of the vehicle requiring leveling, then press the rocker switch accordingly (up or down) to inflate or deflate the selected set of air springs. The front position raises or lowers the front only and does not tilt the vehicle to its sides. Each rear position raises or lowers its respective side, therefore, the rear positions can be used to tilt the vehicle to one side or the other, or they can be used to raise or lower the rear of the vehicle. When leveling, it is often necessary to run the engine in order to get an adequate air supply.

NOTE

For maximum ease of ingress and egress as well as for maximum leveling range, lower the vehicle completely before leveling.

NOTE

It is always better to first level the rear of the vehicle (right to left) before raising or lowering the front. After adjusting the rear, watch the level indicator as you adjust the front. If the level indicator shows that the vehicle is starting to tilt to either side, stop adjusting the front as one of the air springs has come to the end of its travel range.

After manual leveling, turn OFF the engine. The vehicle will stay in the leveled position (the air is "locked" in the air springs) as long as there are no air leaks. The vehicle will hold this position for several days. When engine is restarted, with the level selector switch in the OFF position and air pressure is adequate, the vehicle will automatically level itself for driving conditions.

⚠ WARNING ⚠

Do not drive the vehicle with the level low selector switch in any position other than OFF, as this may render the vehicle unsafe and uncontrollable. If this is the case, the Level Low warning telltale light in the dashboard will flash, reminding you that the selector is not in the OFF position.

NOTE

If, for any reason, you wish to start the engine without moving the vehicle (to warm up the engine for instance) while keeping the vehicle in the manually leveled position, place selector switch in any position except OFF. When ignition switch is turned to the OFF position, reset the selector switch to the OFF position.

PARKING BRAKES CONTROL VALVE (7)

Spring-loaded parking brakes are applied by pulling up the control valve knob and protector assembly. Lift the safety cover and push down to release brakes. Refer to "Emergency and Parking Brakes" in "Chapter: Emergency Features and Safety Equipment".

TAG AXLE CONTROL VALVE (8)

Unload (or lift) the tag axle by pushing the lever forward. Pulling the lever back will load (or lower) the tag axle. Refer to "Other Features" chapter for additional information.

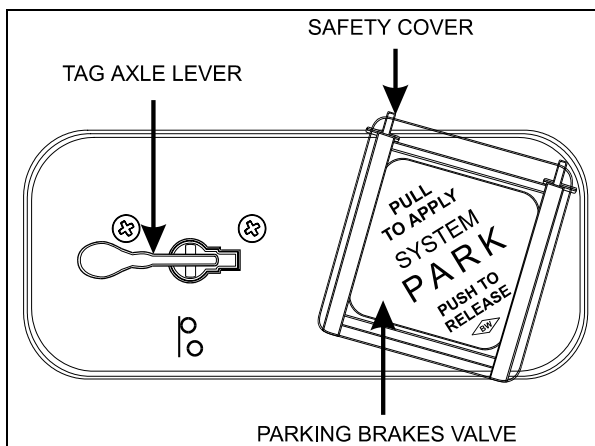

CONTROL VALVES

12177

12-VOLT DC POWER OUTLET (9)

This socket can be used to power small 12 volt DC appliances such as a cellular phone or a vacuum cleaner. The maximum power consumption allowed for appliances plugged in this socket is 130 watts. Make sure appliances are equipped with suitable plugs that will not damage the socket.

ACCESSORY POCKET (10)

If no ashtray is installed, the space becomes an accessory pocket.

To open the ashtray, push slightly on the cover's side. The ashtray can be removed for cleaning by pulling it out.

WARNING

To prevent a fire, never put paper or plastic wrappers in the ashtray. Empty ashtray often.

BLANK (11)

POWER WINDOW SWITCH (12)

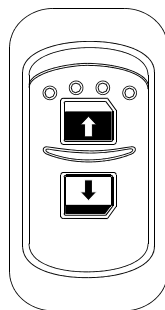

06338

Use the rocker switch to open or close the driver's power window. The switch for the power window in the entrance door is on the R.H. dashboard panel.

ASHTRAY (13)

To open the ashtray, push slightly on the cover's side. The ashtray can be removed for cleaning by pulling it out.

WARNING

To prevent a fire, never put paper or plastic wrappers in the ashtray. Empty ashtray often.

CIGARETTE LIGHTER (14)

Push lighter in to activate. When ready to use, it will spring out automatically. Replace lighter in non-activated position. The cigarette lighter socket can be used to power 12-volt appliances (e.g. flashlight, vacuum cleaner). The maximum power consumption allowed for appliances plugged in this socket is 130 watts. Make sure the appliances are equipped with suitable plugs that will not damage the socket.

NOTE

The cigarette lighter can still be used after the ignition key has been removed.

Diagnostic Data Reader (DDR) Receptacle

To facilitate troubleshooting of the DDEC, WT and ABS systems and to obtain data logged in the ECM (Electronic Control Module) memory, a Diagnostic Data Reader (DDR) (not supplied) can be connected through the DDR receptacle. A user's manual is supplied with the optional DDR.

The DDR receptacle is located inside the footwell, on the upper left side wall.

DASHBOARD CONTROL SWITCHES

High quality laser-engraved switches are used to control many of the features of the vehicle. Many switches have an embedded witness LED to inform the driver at a glance which features are active. Some switches' LED will turn *OFF* after a short while when the engine is running. This is normal and is designed to reduce glare when driving. The functions still operate even if the LED is *OFF*. If the switches are still *ON* when the engine is turned *OFF*, the LEDs will illuminate to warn the driver to turn them *OFF*. Switches are described in the order they appear, from left to right, top to bottom.

L.H. DASHBOARD PANEL

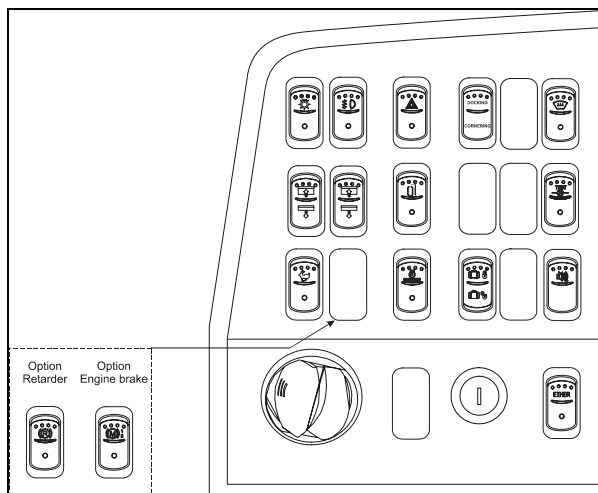

L.H. DASHBOARD PANEL

06567

The dashboard is designed with driver-exclusive controls at the left side and controls shareable with travel companions at the right side.

Headlights

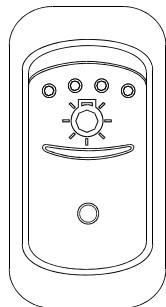

06254

Push down rocker switch to the first position to activate clearance, tail and marker lights. Push down fully to turn *ON* both the clearance and marker lights and the headlights. The controls and instrument lights will illuminate.

NOTE

Daytime running lights will be automatically cancelled when the exterior lighting switch is fully depressed.

Fog Lights

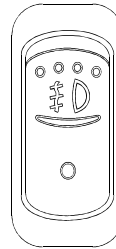

06255

Optional halogen fog lights provide better visibility in fog and precipitation. They improve close range visibility and provide added safety. Remove protective covers from fog lights before use.

WARNING

Turn *OFF* engine and apply parking brake before removing fog light covers.

NOTE

Some states and provinces restrict the use of fog lights. Verify local state or provincial regulations before using.

Hazard Warning Flashers

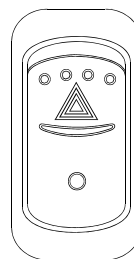

06256

Depress the rocker switch to make all turn signal lights flash at once. The dashboard telltale lights will flash when the hazard warning flashers are *ON*.

Activating the hazard flashers also activates the vehicle's electrical circuits.

CAUTION

Do not use the hazard flashers for an extended period of time unless necessary because the electrical circuits are activated when the hazard switch is depressed.

Docking/Cornering Lights

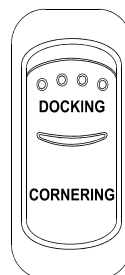

06337

Depress the upper portion of the switch to activate both the docking and the cornering lights. Depress the lower portion of the switch to activate the cornering lights.

Two sealed beam halogen lights are installed on each side of the vehicle. One near the front and one near the rear.

When the switch is set to *DOCKING*, all four beams illuminate to ease parking.

When the switch is set to *CORNERING* and the left or right turn signal is activated, the corresponding front beam will illuminate to increase lateral visibility.

Windshield Upper Section De-icing

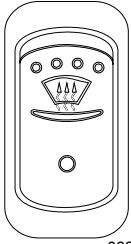

06259

Optionally on Entertainers only, the vehicle may be equipped with a de-icing system in the windshield upper section. Press the rocker switch to activate the blower in order to clear fog, frost or thin ice from either side of the windshield upper sections.

Fast Idle

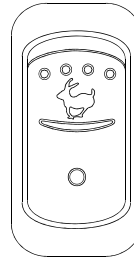

06264

For extended idling periods, run the engine at fast idle. Press down the rocker switch to engage fast idle. This increases the engine speed to approximately 1,000 rpm. Return to slow idle before driving or when stopping engine.

Left and Right Sunshades (Optional)

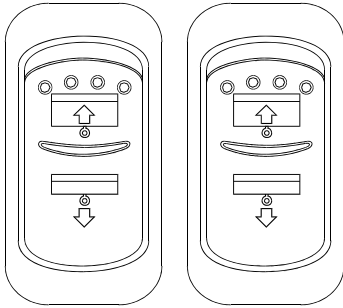

06353

Press and hold to lower or raise left or right sun shade.

⚠ CAUTION ⚠
Do not attempt to raise or lower these shades manually. Damage to electric motor or roller mechanism could result.

NOTE

If the parking brake is released and/or the transmission is engaged with the engine running at fast idle, the engine will return to low idle and remain there as long as the parking brake is not applied and/or transmission is not placed in neutral (N).

⚠ CAUTION ⚠

Reduce the engine to low idle before shutting the engine OFF.

Outside Mirror Heat (Optional)

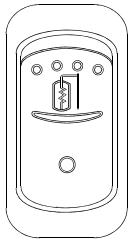

06261

Turn ON to clear fog, frost or thin ice from outside mirrors.

Transmission Retarder (Optional)

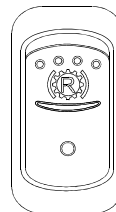

06252

Press down rocker switch to activate the transmission retarder. Refer to "Steering Column Controls" in this chapter.

Telltale Light Test

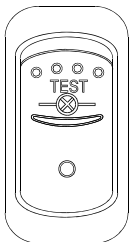

06263

Press this switch while ignition is in the ON position to illuminate the telltale light cluster. Perform this test to verify indicator light functionality. Telltale lights will extinguish automatically after about three seconds.

JACOBS Engine Retarder (Optional)

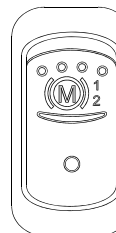

06253

Press down rocker switch to the first position to actuate system to 2/3 engine brake and press to the second position for a full application of engine brake. Refer to "Other Features" chapter.

⚠ WARNING ⚠

Engine brake must be used on dry road only. Never use the engine brake on slippery roads; loss of control could result.

NOTE

Engine brake is activated when accelerator pedal is released and the engine speed is higher than 750 rpm. Stop lights turn ON when the engine brake is used.

CONTROLS AND INSTRUMENTS

Engine Stop Override

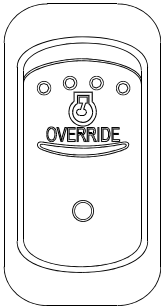

06265

Press down this switch and release to override emergency engine shut down protection. Engine emergency shut down will be turned *OFF* for 30 seconds. This procedure can be repeated if done before the 30 seconds are up.

⚠ CAUTION ⚠

Use sparingly and in order to move the vehicle to a safe parking place only. Excessive use can cause severe engine damage.

DDEC Diagnostic Request

⚠ CAUTION ⚠

Prior to reading blink codes, park coach and set parking brake.

With the engine at idle or *OFF* and with the ignition switch in the *ON* position, press and release the Engine Stop Override rocker switch. Active codes will be flashed on the "Stop Engine" and inactive codes on the "Check Engine" telltale lights alternately. The first digit of the diagnostic code is determined by the number of flashes before a short pause. The second number of the diagnostic code is then flashed in the same manner. As an example, code "25" (everything O.K.) consists of two flashes, followed by a short pause, then five flashes. Refer to the "Technical Information" chapter under "DDEC V Diagnostic Codes".

Central Locking System (Optional)

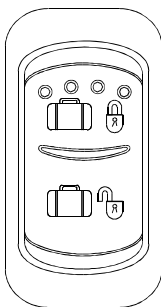

06266

This system enables locking all compartments and doors by pressing down on the upper portion of the switch. To unlock all compartments, press down on the lower portion of the switch.

NOTE

Service panels are not linked to the central locking system.

Back-Up Alarm Cancel Switch

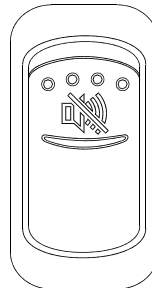

06311

Press down this switch to cancel the Back-Up Alarm

Note: After use, return to normal operation.

Ether Start Control (Optional)

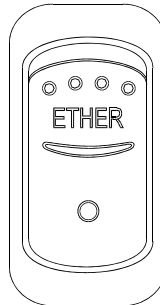

06237

Activates the engine cold starting aid. Refer to "Starting and Stopping Procedures" chapter.

Driver Controlled Differential Lock (DCDL) (Optional)



06571

Press the rocker switch to lock or unlock differential action. Refer to "Other Features" chapter for the complete operating instructions.

⚠ CAUTION ⚠

- Engage DCDL only under poor road surface conditions.
- DCDL will not engage and will disengage in speed higher than 5 MPH.
- Do not lock DCDL when one or more wheels are slipping, spinning or losing traction. You can damage the drive axle.

- Using the rocker switch, unlock DCDL when the need for improved traction has passed otherwise it will reengage automatically as speed gets below 5 MPH. Over a prolonged period, this situation will increase tire wear and stress to the vehicle.
- Do not engage during downhill operation.

R.H. DASHBOARD PANEL

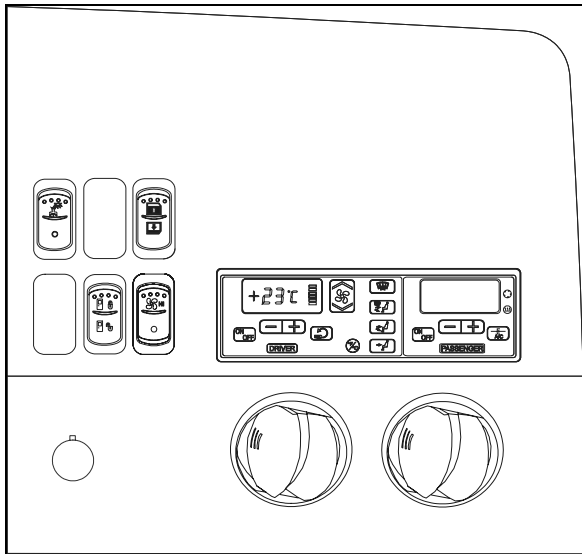

R.H. DASHBOARD PANEL 06568

The HVAC control module as well as the cluster dimmer switch, miscellaneous control switches and air vents, are located in the R.H. dashboard panel.

Driver's Area Lighting

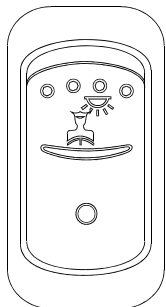

06244

Press down the rocker switch to illuminate the ceiling lights in the driver's area as needed.

Back-Up Camera Switch

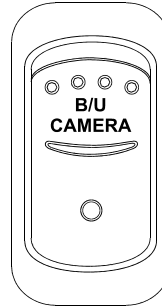

06314

Press down this switch to turn ON the Back-up Camera monitor when the transmission is not in reverse gear.

Entrance Door Power Window

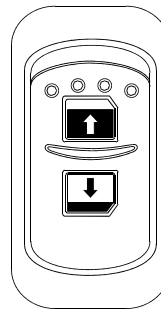

06338

Use the rocker switch to open or close the power window in the entrance door. The switch for the driver's power window is on the Lateral control panel.

Entrance Door Switch

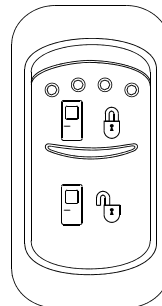

06313

Use this rocker switch located on the dashboard's R.H. side panel for locking or unlocking the entrance door from the driver's seat.

Cabin Fan Speed Control Switch

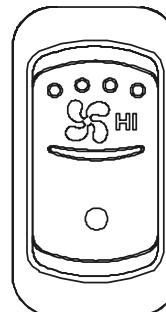

06566

Switches fan speed to HI for cabin ventilation (only available on models equipped with central HVAC).

CONTROLS AND INSTRUMENTS

Brightness Control

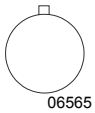

Adjusts the brightness of the dashboard instruments and switches.

HVAC CONTROL UNIT

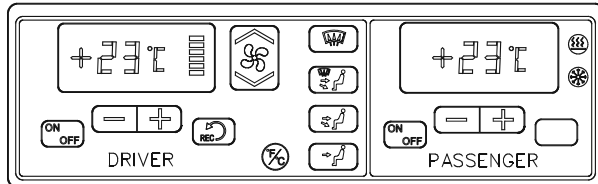

CENTRAL HVAC SYSTEM CONTROL UNIT

22274

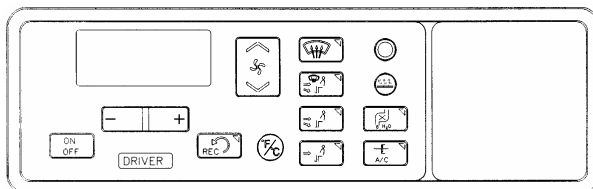

DRIVER'S HVAC SYSTEM CONTROL UNIT

22184

The vehicle is slightly pressurized by the central HVAC system to prevent dust and moisture from entering. Air flow and controls divide the vehicle into two areas: driver's area with defroster and cabin area.

Fresh air is fed in each area and has a separate return air and discharge air duct.

WARNING

Warm temperatures may cause drowsiness and affect alertness while driving. For optimum driving conditions, keep temperature between 68°F and 72°F (20°C to 22°C).

NOTE

To operate the air conditioning system when stationary, run engine at fast idle. When the A/C system is running, keep windows and door closed.

To prevent battery run-down, the A/C and heating systems will not operate if the charging system is not working properly.

When the A/C system is running, park at least 4 feet (1,5 m) from other vehicles or buildings to allow sufficient air flow through the condenser core.

Separate driver and passenger (cabin) heating, ventilation and air conditioning controls are located on this panel. To operate, the vehicle's engine must be running.

The driver's or the cabin unit may be turned ON by pressing or or buttons. On central HVAC system, the driver's HVAC section turns on automatically at starting of the engine and uses the settings that were kept in memory before turning off of the system.

Heating Mode Indicator



22135

Illuminates when system is heating.

Cooling Mode Indicator



22134

Illuminates when system is cooling.

Fan Speed

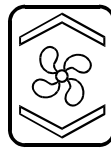

22135

The driver's fans have six speeds. Increase speed by pressing on the upper portion of the button, decrease by pressing on the lower portion.

Driver's section temperature display

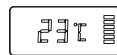

The temperature displayed on the driver's side HVAC control unit is the temperature set point.

Passenger's section temperature display

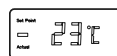

The temperature displayed on the passenger's side HVAC control unit is the actual temperature in the passenger's area.

Temperature Set Button

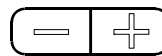

22132

The driver's side and the passenger's side have independent temperature controls.

These buttons determine the heating and cooling set points.

To increase the temperature set point, press on the "+" sign, to decrease the temperature set point, press on the "-" sign. Temperature range is between 55°F and 85°F (13°C to 29°C).

Air Recirculation



22138

Closes or opens the fresh air damper. A red LED in the top right corner of the button illuminates when driver's section air is recirculated. Use for faster driver's section heating.

Water Pump (small system only)

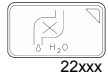

22xxx

Engages the water recirculating pump to increase the coolant flow when more heat is necessary.

A/C Button (small system only)



06385

Engages the A/C compressor.

NOTE

With the central HVAC system, the A/C compressor starts automatically upon a cooling demand in summer. During winter, the A/C compressor starts automatically for dehumidification purposes if the outside temperature is over 32°F (0°C) and the passenger's area temperature has reached 7°F (4°C) under the set point.

Windshield Defogger



22139

The dashboard damper sends air only to the lower windshield when activated. The footwell damper is closed also. A red LED in the top right corner of the button illuminates when activated.

With central HVAC system, at this position, fan speed 1 & 2 are not available when the outside temperature is below 37°F (3°C).

NOTE

If the windshield is continuously fogged, check that the driver's air filter is not clogged.

All Vents Open



22140

Air is sent to defogger vents as well as panel and footwell vents.

Panel and Footwell



22137

Air is sent to panel and footwell vents only.

Panel



22136

Air is sent to panel vents only.

Temperature Degree Selector



22133

Toggles between Fahrenheit and Celsius units (Driver's HVAC unit must be turned ON).

AIR VENTS

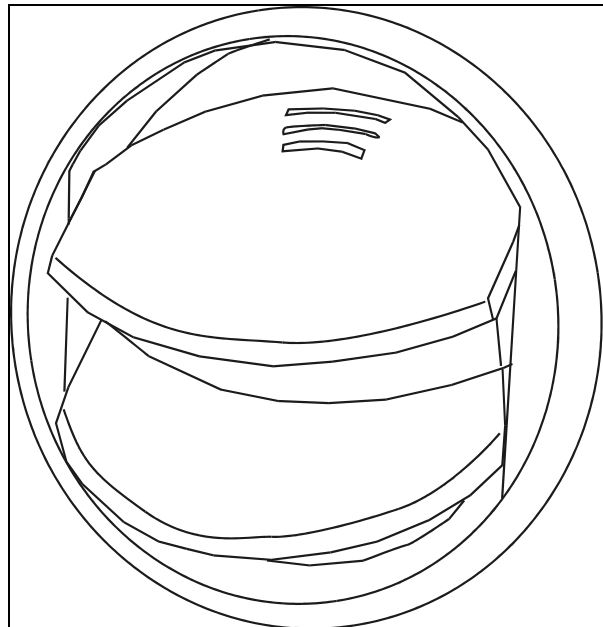

AIR VENT

22249

Three adjustable driver air vents in the dashboard and one near the door feed air to the driver's compartment. Use the HVAC control panel to set air temperature.

INSTRUMENT CLUSTER

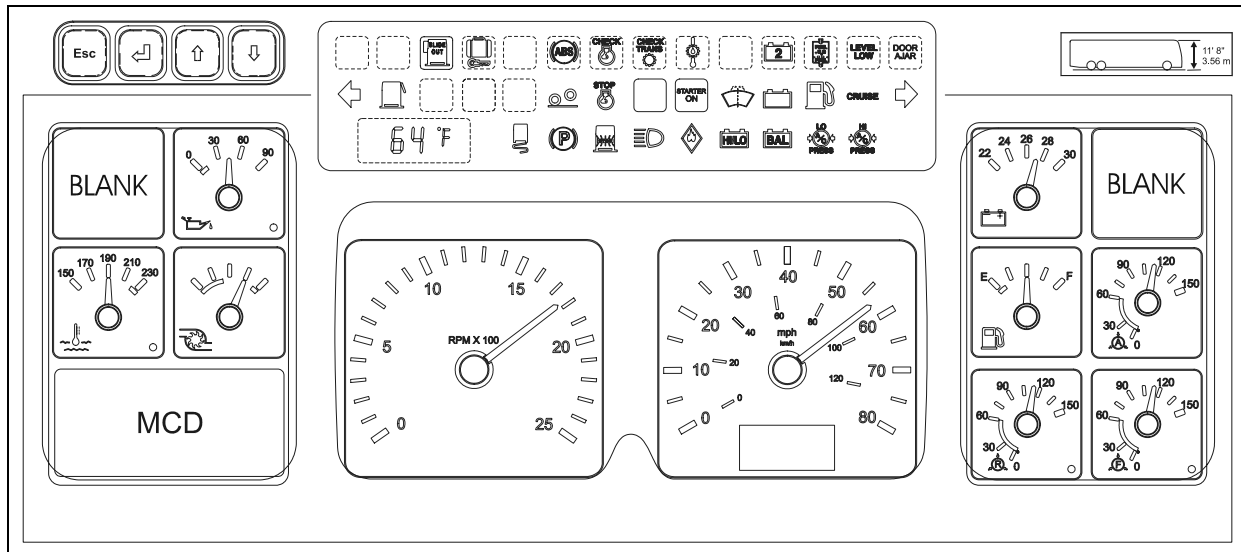

CLUSTER

06379

CLUSTER

The instrument cluster incorporates the Message Center Display, the Telltale Panel, the Gauges and Vehicle Clearance Information.

MESSAGE CENTER DISPLAY (MCD)

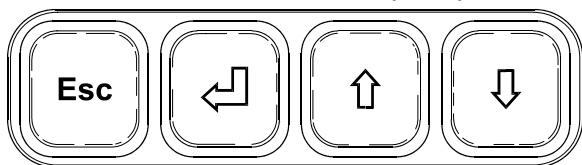

06399

This standard feature gathers stores and displays important information about the vehicle's operation on a display screen on the lower left portion of the cluster. Refer to "Message Center Display" heading in "Other Features" chapter for a description of how to set-up and operate the Message Center Display (MCD).

DASHBOARD GAUGES

NOTE

Do not refer to dashboard instruments during adjustment procedures. Use only calibrated gauges.

Engine Oil Pressure Gauge

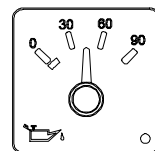

06229

Indicates engine oil pressure. The normal reading should be between 50 and 70 psi (345 - 480 kPa) at 55 mph (90 km/h). A low oil pressure indicator LED (bottom right corner) illuminates when the oil pressure drops below 50 psi (345 kPa).

An audible alert signal also informs the driver of low oil pressure. Refer to Safety Features and Equipment chapter for table of audible alarms.

⚠ CAUTION ⚠

Loss of oil pressure may cause severe engine damage. If low-oil pressure LED illuminates, park the vehicle safely and stop the engine immediately. Request service assistance.

Engine Coolant Temperature Gauge

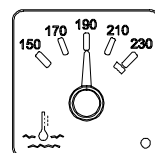

06231

Indicates the operating temperature of the engine coolant. The normal reading should be between 190°F and 222°F (88°C to 106°C).

A high coolant temperature indicator LED (bottom right corner of gauge) illuminates when the coolant temperature rises above 223°F (106°C). An audible alert signal also informs the driver of this condition. Refer to Safety Features and Equipment chapter for table of audible alarms.

Turbo Boost Pressure Gauge

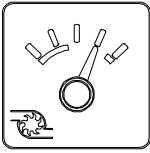

06230

Indicates turbo boost pressure in psi. Reading depends on engine rpm and load conditions.

Tachometer

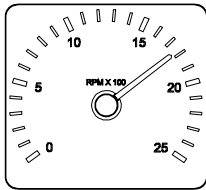

06221

Indicates the operating speed of the engine in hundreds of revolutions per minute (rpm x 100).

The tachometer serves as a guide for gear shifting and helps to prevent engine over-speeding when driving downhill with the JACOBS engine brake operating. The maximum allowed engine speed is 2,450 rpm.

Speedometer

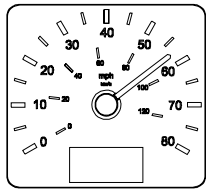

06222

Indicates the vehicle speed in miles per hour (mph) and kilometers per hour (km/h). The digital odometer registers the distance traveled in miles or in kilometers (units are driver selectable).

Voltmeter (24-Volt System)

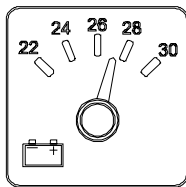

06224

Indicates the condition of the 24-volt electrical system. With the engine running, the normal reading should be between 26.5 and 28.0 volts.

Fuel Level

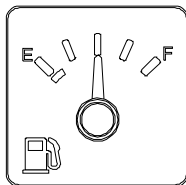

06225

Indicates the amount of fuel remaining in the fuel tank.

A telltale light illuminates when about 12 US gallons (45 liters) of fuel remain in the fuel tank.

⚠ CAUTION ⚠

Operating the vehicle when the reading is below 1/8 full is not recommended.

Air Pressure Gauge (Accessories)

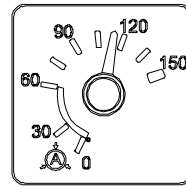

06226

Indicates the accessories air system pressure. The normal operating pressure is from 95 to 125 psi (655 to 860 kPa).

Air Pressure Gauge (Primary System)

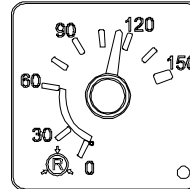

06228

Indicates the primary air system pressure. The normal operating pressure is from 95 to 125 psi (655 to 860 kPa).

A low air pressure indicator LED (bottom right corner) illuminates when the primary air system pressure drops below 66 psi (455 kPa). An audible alarm signal also informs the driver of low air pressure. Refer to Safety Features and Equipment chapter for table of audible alarms. If the air pressure drops below 40 psi (276 kPa), the emergency brake applies at full capacity.

⚠ WARNING ⚠

Do not drive the coach when air pressure is low.

Air Pressure Gauge (Secondary System)

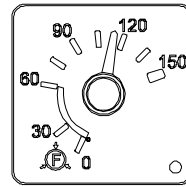

06227

Indicates the secondary air system pressure. The normal operating pressure is from 95 to 125 psi (655 to 860 kPa).

A low air pressure indicator LED (bottom right corner) illuminates when the secondary air system pressure drops below 66 psi (455 kPa). An audible alarm signal also informs the driver of low air pressure. Refer to Safety Features and Equipment chapter for table of audible alarms. If the air pressure drops below 40 psi (276 kPa), the emergency brake applies at full capacity.

⚠ WARNING ⚠

Do not drive the coach when air pressure is low.

CONTROLS AND INSTRUMENTS

VEHICLE CLEARANCE INFORMATION

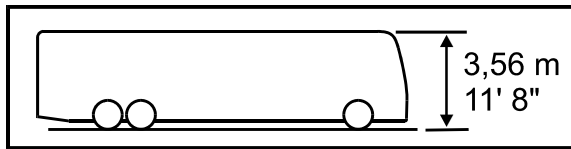

TYPICAL VEHICLE CLEARANCE

00018

⚠ CAUTION ⚠

Vehicle clearance will vary depending on type of vehicle. Vehicle clearance is higher when escape hatch is open or if additional equipment is installed on the roof.

TELLTALE PANEL

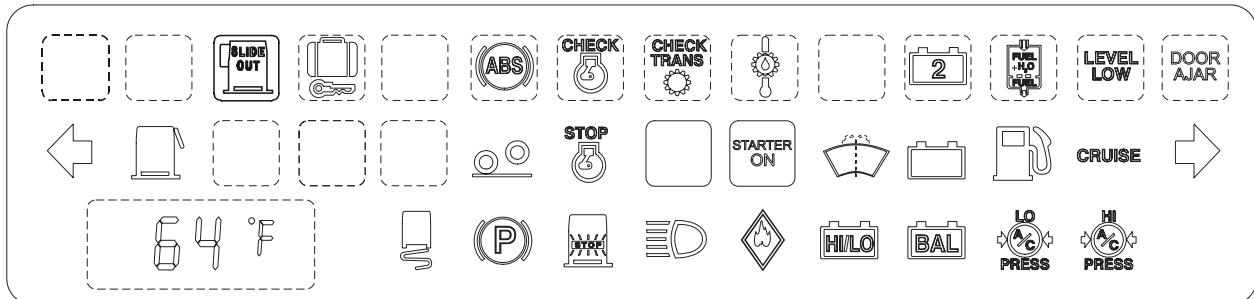

TELLTALE PANEL

06377

Some telltale lights described bellow appear on the telltale panel only if the corresponding optional equipment is installed on the vehicle.

Slide-Out



06559

Illuminates when one or both slide-outs are partially or fully extended. Blinks to indicate that an error condition has been detected.

Compartments Locked Indicator



06387

Illuminates when one or more compartments are unlocked.

ABS Brake System



06272

Illuminates when the ABS is not available or when the ABS is malfunctioning. Since the ABS system does not operate under 4 mph (7 km/h), the indicator will remain illuminated until the coach reaches that speed. Refer to "Other Features" chapter.

Check Engine Indicator



06281

Illuminates when the ignition switch is ON as a light bulb check. The light should turn OFF after five seconds. If the indicator remains

ON after five seconds or comes ON sometime after starting the engine; the Detroit Diesel Electronic Control (DDEC) system has detected a minor problem.

The indicator will remain ON until the malfunction has been corrected.

A diagnostic code will be stored in the memory and the indicator can be used to identify the problem. Refer to the "Technical Information" chapter under "DDEC V Diagnostic Codes".

Check Transmission Indicator

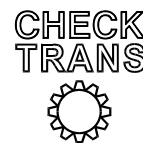

06282

Illuminates briefly when the ignition is switched ON as a light test. The indicator light should go out after two seconds.

When the "CHECK TRANS" indicator is illuminated and the shift selector emits short beeps for 8 seconds, the ECU is restricting transmission shifting because special or abnormal conditions are detected. The control pad display will be blank. An audible alarm will sound when this condition occurs. Refer to Safety Features and Equipment chapter.

If this happens, drive the coach to the next available service station to receive assistance. The ECU will not respond to shift selector requests since operating limitations are being placed on the transmission (i.e. upshifts and downshifts may be restricted). Direction changes and shifts to and from neutral (N) will not occur.

Any time the CHECK TRANS telltale light illuminates, the ECU will register a diagnostic code. It may be identified on the display or by using a diagnostic tool. Refer to "Technical Information" chapter under "World Transmission (WT) Diagnostic Codes".

NOTE

The CHECK TRANS indicator may also illuminate when starting the engine in extremely cold weather. Refer to "Starting and Stopping Procedures" under "World Transmission (WT) Warm-up".

Transmission Oil High Temperature Indicator

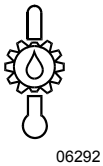

Illuminates when the transmission oil temperature is too high. Disengage the retarder to allow the oil temperature to cool down. An audible alarm will sound when this condition occurs. Refer to Safety Features and Equipment chapter.

Secondary Charge System Indicator

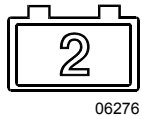

Illuminates when the secondary alternator is not functional.

Fuel/Water Separator Indicator



Illuminates when accumulated water in the fuel filter/water separator needs to be drained. Refer to "Care and Maintenance" chapter.

Level Low System Indicator



Illuminates when the vehicle leveling system is activated.

Door Ajar Indicator



Illuminates when the central entrance door (if equipped) is ajar.

Left Turn Signal Indicator

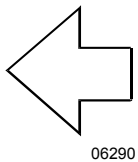

Flashes when the left turn signals are activated. Signal right and left turns by operating the multi-function lever. See "Steering Column Controls" in this chapter.

Window Open Indicator

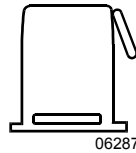

Illuminates when an awning window is open.

Retracted Tag Axle Indicator

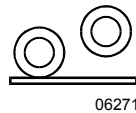

Illuminates when the tag axle is retracted or unloaded. When the tag axle is retracted, an audible alarm will sound to inform the driver. Refer to Safety Features and Equipment chapter. The control valve is located on the L.H. lateral console.

STOP Engine Indicator



Illuminates when the ignition switch is ON as a light bulb and DDEC system check. The indicator should go OFF after five seconds.

If the indicator remains illuminated after five seconds or comes ON sometime after starting the engine, the DDEC system has detected a major problem. An audible alarm will sound when this condition occurs. Refer to Safety Features and Equipment chapter.

When a problem is detected, the engine power will automatically begin to decrease gradually, followed by full shutdown after 30 seconds.

The engine emergency shutdown may be bypassed by using the "Engine Stop Override" switch on the L.H. lower control panel.

NOTE

Once the engine is stopped, it cannot be restarted until the problem has been corrected. A diagnostic code will be stored in memory. The STOP engine indicator can be used to identify the problem. Refer to "Technical Information" chapter under "DDEC V Diagnostic Codes".

Starter ON Indicator



Illuminates when the engine starter is ON.

CONTROLS AND INSTRUMENTS

⚠ WARNING ⚠

If the "STARTER ON" Indicator light remains illuminated even after releasing the ignition switch, Stop the engine immediately and set the battery master switch (ignition key) to the OFF position. Have the starter checked immediately.

Low Windshield Washer Fluid Level



06403

Illuminates when the windshield washer fluid level is low. The washer fluid container is located on the inside of the front service compartment door.

⚠ WARNING ⚠

Do not drive without sufficient windshield washer fluid.

Primary Charge System Indicator

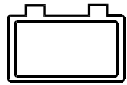

06277

Illuminates when the alternator is not charging the batteries.

Low Fuel Level Indicator

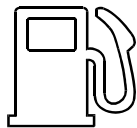

06286

Illuminates when approximately 12 US gallons (45 liters) of fuel remain in the tank. After the light comes ON, the remaining fuel will provide less than 60 miles (100 km) of travel. Do not exceed this distance.

NOTE

Refuel as soon as possible.

Cruise Control Indicator

CRUISE

06284

Illuminates when cruise control is activated.

Right Turn Signal Indicator

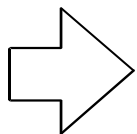

06289

Flashes when the right turn signals are activated. Signal right and left turns by operating the multi-function lever. See "Steering Column Controls" in this chapter.

Freezing Conditions Indicator



06273

Flashes for about 10 seconds when the outside temperature is between 2°C and 1°C (35°F and 34°F), when the road is most slippery. An audible alarm will sound when these conditions arise. Refer to Safety Features and Equipment chapter.

Emergency/Parking Brake Indicator



06303

Illuminates when the emergency /parking brake is applied. The control valve is located on the L.H. control panel. A buzzer will sound if ignition is turned to OFF and the parking brake is not engaged.

Stoplight Indicator



06305

Illuminates when rear stop lights illuminate. This occurs when either cruise control DECEL switch, service brakes, parking brakes, engine retarder or transmission retarder is applied.

High Beam Indicator



06300

Illuminates when high beams are selected. High and low beams are selected by operating the multi-function lever. Refer to "Steering Column Controls" heading in this chapter.

Fire Indicator (Engine Compartment)



06288

Illuminates if a fire is detected in the engine compartment. An audible alarm also informs the driver when a fire is detected. Refer to Safety Features and Equipment chapter.

⚠ WARNING ⚠

In case of a fire, stop the vehicle immediately, stop the engine and evacuate the vehicle.

NOTE

For extinguisher's location, refer to "Safety Features and Equipment" chapter.

High/Low Battery Voltage Indicators



Illuminates when the battery voltage exceeds 30 volts or drops below 24 volts.

NOTE

The high/low battery voltage indicator will illuminate for a few seconds after the engine is started because of the voltage drop when the starter is engaged.

Battery Equalizer Indicator



Illuminates when the battery voltage is not equalized.

NOTE

If the battery equalizer indicator illuminates, make sure that the battery equalizer circuit breakers are reset before requesting breakdown assistance (if battery equalizer is equipped with circuit breakers). Wait 15 minutes after setting breakers to allow batteries to equalize. The breakers are located in the main power compartment.

Low Air Conditioning (A/C) Pressure Indicator



Illuminates when the A/C system pressure is too low. If the A/C pressure is too low, the compressor clutch is disengaged but the fan still runs.

NOTE

In cold weather, the low A/C pressure indicator may light up. This is not an abnormal condition.

High A/C Pressure Indicator



Illuminates when the A/C system pressure is too high. If the A/C pressure is too high, the compressor clutch is disengaged, but the fan remains activated.

NOTE

In hot weather, the high A/C pressure indicator may light up. This is not an abnormal condition.

STEERING COLUMN CONTROLS

Many of the most frequently used controls are conveniently placed on the steering column or the steering wheel, just like a passenger car. The Multi-function lever is located on the left side of the steering wheel while the optional transmission retarder lever is located on the right side of the steering wheel. Switches for the electric horn and the air horn are located directly on the steering wheel.

MULTI-FUNCTION LEVER

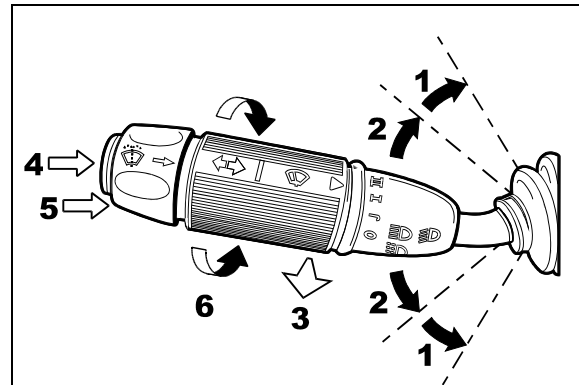

MULTI-FUNCTION LEVER

23133

The multi-function lever is used to operate the following:

Turn Signal (1)

Move the lever all the way up until it locks in position to signal a right turn. Move the lever all the way down until it locks in position to signal a left turn. The lever automatically returns to the horizontal OFF position once the turn is completed.

Lane Change Signal (2)

Move the lever part way to the catch position and hold until the lane change maneuver is completed. The lever will spring back into the OFF position once released.

Headlight Beam Toggle Switch (3)

Toggle between high and low beams by pulling the lever up towards you. To flash the headlights, pull the lever up halfway. The lever will spring back into normal position once released.

CONTROLS AND INSTRUMENTS

Courtesy Blinkers (4)

Clearance and parking lights can be flashed by pressing the button located on the lever tip.

Windshield Washer Control (5)

Push the external ring at the end of the lever toward the steering column to activate the windshield washers. The wipers come *ON* and continue wiping for a few seconds after the ring is released.

⚠ WARNING ⚠

Before using the windshield washer in cold weather, heat the windshield with the defroster to prevent icing and reduced visibility.

⚠ CAUTION ⚠

To avoid damaging the pump mechanism, do not use the windshield washer when the fluid level is very low or empty.

Windshield Wipers (6)

Turn the lever counterclockwise to activate the windshield wipers. The first position activates the wipers intermittently. The second position is the slow speed and the third position is for high speed wiping.

⚠ CAUTION ⚠

To avoid scratching the windshield, do not operate the wipers when the windshield is dry. To avoid damaging the wiper motor, free wiper blades that may be frozen to the windshield before operating the wipers.

TRANSMISSION OUTPUT RETARDER (OPTIONAL)

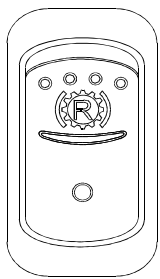

06252

Press down this rocker switch to activate the transmission retarder.

Operating the Retarder Using the Hand Lever

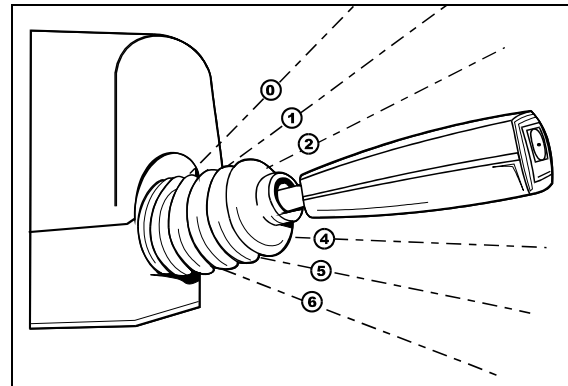

RETARDER HAND LEVER

07043

With the retarder activated (retarder switch depressed) and the accelerator pedal released, move the output retarder lever clockwise from the first to the sixth position. The efficiency for each position is as follows:

Position	Efficiency
Initial	0%
1st	16%
2nd	33%
3rd	49%
4th	71%
5th	89%
6th	100%

NOTE

The output retarder lever is located on the right side of the steering column.

Operating the Retarder Using the Brake Pedal

With the retarder activated (retarder switch depressed), the accelerator pedal released and the output retarder lever in the initial position, apply the brake pedal as if using the service brakes. The further the brake pedal is depressed, the more the output retarder is applied. Refer to "Other Features" chapter for more information about the transmission retarder.

NOTE

For vehicles equipped with the Anti-lock Braking System (ABS), if the wheels start to lock-up on slippery roads, the output retarder will automatically deactivate until the wheels turn freely.

HORN

Electric Horn

The electric horn buttons are on the steering wheel spokes. Use only the electric horn in urban areas.

Air Horn

The air horn button is located on the center of the steering wheel. Use this horn only on the highway.

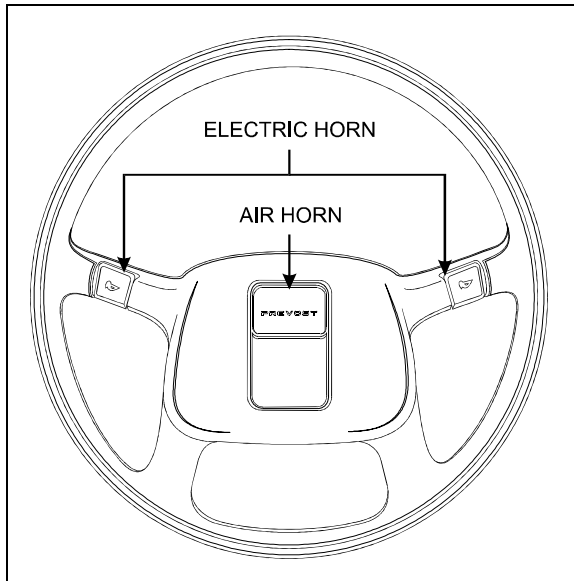

STEERING WHEEL

14029

FOOT-OPERATED CONTROLS

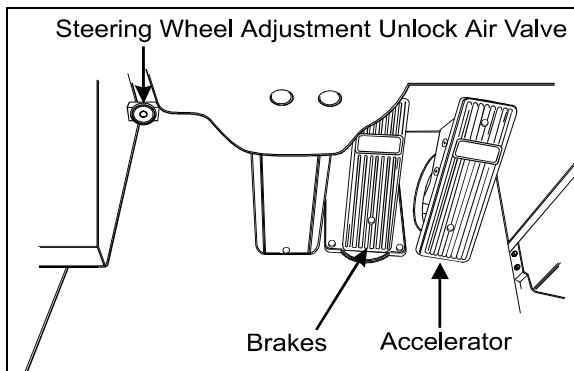

FOOT OPERATED CONTROLS

18118A

SERVICE BRAKES

The coach is equipped with a dual braking system. The front brakes operate differently from the drive and tag axle brakes.

The dual braking system becomes a modulated emergency system if a pressure drop occurs in the rear brake system. Only the drive and tag axles are equipped with parking brakes.

Service brakes are applied by depressing the brake pedal. Braking increases with the amount of pressure applied to the foot pedal. Refer to "Other Features" chapter under "Anti-lock Braking System". When the brake pedal is depressed, the brake lights turn ON automatically.

For safe and effective braking, the air system pressure should reach at least 95 psi (655 kPa) in both the primary and secondary circuits.

A warning light and a buzzer will sound when the air pressure in either the primary or secondary circuits drops below 70 psi (483 kPa). If this occurs, stop the coach; determine the cause of the pressure loss before proceeding. The brake pedal can be used in conjunction with the transmission retarder. Refer to Transmission Output Retarder in this section.

⚠ WARNING ⚠

Immediately report any brake system problem to the nearest Prévost or Prévost-authorized service center.

⚠ WARNING ⚠

Do not "fan" or "pump" the brake pedal. This practice does not increase brake system effectiveness but rather reduces system air pressure thereby causing reduced braking effectiveness.

⚠ CAUTION ⚠

"Riding" the brake by resting one's foot on the brake pedal when not braking can cause abnormally high brake temperature, can damage and cause premature wear of brake components and reduce brake effectiveness.

ACCELERATOR PEDAL

Controls engine RPM as needed.

NOTE

The accelerator pedal will not operate when the front door is open.

⚠ CAUTION ⚠

Do not let the engine operate above 2,450 RPM.

CONTROLS AND INSTRUMENTS

STEERING WHEEL ADJUSTMENT UNLOCK AIR VALVE

Push on the valve button with the left foot to unlock the steering wheel for tilt and telescopic adjustment.

⚠ WARNING ⚠

Do not adjust the steering wheel while the vehicle is moving. Loss of control could result. Park the vehicle safely and apply parking brakes before adjusting the steering wheel.

AUTOMATIC TRANSMISSION

The operation and driving of this vehicle with an automatic transmission is similar to that of an automobile equipped with an automatic transmission.

The transmission is fully automatic: Proper ranges will be automatically selected according to driving speeds to improve vehicle performance and control. The speed ratio of the power converter changes automatically as vehicle speed increases and direct-drive goes in and out as necessary. The speed ratio is modulated by vehicle speed and accelerator position.

OPERATION

When a push button is depressed, the corresponding letter or number is displayed indicating that the transmission is ready to operate in the selected range. When the electronic control system detects a serious problem in the transmission, a buzzing tone sounds for 5 seconds and the "CHECK TRANS" light on the dashboard illuminates to warn the driver that the transmission is held in gear. If another is depressed, the buzzing sound will continue until the original range is selected.

NOTE

As a light bulb and systems check, the "CHECK TRANS" light will illuminate when the ignition switch is turned to ON. After about two seconds the light will turn off. If the "CHECK TRANS" light remains on, the self-diagnostic system has detected a problem. If the problem disappears, the light will go out, but a trouble code will remain stored in the ECU.

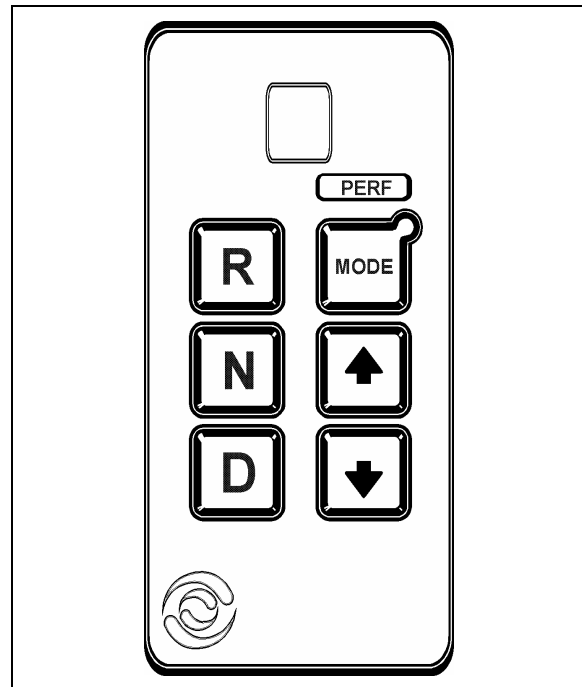

CONTROL PAD

07025

RANGE SELECTION – PUSH BUTTON SHIFTER

The push button shifter is used by the operator to select Neutral (N), Reverse gear (R) or a range of forward gears (D). When a forward gear range has been selected, the transmission starts in the lowest gear of the range and, as conditions permit, automatically upshifts until the highest gear in the selected range is in use.

The digital display indicates the current gear of transmission operation.

The function of each button is as follows:

- Select REVERSE gear by pressing "R".
- Select NEUTRAL by pressing "N". Note the raised edge around the "N" button so the driver can orient his hand to the push buttons by touch, without looking at the display. It is not necessary to press this button prior to starting the vehicle.
- Select DRIVE range by pressing "D". The highest forward gear will appear on the digital display and the transmission will shift to the starting gear (not indicated on the digital display).

The "▲" and "▼" buttons are used to shift to a higher or lower range selected. One press changes gears by one range. If the button is held down, the selection will scroll up or down until the button is released or until the highest or lowest possible gear is selected. Protection mechanisms will inhibit selecting ranges that are not appropriate or that may damage driveline components.

FUNCTIONS OF THE MODE BUTTON

This button is used to invoke a special function (mode) that has been programmed into the ECU. Both modes are equivalent from the first to the fourth gear as the transmission upshifts at around 2000 rpm.

The default "ECONOMY" mode allows for upshifts in fifth and sixth gear at around 1700 rpm. This is a more efficient operation of the transmission and thereby helps improve fuel economy.

The "PERF" (performance) mode keeps upshifts at 2000 rpm in fifth and sixth gears. This makes for better performance than the economy mode but with higher fuel consumption. It is recommended that this mode be selected while driving up or down grades. The mode status will be indicated on the digital display by a red LED illuminating in the upper right corner of the MODE button when selected.

Oil Level Display Mode (optional)

Oil level codes are obtained as follows:

Press both the "▲" (up arrow) and "▼" (down arrow) push-buttons simultaneously. Oil level codes are displayed in 2 minutes (e.g. display will flash and 8, 7, ...; countdown will occur during the 2 minutes) once the following parameters are met:

- Waiting time, vehicle must be stationary for at least 2 minutes to allow the oil to settle;
- Engine at idle;
- Oil at normal operating temperature, between 140°F (60°C) and 220°F (104°C):
- Transmission in neutral (N);
- Transmission output shaft stopped;
- Oil level sensor present and working.
- After 2 minutes, the display will flash one of the codes shown hereafter:

CODE	CAUSE OF CODE
O, L...O, K	Oil level is correct
O, L...L, O...01	One quart low
O, L...L, O...02	Two quarts low
O, L...H, I...01	One quart high
O, L...H, I...02	Two quarts high

NOTE

Failure to meet one of the above parameters will stop the two minute countdown. One of the codes shown hereafter will indicate the cause of the countdown interruption. Once all parameters are met, the countdown will continue from where it left off.

CODE	CAUSE OF CODE
O, L...-...0,X	Waiting time too short
OL-50	Engine speed (rpm) too low
OL-59	Engine speed (rpm) too high
OL-65	Neutral must be selected
OL-70	Sump oil temperature too low
OL-79	Sump oil temperature too high
OL-89	Output shaft rotation
OL-95	Sensor failure

Exiting the Fluid Level Display Mode

To exit the Oil Level Display Mode, press any range button ("R", "N" or "D").

Reverse (R)

Use this position to back-up the vehicle. Stop completely before shifting from forward to reverse or from reverse to forward. Touch the reverse (R) button, "R" will be displayed and the reverse warning signal will be activated.

Neutral (N)

Use this position to start engine. Select neutral (N) when checking vehicle accessories and for extended periods of engine idle operation; parking brake must then be applied. The push-button shifter will automatically select neutral when the master switch is turned ON.

CONTROLS AND INSTRUMENTS

NOTE

The automatic transmission does not have a park (P) position. Select neutral (N) and apply parking brake when the vehicle is left unattended. A warning buzzer will sound if the engine is stopped and the parking brake has not been applied when foot pressure is removed from the brake pedal.

IMPORTANT NOTE

Brake pedal must be applied when selecting Drive (D) otherwise the transmission will stay in neutral (N).

⚠ WARNING ⚠

Always apply parking brake before leaving driver's seat.

⚠ CAUTION ⚠

Detroit Diesel engines should not be idled for extended periods at "slow" idle. For extended idling, engine should run at "fast" idle.

⚠ CAUTION ⚠

Do not allow your vehicle to "coast" in neutral. This practice can result in transmission damage. Also, no engine braking is available in neutral.

Drive (D)

Use this position for all normal driving conditions. After touching this pad, the vehicle will start in first or second range and will automatically upshift to a higher range as output speed increases. As the vehicle slows down, output speed decreases, the transmission automatically downshifts to the correct range. If a locked brake or a slick surface condition should occur, the ECU (Electronic Control Unit) will command converter operation (disconnect lockup) and inhibit downshifts for a period of time or until normal wheel speed has been restored.

● First range (1):

Select this range when pulling through mud and snow or when speed control is needed for driving up steep grades. This range also provides maximum engine braking power or retarder braking effect. In the lower ranges (1, 2, 3 and 4), the transmission will not upshift above the highest gear selected unless engine overspeed is detected.

NOTE

The transmission should normally be allowed to shift by itself, but manual shifting can be done as described below.

● Second range (2)

Select this range when operating in heavy and congested traffic. The transmission will start in first and automatically upshift to second. When slowing, the transmission will automatically downshift to first range. Low ranges provide progressively greater engine and retarder braking power (the lower the range, the greater the engine and retarder braking effect).

● Third and fourth ranges (3 and 4)

Select these ranges when driving on moderate grades or when load and traffic conditions limit speed.

⚠ WARNING ⚠

Service brakes should not be used to control the speed of vehicle on long, steep descents. Instead, lower transmission ranges should be used (in conjunction with output retarder. Refer to "JACOBS Engine Brake" and "Transmission Retarder" headings in "Technical Information" chapter for details regarding both systems. This procedure keeps service brakes cool and ready for emergency stopping.

⚠ CAUTION ⚠

When descending in lower ranges, care must be taken that engine speed does not exceed 2,450 rpm.