

SECTION 22: HEATING AND AIR CONDITIONING

CONTENTS

1. HEATING AND AIR CONDITIONING	4
2. AIR CIRCULATION WITH CENTRAL HVAC SYSTEM	4
2.1 DRIVER'S AREA.....	4
2.2 PASSENGERS' AREA.....	4
3. CENTRAL HVAC SYSTEM OPERATION	5
3.1 DRIVER'S SECTION OPERATION	5
3.2 PASSENGERS' SECTION OPERATION	6
4. HVAC UNIT MAINTENANCE	7
4.1 COIL CLEANING.....	7
4.2 DRIVER'S SECTION AIR FILTERS	8
4.3 PASSENGERS' SECTION AIR FILTER	9
4.4 OVERHEAD COMPARTMENT FAN AIR FILTER.....	9
5. HVAC SYSTEM PARTICULARITIES, TESTING AND TROUBLESHOOTING	9
5.1 HVAC SYSTEM AND TEST MODE FOR SWITCHES AND SENSORS	9
5.2 HVAC SYSTEM AND TEST MODE FOR ELECTRIC MOTORS	10
5.3 PARTICULARITIES	10
5.4 HVAC SYSTEM TROUBLESHOOTING	11
6. CENTRAL AIR CONDITIONING SYSTEM	12
6.1 A/C CYCLE	12
6.2 REFRIGERANT.....	13
6.2.1 <i>Procurement</i>	13
6.2.2 <i>Precautions in Handling Refrigerant</i>	13
6.2.3 <i>Treatment in Case of Injury</i>	13
6.2.4 <i>Precautions in Handling Refrigerant Lines</i>	13
6.3 PUMPING DOWN	16
6.4 ADDING REFRIGERANT (VAPOR STATE).....	17
6.5 EVACUATING SYSTEM	17
6.5.1 <i>Double Sweep Evacuation Procedure</i>	17
6.6 CHARGING SYSTEM.....	18
6.7 REFRIGERANT SYSTEM CLEAN-OUT AFTER COMPRESSOR FAILURE.....	19
6.7.1 <i>Determining Severity of Failure</i>	19
6.7.2 <i>Clean-out after Minor Compressor Failure</i>	19
6.7.3 <i>Clean-out After Major Compressor Failure</i>	19
7. CENTRAL A/C SYSTEM COMPONENTS	20
7.1 COMPRESSOR (CENTRAL SYSTEM).....	20
7.1.1 <i>Belt Replacement</i>	20
7.1.2 <i>Belt Tension Adjustment</i>	21
7.1.3 <i>Pulley Alignment</i>	21
7.1.4 <i>Longitudinal Compressor Alignment</i>	21
7.1.5 <i>Horizontal Compressor Alignment</i>	21
7.1.6 <i>Vertical Compressor Alignment</i>	21
7.1.7 <i>Compressor Maintenance</i>	22
7.1.8 <i>Troubleshooting Guide</i>	22
7.2 MAGNETIC CLUTCH	23
7.3 EVAPORATOR MOTOR	23
7.3.1 <i>Removal</i>	23
7.3.2 <i>Installation</i>	23

Section 22: HEATING AND AIR CONDITIONING

7.4	CONDENSER.....	24
7.4.1	Condenser Fan Motors.....	24
7.4.2	Condenser Fan Motor Removal.....	24
7.5	RECEIVER TANK.....	24
7.6	FILTER DRYER.....	25
7.6.1	Replacement.....	25
7.6.2	Moisture Indicator.....	25
7.7	LIQUID REFRIGERANT SOLENOID VALVE.....	26
7.7.1	Manual Bypass.....	26
7.7.2	Coil Replacement.....	26
7.7.3	Valve Disassembly.....	26
7.7.4	Valve Reassembly.....	26
7.8	EXPANSION VALVE.....	27
7.8.1	Passenger's Section HVAC Unit.....	27
7.8.2	Driver's HVAC Unit.....	29
7.9	TORCH BRAZING.....	29
7.10	TROUBLESHOOTING.....	30
7.10.1	Expansion Valve.....	30
7.10.2	A/C.....	31
7.11	TEMPERATURES & PRESSURES.....	33
7.12	LEAK TESTING.....	34
8.	CENTRAL HEATING SYSTEM.....	36
8.1	DRAINING HEATING SYSTEM.....	36
8.2	FILLING HEATING SYSTEM.....	37
8.3	BLEEDING HEATING SYSTEM.....	37
8.4	SOLDERING.....	37
8.5	DRIVER'S HOT WATER PNEUMATIC VALVE ASSEMBLY.....	38
8.6	CENTRAL HOT WATER PNEUMATIC VALVE ASSEMBLY.....	39
8.7	WATER RECIRCULATING PUMP.....	40
9.	SPECIFICATIONS.....	42

ILLUSTRATIONS

FIGURE 1:	DRIVER'S AIR CIRCULATION.....	4
FIGURE 2:	PASSENGERS' AREA RECIRCULATION DAMPER.....	4
FIGURE 3:	CENTRAL HVAC SYSTEM AIR CIRCULATION.....	5
FIGURE 4:	PASSENGERS OVERHEAD COMPARTMENT VENTILATION SYSTEM.....	5
FIGURE 5:	CENTRAL HVAC SYSTEM CONTROL UNIT.....	6
FIGURE 6:	THERMISTOR SENSOR.....	6
FIGURE 7:	EVAPORATOR COMPARTMENT.....	6
FIGURE 8:	CONDENSER COMPARTMENT.....	7
FIGURE 9:	A/C JUNCTION BOX.....	7
FIGURE 10:	DRIVER'S HVAC UNIT COIL ACCESS PANEL.....	8
FIGURE 11:	EVAPORATOR COIL ACCESS PANEL (TYPICAL).....	8
FIGURE 12:	EVAPORATOR COIL CLEANING.....	8
FIGURE 13:	CONDENSER COMPARTMENT.....	8
FIGURE 14:	DRIVER'S SECTION ACCESS GRILL.....	8
FIGURE 15:	DRIVER'S SECTION AIR FILTERS.....	9
FIGURE 16:	PASSENGERS' SECTION AIR FILTER.....	9
FIGURE 17:	OVERHEAD COMPARTMENT FAN AIR FILTER.....	9
FIGURE 18:	REFRIGERANT CIRCUIT (CENTRAL SYSTEM).....	15
FIGURE 19:	DOUBLE-SWEEP EVACUATION SET-UP.....	18
FIGURE 20:	AIR PRESSURE REGULATOR.....	20
FIGURE 21:	BELT ARRANGEMENT.....	20
FIGURE 22:	IDLER PULLEY INSTALLATION ON VOLVO D13 ENGINE.....	21

Section 22: HEATING AND AIR CONDITIONING

FIGURE 23: A/C COMPRESSOR BELT ADJUSTMENT.....	21
FIGURE 24: COMPRESSOR ALIGNMENT	21
FIGURE 25: COMPRESSOR ALIGNMENT	22
FIGURE 26: EVAPORATOR COMPARTMENT.....	23
FIGURE 27: EVAPORATOR MOTOR ASSY FIXING BOLTS.....	23
FIGURE 28: EVAPORATOR MOTOR ASSEMBLY	24
FIGURE 29: CONDENSER FAN MOTOR	24
FIGURE 30: A/C CONDENSER COMPARTMENT.....	24
FIGURE 31: DRIVER'S EVAPORATOR LIQUID SOLENOID VALVE	26
FIGURE 32: REFRIGERANT SOLENOID VALVE.....	27
FIGURE 33: EXPANSION VALVE	27
FIGURE 34: SUPERHEAT ADJUSTMENT INSTALLATION	28
FIGURE 35: HIGH & LOW SWING TEMPERATURE AT REMOTE BULB	28
FIGURE 36: CENTRAL HEATING SYSTEM COMPONENTS	35
FIGURE 37: CEILING OF THE SPARE WHEEL COMPARTMENT	36
FIGURE 38: DRIVER'S HVAC UNIT.....	36
FIGURE 39: HEATER LINE SHUT-OFF VALVES	37
FIGURE 40: EVAPORATOR COMPARTMENT.....	37
FIGURE 41: DRIVER'S HOT WATER PNEUMATIC VALVE ASSEMBLY	38
FIGURE 42: PNEUMATIC WATER VALVE	38
FIGURE 43: CENTRAL HOT WATER PNEUMATIC VALVE ASSEMBLY	39
FIGURE 44: PNEUMATIC WATER VALVE	40
FIGURE 45: PUMP LOCATION (CENTRAL A/C).....	40

Section 22: HEATING AND AIR CONDITIONING

1. HEATING AND AIR CONDITIONING

The interior of the vehicle is pressurized by its Heating, Ventilation, Air Conditioning (HVAC) system. The vehicle is equipped with a Central HVAC System; air flow and controls divide the vehicle in two areas: driver's area and passengers' area. The interior of the vehicle should always be slightly pressurized to prevent dust and moisture from entering vehicle. Each section has its own fresh air, returning air and discharge air ducting. The exhaust is mainly done through the rear ventilator and through normal air-tightness losses.

2. AIR CIRCULATION WITH CENTRAL HVAC SYSTEM

2.1 DRIVER'S AREA

Fresh air is taken from a plenum underneath the front service compartment and enters the mixing box through an ON/OFF damper. Return air is taken through the base of the dashboard panel utility compartments into the mixing box. Mixed air goes through cooling and heating coils, fans and discharge ducts.

Both right and left discharge ducts defrost one half of the windshield. The driver can also divert some air flow to the console, from which he can direct air to his knees and/or upper body with adjustable HVAC air registers and to his feet with the appropriate button (see Fig. 1 and Operator's manual).

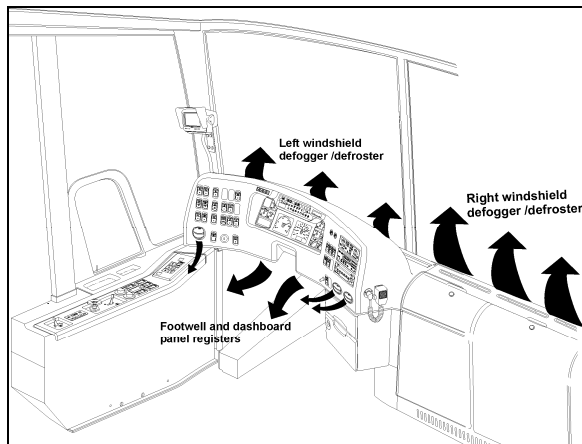

FIGURE 1: DRIVER'S AIR CIRCULATION 22307

X3-45 coaches are also equipped with a windshield upper section de-icing system. Also, one additional air register is located in the driver's area but supplied by the passengers' air ducting system. It is installed in the stepwell for step de-icing.

2.2 PASSENGERS' AREA

Fresh air enters the vehicle on the L.H. side, through the recirculation damper located inside the evaporator compartment door (Fig. 2). The damper can be fully opened for normal operation or closed for extreme weather or highly polluted areas (Refer to the Operator's Manual for more details). The recirculation REC button is located on the HVAC control unit. Press down the button to partially close the fresh air damper. Return air is drawn from inside the vehicle through the register duct located on L.H. side of vehicle (Fig. 3).

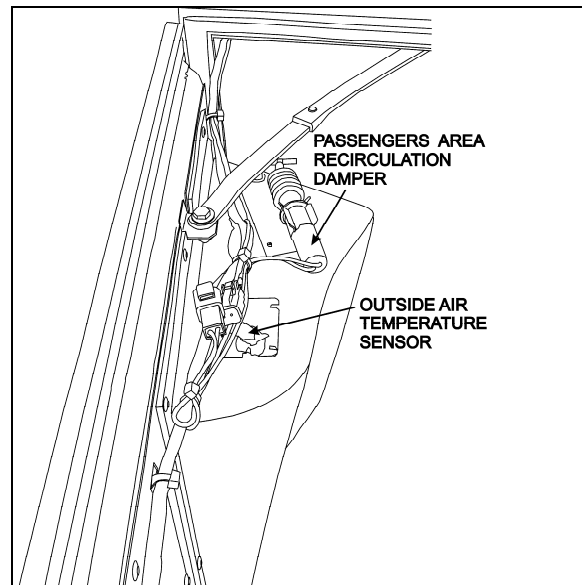

FIGURE 2: PASSENGERS' AREA RECIRCULATION DAMPER 22302

A double blower fan unit, which is activated by the evaporator motor, draws mixed air through an air filter, cooling and heating coils, then forces this air in the ventilation ducts along the walls, and finally exhausts it just below side windows.

X3-45 coaches are also equipped with an overhead compartment ventilation system, a

three-position rocker switch (OFF - 1st speed - 2nd speed) located on R.H. dashboard panel controls the speed of both fans. Return air is drawn just below the middle side windows through an air filter into the overhead compartment fan; discharge air is fed to the rotating registers through the ventilation duct (Fig. 4).

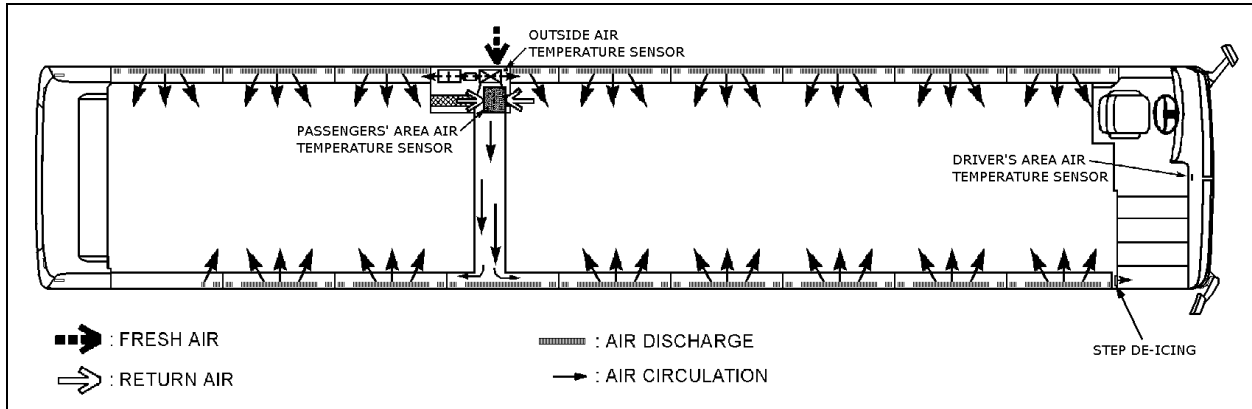

FIGURE 3: CENTRAL HVAC SYSTEM AIR CIRCULATION

22308

The overhead compartment air registers are used to control air flow for the passenger seats. One register per seat direct air flow by pointing or rotating register. Open or close register to adjust air flow.

controlled. It requires the passengers HVAC section to engage the A/C compressor magnetic clutch. Consequently, the driver's section cannot be operated in the A/C mode alone.

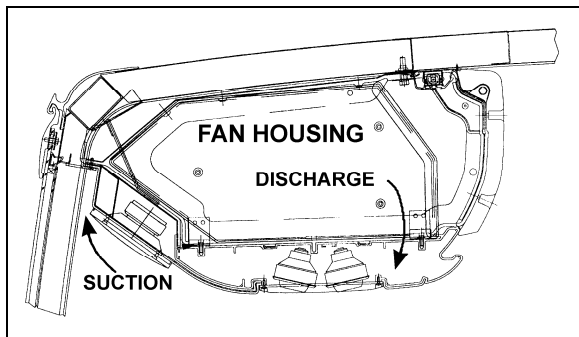

FIGURE 4: PASSENGERS OVERHEAD COMPARTMENT VENTILATION SYSTEM

22211

NOTE

The driver's HVAC section turns on automatically at starting of the engine and uses the settings that were kept in memory before turning off of the system.

The A/C compressor starts automatically when the two following conditions are satisfied:

1. The outside temperature is above 32°F (0°C).
2. The passenger's area temperature has reached 7°F (4°C) under the set point.

3. CENTRAL HVAC SYSTEM OPERATION

To operate the air conditioning system when vehicle is stationary, engine should run at fast idle. During operation of the air conditioning system, windows should be kept closed and door not left open longer than necessary. In order to prevent battery discharge, HVAC system will not operate if vehicle charging system is not working properly.

Using the Up/Down type switch  sets the fan speed and the speed chosen is illustrated on the window display.

NOTE

Upon starting, if the outside temperature is above 32°F (0°C) and then drops below 32°F (0°C), the compressor will keep running up to a temperature of 15°F (-9°C) to prevent condensation from forming on the windows.

3.1 DRIVER'S SECTION OPERATION

The temperature control in the driver's area is provided directly by the L.H. portion of the HVAC control unit mounted on the R.H. dashboard panel (Fig. 5).

NOTE

To perform a test of the driver's section windshield defroster, it is possible to run the system without running the engine.

The driver's HVAC section piping is paralleled with the passengers HVAC section piping. Both sections use the same refrigerant and coolant, and are linked to the same condenser and compressor, even if they are individually

The following 2% error chart and table can be used to troubleshoot the driver's area air temperature sensor and the outside air temperature sensor.

Section 22: HEATING AND AIR CONDITIONING

NOTE

The driver's area air temperature sensor is located behind the grill of the R.H. side console (Refer to fig.14).

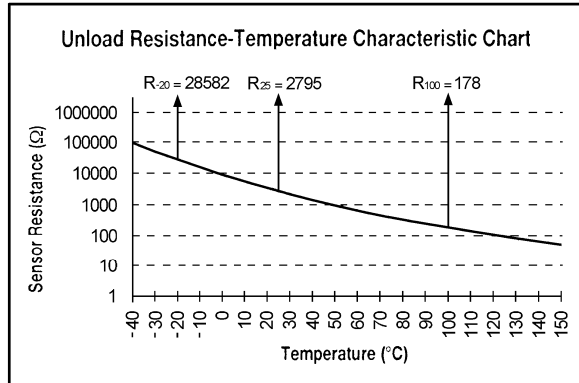

Temp °C	Temp °F	Resistance Ohms
-40	-40	100865
-35	-31	72437
-30	-22	52594
-25	-13	38583
-20	-4	28582
-15	5	21371
-10	14	16120
-5	23	12261
0	32	9399
5	41	7263
10	50	5658
15	59	4441
20	68	3511
25	77	2795
30	86	2240
35	95	1806
40	104	1465
45	113	1195
50	122	980
55	131	808
60	140	670
65	149	559
70	158	468
75	167	394
80	176	333
85	185	283
90	194	241
95	203	207
100	212	178
105	221	153
110	230	133
115	239	115
120	248	100
125	257	88
130	266	77
135	275	68
140	284	60
145	293	53
150	302	47

3.2 PASSENGERS' SECTION OPERATION

The passenger's section has a preset temperature of 68°F (20°C).

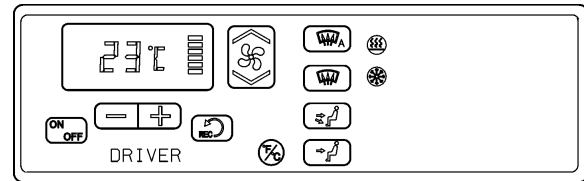

FIGURE 5: CENTRAL HVAC SYSTEM CONTROL UNIT

Temperature control is provided in conjunction with a thermistor sensor inside register duct, located on L.H. side of vehicle (Figs. 3 & 6).

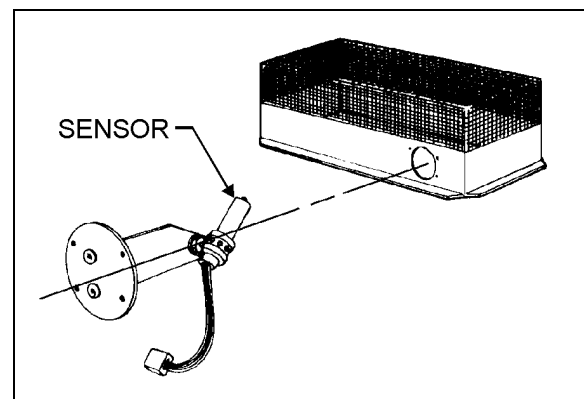

FIGURE 6: THERMISTOR SENSOR

The flow of water to the vehicle's main heater core is controlled by a pneumatic water valve which varies the cycling rate depending on selected temperature. A red LED, located on HVAC control unit, illuminates when heating mode is selected. A green LED illuminates when compressor clutch is in operation.

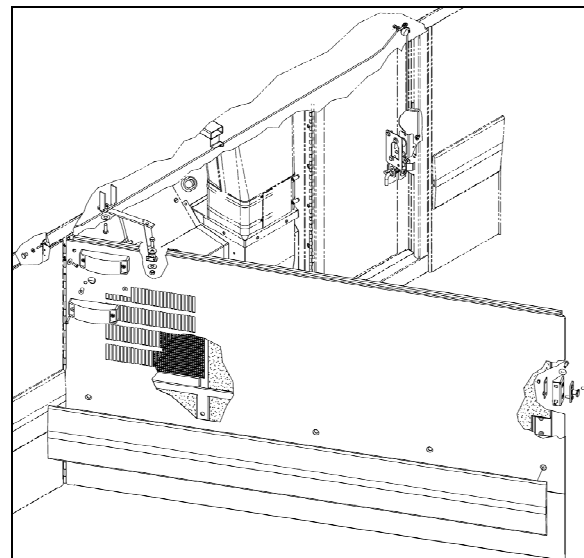

FIGURE 7: EVAPORATOR COMPARTMENT

22301

The evaporator fan motor, located in the evaporator compartment, is protected by a 90 amps, manually-resettable (CB3) circuit breaker located on the rear junction panel and is accessible from the engine compartment curb-side door, on R.H. side of the vehicle (refer to Section 06, "Electrical System" in this manual for details).

The condenser coil mounted on the opposite side of the evaporator is ventilated by four axial fans. The fan motors are protected by a manually-resettable 70 amp circuit breaker (CB7) mounted on the rear junction panel and accessible from the engine compartment curb-side door.

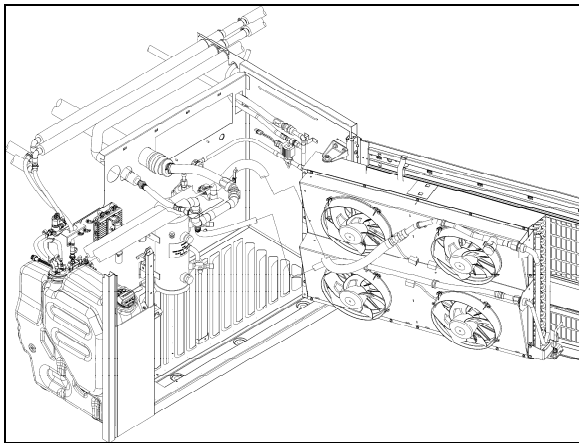

FIGURE 8: CONDENSER COMPARTMENT 22299

Furthermore, the following relays, diodes and multiplex module are located in the evaporator compartment (Fig. 9). They are mounted in the HVAC junction box located inside the evaporator compartment door.

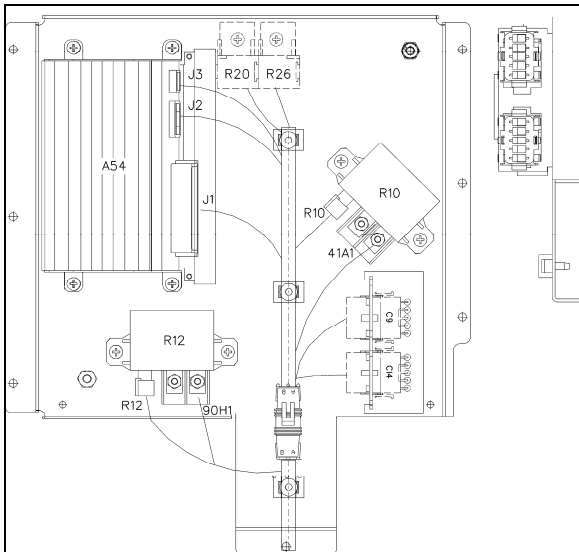



FIGURE 9: A/C JUNCTION BOX

A/C Junction Box			
Multiplex Module			
A54	I/O-B		
Relays			
R10	Condenser Fan Sp. 2		
R12	Evaporator Fan		
R20	Water Pump Relay		
Diodes			
D9	HVAC		
D11	Pass. Liq. Sol.	D17	Lugg. 5 th Compt
D19	Lugg. 2 nd Compt	D20	Lugg. 1 st Compt
D25	Evap. Fan	D30	Water Pump
D73	Opt.	D80	Opt.

4. HVAC UNIT MAINTENANCE

No special maintenance is required on the passengers and driver's HVAC units, with the exception of cleaning their respective coils and air filters, plus periodic inspection for broken drains, hoses and charging of system.

 **MAINTENANCE**

Squeeze rubber discharge tubes located underneath the appropriate compartment to eliminate the accumulated water and dirt every three months.

4.1 COIL CLEANING

Check the external surface of the coil at regular intervals for dirt or any foreign matter.

 **MAINTENANCE**

For the driver's HVAC unit, remove the grill and the access panels and back flush the coil every 12,500 miles (20 000 km) or once a year, whichever comes first

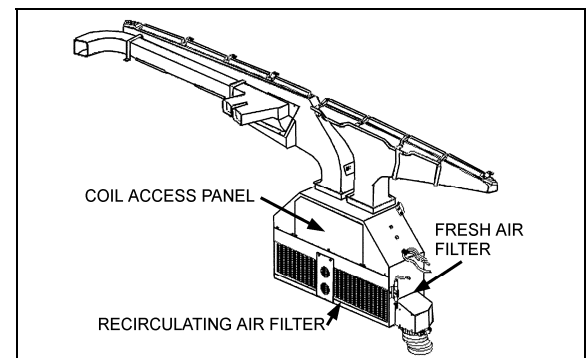

FIGURE 10: DRIVER'S HVAC UNIT COIL ACCESS PANEL

Section 22: HEATING AND AIR CONDITIONING



MAINTENANCE

For the passengers' section evaporator coil, remove the access panel and back flush the coil every 12,500 miles (20 000 km) or once a year, whichever comes first

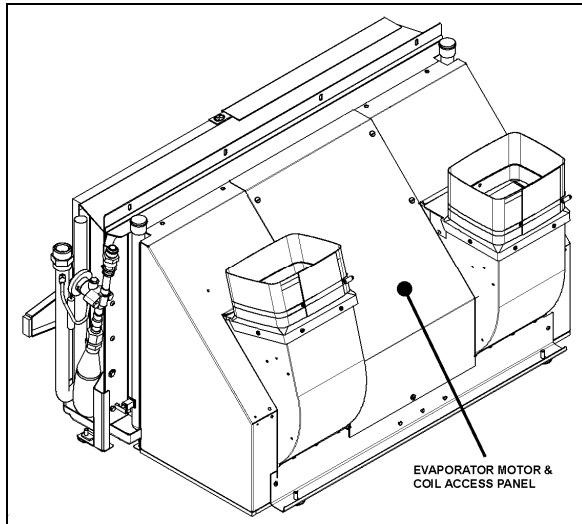

FIGURE 11: EVAPORATOR COIL ACCESS PANEL (TYPICAL) 22309

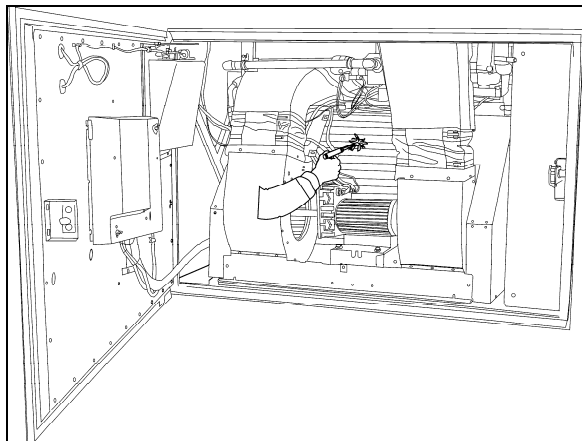

FIGURE 12: EVAPORATOR COIL CLEANING 22373



MAINTENANCE

For the condenser coil, back flush the coil (Fig. 13) every 6,250 miles (10 000 km) or twice a year, whichever comes first.



CAUTION

Use a water jet or water mixed with low air pressure to clean the coil.



CAUTION

Direct the pressure straight through the coil to prevent bending of fins and do not use extremely high pressure. Do not use hot water, steam or caustic soap.

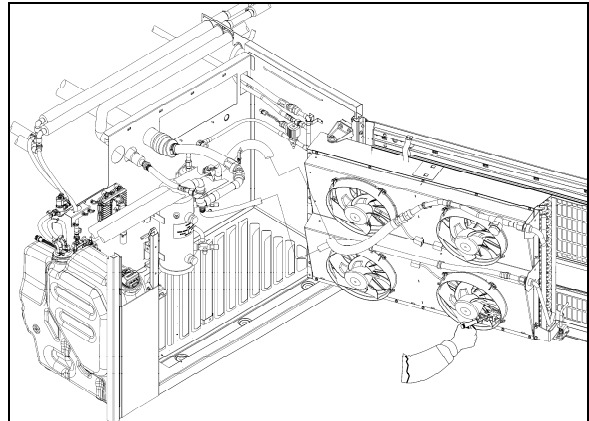

FIGURE 13: CONDENSER COMPARTMENT 22311

4.2 DRIVER'S SECTION AIR FILTERS

The driver HVAC system is located behind the dashboard's R.H. side lateral plastic panel. To gain access to the A/C filters, unscrew the R.H. lateral console's grill located at the top step of the entrance door steps. Slide out the recirculating air and fresh air filters.



MAINTENANCE

Back flush filters with water, then dry with air every 12,500 miles (20 000 km) or once a year, whichever comes first (Fig. 14 & 15).

NOTE

If the windshield is continuously fogged, check that the driver's air filter is not clogged.

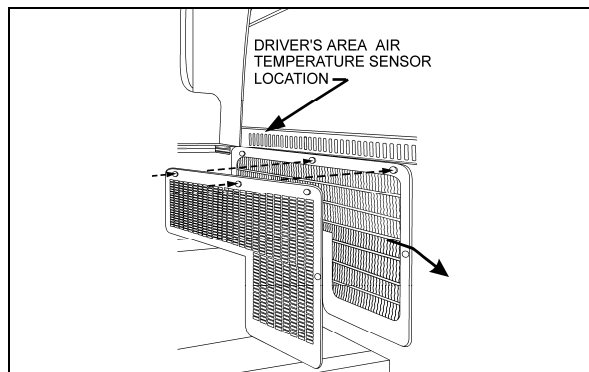

FIGURE 14: DRIVER'S SECTION ACCESS GRILL 22312

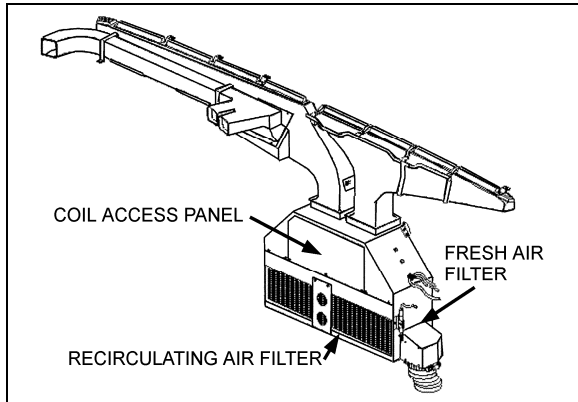

FIGURE 15: DRIVER'S SECTION AIR FILTERS 22171

4.3 PASSENGERS' SECTION AIR FILTER

The passengers' section air filter is located in the evaporator compartment. To access the filter, open baggage compartment door located forward of the evaporator compartment (L.H. side). Open access panel by turning the three screws of panel ¼ of a turn, unsnap both fasteners on top of filter, and slide out filter (Fig. 16).

MAINTENANCE

Back flush filter with water or soapy water, then dry with air every 12,500 miles (20 000 km) or once a year, whichever comes first.

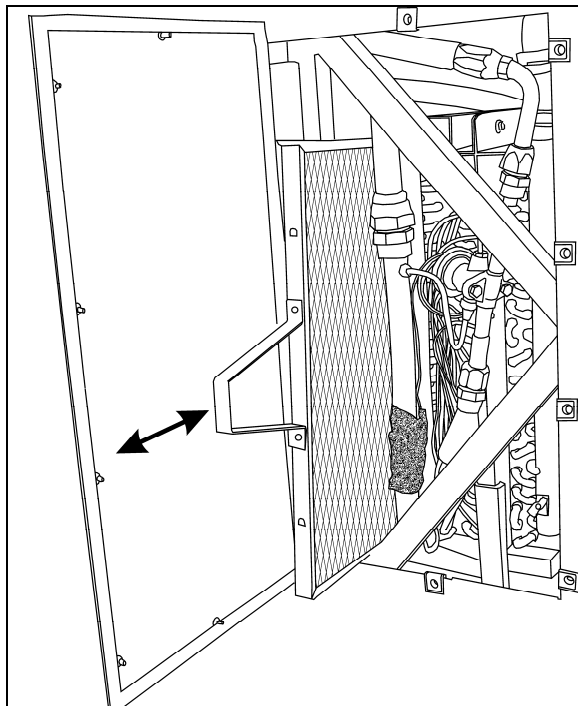

FIGURE 16: PASSENGERS' SECTION AIR FILTER 22306



CAUTION

Do not use high pressure water jet to avoid damaging filter. Be sure not to reverse filter upon installation.

4.4 OVERHEAD COMPARTMENT FAN AIR FILTER

The air filters are accessible from inside the overhead compartments.



MAINTENANCE

Slide out filters, back flush with water then dry with air and replace. This procedure should be done every 12,500 miles (20,000 km) or once a year, whichever come first.

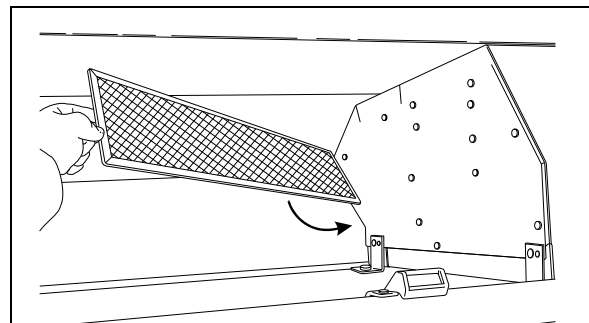

FIGURE 17: OVERHEAD COMPARTMENT FAN AIR FILTER 22201

5. HVAC SYSTEM PARTICULARITIES, TESTING AND TROUBLESHOOTING

Before undertaking any troubleshooting on the HVAC system, study the appropriate wiring diagrams to get a complete understanding of the HVAC components circuitry, read and understand section 06: ELECTRICAL of this manual under "Troubleshooting And Testing The Multiplex Vehicles" and "Test Mode For Switches And Sensors". The information included in these paragraphs is necessary for troubleshooting the HVAC system on Multiplex vehicles.

5.1 HVAC SYSTEM AND TEST MODE FOR SWITCHES AND SENSORS

When in switch/sensor test mode (see Section 06: ELECTRICAL for complete information), the A/C compressor HI and LO pressure values are displayed one after the other instead of the outside temperature in the telltale panel LCD

Section 22: HEATING AND AIR CONDITIONING

display. This feature can be used when the vehicle is traveling to check the A/C compressor pressure values.

NOTE

When starting the A/C compressor wait 5 seconds before checking pressures in order to give the system a chance to build its pressure. During the first 5 seconds after startup, the compressor is active on 6 cylinders and the A/C valve is open regardless of the pressure readings.

In test mode, with the parking brake applied and the passenger set point set to a value higher than 64°F (18°C), the hot water circulating pump is not set to OFF as it would normally do when the outside temperature gets above 50°F (10°C).

This feature allows verification of the pump when inside a garage. This is also useful when working on the heating system to remove air pockets trapped in the system.

When performing an A/C cooling test and having the water pump shut off in switch/sensor test mode is required, just set the passenger set point temperature to the minimum 64°F (18°C) to shut off the pump.

5.2 HVAC SYSTEM AND TEST MODE FOR ELECTRIC MOTORS

The test mode allows testing the motors and electric contactors without the need to have the engine running (see Section 06: ELECTRICAL under "TEST MODE FOR ELECTRICAL MOTORS" for complete information).

Use this test mode for testing of the condenser motors, the A/C compressor clutch activation, left and right unloaders, evaporator motor, water pump, hot water solenoid valve and overhead compartment air register fan.

5.3 PARTICULARITIES

Conditions for engaging the 2 nd speed on the evaporator motor (cooling demand).	The 2 nd speed engages if the passenger's area temperature is 1 degree above the set point and it reverts to speed 1 if the temperature gets equal or below the set point.
Conditions for hot water recirculating pump activation (heating demand).	The pump turns to OFF if the outside temperature is above 50°F (10°C), when there is less demand for heating. Note: To test a working pump, it is possible to keep it active even if the outside temperature is above 50°F (10°C). See paragraph 7.2 HVAC SYSTEM AND TEST MODE FOR ELECTRIC MOTORS.
The compressor unloaders are working based on pressure and also on the difference between the passenger's area temperature and the set point.	2 left compressor cylinders: Stop if: passenger's area temperature is at less than 0.4°C degree above the set point or if the compressor output is above 280 psi, or if the compressor input is below 26 psi. Restart if: passenger's area temperature is 0.9°C or more above the set point and the compressor pressure output is less than 220 psi and the compressor pressure input is above 34 psi. 2 right compressor cylinders: Stop if: passenger's area temperature is at less than 0.2°C above the set point or if the compressor input falls below 23 psi. Restart if: passenger's area temperature is 0.7°C or more above the set point and the compressor input pressure is above 32 psi.
The A/C deactivation pressure is 320 psi.	In case of high pressure, the analog pressure sensor connected to the Multiplex module deactivates the compressor. There is also a « Pressure switch » adjusted to 350 PSI that acts to stop the compressor in the instance that the Multiplex module fails.

5.4 HVAC SYSTEM TROUBLESHOOTING

Problem/Symptom	Probable Causes	Actions
Defroster fan not functioning	Module A47 is not powered or is faulty	<ol style="list-style-type: none"> 1. Check the Diagnostics menu of the Driver Information Display (DID). Select Fault Diagnostics and Electrical System. The message “No Response ModA47, Active” indicates a power problem on the module. (A CAN network problem would show the same message but doesn't produce these symptoms). 2. Check / reset circuit breaker CB6 3. Check / replace fuse F5 4. Check / replace relay R18 5. Probe gray connector on module to see if it is powered. 6. Use the air release valves on the dashboard and in the front service compartment to lock / unlock the door
HVAC condenser fans not functioning in speed 1	Circuit breaker CB7 was manually tripped and not reset Seized bearing Faulty brushes or bad wiring	Check / reset circuit breaker CB7
HVAC condenser fans not functioning in speed 1	Module A54 is not powered or is faulty	<ol style="list-style-type: none"> 1. Check the Diagnostics menu of Driver Information Display (DID). Select Fault Diagnostics and Electrical System. The message “No Response ModA54, Active” indicates a power problem on the module. (A CAN network problem would show the same message but doesn't produce this symptom). 2. Check / reset circuit breaker CB5 3. Check / replace fuse F67 , F68 4. Probe gray connector on module to see if it is powered.
HVAC condenser fans not functioning in speed 2	Circuit breaker CB7 was manually tripped and not reset Seized bearing Faulty brushes Bad wiring	Check / reset circuit breaker CB7
Defroster fan is functioning but no heat or cooling available in the driver's area	Module A46 is not powered or is faulty Faulty speed control Bad wiring	<ol style="list-style-type: none"> 1. Check the Diagnostics menu of Driver Information Display (DID). Select Fault Diagnostics and Electrical System. The message “No Response ModA46, Active” indicates a power problem on the module. (A CAN network problem would show the same message but doesn't produce these symptoms). 2. Check / reset circuit breaker CB1 3. Check / replace fuse F12 or F13 4. Probe gray connector on module to see if it is powered.

Section 22: HEATING AND AIR CONDITIONING

Problem/Symptom	Probable Causes	Actions
The A/C compressor clutch does not engage	Module A52 is not powered or is faulty	<ol style="list-style-type: none"> 1. Check the Diagnostics menu of Driver Information Display (DID). Select Fault Diagnostics and Electrical System. The message "No Response ModA52, Active" indicates a power problem on the module. (A CAN network problem would show the same message but doesn't produce this symptom). 2. Check / reset circuit breaker CB5 3. Check / replace fuse F65 4. Probe gray connector on module to see if it is powered.
Evaporator fan not functioning	Circuit breaker CB3 tripped Module A54 is not powered or is faulty Faulty brushes	<ol style="list-style-type: none"> 1. Check / reset circuit breaker CB3 2. Check the Diagnostics menu of Driver Information Display (DID). Select Fault Diagnostics and Electrical System. The message "No Response ModA54, Active" indicates a power problem on the module. (A CAN network problem would show the same message but doesn't produce this symptom). 3. Check / reset circuit breaker CB5 4. Check / replace fuse F67 , F68 5. Probe gray connector on module to see if it is powered.

6. CENTRAL AIR CONDITIONING SYSTEM

The schematic of Figure 18 shows the central A/C system and its components. The central system is equipped with a 6 cylinder, 05G Twin Port Carrier compressor with an air conditioning capacity of 7½ tons. The receiver tank and filter dryer are mounted inside the condenser compartment.

6.1 A/C CYCLE

Refrigeration may be defined as "the transfer of heat from a place where it is not wanted to a place where it is unobjectionable". Components required for a closed circuit refrigeration system are shown in Figure 18.

The air conditioning system used on X3-45 coaches is of the "Closed" type using "R-134a".

1. The refrigerant flowing to the compressor is compressed to high pressure and reaches a temperature higher than the surrounding air. It is passed through the air-cooled fins and tubes of the condenser causing the hot, high pressure gas to be condensed into a liquid form.

2. The liquid refrigerant flows to the receiver tank, then passes through a filter dryer where moisture, acids and dirt are removed and then through a moisture indicator which indicates if any moisture is present in the system.
3. By its own pressure, the liquid refrigerant flows through a thermal expansion valve where the pressure drop causes the refrigerant to vaporize in a vapor-liquid state at a low temperature pressure.
4. The cold low pressure refrigerant passes through the passengers and the driver's evaporator coils which absorbs heat from the air passing over the fins and tubes, and changes into gas. In this form, the refrigerant is drawn into the compressor to repeat the air conditioning cycle.
5. The success of the air conditioning system depends on retaining the conditioned air within the vehicle. All windows and intake vents should be closed. An opening of approximately 8 in² (5162 mm²) could easily neutralize the total capacity of the system.

6. Other causes of inadequate cooling are dirty coils or filter. Dirt acts as insulation and is also serves as a restriction to the air flow.
7. The refrigeration load is not constant and varies. It is also affected by outside temperature, relative humidity, passenger load, compressor speed, the number of stops, etc.
8. The compressor will load or unload depending on operating conditions.

6.2 REFRIGERANT

The A/C system of this vehicle has been designed to use Refrigerant 134a as a medium. Regardless of the brand, only R-134a must be used in this system. The chemical name for this refrigerant is Ethane, 1, 1, 1, 2-Tetrafluoro.



DANGER

Refrigerant in itself is nonflammable, but if it comes in contact with an open flame, it will decompose.

6.2.1 Procurement

Refrigerant is shipped and stored in 30 and 100 pound (13,6 and 45 kg) metal cylinders. Approximately 24 pounds (10,9 kg) are used in the central system.

It will be impossible to draw the entire refrigerant out of the cylinder. However, the use of warm water when charging the system will assure the extraction of a maximum amount of refrigerant from the cylinder.

6.2.2 Precautions in Handling Refrigerant

1. Do not leave refrigerant cylinder uncapped.
2. Do not subject cylinder to high temperatures, do not weld or steam clean near system or cylinder.
3. Do not fill cylinder completely.
4. Do not discharge vapor into an area where a flame is exposed.
5. Do not expose the eyes to liquid refrigerant.

All refrigerant cylinders are shipped with a heavy metal screw cap. The purpose of the cap is to protect the valve and safety plug from damage. It is a good practice to replace the cap after each use of the cylinder for the same reason. If

the cylinder is exposed to the sun's radiant heat pressure increase resulting may cause release of the safety plug or the cylinder may burst.

For the same reason, the refrigerant cylinder should never be subjected to excessive temperature when charging a system. The refrigerant cylinder should be heated for charging purposes by placing it in 125°F (52°C) water. Never heat above 125°F (52°C) or use a blowtorch, radiator, or stove to heat the cylinder. Welding or steam cleaning on or near any refrigerant line or components of the A/C system could build up dangerous and damaging pressures in the system.

If a small cylinder is ever filled from a large one, never fill the cylinder completely. Space should always be allowed above the liquid for expansion. Weighing cylinders before and during the transfer will determine the fullness of the cylinders.



WARNING

One of the most important precautions when handling refrigerant consists in protecting the eyes. Any liquid refrigerant which may accidentally escape is approximately -40°F (-40°C). If refrigerant comes in contact with the eyes, serious injury could result. Always wear goggles to protect the eyes when opening refrigerant connections.

6.2.3 Treatment in Case of Injury

If liquid refrigerant comes in contact with the skin, treat the injury as if the skin was frost-bitten or frozen. If liquid refrigerant comes in contact with the eyes, consult an eye specialist or doctor immediately. Give the following first aid treatment:

1. Do not rub the eyes. Splash eyes with cold water to gradually bring the temperature above the freezing point.
2. Apply drops of sterile mineral oil (obtainable at any drugstore) in the eyes to reduce the possibility of infection. The mineral oil will also help in absorbing the refrigerant.

6.2.4 Precautions in Handling Refrigerant Lines

1. All metal tubing lines should be free of kinks, because of the resulting restrictions

Section 22: HEATING AND AIR CONDITIONING

on the flow of refrigerant. A single kink can greatly reduced the refrigeration capacity of the entire system.

2. The flexible hose lines should never be allowed to come within a distance of 2-1/2" (6,3 cm) from the exhaust manifold.
3. Use only sealed lines from parts stock.
4. When disconnecting any fitting in the refrigeration system, the system must first be discharged of all refrigerant. However, proceed very cautiously, regardless of gauge readings. If liquid refrigerant happens to be in the line, disconnect fittings very slowly, keeping face and hands away so that no injury can occur. If pressure is noticed when fitting is loosened, allow it to bleed off very slowly.

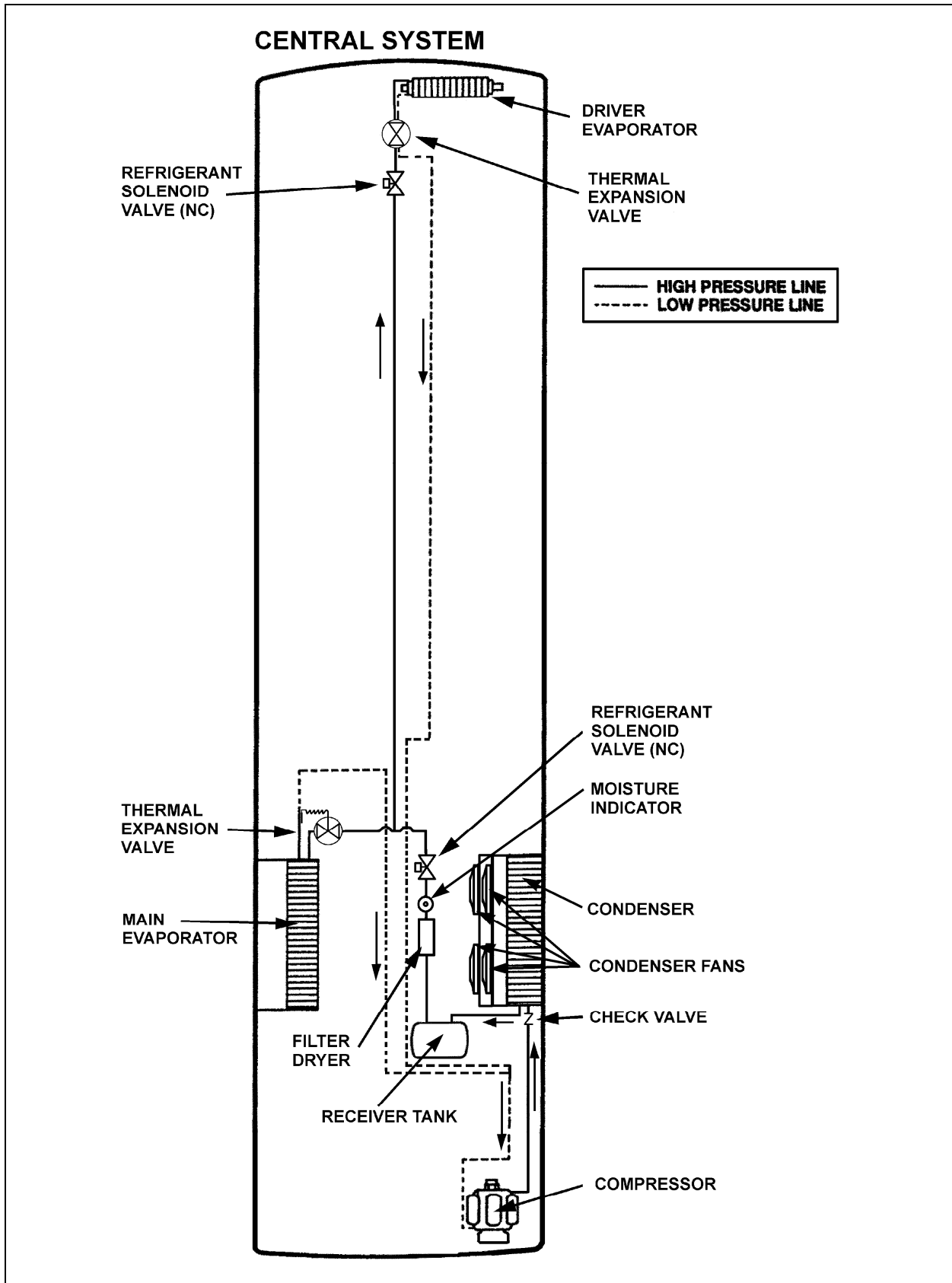

FIGURE 18: REFRIGERANT CIRCUIT (CENTRAL SYSTEM)



WARNING

Always wear safety goggles when opening refrigerant lines.

5. In the event that any line is opened to the atmosphere, it should be immediately capped to prevent entrance of moisture and dirt.
6. The use of the proper wrenches when making connections on O-ring fittings is important. The use of improper wrenches may damage the connection. The opposing fitting should always be backed up with a wrench to prevent distortion of connection lines or components. When connecting the flexible hose connections, it is important that the swaged fitting and the flare nut, as well as the coupling to which it is attached, be held at the same time using three different wrenches to prevent turning the fitting and damaging the ground seat.
7. The O-rings and seats must be in perfect condition. The slightest burr or piece of dirt may cause a leak.
8. O-rings should be coated with refrigeration oil and installed on the line before the line is inserted into the fitting to prevent damaging the O-ring. If leaks are encountered at the couplings or connectors, no attempt should be made to correct the leaks by tightening the connections beyond the recommended torque. The O-rings are designed to seal at the specified torque and overtightening the connection does not result in a satisfactory and permanently sealed connection. The connection must be disassembled and the cause of the leak (damaged O-ring, defective lines, etc.) corrected. Use new O-ring.

6.3 PUMPING DOWN

This procedure is intended to reduce refrigerant loss, by isolating it in the compressor and the receiver tank, as well as in their connecting line, in order to carry out repairs on other sections of the air conditioning system (lines and components).

NOTE

Before attempting any repair between compressor and receiver tank, use a recovery unit to remove refrigerant from the system.



WARNING

To prevent any injury, when air conditioning system must be opened, refer to previous paragraph "PRECAUTIONS IN HANDLING REFRIGERANT".



CAUTION

The filter dryer must be changed each time a line in the system is opened.

Procedure

1. Energize passengers 'section liquid solenoid valve.
2. Run the system for 10 minutes, shut it OFF, then close the receiver tank outlet valve by turning it clockwise, backseat the suction service valve on the compressor, install an appropriate pressure gauge set, and turn the valve forward ¼ turn to enable a visual check of the suction pressure.
3. Disconnect the "Low Pressure Switch" connector (mounted near the A/C compressor, and install a jumper wire.

NOTE

This jumper wire will allow the clutch to remain engaged after pressure drops below 15 psi (103,5 kPa).

4. Start the engine, press the "Driver's ON/OFF" switch then adjust (lower) temperature control  to maximum A/C.
5. Run the compressor until pressure reaches 1-2 psi (7-14 kPa).

NOTE

During this operation, care must be taken not to fill the receiver tank over the upper sight glass. If so, stop process immediately. Always allow refrigerant piping and units to warm up to the ambient air temperature before opening system or sweating will take place inside the lines.

6. Stop engine, and close compressor outlet valve by turning it clockwise until valve is properly seated.

7. Close compressor suction valve by turning it clockwise until it is properly seated.
8. Wait until pressure gauge reaches 1 to 2 psi (7 to 14 kPa). To accelerate procedure, lightly open compressor suction valve until pressure reaches this value.

6.4 ADDING REFRIGERANT (VAPOR STATE)

Use the suction service valve on the compressor to add a small quantity of refrigerant to the system. Backseat the valve and connect a charging line from the refrigerant cylinder to the valve. Tighten connection at level of refrigerant cylinder and open tank end slightly to purge air from the charging line. Tighten the charging line at the compressor. Screw in the stem of suction valve approximately two turns. Start the engine and run at fast idle. Add sufficient refrigerant to bring the level in lower sight glass of receiver tank to mid-point. Always charge the system with the cylinder upright and the valve on top to avoid drawing liquid out of the cylinder.

6.5 EVACUATING SYSTEM

1. Open both receiver valves by turning "out" (normal position).
2. Remove the caps from the two 90° adapters on the suction, discharge valves and connect two hoses to the vacuum.
3. Place the two compressor valves, suction and discharge, in neutral position by turning each one 3 to 4 turns "in" from the "out" position.
4. Open the solenoid valve by energizing or manually bypass.
5. Start the vacuum pump. Open the large (suction) shutoff valve and close the small vacuum gauge valve.
6. The pressure will drop to approximately 29 inches vacuum (14.2 psi or 97,9 kPa) (the dial gauge only gives a general idea of the absolute system pressure).
7. Backseat the compressor valves by turning "out" all the way.
8. Shut down the vacuum pump.
9. Remove the hoses.
10. Reinstall the caps at the suction valve take-off points.

6.5.1 Double Sweep Evacuation Procedure

1. Remove any remaining refrigerant from the system using a refrigerant recovery machine.
2. Connect the evacuation manifold, vacuum pump, hoses and micron gauge to the unit.
3. With the unit service valves closed (back seated) and the vacuum pump and the thermistor valves open, start the pump and draw the manifold and hoses into a very deep vacuum. Shut the vacuum pump off and see if the vacuum holds. This is to check the setup for leaks.
4. Midseat the system service valves.
5. Open the vacuum pump and the thermistor valves. Start the pump and evacuate to a system pressure of 2000 microns.
6. Close the vacuum pump and the thermistor valves, turn off the vacuum pump (closing the thermistor valve protect the valve from damage).
7. Break the vacuum with clean refrigerant (or dry nitrogen) and raise the pressure to approximately 2 PSIG. Monitor the pressure with the compound gauge.
8. Remove the refrigerant with the recovery machine.
9. Repeat steps #5 – 8 one time.
10. After the second "sweep", change the filter dryer (if you have not yet done so) and evacuate to 500 microns.
11. Evacuating the system below 500 microns on systems using the Carrier 05G compressor may risk drawing air into the system past the carbon shaft seal.
12. Check to insure that vacuum holds. (If the pressure continues to rise, it indicates a leak or moisture in the system).
13. Charge the system with the proper amount of refrigerant using recommended charging procedures.

NOTE

This method will aid in preventing unnecessary system failures by ensuring that the refrigeration system is free of contaminants.

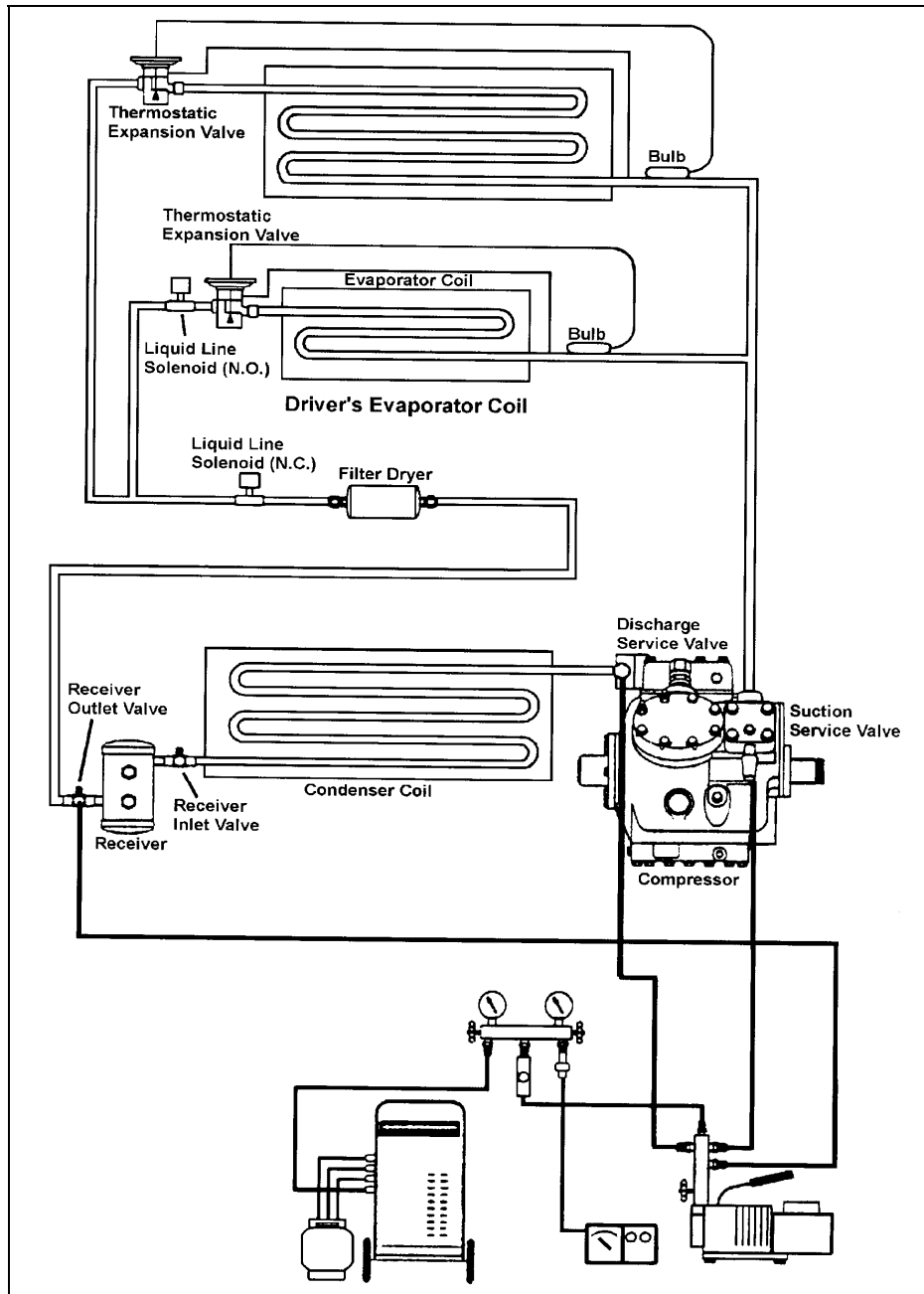

FIGURE 19: DOUBLE-SWEEP EVACUATION SET-UP

22298

6.6 CHARGING SYSTEM

When a system has been opened or if there are any questions about the air or moisture in the system, evacuate the system. Charging of an evacuated system may be accomplished by forcing liquid R-134a directly into the receiver tank. This may be accomplished by placing the refrigerant cylinder upside down on a scale with the valves at the bottom. This ensures that only liquid will enter the receiver tank.

When charging an empty system, weigh the amount of refrigerant put into the system. This will eliminate any possibility of overfilling. A nominal charge requires 24 pounds (10,9 kg).

1. Backseat the two compressor shutoff valves ("out").
2. Install the test gauges at the shutoff valves noting that the 400 psi (2758 kPa) gauge is connected to the discharge.

3. Turn in the two shutoff valves 3 to 4 turns.
4. Open the lower receiver valve by turning "out" all the way.
5. Backseat the upper receiver valve by turning out all the way.
6. Remove the cover cap from the service fitting in the top receiver valve.
7. Attach a charging hose to the R-134a tank. Open the tank valve slightly permitting R-134a to escape thus purging the hose of air.
8. Connect the charging hose to the service fitting.
9. Open the R-134a tank valve.
10. To build up pressure in the receiver tank, heat the receiver tank with a heating blanket.
11. Turn in the upper receiver valve several turns. The R-134a will now enter the system.
12. The proper charge of R-134a is 24 lbs (10.89 kg). When the scale indicates this amount of charge, backseat the receiver valve and close the R-134a tank valve.
13. Disconnect the charging hose. Replace the cover caps.
14. The system is now ready for operation.



CAUTION

The evacuation of the system must be made by authorized and qualified personnel only. Refer to local laws for R-134a recuperation.

6.7 REFRIGERANT SYSTEM CLEAN-OUT AFTER COMPRESSOR FAILURE

Although the vast majority of reciprocating refrigerant compressors manufactured today are extremely reliable, a small percentage do fail. These failures usually result in minor or extensive system contamination depending on the severity of the failure. When an open type compressor becomes damaged internally, this provokes small particles of bearings, steel, brass, copper, and aluminum and, in severe cases, carbonized oil, which could contaminate the system. To prevent repeated failures, the problem which caused the failure should be corrected, and depending upon the severity of the failure, the system should be thoroughly

cleaned out using one of the clean-out procedures mentioned.

6.7.1 Determining Severity of Failure

The severity of compressor failure can be categorized as minor or major. A failure is considered minor when the contamination is limited to the compressor with little or no system contamination. A major failure, or burnout, results in extensive system contamination as well as compressor damage. Extensive system contamination can be determined by withdrawing a small sample of compressor oil and checking its color, odor and acidity. A Virginia Chemical "TKO" one step acid test kit is one of several compressor oil test kits that may be used. A high acid content would indicate a major failure or burnout. A small amount of refrigerant gas may be discharged. A characteristic burned odor would also indicate severe system contamination.

6.7.2 Clean-out after Minor Compressor Failure

1. Be sure to correct the problem which caused the failure.
2. Change liquid line filter dryer.
3. Run the unit for 2 hours on high speed cool only.
4. Check compressor oil level to ensure compressor is not overcharged with oil. Sometimes a significant amount of oil is pumped out of the compressor to other parts of the system when a compressor fails. This oil will return to the replacement compressor when it is started, causing an overcharge of oil in the sump of the replacement compressor. In this case, it is important that the oil level be adjusted to the proper level.
5. Withdraw a sample of the compressor oil and check its color, odor, and acidity, using instructions supplied above. If the oil is contaminated, change the oil and filter dryer, and repeat the procedure until the system is clean.

6.7.3 Clean-out After Major Compressor Failure

1. Reclaim the refrigerant into a refrigerant bottle through a filter dryer to filter out contaminants.

Section 22: HEATING AND AIR CONDITIONING

2. Remove the failed compressor and repair it if possible.
3. Install new or repaired compressor.
4. Change the filter dryer.
5. Circulate clean R-134a or nitrogen using a pressurized metal cylinder or a reclaiming machine to clean out many of the contaminants collected in the coil valves, TXV (Thermal Expansion Valve), solenoid valves, check valves, and any other mechanical component that may have collected contaminants.
6. Evacuate and charge the system normally.
7. Run the unit for 8 hours and monitor the pressure drop across the filter dryer. Also check the liquid line dryer for signs of restriction. If the pressure drop across the filter dryer exceeds 12 to 14 psig (82,75 to 96,5 kPa) with a 40°F (5°C) evaporator coil temperature, stop the unit and change the liquid line and suction line filter dryer. After 4 or 5 hours of operation, stop the unit and replace the filter dryer.
8. After 8 hours of operation, stop the unit and remove a sample of the compressor oil and check its color, odor, and acidity, using instructions supplied above. If the oil is contaminated, replace the oil and repeat step 7. If the oil is not contaminated, change the filter dryer again and replace the moisture-liquid indicator.
9. After approximately 7 days of operation, recheck the compressor oil for cleanliness and acidity.

7. CENTRAL A/C SYSTEM COMPONENTS

7.1 COMPRESSOR (CENTRAL SYSTEM)

7.1.1 Belt Replacement



DANGER

Set the battery master switch to the "Off" position. For greater safety, set the engine starter selector switch in engine compartment to the "Off" position.

1. Open engine compartment rear doors and locate the belt tensioner pressure releasing valve (Fig. 20), mounted above the engine

R.H. side door next to the air pressure regulator, then turn handle clockwise in order to release pressure and tension on belts.

2. Remove the radiator fan driving mechanism belt (Refer to Section 05: Cooling).
3. Slip the old A/C compressor belts off and the new ones on.
4. Reset belt tensioner pressure releasing valve (Fig. 20) to 45 psi (310 kPa) to apply tension on the new belts as explained in Section 12.

NOTE

Both belts must always be replaced simultaneously to ensure an equal distribution of load on each of them.

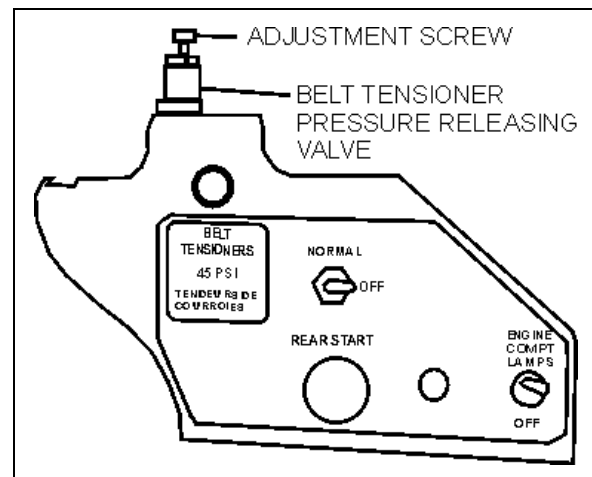

FIGURE 20: AIR PRESSURE REGULATOR

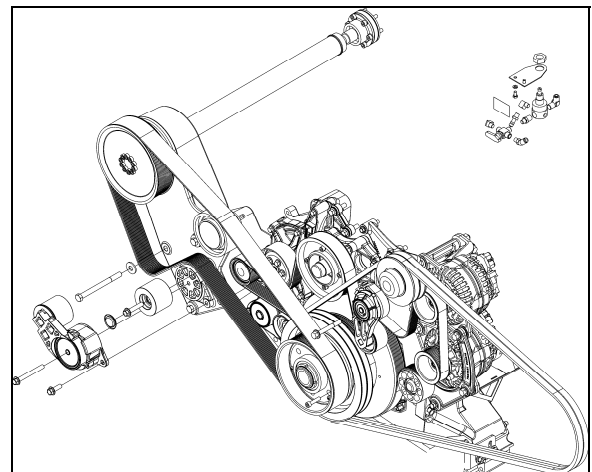

FIGURE 21: BELT ARRANGEMENT

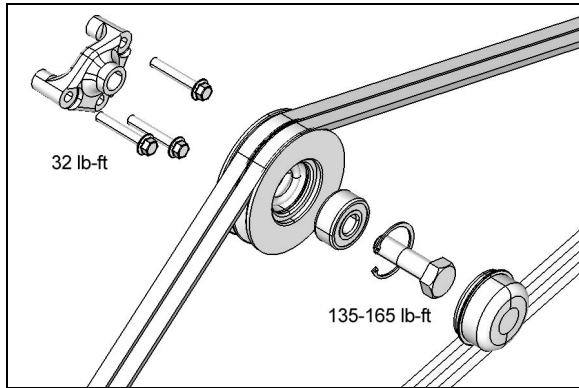

FIGURE 22: IDLER PULLEY INSTALLATION ON VOLVO D13 ENGINE

7.1.2 Belt Tension Adjustment

Belt tensioning is applied through air bellows which are adjusted by an air pressure regulating valve. The correct pressure of 45 psi (310 kPa) is set at the factory. Periodically verify the pressure at the regulating valve using a pressure gauge and correct if necessary.

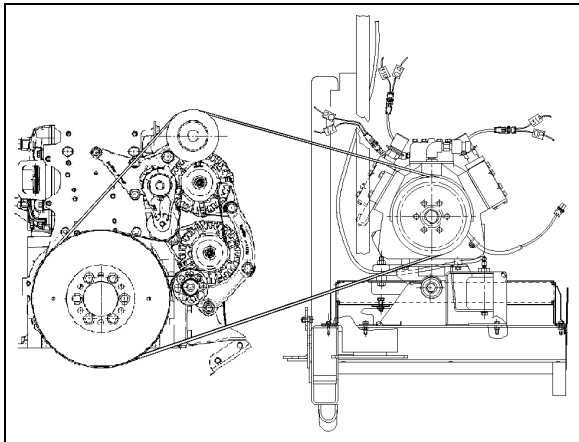

FIGURE 23: A/C COMPRESSOR BELT ADJUSTMENT²²²⁸⁸

7.1.3 Pulley Alignment

In order to avoid skipping, disengagement and a premature wear of compressor belt, it is necessary to align compressor pulley with the crankshaft pulley. Before performing the following procedure, release air from belt tensioner bellows by means of the air pressure releasing valve. After completing these procedures reset belt tensioner air pressure regulator to 45 psi (310 kPa).

7.1.4 Longitudinal Compressor Alignment

1. Rest an extremity of a straight edge of approximately 46 inches (117 cm) against the upper part of the outer face of crankshaft pulley, positioning the other end close to the compressor clutch pulley (Figs. 24 & 25).
2. Check the distance between each extremity of straight edge (1. Fig. 25) and the first drive belt. If they are different, loosen the compressor support bolts and with a hammer, knock support to slide it in order to obtain the same distance; then tighten bolts.

7.1.5 Horizontal Compressor Alignment

1. Rest an extremity of the straight edge against the upper part of the outer face of compressor pulley, positioning the other end close to the crankshaft pulley.
2. Check the distance between each extremity of straight edge (1, Fig. 25) and drive belt. If they are different, loosen the pillow block compressor bolts and with a hammer, knock compressor pillow block to slide it, in order to obtain the same distance; then tighten bolts.

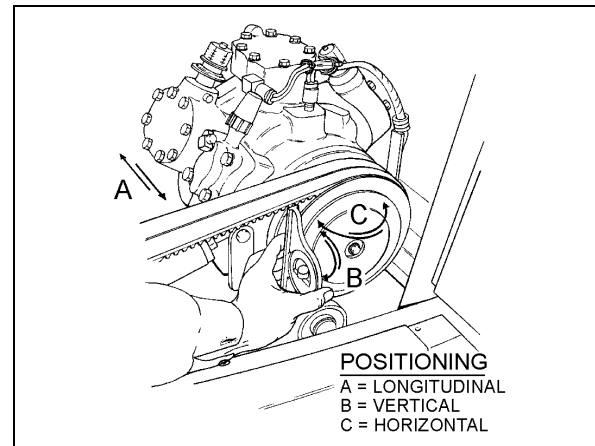

FIGURE 24: COMPRESSOR ALIGNMENT 22072

7.1.6 Vertical Compressor Alignment

Rest a short "angle and level indicator" on the outer side face of the crankshaft pulley, adjust the level indicator inclination at 0° and check if the compressor pulley is at same angle (Fig. 24). If it is not the same, shim under the appropriate pillow block in order to obtain the correct angle.

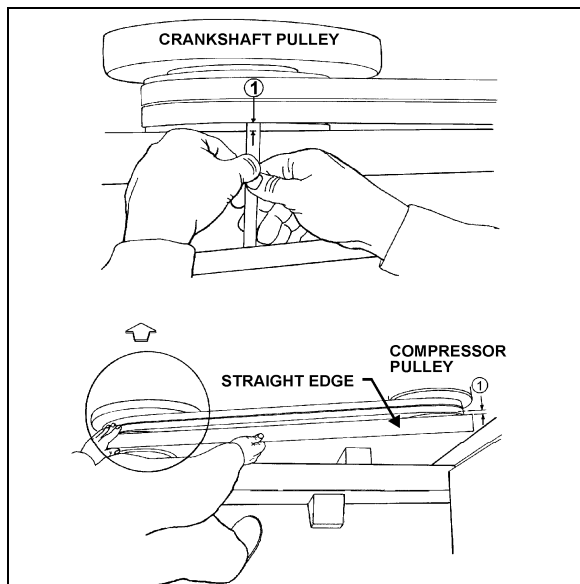



FIGURE 25: COMPRESSOR ALIGNMENT 22040

7.1.7 Compressor Maintenance

For the maintenance of the A/C compressor, see the *Carrier Compressor "WORKSHOP MANUAL for MODEL 05G TWIN PORT COMPRESSOR"* included at the end of this section.

 <p>MAINTENANCE</p>
<p>Check compressor oil level and add if necessary, every 6,250 miles (10 000 km) or twice a year, whichever comes first.</p>

 <p>CAUTION</p>
<p>Use only Castrol SW 68 (POE) oils with refrigerant 134a.</p>

7.1.8 Troubleshooting Guide

A preliminary check may be made by simply feeling the cylinder heads with the unit in operation at ambient temperatures of 35°F (2°C) and over. The cylinder heads are internally divided into suction and discharge valves. The lower half of the cylinder head is the suction side, and it should be relatively cool to the touch, as opposed to the hot upper discharge side. If a valve plate or head gasket is blown, or a compressor unloader is stuck open, partially compressed refrigerant vapor will be circulated between the suction and discharge sides of the head. The affected cylinder head will then have

a relatively even temperature across its surface and be neither as hot as the normal discharge temperature nor as cool as the normal suction temperature.

Blown Head Gaskets

Symptom:

- * Loss of unit capacity at low temperature.
- * Even cylinder head temperature.

Cause:

- * Improperly torqued cylinder head bolts.
- * Improperly positioned gasket at assembly.
- * Warped cylinder head.
- * Severe liquid refrigerant floodback.

Blown Valve Plate Gaskets

Symptom:

- * Loss of unit capacity at medium and low temperatures.
- * Very hot cylinder head surface.
- * Higher than normal suction pressure.

Cause:

- * Improperly torqued cylinder head bolts.
- * Severe liquid refrigerant floodback.
- * Oil slugging caused by an overcharge of oil or flood starts.
- * Discharge valves not seated properly (liquid drainback during shutdown).

Broken Suction Valves

Symptom:

- * Loss of unit capacity at all temperatures.
- * Compressor unable to pull extremely low vacuum with suction service valve frontseated.

Cause:

- * Repeated liquid refrigerant floodback.
- * Flooded starts.
- * Overcharge of oil.
- * Discharge valves not seated properly (liquid drainback during shutdown).

- * Expansion valve not controlling properly.

Unloader Valve Stuck Open

Symptom:

- * Loss of unit capacity at all temperatures.
- * Higher than normal suction pressure.
- * Even cylinder head temperature.

Cause:

- * Unloader body stem bent.
- * Foreign material binding unloader piston or plunger.

7.2 MAGNETIC CLUTCH

Refer to Carrier service information entitled "Housing-Mounted Electric Clutch" at the end of this section for the description and maintenance of the magnetic clutch.

7.3 EVAPORATOR MOTOR

The evaporator motor is installed in the evaporator compartment (L.H. side of vehicle) (Fig. 26). It is a 27.5 volt, 2 HP (1.5 kW) motor which activates a double blower fan unit.

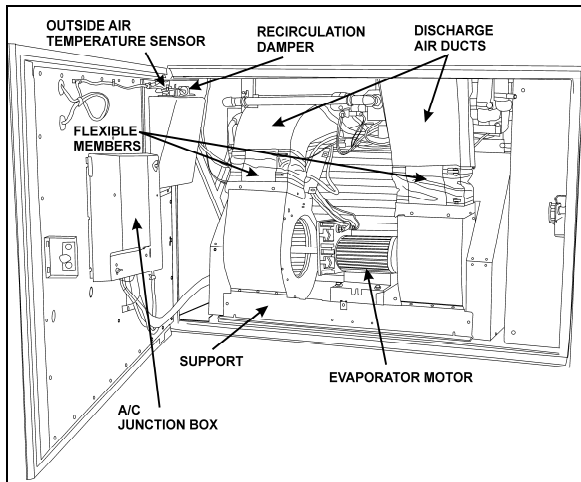

FIGURE 26: EVAPORATOR COMPARTMENT 22372

7.3.1 Removal

- Set the battery master switch (master cut-out) to the "OFF" position and trip circuit breakers CB3.
- Open the last L.H. side baggage compartment door. Pull the black release button located on the L.H. side in order to

unlock and open the evaporator compartment door.

- Remove the evaporator motor and coil access panel.
- Identify the L.H. side discharge duct inside compartment and remove the Phillips head screws retaining the flexible member to duct.
- Repeat step 4 for the R.H. side air duct.
- Disconnect the electrical motor speed control connections on the motor plate.
- From under the vehicle, remove the eight bolts retaining the evaporator fan motor support. Remove the complete unit from the evaporator compartment (Fig. 27 & 28).

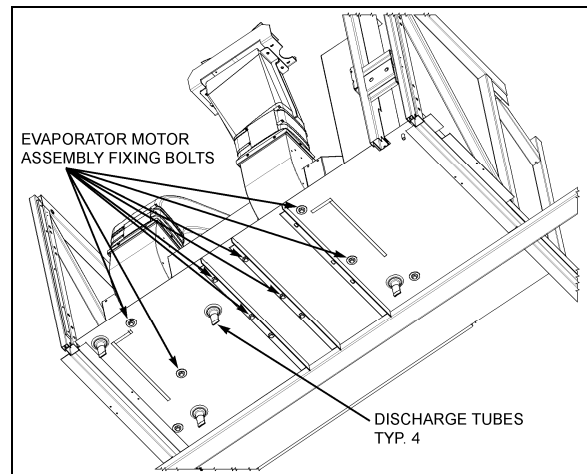

FIGURE 27: EVAPORATOR MOTOR ASSY FIXING BOLTS 22315

CAUTION

Never support evaporator motor by its output shafts while moving it.

- On a work bench, unscrew the fan square head set screws, the Phillips head screws retaining cages to support and slide out the assemblies from the evaporator motor output shaft.

7.3.2 Installation

To reinstall the evaporator motor, reverse "Evaporator Motor Removal" procedure.

Section 22: HEATING AND AIR CONDITIONING

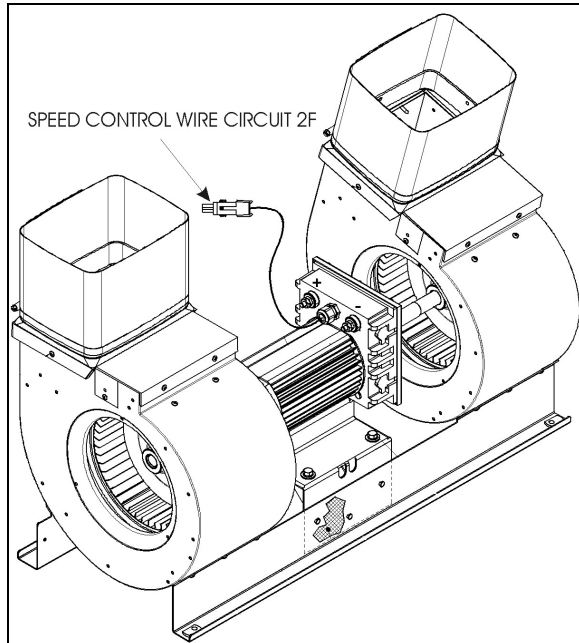

FIGURE 28: EVAPORATOR MOTOR ASSEMBLY

7.4 CONDENSER

The central A/C system condenser coil is hinge mounted on the R.H. side of the vehicle on the A/C condenser door (Fig. 30). Since condenser's purpose is to dissipate heat from the hot refrigerant, it is important to keep the cooling coils and fins clean. A clogged coil will cause high discharge pressure and insufficient cooling.

7.4.1 Condenser Fan Motors

Four brushless fan motors (Fig. 29), 28.5 V - (0.6 HP - 0.42 kW) are installed in the condenser compartment on R.H. side of vehicle in order to ventilate the condenser coil. They are mounted on a support, fastened to the door. The fans pull outside air through the condenser coil and discharge it through an opening at bottom of compartment. When temperature drops inside condenser, the pressure in the refrigerant line also drops and it is, therefore, no longer required to cool condenser. Consequently, when pressure drops to 130 psi, the motors will run at low speed and if the pressure continues to drop to 90 psi, a pressure switch stops the motors so that fans do not operate needlessly. When pressure rises to 120 psi, the pressure switch reactivates the motors. If the pressure rises to 170 psi, the motors will switch to high speed.

For details about electrical wiring, refer to "A/C and Heat system" in the master wiring diagram.

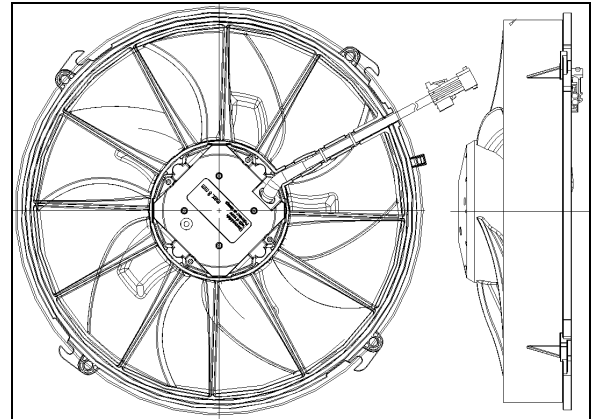

FIGURE 29: CONDENSER FAN MOTOR

22322

7.4.2 Condenser Fan Motor Removal

1. Set the battery master switch to the "Off" position.
2. Disconnect wiring from terminals on motor. Tag each wire to aid in identification at time of reconnection.
3. Remove the four hexagonal head cap screws retaining the fan motor assembly to the mounting support.
4. Remove the motor.

7.5 RECEIVER TANK

The receiver tank is located in the condenser compartment (Fig. 30). The function of the receiver tank is to store the liquid refrigerant. During normal operation, the level of the refrigerant should be approximately at the mid-point of the lower sight glass.

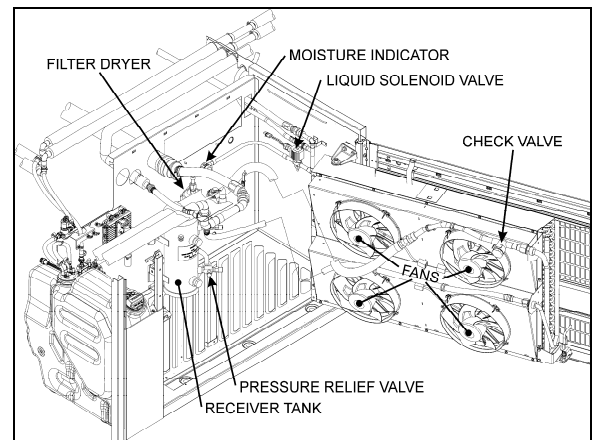



FIGURE 30: A/C CONDENSER COMPARTMENT

22323

In case of extreme pressure there will be a rise in the liquid receiver tank. A pressure relief valve will break at 450 psi (3103 kPa) and relieve the receiver tank pressure.



MAINTENANCE

Check refrigerant level and add if necessary, every 6,250 miles (10 000 km) or twice a year, whichever comes first.

The receiver tank incorporates an inlet valve on the inlet side (upper section) which allows the tank to be isolated or serviced. An outlet valve on the outlet side (lower section) permits complete isolation from the rest of the system.

7.6 FILTER DRYER

A filter dryer, also located in the condenser compartment, is installed on the liquid refrigerant line after the receiver tank. It is used to absorb moisture and foreign matter from refrigerant before it reaches the expansion valves.

The filter should be replaced if the system has been opened or after a prolonged exposure, when the moisture indicator sight glass turns to pink.

7.6.1 Replacement

The filter is of the disposable type. When replacement is required, remove and discard the complete unit and replace with a new unit of the same type according to this procedure:

1. Isolate the refrigerant in the receiver tank by following the "Pumping Down" procedure explained in this section



MAINTENANCE

Check refrigerant moisture indicator every 6,250 miles (10 000 km) or twice a year, whichever comes first. Replace filter dryer unit according to moisture indicator

2. Change the filter dryer as a unit.
3. Add a small quantity of refrigerant R-134a to the low side of the system. Check for leaks. Return the system to normal operation.



CAUTION

Do not use carbon tetrachloride or similar solvents to clean parts. Do not use steam guns. Use mineral spirits or naphtha. All parts should be thoroughly cleaned. Use a stiff brush to wash dirt from grooves, holes, etc.



DANGER

Cleaning products are flammable and may explode under certain conditions. Always handle in a well ventilated area.

7.6.2 Moisture Indicator

The moisture sensitive element consists of a color changing ring which is reversible from pink to blue and vice versa as the moisture content in the refrigerant changes. Pink indicates a wet refrigerant, light violet (caution) and blue indicates a dry refrigerant.

Since temperature changes affect the solubility, color change will also vary with the refrigerant temperature. The above table shows the color change for R-134a at various moisture levels and liquid line refrigerant temperatures.

COLOR INDICATOR			
TEMPERATURE	BLUE (ppm)	LIGHT VIOLET (ppm)	PINK (ppm)
75°F (24°C)	Below 5	5-15	Above 15
100°F (38°C)	Below 10	10-30	Above 30
125°F (52°C)	Below 15	15-45	Above 45
p.p.m.= parts per million (moisture content)			

A moisture level of less than 15 p.p.m. for R-134a indicated in the blue color range of the above table is generally considered dry and safe. A color indication of light blue to light violet indicates the caution range of moisture level. For positive protection, the drying of the system should be continued until the color of the element turns to deep blue.

The liquid refrigerant is readily visible through the center opening of the moisture element where the presence of bubbles indicates a shortage of refrigerant or restriction in line.

Section 22: HEATING AND AIR CONDITIONING

Moisture is one of the main causes of chemical instability or contamination in air conditioning systems. If moisture is present, it can corrode the valves, condenser and evaporator coils, compressor and other components causing a malfunction and eventual failure of the system. Uncontrolled moisture in the system can result in very expensive multiple component replacements if not corrected at an early stage. The moisture indicator permits an early detection of moisture in the system and when corrected by a desiccant charge, system contamination is greatly minimized.

7.7 LIQUID REFRIGERANT SOLENOID VALVE

The flow of liquid refrigerant to the driver's and main evaporators is controlled by a normally-closed solenoid valve. The driver's liquid solenoid valve is located on the ceiling of the spare wheel and tire compartment and is accessible through the reclining bumper.

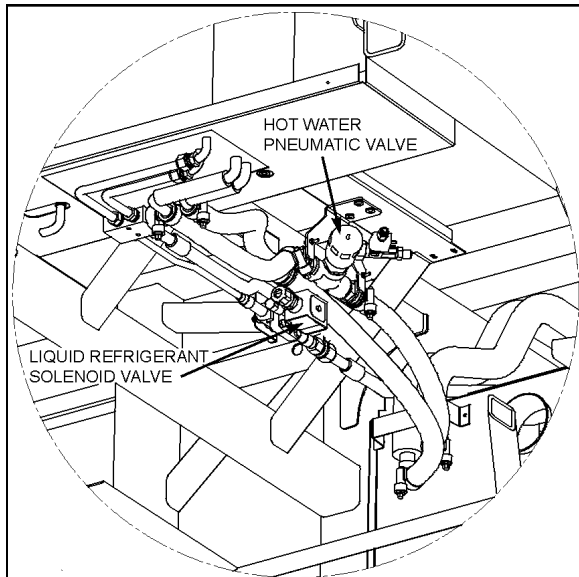

FIGURE 31: DRIVER'S EVAPORATOR LIQUID SOLENOID VALVE

22324

7.7.1 Manual Bypass

This type of solenoid valve is equipped with a manual operating stem. The 3/16" square stem located on the bonnet is exposed when the seal cap is removed. To manually open valve, turn stem 1/2 turn counterclockwise. To manually close valve, turn stem clockwise until tight against seat. Manual stem must be in closed position for automatic electric operation.

7.7.2 Coil Replacement

1. Disconnect connector from the coil connector.
2. Take out the retaining screw at the top of the coil housing. The entire coil assembly can then be lifted off the enclosing tube.
3. Place the new coil and yoke assembly on the enclosing tube. Lay data identification plate in place.
4. Insert the coil retaining screw, rotate housing to proper position and tighten screw securely.
5. Connect connector from coil connector.

7.7.3 Valve Disassembly

1. Remove the coil as stated previously.
2. Pump down the system as stated earlier in this section.
3. Remove the four socket head screws which hold the body and bonnet together (Fig. 32).
4. Carefully lift off the bonnet assembly (upper part of the valve) so that plunger will not fall out. The diaphragm can now be lifted out.

NOTE

The above procedure must be followed before brazing solder-type bodies into the line.



CAUTION

Be careful not to damage the machined faces while the valve is apart.

7.7.4 Valve Reassembly

1. Place the diaphragm in the body with the pilot port extension up.
2. Hold the plunger with the synthetic seat against the pilot port.
3. Make sure the bonnet O-rings are in place. Lower the bonnet assembly over the plunger, making sure that the locating sleeve in the bonnet enters the mating hole in the body.
4. Insert the four socket head screws and tighten evenly.

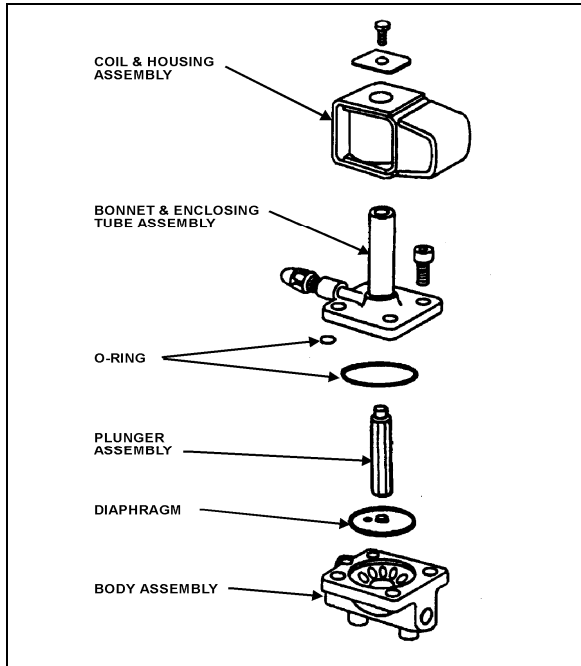

FIGURE 32: REFRIGERANT SOLENOID VALVE 22044

5. Replace the coil as stated previously.
6. Add a small quantity of refrigerant R-134a to the low side of the system. Check for leaks. Return the system to normal operation.

7.8 EXPANSION VALVE

7.8.1 Passenger's Section HVAC Unit

The expansion valve for the passenger's section HVAC unit is a thermo-sensitive valve with a remote control bulb head attached to the evaporator outlet line and is accessible by the evaporator coil access door (Fig. 16 & 33). The valve regulates the flow of refrigerant liquid into the evaporator coils and is controlled by the suction gas temperature leaving the evaporator. The bulb head senses the refrigerant gas temperature as it leaves the evaporator. High temperature will cause expansion and pressure on the power head and spring. Such action causes the assembly valve to open, allowing a flow of refrigerant liquid into the evaporator.

The remote bulb and power assembly is a closed system. The pressure within the remote bulb and power assembly corresponds to the saturation pressure of the refrigerant temperature leaving the evaporator and moves the valve pin in the opening direction. Opposed to this force, on the under side of the diaphragm and acting in the closing direction, is the force exerted by the superheat spring.

As the temperature of the refrigerant gas at the evaporator outlet increases above the saturation temperature corresponding to the evaporator pressure, it becomes superheated. The pressure thus generated in the remote bulb and power assembly surpasses the combined pressures of the evaporator pressure and the superheat spring, causing the valve pin to move in the opening direction. Conversely, as the temperature of the **refrigerant** gas leaving the evaporator decreases, the pressure in the remote bulb and power assembly also decreases and the combined evaporator and spring pressures cause the valve pin to move in the closing position.

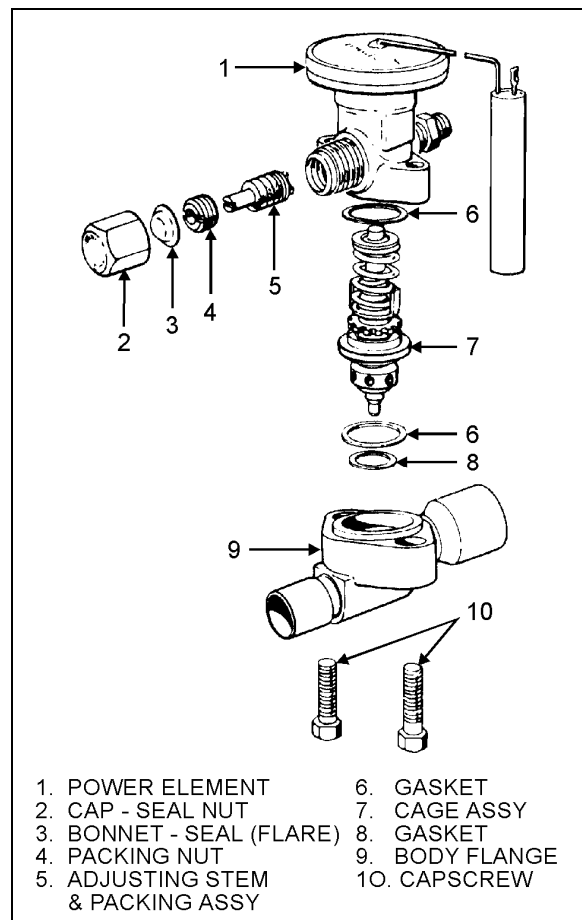

FIGURE 33: EXPANSION VALVE 22045

As the operating superheat is raised, the evaporator capacity decreases, since more of the evaporator surface is required to produce the superheat necessary to open the valve. It is obvious, then, that it is most important to adjust the operating superheat correctly and that a minimum change in superheat to move the valve pin to full open position, is of vital importance

Section 22: HEATING AND AIR CONDITIONING

because it provides savings in both initial evaporator cost of operation.

Accurate and sensitive control of the refrigerant liquid flowing to the evaporator is necessary to provide maximum evaporator capacity under load conditions. The spring is adjusted to give 12 to 16° F (-11.1 to -8.8° C) of superheat at the evaporator outlet.

This ensures that the refrigerant leaving the evaporator is in a completely gaseous state when drawn into the suction side of the compressor. Liquid would damage the compressor valve, piston and heads if allowed to return in the suction line.

A vapor is said to be superheated when its temperature is higher than the saturation temperature corresponding to its pressure. The amount of the superheat is, of course, the temperature increase above the saturation temperature at the existing pressure.

As the refrigerant moves along in the evaporator, the liquid boils off into a vapor and the amount of liquid decreases until all the liquid has evaporated due to the absorption of a quantity of heat from the surrounding atmosphere equal to the latent heat of vaporization of the refrigerant. The gas continues along in the evaporator and remains at the same pressure. However, its temperature increases due to the continued absorption of heat from the surrounding atmosphere. The degree to which the gas refrigerant is superheated is related to the amount of refrigerant being fed to the evaporator and the load to which the evaporator is exposed.

Superheat Adjustment

The starting method of adjusting the superheat is to unscrew completely the main evaporator expansion valve adjusting screw, then screw in 13 turns clockwise for 134A (Fig. 34).

Afterwards, the following procedure should be followed:

1. Operate coach for at least one-half hour at fast idle with temperature control set at 82°F (27,7°C), Then set temperature to minimum to keep the compressor on 6 cylinders.
2. Install pressure gauge at the evaporator suction header. You may install the pressure gauge at compressor suction, but then add 3 PSI to reading.

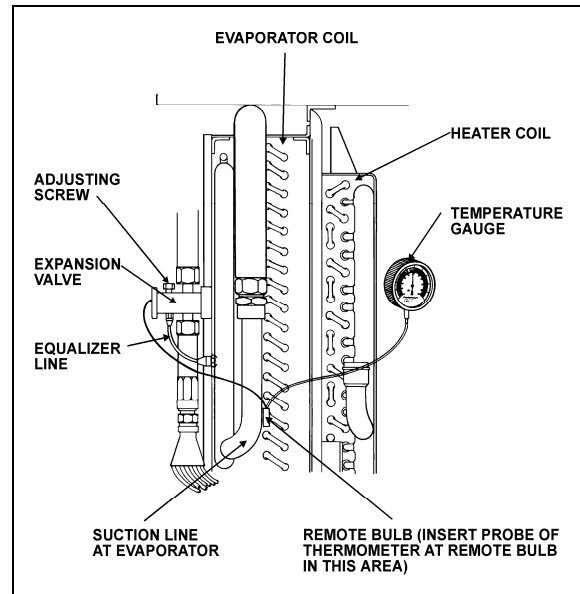

FIGURE 34: SUPERHEAT ADJUSTMENT INSTALLATION²²⁰⁴⁶

3. Install a remote reading thermometer to the evaporator outlet line near the existing remote bulb (Fig. 34).
4. Apply thermostatic tape around the bulb and evaporator outlet line to get a true reading of the line temperature.
5. Block condenser if necessary to keep pressure over 150 psi.

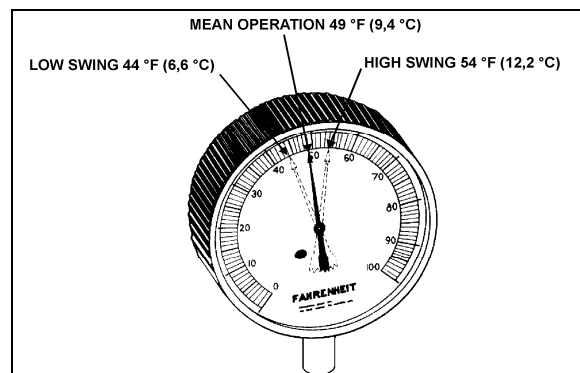

FIGURE 35: HIGH & LOW SWING TEMPERATURE AT REMOTE BULB²²⁰⁴⁷

6. Check approximately 5 readings of pressure at 2-minute intervals and convert to temperature using the temperatures & pressures table (page 35). Likewise check the temperature reading at the remote bulb at the same 2-minute intervals and record the low and high swing readings of the needle (refer to Fig. 35).

Example of readings taken at fig. 35:

A/C pressure gauge converted to temperature at expansion valve fitting	Temperature on remote bulb	
40°F (4,4°C)	Low-swing 44°F (6,6°C)	High swing 54°F (12,2°C)
Formula for superheat 49°F-40°F=9°F (9,4°C-4,4°C = 5°C)	Average of low and high swing is 49°F (9,4°C)	

NOTE

The low swing of the superheat should be a minimum of 4°F (2,2°C) higher at the remote bulb and have an average of 8 to 12°F (4 to 6°C) higher range at the bulb than the fitting at the expansion valve.

NOTE

To reduce the superheat, flow of refrigerant is increased by turning adjusting screw of expansion valve lower evaporator temperature counterclockwise. To increase temperature or increase superheat, flow of refrigerant is reduced by turning adjustment screw of expansion valve clockwise.

6. Regulate suction pressure to temperature reading according to temperature chart or to the R-134a temperature scale on the pressure gauge.

Example: Suction pressure 30 psi (207 kPa) converted to 32°F (0°C) on chart. If temperature reading is 40°F (4,4°C), subtract 32°F (0°C) and the result will be 8°F (4,4°C) of superheat.



CAUTION

Before proceeding to the expansion valve adjustment, check for restriction on suction side for plugged filter dryer and partially open valves. These conditions will give a high superheat.

Maintenance

1. Pump down the system as previously indicated in this section.

2. Disconnect the external equalizer line from the under side of the power head, and unclamp the remote control bulb from the evaporator coil outlet line.
3. Remove the two cap screws holding the power assembly to the valve body flange. Lift off the power assembly and remove the cage assembly.
4. When reassembling, replace with the new gaskets in proper location. Make sure the two lugs on the cage assembly fit into grooves provided in the power assembly. Do not force the valves together. The cage must fit properly before tightening the body flange. Tighten bolts evenly.
5. Check for leaks.

Safety Instructions

1. Make sure the valve is installed with the flow arrow on the valve body corresponding to the flow direction through the piping system.
2. Before opening any system, make sure the pressure in the system is brought to and remains at the atmospheric pressure. Failure to comply may result in system damage and/or personal injury.

7.8.2 Driver's HVAC Unit

The function and operation of the expansion valve for the driver's HVAC unit are similar to the passenger's HVAC unit but no superheat adjustment is required (see figures 19 and 33).

7.9 TORCH BRAZING

Use electrode containing 35% silver.



CAUTION

When using heat near a valve, wrap with water saturated rag to prevent overheating of vital parts.



DANGER

Before welding any part of refrigeration system, make sure the area is well ventilated.

Section 22: HEATING AND AIR CONDITIONING

7.10 TROUBLESHOOTING

7.10.1 Expansion Valve

PROBABLE CAUSE	PROBABLE REMEDY
LOW SUCTION PRESSURE-HIGH SUPERHEAT	
EXPANSION VALVE LIMITING FLOW:	
Gas in liquid line due to pressure drop in the line or insufficient refrigerant charge.	Locate cause of line flash and correct by use of any of the following methods. Add R-134a. Replace or clean filter dryer.
Inlet pressure too low from excessive low condensing temperature. Resulting pressure difference across valve too small.	Increase head pressure. Verify pressure switch for fan speed control.
Superheat adjustment too high.	Adjust superheat as outlined under "Superheat Adjustment".
Power assembly failure or partial loss of charge.	Replace power assembly or replace valve.
Air filter screen clogged.	Clean or replace air filter.
Plugged lines.	Clean, repair or replace lines.
LOW SUCTION PRESSURE-LOW SUPERHEAT	
Uneven or inadequate evaporator loading due to poor air distribution or liquid flow.	Balance evaporator load distribution by providing correct air or liquid distribution.
HIGH SUCTION PRESSURE-HIGH SUPERHEAT	
Compressor discharge valve leaking.	Replace or repair valve.
HIGH SUCTION PRESSURE-LOW SUPERHEAT (DEFECTIVE UNLOADER)	
Valve superheat setting too low.	Adjust superheat as outlined under "Superheat Adjustment".
Compressor discharge valves leaking.	Replace or repair discharge valve.
Incorrect superheat adjustment.	Superheat adjustment 12 to 16°F.
FLUCTUATING DISCHARGE PRESSURE	
Insufficient charge.	Add R-134a to system.
HIGH DISCHARGE PRESSURE	
Air or non-condensable gases in condenser.	Purge and recharge system.
Overcharge or refrigerant.	Bleed to proper charge.
Condenser dirty.	Clean condenser.

7.10.2 A/C

TROUBLE	CAUSE
Low suction pressure and frosting at dryer outlet.	Clogged filter.
Low Oil Level.	Check for oil leaks and for leaking oil seal. Do not attempt to check oil level unless system has been stabilized at least 20 minutes. See oil level verification.
Excessively cold suction line.	Loss of contact between the expansion valve bulb and the suction line or sticking of the expansion valve. Check for foreign matter and clean, repair or replace the valve.
Excessively cold suction line and noisy compressor.	Check superheat adjustment. Check remote bulb contact. Check expansion valve for sticking.
Compressor squeaks or squeals when running.	Check oil level. Replace oil seal.
Noisy or knocking compressor.	Check for broken internal parts. Overhaul if required.
Compressor vibrates.	Check and tighten compressor mounting bolts and belt tension.
Low refrigerant level	Check for refrigerant leaks and add refrigerant if required.
Suction pressure rises faster than 5 pounds per minute after shutdown.	Check compressor valve for breakage or damage.
Insufficient cooling.	Check for refrigerant leaks. Check condition of air filter and motors.
Insufficient air flow.	Dirty or iced evaporator. Dirty air filter. Blowers inactive. Clogged ducts.
No flow of refrigerant through expansion valve.	Filter dryer is clogged. Remote bulb has lost charge or expansion valve is defective.
Expansion valve hisses. Bubbles in moisture and liquid indicator.	Gas in liquid line. Add refrigerant.
Loss of capacity	Clogged filter. Obstructed or defective expansion valve.
Superheat too high.	Reset superheat adjustment. Check for clogged external equalizer line, or filter dryer.
Reduced air flow: a. Dirty or clogged air filter; b. Evaporator motor inoperative; or c. Plugged return air ducts.	Dirty or iced evaporator coil. Clean or replace air filter. Check return ducts for obstructions. Check blower motor.
Frequent starting and stopping on low pressure control switch.	Lack of refrigerant. Check for leaks. Recharge.
Compressor intermittently starts and stops.	Intermittent contact in electrical control circuit. Compressor valves not in operating position.
Non-condensable in the refrigeration system.	Leak on system, system in vacuum in low temp. Specific symptom, pressure in system will not correspond to ambient temperature on shutdown. Only non-condensable will cause this. (Example: Pressure of idle R-134a system in 80°F (26.6°C) room should be 86.4 psi (595.7 kPa). See temperature chart in this section.)

Section 22: HEATING AND AIR CONDITIONING

TROUBLE	CAUSE
	<p>An evaporator just does a proper cooling job without sufficient air. Shortage of air can be caused by the following:</p> <ul style="list-style-type: none"> * Dirty filters; or * Dirty coils.
<p>Testing condenser pressure.</p> <p><i>NOTE: R-134A pressure is function of the temperature variation.</i></p> <p>Example, for an exterior temperature of 100°F. Exterior temperature (100°F) + 30°F = 130°F. Refer to paragraph "10.11 Temperature & Pressure". Note the corresponding pressure for a temperature of 130°F, 199.8 psi. Read the condenser pressure, example 171.9 psi. 171.9 psi & 199.8 psi, the pressure in the condenser is inferior to the pressure corresponding to the exterior temperature, in this case the condenser pressure may be too low. Check for refrigerant leaks and add refrigerant if necessary. If the pressure corresponding to the condenser temperature is superior to the pressure corresponding to the exterior temperature, then the air cooled condenser pressure may be too high. Most frequent causes are:</p> <p>Reduced air quantity. This may be due to:</p> <ul style="list-style-type: none"> * Non-condensable in system; * Dirt on the coil; * Restricted air inlet or outlet; * Dirty fan blades; * Incorrect rotation of fan; * Fan speed too low; * Fan motor going out on overload; or * Prevailing winds. * Too much refrigerant in system. Remove refrigerant if necessary. 	

7.11 TEMPERATURES & PRESSURES

VAPOR-PRESSURE			
TEMPERATURE		PRESSURE	
°F	°C	psi	kPa
-100	-73.3	27.8	191.7
-90	-67.8	26.9	185.5
-80	-62.2	25.6	176.5
-70	-56.7	23.8	164.1
-60	-51.1	21.5	148.2
-50	-45.6	18.5	127.6
-40	-40.0	14.7	101.4
-30	-34.4	9.8	67.6
-20	-29	3.8	26.2
-10	-23	1.8	12.4
0	-18	6.3	43.4
10	-12	11.6	80
20	-7	18.0	124.1
30	-1	25.6	176.5
40	4	34.5	237.9
50	10	44.9	309.6
60	16	56.9	392.3
70	21.1	70.7	487.5
80	27	86.4	595.7
90	32.2	104.2	718.5
100	38	124.3	857.0
110	43.3	146.8	1012.2
120	49	171.9	1185.3
130	54.4	199.8	1377.6
140	60	230.5	1589.3
150	65.6	264.4	1823.0
160	71	301.5	2078.8
170	76.7	342.0	2358.1
180	82.2	385.9	2660.8

Section 22: HEATING AND AIR CONDITIONING

VAPOR-PRESSURE			
TEMPERATURE		PRESSURE	
°F	°C	psi	kPa
190	87.8	433.6	2989.7
200	93.3	485.0	3344.1
210	98.9	540.3	3725.4

7.12 LEAK TESTING

Some methods such as nitrogen pressure, soap and electronic sniffer can be used for leak testing. However, the most common method used is a "Halide" torch consisting of an acetylene tank, a burner and a suction test hose. Proceed as follows:



The flow of acetylene to the burner causes suction in the test line. Any gas refrigerant present will be drawn through the hose and into the burner where it decomposes into free acids.

These acids come in contact with the hot copper reaction plate in the burner, causing color reaction in the flame. A small concentration is indicated by a green tint and a large concentration by an intense blue. Do not confuse this change in color with the change caused by shutting off the air supply through the hose by holding the end too close to an object.

The procedure for testing is:

1. Adjust flame so that the top of the cone is approximately level or within one-half inch above the plate.
2. Probe end of suction test tube around all joints, valves, etc. When a leak has been found at a soldered joint, this section of the system must be pumped down. Do not solder as pressure will force hot solder out. If the system is empty, it is more economical to put in just enough R-134a to produce about 15 psi (103 kPa). The pressure can be raised to about 150 psi (1034 kPa) with dry nitrogen.

NOTE

This gas is put into the suction and discharge shutoff valves at the compressor. The receiver valves must be opened. If no leaks are found, dump this mixture, evacuate the system and fill with refrigerant.

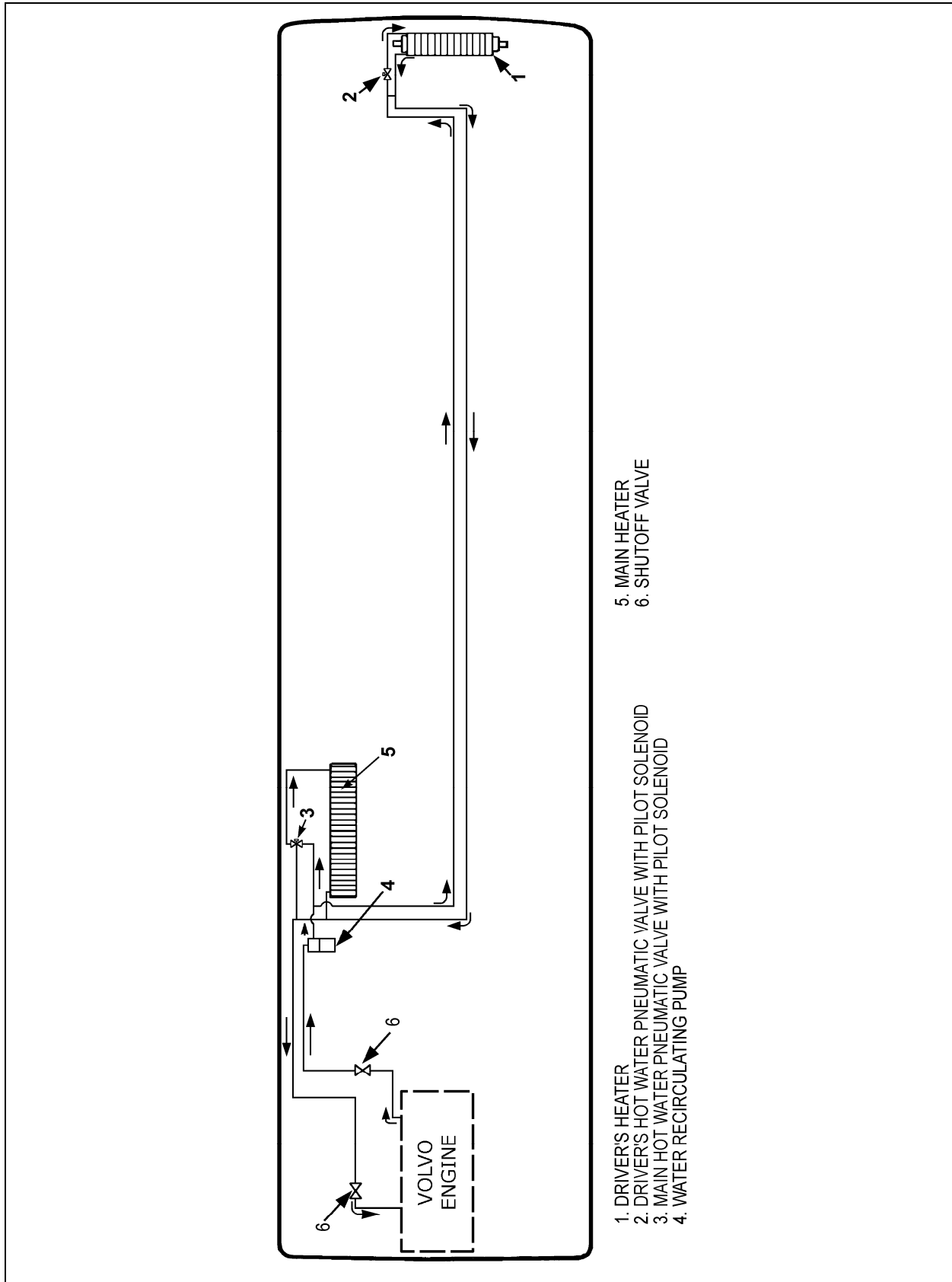

FIGURE 36: CENTRAL HEATING SYSTEM COMPONENTS

Section 22: HEATING AND AIR CONDITIONING

8. CENTRAL HEATING SYSTEM

As seen earlier in this section, the vehicle interior is pressurized by its Heating, Ventilation and Air Conditioning (HVAC) system. The vehicle interior should always be slightly pressurized to prevent cold and moisture from entering. Air flow and controls divide the vehicle into two areas: driver's area and passenger's area.

The schematic of figure 36 shows the central heating system with its components.

8.1 DRAINING HEATING SYSTEM

To drain the entire system, refer to Section 05, "Cooling". If only the driver's or main heater core must be drained, refer to the following instructions.

- **Draining Driver's Heater Core**

1. Stop engine and allow engine coolant to cool.
2. Locate the normally open water pneumatic valve on the ceiling of the spare wheel compartment (Fig. 37), move the pilot-solenoid valve red tab to close the valve.

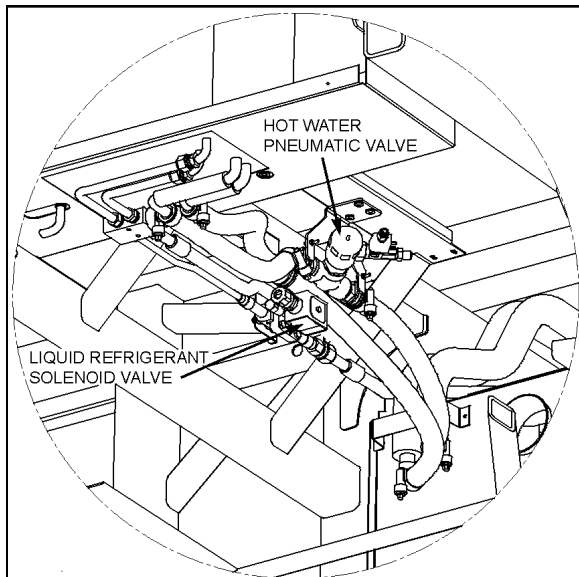

FIGURE 37: CEILING OF THE SPARE WHEEL COMPARTMENT



WARNING

Before proceeding with the following steps, check that coolant has cooled down.

3. Loosen hose clamp, install an appropriate container to recover coolant, and disconnect silicone hose from water solenoid valve.
4. From inside of vehicle, remove the two finishing panels in front of unit. Remove the three screws fixing the unit front panel. Open the manual vent located inside the HVAC unit, on the driver's side (Fig. 38) to ensure an efficient draining.

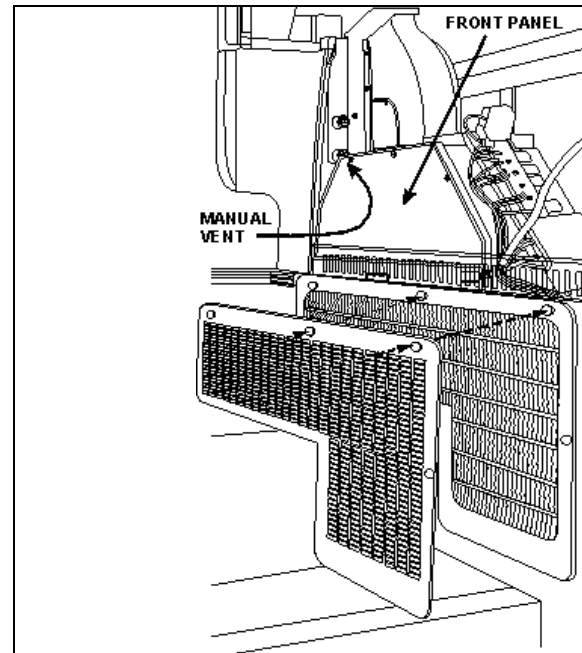

FIGURE 38: DRIVER'S HVAC UNIT

- **Draining Main Heater Core**

1. Stop engine and allow engine coolant to cool.
2. Close both heater line shutoff valves.

On X Series vehicles, the valves are located in the engine compartment. One is on the L.H. side of compartment in front of the radiator and the other valve is located under the radiator fan gearbox (Fig. 39).

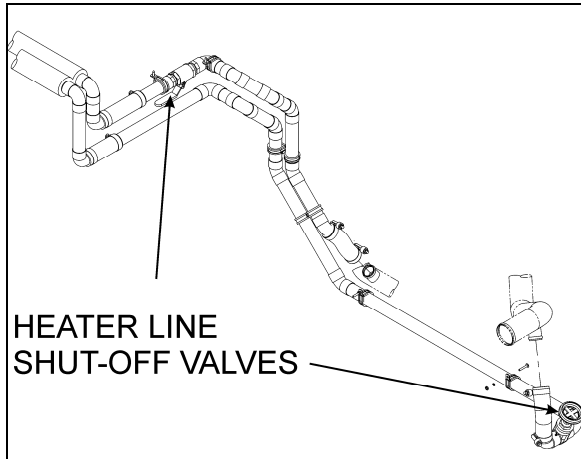

FIGURE 39: HEATER LINE SHUT-OFF VALVES

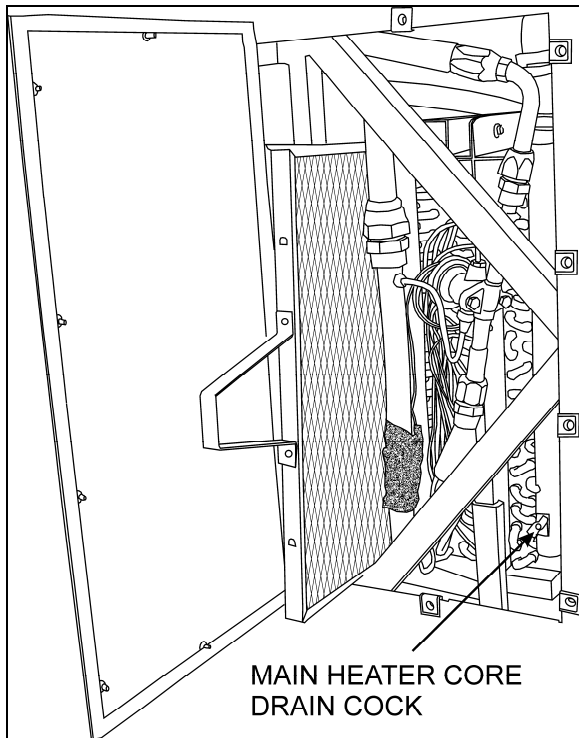

FIGURE 40: EVAPORATOR COMPARTMENT

3. The main heater core drain cock is located in the evaporator compartment. To access the valve on X3-45 coaches, open baggage compartment door located in front of the evaporator compartment (L.H. side). Open access panel by turning the three screws of panel ¼ of a turn.



WARNING

Before proceeding with the following steps, check that coolant has cooled down.

4. Open drain cock in bottom of heater core, you can unfasten a hose connection on top of heater core (Fig.40) in order to allow air to enter while draining.

8.2 FILLING HEATING SYSTEM

1. Ensure that the drain hose is reconnected and the manual vent and drain cock are closed.
2. Open the surge tank filler cap and slowly fill the system to level of filler neck.
3. After initial filling, the water shut-off valves should be open and the water recirculating pump should be energized to assist in circulating coolant through the heating system. To perform this operation, start the engine, switch on the HVAC control unit, both driver and passengers' sections, and set temperature to the maximum position in order to request the heating mode in each of these sections.
4. When coolant level drops below the surge tank filler neck, slowly fill the system to level of filler neck.
5. Once the level has been stabilized, replace cap.

8.3 BLEEDING HEATING SYSTEM

Whenever the heating system has been drained and refilled, or the system has run low on coolant and coolant has been added, it is necessary to bleed air from heating system. Locate the manual vent illustrated in Figure 38, and open momentarily until no air escapes from the line.

8.4 SOLDERING

Before soldering any part of the system, make sure the area is well ventilated. Use (stay clean) flux sparingly and apply solder (95-5 round wire 1/8 inch). After completing repairs, test for leaks.

When using heat at or near a valve, wrap with water saturated rag to prevent overheating of vital parts.

Section 22: HEATING AND AIR CONDITIONING

8.5 DRIVER'S HOT WATER PNEUMATIC VALVE ASSEMBLY

• Description

The flow of hot water to the driver's heater core is controlled by a pneumatic NO water valve assembly. The valve, located at the ceiling of the spare wheel compartment, is designed so that the pilot solenoid valve, which is part of the assembly, opens and closes a port which directs air pressure to the actuator casing, thereby opening or closing the valve.

When the vehicle is operating with no current to the pilot solenoid valve, no air pressure is admitted to the actuator casing, the cylinder spring pushes up against the cylinder, thereby keeping the water valve open.

The driver's heater water valve requires a minimum amount of maintenance. The valve should be free of dirt sediment that might interfere with its operation. No other maintenance is needed unless a malfunction occurs.

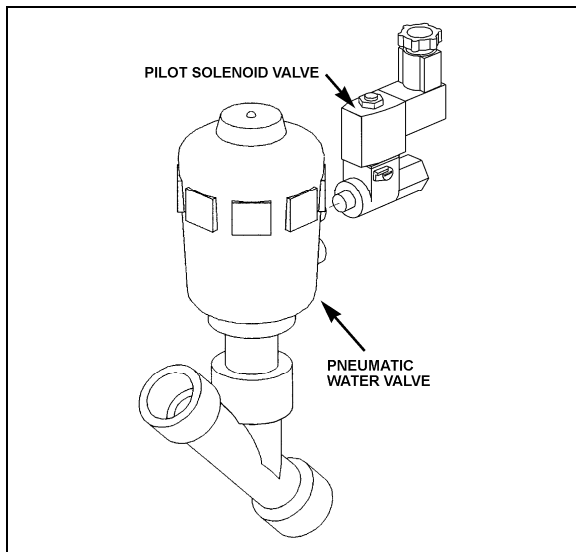

FIGURE 41: DRIVER'S HOT WATER PNEUMATIC VALVE ASSEMBLY

• Pneumatic Water Valve Disassembly

1. Shut off air supply pressure and electrical current to the pilot solenoid valve. Disconnect wires.
2. The water valve need not be removed from the line. Unscrew nipple, the actuator casing, tube, spindle and closure member can be removed (Fig. 42).
3. Remove the snap ring using a pair of pliers.

4. You can now access all seals for replacement

Pneumatic water valve replacement seal kits:

- * Water Side: 871311
- * Actuator Side: 871312

• Pneumatic Water Valve Reassembly

1. Assemble the actuator casing, tube, nipple, spindle and closure member.
2. Tighten the nipple in place in the body cavity as per figure 42. Fasten pilot solenoid valve to the pneumatic water valve. Reconnect air supply pressure and electrical current to the pilot solenoid valve.
3. Check for proper operation.

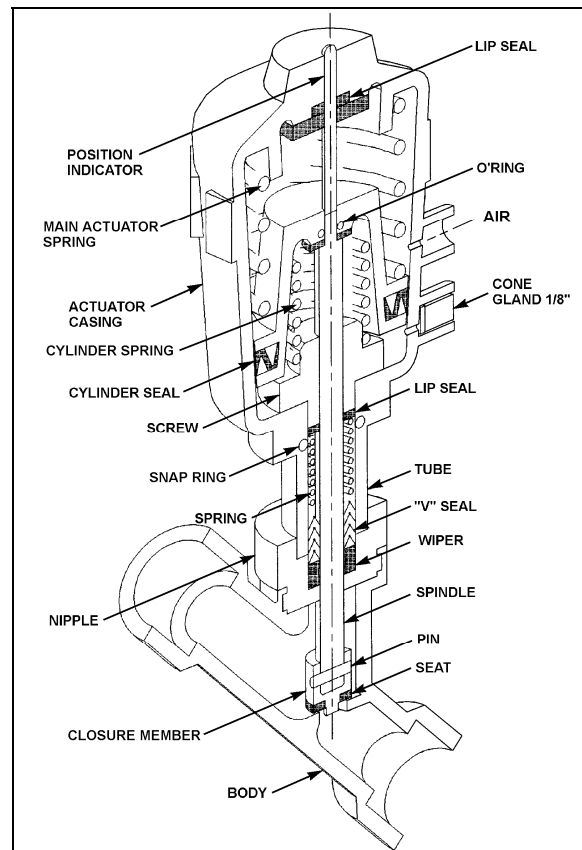

FIGURE 42: PNEUMATIC WATER VALVE

• Pilot Solenoid Valve

1. No maintenance is needed unless a malfunction occurs.
2. A pilot solenoid valve replacement seal kit is available: 871313.

• **Valve Troubleshooting**

PROBLEM	PROCEDURE
Valve fails to close	<ol style="list-style-type: none"> 1. Check electrical supply with a voltmeter. It should agree with nameplate rating. 2. Check pressure at pilot solenoid valve inlet. It must be at least equal to the minimum pressure stamped on the nameplate. It should not go below minimum while valve is operating.
	<ol style="list-style-type: none"> 1. Check that the closure member assembly, and that main actuator and cylinder springs are free to travel. 2. Check that there is no restriction to the air escaping from the actuator casing. 3. Make sure that pilot solenoid valve operates properly.

8.6 CENTRAL HOT WATER PNEUMATIC VALVE ASSEMBLY

• **Description**

The flow of hot water to the vehicle's central heater core is controlled by a 3-way pneumatic water valve assembly. The valve, located in the evaporator compartment, is designed so that the pilot solenoid valve, which is part of the assembly, opens and closes a port which directs air pressure to the actuator casing, thereby allowing the hot water to enter the main heater core or bypassing it.

When the vehicle is operating with no current to the pilot solenoid valve, no air pressure is admitted to the actuator casing, the cylinder spring pushes up against the cylinder, thereby allowing the hot water to enter the main heater core.

The central heater water valve requires a minimum amount of maintenance. The valve should be free of dirt sediment that might interfere with its operation. No other maintenance is needed unless a malfunction occurs.

• **Pneumatic Water Valve Disassembly**

1. Shut off air supply pressure and electrical current to the pilot solenoid valve. Disconnect wires.
2. The water valve need not be removed from the line. Unscrew nipple, the actuator casing, tube, spindle and closure member can be removed (Fig. 44).
3. Remove the snap ring using a pair of pliers.

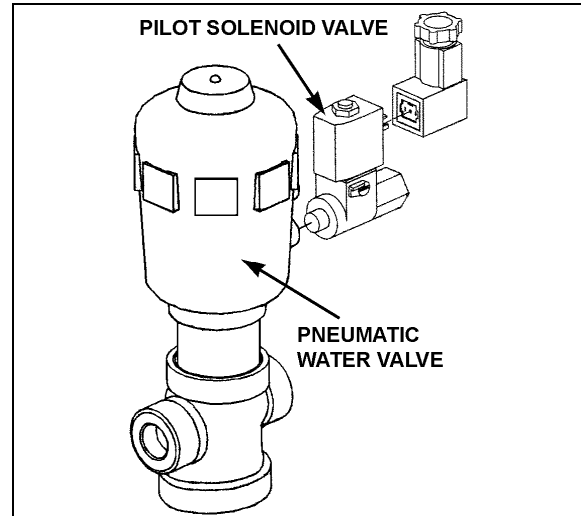

FIGURE 43: CENTRAL HOT WATER PNEUMATIC VALVE ASSEMBLY 22329

4. You can now access all seals for replacement

Pneumatic water valve replacement seal kits:

- * Water Side: 871389
- * Actuator Side: 871388

• **Pneumatic Water Valve Reassembly**

1. Assemble the actuator casing, tube, nipple, spindle and closure member.
2. Tighten the nipple in place in the body cavity as per figure 44. Fasten pilot solenoid valve to the pneumatic water valve. Reconnect air supply pressure and electrical current to the pilot solenoid valve.
3. Check for proper operation.

• **Pilot Solenoid Valve**

1. No maintenance is needed unless a malfunction occurs.

Section 22: HEATING AND AIR CONDITIONING

- A pilot solenoid valve replacement seal kit is available: 871390.

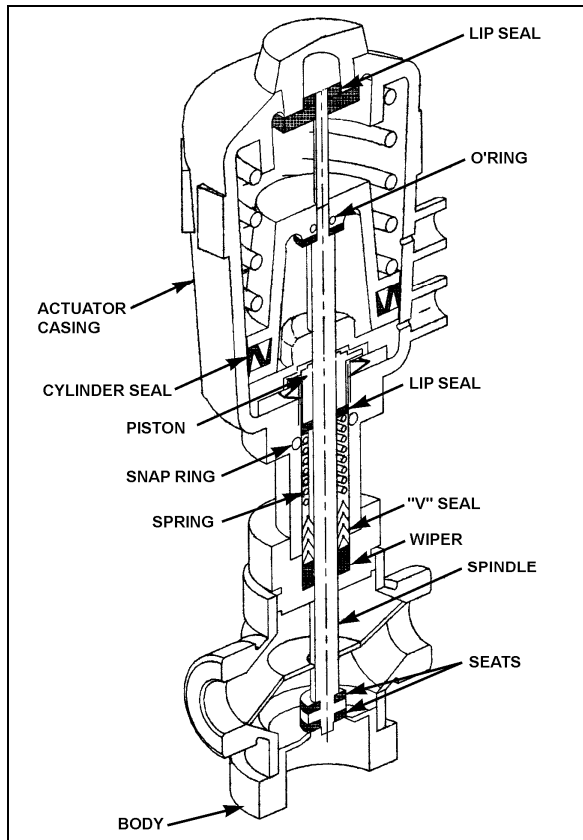

FIGURE 44: PNEUMATIC WATER VALVE 22330

• Valve Troubleshooting

PROBLEM	PROCEDURE
Valve fails to close	<ol style="list-style-type: none"> 1. Check electrical supply with a voltmeter. It should agree with nameplate rating. 2. Check pressure at pilot solenoid valve inlet. It must be at least equal to the minimum pressure stamped on the nameplate. It should not go below minimum while valve is operating.
Valve fails to open.	<ol style="list-style-type: none"> 1. Check that the closure member assembly, and that main actuator and cylinder springs are free to travel. 2. Check that there is no restriction to the air escaping from the actuator casing. 3. Make sure that pilot solenoid valve operates properly.

8.7 WATER RECIRCULATING PUMP

This vehicle is provided with a Rotron® brushless DC sealess water circulation pump which is located in the engine coolant heater compartment (Fig. 45). The assembly consists of a centrifugal pump and an electric motor which are mounted in a compact assembly.

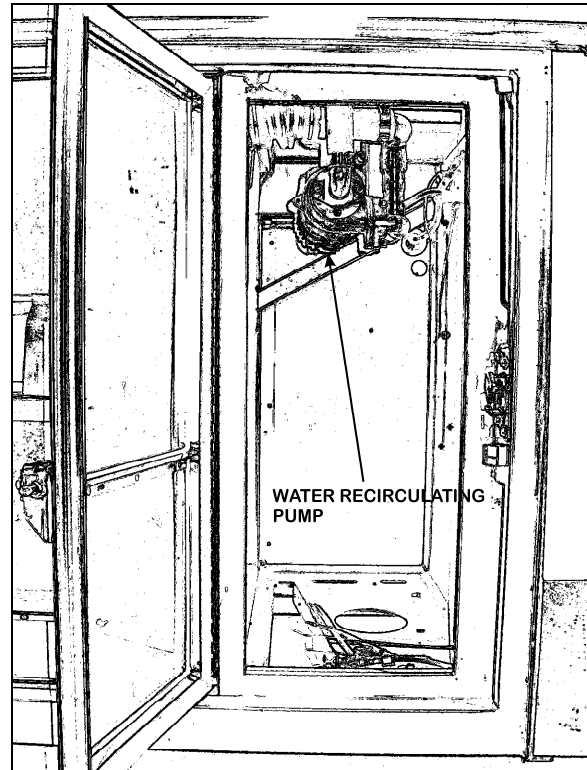

FIGURE 45: PUMP LOCATION (CENTRAL A/C) 22331

The brushless DC sealess pump requires no periodic maintenance. The sealess design offers leak-proof protection and the capability to resist harsh environmental conditions. The pump magnetically couples to the brushless DC motor without a wet seal to wear or replace, this coupling method also enables easy motor removal without requiring system draining. The pump electronically commutated brushless DC motor provides virtually maintenance-free operation over time by eliminating brush maintenance and associated brush motor failure.

Disassembly of the pump will be necessary only in the case of a rotor failure or motor failure.

• Removal

1. Stop engine and allow engine coolant time to cool.

2. Close shutoff valves. Refer to "05 COOLING" under heading "*Draining Cooling System*" for location of valves.
3. Disconnect the electrical wiring from the motor.



WARNING

Before proceeding with the following steps, check that coolant has cooled down.

4. Disconnect water lines from pump at flange connections. Place a container to recover the residual coolant in the line.
5. Remove the two clamps holding the pump motor to its mounting bracket. Remove the pump with the motor as an assembly.

• **Installation**

1. Apply gasket cement to the line flanges, put the two gaskets in place, and connect water lines to the pump at the flange connections. Position the pump and motor assembly on the mounting bracket. Position the mounting clamps over the motor and secure with mounting bolts.
2. Connect electrical wiring to the pump motor.
3. Open shutoff valve. Refer to "05 COOLING" under heading "*Draining Cooling System*" for location of valves.
4. Fill the cooling system as previously instructed in this section under "*8.2 Filling Heating System*", then bleed the system as previously instructed in this section under "*8.3 Bleeding Heating System*".

9. SPECIFICATIONS

Main evaporator motor

Make..... AMETEK ROTRON
Type BRUSHLESS DC MICROPROCESSOR CONTROLLED
Voltage 27.6 V DC
Current draw 68 amps
Horsepower..... 2
Revolution 1400 & 1700 rpm
Insulation Class F
Motor Prevost number..... 563586

Condenser fan motors

Make..... EBMPAPST
Type AXIAL BRUSHLESS
Voltage 24 V DC
Qty..... 4
Prevost number..... 563461

Evaporator air filter (Central system)

Make..... Permatron Corp.
Type Polypropylene
Prevost number..... 874272

Driver's unit evaporator motors

Make..... MCC
Voltage 24 V DC
Quantity 1
Prevost number..... 871135

Driver's unit evaporator air filters

Make..... MCC
TYPE Recirculating air 6-1/4" x 28" Washable
Prevost number..... 871147

Make..... MCC
TYPE Fresh air 3-5/8" X 5-1/4" Washable
Prevost number..... 871144

Refrigerant

Type R-134a
Quantity (standard) 24 lbs (10.89 Kg)

Compressor (Central system)

Make..... Carrier Transicold
 Capacity, option R-134a 41 CFM
 Model, option R-13405G-134A
 No. of cylinders 6
 Bore..... 2” (50,8 mm)
 Operating speed.....400 to 2200 rpm (1750 rpm. Nominal)
 Minimum speed (for lubrication).....400 rpm
 Nominal horsepower 15
 Oil pressure at 1750 rpm 15 to 30 psi (103-207 kPa)
 Oil capacity..... 1.13 U.S. gal (4,3 liters)
 Weight 142 lbs (64,5 kg)
 Approved oil - Castrol..... SW 68 (POE)
 Prevost number, option R-134a 950314

Compressor unloader valve

Make..... Carrier Transicold
 Type Electric (AMC)
 Voltage 24 V DC)
 Watts 15
 Prevost number (without coil) 950095
 Coil Prevost numbert..... 950096

Magnetic clutch

Make..... Carrier Transicold
 Type Housing mounted 9” dia., 2-B grooves
 Voltage 24 V DC
 Coil resistance at 68 °F (20 °C)..... 5.15 – 5.69 ohms
 Prevost number 950204

Compressor V belt (Carrier)

Make..... Dayco
 Model..... BX100
 Prevost number (with two BOSH Alternators) 506864

Condenser coil (Central system)

Make..... Carrier Transicold
Copper
 Prevost number 870729

Section 22: HEATING AND AIR CONDITIONING

Evaporator coil (Central system)

Make..... Carrier Transicold
Prevost number..... 871070

Receiver tank (with sight glasses)

Make..... HENRY
Maximum pressure..... 450 psig
Prevost number..... 950261

Moisture indicator

Make..... Henry
Prevost number..... 950029

Driver's refrigerant liquid solenoid valve

Make..... Parker
Type Normally closed with manual bypass
Voltage 24 V DC
Amperage draw..... 0.67 amps
Watts 16
Prevost number (without coil) 95-0054
Coil Prevost number..... 950055
Repair kit Prevost number 950056

Hot water pneumatic valve (Central system)

Make..... Burkert
Type 3-WAY
Voltage 24 V DC
Prevost number..... 871381
Seal kit, Water Side..... 871389
Seal kit, Actuator Side..... 871388
Seal kit, Pilot Solenoid Valve 871390

Driver's hot water pneumatic valve

Make..... Burkert
Type Normally open
Voltage 24 V DC
Prevost number..... 871252
Seal kit, Water Side..... 871311
Seal kit, Actuator Side..... 871312
Seal kit, Pilot Solenoid Valve 871313

Water recirculating pump

Make.....AMETEK ROTRON
Voltage 24 V DC
Prevost number 871327

Driver's expansion valve

Prevost number, option R-134a 950221
Prevost number, option R-22 950282

Expansion valve (Central system)

Make..... Alco
Model..... TCLE 5-1/2
Prevost number 950320