

SECTION 03: FUEL SYSTEM

CONTENTS

1. FUEL SYSTEM DESCRIPTION	3
2. FUEL LINES AND FLEXIBLE HOSES	4
3. FUEL VALVES	4
4. FILTERS AND WATER SEPARATOR	5
4.1 FUEL FILTER/WATER SEPARATOR SERVICING	5
4.2 FUEL FILTER SERVICING (PRIMARY AND SECONDARY)	5
4.3 DAVCO FUEL PRO 382	6
4.4 PREHEATER FUEL FILTER	8
5. FUEL TANK	8
5.1 TANK REMOVAL	8
5.2 TANK INSTALLATION	9
5.3 FUEL TANK VERIFICATION.....	10
5.4 POLYETHYLENE FUEL TANK REPAIR	10
6. PRIMING FUEL SYSTEM	10
7. FUEL PUMP INSTALLATION	10
8. FUEL SPECIFICATIONS	11
8.1 FUEL TYPE	11
8.2 BLENDING.....	12
9. AIR CLEANER (DRY TYPE)	12
9.1 PRE-CLEANER SERVICING	12
9.2 AIR CLEANER SERVICING	12
9.3 GENERAL RECOMMENDATIONS	12
9.4 AIR CLEANER RESTRICTION INDICATOR.....	13
10. FUEL COOLER	13
11. FUEL PEDAL	13
11.1 FUEL PEDAL ADJUSTMENT.....	13
11.2 POTENTIOMETER REPLACEMENT	14
12. SPECIFICATIONS	15

ILLUTRATIONS

FIGURE 1: FUEL SYSTEM SCHEMATIC 3
FIGURE 2: FUEL FILTERS..... 4
FIGURE 3: MANUAL SHUT-OFF VALVES LOCATION..... 4
FIGURE 4: MANUAL SHUT-OFF VALVE WITH DAVCO PRO 382 4
FIGURE 5: FUEL FILTER/WATER SEPARATOR..... 5
FIGURE 6: DAVCO FUEL PRO 382 FUEL FILTER..... 7
FIGURE 7: DAVCO FUEL PRO 382 EXPLODED VIEW..... 8
FIGURE 8: 208 US GAL. FUEL TANK..... 9
FIGURE 9: FUEL TANK REPAIR 10
FIGURE 10: FUEL PUMP LOCATION..... 11
FIGURE 11: RESTRICTION INDICATOR..... 13
FIGURE 12: FUELRETURN LINE 13
FIGURE 13: FUEL COOLER LOCATION 13
FIGURE 15: ELECTRONIC FOOT PEDAL ASSEMBLY..... 14

1. FUEL SYSTEM DESCRIPTION

Figure 1 shows a schematic of the fuel system. Fuel is drawn from the fuel tank through a manual shut-off valve, a primary fuel filter (fuel-filter/water-separator) before it enters the MCM and the fuel pump. If the vehicle is equipped with the optional “Davco Fuel Pro 382”, this one replaces the primary fuel filter. Leaving the pump under pressure, the fuel flows through a secondary fuel filter and a shut-off valve, then to the cylinder head. The fuel reaches the injectors in the cylinder head through passages within the head. Excess fuel exits at the rear of the head just above the inlet, through a restrictive return fitting which maintains fuel pressure in the system. Finally, the fuel flows through the check valve and the fuel cooler before it returns to the fuel tank. One preheater is available: 104 000 BTU. If the vehicle is equipped with the 104 000 BTU preheater, the fuel is drawn from the fuel tank through the fuel filter to the preheater. Excess fuel returns to the fuel tank.

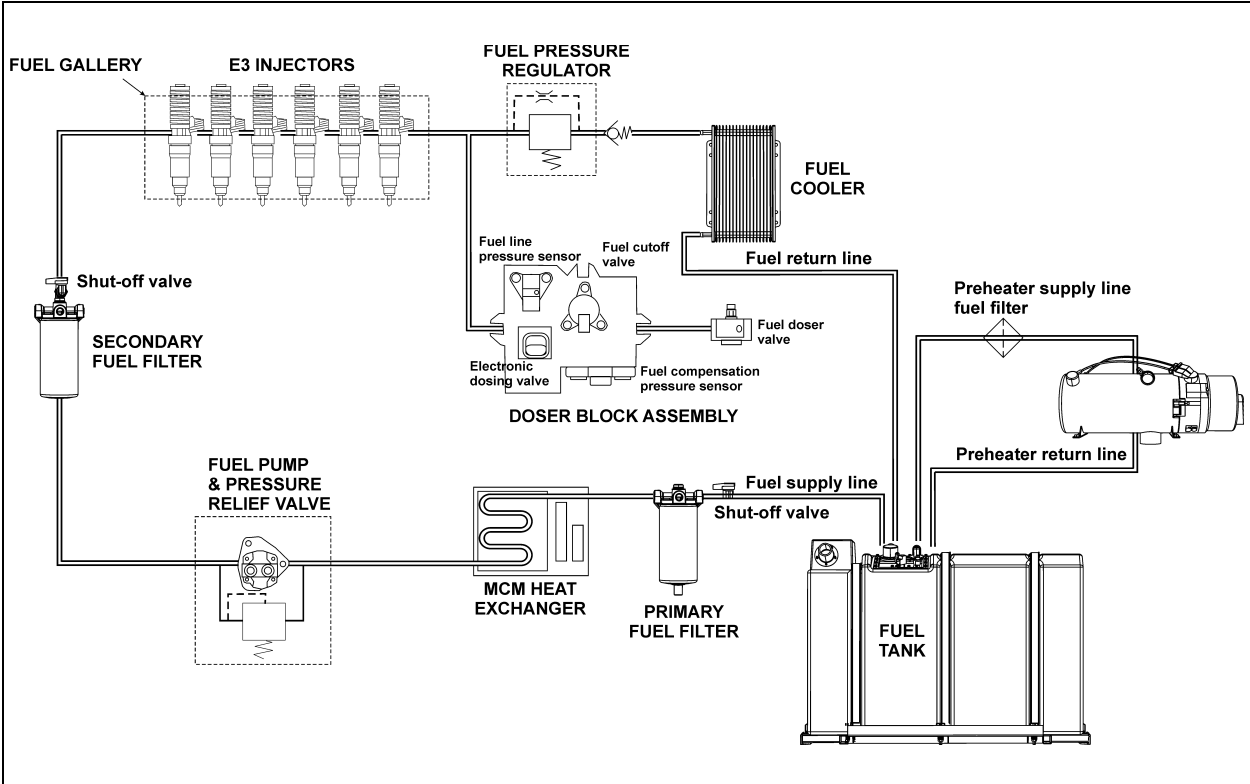

FIGURE 1: FUEL SYSTEM SCHEMATIC

03075

Section 03: FUEL SYSTEM

2. FUEL LINES AND FLEXIBLE HOSES

Make a visual check for fuel leaks at all engine-mounted fuel lines and connections and at the fuel tank suction and return lines. Since fuel tanks are susceptible to road hazards, leaks in this area may best be detected by checking for accumulation of fuel under the tank. Engine performance and auxiliary equipment is greatly dependent on the ability of flexible hoses to transfer lubricating oil, air, coolant and fuel oil. Diligent maintenance of hoses is an important step in ensuring efficient, economical and safe operation of engine and related equipment.



MAINTENANCE

Check hoses daily as part of the pre-start-up inspection. Examine hoses for leaks and check all fittings, clamps and ties carefully. Make sure that the hoses are not resting on or touching shafts, couplings, and heated surfaces, including exhaust manifolds, any sharp edges or other obviously hazardous areas.

Since all machinery vibrates and moves to a certain extent, clamps and ties can fatigue with age. To ensure continued proper support, inspect fasteners frequently and tighten or replace them as necessary. Refer to the schematic diagram of the fuel system (Fig. 1).



CAUTION

Oil level above the dipstick full mark or a decrease in lube oil consumption may indicate internal fuel leaks. Check oil level frequently.

3. FUEL VALVES

Manual shut-off valves on engine fuel-supply line are located on the R.H. side of engine compartment (Fig. 2). A manual shut-off valve is located at the inlet side of the primary fuel filter (fuel filter/water separator, if vehicle is so equipped) under the starter or at the inlet side of the optional Davco Fuel Pro 382 filter. Another manual shut-off valve is located at the outlet side of the secondary fuel filter, under the air compressor. Shut-off valve are designed to prevent loss of fuel prime at time of filter replacement. No manual valve is required on preheater fuel-supply line, since the positive-

displacement fuel pump (located close to the fuel tank) prevents fuel flow when not activated.

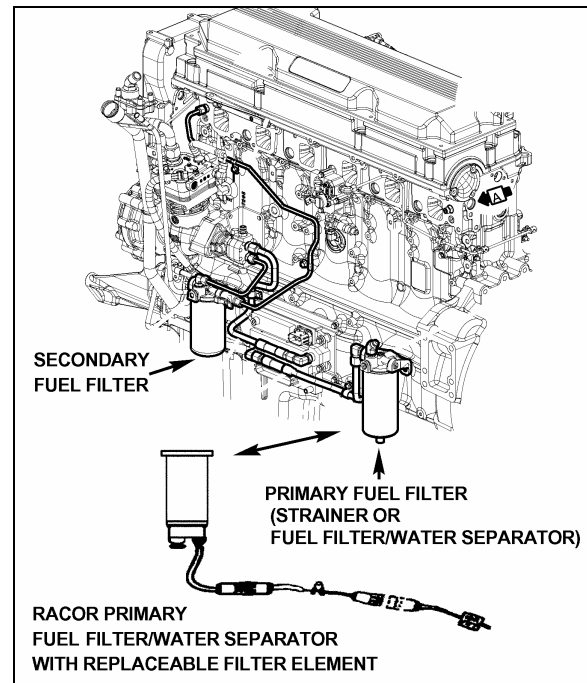

FIGURE 2: FUEL FILTERS

03069

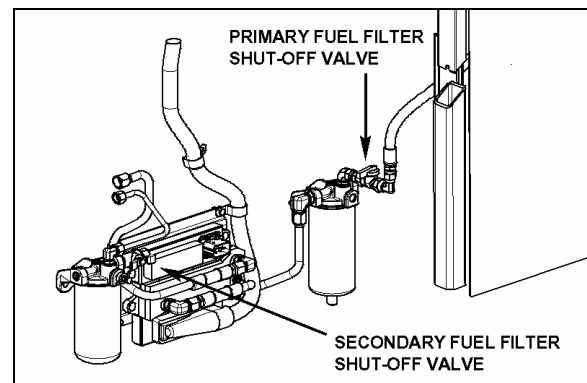

FIGURE 3: MANUAL SHUT-OFF VALVES LOCATION

03072

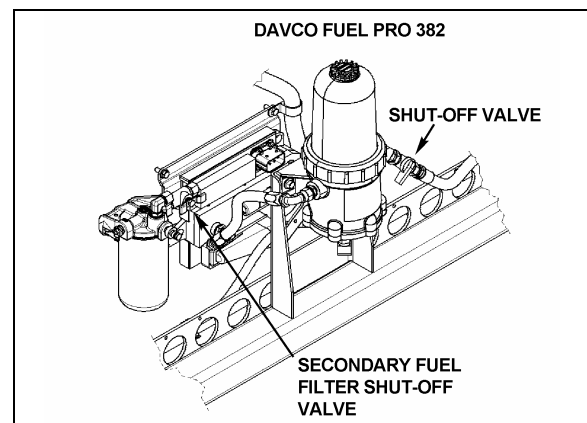

FIGURE 4: MANUAL SHUT-OFF VALVE WITH DAVCO PRO 382

03077

4. FILTERS AND WATER SEPARATOR

The fuel system is equipped with primary and secondary fuel filters for additional protection of the injectors. A fuel-filter/water-separator may be installed in primary fuel-filter location, to prevent water infiltration in engine fuel system (Fig. 2).

NOTE

The operating conditions and cleanliness of type of fuel used determine the service intervals of the filter/water separator element and the secondary fuel filter cartridge.

4.1 FUEL FILTER/WATER SEPARATOR SERVICING



MAINTENANCE

The Racor fuel-filter/water-separator should be drained periodically, or when the water separator telltale light on the dashboard illuminates.

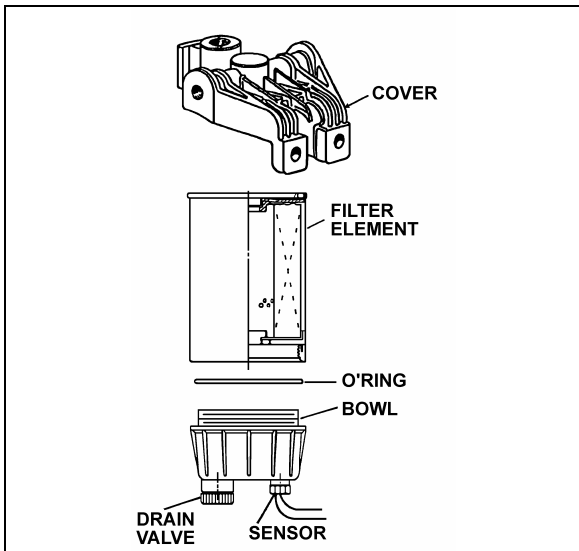

FIGURE 5: FUEL FILTER/WATER SEPARATOR 03025

Replace the water separator element as follows:

1. Drain the fuel filter/water separator as stated previously.
2. With engine "OFF" and engine fuel supply line valves closed; remove the filter element/bowl assembly from cover (for

valve location, see "3. FUEL VALVES" in this section).

3. Separate bowl from filter element. Clean bowl and O-ring groove.

NOTE

Bowl is reusable, do not discard.

4. Lubricate O-ring with clean diesel fuel or motor oil and place it in bowl groove.
5. Screw new filter element onto bowl snugly by hand.



CAUTION

Do not use tool to tighten. Tighten by hand only.

6. Lubricate filter seal with clean diesel fuel or motor oil.



CAUTION

If the water separator continuously requires draining, it is possible that water or sediment has accumulated in the fuel tank. To correct this situation, open the drain plug under the tank when the fuel gauge indicates tank is 1/4 full in order to drain any contaminant.

7. Fill filter element/bowl assembly with clean diesel fuel and attach onto cover. Hand tighten an additional 1/3 to 1/2 turn after making full seal contact.
8. Open valves of the engine fuel supply line.
9. Run the engine and check for leaks.

4.2 FUEL FILTER SERVICING (PRIMARY AND SECONDARY)

The primary and secondary fuel filters are located on the R.H. side of the engine. The primary filter is located below the starter, and the secondary fuel filter is below the air compressor. The threaded sleeves that accept the filters body are different sizes to prevent mismatching. Primary filter thread is 1in.X12 while secondary is 13/16in.X12. The word "primary" or "secondary" is cast onto the top of the respective adaptor.

Section 03: FUEL SYSTEM

NOTE

The fuel filter adaptors are mounted to the engine block with two bolts each. Torque these bolts to 43-54 lbf·ft (58-73 N·m).



MAINTENANCE

The primary and secondary fuel filters are of a spin-on type and must be replaced every 12,500 miles (20 000 km) or once a year, whichever comes first. If the primary fuel filter is a fuel filter/water separator type, it is equipped with a positive seal drain-valve to prevent water infiltration in engine fuel system. To drain, loosen positive seal drain-valve below filter and tighten after water has been flushed out.

A method of determining when filters are clogged to the extent that they should be changed is based on the fuel pressure at the cylinder head fuel inlet fitting and the inlet restriction at the fuel pump. In a clean system, the maximum pump-inlet restriction should not exceed 6 inches of mercury (20.3 kPa) and must not exceed 12 inches of mercury (41 kPa) with a dirty system.

At normal operating speeds and with the standard fuel pressure regulator, the fuel pressure at the cylinder head inlet is 50-75 psi (345-577 kPa). Change the fuel filters whenever the inlet restriction at the fuel pump reaches 12 inches of mercury (42 kPa) at normal operating speeds. Also, change whenever the fuel pressure at the cylinder head inlet fitting falls to the minimum fuel pressure given above.

Change the filter cartridge(s) as follows:

NOTE

Use a suitable band wrench or filter wrench, such as J22775, to remove the filters.

1. Stop engine and place a suitable container under the filter.
2. Close the primary and secondary filter shut-off valves (for valve location, See paragraph "3. FUEL VALVES").
3. Using a band filter wrench, unscrew and discard filters.

4. Fill new filter replacement cartridge(s) with clean fuel oil, about two thirds (2/3). Apply a thin coat of clean fuel oil on gasket.
5. Install new filters. Tighten until filter is snug against the gasket, with no side movement. Rotate an additional 1/2 turn by hand.
6. Open engine fuel supply line shut-off valves.



CAUTION

Mechanical tightening of the fuel filters is not recommended and may result in seal and/or cartridge damage. Tighten the fuel filters by hand only.

5. Start the engine and check for leaks.

NOTE

There is a fuel system shut-off valve on the discharge side of the secondary fuel filter. This check valve is designed to prevent fuel loss at time of filter replacement.

4.3 DAVCO FUEL PRO 382

The optional Fuel Pro 382 diesel fuel filter system consists of a permanently mounted fuel processor, a replaceable filter element, a filter element cover and collar and a fluid filter base assembly. This system is installed between the fuel tank and the fuel pump and is designed to be the only fuel filter in the fuel system. The filter serves as a water separator as well as a fuel filter (refer to figure 6).

The filter fibers used in the Davco Fuel Pro 382 element may cause the fuel level to read artificially high when the filter is first installed. Over the first few days, the filter fibers eventually become fully saturated and the fuel level will drop to normal levels. Do not be concerned about an abnormally high fuel level when a new Davco element is installed.

When new, the fuel level as seen through the clear cover in the 382 filter is very low. It rises as dirt collects on the filter from the bottom up. Restriction remains consistently low because fuel always flows through clean, new media.



MAINTENANCE

Replace Fuel Pro 382 filter element when the fuel level in the see-thru filter cover reaches the top of the filter element or after one year of service, whichever comes first.

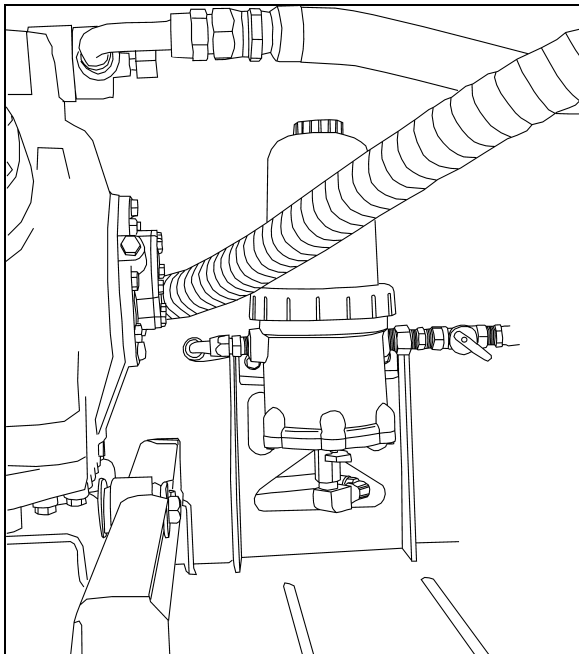

FIGURE 6: DAVCO FUEL PRO 382 FUEL FILTER 03062

Filter renewal:

1. Stop engine;
2. Place a suitable container under the fuel processor;
3. Close the shut-off valve at the inlet side of the fuel filter;
4. Open the drain valve at the base of the fuel processor and drain the fuel until it is below the level of the filter;
5. Untighten upper collar, remove cover, filter hold down spring, filter element and cover seal;
6. Dispose of used filter element;
7. Ensure the filter grommet is included at the base of the new filter element and then install the element onto the center stud;
8. Ensure the filter spring is installed at the top of the cover. If missing, the spring must be replaced to insure proper filter operation.

9. Wipe the cover lid and seal clean. After ensuring the seal is properly positioned at the base of the cover, install the cover and collar onto the fuel processor. Tighten the collar by hand until secure;
10. Fill the cover full of clean fuel through spin off cap located on top of cover. Install vent cap seal and then reinstall the cap and tighten by hand only;
11. Open the shut-off valve;
12. Start engine, raise rpm for 2-3 minutes, hand tighten collar again;
13. After the air is purged and with the engine still running, slowly loosen the vent cap on the filter cover. The fuel level in the cover will start falling. When the fuel level falls to the top of the collar, tighten the vent cap quickly by hand;
14. Shut down the engine and hand-tighten the collar again.

NOTE

Fuel Pro 382 also accepts standard secondary spin-on fuel filters.

ENVIRONMENTAL NOTICE

Diesel fuel is an environmentally hazardous product. Dispose in an environmentally friendly manner.

Section 03: FUEL SYSTEM

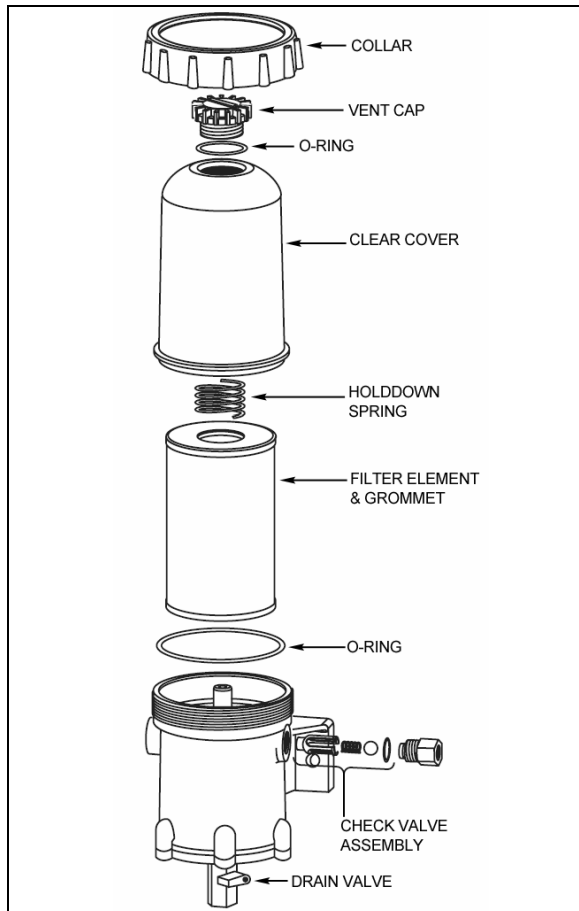

FIGURE 7: DAVCO FUEL PRO 382 EXPLODED VIEW 03034

4.4 PREHEATER FUEL FILTER

The preheater fuel filter is located near the preheater, on the R.H. side of the engine compartment.



MAINTENANCE

Replace preheater fuel filter every 50,000 miles (80 000 km) or once a year, whichever comes first.

5. FUEL TANK

X3-45 coaches are equipped with a high-density cross-link polyethylene fuel tank with a capacity of 208 US gallons (787 liters).

On all vehicles, fuel filling access doors on both sides of vehicle provide direct access to filler necks; offering the added advantage of refueling from either side of vehicle.

A pressure relief valve on the fuel tank connection-panel relieves high-pressure buildup and an overflow tube allows offset air in the tank to escape during filling. For 95% of the tank volume, 5% of tank inside space is kept filled with air with no exit opening, allowing for a fuel expansion safety margin. A drain plug, accessible from under the vehicle, is fitted at the bottom of the tank(s).

5.1 TANK REMOVAL



DANGER

Park vehicle safely, apply parking brake, stop engine and set battery master switch(es) to the OFF position prior to working on the vehicle.

Before working under an air-suspended vehicle, it is strongly recommended to support the body at the recommended jacking points.

NOTE

Before removal, the fuel tank should be completely drained by unscrewing the drain plug. Ensure that the container used has a capacity equal to the amount of fuel remaining in the tank.

1. Open the condenser door and remove the fuel tank access panel. The rear baggage compartment fuel tank access panel may also be removed to facilitate access to components.
2. If applicable, unscrew clamps retaining L.H. side filler tube to the fuel tank, then disconnect tube and remove it.
3. Unscrew clamps retaining R.H. side filler tube to fuel tank and filler neck. Disconnect tube and remove it.
4. If applicable, unscrew preheater supply line, preheater return line, auxiliary return line and/or auxiliary return line from fuel tank connection-panel.
5. Unscrew engine supply and return lines from fuel tank connection-panel, identify them for reinstallation.
6. Disconnect electrical wiring from tank on connection plate.

**DANGER**

Before removing the bolts securing the tank support to the frame, make sure the tank is supported adequately. Failure to do so could result in injury as well as damage to the tank.

7. From under the vehicle, on R.H. side, unscrew the 4 bolts (2 in front, 2 in back) retaining the tank support to the frame.

8. From under the vehicle, on the L.H. side, unscrew the 2 bolts (1 in front, 1 in back) retaining the tank support to the frame.

9. Carefully remove tank from under the vehicle.

5.2 TANK INSTALLATION

To install tank, simply reverse the "Tank Removal" procedure.

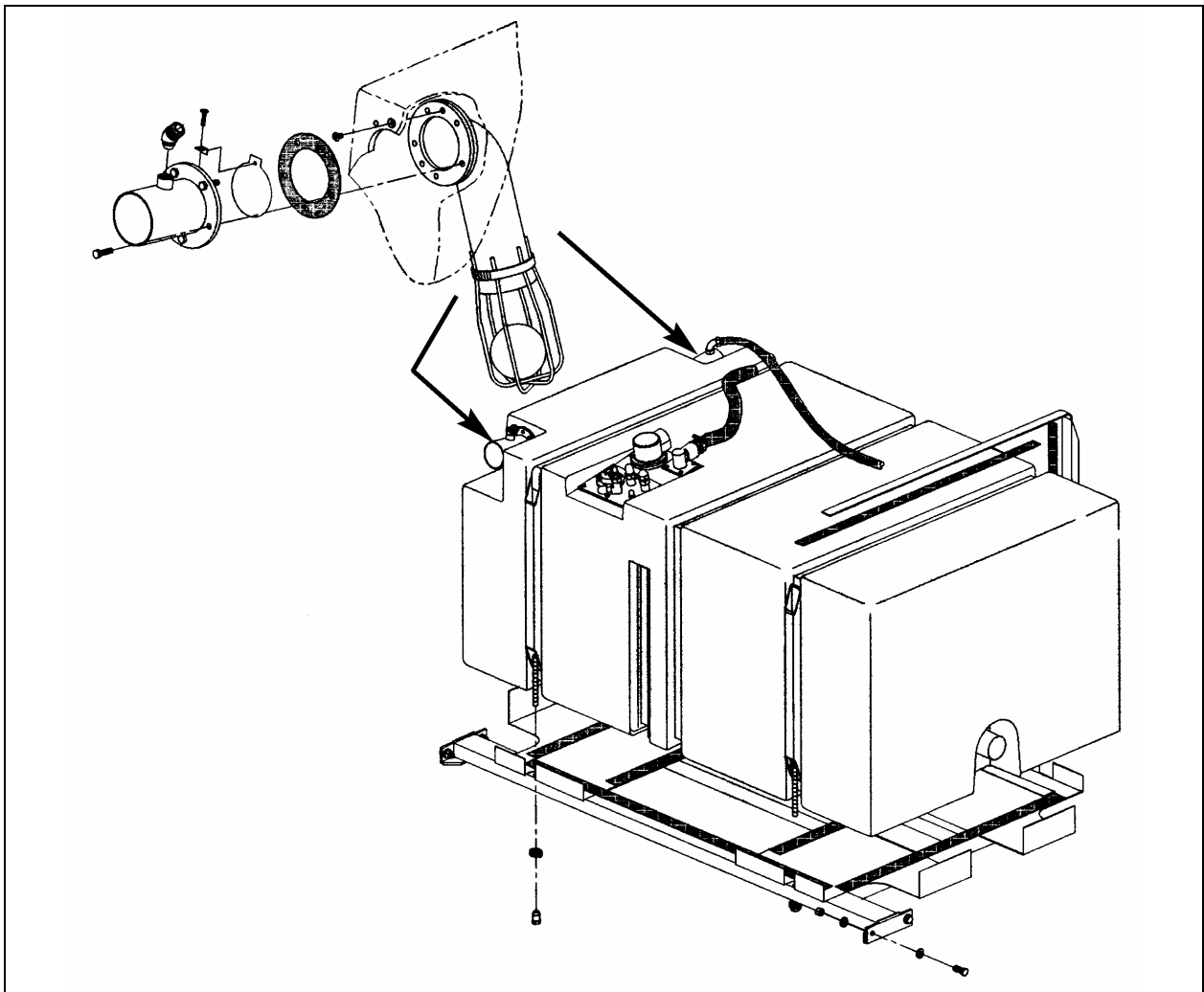

FIGURE 8: 208 US GAL. FUEL TANK

03063

Section 03: FUEL SYSTEM

5.3 FUEL TANK VERIFICATION

Inspect fuel tank from under vehicle for leaks or fuel traces. If a leak is detected, repair immediately as per "Polyethylene Fuel Tank Repair" in this section.



DANGER

Park vehicle safely, apply parking brake, stop engine and set battery master switch(es) to the OFF position prior to working on the vehicle.

Before working under an air-suspended vehicle, it is strongly recommended to support the body at the recommended jacking points.

5.4 POLYETHYLENE FUEL TANK REPAIR

NOTE

Fuel level must be lower than perforation to carry out this procedure.



DANGER

Park vehicle safely, apply parking brake, stop engine and set battery master switch(es) to the OFF position prior to working on the vehicle.

1. Locate perforation on fuel tank.
2. If necessary, remove fuel tank as per instructions in this section.
3. Drill perforation with a 23/64" bit. Make sure drill hole is perfectly round.
4. Insert a screw (Prevost #500196) and a washer (Prevost #5001244) into anchor nut (Prevost #500331).
5. Place assembly in drill hole. Tighten screw by 10 complete turns. Refer to Fig. 7.
6. Apply sealant on head plug (Prevost #507300) and seal hole with the head plug.

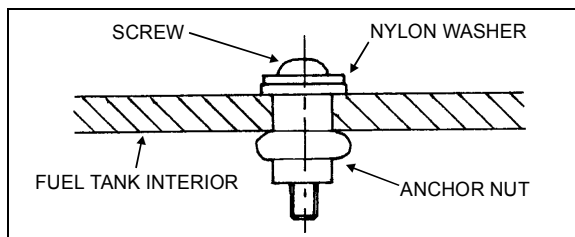

FIGURE 9: FUEL TANK REPAIR

03014

6. PRIMING FUEL SYSTEM

The problem with restarting a diesel engine that has run out of fuel, is that after the fuel is exhausted from the tank, it is pumped from the primary fuel filter or the fuel filter/water separator (if vehicle is so equipped), and sometimes partially removed from the secondary filter. This results in an insufficient fuel supply to sustain engine firing. The primary fuel filter or fuel filter/water separator and secondary filter must be free of air in order for the systems to provide adequate fuel for the injectors. When the engine runs out of fuel, the following operations must be performed before restarting:

Fill fuel tank with the recommended fuel oil. If only partial filling is possible, add a minimum of 10 gallons (38 liters) of fuel.

- * If the vehicle is equipped with a Fuel Pro 382 fuel filter/water separation, pour fuel through spin on cap as per "4.3 DAVCO FUEL PRO 382".

First method:

1. Close the primary fuel filter shut-off valve. Close the shut-off valve on the secondary filter head and remove the spin-on fuel filters. Fill with clean fuel through the fuel inlet holes (the outer ring of small holes on the element) to insure the fuel is filtered;
2. Thread the elements onto the adaptor inserts until the gaskets make full contact with the adaptor head and no side movement is evident. Tighten filters an additional one-half turn by hand, or as indicated on the filter.
3. Open the fuel shut-off valves, start the engine and check for leaks.

Second method:

1. Unscrew the cap on the priming valve located on the secondary filter;
2. Direct fuel under pressure 25 psi (172 kPa) to the priming valve using a quick coupling;
3. Start the engine and check for leaks.

7. FUEL PUMP INSTALLATION

The fuel pump is driven off the rear of the air compressor.

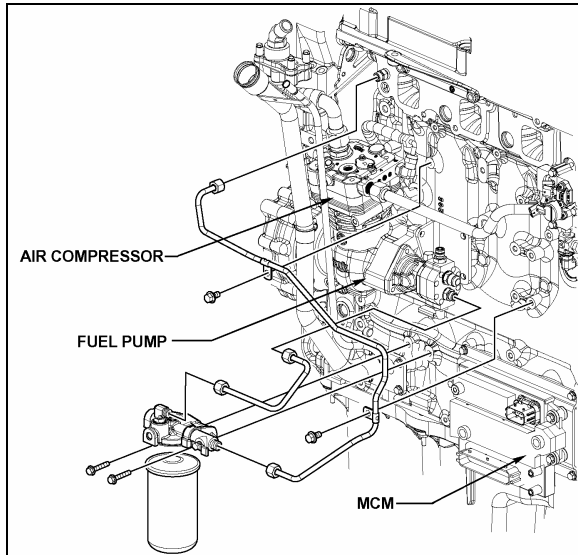

FIGURE 10: FUEL PUMP LOCATION

03070

1. If removed, install inlet and outlet fittings in the cover of the fuel pump.

NOTE

New fittings have sealant already applied. When reusing fittings, coat the threads lightly with Loctite Pipe Sealant, Detroit Diesel number J 26558-92, or equivalent, before installing. To prevent sealant from entering fuel system, do not apply to the first two threads of the fitting. Do not use Teflon tape or paste on the fittings.

2. Install drive coupling in drive hub of the fuel pump. Install a new gasket to the mounting flange of the pump.
3. Index the drive coupling with the drive hub on the end of the air compressor crankshaft and align the pump mounting bolt holes with those in the air-compressor rear cover.

NOTE

When correctly positioned, the outlet fitting on the pump should be in approximately an 8 o'clock position when viewed from the rear, and the drain opening in the pump body facing down.

4. Seat the fuel pump squarely against the air compressor. Pilot the flange on the pump body, in the opening in the rear cover of the compressor. Install three mounting bolts and tighten them to 22-28 Lbf-ft (30-38 Nm).
5. Connect the fuel inlet and outlet lines to the fuel pump and tighten.

6. Prime engine fuel system before starting engine to ensure pump seal lubrication and prompt engine starting.

8. FUEL SPECIFICATIONS

The quality of fuel oil used for high-speed diesel engine operation is a very important factor in obtaining satisfactory engine performance, long engine life and acceptable exhaust emission levels.

The U.S. Environmental Protection Agency (EPA) has issued new standards to improve air quality by significantly reducing emissions through a combination of cleaner-burning diesel engines and vehicles.

To meet EPA standards, the petroleum industry produces **Ultra Low Sulfur Diesel** (ULSD) fuel, also referred to as S15, containing a maximum 15ppm (parts-per-million) sulfur.

On-highway diesel engines meeting 2007 emission regulations are designed to operate **ONLY** with ULSD fuel. ULSD fuel will enable the use of cleaner technology diesel engines and vehicles with advanced emissions control devices, resulting in significantly improved air quality.

8.1 FUEL TYPE

EPA-07 engines like the DDC 2007 Series 60 are designed to run on **Ultra Low Sulfur Diesel** (ULSD) fuel, which can contain no more than 15 ppm sulfur.

**CAUTION**

ULSD fuel is necessary to avoid fouling the engine's Aftertreatment Device (ATD). Improper fuel use will reduce the efficiency of the engine's Aftertreatment System and may permanently damage the system.

**CAUTION**

Owners of 2007 and later model year on-highway diesel engine must refuel only with ULSD fuel.

NOTE

Burning Low Sulfur Diesel fuel (instead of ULSD fuel) in 2007 and later model year diesel engines is illegal and punishable with

Section 03: FUEL SYSTEM

civil penalties.

NOTE

Owners of 2006 and earlier model year on-highway diesel engine may use ULSD or regular Low Sulfur Diesel fuel.

NOTE

Engine and vehicle manufacturers expect ULSD fuel to be fully compatible with the existing fleet, including 2006 and earlier model year vehicles. In some instances, the introduction of ULSD fuel to older vehicles may affect fuel system components or loosen deposits in fuel tanks. As part of a good maintenance program, owners and operators of existing cars, trucks and buses are encouraged to monitor their diesel-powered vehicles closely for potential fuel system leaks or premature fuel filter plugging during the change-over to ULSD fuel.

NOTE

Like Low Sulfur Diesel fuel, ULSD fuel requires good lubricity and corrosion inhibitors to prevent unacceptable engine wear. As necessary, additives to increase lubricity and to inhibit corrosion will be added to ULSD fuel prior to its retail sale.

8.2 BLENDING

Only ultra low sulfur kerosene – No.1 diesel with no more than 15ppm sulfur may be blended with ULSD fuel to improve cold weather performance. With so many kerosene formulations on the market, care must be taken to select kerosene with a maximum of 15ppm sulfur.

Blend rates remain the same as with Low Sulfur Diesel fuel.

9. AIR CLEANER (DRY TYPE)

The vehicle is equipped with a dry-type replaceable element air cleaner, located in the engine compartment. Access the air cleaner through the engine R.H. side door. Engine air enters the air cleaner through (2) two intake ducts located just above engine side doors. It then flows through a pre-cleaner and finally through the air cleaner. The pre-cleaner removes dust and moisture by means of a

discharge tube at the bottom of the element. It is in series with a replaceable impregnated paper filter element (air cleaner).

9.1 PRE-CLEANER SERVICING



MAINTENANCE

The pre-cleaner is designed to be self-cleaning; however, it should be inspected and any accumulated foreign material removed during the periodic replacement of the impregnated paper filter element.

9.2 AIR CLEANER SERVICING

Stop the engine, open the R.H. side engine compartment door, and loosen the wing nut retaining the air cleaner element to the air cleaner. Remove the element by pulling on the handle in the center of the air cleaner element.

Install cleaner element as follows:

1. Inspect the gasket-sealing surface inside the air cleaner. It must be smooth, flat and clean;
2. Install the air cleaner element;
3. Make sure that the element seals securely;
4. Inspect element cover gasket and replace if necessary.

Whenever it becomes necessary to remove the air cleaner assembly (dry type) for maintenance or other repair in this area, great care should be taken when installing air cleaner assembly.

The pre-filter should be installed snugly in the air duct and clamped tightly to the air cleaner inlet to prevent any dust infiltration into the air cleaner.

9.3 GENERAL RECOMMENDATIONS

The following maintenance procedures will ensure efficient air cleaner operation:

1. Keep the air cleaner housing tight on the air intake pipe;
2. Make sure the correct filters are used for replacement;
3. Keep the air cleaner properly assembled so the joints are air-tight;
4. Immediately repair any damage to the air cleaner or related parts;

5. Inspect, clean or replace the air cleaner or elements as operating conditions warrant. Whenever an element has been removed from the air cleaner housing the inside surface of the housing must be cleaned with a soft clean cloth;
6. Periodically inspect the entire system. Dust-laden air can pass through an almost invisible crack or opening which may eventually cause damage to an engine;
7. Never operate the engine without an element in the air cleaner assembly;



CAUTION

Do not ignore the Warning given by the air restriction indicator. This could result in serious engine damage.

8. Store new elements in a closed area free from dust and possible damage.

9.4 AIR CLEANER RESTRICTION INDICATOR

A resettable restriction indicator may be installed on the engine air-intake duct, clearly visible from the rear engine compartment. The indicator monitors the vacuum level between the air filter and the engine. A red marker is displayed when the air filter is clogged and must be replaced. Reset by pressing on the indicator's extremity.

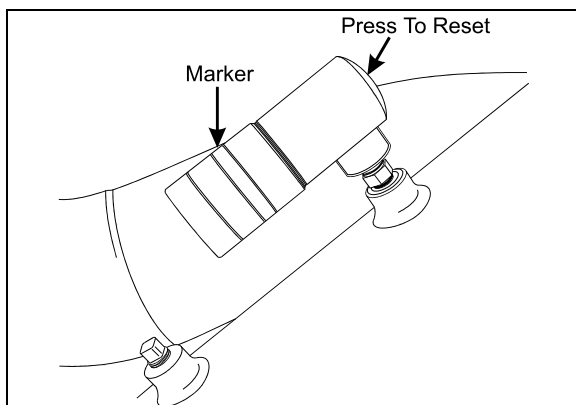

FIGURE 11: RESTRICTION INDICATOR 01052

10. FUEL COOLER

The fuel cooler serves to cool the surplus diesel fuel after it has exited the cylinder head, on its way back to the fuel tank. It is accessible through the engine radiator door, and is located in front of the charge air cooler (CAC) and the coolant radiator (Fig. 12 & 13).

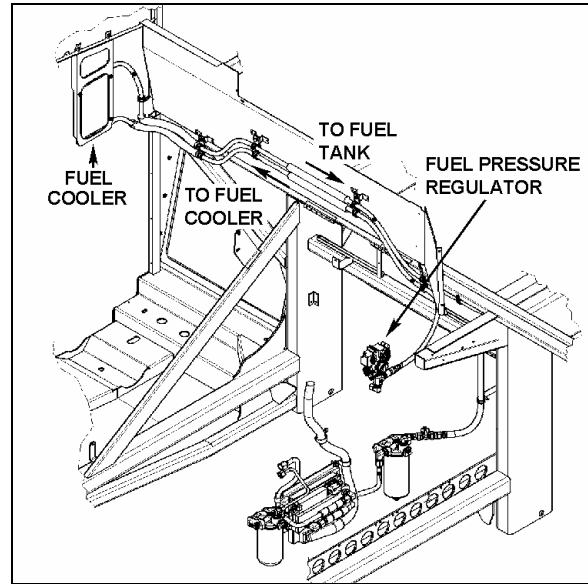

FIGURE 12: FUEL RETURN LINE 03078

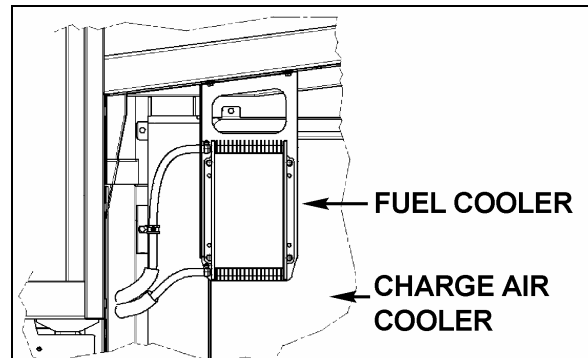

FIGURE 13: FUEL COOLER LOCATION 03079

11. FUEL PEDAL

The EFPA (Electronic Foot Pedal Assembly) connects the accelerator pedal to a potentiometer (a device that sends an electrical signal to the ECM, which varies in voltage, depending on how far down the pedal is depressed). The EFPA is installed in the space normally occupied by a mechanical foot pedal. It has maximum and minimum stops that are built into the unit during manufacturing.

11.1 FUEL PEDAL ADJUSTMENT

The EFPA contains a throttle position sensor that varies the electrical signal sent to the ECM. The sensor must be adjusted whenever an EFPA is serviced. In addition, the sensor should be adjusted any time codes 21 and 22 are flashed.

With the ignition "ON" and the proper diagnostic tool (DDR) (for information regarding the DDR,

Section 03: FUEL SYSTEM

see "01 ENGINE" in this manual), check the throttle counts at idle and full throttle positions. Proper pedal output should be 20/30 counts at idle and 200/235 at full throttle. If adjustment is necessary, remove the potentiometer retaining screws and rotate the potentiometer clockwise to increase counts or counterclockwise to decrease. When correct output is confirmed, tighten retaining screws.

11.2 POTENTIOMETER REPLACEMENT

1. Disconnect cable harness connector.
2. Loosen the two screws and remove potentiometer. Retain for re-assembly.
3. Discard potentiometer (Fig. 15).



CAUTION

Note the routing and clamping locations of the cable before disassembly. Proper cable routing and fastening is critical to the operation of this system. Marking the foot pedal assembly to record cable routing is recommended.

4. Position new potentiometer. Press potentiometer onto the potentiometer shaft, matching cutouts in shaft to drive tangs of potentiometer. Apply hand pressure until potentiometer has bottomed out in housing. Reinstall screws (Fig. 15) and tighten just enough to secure potentiometer lightly. Tighten screws to 10 - 20 Lbf-in (1.13 - 2.26 Nm).
5. Reconnect electronic foot pedal assembly's cable harness to the ECM connector. If potentiometer calibration is necessary (see "FUEL PEDAL ADJUSTMENT" in this section).



CAUTION

Make sure the cable harness is routed correctly, and securely installed so that it does not become pinched, stretched, or otherwise damaged during vehicle operation.

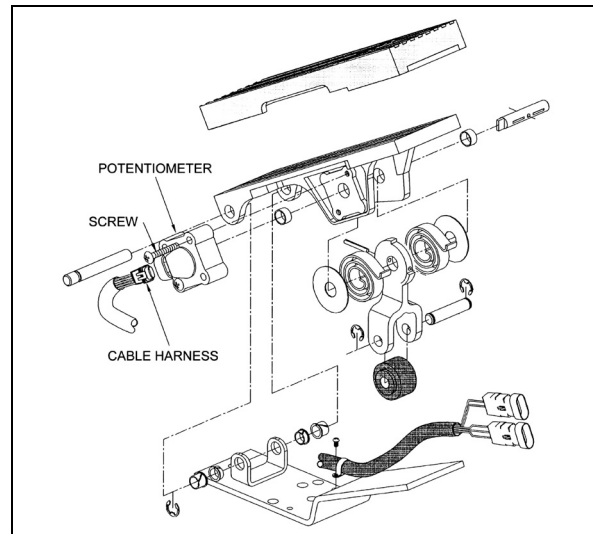

FIGURE 14: ELECTRONIC FOOT PEDAL ASSEMBLY 03035

12. SPECIFICATIONS

Davco Fuel Pro 382 Fuel Filter / Water Separator Element

Prevost number510795

Racor Primary Fuel Filter / Water Separator (optional)

(May be used instead of regular primary filter (never use with a primary filter).

Make Racor

Type Replaceable cartridge

ELEMENT

Prevost number531390

BOWL

Prevost number531389

DRAIN VALVE AND SEAL

Prevost number531397

O-RING

Prevost number531398

PROBE/WATER SENSOR

Prevost number531391

Primary Fuel Filter

Make AC

Type Spin-on

Filter No. T-915D

Service Part No.25014274

Prevost number510137

OR

Service Part No (Type with Water Separator)23512317

Prevost number032700

Element torque 1/2 turn after gasket contact

Secondary Fuel Filter

Make AC

Type Spin-on

Filter No. T-916D

Prevost number510794

Element torque 1/2 turn after gasket contact

Fuel tank Capacity

Standard (X3-45)208 US gallons (787 liters)

Air Cleaner

Make Nelson

Prevost Number530206

Service Part No7182 8N

Prevost number (element cartridge)530197

Air Cleaner Restriction Indicator

Make Donaldson

ModelRBX00-2220

Indicates at 20" (508 mm) of water

Prevost number530161

Preheater Fuel Filter

Make Webasto

Prevost number871037

Section 03: FUEL SYSTEM

Fuel Cooler

Make Long Manufacturing
Prevost number531422