

SECTION 16: SUSPENSION

CONTENTS

1	DESCRIPTION	5
2	FRONT I-BEAM AXLE SUSPENSION	5
2.1	AIR SPRINGS.....	5
2.1.1	<i>Inspection</i>	5
2.1.2	<i>Removal</i>	5
2.1.3	<i>Installation</i>	6
2.2	SHOCK ABSORBERS.....	6
2.2.1	<i>Inspection</i>	6
2.2.2	<i>Removal</i>	7
2.2.3	<i>Installation</i>	7
2.3	RADIUS RODS.....	8
2.3.1	<i>Inspection</i>	8
2.3.2	<i>Radius Rod Removal</i>	8
2.3.3	<i>Bushing removal</i>	8
2.3.4	<i>Bushing installation</i>	8
2.3.5	<i>Radius Rod Installation</i>	9
2.4	SWAY BAR.....	9
2.4.1	<i>Removal</i>	9
2.4.2	<i>Installation</i>	9
2.5	TORQUE SPECIFICATIONS - FRONT I-BEAM AXLE SUSPENSION AND STEERING	11
3	INDEPENDENT FRONT SUSPENSION (IFS).....	15
3.1	STEERING LINKAGE.....	15
3.2	STEERING LINKAGE INSTALLATION SEQUENCE	20
3.3	PITMAN ARM	20
3.3.1	<i>Removal</i>	20
3.3.2	<i>Installation</i>	20
3.4	DRAG LINK.....	21
3.4.1	<i>Adjustment</i>	21
3.5	BELL CRANK AND IDLER ARM.....	21
3.5.1	<i>Bell Crank or Idler Arm Removal</i>	21
3.5.2	<i>Bell crank or Idler Arm Hub Disassembly</i>	22
3.5.3	<i>Bell Crank or Idler Arm Hub Reassembly</i>	22
3.6	RELAY ROD	23
3.6.1	<i>Replacement</i>	23
3.7	TIE RODS.....	23
3.7.1	<i>Removal</i>	23
3.7.2	<i>Installation</i>	23
3.8	STEERING ARMS	24
3.8.1	<i>Removal</i>	24
3.8.2	<i>Installation</i>	24
3.9	LUBRICATION FITTINGS	26
3.10	BALL JOINTS – GENERAL RECOMMENDATIONS	27
3.11	FRONT-END ALIGNMENT.....	27
3.11.1	<i>Alignment Terminology</i>	27
3.11.2	<i>Front End Inspection</i>	28
3.11.3	<i>Front Wheel Camber</i>	28
3.11.4	<i>Front Wheel Toe-In</i>	28
3.11.5	<i>Front Wheel Caster</i>	29
3.11.6	<i>Major Damage</i>	29
3.11.7	<i>Alignment Specifications</i>	29
3.12	LOWER AND UPPER A-ARM BAR PIN BUSHING REPAIR.....	33

Section 16: SUSPENSION

3.12.1	Inspection	33
3.12.2	Stripping Down	33
3.12.3	Assembly	33
3.13	LOWER A-ARM BALL JOINT REPAIR	34
3.13.1	Stripping Down	34
3.13.2	Assembly	34
3.14	UPPER A-ARM BALL JOINT	35
3.14.1	Visual Inspection	35
3.14.2	Play Measurement	35
3.15	FRONT AIR SPRINGS	35
3.15.1	Inspection	35
3.15.2	Removal	36
3.15.3	Installation	36
3.16	SHOCK ABSORBERS	36
3.16.1	Shock Absorber Removal	37
3.16.2	Shock Absorber Installation	37
3.17	SWAY BAR	37
3.17.1	Removal	37
3.17.2	Installation	38
3.18	INDEPENDENT FRONT SUSPENSION HEIGHT ADJUSTMENT	38
4	REAR SUSPENSION	40
4.1	AIR SPRINGS	41
4.1.1	Inspection	41
4.1.2	Removal	41
4.1.3	Installation	41
4.2	SHOCK ABSORBERS	42
4.2.1	Inspection	42
4.2.2	Removal	43
4.2.3	Installation	43
4.3	RADIUS RODS	43
4.3.1	Rear Underframe Suspension	43
4.3.2	Tag Axle Suspension	45
5	SUSPENSION AIR SYSTEM	46
5.1	INSPECTION	46
5.2	AIR LINE TEST	46
5.3	AIR TANK MAINTENANCE	46
6	SUSPENSION HEIGHT ADJUSTMENT	46
7	HEIGHT CONTROL VALVES	47
7.1	MAINTENANCE	48
7.1.1	Removal and installation	48
7.1.2	Air leakage test	48
8	"LEVEL-LOW" LEVELING SYSTEM – VIP SERIES OPTION ONLY	48
8.1	PRINCIPLES OF OPERATION	48
8.2	MAINTENANCE	49
9	FRONT KNEELING SYSTEM	49
9.1	PRINCIPLE OF OPERATION	49
9.2	MAINTENANCE	49
9.3	AIR SPRING CONTROL SOLENOID VALVES	49
9.3.1	Removal and installation	49
10	HIGH-BUOY SYSTEM	50

10.1	PRINCIPLES OF OPERATION	50
10.2	MAINTENANCE.....	50
10.3	HIGH-BUOY – PRESSURE REGULATOR	50
10.3.1	<i>Adjustment</i>	50
10.3.2	<i>Disassembly</i>	50
10.3.3	<i>Cleaning</i>	51
10.3.4	<i>Reassembly</i>	51
11	LOW-BUOY SYSTEM	51
11.1	PRINCIPLES OF OPERATION	51
11.2	MAINTENANCE.....	51
12	AIR SYSTEM	51
12.1	AIR TANK MAINTENANCE	52
12.1.1	<i>Wet Air Tank</i>	52
12.1.2	<i>Primary Air Tank</i>	52
12.1.3	<i>Secondary Air Tank</i>	53
12.1.4	<i>Accessory Air Tank</i>	53
12.1.5	<i>Expansion Air Tank</i>	53
12.2	EMERGENCY FILL VALVES.....	53
13	REAR SUSPENSION TORQUE SPECIFICATIONS	55
14	TROUBLESHOOTING.....	58
15	SPECIFICATIONS	58

ILLUSTRATIONS

FIGURE 1:	FRONT I-BEAM AXLE SUSPENSION	5
FIGURE 2:	AIR SPRING	5
FIGURE 3:	SHOCK ABSORBER.....	7
FIGURE 4:	TYPICAL SHOCK ABSORBER SETUP	7
FIGURE 5:	TYPICAL RADIUS ROD SETUP.....	8
FIGURE 6:	RADIUS ROD BUSHING REMOVAL	8
FIGURE 7:	RADIUS ROD BUSHING INSTALLATION	9
FIGURE 8:	RADIUS ROD INSTALLATION.....	9
FIGURE 9:	FRONT & DRIVE AXLE SWAY BAR.....	9
FIGURE 10:	INDEPENDENT FRONT SUSPENSION.....	15
FIGURE 11:	IFS STEERING LINKAGE OVERVIEW	17
FIGURE 12:	IFS - SUSPENSION COMPONENTS	17
FIGURE 13:	IFS STEERING LINKAGE	18
FIGURE 14:	STEERING GEARBOX INPUT SHAFT MARKS	20
FIGURE 15:	STEERING GEARBOX OUTPUT SHAFT AND PITMAN ARM MARKS ALIGNED.....	20
FIGURE 16:	FIXING NUT PUNCH MARK	21
FIGURE 17:	BELL CRANK OR IDLER ARM HUB	22
FIGURE 18:	BELL CRANK.....	22
FIGURE 19:	BELL CRANK.....	23
FIGURE 20:	STEERING LINKAGE NOMINAL LENGTHS	25
FIGURE 21:	LUBRICATION FITTINGS LOCATION	26
FIGURE 22:	ADEQUATE CLAMPING CONDITION	27
FIGURE 23:	SHIMS AT THE LOWER AARMS	28
FIGURE 24:	IFS PITMAN ARM ALIGNMENT.....	29
FIGURE 25:	IFS NOMINAL DIMENSIONS	31
FIGURE 26:	NOTE 2 INDICATES WHERE ADJUSTMENT MAY BE PERFORMED	31
FIGURE 27:	FRONT END ALIGNMENT DIAGRAM	32
FIGURE 28:	A-ARM JOINT IDENTIFICATION	33

Section 16: SUSPENSION

FIGURE 29: BAR PIN BUSHING	33
FIGURE 30: LOWER A-ARM BAR PIN BUSHING	34
FIGURE 31: UPPER A-ARM BAR PIN BUSHING	34
FIGURE 32: LOWER A-ARM BALL JOINT	35
FIGURE 33: UPPER A-ARM BALL JOINT	35
FIGURE 34: AIR SPRINGS	35
FIGURE 35: SHOCK ABSORBER.....	37
FIGURE 36: SWAY BAR (INDEPENDENT FRONT SUSPENSION)	38
FIGURE 37: HEIGHT CONTROL VALVE LOCATION	38
FIGURE 38: TYPICAL AIR SPRING CLEARANCE	39
FIGURE 39: FRONT HEIGHT CONTROL VALVE	39
FIGURE 40: DETAILS OF REAR SUSPENSION	40
FIGURE 41: TAG AXLE SUSPENSION	40
FIGURE 42: REAR SUSPENSION COMPONENTS.....	40
FIGURE 43: AIR SPRING	41
FIGURE 44: SHOCK ABSORBER.....	43
FIGURE 45: TYPICAL SHOCK ABSORBER SETUP.....	43
FIGURE 46: TYPICAL RADIUS ROD SETUP.....	44
FIGURE 47: RADIUS ROD BUSHING REMOVAL	44
FIGURE 48: RADIUS ROD BUSHING INSTALLATION	44
FIGURE 49: TYPICAL RADIUS ROD SETUP ON TAG AXLE.....	45
FIGURE 50: BALL JOINTS.....	45
FIGURE 51: TYPICAL AIR SPRING CLEARANCE, FRONT I-BEAM AXLE	47
FIGURE 52: HEIGHT CONTROL VALVE	47
FIGURE 53: AIR PRESSURE REGULATOR.....	51
FIGURE 54: LOCATION OF AIR TANKS	52
FIGURE 55: REAR VALVE LOCATION	53
FIGURE 56: FRONT VALVE LOCATION	53
FIGURE 57: TORQUE SPECIFICATIONS – DRIVE AXLE	55
FIGURE 58: TORQUE SPECIFICATIONS – DRIVE AXLE	55
FIGURE 59: TORQUE SPECIFICATIONS – TAG AXLE	56
FIGURE 60: TORQUE SPECIFICATIONS – TAG AXLE	56
FIGURE 61: TORQUE SPECIFICATIONS – REAR SUBFRAME	57

1 DESCRIPTION

The vehicle is provided with an air suspension system. The system consists of air springs, height control valves, radius rods, sway bars, tripod and shock absorbers (Fig. 1-6). The system operation is fully automatic and maintains a constant vehicle height regardless of load, or load distribution.

The vehicle can also be equipped with systems such as:

- Front Kneeling + Front High-Buoy;
- Front Kneeling + Full High-Buoy;
- Front Kneeling + Front High-Buoy and Low-Buoy Combination;
- Front Kneeling + Full High-Buoy and Low-Buoy Combination;

For a description of each of these systems, refer to the appropriate heading in this section

2 FRONT I-BEAM AXLE SUSPENSION

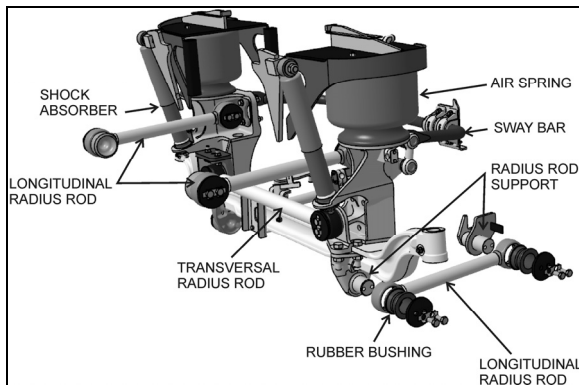

FIGURE 1: FRONT I-BEAM AXLE SUSPENSION 16105

2.1 AIR SPRINGS

The air springs are made from a special compound rubber molded to the proper contour and dimensions. The entire vertical load of the vehicle is supported by these springs. Each of the three axles is provided with air springs that are attached to the subframe and to the axles .

2.1.1 Inspection

1. Check operation of bellows.
2. Visually inspect bellows for evidence of cracks, punctures, deterioration, or chafing. Replace the bellows if any damage is evident.
3. With the primary air system at normal operating pressure (95 - 125 psi (655 - 860 kPa)), coat all suspension air line

connections and bellows mounting areas with a water and soap solution. Bubbles will indicate an air leak, and none is permissible. Repair or replace defective parts.

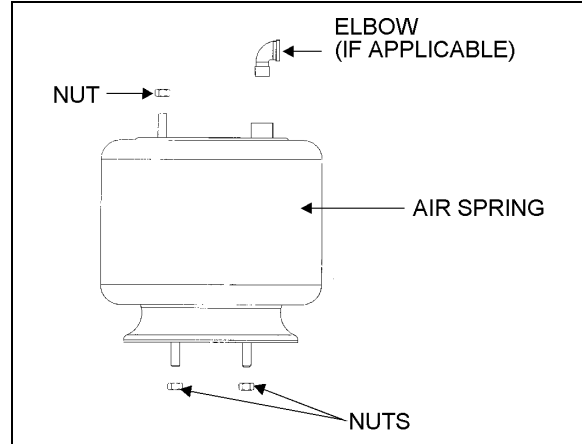

FIGURE 2: AIR SPRING 16052

NOTE

If air spring is removed from vehicle, bellows can be lightly inflated and submerged in water to detect any leakage. If any leakage is detected, replace bellows.



WARNING

To prevent personal injury, do not apply more than 10 psi (69 kPa) of air pressure to the uninstalled air spring.

2.1.2 Removal

NOTE

Front suspension air springs can be removed without removing the entire axle assembly.

1. Safely support vehicle at the recommended body jacking points. To gain access to a given air spring, the corresponding wheel can be removed as follows:
 - a) Jack vehicle until the tire clears the ground, and place safety supports underneath body.



CAUTION

Only the recommended jacking points must be used as outlined in Section 18, "Body".

- b) Support the axle with a suitable hydraulic floor jack at the recommended jacking points.

Section 16: SUSPENSION

- c) Remove wheel.
2. Exhaust compressed air from accessory air tank by opening drain cock under reservoir.
3. Disconnect the height control valve link and pull down the overtravel lever to ensure all air is exhausted from air springs.

NOTE

While performing this step, do not change the height control valve overtravel lever adjustment.

4. Disconnect air line from air spring, remove elbow (if applicable), and cover both the line end and fitting to prevent the entry of foreign matter.
5. Remove the air spring upper nut, and then the two lower nuts. Remove air spring.

2.1.3 Installation

1. Compress air spring as necessary, then aligning studs with their holes, position air spring between both the lower and upper supports. Thread the lower nuts and the small upper nut a few turns.

NOTE

To facilitate air spring installation, compress it manually then put a piece of tape over the air line threaded fitting. This prevents air from getting back into the bag and keeps it compressed, thus enabling to place the bag in between the mounting plates and greatly easing installation.

2. Tighten and torque the lower stud nuts, and then the upper one according to Torque Table under heading Torque Specifications.
3. Thread the remaining upper nut (large nut) and tighten according to Torque Table under heading Torque Specifications in this section.
4. Install elbow (if applicable), then connect air line.
5. Connect the height control valve link.
6. Build up air pressure in system.

NOTE

To accelerate this operation, air reservoirs can be filled from an exterior air supply connected to the accessory tank fill valve or to the emergency fill valve.

7. Check operation of bellows and with the primary air system at normal operating

pressure (95 – 125 psi (655 – 860 kPa)), coat the air line connections and air spring mounting areas with a water and soap solution. Bubbles will indicate an air leak, and none is permissible. Repair or replace defective parts.

8. Reinstall wheel.
9. Remove the hydraulic floor jack from under the axle, then lower vehicle to ground.

2.2 SHOCK ABSORBERS

Double-action, telescoping-type shock absorbers ensure a smooth ride and enhance vehicle stability on the road. All shock absorbers are eye-type mountings. The front and tag axles are each provided with two shock absorbers while the drive axle is provided with four of them (Fig. 1 & 2).

Shock absorbers are non-adjustable and non-repairable. Maintenance requirements involve replacement of the rubber mounting bushings, and tightening of all shock absorber pins according to Torque Table under heading Torque Specifications when shock absorber replacement occurs. If a shock absorber becomes inoperative, complete unit must be replaced.



CAUTION

When a shock absorber is found defective, always replace with a new set on affected axle, except if there has been a recent replacement of one unit. The following method will help in determining if both shock absorbers on the same axle have to be replaced.

2.2.1 Inspection

Loosen lower mounting of both shocks, and then carefully attempt to raise and lower the bottom portion of each shock. Note the rate of effort for distance of travel. Replace both shocks if a definite differential rate is found.

The shock must be bench checked in an upright, vertical position. If checked in any other position, air will enter the cylinder tube and make the shock absorber appear defective.

Proceed as follows to check shock absorbers:

1. With the shock absorber in a vertical position (top end up), clamp the bottom mount in a vise.

**CAUTION**

Do not clamp the reservoir tube or the dust tube.

2. Rotate the dust tube. Notice any binding condition (may be compared with new unit). Binding condition indicates a scored rod. Units with scored rods should be replaced.
3. Fully extend shocks and check for leaks in the seal cover area. Shock fluid is a very thin hydraulic fluid that has a characteristic odor and dark brown tint. A slight trace of shock fluid around the seal cover area is not a cause for replacement (Refer to the SACHS document "Guideline to Evaluate Warranty Claims" annexed at the end of this section before replacing a shock). The shock seal is designed to permit a very slight seepage to lubricate the rod. Units that leak should be replaced.
4. Visually check shock for dents that could cause the shock to bind. Also, check for a bent rod.
5. Extend and collapse shock several times to determine that it has control (resistance) in both rebound and compression.
6. Visually inspect the shock mountings and vehicle mounting for:
 - a. Broken mounts;
 - b. Extreme bushing wear;
 - c. Shifted bushing or sleeve;
 - d. Deep cracks in bushing material (shallow surface cracks are normal);
 - e. Loose shock absorber pins;
 - f. Presence of convex washers, and their position relative to the rubber bushing.

2.2.2 Removal

1. Remove nuts and washers from shock absorbers on upper and lower mounting pins, taking care to identify the inner and outer washers to ease reinstallation. Refer to figure 5 for details.
2. Remove the shock absorber assembly from pins.
3. Remove the two inner bushings from the shock absorber and discard them.

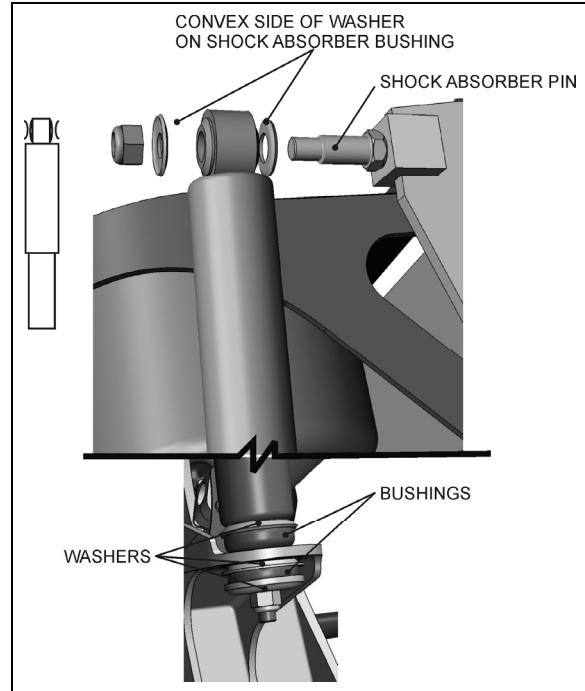
**FIGURE 3: SHOCK ABSORBER**

16008

2.2.3 Installation

1. Ensure that the shock absorber mounting pins are tight and that the threads are not stripped.
2. Install new rubber mounting bushings on shock absorbers (upper and lower).
3. Place the inner washers (with washer convex side facing the shock absorber rubber bushing) on each shock absorber pin (Fig. 4).

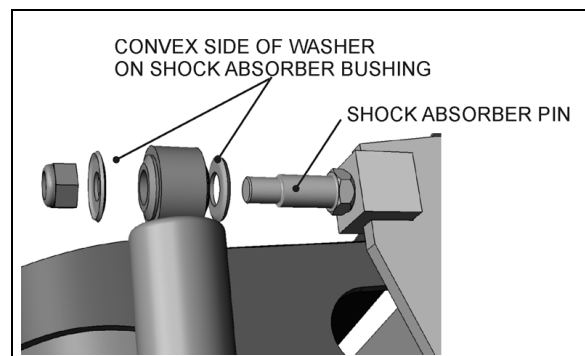
**FIGURE 4: TYPICAL SHOCK ABSORBER SETUP**

16009

4. Install the shock absorber eyes over the mounting pins, then the outer washers (with washer convex side facing the shock absorber rubber bushing) on each shock absorber extremity.

Section 16: SUSPENSION

NOTE

If shock absorber pins are removed, they must be reinstalled using "Loctite" (see "Parts Specifications" in this section).

5. Place the lower and upper mounting pin stud nuts and torque according to paragraph 13 Torque Specifications.

2.3 RADIUS RODS

Radius rods are used to secure the axles in the proper transversal and longitudinal positions. Four radius rods are provided on the front I-beam axle suspension (three longitudinal and one transversal). Refer to figures 1 and 5 for details. These rods transmit both braking and driving forces from the axles to the vehicle body.

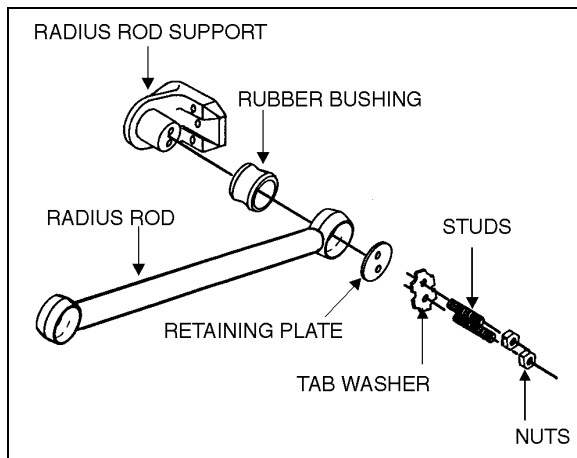

FIGURE 5: TYPICAL RADIUS ROD SETUP 16010

2.3.1 Inspection

The following instructions apply to all radius rods used on this vehicle:

1. Clean all parts thoroughly.
2. Inspect radius rods for distortion and cracks. We recommend the "Magnaflux" process to detect cracks in the radius rod. Any damaged part should be replaced with a new one.

NOTE

New bushings should be used when rods are replaced.

3. The radius rod bushings should be checked periodically for signs of shearing, deterioration, or damage. Any defective part should be replaced with a new one.

2.3.2 Radius Rod Removal

1. Flatten the tab washer which secures the two retaining nuts (or bolts), and then unscrew the nuts (or bolts) at each extremity of the radius rod (Fig. 5).
2. Remove the tab washer and the retaining plates and radius rod ends from anchor pins, and then remove the radius rod.

2.3.3 Bushing removal

1. Safely support the radius rod as shown in figure 6.

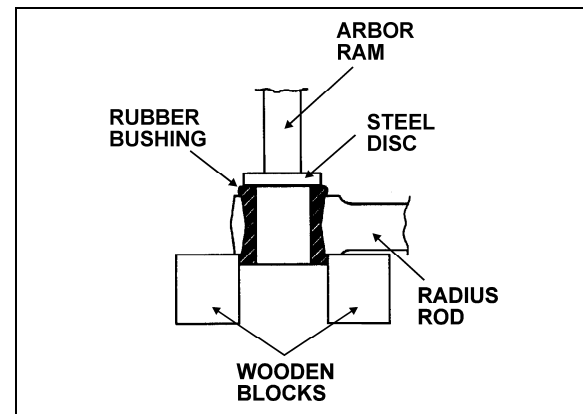

FIGURE 6: RADIUS ROD BUSHING REMOVAL 16011

2. Place a flat steel disc, slightly smaller than the outside diameter of the bushing (Fig. 8).
3. Using an arbor press or a suitable driving tool, press or drive the old bushing out of the rod and discard the bushing.

2.3.4 Bushing installation

1. Lightly spray the inner and outer surfaces of radius rod bushing with water.



CAUTION

No lubricant whatsoever is to be used on the rubber bushing.

2. Safely support the radius rod, and place new bushing on top of the radius rod end (Fig. 7).
3. Place a block of wood on top of bushing and press on it manually.
4. If necessary, use an arbor press or a suitable driving tool. Press or drive the bushing into the radius rod end until it extends equally on both sides of the rod.
5. It is also possible to proceed differently. Place radius rod bushing on a plane

surface. Spray a light coat of water on the inner and outer surfaces of radius rod bushing.

6. Take radius rod, align the bushing. Tap radius rod on bushing until latter is positioned correctly.

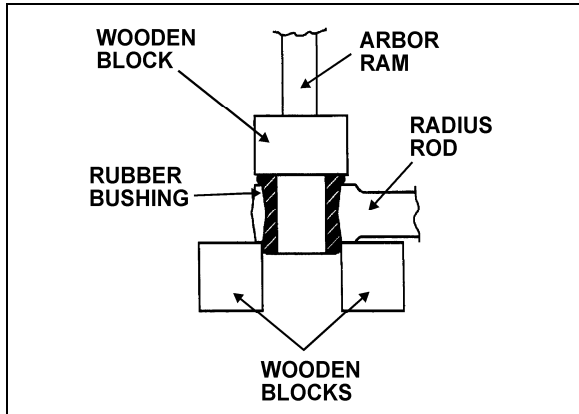



FIGURE 7: RADIUS ROD BUSHING INSTALLATION 16012

2.3.5 Radius Rod Installation

1. Lightly spray the radius rod support with water. Place the radius rod end over the radius rod support (Fig. 8).
2. Put 3 drops of Loctite243 (Prevost #680038) in each radius rod support tapped blind holes and a line of Loctite on bolts.
3. Position the retaining plate. Install the tab washer and nuts (or bolts).

	CAUTION
Always use new tab washers at installation.	

4. Tighten the nuts (or bolts) lightly, and repeat at the other end.
5. Refer to heading "SUSPENSION HEIGHT ADJUSTMENT" later in this section, and set the vehicle to normal ride height.
6. With the vehicle at normal ride height, all radius rod anchor pin nuts or bolts according to Torque Table.

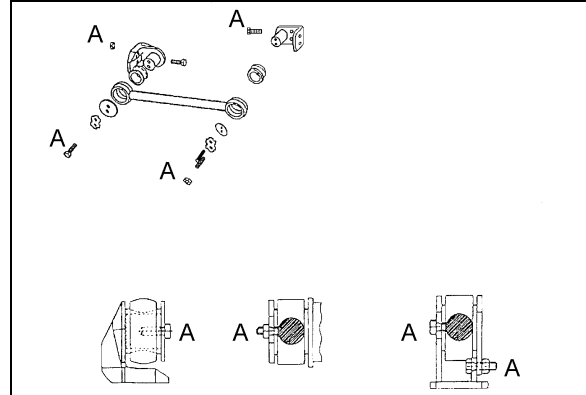



FIGURE 8: RADIUS ROD INSTALLATION 16028

	CAUTION
<p>It is extremely important upon reconnection of the rods that the proper clearance height between the axle and body be maintained. Otherwise, the rubber bushings in radius rod ends will become preloaded, thus reducing their life span.</p>	

2.4 SWAY BAR

A sway bar is provided on the front axle to increase vehicle stability. It controls lateral motion (swaying movement) of vehicle (Fig. 9).

2.4.1 Removal

1. Disconnect the two links from sway bar.
2. Safely support the sway bar. Unbolt the four bushing collars from subframe.
3. Remove sway bar.

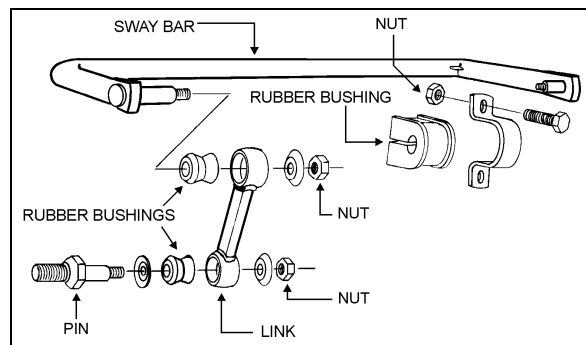

FIGURE 9: FRONT & DRIVE AXLE SWAY BAR

NOTE
<p>Sway bar bushings are slit to ease their removal.</p>

2.4.2 Installation

1. Loosely install the sway bar.

Section 16: SUSPENSION

2. Tighten the eight bushing collar nuts according to Torque Table under heading Torque Specifications (Fig. 9).
3. Tighten sway bar link upper nuts and lower nuts according to Torque Table under heading Torque Specifications (Fig. 9).

2.5 TORQUE SPECIFICATIONS - FRONT I-BEAM AXLE SUSPENSION AND STEERING

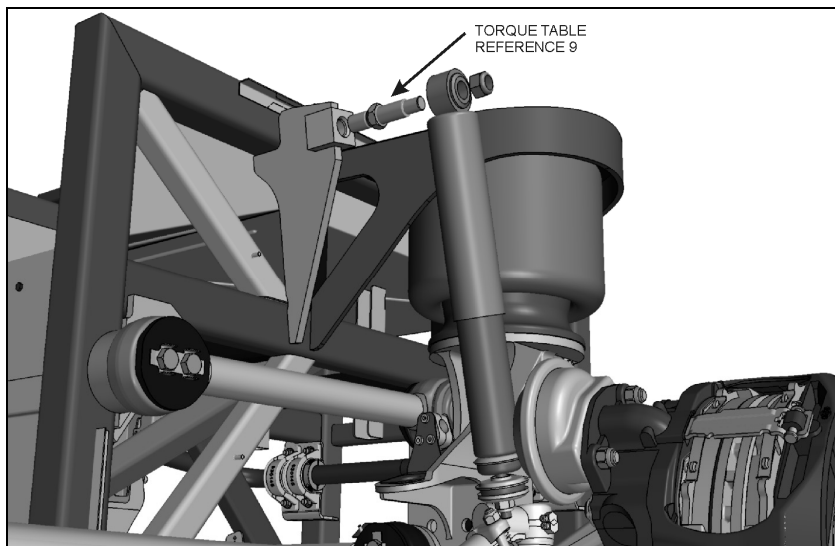
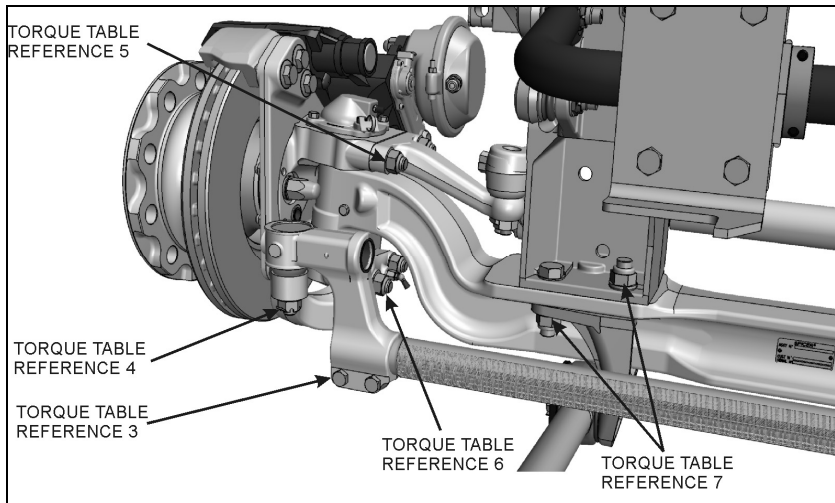
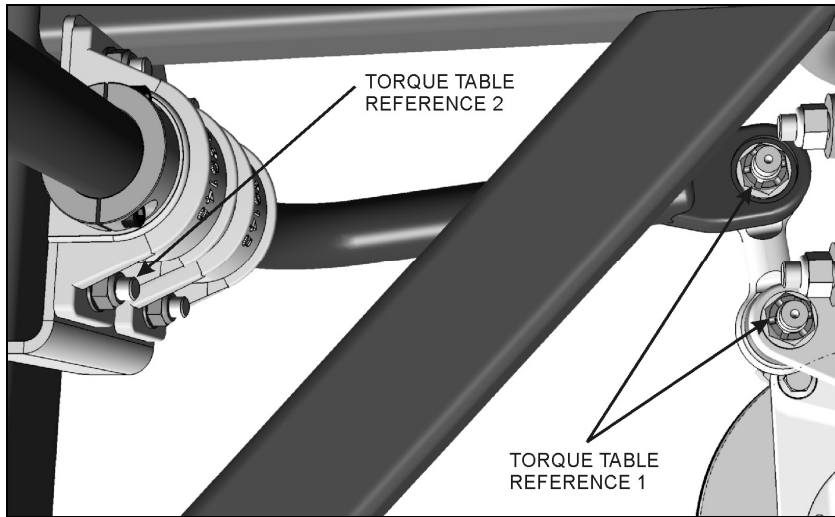

Section 16: SUSPENSION

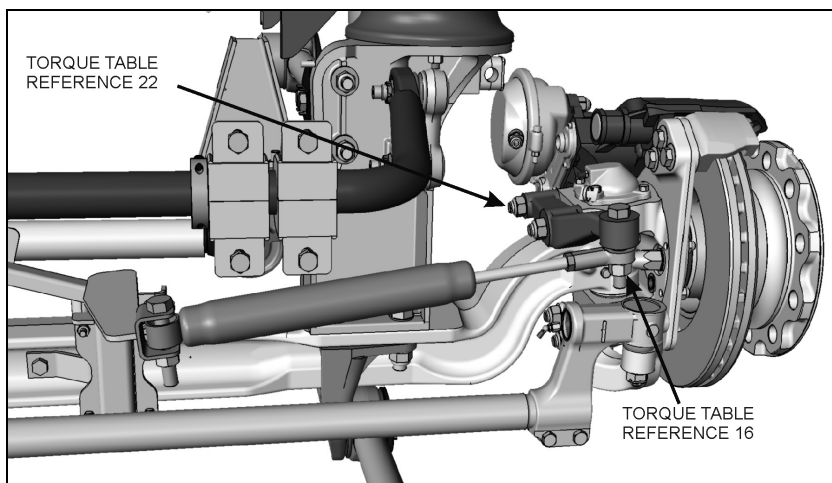
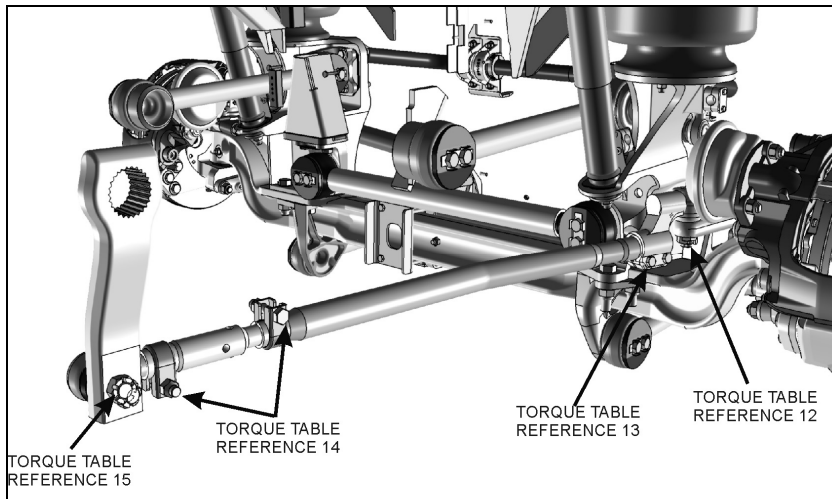
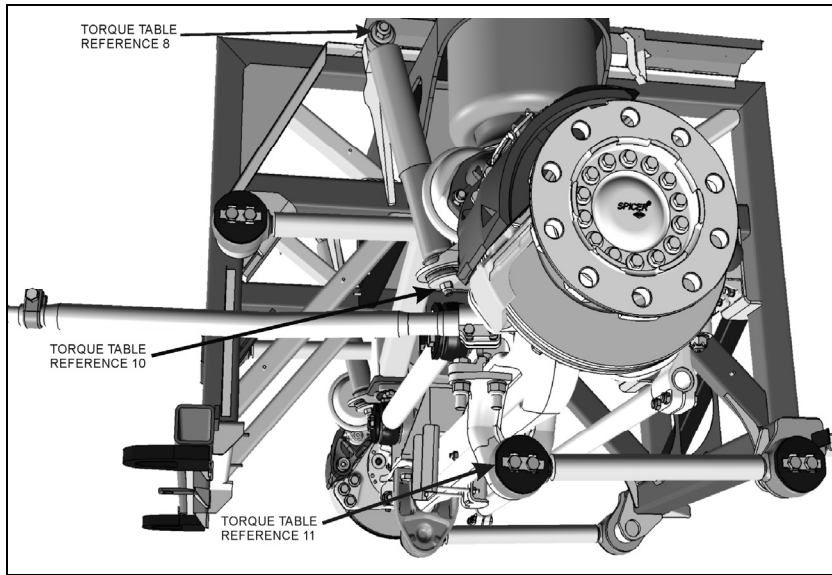

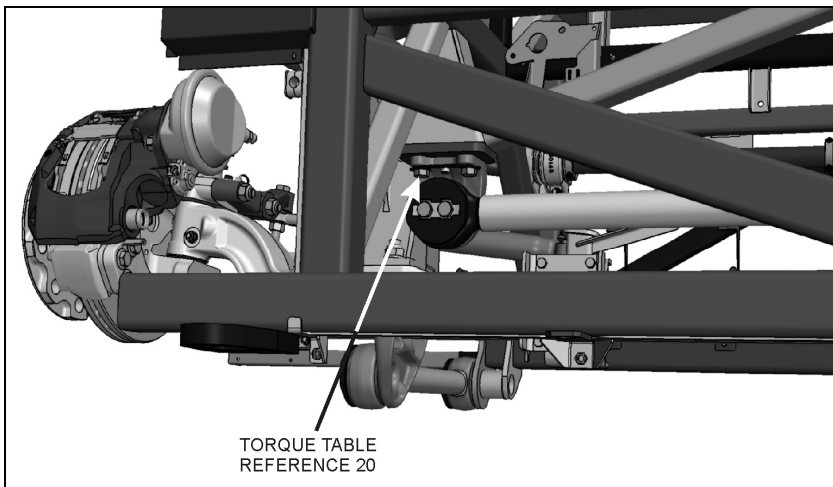
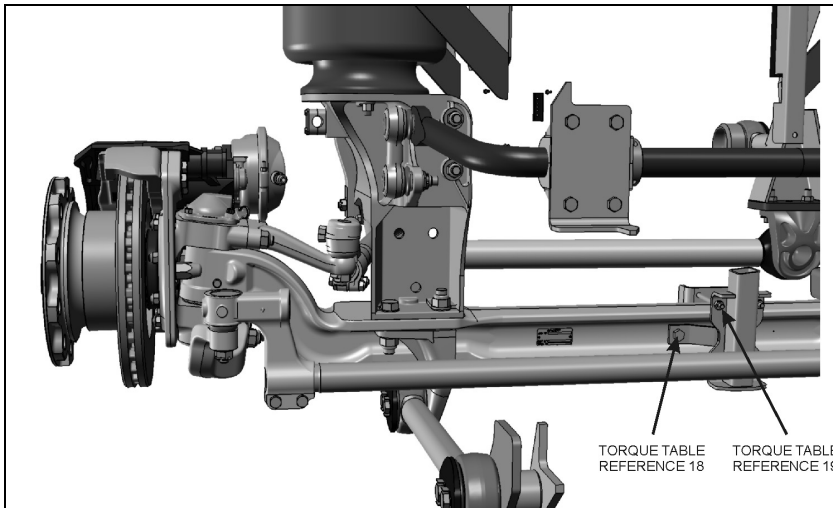
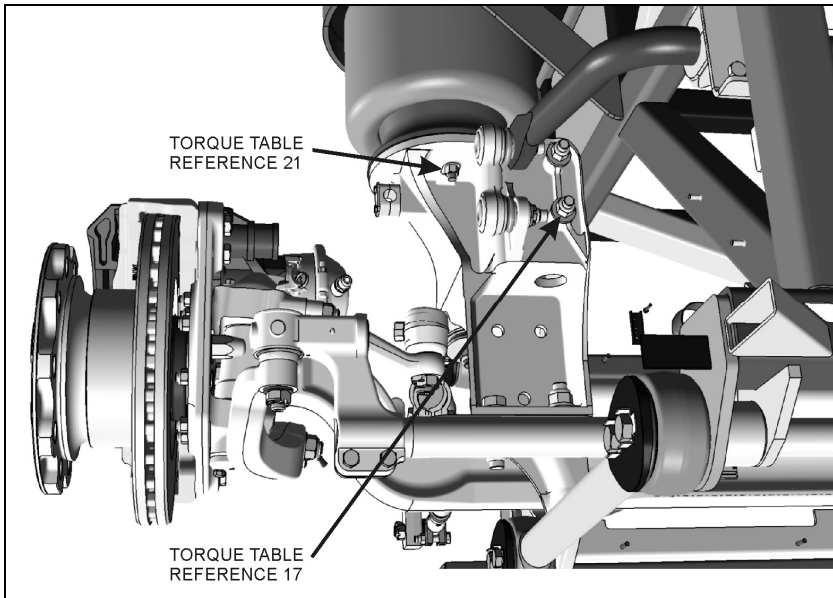

Section 16: SUSPENSION

The following table lists the tightening torques which do require a specific torque value. When no torque specifications are indicated, use the Standard Torque Specifications table found in Section 00: General Information of the Maintenance Manual.

SPECIFIC TORQUE TABLE 1 – FRONT I-BEAM AXLE SUSPENSION & STEERING				
DESCRIPTION	QTY	REFERENCE	TORQUE DRY (lbf-ft / Nm) <i>threads must be free of oil or other lubricant</i>	
SWAY BAR LINK UPPER AND LOWER NUTS	4	1	165-200	224-271
SWAY BAR BUSHING COLLAR (FRONT SUSPENSION)	8	2	80-100	108-136
TIE ROD END CLAMP PINCH BOLT	4	3	65-75	88-102
TIE ROD END BALL STUD NUT	2	4	150-200	203-271
STEERING ARM STUD NUT	2	5	520-575	705-780
TIE ROD ARM STUD NUT	4	6	520-575	705-780
I-BEAM AXLE MOUNT	8	7	230-280	311-378
SHOCK ABSORBER UPPER MOUNTING PIN STUD NUT	2	8	99-121	134-164
SHOCK ABSORBER PIN	2	9	350-400	475-545
SHOCK ABSORBER LOWER MOUNTING PIN NUT	2	10	60-75	81-102
RADIUS ROD RETAINING BOLT	20	11	140-155	190-210
DRAG LINK BALL STUD NUT	1	12	150-200	203-271
DRAG LINK CLAMP BOLT NUT	2	13	65-75	88-102
DRAG LINK SOCKET END CLAMP PINCH BOLT	2	14	50-60	68-81
DRAG LINK TO PITMAN ARM STUD NUT	1	15	150-200	203-271
STEERING DAMPER	2	16	100-120	135-160
RADIUS ROD SUPPORT	4	17	228-252	309-342
STEERING DAMPER BRACKET	1	18	39-45	53-61
STEERING DAMPER BRACKET	4	19	30-36	41-49
RADIUS ROD SUPPORT	2	20	200-220	271-298
AIR SPRING NUT	6	21	31-38	42-52
STEERING DAMPER ARM NUTS	2	22	285-315	386-427

3 INDEPENDENT FRONT SUSPENSION (IFS)

This section contains information and specifications unique to the independent front suspension (IFS), including suspension and steering.

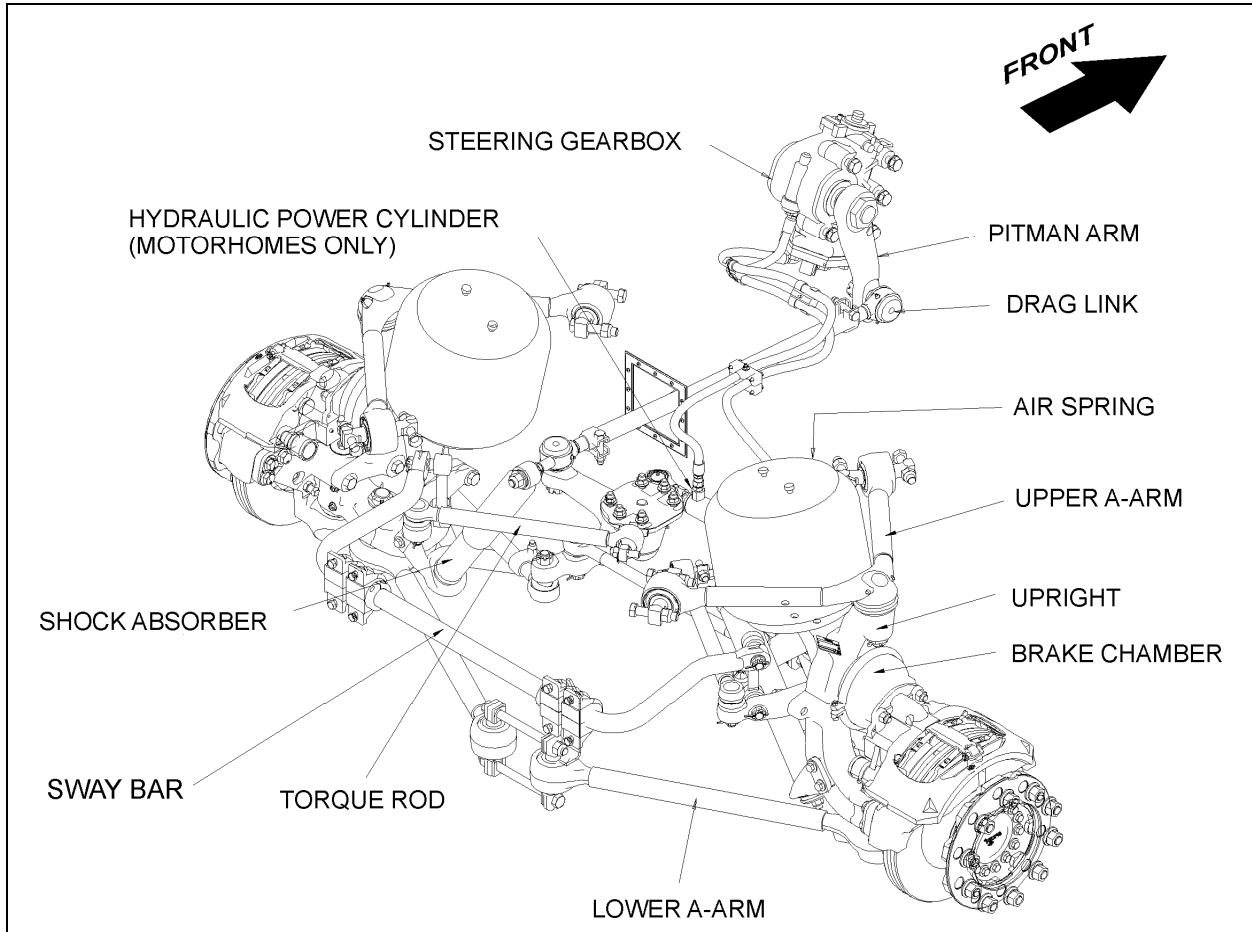

FIGURE 10: INDEPENDENT FRONT SUSPENSION

16124

3.1 STEERING LINKAGE

Turning motion of the steering wheel is transferred by the steering gear and steering linkage to the steering arms at the right and left front wheels. The steering linkage consists of tie rods connected to the bell crank and the steering arm at the left side of the coach, and to the idler arm and steering arm at the right side of the coach. The bell crank and idler arm are connected by a relay rod. A drag link connected to the bell crank and the pitman arm, which is mounted to the steering gear, transfers the turning motion of the steering wheel to the steering arms. On VIP series, a hydraulic power cylinder provides an added source of assistance

and being connected to the R.H. wheel, makes it such that the total steering forces are produced with minimal stress on mechanical linkages (Fig. 10).

Lower and upper A-arms are widely spaced. They are mounted on ball joints. Torque rods prevent rotation of the uprights around the lower and upper ball joints.

If the steering linkage is bent, twisted or worn, steering action of the coach will be seriously affected. Any time steering linkage components are replaced or adjusted, steering geometry and front wheel alignment must be checked as explained in this section.

Section 16: SUSPENSION

Turning Angle

The maximum turning angle is set mechanically through the two steering stop screws installed on the swivel assembly. The turning angle mechanical stop is factory adjusted to accommodate the chassis design, and therefore, does not require adjustment on new vehicles.

However, turning angle should be checked and adjusted hydraulically, if necessary, any time a component of the steering system is repaired, disassembled or adjusted.

Turning angles are as follows:

Exterior: $49.5^\circ \pm 0.5^\circ$

Interior: $58^\circ \pm 0.5^\circ$

Before checking the turning angle, be sure the front end is properly aligned as described under paragraph FRONT END ALIGNMENT in this section.

To check steering maximum turning angle, proceed with the following method:

1. Lift the vehicle using the axles lifting points. Suspension must be at normal ride height.
2. Check if front tires rub against the frame or if the steering gear has been serviced.
3. While performing a full left and right turn, check for proper position of the tie rod end clamp bolt and nut and drag link end clamps in order to avoid clamps interfering with close parts. Refer to figure 11 for location and positioning of clamp bolts and nuts. Reposition if required.



CAUTION

Clamp bolts are either in a vertical or horizontal position. Reinstall clamp bolts exactly as they were before removal as they might interfere with other components.

NOTE

Prior to hydraulic steering limiter adjustment, verify vehicle wheel alignment, and ensure that oil level is adequate and that air bleeding is done.

4. If necessary readjust hydraulic steering limiter. Refer to these manuals annexed to the Maintenance Manual, Section 14: STEERING:

- ZF-SERVOCOM Types 8090-8099 Single and Dual-Circuit Versions Repair Manual.
- ZF-SERVOCOM Types 8090, 8095, 8097 and 8098 Design, Operation, Maintenance, Inspection.

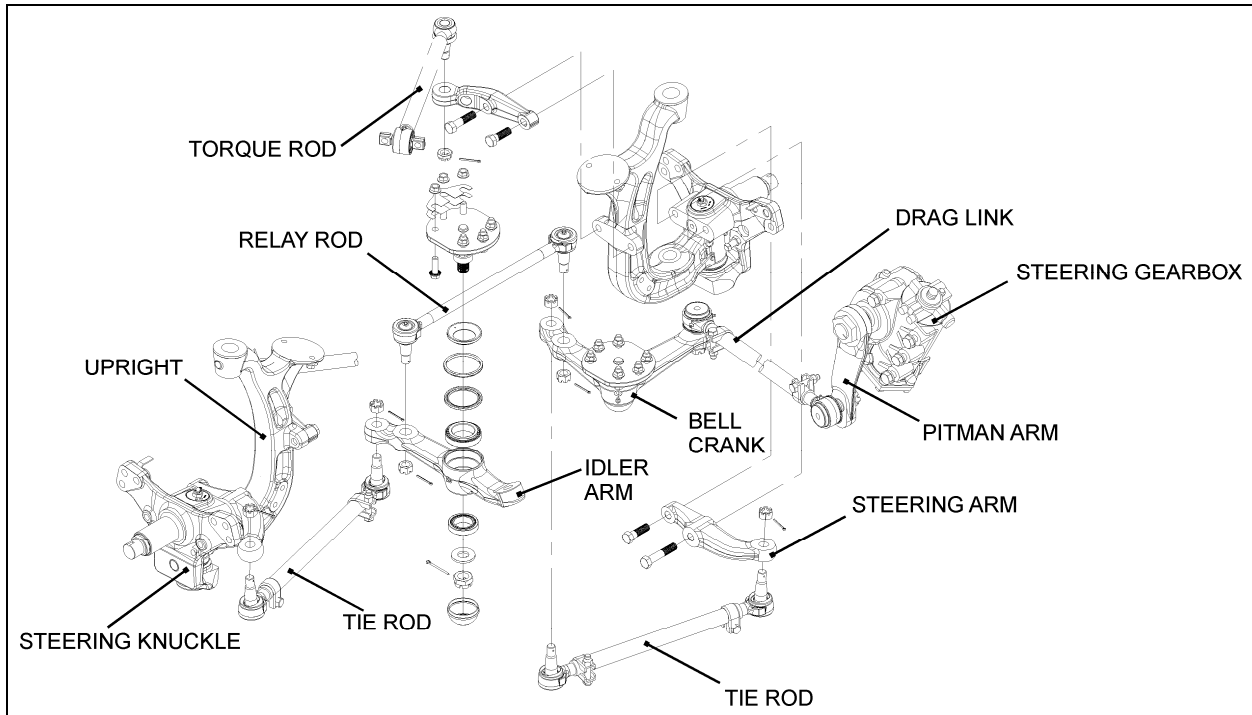

FIGURE 11: IFS STEERING LINKAGE OVERVIEW

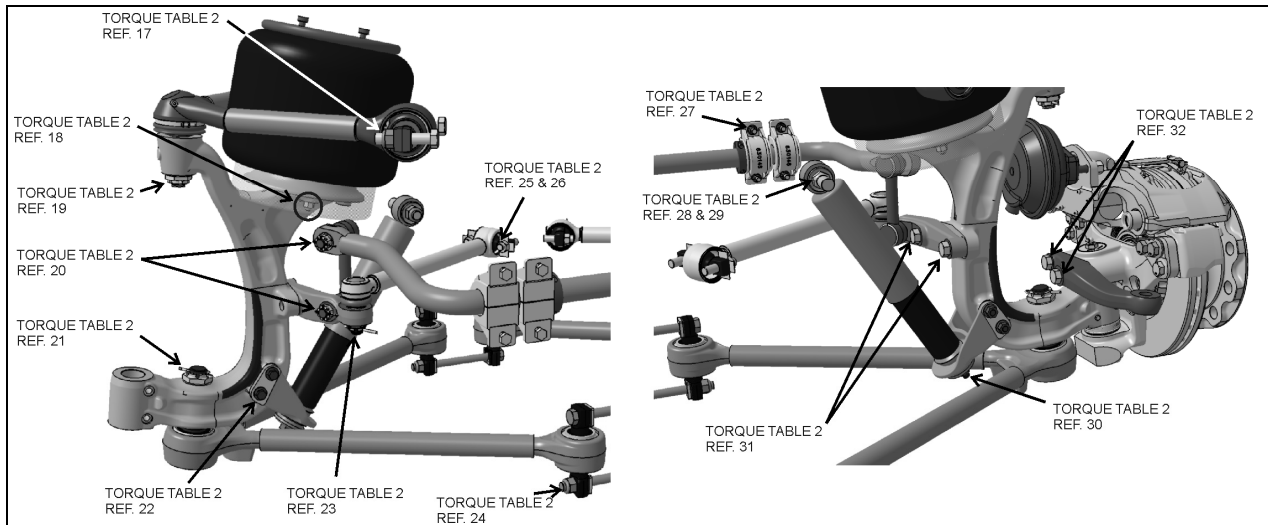

FIGURE 12: IFS - SUSPENSION COMPONENTS

Section 16: SUSPENSION

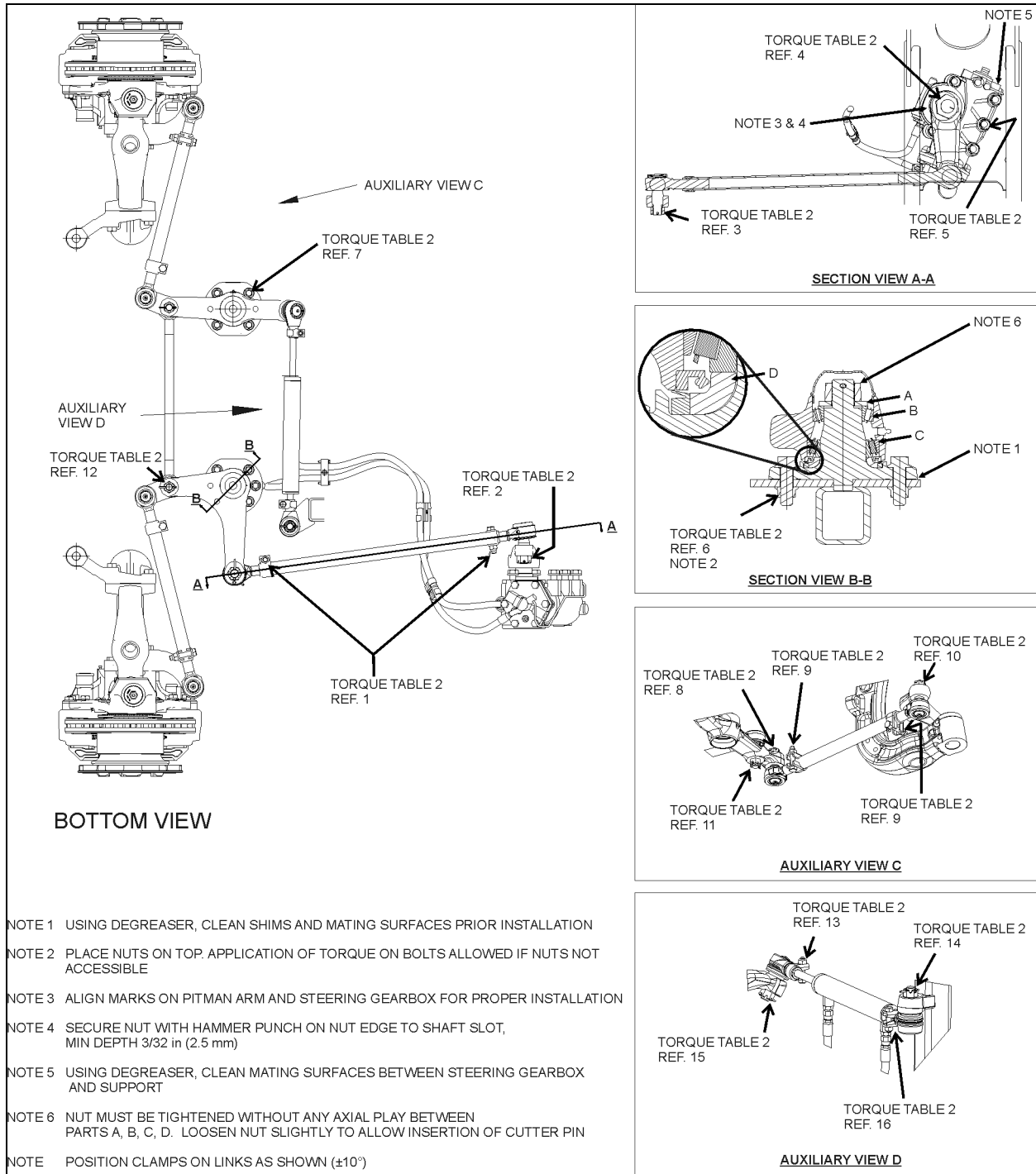

FIGURE 13: IFS STEERING LINKAGE

The following table lists the tightening torques which do require a specific torque value. When no torque specifications are indicated, use the Standard Torque Specifications table found in Section 00: General Information of the Maintenance Manual.

SPECIFIC TORQUE TABLE 2 – INDEPENDENT FRONT SUSPENSION				
DESCRIPTION	QTY	REFERENCE	TORQUE DRY	
			<i>threads must be free of oil or other lubricant</i>	
			<i>lbf-ft</i>	<i>Nm</i>
<i>Drag link socket end clamp pinch bolt</i>	2	1	50-60	68-81
<i>Drag link ball stud nut to pitman arm</i>	1	2	245-270	332-366
<i>Drag link ball stud nut to bell crank</i>	1	3	245-270	332-366
<i>Pitman arm to steering gear fixing nut</i>	1	4	470-570	637-772
<i>Steering gearbox to mounting bracket bolt</i>	5	5	365-405	495-549
<i>Bell crank spindle mounting nut</i>	6	6	208-254	282-344
<i>Idler arm spindle mounting nut</i>	6	7	208-254	282-344
<i>Tie rod end ball stud nut to idler arm or bell crank</i>	2	8	150-200	203-271
<i>Tie rod end clamp pinch bolt</i>	4	9	50-60	68-81
<i>Tie rod end ball stud nut to steering arm stud *</i>	2	10	150-200	203-271
<i>Relay rod stud nut to idler arm *</i>	1	11	150-200	203-271
<i>Relay rod stud nut to bell crank *</i>	1	12	150-200	203-271
<i>Hydraulic power cylinder end clamp pinch bolt</i>	1	13	50-60	68-81
<i>Hydraulic power cylinder to bracket stud nut*</i>	1	14	150-200	203-271
<i>Hydraulic power cylinder to idler arm stud nut*</i>	1	15	150-200	203-271
<i>Hydraulic power cylinder end clamp pinch bolt</i>	1	16	50-60	68-81
<i>Upper a-arm ball joint</i>	4	17	230-255	312- 346
<i>Air spring lower stud nut (6 air springs)</i>	2	18	31-38	42- 51
<i>Upper a-arm central ball joint (castellated hex nut)*</i>	1	19	210-250	284-339
<i>Sway bar link, upper and lower ball stud nuts (front suspension)*</i>	2	20	165-200	224-271
<i>Lower a-arm central ball joint (castellated nut)*</i>	1	21	490-540	664- 732
<i>Shock absorber support</i>	4	22	145-165	196-224
<i>Torque Rod ball stud nut*</i>	1	23	150-200	203-271
<i>Lower a-arm ball joint</i>	4	24	270-300	366-407
<i>Torque rod, nut</i>	2	25	140-155	190-210
<i>Torque rod, stud</i>	2	26	90-110	122-150
<i>Sway bar bushing collar (front suspension)</i>	8	27	80-100	108-136
<i>Shock absorber mounting stud nut</i>	1	28	99-121	134-164
<i>Shock absorber mounting stud</i>	1	29	350-400	475-545
<i>Shock absorber lower mounting pin nut</i>	1	30	60-75	81-102
<i>Torque rod lever bolt (M20-2.5)</i>	2	31	520-575	705-780
<i>Steering arm bolt (M22-2.5)</i>	2	32	642-708	870-960

* Tighten nut to specified torque, then advance to next aligning cotter pin slot and install a new cotter pin.

Section 16: SUSPENSION

3.2 STEERING LINKAGE INSTALLATION SEQUENCE

NOTE

Whenever a steering linkage component has been removed and replaced, check steering geometry and front end alignment as directed in this Section. Check to insure that all stud nuts and mounting bolts and nuts have been tightened to prescribed torque.

1. Position front wheels in straight ahead position.
2. First, align the steering gearbox input shaft marks.
3. Afterwards, the pitman arm should be adjusted with output shaft and pitman arm reference marks aligned (for proper tightening torque, refer to Torque Table 2).

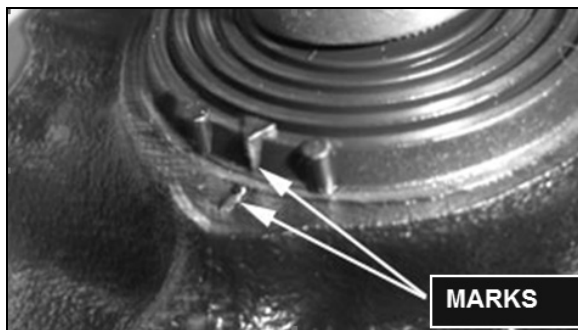

FIGURE 14: STEERING GEARBOX INPUT SHAFT MARKS

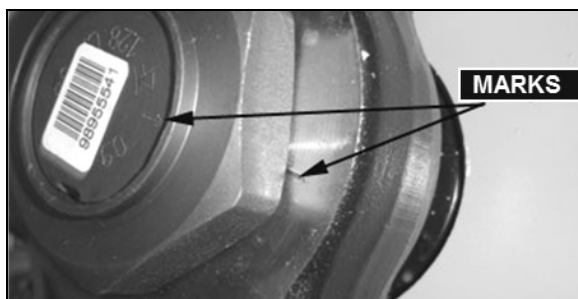

FIGURE 15: STEERING GEARBOX OUTPUT SHAFT AND PITMAN ARM MARKS ALIGNED

4. Locate centerline of vehicle then install relay rod in boss at steering bell crank and idler arm. Align center of relay rod with centerline of vehicle.
5. Install drag link to pitman arm and adjust opposite end of drag link to fit ball stud hole in bell crank.
6. Install tie rods then adjust toe-in as described in "Front End Alignment" in this section (for proper tightening torque, refer to Torque Table 2).

3.3 PITMAN ARM

3.3.1 Removal

1. Remove cotter pin, nut and washer from drag link ball stud at pitman arm.
2. Disconnect drag link from pitman arm, using jaw style pullers (pressure screw type).



WARNING

Always wear approved eye protection when operating pullers.



CAUTION

Do not drive pitman arm on or off sector gear shaft as this can damage the steering gear.



CAUTION

Heating of components to aid in disassembly is not allowed because it has a detrimental effect on axle components and steering linkage.

3. Remove pitman arm fixing nut.
4. Check the radial position of the pitman arm in relation to the sector shaft prior removal of pitman arm.
5. Locate the reference marks to the arm and shaft to ensure correct alignment at reassembly.
6. Use a puller to remove pitman arm.

3.3.2 Installation

1. Position pitman arm on sector gear shaft with reference marks aligned.
2. Install fixing nut. Tighten nut (dry) as per Torque Table 2.

NOTE

Use a new nut if the previously removed nut was punched.



CAUTION

Lock nut with sector shaft using a punch mark into the groove, minimum depth 3/32 inch (2.5mm) (see figure 16).

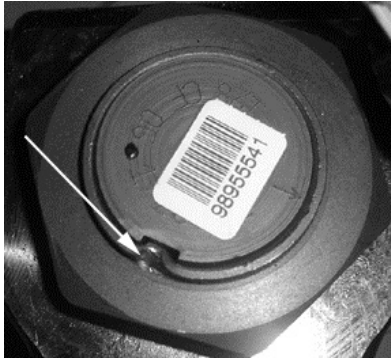

FIGURE 16: FIXING NUT PUNCH MARK

16098

3. Connect drag link to pitman arm. Ball stud and taper bore must be clean and free of grease. Install washers. Tighten nut (dry) as per Torque Table 2. Advance nut to next alignment cotter pin slot and install a new cotter pin.

3.4 DRAG LINK

Drag link assembly consists of three parts; a drag link and two end assemblies. Both end assemblies are identical and they are retained on the drag link with a clamp bolt and nut.

Stud nuts at the pitman arm and bell crank ends of the drag link must be kept tight or hole at ball stud end of drag link and hole in pitman arm may become enlarged as a result of excessive looseness. Subsequent tightening of stud nuts may draw studs too far into holes and dust cover parts may become damaged which can result in component failure.

Drag link end sockets are equipped with lubrication fittings and should be lubricated as directed in "Lubrication Fittings" in this section.

NOTE

The drag link nominal length is 41 17/32 inch (1055 mm) measured from the center of one ball socket to the other. Nominal length is given only for preliminary adjustment.

3.4.1 Adjustment

It should not be necessary to alter the length of the drag link except when a new link is installed or when removable end assembly has been replaced. If drag link adjustment is necessary, proceed as follows:

1. Position front wheels in straight ahead position.

2. Center steering gear as previously explained in "Steering Linkage Adjustment".
3. Remove cotter pin, nut and stud from drag link at bell crank. Locate centerline of vehicle and center of relay rod. With center of relay rod aligned with centerline of vehicle, loosen clamp bolt at socket end (bell crank end) of drag link and adjust length of socket end assembly to fit in boss of bell crank.

NOTE

Do not change position of pitman arm.

5. Install stud with nut and torque to proper torque. Ball stud and taper bore must be clean and free of grease. Align nut with cotter pin slot (tighten) and install a new cotter pin.
6. Torque mounting clamp bolt nut to prescribed torque, then test the adjustment. Front wheels should turn from full right to full left end of stroke without noticeable binding at drag link ends.



CAUTION

Clamp bolts are either in a vertical or horizontal position. Reinstall clamp bolts exactly as they were before removal as they might interfere with other components.

3.5 BELL CRANK AND IDLER ARM

Bell crank and idler arm are equipped with one lubrication fitting and should be lubricated as directed in "Lubrication Fittings" in this section.

3.5.1 Bell Crank or Idler Arm Removal

NOTE

Use a piece of wire to support loosen end of relay rod and tie rod in order to prevent placing an excessive load on opposite socket end.

Bell crank: Disconnect drag link, tie rod and relay rod from bell crank by removing cotter pins and nuts from ball studs. Separate socket assemblies from the bell crank.

Idler arm: Remove cotter pins and nuts from ball studs connecting relay rod, tie rod and hydraulic power cylinder to idler arm. Separate socket assemblies from idler arm.

Section 16: SUSPENSION

Remove nuts from bolts attaching bell crank or idler arm mounting spindle to vehicle subframe. Remove bell crank or idler arm mounting spindle.

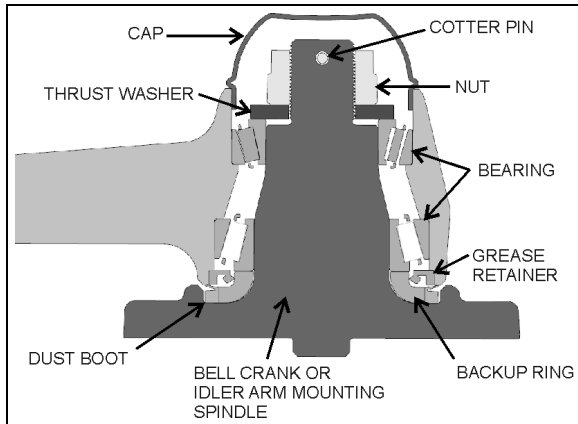

FIGURE 17: BELL CRANK OR IDLER ARM HUB

3.5.2 Bell crank or Idler Arm Hub Disassembly

1. Remove adjacent link assemblies from bell crank or idler arm as previously described.
2. Remove the cap (fig. 17).
3. Remove the cotter pin, nut and thrust washer. Remove bearings, grease retainer, backup ring and the bell crank or idler arm from its mounting spindle (fig. 17).

3.5.3 Bell Crank or Idler Arm Hub Reassembly

NOTE

For bearing installation use tool Prevost # 110684.

NOTE



Install grease retainer according to figure 18. Grease must be able to exit the bell crank or idler arm mechanism. For grease retainer installation use tool Prevost # 110683.

NOTE

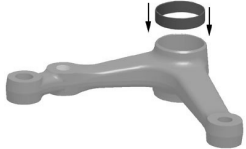
Apply grease on bearings before installation.

1. Clean parts thoroughly with degreaser.
2. Insert the small bearing outer race into appropriate bore (done on a press). 
3. Insert the large bearing outer race into

appropriate bore (done on a press).

4. Insert the large bearing into outer race and then, add grease retainer. 
5. Apply good quality lithium grease (#680752) on backup ring and dust boot. 
6. Install backup ring and dust boot on bell crank or idler arm spindle.
7. Apply a thin layer of grease on spindle shaft.
8. Install bell crank or idler arm onto its mounting spindle, while holding the bell crank or idler arm, slide on the small bearing assembly, thrust washer and secure using nut. 
9. Tighten nut to 130 lbf-ft.
10. Rotate assembly 3 turns in each direction.

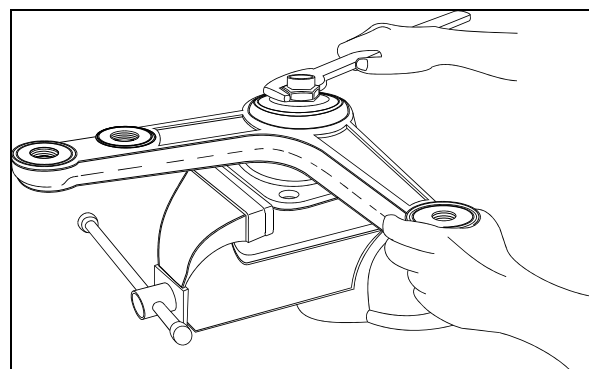

FIGURE 18: BELL CRANK

16044

11. Unscrew nut until bell crank or idler arm starts to turn with the application of 1 to 3 lbs force load as shown on figure 19.
12. Check for loose bearings by applying an up and down load on bell crank or idler lever. The lever is not supposed to move in the vertical axis direction.

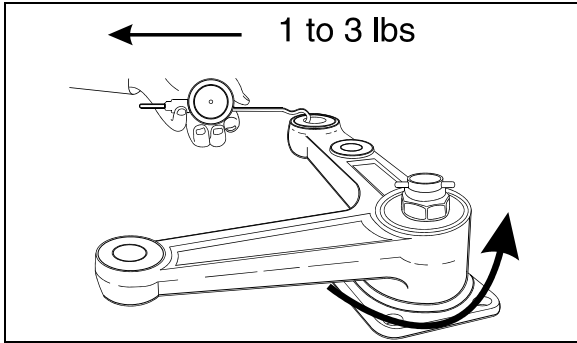

FIGURE 19: BELL CRANK 16045

13. Align nut with cotter pin slot (tighten) and install a new cotter pin.

NOTE

Bend cotter pin around the nut. Do not bend the cotter pin in the direction of the cap as it may interfere with the cap.

14. Install the cap.
15. **Bell crank:** Install drag link, tie rod and relay rod as directed herein under each specific subject.
16. **Idler arm:** Install hydraulic power cylinder, tie rod and relay rod as directed herein under each specific subject.
17. Adjust turning angle as previously directed under paragraph "**Turning Angle**" and check front end alignment as specified under heading "Front End Alignment".

3.6 RELAY ROD

Relay rod ends are equipped with lubrication fittings and should be lubricated as directed in "Lubrication Fittings" in this section.

NOTE

The relay rod is crimped in place and it is not possible to remove and replace the ball joint socket end assemblies.

3.6.1 Replacement

1. Remove cotter pins from bell crank and idler arm end of relay rod. Loosen nuts flush with end of studs.
2. Use a puller or place a sledge hammer behind the adjacent part to absorb shocks. Strike the studs with a brass hammer to loosen end assemblies.
3. Remove stud nuts then remove relay rod.

4. Position new relay rod studs into bell crank and idler arm then tap stud ends with a brass hammer to seat tapered surfaces. Ball stud and taper bore must be clean and free of grease.
5. Install stud nuts. Tighten nuts to prescribed torque (refer to Torque Table 2). Align cotter pin slot (tighten) and install a new cotter pin.

3.7 TIE RODS

Tie rod ends are connected to the bell crank and left steering arm, and to the idler arm and right steering arm. Each tie rod assembly consists of three parts; a tube and two socket end assemblies. The tie rod ends are threaded into the tube and secured with clamp bolts. Right and left hand threads are provided to ease toe-in adjustment. Tie rod assemblies are interchangeable from the right to the left side of the coach.

Tie rod end sockets require periodic lubrication and inspection to see that ball studs are tight. Replace socket ends when there is excessive up and down motion, lost motion or end play at ball end of stud.

1. Periodically check bolt nut for tightness.
2. Inspect tie rod for bent condition and inspect tube for damaged threads. If tie rod is bent or threads are damaged, replace the assembly.
3. Lubricate tie rod end fittings as directed in "Lubrication Fittings" in this section.

3.7.1 Removal

1. Remove cotter pins and stud nuts which attach tie rod socket ends to bell crank and left steering arm (or idler arm) and right steering arm.
2. Remove tie rod ball stud by tapping on steering arm and bell crank or idler arm with brass hammer, while using a sledge hammer to absorb shocks.

NOTE

If tie rod end assemblies are damaged in any way, they must be replaced

3.7.2 Installation

1. Install socket end assemblies on tie rod. Be sure both ends are threaded an equal distance into the tube.

Section 16: SUSPENSION

2. Make sure threads on stud and in stud nut are clean and not damaged.
3. Position ball studs (socket ends of tie rod) in holes in steering arm and bell crank or idler arm. Ball stud and taper bore must be clean and free of grease. Install a ball stud nut on each stud and tighten firmly.
4. Torque stud nuts to prescribed torque (refer to Torque Table 2). Align cotter pin slot (tighten) and install a new cotter pin.

NOTE

Adjust toe-in as directed under heading "Toe-In Adjustment" in this section.

5. Make sure tie rod ends are properly aligned with ball studs, and then torque tie rod end clamp bolts to prescribed torque (refer to Torque Table 2).



CAUTION

Clamp bolts are either in a vertical or horizontal position. Reinstall clamp bolts exactly as they were before removal as they might interfere with other components.

NOTE

If tie rod is not properly aligned with stud, binding will result.

2. Torque steering arm to steering knuckle fixing bolts. Torque bolt to prescribed torque (refer to Torque Table 2).
3. Position tie rod ball stud in steering arm and tap with a brass hammer to seat ball stud in steering arm. Ball stud and taper bore must be clean and free of grease. Install nut on stud. Torque nut to prescribed torque (refer to Torque Table 2). Tighten nut to nearest cotter pin slot and install a new cotter pin.
4. Install wheel as directed in Section 13, "Wheel, Hubs and Tires" under paragraph "Installation" of the maintenance manual.

3.8 STEERING ARMS

The left and right wheel steering arms are secured to a steering knuckle at one end and to a tie rod at the other end.

3.8.1 Removal

1. Remove wheel as directed in Section 13, "Wheel, Hubs and Tires" of the maintenance manual.
2. Remove cotter pin and nut from stud securing tie rod to steering arm. Remove ball stud from steering arm by tapping on arm with a hammer, placing a sledge hammer underneath steering arm to absorb shocks.
3. Remove bolts securing steering arm to steering knuckle assembly. Remove steering arm from steering knuckle.

3.8.2 Installation

1. Install steering arm onto steering knuckle.

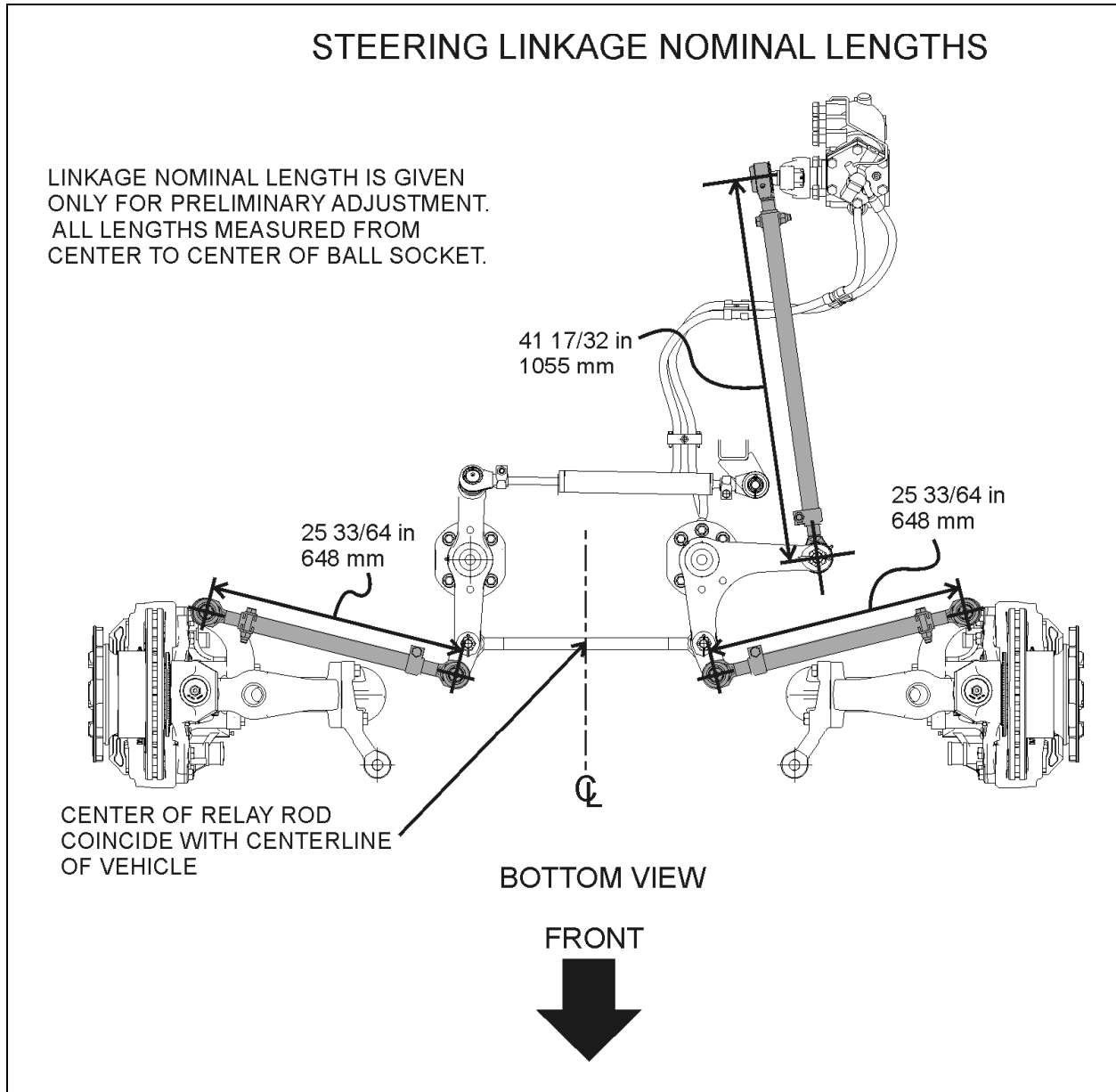

Figure 20: STEERING LINKAGE nominal lengths

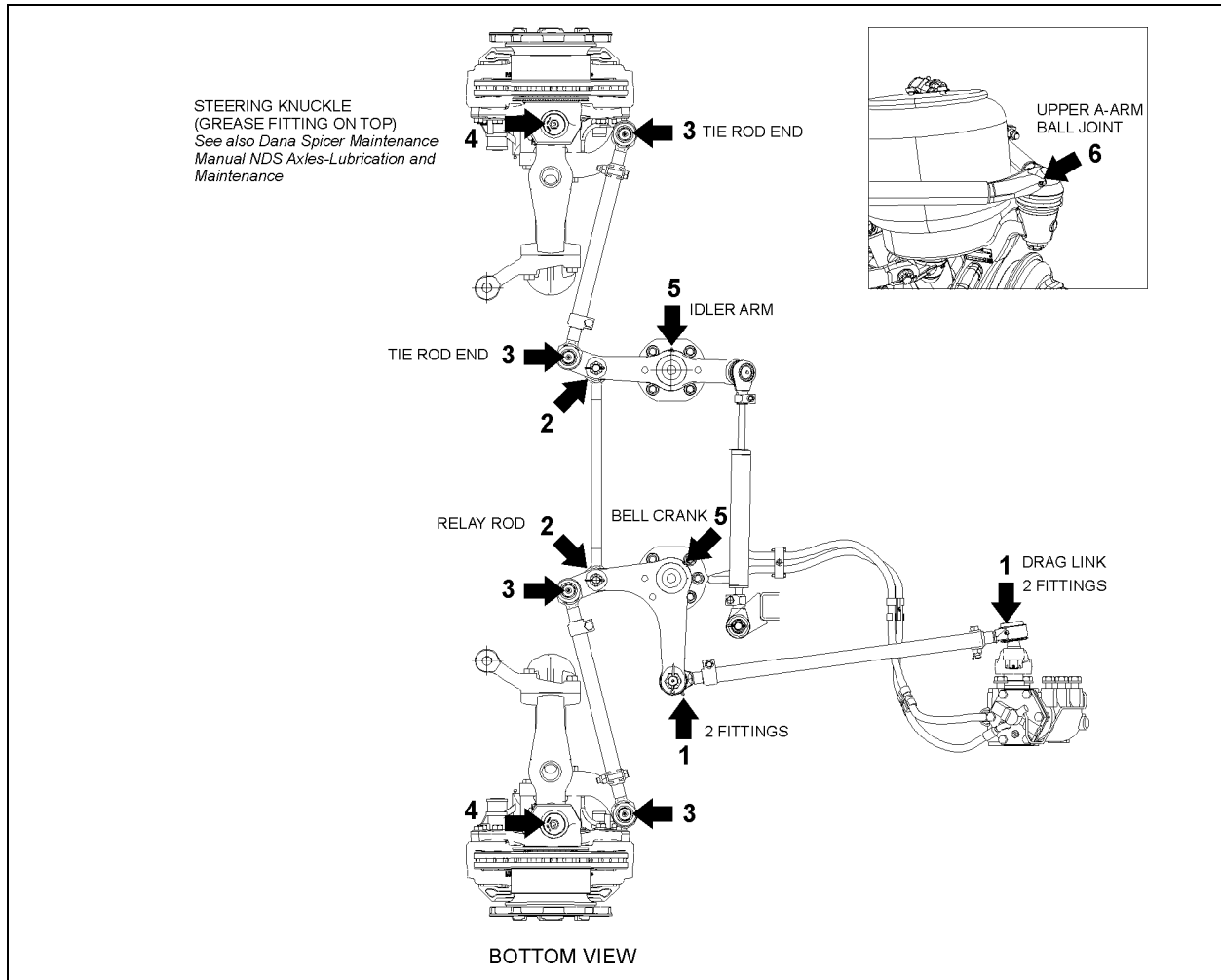

FIGURE 21: LUBRICATION FITTINGS LOCATION

3.9 LUBRICATION FITTINGS

All lubrication fittings must be clean before applying lubricant. Also, always be sure equipment used in applying lubricant is clean. Every precaution should be taken to prevent entry of dirt, grit, lint or other foreign matter into lubricant containers. Replace fitting when become broken or damaged.

Re-charge ball joint until grease can be seen escaping from socket. On ball joints fitted with a rubber boot, do not add too much grease as the rubber boot might expand and rupture.

Intervals of application given in the following paragraphs are recommended for normal service. More frequent intervals may be applied under severe operating conditions. In selecting proper lubricants, supplier reputation must be considered. The supplier must be responsible for product quality. Figure 21 shows

approximate location of steering lubrication fittings.

 MAINTENANCE
(1) Drag Link Ends: Lubricate at four fittings, two at each end of link, every 6,250 miles (10 000 km) with good quality lithium-base grease NLGI No. 2 (Shell Retinax LX or equivalent).
(2) Relay Rod Ends: Lubricate at two fittings, one at each end of rod, every 6,250 miles (10 000 km) with good quality lithium-base grease NLGI No. 2 (Shell Retinax LX or equivalent).
(3) Tie Rod Ends: Lubricate at four fittings, one at each end of both tie rods, every 6,250 miles (10 000 km) with good quality lithium-base grease NLGI No. 2 (Shell

Retinax LX or equivalent).

- (4) **Steering Knuckle (swivel assembly):** Refer to DANA SPICER MAINTENANCE MANUAL NDS AXLES Lubrication and Maintenance" annexed at the end of section 10.
- (5) **Idler Arm and Bell Crank:** Lubricate at two fittings, one on the idler arm and the other on the crank bell, every 6,250 miles (10 000 km) with good quality lithium-base grease NLGI No. 2 (Shell Retinax LX or equivalent). Apply grease gun pressure to the fitting until lubricant appears at the top seal.
- (6) **Upper A-Arm Ball Joint:** Lubricate at fitting until you see some grease on the relief valve nearby, every 6,250 miles (10 000 km) with good quality lithium-base grease NLGI No. 2 (Shell Retinax LX or equivalent).

3.10 BALL JOINTS – GENERAL RECOMMENDATIONS

Visual Inspection

- Visually inspect for missing or damages grease fittings and replace if required.
- Check ball joint connection for missing cotter pins.
- Check for looseness in the ball/socket assembly.

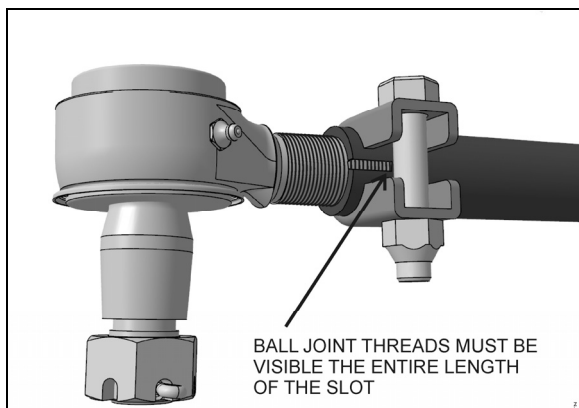

FIGURE 22: ADEQUATE CLAMPING CONDITION

For adequate clamping, the ball joint threads must be visible the entire length of the tube slot. If not, the drag link must be adjusted or replaced. It is either the wrong size, or improper adjustment was used to compensate for another problem (e.g. bent steering arm).

Damaged sealing boots, salt and climatic conditions can cause loss of the corrosion protection coating applied at time of manufacturing. To prevent corrosion from forming around the ball pin, remove the old grease bead and assure sufficient grease is applied to purge the old grease and fill the joint and dust seal (if applicable).

Good quality lithium-base mineral grease NLGI No. 2 like Shell Retinax LX is recommended.

3.11 FRONT-END ALIGNMENT

Proper front end alignment must be maintained to insure ease of steering and provide satisfactory tire life. When making front end alignment inspections, the vehicle must be level and empty with the full weight of the vehicle on the wheels.

Front end alignment inspections fall into two groups: regular service inspections performed at periodic intervals, and inspections to determine the extent of damage after a collision or severe service.

Regular service inspections concern toe-in, camber and caster.

Any variation from the specified alignment will indicate either a need for adjustment or a more thorough inspection to determine if parts replacement is required.



WARNING

During alignment, both camber and caster among other angles are adjusted. When adjusting these, we install or remove shims at the IFS lower A-arms. After performing alignment, make sure that the following is done:

- Installing a new lock nut after all shims are finalized.
- Torque replaced nuts as per Torque Table 2.
- Installing a longer bolt if less than 2 threads are remaining after the nut.
- Using a torque seal, leave a mark on the nut for future visual inspection.

3.11.1 Alignment Terminology

Wheel Camber: Camber is the number of degrees the top of the wheel is tilted inward or outward from a true vertical (fig. 27).

Section 16: SUSPENSION

Wheel Toe-In: a slight forward convergence given to the wheels of motor vehicles to improve steering and equalize tire wear (D minus E, fig. 27).

Kingpin Inclination: The inclination of the kingpin from vertical toward the center of the vehicle at the top and outward at the bottom (B, fig. 27).

Front Axle Caster: The inclination of the kingpin from vertical in the fore and aft direction (C, fig. 27).

3.11.2 Front End Inspection

Before checking front end alignment, make the following inspection:

1. Check that the vehicle is at normal ride height (see paragraph "8. Suspension Height Adjustment").
2. Check the tires for proper inflation.
3. Check wheel installation and run-out.
4. Check wheel bearing adjustment.
5. Check tie rods and drag link ends for looseness.
6. Check kingpins for looseness.
7. Check if the length of the torque rod is 21 17/64" (540 mm) (Fig. 11). Check if the length of the relay rod is 23 19/64" (592 mm).

3.11.3 Front Wheel Camber

Positive camber is the outward inclination of the wheels at the top, negative or reverse camber is the inward inclination of the wheels at the top. Camber variations may be caused by wear at the wheel bearings, wheel spindle bushings, or bent suspension parts.

Check camber, with an accurate gauge. If camber is incorrect, check suspension parts for wear and replace worn parts. If wear is not perceptible, suspension parts may be bent or lower A-arm may be improperly shimmed.

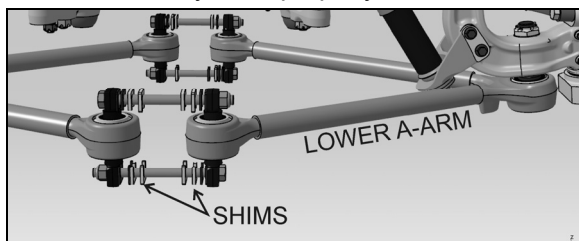

FIGURE 23: SHIMS AT THE LOWER AARMS

Check kingpin inclination. If kingpin inclination is incorrect, readjust the camber and check kingpin inclination again.

NOTE

Camber is more important than kingpin inclination, so adjust camber and verify kingpin inclination.

Shim the lower A-arm to adjust camber (figure 23 & 26). If the kingpin inclination is incorrect, the wheel kingpin assembly may be bent and therefore should be replaced.

Excessive positive camber results in irregular wear of the tires at the outer shoulders. Negative or reverse camber causes wear at the inner shoulders.

NOTE

Shim only the lower suspension arm to adjust the front wheel camber.



CAUTION

Once the perfect shim combination is achieved, always install new Stover nuts because the self-locking effect is lost after tightening and loosening of the nut. It is recommended to punch marks to detect loosening of the nuts during future visual inspections.

3.11.4 Front Wheel Toe-In

Toe-in is measured from the center of the tire treads. Measurements at the front and rear of the tires must be made at the same height from the floor. Incorrect toe-in results in excessive tire wear and steering instability with a tendency to wander.

Toe-In Check

1. Check the camber adjustment and adjust if necessary.
2. Hoist the front of the vehicle and spin the wheels marking the centerline of the tire treads.
3. Place the wheels in the straight ahead position and lower the vehicle to rest on the floor.
4. Roll the vehicle ahead several feet. This removes any slack caused by looseness in the wheel bearings or steering connections.

5. Check the distance between the tire centerlines at the front and rear of the front tires. These two measurements must be made at the same height above the floor. The front measurement must be $3/32 \pm 1/32$ of an inch less than the rear measurement.

Toe-In Adjustment

1. Loosen the tie rod clamp bolts.
2. Using a pipe wrench, turn the tie rod tubes to obtain the toe-in measurement specified in step 5 under paragraph "Toe-in Check" (figure 26).
3. Tighten the tie rod clamp bolts and recheck toe-in.
4. Check that the angular relationship of the pitman arm to the steering gear is as shown in figure 24.

NOTE
Use only tie rods to adjust toe-in.

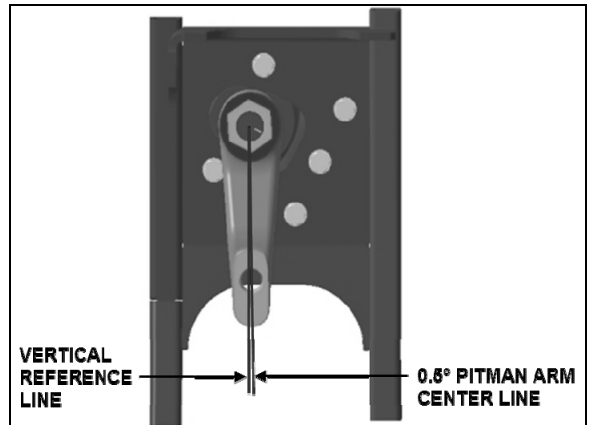

FIGURE 24: IFS PITMAN ARM ALIGNMENT 14056

3.11.5 Front Wheel Caster

Positive caster is the inclination of the top of the kingpins toward the rear of the vehicle. Negative or reverse caster is the inclination of the kingpins toward the front of the vehicle. This vehicle is designed with positive caster. The purpose of caster is to provide steering stability by keeping the wheels in a straight ahead position.

Caster variations may be caused by bent upper suspension A-arm, lower suspension A-arm, or kingpin housing. Caster should be adjusted with shims. Precision instruments should be used to measure caster. Shim bell crank and idler arm to adjust caster (figure 26).

Variations from the specified caster will affect steering stability, cause wandering, wheel shimmy, and reduce steer re-centering when pulling out of curves.

NOTE
On Independent Front Suspension, caster on right wheel must be equal or greater than caster on left wheel, without exceeding 0.3°.

3.11.6 Major Damage

If the suspension has sustained major damage, it may be necessary to shim the bell crank and the idler arm to avoid the bump steer or roll steer. Moreover refer to paragraph "Front End Alignment".

3.11.7 Alignment Specifications

See figure 26 & 27.

NOTE
On Independent Front Suspension, caster on right wheel must be equal or greater than caster on left wheel, with a maximum difference of 0.3°.

VIP INDEPENDENT FRONT SUSPENSION						
Load	Minimum value		Nominal value		Maximum value	
	Non-converted	Converted	Non-converted	Converted	Non-converted	Converted
Right camber	0.20°	-0.20°	0.30°	0°	0.50°	0.20°
Left camber	0.20°	-0.20°	0.30°	0°	0.50°	0.20°
Right caster	2.55°		2.8°		3.05°	
Left caster	2.55°		2.8°		3.05°	
Total toe-in	0.02°	0.04°	0.04°	0.06°	0.06°	0.08°

Section 16: SUSPENSION

H3-45 Coaches WITH INDEPENDENT FRONT SUSPENSION			
	Minimum value	Nominal value	Maximum value
Right camber	0.0°	0.150°	0.30°
Left camber	0.0°	0.150°	0.30°
Right caster	2.35°	2.6°	2.85°
Left caster	2.35°	2.6°	2.85°
Total toe-in	0.04°	0.06°	0.08°

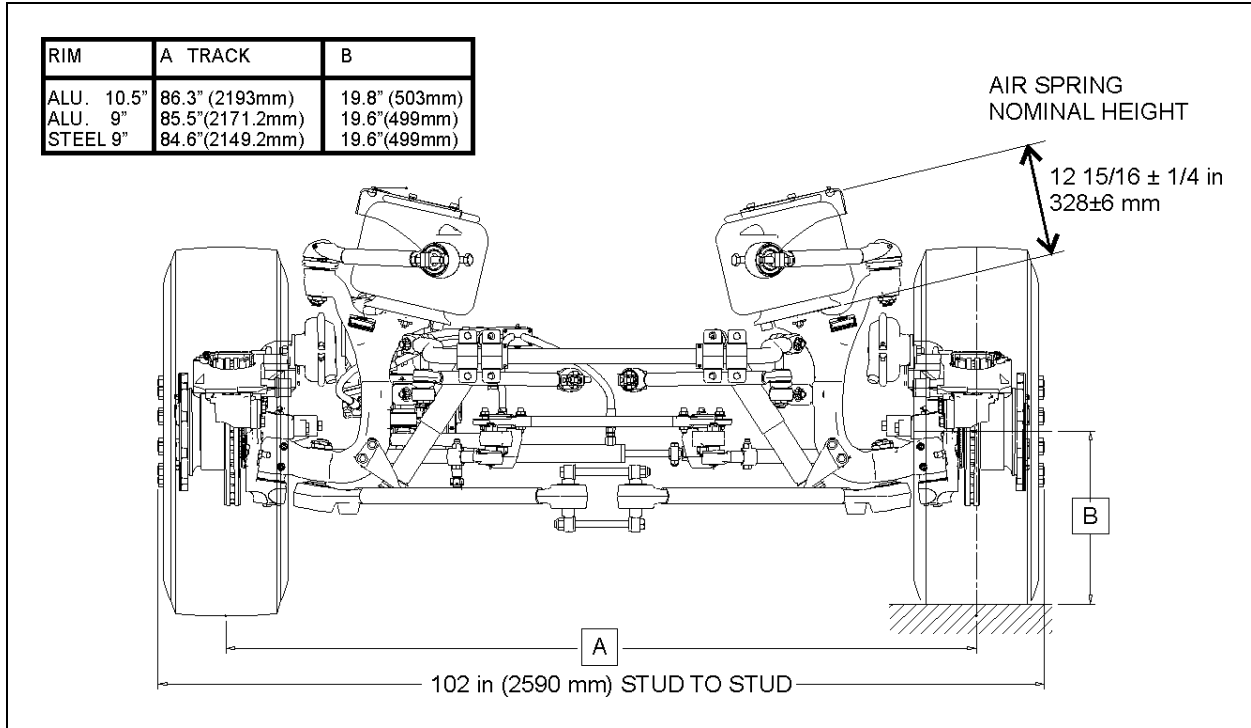

FIGURE 25: IFS NOMINAL DIMENSIONS

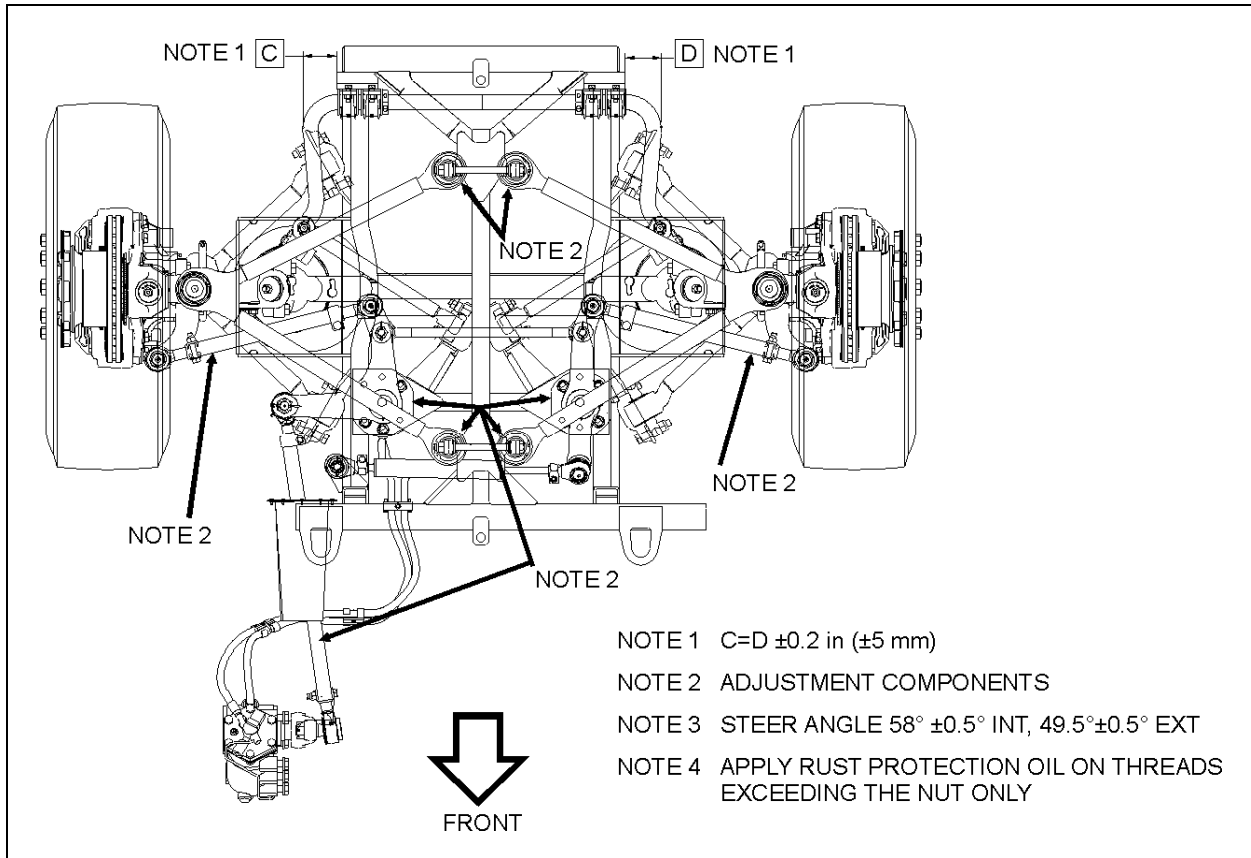

FIGURE 26: NOTE 2 INDICATES WHERE ADJUSTMENT MAY BE PERFORMED IF NEEDED WHEN PROCEEDING TO IFS ALIGNMENT

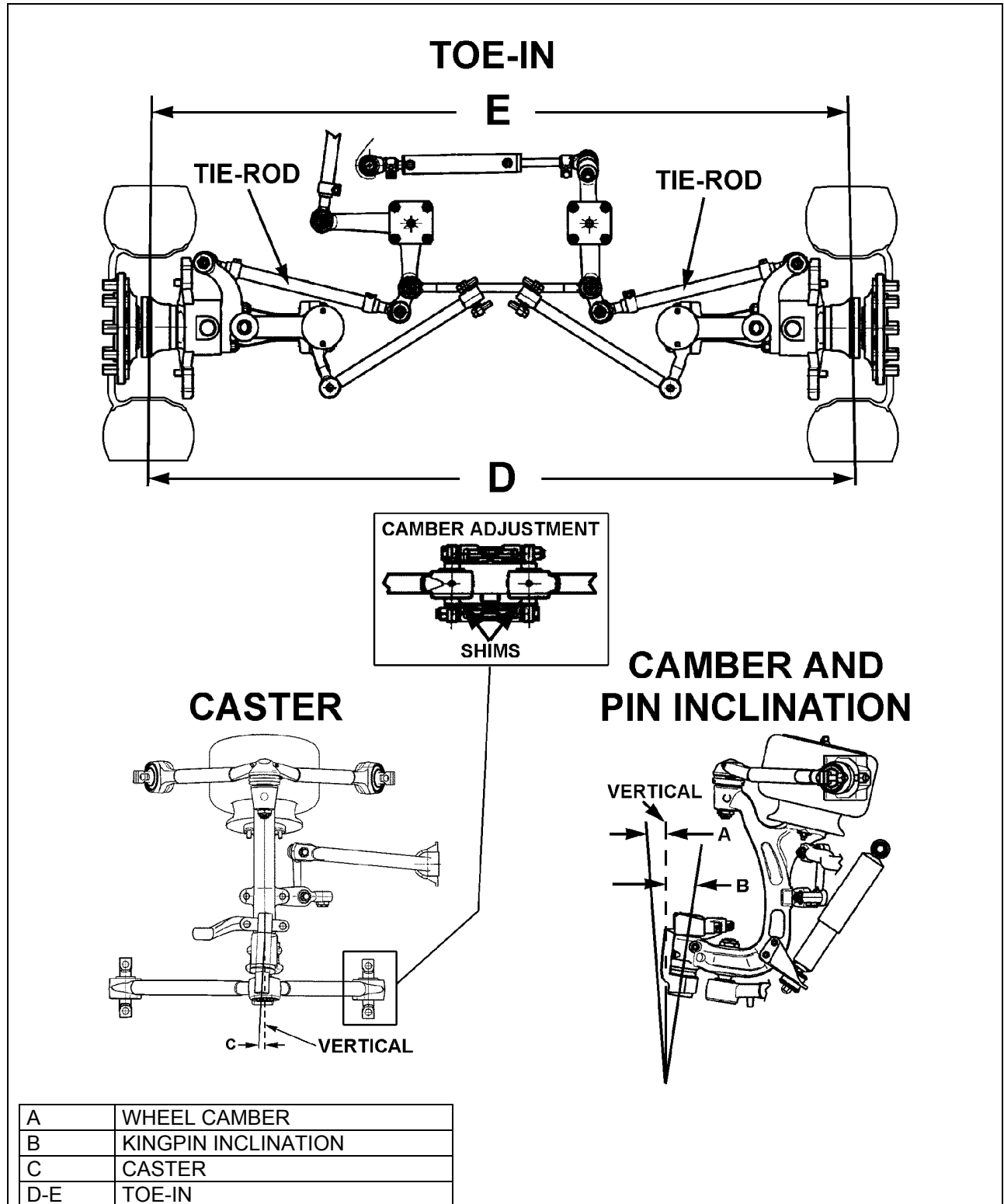

FIGURE 27: FRONT END ALIGNMENT DIAGRAM

16051

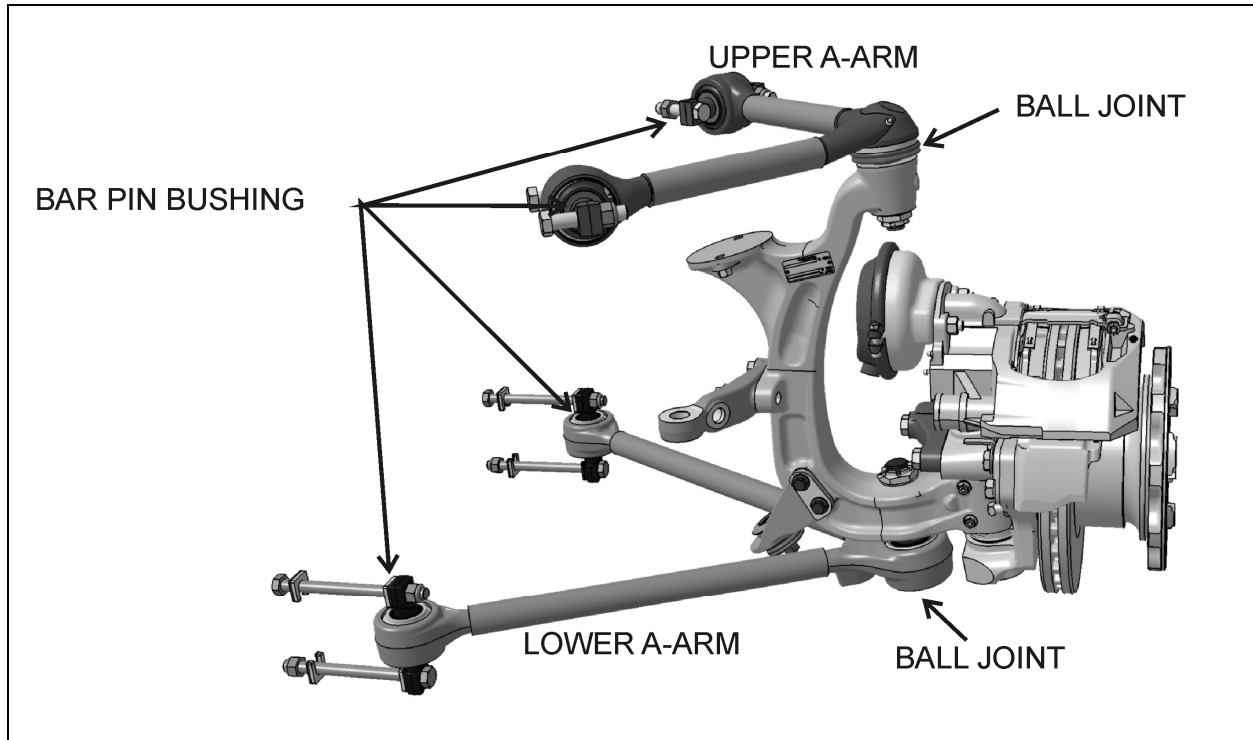

FIGURE 28: A-ARM JOINT IDENTIFICATION

3.12 LOWER AND UPPER A-ARM BAR PIN BUSHING REPAIR

The assembly work may be done only by a recognized specialized workshop. Ensure that old and new parts do not get mixed up with each other. It is for this reason that all the old parts are to be scrapped immediately after a joint has been stripped down. A complete repair set must be used for each joint repaired, i.e. use of only part of a repair set is not permissible.

3.12.1 Inspection

Take off the load from the joint by lifting the front of the vehicle. Apply a load on the joint in all of the degrees of freedom in an axial, radial, etc. sense with a suitable lever tool. After the load is taken off, the joint has to spring back into its starting position. Free play is not acceptable.

Separation of rubber from ball pin or external joint shell is in accordance with "normal wear characteristics".

When the following characteristics are noted, the joint is to be changed:

- Free play;
- Radial cracking of the external sheet-metal race.

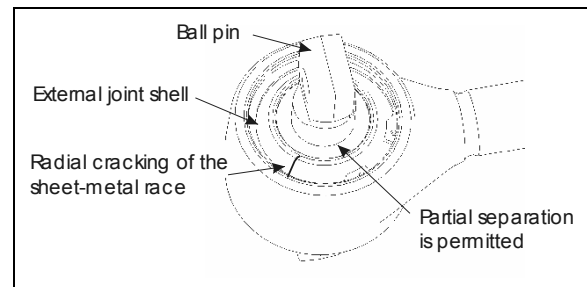

FIGURE 29: BAR PIN BUSHING

3.12.2 Stripping Down

Strip down the defective joint through removal of retaining ring, annular spacer and bar pin bushing assembly and thereafter clean out housing bore and locking circlips groove.

3.12.3 Assembly

Execute assembly of the new joint parts in the following sequence:

1. Complete moistening of the contact surface between housing bore and bar pin bushing through application of the grease.

NOTE

Apply grease, only in the case of repair kit (Prevost # 611114).

Section 16: SUSPENSION

2. Insert bar pin bushing assembly. In case of the two-bolt type, ensure that the bolt bores are in the correct position in relation to the axis of the tube.
3. Place joint in receiving fixture and mount annular assembly tool on the housing. Then locate annular spacer and retaining ring in the housing using axial load with the aid of assembly matrix. If the ends of the annular spacer are not in contact with each other, the thus formed opening must be located at 180° to the opening of the retaining ring. Pay attention during assembly to ensure that the retaining ring eyelets are located at each side of the housing shaft axis (retaining ring eyelet lug points to tube), and that retaining ring is properly engaged in the groove of the housing.
4. When repairing defective ball pin assemblies, the necked down-bolt must regularly be replaced with a new one.

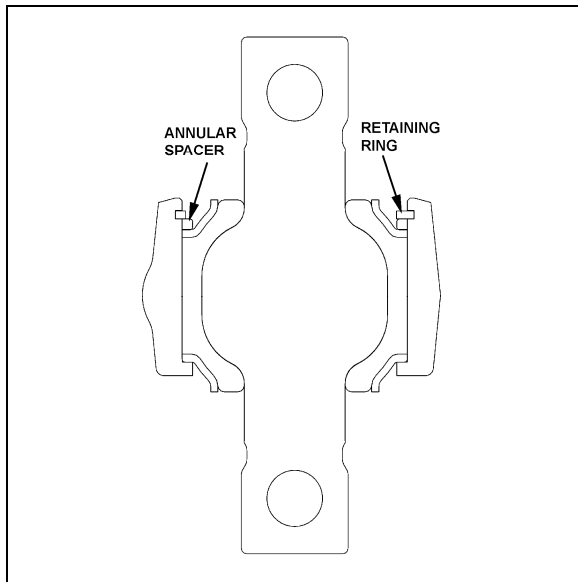

FIGURE 30: LOWER A-ARM BAR PIN BUSHING 16047

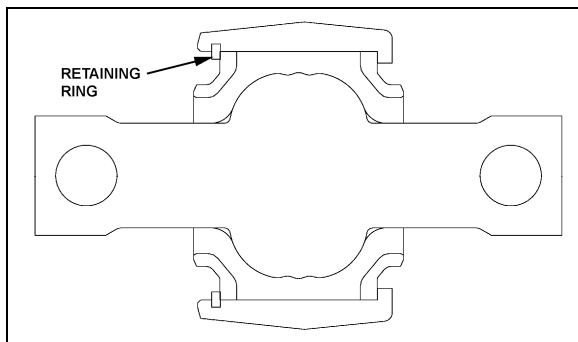

FIGURE 31: UPPER A-ARM BAR PIN BUSHING

3.13 LOWER A-ARM BALL JOINT REPAIR

Take off the load from the ball joint by lifting the front of the vehicle. Apply a load on the joint in all of the degrees of freedom in an axial, radial, etc. sense with a suitable lever tool. After the load is taken off, the joint has to spring back into its starting position. Free play is not acceptable.

Separation of rubber from ball pin or external joint bushing shell is in accordance with "normal wear characteristics".

When the following characteristics are noted, the joint is to be changed:

- Free play;
- Radial cracking of the external bushing shell.

3.13.1 Stripping Down

Strip down the defective joint through removal of retaining ring, annular spacer and ball pin/bushing, assembly and thereafter clean out housing bore and locking circlips groove

3.13.2 Assembly

Assemble the new component parts of the joint in the following sequence:

1. Complete moistening of the contact surface between housing bore and ball pin through application of the grease.
2. Place joint in receiving fixture and mount annular assembly tool on the housing. Then locate annular spacer and retaining ring in the housing using axial load with the aid of assembly matrix. If the ends of the annular spacer are not in contact with each other, the thus formed opening must be located at 180° to the opening of the retaining ring. Pay attention during assembly to ensure that the retaining ring eyelets are located at each side of the housing shaft axis (retaining ring eyelet lug points to tube), and that retaining ring is properly engaged in the groove of the housing.
3. Faultlessly apply grease by mechanical means to bracket-outer core and ball-inner cone. Insert bracket outer cone in fixture with distance ring and then use press tool to apply pressure to press mount with ball-inner cone.

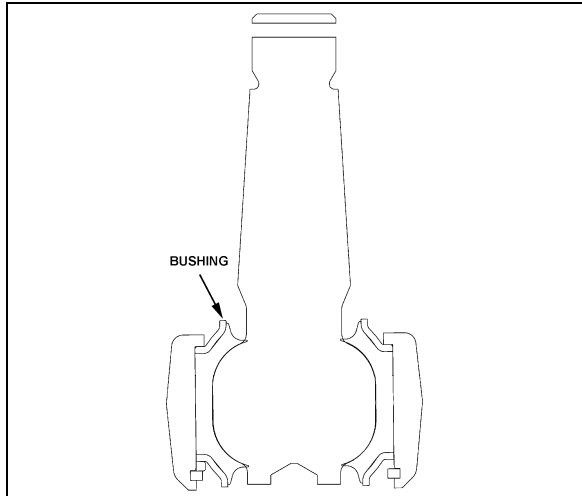

FIGURE 32: LOWER A-ARM BALL JOINT

3.14 UPPER A-ARM BALL JOINT

3.14.1 Visual Inspection

Check the condition of the sealing boot, in particular:

Check if the retainer ring, which secures the sealing boot at the conical section of the ball stud, is still present.

Check if grease is present on the external surface of the sealing boots. Escaped fluid and accumulations of grease on the sealing boot may be the result of the sealing boot's rupturing. In this case, the ball joint must be systematically replaced.

3.14.2 Play Measurement

1. Raise the vehicle and support through axle jacking points.
2. Using a caliper, measure dimension A on figure 33.
3. With a lever tool, exert sufficient force under the upper A-arm as to separate the upper A-arm from the upright in order to have the ball joint to its maximum extent. Measure dimension A again. If the difference between the two dimensions is greater than 0.060" (1.5mm), then the ball joint should be replaced.

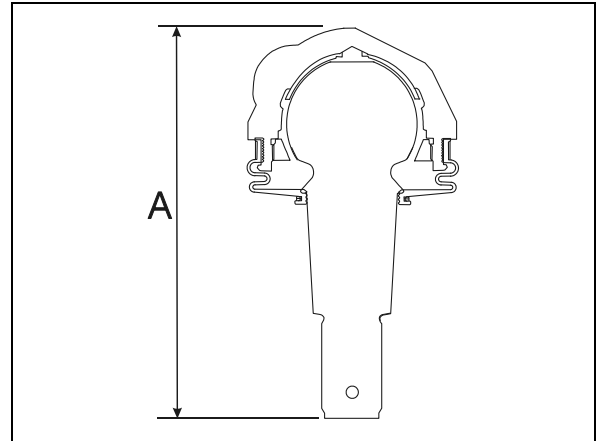

FIGURE 33: UPPER A-ARM BALL JOINT 16116

3.15 FRONT AIR SPRINGS

Two 14-inch "rolling lobe" type air springs are used with the independent front suspension, one at each wheel. These air springs are special and use the complete piston as an extra reservoir to lower the spring stiffness. Front air springs are attached to the subframe and to uprights.

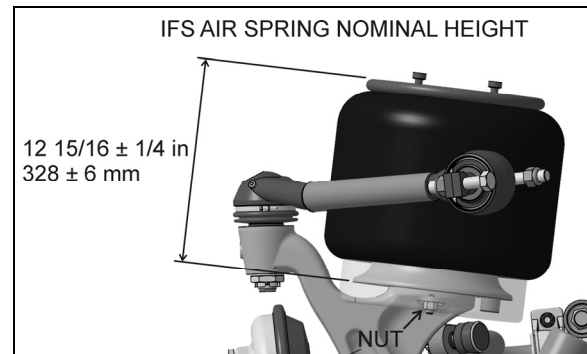

FIGURE 34: AIR SPRINGS 16052

3.15.1 Inspection

1. Check operation of air springs.
2. Visually inspect bellows for evidence of cracks, punctures, deterioration, or chafing. Replace the air spring if damage is evident.
3. With the primary air system at normal operating pressure (95 - 125 psi (655 - 860 kPa)), coat all suspension air line connections and bellows mounting areas with a water and soap solution. Bubbles will indicate an air leak, and none is permissible. Repair or replace defective parts.

Section 16: SUSPENSION

NOTE

If air spring is removed from vehicle, bellows can be lightly inflated and submerged in water to detect any leakage. If leakage is detected, replace air spring.



WARNING

To prevent personal injury, do not apply more than 10 psi (69 kPa) air pressure to the dismounted air spring.

3.15.2 Removal

NOTE

Front air springs can be removed without removing the entire suspension assembly.

1. Jack up the vehicle using the axles jacking points.
2. Safely support the front of the vehicle at the recommended body jacking points.
3. To gain access to a given air spring, the corresponding wheel can be removed.



CAUTION

Only the recommended jacking points must be used as outlined in Section 18, "Body" in the maintenance manual.



CAUTION

Always adequately support the IFS assembly when lifting up the vehicle to avoid maximum extension of shock absorber.

4. Exhaust compressed air from accessory air tank by opening drain cock under reservoir.
5. Disconnect the height control valve link and pull down the overtravel lever to ensure all air is exhausted from air springs.
6. Lower the IFS slightly while maintaining the vehicle body at the same level.

NOTE

While performing this step, do not change the height control valve overtravel lever adjustment.

7. Disconnect air line from air spring, remove elbow (if applicable), and cover both the line end and fitting to prevent the entry of foreign matter.

8. Unscrew the two air spring lower nuts (2 nuts). Rotate the air spring to disengage the upper mounting and remove the air spring.

3.15.3 Installation

NOTE

To facilitate air spring installation, compress it manually then put a piece of tape over the air line threaded fitting. This prevents air from getting back into the bag and keeps it compressed, thus enabling to place the bag in between the mounting plates and greatly easing installation.

1. Compress air spring as necessary, then aligning studs with their holes, position air spring between both the lower and upper supports. Thread the lower nuts a few turns.
2. Tighten and torque the lower stud nuts as prescribed in Torque Table 2.
3. Install elbow (if applicable), then connect air line.
4. Connect the height control valve link.
5. Build up air pressure in system.

NOTE

To accelerate this operation, air reservoirs can be filled from an exterior air supply connected to the accessory tank fill valve or to the emergency fill valve.

6. Check operation of air springs and with the primary air system at normal operating pressure (95 - 125 psi (655 - 860 kPa), coat the air line connections and air spring mounting areas with a water and soap solution. Bubbles will indicate an air leak, and none is permissible. Repair or replace defective parts.

3.16 SHOCK ABSORBERS

The two front shock absorbers are double-acting and telescopic type. Shock absorbers ensure a smooth ride and enhance vehicle stability on the road. Front shock absorbers have eye-type mountings on the upper side and bayonet type on lower side. Shock absorbers are non-adjustable and non-repairable.



CAUTION

When a shock absorber is found defective, always replace with a new set on affected axle, except if there has been a recent

replacement of one unit. The following method will help in determining if both shock absorbers on the same axle have to be replaced. (Refer to the SACHS document "Guideline To Evaluate Warranty Claims" annexed at the end of this section before replacing a shock).

3.16.1 Shock Absorber Removal

1. Remove the nut, washer and rubber joint from shock absorber mounting stud. Discard the rubber joints.

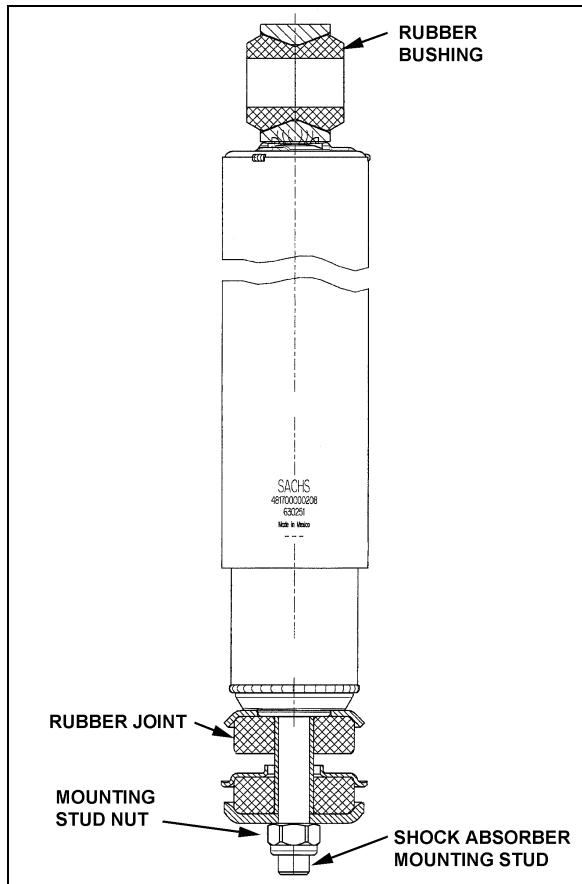

FIGURE 35: SHOCK ABSORBER

161124

2. Remove the nut and washer from shock absorber mounting pin (upper side), taking care to identify the inner and outer washers to ease reinstallation.
3. Remove the shock absorber from the vehicle.
4. Remove inner: washers, rubber joint and bushings from the shock absorber. Discard bushings and rubber joint.

3.16.2 Shock Absorber Installation

1. Check that the shock absorber mounting stud is tightened as prescribed in Torque Table 2. Ensure that the stud is clean and not stripped (upper end).
2. Install new rubber (mounting) bushing on shock absorber (upper end).
3. Place the inner washer on shock absorber stud.
4. Install washer and rubber joint on shock absorber mounting stud (lower end).
5. Install the shock absorber as shown in figure 36 with the mounting stud protruding through the hole in the mounting bracket and the shock absorber eyes over the mounting pins. Install the outer washer.
6. Place a rubber joint and washer on the shock absorber mounting stud. Place the lower shock absorber mounting stud nut and torque as prescribed in Torque Table 2.
7. Place the upper mounting pin stud nut and torque as prescribed in Torque Table 2.

3.17 SWAY BAR

A sway bar is provided on the IFS and rear suspension to increase vehicle stability. It controls lateral motion (swaying movement) of vehicle.

3.17.1 Removal

1. Disconnect the two links from sway bar.
2. Safely support the sway bar. Unbolt bushing collars from subframe.
3. Remove sway bar.

NOTE

Sway bar bushings are slit to ease their removal.

Section 16: SUSPENSION

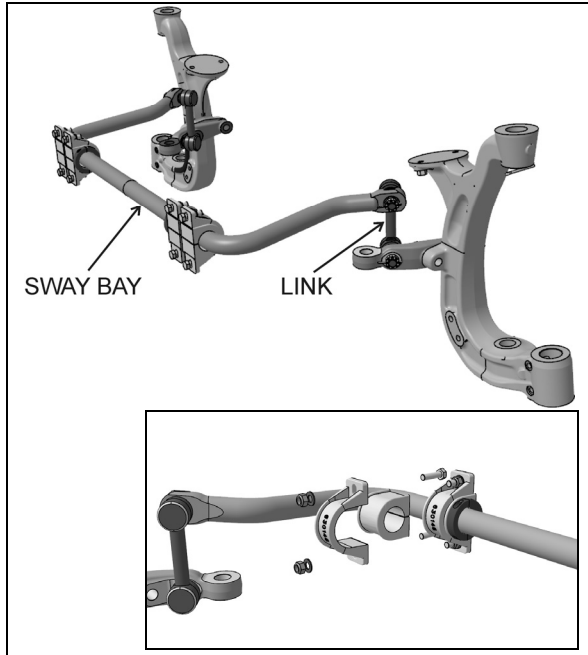

FIGURE 36: SWAY BAR (INDEPENDENT FRONT SUSPENSION) 16138_C

3.17.2 Installation

1. Loosely install the sway bar.
2. Torque bushing collar nuts as prescribed per Torque Table 2.
3. Torque sway bar link nuts as prescribed per Torque Table 2.

3.18 INDEPENDENT FRONT SUSPENSION HEIGHT ADJUSTMENT

VIP coach shells are equipped with "LEVEL-LOW" leveling system. The purpose of the "LEVEL-LOW" is to adjust suspension in three separate points; front, rear right and rear left air springs in order to level vehicle body. Three height control valves, automatically control air pressure in the three separate points (air springs) and maintains a constant vehicle height regardless of load, or load distribution. The control solenoid valve supplies air to the five way three-position air control valve, which bypasses the height control valve, and opens a passage to allow the air control and exhaust valve to release/supply air from air springs. To improve road comfort, an expansion air tank is installed in series with each air spring.

The flow of pressurized air from the accessory air tank to the air springs is controlled by three height control valves. The two rear valves are mounted to the subframe and connected to the rear axles through an arm and link connection.

The front valve is mounted to the subframe and connected to the front air tank support (fig. 37). These connections allow the valves to apportion air pressure in the springs to the vehicle load, maintaining normal ride height.

Immediate response height control valves increase or decrease the air pressure in the suspension system as required. One height control valve is located **at center of front sway bar**, and regulates air to front suspension air springs in order to maintain the vehicle at the required height. Two are located at the drive axle, one on each inner side of rear wheelhousing.

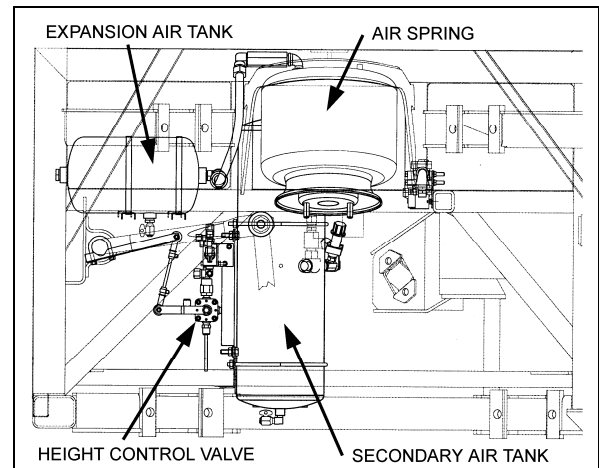

FIGURE 37: HEIGHT CONTROL VALVE LOCATION 16057

The appropriate vehicle body height is obtained by measuring the clearance of all the air springs installed on the vehicle. The two front air springs clearance should be $12 \frac{15}{16} \pm \frac{1}{4}$ in (328 ± 6 mm). Refer to figure 38 to identify the correct area to take measurement. The rear air springs clearance should be $11 \frac{1}{2} \pm \frac{1}{4}$ " (292 ± 6 mm) (refer to paragraph "6.0 Suspension Height Adjustment" for rear height control valves' adjustment). At this point, it should not be necessary to make an adjustment under normal service conditions. However, if an adjustment is required, change the position of the overtravel lever in relation to the overtravel control body. The lever should be moved up to raise vehicle height, and down to lower it. Check that main air pressure is at normal operating pressure and raise the vehicle to the specified height.



CAUTION

Always adjust on "fill cycle". If it is necessary to lower vehicle height, release sufficient air to be well below height, and adjust to height or fill cycle.

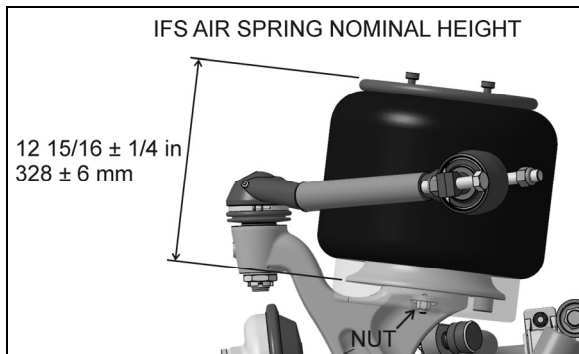

FIGURE 38: TYPICAL AIR SPRING CLEARANCE 16058

When the desired height is obtained, tighten clamp.

Rear air springs clearance

Refer to «Suspension Height Adjustment».

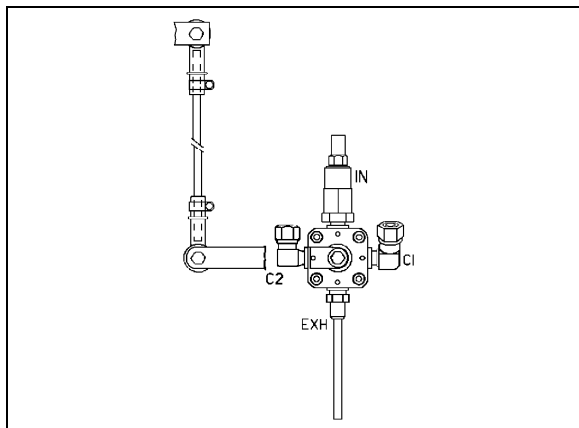

FIGURE 39: FRONT HEIGHT CONTROL VALVE 16100

The normal ride height is obtained by adjusting air spring clearance of both front and rear suspension as follows:

Front air spring clearance

1. With the vehicle at normal operating air pressure (100 - 125 psi (689 - 860 kPa)), measure air spring clearance. This clearance should be 12 15/16 ± 1/4 in (328 ± 6 mm).

NOTE

The measurement should be taken from underneath the upper air spring support on subframe to top of air spring mounting surface on the upright. If adjustment is required, begin with the drive axle.

2. Loosen the clamp on the height control valve rubber coupling and bring it up or down (Fig. 39).

NOTE

Allow suspension to stabilize before taking reading.

Section 16: SUSPENSION

4 REAR SUSPENSION

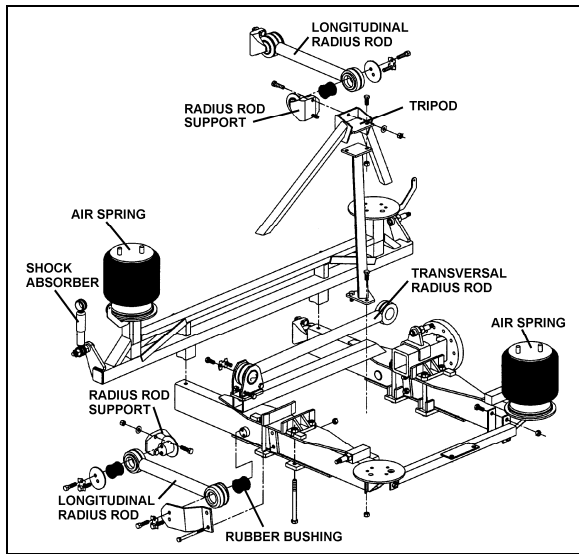

FIGURE 40: DETAILS OF REAR SUSPENSION 16106

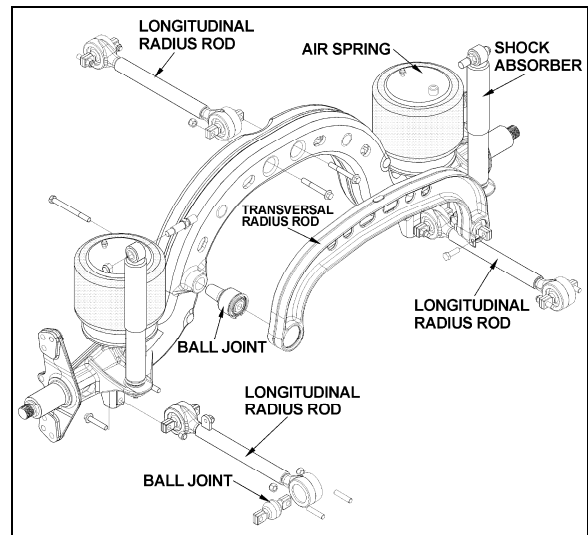

FIGURE 41: TAG AXLE SUSPENSION

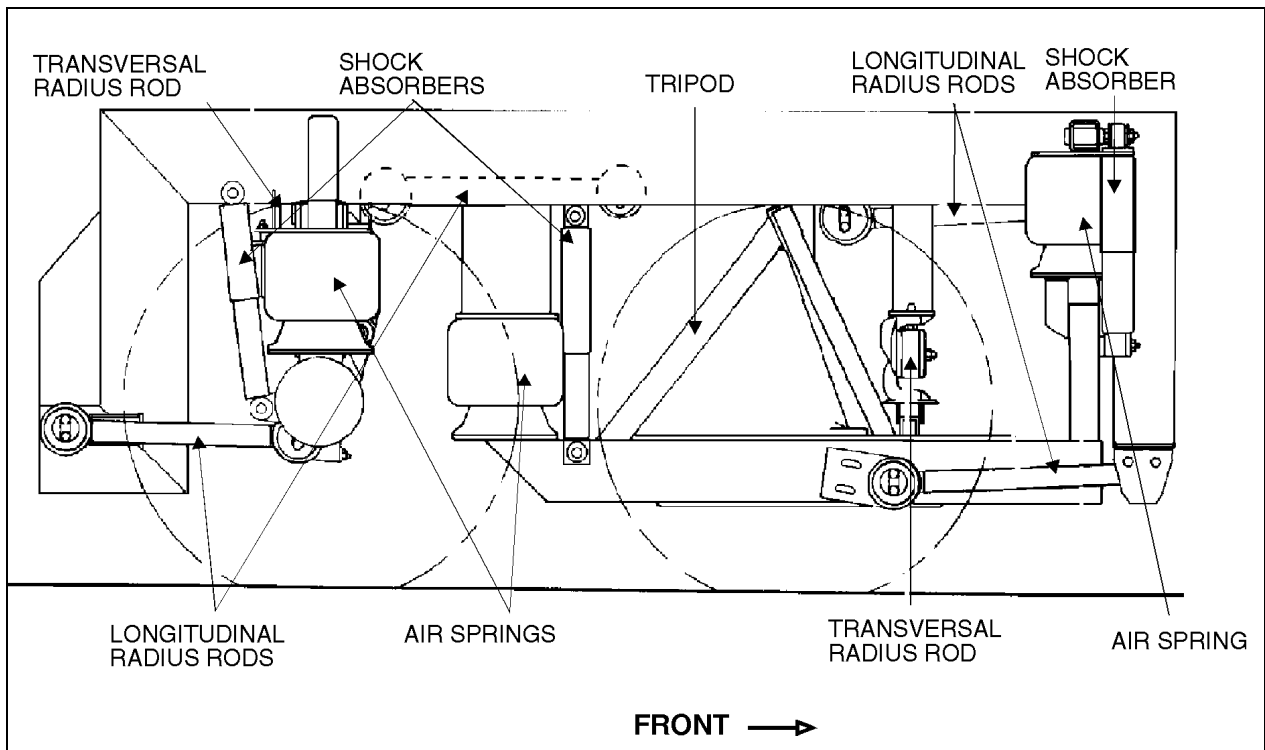

FIGURE 42: REAR SUSPENSION COMPONENTS

16003

4.1 AIR SPRINGS

The air springs are made from a special compound rubber molded to the proper contour and dimensions. The entire vertical load of the vehicle is supported by these springs. Each of the two axles is provided with air springs that are attached to the subframe and to the axles (Fig. 43).

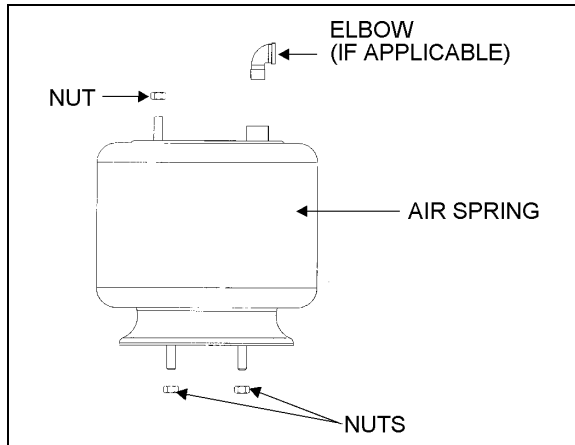

FIGURE 43: AIR SPRING

16052

4.1.1 Inspection

1. Check operation of bellows.
2. Visually inspect bellows for evidence of cracks, punctures, deterioration, or chafing. Replace the bellows if any damage is evident.
3. With the primary air system at normal operating pressure (95 - 125 psi (655 - 860 kPa)), coat all suspension air line connections and bellows mounting areas with a water and soap solution. Bubbles will indicate an air leak, and none is permissible. Repair or replace defective parts.

NOTE

If air spring is removed from vehicle, bellows can be lightly inflated and submerged in water to detect any leakage. If any leakage is detected, replace bellows.



WARNING

To prevent personal injury, do not apply more than 10 psi (69 kPa) of air pressure to the uninstalled air spring.

4.1.2 Removal

NOTE

Suspension air springs (drive and tag axles) can be removed without removing the entire axle assembly.

1. Safely support vehicle at the recommended body jacking points. To gain access to a given air spring, the corresponding wheel can be removed as follows.
 - a) Jack vehicle until the tire clears the ground, and place safety supports underneath body.



CAUTION

Only the recommended jacking points must be used as outlined in Section 18, "Body".

- b) Support the axle with a suitable hydraulic floor jack at the recommended jacking point.
 - c) Remove wheel.
2. Exhaust compressed air from accessory air tank by opening drain cock under reservoir.
 3. Disconnect the height control valve link and pull down the overtravel lever to ensure all air is exhausted from air springs.

NOTE

While performing this step, do not change the height control valve overtravel lever adjustment.

4. Disconnect air line from air spring, remove elbow (if applicable), and cover both the line end and fitting to prevent the entry of foreign matter.
5. Remove the air spring upper nut, and then the two lower nuts. Remove air spring.

4.1.3 Installation

1. Compress air spring as necessary, then aligning studs with their holes, position air spring between both the lower and upper supports. Thread the lower nuts and the small upper nut a few turns.

NOTE

To facilitate air spring installation, compress it manually then put a piece of tape over the air line threaded fitting. This prevents air from getting back into the bag and keeps it compressed, thus enabling to place the bag in between the mounting plates and greatly easing installation.

2. Tighten and torque the lower stud nuts, and then the upper one as prescribed in Torque Table 3.
3. Thread the remaining upper nut (large nut) and tighten as prescribed in Torque Table 3.
4. Install elbow (if applicable), then connect air line.
5. Connect the height control valve link.
6. Build up air pressure in system.

NOTE

To accelerate this operation, air reservoirs can be filled from an exterior air supply connected to the accessory tank fill valve or to the emergency fill valve.

7. Check operation of bellows, and with the primary air system at normal operating pressure (95 – 125 psi (655 – 860 kPa)), coat the air line connections and air spring mounting areas with a water and soap solution. Bubbles will indicate an air leak, and none is permissible. Repair or replace defective parts.
8. Reinstall wheel.
9. Remove the hydraulic floor jack from under the axle, then lower vehicle to ground.

4.2 SHOCK ABSORBERS

Double-action, telescoping-type shock absorbers ensure a smooth ride and enhance vehicle stability on the road. All shock absorbers are eye-type mountings. The tag axle is provided with two shock absorbers while the drive axle is provided with four of them (Fig. 42).

Shock absorbers are non-adjustable and non-repairable. Maintenance requirements involve replacement of the rubber mounting bushings, and tightening of all shock absorber mounting pins at the proper torque (refer to Torque Table 3) when shock absorber replacement occurs. If

a shock absorber becomes inoperative, complete unit must be replaced.



CAUTION

When a shock absorber is found defective, always replace with a new set on affected axle, except if there has been a recent replacement of one unit. The following method will help in determining if both shock absorbers on the same axle have to be replaced.

4.2.1 Inspection

Loosen lower mounting of both shocks, and then carefully attempt to raise and lower the bottom portion of each shock. Note the rate of effort for distance of travel. Replace both shocks if a definite differential rate is found.

The shock must be bench checked in an upright, vertical position. If checked in any other position, air will enter the cylinder tube and make the shock absorber appear defective.

Proceed as follows to check shock absorbers:

1. With the shock absorber in a vertical position (top end up), clamp the bottom mount in a vise.



CAUTION

Do not clamp the reservoir tube or the dust tube.

2. Rotate the dust tube. Notice any binding condition (may be compared with new unit). Binding condition indicates a scored rod. Units with scored rods should be replaced.
3. Fully extend shocks and check for leaks in the seal cover area. Shock fluid is a very thin hydraulic fluid that has a characteristic odor and dark brown tint. A slight trace of shock fluid around the seal cover area is not a cause for replacement. The shock seal is designed to permit a very slight seepage to lubricate the rod. Units that leak should be replaced.
4. Visually check shock for dents that could cause the shock to bind. Also, check for a bent rod.
5. Extend and collapse shock several times to determine that it has control (resistance) in both rebound and compression.

6. Visually inspect the shock mountings and vehicle mounting for:
 - a) Broken mounts;
 - b) Extreme bushing wear;
 - c) Shifted bushing or sleeve;
 - d) Deep cracks in bushing material (shallow surface cracks are normal);
 - e) Loose shock absorber pins;
 - f) Presence of convex washers, and their position relative to the rubber bushing.

4.2.2 Removal

1. Remove nuts and washers from shock absorbers on upper and lower mounting pins, taking care to identify the inner and outer washers to ease reinstallation. Refer to figure 44 for details.
2. Remove the shock absorber assembly from pins.
3. Remove the two inner bushings from the shock absorber and discard them.

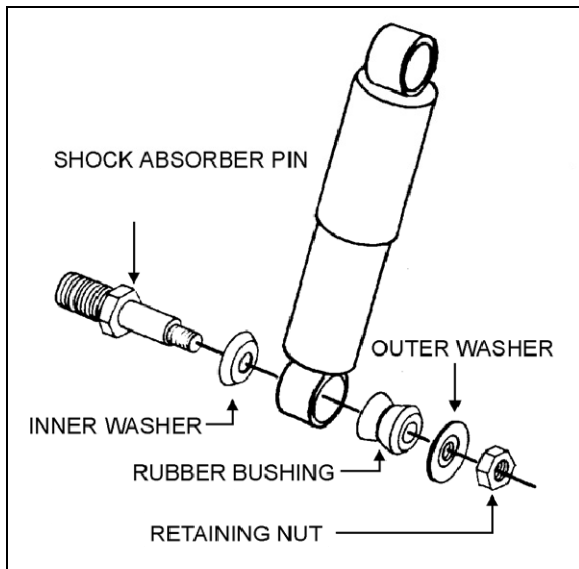

FIGURE 44: SHOCK ABSORBER 16008

4.2.3 Installation

1. Ensure that the shock absorber mounting pins are tight and that the threads are not stripped.
2. Install new rubber mounting bushings on shock absorbers (upper and lower).
3. Place the inner washers (with washer convex side facing the shock absorber rubber bushing) on each shock absorber pin (Fig. 45).

4. Install the shock absorber eyes over the mounting pins, then the outer washers (with washer convex side facing the shock absorber rubber bushing) on each shock extremity.

NOTE

If shock absorber pins are removed, they must be reinstalled using "Loctite" (see "Parts Specifications" in this section).

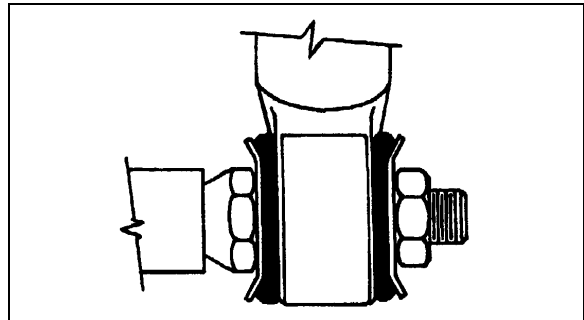

FIGURE 45: TYPICAL SHOCK ABSORBER SETUP 16009

5. Place the lower and upper mounting pin stud nuts and torque as prescribed in Torque Table 3.

4.3 RADIUS RODS

Radius rods are used to secure the axles in the proper transversal and longitudinal positions. Four radius rods are provided on the drive axle suspension (three longitudinal and one transversal) and also four on the tag axle with a layout similar to the drive axle. Refer to figures 40, 41 and 42 for details. These rods transmit both braking and driving forces from the axles to the vehicle body.

4.3.1 Rear Underframe Suspension

Radius Rod Inspection

The following instructions apply to the radius rods used on the rear underframe suspension:

1. Clean all parts thoroughly.
2. Inspect radius rods for distortion and cracks. We recommend the "Magnaflux" process to detect cracks in the radius rod. Any damaged part should be replaced.

NOTE

New bushings should be used when rods are replaced.

3. The radius rod bushings should be checked periodically for signs of shearing,

Section 16: SUSPENSION

deterioration, or damage. Any defective part should be replaced with a new one.

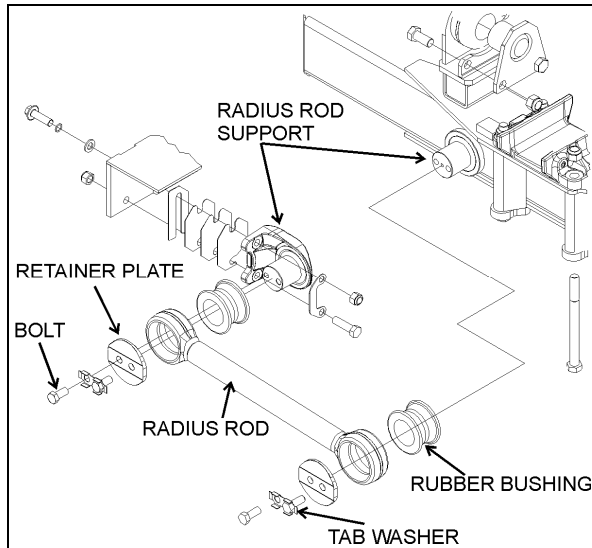

FIGURE 46: TYPICAL RADIUS ROD SETUP 16010

Radius Rod Removal

1. Flatten the tab washer which secures the two retaining bolts, and then unscrew the bolts at each extremity of the radius rod (Fig. 46).
2. Remove the tab washer and the retaining plates and radius rod ends from anchor pins, and then remove the radius rod.

Bushing removal

1. Safely support the radius rod as shown in figure 47.

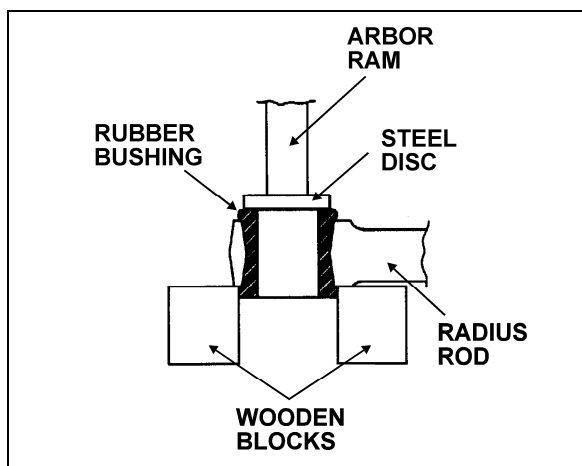

FIGURE 47: RADIUS ROD BUSHING REMOVAL 16011

2. Place a flat steel disc, slightly smaller than the outside diameter of the bushing (Fig. 47).

3. Using an arbor press or a suitable driving tool, press or drive the old bushing out of the rod and discard the bushing.

CAUTION

Make sure to prevent the steel disc from contacting the radius rod end.

Bushing installation

1. Lightly spray the inner and outer surfaces of radius rod bushing with water.

CAUTION

No lubricant whatsoever is to be used on the rubber bushing.

2. Safely support the radius rod, and place new bushing on top of the radius rod end (Fig. 48).
3. Place a block of wood on top of bushing and press on it manually.
4. If necessary, use an arbor press or a suitable driving tool. Press or drive the bushing into the radius rod end until it extends equally on both sides of the rod.
5. It is also possible to proceed differently. Place radius rod bushing on a plane surface. Spray a light coat of water on the inner and outer surfaces of radius rod bushing.
6. Take radius rod, align the bushing. Tap radius rod on bushing until latter is positioned correctly.

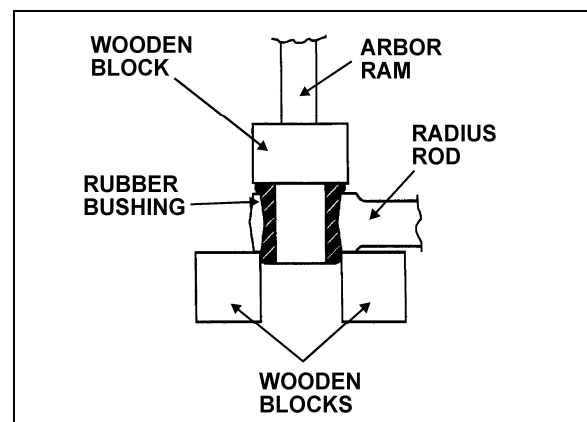

FIGURE 48: RADIUS ROD BUSHING INSTALLATION 16012

Radius Rod Installation

1. Lightly spray the radius rod support with water. Place the radius rod end over the radius rod support (Fig. 46).
2. Position the retaining plate. Install the tab washer and nuts (or bolts).

CAUTION
Always use new tab washers at installation.

3. Tighten the nuts (or bolts) lightly, and repeat at the other end.
4. Refer to heading "Suspension Height Adjustment" later in this section, and set the vehicle to normal ride height.
5. With the vehicle at normal ride height, tighten all radius rod anchor pin nuts or bolts as prescribed in Torque Table 3.

CAUTION
It is extremely important upon reconnection of the rods that the proper clearance height between the axle and body be maintained. Otherwise, the rubber bushings in radius rod ends will become preloaded, thus reducing their life span.

4.3.2 Tag Axle Suspension

The assembly work may be done only by a recognized specialized workshop. Ensure that old and new parts do not get mixed up with each other. It is for this reason that all the old parts are to be scrapped immediately after a joint has been stripped down. A complete repair set must be used for each joint repaired, i.e. use of only part of a repair set is not permissible.

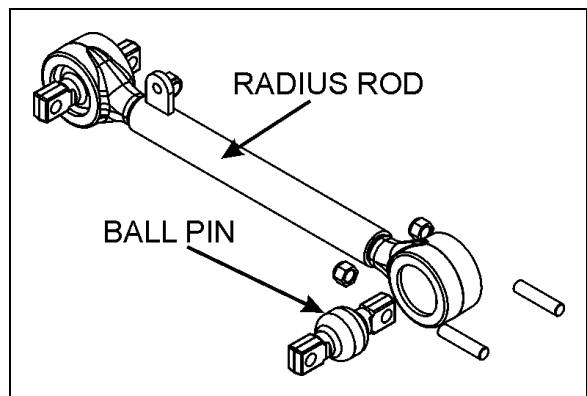

FIGURE 49: TYPICAL RADIUS ROD SETUP ON TAG AXLE 16010

Inspection

Take off the load from the ball joint by lifting the rear of the vehicle. Apply a load on the joint in all of the degrees of freedom in an axial, radial, etc. sense with a suitable lever tool. After the load is taken off, the joint has to spring back into its starting position. Free play is not acceptable.

Separation of rubber from ball pin or external joint shell is in accordance with "normal wear characteristics".

When the following characteristics are noted, the joint is to be changed:

- Free play;
- Radial cracking of the external sheet-metal race.

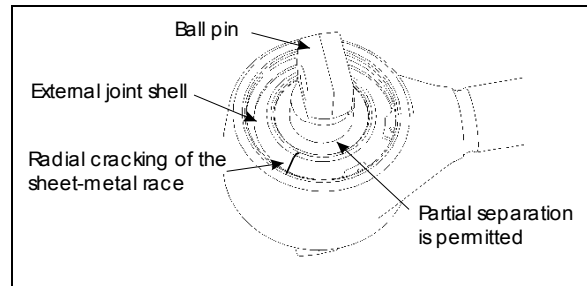

FIGURE 50: BALL JOINTS 16173

Stripping Down

Strip down the defective joint through removal of retaining ring, annular spacer and ball pin/bushing, assembly and thereafter clean out housing bore and locking circlips groove.

Assembly

Execute assembly of the new joint parts in the following sequence:

1. Complete moistening of the contact surface between housing bore and ball pin through application of the grease.

NOTE
Apply grease, only in the case of repair kit (Prevost # 611114).

2. Insert ball pin/bushing, assembly. In case of the two-bolt type, ensure that the bolt bores are in the correct position in relation to the axis of the tube.
3. Place joint in receiving fixture and mount annular assembly tool on the housing. Then locate annular spacer and retaining ring in the housing using axial load with the aid of assembly matrix. If the ends of the annular spacer are not in contact with each other,

Section 16: SUSPENSION

the thus formed opening must be located at 180° to the opening of the retaining ring. Pay attention during assembly to ensure that the retaining ring eyelets are located at each side of the housing shaft axis (retaining ring eyelet lug points to tube), and that retaining ring is properly engaged in the groove of the housing.

When repairing defective ball pin assemblies, the necked down-bolt must regularly be replaced with a new one.

5 SUSPENSION AIR SYSTEM

The suspension air system has its own air reservoir (accessory tank) which is located in the reclining bumper compartment. Pressurized air from the main tank (wet tank) flows through a pressure protection valve (PR-4), to the accessory air tank and through an air filter which is located in front service compartment.

The pressure protection valve (PR-4) is mounted to the supply port of the tank. This valve controls the pressure at which compressed air is delivered to the accessory air tank. The valve remains closed until a preset pressure is reached (approximately 70 psi (485 kPa)). It then opens and passes air out the delivery port.

The main use for this valve is to protect the main air system by ensuring at all times a sufficient air pressure in the main system (i.e. air delivered to the accessories will be shut off in case of a decrease in pressure). Maintenance and repair information on the pressure protection valve is supplied in the applicable booklet, annexed to Section 12, "Brakes and Air System" under reference number SD-03-2010.



WARNING

Depressurize parts prior to removal.

5.1 INSPECTION

The following inspection should be performed at established service inspection periods. Performing these procedures will allow substandard performance to be discovered before the condition becomes bad enough to cause operator complaints and failure on a run.

1. Visually inspect the suspension air lines for evidence of chafing on metal parts or other damage.

2. Visually inspect the air springs for cracks, abrasion or other damage.
3. Replace any parts found to be damaged.

5.2 AIR LINE TEST

With the main air system at normal operating pressure, coat all suspension air line connections and air spring mountings with a solution of soap and water. Air leakage will produce soap bubbles. Any leak found must be corrected as no air leakage is permissible.

5.3 AIR TANK MAINTENANCE

Refer to Section 12, "Brakes and Air System" under "MAINTENANCE" for complete instructions on air tank maintenance.

6 SUSPENSION HEIGHT ADJUSTMENT

The flow of pressurized air from the accessory air tank to the air springs is controlled by three height control valves. These valves are mounted to the subframe and connected to the axles through an arm and link connection. This connection allows the valves to apportion air pressure in the springs to the vehicle load, maintaining normal ride height.

Immediate response height control valves increase or decrease the air pressure in the suspension system as required. One height control valve is located at center of front axle, and regulates air to front axle air springs in order to maintain the vehicle at the required height. Two are located at the drive axle, one on each inner side of rear wheelhouse. Refer to figure 43.

The appropriate vehicle body height is obtained by measuring the clearance of all the air springs installed on the front and drive axles. The clearance should be $12 \pm \frac{1}{4}$ " (305 ± 6 mm) for the air springs installed on the front I-beam axle, $12 \frac{15}{16} \pm \frac{1}{4}$ in (328 ± 6 mm)) for the air springs installed on the Independent Front Axle and $11\frac{1}{2} \pm \frac{1}{4}$ " (292 ± 6 mm) for those installed on the drive axle. Refer to figure 39 and 53 to identify the correct location where the measure has to be taken. At this point, it should not be necessary to make an adjustment under normal service conditions. However, if an adjustment is required, change the position of the overtravel lever in relation to the overtravel control body. The lever should be moved up to raise the height of vehicle and down to lower it. Check

that main air pressure is at normal operating pressure and raise the vehicle to the specified height.



CAUTION

Always adjust on "fill cycle". If it is necessary to lower vehicle height, release sufficient air to be well below height, and adjust to height or fill cycle.

To adjust suspension height, proceed as follows:

1. With the vehicle at normal operating air pressure, check the air spring clearance as illustrated in figure 51. This clearance should be $12 \pm \frac{1}{4}$ " (305 \pm 6 mm) for the front I-beam axle air springs, $12 \frac{15}{16} \pm \frac{1}{4}$ in (328 \pm 6 mm) for the Independent Front Suspension air springs and $11\frac{1}{2} \pm \frac{1}{4}$ " (292 \pm 6 mm) for those on the drive axle.

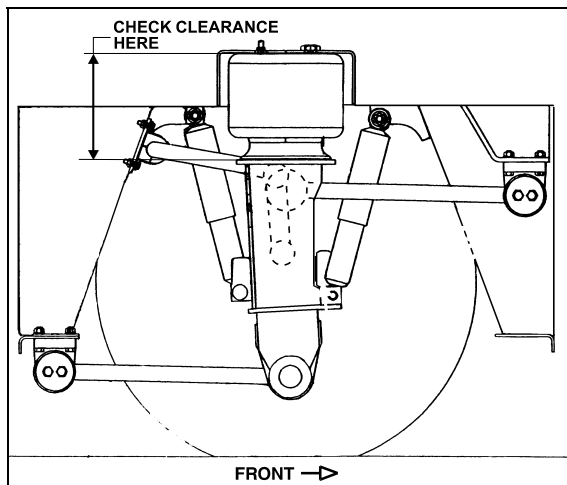

FIGURE 51: TYPICAL AIR SPRING CLEARANCE, FRONT I-BEAM AXLE 16108

NOTE

The measure should be taken from under the upper air spring support on subframe to top of the lower air spring support on axle (refer to figure 39 for more details). If adjustment is required, begin with the drive axle.

2. Loosen the adjusting nuts on the connecting rod of height control valve to raise or lower the overtravel lever until the desired clearance is reached.
3. If there is not enough play on adjusting nuts, it is possible to make further adjustments by loosening the clamp on the rubber coupling and bringing it up or down.

NOTE

Allow suspension to stabilize before taking reading.

4. When the desired height is obtained, tighten adjusting nuts and clamp.

7 HEIGHT CONTROL VALVES

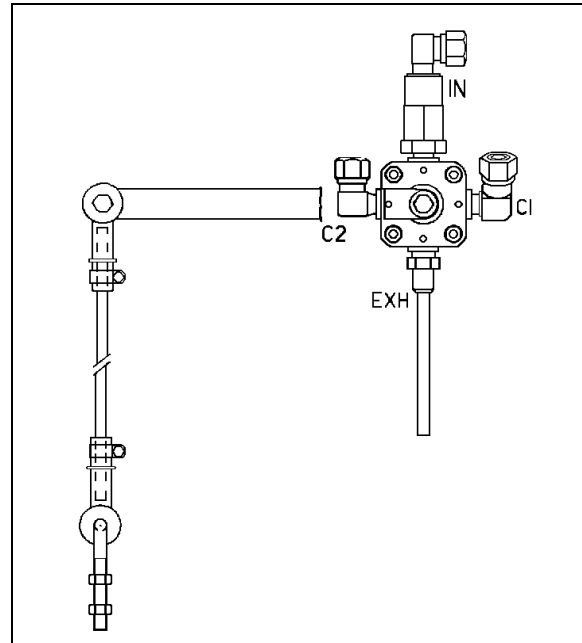

FIGURE 52: HEIGHT CONTROL VALVE 16093

The height control valves automatically add air to, or release air from air springs to maintain constant suspension height regardless of load, or load distribution. Each valve adjusts independently according to the following conditions:

Loading position

As the load increases and lowers the vehicle body, the overtravel lever commands the height control valve to add air to air springs.

Neutral position

When vehicle body reaches the normal ride height, the height control valve overtravel lever reaches the "neutral" position and keeps both the supply and exhaust ports closed to ensure normal ride height is maintained. This condition remains static until the vehicle load is altered.

Unloading position

As the load decreases and raises the vehicle body, the overtravel lever commands the height control valve to release air from air springs.

Section 16: SUSPENSION

7.1 MAINTENANCE

The height control valve requires no periodic maintenance. Height control valve linkage operates on rubber bushings and no lubrication should be attempted at this point. Inspect the valve for loose joints, air leaks and worn bushings.

7.1.1 Removal and installation

Before disconnecting any height control valve air lines, securely support the vehicle by its jacking points on the body, and place safety support underneath body. Refer to "VEHICLE JACKING POINTS" in Section 18, "Body".

1. Exhaust air from air system by opening the drain cock on accessory air reservoir. Remove height control valves.
2. Disconnect overtravel lever from link and pull down lever to exhaust remaining air from air springs.
3. Disconnect air supply and delivery lines from the height control valve. Cover ends of the lines with tape to prevent entry of foreign matter.
4. Remove the nuts retaining the height control valve to the mounting bracket, then remove valve assembly.

Reverse removal procedure to replace height control valve. After installation, check for leakage using a soap and water solution.

7.1.2 Air leakage test

NOTE
The following procedure applies when valve assembly has been removed from vehicle.

1. Clean the exterior of valve assembly.
2. Connect air pressure line to air inlet port, then allow air pressure build-up (70- 100 psi (480 - 690 kPa)).
3. Dip the valve assembly in a container of water, and watch for air bubbles when the overtravel lever is in the center position. No air should escape from any point of the valve assembly.
4. If bubbles appear from the air spring port, this is an indication that the air inlet valve assembly is defective and must be replaced.
5. Remove air pressure line from air inlet fitting and connect it to the air spring port. If bubbles appear at the air inlet check valve

port, this is an indication that the check valve unit is defective and must be replaced.

6. If bubbles appear at the exhaust port, this is an indication that the exhaust valve assembly is defective and must be replaced.
7. If bubbles appear around edge of valve cover plate, the cover plate gasket must be replaced.
8. If no leaks are found, remove valve assembly from water, then with air pressure still connected to the air spring port, actuate overtravel lever to remove any excess water which may have entered exhaust valve chamber. Remove air line, connect it to the air inlet port, and repeat operation to remove water from the air inlet valve chamber.

8 "LEVEL-LOW" LEVELING SYSTEM – VIP SERIES OPTION ONLY

The purpose of the *Level-Low* leveling system is to adjust suspension in three separate points (front, rear right and rear left) in order to level vehicle body. This system can be put into service when the ignition key is turned to the "ON" position, and must be used only when the parking brake is applied. The *Level-Low* warning light on the dashboard indicates that the selector switch is not in the "OFF" position. Level low system controls are located on L.H. side control panel.

8.1 PRINCIPLES OF OPERATION

Down

The (front/rear right/rear left) control solenoid valve supplies air to the (front/rear right/rear left) five-way three-position air control valve, which bypasses the (front/rear right/rear left) height control valve, and opens a passage to allow the air control and exhaust valve to release air from (front/rear right/rear left) air springs.

Up

The (front/rear right/rear left) control solenoid valve supplies air to the (front/rear right/rear left) five-way three-position air control valve, which bypasses the (front/rear right/rear left) height control valve, and opens a passage to allow the air control and exhaust valve to supply air to (front/rear right/rear left) air springs.

Drive

When the ignition key is turned to the "ON" position with selector knob in the "DRIVE" position, the drive control solenoid valve

supplies air to all five-way three-position air control valves, each one opening a passage to allow height control valves to accomplish their function.

When the ignition key is turned to the "OFF" position and selector knob to the "DRIVE" position, the air is entrapped between air springs and five-way three-position air control valves to ensure the adjusted level will be kept.



WARNING

Never move vehicle with selector knob in any other position than the "DRIVE" position.

8.2 MAINTENANCE

Since the kneeling action is issued from both the air system and electrical system, refer to Section: 12, "Brake and Air System" and Section 06, "Electrical System".

For diagnosis and understanding of the system, refer to wiring diagrams, and to the appropriate air system schematic diagram annexed to Section 12, "Brake and Air System".

9 FRONT KNEELING SYSTEM

The kneeling system is used to lower front of vehicle. This allows passengers to board the vehicle with greater ease. The kneeling action is achieved by exhausting air from the front air springs (bellows). This system bypasses the height control valve to provide a fast up and down movement of the front suspension. Only seven seconds are required to lower vehicle from normal level to the lowered position, and approximately the same time to raise the vehicle back to normal level. The quick response is achieved by the kneeling air tank installed beside the secondary air reservoir (for exact position, refer to Section 12, "Brake and Air System").

This tank provides sufficient air supply to the kneeling system for some successive operations. On I-beam axle, a second kneeling air tank is available as an option. This second kneeling air tank is standard on coaches with Independent Front Suspension (IFS).

The system is provided with two safety features; first, a speed switch will enable the kneeling system to work only below 5 mph (8 km/h). Secondly, the parking brake is automatically applied, and a limit switch will keep it applied as long as the vehicle has not returned to a certain

height where the driver will be able to manually remove the parking brake.

The purpose of the front axle hi-buoy function in this system is to raise the front end of the vehicle to allow an extra ground clearance for particular situations. In driving condition, the height control valve is in operation and only the hi-buoy can be operated.

9.1 PRINCIPLE OF OPERATION

Refer to the air system schematic diagram annexed at the end of Section 12, "Brake and Air System".

DOWN (FRONT KNEELING):

Both the air spring control and air spring exhaust solenoid valves are energized, so the air control valves release air from front air springs. The height control valve is bypassed to ensure no air is forwarded to air springs while lowering the front suspension.

UP (FRONT HIGH-BUOY):

Only the air spring control solenoid valve is energized, so the air coming from the kneeling air tank is routed through air control valves, and up to front air springs.

The height control valve is bypassed until the kneeling proximity switch signals the kneeling module to cut off the air spring control solenoid valve, about 1" (25 mm) below normal ride height. The final height adjustment is achieved by the height control valve.

9.2 MAINTENANCE

Since the kneeling action is issued from both the air system and electrical system, refer to Section: 12, "Brake and Air System" and Section 06, "Electrical System".

For diagnosis and understanding of the system, refer to wiring diagrams, and to the appropriate air system schematic diagram annexed to Section 12, "Brake and Air System".

9.3 AIR SPRING CONTROL SOLENOID VALVES

9.3.1 Removal and installation

1. On the rear side of steering compartment, locate both the air spring control and air spring exhaust solenoid valves.
2. Identify hoses and wires to ease reinstallation. Disconnect solenoid wires and

Section 16: SUSPENSION

the three flexible black hoses from solenoid valves.

3. Unscrew and remove the control solenoid valve and exhaust solenoid valve assembly. Place on a clean working place.

Reverse removal procedure to reinstall.



CAUTION

Always adjust on "fill cycle". If it is necessary to lower vehicle height, release sufficient air to be well below height, and adjust to height or fill cycle.

10 HIGH-BUOY SYSTEM

The purpose of the full high-buoy system is to raise the entire vehicle body about 4" (100 mm) in order to increase ground clearance to board a ferryboat, to jump a curb, etc. This system can be put into service during normal vehicle operation.

10.1 PRINCIPLES OF OPERATION

The rear high-buoy system is added over the front kneeling (with front high-buoy). The front end uses the same valves as the front kneeling (with front high-buoy). A solenoid valve is added to send air to the double shuttle valves for the rear end. It uses the same dash switch as the kneeling.

UP:

The air coming from the control valve flows through double shuttle valves, to supply air springs. The double shuttle valves prevent height control valves from releasing air from air springs.

DOWN:

The control valve, on the dashboard, cuts off air supply, so the double shuttle valves allow height control valves to accomplish their function. Height control valves release air from air springs until suspension returns to its normal position.

10.2 MAINTENANCE

Refer to the air system schematic diagram "OPT. FRONT KNEELING WITH REAR HIGH-BUOY COMBINATION."

10.3 HIGH-BUOY – PRESSURE REGULATOR

The pressure regulator is located on ceiling of the spare wheel and tire compartment and is accessible through the reclining bumper. This valve should be adjusted to 90 psi (621 kPa).

10.3.1 Adjustment

1. Before turning on system air pressure, release jam nut (2, Fig. 53) then turn regulator adjustment handle counterclockwise until the load is removed from the regulating spring.
2. Turn on system pressure.
3. Turn regulator adjustment handle clockwise until the desired outlet pressure is reached.
4. To avoid minor readjustment after making a change in pressure setting, always approach the desired pressure from a lower pressure. When reducing from a higher to a lower setting, first reduce the pressure at a lower pressure, and then increase it to the desired level of pressure.
5. Tighten jam nut (2, Fig. 53) to lock pressure setting.

10.3.2 Disassembly

1. Shut off inlet pressure and reduce pressure in inlet and outlet lines to zero. Turn regulator adjustment handle (1, Fig. 53) counterclockwise until all load is removed from regulating spring. Regulator can be disassembled without removal from air line.
2. Disassemble regulator in accordance with the item numbers on the exploded view.

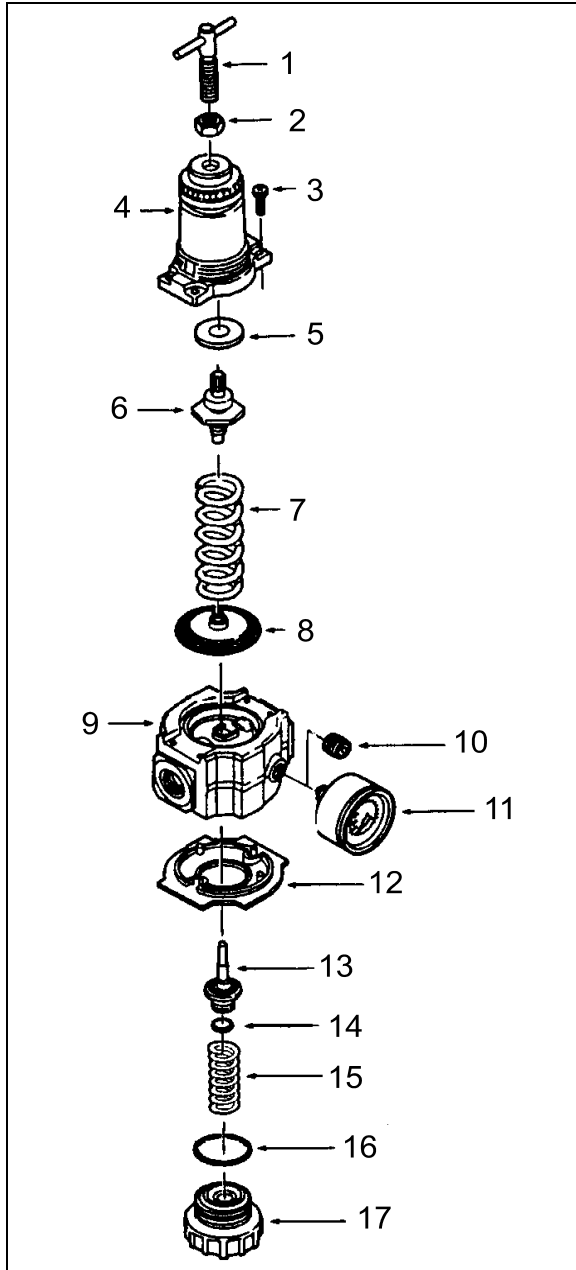

FIGURE 53: AIR PRESSURE REGULATOR 16035

Torque Table	
Item	Torque in lbf-in (Nm)
3 (Screw)	25-35 (2.8-3.9)
17 (Bottom plug)	20-25 (2.3-2.8)

10.3.3 Cleaning

1. Clean parts with warm water and soap. Dry parts and blow out internal passages in body using clean, dry compressed air.

2. Inspect parts. Replace those found to be damaged.

10.3.4 Reassembly

1. Lubricate O-ring (14 and 16, Fig. 53), valve stem (13), tip of adjusting screw (1), and the outer circumference and both sides of the thrust washer (8) with a light coat of good quality O-ring grease.
2. Assemble the regulator as shown on the exploded view.

11 LOW-BUOY SYSTEM

The purpose of the low-buoy system is to lower the whole suspension by about 4" (100 mm) in order to reduce the overall height for low clearances. This system can be put into service during normal vehicle operation.

11.1 PRINCIPLES OF OPERATION

On H3-41 and H3-45 coaches, the rear low-buoy is added over the front kneeling system. The control valve on the left console panel sends an electric signal from its pressure switch to control the front suspension as if kneeling. It also removes air from a relay valve that exhausts air supply to all leveling valves and the quick release in the rear section. Air from the rear suspension can then be depleted through the check valve-quick release assembly.

DOWN:

The control valve, on the L.H. control panel, cuts off air supply, so air is released from air springs. A relay valve prevents height control valves from supplying air springs.

UP:

The control valve, on the L.H. control panel, supplies air to close the passage between both the delivery and supply ports. A relay valve opens and provides air springs until the suspension reaches the normal ride height.

11.2 MAINTENANCE

Refer to the air system schematic diagram "OPT. FRONT KNEELING WITH REAR LOW-BUOY COMBINATION".

12 AIR SYSTEM

The basic air system consists of an air compressor, tanks, valves, filters and

Section 16: SUSPENSION

interconnecting lines and hoses (refer to Section 12, "Brake and Air System" for complete information). It provides a means for braking, operating controls and accessories, and suspension.

The air coming from the air dryer is first directed to the wet air tank, then to the primary (for the primary brake system), secondary (for the secondary brake system), and accessory (for the pneumatic accessories) air tanks (Fig. 54).

In addition, an expansion air tank is installed in series with each air spring.

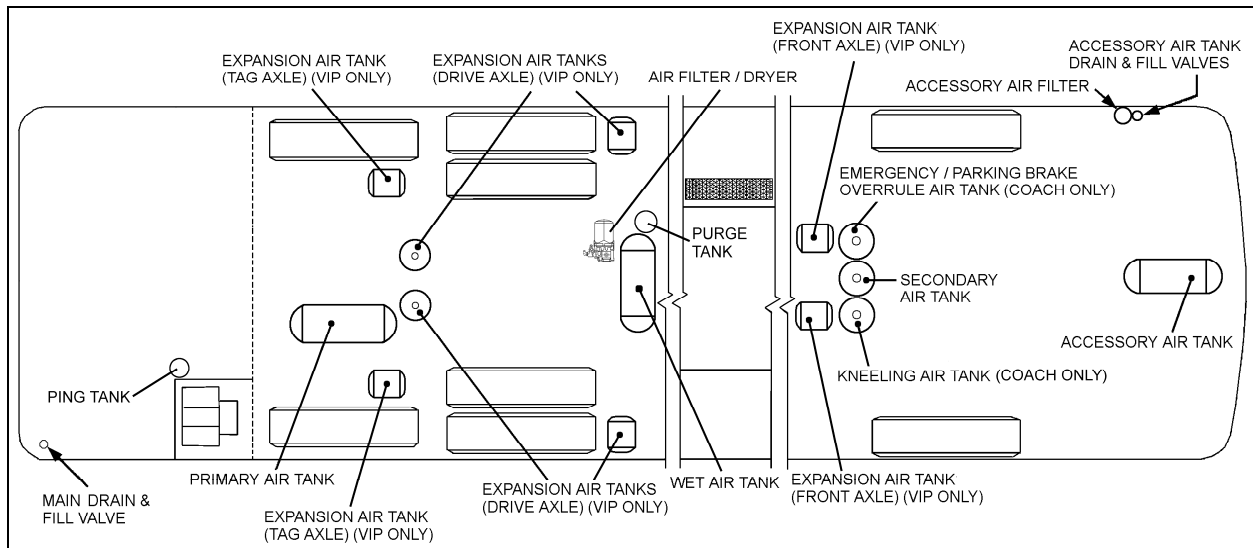

FIGURE 54: LOCATION OF AIR TANKS

12195

12.1 AIR TANK MAINTENANCE

Ensure that the accessory air tank is purged during pre-starting inspection. A good practice is to purge this tank at the end of every driving day by the remote air tank drain valve located in the steering compartment (Fig. 56).

Moreover, purge all tanks by their bottom drain valves at specified intervals.

12.1.1 Wet Air Tank

This tank is installed in front of and above drive axle in the rear wheelhousing and is provided with a bottom drain valve.



MAINTENANCE

It is recommended to **purge** the wet air tank by its bottom drain valve every 12,500 miles (20 000 km), or once a year, whichever comes first.

A remote valve located in engine compartment and accessible through engine R.H. side door is used to **purge daily** (Fig. 55).

12.1.2 Primary Air Tank

The primary air tank is located above tag axle.

This tank is also provided with a bottom drain valve.



MAINTENANCE

It is recommended to **purge** the primary air tank by its bottom drain valve every 12,500 miles (20 000 km), or once a year, whichever comes first.

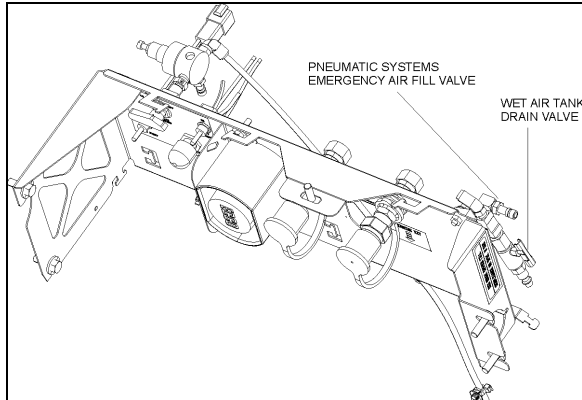



FIGURE 55: REAR VALVE LOCATION 12162

12.1.3 Secondary Air Tank

This tank is located in front wheelhousing. The tank is installed vertically and is provided with a bottom drain valve (Fig. 54).

 <h2 style="margin: 0;">MAINTENANCE</h2>
<p>It is recommended to purge the secondary air tank by its bottom drain valve every 12,500 miles (20 000 km), or once a year, whichever comes first.</p>

12.1.4 Accessory Air Tank

The accessory air tank is installed at the ceiling of spare wheel compartment. The tank is provided with a bottom drain valve (Fig. 54).

 <h2 style="margin: 0;">MAINTENANCE</h2>
<p>It is recommended to purge the accessory air tank by its bottom drain valve every 12,500 miles (20 000 km), or once a year, whichever comes first.</p>

A remote drain valve is located in front service compartment (Fig. 56) underneath the accessory air filter. Refer to Section 12, paragraph "4. Accessory Air Filter" of the maintenance manual for daily purge procedure.

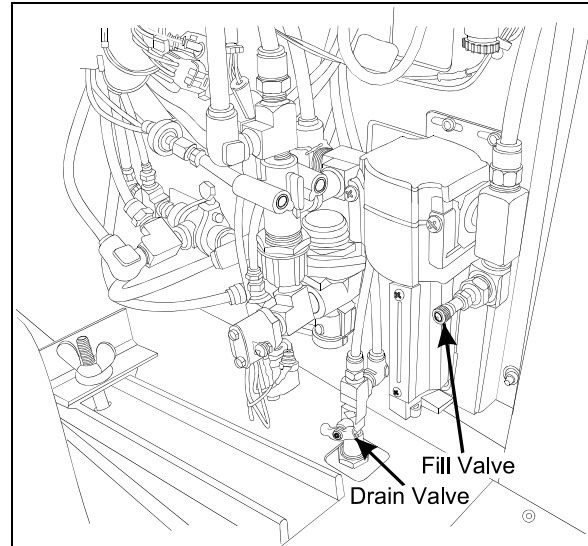



FIGURE 56: FRONT VALVE LOCATION 12144

12.1.5 Expansion Air Tank

Two expansion tanks are located in front wheelhousing. These air tanks are located behind secondary air tank. Also, six expansion tanks are located near rear air springs (Fig. 54). Expansion tanks are connected in series with air springs. Expansion tanks are used to lower the stiffness of the air spring. They are provided with a bottom drain valve.

 <h2 style="margin: 0;">MAINTENANCE</h2>
<p>It is recommended to purge the expansion air tanks every 12,500 miles (20 000 km), or once a year, whichever comes first.</p>

12.2 EMERGENCY FILL VALVES

The vehicle is equipped with two air system emergency fill valves to supplement the air system when air pressure is low and engine cannot be operated.

The rear valve is located in engine compartment and accessible from engine R.H. side door (Fig. 55).

 <h2 style="margin: 0;">CAUTION</h2>
<p>No other point should be used to supply air system. The maximum allowable air pressure is 125 psi (860 kPa).</p>

The front valve is located in the front service compartment close to accessory air filter (Fig. 56).

Section 16: SUSPENSION

These two air valves are fitted with the same valve stems as standard tires, and can be filled by any standard external air supply line.

The rear valve will supply air for all systems (brakes, suspension and accessories) while the front valve will supply air for accessories only.



CAUTION

Air filled through these two points will pass through the standard air filtering system provided by Prevost. Do not fill air through any other points.

13 REAR SUSPENSION TORQUE SPECIFICATIONS

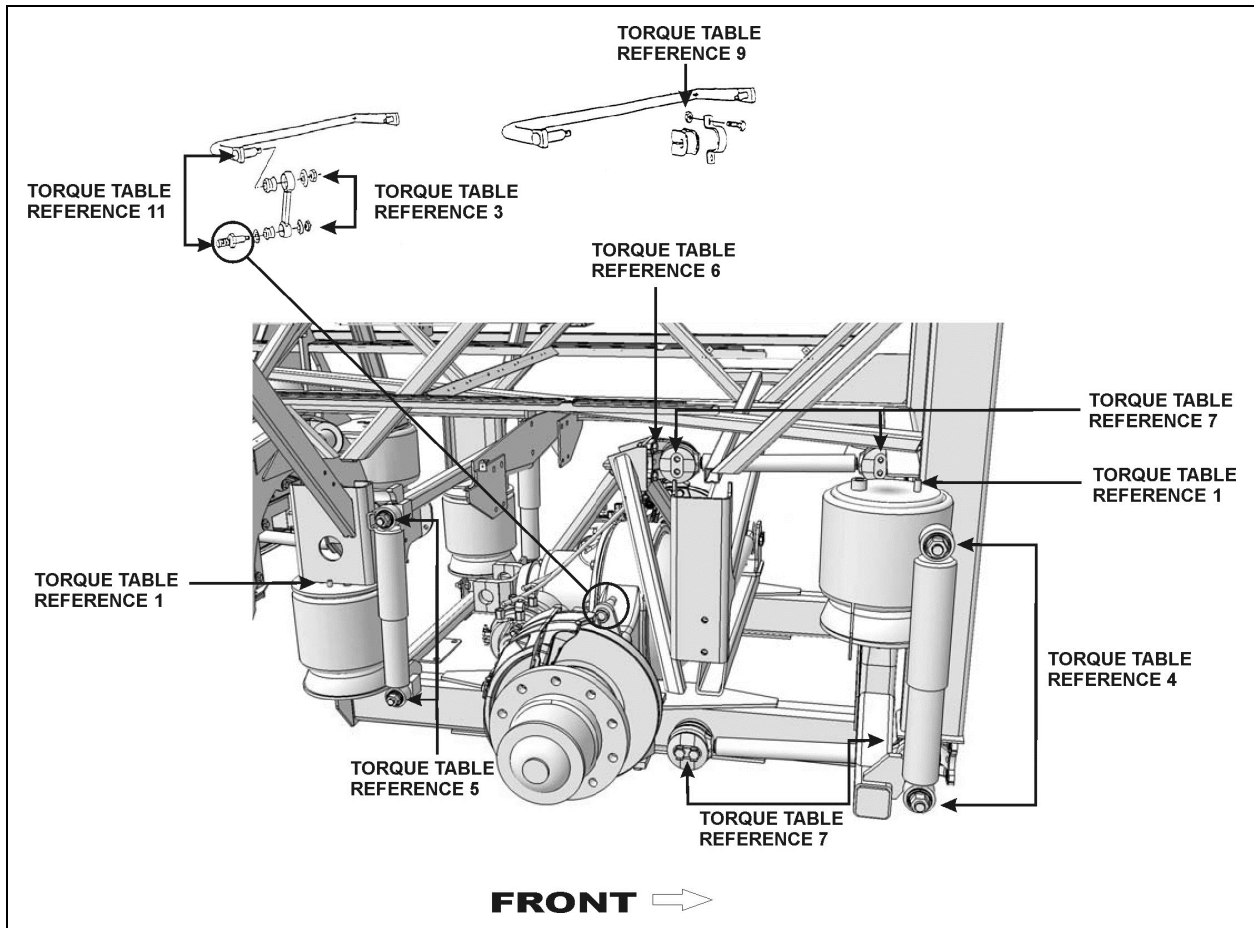

FIGURE 57: TORQUE SPECIFICATIONS – DRIVE AXLE

16158

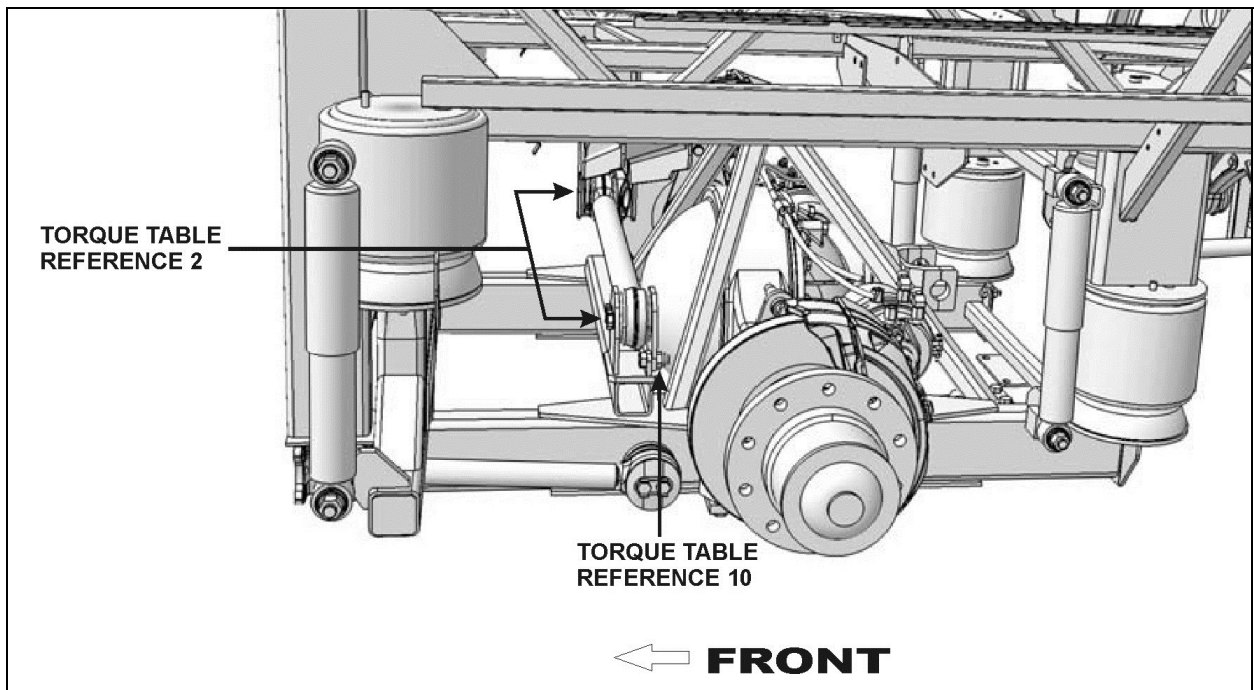

FIGURE 58: TORQUE SPECIFICATIONS – DRIVE AXLE

16159

Section 16: SUSPENSION

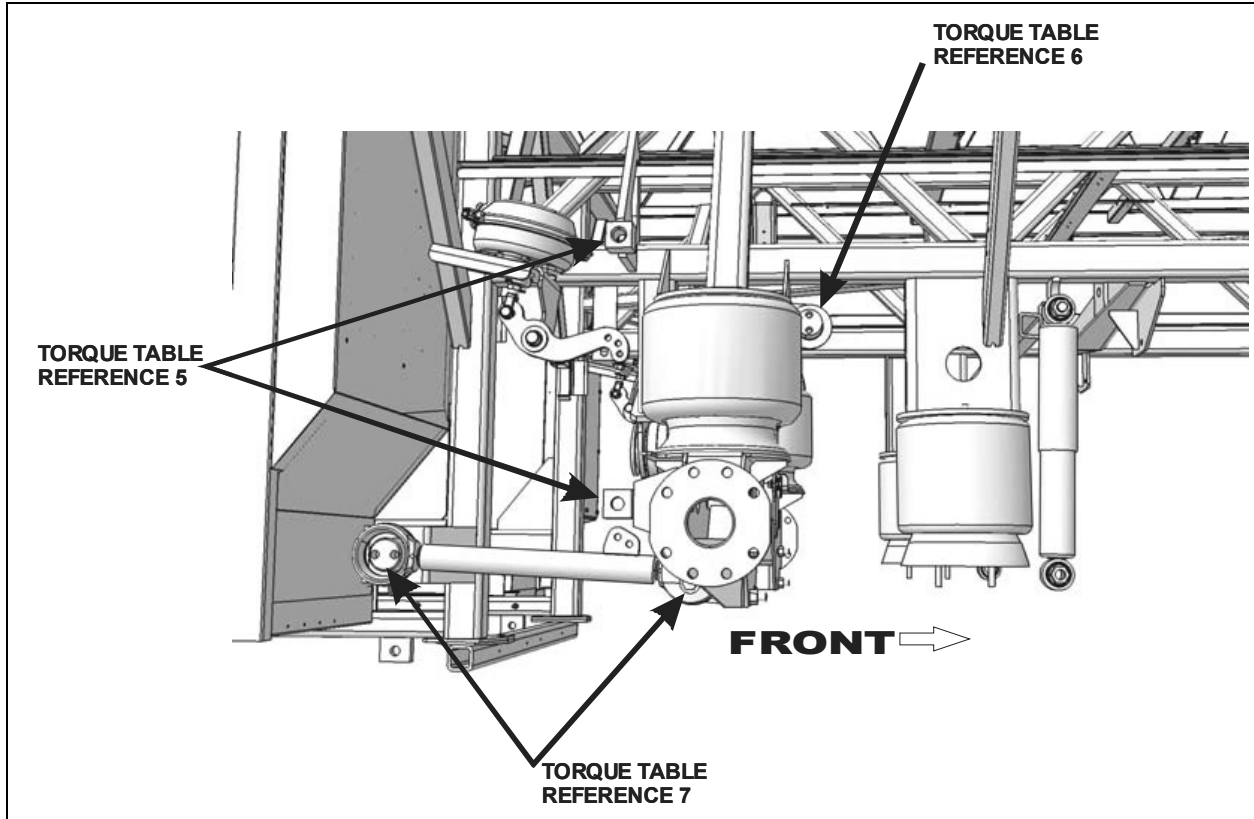

FIGURE 59: TORQUE SPECIFICATIONS – TAG AXLE

16160

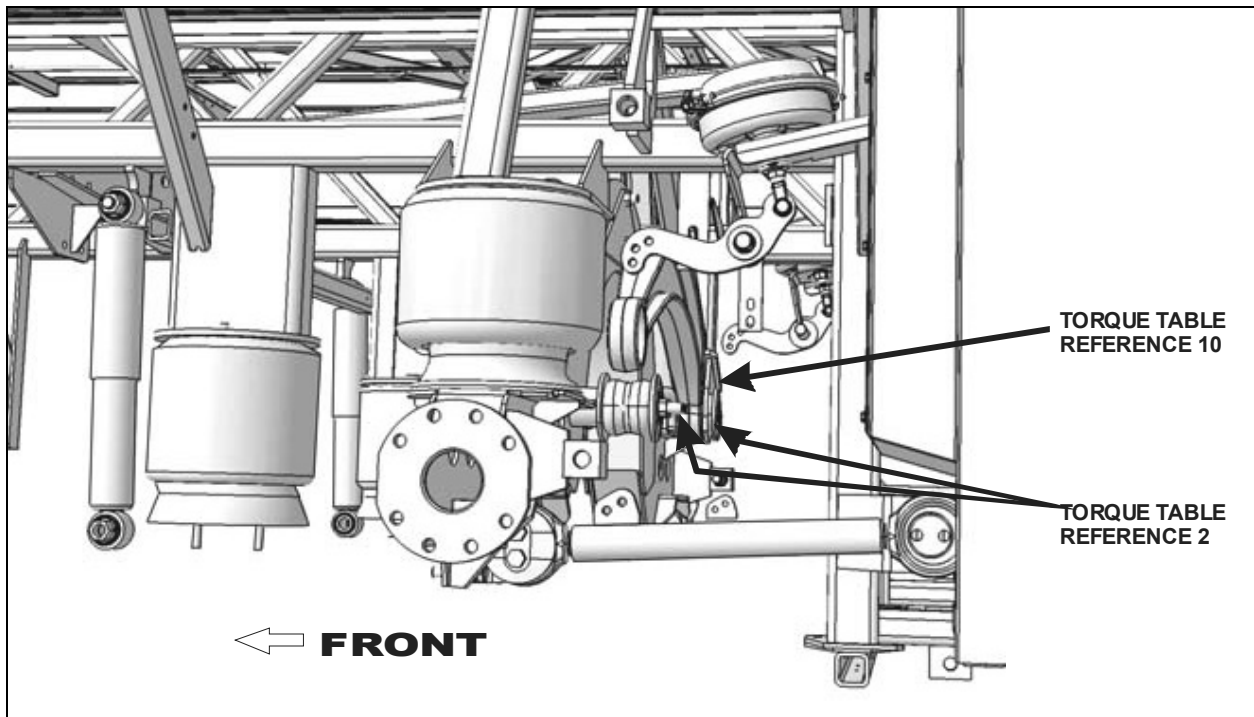

FIGURE 60: TORQUE SPECIFICATIONS – TAG AXLE

16161

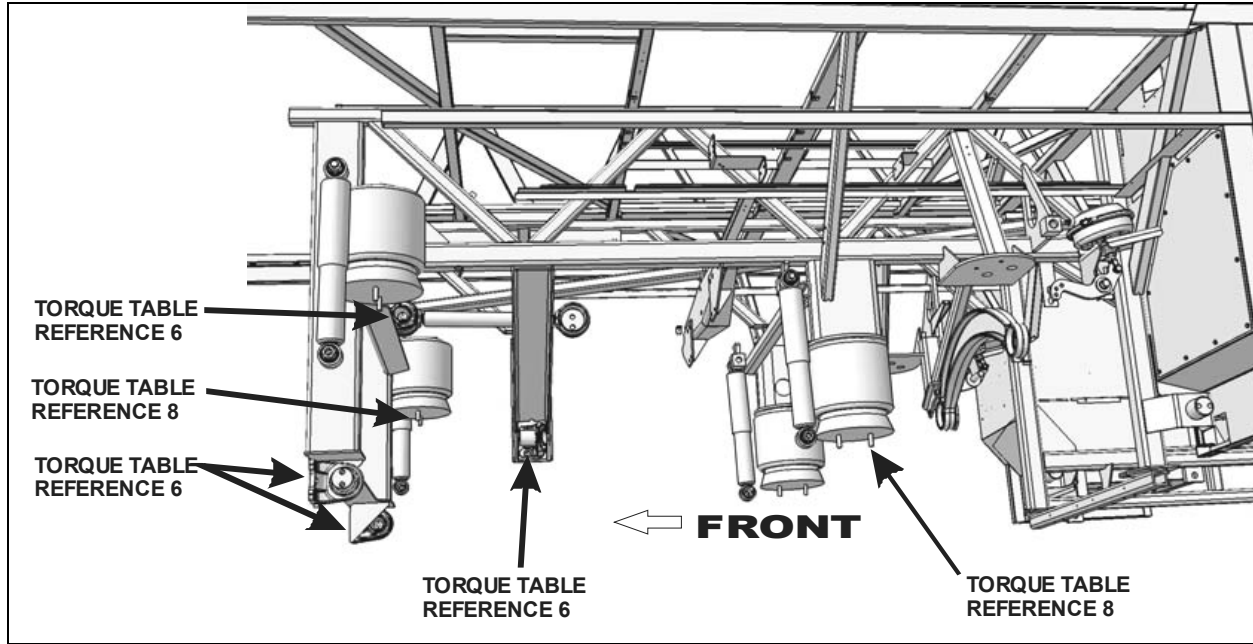

FIGURE 61: TORQUE SPECIFICATIONS – REAR SUBFRAME

16162

The following table lists the tightening torques of bolts and nuts requiring a specific torque value. When no torque specifications are indicated, use the Standard Torque Specifications table found in Section 00: General Information of the Maintenance Manual.

SPECIFIC TORQUE TABLE 3 – REAR SUSPENSION				
DESCRIPTION	QTY	REFERENCE	TORQUE DRY (lbf-ft / Nm)	
Air Spring Upper Stud Nut (8 air springs)	-	1	20-25	27-34
Transversal Radius Rod Retaining Bolts (Tag, drive & front axle)	-	2	140-155	190-210
Sway Bar Link Upper & Lower Nut	-	3	70-85	95-115
Shock Absorber Pin Nut (6 shock absorbers)	-	4	70-85	95-115
Shock Absorber Pin (8 shock absorbers) ¹	-	5	350-400	475-545
Radius Rod Support Nut/bolt (13 supports)	-	6	200-220	271-298
Radius Rod Retaining Bolts (10 longitudinal radius rods)	-	7	140-155	190-210
Sway Bar Bushing Collar Bolt	-	9	80-100	108-136
Transversal Radius Rod Support Nut (Tag, drive & front axle)	-	10	250-280	339-380
Sway Bar Link Pin Stud	-	11	350-400	475-545
Air Spring Lower Stud Nut (2 front axle air springs)	-	12	20-25	27-34
Air Spring Lower Nut (Front Suspension)	4	25	20-25	27-34
Air Spring Upper Nut (Front Suspension)	2	26	20-25	27-34
Shock Absorber Support	4	27	145-165	196-224
Shock Absorber Upper Mounting Pin Stud Nut	2	28	70-85	95-115
Shock Absorber Lower Mounting Pin Stud Nut	2	29	60-75	81-102
Shock Absorber Pin	2	51	350-400	475-545
Sway Bar Link Upper Nuts (Rear Suspension)	2	-	100-120	135-160
Sway Bar Link Lower Nuts (Rear Suspension)	2	-	70-80	95-110

* Tighten nut to specified torque, then advance to next aligning cotter pin slot and install a new cotter pin.

Section 16: SUSPENSION

<i>NOTE</i>
<i>Apply corrosion-protective compound on exposed threads.</i>

14 TROUBLESHOOTING

Condition	Cause	Correction
Air springs deflate over time	<ol style="list-style-type: none"> 1. Defective check valve assembly. 2. Defective exhaust valve assembly. 3. Leak in air line and/or air springs. 4. Defective valve cover, rubber O-rings or gasket. 	<ol style="list-style-type: none"> 1. Replace check valve assembly. 2. Replace exhaust valve assembly. 3. Replace air line or air springs. 4. Replace valve cover, O-rings or gasket.
Air springs raise to full height and fail to exhaust air pressure	<ol style="list-style-type: none"> 1. A clogged exhaust screen in height control valve assembly. 2. A combination clogged exhaust screen and defective air inlet valve assembly. 	<ol style="list-style-type: none"> 1. Remove and clean screen. 2. Clean exhaust screen and replace air inlet valve assembly.
Erratic valve action	<ol style="list-style-type: none"> 1. Dirt or foreign matter in the air valve lever chamber. 2. Defectives valves. 	<ol style="list-style-type: none"> 1. Remove valve cover and blow out dirt. Install cover using new gasket. 2. Overhaul height control valve assembly
Vehicle body fails to level to satisfactory ride height	<ol style="list-style-type: none"> 1. Improper height control valve overtravel lever adjustment 	<ol style="list-style-type: none"> 1. Adjust lever as directed.

15 SPECIFICATIONS

Independent Front Suspension Air Springs

Make.....Goodyear Tire and Rubber
 Diameter..... 14 inches
 Air Inlet 1/2"-14 NPTF AIR INLET
 Prevost number Refer to Parts Manual

Front I-Beam axle air springs and tag axle air springs

Make.....Goodyear Tire and Rubber
 Type Mae West
 Nominal diameter 12" (304 mm)
 Prevost numberRefer to Parts Manual

Drive axle air springs

Make.....Goodyear Tire and Rubber
 Type Double Flare
 Nominal diameter 11" (279 mm)
 Prevost numberRefer to Parts Manual

Independent Front Suspension - Shock Absorbers

Prevost number Refer to Parts Manual

Shim (Camber Adjustment)

Thickness 3.175 mm
 Prevost number Refer to Parts Manual
 Thickness 6.35 mm
 Prevost number Refer to Parts Manual
 Thickness 4.76 mm
 Prevost number 661094
 Thickness 1.52 mm
 Prevost number Refer to Parts Manual

Front I-Beam axle shock absorbers

Make Sachs
 Color Black
 Ext. Diam. 75 mm
 Collapsed length 15.51" (394 mm)
 Extended length 24.37" (619 mm)
 Prevost number Refer to Parts Manual

Drive and tag axle shock absorbers

Make Sachs
 Color Black
 Ext. Diam. 75 mm
 Collapsed length 15.51" (394 mm)
 Extended length 24.37" (619 mm)
 Prevost number Refer to Parts Manual

Height control valve (IFS)

Quantity used 1
 Prevost number Refer to Parts Manual

Height control valve (coach, all axles & VIP, rear only)

Quantity 2 or 3
 Prevost number Refer to Parts Manual

Bellows control and exhaust solenoid valve assembly

Make Norgren

Solenoid valve manifold

Prevost number Refer to Parts Manual

Coil

Voltage 24 V DC
 Current draw 29 amperes
 Prevost number Refer to Parts Manual

Valve (3-way, 2 positions)

Type N/C
 Prevost number Refer to Parts Manual

Section 16: SUSPENSION

TypeN/O

Prevost numberRefer to Parts Manual

Radius rod bushing

Make.....Prevost

Prevost numberRefer to Parts Manual

Sway bar bushing (Independent Front Suspension)

Make.....Prevost

Prevost numberRefer to Parts Manual

Sway bar bushing (Front Axle)

Make.....Prevost

Prevost numberRefer to Parts Manual

Sway bar bushing (Drive Axle)

Make.....Prevost

Prevost numberRefer to Parts Manual

Sway bar link bushings

Prevost numberRefer to Parts Manual

Shock absorber bushings

Prevost numberRefer to Parts Manual

High-Buoy Pressure regulator

Recommended pressure setting 90 psi (621 kPa)

Prevost numberRefer to Parts Manual