

# SECTION 24: LUBRICATION

## CONTENTS

- 1. LUBRICATION.....2
- 2. LUBRICATION AND SERVICE SCHEDULE.....2
  - 2.1 FLEXIBLE HOSE MAINTENANCE ..... 2
    - 2.1.1 *Hose Inspection*..... 2
    - 2.1.2 *Leaks*..... 2
    - 2.1.3 *Service life* ..... 2
  - 2.2 LUBRICANT AND COOLANT SPECIFICATIONS..... 8
  - 2.3 LUBRICATION AND SERVICING SCHEDULE ..... 8

## ILLUSTRATIONS

- FIGURE 1: LUBRICATION AND SERVICING POINTS ON I-BEAM AXLE FRONT SUSPENSION VEHICLES .....4
- FIGURE 2: LUBRICATION AND SERVICING POINTS – HVAC UNIT .....6
- FIGURE 3: LUBRICATION AND SERVICING POINTS ON INDEPENDENT FRONT SUSPENSION VEHICLES (TYPICAL) .....7

## Section 24: LUBRICATION

---

### 1. LUBRICATION

The efficiency and life expectancy of mechanical equipment is largely dependent on proper lubrication and servicing. All mechanical components rely on a lubricating film between moving parts to reduce friction, prevent wear and oxidation. Proper lubrication also helps cool the parts and keep dirt particles away from mating surfaces. Efficient lubrication depends upon using the right type of lubricant, at specified intervals and by filling to correct capacities. Past experience shows that many service problems can be traced to an improper lubricant or to incorrect lubrication procedures.

A comprehensive maintenance and lubrication program is important to ensure the long service life this vehicle was designed for and to avoid costly repairs and associated downtime caused by premature part failure.

A lubrication schedule is included in this section to give the location of key service points on the vehicle as well as the lubricant specifications for each component to be serviced. Specific instructions on how to check and service different components are covered in their respective sections in this maintenance manual.

The recommended lubrication intervals are based on normal operating conditions and mileage accumulation.

Shorten the intervals if your vehicle operates in more severe conditions. Severe conditions include heavy towing, high vehicle weight or operation in mountainous areas. Some parts and equipment referred to in this section may not be installed on your vehicle. Check your vehicle's "Coach Final Record" for equipment list.

Dispose of used lubricants and filters in an environmentally safe manner, according to federal and/or local recommendations.

### 2. LUBRICATION AND SERVICE SCHEDULE

Following this service schedule is the most economical and easiest way to ensure your vehicle performs at its best, safest and longest. Also, unscheduled maintenance will be minimized since inspection should expose potential problems before they become major ones.

### 2.1 FLEXIBLE HOSE MAINTENANCE

The performance of engine and equipment are greatly related to the ability of flexible hoses to supply lubricating oil, air, coolant, and fuel oil. Maintenance of hoses is an important step to ensure efficient, economical, and safe operation of the engine and related equipment.

#### 2.1.1 Hose Inspection

Check hoses daily as part of the pre-starting inspection. Examine hose for leaks, and check all fittings, clamps, and ties carefully. Ensure that hoses are not resting on or touching shafts, couplings, heated surfaces including exhaust manifolds, any sharp edges, or other obviously damaging areas. Since all machinery vibrates and moves to a certain extent, clamps and ties can fatigue with time. To ensure proper support, inspect fasteners frequently and tighten or replace them as necessary.

#### 2.1.2 Leaks

Investigate leaks immediately to determine if fittings have loosened or cracked, and also if hoses have ruptured or worn through. Take corrective action immediately. Leaks are not only potentially detrimental to machine operation, but can also result in added expenses caused by the need to replace lost fluids.

	<b>WARNING</b>
Personal injury and/or property damage may result from fire due to the leakage of flammable fluids, such as fuel or lube oil.	

#### 2.1.3 Service life

The limited service life of a hose is determined by the temperature and pressure of the gas or fluid within it, the time in service, its installation, the ambient temperatures, amount of flexing, and the vibration it is subjected to. With this in mind, it is recommended that all hoses be thoroughly inspected at least every 500 operating hours or after 15,000 miles (24 000 km). Look for surface damage or indications of damaged, twisted, worn, crimped, brittle, cracked, or leaking lines. Hoses having a worn outer surface or hoses with a damaged metal reinforcement should be considered unfit for further service.

It is also recommended that all hoses in this vehicle be replaced during major overhaul and/or after a maximum of five service years. Quality of replacement hose assemblies should always be equal to or superior to those supplied by the Original Equipment Manufacturer.

Section 24: LUBRICATION

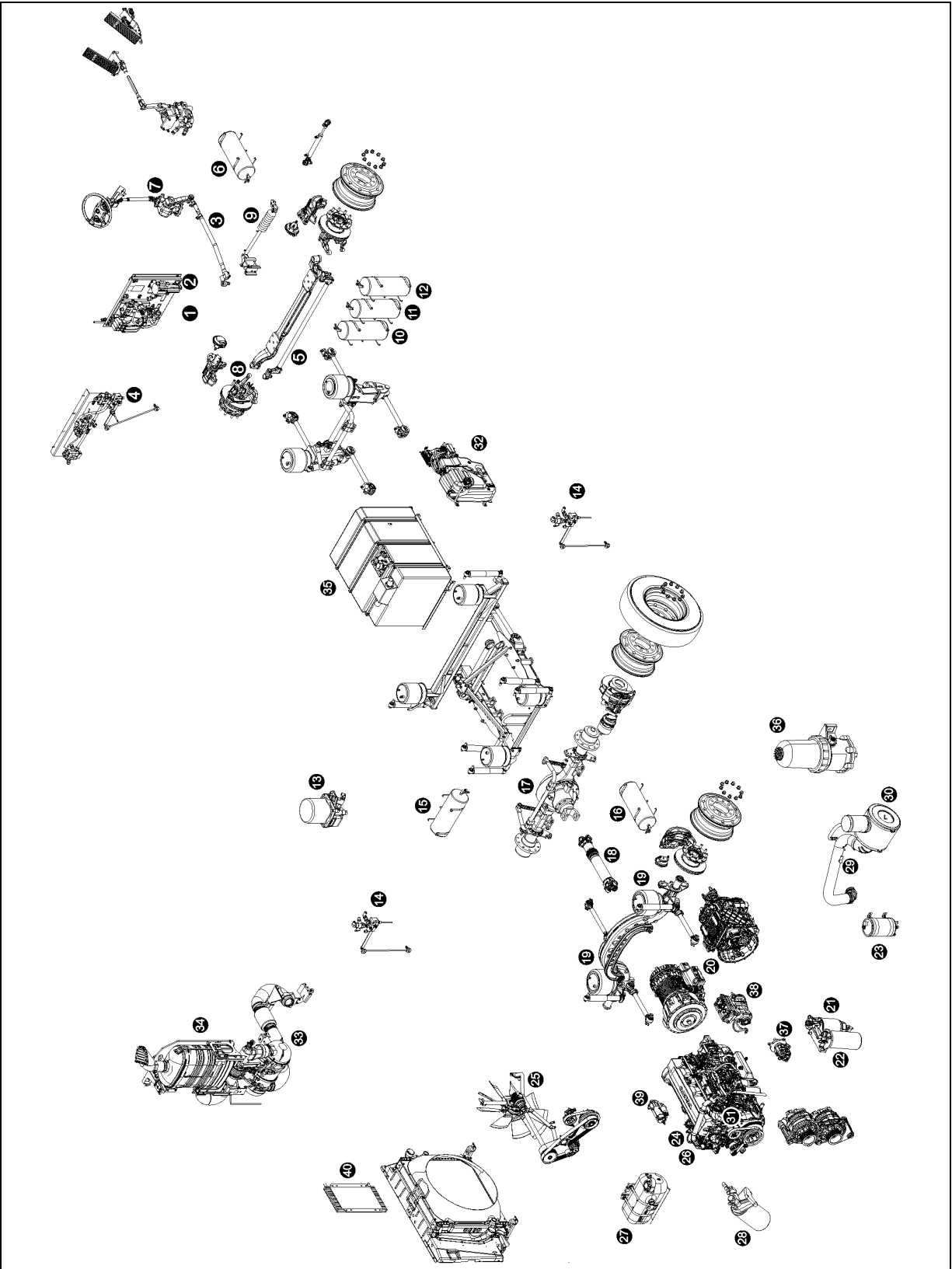

FIGURE 1: LUBRICATION AND SERVICING POINTS ON I-BEAM AXLE FRONT SUSPENSION VEHICLES 24030\_1

1	Accessories air tank drain cock	21	Primary fuel filter
2	Accessories air filter	22	Secondary fuel filter
3	Steering drag link	23	Power steering fluid tank
4	Height control valve (front)	24	Engine oil filter
5	Steering tie rod	25	Cooling fan gearbox
6	Accessories air tank	26	Allison transmission oil dipstick
7	Steering column U-joints	27	Engine coolant surge tank
8	Steering knuckle pins	28	Coolant filter & conditioner
9	Steering damper cylinder	29	Engine air filter restriction indicator
10	Emergency / parking brake overrule tank	30	Engine air filter
11	Secondary air tank	31	Engine oil dipstick and filler tube
12	Kneeling air tank	32	DEF tank
13	Air dryer	33	Diesel particulate filter
14	Height control valve (rear)	34	SCR catalytic converter
15	Wet air tank	35	Diesel fuel tank
16	Primary air tank	36	Davco Fuel Pro 382 fuel filter
17	Differential	37	Power steering pump
18	Propeller shaft	38	Air compressor
19	Tag axle lever pivot	39	Starter
20	Transmission	40	Fuel cooler

## Section 24: LUBRICATION

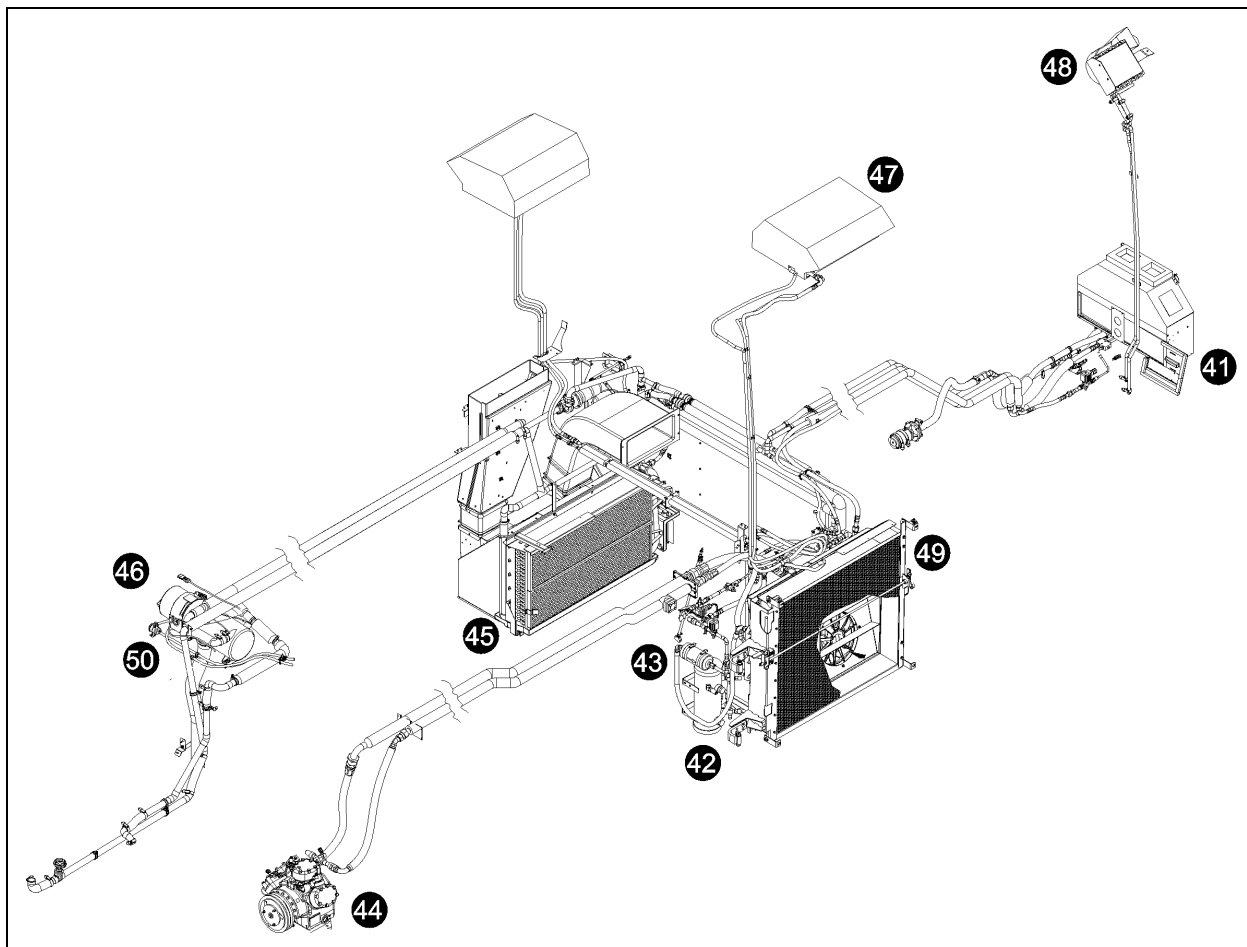

FIGURE 2: LUBRICATION AND SERVICING POINTS – HVAC UNIT

- |    |                                    |    |   |
|----|------------------------------------|----|---|
| 41 | HVAC air filter – driver's unit    | 46 | Coolant preheater                         |
| 42 | A/C receiver tank                  | 47 | A/C system – passenger's overhead console |
| 43 | Refrigerant moisture indicator     | 48 | Upper windshield defrost unit             |
| 44 | A/C compressor                     | 49 | Condenser coil                            |
| 45 | HVAC air filter – passenger's unit | 50 | Preheater fuel filter                     |

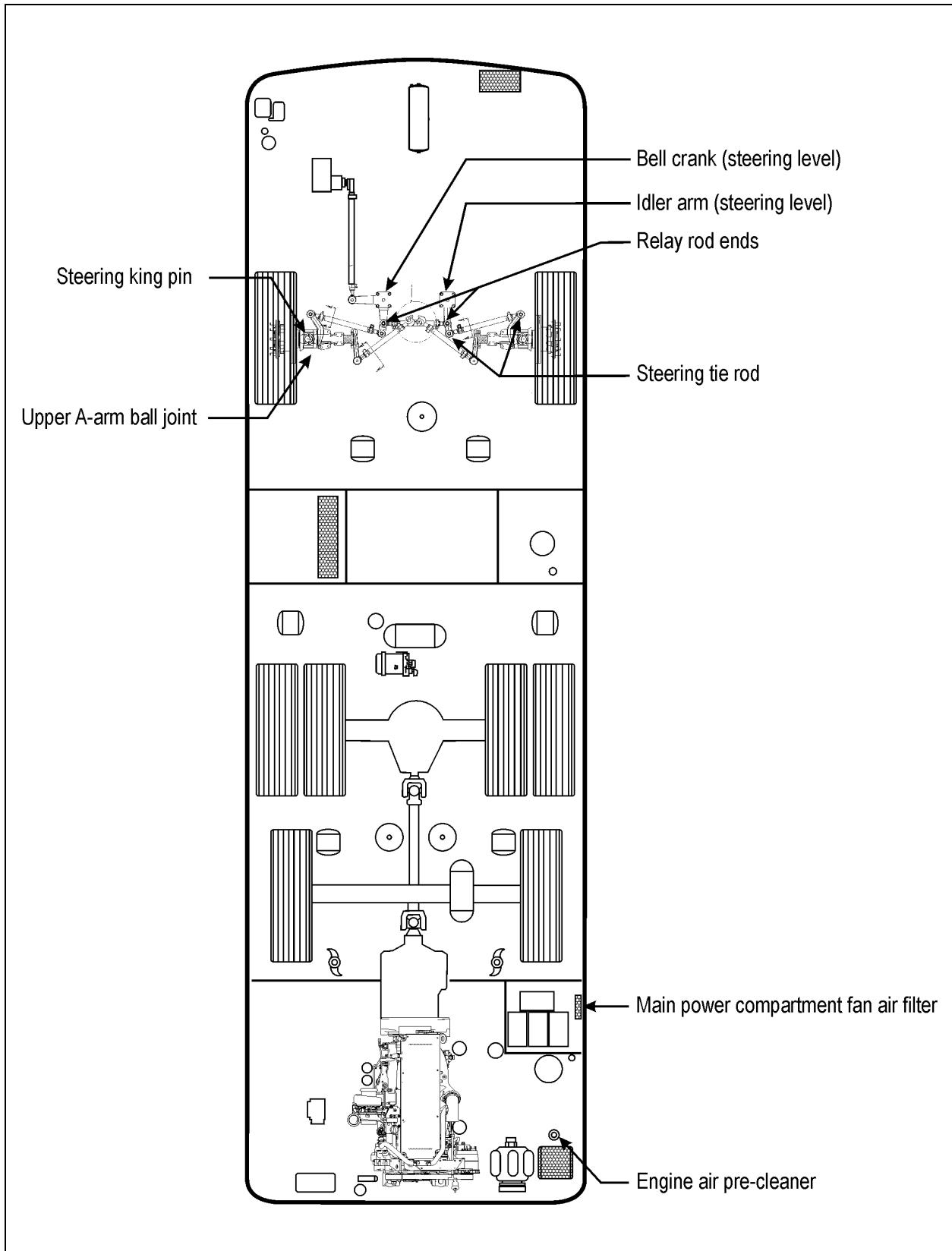

FIGURE 3: LUBRICATION AND SERVICING POINTS ON INDEPENDENT FRONT SUSPENSION VEHICLES (TYPICAL) 24038

## Section 24: LUBRICATION

### 2.2 LUBRICANT AND COOLANT SPECIFICATIONS

REF	DESCRIPTION	SPECIFICATIONS
A	Engine Oil	VOLVO D13 SAE Viscosity Grade: 15W-40 API Classification: CJ-4 meeting Volvo specification VDS-4
B	Power Steering Oil	Automatic Transmission Oil, Dexron-III
C	Engine Coolant	VOLVO D13 Texaco or Chevron Extended Life Coolant (ELC) 50% antifreeze/water solution is normally used
D	A/C Compressor Oil	Central HVAC system: Polyolester oil, HFC 134a compatible; Castrol SW-68 (POE) or equivalent  Small HVAC system: PAG oil
E	Differential Oil	Multigrade gear oil meeting MIL-L-2105-D: 85W140. If temperature drops below 10°F (-12°C), 80W90 should be used. Below -15°F (-26°C), 75W90 should be used. (In extreme conditions or for better performance, full synthetic gear oil can be used.)
F	Differential Oil (Full Synthetic)	Multigrade gear oil meeting MIL-L-2105-D: 85W140. If temperature drops below 10°F (-12°C), 80W90 should be used. Below -15°F (-26°C), 75W90 should be used.
G	Radiator Fan Gearbox Oil	Shell transmission oil MA 75W-90
H	Allison Automatic Transmission Oil	Castrol TranSynd™ Synthetic Transmission Fluid for Allison or TES 295 approved equivalent
I	Allison Automatic Transmission Oil	Dexron-VI® or approved equivalent 1 Schedule 1 TES-389 fluids;
J	Volvo I-Shift Transmission Oil	Castrol Syntrans Grade SAE 75W-85 (Synthetic)
K	Multi Purpose Grease	Good quality lithium-base grease: NLGI No.2 Grade is suitable for most temperatures NLGI No.1 Grade is suitable for extremely low temperatures
L	Multi Purpose Grease	Molykote longterm 2/78 grease

### 2.3 LUBRICATION AND SERVICING SCHEDULE

For lubrication and servicing schedule, refer to table A.

<b><i>IMPORTANT NOTE</i></b>
<i>Refer to the manufacturers documentation included in this maintenance manual for specific manufacturer's maintenance requirements.</i>



LUBRICATION AND SERVICING SCHEDULE		Item	Months	Odometer reading <sup>1</sup> (miles / km)																	LUBRICANT / FLUID <sup>2</sup>																		
				6 250 / 10 000	12 500 / 20 000	18 750 / 30 000	25 000 / 40 000	31 250 / 50 000	37 500 / 60 000	43 750 / 70 000	50 000 / 80 000	56 250 / 90 000	62 500 / 100 000	68 750 / 110 000	75 000 / 120 000	81 250 / 130 000	87 500 / 140 000	93 750 / 150 000	100 000 / 160 000	106 250 / 170 000		112 500 / 180 000	118 750 / 190 000	125 000 / 200 000	131 250 / 210 000	137 500 / 220 000	143 750 / 230 000	150 000 / 240 000	185 000 / 300 000	200 000 / 320 000	225 000 / 360 000	250 000 / 400 000	275 000 / 440 000	300 000 / 500 000	500 000 / 800 000	600 000 / 960 000			
				proceed to maintenance operation at																	each																		
<b>GENERAL</b>																																							
Flexible hoses, thoroughly inspect all hoses				-	12																																		
<b>01 ENGINE</b>																																							
Air cleaner, change as per mileage or according to restriction indicator				30	24																																		
Engine oil and filter, change (normal <sup>3</sup> operation condition) <b>Volvo recommends 35,000miles/55,000km</b>				24																																			
Engine oil and filter, change (heavy <sup>3</sup> operation condition)				24																																			
Valves and injectors, initial adjust				-	12																																		
Valves and injectors, check and adjust				-	24																																		
Drive belts, check				-	36																																		
<b>03 FUEL</b>																																							
Primary & secondary fuel filters, change at every engine oil change <b>Volvo recommends 35,000miles/55,000km</b>				21																																			
Preheater fuel filter, replace				22																																			
Preheater fuel filter, replace				50																																			
<b>04 EXHAUST AND AFTERTREATMENT SYSTEM</b>																																							
DPF filter, change				-																																			
DEF tank, drain and clean with water, clean filler neck strainer				32	12																																		
DEF pump, replace filter element				32	36																																		
<b>05 COOLING</b>																																							
Cooling fan gearbox, check oil level and add if required				25	6																																		
Cooling fan gearbox, change oil				25	12																																		
Coolant surge tank, test coolant solution				27	12																																		
Coolant filter, change (with Extended Life Coolant)				28	12																																		
Cooling system, drain, flush & refill (with Extended Life Coolant) (may require "extender")				27	48																																		
<b>06 ELECTRICAL</b>																																							
Battery terminals, clean and coat terminals				-	12																																		
Bosch HD10 alternator brushes, check and replace if required (commuter application)				-	-																																		

<sup>1</sup> Proceed to maintenance operation at distance indicated on odometer or specified number of month, whichever comes first.

<sup>2</sup> See paragraph 2.2 of this section for lubricant specifications.

<sup>3</sup> Normal=fuel consumption more than 6 MPG (less than 39 L/100km) ; Heavy= fuel consumption between 4.7 MPG and 6 MPG (between 39 L/100km and 50 L/100km)

**TABLE A**



LUBRICATION AND SERVICING SCHEDULE		Item	Months	Odometer reading <sup>1</sup> (miles / km)																				LUBRICANT / FLUID <sup>2</sup>																												
				6 250 / 10 000	12 500 / 20 000	18 750 / 30 000	25 000 / 40 000	31 250 / 50 000	37 500 / 60 000	43 750 / 70 000	50 000 / 80 000	56 250 / 90 000	62 500 / 100 000	68 750 / 110 000	75 000 / 120 000	81 250 / 130 000	87 500 / 140 000	93 750 / 150 000	100 000 / 160 000	106 250 / 170 000	112 500 / 180 000	118 750 / 190 000	125 000 / 200 000		131 250 / 210 000	137 500 / 220 000	143 750 / 230 000	150 000 / 240 000	185 000 / 300 000	200 000 / 320 000	225 000 / 360 000	250 000 / 400 000	275 000 / 440 000	300 000 / 500 000	500 000 / 800 000	600 000 / 960 000																
				proceed to maintenance operation at															each																																	
	Steering knuckle (king) pins, grease two fittings per knuckle	8	6	●	●	●	●	●	●	●	●	●	●	●	●	●	●	●	●	●	●	●	●	●	●															K												
<b>11 REAR AXLE</b>																																																				
	Differential, check oil level, add if required	17	6				●			●			●				●				●			●																		E										
	Differential, change oil, clean breathers	17	12															●																								E										
	Differential, change oil, clean breathers (with full synthetic oil)	17	48																																	●						E										
	Tag axle lever pivot, grease one fitting on each pivot	19	6	●	●	●	●	●	●	●	●	●	●	●	●	●	●	●	●	●	●	●	●	●	●	●	●	●	●	●	●	●	●	●	●	●	●	●	●	●	●	●	●	●	K							
<b>12 BRAKE &amp; AIR</b>																																																				
	Air tanks, drain water from all tanks	-	12		●		●		●		●		●		●		●		●		●		●		●		●		●		●		●		●		●		●		●		●									
	Accessories air filter, change filter element	2	24																●																																	
	Air dryer, change cartridge	13	24															●																																		
	Brake pads, check pad wear indicator and perform caliper slide check	-	12		●		●		●		●		●		●		●		●		●		●		●		●		●		●		●		●		●		●		●		●		●							
<b>13 WHEELS, HUBS &amp; TIRES</b>																																																				
	Hub bearing inspect 30, 000 miles. See Dana Spicer Service Manual NDS Axle Range	8	12				●			●					●						●				●						●																					
<b>14 STEERING</b>																																																				
	Steering tie rod ends, clean and grease one fitting at each end	5	6	●	●	●	●	●	●	●	●	●	●	●	●	●	●	●	●	●	●	●	●	●	●	●	●	●	●	●	●	●	●	●	●	●	●	●	●	●	●	●	●	●	●	●	●	●	●	K		
	Drag link ends, clean and grease one fitting at each end	3	6	●	●	●	●	●	●	●	●	●	●	●	●	●	●	●	●	●	●	●	●	●	●	●	●	●	●	●	●	●	●	●	●	●	●	●	●	●	●	●	●	●	●	●	●	●	●	●	K	
	Tie rod end & drag link end ball joints, inspect for corrosion		12																																																	
	Steering damper cylinder, grease one fitting at rod end	9	6	●	●	●	●	●	●	●	●	●	●	●	●	●	●	●	●	●	●	●	●	●	●	●	●	●	●	●	●	●	●	●	●	●	●	●	●	●	●	●	●	●	●	●	●	●	●	●	K	
	Power steering reservoir, replace oil and filter cartridges	23	12							●								●																															B			
	VIP only- Idler arm, grease fitting	-	6	●	●	●	●	●	●	●	●	●	●	●	●	●	●	●	●	●	●	●	●	●	●	●	●	●	●	●	●	●	●	●	●	●	●	●	●	●	●	●	●	●	●	●	●	●	●	●	K	
	VIP only- Bell crank, grease fitting	-	6	●	●	●	●	●	●	●	●	●	●	●	●	●	●	●	●	●	●	●	●	●	●	●	●	●	●	●	●	●	●	●	●	●	●	●	●	●	●	●	●	●	●	●	●	●	●	●	K	
	VIP only- Relay rod ends, grease one fitting at each end	-	6	●	●	●	●	●	●	●	●	●	●	●	●	●	●	●	●	●	●	●	●	●	●	●	●	●	●	●	●	●	●	●	●	●	●	●	●	●	●	●	●	●	●	●	●	●	●	●	K	
<b>16 SUSPENSION</b>																																																				
	Upper A-Arm ball joint, grease fitting	6	6	●	●	●	●	●	●	●	●	●	●	●	●	●	●	●	●	●	●	●	●	●	●	●	●	●	●	●	●	●	●	●	●	●	●	●	●	●	●	●	●	●	●	●	●	●	●	●	L	
<b>22 HEATING &amp; AIR CONDITIONING</b>																																																				
	A/C compressor, check oil level, add if required	44	6	●	●	●	●	●	●	●	●	●	●	●	●	●	●	●	●	●	●	●	●	●	●	●	●	●	●	●	●	●	●	●	●	●	●	●	●	●	●	●	●	●	●	●	●	●	●	●	●	D

LUBRICATION AND SERVICING SCHEDULE		Odometer reading <sup>1</sup> (miles / km)																				LUBRICANT / FLUID <sup>2</sup>															
		For higher odometer readings, repeat at the frequency interval established																																			
		Item	Months	6 250 / 10 000	12 500 / 20 000	18 750 / 30 000	25 000 / 40 000	31 250 / 50 000	37 500 / 60 000	43 750 / 70 000	50 000 / 80 000	56 250 / 90 000	62 500 / 100 000	68 750 / 110 000	75 000 / 120 000	81 250 / 130 000	87 500 / 140 000	93 750 / 150 000	100 000 / 160 000	106 250 / 170 000	112 500 / 180 000		118 750 / 190 000	125 000 / 200 000	131 250 / 210 000	137 500 / 220 000	143 750 / 230 000	150 000 / 240 000	185 000 / 300 000	200 000 / 320 000	225 000 / 360 000	250 000 / 400 000	275 000 / 440 000	300 000 / 500 000	500 000 / 800 000	600 000 / 960 000	
		proceed to maintenance operation at															each																				
A/C receiver tank, check refrigerant level, add if required	42	6	●	●	●	●	●	●	●	●	●	●	●	●	●	●	●	●	●	●	●	●	●	●	●	●											
Refrigerant moisture indicator, replace filter dryer unit according to moisture indicator (as needed)	43	6	●	●	●	●	●	●	●	●	●	●	●	●	●	●	●	●	●	●	●	●	●	●	●	●											
HVAC air filters, clean or replace all elements	41 45	6		●		●		●		●		●		●		●		●		●		●		●		●											
Parcel rack fan air filters, clean or replace	47	6		●		●		●		●		●		●		●		●		●		●		●		●											
Condenser discharge tube, qty:2, check to see if clogged <sup>7</sup>	-	3																																			
Front discharge tube, qty:2, check to see if clogged	-	3																																			
Evaporator discharge tube, qty:6, check to see if clogged	-	3																																			
Evaporator motor, condenser motor, recirculating pump drive motor, inspect brush, replace if required	-	12							●								●										●										

<sup>7</sup> Discharge tubes are rubber tubes located under vehicle

TABLE A