

PREVOST®

COACH MANUFACTURER

MAINTENANCE MANUAL

X3-45 COACH

DOB Bus Number Series 2400 - 2489



Revision 03 - September 2016

PA1593 revision 02

First issue of this manual: May 31, 2011

REVISION	DESCRIPTION	DATE
01	Sections modified: 06 Electrical 10 Front Axle 12 Brake And Air System 13 Wheels, Hubs And Tires 14 Steering 16 Suspension 18 Body 22 Heating And Air Conditioning 24A Lubrication And Servicing Schedule	March 2012
02	Sections modified: 00 General Information 04 Exhaust And Aftertreatment System 06 Electrical System 10 Front Axle 12 Brake And Air System 14 Steering 18 Body 24a Lubrication And Servicing Schedule	July 2012 Addition of standard torque specifications Removal of aftertreatment fuel injector cleaning procedure Minor edit Addition of steering knuckle exploded view, tie rod ends information moved to section 14:Steering Addition of information regarding brake pad wear indicator and minimal tolerance limits Addition of tie rod ends (ball joints) information PR20103-05 updated Removal of aftertreatment fuel injector cleaning requirement, moving of some maintenance requirements in the table in order to match the maintenance manual sections
03	Section modified: 05 Cooling System	Sept 2016 Cooling fan right angle gearbox oil change interval corrected to 100 000 miles (former value was 56000 miles).

CRITICAL EMISSION-RELATED MAINTENANCE

Source of parts and repair:

A repair shop or person of the owner's choosing must maintain, replace, or repair emission control devices and systems per manufacturer's recommendations.

Replacement of tires that are GHG certified:

The original equipment tires installed on this vehicle at the factory were certified to the U.S. EPA Greenhouse Gas (GHG) and **National Highway Traffic Safety Administration (NHTSA)** Fuel Efficiency regulations. Replacement of these tires should be with a tire of equal or lower rolling resistance levels (TRRL or Crr). Please consult your tire supplier(s) for appropriate replacement tires.

Maintaining a GHG certified tire:

In order to maintain the certified rolling resistance of the tires which optimize fuel economy, the maintenance procedures provide by the tire manufacturer must be followed.

SECTION 00: GENERAL INFORMATION

CONTENTS

1. FOREWORD	2
2. SCHEMATICS	2
3. PRECAUTIONS TO BE OBSERVED BEFORE WELDING	2
4. SAFETY NOTICE	4
4.1 DATA PLATES AND CERTIFICATIONS	4
4.1.1 <i>Engine</i>	4
4.1.2 <i>Transmission</i>	5
4.1.3 <i>Drive Axle</i>	5
4.1.4 <i>Front Axle</i>	5
4.1.5 <i>Power Steering Pump</i>	5
4.1.6 <i>Coach Final Record</i>	5
4.1.7 <i>Safety Certification</i>	5
4.1.8 <i>DOT Certification Label</i>	6
4.1.9 <i>Fuel Tank Label</i>	6
4.1.10 <i>Vehicle Identification Number (VIN)</i>	6
5. FASTENER STRENGTH IDENTIFICATION	8
5.1 STANDARD TORQUE SPECIFICATIONS	9
5.2 SELF-LOCKING FASTENERS	11
5.3 RECOMMENDATIONS FOR REUSE	11
5.4 SIX LOBED SOCKET HEAD	11

ILLUSTRATIONS

FIGURE 1: VOLVO D13 ENGINE DATA PLATE	4
FIGURE 2: ALLISON TRANSMISSION	5
FIGURE 3: TYPICAL SERIAL & MODEL NUMBERS.....	5
FIGURE 4: I-BEAM AXLE TYPICAL SERIAL & MODEL NUMBERS	5
FIGURE 5: POWER STEERING PUMP	5
FIGURE 6: DOT CERTIFICATION PLATE	6
FIGURE 7 : VEHICLE I.D.....	6
FIGURE 8 : VEHICLE IDENTIFICATION NUMBER	7
FIGURE 9 : THREAD NOTATION	8
FIGURE 10: BOLT STRENGTH MARKINGS	8
FIGURE 11 : SELF-LOCKING FASTENERS	11
FIGURE 12: METRIC - US STANDARD CONVERSION TABLE.....	12
FIGURE 13: CONVERSION CHART	13

Section 00: GENERAL INFORMATION

1. FOREWORD

This manual includes procedures for diagnosis, service, maintenance and repair for components of the X3-45 series coaches listed on the front cover page. This manual should be kept in a handy place for ready reference by the technician. If properly used, it will meet the needs of the technician and owner.

Information provided in Section 1 through 24 pertains to standard equipment items, systems and components as well as the most commonly used optional equipment and special equipment offered on the vehicle models covered by this manual. At the beginning of each section: a Table of Contents and a list of illustrations give the page number on which each subject begins and where each figure is located. Vehicle operating information is provided in a separate Manual

More specific information on engine and transmission operating, maintenance, and overhaul information is contained in the applicable engine or transmission service manual published by the engine or transmission manufacturer. Engine and transmission parts information is contained in the applicable engine or transmission parts catalog published by the engine or transmission manufacturer. All information, illustrations and specifications contained in this manual are based on the latest product information available at the time of publication approval. The right is reserved to make product changes at any time without notice.

NOTE

Typical illustrations may be used; therefore minor illustration difference may exist when compared to actual parts or other publications.

Prevost occasionally sends Maintenance Information, Warranty Bulletins, Safety Recalls or other literature to update users with the latest service procedures. They are issued, when required, to supplement or supersede information in this manual. Update sheet should be filled out and bulletins should be filed at the end of their respective section for future reference.

2. SCHEMATICS

Vehicle Air Schematics are provided at the end of Section 12, "Brake". SUSPENSION AIR SCHEMATICS are provided at the end of Section 16: "Suspension". Moreover, Electrical Schematics are provided in the technical publications box. Refer to those schematics for detailed circuit information or during diagnosis.

3. PRECAUTIONS TO BE OBSERVED BEFORE WELDING



CAUTION

Precautions are to be observed before welding to minimize the risk of major and costly damage caused to the vehicle electronic components.

NOTE

For X3-45 Series Multiplex coaches, also execute procedure no: PR060041 "MULTIPLEX MODULES DISCONNECTION PROCEDURE PRIOR TO WELDING" included at the end of this section.



CAUTION

For vehicles equipped with a WCL system, disconnect electronic controller connector.



CAUTION

Cover electronic control components and wiring to protect from hot sparks, etc.



CAUTION

Position welding machine ground clamp as close as possible to the work. Ensure that the welding machine ground return clamp is well secured and makes a good electrical contact with a large metallic area of the chassis located as close as possible to the welding point.



CAUTION

Do not use TIG welding process on the vehicle. This high frequency current process can seriously damage the electronic components.

STEEL – STEEL WELDING

 CAUTION
Before welding, perform multiplex modules disconnection procedure.

NOTE
 Welding surfaces must be free of scale, slag, rust, paint, grease, humidity or other foreign material that would render welding impossible.

 DANGER
Only a qualified and experienced person must do welding.

- FCAW (Flux Cored Arc Welding) process ;
- Electrode wire conforms to A5.20 AWS (American Welding Society) specifications ;
- E4801T-9-CH, type electrode wire with 0,045" diameter (1,14 mm) ;

Material Thickness	Voltage	Current	Wire Feed Rate	Shielding Gas
1/8" to 1/2"	26 ± 2 volts	260 Amps	450 ipm. approx.	75% argon – 25% CO2 or 100% CO2

If necessary and with great care to prevent perforating the material, it is possible to use a conventional electric arc welding machine according to the following specifications:

- SMAW (Shielded Metal-Arc Welding) process ;
- Welding rod conforms to A5.1 of AWS (American Welding Society) specifications; E 7018 type welding rod with 1/8" diameter (3,2 mm).
- Current: 100 amperes to 150 amperes; optimum at 120 amps.

It is important to grind weld bead starts and stops and also to grind arc strikes from surfaces.

STEEL - STAINLESS STEEL OR STAINLESS STEEL - STAINLESS STEEL WELDING

 CAUTION
Before welding, perform multiplex modules disconnection procedure.

NOTE
 Welding surfaces must be free of scale, slag, rust, paint, grease, humidity or other foreign material that would render welding impossible.

 DANGER
Only a qualified and experienced person must do welding.

- GMAW (Gas Metal-Arc Welding) process;
- Welding wire conforms to AWS (American Welding Standards) A5.9 specifications;
- 308LSi type welding wire with 0.035" diameter (0,9 mm);

STEEL - STAINLESS STEEL WELDING

Steel Thickness	SS Thickness	Voltage	Current	Wire Feed Rate	Shielding Gas
Less than 1/8"	Any type	20±1.5 volts	130±15 Amps	290 ipm approx.	90% He, 7.5% Ar, 2.5% CO2
1/8" and more	Any type	22±1.5 volts	160±15 Amps	330 ipm approx.	90% He, 7.5% Ar, 2.5% CO2

Section 00: GENERAL INFORMATION

STAINLESS STEEL - STAINLESS STEEL WELDING

SS Thickness	Voltage	Current	Wire Feed Rate	Shielding Gas
Any type	20 ± 1.5 volts	130 ± 15 Amps	290 ipm approx.	90% He – 7.5% Ar, 2.5% CO2

If necessary and with great care to prevent perforating the material, it is possible to use a conventional electric arc welding machine according to the following specifications:

- SMAW (Shield Metal-Arc Welding) process;
- Welding rod conforms to AWS (American Welding Standards) A5.4 specifications; 308L-17 type welding rod with 3/32" diameter (2,4 mm);
- Current: - 50 amperes to 90 amperes, optimum at 60 amperes.

It is important to grind weld bead starts and stops and also to grind arc strikes from surfaces.

4. SAFETY NOTICE

This maintenance manual has been prepared in order to assist skilled mechanics in the efficient repair and maintenance of PREVOST vehicles.

This manual covers only the procedures as of manufacturing date.

Safety features may be impaired if other than genuine PREVOST parts are installed.

Torque wrench tightening specifications must be strictly observed. Locking devices must be installed or replaced by new ones, where specified. If the efficiency of a locking device is impaired, it must be replaced.

This manual emphasizes particular information outlined by the wording and symbols:

DANGER

Directs the operator's attention to unsafe practices which could result in serious personal injury or death.

WARNING

Directs the operator's attention to unsafe practices which could result in serious personal injury or severe damage to the vehicle.

CAUTION

Directs the operator's attention to unsafe practices where personal injury is not likely but damage to vehicle components could occur.

NOTE

Indicates supplementary information essential to the proper operation of the vehicle. Although, the mere reading of such information does not eliminate the hazard, understanding of the information will promote its correct use.

4.1 DATA PLATES AND CERTIFICATIONS

Delay and confusion can be avoided by placing the complete vehicle identification number of the vehicle and the serial numbers of the engine on parts orders and correspondence. Also, the transmission, axles, power steering pump chassis and other major components are identified by serial numbers.

4.1.1 Engine

Volvo D13 engine serial and model numbers are stamped on the cylinder head (Fig. 1).

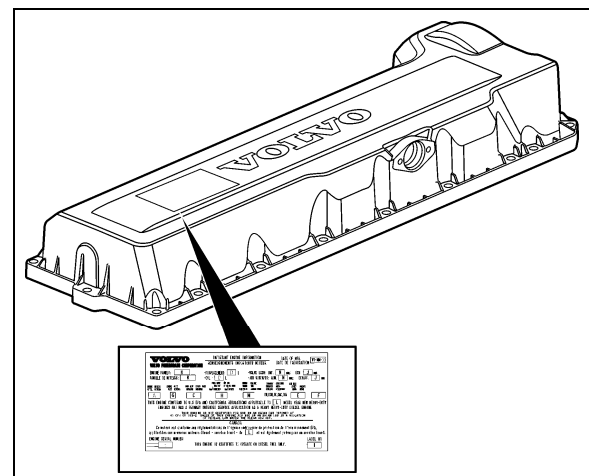

FIGURE 1: VOLVO D13 ENGINE DATA PLATE

00052

Also the engine data plate certifies that the engine conforms to federal and any state exhaust emissions regulations.

4.1.2 Transmission

The transmission identification plate is located on the oil level dipstick side of the transmission (WT) (Fig. 2). The identification plate shows the transmission serial number, part number (assembly number), and model number. Use all three numbers when ordering parts.

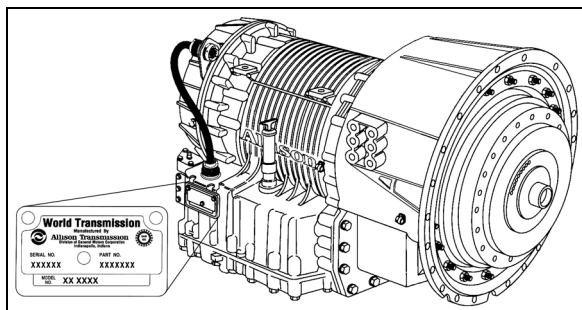

FIGURE 2: ALLISON TRANSMISSION 07076

4.1.3 Drive Axle

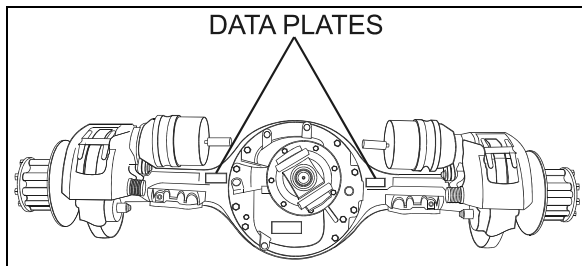

FIGURE 3: TYPICAL SERIAL & MODEL NUMBERS 00007

4.1.4 Front Axle

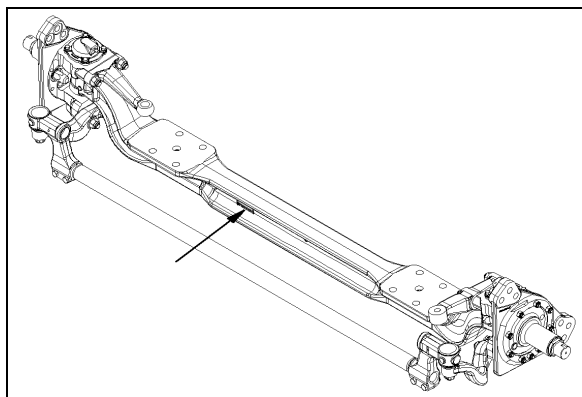

FIGURE 4: I-BEAM AXLE TYPICAL SERIAL & MODEL NUMBERS 00008

4.1.5 Power Steering Pump

Power steering pump is mounted on the engine and located underneath the air compressor (Fig. 5).

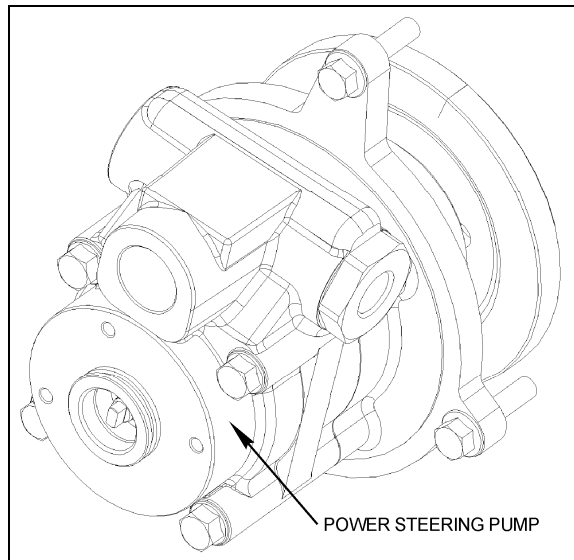

FIGURE 5: POWER STEERING PUMP

4.1.6 Coach Final Record

The Coach Final Record is a record of all data pertaining to the assembly of the vehicle. This record is shipped to the new customer via a courier company. Retain this record in the company records office for reference and safe-keeping.

4.1.7 Safety Certification

Vehicle components meet specifications and standards as follows:

- Material and parts conform to ASTM and/or SAE standards in effect at the time of manufacture.
- All factory-installed interior materials meet FMVSS 302 for fire resistance.
- Certified according to Provincial, State and Federal Safety standards (Canadian and US) BMCSS, FMVSS, and CMVSS.

Other applicable certification labels are affixed to the component.

Section 00: GENERAL INFORMATION

4.1.8 DOT Certification Label

This certifies that vehicles manufactured by Prevest Inc., comply with all Federal Motor Vehicle Safety Standards at the time of manufacture. Information such as date of manufacture, model year, gross vehicle weight rating, tire types and inflation pressure is also etched on this plate. The DOT Certification plate is affixed to the side of the L.H. control panel.

		PREVOST		<input type="text"/>	
MANUFACTURED BY : PREVOST FABRIQUE PAR : STE-CLAIRE, QUE.		EC		<input type="text"/>	
G.V.W.R. : P.N.B.V. : 24040 KG. (53000 LBS).		DATE OF MFG. DATE DE FAB. : <input type="text"/>		<input type="text"/>	
AXLES/ ESSELUX	G.A.W.R./ P.N.B.E.	TIRES/ PNEUS	RIMS/ JANTES	COLD INFLATION PRESS. / FROID	SINGLE OR DUAL SIMPLE OU DOUBLE KPA (PSI)
KG (LBS)					
FRONT: AVANT :	7484 (16500)	315/80R22.5 (J)	22.5X9	827 (120)	S
INT. DIFF. :	10206 (22500)	315/80R22.5 (J)	22.5X9	621 (90)	D
REAR: TANDEM :	6350 (14000)	315/80R22.5 (J)	22.5X9	689 (100)	S
THIS VEHICLE CONFORMS TO ALL APPLICABLE U.S. FEDERAL MOTOR VEHICLE SAFETY STANDARDS IN EFFECT ON THE DATE OF MANUFACTURE SHOWN ABOVE.					
VEHICLE IDENTIFICATION NO. <input type="text"/> NO. IDENTIFICATION VEHICULE <input type="text"/>					
TYPE: BUS B/A				#405405	

FIGURE 6: DOT CERTIFICATION PLATE

00016

4.1.9 Fuel Tank Label

The fuel tank label is molded on the side of the fuel tank. To read this label, unscrew the fuel tank access panel nuts located at the left in the condenser compartment.

4.1.10 Vehicle Identification Number (VIN)

The seventeen digit vehicle identification number (VIN) is located on a plate (Fig. 7 & 8) located on the windshield frame pillar (driver's side). The VIN is visible from the outside of the vehicle. Make sure the correct vehicle identification number is given when ordering replacement parts. Using the VIN when ordering parts will facilitate processing.



FIGURE 7 : VEHICLE I.D.

00048

NOTE

Record the VIN in the vehicle documentation and keep with company records. The VIN will normally be used for vehicle registration and for obtaining vehicle insurance coverage.

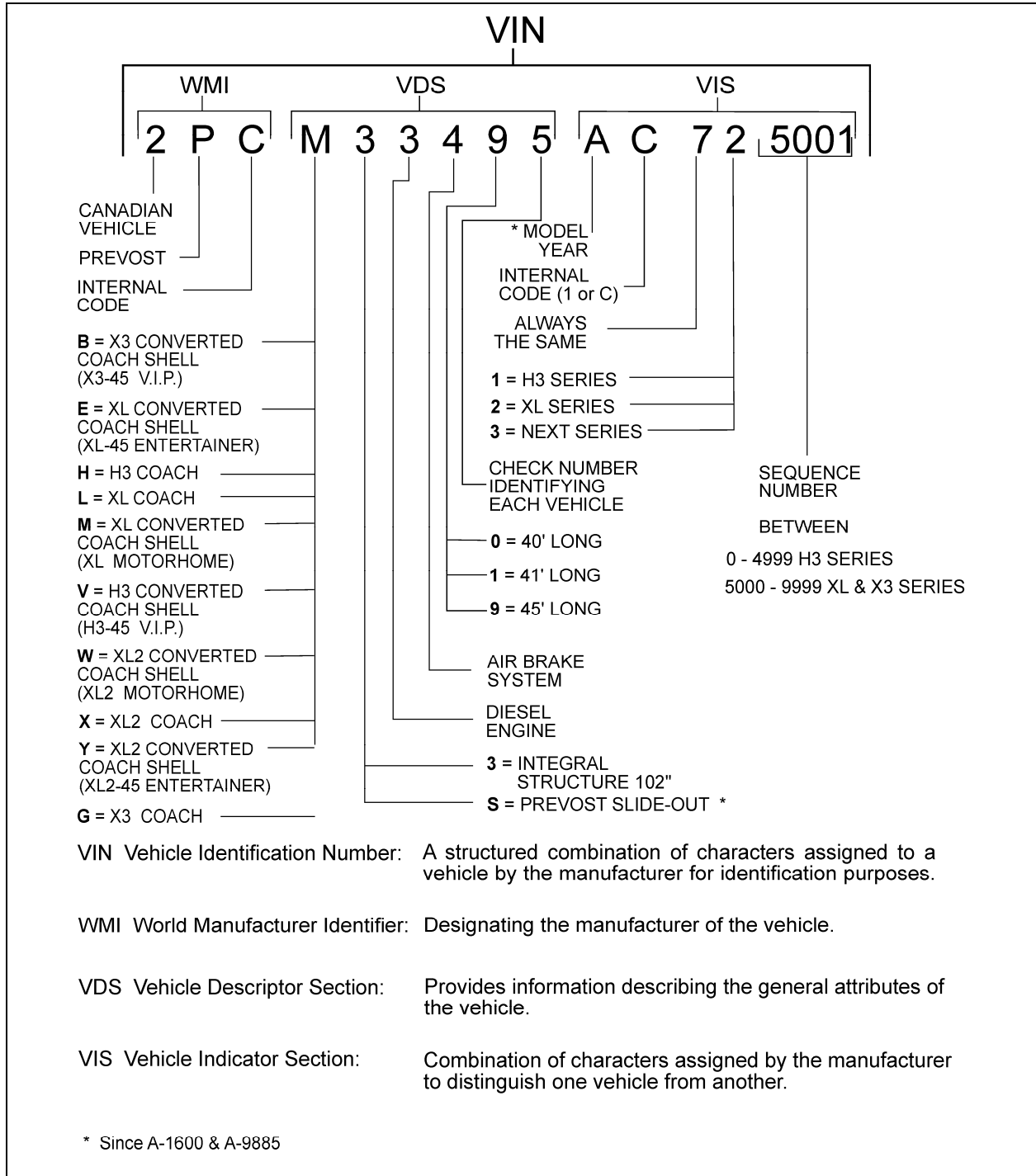

FIGURE 8 : VEHICLE IDENTIFICATION NUMBER

00056

YEAR	CODE	YEAR	CODE	YEAR	CODE
2000	Y	2006	6	2012	C
2001	1	2007	7	2013	D
2002	2	2008	8	2014	E
2003	3	2009	9	2015	F
2004	4	2010	A	2016	G
2005	5	2011	B	2017	H

Section 00: GENERAL INFORMATION

5. FASTENER STRENGTH IDENTIFICATION

Most commonly used metric fastener strength property classes are 9.8 and 10.9 with the class identification embossed on the head of each bolt. Customary (inch) strength classes range from grade 2 to 8 with radial line identification embossed on each bolt head actual grade (i.e., a grade 7 bolt will have 5 embossed radial lines on the bolt head). Some metric nuts will be marked with single digit strength identification numbers on the nut face. Fig. 10 shows the different strength markings. When replacing

metric fasteners, be careful to use fasteners of the same or greater strength than the original fasteners (the same number marking or higher). It is also important to select replacement fasteners of the correct size. Correct replacement fasteners are available through the parts division. Some metric fasteners available in after-market parts sources were designed to metric standards of countries other than the United States and may be of a lower strength, may not have the numbered head marking system, and may be of a different thread pitch.

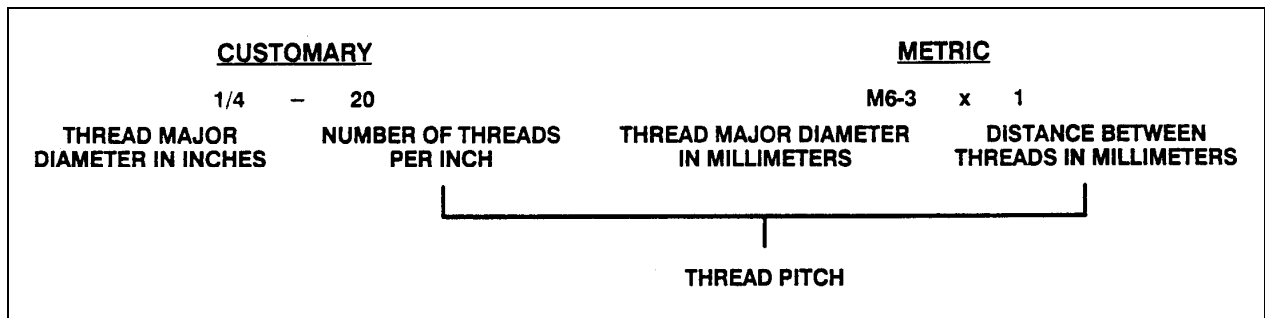

FIGURE 9 : THREAD NOTATION

00002

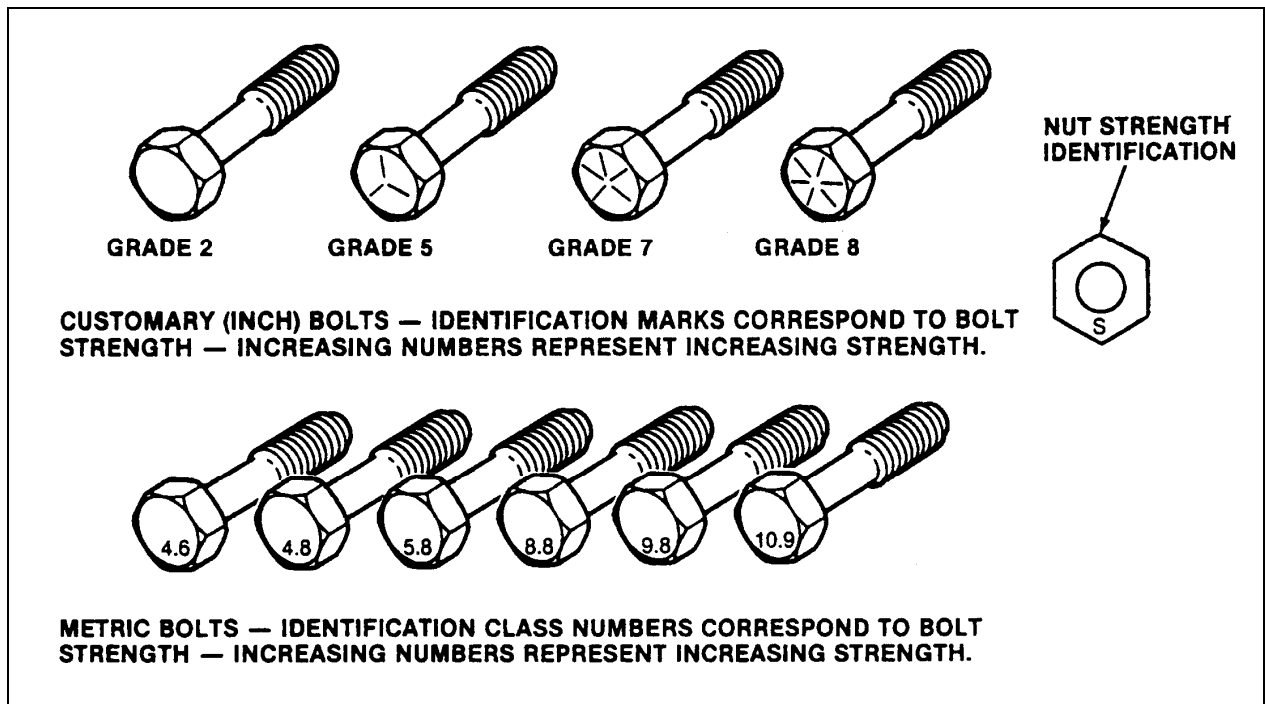

FIGURE 10: BOLT STRENGTH MARKINGS

00003

The metric fasteners used on the coach are designed to new standards and may not yet be manufactured by some non-domestic fastener suppliers. In general, except for special applications, the common sizes and pitches are:

- M 8 X 1.25;
- M 10 X 1.5;
- M 12 X 1.75;
- M 14 X 2;

5.1 STANDARD TORQUE SPECIFICATIONS

The following table lists the standard tightening torques for bolts and nuts, relating tightening torque to thread diameter. Use the following table as a general guide for tightening torques. Use this table only for the bolts and nuts which do not require a specific torque value. All of the values are for use with dry solvent-cleaned threads.

TYPE	DESCRIPTION	THREAD	GRADE	RECOMMENDED TORQUE	
				lbf-ft (dry) otherwise specified	
Tolerance: ±10%					
SAE	1/4-20	unc	5	100	lbf-in (dry)
SAE	1/4-20	unc	8	143	lbf-in (dry)
SAE	1/4-28	unf	5	115	lbf-in (dry)
SAE	1/4-28	unf	8	163	lbf-in (dry)
SAE	5/16-18	unc	5	210	lbf-in (dry)
SAE	5/16-18	unc	8	305	lbf-in (dry)
SAE	5/16-24	unf	2	120	lbf-in (dry)
SAE	5/16-24	unf	5	230	lbf-in (dry)
SAE	5/16-24	unf	8	325	lbf-in (dry)
SAE	3/8-16	unc	5	31	
SAE	3/8-16	unc	8	44	
SAE	3/8-24	unf	5	35	
SAE	3/8-24	unf	8	50	
SAE	7/16-14	unc	5	50	
SAE	7/16-14	unc	8	70	
SAE	7/16-20	unf	5	55	
SAE	7/16-20	unf	8	78	
SAE	1/2-13	unc	5	75	
SAE	1/2-13	unc	8	107	
SAE	1/2-20	unf	5	85	
SAE	1/2-20	unf	8	120	
SAE	9/16-12	unc	5	109	
SAE	9/16-12	unc	8	154	
SAE	9/16-18	unf	5	122	
SAE	9/16-18	unf	8	172	
SAE	5/8-11	unc	5	151	
SAE	5/8-11	unc	8	211	
SAE	5/8-18	unf	5	170	

Section 00: GENERAL INFORMATION

TYPE	DESCRIPTION	THREAD	GRADE	RECOMMENDED TORQUE
				lbf-ft (dry) otherwise specified Tolerance: ±10%
SAE	5/8-18	unf	8	240
SAE	3/4-10	unc	5	266
SAE	3/4-10	unc	8	376
SAE	3/4-16	unf	5	298
SAE	3/4-16	unf	8	420
SAE	7/8-9	unc	5	430
SAE	7/8-9	unc	8	607
SAE	7/8-14	unf	5	470
SAE	7/8-14	unf	8	670
METRIC	M6 X 1		nut 9 / screw 8.8	7
METRIC	M6 X 1		nut 10 / screw 10.9	9
METRIC	M8 X 1.25		nut 9 / screw 8.8	16
METRIC	M8 X 1.25		nut 10 / screw 10.9	22
METRIC	M10 X 1.5		nut 9 / screw 8.8	32
METRIC	M10 X 1.5		nut 10 / screw 10.9	43
METRIC	M12 X 1.75		nut 9 / screw 8.8	60
METRIC	M12 X 1.75		nut 10 / screw 10.9	74
METRIC	M14 X 2		nut 9 / screw 8.8	90
METRIC	M14 X 2		nut 10 / screw 10.9	120
METRIC	M16 X 2		nut 9 / screw 8.8	140
METRIC	M16 X 2		nut 10 / screw 10.9	190
METRIC	M16 X 1.5		nut 10 / screw 10.9	230
METRIC	M20 X 2.5		nut 9 / screw 8.8	275
METRIC	M20 X 2.5		nut 10 / screw 10.9	450
METRIC	M20 X 1.5		nut 10 / screw 10.9	465
METRIC	M22 X 2.5		nut 9 / screw 8.8	345
METRIC	M22 X 2.5		nut 10 / screw 10.9	493
METRIC	M24 X 3		nut 9 / screw 8.8	475
METRIC	M24 X 3		nut 10 / screw 10.9	640

5.2 SELF-LOCKING FASTENERS

A self-locking fastener is designed with an interference fit between the nut and bolt threads. This is most often accomplished by distortion of the top thread of an all-metal nut or bolt or by using a nylon patch on the threads. A nylon insert or the use of adhesives may also be used as a method of interference between nut and bolt threads (Fig. 11).

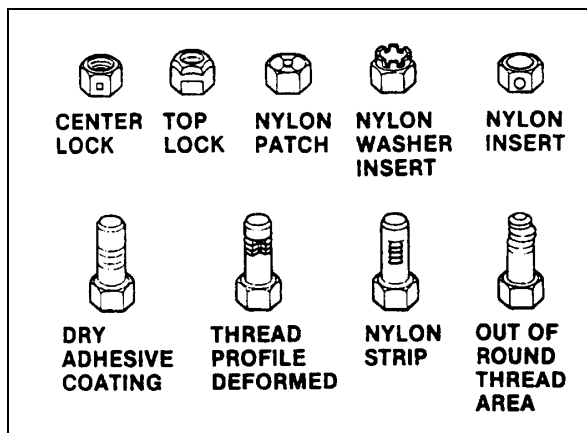

FIGURE 11 : SELF-LOCKING FASTENERS 00004

5.3 RECOMMENDATIONS FOR REUSE

Clean, rust-free self-locking fasteners may be reused as follows:

- a) Clean dirt and other foreign matter from the fastener;
- b) Inspect the fastener to ensure there is no crack, elongation, or other sign of fatigue or overtightening. If there is any doubt, replace with a new self-locking fastener of equal or greater strength;
- c) Assemble parts and hand start fastener;
- d) Observe that, before the fastener seats, it develops torque per the chart in table two. If there is any doubt, replace with a new self-locking fastener of equal or greater strength;
- e) Tighten the fastener to the torque specified in the applicable section of this manual;

Fasteners which are rusty or damaged should be replaced with new ones of equal or greater strength.

SELF-LOCKING FASTENER TORQUE CHART									
METRIC		6 & 6.3	8	10	12	14	16	20	
NUTS AND ALL-METAL BOLTS	Nm	0.4	0.8	1.4	2.2	3.0	4.2	7.0	
	Lbf-in	4.0	7.0	12	18	25	35	57	
ADHESIVE OR NYLON COATED BOLTS	Nm	0.4	0.6	1.2	1.6	2.4	3.4	5.6	
	Lbf-in	4.0	5.0	10	14	20	28	46	
US STANDARD		¼	5/16	3/8	7/16	½	9/16	5/8	¾
NUTS AND ALL-METAL BOLTS	Nm	0.4	0.6	1.4	1.8	2.4	3.2	4.2	6.2
	Lbf-in	4.0	5.0	12	15	20	27	35	51
ADHESIVE OR NYLON COATED BOLTS	Nm	0.4	0.6	1.0	1.4	1.8	2.6	3.4	5.2
	Lbf-in	4.0	5.0	9.0	12	15	22	28	43

5.4 SIX LOBED SOCKET HEAD

Six lobed socket head (Torx) fasteners are used in some applications on vehicles covered in this manual. The tools designed for these fasteners are available commercially. However, in some cases, if the correct tool is not available, a hex socket head wrench may be used.

Section 00: GENERAL INFORMATION

Multiply	by	to get equivalent number of:	Multiply	by	to get equivalent number of:
	LENGTH			ACCELERATION	
Inch	25.4	millimeters (mm)	Foot/sec ²	0.305	meter/sec ² (m/s ²)
Foot	0.305	meters (m)	Inch/sec ²	0.026	meter/sec ²
Yard	0.914	meters			
Mile	1.609	kilometers (km)			
	AREA			TORQUE	
Inch ²	645.2	millimeters ² (mm ²)	Pound-inch	0.113	newton-meters (N·m)
Foot ²	6.45	centimeters ² (cm ²)	Pound-foot	1.35	newton-meters
Yard ²	0.093	meters ² (m ²)			
	0.836	meters ²			
	VOLUME			POWER	
Inch ³	16	mm ³	Horsepower	0.746	kilowatts (kW)
Quart	0.016	cm ³			
Gallon	0.946	liters (l)			
Yard ³	3.785	liters			
	0.765	meters ³ (m ³)			
	MASS			PRESSURE OR STRESS	
Pound	0.453	kilograms (kg)			
Ton	907.18	kilograms (kg)			
Ton	0.907	ton (t)			
	FORCE			ENERGY OR WORK	
Kilogram	9.807	newtons (N)	BTU	1	055.0 joules (J)
Ounce	0.278	newtons	Foot-pound	1.356	joules
Pound	4.448	newtons	Kilowatt-hour	3	600 000.0 joules (J = one W's)
					or 3.6 x 10 ⁶
	TEMPERATURE			LIGHT	
Degree Fahrenheit	(°F - 32) ÷ 1.8	Degree Celsius (C)	Foot candle	1.076	lumens/meter ² (lm/m ²)
			Miles/hour		kilometers/hr (km/h)

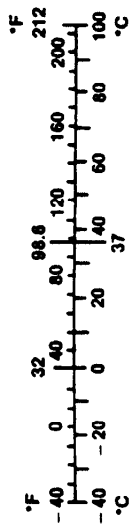

FIGURE 12: METRIC - US STANDARD CONVERSION TABLE

00005

DECIMAL AND METRIC EQUIVALENTS

FRACTIONS	DECIMAL IN.	METRIC MM	FRACTIONS	DECIMAL IN.	METRIC MM
1/64	.015625	.39688	33/64	.515625	13.09687
1/32	.03125	.79375	17/32	.53125	13.49375
3/64	.046875	1.19062	35/64	.546875	13.89062
1/16	.0625	1.58750	9/16	.5625	14.28750
5/64	.078125	1.98437	37/64	.578125	14.68437
3/32	.09375	2.38125	19/32	.59375	15.08125
7/64	.109375	2.77812	39/64	.609375	15.47812
1/8	.125	3.1750	5/8	.625	15.87500
9/64	.140625	3.57187	41/64	.640625	16.27187
5/32	.15625	3.96875	21/32	.65625	16.66875
11/64	.171875	4.36562	43/64	.671875	17.06562
3/16	.1875	4.76250	11/16	.6875	17.46250
13/64	.203125	5.15937	45/64	.703125	17.85937
7/32	.21875	5.55625	23/32	.71875	18.25625
15/64	.234375	5.95312	47/64	.734375	18.65312
1/4	.250	6.35000	3/4	.750	19.05000
17/64	.265625	6.74687	49/64	.765625	19.44687
9/32	.28125	7.14375	25/32	.78125	19.84375
19/64	.296875	7.54062	51/64	.796875	20.24062
5/16	.3125	7.93750	13/16	.8125	20.63750
21/64	.328125	8.33437	53/64	.828125	21.03437
11/32	.34375	8.73125	27/32	.84375	21.43125
23/64	.359375	9.12812	55/64	.859375	21.82812
3/8	.375	9.52500	7/8	.875	22.22500
25/64	.390625	9.92187	57/64	.890625	22.62187
13/32	.40625	10.31875	29/32	.90625	23.01875
27/64	.421875	10.71562	59/64	.921875	23.41562
7/16	.4375	11.11250	15/16	.9375	23.81250
29/64	.453125	11.50937	61/64	.953125	24.20937
15/32	.46875	11.90625	31/32	.96875	24.60625
31/64	.484375	12.30312	63/64	.984375	25.00312
1/2	.500	12.70000	1	1.00	25.40000

FIGURE 13: CONVERSION CHART

00006

PREVOST

MULTIPLEX MODULES DISCONNECTION PROCEDURE PRIOR TO WELDING

PROCEDURE NO: PR060041

**REVISION 01
2010-12-01**

Material: N/A

Equipment(s): Phillips-head screwdriver
Ratchet handle
3/8" socket
Electric tape
Long nose pliers

Reference schematics: N/A

Safety rules: - Wear safety goggles
- Set the battery master switch to the OFF position first



Recommendations: This procedure should be performed by qualified personnel only.

	Effective
Revision 00 : New procedure for cooling 2007 Revision 01 : Modified for EPA 2010	

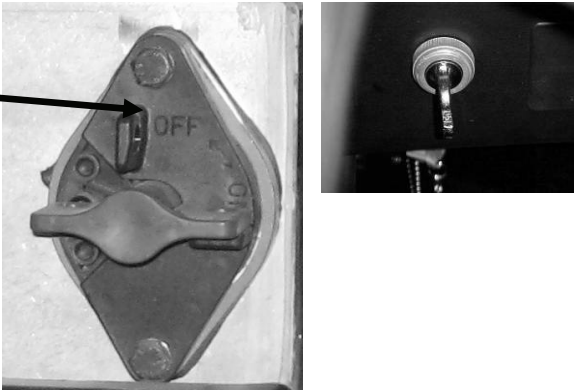
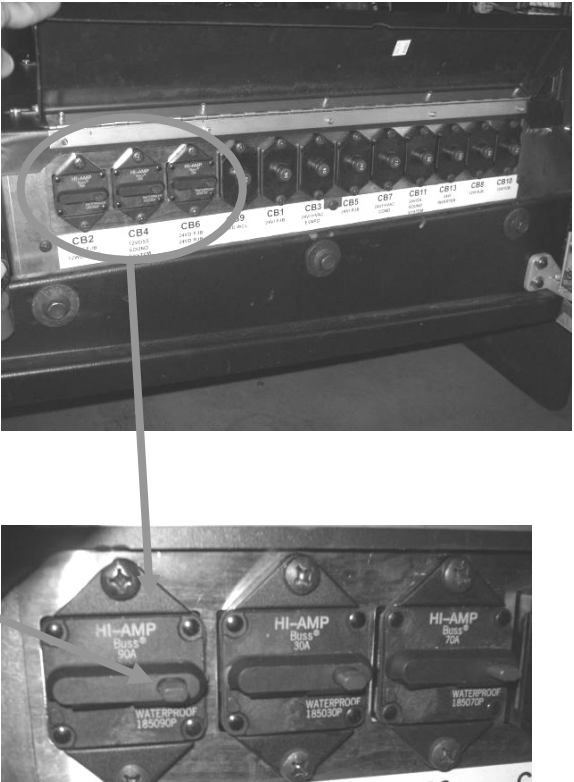
X3-45 Coaches

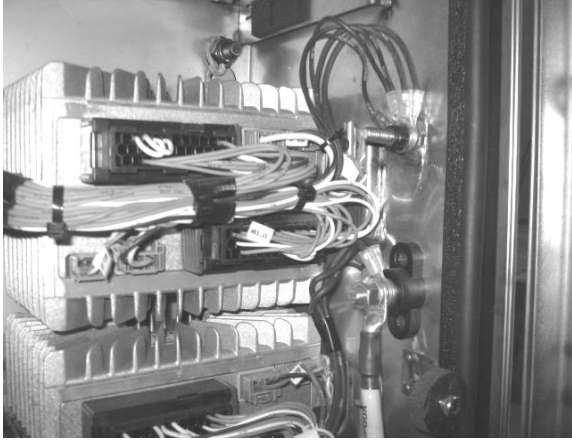
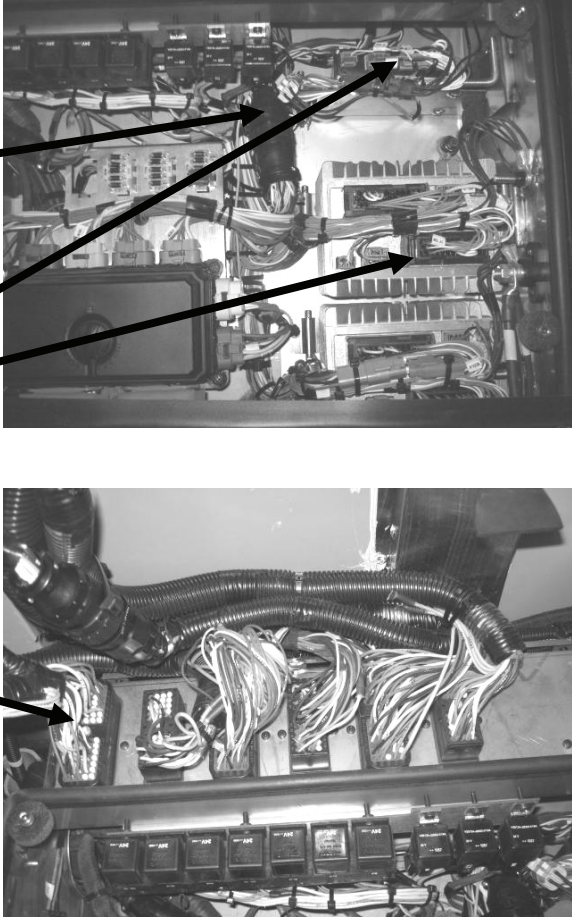
<p>2.00*</p>	<p>Location: Rear Electrical Panel and Dashboard</p> <p>Set the battery master switch to the OFF position</p> <p>Place the ignition switch to the OFF position.</p>	
<p>2.05*</p>	<p>Location: Rear Junction Panel</p> <p>Lift cover, trip circuit breakers CB2-CB4-CB6 located on junction panel.</p> <p>Push the red button to open the circuit</p>	

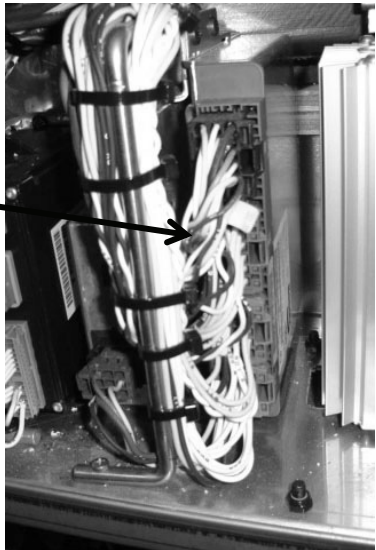
<p>2.10*</p>	<p>Location: Rear Electrical Panel</p> <p>Disconnect the electronic ground terminals from this stud.</p> <p>Use electric tape; make sure that cables do not touch each others and the vehicle body.</p> <p>Note :</p> <p><i>With disconnection of the electronic ground terminals, disconnecting the engine ECM, transmission TCM and the dashboard electronic components (telltale module, HVAC module, radio, control head ...) is not required.</i></p>	
<p>2.15*</p>	<p>Location: Rear Electrical Panel</p> <p>Disconnect the electronic modules:</p> <p>Disconnect all I/O A, I/O B modules.</p> <p style="padding-left: 100px;">Disconnect C717</p> <p>Disconnect 3 connectors from each I/O A module</p> <p>Disconnect 3 connectors from each I/O B module</p> <p style="padding-left: 100px;">Disconnect C397</p>	

<p>2.20 *</p>	<p>Location: Front Electrical Compartment</p> <p>Disconnect the I/O A, I/O B, ABS, master ID, VECU, CECM, BERU, Volvo Link, Gsecu modules.</p> <p>Disconnect 3 connectors from I/O B and I/O A modules</p>	
	<p>Disconnect 4 connectors from the ABS module</p>	
	<p>Disconnect connector from master ID</p>	

Disconnect 3 connectors from VECU

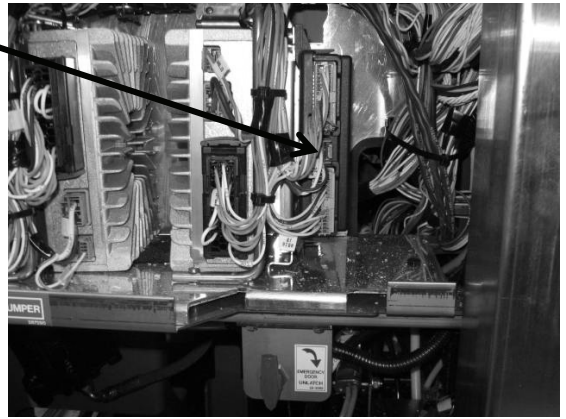

Disconnect 3 connectors from CECM

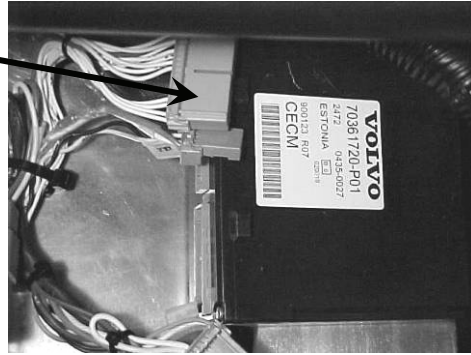

Disconnect connector A 83 under Volvo Link module

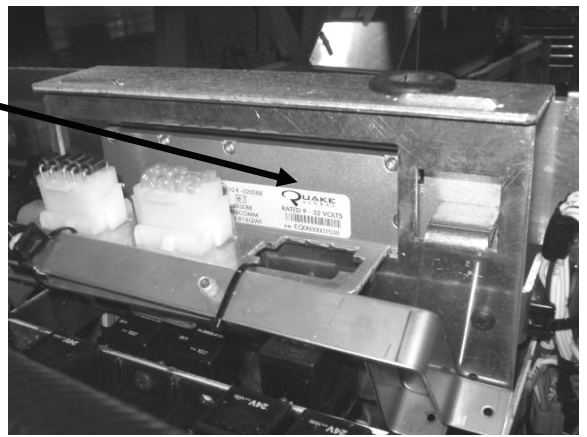

2.30 **Location: Pneumatic accessory panel inside right console**

Remove the access panel on the right console (R.H. side of dashboard)

Disconnect both I/O B modules

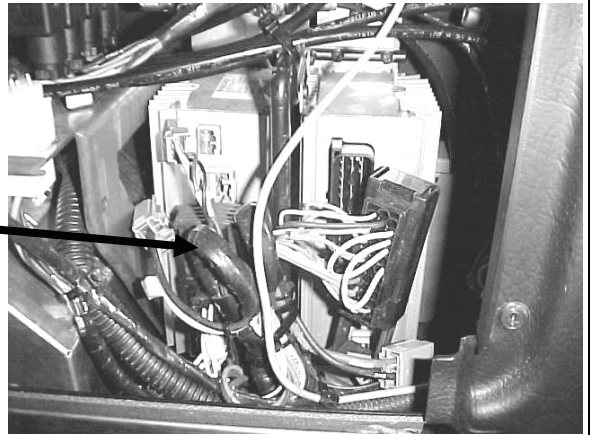

2.40 **Location: Condenser Compartment**

Disconnect connector A 137

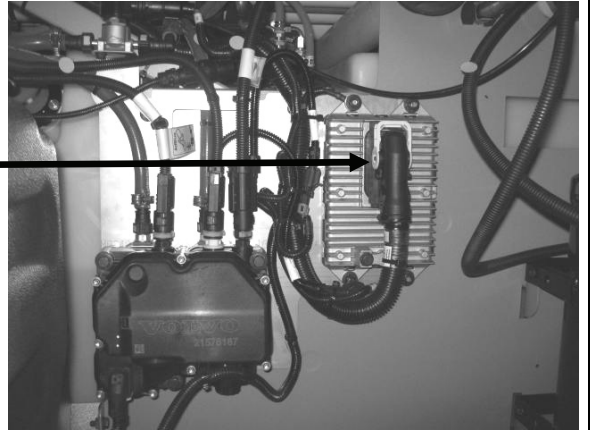

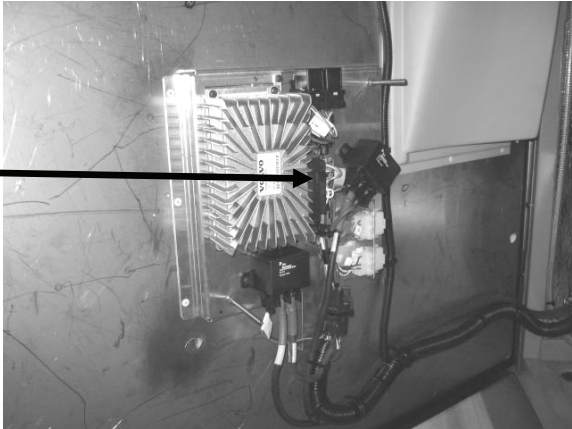
<p>2.50</p>	<p>Location: Evaporator Compartment</p> <p>Disconnect A 54 module located inside the evaporator compartment, on the door.</p>	
<p>2.60</p>	<p>When all the previous steps are done, you can do welding on the vehicle.</p>	<p>ENSURE THAT THE WELDING GROUND RETURN CLAMP IS WELL SECURED AND MAKES A GOOD ELECTRICAL CONTACT WITH A LARGE METALLIC AREA OF THE CHASSIS LOCATED NEAR THE WELDING POINT AS MUCH AS POSSIBLE.</p>
<p>2.70</p>	<p>When welding is completed, reconnect all the modules.</p> <p>Make sure that the connectors locking tab are well engaged!</p>	<p>BE CAREFUL TO MAKE THE PROPER CONNECTIONS, IF NOT, SOME SYSTEMS OR COMPONENTS MAY NOT BE USABLE.</p>

CONTENTS

1. VOLVO D13 ENGINE	2
1.1 SYSTEM OVERVIEW.....	2
1.2 ENGINE OVERVIEW	6
1.3 ENGINE OIL	7
1.3.1 <i>General</i>	7
1.3.2 <i>Oil Quality</i>	7
1.3.3 <i>Oil Change Intervals</i>	8
1.3.4 <i>Oil Filters</i>	8
1.3.5 <i>Synthetic Lubrication</i>	8
1.3.6 <i>Oil Viscosity</i>	8
1.3.7 <i>Oil Additives</i>	9
1.3.8 <i>Oil Consumption</i>	9
1.3.9 <i>Oil Change</i>	9
1.3.10 <i>Oil Filters Change</i>	10
1.3.11 <i>Checking the Oil Level</i>	11
1.4 POWER PLANT ASSEMBLY REMOVAL.....	11
1.5 POWER PLANT ASSY. INSTALLATION	14
1.6 ENGINE MOUNTS	15
2. ELECTRONIC FOOT PEDAL ASSEMBLY (EFPA) & THROTTLE POSITION SENSOR	16
3. SPECIFICATIONS	17

ILLUSTRATIONS

FIGURE 1: ENGINE SENSORS LOCATION.....	5
FIGURE 2: D13F ENGINE, TURBO SIDE (TYPICAL).....	6
FIGURE 3: D13F ENGINE, ALTERNATOR SIDE (TYPICAL).....	7
FIGURE 4: D13F OIL FILTERS	8
FIGURE 5: OIL FILTER WRENCH	10
FIGURE 6: OIL FILTER REPLACEMENT	10
FIGURE 7: ENGINE OIL FILLING TUBE.....	11
FIGURE 8: ENGINE OIL LEVEL DIPSTICK.....	11
FIGURE 9: COOLER POSITION DURING ENGINE CRADLE INSERTION OR REMOVAL	12
FIGURE 10: BELT TENSIONER VALVE	12
FIGURE 11: ENGINE COMPARTMENT X3 COACHES (TYPICAL).....	14
FIGURE 12: NORMAL OIL COOLER POSITION	14
FIGURE 13: VOLVO ENGINE POWER PLANT CRADLE INSTALLATION.....	15
FIGURE 14: ELECTRONIC FOOT PEDAL ASSEMBLY	17

Section 01: ENGINE

1. VOLVO D13 ENGINE

1.1 SYSTEM OVERVIEW

NOTE

The "Premium Tech Tool" (PTT) is the preferred tool for performing diagnostic work. Contact your local dealer for more information.

The Engine Management System (EMS) controls many engine functions such as: fuel timing and delivery, engine protection functions, engine brake operation, EGR valve function and the turbocharger nozzle function. The Engine Electronic Control Unit (EECU) along with other supporting control units and sensors are responsible for monitoring and controlling these functions. These control units communicate through the J1939 high speed serial data line to share data.

In addition to their control functions, the modules have on-board diagnostic capabilities. The on-board diagnostics are designed to detect faults or abnormal conditions that are not within their operating parameters. When the system detects a fault or abnormal condition, the fault will be logged in one or both of the modules' memory. The vehicle operator will be advised that a fault has occurred by the illumination of a malfunction indicator lamp and a message in the driver information display, if equipped. The module may initiate the engine shutdown procedure if the system determines that the abnormal condition could damage the engine. In some situations, the system will enter the "limp home" mode. Limp home mode allows continued vehicle operation but, the system may substitute a sensor or signal value that may result in reduced engine performance.

Fault codes logged in the system memory, can later be read to aid in diagnosing the fault. These faults can be read via a diagnostic computer or through the instrument cluster display, if equipped. The "Premium Tech Tool" (PTT) is the preferred tool for performing diagnostic work. Using a diagnostic computer (or PTT) connected to the Serial Communication Port, expands the technicians diagnostic capabilities with additional data and tests.

For diagnostic software, contact your local dealer.

The following is a list of engine sensors that provide input to the EMS:

- Ambient Air Temperature Sensor
- Ambient Pressure sensor
- Boost Air Pressure (BAP) Sensor
- Camshaft Position (Engine Position) Sensor
- Crankshaft Position (Engine Speed) Sensor
- Differential Pressure DPF Sensor
- EGR Differential Pressure Sensor
- EGR Temperature Sensor
- Engine Coolant Level (ECL) Sensor
- Engine Coolant Temperature (ECT) Sensor
- Engine Oil Pressure (EOP) Sensor
- Engine Oil Level (EOL) Sensor
- Engine Oil Temperature (EOT) Sensor
- Exhaust Temperature Sensor (DPF Sensors)
- Fuel Pressure Sensor
- Intake Air Temperature And Humidity (IATH) Sensor
- Intake Manifold (Boost) Temperature Sensor
- Throttle Position (TP) Sensor
- Turbo Speed Sensor
- Variable Geometry Turbocharger (VGT) Position Sensor

Sensors

Ambient Air Temperature Sensor

The Ambient Air Temperature Sensor is used to detect the outside air temperature. The sensor modifies a voltage signal from the ECM. The modified signal returns to the ECM as the ambient air temperature. The sensor uses a thermistor that is sensitive to the change in temperature. The electrical resistance of the thermistor decreases as temperature increases.

The Ambient Air Temperature Sensor is located in the front of the vehicle.

Ambient (Atmospheric) Pressure Sensor

The Ambient (Atmospheric) Pressure Sensor contains a pressure sensitive diaphragm and an electrical amplifier. Mechanical pressure applied to the diaphragm causes the diaphragm to deflect and the amplifier to produce an electrical signal proportional to the deflection.

The Ambient (Atmospheric) Pressure Sensor is built into the Engine Management System (EMS) Module.

Camshaft Position Sensor

The Camshaft Position (Engine Position) Sensor is located in the rear face of the timing gear cover at the rear of the engine, near the bottom of the valve cover. It uses magnetic induction to generate a pulsed electrical signal. It senses the passage of seven (7) timing bumps on the edge of the camshaft dampener. Six of the holes correspond to the phasing of the electronic unit injectors, while the seventh hole indicates the top dead center position.

Crankshaft Position (Engine Speed) Sensor

The Crankshaft Position (Engine Speed) Sensor uses magnetic induction to generate a pulsed electrical signal. Notches are machined into the edge of the flywheel. When one of the notches passes close to the sensor, electric pulses result.

The Crankshaft Position (Engine Speed) Sensor also indicates when the crankshaft is at the top dead center position.

Differential Pressure DP Sensor

The differential pressure sensor is used for flow measurement of the Diesel Particulate Filter (DPF). This sensor has two pressure ports and senses the difference in pressure between the two ports. Measurement of the pressure before and after the DPF is used to calculate diesel filter regeneration.

The Differential Pressure DPF Sensor is located on the side of the Diesel Particulate Filter (DPF).

EGR Differential Pressure Sensor

The EGR differential pressure sensor is used for flow measurement of the Exhaust Gas Recirculation (EGR) valve. This sensor has two pressure ports and senses the difference in pressure between the two ports. Measurement of the pressure before and after the EGR valve is used to calculate EGR flow.

The EGR Differential Pressure Sensor is located on the left or right side of the engine.

EGR Temperature Sensor

The EGR temperature sensor detects exhaust gas temperature for EGR system. The sensor modifies a voltage signal from the control unit. The modified signal returns to the control unit as

the exhaust temperature of the EGR system to confirm EGR operation. The sensor uses a thermistor that is sensitive to the change in temperature.

The EGR Temperature Sensor is located near the EGR valve.

Engine Coolant Level (ECL) Sensor

The Engine Coolant Level (ECL) Sensor is a switch. If engine coolant level falls below a calibrated point the contacts open and the driver will be notified of the low coolant level.

The Engine Coolant Level (ECL) Sensor is located in the cooling system reservoir tank.

Engine Coolant Temperature (ECT) Sensor

The Engine Coolant Temperature Sensor is located at the front of the engine. The sensor will indicate a high coolant temperature caused by problems like radiator blockage, thermostat failure, heavy load, or high ambient temperatures. This sensor is also used for cold start enhancement and for fan clutch engagement.

Engine Oil Pressure (EOP) Sensor

The Engine Oil Pressure Sensor contains a pressure sensitive diaphragm and a electrical amplifier. Mechanical pressure applied to the diaphragm causes the diaphragm to deflect and the amplifier to produce an electrical signal proportional to the deflection.

The Engine Oil Pressure Sensor is located on the oil filter assembly. The sensor monitors engine oil pressure to warn of lubrication system failure.

Engine Oil Level (EOL) Sensor

The Engine Oil Level Sensor is located in the oil pan.

Engine Oil Temperature (EOT) Sensor

The Engine Oil Temperature Sensor is a thermistor whose resistance varies inversely to temperature. The sensor has a negative temperature coefficient, which means the sensor resistance will decrease as the engine oil temperature increases.

The Engine Oil Temperature Sensor is located in the oil pan.

Exhaust Temperature Sensor (DPF Sensors)

The exhaust gas temperature sensor detects exhaust gas temperature for DPF protection as well as DPF regeneration control. The sensor modifies a voltage signal from the control unit. The modified signal returns to the control unit as the exhaust temperature at that specific location of the exhaust. The sensor uses a thermistor that is sensitive to the change in temperature.

The Exhaust Temperature Sensors are located in the DPF assembly.

Fuel Pressure Sensor

The fuel pressure sensor contains a diaphragm that senses fuel pressure. A pressure change causes the diaphragm to flex, inducing a stress or strain in the diaphragm. The resistor values in the sensor change in proportion to the stress applied to the diaphragm and produces an electrical output.

The Fuel Pressure Sensor is located on top of the fuel filter housing.

Intake Air Temperature and Humidity (IATH) Sensor

The Intake Air Temperature and Humidity (IATH) Sensor contains a thermistor and a capacitive sensor. The resistance of the thermistor varies inversely to temperature. The output of the capacitive sensor increases as the humidity of the surrounding air increases. By monitoring the signals from both portions of the sensor, the Engine Management System (EMS) Module calculates the temperature and humidity of the air passing through the air filter housing.

The Intake Air Temperature and Humidity (IATH) Sensor is located in the air intake tube just downstream from the air filter canister.

Intake Manifold (Boost) Temperature Sensor

The Intake Manifold (Boost) Temperature Sensor is a thermistor whose resistance varies inversely to temperature. The sensor has a negative temperature coefficient, which means the sensor resistance will decrease as the inlet air temperature increases.

The Intake Manifold (Boost) Temperature Sensor is located in the intake manifold.

Intake Manifold Pressure Sensor

The Intake Manifold Pressure Sensor contains a pressure sensitive diaphragm and an electrical amplifier. Mechanical pressure applied to the diaphragm causes the diaphragm to deflect and the amplifier to produce an electrical signal proportional to the deflection.

The Intake Manifold Pressure Sensor is located on the air inlet pipe before the intake manifold.

Throttle Position (TP) Sensor

The Throttle Position Sensor is a potentiometer that is mechanically linked to the accelerator pedal. A potentiometer is a variable resistor whose resistance will change as the pedal is pressed. As the resistance changes, the signal voltage of the sensor changes indicating the accelerator pedal position.

The Throttle Position Sensor is located above the accelerator pedal. The sensor is designed to improve the driver's control by reducing sensitivity to chassis motion. This sensor provides the driver's fuel request input to the VECU.

Turbo Speed Sensor

The Turbo Speed Sensor informs the EMS of the turbo shaft speed. The sensor does not read from the vanes, but reads from the shaft. The Engine Management System (EMS) Module uses this signal in conjunction with the VGT position sensor signal to control the speed of the turbocharger and therefore optimize the intake manifold pressure.

The Turbo Speed Sensor is mounted in the center of the turbocharger.

Variable Geometry Turbocharger Smart Remote Actuator (VGT SRA)

The Variable Geometry Turbocharger Smart Remote Actuator (VGT SRA) takes the position commands from the EMS, moves the nozzle of the turbocharger to the desired position, and performs all of the diagnostics and self checks on the actuator.

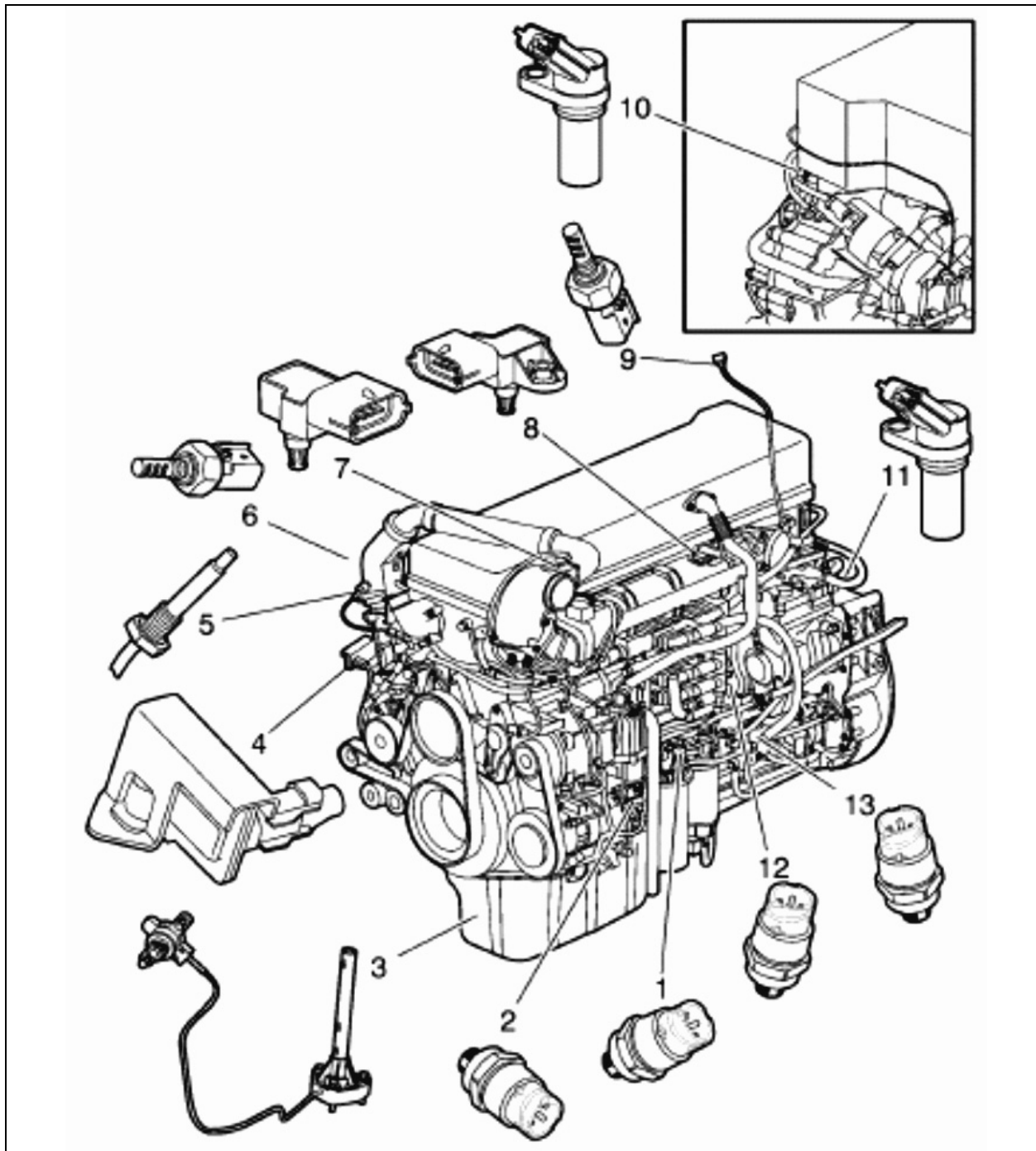

FIGURE 1: ENGINE SENSORS LOCATION

1	Fuel Pressure	8	Air Temperature
2	Crankcase Pressure	9	Humidity/Ambient Air Temperature
3	Oil Level/Temperature	10	Camshaft Speed
4	EGR Differential Pressure	11	Crankshaft Speed
5	EGR Temperature	12	Oil Pressure
6	Coolant Temperature	13	AFI Fuel Pressure
7	Boost Pressure		

Section 01: ENGINE

1.2 ENGINE OVERVIEW

NOTE

For maintenance on or repair of engine components or engine-related components, please refer to Volvo Trucks Canada or Volvo Trucks North America Web Site under: Parts & Service, purchase engine literature, D13F engine.

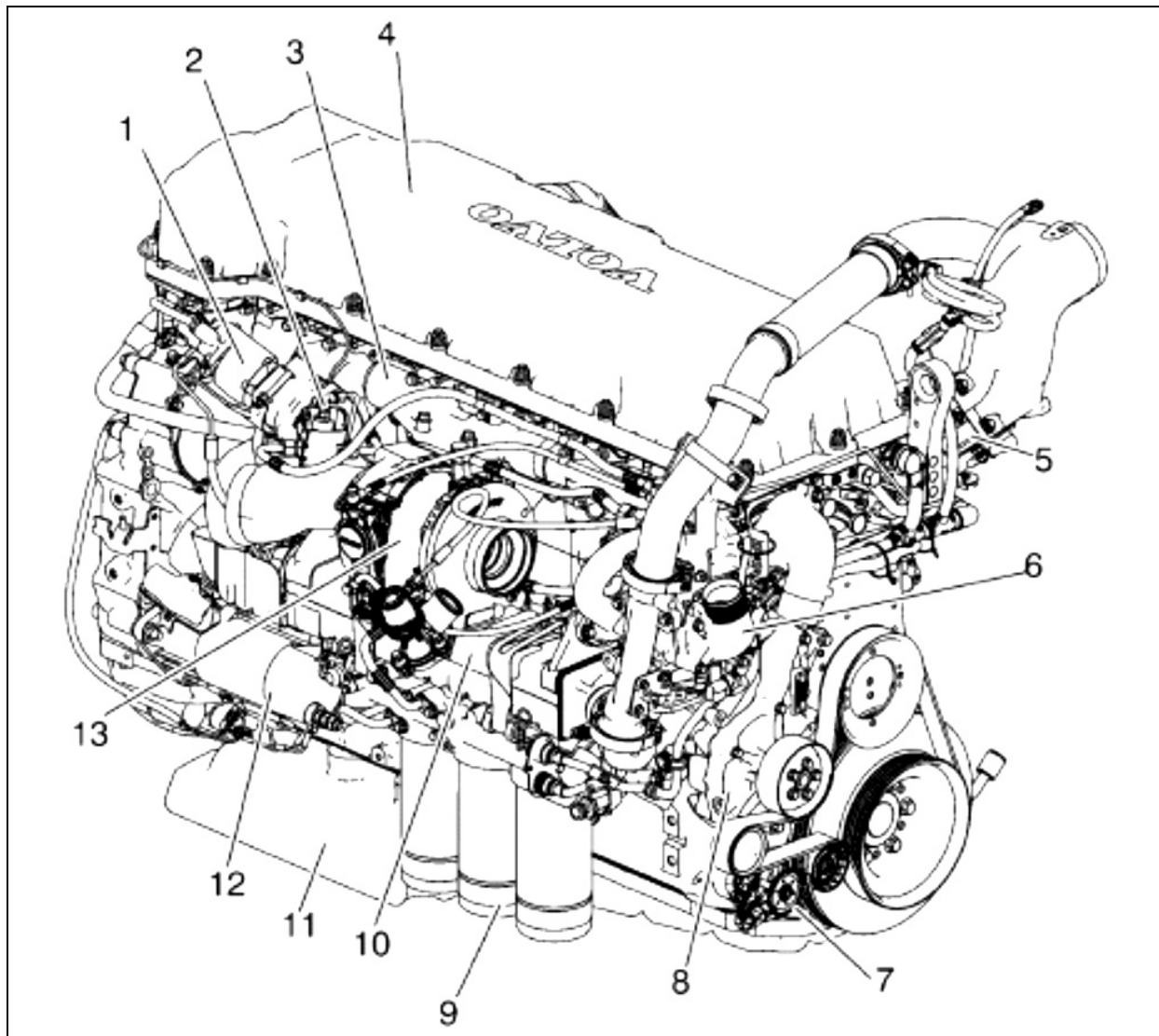

FIGURE 2: D13F ENGINE, TURBO SIDE (TYPICAL)

1. EGR Valve	8. Coolant Pump
2. Aftertreatment Fuel Injector	9. Oil Filters
3. Exhaust Manifold	10. EGR Cooler
4. Valve Cover	11. Oil Pan
5. Engine Preheater Element	12. Starter Motor
6. Thermostat Cover	13. Turbocharger
7. Belt Tensioner	

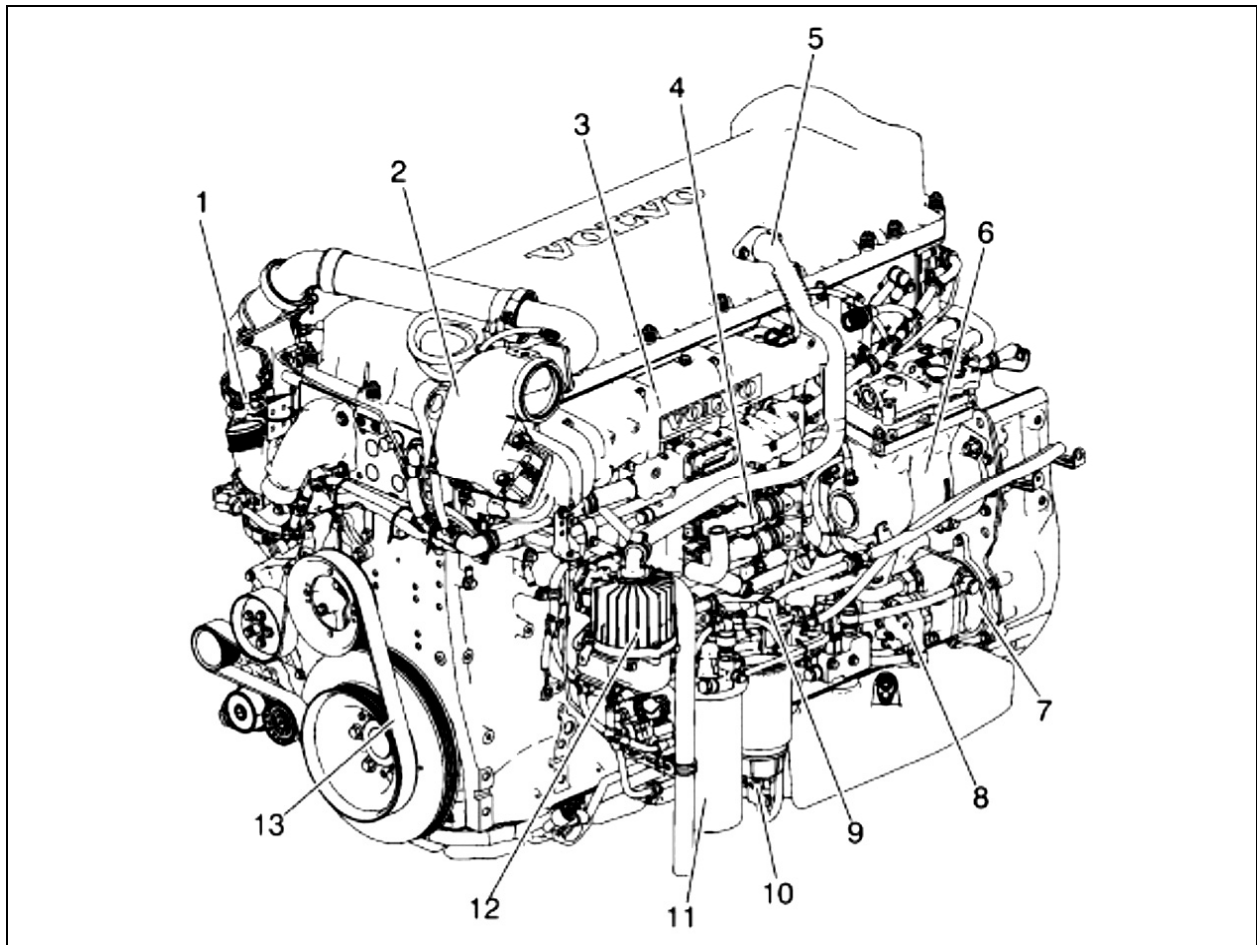

FIGURE 3: D13F ENGINE, ALTERNATOR SIDE (TYPICAL)

1. Venturi Pipe	8. Fuel Pump
2. EGR Mixing Chamber	9. Hand Primer
3. Intake Manifold	10. Fuel/Water Separator
4. Engine Electronic Control Unit (EECU)	11. Fuel Filter
5. Breather Tube	12. Crankcase Ventilator
6. Air Compressor	13. Fan/Coolant Pump Belt
7. Power Steering Pump	

1.3 ENGINE OIL

1.3.1 General

Keep the engine oil at the proper level and change it at the recommended intervals. Always replace the oil filters at the same time as when the oil is changed.

1.3.2 Oil Quality

Volvo North America recognizes engine oils that meet or exceed the standards given by American Petroleum Institute (API) for the oil classifications listed in this manual. Only oils licensed to carry the API symbol should be used. Lubricants meeting API standards have provided maximum engine life when used together with the recommended oil and oil filter change intervals.

Section 01: ENGINE

EO-O Premium Plus (or VDS-4) diesel engine oil is mandatory for use in all 2010 emission compliant Volvo engines. These engines, which can be identified by the presence of an exhaust aftertreatment system using Selective Catalytic Reduction (SCR), also require the use of Ultra Low Sulfur Diesel (ULSD) fuel. EO-O Premium Plus oils exceed the new API service category CJ-4.



CAUTION

DO NOT add extra oil additives. Additives such as break-in oils, top oils, graphitizers, and friction-reducing liquids are not necessary and can harm the engine.

1.3.3 Oil Change Intervals

The length of time an engine can operate before an oil change depends on the quality oil used, the type of fuel used, fuel consumption, engine oil consumption, vehicle application, level of dust in the air, and fuel consumption. The change intervals given in this manual are maximum intervals. If the vehicle is operating in heavy-duty operation, dusty or off-road conditions, etc., reduce the intervals for more frequent oil changes.

NOTE

Use the information in the table below to determine the operating condition and usage applicable to your vehicle.

Engine Operating Condition	Medium	Heavy	Severe
Total Fuel Consumption (mpg)	More than 6	More than 4.7	More than 3.7
Total Fuel Consumption (L/100 KM)	Less than 39	Less than 50	Less than 64
Engine Oil and Filter Change Interval, miles (km) – 41 U.S. quarts (39L) Oil capacity	35,000 (55 000)	25,000 (40 000)	15,000 (24 000)
NOTE: If idle time is greater than 25%, use the next lower drain interval.			

NOTE

Oil filters should always be changed when changing the oil.

1.3.4 Oil Filters

There are three filters on the engine, one of which is a bypass filter. This should be changed at the same time as the full-flow filter(s).



CAUTION

Volvo branded oil filters are designed to provide the proper level of filtration and protection for Volvo engines. Filters that do not meet the same stringent requirements may void engine warranty.

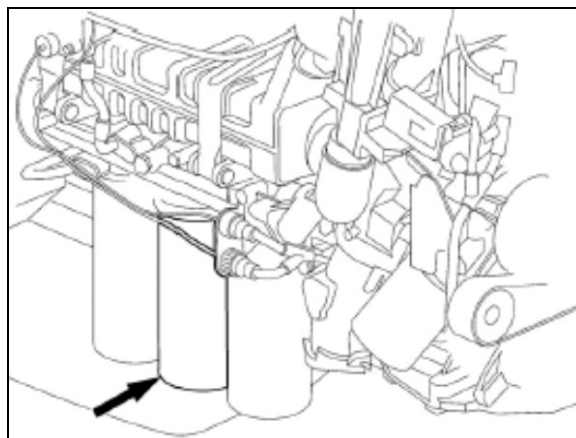

FIGURE 4: D13F OIL FILTERS

1.3.5 Synthetic Lubrication

Synthetic oils are offered by some oil suppliers as an alternative to the traditional, petroleum based oils for engines. These oils may be used in Volvo engines, provided they meet the quality levels specified on the previous pages, that is: both VDS-4 and EO-O Premium Plus.

The use of synthetic oils does not permit the extension of the recommended oil change intervals.

1.3.6 Oil Viscosity

The viscosity grade defines the thickness of the oil. The oil must be thin enough at low temperatures for easy cold starts and thick enough to protect at high temperatures. An oil is not fully defined until both the API quality classification and the viscosity grade are specified.

Choose the viscosity grade for the typical ambient temperature for the application. Multigrade oils have a broad range that suit operation in changing temperature.

Volvo North America recommends the viscosities shown in the viscosity/temperature table for Volvo engines.

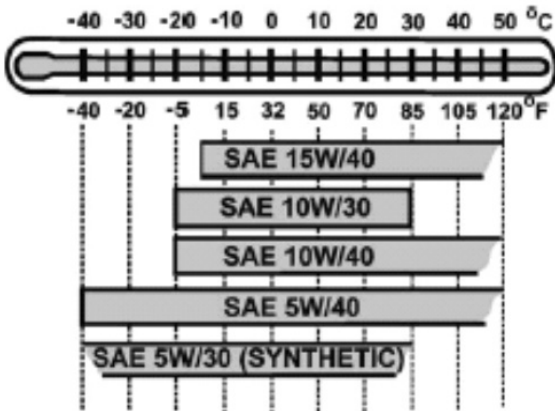

1.3.7 Oil Additives

CAUTION

Extra oil additives must never be added to any engine oil used. Additives such as break-in oils, top oils, graphitizers, and friction reducing liquids are not necessary and may even harm the engine.

Using oils to the quality standards recommended in this manual makes the use of extra oil additives unnecessary, as these oils already contain a balanced treatment of additives.

1.3.8 Oil Consumption

Once the engine is stopped, check the oil level daily. If the engine has just been stopped and it is warm, wait approximately five minutes to allow the oil to drain back to the oil pan before checking. Add oil as necessary.

CAUTION

DO NOT overfill engine with oil.

All diesel engines are designed to consume some oil, so it is normal to add oil periodically. An engine used in heavy-duty operation will consume more oil than one in normal operation.

1.3.9 Oil Change

WARNING

A hot engine or engine oil can be dangerous. Serious burns can result from contact with a hot engine or oil. Take precautions when draining the oil. Wear gloves or let the engine cool down before draining.

WARNING

When draining the oil, use the proper tools and keep away as far as possible. Raise the elbow so the forearm is parallel to the ground to prevent oil running down the arm, causing burns.

CAUTION

Always dispose of all lubricants (motor oil, coolant, gear box oils, etc) and filters according to Federal or local regulations. Used oil disposed of in nature or waterways contaminates our drinking water and kills wildlife.

WARNING

Prolonged contact with used engine oil may be harmful. Use rubber gloves when handling used oil. Wash skin thoroughly if it comes in contact with used oil.

It is important to drain as much oil as possible. Try to change oil immediately after driving, when the oil is warm. Always replace the oil filters when changing the oil.

Component	Capacity (L)
Oil pan	24 (min) – 32 (max)
Engine block	1
Filters (3)	6
Total oil fill (empty)	39

NOTE

Since about 1 liter of oil remains in the engine after draining, approximately 38 liters will be needed for a complete oil change.

Section 01: ENGINE

1.3.10 Oil Filters Change



WARNING

Hot oil can cause severe burns. DO NOT allow hot oil to contact the skin. When changing oil, wear protective gloves.



CAUTION

Volvo-branded oil filters are designed to provide the proper level of filtration and protection for Volvo engines. Filters that do not meet the same stringent requirements may cause unsatisfactory results.

- Clean around the oil filter housing and remove the filters using the oil filter wrench or the oil filter socket.

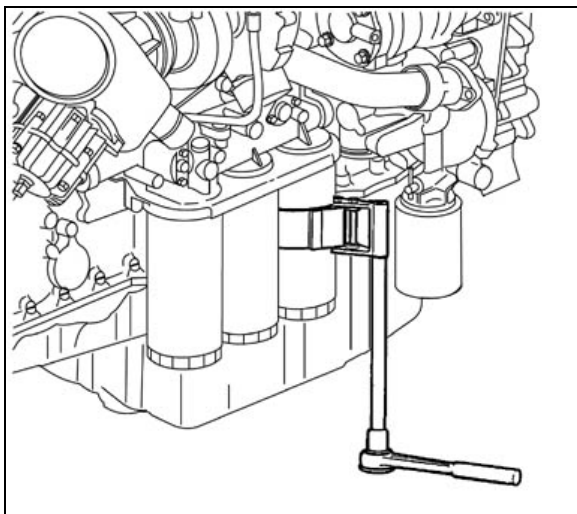

FIGURE 5: OIL FILTER WRENCH

- Prefill the new oil filters with approved engine oil. Also, lubricate the filter gaskets with engine oil (1). Hand tighten the oil filters until they contact the sealing surface of the oil filter housing (2). Manually tighten the oil filters an additional $\frac{3}{4}$ to 1 full turn (3).

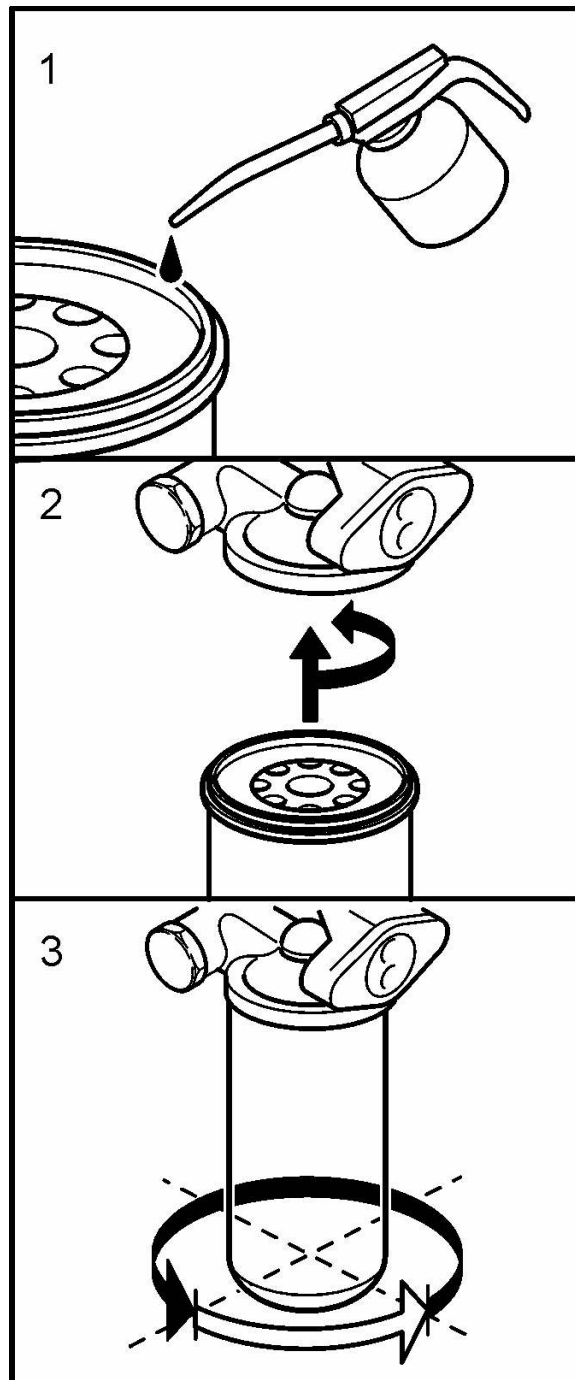

FIGURE 6: OIL FILTER REPLACEMENT

- Start the engine and check for leaks around the oil filter housing and filters.
- Check the oil level. Add approved engine oil to the recommended level, if necessary. Do not overfill.

1.3.11 Checking the Oil Level

Ensure that the vehicle is parked on level ground before checking the oil level. Wait five minutes after shutting off the engine and then proceed with checking the oil.

**CAUTION**

DO NOT let the oil level fall below the marking on the dipstick. **DO NOT** overfill so the level is above the upper marking on the dipstick. This could lead to excessive oil temperature and/or poor crankcase breather performance. Add oil through the oil filler pipe as required in order to maintain level within the safe range.

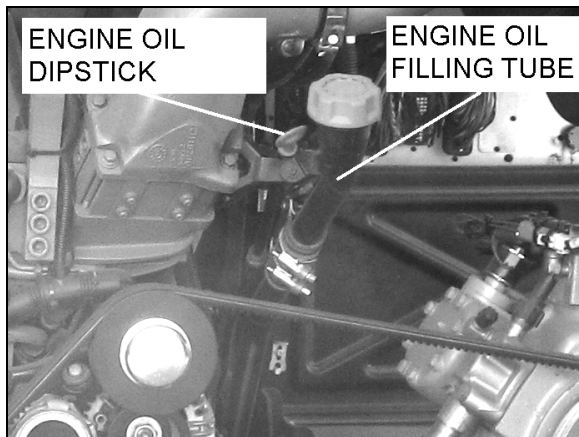

FIGURE 7: ENGINE OIL FILLING TUBE

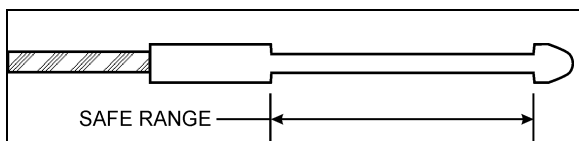

FIGURE 8: ENGINE OIL LEVEL DIPSTICK

1.4 POWER PLANT ASSEMBLY REMOVAL

To access the engine or engine-related components, the vehicle power plant assembly must be removed as a whole unit by means of a slide-out cradle. The power plant assembly includes the engine, transmission (including retarder if so equipped), air compressor, alternator and transmission oil cooler.

Remove the power plant assembly as follows:

**CAUTION**

Tag hoses and cables for identification before disconnecting in order to facilitate reinstallation. Plug all openings to prevent dirt from entering the system.

NOTE

No parts within the EECU are serviceable. If found defective, replace the EECU as a unit.

- **First**

1. Shut off the heater line shut-off valves.
2. Disconnect the battery or batteries from the starting system by removing one or both of the battery cables from each battery system. With the electrical circuit disrupted, accidental contact with the starter button will not produce an engine start.

**WARNING**

Due to the heavy load of the rear bumper assembly, it must be adequately supported before attempting to remove it.

3. Remove the rear bumper assembly complete with hitch if applicable from the vehicle. Refer to Section 18, BODY, under "REAR BUMPER REMOVAL".
 4. Using the quick-connect drain hose, drain the engine cooling system. Refer to Section 05, COOLING under "DRAINING COOLING SYSTEM".
 5. If applicable, disconnect the block heater connector located near the EGR mixing chamber.
- **With Vehicle Raised**
1. Using a vehicle lift or jack, raise vehicle to access transmission fasteners and wire harness.
 2. Disconnect propeller shaft.
 3. Partially remove L.H. side transmission protective panel to access connectors.
 4. On vehicles equipped with an automatic transmission provided with a hydraulic output retarder, disconnect steel-braided airline from pressure regulator output. The pressure regulator is mounted in the upper section of engine compartment backwall and is accessible through the engine compartment R.H. side door.
 5. Untighten bolts A and C. Remove bolts B and D and pivot oil cooler towards transmission. Reinstall bolts B and D.

Section 01: ENGINE

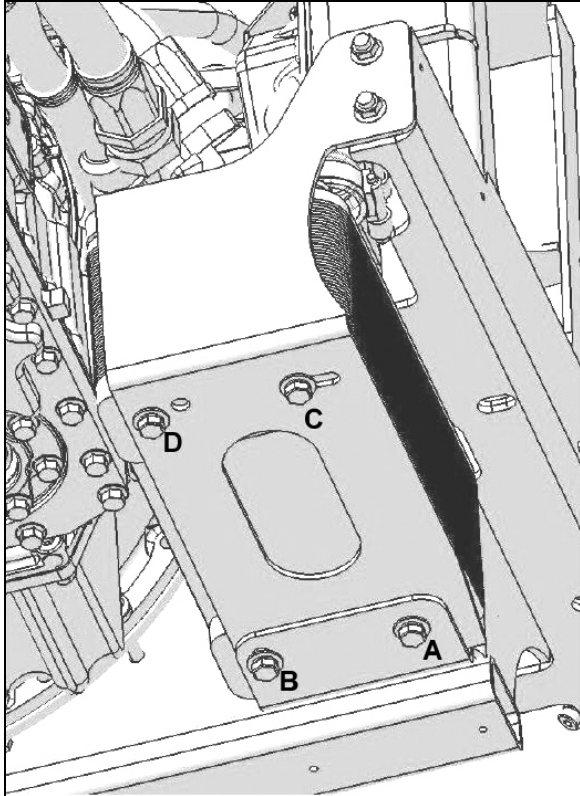

FIGURE 9: COOLER POSITION DURING ENGINE CRADLE INSERTION OR REMOVAL

6. From underneath, unfasten the bolts fixing the engine cradle.
7. Disconnect the engine coolant hose near the starter.
8. Disconnect air compressor suction and discharge hoses.

• With Vehicle Lowered

Lower the vehicle enough to access all components.

- Engine Compartment R.H. side
 - Disconnect cables from two chassis grounds located on diagonal member.
 - Inside engine compartment, disconnect starter, alternators and heater cables. Also disconnect AFSS cable if applicable.
 - Disconnect from engine, connector C398 and vehicle interface harness connector located above EECU connectors. Also disconnect DPF cable.
 - Disconnect power steering pump hoses.
 - Shut off fuel line shut-off valve.

- Close engine fuel supply shut-off valve on primary fuel filter. Disconnect the fuel line located above fuel filters and connected to inlet port.
- Disconnect fuel return line located above fuel filters.
- Disconnect alternators cooling duct and put aside.

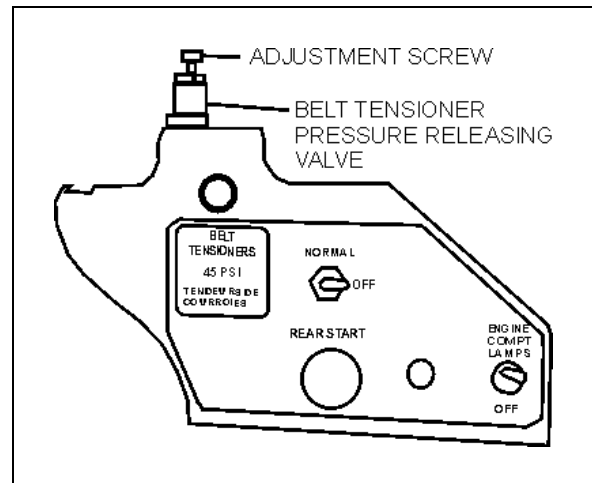

FIGURE 10: BELT TENSIONER VALVE

12200

- Locate the A/C compressor belt tensioner pressure releasing valve (Fig. 10). Turn pressure releasing valve handle counterclockwise in order to release pressure in belt-tensioner air bellows and loosen belts. Remove the belts.
- Disconnect and remove the engine-air intake duct mounted between air cleaner housing and turbocharger inlet.



CAUTION

To avoid damage to turbocharger, cover the turbocharger inlet opening to prevent foreign material from entering.

- Disconnect and remove the exhaust pipe mounted between the flexible coupling and the pipe going to the Diesel Oxidation Catalyst (DOC) and Diesel Particulate Filter (DPF) assembly. If necessary, refer to Section 4: EXHAUST SYSTEM under "EXHAUST AFTERTREATMENT SYSTEM OVERVIEW".

- Disconnect and remove the air intake duct mounted between the charge air cooler outlet and the engine intake.

➤ Engine Compartment L.H. side

- Disconnect fan driving shaft from radiator fan drive mechanism support.



CAUTION

To avoid damage to cooling fan right angle gearbox, make sure the power plant cradle clears the gearbox when pulling the engine out.

- Disconnect and remove section of coolant pipe assembly mounted between the radiator outlet and the water pump inlet.
- Disconnect and remove a section of coolant pipe assembly mounted between the thermostat housing and the radiator inlet.
- Disconnect the electric fan-clutch connector located near the cooling fan right angle gearbox.
- Disconnect and remove the air intake duct mounted between the turbocharger outlet and the air cooler inlet.
- Disconnect and remove surge tank hose connected to pump inlet pipe and hose connected to engine.

- Unfasten and put aside engine compartment lighting fixture and turbocharger fire suppression nozzle if applicable.

- Disconnect Exhaust Aftertreatment System control cable.

• **Last**

1. Inspect the power plant assembly to ensure that nothing will interfere when sliding out the cradle. Check for connections or hoses not mentioned in this list as some vehicles are equipped with special or aftermarket components.
2. Make sure the ten retaining bolts, washers and nuts securing the power plant cradle to the vehicle rear subframe are removed (Fig. 13).

NOTE

Check if any spacer(s) have been installed between power plant cradle and vehicle rear subframe, and if so, note position of each washer for reinstallation purposes.

3. Using a suitable equipment with a minimum capacity of 4,000 lbs (1 800 kg), slightly raise the power plant cradle.
4. Pull engine out slowly from the engine compartment. Make sure all lines, wiring and accessories are disconnected and are not tangled.

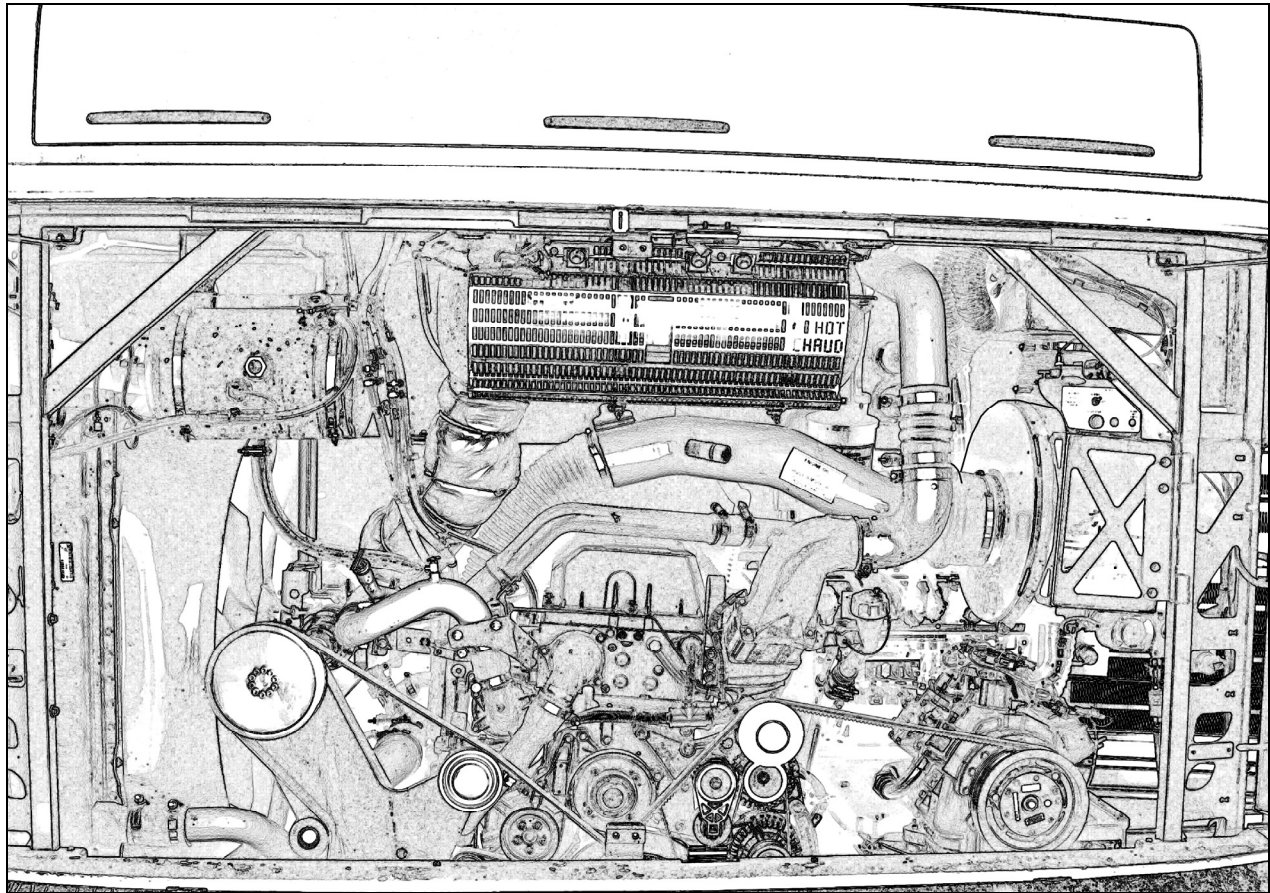

FIGURE 11: ENGINE COMPARTMENT X3 COACHES (TYPICAL)

01184_A

1.5 POWER PLANT ASSY. INSTALLATION

To install a power plant assembly, follow the same procedure as in "Power Plant Assembly Removal" except in reverse order, then proceed with the following:

1. Torque the power plant cradle mounting bolts to 190 lbf-ft (258 Nm).
2. Remove bolts B and D. Untighten bolts A and C then pivot oil cooler as per figure 12. Install bolts B and D and tighten all bolts.
3. Refill cooling system with saved fluid (refer to Section 05, COOLANT SYSTEM).
4. Once engine fuel system has been drained, it will aid restarting if fuel filters are filled with fuel oil (refer to Section 03, FUEL SYSTEM).
5. Start engine for a visual check. Check fuel, oil, cooling, pneumatic and hydraulic system connections for leakage. Test operation of engine controls and accessories.

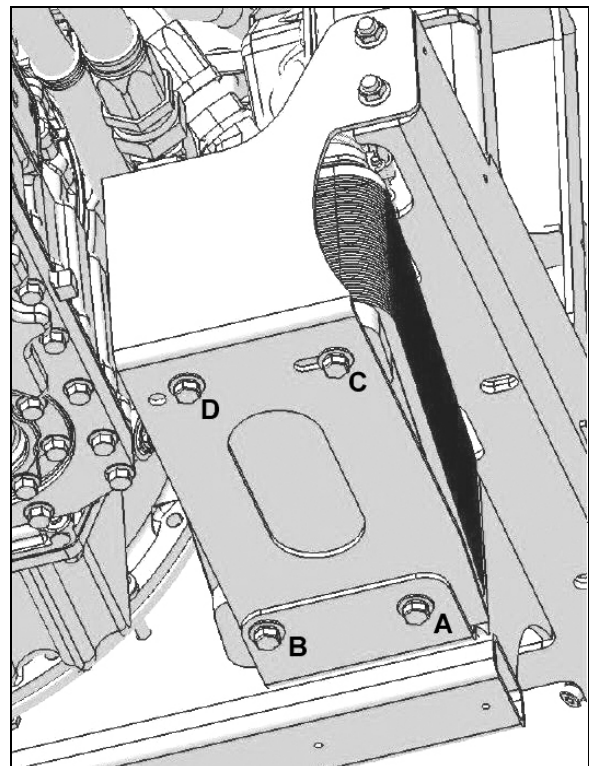

FIGURE 12: NORMAL OIL COOLER POSITION

1.6 ENGINE MOUNTS

The power plant assembly is mounted to the cradle by means of rubber mounts and supports.

Two engine support brackets are used at the front of the engine while two rubber mounts are mounted underneath the engine & radiator fan drive mechanism support and the engine & alternator support (Fig. 13).

It is recommended that new rubber mounts be installed at each major overhaul.

NOTE

Refer to the table on the following page for engine cradle tightening torques.

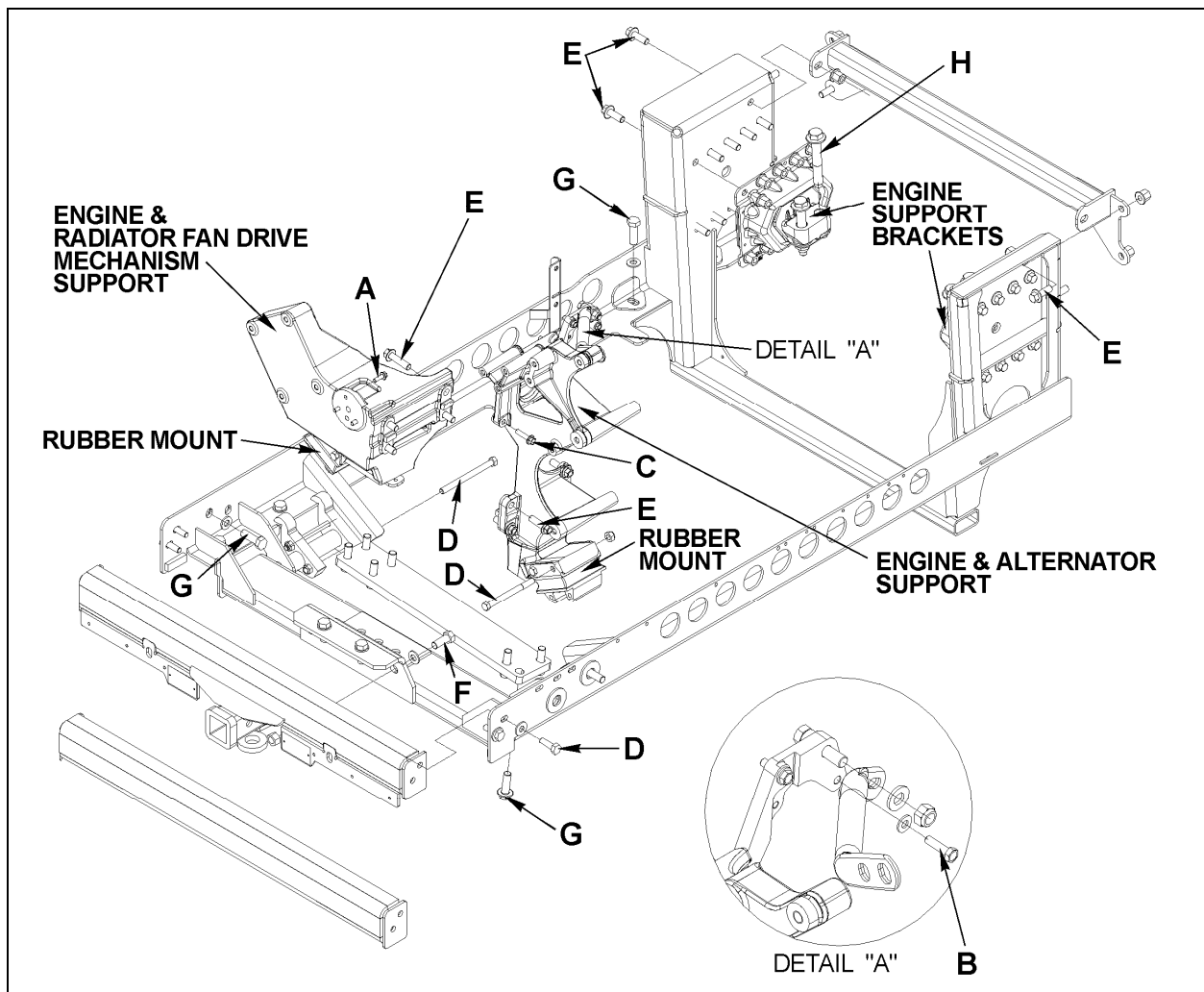

FIGURE 13: VOLVO ENGINE POWER PLANT CRADLE INSTALLATION

Section 01: ENGINE

DRY TORQUES			
REFERENCE	DESCRIPTION	Lbf-Ft	Nm
A	SCREW, CAP HEXAGONAL HEAD M8 – 1.25 G8.8	16	22
B	SCREW, CAP HEXAGONAL HEAD M8 – 1.25 G10.9	22	30
C	SCREW, CAP HEXAGONAL HEAD M10 – 1.5 G10.9	43	58
D	SCREW, CAP HEXAGONAL HEAD M12 – 1.75 G8.8	60	81
E	SCREW, CAP HEXAGONAL HEAD M14 – 2.0 G8.8	90	122
F	SCREW, CAP HEXAGONAL HEAD M16 – 2.0 G8.8	140	190
G	SCREW, CAP HEXAGONAL HEAD M16 – 2.0 G10.9	190	258
H	SCREW, CAP HEXAGONAL HEAD M20 – 2.5 G10.9	450	610

2. ELECTRONIC FOOT PEDAL ASSEMBLY (EFPA) & THROTTLE POSITION SENSOR

The Electronic Foot Pedal Assembly (EFPA) connects the accelerator pedal to a Throttle Position Sensor (TPS). The (TPS) is a device, which sends an electrical signal to the Motor Control Module (MCM). The TPS varies in voltage depending on how far the pedal is depressed. The system is installed in the space normally occupied by a mechanical foot pedal. The (EFPA) has maximum and minimum stops that are built into the unit during manufacturing (Fig. 14). The (TPS) converts the operator's foot pedal input into a signal for the MCM.

When installed by the equipment manufacturer, the TPS should not require adjustment. If the TPS is suspected of being misadjusted, confirm that the sensor is installed in accordance with the manufacturer's specifications. It is recommended that the idle count be at 50 or higher with a full throttle count of up to 200.

The TPS is self-calibrating and therefore has no optimum closed throttle or wide open throttle count value. If the counts are within the 50 to 200 range, the sensor is properly set.

Monitor the (TPS) at the controls as you move it through its full stroke. Be sure there is no misalignment or obstruction preventing the smooth movement of the TPS through the full stroke. Using a diagnostic data reader, check that the idle and full throttle position counts do not fall within the error zones. The error zones occur when the idle position is less than 14 counts, or when the full throttle position is more than 233 counts. Should these conditions occur, the CPC will signal diagnostic codes of 21-12 for idle error and 21-23 for wide-open throttle error.

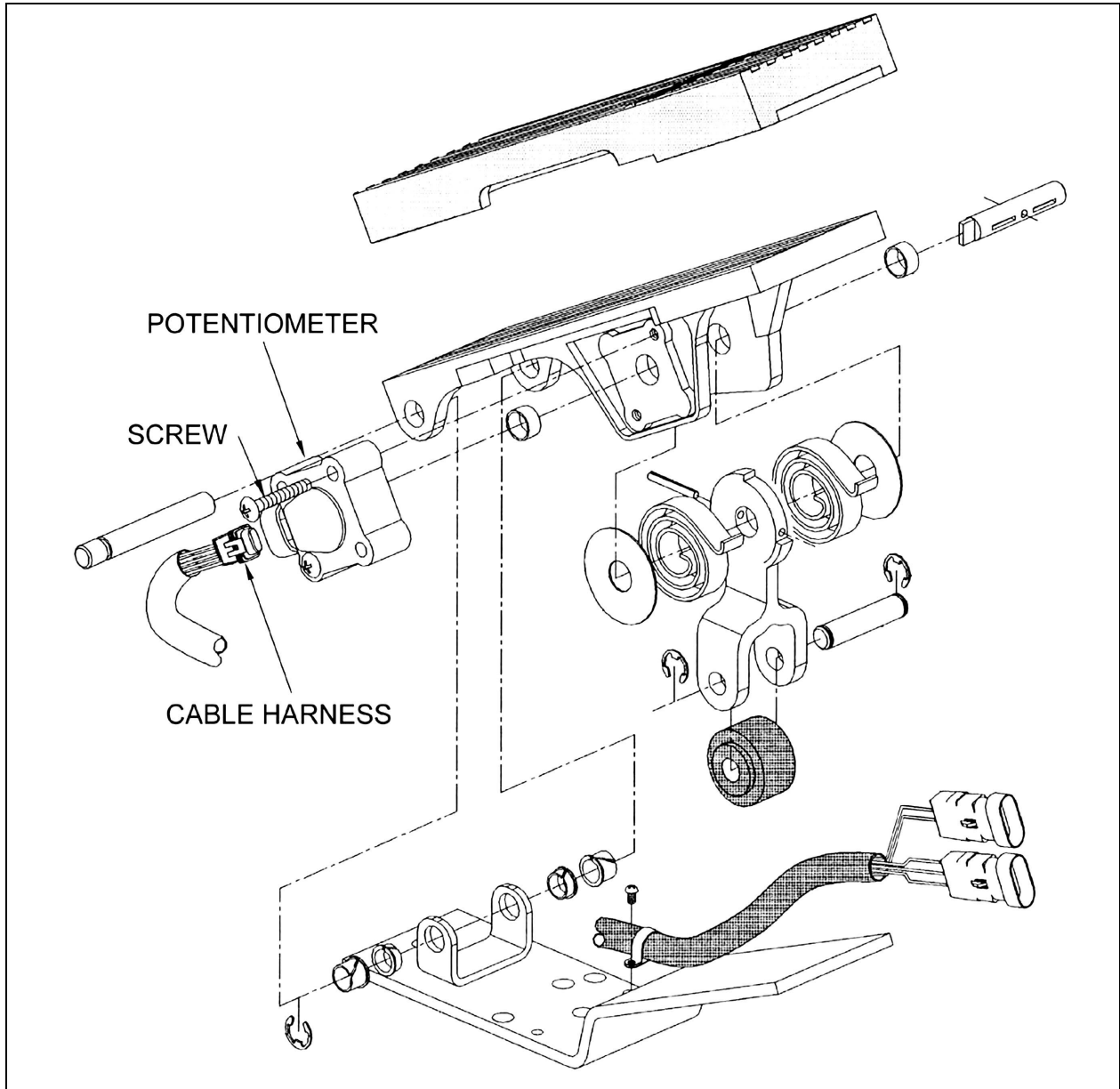

FIGURE 14: ELECTRONIC FOOT PEDAL ASSEMBLY

03035

3. SPECIFICATIONS

Volvo D13 Engine

Make	Volvo
Type	Diesel four cycle/in-line direct injection engine
Description	Turbo/Air to air charge cooled
No. of cylinders	6
Operating range	1400-1800 RPM
X3-45 Coaches Peak Power Rating	435 HP (324 kW)
X3-45 Coaches Peak Torque Rating	1700 Ft-lb (2304 Nm)

Section 01: ENGINE

Low Idle	600 rpm
Fast Idle.....	2150 rpm
Maximum full load revolutions.....	1900 rpm

Engine oil level quantity

Oil Pan Capacity, Low Limit	25 quarts/24 liters
Oil Pan Capacity, High Limit	34 quarts/32 liters
Total Engine Oil Capacity with Filters	41 quarts/39 liters

Lubricating oil filter elements

Type	By-pass
Prevost number	510938
Type	Full Flow
Prevost number	488736

Torque specification

Engine oil filter.....	Tighten $\frac{3}{4}$ of a turn to 1 full turn after gasket contact
------------------------	---

Filters

Engine Air Cleaner Filter	
Prevost number	530197
Engine Coolant Filter/Conditioner	
Prevost number	20458771

SECTION 03: FUEL SYSTEM

CONTENTS

1. FUEL SYSTEM WITH VOLVO D13 ENGINE	3
1.1 DESCRIPTION.....	3
1.2 FUEL VALVES.....	4
1.3 FUEL FILTERS.....	4
1.3.1 <i>Primary Fuel Filter Replacement</i>	5
1.3.2 <i>Secondary Fuel Filter Replacement</i>	5
1.4 PRIMING THE FUEL SYSTEM	6
1.5 FUEL PUMP REMOVAL AND INSTALLATION	6
2. FUEL LINES AND FLEXIBLE HOSES	7
3. FUEL TANK.....	7
3.1 TANK REMOVAL	8
3.2 TANK INSTALLATION	8
3.3 FUEL TANK VERIFICATION.....	8
3.4 POLYETHYLENE FUEL TANK REPAIR.....	8
4. FUEL SPECIFICATIONS	9
4.1 FUEL TYPE	9
4.2 BLENDING.....	10
4.3 BIODIESEL FUELS.....	10
5. AIR CLEANER (DRY TYPE).....	10
5.1 PRE-CLEANER SERVICING	10
5.2 AIR CLEANER SERVICING	11
5.3 GENERAL RECOMMENDATIONS	11
5.4 AIR CLEANER RESTRICTION INDICATOR.....	11
6. FUEL PEDAL	11
6.1 FUEL PEDAL ADJUSTMENT.....	11
6.2 POTENTIOMETER REPLACEMENT	12
7. SPECIFICATIONS.....	12

ILLUTRATIONS

FIGURE 1: FUEL SYSTEM SCHEMATIC (VOLVO D13 ENGINE) 3
FIGURE 2: MANUAL SHUT-OFF VALVE (VOLVO D13 ENGINE)..... 4
FIGURE 3: FUEL LINE COMPRESSION FITTING 4
FIGURE 4: FUEL FILTERS WITH VOLVO D13 ENGINE..... 5
FIGURE 5: HAND PRIMING PUMP 6
FIGURE 6: FUEL PUMP REMOVAL 7
FIGURE 7: FUEL PUMP DRIVE AXLE 7
FIGURE 8: 208 US GAL. FUEL TANK 9
FIGURE 9: FUEL TANK REPAIR 9
FIGURE 10: RESTRICTION INDICATOR 11
FIGURE 11: ELECTRONIC FOOT PEDAL ASSEMBLY 12

1. FUEL SYSTEM WITH VOLVO D13 ENGINE

1.1 DESCRIPTION

NOTE

For additional information concerning Volvo D13 engine components or engine-related components, consult Volvo Trucks Canada or Volvo Trucks North America Web Site under: Parts & Service. On Volvo web site, you will find detailed service procedures for parts replacement, repair and maintenance.

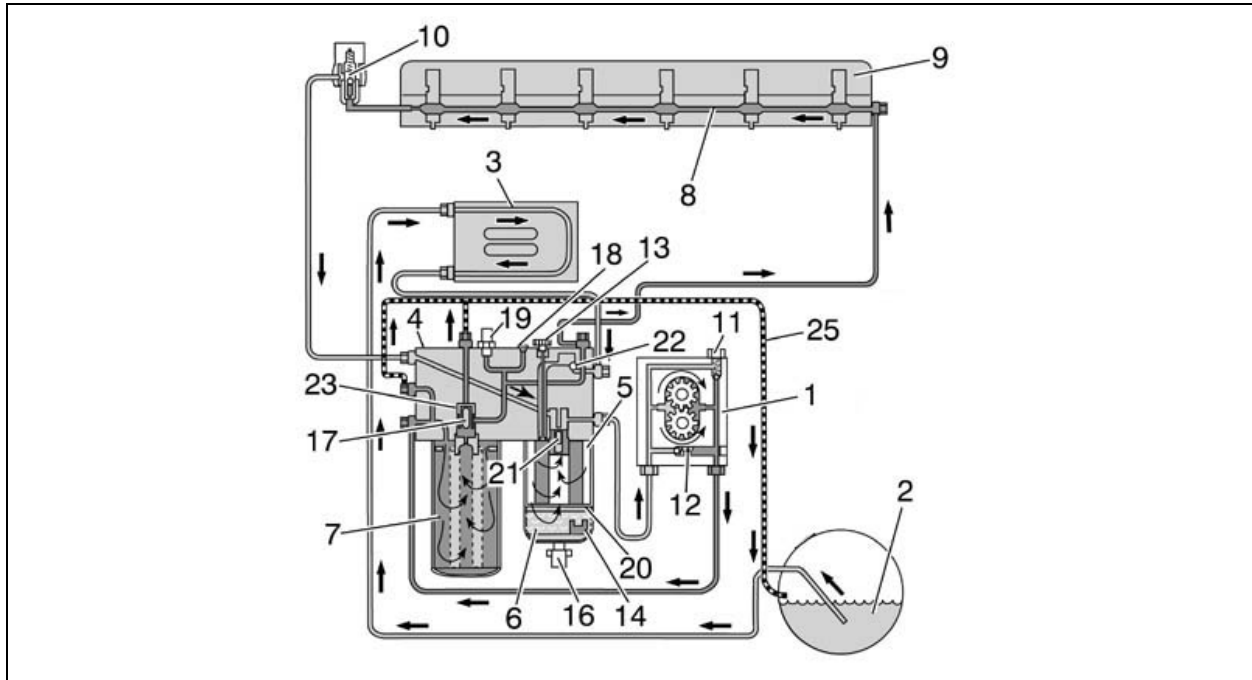

FIGURE 1: FUEL SYSTEM SCHEMATIC (VOLVO D13 ENGINE)

03086

Fuel is drawn up the fuel lines by the supply pump (1) through the pickup tube in the tank (2) and through the Engine Electronic Control Unit (EECU) cooling coil (3) and into the fuel filter housing (4). The fuel housing is equipped with a primary fuel filter (fuel/water separator) consisting of a filter cartridge and a water separation bowl.

The supply pump (1) forces the fuel into the fuel filter housing through the secondary filter (main) to a cylinder head longitudinal gallery (8). This channel supplies each unit injector (9) with pressurized fuel by a circular groove around each unit injector in the cylinder head. The overflow valve (10) controls the fuel supply pressure to the unit injectors.

The return fuel from the overflow valve (10) is returned back to the fuel filler housing and is mixed with the fuel from the fuel tank in a channel within the fuel filter housing (4).

Supply Pump Valves

Two valves are located in the supply pump (1). The safety valve (11) allows fuel to flow back to the suction side when the pressure becomes too high, e.g., if the fuel filter is blocked or is too restricted. The non-return valve (12) opens when the hand-priming pump is used.

Automatic Bleeding

If air gets into the system, it is bled when the engine starts. During bleeding, air is pressed out through the fuel filter housing over to the fuel tank through the return line (25). Bleeding for the filter replacement is controlled by valves (17) and (23).

Section 03: FUEL SYSTEM

Other

The fuel filter housing eliminates the need to drain the fuel when replacing the filter. The valve pegs (17) and (21) close when the fuel filter is removed. It is not necessary to bleed the fuel system after replacing the filter, since this is performed automatically when the engine is started and runs for more than 2 minutes.

The plugged outlet (18) is fitted on the fuel filter housing. This outlet is used when measuring supply pressure after the fuel filter with an external pressure gauge. The pressure sensor (19) on the fuel filter housing monitors the supply pressure after the fuel filter. A fault code is displayed on the instrument cluster if the fuel supply pressure is less than the specified value.

Hand Priming Pump

The hand priming pump (13) is located on the fuel filter housing and is used to pump fuel (when engine is not running) after the fuel system has been drained for repair, etc. The non-return valve (22) for the hand priming pump is also located in the fuel filter housing.

1.2 FUEL VALVES

The manual shut-off valve on engine fuel-supply line is located on the R.H. side of engine compartment. A manual shut-off valve is located at the inlet side of the primary fuel filter.

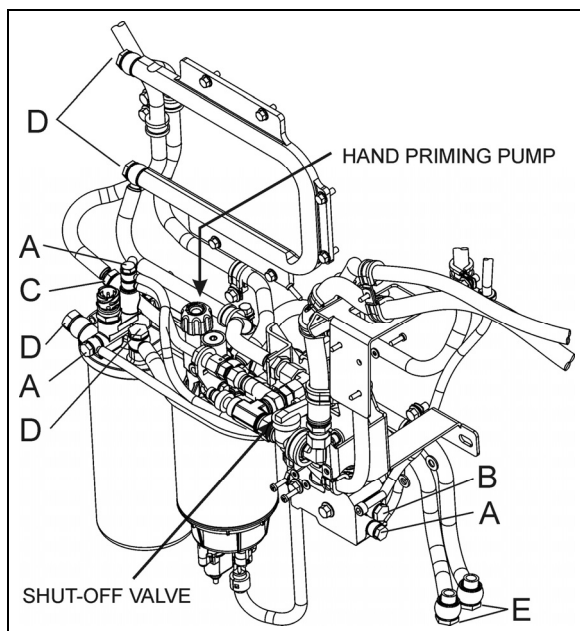

FIGURE 2: MANUAL SHUT-OFF VALVE (VOLVO D13 ENGINE)
03088

Shut-off valve is designed to prevent loss of fuel prime. No manual valve is required on preheater fuel-supply line, since the positive-displacement fuel pump (located close to the fuel tank) prevents fuel flow when not activated.

FUEL LINE FITTINGS – VOLVO D13 ENGINE	
A	13 ± 2 ft-lb (18 ± 3 Nm)
B	20.5 ± 3 ft-lb (28 ± 4 Nm)
C	22 ± 3 ft-lb (30 ± 4 Nm)
D	26 ± 4 ft-lb (35 ± 5 Nm)
E	29.5 ± 4 ft-lb (40 ± 5 Nm)
F	35 ± 4 ft-lb (48 ± 5 Nm)

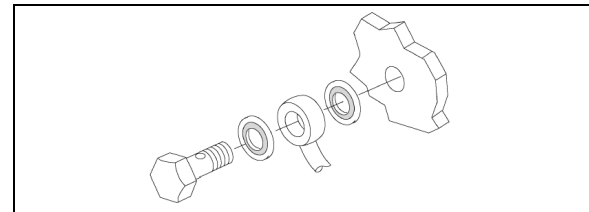

FIGURE 3: FUEL LINE COMPRESSION FITTING



CAUTION

Always replace the fuel line compression sealing washers when troubleshooting for fuel aeration or performing any service procedure that requires the removal of engine fuel lines.

1.3 FUEL FILTERS

A primary fuel filter is installed on the engine. This filter consists of a filter cartridge, a water separation bowl with a drain valve. It is used to prevent water from entering the fuel system.



MAINTENANCE

The primary and secondary fuel filters are of a spin-on type and must be replaced at **every engine oil change**.

The primary fuel filter should be drained periodically or when the telltale light on the dashboard illuminates if equipped with this system. To drain water, loosen the drain valve below the separator. Place an appropriate container under the filter. Close the drain valve when finished.

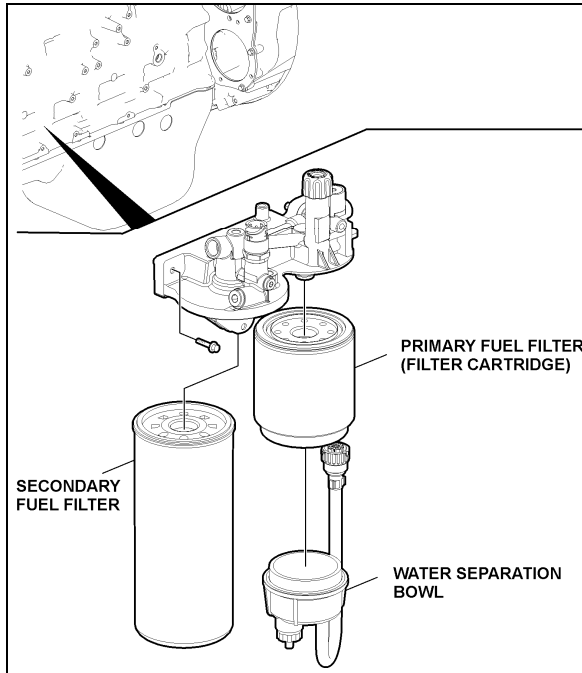
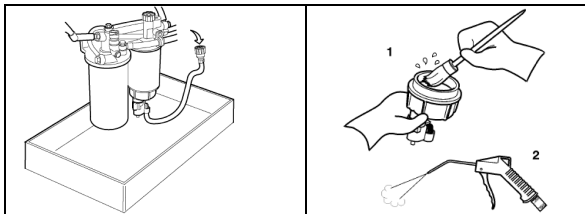

FIGURE 4: FUEL FILTERS WITH VOLVO D13 ENGINE
03085

1.3.1 Primary Fuel Filter Replacement

1. Stop engine, close the fuel supply line shut-off valve.
2. Place an appropriate container under the fuel filter housing, then drain the water from the water separation bowl.
3. Disconnect the fuel/water separator indicator electrical connector.



4. Unscrew and remove the primary fuel filter from the fuel filter housing. Drain filter.
5. Unscrew and remove the separation bowl from the filter cartridge.
6. Remove and discard the old gasket from the water separation bowl. Clean the bowl thoroughly and then blow dry with filtered compressed air.



7. Check that the drainage hole in the water separator bowl is not blocked.
8. Apply a thin coating of clean engine oil to the surface of the water separation bowl.

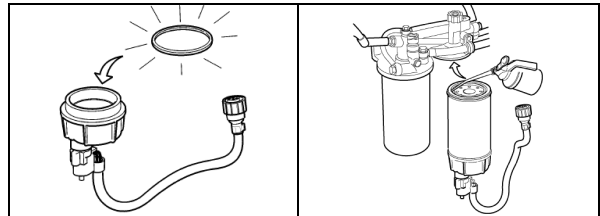

9. Install a new gasket to the water separation bowl and then reinstall the separation bowl to the new primary fuel filter cartridge.
10. Apply a thin coating of clean engine oil to the surface of the primary fuel filter, install the primary fuel filter to the fuel filter housing, then tighten the primary fuel filter $\frac{1}{2}$ - $\frac{3}{4}$ turn.

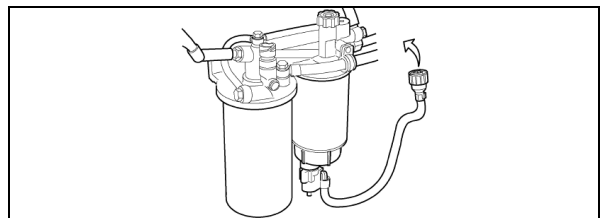

11. Connect the electrical connector for the water/fuel separation bowl indicator.
12. Open the fuel supply line shut-off valve.
13. Purge air from the filter by operating the priming pump to draw fuel and fill the filter. When using the hand priming pump, approximately 100 strokes will be required.
14. Start the engine and carry out a fuel-tightness check. Let the engine run for about 5 minutes to remove air pockets from the fuel system.

1.3.2 Secondary Fuel Filter Replacement

1. Stop engine, close the fuel supply line shut-off valve. Place an appropriate container under the fuel filter housing.

Section 03: FUEL SYSTEM

2. Clean around sealing area on fuel filter and housing.
3. Unscrew and remove the secondary fuel filter from the fuel filter housing.
4. Apply a thin coating of clean engine oil to the gasket of the secondary fuel filter. Screw the fuel filter into position. Tighten the filter $\frac{3}{4}$ to 1 turn after the gasket makes contact with the fuel filter housing.

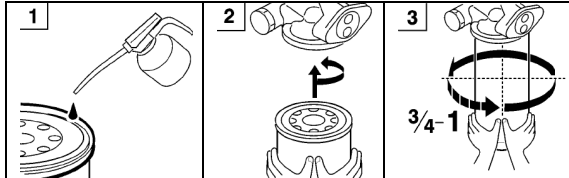

CAUTION

Fuel in the old filter **must absolutely not** be poured into the new filter. This kind of contaminated fuel can damage the unit injectors.

5. Prime the fuel system by pumping the hand priming pump on the fuel filter housing until resistance is felt indicating that the system is full of fuel.
6. Start the engine and carry out a fuel-tightness check. Let the engine run for about 5 minutes to remove air pockets from the fuel system.

1.4 PRIMING THE FUEL SYSTEM

The fuel system will need to be bled if:

- The vehicle has run out of fuel.
- The engine has not been running for an extended period of time.
- Service work has been done on the fuel system, (tank, fuel lines, filters, valves, etc.) for example cleaning or replacing fuel filter cartridges.
- The engine is new or rebuilt.



CAUTION

When priming the system, movement of the primer pump should be as up and down as possible. Avoid putting any side load on the pump or causing a binding condition. Failure to follow these instructions could prematurely damage the primer pump.

NOTE

When the fuel system is empty, 200 or more pump strokes may be needed to properly prime system. There are no bleed nipples to be opened to prime the fuel system.

1. Stop engine;
2. Unlock the hand pump by turning the handle counterclockwise.
3. Prime the system by moving the primer pump in an up and down pumping motion. Avoid putting any side load on the pump or causing a binding condition.

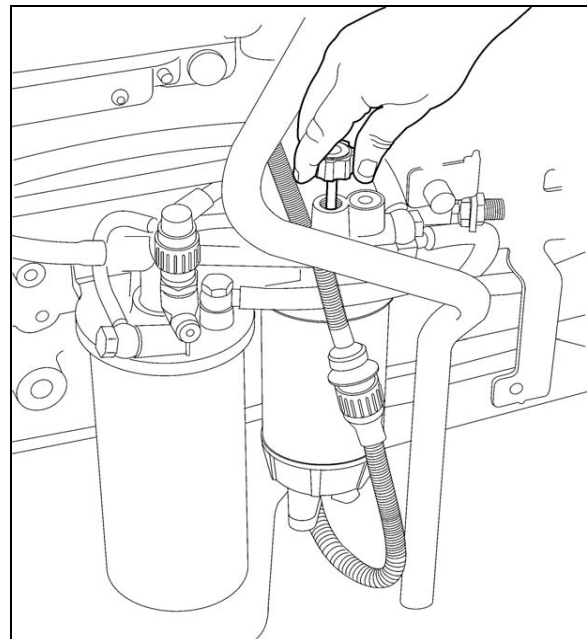

FIGURE 5: HAND PRIMING PUMP

4. Lock the hand primer pump by retracting it into the housing and turning it clockwise.
5. Start the engine and run it at an increased idle speed for approximately 5 minutes to remove any remaining air in the system. Check the fuel system for leaks.

1.5 FUEL PUMP REMOVAL AND INSTALLATION

The pump is located underneath the air compressor and is accessible through the engine compartment R.H. access door.

To remove the pump, proceed as follows:

- Clean around the fuel pump and fuel lines. Position a container to catch any fuel that might drain from the pump or lines.

- Remove the fuel pump.

NOTE

Only unfasten the bolts marked with arrows.

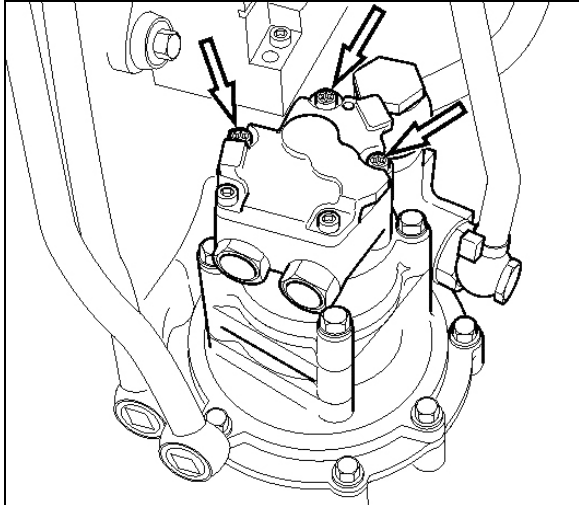

FIGURE 6: FUEL PUMP REMOVAL



CAUTION

Ensure to clean around the head of the bolts. Debris will prevent the tool from fitting properly and cause damage to the fasteners..

- Check that the adapter and fuel pump drive axle are not damaged.

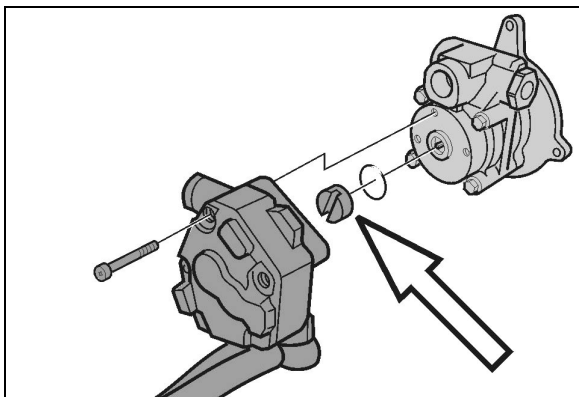

FIGURE 7: FUEL PUMP DRIVE AXLE

- Install the fuel pump. Torque-tighten bolts to specification.

NOTE

Use a new sealing ring. Check that the fuel pump drive axle sits correctly in the power steering pump.

- Using the hand primer on the fuel filter housing, prime the fuel system.

- Start the engine and let run for 5 minutes. Make sure that there are no leaks.

2. FUEL LINES AND FLEXIBLE HOSES

Make a visual check for fuel leaks at all engine-mounted fuel lines and connections and at the fuel tank suction and return lines. Since fuel tanks are susceptible to road hazards, leaks in this area may best be detected by checking for accumulation of fuel under the tank. Engine performance and auxiliary equipment is greatly dependent on the ability of flexible hoses to transfer lubricating oil, air, coolant and fuel oil. Diligent maintenance of hoses is an important step in ensuring efficient, economical and safe operation of engine and related equipment.



MAINTENANCE

Check hoses daily as part of the pre-start-up inspection. Examine hoses for leaks and check all fittings, clamps and ties carefully. Make sure that the hoses are not resting on or touching shafts, couplings, and heated surfaces, including exhaust manifolds, any sharp edges or other obviously hazardous areas.

Since all machinery vibrates and moves to a certain extent, clamps and ties can fatigue with age. To ensure continued proper support, inspect fasteners frequently and tighten or replace them as necessary. Refer to the schematic diagram of the fuel system (Fig. 1).



CAUTION

Oil level above the dipstick full mark or a decrease in lube oil consumption may indicate internal fuel leaks. Check oil level frequently.

3. FUEL TANK

X3-45 coaches are equipped with a high-density cross-link polyethylene fuel tank with a capacity of 208 US gallons (787 liters).

The fuel filling access door is located on the R.H. side of vehicle providing easy fuel filling.

A pressure relief valve on the fuel tank connection-panel relieves high-pressure buildup and an overflow tube allows offset air in the tank to escape during filling. For 95% of the tank volume, 5% of tank inside space is kept filled with air with no exit opening, allowing for a fuel

Section 03: FUEL SYSTEM

expansion safety margin. A drain plug, accessible from under the vehicle, is fitted at the bottom of the tank.

3.1 TANK REMOVAL



DANGER

Park vehicle safely, apply parking brake, stop engine and set battery master switch(es) to the OFF position prior to working on the vehicle.

Before working under an air-suspended vehicle, it is strongly recommended to support the body at the recommended jacking points.

NOTE

Before removal, the fuel tank should be completely drained by unscrewing the drain plug. Ensure that the container used has a capacity equal to the amount of fuel remaining in the tank.

1. Open the condenser door and remove the fuel tank access panel. The rear baggage compartment fuel tank access panel may also be removed to facilitate access to components.
2. Unscrew clamps retaining R.H. side filler tube to fuel tank and filler neck. Disconnect tube and remove it.
3. If applicable, unscrew preheater supply line, preheater return line, auxiliary return line and/or auxiliary return line from fuel tank connection-panel.
4. Unscrew engine supply and return lines from fuel tank connection-panel, identify them for reinstallation.
5. Disconnect electrical wiring from tank on connection plate.



DANGER

Before removing the bolts securing the tank support to the frame, make sure the tank is supported adequately. Failure to do so could result in injury as well as damage to the tank.

6. From under the vehicle, on R.H. side, unscrew the 4 bolts (2 in front, 2 in back) retaining the tank support to the frame.

7. From under the vehicle, on the L.H. side, unscrew the 2 bolts (1 in front, 1 in back) retaining the tank support to the frame.

8. Carefully remove tank from under the vehicle.

3.2 TANK INSTALLATION

To install tank, simply reverse the "Tank Removal" procedure.

3.3 FUEL TANK VERIFICATION

Inspect fuel tank from under vehicle for leaks or fuel traces. If a leak is detected, repair immediately as per "Polyethylene Fuel Tank Repair" in this section.



DANGER

Park vehicle safely, apply parking brake, stop engine and set battery master switch(es) to the OFF position prior to working on the vehicle.

Before working under an air-suspended vehicle, it is strongly recommended to support the body at the recommended jacking points.

3.4 POLYETHYLENE FUEL TANK REPAIR

NOTE

Fuel level must be lower than perforation to carry out this procedure.



DANGER

Park vehicle safely, apply parking brake, stop engine and set battery master switch(es) to the OFF position prior to working on the vehicle.

1. Locate perforation on fuel tank.
2. If necessary, remove fuel tank as per instructions in this section.
3. Drill perforation with a 23/64" bit. Make sure drill hole is perfectly round.
4. Insert a screw (Prevost #500196) and a washer (Prevost #5001244) into anchor nut (Prevost #500331).
5. Place assembly in drill hole. Tighten screw by 10 complete turns. Refer to Fig. 9.
6. Apply sealant on head plug (Prevost #507300) and seal hole with the head plug.

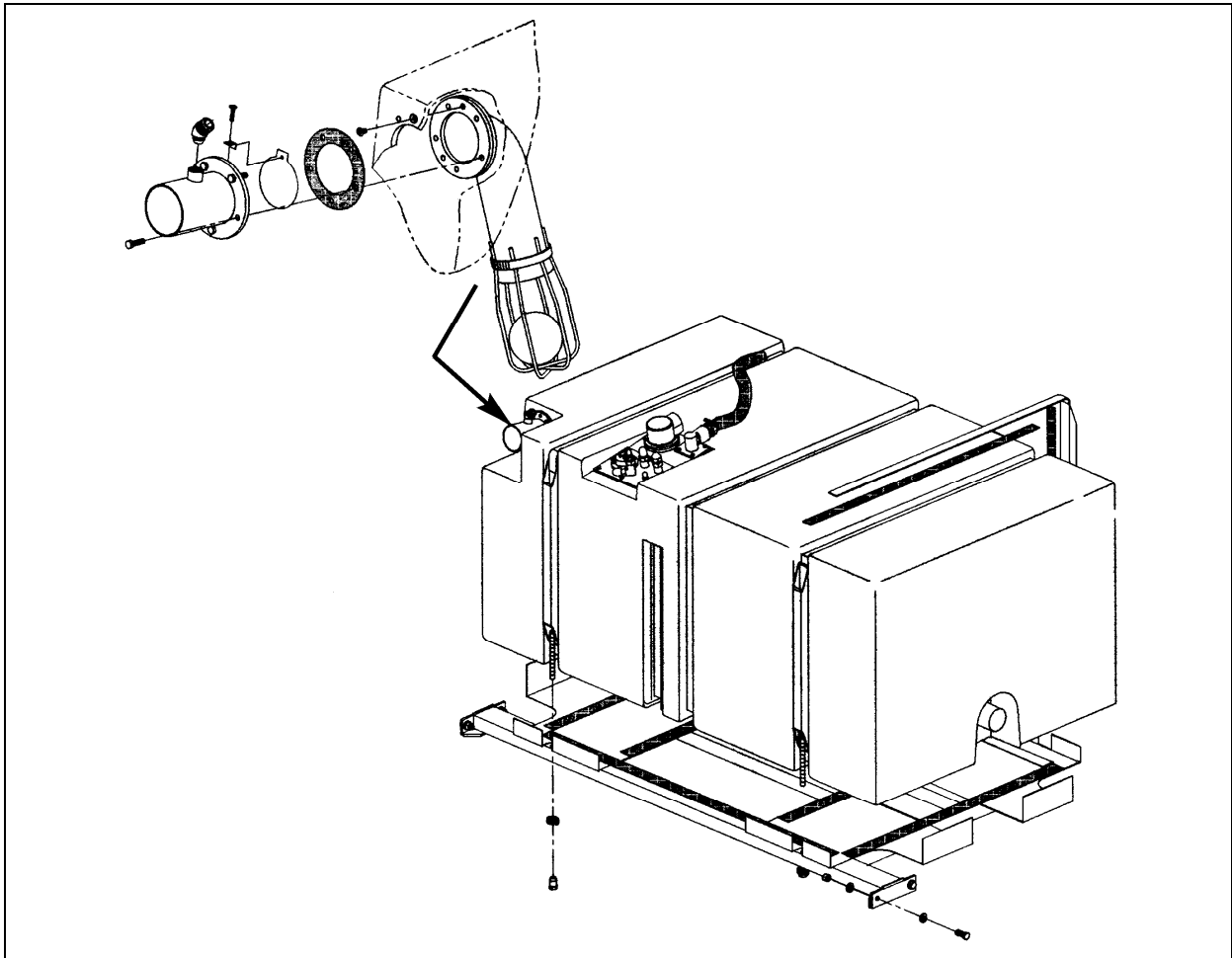

FIGURE 8: 208 US GAL. FUEL TANK

03094

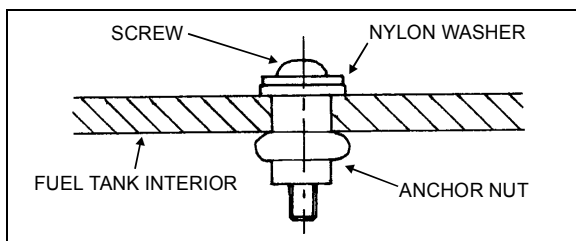

FIGURE 9: FUEL TANK REPAIR

03014

4. FUEL SPECIFICATIONS

The quality of fuel oil used for high-speed diesel engine operation is a very important factor in obtaining satisfactory engine performance, long engine life and acceptable exhaust emission levels.

The U.S. Environmental Protection Agency (EPA) has issued new standards to improve air quality by significantly reducing emissions through a combination of cleaner-burning diesel engines and vehicles.

To meet EPA standards, the petroleum industry produces **Ultra Low Sulfur Diesel (ULSD)** fuel, also referred to as S15, containing a maximum 15ppm (parts-per-million) sulfur.

On-highway diesel engines meeting 2010 emission regulations are designed to operate **ONLY** with ULSD fuel. ULSD fuel will enable the use of cleaner technology diesel engines and vehicles with advanced emissions control devices, resulting in significantly improved air quality.

4.1 FUEL TYPE

EPA-10 engines like the Volvo D13 are designed to run on **Ultra Low Sulfur Diesel (ULSD)** fuel, which can contain no more than 15 ppm sulfur.

Fuel used must meet engine manufacturer's specification. Refer to Volvo engine specifications.



CAUTION

ULSD fuel is necessary to avoid fouling the engine's Exhaust Aftertreatment System. Improper fuel use will reduce the efficiency of the engine's Aftertreatment System and may permanently damage the system.



CAUTION

Owners of 2010 and later model year on-highway diesel engine must refuel only with ULSD fuel.

NOTE

Burning Low Sulfur Diesel fuel (instead of ULSD fuel) in 2010 and later model year diesel engines is illegal and punishable with civil penalties.

NOTE

Engine and vehicle manufacturers expect ULSD fuel to be fully compatible with the existing fleet, including 2006 and earlier model year vehicles. In some instances, the introduction of ULSD fuel to older vehicles may affect fuel system components or loosen deposits in fuel tanks. As part of a good maintenance program, owners and operators of existing cars, trucks and buses are encouraged to monitor their diesel-powered vehicles closely for potential fuel system leaks or premature fuel filter plugging during the change-over to ULSD fuel.

NOTE

Like Low Sulfur Diesel fuel, ULSD fuel requires good lubricity and corrosion inhibitors to prevent unacceptable engine wear. As necessary, additives to increase lubricity and to inhibit corrosion will be added to ULSD fuel prior to its retail sale.

4.2 BLENDING

Only ultra low sulfur kerosene – No.1 diesel with no more than 15ppm sulfur may be blended with ULSD fuel to improve cold weather performance. With so many kerosene formulations on the market, care must be taken to select kerosene with a maximum of 15ppm sulfur.

Blend rates remain the same as with Low Sulfur Diesel fuel.

4.3 BIODIESEL FUELS

ULSD-B5 biodiesel may be used. B5 tells you the percentage of biodiesel mixed in with ULSD. B5 is 5% biodiesel and 95% ULSD.

Fuel used must meet engine manufacturer's specification for biodiesel fuel. Refer to Volvo engine specifications.

Biodiesel fuels are alkyl esters of long chain fatty acids derived from renewable resources. Volvo highly recommends biodiesel fuels made from soybean or rapeseed oil through the proper transesterification reaction process. Other feedstock source of biodiesel fuels such as animal fat and used cooking oils are not recommended by Volvo. Failures attributed to the use of biodiesel fuel will not be covered by Volvo or Prevost product warranty. Also, any engine performance problem related to the use of biodiesel fuel would not be recognized nor considered as Volvo or Prevost's responsibility.

5. AIR CLEANER (DRY TYPE)

The vehicle is equipped with a dry-type replaceable element air cleaner, located in the engine compartment. Access the air cleaner through the engine R.H. side door. Engine air enters the air cleaner through (1) one intake duct located just above engine R.H. side door. It then flows through a pre-cleaner and finally through the air cleaner. The pre-cleaner removes dust and moisture by means of a discharge tube at the bottom of the element. It is in series with a replaceable impregnated paper filter element (air cleaner).

5.1 PRE-CLEANER SERVICING



MAINTENANCE

The pre-cleaner is designed to be self-cleaning; however, it should be inspected and any accumulated foreign material removed during the periodic replacement of the impregnated paper filter element.

5.2 AIR CLEANER SERVICING

Stop the engine, open the R.H. side engine compartment door, and loosen the wing nut retaining the air cleaner element to the air cleaner. Remove the element by pulling on the handle in the center of the air cleaner element.

Install cleaner element as follows:

1. Inspect the gasket-sealing surface inside the air cleaner. It must be smooth, flat and clean;
2. Install the air cleaner element;
3. Make sure that the element seals securely;
4. Inspect element cover gasket and replace if necessary.

Whenever it becomes necessary to remove the air cleaner assembly (dry type) for maintenance or other repair in this area, great care should be taken when installing air cleaner assembly.

The pre-filter should be installed snugly in the air duct and clamped tightly to the air cleaner inlet to prevent any dust infiltration into the air cleaner.

5.3 GENERAL RECOMMENDATIONS

The following maintenance procedures will ensure efficient air cleaner operation:

1. Keep the air cleaner housing tight on the air intake pipe;
2. Make sure the correct filters are used for replacement;
3. Keep the air cleaner properly assembled so the joints are air-tight;
4. Immediately repair any damage to the air cleaner or related parts;
5. Inspect, clean or replace the air cleaner or elements as operating conditions warrant. Whenever an element has been removed from the air cleaner housing the inside surface of the housing must be cleaned with a soft clean cloth;
6. Periodically inspect the entire system. Dust-laden air can pass through an almost invisible crack or opening which may eventually cause damage to an engine;
7. Never operate the engine without an element in the air cleaner assembly;



CAUTION

Do not ignore the Warning given by the air restriction indicator. This could result in serious engine damage.

8. Store new elements in a closed area free from dust and possible damage.

5.4 AIR CLEANER RESTRICTION INDICATOR

A resettable restriction indicator may be installed on the engine air-intake duct, clearly visible from the rear engine compartment. The indicator monitors the vacuum level between the air filter and the engine. A red marker is displayed when the air filter is clogged and must be replaced. Reset by pressing on the indicator's extremity.

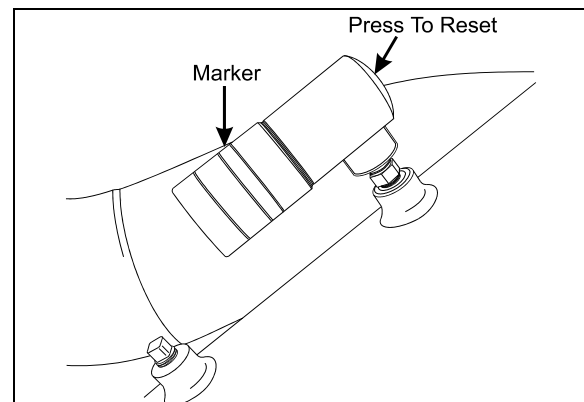

FIGURE 10: RESTRICTION INDICATOR

01052

6. FUEL PEDAL

The EFPA (Electronic Foot Pedal Assembly) connects the accelerator pedal to a potentiometer (a device that sends an electrical signal to the ECM, which varies in voltage, depending on how far down the pedal is depressed). The EFPA is installed in the space normally occupied by a mechanical foot pedal. It has maximum and minimum stops that are built into the unit during manufacturing.

6.1 FUEL PEDAL ADJUSTMENT

The EFPA contains a throttle position sensor that varies the electrical signal sent to the ECM. The sensor must be adjusted whenever an EFPA is serviced. In addition, the sensor should be adjusted any time codes 21 and 22 are flashed.

Section 03: FUEL SYSTEM

With the ignition "ON" and the proper diagnostic tool (DDR) (for information regarding the DDR, see "01 ENGINE" in this manual), check the throttle counts at idle and full throttle positions.

Proper pedal output should be 20/30 counts at idle and 200/235 at full throttle. If adjustment is necessary, remove the potentiometer retaining screws and rotate the potentiometer clockwise to increase counts or counterclockwise to decrease. When correct output is confirmed, tighten retaining screws.

6.2 POTENTIOMETER REPLACEMENT

1. Disconnect cable harness connector.
2. Loosen the two screws and remove potentiometer. Retain for re-assembly.
3. Discard potentiometer (Fig. 11).



CAUTION

Note the routing and clamping locations of the cable before disassembly. Proper cable routing and fastening is critical to the operation of this system. Marking the foot pedal assembly to record cable routing is recommended.

2. Position new potentiometer. Press potentiometer onto the potentiometer shaft, matching cutouts in shaft to drive tangs of potentiometer. Apply hand pressure until potentiometer has bottomed out in housing.

Reinstall screws (Fig. 11) and tighten just enough to secure potentiometer lightly. Tighten screws to 10 - 20 Lbf-in (1.13 - 2.26 Nm).

3. Reconnect electronic foot pedal assembly's cable harness to the ECM connector. If potentiometer calibration is necessary (see "FUEL PEDAL ADJUSTMENT" in this section).



CAUTION

Make sure the cable harness is routed correctly, and securely installed so that it does not become pinched, stretched, or otherwise damaged during vehicle operation.

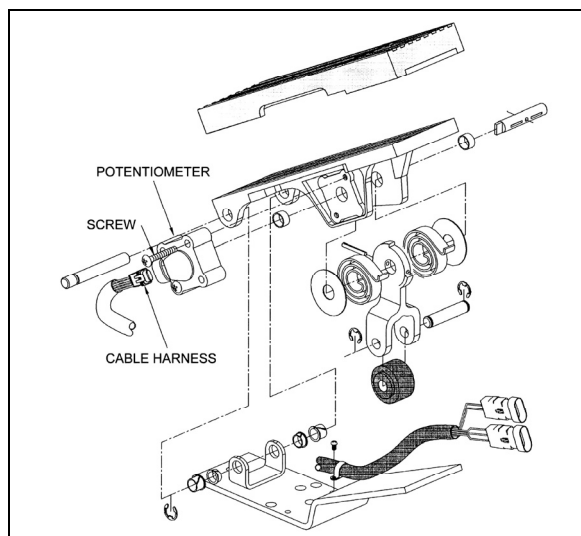

FIGURE 11: ELECTRONIC FOOT PEDAL ASSEMBLY 03035

7. SPECIFICATIONS

Primary Fuel Filter (Fuel/Water Separator) With Volvo D13 Engine

Part number.....21380475

Filter torque..... 1/2-3/4 turn after gasket contact

Secondary Fuel Filter With Volvo D13 Engine

Part number.....20972293

Filter torque..... 3/4- 1 turn after gasket contact

Fuel tank Capacity

Standard (All vehicles)208 US gallons (787 liters)

Air Cleaner

Service Part No 7182 8N

Prevost number (element cartridge).....530197

Air Cleaner Restriction Indicator

Indicatesat 20" (508 mm) of water

Prevost number530161

SECTION 04: EXHAUST AND AFTERTREATMENT SYSTEM

CONTENTS

1. EXHAUST AFTERTREATMENT SYSTEM OVERVIEW	2
1.1 MAINTENANCE.....	2
1.2 FLEXIBLE COUPLING INSTALLATION.....	3
2. DIESEL PARTICULATE FILTER (DPF)	3
2.1 DIESEL PARTICULATE FILTER ASSEMBLY REMOVAL	4
3. CATALYTIC CONVERTER.....	5
3.1 REMOVAL	5
3.2 ASSEMBLING CATALYTIC CONVERTER.....	7
4. DIFFUSER ASSEMBLY	8
4.1 DIFFUSER ADJUSTMENT.....	8
4.2 MAINTENANCE.....	9
5. DIESEL EXHAUST FLUID (DEF) TANK AND INJECTION SYSTEM	9
5.1 DIESEL EXHAUST FLUID.....	10
5.2 DEF TANK CLEANING	10
5.3 PUMP ASSEMBLY FILTER ELEMENT REPLACEMENT	11
6. AFTERTREATMENT FUEL INJECTOR.....	12
6.1 REPLACEMENT.....	12
7. TORQUE SPECIFICATIONS	14

ILLUSTRATIONS

FIGURE 1: EXHAUST SYSTEM.....	2
FIGURE 2: FLEXIBLE COUPLING	3
FIGURE 3: DIESEL OXIDATION CATALYST (DOC) & DIESEL PARTICULATE FILTER (DPF) ASSEMBLY	4
FIGURE 4: TAKING DOC AND DPF APART	5
FIGURE 5: CATALYTIC CONVERTER	6
FIGURE 6: DIFFUSER ASSEMBLY	8
FIGURE 7: DIFFUSER POSITION ADJUSTMENT.....	9
FIGURE 8: DEF TANK AND PUMP LOCATION	9
FIGURE 12: AFTERTREATMENT FUEL INJECTOR	12
FIGURE 13: FUEL LINE FITTING	13

Section 04: EXHAUST AND AFTERTREATMENT SYSTEM

1. EXHAUST AFTERTREATMENT SYSTEM OVERVIEW

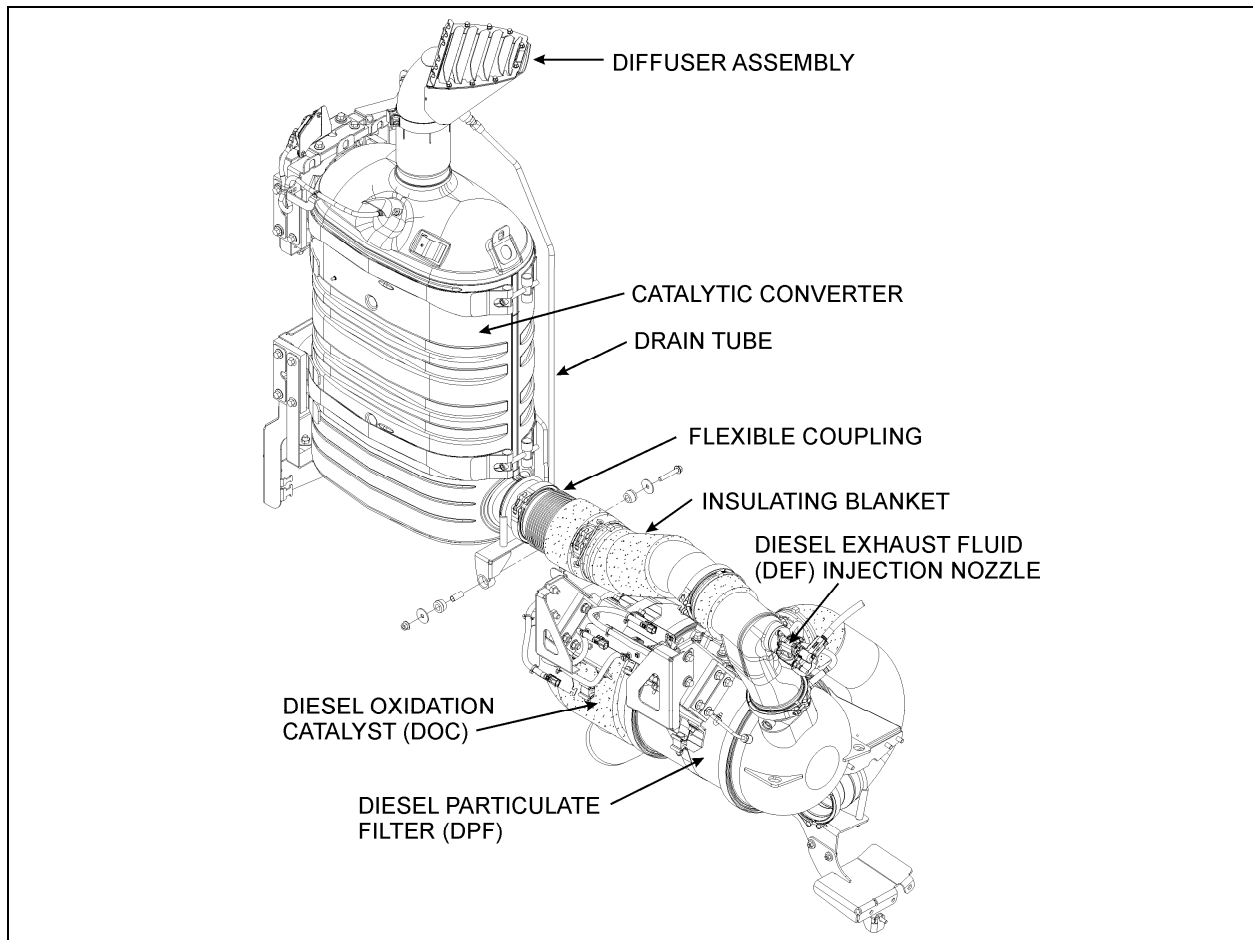

FIGURE 1: EXHAUST SYSTEM

The technology behind clean emissions is through the immediate aftertreatment of engine exhaust. The process for reducing NO_x via aftertreatment is called Selective Catalytic Reduction (SCR). It requires a catalytic converter into which is injected Diesel Exhaust Fluid (DEF). The primary component of DEF is water; the active component is urea. Urea is a nitrogen compound that turns to ammonia when heated. When a urea-and-water solution is injected into the exhaust stream and passed over a catalyst, the urea reacts with the NO_x to form nitrogen and water vapor – two clean and harmless components of the air we breathe. The aftertreatment system primary function is to capture and oxidize (regenerate) the particulate matter (soot) in the engine exhaust gases and to reduce NO_x. To achieve this goal, the exhaust aftertreatment system is split into two main sections: the exhaust gases first enter the **Diesel Oxidation Catalyst (DOC)** and **Diesel**

Particulate Filter (DPF) assembly to capture and regenerate the soot on a regular or passive basis, then the exhaust gases flow through the **catalytic converter** to reduce NO_x to minimum level. Through constant monitoring of the exhaust gas temperature and the system back pressure, the engine management system (EMS) is able to manage regeneration.

The exhaust aftertreatment system is rubber mounted to the vehicle structure. This feature reduces the transmission of vibrations to the exhaust aftertreatment system thus resulting in extended life of the system, brackets and also noise reduction.

1.1 MAINTENANCE

Inspect the exhaust system periodically for restrictions and leaks. Figure 1 presents the major components of the exhaust system. Exhaust leaks are commonly the result of loose

clamp bolts, corroded or punctured pipes. In addition to excessive noise, a leaking exhaust system could allow toxic gases to enter the vehicle. Damage to surrounding components from hot gases could result as well. Replace damaged or corroded exhaust components immediately.

Inspect the exhaust system as follows:

- At vehicle inspection intervals ;
- Whenever a change is noticed in the sound of the exhaust system ;
- When components close to the exhaust system get unnaturally dirty ;
- Whenever the exhaust system is damaged.

Replace damaged or corroded exhaust system components without delay.

When operating the engine in a service garage or in a closed area, the exhaust must be vented to the outside. Place the shop vent hose over the exhaust outlet pipe.

DANGER

Avoid breathing exhaust gases since they contain carbon monoxide which is odorless and colorless but harmful. Carbon monoxide is a dangerous gas that can cause unconsciousness and can be lethal. If, at any time you suspect that exhaust fumes are entering the vehicle, locate and correct the cause(s) as soon as possible.

NOTE

The key to successful regeneration is high exhaust temperature for an extended period of time. For this reason, insulating blankets must remain permanently on the exhaust system.

If insulating blankets are removed from the system, the exhaust gases temperature may not be high enough to permit efficient particulate oxidation during passive regeneration, resulting in increased fuel consumption due to overuse of active or stationary regeneration.

1.2 FLEXIBLE COUPLING INSTALLATION

The flexible coupling contains a rigid interior pipe (Fig. 2). To allow appropriate flexibility once installed, be sure interior pipe is concentric to

flexible part and that the flexible coupling is straight when installed. This piece of equipment handles vibration and thermal expansion.

CAUTION

Adequately support the exhaust system line. The load of the exhaust line **must not** be transferred to the turbocharger.

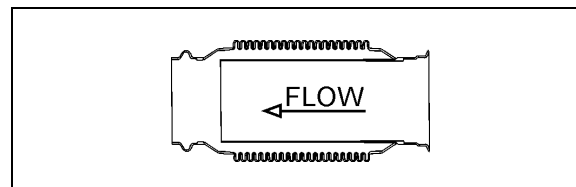



FIGURE 2: FLEXIBLE COUPLING 04022

2. DIESEL PARTICULATE FILTER (DPF)

Besides trapping soot, the **DPF (Diesel Particulate Filter)** also traps the ash that has been generated when additives in engine oil are burned. However, unlike soot, ash cannot be oxidized. The ash that accumulates in the filter will eventually cause an increase in exhaust back pressure. EMS will constantly monitor the ash accumulation and forecast the approximate time until DPF ash cleaning is required. This allows you the opportunity to plan for the DPF ash cleaning interval. If ash cleaning is not performed proactively, and the back pressure increases beyond the system limit, EMS will flag the amber warning light on the telltale panel, notifying the operator that an ash cleaning is required. Clean remanufactured DPF cartridge will be available through Prevest on an exchange basis. For most commuter vehicle applications and duty cycle, this will occur after approximately 4500 hours of operation.

WARNING

HOT SURFACES

Keep yourself clear of hot Aftertreatment System surfaces, particularly during and after active or stationary regeneration. Hot surfaces can cause serious burns.

Make sure Aftertreatment System components are cold before handling.

Section 04: EXHAUST AND AFTERTREATMENT SYSTEM

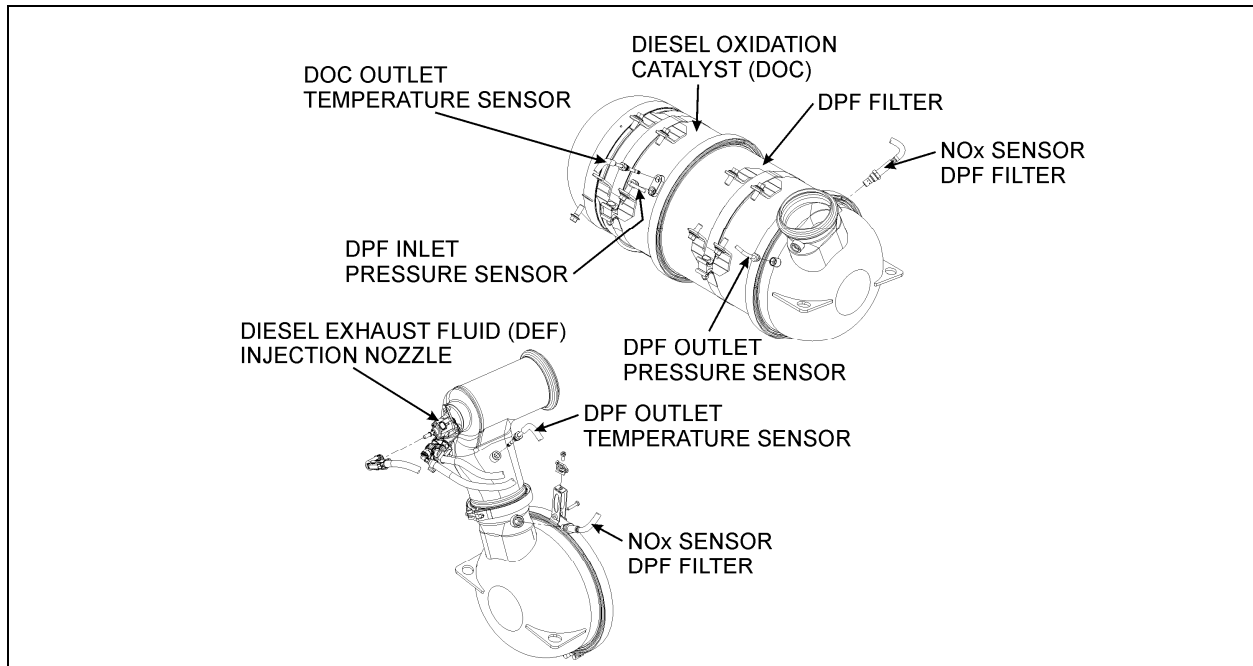

FIGURE 3: DIESEL OXIDATION CATALYST (DOC) & DIESEL PARTICULATE FILTER (DPF) ASSEMBLY

04016

WARNING

HOT EXHAUST

During stationary regeneration, exhaust gases temperature may get very hot at the diffuser outlet. Do not direct diffuser at combustible materials. Before initiating stationary regeneration, make sure that the diffuser outlet is clear of objects and that no one is working near the diffuser outlet. Stationary regenerations must be undertaken outdoors only.

Never initiate regeneration when exhaust gas collection system is in place.

CAUTION

External and internal temperatures remain hot long after engine has been shut down. Allow the Exhaust Aftertreatment System to cool before handling. Wear protective clothing and glove while servicing.

1. First, open the engine compartment doors;
2. Put insulating blanket aside;
3. Disconnect pressure, temperature and NOx sensors;
4. Support Diesel Oxidation Catalyst (DOC) and Diesel Particulate Filter (DPF) assembly;

WARNING

TOXICITY

Do not initiate a stationary regeneration in a closed area like a garage. **Stationary regeneration must be undertaken outdoors only.**

CAUTION

HEAVY DEVICE

A suitable lifting or holding device is required. Properly support and attach lifting equipment to prevent the DOC and DPF assembly from falling when servicing.

5. Unfasten straps holding DOC and DPF assembly;
6. Carefully lower DOC and DPF assembly;

2.1 DIESEL PARTICULATE FILTER ASSEMBLY REMOVAL

To remove the DPF, proceed as follows:

SECTION 04: EXHAUST AND AFTERTREATMENT SYSTEM

- To make sure components are reinstalled in the same position, mark position of DOC, DPF and V-band clamps in relation with one another before taking apart;

⚠ CAUTION

FRAGILE - HANDLE WITH CARE

Use extreme care when handling DPF cartridge as it could be damaged or destroyed by dropping or sudden impact.

Clean remanufactured DPF cartridge will be available on an exchange basis. For this reason, it is very important to maintain the cartridge in perfect condition. Damaged cartridge may not be refunded.

- Also replace V-band clamps and gaskets when replacing DPF filtration module;

NOTE

When replacing the DPF cartridge, refer to the specifications on the DPF attached tag for proper replacement DPF selection.

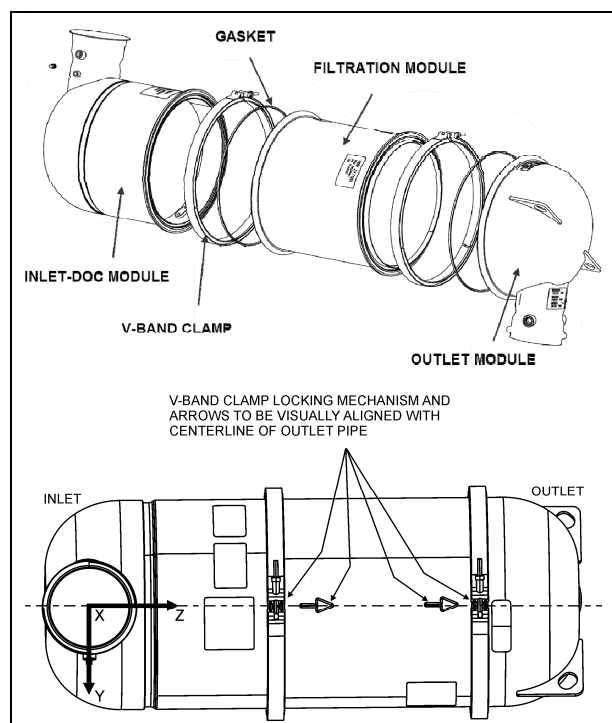
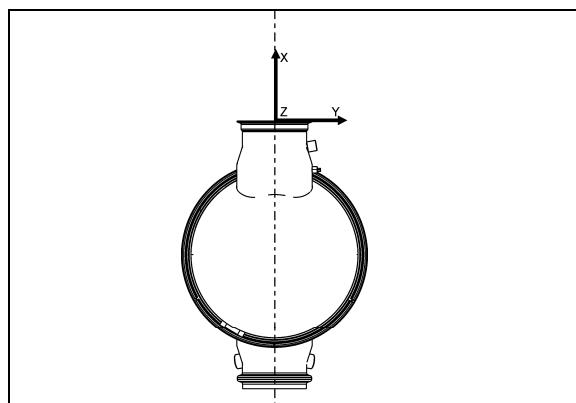

FIGURE 4: TAKING DOC AND DPF APART

- Always put DOC and DPF filtration module back together again in a vertical position to facilitate gaskets positioning;

For proper DPF assembly installation, inlet and outlet alignment is important. When reassembling the DPF, a straight edge must be used to align inlet and outlet.



- Torque V-band clamps to 20 lbf-ft;

⚠ CAUTION

Always torque clamps by hand.

- With a rubber mallet, hit clamps forcefully around circumference to make sure gasket is fully seated;
- Support Diesel Oxidation Catalyst (DOC) and Diesel Particulate Filter (DPF) assembly during reinstallation;
- Reconnect pressure, NOx and temperature sensors;
- Fasten straps holding DOC and DPF assembly;
- Put insulating blanket back.

3. CATALYTIC CONVERTER

In the first instance, the catalytic converter of the Selective Catalytic Reduction (SCR) does not need any maintenance. Unless an accident or damage occurs in the vicinity of the engine compartment; the catalytic converter will not have to be replaced.

However if the catalytic converter must be replaced, use one of the two following procedures:

3.1 REMOVAL

Procedure # 1

Radiator must be removed in order to lower the catalytic converter for replacement.

Section 04: EXHAUST AND AFTERTREATMENT SYSTEM

- Set the starter selector switch to the *OFF* position.
- Shut off the heater line shut-off valves.
- Using the quick-connect drain hose, drain the engine cooling system. Refer to Section 05, COOLING under "DRAINING COOLING SYSTEM".



CAUTION

Tag hoses and cables for identification before disconnecting in order to facilitate re-installation. Plug all openings to prevent dirt from entering the system.

- Disconnect and remove section of coolant pipe assembly mounted between the radiator outlet and the water pump inlet.

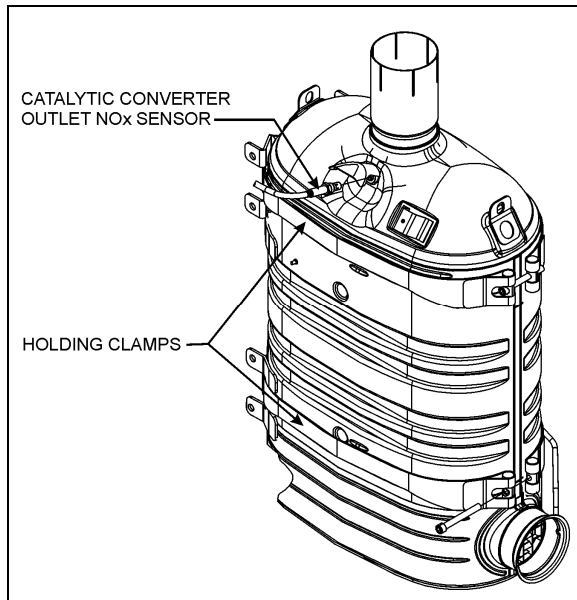

FIGURE 5: CATALYTIC CONVERTER

- Disconnect and remove a section of coolant pipe assembly mounted between the thermostat housing and the radiator inlet.
- Disconnect the electric fan-clutch connector located near the cooling fan right angle gearbox.
- Disconnect and remove the air intake duct mounted between the turbocharger outlet and the air cooler inlet.
- Open radiator door. Unfasten bolts and screws fixing radiator sealing frame.
- Remove radiator and air cooler assembly.



WARNING

Due to the heavy load of the radiator assembly, it must be adequately supported before attempting to remove it.

- Safely support catalytic converter from the top.
- Disconnect catalytic converter outlet NOx sensor.
- Remove clamps holding catalytic converter then lower.
- Remove or disconnect any piece of equipment or component that might be in the way or that might prevent removing the catalytic converter.

Procedure # 2

- Set the starter selector switch to the *OFF* position.
- Shut off the heater line shut-off valves.
- Remove DOC and DPF assembly (Refer to paragraph 2.1 in this Section).
- Remove pipe connecting DOC & DPF assembly to catalytic converter.
- Using the quick-connect drain hose, drain the engine cooling system. Refer to Section 05, COOLING under "DRAINING COOLING SYSTEM".



CAUTION

Tag hoses and cables for identification before disconnecting in order to facilitate re-installation. Plug all openings to prevent dirt from entering the system.

- Disconnect and remove section of coolant pipe assembly mounted between the radiator outlet and the water pump inlet.
- Disconnect and remove a section of coolant pipe assembly mounted between the thermostat housing and the radiator inlet.
- Disconnect and remove a section of air intake duct mounted between the air cooler outlet and the engine.
- Remove coolant surge tank.

SECTION 04: EXHAUST AND AFTERTREATMENT SYSTEM

- Release tension from drive belt (Refer to paragraph 12.1 and 15.1 in Section 05: Cooling System).
- Cut cable ties and disconnect electrical connector from fan clutch. Remove fan drive shaft fasteners at the gear box.
- Remove radiator fan drive mechanism support.
- Safely support catalytic converter from the top.
- Disconnect catalytic converter outlet NOx sensor.
- Remove clamps holding catalytic converter then lower.
- Remove or disconnect any piece of equipment or component that might be in the way or that might prevent removing the catalytic converter.

3.2 ASSEMBLING CATALYTIC CONVERTER

Before removing

- Mark, with a vertical line the angular position of the lower (both sides) and upper clamps with regard to the clamps support located on the catalytic converter.

Lower

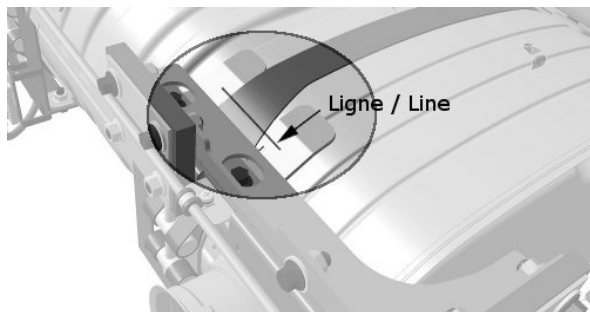

Upper

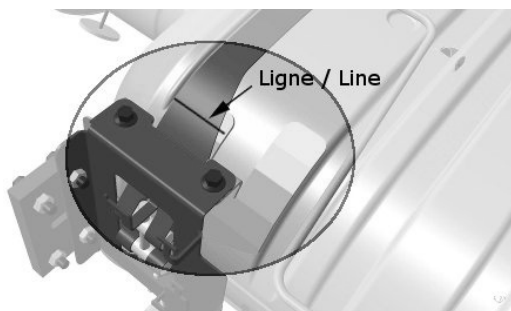

- Mark, with a vertical line the central position of the lower and upper clamps with regard to

the emboss located at the bottom and at the top of the catalytic converter.

Lower

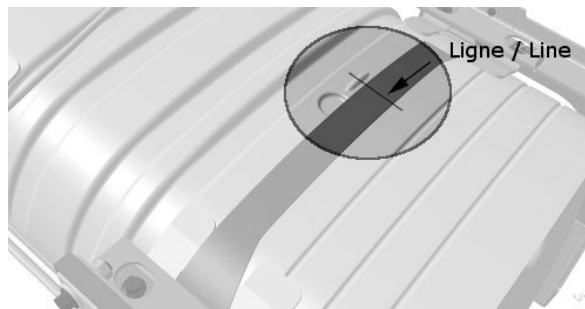

Upper

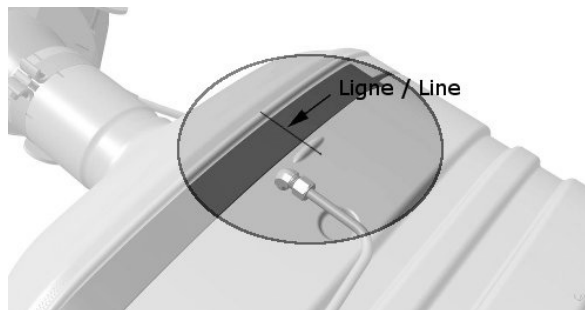

Assembling

- Position the upper clamps above the upper emboss and the lower clamps below the lower emboss of the catalytic converter.

Lower

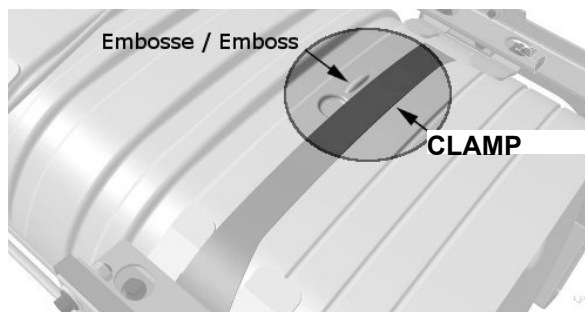

Upper

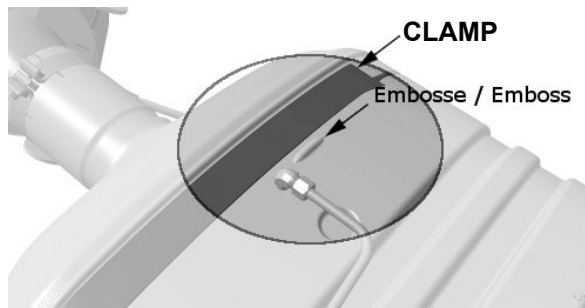

Section 04: EXHAUST AND AFTERTREATMENT SYSTEM

- Using the lines made earlier, line up the lower and upper clamps with regard to the emboss of the converter and afterward, line up the lines made earlier on the clamps with regard to the clamp supports on the catalytic converter.

Lower

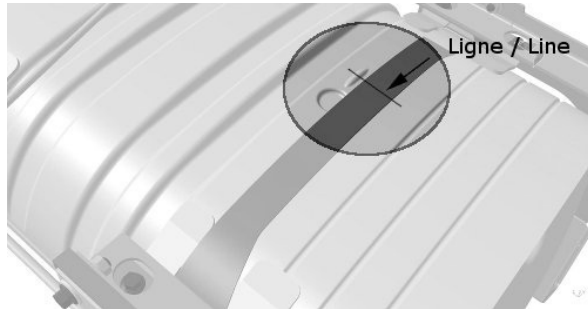

Upper

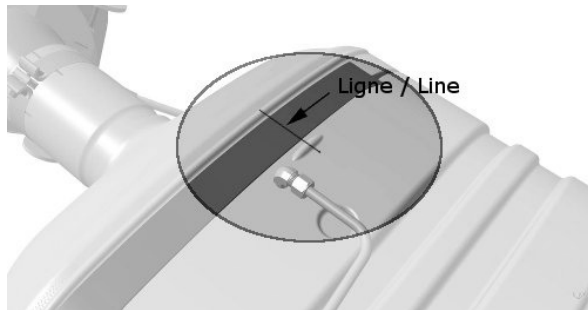

Lower

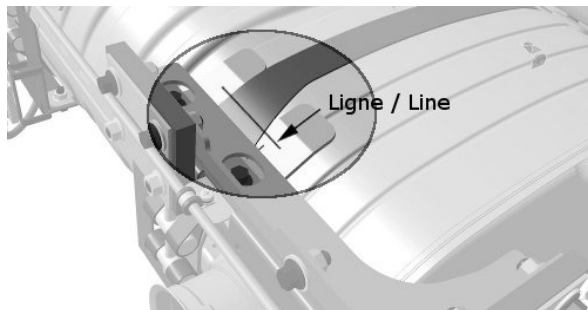

Upper

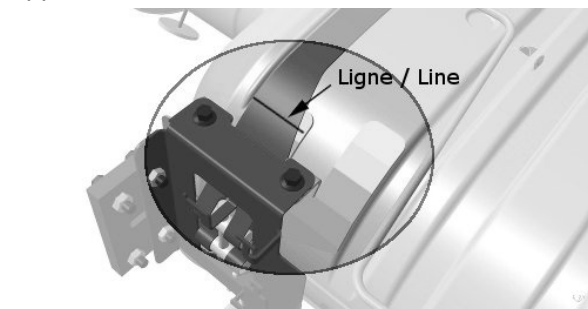

- Before tightening the parts, make sure that the catalytic converter lower support is well

centered with the exhaust inlet of the catalytic converter.

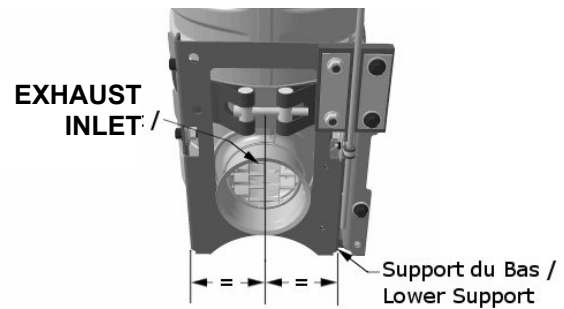

- While tightening the bolts, keep in mind to respect the alignment of the parts and keep the lower support as centered as possible with the catalytic converter exhaust inlet.

4. DIFFUSER ASSEMBLY

During stationary regeneration, exhaust gases temperature may get very hot at the DPF outlet. The diffuser decreases the exhaust gases temperature by about half approximately, at 6 inches above the diffuser. The diffuser is an important component of the exhaust system and must remain on the vehicle at all times. Operating the vehicle without the diffuser may seriously damage the vehicle.

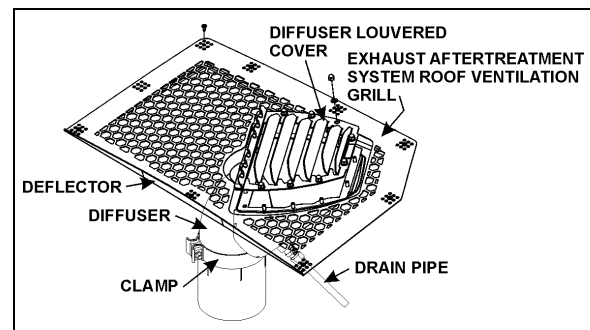

FIGURE 6: DIFFUSER ASSEMBLY

04014

4.1 DIFFUSER ADJUSTMENT

Should an adjustment of the diffuser position be necessary, first remove the exhaust aftertreatment roof ventilation grill.



CAUTION

To prevent paint damage and fiberglass overheating caused by hot exhaust gases, the diffuser louvered cover must be flush with the roof surface or may exceed the roof surface not more than 3/32" (2mm).



CAUTION

Tighten clamps properly in order to prevent any movement of the diffuser assembly. An impact wrench is necessary.

1. Loosen the clamp securing the diffuser assembly to the catalytic converter.

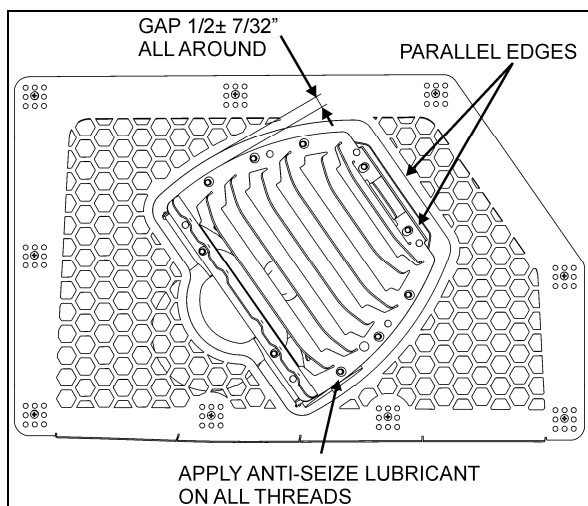

FIGURE 7: DIFFUSER POSITION ADJUSTMENT 04015_1

2. For proper angular position, make sure that the two edges shown on figure 7 are parallel with each other.
3. Using a straightedge, adjust the diffuser assembly level. The top surface of the warning plate fixed on the diffuser louvered cover must be flush with the roof surface or may exceed about 3/32".
4. Tighten the clamp securing the diffuser assembly to the catalytic converter.
5. Reinstall the exhaust aftertreatment system roof ventilation grill and deflector.

4.2 MAINTENANCE

At vehicle inspection intervals, inspect the diffuser assembly as follows:

- Inspect diffuser grille for stress cracking;
- Check for presence of foreign matter and debris inside the diffuser housing, remove and clean if applicable;
- Check for proper functioning of the rain cap inside the diffuser housing, make sure that it moves freely;

- Make sure that the water drain tube is not clogged. Pour a cup of water into the diffuser housing and assure that all the water is drained at once at the other end of the drain tube. If tube is clogged, remove tube and blow compressed air inside in reverse flow;
- Check that the warning plate "THIS DIFFUSER SURFACE MUST BE FLUSH WITH THE ROOF SURFACE" is still in place.

5. DIESEL EXHAUST FLUID (DEF) TANK AND INJECTION SYSTEM

The DEF tank and injection system control unit continuously vary the amount of DEF injected in response to the engine's current load conditions.

Diesel Exhaust Fluid (DEF) is stored in a 16 gallons plastic tank located aft of the condenser compartment.

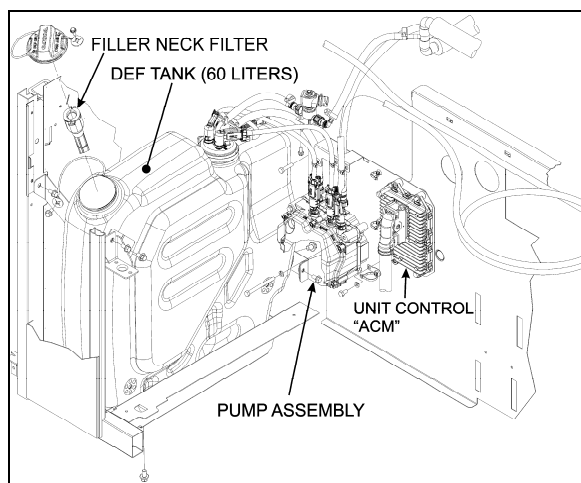

FIGURE 8: DEF TANK AND PUMP LOCATION

A pump located beside the DEF tank is used to pressurize the system and deliver the fluid.

A heating coil located inside the tank use engine coolant to keep the DEF warm during cold season.

DEF is injected into the exhaust gases through an injection nozzle located between the DPF and the catalytic converter (refer to figure 1).

In the catalytic converter, nitrogen oxides are transformed into harmless nitrogen gas and water.

The system notifies the driver when it is time to top up with DEF.

Section 04: EXHAUST AND AFTERTREATMENT SYSTEM

5.1 DIESEL EXHAUST FLUID

When handling DEF solution, it is important that electrical connectors to be connected or well encapsulated, otherwise there is a risk that the DEF will cause oxidation that cannot be removed. Water or compressed air will not help, since DEF quickly oxidizes certain metals. If a disconnected connector comes into contact with the DEF solution, it must be replaced immediately to prevent the DEF solution from creeping further into the copper wiring, which takes place at a speed of about 2.4 in (60 mm) per hour.



CAUTION

Diesel Exhaust Fluid (DEF) is a nontoxic aqueous solution of urea (32.5%) and ultra-pure water (67.5%). Urea is a compound of nitrogen that turns to ammonia when heated. The fluid is non-flammable, and is not dangerous when handled as recommended. However, it is highly corrosive to certain metals, especially copper and brass.

When detaching hoses and components, do not spill DEF on disconnected or unsealed connectors. If DEF is spilled on a disconnected or unsealed connector, the connector must be removed immediately and replaced.

Things to know about spilled diesel exhaust fluid (DEF):

- If urea solution comes into contact with the skin, rinse with plenty of water and remove contaminated clothing.
- If urea solution comes into contact with the eyes rinse for several minutes and call for medical help if necessary.
- If inhaled breathe fresh air and call for medical help if necessary.
- Do not allow the DEF solution to come into contact with other chemicals.
- The DEF solution is not flammable. If the DEF solution is exposed to high temperatures, it breaks down into ammonia and carbon dioxide.
- The DEF solution is highly corrosive to certain metals, including copper and aluminum.

- If the DEF solution is spilled onto the vehicle, wipe off the excess and rinse with water. Spilled DEF solution can form concentrated white crystals on the vehicle. Rinse off these crystals with water.



WARNING

DEF spilt onto hot components will quickly vaporize. Turn your face away!

5.2 DEF TANK CLEANING

Removing the DEF tank for cleaning is not necessary.

1. Put a suitable container under the DEF tank.
2. Remove the DEF tank drain plug through the DEF tank support pan access hole.
3. Let all of the DEF drain from the tank. Discard the used DEF according to local regulations.
4. Remove the DEF tank filler neck insert. To do so, release the retaining tab and remove filler neck insert. Replace old seal if damaged.

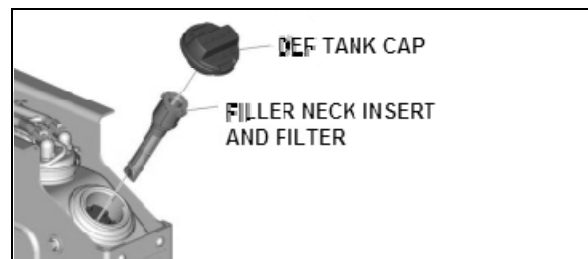

5. Flush the tank with hot water. Let all of the water drain from the tank.
6. Clean the filler neck insert screen with hot water.
7. Reinstall the filler neck insert until the retaining tabs snap into filler neck. Reinstall DEF tank drain plug.



MAINTENANCE

Drain and clean DEF tank and filler neck insert filter with hot water every 175,000 miles or once a year, whichever comes first.

5.3 PUMP ASSEMBLY FILTER ELEMENT REPLACEMENT

- Remove filter cover.

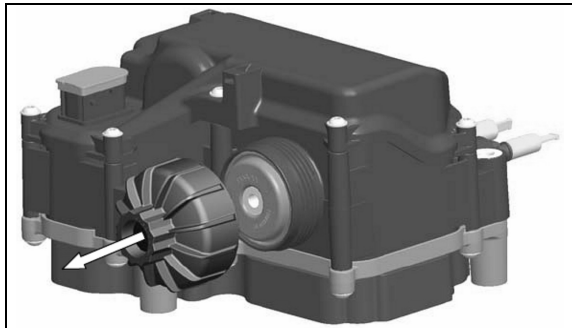

CAUTION

Contamination or damage of the sealing surface on the housing is not acceptable.

- Remove the equalizing element (a) and the filter element (b).

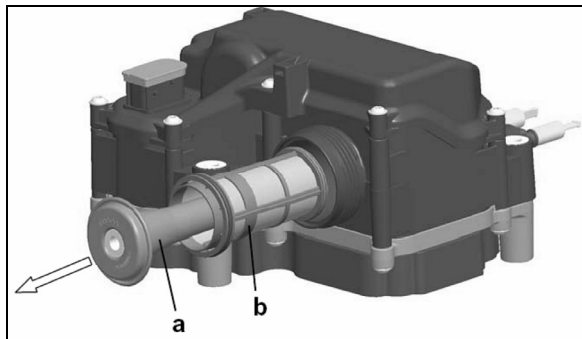

CAUTION

Protect filter area in the housing from contamination.

- Replace the filter element (a) and the equalizing element (b).

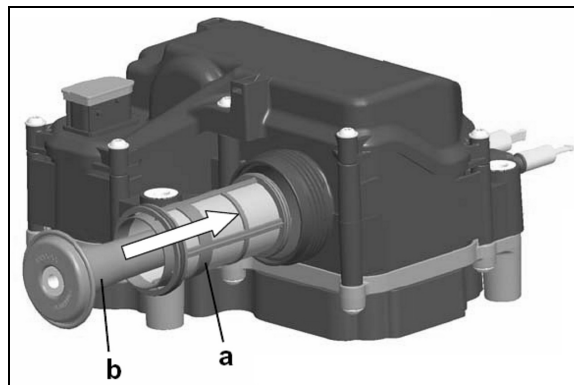

CAUTION

The sealing surfaces on the housing must be clean. No contamination or particles acceptable.

- Install filter cover. Torque to 16.5 lbf-ft.

Section 04: EXHAUST AND AFTERTREATMENT SYSTEM

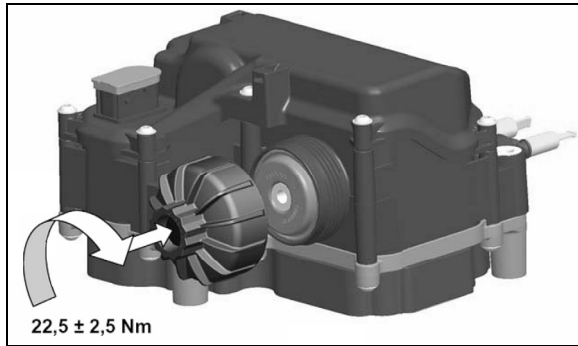

CAUTION

It must be checked if there are cracks around the area of the filter cover. No cracks in the material are allowed. If there are cracks in the housing, the entire Supply Module must be replaced! If there are cracks in the filter cover, the filter cover must be replaced.



MAINTENANCE

Replace pump assembly filter element every 150,000 miles or every three years, whichever comes first.

6. AFTERTREATMENT FUEL INJECTOR

Proper functioning of the aftertreatment fuel injector a.k.a. aftertreatment hydrocarbon injector (AHI) is required in order to obtain efficient regeneration process of the DPF. Clogged aftertreatment fuel injector will result in clogged DPF.

In addition to the activation of the CHECK telltale, emission of diagnostic troubleshooting codes (DTC) by the engine ECM (MID128) will indicate malfunction of the aftertreatment system and/or aftertreatment fuel injector. DTC may be accessed through the Driver Information Display. Select DIAGNOSTICS menu then FAULT DIAGNOSTICS and ENGINE ECU submenus.

Check status of the aftertreatment system through the Driver Information Display. Select AFTERTREATMENT menu then ATS STATUS. Then check the DPF soot level with SOOT LEVEL GAUGE.

6.1 REPLACEMENT

1. Remove fastener and p-clamp securing the line to the mounting bracket on the diffuser pipe.



WARNING

Fuel leaked or spilled onto hot surfaces or electrical components can cause a fire and result in component damage and serious personal injury.

2. Disconnect the line from the aftertreatment hydrocarbon injector fitting. Collect any residual fuel that might be in the line in a suitable container.



CAUTION

Do not kink the line. Kinking the line may result in leakage.

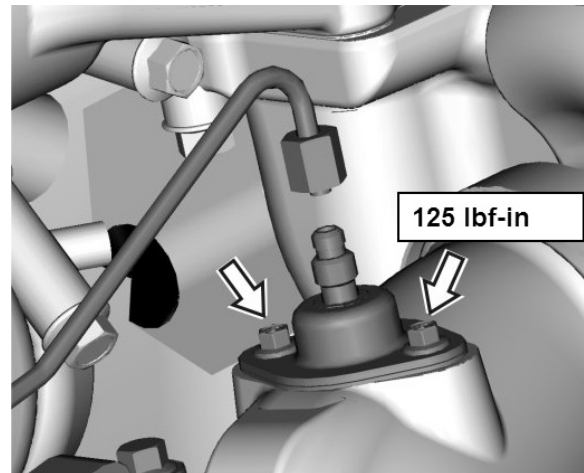

FIGURE 9: AFTERTREATMENT FUEL INJECTOR

3. Remove the aftertreatment hydrocarbon injector mounting fasteners. Remove the aftertreatment hydrocarbon injector from the diffuser pipe (which attaches to the turbocharger outlet).
4. Clean the sealing surface on the diffuser pipe before mounting the aftertreatment hydrocarbon injector.
5. Install the aftertreatment hydrocarbon injector onto the diffuser pipe (which attaches to the turbocharger outlet). Tighten the fasteners to **125 lbf-in.**

NOTE

The fasteners already include pre-applied high-temperature anti-seize compound.

6. Connect the line to the aftertreatment hydrocarbon injector. Tighten the line fitting to **135 lbf-in**.

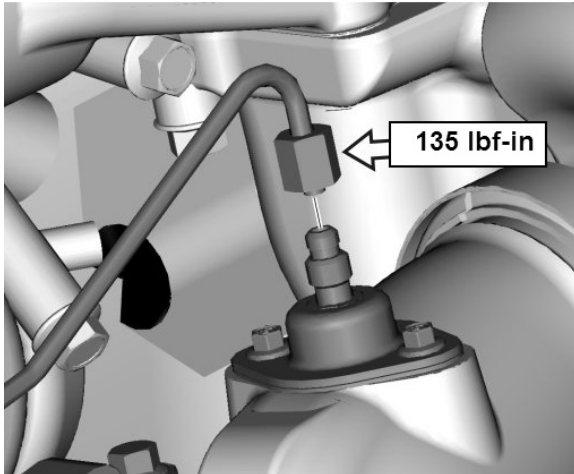

FIGURE 10: FUEL LINE FITTING

7. Install the P-clamp and fastener to secure the line to the mounting bracket on the diffuser pipe.
8. Start the service regeneration process. When fuel dosing starts, check for leaks starting on the hot side of the engine. Clear any diagnostic trouble codes, if needed.

NOTE

If fault tracing was performed using Guided Diagnostics, return to Guided Diagnostics for repair verification.

Section 04: EXHAUST AND AFTERTREATMENT SYSTEM

7. TORQUE SPECIFICATIONS

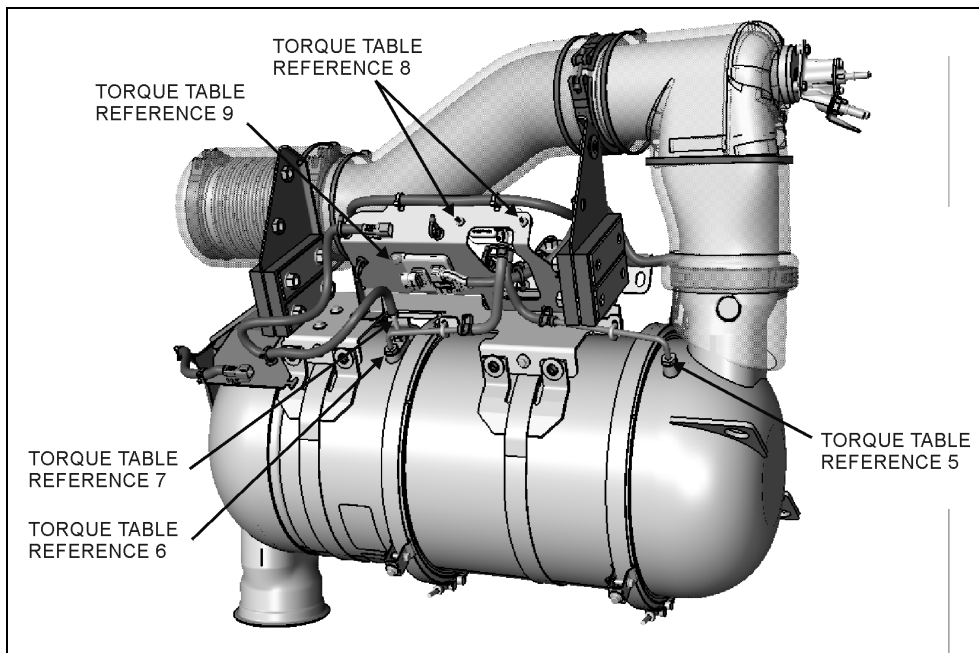
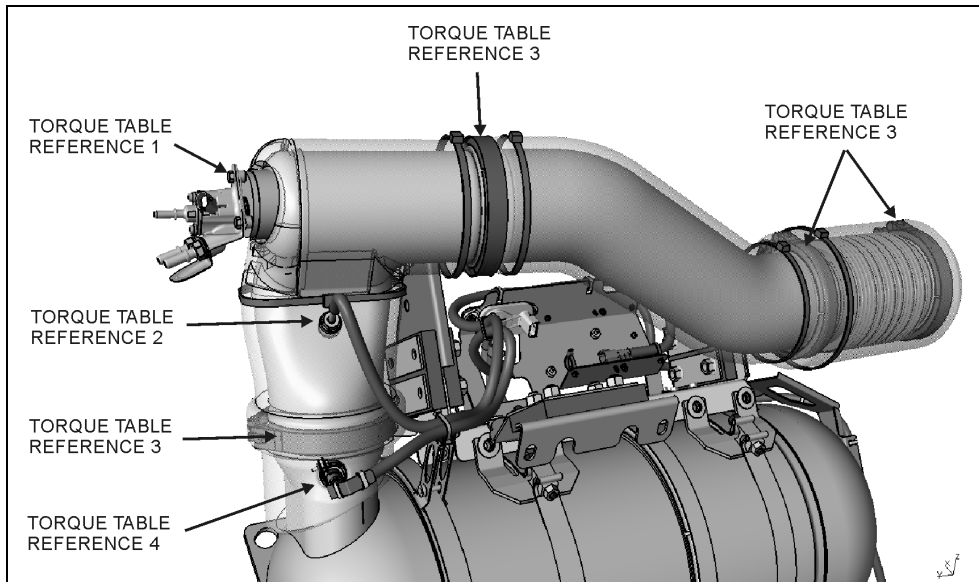

SECTION 04: EXHAUST AND AFTERTREATMENT SYSTEM

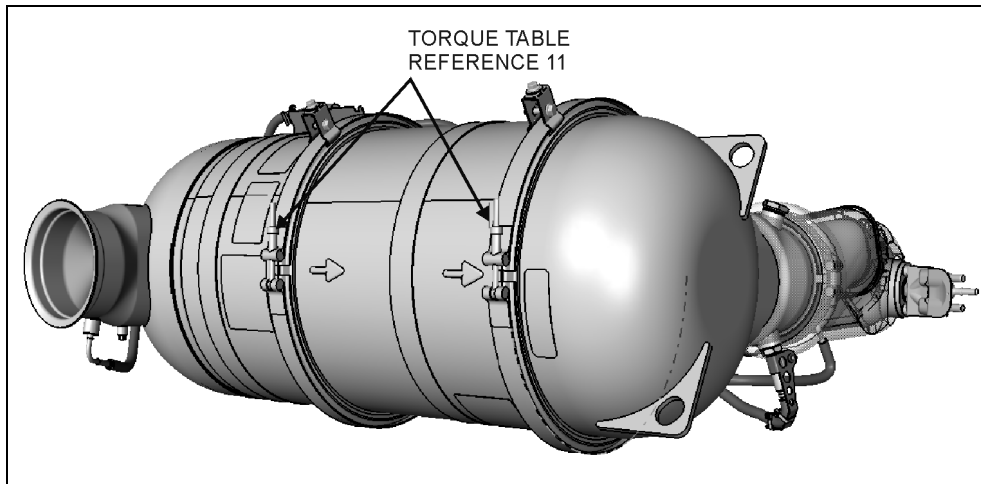
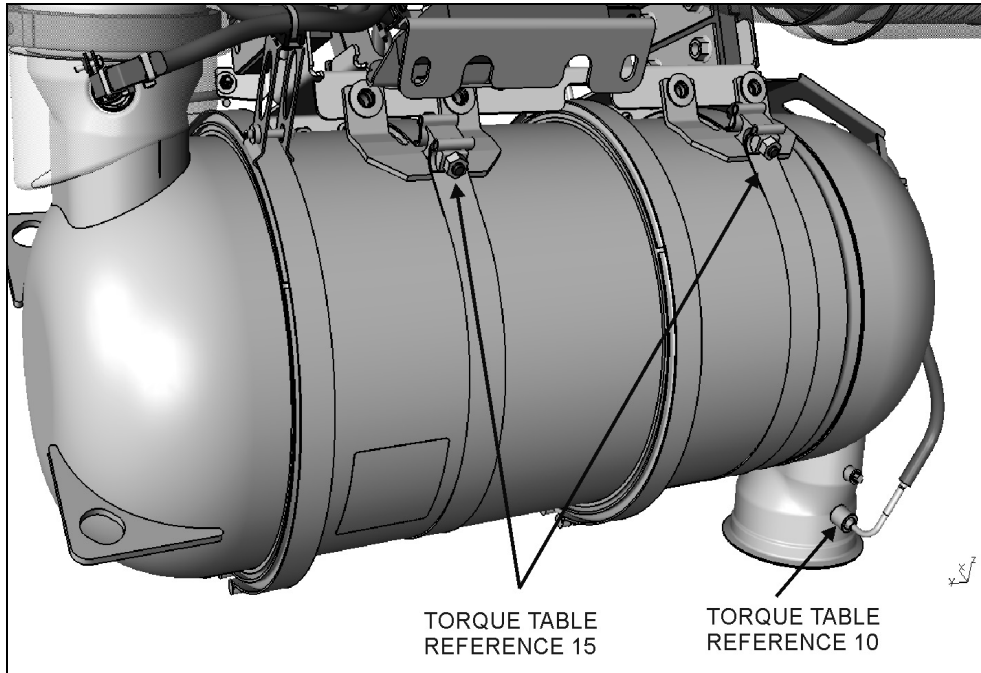

Section 04: EXHAUST AND AFTERTREATMENT SYSTEM

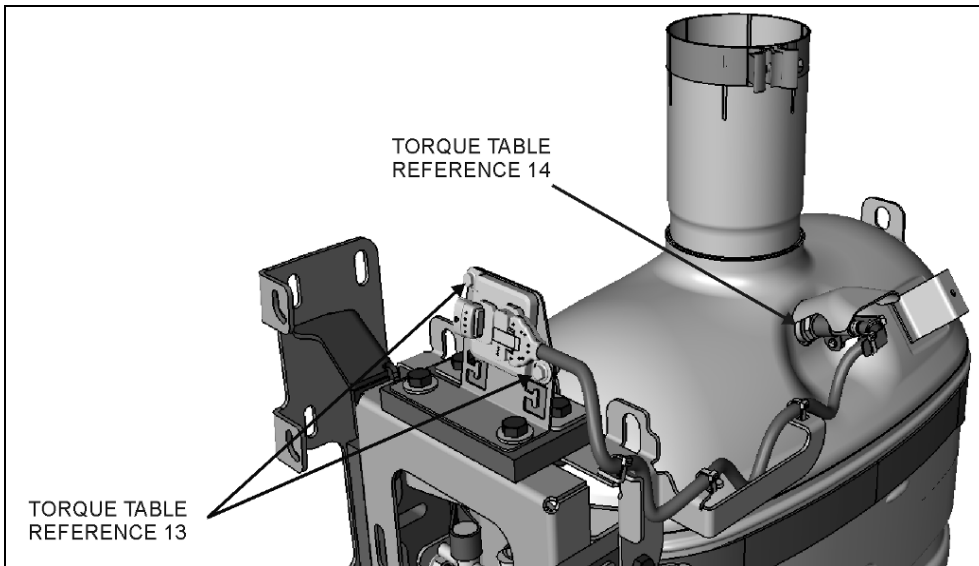
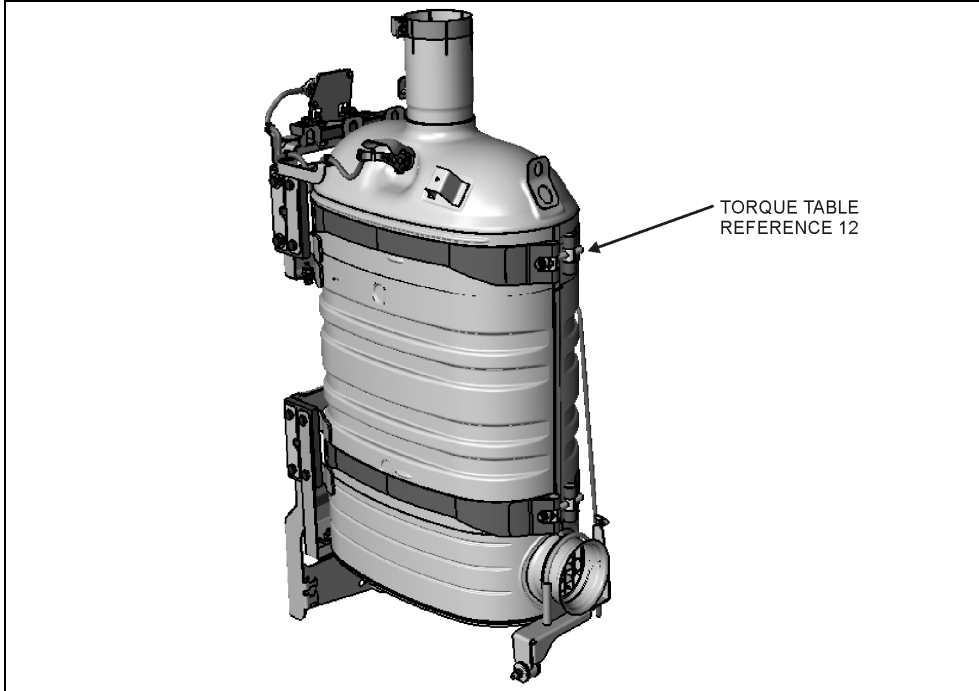

SECTION 04: EXHAUST AND AFTERTREATMENT SYSTEM

The following table lists the tightening torques for the bolts, nuts, etc. on the DPF assembly which do require a specific torque value. When no torque specifications are indicated, use the Standard Torque Specifications table found in Section 00: General Information of the Maintenance Manual.

SPECIFIC TORQUE TABLE			
DESCRIPTION	QTY	REFERENCE	TORQUE DRY (± 10 lbf-ft)
<i>DEF injection nozzle mounting bolt</i>	3	1	7.5
<i>DPF outlet temperature sensor *</i>	1	2	33
<i>V-band clamp 5 inch</i>	7	3	8
<i>NOx sensor *</i>	1	4	37
<i>DPF outlet pressure sensor *</i>	1	5	4
<i>DPF inlet pressure sensor *</i>	1	6	4
<i>Diesel Oxidation Catalyst (DOC) temperature sensor *</i>	1	7	33
<i>Cap screw</i>	2	8	4.5
<i>Cap screw</i>	-	9	7.5
<i>DPF inlet temperature sensor *</i>	1	10	33
<i>V-band clamp</i>	2	11	20
<i>Strap – SCR tank</i>	4	12	33
<i>NOx sensor – SCR tank</i>	1	13	37
<i>Bolts – SCR tank</i>	2	14	7.5
<i>Strap – DPF tank</i>	2	15	20

* Use Permatex 454G anti-seize lubricant or Loctite 76764 silver grade anti-seize

SECTION 05: COOLING SYSTEM

CONTENTS

1. DESCRIPTION	3
2. MAINTENANCE	4
2.1 GENERAL RECOMMENDATIONS.....	4
2.2 MTA VEHICLES EQUIPPED WITH VOLVO D13 ENGINE	4
3. HOSES	4
3.1 CONSTANT-TORQUE HOSE CLAMPS ON COOLANT LINES –VOLVO D13.....	5
3.1.1 <i>Installation</i>	5
3.1.2 <i>Maintenance</i>	5
3.2 CONSTANT-TORQUE HOSE CLAMPS ON CHARGE AIR COOLER (CAC)	5
3.2.1 <i>Maintenance</i>	6
4. THERMOSTAT OPERATION	6
4.1 THERMOSTAT REPLACEMENT.....	6
4.2 CHECKING THERMOSTAT	6
5. COOLANT	6
5.1 COOLANT LEVEL VERIFICATION	6
5.2 COOLANT LEVEL SENSOR	7
5.3 THAWING COOLING SYSTEM.....	7
5.4 COOLING SYSTEM RECOMMENDATIONS	7
5.5 COOLANT RECOMMENDATIONS FOR MTA COACHES EQUIPPED WITH VOLVO D13 ENGINE	7
6. DRAINING COOLING SYSTEM	8
7. FILLING COOLING SYSTEM	9
8. FLUSHING	9
8.1 COOLING SYSTEM DESCALERS	10
8.2 REVERSE FLUSHING	10
9. SPIN-ON COOLANT FILTER	10
10. RADIATOR	11
10.1 MAINTENANCE.....	11
10.2 RADIATOR REMOVAL & INSTALLATION.....	11
11. CHARGE AIR COOLER LEAKAGE	14
12. COOLING FAN DRIVE MECHANISM	14
12.1 DRIVE PULLEY AND UNIVERSAL JOINT SHAFT	14
12.2 IDLER REPLACEMENT.....	15
13. VARIABLE SPEED COOLING FAN	15
13.1 LOCKING RADIATOR FAN FOR EMERGENCY OPERATION	16
13.1.1 <i>Electrical Locking</i>	16
13.1.2 <i>Mechanical Locking</i>	16
13.2 MAINTENANCE.....	17
13.3 INSPECTION	17
13.4 FAN REMOVAL / INSTALLATION	17

Section 05: COOLING SYSTEM

14.	FAN RIGHT ANGLE GEARBOX.....	17
14.1	MAINTENANCE.....	17
14.2	OIL CHANGE	18
14.3	REMOVAL / INSTALLATION	18
15.	COOLING FAN DRIVE BELT.....	18
15.1	MOUNTING THE DRIVE BELT.....	18
16.	SPECIFICATIONS.....	19

ILLUSTRATIONS

FIGURE 1:	COOLANT SURGE TANK.....	3
FIGURE 2:	HANSEN QUICK COUPLING.....	4
FIGURE 3:	COOLANT FLOW TO RADIATOR (VOLVO D13).....	5
FIGURE 4:	CONSTANT-TORQUE CLAMP	5
FIGURE 5:	CHARGE AIR COOLER HOSE CLAMPS.....	6
FIGURE 6:	VOLVO D13 THERMOSTAT HOUSING.....	6
FIGURE 7:	LOCATION OF HEATER LINE SHUT-OFF VALVES IN ENGINE COMPARTMENT	8
FIGURE 8:	EXTRACTING COOLANT	8
FIGURE 9:	COOLANT FILTER (VOLVO D13).....	11
FIGURE 10:	RADIATOR DRAIN PLUG	11
FIGURE 11:	ACCESS PANEL (TYPICAL).....	12
FIGURE 12:	RADIATOR SEALING FRAME	12
FIGURE 13:	RADIATOR HOSE CLAMPS.....	12
FIGURE 14:	CHARGE AIR COOLER HOSE CLAMPS.....	12
FIGURE 15:	UPPER SUPPORT BRACKET & TUBE PROTECTOR	13
FIGURE 16:	RADIATOR ASSEMBLY LOWER MOUNTING FASTENERS	13
FIGURE 17:	DISCONNECTING FAN DRIVE SHAFT.....	13
FIGURE 18:	POSITIONING FORKLIFT	13
FIGURE 19:	REMOVING FASTENERS	14
FIGURE 20:	REMOVING UPPER FAN DRIVE SUPPORT BRACKET	14
FIGURE 21:	REMOVING FAN SHROUD FROM RADIATOR.....	14
FIGURE 22:	COOLING FAN DRIVE MECHANISM	14
FIGURE 23:	TIGHTENING SPECIFICATION.....	15
FIGURE 24:	TIGHTENING SPECIFICATION (VOLVO D13 ENGINE).....	15
FIGURE 25:	IDLER MOUNTED ON THE CAST ALUMINUM SUPPORT	15
FIGURE 26:	MECHANICAL LOCKING	16
FIGURE 27:	RADIATOR FAN MOUNTING BOLTS	17
FIGURE 28:	RIGHT ANGLE GEARBOX.....	17
FIGURE 29:	RIGHT ANGLE GEARBOX MOUNTING	18
FIGURE 30:	DRIVE BELT ROUTING (VOLVO D13 ENGINE)	19

1. DESCRIPTION

A radiator and thermo-modulated fan are used to effectively dissipate the heat generated by the engine. A centrifugal-type water pump is used to circulate the engine coolant.

One full blocking-type thermostat is used in the water outlet passage to control the flow of coolant, providing fast engine warm-up and regulating coolant temperature.

The engine coolant is drawn from the lower portion of the radiator by the water pump and is forced through the transmission cooler before going through the oil cooler and into the cylinder block.

From the cylinder block, the coolant passes up through the cylinder head and, when the engine is at normal operating temperature, it goes through the thermostat housing and into the upper portion of the radiator. The coolant then passes through a series of tubes where its heat is dissipated by air streams created by the revolving fan and the motion of the vehicle.

Upon starting a cold engine or when the coolant is below normal operating temperature, the closed thermostat directs coolant flow from the thermostat housing through the by-pass tube to the water pump. Coolant is recirculated through the engine to aid engine warm up.

When the thermostat opening temperature is reached, coolant flow is divided between the radiator inlet and the by-pass tube. When the thermostat is completely open, all of the coolant flow is to the radiator inlet.

The cooling system is filled through a pressure & filler cap on the surge tank (Fig. 1), the cap is also used to maintain pressure within the system. When system exceeds normal pressure rating (14 psi - 96.53 kPa), the cap releases air and if necessary, coolant through the overflow tube (Fig. 1). The thermostat is located in the housing bolted to the engine on the L.H. side.

The engine cooling system also provides hot coolant fluid for the vehicle heating system. Refer to section 22, "HEATING AND AIR CONDITIONING" in this manual for information relating to heating system water circulation.

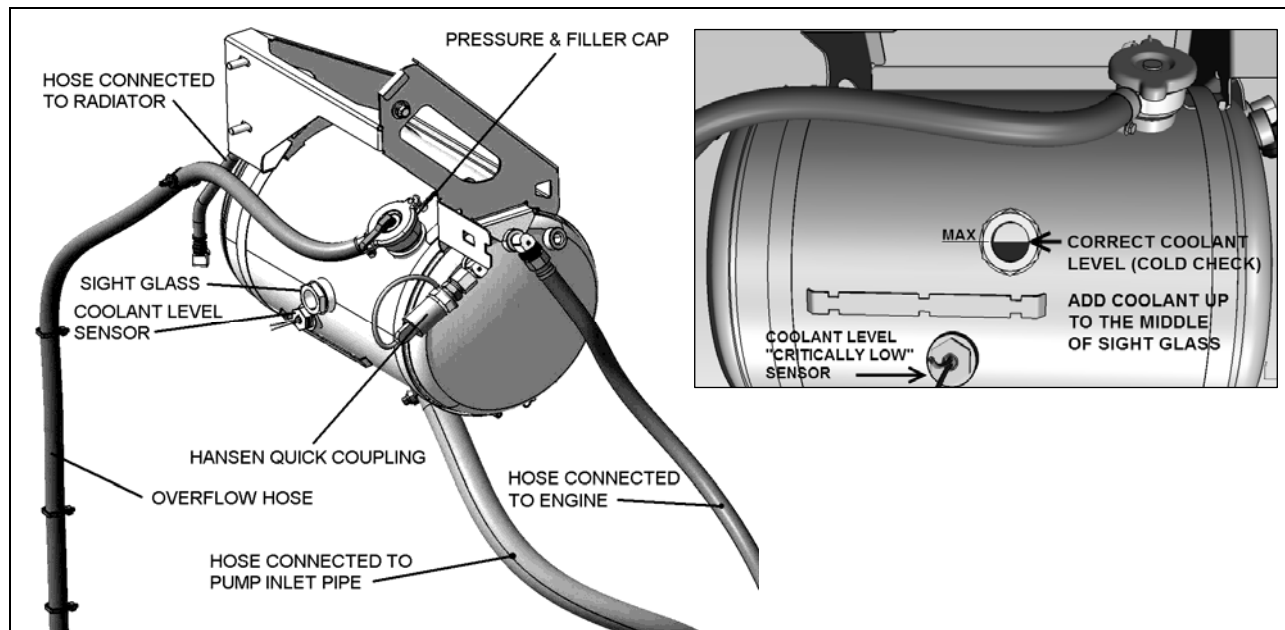

FIGURE 1: COOLANT SURGE TANK

05132

2. MAINTENANCE

2.1 GENERAL RECOMMENDATIONS

A systematic routine inspection of cooling system components is essential to ensure maximum engine and heating system efficiency.

- Check coolant level in the surge tank daily, and correct if required. Test antifreeze strength.
- Check belts for proper tension; adjust as necessary and replace any frayed or badly worn belts.
- Check radiator cores for leaks and make sure the cores are not clogged with dirt or insects. To avoid damaging the fins, clean cores with a low-pressure air hose. Steam clean if required.
- Inspect the water pump operation. A leaky pump sucks in air, increasing corrosion.
- Repair all leaks promptly. Unrepaired leaks can lead to trouble. Inspect and tighten radiator mounts periodically. Test and replace thermostat regularly.
- Pressurize system periodically using Hansen Quick Coupling (Fig. 1 & 2).

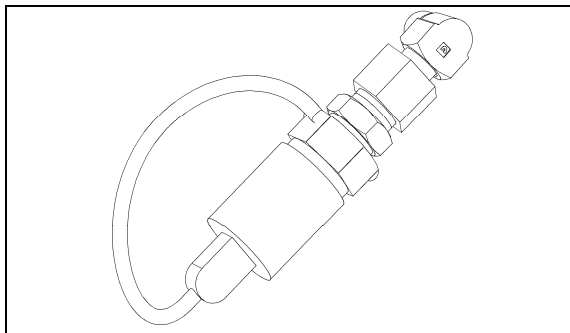

FIGURE 2: HANSEN QUICK COUPLING

NOTE

In order to ensure the integrity of the system, it is recommended that a periodic cooling system pressure check be made. Pressurize the cooling system to 103-138 kPa (15-20 psi) using Hansen Quick Coupling. Do not exceed 138 kPa (20 psi).

Any measurable drop in pressure may indicate a leak. Whenever the oil pan is removed, the cooling system should be pressure checked as a means of identifying any incipient coolant leaks. Make sure the

cause of the internal leak has been corrected before flushing the contaminated system.

Leaks at the thermostat housing hose connections may be caused by deformation of connections or by rough surfaces on the castings of the hose mounting surfaces. It is recommended that "Dow Corning RTV-102 Compound" or any equivalent product be applied on cast surfaces prior to hose installation.



CAUTION

Castings should be clean and free of oil and grease before applying compound. No other sealer should be used with RTV-102 compound.

2.2 MTA VEHICLES EQUIPPED WITH VOLVO D13 ENGINE

NOTE

For additional information concerning Volvo D13 engine components or engine-related components, consult Volvo Trucks Canada or Volvo Trucks North America Web Site under: Parts & Service. On Volvo web site, you will find detailed service procedures for parts replacement, repair and maintenance.



MAINTENANCE

Drain, flush, thoroughly clean and refill the system with Fleet Charge 50/50 Fully Formulated Coolant every two years or every 250,000 miles (400 000 km), whichever comes first. Change the coolant filter every 50,000 miles (80 000 km). When using Fleet Charge 50/50, use a filter that contains Supplemental Coolant Additives (SCA).

3. HOSES

Rotten, swollen, and worn out hoses or loose connections are frequent causes of cooling system problems.

Serious overheating is often caused by an old hose collapsing or from rotten rubber shedding from hoses and clogging the coolant passages.

Connections should be inspected periodically and hose clamps tightened. Replace any hose found to be cracked or swollen.

When installing a new hose, clean pipe connections and apply a thin layer of a non-hardening sealing compound. Replace worn out clamps or clamps that pinch hoses.

3.1 CONSTANT-TORQUE HOSE CLAMPS ON COOLANT LINES –VOLVO D13

All hose clamps of 1 3/8" ID and over, used on the heating and cooling systems, are of the "Constant-torque" type. These clamps are worm-driven, made of stainless steel, and supplied with a series of Belleville spring washers. They also feature an extended integral liner that covers the band slots to protect soft/silicone hoses from damage, and help maintain consistent sealing pressure.

This type of clamp is designed to automatically adjust its diameter to compensate for the normal expansion/contraction of a hose and metal connection that occurs during vehicle operation and shutdown. The constant-torque clamp virtually eliminates coolant losses due to "Cold flow" leakage and greatly minimizes clamp maintenance.

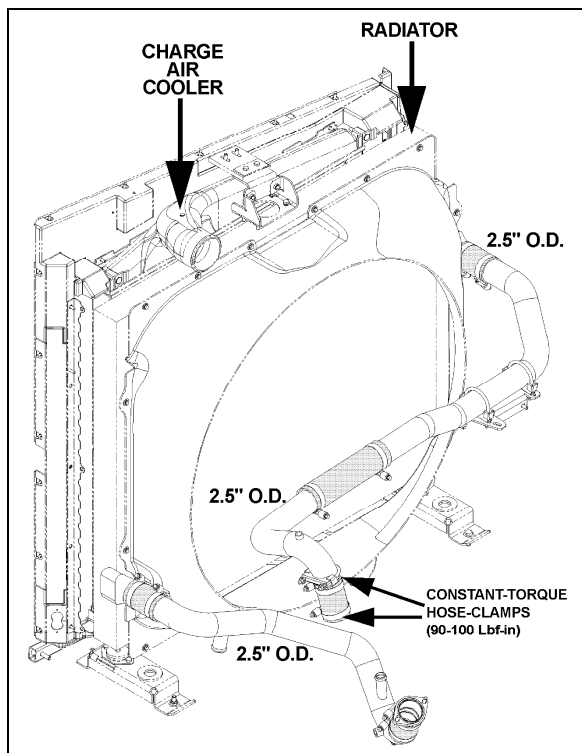

FIGURE 3: COOLANT FLOW TO RADIATOR (VOLVO D13)

3.1.1 Installation

A torque wrench should be used for proper installation. The recommended torque is 90 to

100 lbf-in. (10 to 11 Nm). The Belleville spring washer stacks should be nearly collapsed flat and the screw tip should extend 1/4" (6 mm) beyond the housing (Fig. 4).



CAUTION

The hose clamps will break if over-torqued. Do not over-tighten, especially during cold weather when hose has contracted.

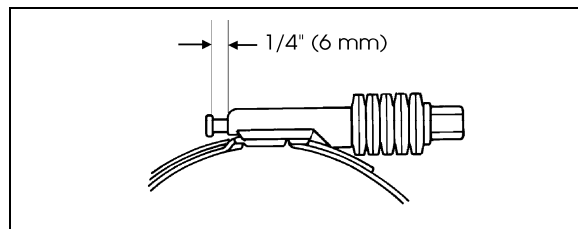

FIGURE 4: CONSTANT-TORQUE CLAMP

05037

3.1.2 Maintenance

The constant-torque clamps contain a "Visual torque check" feature. When the tip of the screw is extending 1/4" (6 mm) out of the housing, the clamp is properly installed and maintains a leak-proof connection. Since the constant-torque clamp automatically adjusts to keep a consistent sealing pressure, there is no need to re-torque hose clamps on a regular basis. During vehicle operation and shutdown, the screw tip will adjust according to the temperature and pressure changes.

Checking for proper torque should be done at room temperature.

3.2 CONSTANT-TORQUE HOSE CLAMPS ON CHARGE AIR COOLER (CAC)

If for any reason such as an accident, hose clamps need to be changed; install and tighten hose clamps to 10±1 lbf-ft (dry) (Fig. 5).



CAUTION

The hose clamps will break if over-tighten. Do not over-tighten, especially during cold weather when hose has contracted.

Section 05: COOLING SYSTEM

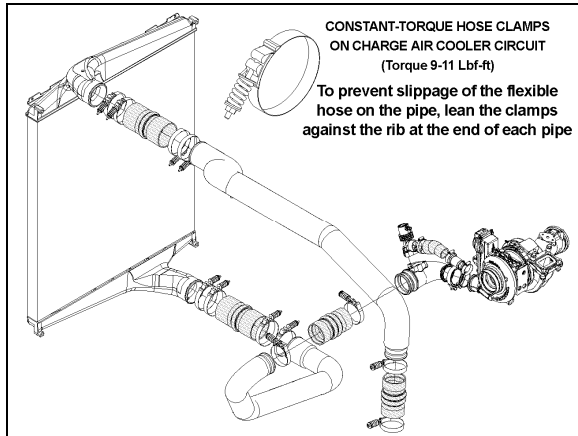

FIGURE 5: CHARGE AIR COOLER HOSE CLAMPS

3.2.1 Maintenance

Since the constant-torque clamp automatically adjusts to keep a consistent sealing pressure, there is no need to retorque hose clamps on a regular basis. During vehicle operation and shutdown, the screw tip will adjust according to the temperature and pressure changes.

Checking for proper torque should be done at room temperature.

4. THERMOSTAT OPERATION

4.1 THERMOSTAT REPLACEMENT

1. Drain the cooling system.
2. Remove the bolts, the thermostat housing and the thermostat. Carefully clean the thermostat seat and all cylinder head-to-thermostat housing mating surfaces.

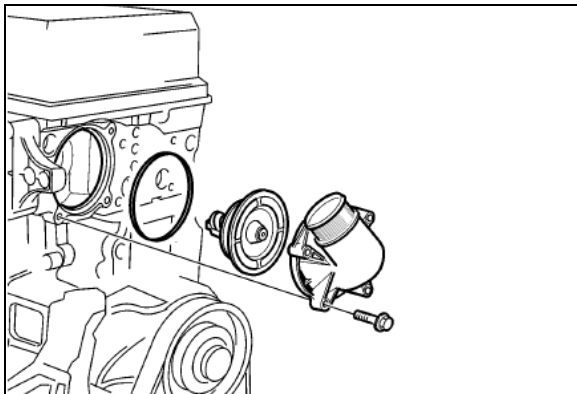

FIGURE 6: VOLVO D13 THERMOSTAT HOUSING

3. Install the new thermostat. Make sure that the rubber seal remains properly seated.

4. Position the thermostat housing to the cylinder head, install the bolts and torque-tighten to 24 ± 4 Nm (18 ± 3 ft-lb).
5. Install the rubber radiator hose to the thermostat housing. Position the clamp and tighten to secure.
6. Fill the system with the recommended coolant.
7. Start the engine, check for leaks and proper operation. After shutdown, replenish fluids as necessary.

4.2 CHECKING THERMOSTAT

A function check must be carried out before installing a new thermostat.

NOTE

Check to be sure that the thermostat closes fully. This can be done by holding it up to the light to check that there is no visible gap at the opening point. If the thermostat does not close properly, replace it.

1. Warm up water in a receptacle to 75°C (167°F) and immerse the thermostat in the water. Use a piece of wire attached to the thermostat.

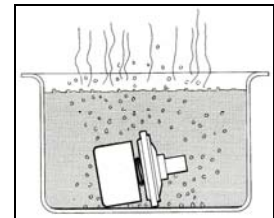
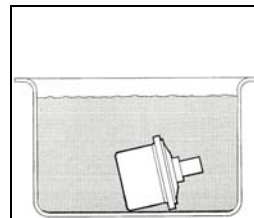

2. After at least 30 seconds, check that the thermostat is still closed.
3. Now warm the water to 100°C (212°F). After at least 30 seconds at the boiling point, check that the thermostat has opened at least 7mm ($9/32$ ""). If the thermostat has not opened, it must be replaced. A good thermostat starts to close at 95°C (203°F) and is fully closed at approximately 85°C (185°F).

5. COOLANT

5.1 COOLANT LEVEL VERIFICATION

If coolant level has reached the bottom of the sight glass, add coolant. Coolant level is correct

when cold coolant level is up to the middle of the surge tank sight glass (Fig. 1).

5.2 COOLANT LEVEL SENSOR

This warning device consists of a fluid level probe mounted on the surge tank. The probe sends a signal to the engine control module to indicate coolant level. If the coolant level drops below the probe, the "Check Engine" light flashes and a diagnostic code is registered (see section 01 "ENGINE").

 CAUTION
Do not run engine with the "Check Engine" light flashing.

The level probe is mounted on the front of the surge tank.

5.3 THAWING COOLING SYSTEM

If the cooling system becomes frozen solid, place the coach in a warm area until the ice is completely thawed.

 CAUTION
Under no circumstances should the engine be operated when the cooling system is frozen, as it will result in engine overheating due to insufficient coolant.

Once thawed, check engine, radiator and related components for damage caused by expansion of frozen coolant fluid.

5.4 COOLING SYSTEM RECOMMENDATIONS

Always maintain cooling system at the proper coolant level. Check daily.

The cooling system must be pressurized to prevent localized boiling of coolant. The system must be kept clean and leak-free. The filler and pressure caps must be checked periodically for proper operation.

The coolant provides a medium for heat transfer and controls the internal temperature of the engine during operation. In an engine having proper coolant flow, some of the combustion heat is conveyed through the cylinder walls and the cylinder head into the coolant. Without adequate coolant, normal heat transfer cannot take place within the engine, and engine temperature rapidly rises. Coolant must

therefore be carefully selected and properly maintained.

Select and maintain coolant in order to meet the following basic requirements:

- Provide for adequate heat transfer.
- Provide protection from cavitation damage.
- Provide a corrosion and erosion resistant environment within the cooling system.
- Prevent formation of scale or sludge deposits in the cooling system.
- Be compatible with the cooling system hose and seal materials.
- Provide adequate freeze protection during cold weather operation.

When freeze protection is required, a mixture of suitable water and antifreeze containing adequate inhibitors will provide a satisfactory coolant fluid.

Freeze protection down to:	Boiling up protection to:	% of antifreeze in mixture
-10°F (-25°C)	259°F (126°C)	40%
-34°F (-38°C)	265°F (129°C)	50%
-62°F (-46°C)	270°F (132°C)	60%

5.5 COOLANT RECOMMENDATIONS FOR MTA COACHES EQUIPPED WITH VOLVO D13 ENGINE

Fleet Charge Fully formulated Coolant mixture consisting of 50/50 antifreeze solution should be used year-round to provide freeze and boil-over protection as well as providing a stable environment for seals and hoses.

When topping up coolant, use the same coolant mixture type as the mixture already in the cooling system. Do not mix two different types of coolant.

Do not use antifreeze formulated for automobile gasoline engines, these have a very high silicate content that will clog the radiator and leave unwanted deposits in the engine.

<p>Recommended coolants for MTA X3-45 coaches equipped with Volvo D13 engine:</p> <ul style="list-style-type: none"> • Prevost #685352 (pre-diluted 50/50 mixture);

Section 05: COOLING SYSTEM

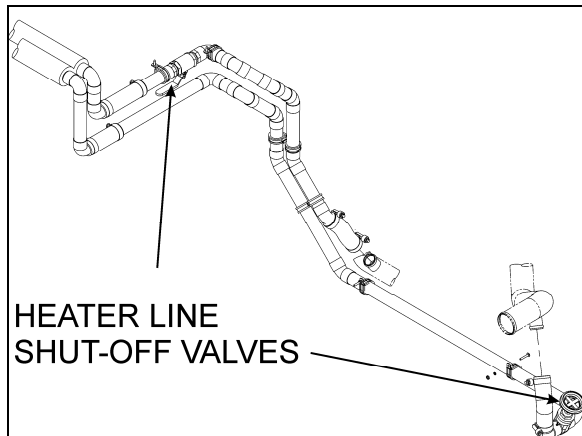

FIGURE 7: LOCATION OF HEATER LINE SHUT-OFF VALVES IN ENGINE COMPARTMENT

05105

6. DRAINING COOLING SYSTEM

Use the following procedures to drain the cooling system partially or completely.

To drain engine and related components:

1. Stop engine and allow engine to cool. Close both heater line shutoff valves.

On X3-45 coaches, the valves are located in the engine compartment. One is located under the radiator fan drive mechanism support; another valve is on the L.H. side of the engine compartment in front of the radiator (Fig. 7).

NOTE

Refer to section 22 under "Preheating System" for information about preheater access and heater line shutoff valve.



WARNING

Before proceeding with the following steps, make sure the coolant has cooled down. The sudden release of pressure from a heated cooling system can result in loss of coolant and possible personal injury (scalding) from the hot liquid.

2. Close the shut-off valve on the coolant filter mounting head and remove filter (perform only if filter as to be replaced).
3. Open the shut-off valve on the coolant filter mounting head and drain the coolant into a suitable container. Close the shut-off valve.

4. Unscrew the surge tank pressure cap counterclockwise, $\frac{1}{4}$ turn to let air enter the system and permit the coolant to drain completely from system.
5. Connect coolant extractor (Fig. 8). Use coolant extractor to drain the coolant from the engine. An alternate method is to drain the coolant into a suitable container using the drain hose.



DANGER

Coolant is toxic; risk of poisoning. Do not drink coolant. Use proper hand protection when handling. Keep coolant out of reach of children and animals. Failure to follow these precautions can cause serious illness or death.

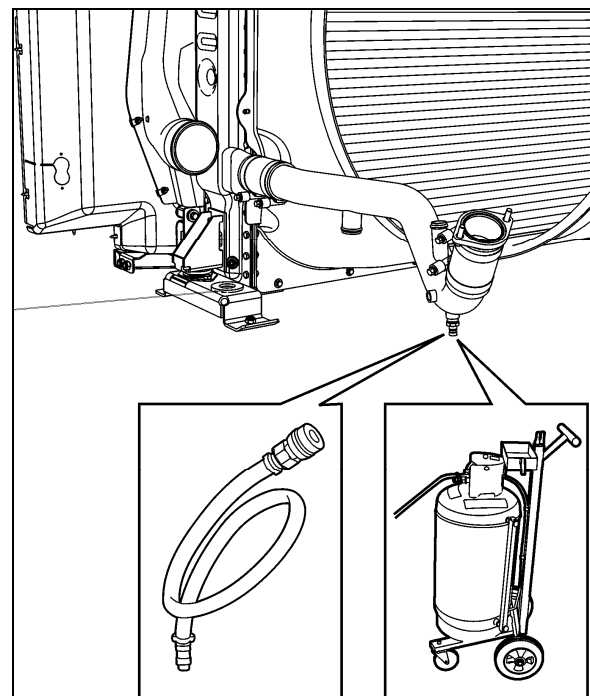

FIGURE 8: EXTRACTING COOLANT

05093

6. Open the radiator drain cock.
7. Remove the transmission oil cooler. Drain, flush and inspect. Refer to Section 7, "TRANSMISSION" for oil cooler maintenance or preventive replacement.



CAUTION

Drain water pump completely before extended storage to avoid possible water pump damage.

If freezing weather is anticipated and the engine is not protected with antifreeze, drain the cooling system completely when vehicle is not in use. Trapped water in the cylinder block, radiator or other components may freeze and expand resulting in damages. Leave the drain plugs open until the cooling system can be filled with coolant fluid. Do not run engine with cooling system empty.

To drain the entire system, do the previous steps while maintaining the shut-off valves in the open position; then follow the procedure under "Draining Heating System" in Section 22.

7. FILLING COOLING SYSTEM

If only the engine and related components were drained, maintain the two heater line shutoff valves in their closed position, then proceed as follows:

1. Close radiator drain cock.
2. Open the shut-off valve on the coolant filter mounting head.
3. Refill cooling system from the surge tank filler cap inlet with Fleet Charge Fully Formulated universal formula antifreeze of the required concentration using the coolant extractor.

NOTE

Make sure the purge lines are properly connected and not obstructed. The purge lines (thermostat housing dome, radiator top tank, transmission oil cooler or delivery line) are required to ensure complete engine fill and proper purging of air in the system.

NOTE

The coolant level should remain within two inches of the surge tank filler neck.

4. Install the filler and pressure cap, then start the engine and run it at fast idle until reaching normal operating temperature. Check for leaks.

NOTE

If for any reason, the coolant level drops below the surge tank level probe, the Check Engine warning light will illuminate.

5. Stop engine and allow cooling.
6. Open the two heater line shutoff valves, check the coolant level in the surge tank, and then add as required.



CAUTION

Never pour cold coolant into a hot engine. The sudden change in temperature may crack the cylinder head or block.

If the entire system has been drained, redo the previous steps while maintaining the two heater line shutoff valves in the "Open" position. With engine running, activate the driver's and central heating systems to permit coolant circulation. Complete the procedure by bleeding the heater cores as explained in Section 22, under "Bleeding Heating System".

8. FLUSHING

If the cooling system is contaminated, flush the cooling system as follows:

1. Drain the coolant from the engine.
2. Refill with clean water.



CAUTION

If the engine is hot, fill slowly to prevent rapid cooling and distortion of the engine castings.

3. To thoroughly circulate the water, start and run the engine for 15 minutes after the thermostats have opened.
4. Fully drain system.
5. Refill with clean water and operate for 15 minutes after the thermostats have opened.
6. Stop engine and allow cooling.
7. Fully drain system.

Vehicles with coolant filters:

Fill with a 50/50-antifreeze/water solution. Replace coolant filter as per the Lubrication and Servicing Schedule in section 24 if required.

Section 05: COOLING SYSTEM

Dispose of spent fluids in an environmentally responsible manner according to regulations in effect in your area.

COOLING SYSTEM CAPACITY (approximation)
--

Includes heating system: 24 US gal (91 liters)
--

8.1 COOLING SYSTEM DESCALERS

If the engine overheats and the fan belt tension, coolant level and thermostat operation have been found to be satisfactory, it may be necessary to de-scale and flush the entire cooling system.

Remove scale formation by using a reputable and safe de-scaling solvent. Immediately after using the de-scaling solvent, neutralize with a neutralizing agent. It is important that product directions be thoroughly read and followed.

After using the solvent and neutralizer, fully drain the system, and then reverse flush the engine and radiator (see "*Reverse Flushing*" in this section) before filling the system with coolant solution.

8.2 REVERSE FLUSHING

After the engine and radiator have been thoroughly de-scaled, they should be reverse-flushed. The water pump should be removed and the radiator and engine reverse-flushed separately to prevent dirt and scale deposits from clogging the radiator tubes or being forced through the pump. Reverse flushing is accomplished by hot water, under pressure, being forced through the cooling system in a direction opposite to the normal flow of coolant, loosening and forcing deposits out.

The radiator is reverse flushed as follows:

1. Remove the radiator inlet and outlet hoses and replace existing radiator cap with a new one.
2. Attach a hose to the top of the radiator to lead water away from the engine.
3. Attach a hose at the bottom of the radiator and insert a flushing gun in the hose.
4. Connect the water hose of the gun to the water outlet and the air hose to the compressed air outlet.

5. Turn on the water and when the radiator is full, turn on the air in short blasts, allowing the radiator to fill between blasts.

NOTE

<i>Apply air gradually. Do not exert more than 138 kPa (20 psi) air pressure. Too great a pressure may rupture a radiator tube.</i>

6. Continue flushing until only clean water is expelled from the radiator.

The cylinder block and cylinder head water passages are reverse flushed as follows:

1. Remove the thermostats and the water pump.
2. Attach a hose to the water inlet of oil cooler housing to drain water away from engine.
3. Attach a hose to the water outlet at the top of the cylinder head (thermostat housing) and insert the flushing gun in the hose.
4. Turn on the water until the jackets are filled, and then turn on the air in short blasts. Allow jackets to fill with water between air blasts.
5. Continue flushing until the water from the engine runs clean.

If scale deposits in the radiator cannot be removed by chemical cleaners or reverse flushing as outlined above, it may be necessary to remove the upper tank and rod out the individual radiator tubes with flat steel rods. Circulate the water through the radiator core from the bottom to the top during this operation.

9. SPIN-ON COOLANT FILTER

The engine cooling system filter is used to filter out impurities such as scale or sand from the coolant and it also eliminates the process of adding inhibitors to the antifreeze/water solution. The filter is mounted onto the cooling fan drive mechanism aluminum casting (Fig. 9).

To replace a filter:

1. Close the filter shutoff cock on the filter mounting head and unscrew the old filter from mounting.



WARNING

Failure to relieve cooling system pressure may result in personal injury.

2. Remove and discard the filter. Recover the coolant remaining in the filter with a suitable container.
3. Clean the filter adapter with a clean, lint-free cloth.
4. Coat surface of gasket with clean antifreeze, tighten 2/3 to 1 turn after gasket makes contact with head.
5. Open the filter shutoff cock.
6. Start engine and check for leaks.

	CAUTION
Do not exceed recommended service intervals.	

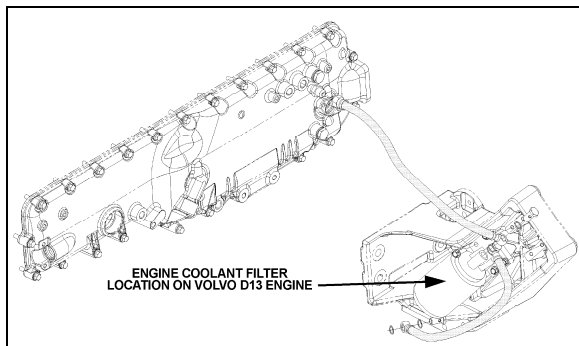



FIGURE 9: COOLANT FILTER (VOLVO D13) 05145

	MAINTENANCE
VOLVO D13 ENGINE	
Replace the coolant filter cartridge after 50,000 miles (80 000 km) to prevent external rust damage to the filter walls. Use a coolant filter containing Supplemental Coolant Additives (SCA).	
Coolant filter cartridge (Volvo D13): #21388476	

10. RADIATOR

The radiator is mounted on the L.H. side of engine compartment. It is designed to reduce the temperature of the coolant under all operating conditions. It is essential that the radiator core be kept clean and free from corrosion and scale at all times.

10.1 MAINTENANCE

	MAINTENANCE
Inspect the exterior of the radiator core every 25,000 miles (40 000 km) or once a year, whichever comes first. Clean with a quality grease solvent, such as a mineral spirits and dry with compressed air. Do not use fuel oil, kerosene, gasoline, or any caustic material. It may be necessary to clean the radiator more frequently if the vehicle is operated in extremely dusty or dirty areas. Refer to coolant system flushing and reverse flushing in this section for maintenance of radiator interior.	

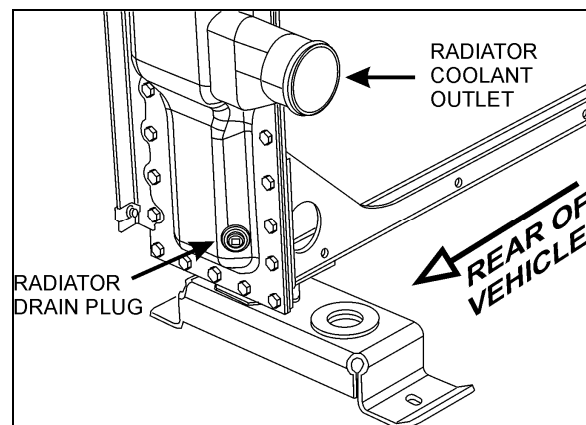

FIGURE 10: RADIATOR DRAIN PLUG 05139

10.2 RADIATOR REMOVAL & INSTALLATION

1. Apply the parking brake and shift the transmission to neutral. Shut off all electrical loads. Turn the ignition switch to the OFF position.
2. Open engine compartment doors.
3. Set starter selector switch to the OFF position.
4. Connect coolant extractor (Fig. 8). Use coolant extractor to drain the coolant from the engine. An alternate method is to drain the coolant into a suitable container using the drain hose.
5. Raise L.H. side hinged rear fender.
6. Remove tag axle L.H. side wheel.

Section 05: COOLING SYSTEM



DANGER

Coolant is toxic; risk of poisoning. Do not drink coolant. Use proper hand protection when handling. Keep coolant out of reach of children and animals. Failure to follow these precautions can cause serious illness or death.

7. Unfasten 4 cap screws and remove access panel located behind tag axle L.H. side wheel (refer to figure 11).

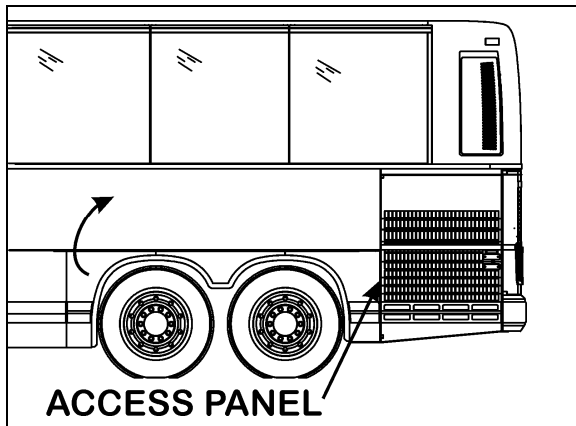

FIGURE 11: ACCESS PANEL (TYPICAL)

8. Open radiator door to access radiator assembly. Unfasten upper arm assembly.
9. Remove radiator sealing frame.

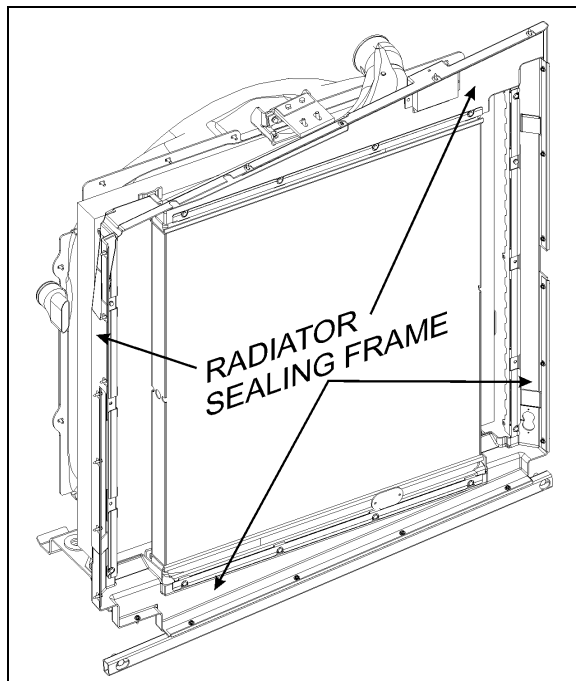

FIGURE 12: RADIATOR SEALING FRAME

10. Remove clamps and then break hoses from the front coolant and charge air pipes (Fig. 13 & 14).

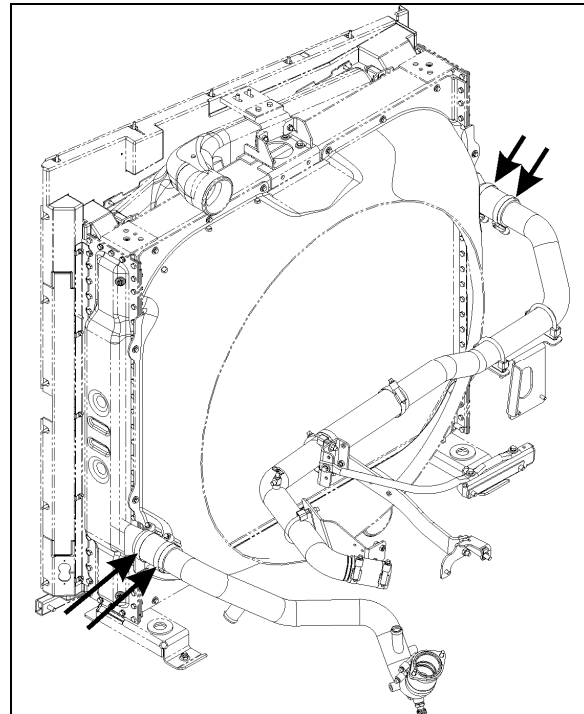

FIGURE 13: RADIATOR HOSE CLAMPS

11. Remove rear coolant and charge air hose clamps then break hoses loose (Fig. 13 & 14).

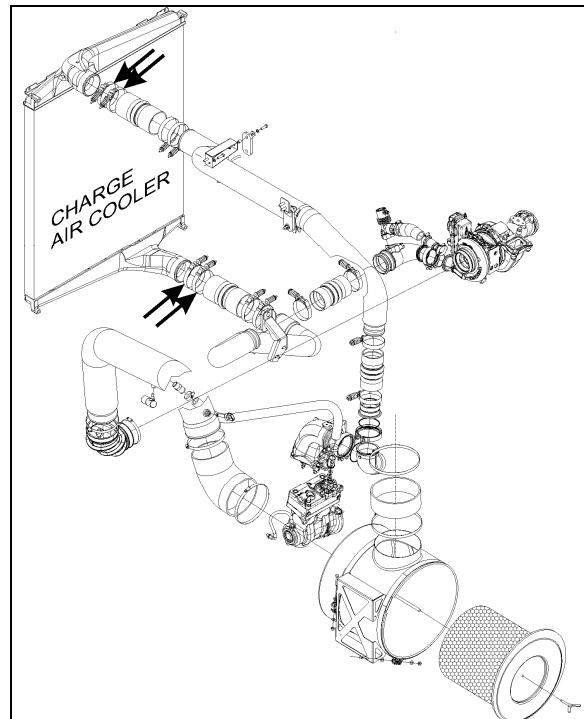

FIGURE 14: CHARGE AIR COOLER HOSE CLAMPS

- Remove the upper radiator assembly support bracket (Fig. 15).

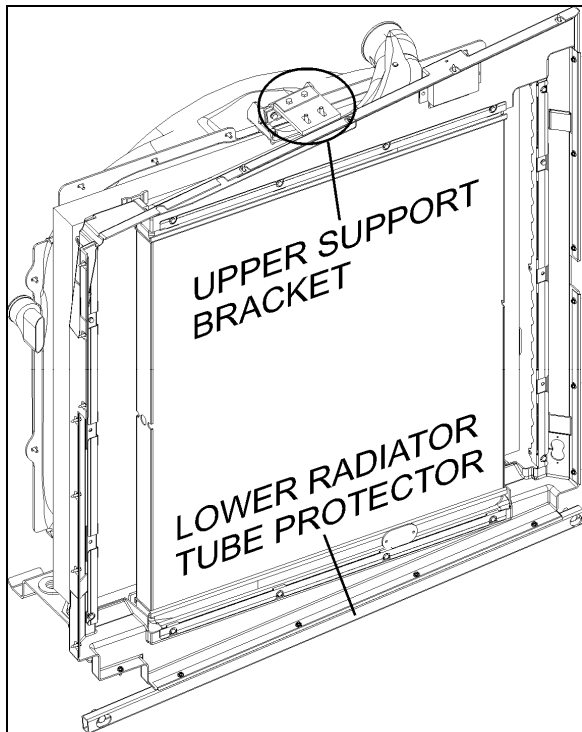

FIGURE 15: UPPER SUPPORT BRACKET & TUBE PROTECTOR

- Remove the lower radiator assembly tube protector from the lower section (Fig. 15).
- Remove all lower radiator assembly mounting fasteners.

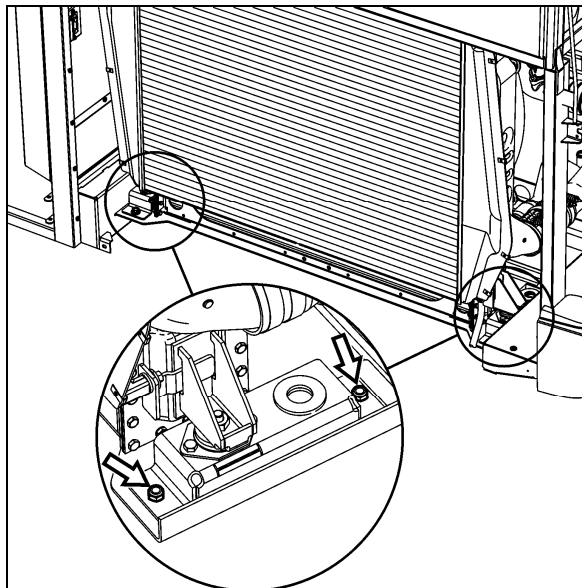

FIGURE 16: RADIATOR ASSEMBLY LOWER MOUNTING FASTENERS

- Cut cable tie and disconnect electrical connector from fan clutch. Remove fan drive shaft fasteners at the gear box.

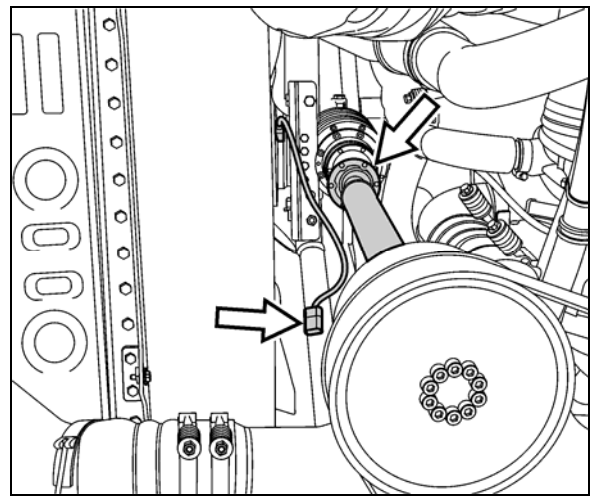

FIGURE 17: DISCONNECTING FAN DRIVE SHAFT

- Position a forklift under the radiator assembly that is capable of safely lifting the radiator.

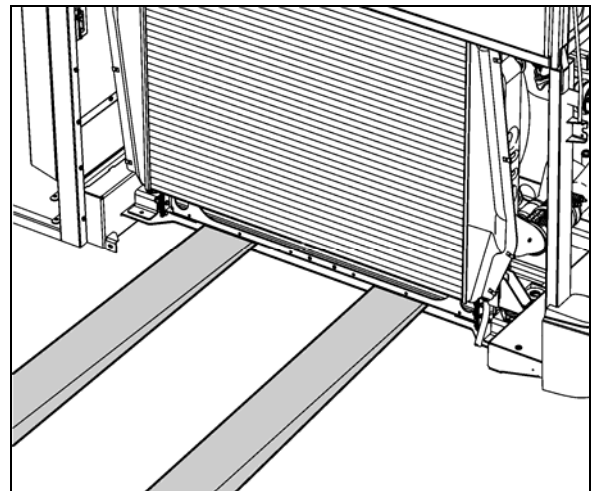

FIGURE 18: POSITIONING FORKLIFT

- With assistance, slide radiator assembly out and onto the forklift. Transfer radiator assembly to a secure location.
- Separate charge air cooler from radiator.
- Lay radiator face down. Remove the fasteners that connect lower radiator mounts to radiator.

Section 05: COOLING SYSTEM

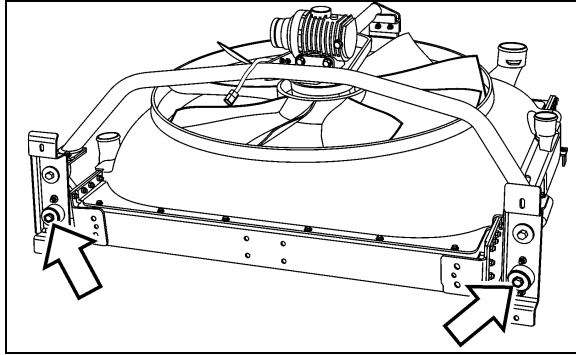

FIGURE 19: REMOVING FASTENERS

20. Remove upper fan drive support bracket from the upper section of the radiator.

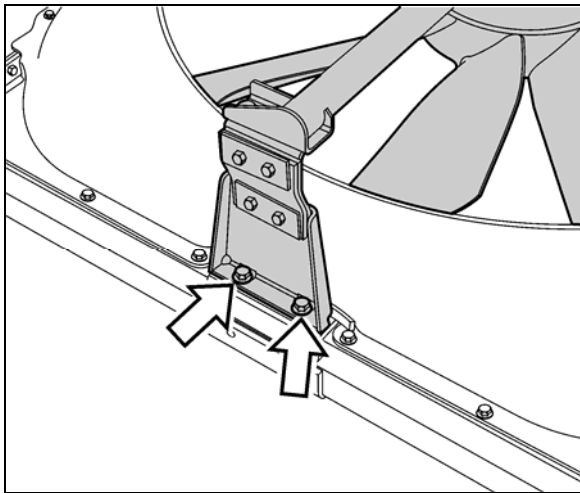

FIGURE 20: REMOVING UPPER FAN DRIVE SUPPORT BRACKET

21. With assistance, remove fan drive and drive frame from radiator.
22. Remove fan shroud from radiator.

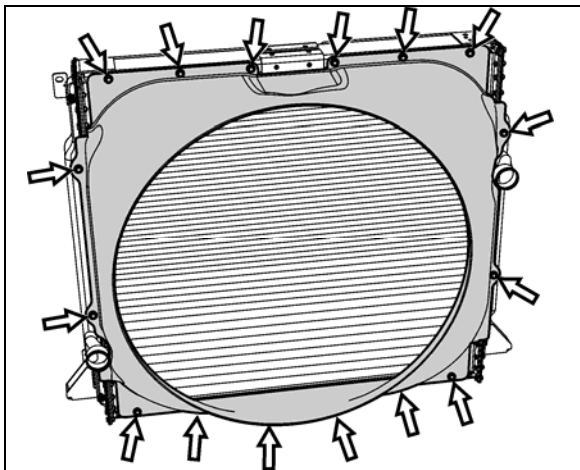

FIGURE 21: REMOVING FAN SHROUD FROM RADIATOR

23. Reverse removal procedure to reinstall radiator assembly.

11. CHARGE AIR COOLER LEAKAGE

Spec for CAC acceptable leakage:

“The CAC is considered acceptable if it can hold 30 psi (206 kpa) gauge pressure with less than 5 psi (34.5 kpa) loss in 15 seconds after turning off the hand valve.”

NOTE

This spec does not apply if there is any evidence that the leak was caused by a foreign object impact.

12. COOLING FAN DRIVE MECHANISM

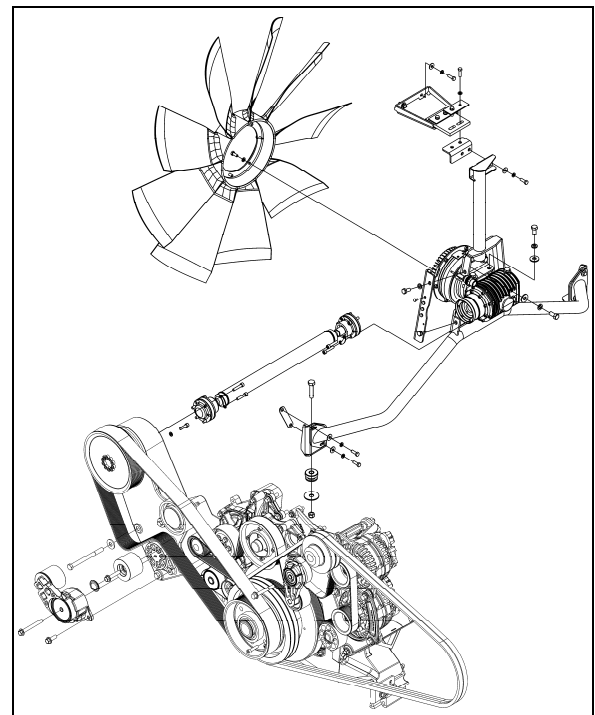

FIGURE 22: COOLING FAN DRIVE MECHANISM

12.1 DRIVE PULLEY AND UNIVERSAL JOINT SHAFT

To disconnect the universal shaft, proceed as follow:



WARNING

Turn the ignition switch to the OFF position and set starter selector switch to the OFF position to prevent accidental starting of the engine.

1. Unwrap the drive belt from around the pulley (see paragraph MOUNTING THE DRIVE BELT).
2. Dismount the drive pulley. Gain access to the 6 mounting bolts from behind the pulley, through the opening in the cast aluminum support (Fig. 23).
3. Unscrew and remove the universal joint shaft mounting bolts (6) at the right angle gearbox.
4. Slowly, move the shaft toward the rear of the vehicle.
5. Finally, dismount the universal joint shaft from the drive pulley (6 bolts).

Installation of the universal joint shaft is the same as removal, but in reverse order.

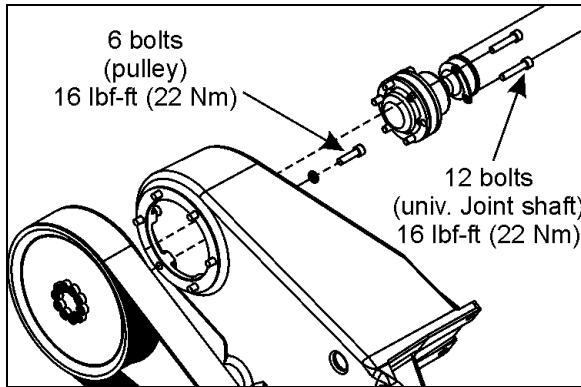

FIGURE 23: TIGHTENING SPECIFICATION 05123A

12.2 IDLER REPLACEMENT

If an idler is defective, replace as follow:

WARNING

Turn the ignition switch to the OFF position and set starter selector switch to the OFF position to prevent accidental starting of the engine.

1. Remove the protective cap (replace with a new one).
2. Unscrew the idler mounting bolt.
3. Replace idler with a new one.

CAUTION

When installing the idler, make sure it rests perfectly against the bearing surface on the cast aluminum support. If not, the drive belt may slip of the idler. See following figure.

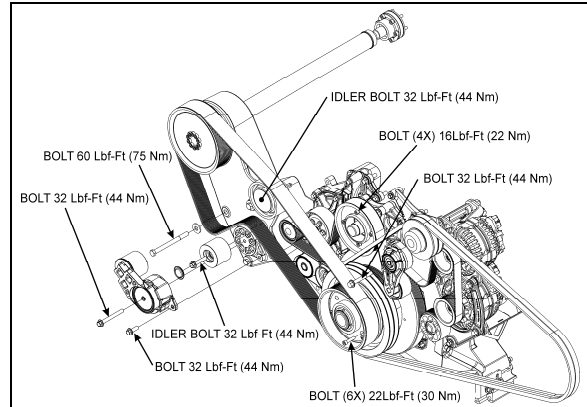

FIGURE 24: TIGHTENING SPECIFICATION (VOLVO D13 ENGINE)

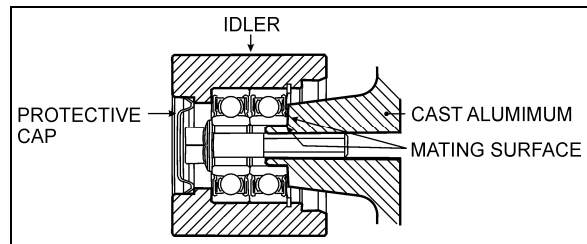

FIGURE 25: IDLER MOUNTED ON THE CAST ALUMINUM SUPPORT

4. Bolt the new idler on the cast aluminum support. Tighten to 32 lbf-ft (44 Nm).
5. Place a new protective cap.

13. VARIABLE SPEED COOLING FAN

The cooling fan clutch has two thermostatically controlled speeds, plus a neutral (clutch disengaged). The engine control module controls the speed by comparing data from engine coolant temperature, charge air temperature, Allison transmission oil temperature (if applicable) and small A/C High side pressure to a set of calibration data. The fan drive clutch is electromagnetic; the engine control module sends an electric current to regulate speed by activating one magnetic coil for the first speed and two magnetic coils for the second speed.

The settings are:

	Engine coolant temp.	Air intake temp.	Allison trans. oil temp.
temperature rising ↑	208°F: fan engages in HIGH SPEED	194°F: fan engages in HIGH SPEED	230°F: fan engages in HIGH SPEED
	203°F: fan engages in LOW SPEED	176°F: fan engages in LOW SPEED	216°F: fan engages in LOW SPEED

Section 05: COOLING SYSTEM

temperature dropping 	203°F: fan HIGH SPEED disengages	189°F: fan HIGH SPEED disengages	225°F: fan HIGH SPEED disengages
	198°F: fan LOW SPEED disengages	170°F: fan LOW SPEED disengages	210°F: fan LOW SPEED disengages



WARNING

DO NOT work near the fan with the engine running or the ignition switch in the ON position. The engine fan can engage at any time without warning. Anyone near the fan when it turns on could be seriously injured.

13.1 LOCKING RADIATOR FAN FOR EMERGENCY OPERATION

13.1.1 Electrical Locking

If the cooling fan clutch does not function due to an electrical control system malfunction and the engine is overheating, execute the following procedure:

1. Turn the ignition switch to the ON position.
2. Activate the dashboard Telltale Light Test switch 3 times within 4 seconds.
3. In the engine compartment, set the starter selector switch to REAR START and then start the engine from the rear.



WARNING

Potential Accident Risk. Always use extreme caution when working in the vicinity of hot, rotating or moving parts.

While in this mode, the rear start push-button can be used to manually engage the fan clutch. The multiplex system knows when the engine is already running, and it will not activate the starter.

4. Press the push-button one time to engage the clutch to 1st speed, press a second time to engage to 2nd speed, press a third time to stop the fan, press once again to return to 1st speed.

NOTE

If the fan clutch does not engage using this procedure then the clutch is faulty or the wiring between the multiplex module and the clutch is faulty. Mechanically lock the fan as described hereafter in section 13.1.2.

13.1.2 Mechanical Locking

Once mechanically locked, the fan is rigidly connected to the drive mechanism and will rotate continuously, with no considerations for the cooling needs. This is an emergency situation and the vehicle shall not be operated in that situation for an extended period.

In case of a magnetic clutch malfunction:

1. Turn the ignition switch to the OFF position and set starter selector switch to the OFF position to prevent accidental starting of the engine.
2. Disconnect the fan clutch electrical connector.
3. Unscrew and remove the 4 spare bolts screwed to the angle on the fan gearbox mounting support.
4. Turn the fan blades in order to position the locking plate bores over the rotor's threaded sockets.
5. Screw in and tighten the spare bolts (Fig. 26).
6. Using the automatic belt tensioner, release tension on the drive belt in order to be able to rotate the fan clutch drive mechanism by hand.
7. Rotate the shaft to get access to the second locking plate and rotor threaded sockets.
8. Screw in and tighten the spare bolts.

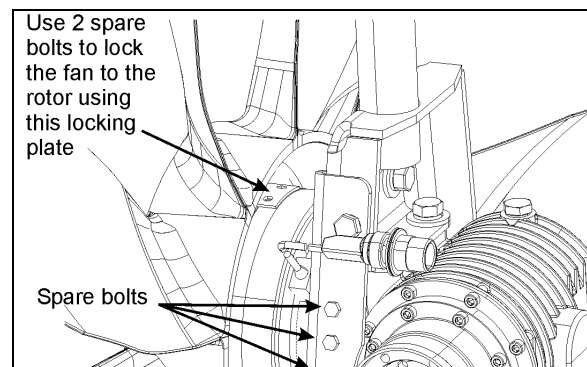



FIGURE 26: MECHANICAL LOCKING

05124

13.2 MAINTENANCE

1. Clean the fan and related parts with clean fuel oil and dry them with compressed air. Do not clean with steam or high-pressure jet.
2. Check the fan blades for cracks or other damage. Replace the fan if the blades are cracked or deformed.
3. Remove any rust or rough spots in the grooves of the fan pulley. If the grooves are damaged or severely worn, replace the pulley.
4. Do not restrict fan rotation during engine operation for any reason.
5. Do not operate fan-driving mechanism with a damaged fan assembly. Replace a damaged fan as soon as the fault is noted.
6. Immediately investigate and correct any operator complaint involving driving mechanism or cooling system performance.
7. When questions arise, obtain answers before proceeding. Assistance is available through the Prevost After-Sales Service Support serving your area.

13.3 INSPECTION



DANGER

Set the starter selector switch in engine compartment to the "Off" position to prevent accidental starting of the engine.

- Check security of fasteners securing fan blade assembly to fan clutch.
- Visually inspect fan driving mechanism, fan blade assembly, shroud, radiator, and surrounding area for evidence of contact between rotating and non-rotating parts.
- Check drive belt for fraying, cracking, and proper tension.
- Turn fan through at least 360° of rotation. It should turn smoothly with no resistance.

13.4 FAN REMOVAL / INSTALLATION

The fan is bolted to the magnetic clutch. To remove the fan:

- Unscrew and remove the mounting bolts and washers.

To reinstall the fan:

- If the fan is still in the radiator fan shroud, place 2 of the mounting bolts on the opposite side of the clutch, in reverse direction, in order to use them as guide pins to position the fan.
- Once properly positioned, screw the 4 remaining bolts back in and tighten properly (16 lbf-ft; 22 Nm).
- Finally, take the 2 bolts that were used as guide pins and screw them back in on the proper side of the clutch and tighten properly.

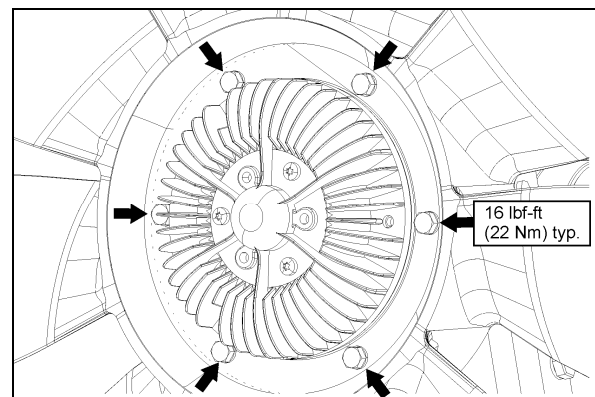

FIGURE 27: RADIATOR FAN MOUNTING BOLTS 05125

14. FAN RIGHT ANGLE GEARBOX

The radiator fan is belt driven from the engine crankshaft pulley through a drive belt, a universal joint shaft, a right angle gear and clutch assembly.

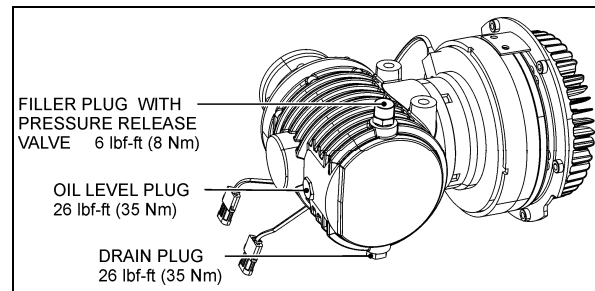



FIGURE 28: RIGHT ANGLE GEARBOX 05118

14.1 MAINTENANCE



MAINTENANCE

Change the right angle gearbox oil every 100,000 miles. Replace seals at every oil change.

Section 05: COOLING SYSTEM

Use **Shell transmission oil MA 75W90**.

14.2 OIL CHANGE

1. Stop engine and make sure that all engine safety precautions have been observed.
2. Turn the ignition switch and set starter selector switch to the OFF position to prevent accidental starting of the engine.
3. Remove the drain plug located underneath the right angle gearbox case and allow the oil to drain into a suitable container.
4. Replace the seal and screw the drain plug back in (torque: 26 lbf-ft).
5. Unscrew and remove the side filler plug.
6. Unscrew and remove the top filler plug.
7. Add gear lubricant. The oil level is correct once the top of the oil has reached the bottom of the side filling point.
8. Replace the seals and screw side and top filler plug back in (torque: 26 lbf-ft).
9. Clean gear case carefully.
10. Start the engine and allow running a few minutes. Stop the engine and check for leaks.



WARNING

Note that warranty may be voided if proper maintenance at oil change intervals is not respected.

14.3 REMOVAL / INSTALLATION

To remove the right angle gearbox, proceed as follow:

1. Turn the ignition switch and set starter selector switch to the OFF position to prevent accidental starting of the engine.
2. Disconnect the fan clutch electrical connector.
3. Dismount the fan and lean it against the radiator (refer to previous paragraph).
4. Disconnect the universal joint shaft.

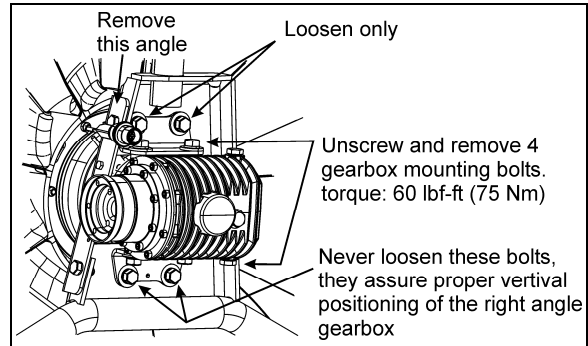

FIGURE 29: RIGHT ANGLE GEARBOX MOUNTING 05126

5. Dismount the angle (see fig. 29).
6. Loosen the gearbox support bracket top bolts.
7. Unscrew and remove 4 gearbox mounting bolts.
8. Slide the gearbox out of the support assembly.

Installation procedure is the same as removal but in reverse order. Tighten the 4 mounting bolts as specified.

15. COOLING FAN DRIVE BELT

15.1 MOUNTING THE DRIVE BELT

To install the cooling fan drive belt, proceed as follow:



WARNING

Turn the ignition switch and set starter selector switch to the OFF position to prevent accidental starting of the engine.



WARNING

Potential Accident Risk. Always use extreme caution when working in the vicinity of hot, rotating or moving parts.

1. Wrap the new drive belt around the fan drive mechanism pulley, the idlers and the automatic tensioner idler as shown on figure 30.

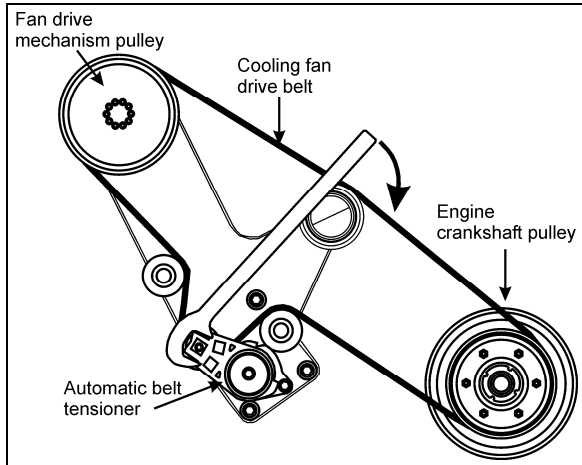

FIGURE 30: DRIVE BELT ROUTING (VOLVO D13 ENGINE)

2. Using the special tool included with your vehicle (see inside the Warning Reflectors box located in the first curb-side baggage bay), rotate the automatic tensioner in clockwise direction to relieve tension on the belt and hold the tensioner in that position (Fig. 30).
3. Finally, place the drive belt around the engine crankshaft pulley.
4. Release the tensioner slowly and let it return to its natural position.

COOLING FAN DRIVE BELT

With Volvo D13 engine

Type: 14PK2526

Prevost number: 5060097

16. SPECIFICATIONS

Cooling System Capacity (Approximation)

Includes heating system..... 24 US gal (91 liters)

Thermostat - Volvo D13 Engine

Number used..... 1
 Start to close..... 203°F (95°C)
 Fully closed..... 185°F (85°C)

Cooling Fan Drive Belt – Volvo D13 Engine

Type..... Poly-Rib 14PK2526
 Qty 1
 Prevost number 5060097

Coolant - Volvo D13 Engine

Type..... Fleet Charge 50/50 Fully Formulated Antifreeze
 Prevost Number 685352

Coolant Filter Cartridge – Volvo D13 Engine

Number used..... 1
 Type..... Spin-on filter containing Supplemental Coolant Additives (SCA)
 Prevost number 21388476

SECTION 06: ELECTRICAL

CONTENTS

1. GENERAL DESCRIPTION	4
1.1 WIRING DIAGRAMS	4
1.1.1 <i>Using Wiring Diagrams</i>	4
1.1.2 <i>Testing Circuits</i>	5
1.2 WIRE SIZES AND COLORS.....	5
1.3 SPARE WIRES	5
1.4 CLEANING CONNECTORS.....	6
1.5 CIRCUIT BREAKERS.....	6
1.5.1 <i>X3-45 Coaches</i>	6
1.6 MULTIPLEX FUSES.....	6
1.7 RELAYS.....	7
1.8 PRECAUTIONS.....	7
2. X3 SERIES COACH	9
2.1 MAINTENANCE.....	9
2.2 REAR ELECTRICAL PANEL, JUNCTION PANEL, BATTERY COMPARTMENT & EQUALIZER.....	9
2.3 REAR ELECTRICAL PANEL.....	10
2.4 REAR JUNCTION PANEL.....	10
2.5 BATTERY COMPARTMENT.....	10
2.6 FRONT ELECTRICAL AND SERVICE COMPARTMENT.....	10
2.7 A/C JUNCTION BOX.....	10
2.8 ENGINE REAR START PANEL.....	11
2.9 ENTRANCE DOOR & WIPER CONTROL PANEL.....	11
3. BATTERIES	11
3.1 BATTERY DISCHARGE PROTECTION	12
3.2 MAIN BATTERY RELAYS	12
3.3 BATTERY REMOVAL AND INSTALLATION.....	12
3.4 BATTERY RATING.....	13
3.5 BATTERY MAINTENANCE.....	14
3.5.1 <i>Visual Inspection</i>	14
3.5.2 <i>Removing Surface Charge</i>	14
3.5.3 <i>Testing Battery Cables</i>	14
3.6 BATTERY CHARGING.....	15
3.6.1 <i>Emergency Jump Starting With Auxiliary (Booster) Battery</i>	15
3.7 COMMON CAUSES OF BATTERY FAILURE.....	16
3.8 TROUBLESHOOTING	17
3.9 "BATTERY VOLTAGE WARNING" PICTOGRAM.....	17
3.9.1 <i>Voltmeter Gauge Definitions</i>	17
4. TROUBLESHOOTING AND TESTING THE MULTIPLEX VEHICLES	17
4.1 ELECTRICAL SYSTEM DIAGNOSTIC	17
4.2 PROBING VOLTAGE ON THE MULTIPLEX CIRCUITS	18
4.3 CAN NETWORK.....	18
4.3.1 <i>Spare CAN</i>	18
4.4 MULTIPLEX INPUT TEST MODE	18
4.4.1 <i>Test Sequence</i>	20
4.5 FORCED ACTIVATION OF THE RADIATOR FAN CLUTCH.....	20
4.6 CAN NETWORK LAYOUT AND TROUBLESHOOTING.....	21
4.7 TROUBLESHOOTING	21
4.8 MULTIPLEX ERROR MESSAGES TROUBLESHOOTING LIST.....	26
4.9 MULTIPLEX MODULE "NO RESPONSE" TROUBLESHOOTING LIST.....	26
4.10 ESSENTIAL FUNCTIONS TO OPERATE THE VEHICLE.....	26

Section 06: ELECTRICAL

4.10.1 Available Functions	27
4.11 LOWER PRIORITY MODULES FOR BREAKDOWN SERVICE	27
4.12 MULTIPLEX MODULES	27
4.12.1 MCM	27
4.12.2 IO-A	27
4.12.3 IO-B	27
4.13 MULTIPLEX MODULES REPLACEMENT	27
4.13.1 Replacing IO-A Or IO-B Modules	27
4.13.2 Replacing The MCM Module	28
5. BOSCH ALTERNATORS.....	28
5.1 ALTERNATOR BRUSH REPLACEMENT	29
5.2 IDENTIFYING THE DEFECTIVE ALTERNATOR.....	30
5.3 ALTERNATOR DRIVE BELT	30
5.4 ADJUSTMENT.....	30
6. BATTERY EQUALIZER	30
7. BATTERY CHARGER.....	30
8. POWER INVERTER	31
9. STARTER	31
10. EXTERIOR LIGHTING.....	31
10.1 HEADLIGHTS.....	31
10.1.1 Headlight Beam Toggle Switch	31
10.1.2 Maintenance	31
10.1.3 Headlight Adjustment	32
10.1.4 Sealed-Beam Unit	33
10.1.5 Front Turn Signal	34
10.2 STOP, TAIL, DIRECTIONAL, BACK-UP, AND HAZARD WARNING LIGHTS	34
10.2.1 Lamp Removal and Replacement.....	34
10.2.2 Center Stoplights and Center High-mounted Stop Light (CHSL) Removal and Replacement.....	34
10.3 LICENSE PLATE LIGHT	34
10.4 CLEARANCE, IDENTIFICATION AND MARKER LIGHTS	34
10.4.1 Clearance and Identification Light Removal and Replacement.....	35
11. INTERIOR LIGHTING EQUIPEMENT	35
11.1 CONTROL PANEL LIGHTING	35
11.1.1 Switch Lighting	35
11.1.2 Telltale Light Replacement.....	35
11.1.3 Gauge Light Bulb Replacement.....	35
11.2 STEPWELL LIGHTS.....	35
11.2.1 Bulb Removal And Replacement.....	35
11.3 DRIVER'S AREA LIGHTS	36
11.3.1 Bulb Removal and Replacement	36
11.4 ENGINE COMPARTMENT LIGHTING.....	36
12. SPECIFICATIONS	37

ILLUSTRATIONS

FIGURE 1: WIRE IDENTIFICATION.....	5
FIGURE 2: REAR ELECTRICAL JUNCTION PANEL	6
FIGURE 3: MULTIPLEX MODULE CONNECTORS PIN-OUT	7
FIGURE 4: ELECTRICAL COMPARTMENTS (X3-45 COACH)	9
FIGURE 5: REAR ELECTRICAL PANEL, JUNCTION PANEL & BATTERY COMPARTMENT	9
FIGURE 6: REAR ELECTRICAL PANEL	9
FIGURE 7: REAR ELECTRICAL PANEL	10
FIGURE 8: REAR ELECTRICAL JUNCTION PANEL	10
FIGURE 9: BATTERY COMPARTMENT	10
FIGURE 10: FRONT ELECTRICAL COMPARTMENT	10
FIGURE 11: A/C JUNCTION BOX.....	11
FIGURE 12: REAR START PANEL	11
FIGURE 13: ENTRANCE DOOR & WIPER CONTROL PANEL.....	11
FIGURE 14: BATTERY PROTECTIVE COVER	12
FIGURE 15: LATCH ON PROTECTIVE COVER.....	12
FIGURE 16: BATTERY FIXING CLAMPS AND LIFTING HANDLES	13
FIGURE 17: HYDRAULIC FLOOR CRANE.....	13
FIGURE 18: ALLIGATOR CLAMPS	15
FIGURE 19: BOOSTER BLOCK	15
FIGURE 20: X3-45 COACHES CAN NETWORK LAYOUT	21
FIGURE 21: IO-B MODULE REMOVAL.....	27
FIGURE 22: ALTERNATORS DRIVE BELT	28
FIGURE 23: TWIN BOSCH ALTERNATORS INSTALLATION.....	29
FIGURE 24: ALTERNATOR MOUNTING - TIGHTENING SEQUENCE	29
FIGURE 25: BOSCH HD10 BRUSH HOLDER MOUNTING SCREWS	29
FIGURE 26: TWIN BOSCH HD10 CONNECTIONS	29
FIGURE 27: HEADLIGHT ASSEMBLY	31
FIGURE 28: FOOT-OPERATED CONTROLS	31
FIGURE 29: OPENING HEADLIGHT ASSEMBLY	31
FIGURE 30: ALIGNMENT OF HEADLIGHT AIMING SCREEN	32
FIGURE 31: HIGH-INTENSITY ZONE (SHADED AREA).....	33
FIGURE 32: HIGH-INTENSITY ZONE (SHADED AREA).....	33
FIGURE 33: AIM INSPECTION LIMITS FOR UPPER-BEAM HEADLIGHTS.....	33
FIGURE 34: AIM INSPECTION LIMITS FOR LOWER-BEAM HEADLIGHTS	33
FIGURE 35: SWITCH	35
FIGURE 36: ENGINE COMPARTMENT LIGHT	36
FIGURE 37: VARIOUS LIGHTS LOCATION	36

1. GENERAL DESCRIPTION

These X3-45 coaches use a dual voltage system to obtain two different voltages (12 and 24 volts) for various electrical controls and accessories. The main power source incorporates two maintenance-free "Deka" commercial batteries connected in parallel-series. All batteries are kept uniformly charged by means of a 100 amp battery equalizer (standard), giving a maximum possible output supply of 100 amps on the 12 volt system. Both the 12 and 24 volt systems are controlled through individual main battery relays. Two 28 volt self-regulated alternators are installed and are belt driven from the engine, and can be reached through the engine compartment doors.

1.1 WIRING DIAGRAMS

A master wiring diagram of the electric circuits, covering standard and optional accessories and systems, is located in the technical publications box. Usually, a separate wiring diagram page is provided for each major function or system. In some cases, more than one circuit may appear on one wiring diagram page; when this occurs, each circuit covered in this page is listed in the wiring diagram index. Moreover, a circuit may appear on several pages; in such case, the number(s) at the extremity of the diagram title will indicate the sheet reference number. Refer to the "*Wiring Diagram Index*" to ensure that the correct diagram is being used to trace the circuit in question. In addition to the major functions page reference, the wiring diagram index contains the following information pages.

- The Multiplexed Device Index,
- The Arrangement-Harness drawing showing the harnesses arrangement and harness number on the vehicle,
- Glossary,
- Circuit number listing,
- Circuit breaker code,
- Connector code,
- Diode number code,
- Resistor number code,
- Fuse code.

1.1.1 Using Wiring Diagrams

Three methods are used to "*work*" with electric wiring diagrams.

Situation: You have identified the defective part (breaker, diode, relay, etc.), and you wish to locate its corresponding circuit.

Problem: Circuit breaker CB13 is released (open circuit) and you don't know which circuit is affected.

- a) Refer to wiring diagram index, and look for "*Circuit breaker code*". You find that the circuit breaker list is on page **F**.
- b) At item CB13, you will find the location, the Prevost number, the breaker function, the breaker ampere rating and the page on which to find the corresponding diagram.
- c) Refer to page 3.1.
- d) When you have located CB13, follow the wiring up to the end and find the diagram page number and function on which the circuit continues.

Situation: You have a problem with a specific system and you want to find the corresponding diagram.

Problem: The last three (3) speakers on the R.H. side of vehicle are inoperative and you must trace the electric circuit.

- a) Refer to wiring diagram index and look for "*Sound system*".
- b) You will find on page 35.2 the components as well as the electric wiring, thus providing you with a complete understanding of this circuit.

Situation: Using the Driver Information Display (DID), you check on arrival if there are active errors in the vehicle electrical system. With the **Diagnostics** menu, highlight **Fault Diagnostics**, highlight **Electrical System** to request a diagnostic of the electrical system and then press the enter key. If applicable, the DID shows the fault messages or fault codes recorded. When more than one fault is recorded, an arrow pointing down appears on the right of the display. Use the down button to see all the fault messages.

Problem: DID displays the fault "Elec. Horn SW61 SW62; shorted to ground" as being active.

- a) Refer to wiring diagram index, and look for "Multiplex Device Index", pages B1-B8.
- b) In first column DEVICE ID, look for device SW61, SW62.
- c) At device SW61,SW62, find the fault message, the minimum condition to activate, other inputs involved in logic, the multiplex module related to switch 61 and switch 62, the connector and pin number on the module and the page on which to find the corresponding diagram.
- d) Once the problem corrected, the DID still shows the fault as being active. You have to leave the **Fault Diagnostics** menu, wait approximately 20 to 30 seconds and then return to **Fault Diagnostics** to request a new diagnostic of the **Electrical System** from the MCM. The DID should display the fault as being inactive.

1.1.2 Testing Circuits

A careful study of the wiring diagrams should be made to determine the source and flow of current through each circuit. When a circuit is thoroughly understood, a point-to-point check can be made with the aid of the applicable wiring diagrams. Any circuit can be tested for continuity or short circuits with a multimeter or a suitable voltmeter.

All electrical connections must always be kept clean and adequately tight. Loose or corroded connections can result in discharged batteries, difficult starting, dim lights and improper functioning of other electric circuits. Inspect all wiring connections at regular intervals. Make sure knurled nuts on all amphenol-type plugs are securely tightened. Knurled nuts on the plastic amphenol-type connectors will click into a detent when properly tightened. Line connectors, who have the side locking tabs, must have the locks latched in place to ensure a proper electrical connection.

1.2 WIRE SIZES AND COLORS

Each wire in the electrical system has a specific size as designated on the wiring diagram. When replacing a wire, the correct size must be used. Never replace a wire with one of a smaller size. The vehicle electrical system is provided with different voltages. The insulation on each wire is

distinctly colored in order to determine visually the wiring voltage and to assist in making connectors. The wires are color coded as follows:

Yellow	Multiplex modules communication CAN-H (twisted with green)
Green	Multiplex modules communication CAN-L (twisted with yellow)
Orange	Connected to multiplex outputs
White	Connected to multiplex inputs
Red	24 volt system
Yellow	12 volt system
Black	grounded wire
Blue	110 V ac system (live)
White	110 V ac system (neutral)
Green	110 V ac system (ground)
Orange	speakers (+) (Coaches Only)
Brown	speakers (-) (Coaches Only)
Grey	spare wire

NOTE

Wires are identified at each 2-4 inch (5-10 cm) intervals by a printed number.

Each wire on a diagram is patterned to assist in tracing and testing circuits. The wire number identifies the voltage rating, the wire identification number and the basic wire gauge as illustrated in figure 1.

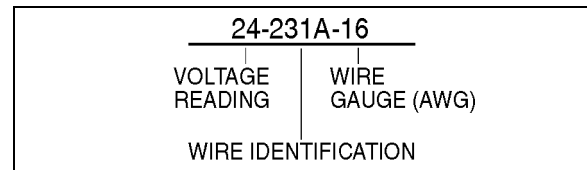

FIGURE 1: WIRE IDENTIFICATION

06048

1.3 SPARE WIRES

When the vehicle leaves the factory, and even in the case of a fully-equipped vehicle, an important number of unconnected spare wires are routed between the junction boxes. Consequently, for any connection of an additional accessory, look in Wiring Diagram for "spare" wires in the circuit number listing of pages E.1 thru E.8 to determine the circuit number. Refer to page 8.1 in Wiring Diagram to find location of these wires.

CAUTION

Wire size is calibrated according to the breaker or fuse that protects it. When using a spare wire to replace a damaged wire, assure that the spare wire size is equal or larger than the wire being replaced. Using a wire too small for the breaker or fuse amperage might cause overheating of the wire.

Section 06: ELECTRICAL

NOTE

Spare wires are identified by a wire identification number and by the letters "SP", to designate "spare".

1.4 CLEANING CONNECTORS

When the pins and sockets of connectors become dirty, clean them with a good quality solvent containing HFC 134A refrigerant as its active ingredient. HFC 134A has two qualities that recommend it. First, it does not conduct electricity and therefore, will not cause shorting between connector pins and sockets. Second, it evaporates quickly, eliminating the possibility of condensation within the connectors.

Always shake out or gently blow out any excess HFC 134A before assembling a connector to its mating connector or hardware. HFC 134A trapped in the connector can affect the connector seal.

DANGER

HFC 134A is toxic. HFC 134A bases compounds should always be used in a well-ventilated area, never in a confined space. Use outdoor whenever possible.

1.5 CIRCUIT BREAKERS

Most electric circuits are protected by circuit breakers of the "Manual Reset" type. The main circuit breakers, as well as those protecting the A/C system, are located on the rear electrical junction panel and are accessible from the engine compartment curb-side door, on R.H. side of the vehicle.

This type of circuit breaker deenergizes the circuit without disconnecting any wire.

1.5.1 X3-45 Coaches

Circuit breakers CB2, CB4 & CB6 are different in the fact that you may open the circuit manually, to do so simply press down the red tab on breaker to open the circuit, repair defective circuit, and afterwards depress black button in center of breaker to close the circuit.

Smaller circuit breakers may be located in the VECF of the front service compartment.

CIRCUIT BREAKERS			
CB1	Front distribution	24 VI	90 amps
CB2	Distribution	12 VD	90 amps
CB3	HVAC - evaporator	24 VI	90 amps
CB4	Sound system	12 VD	30 amps
CB5	Rear distribution	24 VI	150 amps
CB6	Distribution	24 VD	70 amps
CB7	HVAC - condenser	24 VI	70 amps
CB8	Rear distribution	12 VI	40 amps
CB9	WCL or other option	24VD	50 amps
CB10	Front distribution	12 VI	70 amps
CB11	Sound system	24 VD	50 amps
CB13	Inverter	24 VI	90 amps

VD= volts direct. The electrical components connected to these circuit breakers are direct-connected to the battery.

VI= volts indirect. Electrical power is supplied via master relay R1 which engages when ignition key is in the ON or ACC position and battery master switch (master cut-out) is set to ON.

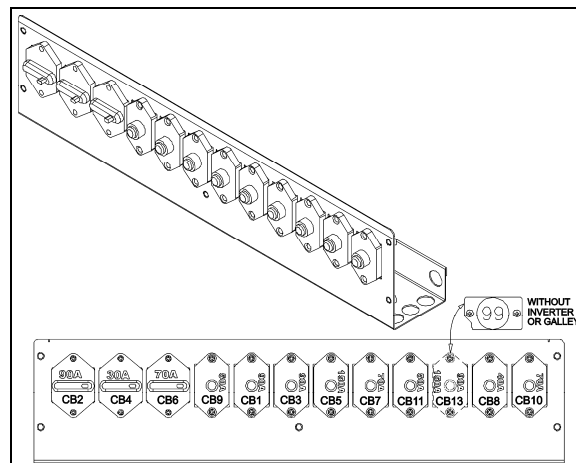

FIGURE 2: REAR ELECTRICAL JUNCTION PANEL 06621

1.6 MULTIPLEX FUSES

The multiplex outputs are protected in current by an internal "soft-fuse". Each output has programmed specific maximum amperage. When an output is shorted, the current gets above the limit and the soft-fuse intervenes to turn the output OFF. The output stays OFF until the "soft-fuse" is reset.

Turn the ignition switch to the OFF position and turn to the ON position again. This resets all "soft-fuses".

There is also hardware fuses used to protect the incoming power to the multiplex modules. These fuses are located inside the VECF (Vehicle

Electrical Center Front) and VECR (Vehicle Electrical Center Rear).

1.7 RELAYS

Relays are used to automatically energize or deenergize a circuit from a remote location. The relay draws a very low current to energize its coil. Once the coil is energized, it develops a magnetic field that pulls a switch arm closed or open, to either energize or deenergize a given component. As the control current required for the coil is very low, the relay allows a remote station to control a high energy circuit without running great lengths of costly high capacity cable, and also eliminates the need for high amperage switches and heavy connectors.

NOTE

Each relay is identified with "12V" or "24V" printed on its casing in order to identify the coil operating voltage.



CAUTION

The Multiplex vehicle uses a VF4 relay designed specially for Volvo that has different internal characteristics than the current VF4 relay. It is important to use only the new part marked Volvo as a replacement in Multiplex vehicles. Regular relays have an inadequate lifespan for Multiplex vehicles.

1.8 PRECAUTIONS



DANGER

Prior to working on a system inside vehicle, make sure to cut electrical power and air supply. A component could be supplied with electricity even if the ignition switch is set to the OFF position and/or a component could be pressurized even if air tanks are emptied. Always refer to the appropriate wiring and pneumatic diagrams prior to working on electrical and/or pneumatic systems.

NOTE

When the ignition switch is set to the OFF position, the electrical components are not energized except for the MCM (Master Chassis Module), ECM (Engine Control Module), TCM (Transmission Control Module), instrument cluster module, the battery equalizer, the wheelchair lift system and some Multiplex modules which are energized during 15 minutes after the ignition has been set to the OFF position. Prior to working on one of these electrical components, set the master cut-out switch located above the rear electrical panel to the OFF position.

If the vehicle will not be operated for a long period (more than 2 weeks), it is recommended, in order to prevent the batteries from discharging, to trip main circuit breakers (2, 4 and 6) located on the rear junction panel to stop the small current drawn by the radio preset station memory, the MCM memory and the instrument cluster clock. Note that the radio station presets will be erased, same thing for the diagnostic codes history and the instrument cluster clock will have to be reset.



CAUTION

Prior to arc welding on the vehicle, refer to "Multiplex Modules Disconnection Procedure Prior To Welding" in section 00 GENERAL of this manual to avoid serious damage to the vehicle components.

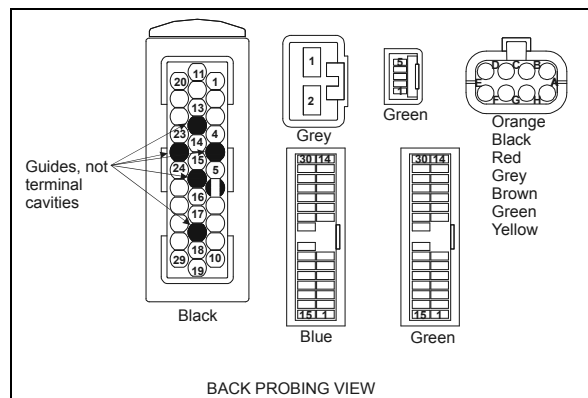
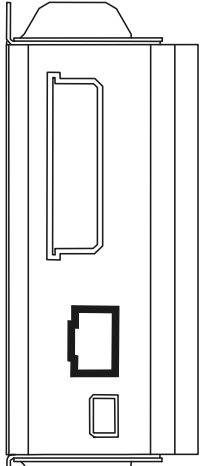
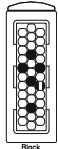
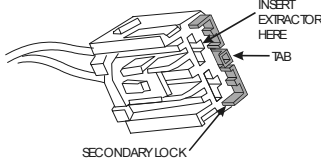
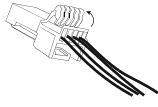
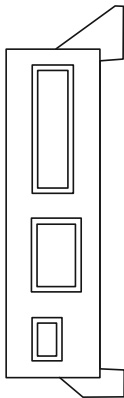
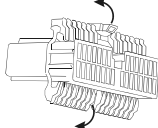
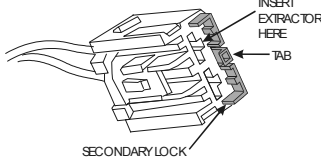
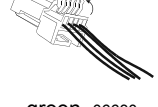
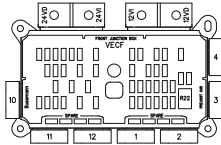
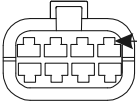

FIGURE 3: MULTIPLEX MODULE CONNECTORS PIN-OUT
06624

Section 06: ELECTRICAL

Multiplex modules	Connector type	Terminal removal
 <p>IO-B 06625</p>	 <p>Block AMP 06628</p>	<p>EXTRACTOR/TOOL: Prevost #683594</p> <p>Insert the extractor on the front of the connector. Remove the terminal by disengaging the flexible lock tabs on the terminal. Gently remove the terminal from the connector by pulling on the wire.</p>
	 <p>INSERT EXTRACTOR HERE TAB SECONDARY LOCK grey 06629 YAZAKI</p>	<p>EXTRACTOR/TOOL: Packard #12094430</p> <p>Using a small flat blade screwdriver, open the hinged secondary lock. Insert the extractor on the front of the connector, over the terminal cavity. Remove the terminal by disengaging the flexible lock tab on the terminal. Gently remove the terminal from the connector by pulling on the wire.</p>
	 <p>green 06630 JAE</p>	<p>EXTRACTOR/TOOL: Prevost #683766</p> <p>Using a small flat blade screwdriver, open the hinged secondary lock. Insert the extractor on the front of the connector, over the terminal cavity. Remove the terminal by disengaging the flexible lock tab on the terminal. Gently remove the terminal from the connector by pulling on the wire.</p>
 <p>IO-A 06626</p>	 <p>green, blue (MCM) JAE 06631</p>	<p>EXTRACTOR/TOOL: Prevost #683766</p> <p>Using a small flat blade screwdriver, open both hinged secondary locks. Insert the extractor on the front of the connector, over the terminal cavity. Remove the terminal by disengaging the flexible lock tab on the terminal. Gently remove the terminal from the connector by pulling on the wire.</p>
	 <p>INSERT EXTRACTOR HERE TAB SECONDARY LOCK grey 06629 YAZAKI</p>	<p>EXTRACTOR/TOOL: Packard #12094430</p> <p>Using a small flat blade screwdriver, open the hinged secondary lock. Insert the extractor on the front of the connector, over the terminal cavity. Remove the terminal by disengaging the flexible lock tab on the terminal. Gently remove the terminal from the connector by pulling on the wire.</p>
	 <p>green 06630 JAE</p>	<p>EXTRACTOR/TOOL: Prevost #683766</p> <p>Using a small flat blade screwdriver, open the hinged secondary lock. Insert the extractor on the front of the connector, over the terminal cavity. Remove the terminal by disengaging the flexible lock tab on the terminal. Gently remove the terminal from the connector by pulling on the wire.</p>
 <p>VECF 06627</p>	 <p>INSERT EXTRACTOR HERE Orange Black Red Grey Brown Green Yellow BUSSMAN 06632</p>	<p>EXTRACTOR/TOOL: Prevost #682256 (Packard 12094429)</p> <p>Remove the terminal by disengaging the flexible lock tab on the terminal. Gently remove the terminal from the connector by pulling on the wire.</p>

2. X3 SERIES COACH

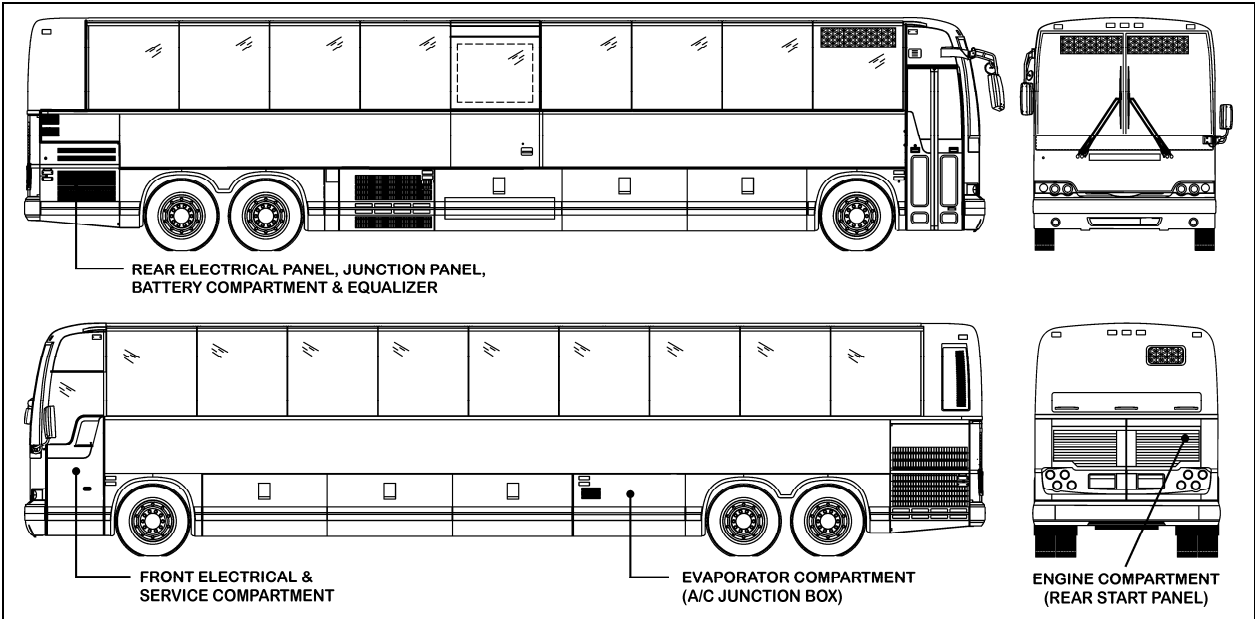



FIGURE 4: ELECTRICAL COMPARTMENTS (X3-45 COACH)

06672

2.1 MAINTENANCE

A corrosion inhibitor has been sprayed on certain electrical components in order to protect them from corrosion. Refer to procedure SAV00002E at the end of this section for recommended products and where they are used.

	CAUTION
<p>Never put grease or other product on the multiplex modules connector terminals.</p>	

	DANGER
<p>Use sprayed sealer in a well ventilated area. Do not smoke. Avoid prolonged contact with skin and breathing of spray mist.</p>	



FIGURE 5: REAR ELECTRICAL PANEL, JUNCTION PANEL & BATTERY COMPARTMENT

2.2 REAR ELECTRICAL PANEL, JUNCTION PANEL, BATTERY COMPARTMENT & EQUALIZER

The rear electrical panel, junction panel, battery compartment & battery equalizer are located on the R.H. side of the engine compartment and are accessible from the engine compartment curb-side door.

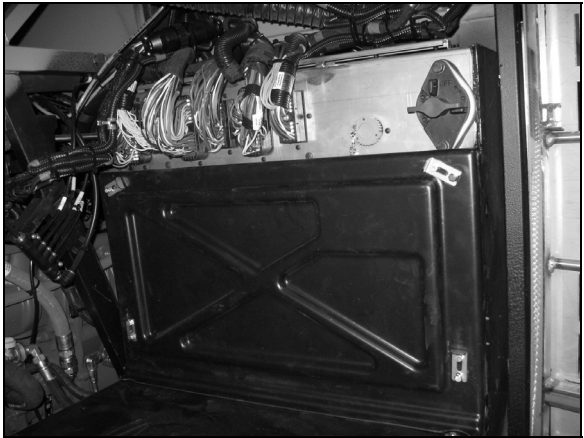

FIGURE 6: REAR ELECTRICAL PANEL

Section 06: ELECTRICAL

2.3 REAR ELECTRICAL PANEL



FIGURE 7: REAR ELECTRICAL PANEL

The rear electrical panel provides access to the following:

- Rear terminal block;
- Multiplex modules;
- Vehicle Electrical Center Rear (VECR)
- Relays and fuses;
- Transmission TCM;
- Battery master switch (Master cut-out);
- Diagnostic Data Reader (DDR) receptacle, (refer to "Other Features" chapter).

2.4 REAR JUNCTION PANEL

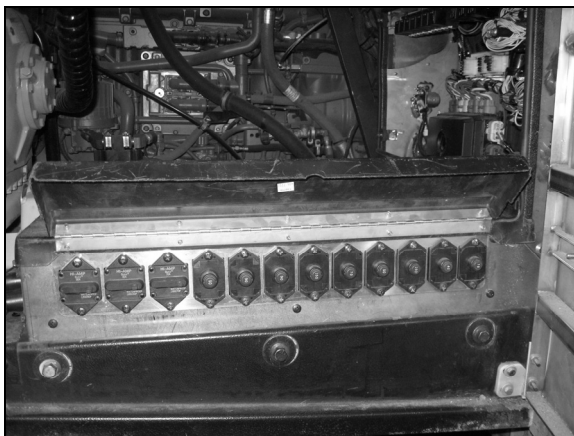

FIGURE 8: REAR ELECTRICAL JUNCTION PANEL 06634

2.5 BATTERY COMPARTMENT

The Battery Compartment provides access to the batteries (2), battery equalizer and master relay (R1).

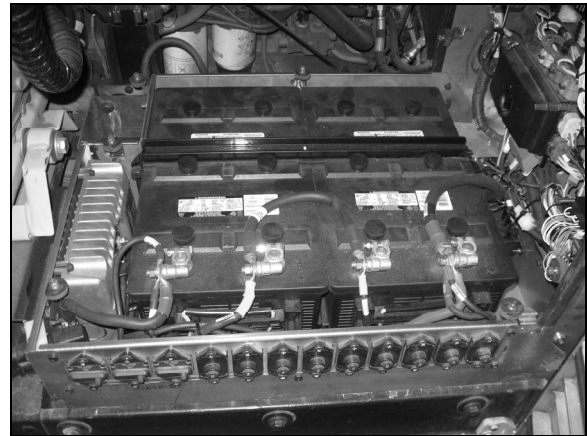

FIGURE 9: BATTERY COMPARTMENT

2.6 FRONT ELECTRICAL AND SERVICE COMPARTMENT

The front electrical and service compartment is located on L.H. side of vehicle, under the driver's window. It contains the following components (Fig. 10):

- Front terminal block;
- Master Chassis Module (MCM);
- Vehicle Electrical Center Front (VECF) and Multiplex Modules;
- Relays and fuses;
- ABS Electronic Control Unit (ECU);
- Common Powertrain Controller (CPC);
- VECU with Volvo D13 engine;

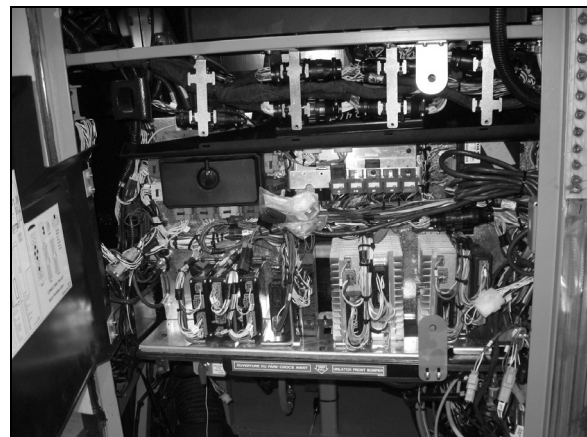

FIGURE 10: FRONT ELECTRICAL COMPARTMENT 06673

2.7 A/C JUNCTION BOX

The A/C junction box is located inside the evaporator compartment on the X3-45 coach.

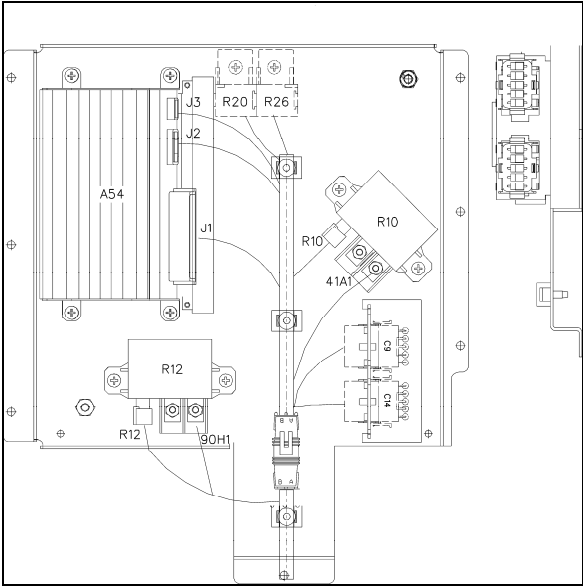

FIGURE 11: A/C JUNCTION BOX

2.8 ENGINE REAR START PANEL

This control panel is located in the R.H. side of engine compartment above the engine air filter. This control panel includes the engine starter selector switch, the rear start push button switch to start engine from engine compartment as well as the engine compartment lights switch.

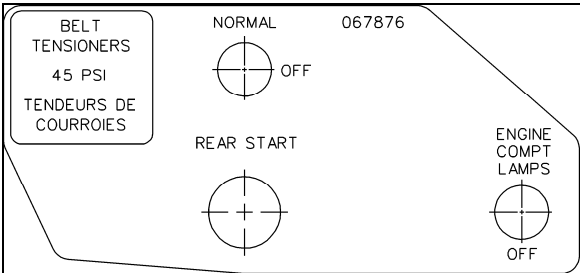

FIGURE 12: REAR START PANEL

NOTE
 When the ignition switch is set to the "OFF" position, the electrical supply from the batteries is cut off, with the exception of the Fire Detection System, the Engine & Transmission Electronic Controls, the Battery Equalizer and the Digital Clock.

2.9 ENTRANCE DOOR & WIPER CONTROL PANEL

To access the entrance door & wiper control panel of the right console, remove the panel under the larger utility compartment at the base of the windshield.

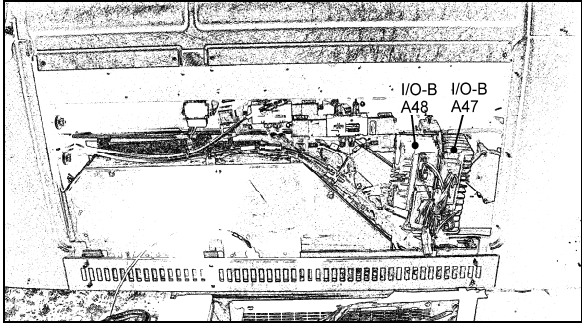

FIGURE 13: ENTRANCE DOOR & WIPER CONTROL PANEL

06619

3. BATTERIES

The vehicle is provided with two (2) maintenance-free Group 8-D 12 volt heavy-duty batteries connected in series-parallel (Fig. 4 & 9). The top-mounted negative and positive terminals are tightly sealed to prevent leaks. Water never needs to be added to this type of battery. There are no filler caps in the cover. The battery is sealed, except for small vent holes in the cover. The vents must not be restricted as they allow small amounts of gases produced in the battery to escape. The special chemical composition inside the battery reduces gassing to a very small amount at normal charging voltages. Besides reducing gassing, the special chemistry greatly reduces the possibility of overcharge damage.

The vents require keeping the battery in an upright position to prevent electrolyte leakage. Tipping the battery beyond a 45° angle in any direction can allow a small amount of electrolyte to leak out of the vent holes.

WARNING
 DO NOT tip battery by more than 45° when carrying or installing the battery.

NOTE
 Evidence of electrolyte leakage does not necessarily mean the battery is defective.

With special cables properly attached to batteries, the metal surfaces that carry the current are completely sealed from the atmosphere. This prevents terminal oxidation and corrosion that may cause starting and charging problems. If new cables are required, sealed terminal cable replacements should be used to retain the reliability of the original maintenance-free connections.

 **DANGER**

All lead-acid batteries generate hydrogen gas, which is highly flammable. If ignited by a spark or flame, the gas may explode violently, causing spraying of acid, fragmentation of the battery, which may result in severe personal injuries. Wear safety glasses and do not smoke when working near batteries. In case of contact with acid, flush immediately with water.

The battery has four (4) major functions:

1. Providing a source of current for starting the engine;
2. Stabilizing the voltage in the electrical system;
3. Supplying current for a limited time, when electrical demands of the equipment exceed the power output of the alternator;
4. Providing a limited source of power for connected accessories, when the engine is not running.

3.1 BATTERY DISCHARGE PROTECTION

To prevent discharge of the batteries when the engine is not running, certain functions are automatically switched off if the battery voltage drops below 24 volts for more than 30 seconds. The "BATTERY VOLTAGE WARNING" pictogram will show on the DID. Set the ignition key to the OFF position and then turn the ignition key to the ON position to reactivate these functions for a period of 30 seconds before they switch off again.

If a prolonged use of the functions with the engine not running is necessary, connect the battery to a charger.

3.2 MAIN BATTERY RELAYS

Main battery (master) relays (12V and 24V) are provided for this vehicle. The relays are located in the battery compartment and on the rear electrical panel. The 24-volt battery relay (R1) engages when ignition switch is in the ON or ACC position and battery master switch (master cut-out) is turned ON.

When the main battery relays (R1 & R3) are tripped to the OFF position, all electrical supply from the batteries is cut off, with the exception of the following items.

- Battery equalizer check module;
- MCM;
- TCM (World transmission);
- ECM (Engine Control Module),
- Water recirculating pump;
- Bi-fold entrance door;
- Cluster memory.

3.3 BATTERY REMOVAL AND INSTALLATION

The batteries are located in the battery compartment on the R.H. side of the engine compartment and are accessible from the engine compartment curb-side door.

1. Remove or put aside the battery compartment protective cover (Fig. 14 & 15).

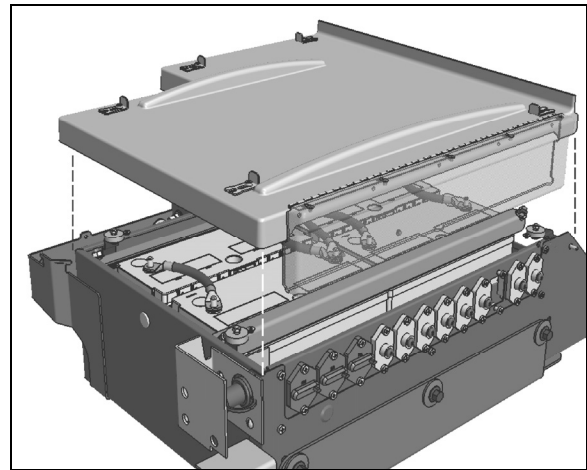

FIGURE 14: BATTERY PROTECTIVE COVER

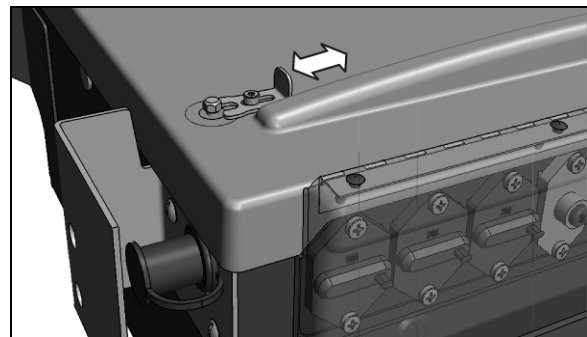



FIGURE 15: LATCH ON PROTECTIVE COVER



CAUTION

To protect battery terminals and circuit breaker bus bars against mist and corrosion, make sure that the battery protective cover is properly fitted and latched (five latches).



To prevent possible electric shocks or sparking, the battery master switches should be in the "Off" position before disconnecting cables from the batteries.

- Remove fixing clamps (1), and unscrew terminal nuts of each defective battery.

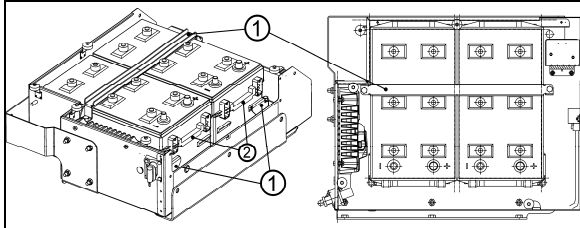

FIGURE 16: BATTERY FIXING CLAMPS AND LIFTING HANDLES

- Remove battery cables from the batteries.
- Using an hydraulic floor crane and battery lifting handle (2) at each battery end, remove batteries.

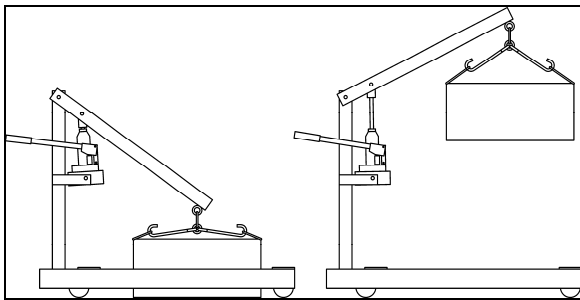

FIGURE 17: HYDRAULIC FLOOR CRANE

- Installation is the reverse of removal.

NOTE

When the battery cables have been removed from the batteries, wrap the battery terminals and cable ends with electric tape to prevent accidental grounding. The ground cables should always be disconnected first and replaced last.

NOTE

In replacing batteries, only batteries of the same specification should be used. Refer to "Specifications" at the end of this section for further details.

 **CAUTION**

Ensure that connections are not reversed when reinstalling batteries, since damage to electrical system components will result.

NOTE

When reinstalling batteries, battery connections must be tightened to 13-15 lbf-ft (18-20 Nm). A torque wrench is required to ensure an accurate tightening torque.

 **DANGER**

To prevent possible electric shock or sparking, the battery master switch must be set to the "Off" position before tightening an electrical connection.

NOTE

A protective coating should be applied on certain power connections that have been disconnected. Refer to Procedure PR00002E included at the end of this section to know the recommended products and where they are used.

3.4 BATTERY RATING

Each of the 12 volt batteries used on the vehicle has the following rating:

- Reserve capacity: 430 minutes
- Cold cranking amperes: CCA 1400 @ 0°F (-18°C)
- Ref. cranking amperes: 1700 @ 32°F (0°C)
- Weight (filled): 130 lb (59 kg)

The reserve capacity is defined as the number of minutes a new, fully charged battery at 80°F (26,6°C) can be discharged at 25 amperes and maintain a minimum of 1.75 volts per cell (10.5 volts total for one 12 volts battery). This rating can be used as a basis for determining how long a vehicle might run after an alternator failure. The cold cranking rating is defined as the minimum discharge current a battery will deliver in amperes for 30 seconds at 0°F (-18°C) while maintaining a minimum of 1.2 volts per cell (7.2 volts total for one 12 volts battery). This rating can be used as a basis for comparing starting performance.

Section 06: ELECTRICAL

3.5 BATTERY MAINTENANCE

Please consult “Deka Group 8D Commercial Battery Care And Maintenance” document included with the OEM publications for specific information concerning battery care and maintenance, load testing and charging tips for group 8D battery.

3.5.1 Visual Inspection

1. Check the outside of the battery for a broken or cracked cover or case that could permit loss of electrolyte. If obvious physical damage is noted, replace the battery.
2. Check for loose terminal posts, cable connections, damaged cables, and for evidence of corrosion. Correct conditions as required before proceeding with tests.

The external condition of the battery and the battery cables should be checked periodically. The top of the battery should be kept clean and the battery hold-down clamp bolts should be kept properly tightened. For best results when cleaning the battery, wash first with a diluted solution of ammonia or soda to neutralize any acid present then wash out with clean water. The battery fixing clamp bolts should be kept tight enough to prevent the batteries from moving, but they should not be tightened to the point that excessive strain is placed on the battery (proper tightening torque: 43 lbf-ft).

To insure good contact, the battery cable ring terminals should be tight on the side terminal battery adapter. If the terminals are corroded, the cables should be disconnected and the posts and clamps cleaned separately with a soda solution and a wire brush. Install cable ring terminals on side terminal battery adapter and tighten to a torque of 13 lbf-ft.

3.5.2 Removing Surface Charge

Disconnect cables from the battery and attach alligator clamps to the contact lead. Connect a 300 ampere load across the terminal for 15 seconds to remove surface charge from the battery.

3.5.3 Testing Battery Cables

Check all cable ring terminals and connections to determine if they are in good condition. Excessive resistance, generally caused by poor connections, produces an abnormal voltage drop which may lower voltage at the starter to such a low value that normal operation of the

starter will not be obtained. An abnormal voltage drop can be detected with a low-reading voltmeter as follows:



DANGER

To prevent the engine from starting during these tests, remove fuses F91 and F99 located in the VECR of the rear electrical compartment. Once the tests are completed, reinstall F91 and F99.

1. Check voltage drop between grounded (negative) battery terminal and vehicle frame by placing one prod of the voltmeter on the battery terminal and the other on a good ground (unpainted surface) on the vehicle. With the starter cranking the engine at a temperature of 70°F (21°C), voltage reading should be less than 0.3 volt. If the voltage reading exceeds 0.3 volt, there is excessive resistance in this circuit.
2. Check voltage drop between the positive battery terminal and the starter positive terminal stud while the motor is operated. If the reading is more than 2.5 volts, there is excessive resistance in this circuit.

NOTE

If it is necessary to extend the voltmeter lead for this test, use a #16 (AWG) or larger wire.

3. Check voltage drop between the starter housing and a good ground on the vehicle. The reading should be less than 0.2 volt.



DANGER

Any procedure other than the following could cause personal injury or damages to the charging system resulting from battery explosion or electrical burns.

Wear adequate eye protection when working on or near the batteries. Ensure that metal tools or jumper cables do not contact the positive battery terminal (or a metal surface in contact with it) as a short circuit will result. Do not attempt to jump start a vehicle suspected of having a frozen battery because the battery may rupture or explode. Both the booster and discharged batteries must be treated carefully when using jumper cables. Follow exactly the procedure outlined later in this section, being careful not to cause sparks.

3.6 BATTERY CHARGING

The batteries used on this vehicle can be charged either on or off the vehicle; however, when they are removed from the vehicle, it is recommended that an adapter kit, which is available from any "A/C DELCO" dealer, be used in charging sealed-terminal batteries. Use the booster block to charge the batteries when they are left on vehicle and **make sure that the main battery disconnect switch is set to the "On" position.**

Please consult "Deka Group 8D Commercial Battery Care And Maintenance" document included with the OEM publications for charging tips.

DANGER

During charging of the batteries, an explosive gas mixture forms in each cell. Part of this gas escapes through the vent holes and may form an explosive atmosphere around the battery itself if ventilation is poor. This explosive gas may remain in or around the battery for several hours after it has been charged. Sparks or flames can ignite this gas causing an internal explosion, which may shatter the battery.

1. Do not smoke near a battery which is being charged or which has been recently charged.
2. Do not break live circuits at battery terminals because a spark usually occurs at the point where a live circuit is broken. Care must always be taken when connecting or disconnecting booster leads or cable clamps on chargers. Poor connections are a common cause of electric arcs, which cause explosions.
3. The electrical system on this vehicle is negative ground. Installing the batteries with the positive terminals grounded or incorrect use of the booster battery and jumper cables will result in serious damage to the alternator, batteries and battery cables.

The alligator clamps of the tester or charger should make firm contact with the side terminal battery adapter. **Never clamp charger or tester directly onto threaded studs or nuts.**

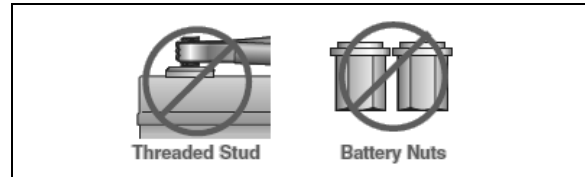

FIGURE 18: ALLIGATOR CLAMPS



WARNING

Always turn off the charger before connecting or disconnecting to a battery.

NOTE

The charge rate must be doubled when the batteries are charged by the booster block, because of the series-parallel circuit.

3.6.1 Emergency Jump Starting With Auxiliary (Booster) Battery.

DANGER

Off-board battery charger with a start boost facility must not be used to jump start the vehicle. This could damage the electrical system. Do not jump start vehicles equipped with maintenance-free batteries if the test indicator is light yellow.

Booster Block

On X3-45 coaches, booster block is located near the batteries in the engine compartment on the R.H. side and is accessible through engine R.H. side door (Fig. 19).

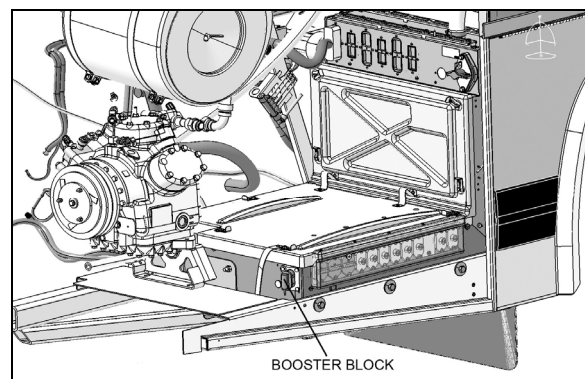



FIGURE 19: BOOSTER BLOCK

Both booster and discharged batteries should be treated carefully when using jumper cables. A vehicle with a discharged battery may be started

Section 06: ELECTRICAL

by using energy from a booster battery or the battery from another vehicle.

 **DANGER**

Jump starting may be dangerous and should be attempted only if the following conditions are met:

The booster battery or the battery in the other vehicle must be of the same voltage as the battery in the vehicle being started, and must be negative grounded. **If the good battery is in another vehicle, that vehicle's engine must be shut OFF before connecting and must remain OFF during jump starting.**

If the booster battery is a sealed-type battery without filler openings or caps, its test indicator must be dark or a green dot must be visible. Do not attempt jump starting if the test indicator of the booster battery or the discharged battery has a light or bright center.

 **DANGER**

Follow the procedure exactly as outlined hereafter. Avoid making sparks.

Wear eye protection and remove rings, watches with metal bands and other metal jewelry.

Apply parking brake and place the transmission shift lever or push-button pads in Neutral (N) position in both vehicles. Turn off lights, heater and other electrical loads.

1. Remove the protective plug from the booster block bulkhead connector located in the R.H. side engine compartment;
2. Connect Whittaker type connector to the bulkhead connector. **If the good battery is in another vehicle, that vehicle's engine must be shut OFF before connecting and must remain OFF during jump starting;**
3. Disconnect the jumper cables in reverse order;
4. Install protective plug on the booster block terminal.

 **DANGER**

Any procedure other than the above could result in personal injury, property damage due to battery explosion, or damage to the charging system of the booster vehicle or of the boosted vehicle.

NOTE

Jumper cables must withstand 500 cranking amperes. If cable length is 20 feet (6m) or less, use 2/0 (AWG) gauge wires. If cable length is between 20-30 feet (6-9m), use 3/0 (AWG) wires.

3.7 COMMON CAUSES OF BATTERY FAILURE

When a battery fails, the cause of failure may be related to something other than the battery. For this reason, when a battery failure occurs, do not be satisfied with merely recharging or replacing the battery. Locate and correct the cause of the failure to prevent recurrence. Some common external causes of battery failure are as follows:

1. A defect in charging system such as high resistance or a faulty alternator or regulator. The dashboard ALTERNATOR telltale light illuminates if one of the alternators is defective.



ALTERNATOR telltale

2. A malfunction within the 12 volts system (equalizer).
3. Overloads caused by a defective starter or excessive use of accessories.
4. Dirt and electrolyte on top of the batteries causing a constant drain.
5. Hardened battery plates, due to battery being in a low state of charge over a long period of time.
6. Shorted cells, loss of active material from plates.
7. Driving conditions or requirements under which the vehicle is driven for short periods **of time.**

8. A constant drain caused by a shorted circuit such as an exposed wire or water infiltration in junction boxes causing ground fault.
9. Failing to close disconnect switches during the night.

3.8 TROUBLESHOOTING

If a battery is known to be good and then has not performed satisfactorily in service for no apparent reason, the following factors may reveal the cause of trouble:

1. Vehicle accessories and disconnect switches inadvertently left on overnight.
2. Defects in the charging system, such as high wiring resistance, faulty alternator, regulator or battery equalizer.
3. A vehicle electrical load exceeding the alternator (or battery equalizer) capacity, with the addition of electrical devices, such as CB radio equipment, a cellular phone or additional lighting systems.
4. Defects in the electrical system, such as shorted or pinched wires.
5. Extended driving at a slow speed while using many accessories.
6. Loose or poor battery cable-to-post connections, previous improper charging of a run-down battery, or loose hold-down clamp bolts.
7. High-resistance connections or defects in the cranking system.

3.9 "BATTERY VOLTAGE WARNING" PICTOGRAM



If the "BATTERY VOLTAGE WARNING" (battery voltage incorrect) pictogram shows up in the DID (Driver Information Display), check the voltmeter gauge to determine if the battery voltage is too high or too low.

3.9.1 Voltmeter Gauge Definitions

Voltmeter drops below 24.4 volts dc

- Check alternator output.
- Check voltage regulator.
- Check battery connections.
- Check battery cells.
- Check battery equalizer connections.

Voltmeter exceeds 30 volts dc

- Check alternator output.
- Check voltage regulator.
- Check battery connections.

Battery Balance

NOTE

Allow at least 15 minutes to balance batteries after any corrective measure has been taken.

1. Batteries out of balance (difference greater than 1.5 volts between the two battery banks).
 - Check battery equalizer connections.
 - Check equalizer cables for proper gauge.
 - Check battery connections.
2. Demand for 12-volt power exceeding rated amperage output of battery equalizers causing batteries to go out of balance.
 - Reduce 12-volt load or install additional battery equalizer(s).

4. TROUBLESHOOTING AND TESTING THE MULTIPLEX VEHICLES

4.1 ELECTRICAL SYSTEM DIAGNOSTIC

Using the Driver Information Display (DID), check if there are active errors in the vehicle electrical system. With the **Diagnostics** menu, highlight **Fault Diagnostics** and then highlight **Electrical System** to request a diagnostic of the electrical system from the MCM. Press the enter key. If applicable, the DID shows the multiplex device ID, the fault messages or fault codes recorded. When more than one fault is recorded, an arrow pointing down appears on the right of the display. Use the down arrow to see all the fault messages.

Once the problem corrected, the DID still shows the fault as being active. You have to leave the **Fault Diagnostics** menu, wait approximately 20 to 30 seconds and then return to **Fault Diagnostics** to request a new diagnostic of the **Electrical System** from the MCM. The DID should display the fault as being inactive. The MCM can store up to 20 faults, i.e. the first 10 and the last 10. Middle faults will be erased. If the breakers are tripped, the fault history will be erased from the MCM memory.

Section 06: ELECTRICAL

NOTE

It is of the utmost importance to have a DID (Driver Information Display) in working condition because it is the most important tool to achieve troubleshooting on a multiplex vehicle.

4.2 PROBING VOLTAGE ON THE MULTIPLEX CIRCUITS

Some Multiplex modules are supplied by 12 volts while others are supplied by 24 volts. The 12-volt or 24-volt information is found on the modules symbol in the wiring diagram. Before taking voltage readings to track the source of a problem, first verify if the module is supplied by 12V or 24V, if not, residual voltage on the module inputs/outputs can draw an erroneous conclusion.

Inactive Multiplex output = Residual voltage of 18% to 33% of supply voltage.

Inactive Multiplex input = Residual voltage of 50% of supply voltage.

NOTE

- *Verify on the wiring diagram whether the voltage is 12V or 24V,*
- *For a 12V module: an active voltage would be 12V or 0V but not in between. If you measure the intermediate tensions (ex. 6V, 2V, or 4V) this must be interpreted as if the input or the output is inactive.*
- *For a 24V module: an active voltage would be 24V or 0V but not in between. If you measure the intermediate tensions (ex. 12V, 4V, or 8V) this must be interpreted as if the input or the output is inactive.*

4.3 CAN NETWORK

The CAN network wiring is separated in sections and uses connectors, with the exception of C27, that are not shared with other circuits. This allows sections of the network to be isolated to help locate short-circuit on the CAN.

In case of a short-circuit on the CAN network, this affects all the modules and they all act as "No response" in the error messages of the "**Electrical System**" menu. To locate a short-circuit, proceed by disconnecting one module zone at a time while verifying if this makes inactive the errors in the modules still

connected. Connector C1 (front electrical & service compartment) disconnects all the modules at the rear of the vehicle from the network. Connector C5 (front electrical & service compartment) disconnects all the modules from the entrance door & wiper control panel. Connector C3 (rear electrical panel) disconnects all the modules at the rear of the vehicle from the network.

Example: Disconnect C5 and C1 and then verify the status of the errors. If the front modules (A41 to A46) now give inactive errors, which means short-circuit is elsewhere than in the front electrical & service compartment.

4.3.1 Spare CAN

A spare CAN network is installed between the front and the rear of the vehicle. It has connectors installed at each end to facilitate swapping from the regular CAN network to the spare CAN network. Refer to the vehicle wiring diagram and section 4.6 for more information.

4.4 MULTIPLEX INPUT TEST MODE

The multiplex input test provides useful information to diagnose multiplexed inputs of switches and sensors, complimentary to the electrical system diagnosis.

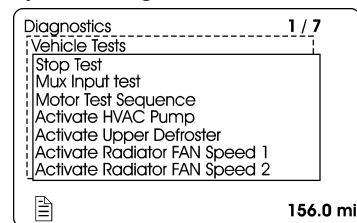

To initiate the test mode, use the Driver Information Display (DID) DIAGNOSTICS menu. Select VEHICLE TESTS submenu and then MUX INPUT TEST. Press ENTER button to start the test. The DID status line will show TEST to confirm the test mode is active. To exit test, press ESCAPE button, select STOP TEST submenu and then press ENTER button twice. TEST will disappear from the DID status line.

Instrument panel audible alarm emits a *beep* each time an OFF/ON transition is detected on a multiplex input. This allows quick verifying if the switches and sensors are detected or seen by the multiplex modules. When the vehicle is parked, the back-up alarm also emits a *beep* that allows verification of the sensors at the rear of the vehicle.

Certain inputs are doubled (door operating buttons) and also other inputs activate at the same time (ex. kneeling switch and Kneeling proximity sensor switch). For these inputs, 2 beeps are emitted. If only one beep is heard, one of the inputs is defective.

SWITCHES AND SENSORS SUPPORTED BY THE SWITCH/SENSOR TEST MODE
HVAC control unit driver's section ON/OFF
HVAC control unit driver recirculate switch
HVAC overhead compartment fan switch
Engine rear start selector switch "rear start"
Engine rear start selector switch "normal"
Engine ignition front switch
Engine ignition rear switch
Entrance door inside opening /closing switch
Entrance door outside opening /closing switch
Kneeling down switch
Electric horn button
LH turn signal
RH turn signal
Headlights beam toggle switch
Windshield wipers intermittent position switch
Windshield washer switch
Kneeling up switch
Interior lighting switch, 2 positions
Driver's area lighting switch
Reading lights switch
Hazard warning flashers switch
Headlights switch, 2 positions
Tag axle lever
Wheelchair lift activation switch
Windshield lower wiper

The following inputs, either certain options or sensors which are difficult to activate, are not supported by the switch/sensor test:

- Service chime enable switch,
- Horn selector switch,
- Outside rear view mirror heat,
- Mirror control switches,
- Low-buoy switch,
- Starter sensor,
- ABS warning input,
- WCL switch,
- Driver's power window switch,
- Fog lights switch,
- Alternator sensors 1 & 2,

- Retarder active signal,
- Radiator fan speed 1 & 2 signals.

In test mode, with the parking brake applied and the passenger set point set to a value higher than 64°F (18°C), the circulator pump is not set to OFF as it would normally do when the outside temperature gets above 50°F (10°C). This feature allows verification of the pump when inside a garage. This is also useful when working on the heating system to remove air pockets trapped in the system. Motor Test Sequence

This test mode allows testing of the electrical motors and electric contactors without the need to have the engine running. Note that while in test mode, the engine cannot be started.

Prerequisite conditions for the motor test mode:

- The battery charger must be connected to a 110-120 volt power supply. If not, the test will be interrupted when the voltage drops below 24 volts,
- Engine not running,
- Parking brake applied,

DANGER

Before starting the test sequence, make sure nobody is working in the evaporator or condenser compartment.

NOTE

The back-up alarm will beep ten (10) times prior the test starts to warn people that may be working on the vehicle.

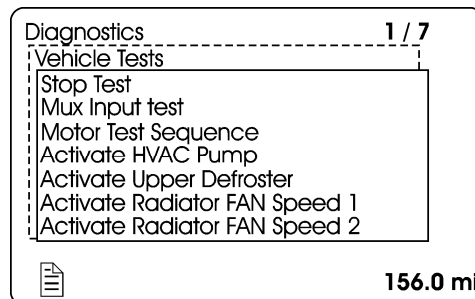

To enter this mode:

- Using the dashboard DID, select DIAGNOSTICS menu and press ENTER button ;
- Select VEHICLE TEST, press ENTER button then select MOTOR TEST

Section 06: ELECTRICAL

SEQUENCE and press ENTER button to initiate the test mode for electrical motors;

3. Ten (10) beeps can be heard indicating the motor test mode has started.

Using the test mode:

During the entire test, the instrument panel audible alarm gives a signal each second to remind that the motor test mode is underway.

4.4.1 Test Sequence

Go to the condenser compartment:

- The condenser fans start at speed 1, then after a short pause, speed 2 activates.
- The passenger's unit refrigerant solenoid valve activates.

Then 5 beeps can be heard from the back-up alarm to indicate to go to the engine compartment.

In the engine compartment, the sequence is as follows:

- Toilet fan motor starts.
- A/C compressor clutch activates 3 times.
- Left compressor unloader activates 3 times.
- Right compressor unloader activates 3 times.
- Fan clutch is disengaged (fan can be turned freely by hand).
- Fan clutch engages in speed 1 (fan can be turned by hand but with a certain resistance).
- Fan clutch engages in speed 2 (cannot be turned but hand).

5 beeps from the back-up alarm indicate to go to the evaporator compartment.

In the evaporator compartment:

- Evaporator fan motor runs at speed 1 for 3 seconds then runs at speed 2 for 2 seconds.
- Hot water pump starts running for 5 seconds and hot water pneumatic valve cycles 3 times.

5 beeps from the back-up alarm indicate to get to the driver's area inside the vehicle.

Inside the vehicle:

- The driver's HVAC unit refrigerant solenoid valve cycles 3 times and the hot water pneumatic valve cycles 3 times also.

To exit the electric motors test sequence, press ESCAPE button, select STOP TEST submenu and then press ENTER button twice.

4.5 FORCED ACTIVATION OF THE RADIATOR FAN CLUTCH

To prevent the engine from overheating in case of malfunction of the clutch activation system, it is possible to force activation of the clutch.

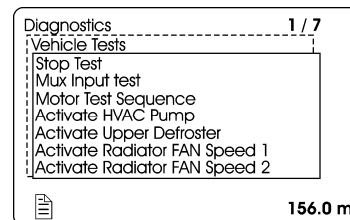

1. On the Driver Information Display, select DIAGNOSTICS menu. Select VEHICLE TESTS submenu and then ACTIVATE RADIATOR FAN SPEED 1 or ACTIVATE RADIATOR FAN SPEED 2 as required.
2. The DID status line will show TEST to confirm the forced activation of the radiator fan clutch. To cancel, turn the ignition switch to the OFF position or press ESCAPE button, select STOP TEST submenu and then press ENTER button twice. TEST will disappear from the DID status line.

If the fan clutch does not engage using this procedure then the clutch is faulty or the wiring between the multiplex module and the clutch is faulty. Mechanically lock the fan clutch as described in section 05: COOLING SYSTEM of the maintenance manual.

4.6 CAN NETWORK LAYOUT AND TROUBLESHOOTING

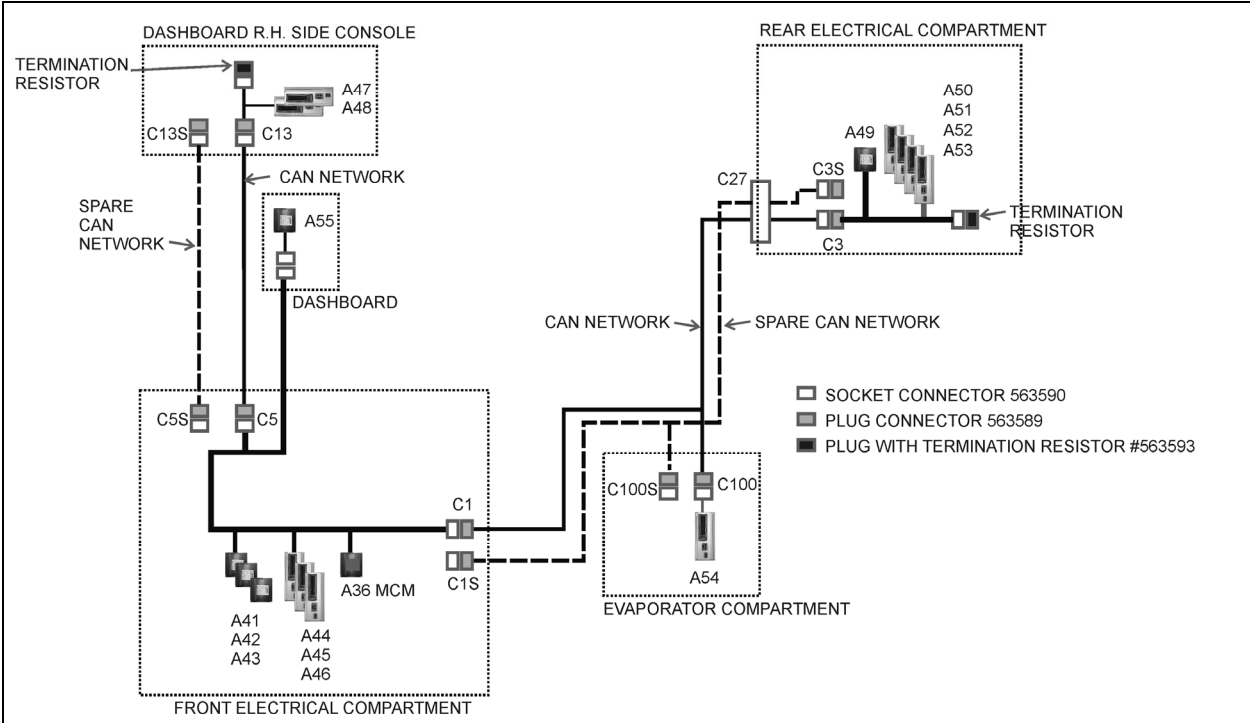

FIGURE 20: X3-45 COACHES CAN NETWORK LAYOUT

06637

4.7 TROUBLESHOOTING

Problem/Symptom	Probable Causes	Actions
Vehicle does not Start	Rear Start selector switch is not in the NORMAL position Master cut-out switch on the rear electrical panel is in the OFF position (down)	1. Check that the rear start selector switch is flipped up to NORMAL start position and master cut-out switch is flipped up to ON and retry cranking 2. Flip the rear start selector switch to "Rear Start" and start the vehicle from the rear
	CAN network problem (Multiplex) Module A53 not powered or is defective Engine ECM does not receive the ignition signal	If the vehicle does not start from the rear: 1. Verify that module A53 is powered: a) Check the Diagnostics menu of Driver Information Display (DID). Select Fault Diagnostics and Electrical System . The message "No Response ModA53, Active", indicates a power problem on the module or a CAN network problem. b) Check / reset circuit breaker CB5 c) Check / replace fuse F65 d) Probe gray connector on module to see if it is powered.

Section 06: ELECTRICAL

Problem/Symptom	Probable Causes	Actions
	Engine ECM is not powered	2. Verify that the engine ECM is powered and get the ignition signal a) Check / reset circuit breaker CB8 Check / replace fuse F74 b) Check / reset circuit breaker CB2 Check / replace fuse F78
None of the Multiplexed functions are operating, including the basic limp-home functions (door opening, flashers, wipers in speed 1) <i>Note: The sunshades are still functioning since these are not multiplexed</i>	The program version in the MCM is different than the program in the I/O modules and the MCM is forcing all I/O modules to stay inactive	1. Engage the auto-programming of the I/O modules: Turn the ignition switch to the OFF position, flip the master cut-out switch on the rear electrical panel to OFF and ON and then turn the ignition switch back ON. The letters CAN will appear in the telltale LCD panel for about 3 minutes Everything shall get back to normal once the letters CAN are replaced with outside temperature display 2. Try disconnecting the green connector on the MCM and reconnect 3. Try disconnecting the MCM completely, leave it disconnected and see if the limp-home functions (start of the vehicle from the engine compartment, wipers speed 1, flashers, etc) are functioning
Many secondary functions (not essential for driving) not functioning (interior lighting, driver's area lighting, wiper speed 2 and intermittent). Marker lights and clearance lights are turned ON when setting ignition to the ON position.	The MCM module does not receive 24 V power. The CAN network is not working. It could be caused by a short on the network, an open circuit, a problem with the MCM or the MCM being disconnected from the network.	1. Check / reset circuit breaker CB6 (3 rd from the left on the junction panel) Check / replace fuse F1 2. Operate in limp-home mode by starting the vehicle from the engine compartment (REAR START). All functions essential to drive are available To close and lock the door, pull the door manually up to its closed position and it will lock by itself. The door opening button is still functioning
Entrance door does not open nor close using the control buttons Defroster fan not functioning Windshield wipers not functioning in speed 1 or intermittent	Module A47 is not powered or is faulty	1. Check the Diagnostics menu of Driver Information Display (DID). Select Fault Diagnostics and Electrical System . The message "No Response ModA47, Active" indicates a power problem on the module. (A CAN network problem would show the same message but doesn't produce these symptoms).

Problem/Symptom	Probable Causes	Actions
		<ol style="list-style-type: none"> 2. Check / reset circuit breaker CB6 3. Check / replace fuse F5 4. Check / replace relay R18 5. Probe gray connector on module to see if it is powered. 6. Use the air release valves near the entrance door and in the front service compartment to lock / unlock the door
Windshield wipers not functioning in speed 1 or intermittent	No power on R23	Check / replace fuse F82
HVAC condenser fans not functioning in speed 1	Circuit breaker CB7 was manually tripped and not reset	Check / reset circuit breaker CB7
HVAC condenser fans not functioning in speed 2	Circuit breaker CB7 was manually tripped and not reset	Check / reset circuit breaker CB7
<p>Windshield washer not functioning</p> <p>Windshield upper section de-icing system not functioning</p> <p>Defroster fan is functioning but no heat or cooling available in the driver area.</p>	Module A46 is not powered or is faulty	<ol style="list-style-type: none"> 1. Check the Diagnostics menu of Driver Information Display (DID). Select Fault Diagnostics and Electrical System. The message “No Response ModA46, Active” indicates a power problem on the module. (A CAN network problem would show the same message but doesn't produce these symptoms). 2. Check / reset circuit breaker CB1 3. Check / replace fuse F12 or F13 4. Probe gray connector on module to see if it is powered.
<p>Low beam headlights and front flasher on left side not functioning</p> <p>Electric horn not functioning</p>	Module A45 is not powered or is faulty	<ol style="list-style-type: none"> 1. Check the Diagnostics menu of Driver Information Display (DID). Select Fault Diagnostics and Electrical System. The message “No Response ModA45, Active” indicates a power problem on the module. (A CAN network problem would show the same message but doesn't produce these symptoms). 2. Check / reset circuit breaker CB2 3. Check / replace fuse F33 and F34 4. Check / replace relay R19 5. Probe gray connector on module to see if it is powered.

Section 06: ELECTRICAL

Problem/Symptom	Probable Causes	Actions
Low beam headlights and flasher on right side not functioning	Module A48 is not powered or is faulty	<ol style="list-style-type: none"> 1. Check the Diagnostics menu of Driver Information Display (DID). Select Fault Diagnostics and Electrical System. The message “No Response ModA48, Active” indicates a power problem on the module. (A CAN network problem would show the same message but doesn't produce these symptoms). 2. Check / reset circuit breaker CB2 3. Check / replace fuse F33 and F34 4. Check / replace relay R19 5. Probe gray connector on module to see if it is powered.
Rear flashers not functioning Stoplights and center stoplights not functioning	Module A51 is not powered or is faulty	<ol style="list-style-type: none"> 1. Check the Diagnostics menu of Driver Information Display (DID). Select Fault Diagnostics and Electrical System. The message “No Response ModA51, Active” indicates a power problem on the module. (A CAN network problem would show the same message but doesn't produce this symptom). 2. Check / reset circuit breaker CB2 3. Check / replace fuse F80 4. Probe gray connector on module to see if it is powered.
Engine is overheating and radiator fan clutch does not engage The A/C compressor clutch does not engage	Module A52 is not powered or is faulty	<ol style="list-style-type: none"> 1. Check the Diagnostics menu of Driver Information Display (DID). Select Fault Diagnostics and Electrical System. The message “No Response ModA52, Active” indicates a power problem on the module. (A CAN network problem would show the same message but doesn't produce this symptom). 2. Check / reset circuit breaker CB5 3. Check / replace fuse F65 4. Probe gray connector on module to see if it is powered.
Evaporator fan not functioning	Circuit breaker CB3 tripped Module A54 is not powered or is faulty	<ol style="list-style-type: none"> 1. Check / reset circuit breaker CB3 2. Check the Diagnostics menu of Driver Information Display (DID). Select Fault Diagnostics and Electrical System. The message “No

Problem/Symptom	Probable Causes	Actions
		<p>Response ModA54, Active” indicates a power problem on the module. (A CAN network problem would show the same message but doesn't produce this symptom).</p> <ol style="list-style-type: none"> 3. Check / reset circuit breaker CB5 4. Check / replace fuse F67 , F68 5. Probe gray connector on module to see if it is powered.
HVAC condenser fans not functioning in speed 1	Module A54 is not powered or is faulty	<ol style="list-style-type: none"> 1. Check the Diagnostics menu of Driver Information Display (DID). Select Fault Diagnostics and Electrical System. The message “No Response ModA54, Active” indicates a power problem on the module. (A CAN network problem would show the same message but doesn't produce this symptom). 2. Check / reset circuit breaker CB5 3. Check / replace fuse F67 , F68 4. Probe gray connector on module to see if it is powered.
Fire alarm telltale light and audible alarm always ON and there is no fire or high temperature in the engine compartment	Short-circuited fire sensor or defective sensor	Prior to start the vehicle, cycle the ignition key to the ON position, OFF position and then ON position again and then start the vehicle. This will deactivate the fire alarm function. This has to be repeated each time the vehicle is re-started
The vehicle is parked and the electrical horn is activated to indicate a fire in the engine compartment but there is no fire	Short-circuited fire sensor or defective sensor	Cycle the ignition switch between the ON and OFF position twice within 3 seconds. This will deactivate the fire alarm function. This has to be repeated each time the vehicle is parked
A single light, a group of LED lights or another function of the vehicle is not functioning	The multiplex outputs are protected in current by an internal “soft-fuse”. When an output is shorted, it turns OFF and stays OFF until the "soft-fuse" is reset	Turn the ignition switch to the OFF position and turn to the ON position again. This resets all "soft –fuses"
No backlighting in the instrument cluster	Circuit breaker CB10 is tripped or fuse F20 blown	<p>Check / reset circuit breaker CB10</p> <p>Check / replace fuse F20</p>

Section 06: ELECTRICAL

Problem/Symptom	Probable Causes	Actions
The radiator fan clutch does not function and the engine is overheating		<p>3. Set the ignition switch to the ON position.</p> <p>4. Activate the dashboard Telltale Light Test switch 3 times within 4 seconds.</p> <p>5. In the engine compartment, set the starter selector switch to REAR START and then start the engine from the rear.</p> <p>While in this mode, the rear start push-button can be used to manually engage the fan clutch. The Multiplex system knows when the engine is already running, and it will not activate the starter.</p> <p>6. Press the push-button one time to engage the clutch in 1st speed, press a second time to engage in 2nd speed, press a third time to stop the fan, press once again to return to 1st speed.</p> <p>If the fan clutch does not engage using this procedure then the clutch is faulty or the wiring between the multiplex module and the clutch is faulty. Mechanically lock the fan clutch as described in section 05: COOLING SYSTEM of the maintenance manual.</p>

4.8 MULTIPLEX ERROR MESSAGES TROUBLESHOOTING LIST

Multiplex error messages that can be displayed on Driver Information Display (DID) are alphabetically listed in Section 06B at the end of Section 06 along with FMI Description, Fault Condition, Possible Symptoms and Possible Causes.

4.9 MULTIPLEX MODULE “NO RESPONSE” TROUBLESHOOTING LIST

Multiplex module “No Response” messages that can be displayed on Driver Information Display (DID) are listed in Section 06C at the end of Section 06 along with FMI Description, Fault Condition, Possible Symptoms and Possible Causes.

4.10 ESSENTIAL FUNCTIONS TO OPERATE THE VEHICLE

Even with a defective MCM (Master Chassis Module) or a CAN network problem, essential base functions are maintained to rear start the vehicle from the engine compartment and drive in a secure manner.

However, many secondary functions are lost. In this case, the following directives must be followed.

- Never connect a battery charger when the ignition is at the ON position on a vehicle with a CAN defective or certain functions will start up by themselves,
- Disconnect the charger before starting the vehicle, if not the default functions will not activate,
- If the default mode does not activate, try to turn the ignition OFF while ensuring that no charger is connected and then restart the vehicle.

4.10.1 Available Functions

- Startup: Turn on the ignition in the driver's area and rear start the vehicle from the engine compartment,
- Opening the door: Functions normally,
- Closing the door: Manually pull on the door panels and it will lock automatically,
- Windshield wipers: Wipers functions at 1st speed only,
- Headlights: Low beams only,
- Directional signals: Rear and front only,
- Stoplights: 2 upper stoplights + high-mounted stoplight are functional,
- HVAC: Functional with set point fixed at 68°F (20°C), evaporator and condenser fixed at speed 1, defroster fixed at speed 4.

4.11 LOWER PRIORITY MODULES FOR BREAKDOWN SERVICE

Modules A43 (IO-A) and A44 (IO-B) affect lower priority functions. These modules can therefore be used as spare parts for breakdown service while on the road.

Functions lost if A43 is removed and used as spare part:

- High beams,
- Ability to turn on the parking lights only,
- "Watch your step" sign,
- Driver's area lighting,
- Tag axle activation,
- Courtesy lights.

Functions lost if A44 is removed and used as spare part:

- Fresh air damper mix trap control,
- Driver's area and entrance overhead light,
- Front clearance lights.

4.12 MULTIPLEX MODULES

4.12.1 MCM

The MCM plays the role of interface between the engine ECM, the transmission TCM, the telltale panel module and other IO-A, IO-B modules. When a multiplex module is being replaced, the MCM will inform the new module of its role and

function accordingly to the vehicle options. It keeps the specific back-up program of the vehicle.

4.12.2 IO-A

IO-A modules receive inputs and control outputs. IO-A's are used for all outputs of 1 amp or less.

4.12.3 IO-B

IO-B modules receive inputs and control outputs. IO-B's are used for outputs up to 30 amps.

4.13 MULTIPLEX MODULES REPLACEMENT

IO-A, IO-B multiplex modules can be replaced and reprogrammed without having to connect a computer to the vehicle. The MCM module must however be reprogrammed using a laptop computer equipped with VPG software.

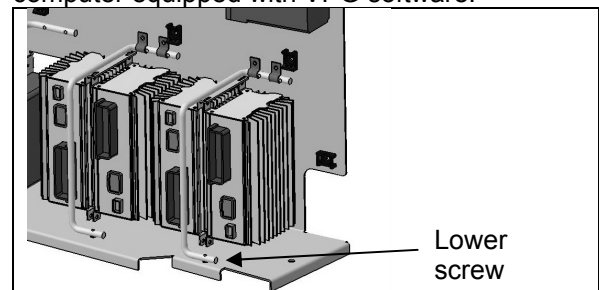

FIGURE 21: IO-B MODULE REMOVAL

06638

4.13.1 Replacing IO-A Or IO-B Modules

- Set the ignition switch to the ON position and leave it in that position at all time while performing this procedure.
- On rear electrical junction panel, trip circuit breaker CB6.
- Replace the module (for IO-B modules, disconnect the green connector first, then the grey one and finish with the black connector. To disconnect the black connector, slide downwards the red latch. Remove the lower screw that holds the cable attachment rod onto the floor portion of the panel and flip the rod up, this will relieve the IO-B module, (see Fig. 21).
- Reset circuit breaker CB6. This engages the i/o autoprogramming.
- The DID indicates "MUX AUTOPROGRAMMING I/O MODULE PLEASE WAIT" until the reprogramming is complete unless a higher priority message

Section 06: ELECTRICAL

must be displayed. If this is the case, press ESCape button repeatedly to acknowledge the higher priority messages.

- Check the **Diagnostics** menu of the Driver Information Display (DID). Select **Fault Diagnostics** and **Electrical System**. Verify the fault message to be certain the module is reprogrammed. If the module is not reprogrammed, the message “Axx Not Responding” appears where Axx is the module number (Ex: A41, A42...etc).

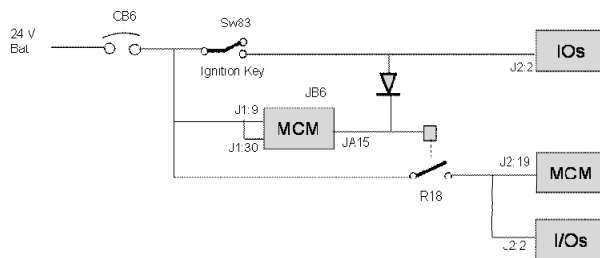

JB6 is a wake-up pin

JA15 output remains active for 15 minutes after JB6 is inactive

To initiate reprogramming:

- Switch SW83 (ignition key) closed, providing 24-volt on JB6, I/O modules and R18. All modules get power.
- CB6 is tripped and reset which is forcing MCM reboot.
- When resetting CB6, all modules gets power, MCM goes into Start Mode. I/O modules needing new program will request reprogramming to MCM while in Start Mode.

4.13.2 Replacing The MCM Module

- Set the ignition key to the ON position and leave it in that position at all time while performing this procedure.
- On rear electrical junction panel, trip circuit breaker CB6.
- Replace the module.
- Reset circuit breaker CB6.
- The vehicle specific program needs to be uploaded in the MCM. A laptop computer equipped with VPG (Vehicle Program Generator) software must be connected to the DB9 (9-pin) connector (identified C226) found in the electrical harness near the MCM. **Please contact your Prevost Service Representative.**

5. BOSCH ALTERNATORS

Two 28 volt 120A, self regulated, belt driven, air-cooled HD 10 BOSCH alternators are used in the 24 volt electrical system.

If the alternators needed to be removed, reinstall as follows. Refer to figure 22 for installation and to figure 23 for tightening specifications:

1. If necessary, tighten screws (6) fixing alternators support assembly onto engine (1, figure 23). Torque tighten to 43 Lb-Ft, use some Loctite 243 blue (680038) onto the threads. Also tighten screw (1) fixing belt tensioner onto alternators support assembly (1, figure 23). Torque tighten to 43 Lb-Ft, use some Loctite 243 blue (680038) onto the threads.
2. If removed, reinstall screw (1) fixing alternators support assembly onto engine (2, figure 23). Torque tighten to 22 Lb-Ft, use some Loctite 243 blue (680038) onto the threads.

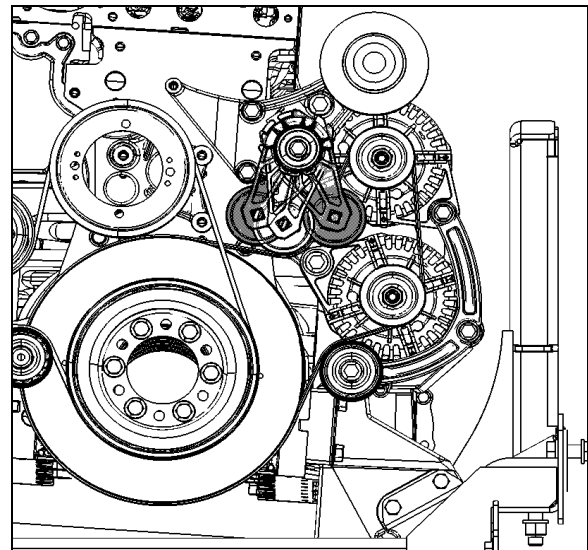

FIGURE 22: ALTERNATORS DRIVE BELT

3. Mount the A/C compressor idler pulley onto alternators support assembly (3, figure 23). Torque tighten to 150 Lb-Ft, use some Loctite 243 blue (680038) onto the threads.
4. Install alternators arched support loosely onto engine. If removed, install alternators idler pulley (4, figure 23) onto alternators arched support, torque tighten to 43 Lb-Ft.

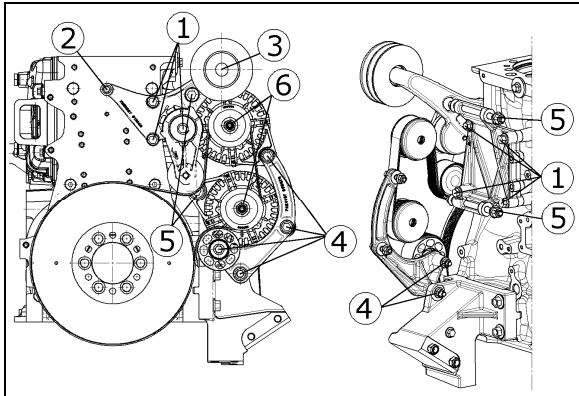

FIGURE 23: TWIN BOSCH ALTERNATORS INSTALLATION

5. Fix lower and upper alternators loosely to alternators support assembly using bolts (5, figure 23). Also, mount the lower and upper alternators onto alternators arched support. If removed install stone guard below lower alternator.
6. In order to assure installation, it is important to tighten the alternator mounting bolts in the following order (figure 24).
 - 1st Nut A, 43 lb-ft.
 - 2nd Nut B, 43 lb-ft (2x).
 - 3rd Nut C, 80 lb-ft (2x)

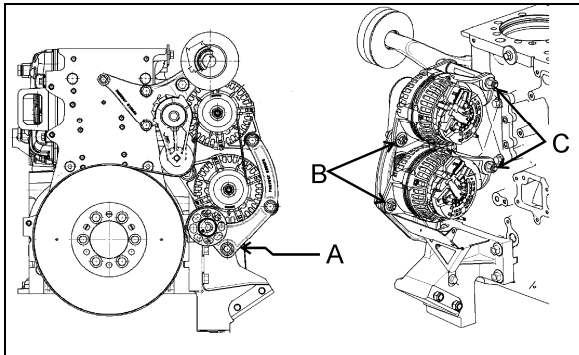

FIGURE 24: ALTERNATOR MOUNTING - TIGHTENING SEQUENCE

7. Mount pulleys (6, figure 23) onto alternators. Torque tighten to 58 Lb-Ft.
8. Install alternators belt (figure 22).

NOTE

Final tightening of the pulleys can be performed once the belt is installed. This will help keep the pulley from turning when tightening.

5.1 ALTERNATOR BRUSH REPLACEMENT

1. Disconnect the electrical harnesses and remove the alternator.
2. Remove the cover located on the rear side of the alternator.
3. Dismount the brush holder and voltage regulator assembly. To do so, remove the 3 screws indicated with arrows.

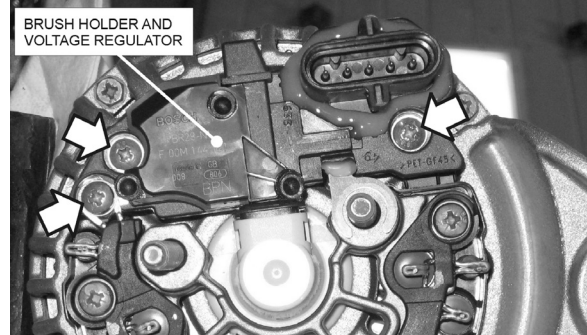

FIGURE 25: BOSCH HD10 BRUSH HOLDER MOUNTING SCREWS

4. Install the new brush holder and tighten the screws.
5. Reinstall the cover. Tighten screw and nuts.
6. Reinstall the alternator loosely.

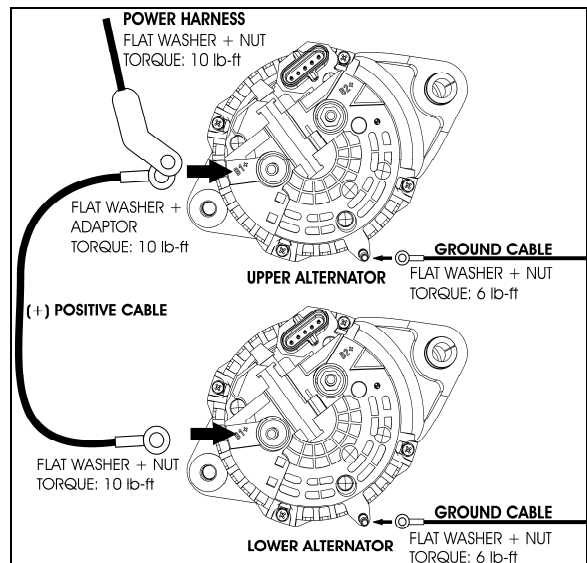

FIGURE 26: TWIN BOSCH HD10 CONNECTIONS

7. Connect ground harness and (+) positive cable on the lower alternator as shown (figure 26).
8. In order to assure proper installation, it is important to tighten the alternator mounting bolts in the following order (figure 24).

Section 06: ELECTRICAL

1st Nut A, 43 lb-ft.

2nd Nut B, 43 lb-ft (2x).

3rd Nut C, 80 lb-ft (2x)

9. On the upper alternator, connect the power harness onto the adaptor. Tighten nut to 10 lb-ft.
10. Connect the 5-pin connector on both alternators.

NOTE

Refer to MI11-13 annexed at the end of this section for complete procedure on replacing Bosh HD10 alternator brush.

11. Apply protective rubber coating (p/n 684013) or similar product on the stud terminals, washers and nuts.



MAINTENANCE

Commuter application

Check Bosch HD10 alternator brushes and replace if necessary after every 50 000 miles (80 000 km).

5.2 IDENTIFYING THE DEFECTIVE ALTERNATOR

When an alternator is not charging, the instrument cluster ALTERNATOR telltale will illuminate.



ALTERNATOR
telltale

To identify which alternator is defective (1=lower alternator, 2=upper alternator), proceed as follows:

1. On the DID (Driver Information Display), select DIAGNOSTICS menu.
2. Select VIEW ACTIVE FAULTS and then ELECTRICAL SYSTEM.
3. The active electrical system faults will appear. Scroll through the active faults. You will find one of the following messages:

MID (188) ELECTRICAL SYSTEM
PSID 34 ALTERNATOR 1
FMI (5) OPEN CIRCUIT

MID (188) ELECTRICAL SYSTEM
PSID 35 ALTERNATOR 2
FMI (5) OPEN CIRCUIT

5.3 ALTERNATOR DRIVE BELT

Removal

1. Insert a 3/4" socket drive into the automatic belt tensioner opening (Fig. 22).
2. Twist the tensioning arm to slacken belt.
3. Remove belt.

NOTE

Belts specifications may vary. For proper belt selection, always consult your vehicle Coach Final Record.

Installation

Installation of the alternator drive belt is the reverse of removal.

5.4 ADJUSTMENT

Correct belt tension is required to maximize belt life. The tensioning arm maintains proper belt tension, no adjustment is required.



MAINTENANCE

Check for wear and proper tension every 6,250 miles (10 000 km) or twice a year, whichever comes first.

6. BATTERY EQUALIZER

Vanner "Vann-Guard 70-Series" Battery equalizer is located beside the batteries in battery compartment. Battery Equalizer Owner's Manual (100 amps) is annexed at the end of this section.

7. BATTERY CHARGER

Vanner Battery charger Model SP00155 is located in the battery charger and power inverter compartment; which is located at the rear of the coach, behind the last row of passenger's seats. An access door is provided in the wall. Battery Charger Owner's Manual is annexed at the end of this section.

8. POWER INVERTER

Xantrex Power Inverter is located in the battery charger and power inverter compartment; which is located at the rear of the coach, behind the last row of passenger's seats. An access door is provided in the wall. Power Inverter Prosine 1000-1800 Owner's Manual is annexed at the end of this section.

9. STARTER

Refer to Mitsubishi Electric Corporation (MELCO) Service bulletin ME003-P annexed at the end of this section for information and maintenance instruction on MELCO 105P70 starter.

	<p>CAUTION</p>
<p>Do not engage starter for more than 15 seconds at a time. If engine does not start within 15 seconds, release ignition key and let starter cool for one minute before attempting to restart.</p>	

10. EXTERIOR LIGHTING

The circuit for exterior lights, as well as their control switches, relays and circuit breakers are shown on the applicable wiring diagrams. Wiring diagrams are located in the technical publication box.

10.1 HEADLIGHTS

Each headlight assembly consists of two 90 mm (3½ inch) headlamp module, the high beam lamp is equipped with a 12-volt halogen bulb, the low beam lamp is a 12-volt LED lamp. The turn/signal lamp is a 100 mm (4 inch) 12-volt LED. Outer lamps have a double function (both low and high beam). Inner lamps are used for high beam or daytime running light.

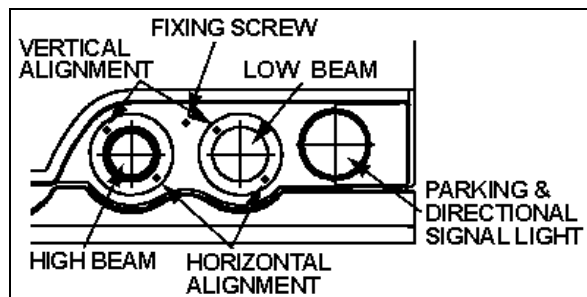

FIGURE 27: HEADLIGHT ASSEMBLY 06546

10.1.1 Headlight Beam Toggle Switch

Toggle between high and low beams by pressing the foot-operated switch.

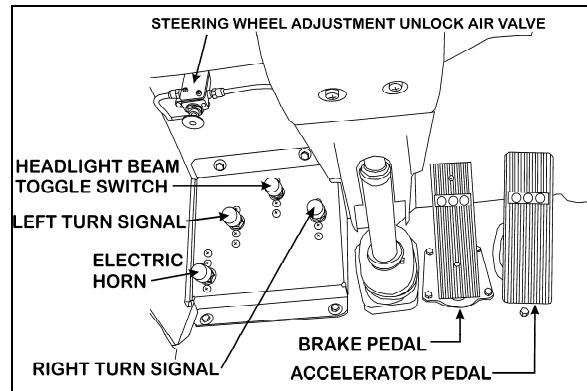

FIGURE 28: FOOT-OPERATED CONTROLS

10.1.2 Maintenance

Clean headlights with soap and water and a good glass cleaner whenever dirty. For maximum illumination, headlight connections must be coated with a dielectric grease to prevent oxidation and proper voltage must be maintained. Low battery voltage, loose or dirty contacts in wiring system and poor ground contribute to a decrease in voltage. Check wiring and connections regularly and keep battery properly charged. When a headlight burns out, a new bulb must be installed. Headlights must be properly aimed to provide maximum allowable road illumination. When using mechanical aiming devices, follow manufacturer's instructions.



FIGURE 29: OPENING HEADLIGHT ASSEMBLY 06547

Section 06: ELECTRICAL

Headlight aim should be checked after installing a new bulb. Aiming can be performed without opening headlight assembly. Horizontal and vertical aiming of each module is provided by two adjusting screws that pivot the module in the housing for proper alignment (fig. 27). There is no adjustment for focus since the module is set for proper focus during manufacturing assembly.

NOTE

Make sure headlight assembly is properly positioned into its housing before securing using fixing screw.



CAUTION

Use a soft cloth to clean the parking and front turn signal lamp.

10.1.3 Headlight Adjustment

1. Headlight aiming and inspection can be accomplished by visual means. This is done on a screen located at a distance of 25 feet (7,6 m) of the headlights. It should be of adequate size with a matte-white surface well shaded from extraneous light and properly adjusted to the floor area on which the vehicle stands. Provisions should be made for moving the screen or its vertical centerline so that it can be aligned with the vehicle axis. In addition to the vertical centerline, the screen should be provided with four laterally adjustable vertical tapes and two vertically adjustable horizontal tapes.
2. The four movable vertical tapes should be located on the screen at the left and right limits called for in the specification with reference to centerlines ahead of each headlight assembly.
3. The headlight centerlines shall be spaced either side of the fixed centerline on the screen by $\frac{1}{2}$ the lateral distance between the light source centers of the pertinent headlights. The horizontal tapes should be located on the screen at the upper and lower limits called for in the specification with reference to the height of beam centers and the plane on which the vehicle rests, not the floor on which the screen rests (Fig. 30).

TABLE 1 – VERTICAL BEAM AIM GUIDELINES

Headlight (centerline) Mounting Height	Nominal Vertical Aim	Aim Inspection Limits for Vertical Aim
56 to 90 cm (22 to 36 inch)	0 Vertical	10 cm (4 inch) up to 10 cm (4 inch) down
90 to 120 cm (36 to 48 inch)	5 cm (2 inch) down	5 cm (2 inch) up to 15 cm (6 inch) down
120 to 140 cm (48 to 54 inch)	6.4 cm (4 inch) down	4 cm (1.5 inch) up to 16.5 cm (6.5 inch) down

4. The nominal vertical aim position on lower beam headlights shall be adjusted based on the headlight mounting height, from the ground to the light source center of the headlight, according to table 1.

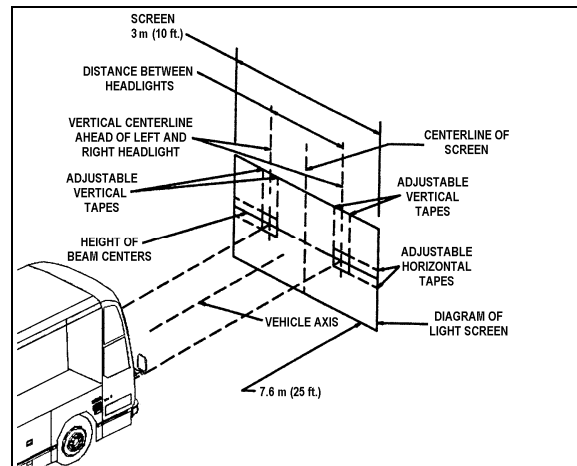

FIGURE 30: ALIGNMENT OF HEADLIGHT AIMING SCREEN

06502

5. High beam headlights are aimed so that the center of the high-intensity zone is located at the horizontal and straight ahead vertically (Fig. 31).
6. Low beam headlights are aimed so that the top edge (the cutoff) of the high-intensity zone is at the vertical location as per Table 1 and the left edge of the high-intensity zone is at the vertical centerline of the headlight (Fig. 32).
7. The inspection limits for high-beam headlights shall be with the center of the high-intensity zone from 10 cm (4 in) up to 10 cm (4 in) down; and, from 10 cm (4 in) left to 10 cm (4 in) right on a screen at 7.6 m (25 ft) (Fig. 33).

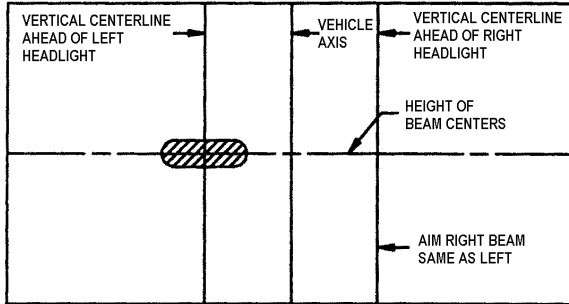

FIGURE 31: HIGH-INTENSITY ZONE (SHADED AREA) OF A PROPERLY AIMED UPPER BEAM ON THE AIMING SCREEN 7.6 M (25FT) IN FRONT OF VEHICLE 06503

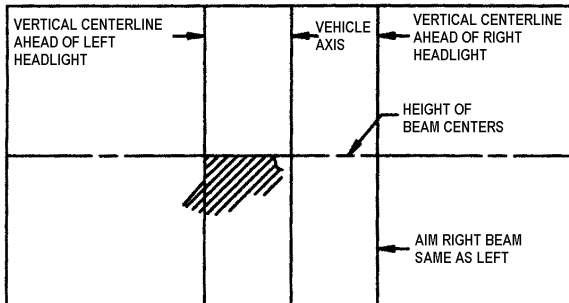

FIGURE 32: HIGH-INTENSITY ZONE (SHADED AREA) OF A PROPERLY AIMED LOWER BEAM ON THE AIMING SCREEN 7.6 M (25FT) IN FRONT OF VEHICLE 06504

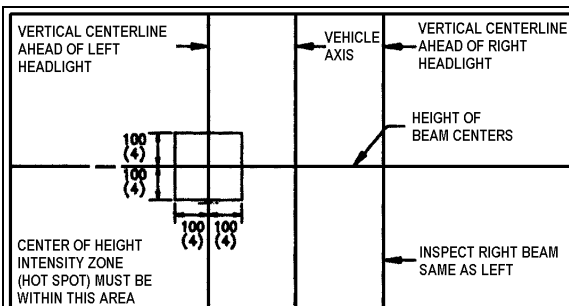

FIGURE 33: AIM INSPECTION LIMITS FOR UPPER-BEAM HEADLIGHTS 06505

- The inspection limits in the vertical direction for low-beam headlights or the low beam of a dual-beam headlight, shall be as described in Table 1. In the horizontal direction, the left edge of the high-intensity zone shall be located from 10 cm (4 in) left to 10 cm (4 in) right of the vertical centerline of the beam. The viewing screen shall be located 7.6 m (25 ft) in front of the vehicle (Fig. 34).

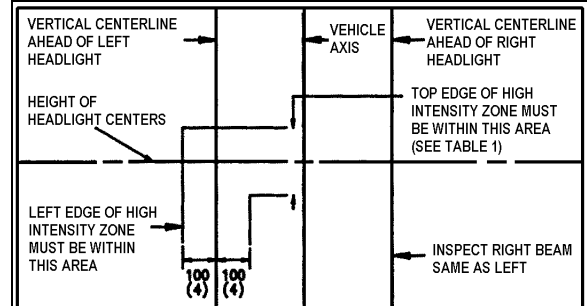

FIGURE 34: AIM INSPECTION LIMITS FOR LOWER-BEAM HEADLIGHTS 06506

10.1.4 Sealed-Beam Unit

Bulb Removal and Replacement

- Pull the release handle located inside the front service compartment to tilt down the entire bumper assembly.
- Remove the headlight screw fixing the headlight assembly, then tilt headlight assembly down (Fig. 27 and 29).
- Remove connector from headlight bulb.
- Remove the bulb by pushing and rotating it out of the socket.
- Install the new bulb by reversing the previous procedure.



CAUTION

During this step, avoid contacting the bulb with the fingers not to alter the bulb life.

NOTE

Do not disrupt headlight adjustment screws.

Module Replacement

- Pull the release handle located inside the front service compartment to tilt down the entire bumper assembly.
- Remove the headlight screw fixing the headlight assembly, then tilt headlight assembly down (Fig. 27 and 29).
- Remove connector from headlight bulb.
- Unfasten three metal clips attaching headlight unit to support.
- Install new module and fasten metal clips.
- Install wiring connector on back of new sealed beam unit.

Section 06: ELECTRICAL

7. Tilt headlight assembly up into its housing then secure using fixing screw.

NOTE

Make sure headlight assembly is properly positioned into its housing before securing using fixing screw.

8. Perform alignment procedure.

NOTE

The headlight aim must be checked and adjusted even if it was properly adjusted before the sealed beam unit was replaced.

10.1.5 Front Turn Signal

The front turn signal is part of the front headlight assembly. The turn signal is a sealed unit (LED) located on each front corner and should be replaced as an assembly. Turn signal is visible from both front and side.

Removal and Replacement

1. Pull the release handle located inside the front service compartment to tilt down the entire bumper assembly.
2. Remove the headlight screw fixing the headlight assembly, then tilt headlight assembly down (Fig. 27 and 29).
3. Partially unfasten back plate fixing screws, then remove signal lamp.
4. Remove socket from signal lamp.
5. Install wiring connector on back of new signal lamp then install signal lamp.
6. Fasten back plate fixing screws then tilt headlight assembly up into its housing then secure using fixing screw.

NOTE

Make sure headlight assembly is properly positioned into its housing before securing using fixing screw.

10.2 STOP, TAIL, DIRECTIONAL, BACK-UP, AND HAZARD WARNING LIGHTS

A combination stoplight, taillight, directional signal light and back-up light assembly is mounted at the rear, on each side of the vehicle. Furthermore, when braking, two center stoplights (LED) and a center high-mounted stop light (CHSL) (LED) will illuminate simultaneously with the stoplights on the sides for increased safety. The L.H. and R.H. side center stop lights

are also used as directional signal and marker lights.

The stop, tail, directional signal and back-up lights consist of individual LED lights mounted on the engine rear door, and each light is serviced individually as a complete unit. The back-up light uses a regular tungsten bulb.

The hazard warning flashing system uses the front, side and rear directional lights simultaneously. This system is energized by a switch on the L.H. dashboard.

10.2.1 Lamp Removal and Replacement

1. Open engine compartment rear door.
2. Remove the lamp support retaining screws (2), and then from the outside, remove the lamp and its support.
3. From the outside, install the new lamp with its support then fasten the retaining screws.

10.2.2 Center Stoplights and Center High-mounted Stop Light (CHSL) Removal and Replacement

These (LED) lights are sealed unit and should be replaced as an assembly in accordance with the following procedure:

1. Unscrew both "Phillips" light screws then remove the light assembly.
2. Install new light assembly and secure using screws.

10.3 LICENSE PLATE LIGHT

Two LED units are mounted above the rear license plate(s) of vehicle. In case of burn out, the LED unit must be changed according to the following procedure.

1. Pry out the rubber seal with a small screwdriver. Pull on the LED unit and disconnect it.
2. Reconnect new LED unit, place rubber seal, and press on it until it is seated in position.

10.4 CLEARANCE, IDENTIFICATION AND MARKER LIGHTS

The vehicle is equipped with marker, identification and clearance lights (LED). The clearance lights are mounted at each corner of the coach near the top and the identification lights are in the upper center of rear and front sections.

The rear clearance and identification lights are red and the front ones are amber.

The amber marker lights are mounted along the sides of vehicle.

The side marker light is a sealed unit (LED) and should be replaced as an assembly in accordance with the following procedure:

1. Unscrew both "Phillips" light screws, and then remove the light assembly.
2. Position the new light assembly and install the "Phillips" screws.

10.4.1 Clearance and Identification Light Removal and Replacement

The clearance and identification light are sealed units (LED) and can be replaced in accordance with the following procedure:

1. Unscrew both "Phillips" light screws, and then remove the light assembly.
2. Position the new light assembly, and then install the "Phillips" screws.

11. INTERIOR LIGHTING EQUIPEMENT

11.1 CONTROL PANEL LIGHTING

The instrument gauges and switches mounted on all control panels are energized whenever the exterior light switch is pushed to the first position. A control dimmer located on the dashboard is used to vary the brightness of the panel gauges, switches and indicator lights.

The gauge lights, panel lights, switch lights and indicator lights have a different bulb arrangement. Thus, the procedure to change a defective bulb can vary according to the application.

11.1.1 Switch Lighting

1. Slightly pull the switch with a defective LED away from the control panel.
2. Disconnect the electric cable from the switch.
3. To install a new switch, reverse the procedure (Fig. 35).

NOTE

Switches are lighted by the use of LED. When lighting on a switch fails, replace defective switch as a unit.

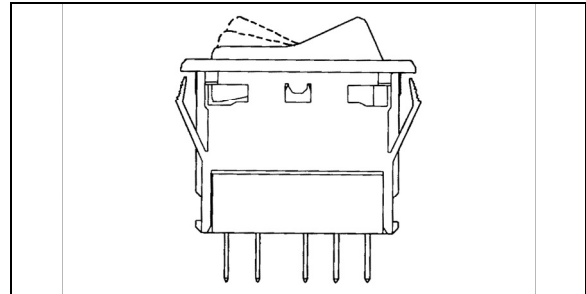

FIGURE 35: SWITCH

06321

11.1.2 Telltale Light Replacement

Telltale module is non-serviceable and must be replaced as a unit.

1. Unscrew and remove the top dashboard panel.
2. Remove the telltale back wire electric connectors.
3. Unscrew and remove the telltale module.
4. To replace the telltale module, reverse the procedure.

11.1.3 Gauge Light Bulb Replacement

1. For any gauge light bulb replacement, the dashboard panel must be removed in order to have access to the rear of gauges.
2. Remove bulb socket from the gauge, turn the defective bulb counterclockwise and pull it out of the gauge.
3. Push a new bulb and socket ASM and turn clockwise to lock in place.
4. Replace the rear dashboard housing.

11.2 STEPWELL LIGHTS

Two Stepwell lights are illuminated when the door opening system is activated.

11.2.1 Bulb Removal and Replacement

Proceed as follows to replace a defective bulb:

1. Unscrew the two Phillips-head screws retaining the lens to the wall, and remove it.
2. With the light lens removed, pull bulb from the lamp while applying lateral pressure.
3. Install the new bulb into the lamp.
4. Position the light lens and install it.

Section 06: ELECTRICAL

11.3 DRIVER'S AREA LIGHTS

Two halogen ceiling lights are installed over the stepwell and the driver's area. These lights are frequently used for night-time operation when passengers board or leave coach.

11.3.1 Bulb Removal and Replacement

1. Unsnap the lamp with a flat head screwdriver and remove it.
2. Pull the defective bulb out of the socket.
3. Install the new bulb by pushing it in position.
4. Replace the lamp by snapping it back in place.



CAUTION

Do not touch halogen bulbs with bare hands as natural oils on skin will shorten bulb life span.

11.4 ENGINE COMPARTMENT LIGHTING

A switch located on R.H. side of rear junction box can be used to actuate the engine compartment LED lights.

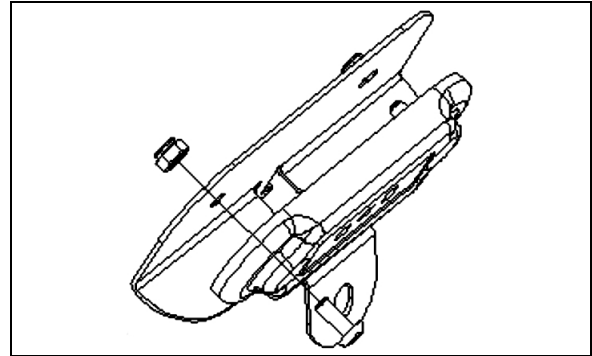

FIGURE 36: ENGINE COMPARTMENT LIGHT

Each light is sealed and can be replaced as follows:

1. Disconnect the light unit connection.
2. Unfasten the two fixing screws then remove the lamp.
3. Position and fasten new lamp.
4. Connect the light unit.

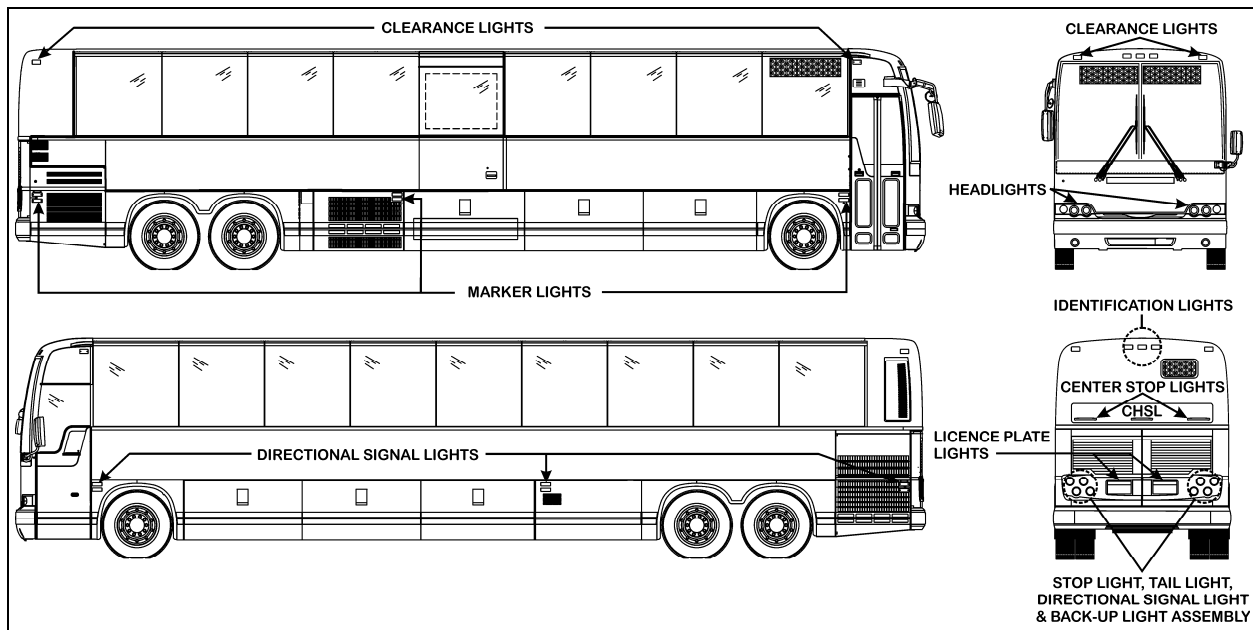

FIGURE 37: VARIOUS LIGHTS LOCATION

06640

12. SPECIFICATIONS

Battery

Make.....Deka
 Model..... 908D
 Type Maintenance-free
 Terminal type Top Stud
 Group size8D
 Volts 12
 Reserve capacity (minutes) 430
 Cold cranking (in amps)-At 0°F (-18°C) 1400 (each battery)

Maximum dimensions (inches/mm)
 -Length (including flange) 20 3/4/527
 -Width 11/279
 -Height (including top posts) 10/254
 -Approximate weight (wet/dry) 130/80

Torque specifications

Battery cable to post 10-15 Ft-lbs (13-20 Nm)

Alternator

Make..... BOSCH
 Series HD 10
 Amperes 120
 Volts 28.4
 Output Power 3 Kw
 Ground negative
 Prevost Number 564119

Battery equalizer

Make..... Vanner
 Model..... Vann-Guard 70-Series
 Amperes 100 amps

Starter

Make..... Mitsubishi Electric Corporation (MELCO)
 Type 105P70
 Voltage 24
 Prevost Number 510752

No-load test

-Volts 23.5
 -Max. current draw 125 amperes
 -Min. rpm 3000 rpm

Starter solenoid

Make..... Mitsubishi Electric Corporation (MELCO)
 Pull In Voltage 16 volts max.

ELECTRICAL CONNECTORS PROTECTION

PROCEDURE NO SAV00002E

**NOVEMBER 2009
REVISION 02**

Kent Sealer

Sprayed sealer. It is used for structure ground connections. It prevents corrosion and ensures maximum contact. Refer to table for proper use.

Apply this product once installation is finished.

Warning: *It is very important to be in a well ventilated area when applying this product.*



680324

Nyogel Grease

Grease-type product.

It is used to facilitate connectors or terminals insertion.

Refer to table for proper use of Nyogel grease.

It is preferable to apply Nyogel into the female part of connector.

Apply this product as the last assembling operation.



3 Oz. tube: 681095

Container 500g: 683409

“Color Guard” black rubber coating

This product may be applied with a brush.

It is used for structure ground connections or other connections that will most likely not be disconnected later on.

Apply this product once installation is finished.

Warning : *Wear goggles and rubber gloves.*



684013

Vehicle Zoning

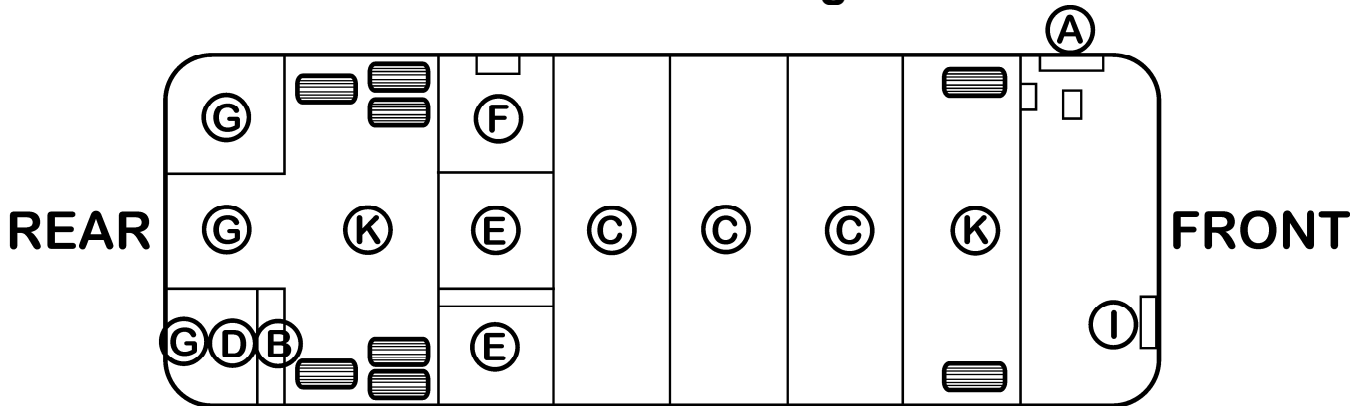

Electrical Connectors Protection Procedure Table

Zone	Component	Model	Product	Note
		X3-45		
A- Front Elect. Compt	Diode Block	X	Nyogel	Accepted to ease connection
A- Front Elect. Compt	Customer Terminal Block	X	Nothing	
A Front Elect. Compt	Terminal Block Electronic Ground	X	Kent	
A- Front Elect. Compt	Structure Ground	X	Kent	
A- Front Elect. Compt	Electronic Module	X	Nothing	
A- Front Elect. Compt	VEC Power	X	Nothing	
A- Front Elect. Compt	70A Relay	X	Nyogel	Accepted to ease connection
A- Front Elect. Compt	Control Relay	X	Nyogel	Accepted to ease connection
A- Front Elect. Compt	All connectors except those specified in this zone	X	Nothing	
A- Front Service Compt	All connectors except those specified in this zone	X	Nothing	
B- Rear Electrical panel	Customer Terminal Block	X	Nothing	
B- Rear Electrical panel	Power Terminal Block	X	Nothing	
B- Rear Electrical panel	Circuit Breaker	X	Nothing	
B- Rear Electrical panel	Structure Ground	X	Kent	
B- Rear Electrical panel	Electronic Module	X	Nothing	
B- Rear Electrical panel	VEC Power	X	Nothing	
B- Rear Electrical panel	70A Relay	X	Nyogel	Accepted to ease connection
B- Rear Electrical panel	Master Switch Relay	X	Nothing	
B- Rear Electrical panel	Control Relay	X	Nyogel	Accepted to ease connection
B- Rear Electrical panel	200A Power Relay	X	Nothing	
B- Rear Electrical panel	Power Relay Stud	X	Nothing	
B- Rear Electrical panel	All connectors except those specified in this zone	X	Nothing	

Zone	Component	Model	Product	Note
		X3-45		
C- Baggage Compt	Structure Ground	X	Color Guard or Kent	
C- Baggage Compt	Door Switch	X	Nyogel	Accepted to ease connection
C- Baggage Compt	Door lock Actuator Module (switch and solenoid)	X	Nyogel	Accepted to ease connection
C- Baggage Compt	Electronic Module	X	Nothing	
C- Baggage Compt	WCL Junction Panel	X	Nothing	
C- Baggage Compt	120V Inverter Connector	X	Nothing	
C- Baggage Compt	Stud inverter	X	Color Guard or Kent	
C- Baggage Compt	WCL Remote Control	X	Nyogel	Accepted to ease connection
C- Baggage Compt	All connectors except those specified in this zone	X	Nothing	
D- Battery Compt	Battery	X	Nyogel	
D- Battery Compt	Structure Ground	X	Color Guard or Kent	
D- Battery Compt	Electronic Module	X	Nothing	
D- Battery Compt	All connectors except those specified in this zone	X	Nothing	
D- Battery Compt	Battery Equalizer	X	Kent	
E- Condenser Compt	Fuel sender	X	Kent	
E- Condenser Compt	Structure Ground	X	Color Guard or Kent	
E- Condenser Compt	Door Switch	X	Nyogel	Accepted to ease connection
E- Condenser Compt	Condenser Motor	X	Nothing	
F- Evaporator Compt	Structure Ground	X	Color Guard or Kent	
F- Evaporator Compt	Evaporator Motor	X	Color Guard or Kent	
G- Engine Compt	120A Alternator	X	Color Guard	
G- Engine Compt	Booster Block (+)	X	Color Guard	
G- Engine Compt	Starter Terminal	X	Color Guard	
G- Engine Compt	Volvo Air Element Terminal	X	Color Guard	
G- Engine Compt	Power Terminal Block	X	Color Guard	
G- Engine Compt	Air Heater Fuse & Relay	X	Nyogel	Accepted here
G- Engine Compt	Engine Ground	X	Color Guard	
G- Engine Compt	Structure Ground	X	Color Guard	
G- Engine Compt	Starter Relay	X	Color Guard	
G- Engine Compt	All connectors except those specified in this zone	X	Nothing	

Zone	Component	Model	Product	Note
		X3-45		
H- Vehicle Exterior	ABS Sensor	X	Nothing	
H- Vehicle Exterior	Docking & Cornering Lamps	X	Nyogel	Accepted to ease connection
H- Vehicle Exterior	Marker Light	X	Nothing	
H- Vehicle Exterior	Mirror	X	Nothing	
H- Vehicle Exterior	Light Module	X	Nothing	
H- Vehicle Exterior	Stop light, Backup light, Directional Signal Light	X	Nothing	
I- Vehicle Interior	Diode Block	X	Nyogel	Accepted to ease connection
I- Vehicle Interior	Junction Block	X	Nothing	
I- Vehicle Interior	A3 & A4 Transmission Retarder Hand lever	X	Nyogel	Accepted to ease connection
I- Vehicle Interior	C258 & C259 Multi-function Lever Connector	X	Nyogel	Accepted to ease connection
I- Vehicle Interior	Audio - video Connection	X	Nothing	
I- Vehicle Interior	Defrost Compt Ground	X	Kent	
I- Vehicle Interior	Video Plate Direct Ground	X	Nothing	
I- Vehicle Interior	Structure Ground	X	Kent	
I- Vehicle Interior	Terminal Block Ground	X	Nothing	
I- Vehicle Interior	Dashboard Switch	X	Nothing	
I- Vehicle Interior	Electronic Module	X	Nothing	
I- Vehicle Interior	Wiper Motor	X	Nyogel	Accepted to ease connection
I- Vehicle Interior	200A Power Relay	X	Nothing	
I- Vehicle Interior	70A Relay	X	Nyogel	Accepted to ease connection
I- Vehicle Interior	Control Relay	X	Nyogel	Accepted to ease connection
I- Vehicle Interior	All connectors except those specified in this zone	X	Nothing	
I- Vehicle Interior	All components except those specified in this zone	X	Nothing	
K- Front & Rear Wheelhousing	All connectors except those specified in this zone	X	Nothing	
K- Front & Rear Wheelhousing	All components except those specified in this zone	X	Nothing	

SECTION 06B: ELECTRICAL

MULTIPLEX ERROR MESSAGES TROUBLE SHOOTING LIST

- MID (Message Identification Description) : Identification of a control unit**
- PID (Parameter Identification Description) : Identification of a parameter (value)**
- PPID (Proprietary Parameter Identification Description) : Unique Identification of a parameter (value)**
- SID (Subsystem Identification Description) : Identification of a component**
- PSID (Proprietary Subsystem Identification Description) : Unique Identification of a component**
- FMI (Failure Mode Identifier) : Identification of fault types**

MID 188 PSID # 4 A/C Clutch So9 (A52 J1:20)

Type of fault:	FMI Description:	Fault Condition:	Possible Symptoms:	Possible Causes:
FMI 3	Shorted High	Voltage present on output A52 J1:20 but output not active	A/C clutch always ON	<ul style="list-style-type: none"> • A52 module failure • Connector C91 corroded • Circuit 77BA shorted to battery
FMI 4	Shorted Low	Output A52 J1:20 shorted to ground	A/C clutch not working	<ul style="list-style-type: none"> • A52 module failure • Connector C91 corroded • Circuit 77BA shorted to ground
FMI 5	Open Circuit	A52 module does not detect A/C clutch So9	A/C clutch not working	<ul style="list-style-type: none"> • A52 module failure • So9 open circuit • Se29 failure • Circuit 77BA open • Circuit 78 open • Circuit ORA2 open
FMI 6	Current above normal	Output A52 J1:20 internal software fuse active for overcurrent	A/C clutch not working	<ul style="list-style-type: none"> • A52 module failure • Connector C91 corroded • Circuit 77BA shorted to ground • A/C clutch resistance value lower than 5 ohms (7 ohms expected)

MID 188 PSID # 12 A/C Pres HiSd (A52 J1:13)

Type of fault:	FMI Description:	Fault Condition:	Possible Symptoms:	Possible Causes:
FMI 3	Shorted High	Voltage above normal on A52 J1:13	High side pressure not displayed on dash	<ul style="list-style-type: none"> • A52 module failure • Se23 failure • Connector C91 corroded • Circuit 77-20 shorted to battery
FMI 4	Shorted Low	Voltage below normal on A52 J1:13	High side pressure not displayed on dash	<ul style="list-style-type: none"> • A52 module failure • Se23 failure • Connector C91 corroded • Circuit 77-20 shorted to ground
FMI 5	Open Circuit	A52 module does not detect Se23	High side pressure not displayed on dash	<ul style="list-style-type: none"> • A52 module failure • Se23 failure • Circuit 77-20 open

SECTION 06B: ELECTRICAL

MID 188 PSID # 13 A/C Pres LoSd (A52 J1:14)

Type of fault:	FMI Description:	Fault Condition:	Possible Symptoms:	Possible Causes:
FMI 3	Shorted High	Voltage above normal on A52 J1:14	Low side pressure not displayed on dash	<ul style="list-style-type: none"> • A52 module failure • Se24 failure • Connector C91 corroded • Circuit 93-20 shorted to battery
FMI 4	Shorted Low	Voltage below normal on A52 J1:14	Low side pressure not displayed on dash	<ul style="list-style-type: none"> • A52 module failure • Se24 failure • Connector C91 corroded • Circuit 93-20 shorted to ground
FMI 5	Open Circuit	A52 module does not detect Se24	Low side pressure not displayed on dash	<ul style="list-style-type: none"> • A52 module failure • Se24 failure • Circuit 93-20 open

MID 188 SID # 69 Aux Bypass Sw (A42 J1:10)

Type of fault:	FMI Description:	Fault Condition:	Possible Symptoms:	Possible Causes:
FMI 3	Shorted High	Voltage above normal on A42 J1:10	Aux bypass switch not working	<ul style="list-style-type: none"> • A42 module failure • Sw142 failure • Connector C71 corroded • Connector C171 corroded • Circuit AuxBP shorted to battery
FMI 4	Shorted Low	Voltage below normal on A42 J1:10	Aux bypass switch always ON	<ul style="list-style-type: none"> • A52 module failure • Sw142 failure • Connector C71 corroded • Connector C171 corroded • Circuit AuxBP shorted to ground

MID 188 SID # 61 (A45 J1:12)

Type of fault:	FMI Description:	Fault Condition:	Possible Symptoms:	Possible Causes:
FMI 3	Shorted High	Voltage above normal on A45 J1:12	Left side high and low beam not working	<ul style="list-style-type: none"> • A45 module failure • Sw2 failure • Connector C71 corroded • Circuit 61-20 shorted to battery
FMI 4	Shorted Low	Voltage below normal on A45 J1:12	Left high beam always ON	<ul style="list-style-type: none"> • A45 module failure • Sw2 failure • Connector C71 corroded • Circuit 61-20 shorted to ground

MID 188 SID # 76 Brake Interlock Sol (A42 J1:11)

Type of fault:	FMI Description:	Fault Condition:	Possible Symptoms:	Possible Causes:
FMI 3	Shorted High	Voltage present on output A42 J1:11 but output not active	Parking brake won't release	<ul style="list-style-type: none"> • A42 module failure • Connector C172 corroded • Connector C8 corroded

SECTION 06B: ELECTRICAL

				<ul style="list-style-type: none"> • Circuit BrkAux shorted to battery
FMI 4	Shorted Low	Output A42 J1:11 shorted to ground	Brake interlock not working	<ul style="list-style-type: none"> • A42 module failure • Connector C172 corroded • Connector C8 corroded • Circuit BrkAux shorted to ground
FMI 5	Open Circuit	A42 module does not detect So55	Brake interlock not working	<ul style="list-style-type: none"> • A42 module failure • So55 open circuit • Circuit BrkAux open • Ground 618Rtn open
FMI 6	Current above normal	Output A42 J1:11 internal software fuse active for overcurrent	Brake interlock not working	<ul style="list-style-type: none"> • A42 module failure • Connector C172 corroded • Connector C8 corroded • Circuit BrkAux shorted to ground • So55 Low resistance value (expected value \pm 100 ohms)

MID 188 SID # 73 Brake Pres Driver (A45 J1:14)

Type of fault:	FMI Description:	Fault Condition:	Possible Symptoms:	Possible Causes:
FMI 3	Shorted High	Voltage above normal on A45 J1:14	Brake interlock pressure not displayed on dash	<ul style="list-style-type: none"> • A45 module failure • Se77 failure • Connector C8 corroded • Circuit ANA-BRKP shorted to battery
FMI 4	Shorted Low	Voltage below normal on A45 J1:14	Brake interlock pressure not displayed on dash	<ul style="list-style-type: none"> • A45 module failure • Se77 failure • Connector C8 corroded • Circuit ANA-BRKP shorted to ground

MID 188 SID # 74 Brake Pres Intrlk (A45 J1:13)

Type of fault:	FMI Description:	Fault Condition:	Possible Symptoms:	Possible Causes:
FMI 3	Shorted High	Voltage above normal on A45 J1:13	Brake interlock not working	<ul style="list-style-type: none"> • A45 module failure • Se78 failure • Connector C8 corroded • Circuit ANA-INTLK shorted to battery
FMI 4	Shorted Low	Voltage below normal on A45 J1:13	Brake interlock not working	<ul style="list-style-type: none"> • A45 module failure • Se78 failure • Connector C8 corroded • Circuit ANA-INTLK shorted to ground

SECTION 06B: ELECTRICAL

MID 188 PSID # 119 Brk Lts Sens (A36 JB:13)

Type of fault:	FMI Description:	Fault Condition:	Possible Symptoms:	Possible Causes:
FMI 3	Shorted High	Voltage above normal on A36 JB:13	Stop lights always ON	<ul style="list-style-type: none"> • A36 module failure • A51 module failure • Connector C4 corroded • Connector C2 corroded • Connector C21 corroded • Circuit 78 shorted to battery • Circuit 79A shorted to battery • Circuit 953 shorted to battery
FMI 4	Shorted Low	Voltage below normal on A36 JB:13	Stop lights not working	<ul style="list-style-type: none"> • A36 module failure • Se19 failure • Se19A failure • Connector C4 corroded • Connector C2 corroded • Connector C21 corroded • Circuit 78 shorted to ground • Circuit 79A shorted to ground • Circuit 953 shorted to ground

MID 188 PSID # 108 Ceiling Door Lt (A44 J1:5)

Type of fault:	FMI Description:	Fault Condition:	Possible Symptoms:	Possible Causes:
FMI 3	Shorted High	Voltage present on output A44 J1:5 but output not active	L17 always ON	<ul style="list-style-type: none"> • A44 module failure • Connector C45 corroded • Circuit 35 shorted to battery
FMI 4	Shorted Low	Output A44 J1:5 shorted to ground	L17 not working	<ul style="list-style-type: none"> • A44 module failure • Connector C45 corroded • Circuit 35 shorted to ground
FMI 5	Open Circuit	A44 module does not detect L17	L17 not working	<ul style="list-style-type: none"> • A44 module failure • L17 open circuit • Circuit 35 open
FMI 6	Current above normal	Output A44 J1:5 internal software fuse active for overcurrent	L17 not working	<ul style="list-style-type: none"> • A44 module failure • Connector C45 corroded • Circuit 35 shorted to ground

MID 188 PSID # 124 Center Flash LH (A50 J1:5)

Type of fault:	FMI Description:	Fault Condition:	Possible Symptoms:	Possible Causes:
FMI 3	Shorted High	Voltage present on output A50 J1:5 but output not active	L70 always ON	<ul style="list-style-type: none"> • A50 module failure • Connector C15 corroded • Connector C21 corroded • Circuit 21A shorted to battery
FMI 4	Shorted Low	Output A50 J1:5 shorted to ground	L70 not working	<ul style="list-style-type: none"> • A50 module failure • Connector C15 corroded • Connector C21 corroded • Circuit 21A shorted to ground
FMI 6	Current above normal	Output A50 J1:5 internal software fuse active for overcurrent	L70 not working	<ul style="list-style-type: none"> • A50 module failure • Connector C15 corroded • Connector C21 corroded

SECTION 06B: ELECTRICAL

				<ul style="list-style-type: none"> • Circuit 21A shorted to ground • L70 low resistance value
--	--	--	--	---

MID 188 PSID # 125 Center Flash RH (A50 J1:7)

Type of fault:	FMI Description:	Fault Condition:	Possible Symptoms:	Possible Causes:
FMI 3	Shorted High	Voltage present on output A50 J1:7 but output not active	L68 always ON	<ul style="list-style-type: none"> • A50 module failure • Connector C58 corroded • Connector C21 corroded • Circuit 23A shorted to battery
FMI 4	Shorted Low	Output A50 J1:7 shorted to ground	L68 not working	<ul style="list-style-type: none"> • A50 module failure • Connector C58 corroded • Connector C21 corroded • Circuit 23A shorted to ground
FMI 6	Current above normal	Output A50 J1:7 internal software fuse active for overcurrent	L68 not working	<ul style="list-style-type: none"> • A50 module failure • Connector C58 corroded • Connector C21 corroded • Circuit 23A shorted to ground • L68 low resistance value

MID 188 PSID # 27 Center Mkr (A50 J1:8)

Type of fault:	FMI Description:	Fault Condition:	Possible Symptoms:	Possible Causes:
FMI 3	Shorted High	Voltage present on output A50 J1:8 but output not active	L67 and L69 always ON	<ul style="list-style-type: none"> • A50 module failure • Connector C21 corroded • Connector C58 corroded • Connector C15 Corroded • Circuit 46B shorted to battery
FMI 4	Shorted Low	Output A50 J1:8 shorted to ground	L67 and L69 not working	<ul style="list-style-type: none"> • A50 module failure • Connector C21 corroded • Connector C58 corroded • Connector C15 Corroded • Circuit 46B shorted to ground
FMI 5	Open Circuit	A50 module does not detect L67, L68, L69 or L70	L67 and L69 not working	<ul style="list-style-type: none"> • A50 module failure • L67, L68, L69 or L70 open circuit • Circuit 46B open
FMI 6	Current above normal	Output A50 J1:8 internal software fuse active for overcurrent	L67 and L69 not working	<ul style="list-style-type: none"> • A50 module failure • Connector C21 corroded • Connector C58 corroded • Connector C15 Corroded • Circuit 46B shorted to ground • L67 or L69 low resistance value

MID 188 PSID # 41 Cond Rly spd1 (A54 J1:5)

Type of fault:	FMI Description:	Fault Condition:	Possible Symptoms:	Possible Causes:
FMI 3	Shorted High	Voltage present on output A54 J1:5 but output not active	Condenser fans always ON speed 1	<ul style="list-style-type: none"> • A54 module failure • Cond Power Relay R10 failure • Circuit 67A shorted to battery

SECTION 06B: ELECTRICAL

FMI 4	Shorted Low	Output A54 J1:5 shorted to ground	Condenser fans not working	<ul style="list-style-type: none"> • A54 module failure • Cond Power Relay R10 failure • Circuit 67A shorted to ground
FMI 5	Open Circuit	A54 module does not detect power relay R10	Condenser fans not working	<ul style="list-style-type: none"> • A54 module failure • Cond Power Relay R10 failure • Power Relay R10 open circuit • Circuit 67A open
FMI 6	Current above normal	Output A54 J1:5 internal software fuse active for overcurrent	Condenser fans not working	<ul style="list-style-type: none"> • A54 module failure • Circuit 67A shorted to ground

MID 188 PSID # 42 Cond Rly spd2 (A49 J1:16)

Type of fault:	FMI Description:	Fault Condition:	Possible Symptoms:	Possible Causes:
FMI 3	Shorted High	Voltage present on output A49 J1:16 but output not active	Condenser fans not working on speed 2	<ul style="list-style-type: none"> • A49 module failure • Connector C21 corroded • Connector C58 corroded • Circuit 2B shorted to battery
FMI 4	Shorted Low	Output A49 J1:16 shorted to ground	Condenser fans always ON speed 2	<ul style="list-style-type: none"> • A49 module failure • Connector C21 corroded • Connector C58 corroded • Circuit 2B shorted to ground
FMI 6	Current above normal	Output A49 J1:16 internal software fuse active for overcurrent	Condenser fans always ON speed 2	<ul style="list-style-type: none"> • A49 module failure • Condenser motors failure • Connector C21 corroded • Connector C58 corroded • Circuit 2B shorted to ground

MID 188 PSID # 116 Cyclope Lt (A51 J1:7)

Type of fault:	FMI Description:	Fault Condition:	Possible Symptoms:	Possible Causes:
FMI 3	Shorted High	Voltage present on output A51 J1:7 but output not active	Center High mounted stop light L81 always ON	<ul style="list-style-type: none"> • A51 module failure • Connector C12 corroded • Connector C91 corroded • Circuit 82A shorted to battery
FMI 4	Shorted Low	Output A51 J1:7 shorted to ground	Center High mounted stop light L81 not working	<ul style="list-style-type: none"> • A51 module failure • Connector C12 corroded • Connector C91 corroded • Circuit 82A shorted to ground
FMI 6	Current above normal	Output A51 J1:7 internal software fuse active for overcurrent	Center High mounted stop light L81 not working	<ul style="list-style-type: none"> • A51 module failure • Connector C12 corroded • Connector C91 corroded • Circuit 82A shorted to ground • Low resistance value

MID 188 PSID # 102 Direct Lts Relay (A49 J1:11)

Type of fault:	FMI Description:	Fault Condition:	Possible Symptoms:	Possible Causes:
FMI 3	Shorted High	Voltage present on output A49 J1:11 but output not active	Direct Lights Relay R6 always ON	<ul style="list-style-type: none"> • A49 module failure • Direct Lights Relay R6 failure • Circuit 38 shorted to battery

SECTION 06B: ELECTRICAL

FMI 4	Shorted Low	Output A49 J1:11 shorted to ground	Direct lights not working	<ul style="list-style-type: none"> • A49 module failure • Direct Lights Relay R6 failure • Circuit 38 shorted to ground
FMI 5	Open Circuit	A49 module does not detect direct lights relay R6	Direct lights not working	<ul style="list-style-type: none"> • A49 module failure • Direct Lights Relay R6 failure • Direct Lights Relay R6 open circuit • Circuit 38 open
FMI 6	Current above normal	Output A49 J1:11 internal software fuse active for overcurrent	Direct lights not working	<ul style="list-style-type: none"> • A49 module failure • Circuit 38 shorted to ground

MID 188 PSID # 180 Driver Def Fan (A47 J1:1)

Type of fault:	FMI Description:	Fault Condition:	Possible Symptoms:	Possible Causes:
FMI 3	Shorted High	Voltage present on output A47 J1:1 but output not active	Defroster fans Mo24 and Mo25 not working	<ul style="list-style-type: none"> • A47 module failure • A24 module failure • Circuit 86 shorted to battery
FMI 4	Shorted Low	Output A47 J1:1 shorted to ground	Defroster fans Mo24 and Mo25 on full speed	<ul style="list-style-type: none"> • A47 module failure • A24 module failure • Circuit 86 shorted to ground
FMI 5	Open Circuit	A47 module does not detect Defroster Speed Ctrl A24	Defroster fans Mo24 and Mo25 on full speed	<ul style="list-style-type: none"> • A47 module failure • A24 module failure • Circuit 86 open
FMI 6	Current above normal	Output A47 J1:1 internal software fuse active for overcurrent	Defroster fans Mo24 and Mo25 on full speed	<ul style="list-style-type: none"> • A47 module failure • A24 module failure • Circuit 86 shorted to ground

MID 188 PSID # 16 Driver heat Sol (A46 J1:6)

Type of fault:	FMI Description:	Fault Condition:	Possible Symptoms:	Possible Causes:
FMI 3	Shorted High	Voltage present on output A46 J1:6 but output not active	No heat in driver's area	<ul style="list-style-type: none"> • A46 module failure • Connector C4 corroded • Circuit 50 shorted to battery
FMI 4	Shorted Low	Output A46 J1:6 shorted to ground	Full heat in driver's area	<ul style="list-style-type: none"> • A46 module failure • Connector C4 corroded • Circuit 50 shorted to ground
FMI 5	Open Circuit	A46 module does not detect Driver Heat Solenoid So8	Full heat in driver's area	<ul style="list-style-type: none"> • A46 module failure • So8 open • Circuit 50 open
FMI 6	Current above normal	Output A46 J1:6 internal software fuse active for overcurrent	Full heat in driver's area	<ul style="list-style-type: none"> • A46 module failure • Connector C4 corroded • Circuit 50 shorted to ground • Driver heat solenoid So8 Low resistance value (expected value \pm 40 ohms)

SECTION 06B: ELECTRICAL

MID 188 PSID # 104 Driver Light Sw (A44 J1:3)

Type of fault:	FMI Description:	Fault Condition:	Possible Symptoms:	Possible Causes:
FMI 3	Shorted High	Voltage present on output A44 J1:3 but output not active	Driver Light L16 always ON	<ul style="list-style-type: none"> • A44 module failure • Connector C45 corroded • Circuit 39D shorted to battery
FMI 4	Shorted Low	Output A44 J1:3 shorted to ground	Driver Light L16 not working	<ul style="list-style-type: none"> • A44 module failure • Connector C45 corroded • Circuit 39D shorted to ground
FMI 5	Open Circuit	A44 module does not detect Driver Light L16	Driver Light L16 not working	<ul style="list-style-type: none"> • A44 module failure • L16 open circuit • Circuit 39D open
FMI 6	Current above normal	Output A44 J1:3 internal software fuse active for overcurrent	Driver Light L16 not working	<ul style="list-style-type: none"> • A44 module failure • Connector C45 corroded • Circuit 39D shorted to ground • Low resistance value

MID 188 SID # 67 Driver Light Sw (A55 J1:5)

Type of fault:	FMI Description:	Fault Condition:	Possible Symptoms:	Possible Causes:
FMI 3	Shorted High	Voltage above normal on A55 J1:5	Driver Light not working	<ul style="list-style-type: none"> • A55 module failure • Sw24 failure • Circuit 39 shorted to battery
FMI 4	Shorted Low	Voltage below normal on A55 J1:5	Driver light always ON	<ul style="list-style-type: none"> • A55 module failure • Sw24 failure • Circuit 39 shorted to ground

MID 188 PSID # 29 Driver Rfg Sol (A46 J1:5)

Type of fault:	FMI Description:	Fault Condition:	Possible Symptoms:	Possible Causes:
FMI 3	Shorted High	Voltage present on output A46 J1:5 but output not active	Driver's A/C always ON	<ul style="list-style-type: none"> • A46 module failure • Connector C4 corroded • Connector C18 corroded • Circuit 116A shorted to battery
FMI 4	Shorted Low	Output A46 J1:5 shorted to ground	Driver's A/C not working	<ul style="list-style-type: none"> • A46 module failure • Connector C4 corroded • Connector C18 corroded • Circuit 116A shorted to ground
FMI 5	Open Circuit	A46 module does not detect Driver Liquid Solenoid Valve So7	Driver's A/C not working	<ul style="list-style-type: none"> • A46 module failure • So7 open • Circuit 116A open
FMI 6	Current above normal	Output A46 J1:5 internal software fuse active for overcurrent	Driver's A/C not working	<ul style="list-style-type: none"> • A46 module failure • Connector C4 corroded • Connector C18 corroded • Circuit 116A shorted to ground • Solenoid Valve So7 low resistance value (expected value \pm 40 ohms)

SECTION 06B: ELECTRICAL

MID 188 PSID # 28 Driver Sensor (A55 J1:1)

Type of fault:	FMI Description:	Fault Condition:	Possible Symptoms:	Possible Causes:
FMI 3	Shorted High	Voltage above normal on A55 J1:1	Driver temperature not displayed on HVCA module. Driver is full heat with set point above 70°F and full A/C with set point below 70°F.	<ul style="list-style-type: none"> • A55 module failure • Se21 failure • Circuit ANA-89 shorted to battery
FMI 4	Shorted Low	Voltage below normal on A55 J1:1	Driver temperature not displayed on HVCA module. Driver is full heat with set point above 70°F and full A/C with set point below 70°F.	<ul style="list-style-type: none"> • A55 module failure • Se21 failure • Circuit ANA-89 shorted to ground
FMI 5	Open Circuit	A55 module does not detect Driver Temperature Sensor Se21	Driver temperature not displayed on HVCA module. Driver is full heat with set point above 70°F and full A/C with set point below 70°F.	<ul style="list-style-type: none"> • A55 module failure • Se21 failure • Circuit ANA-89 open

MID 188 PSID # 26 Passenger Sensor (A54 J1:13)

Type of fault:	FMI Description:	Fault Condition:	Possible Symptoms:	Possible Causes:
FMI 3	Shorted High	Voltage above normal on A54 J1:13	Following message appears on the DID: PSID 26 PASS. SENSOR {psid +26, 188, pass. sensor} Out of range	<ul style="list-style-type: none"> • A54 module failure • Se25 failure • Circuit ANA-86 shorted to battery
FMI 4	Shorted Low	Voltage below normal on A54 J1:13		<ul style="list-style-type: none"> • A54 module failure • Se25 failure • Circuit ANA-86 shorted to ground
FMI 5	Open Circuit	A54 module does not detect Passenger Temperature Sensor Se25		<ul style="list-style-type: none"> • A54 module failure • Se25 failure • Circuit ANA-86 open

MID 188 SID # 64 Drv air Trap (A44 J1:2)

Type of fault:	FMI Description:	Fault Condition:	Possible Symptoms:	Possible Causes:
FMI 3	Shorted High	Voltage present on output A44 J1:2 but output not active	Dash damper not moving	<ul style="list-style-type: none"> • A44 module failure • Dash Damper Mo3 failure • Connector C72 corroded • Circuit 68A shorted to battery
FMI 4	Shorted Low	Output A44 J1:2 shorted to ground	Dash damper not moving	<ul style="list-style-type: none"> • A44 module failure • Dash Damper Mo3 failure • Connector C72 corroded • Circuit 68A shorted to ground
FMI 6	Current above normal	Output A44 J1:2 internal software fuse active for overcurrent	Dash damper not moving	<ul style="list-style-type: none"> • A44 module failure • Connector C72 corroded • Circuit 68A shorted to ground

SECTION 06B: ELECTRICAL

				• Mo3 low resistance value
--	--	--	--	----------------------------

MID 188 PSID # 30 Drv Rec Cylind (A47 J1:4)

Type of fault:	FMI Description:	Fault Condition:	Possible Symptoms:	Possible Causes:
FMI 3	Shorted High	Voltage present on output A47 J1:4 but output not active	Driver's area always in recirculation mode. Windshield could fog up	<ul style="list-style-type: none"> • A47 module failure • Gaz Cylinder driver LH L283 failure • Gaz Cylinder driver RH L203 failure • Circuit 65D shorted to battery
FMI 4	Shorted Low	Output A47 J1:4 shorted to ground	Recirculation mode not working, low A/C performance	<ul style="list-style-type: none"> • A47 module failure • Gaz Cylinder driver LH L283 failure • Gaz Cylinder driver RH L203 failure • Circuit 65D shorted to ground
FMI 5	Open Circuit	A47 module does not detect Gaz Cylinder driver LH L283 and RH L203	Recirculation mode not working. Low A/C performance	<ul style="list-style-type: none"> • A47 module failure • Gaz Cylinder driver LH L283 open circuit • Gaz Cylinder driver RH L203 open circuit • Circuit 65D open • Circuit ORC3 open
FMI 6	Current above normal	Output A47 J1:4 internal software fuse active for overcurrent	Recirculation mode not working. Low A/C performance	<ul style="list-style-type: none"> • A47 module failure • Circuit 65D shorted to ground • LH L283 or RH L203 low resistance value

MID 188 PSID # 82 Elec Horn SW61 (A45 J1:10)

Type of fault:	FMI Description:	Fault Condition:	Possible Symptoms:	Possible Causes:
FMI 3	Shorted High	Voltage above normal on A45 J1:10	Electrical horn not working	<ul style="list-style-type: none"> • A45 module failure • Connector C71 corroded • Circuit 69 shorted to battery
FMI 4	Shorted Low	Voltage below normal on A45 J1:10	Electrical horn always ON	<ul style="list-style-type: none"> • A45 module failure • Connector C71 corroded • Circuit 69 shorted to ground

MID 188 SID # 47 Emergency Lt R15 (A49 J1:13)

Type of fault:	FMI Description:	Fault Condition:	Possible Symptoms:	Possible Causes:
FMI 3	Shorted High	Voltage present on output A49 J1:13 but output not active	Emergency lights always ON	<ul style="list-style-type: none"> • A49 module failure • Relay R15 failure • Connector C35 corroded • Circuit 64 shorted to battery
FMI 4	Shorted Low	Output A49 J1:13 shorted to ground	Emergency lights not working	<ul style="list-style-type: none"> • A49 module failure • Relay R15 failure • Connector C35 corroded • Circuit 64 shorted to ground
FMI 5	Open Circuit	A49 module does not	Emergency	<ul style="list-style-type: none"> • A49 module failure

SECTION 06B: ELECTRICAL

		detect relay R15	lights not working	<ul style="list-style-type: none"> • Relay R15 open circuit • Circuit 64 open
FMI 6	Current above normal	Output A49 J1:13 internal software fuse active for overcurrent	Emergency lights not working	<ul style="list-style-type: none"> • A49 module failure • Connector C35 corroded • Circuit 64 shorted to ground • Relay R15 low resistance value (expected value \pm 200 ohms)

MID 188 PSID # 44 Emergency Relay (A36 JA:24)

Type of fault:	FMI Description:	Fault Condition:	Possible Symptoms:	Possible Causes:
FMI 3	Shorted High	Voltage present on output A36 JA:24 but output not active	Engine will shut down or cannot be started	<ul style="list-style-type: none"> • A36 module failure • Relay R21 failure • Connector C2 corroded • Connector C21 corroded • Circuit 911 shorted to battery
FMI 4	Shorted Low	Output A36 JA:24 shorted to ground	Emergency cutout system not working	<ul style="list-style-type: none"> • A36 module failure • Relay R21 failure • Connector C2 corroded • Connector C21 corroded • Circuit 911 shorted to ground
FMI 5	Open Circuit	A36 module does not detect Emergency Cutout Relay R21	Emergency cutout system not working	<ul style="list-style-type: none"> • A36 module failure • Relay R21 open circuit • Circuit 911 open
FMI 6	Current above normal	Output A36 JA:24 internal software fuse active for overcurrent	Emergency cutout system not working	<ul style="list-style-type: none"> • A36 module failure • Connector C2 corroded • Connector C21 corroded • Circuit 911 shorted to ground • Relay R21 low resistance value

MID 188 PSID # 101 Emgy & Aisle Lts (A46 J1:4)

Type of fault:	FMI Description:	Fault Condition:	Possible Symptoms:	Possible Causes:
FMI 3	Shorted High	Voltage present on output A46 J1:4 but output not active	Aisle lights always ON	<ul style="list-style-type: none"> • A46 module failure • Connector C144 corroded • Circuit 5 shorted to battery
FMI 4	Shorted Low	Output A46 J1:4 shorted to ground	Aisle lights not working	<ul style="list-style-type: none"> • A46 module failure • Connector C144 corroded • Circuit 5 shorted to ground
FMI 6	Current above normal	Output A46 J1:4 internal software fuse active for overcurrent	Aisle lights not working	<ul style="list-style-type: none"> • A46 module failure • Connector C144 corroded • Circuit 5 shorted to ground • Low resistance value

MID 188 PSID # 6 Engine Door Se (A49 J1:2)

Type of fault:	FMI Description:	Fault Condition:	Possible Symptoms:	Possible Causes:
FMI 3	Shorted High	Voltage above normal on A49 J1:2	Engine door switch Se30 &	<ul style="list-style-type: none"> • A49 module failure • Se30 failure

SECTION 06B: ELECTRICAL

			compressor door switch Se31 always ON	<ul style="list-style-type: none"> • Se31 failure • Connector C91 corroded • Circuit 9A shorted to battery
FMI 4	Shorted Low	Voltage below normal on A49 J1:2	Engine door switch Se30 & compressor door switch Se31 not working	<ul style="list-style-type: none"> • A49 module failure • Se30 failure • Se31 failure • Connector C91 corroded • Circuit 9A shorted to ground

MID 188 PSID # 53 Engine Fan Spd1 (A52 J1:1)

Type of fault:	FMI Description:	Fault Condition:	Possible Symptoms:	Possible Causes:
FMI 3	Shorted High	Voltage present on output A52 J1:1 but output not active	Radiator fan clutch Mo2 not working on speed 1	<ul style="list-style-type: none"> • A52 module failure • Radiator fan clutch Mo2 failure • Connector C91 corroded • Connector C426 corroded • Diode D37 shorted internally • Circuit 291 shorted to battery
FMI 4	Shorted Low	Output A52 J1:1 shorted to ground	Radiator fan clutch Mo2 always ON speed 1	<ul style="list-style-type: none"> • A52 module failure • Radiator fan clutch Mo2 failure • Connector C91 corroded • Connector C426 corroded • Circuit 291 shorted to ground
FMI 5	Open Circuit	A52 module does not detect radiator fan clutch Mo2	Radiator fan clutch Mo2 not working on speed 1	<ul style="list-style-type: none"> • A52 module failure • Radiator fan clutch Mo2 open circuit • Circuit 291 open
FMI 6	Current above normal	Output A52 J1:1 internal software fuse active for overcurrent	Radiator fan clutch Mo2 not working on speed 1	<ul style="list-style-type: none"> • A52 module failure • Connector C91 corroded • Connector C426 corroded • Circuit 291 shorted to battery

MID 188 PSID # 54 Engine Fan Spd2 (A52 J1:2)

Type of fault:	FMI Description:	Fault Condition:	Possible Symptoms:	Possible Causes:
FMI 3	Shorted High	Voltage present on output A52 J1:2 but output not active	Radiator fan clutch Mo2 not working on speed 2	<ul style="list-style-type: none"> • A52 module failure • Radiator fan clutch Mo2 failure • Connector C91 corroded • Connector C426 corroded • Diode D36 shorted internally • Circuit 292 shorted to battery
FMI 4	Shorted Low	Output A52 J1:2 shorted to ground	Radiator fan clutch Mo2 always ON speed 2	<ul style="list-style-type: none"> • A52 module failure • Radiator fan clutch Mo2 failure • Connector C91 corroded • Connector C426 corroded • Circuit 292 shorted to ground
FMI 5	Open Circuit	A52 module does not detect radiator fan clutch Mo2	Radiator fan clutch Mo2 not working on speed 2	<ul style="list-style-type: none"> • A52 module failure • Radiator fan clutch Mo2 open circuit • Connector C91 corroded

SECTION 06B: ELECTRICAL

				<ul style="list-style-type: none"> • Connector C426 corroded • Circuit 292 open
FMI 6	Current above normal	Output A52 J1:2 internal software fuse active for overcurrent	Radiator fan clutch Mo2 not working on speed 2	<ul style="list-style-type: none"> • A52 module failure • Connector C91 corroded • Connector C426 corroded • Circuit 292 shorted to battery

MID 188 PSID # 70 Ent Close Out (A36 JB:17)

Type of fault:	FMI Description:	Fault Condition:	Possible Symptoms:	Possible Causes:
FMI 3	Shorted High	Voltage above normal on A36 JB:17	Entrance door cannot be opened	<ul style="list-style-type: none"> • A36 module failure • Sw34 failure • Connector C6 corroded • Circuit 49 shorted to battery
FMI 4	Shorted Low	Voltage below normal on A36 JB:17	Entrance door cannot be closed with switch	<ul style="list-style-type: none"> • A36 module failure • Sw34 failure • Connector C6 corroded • Circuit 49 shorted to ground

MID 188 PSID # 63 Ent Close Sens (A47 J1:10)

Type of fault:	FMI Description:	Fault Condition:	Possible Symptoms:	Possible Causes:
FMI 3	Shorted High	Voltage above normal on A47 J1:10	Entrance door cannot be opened	<ul style="list-style-type: none"> • A47 module failure • Se76 failure • Connector CXC1 corroded • Circuit 3 shorted to battery
FMI 4	Shorted Low	Voltage below normal on A47 J1:10	Entrance door cannot be closed with switch	<ul style="list-style-type: none"> • A47 module failure • Se76 failure • Connector CXC1 corroded • Circuit 3 shorted to ground

MID 188 PSID # 65 Ent Close Sol (A47 J1:6)

Type of fault:	FMI Description:	Fault Condition:	Possible Symptoms:	Possible Causes:
FMI 3	Shorted High	Voltage present on output A47 J1:6 but output not active	Close Solenoid Valve So6 always ON - Entrance door cannot be opened	<ul style="list-style-type: none"> • A47 module failure • Close solenoid valve So6 failure • Circuit 49A shorted to battery
FMI 4	Shorted Low	Output A47 J1:6 shorted to ground	Entrance door cannot be closed with switch	<ul style="list-style-type: none"> • A47 module failure • Close solenoid valve So6 failure • Circuit 49A shorted to ground
FMI 5	Open Circuit	A47 module does not detect Close Solenoid Valve So6	Entrance door cannot be closed with switch	<ul style="list-style-type: none"> • A47 module failure • Close solenoid valve So6 open • Circuit 49A open
FMI 6	Current above normal	Output A47 J1:6 internal software fuse active for overcurrent	Entrance door cannot be closed with switch	<ul style="list-style-type: none"> • A47 module failure • Circuit 49A shorted to ground • Close solenoid valve So6 shorted to ground

SECTION 06B: ELECTRICAL

MID 188 PSID # 64 Ent Door Close (A36 JB:10)

Type of fault:	FMI Description:	Fault Condition:	Possible Symptoms:	Possible Causes:
FMI 3	Shorted High	Voltage above normal on A36 J1:10	Entrance door cannot be closed with switch	<ul style="list-style-type: none"> • A36 module failure • Connector C71 corroded • Circuit 49A shorted to battery
FMI 4	Shorted Low	Voltage below normal on A36 JB:10	Entrance door cannot be opened	<ul style="list-style-type: none"> • A36 module failure • Inside switch close Sw32 failure • Connector C71 corroded • Circuit 49A shorted to ground

MID 188 PSID # 71 Ent open out (A36 JB:15)

Type of fault:	FMI Description:	Fault Condition:	Possible Symptoms:	Possible Causes:
FMI 3	Shorted High	Voltage above normal on A36 J1:15	Entrance door cannot be closed	<ul style="list-style-type: none"> • A36 module failure • Sw34 failure • Connector C6 corroded • Circuit 47 shorted to battery
FMI 4	Shorted Low	Voltage below normal on A36 JB:15	Entrance door cannot be opened with switch	<ul style="list-style-type: none"> • A36 module failure • Sw34 failure • Connector C6 corroded • Circuit 47 shorted to ground

MID 188 PSID # 67 Ent Open Sol (A47 J1:7)

Type of fault:	FMI Description:	Fault Condition:	Possible Symptoms:	Possible Causes:
FMI 3	Shorted High	Voltage present on output A47 J1:7 but output not active	Open Solenoid Valve So5 always ON - Entrance door cannot be closed	<ul style="list-style-type: none"> • A47 module failure • Open solenoid valve So5 failure • Connector C70 corroded • Connector C6 corroded • Circuit 48A shorted to battery
FMI 4	Shorted Low	Output A47 J1:7 shorted to ground	Entrance door cannot be opened with switch	<ul style="list-style-type: none"> • A47 module failure • Open solenoid valve So5 failure • Circuit 48A shorted to ground
FMI 5	Open Circuit	A47 module does not detect Open Solenoid Valve So5	Entrance door cannot be opened with switch	<ul style="list-style-type: none"> • A47 module failure • Open solenoid valve So5 open • Circuit 48A open
FMI 6	Current above normal	Output A47 J1:7 internal software fuse active for overcurrent	Entrance door cannot be opened with switch	<ul style="list-style-type: none"> • A47 module failure • Circuit 48A shorted to ground • Open solenoid valve So5 shorted internally

MID 188 PSID # 72 Ent Unlk Sol (A47 J1:8)

Type of fault:	FMI Description:	Fault Condition:	Possible Symptoms:	Possible Causes:
FMI 3	Shorted High	Voltage present on	Unlk Solenoid	<ul style="list-style-type: none"> • A47 module failure

SECTION 06B: ELECTRICAL

		output A47 J1:8 but output not active	Valve So3 or Unlk Solenoid Valve So4 always ON - Entrance door cannot be locked	<ul style="list-style-type: none"> • Unlk solenoid valve So3 failure • Unlk solenoid valve So4 failure • Circuit 12W shorted to battery
FMI 4	Shorted Low	Output A47 J1:8 shorted to ground	Entrance door cannot be unlocked	<ul style="list-style-type: none"> • A47 module failure • Unlk solenoid valve So3 failure • Unlk solenoid valve So4 failure • Circuit 12W shorted to ground
FMI 5	Open Circuit	A47 module does not detect Unlk Solenoid Valve So3 or Unlk Solenoid Valve So4	Entrance door cannot be unlocked	<ul style="list-style-type: none"> • A47 module failure • Unlk solenoid valve So3 open • Unlk solenoid valve So4 open • Circuit 12W open
FMI 6	Current above normal	Output A47 J1:8 internal software fuse active for overcurrent	Entrance door cannot be unlocked	<ul style="list-style-type: none"> • A47 module failure • Circuit 12W shorted to ground • Unlk solenoid valve So3 or So4 shorted internally

MID 188 PSID # 77 Evap Motor Rly (A54 J1:7)

Type of fault:	FMI Description:	Fault Condition:	Possible Symptoms:	Possible Causes:
FMI 3	Shorted High	Voltage present on output A54 J1:7 but output not active	Evaporator fan always ON	<ul style="list-style-type: none"> • A54 module failure • Evaporator Relay R12 failure • Circuit 67 shorted to battery
FMI 4	Shorted Low	Output A54 J1:7 shorted to ground	Evaporator fan not working	<ul style="list-style-type: none"> • A54 module failure • Evaporator Relay R12 failure • Circuit 67 shorted to ground
FMI 5	Open Circuit	A54 module does not detect evaporator relay R12	Evaporator fan not working	<ul style="list-style-type: none"> • A54 module failure • Evaporator Relay R12 open circuit • Circuit 67 open
FMI 6	Current above normal	Output A54 J1:7 internal software fuse active for overcurrent	Evaporator fan not working	<ul style="list-style-type: none"> • A54 module failure • Circuit 67 shorted to ground

MID 188 PSID # 133 Flash RH Sw (A48 J1:12)

Type of fault:	FMI Description:	Fault Condition:	Possible Symptoms:	Possible Causes:
FMI 3	Shorted High	Voltage present on input A48 J1:12 but output not active	RH flasher not working	<ul style="list-style-type: none"> • A48 module failure • Connector C4 corroded • Connector Foot:C corroded • Circuit 23 shorted to battery
FMI 4	Shorted Low	Input A48 J1:12 shorted to ground	RH flasher always ON	<ul style="list-style-type: none"> • A48 module failure • Foot switch Sw139 failure • Connector C4 corroded • Connector Foot:C corroded • Circuit 23 shorted to ground

SECTION 06B: ELECTRICAL

MID 188 PSID # 130 Flasher LH (A45 J1:9)

Type of fault:	FMI Description:	Fault Condition:	Possible Symptoms:	Possible Causes:
FMI 3	Shorted High	Voltage present on input A45 J1:9 but output not active	LH flasher not working	<ul style="list-style-type: none"> • A45 module failure • Connector Foot:B corroded • Circuit 21 shorted to battery
FMI 4	Shorted Low	Input A45 J1:9 shorted to ground	LH flasher always ON	<ul style="list-style-type: none"> • A45 module failure • Foot switch Sw138 failure • Connector Foot:B corroded • Circuit 21 shorted to ground

MID 188 PSID # 37 Foot trap (A45 J1:2)

Type of fault:	FMI Description:	Fault Condition:	Possible Symptoms:	Possible Causes:
FMI 3	Shorted High	Voltage present on output A45 J1:2 but output not active	Foot damper Mo4 always ON	<ul style="list-style-type: none"> • A45 module failure • Foot Damper Mo4 failure • Connector C72 corroded • Circuit 65A shorted to battery
FMI 4	Shorted Low	Output A45 J1:2 shorted to ground	Foot damper Mo4 not working	<ul style="list-style-type: none"> • A45 module failure • Foot Damper Mo4 failure • Connector C72 corroded • Circuit 65A shorted to ground
FMI 6	Current above normal	Output A45 J1:2 internal software fuse active for overcurrent	Foot damper Mo4 not working	<ul style="list-style-type: none"> • A45 module failure • Connector C72 corroded • Circuit 65A shorted to ground

MID 188 PSID # 137 FR Clearance lights (A44 J1:8)

Type of fault:	FMI Description:	Fault Condition:	Possible Symptoms:	Possible Causes:
FMI 3	Shorted High	Voltage present on output A44 J1:8 but output not active	Front Clearance Lights always ON	<ul style="list-style-type: none"> • A44 module failure • Connector C45 corroded • Circuit 63A shorted to battery
FMI 4	Shorted Low	Output A44 J1:8 shorted to ground	Front Clearance Lights not working	<ul style="list-style-type: none"> • A44 module failure • Connector C45 corroded • Circuit 63A shorted to ground
FMI 5	Open Circuit	A44 module does not detect Front Clearance Lights	Front Clearance Lights not working	<ul style="list-style-type: none"> • A44 module failure • L16 open circuit • Circuit 63A open
FMI 6	Current above normal	Output A44 J1:8 internal software fuse active for overcurrent	Front Clearance Lights not working	<ul style="list-style-type: none"> • A44 module failure • Connector C45 corroded • Circuit 63A shorted to ground

MID 188 PSID # 128 Fr Fish-Mkr LH (A45 J1:3)

Type of fault:	FMI Description:	Fault Condition:	Possible Symptoms:	Possible Causes:
FMI 3	Shorted High	Voltage present on output A45 J1:3 but output not active	Front LH flasher and marker lights always ON	<ul style="list-style-type: none"> • A45 module failure • Connector C4 corroded • Connector C242 corroded • Circuit 21A shorted to battery

SECTION 06B: ELECTRICAL

FMI 4	Shorted Low	Output A45 J1:3 shorted to ground	Front LH flasher and marker lights not working	<ul style="list-style-type: none"> • A45 module failure • Connector C4 corroded • Connector C242 corroded • Circuit 21A shorted to ground
FMI 6	Current above normal	Output A45 J1:3 internal software fuse active for overcurrent	Front LH flasher and marker lights not working	<ul style="list-style-type: none"> • A45 module failure • Connector C4 corroded • Connector C242 corroded • Circuit 21A shorted to ground

MID 188 PSID # 10 Fr Side Flsh (A48 J1:20)

Type of fault:	FMI Description:	Fault Condition:	Possible Symptoms:	Possible Causes:
FMI 3	Shorted High	Voltage present on output A48 J1:20 but output not active	Flasher RH Front side L64 always ON	<ul style="list-style-type: none"> • A48 module failure • Flasher RH Front Side L64 failure • Circuit 23AA shorted to battery
FMI 4	Shorted Low	Output A48 J1:20 shorted to ground	Flasher RH Front side L64 not working	<ul style="list-style-type: none"> • A48 module failure • Flasher RH Front Side L64 failure • Circuit 23AA shorted to ground
FMI 6	Current above normal	Output A48 J1:20 internal software fuse active for overcurrent	Flasher RH Front side L64 not working	<ul style="list-style-type: none"> • A48 module failure • Circuit 23AA shorted to ground

MID 188 PSID # 58 Fr Start Sw (A36 JB:22)

Type of fault:	FMI Description:	Fault Condition:	Possible Symptoms:	Possible Causes:
FMI 3	Shorted High	Voltage present on output A36 JB:22 but switch not in Start position	Engine will start on ignition	<ul style="list-style-type: none"> • A36 module failure • Front start switch Sw83 failure • Connector C40 corroded • Connector C71 corroded • Circuit 84B shorted to battery
FMI 4	Shorted Low	Input A36 JB:22 shorted to ground	Engine cannot be started from front	<ul style="list-style-type: none"> • A36 module failure • Front start switch Sw83 failure • Connector C40 corroded • Connector C71 corroded • Circuit 84B shorted to ground

MID 188 PSID # 126 Front Flash RH (A48 J1:6)

Type of fault:	FMI Description:	Fault Condition:	Possible Symptoms:	Possible Causes:
FMI 3	Shorted High	Voltage present on output A48 J1:6 but output not active	Front Flasher RH L61 always ON	<ul style="list-style-type: none"> • A48 module failure • Connector C243 corroded • Circuit 23A shorted to battery
FMI 4	Shorted Low	Output A48 J1:6 shorted to ground	Front Flasher RH L61 not working	<ul style="list-style-type: none"> • A48 module failure • Connector C243 corroded • Circuit 23A shorted to ground
FMI 6	Current above normal	Output A48 J1:6 internal software fuse active for overcurrent	Front Flasher RH L61 not working	<ul style="list-style-type: none"> • A48 module failure • Connector C243 corroded • Circuit 23A shorted to ground

SECTION 06B: ELECTRICAL

MID 188 PSID # 148 FrontMkr Lts LH (A45 J1:21)

Type of fault:	FMI Description:	Fault Condition:	Possible Symptoms:	Possible Causes:
FMI 3	Shorted High	Voltage present on output A45 J1:21 but output not active	Front Flasher LH L62 always ON	<ul style="list-style-type: none"> • A45 module failure • Connector C4 corroded • Connector C242 corroded • Circuit 46A shorted to battery
FMI 4	Shorted Low	Output A45 J1:21 shorted to ground	Front Flasher LH L62 not working	<ul style="list-style-type: none"> • A45 module failure • Connector C4 corroded • Connector C242 corroded • Circuit 46A shorted to ground
FMI 5	Open Circuit	A45 module does not detect Front Flasher LH L62	Front Flasher LH L62 not working	<ul style="list-style-type: none"> • A45 module failure • Front Flasher LH L62 open circuit • Circuit 46A open
FMI 6	Current above normal	Output A45 J1:21 internal software fuse active for overcurrent	Front Flasher LH L62 not working	<ul style="list-style-type: none"> • A45 module failure • Connector C4 corroded • Connector C242 corroded • Circuit 46A shorted to ground

MID 188 PSID # 149 FrontMkr Lts RH (A48 J1:7)

Type of fault:	FMI Description:	Fault Condition:	Possible Symptoms:	Possible Causes:
FMI 3	Shorted High	Voltage present on output A48 J1:7 but output not active	Front Flasher RH L61 and Marker L63 always ON	<ul style="list-style-type: none"> • A48 module failure • Connector C243 corroded • Circuit 46 shorted to battery
FMI 4	Shorted Low	Output A48 J1:7 shorted to ground	Front Flasher RH L61 and Marker L63 not working	<ul style="list-style-type: none"> • A48 module failure • Connector C243 corroded • Circuit 46 shorted to ground
FMI 5	Open Circuit	A48 module does not detect Front Flasher LH L62	Front Flasher RH L61 and Marker L63 not working	<ul style="list-style-type: none"> • A48 module failure • Front Flasher RH L61 and Marker L63 open circuit • Circuit 46 open
FMI 6	Current above normal	Output A48 J1:7 internal software fuse active for overcurrent	Front Flasher RH L61 and Marker L63 not working	<ul style="list-style-type: none"> • A48 module failure • Connector C243 corroded • Circuit 46 shorted to ground

MID 188 PSID # 56 FrStart Enable Sw (A53 J1:9)

Type of fault:	FMI Description:	Fault Condition:	Possible Symptoms:	Possible Causes:
FMI 3	Shorted High	Voltage present on input A53 J1:9 but switch Sw58 not active	Engine cannot be started or stopped from rear	<ul style="list-style-type: none"> • A53 module failure • Rear start switch Sw58 failure • Connector C91 corroded • Circuit 85C shorted to battery
FMI 4	Shorted Low	Output A53 J1:9 shorted to ground	Engine cannot be started from front	<ul style="list-style-type: none"> • A53 module failure • Rear start switch Sw58 failure • Connector C91 corroded • Circuit 85C shorted to ground

SECTION 06B: ELECTRICAL

MID 188 PSID # 81 Fuel Filtr Sens (A49 J1:20)

Type of fault:	FMI Description:	Fault Condition:	Possible Symptoms:	Possible Causes:
FMI 3	Shorted High	Voltage present on input A49 J1:20	No warning of water in fuel filter on dash	<ul style="list-style-type: none"> • A49 module failure • Connector C91 corroded • Connector C78 corroded • Circuit 197 shorted to battery
FMI 4	Shorted Low	Input A49 J1:20 shorted to ground	Fuel water filter sensor always On on dash	<ul style="list-style-type: none"> • A49 module failure • Fuel water filter Se12 failure • Connector C91 corroded • Connector C78 corroded • Circuit 197 shorted to ground

MID 188 PSID # 138 Hazard Switch (A36 JB:4)

Type of fault:	FMI Description:	Fault Condition:	Possible Symptoms:	Possible Causes:
FMI 3	Shorted High	Voltage present on input A36 JB:4 but switch Sw4 not active	Hazard lights always ON	<ul style="list-style-type: none"> • A36 module failure • Hazard switch Sw4 failure • Connector C71 corroded • Circuit 22 shorted to battery
FMI 4	Shorted Low	Input A36 JB:4 shorted to ground	Hazard lights not working	<ul style="list-style-type: none"> • A36 module failure • Hazard switch Sw4 failure • Connector C71 corroded • Circuit 22 shorted to ground

MID 188 SID # 48 HdLamp Wsh Pmp (A46 J1:21)

Type of fault:	FMI Description:	Fault Condition:	Possible Symptoms:	Possible Causes:
FMI 3	Shorted High	Voltage present on output A46 J1:21 but output not active	Headlamp washer pump Mo54 always ON	<ul style="list-style-type: none"> • A46 module failure • Connector C4 corroded • Circuit 202 shorted to battery
FMI 4	Shorted Low	Output A46 J1:21 shorted to ground	Headlamp washer pump Mo54 not working	<ul style="list-style-type: none"> • A46 module failure • Headlamp washer pump Mo54 failure • Connector C4 corroded • Circuit 202 shorted to ground
FMI 5	Open Circuit	A46 module does not detect Headlamp washer pump Mo54	Headlamp washer pump Mo54 not working	<ul style="list-style-type: none"> • A46 module failure • Headlamp washer pump Mo54 open circuit • Circuit 202 open
FMI 6	Current above normal	Output A46 J1:21 internal software fuse active for overcurrent	Headlamp washer pump Mo54 not working	<ul style="list-style-type: none"> • A46 module failure • Connector C4 corroded • Circuit 202 shorted to ground

MID 188 PSID # 143 Head Lights Pos1 (A43 J1:4)

Type of fault:	FMI Description:	Fault Condition:	Possible Symptoms:	Possible Causes:
FMI 3	Shorted High	Voltage present on input A43 J1:4 but switch Sw2 not active	Low Beam headlights not working	<ul style="list-style-type: none"> • A43 module failure • Headlight switch Sw2 failure • Connector C71 corroded • Circuit 66 shorted to battery
FMI 4	Shorted Low	Input A43 J1:4	Headlights	<ul style="list-style-type: none"> • A43 module failure

SECTION 06B: ELECTRICAL

		shorted to ground	always ON low beam	<ul style="list-style-type: none"> • Headlight switch Sw2 failure • Connector C71 corroded • Circuit 66 shorted to ground
--	--	-------------------	--------------------	--

MID 188 SID # 62 Hi Low Beam (A43 J1:8)

Type of fault:	FMI Description:	Fault Condition:	Possible Symptoms:	Possible Causes:
FMI 3	Shorted High	Voltage present on input A43 J1:8 but switch Sw141 not active	Headlights always ON High beam	<ul style="list-style-type: none"> • A43 module failure • Foot switch Sw141 failure • Connector Foot:A corroded • Connector C71 corroded • Circuit 59 shorted to battery
FMI 4	Shorted Low	Input A43 J1:8 shorted to ground	High Low Beam headlights foot switch not working	<ul style="list-style-type: none"> • A43 module failure • Foot switch Sw141 failure • Connector Foot:A corroded • Connector C71 corroded • Circuit 59 shorted to ground

MID 188 PSID # 141 High Beam LH (A45 J1:6)

Type of fault:	FMI Description:	Fault Condition:	Possible Symptoms:	Possible Causes:
FMI 3	Shorted High	Voltage present on output A45 J1:6 but output not active	LH High beam Headlamp L60B always ON	<ul style="list-style-type: none"> • A45 module failure • Connector C4 corroded • Connector C242 corroded • Circuit 57L shorted to battery
FMI 4	Shorted Low	Output A45 J1:6 shorted to ground	LH High beam Headlamp L60B not working	<ul style="list-style-type: none"> • A45 module failure • Connector C4 corroded • Connector C242 corroded • Circuit 57L shorted to ground
FMI 5	Open Circuit	A45 module does not detect LH High beam Headlamp L60B	LH High beam Headlamp L60B not working	<ul style="list-style-type: none"> • A45 module failure • LH High beam Headlamp L60B open circuit • Circuit 57L open
FMI 6	Current above normal	Output A45 J1:6 internal software fuse active for overcurrent	LH High beam Headlamp L60B not working	<ul style="list-style-type: none"> • A45 module failure • Connector C4 corroded • Connector C242 corroded • Circuit 57L shorted to ground

MID 188 PSID # 145 High Beam RH (A48 J1:3)

Type of fault:	FMI Description:	Fault Condition:	Possible Symptoms:	Possible Causes:
FMI 3	Shorted High	Voltage present on output A48 J1:3 but output not active	RH High beam Headlamp L59B always ON	<ul style="list-style-type: none"> • A48 module failure • Connector C243 corroded • Circuit 57R shorted to battery
FMI 4	Shorted Low	Output A48 J1:3 shorted to ground	RH High beam Headlamp L59B not working	<ul style="list-style-type: none"> • A48 module failure • Connector C243 corroded • Circuit 57R shorted to ground
FMI 5	Open Circuit	A48 module does not detect RH High beam	RH High beam Headlamp	<ul style="list-style-type: none"> • A48 module failure • RH High beam Headlamp

SECTION 06B: ELECTRICAL

		Headlamp L59B	L59B not working	L59B open circuit • Circuit 57R open
FMI 6	Current above normal	Output A48 J1:3 internal software fuse active for overcurrent	RH High beam Headlamp L59B not working	• A48 module failure • Connector C243 corroded • Circuit 57R shorted to ground

MID 188 PSID # 83 Horn (A45 J1:20)

Type of fault:	FMI Description:	Fault Condition:	Possible Symptoms:	Possible Causes:
FMI 3	Shorted High	Voltage present on output A45 J1:20 but output not active	Electrical horn L185 and L186 always ON	<ul style="list-style-type: none"> • A45 module failure • Electrical horn L185 or L186 failure • Connector C4 corroded • Connector C101 corroded • Circuit 52A shorted to battery
FMI 4	Shorted Low	Output A45 J1:20 shorted to ground	Electrical horn L185 and L186 not working	<ul style="list-style-type: none"> • A45 module failure • Electrical horn L185 or L186 failure • Connector C4 corroded • Connector C101 corroded • Circuit 52A shorted to ground
FMI 5	Open Circuit	A45 module does not detect Electrical horn L185 or L186	Electrical horn L185 and L186 not working	<ul style="list-style-type: none"> • A45 module failure • Electrical horn L185 or L186 open circuit • Circuit 52A open
FMI 6	Current above normal	Output A45 J1:20 internal software fuse active for overcurrent	Electrical horn L185 and L186 not working	<ul style="list-style-type: none"> • A45 module failure • Connector C4 corroded • Connector C101 corroded • Circuit 52A shorted to ground

MID 188 PSID # 110 Indir Lts Rly (A49 J1:12)

Type of fault:	FMI Description:	Fault Condition:	Possible Symptoms:	Possible Causes:
FMI 3	Shorted High	Voltage present on output A49 J1:12 but output not active	Indirect lighting always ON	<ul style="list-style-type: none"> • A49 module failure • Indirect Light Relay R13 failure • Circuit 132 shorted to battery
FMI 4	Shorted Low	Output A49 J1:12 shorted to ground	Indirect lighting not working	<ul style="list-style-type: none"> • A49 module failure • Indirect Light Relay R13 failure • Circuit 132 shorted to ground
FMI 5	Open Circuit	A49 module does not detect Indirect Light Relay R13	Indirect lighting not working	<ul style="list-style-type: none"> • A49 module failure • Indirect Light Relay R13 open circuit • Circuit 132 open
FMI 6	Current above normal	Output A49 J1:12 internal software fuse active for overcurrent	Indirect lighting not working	<ul style="list-style-type: none"> • A49 module failure • Circuit 132 shorted to ground • Relay R13 coil shorted to ground

SECTION 06B: ELECTRICAL

MID 188 PSID # 89 Knee down Sol (A41 J1:14)

Type of fault:	FMI Description:	Fault Condition:	Possible Symptoms:	Possible Causes:
FMI 3	Shorted High	Voltage present on output A41 J1:14 but output not active	Kneeling down always ON, coach cannot be raised	<ul style="list-style-type: none"> • A41 module failure • Kneeling down solenoid valve So16 failure • Connector C4 corroded • Connector C172 corroded • Circuit 126F shorted to battery
FMI 4	Shorted Low	Output A41 J1:14 shorted to ground	Kneeling down not working	<ul style="list-style-type: none"> • A41 module failure • Kneeling down solenoid valve So16 failure • Connector C4 corroded • Connector C172 corroded • Circuit 126F shorted to ground
FMI 5	Open Circuit	A41 module does not detect Knee. Down Solenoid Valve So16	Kneeling down not working	<ul style="list-style-type: none"> • A41 module failure • Kneeling down solenoid valve So16 open circuit • Circuit 126F open
FMI 6	Current above normal	Output A41 J1:14 internal software fuse active for overcurrent	Kneeling down not working	<ul style="list-style-type: none"> • A41 module failure • Connector C4 corroded • Connector C172 corroded • Circuit 12W shorted to ground

MID 188 PSID # 93 Knee Down Sw (A41 J1:7)

Type of fault:	FMI Description:	Fault Condition:	Possible Symptoms:	Possible Causes:
FMI 3	Shorted High	Voltage present on input A41 J1:7 but switch Sw10A not active	Kneeling down not working	<ul style="list-style-type: none"> • A41 module failure • Kneeling switch Sw10A failure • Connector C71 corroded • Connector C170 corroded • Circuit 126A shorted to battery
FMI 4	Shorted Low	Input A41 J1:7 shorted to ground	Kneeling down always ON, coach cannot be raised	<ul style="list-style-type: none"> • A41 module failure • Kneeling switch Sw10A failure • Connector C71 corroded • Connector C170 corroded • Circuit 126A shorted to ground

MID 188 PSID # 94 Knee Up Sw (A41 J1:6)

Type of fault:	FMI Description:	Fault Condition:	Possible Symptoms:	Possible Causes:
FMI 3	Shorted High	Voltage present on input A41 J1:6 but switch Sw10A not active	Kneeling up not working	<ul style="list-style-type: none"> • A41 module failure • Kneeling switch Sw10A failure • Connector C71 corroded • Connector C170 corroded • Circuit 126B shorted to battery
FMI 4	Shorted Low	Input A41 J1:6 shorted to ground	Kneeling Up always ON, coach cannot be lowered	<ul style="list-style-type: none"> • A41 module failure • Kneeling switch Sw10A failure • Connector C71 corroded • Connector C170 corroded • Circuit 126B shorted to ground

SECTION 06B: ELECTRICAL

MID 188 SID # 81 Kneeling Level Se (A46 J1:13)

Type of fault:	FMI Description:	Fault Condition:	Possible Symptoms:	Possible Causes:
FMI 3	Shorted High	Voltage present on signal A46 J1:13 but sensor Se79 not active	Momentary switch function lost, holding switch will raise coach past the normal ride height	<ul style="list-style-type: none"> • A46 module failure • Kneeling level sensor Se79 failure • Connector CSe79 corroded • Circuit ANA-KneeLevel shorted to battery
FMI 4	Shorted Low	Signal A46 J1:13 shorted to ground	Momentary switch function lost, holding switch will lower coach below standard kneeling height and raise coach above the normal ride height	<ul style="list-style-type: none"> • A46 module failure • Kneeling level sensor Se79 failure • Connector CSe79 corroded • Circuit ANA-KneeLevel shorted to ground

MID 188 PSID # 98 Lavatory Fan4 (A52 J1:4)

Type of fault:	FMI Description:	Fault Condition:	Possible Symptoms:	Possible Causes:
FMI 4	Shorted Low	Output A52 J1:4 shorted to ground	Air Exhaust Fan Mo14 not working	<ul style="list-style-type: none"> • A52 module failure • Air Exhaust Fan Mo14 failure • Connector C91 corroded • Circuit 225 shorted to ground
FMI 5	Open Circuit	A52 module does not detect Air Exhaust Fan Mo14	Air Exhaust Fan Mo14 not working	<ul style="list-style-type: none"> • A52 module failure • Air Exhaust Fan Mo14 open circuit • Circuit 225 open
FMI 6	Current above normal	Output A52 J1:4 internal software fuse active for overcurrent	Air Exhaust Fan Mo14 not working	<ul style="list-style-type: none"> • A52 module failure • Connector C91 corroded • Circuit 225 shorted to ground

MID 188 PSID # 142 Low Beam LH (A45 J1:7)

Type of fault:	FMI Description:	Fault Condition:	Possible Symptoms:	Possible Causes:
FMI 3	Shorted High	Voltage present on output A45 J1:7 but output not active	LH Low beam Headlamp L60A always ON	<ul style="list-style-type: none"> • A45 module failure • Connector C4 corroded • Connector C242 corroded • Circuit 58L shorted to battery
FMI 4	Shorted Low	Output A45 J1:7 shorted to ground	LH Low beam Headlamp L60A not working	<ul style="list-style-type: none"> • A45 module failure • Connector C4 corroded • Connector C242 corroded • Circuit 58L shorted to ground
FMI 6	Current above normal	Output A45 J1:7 internal software fuse active for overcurrent	LH Low beam Headlamp L60A not working	<ul style="list-style-type: none"> • A45 module failure • Connector C4 corroded • Connector C242 corroded • Circuit 58L shorted to ground

MID 188 PSID # 146 Low Beam RH (A48 J1:4)

Type of fault:	FMI Description:	Fault Condition:	Possible Symptoms:	Possible Causes:
FMI 3	Shorted High	Voltage present on	RH Low beam	<ul style="list-style-type: none"> • A48 module failure

SECTION 06B: ELECTRICAL

		output A48 J1:4 but output not active	Headlamp L59A always ON	<ul style="list-style-type: none"> • Connector C243 corroded • Circuit 58R shorted to battery
FMI 4	Shorted Low	Output A48 J1:4 shorted to ground	RH Low beam Headlamp L59A not working	<ul style="list-style-type: none"> • A48 module failure • Connector C243 corroded • Circuit 58R shorted to ground
FMI 6	Current above normal	Output A48 J1:4 internal software fuse active for overcurrent	RH Low beam Headlamp L59A not working	<ul style="list-style-type: none"> • A48 module failure • Connector C243 corroded • Circuit 58R shorted to ground

MID 188 PSID # 153 Lower Stop Lamps (A50 J1:6)

Type of fault:	FMI Description:	Fault Condition:	Possible Symptoms:	Possible Causes:
FMI 3	Shorted High	Voltage present on output A50 J1:6 but output not active	Lower stop lamps always ON	<ul style="list-style-type: none"> • A50 module failure • Circuit 82Low shorted to battery
FMI 4	Shorted Low	Output A50 J1:6 shorted to ground	Lower stop lamps not working	<ul style="list-style-type: none"> • A50 module failure • Circuit 82Low shorted to ground
FMI 6	Current above normal	Output A50 J1:6 internal software fuse active for overcurrent	Lower stop lamps not working	<ul style="list-style-type: none"> • A50 module failure • Circuit 82Low shorted to ground

MID 188 PSID # 181 Lower Washer pmp (A46 J1:3)

Type of fault:	FMI Description:	Fault Condition:	Possible Symptoms:	Possible Causes:
FMI 4	Shorted Low	Output A46 J1:3 shorted to ground	Windshield washer pumps Mo19 and Mo20 not working	<ul style="list-style-type: none"> • A46 module failure • Windshield washer pump Mo19 or Mo20 failure • Connector C4 corroded • Connector C61 corroded • Circuit 53F shorted to ground
FMI 5	Open Circuit	A46 module does not detect Windshield washer pumps Mo19 and Mo20	Windshield washer pumps Mo19 and Mo20 not working	<ul style="list-style-type: none"> • A46 module failure • Windshield washer pump Mo19 or Mo20 open circuit • Circuit 53F open
FMI 6	Current above normal	Output A46 J1:3 internal software fuse active for overcurrent	Windshield washer pumps Mo19 and Mo20 not working	<ul style="list-style-type: none"> • A46 module failure • Connector C4 corroded • Connector C61 corroded • Circuit 53F shorted to ground

MID 188 SID # 71 Master Interlock Sw (A36 JB:16)

Type of fault:	FMI Description:	Fault Condition:	Possible Symptoms:	Possible Causes:
FMI 3	Shorted High	Voltage present on input A36 JB:16 but switch Sw140 not active	Master Interlock Bypass not working	<ul style="list-style-type: none"> • A36 module failure • Circuit Master shorted to battery
FMI 4	Shorted Low	Input A36 JB:16 shorted to ground	Master Interlock	<ul style="list-style-type: none"> • A36 module failure • Master Interlock Bypass switch

SECTION 06B: ELECTRICAL

			Bypass always ON	Sw140 failure • Circuit Master shorted to ground
--	--	--	---------------------	---

MID 188 SID # 80 Next Stop Sign (A41 J1:13)

Type of fault:	FMI Description:	Fault Condition:	Possible Symptoms:	Possible Causes:
FMI 3	Shorted High	Voltage present on output A41 J1:13 but output not active	Next Stop Light L310 always ON	<ul style="list-style-type: none"> • A41 module failure • Connector C70 corroded • Circuit 10 shorted to battery
FMI 4	Shorted Low	Output A41 J1:13 shorted to ground	Next Stop Light L310 not working	<ul style="list-style-type: none"> • A41 module failure • Connector C70 corroded • Circuit 10 shorted to ground
FMI 6	Current above normal	Output A41 J1:13 internal software fuse active for overcurrent	Next Stop Light L310 not working	<ul style="list-style-type: none"> • A41 module failure • Connector C70 corroded • Circuit 10 shorted to ground

MID 188 SID # 70 Next Stop Sw (A42 J1:9)

Type of fault:	FMI Description:	Fault Condition:	Possible Symptoms:	Possible Causes:
FMI 3	Shorted High	Voltage present on input A42 J1:9 but switch Sw5 not active	Next Stop Request not working	<ul style="list-style-type: none"> • A42 module failure • Connector C70 corroded • Connector C25A corroded • Circuit 4C shorted to battery
FMI 4	Shorted Low	Input A42 J1:9 shorted to ground	Next Stop Request always ON	<ul style="list-style-type: none"> • A42 module failure • Connector C70 corroded • Connector C25A corroded • Circuit 4C shorted to ground

MID 188 SID # 75 Oil Separator (A52 J1:6)

Type of fault:	FMI Description:	Fault Condition:	Possible Symptoms:	Possible Causes:
FMI 3	Shorted High	Voltage present on output A52 J1:6 but output not active	Drain valve discharge always ON	<ul style="list-style-type: none"> • A52 module failure • Oil separator L350A failure • Connector C27 corroded • Circuit OilSep shorted to battery
FMI 4	Shorted Low	Output A52 J1:6 shorted to ground	Drain valve discharge not working	<ul style="list-style-type: none"> • A52 module failure • Oil Separator L350A failure • Connector C27 corroded • Circuit OilSep shorted to ground
FMI 5	Open Circuit	A52 module does not detect oil Separator L350A	Drain valve discharge not working	<ul style="list-style-type: none"> • A52 module failure • Oil separator L350A open circuit • Circuit OilSep open
FMI 6	Current above normal	Output A52 J1:6 internal software fuse active for overcurrent	Drain valve discharge not working	<ul style="list-style-type: none"> • A52 module failure • Connector C27 corroded • Circuit OilSep shorted to ground

SECTION 06B: ELECTRICAL

MID 188 SID # 78 Open Door Sw (A44 J1:4)

Type of fault:	FMI Description:	Fault Condition:	Possible Symptoms:	Possible Causes:
FMI 3	Shorted High	Voltage present on output A44 J1:4 but output not active	Interlock is disabled and the door can be opened even above 3m/hr (5 KM/h)	<ul style="list-style-type: none"> • A44 module failure • Inside switch open Sw33 or Inside switch close Sw32 failure • Connector C72 corroded • Circuit 2mph shorted to battery
FMI 4	Shorted Low	Output A44 J1:4 shorted to ground	Entrance door cannot be opened with Inside switches	<ul style="list-style-type: none"> • A44 module failure • Inside switch open Sw33 or Inside switch close Sw32 failure • Connector C72 corroded • Circuit 2mph shorted to ground
FMI 5	Open Circuit	A44 module does not detect Inside switch open Sw33 or Inside switch close Sw32	Entrance door cannot be opened with Inside switches	<ul style="list-style-type: none"> • A44 module failure • Inside switch open Sw33 or Inside switch close Sw32 open circuit • Circuit 2mph open
FMI 6	Current above normal	Output A44 J1:4 internal software fuse active for overcurrent	Entrance door cannot be opened with Inside switches	<ul style="list-style-type: none"> • A44 module failure • Connector C72 corroded • Circuit 2mph shorted to ground

MID 188 PSID # 19 P Rack Fan (A54 J1:1)

Type of fault:	FMI Description:	Fault Condition:	Possible Symptoms:	Possible Causes:
FMI 4	Shorted Low	Output A54 J1:1 shorted to ground	P Rack LH Fan Mo10 not working	<ul style="list-style-type: none"> • A54 module failure • P Rack LH Fan Mo10 failure • Connector C15, C21, C35 or C56 corroded • Circuit 44 shorted to ground
FMI 5	Open Circuit	A54 module does not detect P Rack LH Fan Mo10	P Rack LH Fan Mo10 not working	<ul style="list-style-type: none"> • A54 module failure • P Rack LH Fan Mo10 open circuit • Circuit 44 open
FMI 6	Current above normal	Output A54 J1:1 internal software fuse active for overcurrent	P Rack LH Fan Mo10 not working	<ul style="list-style-type: none"> • A54 module failure • Connector C15, C21, C35 or C56 corroded • Circuit 44 shorted to ground

MID 188 PSID # 20 P Rack Fan (A54 J1:2)

Type of fault:	FMI Description:	Fault Condition:	Possible Symptoms:	Possible Causes:
FMI 4	Shorted Low	Output A54 J1:2 shorted to ground	P Rack RH Fan Mo11 not working	<ul style="list-style-type: none"> • A54 module failure • P Rack RH Fan Mo11 failure • Connector C15, C21, C35, C57 or C75 corroded • Circuit 43 shorted to ground
FMI 5	Open Circuit	A54 module does not detect P Rack RH Fan Mo11	P Rack RH Fan Mo11 not working	<ul style="list-style-type: none"> • A54 module failure • P Rack RH Fan Mo11 open circuit

SECTION 06B: ELECTRICAL

FMI 6	Current above normal	Output A54 J1:2 internal software fuse active for overcurrent	P Rack RH Fan Mo11 not working	<ul style="list-style-type: none"> • Circuit 43 open • A54 module failure • Connector C15, C21, C35, C57 or C75 corroded • Circuit 43 shorted to ground
-------	----------------------	---	--------------------------------	---

MID 188 PSID # 21 P Rack Fan (A41 J1:20)

Type of fault:	FMI Description:	Fault Condition:	Possible Symptoms:	Possible Causes:
FMI 3	Shorted High	Voltage present on input A41 J1:20 but Switch Sw27 not active	Parcel Rack Fans not working	<ul style="list-style-type: none"> • A41 module failure • Parcel Rack Fan switch Sw27 failure • Connector C74 corroded • Circuit 43G shorted to battery
FMI 4	Shorted Low	Output A41 J1:20 shorted to ground	Parcel Rack Fans always ON	<ul style="list-style-type: none"> • A41 module failure • Parcel Rack Fan switch Sw27 failure • Connector C74 corroded • Circuit 43G shorted to ground

MID 188 PSID # 162 Park brak Sens (A36 JB:9)

Type of fault:	FMI Description:	Fault Condition:	Possible Symptoms:	Possible Causes:
FMI 3	Shorted High	Voltage present on input A36 JB:9	Parking Brake sensor not working	<ul style="list-style-type: none"> • Vehicle ECU failure • A36 module failure • Connector C4 or C48 corroded • Circuit 91 shorted to battery
FMI 4	Shorted Low	Input A36 JB:9 shorted to ground	Parking Brake sensor always ON	<ul style="list-style-type: none"> • Vehicle ECU failure • A36 module failure • Parking Brake sensor Se18 failure • Connector C4 or C48 corroded • Circuit 91 shorted to ground

MID 188 PSID # 163 Park brake Sol (A42 J1:12)

Type of fault:	FMI Description:	Fault Condition:	Possible Symptoms:	Possible Causes:
FMI 3	Shorted High	Voltage present on output A42 J1:12 but output not active	Parking Brake solenoid valve So17 not working	<ul style="list-style-type: none"> • A42 module failure • Parking Brake solenoid valve So17 failure • Connector C4 or C172 corroded • Circuit 8 shorted to battery
FMI 6	Current above normal	Output A42 J1:12 internal software fuse active for overcurrent	Parking Brake solenoid valve So17 not working	<ul style="list-style-type: none"> • A42 module failure • Connector C4 or C172 corroded • Circuit 8 shorted to ground • Parking Brake solenoid valve So17 shorted to ground

MID 188 PSID # 24 Pass Heat Sol (A54 J1:8)

Type of fault:	FMI Description:	Fault Condition:	Possible Symptoms:	Possible Causes:

SECTION 06B: ELECTRICAL

FMI 3	Shorted High	Voltage present on output A54 J1:8 but output not active	Pass heat Solenoid valve So13 always ON if R26 is ON	<ul style="list-style-type: none"> • A54 module failure • Pass heat Solenoid valve So13 failure • Circuit 45 shorted to battery
FMI 4	Shorted Low	Output A54 J1:8 shorted to ground	Pass heat Solenoid valve So13 not working	<ul style="list-style-type: none"> • A54 module failure • Pass heat Solenoid valve So13 failure if R26 is ON • Circuit 45 shorted to ground
FMI 6	Current above normal	Output A54 J1:8 internal software fuse active for overcurrent	Pass heat Solenoid valve So13 not working	<ul style="list-style-type: none"> • A54 module failure • Circuit 45 shorted to ground

MID 188 SID # 29 Pass On_Off Sig (A54 J1:21)

Type of fault:	FMI Description:	Fault Condition:	Possible Symptoms:	Possible Causes:
FMI 3	Shorted High	Voltage present on output A54 J1:21 but output not active	Pre-Heat relay R26 always ON	<ul style="list-style-type: none"> • A54 module failure • Pre-Heat relay R26 failure • Circuit 13 shorted to battery
FMI 4	Shorted Low	Output A54 J1:21 shorted to ground	Pre-Heat relay R26 not working	<ul style="list-style-type: none"> • A54 module failure • Pre-Heat relay R26 failure • Circuit 13 shorted to ground
FMI 5	Open Circuit	A54 module does not detect Pre-Heat relay R26	Pre-Heat relay R26 not working	<ul style="list-style-type: none"> • A54 module failure • Pre-Heat relay R26 open circuit • Circuit 13 open
FMI 6	Current above normal	Output A54 J1:21 internal software fuse active for overcurrent	Pre-Heat relay R26 not working	<ul style="list-style-type: none"> • A54 module failure • Circuit 13 shorted to ground

MID 188 SID # 63 Pass Rec. Cylinder (A54 J1:20)

Type of fault:	FMI Description:	Fault Condition:	Possible Symptoms:	Possible Causes:
FMI 3	Shorted High	Voltage present on output A54 J1:20 but output not active	Pass Gaz Cylinder L205 always ON	<ul style="list-style-type: none"> • A54 module failure • Pass Gaz Cylinder L205 failure • Circuit 65P or 0EV3 shorted to battery
FMI 4	Shorted Low	Output A54 J1:20 shorted to ground	Pass Gaz Cylinder L205 not working	<ul style="list-style-type: none"> • A54 module failure • Pass Gaz Cylinder L205 failure • Circuit 65P shorted to ground
FMI 5	Open Circuit	A54 module does not detect Pass Gaz Cylinder L205	Pass Gaz Cylinder L205 not working	<ul style="list-style-type: none"> • A54 module failure • Pass Gaz Cylinder L205 open circuit • Circuit 65P or 0EV3 open
FMI 6	Current above normal	Output A54 J1:20 internal software fuse active for overcurrent	Pass Gaz Cylinder L205 not working	<ul style="list-style-type: none"> • A54 module failure • Circuit 65P shorted to ground

MID 188 PSID # 23 Pass Rfg Sol (A54 J1:3)

Type of fault:	FMI Description:	Fault Condition:	Possible Symptoms:	Possible Causes:
FMI 3	Shorted High	Voltage present on output A54 J1:3 but	Pass Liquid Solenoid	<ul style="list-style-type: none"> • A54 module failure • Pass Liquid Solenoid Valve So11

SECTION 06B: ELECTRICAL

		output not active	Valve So11 always ON	failure <ul style="list-style-type: none"> • Connector C9, C15 or C58 corroded • Circuit 77C or 77B shorted to battery
FMI 4	Shorted Low	Output A54 J1:3 shorted to ground	Pass Liquid Solenoid Valve So11 not working	<ul style="list-style-type: none"> • A54 module failure • Pass Liquid Solenoid Valve So11 failure • Connector C9, C15 or C58 corroded • Circuit 77C or 77B shorted to ground
FMI 5	Open Circuit	A54 module does not detect Pass Liquid Solenoid Valve So11	Pass Liquid Solenoid Valve So11 not working	<ul style="list-style-type: none"> • A54 module failure • Pass Liquid Solenoid Valve So11 open circuit • Circuit 77C or 77B open
FMI 6	Current above normal	Output A54 J1:3 internal software fuse active for overcurrent	Pass Liquid Solenoid Valve So11 not working	<ul style="list-style-type: none"> • A54 module failure • Connector C9, C15 or C58 corroded • Circuit 77C or 77B shorted to ground

MID 188 PSID # 17 Pass Wtr pump (A54 J1:4)

Type of fault:	FMI Description:	Fault Condition:	Possible Symptoms:	Possible Causes:
FMI 3	Shorted High	Voltage present on output A54 J1:4 but output not active	Pass Water pump always ON	<ul style="list-style-type: none"> • A54 module failure • Water pump relay R20 failure • Connector C9 corroded • Circuit 57G shorted to battery
FMI 4	Shorted Low	Output A54 J1:4 shorted to ground	Pass Water pump not working	<ul style="list-style-type: none"> • A54 module failure • Water pump relay R20 failure • Connector C9 corroded • Circuit 57G shorted to ground
FMI 6	Current above normal	Output A54 J1:4 internal software fuse active for overcurrent	Pass Water pump not working	<ul style="list-style-type: none"> • A54 module failure • Connector C9 corroded • Circuit 57G shorted to ground • Water pump relay R20 shorted to ground

MID 188 SID # 68 Read Light Tst (A42 J1:19)

Type of fault:	FMI Description:	Fault Condition:	Possible Symptoms:	Possible Causes:
FMI 3	Shorted High	Voltage present on input A42 J1:19 but switch Sw5 not active	Reading Lights not working	<ul style="list-style-type: none"> • A42 module failure • Reading Lamp Test switch Sw5 failure • Connector C72 corroded
FMI 4	Shorted Low	Input A42 J1:19 shorted to ground	Reading Lights always ON	<ul style="list-style-type: none"> • A42 module failure • Reading Lamp Test switch Sw5 failure • Connector C72 corroded • Wire between A42 J1:19 and Sw5 pin 3 shorted to ground

SECTION 06B: ELECTRICAL

MID 188 PSID # 113 Read Lts Rly (A49 J1:15)

Type of fault:	FMI Description:	Fault Condition:	Possible Symptoms:	Possible Causes:
FMI 3	Shorted High	Voltage present on output A49 J1:15 but output not active	Reading Lights always ON	<ul style="list-style-type: none"> • A49 module failure • Reading Lights Master Relay R14 failure • Circuit 74C shorted to battery
FMI 4	Shorted Low	Output A49 J1:15 shorted to ground	Reading Lights not working	<ul style="list-style-type: none"> • A49 module failure • Reading Lights Master Relay R14 failure • Circuit 74C shorted to ground
FMI 5	Open Circuit	A49 module does not detect Reading Lights Master Relay R14	Reading Lights not working	<ul style="list-style-type: none"> • A49 module failure • Reading Lights Master Relay R14 open circuit • Circuit 74C open
FMI 6	Current above normal	Output A49 J1:15 internal software fuse active for overcurrent	Reading Lights not working	<ul style="list-style-type: none"> • A49 module failure • Circuit 74C shorted to ground • Relay R14 coil shorted to ground

MID 188 PSID # 114 Read Lts Sw (A41 J1:10)

Type of fault:	FMI Description:	Fault Condition:	Possible Symptoms:	Possible Causes:
FMI 3	Shorted High	Voltage present on input A41 J1:10 but switch Sw26 not active	Reading Lights not working	<ul style="list-style-type: none"> • A41 module failure • Reading Lamp Switch Sw26 failure • Connector C71 corroded • Circuit 74 shorted to battery
FMI 4	Shorted Low	Input A41 J1:10 shorted to ground	Reading Lights always ON	<ul style="list-style-type: none"> • A41 module failure • Reading Lamp Switch Sw26 failure • Connector C71 corroded • Circuit 74 shorted to ground

MID 188 PSID # 131 RearFlsh LH (A51 J1:21)

Type of fault:	FMI Description:	Fault Condition:	Possible Symptoms:	Possible Causes:
FMI 3	Shorted High	Voltage present on output A51 J1:21 but output not active	Rear Flasher Light LH L71, upper rear LH L286 and Rear Side markers LH L75 always ON	<ul style="list-style-type: none"> • A51 module failure • Connector C91 or C120 corroded • Circuit 21AA shorted to battery
FMI 4	Shorted Low	Output A51 J1:21 shorted to ground	Rear Flasher Light LH L71, upper rear LH L286 and Rear Side markers LH L75 not working	<ul style="list-style-type: none"> • A51 module failure • Connector C91 or C120 corroded • Circuit 21AA and 21C shorted to ground
FMI 6	Current above normal	Output A51 J1:21 internal software fuse active for overcurrent	Rear Flasher Light LH L71, upper rear LH L286 and Rear Side markers LH L75 not working	<ul style="list-style-type: none"> • A51 module failure • Connector C91 or C120 corroded • Circuit 21AA and 21C shorted to ground

SECTION 06B: ELECTRICAL

MID 188 PSID # 132 RearFish RH (A51 J1:3)

Type of fault:	FMI Description:	Fault Condition:	Possible Symptoms:	Possible Causes:
FMI 3	Shorted High	Voltage present on output A51 J1:3 but output not active	Rear Flasher Light RH L73, upper rear RH L285 and Rear Side markers RH L76 always ON	<ul style="list-style-type: none"> • A51 module failure • Connector C91 or C119 corroded • Circuit 23AA shorted to battery
FMI 4	Shorted Low	Output A51 J1:3 shorted to ground	Rear Flasher Light RH L73, upper rear RH L285 and Rear Side markers RH L76 not working	<ul style="list-style-type: none"> • A51 module failure • Connector C91 or C119 corroded • Circuit 23AA shorted to ground
FMI 6	Current above normal	Output A51 J1:3 internal software fuse active for overcurrent	Rear Flasher Light RH L73, upper rear RH L285 and Rear Side markers RH L76 not working	<ul style="list-style-type: none"> • A51 module failure • Connector C91 or C119 corroded • Circuit 23AA shorted to ground

MID 188 PSID # 164 Retarder signal (A50 J1:12)

Type of fault:	FMI Description:	Fault Condition:	Possible Symptoms:	Possible Causes:
FMI 3	Shorted High	Voltage present on input A50 J1:12	Retarder active lamp not working	<ul style="list-style-type: none"> • Transmission ECU failure • A50 module failure • Connector C717 corroded • Circuit 125 shorted to battery
FMI 4	Shorted Low	Input A50 J1:12 shorted to ground	Retarder active lamp always ON	<ul style="list-style-type: none"> • A50 module failure • Connector C717 corroded • Circuit 125 shorted to ground

MID 188 PSID # 151 Rr Clearance lights (A50 J1:4)

Type of fault:	FMI Description:	Fault Condition:	Possible Symptoms:	Possible Causes:
FMI 3	Shorted High	Voltage present on output A50 J1:4 but output not active	Rear Clearance Lights L84, L85, L86, L87, L88, L89, L90, L285 and L286 always ON	<ul style="list-style-type: none"> • A50 module failure • Connector C91 or C10 corroded • Circuit 63 shorted to battery
FMI 4	Shorted Low	Output A50 J1:4 shorted to ground	Rear Clearance Lights L84, L85, L86, L87, L88, L89, L90, L285 and L286 not working	<ul style="list-style-type: none"> • A50 module failure • Connector C91 or C10 corroded • Circuit 63, 21C or 23C shorted to ground
FMI 5	Open Circuit	A50 module does not detect Rear Clearance Lights L84 and L85	Rear Clearance Lights L84, L85, L86, L87, L88, L89, L90, L285 and L286 not working	<ul style="list-style-type: none"> • A50 module failure • Circuit 63 open
FMI 6	Current above normal	Output A50 J1:4 internal software fuse active for overcurrent	Rear Clearance Lights L84, L85, L86, L87, L88, L89, L90, L285 and L286 not working	<ul style="list-style-type: none"> • A50 module failure • Connector C91 or C10 corroded • Circuit 63, 21C or 23C shorted to ground

SECTION 06B: ELECTRICAL

MID 188 PSID # 59 Rear Start Sw (A53 J1:11)

Type of fault:	FMI Description:	Fault Condition:	Possible Symptoms:	Possible Causes:
FMI 3	Shorted High	Voltage present on output A53 J1:11 but output not active	Rear Start Switch Sw59 always ON	<ul style="list-style-type: none"> • A53 module failure • Rear Start Switch Sw59 failure • Connector C91 corroded • Circuit 85E shorted to battery
FMI 4	Shorted Low	Output A53 J1:11 shorted to ground	Rear Start Switch Sw59 not working	<ul style="list-style-type: none"> • A53 module failure • Rear Start Switch Sw59 failure • Connector C91 corroded • Circuit 85E shorted to ground

MID 188 PSID # 57 RrStart Enable Sw (A53 J1:10)

Type of fault:	FMI Description:	Fault Condition:	Possible Symptoms:	Possible Causes:
FMI 3	Shorted High	Voltage present on input A53 J1:10 but output not active at switch Sw58	Rear Start Selector Switch Sw58 always ON Rear Start	<ul style="list-style-type: none"> • A53 module failure • Rear Start Selector Switch Sw58 failure • Connector C91 corroded • Circuit 85D shorted to battery
FMI 4	Shorted Low	Input A53 J1:10 shorted to ground	Rear Start Selector Switch Sw58 not working, rear start switch Sw59 will not function	<ul style="list-style-type: none"> • A53 module failure • Rear Start Selector Switch Sw58 failure • Connector C91 corroded • Circuit 85D shorted to ground

MID 188 SID # 49 Ser Brake Trans (A51 J1:1)

Type of fault:	FMI Description:	Fault Condition:	Possible Symptoms:	Possible Causes:
FMI 3	Shorted High	Voltage present on output A51 J1:1 but output not active	Cruise control not working	<ul style="list-style-type: none"> • A51 module failure • Connector C717 corroded • Circuit 79 shorted to battery
FMI 4	Shorted Low	Output A51 J1:1 shorted to ground	Cruise control not working, transmission sees service brake signal ON all the time	<ul style="list-style-type: none"> • A51 module failure • Connector C717 corroded • Circuit 79 shorted to ground
FMI 6	Current above normal	Output A51 J1:1 internal software fuse active for overcurrent	Cruise control not working	<ul style="list-style-type: none"> • A51 module failure • Connector C717 corroded • Circuit 79 shorted to ground

MID 188 PSID # 60 Starter Relay (A53 J1:6)

Type of fault:	FMI Description:	Fault Condition:	Possible Symptoms:	Possible Causes:
FMI 4	Shorted Low	Output A53 J1:6 shorted to ground	Rear Starter not working	<ul style="list-style-type: none"> • Vehicle ECU failure • A53 module failure • Rear Starter Relay failure • Connector C397 corroded • Circuit 231A shorted to ground
FMI 6	Current	Output A53 J1:6	Rear Starter	<ul style="list-style-type: none"> • A53 module failure

SECTION 06B: ELECTRICAL

	above normal	internal software fuse active for overcurrent	not working	<ul style="list-style-type: none"> • Connector C397 corroded • Circuit 231A shorted to ground
--	--------------	---	-------------	---

MID 188 SID # 77 Step Led light (A43 J1:30)

Type of fault:	FMI Description:	Fault Condition:	Possible Symptoms:	Possible Causes:
FMI 3	Shorted High	Voltage present on output A43 J1:30 but output not active	Step Nozzle Light L20A always ON	<ul style="list-style-type: none"> • A43 module failure • Connector C6 or C65 corroded • Circuit 35A shorted to battery
FMI 4	Shorted Low	Output A43 J1:30 shorted to ground	Step Nozzle Light L20A not working	<ul style="list-style-type: none"> • A43 module failure • Connector C6 or C65 corroded • Circuit 35A shorted to ground
FMI 6	Current above normal	Output A43 J1:30 internal software fuse active for overcurrent	Step Nozzle Light L20A not working	<ul style="list-style-type: none"> • A43 module failure • Connector C6 or C65 corroded • Circuit 35A shorted to ground

MID 188 PSID # 117 StepLts (A47 J1:5)

Type of fault:	FMI Description:	Fault Condition:	Possible Symptoms:	Possible Causes:
FMI 3	Shorted High	Voltage present on output A47 J1:5 but output not active	Step Lights L18, L19 or L20 always ON	<ul style="list-style-type: none"> • A47 module failure • Connector C63 corroded • Circuit 35 shorted to battery
FMI 4	Shorted Low	Output A47 J1:5 shorted to ground	Step Lights L18, L19 or L20 not working	<ul style="list-style-type: none"> • A47 module failure • Connector C63 corroded • Circuit 35 shorted to ground
FMI 5	Open Circuit	A47 module does not detect Step Lights L18, L19 or L20	Step Lights L18, L19 or L20 not working	<ul style="list-style-type: none"> • A47 module failure • Circuit 35 open
FMI 6	Current above normal	Output A47 J1:5 internal software fuse active for overcurrent	Step Lights L18, L19 or L20 not working	<ul style="list-style-type: none"> • A47 module failure • Connector C63 corroded • Circuit 35 shorted to ground

MID 188 PSID # 165 Tag axle Sw (A43 J1:19)

Type of fault:	FMI Description:	Fault Condition:	Possible Symptoms:	Possible Causes:
FMI 3	Shorted High	Voltage present on input A43 JB:19 but output not active	Pressure Tag Switch Sw64 not working	<ul style="list-style-type: none"> • A43 module failure • Connector C71 or C171 corroded • Circuit 160 shorted to battery
FMI 4	Shorted Low	Input A43 J1:19 shorted to ground	Pressure Tag Switch Sw64 always ON	<ul style="list-style-type: none"> • A43 module failure • Pressure Tag Switch Sw64 failure • Connector C71 or C171 corroded • Circuit 160 shorted to ground

MID 188 PSID # 152 Tail Lights (A51 J1:8)

Type of fault:	FMI Description:	Fault Condition:	Possible Symptoms:	Possible Causes:
FMI 3	Shorted High	Voltage present on output A51 J1:8 but	Tail Lights L72, L74, L77, L78,	<ul style="list-style-type: none"> • A51 module failure • Connector C119, C91 or

SECTION 06B: ELECTRICAL

		output not active	L79, L80, L82 or L83 always ON	C120 corroded • Circuit 46 shorted to battery
FMI 4	Shorted Low	Output A51 J1:8 shorted to ground	Tail Lights L72, L74, L77, L78, L79, L80, L82 or L83 not working	• A51 module failure • Connector C119, C91 or C120 corroded • Circuit 46 shorted to ground
FMI 5	Open Circuit	A51 module does not detect Tail Lights L72, L74, L77, L78, L79, L80, L82 or L83	Tail Lights L72, L74, L77, L78, L79, L80, L82 or L83 not working	• A51 module failure • Circuit 46 open
FMI 6	Current above normal	Output A51 J1:8 internal software fuse active for overcurrent	Tail Lights L72, L74, L77, L78, L79, L80, L82 or L83 not working	• A51 module failure • Connector C119, C91 or C120 corroded • Circuit 46 shorted to ground

MID 188 SID # 25 Trans Inh Sig (A50 J1:2)

Type of fault:	FMI Description:	Fault Condition:	Possible Symptoms:	Possible Causes:
FMI 3	Shorted High	Voltage present on output A50 J1:2 but output not active	Transmission Shifting not working	• Transmission ECU failure • A50 module failure • Connector C717 corroded • Circuit 185 shorted to battery
FMI 4	Shorted Low	Output A50 J1:2 shorted to ground	Transmission Shifting not working	• A50 module failure • Connector C717 corroded • Circuit 185 shorted to ground
FMI 5	Open Circuit	A50 module does not detect Transmission ECU	Transmission Shifting not working	• A50 module failure • Circuit 185 open • Transmission ECU failure
FMI 6	Current above normal	Output A50 J1:2 internal software fuse active for overcurrent	Transmission Shifting not working	• A50 module failure • Connector C717 corroded • Circuit 185 shorted to ground

MID 188 PSID # 168 Trans Neutral Sens (A50 J1:11)

Type of fault:	FMI Description:	Fault Condition:	Possible Symptoms:	Possible Causes:
FMI 3	Shorted High	Voltage present on output A50 J1:11 but output not active	Transmission always on Neutral	• A50 module failure • Connector C717 corroded • Circuit 231 shorted to battery
FMI 4	Shorted Low	Output A50 J1:11 shorted to ground	Transmission Shifting not working	• A50 module failure • Connector C717 corroded • Circuit 231 shorted to ground

MID 188 PSID # 112 Under Floor lights (A47 J1:20)

Type of fault:	FMI Description:	Fault Condition:	Possible Symptoms:	Possible Causes:
FMI 4	Shorted Low	Output A47 J1:20 shorted to ground	Baggage compartment lights L176, L177, L180, L181, L182 or L183 not working	• A47 module failure • Connector C6, C2 or C59 corroded • Circuit 10A shorted to ground
FMI 6	Current	Output A47 J1:20	Baggage	• A47 module failure

SECTION 06B: ELECTRICAL

	above normal	internal software fuse active for overcurrent	compartment lights L176, L177, L180, L181, L182 or L183 not working	<ul style="list-style-type: none"> • Connector C6, C2 or C59 corroded • Circuit 10A shorted to ground
--	--------------	---	---	---

MID 188 PSID # 31 Unloader LH (A52 J1:8)

Type of fault:	FMI Description:	Fault Condition:	Possible Symptoms:	Possible Causes:
FMI 3	Shorted High	Voltage present on output A52 J1:8 but output not active	Unloader LH L200 always ON	<ul style="list-style-type: none"> • A52 module failure • Connector C91 or C19 corroded • Circuit 33 shorted to battery
FMI 4	Shorted Low	Output A52 J1:8 shorted to ground	Unloader LH L200 not working	<ul style="list-style-type: none"> • A52 module failure • Unloader LH L200 failure • Connector C91 or C19 corroded • Circuit 33 shorted to ground
FMI 5	Open Circuit	A52 module does not detect Unloader LH L200	Unloader LH L200 not working	<ul style="list-style-type: none"> • A52 module failure • Unloader LH L200 failure • Circuit 33 open
FMI 6	Current above normal	Output A52 J1:8 internal software fuse active for overcurrent	Unloader LH L200 not working	<ul style="list-style-type: none"> • A52 module failure • Connector C91 or C19 corroded • Circuit 33 shorted to ground

MID 188 PSID # 32 Unloader RH (A52 J1:21)

Type of fault:	FMI Description:	Fault Condition:	Possible Symptoms:	Possible Causes:
FMI 3	Shorted High	Voltage present on output A52 J1:21 but output not active	Unloader RH L199 always ON	<ul style="list-style-type: none"> • A52 module failure • Connector C91 or C19 corroded • Circuit 31 shorted to battery
FMI 4	Shorted Low	Output A52 J1:21 shorted to ground	Unloader RH L199 not working	<ul style="list-style-type: none"> • A52 module failure • Unloader RH L199 failure • Connector C91 or C19 corroded • Circuit 31 shorted to ground
FMI 5	Open Circuit	A52 module does not detect Unloader RH L199	Unloader RH L199 not working	<ul style="list-style-type: none"> • A52 module failure • Unloader RH L199 failure • Circuit 31 open
FMI 6	Current above normal	Output A52 J1:21 internal software fuse active for overcurrent	Unloader RH L199 not working	<ul style="list-style-type: none"> • A52 module failure • Connector C91 or C19 corroded • Circuit 31 shorted to ground

MID 188 SID # 34 Up Def Heater1 (A46 J1:1)

Type of fault:	FMI Description:	Fault Condition:	Possible Symptoms:	Possible Causes:
FMI 3	Shorted High	Voltage present on output A46 J1:1 but output not active	Upper Defrost LH Heater Res37 always ON	<ul style="list-style-type: none"> • A46 module failure • Connector C45 or CMo5 corroded • Circuit 5A shorted to battery
FMI 4	Shorted Low	Output A46 J1:1 shorted to ground	Upper Defrost LH Heater Res37 not working	<ul style="list-style-type: none"> • A46 module failure • Upper Defrost LH Heater Res37 failure • Connector C45 or CMo5 corroded • Circuit 5A shorted to ground

SECTION 06B: ELECTRICAL

FMI 5	Open Circuit	A46 module does not detect Upper Defrost LH Heater Res37	Upper Defrost LH Heater Res37 not working	<ul style="list-style-type: none"> • A46 module failure • Upper Defrost LH Heater Res37 failure • Circuit 5A open
FMI 6	Current above normal	Output A46 J1:1 internal software fuse active for overcurrent	Upper Defrost LH Heater Res37 not working	<ul style="list-style-type: none"> • A46 module failure • Connector C45 or CMo5 corroded • Circuit 5A shorted to ground

MID 188 SID # 35 Up Def Heater2 (A46 J1:2)

Type of fault:	FMI Description:	Fault Condition:	Possible Symptoms:	Possible Causes:
FMI 3	Shorted High	Voltage present on output A46 J1:2 but output not active	Upper Defrost RH Heater Res37 always ON	<ul style="list-style-type: none"> • A46 module failure • Connector C45 or CMo5 corroded • Circuit 5B shorted to battery
FMI 4	Shorted Low	Output A46 J1:2 shorted to ground	Upper Defrost RH Heater Res37 not working	<ul style="list-style-type: none"> • A46 module failure • Upper Defrost RH Heater Res37 failure • Connector C45 or CMo5 corroded • Circuit 5B shorted to ground
FMI 5	Open Circuit	A46 module does not detect Upper Defrost RH Heater Res37	Upper Defrost RH Heater Res37 not working	<ul style="list-style-type: none"> • A46 module failure • Upper Defrost RH Heater Res37 failure • Circuit 5B open
FMI 6	Current above normal	Output A46 J1:2 internal software fuse active for overcurrent	Upper Defrost RH Heater Res37 not working	<ul style="list-style-type: none"> • A46 module failure • Connector C45 or CMo5 corroded • Circuit 5B shorted to ground

MID 188 PSID # 43 Upper Brk Lamp (A51 J1:6)

Type of fault:	FMI Description:	Fault Condition:	Possible Symptoms:	Possible Causes:
FMI 3	Shorted High	Voltage present on output A51 J1:6 but output not active	Upper Stop Lights RH L78 or LH L80 always ON	<ul style="list-style-type: none"> • A51 module failure • Connector C91, C119 or C120 corroded • Circuit 82Up shorted to battery
FMI 4	Shorted Low	Output A51 J1:6 shorted to ground	Upper Stop Lights RH L78 or LH L80 not working	<ul style="list-style-type: none"> • A51 module failure • Connector C91, C119 or C120 corroded • Circuit 82Up shorted to ground
FMI 6	Current above normal	Output A51 J1:6 internal software fuse active for overcurrent	Upper Stop Lights RH L78 or LH L80 not working	<ul style="list-style-type: none"> • A51 module failure • Connector C91, C119 or C120 corroded • Circuit 82Up shorted to ground

MID 188 SID # 30 WakeUp Rly (A36 JA:15)

Type of fault:	FMI Description:	Fault Condition:	Possible Symptoms:	Possible Causes:
FMI 4	Shorted Low	Output A36 JA:15 shorted to ground	Various systems not working depending on relay	<ul style="list-style-type: none"> • A36 module failure • Various WUp Relays failure • Connector C2 or C21 corroded

SECTION 06B: ELECTRICAL

			or position	<ul style="list-style-type: none"> • Circuit 85B shorted to ground
FMI 5	Open Circuit	A36 module does not detect 24v Fr WUp relay R18, 12v Fr WUp relay R19, 12v Rr WUp relay R17 or 12v Rr Engine ECU relay R34	Various systems not working depending on relay or position	<ul style="list-style-type: none"> • A36 module failure • Various WUp Relays R17, R18, R19, R34 open circuit • Circuit 85B open
FMI 6	Current above normal	Output A36 JA:15 internal software fuse active for overcurrent	Various systems not working depending on relay or position	<ul style="list-style-type: none"> • A36 module failure • Connector C2 or C21 corroded • Circuit 85B shorted to ground

MID 188 PSID # 176 WCL Pump Rly (A53 J1:5)

Type of fault:	FMI Description:	Fault Condition:	Possible Symptoms:	Possible Causes:
FMI 3	Shorted High	Voltage present on output A53 J1:5 but output not active	WCL Pump Assy L207 can be operated is sensor Se100 is active	<ul style="list-style-type: none"> • A53 module failure • WCL Door open Relay R47 failure • Connector C27, C31 or C29 corroded • Circuit 304 shorted to battery
FMI 4	Shorted Low	Output A53 J1:5 shorted to ground	WCL Pump Assy L207 not working	<ul style="list-style-type: none"> • A53 module failure • WCL Door open Relay R47 failure • Connector C27, C31 or C29 corroded • Circuit 304 shorted to ground
FMI 6	Current above normal	Output A53 J1:5 internal software fuse active for overcurrent	WCL Pump Assy L207 not working	<ul style="list-style-type: none"> • A53 module failure • Connector C27, C31 or C29 corroded • Circuit 304 shorted to ground

MID 188 SID # 24 WCLDorSig to USonic (A53 J1:7)

Type of fault:	FMI Description:	Fault Condition:	Possible Symptoms:	Possible Causes:
FMI 3	Shorted High	Voltage present on output A53 J1:7 but output not active	WCL Door open Relay R47 always ON	<ul style="list-style-type: none"> • A53 module failure • WCL Door open Relay R47 failure • Connector C27, C31 or C29 corroded • Circuit 306 shorted to battery
FMI 4	Shorted Low	Output A53 J1:7 shorted to ground	WCL Door open Relay R47 not working	<ul style="list-style-type: none"> • A53 module failure • WCL Door open Relay R47 failure • Connector C27, C31 or C29 corroded • Circuit 306 shorted to ground
FMI 5	Open Circuit	A53 module does not detect WCL Door open Relay R47	WCL Door open Relay R47 not working	<ul style="list-style-type: none"> • A53 module failure • WCL Door open Relay R47 failure • Circuit 306 open
FMI 6	Current above normal	Output A53 J1:7 internal software fuse active for	WCL Door open Relay R47 not	<ul style="list-style-type: none"> • A53 module failure • Connector C27, C31 or C29 corroded

SECTION 06B: ELECTRICAL

		overcurrent	working	• Circuit 306 shorted to ground
--	--	-------------	---------	---------------------------------

SECTION 06C: ELECTRICAL

MULTIPLEX MODULE “NO RESPONSE” TROUBLESHOOTING LIST FRONT JUNCTION BOX MODULES

MID 188 PSID # 216 A41 MODULE NO RESPONSE

Type of fault:	FMI Description:	Fault Condition:	Possible Symptoms:	Possible Causes:
FMI 2	Data Error	A41 Module not responding on CAN network	A41 module all inputs and outputs not responding	<ul style="list-style-type: none">• CAN network open• Address Jumper open circuit• Fuse F110 defective• Relay R18 defective

MID 188 PSID # 217 A42 MODULE NO RESPONSE

Type of fault:	FMI Description:	Fault Condition:	Possible Symptoms:	Possible Causes:
FMI 2	Data Error	A42 Module not responding on CAN network	A42 module all inputs and outputs not responding	<ul style="list-style-type: none">• CAN network open• Address Jumper open circuit• Fuse F12 or F13 defective

MID 188 PSID # 218 A43 MODULE NO RESPONSE

Type of fault:	FMI Description:	Fault Condition:	Possible Symptoms:	Possible Causes:
FMI 2	Data Error	A43 Module not responding on CAN network	A43 module all inputs and outputs not responding	<ul style="list-style-type: none">• CAN network open• Address Jumper open circuit• Fuse F12 or F13 defective

MID 188 PSID # 219 A44 MODULE NO RESPONSE

Type of fault:	FMI Description:	Fault Condition:	Possible Symptoms:	Possible Causes:
FMI 2	Data Error	A44 Module not responding on CAN network	A44 module all inputs and outputs not responding	<ul style="list-style-type: none">• CAN network open• Address Jumper open circuit• Fuse F21 defective

MID 188 PSID # 220 A45 MODULE NO RESPONSE

Type of fault:	FMI Description:	Fault Condition:	Possible Symptoms:	Possible Causes:
FMI 2	Data Error	A45 Module not responding on CAN network	A45 module all inputs and outputs not responding	<ul style="list-style-type: none">• CAN network open• Address Jumper open circuit• Fuse F33 or F34 defective• Relay R19 defective

MID 188 PSID # 221 A46 MODULE NO RESPONSE

Type of fault:	FMI Description:	Fault Condition:	Possible Symptoms:	Possible Causes:
FMI 2	Data Error	A46 Module not responding on CAN network	A46 module all inputs and outputs not responding	<ul style="list-style-type: none">• CAN network open• Address Jumper open circuit• Fuse F12 or F13 defective

SECTION 06C: ELECTRICAL

ENTRANCE DOOR & WIPER CONTROL PANEL MODULES

MID 188 PSID # 222 A47 MODULE NO RESPONSE

Type of fault:	FMI Description:	Fault Condition:	Possible Symptoms:	Possible Causes:
FMI 2	Data Error	A47 Module not responding on CAN network	A47 module all inputs and outputs not responding	<ul style="list-style-type: none">• CAN network open• Address Jumper open circuit• Fuse F5 defective• Relay R18 defective

MID 188 PSID # 223 A48 MODULE NO RESPONSE

Type of fault:	FMI Description:	Fault Condition:	Possible Symptoms:	Possible Causes:
FMI 2	Data Error	A48 Module not responding on CAN network	A48 module all inputs and outputs not responding	<ul style="list-style-type: none">• CAN network open• Address Jumper open circuit• Fuse F33 or F34 defective• Relay R19 defective

A/C JUNCTION BOX MODULE

MID 188 PSID # 229 A54 MODULE NO RESPONSE

Type of fault:	FMI Description:	Fault Condition:	Possible Symptoms:	Possible Causes:
FMI 2	Data Error	A54 Module not responding on CAN network	A54 module all inputs and outputs not responding	<ul style="list-style-type: none">• CAN network open• Address Jumper open circuit• Fuse F67 or F68 defective

DASH MODULES

MID 188 SID # 51 A55 MODULE NO RESPONSE

Type of fault:	FMI Description:	Fault Condition:	Possible Symptoms:	Possible Causes:
FMI 2	Data Error	A55 Module not responding on CAN network	A55 module all inputs and outputs not responding	<ul style="list-style-type: none">• CAN network open• Address Jumper open circuit• Fuse F12 or F13 defective

REAR JUNCTION BOX MODULES

MID 188 PSID # 224 A49 MODULE NO RESPONSE

Type of fault:	FMI Description:	Fault Condition:	Possible Symptoms:	Possible Causes:
FMI 2	Data Error	A49 Module not responding on CAN network	A49 module all inputs and outputs not responding	<ul style="list-style-type: none"> • CAN network open • Address Jumper open circuit • Fuse F65 defective

MID 188 PSID # 225 A50 MODULE NO RESPONSE

Type of fault:	FMI Description:	Fault Condition:	Possible Symptoms:	Possible Causes:
FMI 2	Data Error	A50 Module not responding on CAN network	A50 module all inputs and outputs not responding	<ul style="list-style-type: none"> • CAN network open • Address Jumper open circuit • Fuse F72 defective

MID 188 PSID # 226 A51 MODULE NO RESPONSE

Type of fault:	FMI Description:	Fault Condition:	Possible Symptoms:	Possible Causes:
FMI 2	Data Error	A51 Module not responding on CAN network	A51 module all inputs and outputs not responding	<ul style="list-style-type: none"> • CAN network open • Address Jumper open circuit • Fuse F80 defective

MID 188 PSID # 227 A52 MODULE NO RESPONSE

Type of fault:	FMI Description:	Fault Condition:	Possible Symptoms:	Possible Causes:
FMI 2	Data Error	A52 Module not responding on CAN network	A52 module all inputs and outputs not responding	<ul style="list-style-type: none"> • CAN network open • Address Jumper open circuit • Fuse F65 defective

MID 188 PSID # 228 A53 MODULE NO RESPONSE

Type of fault:	FMI Description:	Fault Condition:	Possible Symptoms:	Possible Causes:
FMI 2	Data Error	A53 Module not responding on CAN network	A53 module all inputs and outputs not responding	<ul style="list-style-type: none"> • CAN network open • Address Jumper open circuit • Fuse F65 defective

SECTION 07: TRANSMISSION

CONTENTS

1. DESCRIPTION	2
2. WELDING PROCEDURES	2
3. MAINTENANCE	3
3.1 MANUAL FLUID LEVEL CHECK	3
3.1.1 <i>Cold Check</i>	3
3.1.2 <i>Hot Check</i>	4
3.2 FLUID LEVEL CHECK USING THE PUSHBUTTON SHIFT SELECTOR	4
3.3 IMPORTANCE OF PROPER FLUID LEVEL	5
3.4 KEEPING OIL CLEAN	5
3.5 RECOMMENDED AUTOMATIC TRANSMISSION FLUID	5
3.6 OIL CONTAMINATION	6
3.7 METAL PARTICLES	6
3.8 COOLANT LEAKAGE	6
3.9 CONTROL SYSTEM PROGNOSTICS	6
3.10 OIL AND FILTER CHANGE INTERVAL	10
4. ALLISON TRANSMISSION REMOVAL	11
5. TRANSMISSION OIL COOLER REMOVAL	12
6. CLEANING AND INSPECTION OF ALLISON AUTOMATIC TRANSMISSION	13
6.1 BREATHER	13
7. ALLISON TRANSMISSION INSTALLATION	13
8. ALLISON AUTOMATIC TRANSMISSION TROUBLESHOOTING	14
8.1 4 TH GENERATION TRANSMISSION CONTROL MODULE	14
8.2 DIAGNOSTIC TROUBLESHOOTING CODES (DTC) — ALLISON 4 TH GENERATION CONTROLS	15
8.3 DIAGNOSTIC CODES — ALLISON 4 TH GENERATION CONTROLS	15
8.4 DIAGNOSTIC CODE DISPLAY AND CLEARING PROCEDURE — ALLISON 4 TH GENERATION CONTROLS	15
8.5 DIAGNOSTIC CODE RESPONSE	16
8.6 DIAGNOSTIC TROUBLESHOOTING CODES (DTC) LIST - ALLISON 4 TH GENERATION CONTROLS	18
9. SPECIFICATIONS	21

ILLUSTRATIONS

FIGURE 1: ALLISON TRANSMISSION	2
FIGURE 2: ALLISON TRANSMISSION CONTROL PAD	2
FIGURE 3: OIL LEVEL DIPSTICK (AUTO. TRANS.)	3
FIGURE 4: COLD CHECK	3
FIGURE 5: HOT CHECK	4
FIGURE 6: DRAIN PLUG AND FILTERS	11
FIGURE 7: VOLVO ENGINE CRANKING POSITION	12
FIGURE 8: ALLISON OIL COOLER	12
FIGURE 9: AIR PRESSURE REGULATOR (TYPICAL)	14
FIGURE 10: TRANSMISSION CONTROL MODULE	14

1. DESCRIPTION

X3 Series coaches featuring Metropolitan Transportation Authority (MTA) specifications are provided with an Allison automatic transmission

- **ALLISON AUTOMATIC TRANSMISSION**

The B500R (with retarder) Allison Transmission has 6 speeds with two top range (fifth and sixth) overdrives. Total coverage is determined by dividing the highest gear ratio by the lowest gear ratio. Total coverage expresses the transmission gear ratio versatility. Transmissions with larger total coverage number have a wider variety of available ratios.

An electronic control allows the transmission to shift at exactly the right point on the engine's fuel consumption curve for best economy. Early lockup maintains the highest possible mechanical efficiency through the closely-spaced gear steps, culminating in two overdrive ratios. This combination allows progressive shifting techniques, where engine speeds are reduced for higher efficiency and lower fuel consumption.

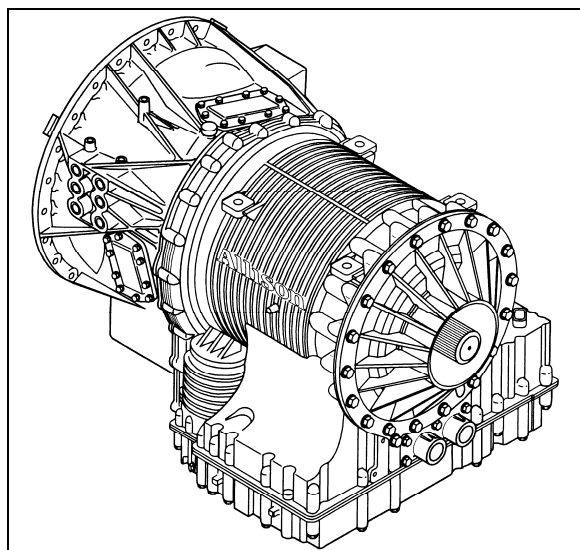

FIGURE 1: ALLISON TRANSMISSION 07136

Gear selection and torque converter modes are controlled by a microcomputer-based electronic transmission management system. It is fed information regarding throttle position, operator range selection, engine speed, turbine speed, transmission output speed and various system pressures from special electronic sensors. With this information, it computes shift points and clutch pressures to meet immediate needs. Using closed loop adaptive logic; the electronic control looks at a number of parameters during the shift, and makes minute adjustments to

match the shift to desired profile stored in its memory. It then looks at these adjustments and resets the parameters, which allow the transmission to quickly compensate for variations in load, terrain or environment and to adjust for clutch wear and engine power changes. A Diagnostic Data Reader can be connected to the electronic control unit to provide a self-check of all systems in the transmission. Five-digit trouble codes greatly reduce the time it takes to pinpoint potential problems. (Refer to paragraph "8. TROUBLESHOOTING" in this section).

- **Retarder**

This auxiliary braking device for the automatic transmission is integrated into the basic envelope of the transmission and transmits its braking force directly to the propeller shaft. It requires no additional length and adds only 75 pounds (34 kg) of weight. Operation of the retarder is controlled electronically by the driver's use of the brake pedal.

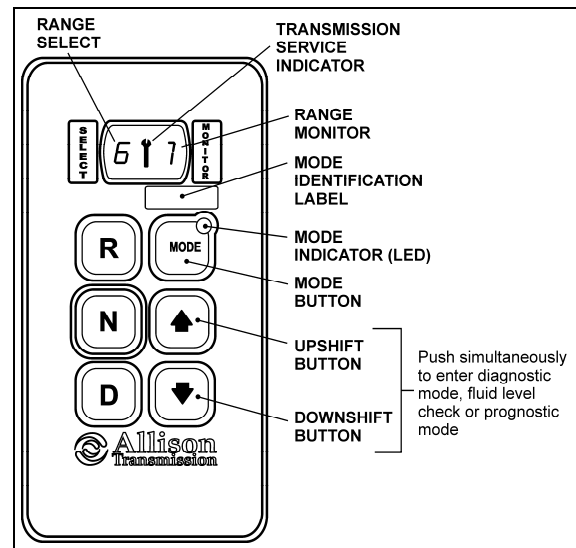

FIGURE 2: ALLISON TRANSMISSION CONTROL PAD 07142

When activated, fluid enters a cavity and provides resistance to the turning of rotor blades revolving with the output shaft. This effectively slows the vehicle to the point where the service brakes are needed only for final stopping. The retarder is fully modulated and is compatible with ABS.

2. WELDING PROCEDURES

These procedures are intended only for vehicles equipped with transmission electronic controls. When frame or other welding is required on the vehicle, precautions are to be taken to protect the electronic control components. Refer to section

00: GENERAL INFORMATION, paragraph 3: "Precautions to be observed before welding" for complete procedure.

3. MAINTENANCE

To gain access to the dipstick, open the engine compartment rear doors; dipstick is located on the radiator side of the engine (Fig. 3).

3.1 MANUAL FLUID LEVEL CHECK

DANGER

When checking the oil level, be sure that the parking brake and/or emergency brakes are set and properly engaged, and the wheels are chocked. Unexpected and possible sudden vehicle movement may occur if these precautions are not taken.

- Special care must be taken not to touch the engine coolant tubing and/or exhaust pipe, since this could cause severe burns.
- Do not wear loose clothing and, stay away from rotating parts during procedure; personal injury could occur.

Clean all dirt from around the end of the oil filler tube before removing the dipstick. Dirt or foreign matter must not be permitted to enter the oil system since it will cause valves to stick, undue wear of transmission parts, and clogged passages. Check the oil level using the procedures in Cold Check and Hot Check. Record any abnormal level on your "Maintenance Records".

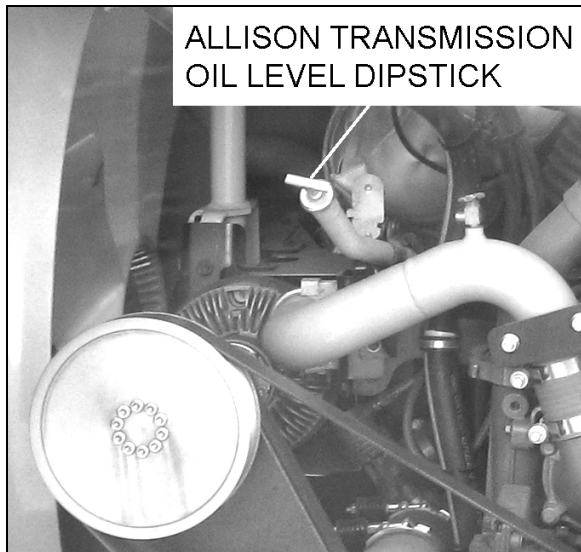

FIGURE 3: OIL LEVEL DIPSTICK (AUTO. TRANS.) 07113

Always check the oil level reading at least twice when the engine is running. Consistency is important in maintaining the accuracy of the reading. If inconsistent readings persist, check the transmission breather to ensure it is clean and free of debris.

3.1.1 Cold Check

The purpose of the **Cold Check** is to determine if the transmission has enough fluid to be operated safely until a **Hot Check** can be made.

1. If the engine has been shut down for an extended period of time, park the vehicle on a level surface and apply the parking brake.

CAUTION

The oil level rises as sump temperature increases. **DO NOT** fill above the "Cold Run" band if the transmission oil is below normal operating temperature. During operation, an overfull transmission can become overheated, leading to transmission damage.

2. Run the engine at idle in "N" (Neutral) for about one minute.
3. Shift to Drive (D) and operate the engine for 30 seconds at 1000-1500 rpm; then shift to Reverse (R) to clear the hydraulic system of air.
4. Move the vehicle to a level surface, put transmission in «N» (Neutral), and set the parking brake.
5. Finally shift to Neutral (N) and allow the engine to idle (500 - 800 rpm).
6. While the engine is running, remove the dipstick from the tube and wipe it clean (Figs. 4 & 5). Insert the dipstick into the fill tube, pushing down until it stops.

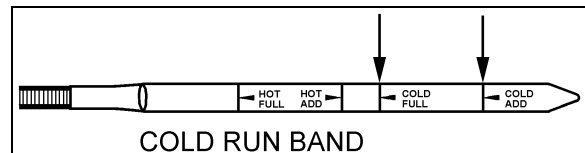

FIGURE 4: COLD CHECK

07050

7. Remove the dipstick and observe the fluid level. Repeat the check procedure to verify the reading. If the fluid on the dipstick is within the COLD CHECK band, the level is satisfactory for operating the transmission until the oil is hot enough to perform a **Hot Check**. If the fluid level is **not** within this band, add or drain

Section 07: TRANSMISSION

fluid as necessary to bring the level within the COLD CHECK band.

8. Perform a **Hot Check** at the first opportunity after the normal operating temperature of 160°F (71°C) to 200°F (93°C) is attained.



CAUTION

DO NOT operate the transmission for extended periods of time until a **Hot Check** has verified proper fluid level. Transmission damage can result from extended operation at improper fluid level conditions.



CAUTION

Obtain an accurate fluid level by imposing the following conditions:

- Engine is idling (500-800 rpm) in «N» (Neutral).
- Transmission fluid is at normal operating temperature.
- The vehicle is on a level surface.

3.1.2 Hot Check



CAUTION

The oil **must be hot** to ensure an accurate check for this procedure. The oil level rises as temperature increases.

To perform a **Hot Check**, do the following:

1. The **Hot Check** can be performed when the transmission oil reaches the normal operating temperature (160°F to 200°F / 71°C to 93°C). The transmission oil temperature can be checked with the dashboard message center display (MCD) when selecting the Gauge Mode (refer to the "Operator's Manual" for added information).
2. Park the vehicle on a level surface and shift to Neutral (N). Apply the parking brake and allow the engine to idle (500 - 800 rpm).
3. Remove the dipstick from the tube and wipe it clean. Insert the dipstick into the fill tube, pushing down until it stops.
4. Remove the dipstick and observe the fluid level. The safe operating level is anywhere within the HOT RUN band on the dipstick.

Repeat the check procedure to verify the reading.

5. If the level is **not** within this band, add or drain fluid as necessary to bring the level within the HOT RUN band. (Fig. 5).

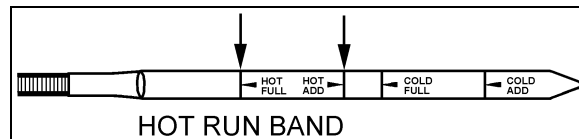

FIGURE 5: HOT CHECK

07049

6. Be sure fluid level checks are consistent. Check level more than once and if readings are not consistent, check to be sure the transmission breather is clean and not clogged. If readings are still not consistent, contact your nearest Allison dealer or distributor.

NOTE

The Cold Check is more appropriate for verifying the oil level after the first fill-up. In case of conflict, the Hot Check has priority over the Cold Check; the fluid level check using the pushbutton shift selector has priority over the Hot Check.

3.2 FLUID LEVEL CHECK USING THE PUSHBUTTON SHIFT SELECTOR

Oil level codes are obtained as follows:

1. Park vehicle on a level surface, select «N» (neutral) on the pushbutton shift selector and apply parking brake.
2. Press simultaneously the ▲ (Up) and ▼ (Down) arrow buttons once.
3. Oil level codes are displayed in 2 minutes (e.g. display will flash and 8, 7, 6, 5, ...; countdown will occur during the 2 minutes) once the following parameters are met:
 - **Waiting time, vehicle must be stationary for at least 2 minutes to allow the oil to settle;**
 - **Engine at idle;**
 - **Oil at normal operating temperature, between 140°F (60°C) and 220°F (104°C);**
 - **Transmission in «N» (Neutral);**
 - **Transmission output shaft stopped;**
 - **Oil level sensor present and working.**

After 2 minutes, the display will flash one of the codes shown below:

CODE	CAUSE OF CODE
O L...O K	Oil level is correct
O L...L O... 1	Oil Level is LOw 1 quart
O L...L O... 2	Oil Level is LOw 2 quart
O L...L O... 3	Oil Level is LOw 3 quarts
O L...L O... 4	Oil Level is LOw 4 or more quarts
O L...H I... 1	Oil Level is Hlgh 1 quart
O L...H I... 2	Oil Level is Hlgh 2 quarts
O L...H I... 3	Oil Level is Hlgh 3 or more quarts
O L... – (fc)	Oil Level is invalid. Source of invalid reading is defined by a two-character fault code (fc)

NOTE

Note that the quantities LO 4 and HI 3 are the largest values displayed and that the actual variation in oil level may exceed these numbers.

NOTE

Failure to meet one of the above parameters will stop the two minute countdown. One of the codes shown hereafter will indicate the cause of the countdown interruption. Once all parameters are met, the countdown will continue from where it left off.

If the fluid level check cannot be completed, an Invalid for Display fault is reported. This condition is reflected by the display of "OL", followed by "–", followed by one or two additional characters. The displayed characters define the cause of the fault, which may be either a system malfunction or an improper condition for conducting the check.

CODE	CAUSE OF CODE
OL...-...0X	Waiting period is not complete
OL...-...EL	Engine speed (rpm) too low
OL...-...EH	Engine speed (rpm) too high
OL...-...SN	N (neutral) must be selected
OL...-...TL	Sump oil temperature too low
OL...-...TH	Sump oil temperature too high
OL...-...SH	Output shaft rotation
OL...-...FL	Sensor failure

To exit the Oil Level Display Mode, press any range button: "R", "N" or "D" at any time.

3.3 IMPORTANCE OF PROPER FLUID LEVEL

It is important that the proper fluid level be maintained at all times because the transmission fluid cools, lubricates, and transmits hydraulic power. If the fluid level is too low, the converter and clutches do not receive an adequate supply of fluid. If fluid level is too high, the fluid can aerate, causing the transmission to shift erratically or overheat.

3.4 KEEPING OIL CLEAN

Oil must be handled in clean containers, fillers, etc., to prevent foreign material from entering the transmission. Place the dipstick on a clean surface area while filling the transmission.

**CAUTION**

Containers or fillers that have been used to handle antifreeze or engine coolant must NEVER be used for handling transmission fluid. Antifreeze and coolant solutions contain ethylene glycol that, if introduced into the transmission, can cause the clutch plates to fail.

3.5 RECOMMENDED AUTOMATIC TRANSMISSION FLUID

Hydraulic fluids used in the transmission are important influences on transmission performance, reliability and durability. **Castrol TranSynd™ Synthetic Fluid** and **DEXRON-III®** fluids are recommended for on-highway applications.

- **TranSynd™** is a full synthetic transmission fluid developed by Allison Transmission and Castrol Ltd. This fluid meets Allison specifications for Severe Duty and Extended Drain Intervals. TranSynd™ is fully qualified to the Allison TES295 specifications and is available through Prevost Parts.

NOTE

*The prognostics package requires the use of TranSynd™ or an Allison approved TES-295 licensed fluid in the transmission and Allison High Capacity filters. If any other fluids or filters are used, Prognostic mode **must be disabled**. Prognostic information will not be accurate with any other fluids or filters and could result in missed maintenance activities resulting in transmission damage.*

Section 07: TRANSMISSION

- To be sure a fluid is qualified for use in Allison transmission, check for the **DEXRON-III®** license number on the container or consult the lubricant manufacturer. Consult your Allison Transmission dealer or distributor before using other fluid types.

Customers may use TranSynd™/TES 295 equivalent and extend drain intervals. Equivalent TranSynd™ fluid must meet or exceed TES 295 requirements. Customers may choose from a wide variety of approved Dexron-III® fluids.

Customers may choose from a wide variety of approved non-TES 295 like Dexron-III® or approved Schedule 1 TES-389 fluids.

The Transmission Fluid Operating Temperature Requirements table lists the minimum fluid temperatures at which the transmission may be safely operated without preheating. Preheat with auxiliary heating equipment or by running the equipment or vehicle with the transmission in «N» (Neutral) for a minimum of 20 minutes before attempting range operation.

Transmission Fluid Operating Temperature Requirements

Fluid type	Minimum operating temperature	
	Celsius	Fahrenheit
TranSynd™	-30	-22
DEXRON-III®	-25	-13



CAUTION

Disregarding minimum fluid temperature limits can result in transmission malfunction or reduced transmission life.

NOTE

The use of an arctic preheat kit is recommended at temperatures below -25°F (-32°C). If a preheat kit is not available, the TCM will restrict full operation until the sump temperature is increased.

3.6 OIL CONTAMINATION

At each oil change, examine the drained oil for evidence of dirt or water. A nominal amount of condensation will emulsify during operation of the transmission. However, if there is evidence of water; check the cooler (heat exchanger) for other signs of leakage. This, however, may also indicate leakage from the engine oil system.

3.7 METAL PARTICLES

Metal particles in the oil (except for minute particles normally trapped in the oil filter) indicate damage has occurred in the transmission. When these particles are found in the sump, the transmission must be disassembled and closely inspected to find the source. Metal contamination will require complete disassembly of the transmission and cleaning of all internal and external circuits, coolers, and all other areas where the particles could lodge.



CAUTION

If excessive metal contamination has occurred, replacement of the oil cooler and replacement of all bearings within the transmission is recommended.

3.8 COOLANT LEAKAGE

If engine coolant leaks into the transmission oil system, immediate action must be taken to prevent malfunction and possible serious damage. The transmission must be completely disassembled, inspected, and cleaned. All traces of the coolant contamination must be removed. Friction clutch plates contaminated with ethylene glycol must be replaced.

3.9 CONTROL SYSTEM PROGNOSTICS

The transmission control system includes the provision for the user to monitor various transmission operating parameters. Transmission operating parameters monitored by the prognostics feature are:

- Oil Life Monitor
- Filter Life Monitor
- Transmission Health Monitor



NOTE

*The prognostics package requires the use of TranSynd™ or an Allison approved TES-295 licensed fluid in the transmission and Allison High Capacity filters. If any other fluids or filters are used, Prognostic mode **must be disabled**. Prognostic information will not be accurate with any other fluids or filters and could result in missed maintenance activities resulting in transmission damage.*

Refer to TES 295 Approved Fluids list, found under the Service/Fluids heading on the home page of the Allison Transmission web site.

www.allisontransmission.com

When a specified threshold is detected for any of the serviceable conditions, the TRANSMISSION SERVICE indicator  is illuminated to alert the operator. Failure to attend to the service condition and reset the TRANSMISSION SERVICE indicator within a defined operating period will result in illumination of the CHECK TRANS light on the dashboard telltale panel, indicating the increased probability that the service condition will develop into a more serious condition.

To access the Prognostic Mode functions, simultaneously press the  (Up) and  (Down) arrow buttons repeatedly. See the reference table at the end of this section.

- Oil Life Monitor

The display message denotes the calculated remaining life of the transmission fluid. This value is based on the established life for the required baseline fluid, and then is continuously adjusted for cumulative effects of such operating parameters as operating time, retarder operation, output shaft revolutions and shift frequency.

Display: The display is a two-digit number, denoting percentage of the fluid life which remains. New fluid is displayed as 99%.

The TRANSMISSION SERVICE indicator  will be illuminated, denoting a required change of transmission fluid, when the remaining fluid life reaches approximately 1–2 %. The indicator will be lit steadily upon each initialization of the TCM, and will remain on steady for approximately 1–2 minutes after the first selection of “D” (drive) range each time, until service is performed and the indicator is reset.

Failure to perform maintenance and reset the TRANSMISSION SERVICE indicator within a defined period will result in the illumination of the CHECK TRANS light on the dashboard telltale panel and diagnostic code P0897 Transmission Fluid at Limit will be set.

Reset: The TRANSMISSION SERVICE indicator can be reset by a message over the SAE J1939 communication interface, with the Allison DOC™ for PC diagnostic program, or by depressing and holding the MODE button for ten (10) seconds while the Oil Life Monitor function is displayed. It may also be reset by selecting N-D-N-D-N-R-N on the shift selector, pausing briefly (less than 3 seconds) between each

selector movement, with the ignition on and the engine not running.



CAUTION

Required calendar-based oil & filter change intervals (based on month) still apply because Oil Life Monitor function cannot measure time while ignition power is OFF.

If the Oil Life Monitor function has not indicated the need for a fluid change before 60 month (five years) have passed, it will be necessary to change the fluid and filters per calendar requirements and reset the system.

- Filter Life Monitor

The display message denotes operating status of the transmission main fluid filter, based on the measured pressure drop across the filter. The feature is not functional at transmission sump temperatures below 40 °C (105 °F). Both the main and lube filters **must be** changed when the TRANSMISSION SERVICE indicator  shows the main filter should be changed.

Display: An acceptable filter life status is displayed as "OK". An unacceptable filter life status is displayed as "LO".

Once the programmed threshold for maximum filter pressure drop has been observed and verified, the diagnostic code P088A Transmission Filter At/Over Limit will be recorded to indicate that the filter has reached the end of its designed life. At the next initialization of the TCM, the TRANSMISSION SERVICE indicator  will flash for approximately 1–2 minutes after the first selection of “D” (drive) range. Thereafter, the indicator will illuminate and flash upon each TCM initialization, continuing to flash for 1–2 minutes after the first selection of a drive range each time, until service is performed and the indicator is reset.

Failure to perform maintenance and reset the monitor after a calibration-defined number of warnings will result in the illumination of the CHECK TRANS light on the dashboard telltale panel and diagnostic code P088B will be recorded to indicate a highly deteriorated filter.

Reset: The feature will reset automatically when the main fluid filter has been changed and the pressure drop across the filter no longer exceeds the threshold value. A manual reset

Section 07: TRANSMISSION

can be performed by depressing and holding the MODE button for ten (10) seconds while the Filter Life Monitor function is displayed. It may also be reset by selecting N-R-N-R-N-D-N on the shift selector, pausing briefly (less than 3 seconds) between each selector movement, with the ignition on and the engine not running.

- Transmission Health Monitor

The display message denotes clutch life status, as determined by monitored changes and the calculated running clearance of the transmission clutches C1, C2, C3, C4 & C5.

Display: An acceptable clutch life status is displayed as "OK". An unacceptable clutch life status is displayed as "LO". The specific clutch(es) for which the function indicates "LO" cannot be identified with the shift selector. Allison DOC™ for PC-Service Tool displays clutch condition as OK or NOT OK for each clutch, C1 through C5.

The TRANSMISSION SERVICE indicator will be illuminated, indicating the need for clutch maintenance, when the remaining clutch life reaches approximately 10%, or if the running clearance exceeds a maximum value which may indicate a non-wear-related issue. Thereafter, the indicator will be lit upon each initialization of the TCM, and will remain on steady during all vehicle operation until service is performed and the indicator is reset.

Failure to perform maintenance and reset the monitor after a number of warnings will result in the illumination of the CHECK TRANS light on the dashboard telltale panel and diagnostic code P2789 Clutch Adaptive learning at Limit will be set.

Reset: The feature will reset automatically upon elimination of the clutch clearance condition which initiated it. The indicator can also be manually reset using the Allison DOC™ for PC diagnostics program if necessary.

The following table illustrates how to access Oil Level Check, Prognostics & Diagnostic Troubleshooting Codes functions on the Allison pushbutton shift selector.

▲ (up) & ▼ (down) arrow buttons pressed simultaneously	Description	SELECT	MONITOR
1 st press	Allison transmission oil level check	" _ "	" _ "
	Other codes will be displayed		
2 nd press	Oil Life Monitor	" O "	" M "
	Oil life remaining will range from 99% down to 00%	Some number from 9 to 0	Some number from 9 to 0
3 rd press	Filter Life Monitor	" F "	" M "
	Present life of filter is OK	" O "	" K "
	Present life of filter is low	" L "	" O "
4 th press	Transmission Health Monitor	" O "	" K "
	Shows "OK" until remaining life of one or more of the clutch(es) wear enough so that the programming changes	" O "	" K "
	One or more of the clutches C1 through C5 have worn enough to change the program	" L "	" O "
5 th press	Display of diagnostic codes	" d "	" 1 "
	Other codes will be displayed		

TABLE 1

Recommended Fluid and Filter Change Intervals Using Dexron-III / Non-TranSynd™/Non-TES 295/Mixture			
Severe ³ All vehicles equipped with a retarder and not using High-Capacity Filters			
Fluid	Filters		
	Main	Internal	Lube/ Auxiliary
12,000 Miles (20 000 km) 6 Months/ 500 Hrs	12,000 Miles (20 000 km) 6 Months/ 500 Hrs	Overhaul	12,000 Miles (20 000 km) 6 Months/ 500 Hrs

TABLE 2

Recommended Fluid and Filter Change Intervals ¹ Using 100% TranSynd™/TES 295 Approved Fluid ²			
Severe ³ All vehicles equipped with a retarder and not using High-Capacity Filters			
Fluid	Filters		
	Main	Internal	Lube/ Auxiliary
50,000 Miles (80 000 km) 24 Months/ 2000 Hrs	50,000 Miles (80 000 km) 24 Months/ 2000 Hrs	Overhaul	50,000 Miles (80 000 km) 24 Months/ 2000 Hrs

TABLE 3

Recommended Fluid and Filter Change Intervals ¹ Using 100% TranSynd™/TES 295 Approved Fluid ²			
Severe ³ All vehicles equipped with a retarder and using High-Capacity Filters			
Fluid	Filters		
	Main	Internal	Lube/ Auxiliary
150,000 Miles (240 000 km) 48 Months/ 6000 Hrs	75,000 Miles (120 000 km) 36 Months/ 3000 Hrs	Overhaul	75,000 Miles (120 000 km) 36 Months/ 3000 Hrs

2 inch Control Module (1.75 approximately) – Requires High-Capacity Filter kit Allison P/N 571709

¹ Extended TranSynd™/TES 295 fluid and filter change intervals are only allowed with Allison High-Capacity filters.

² Less than 100% concentration of TranSynd™/TES 295 approved fluid is considered a mixture and should utilize non-TES 295 change intervals. If the customer replaces non-TranSynd™/non-TES 295 fluid with TranSynd™/TES 295 equivalent, the change interval recommendations of non-TranSynd™/non-TES 295/mixture must be followed. Upon the next oil change, if the customer reinstall TranSynd™/TES 295 equivalent, the fluid & filter change recommendation outlined in 100% TES 295 approved fluids must be followed.

³ Severe vocation= All retarder, On/Off highway, transit and intercity coaches with duty cycle greater than one (1) stop per mile.

3.10 OIL AND FILTER CHANGE INTERVAL

- Oil and Filter Change interval With Prognostics Mode Disabled

Allison transmissions are factory fill with **Castrol TranSynd™** fluid. Oil change must be performed with the vehicle on a flat and level surface and with parking brake applied. Oil and oil filter change frequency is determined by the severity of service and operating conditions of the transmission and by the filter equipment installed. See "TABLE 1, TABLE 2 or TABLE 3 " for oil and filter change intervals. More frequent changes may be required when operations are subject to high levels of contamination or overheating. Filters must be changed at or before recommended intervals.

IMPORTANT NOTE

Allison Transmission recommends that customers use fluid analysis as the primary method for determining fluid change intervals. Many customers have a systematical annual transmission fluid change while, in many cases, fluid analysis could demonstrate that the transmission fluid is still in good condition and a fluid change is not required. In the absence of a fluid analysis program, the fluid change interval listed in TABLE 1, TABLE 2 & TABLE 3 should be used.

IMPORTANT NOTE

Your transmission is equipped with **High Capacity filters**. High Capacity filters allow for increased fluid and filter change intervals in transmissions utilizing TES 295 approved fluid/TranSynd™. High Capacity filters eliminate the requirement of the initial 5000 miles (8000km) main filter change.

Former Gold Series filter kits are completely cancelled and serviced with current High Capacity filter kits. However, if you are using stocked Gold Series filter kits with TES 295 approved fluid/TranSynd™, use TABLE 2 for oil and filter change intervals.

- Oil And Filter Change Interval With Prognostics Mode Enabled

Oil Life Monitor and Filter Life Monitor of the Prognostics mode provide indicators of required maintenance actions. They are designed to maximize fluid and filter utilization. **Prognostics enabled requires the use of 100% TranSynd™ or an Allison approved TES-295 transmission fluid and Allison High Capacity**

filters. If any other fluids or filters are used, Prognostic mode **must be disabled**. Prognostic information will not be accurate with any other fluids or filters and could result in missed maintenance activities resulting in transmission damage.

IMPORTANT NOTE

The following schedule is to be used with Prognostics enabled.

100% concentration of TES-295 Allison approved fluids and Allison High Capacity Filters is **required**. Less than 100% concentration of TES-295 Allison approved fluids are considered a mixture and shall not be used with Prognostics mode or this change schedule. Utilization of previous Non-TES 295 fluid/filter change intervals (Table 1) is required.

Severe Vocation	
FLUIDS Prognostics enabled	Change fluid when indicated by TRANSMISSION SERVICE indicator or 60 month (five years) whichever occurs first. In addition, change filters with fluid.
FILTERS Prognostics enabled	Change filters (Main & Lube) when indicated by TRANSMISSION SERVICE indicator between fluid change or 60 month (five years) whichever occurs first.

- Changing The Transmission Oil And Oil Filters

The procedure for changing the transmission oil and oil filters is as follows:

Drain

- The transmission should be at an operating temperature of 160°F (71°C) to 200°F (93°C) when the oil is drained. This will ensure quicker and more complete fluid drainage.

NOTE

Remove transmission protective panel located underneath transmission for easier access.

- Remove the drain plug from under the transmission (Fig. 6) and allow the oil to drain into a suitable container. Check the condition of the oil as described previously.
- To replace the integral filters, remove twelve bolts (6 on each cover), two filter covers, two O-rings, two square cut seals and the two filters from the bottom of the control module (Fig. 6).

- To install filters, pre-lube and install the two O-rings, the two square cut seals followed by the filters (lube the O-ring in filter cartridge only) into the filter compartment. Index each filter/cover assembly to holes in channel plate/sump. Push the cover assembly in by hand to seat the seals.



CAUTION

Do not use bolts to draw the cover to sump. This can damage the cover, seal, or sump.

- Install twelve bolts and both covers, and then tighten to 38-45 lbf-ft (51-61 Nm).
- Inspect the drain plug and O-ring. Replace if necessary. Reinstall the drain plug and tighten to 18-24 lbf-ft (25-32 Nm).
- Reinstall transmission protective panel

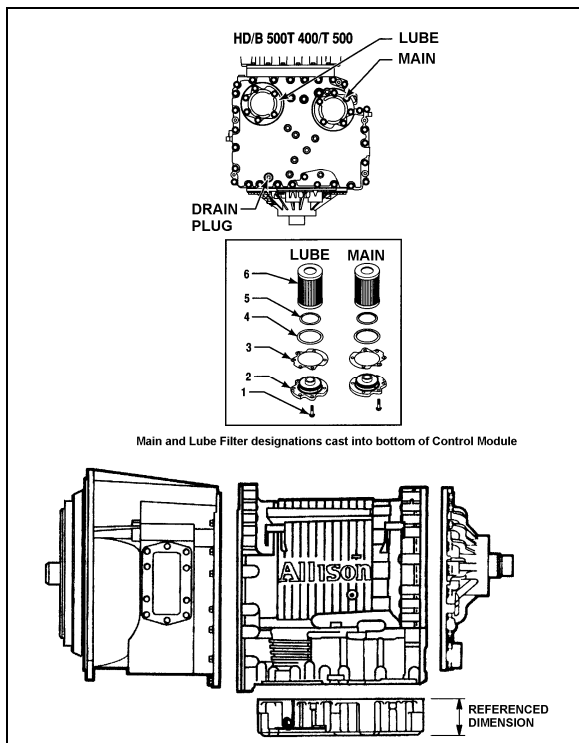

FIGURE 6: DRAIN PLUG AND FILTERS

07074

Fluid loss with filter change only

When changing main and lube filters at recommended intervals, approximate fluid loss for each filter as follows:

Main filter = 2 quarts (1.9 liters)
Lube filter = 8 quarts (7.6 liters)

Refilling Transmission

The amount of refill fluid is less than the amount used for the initial fill. Fluid remains in the external circuits and transmission cavities after draining the transmission.

NOTE

Quantities listed above are approximations and do not include external oil cooler lines.

Using the oil level dipstick filler tube, refill with 24 US qts (23 liters) [28 US qts (26.5 liters) if equipped with retarder] and check the oil level using the **Fluid Level Check Using Pushbutton Shift Selector** procedure in this section.

4. ALLISON TRANSMISSION REMOVAL

The following procedure deals with the removal of the Allison transmission without removing the power plant cradle from vehicle. The methods used to support the transmission and engine depend upon conditions and available equipment.

- Select transmission's "NEUTRAL" position, apply parking brake, then set battery master switch to the "OFF" position.
- Jack up vehicle, then place safety supports underneath body.



CAUTION

Only the recommended jacking points must be used as outlined in Section 18, "BODY".

NOTE

For more clearance between the tag axle and transmission, the tag axle may be unloaded and jacked up or retracted (if applicable).

- Remove engine splash guards and protective panels surrounding transmission.
- Remove cross member from under transmission.
- Remove the transmission drain plug and allow oil to drain. Inspect the drain plug washer and replace it if necessary. Reinstall the drain plug and tighten to 33-41 lbf-ft (45-56 Nm) (see "3.10 OIL AND FILTER CHANGE" in this section).



WARNING

It is better to drain oil when it is still warm. Avoid contact with oil since it can be very hot and cause personal injury.

6. Remove transmission dipstick and filler tube.
7. Disconnect propeller shaft from transmission and remove its safety guard. Refer to Section 09, "PROPELLER SHAFT".
8. Disconnect the two oil cooler hoses from transmission. Cover hose ends and fittings to prevent fluid contamination.



WARNING

A significant amount of oil may drain from oil lines when they are disconnected.

9. Disconnect all sensors on L.H. side of the transmission.
10. Disconnect main wiring harness.
11. Disconnect the air supply line (steel-braided hose) from retarder control valve (if applicable).
12. Remove any locking tie, clamp and bracket that may interfere with the removal of transmission.
13. Support transmission using a suitable transmission jack.

NOTE

Remove starter motor located on engine L.H. side. Removing the starter motor will allow access to unfasten the 12 converter-to-flexible plate attaching screws. Remove the plug located below starter motor and install cranking tool (88800014). Cranking the engine to gain access to the attaching screws may be done by turning the cranking tool using a suitable adapter (fig. 7).



CAUTION

Do not rotate alternator shaft clockwise to avoid removing tension on belt.

14. Remove the 12 screws retaining the torque converter housing to the flywheel housing.

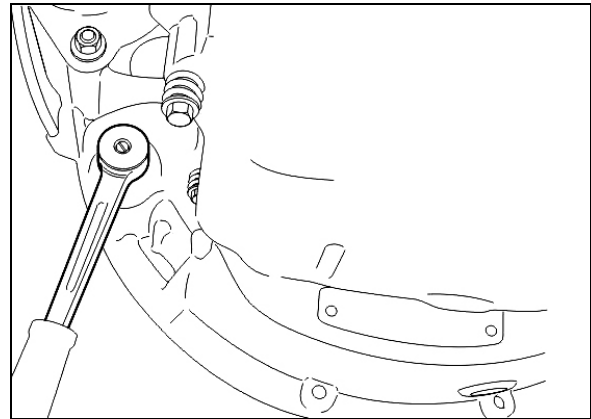

FIGURE 7: VOLVO ENGINE CRANKING POSITION



CAUTION

Make sure transmission-to-engine alignment is maintained when removing screws to avoid damaging torque converter housing.

15. Slowly pull transmission straight out to clear the engine.
16. Remove the transmission.

5. TRANSMISSION OIL COOLER REMOVAL

Stop engine and allow engine to cool. Close both heater line shutoff valves (refer to Section 05 "Cooling").

1. To drain the cooling system, proceed as per Section 05 "Cooling", paragraph 5: Draining. If the cooling system is contaminated, flush system as per Section 05 "Cooling", paragraph 7: Flushing.
2. Remove the rear L.H. side tag axle wheel, then remove the rear L.H. side fender panel.
3. Disconnect the transmission hoses from oil cooler. Cover hose ends and fittings to prevent fluid contamination.

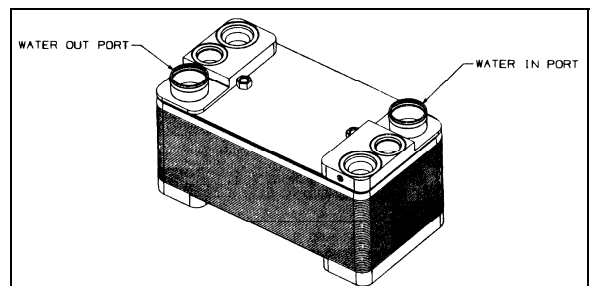

FIGURE 8: ALLISON OIL COOLER

**WARNING**

A significant amount of oil may drain from oil lines when they are disconnected.

4. Unfasten the constant-torque hose clamps and remove the two hoses.
5. Unscrew the holding bolts and nuts and remove the oil cooler from engine compartment.

6. CLEANING AND INSPECTION OF ALLISON AUTOMATIC TRANSMISSION

The exterior of the transmission should be cleaned and inspected at regular intervals. The length of service and severity of operating conditions will determine the frequency of such inspections. Inspect the transmission for:

1. Loose bolts (transmission and mounting components);
2. Oil leaks (correct immediately);
3. Loose, dirty, or improperly adjusted throttle sensor linkage;
4. Damaged or loose oil lines;
5. Worn or frayed electrical harnesses, improper routing;
6. Worn or out of phase drive line U-joint and slip fittings.

**CAUTION**

DO NOT pressure wash the transmission electrical connectors. Water and detergent will cause the contacts to corrode or become faulty.

6.1 BREATHER

The breather is located on the engine, flywheel side near the valve cover. It serves to prevent pressure build-up within the transmission and must be cleaned to keep the passage opened. The prevalence of dust and dirt will determine the frequency at which the breather requires cleaning. Use care when cleaning the engine. Spraying steam, water or cleaning solution directly at the breather can force the water or solution into the transmission. Always use care when removing the hose connector from transmission to prevent the entry of foreign matter.

7. ALLISON TRANSMISSION INSTALLATION**NOTE**

For more clearance between the tag axle and transmission, the tag axle may be unloaded and jacked up, or retracted (if applicable).

1. With the starter motor removed, align one of the 12 attaching screw holes in the flexible plate with the access opening.
2. Place the transmission on a transmission jack.
3. Install a headless guide bolt into one of the 12 threaded holes for flexible plate attaching screws in the flywheel.
4. Lubricate the flywheel center pilot boss with molybdenum disulfide grease (Molycote G, or equivalent).
5. Raise transmission and position the flywheel pilot boss into the flexible plate adapter. Align the guide bolt previously installed in the flywheel with the flexible plate hole facing the access opening in the flywheel housing.

**DANGER**

Severe damages and/or personal injury can occur if transmission is not adequately supported.

5. Seat the transmission against the engine flywheel housing. **NO FORCE IS REQUIRED.** If interference is encountered, move the transmission away from engine, then investigate the cause.

**CAUTION**

The torque converter housing must be seated against the flywheel housing prior to tightening any screws. **DO NOT USE SCREWS TO SEAT THE HOUSING.**

6. Start all torque converter housing screws, and then tighten four of them gradually and in a criss-cross sequence around the housing. Tighten the 12 remaining screws. Recommended torque is between 42-50 lbf-ft (57-68 Nm).
7. Remove the guide bolt through the access opening in the flywheel housing. Replace it with a self-locking screw, finger-tighten then

Section 07: TRANSMISSION

start the remaining screws; tighten to 17-21 lbf-ft (23-28 Nm).

NOTE

Remove the plug located below starter motor and install cranking tool (88800014). Crank the engine to gain access to the threaded holes by turning the cranking tool using a suitable adapter (Refer to fig. 7).

Reinstall starter motor and connect cables.

Reinstall access plug below starter motor.

8. Remove jack from under transmission.
9. Connect all sensors.
10. Connect the main wiring harness.
11. Connect the air supply line (steel-braided hose) to the retarder control valve (if applicable).
12. Connect the two transmission oil cooler hoses as they were previously.
13. Reinstall clamps and brackets, and replace locking ties previously removed during removal procedure.
14. Install propeller shaft and its safety guard. Refer to Section 09, "PROPELLER SHAFT".
15. Install transmission dipstick and filler tube.
16. Install cross member under transmission.
17. Install engine splash guards.
18. Adjust the retarder pressure to 85 ± 3 psi with the air pressure regulator. For more information refer to Section 12, "BRAKE AND AIR SYSTEM", under heading "AIR PRESSURE REGULATOR". The air pressure regulator is located in the engine compartment, on engine cradle R.H. side (Fig. 9).
19. Make sure that the drain plug is in place, and then remove the transmission dipstick and pour approximately 24 US quarts (23 L) of automatic transmission fluid through the filler tube. Check and adjust oil level.



CAUTION

Do not overfill the transmission. Overfilling can cause oil aeration (milky appearance) and overheating. If overfilling occurs, drain oil as required to bring it to the proper level.

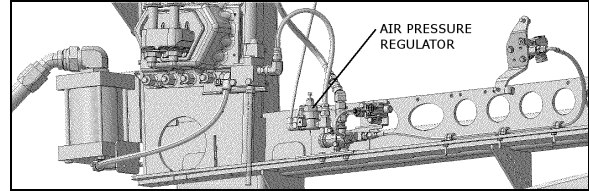

FIGURE 9: AIR PRESSURE REGULATOR (TYPICAL) 07130

8. ALLISON AUTOMATIC TRANSMISSION TROUBLESHOOTING

For complete information about Allison transmission troubleshooting, refer to "Allison 4th Generation Controls – Troubleshooting Manual: 3000 and 4000 Product families (TS3989)".

8.1 4TH GENERATION TRANSMISSION CONTROL MODULE

The Allison transmission has a new Transmission Control Module (TCM) which involves specific diagnostic incident codes. The TCM unit is located on the coach rear electrical panel.

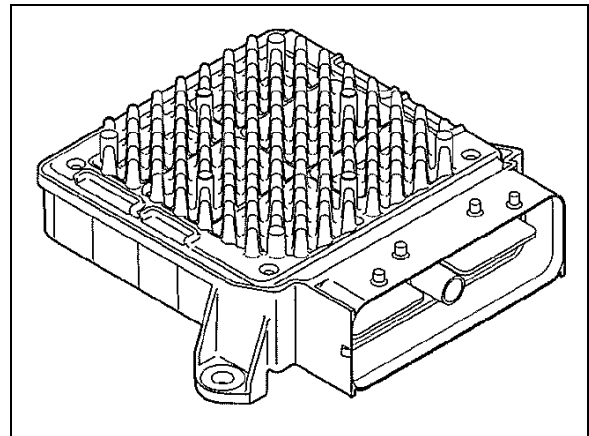



FIGURE 10: TRANSMISSION CONTROL MODULE 07140

TCM Replacement

The TCM is a non-serviceable electronic device. When it fails, it must be replaced using the following procedure:

- Open the engine compartment R.H. side door then remove the rear electrical panel cover in order to get access to the TCM;
- Remove the electrical cable connectors;
- Unscrew the TCM unit;
- Replace by reversing the procedure.

 CAUTION
Place the battery master switch to the "OFF" position.

8.2 DIAGNOSTIC TROUBLESHOOTING CODES (DTC) — ALLISON 4TH GENERATION CONTROLS

Diagnostic codes (DTC) are numerical indications relating to a malfunction in transmission operation. These codes are logged in a list in the TCM memory with the most severe or most recent code listed first. A maximum of five codes (numbered d1 to d5) may be listed in memory at one time. As codes are added, the oldest inactive code is dropped from the list. If all codes are active, the code with the lowest priority that is not included on the severity list is dropped from the list.

Diagnostic codes (DTC) and code information may be accessed through the pushbutton shift selector or using an Allison DOC™ diagnostic tool.

The TCM separately stores the active and inactive codes. An active code is any code that is current in the TCM decision-making process. Inactive codes are codes that are retained in the TCM memory and will not necessary affect the TCM decision-making process. Inactive codes are useful in determining if a problem is:

- Isolated ;
- Intermittent ;
- Result from a previous malfunction.



The TCM may automatically delete a code from memory if it has not recurred. If the MODE INDICATOR (LED) is not illuminated, the displayed code is not active. An illuminated MODE INDICATOR (LED) during normal operation signifies secondary shift mode operation.

8.3 DIAGNOSTIC CODES – ALLISON 4TH GENERATION CONTROLS

When the diagnostic mode is entered, the first code (position d1) is displayed as follows:

Example: Code P0722

Displayed as: **d1...P...07...22**

The code list position is the first item displayed, followed by the DTC. Each item is displayed for about one second. The display cycles continuously until the next code list position is accessed by pressing the **MODE** button. The following example shows how DTC P0722 is displayed on the pushbutton shift selector.

SELECT	d	1	MONITOR
		P	
	0	7	
	2	2	

- d1 (code list position) – The position which a code occupies in the list. Positions are displayed as « d1 » through « d5 » (code list position 1 through code list position 5).
- P0722 (DTC) – The diagnostic troubleshooting code number referring to the general condition or area of fault detected by the TCM.

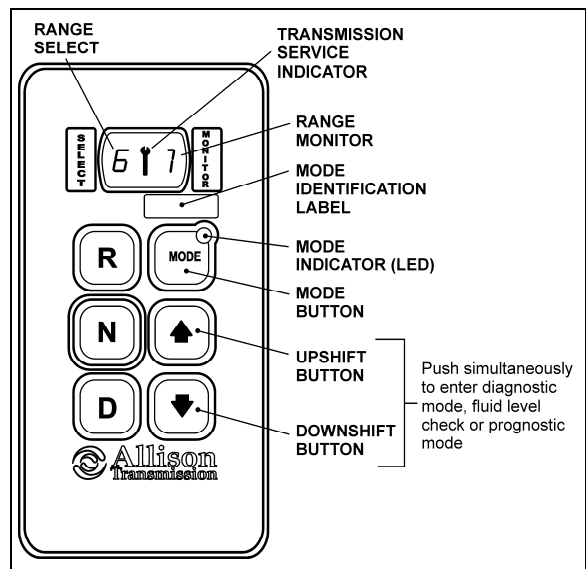

8.4 DIAGNOSTIC CODE DISPLAY AND CLEARING PROCEDURE – ALLISON 4TH GENERATION CONTROLS

Diagnostic codes can be read and cleared by two methods:

- Using an Allison DOC™ diagnostic tool. For specific instructions on how to use an Allison DOC™ diagnostic tool, refer to the User Guide.
- Using the pushbutton shift selector.

To begin the diagnostic process:

1. Bring the vehicle to a stop at a safe location.
2. Apply the parking brake.

To display stored codes:

1. Simultaneously press the ▲ (Up) and ▼ (Down) arrow buttons twice to access the Diagnostic Display Mode.

NOTE

To access the Oil Level Display Mode, simultaneously press the ▲ (Up) and ▼ (Down) arrow buttons once. Consult paragraph: "ALLISON TRANSMISSION OIL LEVEL CHECK USING THE PUSHBUTTON SHIFT SELECTOR" at the end of this section.

2. Observe the digital display for code (d1).
3. Press the MODE button to see the next code (d2) – repeat for subsequent codes (d3, d4 & d5).

NOTE

Be sure to record all codes displayed before they are cleared. This is essential for troubleshooting.

NOTE

The Diagnostic Display Mode can be entered for viewing codes at any speed. Codes can only be cleared when the output speed = 0 and no output speed sensor failure is active

Active indicators (MODE INDICATOR LED) and inactive codes can be cleared manually, while in the diagnostic display mode, after the condition causing the code is identified.

To clear active indicators and inactive codes:

1. While in Diagnostic Display Mode, press and hold the MODE button for 10 seconds to clear both active indicators and inactive codes.
2. Begin operating as normal. Have the transmission checked at the earliest opportunity by an Allison Transmission distributor or dealer.

NOTE

All active indicators are cleared at TCM power down.

Some codes will clear their active indicator when the condition causing the code is no longer detected by the TCM.

The Diagnostic Display Mode can be exited by any of the following methods:

- Press simultaneously the ▲ (Up) and ▼ (Down) arrow buttons at the same time on the pushbutton shift selector.
- Press any range button «D», «N» or «R» on the pushbutton shift selector (the shift will be commanded if it is not inhibited by an active code).
- Wait until the calibrated time (approximately 10 minutes) has passed. The system will automatically return to the normal operating mode.
- Turn off power to the TCM (shut off the engine using the ignition switch).

NOTE

If clearing a code while locked in a "D" (Drive) or "R" (Reverse) position (fail-to-range), the transmission will still be in "D" (Drive) or "R" (Reverse) when the clearing procedure is completed. "N" (Neutral) must be manually selected.

8.5 DIAGNOSTIC CODE RESPONSE

The following responses are used in the "Diagnostic Troubleshooting Code List and Inhibited Operation Description" table to command safe operation when diagnostic codes are sent.

DNS - Do Not Shift Response

Release lock up clutch and inhibit lock up operation.

Inhibit all shifts.

Turn ON the CHECK TRANS light.

Display the range attained.

Ignore any range selection inputs from the shift selector.

DNA - Do Not Adapt Response

The TCM stops adaptive shift control while the code is active.

SOL OFF - SOLenoid OFF Response

All solenoids are commanded *OFF* (turning solenoids "A" and "B" off electrically cause them to be on hydraulically).

RPR - Return to Previous Range Response

When the speed sensor ratio or C3 pressure switch test associated with a shift not successful, the TCM commands the same range as commanded before the shift.

NNC - Neutral No Clutches Response

When certain speed sensor ratio or C3 pressure switch tests are not successful, the TCM commands a neutral condition with no clutches applied.

Section 07: TRANSMISSION

8.6 DIAGNOSTIC TROUBLESHOOTING CODES (DTC) LIST - ALLISON 4TH GENERATION CONTROLS

DTC	Description	CHECK TRANS Light	Inhibited Operation Description
C1312	Retarder Request Sensor Failed Low	No	May inhibit retarder operation if not using J1939 datalink
C1313	Retarder Request Sensor Failed High	No	May inhibit retarder operation if not using J1939 datalink
P0122	Pedal Position Sensor Low Voltage	No	Use default throttle values. Freezes shift adapts.
P0123	Pedal Position Sensor High Voltage	No	Use default throttle values. Freezes shift adapts.
P0218	Transmission Fluid Over Temperature	No	Use hot mode shift schedule. Holds fourth range. TCC is inhibited. Freezes shift adapts.
P0561	System Voltage Performance		
P0562	System Voltage Low		
P0563	System Voltage High		
P0602	TCM Not Programmed	Yes	Lock in Neutral
P0610	TCM Vehicle Options (Trans ID) Error	Yes	Use TID A calibration
P0613	TCM Processor	No	All solenoids off
P0614	Torque Control Data Mismatch - ECM/TCM	Yes	Allows operation only in reverse and second range.
P0634	TCM Internal Temperature Too High	Yes	SOL OFF (hydraulic default)
P063E	Auto Configuration Throttle Input Not Present	Yes	Use default throttle values
P063F	Auto Configuration Engine Coolant Temp Input Not Present	No	None
P0658	Actuator Supply Voltage 1 (HSD1) Low	Yes	DNS, SOL OFF (hydraulic default)
P0659	Actuator Supply Voltage 1 (HSD1) High	Yes	DNS, SOL OFF (hydraulic default)
P0667	TCM Internal Temperature Sensor Circuit Range / Perform		
P0668	TCM Internal Temperature Sensor Circuit Low		
P0669	TCM Internal Temperature Sensor Circuit High		
P0701	Transmission Control System Performance		
P0702	Transmission Control System Electrical (TransID)	Yes	Use TID A calibration
P0703	Brake Switch Circuit Malfunction	No	No Neutral to Drive shifts for refuse packer. TCM inhibits retarder operation if a TPS code is also active.
P0708	Transmission Range Sensor Circuit High Input	Yes	Ignore defective strip selector inputs
P070C	Transmission Fluid Level Sensor Circuit – Low Input	No	None
P070D	Transmission Fluid Level Sensor Circuit – High Input	No	None
P0711	Transmission Fluid Temperature Sensor Circuit Performance	Yes	Use default sump temp
P0712	Transmission Fluid Temperature Sensor Circuit Low Input	Yes	Use default sump temp
P0713	Transmission Fluid Temperature Sensor Circuit High Input	Yes	Use default sump temp
P0716	Turbine Speed Sensor Circuit Performance	Yes	DNS, Lock in current range
P0717	Turbine Speed Sensor Circuit No Signal	Yes	DNS, Lock in current range
P0719	Brake Switch ABS Input Low	No	TCM assumes ABS is OFF

DTC	Description	CHECK TRANS Light	Inhibited Operation Description
P071A	RELS Input Failed On	Yes	Inhibit RELS operation
P071D	General Purpose Input Fault	Yes	None
P0720	Output Speed Sensor Circuit		
P0721	Output Speed Sensor Circuit Performance	Yes	DNS, Lock in current range
P0722	Output Speed Sensor Circuit No Signal	Yes	DNS, Lock in current range
P0726	Engine Speed Sensor Circuit Performance	No	Default to turbine speed
P0727	Engine Speed Sensor Circuit No Signal	No	Default to turbine speed
P0729	Incorrect 6 th Gear Ratio	Yes	DNS, Attempt 5 th , then 3 rd
P0730	Incorrect Neutral Gear ratio		
P0731	Incorrect 1 st Gear ratio	Yes	DNS, Attempt 2 nd , then 5 th
P0732	Incorrect 2 nd Gear ratio	Yes	DNS, Attempt 3 rd , then 5 th
P0733	Incorrect 3 rd Gear ratio	Yes	DNS, Attempt 4 th , then 6 th
P0734	Incorrect 4 th Gear ratio	Yes	DNS, Attempt 5 th , then 3 rd
P0735	Incorrect 5 th Gear ratio	Yes	DNS, Attempt 6 th , then 3 rd , then 2 nd
P0736	Incorrect Reverse Gear ratio	Yes	DNS, Lock in Neutral
P0741	Torque Converter Clutch System Stuck Off	Yes	None
P0776	Pressure Control Solenoid 2 Stuck Off	Yes	DNS, RPR
P0777	Pressure Control Solenoid 2 Stuck On	Yes	DNS, RPR
P0796	Pressure Control Solenoid 3 Stuck Off	Yes	DNS, RPR
P0797	Pressure Control Solenoid 3 Stuck On	Yes	DNS, RPR
P0842	Transmission Pressure Switch 1 Circuit Low	Yes	DNS, Lock in current range
P0843	Transmission Pressure Switch 1 Circuit High	Yes	DNS, Lock in current range
P0847	Transmission Pressure Switch 2 Circuit Low		
P0848	Transmission Pressure Switch 2 Circuit High		
P088A	Transmission Fluid Filter Deteriorated		
P088B	Transmission Fluid Filter Very Deteriorated		
P0880	TCM Power Input Signal	No	None
P0881	TCM Power Input Signal Performance	No	None
P0882	TCM Power Input Signal Low	Yes	DNS, SOL OFF (hydraulic default)
P0883	TCM Power Input Signal High	No	None
P0894	Transmission Component Slipping	Yes	DNS, Lock in first
P0960	Pressure Control Solenoid Main Mod Control Circuit Open	Yes	None
P0961	Pressure Control Solenoid (PCS) MM System Performance		
P0962	Pressure Control Solenoid Main Mod Control Circuit Low	Yes	DNS, SOL OFF (hydraulic default)
P0963	Pressure Control Solenoid Main Mod Control Circuit High	Yes	None
P0964	Pressure Control Solenoid 2 (PCS2) Control Circuit Open	Yes	DNS, SOL OFF (hydraulic default)
P0965	Pressure Control Solenoid (PCS) 2 System Performance		
P0966	Pressure Control Solenoid 2 (PCS2) Control Circuit Low	Yes	DNS, SOL OFF (hydraulic default)
P0967	Pressure Control Solenoid 2 (PCS2) Control Circuit High	Yes	DNS, SOL OFF (hydraulic default)
P0968	Pressure Control Solenoid 3 (PCS3) Control Circuit Open	Yes	DNS, SOL OFF (hydraulic default)
P0969	Pressure Control Solenoid (PCS) 3 System Performance		
P0970	Pressure Control Solenoid 3 (PCS3) Control Circuit Low	Yes	DNS, SOL OFF (hydraulic default)

Section 07: TRANSMISSION

DTC	Description	CHECK TRANS Light	Inhibited Operation Description
P0971	Pressure Control Solenoid 3 (PCS3) Control Circuit High	Yes	DNS, SOL OFF (hydraulic default)
P0973	Shift Solenoid 1 (SS1) Control Circuit Low	Yes	DNS, SOL OFF (hydraulic default)
P0974	Shift Solenoid 1 (SS1) Control Circuit High	Yes	DNS, SOL OFF (hydraulic default)
P0975	Shift Solenoid 2 (SS2) Control Circuit Open	Yes	7-speed: Allow 2 through 6, N, R
P0976	Shift Solenoid 2 (SS2) Control Circuit Low	Yes	7-speed: Allow 2 through 6, N, R Inhibit TCC operation
P0977	Shift Solenoid 2 (SS2) Control Circuit High	Yes	7-speed: Allow 2 through 6, N, R
P0989	Retarder Pressure Sensor Failed Low	No	None
P0990	Retarder Pressure Sensor Failed High	No	None
P1739	Incorrect Low Gear Ratio	Yes	Command 2 nd and allow shifts 2 through 6, N, R
P1891	Throttle Position Sensor PWM Signal Low Input	No	Use default throttle values
P1892	Throttle Position Sensor PWM Signal High Input	No	Use default throttle values
P2184	Engine Coolant Temperature Sensor Circuit Low Input	No	Use default engine coolant values
P2185	Engine Coolant Temperature Sensor Circuit High Input	No	Use default engine coolant values
P2637	Torque Management Feedback Signal (SEM)	Yes	Inhibit SEM
P2641	Torque Management Feedback Signal (LRTP)	Yes	Inhibit LRTP
P2670	Actuator Supply Voltage 2 (HSD2) Low	Yes	DNS, SOL OFF (hydraulic default)
P2671	Actuator Supply Voltage 2 (HSD2) High	Yes	DNS, SOL OFF (hydraulic default)
P2685	Actuator Supply Voltage 3 (HSD3) Low	Yes	DNS, SOL OFF (hydraulic default)
P2686	Actuator Supply Voltage 3 (HSD3) High	Yes	DNS, SOL OFF (hydraulic default)
P2714	Pressure Control Solenoid 4 (PCS4) Stuck Off	Yes	DNS, RPR
P2715	Pressure Control Solenoid 4 (PCS4) Stuck On	Yes	DNS, SOL OFF (hydraulic default)
P2718	Pressure Control Solenoid 4 (PCS4) Control Circuit Open	Yes	DNS, SOL OFF (hydraulic default)
P2719	Pressure Control Solenoid (PCS) 4 System Performance		
P2720	Pressure Control Solenoid 4 (PCS4) Control Circuit Low	Yes	DNS, SOL OFF (hydraulic default)
P2721	Pressure Control Solenoid 4 (PCS4) Control Circuit High	Yes	DNS, SOL OFF (hydraulic default)
P2723	Pressure Control Solenoid 1 (PCS1) Stuck Off	Yes	DNS, RPR
P2724	Pressure Control Solenoid 1 (PCS1) Stuck On	Yes	DNS, RPR
P2727	Pressure Control Solenoid 1 (PCS1) Control Circuit Open	Yes	DNS, SOL OFF (hydraulic default)
P2728	Pressure Control Solenoid (PCS) 1 System Performance		
P2729	Pressure Control Solenoid 1 (PCS1) Control Circuit Low	Yes	DNS, SOL OFF (hydraulic default)
P2730	Pressure Control Solenoid 1 (PCS1) Control Circuit High	Yes	DNS, SOL OFF (hydraulic default)
P2736	Pressure Control Solenoid 5 (PCS5) Control Circuit Open	Yes	Inhibit retarder operation
P2737	Pressure Control Solenoid (PCS) 5 System Performance		
P2738	Pressure Control Solenoid 5 (PCS5) Control Circuit Low	Yes	Allow 2 through 6, N, R. Inhibit retarder and TCC operation
P2739	Pressure Control Solenoid 5 (PCS5) Control Circuit High	Yes	Inhibit retarder operation
P2740	Retarder Oil Temperature Hot	No	None
P2742	Retarder Oil Temperature Sensor Circuit – Low Input	No	Use default retarder temp values
P2743	Retarder Oil Temperature Sensor Circuit – High Input	No	Use default retarder temp values
P2761	TCC PCS Control Circuit Open	Yes	Inhibit TCC operation

9. SPECIFICATIONS

ALLISON AUTOMATIC TRANSMISSION WITH RETARDER

X3-45 Coaches

Gross input power (maximum).....	500 HP (373 kW)
Gross input torque (maximum)	1525 Lbf-ft- (2068 Nm)
Rated input speed (minimum-maximum)	1600-2300 rpm

Mounting:

Engine.....	SAE #1 flywheel housing, flex disk drive
-------------	--

Torque converter:

Type	One stage, three element, polyphase
Stall torque ratio	TC 551-1.8
Lockup clutch with torsional damper	Integral/standard

Gearing:

Type	Patented, constant mesh, helical, planetary
------------	---

Ratio:

First	3.51:1
Second.....	1.91:1
Third	1.43:1
Fourth.....	1.00:1
Fifth	0.74:1
Sixth	0.64:1
Reverse	4.80:1

Ratio coverage:

6 speed	5.48:1
---------------	--------

* Gear ratios do not include torque converter multiplication.

Oil System:

Oil type.....	TRANSYND, DEXRON-III
Capacity (excluding external circuits)	Initial fill 47 US qts (45 liters)
Oil change.....	24 US qts (23 liters)
Oil change (with retarder).....	27.6 US qts (26 liters)

Oil Filters:

Make	Allison Transmission
Type	Disposable cartridge
Prevost Part Number (2-filter replacement kit).....	571709

SECTION 09: PROPELLER SHAFT

CONTENTS

1. PROPELLER SHAFT	2
1.1 DESCRIPTION.....	2
2. REMOVAL, DISASSEMBLY, REASSEMBLY AND INSTALLATION	2
3. CLEANING, INSPECTION AND LUBRICATION	2
3.1 CLEANING AND INSPECTION.....	2
3.2 LUBRICATION	2
4. EXPLANATION OF COMMON DAMAGES.....	4
5. TROUBLESHOOTING	4
6. SPECIFICATIONS.....	4

ILLUSTRATIONS

FIGURE 1: PROPELLER SHAFT ASSEMBLY	3
--	---

1. PROPELLER SHAFT

1.1 DESCRIPTION

The propeller shaft transmits power from the transmission to the differential (Fig. 1). Refer to paragraph "6. SPECIFICATIONS" at the end of this section for propeller shaft length. The propeller shaft is "Dana Spicer Life Series SPL250" type with tubular shafts. It is provided with two heavy-duty universal joints (Fig. 1).

The propeller shaft has a half round end yoke at each end. The slip yoke is connected to the differential by a half round end yoke with two needle bearings.

The other extremity (tube yoke assembly) is connected to the transmission by a half round end yoke with two needle bearings (Allison transmission) or a flange yoke and companion flange with two needle bearings (I-Shift Transmission).

Furthermore, a slip joint on the propeller shaft compensates for variations in distance between the transmission and the differential, or between the output retarder and differential.

The rise and fall of the drive axle bring about these variations as the vehicle passes over uneven surfaces. The slip joint also eases removal of the transmission or the drive axle.

2. REMOVAL, DISASSEMBLY, REASSEMBLY AND INSTALLATION

Refer to "SPICER LIFE SERIES DRIVESHAFTS Service Manual" annexed to this section.

Where applicable:

- Remove or install propeller shaft safety guard.
- Screw bolts to the specified torque (Fig. 1).

3. CLEANING, INSPECTION AND LUBRICATION

3.1 CLEANING AND INSPECTION

Thoroughly clean grease from bearings, journal, lubricating grease fittings and other parts. Needle bearing assemblies may be soaked in a cleaning solution to soften hard grease particles.

It is extremely important that bearing assemblies be absolutely clean and blown out with compressed air, since small particles of dirt or grit can cause rapid bearing wear. Do not attempt to disassemble needle bearings.

Bearing journal areas should be inspected for roughness or grooving. If light honing does not remove roughness, the entire bearing assembly should be replaced. Excessive wear of the needle bearing is indicated if the needles drop out of the retainer, or if marks are present on the journal bearing surface. In such case, replace bearing assembly. Finally, inspect yokes for cracks, wear or distortion.

NOTE

Repair kits are available for overhaul of the propeller shaft assembly. Refer to Parts Manual, Section 9.

3.2 LUBRICATION



MAINTENANCE

Lubricate propeller shaft universal joints periodically, every 25,000 miles (40 000 km) or every 3 months, whichever comes first.

Apply grease gun pressure to the lube fitting. Use a good quality lithium-base grease such as: NLGI No.2 E.P. Grease (suitable for most temperatures). Refer to "Spicer Life Series Driveshafts Service Manual", under heading, "Lubrication Procedures – Universal Joints".

NOTE

Do not assume that bearing cavities have been filled with new grease unless it has expelled around all seals.

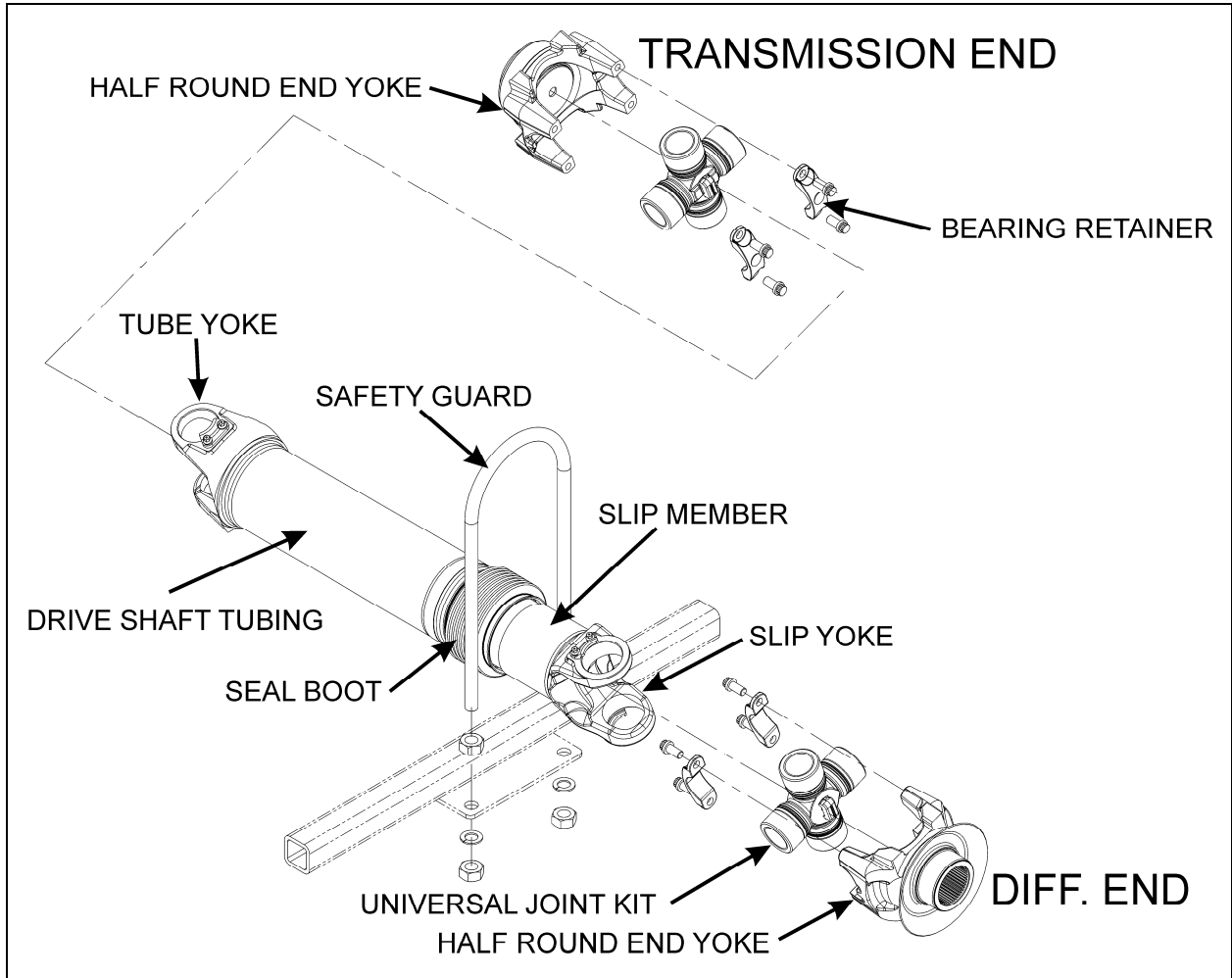

FIGURE 1: PROPELLER SHAFT ASSEMBLY

09002

4. EXPLANATION OF COMMON DAMAGES

1. Cracks: Stress lines due to metal fatigue. Severe and numerous cracks will weaken the metal until it breaks.

2. Galling: Scraping off of metal or metal displacement due to friction between surfaces. This is commonly found on trunnion ends.

3. Spalling (surface fatigue): Breaking off of chips, scales, or flakes of metal due to fatigue rather than wear. It is usually found on splines and U-joint bearings.

4. Pitting: Small pits or craters in metal surfaces due to corrosion. If excessive, pitting can lead to surface wear and eventual failure.

5. Brinelling: Surface wear failure due to the wearing of grooves in metal. It is often caused by improper installation procedures. Do not confuse the polishing of a surface (false brinelling), where no structural damage occurs, with actual brinelling.

6. Structural Overloading: Failure caused by a load greater than the component can stand. A structural overload may cause propeller shaft tubing to twist under strain or it may cause cracks or breaks in U-joints and spline plugs.

5. TROUBLESHOOTING

Refer to *"Spicer Life Series Driveshafts Service Manual"*.

6. SPECIFICATIONS

PROPELLER SHAFT

ALL VEHICLES EQUIPPED WITH ALLISON WORLD TRANSMISSION

Make	Hayes-Dana Inc.
Series.....	SPL250
Prevost number	580090
Length.....	485 mm

SECTION 10: FRONT AXLE

CONTENTS

1. FRONT AXLE	2
1.1 DESCRIPTION	2
2. LUBRICATION	2
3. MAINTENANCE	4
4. REMOVAL AND REPLACEMENT	4
4.1 REMOVAL	4
4.2 REPLACEMENT	4
5. SERVICE INSTRUCTIONS FOR STEER AXLE	5
5.1 STEERING KNUCKLE (KING) PIN INSPECTION	5
5.1.1 <i>Checking Lateral Slackness</i>	5
5.1.2 <i>Checking Vertical Slackness</i>	6
6. FRONT WHEEL ALIGNMENT	6
6.1 INSPECTION BEFORE ALIGNMENT	6
6.2 MINOR FRONT WHEEL ALIGNMENT	6
6.3 MAJOR FRONT WHEEL ALIGNMENT	7
6.4 TURNING ANGLE ADJUSTMENT	7
6.4.1 <i>R.H. Turn Adjustment</i>	7
6.4.2 <i>L.H. Turn Adjustment</i>	7
6.5 HYDRAULIC STOP	8
6.6 FRONT WHEEL CAMBER	8
6.6.1 <i>Camber Check</i>	8
6.7 FRONT AXLE CASTER.....	8
6.8 FRONT WHEEL TOE-IN.....	9
6.8.1 <i>Inspection and Adjustment</i>	10
7. TROUBLESHOOTING	11
8. SPECIFICATIONS	12
9. TORQUE SPECIFICATIONS	12

ILLUSTRATIONS

FIGURE 1: FRONT AXLE ASSEMBLY	2
FIGURE 2: FRONT AXLE GREASING POINTS	2
FIGURE 3: CAMBER	8
FIGURE 4: CASTER	9
FIGURE 5: TOE-IN MEASUREMENTS	9

Section 10: FRONT AXLE

1. FRONT AXLE

1.1 DESCRIPTION

The Dana Spicer S84U front axle is of the "Reverse Elliot" type manufactured by Dana Spicer Europe. The front axle consists of a girder section axle bed or beam with stub axles. Each stub axle is carried on a taper kingpin, with a plain phosphor bronze bushing at the top and at the bottom. The unitized hub bearings used on the NDS range of axles, are non-serviceable items. Bearings are pre-adjusted, lubricated and have seals fitted as part of the manufacturing process. The bearings are greased for life and there is no need or facility for re-lubrication. Brakes are manufactured by KNORR-BREMSE. Steering ball joints with hardened balls and rubbing pads incorporate compression springs which automatically take up any wear.

The tie rod simplifies toe-in adjustment. The maximum turning angle is set through stop screws installed on the inner side of the knuckle.

Steering stabilizer (damper) and steering drag link which are mounted on the front axle are described in Section 14; "Steering" of this manual.

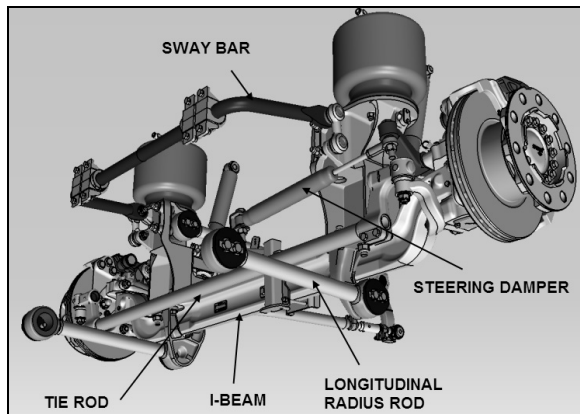



FIGURE 1: FRONT AXLE ASSEMBLY

10026

2. LUBRICATION

	<h2>MAINTENANCE</h2>
<h4>Commuter application</h4>	
<p>Knuckle pins are provided with grease fittings for pressure lubrication. These grease fittings should be serviced every 6,250 miles (10 000 km) or every three months whichever comes first.</p>	

Good quality lithium-base roller bearing grease NLGI No.1 and 2 are recommended.

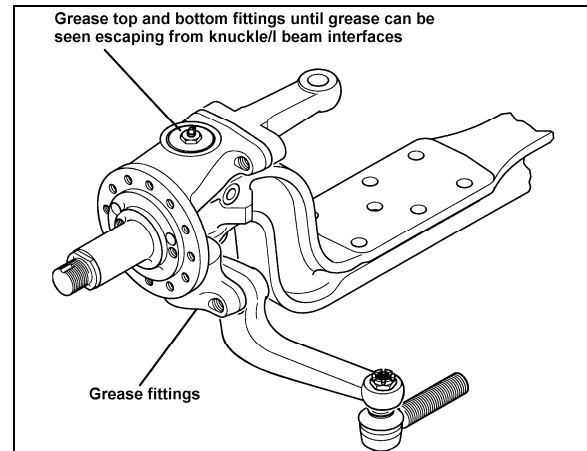
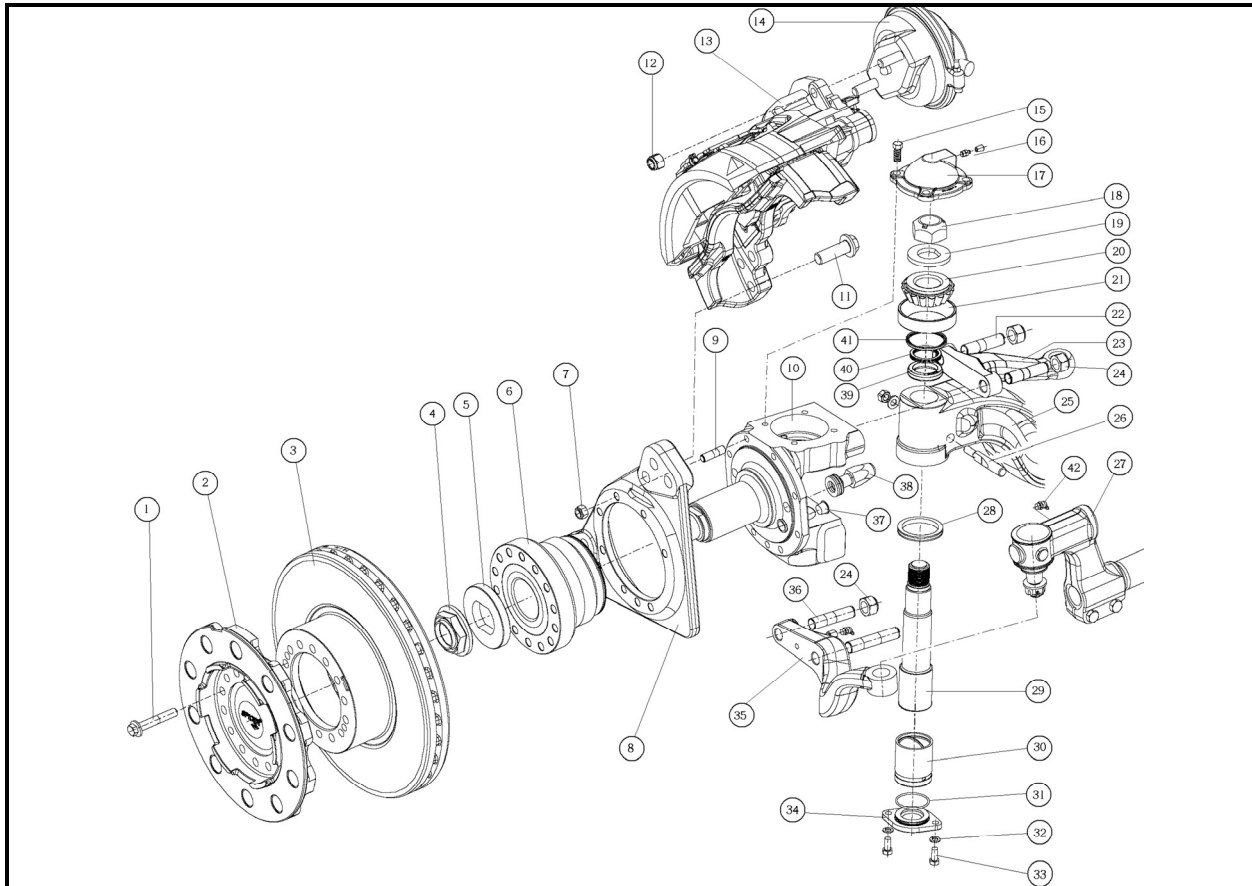

FIGURE 2: FRONT AXLE GREASING POINTS

10031

Section 10: FRONT AXLE



TYPICAL S84U AXLE

ITEM	DESCRIPTION	QTY	ITEM	DESCRIPTION	QTY		
1	Flanged Bolt	161-197 lbf-ft	28	26	Draw key, Nut, Washer	51-62 lbf-ft	2
2	Hub		2	27	Tie Rod End		2
3	Brake Disc		2	28	V-Ring Seal		2
4	Stake Hub Nut	563-687 lbf-ft	2	29	Kingpin		2
5	Collet Washer		2	30	Kingpin - Bushing		2
6	Hub Bearing		2	31	O-Ring Seal		2
7	Nut – Self Lock	85-103 lbf-ft	16	32	Washer		4
8	Brake Mounting Bracket		2	33	Screw	26-32 lbf-ft	4
9	Stud		16	34	Cap - Knuckle Bottom		2
10	Knuckle		2	35	Bottom Steering Lever		2
11	Brake Fixing – Bolt	325-375 lbf-ft	12	36	Bottom Steering Lever - Stud		4
12	Nut – Self Lock	133-155 lbf-ft	4	37	Abs Sensor - Bush		2
13	Brake		1	38	Back Lock - Stop Bolt	85-103 lbf-ft	2
14	Brake Chamber		2		Front Lock - Stop Bolt	85-103 lbf-ft	1
15	Screw	51-62 lbf-ft	8	39	Sleeve - Knuckle Bearing		2
16	Grease Fitting		4	40	Shim .005"		8
17	Cap - Knuckle Top		2		Shim .010"		8
18	Nut – Self Lock	500-700 lbf-ft	2		Shim .015"		8
19	Washer		2		Shim .008"		4
20	Bearing Cone		2		Shim .006"		2
21	Bearing Cup		2	41	Oil Seal		2
22	Steering Lever - Stud		4	42	Grease Fitting		2
23	Steering Lever		2				
24	Nut - Self Lock		4				
25	Axle, I-Beam		1				

Additional torque specifications applicable to the front axle are grouped with information regarding the front suspension. Please refer to Section 16: SUSPENSION of this manual.

Section 10: FRONT AXLE

3. MAINTENANCE

A periodic inspection of the front axle assembly should be made to check that all bolts are tight, and that no damage and distortion have taken place. Suspension support stud nuts, U-bolt nuts, tie rod arms, steering arm nuts and stop screws should be checked and tightened, as required, to the torque specifications (refer to Section 16: SUSPENSION of this manual). Also check the condition of the steering knuckle pins and bushings. In case of excessive looseness, the bushings and pins should be replaced.

Any looseness in the steering linkage, under normal steering loads, is sufficient cause to immediately check all pivot points for wear, regardless of accumulated mileage. Steering linkage pivot points should be checked each time the front axle assembly is lubricated. Any looseness can be visually detected while rotating the steering wheel in both directions.

Steering knuckles, knuckle pins and bushings can be overhauled or replaced without removing the axle from the vehicle. However, if extensive overhaul work is necessary, the axle assembly should be removed.



CAUTION

Should removal of a locking device be required when undergoing repairs, disassembly or adjustments, always replace with a new one.

4. REMOVAL AND REPLACEMENT

The following procedure deals with the removal of the front axle assembly. The method used to support the axle assembly and suspension components during removal and disassembly depends upon local conditions and available equipment.

4.1 REMOVAL

1. Raise the vehicle by its jacking points on the body (see Section 18, "Body" under heading 16; Vehicle Jacking Points) until vehicle body is approximately 30 inches (760 mm) from the floor. Place jack stands under frame. Remove the wheels (if required, refer to Section 13, "Wheels, Hubs and Tires").



CAUTION

Use only the recommended jacking points as outlined in section 18 "Body".

2. Exhaust compressed air from the air supply system by opening the drain valve of each reservoir.
3. Install jacks under axle jacking points to support the axle weight.



DANGER

To help prevent injury caused by the axle rolling off the jacks, these should be equipped with U-adapters, or similar precautions must be taken.

4. Disconnect the steering drag link from the steering arm.
5. Remove the ABS sensors from their location in hubs (if applicable).
6. Disconnect the height control valve link from its support on the axle.
7. Disconnect air lines from front brake chambers, and cover line ends and fittings to prevent the entry of foreign matter.



CAUTION

Position the air lines and electric wires so they will not be damaged while removing the front axle assembly.

8. Proceed with steps a, b and c, while referring to Section 16: "Suspension".
 - a) Disconnect sway bar links from axle brackets.
 - b) Remove shock absorbers.
 - c) Disconnect five radius rods: one transversal and two longitudinal from subframe, and two upper rods from axle.
9. Remove the bolts and nuts fixing the axle to the left-hand and right-hand side air bellows mounting supports.
10. Using the jacks, slowly lower the axle assembly, and carefully pull away from underneath vehicle.

4.2 REPLACEMENT

Reverse front axle "Removal" procedure. Ensure cleanliness of air bellows support mounting plates.

NOTE

Refer to Section 16: Suspension for recommended tightening torques.

5. SERVICE INSTRUCTIONS FOR STEER AXLE

5.1 STEERING KNUCKLE (KING) PIN INSPECTION



MAINTENANCE

An inspection should be made at intervals of 30,000 miles (48 000 km) or twice a year whichever comes first.

Aspects to be considered are:

- **Lateral slackness**
- **Vertical slackness**

Refer to "DANA SPICER Service Manual NDS Axle Range" found in the OEM manuals folder.

NOTE

Before commencing checks, apply parking brake, raise wheels off ground and support axle on stands.

5.1.1 Checking Lateral Slackness

Following regular and thorough greasing practices will maximise bushing life. This procedure measures the upper & lower bushing wear due to side and vertical loading. While this is being carried out, the brake must be applied.

Upper Bushing Lateral Inspection

1. Mount dial indicator on the axle. Reference the upper part of the steering knuckle.
2. Move the tire and wheel assembly in and out with a push/pull motion and have an assistant record the dial indicator reading.
3. Replace the upper bushing if readings are in excess of 0.020" (0.5mm).
4. If displacement exceeds stated allowance then need for bush / bearing attention and possible renewal, is in evidence.

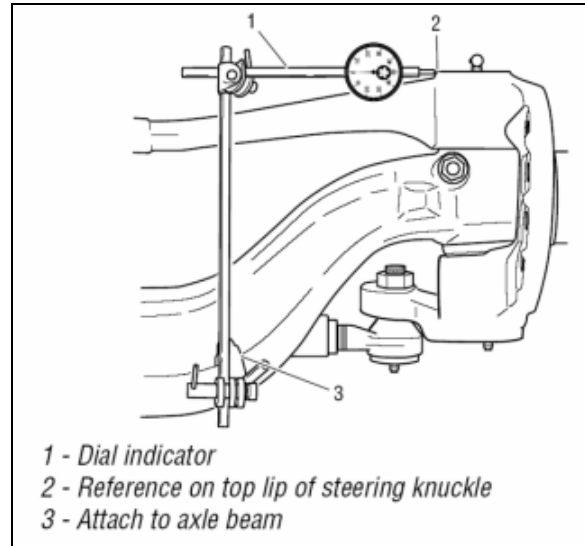

Lower Bushing Lateral Inspection

1. Mount dial indicator on the axle. Reference the base of the lower arm on the steering knuckle.
2. Move the tire and wheel assembly in and out with a push/pull motion and have an assistant record the dial indicator reading.
3. Replace the upper bushing if readings are in excess of 0.020" (0.5mm).
4. If displacement exceeds stated allowance then need for bush / bearing attention and possible renewal, is in evidence.

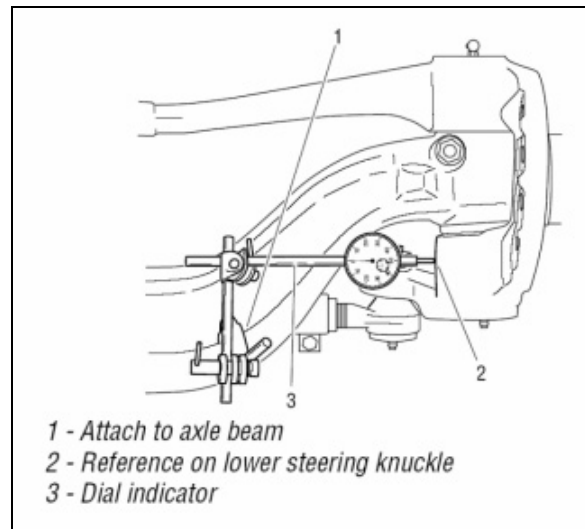

Section 10: FRONT AXLE

NOTE

To avoid inaccurate measurements, be careful not to let the knuckle turn while moving assembly in and out. Applying brakes will help lock wheel assembly.

Locate indicator on a smooth, flat surface for best reading.

5.1.2 Checking Vertical Slackness

1. This is measured by a dial indicator anchored to axle beam and having its pointer placed vertical against swivel top.
2. Place a jack against underside of swivel and, while applying a lifting force, observe any movement on indicator dial.
3. **If vertical movement is evident and it exceeds 0.040" (1.02mm)** then readjustment of swivel is required by adjusting thickness of bearing adjusting washers.

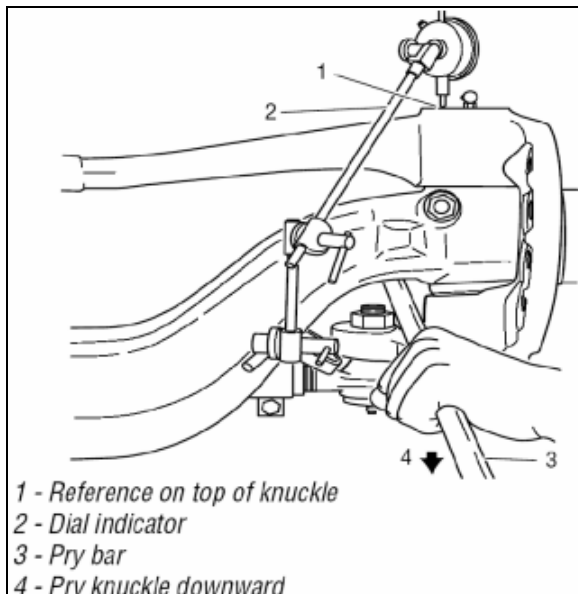

6. FRONT WHEEL ALIGNMENT

Correct front wheel alignment must be maintained for steering comfort and satisfactory tire life. Road shocks and vibrations, as well as normal stress and strains on the front-end system can, under normal operating conditions, result in loss of front wheel alignment.

Check the front wheel alignment when the following occurs:

1. Every 200,000 miles (320 000 km) or 24 months (normal maintenance);
2. When the vehicle does not steer correctly; or
3. To correct a tire wear condition.

There are two types of front wheel alignment: **minor alignment** and **major alignment**.

6.1 INSPECTION BEFORE ALIGNMENT

Check the following before doing a front wheel alignment:

1. Ensure that the vehicle is at normal riding height. See Section 16, "Suspension" under heading 7: "Suspension Height Adjustment".
2. Ensure that front wheels are not the cause of the problem. See Section 13, "Wheels, Hubs and Tires". Inspect the tires for wear patterns indicating suspension damage or misalignment.
 - a. Make sure the tires are inflated to the specified pressure.
 - b. Make sure the front tires are the same size and type.
 - c. Make sure the wheels are balanced.
 - d. Check wheel installation and straightness.
3. Check the wheel bearing adjustment.
4. Check steering linkage for bending and pivot points for looseness.
5. Check knuckle pins for evidence of excessive wear.
6. Check radius rods for bending and rubber bushings for evidence of excessive wear.
7. Make sure all fasteners are tightened to the specified torque. Use a torque wrench for verification. As soon as the fastener starts to move, record the torque. Correct if necessary. Replace any worn or damaged fasteners.

6.2 MINOR FRONT WHEEL ALIGNMENT

Perform a minor front wheel alignment for all normal maintenance conditions.

Perform the minor front wheel alignment in the following sequence :

1. Inspect all the systems that affect the wheel alignment. See paragraph 6.1, "Inspection Before Alignment" in this section.
2. Check the hub bearings. See section 13, "Wheels, hubs and Tires" under heading 8: Front and Tag Axle Wheel Hubs.
3. Check and adjust the toe-in.

6.3 MAJOR FRONT WHEEL ALIGNMENT

Perform a major front wheel alignment to correct steering and tire wear conditions.

Perform the major front wheel alignment in the following sequence:

1. Inspect all systems affecting the wheel alignment. See paragraph 6.1, "Inspection Before Alignment" in this section.
2. Check the hub bearings. See section 13, "Wheels, hubs and Tires" under heading 8: Front and Tag Axle Wheel Hubs.

NOTE

If steering angle stoppers are changed, a special procedure is required for readjusting gearbox steering limiter. See paragraph 6.5 "Hydraulic Stop" in this section.

3. Check and adjust the turning angle adjustment.
4. Check the camber angle.
5. Check and adjust the caster angle.
6. Check and adjust the toe-in.

6.4 TURNING ANGLE ADJUSTMENT

The maximum turning angle is set through the two steering stop screws installed on the axle center. The turning angle is factory adjusted to accommodate the chassis design, and therefore, does not require adjustment on new vehicles. However, it should be checked and adjusted any time any component of the steering system is repaired, disassembled or adjusted.

Check if front tires rub against the frame or if the steering gear has been serviced.

Proceed with the following method to check the steering maximum turning angle :

6.4.1 R.H. Turn Adjustment



CAUTION

To prevent the steering damper from interfering with the adjustment of turning angles, make sure its fixing bracket is at the correct location on the axle center (refer to section 14 "Steering").

1. Turn steering wheel to the right until the boss on the axle center touches the right stop screw.
2. Verify the nearest point of contact of the ball socket body with the air bellows support assembly. Measure the distance between those two points.
3. The distance between these two points should be approximately 1/8 inch (3 mm). If not, the steering stop screws must be readjusted.
4. Verify the nearest point of contact of the drag link with the tire. Measure the distance between those two points.
5. The distance should be 1 inch (25 mm) or more. If not, the steering stop screws must be readjusted.
6. This must be done for a full right turn.
7. If readjustment is required:
 - a. Remove the swivel stop screw.
 - b. Add to the stop screw the required number of washers to obtain the proper measure, tighten the stop screw afterwards. Two washers of different thickness are available: 1/16 inch and 3/16 inch.

6.4.2 L.H. Turn Adjustment

1. Turn steering wheel to the left until the boss on the axle center touches the left stop screw.
2. Verify the nearest point of contact of the ball socket body with the air bellows support assembly. Measure the distance between those two points.
3. The distance between these two points should be approximately 1/8 inch (3 mm). If not, the steering stop screws must be readjusted.

Section 10: FRONT AXLE

4. Check the stroke of the steering stabilizer cylinder (damper). It should not exceed 12.59 inches (320 mm).
5. This must be done for a full left turn.
6. If readjustment is required:
 - a. Remove the swivel stop screw.
 - b. Add to the stop screw the required number of washers to obtain the proper measure, tighten the stop screw afterwards. Two washers of different thickness are available: 1/16 inch and 3/16 inch.

NOTE

If steering angle stoppers are changed, a special procedure is required for readjusting gearbox steering limiter. See paragraph 6.5 "Hydraulic Stop" in this section.

6.5 HYDRAULIC STOP

NOTE

Before steering limiter readjustment, verify vehicle wheel alignment and ensure that oil level is checked and that air bleeding is done.

Refer to "ZF-Servocom Repair Manual" annexed at the end of Section 14 "Steering" under heading 'Setting and Functional Test'.

6.6 FRONT WHEEL CAMBER

Wheel camber is the number of degrees the top of the wheel tilts outward (positive) or inward (negative) from a vertical angle (Fig. 3).

The camber angle is not adjustable. Camber variations may be caused by wear at the wheel bearings, steering knuckle pins or by a bent knuckle or sagging axle center. Steering effort is affected by improper camber, and uneven tire wear will result. Excessive positive camber causes an irregular wear of tire at the outer shoulder and excessive negative camber causes wear at the inner shoulder.

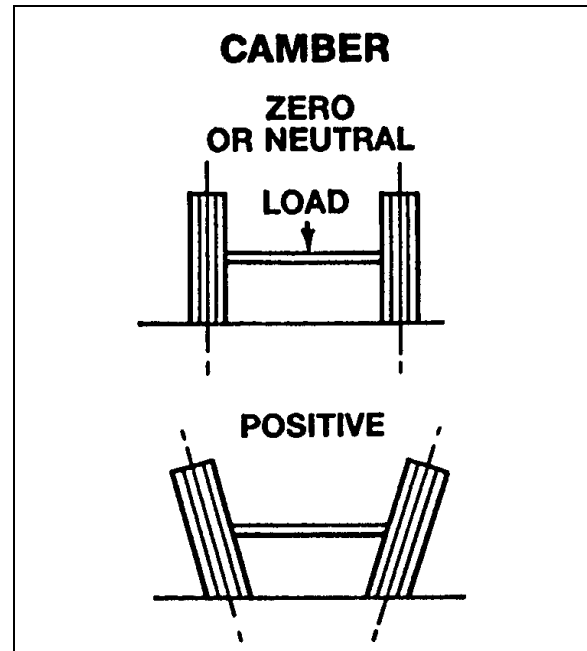

FIGURE 3: CAMBER

10006

6.6.1 Camber Check

For camber specifications, refer to paragraph 8: "Specifications" in this section

1. Use an alignment machine to check the camber angle.
2. If camber reading is not in the specifications, check the wheel bearings and repeat the check. If the reading is still not within specifications, verify the steering knuckle pins and axle center.

See instructions in "DANA SPICER Service Manual NDS Axle Range" found in the OEM manuals folder.

3. Check the wheel lateral distortion as instructed in Section 13, "Wheels, Hubs and Tires" under heading, "Checking for Distorted Wheel on Vehicle". If distortion is excessive, straighten or replace wheel(s).

6.7 FRONT AXLE CASTER

For caster specifications, refer to paragraph 8: "Specifications" in this section.

Positive caster is the rearward tilt from the vertical axis of the knuckle pin. Negative caster is the forward tilt from the vertical axis of the knuckle pin (Fig. 4). This vehicle is designed with a positive caster. The purpose of the caster angle is to give a trailing effect. This results in stabilized steering

and a tendency for the wheels to return to the straight-ahead position after taking a turn.

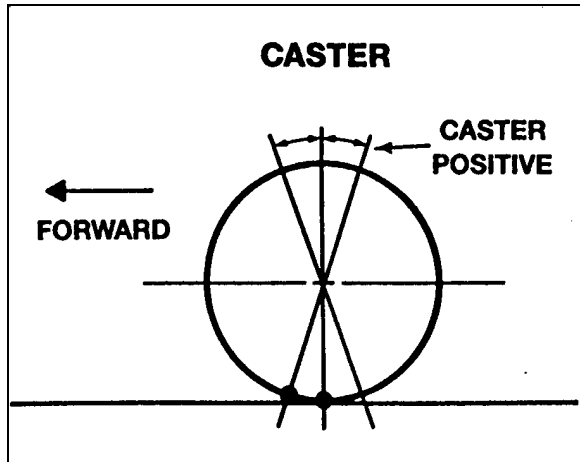

FIGURE 4: CASTER

10007

Excessive caster results in hard steering around corners. A shimmy may also develop when returning to the straight ahead position (pulling out of curves).

Insufficient caster will cause wandering and steering instability. Caster variations may be caused by a bent axle, tilting or distortion of the side suspension supports, damaged radius rod bushings, or unequal tightening of the front and rear suspension support bolts. Incorrect caster must be corrected by replacing the damaged suspension parts. A precision instrument should be used to measure the caster.

NOTE

The caster of this vehicle is factory set and is not adjustable. However, if after replacing damaged parts or in case of improper caster due to irregular setting, the front axle caster needs adjustment; it can be adjusted by means of shims (Prevost #110663) on the left-hand side upper radius rod support in order to obtain minor adjustment.

6.8 FRONT WHEEL TOE-IN

Wheel toe-in is the degree (usually expressed in fractions of an inch) to which the forward part of the vehicle front wheels are closer together than the rear part, measured at wheel centerline height with the wheels in the normal "straight-ahead" position of the steering gear.

Incorrect toe-in results in excessive tire wear caused by side slippage and also steering instability with a tendency to wander. Toe-in may be measured from the center of tire tread or from

the inside of the tires. Take measurements at both front and rear of axle (see "A and "B" in fig. 5).

When setting toe-in adjustment, the front suspension must be neutralized; that is, all component parts must be in the same relative position when marking the adjustment as they will be when in operation.

To neutralize the suspension, the vehicle must be rolled forward, approximately ten feet.

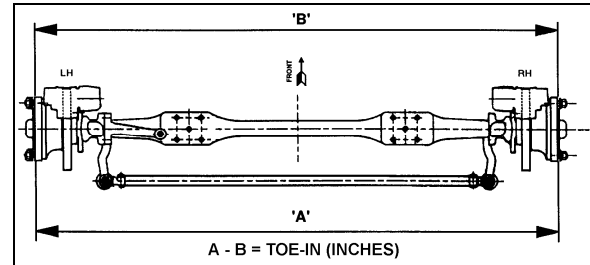

FIGURE 5: TOE-IN MEASUREMENTS

10032

For toe-in specifications, refer to paragraph 8 "Specifications" in this section.

By rolling the vehicle forward, all tolerances in the front suspension are taken up and the suspension is then in its normal operating position. Neutralizing the front suspension is extremely important, especially if the vehicle has been jacked up in order to mark the tires. Otherwise, the front wheels will not return to their normal operating position due to the tires gripping the floor surface when the vehicle jack is lowered.

NOTE

"Toe-in" measurements must be taken at the horizontal axis of the wheel centerline.

Section 10: FRONT AXLE

6.8.1 Inspection and Adjustment

Before checking front wheel toe-in, first check the camber angles and make the necessary corrections.

1. Measure the toe-in.
2. If the toe-in measurement is not within the specified tolerance, carry out the following procedure :
 - a. Loosen the pinch bolt nuts and bolts on each tie rod end.
 - b. Turn the tie rod until the specified toe-in measurement is obtained.
 - c. Tighten the pinch bolt nuts alternately and progressively to 65-75 lbf-ft (88-102 Nm), thus securing all tie rod joints.

FRONT WHEEL ALIGNMENT SPECIFICATIONS			
Front Wheel Alignment	Minimal	Nominal	Maximal
Camber, (degrees) R.H. and L.H. *	-0.250	0.125	0.375
Caster, (degrees) R.H. and L.H.	2	2.75	3.5
Toe-in (A minus B), (degrees)	0.04	0.06	0.08

NOTE

Camber angle changes with loading. The given numbers are for an empty vehicle.

7. TROUBLESHOOTING

CONDITION	CAUSE	CORRECTION
Tires wear out quickly or have uneven tire tread wear.	<ol style="list-style-type: none"> 1. Tires have incorrect air pressure. 2. Tires out-of-balance. 3. Incorrect tag axle alignment. 4. Incorrect toe-in setting. 5. Incorrect steering arm geometry. 	<ol style="list-style-type: none"> 1. Put specified air pressure in tires. 2. Balance or replace tires. 3. Align tag axle. 4. Adjust toe-in specified setting. 5. Service steering system as necessary.
Vehicle is hard to steer.	<ol style="list-style-type: none"> 1. Low pressure in the power steering system. 2. Steering gear not assembled correctly. 3. Steering linkage needs lubrication. 4. Kingpins binding. 5. Incorrect steering arm geometry. 6. Caster improperly adjusted. 7. Tie rod ends hard to move. 8. Worn thrust bearing. 	<ol style="list-style-type: none"> 1. Repair power steering system. 2. Assemble steering gear correctly. 3. Lubricate steering linkage. 4. Replace kingpins. 5. Service steering system as necessary. 6. Adjust caster as necessary. 7. Replace tie rod ends. 8. Replace thrust bearing.
Bent or broken steering arm, steering top lever or tie rod assembly.	<ol style="list-style-type: none"> 1. Too much pressure in the power steering system. 2. Cut-off pressure of the power steering system improperly adjusted. 3. Vehicle not powered on correctly. 4. Power steering system not installed correctly. 	<ol style="list-style-type: none"> 1. Replace damaged part(s), adjust power steering system to specified pressure. 2. Make sure vehicle is powered on correctly. 3. Correctly install the power steering system. 4. Correctly install the power steering system.
Worn or broken steering ball stud.	<ol style="list-style-type: none"> 1. Drag link fasteners tightened past specified torque. 2. Lack of lubrication or incorrect lubricant. 3. Power steering stops improperly adjusted. 	<ol style="list-style-type: none"> 1. Replace damaged part(s), tighten drag link fasteners to specified torque. 2. Lubricate linkage with specified lubricant. 3. Adjust stops to specified dimension.
Worn king pins and knuckle bushings.	<ol style="list-style-type: none"> 1. Worn or missing seals and gaskets. 2. Incorrect lubricant. 3. Axle not lubricated at scheduled frequency. 4. Incorrect lubrication procedures. 5. Lubrication schedule does not match operating conditions. 	<ol style="list-style-type: none"> 1. Replace damaged part(s), replace seals and gaskets. 2. Lubricate axle with specified lubricant. 3. Lubricate axle at scheduled frequency. 4. Use correct lubrication schedule to match operating conditions. 5. Change lubrication schedule to match operating conditions.
Vibration or shimmy of front axle during operation.	<ol style="list-style-type: none"> 1. Caster not adjusted properly. 2. Wheels and/or tires out-of-balance. 3. Worn steering stabilizer cylinder. 	<ol style="list-style-type: none"> 1. Adjust caster. 2. Balance or replace wheels and/or tires. 3. Replace steering stabilizer cylinder.

Section 10: FRONT AXLE

8. SPECIFICATIONS

Front Axle

Make DANA SPICER EUROPE

Model NDS

Front Track 84.4 inches (2 145 mm)

Rated load capacity 16,500 lbs (7 500 kg)

9. TORQUE SPECIFICATIONS

The torque specifications applicable to the front axle are grouped with information regarding the front suspension. Please refer to Section 16: SUSPENSION of this manual.

For more torque specifications, see Dana Spicer Maintenance Manual NDS Axles Lubrication And Maintenance.

SECTION 11: REAR AXLES

CONTENTS

1. DRIVE AXLE	2
1.1 DESCRIPTION	2
1.2 DRIVE AXLE LUBRICATION.....	2
1.3 MAINTENANCE.....	2
1.3.1 <i>Checking and Adjusting the Oil Level</i>	3
1.3.2 <i>Draining and Replacing the Oil</i>	3
1.3.3 <i>Speed Sensors (Anti-Lock Brake system, ABS)</i>	3
1.4 REMOVAL AND REINSTALLATION	3
1.5 DISASSEMBLY AND REASSEMBLY.....	4
1.6 GEAR SET IDENTIFICATION	4
1.7 ADJUSTMENTS	4
1.8 FASTENER TORQUE CHART	4
1.9 TIRE MATCHING	4
1.10 DRIVE AXLE ALIGNMENT	4
1.10.1 <i>Procedure</i>	5
1.11 AXLE SHAFT SEALING METHOD	6
2. TAG AXLE	7
2.1 UNLOADING TAG AXLE	7
2.2 RETRACTING TAG AXLE	7
2.3 RETRACTING TAG AXLE FOR REPAIR PURPOSES	8
2.4 GREASE LUBRICATED WHEEL BEARINGS.....	8
2.5 REMOVAL AND INSTALLATION	8
2.5.1 <i>Removing Tag Axle Only</i>	8
2.5.2 <i>Removing Tag Axle Along With Suspension Components</i>	8
2.5.3 <i>Removing Transversal radius Rod</i>	9
2.6 TAG AXLE ALIGNMENT	9
3. SPECIFICATIONS	10

ILLUSTRATIONS

FIGURE 1: DRIVE AXLE.....	2
FIGURE 2: DIFFERENTIAL ASSEMBLY	2
FIGURE 3: DIFFERENTIAL HOUSING BOWL	2
FIGURE 4: JACKING POINTS ON FRAME (TYPICAL)	3
FIGURE 5: JACKING POINTS ON DRIVE AXLE.....	4
FIGURE 6: FRONT & DRIVE AXLE ALIGNMENT	6
FIGURE 7: TAG AXLE ALIGNMENT	6
FIGURE 8: AXLE SHAFT INSTALLATION	7
FIGURE 9: TORQUE SPECIFICATION.....	7
FIGURE 10: JACKING POINTS ON TAG AXLE.....	9
FIGURE 11: INSTALLING EXTRACTOR TOOL.....	9

Section 11: REAR AXLES

1. DRIVE AXLE

1.1 DESCRIPTION

The Meritor drive axle is equipped with a single reduction standard carrier mounted in front of the axle housing. The carrier consists of a hypoid drive pinion, a ring gear set and gears in the differential assembly.

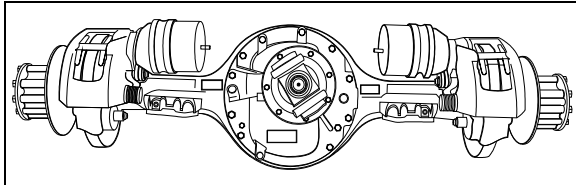

FIGURE 1: DRIVE AXLE

11019

A straight roller bearing (spigot) is mounted on the head of the drive pinion. All other bearings in the carrier are tapered roller bearings. When the carrier operates, there is a normal differential action between the wheels all the time.

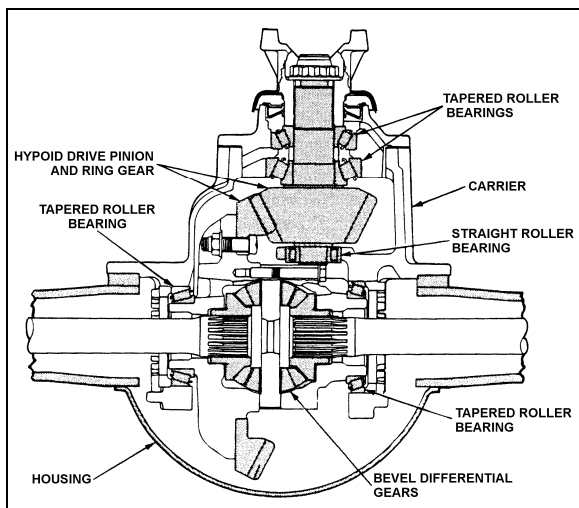

FIGURE 2: DIFFERENTIAL ASSEMBLY

11024

Several speed ratios are available for the drive axle. These ratios depend upon the motor and transmission. Also, special applications may suggest slightly different gear ratios.

1.2 DRIVE AXLE LUBRICATION

Use Multigrade gear oil 85W140 meeting MIL-PRF-2105-E, tested and approved to SAE J2360. If temperature drops below 10°F (-12°C), 80W90 should be used, and below -15°F (-26°C), 75W90 should be used. Additional lubrication information is covered in the Meritor Technical Bulletin "Approved Rear Drive Axle Lubricants" annexed to this section.

In extreme conditions, or for better performance, fill with synthetic gear oil.



MAINTENANCE

Check oil level and add (if necessary) every 5,000 miles (8 000 km) or once a month, whichever comes first (Fig. 3).



MAINTENANCE

Change differential oil and clean the breathers, magnetic fill and drain plugs, every 25,000 miles (40 000 km) or once a year, whichever comes first.

If using full synthetic gear oil, change differential oil and clean the breathers, magnetic fill and drain plugs, every 100,000 miles (160 000 km) or every two years, whichever comes first.

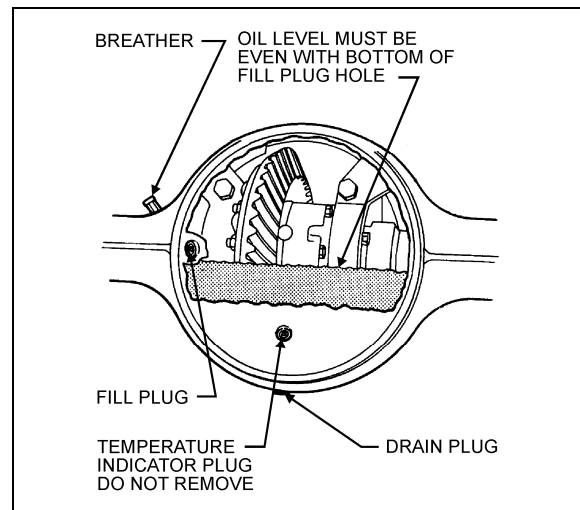

FIGURE 3: DIFFERENTIAL HOUSING BOWL

11007

1.3 MAINTENANCE

Proper vehicle operation begins with preventive maintenance, such as good differential use. The most common types of drive axle carrier failures are spinout, shock, fatigue, overheating and lubrication. Avoid neglecting these points since they would be the first steps to improper maintenance, expensive repairs, and excessive downtime.

Inspect the pinion oil seal, axle shaft flange and carrier housing gaskets for evidence of lubricant leakage. Tighten the bolts and nuts, or replace the gaskets and seals to correct leaks.

Maintenance of the axle mountings consists primarily in a regular and systematic inspection of the air suspension units and radius rods, as directed in Section 16, "Suspension".

1.3.1 Checking and Adjusting the Oil Level

DANGER

Before servicing, park safely over a repair pit; apply parking brake, stop engine and set battery master switch to the "OFF" position.

1. Make sure the vehicle is parked on a level surface.

WARNING

Check the oil level when the axle is at room temperature. When hot, the oil temperature may be 190°F (88°C) or more and can cause burns. Also, a correct reading is not obtained when the axle is warm or hot.

2. Make sure the axle is "cold" or at room temperature.
3. Clean the area around the fill plug. Remove the fill plug from the differential axle housing bowl (Fig. 4).
4. The oil level must be even with the bottom of the hole of the fill plug.
 - a. If oil flows from the hole when the plug is loosened, the oil level is high. Drain the oil to the correct level.
 - b. If the oil level is below the bottom of the hole of the fill plug, add the specified oil.
5. Install and tighten the fill plug to 35-50 lbf-ft (48-67 Nm).

1.3.2 Draining and Replacing the Oil

DANGER

Before servicing, park safely over a repair pit, apply parking brake, stop engine and set battery master switch to the "OFF" position.

1. Make sure the vehicle is parked on a level surface. Put a large container under the axle's drain plug.

NOTE

Drain the oil when the axle is warm.

2. Remove the drain plug from the bottom of the axle. Drain and discard the oil in an environment friendly manner.
3. Install and tighten the drain plug to 35-50 lbf-ft (48-67 Nm).
4. Clean the area around the fill plug. Remove the fill plug from the differential housing bowl.
5. Add the specified oil until the oil level is even with the bottom of the hole of the fill plug. Allow the oil to flow through the axle and check the oil level again (lube capacity 41 pints [13,3 liters]).

CAUTION

The differential overheats when the oil temperature rises above 250°F (120°C).

6. Install and tighten the fill plug to 35-50 lbf-ft (48-67 Nm).

1.3.3 Speed Sensors (Anti-Lock Brake system, ABS)

For removing and installing the drive axle speed sensors (for anti-lock brake systems, ABS), refer to Section 12: "Brake and Air System" and to Rockwell WABCO Maintenance Manual: "Anti-Lock Brake Systems For Trucks, Tractors and Buses", annexed at the end of section 12.

1.4 REMOVAL AND REINSTALLATION

The following procedure deals with the removal of the drive axle assembly and its attachments as a unit. The method used to support the axle during removal and disassembly depends upon local conditions and available equipment.

1. Raise vehicle by its jacking points on the body (fig. 4 or see Section 18, "Body" under heading "Vehicle Jacking Points"). Place jack stands under frame. Remove drive axle wheels (if required, refer to Section 13, "Wheels, Hubs And Tires".

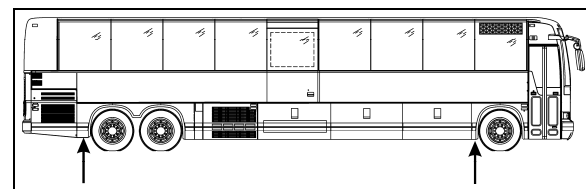

FIGURE 4: JACKING POINTS ON FRAME (TYPICAL) 18618

Section 11: REAR AXLES

2. Exhaust compressed air from the air supply system by opening the drain cock on each air reservoir.
3. Disconnect the propeller shaft as directed in Section 9, "Propeller Shaft", in this manual.
4. On both sides of the vehicle, unscrew fasteners retaining front wheel housing plastic guards, and remove them from vehicle.
5. Disconnect both height control valve links from air spring mounting plate brackets then move the arm down to exhaust air suspension.
6. Remove cable ties securing the ABS cables (if vehicle is so equipped) to service brake chamber hoses. Disconnect the ABS cable plugs from the drive axle wheel hubs.

NOTE

When removing drive axle, if unfastening cable ties is necessary for ease of operation, remember to replace them afterwards.

7. Disconnect the brake chamber hoses.

NOTE

Position the hoses so they will not be damaged when removing the axle.

8. Install jacks under the axle jacking points to support the axle weight (refer to figure 5).

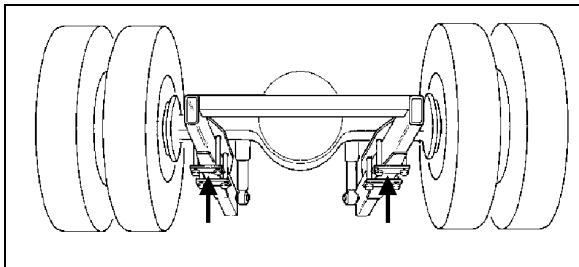

FIGURE 5: JACKING POINTS ON DRIVE AXLE 11005

9. Remove the four shock absorbers as outlined in Section 16, "Suspension" under heading "Shock Absorber Removal".
10. Remove the sway bar.
11. Remove the lower and upper longitudinal radius rod supports from vehicle sub-frame as outlined in Section 16, "Suspension", under heading "Radius Rod Removal".
12. Remove the transversal radius rod support from the vehicle sub-frame.

13. Remove the two retaining nuts from each of the four air bellows lower mounting supports.
14. Use the jacks to lower axle. Carefully pull away the jacks axle assembly from underneath vehicle.
15. Reverse removal procedure to reinstall drive axle.

NOTE

Refer to Section 16, "Suspension" for suspension components' proper tightening torques.

NOTE

Refer to section 13 "Wheels, Hubs And Tires" for correct wheel bearing adjustment procedure.

1.5 DISASSEMBLY AND REASSEMBLY

Disassembly and re-assembly procedures are covered under applicable headings in Meritor's "MAINTENANCE MANUAL, NO. 5", annexed to this section.

1.6 GEAR SET IDENTIFICATION

Gear set identification is covered under applicable heading in Meritor's "MAINTENANCE MANUAL NO. 5", annexed to this section.

1.7 ADJUSTMENTS

Adjustments are covered under applicable headings in Meritor's "MAINTENANCE MANUAL NO. 5", annexed to this section.

1.8 FASTENER TORQUE CHART

A differential fastener torque chart is provided in Meritor's "MAINTENANCE MANUAL NO. 5", annexed to this section.

1.9 TIRE MATCHING

Drive axle tire matching is covered under the applicable heading in Section 13, "Wheels, Hubs And Tires" in this manual.

1.10 DRIVE AXLE ALIGNMENT

NOTE

For drive axle alignment specifications, refer to paragraph 3: "Specifications" in this section.

The drive axle alignment consists in aligning the axle according to the frame. The axle must be perpendicular to the frame. The alignment is achieved with the use of shims inserted between the lower longitudinal radius rod supports and the frame.

Drive axle alignment is factory set and is not subject to any change, except if the vehicle has been damaged by an accident or if there are requirements for replacement.

If the axle has been removed for repairs or servicing and if all the parts are reinstalled exactly in the same place, the axle alignment is not necessary. However, if the suspension supports have been replaced or altered, proceed with the following instructions to verify or adjust the drive axle alignment.

NOTE
When drive axle alignment is modified, tag axle alignment must be re-verified.

2. Using two jacking points (which are at least 30 inches [76 cm] apart) on drive axle, raise the vehicle sufficiently so that wheels can turn freely at about ½ inch from ground. Secure in this position with safety stands, and release parking brake.
3. Install wheel mount sensors on front end and drive axle wheels (fig. 6).

NOTE
See reference numbers on wheel mount sensors (fig.7).

NOTE
Select axle specifications in the appropriate chart.

1.10.1 Procedure

1. Park vehicle on a level surface, then chock front vehicle wheels.

DRIVE AXLE ALIGNMENT

- With the system installed as in figure 7, adjust drive axle according to specifications' chart below.

DRIVE AXLE ALL VEHICLES			
Alignment / value	Minimum value	Nominal value	Maximum value
Thrust angle (deg.)	-0.04	0	0.04
Total Toe (deg.)	0.18 Toe-in	0	0.18 Toe-out

TAG AXLE ALIGNMENT

- Remove and reinstall all wheel mount sensors on the drive and tag axles (fig. 7);

NOTE
For an accurate alignment, the tag axle must be aligned with the drive axle.

NOTE
Reinstall wheel mount sensors as shown in figure 7.

- Adjust tag axle according to specifications' chart below in reference with drive axle.

Section 11: REAR AXLES

TAG AXLE ALL VEHICLES			
Alignment / value	Minimum value	Nominal value	Maximum value
Parallelism (deg.)	-0.02	0	0.02
Total Toe (deg.)	0.18 Toe-in	0	0.18 Toe-out

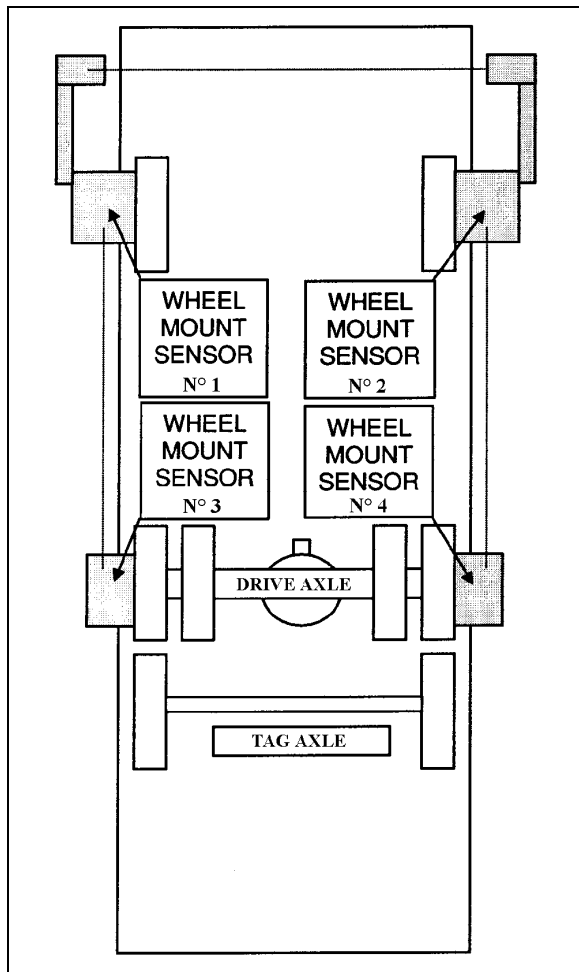

FIGURE 6: FRONT & DRIVE AXLE ALIGNMENT 11025

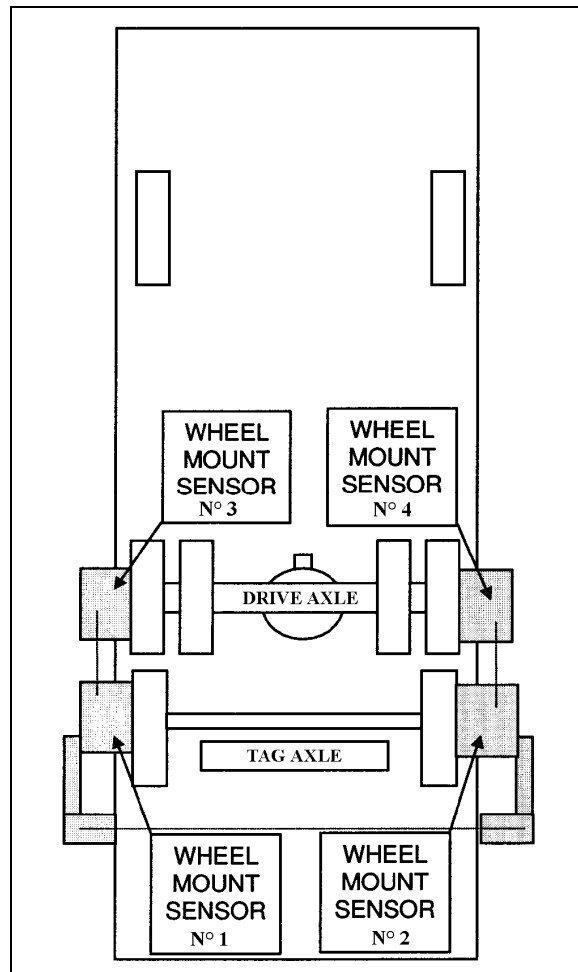

FIGURE 7: TAG AXLE ALIGNMENT 11026

NOTE

Refer to Section 16, "Suspension", for proper torque tightening of the longitudinal radius rod support nuts.

NOTE

When the drive alignment is changed, the tag alignment must also be adjusted.

1.11 AXLE SHAFT SEALING METHOD

The following method is to be used to ensure that axle shaft installation is fluid-tight:

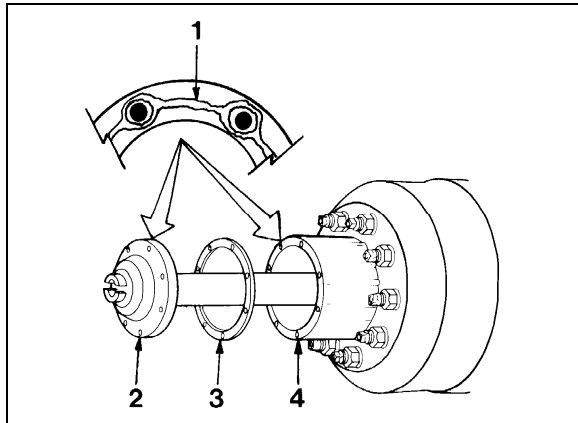

FIGURE 8: AXLE SHAFT INSTALLATION 11003

- 1..... Silicone sealant*
- 2..... Axle shaft
- 3..... Gasket
- 4..... Wheel hub

1. Clean the mounting surfaces of both the axle shaft flange and wheel hub where silicone sealant will be applied. Remove all old silicone sealant, oil, grease, dirt and moisture. Dry both surfaces.
2. Apply a continuous thin bead of silicone sealant* (Prevost P/N 680053) on the mounting surfaces and around the edge of all fastener holes of both the axle shaft flange and wheel hub.

* GENERAL ELECTRIC Silicone Rubber Adhesive Sealant RTV 103 Black.

WARNING

Carefully read cautions and instructions on the tube of silicone sealant and its packing.

3. Assemble components immediately to permit the silicone sealant to compress evenly between parts.
 - a. Place a new gasket and then install the axle shaft into the wheel hub and differential carrier. The gasket and flange of the axle shaft must fit flat against the wheel hub.
 - b. Install the tapered dowels at each stud and into the flange of the axle shaft. Use a punch or drift and hammer if needed.
 - c. Install the lock washers and nuts on the studs. Tighten nuts to the correct torque value.

NOTE

Torque values are for fasteners that have a light application of oil on the threads (refer to Meritor Maintenance Manual).

- 9/16-18 plain nut: 110 - 165 lbf-ft (149 -224 Nm)
- 5/8-18 plain nut: 150 - 230 lbf-ft (203 - 312 Nm)

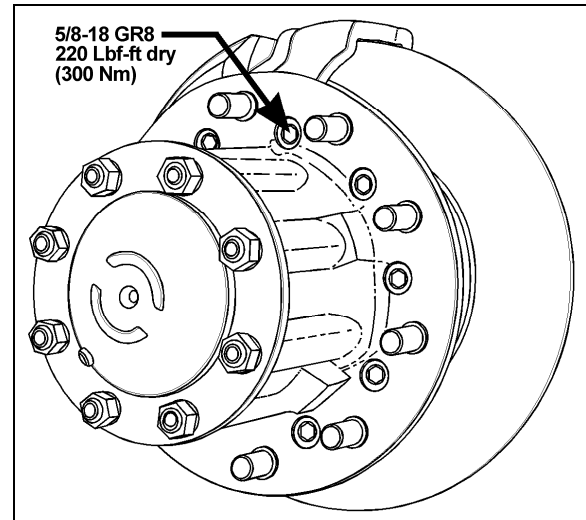

FIGURE 9: TORQUE SPECIFICATION

2. TAG AXLE

The tag axle is located behind the drive axle. It carries a single wheel and tire on each side.

2.1 UNLOADING TAG AXLE

To reduce the turning radius, the air springs pressure will be automatically reduced by 75% when the coach is moving at speed lower than 5 mph (8 km/h) and with more than 1½ turn from the steering.

2.2 RETRACTING TAG AXLE

The standard tag axle retraction system is controlled by a valve located on the left lateral console and enables unloading and raising the tag axle (refer to the "OPERATOR'S MANUAL" for location of controls). This system has been designed for the following purposes:

1. Shortening of wheelbase, thus allowing tighter turning in tight maneuvering areas such as parking lots or when making a sharp turn.
2. Transferring extra weight and additional traction to the drive wheels on slippery surfaces.

The tag axle service brakes operate only when the axle is in normal driving (loaded) position.

Section 11: REAR AXLES



CAUTION

Do not use tag axle in raised position for an extended period. Raising tag axle increases load on the drive axle, suspension and tires.

Do not drive vehicle with tag axle raised when speed is exceeding 12mph (20 km/h).

In order to prevent damage to the suspension, always raise the tag axle before lifting the coach.

2.3 RETRACTING TAG AXLE FOR REPAIR PURPOSES

- Connect an external air pressure line to the emergency fill valve in the engine compartment.
- Lift the axle by pushing the lever forward.



WARNING

Install a protective cover to prevent unfortunate lever operation while work is being carried out under the vehicle.

- Raise the vehicle using the lifts.



WARNING

Lift manufacturers recommend lowering the vehicle to the ground or installing some safety stands before activating the suspension to prevent the lifts from becoming unstable.

- For added safety, install nylon slings over tag axle shock absorbers.

2.4 GREASE LUBRICATED WHEEL BEARINGS

The unitized hub bearings used on the NDS range of axles, are non-serviceable items. Bearings are pre-adjusted, lubricated and have seals fitted as part of the manufacturing process. The bearings are greased for life and there is no need or facility for re-lubrication



MAINTENANCE

Front and tag axle hub bearings need to be checked at intervals of 30,000 miles (48 000 km) or twice a year whichever comes first.

NOTE

For more information on front and tag axle wheel hub, refer to "DANA SPICER Service Manual NDS Axle Range" found in the OEM manuals folder.

2.5 REMOVAL AND INSTALLATION

2.5.1 Removing Tag Axle Only

The following procedure deals with the removal of the tag axle while keeping the air springs installed. The method used to support the axle and suspension components during removal and disassembly depends upon local conditions and available equipment.

- Connect an external air pressure line to the emergency fill valve in the engine compartment.
- Lift the axle by pushing the lever forward.



WARNING

Install a protective cover to prevent unfortunate lever operation while work is being carried out under the vehicle.

- Disconnect tag axle air springs pneumatic hoses and install valves or plugs.
- Raise the vehicle using the lifts.
- Dismount tag axle components.
- Before reinstalling air spring hoses, make sure there is no pressure left inside by opening the valves or unloading tag axle.

2.5.2 Removing Tag Axle Along With Suspension Components

The following procedure deals with the removal of the tag axle assembly along with the suspension components. The method used to support the axle and suspension components during removal and disassembly depends upon local conditions and available equipment.

1. Raise vehicle by its jacking points on the body (fig. 5 or see Section 18, "Body" under heading: "Vehicle Jacking Points"). Place jack under frame. Remove drive axle wheels (if required, refer to Section 13, "Wheels, Hubs And Tires").

2. Exhaust compressed air from the air supply system by opening the drain cock on each air reservoir and deplete air bags by moving leveling valve arm down.
3. Install jacks under tag axle jacking points to support the axle weight (refer to figure 10).

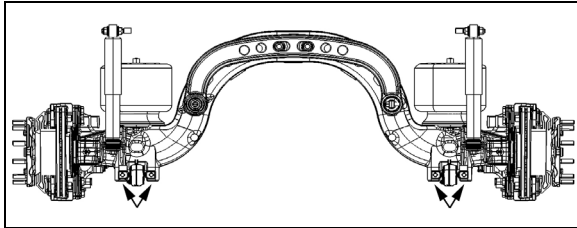

FIGURE 10: JACKING POINTS ON TAG AXLE 11029

4. Disconnect tag axle lifting chain collars from lower longitudinal radius rods.
5. Remove the propeller shaft as directed in Section 9, "Propeller Shaft", in this manual.
6. Disconnect the tag axle brake chamber hoses.



CAUTION

Position the hoses so they will not be damaged when removing axle.

7. Disconnect hose from the air spring upper mounting plate.
8. Remove the two shock absorbers as outlined in Section 16, "Suspension", under "Shock Absorber Removal".
9. Disconnect the lower longitudinal radius rods as outlined in Section 16, "Suspension", under "Radius Rod Removal".
10. Disconnect the transversal radius rod.
11. Disconnect the upper longitudinal radius rod.
12. Remove the air bellows retaining nuts from each of the two upper mounting plates.
13. Use the jacks to move the axle forward to clear the axle off the transmission. Lower the axle.



CAUTION

On vehicles equipped with an output retarder and an automatic transmission, move tag assembly very carefully. Pay special attention to the U-shaped section, as the transmission end components may be easily damaged through a false maneuver.

14. Reverse removal procedure to reinstall tag axle.

NOTE

Refer to Section 16, "Suspension", for proper torque tightening of suspension components.

NOTE

Refer to section 13 "Wheels, Hubs And Tires" for correct wheel bearing adjustment procedure.

2.5.3 Removing Transversal radius Rod

Unfasten bolts and nuts fixing transversal radius rod ball joint to rear underframe.

Install extractor tool G32952 onto transversal rod.

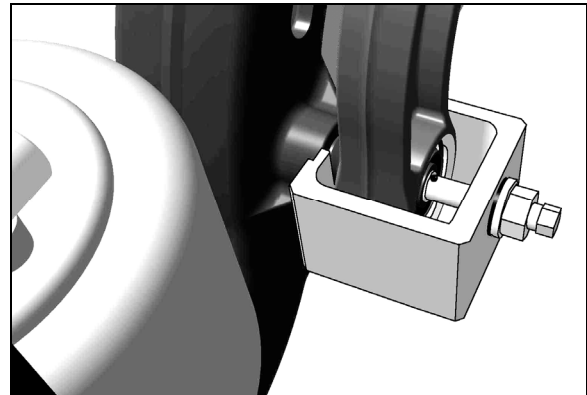

FIGURE 11: INSTALLING EXTRACTOR TOOL



CAUTION

It is strongly suggested to use the extractor tool in order to remove transversal radius rod.

Partially unscrew ball joint fixing bolt. Tighten extractor threaded rod.

Supporting the transversal radius rod at all times, gradually extract transversal radius rod from tag axle.

Reinstall by reversing procedure. Torque bolt to 190 Lb-Ft dry (255 Nm) dry.

2.6 TAG AXLE ALIGNMENT

The tag axle alignment consists in aligning the tag axle parallel to the drive axle position. Before aligning the tag axle, proceed with the drive axle alignment (paragraph 1.10). Tag axle alignment is achieved with the use of shims inserted between the lower longitudinal radius rod

Section 11: REAR AXLES

supports and axle. Tag axle alignment is factory set and is not subject to any change, except if vehicle has been damaged by an accident or if there are requirements for parts replacement.



CAUTION

If this setting is altered significantly, it will cause excessive tire wear.

NOTE

It may be necessary to adjust the axle TOE as well as its alignment. In this case, insert shims (7 min. - P/N 121203 or 15 min. - P/N 121240) in between mounting plate and spindle, as required.

If axle has been removed for repair or servicing and if all parts are reinstalled exactly in their previous locations, axle alignment is not necessary. However, if the suspension supports have been replaced or have changed position, proceed with the following instructions to verify or adjust the tag axle alignment.

3. SPECIFICATIONS

Drive Axle

MakeMeritor
Drive track..... 76.7 inches (1 949 mm)
Gear typeHypoid
Axle type Full floating
Lube capacity41 pints (19,3 liters)

Drive axle ratio

World Transmission

3.91:1

NOTE

The drive axle alignment consists in aligning the axle with reference to the frame. The axle must be perpendicular to the frame.

Tag Axle

MakePrevost
Rear track 83.6 inches (2 124 mm)
Axle type Forged

NOTE

The tag axle alignment consists in aligning the tag axle parallel to the drive axle.

SECTION 12: BRAKE AND AIR SYSTEM

CONTENTS

1. AIR SYSTEM	4
2. BRAKES	4
3. AIR RESERVOIRS	4
3.1 MAINTENANCE	4
3.1.1 <i>Wet (Main) Air Tank</i>	4
3.1.2 <i>Primary Air Tank</i>	4
3.1.3 <i>Accessory Air Tank</i>	4
3.1.4 <i>Secondary Air Tank</i>	5
3.1.5 <i>Kneeling Air Tank</i>	5
3.1.6 <i>Parking Brakes Override Air Tank</i>	5
3.2 PING TANK	5
4. AIR SYSTEM EMERGENCY FILL VALVES	5
5. ACCESSORY AIR FILTER	6
5.1 FILTER ELEMENT REPLACEMENT	6
5.2 CLEANING	6
6. AIR GAUGES (PRIMARY, SECONDARY AND ACCESSORY)	6
7. AIR FILTER/DRYER	6
7.1 AIR FILTER/DRYER PURGE TANK	7
8. HALDEX CONSEP ® CONDENSER / SEPARATOR	7
8.1 MAINTENANCE	7
9. AIR LINES	7
9.1 COPPER PIPING	7
9.2 FLEXIBLE HOSES	8
9.3 NYLON TUBING	8
9.4 AIR LINE OPERATING TEST	8
9.5 AIR LINE LEAKAGE TEST	8
9.6 MAINTENANCE	8
10. PRESSURE REGULATING VALVES	8
10.1 MAINTENANCE	8
10.2 PRESSURE SETTING PROCEDURE	9
11. AIR COMPRESSOR	9
11.1 COMPRESSOR REMOVAL AND INSTALLATION	10
12. EMERGENCY/PARKING BRAKE CONTROL VALVE (PP-1)	10
13. EMERGENCY / PARKING BRAKES OVERRULE CONTROL VALVE (RD-3)	10
14. FLIP-FLOP CONTROL VALVE (TW-1)	11
15. DUAL BRAKE APPLICATION VALVE (E-10P)	11
15.1 BRAKE PEDAL ADJUSTMENT	11
15.1.1 <i>Maintenance</i>	11

Section 12: BRAKE AND AIR SYSTEM

16.	STOPLIGHT SWITCHES	11
17.	PARKING BRAKE ALARM SWITCH	12
18.	BRAKE RELAY VALVE (R-12 & R-14)	12
19.	QUICK RELEASE VALVES (QR-1)	12
20.	SPRING BRAKE VALVE (SR-7)	12
21.	PRESSURE PROTECTION VALVE (PR-4)	13
22.	LOW PRESSURE INDICATOR (LP-3)	13
23.	SHUTTLE-TYPE DOUBLE CHECK VALVE (DC-4)	13
24.	EMERGENCY BI-FOLD ENTRANCE DOOR OPENING VALVES	14
25.	AIR SYSTEM TROUBLESHOOTING	14
26.	BRAKE OPERATION	14
27.	AIR BRAKES	14
27.1	CHECKING DISC BRAKE PADS.....	15
27.1.1	<i>Drive Axle – Equipped With a Solid Rubber Bushing and Exposed Guide Pin</i>	15
27.1.2	<i>Front and Tag Axle – Equipped With L-bracket Wear Indicator</i>	15
27.1.3	<i>Vehicles Equipped with a Continuous Wear Sensor</i>	15
27.2	BRAKE PADS AND DISCS MINIMAL TOLERANCE LIMITS.....	16
27.2.1	<i>Brake Pads</i>	16
27.2.2	<i>Brake Disc</i>	16
27.3	CALIPER RUNNING CLEARANCE	16
27.4	TORQUE SPECIFICATIONS	17
28.	SAFE SERVICE PROCEDURES	17
29.	AIR BRAKE TROUBLESHOOTING	18
30.	BRAKE AIR CHAMBER	20
30.1	MAINTENANCE.....	20
30.2	EMERGENCY/PARKING BRAKE MANUAL RELEASE	21
30.3	BRAKE CHAMBER REMOVAL	21
30.4	BRAKE CHAMBER INSTALLATION	21
30.5	BRAKE CHAMBER DISASSEMBLY	21
31.	ANTI-LOCK BRAKING SYSTEM (ABS)	22
31.1	TROUBLESHOOTING AND TESTING.....	22
31.2	ABS COMPONENTS	22
31.2.1	<i>Electronic Control Unit (ECU)</i>	23
31.2.2	<i>ABS Modulator Valve</i>	23
31.2.3	<i>Sensors</i>	23
31.2.4	<i>Spring clip</i>	24
32.	FITTING TIGHTENING TORQUES	24
33.	SPECIFICATIONS	25

ILLUSTRATIONS

FIGURE 1: I-BEAM FRONT SUSPENSION AIR RESERVOIRS LOCATION 12213.....4

FIGURE 2: REAR VALVE LOCATION (TYPICAL) 12211.....5

FIGURE 3: FRONT SERVICE COMPARTMENT 12210.....5

FIGURE 4: ACCESSORY AIR FILTER 12088.....6

FIGURE 5: HALDEX AIR FILTER DRYER 12194.....6

FIGURE 6: HALDEX CONSEP CONDENSER/SEPARATOR.....7

FIGURE 7: AIR PRESSURE REGULATING VALVE 12141A.....9

FIGURE 8: AIR PRESSURE REGULATOR 12200.....9

FIGURE 9: AIR COMPRESSOR LOCATION 03061.....9

FIGURE 10: PP-1 12142.....10

FIGURE 11: RD-3 12136.....11

FIGURE 12: TW-1 12138.....11

FIGURE 13: BRAKE PEDAL ADJUSTMENT 12208.....11

FIGURE 14: DELCO SWITCH 12139.....11

FIGURE 15: BENDIX SWITCH 12140.....12

FIGURE 16: R-12 12074.....12

FIGURE 17: R-14 12207.....12

FIGURE 18: QR-1 12075.....12

FIGURE 19: SR-7 12206.....13

FIGURE 20: PR-4 12174.....13

FIGURE 21: LP-3 12214.....13

FIGURE 22: DC-4 12134.....13

FIGURE 23: THREE-WAY VALVE 12186.....14

FIGURE 24: BRAKE PAD WEAR CHECK ON DRIVE AXLE.....15

FIGURE 25: BRAKE PAD WEAR CHECK ON FRONT AND TAG AXLE 12119.....15

FIGURE 26: RUNNING CLEARANCE 12116.....17

FIGURE 27: CALIPER CARRIER MOUNTING BOLTS TORQUE SPECIFICATION – TAG AXLE & FRONT I-BEAM AXLE
12145 17

FIGURE 28: CALIPER CARRIER MOUNTING BOLTS - MERITOR DRIVE AXLE.....17

FIGURE 29: TORQUE SPECIFICATION 11030.....17

FIGURE 30: FRONT AXLE BRAKE AIR CHAMBER 12158.....20

FIGURE 31: DRIVE AXLE BRAKE AIR CHAMBER 12126.....20

FIGURE 32: ABS ECU LOCATION 06617.....23

FIGURE 33: ABS MODULATOR VALVE 12221.....23

FIGURE 34: ABS SENSOR LOCATION 12153.....24

FIGURE 35: SPRING CLIP 12161.....24

FIGURE 36: HOSE FITTINGS 12053.....24

FIGURE 37: HOSE FITTING 12054.....25

FIGURE 38: HOSE FITTING 12055.....25

FIGURE 39: HOSE FITTING 12056.....25

Section 12: BRAKE AND AIR SYSTEM

1. AIR SYSTEM

The basic air system consists of an air compressor, reservoirs, valves, filters and interconnecting lines and hoses. It provides a means for braking; operating controls and accessories, and suspension (refer to Section 16, "Suspension", for complete information on suspension description and maintenance). An air system schematic diagram is annexed in the technical publications box provided with the vehicle for better understanding of the system.

2. BRAKES

This vehicle uses both the service brake and emergency/parking brake. The service brake air system is divided into two independent circuits to isolate front brakes from rear brakes, thus providing safe braking in the event that one circuit fails. Front axle brakes operate from the secondary air system, while brakes on both the drive axle and tag axle operate from the primary air system.

NOTE

The tag axle service brake operates only when the axle is in normal ride position (loaded and down).

Furthermore, the brake application or release, which is speed up by a pneumatic relay valve (R-12), will start with the rear axles and will be followed by the front axle, thus providing uniform braking on a slippery road. The vehicle is also equipped with an Anti-Lock Braking System (ABS), which is detailed later in this section.

The drive axle is provided with spring-loaded emergency/parking brakes, which are applied automatically whenever the control valve supply pressure drops below 40 psi (275 kPa).

3. AIR RESERVOIRS

The air coming from the air dryer is first forwarded to the wet air tank, then to the primary (for the primary brake system), secondary (for the secondary brake system), and accessory (for the pneumatic accessories) air tanks (Fig. 1).

Two additional air reservoirs are installed on the vehicle: the kneeling air tank and the parking brakes overrule air tank.

3.1 MAINTENANCE

Ensure that the wet (main) air tank is purged during pre-starting inspection. In addition, it is good practice to purge this reservoir at the end of every working day. The remaining reservoirs must be purged at every 12,500 miles (or 20 000 km) or once every year, whichever comes first.

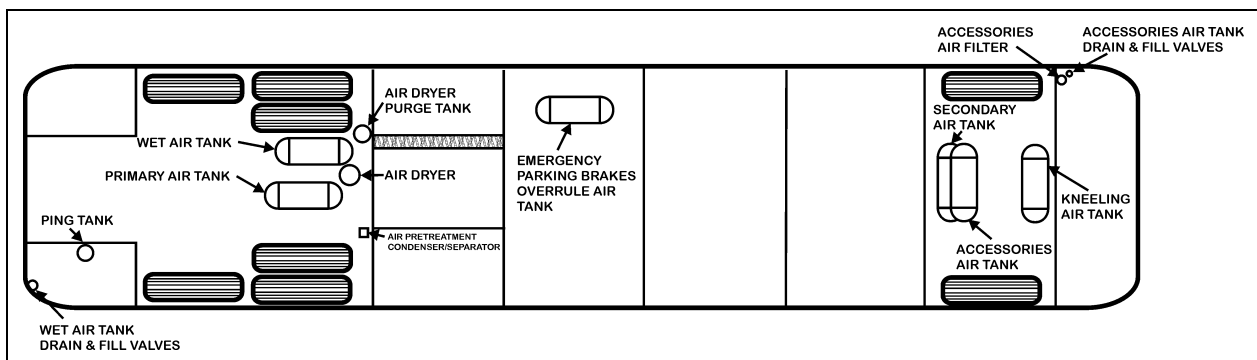

FIGURE 1: I-BEAM FRONT SUSPENSION AIR RESERVOIRS LOCATION

12213

3.1.1 Wet (Main) Air Tank

This reservoir, located above the L.H. wheel of drive axle in the rear wheelhousing, is provided with a bottom drain valve. A recommended purge using the bottom drain valve should be done every 12,500 miles (20 000 km), or once a year, whichever comes first.

3.1.2 Primary Air Tank

This reservoir is located above the R.H. wheel of the drive axle and is provided with a bottom drain valve (Fig. 1). It is recommended to purge the primary air tank every 12,500 miles (20 000 km) or once a year, whichever comes first.

3.1.3 Accessory Air Tank

The accessory air tank is installed close to the front axle and is provided with a bottom drain valve (Fig. 1).

Purge the reservoir by its drain valve every 12,500 miles (20 000 km) or once a year, whichever comes first.

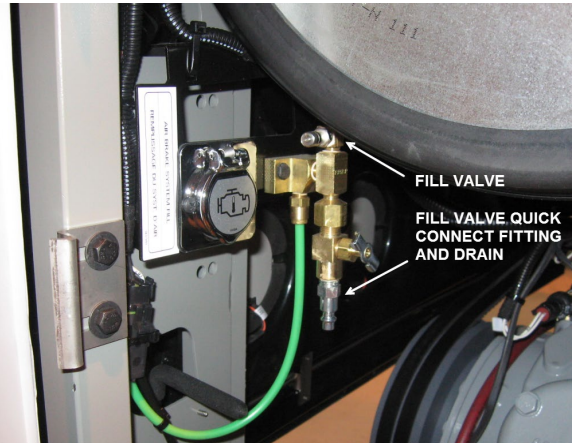

FIGURE 2: REAR VALVE LOCATION (TYPICAL) 12211

3.1.4 Secondary Air Tank

This tank is located in the front wheelhousing, behind the steering axle (Fig. 1). It is provided with a bottom drain valve.

Purge this reservoir every 12,500 miles (20 000 km) or once a year, whichever comes first.

3.1.5 Kneeling Air Tank

The kneeling air tank is located in the front wheelhousing (Fig. 1), and is provided with a bottom drain valve.

3.1.6 Parking Brakes Override Air Tank

The parking brakes override air tank is installed at the ceiling of the rear baggage compartment, on the L.H. side, and is provided with a bottom drain valve.

3.2 PING TANK

The ping tank is located in the engine compartment; it is accessible through the engine compartment R.H. side door. It is used to dissipate heat and to reduce noise produced by the air compressor cycling on and off.

4. AIR SYSTEM EMERGENCY FILL VALVES

All vehicles come equipped with two emergency fill valves that enable system pressurization by

an external source such as an air compressor. The rear valve is located in the engine compartment and is accessible from engine R.H. side door (Fig 2). It is positioned close to the door opening.



CAUTION

Maximum allowable air pressure is 125 psi (860 kPa). Air filled through these two points will pass through the standard air filtering system provided by Prevost. Do not fill system by any point on the system.

The front valve is located in the front service compartment close to R.H. side of door frame (Fig. 3).

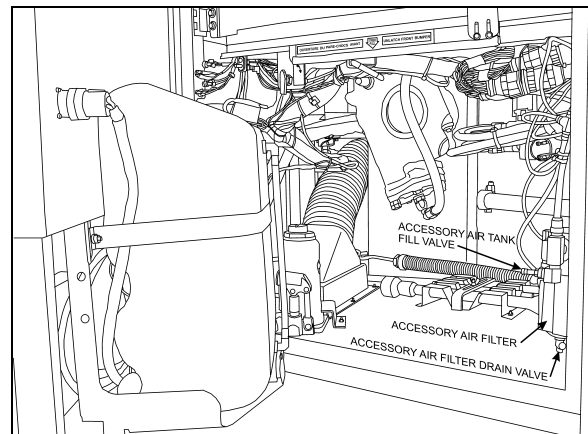

FIGURE 3: FRONT SERVICE COMPARTMENT 12210

These two air system emergency fill valves are fitted with the same valve stems as standard tires, and can be filled by any standard external air supply line.

The rear air system emergency fill valve will supply air for all systems (brakes, suspension and accessories) while the front fill valve will supply air for accessories only.

5. ACCESSORY AIR FILTER

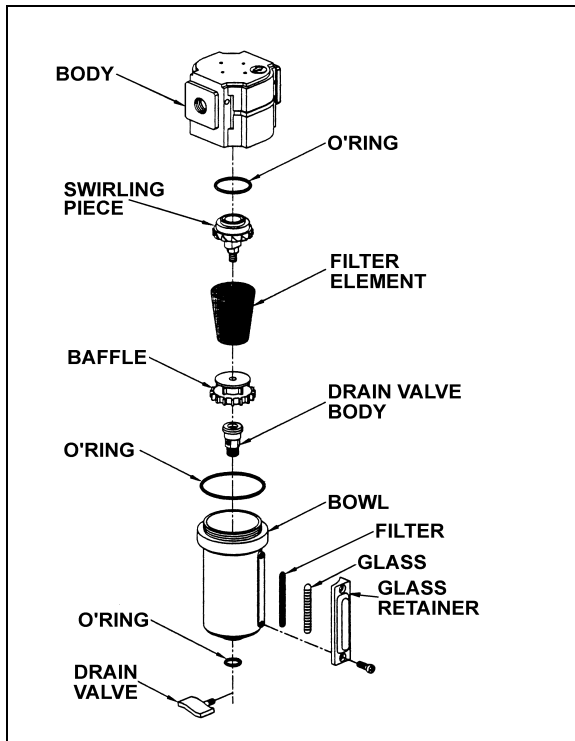

FIGURE 4: ACCESSORY AIR FILTER

12088

This filter is located inside the front service compartment (Fig. 3). Its main function consists in filtering the air supplied to the accessory air system, when connected to an external supply line. Ensure filter is purged whenever supplying the system with an external air line and at least every 12,500 miles (20 000 km). To purge, open drain valve (Fig. 4), let the moisture come out, then close the drain valve.

5.1 FILTER ELEMENT REPLACEMENT

Replace filter element whichever of the following occurs first: every 100,000 miles (160 000 km), every two years, or whenever differential pressure exceeds 15 psi (105 kPa) between filter inlet and outlet ports. Check condition of all three O-rings for damage. Replace when necessary (Fig. 4).

5.2 CLEANING

Clean filter body and bowl with a warm water and soap solution. Rinse thoroughly with clean water. Blow dry with compressed air making sure the air stream is moisture free and clean. Pay particular attention to the internal passages. Inspect all parts for damage and replace if necessary.

6. AIR GAUGES (PRIMARY, SECONDARY AND ACCESSORY)

The air pressure gauges, located on the dashboard (see "Operator's Manual"), are connected to the DC-4 double check valve, located on the pneumatic accessory panel in the front service compartment.

The latter is connected to the air lines running from the primary and secondary air tanks, as shown on the pneumatic system diagram provided in the technical publications box. The accessory air gauge is connected to the accessory air tank using the drain valve connector. The vehicle should never be set in motion until the buzzer alarm and warning lights turn off, i.e. when air pressure registers at least 66 psi (455 kPa). Moreover, if pressure drops below 66 psi (455 kPa), the "Low air pressure" warning lights will turn on, and the "Low air pressure" buzzer will sound. Stop the vehicle immediately, determine and correct the cause(s) of pressure loss. Check the gauges regularly with an accurate test gauge. Replace the gauge with a new unit if there is a difference of 4 psi (27 kPa) or more in the reading.

7. AIR FILTER/DRYER

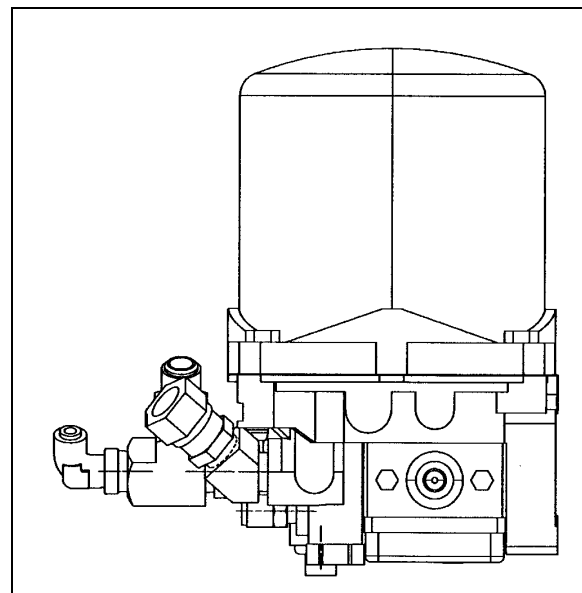

FIGURE 5: HALDEX AIR FILTER DRYER

12194

The air filter/dryer is located in front of rear wheelhousing (Fig. 1 & 5). Its purpose is to remove moisture that could damage the system reservoir. The air filter/dryer also filters the air to remove dirt, compressor oil, and other contaminants that can damage the system.

Change cartridge every 100,000 miles (160 000 km) or once every two years, whichever comes first. The air dryer may be purged for maintenance purposes using the remote drain valve located in the engine compartment and accessible through the engine compartment R.H. side door. The valve is positioned close to the L.H. side of door opening (Fig. 2). The air filter/dryer has a built-in governor to maintain the system between 108 psig and 123 psig.

Maintenance and repair information is supplied in the maintenance information annexed to this section.

7.1 AIR FILTER/DRYER PURGE TANK

A tank is supplied to purge the air filter/dryer to remove moisture and contaminants.

8. HALDEX CONSEP® CONDENSER / SEPARATOR

The Consep® Air Pretreatment Condenser/ Separator is located in front of rear wheelhousing (Fig. 1 & 6). Within the vehicle's air brake system, the Haldex Consep condenses, separates and removes 90% of the oils, liquids and other contaminants, while treating up to 30 SCFM. It reduces corrosion and possible failure of air brake system components caused by contamination and significantly increases the air dryer desiccant life.

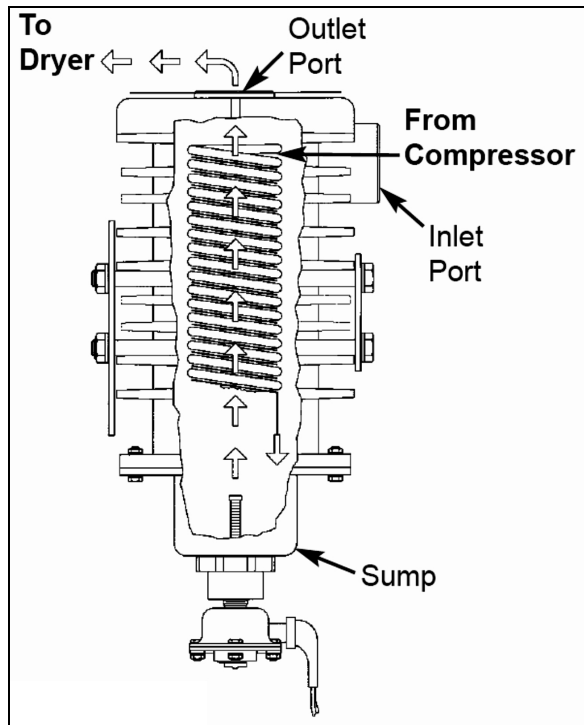

FIGURE 6: HALDEX CONSEP CONDENSER/SEPARATOR

8.1 MAINTENANCE

Mounted between the air compressor and the air dryer, the compact Consep requires little maintenance during its long service life. An automatic drain valve installed on the Consep saves time while ensuring that liquids are removed regularly for optimum performance. The drain valve's integrated filter prevents damage from large debris, while a built-in heater prevents freeze up.

The Consep must be inspected periodically for proper operation. The interval between inspections is determined by the type of service (every 6 months for City Transit). High compressor duty cycles and high temperatures can cause a buildup of carbon in the condenser, drain valve and filter. This contamination must be removed for proper operation.

Installation, Maintenance and Inspection information is supplied in the maintenance information annexed to this section under reference number L31167.

9. AIR LINES

Copper piping, nylon-reinforced tubing, and flexible hoses are used to connect the units in the pneumatic system, including air brake system, suspension system and accessory systems such as the entrance door, fresh air damper cylinder, air horns, etc. Furthermore, the nylon tubing is color coded to ease identification. Refer to the following table for the complete color identification code. Service instructions for each type of air line are also provided under the applicable headings.

Color	Circuit
Red	Secondary
Green	Primary and Delivery
Yellow	Parking Brake
Blue	Suspension
Black	Accessory

9.1 COPPER PIPING

A heat dissipation copper piping assembly is used to dissipate the heat coming from the compressor before it enters the air filter/dryer. Connections should be checked for leakage at least every 6,250 miles (10 000 km) or twice a

Section 12: BRAKE AND AIR SYSTEM

year, whichever comes first. Tighten or replace when necessary. When replacing copper piping, the parts must be free of burrs, copper cuttings, and dirt. Blow out piping with compressed air. Any such particles will destroy sealing seats in air control units. Also, new piping must be the same size as the old one.

9.2 FLEXIBLE HOSES

A flexible hose is used normally where it is impractical to use copper or nylon tubing due to constant flexing during operation, such as brake chamber hoses. Hose connections should be tested for leakage at least every 6,250 miles (10 000 km) or twice a year, whichever comes first and tightened or replaced if necessary. Any hose which is chafed, worn or kinked should be replaced.

Teflon-braided stainless steel hoses used in the engine compartment must be replaced only with similar hoses.

9.3 NYLON TUBING

Nylon tubing is used for air lines in areas where usage of this material is suitable. Nylon tubing is flexible, durable, and weather resistant. When replacing an air line, use nylon tubing only where it has been used previously.

Nylon air lines must never be routed in areas where temperature could exceed 200°F (93°C).



CAUTION

Nylon air lines should be used to replace existing nylon lines only, and must comply with the color identification code to ease pneumatic system troubleshooting.

9.4 AIR LINE OPERATING TEST

If any trouble symptom such as slow brake application or slow brake release indicates a restricted or clogged air line, disconnect the suspected tube or hose at both ends and blow through it to clear the passage.

Inspect tubing and hose for partial restriction that may be caused by dents or kinks. If such a condition is found, the tubing or hose should be replaced.

9.5 AIR LINE LEAKAGE TEST

With air system fully charged and the brakes applied, coat all tubing and hose connections

with a soapy solution to check for air leakage. No leakage is permitted. Leakage can sometimes be corrected by tightening the connection. If this fails to correct the leakage, new fittings, nylon tubing, copper tubing, teflon-braided stainless steel and flexible hoses must be installed as applicable.

9.6 MAINTENANCE

Inspect all lines for cuts, swelling, kinks or other damage or deterioration. Check for lines being pinched by other components. Retaining clips and ties must be in place.

Any support or bracket should be in good condition and mounted firmly in position. Hose spring guards should be in usable condition and not distorted. Particular attention should be given to long lines. Any supporting component (clips, ties, grommets, etc.) must be secured to prevent against unnecessary vibration and eventual loosening of connection. Any detected leak should be repaired. Be sure nylon lines are not near areas of intense heat. Check for any missing grommets or loose material where chafing or cutting may occur. Replace with new material as required. In general, lines should be securely located in position and free from any binding condition which would hinder air flow.

10. PRESSURE REGULATING VALVES

There is one pressure regulator for the belt tensioners, and another one installed on vehicles equipped with the World transmission output retarder.

The belt tensioner pressure regulating valve is located in the engine compartment above the engine air filter and is used to limit the air pressure in belt tensioners to 45 ± 2 psi (310 ± 15 kPa) (Fig. 7).

The other regulator is located in the engine compartment, on the engine cradle R.H. side (accessible through the engine R.H. side door). It is used for transmission retarder and should be adjusted to 85 ± 3 psi (586 ± 20 kPa).

	Air Pressure (psi)	Air Pressure (kPa)
Belt Tensioner	45	310
Retarder	85	586

10.1 MAINTENANCE

Every 100,000 miles (160 000 km) or once every two years, whichever comes first, disassemble

the regulating valve and wash all metal parts in a cleaning solvent (Fig. 7). Examine the diaphragm; if cracked, worn or damaged, replace with a new one. If the valve is excessively grooved or pitted, it should be replaced. Replace any other part that appears worn or damaged. After reassembly, adjust to the specified pressure setting and check for air leakage.

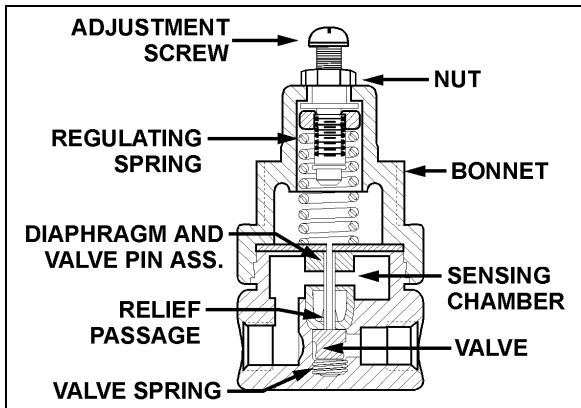

FIGURE 7: AIR PRESSURE REGULATING VALVE 12141A

10.2 PRESSURE SETTING PROCEDURE

Remove the dust cap from the pressure check valve (Fig. 8). Attach a pressure gauge at this port and check the pressure reading. If the pressure reading is incorrect, adjust as follows:

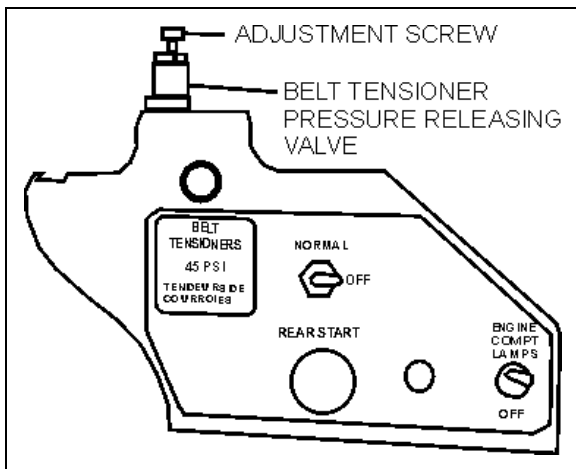

FIGURE 8: AIR PRESSURE REGULATOR 12200

1. Loosen the locking nut, turn the adjustment screw counterclockwise to decrease pressure by approximately 10 psi (70 kPa) below the required pressure.
2. Turn the adjustment screw clockwise to increase the pressure slowly until the required pressure setting is reached. Tighten the locking nut.

3. Remove pressure gauge and replace dust cap on the air pressure check valve.

11. AIR COMPRESSOR

The Wabco System Saver 636 Twin Cylinder air compressor is located on the alternator side of the engine, at the flywheel end (Fig. 9). Its function is to provide and maintain air under pressure to operate devices in brake and air systems.

The compressor is driven by the ring gear, and is water cooled. Engine coolant is fed to the compressor through a flexible hose tapped into the block water jacket and connected to the rear of the compressor. Coolant returns from the top of the compressor (governor side) through a flexible hose to the engine pump.

The air is taken from the air intake manifold and entered in the top of the compressor. The compressed air is pushed into the discharge line located on side of the compressor, which sends air to the air dryer. Lubricating oil is supplied to the compressor by a line from the cylinder block oil gallery connected to the air compressor. Lubricating oil returns to the engine crankcase through the air compressor drive assembly.

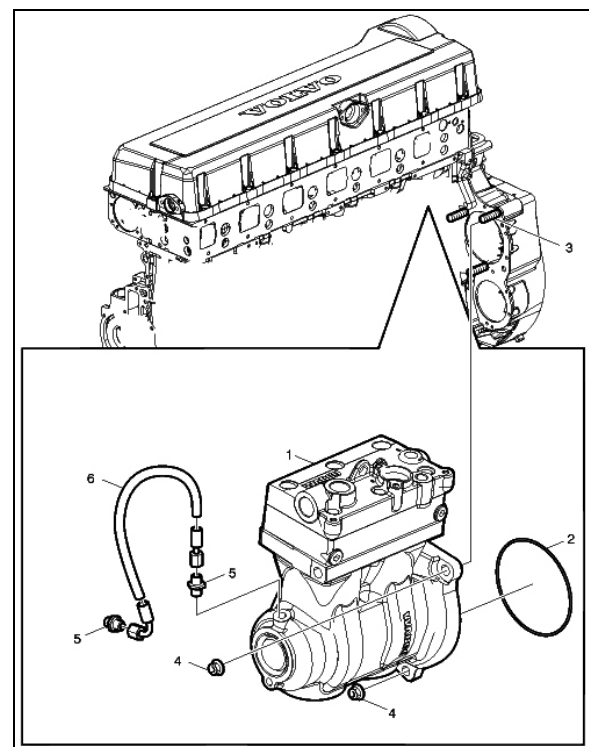

FIGURE 9: AIR COMPRESSOR LOCATION 03061

Maintenance and repair information on the Wabco 636 Twin Cylinder air compressor is

Section 12: BRAKE AND AIR SYSTEM

supplied in the applicable booklet annexed at the end of this section.

Item	Description	Notes
1	Air Compressor	Wabco 636
2	O'Ring	
3	Stud (3)	M12
4	Flange Nut (3)	Torque to 15lb-ft (20 Nm)
5	Nipple (2)	
6	Hose Assembly	

11.1 COMPRESSOR REMOVAL AND INSTALLATION

1. Exhaust compressed air from air system by opening the drain valve of each air tank.
2. Drain the engine cooling system. See Section 5: "*Cooling System*".
3. Access the compressor by the engine R.H. side compartment. Identify and disconnect all air, coolant and oil lines from the compressor assembly.
4. Remove the three compressor flange mounting nuts.
5. Slide air compressor rearward to disengage the hub from coupling. Remove the air compressor.

Remove and retain the oil supply tube that runs between the compressor and the engine

Reverse removal procedure for installation.

12. EMERGENCY/PARKING BRAKE CONTROL VALVE (PP-1)

A push-pull control valve mounted on the L.H. lateral console is provided for parking brake application or release. The spring brakes are self-actuated whenever the control valve supply pressure drops below 60 psi (414 kPa). In the UP position, brakes are ON. In the DOWN position, brakes are RELEASED. A protective case around the knob prevents accidentally releasing the brakes.

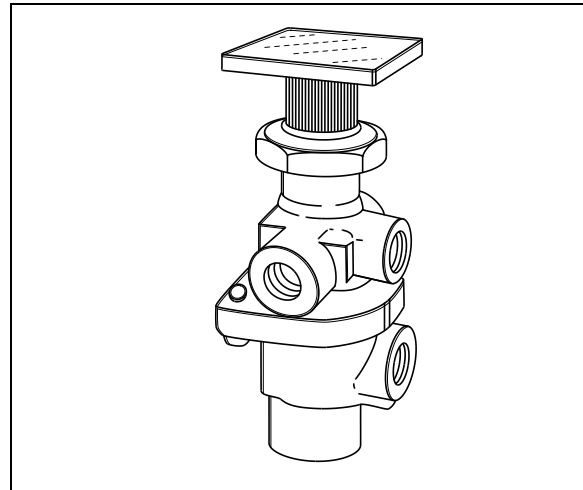

FIGURE 10: PP-1

12142

Maintenance and repair information on this valve is supplied in the applicable booklet annexed to this section under reference number SD-03-3611.

Remove the valve the following way:

1. Drain the air system.
2. Access this valve by tearing out the finishing panel, which holds the controls in place (Fig. 10).
3. Disconnect the air tubes.
4. Remove the retaining screws.
5. Service or replace the valve.
6. Installation is the reverse of removal.

13. EMERGENCY / PARKING BRAKES OVERRULE CONTROL VALVE (RD-3)

A RD-3 control valve is used with the parking brake overrule system. In the case of self-application of spring brakes due to a pressure drop, the brakes can be released by holding down this control valve. Maintenance and repair information on this valve is supplied in the applicable booklet annexed to this section under reference number SD-03-3611.

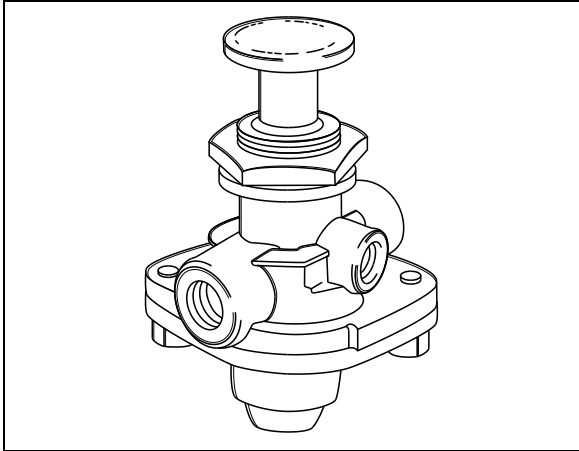

FIGURE 11: RD-3 12136

14. FLIP-FLOP CONTROL VALVE (TW-1)

A flip-flop control valve mounted on the L.H. lateral console is provided to unload tag axle air springs and to lift tag axle. It is a manually operated "on-off" valve. Maintenance and repair information on this valve is supplied in the applicable booklet annexed to this section under reference number SD-03-3602.

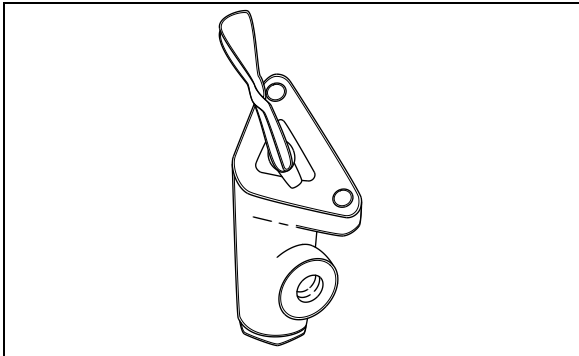

FIGURE 12: TW-1 12138

15. DUAL BRAKE APPLICATION VALVE (E-10P)

The E-10P dual brake valve is a floor mounted, foot-operated type brake valve with two separate supply and delivery circuits. This valve is located in the front service compartment (Fig. 13).

15.1 BRAKE PEDAL ADJUSTMENT

After brake pedal replacement or repair, adjust the pedal to its proper position according to the following procedure:

1. Replace the linkage, loosen threaded rod lock nuts and screw or unscrew the threaded adjustment rod in order to obtain a 45° brake pedal inclination (Fig. 13).

2. Tighten threaded rod lock nuts.

15.1.1 Maintenance

Maintenance and repair information on the E-10P dual brake application valve is supplied in the applicable booklet annexed to this section under reference number SD-03-830.

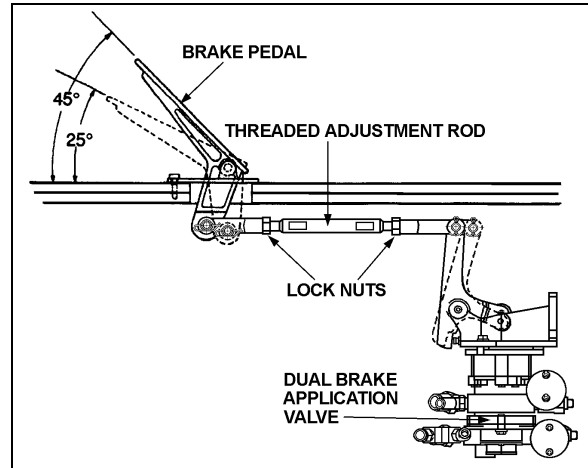

FIGURE 13: BRAKE PEDAL ADJUSTMENT 12208

16. STOPLIGHT SWITCHES

Two electro-pneumatic stoplight switches are mounted on the dual brake application valve (E-12). The upper one is used for the primary air circuit while the lower one is used for the secondary air circuit. Both switches are connected in parallel and have the same purpose, i.e. completing the electrical circuit and lighting the stoplights when a brake application is made. The upper switch (AC Delco) is designed to close its contact between 2 psi and 4 psi (14 kPa to 28 kPa) (Fig. 14), while the lower one (Bendix, SL-5) closes its contact at 4 psi (28 kPa) (Fig. 15). The switches are not serviceable items; if found defective, the complete unit must be replaced.

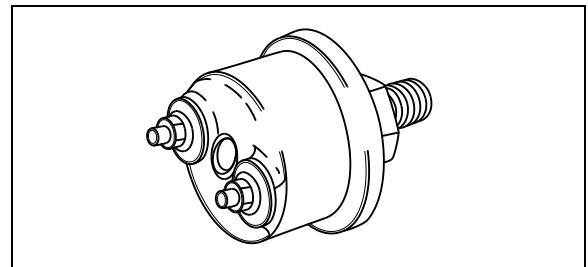

FIGURE 14: DELCO SWITCH 12139

Section 12: BRAKE AND AIR SYSTEM

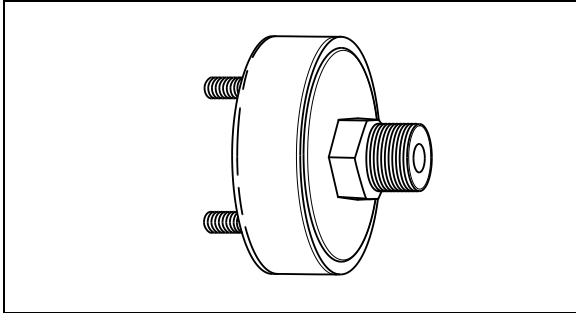

FIGURE 15: BENDIX SWITCH

12140

17. PARKING BRAKE ALARM SWITCH

Refer to the appropriate annexed booklet (Bendix, SL-5 Stop Light Switch; reference no. SD-06-2501).

The parking brake alarm uses the same switch as the stoplights. It is mounted on the spring brake valve and operates in conjunction with a NC relay to sound a warning alarm by completing the electrical circuit when the ignition switch is turned OFF with parking brake released.

18. BRAKE RELAY VALVE (R-12 & R-14)

The primary air system includes three brake relay valves being supplied by the dual brake valve, and which function is to speed up the application and release of the service brakes.

One Wabco R-14 valve located in the rear underframe supplies the drive axle service brake air line, while the other two R-12 valves supply independently both the tag axle right and left service brake air line and act as interlock valves. These valves are accessible from under the vehicle at the level of the tag axle. Maintenance and repair information on these valves is supplied in the applicable booklet annexed to this section under reference number SD-03-1064.

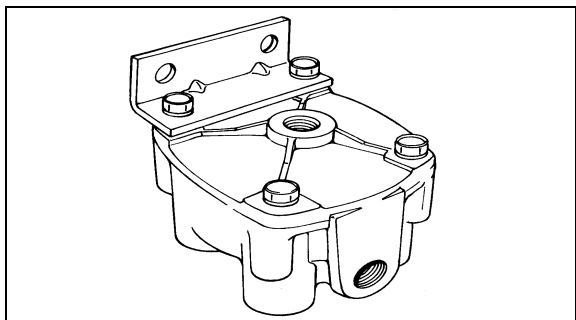

FIGURE 16: R-12

12074

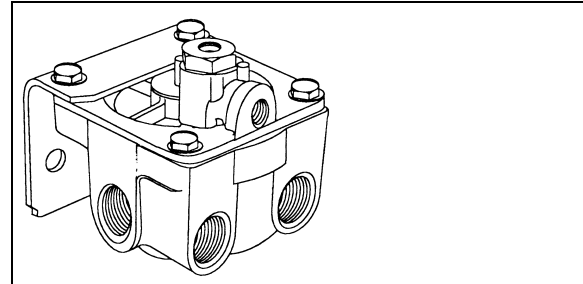

FIGURE 17: R-14

12207

19. QUICK RELEASE VALVES (QR-1)

The quick release valve is located on the front axle service brakes air line and permit rapid exhaust of air pressure from brakes, thus decreasing the brake release time.

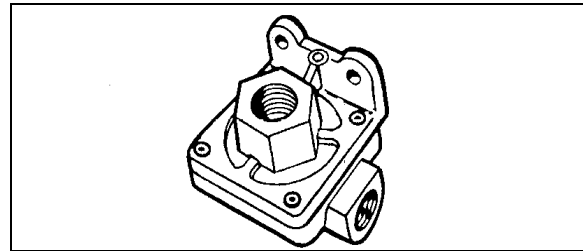

FIGURE 18: QR-1

12075

Maintenance and repair information on this valve is supplied in the applicable booklet annexed to this section under reference number SD-03-901.

20. SPRING BRAKE VALVE (SR-7)

The spring brake valve is located in the rear underframe. The SR-7 Modulating Valve is used in conjunction with a dual air brake system and spring brake actuator and performs the following functions:

- Provides a rapid application of the spring brake actuator when parking.
- Modulates the spring brake actuator application using the dual brake valve should a primary failure occur in the service brake system.
- Prevents compounding of service and spring forces.

Maintenance and repair information on the spring brake valve is supplied in the applicable booklet annexed to this section under reference number SD-03-9043.

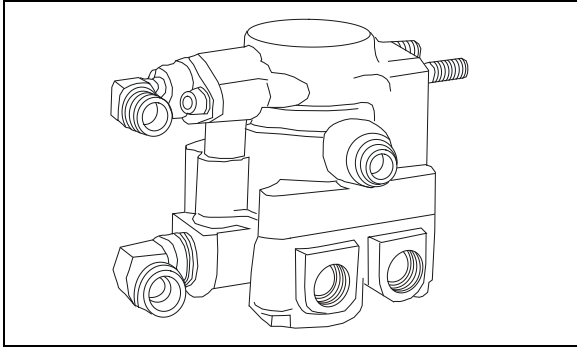

FIGURE 19: SR-7 12206

21. PRESSURE PROTECTION VALVE (PR-4)

Maintenance and repair information on the pressure protection valve is supplied in the applicable booklet annexed to this section under reference number SD-03-2010.

The air system includes two pressure protection valves (Fig. 20). One valve is installed on the manifold block, and insures at all times a minimum pressure of 70 psi (482 kPa) in the suspension air system in the event that a pressure drop occurs in either the suspension air system or accessory air system. This valve is located in the front service compartment beside the air filter.

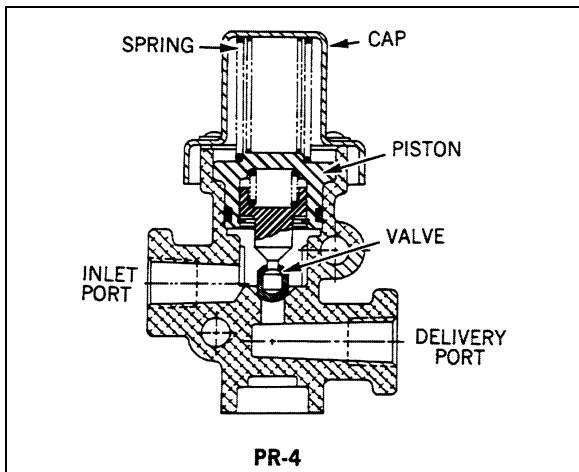

FIGURE 20: PR-4 12174

The other valve is installed on the accessory air tank, and insures a minimum pressure of 70 psi (482 kPa) in the accessory air system in the event that a pressure drop occurs in either the suspension air system or braking air system (refer to Fig. 1 for accessory air tank location).

22. LOW PRESSURE INDICATOR (LP-3)

Maintenance and repair information on the low pressure indicators is supplied in the applicable booklet annexed to this section under reference number SD-06-1600.

The air system includes two low pressure switches (Fig. 21), both located on the pneumatic accessory panel in the front service compartment. One serves for the parking brake signal, its pressure setting is 66 ± 6 psi (455 ± 40 kPa). The remaining pressure switch monitors the parking brake telltale panel indicator; its pressure setting is 30 psi (205 kPa).

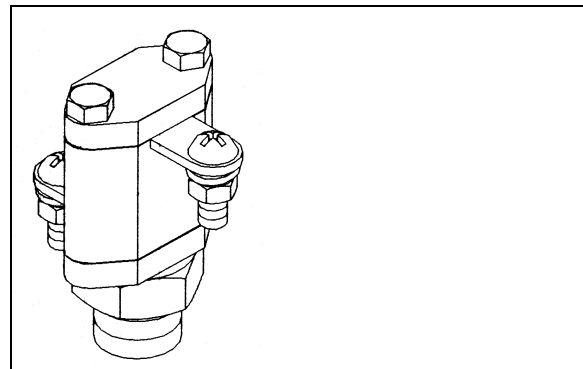

FIGURE 21: LP-3 12214

23. SHUTTLE-TYPE DOUBLE CHECK VALVE (DC-4)

Maintenance and repair information on the shuttle-type double check valve is supplied in the applicable booklet annexed to this section under reference number SD-03-2202.

The double check valve is located on the pneumatic accessory panel in the front service compartment. In the event of a pressure drop in either the primary or secondary system, this unit will protect the emergency /parking brake control valve and the intact portion of the air system from pressure loss.

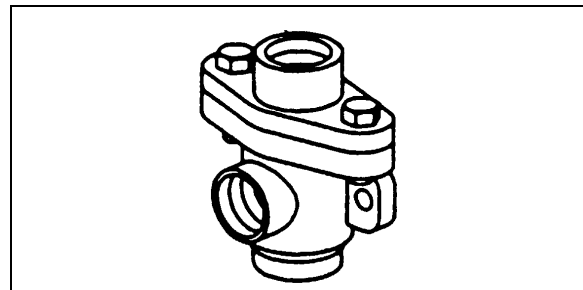

FIGURE 22: DC-4 12134

Section 12: BRAKE AND AIR SYSTEM

24. EMERGENCY BI-FOLD ENTRANCE DOOR OPENING VALVES

Two emergency door opening three-way valves are installed on the coach. One is in the front service compartment, readily accessible. The other one is below the R.H. dashboard panel. When used, the valve releases pressure in the entrance door locking cylinders, thus allowing the door to be manually opened.

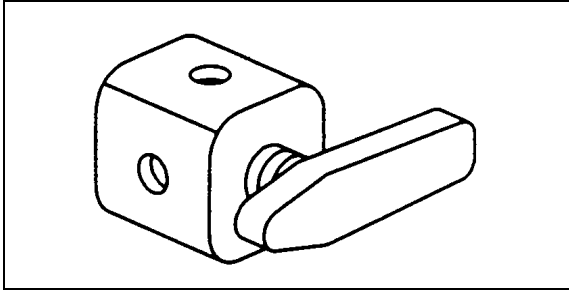

FIGURE 23: THREE-WAY VALVE

12186

25. AIR SYSTEM TROUBLESHOOTING

The following list has been designed to help in troubleshooting some of the most common problems in the air system and main causes. For air brakes troubleshooting, refer to “*Air Brakes Troubleshooting*” in this section. For more troubleshooting information, refer to the manufacturer’s brochures annexed to this section.

Air pressure doesn’t rise to, or doesn’t maintain, a normal setting:

- Defective air gauge (registering incorrectly).
- Excessive leaking in air system.
- Reservoir drain cock open.
- Governor poorly adjusted or defective.
- Defective compressor.
- Worn compressor or excessive wear on piston and/or ring.
- Air pressure rises to normal setting too slowly.

Excessive leaking in air system:

- Clogged engine air cleaner.
- Worn compressor or excessive wear on piston and/or ring.
- Engine speed too low.

Air pressure rises above a normal setting:

- Defective air gauge (registering incorrectly).
- Governor poorly adjusted or defective.
- Restriction in line between governor and compressor unloading mechanism.

Air pressure drops quickly when engine is stopped:

- Leaks in compressor discharge valve.
- Leaks in governor.
- Leaks in air lines.
- Leaks in air system valves.

26. BRAKE OPERATION

The vehicle braking system uses both service and parking air-operated brakes. The air system is divided into two independent circuits to isolate the front axle brakes and the rear axle brakes (drive and tag), thus providing safe brake operation in the event that one circuit of the system fails. The primary circuit is connected to the drive and tag axle brakes, while the secondary circuit is connected to the front axle brakes. The tag axle service brakes operate only when the axle is in the normal driving (loaded) position. The spring-type emergency brakes are mounted on the drive axle, and will apply automatically if primary system pressure falls below 40 psi (276 kPa).

Furthermore, brake application or release, which is speed up by a pneumatic relay valve (R-12), will start with the rear axles and be followed by the front axle, thus providing uniform braking on a slippery surface. The vehicle is also equipped with an Anti-lock Brake System (ABS), detailed later in this section.

Brake and air system maintenance consists of periodic inspections. Check all parts for damage and brake adjustment (refer to subsequent headings in this section for more details). Ensure all fasteners are tight (refer to “*Specifications*” for recommended tightening torques).

27. AIR BRAKES

DISC BRAKES

Knorr-Bremse SN7000 disc brakes are used on all axles. The front and drive axle discs are actuated by 24 square inch effective area air brake chambers, while on tag axle, the brake

chambers have a 14 or 16 square inch effective area for service. The *Knorr-Bremse SN7000* brakes are supplied with automatic clearance (slack) adjusters as standard equipment for easier adjustment. For more information on disc brake components and scheduled maintenance, refer to Knorr-Bremse Service Manual.

27.1 CHECKING DISC BRAKE PADS

Brake pads have to be checked on a regular basis depending on the vehicle operation. The remaining thickness of the pads should never be less than 0.079 in (2 mm). When replacing brake pads, all four pads on an axle have to be changed at the same time. There is no inner or outer pad, since all pads are the same. Once removed, worn pads should be replaced in their original position.

27.1.1 Drive Axle – Equipped With a Solid Rubber Bushing and Exposed Guide Pin

The condition of the pads can be visually determined without removing the wheel by checking the position of the caliper (1) compared to the fixed guide pin (4).

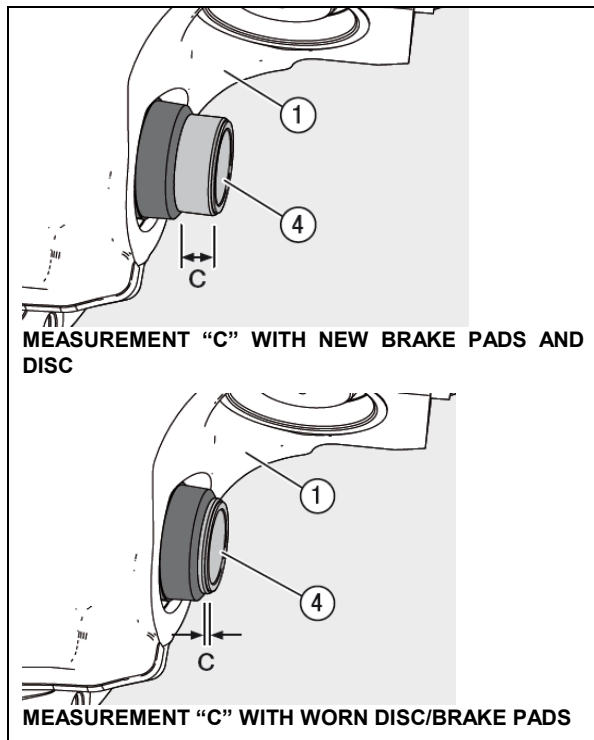

FIGURE 24: BRAKE PAD WEAR CHECK ON DRIVE AXLE

If measurement “C” is less than 0.039” (1 mm), this condition requires a check of the brake pad thickness and the brake disc with the wheel

removed. If any minimal tolerance limits have been reached, the pads and/or disc must be changed.

27.1.2 Front and Tag Axle – Equipped With L-bracket Wear Indicator

The condition of the pads can be visually determined without removing the wheel by checking the position of the caliper compared to the tip of the wear indicator.

If the side of the caliper (flat surface around guide pin cap) lines up with the tip of the wear indicator (i.e. measurement A would be 0.0 in), the brake pad thickness and the brake disc must be checked with the wheel removed. If any minimal tolerance limits have been reached, the pads and/or disc must be changed.

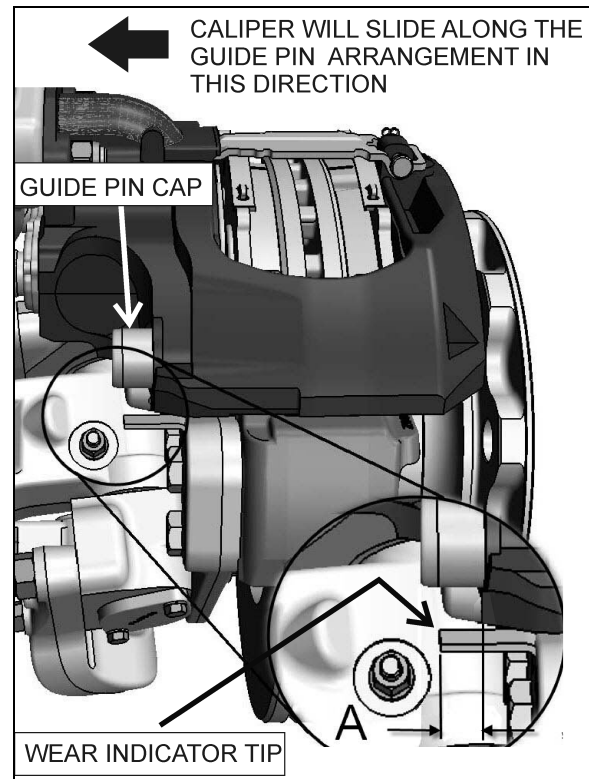

FIGURE 25: BRAKE PAD WEAR CHECK ON FRONT AND TAG AXLE

12119

27.1.3 Vehicles Equipped with a Continuous Wear Sensor.

These vehicles have a potentiometer installed directly on the brake caliper.

Section 12: BRAKE AND AIR SYSTEM

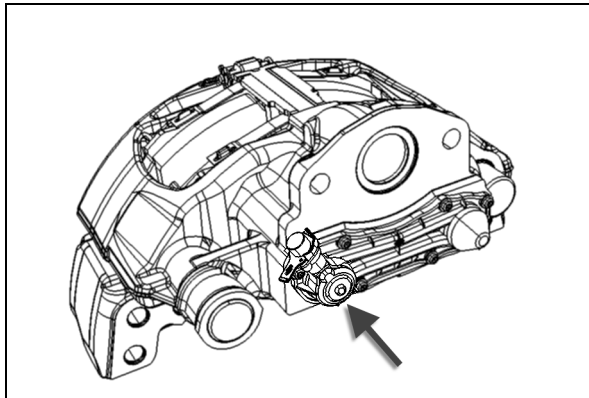

BRAKE PAD ARE NOT PERMITTED

If the thickness of the friction material at its thinnest point is less than 0.079 inch or 2 mm (measurement C), the pads must be replaced.

- A= Overall thickness of new brake pad: 1.18 in (30 mm)
- B= Back plate SN7 type: 0.354 in (9 mm)
- C= Minimal thickness of friction material: 0.079 in (2 mm)
- D= Minimum allowed thickness in worn condition for back plate and friction material: 0.433 in (11 mm)

27.2 BRAKE PADS AND DISCS MINIMAL TOLERANCE LIMITS

27.2.1 Brake Pads

The thickness of the pads must be checked regularly dependent on the usage of the vehicle. The pads should be checked corresponding to any legal requirements that may apply. Even if a wear indicator is fitted and connected, this must be at least every 12 months.

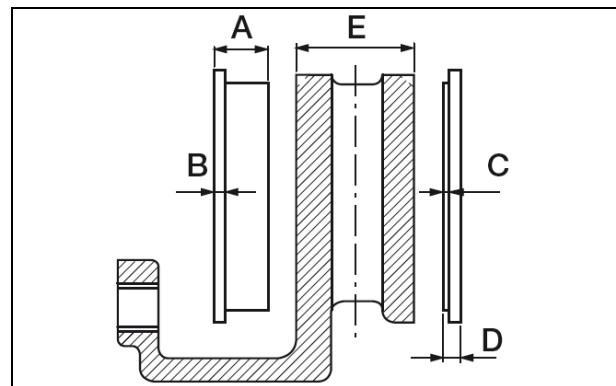
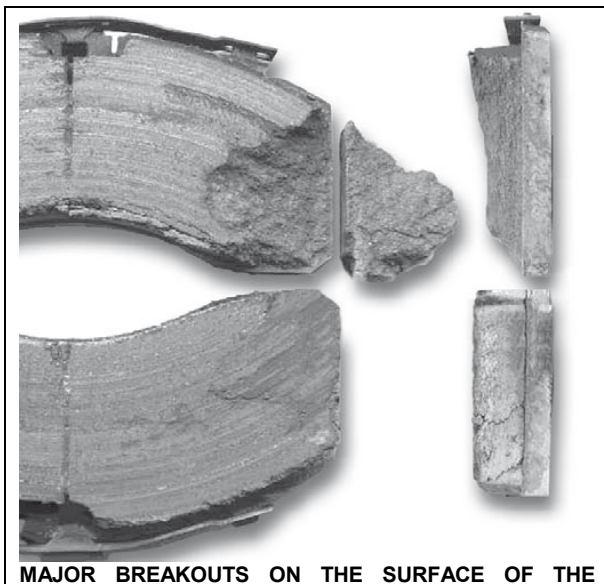
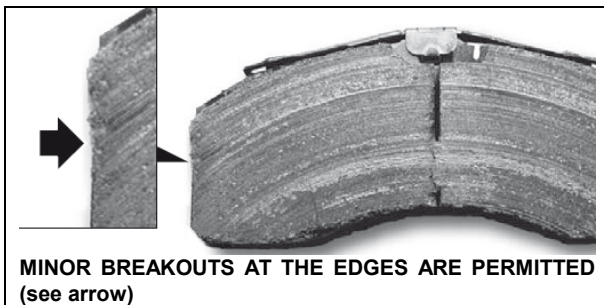

27.2.2 Brake Disc

Measure the thickness of the brake disc at the thinnest point. Be aware of possible burring at the edge of the disc.

- E= Total thickness of the brake disc
New condition = 1.77 in (45mm)
Worn condition = 1.457 in (37mm) (the disc must be replaced)
If the disc dimension E \leq 1.535 in (39mm), it is recommended that the disc should be renewed when the brake pads are changed.

Refer to Knorr-Bremse Pneumatic Disc Brake SN7 Service Manual included on the technical manuals CD for additional brake disc visual checks.

27.3 CALIPER RUNNING CLEARANCE

The Knorr/Bendix air disc brake is designed to move freely, with minimal force. By pushing and pulling the caliper in an axial direction by hand (see arrow A in Figure 26), a movement of 0.6 - 1.1 mm must be possible.

If, even using a high level of hand pressure (no tools), the caliper is not moveable, the caliper guidance must be further examined.

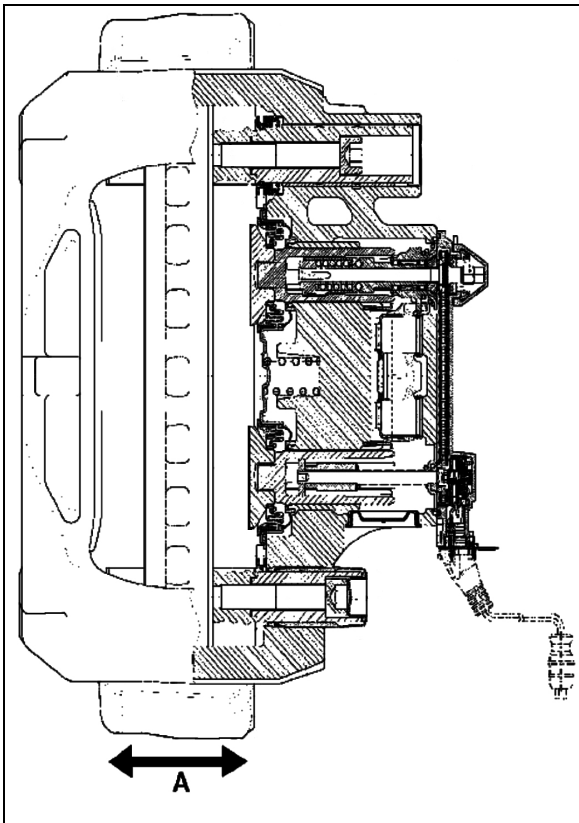

FIGURE 26: RUNNING CLEARANCE 12116

27.4 TORQUE SPECIFICATIONS

For proper caliper maintenance, refer to the following figures.

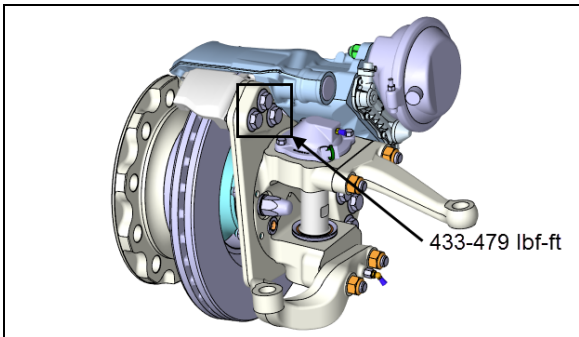

FIGURE 27: CALIPER CARRIER MOUNTING BOLTS TORQUE SPECIFICATION – TAG AXLE & FRONT I-BEAM AXLE (FRONT AXLE SHOWN) 12145

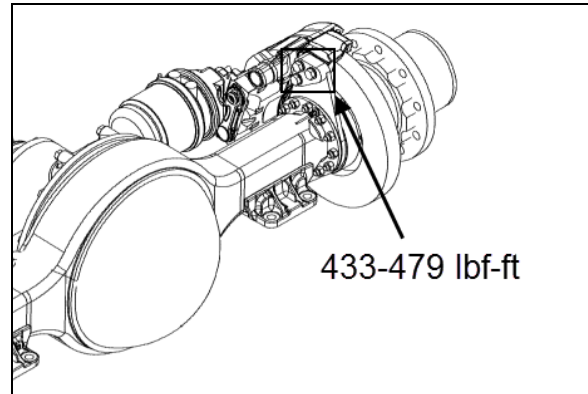

FIGURE 28: CALIPER CARRIER MOUNTING BOLTS - MERITOR DRIVE AXLE

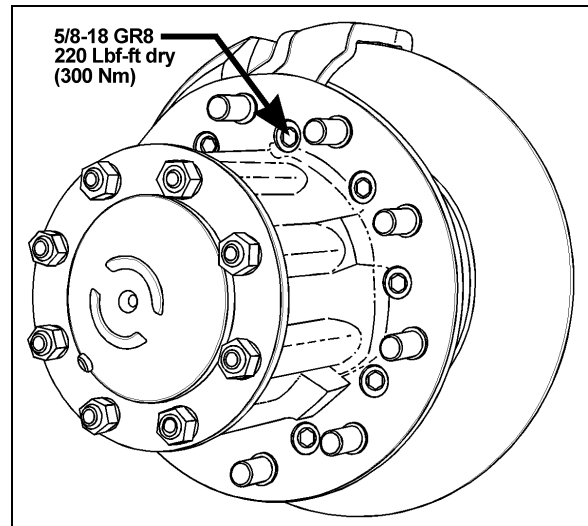



FIGURE 29: TORQUE SPECIFICATION 11030

28. SAFE SERVICE PROCEDURES

Most recently manufactured brake linings no longer contain asbestos fibers. Instead of asbestos, these linings contain a variety of ingredients, including glass fibers, mineral wool, aramid fibers, ceramic fibers, and carbon fibers. At present, OSHA (Occupational Safety and Health Administration) does not specifically regulate these non-asbestos fibers, except as nuisance dust. Medical experts do not agree about the potential long-term risks from working with and inhaling non-asbestos fibers. Nonetheless some experts think that long-term exposure to some non-asbestos fibers could cause diseases of the lung, including pneumoconiosis, fibrosis, and cancer. Therefore, lining suppliers recommend that workers use caution to avoid creating and breathing dust when working on brakes that contain non-asbestos fibers.



WARNING

Whenever possible, work on brakes in a separate area away from other operations.

Always wear a respirator approved by NIOSH (National Institute of Occupational Safety and Health) or MSHA (Mine Safety and Health Administration) during all brake service procedures. Wear the respirator from removal of the wheels through assembly.



WARNING

NEVER use compressed air or dry brushing to clean brake parts or assemblies. OSHA recommends that you use cylinders that enclose the brake. These cylinders have vacuums with high efficiency (HEPA (Health and Environment Protection Agency)) filters and workmans' arm sleeves. But, if such equipment is not available, carefully clean parts and assemblies in the open air.

Clean brake parts and assemblies in the open air. During disassembly, carefully place all parts on the floor to avoid getting dust into the air. Use an industrial vacuum cleaner with a HEPA filter system to clean dust from the brake drums, backing plates and other brake parts. After using the vacuum, remove any remaining dust with a rag soaked in water and wrung until nearly dry.

If you must grind or machine brake linings, take additional precautions because contact with fiber dust is higher during these operations. In addition to wearing an approved respirator, do such work in an area with exhaust ventilation.

When cleaning the work area, NEVER use compressed air or dry sweeping to clean the work area. Use an industrial vacuum with a HEPA filter and rags soaked in water and wrung until nearly dry. Dispose of used rags with care to avoid getting dust into the air. Use an approved respirator when emptying vacuum cleaners and handling used rags.

Wash your hands before eating, drinking or smoking. Do not wear your work clothes home. Vacuum your work clothes after use and then launder them separately, without shaking, to prevent fiber dust from getting into

the air.
Material safety data sheets on this product, as required by OSHA, are available from Rockwell and Knorr-Bremse.

29. AIR BRAKE TROUBLESHOOTING

The following tests and check lists have been designed to identify the cause(s) of a sluggish performance and/or leaks in the system. These tests require very little time to perform, and give you a general idea of the system condition. Each test is provided with a corresponding check list which will guide you to the most common causes of problems.

Before performing any test, check all air lines for kinks or dents, and hoses for signs of wear, drying out or overheating.



WARNING

When working on or around a brake system and its related components, the following precautions should be observed:

Always block vehicle wheels. Stop engine when working under a vehicle. Keep hands away from chamber push rods and slack adjusters as they may apply when system pressure drops.

Never connect or disconnect a hose or line containing air pressure. It may whip as air escapes. Never remove a component or pipe plug unless you are sure all system pressure has been depleted.

Never exceed recommended air pressure and always wear safety glasses when working with air pressure. Never look into air jets or direct them at anyone.

Never attempt to disassemble a component until you have read and understood the recommended procedures. Some components contain powerful springs and injury can result if not properly disassembled. Use only proper tools and observe all precautions pertaining to the use of those tools.

Always clean connecting piping and/or fittings, and coat pipe threads with Teflon pipe sealant before installing any air brake system component.

Pressure Build-Up / Low Pressure Warning / Cutoff Point / Air Filter/Dryer Built-in Governor Cutout

CONDITION: Vehicle leveled, parking brake applied.

1. Completely drain wet, primary and secondary air reservoirs only.
2. Start engine and run at fast idle. Low pressure warning lights should be "On".
3. Start checking pressure at 50 psi (344 kPa).
4. Low pressure warning lights and buzzer should go off at or above 60 psi (415 kPa).
5. At 85 psi (586 kPa), run engine at full rpm, then check that build up time to 100 psi (690 kPa) is 30 seconds or less.
6. Air filter/dryer built-in governor cut-out. Cuts out at the correct pressure of 123 psi \pm 3 (847 \pm 21 kPa).
7. Air filter/dryer built-in governor cut-in. Cuts in around 110 psi (758 kPa).

For common corrections, refer to the following check list:

High or Low Warning Cutoff Point

- Perform a telltale light and gauge test. Replace entire cluster if found defective.

High or Low Air Filter/Dryer Built-in Governor Cutout Point

- Perform a telltale light and gauge test. Replace entire cluster if found defective.

OR

- Repair or replace air filter/dryer as necessary after checking that compressor unloader mechanism operates correctly.

More than 30 seconds to build-up pressure from 85 to 100 psi (585 - 690 kPa) at full engine RPM

- Perform a telltale light and gauge test. Replace entire cluster if found defective.
- Check compressor strainer or inlet line. If restricted, clean or replace element or faulty line.
- Check compressor head or discharge line for carbonization or restriction. Clean or replace as necessary.

- If discharge valves leak, pull head and correct or replace cylinder head.
- If drive is slipping, replace gear.
- If inlet valves are stuck, open or leaking severely, replace unloader kit, inlet valves and/or seats as necessary.
- If drain cock is found open, close it.
- Listen for air leaks and repair.
- Redo list to check all items repaired or replaced.

Air Supply Reservoir Leakage

CONDITION: Full pressure, engine stopped, parking brake applied

1. Allow at least 1 minute for pressure to stabilize.
2. Stop engine, then check air pressure gauge for 2 minutes. Note any pressure drop.
3. Pressure should not drop by more than 3 psi (20 kPa) per minute.

For common corrections, refer to the following check list:

Excessive air loss:

- With the primary air system at normal operating pressure (95 - 125 psi (655 - 860 kPa)), coat all air line connections and pneumatic components with a water and soap solution. Bubbles will indicate an air leak, and none should be permissible. Repair or replace defective parts.
- Listen for leaks and correct as required.
- Redo test to check all items repaired or replaced.

Brake System Air Leakage

CONDITION: Full pressure, engine stopped, parking brake released.

1. Apply service (foot) brakes, allow at least 1 minute for pressure to stabilize.
2. Hold down foot valve for 2 minutes while observing air pressure gauge on the dashboard.
3. Pressure drop should not be more than 4 psi (27 kPa) per minute.

Section 12: BRAKE AND AIR SYSTEM

For common corrections, refer to the following check list.

Excessive leakage on brake service side:

- With the primary air system at normal operating pressure (95 - 125 psi (655 - 860 kPa)) and foot brake applied, coat all air line connections and brake pneumatic components with a water and soap solution. Bubbles will indicate an air leak, and none should be permissible. Repair or replace defective parts.
- Listen for leaks and correct as required.
- Redo test to check all items repaired or replaced.

IMPORTANT NOTE

To maintain your vehicle's air disc brakes at their original performance standard, we strongly recommend use of only genuine, approved service replacement parts on Bendix and Knorr-Bremse air disc brake systems.

If non-approved friction materials or replacement components are used, neither Prevest Car nor Bendix Spicer Foundation Brake LLC will accept any air disc brake-related warranty returns or claims.

For more information on this policy, refer to Bendix-Prevest product notification annexed at the end of Section 12 of Maintenance Manual.

30. BRAKE AIR CHAMBER

If this vehicle is equipped with *Knorr-Bremse SN7000* disc brakes on all axles, it also uses "Knorr-Bremse" brake chambers. The drive axle chambers consist of two separate air chambers, each having its own diaphragm and push rod. They are used as a service brake chamber, an emergency brake in case of air pressure loss and a spring-applied parking brake. Refer to figures 29 and 30.

The front and tag axle brake air chambers are used only for service brake duty (Fig. 29).

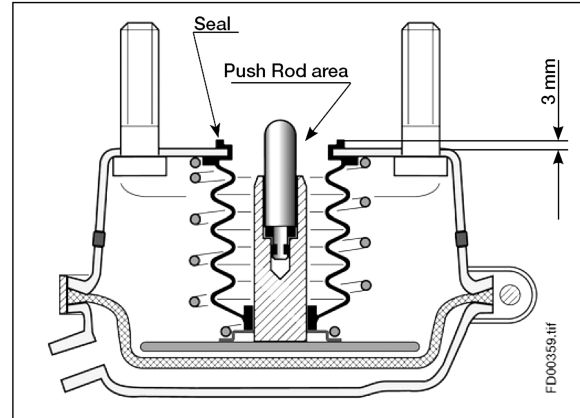

FIGURE 30: FRONT AXLE BRAKE AIR CHAMBER 12158

30.1 MAINTENANCE

Every 6,250 Miles (10 000 km) or twice a year, whichever comes first depending on type of operation:

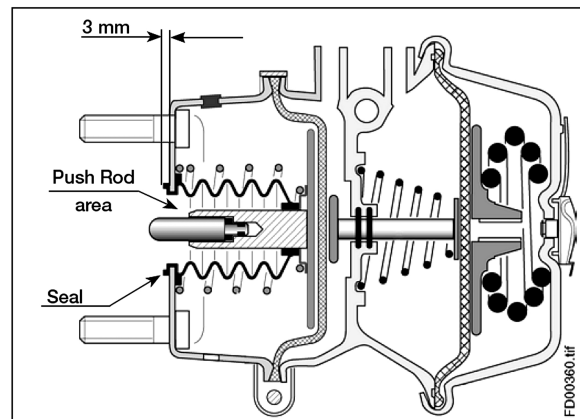

FIGURE 31: DRIVE AXLE BRAKE AIR CHAMBER 12126

Check all hoses and lines. They should be secure and in good condition.

Every 100,000 Miles (160 000 km) or once a year, whichever comes first depending on type of operation:

1. Disassemble and clean all parts.
2. Install new diaphragm or any other part if worn or deteriorated.

NOTE

When the diaphragm, spring, or both are replaced, they should be replaced in the corresponding chamber on the same axle.

3. Perform an airtightness test:
 - a) Make and hold a full brake application.
 - b) Coat clamping ring(s) with a soapy solution. If leakage is detected, tighten clamping ring

only enough to stop leakage. **Do not overtighten** as this can distort sealing surface or clamping ring. Coat area around push rod hole (loosen boot if necessary). No leakage is permitted. If leakage is detected, the diaphragm must be replaced.

30.2 EMERGENCY/PARKING BRAKE MANUAL RELEASE

! DANGER

Never stand in the axis line of the spring brake chambers, especially when caging the spring.

Drive Axle

1. Block the wheels to prevent the vehicle from moving.
2. Screw-out the spring brake release bolt (arrow) with a maximum of 26 lbf-ft (35 Nm) to the release position.

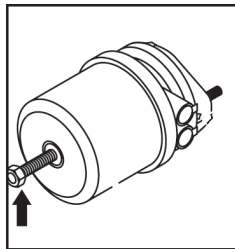

3. To manually reset the emergency/parking brake, screw in the spring brake release bolt with a maximum of 52 lbf-ft (70 Nm).

30.3 BRAKE CHAMBER REMOVAL

! WARNING

To prevent personal injuries, brakes should be inoperative prior to working on any of their components.

To prevent personal injuries, brake chambers should be made inoperative by releasing spring tension prior to disposal.

1. Block the wheels to prevent the vehicle from moving.
2. Safely support vehicle at the recommended body jacking points.
3. To gain access to a given brake air chamber, the corresponding wheel can be removed (refer to Section 13: "Wheels, Hubs and Tires").

4. Exhaust compressed air from system by opening the drain valve of each reservoir.
5. For the drive axle brake chambers, manually release spring brakes (refer to "Emergency/Parking Brake, Manual Release" procedure in this section).
6. Disconnect air line(s) from brake chamber.
7. Remove the cotter pin connecting brake chamber and slack adjuster (drive axle).
8. Unbolt and remove the brake chamber from vehicle.

30.4 BRAKE CHAMBER INSTALLATION

Reverse removal procedure and then check brake adjustment.

! CAUTION

Always clean air lines and fittings, and coat pipe threads with teflon pipe sealant before reconnecting air lines.

30.5 BRAKE CHAMBER DISASSEMBLY

! DANGER

Spring brake chambers, on drive and tag axles contain an extremely high compressive force spring, which can possibly cause serious injury if special precautions are not taken when working around this area.

To avoid such injury, the following recommendations must be applied:

- Prevost recommends the installation of a new spring brake chamber if it is found to be defective.
- Spring brake chamber maintenance and/or repair must be performed by trained and qualified personnel only.
- Before manually releasing spring brakes, visually check spring brake for cracks and/or corrosion.
- On "MGM" brake chambers (drive axle), make sure the release stud is properly anchored in spring plate receptacle prior to caging the spring.
- Never stand in the axis line of the spring brake chambers, especially when caging the spring.

Section 12: BRAKE AND AIR SYSTEM



WARNING

To prevent personal injuries, brakes should be inoperative prior to working on any of their components.

1. Block the wheels to prevent the vehicle from moving.
2. Safely support vehicle at the recommended body jacking points.

NOTE

To gain access to a given brake air chamber, the corresponding wheel can be removed (refer to Section 13: "Wheels, Hubs and Tires").

3. Exhaust compressed air from air system by opening the drain valve of each reservoir.
4. For the drive axle brake chambers, manually release spring brakes (refer to "Emergency/Parking Brake Manual Release" procedure in this section).
5. Remove clamp ring, remove and discard the existing diaphragm. Install the new diaphragm squarely on body.
6. Reverse the procedure for assembly. Tap clamp ring to ensure proper seating. Check for proper operation before placing vehicle in service.

31. ANTI-LOCK BRAKING SYSTEM (ABS)

This device has been designed to ensure stability and permit steering control of vehicle during hard braking, and to minimize its stopping distance whatever the road conditions are. On slippery roads and generally in emergency situations, over-braking frequently induces wheel lock. The anti-lock braking system provides maximum braking performance while maintaining adequate steering control on slippery roads.

The ABS continuously monitors wheel behavior during braking. Sensors on each wheel of front and drive axles (tag axle is slave to drive axle) transmit data to a four channel electronic processor which senses when any wheel is about to lock. Modulator valves quickly adjust the brake pressure (up to 5 times per second) to prevent wheel locking. Each wheel is therefore controlled according to the grip available between its tire and the road.

With this device, the vehicle is brought to a halt in the shortest possible time, while remaining stable and under the driver's control.

Since the braking system has dual circuits, the ABS is also provided with a secondary system should a fault develop in the ABS. Anti-lock systems are a parallel system which does not hinder brake functioning in case of failure. Braking system functions in normal, non anti-lock controlled operation during ABS system failure.

The ABS system consists of two diagonally related circuits, only the half of the system which has sustained damage or other fault is switched off (i.e. wheels return to normal non-ABS braking). The other diagonal half remains under full ABS control.

NOTE

ABS is active on service brake, transmission retarder, Jake brake, but is inactive on emergency/parking brake.

NOTE

The ABS system is inoperative at speeds under 4 mph (6 Km/h). Illumination of ABS telltale indicator at these speeds is normal.



CAUTION

Disconnect the ECU or pull the ABS fuse before towing vehicle.

31.1 TROUBLESHOOTING AND TESTING

For troubleshooting and testing of the vehicle's anti-lock braking system, refer to Meritor Wabco Maintenance Manual MM-0112: "Anti-Lock Braking System (ABS) for Trucks, Tractors and Buses", at the end of this section. Use dashboard Message Center Display (MCD) Diagnostic Mode for troubleshooting and repair.

31.2 ABS COMPONENTS

The main components of the ABS system are listed hereafter. Refer to each component for its specific function in the system and for proper maintenance.

31.2.1 Electronic Control Unit (ECU)

This control unit is located in the front electrical compartment, (refer to figure 31 for location). According to the data transmitted by the sensors (number of pulses/sec is proportional to the speed of each wheel), the electronic control unit determines which wheel is accelerating or decelerating. It then establishes a reference speed (average speed) from each wheel data, and compares the speed of each wheel with this reference speed to determine which wheel is accelerating or decelerating.

As soon as wheel deceleration or wheel slip threshold values are exceeded, the electronic control unit signals a solenoid control valve to limit the excessive brake pressure produced by the driver in the appropriate brake chamber.

Maintenance

No specific maintenance is required. The ECU is not serviceable. When found to be defective, replace.

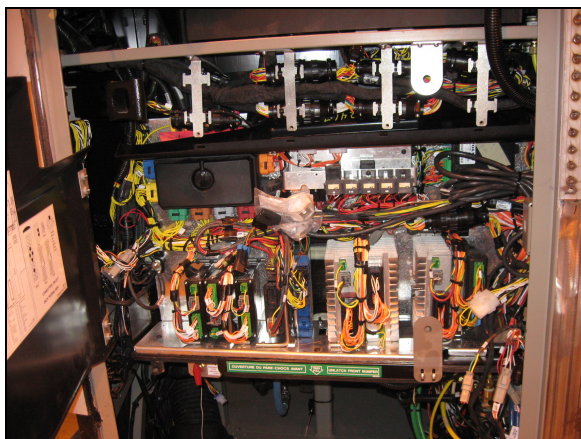



FIGURE 32: ABS ECU LOCATION 06617

	<h3>CAUTION</h3>
<p>In order to protect the ABS electronic control unit from voltage surges, always disconnect before performing any welding procedure on vehicle.</p>	

31.2.2 ABS Modulator Valve

This ABS system is equipped with four or five modulator valves, located between the brake chamber and the relay valve or quick release valve (Fig. 32). Note that on the basic ABS system, there is only one solenoid valve controlling the drive and tag axle wheels on the same side (tag axle is slave to drive axle).

This is an "On/Off" type valve, i.e., at brake application, the valve exhausts air from the brake chamber when the electronic unit senses that the corresponding wheel speed is decreasing in relation to the other wheels.

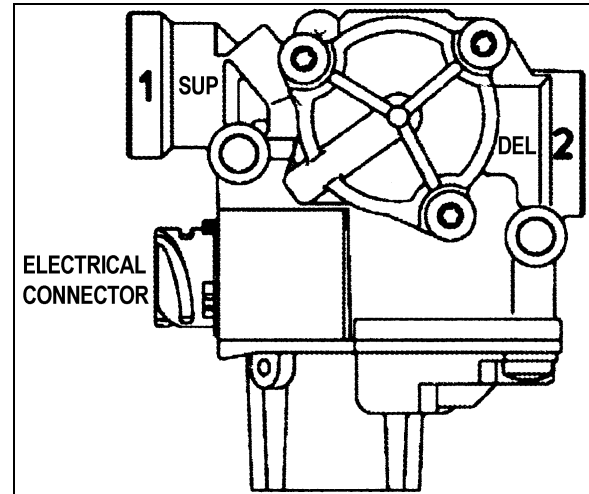

FIGURE 33: ABS MODULATOR VALVE 12221

Maintenance

Refer to Bendix Service Data sheet SD-13-4870 located at the end of this section.

31.2.3 Sensors

The sensors are mounted on the front, drive and tag axle (if applicable) wheel hubs (Fig. 33). The inductive sensors consist essentially of a permanent magnet with a round pole pin and a coil. The rotation of the toothed wheel alters the magnetic flux picked up by the coil, producing an alternating voltage, the frequency of which is proportional to wheel speed. When wheel speed decreases, magnetic flux decreases proportionately. Consequently, the electronic control unit will command the solenoid control valve to decrease the pressure at the corresponding brake chamber.

Maintenance

No specific maintenance is required for sensors, except if the sensors have to be removed for axle servicing. In such a case, sensors should be lubricated with special grease (Prevost #680460) before reinstallation. Refer to paragraph "Sensor Installation" for details.

Section 12: BRAKE AND AIR SYSTEM

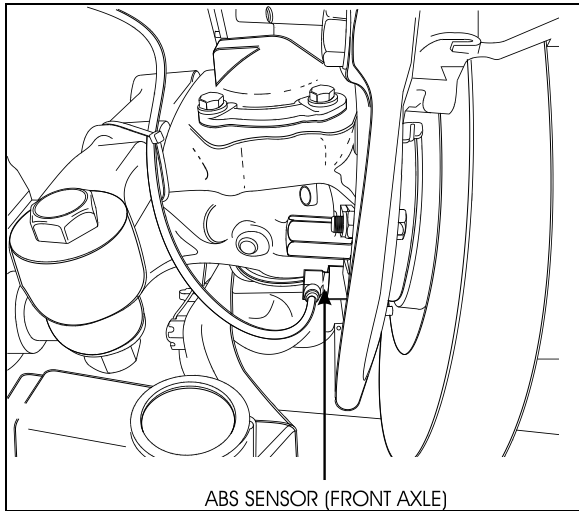

FIGURE 34: ABS SENSOR LOCATION

12153

NOTE

The resistance value, when sensors are checked as a unit, must be equal to 1,75 k ohms. To check the sensors for proper output voltage after the sensors and toothed wheels have been assembled to the axle, connect a suitable AC voltmeter across the output terminals. With the hubs rotating at 30 rpm, the output voltages should read from 50 to 1999 mV to be acceptable.

Sensor Installation

The following procedure deals with sensor installation on the axle wheel hubs. Read procedure carefully before reinstalling a sensor, as its installation must comply with operational tolerances and specifications.

1. Apply recommended lubricant (Prevost #680460) to spring clip and sensor.



CAUTION

Use only this type of grease on the sensors.

2. Insert spring clip in the holder on hub. Make sure the spring clip tabs are on the inboard side of the vehicle. Push in until the clip stops.
3. Push the sensor completely inside the spring clip until it is in contact with the tooth wheel. Ensure mounting is rigid, as it is an important criterion for adequate sensor operation.

NOTE

This installation should be of the "press fit" type.

31.2.4 Spring clip

The spring clip retains the sensor in its mounting bracket close to the toothed pulse wheel. The gap between the sensor end and teeth is set automatically by pushing the sensor in the clip hard up against the tooth wheel, and the latter knocks back the sensor to its adjusted position (Fig. 34).

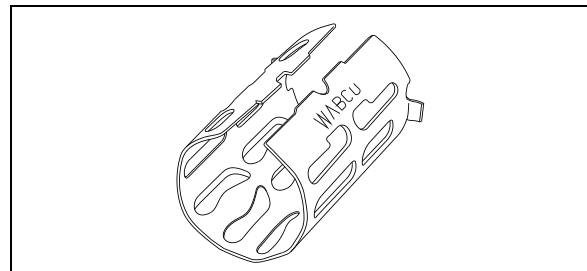

FIGURE 35: SPRING CLIP

12161

Maintenance

The spring clip requires no specific maintenance.

32. FITTING TIGHTENING TORQUES

45° Flare and Inverted Flare: Tighten assembly with a wrench until a solid feeling is encountered. From that point, tighten 1/6 turn (Fig. 35).

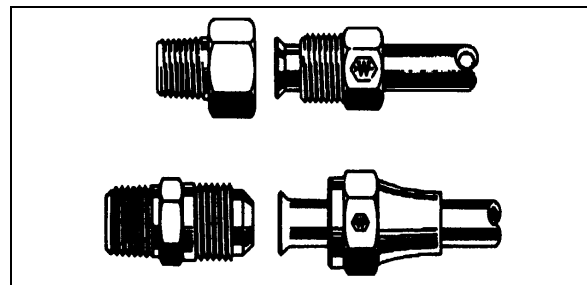

FIGURE 36: HOSE FITTINGS

12053

Compression: Tighten nut by hand (Fig. 36). From that point, tighten using a wrench the number of turns indicated in the chart hereafter.

Fitting size	Pipe diameter (inches)	Number of additional turns required following hand tightening
2	1/8	1 ¼
3	3/16	1 ¼
4	1/4	1 ¼
5	5/16	1 ¾
6	3/8	2 ¼
8	1/2	2 ¼
10	5/8	2 ¼
12	3/4	2 ¼
16	1	2 ¼

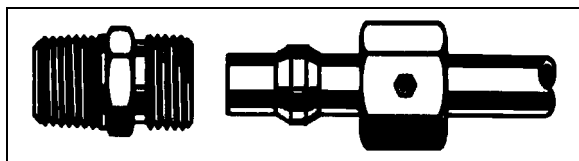

FIGURE 37: HOSE FITTING 12054

NTA-Type Plastic Tubing: Hand tighten nut (Fig. 37). From that point, tighten using a wrench the number of turns indicated in the following chart.

Tubing diameter (inches)	Number of additional turns required following hand tightening
1/4	3
3/8 to 1/2	4
5/8 to 3/4	3 ½

33. SPECIFICATIONS

Air Compressor

Make.....Meritor Wabco
 Model..... SS636
 Capacity (at 1250 rpm).....37.4 cfm (1,059 m³/min.)
 Prevost number

Air Dryer

Make..... Haldex
 Model..... AT-87192
 Prevost number 70303498
 Desiccant cartridge Prevost number 3097369

Flip-Flop Control Valve

Make..... Bendix Westinghouse
 Model..... TW-1

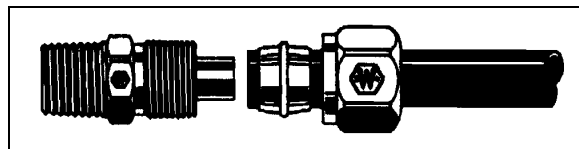

FIGURE 38: HOSE FITTING 12055

AB-Type Copper Piping: Hand tighten nut (Fig. 38). From that point, tighten with a wrench the number of turns indicated in the following chart.

Piping diameter (inches)	Number of additional turns required following hand tightening
1/4, 3/8, 1/2	2
5/8, 3/4	3

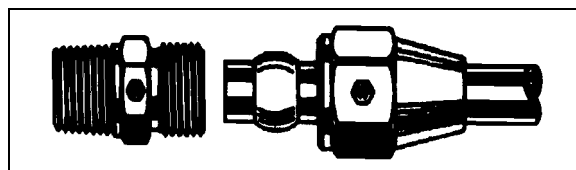

FIGURE 39: HOSE FITTING 12056

Pipe Tightening: All connections must be hand tightened. From that point, tighten a minimum of 2 ½ additional turns.

NOTE

Use Loctite (Prevost number 680098) pipe sealant to seal pipe thread.

Section 12: BRAKE AND AIR SYSTEM

Type On-Off
Prevost number 640136

Emergency/Parking Brake Control Valve

Make..... Bendix Westinghouse
Model..... PP-1
Automatic release pressure 60 psi (414 kPa) nominal
Prevost number 641128

Dual Brake Application Valve

Make..... Bendix Westinghouse
Model..... E-10P
Prevost number 642169

Stoplight Switches

Make..... Bendix Westinghouse
Model..... SL-5
Contact close (ascending pressure)..... 4 psi and more (28 kPa)
Prevost number 641462

Brake Relay Valves

Make..... Bendix Westinghouse
Model..... R-12

Brake Relay Valve

Make..... Meritor Wabco
Model..... R-14

Quick Release Valve

Make..... Bendix Westinghouse
Model..... QR-1
Prevost number 641429

Spring Brake Valve

Make..... Bendix Westinghouse
Model..... SR-7

Pressure Protection Valve

Make..... Bendix Westinghouse
Model..... PR-4
Nominal closing pressure 70 psi (482 kPa)
Prevost number 641137

Shuttle-Type Double Check Valve

Make..... Bendix Westinghouse
Model..... DC-4
Prevost number 641015

Low Pressure Indicators

Make..... Bendix Westinghouse
Model..... LP-3
Contact close 66 psi (455 kPa)
Prevost number 640975

Air Pressure Regulator

Make..... Norgren
Adjustable output range 0-80/85 psi (0-552/586 kPa)
Recommended pressure setting 75 psi (517 kPa)

Prevost number 641472

Air Filter Element

Make..... Norgren
 Type With manual drain
 Prevost number 641338

Front Wheel Brake Chambers

Make.....Knorr-Bremse
 Type 24
 Prevost number (R.H.) 641414
 Prevost number (L.H.)..... 641413

Drive Axle Brake Chambers

Make.....Knorr-Bremse
 Type 24 as service -24 as emergency
 Prevost number 641432

Piggy Back (On Drive Brakes)

Make.....Knorr-Bremse
 Type24 as emergency
 Prevost number 641433

Tag Axle Brake Chambers

Make.....Knorr-Bremse
 Type 14
 Prevost number 642087

Tag Axle Brake Chambers

Make.....Knorr-Bremse
 Type 16
 Prevost number 642086

Brake Lining (All Axles)

Make.....Knorr-Bremse
 Prevost number 611049
 Prevost number 641226

ABS ANTILOCK BRAKING SYSTEM

ABS MODULATOR VALVE

Make..... Bendix
 Voltage 12 V
 Prevost number 642077

Sensor

Prevost number 642085

Sensor (90°)

Prevost number 642084

SECTION 13: WHEELS, HUBS & TIRES

CONTENTS

1. WHEELS	2
2. WHEEL MAINTENANCE	2
2.1 INSPECTION.....	2
2.2 SINGLE WHEEL REMOVAL	2
2.3 SINGLE WHEEL INSTALLATION	3
3. DUAL WHEELS	3
3.1 OUTER WHEEL REMOVAL	3
3.2 INNER WHEEL REMOVAL	3
3.3 INNER WHEEL INSTALLATION	3
3.4 OUTER WHEEL INSTALLATION	3
3.5 INSPECTION.....	3
4. WHEEL STRAIGHTNESS TEST	4
5. WHEEL STUDS	4
5.1 DRIVE AXLE WHEEL STUDS	4
5.2 FRONT AND TAG AXLE WHEEL STUDS	4
6. HUB MOUNTED WHEELS	5
6.1 CARE OF WHEELS	6
7. FRONT AND TAG AXLE WHEEL HUBS	6
7.1 HUB BEARING INSPECTION	6
7.2 HUB BEARING REMOVAL.....	7
7.3 HUB BEARING INSTALLATION.....	7
8. DRIVE AXLE WHEEL HUBS	7
8.1 BEARING ADJUSTMENT	7
8.2 DISASSEMBLY AND REPAIR.....	8
9. TIRE MAINTENANCE	8
9.1 INFLATION PRESSURE	9
9.2 TIRE MATCHING	10
9.3 WHEEL BALANCING	10
9.4 TIRE ROTATION	10
10. SPECIFICATIONS	11

ILLUSTRATIONS

FIGURE 1: ALUM/STEEL WHEEL ARRANGEMENT	2
FIGURE 2: TIGHTENING SEQUENCE	2
FIGURE 3: DIAL GAUGE INSTALLATION	4
FIGURE 4: DRIVE AXLE WHEELS	4
FIGURE 5: SINGLE WHEEL.....	4
FIGURE 6: FRONT & TAG AXLE WHEEL HUB	5
FIGURE 7: FRONT & TAG AXLE HUB AND ROTOR ASSEMBLY	6
FIGURE 8: TIRE INFLATION	9
FIGURE 9: TIRE LIFE / INFLATION PRESSURE	10

Section 13: WHEELS, HUBS & TIRES

1. WHEELS

The vehicle is equipped with hub-mounted wheels as standard equipment, all studs and nuts have right-hand threads. Steel wheels are installed on the vehicle and are mounted with radial tubeless tires.

All wheel dimensions are 22.50 X 9.0 inches (571.5 X 228.6 mm) for 315/80 R 22.5 tires except inner drive wheels which are always 22.50 X 8.25 inches (571.5 X 209.6 mm) for 315/80 R 22.5 tires.

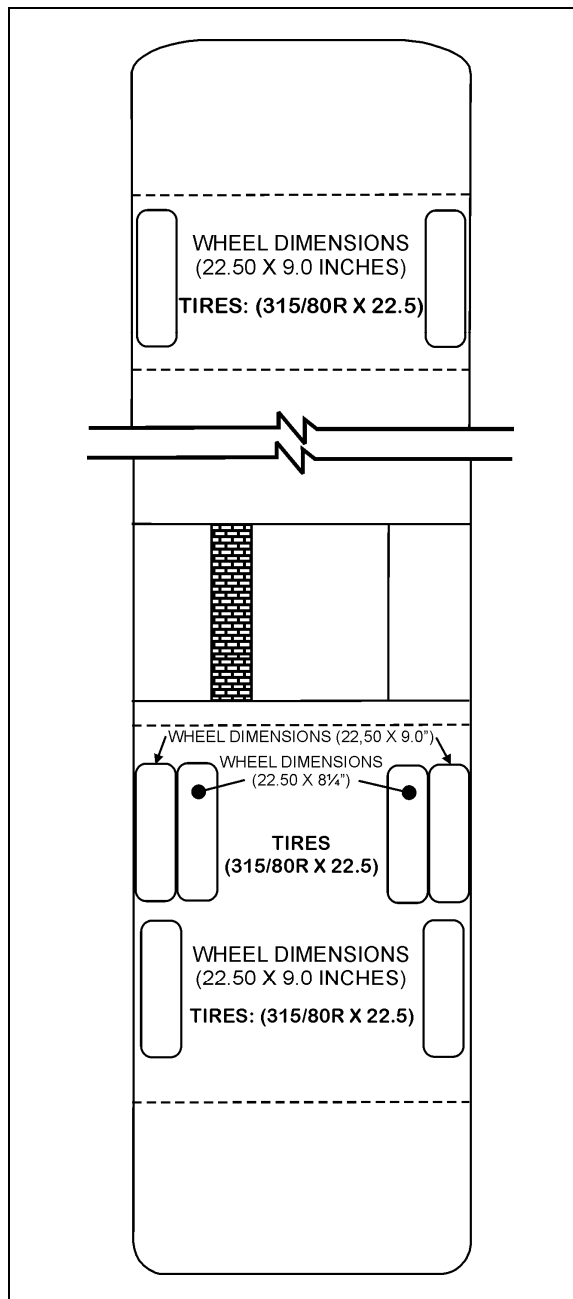

FIGURE1: ALUM/STEEL WHEEL ARRANGEMENT 13001

2. WHEEL MAINTENANCE

Wheel maintenance consists of periodic inspections. Check all parts for damage and make sure that wheel nuts are tightened to the proper torque. In the case of a new vehicle, or after a wheel installation, stud nuts should be tightened every 100 miles (160-km) for the first 500 miles (800-km) to allow setting in of clamping surfaces.

Wheel studs and nuts must be kept free from grease and oil. No lubricant whatsoever should be used. Cleanliness of the wheel and its rotor mating surfaces is important for proper wheel mounting.

However, for hub mounted wheels, it is recommended to add some rust protection lubricant on the pilot diameter of the hub (to facilitate future removal).

It is also important that wheel stud nuts be tightened alternately on opposite sides of the wheel. Refer to Figure 2 for the suggested tightening sequence.

2.1 INSPECTION

Tighten stud nuts progressively as shown in Figure 2. The final tightening should be done with a torque wrench. Tighten stud nuts to 450 - 500 lbf-ft (610 - 680 Nm) for steel wheels.

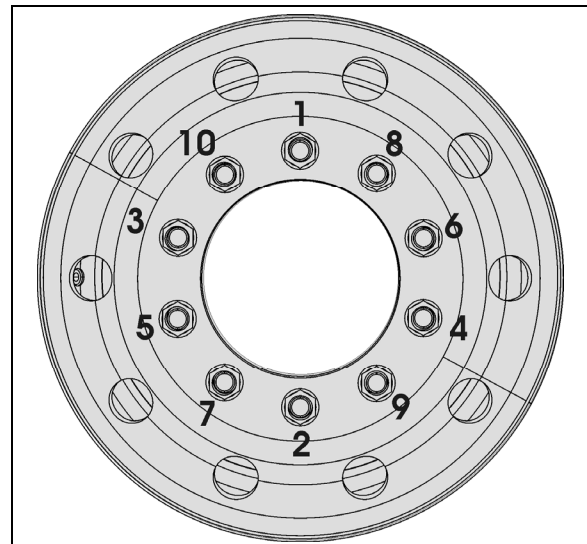



FIGURE 2: TIGHTENING SEQUENCE

13018

2.2 SINGLE WHEEL REMOVAL

1. Stop engine and apply parking brake.

2. Loosen wheel nuts about one turn (do not remove the nuts). This is not necessary if equipped with hydraulic powered gun.
3. Raise the vehicle by its jacking points on the body. See Section 18, "Body", under heading "Vehicle Jacking Points";
4. Unscrew wheel hex stud nuts and remove the wheel;

 CAUTION
<p>Always mark position of the wheel on the axle prior to removal in order to replace wheel at the same location, thus avoiding a new wheel balancing.</p>

2.3 SINGLE WHEEL INSTALLATION

1. Mount the wheel over studs, being careful not to damage stud threads;
2. Screw in the hex stud nuts (refer to Figure 2 for sequence) so that wheel will position itself concentrically with hub. This is important, otherwise wheel may be eccentric with hub and will not run straight. In this initial step, slightly tighten the nuts to correctly position the wheel;
3. Tighten stud nuts progressively as shown in Figure 2. The final tightening should be done with a torque wrench. Tighten stud nuts to 450 - 500 lbf-ft (610 - 680 Nm) for all steel wheel.

 CAUTION
<p>Insufficient mounting-torque can result in damage to parts. Excessive mounting torque can cause studs to break and the wheel to crack in stud hole area.</p>

3. DUAL WHEELS

3.1 OUTER WHEEL REMOVAL

Same as described in "Single Wheel Removal" procedure described previously.

3.2 INNER WHEEL REMOVAL

1. Remove outer wheel;
2. Remove inner wheel.

3.3 INNER WHEEL INSTALLATION

Mount the wheel over studs, being careful not to damage stud threads;

3.4 OUTER WHEEL INSTALLATION

With inner and outer wheels installed, tighten the stud nuts progressively as shown in Figure 2. The final tightening should be done with a torque wrench. Tighten stud nuts to 450 - 500 lbf-ft (610 - 680 Nm) for all steel wheel.

 CAUTION
<p>Insufficient mounting-torque can result in damage to parts. Excessive mounting torque can cause studs to break and the wheel to crack in stud hole area.</p>

NOTE

On dual wheel assemblies, position the wheels with the tire valves 180° apart in order to have access to both the inner and outer valves.

3.5 INSPECTION

1. Loosen a hex stud nut three turns (Fig. 4);
2. Retighten the hex stud nut to 450 - 500 lbf-ft (610 - 680 Nm).

Repeat for each of the 10 "hex stud nuts" according to the tightening sequence in figure 2.

 CAUTION
<p>The actual length of thread engagement present in an assembled wheel can not always be determined by visual inspection of measurement of a tightened assembly. The relationship of the wheel cap nut seat to the end of the stud may vary. If there is any doubt that enough thread engagement is present, the number of engaged threads may be counted. Tighten all nuts in the regular manner, then loosen one to hand-tightness. The number of turns to disengage a 1-1/8-inch nut should be at least five full turns.</p> <p>At least seven full turns should be required to disengage a 3/4-inch nut or a M22 nut. Ideally, when torqued to the proper load, the stud should be flush with the face of the nut. The face of the nut may be recessed in nuts that are taller for improved wrenching. With most</p>

Section 13: WHEELS, HUBS & TIRES

of the nuts in present use, a few unengaged threads at the outer end will cause no problem provided at least 5-7 full turns are required to disengage the nut depending on thread size.

4. WHEEL STRAIGHTNESS TEST

1. Slightly raise axle to be checked and place a safety support underneath;
2. Check wheel lateral run-out. Install a dial gauge as shown in figure 3, then rotate the wheel by hand one full turn. As the wheel turns, note any variation on the dial gauge;



CAUTION

Damage to the dial gauge could occur if it strikes a wheel balancing weight.

3. If the variation in lateral run-out exceeds 0.0625 inch (1,6 mm), the wheel must be replaced.

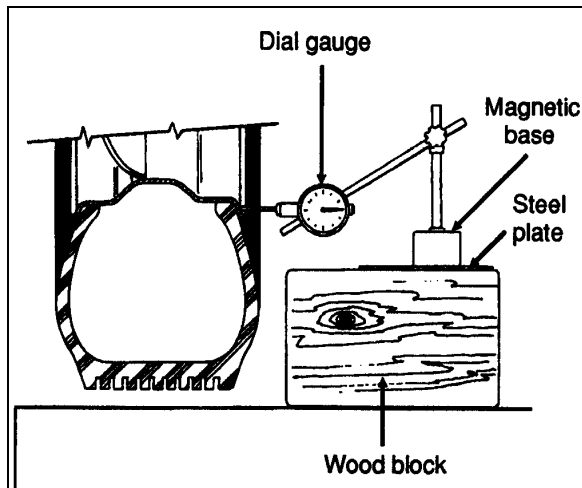

FIGURE 3: DIAL GAUGE INSTALLATION

13008

If doubt exists whether wheel or hub is distorted, hub may be checked as follows:

- Replace the existing wheel with a wheel known to be correct;
- Check wheel lateral run-out as outlined in step 2;
- If, within specifications, the hub is correct but the suspected wheel must be replaced.

5. WHEEL STUDS

Stripped threads may be the result of excessive torquing or may have been damaged during wheel installation when placing the wheel over

the studs. A stud having damaged threads must be replaced. Broken studs are a direct result of operating with loose stud nuts or improperly seated wheels. When a broken stud is replaced, the adjacent studs, on each side of the broken one must also be replaced since they could have been subjected to excessive strain and may be fatigued.

When installing wheel studs to hubs, check nuts retaining the wheel stud to wheel hub and replace if they are deformed, damaged or severely corroded. Install nut (and washer where applicable) to new stud. Torque to 450 - 500 Ft-lbs (610 - 680 Nm).

5.1 DRIVE AXLE WHEEL STUDS

Hub-mounted wheels are mounted with M22 x 1.5 studs and an M22 flange nut.

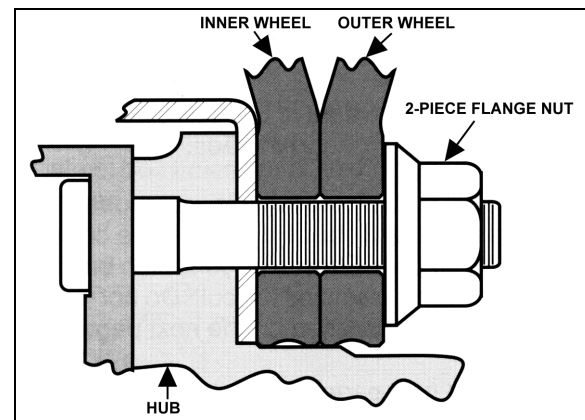

FIGURE 4: DRIVE AXLE WHEELS

13007

5.2 FRONT AND TAG AXLE WHEEL STUDS

Wheel is hub mounted on front and tag axle (M22 x 1.5 thread).

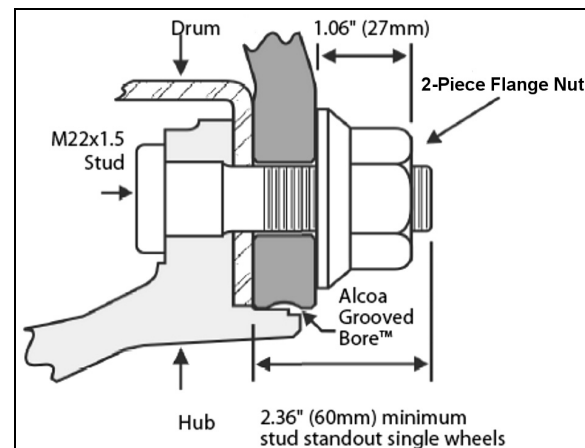

FIGURE 5: SINGLE WHEEL

13025

NOTE

Wheel studs and nuts must be kept free from grease and oil. No lubricant whatsoever should be used.

NOTE

Tightening should not be done immediately after prolonged braking or when wheel ends are hot.

6. HUB MOUNTED WHEELS

Wheel surfaces in contact with hubs, nuts or other wheels should be kept free of all rust, grease and paint (except for initial "E" coat protection, applied to stop rusting and to facilitate wheel removal). The reason for this is to assure that all faces are clamped together without buildup of any coating. The threads of the wheel studs and the wheel nuts should be clean and undamaged.

Check wheel nut torque at every 100 miles (160 km) for 500 miles (800 km) after fitting wheels. Let cool before checking. If any relaxation of the initial 450 - 500 lbf-ft (610 - 680 Nm) of torque has occurred, retighten. Relaxation of initial torque may occur because of the "bedding down" of the hub and wheel surfaces.

NOTE

When painting wheels, make sure to mask all surfaces identified above.

NOTE

Torque relaxation occurs when wheel ends are hot but should revert to original setting when cool. Retightening when hot will produce a higher torque reading than recommended.

Using a calibrated torque wrench, tighten wheel nuts to 450 - 500 lbf-ft (610 - 680 Nm) of torque. Do not use power tools or long bars for tightening. Tighten wheel nuts alternately as shown in figure 2.

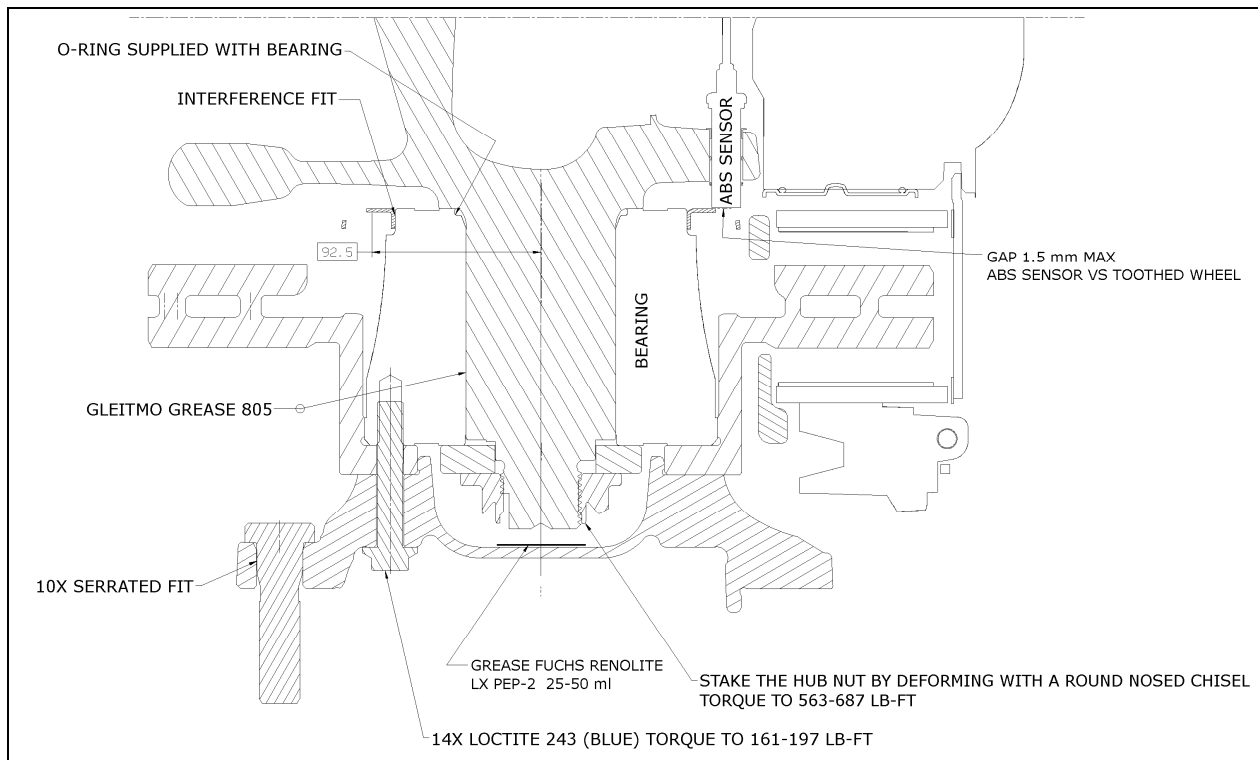

FIGURE 6: FRONT & TAG AXLE WHEEL HUB

Section 13: WHEELS, HUBS & TIRES

6.1 CARE OF WHEELS

Check for cracks in wheels, especially around the fixing holes, studs, nuts and washers. If in doubt, renew.

Do not simply retighten very loose wheel fixings or wheels that are continually becoming loose. Find out why they are loose and whether any damage has been caused.

Use trained personnel and keep records of all attention to wheels and fixings, including which parts were renewed and when.

7. FRONT AND TAG AXLE WHEEL HUBS

The unitized hub bearings used on the NDS range of axles, are non-serviceable items. Bearings are pre-adjusted, lubricated and have seals fitted as part of the manufacturing process. The bearings are greased for life and there is no need or facility for re-lubrication

7.1 HUB BEARING INSPECTION

 MAINTENANCE
An inspection should be made at intervals of 30,000 miles (48 000 km) or twice a year whichever comes first.

- Apply parking brake, raise wheels off the ground and support axle on stands.
- When the wheels are raised, they should revolve quite freely without roughness.
- Place magnetic base of a dial indicator on brake caliper and position dial indicator stem against a convenient marked spot on face of hub flange.
- With dial indicator in position pull hard but steadily on hub flange and oscillate at same time until a steady reading is achieved.
- Without releasing the pressure, turn bearing so that dial indicator stem contacts marked spot and note reading on indicator.
- Push bearing flange hard and oscillate as before until a steady reading is achieved.
- Without releasing the pressure, turn bearing so that indicator stem again contacts the marked spot and note new reading on indicator.
- The difference between readings is the amount of mounted end play in bearing unit.
- The mounted end play figure should not exceed 0.004" (0.105mm) for a new bearing in a used hub and 0.008" (0.20mm) for a bearing which has been in service.

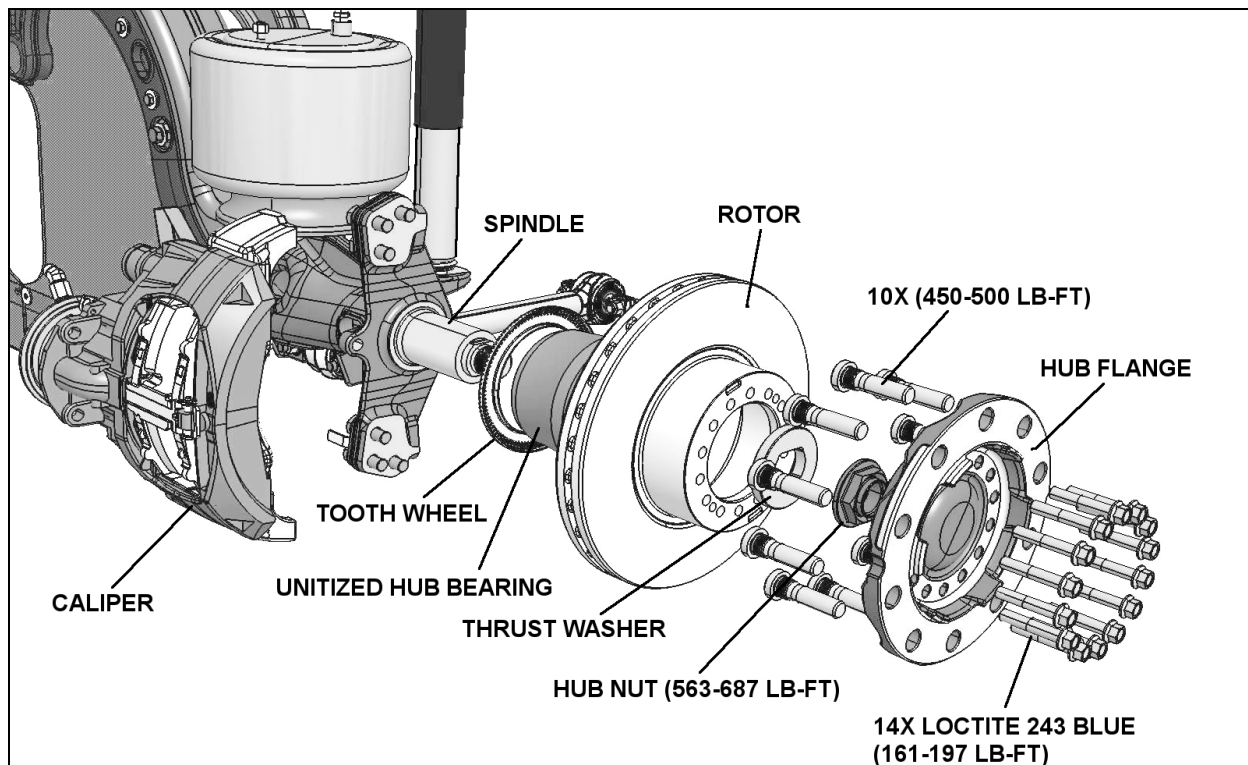

FIGURE 7: FRONT & TAG AXLE HUB AND ROTOR ASSEMBLY

NOTE

If original bearing unit is re-fitted, and end-float is measured at 1 mm, with hub not fully tightened to correct torque [563-687 lb-ft (763-931 Nm)], then the retaining clip within the unit is damaged and a new unit must be fitted.

NOTE

For more information on front and tag axle wheel hub, refer to "DANA SPICER Service Manual NDS Axle Range" found in the OEM manuals folder.

7.2 HUB BEARING REMOVAL

- Stop engine and apply parking brake.
- Loosen wheel nuts about one turn (do not remove the nuts). This is not necessary if equipped with hydraulic powered gun.
- Raise the vehicle by its jacking points on the body. See Section 18, "Body", under heading "Vehicle Jacking Points".
- Unscrew wheel hex stud nuts (10) and remove the wheel.
- Unscrew hub flange hex cap screws (14).
- Remove hub flange and rotor.
- Unscrew hub nut and discard.
- Remove bearing thrust washer.
- Remove unitized hub bearing by hand or use a puller if necessary.

7.3 HUB BEARING INSTALLATION

- Clean spindle using EFX degreaser (Prevost #685313).
- Lubricate part of spindle where bearing will be located, use Gleitmo 805 grease (Prevost #685274).
- Slide unitized hub bearing over spindle and position using insertion tool #491115.
- Clean thrust washer and hub nut using EFX degreaser.
- Install thrust washer and hub nut then torque hub nut to [563-687 lb-ft (763-931 Nm)].
- Stake the hub nut by deforming with a round nosed chisel.

- Clean hub bearing, rotor and hub flange clamping surfaces using EFX degreaser.
- Install rotor onto hub bearing.
- Add some grease (25-50 ml) (Fuchs Renolite LX PEP-2) (Prevost #685325) into the bottom of the hub flange cap. Mount hub flange onto rotor.
- Apply some Loctite 243 blue onto cap screw threads then secure hub flange and rotor to unitized hub bearing using cap screws (14). Torque to [161-197 Lb-Ft (218-267 Nm)] (Refer to figure 3 for tightening sequence).
- Mount the wheel over studs, being careful not to damage stud threads.
- Screw in the hex stud nuts (refer to Figure 2 for sequence) so that wheel will position itself concentrically with hub. This is important, otherwise wheel may be eccentric with hub and will not run straight. In this initial step, slightly tighten the nuts to correctly position the wheel.
- Tighten stud nuts progressively as shown in Figure 2. The final tightening should be done with a torque wrench. Tighten stud nuts to [450 - 500 lbf-ft (610 - 680 Nm)] for all steel wheel.

8. DRIVE AXLE WHEEL HUBS

Drive wheels use a single oil-seal assembly. They are lubricated from the oil supply in the differential housing. Bearings are tapered rollers, adjustable to compensate wear. Maintain differential oil level with general-purpose gear lubricant (refer to Section 24 "Lubrication" for proper oil grade selection) to ensure adequate oil supply to wheel bearings at all times.

8.1 BEARING ADJUSTMENT

To adjust drive wheel bearings:

1. Raise vehicle until both dual wheels can be turned freely (approximately 6 inches from the ground). Position jack stands under drive axle, then lower vehicle approximately 2 inches in order to avoid entire weight of the axle being supported by the suspension air bellows and the shock absorber pins.
2. Remove axle shaft as indicated in "Meritor - Maintenance Manual No. 5" under heading "Single Reduction Differential Carriers" annexed to "Section 11" of this manual.

Section 13: WHEELS, HUBS & TIRES

Remove gaskets. Unscrew lock nut and remove adjusting nut lock ring.

3. To adjust, tighten adjusting nut until the wheel binds. Rotate the wheel while tightening so that all surfaces are in proper contact. Back off adjusting nut approximately, $\frac{1}{4}$ to $\frac{1}{3}$ turn to assure 0.001/0.007" (0.0254/0.1778 mm) endplay and to ensure that wheel turns freely. Replace the lock ring, and adjust nut dowel pin in one of the holes. The ring may be turned over if necessary to allow more accurate bearing adjustment.
4. Tighten lock nut and check bearing adjustment. Replace the axle shaft using a new gasket.

8.2 DISASSEMBLY AND REPAIR

1. Jack vehicle as per "Bearing Adjustment" and remove axle shaft as indicated in "Meritor - Maintenance Manual No. 5" entitled "Single Reduction Differential Carriers" annexed to Section 11 of this manual.
2. Remove wheels and tires.



CAUTION

To replace wheel at the same location, always mark position of the wheel on the axle before removal, thus avoiding a new wheel balancing.

3. Remove lock nut, lock ring and adjusting nut from axle housing to prevent the outer bearing from falling out. Remove outer bearing cone and roller assembly.
4. Remove screws attaching inner oil seal retainer to hub, and remove inner oil seal assembly. Remove inner bearing cone and roller assembly. Bearing cups can be separated from the hub using a hammer and a long brass drift.
5. Thoroughly clean all parts. Bearing cone and roller assemblies can be cleaned in a suitable cleaning solvent using a stiff brush to remove old lubricant.
6. In case that excessive wear, deterioration, cracking or pitting is present on the bearing cups, rollers or cones, the bearings should be replaced. Seals should be replaced each time they are removed from the hub. To install new oil seal, use a suitable adapter

and drive the seal into the retainer bore until it bottoms.

7. When installing wheel on spindle, center the wheel hub with spindle to avoid damaging the seal with the end of the spindle. Push wheel straight over the spindle until inside diameter of seal press fits on wiper ring. Fill hub cavity with general-purpose gear lubricant (refer to Section 24 "Lubrication" for proper oil grade selection). Lubricate, then install outer bearing cone. Adjust bearing and lock.
8. Assemble axle flange to axle using a new gasket. Apply sealant in stud area. After both wheels have been assembled according to above procedure, fill the differential with the recommended lubricant to the proper factory recommended level.

NOTE

During regular inspection, do not forget to check lubricant level in differential. Clean thoroughly or replace vent as required.

9. TIRE MAINTENANCE

The most critical factor in tire maintenance is proper inflation (Fig. 8). No tire is impervious to loss of air pressure. To avoid the hazards of under inflation, always maintain tires at their recommended inflation pressure. Improper inflation decreases tire life.

An under inflated tire builds up heat that can cause sudden tire destruction, resulting in improper vehicle handling and possible loss of vehicle control. At least once a week, before driving (when tires are cold), check inflation pressure on all the tires, including the spare tire. This is especially important in cases when different drivers operate the vehicle.



WARNING

Failure to maintain correct tire inflation pressure may result in sudden tire destruction, improper vehicle handling, and will cause rapid and irregular tire wear. Inflation pressure should be checked weekly and always before long distance trips.

9.1 INFLATION PRESSURE

The condition and pressure of the tires can greatly affect both useful tire life and road safety.

At regular intervals, verify the tire pressures. Use an accurate tire pressure gauge when checking inflation pressures. Never exceed the maximum inflation pressure specified on each tire.

NOTE
Inflation pressure should be checked when tires are cold. Cold tire inflation pressure can be measured when a vehicle has not been driven for at least 3 hours or less than 1 mile (1.6 km). Driving, even for a short distance, causes tires to heat up and air pressure to increase. Check inflation pressure on all tires (including the spare tire) using an accurate tire gauge.

NOTE
The recommended tire inflation pressures are given in the applicable documents supplied with the vehicle. In addition, cold tire inflation pressures are listed on the Department of Transport's certification plate, affixed on the panel behind the driver's seat. For special tire selection, a "PREVOST COACH SPECIAL SPECIFICATION" chart is supplied with the vehicle and is affixed on the left wall near the driver's seat. Remember, tire inflation pressure must be adjusted according to vehicle loading - see table in "Coach Final Record"

CAUTION
 Never bleed air from hot tires as tires will then be under inflated. Use an accurate tire gauge to check pressures (Do not kick tires as an inflation check. This is an unreliable method).

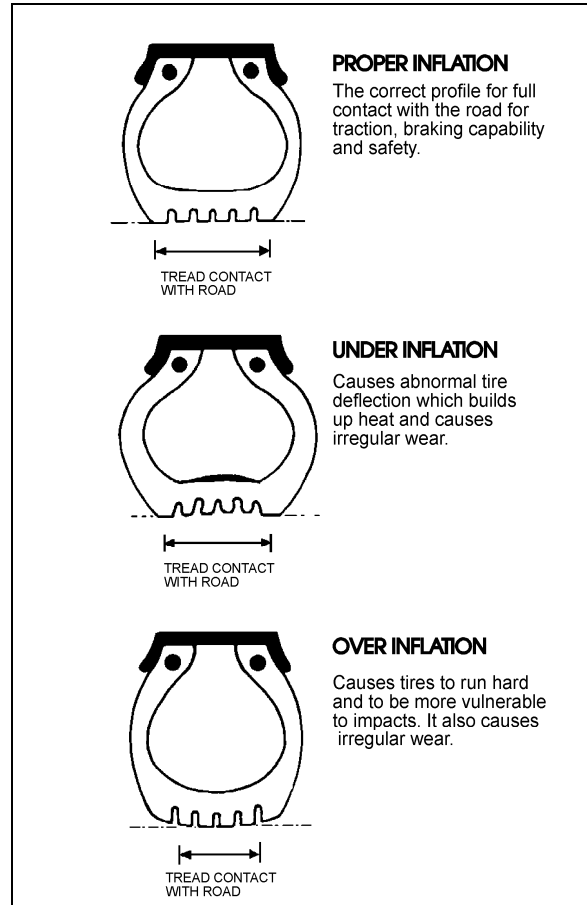

FIGURE 8: TIRE INFLATION 13009

CAUTION
 These tire pressures are established in accordance with the maximum allowable load on each axle. A lower pressure is recommended if the axle load is less than the above specifications. Weigh vehicle fully loaded and pressurize according to tire manufacturer's recommendations. For other tire and wheel specifications, see Prevost tire pressure tabulation in "Coach Final Record".

WARNING
 Incorrect tire pressures cause increased tire wear and adversely affect road holding of the vehicle, which may lead to loss of vehicle control.

Section 13: WHEELS, HUBS & TIRES

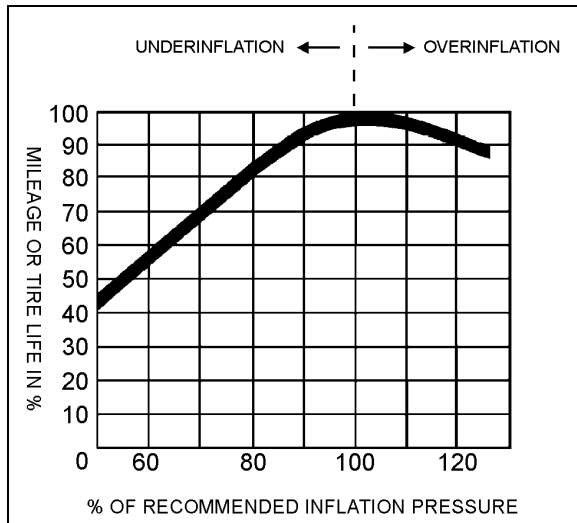

FIGURE 9: TIRE LIFE / INFLATION PRESSURE 13010



WARNING

Recommended tire inflation pressures and maximum allowable loads apply to speeds up to 65 mph (105 km/hr). Do not drive vehicle at a higher speed than 65 mph (105 km/h) or above the posted speed limit.



WARNING

All tires on the same axle should always be inflated to the same pressure. There should not be a difference in pressure between right and left tires on the same axle.

A 5-psi (35-kPa) underinflation in one front tire can not only reduce vehicle maneuverability, but will create steering hazards which can lead to an accident.

9.2 TIRE MATCHING

Unmatched tires on drive axle will cause tire wear and scuffing, as well as possible damage to the drive unit. Consequently, we recommend that tires be matched within 1/8" (3 mm) of the same rolling radius.

NOTE

It is recommended that all tires on coach be of the same type.

9.3 WHEEL BALANCING

Before balancing, wheels must be clean and free from all foreign matter. The tires should be in good condition and properly mounted. An unbalanced wheel can be due to a bent wheel or improper mounting. Before removing the wheel from the vehicle, check for swaying movement and if necessary, check the wheel lateral runout as outlined under heading "Wheel Straightness Check".



WARNING

When balancing wheel and tire assemblies, it is strongly recommended to closely follow instructions covering the operation of wheel balancer.



CAUTION

A maximum of 16-oz (450 g) of balancing weight is recommended. If more weight is necessary, check and correct the cause.

9.4 TIRE ROTATION

Radial tires should be rotated only when necessary. If the tires are wearing evenly, there is no need to rotate. If irregular wear becomes apparent or if the wear rate on the tires is perceptively different (from axle to axle), then tires should be rotated in such a manner as to alleviate the condition.

NOTE

There is no restriction on criss-cross rotation.

10. SPECIFICATIONS

STEEL WHEELS (except inner drive axle)

Wheel size..... 9.0" X 22.5"
 Wheel nut torque..... 450 - 500 lbf-ft (610 - 680 Nm)
 Tire size..... 315/80 R 22.5

STEEL WHEELS (inner drive axle)

Wheel size..... 8.25" X 22.5"
 Wheel nut torque..... 450 - 500 lbf-ft (610 - 680 Nm)
 Tire size..... 315/80 R 22.5

RECOMMENDED TIRE INFLATION PRESSURE AT MAXIMUM LOAD (cold)

<i>NOTE</i>
<i>Vehicle is delivered with the specific inflation pressure certification plate according to the tire selection.</i>

 WARNING
Special tire selection may lower maximum allowable speed limit, even below posted speed limit. For maximum safety, check with tire manufacturer.

 WARNING
Recommended tire inflation pressures and maximum allowable loads apply to speeds up to 65 mph (105 km/hr). Do not drive vehicle at a higher speed than 65 mph (105 km/h) or above the posted speed limit.

SECTION 14: STEERING

CONTENTS

1. STEERING SYSTEM DESCRIPTION	3
2. POWER STEERING GEAR.....	4
2.1 DESCRIPTION	4
2.2 POWER STEERING GEAR REMOVAL	4
2.3 POWER STEERING GEAR INSTALLATION	5
2.4 TROUBLESHOOTING.....	5
3. BLEEDING POWER STEERING HYDRAULIC SYSTEM	5
4. HYDRAULIC PRESSURE TEST	5
5. POWER STEERING HYDRAULIC PUMP	5
5.1 REMOVAL AND INSTALLATION	5
6. STEERING COLUMN.....	6
6.1 REMOVAL	6
7. STEERING WHEEL.....	7
7.1 REMOVAL	7
7.2 INSTALLATION	8
7.3 CLOCKSPrING REPLACEMENT	8
8. TURNING ANGLE ADJUSTMENT	8
9. STEERING LINKAGE ADJUSTMENT	9
10. PITMAN ARM.....	9
10.1 REMOVAL	9
10.2 INSTALLATION	10
10.3 ADJUSTMENT.....	10
10.4 TAG AXLE UNLOADING SWITCH ADJUSTMENT.....	10
11. MAINTENANCE	10
11.1 POWER STEERING RESERVOIR AND FILTER	11
11.1.1 <i>Oil Level Check Procedure</i>	11
11.1.2 <i>Filter Replacement</i>	11
11.2 STEERING STABILIZER CYLINDER (DAMPER)	12
11.3 DRAG LINK.....	12
11.4 TIE ROD	13
11.5 DRAG LINK AND TIE ROD BALL JOINTS INSPECTION FOR CORROSION	13
11.6 DROP TYPE BALL JOINT	13
11.6.1 <i>Drop Type Ball Joint End Play</i>	13
11.6.2 <i>Dismantling Drop Type Ball Joint</i>	14
11.6.3 <i>Assembling Drop Type Ball Joint</i>	14
11.7 STRAIGHT BODY TYPE BALL JOINT	15
11.7.1 <i>Visual Inspection</i>	15
11.7.2 <i>Straight Body Type Ball joint End Play And Looseness</i>	15
12. DRIVING TIPS	15
13. TROUBLESHOOTING.....	15

Section 14: STEERING

14. TORQUE SPECIFICATIONS.....	16
15. SPECIFICATIONS	16

ILLUSTRATIONS

FIGURE 1: I-BEAM AXLE STEERING SYSTEM SETUP	3
FIGURE 2: POWER STEERING GEAR	4
FIGURE 3: FRONT SERVICE COMPARTMENT.....	4
FIGURE 4: FUEL PUMP REMOVAL	5
FIGURE 5: FUEL PUMP DRIVE AXLE	6
FIGURE 6: POWER STEERING PUMP REMOVAL.....	6
FIGURE 7: STEERING COLUMN.....	6
FIGURE 8: STEERING COLUMN COVERS	7
FIGURE 9: REMOVING THE HORN PAD	7
FIGURE 10: STEERING HARNESS & HORN WIRE	7
FIGURE 11: LOCKING THE CLOCKSPrING IN PLACE	8
FIGURE 12: CLOCKSPrING INSTALLATION	8
FIGURE 13: PROPER CLOCKSPrING POSITION.....	8
FIGURE 14: PITMAN ARM ADJUSTMENT	9
FIGURE 15: FIXING NUT PUNCH MARK	10
FIGURE 16: TAG AXLE UNLOADING SWITCH ADJUSTMENT.....	10
FIGURE 17: HYDRAULIC FLUID RESERVOIR LOCATION	11
FIGURE 18: POWER STEERING FLUID RESERVOIR.....	12
FIGURE 19: STEERING STABILIZER (DAMPER).....	12
FIGURE 20: DRAG LINK	12
FIGURE 21: TIE ROD	13
FIGURE 22: DROP TYPE BALL JOINT FOUND ON TIE ROD (2X) AND DRAG LINK (1X)	14
FIGURE 23: STRAIGHT BODY TYPE BALL JOINT	15
FIGURE 24: ADEQUATE CLAMPING CONDITION.....	15

1. STEERING SYSTEM DESCRIPTION

The steering system consists of the steering wheel and column assembly, a vane-type hydraulic pump, reservoir, filter, interconnecting system lines and hoses, integral power steering gear, linkage and steering damper (Fig. 1). The steering linkage includes the pitman arm, drag link, steering arm, tie rod arms and tie rod.

Hydraulic components are added to transmit, increase and regulate steering control forces.

These elements are:

1. Steering stabilizer (damper);
2. A vane type hydraulic pump; and
3. Hydraulic reservoir and hoses.

The steering stabilizer reduces road shocks and vibrations in the system. The steering gearbox is self powered and provides movement with power assistance to the left wheel.

Steering stability and tire wear are influenced by wheels, hubs, tires, air suspension, brakes, front suspension and front end alignment which are all covered in their respective sections in this manual.

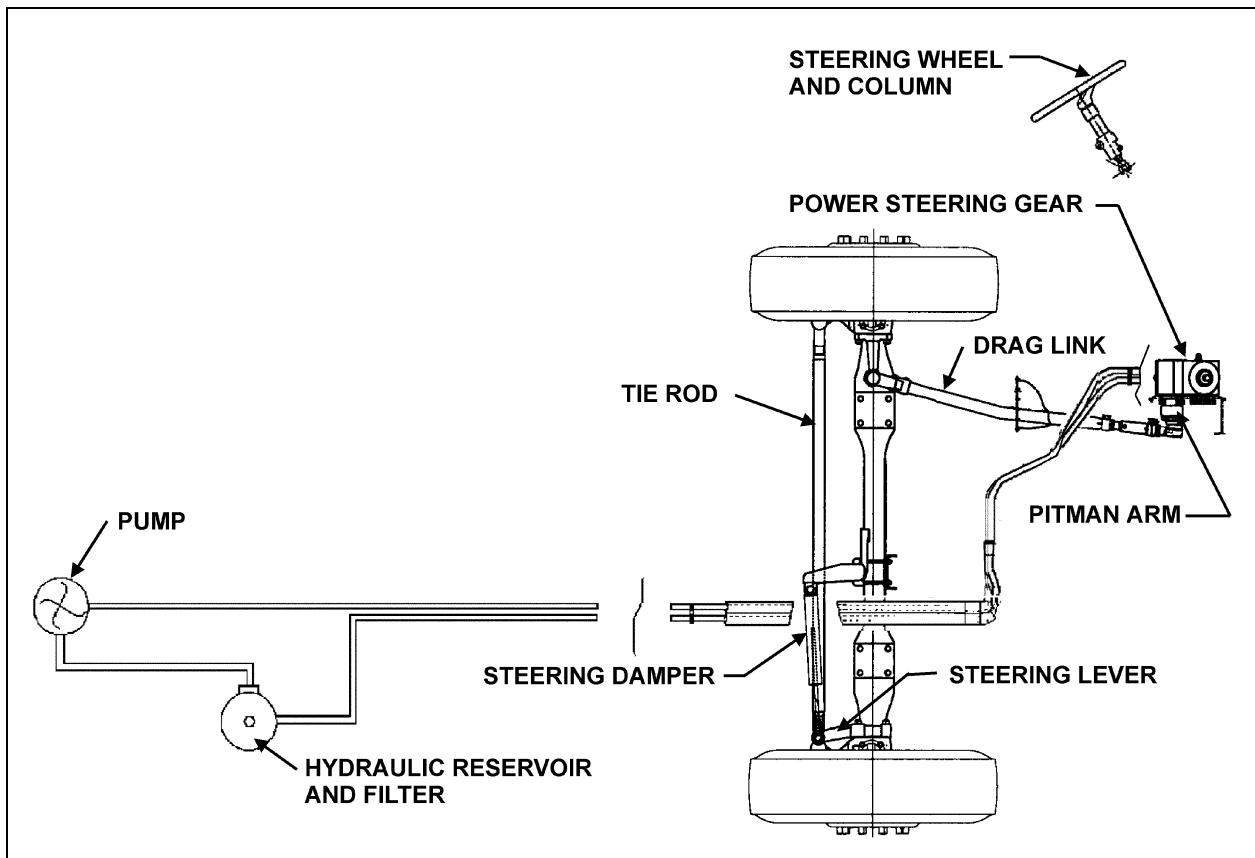

FIGURE 1: I-BEAM AXLE STEERING SYSTEM SETUP

14041

2. POWER STEERING GEAR

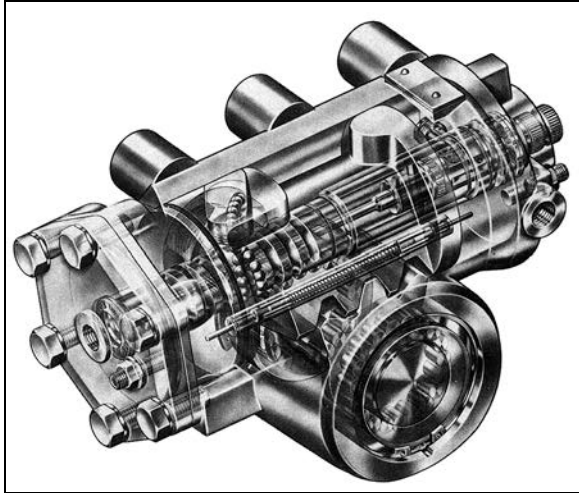

FIGURE 2: POWER STEERING GEAR 14035

2.1 DESCRIPTION

The power steering gear is located in the lower part of front service compartment (Figs. 2 & 3). The housing of the ZF-Servocom contains a control valve, working cylinder and a complete mechanical steering gear. The pressure oil for the steering is delivered by a motor-driven oil pump which is supplied with oil from an oil tank.

The housing is designed as a cylinder for the piston, which converts the rotation of the steering shaft and the worm into an axial movement and transfers this to the steering worm sector shaft. The serration of the sector shaft is straight-cut with a high surface quality in such a way that it is only possible to set a unique setting without play on installation in the straight-ahead driving area by means of the two eccentrically designed lateral housing covers.

The piston and worm are connected via a ball chain. When the worm is turned, the balls are collected by a circulating pipe at one end of the chain and fed in again at the other end, thus producing an endless ball chain.

The control valve consists of the valve slide in a needle bearing in the worm, with six control grooves on the circumference and the control sleeve on the worm, which also has six control grooves. The valve slide, designed with steering shaft connection, turns together with the worm as the steering wheel is turned.

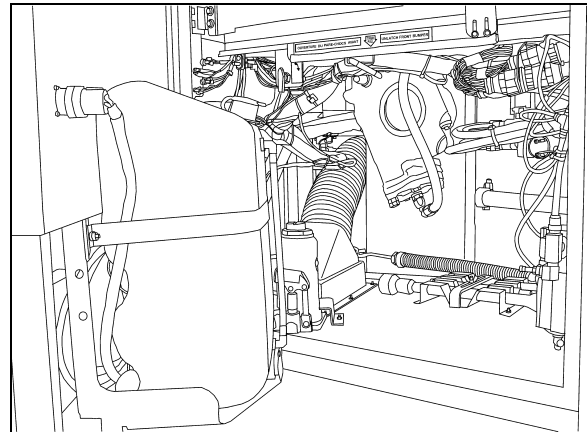

FIGURE 3: FRONT SERVICE COMPARTMENT 18611

A torsion bar, which is pinned with the valve slide and the worm, keeps the control valve in the neutral position as long as no opposing force is applied to the steering wheel. The steering housing contains a pressure relief valve, which limits the discharge pressure of the oil pump to the maximum value required. A replenishing valve can also be used, through which oil is sucked from the return if steering is not hydraulically boosted.

Compared with constant ratio, steering versions with variable ratio are more directly designed in the center area than outside the center area. The resulting smaller steering corrections benefit steering behavior in straight-ahead driving. At the same time, the indirect transmission means that there is a higher hydraulic torque available at the steering arm in parking movement. If the hydraulic assistance fails, the operating forces on the steering wheel are correspondingly lower in this area. This is achieved through a piston/steering worm sector shaft serration with differing modulus and angle of pressure.

Upon transfer of a torque from the steering shaft to the worm, or vice versa, the torsion bar is deformed in the elastic area so that there is torsion between the valve slide and the control sleeve. When the steering wheel is released, the torsion bar ensures that the valve is returned to the neutral position.

Refer to the *"ZF-SERVOCOM Repair Manual"* and *"ZF-SERVOCOM Operating, Servicing /Maintenance and Inspection Instructions"* annexed to this section for the functional aspects and maintenance procedure of the steering gear.

2.2 POWER STEERING GEAR REMOVAL

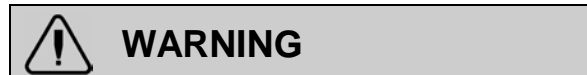

The steering gearbox weighs approximately 100 lbs (45 kg) dry. Exercise caution when handling.

1. Put a container into place, then disconnect both the inlet and outlet hoses from the power steering gear. Cover fittings to prevent fluid contamination.
2. Mark both the pitman arm and sector shaft with a line, then remove pitman arm. Refer to "11.1 Pitman Arm Removal" procedure.
3. Mark both the steering shaft universal joint yoke and steering gear input shaft with a line, then disconnect universal joint.
4. Unscrew and remove the power steering gear.

2.3 POWER STEERING GEAR INSTALLATION

Reverse "Power Steering Gear Removal" procedure paying particular attention to the following:

1. Tighten fasteners as recommended under paragraph 14: "Torque Specifications".
2. Bleed air from the system as per step 3, next.

2.4 TROUBLESHOOTING

Perform troubleshooting of the steering gear as outlined in the "ZF-SERVOCOM Repair Manual", the "ZF-SERVOCOM Operating, Servicing /Maintenance and Inspection Instructions".

3. BLEEDING POWER STEERING HYDRAULIC SYSTEM

To bleed the power steering hydraulic system, refer to the "ZF-SERVOCOM Repair Manual" annexed to this section, under heading "Setting And Functional Test".

4. HYDRAULIC PRESSURE TEST

Perform a pressure test as outlined in the "ZF-SERVOCOM Repair Manual" annexed to this section under heading "Setting And Functional Test".

5. POWER STEERING HYDRAULIC PUMP

The power steering pump is a gear driven hydraulic unit which supplies hydraulic pressure for the operation of the steering gear. The pump is mounted on the engine, at the flywheel end and is also used for driving the fuel pump.

5.1 REMOVAL AND INSTALLATION

The pump is accessible through the engine compartment R.H. access door.

To remove the pump, proceed as follows:

- You must first remove the fuel feed pump.
- Clean around the fuel pump and fuel lines. Position a container to catch any fuel that might drain from the pump or lines.
- Remove the fuel pump.

NOTE

Only unfasten the bolts marked with arrows.

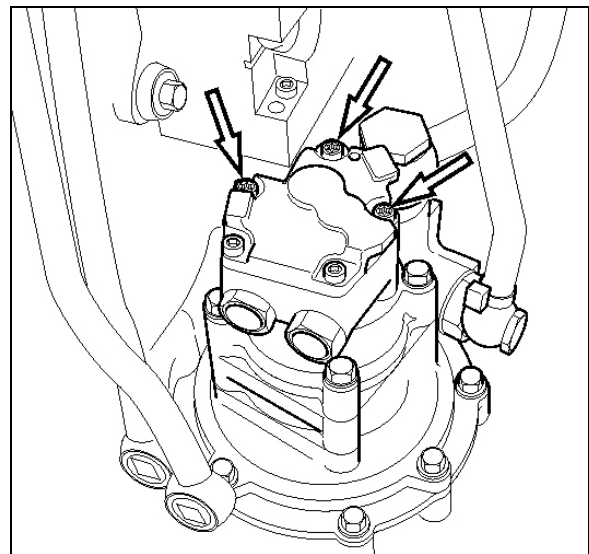

FIGURE 4: FUEL PUMP REMOVAL



CAUTION

Ensure to clean around the head of the bolts. Debris will prevent the tool from fitting properly and cause damage to the fasteners.

- Check that the adapter and fuel pump drive axle are not damaged.

Section 14: STEERING

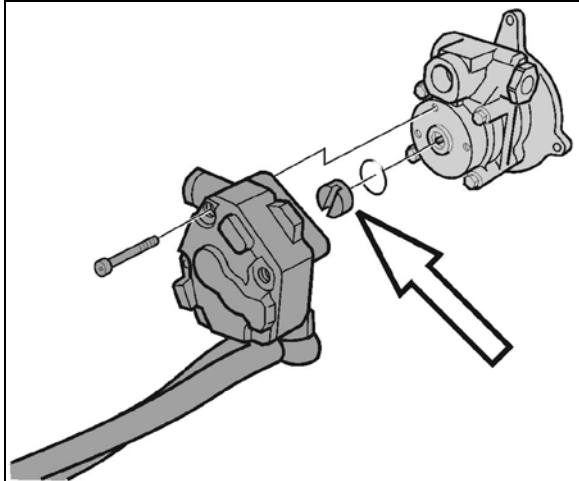

FIGURE 5: FUEL PUMP DRIVE AXLE

- Set the fuel pump aside.
- Clean around the power steering pump and loosen the steering lines. Position a container to catch any hydraulic fluid that might drain from the pump or lines.
- Unfasten the power steering pump bolts.

NOTE

Only unfasten the bolts marked with arrows.

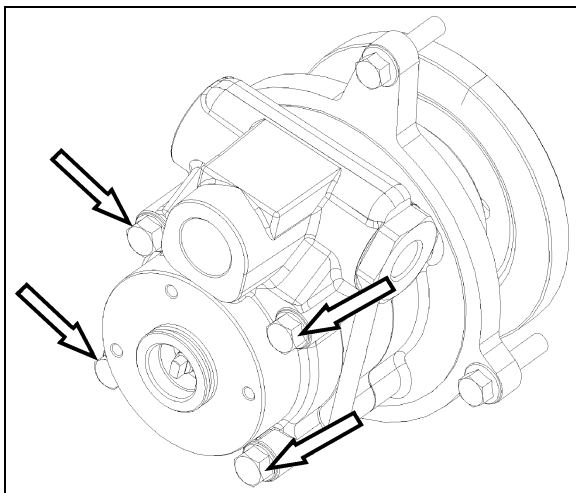

FIGURE 6: POWER STEERING PUMP REMOVAL

- Install the new power steering pump. Torque-tighten bolts to specification.

NOTE

Use a new gasket.

- Connect the hydraulic lines to the power steering pump.

- Install the fuel pump. Torque-tighten bolts to specification.

NOTE

Use a new sealing ring. Check that the fuel pump drive axle sits correctly in the power steering pump.

- Start the engine and let run for 5 minutes. Make sure that there are no leaks.

6. STEERING COLUMN

6.1 REMOVAL

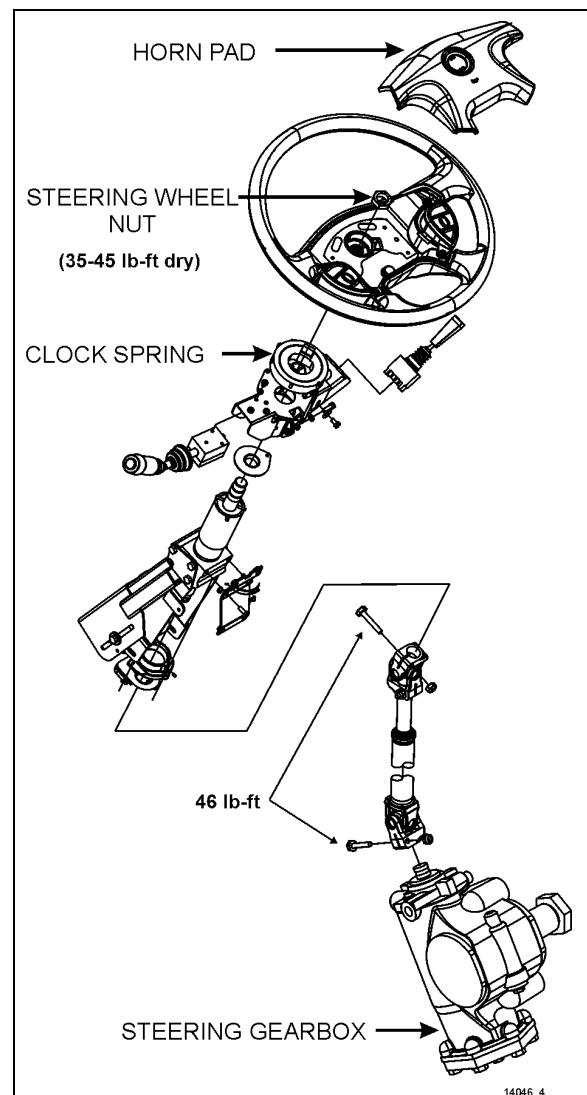

FIGURE 7: STEERING COLUMN

To disassemble the steering column from system, refer to figure 7 & 8. The steering column has no lubrication points. The lower steering column

U-joint is easily accessible through the front service compartment. The upper steering column U-joint and the steering slip joint are accessible from the front driver's area. To access these joints, proceed as follows:

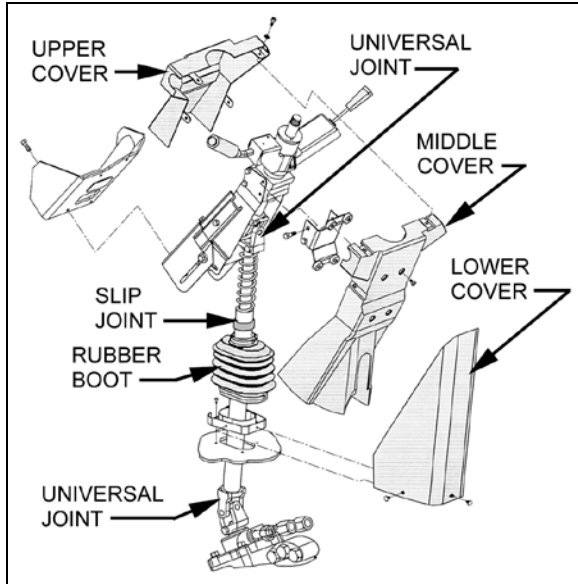

FIGURE 8: STEERING COLUMN COVERS 14040

1. From the front driver's compartment area, remove the three plastic fasteners on steering column lower cover. Remove the lower cover (Fig. 8).
2. Unscrew the four retaining screws on steering column middle cover.
3. Unscrew the four retaining screws fixing steering column upper cover to middle cover. Remove the steering column middle and upper covers.
4. Position the steering wheel in order to gain access to the joints.

7. STEERING WHEEL

7.1 REMOVAL

NOTE
Before undertaking the steering wheel removal, assure that the front wheels are pointing straight ahead, aligned with the vehicle.

1. Set the battery master switch located on the rear electrical panel to the "OFF" position.
2. Pull the horn pad straight up gently to detach it from the steering wheel (Fig. 9).

3. Disconnect the horn wire (white) connected to the horn pad and the steering wheel harness 4-pin connector.

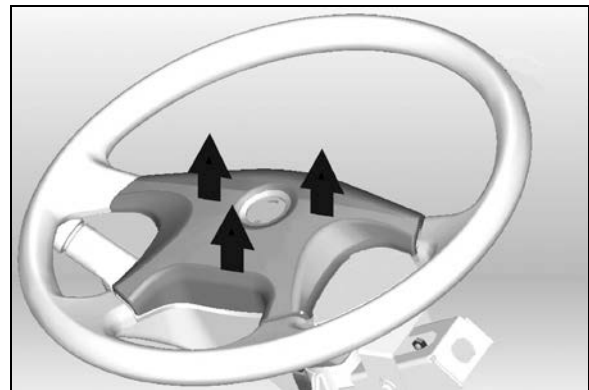

FIGURE 9: REMOVING THE HORN PAD

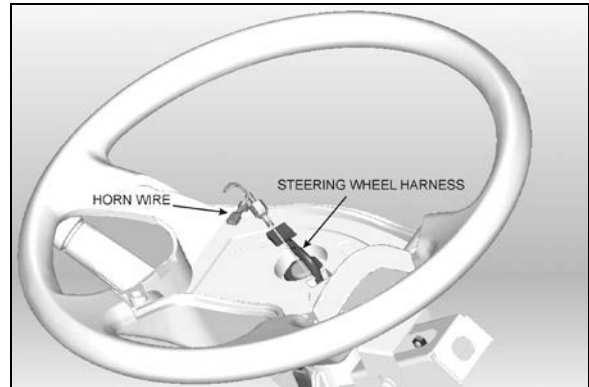

FIGURE 10: STEERING HARNESS & HORN WIRE

4. Unscrew the steering wheel nut. To simplify installation and ensure steering wheel alignment, mark the relationship of the spline shaft to the steering wheel hub (if marks don't already exist or don't line up).
5. Using an appropriate puller, separate the steering wheel from the spline shaft.
6. From behind the steering wheel, pull gently on the electrical wires passing through the rectangular opening in the steering wheel to finish removal of the steering wheel.
7. Once the steering wheel is removed, it is important to block any rotating movement of the clockspring in order to prevent it from losing its neutral position. Use two pieces of masking tape to lock it in place (Fig. 11).

Section 14: STEERING

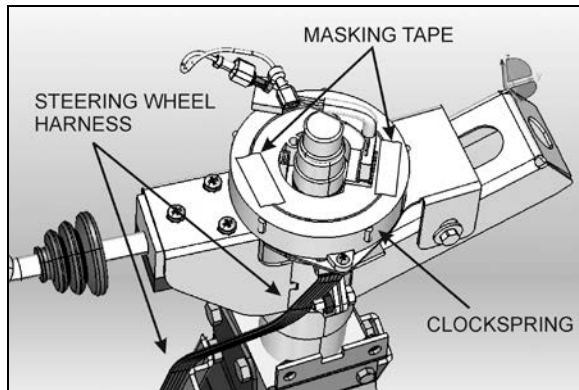

FIGURE 11: LOCKING THE CLOCKSPRING IN PLACE

NOTE

The clockspring mechanism permits a certain number of turns in each direction. At the moment of reinstalling the steering wheel, if the clockspring is not at its neutral position, the number of available turns will be reduced. That may damage the clockspring if the steering wheel is turned to its maximum amplitude.

7.2 INSTALLATION

1. Route the white horn wire and the 4-pin connector through the opening on the steering wheel.
2. Align the mark on the steering wheel hub with the mark on the spline shaft and slide the wheel onto the shaft.
3. Tighten wheel retaining nut to a torque of 35-45 lbf·ft.
4. Plug the 4-pin connector and connect the white horn wire to the center pad.
5. Reinstall the center pad and test for proper horn functioning.

7.3 CLOCKSPRING REPLACEMENT

1. Remove the steering wheel.
2. Remove the 2 clockspring mounting screws and then remove the clockspring. You will have to disconnect the clockspring harness connector located lower along the steering wheel column. If necessary, remove the steering column covers (Fig. 8).
3. Route the new clockspring harness through the opening in the clockspring support (Fig. 12). Plug the connector at the base of the steering wheel column and fix harness along the steering wheel column.

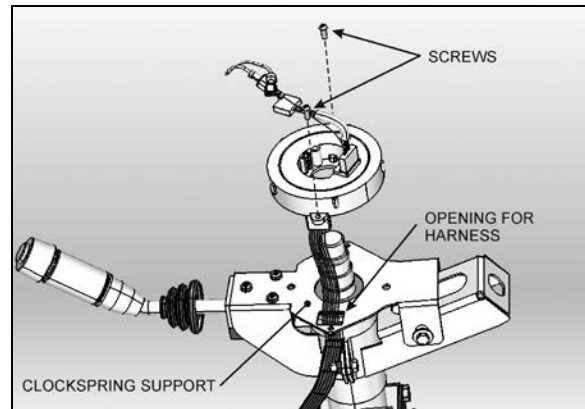

FIGURE 12: CLOCKSPRING INSTALLATION

4. Mount the clockspring in place with 2 screws.
5. Break the paper seal and rotate the center part of the clockspring about 50° clockwise (Fig. 13). This step is necessary for the installation of the steering wheel.

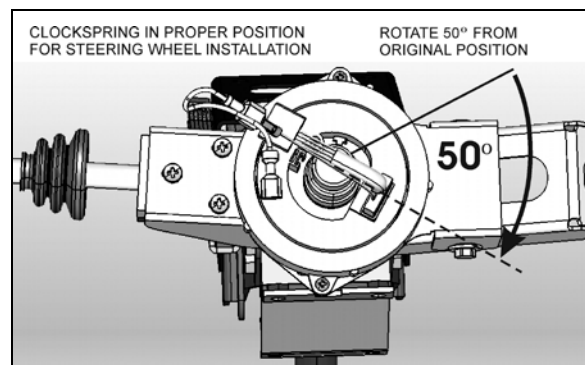

FIGURE 13: PROPER CLOCKSPRING POSITION

6. Reinstall the steering wheel.

8. TURNING ANGLE ADJUSTMENT

The maximum turning angle is set through two (2) steering stop screws installed on the axle center. Steering stop screws are factory adjusted to accommodate the chassis design, and therefore, do not require adjustment on new vehicles. However, these should be checked and adjusted if necessary, any time a steering system component is repaired, disassembled or adjusted. Refer to section 10 "Front Axle" under heading "6.4 "Turning Angle Adjustment".



CAUTION

To prevent the steering damper from interfering

with the adjustment of turning angles, make sure its fixing bracket is at correct location on the axle (refer to "12.2 Steering Stabilizer Cylinder (Damper)").

Hydraulic Stop

CAUTION

Reduce or shut off the power steering hydraulic pressure before the boss on the axle touches the stop screw. If not, the components of the front axle will be damaged (refer to "ZF-SERVOCOM Repair Manual" and "ZF-SERVOCOM Operating, Servicing /Maintenance and Inspection Instructions" annexed to this section, under heading "Setting The Steering Limiter").

CAUTION

Never maintain the relief pressure for more than 5 seconds, since damage to the power steering pump may occur.

9. STEERING LINKAGE ADJUSTMENT

The steering linkage includes the pitman arm, drag link, steering arm, tie rod arms and tie rod. Perform lubrication according to "DANA SPICER Service Manual NDS Axle Range" found in the OEM manuals folder.

Steering linkage pivot points should be checked each time they are lubricated. Looseness can be visually detected while rotating the steering wheel in both directions. Replace defective parts.

CAUTION

Front wheel alignment should be checked and adjusted if necessary, any time a component of the steering system is repaired, disassembled or adjusted. Refer to section 10 "Front Axle" under heading 6. "Front Wheel Alignment".

10. PITMAN ARM

10.1 REMOVAL

1. Remove cotter pin, nut and washers from drag link ball stud at pitman arm.

2. Disconnect drag link from pitman arm, using jaw style pullers (pressure screw type).



WARNING

Always wear approved eye protection when operating pullers.



CAUTION

Do not drive (hammer in) pitman arm on or off pitman shaft as this can damage the steering gear.



CAUTION

Heating of components to aid in disassembly is not allowed because it has a detrimental effect on axle components and steering linkages.

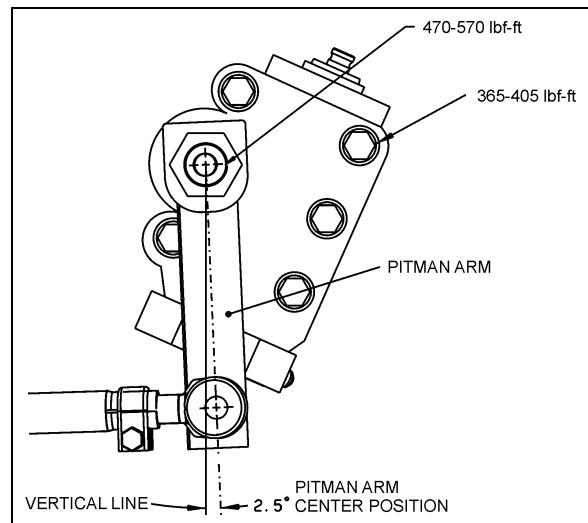

FIGURE 14: PITMAN ARM ADJUSTMENT 14037

3. Using a cold chisel, undo punch mark that locks fixing nut to the pitman arm.
4. Remove pitman arm fixing nut.
5. Check the radial position of the pitman arm in relation to the sector shaft prior to removal of pitman arm.
8. Add reference marks to the arm and shaft if necessary to ensure correct alignment at reassembly.
7. You must use a puller to remove pitman arm.

Section 14: STEERING

10.2 INSTALLATION

1. Position pitman arm on sector gear shaft with reference marks aligned.
2. Install fixing nut (Prevost #661050). Tighten nut to 470-570 lbf-ft (637-773 Nm).

NOTE

Use a new nut if the previously removed nut was punched.

3. Lock nut with sector shaft using a punch mark into the groove (Refer to figure 15).

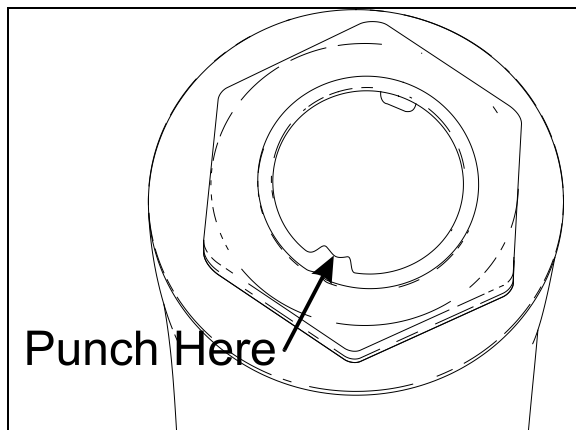

FIGURE 15: FIXING NUT PUNCH MARK

16098

4. Connect drag link to pitman arm while ensuring that rubber stabilizer is in place on the rod end. Install washers. Tighten nut to 150-200 lbf-ft (203-271 Nm). Afterwards, install a new cotter pin.



CAUTION

Input shaft marks must be aligned before adjusting pitman arm.

10.3 ADJUSTMENT

1. Disconnect the drag link from pitman arm. Center steering wheel by dividing the total number of steering wheel turns in two. Scribe a reference mark on steering gearbox at the center previously determined.
2. Using a protractor, check the angle of the pitman arm (refer to Fig. 14 for details).
3. The pitman arm should be adjusted to an angle of 2.5° in relation with the vertical axis (towards front of vehicle). If not, unscrew and remove fixing nut. Remove the pitman arm according to the procedure outlined under

previous heading "Pitman arm removal". Adjust to the proper angle.

4. When adjustment is achieved, replace fixing nut and torque to 470-570 lbf-ft (637-773Nm).

10.4 TAG AXLE UNLOADING SWITCH ADJUSTMENT

1. Make sure vehicle wheels are straight and facing forward.
2. Line up switch lever with reference to the bracket center (Refer to figure 16).

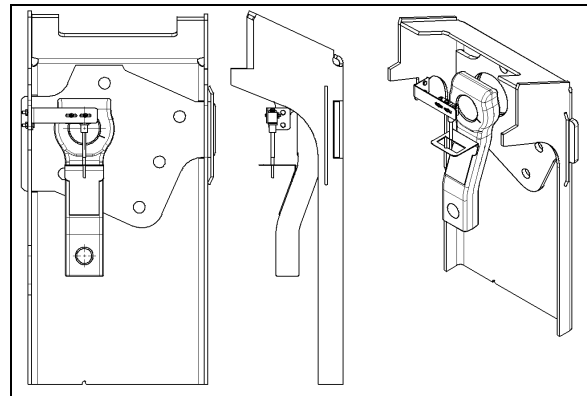

FIGURE 16: TAG AXLE UNLOADING SWITCH ADJUSTMENT

14061

11. MAINTENANCE

The power steering system requires little maintenance. However, the system should be kept clean to ensure maximum operating performance and trouble-free service. Periodic inspections should also be made to check for leakage and all parts for damage or distortion. Insure all fasteners are tight (see "14. Specifications" for recommended tightening torques).

When the slightest evidence of dirt, sludge or water is discovered in the system, disconnect fluid lines at the power steering gear to drain the system. Drain and refill the system with "Dexron-II or Dexron-III" automatic transmission oil.

Air in the hydraulic system will cause spongy action and noisy operation. When a hose has been disconnected or when fluid has been lost for any reason, the system must be bled. Bleed system as outlined under heading 3: "Bleeding Power Steering Hydraulic System".



CAUTION

Do not operate the pump without fluid in the

power steering fluid reservoir.

If the steering linkage between the steering gear and the two front wheels is not properly adjusted, or if it is bent, twisted or worn, the steering of the vehicle will be seriously impaired. Whenever a steering linkage part is repaired, replaced or adjusted, steering geometry and front wheel alignment must be checked and necessary corrections made. Refer to section 10 "Front Axle" under heading 6: "Front Wheel Alignment".

At regular lubrication intervals, the steering linkage should be thoroughly inspected for worn or loose components.

After the vehicle has been operated continually and high mileage figures have been reached, overhaul of the various steering units will be required. General overhaul procedure normally requires removal of the entire assembly, cleaning and inspection of all parts and final assembly. Careful inspection of all parts during overhaul is very important and must not be neglected.

Lubrication fittings must all be cleaned before applying lubricant. Moreover, always be sure the equipment used in applying lubricant is clean. Every precaution should be taken to prevent entry of dirt, grit, lint or other foreign matter into lubricant containers. Replace fittings that have become broken or damaged. Lubrication intervals, as well as the recommended lubricants for the steering components, are given in the "Lubrication And Servicing Schedule" in Section 24 of this manual. The intervals given in the schedule are recommended for normal service. More frequent intervals may be required under severe operating conditions.

11.1 POWER STEERING RESERVOIR AND FILTER

The power steering reservoir is located on R.H. side of engine compartment and accessible through the engine compartment doors. (Fig. 17).

11.1.1 Oil Level Check Procedure

1. Stop engine. Open engine compartment doors.
2. Unscrew and remove the dipstick located on top of reservoir and wipe with a clean rag.
3. Insert dipstick in reservoir. Remove it again to check fluid level (Fig. 18).
4. Adjust level to "FULL" mark using proper dipstick side depending on fluid temperature,

use "Dexron-IIIE or Dexron-III" automatic transmission oil.

5. Reinsert and tighten the dipstick.
6. At regular intervals, fluid level should be checked in the reservoir and filter assembly.

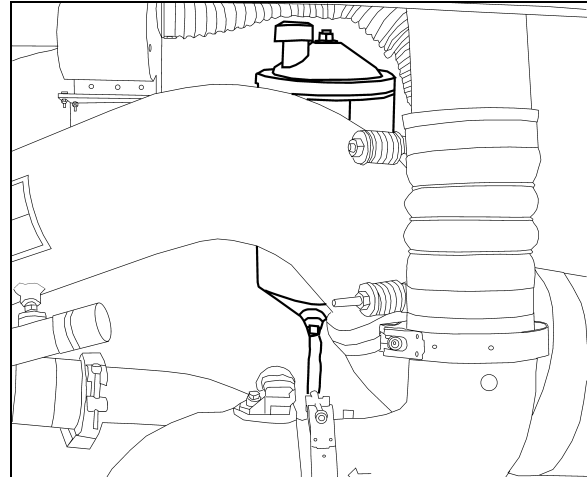

FIGURE 17: HYDRAULIC FLUID RESERVOIR LOCATION
14059



MAINTENANCE

Replace the oil filter cartridge element in the power steering reservoir every 50,000 miles (80 000 km) or once a year, whichever comes first.

11.1.2 Filter Replacement

1. Unscrew and remove the cover nut located on top of the power steering reservoir.
2. Remove the reservoir cover and the gasket.
3. Remove the retaining spring and finally the filter cartridge element.

NOTE

Power steering fluid reservoir is equipped with a magnetic drain plug. Check for trapped metal particle when replacing filter cartridge element.

Section 14: STEERING

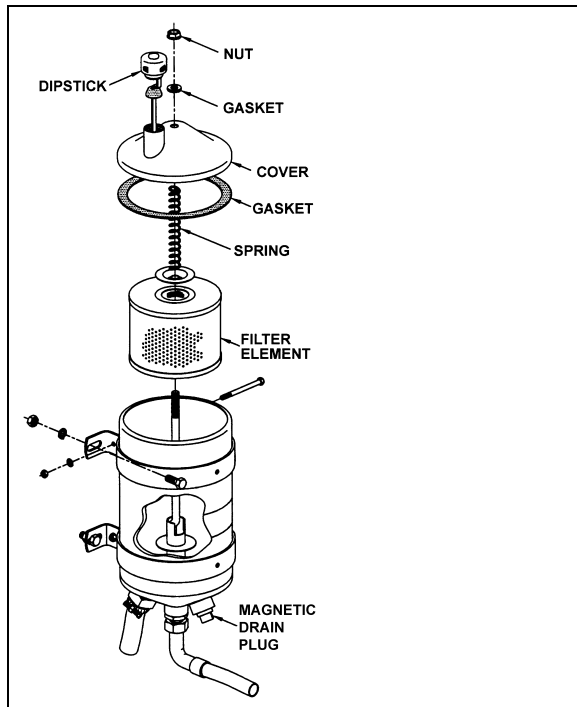

FIGURE 18: POWER STEERING FLUID RESERVOIR 14018

11.2 STEERING STABILIZER CYLINDER (DAMPER)

The steering damper is located on R.H. side, aft of front axle (Fig. 19).

The cylinder is non-adjustable and non-repairable. Check for oil leaks or lack of resistance. Disconnect the cylinder from axle, then carefully attempt to extend and collapse it manually.



MAINTENANCE

Steering damper ball joint (rod end) is provided with a grease fitting for pressure lubrication. This grease fitting should be serviced every 6,250 miles (10 000 km) or twice a year whichever comes first.

Check the ball joint for wear, and replace if necessary.

Good quality lithium-base mineral grease NLGI No. 1 and 2 like Shell Retinax LX are recommended.

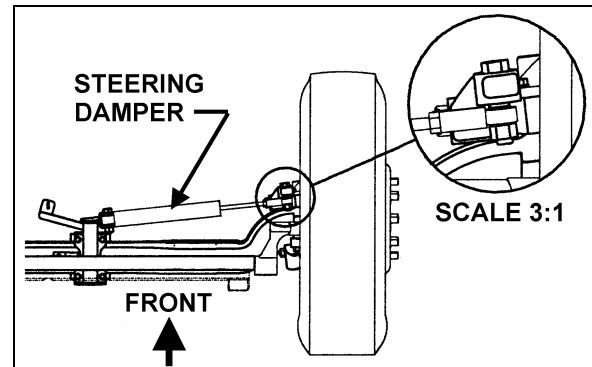

FIGURE 19: STEERING STABILIZER (DAMPER) 14042

11.3 DRAG LINK

Visually inspect drag link components for broken clamps, loose nuts and gauges on tube from rubbing parts.



MAINTENANCE

Drag link ends (ball joint) are provided with grease fittings for pressure lubrication. These grease fittings should be serviced every 6,250 miles (10 000 km) or every 3 months whichever comes first.

To prevent corrosion from forming around the ball pin (particularly the drop type ball joint as it is exposed to dirt and water), remove the old grease bead and assure sufficient grease is applied to purge the old grease and fill the joint and dust seal.

Good quality lithium-base mineral grease NLGI No. 2 like Shell Retinax LX are recommended.

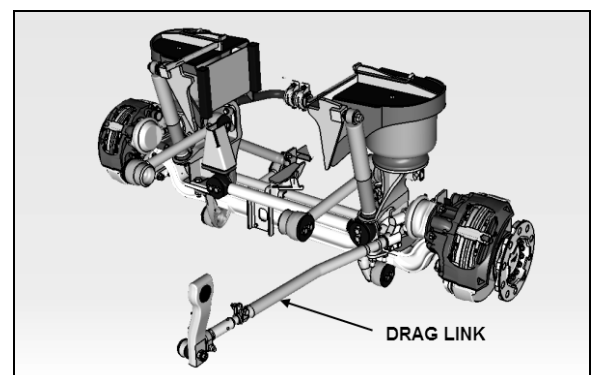

FIGURE 20: DRAG LINK

11.4 TIE ROD

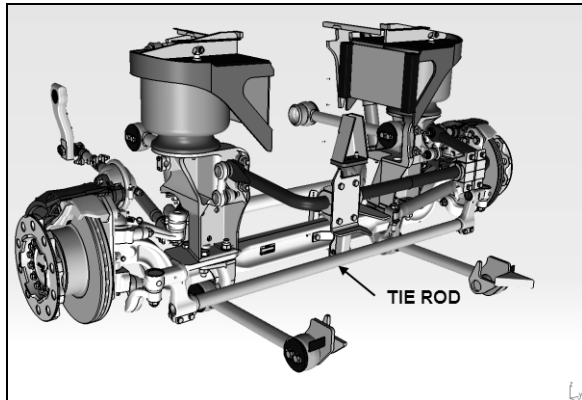



FIGURE 21: TIE ROD

 <p>MAINTENANCE</p>
<p>Tie rod ends (ball joint) are provided with grease fittings for pressure lubrication. These grease fittings should be serviced every 6,250 miles (10 000 km) or every 3 months whichever comes first.</p> <p>To prevent corrosion from forming around the ball pin, remove the old grease bead and assure sufficient grease is applied to purge the old grease and fill the joint and dust seal.</p> <p>Good quality lithium-base mineral grease NLGI No. 2 like Shell Retinax LX are recommended.</p>

11.5 DRAG LINK AND TIE ROD BALL JOINTS INSPECTION FOR CORROSION

Inspection of ball joints is important. Damaged sealing boots, salt and climatic conditions can cause loss of the corrosion protection coating applied at time of manufacturing.

 <p>MAINTENANCE</p>
<p>Inspect drag link end and tie rod end ball joints for corrosion once a year.</p>

- Carefully clean the sealing boot or dirt seal contact area to ensure that no contaminants can get under the sealing boot or dirt seal during the following inspection procedure.
- Use an appropriate inspection tool (e.g. spatula with cut out) to push up (sealing boot) or down (dirt seal) the seal (without damaging it) until ball pin surface is visible.

Degrease the ball pin surface and inspect carefully.

- If there is corrosion of the ball pin or the sealing boot has deteriorated through ageing or is damaged, replace the ball joint.
- If there is corrosion of the steering arm or tie rod arm area which is in contact with the sealing boot or dirt seal, clean and eliminate all surface irregularities.
- If there is no corrosion or damage to the sealing boot or dirt seal, smear the steering arm and tie rod arm with Lithium grease and push seal back into its properly seated position.

When dismantling tie rod or drag link, ensure that no damage is caused to the sealing boots, dirt seals or ball joint housings.

11.6 DROP TYPE BALL JOINT

11.6.1 Drop Type Ball Joint End Play

If end play exceeds 0.047" (1.2 mm), readjustment is necessary.

Remove protective cap, using a suitable tool i.e.: a 1" x 1/8" x 9" long flat bar, tighten adjuster piece fully home (SOLID) locating thrust cup onto ball pin.

Still with tool located on adjuster piece, back off carefully (LEAST AMOUNT) until adjuster piece cotter pin is allowed to pass through body, then remove tool.

Reinstall protective cap.

Section 14: STEERING

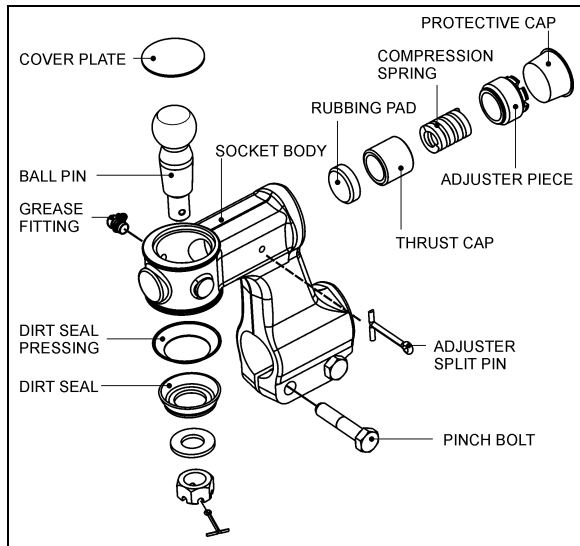

FIGURE 22: DROP TYPE BALL JOINT FOUND ON THE ROD (2X) AND DRAG LINK (1X)

11.6.2 Dismantling Drop Type Ball Joint

1. Remove dirt seal and dirt seal pressing from ball pin.
2. Slacken pinch bolt nut then unscrew and remove ball socket assembly from tie rod having first marked ball socket body and tie rod to enable tracking on re-assembly.
3. Remove adjuster split pin from ball socket body.
4. Remove cap then using a suitable tool i.e.: a piece or 1"x1/8"x 9" flat bar, unscrew and remove adjuster piece. Waggle ball pin to free thrust cap.
5. Remove compression spring and thrust cap from ball socket body.
6. Relieve peening on socket body top then using a hide faced mallet, tap ball pin out of body. This operation will also remove cover plate from body.
7. The rubbing pad can now be removed from body.

Thoroughly clean all parts and check for wear, renewing where necessary.

11.6.3 Assembling Drop Type Ball Joint

1. Apply a bead of Loctite 638 sealant to mating corner of rubbing pad in socket body then knock rubbing pad into its recess in ball socket body.

2. Thoroughly grease rubbing pad and ball pin with Shell Retinax LX or equivalent.
3. Insert ball pin into body.
4. Insert thrust cap, compression spring and adjuster piece into body.
5. Tighten adjuster piece fully home (SOLID) locating thrust cup onto ball pin.
6. Still with tool located on adjuster piece, back off carefully (LEAST AMOUNT) until adjuster piece split pin is allowed to pass through body, and that ball pin shank can be moved by moved of hand, then remove tool.

NOTE: If ball pin does not rotate when re-adjusted in line with above instructions, this suggests that ball pin has local worn flats. In this instance ball pin, thrust cup and rubbing pad **MUST** be replaced, if not **FAILURE** could occur in service, i.e. ball pin not being able to move in assembly when turning from lock to lock.

7. Fit cover plate into top of ball socket body, re-peen using a cold chisel to secure.
8. Screw assembled ball socket onto tie rod. Lining up marks on both body and tie rod previously made, or retracking using manual instructions.
9. Fit pinch bolts and nuts then tighten nuts alternately and progressively to 65- 75 lbf-ft (88-102 Nm.) thus securing ball joint to tie rod.
10. Fit dirt seal (pressing) and dirt seal (rubber) onto ball pin.
11. Locate ball socket and tie rod assembly with lever, carefully align and fit ball pin into hole in tie rod arm.

NOTE: Ball pin and ball pin tapers in bottom tie rod arms must be clean, dry and free from oil prior to assembly.

12. Fit pin washer onto ball pin.
13. Screw pin nut onto ball pin then tighten to 175 lbf-ft (237 Nm) torque.
14. Using a 2lb hammer, tap tie rod arm to "shock" ball pin into taper hole.
15. Re-torque pin nut to 175 lbf-ft (23 7Nm).
16. Fit split pin, if slot/hole are not in line, adjust up to next slot.

Pin nut torque 175 lbf-ft, max pin nut torque 200 lbf-ft.

- 17. Re-charge ball socket with Shell “Retinax LX” or equivalent grease through grease fitting.

11.7 STRAIGHT BODY TYPE BALL JOINT

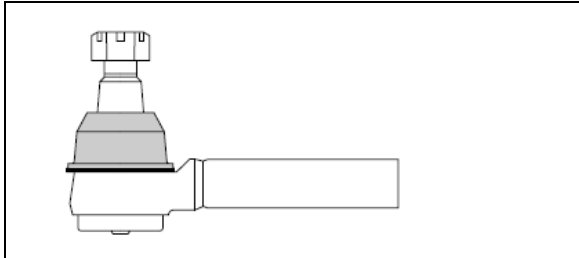

FIGURE 23: STRAIGHT BODY TYPE BALL JOINT

11.7.1 Visual Inspection

- Visually inspect for missing or damages grease fittings and replace if required.
- Damaged sealing boot or improper sealing requires seal replacement.
- Check ball joint connection for missing cotter pins.
- Check for looseness in the ball/socket assembly.

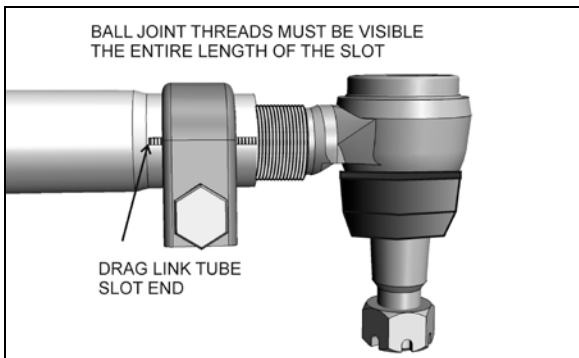

FIGURE 24: ADEQUATE CLAMPING CONDITION

For adequate clamping, the ball joint threads must be visible the entire length of the tube slot. If not, the drag link must be adjusted or replaced. It is either the wrong size, or improper adjustment was used to compensate for another problem (e.g. bent steering arm).

11.7.2 Straight Body Type Ball joint End Play And Looseness

What creates movement in sockets?

In each TRW straight body type ball joints, the compressive force of the spring creates resistive

torque by applying a constant load on the bearing and stud.

As wear occurs on the components, the spring creates less resistive torque. With less torque, you no longer have the precise joint needed for optimum steering, but you do still have a safe linkage. **When all compression is lost, it's time to replace the linkage.** This wear can be caused by impact, lack of lubrication and normal wear.

1. With vehicle engine on, lightly rock the steering wheel while checking for looseness in any threaded joint. Observe any looseness in the two mating tapers or any movement of the ball pin nut. Any looseness requires further inspection. If either of the mating tapered parts show distortion or wear, both parts must be replaced.
2. With the engine off and wheels straight ahead and no force is being exerted on the linkage by the steering gear, push and pull the ball joint in and out by hand (approximately 100 lbs. force) in the direction of the ball pin. If no movement is detected, the ball joint is safe. **Any movement detected by hand requires replacement of the ball joint.**

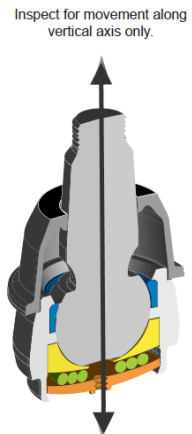

CAUTION

Do not use a wrench or other object to apply leverage when inspecting ball joint. Applying leverage can give distorted results and damage components.

12. DRIVING TIPS

In order to maximize power steering pump service life, do not attempt to turn the steering wheel when the vehicle is stationary, and especially when service brakes are applied (wheel locking will oppose the effect of steering geometry which tends to make the front wheels rotate in opposite directions).

Persisting in turning, or maintaining the steering wheel with an extra effort, could make the

Section 14: STEERING

hydraulic system work at the relief pressure, and consequently, cause the hydraulic fluid to become overheated.



CAUTION

Never maintain the hydraulic system at the relief pressure for longer than 5/10 seconds to avoid damaging the power steering pump.

NOTE

Unequal or low tire pressure, oversize tires, and vehicle overloading are some of the causes that may increase steering effort.

13. TROUBLESHOOTING

CONDITION	CAUSE	CORRECTION
Tires wear out quickly or have uneven tire tread wear.	<ol style="list-style-type: none"> 1. Tires have incorrect air pressure. 2. Tires out-of-balance. 3. Incorrect tag axle alignment. 4. Incorrect toe-in setting. 5. Incorrect steering arm geometry. 	<ol style="list-style-type: none"> 1. Put specified air pressure in tires. 2. Balance or replace tires. 3. Align tag axle. 4. Adjust toe-in specified setting. 5. Service steering system as necessary.
Vehicle is hard to steer.	<ol style="list-style-type: none"> 1. Low pressure in the power steering system. 2. Steering gear not assembled correctly. 3. Steering linkage needs lubrication. 4. Kingpins binding. 5. Incorrect steering arm geometry. 6. Caster improperly adjusted. 7. Tie rod ends hard to move. 8. Worn thrust bearing. 	<ol style="list-style-type: none"> 1. Repair power steering system. 2. Assemble steering gear correctly. 3. Lubricate steering linkage. 4. Replace kingpins. 5. Service steering system as necessary. 6. Adjust caster as necessary. 7. Replace tie rod ends. 8. Replace thrust bearing.
Bent or broken steering arm, steering top lever or tie rod assembly.	<ol style="list-style-type: none"> 1. Too much pressure in the power steering system. 2. Cut-off pressure of the power steering system improperly adjusted. 3. Vehicle not powered on correctly. 4. Power steering system not installed correctly. 	<ol style="list-style-type: none"> 1. Replace damaged part(s), adjust power steering system to specified pressure. 2. Make sure vehicle is powered on correctly. 3. Correctly install the power steering system. 4. Correctly install the power steering system.
Worn or broken steering ball pin.	<ol style="list-style-type: none"> 1. Drag link fasteners tightened past specified torque. 2. Lack of lubrication or incorrect lubricant. 3. Power steering stops improperly adjusted. 	<ol style="list-style-type: none"> 1. Replace damaged part(s), tighten drag link fasteners to specified torque. 2. Lubricate linkage with specified lubricant. 3. Adjust stops to specified dimension.
Worn kingpins and knuckle bushings.	<ol style="list-style-type: none"> 1. Worn or missing seals and gaskets. 2. Incorrect lubricant. 3. Axle not lubricated at scheduled frequency. 4. Incorrect lubrication procedures. 5. Lubrication schedule does not match operating conditions. 	<ol style="list-style-type: none"> 1. Replace damaged part(s), replace seals and gaskets. 2. Lubricate axle with specified lubricant. 3. Lubricate axle at scheduled frequency. 4. Use correct lubrication schedule to match operating conditions. 5. Change lubrication schedule to match operating conditions.
Vibration or shimmy of front axle during operation.	<ol style="list-style-type: none"> 1. Caster not adjusted properly. 2. Wheels and/or tires out-of balance. 3. Worn steering stabilizer cylinder. 	<ol style="list-style-type: none"> 1. Adjust caster. 2. Balance or replace wheels and/or tires. 3. Replace steering stabilizer cylinder.

Section 14: STEERING

14. TORQUE SPECIFICATIONS

The torque specifications applicable to the front axle steering are grouped with information regarding the front suspension. Please refer to Section 16: SUSPENSION of this manual.

15. SPECIFICATIONS

Power Steering Gear

MakeZF-SERVOCOM
Model 8098
Prevost number661045
F.E.W..... 16,600 lbs (7 545 kg)
Pressure rating2,175 psi (150 Bar)
Gear ratio (center) 22.2 : 1
Gear ratio (extremities)..... 26.2 : 1
Minimum pump flow for 1.5 hwt/sec 4.22 gpm (16 lpm)

Power Steering Reservoir

Make Nelson Muffler
Oil capacity 4 US qts (3.7 liters)
Prevost number 660982
Make Nelson Muffler
Element filter - Prevost number..... 660987
Magnetic Drain Plug 667586

Steering Stabilizer Cylinder (Damper)

MakeArvin
Extended length..... 32.73±0.12"
Collapsed length..... 20.26±0.12"
Stroke..... 12.47±0.12"
Prevost number 660979
Dust cap - Prevost number 660980

SECTION 16: SUSPENSION

CONTENTS

1. Description	3
2. I-Beam Axle Front Suspension.....	3
2.1 AIR SPRINGS	3
2.1.1 Inspection	3
2.1.2 Removal	4
2.1.3 Installation	4
2.2 SHOCK ABSORBERS.....	4
2.2.1 Inspection	5
2.2.2 Removal	5
2.2.3 Installation	6
2.3 RADIUS RODS.....	6
2.3.1 Radius Rod Inspection	6
2.3.2 Radius Rod Removal	6
2.3.3 Bushing Removal	6
2.3.4 Bushing Installation	7
2.3.5 Radius Rod Installation	7
2.4 SWAY BAR.....	8
2.4.1 Removal	8
2.4.2 Installation	8
2.5 TORQUE SPECIFICATIONS.....	9
3. Rear Suspension.....	13
3.1 AIR SPRINGS	14
3.1.1 Inspection	14
3.1.2 Removal	14
3.1.3 Installation	15
3.2 SHOCK ABSORBERS.....	15
3.2.1 Inspection	16
3.2.2 Removal	16
3.2.3 Installation	16
3.3 RADIUS RODS.....	17
3.3.1 Rear Underframe Suspension.....	17
3.3.2 Tag Axle Suspension	18
3.4 TORQUE SPECIFICATIONS.....	20
4. Suspension Height Adjustment	21
5. Height Control Valve.....	22
5.1 MAINTENANCE	22
5.2 REMOVAL AND INSTALLATION	22
6. Air System	23
6.1 AIR TANK MAINTENANCE	23
6.1.1 Wet Air Tank.....	23
6.1.2 Primary Air Tank.....	23
6.1.3 Secondary Air Tank.....	23
6.1.4 Accessory Air Tank	24
6.1.5 Kneeling Air Tank	24
6.1.6 Parking Brakes Overtake Air Tank.....	24
6.2 EMERGENCY FILL VALVES	25

Section 16: SUSPENSION

7. Front Kneeling System	25
7.1 PRINCIPLE OF OPERATION	25
7.2 MAINTENANCE	26
7.3 BELLOWS CONTROL SOLENOID VALVES	26
7.3.1 <i>Removal And Installation</i>	26
8. Troubleshooting	26
9. Parts Specifications	27

ILLUSTRATIONS

FIGURE 1: FRONT SUSPENSION COMPONENTS	3
FIGURE 2: DETAILS OF FRONT SUSPENSION	3
FIGURE 3: AIR SPRING.....	3
FIGURE 4: SHOCK ABSORBER	5
FIGURE 5: TYPICAL SHOCK ABSORBER SETUP	6
FIGURE 6: TYPICAL RADIUS ROD SETUP	6
FIGURE 7: RADIUS ROD BUSHING REMOVAL.....	7
FIGURE 8: RADIUS ROD BUSHING INSTALLATION	7
FIGURE 9: RADIUS ROD INSTALLATION	7
FIGURE 10: I-BEAM FRONT AXLE SWAY BAR	8
FIGURE 11: REAR SUSPENSION COMPONENTS	13
FIGURE 12: SWAY BAR (REAR SUSPENSION)	13
FIGURE 13: REAR UNDERFRAME SUSPENSION	14
FIGURE 14: TAG AXLE SUSPENSION	14
FIGURE 15: AIR SPRING.....	14
FIGURE 16: SHOCK ABSORBER	16
FIGURE 17: TYPICAL SHOCK ABSORBER SETUP	17
FIGURE 18: TYPICAL RADIUS ROD SETUP	17
FIGURE 19: RADIUS ROD BUSHING REMOVAL.....	17
FIGURE 20: RADIUS ROD BUSHING INSTALLATION	18
FIGURE 21: RADIUS ROD INSTALLATION	18
FIGURE 22: TYPICAL RADIUS ROD SETUP	18
FIGURE 23: BALL JOINTS	19
FIGURE 24: TYPICAL AIR SPRING CLEARANCE	21
FIGURE 25: FRONT HEIGHT CONTROL VALVE.....	21
FIGURE 26: REAR HEIGHT CONTROL VALVE.....	22
FIGURE 27: I-BEAM FRONT SUSPENSION AIR TANKS LOCATION	24
FIGURE 28: REAR VALVE LOCATION.....	25
FIGURE 29: FRONT SERVICE COMPARTMENT	25

1. DESCRIPTION

The vehicle is provided with an air suspension system. The system consists of air springs, height control valves, radius rods, sway bars, tripod and shock absorbers. The system operation is fully automatic and maintains a constant vehicle height regardless of load, or load distribution.

The vehicle is also equipped with this system:

- Front Kneeling;

2. I-BEAM AXLE FRONT SUSPENSION

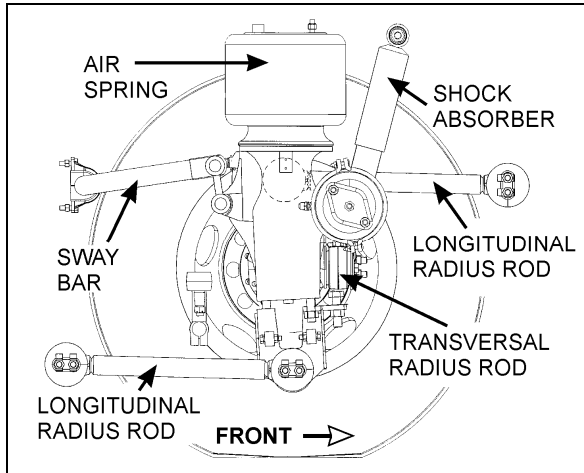

FIGURE 1: FRONT SUSPENSION COMPONENTS 16096

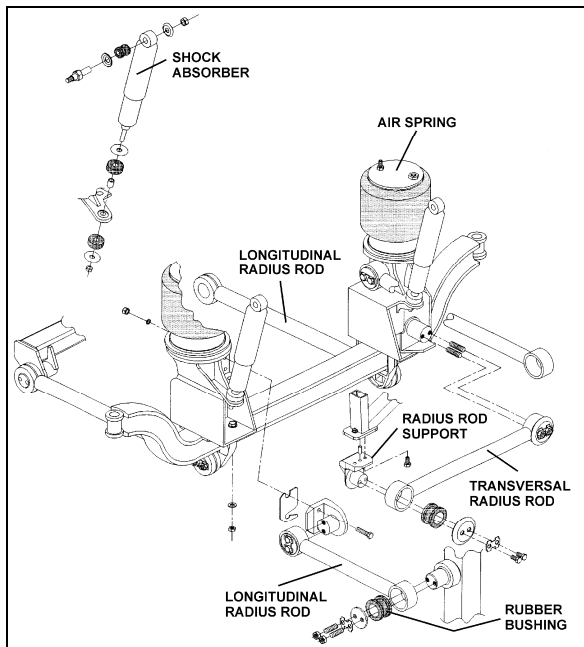

FIGURE 2: DETAILS OF FRONT SUSPENSION 16110

2.1 AIR SPRINGS

The air springs are made from a special compound rubber molded to the proper contour and dimensions. The entire vertical load of the

vehicle is supported by these springs. The I-beam front axle is provided with air springs that are attached to the subframe and to the axle (Fig. 3).

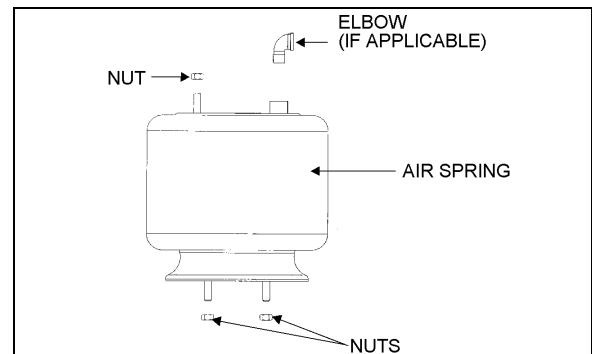



FIGURE 3: AIR SPRING 16052

2.1.1 Inspection

1. Check operation of bellows.
2. Visually inspect bellows for evidence of cracks, punctures, deterioration, or chafing. Replace the bellows if any damage is evident.

 <p>MAINTENANCE</p>
<p>Inspect air bellows every 6,250 miles (10 000 km) or twice a year whichever comes first.</p>

3. With the primary air system at normal operating pressure (95 - 125 psi (655 - 860 kPa)), coat all suspension air line connections and bellows mounting areas with a water and soap solution. Bubbles will indicate an air leak, and none is permissible. Repair or replace defective parts.

<p>NOTE</p> <p><i>If air spring is removed from vehicle, bellows can be lightly inflated and submerged in water to detect any leakage. If any leakage is detected, replace bellows.</i></p>
--

Section 16: SUSPENSION



WARNING

To prevent personal injury, do not apply more than 10 psi (69 kPa) of air pressure to the uninstalled air spring.

2.1.2 Removal

NOTE

Front suspension air springs can be removed without removing the entire axle assembly.

1. Safely support vehicle at the recommended body jacking points. To gain access to a given air spring, the corresponding wheel can be removed as follows.
 - a) Jack vehicle until the tire clears the ground, and place safety supports underneath body.



CAUTION

Only the recommended jacking points must be used as outlined in Section 18, "Body".

- b) Support the axle with a suitable hydraulic floor jack at the recommended jacking point.
 - c) Remove wheel.
2. Exhaust compressed air from accessory air tank by opening drain cock under reservoir.
 3. Disconnect the height control valve link and pull down the overtravel lever to ensure all air is exhausted from air springs.

NOTE

While performing this step, do not change the height control valve overtravel lever adjustment.

4. Disconnect air line from air spring, remove elbow (if applicable), and cover both the line end and fitting to prevent the entry of foreign matter.
5. Remove the air spring upper nut, and then the two lower nuts. Remove air spring.

2.1.3 Installation

1. Compress air spring as necessary, then aligning studs with their holes, position air spring between both the lower and upper

supports. Thread the lower nuts and the small upper nut a few turns.

NOTE

To facilitate air spring installation, compress it manually then put a piece of tape over the air line threaded fitting. This prevents air from getting back into the bag and keeps it compressed, thus enabling to place the bag in between the mounting plates and greatly easing installation.

2. Tighten the lower stud nuts, and then the upper one to appropriate torque (see Torque Table 1).
3. Thread the remaining upper nut (large nut) and tighten to appropriate torque (see Torque Table 1).
4. Install elbow (if applicable), then connect air line.
5. Connect the height control valve link.
6. Build up air pressure in system.

NOTE

To accelerate this operation, air reservoirs can be filled from an exterior air supply connected to the accessory tank fill valve or to the emergency fill valve.

7. Check operation of bellows, and with the primary air system at normal operating pressure (95 – 125 psi (655 – 860 kPa)), coat the air line connections and air spring mounting areas with a water and soap solution. Bubbles will indicate an air leak, and none is permissible. Repair or replace defective parts.
8. Reinstall wheel.
9. Remove the hydraulic floor jack from under the axle, then lower vehicle to ground.

2.2 SHOCK ABSORBERS

Double-action, telescoping-type shock absorbers ensure a smooth ride and enhance vehicle stability on the road. The front axle is provided with two shock absorbers (Fig. 1, 2, and 4).

Shock absorbers are non-adjustable and non-repairable. Maintenance requirements involve replacement of the rubber mounting bushings, and tightening of all shock absorber pins at the proper torque (see Torque Table 1) when shock

absorber replacement occurs. If a shock absorber becomes inoperative, complete unit must be replaced.

	<h2>CAUTION</h2>
<p>When a shock absorber is found defective, always replace with a new set on affected axle, except if there has been a recent replacement of one unit. The following method will help in determining if both shock absorbers on the same axle have to be replaced.</p>	

2.2.1 Inspection

Loosen lower mounting of both shocks, and then carefully attempt to raise and lower the bottom portion of each shock. Note the rate of effort for distance of travel. Replace both shocks if a definite differential rate is found.

The shock must be bench checked in an upright, vertical position. If checked in any other position, air will enter the cylinder tube and make the shock absorber appear defective.

Proceed as follows to check shock absorbers:

1. With the shock absorber in a vertical position (top end up), clamp the bottom mount in a vise.

	<h2>CAUTION</h2>
<p>Do not clamp the reservoir tube or the dust tube.</p>	

2. Rotate the dust tube. Notice any binding condition (may be compared with new unit). Binding condition indicates a scored rod. Units with scored rods should be replaced.
3. Fully extend shocks and check for leaks in the seal cover area. Shock fluid is a very thin hydraulic fluid that has a characteristic odor and dark brown tint. A slight trace of shock fluid around the seal cover area is not a cause for replacement. The shock seal is designed to permit a very slight seepage to lubricate the rod. Units that leak should be replaced.
4. Visually check shock for dents that could cause the shock to bind. Also, check for a bent rod.

5. Extend and collapse shock several times to determine that it has control (resistance) in both rebound and compression.
6. Visually inspect the shock mountings and vehicle mounting for:
 - a. Broken mounts;
 - b. Extreme bushing wear;
 - c. Shifted bushing or sleeve;
 - d. Deep cracks in bushing material (shallow surface cracks are normal);
 - e. Loose shock absorber pins;
 - f. Presence of convex washers, and their position relative to the rubber bushing.

2.2.2 Removal

1. Remove nuts and washers from shock absorbers on upper and lower mounting pins, taking care to identify the inner and outer washers to ease reinstallation. Refer to figure 4 for details.
2. Remove the shock absorber assembly from pins.
3. Remove the inner bushings from the shock absorber and discard.

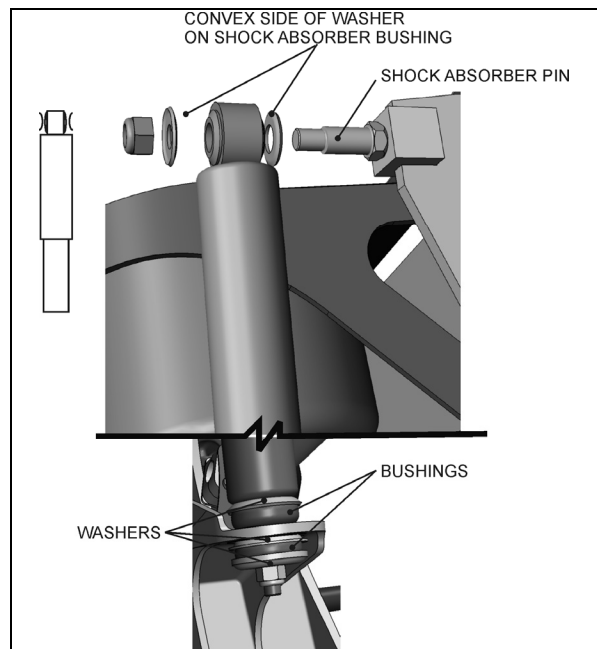

FIGURE 4: SHOCK ABSORBER

16008

Section 16: SUSPENSION

2.2.3 Installation

1. Ensure that the shock absorber mounting pins are tight and that the threads are not stripped.
2. Install new rubber mounting bushings on shock absorbers (upper and lower).
3. Place the inner washer (with washer convex side leaning on the shock absorber rubber bushing).
4. Install the shock absorber eyes over the mounting pins, then the outer washers (with washer convex side leaning on the shock absorber rubber bushing) on each shock absorber extremity.

NOTE

If shock absorber pins are removed, they must be reinstalled using "Loctite" (see "Parts Specifications" in this section).

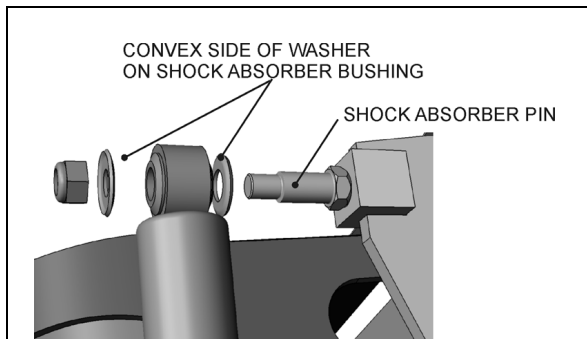

FIGURE 5: TYPICAL SHOCK ABSORBER SETUP 16009

5. Place the lower and upper mounting pin stud nuts and tighten to appropriate torque (see Torque Table 1).

2.3 RADIUS RODS

Radius rods are used to secure the axles in the proper transversal and longitudinal positions. Five radius rods are provided on the front axle suspension (four longitudinal and one transversal).

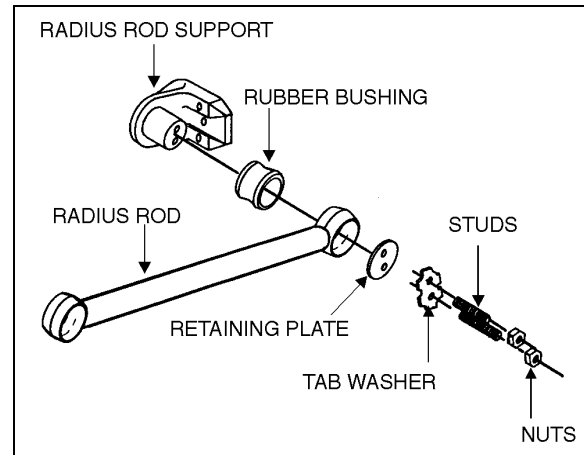

FIGURE 6: TYPICAL RADIUS ROD SETUP 16010

Refer to figures 1, 2 and 6 for details. These rods transmit both braking and driving forces from the axles to the vehicle body.

2.3.1 Radius Rod Inspection

The following instructions apply to all radius rods used on this vehicle:

1. Clean all parts thoroughly.
2. Inspect radius rods for distortion and cracks. We recommend the "Magnaflux" process to detect cracks in the radius rod. Any damaged part should be replaced with a new one.

NOTE

New bushings should be used when rods are replaced.

3. The radius rod bushings should be checked periodically for signs of shearing, deterioration, or damage. Any defective part should be replaced with a new one.

2.3.2 Radius Rod Removal

1. Flatten the tab washer which secures the two retaining nuts (or bolts), then unscrew the nuts (or bolts) at each extremity of the radius rod (Fig. 6).
2. Remove the tab washer and the retaining plates and radius rod ends from anchor pins, and then remove the radius rod.

2.3.3 Bushing removal

1. Safely support the radius rod as shown in figure 7.

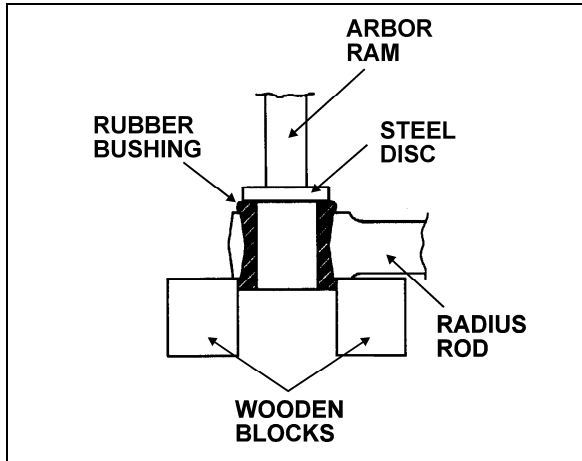

FIGURE 7: RADIUS ROD BUSHING REMOVAL 16011

2. Place a flat steel disc, slightly smaller than the outside diameter of the bushing (Fig. 7).
3. Using an arbor press or a suitable driving tool, press or drive the old bushing out of the rod and discard the bushing.

CAUTION

Make sure to prevent the steel disc from contacting the radius rod end.

2.3.4 Bushing installation

1. Lightly spray the inner and outer surfaces of radius rod bushing with water.

CAUTION

No lubricant whatsoever is to be used on the rubber bushing.

2. Safely support the radius rod, and place new bushing on top of the radius rod end (Fig. 8).
3. Place a block of wood on top of bushing and press on it manually.
4. If necessary, use an arbor press or a suitable driving tool. Press or drive the bushing into the radius rod end until it extends equally on both sides of the rod.
5. It is also possible to proceed differently. Place radius rod bushing on a plane surface. Spray a light coat of water on the inner and outer surfaces of radius rod bushing.
6. Take radius rod, align the bushing. Tap radius rod on bushing until latter is positioned correctly.

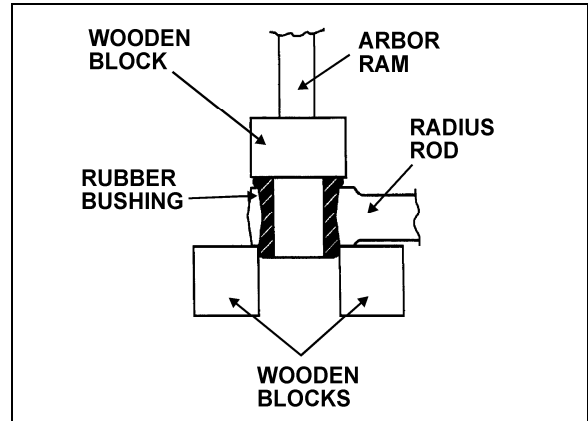

FIGURE 8: RADIUS ROD BUSHING INSTALLATION 16012

2.3.5 Radius Rod Installation

1. Lightly spray the radius rod support with water. Place the radius rod end over the radius rod support (Fig. 9).
2. Position the retaining plate. Install the tab washer and nuts (or bolts).

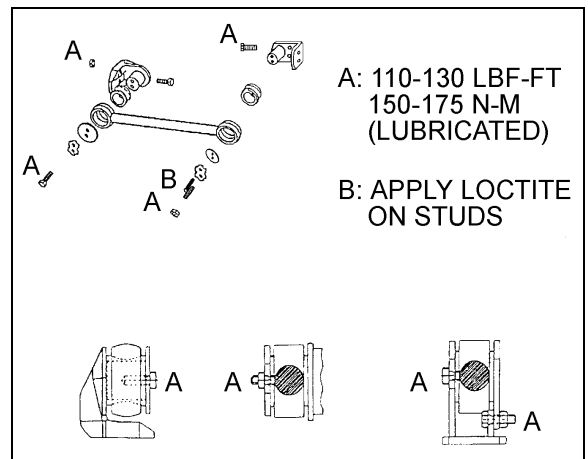

FIGURE 9: RADIUS ROD INSTALLATION 16028

CAUTION

Always use new tab washers at installation.

3. Tighten the nuts (or bolts) lightly, and repeat at the other end.
4. Refer to heading "Suspension Height Adjustment" later in this section, and set the vehicle to normal ride height.
5. With the vehicle at normal ride height, apply oil on threads and tighten all radius rod anchor pin nuts or bolts to appropriate torque (see Torque Table 1).

Section 16: SUSPENSION



CAUTION

It is extremely important upon reconnection of the rods that the proper clearance height between the axle and body be maintained. Otherwise, the rubber bushings in radius rod ends will become preloaded, thus reducing their life span.

2.4 SWAY BAR

A sway bar is provided on the front axle to increase vehicle stability. It controls lateral motion (swaying movement) of the vehicle (Fig. 10).

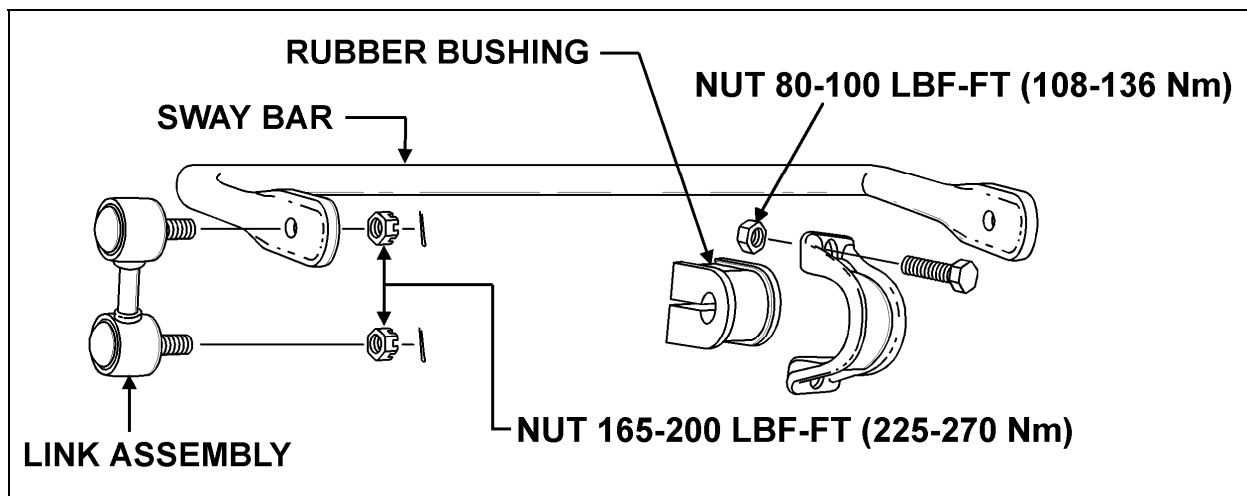

FIGURE 10: I-BEAM FRONT AXLE SWAY BAR

16099

2.4.1 Removal

1. Disconnect the two links from sway bar.
2. Safely support the sway bar. Unbolt the four bushing collars from subframe.
3. Remove sway bar.

NOTE

Sway bar bushings are slitted to ease their removal.

2.4.2 Installation

1. Loosely install the sway bar.
2. Tighten the eight bushing collar nuts to appropriate torque (see Torque Table 1).
3. Install two sway bar link upper and lower nuts and tighten to appropriate torque (see Torque Table 1).
4. Install a cotter pin on each nut and bend.

SECTION 16: SUSPENSION

2.5 TORQUE SPECIFICATIONS

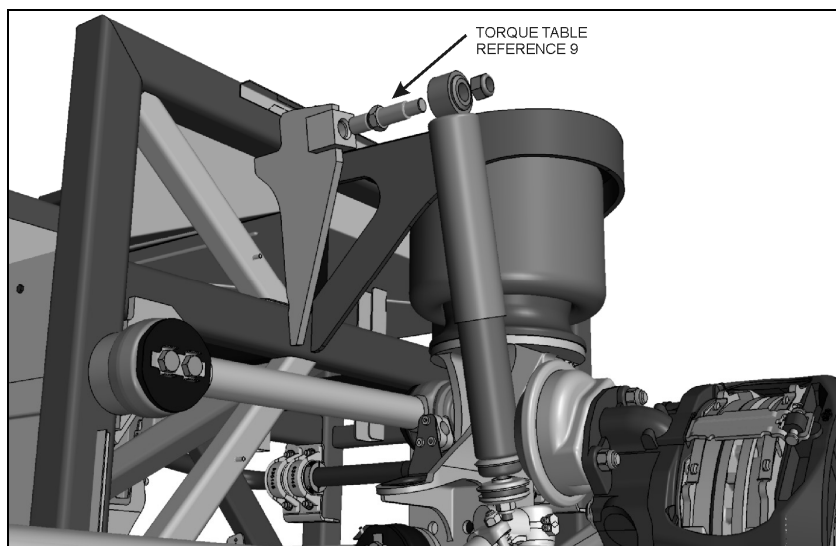
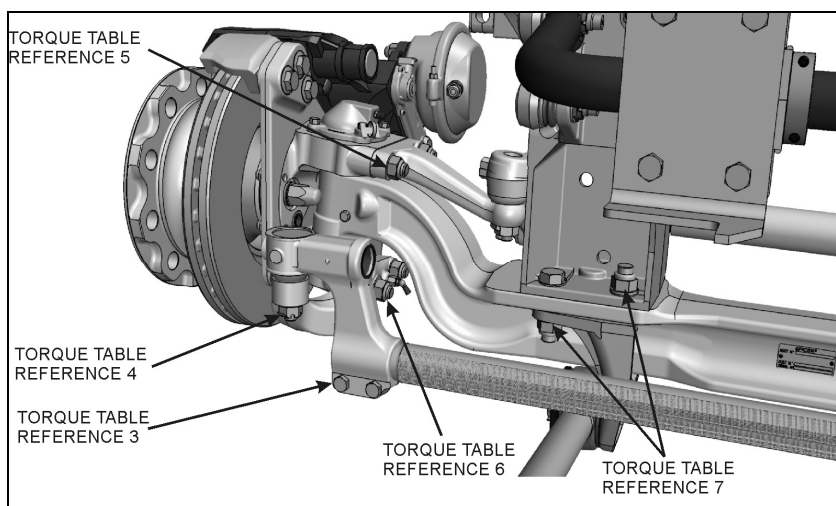
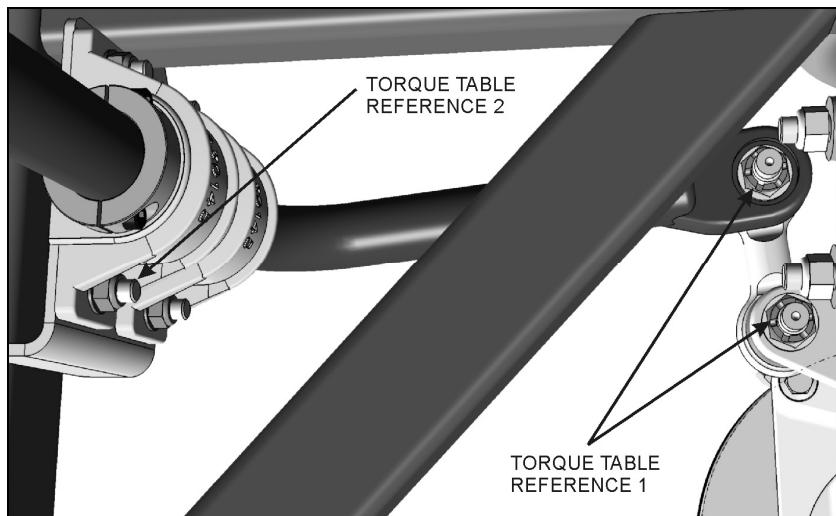

Section 16: SUSPENSION

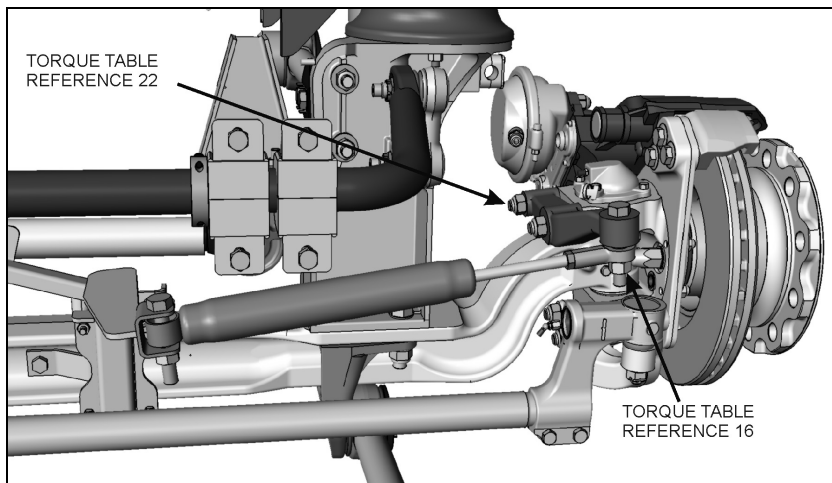
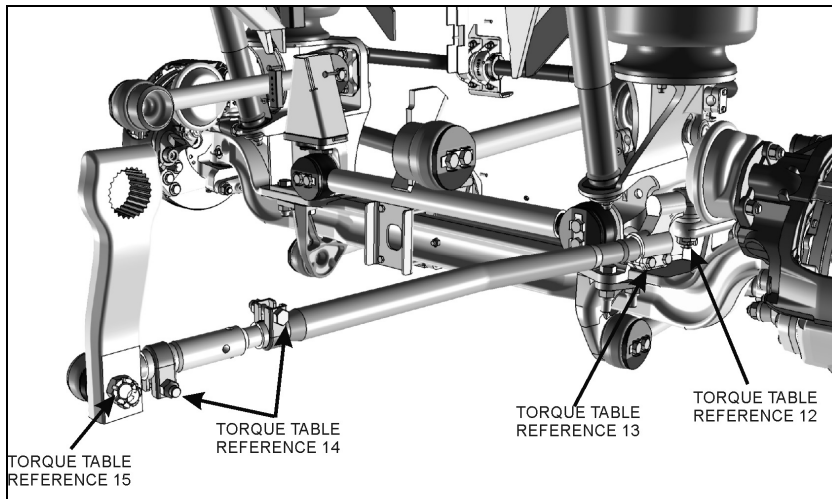
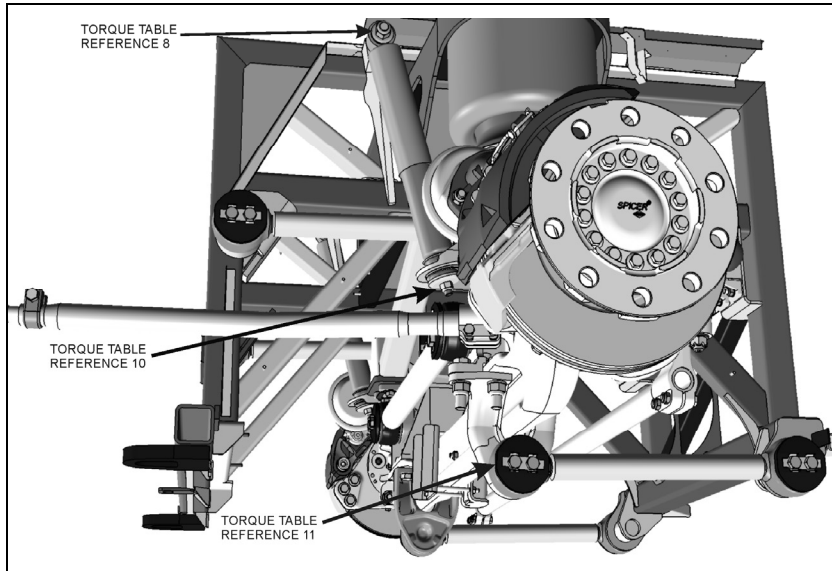

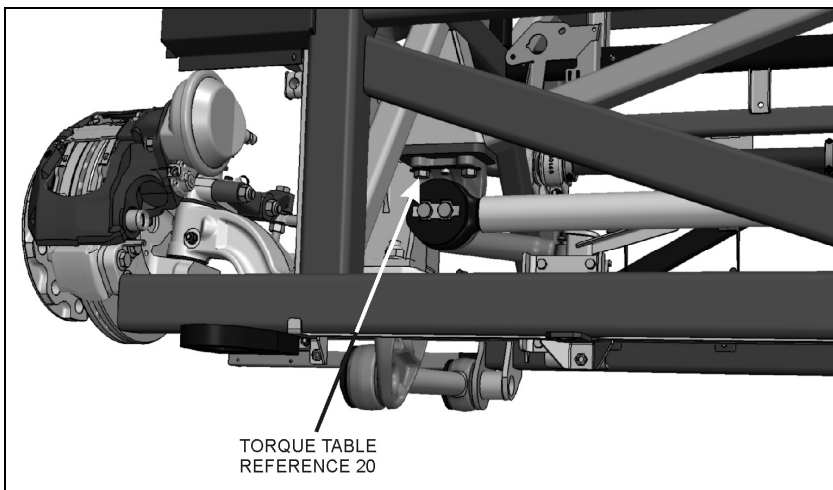
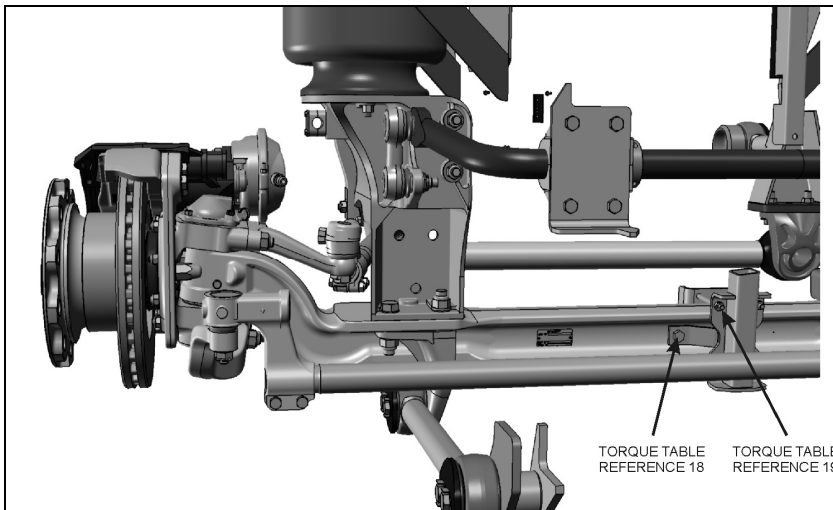
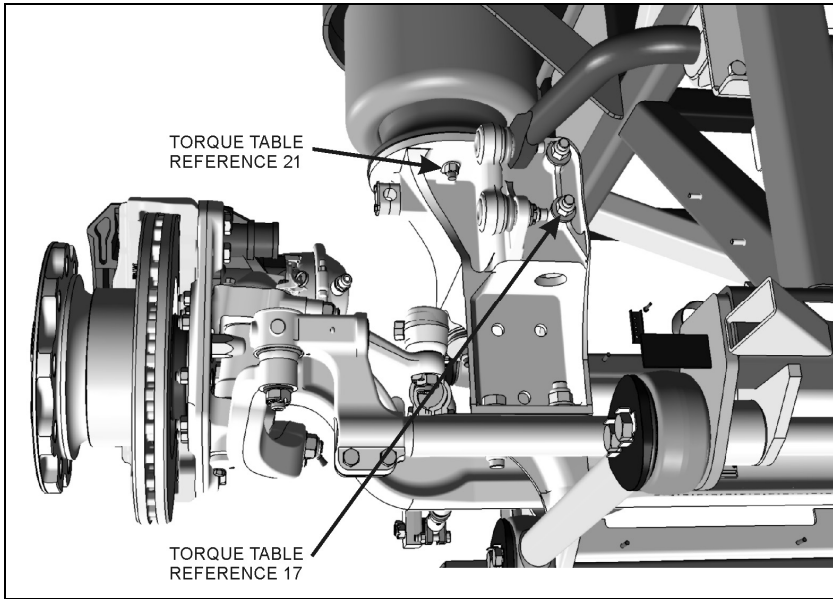

Section 16: SUSPENSION

The following table lists the tightening torque for fasteners requiring a specific torque value. When no torque specifications are indicated, use the Standard Torque Specifications table found in Section 00: General Information of the Maintenance Manual.

SPECIFIC TORQUE TABLE 1 – FRONT AXLE SUSPENSION & STEERING				
DESCRIPTION	QTY	REFERENCE	TORQUE DRY (lbf-ft / Nm)	
SWAY BAR LINK UPPER AND LOWER NUTS	4	1	165-200	224-271
SWAY BAR BUSHING COLLAR (FRONT SUSPENSION)	8	2	80-100	108-136
TIE ROD END CLAMP PINCH BOLT	4	3	65-75	88-102
TIE ROD END BALL PIN NUT	2	4	150-200	203-271
STEERING ARM STUD NUT	2	5	520-575	705-780
TIE ROD ARM STUD NUT	4	6	520-575	705-780
I-BEAM AXLE MOUNT	8	7	230-280	311-378
SHOCK ABSORBER UPPER MOUNTING PIN STUD NUT	2	8	99-121	134-164
SHOCK ABSORBER PIN	2	9	350-400	475-545
SHOCK ABSORBER LOWER MOUNTING PIN NUT	2	10	60-75	81-102
RADIUS ROD RETAINING BOLT	20	11	140-155	190-210
DRAG LINK BALL PIN NUT	1	12	150-200	203-271
DRAG LINK CLAMP BOLT NUT	2	13	65-75	88-102
DRAG LINK SOCKET END CLAMP PINCH BOLT	2	14	50-60	68-81
DRAG LINK TO PITMAN ARM STUD NUT	1	15	150-200	203-271
STEERING DAMPER	2	16	100-120	135-160
RADIUS ROD SUPPORT	4	17	228-252	309-342
STEERING DAMPER BRACKET	1	18	39-45	53-61
STEERING DAMPER BRACKET	4	19	30-36	41-49
RADIUS ROD SUPPORT	2	20	200-220	271-298
AIR SPRING NUT	6	21	31-38	42-52
STEERING DAMPER ARM NUTS	2	22	285-315	386-427

3. REAR SUSPENSION

For a description of all these systems, refer to the appropriate heading in this section.

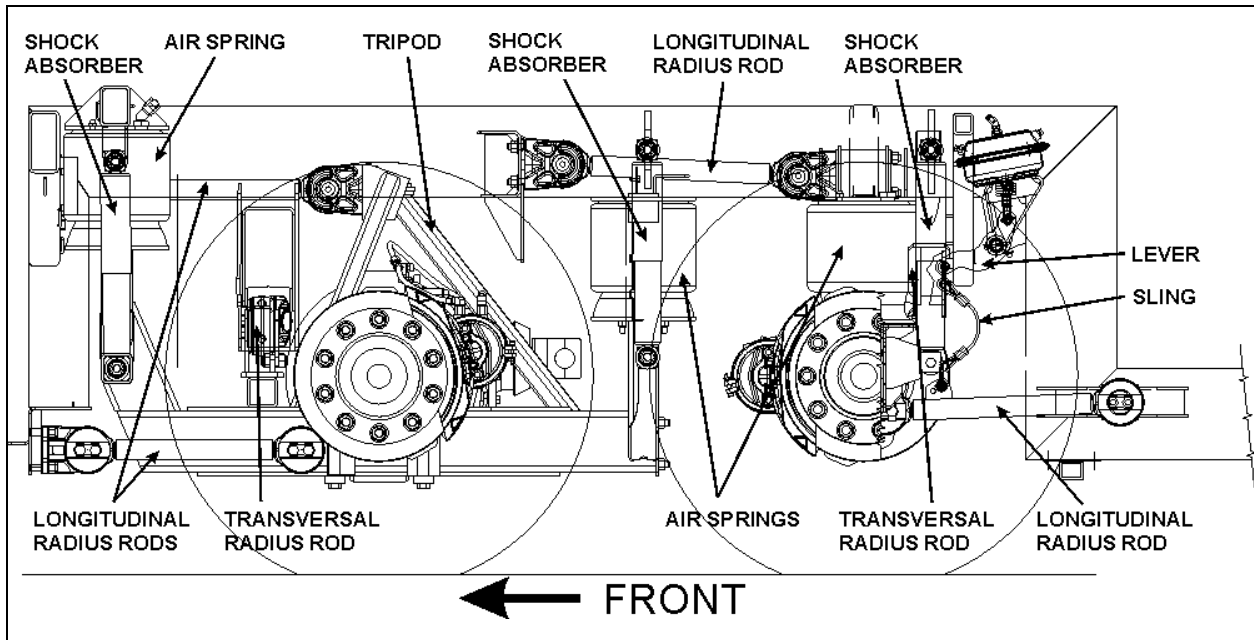

FIGURE 11: REAR SUSPENSION COMPONENTS

16167

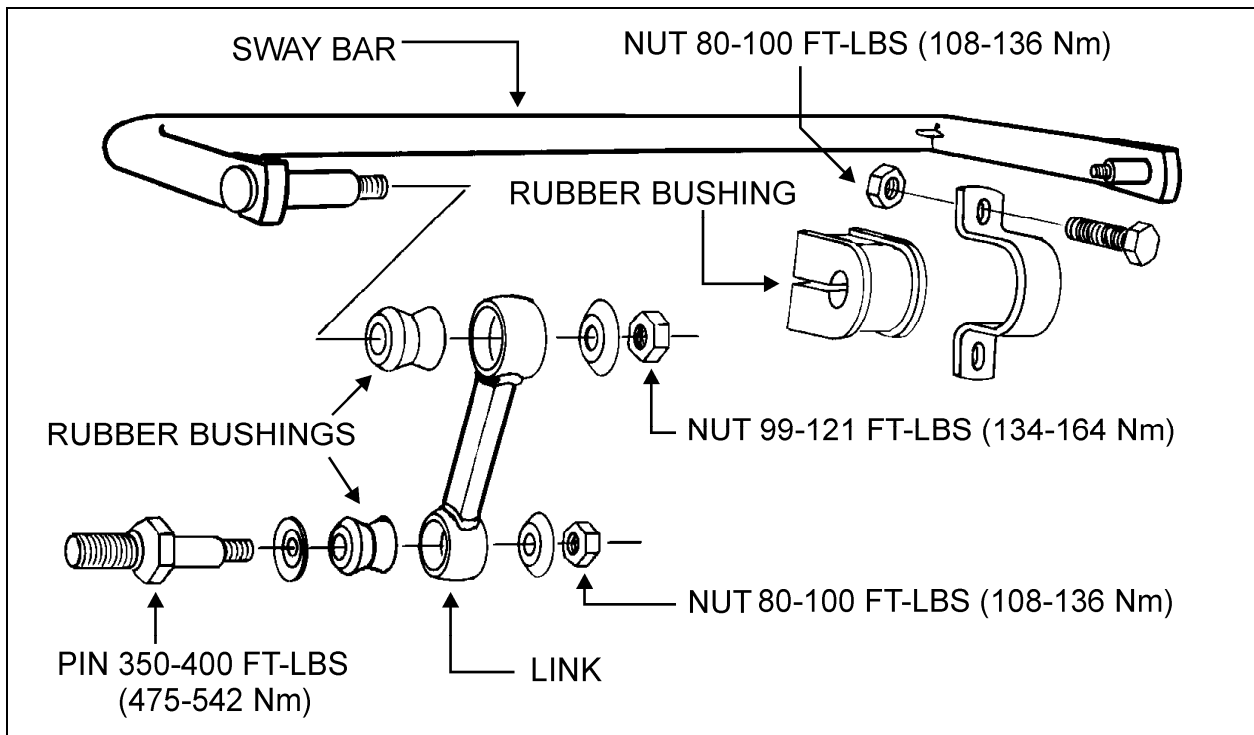

FIGURE 12: SWAY BAR (REAR SUSPENSION)

16144

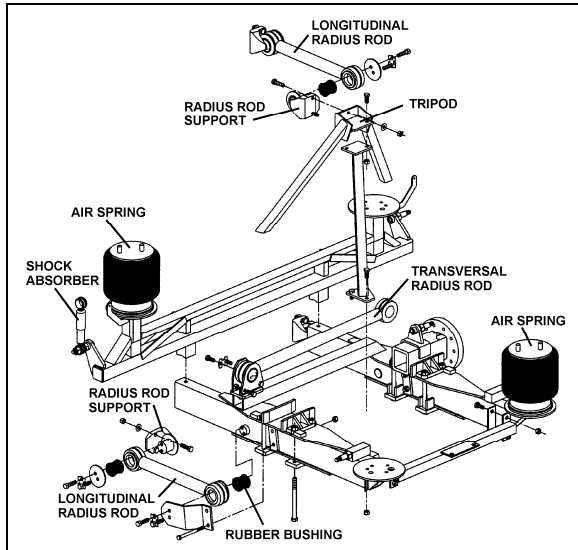

FIGURE 13: REAR UNDERFRAME SUSPENSION 16106

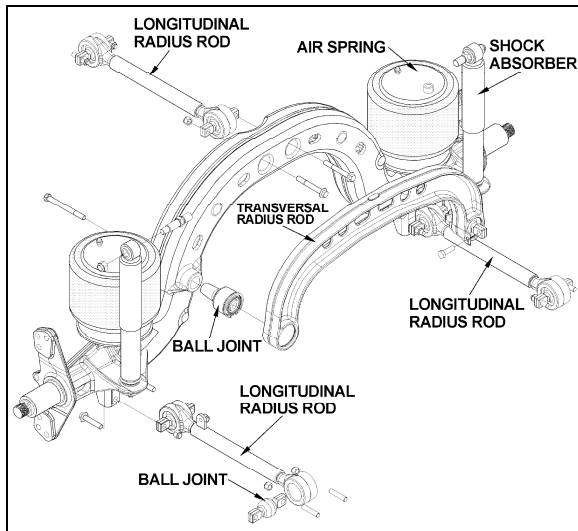

FIGURE 14: TAG AXLE SUSPENSION 16107

3.1 AIR SPRINGS

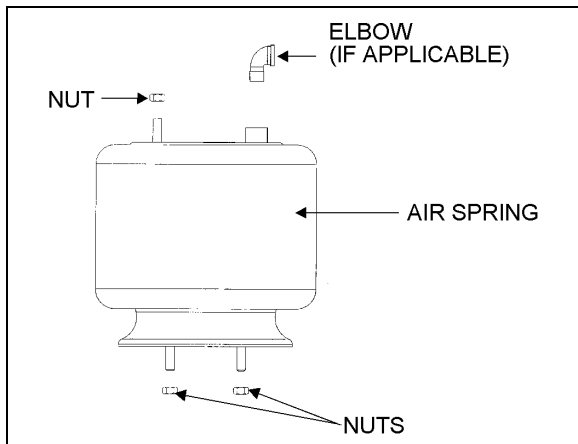

FIGURE 15: AIR SPRING 16052

The air springs are made from a special compound rubber molded to the proper contour and dimensions. The entire vertical load of the vehicle is supported by these springs. Each of the two axles is provided with air springs that are attached to the subframe and to the axles (Fig. 41).

3.1.1 Inspection

1. Check operation of bellows.
2. Visually inspect bellows for evidence of cracks, punctures, deterioration, or chafing. Replace the bellows if any damage is evident.

MAINTENANCE

Inspect air bellows every 6,250 miles (10 000 km) or twice a year whichever comes first.

3. With the primary air system at normal operating pressure (95 - 125 psi (655 - 860 kPa)), coat all suspension air line connections and bellows mounting areas with a water and soap solution. Bubbles will indicate an air leak, and none is permissible. Repair or replace defective parts.

NOTE

If air spring is removed from vehicle, bellows can be lightly inflated and submerged in water to detect any leakage. If any leakage is detected, replace bellows.

WARNING

To prevent personal injury, do not apply more than 10 psi (69 kPa) of air pressure to the uninstalled air spring.

3.1.2 Removal

NOTE

Suspension air springs (drive and tag axles) can be removed without removing the entire axle assembly.

1. Safely support vehicle at the recommended body jacking points. To gain access to a given air spring, the corresponding wheel can be removed as follows.

- a) Jack vehicle until the tire clears the ground, and place safety supports underneath body.

**CAUTION**

Only the recommended jacking points must be used as outlined in Section 18, "Body".

- b) Support the axle with a suitable hydraulic floor jack at the recommended jacking point.
 - c) Remove wheel.
2. Exhaust compressed air from accessory air tank by opening drain cock under reservoir.
 3. Disconnect the height control valve link and pull down the overtravel lever to ensure all air is exhausted from air springs.

NOTE

While performing this step, do not change the height control valve overtravel lever adjustment.

4. Disconnect air line from air spring, remove elbow (if applicable), and cover both the line end and fitting to prevent the entry of foreign matter.
5. Remove the air spring upper nut, and then the two lower nuts. Remove air spring.

3.1.3 Installation

1. Compress air spring as necessary, then aligning studs with their holes, position air spring between both the lower and upper supports. Thread the lower nuts and the small upper nut a few turns.

NOTE

To facilitate air spring installation, compress it manually then put a piece of tape over the air line threaded fitting. This prevents air from getting back into the bag and keeps it compressed, thus enabling to place the bag in between the mounting plates and greatly easing installation.

2. Tighten and torque the lower stud nuts, and then the upper one to 20–25 lbf-ft (27–34 Nm).
3. Screw on the remaining upper nut (large nut) and tighten to 20–25 lbf-ft (27–34 Nm).

4. Install elbow (if applicable), then connect air line.
5. Connect the height control valve link.
6. Build up air pressure in system.

NOTE

To accelerate this operation, air reservoirs can be filled from an exterior air supply connected to the accessory tank fill valve or to the emergency fill valve.

7. Check operation of bellows, and with the primary air system at normal operating pressure (95 – 125 psi (655 – 860 kPa)), coat the air line connections and air spring mounting areas with a water and soap solution. Bubbles will indicate an air leak, and none is permissible. Repair or replace defective parts.
8. Reinstall wheel.
9. Remove the hydraulic floor jack from under the axle, then lower vehicle to ground.

3.2 SHOCK ABSORBERS

Double-action, telescoping-type shock absorbers ensure a smooth ride and enhance vehicle stability on the road. All shock absorbers are eye-type mountings. The tag axle is provided with two shock absorbers while the drive axle is provided with four of them (Fig. 13, 14 and 16).

Shock absorbers are non-adjustable and non-repairable. Maintenance requirements involve replacement of the rubber mounting bushings, and tightening of all shock absorber pins at the proper torque of 500 - 550 lbf-ft (680 - 750 Nm) when shock absorber replacement occurs. If a shock absorber becomes inoperative, complete unit must be replaced.

**CAUTION**

When a shock absorber is found defective, always replace with a new set on affected axle, except if there has been a recent replacement of one unit. The following method will help in determining if both shock absorbers on the same axle have to be replaced.

Section 16: SUSPENSION

3.2.1 Inspection

Loosen lower mounting of both shocks, and then carefully attempt to raise and lower the bottom portion of each shock. Note the rate of effort for distance of travel. Replace both shocks if a definite differential rate is found.

The shock must be bench checked in an upright, vertical position. If checked in any other position, air will enter the cylinder tube and make the shock absorber appear defective.

Proceed as follows to check shock absorbers:

1. With the shock absorber in a vertical position (top end up), clamp the bottom mount in a vise.



CAUTION

Do not clamp the reservoir tube or the dust tube.

2. Rotate the dust tube. Notice any binding condition (may be compared with new unit). Binding condition indicates a scored rod. Units with scored rods should be replaced.
3. Fully extend shocks and check for leaks in the seal cover area. Shock fluid is a very thin hydraulic fluid that has a characteristic odor and dark brown tint. A slight trace of shock fluid around the seal cover area is not a cause for replacement. The shock seal is designed to permit a very slight seepage to lubricate the rod. Units that leak should be replaced.
4. Visually check shock for dents that could cause the shock to bind. Also, check for a bent rod.
5. Extend and collapse shock several times to determine that it has control (resistance) in both rebound and compression.
6. Visually inspect the shock mountings and vehicle mounting for:
 - a) Broken mounts;
 - b) Extreme bushing wear;
 - c) Shifted bushing or sleeve;
 - d) Deep cracks in bushing material (shallow surface cracks are normal);
 - e) Loose shock absorber pins;
 - f) Presence of convex washers, and their position relative to the rubber bushing.

3.2.2 Removal

1. Remove nuts and washers from shock absorbers on upper and lower mounting pins, taking care to identify the inner and outer washers to ease reinstallation. Refer to figure 16 for details.
2. Remove the shock absorber assembly from pins.
3. Remove the two inner bushings from the shock absorber and discard them.

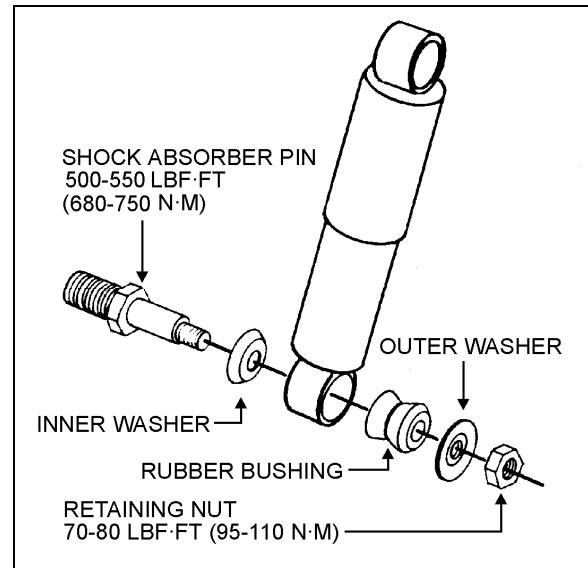

FIGURE 16: SHOCK ABSORBER

16008

3.2.3 Installation

1. Ensure that the shock absorber mounting pins are tight and that the threads are not stripped.
2. Install new rubber mounting bushings on shock absorbers (upper and lower).
3. Place the inner washers (with washer convex side facing the shock absorber rubber bushing) on each shock absorber pin (Fig. 16).
4. Install the shock absorber eyes over the mounting pins, then the outer washers (with washer convex side facing the shock absorber rubber bushing) on each shock extremity.

NOTE

If shock absorber pins are removed, they must be reinstalled using "loctite" (see "Parts Specifications" in this section).

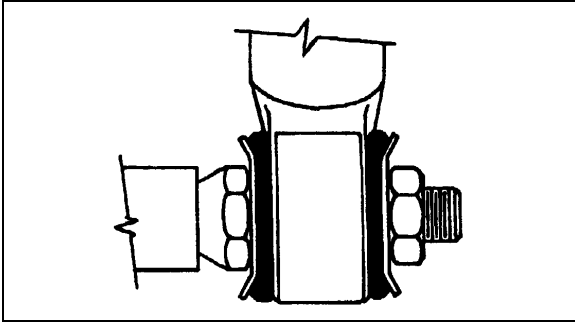

FIGURE 17: TYPICAL SHOCK ABSORBER SETUP 16009

- Place the lower and upper mounting pin stud nuts and torque to 70 - 80 lbf-ft (95 - 110 Nm).

3.3 RADIUS RODS

Radius rods are used to secure the axles in the proper transversal and longitudinal positions. Four radius rods are provided on the drive axle suspension (three longitudinal and one transversal) and also four on the tag axle with a layout similar to the drive axle. Refer to figures 13, 14 and 18 for details. These rods transmit both braking and driving forces from the axles to the vehicle body.

3.3.1 Rear Underframe Suspension

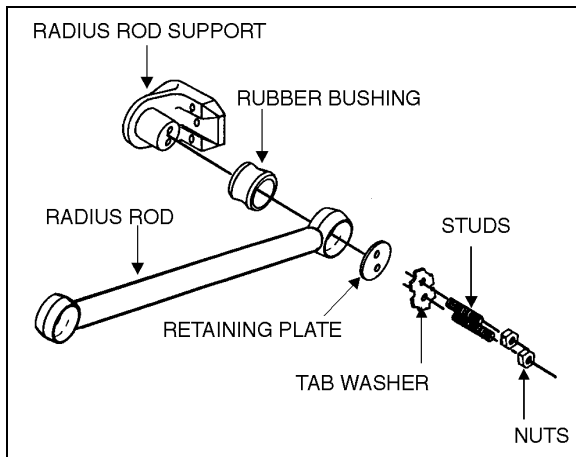

FIGURE 18: TYPICAL RADIUS ROD SETUP 16010

Radius Rod Inspection

The following instructions apply to the radius rods used on the rear underframe suspension:

- Clean all parts thoroughly.
- Inspect radius rods for distortion and cracks. We recommend the "Magnaflux" process to detect cracks in the radius rod. Any

damaged part should be replaced with a new one.

NOTE

New bushings should be used when rods are replaced.

- The radius rod bushings should be checked periodically for signs of shearing, deterioration, or damage. Any defective part should be replaced with a new one.

Radius Rod Removal

- Flatten the tab washer which secures the two retaining nuts (or bolts), then unscrew the nuts (or bolts) at each extremity of the radius rod (Fig. 19).
- Remove the tab washer and the retaining plates and radius rod ends from anchor pins, and then remove the radius rod.

Bushing removal

- Safely support the radius rod as shown in figure 19.

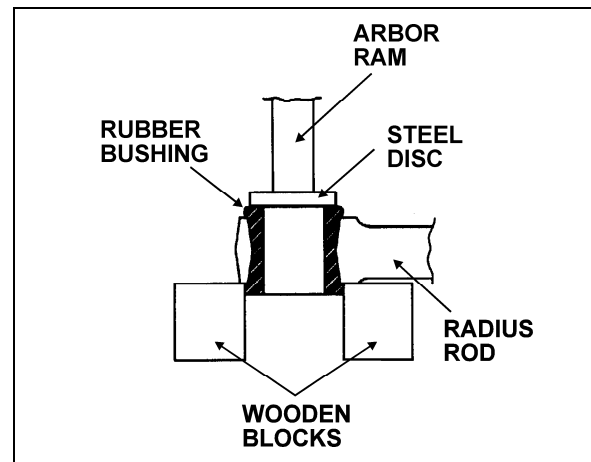

FIGURE 19: RADIUS ROD BUSHING REMOVAL 16011

- Place a flat steel disc, slightly smaller than the outside diameter of the bushing (Fig. 19).
- Using an arbor press or a suitable driving tool, press or drive the old bushing out of the rod and discard the bushing.



CAUTION

Make sure to prevent the steel disc from contacting the radius rod end.

Bushing installation

1. Lightly spray the inner and outer surfaces of radius rod bushing with water.

CAUTION

No lubricant whatsoever is to be used on the rubber bushing.

2. Safely support the radius rod, and place new bushing on top of the radius rod end (Fig. 20).
3. Place a block of wood on top of bushing and press on it manually.
4. If necessary, use an arbor press or a suitable driving tool. Press or drive the bushing into the radius rod end until it extends equally on both sides of the rod.
5. It is also possible to proceed differently. Place radius rod bushing on a plane surface. Spray a light coat of water on the inner and outer surfaces of radius rod bushing.
6. Take radius rod, align the bushing. Tap radius rod on bushing until latter is positioned correctly.

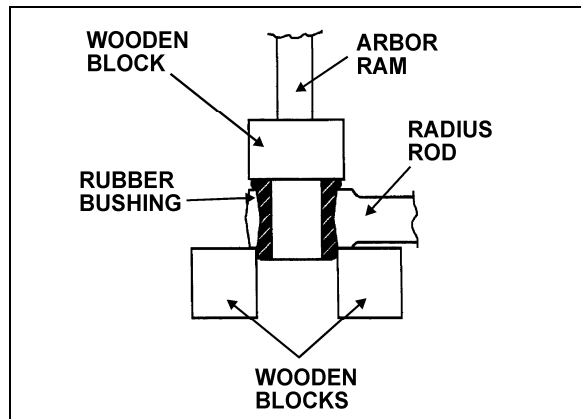

FIGURE 20: RADIUS ROD BUSHING INSTALLATION 16012

Radius Rod Installation

1. Lightly spray the radius rod support with water. Place the radius rod end over the radius rod support (Fig. 21).
2. Position the retaining plate. Install the tab washer and nuts (or bolts).

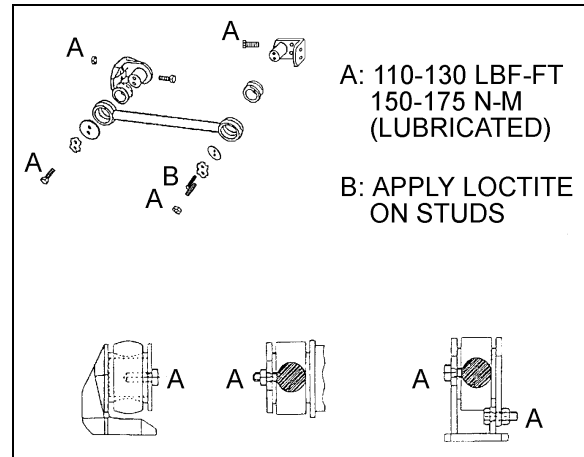

FIGURE 21: RADIUS ROD INSTALLATION 16028

CAUTION

Always use new tab washers at installation.

3. Tighten the nuts (or bolts) lightly, and repeat at the other end.
4. Refer to heading "Suspension Height Adjustment" later in this section, and set the vehicle to normal ride height.
5. With the vehicle at normal ride height, apply oil on threads and tighten all radius rod anchor pin nuts or bolts to 110 – 130 lbf-ft (150 – 175 Nm).

CAUTION

It is extremely important upon reconnection of the rods that the proper clearance height between the axle and body be maintained. Otherwise, the rubber bushings in radius rod ends will become preloaded, thus reducing their life span.

3.3.2 Tag Axle Suspension

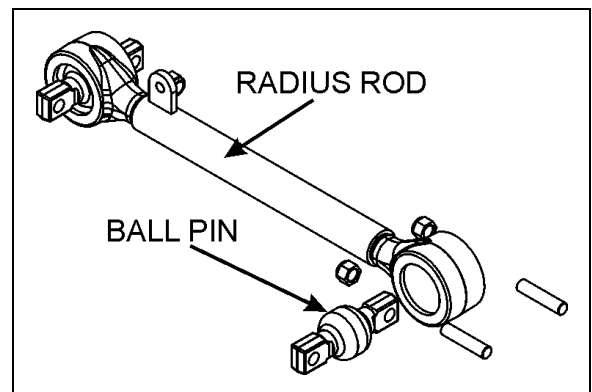

FIGURE 22: TYPICAL RADIUS ROD SETUP 16010

The assembly work may be done only by a recognized specialized workshop. Ensure that old and new parts do not get mixed up with each other. It is for this reason that all the old parts are to be scrapped immediately after a joint has been stripped down. A complete repair set must be used for each joint repaired, i.e. use of only part of a repair set is not permissible.

Radius Rod Inspection

Take off the load from the ball joint by lifting the rear of the vehicle. Apply a load on the joint in all of the degrees of freedom in an axial, radial, etc. sense with a suitable lever tool. After the load is taken off, the joint has to spring back into its starting position. Free play is not acceptable.

Separation of rubber from ball pin or external joint shell is in accordance with "normal wear characteristics".

When the following characteristics are noted, the joint is to be changed:

- Free play;
- Radial cracking of the external sheet-metal race.

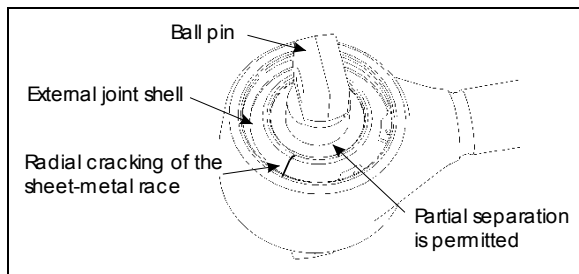

FIGURE 23: BALL JOINTS

16173

Stripping Down

Strip down the defective joint through removal of retaining ring, annular spacer and ball pin/bushing, assembly and thereafter clean out housing bore and locking circlips groove.

Radius Rod Assembly

Execute assembly of the new joint parts in the following sequence:

1. Complete moistening of the contact surface between housing bore and ball pin through application of the grease.

NOTE

Apply grease, only in the case of repair kit (Prevost # 611114).

2. Insert ball pin/bushing, assembly. In case of the two-bolt type, ensure that the bolt bores are in the correct position in relation to the axis of the tube.
3. Place joint in receiving fixture and mount annular assembly tool on the housing. Then locate annular spacer and retaining ring in the housing using axial load with the aid of assembly matrix. If the ends of the annular spacer are not in contact with each other, the thus formed opening must be located at 180° to the opening of the retaining ring. Pay attention during assembly to ensure that the retaining ring eyelets are located at each side of the housing shaft axis (retaining ring eyelet lug points to tube), and that retaining ring is properly engaged in the groove of the housing.

When repairing defective ball pin assemblies, the necked down-bolt must regularly be replaced with a new one.

Section 16: SUSPENSION

3.4 TORQUE SPECIFICATIONS

The following table lists the tightening torque for fasteners requiring a specific torque value. When no torque specifications are indicated, use the Standard Torque Specifications table found in Section 00: General Information of the Maintenance Manual.

SPECIFIC TORQUE TABLE 2 – REAR SUSPENSION			
DESCRIPTION	QTY	TORQUE DRY (lb-ft / Nm)	
<i>Radius Rod Stud</i>	2	20-40	27-54
<i>Radius Rod Retaining Nut or Bolt</i>	2	110-130	150-175
<i>Radius Rod Support Nut</i>	4	110-130	150-175
<i>Sway Bar Link Upper Nuts</i>	2	99-121	134-164
<i>Sway Bar Link Lower Nuts</i>	2	80-100	108-136
<i>Shock Absorber Support</i>	4	145-165	196-224
<i>Air Spring Lower Nut</i>	4	20-25	27-34
<i>Air Spring Upper Nut</i>	2	20-25	27-34

* Tighten nut to specified torque, then advance to next aligning cotter pin slot and install a new cotter pin.

4. SUSPENSION HEIGHT ADJUSTMENT

The flow of pressurized air from the accessory air tank to the air springs is controlled by three height control valves. The two rear valves are mounted to the subframe and connected to the rear axles through an arm and link connection. The front valve is mounted to the subframe and connected to the front air tank support. These connections allow the valves to apportion air pressure in the springs to the vehicle load, maintaining normal ride height.

Immediate response height control valves increase or decrease the air pressure in the suspension system as required. One height control valve is located **at center of front sway bar**, and regulates air to front suspension air springs in order to maintain the vehicle at the required height. Two are located at the drive axle, one on each inner side of rear wheelhousing.

The appropriate vehicle body height is obtained by measuring the clearance of all the air springs installed on the vehicle. The two front air springs clearance should be $11 \pm \frac{1}{4}$ " (279 \pm 6 mm). Refer to figure 24 to identify the correct area to take measurement. The rear air springs clearance should be $11 \frac{1}{2} \pm \frac{1}{4}$ " (292 \pm 6 mm).

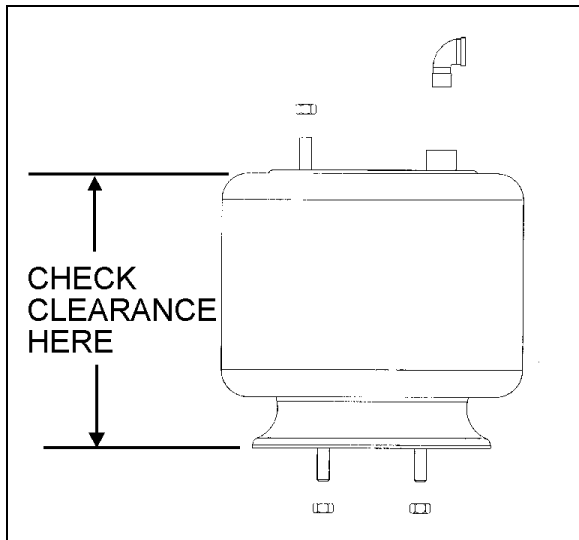

FIGURE 24: TYPICAL AIR SPRING CLEARANCE 16058

At this point, it should not be necessary to make an adjustment under normal service conditions. However, if an adjustment is required, change the position of the overtravel lever in relation to the overtravel control body. The lever should be moved up to raise vehicle height, and down to lower it. Check that main air pressure is at

normal operating pressure and raise the vehicle to the specified height.



CAUTION

Always adjust on "fill cycle". If it is necessary to lower vehicle height, release sufficient air to be well below height, and adjust to height or fill cycle.

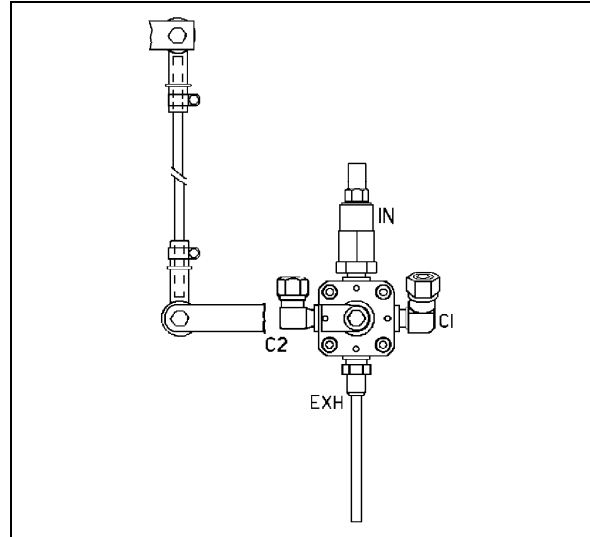

FIGURE 25: FRONT HEIGHT CONTROL VALVE 16100

The normal ride height is obtained by adjusting air spring clearance of both front and rear suspension as follows:

Front air spring clearance

1. With the vehicle at normal operating air pressure [100 - 125 psi (689 - 860 kPa)], measure air spring clearance. This clearance should be $11 \pm \frac{1}{4}$ " (279 \pm 6 mm).

NOTE

The measurement should be taken from underneath the upper air spring support on subframe to top of the lower air spring support on axle (refer to figure 24 for more details). If adjustment is required, begin with the drive axle.

2. Loosen the clamp on the height control valve rubber coupling and bring it up or down (Fig. 25).

NOTE

Allow suspension to stabilize before taking reading.

When the desired height is obtained, tighten clamp.

Rear air spring clearance

1. With the vehicle at normal operating air pressure [100 - 125 psi (689 - 860 kPa)], measure air spring clearance. This clearance should be $11 \frac{1}{2} \pm \frac{1}{4}$ " (292 \pm 6 mm).

NOTE
The measurement should be taken from underneath the upper air spring support on subframe to top of the lower air spring support on axle (refer to figure 24 for more details).

2. Loosen the clamp on the height control valve rubber coupling and bring it up or down (Fig. 26).

NOTE
Allow suspension to stabilize before taking reading.

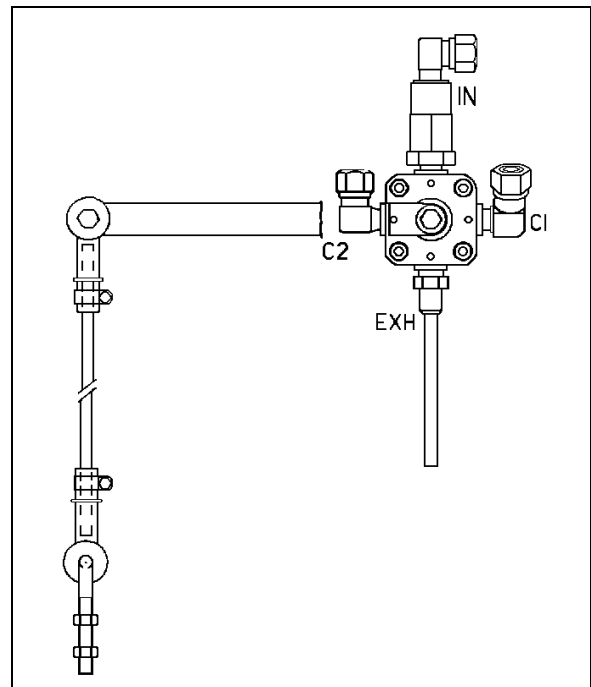

FIGURE 26: REAR HEIGHT CONTROL VALVE 16093

When the desired height is obtained, tighten clamp.

5. HEIGHT CONTROL VALVE

The height control valves automatically add air to, or release air from air springs to maintain constant suspension height regardless of load,

or load distribution. Each valve adjusts independently according to the following conditions:

Loading Position

As the load increases and lowers the vehicle body, the overtravel lever commands the height control valve to add air to air springs.

Neutral Position

When vehicle body reaches the normal ride height, the height control valve overtravel lever reaches the "neutral" position and keeps both the supply and exhaust ports closed to ensure normal ride height is maintained. This condition remains static until the vehicle load is altered.

Unloading Position

As the load decreases and raises the vehicle body, the overtravel lever commands the height control valve to release air from air springs.

5.1 MAINTENANCE

The height control valve requires no periodic maintenance. Height control valve linkage operates on rubber bushings and no lubrication should be attempted at this location. Inspect the valve for loose joints, air leaks and worn bushings.

5.2 REMOVAL AND INSTALLATION

Before disconnecting a height control valve air line, securely support the vehicle by its jacking points on the body, and place safety supports underneath body. Refer to paragraph "16. Vehicle Jacking Points" in Section 18, "Body".

1. Exhaust air from air system by opening all air tank drain cocks. Remove height control valves.
2. Disconnect overtravel lever from link and pull down lever to exhaust remaining air from air springs.
3. Disconnect air supply and delivery lines from the height control valve. Cover line ends with tape to prevent entry of foreign matter.
4. Remove the nuts retaining the height control valve to the mounting bracket, then remove valve assembly.

Reverse removal procedure to replace height control valve. After installation, check for leakage using a soap and water solution.

6. AIR SYSTEM

The basic air system consists of an air compressor, tanks, valves, filters and interconnecting lines and hoses (refer to Maintenance Manual, Section 12, "Brake and Air System" for complete information). It provides a means for braking, operating controls and accessories, and suspension. An air system schematic diagram is annexed at the end of this section for better understanding of the system.

The air coming from the air dryer is first directed to the wet air tank, then to the primary (for the primary brake system), secondary (for the secondary brake system), and accessory (for the pneumatic accessories) air tanks (Fig. 27).

6.1 AIR TANK MAINTENANCE

Ensure that the accessories air tank is purged during pre-starting inspection. A good practice is to purge this tank at the end of every driving day by the remote air tank drain valve located in the front service compartment (Fig. 29).

Moreover, purge all tanks by their bottom drain valves at specified intervals.

6.1.1 Wet Air Tank

This tank is installed above the drive axle on the L.H. side, and is provided with a bottom drain valve. It is recommended to **purge** the wet air tank by its bottom drain valve every 12,500 miles (20 000 km), or once a year, whichever comes first.

A remote valve located in engine compartment and accessible through engine R.H. side door is used to **drain** the air dryer (Fig. 28).

6.1.2 Primary Air Tank

The primary air tank is located above the drive axle on the R.H. side.

This tank is provided with a bottom drain valve (Fig. 53 and 54). It is recommended to purge the primary air tank by its bottom drain valve every 12,500 miles (20 000 km) or once a year, whichever comes first.

6.1.3 Secondary Air Tank

This tank is located in front wheelhousing, between air springs. The tank is provided with a bottom drain valve (Fig. 27).

It is recommended to purge the tank by its bottom drain valve, every 12,500 miles (20 000 km) or once a year, whichever comes first.

Section 16: SUSPENSION

6.1.4 Accessory Air Tank

The accessory air tank is installed next to the secondary air tank. The tank is provided with a bottom drain valve (Fig. 27).

It is recommended to purge the tank by its bottom drain valve, every 12,500 miles (20 000 km) or once a year, whichever comes first.

A remote drain valve is located in front service compartment (Fig. 29) underneath the accessory air filter. Refer to Section 12, paragraph "4. Accessory Air Filter" of the maintenance manual for daily purge procedure.

6.1.5 Kneeling Air Tank

The kneeling air tank is located in the front wheelhousing (Fig. 27), and is provided with a bottom drain valve.

6.1.6 Parking Brakes Override Air Tank

The parking brakes override air tank is installed at the ceiling of the rear baggage compartment, on the L.H. side and is provided with a bottom drain valve.

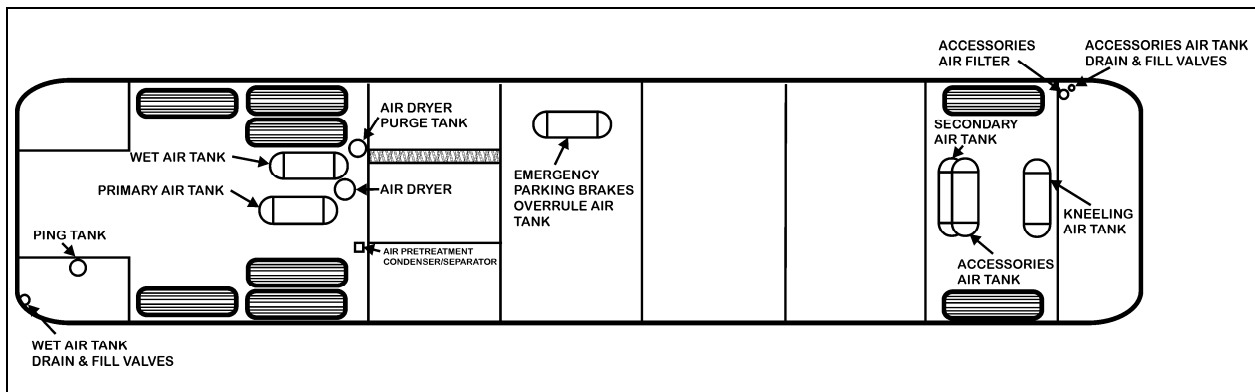

FIGURE 27: I-BEAM FRONT SUSPENSION AIR TANKS LOCATION

24035

6.2 EMERGENCY FILL VALVES

The vehicle is equipped with two air system emergency fill valves to supplement the air system when air pressure is low and engine cannot be operated.

The **rear valve** is located in engine compartment and accessible from engine R.H. side door (Fig. 28).

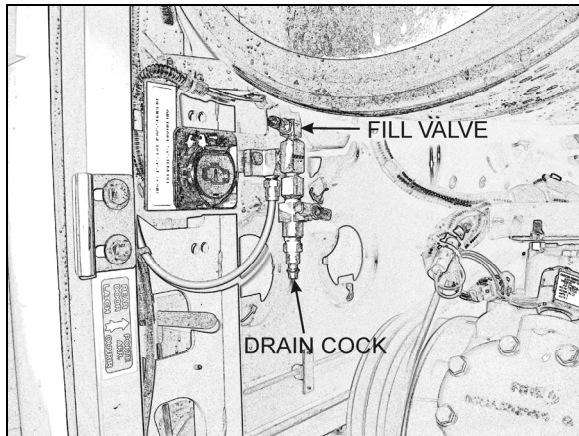

FIGURE 28: REAR VALVE LOCATION

12211



CAUTION

No other point should be used to supply air system. The maximum allowable air pressure is 125 psi (860 kPa).

The front valve is located in the front service compartment close to accessory air filter (Fig. 29).

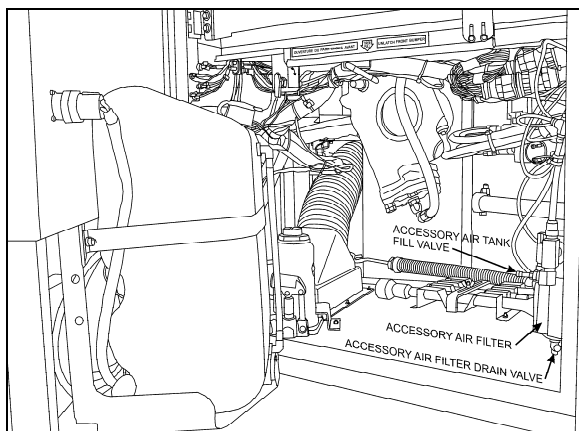

FIGURE 29: FRONT SERVICE COMPARTMENT

These two air valves are fitted with the same valve stems as standard tires, and can be filled by any standard external air supply line.

The rear valve will supply air for all systems (brakes, suspension and accessories) while the front valve will supply air for accessories only.



CAUTION

Air filled through these two points will pass through the standard air filtering system provided by Prevost. Do not fill air through any other points.

7. FRONT KNEELING SYSTEM

The kneeling system is used to lower the front of vehicle. This allows passengers to board the vehicle with greater ease. The kneeling action is achieved by exhausting air from the front air springs (bellows). This system bypasses the height control valve to provide a fast up and down movement of the front suspension. Only four seconds are required to lower vehicle from normal level to the lowered position, and approximately the same time to raise the vehicle back to normal level. The quick response is achieved by an auxiliary air tank installed beside the secondary air reservoir (for exact position, refer to Section 12, "Brake and Air System"). This tank provides sufficient air supply to the kneeling system for some successive operations.

The system is provided with two safety features; first, a speed switch will enable the kneeling system to work only at less than 5 mph (8 km/h). Secondly, the parking brake is automatically applied, and a limit switch will keep it applied as long as the vehicle has not returned to a certain height where the driver will be able to manually remove the parking brake.

7.1 PRINCIPLE OF OPERATION

Refer to the air system schematic diagram annexed at the end of Section 12, "Brake and Air System".

DOWN (FRONT KNEELING):

Both the bellows control and bellows exhaust solenoid valves are energized, so the air control valves release air from front air springs. The height control valve is bypassed to ensure no air is forwarded to air springs while lowering the front suspension.

Section 16: SUSPENSION

7.2 MAINTENANCE

Since the kneeling action is issued from both the air system and electrical system, refer to Section: 12, "*Brake and Air System*" and Section 06, "*Electrical System*".

For diagnosis and understanding of the system, refer to wiring diagrams, and to the appropriate air system schematic diagram annexed to Section 12, "*Brake and Air System*".

7.3 BELLOWS CONTROL SOLENOID VALVES

7.3.1 Removal and installation

1. On the rear side of steering compartment, locate both the bellows control and bellows exhaust solenoid valves.
2. Identify hoses and wires to ease reinstallation. Disconnect solenoid wires and the three flexible black hoses from solenoid valves.
3. Unscrew and remove the control solenoid valve and exhaust solenoid valve assembly. Place on a clean working place.

Reverse removal procedure to reinstall.



CAUTION

Any cable tie that has been cut during removal procedure should be replaced with a new one.

8. TROUBLESHOOTING

Condition	Cause	Correction
Bellows deflate over time	<ol style="list-style-type: none"> 1. Defective check valve assembly. 2. Defective exhaust valve assembly. 3. Leak in air line and/or bellows. 4. Defective valve cover, rubber O-rings or gasket. 	<ol style="list-style-type: none"> 1. Replace check valve assembly. 2. Replace exhaust valve assembly. 3. Replace air line or bellows. 4. Replace valve cover, O-rings or gasket.
Bellows raise to full height and fail to exhaust air pressure	<ol style="list-style-type: none"> 1. A clogged exhaust screen in height control valve assembly. 2. A combination clogged exhaust screen and defective air inlet valve assembly. 	<ol style="list-style-type: none"> 1. Remove and clean screen. 2. Clean exhaust screen and replace air inlet valve assembly.
Erratic valve action	<ol style="list-style-type: none"> 1. Dirt or foreign matter in the air valve lever chamber. 2. Defectives valves. 	<ol style="list-style-type: none"> 1. Remove valve cover and blow out dirt. Install cover using new gasket. 2. Overhaul height control valve assembly
Vehicle body fails to level to satisfactory ride height	<ol style="list-style-type: none"> 1. Improper height control valve overtravel lever adjustment 	Adjust lever as directed.

9. PARTS SPECIFICATIONS**I-Beam Front Axle and tag axle air springs**

Type Mae West
 Nominal diameter 12" (304 mm)
 Prevost number 630125

Drive axle air springs

Type Double Flare
 Nominal diameter 11.5" (292 mm)
 Prevost number 630104

I-Beam Front suspension shock absorbers

Color Black
 Ext. Diam. 75 mm
 Collapsed length 14.88" (378 mm)
 Extended length 23.86" (606 mm)
 Prevost number 630254

Drive and tag axle shock absorbers

Color Black
 Ext. Diam. 75 mm
 Collapsed length 15.51" (394 mm)
 Extended length 24.37" (619 mm)
 Prevost number 630253

Height control valve (Front only)

Quantity used 1
 Prevost number 630157

Height control valve (Rear only)

Quantity 2
 Prevost number 630156

Bellows control and exhaust solenoid valve assembly**Solenoid valve manifold**

Prevost number 641130

Coil

Voltage 24 V DC
 Current draw 29 amperes
 Prevost number 641144

Valve (3 way, 2 positions)

Type N/C
 Prevost number 641357

Type N/O
 Prevost number 641356

Radius rod bushing

Make Prevost
 Prevost number 630021

Loctite

Make Loctite
 Prevost number 680039

Sway bar bushing (Front Suspension)

Make Prevost
 Prevost number 630020

Sway bar link

Prevost number 630230

Shock absorber bushings

Prevost number 630062

Air regulator

Recommended pressure sett. . 90 psi (621 kPa)
 Prevost number 641352

SECTION 18: BODY

CONTENTS

1. VEHICLE EXTERIOR	4
2. VEHICLE STRUCTURE	5
3. VEHICLE EXTERIOR MAINTENANCE	5
3.1 CORROSION PREVENTION	5
3.2 PREVENTIVE MAINTENANCE SCHEDULE	6
3.3 RUST INHIBITOR APPLICATION	6
4. COMMON FIBERGLASS REPAIR PROCEDURE	11
4.1 REPAIR USING FIBERGLASS CLOTH	11
4.2 REPAIR USING FIBERGLASS PASTE.....	11
4.3 TYPICAL FIBERGLASS REPAIR PROCEDURE	12
5. COMMON PAINTING PROCEDURE	13
5.1 NEW PAINT CARE	13
5.2 PAINT TOUCHUP	13
5.3 PAINTING.....	14
5.3.1 Safety	14
5.3.2 Surface Preparation And Paint Application	14
6. X3-45 COACHES EXTERIOR FINISHING AND BODY REPAIR	15
6.1 ZONE 1	15
6.1.1 Front Bumper.....	15
6.1.2 Headlights.....	16
6.1.3 Rear View Mirrors (Rosco).....	16
6.1.4 Windshield Wipers.....	18
6.1.5 Windshield.....	18
6.1.6 Bi-Fold Entrance Door.....	19
6.1.7 Front Electrical & Service Compartment Door.....	23
6.1.8 Front Cap.....	27
6.2 ZONE 2	28
6.2.1 Lateral Fixed Window.....	28
6.2.2 Emergency Exit Windows.....	29
6.2.3 Roof Escape Hatch	30
6.3 ZONE 3	32
6.3.1 Rear Cap	32
6.3.2 Engine Compartment Doors.....	32
6.3.3 Rear Bumper.....	33
6.3.4 Exhaust Aftertreatment System Access Door.....	33
6.4 ZONE 4	33
6.4.1 Rear Fender	34
6.4.2 Engine Compartment R. H. Side Door.....	34
6.4.3 Engine Radiator Door.....	34
6.5 ZONE 5	35
6.5.1 Baggage Compartment Doors	35
6.5.2 Baggage Compartment Floor.....	37
6.5.3 Evaporator Compartment Door.....	40
6.5.4 Condenser Compartment Door.....	41
6.5.5 Fuel Filler Door.....	41
6.6 ZONE 6	42
6.6.1 Front Fender.....	42

Section 18: BODY

6.7	ZONE 7	42
6.7.1	X3 Smooth Side Panel Replacement Procedure	43
6.7.2	Side Crest	49
6.8	BODY PANEL AND WINDOW SPACING	50
6.9	PASSENGER SEATS	51
6.9.1	Rotating Seats	51
6.9.2	Removing Fixed Seats	51
6.9.3	Upholstery Maintenance	51
6.10	TARABUS FLOOR COVERING REPAIR OR REPLACEMENT	53
6.10.1	Front Steps Replacement Procedure	55
6.10.2	Welding Of Joint Between White Safety Strip And "Tarabus" Floor Covering	58
6.10.3	Repair Of A Welded Joint	61
7.	VEHICLE JACKING POINTS	61
7.1	HYDRAULIC JACK	62
8.	TOWING THE VEHICLE	62
8.1	LIFTING FROM THE FRONT	62
8.2	TOWING WITH A FRONT FLAT TIRE	64
8.3	MOVING A VEHICLE FROM THE REAR	65

ILLUSTRATIONS

FIGURE 1:	X3 COACHES EXTERIOR VIEW	4
FIGURE 2:	FIBERGLASS REPAIR	12
FIGURE 3:	FIBERGLASS REPAIR	12
FIGURE 4:	FIBERGLASS REPAIR	12
FIGURE 5:	FIBERGLASS REPAIR	13
FIGURE 6:	FIBERGLASS REPAIR	13
FIGURE 7:	X3 COACHES ZONING	15
FIGURE 8:	ZONE 1	15
FIGURE 9:	FRONT BUMPER RELEASE HANDLE	16
FIGURE 10:	FRONT BUMPER COMPARTMENT	16
FIGURE 11:	FRONT BUMPER REMOVAL	16
FIGURE 12:	REAR VIEW MIRROR (ROSCO)	16
FIGURE 13:	OUTSIDE REAR-VIEW MIRROR	17
FIGURE 14:	WINDSHIELD INSTALLATION USING ROPE	18
FIGURE 15:	APPLICATION OF SIKA 221 BLACK	19
FIGURE 16:	ENTRANCE DOOR & WIPER CONTROL PANEL	19
FIGURE 17:	ENTRANCE DOOR - VIEW FROM INSIDE	19
FIGURE 18:	ENTRANCE DOOR OPERATING BUTTONS	20
FIGURE 19:	ENTRANCE DOOR CONTROL SWITCH	20
FIGURE 20:	ENTRANCE DOOR - VIEW FROM OUTSIDE	21
FIGURE 21:	EXTERIOR UNLATCH AIR VALVE	21
FIGURE 22:	INTERIOR UNLATCH AIR VALVE	21
FIGURE 23:	DAMPER	22
FIGURE 24:	DOOR PANEL ADJUSTMENTS	22
FIGURE 25:	UPPER DOOR HINGE	23
FIGURE 26:	SEAL COMPRESSION ADJUSTMENT	23
FIGURE 27:	ZONE 2	28
FIGURE 28:	X3-45 COACH	30
FIGURE 29:	EMERGENCY EXIT WINDOW	30
FIGURE 30:	ESCAPE HATCH	31
FIGURE 31:	ESCAPE HATCH	32

FIGURE 32: ZONE 3.....	32
FIGURE 33: ENGINE COMPARTMENT DOORS	33
FIGURE 34: REAR BUMPER	33
FIGURE 35: ZONE 4.....	33
FIGURE 36: ENGINE COMPARTMENT R.H. SIDE DOOR	34
FIGURE 37: RADIATOR DOOR	34
FIGURE 38: ZONE 5.....	35
FIGURE 39: EVAPORATOR DOOR.....	41
FIGURE 40: CONDENSER DOOR	41
FIGURE 41: FUEL FILLER DOOR.....	41
FIGURE 42: ZONE 6.....	42
FIGURE 43: ZONE 7.....	42
FIGURE 44: SIDE CREST POSITIONING	49
FIGURE 45: BODY PANEL AND WINDOW SPACING (TYPICAL)	50
FIGURE 46: ARMREST	51
FIGURE 47: SEAT PEDESTAL ASSEMBLY.....	51
FIGURE 48: TARABUS FLOOR COVERING ADHESIVE APPLICATION	54
FIGURE 49: APPLICATION OF SIKA 221 GRAY	54
FIGURE 50: JACKING POINTS ON FRAME	62
FIGURE 51: REAR END JACKING POINTS.....	62
FIGURE 52: JACKING POINTS ON I-BEAM FRONT AXLE	62
FIGURE 53: JACKING POINTS ON DRIVE AXLE	62
FIGURE 54: JACKING POINTS ON TAG AXLE	62
FIGURE 55: TOW EYES UNDER VEHICLE.....	63
FIGURE 56: AXLE FORKS	63
FIGURE 57: FRONT TOWING AIR SUPPLY CONNECTORS.....	64

1. VEHICLE EXTERIOR

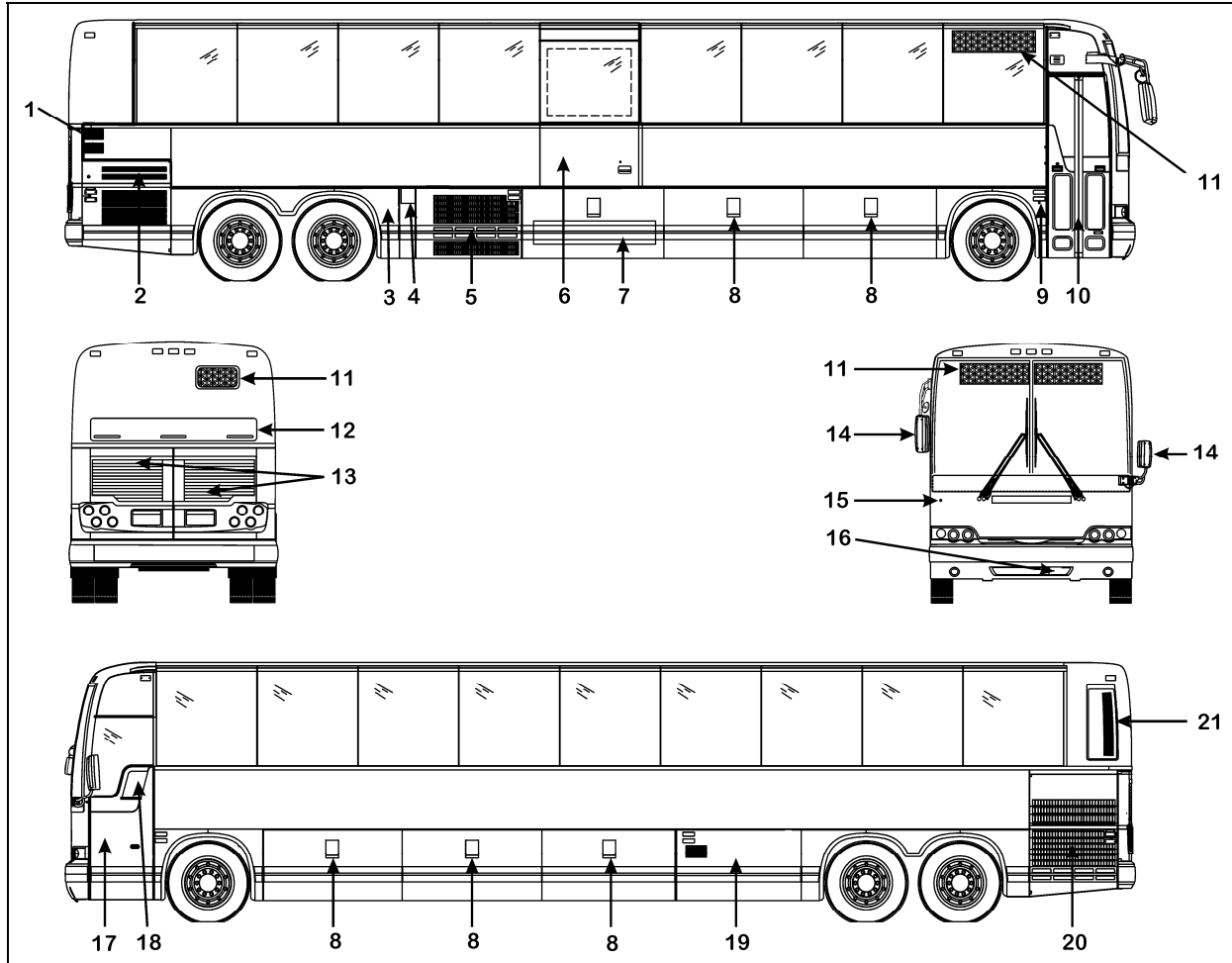

FIGURE 1: X3 COACHES EXTERIOR VIEW

18606

- | | |
|---|--|
| 1. Engine air intake | 13. Engine compartment rear doors |
| 2. Engine compartment curb-side door | 14. Rear-view mirrors |
| 3. Hinged rear fender | 15. Transmission retarder OFF indicator light |
| 4. Fuel filler door | 16. Front towing air supply connectors access door |
| 5. Condenser compartment | 17. Front electrical and service compartment |
| 6. Wheelchair access door | 18. Driver's power window |
| 7. Lift mechanism access door | 19. Evaporator compartment and engine coolant heater compartment |
| 8. Baggage compartment | 20. Radiator door |
| 9. Entrance door control switch | 21. Catalytic converter access door |
| 10. Bi-fold entrance door | |
| 11. Electronic destination sign or route number | |
| 12. Exhaust aftertreatment system access door | |

2. VEHICLE STRUCTURE

The body of the X3-45 coaches is an integral structure made of 14, 16 and 18 gauge welded and braced high tensile steel and stainless steel members. All stainless exterior panels are glued to anti-corrosion coated members. The complete structure is protected against corrosion prior to assembly. The front and rear caps are made of molded fiberglass. The main roof is made of high tensile aluminum panels riveted to the roof structure. The floor is made of 2 layers of ½" (13 mm) thick plywood separated by a 1/8" (3 mm) insulation to reduce power train and road noises.

Welding

Since welding is a procedure that may be carried out either as specific instructions from Prévost or by an independent decision of the owner, the following information pertaining to welding should be read before beginning any welding procedure. The prohibitions and requirements outlined below must be followed during welding procedure:

1. Welding must be done only by a qualified and experienced person.
2. Adequate ground contacts and shields must be positioned as required to protect components from damage due to heat, contact by weld splatter, arcing, or other potentially damaging events associated with welding.
3. The following precautions are to be taken to protect the electronic control components. Refer to section 00, paragraph 3: "PRECAUTIONS TO BE OBSERVED BEFORE WELDING" in this manual.
4. Always wear the appropriate safety equipment.
5. Weld in clean and well ventilated area, and always have an appropriate fire extinguisher within your reach.

3. VEHICLE EXTERIOR MAINTENANCE

Regular washing to remove dust and dirt is recommended. See *"Operator's Manual"* for more details on washing and cleaning your vehicle.

3.1 CORROSION PREVENTION

Preventive maintenance is a key factor in avoiding corrosion and must be considered as part of the regular service intervals. The entire

underside of the vehicle is sprayed with a heavy application of asphalt base undercoating.

The operating environment the vehicle is subjected to will largely influence the amount of dirt and corrosion that will accumulate over a given period. Corrosion is one of the most costly factors of part failure and shortened part life. It is, however, an item that can be controlled when it is conscientiously looked after and the proper steps are taken in a timely manner.

Certain areas of the coach are more vulnerable to corrosion than others, and it is these areas that should be addressed. For example, the rear baggage compartment bulkhead in the rear wheelhousing area contains many key components and should be examined regularly for corrosion. Other areas include the front wheelhousing area and the engine compartment.

Road splash will affect undercarriage, condenser coil and engine compartment. These areas must be thoroughly cleaned to remove dirt accumulations from flanges, channels and ledges. These places accumulate dirt and salt and hold it in direct contact with steel and aluminum surfaces. Use an understructure high pressure spray as part of a regular wash. Damaged undercoating or paint should be promptly repaired before corrosion can start.

Frequency of wash periods depends on operating conditions. During periods of exposure to salt, daily washing as described above is recommended. If underbody parts show evidence of rust or corrosion, treat as follows:

1. Remove dirt, grease and oil by solvent washing.
2. Remove corrosion as well as all loose coating by cleaning with a wire brush or sandblasting.



CAUTION

Sandblasting can be used for cleaning bulkheads, brackets and other structural members. It should not be used for exterior side paneling. Extreme care should be taken not to sandblast excessively.

3. Apply correct primer, paint and undercoating after removing all corrosion to prevent further damage.

Section 18: BODY

3.2 PREVENTIVE MAINTENANCE SCHEDULE

NOTE

TECTYL 185 GW rust inhibitor has been applied on your vehicle underbody, follow this procedure thoroughly. For future application of product, refer to paragraph 3.3 in this section.

DESCRIPTION	INTERVALS		MAINTENANCE	CORRECTIVE ACTION	REFERENCE
	MONTHS	KM MILES			
BODY, EXTERNAL WINDOW FRAME	6	40 000 25 000	VISUALLY INSPECT SEALING BEADS CONDITION	REPAIR OR REPLACE SEALING BEADS IF NECESSARY	
VEHICLE UNDERBODY	12	100 000 60 000	USE A LOW PRESSURE SPRAY TO CLEAN UNDERSTRUCTURE AND VISUALLY INSPECT FOR CALCIUM DEPOSIT, CORROSION OR ANY DIRT ACCUMULATED ONTO EXPOSED SURFACES. VISUALLY INSPECT SEALING BEADS CONDITION. VISUALLY INSPECT IF UNDERFLOOR IS PEELING. VISUALLY INSPECT WHEELHOUSING COATING. MAKE SURE DISCHARGE TUBES ARE FREE FROM OBSTRUCTIONS	APPLY UNDERCOATING LOCALLY AS NECESSARY. APPLY UNDERCOATING LOCALLY AS NECESSARY REMOVE ANY OBSTRUCTION OR REPLACE DEFECTIVE TUBE	
SUSPENSION AND UNDERSTRUCTURE	12	100 000 60 000	VERIFY THE CONDITION OF ALL SUSPENSION AND UNDERSTRUCTURE FASTENERS AND CLAMPS	TIGHTEN OR REPLACE DEFECTIVE OR MISSING FASTENERS	
FLOOR COVERING	3	20 000 12 500	VISUALLY INSPECT IF FLOOR COVERING IS SHOWING SIGNS OF DETERIORATION SUCH AS CUTS, BURNS, ETC. ALSO, VISUALLY INSPECT SEALANT ALONGSIDE TRACKS. INSPECT WALL PANELS FROM BOTTOM TO WINDOWS	REPAIR OR REPLACE DEFECTIVE COVERING. MAKE SURE PROPER SEALANT IS USED.	
FLOOR CLEANING			CLEAN FLOOR COVERING AS NECESSARY		



WARNING

Failure to follow this preventive maintenance schedule will result in warranty void.



3.3 RUST INHIBITOR APPLICATION

Material: Tectyl 185 GW R1KG21



Safety Rules: Use safety glasses

Supplied air hood

Solvent-resistant rubber gloves

<p>1.0 Wash both wheelhousing mechanical parts before masking.</p>	<p>A water-hose nozzle is recommended. Water may be hot to reduce washing time especially during winter. If parts are soiled with oil, clean using R1KG21. Avoid rubber parts.</p>
<p>2.0 Dry all water sprayed parts. Surface temperature and dew point must be respected before applying rust inhibitor.</p>	<p>Air pressure system may be used, refer to annex 1 for surface temperature and dew point.</p>
<p>3.0 Front wheelhousing a) Mask all rubber joints. Braking system must also be protected (refer to arrows). Commercial aluminum foil may be used for masking.</p>	
<p>3.1 Front wheelhousing Front view</p>	
<p>3.2 Front wheelhousing</p>	

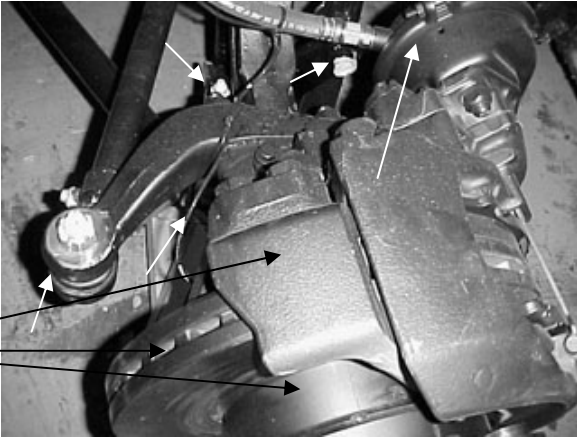
Section 18: BODY

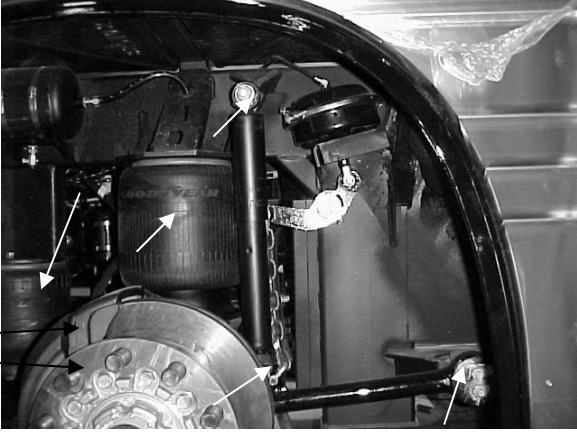
<p>3.3 Front wheelhousing</p> <p>(Entire braking system)</p>	
<p>4.0 Rear wheelhousing</p> <p>a) Mask all rubber joints. Braking system must also be protected (refer to arrows). Commercial aluminum foil may be used for masking</p> <p>(Entire braking system)</p>	
<p>4.1 Rear wheelhousing</p> <p>(Entire braking system)</p>	

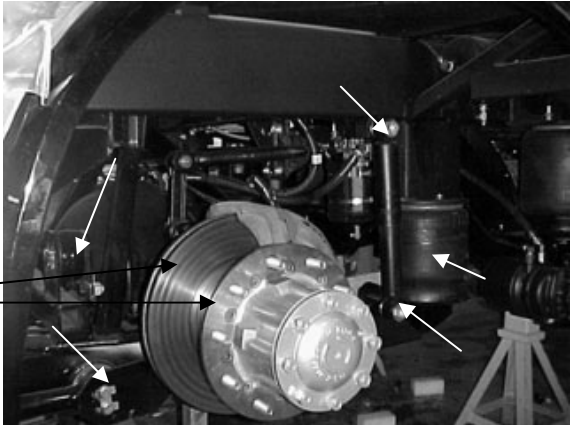
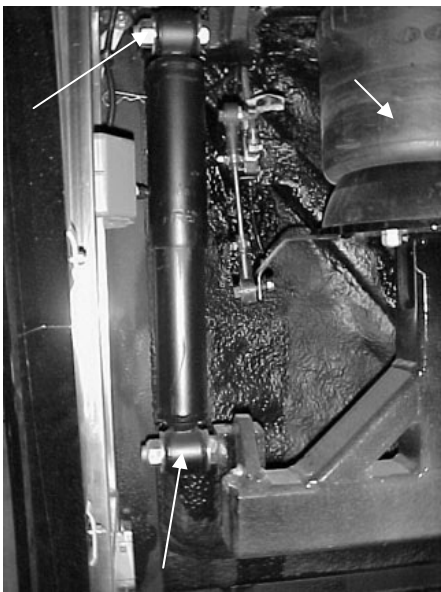
<p>4.2 Rear wheelhousing</p> <p>(Entire braking system)</p>	
<p>4.3 Rear wheelhousing</p>	
<p>5.0 Close off wheelhousing using masking paper.</p>	<p>Prevent rust inhibitor from coming in contact with paint. To close off wheelhousing, a polythene sheet may be used.</p>
<p>6.0 Apply TECTYL 185 GW black rust inhibitor onto wheelhousing mechanical parts.</p>	<p>A spray gun and pumping system are required to apply the rust inhibitor. If the application is done inside a paint room, select high speed ventilation. Minimum required thickness is 10 mils wet or 5 mils dry.</p>
<p>7.0 Remove all masking material 30 minutes after application.</p>	

ANNEX 1

1. Check and confirm that dew point and surface temperature are in accordance with to the following criteria:
 Surface temperature > 10°C
 Surface temperature > or = to dew point + 3°C

NOTE
 Use the following table to determine dew point.

2. Check and confirm that TECTYL temperature is between 10°C and 35°C.

Section 18: BODY

DEW POINT

	Relative Humidity (%)									
	10	20	30	40	50	60	70	80	90	100
Temp (c)										
0	---	-16	-11	-8	-5	-3	-1	0	1	3
1	---	-15	-10	-7	-5	-3	-1	1	2	4
2	---	-14	-10	-6	-4	-1	0	2	3	5
3	---	-13	-9	-5	-3	-1	1	2	4	6
4	---	-13	-8	-5	-2	0	2	4	5	7
5	---	-11	-7	-4	-1	1	3	5	6	8
6	---	-11	-8	-3	0	2	4	6	7	9
7	-18	-10	-6	-2	0	2	5	6	8	10
8	-17	-9	-5	-1	1	4	6	7	9	11
9	-16	-9	-4	-1	2	4	6	9	10	12
10	-16	-8	-3	0	3	5	7	10	11	13
11	-15	-7	-3	1	4	6	9	10	12	14
12	-14	-6	-1	2	5	7	10	11	13	15
13	-14	-6	-1	2	6	8	10	12	14	16
14	-13	-5	0	4	6	9	11	14	15	17
15	-12	-4	1	4	7	10	12	14	16	18
16	-11	-4	1	5	9	11	13	15	17	19
17	-10	-3	2	6	9	12	14	16	18	20
18	-10	-2	3	7	10	13	15	17	19	21
19	-9	-1	4	8	11	14	16	18	20	22
20	-9	0		5	9	12	15	17	19	21 23
21	-8	0		5	10	13	16	18	20	22 24
22	-7	1		6	11	14	16	19	21	23 25
23	-6	2		7	11	15	17	20	22	24 26
24	-6	2		8	12	16	19	21	23	25 27
25	-5	3		9	13	16	20	22	24	26 28
26	-4	4		10	14	17	20	23	25	27 29
27	-4	5		11	15	19	21	24	26	28 30
28	-3	6		11	16	19	22	25	27	29 31
29	-2	6		12	17	20	23	26	28	30 32
30	-1	7		13	17	21	24	27	29	31 33
31	-1	8		14	19	22	25	27	30	32 34
32	0	9		15	20	23	26	29	31	33 35

4. COMMON FIBERGLASS REPAIR PROCEDURE

All repairs to fiberglass parts consist of filling the damaged area with fiberglass cloth and resin or strand fiberglass and resin. The repair is allowed to harden, and then finishing operations may be performed. Use of the various materials is determined by the type of repair to be made. Large holes, torn sections and separate joints require the adhesive qualities of the resin and the reinforcing qualities of the fiberglass. Small dents, scratches or pits can be repaired using resin and strand fiberglass and filler mixed into paste. Instructions for either mix are explained under their respective headings in this section. For best results when making repairs, temperature should be between 70 and 75 °F (21-24 °C). Some people experience a skin reaction to resins. In such cases, wipe resin off with denatured alcohol or a good thinner. Use of protective hand cream is recommended.

	WARNING
<p>Always wear a respirator and goggles when grinding or sanding.</p>	

Extreme care must be taken if the sander is electrically operated, as dust from some resins is combustible when subjected to sparks or open flames. The proper tool for sanding resin is a low speed, air driven disc sander with a water attachment or a dry sander having a vacuum bag. Either will eliminate flying glass and resin dust.

The following additional tools and materials will assist in making repairs: hacksaw blade, assorted files, emery paper or cloth (150 or finer), scissors or tin snips, wax paper or cellophane sheets, a 3" (75 mm) paint roller, paint brush, putty knife, acetone and one or more heat lamps.

4.1 REPAIR USING FIBERGLASS CLOTH

Where necessary, sand paint away around damaged area and scrape away undercoating, if any, and wipe clean with solvent. Grind or file the damaged area to form a "V" at the broken or cracked portion. Sides of "V" should have a shallow pitch for maximum bonding area.

NOTE

Roughening the surface improves adhesion of resin.

If part is warped from original shape, use clamping equipment to straighten the surface. Preheat area to be repaired with one or two heat lamps placed 18 to 24 inches (450-610 mm) from repair.



CAUTION

Temperature should not exceed 140 °F (60 °C) during 30 minutes in order to avoid distortion.

Cut fiberglass cloth with scissors or tin snips, 1 to 3 inches (25-75 mm) larger than area to be repaired. Build area to desired height.

Mix resin and hardener following instructions on their containers. Saturate layers of fiberglass with mixture and place laminates over damaged area. Smooth out wrinkles and make sure general contour of area is maintained. Bubbles and wrinkles can be eliminated with a roller.



CAUTION

The pot life of the mix is approximately 15 minutes. Any accidental contamination to the skin, clothing, tools, etc. must be removed within this period. Use acetone to remove uncured resin.

Heat resin material again by placing heat lamps 18 to 24 inches (450-610 mm) from repaired area. Allow 12 to 15 minutes for repair to cure. After repair is cured, grind, file or sand to contour. Files other than body files may be more suitable. Featheredge and finish sanding.

If small pits or irregularities appear after making repair, correct by using a liberal amount of chopped strand or filler mixed with resin to form a paste. Refer to heading "*Repair using Fiberglass Paste*" in this section.

4.2 REPAIR USING FIBERGLASS PASTE

Fiberglass paste is used for repairing small dents, scratches, and pits. Paste is made by mixing resin, hardener and fiberglass strand or filler to the consistency of putty. Where it may be necessary, sand paint away around damaged area. On underside of coach, scrape away undercoating from damaged area, and wipe clean with solvent.

Section 18: BODY

Preheat the area to be repaired using heat lamps. Mix desired quantities of resin and hardener according to manufacturer's instructions. Add powdered fiberglass strand into mixture to thicken it into a putty state.

NOTE

If repair is made on a vertical surface, adding powdered filler material to mixture will reduce tendency of hot resin to flow or run.

Apply the material with a putty knife or similar object, building material up to the desired contour. For deep filling and on vertical surfaces, several layers of material may be used.

A hacksaw blade, held flat to adjacent contour and then moved in a sawing action across the repair when the resin is in a gel state, will remove excess resin from repair. Finish repair with the same procedure as when using fiberglass cloth.

4.3 TYPICAL FIBERGLASS REPAIR PROCEDURE

Remove all loose particles or damaged material using a power sander or rasp. Clean area, overlapping hole approximately 1" to 1-½" (25-40 mm) all around. Remove all dirt, grease and paint from area to ensure good bonding surface. Feather the cleaned area all around (Fig. 4).

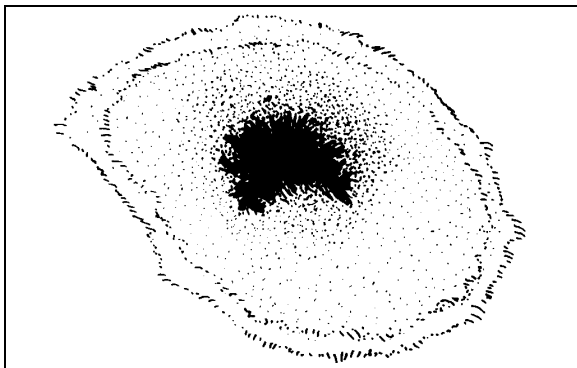

FIGURE 2: FIBERGLASS REPAIR

18089

Cut a piece of fiberglass mat slightly larger than area being repaired. Impregnate mat with general purpose polyester resin catalyzed normally. Use a clean paint brush to apply the polyester resin. Apply impregnated mat over hole and press onto surface with brush to obtain good adherence. Another coat of general purpose polyester resin can be applied at this time (Fig. 5).

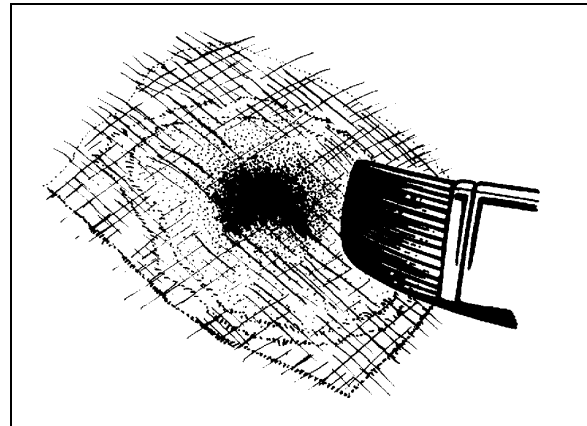

FIGURE 3: FIBERGLASS REPAIR

18090

NOTE

Remove all air between surfaces being joined. Allow area to harden and sand surface to remove any wax.

Apply another mat, followed by a cloth patch, and another mat. All layers must be thoroughly impregnated with polyester resin, brushed well and free of air. Apply more layers of mat and cloth as required until the desired strength and thickness is obtained, minimum two 1-½ oz (43 g) mats and one 9 oz (255 g) cloth (Fig. 6).

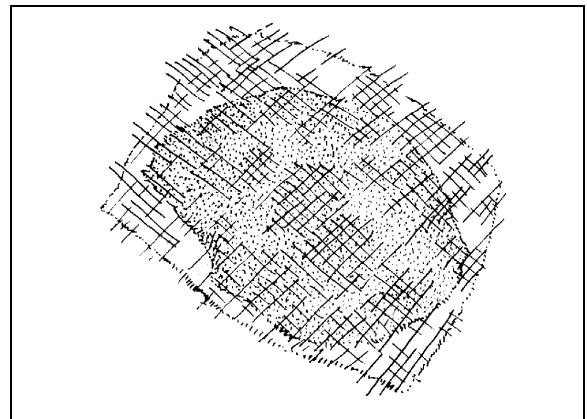

FIGURE 4: FIBERGLASS REPAIR

18091

Allow area to harden and contour the area with coarse sandpaper #100 (Fig. 7).

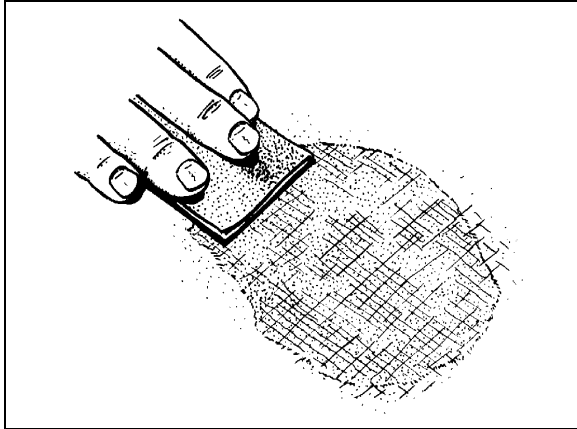

FIGURE 5: FIBERGLASS REPAIR

18092

Cover the area with a layer of resin putty and allow drying for approximately 15 to 20 minutes (Fig. 8).

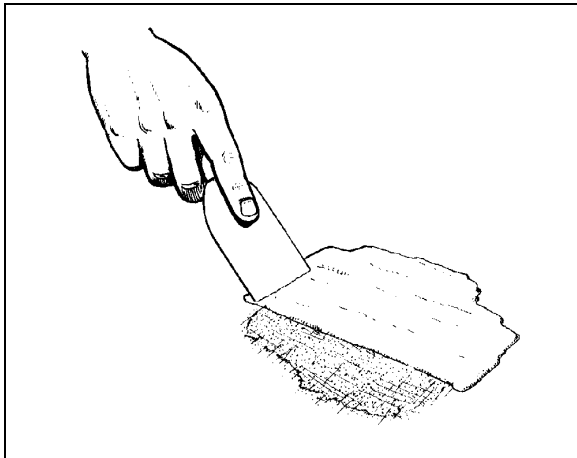

FIGURE 6: FIBERGLASS REPAIR

18093

Smooth off surface with coarse sandpaper #100 to desired shape. Further smooth surface with fine sandpaper #120 until repaired surface matches surrounding area paneling. Prime and paint the area to match surrounding paintwork.

5. COMMON PAINTING PROCEDURE

5.1 NEW PAINT CARE

Our paint supplier recommends that you follow these simple precautions the first months of your new vehicle's life.



CAUTION

Apply these recommendations after repainting vehicle.

During the first 30 days:

- Do not use a commercial bus wash. Stiff brushes or sponges could mar the finish and damage the surface. Wash the vehicle by hand only and with cool water and a very mild bus wash solution. Be careful to use only a soft cloth or sponge;
- Wash vehicle in the shade, never in direct sunlight;
- Do not "dry wipe" vehicle –always use clean water. Dry wiping could scratch the finish;
- Avoid extreme heat and cold. Park vehicle in the shade whenever possible;
- Do not park under trees which drop sap or near factories with heavy smoke fallout. Tree sap and industrial fallout may mar or spot a freshly painted surface;
- Trees are also likely to attract birds. Bird droppings are highly acidic and will damage a freshly painted surface. Bird droppings, tree sap and industrial fallout should be washed off as soon as possible;
- Do not spill oil, gasoline, antifreeze, transmission fluid or windshield solvent on new finish. IMMEDIATELY rinse off any such spill with clean water, DO NOT WIPE;
- Do not drive on gravel roads. Paint finish easily chips during the first 30 days;
- Do not scrape ice or snow from the surface. A snow scraper can act like a paint scraper if the finish is new. Brush off loose material with a soft snow brush.

During the first 90 days:

- Do not wax or polish the vehicle. This will allow the finish to dry and harden completely.

5.2 PAINT TOUCHUP

When paint touchup or partial repainting is necessary, refer to the vehicle's paint scheme for color codes and paint brand.

Prévost recommends using the original paint brand to ease color matching.

In the event you sand through to the gelcoat surface you should prime the area with Standox "Non Stop Fill Primer (ST-11000)".

Section 18: BODY

If you sand through to metal surface, first prime with Standox "Etch Primer (ST-11858)" then with Standox "Non Stop Fill Primer (ST-11000)".

 CAUTION
<p>Be sure to heed all paint manufacturer's recommendations, especially concerning paint dilution and application.</p>

5.3 PAINTING

The standard paint used on the exterior of the vehicle is Standox Basislack. It is a high gloss polyurethane enamel finish designed for exposure to extreme conditions. Other types of paint may be called for as options by owner but are not dealt with in this section.

5.3.1 Safety

Care should be exercised in storing, handling, mixing, and applying paint and chemicals listed in this manual. The topcoat, primer, solvent, catalysts, accelerators, and cleaners are highly volatile and/or toxic if not properly used. Observe all safety instructions marked on the different packaging, as well as the following:

1. Do not smoke in the paint room or in adjacent area exposed to residue fumes.
2. Wear respirators approved by the governing safety and health regulations.
3. Maintain adequate ventilation at all times.
4. Dispose of any leftover paint mix properly.
5. Wear rubber gloves, rubber apron, and face shield during all phases of paint and chemical handling

5.3.2 Surface Preparation And Paint Application

	Aluminum and / or Stainless Steel	Fiberglass	Comments
Surface Preparation	Sand using P-150 grit sandpaper. It is recommended to sandblast rivets and panel edges with OLIMAG 35-70 blast media.	Sand using P-180 or P-240 sandpaper.	Do not use paint remover over aluminum or fiberglass.
Cleaning	STANDOX silicone remover ST-11654 (68-2989)		
Priming	STANDOX Reactive Etch Primer ST-13908 * Wait 30 minutes then apply STANDOX Non-Stop Füllprimer ST-11000 (68-2973)	STANDOX Non-Stop Füllprimer ST-11000 (68-2973)	Refer to product Technical Data sheet for proper mixing
Basecoat	Refer to paint scheme or coach record for proper color code and paint brand. We recommend using the same paint brand to ease color matching.		Refer to product Technical Data sheet for proper mixing
Clearcoat	STANDOX 2K MS Rapid Clear ST-11760 (68-2979) Allow 16 hours for drying		Refer to product Technical Data sheet for proper mixing

If assistance or technical information on STANDOX products is needed, please dial: 1 (800) 551-9296

6. X3-45 COACHES EXTERIOR FINISHING AND BODY REPAIR

The following procedures explain the steps to be followed for proper repair, installation and replacement for various doors, panels and windows. The paragraph divides the vehicle into zones to facilitate the search; each zone is then sub-divided into components.

Refer to the appropriate zone then component for complete procedure.

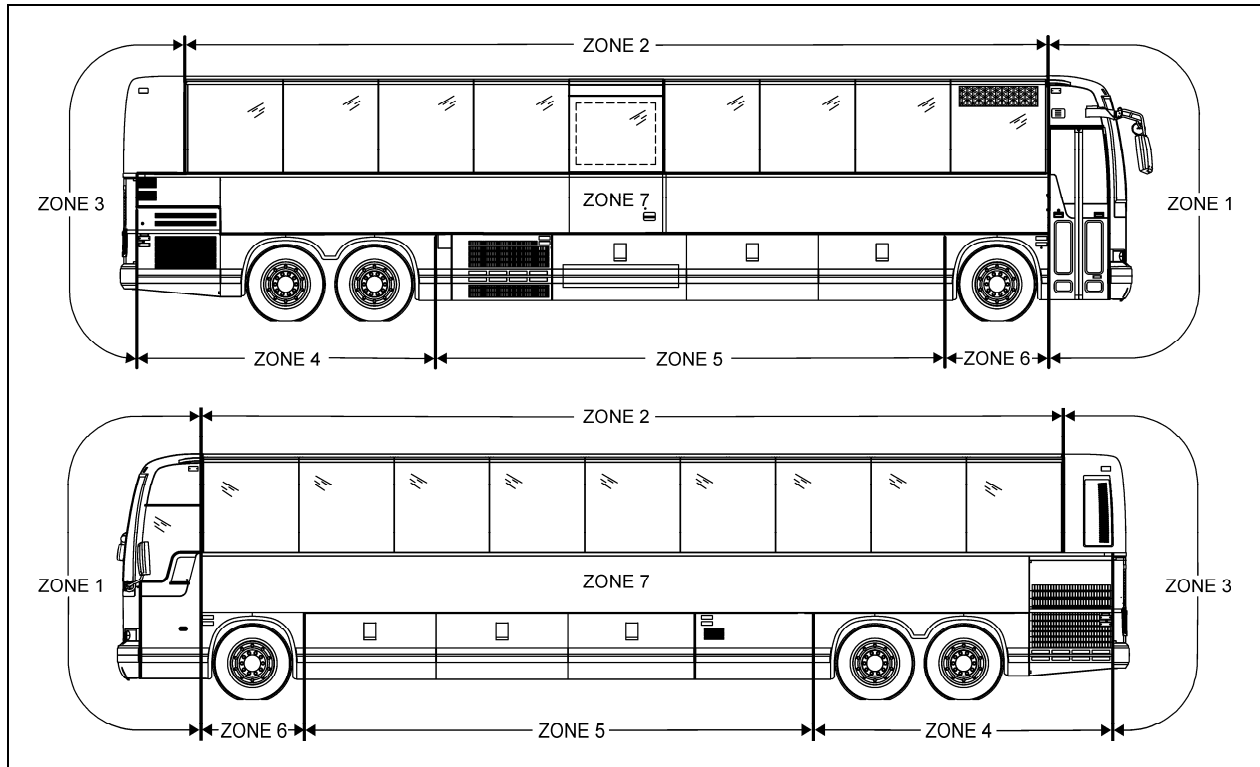

FIGURE 7: X3 COACHES ZONING

18623

6.1 ZONE 1

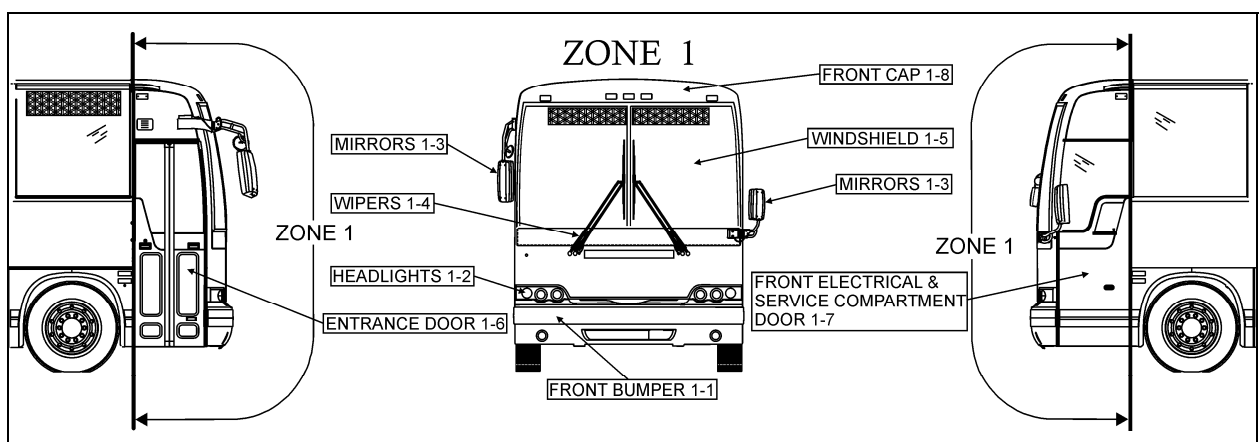

FIGURE 8: ZONE 1

18624

6.1.1 Front Bumper

The front bumper is hinged to give access to the steering gear and front towing quick connectors for maintenance purposes. Pull the handle

located in the front service compartment to open the front bumper compartment. Bumper must first be tilted down before its removal. Two people are required to remove and install the front bumper. Safely support the bumper and

Section 18: BODY

remove the two bolts on each bumper side to separate the bumper from the compartment door. To install bumper, reverse the removal procedure.



WARNING

Front bumper is heavy. Use proper lifting equipment to support the bumper during the removal and installation operations to avoid personal injury.

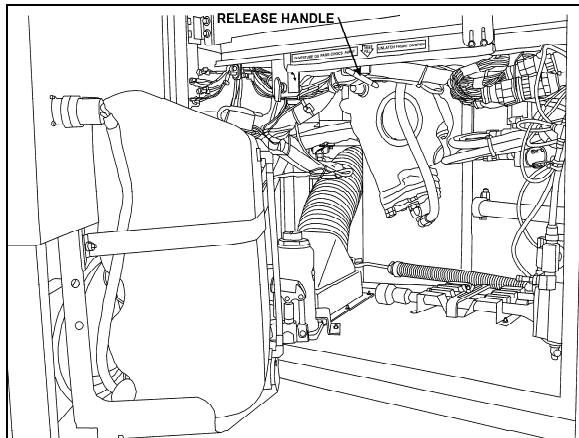

FIGURE 9: FRONT BUMPER RELEASE HANDLE 18613

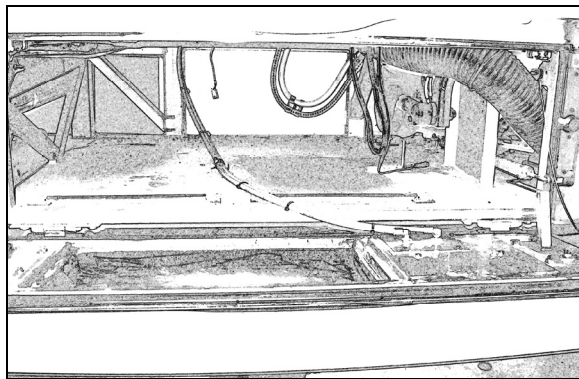

FIGURE 10: FRONT BUMPER COMPARTMENT 18614

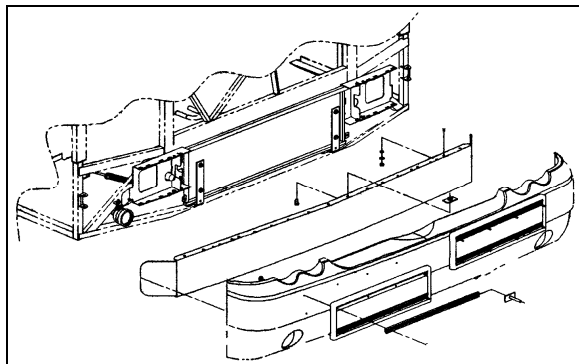

FIGURE 11: FRONT BUMPER REMOVAL 18565

6.1.2 Headlights

Refer to Paragraph Headlights, included in Section 06: Electrical of the Maintenance Manual for complete information on headlights.

6.1.3 Rear View Mirrors (Rosco)

Your vehicle is equipped with two Rosco exterior mirrors.

The mirrors can easily be adjusted by using the remote controls located on the L.H. side control panel. The mirrors have easy to replace glass in case of breakage. Remote control motors can also be replaced.

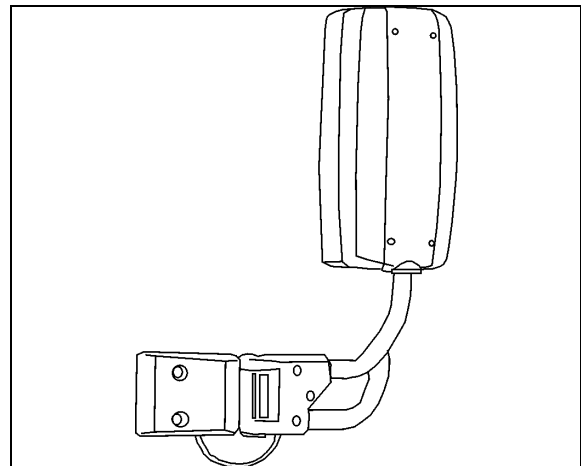

FIGURE 12: REAR VIEW MIRROR (ROSCO) 18398A

• Adjustment

At the base of the mirror arm, loosen the mounting bolt to swing arm in or out.

To pivot the mirror head, loosen the setscrews on each side of the ball stub at the base of the mirror head to facilitate the adjustment.

• Disassembly

At end of mirror arm, loosen the setscrews to relieve tension on the ball stem. Remove the ball stem from the arm.

Remove the four screws fastening the mirror arm base to the coach.

• Assembly

Mount the mirror arm base to the coach. Insert the ball stem into the mirror arm and tighten the socket setscrews.

NOTE

Position the ball cup halves so the joint between them lies on the centerline of the arm. Ensure that the setscrews are not on the joint between the cup halves.

- **Replacement of Mirror Glass**

Remove the broken glass.

Position new glass in mirror head and press to lock the Velcro in place.

- **Remote Controlled Rear View Mirrors**

The remote controlled external rear view mirrors attach to support arms using a pivot collar secured by setscrews. Loosening the setscrews allows the whole head assembly to turn on the support arm for initial adjustment. A mounting bolt and washer hold the arm support to the mounting bracket. The arm support can be moved to position the mirror head into or away from the coach body.

- Mirror Control

The remote control pointer knob(s) for the mirrors is (are) mounted on the L.H. side control panel. The harness to the mirror head runs through the arm support. The remote motor is mounted to the mirror head behind the mirror glass.

Turn pointer knob to the left for mirror head adjustments and to the right for convex mirror adjustment, then push down on either of the button's (4) sides to adjust the selected mirror viewing angle.

- Disassembly

At end of mirror arm, loosen the setscrews to relieve tension on the ball stud. Remove the ball stud. Remove the ball stud from the arm and gently pull the harness out until the connector is exposed.

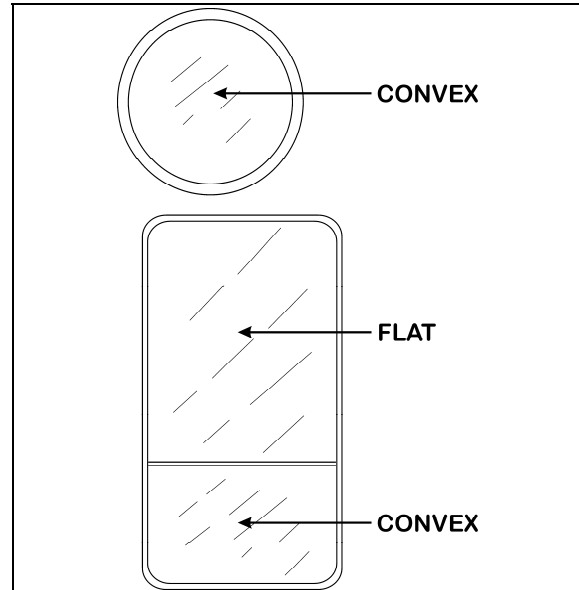

FIGURE 13: OUTSIDE REAR-VIEW MIRROR

Remove the four screws fastening the mirror arm base to the coach. Slide the harness free of the mirror arm base.

- Assembly

Attach a stiff wire (snake) to the end of the harness and insert the wire through the mirror arm base and arm, gently pull the harness through the arm and disconnect the "snake".

Connect the mirror head harness. Insert the harness connector back into the mirror arm. Insert the ball stud into the mirror arm and tighten the socket setscrews.

NOTE

Position the ball cup halves so the joint between them lies on the centerline of the arm. Ensure that the setscrews are not on the joint between the cup halves.

- Convex & Flat Mirror Removal

The mirror glass assembly is mounted to the control mechanism or to mirror base with Velcro strips. Remove the mirror glass by gently pulling the lens to release the Velcro. Disconnect the heater grid at the two connectors.

Connect the connectors of the new mirror's grid to the harness. Install the lens by positioning the lens in the mirror frame and pressing to lock the Velcro in place.

Section 18: BODY

6.1.4 Windshield Wipers

Refer to Paragraph 3 WINDSHIELD WIPERS AND WASHERS, included in Section 23: Accessories of the Maintenance Manual for complete information on windshield wipers.

6.1.5 Windshield

For the removal or installation of windshield, you will need:

A rope,

A plastic spatula to lift the rubber seal lip,

A metal rod or screwdriver to clean the seal groove,

A filler insertion tool,

Goggles and protective gloves.

- From inside of vehicle, remove center post and interior finishing panels surrounding the windshield. In this case, we are replacing the R.H. side windshield.
- From outside of vehicle, remove filler located inside rubber seal to ease damaged windshield removal.
- From inside of vehicle, push against the top L.H. side corner of windshield for the removal of a R.H. side windshield. If the L.H. side windshield had to be removed, you would have to push against the top R.H. side corner.

NOTE

We are referring to the L.H and R.H. side as viewed from the inside of the vehicle.

- At the same time, another person gradually lifts the rubber lip from the vehicle exterior using a plastic spatula from top to bottom.
- Remove the entire damaged windshield and broken glass if applicable.
- If applicable, using a screwdriver or metal rod, remove black butyl sealant residue from rubber seal then clean with Sika 205.

• Windshield Installation

NOTE

Rubber seal may have to be replaced if it was used on several windshield replacements.

- Spray rubber seal with soapy water to ease windshield insertion.
- Insert rope into rubber extrusion leaving enough length at each corner to make a loop. Spray soapy water onto rope and rubber extrusion (Fig. 14).
- Slide windshield into rubber seal groove starting with the bottom curved side edge. Using a plastic spatula, move the rubber seal lip aside to gradually insert the windshield into the groove.
- Spray soapy water on a regular basis to ease this operation.
- Using the same type of plastic spatula, repeat the same operation from inside of vehicle, gradually inserting the windshield into the groove.

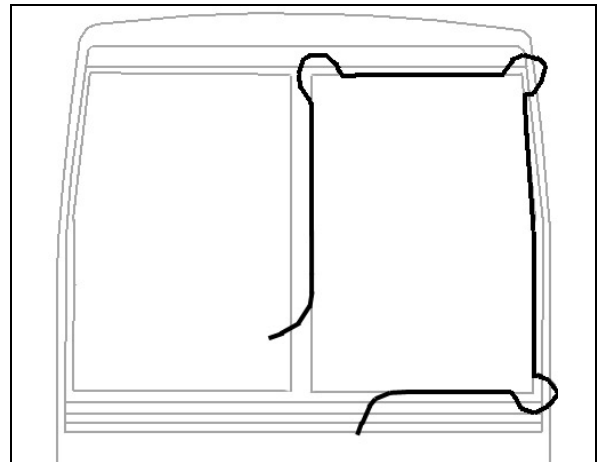

FIGURE 14: WINDSHIELD INSTALLATION USING ROPE

NOTE

Make sure windshield bottom edge is well inserted into the rubber seal groove before proceeding with the sides.

- Then, working from both sides of windshield bottom to top, gradually move the rubber seal lip aside to insert the windshield into the groove. Use also soapy water on the inside of vehicle to insert the windshield into the rubber seal groove.
- Insert the top curved corner then finish with the top of windshield.
- At the top of windshield, clean surface between fiberglass and rubber extrusion using Sika 205 (Fig. 16).
- Apply Sika 221 black between fiberglass and rubber extrusion

- Spray filler and rubber seal groove generously with soapy water.
- Using the special filler insertion tool, insert the filler into the rubber seal groove.
- Gradually insert filler into the rubber seal groove ensuring to leave a 2 inch excess length at the filler extremity.
- Every 6 inches or so, it is important to compress the filler due to its tendency to contract during drying process.
- When filler insertion is almost complete, cut filler leaving ¼" of excess length to thwart filler contraction over time then insert filler into groove.

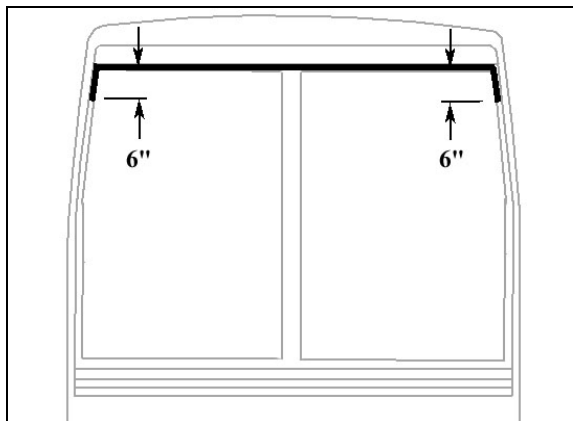

FIGURE 15: APPLICATION OF SIKA 221 BLACK

- Reinstall center post and interior finishing panels.
- Clean windshield surface of butyl residue.

6.1.6 Bi-Fold Entrance Door

An air operated “bi-fold type” entrance door, with an air door cylinder and damper assembly installed under the right hand dash for the R.H. door panel opening. Another air door cylinder is installed behind the wall to the right of the first curb-side passengers’ seat for the L.H. door panel opening. The opening and closing door speed cycle is adjustable by a damper mounted in parallel with the R.H. door panel cylinder on the door hinge. Door activation is controlled by a panel (Fig. 16), located near the defroster and wiper motors. The accessory air reservoir supplies air to this system.

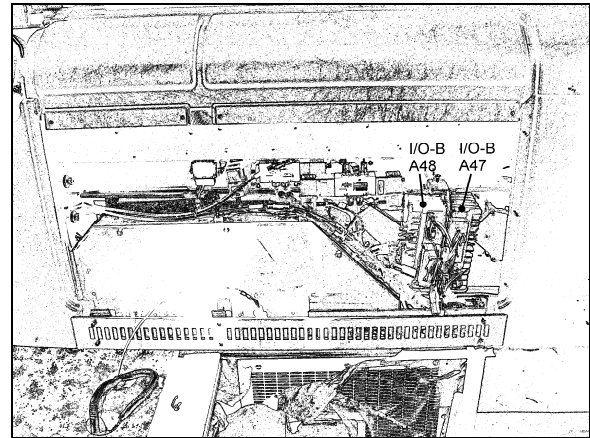

FIGURE 16: ENTRANCE DOOR & WIPER CONTROL PANEL

06619

The door is held in the closed position during coach operation by a two air cylinder locking mechanisms (Fig. 17).

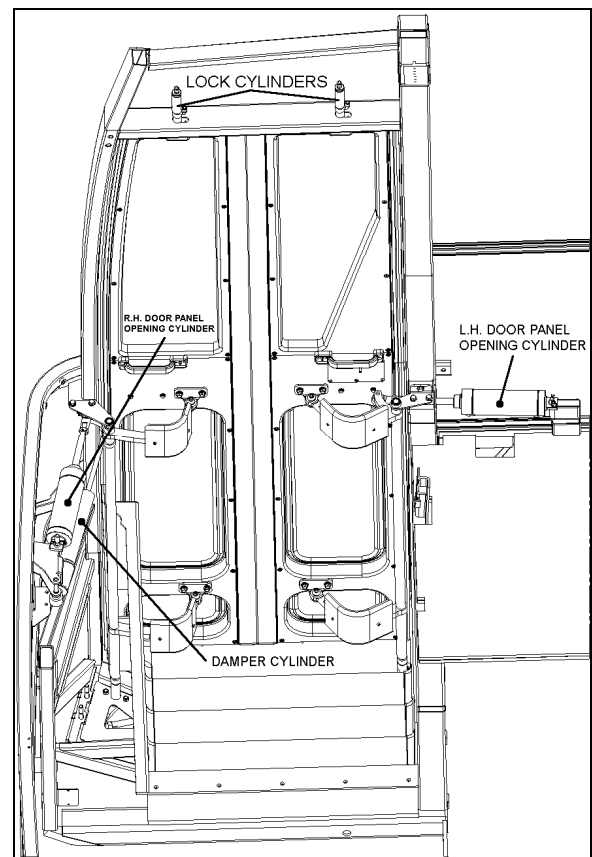

FIGURE 17: ENTRANCE DOOR - VIEW FROM INSIDE

Air cylinders with return spring in the cylinder body are used. Air cylinders are controlled by an electrically operated solenoid valve energized by a multiplex module located under the right hand dashboard.

Section 18: BODY

To open the door, initial action from multiplex module output de-energizes the air lock solenoid valve, venting the door locking cylinders. The return locking spring pulls the door lock away from the latch, unlocking the door. Door movement starts only when pressure in the central air door lock is below 10 psi. The “air cylinder open solenoid valve” opens and allows air to flow to the door cylinders, “the air cylinder close solenoid valve” exhausts air from the rod side of the cylinders.

To close the door, initial movement of the switch energizes the “air cylinder close solenoid valve” and air flows to the cylinders by their rod side ports. The “air cylinder open solenoid valve” exhausts air from cylinders. When entrance door latch is grounded with the door frame, the air lock solenoid valve is de-energized and loads the door lock cylinders. The cylinder moves the door lock in a position which engages a latch on the entrance door, holding the door positively closed.

Emergency exit valve, which opens the air valve circuit should be used only in emergencies, or when the door control system does not function properly.

Refer to the air system schematic diagram annexed at the end of section 12, “Brakes” and to page 29.1 of the wiring diagram.

• Operation

Lock or unlock the bi-fold entrance door from outside the vehicle by turning the key in the door lock (counterclockwise to lock, clockwise to unlock). The entrance door can be unlocked from the inside using the small lever located on the door.

The air-operated door is controlled from inside the coach by two push-button switches located on the R.H. dashboard.

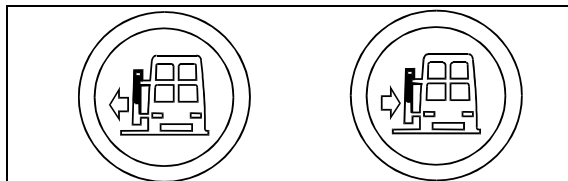

FIGURE 18: ENTRANCE DOOR OPERATING BUTTONS
06464

From the inside, open the door by pressing the door opening switch (L.H. button) on the R.H. dashboard panel. The door will open to full open position within 5 seconds.

Close by pressing and holding the door closing switch (R.H. button) on the dashboard. If the closing switch is released before the door is fully closed, the door will stop in that position.

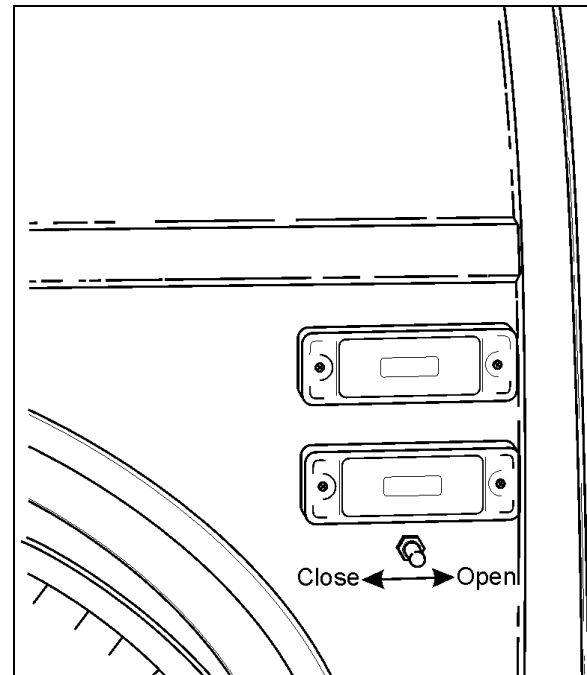

FIGURE 19: ENTRANCE DOOR CONTROL SWITCH 18599

Opening and closing of the door from outside the coach is accomplished by a momentary toggle switch located under the front R.H. side marker light (Fig. 19).

To close the door, the switch must be pushed towards the rear of the coach and held in position until the door has completed its movement. The door can be closed to any position by releasing the switch (or button, if inside) when the desired position is attained. However, the door is not locked in any position other than fully closed. The door can then be closed further by pushing or pulling on the door.

To open the door, the switch must be pushed towards the front of the coach and held in position. When the door reaches the fully opened position, the system will keep pressure in the cylinder locking the door in that position.

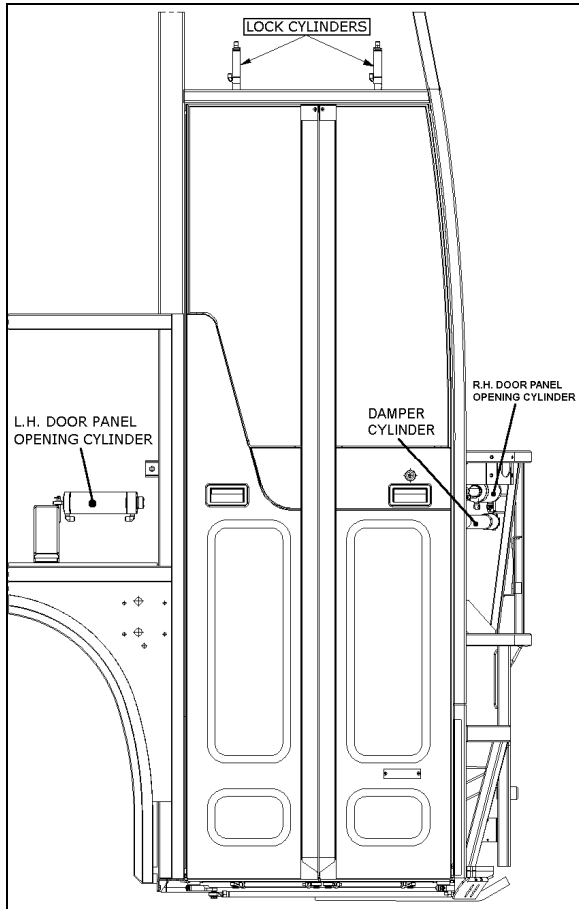

FIGURE 20: ENTRANCE DOOR - VIEW FROM OUTSIDE

• **Emergency Exit Valves**

From inside the vehicle, an emergency exit valve located on the dashboard R.H. side, releases the pressure from the lock cylinders. From the exterior, an emergency exit valve located in the front service compartment, also releases the air from the lock cylinders.

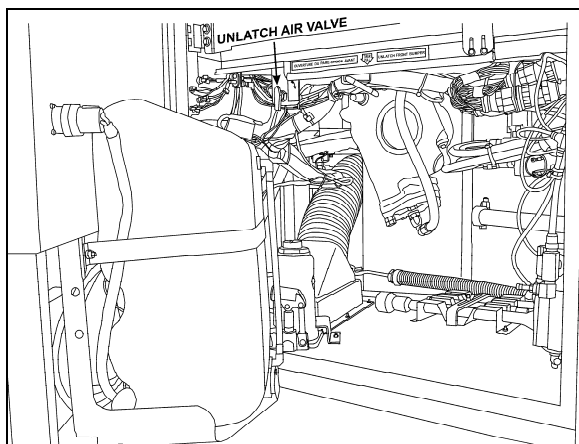

FIGURE 21: EXTERIOR UNLATCH AIR VALVE 12209

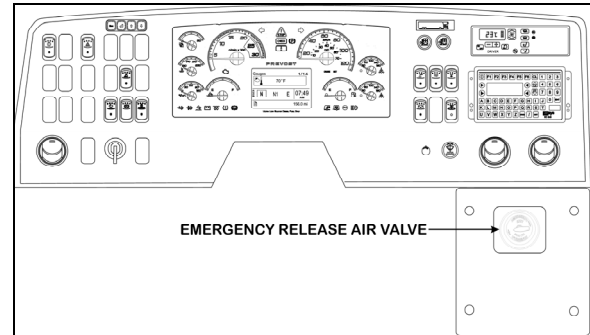

FIGURE 22: INTERIOR UNLATCH AIR VALVE 18330

Without Air and/or Without Electricity

If the air pressure drops while the coach has or hasn't any electricity, the spring loaded cylinders will unlatch the door. In such a case, unlock the door by moving the lever on the door or by using the key, then open the door manually.

With Air but Without Electricity

From inside the vehicle, turn the emergency exit valve to the "UNLOCK" position. Move the lever. From the exterior, turn the emergency exit valve to the "UNLOCK" position. Open the door. Close it, lock with the key and reset the outside emergency exit valve to the "NORMAL" position.

• **Door Cycle Speed Adjustment**

To do any adjustment, remove the panels located next to the R.H door panel hinges.



CAUTION

It is important to make sure that damper does not reach end of stroke when bi-fold entrance door is completely closed or opened. The door cylinders must stop the door on opening. Screw or unscrew rod end to adjust if necessary.

To adjust opening and closing cycle speed on damper (Fig. 23):

1. Remove the damper from the vehicle and hold it vertically with the lower eye or pin attachment in a vice. Use clamp plates to prevent damage.
2. Fully close the damper while turning the dust cap or piston rod slowly CCW until it is felt that the cams of the adjusting nut engage in the recesses of the foot valve assembly (Fig. 23).

NOTE

In figure 23, if there is an indentation (B) in the dust cap (C) and the cover shows two holes (A), the damper is fitted with a bump rubber (D). If so, fully extend the damper and insert a round bar or screwdriver through the holes. Push the bump rubber down and remove. Remove the split plastic collar (E) (if fitted) from the piston rod.

3. The damper may have already been adjusted. Therefore check whether the damper is adjusted or not by keeping it closed and gently turning further CCW, counting at the same time the half-turns until a stop is felt. Stop turning and do not force.
4. While keeping the damper closed, make two CW half-turns. In case of prior adjustment, add the number of half-turns previously counted. The total range is about five half-turns. Pull the damper out vertically without turning for at least 3/8" (1cm) to disengage the adjusting mechanism. The dust cap or piston rod may now be turned freely.
5. The damper can now be refitted in the vehicle.

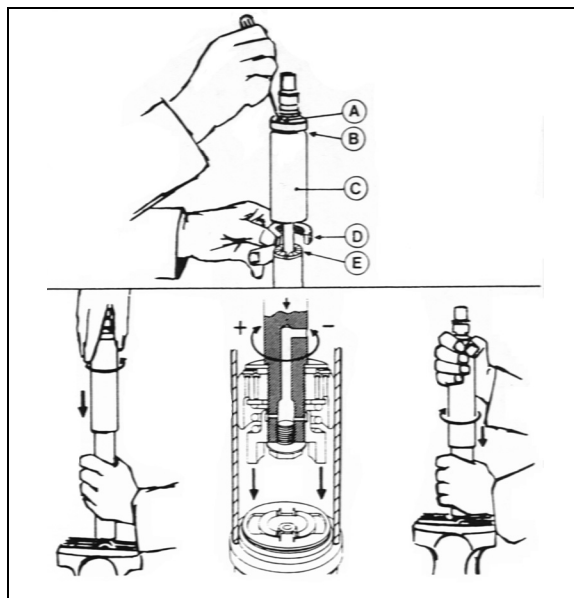

FIGURE 23: DAMPER

18643

NOTE

Where a bump rubber was installed, refit same inside the dust cap and by fully closing the damper, the rubber will seat again at top of the dust cap. Refit the split plastic collar E (Fig. 23).

6. Reinstall panels and R.H. entrance door panel hinge cover.

• **Entrance Door Panel Adjustments**

Before attempting to correct any bi-fold entrance door operating problem by adjusting any part of the air cylinder assembly, first perform the following mechanical checks and procedure.

Check around the perimeter of the door for binding. If any binding is found, adjust as follows:

- Horizontal and vertical adjustment
1. Support the door panel with a wooden block and a hydraulic jack.
 2. Unfasten the bolts fixing the door panel plates. See figure 24

NOTE

Ask an assistant to help you to perform the following adjustments.

3. Adjust the door horizontally and vertically with the jack. Tighten the bolts. Remove the jack and the wooden block.

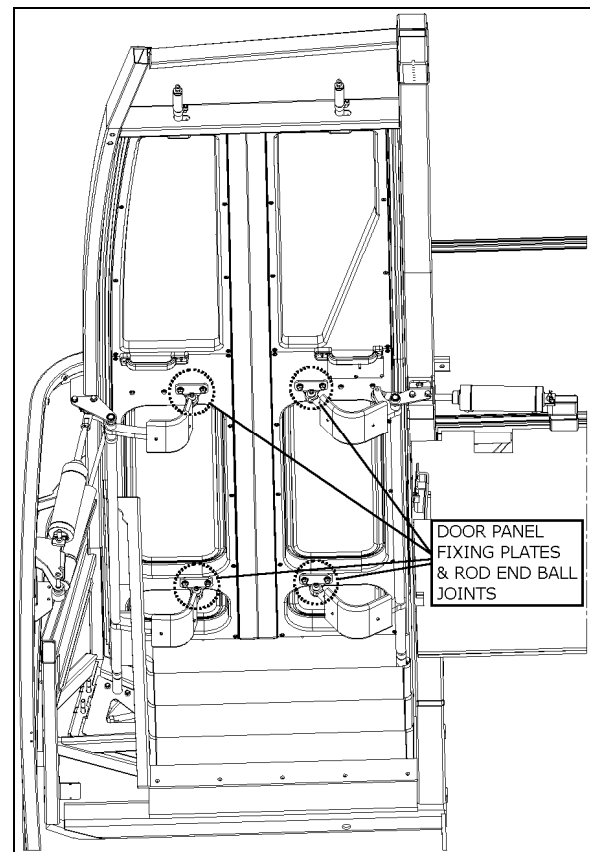

FIGURE 24: DOOR PANEL ADJUSTMENTS

- Depth adjustment

 1. Support the door panel with a wooden block and a hydraulic jack.
 2. Unfasten and then disconnect rod ends from door panel fixing plates. Screw or unscrew rod end in order to adjust door panel depth.
 3. Tighten the bolts. Remove the jack and the wooden block

6.1.7 Front Electrical & Service Compartment Door

• Door adjustment

Check around the perimeter of the door for binding. If any binding is found, adjust as follows:

1. Remove the screws and the plastic molding covering each of the hinges.

NOTE
Ask an assistant to help you to perform the following adjustments.

2. Remove the Allen button head screw and the washer retaining the rod end with bearing to the upper hinge. See figure 25.
3. Support the door with a wooden block and a hydraulic jack.

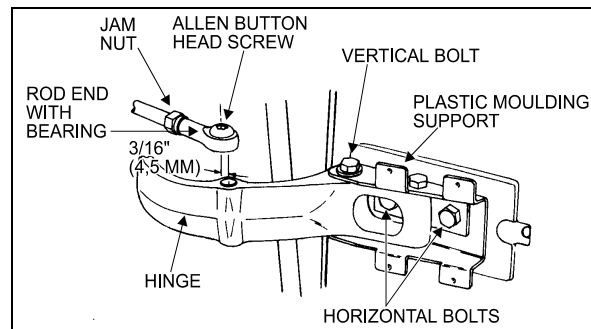

FIGURE 25: UPPER DOOR HINGE 18058

4. Loosen the horizontal bolts retaining the door to the hinges. Adjust the door horizontally and vertically with the jack. Tighten the bolts to 30-36 Lbf-ft (40-50 Nm). Remove the jack and the wooden block.

CAUTION
Make sure the front side door does not interfere with the exterior panel.

5. Pull and fasten the rod end to the hinge with the washer and the button screw.
6. Screw the plastic moldings covering the hinges.

• Seal Compression Adjustment

1. From the outside of vehicle, insert a straight edge in the gap along the door outside perimeter. Measure the distance between the door frame and the door outside surface at the door four corners (refer to figure 26).

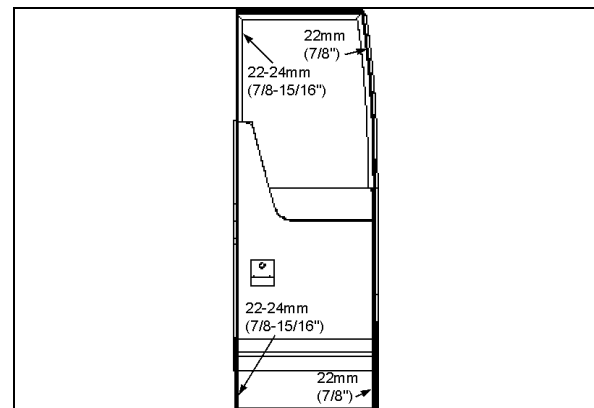

FIGURE 26: SEAL COMPRESSION ADJUSTMENT 18632

NOTE
The front measurements are the most important. If required, ask an assistant to help you to perform the following adjustments.

2. If required loosen the bolts retaining the door to the hinges. Adjust the bolts to obtain the proper seal compression.

• Door Seal Replacement

1. Inspect the seal; if cracked or torn, it must be replaced:
2. Remove the old seal and with a sharp edge knife, scrape tape left on the fiberglass door surface.
3. Sand the surface of the door where a new seal will be applied with 240 grit sandpaper.
4. Clean the surface with alcohol.

WARNING
Wear rubber gloves and do not smoke when cleaning.

Section 18: BODY

5. Peel of protective paper from the seal. Position the seal flush with the top, sides and lower edges of the door.
6. Progress slowly all around the door.
7. Cut the seal and glue both ends with LOCTITE 414 glue.
8. To assure bonding, press a small roller on top of the new seal.

• Lubrication

Part	Lubricant	Frequency
Latches Upper door catch Door cylinder rod end with bearing grease fitting	Low temperature grease	Every six months
Door locking mechanism	White grease	Every six months
Key hole Damper pins Hinges	Low viscosity oil	Every six months

• Body Panel and Window

For the removal of front electrical & service compartment door body panel, you will need:

Pneumatic “Zip gun” type tool;

Razor sharp window scraper;

- Open service door.
- Remove interior finishing panels to access rub rail fixing bolts, then remove rub rail.
- Remove windshield washer reservoir, door lock and power window connector.
- Using the “**Zip Gun**”, cut Sika bead located ¼ inch (7-8 mm) from each body panel edge.

NOTE

Wear ear plugs during this operation.

- Separate body panel from door.
- Using a razor sharp window scraper, remove from door frame Sika bead and double-face self adhesive tape residue.
- Clean door frame using anti-silicone.
- Using a scratch pad “Scotch Brite”, scratch the perimeter of the door frame where the adhesive will be applied.
- Clean door frame again using anti-silicone.

- Apply some Sika 206 G+P onto door frame.

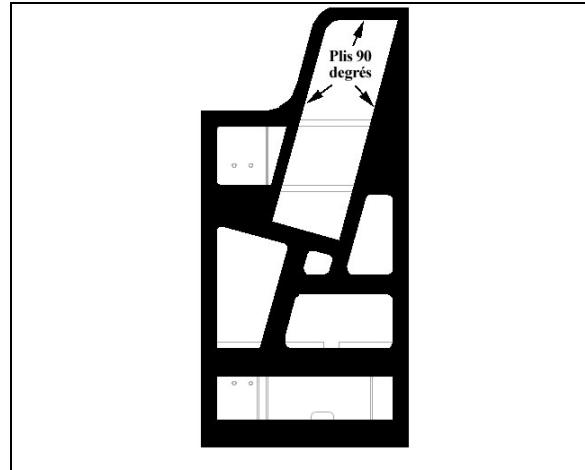

- Prepare new body panel using a scratch pad “Scotch Brite”.
- Use a tack cloth to remove any dust or residue from the body panel surface.
- Clean body panel using anti-silicone.
- Apply some Sika 206 G+P onto body panel.

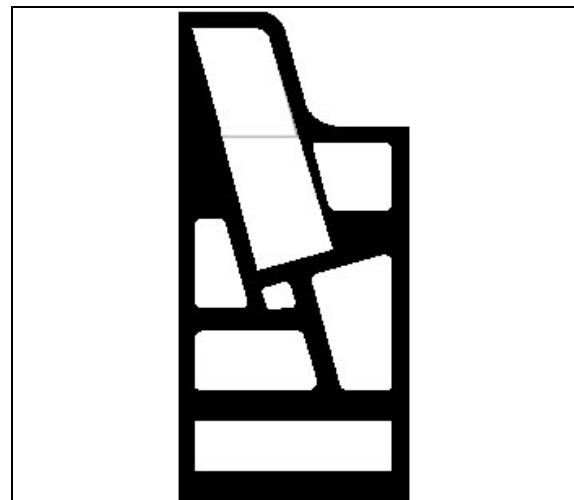

- Apply an even coat of Sika 255 onto the door frame.

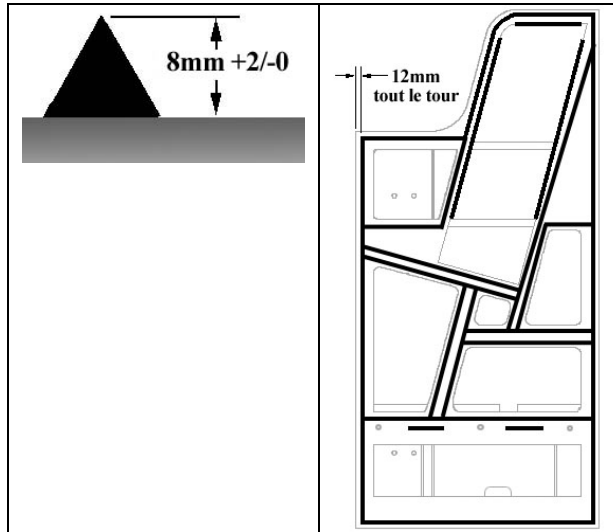

- Position body panel onto door frame and compress with your hands. Use a ruler.

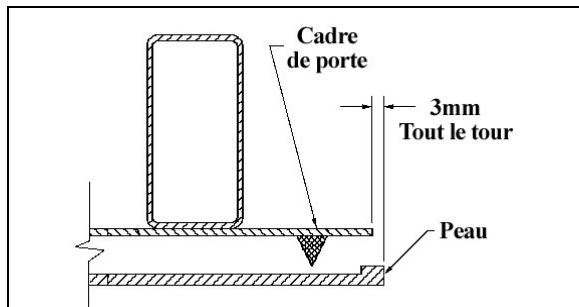

- Check body panel flatness using a 2-foot ruler (must be within 2mm).

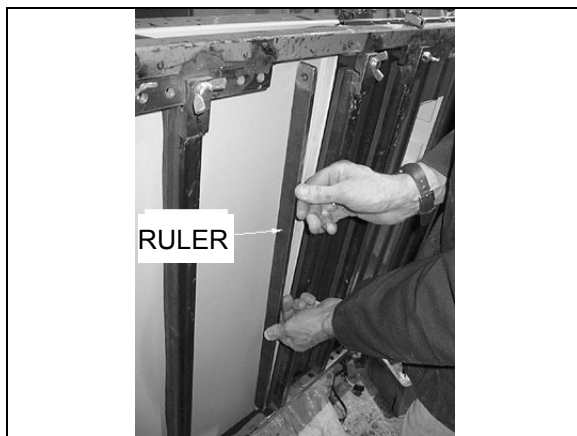

- Check proper power window sliding inside window frame.
- If applicable, remove excess of Sika adhesive all around door frame using Sika 208.

- From the inside of the door, apply some Sika 221 between door body panel and frame and on welding spots as per figure.

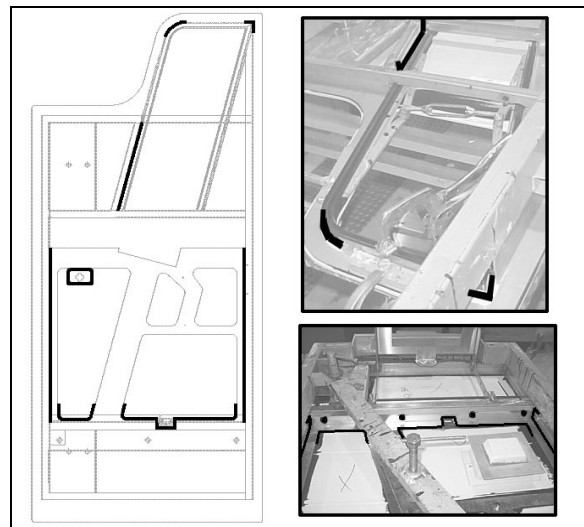

- Apply some #680066 glue inside fiber glass groove and fix power window wiper.

NOTE

Anti-friction side must be on glass side.



- From inside the door, apply some Sika 252 at the corners of window wiper.

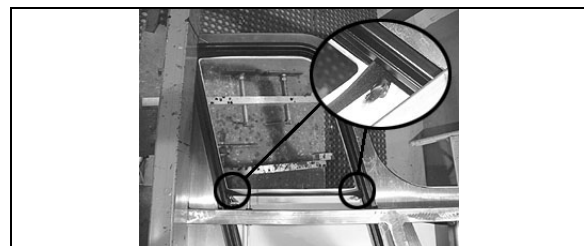

- Apply some #680066 glue inside finishing panel groove and fix power window wiper.

NOTE

Anti-friction side must be on glass side.

Section 18: BODY

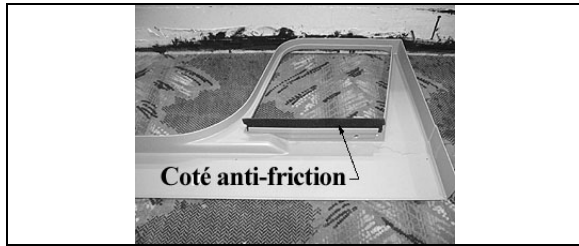

- Discard waste according to applicable environmental regulations, use dangerous waste containers.

Electrical Power Window

- Insert 2 seals in the window frame.
- Apply some #680066 glue at the intersection of the 2 seals and also sparingly in order to fix the seal to the window frame.

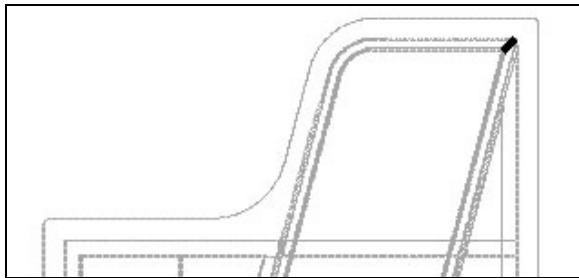

- Clean window using window cleaner.

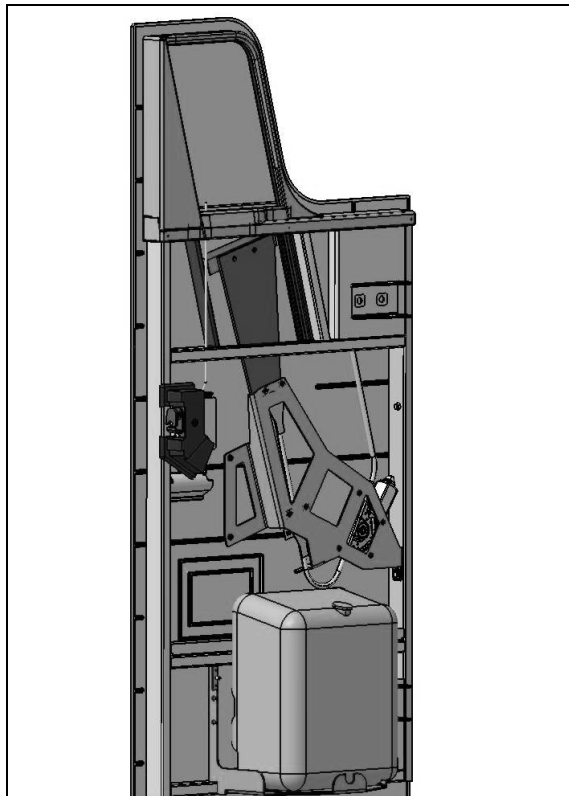

- Insert window into frame.
- Secure window pane to raising mechanism.
- Adjust window travel ($6\pm 3\text{mm}$ above window wiper).

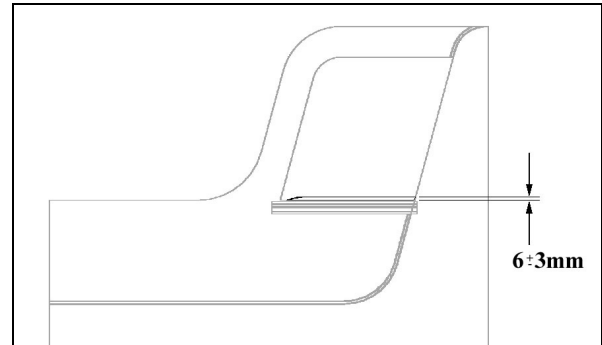

Driver's Window Gutter

- Dry fit the gutter on the vehicle. If required, straighten up gutter using a hammer and a wooden block.

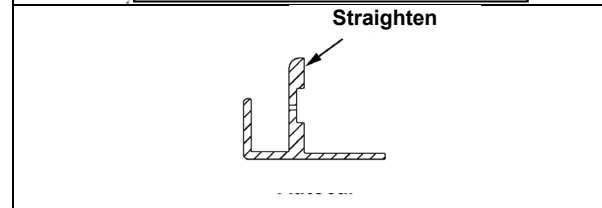

- If applicable, remove plastic film at the bottom of driver's window.
- Remove excess of Sika underneath driver's window.
- Clean bottom of driver's window using window cleaner.
- Apply Sika Aktivator at the bottom of driver's window.
- Install gutter under driver's window then compress in order to fix double face self-adhesive tape.

- Install 3 clamps and allow curing for 4 hours.

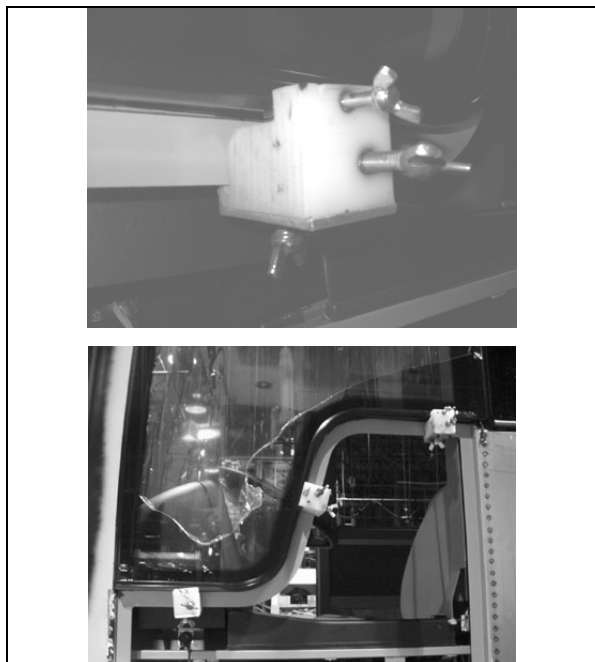

6.1.8 *Front Cap*

The fiberglass front cap does not need any maintenance except painting as needed. It is held in place with adhesive. If ever it has to be replaced, make an appointment at a Prévost service center near you. For minor damages, refer to section 4 "Fiberglass Repair" and section 5 "Painting".

Section 18: BODY

6.2 ZONE 2

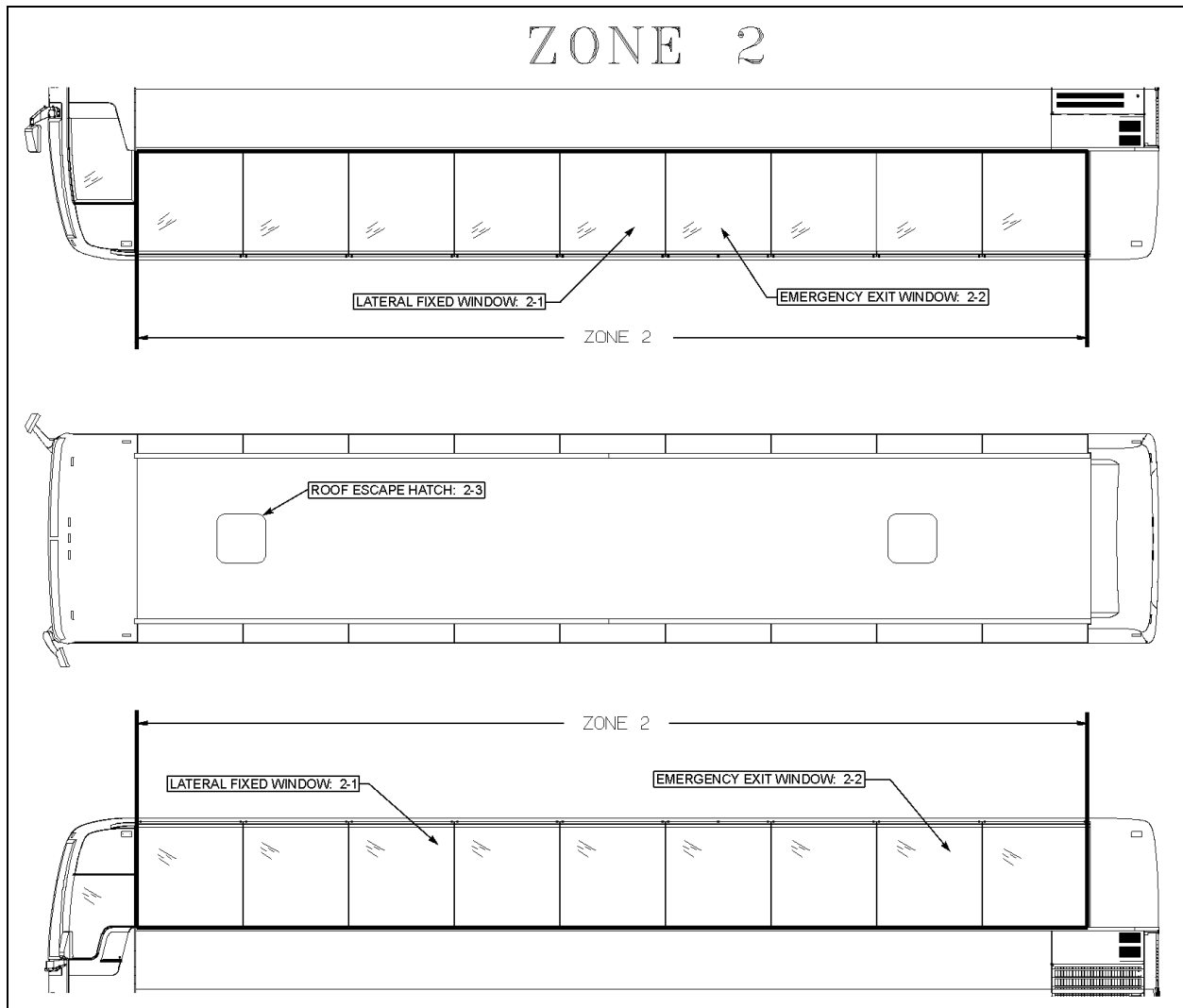

FIGURE 27: ZONE 2

18625

6.2.1 Lateral Fixed Window

Nine passenger side windows are provided on each side on X3-45. They are made of fixed, single or double-glazed, heat absorbing AS-3 glass. Windows are mounted in painted aluminum extrusions, which hold the glass in place from the top rail of the coach. The extrusion also serves as a hinge to allow the window to swing open when needed. The single-glazed windows are made of tinted tempered safety glass, while the double-glazed windows are made of tinted tempered safety glass outside and clear tempered glass inside.

For fixed side window removal or installation, you will need:

Hammer or;

Drill equipped with a sharp pointed rod into which a small hole was drilled;

Braided windshield wire and a pair of handles;

Gloves, goggles or face shield.

- **Fixed Window Removal**

- Method A

- Apply a sticky plastic film onto window outside surface (thermos) and break window. For single pane, apply a sticky plastic film on both sides of window.

Method B

- Using a drill equipped with the special sharp pointed rod, drill through the window seal into one of the bottom corners, from a 30° angle with reference to the vehicle.
- This procedure requires accuracy and it is possible not to succeed on the first attempt. From the inside of vehicle, a second person ensures the rod passes through.
- Remove the rod, thread the wire into the small hole. Reinsert the rod and the wire into the hole far enough so that the person inside the vehicle can pull the rod using a pair of pliers.
- Attach the wire ends to the specially designed handles.
- Pull in turn from the inside and the outside of vehicle to gradually cut the Sika bead on the window perimeter.
- When you reach top corner, detach wire from the outside handle, secure it to a fish wire or rod and thread it underneath the aluminum molding behind the rivets.
- Detach wire from fish wire and continue cutting using the handle.
- Cut Sika bead until you come back to starting point, then you can remove the window by carefully pushing it out from the inside of vehicle.

- **Preparation of Structure and Installation of Window**

Preparation of Structure

- Remove old Sika adhesive.
- If primer was removed at the same time than Sika, perform the following steps:
 - * Clean using anti-silicone.
 - * Remove from structure old primer using a sander (120-150 grit).
 - * Clean again using anti-silicone.
 - * Apply 206 G+P primer.
- Reactivate 206 G+P primer.

Installation of Window

- Use window cleaner around window interior perimeter and edges to remove any oily film while inspecting for damages.
- Apply Sika Aktivator.
- Using a triangular nozzle (20mm X 10mm), apply Sika Ultrafast II onto structure.

NOTE

You only have 8 minutes to install window once the SIKa ULTRAFast II product is applied.

- Install window.

**CAUTION**

To prevent damaging the Sika joint, do not raise the window once it has touched the bead.

- Before compressing window against Sika joint, install two stops into the aluminum extrusion one inch from each window edge.

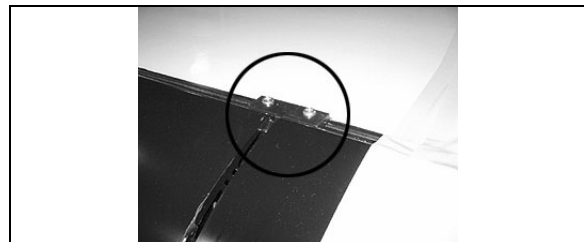

- Verify window alignment with reference to adjacent surfaces.
- Vehicle must remain stationary for 30 minutes at more than 23°C.

6.2.2 Emergency Exit Windows

Three of the windows on curb side of the X3-45 serve as emergency exits, while there are four on driver's side. See figure 28. Except for the top window side, the three other glass sides are unprotected, which causes the workers to be exceptionally careful when manipulating or installing such windows.

In addition, when it becomes necessary to lay down the unprotected edges of the glass window, never use a steel or concrete floor support. It is recommended to use a wooden support, even better, a padded surface.

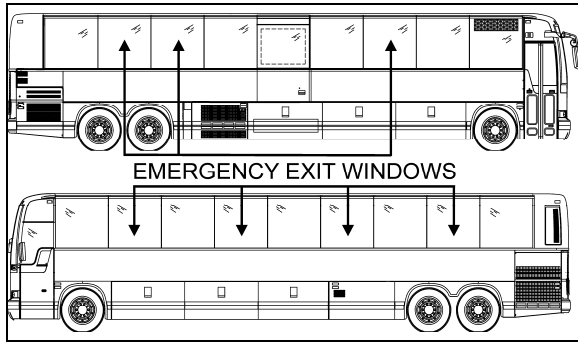

FIGURE 28: X3-45 COACH 18617

An emergency exit window can be opened by pulling the lower part of the release bar to disengage the safety latches, and then by pushing out the window frame (Fig. 29).

Emergency operating instruction decals are affixed under each emergency exit window. To close the window, pull back the window and push down the release bar.

• **Emergency Exit Release Bar**

The emergency exit release bar system is generally maintenance free. It has been designed to answer the twenty pound resistance criteria for opening the emergency window. If this handle should be replaced:

1. Remove the screws and bolts securing it to the emergency exit window;
2. Install a new release bar, reverse the procedure.

NOTE

Check the legal twenty pound maximum resistance to be sure to comply with regulations.

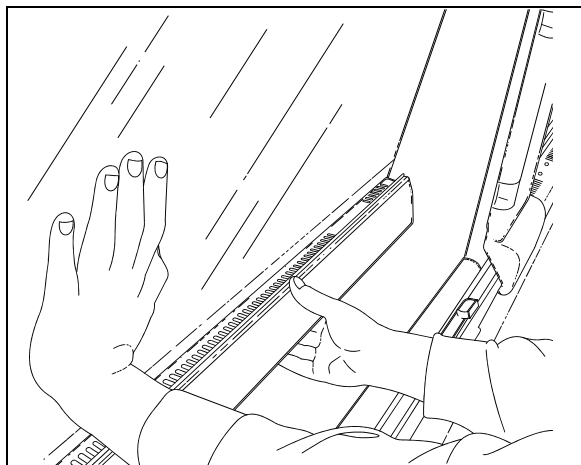

FIGURE 29: EMERGENCY EXIT WINDOW 18008

• **Emergency Exit Window Adjustment**

Emergency exit windows should be checked periodically for easy opening and closing. Pulling the lower part of the release bar with both hands placed near the safety latches should disengage both locks on the window simultaneously. The tension required to release the window should not exceed twenty pounds (9 kg) of force.

The release bar mechanism itself has been designed such as no adjustments are necessary.

If too much effort is required to disengage the locks when pulling the release bar or if the window doesn't close tightly or rattles, check for interference by foreign objects or nearby parts into mechanism, such as the microswitch, rubber seal, wires, etc. Correct situation immediately.

NOTE

Tangs on the lock must be in a horizontal position.

• **Emergency Exit Window Replacement**

1. Lift the bar release system;
2. Remove the stop blocks from the top exterior of the window.
3. Push the glass window out ninety degrees (90°).



WARNING

The window may fall out.

4. The window is free and can be unhooked.

Reverse the procedure to install a new emergency exit window.

6.2.3 *Roof Escape Hatch*

The vehicle is equipped with two escape hatches. The escape hatches are designed to provide years of reliable service with a minimum of maintenance. All components are rust proof, and moving parts are Teflon coated to eliminate need for lubrication. Should water infiltrate the vehicle from the escape hatch, refer to the heading "Sealing" in this paragraph for procedures on how to seal this area.

**CAUTION**

Use of lubricants, paints, or other coatings such as graffiti deterring sprays is not recommended.

Suggested maintenance includes periodic inspection of fasteners for evidence of loosening due to tampering, and regular cleaning with mild soap and water.

Although there are other cleaning solutions available, some contain solvents and other chemicals that can attack the high strength materials used in the production of the escape hatch.

**CAUTION**

Ensure that cleaning solutions are compatible with the materials used on the escape hatch.

Graffiti removing cleaners often contain acetone, ether, lacquer thinner or other solvents known to destroy the high strength properties of many plastics. Use of these cleaners must be avoided. Graffiti-resisting coatings often leave a sticky residue that interferes with smooth up/down movement of the hatch mechanism. Some of these coatings also contain solvents that will reduce the strength of certain components.

**CAUTION**

Use of these coatings is at considerable risk and should be avoided.

- **Repair**

All components used in the production of the escape hatch are available as service parts, except for one hinge that represents a possible hazard when improperly reattached to a hidden tapping plate, itself often damaged whenever the hinge is damaged. The tapping plate is permanently laminated between the inner and outer cover assemblies, and it cannot be inspected or replaced. It is therefore necessary to replace the entire assembly following damage to the hinge. See figure 30.

**CAUTION**

Hinge assembly is critical and hinge should never be removed from cover assembly. Fasteners used in this assembly are special and have critical torque requirements and tamper-resistant heads to discourage tampering.

- **Sealing**

1. Open and tilt up the escape hatch cover.
2. Join the 2 ends of the rubber seal.

**CAUTION**

Seal joint should be toward rear of vehicle.

3. Apply rubber adhesive CA-40 (Prévoist # 681285) in the gap between the seal ends.
4. Apply Sikaflex 221 sealant (Prévoist # 680532) along the outline of the escape hatch on the roof of vehicle.

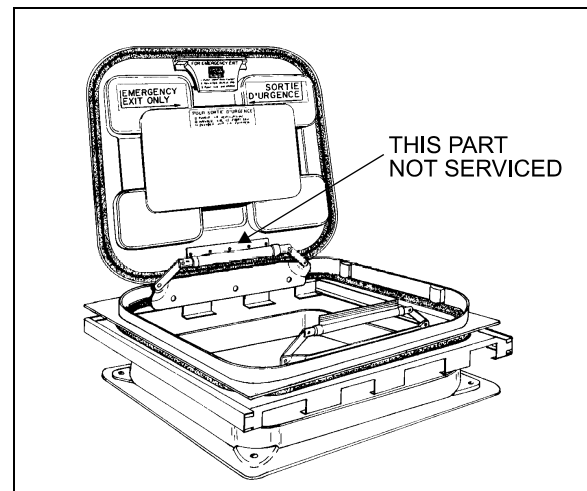

FIGURE 30: ESCAPE HATCH

18104

- **Escape Hatch Panel Assembly**

The frame of the escape hatch is riveted to the roof of the vehicle. The escape hatch panel assembly can be replaced as a unit and a new panel assembly installed in the existing frame. To remove the panel assembly, remove the 4 bolts fastening the 2 hinges to the escape hatch frame and retain the 4 flat washers. Reinstall the panel assembly by fastening the 2 hinges with the 4 bolts and flat washers removed earlier.

CAUTION

When installing, roof escape hatch's hinge must be toward the front of vehicle, to prevent the hatch from being ripped out if accidentally opened while vehicle is running.

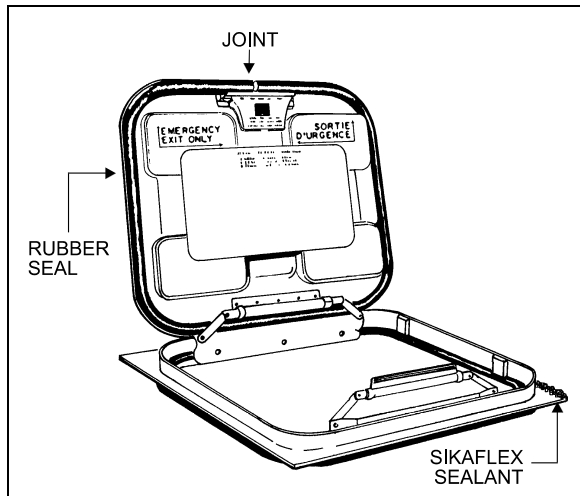

FIGURE 31: ESCAPE HATCH

18105

• **Escape Hatch Frame**

When necessary, the escape hatch frame can be removed and replaced in the following way:

1. Support the frame from inside the vehicle.
2. Remove rivets.
3. Cut the rubber seal with a sharp edge knife and remove the hatch frame.
4. On vehicle top, using the knife, remove as much as possible the remaining rubber seal.
5. Drill holes (if needed) in the new metal frame.
6. Clean both vehicle top and new hatch frame with SIKA 205.
7. Apply rubber adhesive SIKA 221 under the hatch frame surface.
8. Install the frame in place and fix it with rivets.
9. Remove excess adhesive and clean all around.

6.3 ZONE 3

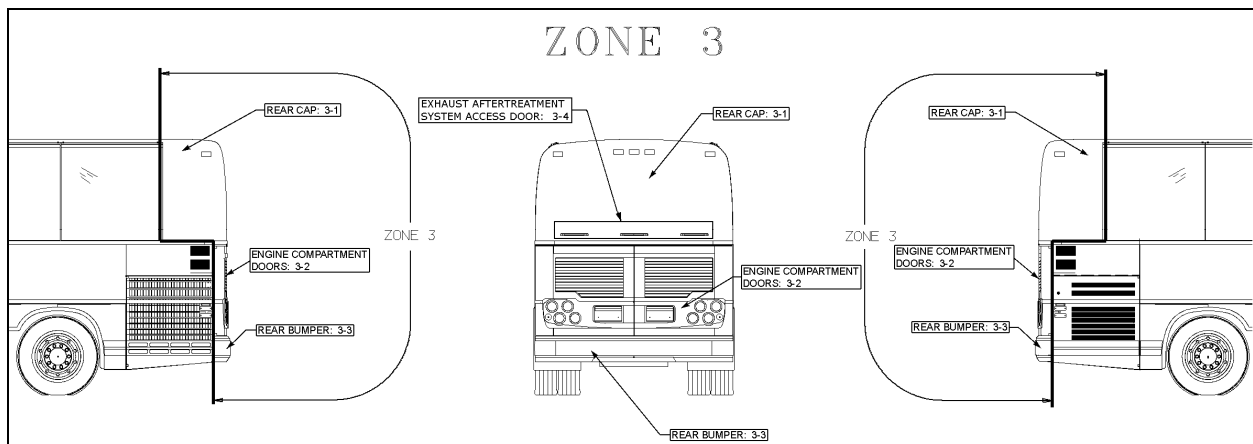

FIGURE 32: ZONE 3

18626

6.3.1 *Rear Cap*

The fiberglass rear cap does not need any maintenance except painting as needed. It is held in place with adhesive. If ever it has to be replaced, make an appointment at a Prévost service center near you. For minor damages, refer to Paragraph 4 "Common Fiberglass Repair Procedure" and Paragraph 5 "Common Painting Procedure".

6.3.2 *Engine Compartment Doors*

Engine compartment doors may be adjusted for proper fit by untightening hinge bolts:

1. Loosen the bolts, (1, 2 Fig. 33) holding the hinge to the vehicle structure to shift the door "UP or DOWN".
2. Loosening the bolts (3, Fig. 33) allows the door to be shifted "LEFT or RIGHT" and "IN or OUT".

3. Adjust the doors position depending on the gap needed between exterior finishing panels.
4. Tighten the bolts.
5. Check that the doors swing freely and close properly. It may be necessary to adjust the door latch to get proper fit and operation.

To adjust the latch mechanism (4, Fig. 33) and the striker pin:

1. Open the doors to access the striker pin.
2. Slightly loosen the striker pin.
3. Using a hammer, adjust the striker pin to center it in the door latch mechanism.
4. Tighten the striker pin.
5. Check doors fit and operation.

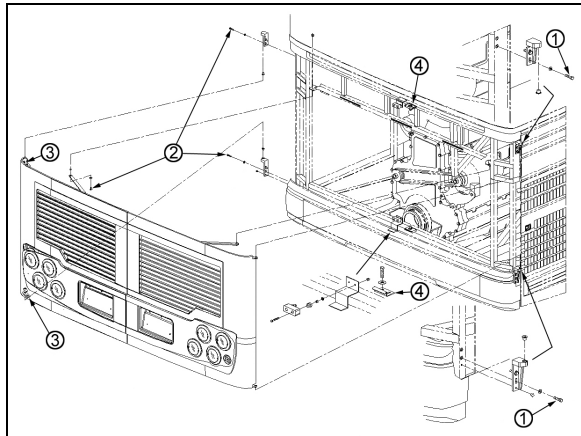

FIGURE 33: ENGINE COMPARTMENT DOORS 18633

6.3.3 Rear Bumper

Remove three bolts on each side holding bumper to vehicle and remove bumper.

To install bumper, reverse the procedure.

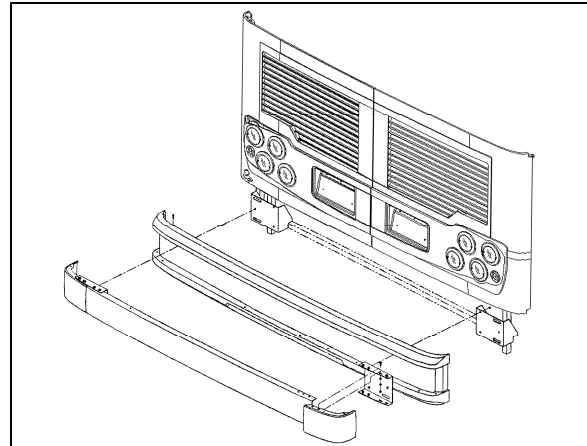

FIGURE 34: REAR BUMPER 18634

6.3.4 Exhaust Aftertreatment System Access Door

1. Open exhaust aftertreatment system access door.
2. Loosen the screws holding the panel to hinge assembly.
3. Adjust the door position according to distance required between exterior finishing parts.
4. Tighten the nuts.
5. Check that the door swings freely and closes properly.

6.4 ZONE 4

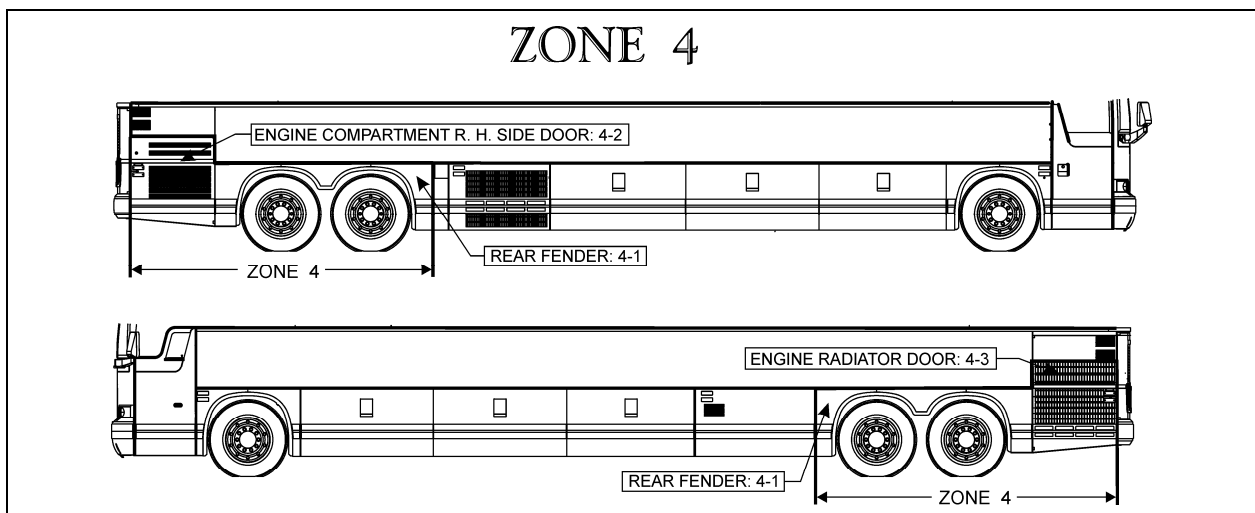

FIGURE 35: ZONE 4 18627

Section 18: BODY

6.4.1 Rear Fender

On the "X3" series vehicle, rear fenders are hinged for maintenance on brakes and suspension. Each rear fender panel has two mechanical spring loaded holding devices fixing it to the vehicle's structure. Push the spring type rod sideways to disengage the lock.

6.4.2 Engine Compartment R. H. Side Door

Engine compartment R. H. side door may be adjusted for proper fit by untightening hinge bolts:

1. Loosen the bolts, (1, Fig. 36) holding the hinge to the vehicle structure to shift the door "IN or OUT" and "UP or DOWN".
2. Loosening the bolts (2, Fig. 36) allows the door to be shifted "LEFT or RIGHT" and "UP or DOWN".

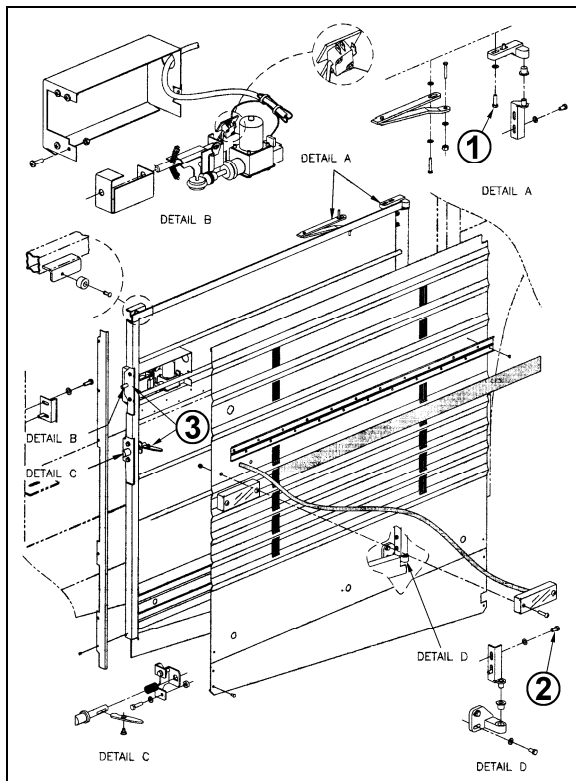

FIGURE 36: ENGINE COMPARTMENT R.H. SIDE DOOR 18635

3. Adjust the door position depending on the gap needed between exterior finishing panels.
4. Tighten the bolts.
5. Check that the door swings freely and closes properly. It may be necessary to

adjust the door latch to get proper fit and operation.

To adjust the latch mechanism (3, Fig. 35) and the striker pin:

1. Open the door to access the striker pin.
2. Slightly loosen the striker pin.
3. Using a hammer, adjust the striker pin to center it in the door latch mechanism.
4. Tighten the striker pin.
5. Check door fit and operation.

6.4.3 Engine Radiator Door

Radiator door may be adjusted for proper fit by untightening hinge bolts:

1. Loosen the bolts, (1, Fig. 37) holding the hinge to the vehicle structure to shift the door "IN or OUT" and "UP or DOWN".
2. Loosening the bolts (2, Fig. 37) allows the door to be shifted "LEFT or RIGHT" and "UP or DOWN".

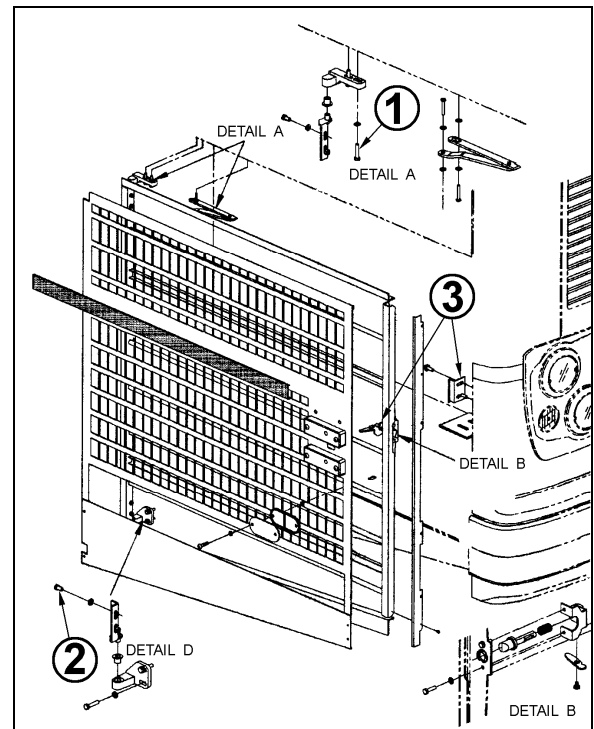

FIGURE 37: RADIATOR DOOR

18636

3. Adjust the door position depending on the gap needed between exterior finishing panels.
4. Tighten the bolts.

5. Check that the door swings freely and closes properly. It may be necessary to adjust the door latch to get proper fit and operation.

To adjust the latch mechanism (3, Fig. 37) and the striker pin:

1. Open the door to access the striker pin.
2. Slightly loosen the striker pin.
3. Using a hammer, adjust the striker pin to center it in the door latch mechanism.
4. Tighten the striker pin.
5. Check door fit and operation.

6.5 ZONE 5

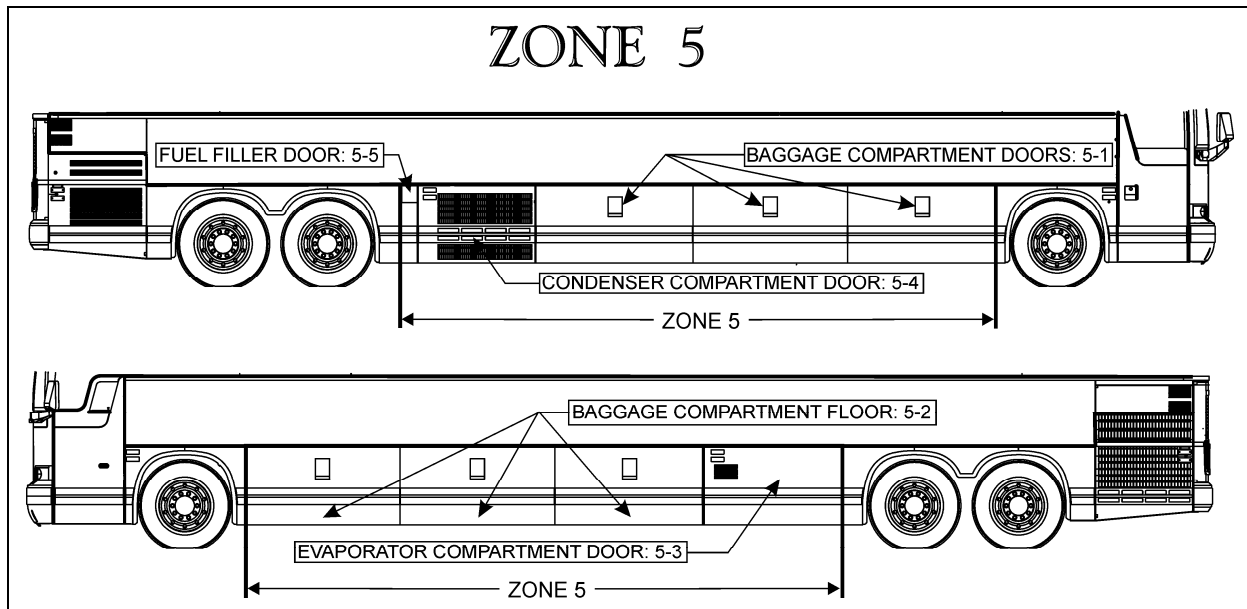

FIGURE 38: ZONE 5

18628

6.5.1 Baggage Compartment Doors

For the removal and installation of baggage compartment door stainless steel body panel, you will need:

A drill with drill bits;

Pneumatic “Zip gun” type tool;

Razor sharp window scraper or putty knife;

- Open damaged compartment door and unfasten rub rail fixing bolts. Remove rub rail.
- Unfasten bolts and disconnect cable if necessary in order to remove door from vehicle.
- Preferably install the door onto a work surface where it can be solidly fixed.

• Door Lower Panel

Panel Removal

- Using the “Zip Gun”, cut Sika bead located $\frac{1}{2}$ inch from the door panel perimeter edge.
- Wearing gloves, goggles and ear plugs, pry loose body panel using a “Zip gun” or lever starting from the door lower part.
- Using the window scraper, remove any Sika bead or self adhesive tape residue left on the door frame.

Lower Panel Preparation and Installation

- Use a Chix cloth and anti-silicone to remove any dust or residue from door frame.
- Prepare door frame using a scratch pad “Scotch Brite”.

Section 18: BODY

- Clean door frame again using anti-silicone.
- Apply some Sika 206 G+P onto door frame.
- Clean door lower panel using anti-silicone.
- Prepare door lower panel using a scratch pad "Scotch Brite".
- Clean door lower panel again using anti-silicone.
- Apply some Sika 206 G+P onto door lower panel.
- Using a triangular nozzle (8mm X 9mm), apply some Sika 255 onto door lower panel.

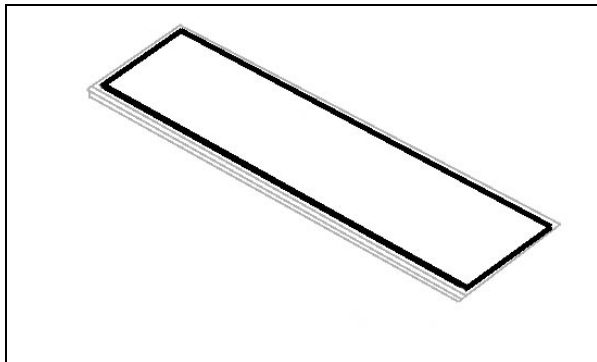

- Position and install door lower panel onto frame.
- Compress and hold for 8 hours.

• Door Upper Panel

Upper Panel Removal

- From the back of the baggage compartment door, remove handle housing fixing screws (6).
- Remove lock access panel
- Wearing gloves, goggles and ear plugs, pry loose body panel using a "Zip gun" or lever starting from the door lower part.
- Cut Sika bead around handle housing.
- Using the window scraper, remove any Sika bead or self adhesive tape residue left on the door frame.

Upper Panel Preparation and Installation

- Use a Chix cloth and anti-silicone to remove any dust or residue from door frame.

- Prepare door frame using a scratch pad "Scotch Brite".
- Clean door frame again using anti-silicone.
- Apply some Sika 206 G+P onto door frame.
- Clean door upper panel using anti-silicone.
- Prepare door upper panel using a scratch pad "Scotch Brite".
- Clean door upper panel again using anti-silicone.
- Apply some Sika 206 G+P onto door upper panel.
- Using a triangular nozzle (8mm X 9mm), apply some Sika 255 onto door upper panel.

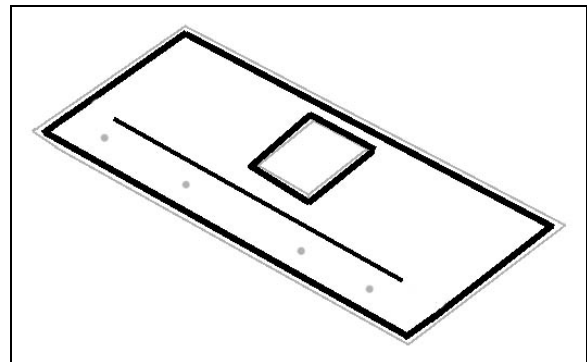

- Position and install door upper panel onto frame.

NOTE

Use rub rail fixing holes for upper panel proper positioning.

- Compress and hold for 8 hours.

Baggage Compartment Door Adjustment

- Adjust door to get a 7mm gap at the top.

NOTE

Adjustment is made using the side plates.

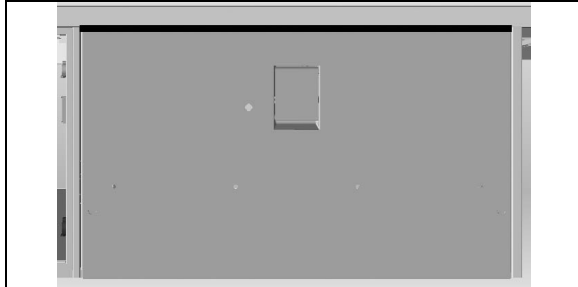

- Center door in the opening using the side plate shims.

NOTE

Adjustment is made using shims on the side plates. A total of 8 shims per door must be used e.g. 4 on L.H. side and 4 on R.H. side or 2 on L.H. side and 6 on R.H. side, etc.

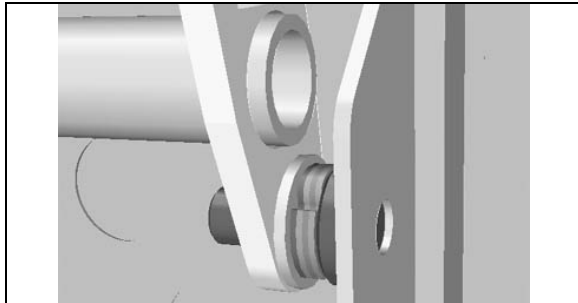

- Adjust door position and evenness with reference to adjacent panels and doors.

NOTE

Adjustment is made by moving IN or OUT the lock plates. Adjust one corner at a time.

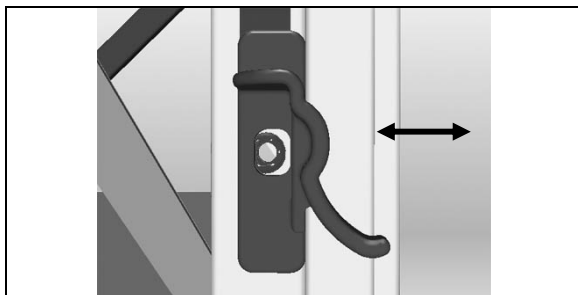

- Check handle adjustment. Handle must remain tight against its plastic housing.

NOTE

Adjustment is made by moving UP or DOWN the lock plates.



- Open baggage compartment door and adjust height using the catch plates.
- Tighten cylinder blocks fixing screws.

6.5.2 Baggage Compartment Floor

• **Repair of Mantex Urethane Covering**

Minor Repair

Use “Dupont IMRON” paint. Apply using a paint brush or roller depending on gravity.

Paint Code: #J4099U

Major Repair (Hole)

Chamfer the whole perimeter of the damaged area. If applicable, remove loose covering. Remove dust and particles.



Cover and protect damaged area surroundings.

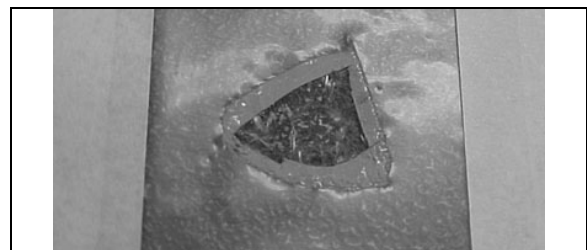

Using a plastic spatula, apply some Sika 221 grey onto the damaged area.

Section 18: BODY

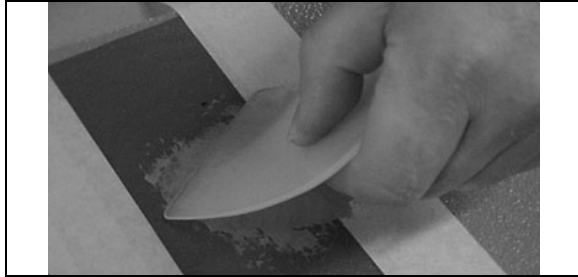

Remove masking tape and protection around damaged area.

Spray pure water onto Sika. Use a floor sample to create some texture onto the adhesive.

If possible spray some more water onto the adhesive to accelerate curing.

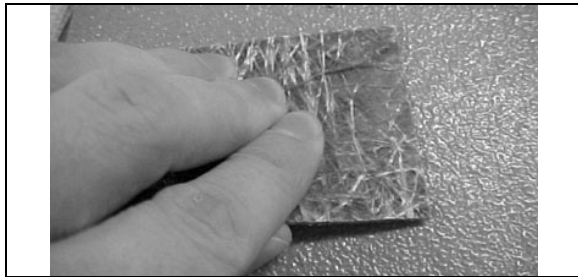

Allow drying for at least **2 hours** then repaint as per paragraph: Minor Repair.

- **Baggage Compartment Floor Installation**

- Preparation and Installation

- Clean baggage compartment support structure using anti-silicone.

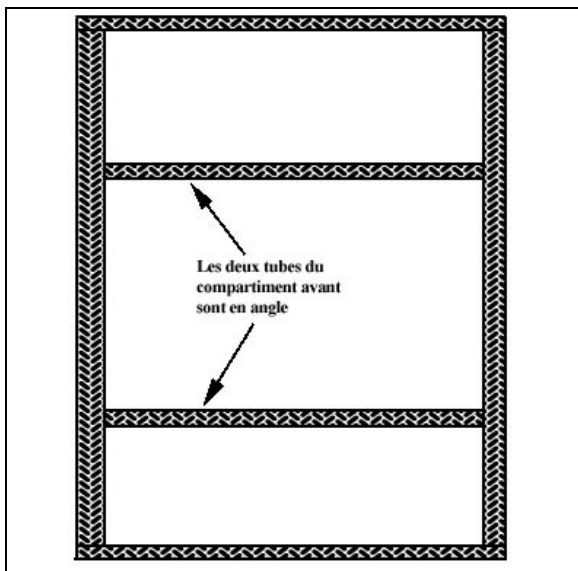

Glue spacers (790392) about 16-inch apart.

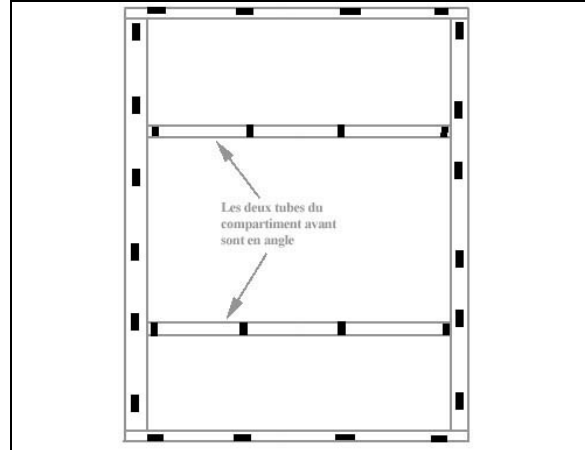

Rear baggage compartment without WCL.

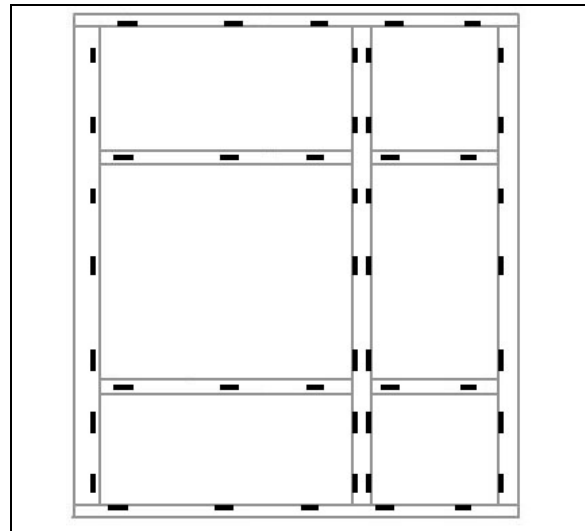

Rear baggage compartment equipped with WCL

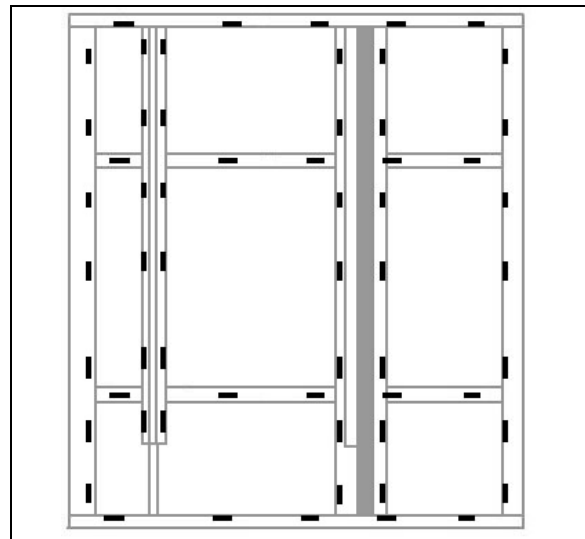

Prepare baggage compartment Mantex floor. Clean panel underside and edges.

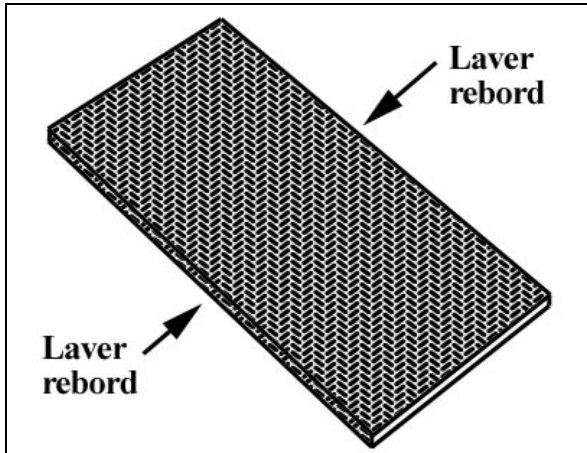

Using a triangular nozzle, apply "Simson" glue (685126) onto support structure.

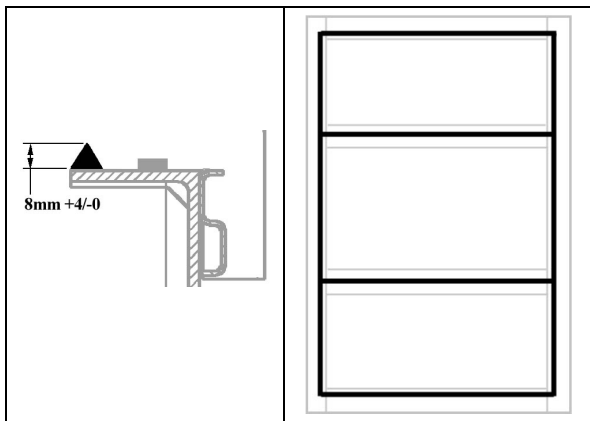

Rear baggage compartment without WCL.

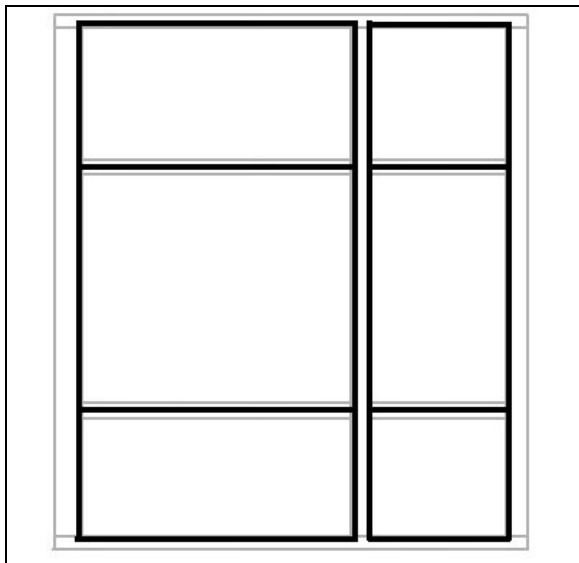

Rear baggage compartment equipped with WCL

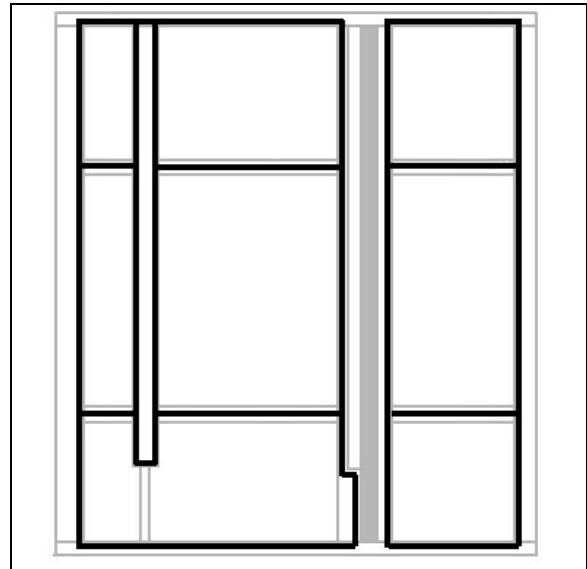

Carefully install panel onto support structure.

Evenly distribute and install conforming weights (6 to 8) (80 to 100 lbs **total**) onto panel for at least **4 hours**. Make sure panel does not move.

Finishing Joints

In the case of lateral finishing joint, apply some masking tape 1/4" from panel edge and 1/4" above panel.

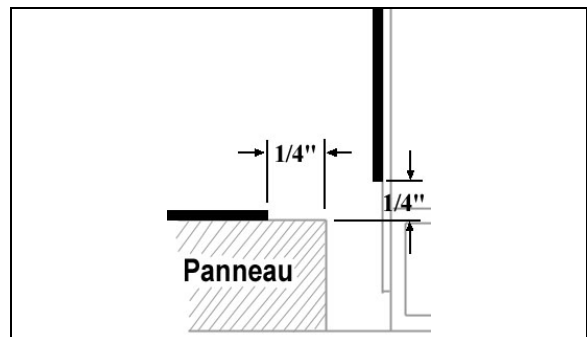

In the case of front finishing joint, apply some masking tape on each side of joint.

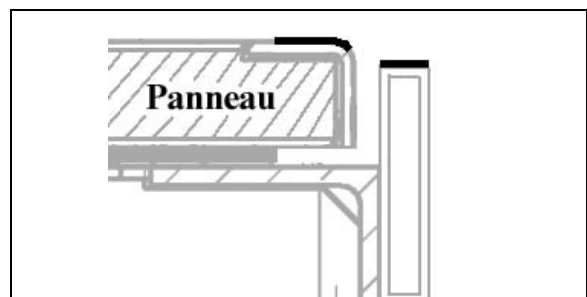

Clean with anti-silicone the area where the Simson glue will be applied.

Section 18: BODY

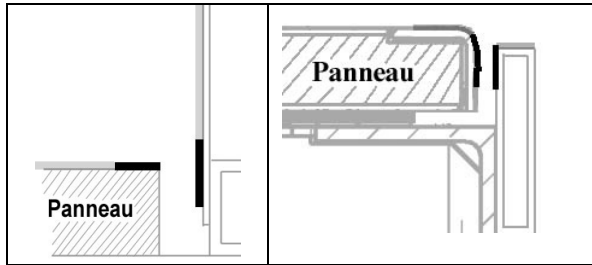

Apply some Simson glue to fill the gap.

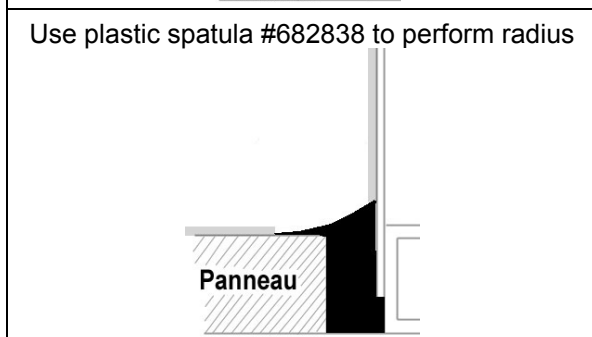
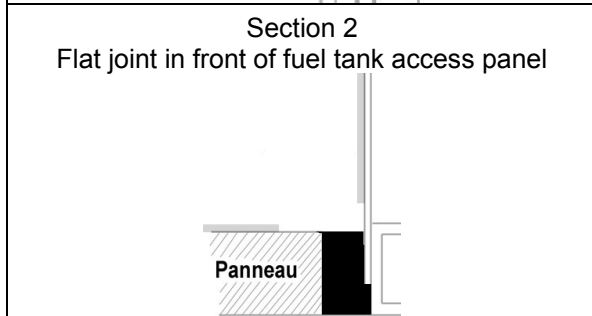
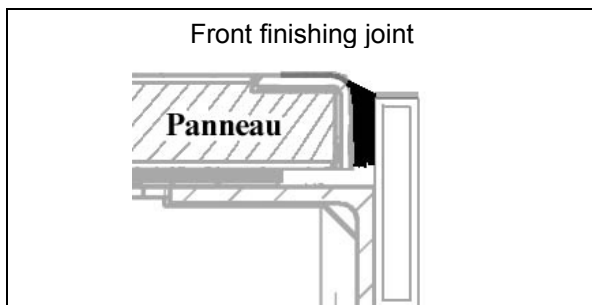
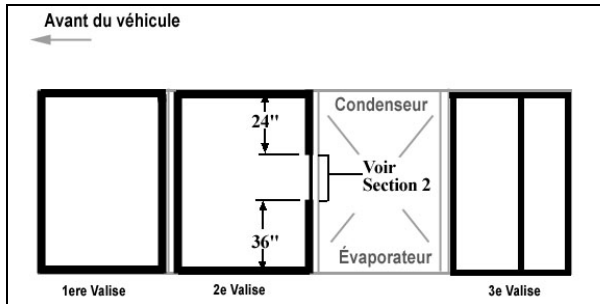

Rear baggage compartment equipped with WCL

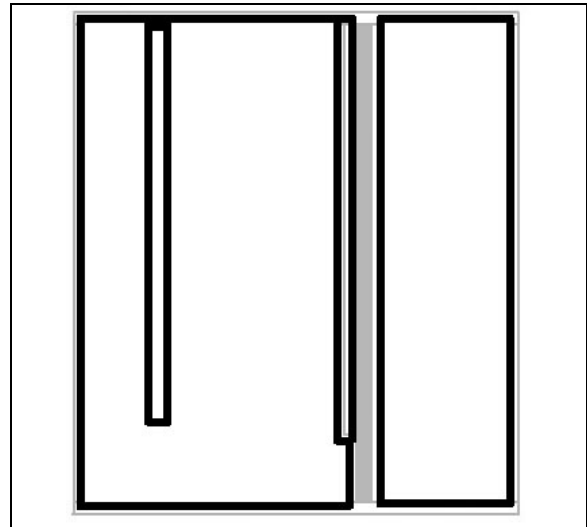

Rear baggage compartment without WCL.

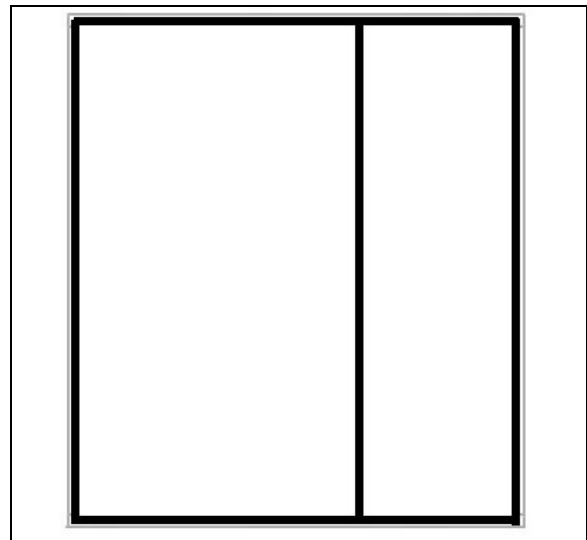

Remove masking tape.

Smooth down joints using soapy water.

6.5.3 Evaporator Compartment Door

1. Open the evaporator door.
2. Loosen the screws fixing the hinge to hinge attachment or hinge to door assembly. Loosening the screws allows the evaporator door assembly to be shifted "LEFT or RIGHT" and "UP or DOWN" or "IN and OUT".
3. Adjust evaporator door assembly position at the hinge.
4. Tighten the screws.

5. Respect the required gap between exterior finishing panels.
6. Check that the door swings freely and closes properly. It may be necessary to adjust the door latch to get proper fit and operation.

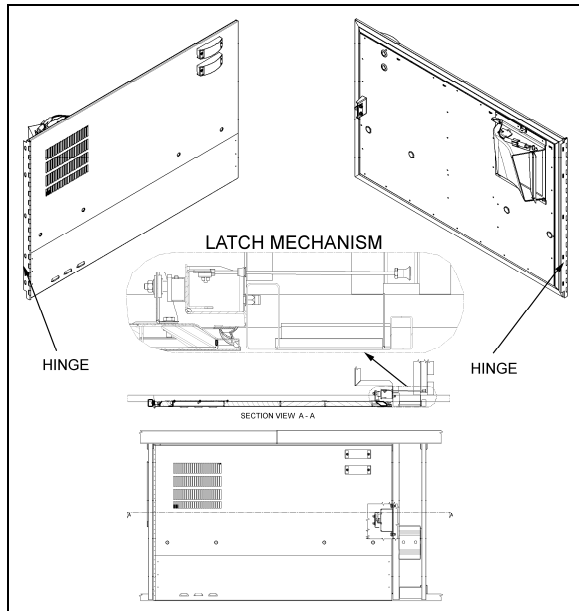

FIGURE 39: EVAPORATOR DOOR

18637

6.5.4 Condenser Compartment Door

1. Open the condenser door.
2. Loosen the screws fixing the hinge to hinge attachment or hinge to door assembly. Loosening the screws allows the condenser door assembly to be shifted "LEFT or RIGHT" and "UP or DOWN" or "IN and OUT".
3. Adjust condenser door assembly position at the hinge.
4. Tighten the screws.
5. Respect the required gap between exterior finishing panels.
6. Check that the door swings freely and closes properly. It may be necessary to adjust the door latch to get proper fit and operation.

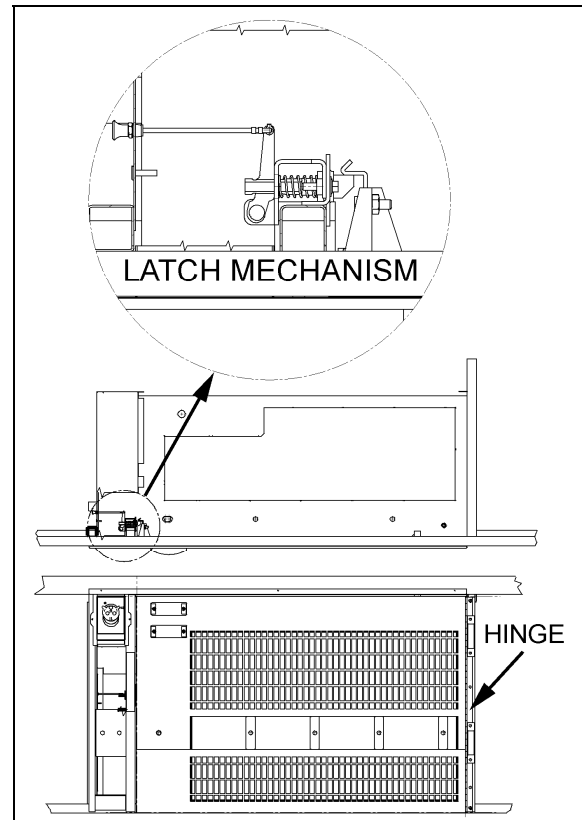

FIGURE 40: CONDENSER DOOR

18638

6.5.5 Fuel Filler Door

1. Open the fuel filler door.
2. Loosen the screws holding the panel to hinge assembly.
3. Adjust the fuel filler door position according to distance required between exterior finishing panels.
4. Tighten the nuts.
5. Check that the door swings freely and closes properly.

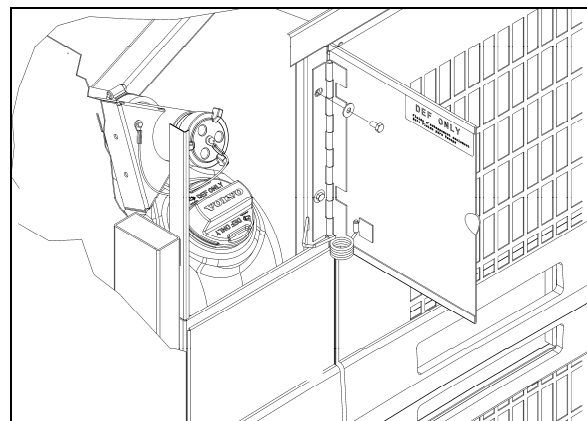

FIGURE 41: FUEL FILLER DOOR

03046

Section 18: BODY

6.6 ZONE 6

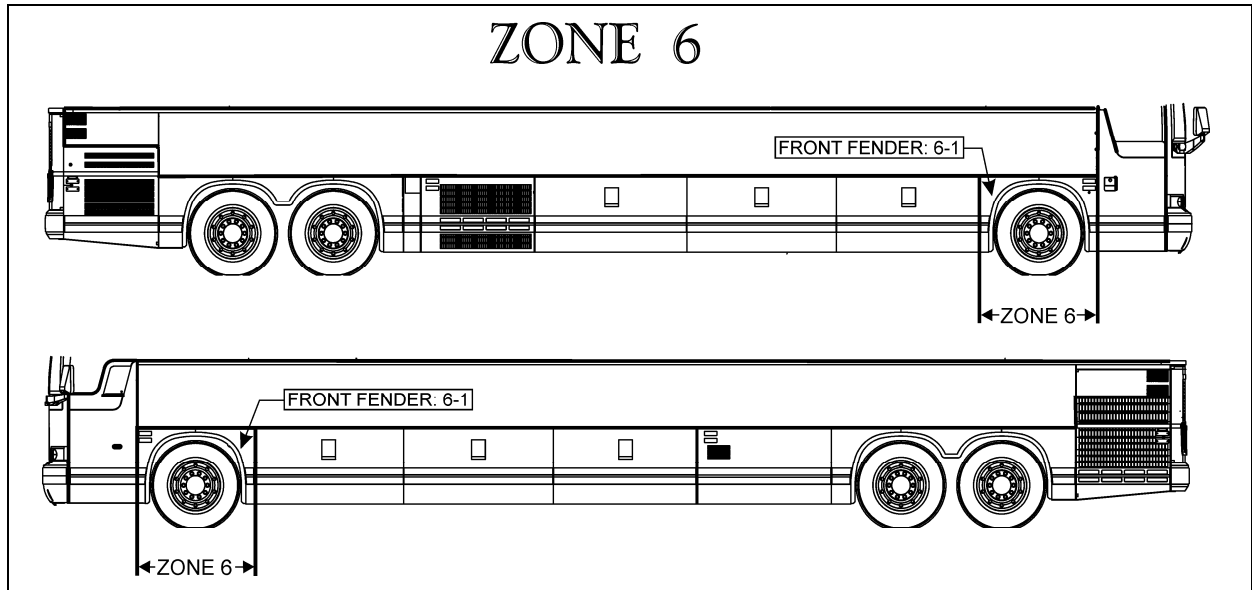

FIGURE 42: ZONE 6

18629

6.6.1 Front Fender

Front fender may be removed using the following procedure:

Remove the nuts on the inside of the fender. Remove the fender from the vehicle. To reinstall, reverse the procedure.

6.7 ZONE 7

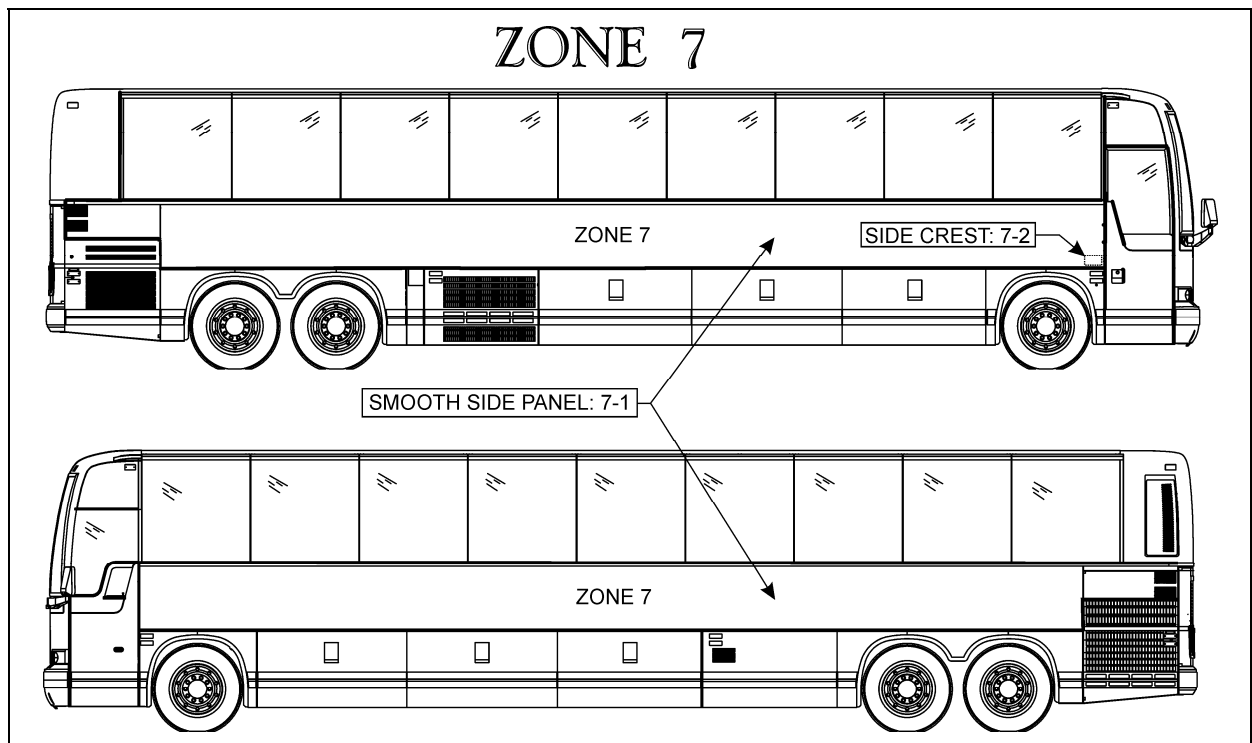

FIGURE 43: ZONE 7

18630

6.7.1 X3 Smooth Side Panel Replacement Procedure

Material:

Anti-silicone (682989)	√	Scotchbrite gray (680226)	√	Sika 221 gray	√
CHIX cloth (682384)	√	Sika 205 1liter (683097)	√	Sika 252 black	√
Blue cloth (682383)	√				

Equipment:

Glue gun	√	
Pencil	√	

SECTION 1 SMOOTH SIDE PANEL REMOVAL		
1.00	REMOVAL	
	A) Remove finishing molding. Insert a screwdriver into snap-on finishing molding joint. Bend finishing molding enough to be able to fix a pair of locking pliers. Using the pair of locking pliers, pull the stainless steel molding and at the same time gradually cut Sika bead with a sharp knife.	Be careful not to damage the adjacent surfaces.
	B) Using a hammer and punch, drive out rivet shanks from top and bottom and from front and rear finishing molding supports. Use a #11 titanium drill bit to remove rivet heads.	
	C) Grind tig weld spots at each end of side panel.	
	D) Safely support or temporary fix side panel.	Warning: Panel weights over 200 pounds
	E) Insert a flat screwdriver between the side panel and the vehicle chassis, in the top left and right corners. Make sure to separate side panel from structure.	Be careful not to damage the adjacent surfaces.
	F) Use the c-clamp to separate the side panel from the back structural panel and at the same time gradually cut Sika bead with a sharp knife.	Ideally, the hoist or chain block must be fastened to the floor while pulling from a 45° angle so as not to damage the vehicle structure
	G) Remove as much glue as possible from the structure using a putty knife or pneumatic knife without damaging 206 G+P primer.	Never heat SikaFlex adhesive to remove.
	H) Check panel horizontal supports for straightness using a straight edge. Take measurements with a ruler.	Tolerance : 1mm towards the outside and 1.5mm towards the inside.

Section 18: BODY

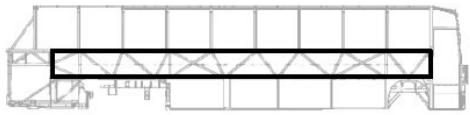
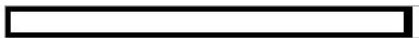
SECTION 2 PREPARATION OF SURFACES			
2.00	VEHICLE SURFACE PREPARATION		
	A)	Clean using "anti-silicone" until all clothes come clean. See PR000001 section A.	
	B)	Use the belt sander (grit coarse) Use a new paper on each vehicle side.	
	C)	Clean using "anti-silicone" until all clothes come clean. See PR000001 section A.	
D)	Apply – Sika 205 See PR000001 section B.		
2.05	SIDE PANEL PREPARATION		
	A)	Clean using "anti-silicone" until all clothes come clean. See PR000001 section A.	
	B)	Use the belt sander (grit coarse) Use a new paper on each vehicle side panel.	
	C)	Clean using "anti-silicone" until all clothes come clean. See PR000001 section A.	
D)	Apply – Sika 205 See PR000001 section B.		

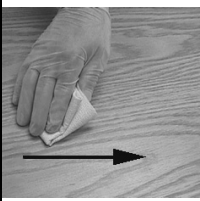
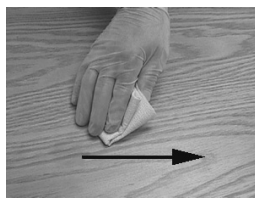
PR000001 Section A Alcohol or Anti-silicone	
	<p>1. Apply</p> <p>CHIX cloth</p>
	<p>2. Dry immediately</p> <p>Blue cloth</p>
<p>3. Allow to dry</p>	
Mandatory	<p>Minimum time : Wait for product to evaporate</p> <p>After 2 hours: Start cleaning operation again</p>
Before applying any other product	<p>If surface seems dusty, greasy or with finger marks, start cleaning operation again.</p>

Section B Sika 205

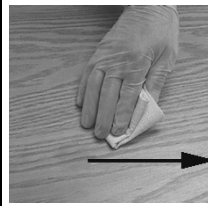

1. Apply

CHIX cloth







2. Allow drying

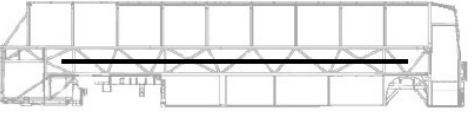
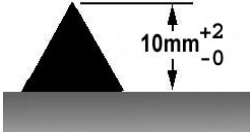
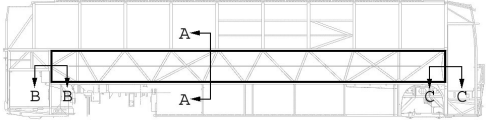
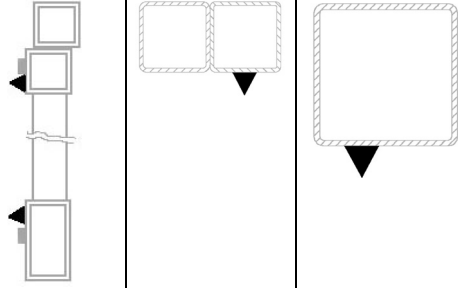

Mandatory	Minimum time	- For a smooth surface (aluminum, stainless steel, fiber glass (gelcoat side), etc.):	2 minutes
		- Pour a porous surface (fiber glass (non gelcoat side), etc.)	10 minutes
After 2 hours : Reactivate surface with Sika 205			
Before applying any other product		If surface seems dusty, greasy or with finger marks, start operation again.	

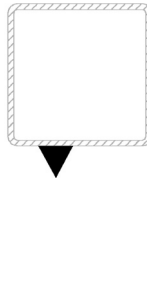
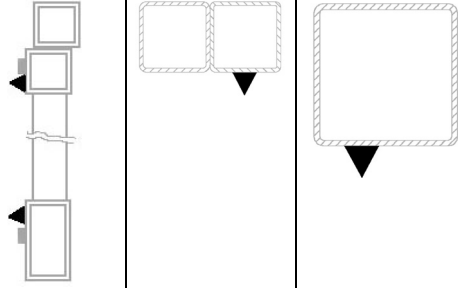
SECTION 3 SIDE PANEL INSTALLATION

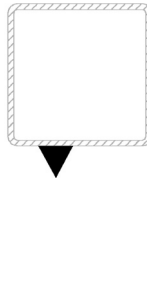
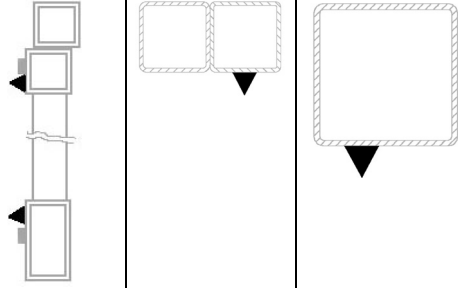
3.00	A)	Using a pencil, mark the double-face self adhesive tape position onto vehicle side.	
	B)	Apply 1/8 X 1/2" double-face tape as per marking.	
	C)	Compress tape	
	D)	Remove protective film from double-face self adhesive tape center section.	

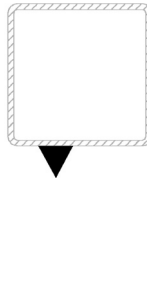
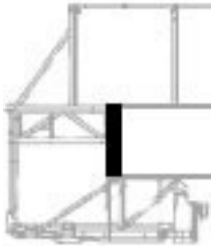
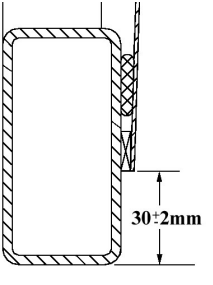
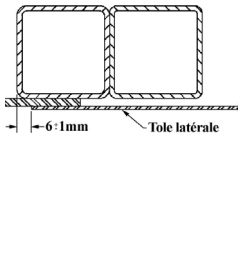
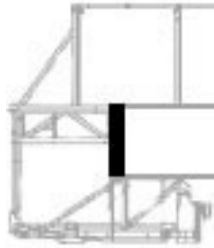
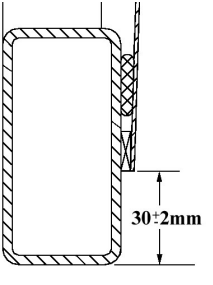
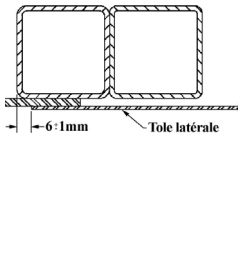
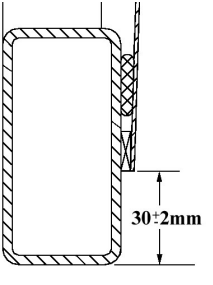
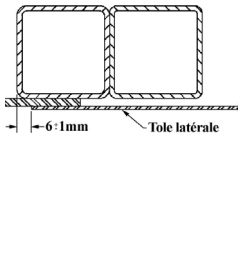
Section 18: BODY

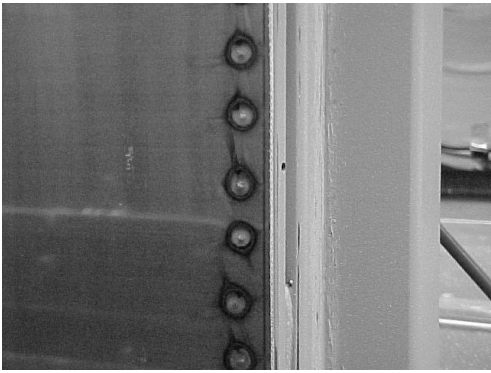

3.05	Install 1/8 X 1/2" foam tape onto middle reinforcement then compress.													
3.10	<p>Apply Sika 252</p>  <ul style="list-style-type: none"> - Onto vehicle surface - Cut nozzle as per template - Use the guide for the application <p>Bead must be continuous for the whole perimeter.</p>	 <table border="1" style="width: 100%; text-align: center;"> <tr> <td data-bbox="954 546 1107 583">Section A-A</td> <td data-bbox="1107 546 1279 583">Section B-B</td> <td data-bbox="1279 546 1448 583">Section C-C</td> </tr> <tr> <td data-bbox="954 598 1107 898">  </td> <td data-bbox="1107 598 1279 898">  </td> <td data-bbox="1279 598 1448 898">  </td> </tr> </table>	Section A-A	Section B-B	Section C-C									
Section A-A	Section B-B	Section C-C												
														
3.15	<table border="1" style="width: 100%;"> <tr> <td data-bbox="284 898 360 1056">A)</td> <td data-bbox="360 898 938 1056">Install side panel onto support jig.</td> </tr> <tr> <td data-bbox="284 1056 360 1407">B)</td> <td data-bbox="360 1056 938 1407">Position side panel in front of vehicle structure</td> </tr> <tr> <td data-bbox="284 1407 360 1539">C)</td> <td data-bbox="360 1407 938 1539">Perform final adjustment to make sure that side panel is true and square</td> </tr> <tr> <td data-bbox="284 1539 360 1808">D)</td> <td data-bbox="360 1539 938 1808">Sand rear of side panel 2" wide</td> </tr> <tr> <td data-bbox="284 1808 360 1869">E)</td> <td data-bbox="360 1808 938 1869">Perform tig spot welding (1" apart)</td> </tr> </table>	A)	Install side panel onto support jig.	B)	Position side panel in front of vehicle structure	C)	Perform final adjustment to make sure that side panel is true and square	D)	Sand rear of side panel 2" wide	E)	Perform tig spot welding (1" apart)	 <table border="1" style="width: 100%; text-align: center;"> <tr> <td data-bbox="954 1056 1193 1407"> Section A-A  </td> <td data-bbox="1193 1056 1448 1407"> Section B-B  </td> </tr> </table> <ul style="list-style-type: none"> - 30 mm. ± 2 with reference to bottom tubing - 6 mm ± 1 with reference to vertical tubing  <p>Quantity of "tig spot": 30 minimum.</p>	Section A-A 	Section B-B 
A)	Install side panel onto support jig.													
B)	Position side panel in front of vehicle structure													
C)	Perform final adjustment to make sure that side panel is true and square													
D)	Sand rear of side panel 2" wide													
E)	Perform tig spot welding (1" apart)													
Section A-A 	Section B-B 													



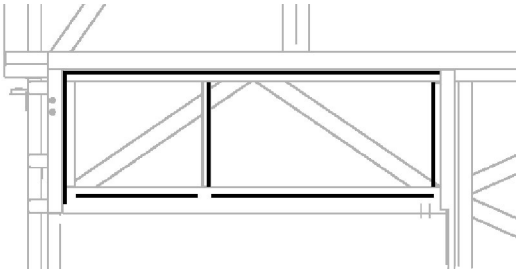

3.20	A)	Install pulling equipment at the other end of side panel	
	B)	Make a final adjustment in height	
	C)	Sand front of side panel 2" wide	
	D)	Pull side panel so that panel moves 1/8"	Make sure the equipment pulls along the whole width of side panel
	E)	Perform tig spot welding	Quantity of "tig spot": 30 minimum.
3.30	Remove pulling equipment		
3.40	A)	Remove protective film from double-face self adhesive tape.	
	B)	Compress top and bottom section of side panel	
3.50	A)	Cut excess of side panel. Make sure that cut is parallel with tubing.	
	B)	Grind side panel end to line up with door tubing.	
3.60	To seal each panel end, apply masking tape on each side of side panel joint. Use a caulking nozzle and grey Sikaflex 221 adhesive to fill the cavity between the panel and vehicle structure. Clean using Sika 205. Allow 5 minutes minimum for drying.		

Section 18: BODY

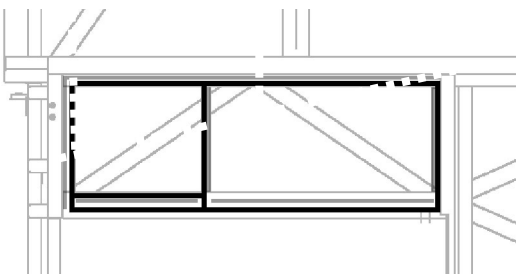
	Wear surgical gloves and smooth down the joint with your finger.	
--	--	--

SECTION 4 ENGINE AIR INTAKE PANEL INSTALLATION		
4.00	Make sure that sealing of structure has been performed properly	
4.05	Prepare vehicle surface as for side panel.	Refer to step # 2.00
4.10	Prepare air intake panel as for side panel	Refer to step # 2.05

4.15	Install foam tape 1/8" X 1/4" onto structure, as shown in picture	
4.20	Install foam tape 1/16" X 1/4" onto air intake panel pleat	
4.25	Apply a bead of 252 onto structure as per picture Important: Make sure bead is continuous Triangular bead: 10mm x 8mm	
4.30	Install panel onto structure	Use a jig to make sure that panel is lined up with engine door tubing.
4.40	Use a brush to compress Sika bead	

5.00 *	Finition Joint		
	A)	Install a protective tape onto the tubing above welding	
	B)	Apply Sika 205 Use a plastic spatula inside a Chix cloth to ensure that Sika 205 reaches as far as the corner. See PR000001 section B.	
	C)	Apply Sika 252 black at the junction of both tubing. Smooth down the joint	
D)	Remove protective tape		

6.7.2 Side Crest

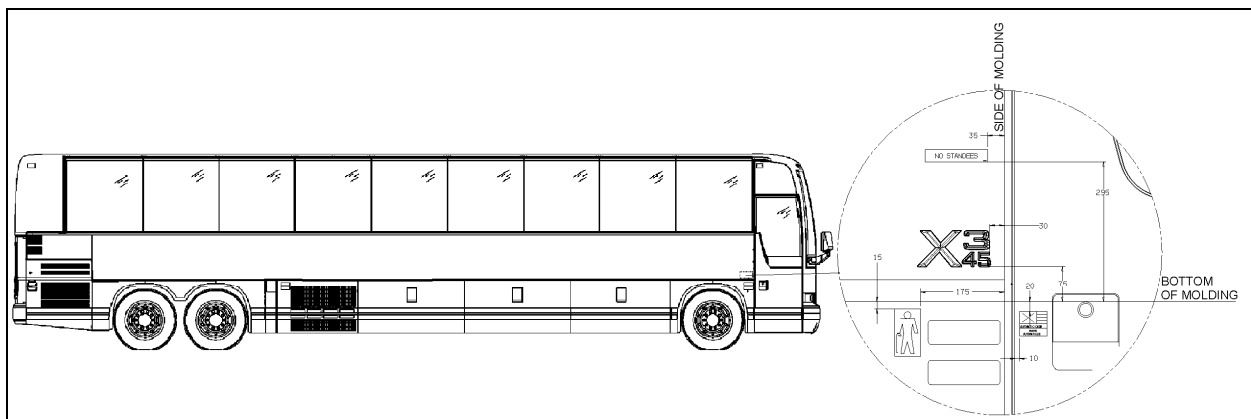

FIGURE 44: SIDE CREST POSITIONING

18639

- Clean vehicle surface using anti-silicone where the side crest and stickers will be applied.
- Using hands apply and compress side crest.
- Apply required stickers.

Section 18: BODY

6.8 BODY PANEL AND WINDOW SPACING

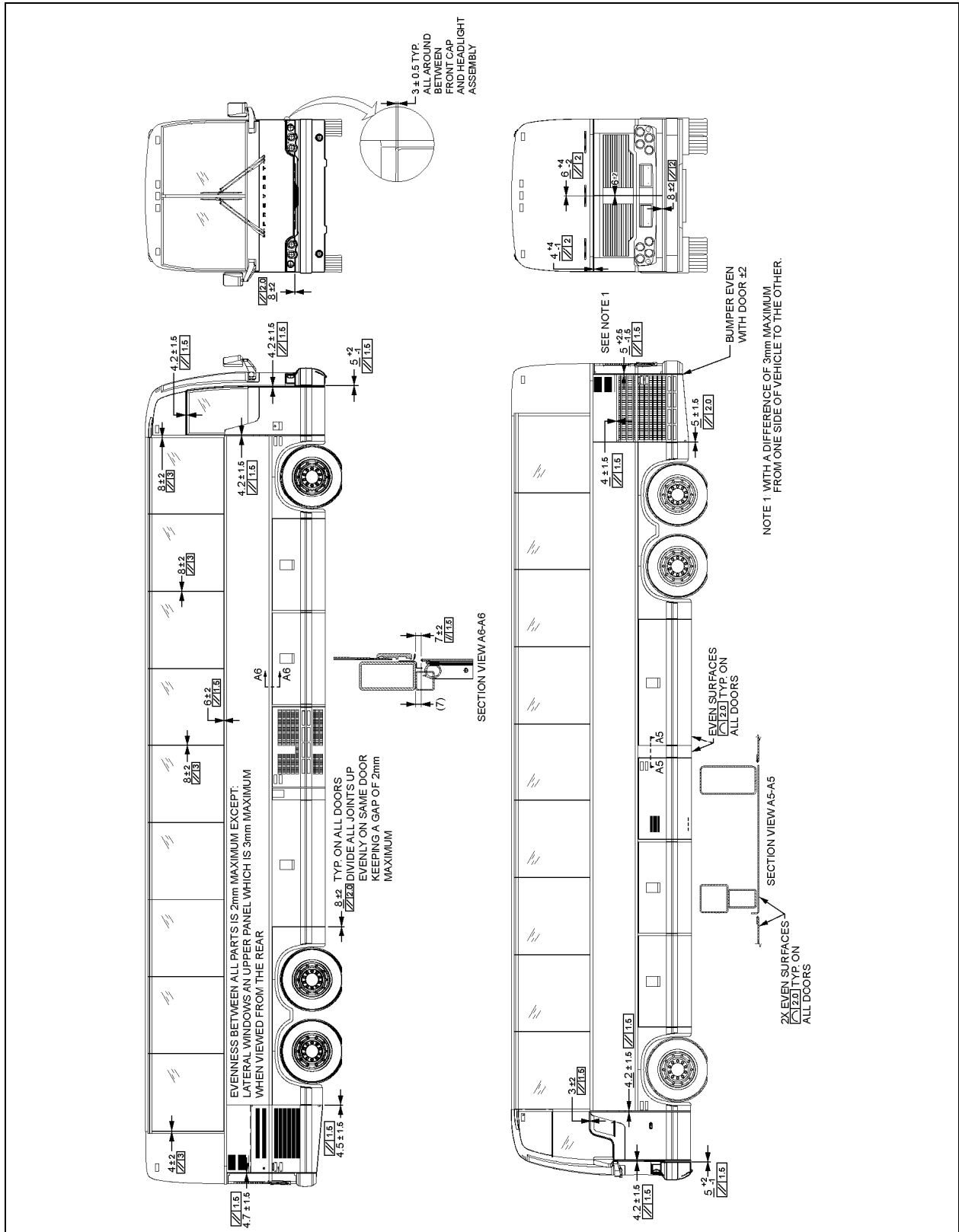

FIGURE 45: BODY PANEL AND WINDOW SPACING (TYPICAL)

18631

6.9 PASSENGER SEATS

X3 coaches are equipped with Torino G 4ONE seat models:

Each pair of seats is built on a welded steel frame fastened to the side wall and on a track-mounted pedestal.

The "Torino G" seats have 3 armrests. The aisle and center armrests can be folded up and down manually, while the window armrest is fixed.

6.9.1 Rotating Seats

1. Remove 1 wing nut holding each seat bottom cushion from under the seat frame.
2. Lift front part of cushions and remove cushions.
3. Remove 4 wing screws fastening seat assembly to seat frame.
4. Pull seat toward aisle and rotate.
5. Align mounting holes and reinstall 4 wing screws.
6. Reinstall seat bottom cushions with wing nuts.

6.9.2 Removing Fixed Seats

NOTE

Seats on one row are not interchangeable with seats of the other row.

To remove fixed seats, proceed as follows:

1. Remove 1 nut holding each seat bottom cushion from under the front part of the seat frame.
2. Lift front part of cushions and remove cushions.
3. Remove 4 finishing screws holding plastic cover between side wall and seat frame.
4. Remove 2 cap screws, nuts, and washers holding seat frame to side wall and retain the 2 holding brackets. See figure 46.
5. Remove 2 nuts and washers holding seat frame to pedestal rods. See figure 47.

NOTE

Bottom end of rod is coated with Loctite and threaded in a steel block which slides in the floor track. Removal of rod is possible if loosened from block. Otherwise, slide rod and block assembly to the front end of track after removing all seats located in front.

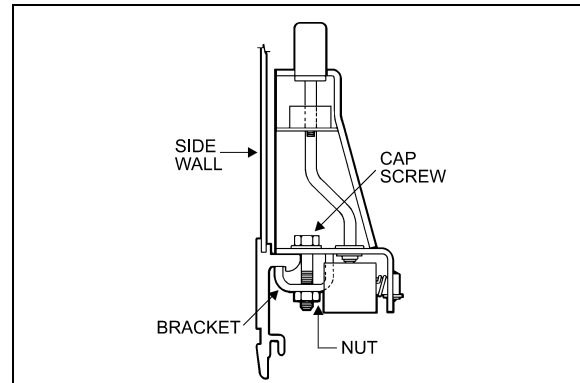

FIGURE 46: ARMREST

18106

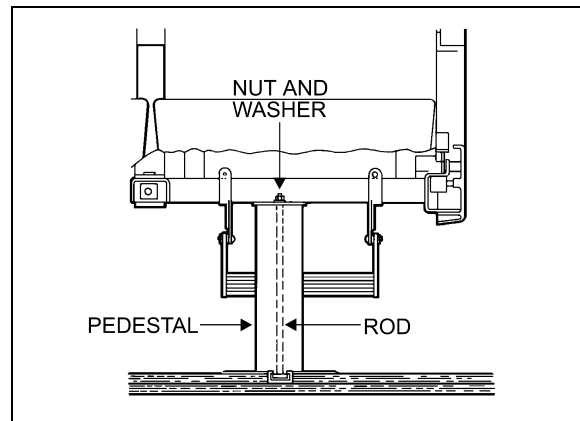

FIGURE 47: SEAT PEDESTAL ASSEMBLY

18107

6. Remove seat assembly.
7. Reverse the above procedure to install seat assembly.

NOTE

On newer vehicles, the rod consists of a carriage bolt inserted in a square plate sliding in the floor track. Removal is possible only by the front or rear end of track.

6.9.3 Upholstery Maintenance

Coach seats are lightweight, with foam-padded backs and cushions. For both appearance and wearability, best results are obtained if upholstery is cleaned at regular intervals before dirt, dust and grit have been ground into the

Section 18: BODY

fabric. Seat fabric is made of 50% wool, 33% cotton, 9% nylon, and 8% acrylic.

- **Routine Cleaning**

All that is required to remove the dirt is a gentle beating with the hand or the back of a brush. This will bring the dirt to the surface where it is easily removed with a vacuum or brush in the direction of the pile which can easily be recognized by running a hand lightly over the pile. If the fabric becomes excessively dirty, particles of grit will cause gradual wear, reducing the life span of the fabric.

- **Dry Cleaning**

If covers are to be removed for cleaning, dry cleaning is recommended since washing might cause some shrinkage, preventing the covers from being reapplied to the seats without damage. Other than spot cleaning the covers while they are in place, dry cleaning is not recommended, since the resulting fumes could be hazardous in the confines of the coach and the solvent could be detrimental to the foam padding of the seats.

- **Cleaning With Covers in Place**

The most effective and economical method to clean the fabric seat covers is by washing with either an approved foam upholstery cleaner or with a mild household detergent.

Thoroughly vacuum the upholstery. Remove any spots or stains before the seats are washed to avoid a cleaning ring.

Dilute household detergent or liquid foam cleaner according to directions on the container. Pour a small quantity into a flat pan and work into a thick foam with a sponge or brush.

Apply only the foam to the fabric with a sponge or brush. Clean a small area of the fabric at a time with the foam. DO NOT SOAK. Rub vigorously. Sponge the suds from the fabric with a clean sponge or cloth moistened with water. Rinse the sponge or cloth often and change the water when it becomes dirty.

Allow the upholstery to dry completely before the coach goes back into service. To speed up drying, excess moisture can be blown off the fabric with compressed air.



CAUTION

Oil in the air line will soil the fabric. Blow the line clear and test air discharge against a plain white piece of paper. It is also effective to press the edge of a flat hardwood stick down on the cushion and slowly draw it across the fabric.

Even very soiled areas can be returned to their original appearance by a thorough cleaning, but a regular schedule of cleaning that keeps the upholstery reasonably clean at all times will greatly enhance the life span of upholstery.

6.10 TARABUS FLOOR COVERING REPAIR OR REPLACEMENT

On X3-45 coaches equipped with “Gerflor Natura Cedar 8813” covering, it is possible to replace or repair this covering. The purpose of this paragraph is to explain the steps to be followed to ensure the best results and adherence.

MATERIAL

Part No	Description	Qty
680028	Adhesive, Tarabus Floor Covering (White)	A/R
684655	Adhesive, Contact (3M)	3.8L
684654	Adhesive, Contact (3M)	18.9L
680532	Sikaflex 221 Gray	A/R

NOTE

Material can be obtained through regular channels.

1. Remove number of passenger seats required to perform repair.
2. Cut and remove damaged section of floor covering.

NOTE

It would be preferable to cut under two rows of seats so that repair is not as noticeable.

3. Clean plywood using a scraper.

NOTE

Make sure that no staples are sticking out beyond surface. Adjacent plywood sheets must be leveled.

4. Fill up holes and imperfections using MAPI PRP 110 then sand.
5. Remove dirt and adhesive residue.

**CAUTION**

Do not leave floor covering folded down except temporarily during installation.

6. Apply floor covering adhesive (680028) onto plywood using a serrated spreader with 1/8-inch serration. If required, apply contact adhesive (3M) (684655 or 684654) onto aluminum molding and also onto section of floor covering, which will be in contact with molding (refer to figure 47).

NOTE

Allow adhesive to dry (3 to 5 minutes).

7. Compress floor covering using a roller so as to remove any trapped air bubble.
8. Apply Sikaflex 221 gray sealant (680532) alongside passenger seat fixing tracks (refer to figure 48).

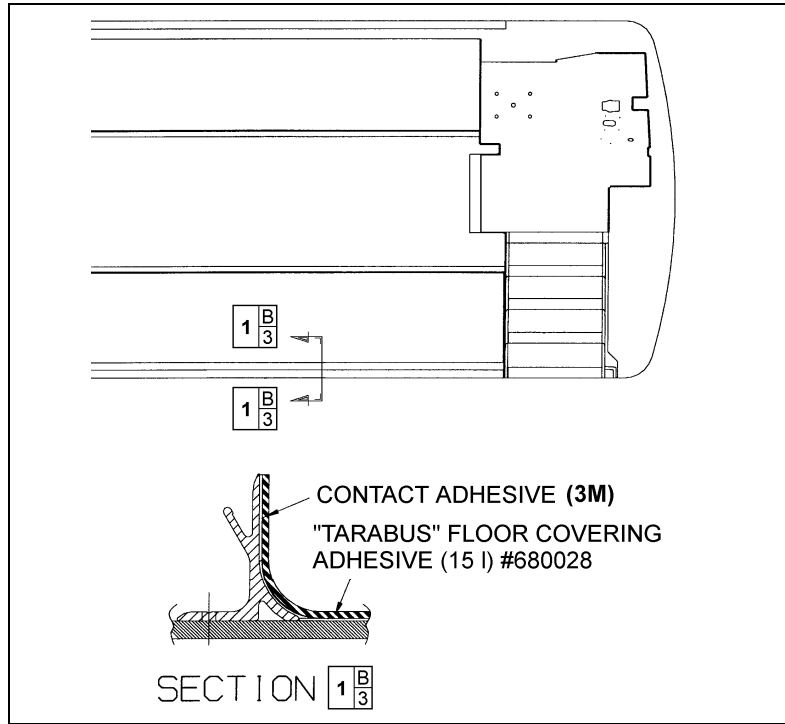

FIGURE 48: TARABUS FLOOR COVERING ADHESIVE APPLICATION

18640

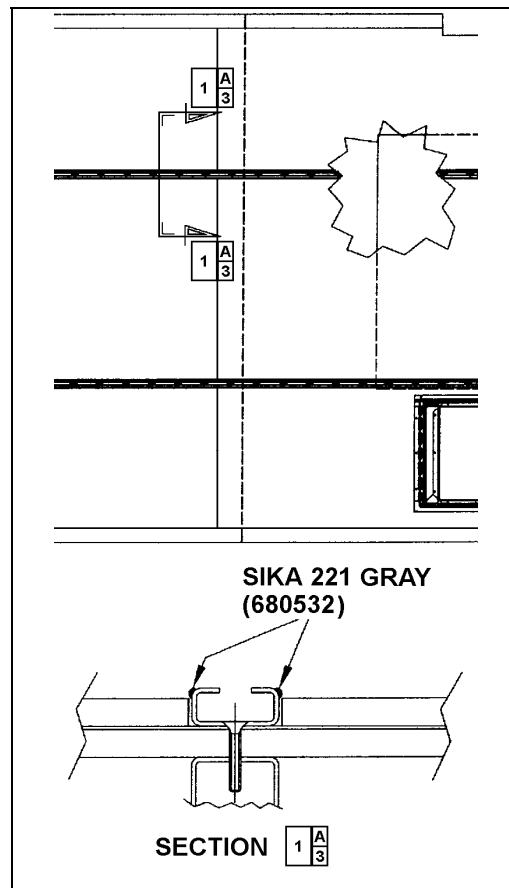

FIGURE 49: APPLICATION OF SIKA 221 GRAY

18641

6.10.1 Front Steps Replacement Procedure

MATERIAL

Part No	Description	Qty
682989	Anti-silicone	A/R
683097	Sika 205 (1 liter)	A/R
685101	Sika Remover 208	A/R
683916	Sika 215 (1 liter)	A/R

1. Cut and remove damaged step(s).
2. Remove dirt and adhesive residue.

NOTE
In wintertime, condensation and cold temperature may greatly influence bonding parameters. Working area must be at a temperature sufficient to prevent reaching condensation point. Mechanically preheat working area (heat lamp or heat gun) or wait until vehicle reaches room temperature.

PREPARATION OF “TARABUS” FLOOR COVERING

1. Sand under step using “Scotchbrite”.
2. Clean using anti-silicone (refer to Section A).

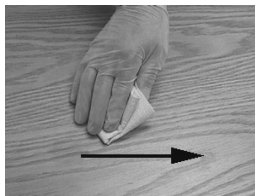
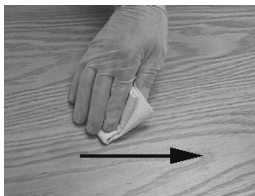
Section A Alcohol or Anti-silicone	
 <p>1. Apply CHIX cloth</p>	 <p>2. Dry immediately Blue cloth</p>
3. Allow drying	
Mandatory	Minimum time : Wait for product to evaporate
	After 2 hours: Start cleaning operation again
Before applying any other product	If surface seems dusty, greasy or with finger marks, start cleaning operation again.

3. Apply Sika Primer 215 (refer to Section D).

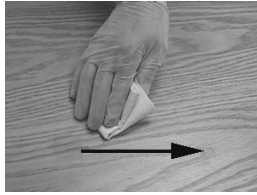
Section D Sika Primer 215			
	1. Shake bottle to mix product		CHIX cloth
	2. Apply a thin layer		
3. Allow drying			
Mandatory	215	Minimum time : 20 minutes	
		After 2 hours : Remove dust using damp cloth (pure water)	
Before applying any other product		If surface seems dusty, dust using damp cloth.	
		If surface seems greasy or with finger marks, reactivate with Aktivator.	

PREPARATION OF FIBERGLASS

1. Clean using anti-silicone (refer to Section A).
2. Apply Sika 205 (refer to Section B).

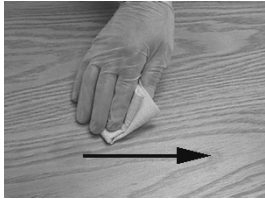
Section B Sika 205			
	1. Apply		CHIX cloth
2. Allow drying			
Mandatory	Minimum time	- For a smooth surface (aluminum, stainless, steel, fiberglass (gelcoat side), etc.):	2 minutes
		- For a porous surface (fiberglass (non gelcoat side), etc.)	10 minutes
After 2 hours : Reactivate surface with Sika 205			
Before applying any other product		If surface seems dusty, greasy or with finger marks, start operation again.	

X3 VEHICLES FRONT STEPS GLUING

1. Use step nosing to measure and cut necessary length of white safety strip.
2. Use a screw to check depth of countersinking in step nosing. Screw top must not stick out beyond the aluminum surface. Countersink if needed.

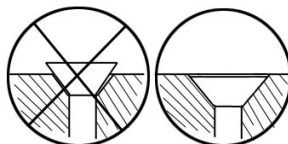

3. Apply some Sika 252 onto the step; make sure to cover the whole surface of the step. Use a serrated spreader with 1/8-inch serration to spread Sika.
4. Apply a bead of Sika 221 onto the perimeter of the step.
5. Install step and press with hands. If Sika overflows, clean with Sika 208. Repeat previous stages for each step if applicable.
6. Remove protective film from double-coated self adhesive tape located underneath step nosing, position step nosing then press. Drill and fix using screws.

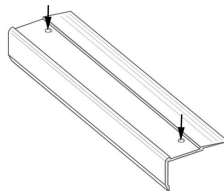

7. Clean top of step nosing using Sika 205 (refer to Section B).

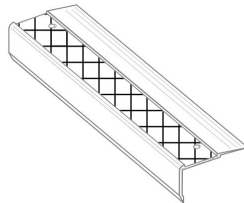

8. Apply some Sika 221 onto white safety strip, spread with a spatula to cover the whole surface.

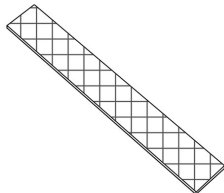

9. Position white safety strip then press using hands. If Sika overflows, clean with Sika 208.

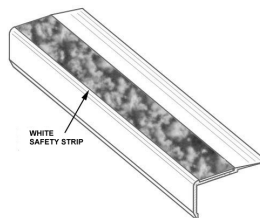

10. Temporarily fix white safety strip with a piece of duct tape, leaving 1 to 2 inches free at each end.

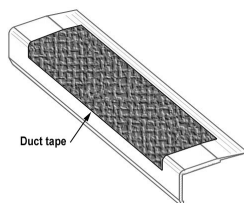

11. Apply some masking tape onto the step perimeter, clean using Sika 205 (refer to Section B) then apply a bead of Sika 252 black. Smooth out the joints then remove masking tape.
12. Install weights onto the steps. Minimum waiting time: 2 hours.

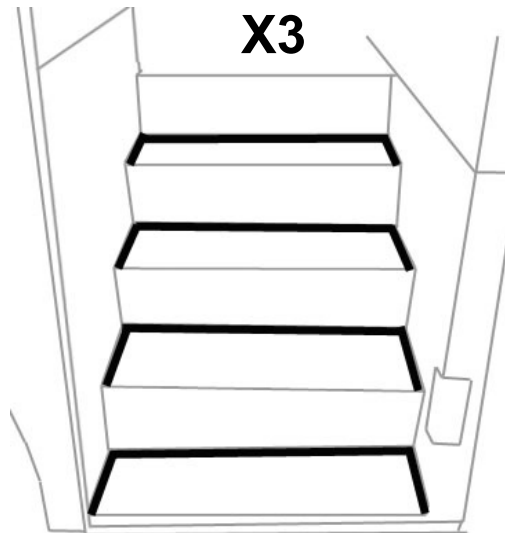

6.10.2 Welding Of Joint Between White Safety Strip And "Tarabus" Floor Covering

1. Pre-heat welding torch;
Set welding torch to position #4.5 (temperature of 500 °C),
Heating time: 5 minutes.
2. Before welding, visually ensure that a 1 to 1.5 mm gap exists between white safety strip and "Tarabus" floor covering. Use a knife if this is not the case.

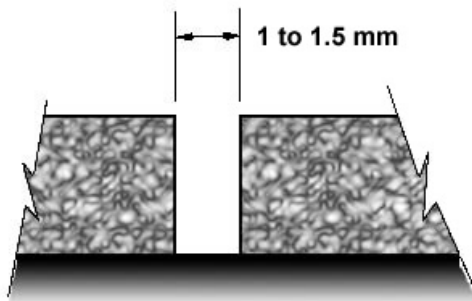

NOTE

There should be no excess of adhesive on top of surfaces, clean if required using "All-Sol".

3. Chamfer the joint.

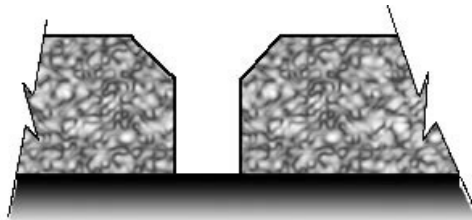

NOTE

The chamfer width must always be less than the filler bead diameter (between 2.5 and 3 mm).

4. Use chamfer knife. **Be careful not to overcut or to cut to the side to prevent damaging “Tarabus” covering.**



5. Add (about 6 inches) some length to the required length of filler bead to make the joint then cut.
6. Take position with welding torch. The proper position is with a slight slope to the rear.



7. Once the welding torch is ready, insert the filler bead into the nozzle and immediately start welding. Move in a regular manner while pressing slightly with torch.



8. The heel of the fast nozzle must not lean against “Tarabus” covering (always parallel to the surface).



Section 18: BODY

9. Allow cooling down of filler bead (about 5 minutes).

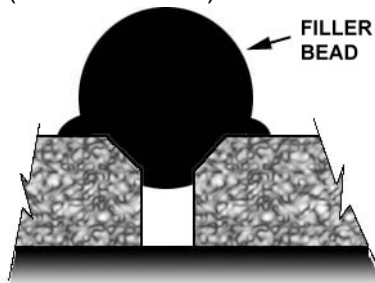

10. Shave filler bead to make it level to the floor. Use supplied knife designed for that purpose.

NOTE

To facilitate the cut, you can spray some soapy water onto the joint.

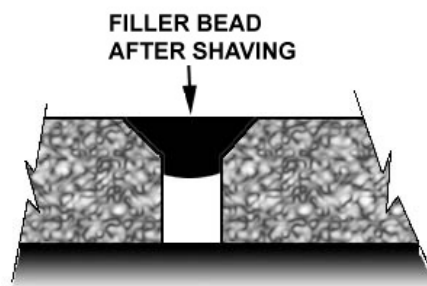

CAUTION

The procedure for turning the torch off must absolutely be followed. If this step is not taken, the element may burn.

11. Set temperature potentiometer to "0" position. Fan will evacuate residual heat. Leave the torch in operation as it is for 3 minutes.
12. Perform adhesion test using the tip of a flat screwdriver; apply a slight pressure on the joint.

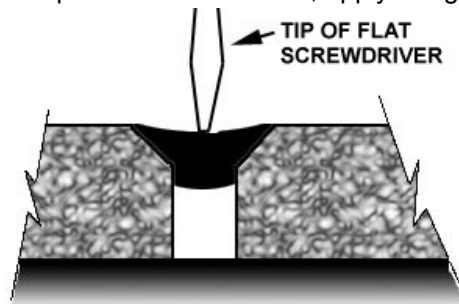

13. If welding was not performed properly, there will a loss of adhesion on one side. If this is the case, repair the joint.

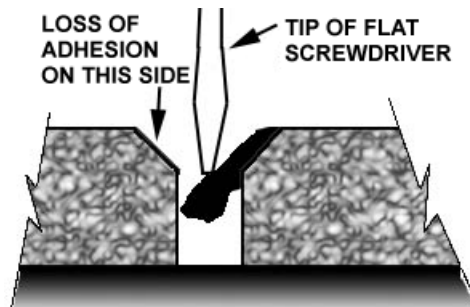

6.10.3 Repair Of A Welded Joint

NOTE

In wintertime, condensation and cold temperature may greatly influenced bonding parameters. Working area must be at a temperature sufficient to prevent reaching condensation point. Mechanically preheat working area (heat lamp or heat gun) or wait until vehicle reaches room temperature.

- Using a knife, remove portion of joint to be repaired.

NOTE

Loss of adhesion may be local. If this is the case, repair may also be local.

- Chamfer the joint again as indicated in paragraph 6.10.2, Section: Welding Of Joint Between White Safety Strip And "Tarabus" Floor Covering.
- Re-weld the joint as indicated in paragraphs 6, 7 and 8. Use your thumb to hold the filler bead end.



WARNING

Nozzle is hot.



- Always add an extra inch of filler bead at the beginning and at the end of repair.
- Perform steps indicated in paragraphs 9, 10 and 11.

7. VEHICLE JACKING POINTS

The vehicle can be lifted by applying pressure under body jacking points or front and drive axle jacking points. When it is necessary to lift the vehicle, care should be taken to ensure that the pressure is applied only on the specified areas. Equipment for lifting the front of the vehicle must have a combined lifting capacity of at least 20,000 lb. (9 100 kg). Equipment for lifting the rear of the vehicle must have a combined lifting capacity of at least 40,000 lb. (18 200 kg).



WARNING

DO NOT tow or jack vehicle with people on board.



WARNING

When it is necessary to raise the vehicle, care should be taken to ensure that pressure is applied only at the points indicated in figures 50 to 54.



WARNING

Extra lift capacity may be required if luggage or any other type of load (e.g. extra equipment) are onboard the vehicle.



CAUTION

The suspension of the vehicle must be in the normal ride position before jacking.

Section 18: BODY

Ten jacking points are located on the vehicle: two are located on each side of the frame and two are located under each axle. Refer to the following illustrations for the location of jacking points.

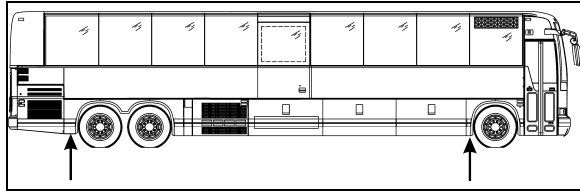

FIGURE 50: JACKING POINTS ON FRAME

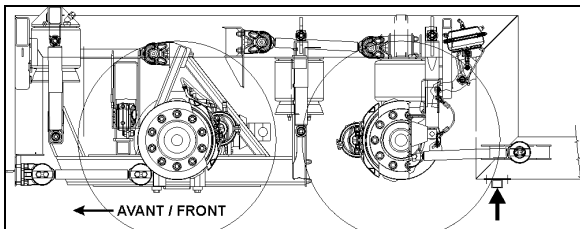

FIGURE 51: REAR END JACKING POINTS

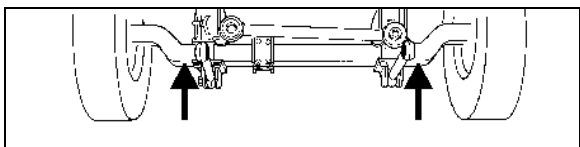

FIGURE 52: JACKING POINTS ON I-BEAM FRONT AXLE

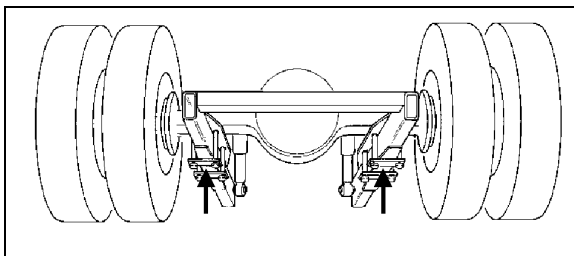

FIGURE 53: JACKING POINTS ON DRIVE AXLE OEH3B762



CAUTION

Always unload or retract the tag axle before jacking the vehicle from the front and drive axle jacking points to prevent damage to suspension components.

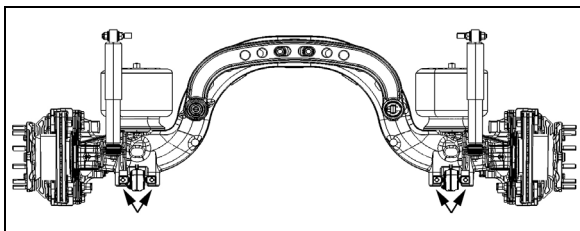

FIGURE 54: JACKING POINTS ON TAG AXLE OEH3B764



WARNING

The jacking points on the tag axle must be used for raising the tag axle only.

Several kinds of hydraulic jacks can be used. Only jack at the specified jacking points. Jack must support the following capacities:

Front axle: 20,000 lb. (9 100 kg);

Drive axle: 40,000 lb. (18 200 kg).

7.1 HYDRAULIC JACK

To raise: turn release valve clockwise. Insert handle in socket and raise vehicle by pumping.

To lower: remove handle and turn the release valve slowly counterclockwise.

Always keep ram and extension screw retracted when jack is not in use.

Service: Check oil level when jack fails to raise to full height. Lower ram completely with release valve open and jack in upright position, remove filler plug and refill to level of filler hole with hydraulic jack oil. **Never use brake fluid.**



DANGER

Jack is intended for lifting only. Do not get under the vehicle or load for any reason unless it is properly supported with safety stands and securely blocked.



DANGER

Do not overload jack above rated capacity. Prevent "side loading", make sure load is centered on ram. Do not push or tilt load off jack.

8. TOWING THE VEHICLE

8.1 LIFTING FROM THE FRONT

To prevent damage to the vehicle, use the two tow eyes fixed to the vehicle frame between the front axle and the front bumper. Use only a solid link tow bar and a safety chain to tow the vehicle.

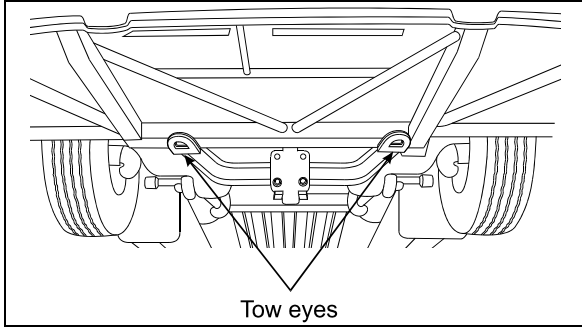

FIGURE 55: TOW EYES UNDER VEHICLE 18401

- Disconnect driveshaft or remove both drive axle shafts to prevent damage to the transmission. Plug axle tube to prevent oil loss. Refer to Rockwell's "Maintenance manual no.5" annexed at the end of Section 11: Rear Axle of the maintenance manual.



CAUTION

To prevent damage to the drive train components, disconnect axle shafts or driveshaft before towing. Do not attempt to push or pull-start a vehicle equipped with an automatic transmission.

Failure to disconnect the driveshaft, remove the drive axle shafts or lift the drive wheels off the ground before towing can cause serious transmission damage and void the warranty.

- The towed vehicle must be lifted from under the front end only. The tow truck must be equipped with the proper lifting equipment to reach under the tow eyes or the front axle since no other lifting points are recommended. Lifting and towing from any other point are unauthorized as it may cause serious damage to the structure. Do not unload or raise the tag axle when lifting and towing to prevent overloading the drive axle.



- Raise the front of the coach then install wooden blocks underneath front tires.
- Install axle forks and supports onto tow bar, position axle forks around beam and into tow eyes, insert chains into tow eyes to secure.

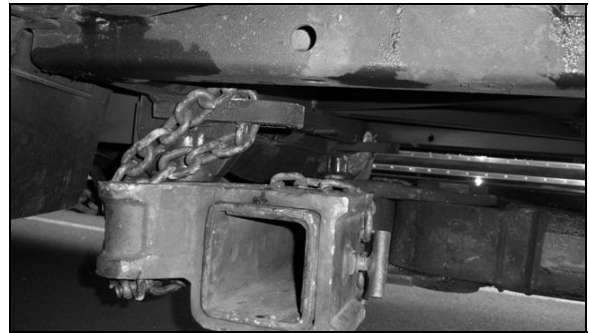

DANGER

Do not carry passengers while the coach is being towed.

- The coach can also be towed by installing axle forks on the front axle.

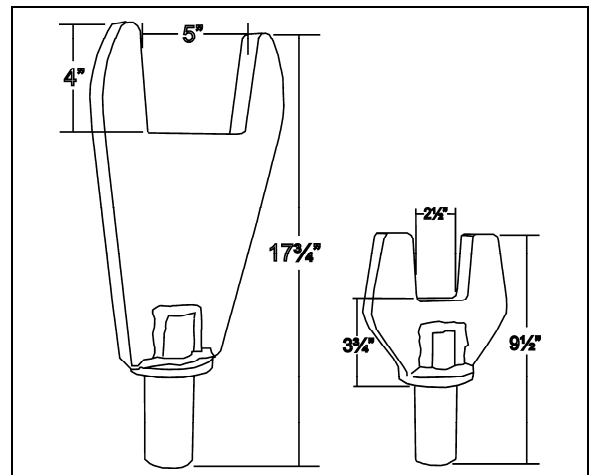
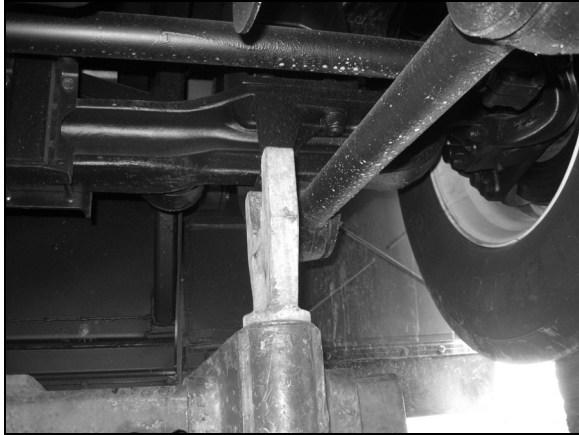

FIGURE 56: AXLE FORKS



- Install chains around tow bar and front axle.



CAUTION

Make sure a safe distance (27-28") is kept between the front of the coach and the tow truck. This space ensures that coach does not suffer damages when being towed.



- Flip down the access door located in the front bumper, connect an auxiliary air supply to the two quick connectors so the emergency/parking brakes don't apply while towing.

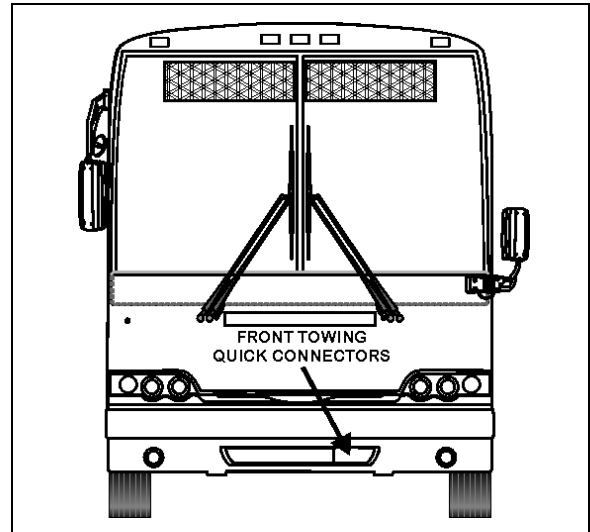

FIGURE 57: FRONT TOWING AIR SUPPLY CONNECTORS

8.2 TOWING WITH A FRONT FLAT TIRE

- In case of a flat tire, drive coach over a wooden block to be able to slide the tow bar underneath.



- Repeat previous steps for attaching tow bar to tow eyes or front axle using axle forks and chains.



8.3 MOVING A VEHICLE FROM THE REAR

The vehicle should not be towed from the rear unless an emergency situation occurs. If the vehicle has to be moved over a short distance as in a parking lot:

- Chock front vehicle wheels.



- Lift the vehicle rear end. Slide axle forks and supports onto tow bar and install onto engine cradle.



CAUTION

To prevent damage to the vehicle structure, it is not recommended to tow the vehicle from the rear. In case of damage to the drive train components, use a low bed semi-trailer to support the rear end.



DANGER

Do not carry passengers while the coach is being towed.



CAUTION

Make sure axle shafts or driveshaft are installed correctly after towing. Tighten axle shaft and driveshaft nuts to the correct torque settings. Do not invert shafts.

PR20103-05				PREVOST For internal use only	
H3	H1	V5	X3	W	
BI-FOLD DOOR HINGE ARM PIVOTS PRE-ADJUSTMENT					
Service issue: Feb. 20, 2012			Effective:	REVISION 05	
This revision: step 30 & 40, new stud part number				2012-06-18	

L.H. SIDE DOOR PANEL HINGE ARM PIVOT

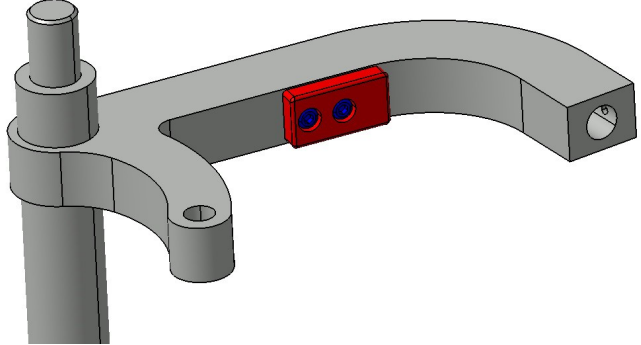
10	Pivot	p/n 281162 (qty 1)	
11	Stop	p/n 281296 (qty 1)	
12	Machine screw	p/n 5001670 (qty 2) machine screw pan head PH M4-0.7x8mm	

R.H. SIDE DOOR PANEL HINGE ARM PIVOT

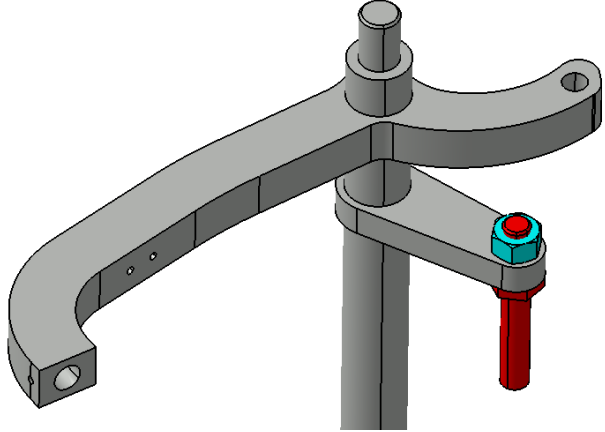
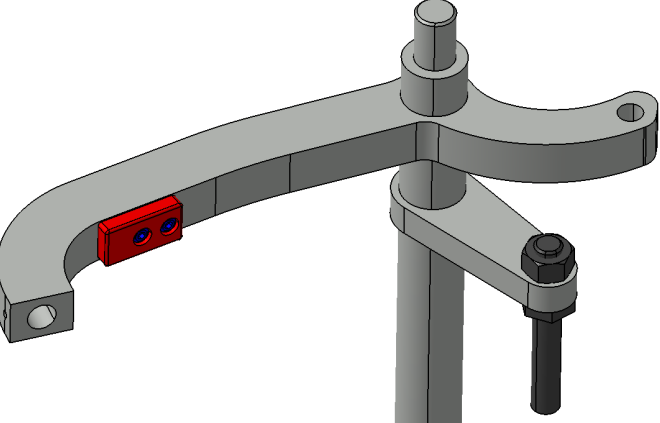
20	Pivot	p/n 281163 (qty 1)	
21	Pivot stud	p/n 285433 (qty 1) 7/16-14x88mm	
22	Nut	p/n 502883 (qty 1) 7/16-14	
23	Stop	p/n 281296 (qty 1)	
24	Machine screw	p/n 5001670 (qty 2) machine screw pan head PH M4-0.7x8mm	

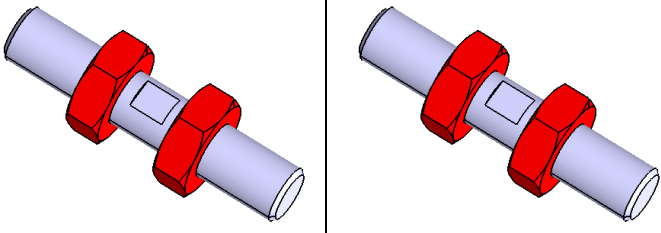
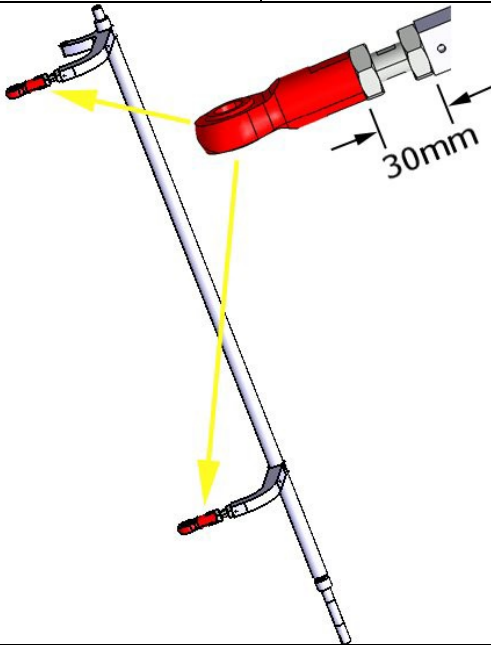
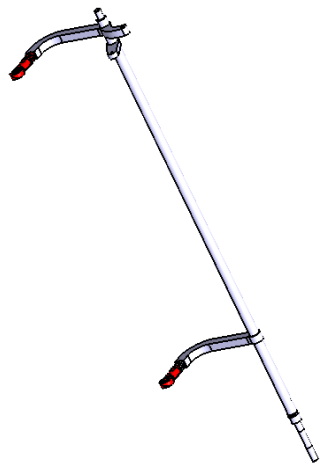
L.H. SIDE DOOR PANEL HINGE ARM PIVOT			
30	Stud	p/n 281252 (qty 2)	
31	Jam nut	p/n 5001806 (qty 2) $\frac{1}{2}$ -20X5/16 left-hand threads	
32	Jam nut	p/n 5001798 (qty 2) $\frac{1}{2}$ -20X5/16	
33	Pivot		
34	Rod end	p/n 502196 (qty 2) Tighten jam nuts to lock rod ends. Pre-adjustment distance between rod end and hinge arm should be: 1 $\frac{3}{16}$ inch (30mm) Center the flat sides of the stud between the nuts	
R.H. SIDE DOOR PANEL HINGE ARM PIVOT			
40	Stud	281252 (qty 2)	
41	Jam nut	5001806 (qty2) $\frac{1}{2}$ -20X5/16 left-hand threads	
42	Jam nut	5001798 (qty 2) $\frac{1}{2}$ -20X5/16	
43	Pivot		
44	Rod end	502196 (qty 2) Same procedure as for L.H. side hinge arm pivot	

PR20103-13					PREVOST <i>For internal use only</i>	
H3	H1	V5	X3	W		
BI-FOLD DOOR POSITION SENSOR						
Service issue: Feb. 10, 2012			Effective:		REVISION 01	
Revision 01 : step 10, part number changed for 068358					2011-06-23	

AIR PRESSURE RELEASE	
<p>Prior to perform the following procedure, release the air pressure from the bi-fold door air cylinders and latch cylinders.</p> <p>To do so, turn the emergency release valve clockwise. This valve is located on the lower R.H. side of the dashboard</p> <p>Releasing the air pressure will unlatch the door and allow opening and closing of the door manually.</p>	

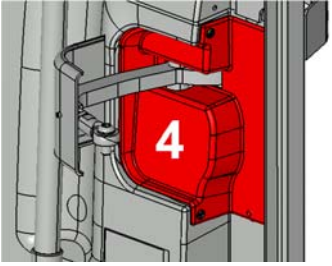
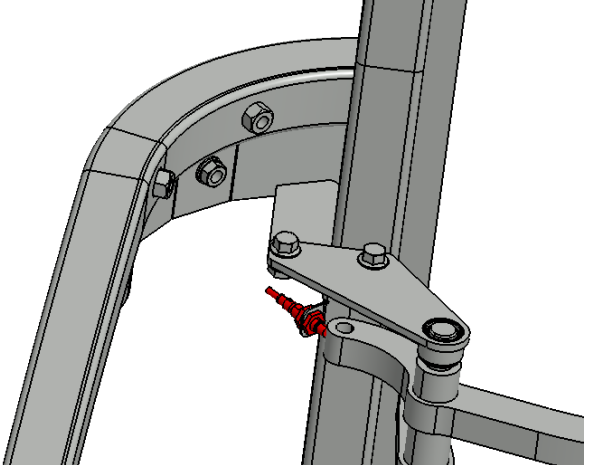
5	Procedure applicable to :		COMMUTER COACH
SENSOR GAP ADJUSTMENT			
10	To gain access to the sensor probe, remove the R.H. side hinge cover (item 4)		
11	Sensor	068358 (qty 1)	
11	Place sensor probe at 0.059" (1.5mm) from hinge lever arm as shown on the image at right. No thread locker required	Toothed washer & clamping nut included with 068358 assembly	

PR20103-14

PREVOST
For internal use only

H3

H1

V5

X3

W

BI-FOLD ENTRANCE DOOR HINGE ARM PIVOTS INSTALLATION

Service issue: Feb. 10, 2012

Effective: C-5176

REVISION 02

Revision 02: torque was 27 lbf-ft, changed for 22 lbf-ft, step 16 and 26

2011-09-29

5

Procedure applicable to:

COMMUTER COACH

R.H. SIDE HINGE ARM PIVOT

10 R.H. side hinge arm pivot
To remove the R.H. side hinge arm pivot, you must remove the dashboard cover first.

11 Unscrew the upper hinge arm pivot support

12 Bolt
Torque as per bolt type and grade: 16 lbf-ft
p/n 5001780
cap screw hex
M8-1.25X16
grade 8.8
(qty 2)

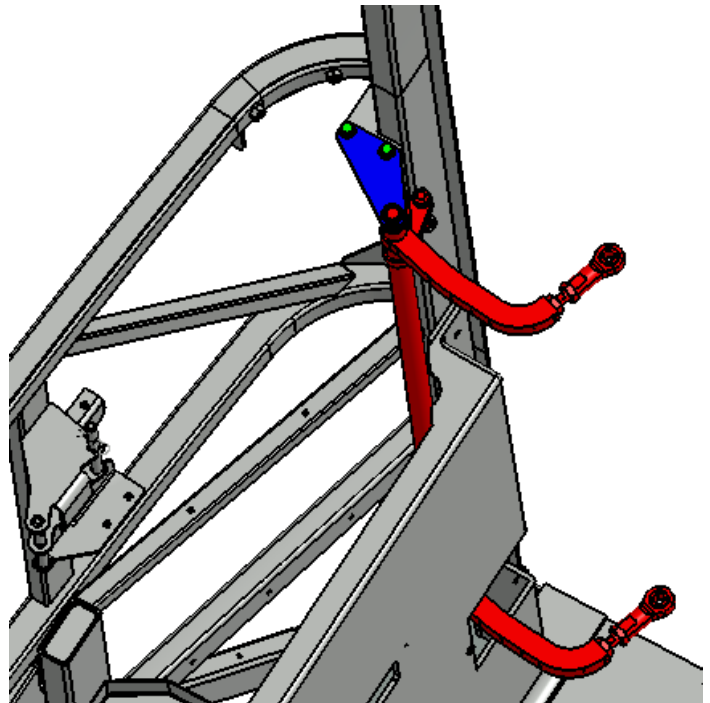

13 Bearing

14 Unscrew/tighten bearing bolts (green on the image)
Apply Loctite 243 on threads prior tightening
Torque: see step 12

p/n 5001780
(qty 2)

15 Woodruff key

p/n 505077
(qty 1)

16 **Long** connecting link
(4 $\frac{7}{16}$ inch long, 113mm)
Loosen/tighten pinch bolt
Torque = 22 lbf-ft

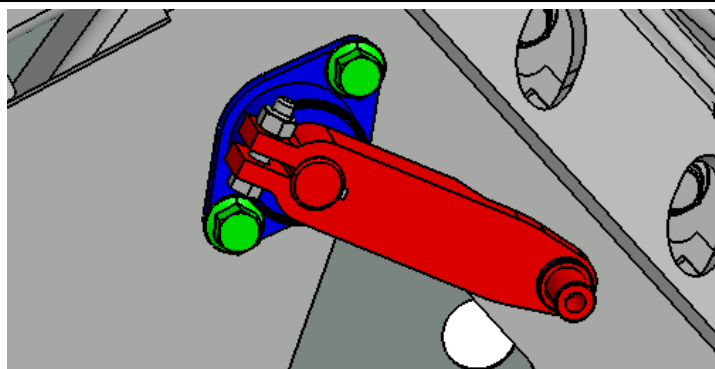

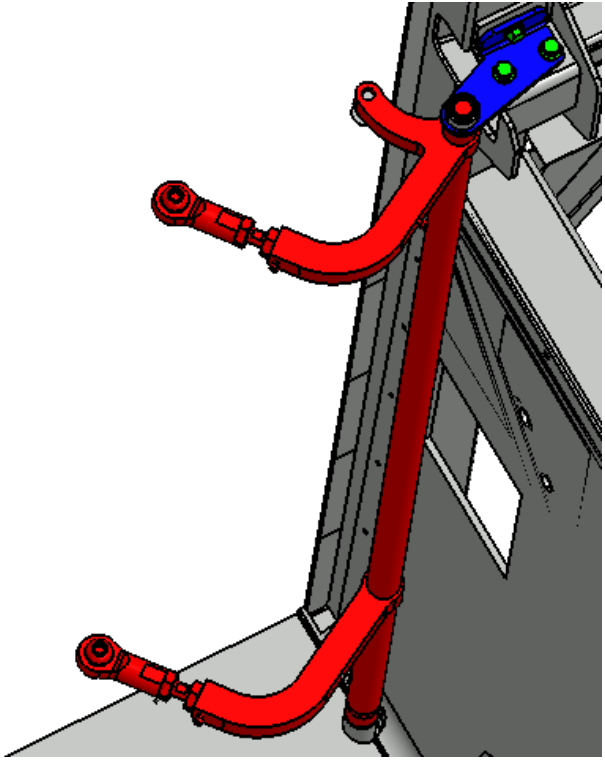
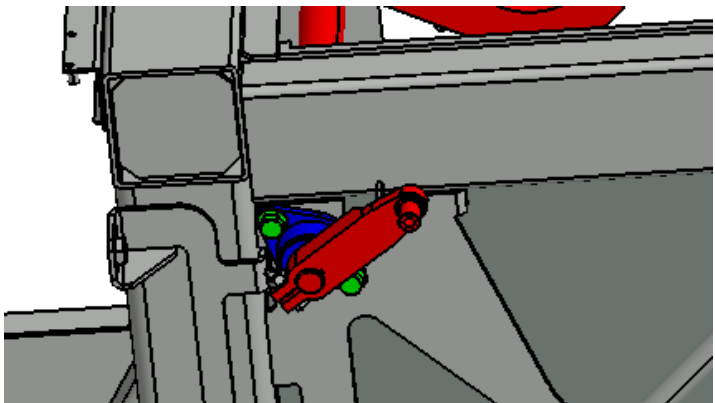
L.H. SIDE HINGE ARM PIVOT			
20	L.H. side hinge arm pivot		
21	Upper support		
22	Bolt Torque as per bolt type and grade: 16 lbf-ft	p/n 5001780 cap screw hex M8-1.25X16 grade 8.8 (qty 3)	
23	Bearing		
24	Unscrew/tighten bearing bolts (green on the image) Apply Loctite 243 on threads prior tightening Torque: see step 22	p/n 5001780 (qty 2)	
25	Woodruff key	p/n 505077 (qty 1)	
26	Short connecting link (4 $\frac{7}{32}$ inch long, 107mm) Loosen/tighten pinch bolt Torque = 22 lbf-ft		

PR20103-18

PREVOST
For internal use only

H3

H1

V5

X3

W

**BI-FOLD DOOR BALANCE ARM AND LINK ARM
LENGTH PRE-ADJUSTMENT**

Service issue: Feb. 10, 2012

Effective:

REVISION 01

Revision 01: Step 11 & 21, part number 500860 changed for 5001757

2011-11-23

5 Procedure applicable to:

COMMUTER COACH

BALANCE ARM

2 balance arms per coach

10	Short rod 10 ⁹/₁₆ inch (268mm)	p/n 281155 (qty 1)
11	Nut hex	p/n 5001757 (qty 1) M12-1.75
12	Nut hex (left-hand threads)	p/n 5001466 (qty 1) M12-1.75
13	Rod end	p/n 502252 (qty 1)
14	Rod end (left-hand threads)	p/n 502253 (qty 1)
15	Adjust length as shown, from rod end to center of eye 37.5mm = 1 ¹⁵/₃₂ " Do not tighten nuts, do not apply thread locker. Rod ends must remain loose for final adjustment at time of installation.	

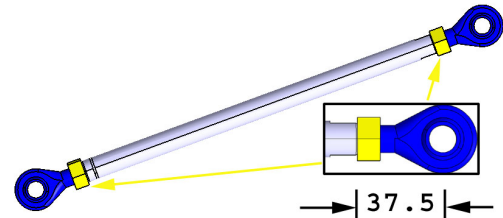

LINK ARM

20	Long rod 26 ³/₄ " (679mm)	p/n 281134 (qty 1)
21	Nut hex	p/n 5001757 (qty 1) M12-1.75
22	Nut hex (left-hand threads)	p/n 5001466 (qty 1) M12-1.75
23	Rod end	p/n 502252 (qty 1)
24	Rod end (left-hand threads)	p/n 502253 (qty 1)
25	Adjust length as shown, from rod end to center of eye 37.5mm = 1 ¹⁵/₃₂ " Do not tighten nuts, do not apply thread locker. Rod ends must remain loose for final adjustment at time of installation.	

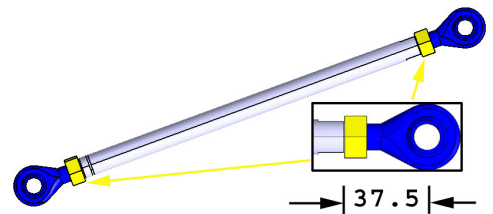

PR20103-20						PREVOST For internal use only		
H3	H1	V5	X3	W				
BI-FOLD DOOR HINGE AIR CYLINDERS AND DAMPER REPLACEMENT								
Service issue: Feb. 10, 2012				Effective:		REVISION 00		
						2011-06-22		

AIR PRESSURE RELEASE

Prior to perform the following procedure, release the air pressure from the bi-fold door air cylinders and latch cylinders.

To do so, turn the emergency release valve clockwise. This valve is located on the lower R.H. side of the dashboard

Releasing the air pressure will unlatch the door and allow opening and closing of the door manually.



10 Procedure applicable to : **COMMUTER COACH**

R.H. SIDE DOOR AIR CYLINDER ACCESS

20 Remove the hand rail (item 1)

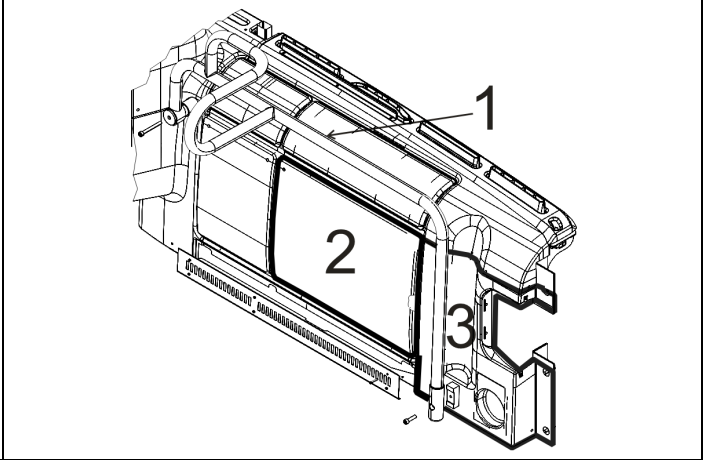

21 Remove the R.H. side dashboard access panels (items 2, 3) and hinge cover (item 4)

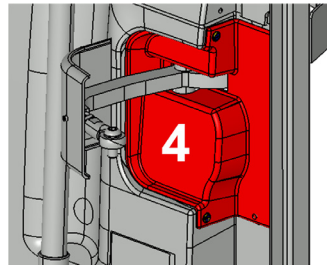

R.H. SIDE DOOR HINGE CYLINDER REMOVAL / INSTALLATION

30 Cylinder

31 Detach bridge pin (fixed eye end, left side of cylinder on the image) p/n 502180 (qty 1)

32 Unscrew bolt at the piston rod end p/n 5001615 (qty 1)
cap screw, button hex socket head M12-1.75X30 grade 10.9

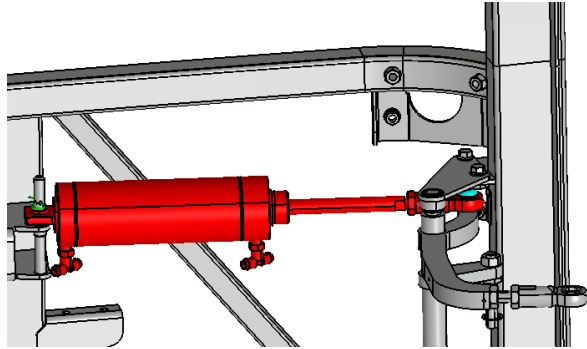

33 Detach cylinder at the fixed eye end. Grab the cylinder rod and from the rod side, take the cylinder out

34 To prevent faulty installation, properly identify the air hoses and fittings. Unscrew fittings, apply thread sealant and install on the new cylinder

35 Installation of the new cylinder is similar as removal but in reverse order
Apply Loctite 243 on the rod end bolt prior tightening. Torque as per bolt type and grade: 80 lbf-ft

DAMPER REMOVAL/REPLACEMENT

40 To ease damper removal, unscrew the multiplex modules mounting support.



41 Damper p/n 780714 (qty 1)

42 Spring nut p/n 502601 (qty 2)

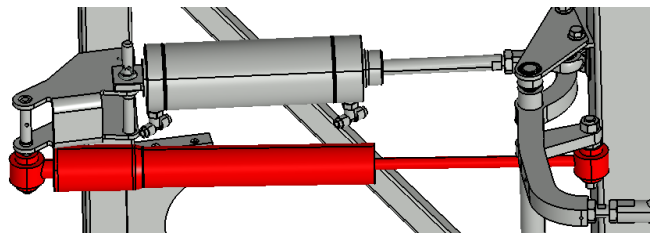

43 The damper is held in place with one spring nut at each end. Detach spring nuts to remove damper

Handle damper with care. **Never extend damper rod when rod points downwards**

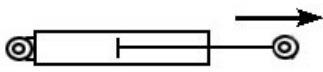
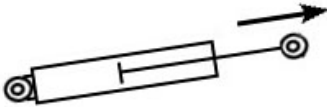
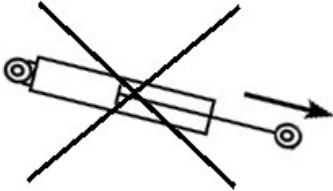
<u>DO</u>	<u>DO</u>	<u>DO NOT</u>
		

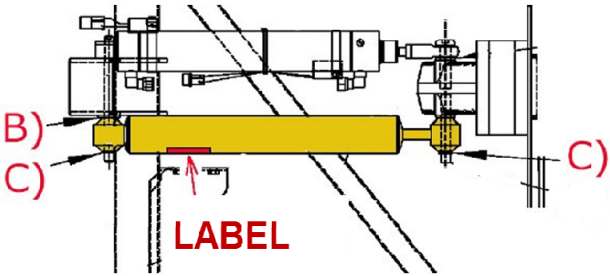
44	Damper Install damper as shown with label facing downwards		
45	Item B= washer p/n 500445 (qty 1)		
46	Item C= spring nut p/n 502601 (qty 2)		

TO PRESSURIZE A DAMPER THAT HAS LOST PRESSURIZATION

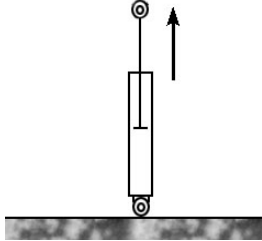
50	Place damper vertically as shown and extend rod at maximum stroke.	
----	--	---

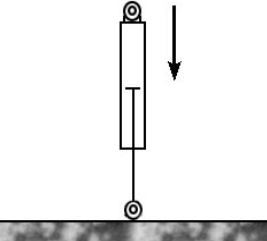
51	Turn the damper upside down and retract rod completely	
52	Repeat steps 50 and 51 as required.	

L.H. SIDE DOOR AIR CYLINDER ACCESS

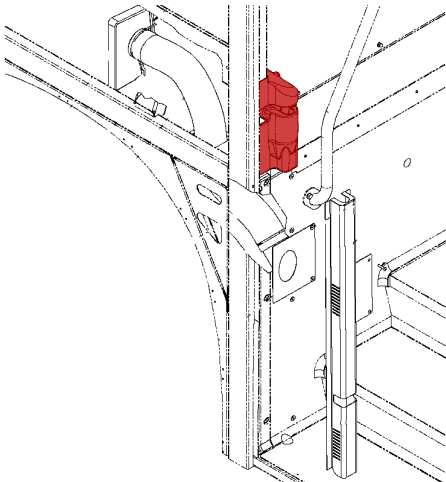
60	Remove the finishing cover shown on the image	
----	---	--

L.H. SIDE DOOR HINGE CYLINDER REMOVAL / INSTALLATION

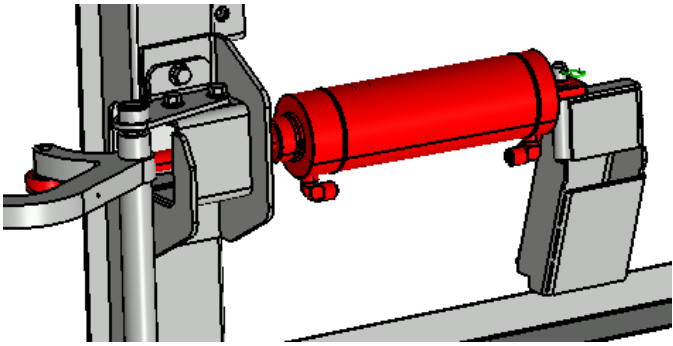
70	Cylinder		
71	Detach bridge pin (fixed eye end, right side of cylinder on the image)	p/n 502180 (qty 1)	
72	Unscrew bolt at the piston rod end	p/n 5001615 (qty 1) cap screw, button hex socket head M12-1.75X30	
73	Remove the cylinder		
74	To prevent faulty installation, properly identify the air hoses and fittings. Unscrew fittings, apply thread sealant and install on the new cylinder		
75	Installation of the new cylinder is similar as removal but in reverse order Apply Loctite 243 on the rod end bolt threads prior tightening. Torque as per bolt type and grade: 80 lbf-ft.		

PR20103-22					PREVOST For internal use only	
H3	H1	VIP	X3	WE		
BI-FOLD ENTRANCE DOOR INSTALLATION AND ADJUSTMENT						
Service issue: Feb. 10, 2012				Effective :	REVISION 04	
Revision 04: Addition of step 81.					2012-01-09	

AIR PRESSURE RELEASE

Prior to perform the following procedure, release the air pressure from the bi-fold door air cylinders and latch cylinders.

To do so, turn the emergency release valve clockwise. This valve is located on the lower R.H. side of the dashboard.

Releasing the air pressure will unlatch the door and allow opening and closing of the door manually.



10	Procedure applicable to:	COMMUTER COACH
-----------	---------------------------------	-----------------------

JIGS INSTALLATION

20 Affix jigs (spacers) temporarily (green on the image) using masking tape

Jig thickness (if jigs not available):

32804=0.366"

33834=0.539"

33175=0.244"

33833=0.417"

33712=0.260"

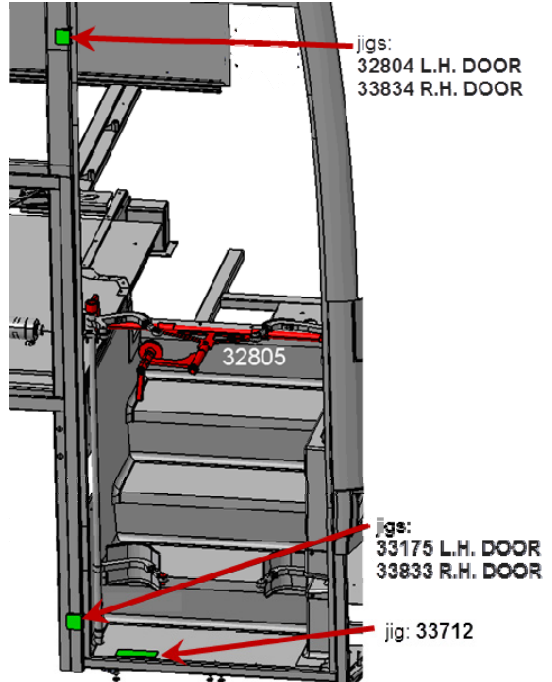

L.H. SIDE DOOR PANEL INSTALLATION

30 L.H. Side Panel

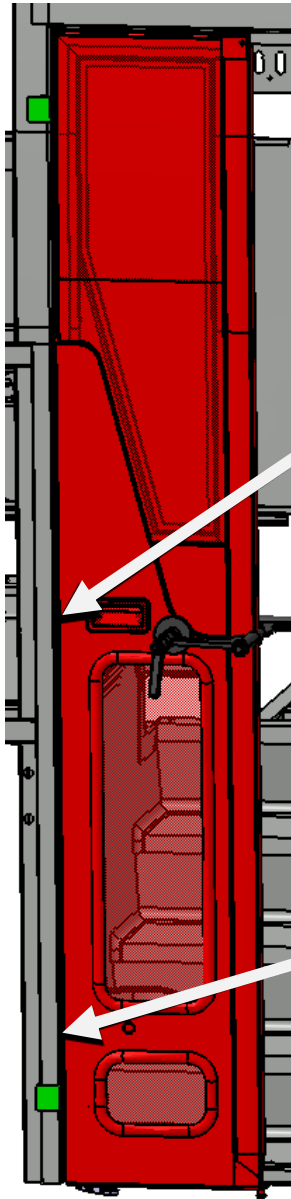

1) Lean L.H. door panel against the 3 jigs (spacers). Top, bottom and underneath

2) Adjust the door panel position in order to have approximately $1\frac{3}{32}$ " (28 mm) between seal jamb and the exterior surface (painted) of the door panel at the upper hinge arm level

3) Adjust the door panel position in order to have approximately $1\frac{3}{32}$ " (28 mm) between seal jamb and the exterior surface (painted) of the door panel at the lower hinge arm level. Having the same measurement as in step 2 is more important than having exactly $1\frac{3}{32}$ " (28 mm)

FIXING LOWER END OF DOOR PANEL

40	Pivot hinge arm until rod end ball joint bolt A lines up with the attachment bracket nut. Bolts B should be slightly untightened to allow bracket to move	
41	Tighten bolt A Torque: 74 lbf-ft	p/n 5001615 cap screw, button hex socket head M12-1.75X30
42	Push hinge arm downwards to take up slack while tightening bolts B . The attachment bracket must be level once bolted Torque: 16 lbf-ft (bolts B)	

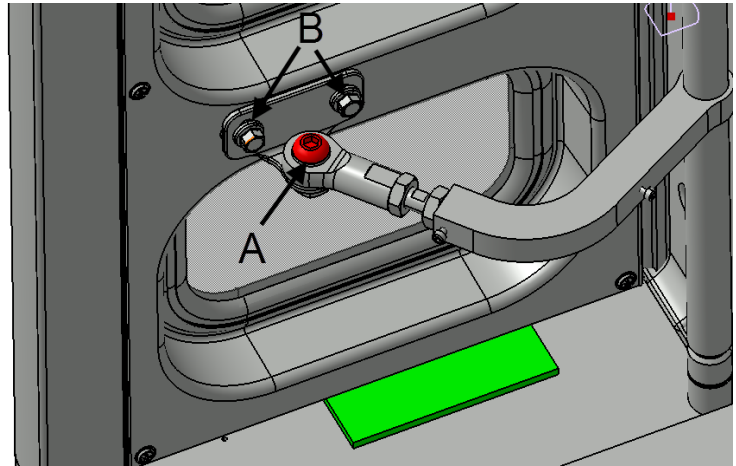

FIXING CENTER PART OF DOOR PANEL

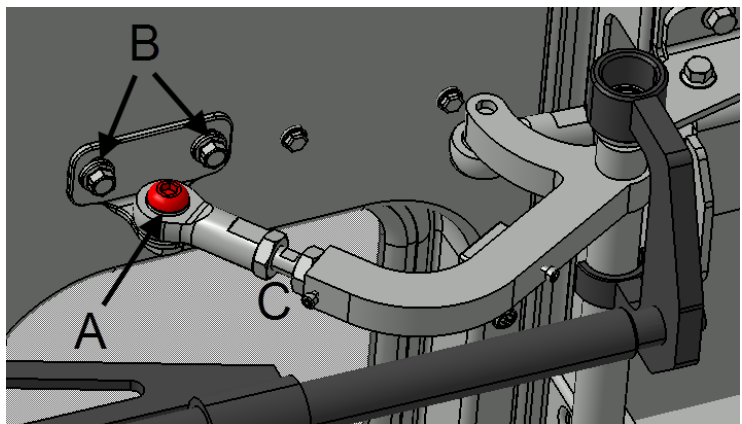

50	If required, adjust threaded rod length C until bolt A can be easily inserted through ball joint and attachment bracket	
51	Tighten bolt A Torque: 74 lbf-ft	p/n 5001615 cap screw, button hex socket head M12-1.75X30
52	Tighten threaded rod C jam nuts	
53	Tighten bolts B while pushing hinge arm down to take up slack. The attachment bracket must be level once bolted Torque: 16 lbf-ft (bolts B)	
54	Remove jigs (spacers) placed at step 20	



R.H. SIDE DOOR PANEL INSTALLATION

70	REPEAT THE SAME STEPS PERFORMED FOR THE L.H. SIDE DOOR PANEL	
----	---	--

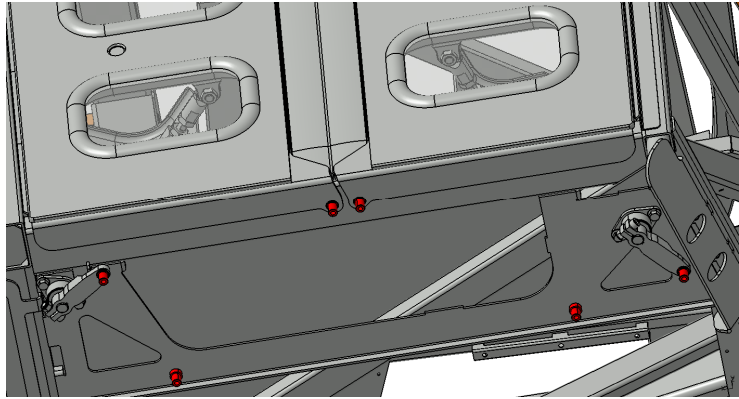
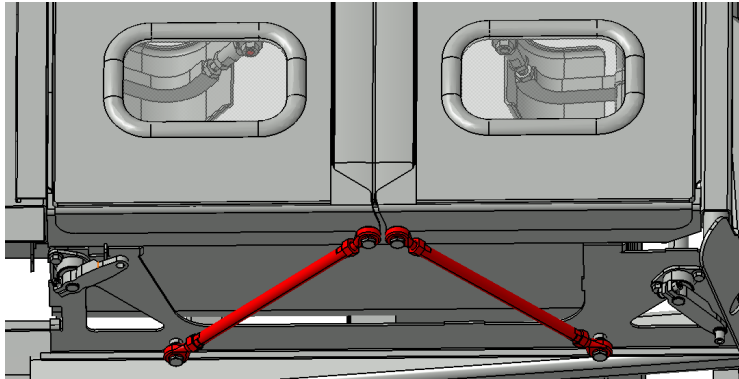
ADJUSTING BALANCE ARM AND LINK ARMS

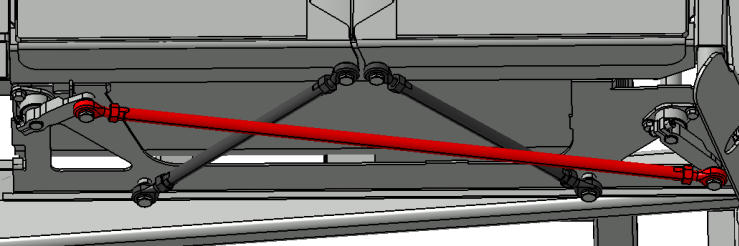
80	CAUTION: For the next steps, air pressure must be applied and bi-fold entrance door panels must have been closed using the dashboard door operating button for the latch cylinders to be extended (latched).		
81	Anti-seize lubricant (Permatex or similar product)	p/n 680335	
Apply anti-seize lubricant on the 6 pivots (red on the image) shown on the image.			
82	Adjust balance arm's length so that they can be easily mounted on the pivots, there must be no tension on the arms. Door panels must remain in the same position as they are when solely maintained with air pressure application. <i>See PR20103-18 for balance arm length pre-adjustment if needed.</i>		
83	Balance arm		
84	Bolts	p/n 507613 (qty 4) cap screw, hex M6-1.0X12	
85	Torque: 60 lbf-in		
86	Lock balance arms using jam nuts		
87	Link arm		
88	Adjust link arm length so it can be easily mounted to the pivots and then lock link arm using jam nuts. <i>See PR20103-18 for link arm length pre-adjustment if needed.</i>		
89	Bolt	p/n 507613 (qty 2) cap screw, hex M6-1.0X12	
90	Torque: 60 lbf-in		

PR20103-30					PREVOST <i>For internal use only</i>	
H3	H1	V5	X3	W		
BI-FOLD ENTRANCE DOOR PANEL REMOVAL AND REINSTALLATION						
Service issue: Feb. 10, 2012				Effective :	REVISION 01	
Revision 01: Changing of word "nuts" for "bolts". Addition of torque specification at step 21.					2011-10-07	

AIR PRESSURE RELEASE

Prior to perform the following procedure, release the air pressure from the bi-fold door air cylinders and latch cylinders.

To do so, turn the emergency release valve clockwise. This valve is located on the lower R.H. side of the dashboard.

Releasing the air pressure will unlatch the door and allow opening and closing of the door manually.



10 Procedure applicable to:		COMMUTER COACH
REMOVAL AND REINSTALLATION OF A BI-FOLD DOOR PANEL		
Removal		
20	Unscrewing the 3 bolts identified on the image will maintain proper door panel adjustment. No adjustment will be required at time of reinstallation.	
Reinstallation		
21	2 upper bolts Torque: 74 lbf-ft	p/n 5001615 cap screw, button hex socket head M12-1.75X30
22	1 lower bolt Torque : 60 lbf-in	p/n 507613 cap screw, hex M6-1.0X12
23	Repeat this procedure for the second door panel.	

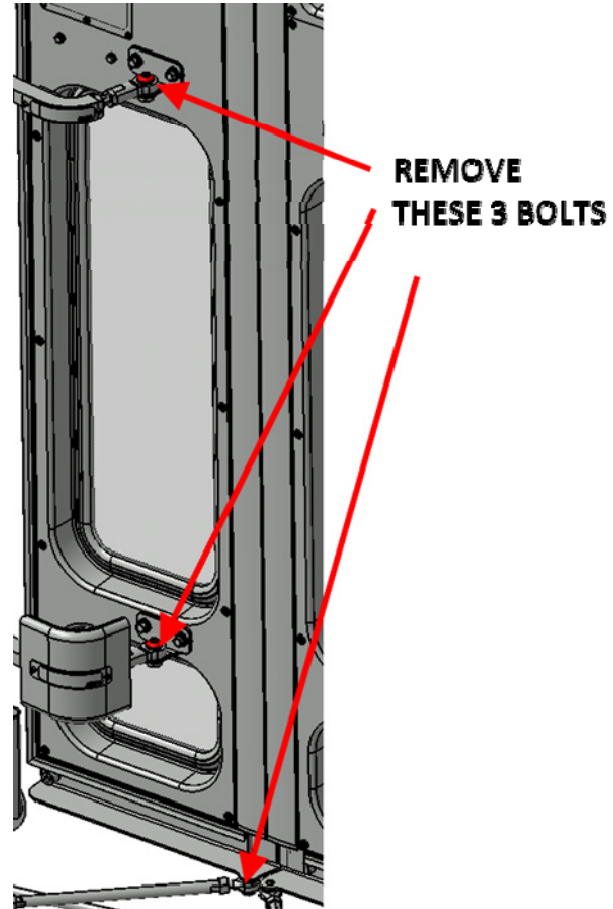

SECTION 22: HEATING AND AIR CONDITIONING

CONTENTS

1. HEATING AND AIR CONDITIONING	4
2. AIR CIRCULATION WITH CENTRAL HVAC SYSTEM	4
2.1 DRIVER'S AREA.....	4
2.2 PASSENGERS' AREA.....	4
3. CENTRAL HVAC SYSTEM OPERATION	5
3.1 DRIVER'S SECTION OPERATION	5
3.2 PASSENGERS' SECTION OPERATION	6
4. HVAC UNIT MAINTENANCE	7
4.1 COIL CLEANING.....	7
4.2 DRIVER'S SECTION AIR FILTERS	8
4.3 PASSENGERS' SECTION AIR FILTER	9
4.4 OVERHEAD COMPARTMENT FAN AIR FILTER.....	9
5. HVAC SYSTEM PARTICULARITIES, TESTING AND TROUBLESHOOTING	9
5.1 HVAC SYSTEM AND TEST MODE FOR SWITCHES AND SENSORS	9
5.2 HVAC SYSTEM AND TEST MODE FOR ELECTRIC MOTORS	10
5.3 PARTICULARITIES	10
5.4 HVAC SYSTEM TROUBLESHOOTING	11
6. CENTRAL AIR CONDITIONING SYSTEM	12
6.1 A/C CYCLE	12
6.2 REFRIGERANT.....	13
6.2.1 <i>Procurement</i>	13
6.2.2 <i>Precautions in Handling Refrigerant</i>	13
6.2.3 <i>Treatment in Case of Injury</i>	13
6.2.4 <i>Precautions in Handling Refrigerant Lines</i>	13
6.3 PUMPING DOWN	16
6.4 ADDING REFRIGERANT (VAPOR STATE).....	17
6.5 EVACUATING SYSTEM	17
6.5.1 <i>Double Sweep Evacuation Procedure</i>	17
6.6 CHARGING SYSTEM.....	18
6.7 REFRIGERANT SYSTEM CLEAN-OUT AFTER COMPRESSOR FAILURE.....	19
6.7.1 <i>Determining Severity of Failure</i>	19
6.7.2 <i>Clean-out after Minor Compressor Failure</i>	19
6.7.3 <i>Clean-out After Major Compressor Failure</i>	19
7. CENTRAL A/C SYSTEM COMPONENTS	20
7.1 COMPRESSOR (CENTRAL SYSTEM).....	20
7.1.1 <i>Belt Replacement</i>	20
7.1.2 <i>Belt Tension Adjustment</i>	21
7.1.3 <i>Pulley Alignment</i>	21
7.1.4 <i>Longitudinal Compressor Alignment</i>	21
7.1.5 <i>Horizontal Compressor Alignment</i>	21
7.1.6 <i>Vertical Compressor Alignment</i>	21
7.1.7 <i>Compressor Maintenance</i>	22
7.1.8 <i>Troubleshooting Guide</i>	22
7.2 MAGNETIC CLUTCH	23
7.3 EVAPORATOR MOTOR	23
7.3.1 <i>Removal</i>	23
7.3.2 <i>Installation</i>	23

Section 22: HEATING AND AIR CONDITIONING

7.4	CONDENSER.....	24
7.4.1	Condenser Fan Motors.....	24
7.4.2	Condenser Fan Motor Removal.....	24
7.5	RECEIVER TANK.....	24
7.6	FILTER DRYER.....	25
7.6.1	Replacement.....	25
7.6.2	Moisture Indicator.....	25
7.7	LIQUID REFRIGERANT SOLENOID VALVE.....	26
7.7.1	Manual Bypass.....	26
7.7.2	Coil Replacement.....	26
7.7.3	Valve Disassembly.....	26
7.7.4	Valve Reassembly.....	26
7.8	EXPANSION VALVE.....	27
7.8.1	Passenger's Section HVAC Unit.....	27
7.8.2	Driver's HVAC Unit.....	29
7.9	TORCH BRAZING.....	29
7.10	TROUBLESHOOTING.....	30
7.10.1	Expansion Valve.....	30
7.10.2	A/C.....	31
7.11	TEMPERATURES & PRESSURES.....	33
7.12	LEAK TESTING.....	34
8.	CENTRAL HEATING SYSTEM.....	36
8.1	DRAINING HEATING SYSTEM.....	36
8.2	FILLING HEATING SYSTEM.....	37
8.3	BLEEDING HEATING SYSTEM.....	37
8.4	SOLDERING.....	37
8.5	DRIVER'S HOT WATER PNEUMATIC VALVE ASSEMBLY.....	38
8.6	CENTRAL HOT WATER PNEUMATIC VALVE ASSEMBLY.....	39
8.7	WATER RECIRCULATING PUMP.....	40
9.	SPECIFICATIONS.....	42

ILLUSTRATIONS

FIGURE 1: DRIVER'S AIR CIRCULATION 22307.....	4
FIGURE 2: PASSENGERS' AREA RECIRCULATION DAMPER.....	4
FIGURE 3: CENTRAL HVAC SYSTEM AIR CIRCULATION.....	5
FIGURE 4: PASSENGERS OVERHEAD COMPARTMENT VENTILATION SYSTEM.....	5
FIGURE 5: CENTRAL HVAC SYSTEM CONTROL UNIT.....	6
FIGURE 6: THERMISTOR SENSOR.....	6
FIGURE 7: EVAPORATOR COMPARTMENT.....	6
FIGURE 8: CONDENSER COMPARTMENT.....	7
FIGURE 9: A/C JUNCTION BOX.....	7
FIGURE 10: DRIVER'S HVAC UNIT COIL ACCESS PANEL.....	7
FIGURE 11: EVAPORATOR COIL ACCESS PANEL (TYPICAL).....	8
FIGURE 12: EVAPORATOR COIL CLEANING.....	8
FIGURE 13: CONDENSER COMPARTMENT.....	8
FIGURE 14: DRIVER'S SECTION ACCESS GRILL 22312.....	8
FIGURE 15: DRIVER'S SECTION AIR FILTERS 22171.....	9
FIGURE 16: PASSENGERS' SECTION AIR FILTER 22306.....	9
FIGURE 17: OVERHEAD COMPARTMENT FAN AIR FILTER.....	9

Section 22: HEATING AND AIR CONDITIONING

FIGURE 18: REFRIGERANT CIRCUIT (CENTRAL SYSTEM).....	15
FIGURE 19: DOUBLE-SWEEP EVACUATION SET-UP	18
FIGURE 20: AIR PRESSURE REGULATOR.....	20
FIGURE 21: BELT ARRANGEMENT	20
FIGURE 22: IDLER PULLEY INSTALLATION ON VOLVO D13 ENGINE	21
FIGURE 23: A/C COMPRESSOR BELT ADJUSTMENT.....	21
FIGURE 24: COMPRESSOR ALIGNMENT	21
FIGURE 25: COMPRESSOR ALIGNMENT	22
FIGURE 26: EVAPORATOR COMPARTMENT.....	23
FIGURE 27: EVAPORATOR MOTOR ASSY FIXING BOLTS	23
FIGURE 28: EVAPORATOR MOTOR ASSEMBLY	24
FIGURE 29: CONDENSER FAN MOTOR	24
FIGURE 30: A/C CONDENSER COMPARTMENT.....	24
FIGURE 31: DRIVER'S EVAPORATOR LIQUID SOLENOID VALVE	26
FIGURE 32: REFRIGERANT SOLENOID VALVE.....	27
FIGURE 33: EXPANSION VALVE	27
FIGURE 34: SUPERHEAT ADJUSTMENT INSTALLATION	28
FIGURE 35: HIGH & LOW SWING TEMPERATURE AT REMOTE BULB.....	28
FIGURE 36: CENTRAL HEATING SYSTEM COMPONENTS.....	35
FIGURE 37: CEILING OF THE SPARE WHEEL COMPARTMENT	36
FIGURE 38: DRIVER'S HVAC UNIT.....	36
FIGURE 39: HEATER LINE SHUT-OFF VALVES	37
FIGURE 40: EVAPORATOR COMPARTMENT.....	37
FIGURE 41: DRIVER'S HOT WATER PNEUMATIC VALVE ASSEMBLY.....	38
FIGURE 42: PNEUMATIC WATER VALVE	38
FIGURE 43: CENTRAL HOT WATER PNEUMATIC VALVE ASSEMBLY.....	39
FIGURE 44: PNEUMATIC WATER VALVE	40
FIGURE 45: PUMP LOCATION (CENTRAL A/C).....	40

Section 22: HEATING AND AIR CONDITIONING

1. HEATING AND AIR CONDITIONING

The interior of the vehicle is pressurized by its Heating, Ventilation, Air Conditioning (HVAC) system. The vehicle is equipped with a Central HVAC System; air flow and controls divide the vehicle in two areas: driver's area and passengers' area. The interior of the vehicle should always be slightly pressurized to prevent dust and moisture from entering vehicle. Each section has its own fresh air, returning air and discharge air ducting. The exhaust is mainly done through the rear ventilator and through normal air-tightness losses.

2. AIR CIRCULATION WITH CENTRAL HVAC SYSTEM

2.1 DRIVER'S AREA

Fresh air is taken from a plenum underneath the front service compartment and enters the mixing box through an ON/OFF damper. Return air is taken through the base of the dashboard panel utility compartments into the mixing box. Mixed air goes through cooling and heating coils, fans and discharge ducts.

Both right and left discharge ducts defrost one half of the windshield. The driver can also divert some air flow to the console, from which he can direct air to his knees and/or upper body with adjustable HVAC air registers and to his feet with the appropriate button (see Fig. 1 and Operator's manual).

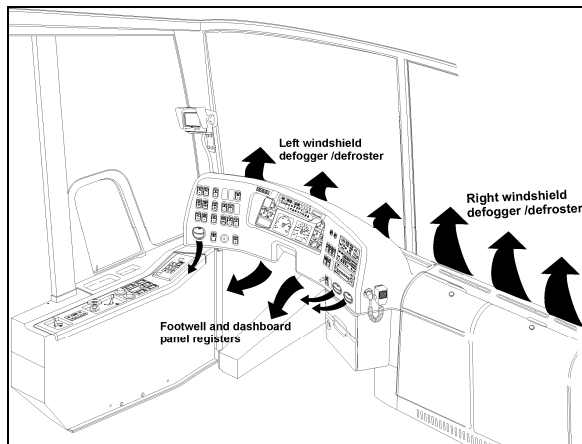

FIGURE 1: DRIVER'S AIR CIRCULATION 22307

X3-45 coaches are also equipped with a windshield upper section de-icing system. Also, one additional air register is located in the driver's area but supplied by the passengers' air ducting system. It is installed in the stepwell for step de-icing.

2.2 PASSENGERS' AREA

Fresh air enters the vehicle on the L.H. side, through the recirculation damper located inside the evaporator compartment door (Fig. 2). The damper can be fully opened for normal operation or closed for extreme weather or highly polluted areas (Refer to the Operator's Manual for more details). The recirculation REC button is located on the HVAC control unit. Press down the button to partially close the fresh air damper. Return air is drawn from inside the vehicle through the register duct located on L.H. side of vehicle (Fig. 3).

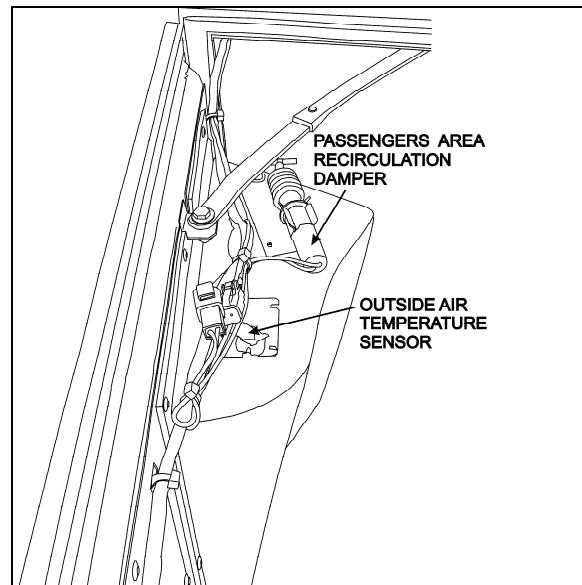

FIGURE 2: PASSENGERS' AREA RECIRCULATION DAMPER 22302

A double blower fan unit, which is activated by the evaporator motor, draws mixed air through an air filter, cooling and heating coils, then forces this air in the ventilation ducts along the walls, and finally exhausts it just below side windows.

X3-45 coaches are also equipped with an overhead compartment ventilation system, a

three-position rocker switch (OFF - 1st speed - 2nd speed) located on R.H. dashboard panel controls the speed of both fans. Return air is drawn just below the middle side windows through an air filter into the overhead compartment fan; discharge air is fed to the rotating registers through the ventilation duct (Fig. 4).

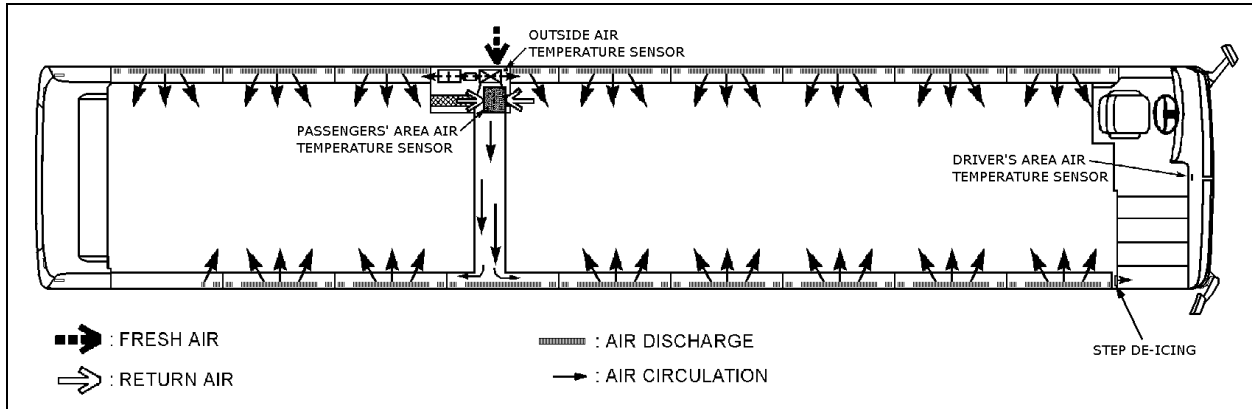

FIGURE 3: CENTRAL HVAC SYSTEM AIR CIRCULATION

22308

The overhead compartment air registers are used to control air flow for the passenger seats. One register per seat direct air flow by pointing or rotating register. Open or close register to adjust air flow.

controlled. It requires the passengers HVAC section to engage the A/C compressor magnetic clutch. Consequently, the driver's section cannot be operated in the A/C mode alone.

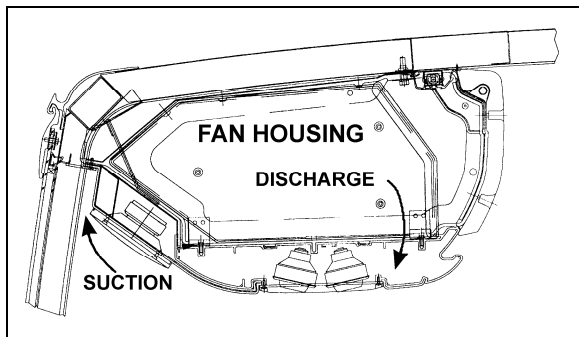

FIGURE 4: PASSENGERS OVERHEAD COMPARTMENT VENTILATION SYSTEM

22211

NOTE

The driver's HVAC section turns on automatically at starting of the engine and uses the settings that were kept in memory before turning off of the system.

The A/C compressor starts automatically when the two following conditions are satisfied:

1. The outside temperature is above 32°F (0°C).
2. The passenger's area temperature has reached 7°F (4°C) under the set point.

3. CENTRAL HVAC SYSTEM OPERATION

To operate the air conditioning system when vehicle is stationary, engine should run at fast idle. During operation of the air conditioning system, windows should be kept closed and door not left open longer than necessary. In order to prevent battery discharge, HVAC system will not operate if vehicle charging system is not working properly.

Using the Up/Down type switch  sets the fan speed and the speed chosen is illustrated on the window display.

NOTE

Upon starting, if the outside temperature is above 32°F (0°C) and then drops below 32°F (0°C), the compressor will keep running up to a temperature of 15°F (-9°C) to prevent condensation from forming on the windows.

3.1 DRIVER'S SECTION OPERATION

The temperature control in the driver's area is provided directly by the L.H. portion of the HVAC control unit mounted on the R.H. dashboard panel (Fig. 5).

NOTE

To perform a test of the driver's section windshield defroster, it is possible to run the system without running the engine.

The driver's HVAC section piping is paralleled with the passengers HVAC section piping. Both sections use the same refrigerant and coolant, and are linked to the same condenser and compressor, even if they are individually

The following 2% error chart and table can be used to troubleshoot the driver's area air temperature sensor and the outside air temperature sensor.

Section 22: HEATING AND AIR CONDITIONING

NOTE

The driver's area air temperature sensor is located behind the grill of the R.H. side console (Refer to fig.14).

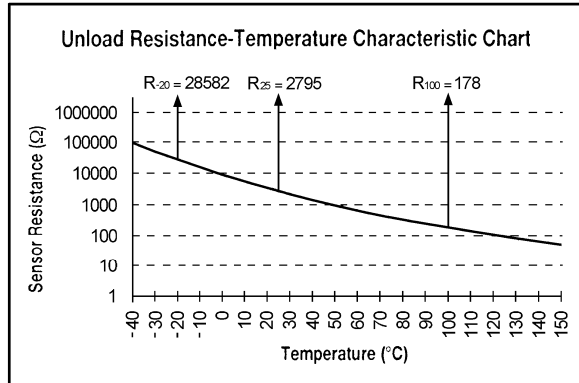

TEMPERATURE SENSOR		
Temp °C	Temp °F	Resistance Ohms
-40	-40	100865
-35	-31	72437
-30	-22	52594
-25	-13	38583
-20	-4	28582
-15	5	21371
-10	14	16120
-5	23	12261
0	32	9399
5	41	7263
10	50	5658
15	59	4441
20	68	3511
25	77	2795
30	86	2240
35	95	1806
40	104	1465
45	113	1195
50	122	980
55	131	808
60	140	670

3.2 PASSENGERS' SECTION OPERATION

The passenger's section has a preset temperature of 68°F (20°C).

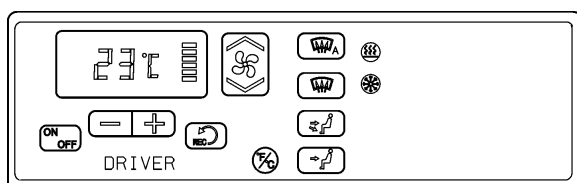

FIGURE 5: CENTRAL HVAC SYSTEM CONTROL UNIT

Temperature control is provided in conjunction with a thermistor sensor inside register duct, located on L.H. side of vehicle (Figs. 3 & 6).

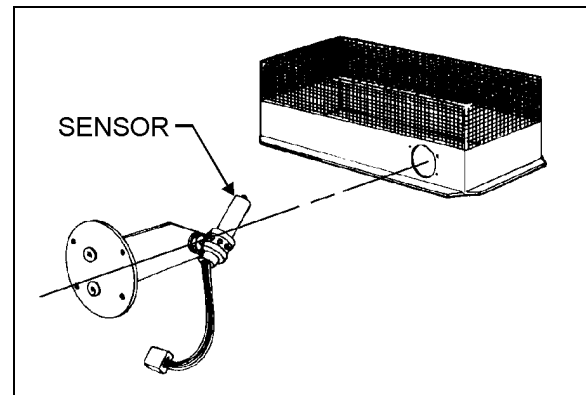

FIGURE 6: THERMISTOR SENSOR

The flow of water to the vehicle's main heater core is controlled by a pneumatic water valve which varies the cycling rate depending on selected temperature. A red LED, located on HVAC control unit, illuminates when heating mode is selected. A green LED illuminates when compressor clutch is in operation.

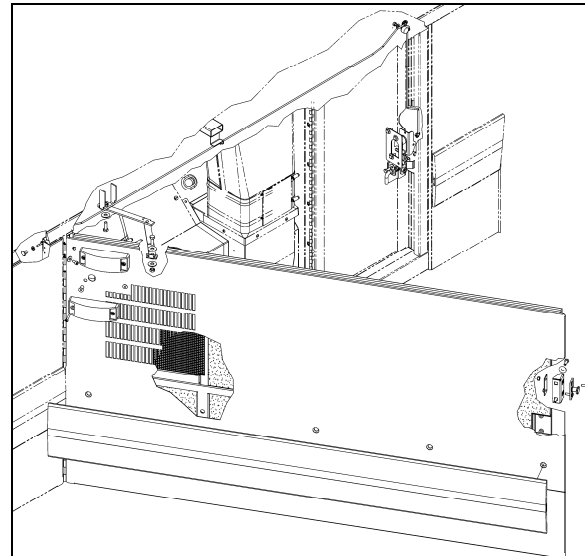

FIGURE 7: EVAPORATOR COMPARTMENT

22301

The evaporator fan motor, located in the evaporator compartment, is protected by a 90 amps, manually-resettable (CB3) circuit breaker located on the rear junction panel and is accessible from the engine compartment curb-side door, on R.H. side of the vehicle (refer to Section 06, "Electrical System" in this manual for details).

The condenser coil mounted on the opposite side of the evaporator is ventilated by four axial fans. The fan motors are protected by a manually-resettable 70 amp circuit breaker (CB7) mounted on the rear junction panel and accessible from the engine compartment curb-side door.

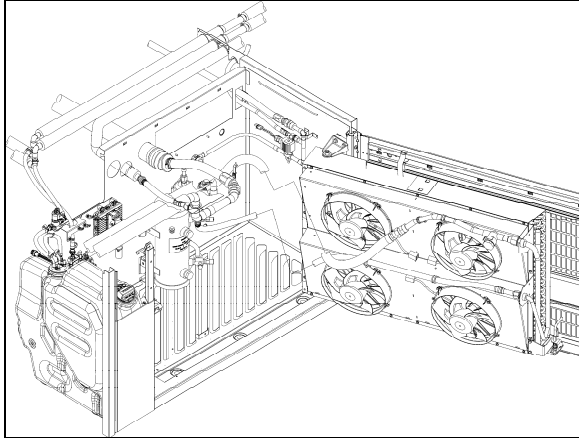

FIGURE 8: CONDENSER COMPARTMENT 22299

Furthermore, the following relays, diodes and multiplex module are located in the evaporator compartment (Fig. 9). They are mounted in the HVAC junction box located inside the evaporator compartment door.

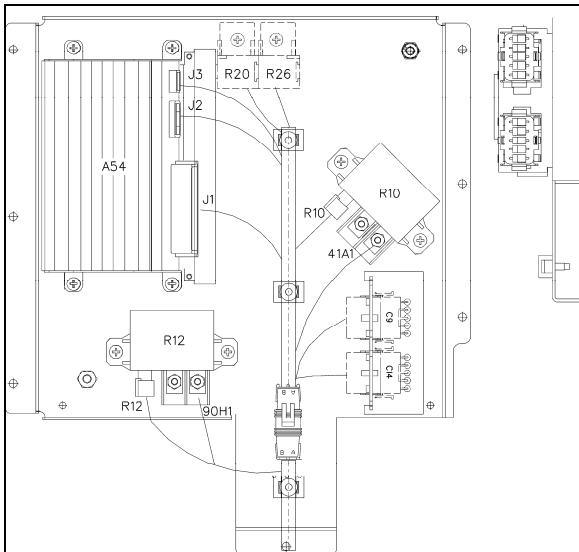

FIGURE 9: A/C JUNCTION BOX

A/C Junction Box	
Multiplex Module	
A54	I/O-B
Relays	
R10	Condenser Fan Sp. 2
R12	Evaporator Fan
R20	Water Pump Relay

Diodes			
D9	HVAC		
D11	Pass. Liq. Sol.	D17	Lugg. 5 th Compt
D19	Lugg. 2 nd Compt	D20	Lugg. 1 st Compt
D25	Evap. Fan	D30	Water Pump
D73	Opt.	D80	Opt.

4. HVAC UNIT MAINTENANCE

No special maintenance is required on the passengers and driver's HVAC units, with the exception of cleaning their respective coils and air filters, plus periodic inspection for broken drains, hoses and charging of system.

MAINTENANCE

Squeeze rubber discharge tubes located underneath the appropriate compartment to eliminate the accumulated water and dirt every three months.

4.1 COIL CLEANING

Check the external surface of the coil at regular intervals for dirt or any foreign matter.

MAINTENANCE

For the driver's HVAC unit, remove the grill and the access panels and back flush the coil every 12,500 miles (20 000 km) or once a year, whichever comes first

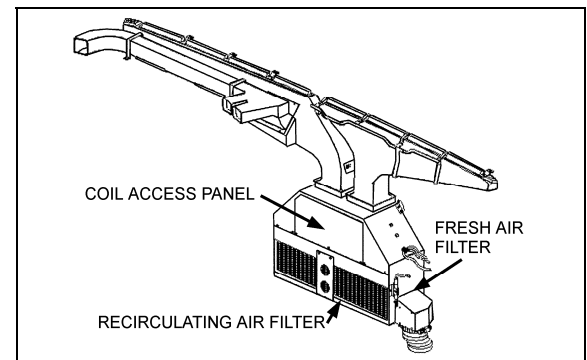

FIGURE 10: DRIVER'S HVAC UNIT COIL ACCESS PANEL

MAINTENANCE

For the passengers' section evaporator coil, remove the access panel and back flush the coil every 12,500 miles (20 000 km) or once a year, whichever comes first

Section 22: HEATING AND AIR CONDITIONING

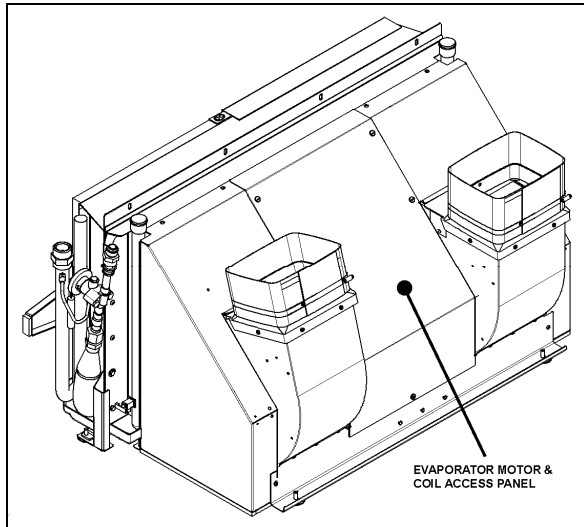

FIGURE 11: EVAPORATOR COIL ACCESS PANEL (TYPICAL) 22309

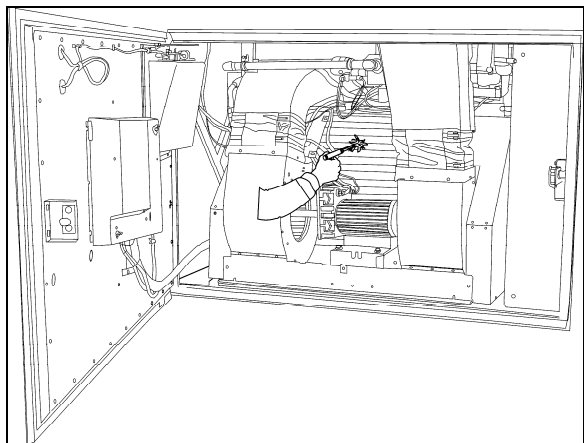





FIGURE 12: EVAPORATOR COIL CLEANING 22373

 **MAINTENANCE**

For the condenser coil, back flush the coil (Fig. 13) every 6,250 miles (10 000 km) or twice a year, whichever comes first.

 **CAUTION**

Use a water jet or water mixed with low air pressure to clean the coil.

 **CAUTION**

Direct the pressure straight through the coil to prevent bending of fins and do not use extremely high pressure. Do not use hot water, steam or caustic soap.

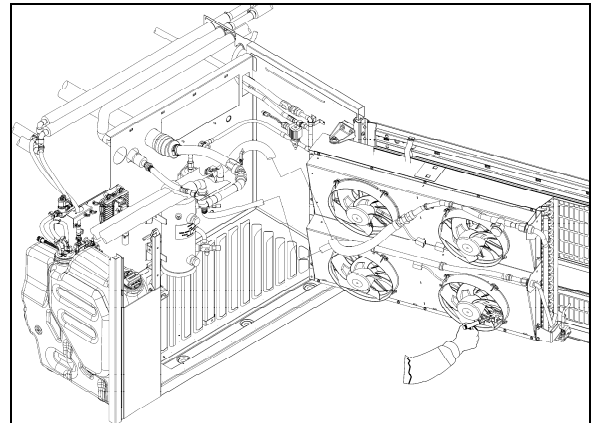



FIGURE 13: CONDENSER COMPARTMENT 22311

4.2 DRIVER'S SECTION AIR FILTERS

The driver HVAC system is located behind the dashboard's R.H. side lateral plastic panel. To gain access to the A/C filters, unscrew the R.H. lateral console's grill located at the top step of the entrance door steps. Slide out the recirculating air and fresh air filters.

 **MAINTENANCE**

Back flush filters with water, then dry with air every 12,500 miles (20 000 km) or once a year, whichever comes first (Fig. 14 & 15).

NOTE

If the windshield is continuously fogged, check that the driver's air filter is not clogged.

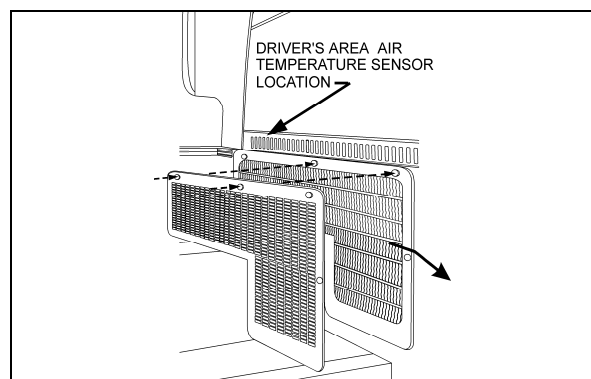

FIGURE 14: DRIVER'S SECTION ACCESS GRILL 22312

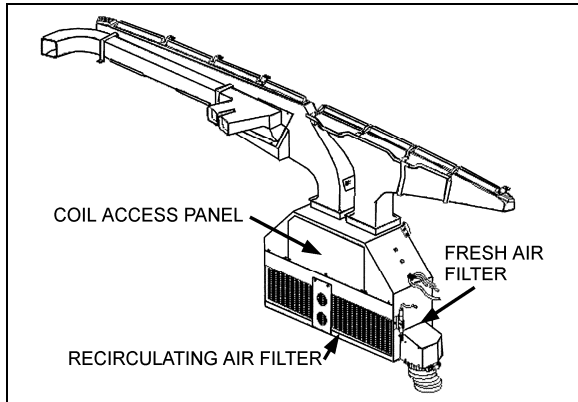

FIGURE 15: DRIVER'S SECTION AIR FILTERS 22171

4.3 PASSENGERS' SECTION AIR FILTER

The passengers' section air filter is located in the evaporator compartment. To access the filter, open baggage compartment door located forward of the evaporator compartment (L.H. side). Open access panel by turning the three screws of panel ¼ of a turn, unsnap both fasteners on top of filter, and slide out filter (Fig. 16).

MAINTENANCE

Back flush filter with water or soapy water, then dry with air every 12,500 miles (20 000 km) or once a year, whichever comes first.

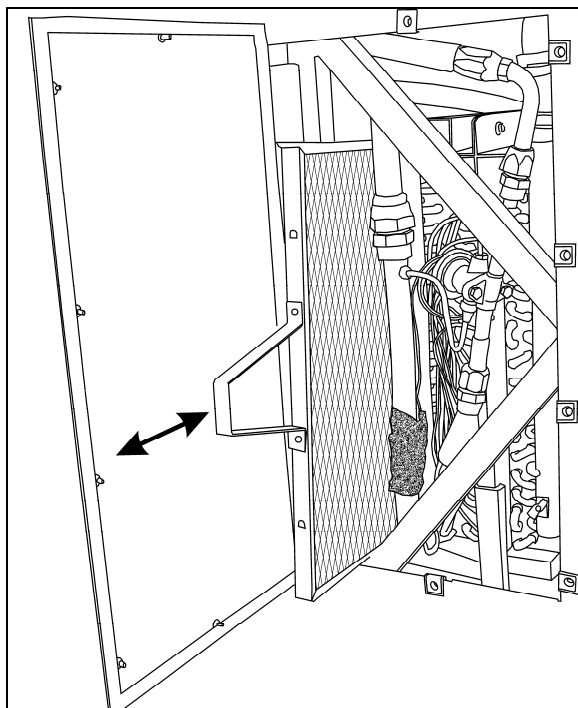

FIGURE 16: PASSENGERS' SECTION AIR FILTER 22306



CAUTION

Do not use high pressure water jet to avoid damaging filter. Be sure not to reverse filter upon installation.

4.4 OVERHEAD COMPARTMENT FAN AIR FILTER

The air filters are accessible from inside the overhead compartments.



MAINTENANCE

Slide out filters, back flush with water then dry with air and replace. This procedure should be done every 12,500 miles (20,000 km) or once a year, whichever come first.

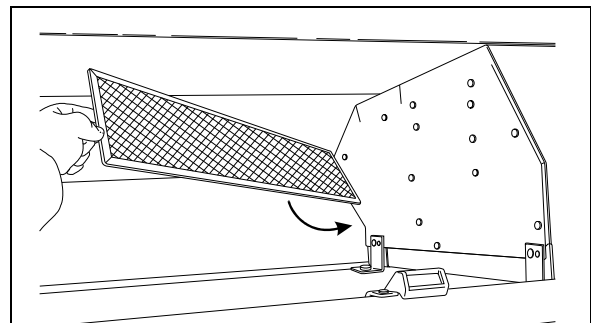

FIGURE 17: OVERHEAD COMPARTMENT FAN AIR FILTER 22201

5. HVAC SYSTEM PARTICULARITIES, TESTING AND TROUBLESHOOTING

Before undertaking any troubleshooting on the HVAC system, study the appropriate wiring diagrams to get a complete understanding of the HVAC components circuitry, read and understand section 06: ELECTRICAL of this manual under "Troubleshooting And Testing The Multiplex Vehicles" and "Test Mode For Switches And Sensors". The information included in these paragraphs is necessary for troubleshooting the HVAC system on Multiplex vehicles.

5.1 HVAC SYSTEM AND TEST MODE FOR SWITCHES AND SENSORS

When in switch/sensor test mode (see Section 06: ELECTRICAL for complete information), the A/C compressor HI and LO pressure values are displayed one after the other instead of the outside temperature in the telltale panel LCD

Section 22: HEATING AND AIR CONDITIONING

display. This feature can be used when the vehicle is traveling to check the A/C compressor pressure values.

NOTE

When starting the A/C compressor wait 5 seconds before checking pressures in order to give the system a chance to build its pressure. During the first 5 seconds after startup, the compressor is active on 6 cylinders and the A/C valve is open regardless of the pressure readings.

In test mode, with the parking brake applied and the passenger set point set to a value higher than 64°F (18°C), the hot water circulating pump is not set to OFF as it would normally do when the outside temperature gets above 50°F (10°C).

This feature allows verification of the pump when inside a garage. This is also useful when working on the heating system to remove air pockets trapped in the system.

When performing an A/C cooling test and having the water pump shut off in switch/sensor test mode is required, just set the passenger set point temperature to the minimum 64°F (18°C) to shut off the pump.

5.2 HVAC SYSTEM AND TEST MODE FOR ELECTRIC MOTORS

The test mode allows testing the motors and electric contactors without the need to have the engine running (see Section 06: ELECTRICAL under "TEST MODE FOR ELECTRICAL MOTORS" for complete information).

Use this test mode for testing of the condenser motors, the A/C compressor clutch activation, left and right unloaders, evaporator motor, water pump, hot water solenoid valve and overhead compartment air register fan.

5.3 PARTICULARITIES

Conditions for engaging the 2 nd speed on the evaporator motor (cooling demand).	The 2 nd speed engages if the passenger's area temperature is 1 degree above the set point and it reverts to speed 1 if the temperature gets equal or below the set point.
Conditions for hot water recirculating pump activation (heating demand).	The pump turns to OFF if the outside temperature is above 50°F (10°C), when there is less demand for heating. Note: To test a working pump, it is possible to keep it active even if the outside temperature is above 50°F (10°C). See paragraph 7.2 HVAC SYSTEM AND TEST MODE FOR ELECTRIC MOTORS.
The compressor unloaders are working based on pressure and also on the difference between the passenger's area temperature and the set point.	2 left compressor cylinders: Stop if: passenger's area temperature is at less than 0.4°C degree above the set point or if the compressor output is above 280 psi, or if the compressor input is below 26 psi. Restart if: passenger's area temperature is 0.9°C or more above the set point and the compressor pressure output is less than 220 psi and the compressor pressure input is above 34 psi. 2 right compressor cylinders: Stop if: passenger's area temperature is at less than 0.2°C above the set point or if the compressor input falls below 23 psi. Restart if: passenger's area temperature is 0.7°C or more above the set point and the compressor input pressure is above 32 psi.
The A/C deactivation pressure is 320 psi.	In case of high pressure, the analog pressure sensor connected to the Multiplex module deactivates the compressor. There is also a « Pressure switch » adjusted to 350 PSI that acts to stop the compressor in the instance that the Multiplex module fails.

5.4 HVAC SYSTEM TROUBLESHOOTING

Problem/Symptom	Probable Causes	Actions
Defroster fan not functioning	Module A47 is not powered or is faulty	<ol style="list-style-type: none"> 1. Check the Diagnostics menu of the Driver Information Display (DID). Select Fault Diagnostics and Electrical System. The message “No Response ModA47, Active” indicates a power problem on the module. (A CAN network problem would show the same message but doesn't produce these symptoms). 2. Check / reset circuit breaker CB6 3. Check / replace fuse F5 4. Check / replace relay R18 5. Probe gray connector on module to see if it is powered. 6. Use the air release valves on the dashboard and in the front service compartment to lock / unlock the door
HVAC condenser fans not functioning in speed 1	Circuit breaker CB7 was manually tripped and not reset Seized bearing Faulty brushes or bad wiring	Check / reset circuit breaker CB7
HVAC condenser fans not functioning in speed 1	Module A54 is not powered or is faulty	<ol style="list-style-type: none"> 1. Check the Diagnostics menu of Driver Information Display (DID). Select Fault Diagnostics and Electrical System. The message “No Response ModA54, Active” indicates a power problem on the module. (A CAN network problem would show the same message but doesn't produce this symptom). 2. Check / reset circuit breaker CB5 3. Check / replace fuse F67 , F68 4. Probe gray connector on module to see if it is powered.
HVAC condenser fans not functioning in speed 2	Circuit breaker CB7 was manually tripped and not reset Seized bearing Faulty brushes Bad wiring	Check / reset circuit breaker CB7
Defroster fan is functioning but no heat or cooling available in the driver's area	Module A46 is not powered or is faulty Faulty speed control Bad wiring	<ol style="list-style-type: none"> 1. Check the Diagnostics menu of Driver Information Display (DID). Select Fault Diagnostics and Electrical System. The message “No Response ModA46, Active” indicates a power problem on the module. (A CAN network problem would show the same message but doesn't produce these symptoms). 2. Check / reset circuit breaker CB1 3. Check / replace fuse F12 or F13 4. Probe gray connector on module to see if it is powered.

Section 22: HEATING AND AIR CONDITIONING

Problem/Symptom	Probable Causes	Actions
The A/C compressor clutch does not engage	Module A52 is not powered or is faulty	<ol style="list-style-type: none"> 1. Check the Diagnostics menu of Driver Information Display (DID). Select Fault Diagnostics and Electrical System. The message "No Response ModA52, Active" indicates a power problem on the module. (A CAN network problem would show the same message but doesn't produce this symptom). 2. Check / reset circuit breaker CB5 3. Check / replace fuse F65 4. Probe gray connector on module to see if it is powered.
Evaporator fan not functioning	Circuit breaker CB3 tripped Module A54 is not powered or is faulty Faulty brushes	<ol style="list-style-type: none"> 1. Check / reset circuit breaker CB3 2. Check the Diagnostics menu of Driver Information Display (DID). Select Fault Diagnostics and Electrical System. The message "No Response ModA54, Active" indicates a power problem on the module. (A CAN network problem would show the same message but doesn't produce this symptom). 3. Check / reset circuit breaker CB5 4. Check / replace fuse F67 , F68 5. Probe gray connector on module to see if it is powered.

6. CENTRAL AIR CONDITIONING SYSTEM

The schematic of Figure 18 shows the central A/C system and its components. The central system is equipped with a 6 cylinder, 05G Twin Port Carrier compressor with an air conditioning capacity of 7½ tons. The receiver tank and filter dryer are mounted inside the condenser compartment.

6.1 A/C CYCLE

Refrigeration may be defined as "the transfer of heat from a place where it is not wanted to a place where it is unobjectionable". Components required for a closed circuit refrigeration system are shown in Figure 18.

The air conditioning system used on X3-45 coaches is of the "Closed" type using "R-134a".

1. The refrigerant flowing to the compressor is compressed to high pressure and reaches a temperature higher than the surrounding air. It is passed through the air-cooled fins and tubes of the condenser causing the hot, high pressure gas to be condensed into a liquid form.

2. The liquid refrigerant flows to the receiver tank, then passes through a filter dryer where moisture, acids and dirt are removed and then through a moisture indicator which indicates if any moisture is present in the system.
3. By its own pressure, the liquid refrigerant flows through a thermal expansion valve where the pressure drop causes the refrigerant to vaporize in a vapor-liquid state at a low temperature pressure.
4. The cold low pressure refrigerant passes through the passengers and the driver's evaporator coils which absorbs heat from the air passing over the fins and tubes, and changes into gas. In this form, the refrigerant is drawn into the compressor to repeat the air conditioning cycle.
5. The success of the air conditioning system depends on retaining the conditioned air within the vehicle. All windows and intake vents should be closed. An opening of approximately 8 in² (5162 mm²) could easily neutralize the total capacity of the system.

6. Other causes of inadequate cooling are dirty coils or filter. Dirt acts as insulation and is also serves as a restriction to the air flow.
7. The refrigeration load is not constant and varies. It is also affected by outside temperature, relative humidity, passenger load, compressor speed, the number of stops, etc.
8. The compressor will load or unload depending on operating conditions.

6.2 REFRIGERANT

The A/C system of this vehicle has been designed to use Refrigerant 134a as a medium. Regardless of the brand, only R-134a must be used in this system. The chemical name for this refrigerant is Ethane, 1, 1, 1, 2-Tetrafluoro.

DANGER

Refrigerant in itself is nonflammable, but if it comes in contact with an open flame, it will decompose.

6.2.1 Procurement

Refrigerant is shipped and stored in 30 and 100 pound (13,6 and 45 kg) metal cylinders. Approximately 24 pounds (10,9 kg) are used in the central system.

It will be impossible to draw the entire refrigerant out of the cylinder. However, the use of warm water when charging the system will assure the extraction of a maximum amount of refrigerant from the cylinder.

6.2.2 Precautions in Handling Refrigerant

1. Do not leave refrigerant cylinder uncapped.
2. Do not subject cylinder to high temperatures, do not weld or steam clean near system or cylinder.
3. Do not fill cylinder completely.
4. Do not discharge vapor into an area where a flame is exposed.
5. Do not expose the eyes to liquid refrigerant.

All refrigerant cylinders are shipped with a heavy metal screw cap. The purpose of the cap is to protect the valve and safety plug from damage. It is a good practice to replace the cap after each use of the cylinder for the same reason. If

the cylinder is exposed to the sun's radiant heat pressure increase resulting may cause release of the safety plug or the cylinder may burst.

For the same reason, the refrigerant cylinder should never be subjected to excessive temperature when charging a system. The refrigerant cylinder should be heated for charging purposes by placing it in 125°F (52°C) water. Never heat above 125°F (52°C) or use a blowtorch, radiator, or stove to heat the cylinder. Welding or steam cleaning on or near any refrigerant line or components of the A/C system could build up dangerous and damaging pressures in the system.

If a small cylinder is ever filled from a large one, never fill the cylinder completely. Space should always be allowed above the liquid for expansion. Weighing cylinders before and during the transfer will determine the fullness of the cylinders.

WARNING

One of the most important precautions when handling refrigerant consists in protecting the eyes. Any liquid refrigerant which may accidentally escape is approximately -40°F (-40°C). If refrigerant comes in contact with the eyes, serious injury could result. Always wear goggles to protect the eyes when opening refrigerant connections.

6.2.3 Treatment in Case of Injury

If liquid refrigerant comes in contact with the skin, treat the injury as if the skin was frost-bitten or frozen. If liquid refrigerant comes in contact with the eyes, consult an eye specialist or doctor immediately. Give the following first aid treatment:

1. Do not rub the eyes. Splash eyes with cold water to gradually bring the temperature above the freezing point.
2. Apply drops of sterile mineral oil (obtainable at any drugstore) in the eyes to reduce the possibility of infection. The mineral oil will also help in absorbing the refrigerant.

6.2.4 Precautions in Handling Refrigerant Lines

1. All metal tubing lines should be free of kinks, because of the resulting restrictions

Section 22: HEATING AND AIR CONDITIONING

on the flow of refrigerant. A single kink can greatly reduced the refrigeration capacity of the entire system.

2. The flexible hose lines should never be allowed to come within a distance of 2-1/2" (6,3 cm) from the exhaust manifold.
3. Use only sealed lines from parts stock.
4. When disconnecting any fitting in the refrigeration system, the system must first be discharged of all refrigerant. However, proceed very cautiously, regardless of gauge readings. If liquid refrigerant happens to be in the line, disconnect fittings very slowly, keeping face and hands away so that no injury can occur. If pressure is noticed when fitting is loosened, allow it to bleed off very slowly.

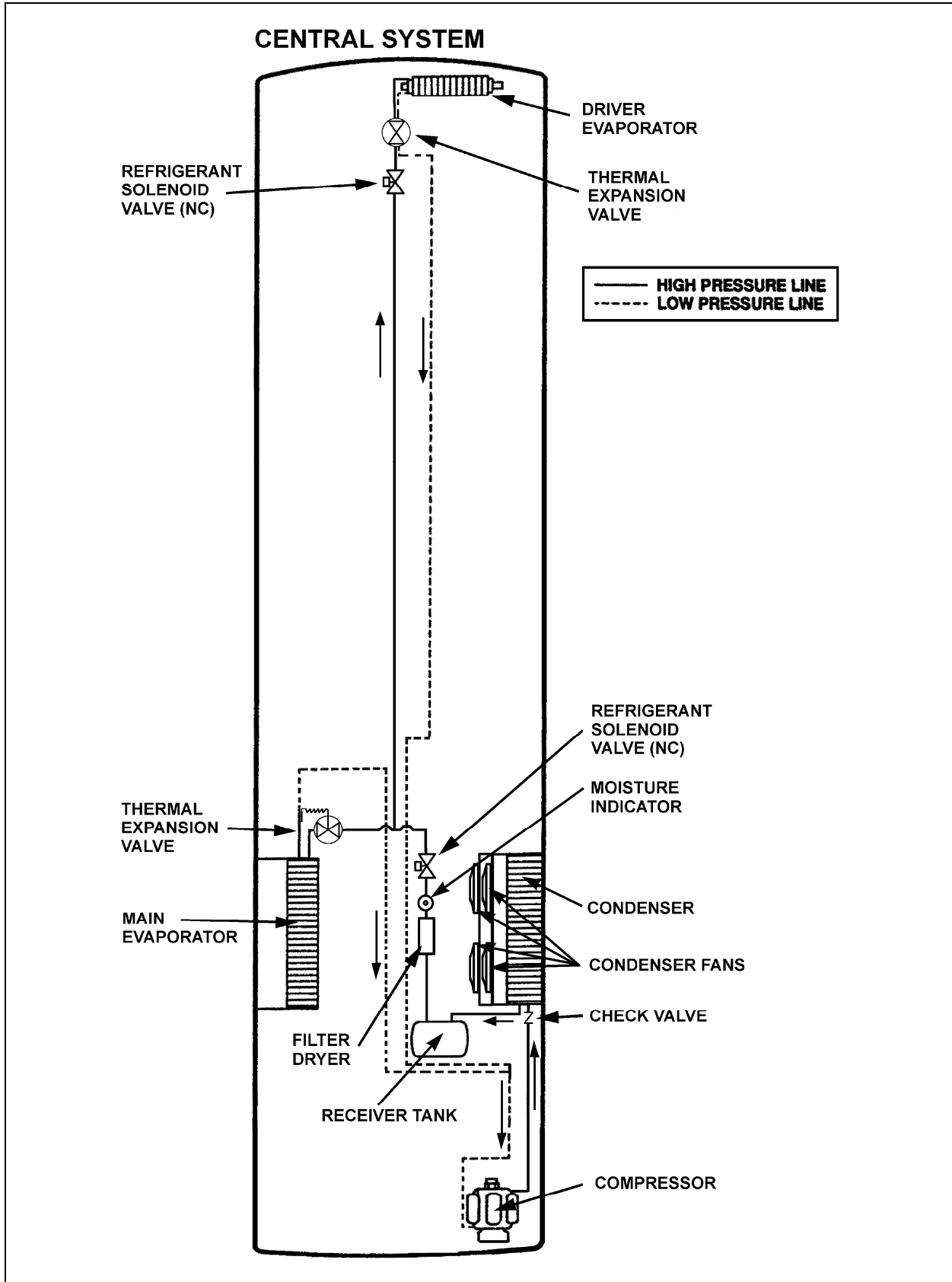



FIGURE 18: REFRIGERANT CIRCUIT (CENTRAL SYSTEM)

	WARNING
Always wear safety goggles when opening refrigerant lines.	

- In the event that any line is opened to the atmosphere, it should be immediately capped to prevent entrance of moisture and dirt.
- The use of the proper wrenches when making connections on O-ring fittings is important. The use of improper wrenches may damage the connection. The opposing fitting should always be backed up with a wrench to prevent distortion of connection lines or components. When connecting the flexible hose connections, it is important that the swaged fitting and the flare nut, as well as the coupling to which it is attached, be held at the same time using three different wrenches to prevent turning the fitting and damaging the ground seat.
- The O-rings and seats must be in perfect condition. The slightest burr or piece of dirt may cause a leak.
- O-rings should be coated with refrigeration oil and installed on the line before the line is inserted into the fitting to prevent damaging the O-ring. If leaks are encountered at the couplings or connectors, no attempt should be made to correct the leaks by tightening the connections beyond the recommended torque. The O-rings are designed to seal at the specified torque and overtightening the connection does not result in a satisfactory and permanently sealed connection. The connection must be disassembled and the cause of the leak (damaged O-ring, defective lines, etc.) corrected. Use new O-ring.

6.3 PUMPING DOWN

This procedure is intended to reduce refrigerant loss, by isolating it in the compressor and the receiver tank, as well as in their connecting line, in order to carry out repairs on other sections of the air conditioning system (lines and components).

NOTE
<i>Before attempting any repair between compressor and receiver tank, use a recovery unit to remove refrigerant from the system.</i>

	WARNING
To prevent any injury, when air conditioning system must be opened, refer to previous paragraph "PRECAUTIONS IN HANDLING REFRIGERANT".	

	CAUTION
The filter dryer must be changed each time a line in the system is opened.	

Procedure

- Energize passengers 'section liquid solenoid valve.
- Run the system for 10 minutes, shut it OFF, then close the receiver tank outlet valve by turning it clockwise, backseat the suction service valve on the compressor, install an appropriate pressure gauge set, and turn the valve forward ¼ turn to enable a visual check of the suction pressure.
- Disconnect the "Low Pressure Switch" connector (mounted near the A/C compressor, and install a jumper wire.

NOTE
<i>This jumper wire will allow the clutch to remain engaged after pressure drops below 15 psi (103,5 kPa).</i>

- Start the engine, press the "Driver's ON/OFF" switch then adjust (lower) temperature control  to maximum A/C.
- Run the compressor until pressure reaches 1-2 psi (7-14 kPa).

NOTE
<i>During this operation, care must be taken not to fill the receiver tank over the upper sight glass. If so, stop process immediately. Always allow refrigerant piping and units to warm up to the ambient air temperature before opening system or sweating will take place inside the lines.</i>

- Stop engine, and close compressor outlet valve by turning it clockwise until valve is properly seated.

7. Close compressor suction valve by turning it clockwise until it is properly seated.
8. Wait until pressure gauge reaches 1 to 2 psi (7 to 14 kPa). To accelerate procedure, lightly open compressor suction valve until pressure reaches this value.

6.4 ADDING REFRIGERANT (VAPOR STATE)

Use the suction service valve on the compressor to add a small quantity of refrigerant to the system. Backseat the valve and connect a charging line from the refrigerant cylinder to the valve. Tighten connection at level of refrigerant cylinder and open tank end slightly to purge air from the charging line. Tighten the charging line at the compressor. Screw in the stem of suction valve approximately two turns. Start the engine and run at fast idle. Add sufficient refrigerant to bring the level in lower sight glass of receiver tank to mid-point. Always charge the system with the cylinder upright and the valve on top to avoid drawing liquid out of the cylinder.

6.5 EVACUATING SYSTEM

1. Open both receiver valves by turning "out" (normal position).
2. Remove the caps from the two 90° adapters on the suction, discharge valves and connect two hoses to the vacuum.
3. Place the two compressor valves, suction and discharge, in neutral position by turning each one 3 to 4 turns "in" from the "out" position.
4. Open the solenoid valve by energizing or manually bypass.
5. Start the vacuum pump. Open the large (suction) shutoff valve and close the small vacuum gauge valve.
6. The pressure will drop to approximately 29 inches vacuum (14.2 psi or 97,9 kPa) (the dial gauge only gives a general idea of the absolute system pressure).
7. Backseat the compressor valves by turning "out" all the way.
8. Shut down the vacuum pump.
9. Remove the hoses.
10. Reinstall the caps at the suction valve take-off points.

6.5.1 Double Sweep Evacuation Procedure

1. Remove any remaining refrigerant from the system using a refrigerant recovery machine.
2. Connect the evacuation manifold, vacuum pump, hoses and micron gauge to the unit.
3. With the unit service valves closed (back seated) and the vacuum pump and the thermistor valves open, start the pump and draw the manifold and hoses into a very deep vacuum. Shut the vacuum pump off and see if the vacuum holds. This is to check the setup for leaks.
4. Midseat the system service valves.
5. Open the vacuum pump and the thermistor valves. Start the pump and evacuate to a system pressure of 2000 microns.
6. Close the vacuum pump and the thermistor valves, turn off the vacuum pump (closing the thermistor valve protect the valve from damage).
7. Break the vacuum with clean refrigerant (or dry nitrogen) and raise the pressure to approximately 2 PSIG. Monitor the pressure with the compound gauge.
8. Remove the refrigerant with the recovery machine.
9. Repeat steps #5 – 8 one time.
10. After the second "sweep", change the filter dryer (if you have not yet done so) and evacuate to 500 microns.
11. Evacuating the system below 500 microns on systems using the Carrier 05G compressor may risk drawing air into the system past the carbon shaft seal.
12. Check to insure that vacuum holds. (If the pressure continues to rise, it indicates a leak or moisture in the system).
13. Charge the system with the proper amount of refrigerant using recommended charging procedures.

NOTE

This method will aid in preventing unnecessary system failures by ensuring that the refrigeration system is free of contaminants.

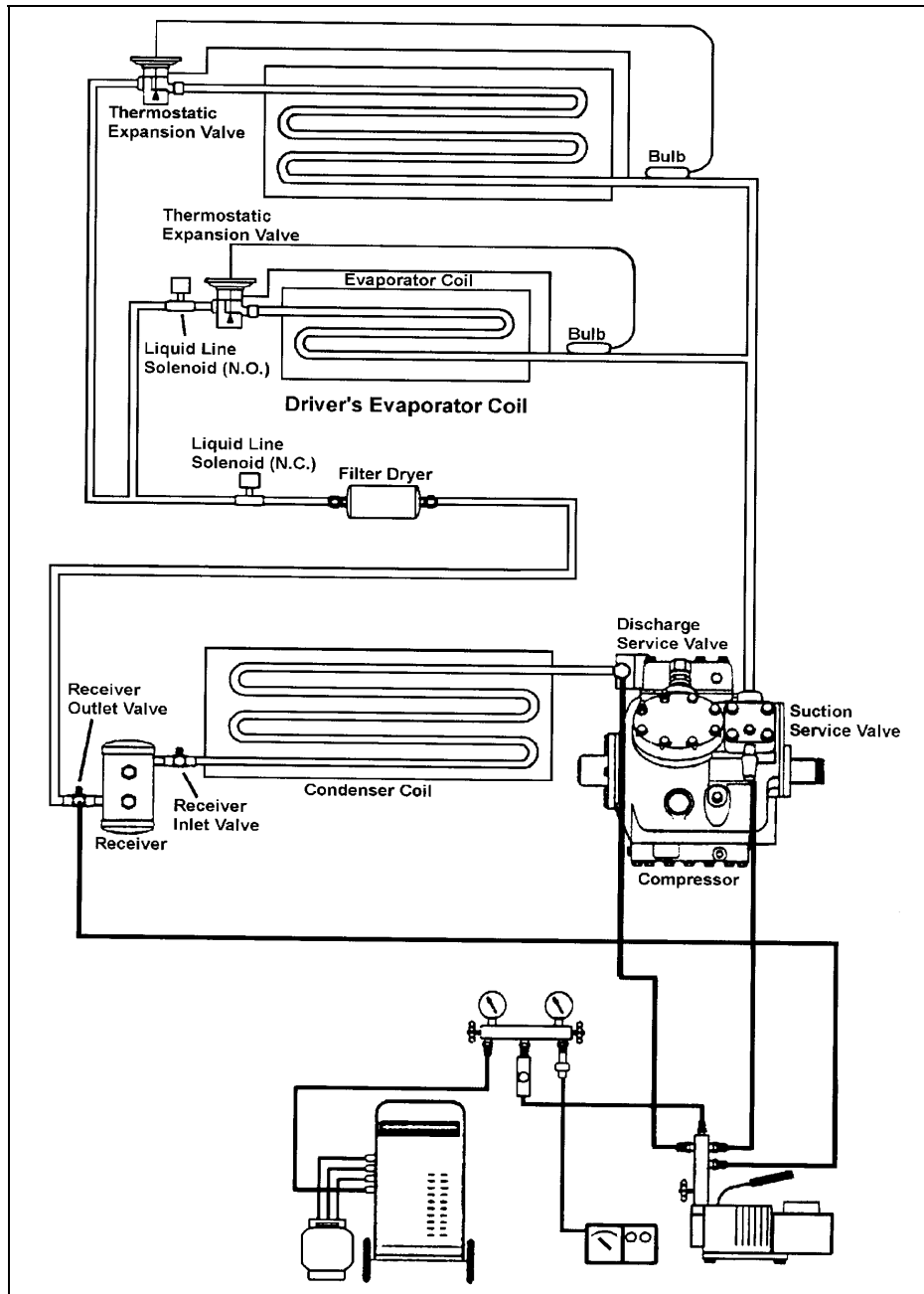

FIGURE 19: DOUBLE-SWEEP EVACUATION SET-UP

22298

6.6 CHARGING SYSTEM

When a system has been opened or if there are any questions about the air or moisture in the system, evacuate the system. Charging of an evacuated system may be accomplished by forcing liquid R-134a directly into the receiver tank. This may be accomplished by placing the refrigerant cylinder upside down on a scale with the valves at the bottom. This ensures that only liquid will enter the receiver tank.

When charging an empty system, weigh the amount of refrigerant put into the system. This will eliminate any possibility of overfilling. A nominal charge requires 24 pounds (10,9 kg).

1. Backseat the two compressor shutoff valves ("out").
2. Install the test gauges at the shutoff valves noting that the 400 psi (2758 kPa) gauge is connected to the discharge.

3. Turn in the two shutoff valves 3 to 4 turns.
4. Open the lower receiver valve by turning "out" all the way.
5. Backseat the upper receiver valve by turning out all the way.
6. Remove the cover cap from the service fitting in the top receiver valve.
7. Attach a charging hose to the R-134a tank. Open the tank valve slightly permitting R-134a to escape thus purging the hose of air.
8. Connect the charging hose to the service fitting.
9. Open the R-134a tank valve.
10. To build up pressure in the receiver tank, heat the receiver tank with a heating blanket.
11. Turn in the upper receiver valve several turns. The R-134a will now enter the system.
12. The proper charge of R-134a is 24 lbs (10.89 kg). When the scale indicates this amount of charge, backseat the receiver valve and close the R-134a tank valve.
13. Disconnect the charging hose. Replace the cover caps.
14. The system is now ready for operation.



CAUTION

The evacuation of the system must be made by authorized and qualified personnel only. Refer to local laws for R-134a recuperation.

6.7 REFRIGERANT SYSTEM CLEAN-OUT AFTER COMPRESSOR FAILURE

Although the vast majority of reciprocating refrigerant compressors manufactured today are extremely reliable, a small percentage do fail. These failures usually result in minor or extensive system contamination depending on the severity of the failure. When an open type compressor becomes damaged internally, this provokes small particles of bearings, steel, brass, copper, and aluminum and, in severe cases, carbonized oil, which could contaminate the system. To prevent repeated failures, the problem which caused the failure should be corrected, and depending upon the severity of the failure, the system should be thoroughly

cleaned out using one of the clean-out procedures mentioned.

6.7.1 Determining Severity of Failure

The severity of compressor failure can be categorized as minor or major. A failure is considered minor when the contamination is limited to the compressor with little or no system contamination. A major failure, or burnout, results in extensive system contamination as well as compressor damage. Extensive system contamination can be determined by withdrawing a small sample of compressor oil and checking its color, odor and acidity. A Virginia Chemical "TKO" one step acid test kit is one of several compressor oil test kits that may be used. A high acid content would indicate a major failure or burnout. A small amount of refrigerant gas may be discharged. A characteristic burned odor would also indicate severe system contamination.

6.7.2 Clean-out after Minor Compressor Failure

1. Be sure to correct the problem which caused the failure.
2. Change liquid line filter dryer.
3. Run the unit for 2 hours on high speed cool only.
4. Check compressor oil level to ensure compressor is not overcharged with oil. Sometimes a significant amount of oil is pumped out of the compressor to other parts of the system when a compressor fails. This oil will return to the replacement compressor when it is started, causing an overcharge of oil in the sump of the replacement compressor. In this case, it is important that the oil level be adjusted to the proper level.
5. Withdraw a sample of the compressor oil and check its color, odor, and acidity, using instructions supplied above. If the oil is contaminated, change the oil and filter dryer, and repeat the procedure until the system is clean.

6.7.3 Clean-out After Major Compressor Failure

1. Reclaim the refrigerant into a refrigerant bottle through a filter dryer to filter out contaminants.

Section 22: HEATING AND AIR CONDITIONING

2. Remove the failed compressor and repair it if possible.
3. Install new or repaired compressor.
4. Change the filter dryer.
5. Circulate clean R-134a or nitrogen using a pressurized metal cylinder or a reclaiming machine to clean out many of the contaminants collected in the coil valves, TXV (Thermal Expansion Valve), solenoid valves, check valves, and any other mechanical component that may have collected contaminants.
6. Evacuate and charge the system normally.
7. Run the unit for 8 hours and monitor the pressure drop across the filter dryer. Also check the liquid line dryer for signs of restriction. If the pressure drop across the filter dryer exceeds 12 to 14 psig (82,75 to 96,5 kPa) with a 40°F (5°C) evaporator coil temperature, stop the unit and change the liquid line and suction line filter dryer. After 4 or 5 hours of operation, stop the unit and replace the filter dryer.
8. After 8 hours of operation, stop the unit and remove a sample of the compressor oil and check its color, odor, and acidity, using instructions supplied above. If the oil is contaminated, replace the oil and repeat step 7. If the oil is not contaminated, change the filter dryer again and replace the moisture-liquid indicator.
9. After approximately 7 days of operation, recheck the compressor oil for cleanliness and acidity.

7. CENTRAL A/C SYSTEM COMPONENTS

7.1 COMPRESSOR (CENTRAL SYSTEM)

7.1.1 Belt Replacement



DANGER

Set the battery master switch to the "Off" position. For greater safety, set the engine starter selector switch in engine compartment to the "Off" position.

1. Open engine compartment rear doors and locate the belt tensioner pressure releasing valve (Fig. 20), mounted above the engine

R.H. side door next to the air pressure regulator, then turn handle clockwise in order to release pressure and tension on belts.

2. Remove the radiator fan driving mechanism belt (Refer to Section 05: Cooling).
3. Slip the old A/C compressor belts off and the new ones on.
4. Reset belt tensioner pressure releasing valve (Fig. 20) to 45 psi (310 kPa) to apply tension on the new belts as explained in Section 12.

NOTE

Both belts must always be replaced simultaneously to ensure an equal distribution of load on each of them.

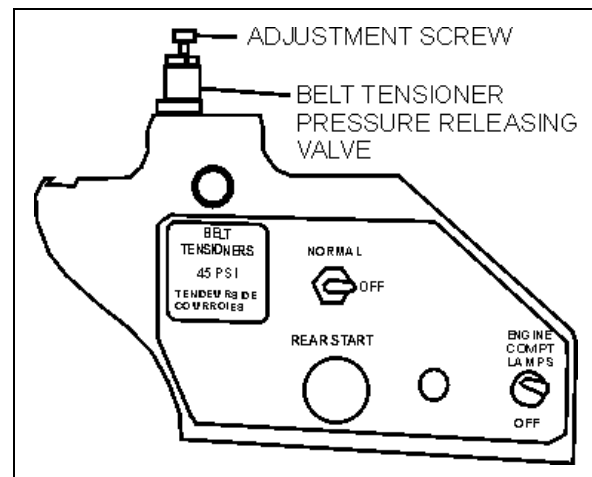

FIGURE 20: AIR PRESSURE REGULATOR

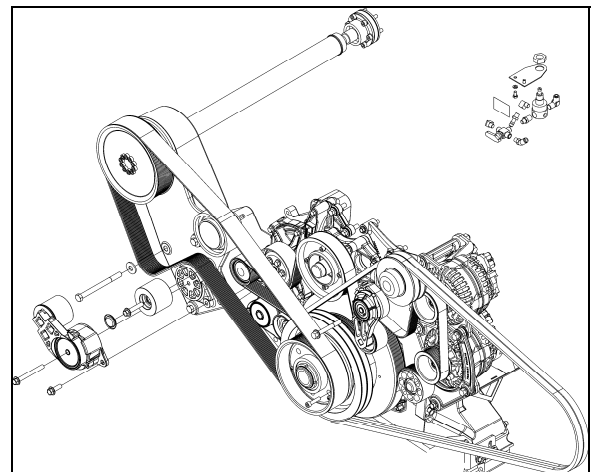

FIGURE 21: BELT ARRANGEMENT

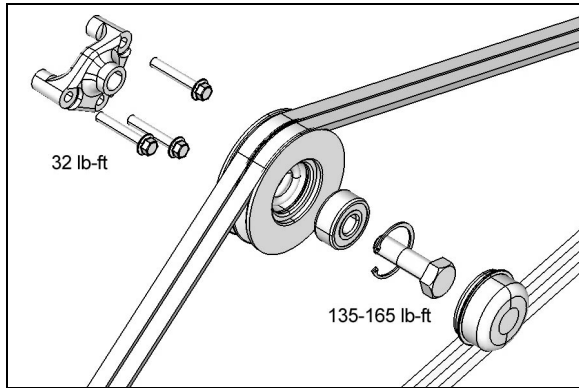

FIGURE 22: IDLER PULLEY INSTALLATION ON VOLVO D13 ENGINE

7.1.2 Belt Tension Adjustment

Belt tensioning is applied through air bellows which are adjusted by an air pressure regulating valve. The correct pressure of 45 psi (310 kPa) is set at the factory. Periodically verify the pressure at the regulating valve using a pressure gauge and correct if necessary.

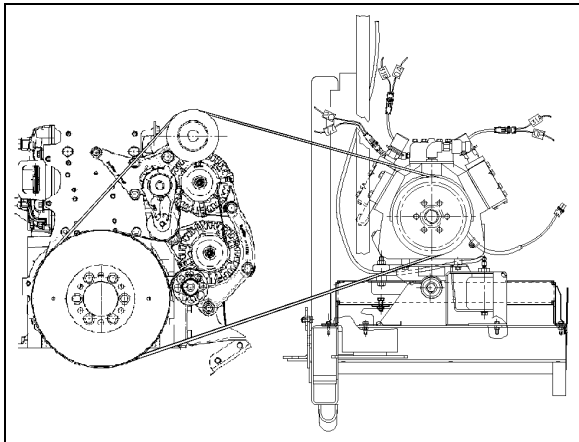

FIGURE 23: A/C COMPRESSOR BELT ADJUSTMENT²²²⁸⁸

7.1.3 Pulley Alignment

In order to avoid skipping, disengagement and a premature wear of compressor belt, it is necessary to align compressor pulley with the crankshaft pulley. Before performing the following procedure, release air from belt tensioner bellows by means of the air pressure releasing valve. After completing these procedures reset belt tensioner air pressure regulator to 45 psi (310 kPa).

7.1.4 Longitudinal Compressor Alignment

1. Rest an extremity of a straight edge of approximately 46 inches (117 cm) against the upper part of the outer face of crankshaft pulley, positioning the other end close to the compressor clutch pulley (Figs. 24 & 25).
2. Check the distance between each extremity of straight edge (1. Fig. 25) and the first drive belt. If they are different, loosen the compressor support bolts and with a hammer, knock support to slide it in order to obtain the same distance; then tighten bolts.

7.1.5 Horizontal Compressor Alignment

1. Rest an extremity of the straight edge against the upper part of the outer face of compressor pulley, positioning the other end close to the crankshaft pulley.
2. Check the distance between each extremity of straight edge (1, Fig. 25) and drive belt. If they are different, loosen the pillow block compressor bolts and with a hammer, knock compressor pillow block to slide it, in order to obtain the same distance; then tighten bolts.

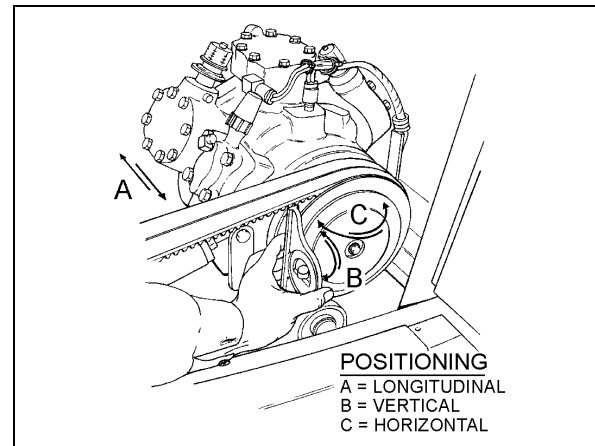

FIGURE 24: COMPRESSOR ALIGNMENT

22072

7.1.6 Vertical Compressor Alignment

Rest a short "angle and level indicator" on the outer side face of the crankshaft pulley, adjust the level indicator inclination at 0° and check if the compressor pulley is at same angle (Fig. 24). If it is not the same, shim under the appropriate pillow block in order to obtain the correct angle.

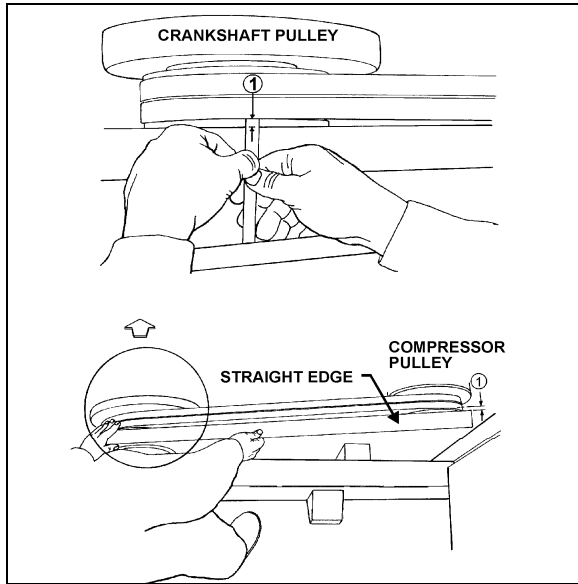



FIGURE 25: COMPRESSOR ALIGNMENT 22040

7.1.7 Compressor Maintenance

For the maintenance of the A/C compressor, see the *Carrier Compressor "WORKSHOP MANUAL for MODEL 05G TWIN PORT COMPRESSOR"* included at the end of this section.

 <p>MAINTENANCE</p>
<p>Check compressor oil level and add if necessary, every 6,250 miles (10 000 km) or twice a year, whichever comes first.</p>

 <p>CAUTION</p>
<p>Use only Castrol SW 68 (POE) oils with refrigerant 134a.</p>

7.1.8 Troubleshooting Guide

A preliminary check may be made by simply feeling the cylinder heads with the unit in operation at ambient temperatures of 35°F (2°C) and over. The cylinder heads are internally divided into suction and discharge valves. The lower half of the cylinder head is the suction side, and it should be relatively cool to the touch, as opposed to the hot upper discharge side. If a valve plate or head gasket is blown, or a compressor unloader is stuck open, partially compressed refrigerant vapor will be circulated between the suction and discharge sides of the head. The affected cylinder head will then have

a relatively even temperature across its surface and be neither as hot as the normal discharge temperature nor as cool as the normal suction temperature.

Blown Head Gaskets

Symptom:

- * Loss of unit capacity at low temperature.
- * Even cylinder head temperature.

Cause:

- * Improperly torqued cylinder head bolts.
- * Improperly positioned gasket at assembly.
- * Warped cylinder head.
- * Severe liquid refrigerant floodback.

Blown Valve Plate Gaskets

Symptom:

- * Loss of unit capacity at medium and low temperatures.
- * Very hot cylinder head surface.
- * Higher than normal suction pressure.

Cause:

- * Improperly torqued cylinder head bolts.
- * Severe liquid refrigerant floodback.
- * Oil slugging caused by an overcharge of oil or flood starts.
- * Discharge valves not seated properly (liquid drainback during shutdown).

Broken Suction Valves

Symptom:

- * Loss of unit capacity at all temperatures.
- * Compressor unable to pull extremely low vacuum with suction service valve frontseated.

Cause:

- * Repeated liquid refrigerant floodback.
- * Flooded starts.
- * Overcharge of oil.
- * Discharge valves not seated properly (liquid drainback during shutdown).

- * Expansion valve not controlling properly.

Unloader Valve Stuck Open

Symptom:

- * Loss of unit capacity at all temperatures.
- * Higher than normal suction pressure.
- * Even cylinder head temperature.

Cause:

- * Unloader body stem bent.
- * Foreign material binding unloader piston or plunger.

7.2 MAGNETIC CLUTCH

Refer to Carrier service information entitled "Housing-Mounted Electric Clutch" at the end of this section for the description and maintenance of the magnetic clutch.

7.3 EVAPORATOR MOTOR

The evaporator motor is installed in the evaporator compartment (L.H. side of vehicle) (Fig. 26). It is a 27.5 volt, 2 HP (1.5 kW) motor which activates a double blower fan unit.

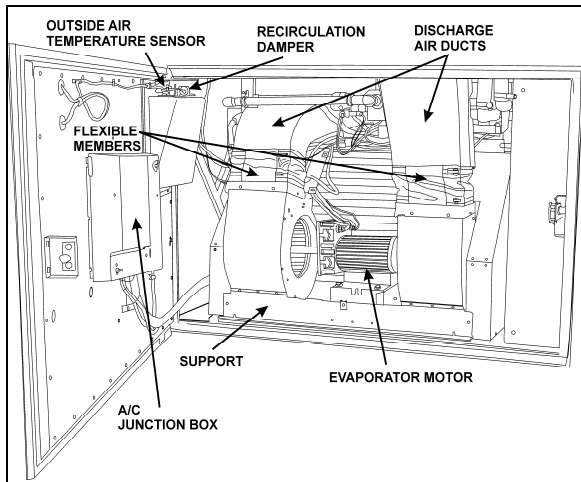

FIGURE 26: EVAPORATOR COMPARTMENT 22372

7.3.1 Removal

- Set the battery master switch (master cut-out) to the "OFF" position and trip circuit breakers CB3.
- Open the last L.H. side baggage compartment door. Pull the black release button located on the L.H. side in order to

unlock and open the evaporator compartment door.

- Remove the evaporator motor and coil access panel.
- Identify the L.H. side discharge duct inside compartment and remove the Phillips head screws retaining the flexible member to duct.
- Repeat step 4 for the R.H. side air duct.
- Disconnect the electrical motor speed control connections on the motor plate.
- From under the vehicle, remove the eight bolts retaining the evaporator fan motor support. Remove the complete unit from the evaporator compartment (Fig. 27 & 28).

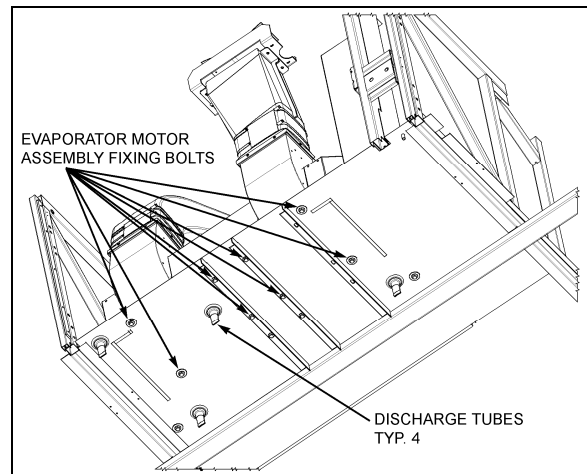

FIGURE 27: EVAPORATOR MOTOR ASSY FIXING BOLTS 22315

CAUTION

Never support evaporator motor by its output shafts while moving it.

- On a work bench, unscrew the fan square head set screws, the Phillips head screws retaining cages to support and slide out the assemblies from the evaporator motor output shaft.

7.3.2 Installation

To reinstall the evaporator motor, reverse "Evaporator Motor Removal" procedure.

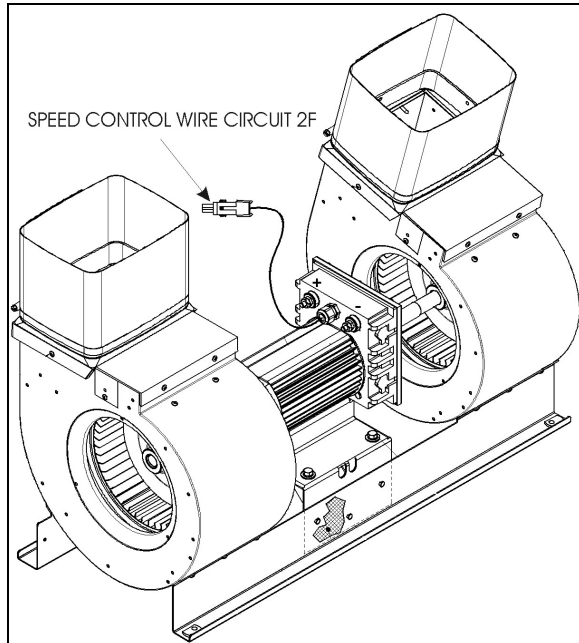

FIGURE 28: EVAPORATOR MOTOR ASSEMBLY

7.4 CONDENSER

The central A/C system condenser coil is hinge mounted on the R.H. side of the vehicle on the A/C condenser door (Fig. 30). Since condenser's purpose is to dissipate heat from the hot refrigerant, it is important to keep the cooling coils and fins clean. A clogged coil will cause high discharge pressure and insufficient cooling.

7.4.1 Condenser Fan Motors

Four brushless fan motors (Fig. 29), 28.5 V - (0.6 HP - 0.42 kW) are installed in the condenser compartment on R.H. side of vehicle in order to ventilate the condenser coil. They are mounted on a support, fastened to the door. The fans pull outside air through the condenser coil and discharge it through an opening at bottom of compartment. When temperature drops inside condenser, the pressure in the refrigerant line also drops and it is, therefore, no longer required to cool condenser. Consequently, when pressure drops to 130 psi, the motors will run at low speed and if the pressure continues to drop to 90 psi, a pressure switch stops the motors so that fans do not operate needlessly. When pressure rises to 120 psi, the pressure switch reactivates the motors. If the pressure rises to 170 psi, the motors will switch to high speed.

For details about electrical wiring, refer to "A/C and Heat system" in the master wiring diagram.

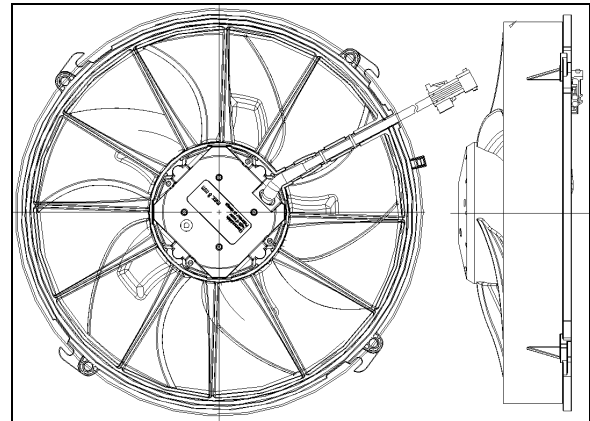

FIGURE 29: CONDENSER FAN MOTOR

22322

7.4.2 Condenser Fan Motor Removal

1. Set the battery master switch to the "Off" position.
2. Disconnect wiring from terminals on motor. Tag each wire to aid in identification at time of reconnection.
3. Remove the four hexagonal head cap screws retaining the fan motor assembly to the mounting support.
4. Remove the motor.

7.5 RECEIVER TANK

The receiver tank is located in the condenser compartment (Fig. 30). The function of the receiver tank is to store the liquid refrigerant. During normal operation, the level of the refrigerant should be approximately at the mid-point of the lower sight glass.

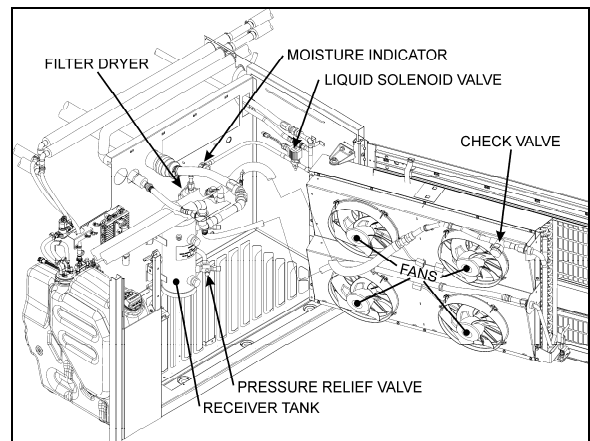



FIGURE 30: A/C CONDENSER COMPARTMENT

22323

In case of extreme pressure there will be a rise in the liquid receiver tank. A pressure relief valve

will break at 450 psi (3103 kPa) and relieve the receiver tank pressure.



MAINTENANCE

Check refrigerant level and add if necessary, every 6,250 miles (10 000 km) or twice a year, whichever comes first.

The receiver tank incorporates an inlet valve on the inlet side (upper section) which allows the tank to be isolated or serviced. An outlet valve on the outlet side (lower section) permits complete isolation from the rest of the system.

7.6 FILTER DRYER

A filter dryer, also located in the condenser compartment, is installed on the liquid refrigerant line after the receiver tank. It is used to absorb moisture and foreign matter from refrigerant before it reaches the expansion valves.

The filter should be replaced if the system has been opened or after a prolonged exposure, when the moisture indicator sight glass turns to pink.

7.6.1 Replacement

The filter is of the disposable type. When replacement is required, remove and discard the complete unit and replace with a new unit of the same type according to this procedure:

1. Isolate the refrigerant in the receiver tank by following the "Pumping Down" procedure explained in this section



MAINTENANCE

Check refrigerant moisture indicator every 6,250 miles (10 000 km) or twice a year, whichever comes first. Replace filter dryer unit according to moisture indicator

2. Change the filter dryer as a unit.
3. Add a small quantity of refrigerant R-134a to the low side of the system. Check for leaks. Return the system to normal operation.



CAUTION

Do not use carbon tetrachloride or similar solvents to clean parts. Do not use steam guns. Use mineral spirits or naphtha. All parts should be thoroughly cleaned. Use a stiff brush to wash dirt from grooves, holes, etc.



DANGER

Cleaning products are flammable and may explode under certain conditions. Always handle in a well ventilated area.

7.6.2 Moisture Indicator

The moisture sensitive element consists of a color changing ring which is reversible from pink to blue and vice versa as the moisture content in the refrigerant changes. Pink indicates a wet refrigerant, light violet (caution) and blue indicates a dry refrigerant.

Since temperature changes affect the solubility, color change will also vary with the refrigerant temperature. The above table shows the color change for R-134a at various moisture levels and liquid line refrigerant temperatures.

COLOR INDICATOR			
TEMPERATURE	BLUE (ppm)	LIGHT VIOLET (ppm)	PINK (ppm)
75°F (24°C)	Below 5	5-15	Above 15
100°F (38°C)	Below 10	10-30	Above 30
125°F (52°C)	Below 15	15-45	Above 45
p.p.m.= parts per million (moisture content)			

A moisture level of less than 15 p.p.m. for R-134a indicated in the blue color range of the above table is generally considered dry and safe. A color indication of light blue to light violet indicates the caution range of moisture level. For positive protection, the drying of the system should be continued until the color of the element turns to deep blue.

The liquid refrigerant is readily visible through the center opening of the moisture element where the presence of bubbles indicates a shortage of refrigerant or restriction in line.

Moisture is one of the main causes of chemical instability or contamination in air conditioning systems. If moisture is present, it can corrode the valves, condenser and evaporator coils,

Section 22: HEATING AND AIR CONDITIONING

compressor and other components causing a malfunction and eventual failure of the system. Uncontrolled moisture in the system can result in very expensive multiple component replacements if not corrected at an early stage. The moisture indicator permits an early detection of moisture in the system and when corrected by a desiccant charge, system contamination is greatly minimized.

7.7 LIQUID REFRIGERANT SOLENOID VALVE

The flow of liquid refrigerant to the driver's and main evaporators is controlled by a normally-closed solenoid valve. The driver's liquid solenoid valve is located on the ceiling of the spare wheel and tire compartment and is accessible through the reclining bumper.

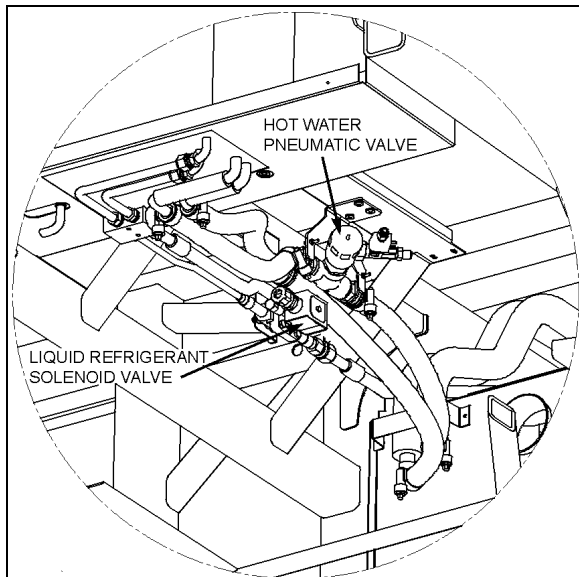

FIGURE 31: DRIVER'S EVAPORATOR LIQUID SOLENOID VALVE

22324

7.7.1 Manual Bypass

This type of solenoid valve is equipped with a manual operating stem. The 3/16" square stem located on the bonnet is exposed when the seal cap is removed. To manually open valve, turn stem 1/2 turn counterclockwise. To manually close valve, turn stem clockwise until tight against seat. Manual stem must be in closed position for automatic electric operation.

7.7.2 Coil Replacement

1. Disconnect connector from the coil connector.

2. Take out the retaining screw at the top of the coil housing. The entire coil assembly can then be lifted off the enclosing tube.
3. Place the new coil and yoke assembly on the enclosing tube. Lay data identification plate in place.
4. Insert the coil retaining screw, rotate housing to proper position and tighten screw securely.
5. Connect connector from coil connector.

7.7.3 Valve Disassembly

1. Remove the coil as stated previously.
2. Pump down the system as stated earlier in this section.
3. Remove the four socket head screws which hold the body and bonnet together (Fig. 32).
4. Carefully lift off the bonnet assembly (upper part of the valve) so that plunger will not fall out. The diaphragm can now be lifted out.

NOTE

The above procedure must be followed before brazing solder-type bodies into the line.



CAUTION

Be careful not to damage the machined faces while the valve is apart.

7.7.4 Valve Reassembly

1. Place the diaphragm in the body with the pilot port extension up.
2. Hold the plunger with the synthetic seat against the pilot port.
3. Make sure the bonnet O-rings are in place. Lower the bonnet assembly over the plunger, making sure that the locating sleeve in the bonnet enters the mating hole in the body.
4. Insert the four socket head screws and tighten evenly.

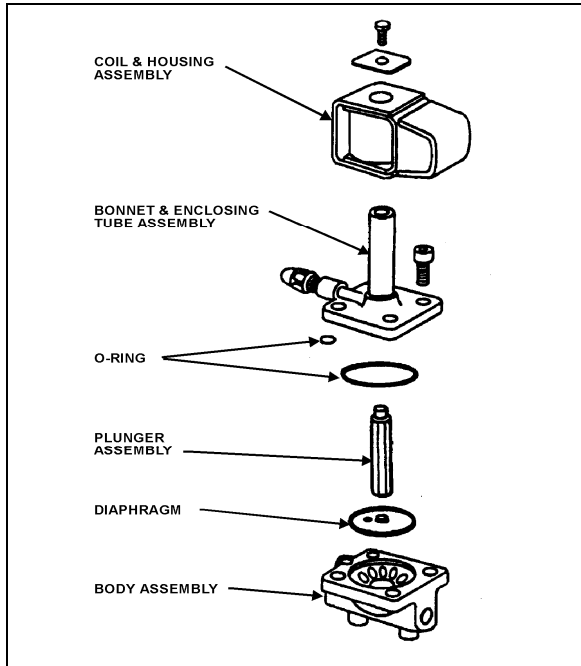

FIGURE 32: REFRIGERANT SOLENOID VALVE 22044

5. Replace the coil as stated previously.
6. Add a small quantity of refrigerant R-134a to the low side of the system. Check for leaks. Return the system to normal operation.

7.8 EXPANSION VALVE

7.8.1 Passenger's Section HVAC Unit

The expansion valve for the passenger's section HVAC unit is a thermo-sensitive valve with a remote control bulb head attached to the evaporator outlet line and is accessible by the evaporator coil access door (Fig. 16 & 33). The valve regulates the flow of refrigerant liquid into the evaporator coils and is controlled by the suction gas temperature leaving the evaporator. The bulb head senses the refrigerant gas temperature as it leaves the evaporator. High temperature will cause expansion and pressure on the power head and spring. Such action causes the assembly valve to open, allowing a flow of refrigerant liquid into the evaporator.

The remote bulb and power assembly is a closed system. The pressure within the remote bulb and power assembly corresponds to the saturation pressure of the refrigerant temperature leaving the evaporator and moves the valve pin in the opening direction. Opposed to this force, on the under side of the diaphragm and acting in the closing direction, is the force exerted by the superheat spring.

As the temperature of the refrigerant gas at the evaporator outlet increases above the saturation temperature corresponding to the evaporator pressure, it becomes superheated. The pressure thus generated in the remote bulb and power assembly surpasses the combined pressures of the evaporator pressure and the superheat spring, causing the valve pin to move in the opening direction. Conversely, as the temperature of the **refrigerant** gas leaving the evaporator decreases, the pressure in the remote bulb and power assembly also decreases and the combined evaporator and spring pressures cause the valve pin to move in the closing position.

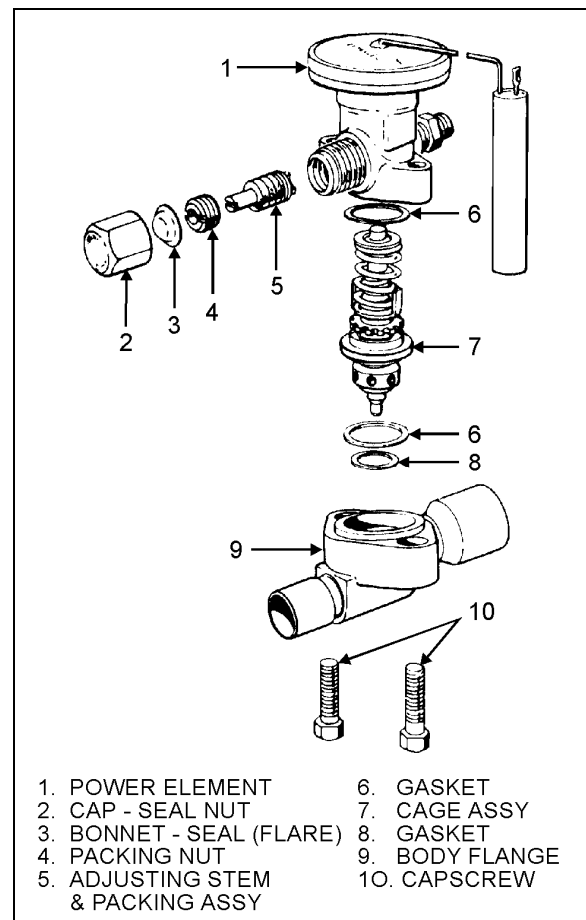

FIGURE 33: EXPANSION VALVE 22045

As the operating superheat is raised, the evaporator capacity decreases, since more of the evaporator surface is required to produce the superheat necessary to open the valve. It is obvious, then, that it is most important to adjust the operating superheat correctly and that a minimum change in superheat to move the valve pin to full open position, is of vital importance

Section 22: HEATING AND AIR CONDITIONING

because it provides savings in both initial evaporator cost of operation.

Accurate and sensitive control of the refrigerant liquid flowing to the evaporator is necessary to provide maximum evaporator capacity under load conditions. The spring is adjusted to give 12 to 16° F (-11.1 to -8.8° C) of superheat at the evaporator outlet.

This ensures that the refrigerant leaving the evaporator is in a completely gaseous state when drawn into the suction side of the compressor. Liquid would damage the compressor valve, piston and heads if allowed to return in the suction line.

A vapor is said to be superheated when its temperature is higher than the saturation temperature corresponding to its pressure. The amount of the superheat is, of course, the temperature increase above the saturation temperature at the existing pressure.

As the refrigerant moves along in the evaporator, the liquid boils off into a vapor and the amount of liquid decreases until all the liquid has evaporated due to the absorption of a quantity of heat from the surrounding atmosphere equal to the latent heat of vaporization of the refrigerant. The gas continues along in the evaporator and remains at the same pressure. However, its temperature increases due to the continued absorption of heat from the surrounding atmosphere. The degree to which the gas refrigerant is superheated is related to the amount of refrigerant being fed to the evaporator and the load to which the evaporator is exposed.

Superheat Adjustment

The starting method of adjusting the superheat is to unscrew completely the main evaporator expansion valve adjusting screw, then screw in 13 turns clockwise for 134A (Fig. 34).

Afterwards, the following procedure should be followed:

1. Operate coach for at least one-half hour at fast idle with temperature control set at 82°F (27,7°C), Then set temperature to minimum to keep the compressor on 6 cylinders.
2. Install pressure gauge at the evaporator suction header. You may install the pressure gauge at compressor suction, but then add 3 PSI to reading.

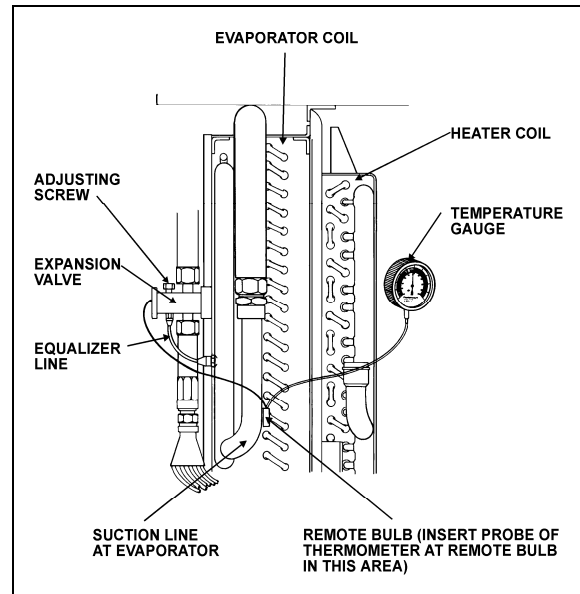

FIGURE 34: SUPERHEAT ADJUSTMENT INSTALLATION²²⁰⁴⁶

3. Install a remote reading thermometer to the evaporator outlet line near the existing remote bulb (Fig. 34).
4. Apply thermostatic tape around the bulb and evaporator outlet line to get a true reading of the line temperature.
5. Block condenser if necessary to keep pressure over 150 psi.

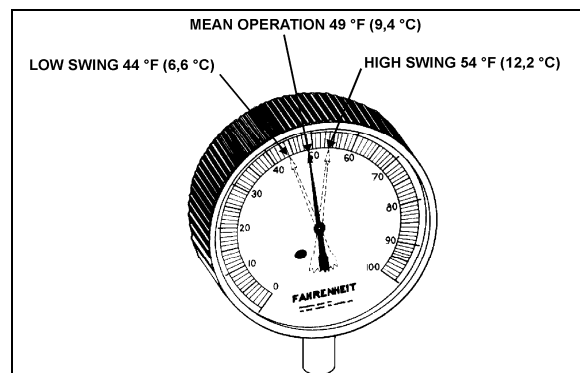

FIGURE 35: HIGH & LOW SWING TEMPERATURE AT REMOTE BULB²²⁰⁴⁷

6. Check approximately 5 readings of pressure at 2-minute intervals and convert to temperature using the temperatures & pressures table (page 35). Likewise check the temperature reading at the remote bulb at the same 2-minute intervals and record the low and high swing readings of the needle (refer to Fig. 35).

Example of readings taken at fig. 35:

A/C pressure gauge converted to temperature at expansion valve fitting	Temperature on remote bulb	
40°F (4,4°C)	Low-swing 44°F (6,6°C)	High swing 54°F (12,2°C)
Formula for superheat 49°F-40°F=9°F (9,4°C-4,4°C = 5°C)	Average of low and high swing is 49°F (9,4°C)	

NOTE

The low swing of the superheat should be a minimum of 4°F (2,2°C) higher at the remote bulb and have an average of 8 to 12°F (4 to 6°C) higher range at the bulb than the fitting at the expansion valve.

NOTE

To reduce the superheat, flow of refrigerant is increased by turning adjusting screw of expansion valve lower evaporator temperature counterclockwise. To increase temperature or increase superheat, flow of refrigerant is reduced by turning adjustment screw of expansion valve clockwise.

6. Regulate suction pressure to temperature reading according to temperature chart or to the R-134a temperature scale on the pressure gauge.

Example: Suction pressure 30 psi (207 kPa) converted to 32°F (0°C) on chart. If temperature reading is 40°F (4,4°C), subtract 32°F (0°C) and the result will be 8°F (4,4°C) of superheat.



CAUTION

Before proceeding to the expansion valve adjustment, check for restriction on suction side for plugged filter dryer and partially open valves. These conditions will give a high superheat.

Maintenance

1. Pump down the system as previously indicated in this section.

2. Disconnect the external equalizer line from the under side of the power head, and unclamp the remote control bulb from the evaporator coil outlet line.
3. Remove the two cap screws holding the power assembly to the valve body flange. Lift off the power assembly and remove the cage assembly.
4. When reassembling, replace with the new gaskets in proper location. Make sure the two lugs on the cage assembly fit into grooves provided in the power assembly. Do not force the valves together. The cage must fit properly before tightening the body flange. Tighten bolts evenly.
5. Check for leaks.

Safety Instructions

1. Make sure the valve is installed with the flow arrow on the valve body corresponding to the flow direction through the piping system.
2. Before opening any system, make sure the pressure in the system is brought to and remains at the atmospheric pressure. Failure to comply may result in system damage and/or personal injury.

7.8.2 Driver's HVAC Unit

The function and operation of the expansion valve for the driver's HVAC unit are similar to the passenger's HVAC unit but no superheat adjustment is required (see figures 19 and 33).

7.9 TORCH BRAZING

Use electrode containing 35% silver.



CAUTION

When using heat near a valve, wrap with water saturated rag to prevent overheating of vital parts.



DANGER

Before welding any part of refrigeration system, make sure the area is well ventilated.

Section 22: HEATING AND AIR CONDITIONING

7.10 TROUBLESHOOTING

7.10.1 Expansion Valve

PROBABLE CAUSE	PROBABLE REMEDY
LOW SUCTION PRESSURE-HIGH SUPERHEAT	
EXPANSION VALVE LIMITING FLOW:	
Gas in liquid line due to pressure drop in the line or insufficient refrigerant charge.	Locate cause of line flash and correct by use of any of the following methods. Add R-134a. Replace or clean filter dryer.
Inlet pressure too low from excessive low condensing temperature. Resulting pressure difference across valve too small.	Increase head pressure. Verify pressure switch for fan speed control.
Superheat adjustment too high.	Adjust superheat as outlined under "Superheat Adjustment".
Power assembly failure or partial loss of charge.	Replace power assembly or replace valve.
Air filter screen clogged.	Clean or replace air filter.
Plugged lines.	Clean, repair or replace lines.
LOW SUCTION PRESSURE-LOW SUPERHEAT	
Uneven or inadequate evaporator loading due to poor air distribution or liquid flow.	Balance evaporator load distribution by providing correct air or liquid distribution.
HIGH SUCTION PRESSURE-HIGH SUPERHEAT	
Compressor discharge valve leaking.	Replace or repair valve.
HIGH SUCTION PRESSURE-LOW SUPERHEAT (DEFECTIVE UNLOADER)	
Valve superheat setting too low.	Adjust superheat as outlined under "Superheat Adjustment".
Compressor discharge valves leaking.	Replace or repair discharge valve.
Incorrect superheat adjustment.	Superheat adjustment 12 to 16°F.
FLUCTUATING DISCHARGE PRESSURE	
Insufficient charge.	Add R-134a to system.
HIGH DISCHARGE PRESSURE	
Air or non-condensable gases in condenser.	Purge and recharge system.
Overcharge or refrigerant.	Bleed to proper charge.
Condenser dirty.	Clean condenser.

7.10.2 A/C

TROUBLE	CAUSE
Low suction pressure and frosting at dryer outlet.	Clogged filter.
Low Oil Level.	Check for oil leaks and for leaking oil seal. Do not attempt to check oil level unless system has been stabilized at least 20 minutes. See oil level verification.
Excessively cold suction line.	Loss of contact between the expansion valve bulb and the suction line or sticking of the expansion valve. Check for foreign matter and clean, repair or replace the valve.
Excessively cold suction line and noisy compressor.	Check superheat adjustment. Check remote bulb contact. Check expansion valve for sticking.
Compressor squeaks or squeals when running.	Check oil level. Replace oil seal.
Noisy or knocking compressor.	Check for broken internal parts. Overhaul if required.
Compressor vibrates.	Check and tighten compressor mounting bolts and belt tension.
Low refrigerant level	Check for refrigerant leaks and add refrigerant if required.
Suction pressure rises faster than 5 pounds per minute after shutdown.	Check compressor valve for breakage or damage.
Insufficient cooling.	Check for refrigerant leaks. Check condition of air filter and motors.
Insufficient air flow.	Dirty or iced evaporator. Dirty air filter. Blowers inactive. Clogged ducts.
No flow of refrigerant through expansion valve.	Filter dryer is clogged. Remote bulb has lost charge or expansion valve is defective.
Expansion valve hisses. Bubbles in moisture and liquid indicator.	Gas in liquid line. Add refrigerant.
Loss of capacity	Clogged filter. Obstructed or defective expansion valve.
Superheat too high.	Reset superheat adjustment. Check for clogged external equalizer line, or filter dryer.
Reduced air flow: a. Dirty or clogged air filter; b. Evaporator motor inoperative; or c. Plugged return air ducts.	Dirty or iced evaporator coil. Clean or replace air filter. Check return ducts for obstructions. Check blower motor.
Frequent starting and stopping on low pressure control switch.	Lack of refrigerant. Check for leaks. Recharge.
Compressor intermittently starts and stops.	Intermittent contact in electrical control circuit. Compressor valves not in operating position.
Non-condensable in the refrigeration system.	Leak on system, system in vacuum in low temp. Specific symptom, pressure in system will not correspond to ambient temperature on shutdown. Only non-condensable will cause this. (Example: Pressure of idle R-134a system in 80°F (26.6°C) room should be 86.4 psi (595.7 kPa). See temperature chart in this section.)

Section 22: HEATING AND AIR CONDITIONING

TROUBLE	CAUSE
	<p>An evaporator just does a proper cooling job without sufficient air. Shortage of air can be caused by the following:</p> <ul style="list-style-type: none"> * Dirty filters; or * Dirty coils.
<p>Testing condenser pressure.</p> <p><i>NOTE: R-134A pressure is function of the temperature variation.</i></p> <p>Example, for an exterior temperature of 100°F. Exterior temperature (100°F) + 30°F = 130°F. Refer to paragraph "10.11 Temperature & Pressure". Note the corresponding pressure for a temperature of 130°F, 199.8 psi. Read the condenser pressure, example 171.9 psi. 171.9 psi & 199.8 psi, the pressure in the condenser is inferior to the pressure corresponding to the exterior temperature, in this case the condenser pressure may be too low. Check for refrigerant leaks and add refrigerant if necessary. If the pressure corresponding to the condenser temperature is superior to the pressure corresponding to the exterior temperature, then the air cooled condenser pressure may be too high. Most frequent causes are:</p> <p>Reduced air quantity. This may be due to:</p> <ul style="list-style-type: none"> * Non-condensable in system; * Dirt on the coil; * Restricted air inlet or outlet; * Dirty fan blades; * Incorrect rotation of fan; * Fan speed too low; * Fan motor going out on overload; or * Prevailing winds. * Too much refrigerant in system. Remove refrigerant if necessary. 	

7.11 TEMPERATURES & PRESSURES

VAPOR-PRESSURE			
TEMPERATURE		PRESSURE	
°F	°C	psi	kPa
-100	-73.3	27.8	191.7
-90	-67.8	26.9	185.5
-80	-62.2	25.6	176.5
-70	-56.7	23.8	164.1
-60	-51.1	21.5	148.2
-50	-45.6	18.5	127.6
-40	-40.0	14.7	101.4
-30	-34.4	9.8	67.6
-20	-29	3.8	26.2
-10	-23	1.8	12.4
0	-18	6.3	43.4
10	-12	11.6	80
20	-7	18.0	124.1
30	-1	25.6	176.5
40	4	34.5	237.9
50	10	44.9	309.6
60	16	56.9	392.3
70	21.1	70.7	487.5
80	27	86.4	595.7
90	32.2	104.2	718.5
100	38	124.3	857.0
110	43.3	146.8	1012.2
120	49	171.9	1185.3
130	54.4	199.8	1377.6
140	60	230.5	1589.3
150	65.6	264.4	1823.0
160	71	301.5	2078.8
170	76.7	342.0	2358.1
180	82.2	385.9	2660.8

Section 22: HEATING AND AIR CONDITIONING

VAPOR-PRESSURE			
TEMPERATURE		PRESSURE	
°F	°C	psi	kPa
190	87.8	433.6	2989.7
200	93.3	485.0	3344.1
210	98.9	540.3	3725.4

7.12 LEAK TESTING

Some methods such as nitrogen pressure, soap and electronic sniffer can be used for leak testing. However, the most common method used is a "Halide" torch consisting of an acetylene tank, a burner and a suction test hose. Proceed as follows:



The flow of acetylene to the burner causes suction in the test line. Any gas refrigerant present will be drawn through the hose and into the burner where it decomposes into free acids.

These acids come in contact with the hot copper reaction plate in the burner, causing color reaction in the flame. A small concentration is indicated by a green tint and a large concentration by an intense blue. Do not confuse this change in color with the change caused by shutting off the air supply through the hose by holding the end too close to an object.

The procedure for testing is:

1. Adjust flame so that the top of the cone is approximately level or within one-half inch above the plate.
2. Probe end of suction test tube around all joints, valves, etc. When a leak has been found at a soldered joint, this section of the system must be pumped down. Do not solder as pressure will force hot solder out. If the system is empty, it is more economical to put in just enough R-134a to produce about 15 psi (103 kPa). The pressure can be raised to about 150 psi (1034 kPa) with dry nitrogen.

NOTE

This gas is put into the suction and discharge shutoff valves at the compressor. The receiver valves must be opened. If no leaks are found, dump this mixture, evacuate the system and fill with refrigerant.

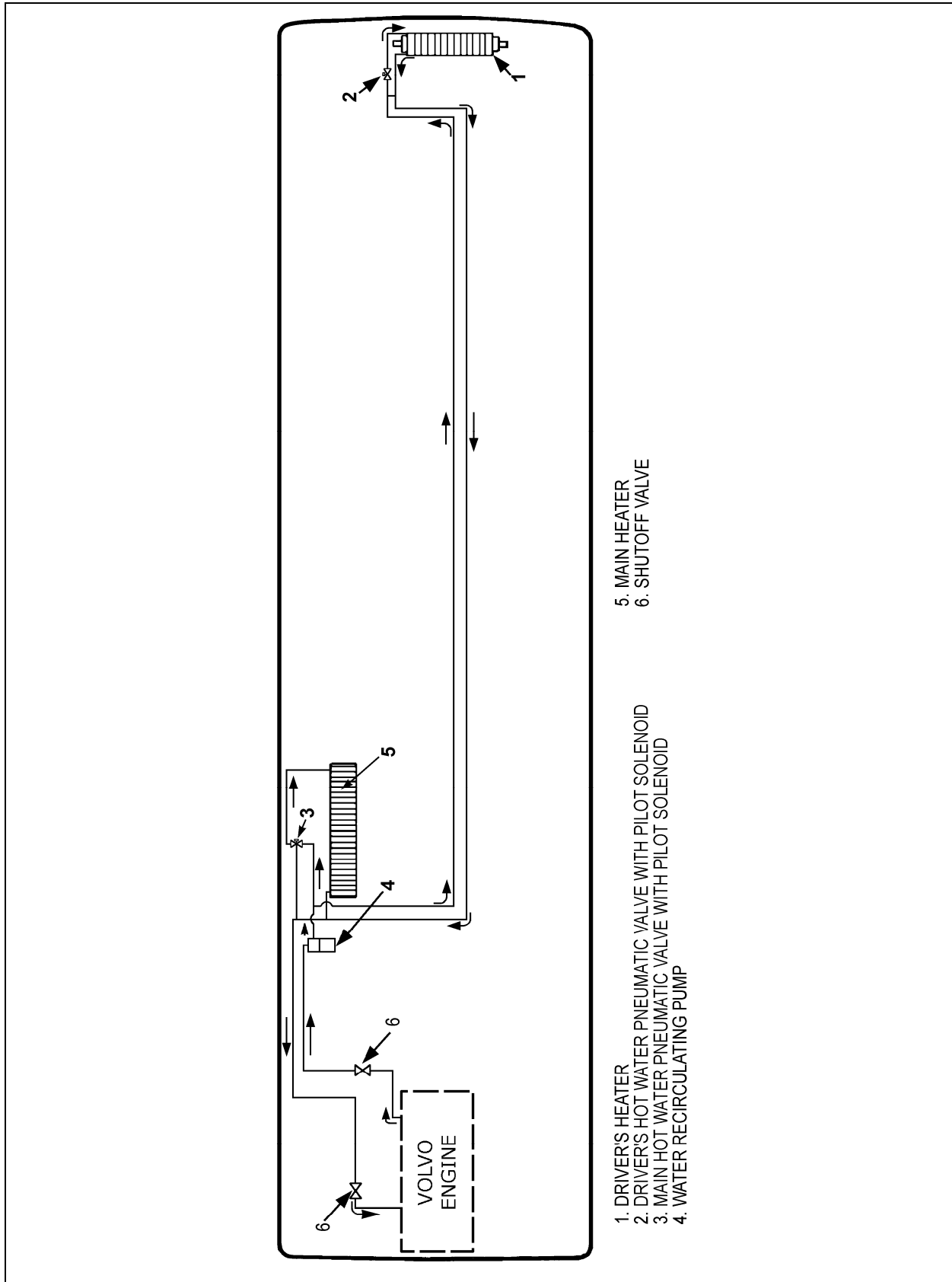

FIGURE 36: CENTRAL HEATING SYSTEM COMPONENTS

Section 22: HEATING AND AIR CONDITIONING

8. CENTRAL HEATING SYSTEM

As seen earlier in this section, the vehicle interior is pressurized by its Heating, Ventilation and Air Conditioning (HVAC) system. The vehicle interior should always be slightly pressurized to prevent cold and moisture from entering. Air flow and controls divide the vehicle into two areas: driver's area and passenger's area.

The schematic of figure 36 shows the central heating system with its components.

8.1 DRAINING HEATING SYSTEM

To drain the entire system, refer to Section 05, "Cooling". If only the driver's or main heater core must be drained, refer to the following instructions.

- **Draining Driver's Heater Core**

1. Stop engine and allow engine coolant to cool.
2. Locate the normally open water pneumatic valve on the ceiling of the spare wheel compartment (Fig. 37), move the pilot-solenoid valve red tab to close the valve.

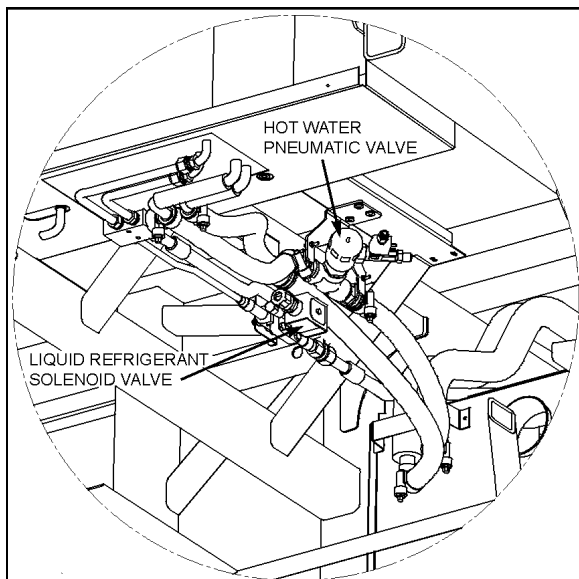

FIGURE 37: CEILING OF THE SPARE WHEEL COMPARTMENT



WARNING

Before proceeding with the following steps, check that coolant has cooled down.

3. Loosen hose clamp, install an appropriate container to recover coolant, and disconnect silicone hose from water solenoid valve.
4. From inside of vehicle, remove the two finishing panels in front of unit. Remove the three screws fixing the unit front panel. Open the manual vent located inside the HVAC unit, on the driver's side (Fig. 38) to ensure an efficient draining.

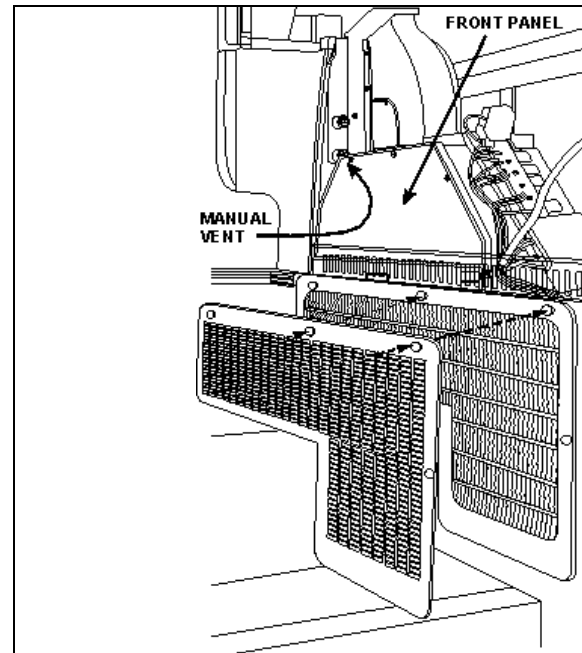

FIGURE 38: DRIVER'S HVAC UNIT

- **Draining Main Heater Core**

1. Stop engine and allow engine coolant to cool.
2. Close both heater line shutoff valves.

On X Series vehicles, the valves are located in the engine compartment. One is on the L.H. side of compartment in front of the radiator and the other valve is located under the radiator fan gearbox (Fig. 39).

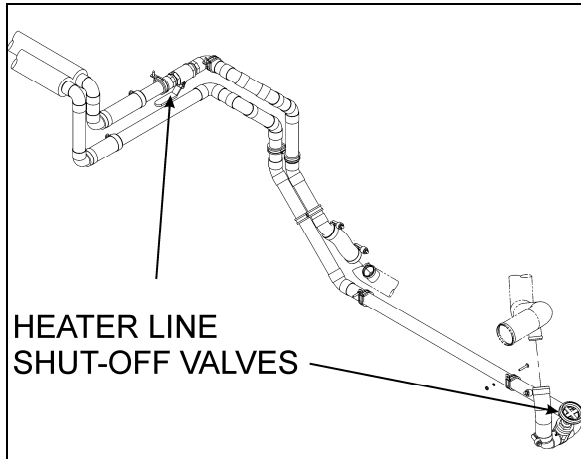

FIGURE 39: HEATER LINE SHUT-OFF VALVES

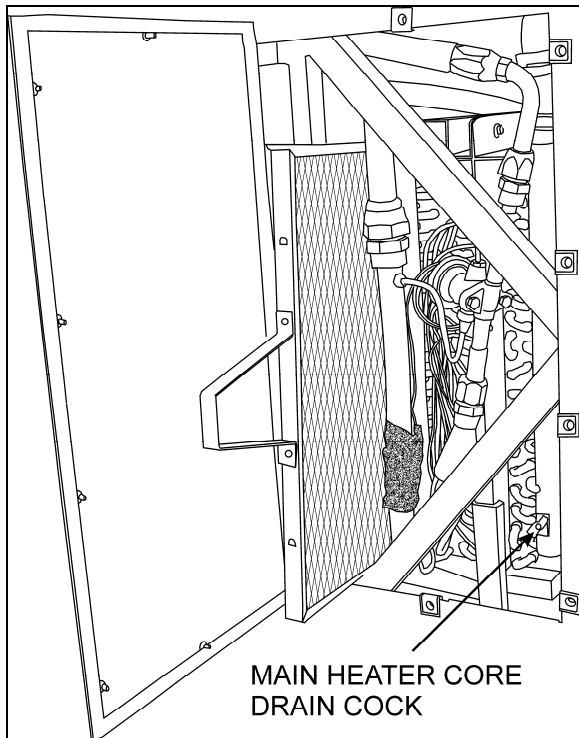

FIGURE 40: EVAPORATOR COMPARTMENT

3. The main heater core drain cock is located in the evaporator compartment. To access the valve on X3-45 coaches, open baggage compartment door located in front of the evaporator compartment (L.H. side). Open access panel by turning the three screws of panel ¼ of a turn.



WARNING

Before proceeding with the following steps, check that coolant has cooled down.

4. Open drain cock in bottom of heater core, you can unfasten a hose connection on top of heater core (Fig.40) in order to allow air to enter while draining.

8.2 FILLING HEATING SYSTEM

1. Ensure that the drain hose is reconnected and the manual vent and drain cock are closed.
2. Open the surge tank filler cap and slowly fill the system to level of filler neck.
3. After initial filling, the water shut-off valves should be open and the water recirculating pump should be energized to assist in circulating coolant through the heating system. To perform this operation, start the engine, switch on the HVAC control unit, both driver and passengers' sections, and set temperature to the maximum position in order to request the heating mode in each of these sections.
4. When coolant level drops below the surge tank filler neck, slowly fill the system to level of filler neck.
5. Once the level has been stabilized, replace cap.

8.3 BLEEDING HEATING SYSTEM

Whenever the heating system has been drained and refilled, or the system has run low on coolant and coolant has been added, it is necessary to bleed air from heating system. Locate the manual vent illustrated in Figure 38, and open momentarily until no air escapes from the line.

8.4 SOLDERING

Before soldering any part of the system, make sure the area is well ventilated. Use (stay clean) flux sparingly and apply solder (95-5 round wire 1/8 inch). After completing repairs, test for leaks.

When using heat at or near a valve, wrap with water saturated rag to prevent overheating of vital parts.

Section 22: HEATING AND AIR CONDITIONING

8.5 DRIVER'S HOT WATER PNEUMATIC VALVE ASSEMBLY

• Description

The flow of hot water to the driver's heater core is controlled by a pneumatic NO water valve assembly. The valve, located at the ceiling of the spare wheel compartment, is designed so that the pilot solenoid valve, which is part of the assembly, opens and closes a port which directs air pressure to the actuator casing, thereby opening or closing the valve.

When the vehicle is operating with no current to the pilot solenoid valve, no air pressure is admitted to the actuator casing, the cylinder spring pushes up against the cylinder, thereby keeping the water valve open.

The driver's heater water valve requires a minimum amount of maintenance. The valve should be free of dirt sediment that might interfere with its operation. No other maintenance is needed unless a malfunction occurs.

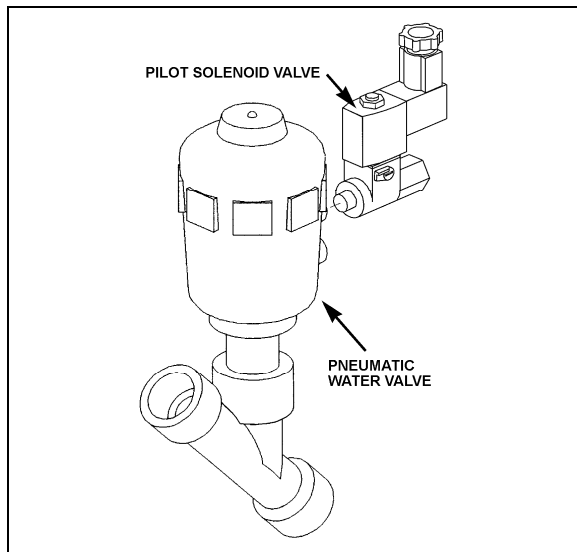

FIGURE 41: DRIVER'S HOT WATER PNEUMATIC VALVE ASSEMBLY

• Pneumatic Water Valve Disassembly

1. Shut off air supply pressure and electrical current to the pilot solenoid valve. Disconnect wires.
2. The water valve need not be removed from the line. Unscrew nipple, the actuator casing, tube, spindle and closure member can be removed (Fig. 42).
3. Remove the snap ring using a pair of pliers.

4. You can now access all seals for replacement

Pneumatic water valve replacement seal kits:

- * Water Side: 871311
- * Actuator Side: 871312

• Pneumatic Water Valve Reassembly

1. Assemble the actuator casing, tube, nipple, spindle and closure member.
2. Tighten the nipple in place in the body cavity as per figure 42. Fasten pilot solenoid valve to the pneumatic water valve. Reconnect air supply pressure and electrical current to the pilot solenoid valve.
3. Check for proper operation.

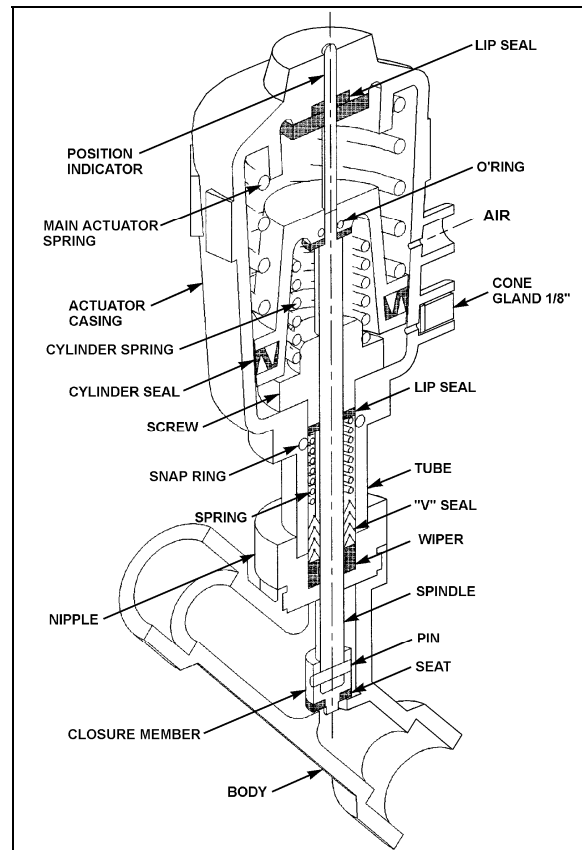

FIGURE 42: PNEUMATIC WATER VALVE

• Pilot Solenoid Valve

1. No maintenance is needed unless a malfunction occurs.
2. A pilot solenoid valve replacement seal kit is available: 871313.

• **Valve Troubleshooting**

PROBLEM	PROCEDURE
Valve fails to close	<ol style="list-style-type: none"> 1. Check electrical supply with a voltmeter. It should agree with nameplate rating. 2. Check pressure at pilot solenoid valve inlet. It must be at least equal to the minimum pressure stamped on the nameplate. It should not go below minimum while valve is operating.
	<ol style="list-style-type: none"> 1. Check that the closure member assembly, and that main actuator and cylinder springs are free to travel. 2. Check that there is no restriction to the air escaping from the actuator casing. 3. Make sure that pilot solenoid valve operates properly.

8.6 CENTRAL HOT WATER PNEUMATIC VALVE ASSEMBLY

• **Description**

The flow of hot water to the vehicle's central heater core is controlled by a 3-way pneumatic water valve assembly. The valve, located in the evaporator compartment, is designed so that the pilot solenoid valve, which is part of the assembly, opens and closes a port which directs air pressure to the actuator casing, thereby allowing the hot water to enter the main heater core or bypassing it.

When the vehicle is operating with no current to the pilot solenoid valve, no air pressure is admitted to the actuator casing, the cylinder spring pushes up against the cylinder, thereby allowing the hot water to enter the main heater core.

The central heater water valve requires a minimum amount of maintenance. The valve should be free of dirt sediment that might interfere with its operation. No other maintenance is needed unless a malfunction occurs.

• **Pneumatic Water Valve Disassembly**

1. Shut off air supply pressure and electrical current to the pilot solenoid valve. Disconnect wires.
2. The water valve need not be removed from the line. Unscrew nipple, the actuator casing, tube, spindle and closure member can be removed (Fig. 44).
3. Remove the snap ring using a pair of pliers.

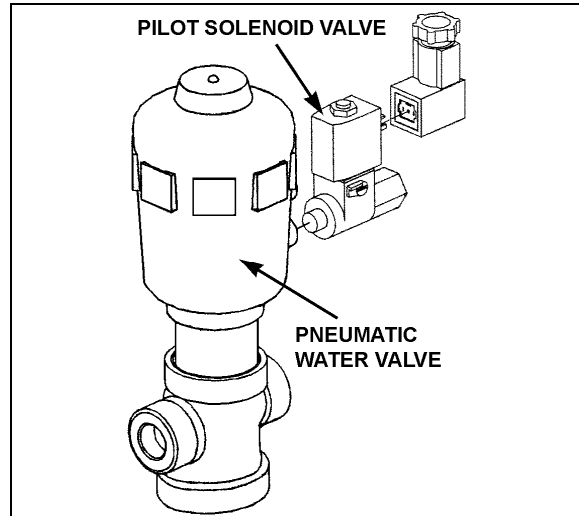

FIGURE 43: CENTRAL HOT WATER PNEUMATIC VALVE ASSEMBLY 22329

4. You can now access all seals for replacement

Pneumatic water valve replacement seal kits:

- * Water Side: 871389
- * Actuator Side: 871388

• **Pneumatic Water Valve Reassembly**

1. Assemble the actuator casing, tube, nipple, spindle and closure member.
2. Tighten the nipple in place in the body cavity as per figure 44. Fasten pilot solenoid valve to the pneumatic water valve. Reconnect air supply pressure and electrical current to the pilot solenoid valve.
3. Check for proper operation.

• **Pilot Solenoid Valve**

1. No maintenance is needed unless a malfunction occurs.

Section 22: HEATING AND AIR CONDITIONING

- A pilot solenoid valve replacement seal kit is available: 871390.

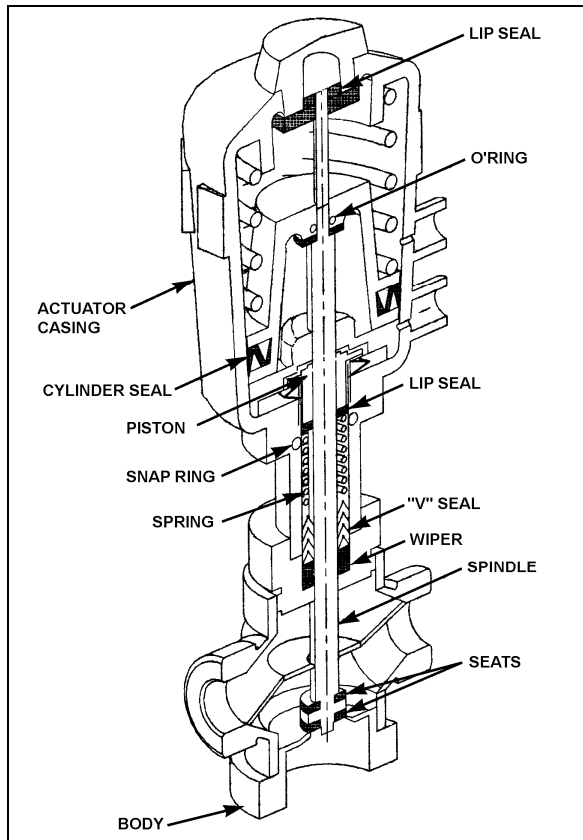

FIGURE 44: PNEUMATIC WATER VALVE 22330

• Valve Troubleshooting

PROBLEM	PROCEDURE
Valve fails to close	<ol style="list-style-type: none"> 1. Check electrical supply with a voltmeter. It should agree with nameplate rating. 2. Check pressure at pilot solenoid valve inlet. It must be at least equal to the minimum pressure stamped on the nameplate. It should not go below minimum while valve is operating.
Valve fails to open.	<ol style="list-style-type: none"> 1. Check that the closure member assembly, and that main actuator and cylinder springs are free to travel. 2. Check that there is no restriction to the air escaping from the actuator casing. 3. Make sure that pilot solenoid valve operates properly.

8.7 WATER RECIRCULATING PUMP

This vehicle is provided with a Rotron® brushless DC sealess water circulation pump which is located in the engine coolant heater compartment (Fig. 45). The assembly consists of a centrifugal pump and an electric motor which are mounted in a compact assembly.

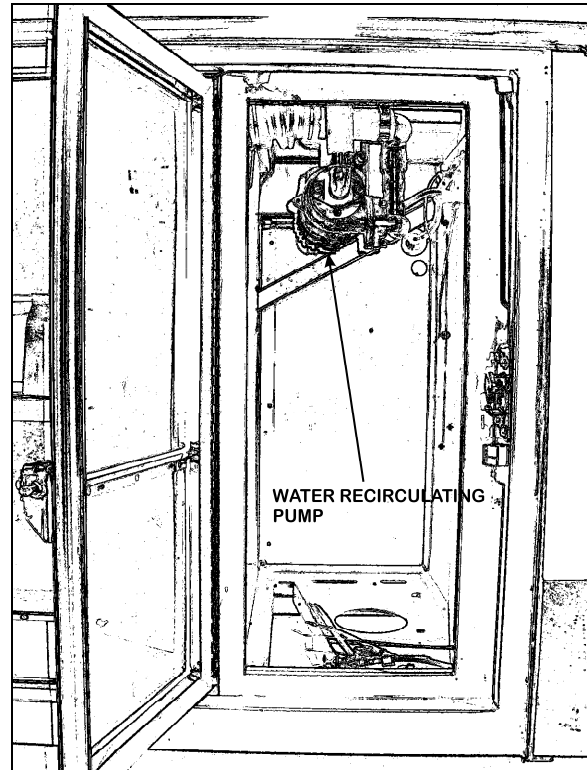

FIGURE 45: PUMP LOCATION (CENTRAL A/C) 22331

The brushless DC sealess pump requires no periodic maintenance. The sealess design offers leak-proof protection and the capability to resist harsh environmental conditions. The pump magnetically couples to the brushless DC motor without a wet seal to wear or replace, this coupling method also enables easy motor removal without requiring system draining. The pump electronically commutated brushless DC motor provides virtually maintenance-free operation over time by eliminating brush maintenance and associated brush motor failure.

Disassembly of the pump will be necessary only in the case of a rotor failure or motor failure.

• Removal

1. Stop engine and allow engine coolant time to cool.

2. Close shutoff valves. Refer to "05 COOLING" under heading "*Draining Cooling System*" for location of valves.
3. Disconnect the electrical wiring from the motor.



WARNING

Before proceeding with the following steps, check that coolant has cooled down.

4. Disconnect water lines from pump at flange connections. Place a container to recover the residual coolant in the line.
5. Remove the two clamps holding the pump motor to its mounting bracket. Remove the pump with the motor as an assembly.

• **Installation**

1. Apply gasket cement to the line flanges, put the two gaskets in place, and connect water lines to the pump at the flange connections. Position the pump and motor assembly on the mounting bracket. Position the mounting clamps over the motor and secure with mounting bolts.
2. Connect electrical wiring to the pump motor.
3. Open shutoff valve. Refer to "05 COOLING" under heading "*Draining Cooling System*" for location of valves.
4. Fill the cooling system as previously instructed in this section under "*8.2 Filling Heating System*", then bleed the system as previously instructed in this section under "*8.3 Bleeding Heating System*".

Section 22: HEATING AND AIR CONDITIONING

9. SPECIFICATIONS

Main evaporator motor

Type BRUSHLESS DC MICROPROCESSOR CONTROLLED
Voltage 27.6 V DC
Current draw 68 amps
Horsepower 2
Revolution 1400 & 1700 rpm
Insulation Class F
Motor Prevost number 563586

Condenser fan motors

Type AXIAL BRUSHLESS
Voltage 24 V DC
Qty 4
Prevost number 563461

Evaporator air filter (Central system)

Type Polypropylene
Prevost number 874272

Driver's unit evaporator motors

Voltage 24 V DC
Quantity 1
Prevost number 871135

Driver's unit evaporator air filters

TYPE Recirculating air 6-1/4" x 28" Washable
Prevost number 871147

TYPE Fresh air 3-5/8" X 5-1/4" Washable
Prevost number 871144

Refrigerant

Type R-134a
Quantity (standard) 24 lbs (10.89 Kg)

Compressor (Central system)

Capacity, option R-134a 41 CFM
Model, option R-134 05G-134A
No. of cylinders 6
Bore 2" (50,8 mm)
Operating speed 400 to 2200 rpm (1750 rpm. Nominal)

Section 22: HEATING AND AIR CONDITIONING

Minimum speed (for lubrication).....	400 rpm
Nominal horsepower	15
Oil pressure at 1750 rpm	15 to 30 psi (103-207 kPa)
Oil capacity.....	1.13 U.S. gal (4,3 liters)
Weight	142 lbs (64,5 kg)
Approved oil - Castrol.....	SW 68 (POE)
Prevost number, option R-134a	950314

Compressor unloader valve

Type	Electric (AMC)
Voltage	24 V DC
Watts	15
Prevost number (without coil)	950095
Coil Prevost number.....	950096

Magnetic clutch

Type	Housing mounted 9" dia., 2-B grooves
Voltage	24 V DC
Coil resistance at 68 °F (20 °C).....	5.15 – 5.69 ohms
Prevost number	950204

Compressor V belt (Carrier)

Model.....	BX100
Prevost number (with two BOSH Alternators)	506864

Condenser coil (Central system)

Make.....	Carrier Transicold
<u>Copper</u>	
Prevost number	870729

Evaporator coil (Central system)

Prevost number	871070
----------------------	--------

Receiver tank (with sight glasses)

Maximum pressure.....	450 psig
Prevost number	950261

Moisture indicator

Prevost number	950029
----------------------	--------

Driver's refrigerant liquid solenoid valve

Type	Normally closed with manual bypass
------------	------------------------------------

Section 22: HEATING AND AIR CONDITIONING

Voltage	24 V DC
Amperage draw	0.67 amps
Watts	16
Prevost number (without coil)	95-0054
Coil Prevost number	950055
Repair kit Prevost number	950056

Hot water pneumatic valve (Central system)

Type	3-WAY
Voltage	24 V DC
Prevost number	871381
Seal kit, Water Side	871389
Seal kit, Actuator Side	871388
Seal kit, Pilot Solenoid Valve	871390

Driver's hot water pneumatic valve

Type	Normally open
Voltage	24 V DC
Prevost number	871252
Seal kit, Water Side	871311
Seal kit, Actuator Side	871312
Seal kit, Pilot Solenoid Valve	871313

Water recirculating pump

Voltage	24 V DC
Prevost number	871327

Driver's expansion valve

Prevost number, option R-134a	950221
Prevost number, option R-22	950282

Expansion valve (Central system)

Prevost number	950320
----------------------	--------

SECTION 23: ACCESSORIES

CONTENTS

1. HUBODOMETER	2
1.1 DESCRIPTION.....	2
1.2 OPERATION	2
1.3 REMOVAL	2
1.4 INSTALLATION	2
2. HORN INSTALLATION	2
2.1 ELECTRIC HORN MAINTENANCE.....	2
3. WINDSHIELD WIPERS AND WASHERS	2
3.1 GENERAL DESCRIPTION	2
3.2 WIPER ARM.....	3
3.2.1 <i>Wiper Arms Positioning</i>	3
3.3 WINDSHIELD WIPER MOTOR	4
3.3.1 <i>Windshield Wiper Motor Replacement</i>	4
3.4 TROUBLESHOOTING	5
4. AUTOMATIC FIRE SUPPRESSION SYSTEM (AFSS)	6
4.1 PERIODIC MAINTENANCE	6
5. SPECIFICATIONS	8

ILLUSTRATIONS

FIGURE 1: HUBODOMETER	2
FIGURE 2: ELECTRIC HORN INSTALLATION	2
FIGURE 3: R.H. DASHBOARD PANEL	3
FIGURE 4: WINDSHIELD WASHER - WIPERS CONTROL.....	3
FIGURE 5: WINDSHIELD WASHER RESERVOIR	3
FIGURE 6: WINDSHIELD WIPER INSTALLATION	3
FIGURE 7: WINDSHIELD WIPER (MOTOR SIDE).....	4
FIGURE 8: WINDSHIELD WIPER (DRIVER SIDE).....	4
FIGURE 9: DRIVING MECHANISM (DRIVER SIDE).....	4
FIGURE 10: DRIVING MECHANISM (MOTOR SIDE)	4
FIGURE 11: WIPER ARMS POSITIONING	5
FIGURE 12: FIRE EXTINGUISHER INSTALLATION.....	7
FIGURE 13: NOZZLE BRACKETS IDENTIFICATION AND INSTALLATION.....	7

1. HUBODOMETER

1.1 DESCRIPTION

A wheel hubodometer (Fig. 1) has been installed on the R.H. side of the drive axle. It indicates the total distance in miles covered by the coach since it has left the factory, including road testing.

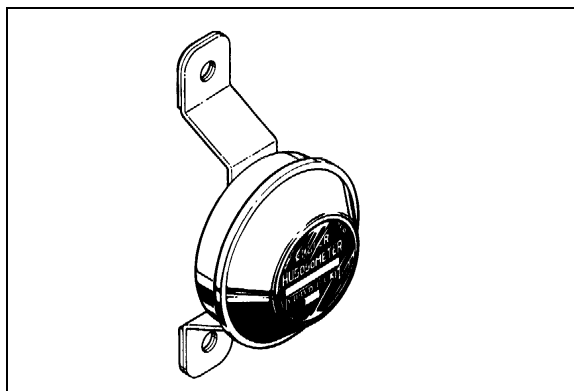

FIGURE 1: HUBODOMETER

23024

1.2 OPERATION

The hubodometer is calibrated for a specific wheel size (diameter). Wheel rotation causes a mechanism inside the hubodometer to record distance after a predetermined number of rotations. The unit should be serviced at a competent speedometer repair facility.

NOTE

Do not use paint, solvent or thinner on hubodometer face or on plastic hubcaps. Do not weld on hubodometer.

1.3 REMOVAL

To remove the unit, remove the two lock nuts and washers securing it to the wheel hub, and pull the unit off the studs.

1.4 INSTALLATION

Place the hubodometer unit over the wheel hub studs. Replace the lock washers and nuts. Torque stud nuts to 110-165 Lbf-ft.(150-225 Nm).

2. HORN INSTALLATION

The electric horn is located in a plastic box under the front stepwell and is accessible from the front body understructure. Refer to Operator's Manual for operation.

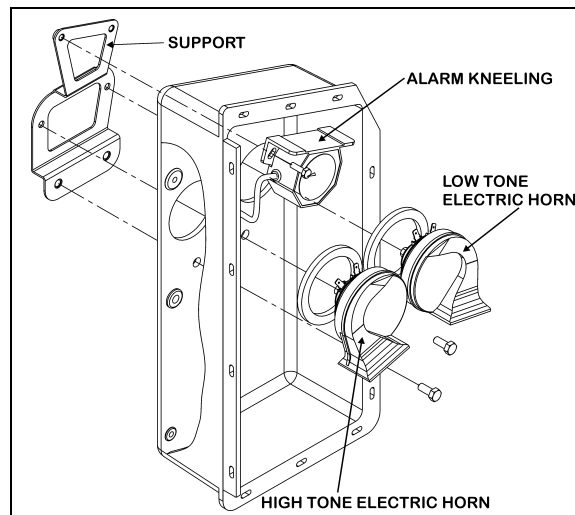

FIGURE 2: ELECTRIC HORN INSTALLATION

23420

2.1 ELECTRIC HORN MAINTENANCE

When needed, the electric horn can be serviced or replaced using the following procedure:

1. Raise vehicle by the jacking points;
2. Unplug the cable connector;
3. Loosen the retaining bolts;
4. Service or replace the defective horn;
5. Reinstall by reversing procedure.

3. WINDSHIELD WIPERS AND WASHERS

3.1 GENERAL DESCRIPTION

NOTE

When installing a wiper motor, arm or blade, follow recommended procedures to prevent misalignment, binding or malfunction. Check the windshield washer liquid hoses, fittings and connectors to be sure they are properly connected and seal with no restriction to the flow of washer liquid. Check that wiper arms have the proper sweep position and the washer nozzles are aimed so that spray is within the proper wiper pattern.

The windshield wipers are controlled by one electric wiper motor that is accessible for maintenance after removing the appropriate access panel beside the footwell (refer to figure 5).

The wiper/washer control button is located on the R.H. dashboard panel. Push the button to activate the windshield washer. Turn the button to activate the wipers. The first position activates

the wipers intermittently. The second position is the slow speed and the third position is for high speed wiping.

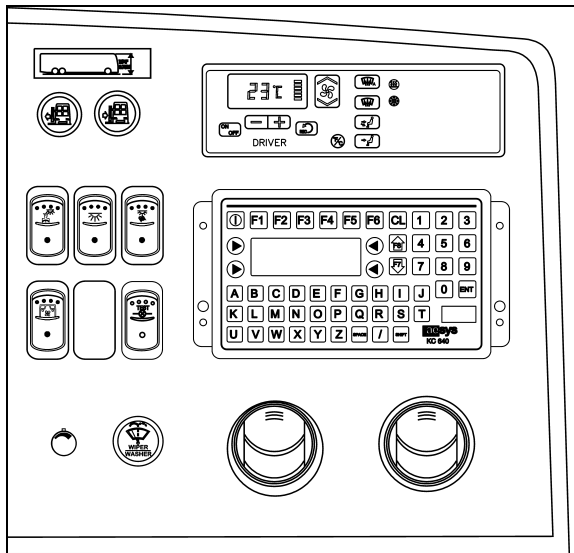

FIGURE 3: R.H. DASHBOARD PANEL



FIGURE 4: WINDSHIELD WASHER - WIPERS CONTROL²³¹³³

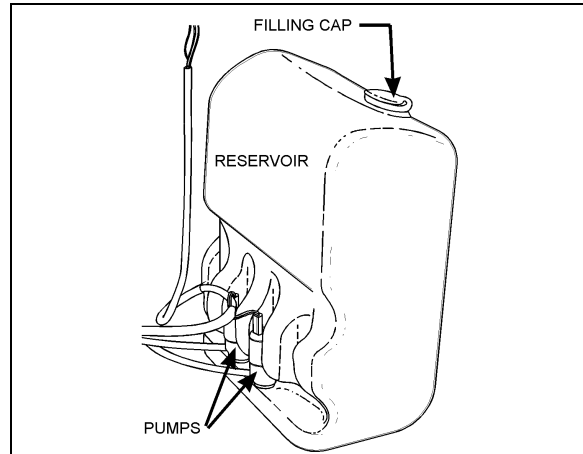

FIGURE 5: WINDSHIELD WASHER RESERVOIR ²³²²⁰

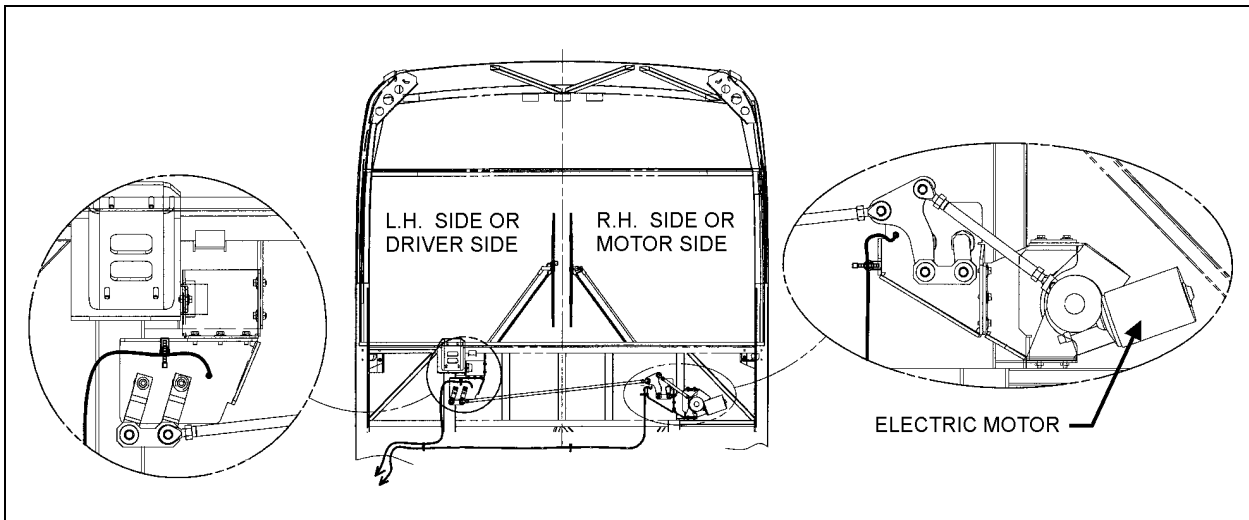

FIGURE 6: WINDSHIELD WIPER INSTALLATION

23287

The windshield washer reservoir is located in the front service compartment (Fig. 5). This unit pumps the washer liquid to the spray nozzles where it is dispersed across the windshield.

3.2 WIPER ARM

Check operation of the wipers for proper blade sweep and angle.

3.2.1 Wiper Arms Positioning

1. Reinstall the wiper arms and position as shown in figure 11. Before positioning the wipers at their final position, tighten the nuts to 9 Ft-lbs (12 Nm) at first.
2. To find the final position of the wiper arms, lift then release the wiper arm so it falls back on the windshield.



CAUTION

Do not attempt to manually move the wiper arms to make wiper blade sweep adjustments as damage to the wiper linkage or motor may occur. If it is necessary to adjust the sweep of blades, remove the arms and make adjustment by positioning the arms using serration on the wiper arm pivot shafts.

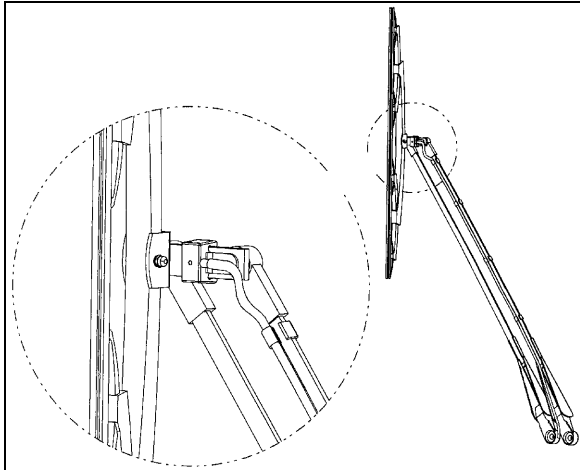

FIGURE 7: WINDSHIELD WIPER (MOTOR SIDE) 23329

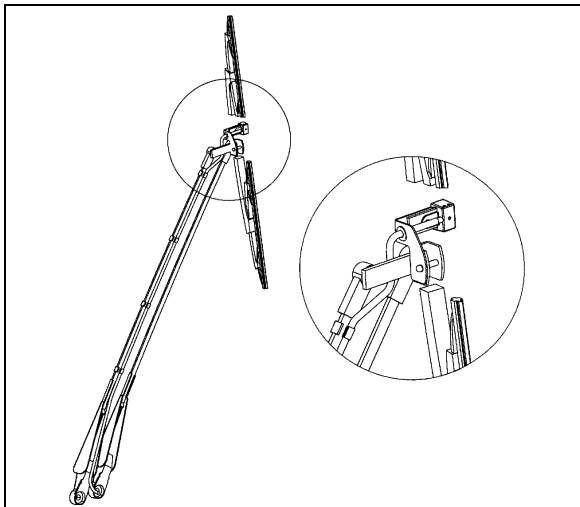

FIGURE 8: WINDSHIELD WIPER (DRIVER SIDE) 23328

3. When the final position is found, tighten the wiper arm nuts to 22 Ft-lbs (30 Nm). Wait 30 minutes and tighten again to 22 Ft-lbs.
4. Lower the protective cover.
5. Connect the windshield washer tubing at the base of the wiper arm.
6. Check the adjustment on a wet windshield.

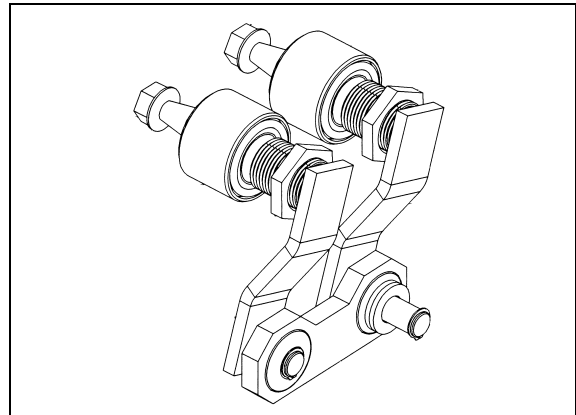

FIGURE 9: DRIVING MECHANISM (DRIVER SIDE) 23284

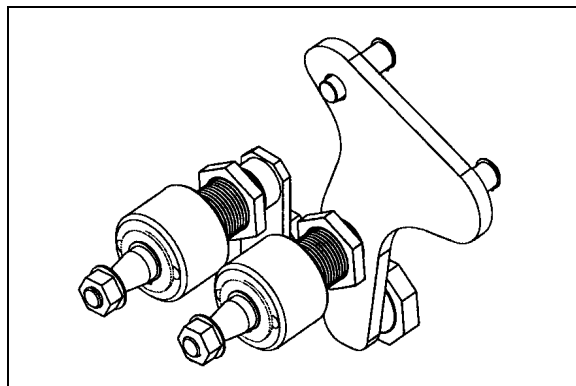

FIGURE 10: DRIVING MECHANISM (MOTOR SIDE) 23285

3.3 WINDSHIELD WIPER MOTOR

3.3.1 Windshield Wiper Motor Replacement

The windshield wiper motor is located at lower front of the vehicle, behind the defroster panel. Refer to figure 6 for motor location.



WARNING

Park vehicle safely, apply parking brake, stop engine and set battery master switch to the "OFF" position prior to working on the vehicle.

1. Remove the Phillips-head screws retaining the defroster panels, and remove panels.
2. Disconnect wiring connector from the windshield wiper motor.
3. Loosen clamping screw retaining the lever at the end of the motor driving shaft.
4. Remove the three bolts holding the motor to the steel plate.
5. Remove the windshield wiper motor (Prevost #800328), reverse removal procedure to reinstall.

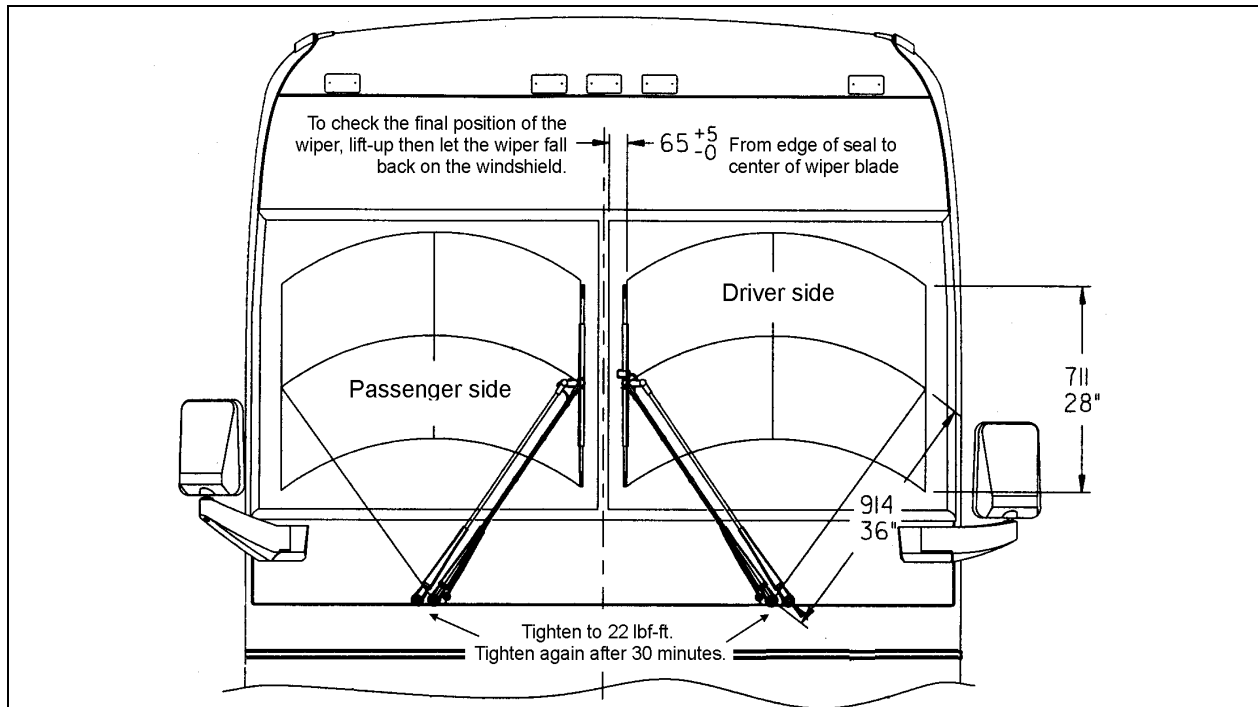

FIGURE 11: WIPER ARMS POSITIONING

23253

3.4 TROUBLESHOOTING

SYMPTOM	PROBABLE CAUSE	REMEDY
FAIL TO SPRAY WASHER FLUID	<ul style="list-style-type: none"> A. Reservoir empty. B. If below 32°F (0°C), improper washer fluid frozen. C. Contamination in tubing or nozzles. D. Tubing damage. E. Tubing bent (kinked) or off one or more connections. 	<ul style="list-style-type: none"> A. Add proper fluid. B. Store coach or parts in heated area, then purge system with low-temperature solution. C. Remove with compressed air, if severely clogged, replace items. D. Replace section. E. Realign tubing and/or refit. Trim end to ensure proper fit or replace.
INADEQUATE SPRAYING	<ul style="list-style-type: none"> A. Tubing failure. 	<ul style="list-style-type: none"> A. Replace tubing.
SLOW OPERATION	<ul style="list-style-type: none"> A. Improper solution. B. Jet stream improperly directed. C. Check if valve is stuck in the open position. 	<ul style="list-style-type: none"> A. Replace with proper type solution. B. Reposition nozzles. C. Remove, clean or replace.

4. AUTOMATIC FIRE SUPPRESSION SYSTEM (AFSS)

This system is used to shut down the engine and to extinguish a fire in the engine.

The system operation is fully automatic and does not require assistance from the operator, however if required, the system can be manually activated by the operator at any time.

Refer to Prevost Operator's Manual for system operation and operational sequence (fire).

If more information is needed on the system, please refer to Kidde Dual Spectrum "Operation & Maintenance Manual annexed at the end of this section.

4.1 PERIODIC MAINTENANCE

PRE-TRIP

- Verify that the Protection Panel "SYSTEM OK" lamp is on solid green.

EVERY 3000 MILES OR MONTHLY (whichever comes first)

General

- Verify that neither the protected equipment nor the hazard has changed.
- Verify that no obvious physical damage or condition exists that might prevent system operation.

Protection Panel

- Verify that all warning lamps and the audible alarm are operational by pressing the "TEST/RESET" button.

Manual Activation Switch

- Verify that the tamper seal is intact and access to the switch is unobstructed.

Fire Detectors

- Optical
 - Verify that the status lamp on the detector face is on solid green.
 - Verify that nothing is blocking the detector's field of view.
 - Verify that the windows on the face of the detector are free of excess contamination (dirt, oil, grease, etc.) – if necessary, clean using a water soaked non-abrasive towel.
- Linear Thermal
 - Verify that there is no obvious physical damage and that the unit is free of excess contamination (dirt, oil, grease, etc) – if necessary, clean using a water soaked non-abrasive towel.
 - Verify that mounting is secure and taught.

Electrical Harness

- Verify that electrical connectors and electrical wiring have no visible damage and all connectors are securely seated.

Extinguisher & Distribution System

- Verify that that the extinguisher pressure gauge pointer is in the green arc at room temperature.
- Verify that distribution piping and nozzles are intact and unobstructed and that nozzle blow-off caps are in place.

EVERY 18000 MILES OR SEMI-ANNUALLY (whichever comes first)

- Perform a comprehensive fire system test using a Kidde Dual Spectrum System Test Set (Optical Test Kit P/N 420871-2).
- Service the extinguisher in accordance with KDS Document 160296, "KDS Pre-Engineered Fire Suppression System: Installation, Operation and Maintenance Manual".

EVERY SIX YEARS

- Have the fire extinguisher rebuilt by a qualified fire protection equipment company familiar with Kidde Dual Spectrum equipment and in accordance with KDS Document 160296, "KDS Pre-Engineered Fire Suppression System: Installation, Operation and Maintenance Manual". Rebuilt shall include actuator, o-ring seals and dry chemical replacement.

EVERY TWELVE YEARS

- Have the Extinguisher cylinder hydrostatically tested by a qualified fire protection equipment company familiar with Kidde Dual Spectrum equipment and in accordance with KDS Document 160296, "KDS Pre-Engineered Fire Suppression System: Installation, Operation and Maintenance Manual".

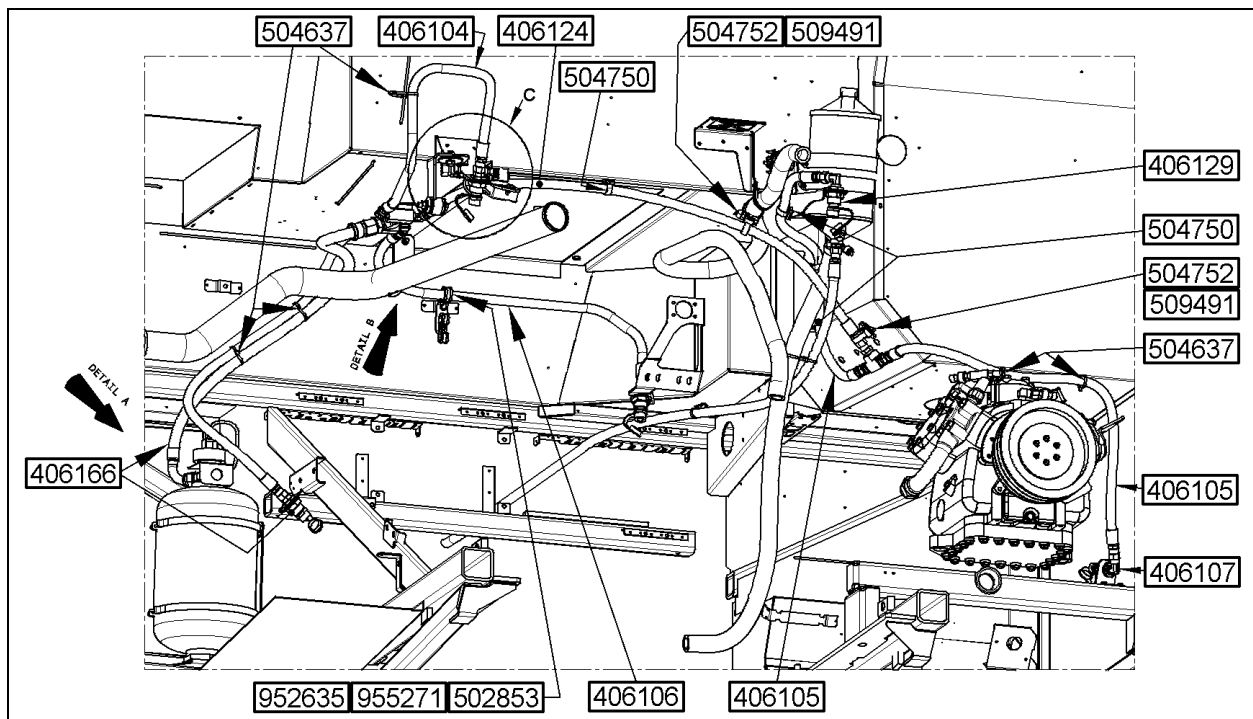

FIGURE 12: FIRE EXTINGUISHER INSTALLATION

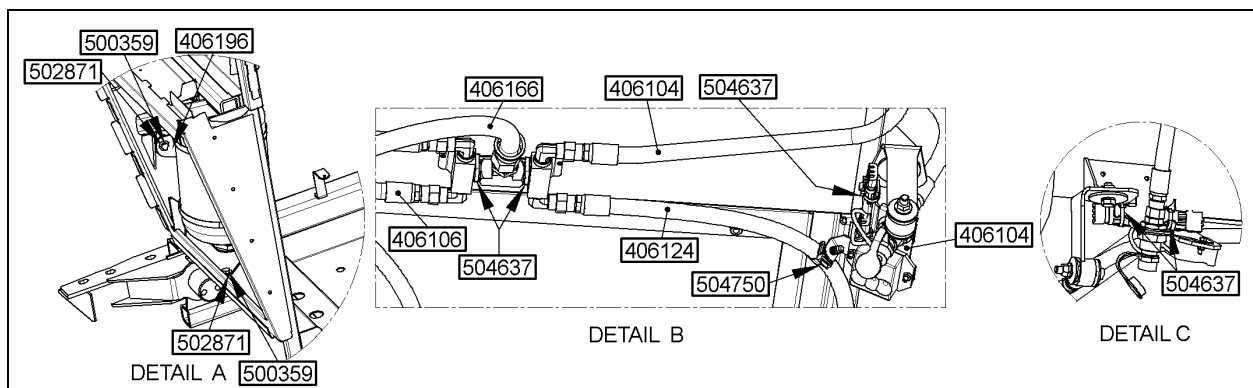

FIGURE 13: NOZZLE BRACKETS IDENTIFICATION AND INSTALLATION

5. SPECIFICATIONS

HUBODOMETER (US model: miles)

Prevost number 650002

ELECTRIC HORN (HIGH)

Prevost number 563023

ELECTRIC HORN (LOW)

Prevost number 563015

WINDSHIELD WIPER MOTOR

Prevost number 800328

WIPER (BLADE)

Prevost number 800329

WIPER ARM

Prevost number 800331

SECTION 24: LUBRICATION

CONTENTS

1. LUBRICATION	2
2. LUBRICATION AND SERVICE SCHEDULE	2
2.1 FLEXIBLE HOSE MAINTENANCE	2
2.1.1 <i>Hose Inspection</i>	2
2.1.2 <i>Leaks</i>	2
2.1.3 <i>Service life</i>	2
2.2 LUBRICANT AND COOLANT SPECIFICATIONS	5
2.3 LUBRICATION AND SERVICING SCHEDULE	6

ILLUSTRATIONS

FIGURE 1: LUBRICATION AND SERVICING POINTS ON I-BEAM AXLE FRONT SUSPENSION VEHICLES.....	4
--	---

Section 24: LUBRICATION

1. LUBRICATION

The efficiency and life expectancy of mechanical equipment is largely dependent on proper lubrication and servicing. All mechanical components rely on a lubricating film between moving parts to reduce friction, prevent wear and oxidation. Proper lubrication also helps cool the parts and keep dirt particles away from mating surfaces. Efficient lubrication depends upon using the right type of lubricant, at specified intervals and by filling to correct capacities. Past experience shows that many service problems can be traced to an improper lubricant or to incorrect lubrication procedures.

A comprehensive maintenance and lubrication program is important to ensure the long service life this vehicle was designed for and to avoid costly repairs and associated downtime caused by premature part failure.

A lubrication schedule is included in this section to give the location of key service points on the vehicle as well as the lubricant specifications for each component to be serviced. Specific instructions on how to check and service different components are covered in their respective sections in this maintenance manual.

The recommended lubrication intervals are based on normal operating conditions and mileage accumulation.

Shorten the intervals if your vehicle operates in more severe conditions. Severe conditions include heavy towing, high vehicle weight or operation in mountainous areas. Some parts and equipment referred to in this section may not be installed on your vehicle. Check your vehicle's "Coach Final Record" for equipment list.

Dispose of used lubricants and filters in an environmentally safe manner, according to federal and/or local recommendations.

2. LUBRICATION AND SERVICE SCHEDULE

Following this service schedule is the most economical and easiest way to ensure your vehicle performs at its best, safest and longest. Also, unscheduled maintenance will be minimized since inspection should expose potential problems before they become major ones.

2.1 FLEXIBLE HOSE MAINTENANCE

The performance of engine and equipment are greatly related to the ability of flexible hoses to supply lubricating oil, air, coolant, and fuel oil. Maintenance of hoses is an important step to ensure efficient, economical, and safe operation of the engine and related equipment.

2.1.1 Hose Inspection

Check hoses daily as part of the pre-starting inspection. Examine hose for leaks, and check all fittings, clamps, and ties carefully. Ensure that hoses are not resting on or touching shafts, couplings, heated surfaces including exhaust manifolds, any sharp edges, or other obviously damaging areas. Since all machinery vibrates and moves to a certain extent, clamps and ties can fatigue with time. To ensure proper support, inspect fasteners frequently and tighten or replace them as necessary.

2.1.2 Leaks

Investigate leaks immediately to determine if fittings have loosened or cracked, and also if hoses have ruptured or worn through. Take corrective action immediately. Leaks are not only potentially detrimental to machine operation, but can also result in added expenses caused by the need to replace lost fluids.

 WARNING
Personal injury and/or property damage may result from fire due to the leakage of flammable fluids, such as fuel or lube oil.

2.1.3 Service life

The limited service life of a hose is determined by the temperature and pressure of the gas or fluid within it, the time in service, its installation, the ambient temperatures, amount of flexing, and the vibration it is subjected to. With this in mind, it is recommended that all hoses be thoroughly inspected at least every 500 operating hours or after 15,000 miles (24 000 km). Look for surface damage or indications of damaged, twisted, worn, crimped, brittle, cracked, or leaking lines. Hoses having a worn outer surface or hoses with a damaged metal reinforcement should be considered unfit for further service.

It is also recommended that all hoses in this vehicle be replaced during major overhaul and/or after a maximum of five service years. Quality of replacement hose assemblies should always be equal to or superior to those supplied by the Original Equipment Manufacturer.

Section 24: LUBRICATION

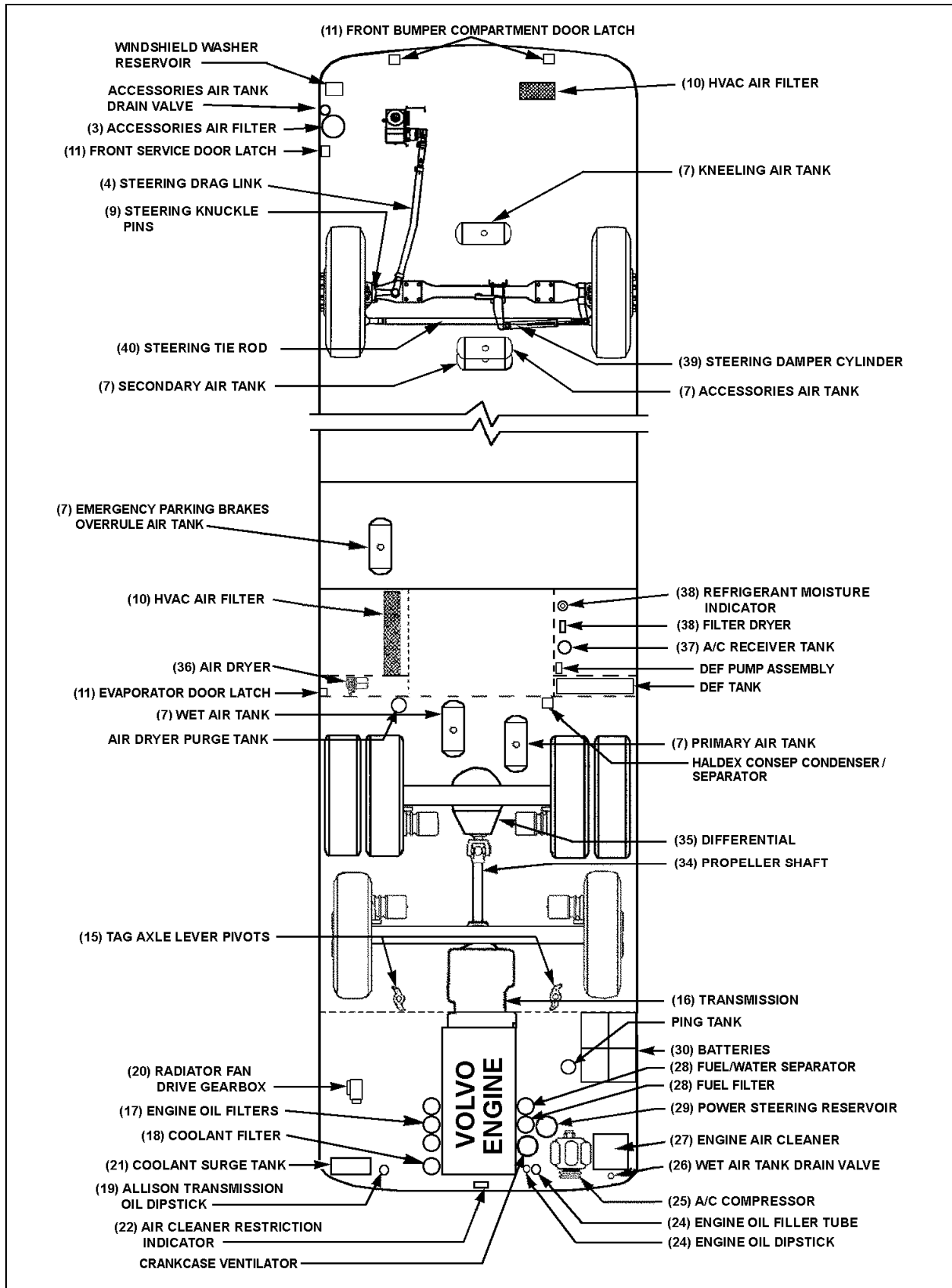

FIGURE 1: LUBRICATION AND SERVICING POINTS ON I-BEAM AXLE FRONT SUSPENSION VEHICLES

24030_1

2.2 LUBRICANT AND COOLANT SPECIFICATIONS

REF	DESCRIPTION	SPECIFICATIONS
A	Engine Oil	VOLVO D13 Total Rubia TIR 10W-30 FE for best fuel economy. SAE Viscosity Grade 5W-30 & 15W-40 oils, meeting Volvo specification VDS-4 and CJ4, are also approved
B	Power Steering Oil	Automatic Transmission Oil, Dexron-III, VI or Exxon Mobil ATF SHC
C	Engine Coolant	VOLVO D13 Fleet Charge Fully Formulated Antifreeze 50% antifreeze/water solution is normally used
D	A/C Compressor Oil	Central HVAC system: Polyolester oil, HFC 134a compatible; Castrol SW-68 (POE) or equivalent
E	Differential Oil	Multigrade gear oil meeting MIL-L-2105-E: 85W140. If temperature drops below 10°F (-12°C), 80W90 should be used. Below -15°F (-26°C), 75W90 should be used. (In extreme conditions or for better performance, full synthetic gear oil can be used.)
F	Differential Oil (Full Synthetic)	Multigrade gear oil meeting MIL-L-2105-E: 85W140. If temperature drops below 10°F (-12°C), 80W90 should be used. Below -15°F (-26°C), 75W90 should be used.
G	Radiator Fan Gearbox Synthetic Oil (Approved by Linnig)	Agip Rota HY DB Synth 75W90 - BP Energear MTB 75W90 Castrol Syntrans-AT 75W90 - Deagear Synth 75W90 Fuchs Titan Cytrac MB Synth 75W90 - Mobiltrans MTB 75W90 OMV gear oil MPX 75W90 - Panolin Super Duty Synth MB 75W90 Shell Transmission MA 75W90 - Total Transmission XI 75W90
H	Allison Automatic Transmission Oil	Castrol TranSynd™ Synthetic Transmission Fluid for Allison or TES 295 approved equivalent
I	Allison Automatic Transmission Oil	Dexron-VI® or approved equivalent 1 Schedule 1 TES-389 fluids;
K	Multi Purpose Grease	Good quality lithium-base grease: NLGI No.2 Grade is suitable for most temperatures NLGI No.1 Grade is suitable for extremely low temperatures

Section 24: LUBRICATION

2.3 LUBRICATION AND SERVICING SCHEDULE

For lubrication and servicing schedule, refer to table A.

IMPORTANT NOTE

Refer to the manufacturers documentation included in this maintenance manual for specific manufacturer's maintenance requirements.

LUBRICATION AND SERVICING SCHEDULE NYCT X3-45 Commuter DOB 2400-2489		Proceed to maintenance operation every (miles)										
		Item	6 000	12 000	18 000	24 000	30 000	50 000	100 000	150 000	200 000	250 000
GENERAL												
1	Flexible hoses - thoroughly inspect all hoses						●					
01 ENGINE												
1	Engine oil & filter - heavy operation condition, change	17	●									A
2	Drive belts and idlers – visually inspect for signs of deterioration, cracks or frayed material		●									
3	Drive belts - change						●					
4	Air cleaner - replace filter element when indicated by restriction indicator or according to this interval whichever comes first	27						●				
5	Valves & injectors - initial adjust							●				
6	Valves & injectors - check & adjust									●		
7	Automatic belt tensioners & idler pulleys inspection – Remove belts, check for noisy bearings, play, bushing play. Perform “AUTOMATIC BELT TENSIONER AND IDLER PULLEYS INSPECTION” procedure						●					
03 FUEL												
1	Primary & secondary fuel filters - change at every engine oil change	28	●									
04 EXHAUST AND AFTERTREATMENT SYSTEM												
1	DEF tank - drain & clean with water, clean filler neck strainer						●					
2	DPF filter - either clean or replace at 66 000 miles ¹											
3	DEF pump filter element – first change at 100 000 miles then according to chart								●			
4	Diffuser assembly, rain cap & drain tube – check proper functioning, clean				●							
05 COOLING												
1	Coolant surge tank - test coolant solution	21	●									
2	Coolant filter - change (Fleet Charge Fully Formulated Coolant)	18	●									
3	Radiator fan gearbox - check oil level	20	●									G
4	Radiator - inspect exterior core & clean with low pressure water jet if necessary						●					
5	Radiator fan gearbox - change oil	20						●				G
6	Cooling system - drain, flush & refill (Fleet Charge 50/50 Fully Formulated Coolant)	21						●				C
06 ELECTRICAL												
1	HD10 Bosch alternators drive belt - replace						●					
2	HD10 Bosch alternators brushes - check & replace brushes if necessary						●					
3	Battery terminals - clean & coat terminals	30					●					
07 TRANSMISSION ²												
1	Filled with TES389 approved fluid - change transmission fluid, Main & Lube filter	16	●									I
2	Severe vocation filled with TranSynd or TES295 synthetic fluid only, no mixture³ & using High-Capacity filters⁴ . Transmission fluid - change every 84 000 miles	16										H
3	Severe vocation filled with TranSynd or TES295 synthetic fluid only, no mixture	16										H

¹ Based on 71347mi on average before 4500hrs at Yukon depot and 55782mi on average before 4500hrs at Ulmer depot. Median value=63565mi, increased to 66000mi to fit with 6000mi interval based schedule.

² Allison Transmission recommends that customers use fluid analysis as the primary method for determining fluid change intervals. In the absence of a fluid analysis program, the fluid change interval listed in the chart above should be used. Change filters according to the Table 1 & Table 2 even if a fluid analysis shows that the fluid doesn't need to be changed.

³ When the transmission contains a mixture of fluids (defined as the quantity of non-TranSynd or non-TES 295 fluid remaining in the transmission after a fluid change combined with the quantity of TranSynd or TES295 required to fill the transmission to the proper level), perform the fluid & filter change according to the TES389 intervals.

⁴ Extended TranSynd or TES 295 fluid & filter change intervals are only allowed with Allison High-Capacity filters.

LUBRICATION AND SERVICING SCHEDULE

NYCT X3-45 Commuter DOB 2400-2489

Proceed to maintenance operation every (miles)

Item	6 000	12 000	18 000	24 000	30 000	50 000	100 000	150 000	200 000	250 000	Lubricant
& using High-Capacity filters. Transmission Main & Lube filters – change every 42 000 miles											
09 PROPELLER SHAFT											
1 Perform Spicer's Driveshaft Assembly Inspection Procedures	34	●									
2 Grease one fitting on each universal joint	34			●							K
10 FRONT AXLE											
1 Steering knuckle (king) pins - grease two fittings per knuckle	9	●									K
2 Steering knuckle (king) pins - inspect	9				●						K
11 REAR AXLES											
1 Drive axle - check oil level, add if necessary	35	●									
2 Tag axle lever pivot - grease one fitting on each pivot	15	●									K
3 Drive axle - change oil, clean breathers	35			●							E
4 Drive axle - change oil, clean breathers (with full synthetic oil)	35						●				F
12 BRAKE & AIR											
1 Brakes – check caliper running clearance at brake pad replacements											
2 Brake – check pad wear indicator. Visually check condition of the slack adjuster cap & guide pin covers		●									
3 Air tanks - drain water from all tanks	7		●								
4 Haldex Consep Condenser/Separator - inspect			●								
5 Brakes – check caliper movement along guide pins, check sealing elements (boots). Check proper functioning of the adjuster			●								
6 Accessories air filter - change filter element	3						●				
7 Air dryer - change cartridge	36						●				
13 WHEELS, HUBS & TIRES											
1 Hub bearing - inspect					●						
14 STEERING											
1 Steering tie rod ends - clean & grease one fitting at each end	40	●									K
2 Drag link ends - clean & grease one fitting at each end	4	●									K
3 Steering damper cylinder - grease one fitting at rod end	39	●									K
4 Drag link end & tie rod end ball joints - inspect for corrosion		●									
5 Power steering reservoir filter cartridge - replace	29						●				
6 Power steering fluid - replace	29							●			B
16 SUSPENSION											
1 Air bellows - inspect		●									
18 BODY											
1 Front bumper, front service compartment & evaporator compartment door latch, grease fitting							●				K
22 HEATING & AIR CONDITIONING											
1 Passengers HVAC unit return air filters (2) - clean	10	●									
2 Evaporator compartment door fresh air intake filter - clean		●									
3 Parcel rack fans air filter – clean		●									
4 Driver HVAC unit return & fresh air filters – clean	10	●									
5 A/C compressor - check oil level, add if necessary	25	●									D
6 A/C receiver tank - check refrigerant level, add if necessary	37		●								
7 Refrigerant moisture indicator - check, replace filter dryer unit according to moisture indicator	38						●				
8 Passengers & Driver HVAC units - clean heater core with low pressure water hose							●				
9 Passengers HVAC unit - clean evaporator core with low pressure water hose							●				

LUBRICATION AND SERVICING SCHEDULE

NYCT X3-45 Commuter DOB 2400-2489

Proceed to maintenance operation every (miles)

Item	6 000	12 000	18 000	24 000	30 000	50 000	100 000	150 000	200 000	250 000	Lubricant
10 Passengers HVAC unit – clean condenser core with low pressure water hose							●				

CHANGE LOG - LUBRICATION AND SERVICING SCHEDULE

	DATE
1 In table heading, "ODOMETER READING IN MILE" removed	09/22/2014
2 UPDATED: 01 ENGINE – Drive belts & idlers visual inspection was 12 000mi, changed to 6 000mi. Automatic belt tensioners & idlers bearing play etc. was 12 000mi, changed to 50 000mi	09/22/2014
3 UPDATED: 01 ENGINE –Automatic belt tensioners & idlers bearing play etc. was 50 000mi, changed to 30 000mi	10/02/2014
4 UPDATED: 01 ENGINE –Automatic belt tensioners & idlers bearing play etc. was 30 000mi, changed to 50 000mi	12/08/2014
5 UPDATED: 12 BRAKE & AIR SYSTEM – Caliper running clearance check was 6 000mi, changed to "at brake pad replacements"	03/25/2015
6 UPDATED: 12 BRAKE & AIR SYSTEM – Brake calipers visual and functional checks separated. Visual check was 12 000mi, changed to 6 000mi	03/25/2015
7 UPDATED: 07 TRANSMISSION – Filled with TES389 approved fluid – change transmission fluid, Main & Lube filters was 12 000mi, changed to 6 000mi	11/11/2015
8 UPDATED: 07 TRANSMISSION – Severe vocation, filled with TranSynd or TES295 synthetic fluid only, no mixture & using High Capacity filters – change transmission fluid was 150 000mi, changed to 84 000mi.	
9 ADDED: 07 TRANSMISSION – Severe vocation, filled with TranSynd or TES295 synthetic fluid only, no mixture & using High Capacity filters – change Main & Lube filters every 42 000mi	
10	
11	
12	
13	
14	