

**CONTENTS**

**1. PROPELLER SHAFT DESCRIPTION ..... 3**

**2. NYCT PROPELLER SHAFT MAINTENANCE DIRECTIVE ..... 4**

**3. U-JOINT SERVICE – QUICK REFERENCE GUIDE ..... 5**

    3.1 LUBRICATION PROCEDURE ..... 6

    3.2 INSPECTION RECOMMENDATIONS ..... 6

    3.3 MARK PROPELLER SHAFT (PHASING MARKS) ..... 7

    3.4 GREASE ZERKS ..... 7

    3.5 OTHER INSPECTIONS ..... 7

**4. REMOVAL ..... 7**

    4.1 PROPELLER SHAFT REMOVAL ..... 7

        4.1.1 *Inspect Companion Flange/Flange Yokes* ..... 8

    4.2 REMOVAL PROCEDURE FOR UNIVERSAL JOINT KITS ..... 9

        4.2.1 *Remove universal joint kit* ..... 9

        4.2.2 *Inspect Tube Yoke and Flange Yoke (If Applicable)* ..... 9

    4.3 REMOVAL PROCEDURE FOR SLIP MEMBER BOOT ..... 10

**5. INSTALLATION ..... 10**

    5.1 SLIP MEMBER AND BOOT INSTALLATION ..... 10

    5.2 PROPELLER SHAFT INSTALLATION ..... 11

    5.3 UNIVERSAL JOINT INSTALLATION ..... 12

**6. EXPLANATION OF COMMON DAMAGES ..... 13**

**7. SPECIFICATIONS ..... 14**

**8. SECTION CHANGE LOG ..... 14**

**ILLUSTRATIONS**

FIGURE 1: PROPELLER SHAFT ASSEMBLY DOB 2490-2789 ..... 3

FIGURE 2: COLD FORMED BEARING RETAINER AND BOLTS AS USED ON PREVOST X3-45 COMMUTER ..... 4

FIGURE 3: BEARING LUBRICATION ZIRK..... 6

FIGURE 4: BEARING LUBRICATION ..... 6

FIGURE 5: C-CLAMP ..... 6

FIGURE 6: CHECK FOR LOOSENESS..... 7

FIGURE 7: PHASING MARKS..... 7

FIGURE 8: PHASING MARKS..... 7

FIGURE 9: PHASING MARKS..... 7

FIGURE 10: PHASING MARKS..... 8

FIGURE 11: PROPELLER SHAFT PROPER ORIENTATION..... 8

FIGURE 12: COLD FORMED BEARING RETAINERS ..... 8

FIGURE 13: UNSEATING BEARING CUP ASSEMBLIES ..... 8

FIGURE 14: RAISED METAL OR FRETTING ON OPEN YOKE CROSS HOLES ..... 8

FIGURE 15: SPRING TAB BOLTS REMOVAL ..... 9

FIGURE 16: CORRECT POSITIONING..... 9

FIGURE 17: INCORRECT POSITIONING ..... 9

FIGURE 18..... 9

FIGURE 19..... 9

FIGURE 20: RAISED METAL OR FRETTING ..... 10

FIGURE 21: BOOT CLAMP ..... 10

FIGURE 22: CLEAN GREASE FROM SPLINE SLEEVE ..... 10

FIGURE 23: APPLY GREASE ..... 10

FIGURE 24: POSITION THE END OF THE BOOT AT THE 2.25 INCHES ..... 11

FIGURE 25: ALIGN THE PHASING MARKS BETWEEN THE YOKE AND PROPELLER SHAFT ..... 11

FIGURE 26: YOKE TAB (EAR)..... 11

FIGURE 27: GREASING BEARING CUP ..... 12

FIGURE 28: POSITION THE JOURNAL CROSS INTO THE YOKE CROSS HOLES..... 12

FIGURE 29..... 12

FIGURE 30..... 13

FIGURE 31..... 13

1. PROPELLER SHAFT DESCRIPTION

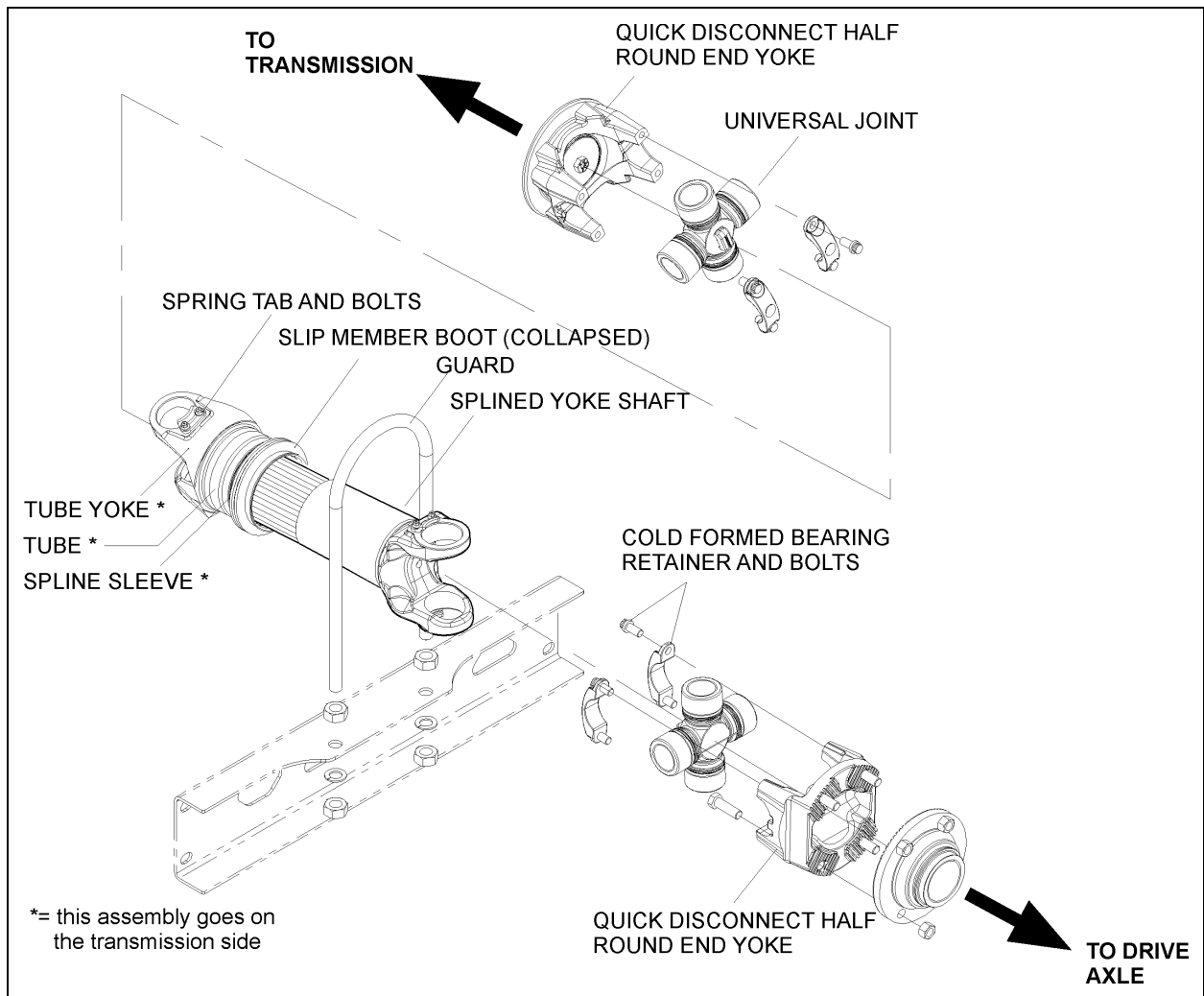

FIGURE 1: PROPELLER SHAFT ASSEMBLY DOB 2490-2789

09002\_2

The propeller shaft transmits power from the transmission to the differential (Figure 1). The propeller shaft is Dana-Spicer Life Series SPL250 type with tubular shafts. It is provided with two heavy-duty universal joints (Figure 1).

The propeller shaft has a half round end yoke at each end. The splined yoke is connected to the differential by a half round end yoke with two needle bearings.

The other extremity (spline sleeve, tube and tube yoke assy) is connected to the transmission by a half round end yoke with two needle bearings.

Furthermore, a **permanently lubricated** slip joint on the propeller shaft compensates for variations in distance between the transmission and the differential. Grease should be cleaned and fresh grease should be applied if slip member components are disassembled.

The rise and fall of the drive axle bring about these variations as the vehicle passes over uneven surfaces. The slip joint also eases removal of the transmission or the drive axle.

 <p><b>MAINTENANCE</b></p>
<p>Lubricate propeller shaft universal joints periodically, every 24,000 miles. Apply grease gun pressure to the lube fittings (1 grease fitting on each universal joint). Use a good quality lithium-base grease such as: NLGI No.2 E.P. Grease (suitable for most temperatures). Refer to Spicer Driveshaft's Service Manual DSSM-0100 for further details.</p>

 <p><b>MAINTENANCE</b></p>
<p>Perform "Inspection Procedures" as per <i>Spicer Life Series Driveshafts Service Manual DSSM-0100</i> every <b>6,000 miles</b>.</p>

<p><b>NOTE</b></p>
<p><i>Do not assume that bearing cavities have been filled with new grease unless it has expelled around all seals.</i></p>

 <p><b>WARNING</b></p>
<p>NYCT MAINTENANCE DIRECTIVE PROHIBITS REUSE OF PROPELLER SHAFT COLD FORMED BEARING RETAINERS AND BOLTS OR STAMPED STRAPS AND STRAP BOLTS</p>

<p><b>FIGURE 2: COLD FORMED BEARING RETAINER AND BOLTS AS USED ON PREVOST X3-45 COMMUTER</b>  <b>DO NOT</b> reuse <b>cold formed bearing retainers</b> and <b>bolts</b>. Reuse of bearing retainer and bolts can cause driveline failure, which can result in separation of the driveline from the vehicle.</p>

**2. NYCT PROPELLER SHAFT MAINTENANCE DIRECTIVE**

- Before removing the driveshaft from vehicle, inspect all components (universal joints, slip joints, hardware, etc.) for deterioration (rust or corrosion) or excessive play. If all components pass inspection, grease universal joints they are able to be lubricated properly (fresh grease showing at all u-joint end caps. If any component does not accept grease, it must be replaced.
- Replace splined slip joint if seal is damaged or if welch plug (cap) is missing (when applicable).
- Unless the slip section (joint) is being replaced, the driveshaft must be removed as an assembly. The driveshaft must be completely disconnected from the differential and transmission yokes **only**; the slip section must not be disconnected unless it is being replaced.
- The driveshaft and yokes must be marked (phasing marks) (see paragraph 3.3 mark propeller shaft (PHASING MARKS)) before removal to ensure reinstallation in the same position as removed.

- **All universal joints securing hardware (bearing retainers and bearing retainers bolts, spring tabs and bolts) must be removed and replaced** using new OEM specified replacement parts (Figure 1, FIGURE 2).
- When removing the universal joint from the yoke, **the end caps must remain attached to the cross at all times** if the universal joint is to be reused (Electrical or masking tape can be used to keep the end caps in place while driveshaft is removed.)
- Unless the universal joint is being replaced, universal joint end caps **must not be removed** for any reason. If the end caps become dislodged while the driveshaft is removed from the vehicle, the universal joint must be replaced. If replacement is needed, the universal joint **must be replaced as a complete assembly**.
- Universal joints **must be treated as a single unit**. This means that parts (such as the cross, needle bearings, or end caps) **must not be interchanged** between new and used joints.
- Universal joints **must be positioned and seated correctly between the yoke tabs (ears)** on the input (tail shaft side) and carrier (differential side) yokes (FIGURE 26).
- The driveshaft must be installed facing the correct direction, in particular, with respect to the splined slip joint.
- The driveshaft must be phased correctly.
- All fasteners must be torqued to manufacturer's specifications and torque-marked. **DO NOT** use air or power tools to install and torque bolts or fasteners.
- Bolt locking tabs, if used, must be bent over the flats of the bolts after final torque is checked.
- The driveshaft guard (hoop) must be in place.
- Driveshaft universal joints must be greased properly.

NOTE: If necessary, rotate driveshaft to allow access to all grease fittings.

- It is the responsibility of the maintainer who begins the driveshaft installation to complete the procedure in its entirety. **The**

**installation procedure must not be carried over (passed on) to the next shift.**

Supervisors must witness and verify the correct installation of the driveshaft as follows:

- The universal joint caps must be seated properly between the yoke tabs (ears) (FIGURE 26).
- All universal joint bearing retainers must have been replaced using new hardware and fasteners.
- All fasteners have been torqued properly and are torque-marked.
- Locking tabs, if used, must be bent over the bolts.
- There must be no mixing of new and old parts on a universal joint.
- The driveshaft must be phased properly.
- Driveshaft guard (hoop) must be in place.
- Driveshaft universal joints must be greased after reinstallation of driveshaft in vehicle (fresh grease showing at all u-joint end caps).

### 3. U-JOINT SERVICE – QUICK REFERENCE GUIDE

This section is intended as a “quick reference” only. Refer to **Spicer Driveshaft’s Service Manual DSSM-0100** for detailed warnings and instructions.

#### Precautions

- Always follow all safety practices when servicing, removing, and/or installing a propeller shaft.
- Always use support strap to prevent this heavy propeller shaft from falling out of the vehicle during removal and installation.
- Always put the transmission in neutral before working on the propeller shaft.
- Never heat components or use a sledgehammer or floor jack to remove the propeller shaft from the vehicle.
- **Do NOT reuse spring tabs and bolts.**
- **Do NOT reuse bearing retainers and bolts.**
- Only replace u-joints with genuine Dana Spicer service parts.

## 3.1 LUBRICATION PROCEDURE

**WARNING**

Read “Spicer Life Series Driveshaft Lubrication Warnings and Cautions” in **Spicer Driveshaft’s Service Manual DSSM-0100**.

1. Use recommended lubricant to purge **all** four seals of each universal joint. This flushes abrasive contaminants from each bearing assembly and assures proper filling of **all** four bearings.

**WARNING**

Maximum grease gun pressure should not exceed 60 psi. Excessive grease gun pressures may cause seal damage.

2. Make sure fresh grease is evident at all u-joint bearing seals.



FIGURE 3: BEARING LUBRICATION ZIRK



FIGURE 4: BEARING LUBRICATION

3. If any of the seals fail to purge, try to move the propeller shaft from side-to-side while applying grease gun pressure.
  - a) If all four bearing positions still do not purge, releasing seal tension may be necessary.

- b) Remove the bearing retainer bolts and bearing retainers and discard. Do NOT reuse.
- c) Once the bearing cups are free, allow the propeller shaft to rest on the support strap.
- d) Apply a c-clamp around the inboard bearings.



FIGURE 5: C-CLAMP

- e) Apply grease gun pressure. Completely purge both bearings.
- f) If bearings still do not purge, complete the removal of the u-joint and inspect for blockage.
- g) If the u-joint still do not purge at all four positions after following the steps in this procedure, replace the u-joint.

## 3.2 INSPECTION RECOMMENDATIONS

- U-joint inspections should be performed every time a vehicle comes in for scheduled maintenance.
- Visually inspect for damaged bearing retainers, loose bearing retainer bolts, loose companion flange, bolts and nuts, loose or missing spring tabs or spring tab bolts, damaged tangs on end fittings, damaged or missing rotating bearing cups. If any of these situations are evident, replacement of the component is necessary.
- Check all input and output end fittings for looseness. Take hold of the end fitting with both hands. Try to move it vertically and horizontally to feel any looseness.





FIGURE 6: CHECK FOR LOOSENESS

- There should be less than **.006"** movement in the u-joint relative to the end yoke. If looseness is greater than **.006"**, the u-joint should be replaced.
- Check for the presence of all grease zerk fittings. Damaged zerks should be replaced. Loose zerks should be tightened.

### 3.3 MARK PROPELLER SHAFT (PHASING MARKS)

- Mark all mating propeller shaft components with a paint marker to assure proper phasing during reassembly.
- Reassembly of a propeller shaft that is out of phase can cause vibration and failure to propeller shaft components.



FIGURE 7: PHASING MARKS

### 3.4 GREASE ZERKS

- Replace damaged zerks.
- Torque zerks to 15 lbf-ft.
- Zerks should be lined up with outboard bearings.
- Clean zerk nipples before greasing.

### 3.5 OTHER INSPECTIONS

Refer to **Spicer Driveshaft's Service Manual DSSM-0100** for detailed information on:

- The slip member inspection,
- Grease zerk inspection,

- Tubing inspection.

## 4. REMOVAL



### WARNING

Read "Spicer Life Series Driveshaft Removal Warnings and Cautions" in **Spicer Driveshaft's Service Manual DSSM-0100**.

### 4.1 PROPELLER SHAFT REMOVAL

1. Mark propeller shaft (phasing marks). It is imperative to mark all the mating components of a propeller shaft, as illustrated below. Mark the propeller shaft with a marking stick, paint marker or other legible marking device. In addition, be sure to mark all bearing positions, spline positions and shaft locations. This assures proper reassembly of the propeller shaft into the vehicle, in its original position.

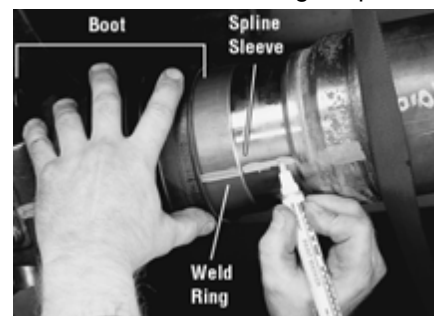

FIGURE 8: PHASING MARKS



FIGURE 9: PHASING MARKS

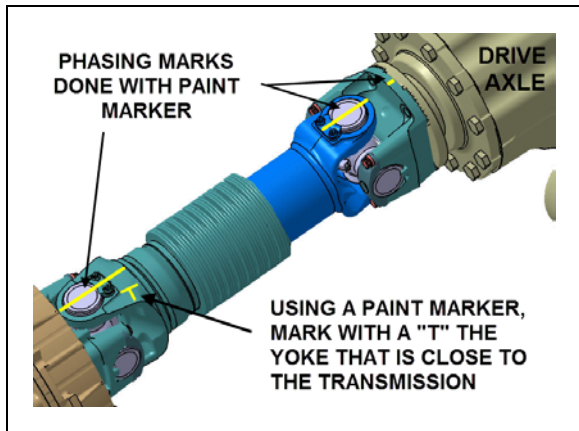

FIGURE 10: PHASING MARKS

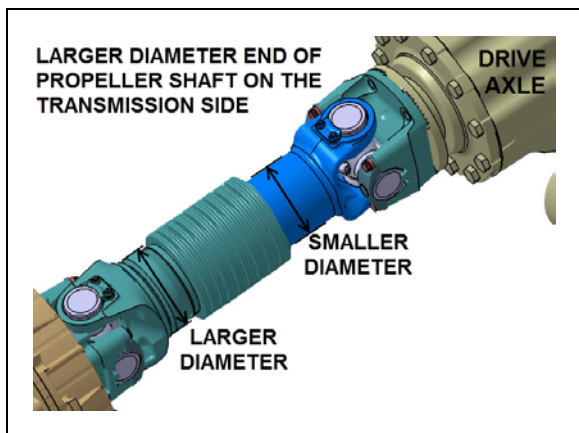

FIGURE 11: PROPELLER SHAFT PROPER ORIENTATION

2. Be sure to ALWAYS use support straps to prevent the propeller shaft from falling out of the vehicle.
3. Remove the bearing retainers and bolts at rear end. Discard bolts, and bearing retainers.



FIGURE 12: COLD FORMED BEARING RETAINERS

4. It may be necessary to unseat bearing cup assemblies by tapping on yoke or bearing cup with a soft-faced hammer. Once the bearing cup assemblies are free, collapse the propeller shaft until both bearing

assemblies clear the open end yoke cross holes. Allow the propeller shaft to rest on support strap.



FIGURE 13: UNSEATING BEARING CUP ASSEMBLIES

5. Remove bearing retainers and bolts at the front end.
6. Inspect all end yoke cross hole surfaces and bolt hole threads for damage. If the bolt hole threads are damaged, the yoke must be replaced.
7. Inspect for raised metal or fretting on open yoke cross holes can be removed with a fine-toothed file and/or emery cloth.



FIGURE 14: RAISED METAL OR FRETTING ON OPEN YOKE CROSS HOLES

8. Inspect the end yoke cross holes for distortion and damage.

#### 4.1.1 Inspect Companion Flange/Flange Yokes

1. Inspect all flange bolt hole threads or through holes for damage. If the bolt hole threads or through holes are damaged, the flange must be replaced.
2. Inspect all flange faces for galling or damage. If damaged, the flange must be replaced.



## 4.2 REMOVAL PROCEDURE FOR UNIVERSAL JOINT KITS

### 4.2.1 Remove universal joint kit

1. **For Quick Disconnect Style:** Remove spring tab bolts and discard, and remove outboard bearing cap assemblies.



FIGURE 15: SPRING TAB BOLTS REMOVAL

2. Make sure universal joints cross assembly is not tilted in the yoke. Place bearing cup spacer onto the base of the arbor press and under the yoke. If the arbor is larger than the bearing cup diameter, a smaller diameter push rod will be needed to avoid damaging the yoke or bearing.



FIGURE 16: CORRECT POSITIONING



FIGURE 17: INCORRECT POSITIONING

3. Using an arbor press, press down on the upper bearing cup assembly until the shoulder of the journal cross makes contact with the inside of the yoke ear.



### CAUTION

DO NOT over press the bearing cup and journal cross. This can damage the inside of the yoke ear.

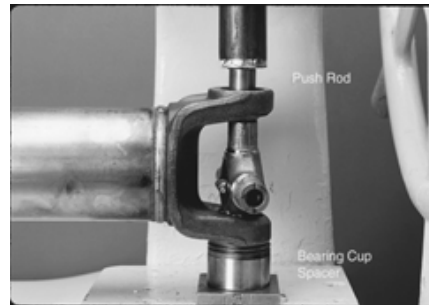

FIGURE 18

4. The bearing cup is not designed to drop out of the yoke. Move the partially pressed-out bearing cup from side to side, to "walk" the bearing cup out of the yoke ear. Remove the bearing cup from the trunnion.
5. Place the yoke in the press, with the remaining bearing cup face down. Using a push rod, press on the end of the journal cross trunnion. Continue to press down on the journal cross trunnion until the shoulder of the journal cross makes contact with the inside of the yoke ear.

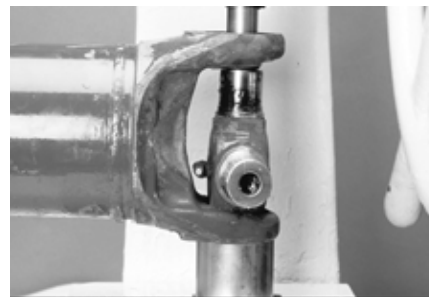

FIGURE 19

### 4.2.2 Inspect Tube Yoke and Flange Yoke (If Applicable)

1. Inspect the tube yoke and flange yoke (if applicable) cross hole surfaces for damage or raised metal. Raised metal or fretting can be removed from yoke cross holes with a fine-toothed file and/or emery cloth.



**FIGURE 20: RAISED METAL OR FRETTING CAN BE REMOVED FROM YOKE CROSS HOLES WITH A FINE-TOOTHED FILE**

#### 4.3 REMOVAL PROCEDURE FOR SLIP MEMBER BOOT

1. It is imperative to mark all mating components of the propeller shaft. Mark the propeller shaft with a marking stick, paint marker or other legible marking device.
2. Remove and discard both boot clamps. Clamps may be separated using a chisel to disengage locking hooks. **DO NOT** reuse clamps.



**FIGURE 21: BOOT CLAMP**

3. Completely collapse the boot toward the yoke shaft to expose weld ring and spline sleeve area. Wipe weld ring and spline sleeve areas clean.
4. Remove the yoke shaft and boot from the spline sleeve. Discard boot.
5. Inspect the yoke shaft spline surface for damage. If the splines are damaged, missing or twisted, or any Glidecote is missing, complete propeller shaft replacement is necessary.
6. Inspect the spline sleeve for damage. If the splines are damaged, missing or twisted, complete propeller shaft replacement is necessary.
7. Inspect the entire slip assembly for contaminants. If the slip assembly shows evidence of rust or the lube is severely

contaminated, complete propeller shaft replacement is necessary.

## 5. INSTALLATION



### WARNING

Read "Spicer Life Series Driveshaft Installation Warnings and Cautions" in **Spicer Driveshaft's Service Manual DSSM-0100**.

#### 5.1 SLIP MEMBER AND BOOT INSTALLATION

1. Clean ALL grease from yoke shaft and spline sleeve. Make sure grease-cutting solvent does not intrude into the tube through the vent hole in the spline sleeve plug. Be sure the phasing marks made during disassembly are not removed.



**FIGURE 22: CLEAN GREASE FROM SPLINE SLEEVE**

2. After all traces of grease and cutting solvent have been removed from the yoke shaft and spline sleeve, apply half of the grease provided to the yoke shaft splines and the other half to the spline sleeve, cover the entire splined surface.



**FIGURE 23: APPLY GREASE**

3. Measure and place a mark 2.25 inches (55-60mm) from yoke shaft shoulder with a marking stick, paint marker or other legible marking device.

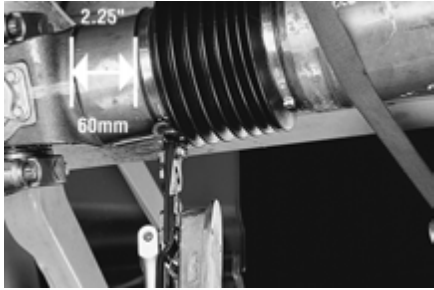

**FIGURE 24: POSITION THE END OF THE BOOT AT THE 2.25 INCHES (55-60MM) MARK MADE ON THE YOKE SHAFT SHOULDER**

4. Position a clamp on each end of the new boot. Slide the boot onto the grease-free yoke shaft shoulder.
5. Collapse the boot and insert the yoke shaft into the splined sleeve, making sure phasing marks are in line. Position the end of the boot at the 2.25 inches (55-60mm) mark made on the yoke shaft shoulder and tighten boot clamps to the specified torque. Yoke shaft shoulder must be clean, dry and grease free.

***Failure to properly install and tighten boot clamps could allow intrusion of contaminants and can cause driveline failure, which can result in separation of the driveline from the vehicle.***

6. Before the propeller shaft is completely installed in the vehicle, slowly collapse and extend the propeller shaft to make sure the boot clamps are stationary. If the clamps are not stationary, recheck for proper clamp torque. If clamps still are not stationary, repeat disassembly and assembly procedure. DO NOT reuse clamps.

## 5.2 PROPELLER SHAFT INSTALLATION

1. Before installing the propeller shaft, inspect the yoke surface for burrs and damage. Mating surfaces should be clear of rust, contamination and grease.
2. With safety straps in place, align the phasing marks between the yoke and propeller shaft.

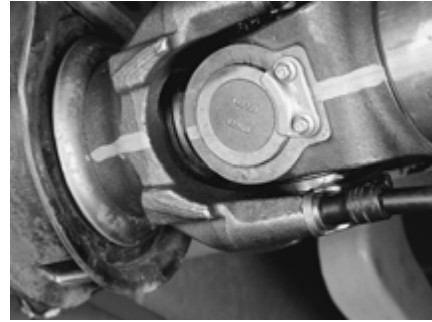

**FIGURE 25: ALIGN THE PHASING MARKS BETWEEN THE YOKE AND PROPELLER SHAFT**

3. Align the bearing cups with the yoke ears making sure that the cups are evenly spaced between the tabs (ears) of the yoke. A soft faced hammer can be used to fully seat the bearing cups into the yoke.

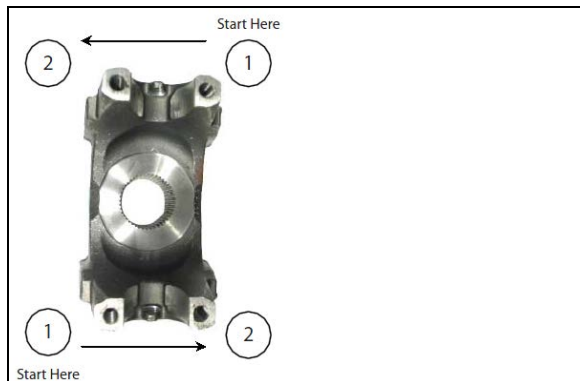

**FIGURE 26: YOKE TAB (EAR)**

***Note: Bearing cups must be fully seated between the yoke tabs (ears). Failure to seat the cups properly will result in a premature failure.***

4. Install bearing retainers and lock bolts.
5. It is important that the bearing retainer bolts are torqued in the correct sequence. Following the diagram below. Torque the number one bolt before moving to the number two bolt. Always torque in a counter clockwise direction starting with the number one position.

***Failure to torque bearing retainer bolts in the proper sequence could result in premature failure.***



#### BEARING RETAINER BOLT TORQUE (HALF ROUND)

Series	Head size	Size	Bolt torque
SPL250	12 point	12-1.25mm	100 lbf-ft <sup>1</sup>

- Grease the U-joint and slip member after propeller shaft installation. Refer to 3.1 *lubrication procedure*.

#### 5.3 UNIVERSAL JOINT INSTALLATION

- Remove needle retaining plugs from all bearing cup assemblies. Using a high quality National Lubricating Grease Institute E. P. Grade 2 lubricating grease, wipe each bearing cup assembly with grease. Fill all cavities between the needle rollers. Also apply a liberal coating of grease on the bottom of each bearing cup assembly and on the lip of the seal.



FIGURE 27: GREASING BEARING CUP

**Caution - Spicer DOES NOT recommend wiping the outside of bearing cup assemblies or yoke cross holes with grease, oil or silicone-based sprays. This could result in bearing cup assembly rotation in yokes.**

- Position the journal cross into the yoke cross holes with the grease zerk fitting inward toward tubing. The double-headed, grease

zerk (nipple) fitting should be perpendicular to the yoke cross holes.

**Note: Failure to properly position the universal joint will result in the inability to grease the universal joint.**



FIGURE 28: POSITION THE JOURNAL CROSS INTO THE YOKE CROSS HOLES WITH THE GREASE ZERK FITTING INWARD TOWARD TUBING

**Note: Always inspect bearing cups for rollers that may have fallen (downed rollers) out of place before installation.**

- Move one end of the journal cross to cause a trunnion to project through the cross hole beyond the outer machined face of the yoke ear. Take one bearing cup assembly and position an installation height tool on the end of the bearing cup assembly. Place the bearing cup assembly over the protruding trunnion diameter and align it to the yoke cross.



FIGURE 29

- Align the yoke in an arbor press with the bearing assembly resting on the base of the press. Cover the yoke ear with a metal plate that has 0.25 inch (6.4mm) minimum thickness. Push the yoke onto the bearing cup assembly until it is flush with the cross hole face. Do not remove the installation height tool.

<sup>1</sup> Prevost production line torque value



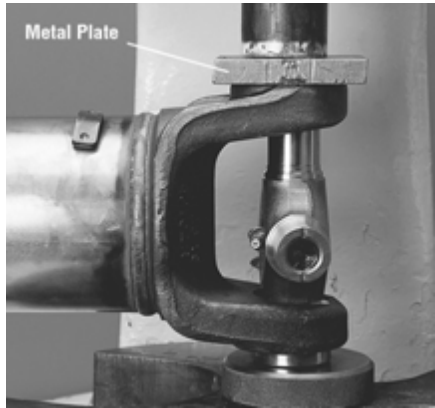

FIGURE 30

5. Flip yoke 180 degrees. Position the remaining installation height tool on the end of another bearing cup assembly. Place bearing cup assembly over trunnion diameter and align it to the yoke cross hole. Push the bearing cup assembly until both installation height tools are flush with the cross hole face.
6. Install new spring tabs and 8mm thread bolts. Make sure that no grease or foreign material is present between the contact areas of the spring tabs, bearing cups and yoke cross hole faces. Tighten bolts to the required torque.



FIGURE 31



**SPRING TAB BOLT TORQUE**

Bolts are specially heat-treated. DO NOT substitute inferior grade bolts.

Series	Head size	Size	Bolt torque
SPL250	6 point	8-1mm	25-30 lbf-ft

**6. EXPLANATION OF COMMON DAMAGES**

1. Cracks: Stress lines due to metal fatigue. Severe and numerous cracks will weaken the metal until it breaks.
2. Galling: Scraping off of metal or metal displacement due to friction between surfaces. This is commonly found on trunnion ends.
3. Spalling (surface fatigue): Breaking off of chips, scales, or flakes of metal due to fatigue rather than wear. It is usually found on splines and U-joint bearings.
4. Pitting: Small pits or craters in metal surfaces due to corrosion. If excessive, pitting can lead to surface wear and eventual failure.
5. Brinelling: Surface wear failure due to the wearing of grooves in metal. It is often caused by improper installation procedures. Do not confuse the polishing of a surface (false brinelling), where no structural damage occurs, with actual brinelling.
6. Structural Overloading: Failure caused by a load greater than the component can stand. A structural overload may cause propeller shaft tubing to twist under strain or it may cause cracks or breaks in U-joints and spline plugs.



**7. SPECIFICATIONS**

**PROPELLER SHAFT**

Make .....Spicer  
Series.....SPL250

**8. SECTION CHANGE LOG**

	<b>DESCRIPTION</b>	<b>DATE</b>
1		
2		
3		
4		
5		
6		