

CONTENTS

SECTION CHANGE LOG	4
1. TORQUE TABLES	5
1.1 ALTERNATORS AND SURROUNDING COMPONENTS	5
1.2 ELECTRICAL CONNECTIONS – BATTERIES, MISCELLANEOUS	7
2. GENERAL DESCRIPTION.....	11
2.1 WIRING DIAGRAMS.....	11
2.1.1 <i>Using Wiring Diagrams</i>	11
2.2 TESTING CIRCUITS.....	12
2.3 WIRE SIZES AND COLORS.....	12
2.4 WIRE IDENTIFICATION	12
2.5 SPARE WIRES	14
2.6 CIRCUIT BREAKERS.....	14
2.6.1 <i>X3 coach main circuit breakers</i>	14
2.6.2 <i>X3 VIP main circuit breakers</i>	14
2.6.3 <i>VECR/VECF breakers</i>	15
2.6.4 <i>Electric Cooling fan circuit breakers</i>	15
2.7 COOLING FAN CONNECTIONS.....	15
2.8 MULTIPLEX FUSES.....	16
2.9 ELECTRONIC GROUND	16
2.10 RELAYS	17
2.11 PRECAUTIONS.....	17
2.12 ELECTRONIC MODULES CONNECTOR PIN-OUT	18
3. TROUBLESHOOTING AND TESTING THE MULTIPLEX VEHICLES	21
3.1 PROBING VOLTAGE ON THE MULTIPLEX CIRCUITS.....	21
3.2 DLO (BBUS MUX) NETWORK	21
3.2.1 <i>DLO (BBUS MUX) Connection On The Telltale Panel And The Hvac Control Unit</i>	21
3.2.2 <i>Spare DLO (BBUS MUX)</i>	21
3.3 ELECTRICAL SYSTEM DIAGNOSTIC	21
3.4 MULTIPLEX INPUT TEST MODE	22
3.5 MOTOR TEST SEQUENCE	23
3.5.1 <i>Test Sequence – Coaches only</i>	24
3.5.2 <i>Test Sequence – VIP With Central HVAC System</i>	25
3.5.3 <i>Test Sequence – VIP With Small HVAC System</i>	26
3.6 FORCED ACTIVATION OF THE COOLING FANS.....	26
3.7 DLO (BBUS MUX) NETWORK LAYOUT AND TROUBLESHOOTING	28
3.8 TROUBLESHOOTING	33
3.9 DRIVER INFORMATION DISPLAY LIMP-HOME MODE	40
3.10 ESSENTIAL FUNCTIONS TO OPERATE THE VEHICLE	40
3.10.1 <i>Available Functions</i>	40
3.11 LOWER PRIORITY MODULES FOR BREAKDOWN SERVICE.....	40
3.12 MULTIPLEX MODULES	40
3.12.1 <i>MCM</i>	40
3.12.2 <i>I/O-EA</i>	40
3.12.3 <i>I/O-EB</i>	41
3.13 MULTIPLEX MODULES REPLACEMENT.....	41
3.13.1 <i>Replacing I/O-EA Or I/O-EB Modules</i>	41
3.13.2 <i>Replacing the MCM Module</i>	41
3.13.3 <i>Uploading the vehicle specific multiplex program into the MCM</i>	41

4.	ELECTRICAL COMPARTMENTS	42
4.1	MAINTENANCE	44
4.2	BATTERY INSTALLATION & REAR JUNCTION BOX	44
4.3	REAR JUNCTION BOX (RJB)	44
4.4	FRONT ELECTRICAL AND SERVICE COMPARTMENT (FJB)	47
4.5	A/C MODULE.....	49
4.6	ENGINE REAR START PANEL.....	49
4.7	ENTRANCE DOOR & WIPER CONTROL MODULES.....	49
4.8	PARCEL RACK MODULE.....	49
5.	BATTERIES	50
5.1	BATTERY INSTALLATION	50
5.2	AGM BATTERIES.....	52
5.3	BATTERY DISCHARGE PROTECTION	52
5.4	MAIN ELECTRICAL SHUT-OFF SWITCH	52
5.5	BATTERY REMOVAL AND INSTALLATION	53
5.6	BATTERY RATING	56
5.7	BATTERY TESTING	56
5.7.1	<i>Visual Inspection</i>	56
5.7.2	<i>Removing Surface Charge</i>	56
5.7.3	<i>Load Test</i>	56
5.8	BATTERY CHARGING	57
5.8.1	<i>Battery Charging Guide</i>	58
5.8.2	<i>Emergency Jump Starting With Auxiliary (Booster) Battery</i>	58
5.9	AGM BATTERY CHARGING PRECAUTIONS	60
5.10	BATTERY EQUALIZATION AND AGM BATTERIES	60
5.11	CLEANING AND INSPECTION.....	60
5.12	COMMON CAUSES OF BATTERY FAILURE	60
5.13	TROUBLESHOOTING	61
5.14	"BATTERY VOLTAGE WARNING" PICTOGRAM.....	61
5.14.1	<i>Voltage Gauge Definitions</i>	61
5.14.2	<i>BATTERY WARNING PICTOGRAM MAY APPEAR AS A REMINDER</i>	62
6.	BATTERY EQUALIZER	62
7.	PRIME ENERGY MANAGEMENT SYSTEM	62
7.1	COMPONENTS	62
7.1.1	<i>Vanner 80 Series Battery Equalizer Fault Codes</i>	64
7.2	DID DISPLAY	65
8.	BOSCH ALTERNATORS	65
8.1	IDENTIFYING THE DEFECTIVE ALTERNATOR	65
8.1.1	<i>Alternator identification</i>	65
8.2	ALTERNATOR DRIVE BELT	66
8.2.1	<i>Removal and installation</i>	66
8.2.2	<i>Adjustment</i>	66
9.	STARTER	66
10.	ENGINE BLOCK HEATER	67
10.1	MAINTENANCE	67
11.	X3 SERIES EXTERIOR LIGHTING	67

11.1	HEADLIGHTS.....	67
11.1.1	Headlight Beam Toggle Switch	67
11.1.2	Maintenance.....	68
11.1.3	Headlight Adjustment.....	68
11.1.4	Sealed-Beam Unit	69
11.1.5	Front Turn Signal.....	70
11.1.6	Optional Xenon Headlamp.....	70
11.2	STOP, TAIL, DIRECTIONAL, BACK-UP, AND HAZARD WARNING LIGHTS	71
11.2.1	Lamp Removal and Replacement	72
11.2.2	Center Stoplights and Cyclops Light Removal and Replacement	72
11.3	LICENSE PLATE LIGHT.....	72
11.4	CLEARANCE, IDENTIFICATION AND MARKER LIGHTS	72
11.4.1	Clearance and Identification Light Removal and Replacement	73
11.5	FOG LIGHTS.....	73
11.5.1	Bulb Removal and Replacement	73
12.	X3 SERIES INTERIOR LIGHTING EQUIPMENT.....	73
12.1	CONTROL PANEL LIGHTING	73
12.1.1	Switch Lighting.....	73
12.1.2	Telltale Light Replacement.....	73
12.1.3	Gauge Light Bulb Replacement.....	74
12.2	STEPWELL LIGHTS	74
12.2.1	Bulb Removal and Replacement	74
12.3	DRIVER'S AREA LIGHTS	74
12.3.1	Bulb Removal and Replacement	75
12.4	PASSENGER SECTION LIGHTING.....	75
12.4.1	LED Indirect Lighting / Parcel Rack Interior Lighting.....	75
12.4.2	LED Direct Lighting.....	75
12.4.3	Removal and Replacement of Reading Lamp Bulb	76
12.5	ENGINE COMPARTMENT LIGHTING.....	76
13.	SPECIFICATIONS.....	77

SECTION CHANGE LOG

DESCRIPTION		DATE
1	Added missing images in Torque Table, items 20 & 21	2017 07 06
2		
3		
4		
5		
6		

1. TORQUE TABLES

1.1 ALTERNATORS AND SURROUNDING COMPONENTS

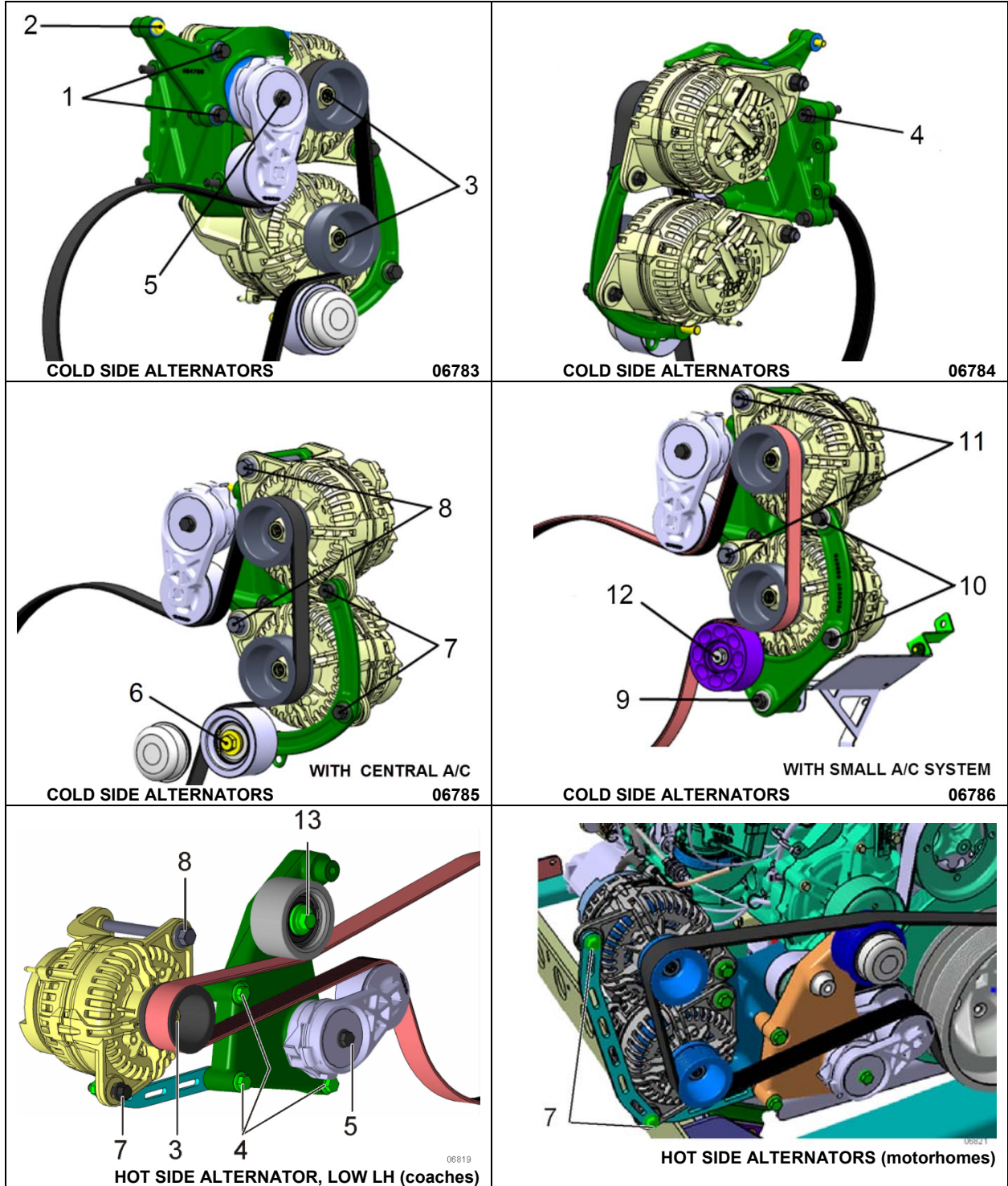

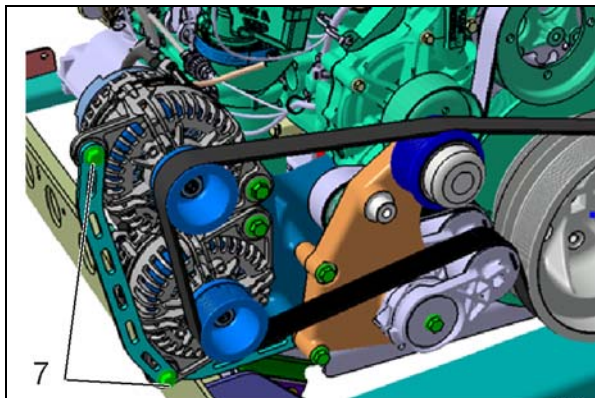

HOT SIDE ALTERNATORS (motorhomes)

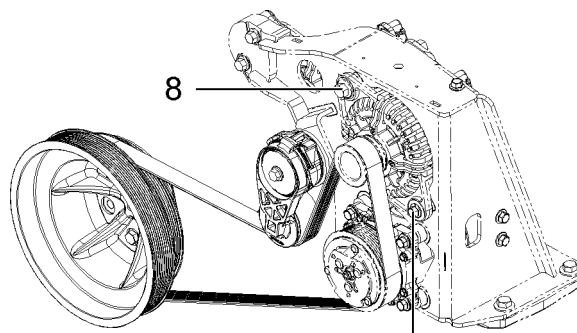









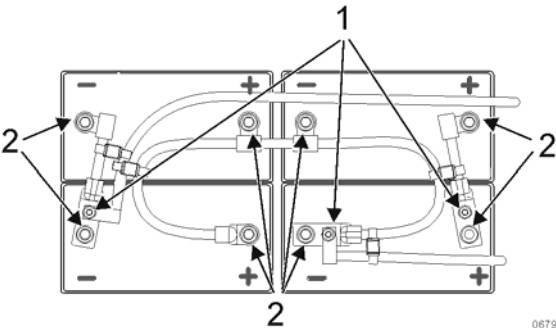
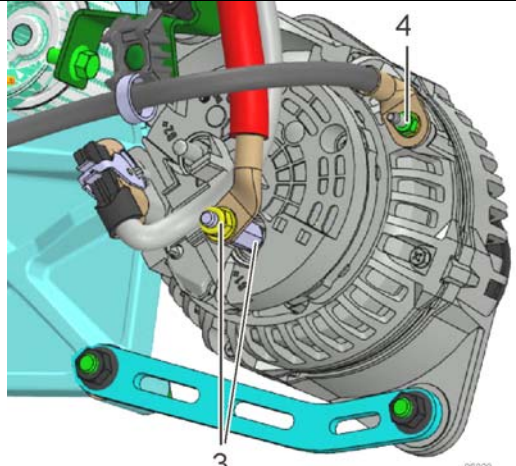
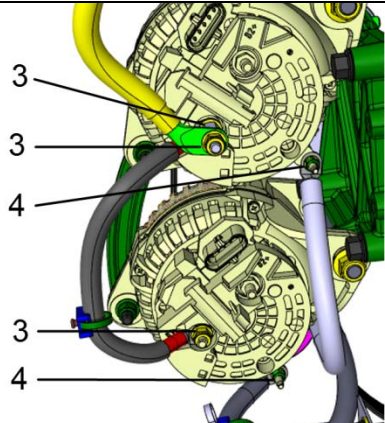
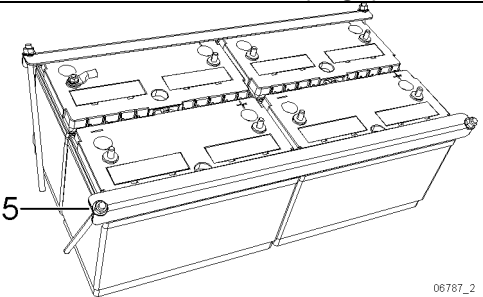

WITH SMALL A/C
06823

BOSCH HD10 ALTERNATORS

No	DESCRIPTION	TORQUE
1	A/C tensioner / idler bracket mounting bolts (2)	43 lb-ft (58 Nm)
2	A/C tensioner / idler bracket mounting bolt (1)	22 lb-ft (30 Nm)
3	Alternator pulley (2) LH threads	70-80 lb-ft (95-108 Nm)
4	Alternator mounting bracket mounting bolts	48 lb-ft (65 Nm)
5	Alternator belt tensioner mounting bolt	48 lb-ft (65 Nm)
6	Alternator belt idler mounting bolt (central A/C config.)	82 lb-ft (111 Nm)
7	Alternator mounting bolts, short	48 lb-ft (65 Nm)
8	Alternator mounting bolts, long	82 lb-ft (111 Nm)
9	Alternator bottom bracket mounting bolt (small A/C system)	48 lb-ft (65 Nm)
10	Alternator mounting bolts (small A/C system)	48 lb-ft (65 Nm)
11	Alternator mounting bolts (small A/C system)	82 lb-ft (111 Nm)
12	Alternator belt idler mounting bolt (small A/C system)	48 lb-ft (65 Nm)
13	Alternator belt idler mounting bolt (hot side)	47 lb-ft (64 Nm)

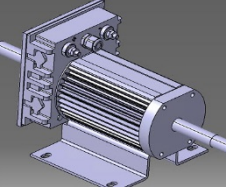
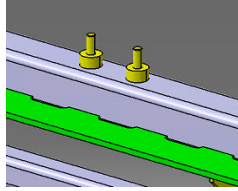
1.2 ELECTRICAL CONNECTIONS – BATTERIES, MISCELLANEOUS

 <p>06791</p>	 <p>06820</p> <p>HOT SIDE ALTERNATOR, LOW LH (single)</p>		
 <p>COLD SIDE ALTERNATORS</p>	 <p>06787_2</p>		
 <p>6</p>	 <p>7</p>	 <p>8</p>	 <p>9</p>
 <p>10</p>	 <p>11</p>	 <p>12</p>	 <p>13</p>
 <p>14</p>	 <p>15</p>	 <p>16</p>	 <p>17</p>

SECTION 06B: X3 SERIES ELECTRICAL

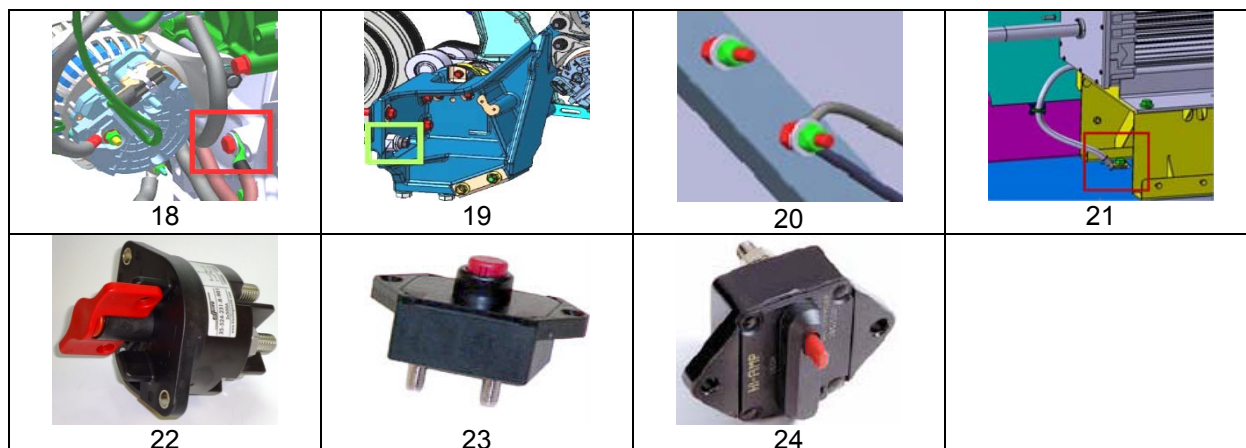

ELECTRICAL CONNECTIONS - BATTERIES, MISC.

No	DESCRIPTION	TORQUE
1	AGM battery Ground, 12VD & 24VD terminal nut	170 lb-in (19 Nm)
2	AGM battery connections, cap nut	170 lb-in (19 Nm)
3	Alternator power connection – nut & adaptor	11 lb-ft (15 Nm)
4	Alternator ground connection – nut	6 lb-ft (8 Nm)
5	Battery tie-down	45-55 lb-in (5-6 Nm)
6	Electronic ground bus bar ¼-20 stud (front & rear electric cmpt)	60 lb-in (7 Nm)
7	Junction block – 1 stud 3/8-16	114-126 lb-in (13-14 Nm)
8	Junction block – 4, 6, 8, 10 studs #10-32 brass	20 lb-in (2 Nm)
9	Booster block – 3/8-16 studs	119-131 lb-in (13-15 Nm)
10	ATC type fuse box – #8-32 screw terminal	15 lb-in (2 Nm)
11	Battery equalizer – 5/16-18 stud	91-101 lb-in (10-11 Nm)
12	VECR/F – M8-1.5 studs	164-181 lb-in (19-20 Nm)
13	24-V Inverter– M8-1.25 studs	104-115 lb-in (12-13 Nm)
14	Evaporator fan motor – 5/16-18 stud	48-50 lb-in (5-6 Nm)
15	Chassis ground studs – 1/2-13 stud stainless steel	170 lb-in (19 Nm)
16	Chassis battery ground studs – 1/2-13 stud stainless steel	170 lb-in (19 Nm)
17	Engine air preheater – M8-1.25 stud	84-108 lb-in (9-12 Nm)
18	Engine ground studs – M10-1.5 stud	240 lb-in (27 Nm)
19	Alternator ground cable stud (hot side) – M10-1.5 stud	240 lb-in (27 Nm)
20	On chassis welded ground stud – M6-1 stud	106 lb-in (12 Nm)
	On chassis welded ground stud – M10-1.5 stud	170 lb-in (19 Nm)
21	Evaporator fan motor ground cable stud – M8-1.25 stud	170 lb-in (19 Nm)
22	Battery master switch (Kissling type) – M12-1.75 stud	166-183 lb-in (19-21 Nm)
23	Circuit breaker (manual reset) 1/4-28 stud nut	58 lb-in (7 Nm)
24	Circuit breaker (switchable, manual reset) 1/4-24 stud nut	58 lb-in (7 Nm)

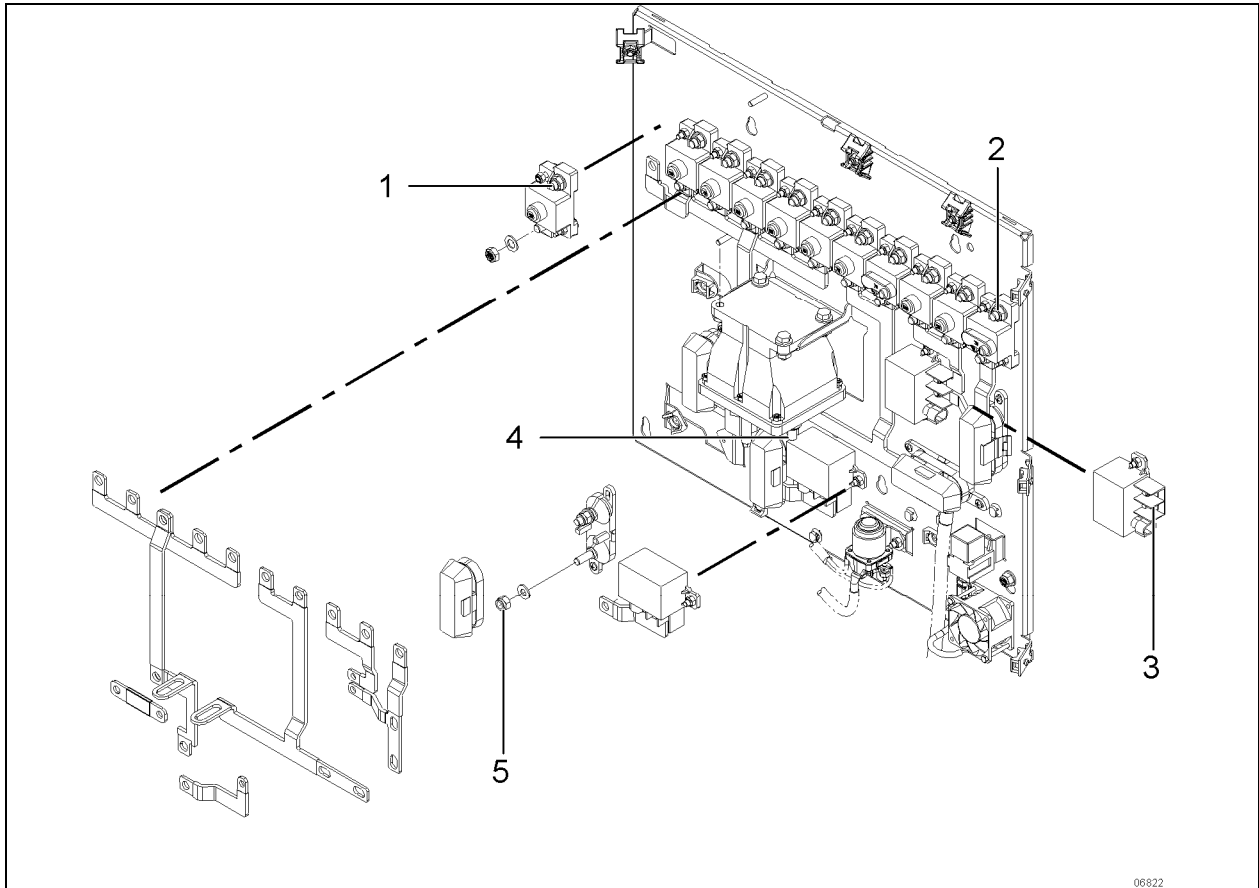

06822

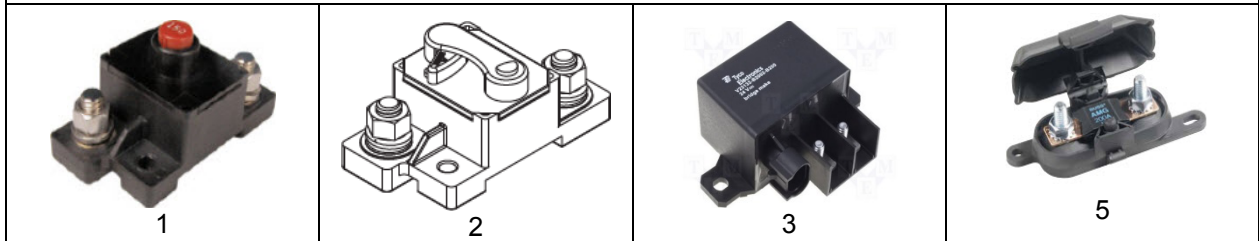

ELECTRICAL CONNECTIONS – MAIN POWER COMPARTMENT

No	DESCRIPTION	TORQUE
1	Main circuit breaker 3/8-16 stud nut	135 lb-in (15 Nm)
2	Main circuit breaker (switchable, manual reset) 3/8-16 stud nut	135 lb-in (15 Nm)
3	Power relay stud nut	44 lb-in (5 Nm)
4	Master relay R1- Port 30 – M10-1.5 buss bar connection stud nut	160-195 lb-in (18-22 Nm)
5	Fuse holder M8-1.25 stud nut	96 lb-in (11 Nm)

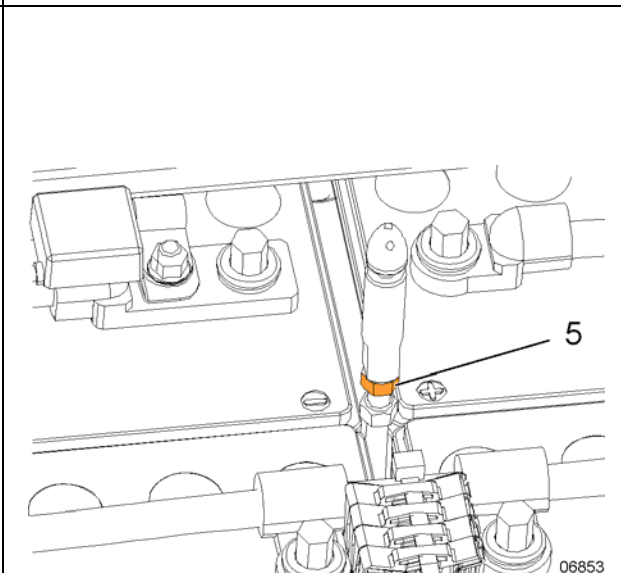
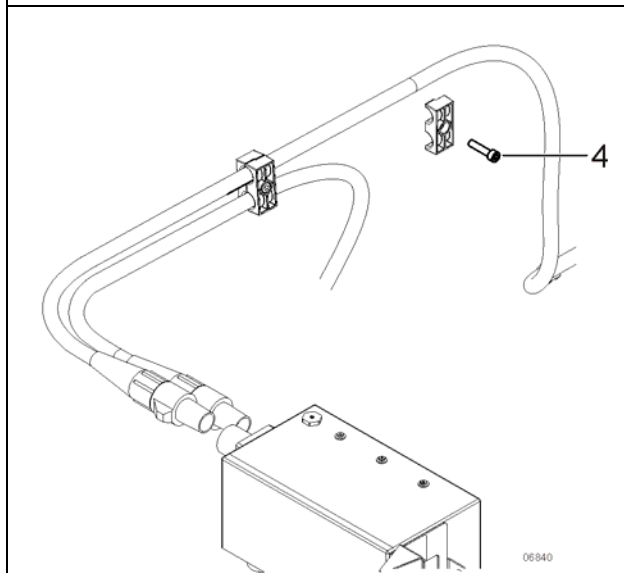
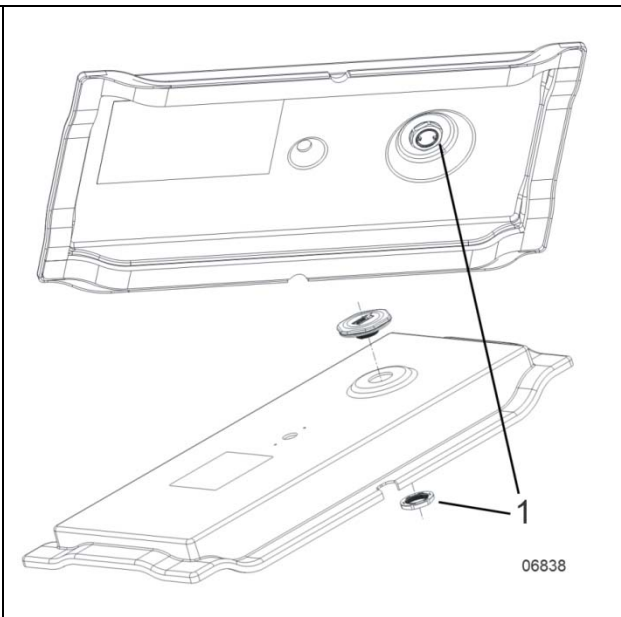
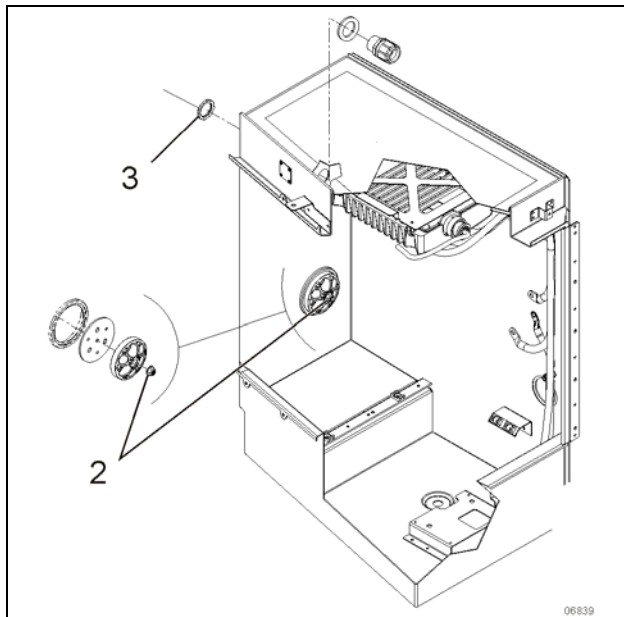

MISCELLANEOUS COMPONENTS

No	DESCRIPTION	TORQUE
1	Battery cover vent mounting nut	40-48 lb-in (4.5-5.4 Nm)
2	Cable pass-through assembly nut	90-110 lb-in (10-12 Nm)
3	Strain relief mounting lock nut	90-110 lb-in (10-12 Nm)
4	Screw - power cable support- electrical cooling fans	50-60 lb-in (5.6-6.8 Nm)
5	Battery cover stud nut	86-106 lb-in (10-12 Nm)

2. GENERAL DESCRIPTION

This vehicle uses a dual voltage system to obtain two different voltages (12-volts and 24-volts) for various electrical controls and accessories. The main power source incorporates four batteries connected in series-parallel. All batteries are kept uniformly charged by means of a 100 amp battery equalizer (standard), giving a maximum possible output supply of 100 amps on the 12 volt system. Both the 12V and 24V systems are controlled through individual main battery relays. Base configuration uses three 24V self-regulated alternators, belt driven from the engine, and can be reached through the engine compartment doors.

This vehicle is equipped with PRIME energy management system which features AGM batteries and a Vanner Vann-Bus 80 Series battery equalizer.

2.1 WIRING DIAGRAMS

A paper copy of the master wiring diagram of the electric circuits, covering standard and optional accessories and systems is located in the Technical Publications box. Usually, a separate wiring diagram page is provided for each major function or system. In some cases, more than one circuit may appear on one wiring diagram page; when this occurs, each circuit covered in this page is listed in the wiring diagram index. Moreover, a circuit may appear on several pages; in such case, the number(s) at the extremity of the diagram title will indicate the sheet reference number. Refer to the *"Wiring Diagram Index"* to ensure that the correct diagram is being used to trace the circuit in question. In addition to the major functions page reference, the wiring diagram index contains the following information pages.

- The Multiplexed Device Index,
- The Arrangement-Harness drawing showing the harnesses arrangement and harness number on the vehicle,
- Glossary,
- Circuit number listing,
- Circuit breaker code,
- Connector code,
- Diode number code,

- Resistor number code,
- Fuse code.

2.1.1 Using Wiring Diagrams

Three methods are used to "work" with electric wiring diagrams.

Situation: You have identified the defective part (breaker, diode, relay, etc.), and you wish to locate its corresponding circuit.

Problem: Circuit breaker CB5 is released (open circuit) and you don't know which circuit is affected.

- a) Refer to wiring diagram index, and look for *"Circuit breaker list"*.
- b) At item CB5, you will find the location, the Prevost number, the breaker function, the breaker ampere rating and the page on which to find the corresponding diagram.
- c) Refer to page 3.1.
- d) When you have located CB5, follow the wiring up to the end and find the diagram page number and function on which the circuit continues.

Situation: You have a problem with a specific system and you want to find the corresponding diagram.

Problem: The last three (3) speakers on the R.H. side of vehicle are inoperative and you must trace the electric circuit.

- a) Refer to wiring diagram index and look for *"Sound system"*.
- b) You will find on page 35.1 & 35.2 the components as well as the electric wiring, thus providing you with a complete understanding of this circuit.

Situation: Using the Driver's Info Display (DID), you check on arrival if there are active errors in the vehicle electrical system. With the SYSTEM DIAGNOSTIC menu, highlight FAULT DIAGNOSTIC, highlight ELECTRICAL SYSTEM to request a diagnostic of the electrical system and then press the enter key. If applicable, the DID shows the fault messages or fault codes recorded. When more than one fault is recorded, an arrow pointing down appears on the right of the display. Use the down arrow to see all the fault messages.

Problem: DID displays the fault "Elec. Horn SW63; shorted to ground" as being active.

- a) Refer to wiring diagram index, and look for "Multiplexed Device Index", pages B1-B8.
- b) In first column DEVICE ID, look for device SW63.
- c) At device SW63, find the fault message, the minimum condition to activate, other inputs involved in logic, the multiplex module related to switch 63, the connector and pin number on the module and the page on which to find the corresponding diagram.
- d) Once the problem corrected, the DID still shows the fault as being active. You have to leave the FAULT DIAGNOSTIC menu, wait approximately 20 to 30 seconds and then return to FAULT DIAGNOSTIC to request a new diagnostic of the ELECTRICAL SYSTEM from the MCM. The DID should display the fault as being inactive.

2.2 TESTING CIRCUITS

A careful study of the wiring diagrams should be made to determine the source and flow of current through each circuit. When a circuit is thoroughly understood, a point-to-point check can be made with the aid of the applicable wiring diagrams. Any circuit can be tested for continuity or short circuits with a multimeter or a suitable voltmeter.

All electrical connections must always be kept clean and adequately tight. Loose or corroded connections can result in discharged batteries, difficult starting, dim lights and improper functioning of other electric circuits. Inspect all wiring connections at regular intervals. Make sure knurled nuts on all amphenol-type plugs are securely tightened. Knurled nuts on the plastic amphenol-type connectors will click into a detent when properly tightened. Line connectors, who have the side locking tabs, must have the locks latched in place to ensure a proper electrical connection.

2.3 WIRE SIZES AND COLORS

Each wire in the electrical system has a specific size as designated on the wiring diagram. When replacing a wire, the correct size must be used. Never replace a wire with one of a smaller size. The vehicle electrical system is provided with different voltages. The insulation on each wire is distinctly colored in order to determine visually the wiring voltage and to assist in making

connectors. The wires are color coded as follows:

Yellow	Data link High
Green	Data link Low
Orange	Connected to multiplex outputs
White	Connected to multiplex inputs
Red	24 volt system
Yellow	12 volt system
Black	grounded wire
Orange	speakers (+) (Coaches Only)
Brown	speakers (-) (Coaches Only)
Grey	spare wire
Black convolute tube with orange tape containing:	
Black	120V ac system (live)
White	120V ac system (neutral)
Green	120V ac system (ground)

NOTE

Wires are identified at each 2-4 inch (5-10 cm) intervals by a printed number.

2.4 WIRE IDENTIFICATION

Each wire on a diagram is patterned to assist in tracing and testing circuits. The wire identification identifies the voltage reading or network, the circuit identification and the basic wire gauge.

12-A47J1.8-16		
VOLTAGE READING OR NETWORK	WIRE GAUGE (AWG)	
CIRCUIT IDENTIFICATION <small>06048_2</small>		
VOLTAGE READING OR NETWORK		
0	120	J1939
5	ANA	J2284
0/12	BBUS	LIN
0/24	DATA	PWM
12	DBUS	GND
24	J1587	...other
CIRCUIT IDENTIFICATION		
Ground circuits		
Electronic: I/O module number followed by an R, followed by the connector number and pin number (cavity) (ex: A47RJ1.8, A54 RJ2.14).		
Electronic ground studs: Number 00 followed with the stud location ¹ and sequential number (ex: 00R1, 00F4).		
Chassis ground studs: Number 0 followed with the stud location and sequential number (ex: 0EV1, 0FH2).		
Power & voltage carrying circuits		
Power distribution: Uphill component identification as circuit number (ex.: F96, CB22).		
Multiplex outputs: Output module number and connector and pin number (cavity) (ex: A55J1.4, A49J2.9)		
Relays, diodes, resistors and any other component output: Component number and pin number as circuit name (ex: SW55A, R30.87, D12.B).		
NETWORKS	WIRE GAUGE (AWG)	
DL0 = Bbus Mux	0000	3 14
DL1 = J1939	000	4 16
DL2 = J2284	00	6 18
DL3 = Dbus Mux	0	8 20
DL7 = Engine subnet	1	10 22
DL9 = Powertrain subnet 900 / 901= J1587	2	12 24

¹ For stud location, refer to page 2.1 of wiring diagram

2.5 SPARE WIRES

When the vehicle leaves the factory, and even in the case of a fully-equipped vehicle, an important number of unconnected spare wires are routed between the junction boxes. Consequently, for any connection of an additional accessory, refer to page "Spare wires" in master wiring diagram to determine the number, the gauge and location of these wires.



CAUTION

Wire size is calibrated according to the breaker or fuse that protects it. When using a spare wire to replace a damaged wire, assure that the spare wire size is equal or larger than the wire being replaced. Using a wire too small for the breaker or fuse amperage might cause overheating of the wire.

NOTE

Spare wires are identified by a wire identification number and by the letters "SP", to designate "spare".

2.6 CIRCUIT BREAKERS

The electric circuits are protected by manual reset type circuit breakers. The main circuit breakers (Figure 2), as well as those protecting the A/C system, are located in the main power compartment and are accessible from the engine compartment curb-side door, on R.H. side of the vehicle.

This type of circuit breaker de-energizes the circuit without disconnecting any wire.

Some circuit breakers such as CB2 & CB6 are different in the fact that you may open the circuit manually, to do so simply press the blue button on breaker to open the circuit, repair defective circuit, and afterwards swing red reset lever of breaker to close the circuit.



FIGURE 1: BREAKER WITH MANUAL TRIP BUTTON AND RESET LEVER SUCH AS CB2 & CB6

2.6.1 X3 coach main circuit breakers

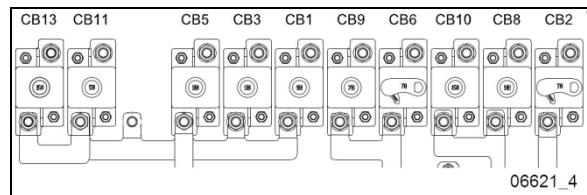

FIGURE 2: MAIN CIRCUIT BREAKERS – X3 SERIES COACHES

MAIN CIRCUIT BREAKERS – X3 COACH			
CB1	24 WUP front distribution	24 VI	90 A
CB2	12 ECU & 12VD front distribution – ignition & engine start	12 VD	70 A
CB3	HVAC – evaporator	24 VI	90 A
CB5	24 WUP rear distribution	24 VI	90 A
CB6	24VD rear distribution & WCL	24 VD	70 A
CB8	12 WUP rear distribution	12 VI	90 A
CB9	battery charger - preheater	24 VD	70 A
CB10	12 WUP front distribution	12 VI	150 A
CB11	Sound system	24 VI	50 A
CB13	Inverter 120 VAC outlets	24 VI	150 A

VD= volts direct. The electrical components connected to these circuit breakers are direct-connected to the battery.

VI= volts indirect. Electrical power is supplied via master relay R1 which engages when ignition key is in the ON or ACC position and main electrical shut-off switch is set to ON.

2.6.2 X3 VIP main circuit breakers

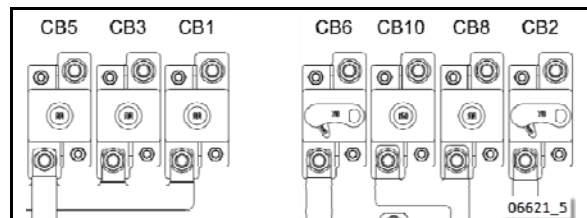

FIGURE 3: MAIN CIRCUIT BREAKERS – X3 VIP SERIES

MAIN CIRCUIT BREAKERS – X3 VIP			
CB1	24 WUP front distribution	24 VI	90 A
CB2	12VD front distribution – ignition & engine start	12 VD	70 A
CB3	24WUP Main distribution power full A/C	24 VI	90 A
CB5	24 WUP rear distribution	24 VI	90 A
CB6	24VD rear distribution	24 VD	70 A
CB8	12 WUP rear distribution	12 VI	90 A
CB10	12 WUP front distribution	12 VI	150 A

VD= volts direct. The electrical components connected to these circuit breakers are direct-connected to the battery.
 VI= volts indirect. Electrical power is supplied via master relay R1 which engages when ignition key is in the ON or ACC position and main electrical shut-off switch is set to ON.

2.6.3 VECR/VECF breakers

Smaller circuit breakers are located in the VECF and VECR in front and rear electrical compartment respectively.

2.6.4 Electric Cooling fan circuit breakers

MAXI 50 Amp automatic reset CB

Each radiator or Charge Air Cooler electric fan may be protected by a MAXI 50 amp single pole thermal type breaker with automatic reset. If tripped, the circuit breaker remains open until it has cooled down sufficiently. These circuit breakers are located in the electric fan drive breaker box (FIGURE 4).



This type of circuit breaker inserts in MAXI fuse blades mounting style. Simply pull the circuit breaker off the blade type mount to replace.

MAXI 50 Amp manual reset CB

Each radiator or Charge Air Cooler electric fan may be protected by a MAXI 50 amp single pole thermal type breaker with manual reset. If tripped, the circuit breaker remains open until it is reset by pressing the reset button.



This type of circuit breaker inserts in MAXI fuse blades mounting style. Simply pull the circuit breaker off the blade type mount to replace.

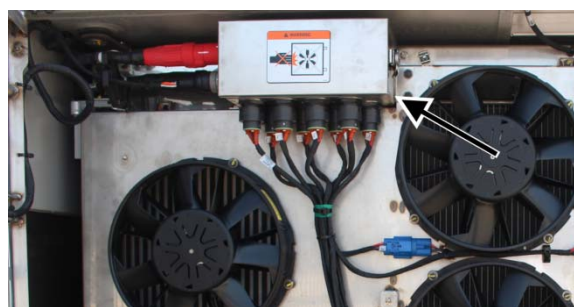

FIGURE 4: ELECTRIC COOLING FAN CIRCUIT BREAKER BOX

ELECTRIC FAN DRIVE 50 Amps CIRCUIT BREAKERS			
ID	Description		connector
CB201	Charge Air Cooler fan #1	Mo65	1
CB202	Charge Air Cooler fan #2	Mo67	2
CB203	Radiator fan #3	Mo68	3
CB204	Radiator fan #4	Mo69	4
CB205	Radiator fan #5	Mo70	5
CB206	Radiator fan #6	Mo71	6
CB207	Radiator fan #7	Mo72	7
CB208	Radiator fan #8	Mo73	8

2.7 COOLING FAN CONNECTIONS

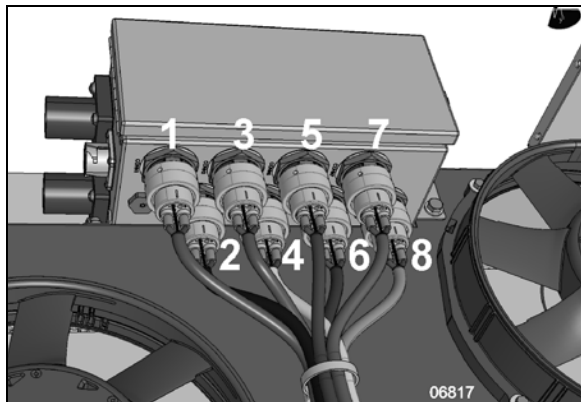

FIGURE 5: COOLING FANS CIRCUIT BREAKER BOX - CONNECTOR NUMBER

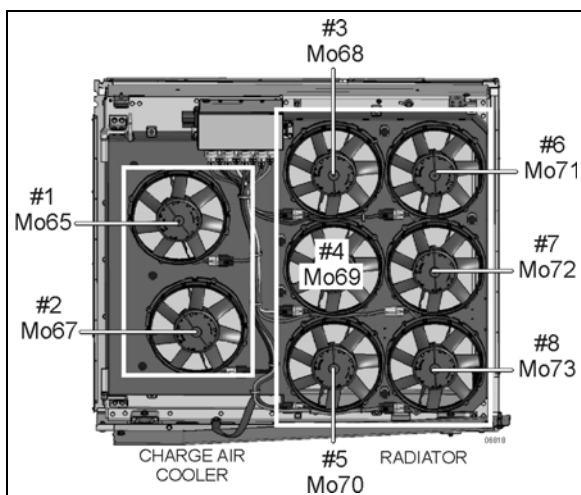

FIGURE 6: COOLING FAN IDENTIFICATION



WARNING

WHEN THE ENGINE IS RUNNING...

Cooling fans may start running at any moment.

Keep hands away from cooling fans or keep the radiator door closed.



WARNING

Cooling fans may be running when the engine is shut down in the following conditions:

- If a High Exhaust Temperature condition exists (e.g. following regeneration). The CAC fans will keep running for a maximum of 15 minutes.
- During the **Electric Motor Test**

Sequence, the cooling fans will start running briefly.

The CAC fans and the radiator fans are controlled by two multiplex modules, i.e. AE49 & AE52. Each module controls one (1) CAC fan and three (3) radiator fans. For this reason, if one module fails, sufficient cooling will still be available for the CAC and the radiator through the second module.

Module AE49: Fans 1, 4, 6, 8

Module AE54: Fans 2, 3, 5, 7

If one fan doesn't function, diagnose the probable causes of failure for this particular fan. If one CAC fan and three radiator fans are not functioning, then you should suspect that one of the multiplex modules (AE49 or AE52) is defective.

2.8 MULTIPLEX FUSES

The multiplex outputs are protected in current by an internal "soft-fuse". Each output has programmed specific maximum amperage. When an output is shorted, the current gets above the limit and the soft-fuse intervenes to turn the output OFF. The output stays OFF until the "soft-fuse" is reset.

Turn the ignition key to the OFF position and turn to the ON position again. This resets all "soft-fuses".

There is also hardware fuses used to protect the incoming power to the multiplex modules. These fuses are located inside the VECF (Vehicle Electrical Center Front) and VECR (Vehicle Electrical Center Rear).

2.9 ELECTRONIC GROUND

All the electronic modules installed on this vehicle are grounded to the electronic ground stud located in the main power compartment, using separate and protected circuits.

All the loads fed by a particular electronic module are grounded to that same module. However, a load can be grounded to another module in the situation when the load can be powered by two different modules for redundancy need.

2.10 RELAYS

Relays are used to automatically energize or de-energize a circuit from a remote location. The relay draws a very low current to energize its coil. Once the coil is energized, it develops a magnetic field that pulls a switch arm closed or open, to either energize or de-energize a given component. As the control current required for the coil is very low, the relay allows a remote station to control a high energy circuit without running great lengths of costly high capacity cable, and also eliminates the need for high amperage switches and heavy connectors.

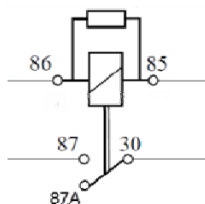

86 coil
85 coil
30 common feed
87 normally open contact NO
87A normally closed contact NC

FIGURE 7: SINGLE POLE DOUBLE THROW RELAY

NOTE

Each relay is identified with "12V" or "24V" printed on its casing in order to identify the coil operating voltage.

**CAUTION**

The Multiplex vehicle uses a VF4 relay specially designed for Volvo that has different internal characteristics than the current VF4 relay. It is important to use only the new part marked Volvo as a replacement in Multiplex

vehicles. Regular relays have an inadequate lifespan for Multiplex vehicles.

2.11 PRECAUTIONS

**DANGER**

Prior to working on a system inside vehicle, make sure to cut electrical power and air supply. A component could be supplied with electricity even if the ignition switch is set to the OFF position and/or a component could be pressurized even if air tanks are emptied. Always refer to the appropriate wiring and pneumatic diagrams prior to working on electrical and/or pneumatic systems.

NOTE

When the ignition switch is set to the OFF position, the electrical components are not energized except for the MCM, engine ECU, transmission ECU, instrument cluster module, the battery equalizer, the preheater system, AFSS, the wheelchair lift system and some Multiplex modules which remain energized during 15 minutes after the ignition has been set to the OFF position. Prior to working on one of these electrical components, set the main electrical shut-off switch located above the batteries, on the exterior wall of the main power compartment to the OFF position.

If the vehicle will not be operated for a long period (more than 2 weeks), it is recommended, in order to prevent the batteries from discharging, to trip main circuit breakers CB2 & CB6 located on the rear junction panel to stop the small current drawn by the radio preset station memory, the MCM memory and the instrument cluster clock. Note that the radio station presets will be erased, same thing for the diagnostic codes history and the instrument cluster clock will have to be reset.

2.12 ELECTRONIC MODULES CONNECTOR PIN-OUT

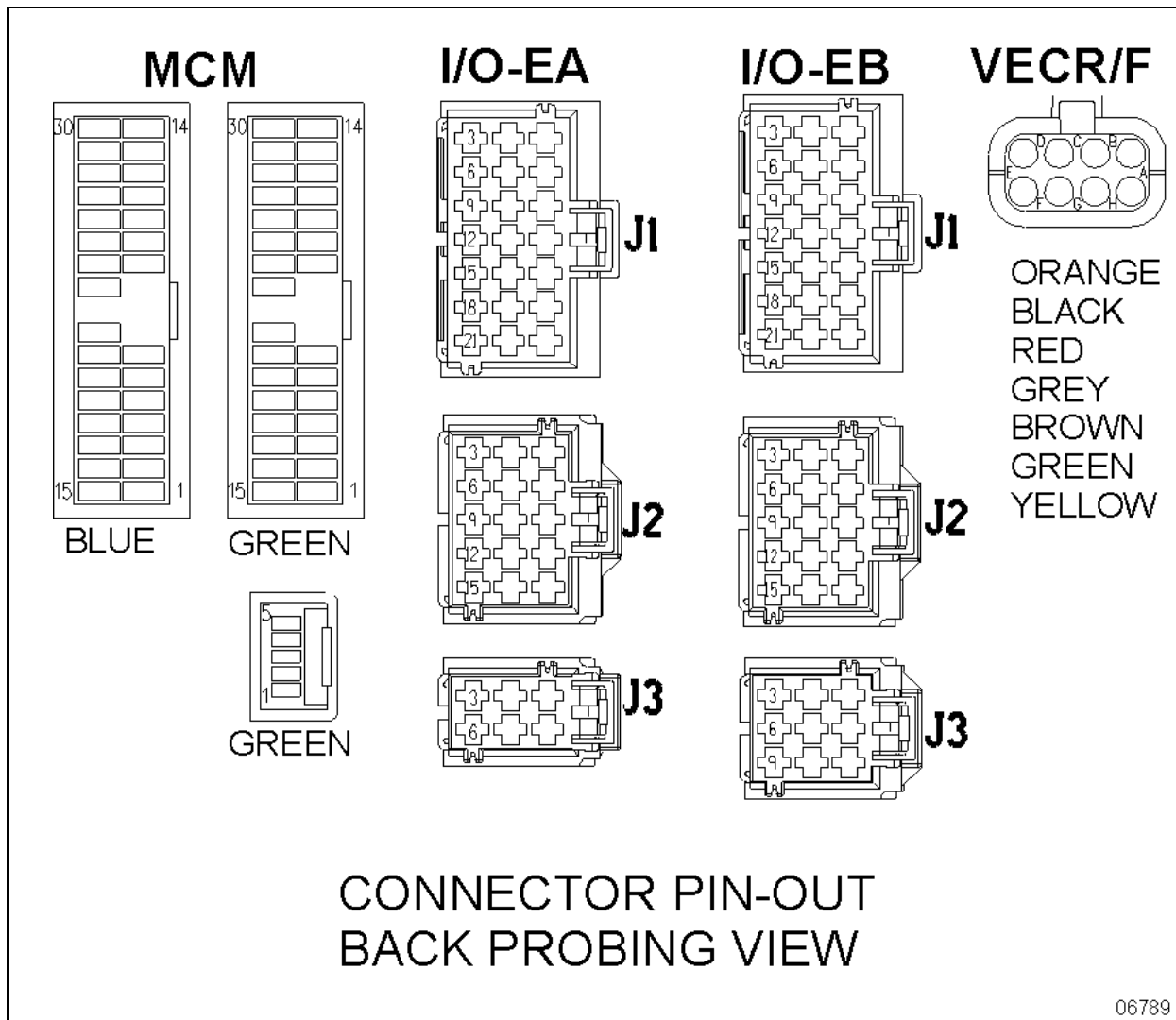

FIGURE 8: VECR/VECF & MULTIPLEX MODULE CONNECTORS PIN-OUT

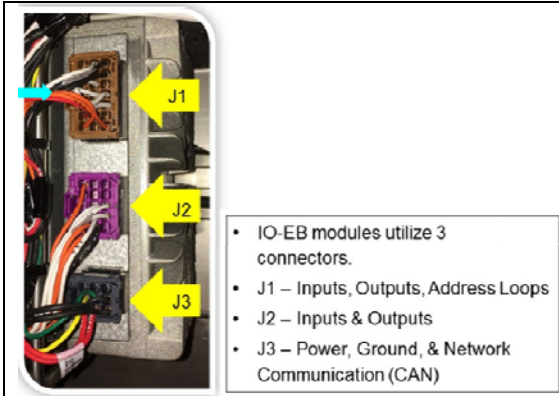

FIGURE 9: I/O-EB MODULE

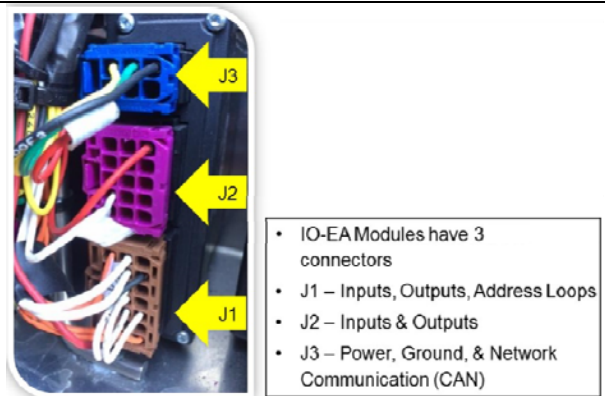

FIGURE 10: I/O-EA MODULE

I/O-EA & I/O-EB MUX modules

Connector: AMP MCP 2.8

Contact loading of housings

Loading the contacts is only possible if the secondary lock is in the unlock position.

Proper orientation of the contact is important. If the orientation is incorrect, the contact stops too early in the region of the secondary lock and the whole crimp stands out from the housing. With correct orientation the secondary lock stops with a metallic “click” sound.

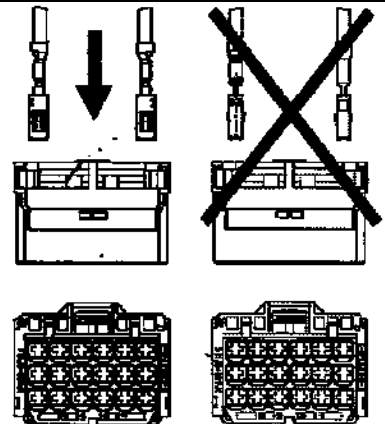

Locking the secondary lock

Delivery state of the secondary lock is the open position. In this position the AMP MCP2.8 contacts can be loaded. After that the secondary lock is moved into the final locking position by hand.

At a sufficient large surface a perpendicular force is initiated by (preferably) the thumb of one hand. Proper final position is reached a click noise can be heard. Make sure that both sides are locked.

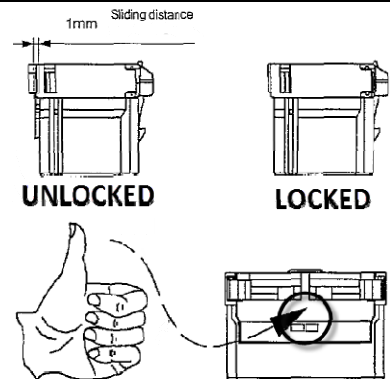

Unlocking the secondary lock

To unlock the secondary lock on these housings, a simple solid commercial ball pen is sufficient. The ball pen has to be inserted perpendicularly according the image, between the locking latch of the housing and the secondary lock block. Then it will be pushed with care until the opening is felt (a “click” sound can be heard).

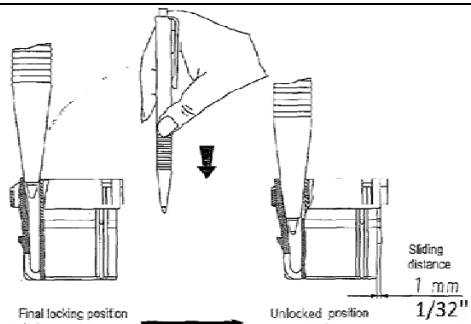
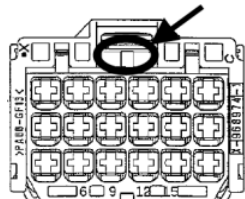

Extracting the contacts from housings

To extract contacts, the secondary lock has to be in the unlock position. The tool has to be inserted from connection side into the cavity of housing up to the stop; the contact will be unlocked thereby. Keep the tool in that position and then take the contact out by pulling on the cable. Note: Do not pull the cable before unlocking the contact; on the other hand by pressing the cable gently against the cable outlet direction the unlocking procedure will be facilitated.



EXTRACTOR/TOOL: Prevast 568103

Multiplex modules	Connector type	Contact removal
<p>VECR / VECF 06627</p>	<p>INSERT EXTRACTOR HERE</p> <p>Orange Black Red Grey Brown Green Yellow</p> <p>BUSSMAN 06632</p>	<p>EXTRACTOR/TOOL: Prevast #682256 (Packard 12094429)</p> <p>Remove the terminal by disengaging the flexible lock tab on the terminal. Gently remove the terminal from the connector by pulling on the wire.</p>

3. TROUBLESHOOTING AND TESTING THE MULTIPLEX VEHICLES

3.1 PROBING VOLTAGE ON THE MULTIPLEX CIRCUITS

Some Multiplex modules are supplied by 12 volts while others are supplied by 24 volts. The 12-volt or 24-volt information is found on the modules symbol in the wiring diagram. Before taking voltage readings to track the source of a problem, first verify if the module is supplied by 12V or 24V, if not, residual voltage on the module inputs/outputs can draw an erroneous conclusion.

Inactive Multiplex output = Residual voltage of 18% to 33% of supply voltage.

Inactive Multiplex input = Residual voltage of 50% of supply voltage.

NOTE

- *Verify on the wiring diagram whether the voltage is 12V or 24V,*
- *For a 12V module: an active voltage would be 12V or 0V but not in between. If you measure the intermediate tensions (ex. 6V, 2V, or 4V) this must be interpreted as if the input or the output is inactive.*
- *For a 24V module: an active voltage would be 24V or 0V but not in between. If you measure the intermediate tensions (ex. 12V, 4V, or 8V) this must be interpreted as if the input or the output is inactive.*

3.2 DL0 (BBUS MUX) NETWORK

The DL0 (BBUS MUX) network wiring is separated in sections and uses connectors that are not shared with other circuits. This allows sections of the network to be isolated to help locate short-circuit on the DL0 (BBUS MUX).

In case of a short-circuit on the DL0 (BBUS MUX) network, this affects all the modules and they all act as “No response” in the error messages of the “ELECTRICAL SYSTEM” menu. To locate a short-circuit, proceed by disconnecting one module zone at a time while verifying if this makes inactive the errors in the modules still connected. Connector C1 (front electrical & service compartment) disconnects all the modules at the rear of the vehicle from the network. Connector C5 (front electrical & service compartment) disconnects all the

modules from the entrance door & wiper control panel. Connector C3 (rear electrical panel) disconnects all the modules at the rear of the vehicle from the network.

Example: Disconnect C5 and C1 and then verify the status of the errors. If the front modules (A41 to A46) now give inactive errors, which means short-circuit is elsewhere than in the front electrical & service compartment.

3.2.1 DL0 (BBUS MUX) Connection On The Telltale Panel And The Hvac Control Unit

The telltale panel module and HVAC module are linked to the MCM by a DL0 (BBUS MUX) connection. In case of a connection default, the telltale panel LCD display shows "CAN", and on the HVAC control unit, the temperature display indicates "---". To confirm a connection default, check that the fan speed on the driver's section HVAC control unit cannot be adjusted.

Moreover, specific error messages from these 2 modules can be read in the ELECTRICAL SYSTEM menu.

NOTE

While downloading a new vehicle program in the MCM from a computer, the DL0 (BBUS MUX) network is temporarily interrupted and therefore a DL0 (BBUS MUX) reference appears in the telltale panel LCD display.

3.2.2 Spare DL0 (BBUS MUX)

A spare DL0 (BBUS MUX) network is installed between the front and the rear of the vehicle. It has connectors installed at each end to facilitate swapping from the regular DL0 (BBUS MUX) network to the spare DL0 (BBUS MUX) network. Refer to the vehicle wiring diagram and section 4.6 for more information.

3.3 ELECTRICAL SYSTEM DIAGNOSTIC

Using the Driver's Info Display (DID), check if there are active errors in the vehicle electrical system. With the SYSTEM DIAGNOSTIC menu, highlight FAULT DIAGNOSTIC and then highlight ELECTRICAL SYSTEM to request a diagnostic of the electrical system from the MCM. Press the enter key. If applicable, the DID shows the multiplex device ID, the fault messages or fault codes recorded. When more than one fault is recorded, an arrow pointing down appears on the right of the display. Use the down arrow to see all the fault messages.

Once the problem corrected, the DID still shows the fault as being active. You have to leave the FAULT DIAGNOSTIC menu, wait approximately 20 to 30 seconds and then return to FAULT DIAGNOSTIC to request a new diagnostic of the ELECTRICAL SYSTEM from the MCM. The DID should display the fault as being inactive. The MCM can store up to 20 faults, i.e. the first 10 and the last 10. Middle faults will be erased. If the breakers are tripped, the fault history will be erased from the MCM memory.

NOTE

When performing an electrical system diagnostic with the DID, the message « No Response ModA41 » indicates either module A41 is not responding due to a DLO (BBUS MUX) link problem or module A41 is not powered. Similar messages exist for all modules (A42, A43, A44, etc.).

NOTE

Because it is easier to do, check first if the module is powered by probing on its gray connector. If it is, then you can conclude that there is a DLO (BBUS MUX) link problem. Refer to DLO (BBUS MUX) NETWORK LAYOUT AND TROUBLESHOOTING in this section.

3.4 MULTIPLEX INPUT TEST MODE

The multiplex input test provides useful information to diagnose multiplexed inputs of switches and sensors, complimentary to the electrical system diagnosis.

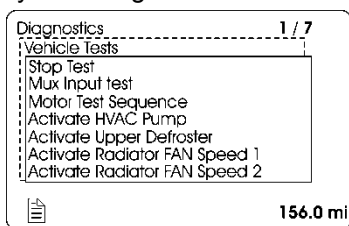

To initiate the test mode, use the Driver Information Display (DID) DIAGNOSTICS menu. Select VEHICLE TESTS submenu and then MUX INPUT TEST. Press ENTER button to start the test. The DID status line will show TEST to confirm the test mode is active. To exit test, press ESCAPE button, select STOP TEST submenu and then press ENTER button twice. TEST will disappear from the DID status line.

Instrument panel audible alarm emits a *beep* each time an OFF/ON transition is detected on a multiplex input. This allows quick verifying if the switches and sensors are detected or seen by the multiplex modules. When the vehicle is parked, the back-up alarm also emits a *beep* that allows verification of the sensors at the rear of the vehicle.

Certain inputs are doubled (for example, turn signal switch on multi-function lever, door operating buttons) and also other inputs activate at the same time (ex. kneeling switch and Kneeling proximity sensor switch). For these inputs, 2 *beeps* are emitted. If only one *beep* is heard, one of the inputs is defective.

SWITCHES AND SENSORS SUPPORTED BY THE SWITCH/SENSOR TEST MODE

HVAC control unit driver's section ON/OFF
HVAC control unit driver recirculate switch
HVAC overhead compartment fan switch
HVAC control unit passenger's section ON/OFF
Radiator fan clutch switch
Engine rear start selector switch "rear start"
Engine rear start selector switch "normal"
Engine ignition front switch
Engine ignition rear switch
Entrance door inside opening /closing switch
Entrance door outside opening /closing switch
Electric horn button
Kneeling down switch
Kneeling up switch
Baggage compartment locking system switch
Baggage compartment door ajar open sensor
Steering wheel control buttons
Lavatory emergency switch
Interior lighting switch, 2 positions
Driver's area lighting switch
Reading lights switch
Multi-function lever LH turn signal
Multi-function lever RH turn signal

Fog lights switch
Hazard warning flashers switch
Multi-function lever courtesy blinkers switch
Headlights switch, 2 positions
Multi-function lever headlights beam toggle switch
Baggage compartment door lock/unlock switch
Tag axle lever
Wheelchair lift activation switch
Windshield lower wiper
Multi-function lever windshield wipers intermit.
Lower windshield wipers backup switch
Lower windshield washer switch
Upper windshield washer switch
Upper windshield wipers switch, 2 positions

The following inputs, either certain options or sensors which are difficult to activate, are not supported by the switch/sensor test:

- Service chime enable switch,
- Horn selector switch,
- Outside rear view mirror heat,
- Mirror control switches,
- Low-buoy switch,
- Starter sensor,
- ABS warning input,
- WCL switch,
- Driver's power window switch,
- Fog lights switch,
- Alternator sensors 1 & 2,
- Retarder active signal,
- Radiator fan speed 1 & 2 signals.

In test mode, with the parking brake applied and the passenger set point set to a value higher than 64°F (18°C), the circulator pump is not set to OFF as it would normally do when the outside temperature gets above 50°F (10°C). This feature allows verification of the pump when inside a garage. This is also useful when

working on the heating system to remove air pockets trapped in the system.

When performing an A/C cooling test and having the water pump shut off is required, initiate the multiplex input test mode. While in this mode, just set the passenger set point temperature to the minimum 64°F (18°C) to shut off the pump.

3.5 MOTOR TEST SEQUENCE

This test mode allows testing of the electric motors, the A/C compressor clutch and unloader and the HVAC system solenoid valves without the need to have the engine running. Note that while in test mode, the engine cannot be started.

Prerequisite conditions for the motor test mode:

- The battery charger must be connected to a 110-120 volt power supply. If not, the test will be interrupted when the voltage drops below 24.4 volts,
- Engine not running,
- Parking brake applied,



DANGER

Before starting the test sequence, make sure that no one is doing maintenance in the evaporator compartment, the condenser compartment or close to the CAC & radiator electric cooling fans.

NOTE

The back-up alarm will sound (beep) ten (10) times prior the test starts to warn the persons who do work on the vehicle. Moreover, the alarm will beep to tell the person conducting the motor test sequence to move to the next test location on the vehicle.

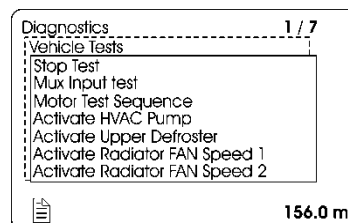

To enter this mode:

- Using the dashboard DID, select DIAGNOSTICS menu and press ENTER button ;

- Select VEHICLE TEST, press ENTER button then select MOTOR TEST SEQUENCE and press ENTER button to initiate the test mode for electrical motors;
- Ten (10) beeps can be heard indicating the motor test mode has started.

Using the test mode:

- During the entire test, the telltale panel audible alarm gives a signal each second to remind that the motor test mode is underway.

3.5.1 Test Sequence – Coaches only

Test Sequence – Coaches only	
Go to the condenser compartment	 <ul style="list-style-type: none"> • The condenser fans start. Speed will gradually increase to maximum speed. • The passenger's unit refrigerant solenoid valve activates. The refrigerant solenoid valve of the overhead compartment A/C system activates.

Then 5 beeps can be heard from the back-up alarm to indicate to go to the engine compartment.

In the engine compartment, the sequence is as follows	 <ul style="list-style-type: none"> • The main power compartment fan activates for 3 seconds. • Toilet fan motor starts. • A/C compressor clutch activates 3 times. • The compressor unloader activates 3 times. • The electric cooling fans start running for 20 seconds.
---	--

Then 5 beeps can be heard from the back-up alarm to indicate to go to the evaporator compartment.

In the evaporator compartment	 <ul style="list-style-type: none"> • Evaporator fan motor runs at speed 1 for 3 seconds then runs at speed 2 for 2 seconds. • Hot water pump starts running for 5 seconds and hot water pneumatic valve cycles 3 times.
-------------------------------	---

5 beeps from the back-up alarm indicate to get to the driver's area inside the vehicle.



Inside the vehicle	 <ul style="list-style-type: none"> • The driver's HVAC unit refrigerant solenoid valve cycles 3 times and the hot water pneumatic valve cycles 3 times also. • Left and right overhead compartment fans start running one after the other for 5 seconds. • The upper windshield defroster (optional) starts
--------------------	--

running.

To exit the electric motors test sequence, press ESCAPE button, select STOP TEST submenu and then press ENTER button twice.

3.5.2 Test Sequence – VIP With Central HVAC System

Test Sequence – VIP With Central HVAC System

		<ul style="list-style-type: none"> • Driver's & passenger's unit fresh air damper open. [20 seconds delay]
Go to the condenser compartment		<ul style="list-style-type: none"> • The condenser fans start. Speed will gradually increase to maximum speed. [3 seconds delay] • The passenger's unit refrigerant solenoid valve activates 3 times. [10 seconds delay]

Then 5 beeps can be heard from the back-up alarm to indicate to go to the engine compartment and main power compartment.

In the engine compartment, the sequence is as follows		<ul style="list-style-type: none"> • The main power compartment fan activates for 3 seconds. • A/C compressor clutch activates 3 times. • A/C compressor unloader activates 3 times. • The electric cooling fans start running for 20 seconds.
---	--	--

5 beeps from the back-up alarm indicate to go to the evaporator compartment.



In the evaporator compartment		<ul style="list-style-type: none"> • Evaporator fan motor runs at speed 1 for 3 seconds then runs at speed 2 for 2 seconds. • Hot water pump starts running for 5 seconds and hot water pneumatic valve cycles 3 times.
-------------------------------	---	---

5 beeps from the back-up alarm indicate to go to the spare wheel compartment behind the reclining bumper.

Inside the spare wheel compartment		<ul style="list-style-type: none"> • Driver's unit refrigerant solenoid valve activates 3 times. • Driver's unit hot water pneumatic valve cycles 3 times. • Closing of the fresh air dampers.
------------------------------------	---	---

To exit the electric motors test sequence, press ESCAPE button, select STOP TEST submenu and then press ENTER button twice.

3.5.3 Test Sequence – VIP With Small HVAC System

Test Sequence – VIP With Small System	
	 <ul style="list-style-type: none"> • Driver's unit fresh air damper opening. [20 seconds delay]
Go to the condenser compartment	 <ul style="list-style-type: none"> • The condenser fan start. Speed will gradually increase to maximum speed. [3 seconds delay]

Then 5 beeps can be heard from the back-up alarm to indicate to go to the engine compartment and main power compartment.

In the engine compartment, the sequence is as follows	 <ul style="list-style-type: none"> • The main power compartment fan activates for 3 seconds. • A/C compressor clutch activated 3 times. [5 seconds delay] • The electric cooling fans start running for 20 seconds.
---	--

5 beeps from the back-up alarm indicate to go to the spare wheel compartment behind the reclining bumper.

Inside the spare wheel compartment	 <ul style="list-style-type: none"> • Auxiliary unit refrigerant solenoid valve activates 3 times. [10 seconds delay] • Hot water pump starts running for 5 seconds. • Driver's unit refrigerant solenoid valve activates 3 times. • Driver's unit hot water pneumatic valve cycles 3 times. • Closing of the fresh air dampers.
<p>To exit the electric motors test sequence, press ESCAPE button, select STOP TEST submenu and then press ENTER button twice.</p>	

3.6 FORCED ACTIVATION OF THE COOLING FANS

To prevent the engine from overheating in case of malfunction of the cooling fans activation

system, it is possible to force activation of the CAC & radiator fans.

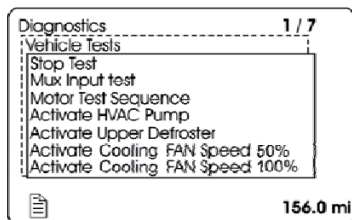

Prerequisite condition: The engine is running (fast idle if at stand still).

1. On the Driver Information Display, select DIAGNOSTICS menu. Select VEHICLE TESTS submenu and then ACTIVATE COOLING SPEED FAN 50% or ACTIVATE COOLING FAN SPEED 100% as required.
2. The DID status line will show TEST to confirm the forced activation of the radiator fan clutch. To cancel, turn the ignition switch to the OFF position or press ESCAPE button, select STOP TEST submenu and then press ENTER button

twice. TEST will disappear from the DID status line.



WARNING

Keep hands away from the cooling fans as they may start running at any moment.

3.7 DL0 (BBUS MUX) NETWORK LAYOUT AND TROUBLESHOOTING

MUX MODULE IDENTIFICATION	MODULE TYPE	LOCATION
A36	MCM	FJB
AE41	I/O-EA	FJB
AE42	I/O-EA	FJB
AE43	I/O-EB	FJB
AE44	I/O-EB	FJB
AE45	I/O-EB	FJB
AE46	I/O-EB	FJB
AE47	I/O-EB	R.H. CONSOLE
AE48	I/O-EB	R.H. CONSOLE
AE49	I/O-EB	RJB
AE50	I/O-EB	RJB
AE51	I/O-EB	RJB
AE52	I/O-EB	RJB
AE53	I/O-EB	PARCEL RACK
AE54	I/O-EB	EVAPORATOR CMPT
AE55	I/O-EA	DASHBOARD
AE56	I/O-EA	DASHBOARD
AE57	I/O-EA	WCL CMPT

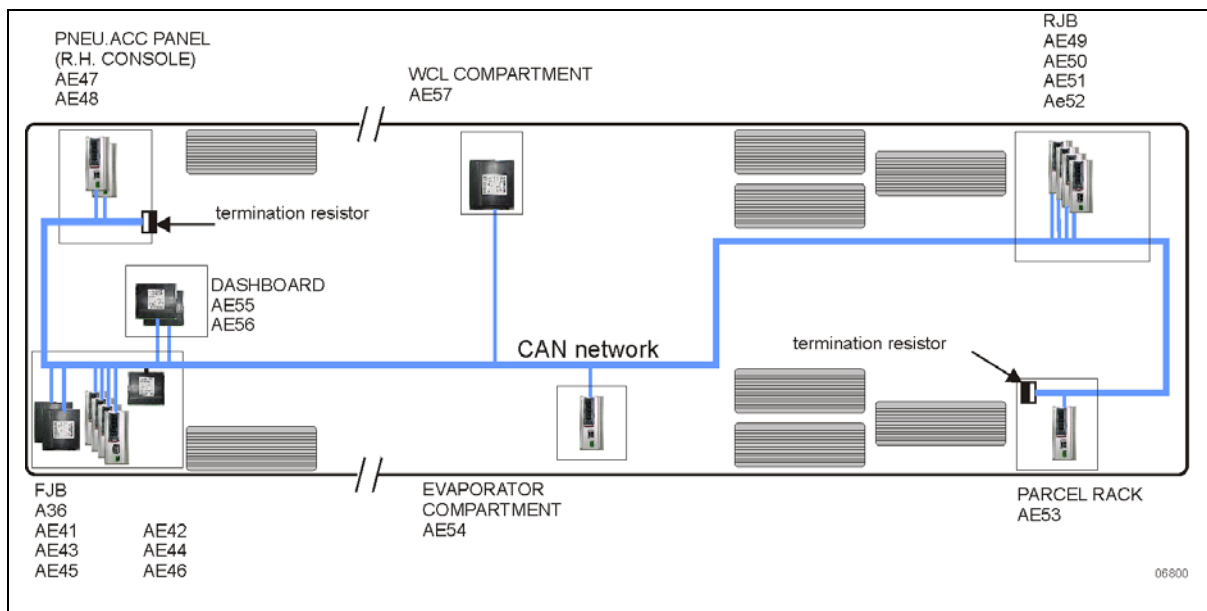

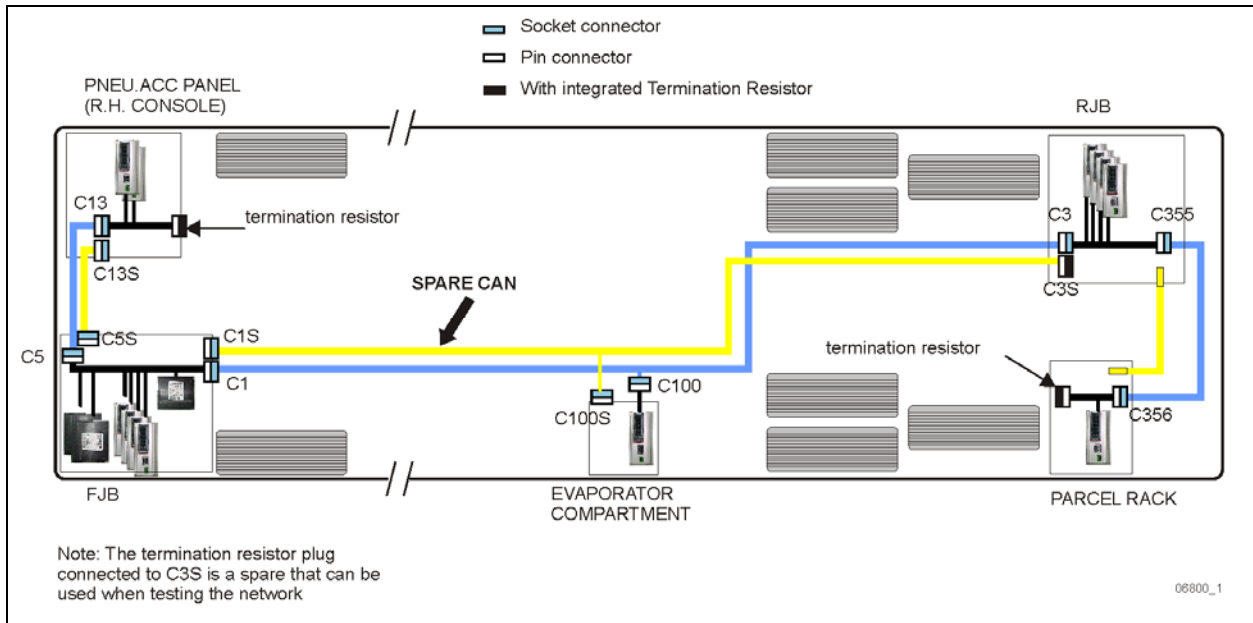

If all 17 modules (A41 to A57) are showed as Not Responding and Active Fault, the problem could be:

- A short circuit somewhere on the DLOH, DL0L (BBUS MUX) network.
- The network is completely open circuit. That means none of the two termination resistors are connected.

Several simple tests can be done to locate the problem.

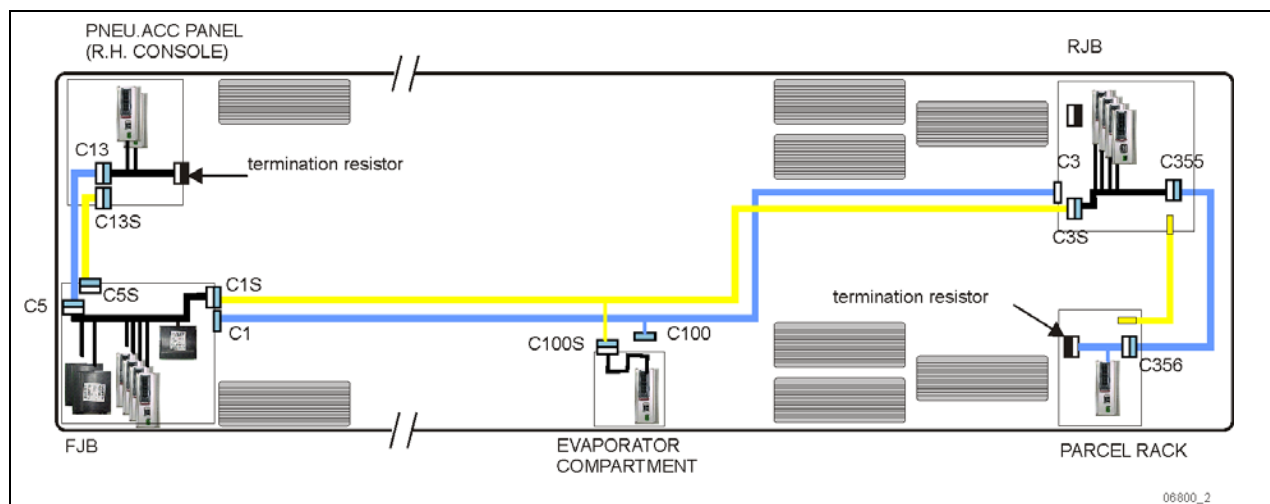

Use the spare "FJB to RJB" CAN

FJB: disconnect C1 and connect C1 pin housing to C1S socket housing.

RJB: disconnect C3 and connect C3 socket housing to C3S pin housing.

5th baggage compartment: disconnect C100 and connect C100 pin housing to C100S socket housing.

NOTE

All modules including Wake-up modules and MCM have to be powered OFF prior to probe the DL0 (BBUS MUX) lines with an ohmmeter.

Probing the resistance between the DL0H and DL0L wire is a useful method to localize short circuits or open circuit on the DL0 (BBUS MUX) network. However, when doing so, make sure none of the modules connected to the DL0 (BBUS MUX) line are powered, including wake-up powered modules and battery direct supply module (MCM). Otherwise the measured value is invalid and will always show OL (Open Load). This is because the modules are applying a voltage on the DL0 (BBUS MUX) lines and this is fooling the ohmmeter.

Proceed as follow when probing the DL0 (BBUS MUX) line with an ohmmeter in order to get a valid reading:

- Turn ignition key to the OFF position.
- Set the main electrical shut-off switch to the OFF position to turn all Wake-up modules power to OFF.

Trip circuit breakers CB2 and CB6 to remove direct battery power from the MCM.

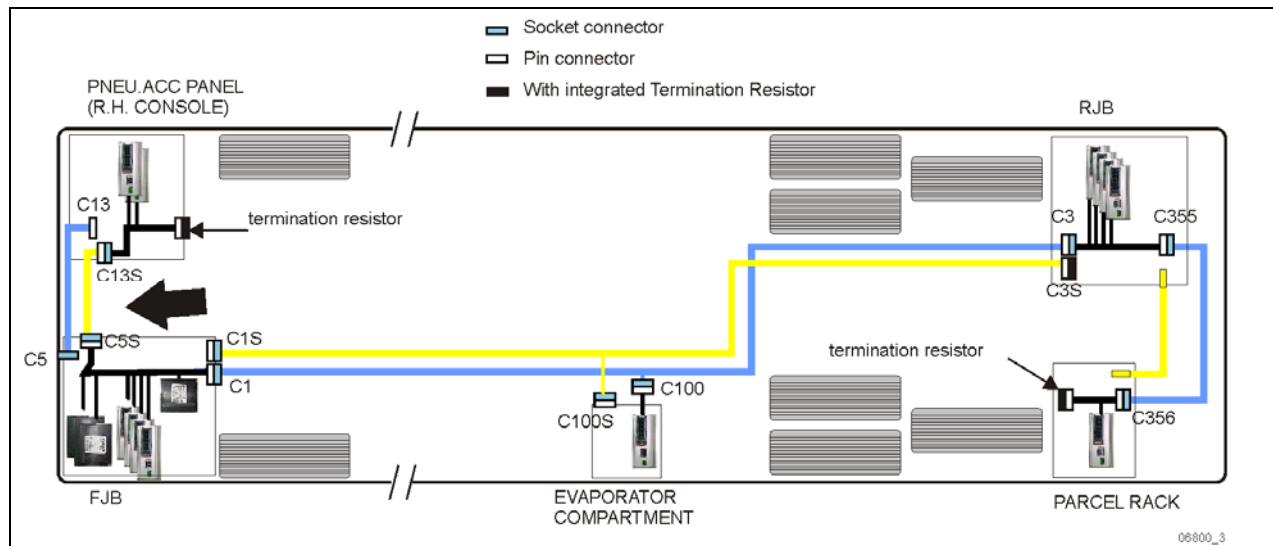

Use the spare "FJB to pneumatic accessory panel" CAN

Pneumatic accessory panel: disconnect C13 and connect C13S pin housing to C13 socket.

FJB: Disconnect C5 and connect C5S socket housing to C5 pin housing.

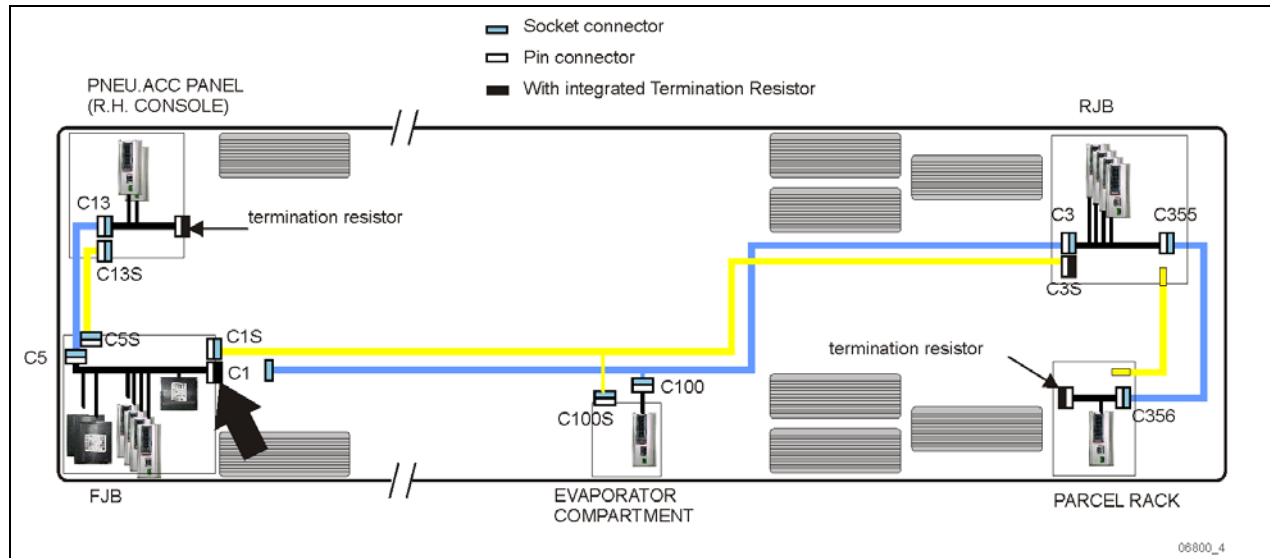

Isolate the front from the rear

Take one of the termination resistors in the RJB.

Disconnect C1 and connect the termination resistor to C1 pin housing.

If all the front modules respond normally, the short circuit is in the rear portion.

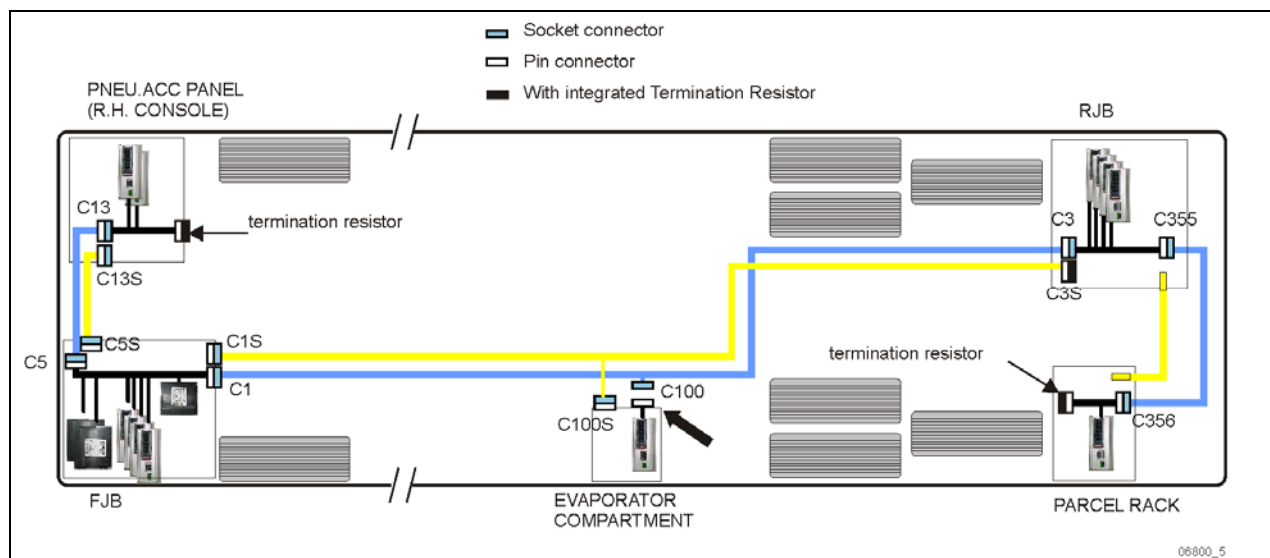

Isolate the evaporator module from the network

Disconnect C100.

No need to connect a termination resistor there since C100 is a stub connection.

If the short circuit problem is in the evaporator panel, all modules except AE54 will respond normally.

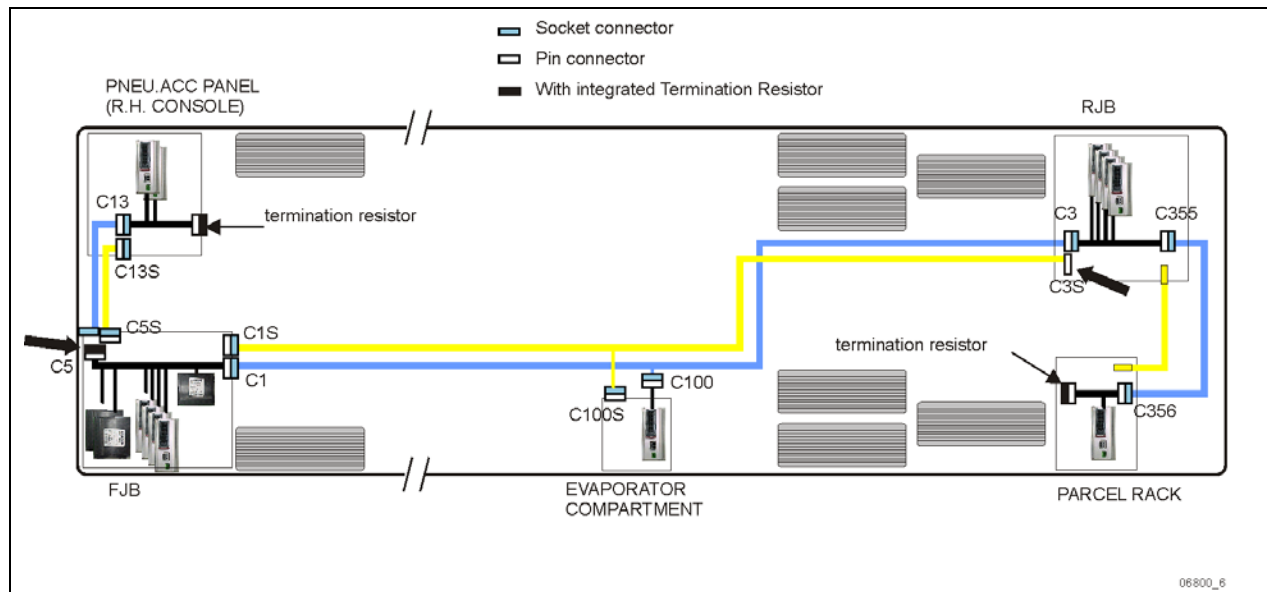

Isolate the pneumatic accessory panel modules from the network

In the FJB, disconnect C5.

Take the spare termination resistor on C3S in the RJB and connect it to C5 pin housing.

If the short circuit problem is in the pneumatic accessory panel all modules except AE47 and AE48 located into the pneumatic accessory panel will respond normally.

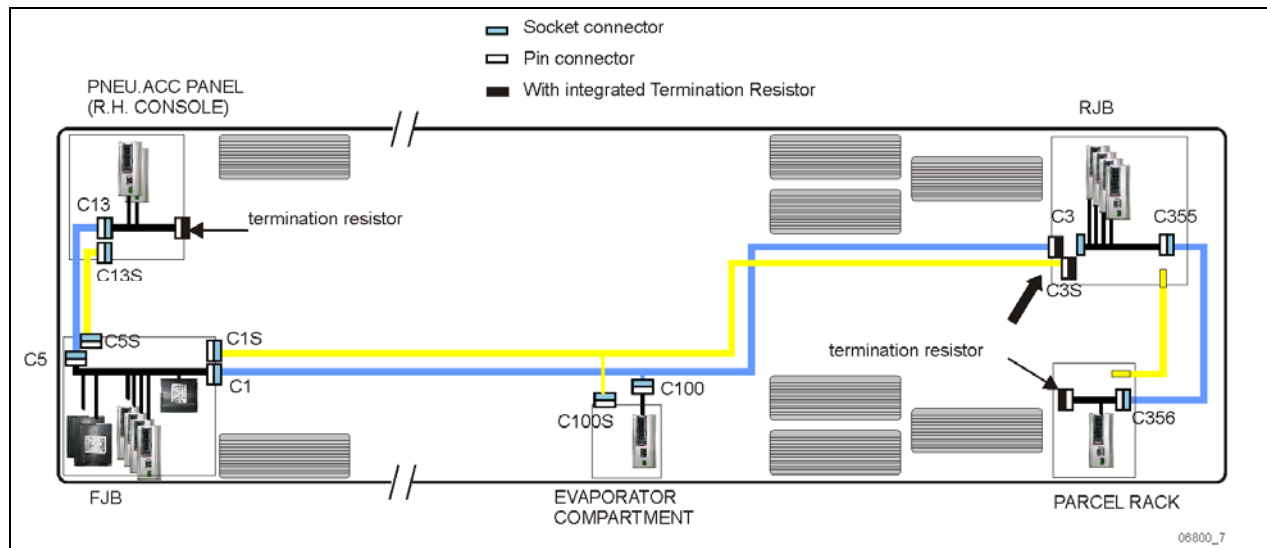

Isolate the RJB from the network

Disconnect C3 Plug and connect the termination resistor into C3 pin housing.

If the short circuit problem is in the RJB or downstream, all front modules + the evaporator module will respond normally.

The same process can be for the parcel rack module.

DL0 (BBUS MUX) wires are not like other common electrical wires.

- Maintaining a proper wire twisting is important. The two yellow and green wires must be twisted and in close contact all along the network to maintain the transmission line impedance.
- A slack handmade twisting is not acceptable.
- There should be no more than 50 mm (2 inches) without twist at the connection points.

We recommend replacing the DL0 (BBUS MUX) harnesses instead of trying to repair them.

3.8 TROUBLESHOOTING

Problem/Symptom	Probable Causes	Actions
Vehicle does not Start	The Engine Stop pushbutton located on the rear start panel is depressed Main electrical shut-off switch is in the OFF position	<ol style="list-style-type: none"> 1. Pull or twist the Engine Stop pushbutton to place it in normal operating position, check that the main electrical shut-off switch is in the ON position and retry cranking from the ignition switch 2. Start the vehicle from the engine compartment using the rear start button
	DL0 (BBUS MUX) network problem (Multiplex) Module AE53 not powered or is defective Engine ECM does not receive the ignition signal Engine ECM is not powered	If the vehicle does not start from the rear: <ol style="list-style-type: none"> 1. Verify that module A53 is powered: <ol style="list-style-type: none"> a) Check the SYSTEM DIAGNOSTIC menu of Driver Information Display (DID). Select FAULT DIAGNOSTIC and ELECTRICAL SYSTEM. The message "No Response ModA53, Active", indicates a power problem on the module or a DL0 (BBUS MUX) network problem. b) Check / reset circuit breaker CB5 c) Check / replace fuse F65 d) Probe gray connector on module to see if it is powered. 2. Verify that the engine ECM is powered and get the ignition signal <ol style="list-style-type: none"> a) Check / reset circuit breaker CB8 Check / replace fuse F74 b) Check / reset circuit breaker CB2 Check / replace fuse F78

Problem/Symptom	Probable Causes	Actions
<p>None of the Multiplexed functions are operating, including the basic limp-home functions (door opening, flashers, wipers in speed 1)</p> <p>“FLIP REAR BREAKER TO INITIATE I/O MODULES PROGRAMMING” pop-up message appears in the DID</p> <p><i>Note: The sunshades are still functioning since these are not multiplexed</i></p>	<p>The program version in the MCM is different than the program in the I/O modules and the MCM is forcing all I/O modules to stay inactive</p>	<ol style="list-style-type: none"> Engage the auto-programming of the I/O modules: Turn the ignition key to the ON position, trip and reset circuit breaker CB6. The DID indicates "MUX AUTOPROGRAMMING I/O MODULE PLEASE WAIT" until the reprogramming is complete.
<p>Many secondary functions (not essential for driving) not functioning (interior lighting, driver's area lighting, wiper speed 2 and intermittent).</p> <p>Marker lights and clearance lights are turned ON when setting ignition to the ON position.</p>	<p>The MCM module does not receive 24 V power.</p> <p>The DL0 (BBUS MUX) network is not working. It could be caused by a short on the network, an open circuit, a problem with the MCM or the MCM being disconnected from the network.</p>	<ol style="list-style-type: none"> Check / reset circuit breaker CB6. Check / replace fuse F1 Operate in limp-home mode by starting the vehicle from the engine compartment (REAR START). All functions essential to drive are available <p>To close and lock the door, pull the door manually up to its closed position and it will lock by itself. The door opening button is still functioning</p>
<p>No temperature control in the passenger area</p> <p>Passenger temperature display indicates two dashes "--"</p>	<p>Problem with the temperature sensor located in the evaporator compartment air intake or the sensor wiring</p>	<p>Instruct the driver to manually control the temperature by playing with the passenger set point. Set above 22°C (72°F) to heat and below 22° C (72°F) to cool</p>

Problem/Symptom	Probable Causes	Actions
<p>Entrance door does not open nor close using the control buttons</p> <p>Defroster fan not functioning</p> <p>Windshield wipers not functioning in speed 1 or intermittent</p>	<p>Module AE47 is not powered or is faulty</p>	<ol style="list-style-type: none"> 1. Check the SYSTEM DIAGNOSTIC menu of Driver Information Display (DID). Select FAULT DIAGNOSTIC and ELECTRICAL SYSTEM. The message "No Response ModA47, Active" indicates a power problem on the module. (A DL0 (BBUS MUX) network problem would show the same message but doesn't produce these symptoms). 2. Check / reset circuit breaker CB1 3. Check / replace fuse F45 4. Probe gray connector on module to see if it is powered. 5. Use the air release valves near the entrance door and in the front service compartment to lock / unlock the door
<p>Windshield wipers not functioning in speed 1 or intermittent</p>	<p>No power on R27</p>	<p>Check CB48 (VECF)</p>
<p>HVAC condenser fans not functioning in speed 1</p>	<p>Circuit breaker CB5 tripped</p>	<p>Check / reset circuit breaker CB5</p>
<p>HVAC condenser fans not functioning in speed 2</p>	<p>Circuit breaker CB5 tripped</p>	<p>Check / reset circuit breaker CB5 Check / replace fuse F135</p>
<p>Windshield washer not functioning</p> <p>Windshield upper section de-icing system not functioning</p>	<p>Module AE44 is not powered or is faulty</p>	<ol style="list-style-type: none"> 1. Check the SYSTEM DIAGNOSTIC menu of Driver Information Display (DID). Select FAULT DIAGNOSTIC and ELECTRICAL SYSTEM. The message "No Response ModA44, Active" indicates a power problem on the module. (A DL0 (BBUS MUX) network problem would show the same message but doesn't produce these symptoms). 2. Check / reset circuit breaker CB1 3. Check / replace fuse F44 4. Probe gray connector on module to see if it is powered.

Problem/Symptom	Probable Causes	Actions
Defroster fan is functioning but no heat or cooling available in the driver area.	Module AE47 is not powered or is faulty	<ol style="list-style-type: none"> 1. Check the SYSTEM DIAGNOSTIC menu of Driver Information Display (DID). Select FAULT DIAGNOSTIC and ELECTRICAL SYSTEM. The message "No Response ModA47, Active" indicates a power problem on the module. (A DL0 (BBUS MUX) network problem would show the same message but doesn't produce these symptoms). 2. Check / reset circuit breaker CB1 3. Check / replace fuse F45 4. Probe gray connector on module to see if it is powered.
<p>Low beam headlights and front flasher on left side not functioning</p> <p>Electric horn not functioning</p>	Module AE46 is not powered or is faulty	<ol style="list-style-type: none"> 1. Check the SYSTEM DIAGNOSTIC menu of Driver Information Display (DID). Select FAULT DIAGNOSTIC and ELECTRICAL SYSTEM. The message "No Response ModA46, Active" indicates a power problem on the module. (A DL0 (BBUS MUX) network problem would show the same message but doesn't produce these symptoms). 2. Check / reset circuit breaker CB10 3. Check / replace fuse F19 4. Probe gray connector on module to see if it is powered.
Low beam headlights and flasher on right side not functioning	Module AE48 is not powered or is faulty	<ol style="list-style-type: none"> 1. Check the SYSTEM DIAGNOSTIC menu of Driver Information Display (DID). Select FAULT DIAGNOSTIC and ELECTRICAL SYSTEM. The message "No Response ModA48, Active" indicates a power problem on the module. (A DL0 (BBUS MUX) network problem would show the same message but doesn't produce these symptoms). 2. Check / reset circuit breaker CB10 3. Check / replace fuse F21 4. Probe gray connector on module to see if it is powered.

Problem/Symptom	Probable Causes	Actions
<p>Rear flashers not functioning</p> <p>Stoplights and center stoplights not functioning</p>	<p>Module AE51 is not powered or is faulty</p>	<ol style="list-style-type: none"> 1. Check the SYSTEM DIAGNOSTIC menu of Driver Information Display (DID). Select FAULT DIAGNOSTIC and ELECTRICAL SYSTEM. The message "No Response ModA51, Active" indicates a power problem on the module. (A DL0 (BBUS MUX) network problem would show the same message but doesn't produce this symptom). 2. Check / reset circuit breaker CB8 3. Check / replace fuse F107 4. Probe gray connector on module to see if it is powered.
<p>Engine is overheating and radiator fans do not engage</p>	<p>Module AE52 or AE49 is not powered or is faulty</p>	<ol style="list-style-type: none"> 1. Check the SYSTEM DIAGNOSTIC menu of Driver Information Display (DID). Select FAULT DIAGNOSTIC and ELECTRICAL SYSTEM. The message "No Response ModA52/ModA49, Active" indicates a power problem on the module. (A DL0 (BBUS MUX) network problem would show the same message but doesn't produce this symptom). 2. Check circuit breaker CB5 3. Check / replace fuse F133, F134 4. CB201-CB208
<p>The A/C compressor clutch does not engage</p>	<p>Module AE54 is not powered or is faulty</p>	<ol style="list-style-type: none"> 5. Check the SYSTEM DIAGNOSTIC menu of Driver Information Display (DID). Select FAULT DIAGNOSTIC and ELECTRICAL SYSTEM. The message "No Response ModA54, Active" indicates a power problem on the module. (A DL0 (BBUS MUX) network problem would show the same message but doesn't produce this symptom). 6. Check / reset circuit breaker CB5 7. Check / replace fuse F135 8. Probe gray connector on module to see if it is powered.

Problem/Symptom	Probable Causes	Actions
Evaporator fan not functioning	Circuit breaker CB3 tripped Module AE54 is not powered or is faulty	<ol style="list-style-type: none"> 1. Check circuit breaker CB3 2. Check relay R12 3. Check the SYSTEM DIAGNOSTIC menu of Driver Information Display (DID). Select FAULT DIAGNOSTIC and ELECTRICAL SYSTEM. The message "No Response ModA54, Active" indicates a power problem on the module. (A DL0 (BBUS MUX) network problem would show the same message but doesn't produce this symptom). 4. Check / reset circuit breaker CB5 5. Check / replace fuse F135 6. Probe gray connector on module to see if it is powered.
HVAC condenser fans not functioning in speed 1	Module AE54 is not powered or is faulty	<ol style="list-style-type: none"> 1. Check the SYSTEM DIAGNOSTIC menu of Driver Information Display (DID). Select FAULT DIAGNOSTIC and ELECTRICAL SYSTEM. The message "No Response ModA54, Active" indicates a power problem on the module. (A DL0 (BBUS MUX) network problem would show the same message but doesn't produce this symptom). 2. Check / reset circuit breaker CB5 3. Check / replace fuse F135 4. Check / replace fuse F141-F144 5. Probe gray connector on module to see if it is powered.
Sound system not functioning	Circuit breaker CB11 tripped	<ol style="list-style-type: none"> 1. Check CB11 2. Check / replace fuse F148, F200
Fire alarm telltale light and audible alarm always ON and there is no fire or high temperature in the engine compartment	Short-circuited fire sensor or defective sensor	Prior to start the vehicle, cycle the ignition key to the ON position, OFF position and then ON position again and then start the vehicle. This will deactivate the fire alarm function. This has to be repeated each time the vehicle is re-started

Problem/Symptom	Probable Causes	Actions
The vehicle is parked and the electrical horn is activated to indicate a fire in the engine compartment but there is no fire	Short-circuited fire sensor or defective sensor	Cycle the ignition key between the ON and OFF position twice within 3 seconds. This will deactivate the fire alarm function. This has to be repeated each time the vehicle is parked
A single light, a group of LED lights or another function of the vehicle is not functioning	The multiplex outputs are protected in current by an internal "soft-fuse". When an output is shorted, it turns OFF and stays OFF until the "soft-fuse" is reset	Turn the ignition key to the OFF position and turn to the ON position again. This resets all "soft -fuses"
No backlighting in the instrument cluster	Circuit breaker CB10 is tripped or fuse F10/F29 blown	Check circuit breaker CB2, CB10 Check / replace fuse F10, F29 Check / replace relay R22, R23
The radiator/CAC fans do not function and the engine is overheating		You can manually engage the radiator/CAC fans half speed (50%) or full speed (100%). 1. On the Driver Information Display, select DIAGNOSTICS menu. Select VEHICLE TESTS submenu and then ACTIVATE RADIATOR FAN SPEED 50% or ACTIVATE RADIATOR FAN SPEED 100%. 2. The DID status line will show TEST to confirm the forced activation of the radiator fans. To cancel, turn the ignition switch to the OFF position or press ESCAPE button, select STOP TEST submenu and then press ENTER button twice. TEST will disappear from the DID status line.

3.9 DRIVER INFORMATION DISPLAY LIMP-HOME MODE

In case of malfunction of unavailability of the steering wheel UP, DOWN, ENTER & ESCAPE buttons, it is still possible to scroll through the DID menus using the multi-function lever.

To activate the DID limp-home mode, press and hold the courtesy blinkers button for 3 seconds. The limp-home mode will cancel if no switch is pressed before a 1 minute delay after activation.

Limp-home mode action	
Activate RH flasher	UP
Activate LH flasher	DOWN
Activate headlights call switch	ENTER
Press courtesy blinkers button	ESCAPE

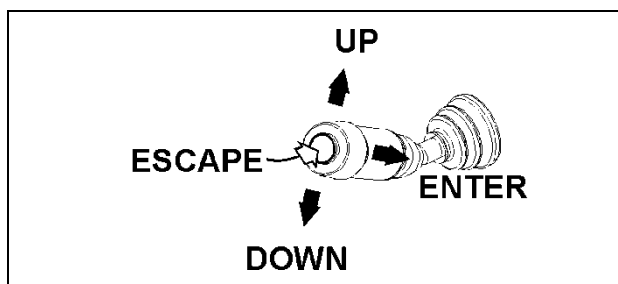

FIGURE 11: MULTIFUNCTION LEVER

3.10 ESSENTIAL FUNCTIONS TO OPERATE THE VEHICLE

Even with a defective MCM (Chassis Electronic Control Module) or a DL0 (BBUS MUX) network problem, essential base functions are maintained to rear start the vehicle from the engine compartment and drive in a secure manner.

However, many secondary functions are lost. In this case, the following directives must be followed.

- Never connect a battery charger when the ignition is at the ON position on a vehicle with a DL0 (BBUS MUX) defective or certain functions will start up by themselves,
- Disconnect the charger before starting the vehicle, if not the default functions will not activate,
- If the default mode does not activate, try to turn the ignition OFF while ensuring that no charger is connected and then restart the vehicle.

3.10.1 Available Functions

- Startup: Turn on the ignition in the driver's area and rear start the vehicle from the engine compartment,
- Opening the door: Functions normally,
- Closing the door: Manually pull on the door and it will lock automatically,
- Windshield wipers: Wipers functions at 1st speed only,
- Headlights: Low beams only,
- Directional signals: Rear and front only,
- Stoplights: 2 upper stoplights + high-mounted stoplight are functional,
- HVAC: Functional with set point fixed at 70°F (22°C), evaporator and condenser fixed at speed 1, defroster fixed at speed 4.

3.11 LOWER PRIORITY MODULES FOR BREAKDOWN SERVICE

Modules AE42 (I/O-EA) and AE43 (I/O-EB) affect lower priority functions. These modules can therefore be used as spare parts for breakdown service while on the road.

Functions lost if AE42 is removed and used as spare part:

- Kneeling system,

Functions lost if AE43 is removed and used as spare part:

- Cruise control & ACB,
- Baggage compartment door lock,
- Door ajar,
- Tire Pressure Monitoring System,

3.12 MULTIPLEX MODULES

3.12.1 MCM

The MCM plays the role of interface between the engine ECM, the transmission ECU, the telltale panel module and other I/O-EA, I/O-EB modules. When a multiplex module is being replaced, the MCM will inform the new module of its role and function accordingly to the vehicle options. The MCM keeps the back-up program of the vehicle specific multiplex program. So, a specific MCM cannot be removed from a vehicle and installed on another vehicle.

3.12.2 I/O-EA

I/O-EA modules receive inputs and control outputs. I/O-EA's are used for all outputs of 1 amp or less.

3.12.3 I/O-EB

I/O-EB modules receive inputs and control outputs. I/O-EB's are used for outputs up to 30 amps.

3.13 MULTIPLEX MODULES REPLACEMENT

3.13.1 Replacing I/O-EA Or I/O-EB Modules

I/O-EA, I/O-EB modules can be replaced and reprogrammed without having to connect a computer to the vehicle.

Set the ignition switch to the ON position and leave it in that position at all time while performing this procedure.

1. On rear electrical junction panel, trip circuit breaker CB6.
2. Replace the defective module.
3. Reset circuit breaker CB6. Doing so will initiate the I/O auto programming.
4. The DID indicates "MUX AUTOPROGRAMMING I/O MODULE PLEASE WAIT" until the reprogramming is complete unless a higher priority message must be displayed. If this is the case, press ESCape button repeatedly to acknowledge the higher priority messages.
5. Check the **Diagnostics** menu of the Driver Information Display (DID). Select **Fault Diagnostics** and **Electrical System**. Verify the fault message to be certain the module is reprogrammed. If the module is not reprogrammed, the message "Axx Not Responding" appears where Axx is the module number (Ex: A41, A42...etc).

NOTE

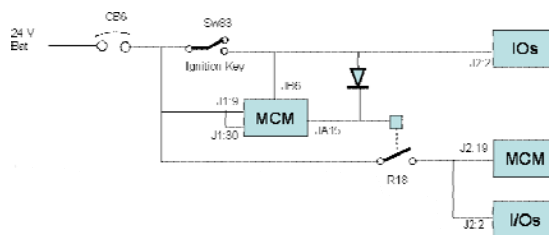

JB6 is a wake-up pin. JA15 output remains active for 5 minutes after JB6 is inactive.

When initiating reprogramming:

Switch SW83 (ignition key) remains closed, providing 24-volt on JB6, I/O modules and R18. All modules get power.

CB6 is tripped and reset which is forcing MCM reboot.

When resetting CB6, all modules get power, MCM goes into "start mode". I/O modules needing new program will request reprogramming to MCM while in "start mode".

3.13.2 Replacing the MCM Module

The MCM must be reprogrammed using a laptop computer equipped with VPG software, connected to C226 (DB9 connector) found in the front electrical compartment. However, an updated vehicle multiplex program saved on a laptop computer can be uploaded into the MCM module without the need of VPG software.

1. Set the ignition key to the ON position and leave it in that position at all time while performing this procedure.
2. On rear electrical junction panel, trip circuit breaker CB6.
3. Replace the module.
4. Reset circuit breaker CB6.
5. The vehicle specific program needs to be uploaded in the MCM.

3.13.3 Uploading the vehicle specific multiplex program into the MCM

A laptop computer running Windows XP or Windows 7 must be connected to the RS232 serial port DB9 connector (identified C226) found on the front service compartment electrical panel. Please contact your Prevost Service Representative in order to get the vehicle specific multiplex program and upload

procedure. Save the specific multiplex program on your laptop computer.



WARNING

WHEN UPLOADING A NEW MUX SOFTWARE INTO THE MCM ...

Cooling fans WILL start running for a short while.

Keep hands away from cooling fans or keep the radiator door closed.

4. ELECTRICAL COMPARTMENTS

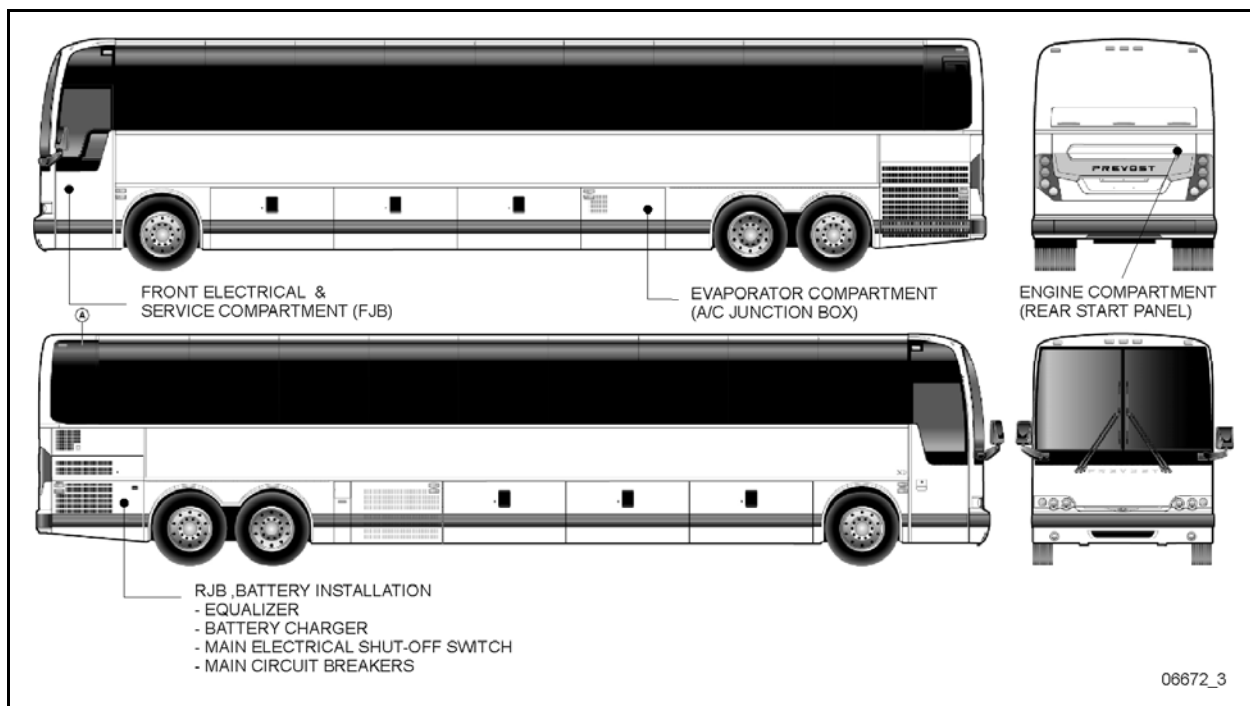

FIGURE 12: ELECTRICAL COMPARTMENTS (X3-45 COACH)

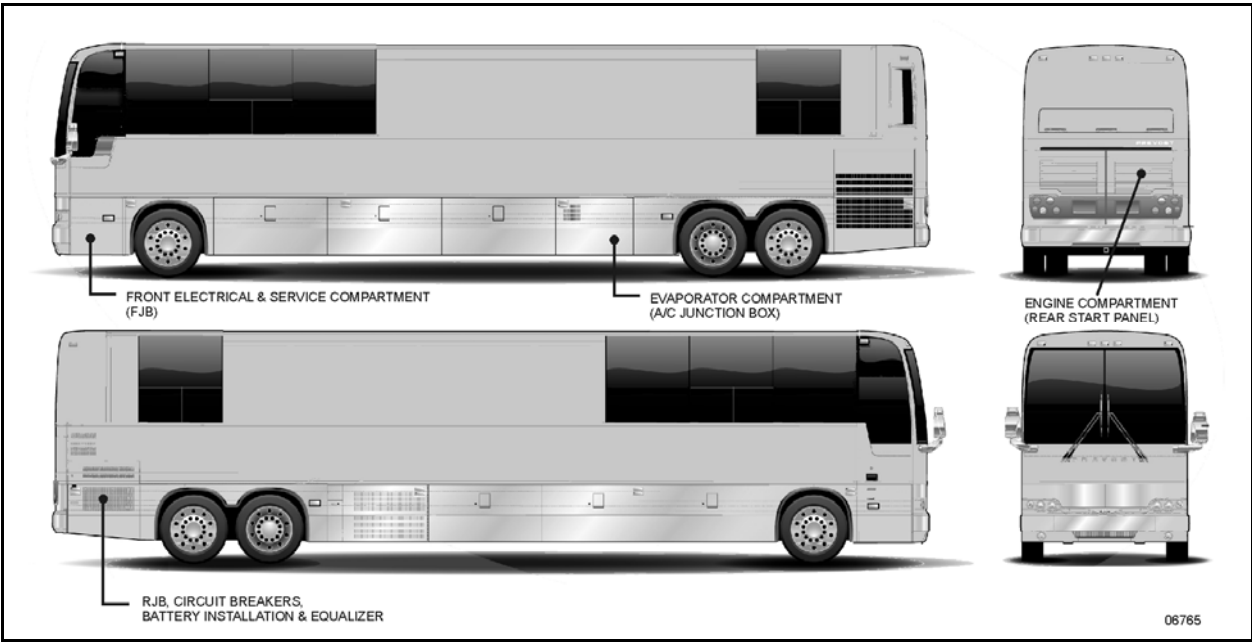

FIGURE 13: ELECTRICAL COMPARTMENTS (X3-45 VIP)

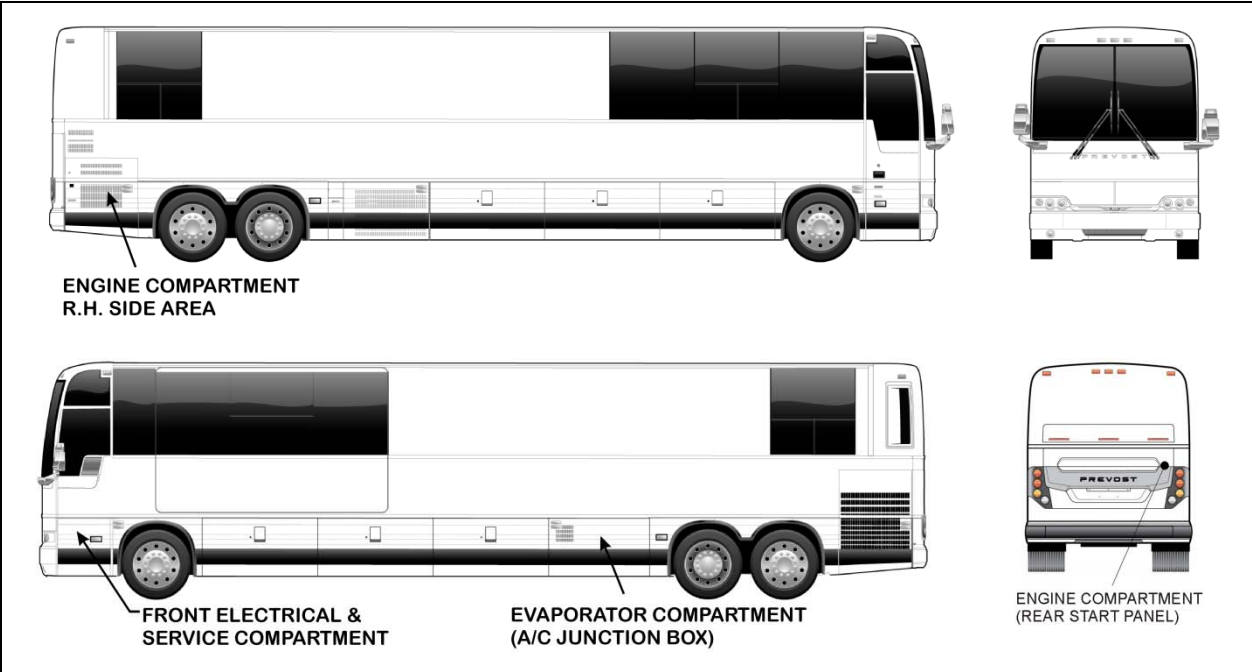

FIGURE 14: ELECTRICAL COMPARTMENTS (X3-45 VIP COMMERCIAL BUS SHELL)

4.1 MAINTENANCE

A corrosion inhibitor has been sprayed on certain electrical components in order to protect them from corrosion. Refer to procedure SAV00002E at the end of this section for recommended products and where they are used.

**CAUTION**

Never put grease or other product on the multiplex modules connector terminals.

**DANGER**

Use sprayed sealer in a well-ventilated area. Do not smoke. Avoid prolonged contact with skin and breathing of spray mist.

4.2 BATTERY INSTALLATION & REAR JUNCTION BOX

The battery installation and rear junction box (RJB) (Figure 15) are accessible from the engine compartment curb-side door.

The batteries are housed and secured on the engine R.H side deck. The battery posts and connections are protected by a watertight cover. The cover is fitted with a built-in vent. The cover can be unlocked and then removed with the use of the same type of hardware that allows opening and closing of the rear fender. Refer to paragraph 5.5 *Battery Removal and Installation* for the battery removal procedure.

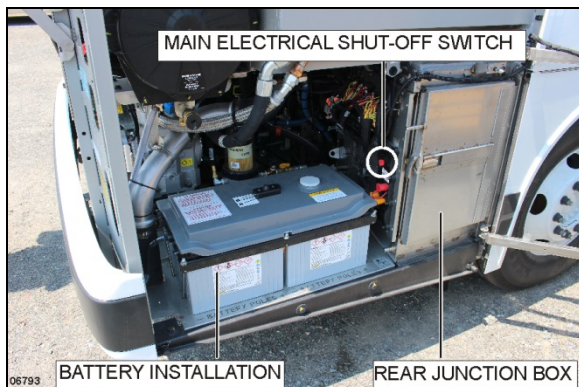

FIGURE 15: ENGINE R.H. SIDE COMPARTMENT

4.3 REAR JUNCTION BOX (RJB)

The main power compartment panel provides access to the following:

- Rear 12VD, 24VD junction blocks;
- Main circuit breakers;
- AE49, AE50, AE51, AE52 I/O-EB Multiplex modules;
- Vehicle Electrical Center Rear (VECR);
- Master relay R1;
- 12V ignition relay R3;
- Starter relay;
- Relays and fuses;
- Battery equalizer;
- 12VD & 24 VD current sensors;

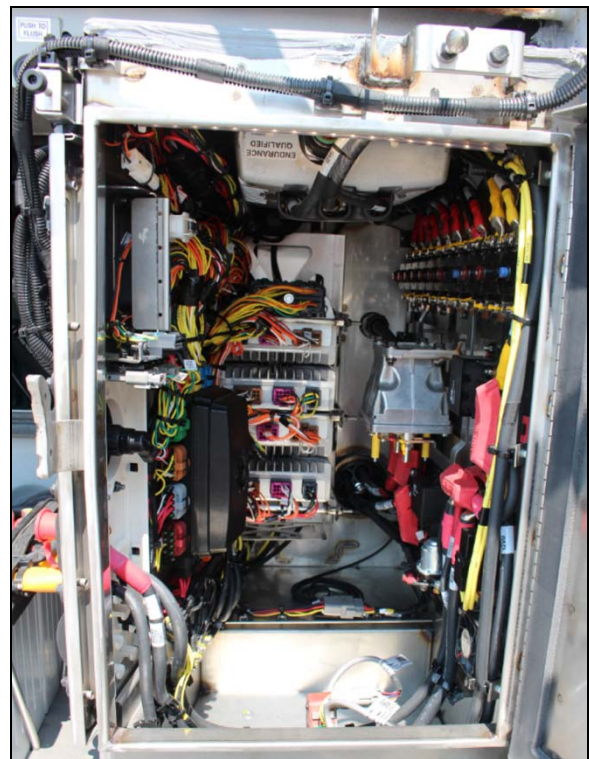

FIGURE 16: MAIN POWER COMPARTMENT

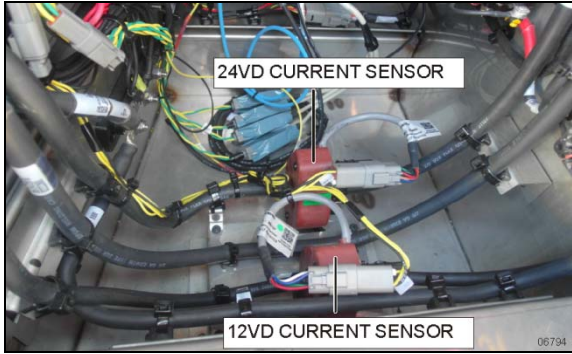

FIGURE 17: 12VD / 24VD CURRENT SENSORS IN MPC

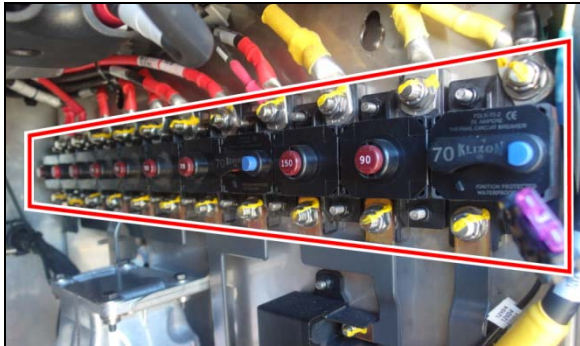

FIGURE 18: MAIN CIRCUIT BREAKERS IN MPC

SECTION 06B: X3 SERIES ELECTRICAL

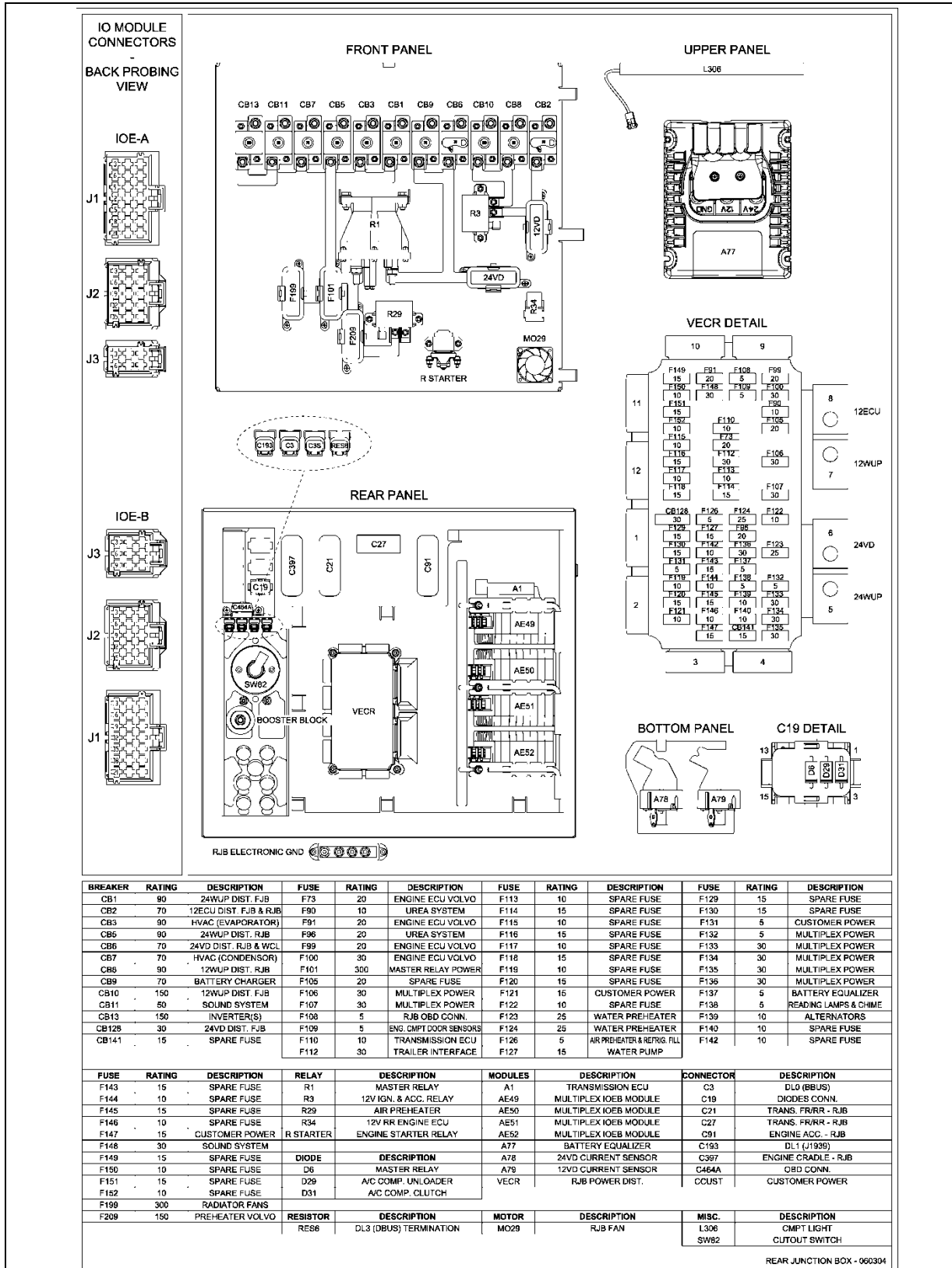

FIGURE 19: MAIN POWER COMPARTMENT COMPONENTS IDENTIFICATION

4.4 FRONT ELECTRICAL AND SERVICE COMPARTMENT (FJB)

The front electrical and service compartment is located on L.H. side of vehicle, under the driver's window. It contains the following components (Figure 20):

- Front terminal block;
- Master Control Module (MCM);
- Vehicle Electrical Center Front (VECF) and Multiplex Modules;
- Relays and fuses;
- ABS Electronic Control Unit (ECU);
- VECU with Volvo D13 engine;



FIGURE 20: FRONT ELECTRICAL & SERVICE COMPARTMENT

SECTION 06B: X3 SERIES ELECTRICAL

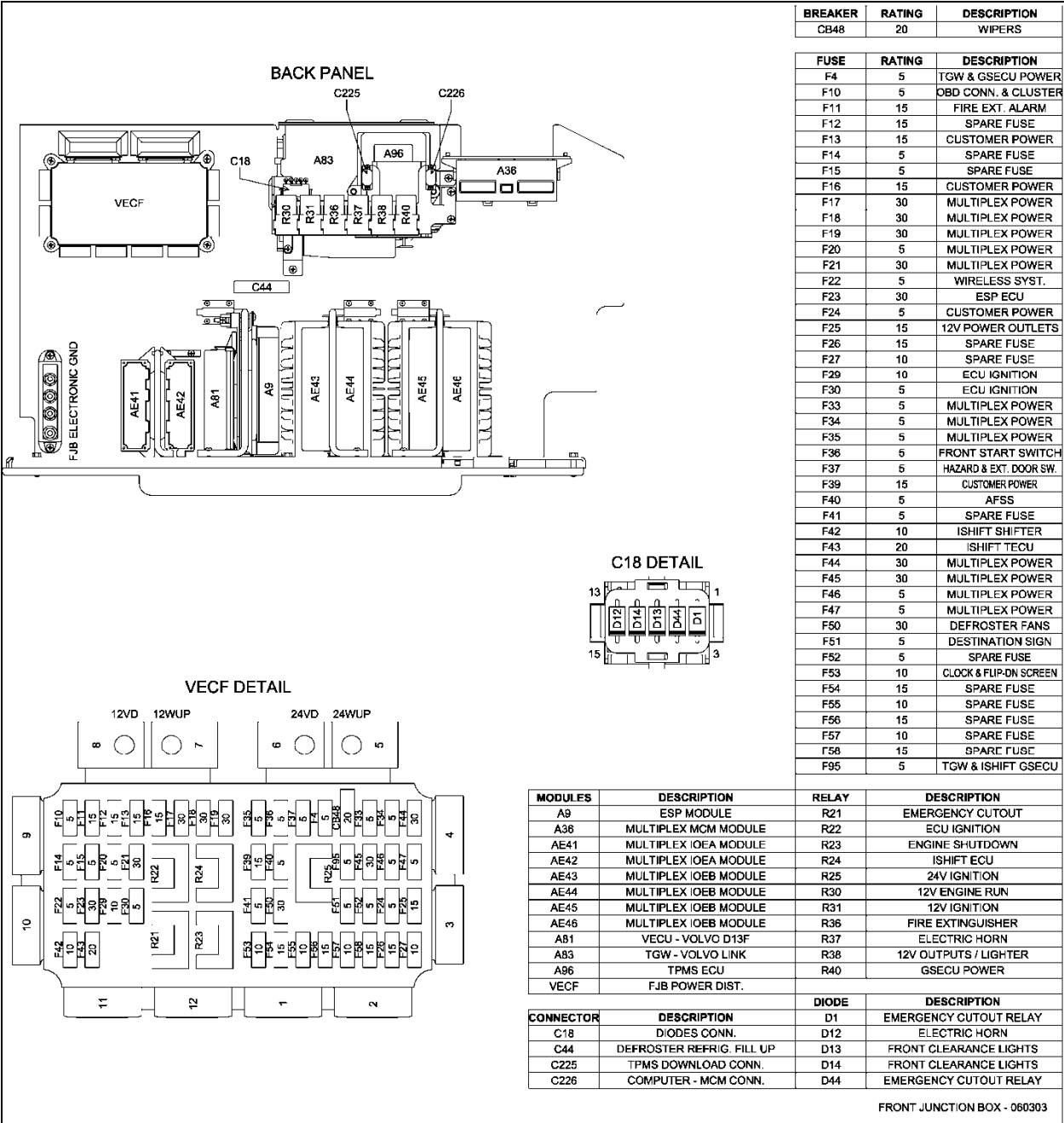

FIGURE 21: FRONT ELECTRICAL & SERVICE COMPARTMENT COMPONENTS IDENTIFICATION

4.5 A/C MODULE

The A/C junction box is located on the evaporator fan housing.

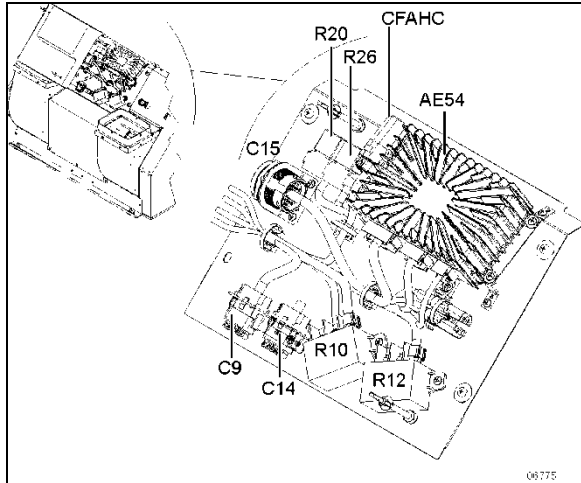

FIGURE 22: A/C JUNCTION BOX

4.6 ENGINE REAR START PANEL

This control panel is located in the R.H. side of engine compartment. This control panel includes the engine STOP push-pull button, the rear start push button switch to start engine from engine compartment as well as the back-up alarm.

When servicing the engine, push the engine STOP button to prevent the engine from being started from the dashboard ignition key or the rear start button. Once servicing is done, pull or twist the button to allow normal engine start. Pressing the engine STOP push-pull button while the engine is running will stop the engine.

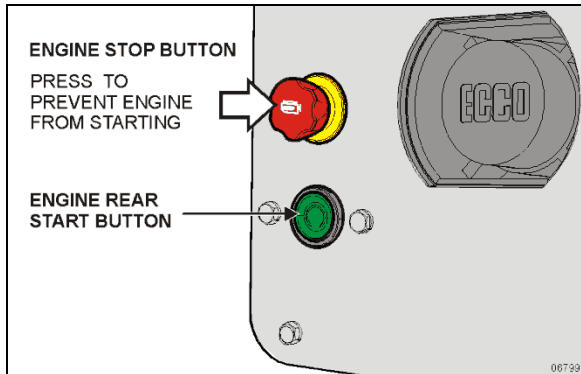

FIGURE 23: REAR START PANEL

4.7 ENTRANCE DOOR & WIPER CONTROL MODULES

To access the entrance door & wiper control panel of the right console, remove the panel under the larger utility compartment at the base of the windshield.

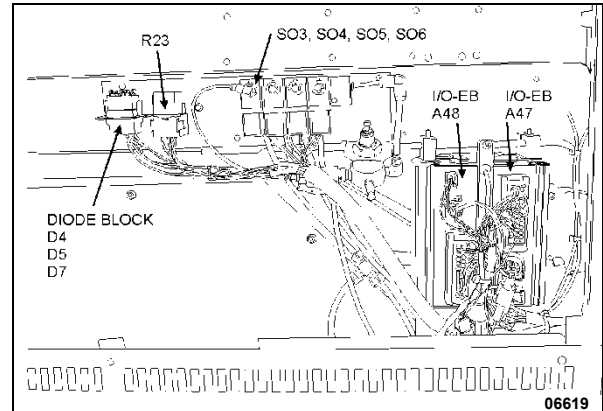

FIGURE 24: ENTRANCE DOOR & WIPER CONTROL PANEL

Entrance Door & Wiper Control Panel			
Multiplex Modules			
AE47	I/O-B	AE48	I/O-B
Relays			
R23	Windshield wipers		
Solenoids			
SO3	Door unlock solenoid valve	SO5	Door opening solenoid valve
SO4	Door unlock solenoid valve	SO6	Door closing solenoid valve
Diodes			
D4	Windshield wipers speed 2	D7	Entrance door
D5	Windshield wipers speed 1		

4.8 PARCEL RACK MODULE

A single I/O B module, AE53 is found at the rear end of the left parcel rack.

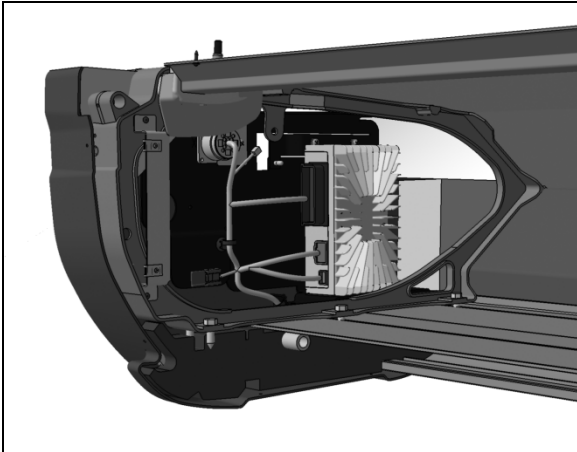

FIGURE 25: PARCEL RACK I/O-EB MODULE AE53

5. BATTERIES

The battery has four (4) major functions:

1. Providing a source of current for starting the engine.
2. Stabilizing the voltage in the electrical system.
3. Supplying current for a limited time, when electrical demands of the equipment exceed the power output of the alternator.
4. Providing a limited source of power for connected accessories, when the engine is not running.



WARNING

Battery posts, terminals and other related accessories contain lead and lead compounds, chemical known to the State of California to cause cancer and other

reproductive harm.

Batteries also contain other chemicals known to the State of California to cause cancer.

Wash hands after handling.

5.1 BATTERY INSTALLATION

The battery bank is composed of four AGM batteries. To prevent improper installation of the batteries, the positive (+) and negative (-) signs are laser cut on the battery deck steel sheet. When installing new batteries, place the battery negative and positive poles according to the signs on the battery deck (Figure 26).

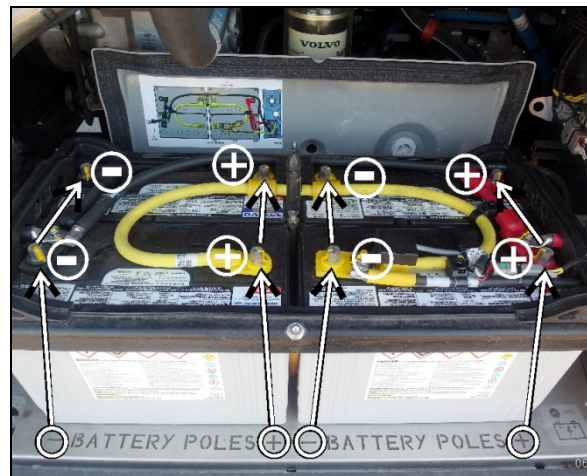

FIGURE 26: BATTERY INSTALLATION

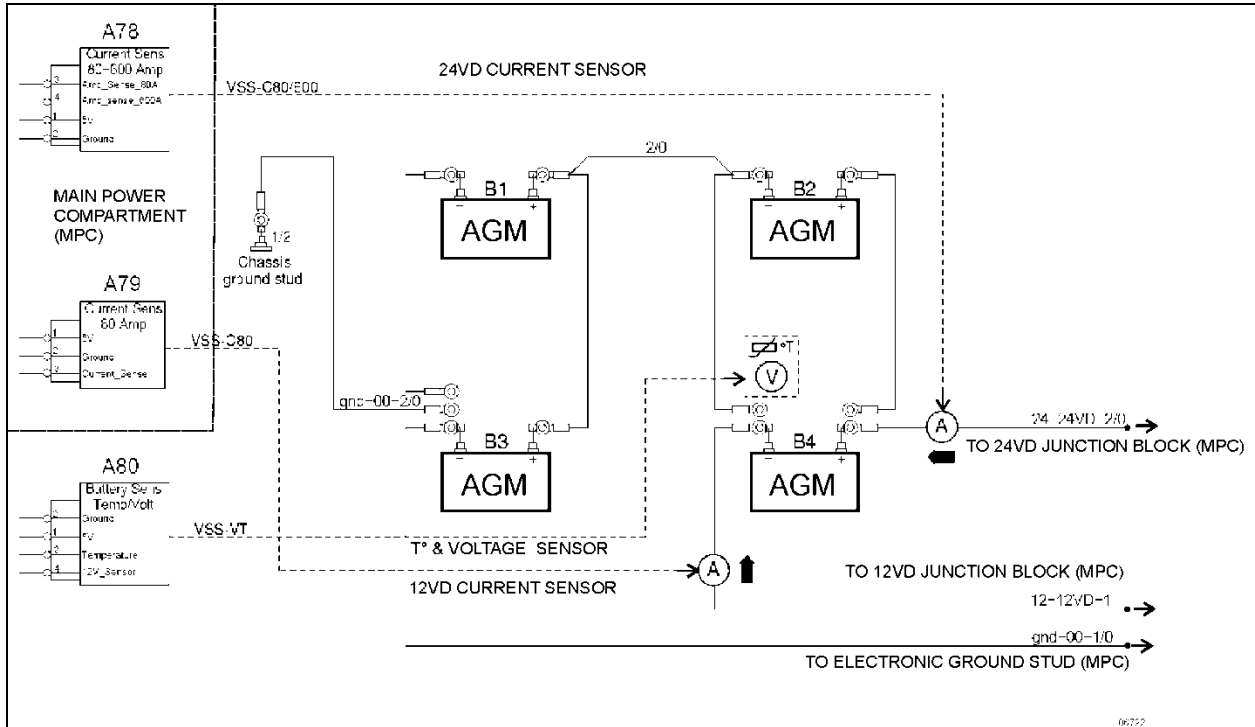

FIGURE 27: BATTERY CONNECTIONS SCHEMATIC

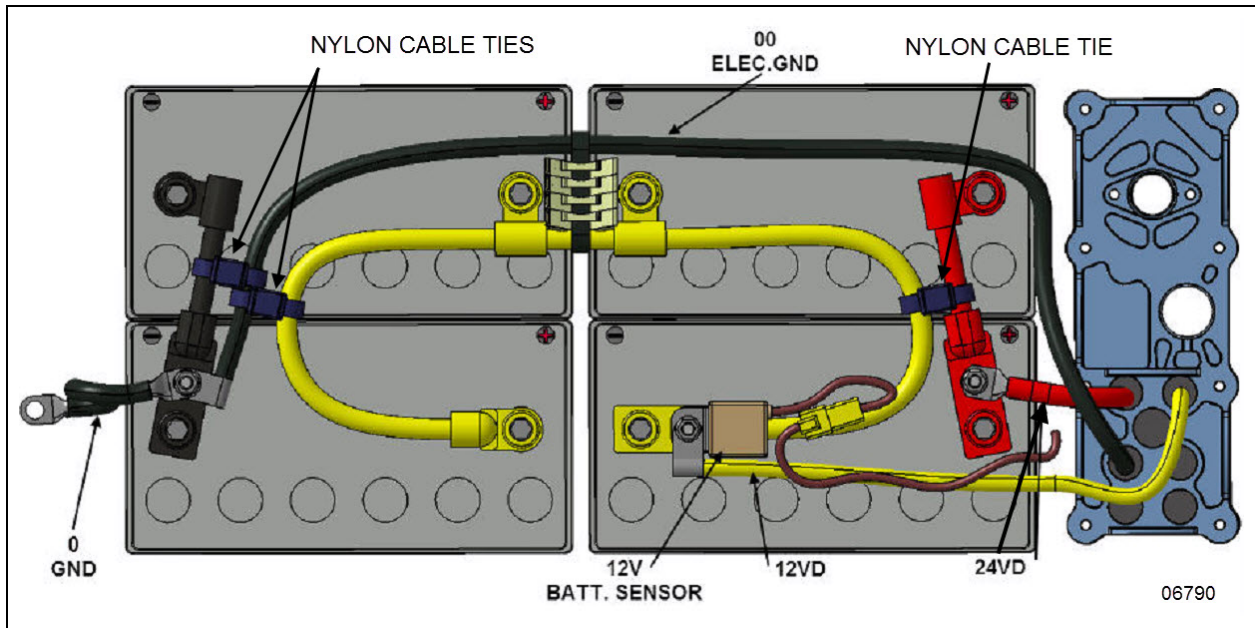

FIGURE 28: AGM BATTERY CONNECTIONS

5.2 AGM BATTERIES

This vehicle is equipped with PRIME energy management system, it is provided with four (4) Absorbed Glass Mat (AGM) 12-volt batteries connected in series-parallel (FIGURE 28).

These batteries require no maintenance for their lifetime. They can withstand deeper discharge cycles and several times the charging cycles of a standard battery.

These are sealed, valve regulated recombinant batteries which means that the oxygen created will recombine with the hydrogen in the battery, creating water and preventing water loss. Water never needs to be added to this type of battery.

The top-mounted negative and positive terminals are tightly sealed to prevent leaks.

The electrolyte in this type of battery is absorbed in micro-porous glass separators. This design prevents spills and results in greater resistance to vibration.

Always replace these batteries with identical make and model batteries as the system is balanced and optimized for this type of battery.



CAUTION

Replace only with AGM type batteries of the same specification and capacity.

PRIME system is programmed for the charging capacity of the batteries installed.

Installing a higher capacity battery will affect the battery life as the system will not fully charge the batteries, which is detrimental to battery performance.

Refer to "Specifications" at the end of this section for further details.

AGM batteries should be replaced in pairs or four at a time.



CAUTION

AGM (Absorbed Glass Mat) batteries require a voltage-limited charger, ideally fitted with a battery temperature sensor for temperature correction of charging parameters.

Charge voltage: 13.8-14.6 Volt @77°F (25°C)

Float voltage: 13.4-13.6 Volt @77°F (25°C)

Charging AGM battery on a typical constant current or taper current charger – even one time – may greatly shorten its life.

5.3 BATTERY DISCHARGE PROTECTION

To prevent discharge of the batteries when the engine is not running, some functions are automatically switched off if the batteries voltage drops below 24.4 volts for more than 30 seconds. The "Battery Voltage Warning" pictogram will show on the DID. Set the ignition key to the OFF position and then turn the ignition key to the ON position to reactivate the functions for a period of 30 seconds before they switch off again.

If a prolonged use of the functions with the engine not running is necessary, connect the battery to a charger.

5.4 MAIN ELECTRICAL SHUT-OFF SWITCH

Main 12-volt and 24-volt battery (master) relays are provided for this vehicle. The relays are located in the main power compartment. The 24-volt battery relay R1 & 12-volt battery relay R3 engage when ignition key is in the ON or ACC position and the main electrical shut-off switch (FIGURE 29) is set to the ON position.

When the main electrical shut-off switch is set to the OFF position, the main battery relays R1 & R3 disengage thus all electrical supply from the batteries to main circuit breakers CB1, CB3, CB5, CB8, CB10, CB11, CB13, is cut off, with the exception of the following items, among others.

- Main circuit breakers CB2, CB6, CB9 which are directly connected to the batteries;
- Battery equalizer check module;
- MCM;
- ECM;

- TCM (World transmission);
- Aftertreatment Control Module (ACM);
- Preheater electronic timer;
- Preheater and water recirculating pump;
- Entrance door;
- Radio memory;
- Fire suppression system (momentarily);
- Horn, Hazard;
- Wheelchair lift system;
- Cluster memory.

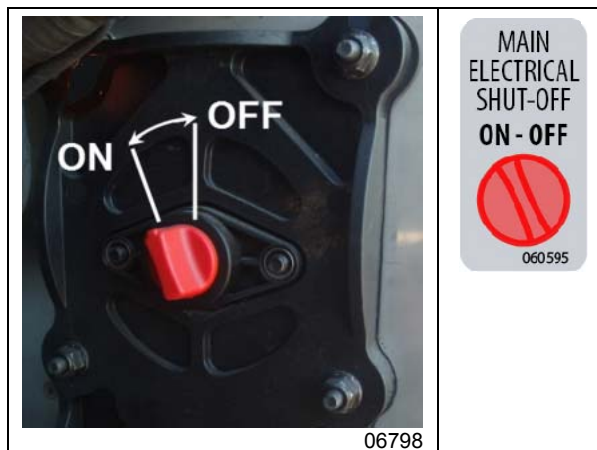

FIGURE 29: MAIN ELECTRICAL SHUT-OFF SWITCH

5.5 BATTERY REMOVAL AND INSTALLATION

The batteries are located in the R.H. side of the engine compartment.

DANGER

To prevent possible electric shocks or sparking, the main electrical shut-off switch should be in the "Off" position before disconnecting cables from the batteries. In addition, trip main circuit breakers CB2 & CB6.

Battery Removal

1. Remove the battery bank cover and place behind the battery bank (FIGURE 30).



FIGURE 30: BATTERY BANK COVER REMOVED

2. Disconnect the ground cable first (FIGURE 31).

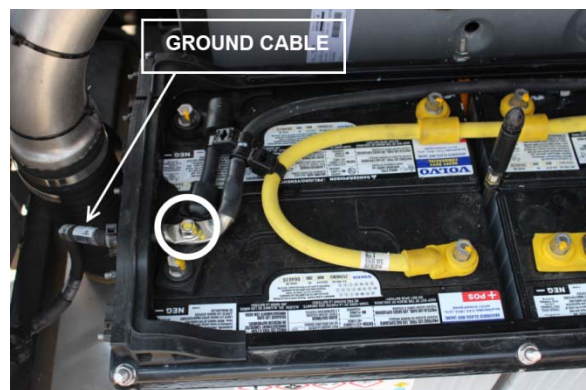

FIGURE 31: DISCONNECT GROUND CABLE FIRST

3. Using a 9/16 hex socket box, disconnect the eight (8) battery cable terminals (FIGURE 32).

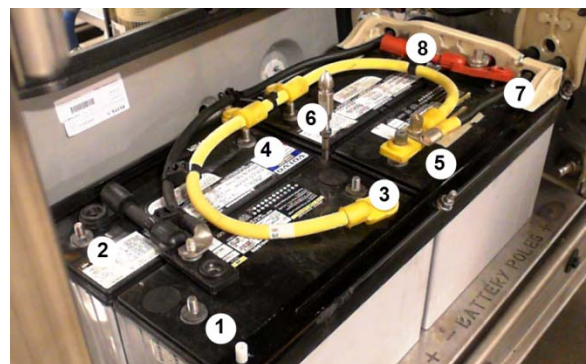

FIGURE 32: DISCONNECT 8 CABLE TERMINALS

4. Put the whole battery cable arrangement aside (FIGURE 33).



FIGURE 33

5. Unscrew three nuts (indicated with arrows) and then remove the front angle (FIGURE 34).

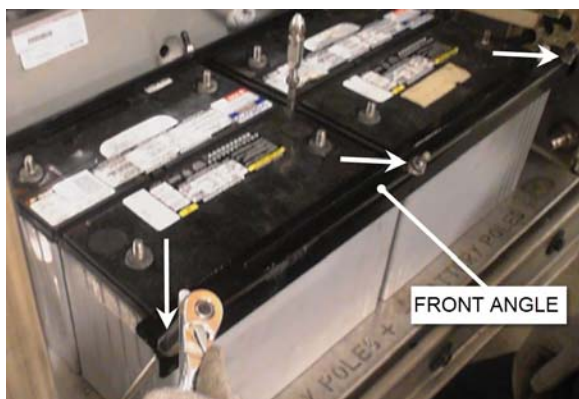

FIGURE 34: REMOVE THE FRONT ANGLE

6. Remove the rear angle similarly.



FIGURE 35: REMOVE THE REAR ANGLE

7. Slide the batteries on a mobile scissor lift table placed slightly lower than the battery deck level.



FIGURE 36

Battery Installation

Reinstalling the batteries is quite similar as the removal procedure but in reverse order.

However, special care should be taken to the following points:

1. To respect battery polarity in the arrangement, positive (+) and negative (-) signs are laser cut on the battery deck steel sheet. When installing the batteries, place the battery negative and positive poles according to the signs on the battery deck (FIGURE 38).

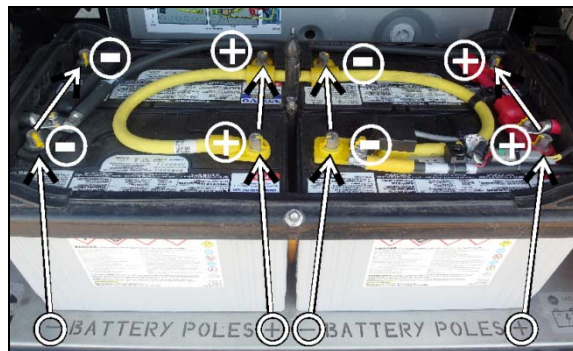

FIGURE 37: BATTERY BANK

2. Rest the aft batteries against the fold on the battery deck. Rest the fore batteries against the aft batteries.

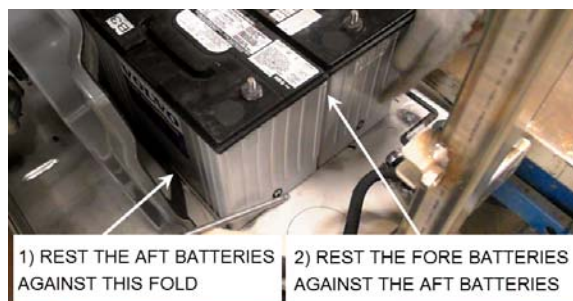

FIGURE 38: PROPER POSITIONING OF THE BATTERIES

3. The upper end of the rods is shaped to match with the angle (FIGURE 39).
4. Tighten the rod nut to the following torque:

TORQUE: 45-55 lb-in (5-6 Nm)

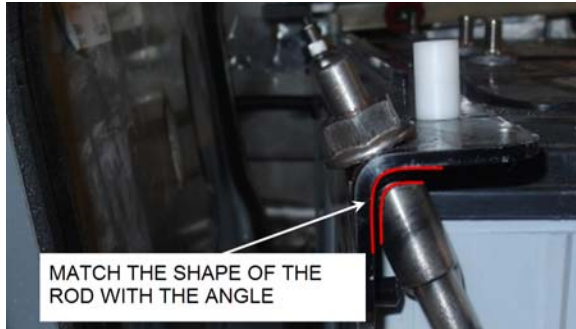

FIGURE 39

5. Align the dowels on the angles with the holes on the cable guides (FIGURE 40).

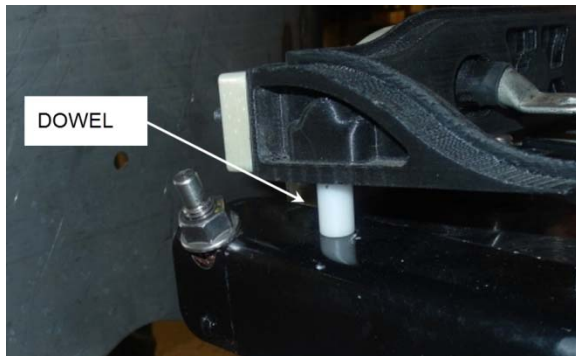

FIGURE 40

NOTE

When partially disconnecting battery cable arrangement, wrap the battery terminals and cable ends with electric tape to prevent accidental grounding. The ground cables should always be disconnected first and connected last.

NOTE

When reinstalling batteries, battery connections must be tightened. A torque wrench is required to ensure an accurate tightening torque.

5. Connect the battery cables. Tighten the cable terminal (item 1, FIGURE 41) nuts to the following torque:

TORQUE: 170 lb-in (19 Nm)

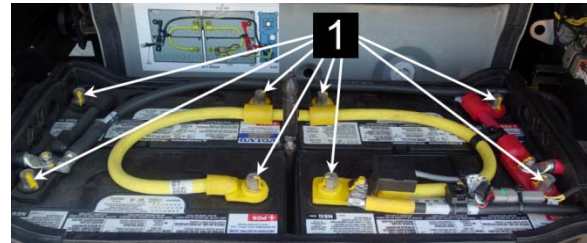

FIGURE 41: INSTALL THE BATTERY CABLE LUGS

6. Connect the ground cable last (FIGURE 42). Tighten the ground cable nut to the following torque:

TORQUE: 170 lb-in (19 Nm)



FIGURE 42: GROUND CABLE

7. To keep the battery connections clean, make sure that battery bank cover leans perfectly on the cable guides and the angles.



DANGER

To prevent possible electric shock or sparking, the main electrical shut-off switch must be set to the "Off" position before tightening an electrical connection.

NOTE

A protective coating should be applied on certain power connections that have been disconnected. Refer to Procedure PR00002E included at the end of this section to know the recommended products and where they are used.

5.6 BATTERY RATING

Each of the 12 volt batteries used on the vehicle has the following rating:

AGM batteries (PRIME):

- Reserve capacity: 200 minutes
- Cold cranking (amps): 800 @ 0°F (-18°C)
- Weight (filled): 69 lb (26,7 kg)

The reserve capacity is defined as the number of minutes a new, fully charged battery at 80°F (26,6°C) can be discharged at 25 amperes and maintain a minimum of 1.75 volts per cell (10.5 volts total for one 12 volts battery). This rating can be used as a basis for determining how long a vehicle might run after an alternator failure.

The cold cranking rating is defined as the minimum discharge current a battery will deliver in amperes for 30 seconds at 0°F (-18°C) while maintaining a minimum of 1.2 volts per cell (7.2 volts total for one 12 volts battery). This rating can be used as a basis for comparing starting performance.

5.7 BATTERY TESTING

Several factors influence battery performance. The methods and inspection procedures proposed here will ensure your batteries are in good shape.

5.7.1 Visual Inspection

1. Check the outside of the battery for a broken or cracked cover or case that could permit loss of electrolyte. If obvious physical damage is noted, replace the battery. If the battery is bulged. Replace the battery. Also check for wet areas around the terminals.
2. Check for loose terminal posts, cable connections, damaged cables, and for evidence of corrosion. Correct conditions as required before proceeding with tests.
3. Check for damaged or loose battery tie-downs.

5.7.2 Removing Surface Charge

Disconnect cables from the battery and attach alligator clamps to the contact lead pad on the battery as shown in Figure 44. Connect a load equal to half the CCA across the terminal for 5 seconds to remove surface charge from the battery.

5.7.3 Load Test

This test is one means of checking the battery to determine its ability to function as required in the vehicle.

To make this test, use test equipment that will withstand a heavy electrical load from the battery, such as a carbon pile resistor along with an ammeter and volt meter (Figure 43). A charging system analyzer test equipment may also be used.

1. Connect a voltmeter, ammeter, and a variable load resistance as illustrated in Figure 43.

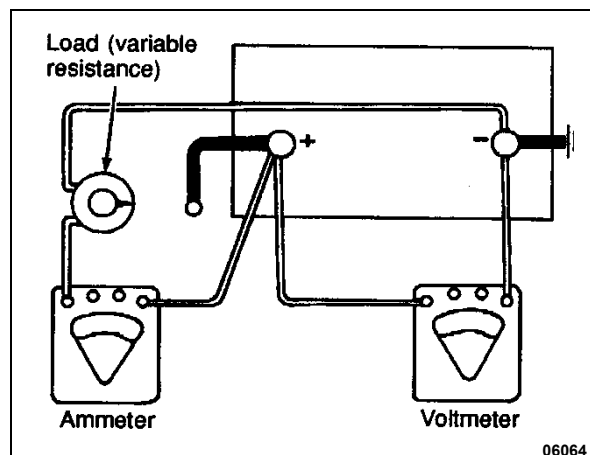

FIGURE 43: LOAD TEST



CAUTION

Observe polarity of the meters and the battery when making connections, and select the correct meter range.

2. Apply a load equal to half the CCA rating @ 0°F for 15 seconds.
3. With an ammeter reading specified load, read voltage. The voltage should be at least 9.6 volts. Disconnect the load. If the voltmeter indicates 9.6 volts or more, the battery is good. If the voltmeter reading is less than 9.6 volts, replace the battery. This voltage is to be used for battery ambient

temperatures of 70°F (21°C) and above. For temperatures below 70°F (21°C), refer to the following "Voltage and Temperature Chart".

Voltage and Temperature Chart

Ambient Temperature	Minimum Voltage
70°F (21°C) and above	9.6
60°F (16°C)	9.5
50°F (10°C)	9.4
40°F (4°C)	9.3
30°F (-1°C)	9.1
20°F (-7°C)	8.9
10°F (-12°C)	8.7
0°F (-18°C)	8.5

NOTE

The accuracy of this test procedure is dependent upon close adherence to the proper load, time and temperature specifications.

5.8 BATTERY CHARGING



DANGER

Any procedure other than the following could cause personal injury or damages to the charging system resulting from battery explosion or electrical burns.

Wear adequate eye protection when working on or near the batteries. Ensure that metal tools or jumper cables do not contact the positive battery terminal (or a metal surface in contact with it) as a short circuit will result. Do not attempt to jump start a vehicle suspected of having a frozen battery because the battery may rupture or explode. Both the booster and discharged batteries must be treated carefully when using jumper cables. Follow exactly the procedure outlined later in this section, being careful not to cause sparks.

The batteries used on this vehicle can be charged either on or off the vehicle; however, when they are removed from the vehicle, it is recommended that an adapter kit, which is available from any "A/C DELCO" dealer, be used in charging sealed-terminal batteries. Use the booster block to charge the batteries when

they are left on vehicle and **make sure that the main battery disconnect switch is set to the "On" position.**



DANGER

During charging of the batteries, an explosive gas mixture forms in each cell. Part of this gas escapes through the vent holes and may form an explosive atmosphere around the battery itself if ventilation is poor. This explosive gas may remain in or around the battery for several hours after it has been charged. Sparks or flames can ignite this gas causing an internal explosion, which may shatter the battery.

1. Do not smoke near a battery which is being charged or which has been recently charged.
2. Do not break live circuits at battery terminals because a spark usually occurs at the point where a live circuit is broken. Care must always be taken when connecting or disconnecting booster leads or cable clamps on chargers. Poor connections are a common cause of electric arcs, which cause explosions.
3. The electrical system on this vehicle is negative ground. Installing the batteries with the positive terminals grounded or incorrect use of the booster battery and jumper cables will result in serious damage to the alternator, batteries and battery cables.

The alligator clamps of the tester or charger must be placed between the terminal nuts and the lead pads of the terminal studs after the vehicle cables are detached. The alligator clamps should make firm contact with the lead pads.

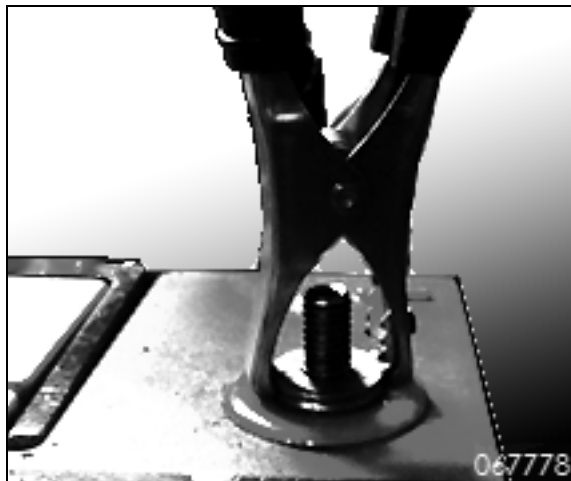

FIGURE 44 ALLIGATOR CLAMP POSITION- TYPICAL AGM BATTERY

A charge rate between 3 and 50 amperes is generally satisfactory for any maintenance-free flooded battery as long as spewing of electrolyte does not occur or the battery does not feel excessively hot (over 125°F (52°C)). If spewing or violent gassing of electrolyte occurs or battery temperature exceeds 125°F (52°C), the charging rate must be reduced or temporarily stopped to allow cooling and to avoid damaging the battery. Battery temperature can be estimated by touching or feeling the battery case. No further charging is required. Shake or tilt the battery at hourly intervals during charging to mix the electrolyte.



WARNING

Always turn off the charger before connecting or disconnecting to a battery.

NOTE

The charge rate must be doubled when the batteries are charged by the booster block, because of the series-parallel circuit.

5.8.1 Battery Charging Guide

NOTE

AGM (Absorbed Glass Mat) batteries require a voltage-limited charger, ideally fitted with a battery temperature sensor for temperature correction of charging parameters. *Do not manually charge AGM batteries. Look for the following voltage values on your voltage-limited charger.*

Charge voltage: 13.8-14.6 Volt @77°F (25°C)

Float voltage: 13.4-13.6 Volt @77°F (25°C)

Charging AGM battery on a typical constant current or taper current charger – even one time – may greatly shorten its life.

The following guidelines are for maintenance-free flooded batteries.

Fast Charging Rate

3-3/4 hours @ 20 amps

2-1/2 hours @ 30 amps

2 hours @ 40 amps

1-1/2 hours @ 50 amps

Slow Charging Rate

15 hours @ 5 amps

7-1/2 hours @ 10 amps

The time required for a charge will vary according to the following factors:

Size of Battery

A completely discharged large heavy-duty battery requires more than twice the recharging time of a completely discharged small passenger car battery.

Temperature

A longer time will be needed to charge any battery at 0°F (-18°C) than at 80°F (27°C). When a fast charger is connected to a cold battery, the current accepted by the battery will be very low at first, and then in time, the battery will accept a higher rate as it warms.

State of Charge

For example, a completely discharged battery requires more than twice as much charge than a half-charged battery. Since the electrolyte is nearly pure water and a poor conductor in a completely discharged battery, the current accepted is very low at first. Later, as the charging current causes the electrolyte acid content to increase, the charging current will likewise increase.

Charger Capacity

A charger supplying only 5 amperes will require a much longer period of charging than a charger that can supply 30 amperes or more.

5.8.2 Emergency Jump Starting With Auxiliary (Booster) Battery.



DANGER

Off-board battery charger with a start boost facility must not be used to jump start the vehicle. This could damage the electrical system.

Booster Block

On X3-45 coaches, booster block is located near the batteries in the engine compartment on the R.H. side and is accessible through engine R.H. side door (Figure 45).

Both booster and discharged batteries should be treated carefully when using jumper cables. A vehicle with a discharged battery may be started by using energy from a booster battery or the battery from another vehicle.



DANGER

Jump starting may be dangerous and should be attempted only if the following conditions are met:

The booster battery or the battery in the other vehicle must be of the same voltage as the battery in the vehicle being started, and must be negative grounded.



DANGER

Follow the procedure exactly as outlined hereafter. Avoid making sparks.



WARNING

DURING EMERGENCY JUMP STARTING ...

Cooling fans WILL start running for a short while.

Keep hands away from cooling fans or keep the radiator door closed.

Wear eye protection and remove rings, watches with metal bands and other metal jewelry.

Apply parking brake and place the transmission shift lever or push-button pads in Neutral (N) position in both vehicles. Turn off lights, heater and other electrical loads.

The following procedure should be used only when the batteries are discharged.

Do not attempt jump starting if you suspect the batteries are charged. Inspect the engine starting system prior to using this procedure.

To jump start, proceed as follows:

1. Remove the red protective cap from the (+) booster block terminal located in the R.H. side engine compartment;

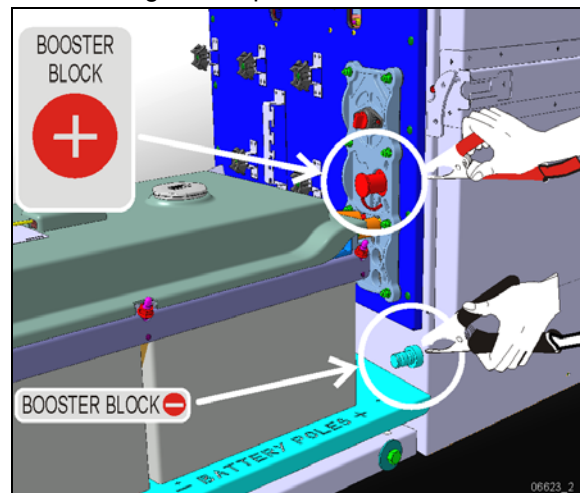

FIGURE 45: BOOSTER BLOCK

2. Connect the red jumper cable to the positive (+) post of the booster power source. If the good battery is in another vehicle, that vehicle's engine must be shut *OFF* before connecting;
3. Connect the other end of the red jumper cable to the positive (+) terminal on the booster block;
4. Connect one end of the black jumper cable to the negative (-) post on the booster power source;
5. Connect the other end of the same black jumper cable to the negative (-) terminal on the booster block; If the good battery is in another vehicle, start that vehicle's engine;
6. Let the engine run for a few minutes, then turn the engine off.
7. Start the vehicle with the run-down battery;
8. Disconnect the jumper cables in reverse order given in steps 2 through 5;
9. Install protective cap on the booster block terminal.

NOTE

Jumper cables must be rated at 500 cranking amperes. If jumper cable length is 20 feet (6 m) or less, use 2/0 (AWG) gauge wires. If cable length is between 20 to 30 feet (6 to 9

m), use 3/0 (AWG) gauge wires.



DANGER

Any procedure other than the above could result in personal injury, property damage due to battery explosion, or damage to the charging system of the booster vehicle or of the boosted vehicle.

5.9 AGM BATTERY CHARGING PRECAUTIONS

AGM (Absorbed Glass Mat) batteries require a voltage-limited, temperature corrected charger.

Make sure your charger is multi-staged and minimally provides the following voltage values:

Charge stage voltage:

13.8-14.6 V @77°F (25°C)

Float stage voltage:

13.4-13.6 V @77°F (25°C)

Charging AGM battery on a typical constant current or taper current charger – even one time – may greatly shorten its life.

5.10 BATTERY EQUALIZATION AND AGM BATTERIES

Equalization is a controlled over charge. Conventional batteries may benefit from this procedure, stirring the chemistry of the entire battery it counters stratification (layers of different concentration of electrolyte), and also counters sulfation that may have accumulated on the battery plates.

AGM battery design prevents chemical unbalance of the electrolyte. Manufacturers of this type of battery generally do not recommend performing equalization.

5.11 CLEANING AND INSPECTION

The external condition of the battery and the battery cables should be checked periodically. The top of the battery should be kept clean and the battery tie-down clamp bolts should be kept

properly tightened. For best results when cleaning the battery, wash first with a diluted solution of ammonia or soda to neutralize any acid present then wash out with clean water. The battery tie-down bolts should be kept tight enough to prevent the batteries from moving, but they should not be tightened to the point that excessive strain is placed on the battery hold-down cover. Tighten as prescribed. Refer to torque tables at the beginning of this section.



MAINTENANCE

Battery terminals

Clean and coat terminals with Nyogel at the intervals specified by the Lubrication And Servicing Schedule in Section 24: LUBRICATION & SERVICING.

A protective coating should be applied on certain power connections that have been disconnected. Refer to Procedure PR00002E included at the end of this section to know the recommended products and where they are used.

To insure good contact, the battery cable ring terminals should be tight on the battery posts. If the posts or cable ring terminals are corroded, the cables should be disconnected and the posts and clamps cleaned separately with a soda solution and a wire brush. Install cable ring terminals on battery posts and tighten. Tighten as prescribed. Refer to torque tables at the beginning of this section.

Replace protective caps to prevent corrosion and sparks.

5.12 COMMON CAUSES OF BATTERY FAILURE

When a battery fails, the cause of failure may be related to something other than the battery. For this reason, when a battery failure occurs, do not be satisfied with merely recharging or replacing the battery. Locate and correct the cause of the failure to prevent recurrence. Some common external causes of battery failure are as follows:

1. A defect in charging system such as high resistance or a faulty alternator or regulator. The dashboard ALTERNATOR telltale light

illuminates if one of the alternators is defective.



ALTERNATOR telltale

2. A malfunction within the 12 volts system (equalizer).
3. Overloads caused by a defective starter or excessive use of accessories.
4. Dirt and electrolyte on top of the batteries causing a constant drain.
5. Hardened battery plates, due to battery being in a low state of charge over a long period of time.
6. Shorted cells, loss of active material from plates.
7. Driving conditions or requirements under which the vehicle is driven for short periods of time.
8. A constant drain caused by a shorted circuit such as an exposed wire or water infiltration in junction boxes causing ground fault.
9. Extended operation of preheating system with engine not running.
10. Failing to close disconnect switches during the night.

5.13 TROUBLESHOOTING

If a battery is known to be good and then has not performed satisfactorily in service for no apparent reason, the following factors may reveal the cause of trouble:

1. Vehicle accessories and disconnect switches inadvertently left on overnight.
2. Defects in the charging system, such as high wiring resistance, faulty alternator, regulator or battery equalizer.
3. A vehicle electrical load exceeding the alternator (or battery equalizer) capacity, with the addition of electrical devices, such as CB radio equipment, a cellular phone or additional lighting systems.
4. Defects in the electrical system, such as shorted or pinched wires.
5. Extended driving at a slow speed while using many accessories.

6. Loose or poor battery cable-to-post connections, previous improper charging of a run-down battery, or loose hold-down clamp bolts.
7. High-resistance connections or defects in the cranking system.

5.14 "BATTERY VOLTAGE WARNING" PICTOGRAM



If the "BATTERY VOLTAGE WARNING" (Low Voltage – Connect Battery Charger) pictogram shows up in the DID (Driver Information Display), check the voltmeter gauge to determine if the battery voltage is too high or too low.

5.14.1 Voltage Gauge Definitions

Voltmeter drops below 24.4 volts dc

- Check alternator output.
- Check voltage regulator.
- Check battery connections.
- Check battery equalizer connections.

Voltmeter exceeds 30 volts dc

- Check alternator output (voltage regulator might be defective).
- Check battery connections.

Checking Battery Balance

NOTE

Allow at least 15 minutes to balance batteries after any corrective measure has been taken.

1. Batteries out of balance (difference greater than 1.5 volts between the two battery banks).
 - Check battery equalizer connections.
 - Check equalizer cables for proper gauge.
 - Check battery connections.
2. Demand for 12-volt power exceeding rated amperage output of battery equalizers causing batteries to go out of balance.
 - Reduce 12-volt load or install additional battery equalizer(s).

5.14.2 BATTERY warning Pictogram MAY appear as a reminder

If you leave *ignition ON, park brake set* and

engine not running, this warning  may appear after 20 minutes as a reminder to connect the battery charger. The reminder will appear even if the batteries are in the right voltage range.

Confirm battery voltage is indeed correct with the DID Gauges screen and if you do need to leave the ignition ON for a prolonged period, connect a battery charger.

6. BATTERY EQUALIZER

For vehicles with PRIME energy management system, a Vanner “Vann-Bus 80 Series” 100amp Battery equalizer with Smart Monitor is installed beside the batteries in the battery compartment. Refer to Vanner Vann-Guard 80 Series Owner's Manual found on your Technical Publications USB flash drive.

7. PRIME ENERGY MANAGEMENT SYSTEM

The acronym “PRIME” stands for Power Recovery by Intelligent Management of Energy.

This system focuses on eliminating parasitic loads on the engine by intelligent management of the alternators and air compressor duty cycle.

Instead of constantly charging, the alternators will use engine negative torque (braking, deceleration) to generate “Free” electricity.

Depending on the compressed air requirement, PRIME will also trigger the production of compressed air on negative torque.

PRIME also introduces maintenance-free Absorbed Glass Mat (AGM) batteries and a new Vanner 80 series battery equalizer that monitors battery State of Charge (SOC).

Battery temperature, voltage and current are also monitored to prevent overcharging and overheating.

Maximum fuel economy is obtained on a ride when the mix of hilly and flat portions allows the batteries to be charged when the vehicle is in free wheel. It basically means that batteries are charged with free energy and that no fuel consumption is dedicated to charge the batteries.

7.1 COMPONENTS

New components includes AGM batteries, a Vanner Battery equalizer, a temperature sensor located on the battery post and two voltage and current sensors monitoring 12V and 24 V circuits. Refer to Figure 46 below.

The compressor duty cycle control is achieved by an electric air dryer. This is covered in section 12 of this manual.

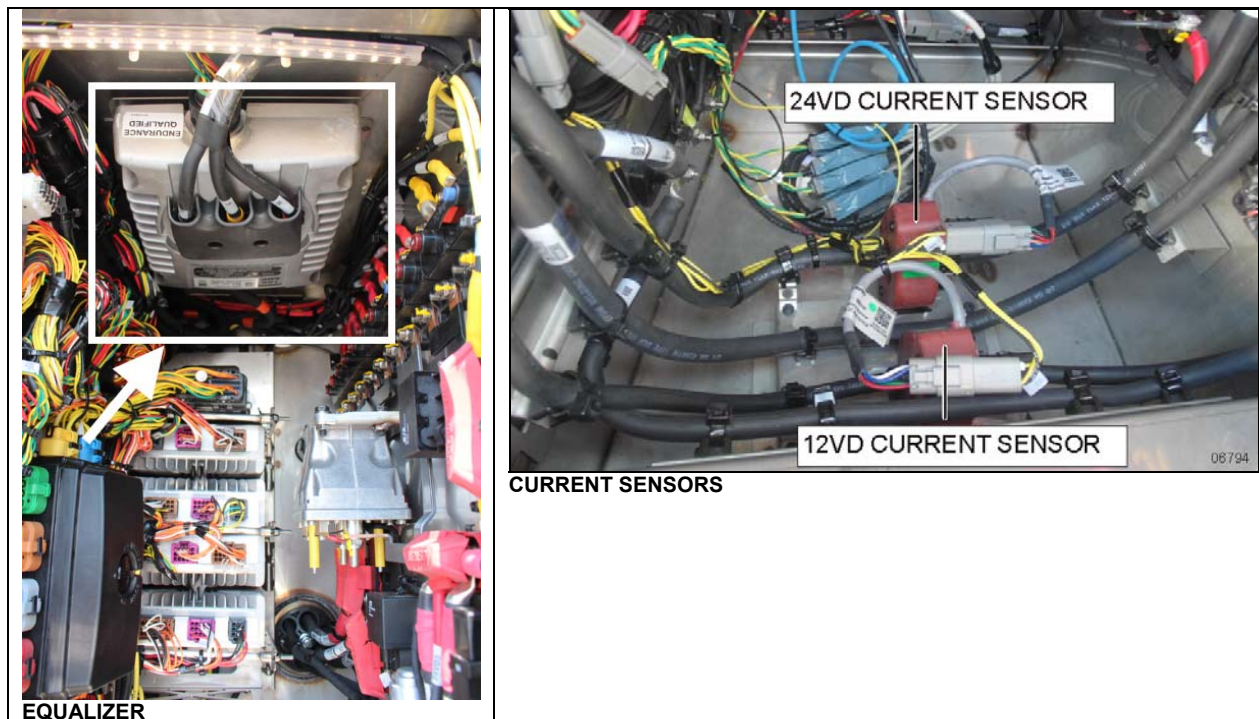

EQUALIZER

FIGURE 46: PRIME ELECTRICAL COMPONENT

7.1.1 Vanner 80 Series Battery Equalizer Fault Codes

The 80 Equalizer Can Bus Interface supports SAE J1939 Diagnostic Message 1 (DM1) for active Diagnostic Trouble Codes. See list below. Refer to OEM publication *Vanner Vann-Guard 80 Series Owner's Manual* PDF for additional details.

Description	SPN	FMI
Over Voltage Fault (OVF)	168	0: Data valid, but above normal operating range – Most Severe
Under Voltage Fault (UVF)	168	1: Data valid, but below normal operating range – Most Severe
Imbalance (IMB)	520448	0: Data valid, but above normal operating range – Most Severe
Equalizer Fault (EQFLT)	520449	1: Data valid, but below normal operating range – Most Severe
Temperature Sensor Fault (TSF)	520450	0: Data valid, but above normal operating range
Temperature Sensor Fault (TSF)	520450	1: Data valid, but below normal operating range
Temperature Sensor Fault (TSF)	520450	2: Data erratic, intermittent, or incorrect – Most Severe
12V Current Sensor Fault (SCSF)	520451	0: Data valid, but above normal operating range – Most Severe
12V Current Sensor Fault (SCSF)	520451	1: Data valid, but below normal operating range
12V Current Sensor Fault (SCSF)	520451	2: Data erratic, intermittent, or incorrect – Most Severe
24V Current Sensor Fault (DCSF)	520452	0: Data valid, but above normal operating range – Most Severe
24V Current Sensor Fault (DCSF)	520452	1: Data valid, but below normal operating range
24V Current Sensor Fault (DCSF)	520452	2: Data erratic, intermittent, or incorrect – Most Severe

7.2 DID DISPLAY

In the DID you will find the percentage of trip made with regenerated electricity displayed along with the instantaneous fuel consumption.

This value is reset each time the engine is restarted.

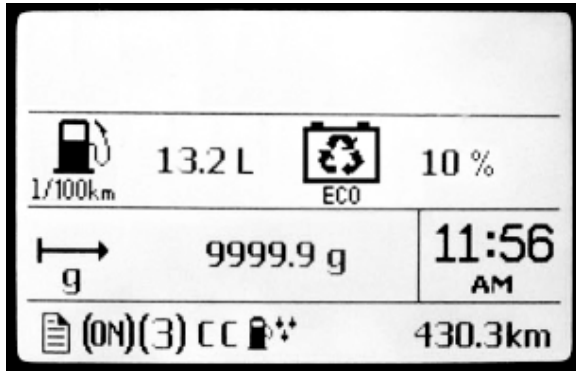

FIGURE 47: PRIME DID DISPLAY

In addition to the standard voltage gage, the DID also includes a state of charge gage for the batteries:

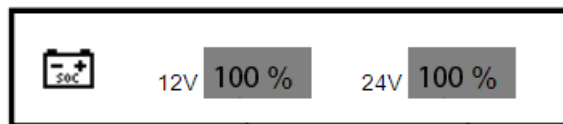

FIGURE 48: BATTERY STATE OF CHARGE

This gage displays the level of charge for the 12V and 24V battery banks in percentage.

8. BOSCH ALTERNATORS

Three 24-volt 150A, self-regulated, belt driven, air-cooled HD 10 BOSCH alternators are used in the 24 volt electrical system.

NOTE

For the complete removal/installation instructions, refer to Maintenance Information **MI16-17 Bosch HD10 alternator removal and installation** included at the end of this section.

8.1 IDENTIFYING A DEFECTIVE ALTERNATOR

When an alternator is not charging, the *charging system warning light* will illuminate.



charging
system
warning
light

8.1.1 Alternator identification

Cold side alternators are the one found on the A/C compressor side. The hot side alternators are the one located on the engine turbo side.

Cold Side (R.H.):

ALTERNATOR Up RH= upper right
ALTERNATOR Low RH=lower right

ALTERNATOR Ext RH= above small A/C comp.
(MTH only)

Hot Side (L.H.):

ALTERNATOR Up LH= upper left (MTH only)
ALTERNATOR Low LH=lower left

8.1.2 Identifying a defective alternator using the instrument cluster DID

1. On the DID (Driver Information Display), select DIAGNOSTICS menu.
2. Select VIEW ACTIVE FAULTS and then ELECTRICAL SYSTEM.
3. The active electrical system faults will appear. Scroll through the active faults. You will find one of the following messages:

MID (188) ELECTRICAL SYSTEM
PSID 34 ALTERNATOR Low RH
FMI (5) OPEN CIRCUIT

MID (188) ELECTRICAL SYSTEM
PSID 35 ALTERNATOR Up RH
FMI (5) OPEN CIRCUIT

8.1.3 Identifying a Defective Alternator – Back-probing AE49 & AE52 Multiplex Modules Method

Prerequisite conditions:

- a) Engine running;

b) Parking brake applied.

Alternator Up RH =pin J1:20, module AE49
 Alternator Low RH=pin J2:8, module AE52
 Alternator Low LH= pin J2:9, module AE52

Back-probe pin 20 (AE49 J1:20):

- If multimeter reads 1-2 volts, the **upper R.H.** alternator is defective;
- If multimeter reads 12 volts, you have an open circuit;
- If multimeter reads 26 volts or greater, the **upper R.H.** alternator operates normally.

Back-probe pin 8 (AE52 J2:8) and a good ground (use ground stud in the compartment):

- If multimeter reads 1-2 volts, the **lower R.H.** alternator is defective;
- If multimeter reads 12 volts, you have an open circuit;
- If multimeter reads 26 volts or greater, the **lower R.H.** alternator operates normally.

Back-probe pin 9 (AE52 J2:9) and a good ground (use ground stud in the compartment):

- If multimeter reads 1-2 volts, the **lower L.H.** alternator is defective;
- If multimeter reads 12 volts, you have an open circuit;
- If multimeter reads 26 volts or greater, the **lower L.H.** alternator operates normally.

8.2 ALTERNATOR DRIVE BELT

 <h3 style="margin: 0;">MAINTENANCE</h3>
<p>Drive belt</p> <p>Inspect for crack or frayed material at the intervals specified by the Lubrication And Servicing Schedule in Section 24: LUBRICATION & SERVICING.</p>

8.2.1 Removal and installation

1. Insert a ½" socket drive into the automatic belt tensioner opening.
2. Twist the tensioning arm to slacken belt.
3. Remove belt.

Installation of the alternator drive belt is the reverse of removal.

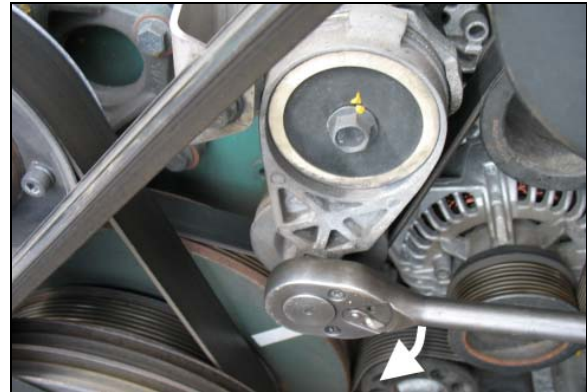

FIGURE 49: ½" SOCKET DRIVE WRENCH

NOTE

Belts specifications may vary. For proper belt selection, always consult your vehicle Coach Final Record.

8.2.2 Adjustment

Correct belt tension is required to maximize belt life. The tensioning arm maintains proper belt tension, no adjustment is required.

9. STARTER

Refer to Mitsubishi Electric Corporation (MELCO) Service bulletin ME003-P annexed at the end of this section for information and maintenance instruction on MELCO 105P70 starter.

NOTE

*For the complete removal/installation instructions, refer to Maintenance Information **MI16-16 Starter removal and installation** included at the end of this section.*



CAUTION

Do not engage starter for more than 15 seconds at a time. If engine does not start within 15 seconds, release ignition key and let starter cool for one minute before attempting to restart.

10. ENGINE BLOCK HEATER

The vehicle may be equipped with an engine immersion-type electric block heater to assist cold weather starting. The heater male electric plug is easily accessible through the engine compartment R.H. side door (FIGURE 50). To use it, connect the female plug of an electrical extension cord to the heater plug. The extension cord must be plugged into a 120 V AC power source only. The engine block heater should be used whenever the vehicle is parked for an extended period of time in cold weather and a suitable power source is available.

10.1 MAINTENANCE

This heater is non-serviceable except for the cord, and if faulty, must be replaced as a unit.

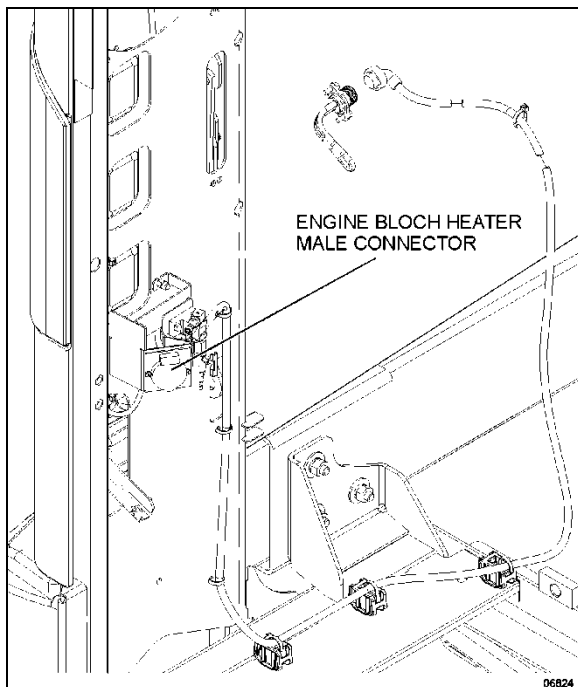

FIGURE 50: ENGINE BLOCK HEATER CONNECTION

11. X3 SERIES EXTERIOR LIGHTING

The circuit for exterior lights, as well as their control switches, relays and circuit breakers are shown on the applicable wiring diagrams. Wiring diagrams are found in the Technical Publication box.

11.1 HEADLIGHTS

Each headlight assembly consists of two headlamp module 90 mm (3½ inch) equipped with a 12-volt halogen bulb and one 100 mm (4 inch) 12-volt LED turn/signal lamp. Outer lamps have a double function (both low and high beam). Inner lamps are used for high beam or daytime running light. The inner or outer lamp uses the same single filament halogen bulb part number.

NOTE

If vehicle is equipped with optional Xenon headlamps, refer to paragraph 9.1.6.

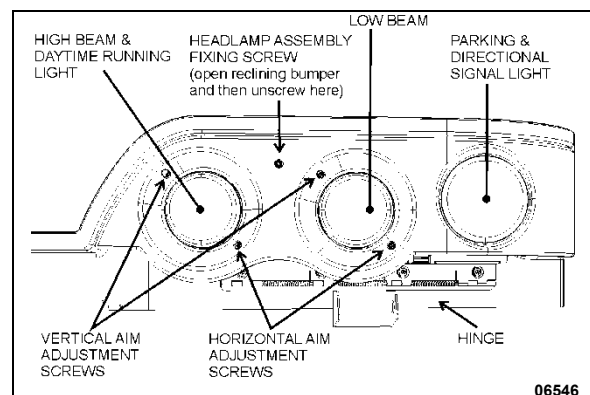

FIGURE 51: HEADLIGHT ASSEMBLY

11.1.1 Headlight Beam Toggle Switch

The multifunction lever located on the steering column is used to select proper lighting. High beams or low beams can be selected by pulling the lever rearward. A high beam indicator on the central dashboard panel is illuminated when the high beam circuit is energized.

NOTE

Pulling the lever rearward while the lights are off will flash the headlights.

11.1.2 Maintenance

Clean headlights with soap and water. When a headlight burns out, a new bulb must be installed. Headlights must be properly aimed to provide maximum allowable road illumination. When using mechanical aiming devices, follow manufacturer's instructions.

Aiming can be performed without opening headlight assembly. Horizontal and vertical aiming of each module is provided by two adjusting screws that pivot the module in the housing for proper alignment (Figure 52). There is no adjustment for focus since the module is set for proper focus during manufacturing assembly.

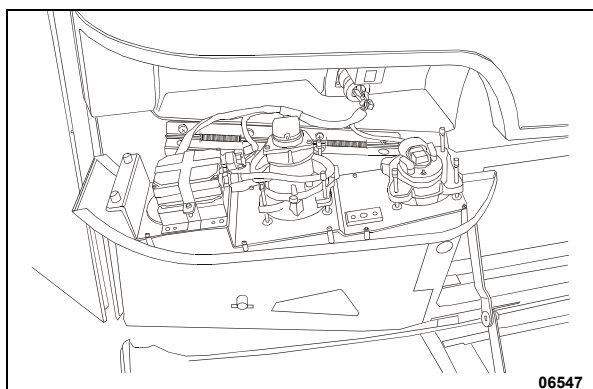

FIGURE 52: OPENING HEADLIGHT ASSEMBLY

NOTE

Make sure headlight assembly is properly positioned into its housing before securing using fixing screw.

**CAUTION**

Use a soft cloth to clean the parking and front turn signal lamp.

11.1.3 Headlight Adjustment

1. Headlight aiming and inspection can be accomplished by visual means. This is done on a screen located at a distance of 25 feet (7,6 m) of the headlights. It should be of adequate size with a matte-white surface well shaded from extraneous light and properly adjusted to the floor area on which the vehicle stands. Provisions should be made for moving the screen or its vertical centerline so that it can be aligned with the vehicle axis. In addition to the vertical

centerline, the screen should be provided with four laterally adjustable vertical tapes and two vertically adjustable horizontal tapes.

2. The four movable vertical tapes should be located on the screen at the left and right limits called for in the specification with reference to centerlines ahead of each headlight assembly.

The headlight centerlines shall be spaced either side of the fixed centerline on the screen by $\frac{1}{2}$ the lateral distance between the light source centers of the pertinent headlights. The horizontal tapes should be located on the screen at the upper and lower limits called for in the specification with reference to the height of beam centers and the plane on which the vehicle rests, not the floor on which the screen rests.

TABLE 1 – VERTICAL BEAM AIM GUIDELINES

Headlight (centerline) Mounting Height	Nominal Vertical Aim	Aim Inspection Limits for Vertical Aim
56 to 90 cm (22 to 36 inch)	0 Vertical	10 cm (4 inch) up to 10 cm (4 inch) down
90 to 120 cm (36 to 48 inch)	5 cm (2 inch) down	5 cm (2 inch) up to 15 cm (6 inch) down
120 to 140 cm (48 to 54 inch)	6.4 cm (4 inch) down	4 cm (1.5 inch) up to 16.5 cm (6.5 inch) down

3. The nominal vertical aim position on lower beam headlights shall be adjusted based on the headlight mounting height, from the ground to the light source center of the headlight, according to table 1.
4. High beam headlights are aimed so that the center of the high-intensity zone is located at the horizontal and straight ahead vertically (Figure 54).
5. Low beam headlights are aimed so that the top edge (the cutoff) of the high-intensity zone is at the vertical location as per Table 1 and the left edge of the high-intensity zone is at the vertical centerline of the headlight (Figure 55).
6. The inspection limits for high-beam headlights shall be with the center of the high-intensity zone from 10 cm (4 in) up to 10 cm (4 in) down; and, from 10 cm (4 in) left to 10 cm (4 in) right on a screen at 7.6 m (25 ft) (Figure 56).

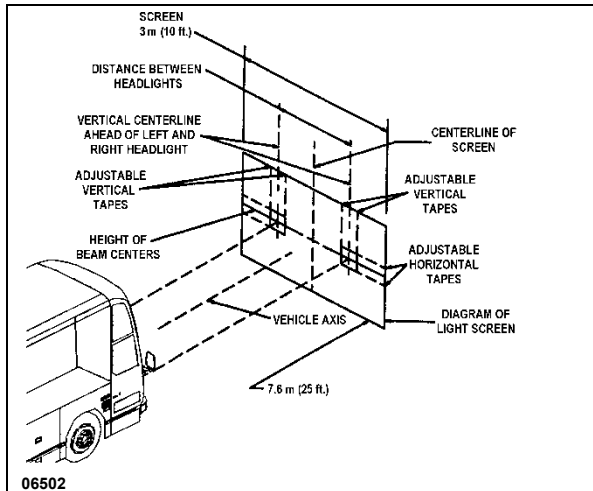

06502
FIGURE 53: ALIGNMENT OF HEADLIGHT AIMING SCREEN

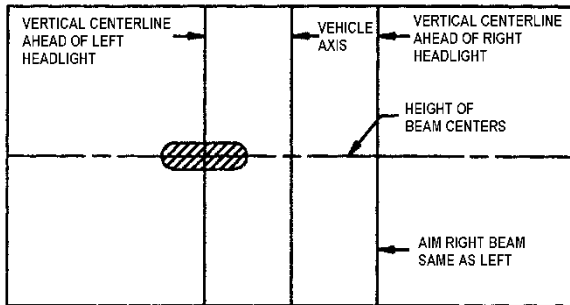

06503
FIGURE 54: UPPER BEAM HIGH-INTENSITY ZONE PROPER LOCATION ON SCREEN

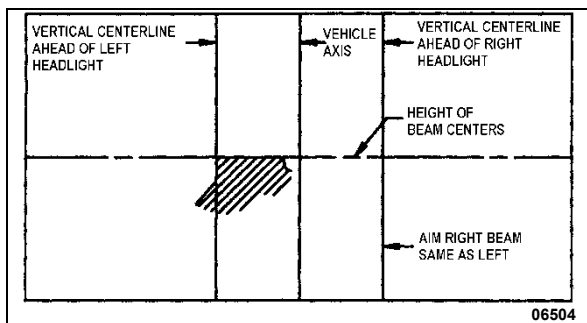

06504
FIGURE 55: LOWER BEAM HIGH-INTENSITY ZONE PROPER LOCATION ON SCREEN

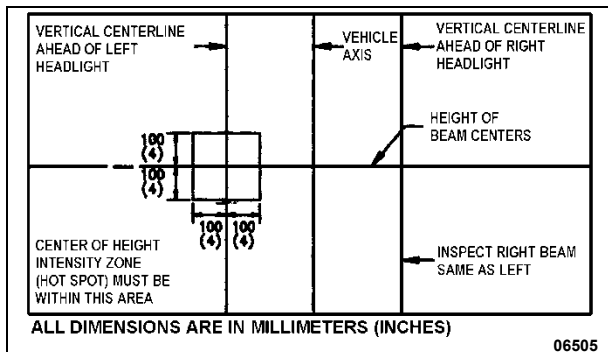

06505
ALL DIMENSIONS ARE IN MILLIMETERS (INCHES)

FIGURE 56: AIM INSPECTION LIMITS FOR UPPER-BEAM HEADLIGHTS

7. The inspection limits in the vertical direction for low-beam headlights or the low beam of a dual-beam headlight, shall be as described in Table 1. In the horizontal direction, the left edge of the high-intensity zone shall be located from 10 cm (4 in) left to 10 cm (4 in) right of the vertical centerline of the beam. The viewing screen shall be located 7.6 m (25 ft) in front of the vehicle (Figure 57).

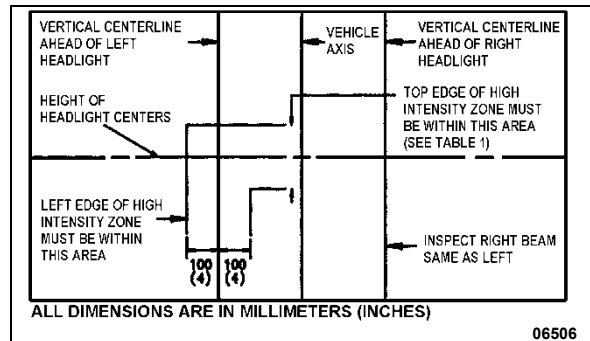

06506
FIGURE 57: AIM INSPECTION LIMITS FOR LOWER-BEAM HEADLIGHTS

11.1.4 Sealed-Beam Unit

Bulb Removal and Replacement

1. Pull the release handle located inside the front service compartment to tilt down the entire bumper assembly.
2. Remove the headlight screw fixing the headlight assembly, then tilt headlight assembly down (Figure 52).
3. Remove connector from headlight bulb.
4. Remove the bulb by pushing and rotating it out of the socket.
5. Install the new bulb by reversing the previous procedure.

CAUTION

During this step, avoid contacting the bulb with the fingers not to alter the bulb life.

NOTE

Do not disrupt headlight adjustment screws.

Module Replacement

1. Pull the release handle located inside the front service compartment to tilt down the entire bumper assembly.
2. Remove the headlight screw fixing the headlight assembly, then tilt headlight assembly down (Figure 52).
3. Remove connector from headlight bulb.
4. Unfasten three metal clips attaching headlight unit to support.
5. Install new module and fasten metal clips.
6. Install wiring connector on back of new sealed beam unit.
7. Tilt headlight assembly up into its housing then secure using fixing screw.

NOTE

Make sure headlight assembly is properly positioned into its housing before securing using fixing screw.

8. Perform alignment procedure.

NOTE

The headlight aim must be checked and adjusted even if it was properly adjusted before the sealed beam unit was replaced.

11.1.5 Front Turn Signal

The front turn signal is part of the front headlight assembly. The turn signal is a sealed unit (LED) located on each front corner and should be replaced as an assembly. Turn signal is visible from both front and side.

Removal and Replacement

1. Pull the release handle located inside the front service compartment to tilt down the entire bumper assembly.
2. Remove the headlight screw fixing the headlight assembly, then tilt headlight assembly down (Figure 52).
3. Partially unfasten back plate fixing screws, then remove signal lamp.
4. Remove socket from signal lamp.
5. Install wiring connector on back of new signal lamp then install signal lamp.

6. Fasten back plate fixing screws then tilt headlight assembly up into its housing then secure using fixing screw.

NOTE

Make sure headlight assembly is properly positioned into its housing before securing using fixing screw.

11.1.6 Optional Xenon Headlamp

The outer lamps of each headlight assembly may be equipped with the optional Xenon lamps. These lamps improve visibility and provide better lifespan.

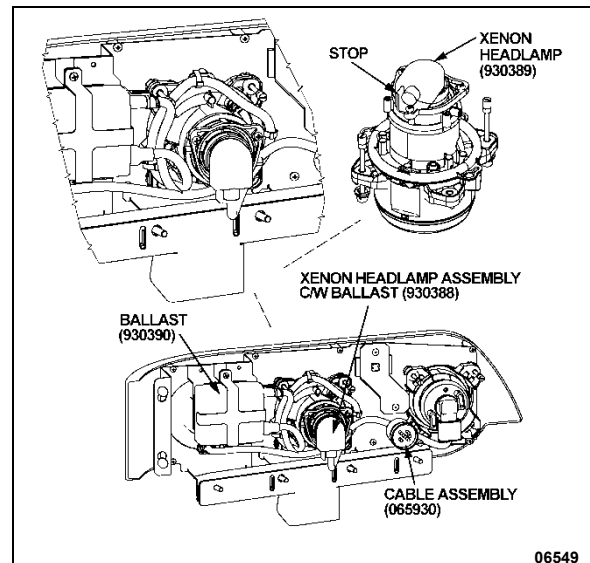

FIGURE 58: XENON HEADLAMP LOCATION

Bulb Removal and Replacement

1. Pull the release handle located inside the front service compartment to tilt down the entire bumper assembly.
2. Remove the headlight screw fixing the headlight assembly, then tilt headlight assembly down (Figure 52).
3. Remove main cable connector (066011).
4. Remove connector from headlamp bulb by turning counterclockwise.
5. Unscrew the three Phillips head screws, pull the retainer and bulb out.

**CAUTION**

To avoid breaking the bulb, make sure the

socket is in proper position against the stop.

- Install the new bulb by reversing the previous procedure.



CAUTION

During this step, avoid contacting the bulb with the fingers not to alter the bulb life.

NOTE

Do not disrupt headlight adjustment screws.



CAUTION

Never connect a voltmeter or V.O.M. to measure bulb voltage as instrument will be destroyed.

Troubleshooting and Safety

When switching on the Xenon headlamp using the rocker switch, a lamp short-circuit test is performed.

Current is detected in the lamp circuit before the ignition time and ignition prevented. Connection of the "hot" lamp to the body mass also prevents ignition. In both cases, the system is cut off within < 0.2 s and can only be restarted via the rocker switch.

In general, the maximum ignition time is < 0.2 s, which period is followed by cutoff. This would happen if a lamp was defected.

Lamp missing: system is cut off after < 0.2 s.

If lamp components or cables are damaged by force (accident) so that contact with hazardous parts is possible, the current in these lines is earthed by the vehicle body and - as with a defective household appliance - switched off when 30 mA are reached within < 0.2 s. the cutoff time is shortened by a more powerful defect current.

To protect the ballast, a counter in the electronic safety system ensures that a defective lamp can only be switched off 7 times consecutively after a successful ignition, after which the device is cut off. This prevents flutter and flashing. This counter is put out of action when the lamp cutoff time repetition interval is longer than 1.3 s so that temporary non-defect disturbances that result in immediate invisible re-ignition do not cause lamp cutoff.

A warning notice on the lamp plug makes you aware of the fact that the lamp is operated in this system on a higher voltage (you should therefore switch off the lamp before working on this part).

After taking out the lamp, the contact pins are in a practically idle state (< 34 Volt) after < 0.5 seconds so that there is no immediate danger of electric shock even if the warning is disregarded.

With this safety concept there is no danger to check the ballast with a new bulb. There is a very high probability that the ballast is OK if the ballast can ignite the bulb.

One simple test to check the ballast would be to measure the Nominal current of 1.58 A after one minute for the 24V ballast.

11.2 STOP, TAIL, DIRECTIONAL, BACK-UP, AND HAZARD WARNING LIGHTS

A combination stoplight, taillight, directional signal light and back-up light assembly is mounted at the rear, on each side of the vehicle. Furthermore, when braking, two center stoplights (LED) and a center high-mounted stop light (CHSL) (LED) will illuminate simultaneously with the stoplights on the sides for increased safety. The L.H. and R.H. side center stop lights are also used as directional signal and marker lights.

The stop, tail, directional signal and back-up lights consist of individual lamps, each equipped with 6 LED lights, mounted on the engine rear door.

LED lights are not replaceable and each lamp is serviced individually as a complete unit.

The hazard warning flashing system uses the front, side and rear directional lights simultaneously. This system is energized by a switch on the L.H. dashboard.

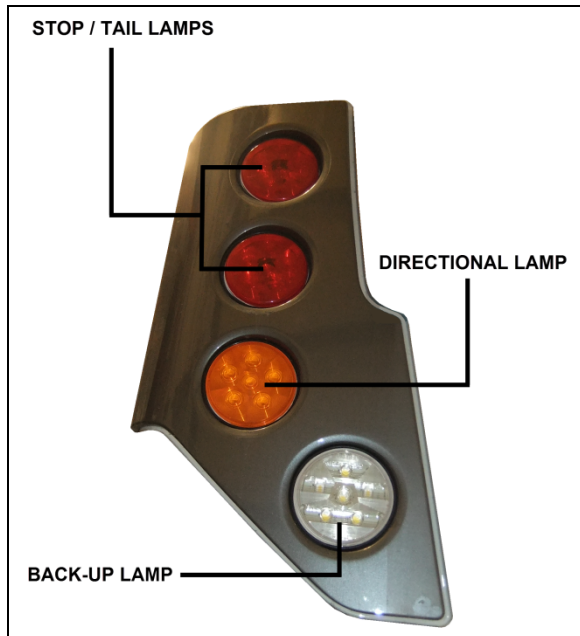

FIGURE 59: REAR TAIL LAMPS

11.2.1 Lamp Removal and Replacement

1. Open engine compartment rear door.
2. Remove the lamp pod from the engine compartment door by unscrewing the Torx hold down screws (4) at the back of the door and the two (2) side retaining nuts.
3. Remove the lamp support retaining screws (2), and then from the outside, disconnect and remove the faulty lamp and its support.
4. From the outside, install the new lamp with its support then fasten the retaining screws.
5. Reinstall the lamp pod on the door and reconnect the lamp.

11.2.2 Center Stoplights and Cyclops Light Removal and Replacement

These (LED) lights are sealed unit and should be replaced as an assembly in accordance with the following procedure:

1. Unscrew both "Phillips" light screws then remove the light assembly.
2. Install new light assembly and secure using screws.

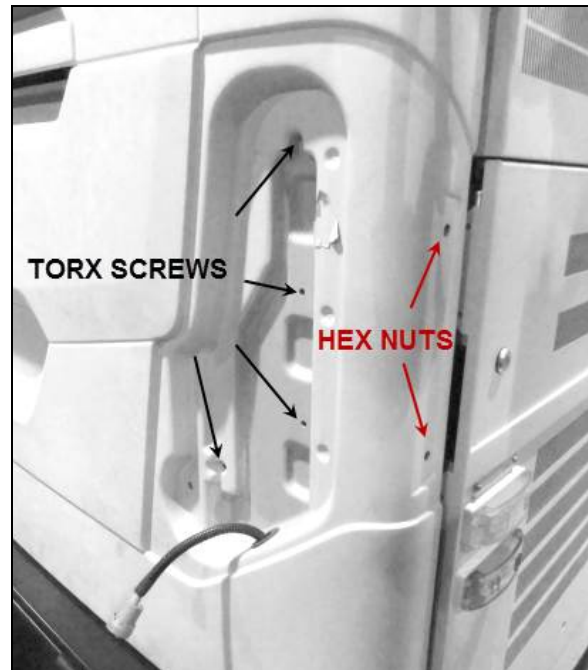

FIGURE 60: TAILLAMP POD RETAINING SCREWS & NUTS

11.3 LICENSE PLATE LIGHT

Two LED units are mounted above the rear license plate(s) of vehicle. In case of burn out, the LED unit must be changed according to the following procedure.

1. Pry out the rubber seal with a small screwdriver. Pull on the LED unit and disconnect it.
2. Reconnect new LED unit, place rubber seal, and press on it until it is seated in position.

11.4 CLEARANCE, IDENTIFICATION AND MARKER LIGHTS

The vehicle is equipped with marker, identification and clearance lights (LED). The clearance lights are mounted at each corner of the coach near the top and the identification lights are in the upper center of rear and front sections.

The rear clearance and identification lights are red and the front ones are amber.

The amber marker lights are mounted along the sides of vehicle.

The side marker light is a sealed unit (LED) and should be replaced as an assembly in accordance with the following procedure:

1. Unscrew both “Phillips” light screws, and then remove the light assembly.
2. Position the new light assembly and install the “Phillips” screws.

11.4.1 Clearance and Identification Light Removal and Replacement

The clearance and identification light are sealed units (LED) and can be replaced in accordance with the following procedure:

1. Unscrew both “Phillips” light screws, and then remove the light assembly.
2. Position the new light assembly, and then install the “Phillips” screws.

11.5 FOG LIGHTS

Optional halogen fog lights can be mounted on this vehicle to give the driver better visibility in foggy weather, or to improve the range of vision just ahead of the coach.

11.5.1 Bulb Removal and Replacement

1. Pull on the release handle located in the front service compartment, near the door lower hinge. The bumper will lower gradually.
2. Unscrew the wing nut and pivot assembly upwards.
3. Unscrew the outer ring. Disconnect the light unit connection and remove the bulb.
4. Install the new bulb, reconnect the light unit and replace in its proper position.



CAUTION

During this step, avoid contacting the bulb with your fingers. This could alter the bulb life.

5. Reinstall the outer ring, pivot the assembly downwards.

Fasten the wing nut and securely close the bumper.

12. X3 SERIES INTERIOR LIGHTING EQUIPMENT

12.1 CONTROL PANEL LIGHTING

The instrument gauges and switches mounted on all control panels are energized whenever the exterior light switch is pushed to the first position. A control dimmer located on the dashboard is used to vary the brightness of the panel gauges, switches and indicator lights.

The gauge lights, panel lights, switch lights and indicator lights have a different bulb arrangement. Thus, the procedure to change a defective bulb can vary according to the application.

12.1.1 Switch Lighting

1. Slightly pull the switch with a defective LED away from the control panel.
2. Disconnect the electric cable from the switch.
3. To install a new switch, reverse the procedure (Figure 61)

NOTE

Switches are lighted by the use of LED. When lighting on a switch fails, replace defective switch as a unit.

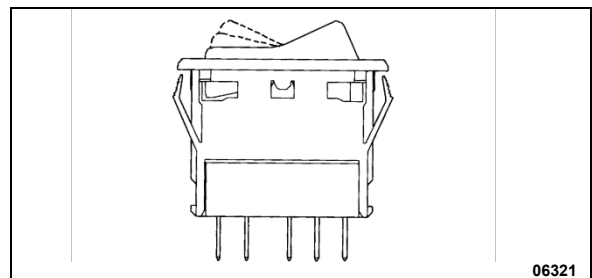

FIGURE 61: SWITCH

12.1.2 Telltale Light Replacement

Telltale module is non-serviceable and must be replaced as a unit.

1. Unscrew and remove the top dashboard panel.
2. Remove the telltale back wire electric connectors.
3. Unscrew and remove the telltale module.

- To replace the telltale module, reverse the procedure.

12.1.3 Gauge Light Bulb Replacement

- For any gauge light bulb replacement, the dashboard panel must be removed in order to have access to the rear of gauges.

- Remove bulb socket from the gauge, turn the defective bulb counterclockwise and pull it out of the gauge.
- Push a new bulb and socket ASM and turn clockwise to lock in place.
- Replace the rear dashboard housing.

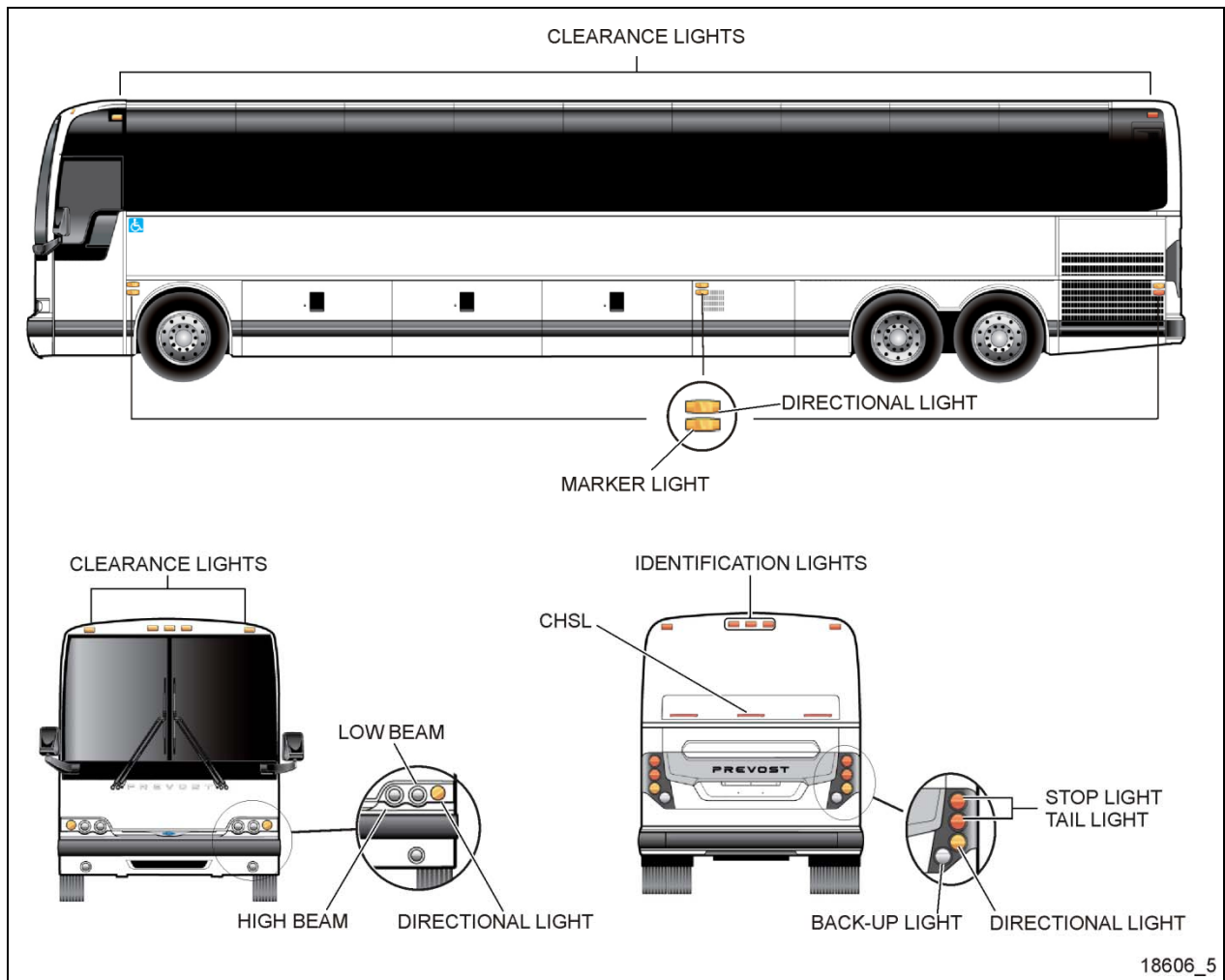

FIGURE 62: VARIOUS LIGHTS LOCATION

12.2 STEPWELL LIGHTS

Two Stepwell lights are illuminated when the door opening system is activated.

12.2.1 Bulb Removal and Replacement

Proceed as follows to replace a defective bulb:

- Unscrew the two Phillips-head screws retaining the lens to the wall, and remove it.

- With the light lens removed, pull bulb from the lamp while applying lateral pressure.
- Install the new bulb into the lamp.
- Position the light lens and install it.

12.3 DRIVER'S AREA LIGHTS

Two halogen ceiling lights are installed over the stepwell and the driver's area. These lights are frequently used for night-time operation when passengers board or leave coach.

12.3.1 Bulb Removal and Replacement

1. Unsnap the lamp with a flat head screwdriver and remove it.
2. Pull the defective bulb out of the socket.
3. Install the new bulb by pushing it in position.
4. Replace the lamp by snapping it back in place.



CAUTION

Do not touch halogen bulbs with bare hands as natural oils on skin will shorten bulb life span.

12.4 PASSENGER SECTION LIGHTING

The passenger section of coach is lit by two types LED strips installed on the parcel racks. The aisle or *indirect lights* are located on front of parcel racks, and provide soft, indirect cabin lighting and parcel rack interior lighting.

More powerful lighting for general is provided by LED strips located under the parcel racks, close to the windows. 24 volt power is available for this lighting. In order to save batteries during extended periods, the battery charger can be connected prior use.

Moreover, adjustable reading lamps are installed under the parcel racks for passenger accommodation.

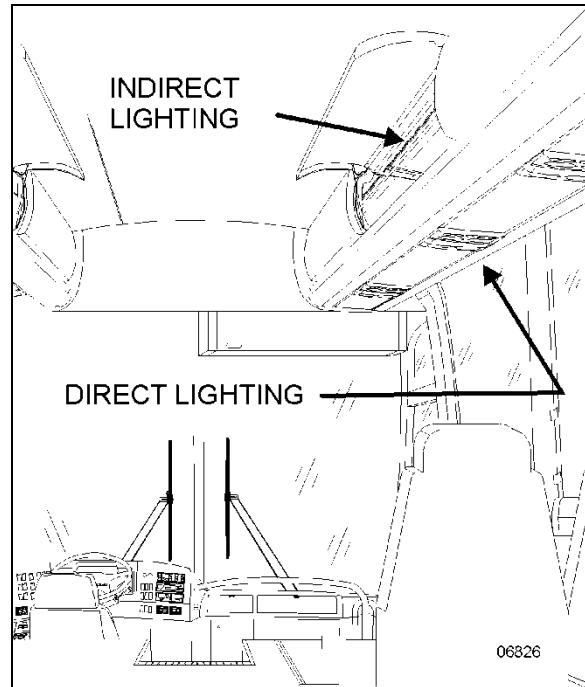

FIGURE 63: PARCEL RACK LIGHTING

12.4.1 LED Indirect Lighting / Parcel Rack Interior Lighting

1. Open the parcel rack access door.
2. Using a Phillips head screwdriver, unscrew and remove the existing LED strip (FIGURE 64).
3. Install a new LED strip as a complete unit.

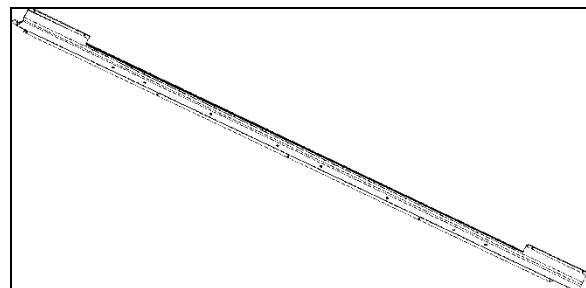

FIGURE 64: LED INDIRECT LIGHTING IN PARCEL RACK

12.4.2 LED Direct Lighting

1. Start by pulling out the corner of the lens then delicately peeling it out of its seat.
2. Unscrew and remove the LED strip assembly (4 Phillips screws).
3. Install a new LED strip assembly.

4. Replace the screen lens by first inserting one side in the seat, then push the other side in and snap it in place by running it in from one corner to the next.

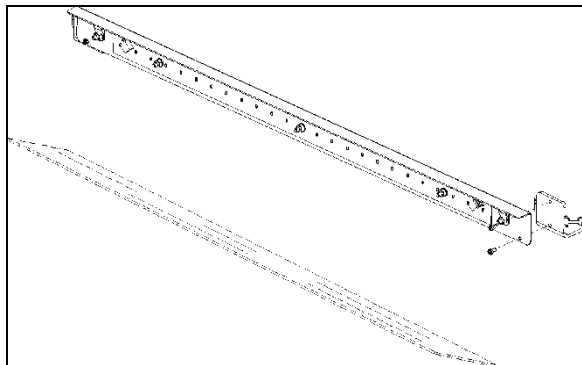

FIGURE 65: LED DIRECT LIGHTING AND LENS

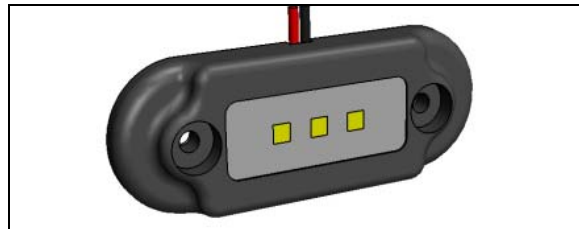

FIGURE 66: ENGINE COMPARTMENT LIGHT

12.4.3 Removal and Replacement of Reading Lamp Bulb

1. Engage the tool (#830164) over the lamp and turn one quarter turn counterclockwise. Then, remove the tool slowly.
2. Pull the bulb socket off the reading lamp unit.
3. Push and turn bulb counterclockwise, then pull it out of the socket.
4. Install new bulb in the socket, then push and turn clockwise to lock bulb in position.
5. Push the bulb socket in the reading lamp unit.
6. Position the reading lamp with the tool (#830164), turn one quarter turn clockwise.

12.5 ENGINE COMPARTMENT LIGHTING

Three 24-volts LED modules illuminate the engine compartment when the following conditions are met:

1. The engine compartment rear door or curbside door is open.
2. Ignition switch in ON or ACC position.

The light module is sealed thus not serviceable.

13. SPECIFICATIONS**AGM Battery**

Make.....	Volvo
Type	Absorbed Glass Mat
Terminal type	Top Stud
Group size	8A31
Volts	12
Load test amperage	400
Reserve capacity (minutes).....	200
Cold cranking (in amps)	
-At 0°F (-18°C).....	800 (each battery)
Maximum dimensions (inches/mm)	
-Length (including flange).....	12.93/328
-Width	6.7/169
-Height (including top posts)	9.3/237
-Approximate weight (lbs/kg).....	61.7/28

Alternator

Make.....	BOSCH
Series	HD 10
Amperes	150
Volts	28.4
Output Power	3 Kw
Ground	negative

Battery equalizer (Prime)

Make.....	Vanner
Model.....	Vann-bus 80-Series
Amperes	100 amps

Starter



Make.....	Mitsubishi Electric Corporation (MELCO)
Type	105P70
Voltage	24
No-load test	
-Volts	23.5
-Max. current draw	125 amperes
-Min. rpm	3000 rpm

Starter solenoid

Make.....	Mitsubishi Electric Corporation (MELCO)
Pull In Voltage	16 volts max.

ELECTRICAL CONNECTORS PROTECTION

PROCEDURE NO SAV00002E	NOVEMBER 2009 REVISION 02
-------------------------------	--------------------------------------

Kent Sealer	
<p>Sprayed sealer. It is used for structure ground connections. It prevents corrosion and ensures maximum contact. Refer to table for proper use.</p> <p>Apply this product once installation is finished.</p> <p><u>Warning:</u> <i>It is very important to be in a well ventilated area when applying this product.</i></p>	 <p>680324</p>
Nyogel Grease	Nyogel Grease
<p>Grease-type product.</p> <p>It is used to facilitate connectors or terminals insertion.</p> <p>Refer to table for proper use of Nyogel grease.</p> <p>It is preferable to apply Nyogel into the female part of connector.</p> <p>Apply this product as the last assembling operation.</p>	 <p>3 Oz. tube: 681095 Container 500g: 683409</p>
“Color Guard” black rubber coating	“Color Guard” black rubber coating
<p>This product may be applied with a brush.</p> <p>It is used for structure ground connections or other connections that will most likely not be disconnected later on.</p> <p>Apply this product once installation is finished.</p> <p><u>Warning :</u> <i>Wear goggles and rubber gloves.</i></p>	 <p>684013</p>

Vehicle Zoning

X3-MTH

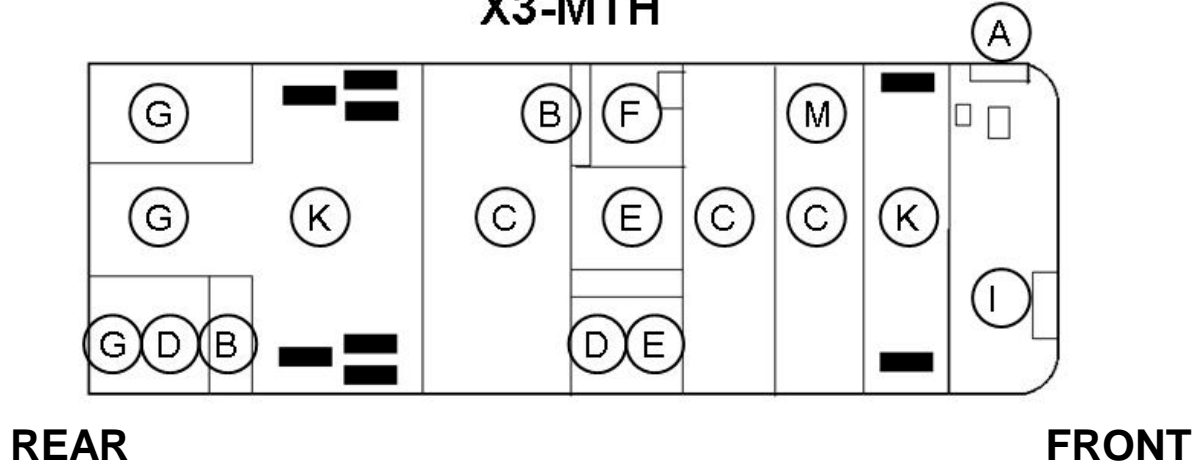

H3- VIP

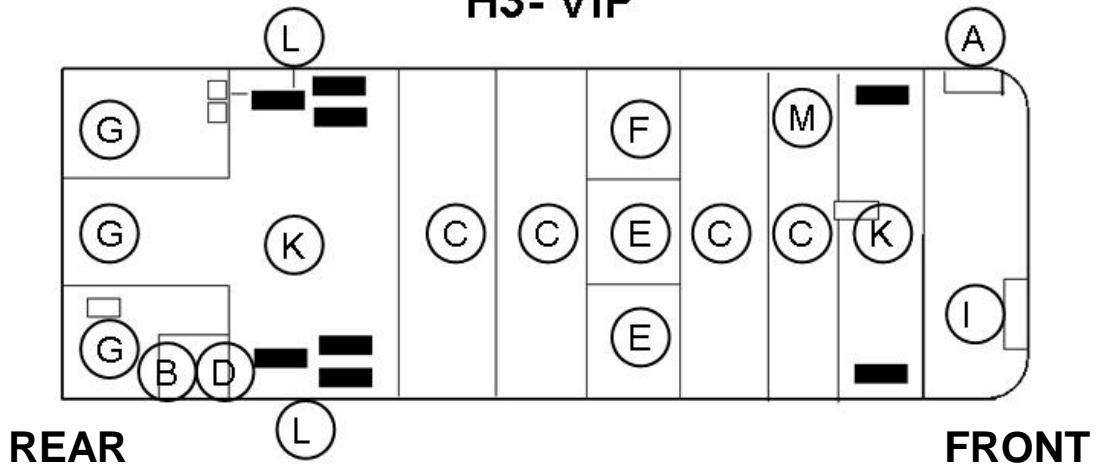

Electrical Connectors Protection Procedure Table

Zone	Component	Model				Product	Note
		MTH	X3	H3	VIP		
A- Front Elect. Compt	Diode Block	X	X	X	X	Nyogel	Accepted to ease connection
A- Front Elect. Compt	Customer Terminal Block	X	X	X	X	Nothing	
A Front Elect. Compt	Terminal Block Electronic Ground	X	X	X	X	Kent	
A- Front Elect. Compt	Structure Ground	X	X	X	X	Kent	
A- Front Elect. Compt	Electronic Module	X	X	X	X	Nothing	
A- Front Elect. Compt	VEC Power	X	X	X	X	Nothing	
A- Front Elect. Compt	70A Relay	X	X	X	X	Nyogel	Accepted to ease connection
A- Front Elect. Compt	Control Relay	X	X	X	X	Nyogel	Accepted to ease connection
A- Front Elect. Compt	All connectors except those specified in this zone	X	X	X	X	Nothing	
A- Front Service Compt	All connectors except those specified in this zone	X	X	X	X	Nothing	
B- Rear Elect. Compt/panel	Customer Terminal Block	X	X	X	X	Nothing	
B- Rear Elect. Compt/panel	Power Terminal Block		X			Nothing	
B- Rear Elect. Compt/panel	Circuit Breaker		X	X	X	Nothing	
B- Rear Elect. Compt/panel	Circuit Breaker	X				Kent	Surface only
B- Rear Elect. Compt/panel	Volvo Air Heater Fuse			X		Nothing	
B- Rear Elect. Compt/panel	Structure Ground		X	X	X	Kent	
B- Rear Elect. Compt/panel	Electronic Module	X	X	X	X	Nothing	
B- Rear Elect. Compt/panel	VEC Power		X	X	X	Nothing	
B- Rear Elect. Compt/panel	VEC Power	X				Kent	Surface only
B- Rear Elect. Compt/panel	70A Relay	X	X	X	X	Nyogel	Accepted to ease connection
B- Rear Elect. Compt/panel	Master Switch Relay		X	X	X	Nothing	
B- Rear Elect. Compt/panel	Master Switch Relay	X				Kent	Surface only
B- Rear Elect. Compt/panel	Control Relay	X	X	X	X	Nyogel	Accepted to ease connection
B- Rear Elect. Compt/panel	200A Power Relay	X	X	X	X	Nothing	
B- Rear Elect. Compt/panel	Power Relay Stud		X			Nothing	
B- Rear Elect. Compt/panel	All connectors except those specified in this zone	X	X	X	X	Nothing	
B- Rear Elect. Compt/panel	Vanner			X	X	Kent	

Zone	Component	Model				Product	Note
		MTH	X3	H3	VIP		
C- Baggage Compt	Structure Ground	X	X	X	X	Color Guard or Kent	
C- Baggage Compt	Door Switch	X	X	X	X	Nyogel	Accepted to ease connection
C- Baggage Compt	Door lock Actuator Module (switch and solenoid)	X	X	X	X	Nyogel	Accepted to ease connection
C- Baggage Compt	Electronic Module	X	X	X	X	Nothing	
C- Baggage Compt	Slide-out Motor	X			X	Nyogel	Accepted to ease connection
C- Baggage Compt	WCL Junction Panel		X	X		Nothing	
C- Baggage Compt	120V Inverter Connector	X	X	X	X	Nothing	
C- Baggage Compt	Stud inverter		X	X		Color Guard or Kent	
C- Baggage Compt	WCL Remote Control		X	X		Nyogel	Accepted to ease connection
C- Baggage Compt	All connectors except those specified in this zone	X	X	X	X	Nothing	
D- Battery Compt	Battery terminals	X	X	X	X	Nyogel	
D- Battery Compt	Structure Ground	X	X			Color Guard or Kent	
D- Battery Compt	Electronic Module	X	X	X	X	Nothing	
D- Battery Compt	All connectors except those specified in this zone	X	X	X	X	Nothing	
D- Battery Compt	Battery Equalizer	X	X			Kent	
E- Condenser Compt	Fuel sender	X	X	X	X	Kent	
E- Condenser Compt	Structure Ground	X	X	X	X	Color Guard or Kent	
E- Condenser Compt	Door Switch	X	X	X	X	Nyogel	Accepted to ease connection
E- Condenser Compt	Condenser Motor	X	X	X	X	Nothing	
F- Evaporator Compt	Diode Block	X		X	X	Nyogel	Accepted to ease connection
F- Evaporator Compt	Structure Ground	X	X	X	X	Color Guard or Kent	
F- Evaporator Compt	Electronic Module	X		X	X	Nothing	
F- Evaporator Compt	Evaporator Motor	X	X	X	X	Color Guard or Kent	
F- Evaporator Compt	200A Power Relay	X		X	X	Nothing	
F- Evaporator Compt	All connectors except those specified in this zone	X		X	X	Nothing	

Zone	Component	Model				Product	Note
		MTH	X3	H3	VIP		
G- Engine Compt	120A Alternator	X	X	X	X	Color Guard	
G- Engine Compt	Booster Block (+)		X	X	X	Color Guard	
G- Engine Compt	Starter Terminal	X	X	X	X	Color Guard	
G- Engine Compt	Volvo Air Element Terminal	X	X	X	X	Color Guard	
G- Engine Compt	Customer Terminal Block	X				Nothing	
G- Engine Compt	Power Terminal Block		X			Color Guard	
G- Engine Compt	Breaker	X				Kent	
G- Engine Compt	Air Heater Fuse & Relay	X	X			Nyogel	Accepted here
G- Engine Compt	Engine Ground	X	X	X	X	Color Guard	
G- Engine Compt	Structure Ground	X	X	X	X	Color Guard	
G- Engine Compt	VEC Power	X				Kent	
G- Engine Compt	Master Switch Relay	X				Kent	
G- Engine Compt	Starter Relay	X	X			Color Guard	
G- Engine Compt	All connectors except those specified in this zone	X	X	X	X	Nothing	
H- Vehicle Exterior	ABS Sensor	X	X	X	X	Nothing	
H- Vehicle Exterior	Docking & Cornering Lamps	X	X	X	X	Nyogel	Accepted to ease connection
H- Vehicle Exterior	Marker Light	X	X	X	X	Nothing	
H- Vehicle Exterior	Mirror	X	X	X	X	Nothing	
H- Vehicle Exterior	Light Module	X	X	X	X	Nothing	
H- Vehicle Exterior	Stop light, Backup light, Directional Signal Light	X	X	X	X	Nothing	
I- Vehicle Interior	Diode Block	X	X	X	X	Nyogel	Accepted to ease connection
I- Vehicle Interior	Junction Block		X	X		Nothing	
I- Vehicle Interior	A3 & A4 Transmission Retarder Hand lever	X	X	X	X	Nyogel	Accepted to ease connection
I- Vehicle Interior	C258 & C259 Multi-function Lever Connector	X	X	X	X	Nyogel	Accepted to ease connection
I- Vehicle Interior	Audio - video Connection		X	X		Nothing	
I- Vehicle Interior	Defrost Compt Ground	X	X	X	X	Kent	
I- Vehicle Interior	Video Plate Direct Ground		X	X		Nothing	
I- Vehicle Interior	Structure Ground		X	X		Kent	
I- Vehicle Interior	Terminal Block Ground		X	X		Nothing	

Zone	Component	Model				Product	Note
		MTH	X3	H3	VIP		
I- Vehicle Interior	Dashboard Switch	X	X	X	X	Nothing	
I- Vehicle Interior	Electronic Module	X	X	X	X	Nothing	
I- Vehicle Interior	Slide-out Motor	X			X	Nyogel	Accepted to ease connection
I- Vehicle Interior	Wiper Motor	X	X	X	X	Nyogel	Accepted to ease connection
I- Vehicle Interior	200A Power Relay	X	X	X	X	Nothing	
I- Vehicle Interior	70A Relay	X	X	X	X	Nyogel	Accepted to ease connection
I- Vehicle Interior	Control Relay	X	X	X	X	Nyogel	Accepted to ease connection
I- Vehicle Interior	All connectors except those specified in this zone	X	X	X	X	Nothing	
I- Vehicle Interior	All components except those specified in this zone	X	X	X	X	Nothing	
K- Front & Rear Wheelhousing	All connectors except those specified in this zone	X	X	X	X	Nothing	
K- Front & Rear Wheelhousing	All components except those specified in this zone	X	X	X	X	Nothing	
L- Compartment above rear wheelhousing	All connectors except those specified in this zone			X	X	Nothing	
L- Compartment above rear wheelhousing	All components except those specified in this zone			X	X	Nothing	
M- Slide-out Panel	All connectors except those specified in this zone	X			X	Nothing	
M- Slide-out Panel	All components except those specified in this zone	X			X	Nothing	



**MAINTENANCE
INFORMATION**

MI15-24

DATE :	MAY 2015	SECTION: 06 - Electrical
SUBJECT :	POWER CABLES INSPECTION GUIDELINES	

APPLICATION

Model	VIN
 <p>All Prevost models</p>	

DESCRIPTION

It is important to carry out a regular inspection of the vehicle power cables. Power cables in poor condition can be the cause of failures and serious damages in the engine compartment.

Please note that some images in this document may represent arrangements different from those found on vehicles of former generations. However, inspection criteria and points to check presented in this document remain applicable in essence for all models of Prevost vehicles.

POWER CABLES MAINTENANCE SCHEDULE	
DESCRIPTION	INTERVAL
Perform power cables inspection	Every 3 months

POWER CABLES

– The power cables are those through which flow the highest currents. These cables are those with the largest electrical conductor diameters on the vehicle.

– The power cables are 1/0, 2/0, 3/0 wire gauges respectively $\varnothing 0.325\text{in}$, $\varnothing 0.365\text{in}$, $\varnothing 0.409\text{in}$.

Note: not to be confused with the 1, 2, 3 wire gauges that are actually smaller.

– There are power cables at the following locations:

- On the **alternators positive (+) stud terminal** and from there, up to Bussman junction block in the electrical compartment (Figure 1, Figure 2, Figure 3).

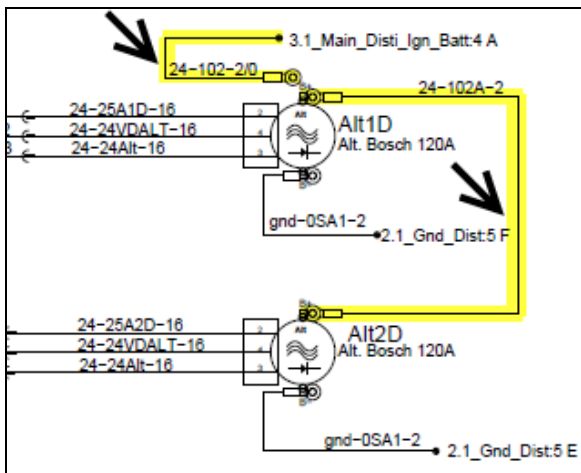

Figure 1

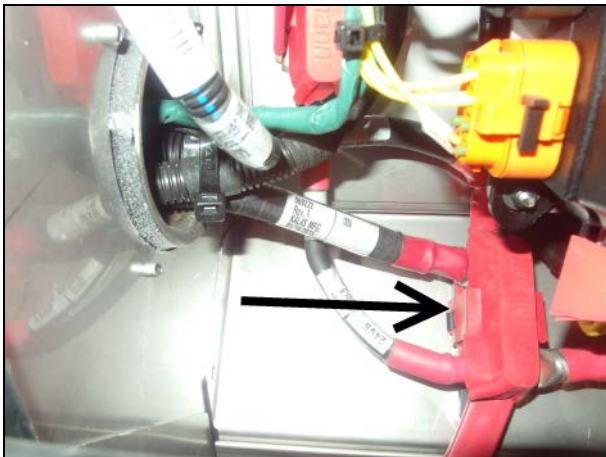

Figure 2: Bussman Junction Block - X3 Series.



Figure 3: Bussman Junction Block - H3 Series.

- On the **starter positive (+) stud terminals** and from there, up to Bussman junction block in the electrical compartment (Figure 4, Figure 5).

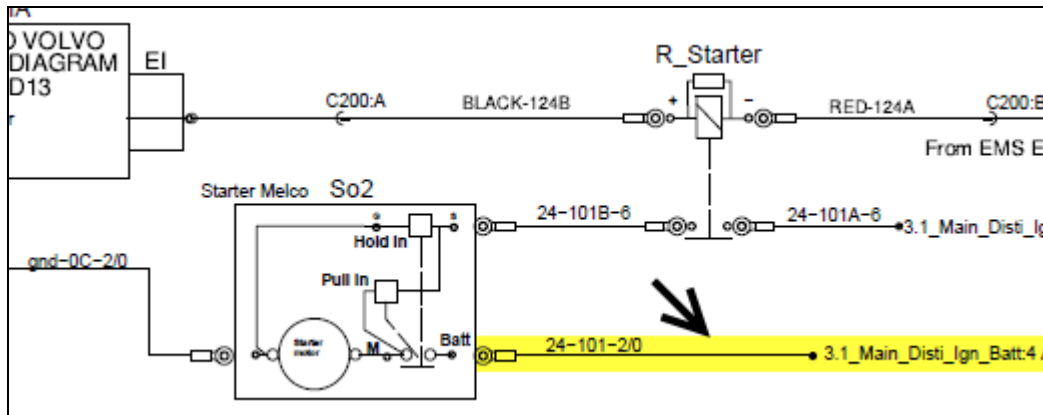

Figure 4



Figure 5: starter cables

- In the electrical compartment, **connected to Bussman junction block** (Figure 6).

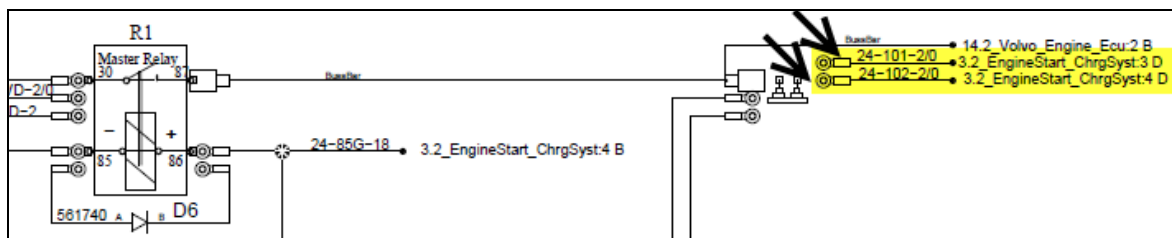

Figure 6

- In the **battery compartment** between **battery no2 and master relay R1** (Figure 7).

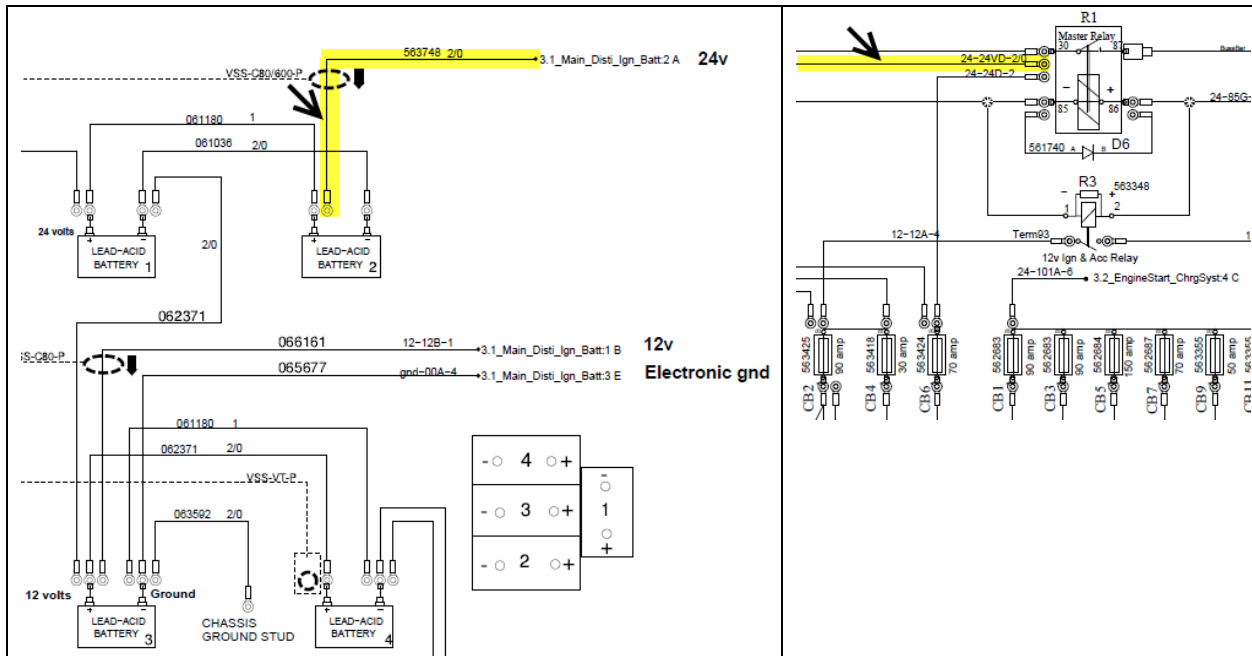

Figure 7

- Between **Bussman junction block** and **main circuit breakers' bus bar** (Figure 8).

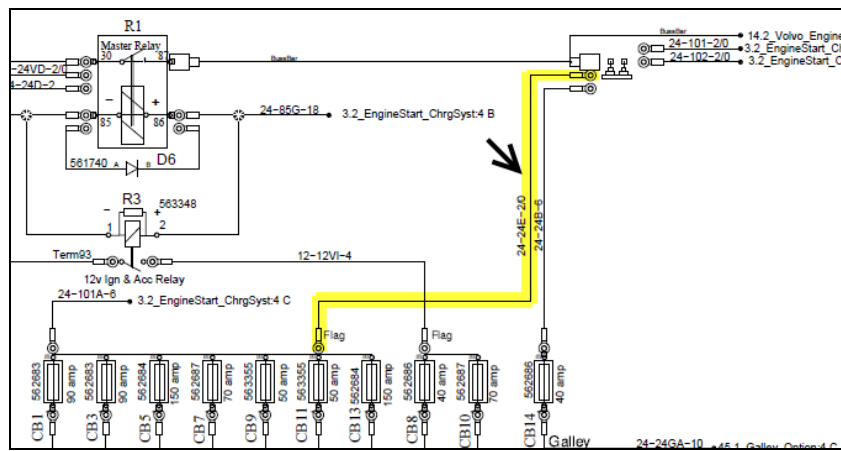

Figure 8

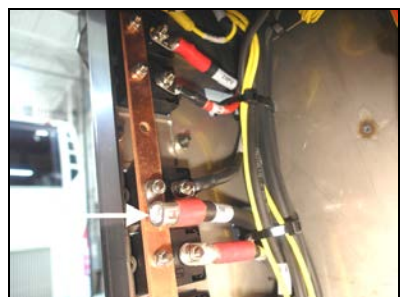

Figure 9: Power cable on main circuit breakers' bus bar.

PROCEDURE



DANGER

Park vehicle safely, apply parking brake, stop engine. Prior to working on the vehicle, set the ignition switch to the OFF position and trip the main circuit breakers equipped with a trip button. On Commuter type vehicles, set the battery master switch (master cut-out) to the OFF position.

POWER CABLES GENERAL INSPECTION CRITERIA

1. **Make sure that the power cables are properly secured with appropriate fasteners so that they do not move. Movement of the cables can cause wear of the extruded protective sheath, strains on stud terminals and ring cable lugs.**
2. **Ensure that the power cables do not rub on other cables or other components.**
3. **Make sure ring cable lugs are securely attached to the stud terminals, that the retaining nut is tightened. Also, make sure that cable lug crimping holds firmly on copper conductor.**

OTHER THINGS TO CHECK

- Check for damages caused by electric arcs with loss of material along the copper conductor.
- Check for damaged cable extruded sheath and having lost its insulating properties.
- Bosch T1 alternator: ensure that the rubber grommets at the rear cap of the alternator are present.
- P-clamp type cable clamps must be suitable for cable diameter. The cable must remain in the P-clamp without moving or rubbing, thus oversized P-clamps are not allowed. Inspect the corrugated protective sheath passing through the P-clamp for signs of wear.
- At certain locations, power cables are protected by a corrugated protective sheath and should remain as such.

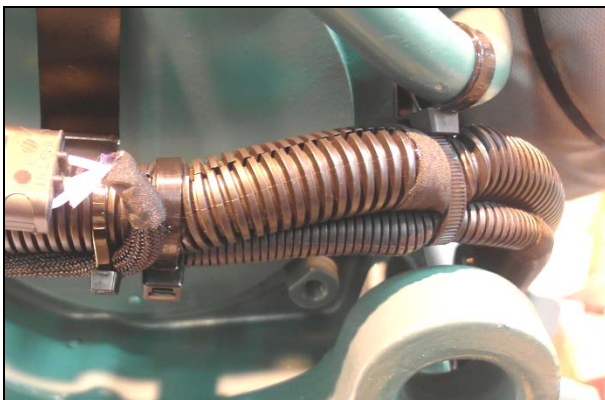

Figure 10: starter cables in a corrugated protective sheath.

- Ensure that the power cables do not rub on bolt heads or sharp metal edges that can cut or wear the cable extruded sheath.
- For power cables passing through a corrugated protective sheath, it is recommended to apply two layers of fabric tape every 3 to 6 inches minimum to prevent the cable from coming out of the

corrugated protective sheath (Figure 11). The ends of the corrugated protective sheath should be covered with fabric tape (Figure 12).

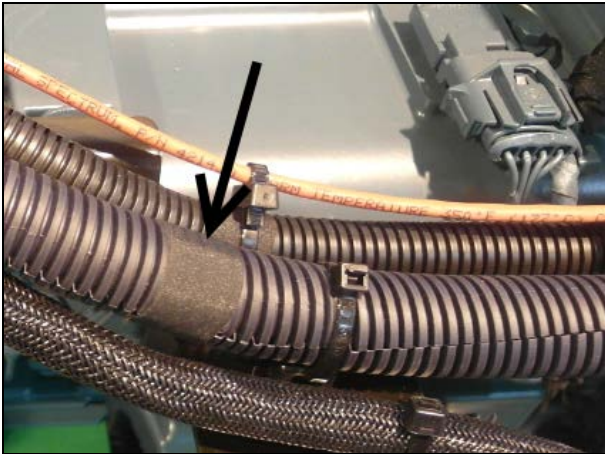

Figure 11: Two layers of fabric tape applied every 3 to 6 inches to prevent the cable from coming out of the corrugated protective sheath.

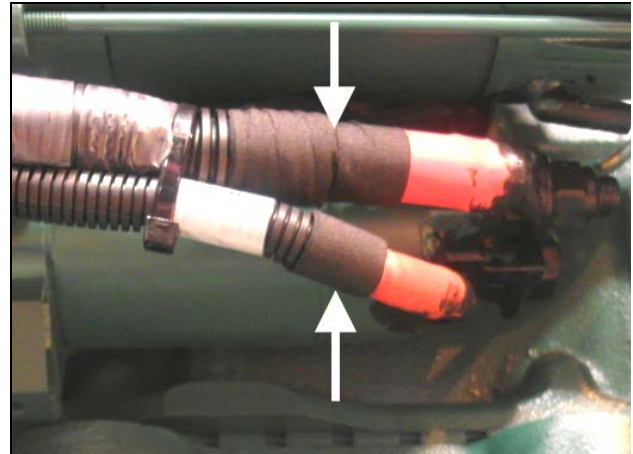

Figure 12: The ends of the corrugated protective sheath should be covered with fabric tape.

- Stud terminal nuts properly tightened. Use a nut with nylon insert to replace a similar nut where applicable. Protect ring cable lugs against tightening force by placing a flat washer between nut and ring cable lug.



RING CABLE LUGS

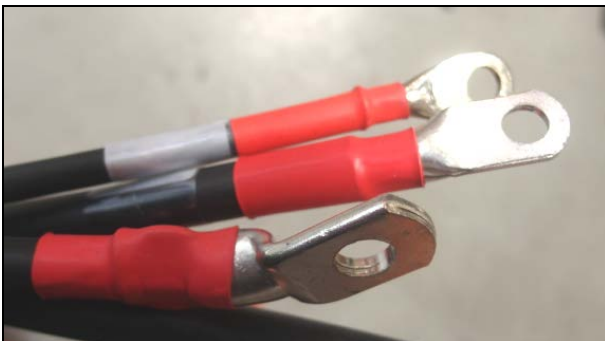

Figure 13: Cable lugs must be closed type, crimped or welded.

- Ring cable lugs should not be distorted.
- Ring cable lugs should not suffer strains that can deform.

- Ring cable lugs must be installed with smooth washers and nuts to prevent damage to the cable lug when tightening.



Figure 14: Power cable shouldn't be bent just next to the cable lug. Angled cable lugs are used to avoid mechanical stress.

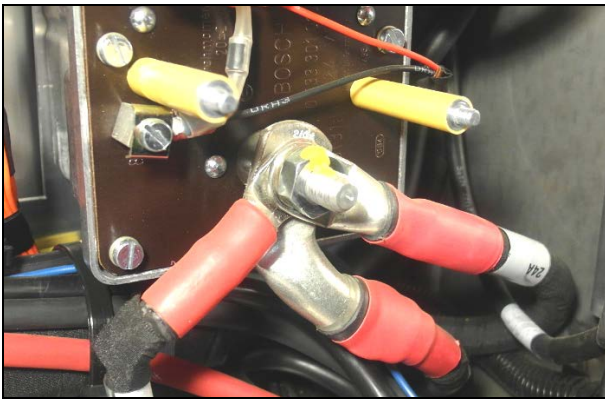

Figure 15: When several terminals are connected on a single stud terminal, the largest cable lug must be placed first, followed by the second larger and so on. Cable lugs should be distributed around the stud terminal in a way that no cable lug is distorted when tightening the nut.



Figure 16: No exposed or broken copper strands.

- A shrink tubing (or fabric tape) should cover the copper strands.
- Ensure that the power cables and ground wire are not stretched tight.
- Ensure that the cable lugs are still properly crimped on the copper conductor, that the conductor strands are not broken so that the power cable retain its capacity and ensure unrestricted current flow.

BATTERY CABLES

- Battery interconnection cables must be checked too :
 - Ensure the cables are properly fastened to battery posts and that the cables are in good condition (consult battery manufacturer documentation for appropriate tightening torque).
 - No corroded or cut copper strands. No apparent copper strands. Protective sheath in good condition, no cuts, no rubbing against metal edges.

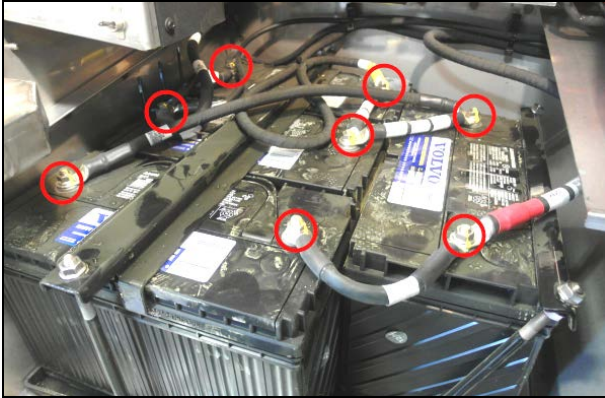

Figure 17: battery bank

STEEL P-CLAMPS



Figure 18: P-clamps are no longer used to secure power cables, but they can nevertheless be found on coaches of older generations. The piece of rubber that protects cable against the P-clamp steel loop must absolutely be in place. Replace any P-clamps where the rubber piece is missing, broken or likely to separate from the steel loop.

NOTE

*Unlike steel P-clamps, plastic clamps have the advantage of being not conductive. A good practice would be to replace P-clamps **securing power cables** with appropriate nylon cable ties like the following:*

#507664 CABLE TIE, DOUBLE LOOP

#509491 CABLE TIE, WIDE



Figure 19: P-clamp with appropriate diameter prevents the power cable or corrugated protective sheath from moving and rubbing inside the clamp.

ALTERNATORS

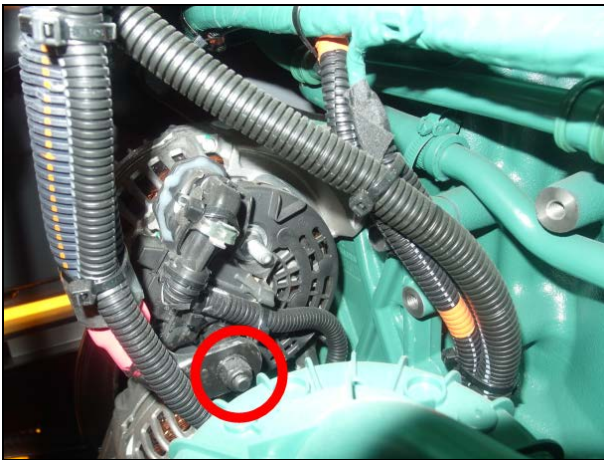

Figure 20: Make sure power cables/positive cables (+) are properly connected to alternator, that stud terminal nuts are properly tightened.

TERMINAL NUT PRESCRIBED TORQUE

Bosch HD10

- B1(+) terminal: 10 lbf-ft
- ground: 6 lbf-ft

Bosch T1

- D+: 21-28 lbf-in
- B+, B-: 88-115 lbf-in
- W: 36-48 lbf-in

Delco 50DN

- DC Output: 30-35 lbf-ft
- F1, F2, Relay: 6 lbf-ft



Figure 21: Bosch T1 alternator with the two required rubber grommets. Alternator cables connected to the alternator stud terminals must be protected against metal edges with rubber grommets.



Figure 22: Fire in engine compartment caused by rubbing of power cable against metal edge of Bosch T1 alternator rear cover. Lower rubber grommet was missing when fire occurred. Evidence of electrical arc can be seen.

CORROSION PROTECTION

- Power cable connections on alternators, starter and ground connections exposed to water, dust, etc. should be protected against corrosion with Loctite Color Guard rubber coating (**Figure 23**) (Prevost p/n: 684013).



Figure 23: Loctite Color Guard.



Figure 24: Upper alternator power cable lug protected with Color Guard rubber coating.

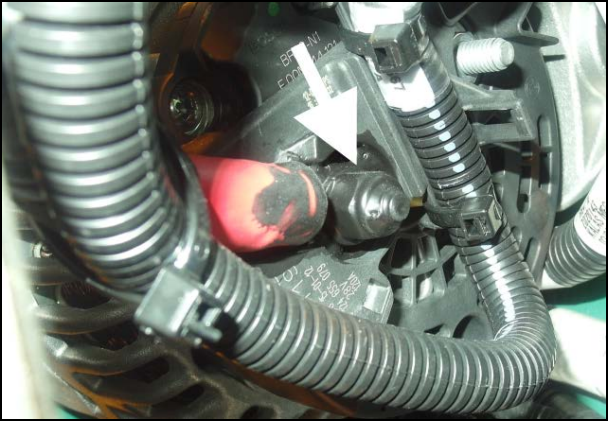

Figure 25: Lower alternator power cable lug protected with Color Guard rubber coating.



Figure 26: Starter power cable and ground cable lugs protected with Color Guard rubber coating.

PARTS / WASTE DISPOSAL

Discard according to applicable environmental regulations (Municipal/State[Prov.]/ Federal)



Access all our Service Bulletins on <https://secureus5.volvo.com/technicalpublications/en/pub.asp>
Or scan the QR-Code with your smart phone.

E-mail us at technicalpublications_prev@volvo.com and type "ADD" in the subject to receive our warranty bulletins
by e-mail.



PREVOST

MAINTENANCE INFORMATION

MI16-17

DATE :	FEBRUARY 2016	SECTION: 06 - Electrical
SUBJECT :	BOSCH HD10 ALTERNATOR REMOVAL AND INSTALLATION	

Please, get the latest revision of Maintenance Information MI16-17 on PrevoSt Technical Publications web site:

<https://techpub.prevoStcar.com/en/>

