

SECTION 9

DIMENSIONS AND WEIGHTS	3
CAPACITIES	6
FUEL TYPE	7
BIODIESEL FUEL	7
WHEELS AND TIRES	7
RECOMMENDED TIRE INFLATION PRESSURE AT MAXIMUM COLD LOAD	7
BELTS	8
VOLVO D13 ENGINE	8
ALLISON TRANSMISSION	8
GEAR RATIOS	8
VOLVO I-SHIFT TRANSMISSION	8
PROPELLER SHAFT	9
BRAKES	9
BRAKE CHAMBER EFFECTIVE AREA	9
AIR SYSTEM	9
ANTILOCK BRAKING SYSTEM (ABS)	9
TROUBLESHOOTING AND TESTING	9
AUTOMATIC TRACTION CONTROL (ATC) – ELECTRONIC STABILITY CONTROL (ESC)	9
STEERING	10
ELECTRICAL SYSTEM	10
AXLES	10
I-BEAM FRONT AXLE	10
FRONT AXLE IFS (INDEPENDENT FRONT SUSPENSION)	10
DRIVE AXLE	10
TAG AXLE	10
SUSPENSION	10
I-BEAM AXLE FRONT SUSPENSION	10
INDEPENDENT FRONT SUSPENSION	10
DRIVE AXLE(ALL)	11
TAG AXLE	11
ALIGNMENT SPECIFICATIONS	11
COOLING SYSTEM	12
FUEL SYSTEM	12
EXHAUST SYSTEM	12
HEATING AND AIR CONDITIONING	12
OIL SPECIFICATIONS	13
ENGINE	13
ALLISON TRANSMISSION	13
I-SHIFT TRANSMISSION	13

Technical Information 9-2

DIFFERENTIAL	13
POWER STEERING RESERVOIR	13
PRE-HEATING SYSTEM	13
PLATES AND CERTIFICATION	13
SAFETY CERTIFICATION	15
DOT CERTIFICATION PLATE	15
EPA ENGINE LABEL	15
VEHICLE IDENTIFICATION NUMBER (VIN)	15
VIN DEFINITION	17
COACH FINAL RECORD	18

DIMENSIONS AND WEIGHTS

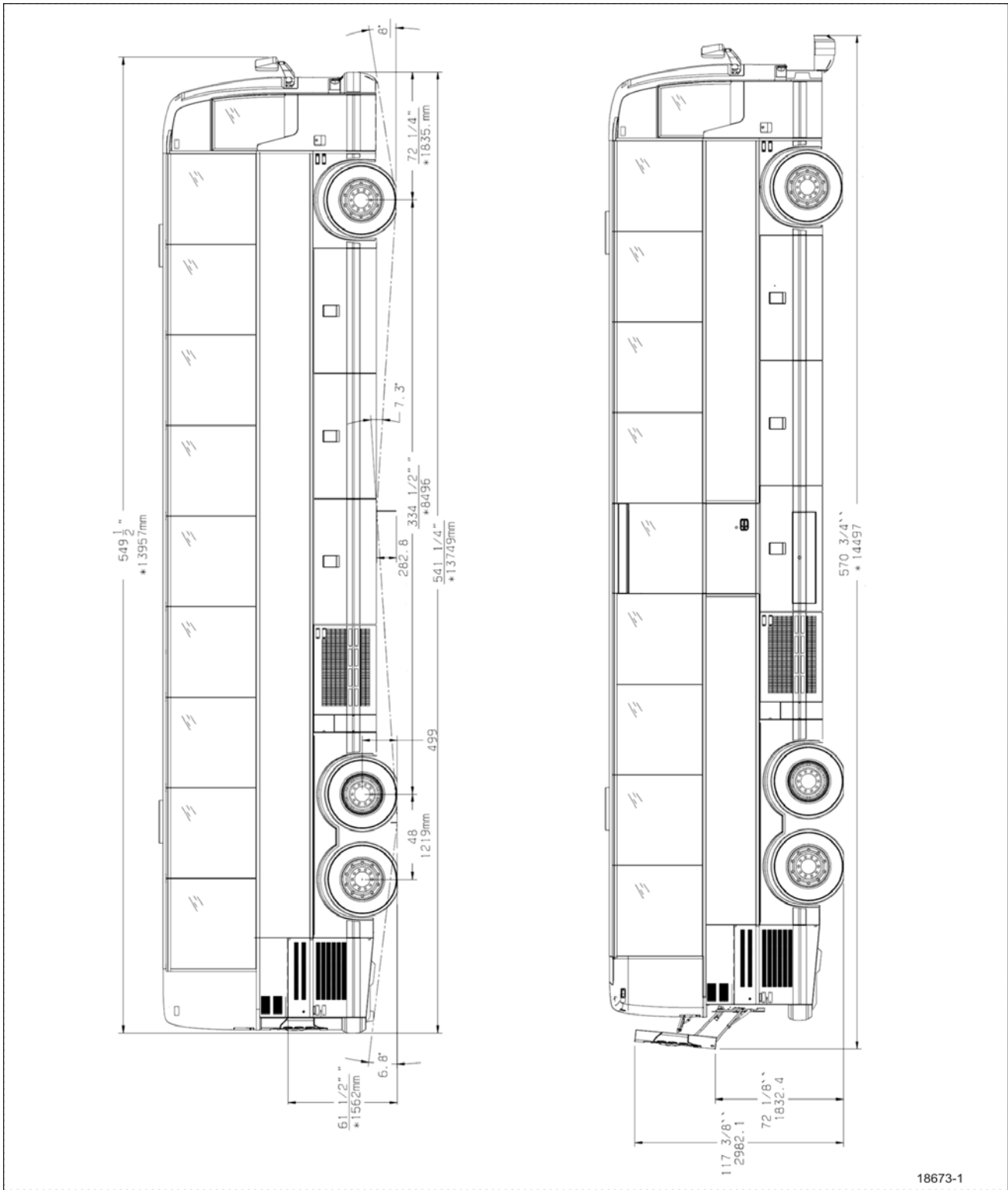

X3-45 OVERALL DIMENSIONS (SIDE ELEVATION)

18673-1

Technical Information 9-4

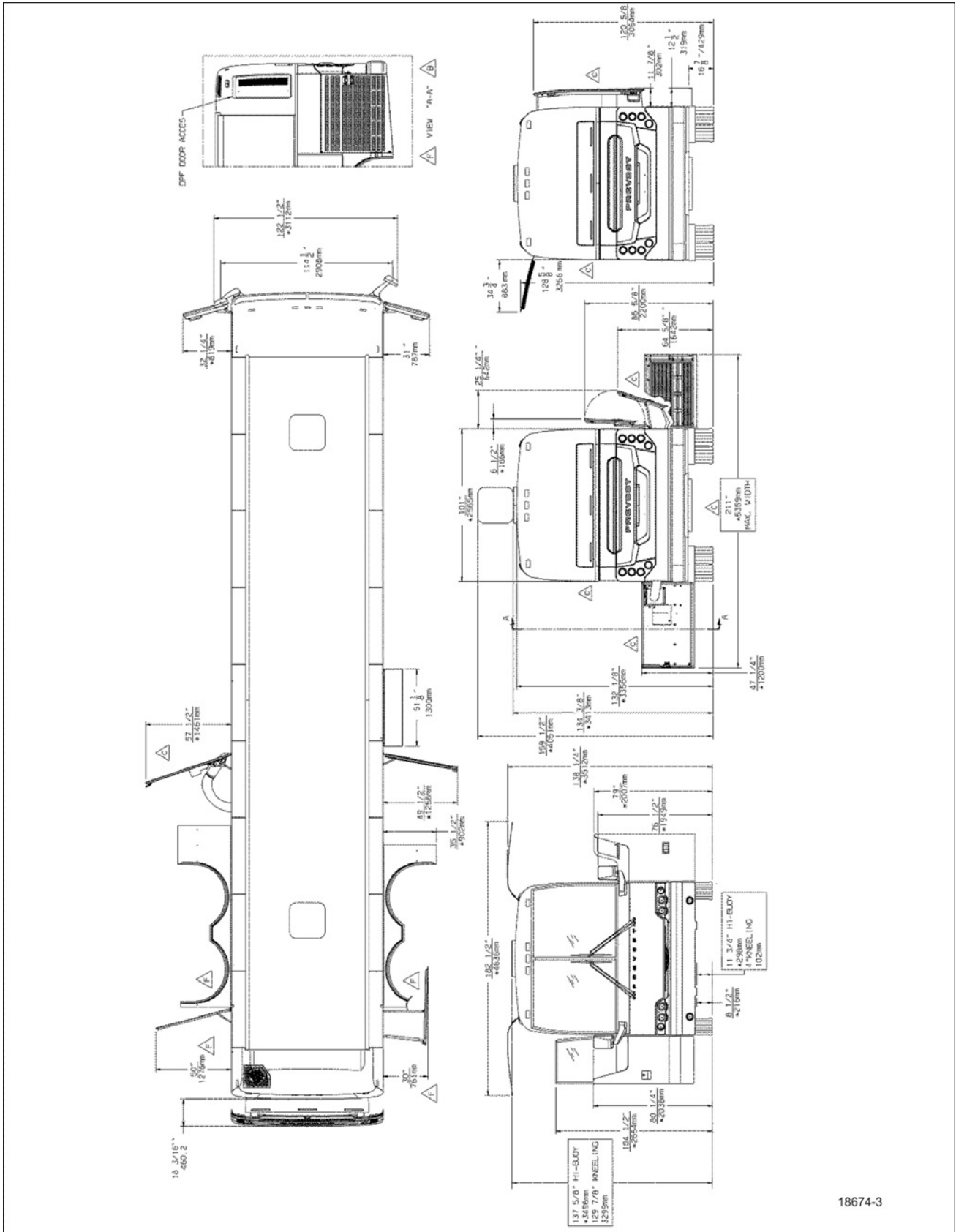

18674-3

X3-45 OVERALL DIMENSIONS (TOP, FRONT AND REAR VIEWS)

DIMENSIONS AND WEIGHTS	X3-45
Overall length (including bumpers)	45' (13,7 m)
Overall width	101.5 (2.57 m)
Overall height	134.38 (3.41 m)
Wheelbase (center of front axle to center of drive axle)	334½" (8496 mm)
Floor height from ground	49" (1,24 m)
Ground clearance	11" (280 mm)
Step height from ground	15" (380 mm)
Step height (other steps)	7" (178 mm)
Headroom	80" (2,03 m)
Entrance door opening width	30¼" (768 mm)
Front overhang	71.2" (1809.3 mm)
Rear overhang	86.6" (2.201 m)
Front track	85.2" (2.162 m)
Drive track	74.3" (1.888 m)
Rear track (Tag axle)	83.8" (2,128 m)
Turning radius (I-Beam Axle)	47'-7" (14.5 m)
Turning radius (independent suspension)	43'-4" (13.2 m)
Curb weight	37 300 lb (16 916 kg)
Gross Vehicle Weight Rating (G.V.W.R.)	53 000 lb (24 040 kg)
Front axle Gross Axle Weight Rating (G.A.W.R.)	16 500 lb (7 500 kg)
Drive axle (G.A.W.R.)	22 500 lb (10 206 kg)
Tag axle (G.A.W.R.)	14 000 lb (6 350 kg)

NOTE

Curb weight is given as an indication only and is subject to vary from coach to coach, mostly due to optional equipment

The Gross Vehicle Weight Rating (G.V.W.R.) and the Gross Axle Weight Rating (G.A.W.R.) for front drive and tag axles are listed on a certification plate located on the L.H. control panel in driver's section.

Technical Information 9-6

CAPACITIES

CAPACITIES	X3-45
Volvo D13 Engine oil (refill volume with filter change)	40 U.S. quarts (38 l)
Fuel tank (legal capacity equal to 95% of volume)	203 U.S. gal. (768 l)
Diesel Exhaust fluid tank (DEF)	16 gall. U.S. (60 l)
Cooling system (excluding heating syst.)	22.5 US gal 85 liters
Allison Automatic Transmission (does not include external circuit)	11.75 U.S. gal (45 l) initial 6 U.S. gal (23 l) refill 6.9 US gal (26.5 l) refill with retarder
I-Shift Transmission	16 U.S. qts (15 l)
Differential oil	20.5 U.S. qts (19.4 l) Meritor Axle 19.5 U.S. qts (18.5 l) ZF A-132 Axle
Power steering reservoir	4.0 U.S. qts (3,7 l)
A/C compressor oil	2.8 US quarts (2.6 liters)
Windshield washer reservoir	5.3 U.S. gal. (20 l)
Refrigerant	24 lb (11 kg)
Toilet sump tank	15.6 US gal. (59 liters)
Baggage compartment	Total volume: 380 ft ³ Loading capacity: 2500 lbs/compartment

FUEL TYPE

Diesel engines for 2007 and later model year vehicles are designed to operate only with Ultra Low Sulfur Diesel (ULSD) fuel, which can contain no more than 15 ppm sulfur.



WARNING

ULSD fuel is necessary to avoid fouling the engine's Exhaust Aftertreatment System. Use of fuel other than ULSD will reduce the efficiency and durability of the engine.

BIODIESEL FUEL

Biodiesel with up to a maximum of 5% biofuel (B5) may be used and will not affect the manufacturer's mechanical warranty as to engine and emissions system related components. The biofuel used in the various blends must conform to ASTM D6751; therefore B1 to B5 blends conforming to ASTM D975. Also, any engine performance problem related to the use of biodiesel fuel would not be recognized nor considered as Volvo or Prevost's responsibility.

However, Volvo engines are certified to comply with U.S. EPA and California emissions standards based upon the use of test fuels with specifications established by these regulatory agencies.

Alternative fuels, including biodiesel, that are not substantially similar to the required test fuels may adversely affect engine emissions compliance. As a result, Volvo does not warrant the engine will conform to applicable Federal or California emissions limits when operated on biodiesel or other alternative fuels that are not substantially similar to specified test fuels used for certification.

Additional maintenance is required and is covered in Section 03: FUEL SYSTEM of the maintenance manual.

WHEELS AND TIRES

Accuride steel wheels: 9" X 22½"

Inner drive axle (steel): 8¼" X 22½"

Alcoa aluminum wheels: 9" X 22½"

Alcoa wheels (super single): . 14" X 22½"

Tires: 315/80 R22.5 load range "L"

Tires: 365/70 R22.5 load range "L"

Tires (super single): 455/55 R22.5 load range "L"

RECOMMENDED TIRE INFLATION PRESSURE AT MAXIMUM COLD LOAD

The recommended tire inflation pressures are given in the applicable documents supplied with the vehicle. In addition, minimum cold tire inflation pressures are listed on the Department of Transport (DOT) certification plate, affixed on the left wall near the driver's seat.

For special tire selection, a "Prevost coach special specification" chart is supplied with the vehicle and is affixed next to the DOT certification plate.

Vehicles equipped with TPMS: The TPMS target pressures are factory set to equal the prevailing tire pressure at delivery time. When tire pressures are increased to account for higher vehicle weight, the TPMS set point needs to be increased accordingly.



CAUTION

These tire pressures are established in accordance with the maximum allowable load on each axle. A lower pressure is recommended if the axle load is less than the above specifications. Weigh vehicle fully loaded and pressurize according to tire manufacturer's recommendations. For non-standard tire and wheel specifications, see Prevost tire pressure tabulation in "Coach Final Record" or special specification chart affixed next to the DOT certification plate.



WARNING

Special tire selection may lower maximum allowable speed limit, even below posted speed limit. For maximum safety, check with tire manufacturer.

Technical Information 9-8

BELTS

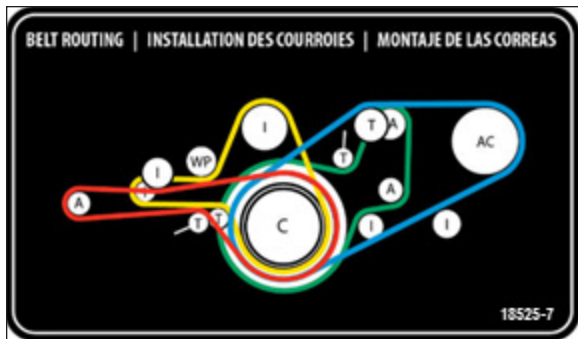

A: Alternator I: Idler T: Tensioner
 C: Crank WP: Water pump AC: A/C compressor

Belt application	Type	Qty
A/C system Bitzer 4NFCY compressor	V Belt BX71	2
Alternator (twin Bosch, curb side)	Multi-V-8 Rib 8PK1575	1
Alternator (emergency)	Multi-V-8 Rib 8PK1512	1
Alternator (single, driver side)	Multi-V-10 Rib 10PK1695	1
Coolant pump	Multi-V-10 Rib 10PK1512	1

NOTE

Belts specifications may vary. For proper belt selection, always consult your vehicle Coach Final Record

VOLVO D13 ENGINE

Type: 4 stroke / inline six cylinders
 Displacement: 12.8 l, SOHC, 4 valve /cylinder
 Power: 435 HP
 Torque: 1700 lbf-ft @ 1100 rpm
 Cruise speed range: 1300-1500 rpm
 Full dress, dry weight: 1174 kg / 2588 lb

ALLISON TRANSMISSION

Allison B500 (B500R with the optional output retarder) electronically controlled six- speed

automatic transmission.

GEAR RATIOS

1st	3.51
2nd	1.91
3rd	1.43
4th	1.00
5th	0.74
6th	0.64
Reverse:	4.80
Converter:	1.90
Differential ratio	3.91
Differential ratio (optional):	3.58
Differential ratio (ZF A-132 axle):	3.54
Maximum input torque:	1700 lb-ft (2304Nm)

VOLVO I-SHIFT TRANSMISSION

Electronically automated twelve speed automatic transmission

Gear & Ratio

1st	14.94
2nd	11.73
3rd	9.04
4th	7.09
5th	5.54
6th	4.35
7st	3.44
8nd	2.70
9rd	2.08
10th	1.63
11th	1.27
12th	1.00

<i>Reverse 1st:</i>	17.48
<i>Reverse 2nd:</i>	13.73
<i>Differential ratio (ZF A-132 axle):</i>	2.50
<i>Maximum input torque:</i>	1920lb-ft (2603Nm)

PROPELLER SHAFT

Hayes-Dana SPL250 type tubular shafts, provided with heavy-duty universal joints.

BRAKES

The features of the braking system include a dual system where the front and rear circuits are completely independent from each other. The brakes are air operated disc type brakes. The emergency/parking brakes are located on the drive. To ensure a constant running clearance between pads and disc, the brakes are equipped with a non-wearing, automatic adjuster mechanism.

BRAKE CHAMBER EFFECTIVE AREA

- Front axle:* 24 in²
- Drive axle:* 24/24 in²
- (service /emergency)
- Tag axle:* 16 in²

AIR SYSTEM

Compressed air is provided by a twin cylinder, 37.4 cfm Wabco, gear-driven, water-cooled and engine oil lubricated air compressor.

ANTILOCK BRAKING SYSTEM (ABS)

The antilock braking system has one Electronic Control Unit (ECU) controlling a 6- sensor/5-modulator (6s/5m) system. A wheel slip sensor is mounted at each wheel.

The Electronic Control Module (ECM) is maintenance free. Its operating voltage is 24 ± 6 volts DC. The thermal operating range for the ECM is from -40 to 167°F (-40 to 75°C).

The solenoid control valves are maintenance free. Their operating voltage is 24 (+4.8, -2.4) volts DC.

The rated current draw is 1.65 amps. The thermal operating range of the solenoid control valves is from -40 to 176°F (-40 to 80°C).

TROUBLESHOOTING AND TESTING

For detailed information, troubleshooting and testing refer to Bendix booklet “Bendix Service Data EC80 ESP Controller (SD- 13- 4986)” found on the Technical Publications USB flash drive and web site or use menu “Diagnostics” of the DID (see ["DRIVER INFORMATION DISPLAY \(DID\) MENUS"](#) on [page 11](#) in Section 5 Other Features).

AUTOMATIC TRACTION CONTROL (ATC) – ELECTRONIC STABILITY CONTROL (ESC)

In addition to the ABS function, vehicle is equipped with a Traction Control System (TCS) feature. This feature is provided by the Bendix ESP EC-80 controller. Bendix refers to this feature as Automatic Traction Control (ATC). Bendix ATC can improve vehicle traction during acceleration, and lateral stability while accelerating through curves. ATC utilizes Engine Torque Limiting (ETL) where the ECU communicates with the engine’s controller and/or Differential Braking (DB) where individual wheel brake applications are used to improve vehicle traction.

The ESP EC-80 model controller also provides an ABS-based Electronic Stability Control (ESC) feature. Bendix refers to it as ESC Electronic Stability Control.

The Bendix ESC system is an ABS-based stability system that enhances vehicle stability by both reducing engine throttle and by applying vehicle braking based on actual vehicle dynamics

Refer to Maintenance Manual, Section 12: Brake and Air System for more information on this system.

	<p>CAUTION</p> <p>Even with ESC-equipped vehicles, the driver remains responsible for ensuring vehicle stability during operation.</p>
---	---



DANGER

ESC may reduce the vehicle speed automatically.

ESC can make the vehicle decelerate automatically. ESC can slow the vehicle with or without the operator applying the brake, and even when the throttle is being applied

STEERING

- ZF 8098 integral hydraulic assisted steering gear;
- ZF hydraulic pump gear driven from engine drive
- Hydraulic reservoir and dipstick accessible from engine compartment.
- System pressure: 2175 psi (150 bars).
- Steering wheel diameter 18". Tilt steering wheel and telescopic steering column; pneumatically locked with foot-operated switch for adjustment.
- Number of turns: 5¾.
- Outside turning radius: See Dimensions and Weight.

ELECTRICAL SYSTEM

- 24-volt, negative ground;
- 12-volt exterior lighting;
- Three 28 volts, 150 amp, self-regulated, belt-driven, air-cooled HD 10 Bosch alternators;
- Four 12 Volts, group 31 AGM type batteries connected in series/parallel. Each one has a reserve capacity of 200 minutes and a cold cranking capacity of 800 amps.
- 100 amp battery equalizer.

AXLES

I-BEAM FRONT AXLE

- Dana Spicer model S84U with forged "I" beam
- Reverse Elliot type
- Unitized wheel bearings (maintenance free)
- Factory pre-adjusted caster

FRONT AXLE IFS (INDEPENDENT FRONT SUSPENSION)

- Prevost independent front suspension with calibrated air springs for improved comfort
- Wide apart double A-arm design mounted on ball joints with torque link
- Double sealed taper roller bearings bell crank and idler steering arm
- Unitized wheel bearing (maintenance-free bearing)
- Factory pre-adjusted caster

DRIVE AXLE

- Meritor model RC23-165
- Full floating banjo type
- Oil lubricated wheel bearings
- Factory pre-adjusted caster

TAG AXLE

- Prevost hollow square beam
- Unitized wheel bearings (maintenance free)

SUSPENSION

Goodyear rolling lobe type air springs (bellows) are used throughout.

I-BEAM AXLE FRONT SUSPENSION

- 2 Bellows;
- 2 Shock absorbers;
- 4 Radius rods;
- 1 Transverse radius rod;
- 1 Height control valve;
- 1 sway bar;

INDEPENDENT FRONT SUSPENSION

- 2 Bellows;
- 2 Shock absorbers;
- 2 Upper A-arms;
- 2 Lower A-arms;

- 2 Torque rods;
- 2 Steering Levers;
- 1 Height control valve;
- 1 sway bar;

DRIVE AXLE(ALL)

- 4 Bellows;
- 4 Shock absorbers;
- 3 Radius rods;
- 1 Panhard rod;
- 2 Height control valves;
- 1 Anti-roll bar;

TAG AXLE

- 2 Bellows;
- 2 Shock absorbers;
- 3 Radius rods;
- 1 Panhard rod;

ALIGNMENT SPECIFICATIONS

Use static wheel alignment systems which work with angle measurements only, such as Josam or Hunter systems. Static alignment specifications are listed in the following tables:

I-BEAM AXLE FRONT axle			
	Minimum value	Nominal value	Maximum value
Right camber	-0.25°	0.125°	0.375°
Left camber	-0.25°	0.125°	0.375°
Right caster	2.0°	2.75°	3.5°
Left caster	2.0°	2.75°	3.5°
Total toe	0.04°	0.06°	0.08°

INDEPENDENT FRONT SUSPENSION			
	Minimum value	Nominal value	Maximum value
Right camber	0.0°	0.150°	0.30°
Left camber	0.0°	0.150°	0.30°
Right caster	2.35°	2.6°	2.85°
Left caster	2.35°	2.6°	2.85°
Total toe	0.04°	0.06°	0.08°

DRIVE AXLE MERITOR			
	Minimum value	Nominal value	Maximum value
Thrust angle	±0.11°		
Total toe	0.18° toe-in	0°	0.18° toe-out

DRIVE AXLE ZF A-132			
	Minimum value	Nominal value	Maximum value
Thrust angle	±0.11°		
Total toe	0.15° toe-in	0°	0.15° toe-out

TAG AXLE			
	Minimum value	Nominal value	Maximum value
Thrust angle*	-0.02°	0	0.02°
Total toe	0.08° toe-in	0°	0.02° toe-out

(*) Use the drive axle as reference

COOLING SYSTEM

- Extra capacity, Aluminum radiator and aluminum charge air cooler arranged side by side.
- 24V ECU controlled electrical cooling fans, total of eight, six over radiator side and two on charge air cooler.
- Rubber insulated from the body.
- Expansion tank above radiator and remote mounted.
- System pressure 15 psi.
- 185° F thermostat.
- Full system capacity 22.5 US gal (85 l).
- Coolant filter.

FUEL SYSTEM

Polyethylene 208 US gallons/787 liters fuel tank centrally located.

Equipped with:

- Anti-spill device.
- Safety filler cap on right side of coach.
- Pressure relief valve.
- Electric fuel gauge.
- Low level signal at 26 US gallons/98.4 liters.
- Primary filter 25 microns (standard).
- Primary fuel filter with electrical water indicator (Volvo D13).
- Fuel pro 382 filter available as an option as a primary filter.
- Secondary filter 3 to 5 microns.
- Shut-off valve on fuel supply line.
- Provided with filling access on the right side of the coach.

EXHAUST SYSTEM

One all stainless steel exhaust & aftertreatment system including:

- Catalytic converter to reduce NOx.
- Aftertreatment system made of a DPF (Diesel Particulate Filter), DOC (Diesel

Oxidation Catalyst) and SCR system. Noise, vibration and heat insulated. This ATD is mounted to the vehicle structure and is accessible through an exterior access door.

- Tail pipe diffuser and rain deviation device.
- Exhaust pipe with Insulation and a flexible section.
- Exhaust to rear rooftop left hand corner.
- Diesel exhaust fluid (DEF) tank (60 liters) and injection system.

HEATING AND AIR CONDITIONING

A large capacity, central A/C provides enough conditioned and filtered air for all climatic conditions. Fresh air is drawn into the system from the evaporator compartment on driver's side of the vehicle. Return air is taken from the middle of the vehicle. The driver's heater and defogger are controlled separately from the central unit. An air mixture selector enables air to be drawn into the system from outside the vehicle or recirculated. Optionally, condensers installed in the overhead storage compartments provide cool air to the seated passengers from the overhead registers.

CENTRAL A/C	
Air conditioning capacity	9 tons
Refrigerant type	134A
Heating capacity	150 000 Btu/h
Air flow, main A/C	2 600 cfm (73,6 m ³ /min)
Air flow, overhead compartment, opt.	450 cfm (12,7 m ³ /min)

COMPRESSOR	
Number of cylinders	4
Operating speed	500 to 3500 rpm
Oil capacity	2.8 US quarts (2.6 liters)
Approved oil	Bitzer BSE55 (POE)

NOTE
The above oils are suitable for use with reciprocating compressors using refrigerant R134a and with evaporator temperatures above 40°F (-40°C).

OIL SPECIFICATIONS

Oil specifications for the vehicle's systems.

ENGINE

For the Volvo D13M engine, we recommend using SAE 10W-30 "Volvo Premium Motor Oil VDS-4.5" or other Volvo approved VDS-4.5 oils.

Volvo VDS-4.5 oils exceed API service category CK-4 oils.

ALLISON TRANSMISSION

Allison Transmission recommends the following fluids:

- Castrol TranSynd™ or TES-295 specification equivalent fluid;
- TES-389 specification equivalent fluid.

I-SHIFT TRANSMISSION

Only use VOLVO-approved synthetic transmission oil in the I-Shift transmission. Refer to section 24 of the Maintenance Manual for more information about oils approved by Volvo;

DIFFERENTIAL

Multigrade gear oil meeting MIL-PRF-2105E: 85W-140 is recommended for use in the Meritor drive axle. This lubricant performs well over a broad temperature range, providing good gear and bearing protection in a variety of climates. If temperature drops below 10°F (-12°C), 80W-90 should be used, and below -15°F (-26°C), 75W-90 should be used. In extreme conditions or for better performance, full synthetic gear oil should be used.

For vehicles equipped with the ZF A-132 drive axle, use ZF Ecofluid 80W-90 (ZF lubricant class 12M) or refer to ZF List of Lubricants TE-ML 12 for other approved lubricants.

POWER STEERING RESERVOIR

Use Automatic Transmission Fluid (ATF) Dexron-III (F, G or H) or Dexron-IV for this system.

PRE-HEATING SYSTEM

Depending on options chosen, a coolant heater may be installed on the coolant circuit. The heater can be used as a pre-heater or as an auxiliary heat source.

The heater is controlled by a 7-day programmable timer. Refer to "[PREHEATER](#)" on page 30 in Other Features, Section 5 for information on how to use the timer.

PRE-HEATER	
Make	Eberspächer
Model	Hydronic L30
Heating output	30 kW
Fuel type	Same as engine
Fuel consumption	0.96 US Gal/hr (3.65 l/hr)
Rated voltage	24 V DC
Operating voltage	20-30 V DC
Electric power consumption without water pump	105 watts
Dimensions	L: 24.01 (600 mm) W: 9.05 (230 mm) H: 8.74 (222 mm)
Weight	40 lb (18 kg)

PLATES AND CERTIFICATION

The main components of the vehicle such as engine, transmission, axles and chassis are identified by different serial numbers. It may be necessary to locate these numbers for warranty purposes.

The engine data plate is located on the rocker cover. The engine serial and model number and a list of the optional engine equipment are written on this plate. Refer to this information when ordering replacement parts. Also the engine data plate certifies that the engine conforms to federal and any state exhaust emissions regulations.

Technical Information 9-14

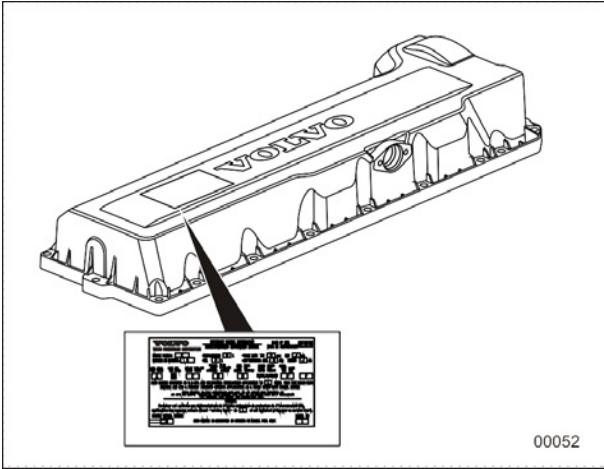

00052

VOLVO D13 ENGINE DATA PLATE

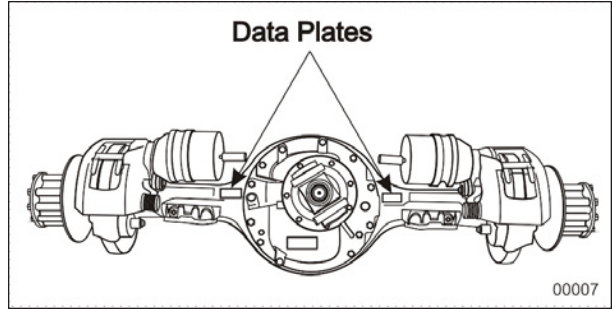

00007

MERITOR DRIVE AXLE

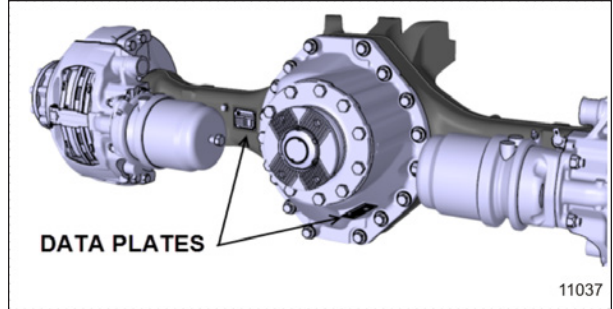

11037

ZF A-132 DRIVE AXLE

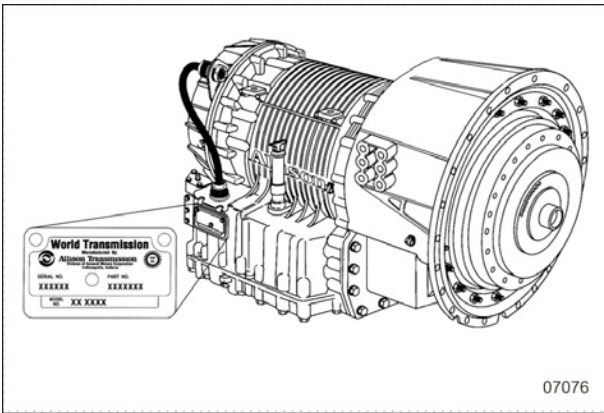

07076

ALLISON TRANSMISSION

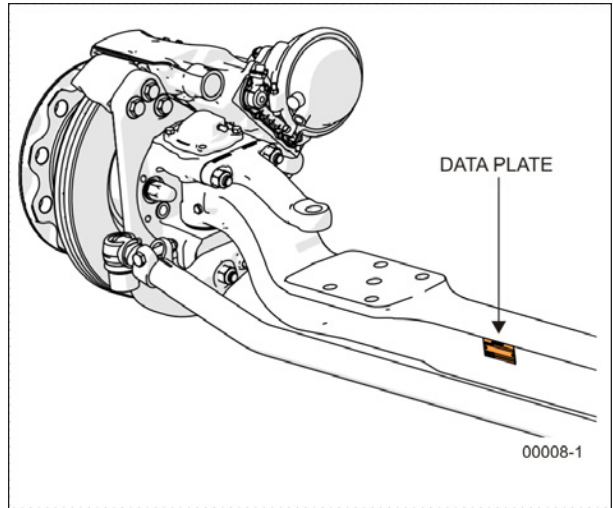

00008-1

I-BEAM FRONT AXLE

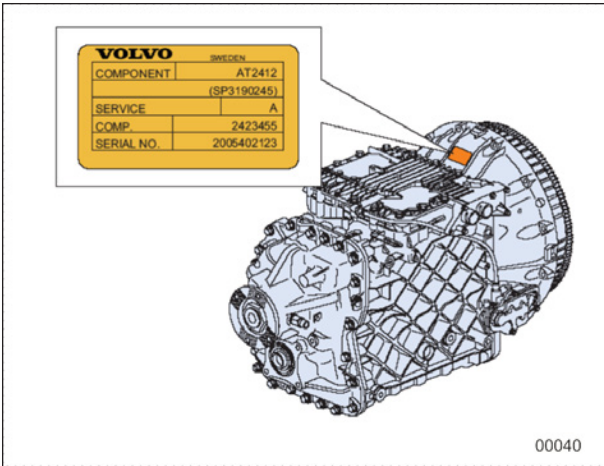

00040

I-SHIFT TRANSMISSION

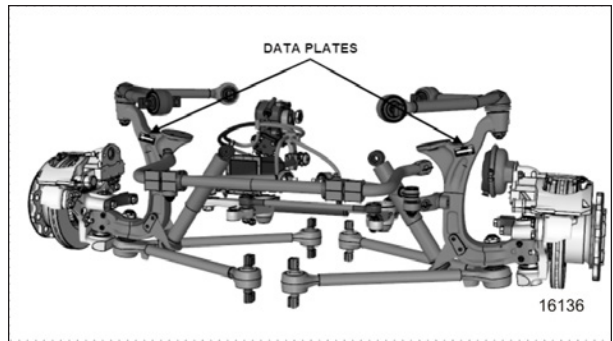

16136

INDEPENDENT FRONT SUSPENSION

SAFETY CERTIFICATION

Vehicle components meet specifications and standards as follows:

Material and parts conform to ASTM and/or SAE standards in effect at the time of manufacture.

All factory-installed interior materials meet FMVSS 302 for fire resistance.

Certified according to Provincial, State and Federal Safety standards (Canadian and US) BMCSS, FMVSS and CMVSS.

Other applicable certification labels are affixed to the component.

DOT CERTIFICATION PLATE

This certifies that vehicles manufactured by Prevost comply with all Federal Motor Vehicle Safety Standards at the time of manufacture. Information such as the date of manufacture, model year, gross vehicle weight rating, tire types and inflation pressure is also etched on this plate.

The DOT Certification plate is affixed to L.H. control panel.

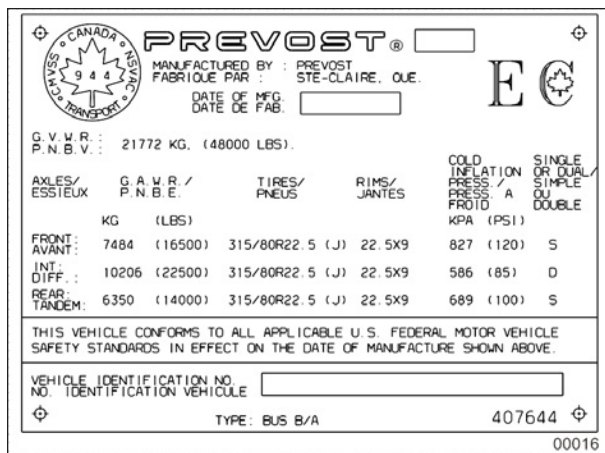

DOT CERTIFICATION PLATE

EPA ENGINE LABEL

The emissions certification label affixed to the panel over the engine oil reserve tank certifies that the engine conforms to federal and any state exhaust emissions regulations.

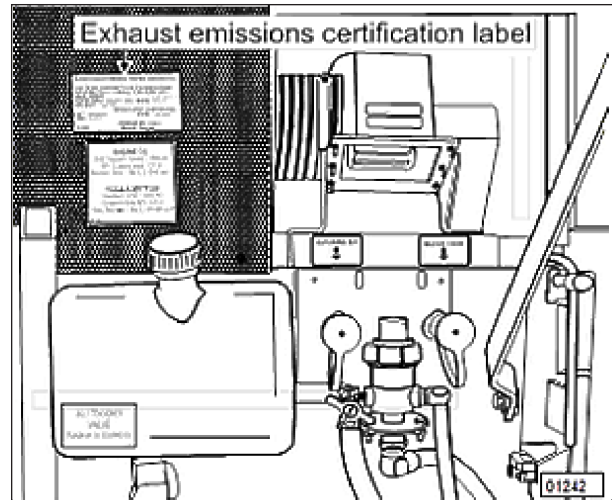

EPA CERTIFICATION LABEL

VEHICLE IDENTIFICATION NUMBER (VIN)

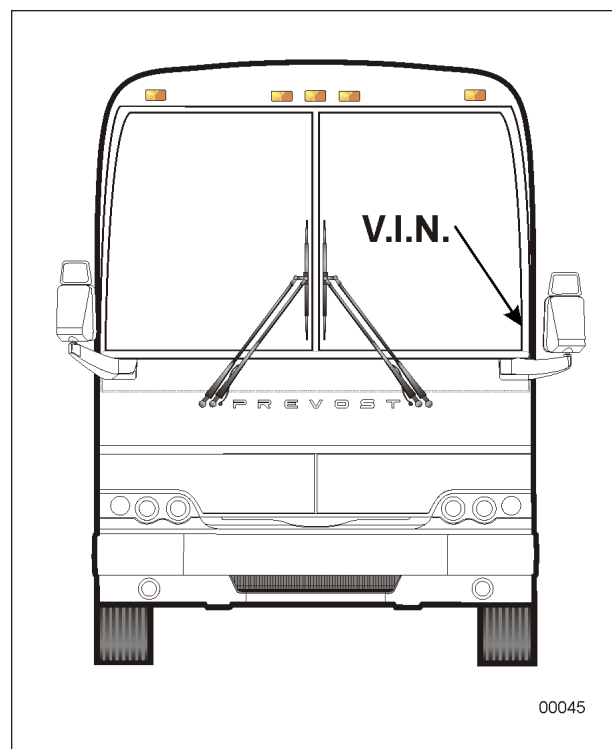

VEHICLE IDENTIFICATION NUMBER (X3 SERIES)

The Vehicle Identification Number is stamped on a plate located on the windshield frame pillar (driver's side). The VIN is visible from the outside of the vehicle. Make sure the correct vehicle identification number is given when ordering replacement parts.

Technical Information 9-16

Using the VIN when ordering parts will facilitate processing.

NOTE

Record the VIN in the vehicle documentation and keep with company records. The VIN will normally be used for vehicle registration, service reference needs and for obtaining vehicle insurance coverage.

VIN DEFINITION

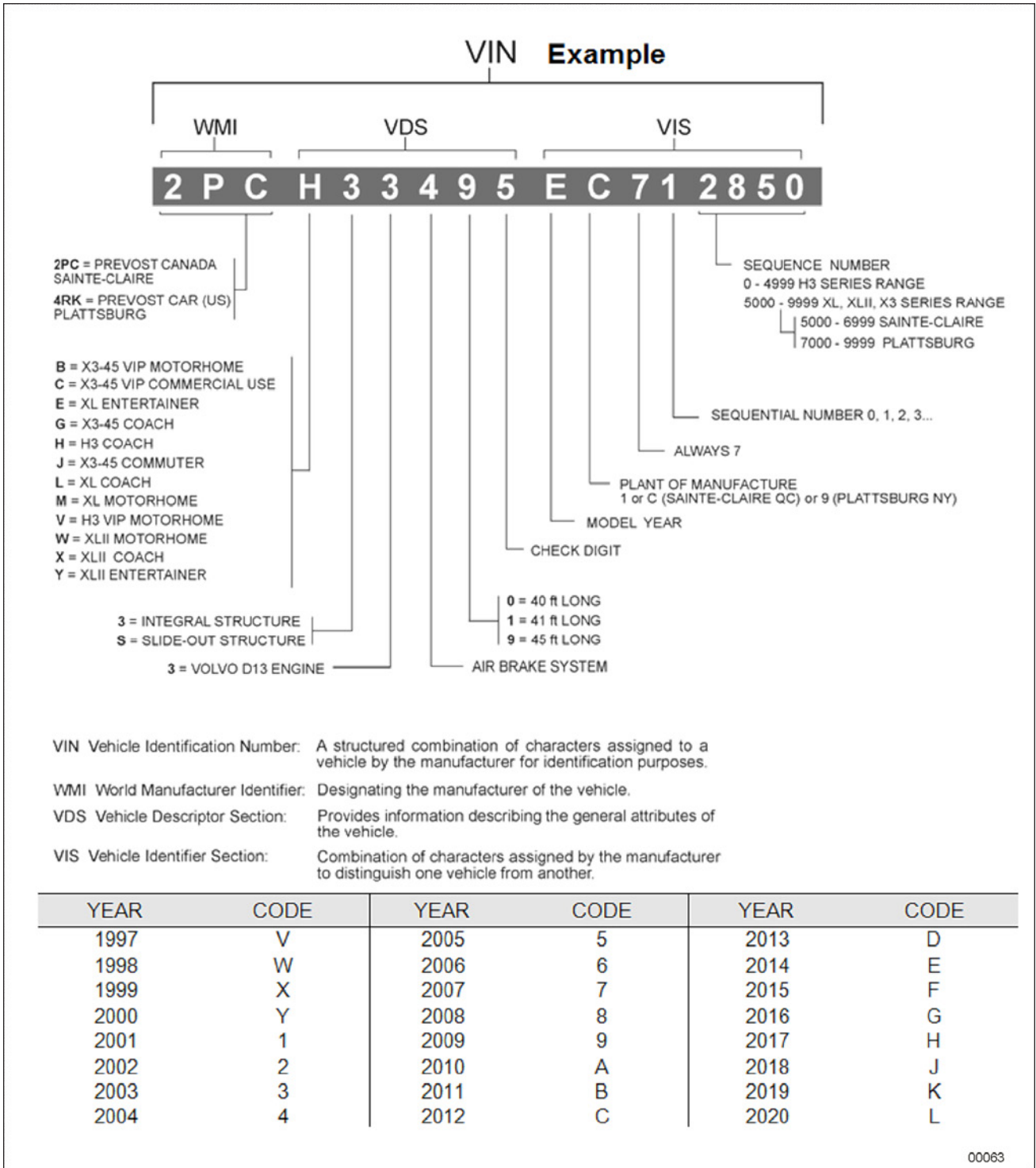

COACH FINAL RECORD

The Coach Final Record is a record of all data pertaining to the assembly of the vehicle. This record is shipped to the new customer via a courier company. Retain this record in the company records office for reference and safe-keeping.