

IMPROVEMENT OF ENGINE COMPARTMENT LIGHTING

REPLACEMENT OF 12-VOLTS INCANDESCENT LAMPS WITH 24-VOLTS LEDs









To replace 12-volts incandescent lamps (Prevost #930383) with 24-volts LED modules, the following steps are required:

- 1- Cutting of wires and removal of existing lamps.
- 2- Making and installation of a harness to supply 24-volts from the 24-VI (indirect, power supplied when ignition key in the ON position). A52 multiplex module will no longer be used to control the engine compartment lighting. The engine compartment lighting switch located on the rear engine start panel will be used instead.
- 3- Making and installation of a harness between the LED modules and the engine compartment lighting switch.
- 4- Re-routing circuit coming from A52 module (formerly supplying power to the incandescent lamps) up to a ground stud inside the main power compartment. This step is important to avoid triggering of error codes.

NOTE: For connector assembly instruction, refer to Deutsch technical document included at the end of this instruction sheet.

MATERIAL

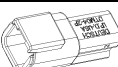
Kit #430672 includes the following parts:

Part No.	Description		Qty
430671	430670 SUPPORT PLATE (1x) 563845 LED MODULE, ENGINE COMPARTMENT (1x) 500235 SCREW, TAPPING #6x3/4 (2x) 509815 CABLE TIE MOUNTING (1x) 504637 CABLE TIE 368mm (1x)		2
560067	FUSE HOLDER		1
560815	RING TERMINAL #10 22-18AWG		2
561568	PIN TERMINAL, DEUTSCH		1
562120	FUSE 3AG (2AMP)		1
562286	PIN TERMINAL, DEUTSCH		1
563623	BUTT SPLICES 16-14 WITH SHRINK		1
563588	PIN TERMINAL, DEUTSCH		6
563590	CONNECTOR, DEUTSCH DTM04-2P PIN RECEPTACLE HOUSING		3
563593	TERMINATION RESISTOR, PLUG 120R CAN-MUX		1
563604	LOCKING WEDGE, DEUTSCH		3
564088	CORRUGATED TUBE 1/8"		17ft
IS-10016	Instruction Sheet		1
FI-10016	Feuille d'instructions		1

Additional material required:

Description	Qty	Prevost No
WIRE PROTECTIVE CLOTH TAPE 150°C	As required	564099
WIRE, ELECTRICAL BLACK 16 AWG	Approx. 20 feet	560673
WIRE, ELECTRICAL RED 18 AWG	Approx. 6 feet	562589
WIRE, ELECTRICAL BLACK 18 AWG	Approx. 6 feet	562587

PROCEDURE



DANGER

Park vehicle safely, apply parking brake, stop engine and set battery master switch(es) to the OFF position prior to working on the vehicle.

1. Pre-assemble LED module and support plate as shown on the following image.

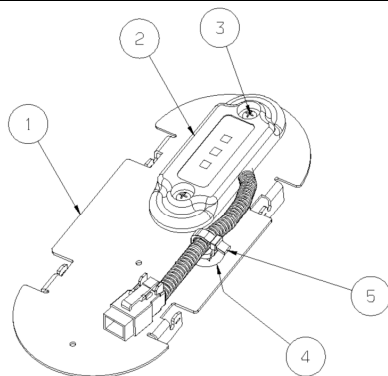

- ① 430670, SUPPORT PLATE
- ② 563845, LED MODULE
- ③ 500235, SCREW, TAPPING #6x3/4
- ④ 509815, CABLE TIE MOUNTING
- ⑤ 504637, CABLE TIE 368mm

- Cut circuit **9B** & **0RA2** close to the existing incandescent lamps in order not to shorten the wires too much and remove the lamps. Consult page 25.1 of your vehicle's wiring diagram.

BEFORE

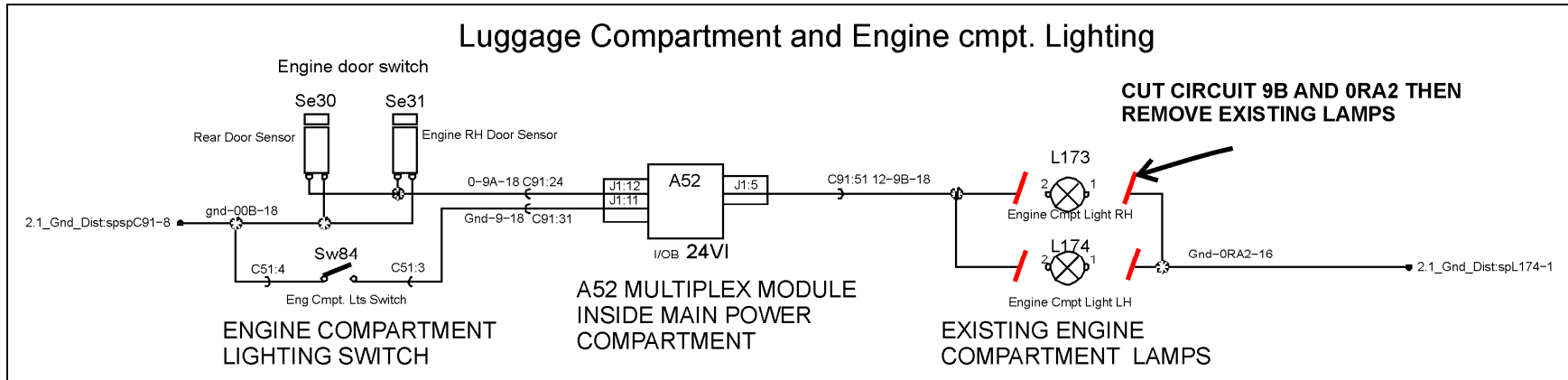

AFTER

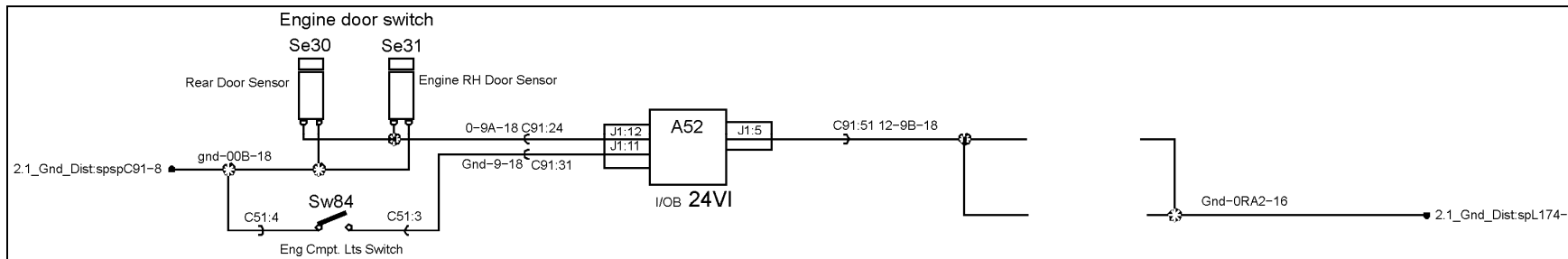

- Make harness B according to the following image.

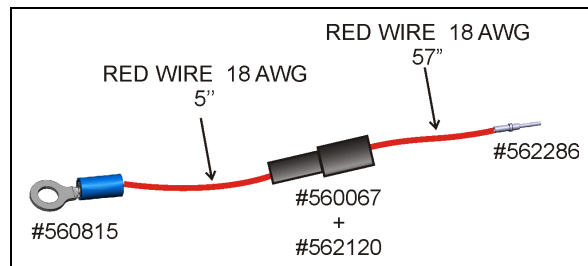

HARNESS B

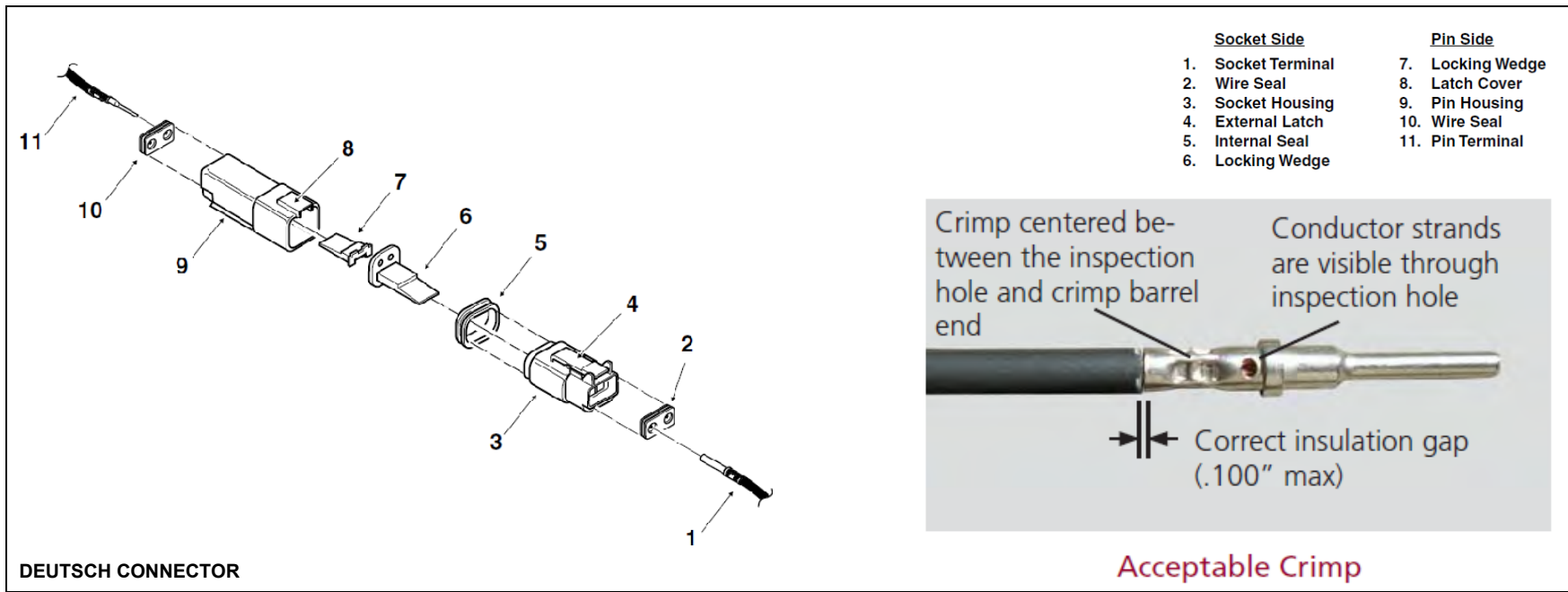

6. Adapt LED module to the existing supports. Fold the tabs identified with arrows to hold the module in place.

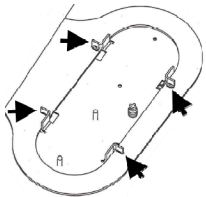

7. Remove circuit 31 between A52 I/O-B module (input J1:11) and connector C91. Remove the remaining part of this circuit (identified gnd-9-18 on the following image) routed from C91 up to the engine compartment lighting switch.

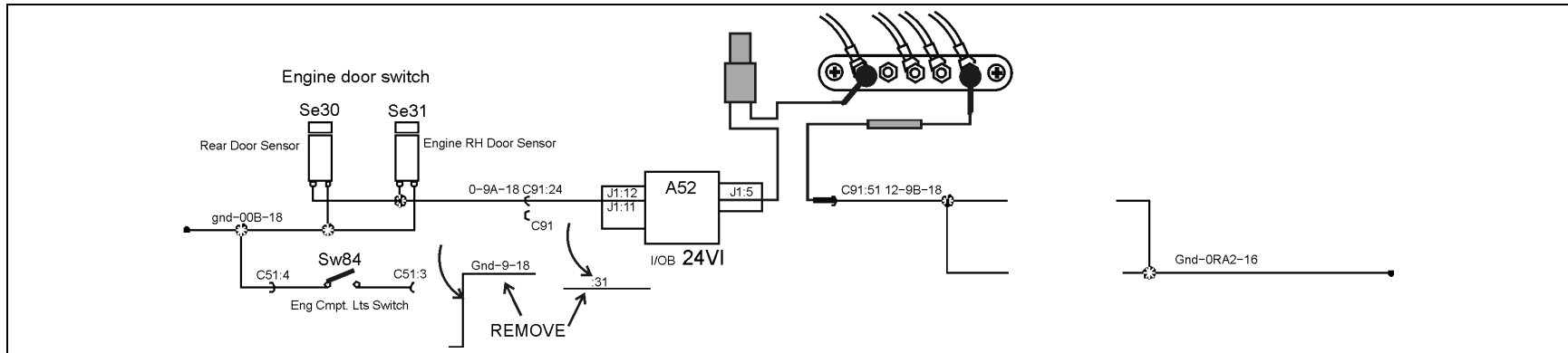

8. Make harness A as shown on the following image. Length of the wires will be determined at time of installation.

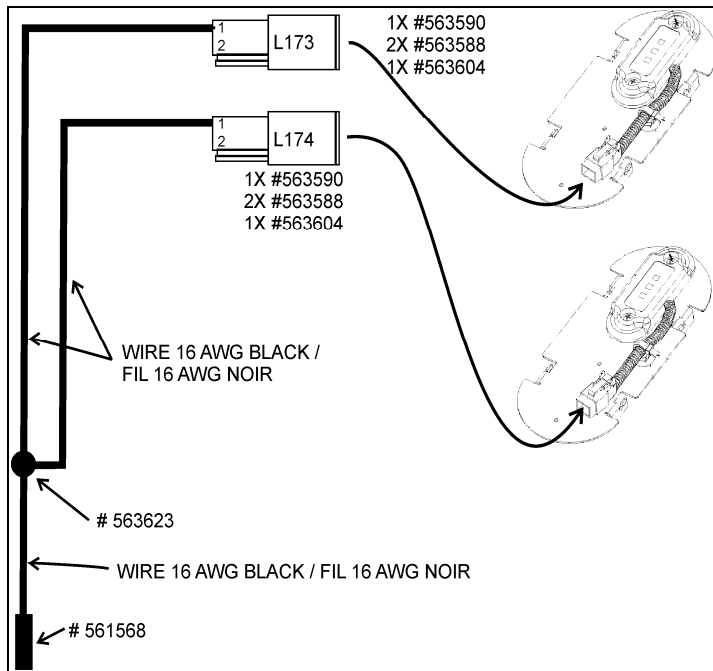

HARNESS A

9. Connect the LED modules to the engine compartment lighting switch (SW84) using **harness A**. Add 24-volts supply circuit 9B to both connectors of harness A using Deutsch pin terminal #563588 (2x).

