

PREVOST

Instruction Sheet

IS-99123

INSTALLATION OF A RECESSED WARM AIR BAFFLE

MATERIAL

Kit #052381 applies to H3-41 and H3-45 vehicles. It contains:

Part No.	Description	Qty
052374	Baffle (960 mm long)	1
052376	Baffle (880 mm long)	1
052377	Metallic strip	2
500874	Washer, flat, zinc plated, 8.4 x 17 x 1.6	8
502744	Nut, hex, zinc plated, M8 – 1.25	8
502780	Screw, cap, hex, SS, M8 x 25	8
IS-99123	Instruction Sheet	1
FI-99123	Feuille d'instructions	1

Kit #052379 applies to XLII-40 and Entertainer vehicles. It contains:

Part No.	Description	Qty
052373	Baffle	1
052372	Angle iron	1
500874	Washer, flat, zinc plated, 8.4 x 17 x 1.6	3
502744	Nut, hex, zinc plated, M8 – 1.25	3
502780	Screw, cap, hex, SS, M8 x 25	3
IS-99123	Instruction Sheet	1
FI-99123	Feuille d'instructions	1

Kit #052380 applies to XLII-45 vehicles. It contains:

Part No.	Description	Qty
052368	Baffle (1148 mm long)	1
052369	Baffle (823 mm long)	1
052370	Angle iron	1
052371	Metallic strip	1
5001319	Screw, cap, hex, SS, M8 x 40	8
500240	Washer, lock, zinc plated, 0.195 x 0.410 x 0.025	1
500874	Washer, flat, zinc plated, 8.4 x 17 x 1.6	8
502744	Nut, hex, zinc plated, M8 – 1.25	8
IS-99123	Instruction Sheet	1
FI-99123	Feuille d'instructions	1

PROCEDURE

Warning : Park vehicle safely, apply parking brake, stop engine and set battery master switch(es) to the OFF position prior to working on the vehicle.

1. Drive the vehicle over a repair pit;
2. Remove the existent baffle;
3. Test fit the new baffles for proper position on the inside of the frame side rail, under the engine cradle, on the driver's side (see figure 1 for H3-41 and H3-45 vehicles, figure 2 for XL-40 and Entertainer vehicles, and figure 3 for XL-45 vehicles);
4. Clean the portions of the side rail where bolts will be welded, using a grinder;
5. Using the baffles as templates, mark where the bolts will go on the side rail;
6. Weld the bolt heads in place;

Caution: Refer to Maintenance Manual, Section 1 under Welding Precautions.

7. Secure the new baffles as illustrated, using the hardware included.

Note: In some cases, it may be necessary to enlarge the holes on the baffles so they fit over the bolt heads.

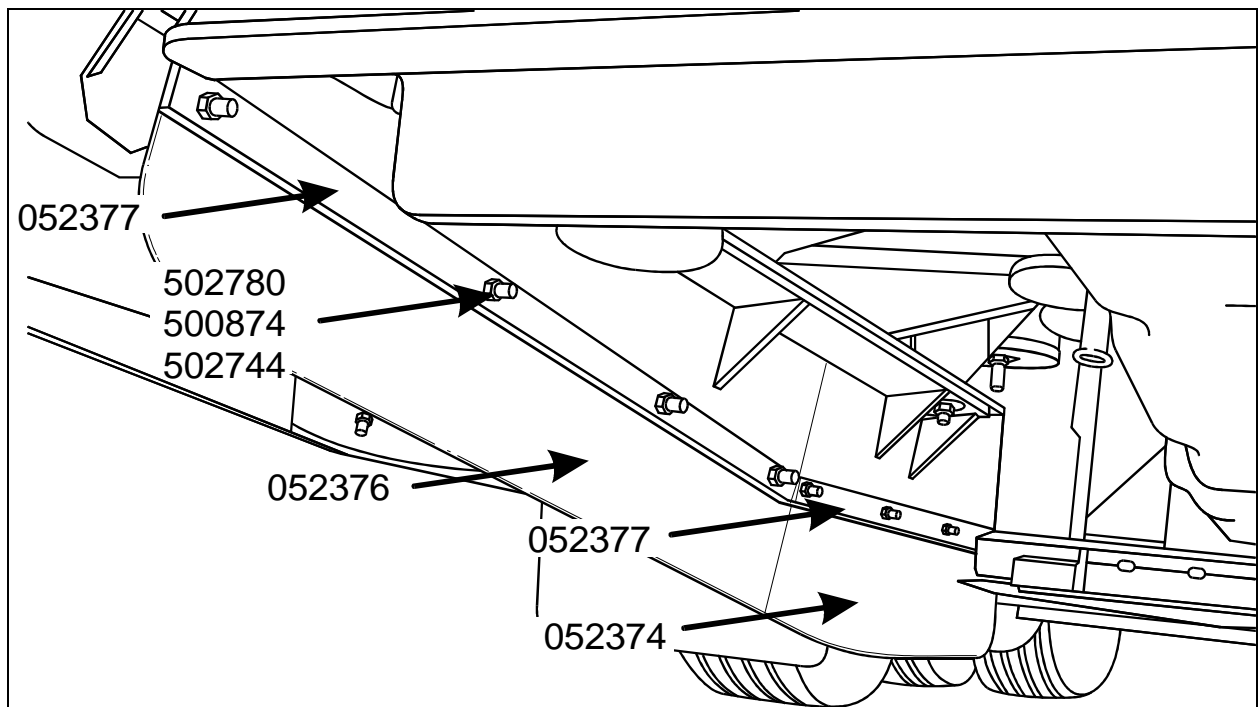

FIGURE 1: WARM AIR BAFFLE (KIT # 052381) INSTALLED ON THE FRAME RAIL OF AN H3-41 OR H3-45 VEHICLE

05085

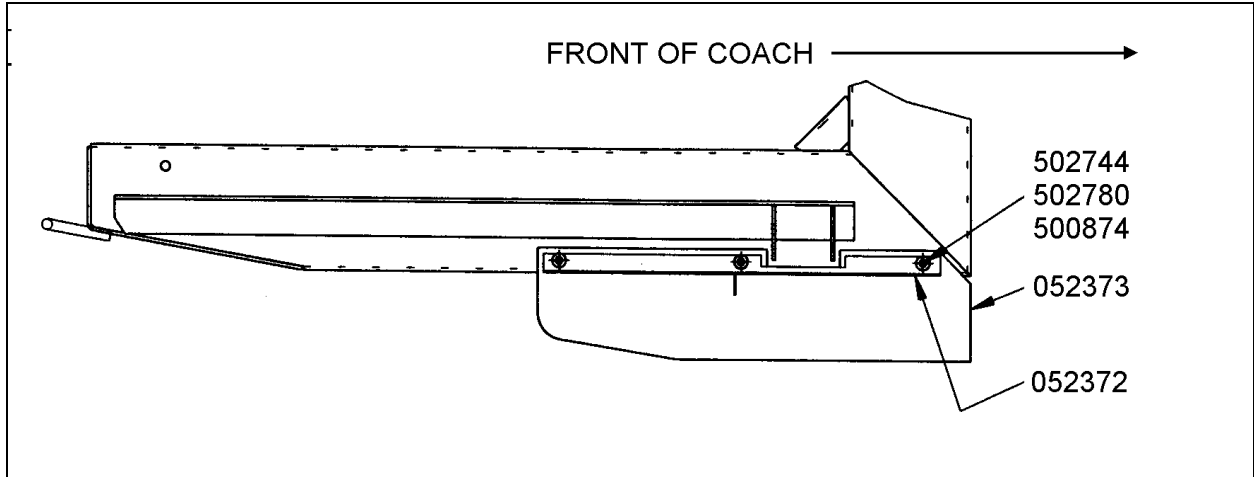

FIGURE 2: WARM AIR BAFFLE (KIT # 052379) INSTALLED ON THE FRAME RAIL OF AN XL-40 OR ENTERTAINER

01090

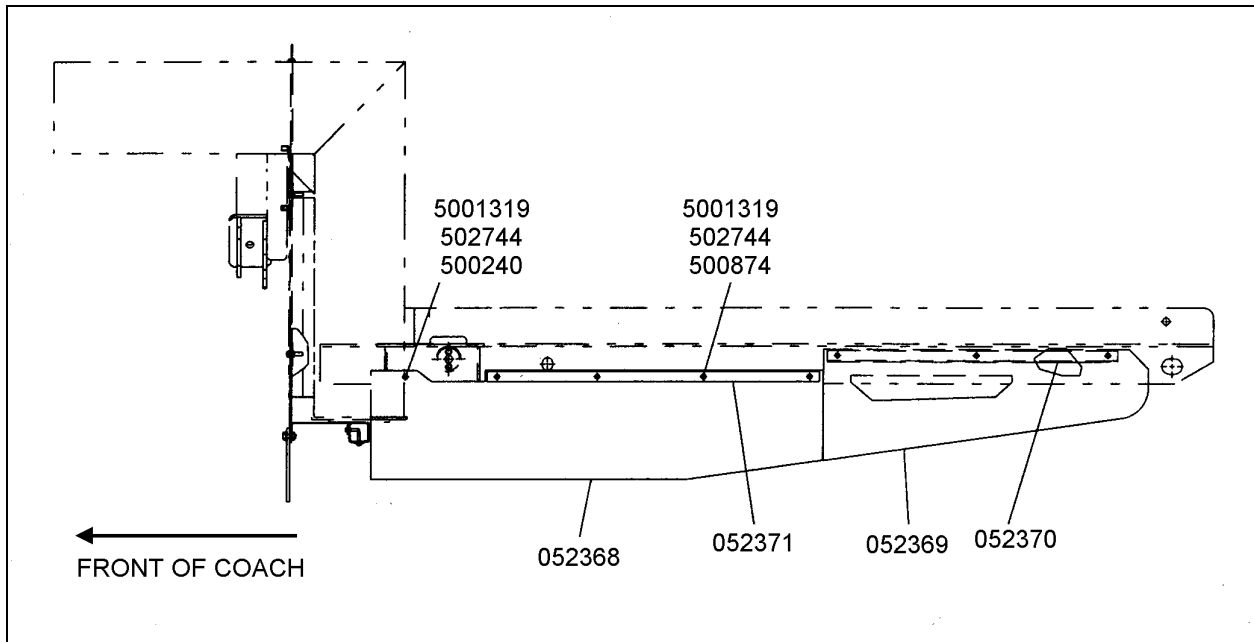

FIGURE 3: WARM AIR BAFFLE (KIT # 052380) INSTALLED ON THE FRAME RAIL OF AN XL-45 VEHICLE

01087