

**PREVOST**

ENREGISTRÉ - REGISTERED  
ISO 9001 & ISO 14001

**MAINTENANCE INFORMATION** Mi06-11



<b>DATE :</b> SEPTEMBER 2006	<b>SECTION :</b> 26 Slide-Out
<b>SUBJECT :</b> REAR SLIDE-OUT GEARBOX LEAKAGE	

**IMPORTANT NOTICE**

*This modification is recommended by PrevoSt Car to increase your vehicle's performance. Note that no reimbursement will be awarded for carrying out this modification.*

**APPLICATION**



Model	VIN 																								
XLII-45 MTH XLII-45 ENTERTAINER Model Year : 2005 - 2007	<p>The following vehicles</p> <table border="0"> <tr> <td>2PCW334975102<b>8529</b></td> <td>2PCW334967172<b>9064</b></td> </tr> <tr> <td>2PCY334996102<b>8638</b></td> <td>2PCW3349X7172<b>9066</b></td> </tr> <tr> <td>2PCY334986102<b>8727</b></td> <td></td> </tr> </table> <p>and</p> <p>from 2PCY334946102<b>8806</b> up to 2PCY334927102<b>9020</b> incl.</p> <p>except</p> <table border="0"> <tr> <td>2PCW334926102<b>8830</b></td> <td>2PCW334996102<b>8985</b></td> </tr> <tr> <td>2PCW334986102<b>8850</b></td> <td>2PCW334986102<b>8993</b></td> </tr> <tr> <td>2PCW334966102<b>8913</b></td> <td>2PCW334936102<b>8996</b></td> </tr> <tr> <td>2PCW334936102<b>8917</b></td> <td>2PCW334936102<b>9002</b></td> </tr> <tr> <td>2PCW334966102<b>8927</b></td> <td>2PCW334937102<b>9003</b></td> </tr> <tr> <td>2PCW334976102<b>8953</b></td> <td>2PCW334927102<b>9008</b></td> </tr> <tr> <td>2PCW334976102<b>8967</b></td> <td>2PCW334947102<b>9012</b></td> </tr> <tr> <td>2PCW334936102<b>8979</b></td> <td>2PCW334937102<b>9017</b></td> </tr> <tr> <td>2PCW334936102<b>8982</b></td> <td></td> </tr> </table>	2PCW334975102 <b>8529</b>	2PCW334967172 <b>9064</b>	2PCY334996102 <b>8638</b>	2PCW3349X7172 <b>9066</b>	2PCY334986102 <b>8727</b>		2PCW334926102 <b>8830</b>	2PCW334996102 <b>8985</b>	2PCW334986102 <b>8850</b>	2PCW334986102 <b>8993</b>	2PCW334966102 <b>8913</b>	2PCW334936102 <b>8996</b>	2PCW334936102 <b>8917</b>	2PCW334936102 <b>9002</b>	2PCW334966102 <b>8927</b>	2PCW334937102 <b>9003</b>	2PCW334976102 <b>8953</b>	2PCW334927102 <b>9008</b>	2PCW334976102 <b>8967</b>	2PCW334947102 <b>9012</b>	2PCW334936102 <b>8979</b>	2PCW334937102 <b>9017</b>	2PCW334936102 <b>8982</b>	
2PCW334975102 <b>8529</b>	2PCW334967172 <b>9064</b>																								
2PCY334996102 <b>8638</b>	2PCW3349X7172 <b>9066</b>																								
2PCY334986102 <b>8727</b>																									
2PCW334926102 <b>8830</b>	2PCW334996102 <b>8985</b>																								
2PCW334986102 <b>8850</b>	2PCW334986102 <b>8993</b>																								
2PCW334966102 <b>8913</b>	2PCW334936102 <b>8996</b>																								
2PCW334936102 <b>8917</b>	2PCW334936102 <b>9002</b>																								
2PCW334966102 <b>8927</b>	2PCW334937102 <b>9003</b>																								
2PCW334976102 <b>8953</b>	2PCW334927102 <b>9008</b>																								
2PCW334976102 <b>8967</b>	2PCW334947102 <b>9012</b>																								
2PCW334936102 <b>8979</b>	2PCW334937102 <b>9017</b>																								
2PCW334936102 <b>8982</b>																									

**DESCRIPTION**

Execute the following procedure to eliminate leakage on the rear slide-out gearbox.

## MATERIAL

Order the following parts:

Part No	Description	Identification	Qty
478251	"CAUTION" DECAL	---	1
500035	WASHER, LOCK SPLIT SS .317x.586x.078		1
5001450	SCREW, CAP HEX DP M8X20 G10.9		1

### NOTE

*Material can be obtained through regular channels.*

## PROCEDURE

### WARNING

Park vehicle safely, apply parking brake, stop engine and set battery master switch(es) to the OFF position prior to working on the vehicle.

### NOTE

*To ease access to the motor, extend the rear slide-out to its full "out" position.*

1. Set the battery master switch to the OFF position.

### CAUTION

The pressure in the inflatable seal must be completely relieved to prevent any damage to the seal before moving the slide-out using the motor shaft extension. Deflate the seal by using the relieving shut-off valve located on the slide-out control panel. Turn the handle clockwise to deflate the seal. Make sure the pressure indicator reading is "0 psi". Refer to "Slide-out manual override procedure" paragraph in your Owner's Manual.

### NOTE

*Rear slide-out motor is accessible from inside the vehicle, under the bed structure.*

2. Unplug the motor electrical cable connector.

3. Disengage the jaw couplings located both sides of the gearbox.

- a. Loosen the clamping screws on each clamping hubs (figure 1). If needed, rotate the motor shaft extension to gain access to the clamping screws.

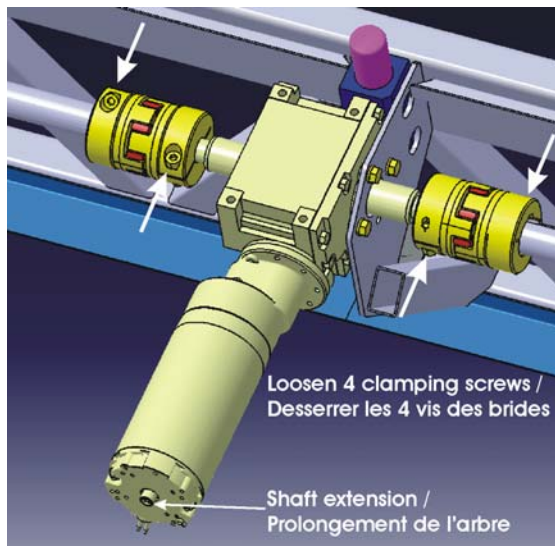

FIGURE 1

- b. Separate clamping hubs and slide onto the shafts, away from the gearbox (figure 2).

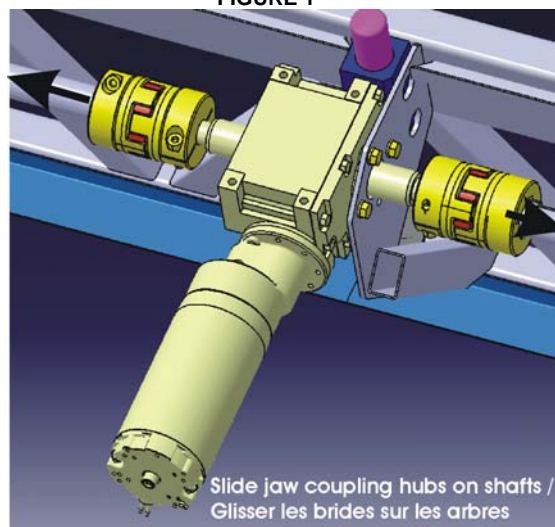

FIGURE 2

4. Unscrew the mounting bolts (3 or 4) securing the motor/gearbox assembly (figure 3).

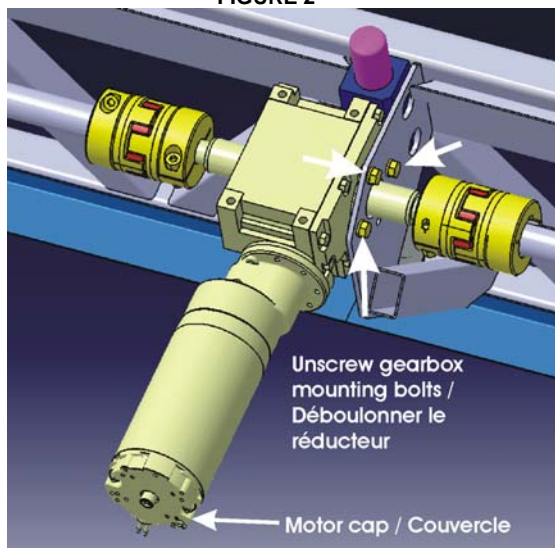

FIGURE 3

5. Remove the motor/gearbox assembly from its mounting support.

**NOTE**

*It may be necessary to loosen the blue flange bearing to move the shaft out of the way.*

6. Unscrew nuts and remove the motor cap (figure 3).
7. Remove the brush holder and the spring washer (figure 4).

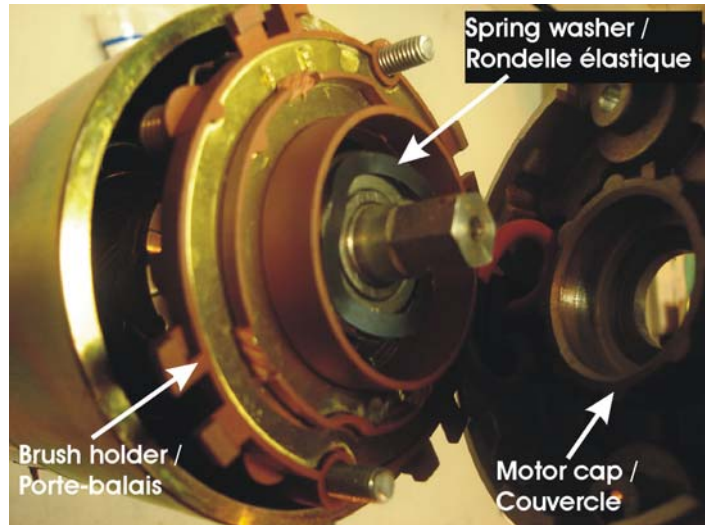

FIGURE 4

**NOTE**

*Because the gearbox will be reinstalled using the mounting holes opposite to the cover, it is necessary to reverse the direction of rotation of the motor. For that reason, the brush holder and the motor cap must be reinstalled after a rotation of 180°. Moreover, that will permit to keep the wires exiting from underneath, preventing them from rubbing on the bed structure during slide-out's back and forth motion.*

8. Read the note above. Reinstall the brush holder after a rotation of 180° from its original position (wires must exit from underneath once the motor reinstalled).
  - a. Pry the brushes gently with a small screwdriver to move them aside from the bearing and the commutator (figure 5 & 6).

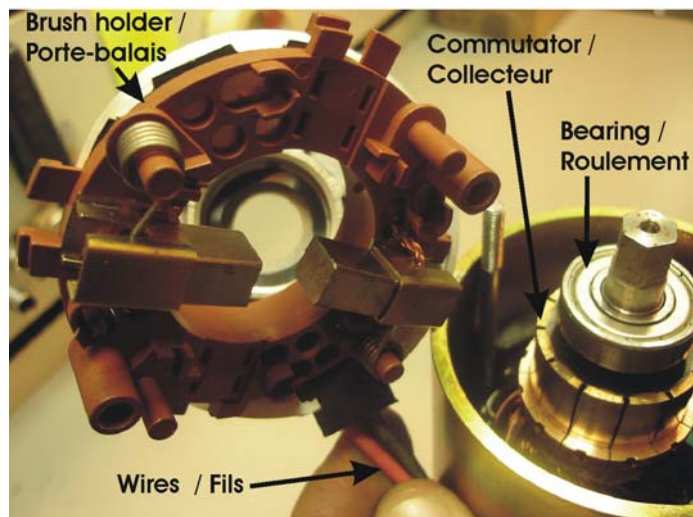

FIGURE 5

9. Place and center the spring washer in the motor cap. Assemble the motor and the cap, placing the motor over the cap in order to help keeping the spring washer at its proper position.

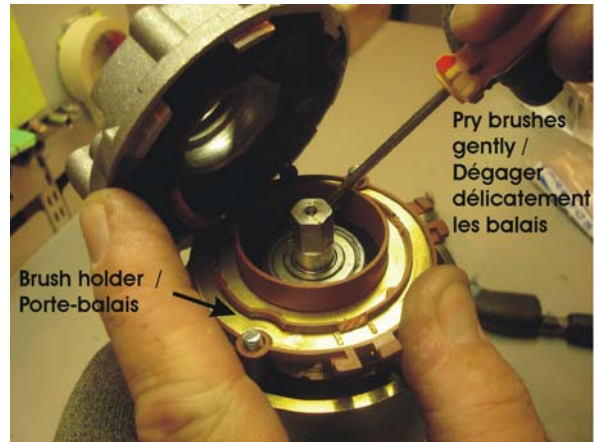

FIGURE 6

10. Tighten nuts.
11. Reinstall the motor/gearbox assembly using the mounting holes opposite to the gearbox cover. Use 4 mounting bolts. Tighten mounting bolts to a torque of 18 ft-lb in a criss-cross pattern (figure 8).

**⚠ CAUTION ⚠**

**To prevent damaging threads, use your fingers to drive the bolts first into the aluminum housing mounting holes.**

12. Reinstall the jaw couplings.
  - a. For both gearbox shafts, slide a clamping hub flush with the gearbox shaft extremity (figure 7).

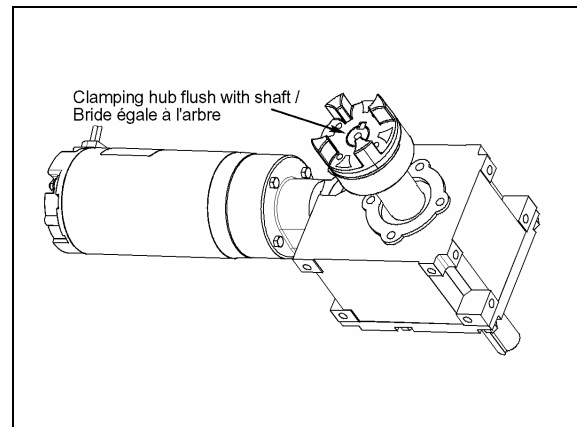

FIGURE 7

- b. Reconnect the clamping hubs. If necessary, rotate the motor shaft extension by hand to align the clamping hubs. Leave a gap of 20mm (13/16" approx) between each clamping hubs as shown on figure 8.
  - c. Tighten clamping screws to a torque of 18 lb-ft (figure 8).

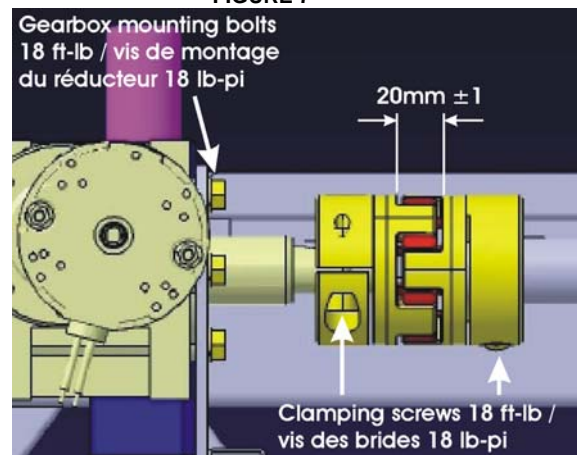

FIGURE 8



13. Connect the motor electrical cable connector. See new installation on figure 9.

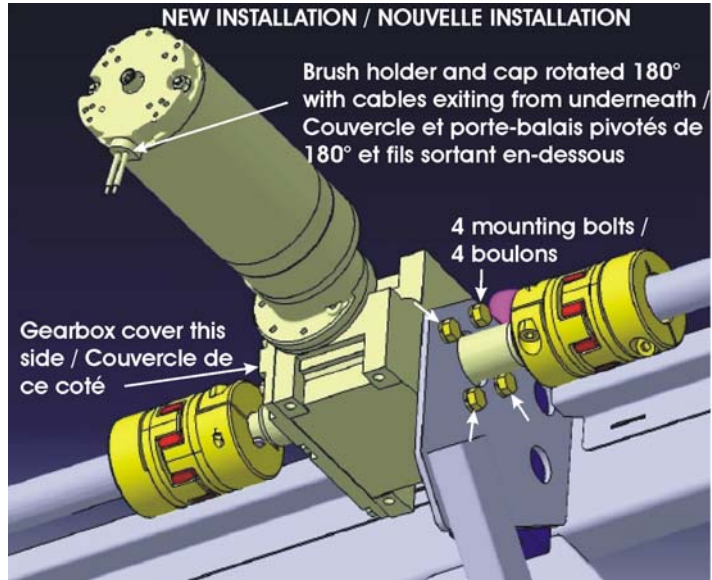

FIGURE 9

14. Place decal #478251 or figure 10 over the existing decal.

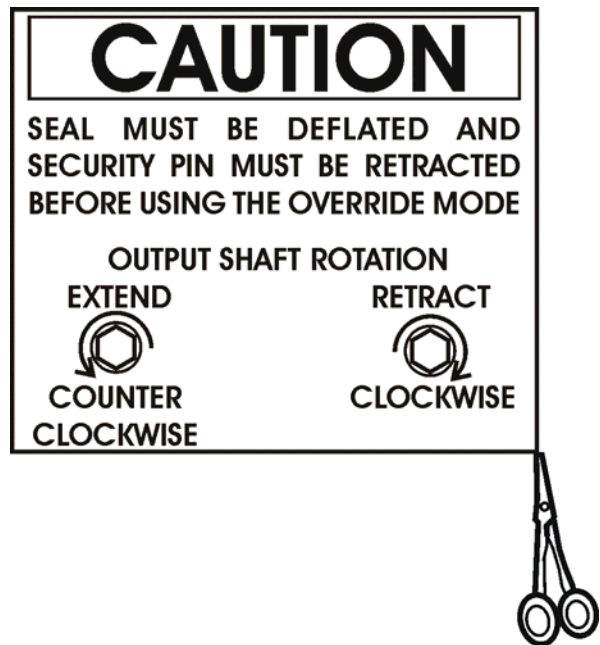

FIGURE 10

**Waste disposal:**

Discard according to applicable environmental regulations (Municipal/State[Prov.]/ Federal)