

## MAINTENANCE INFORMATION

Mi98-36



DATE : August 1998	SECTION : 22
SUBJECT : Improvement of the Condenser Fan Circuit	

### APPLICATION

Model	VIN
All XL Coaches and M-40 Bus Shells Model Year: 1997 - 1999	From 2PCM33402V1026275 up to 2PCM33499X1026680 incl.
All M-45E vehicles Model Year: 1997 - 1998	From 2PCE33499V1026258 up to 2PCE33493W1026631 incl.

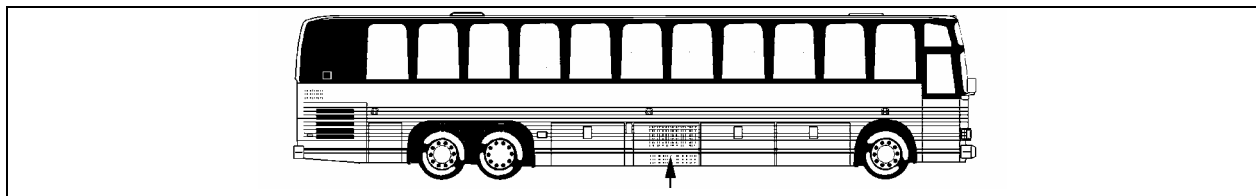
### DESCRIPTION :

In case of a R29 relay failure, one of the two fan motors can be kept working by modifying the electrical circuit of the condenser fan.

### PROCEDURE

**Warning :** Park vehicle safely, apply parking brake, stop engine and set battery master switch(es) to the OFF position prior to working on the vehicle.

1. Open the condenser compartment door (see figure 1). Locate the white junction box of the A/C. Remove the box lid;

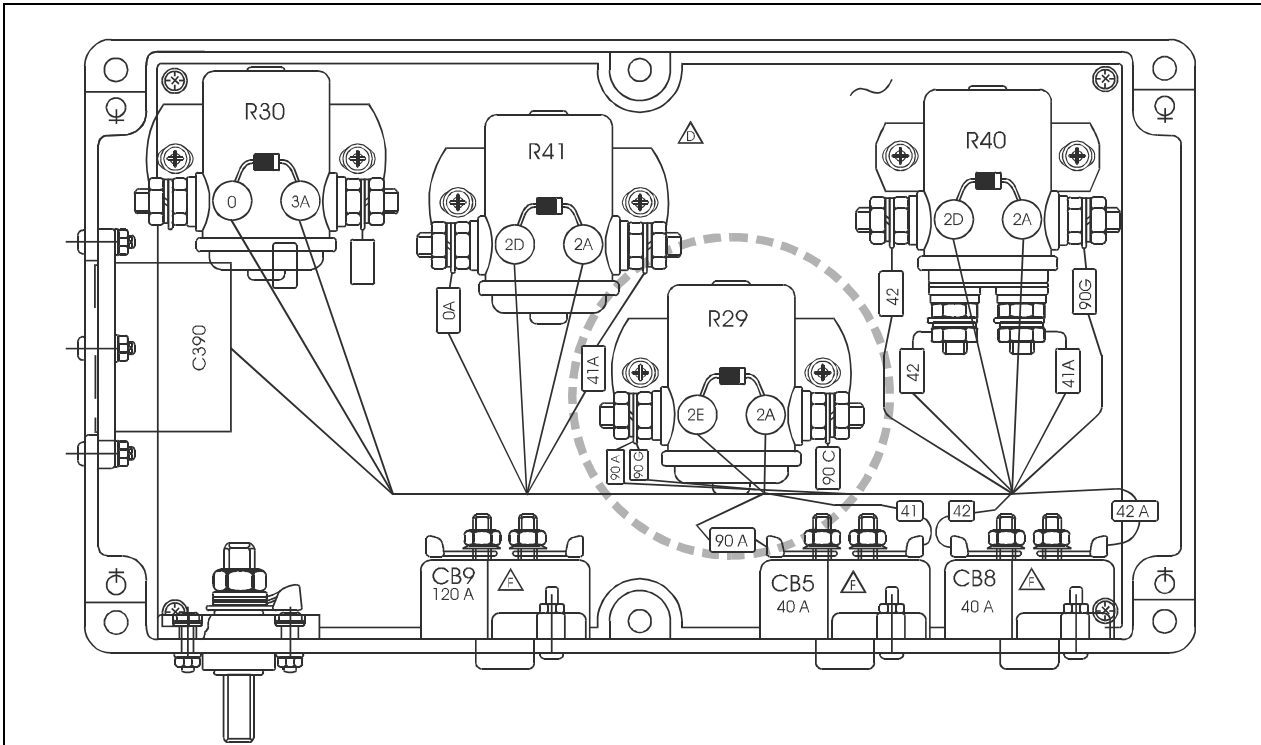


**Figure 1:** Condenser compartment door typical location.

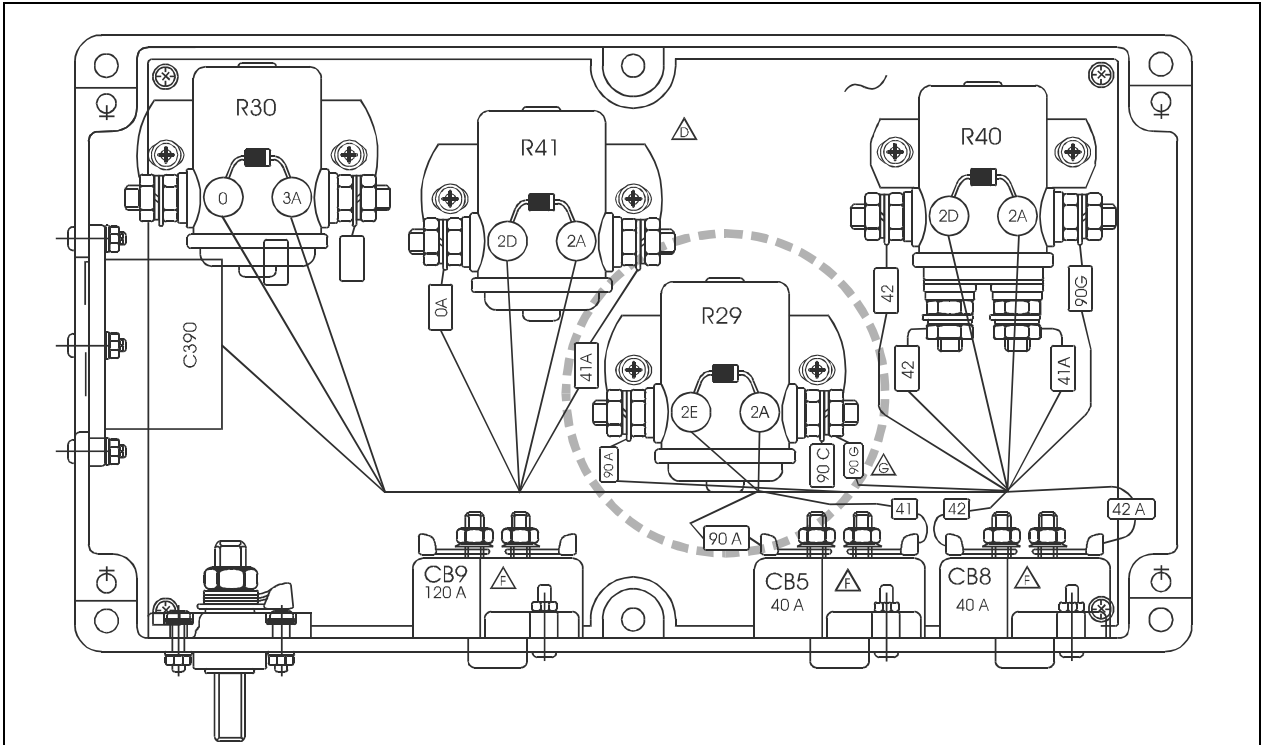
2. Find the R29 relay in the A/C junction box (see figure 2);
3. Remove wire 90G from relay R29 and relocate it on the other R29's terminal (on the side of wire 90C). The result of this change is shown on figure 3;
4. Put lid back and close the condenser compartment door. Replace the former electrical diagram by the new one given in the appendix.

**Note:**

- Appendix 1 applies to M-40 and to M-45E;
- Appendix 2 corresponds to XL-40 Coaches;
- Appendix 3 is applicable for XL-45 Coaches.

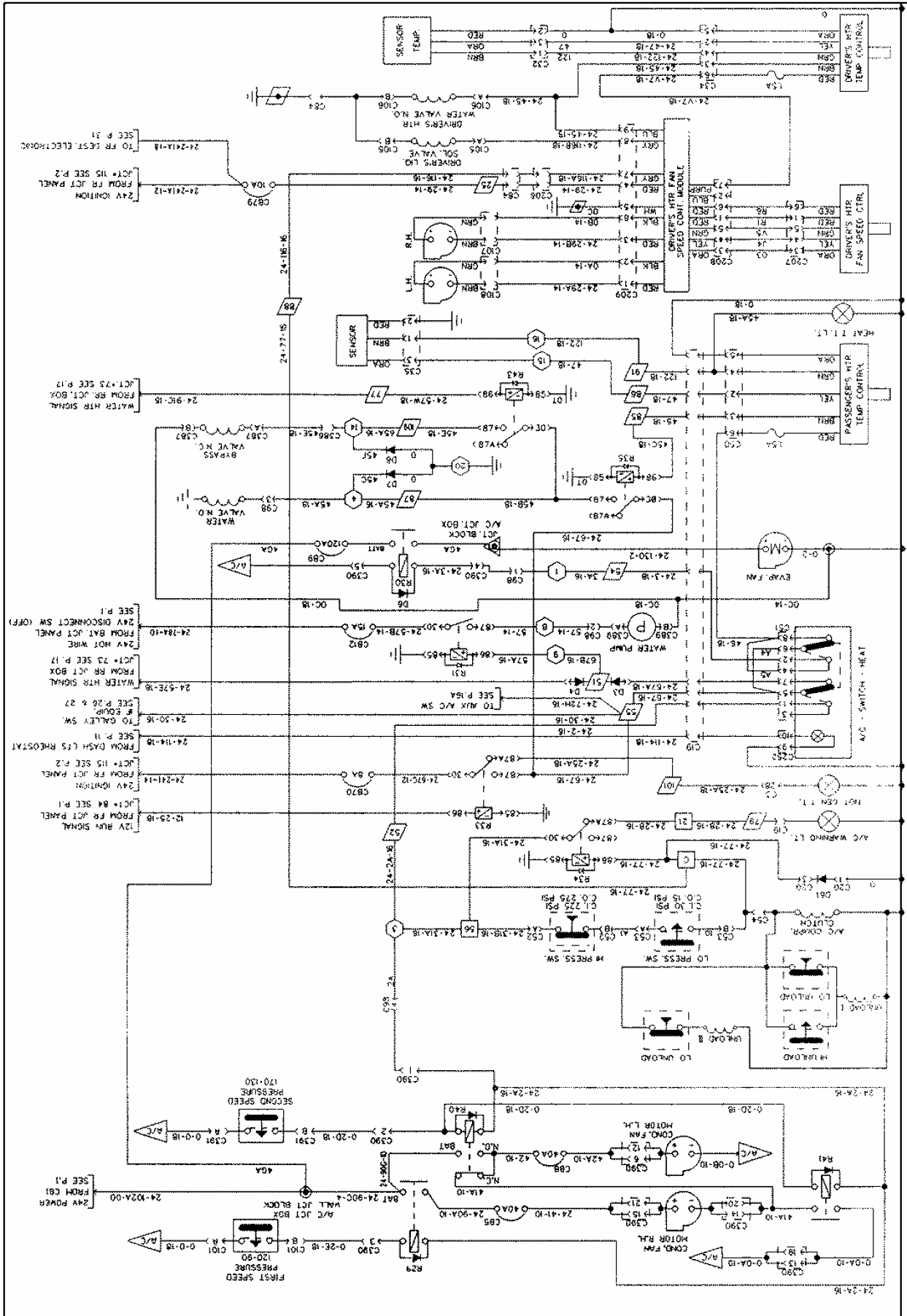


**Figure 2:** Initial aspect of relay R29 in A/C junction box.



**Figure 3:** Final aspect of relay R29 in A/C junction box.





CHASSIS GROUND  
 A/C AND HEAT SYSTEM  
 PREVOST CAR inc. WIRING DIAGRAM NO:D060871 AUTOCAR XL 40 P. 15 REVISION 023

