



**PREVOST**

# SAFETY RECALL

Sr01-03

ENREGISTRÉ - REGISTERED  
**ISO 9001 & ISO 14001**



DATE : March 2001	SECTION : 16
SUBJECT : INSPECTION AND REINFORCEMENT OF TRANSVERSAL RADIUS ROD ATTACHMENT ASSEMBLY	

## APPLICATION

Model	VIN
H3-40 Coaches & H3-40 VIP Model Year : All	All

## DESCRIPTION

It has come to the attention of Prévost Car Inc. that on the above-mentioned vehicles having a high mileage or submitted to severe working conditions, the transversal radius rod attachment assembly may develop fatigue cracks and eventually a failure. This could have adverse effects on the handling of the vehicle. If you are the owner or operator of such vehicle, **it is of the utmost importance to have the attachment inspected right away.** If cracks are present, repair must be performed before vehicle is put back in service. If no cracks are found, repair must be done as soon as possible. Reinforcement parts must be installed and cracks repaired if necessary in order to strengthen the attachment. For more information or help on how to perform this safety recall, contact your service manager or the nearest service center.

## PROCEDURE

**Warning:** Park vehicle safely over a repair pit, apply parking brake, stop engine and set battery master switch(es) to the OFF position prior to working on the vehicle.  
Prior to working under an air-suspended vehicle, it is strongly recommended to securely support the body at the recommended jacking points.

## INSPECTION

1. Raise front axle then remove the curb side wheel or empty air springs then raise front axle using a jack and remove the wheel. You may have to remove both wheels if attachment assembly needs to be replaced.

**Warning:** Ensure to safely support the axle by its jacking points during repair. Only the recommended jacking points must be used as outlined in Section 18 of Maintenance Manual: ?Body? under heading ?Vehicle jacking points? or in Operator's Manual.

- Remove asphalt base undercoating (Gravel Guard 3M) and any rust present near the risk or affected area, the risk areas are the joints between vertical and diagonal parts of the attachment assembly (refer to figure 1).

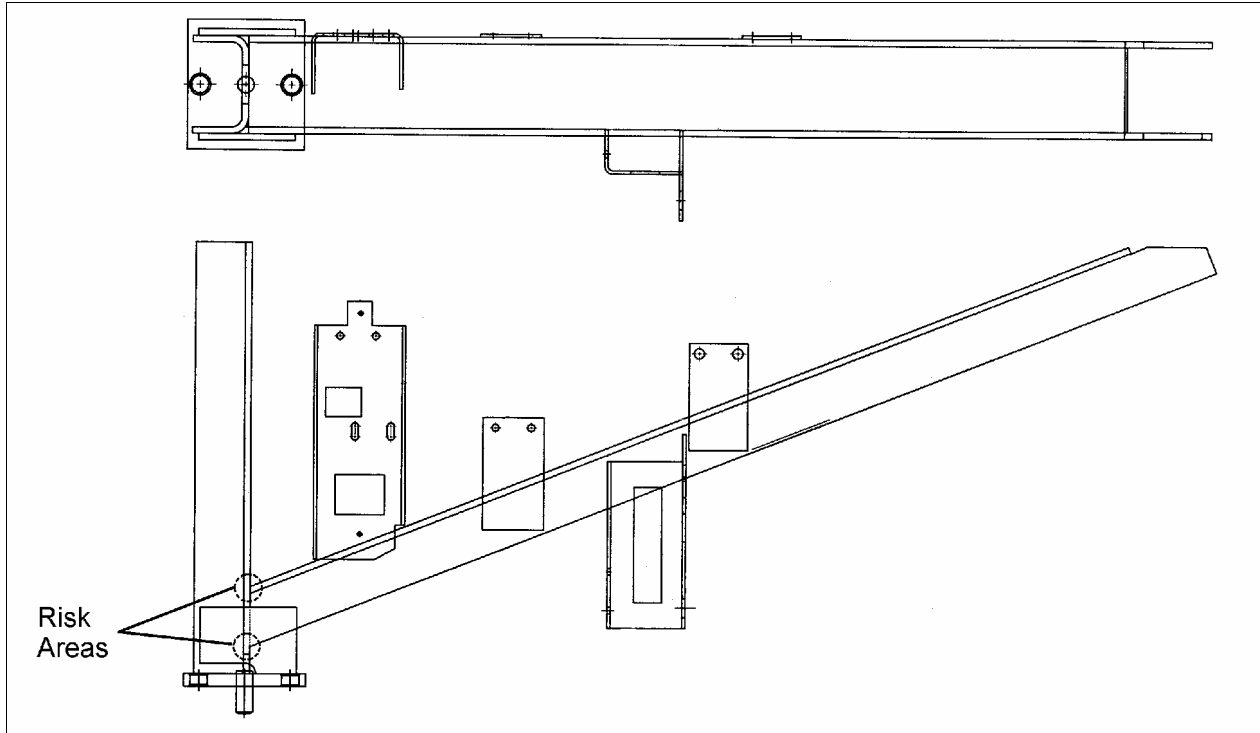

**FIGURE 1: FRONT AXLE TRANSVERSAL RADIUS ROD ATTACHMENT ASSEMBLY**

- Check if attachment is cracked; check if cracks are superficial by grinding the affected area to make the cracks disappear. If cracks are only superficial or no more than ½ inch long, chip off or grind to bare metal then reweld crack referring to paragraph: **Steel – Steel Welding**.
- If no cracks are present on attachment assembly, weld reinforcement plate referring to paragraph: “Reinforcement plate installation without replacing attachment assembly” and figure 2.
- If crack in attachment assembly is more than ½ inch long, replace with a new one. Refer to paragraph: “Transversal radius rod attachment assembly removal and installation”.
- When base metal temperature is below 32 °F (0 °C), base metal must be preheated to at least 50 °F (10 °C) and this temperature must be maintained for the whole welding process. It is therefore preferable to leave the vehicle to repair in a heated area for about half a day or heat the support until it reaches 50 °F (10 °C) minimum. You can also circulate warm air around attachment using a fan.

**Caution:** Do not heat over 150 °F (100°C).

## REINFORCEMENT PLATE INSTALLATION WITHOUT REPLACING ATTACHMENT ASSEMBLY

### MATERIAL

Part No.	Description	Qty
110570	Reinforcement plate	1

**Note :** Material can be obtained through regular channels.

**Note :** Only a qualified and experienced person must do welding.

- Protective shields must be placed in order to protect components against heat, welding flash, welding arc and other elements associated with welding.

2. Always wear the appropriate safety equipment.
3. Weld in clean and well-ventilated area, and always have an appropriate fire extinguisher within your reach.
4. The following precautions are to be taken to protect the electronic control components :
  - ? Cut off battery power (battery master switch) from battery compartment.
  - ? Disconnect wiring harness connectors from ECM (Electronic Control Module). The ECM is mounted on the starter side of the engine.
  - ? For vehicles equipped with an automatic transmission, disconnect wiring harness connectors from ECU (Electronic Control Unit). The ECU is located in rear electrical compartment.
  - ? For vehicles equipped with ABS (Anti-Lock Brake System), disconnect wiring harness connectors from ABS Electronic Control Unit. The ABS Electronic Control Unit is located in the front service compartment.
  - ? Do not connect welding cables to electronic control components.
5. Using a grinder, clean the seating surfaces of the attachment assembly to ensure adequate seating of the reinforcement plate. Seat reinforcement plate on attachment assembly at a distance of 3/8-inch (10 mm) from the base and hold with a C-clamp "Vise-grip".
6. Perform a back step sequence, make only one pass and grind beads. Refer to figure 2 and welding specifications indicated in paragraph: **Steel – Steel Welding**.
7. Reconnect components mentioned at step 4.

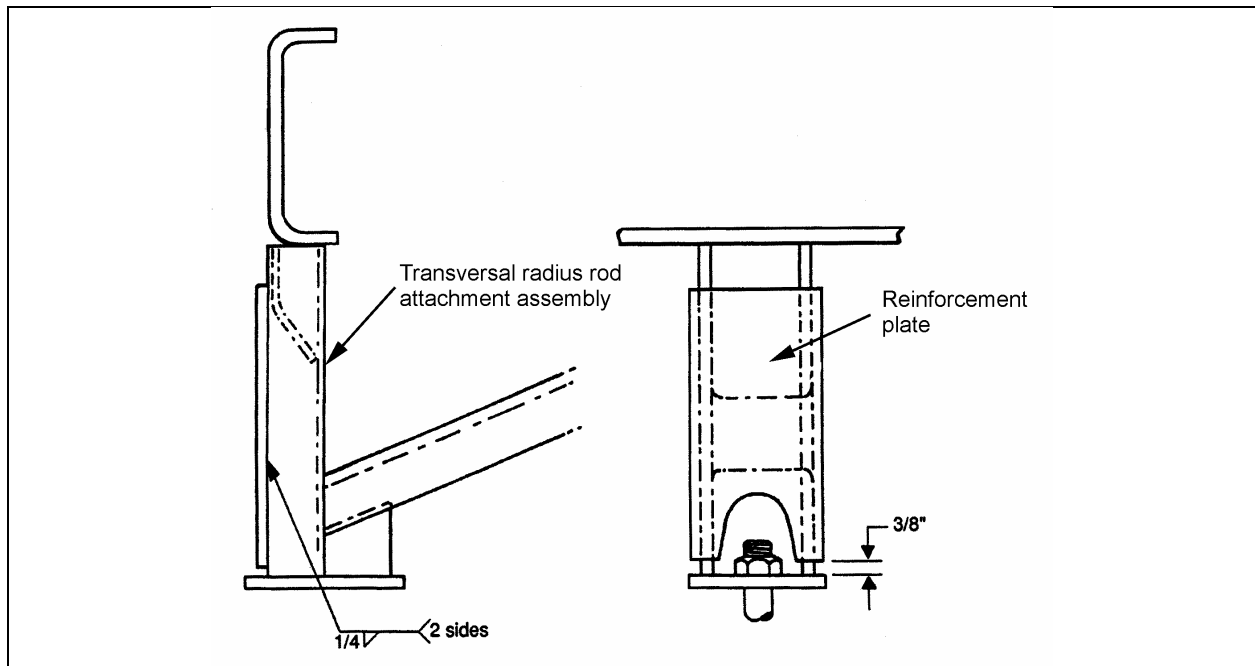

FIGURE 2 : INSTALLATION OF REINFORCEMENT PLATE

## STEEL – STEEL WELDING

**Caution :** Before welding, disconnect electronic modules and battery terminals.

**Warning :** Welding surfaces must be free of scale, slag, rust, paint, grease, humidity or other foreign material that would render welding impossible.

**Warning :** Only a qualified and experienced person must do welding.

- ? FCAW (Flux Core Arc Welding) process ;
- ? Electrode wire conforms to A5.20 AWS (American Welding Standards) specifications ;
- ? E4801T-9-CH, type electrode wire with 0,045" diameter (1,14 mm) ;
- ? Voltage : 26 ± 1 volts ;
- ? Wire feed rate : 295 ipm. ? 10 ;
- ? Shielding gas : 75% argon - 25% CO<sub>2</sub> or 100% CO<sub>2</sub>.
  
- ? If necessary and with great care to prevent perforating the material, it is possible to use a conventional electric arc welding machine according to the following specifications :
- ? SMAW (Shield Metal-Arc Welding) process ;
- ? Welding rod conforms to A5.1 of AWS (American Welding Standards) specifications ;
- ? E 6013 or E 7018 type welding rod with 1/8" diameter (3,2 mm).

## TRANSVERSAL RADIUS ROD ATTACHMENT ASSEMBLY REMOVAL AND INSTALLATION

### MATERIAL

Part No.	Description	Qty
171526P	Transversal radius rod attachment assembly	1
110570	Reinforcement plate	1
170620	Angle iron	1

**Note :** Material can be obtained through regular channels.

1. Flatten the tab washer, which secures the two retaining nuts (or bolts), and then unscrew the nuts (or bolts) at each extremity of the radius rod.
2. Remove the tab washer and the retaining plate and radius rod ends from anchor pins, then remove the radius rod. For more information on radius rod removal and installation, refer to section 16 of Maintenance Manual: "Suspension".
3. Remove the two radius rod supports.

**Note :** Only a qualified and experienced person must do welding.

4. Protective shields must be placed in order to protect components against heat, welding flash, welding arc and other elements associated with welding or cutting.
5. Always wear the appropriate safety equipment.
6. Weld in clean and well-ventilated area, and always have an appropriate fire extinguisher within your reach.
7. The following precautions are to be taken to protect the electronic control components :
  - ? Cut off battery power (battery master switch) from battery compartment.
  - ? Disconnect wiring harness connectors from ECM (Electronic Control Module). The ECM is mounted on the starter side of the engine.
  - ? For vehicles equipped with an automatic transmission, disconnect wiring harness connectors from ECU (Electronic Control Unit). The ECU is located in rear electrical compartment.
  - ? For vehicles equipped with ABS (Anti-Lock Brake System), disconnect wiring harness connectors from ABS Electronic Control Unit. The ABS Electronic Control Unit is located in the front service compartment.
  - ? Do not connect welding cables to electronic control components.

8. Securely support the attachment assembly. Mark the location of the attachment assembly with reference to subframe and suspension to ensure new attachment will be in same location. Using a cutting torch, separate the attachment assembly from subframe.
9. Using a grinder, clean the seating surfaces of the attachment assembly to ensure adequate seating of new attachment.
10. Weld new attachment assembly in place referring to marks and to welding specifications indicated in paragraph: **Steel – Steel Welding**.
11. Weld angle iron as per figure 3 and refer to welding specifications indicated in paragraph: **Steel – Steel Welding**.
12. Using a grinder, clean the seating surfaces of the attachment assembly to ensure adequate seating of the reinforcement plate. Seat reinforcement plate on attachment assembly at a distance of 3/8-inch (10 mm) from the base and hold with a C-clamp "Vise-grip".
13. Perform a back step sequence, make only one pass and grind beads. Refer to figure 3 and welding specifications indicated in paragraph: **Steel – Steel Welding**.
14. Allow welding beads to cool then repaint beads and reinforcement parts.

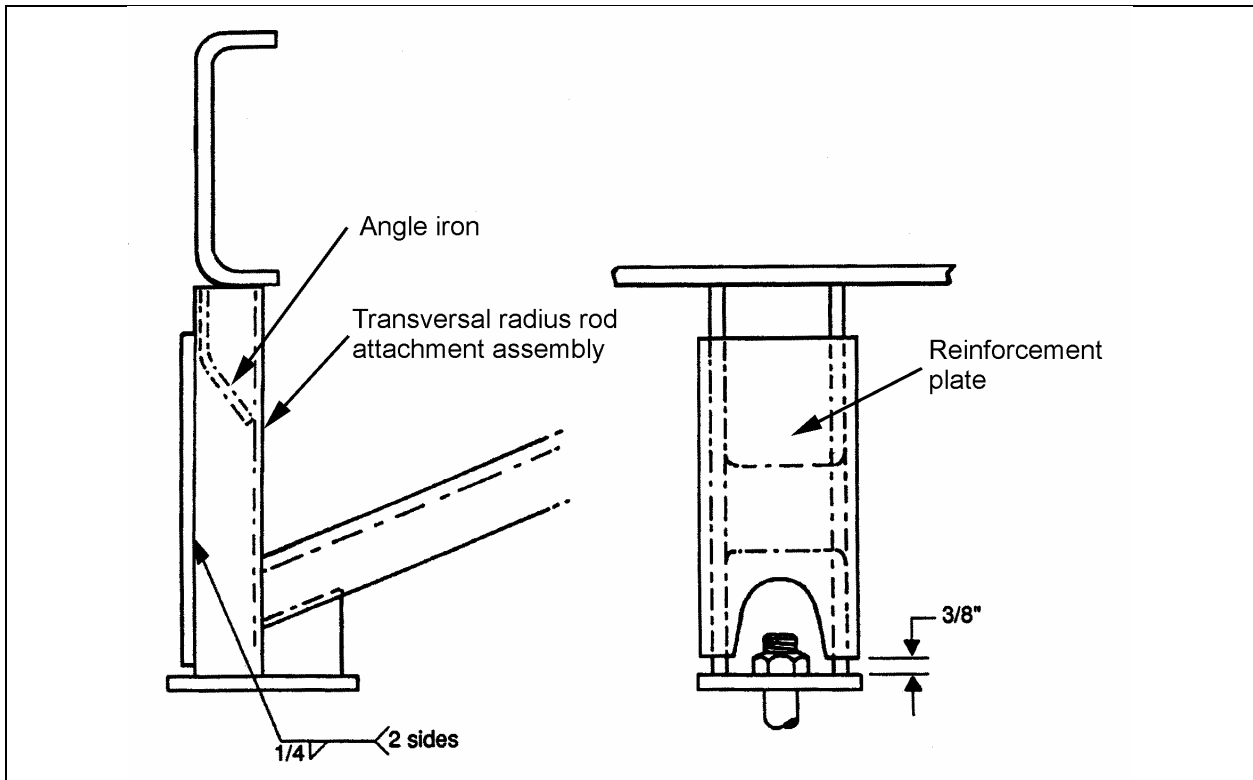

**FIGURE 3: ANGLE IRON & REINFORCEMENT PLATE INSTALLATION**

15. Install radius rod supports and tighten nuts to 160 - 170 lbf-ft lubricated (216 – 230 N·m lubricated).
16. Lightly spray the radius rod support with water. Place the radius rod end over the radius rod support.
17. Position the retaining plate. Install the tab washer and nuts (or bolts).

**Caution :** Always use new tab washers at installation.

18. Tighten the nuts (or bolts) lightly, and repeat at the other end.
19. Refer to heading "*SUSPENSION HEIGHT ADJUSTMENT*" in section 16 of Maintenance Manual, and set the vehicle to normal ride height.

20. With the vehicle at normal ride height, apply oil on threads and tighten all radius rod anchor pin nuts or bolts to 110 – 130 ft•lbf (150 – 175 N•m). Bend tab washers down over nuts or bolts.

**Caution :** *It is extremely important upon reconnection of the rods that the proper clearance height between the axle and body be maintained. Otherwise, the rubber bushings in radius rod ends will become preloaded, thus reducing their life span.*

21. Mount the wheel over studs, being careful not to damage stud threads.

22. Screw in the hex stud nuts (refer to figure 4 for sequence) so that wheel will position itself concentrically with hub. This is important, otherwise wheel may be eccentric with hub and will not run straight. In this initial step, slightly tighten the nuts to correctly position the wheel.

23. Tighten stud nuts progressively as shown in Figure 4. The final tightening should be done with a torque wrench. Tighten stud nuts to 450 - 500 ft-lbf (610 - 680 Nm) for aluminum as well as steel wheel.

**Caution :** *Insufficient mounting-torque can result in damage to parts. Excessive mounting torque can cause studs to break and the wheel to crack in stud hole area.*

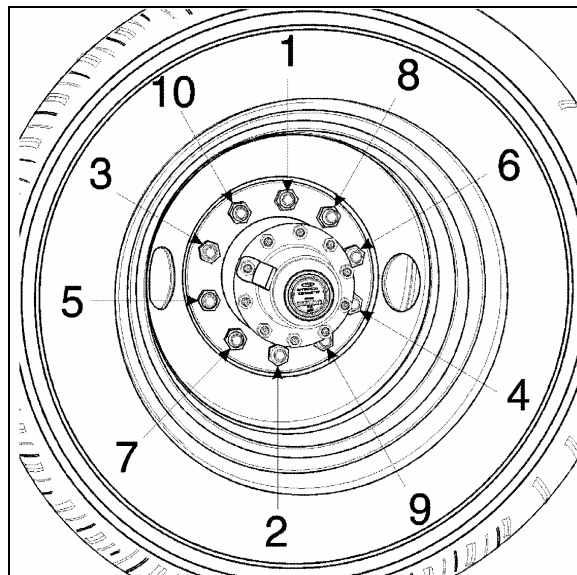

FIGURE 4: TIGHTENING SEQUENCE

13013

## WARRANTY

This modification is covered by Prévost Car's normal warranty. We will reimburse you the parts and one and a half hour (1.5) of labor upon receipt of a completed A.F.A. form on which you must specify as per "Safety Recall 01-03". **You also have to fill the "Safety Recall Certification Sheet" provided with this bulletin and return it with your A.F.A. form to be reimbursed.**

### Parts disposition :

- Discard according to applicable environmental regulations (Municipal/State[Prov.]/ Federal)



**PREVOST**

**Safety Recall  
Certification Sheet  
(Ref: Sr01-03)**

ENREGISTRÉ - REGISTERED  
**ISO 9001 & ISO 14001**



**SERIAL NUMBER:** \_\_\_\_\_

PERFORMED BY		OWNER/OPERATOR	
We hereby certify that Safety Recall Instructions with regards to Safety Recall #01-03 have been performed.			
Name: _____		Name: _____	
Addr: _____		Addr: _____	
Phone: _____		Phone: _____	
Fax: _____		Fax: _____	
Signature :	_____	Signature :	_____
Date:	_____	Date:	_____

**If the information mentioned above is incorrect or you are not the owner of this vehicle anymore, please fill this section and return to sender.**

**NEW OWNER:** \_\_\_\_\_

**BUSINESS:** \_\_\_\_\_

**ADDRESS:** \_\_\_\_\_

\_\_\_\_\_

\_\_\_\_\_

**TELEPHONE:** \_\_\_\_\_ **FAX:** \_\_\_\_\_

**Please return this completed document with your  
A.F.A. form**