



**PREVOST**

ENREGISTRÉ - REGISTERED  
ISO 9001 & ISO 14001

**SAFETY  
RECALL**

Sr05-06A



DATE : May-2005	SECTION : 16
SUBJECT : IMPROPER MOUNTING OF 3 RADIUS ROD SUPPORTS	

REVISION : A

VEHICLES FROM 5-8396 UP TO 5-8406 REMOVED FROM LIST.

**APPLICATION**

Model	VIN																																
XLII-45 coaches XLII-40, XLII-45 motorhomes XLII-45 Entertainer Model Year : 2005	<div style="text-align: center;">  <p>VIN ENREGISTRÉ - REGISTERED PREVOST CAR INC. 215 CLARE BOULEVARD, QUE. CANADA</p> </div> <p>From 2PCW334945102<u>8407</u> up to 2PCX334945102<u>8637</u> incl.            except the following vehicles :</p> <table style="width: 100%; border: none;"> <tr> <td style="border: none;">2PCW3340X5102<u>8509</u></td> <td style="border: none;">2PCW334985102<u>8619</u></td> </tr> <tr> <td style="border: none;">2PCW3340X5102<u>8560</u></td> <td style="border: none;">2PCW334985102<u>8622</u></td> </tr> <tr> <td style="border: none;">2PCW334975102<u>8563</u></td> <td style="border: none;">2PCY334995102<u>8623</u></td> </tr> <tr> <td style="border: none;">2PCW334975102<u>8577</u></td> <td style="border: none;">2PCW334915102<u>8624</u></td> </tr> <tr> <td style="border: none;">2PCW334905102<u>8582</u></td> <td style="border: none;">2PCW334935102<u>8625</u></td> </tr> <tr> <td style="border: none;">2PCW3349X5102<u>8587</u></td> <td style="border: none;">2PCW334955102<u>8626</u></td> </tr> <tr> <td style="border: none;">2PCW334935102<u>8592</u></td> <td style="border: none;">2PCW334975102<u>8627</u></td> </tr> <tr> <td style="border: none;">2PCW334905102<u>8596</u></td> <td style="border: none;">2PCW334995102<u>8628</u></td> </tr> <tr> <td style="border: none;">2PCW334025102<u>8598</u></td> <td style="border: none;">2PCW334975102<u>8630</u></td> </tr> <tr> <td style="border: none;">2PCY334945102<u>8609</u></td> <td style="border: none;">2PCW334995102<u>8631</u></td> </tr> <tr> <td style="border: none;">2PCW334935102<u>8611</u></td> <td style="border: none;">2PCX334955102<u>8632</u></td> </tr> <tr> <td style="border: none;">2PCY334945102<u>8612</u></td> <td style="border: none;">2PCX334975102<u>8633</u></td> </tr> <tr> <td style="border: none;">2PCW334055102<u>8613</u></td> <td style="border: none;">2PCW334945102<u>8634</u></td> </tr> <tr> <td style="border: none;">2PCW334995102<u>8614</u></td> <td style="border: none;">2PCX334905102<u>8635</u></td> </tr> <tr> <td style="border: none;">2PCW334905102<u>8615</u></td> <td style="border: none;">2PCW334985102<u>8636</u></td> </tr> <tr> <td style="border: none;">2PCW334965102<u>8618</u></td> <td></td> </tr> </table>	2PCW3340X5102 <u>8509</u>	2PCW334985102 <u>8619</u>	2PCW3340X5102 <u>8560</u>	2PCW334985102 <u>8622</u>	2PCW334975102 <u>8563</u>	2PCY334995102 <u>8623</u>	2PCW334975102 <u>8577</u>	2PCW334915102 <u>8624</u>	2PCW334905102 <u>8582</u>	2PCW334935102 <u>8625</u>	2PCW3349X5102 <u>8587</u>	2PCW334955102 <u>8626</u>	2PCW334935102 <u>8592</u>	2PCW334975102 <u>8627</u>	2PCW334905102 <u>8596</u>	2PCW334995102 <u>8628</u>	2PCW334025102 <u>8598</u>	2PCW334975102 <u>8630</u>	2PCY334945102 <u>8609</u>	2PCW334995102 <u>8631</u>	2PCW334935102 <u>8611</u>	2PCX334955102 <u>8632</u>	2PCY334945102 <u>8612</u>	2PCX334975102 <u>8633</u>	2PCW334055102 <u>8613</u>	2PCW334945102 <u>8634</u>	2PCW334995102 <u>8614</u>	2PCX334905102 <u>8635</u>	2PCW334905102 <u>8615</u>	2PCW334985102 <u>8636</u>	2PCW334965102 <u>8618</u>	
2PCW3340X5102 <u>8509</u>	2PCW334985102 <u>8619</u>																																
2PCW3340X5102 <u>8560</u>	2PCW334985102 <u>8622</u>																																
2PCW334975102 <u>8563</u>	2PCY334995102 <u>8623</u>																																
2PCW334975102 <u>8577</u>	2PCW334915102 <u>8624</u>																																
2PCW334905102 <u>8582</u>	2PCW334935102 <u>8625</u>																																
2PCW3349X5102 <u>8587</u>	2PCW334955102 <u>8626</u>																																
2PCW334935102 <u>8592</u>	2PCW334975102 <u>8627</u>																																
2PCW334905102 <u>8596</u>	2PCW334995102 <u>8628</u>																																
2PCW334025102 <u>8598</u>	2PCW334975102 <u>8630</u>																																
2PCY334945102 <u>8609</u>	2PCW334995102 <u>8631</u>																																
2PCW334935102 <u>8611</u>	2PCX334955102 <u>8632</u>																																
2PCY334945102 <u>8612</u>	2PCX334975102 <u>8633</u>																																
2PCW334055102 <u>8613</u>	2PCW334945102 <u>8634</u>																																
2PCW334995102 <u>8614</u>	2PCX334905102 <u>8635</u>																																
2PCW334905102 <u>8615</u>	2PCW334985102 <u>8636</u>																																
2PCW334965102 <u>8618</u>																																	

This Safety Recall does not necessarily apply to all the above-mentioned vehicles, some vehicles may have been modified before delivery. The owners of the vehicles affected by this recall will be advised by a letter indicating the Vehicle Identification Number (VIN) of each vehicle concerned.

**DESCRIPTION**

For the above mentioned vehicles, PrevoSt Car has determined that a too large quantity of anti-seize compound has been used for mounting the 3 identified radius rod supports. The bolts securing the supports could come loose and the support may eventually detach from the structure. This could affect

vehicle stability and cause a crash. It is necessary to dismount the radius rod supports, to remove all trace of anti-seize compound and to reinstall the supports according to the corrected factory procedure.

## MATERIAL

Kit #121718 includes the following parts:

Part No.	Description	Qty
110340	Locking tab plate	6
121578	Locking tab plate	3
502544	Bolt M16 X 40 G8.8	12
680038	Loctite 243	1
684901	Brush	1
5001150	Washer	4

**Also, it is necessary to order bolts according to your vehicle identification number.**

For the following vehicles: from 2PCW3349451028407 up to 2PCW3349X51028461 inclusively, order the following bolts.

Part No.	Description	Qty
5001224	Bolt M16 X 60 G10.9	6

For all other vehicles, order the following bolts:

Part No.	Description	Qty
5001372	Bolt M16 X 50 G10.9	6

## PROCEDURE

### WARNING

**Park vehicle safely, apply parking brake, stop engine and set battery master switch(es) to the OFF position prior to working on the vehicle.**

1. Raise the vehicle using the axle jacking points.
2. Using a jack stand each side of vehicle, support rear chassis. See figure 6 for proper positioning of jack stands.
3. Release air from drive axle air springs. To do so, detach the height control valve linkage each side of vehicle. Lower the height control valve overtravel lever to release air (figure 1).
4. With jack stands supporting the rear chassis, adjust the lift supporting the drive axle in order to have the suspension at normal ride height. This must be done in order to ease removal and installation of radius rods.

### *NOTE*

*The normal ride height is obtained by measuring the clearance of the air springs. The clearance should be 11 ½" ± ¼" for the air springs installed on the drive axle. The measure should be taken from under the upper air spring support on subframe to top of the lower air spring support on axle. See figure 2.*

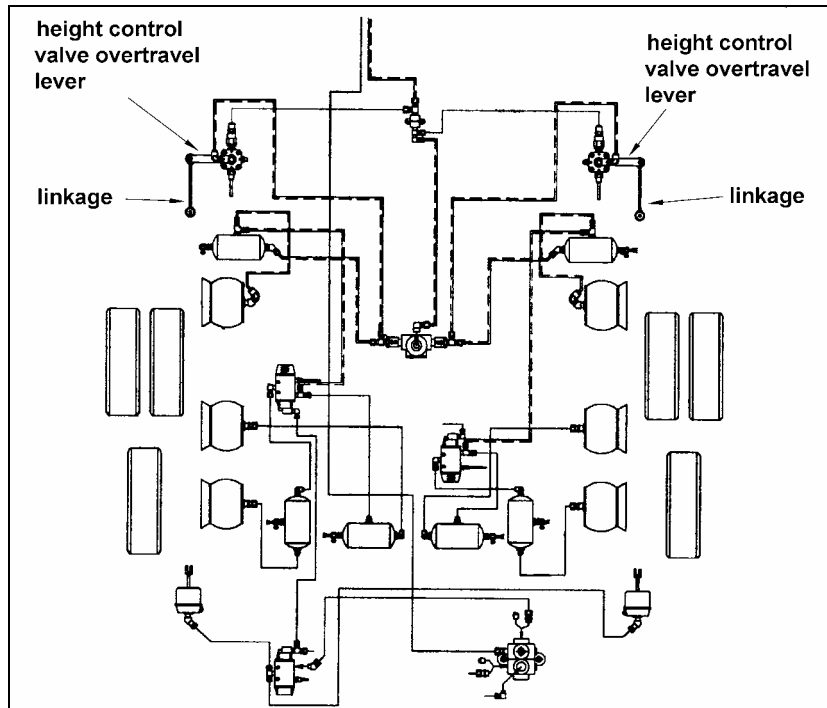

FIGURE 1: HEIGHT CONTROL VALVES

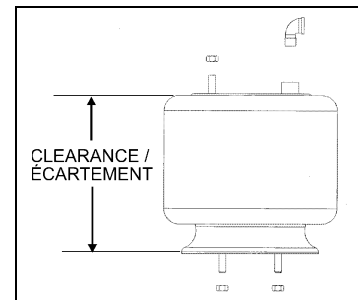

FIGURE 2: CLEARANCE

**⚠ WARNING ⚠**

**For the following steps, it is very important not to remove the 3 radius rods simultaneously because doing this would leave the drive axle unstable. Remove and clean the first radius rod. Once completed, reinstall the radius rod and then repeat this procedure with the second radius rod and finally the third one.**

5. Dismount successively the 3 radius rods identified in figure 3 by flattening the tabs of locking plate and by unscrewing the two bolts directly fastened into radius rod pivot (if needed, refer to maintenance manual).
6. Dismount successively the 3 radius rod supports identified in figure 3. Take note of the position and quantity of shims in order to reinstall the components in the same condition as they were to maintain proper vehicle alignment.
7. Using brake cleaner, thoroughly clean the 3 supports contact surfaces to remove all trace of anti-seize compound. Clean the contact surfaces between support, shim and structure. On supports (see figure 4), clean the contact surface of the bolt head, the passing holes and use brush #684901 to clean the tapped blind holes. Use brake cleaner and a clean clothe to dry.
8. Clean inside the 6 tapped blind holes where the supports are bolted. Use brake cleaner, brush #684901 and a clean clothe to dry.
9. Clean inside the tapped blind holes of the 3 support pins identified in figure 5. Use brake cleaner, brush #684901 and a clean clothe to dry.

10. Reinstall the supports (figure 6). Do not forget to reinstall the shims correctly.

- Use 2 new bolts (#5001372) per support. If your vehicle is included in the range beginning from 2PCW3349451028407 up to 2PCW3349X51028461 inclusively, you must use bolts #5001224 instead.
- Use new tab locking plates (Prevost #121578).
- For the outer left and right supports, you must use new washer (#5001150) if the total thickness of their respective shims is less than 1/8" (3mm).
- Put 3 drops of Loctite 243 (Prevost #680038) in each of the 6 tapped blind holes and a line of Loctite on bolts.
- Tighten bolts to a torque of **185-205 lbf.ft.**

11. Fold locking tab over bolt heads.

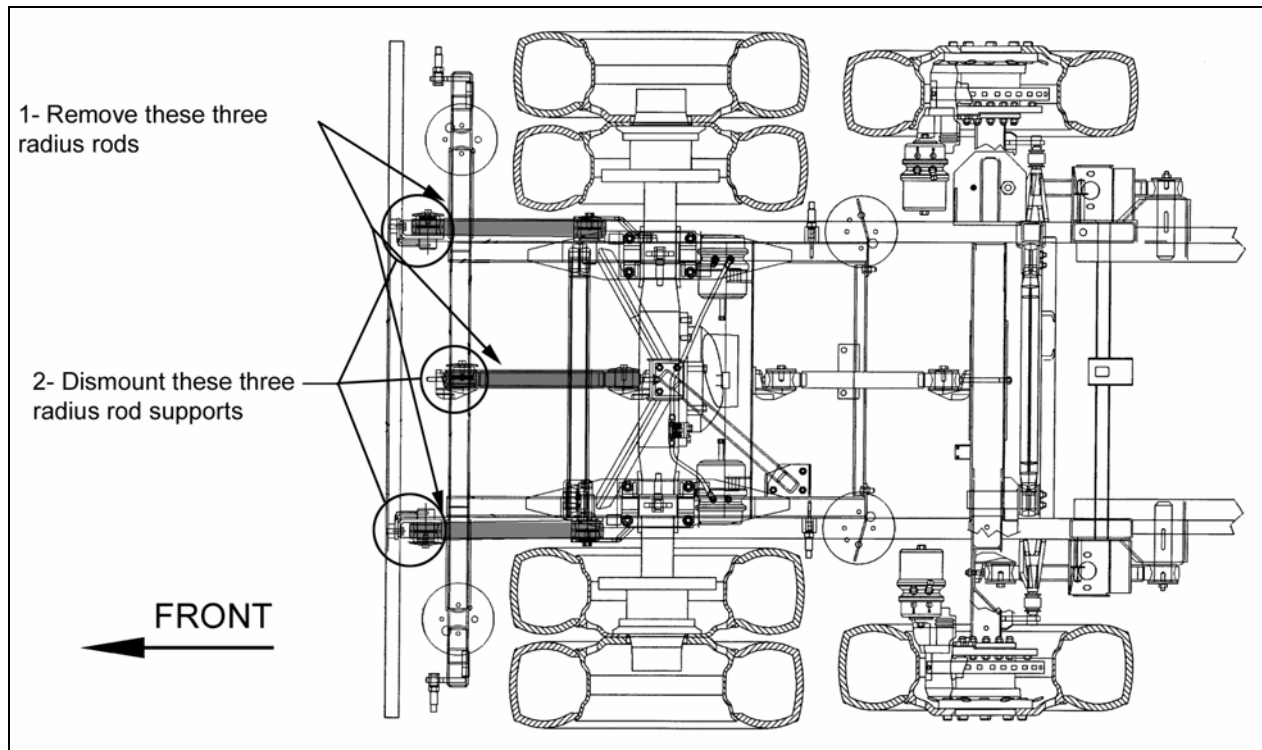

FIGURE 3: REAR SUSPENSION

12. Reinstall the radius rods.

- Use 4 new bolts (#502544) per radius rod.
- Use new tab locking plates (Prevost #110340).
- Put 3 drops of Loctite 243 (Prevost #680038) in each tapped blind holes and a line of Loctite on bolts.
- Tighten bolts to a torque of **140-154 lbf.ft.**

13. Fold locking tab over bolt heads.

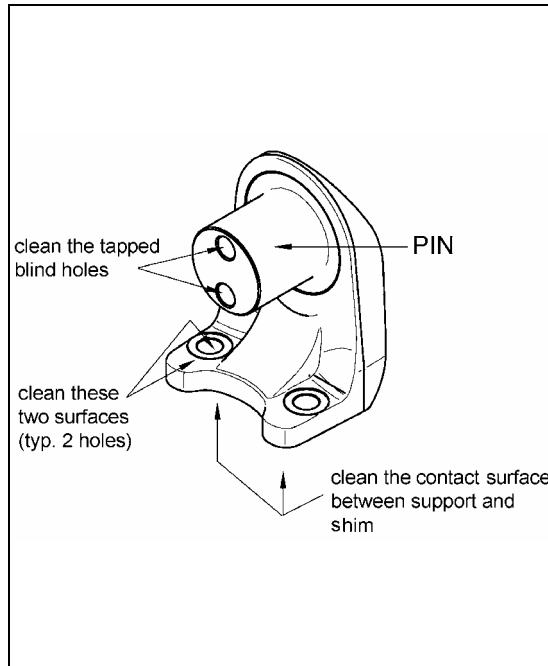

FIGURE 4: SUPPORT CLEANING (typ. 3 supports)

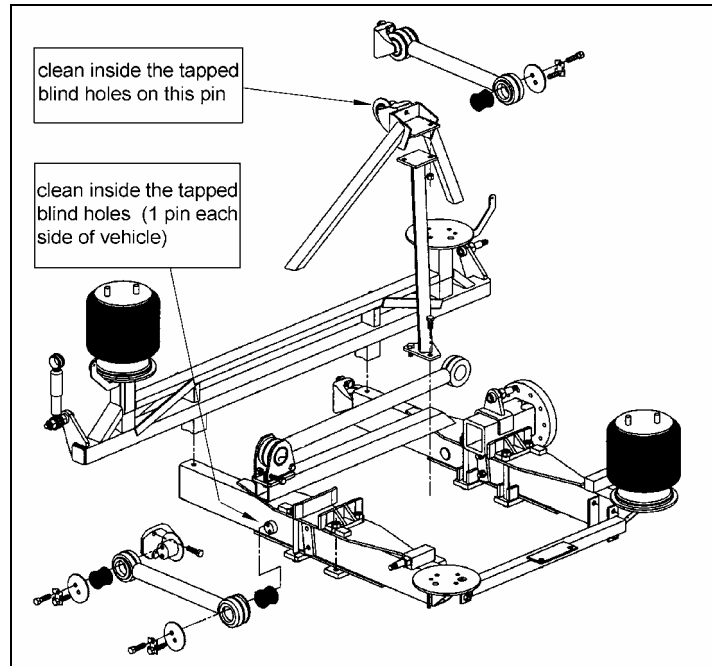

FIGURE 5: CLEANING OF 2 PINS AND THE CENTRAL SUPPORT PIN

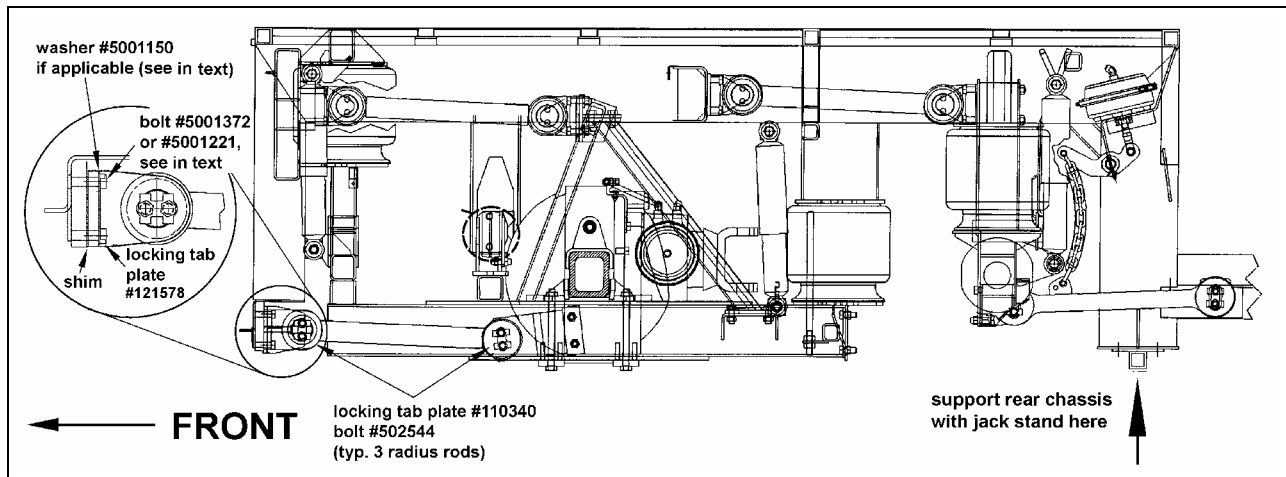

FIGURE 6: REAR SUSPENSION

## WARRANTY

This modification is covered by Prevost Car's normal warranty. We will reimburse you the parts and four hours (4.0) of labor upon receipt of a completed A.F.A. form on which you must specify as per "Safety Recall 05-06A". **You also have to fill the "Safety Recall Certification Sheet" provided with this bulletin and return it with your A.F.A. form to be reimbursed.**





**PREVOST**

**Safety Recall  
Certification Sheet  
(Ref: Sr05-06)**

ENREGISTRÉ - REGISTERED  
**ISO 9001 & ISO 14001**



**SERIAL NUMBER:** \_\_\_\_\_

PERFORMED BY		OWNER/OPERATOR	
We hereby certify that Safety Recall Instructions with regard to Safety Recall #05-06 have been performed.			
Name: _____		Name: _____	
Addr: _____		Addr: _____	
Phone: _____		Phone: _____	
Fax: _____		Fax: _____	
Signature :	_____	Signature :	_____
Date:	_____	Date:	_____

**If the information mentioned above is incorrect or you are not the owner of this vehicle anymore, please fill this section and return to sender..**

**NEW OWNER:** \_\_\_\_\_

**BUSINESS:** \_\_\_\_\_

**ADDRESS (including County):** \_\_\_\_\_

\_\_\_\_\_

**TELEPHONE:** \_\_\_\_\_ **FAX:** \_\_\_\_\_

**Please return this completed document with your  
A.F.A. form**