



PREVOST

**SAFETY
RECALL**

SR15-27B

DATE :	JULY 2015	SECTION :	06 - Electrical
SUBJECT:	BOOSTER STUD AND CABLE PROTECTION		

Revision B This bulletin replaces any previous versions.
 August 12, 2015 Added images, parts and instructions for D13 US07 configuration. Added rivets.

APPLICATION

NOTICE TO SERVICE CENTERS

Verify vehicle eligibility by checking warranty bulletin status with **SAP** or via **ONLINE WARRANTY SYSTEM** available on Service / Warranty tab of PreVost website.

Model	VIN
X3-45 coaches Model Year: 2007 - 2010	From 2PCG3334947102 <u>8754</u> up to 2PCG333490 <u>AC729951</u> incl.





This Safety Recall does not necessarily apply to all the above-mentioned vehicles, some vehicles may have been modified before delivery. The owners of the vehicles affected by this recall will be advised by a letter indicating the Vehicle Identification Number (VIN) of each vehicle concerned.







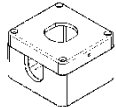
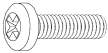



DESCRIPTION

On vehicles affected by this recall, the booster stud connection can become rusted, leading to a weakened connection. A compromised connection could allow the power cable release and consequently ground on the frame, increasing the risk of a vehicle fire.



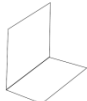

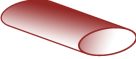
MATERIAL

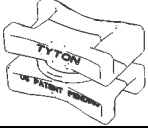
Order Kit SR15-27 which includes the following parts:

Part No.	Identification	Description	Qty
382441	① 	Box, Protective 120x122x91	1
5001305	② 	Screw, Machine Round Head PH, SS 8-32 X 3/4	1
5001137	③ 	Washer, Flat SS .203 x .438 x .05	1
500678	④ 	Nut, Well 8-32 x .450	1

382444		Washer, Foam Sealing	1
500270		Washer, Flat SS .406 x 1 x .063	1
504671		Grommet 1 x .125 x .437 x 1.312	1
5001936		Nut, Hex Nylon Insert, SS 3/8-16	1
560895		RING TERMINAL .375 / 2/0 (CLOSED END)	1
561856		BOOSTER BLOCK, REMOTE / RED	1
5001935		WSH FL SS 10.5 X 18 X 1.6 MM	1
381210		SEPARATOR / FIBERGLASS RED	1
504339		RIVET POP DOME OPEN END 1/8x3/8 SS	1
561755		SHRINK TUBING / 0.750" TO .375" / RED	50mm
563156		SHRINK TUBING / 0.700" TO 0.175" BLACK	60mm
062682	-	DECAL / "BOOSTER BLOCK" ENG & FRENCH	1
063824		BRACKET, BOOSTER BLOCK	1
504752		ROTATING SPACER, DOUBLE	1
504016		CABLE TIE / 5/16" X 14"1/2	6
503784	-	HOSE SILICONE 4PLY 2" I.D.	4"

Other parts that may be required depending on vehicle condition:

Part No.		Description	Qty
684213		COLOR GUARD	90 ml
680532		SEALANT SIKA #221 / GREY / 310ml CARTRIDGE	310ml
682175		3M 08883 RUBBERIZED UNDERCOATING (19.7 oz Can)	A/R
504793		RIVET MONOBOLT 3/16 X 7/16 SS	4
504720		GROMMET 2.375 x 3.000 x .250 x .437 x 3.250	1

Pre-heater hardware and exhaust pipe part numbers below are provided for your convenience. Charge these parts separately, outside the scope of this Recall

Part No.	Description	Qty
374143	EXHAUST PIPE ASSY W/SUPPORT	1
540061	U-CLAMP 2 3/4"	1
5001017	HEX HEAD THREAD CUTTING SCREW #10-24 X 1/2"	1
5001341	WASHER FL 8.4x17.0x1.6 SS (Pre-heater mounting)	4
502780	SCREW CAP HEX M8-1.25x25 SS (Pre-heater mounting)	4

NOTE
Material can be obtained through regular channels.

TOOLS

Use this crimping tool for the recall.

Refer to tool operation manual for instructions and safety recommendations before operating this tool.

/Service tips/Technical information by section/06-Electrical/Greenlee GATOR Crimp Tool/

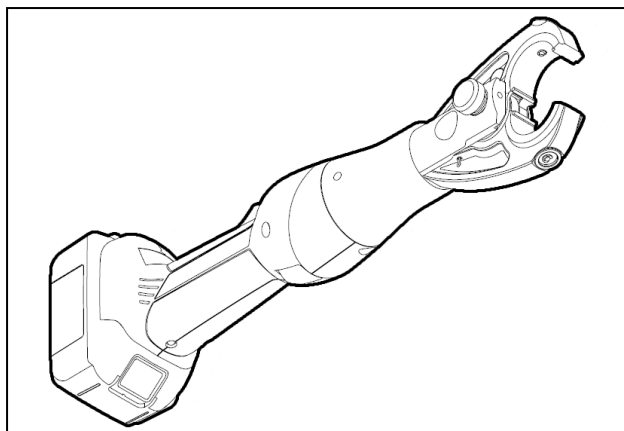

Figure 1 : Greenlee Gator®. Prevost Tool #7770144



Figure 2 : 2/0 Die. Prevost Tool #7770145

PROCEDURE



DANGER

Park vehicle safely, apply parking brake, stop engine. Prior to working on the vehicle, set the ignition switch to the OFF position and trip the main circuit breakers equipped with a trip button. On Commuter type vehicles, set the battery master switch (master cut-out) to the OFF position.



DANGER

Cable **24A** to the positive booster block *remains live* after tripping the breakers. In the main power compartment box, disconnect cables on main relay R1 *before* starting Step "A" below. (Fig 3&4)

Disconnect power source to the positive booster block.

Secure cables to avoid accidental contact.

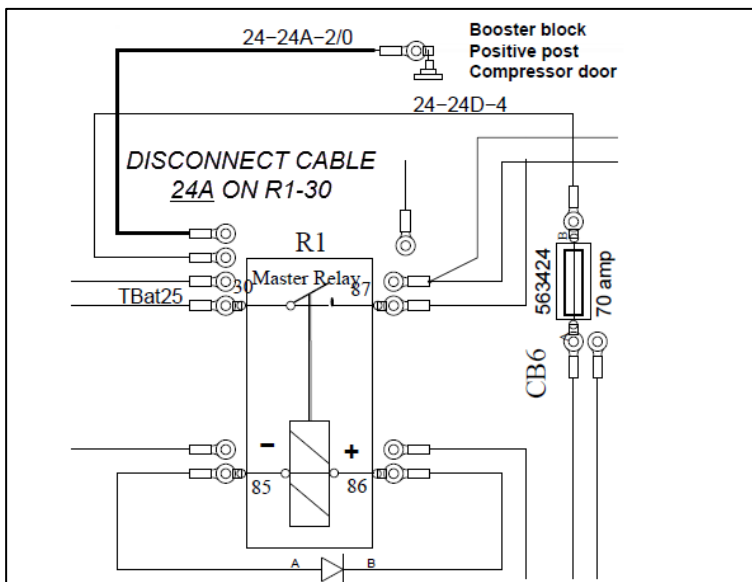

Figure 3 : 24A Cable Disconnection

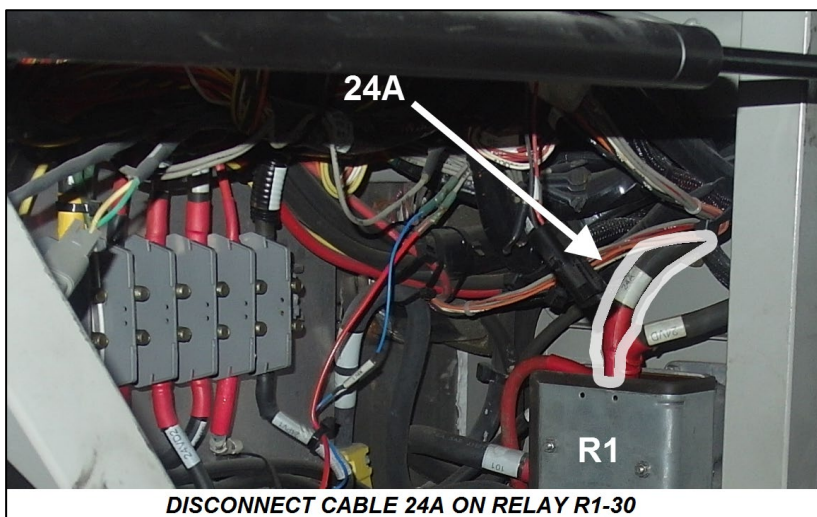

Figure 4

STEP "A" CABLE INSPECTION

If the vehicle has a **Detroit Diesel** engine *and* a **pre-heater** Proceed to step **A1** below.

If the vehicle has a **Volvo D13** engine, proceed to step **A2**.

If the vehicle **has a Detroit Diesel** engine but **no pre-heater**, start at step **A3**.

A1. Only for vehicles with ***Detroit Diesel engines and pre-heater.***

- a. Close the water heating circuit shut-off valves.
- b. Prepare a suitable container and collection gutter or hose to empty coolant at water connections on heating unit. Remove coolant connections and empty cooling system.
- c. Remove heating unit exhaust tube.

If tube and / or clamps are too corroded;
change parts.

Do not charge these parts to this safety recall, as it is outside the scope of the recall.

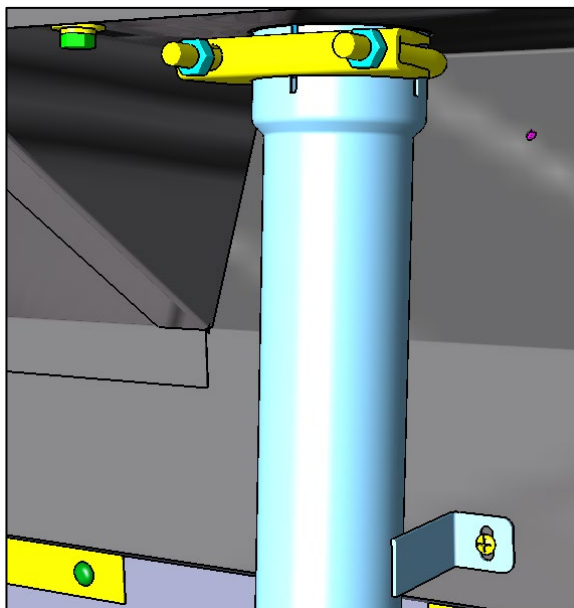

Figure 5

- d. Disconnect the fuel lines to the heater. Protect the surroundings, have a suitable container and absorbing medium close at hand to collect / dispose of any spills, according to local regulations.
- e. Proceed to step **A3**

A2. Vehicles with **Volvo D13 engine** with or without pre-heater: perform a careful visual inspection of cable and grommet condition. (Figure 6)

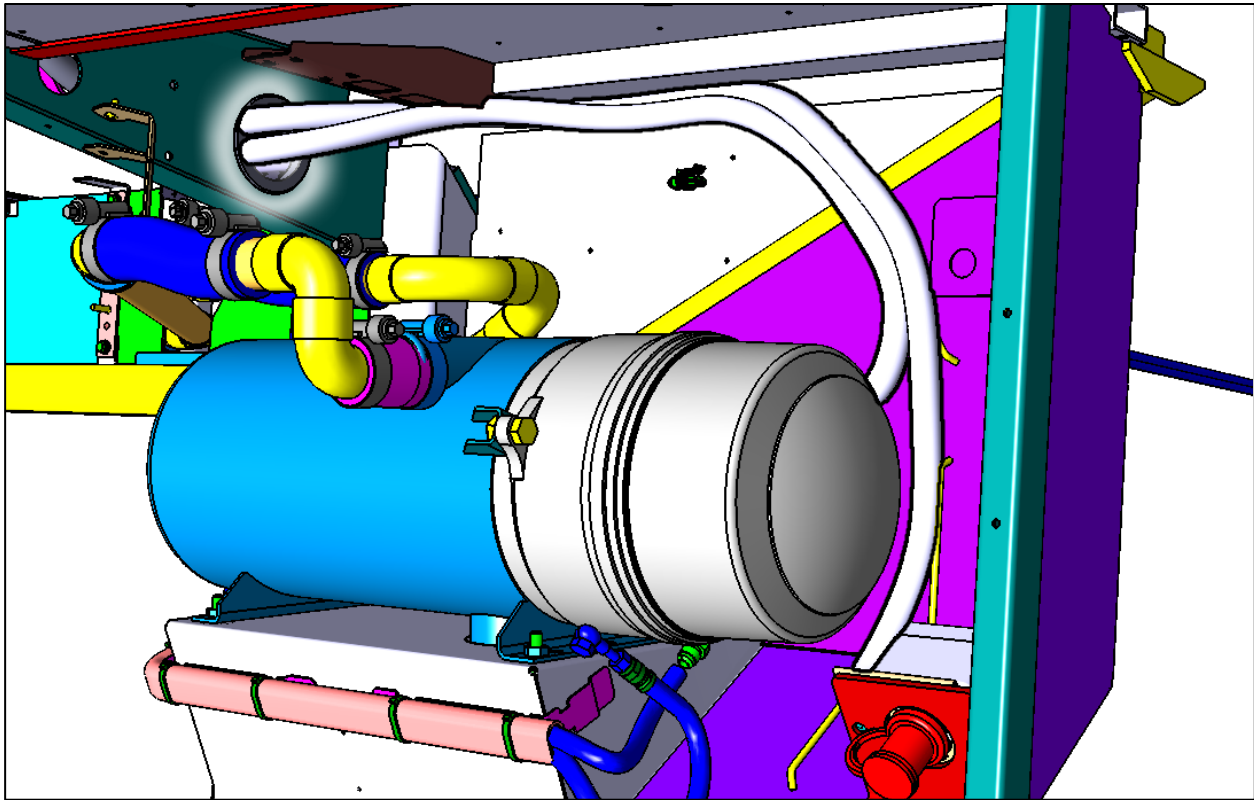

Figure 6 : Typical Volvo D13 cable routing

If cable is significantly damaged, contact a Prevest regional service manager for further instructions.

If grommet appears damaged, replace grommet with a new # 504720.

Proceed to **Step “B”**

A3. For vehicles with **Detroit Diesel** engines only: remove washroom outlet tubes to create some working space.

A4. Remove all cable ties along the wall, from the positive booster stud toward the engine up to the wall bracket on the corner.

A5. *Perform a careful visual inspection of 24A power cable condition.*

If cable is significantly damaged, contact a Prevest regional service manager for further instructions.

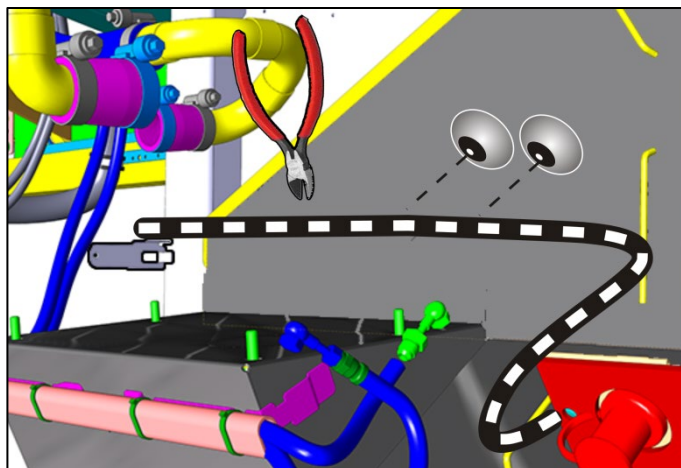

Figure 7

A6. Install a rotating spacer #504752 on the wall bracket with cable tie #504016.

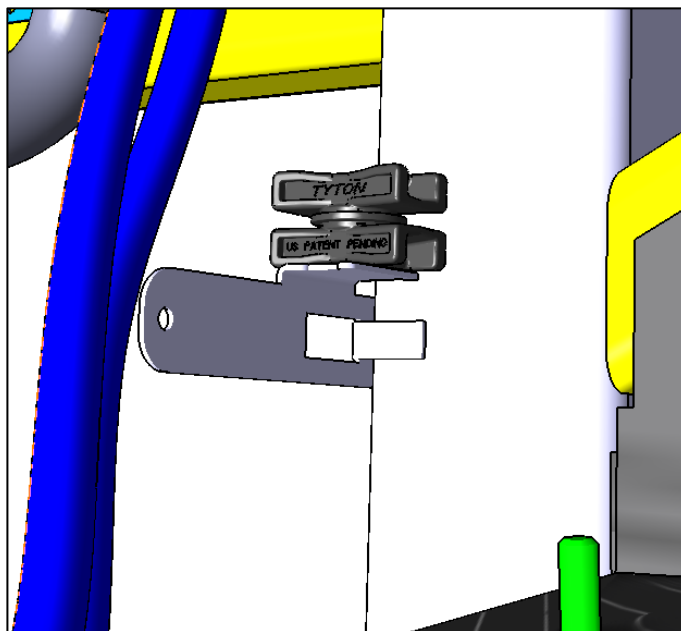

Figure 8

A7. Cut silicone tube #503784 lengthwise and wrap existing cables. Attach with cable ties.

A8. Proceed to **Step "B"**

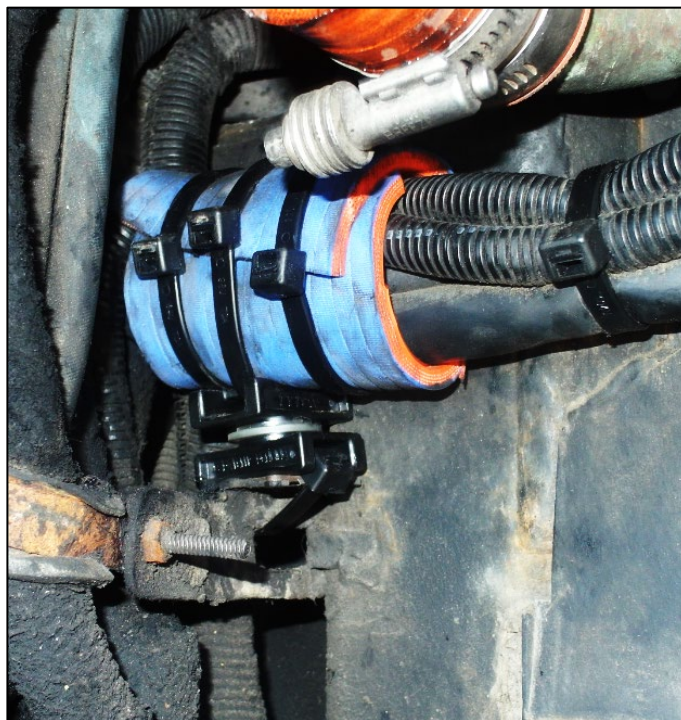

Figure 9

STEP "B" PROTECTIVE BOX

B1. Open engine compartment R.H. side door.

B2. Locate booster block positive terminal.

B3. Unfasten positive terminal block fixing nut. (8, Fig. 11) remove booster block and discard.

B4. Cut power cable just past the ring terminal where cable isolation begins. We must have clean, un-corroded copper for the new connection.

B5. After cutting the cable, look for any trace of corrosion that may have seeped up the cable. If corrosion is found, cut the cable further until good copper is found.

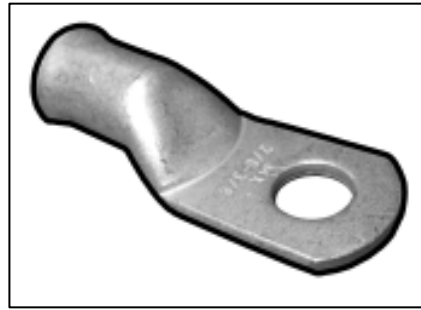

Figure 10

B6. Remove cable isolation and crimp new terminal #560895.

Note terminal orientation before crimping to make sure it is in a "natural" position so that no cable twisting is required to connect. Follow crimp tool recommendations. Perform crimp exclusively with the crimping tool Refer to "TOOLS" section at the beginning of this document.

→ Note that closed barrel terminals for 2/0 cables require two crimps according to tool instructions.



Use closed barrel terminal 560895 only.

Open barrel terminals that expose the cable strands to corrosion should not be used for this recall.

B7. Slip *black* heat shrink tube #563156 over terminal shank and cable, as close as possible from terminal (fig. 10)

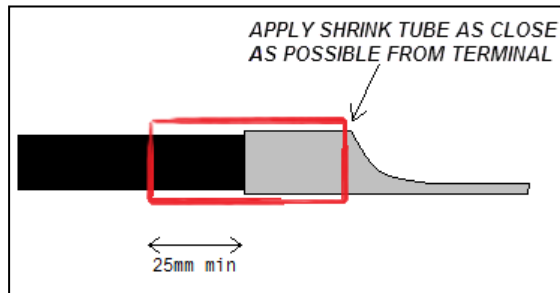

Figure 11

B8. Slip *red* heat shrink tube #561755 over black heat shrink, seal with heat gun

B9. Loosely install the newly crimped cable at original location with the new booster stud.

READ THIS BEFORE PERFORMING NEXT STEPS.

- If newly crimped cable can be easily installed in the original location without any excessive pulling: Skip directly to Step **B11**. (Keep the existing bracket)
- If cable cannot be installed in the original location: Go to Step **B10** (Remove original bracket)

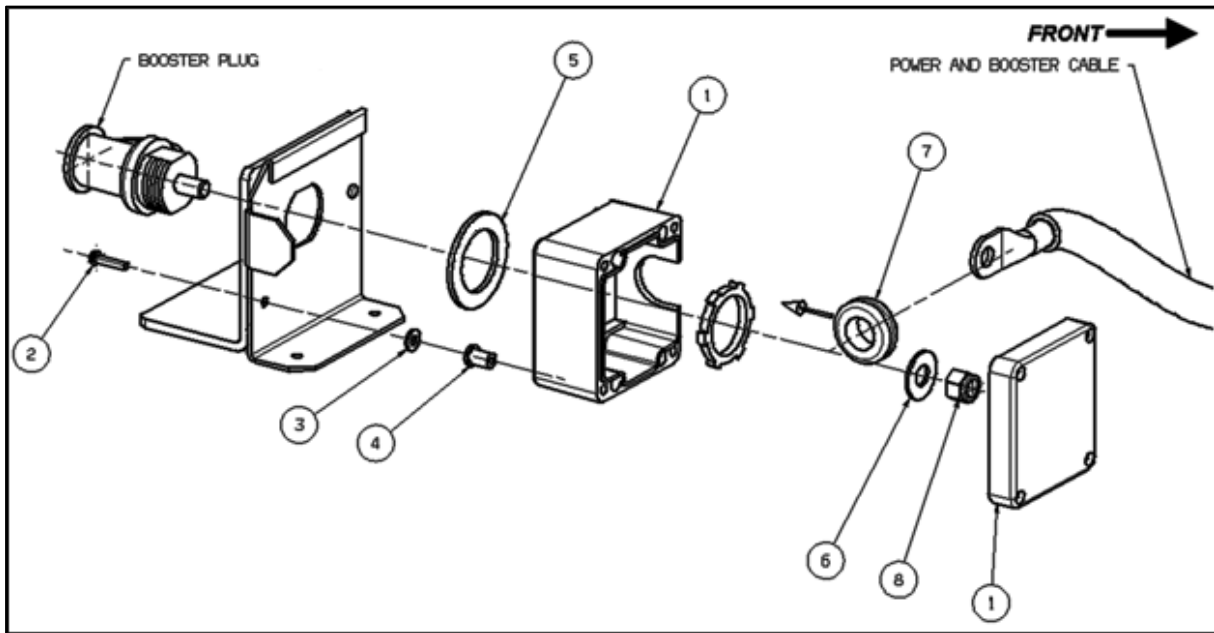

Figure 12

B10. Original bracket removal and new installation.

- a. Protect cables and hoses from projections.
- b. Remove original bracket and grind flush any remaining weld.
- c. Coat exposed metal with rubberized undercoating #682175. Refer to Appendix A for preparation and application instructions.
- d. Protect bracket #063824 with the same process. Refer to appendix A.
- e. Temporarily assemble the booster block, new support bracket and newly crimped terminal "finger tight".
- f. Slide support assembly upward along the slope and wall to find new support location.
- g. Ensure power cable has a smooth routing and no pulling is induced as a result of the new position.
- h. Mark new mounting holes.

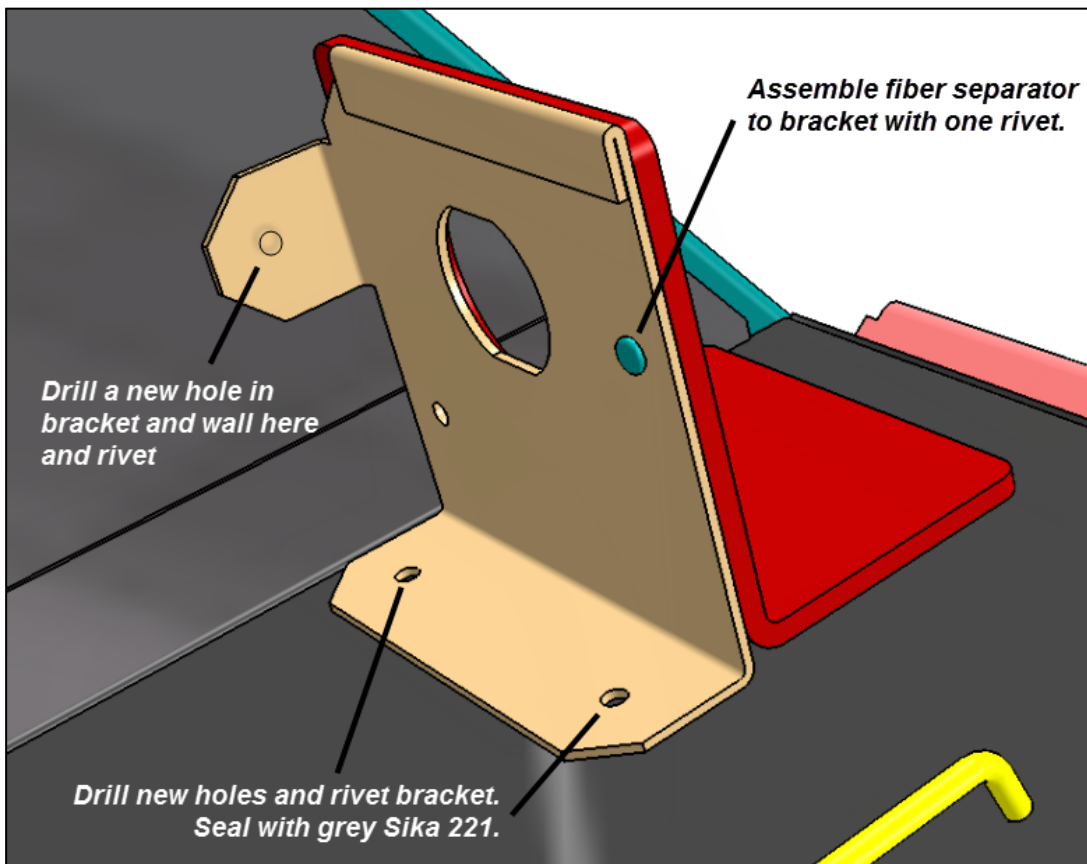

Figure 13, New Location Only: Bracket and fiber separator installation

- i. Assemble bracket #063824 and separator #381210 with one 1/8x3/8 rivet, leaving the second hole blank. (Fig 12)
 - j. Drill holes at previously marked locations and rivet support to frame with 504793 rivets (Fig. 12).
 - k. Protect exposed side with #682175 rubberized undercoating.
 - l. Drill a new hole in bracket wall tab to rivet to wall.(Fig. 12)
 - m. Apply Sika 221 #680532 to seal holes.
- B11. Insert well nut **④** #500678 in protective box lower right mounting hole. (Fig 11, 13) If using the original bracket, remove rivet in this location.
- B12. Clean the back face of the bracket to have a clean surface for the sealing foam washer.
- B13. Insert booster block #561856 through support hole, slide foam sealing washer **⑤** #382444 over and then protective box **①** #382441 making sure drip hole is at the bottom. Fasten fixing nut of booster block terminal (Refer to figure 11).

B14. Secure protective box ① to support using round head machine screw ② #5001305, flat washer ③ #5001137. (Fig. 11 & 13).

B15. Protect head with a drop of Sika 221.



Figure 14

B16. Install grommet ⑦ #504671 onto protective box side. (Fig. 14)

B17. Pass cable ring terminal through grommet ⑦.

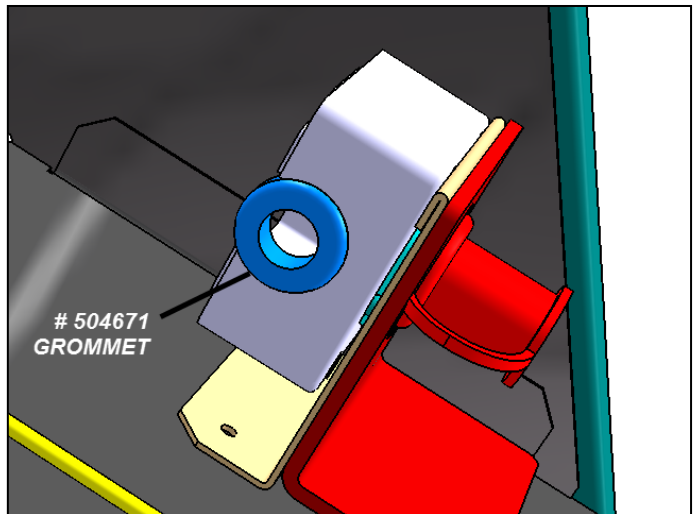

Figure 15

B18. Connect cable.

B19. Tighten to **149 lbf-in (± 28 lbf-in)**
(Ref: Eng. spec 10.2)

B20. Coat nut, post, washer, terminal and threaded booster block, stud with "Colorguard" compound. (Fig. 15)

B21. Do not block water drain hole at bottom of box with compound.

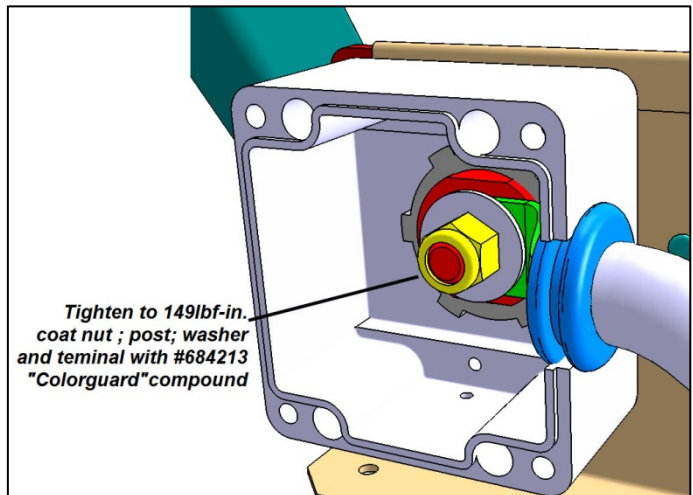

Figure 16

- B22. Install protective box cover with provided screws (Fig. 16).

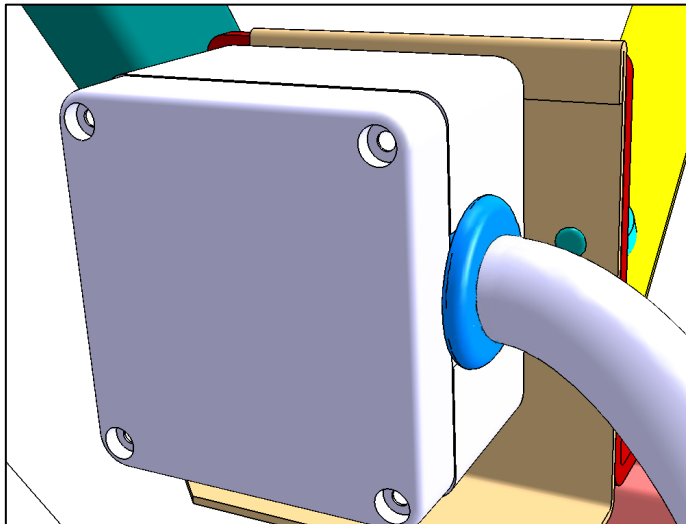

Figure 17

- B23. Re-attach cables along the wall.
B24. Re-install Pre-heater and exhaust pipe.
B25. Re-install washroom hoses.
B26. Re-connect power cables at R1 relay (fig. 3 & 4) Tighten to 15lb-ft (20N-m).
B27. Confirm proper operation of all components involved in the recall.

APPENDIX "A": #682175 UNDERCOATING APPLICATION GUIDELINES

Refer to product safety data sheet before undergoing any work.

1. *Product can be applied over bare metal or primer.*
2. *Clean and dry surface with soap and water, then with a Xylene - Naphta based general purpose adhesive cleaner.*
3. *Shake can thoroughly for 1 minute after the agitator ball begins to move.*
4. *Apply in relatively light coats, allowing for the solvent to evaporate somewhat between coats (3-5minutes). Build to desired thickness.*
5. *Dry time is typically 30 minutes at room temperature. Thicker applications may take longer to dry.*
6. *Product can be painted after 30 minutes (best to wait 1 hour). If waiting longer than 24 hours, scuff lightly before painting.*
7. *Always invert can and purge nozzle after use, to avoid nozzle clogging.*

DO NOT RETURN THE REPLACED PARTS. Discard waste according to applicable environmental regulations (Municipal/State[Prov.]/ Federal)

WARRANTY

This modification is covered by Prevost’s normal warranty. Upon receipt of a completed A.F.A we will reimburse you the parts and pertaining labor time depending on engine type and if vehicle has a pre-heater (Webasto) option or not.

We will reimburse the parts and two hours (2.0h) of labor for vehicles with **Volvo D13** engines.

OR

Parts and two hours (2.0h) of labor for vehicles having a **Detroit Diesel** engine **without pre-heater**.

OR

All parts except pre-heater exhaust parts and four hours (4.0h) of labor for vehicles having a **Detroit Diesel** engine **with pre-heater**.

Please submit claim via our Online Warranty System, available at www.prevostcar.com (under service \ warranty section). Use Claim Type: “Bulletin/Recall” and select “Safety Recall SR15-27”.

Should you only wish to close the safety recall (without reimbursement), fill-in the “Safety Recall Certification Sheet” provided with this bulletin and return it to our warranty department by Email at prevost.onlinewarranty@volvo.com or by fax at 418-831-9301.

OTHER

VBC Bulletin	N/A
Fail Code	06.00
Defect Code	09
Syst.Cond	R
Causal Part	561856

Access all our Service Bulletins on <https://secureus5.volvo.com/technicalpublications/en/pub.asp> or scan the QR-Code with your smart phone.

E-mail us at technicalpublications_prev@volvo.com and type “ADD” in the subject to receive our warranty bulletins by e-mail.





**Safety Recall
Certification Sheet
(Ref: SR15-27)**

VEHICLE SERIAL NUMBER:

2	P	C																	
---	---	---	--	--	--	--	--	--	--	--	--	--	--	--	--	--	--	--	--

PERFORMED BY		OWNER/OPERATOR	
We hereby certify that Safety Recall Instructions with regard to Safety Recall SR15-27 have been performed.			
Name: _____		Name: _____	
Addr: _____		Addr: _____	
Phone: _____		Phone: _____	
Fax: _____		Fax: _____	
Signature :	_____	Signature :	_____
Date:	_____	Date:	_____

If the information mentioned above is incorrect or you are not the owner of this vehicle anymore, please fill this section and return to sender.

NEW OWNER: _____

BUSINESS: _____

ADDRESS (including County): _____

TELEPHONE: _____ **FAX:** _____

Please return this completed document with your A.F.A. form