

# PREVOST

## Instruction Sheet

## IS-20910

### Driver Partition and Door Installation X Series

X series Coaches from L-6493

First Release

10-19-2020





### MATERIAL

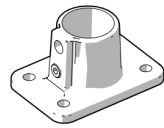
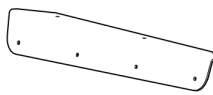
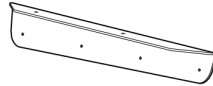
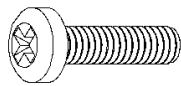

Kit #IS20910 includes the following parts:

CAD Drawing Item	Part No	Description	Qté
-	D320356	PARTITION, DRIVERS INST. DRAWING.	1
-	900062	KIT, DRIVER'S GATE	1
1	3210474	PANEL, DRIVERS	1
	217775	PLATE, BACKING	1
	329671	DECAL BLACK	1
2	329666	POST, DRIVER PARTITION ASSY / DRAWING	-

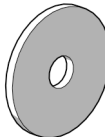
Writer:

<QF7720959 rev 5>

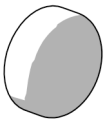
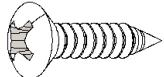
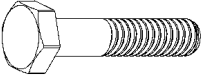
2.1	3210540	TUBE, DRIVERS		1
2.2	406601	STOP, DRIVER PARTITION DOOR		2
2.3	406602	BUSHING, DRIVER PARTITION DOOR		2
2.4	406595	HINGE, DRIVER PARTITION DOOR		2
2.5	500341	SCR SET HEXS DOG Z050 M12-1.75X20		2
2.6	5001783	SCR CAP HEXS SS M6-1.0 X 12 FT		3
2.7	502634	SCR SET HEXS CUP M6-1.0X6		5
3	5011313	FITTING, RECTANGULAR 1 5/16" I.D.		2
4	329688	SUPPORT, REAR		1
5	329687	SUPPORT, FRONT		1
6	502643	SCREW MA PAN PH Z050 8/32X1 1/4		4
7	500240	WASHER, LOCK, EXT Z050 .195X.410X.025 (M4,#10)		8
8	500855	WASHER FL N500 .188X.438X.049 (M4,#10)		19
9	504399	CAP TRIM WASHER, # 10 SCREW		19
10	500805	WASHER FL N500 .218X.875X.062 (M5,#10)		16
11	500501	NUT HEX CAP SS 8-32		4
12	900251	BUSHING, PARTITION MOUNTING		32

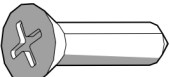
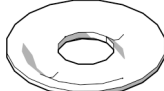
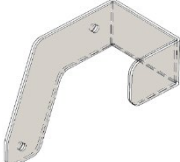
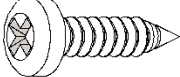
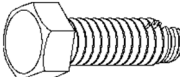
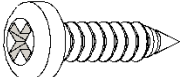
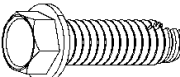
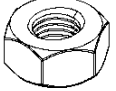
13	504400	CAP TRIM, BLACK 12GA. SCREW		19
15	500436	SCREW TP OV PH Z050 #10X2		6
16	505539	SPACER 13 X 8 OD X 5.3 ID		14
17	N74588	SCREW CAP HEX SS 1/4-20X2"		4
18	329665	TUBE SLEEVE		2
19	500626	SCREW TP OV PH Z050 #8X3/4		4
20	500464	WASHER FN CKF .220X.615 (M4,#8)		4
23	3210494	SUPPORT, GUARD ASSY.		1
25	500637	SCREW TP PAN PH Z050 #8X1 1/2		6
26	500948	SCREW TC HEX Z050 1/4-20X1		4
207	500642	SCREW TP PAN PH Z05010X3/4		3
-	500625	SCREW TC HEXF Z050 1/4-20X2		4
	500770	NUT HEX STOVER 1/4-20 Z050		4
	FI-20910	Feuille d'instructions		1

	IS-20910	Instruction Sheet	1
--	----------	-------------------	---

Other parts that may be required:

Part No.	Description	Qty
680038	LOCTITE 243 50 ML.	A/R
680042	LOCTITE 430	A/R

**NOTE**

Material can be obtained through regular channels.

## PROCEDURE



### DANGER

Park vehicle safely, apply parking brake, stop engine. Prior to working on the vehicle, set the ignition switch to the OFF position and trip the main circuit breakers equipped with a trip button. On Commuter type vehicles, set the battery master switch (master cut-out) to the OFF position.

Lock out & Tag out (LOTO) must be performed during set-up, maintenance or repair activities. Refer to your local procedure for detailed information regarding the control of hazardous energy.

**NOTE**

Use Loctite 243 everywhere except on hardware having Stover type nuts.

**NOTE**

Before starting work, protect LCD monitors, vehicle flooring around the aisle and steps as well as the driver's seat.

Keep protecting paper on the partition until the end of the procedure.

**NOTE**

This procedure requires welding. Contact your Prevost service representative. Refer to maintenance manual SECTION 00 for guidelines on welding.

### Procedure overview.

A reference CAD drawing is available at the end of this document.

Remove any infotainment screen under the parcel rack in this location. The screen will have to be removed or relocated.

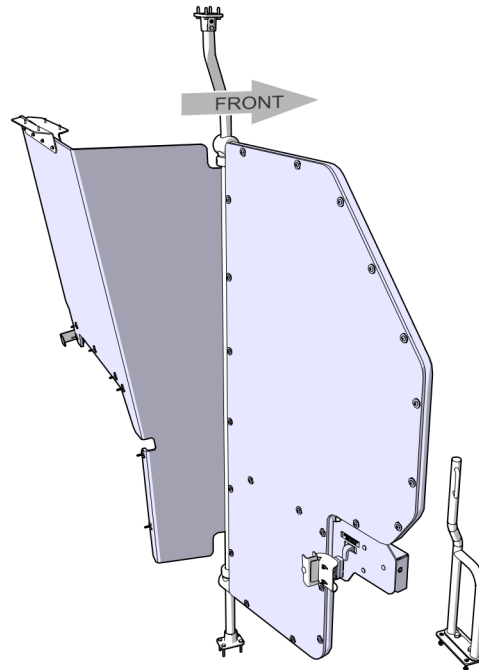

FIGURE 1 : INSTALLATION OVERVIEW

1. Peel off protective film locally, to gain access to mounting holes.
2. Pre-install rubber bushings **#900251** (2 / hole) in each hole on the panel.
3. Bond the bottom right bushings to panel with **#680042** Loctite 430 *glue*.

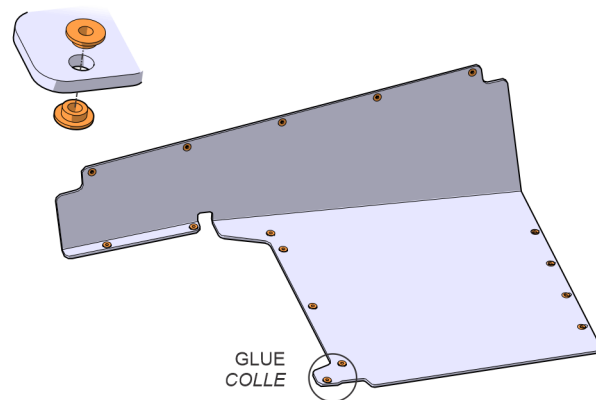

FIGURE 2

#### Panel preparation

4. Install a band of black decal **#329671** in the inside corner of the transparent panel.

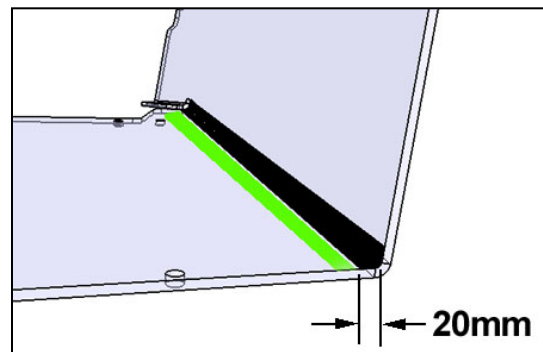

FIGURE 3

5. Loosely install the upper brackets **#329687** and **#329688** to the panel, using:

**#502643** Pan head screw 8-32X1 1/4

**#500855** Flat washer, 7/16" OD

**#504399** Snap cap washer

**#500805** Flat washer, 7/8" OD

**#505539** Spacer

**#500240** Lock washer, ext. tooth (2X)

**#500501** Cap nut 8-32

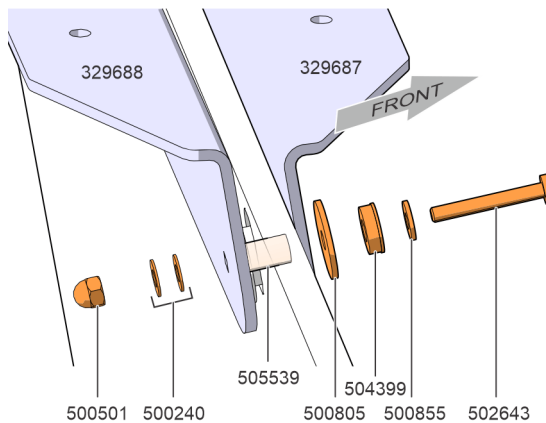

FIGURE 4

6. Place support **#3210494** on modesty panel.

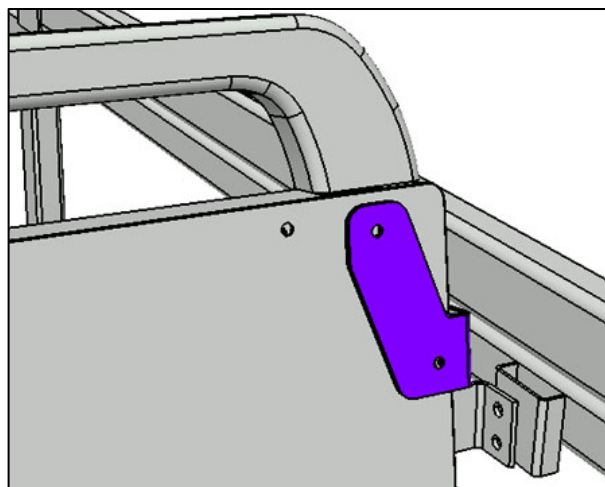

FIGURE 5

7. Request a helping hand from a teammate.  
8. Position panel in place using two taper punches placed in the modesty panel holes.



FIGURE 6

### Panel installation

**IMPORTANT NOTE:**

*Before final tightening of the panel, check passenger window blind operation. Adjust panel position to minimize interference with window blind.*

9. Move panel in place and use a center punch to locate holes.
10. Install with the following hardware
  - #505539** Bushing
  - #500805** Flat washer, 7/8" OD
  - #504399** Snap cap washer
  - #500855** Flat washer, 7/16" OD
  - #500637** #8 Pan head screw 1 1/2" lg
  - #504400** Cap

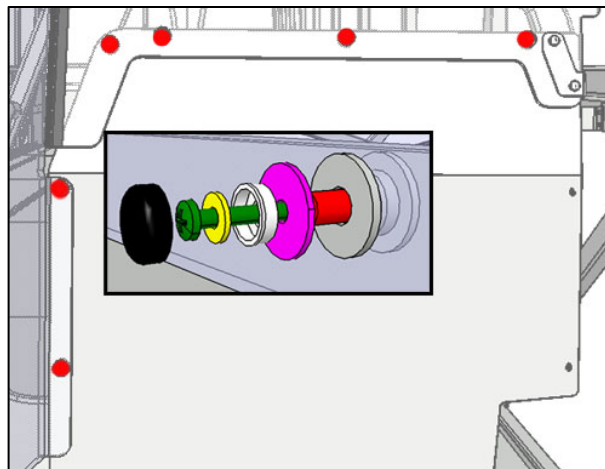

FIGURE 7

11. Use following hardware on the support
  - #500805** Flat washer, 7/8" OD
  - #504399** Snap cap washer
  - #500855** Flat washer, 7/16" OD
  - #500637** #8 Pan head screw 1 1/2" lg
  - #504400** Cap, black

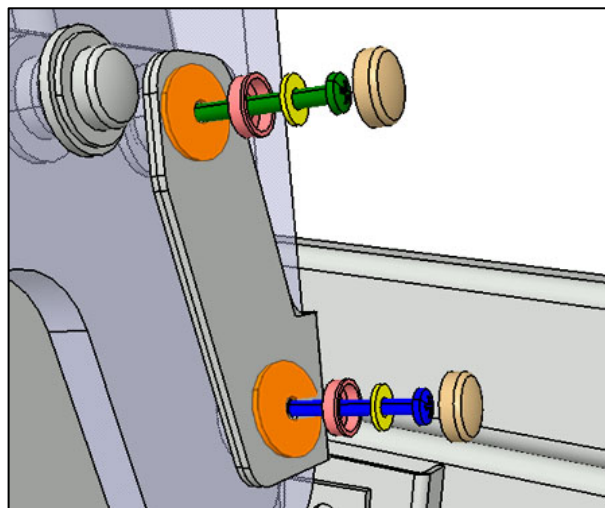

FIGURE 8

### Post preparation

12. Remove the upper setscrew from post base **#5011313**
13. Insert Split sleeve **#329665** slit at 90deg from setscrew for better grip.

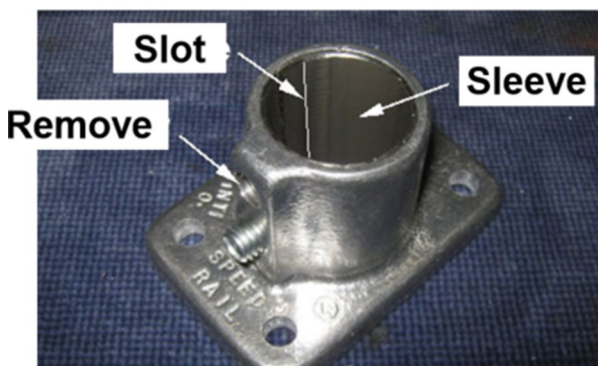

FIGURE 9



14. Slide post into bases

*Note orientation.*

*Upper: setscrew towards center of vehicle.*

*Lower: setscrew towards the front.*

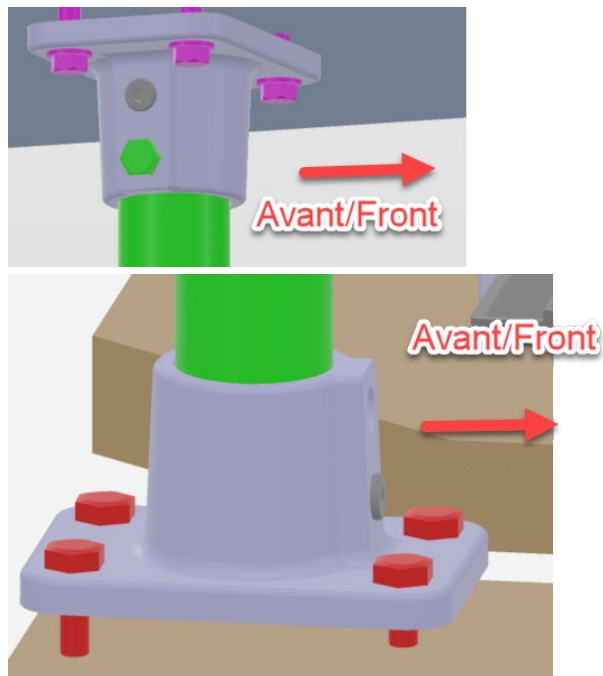

FIGURE 10

15. Secure the panel to the post. (5X)

Use the following hardware:

**#505539 (5X)** Bushing

**#500805 (5X)** Flat washer, 7/8" OD

**#504399 (5X)** Snap cap washer

**#500855 (5X)** Flat washer, 7/16" OD

**#500436 (5X)** #10 Oval head Screw 2" lg

**#504400 (5X)** Cap, black

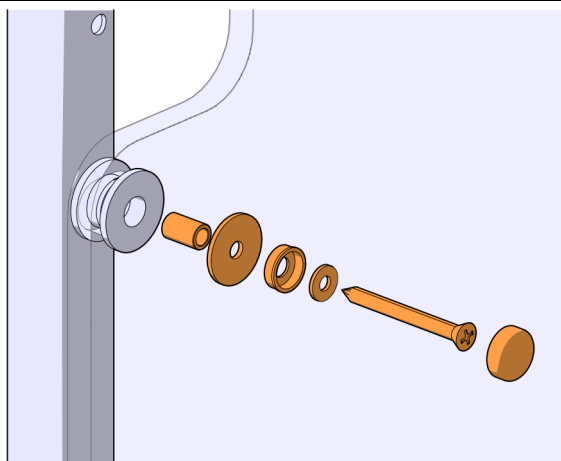

FIGURE 11

16. Locate the lower section of the post.

17. Drill two 7/32" holes through wooden floor to reveal post location for next step.

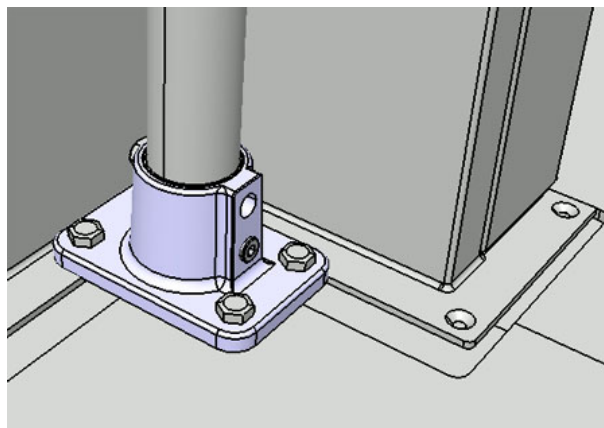

FIGURE 12

18. Lower the front bumper.
19. Place backing **#217775** plate on vertical tube and tunnel wall.
20. Temporarily glue backing plate under door post holes.

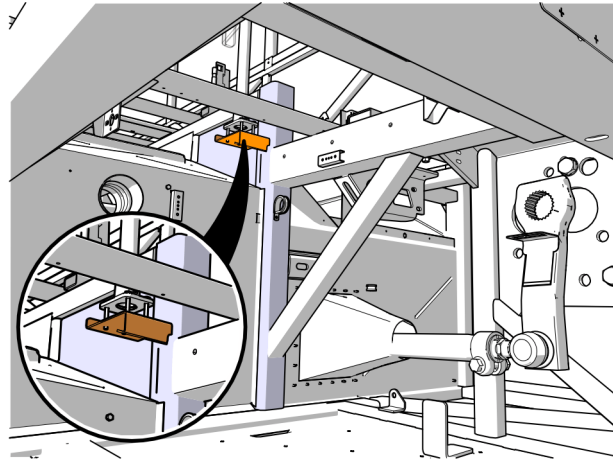

FIGURE 13

21. Get in touch with your Prevest service representative.
22. Carry out MULTIPLEX MODULE DISCONNECTION PROCEDURE PRIOR TO WELDING available in Section 00 of maintenance manual.
23. Place thermal protection blankets to protect components, hoses and wires in the area.
24. Open front electrical compartment. Ensure adequate positive ventilation.
25. Have a qualified welder weld backing plate 217775 under the floor.

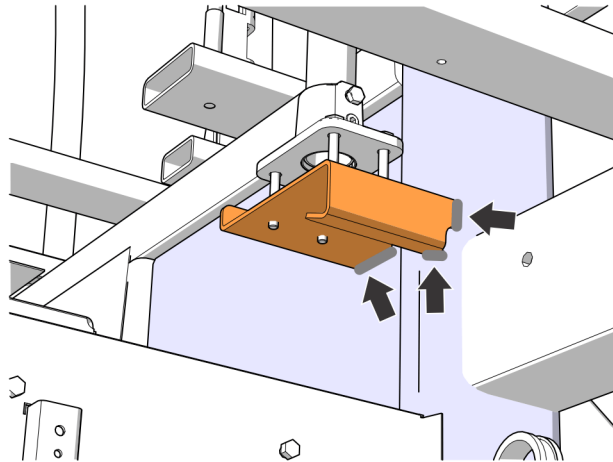

FIGURE 14: WELD BEAD PLACEMENT

26. Drill 4x 1/4" holes through all including backing plate.
27. Install post with **#N74588** 1/4-20 SS hex screws and **#500770** Stover nuts.

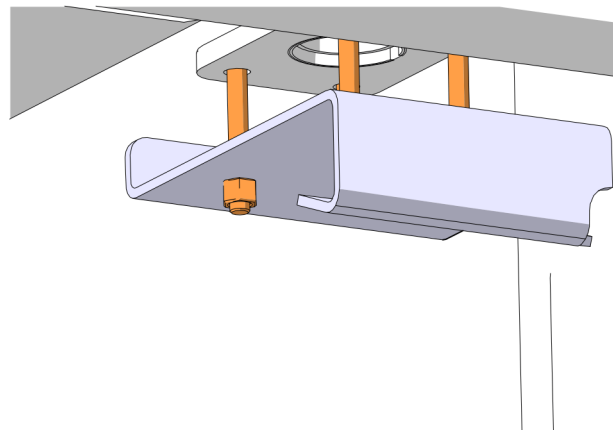

FIGURE 15

28. Locate the upper section of the post.
29. Drill 4x 7/32" pre holes
30. Use 4 **#500625** 1/4-20 self-tapping hex flange screws to tap the holes. Discard tapping screws.
31. Install post with **#500948** 1/4-20 hex screws.

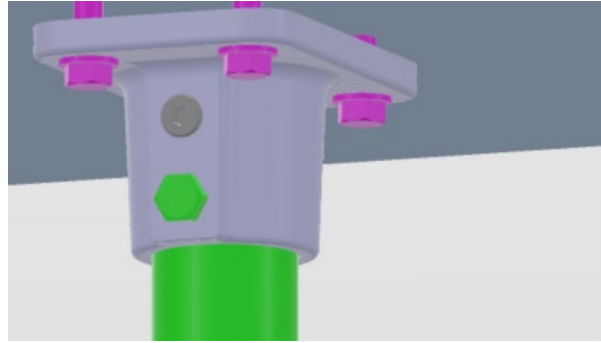

FIGURE 16

32. Install top panel brackets A=376mm±6
33. Use:
  - #500464** Countersink washer
  - #500626** Oval head screw #8 x 3/4

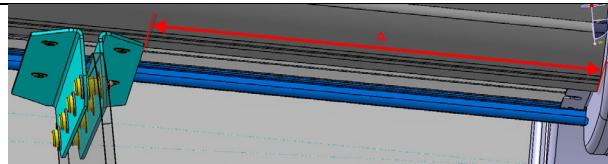

FIGURE 17

34. Tighten panel to brackets.
35. Add caps **#504400**

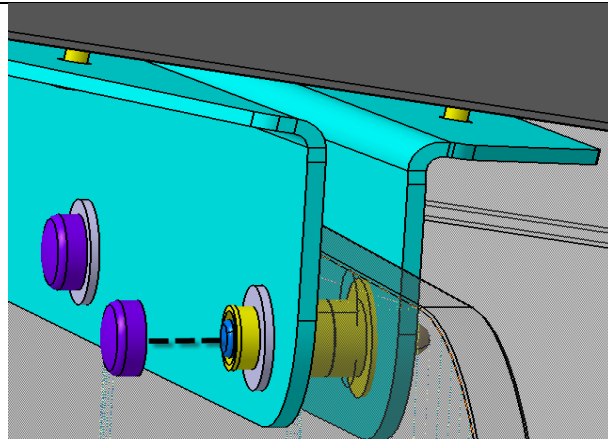

FIGURE 18

36. Install door on the post hinges.

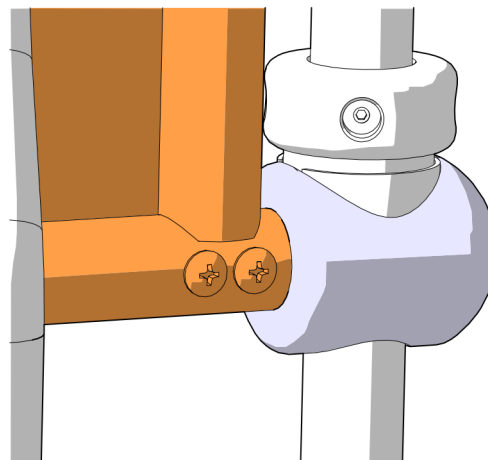

FIGURE 19

**\*\*Lower hinge only\*\***

37. Unscrew the three set screws.
38. Re-install set screws with Loctite 243.

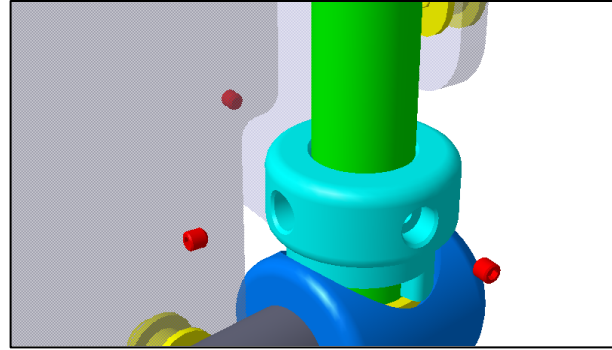

FIGURE 20

39. Door should not turn open by its own upon a sudden stop. Adjust pressure balls if required.

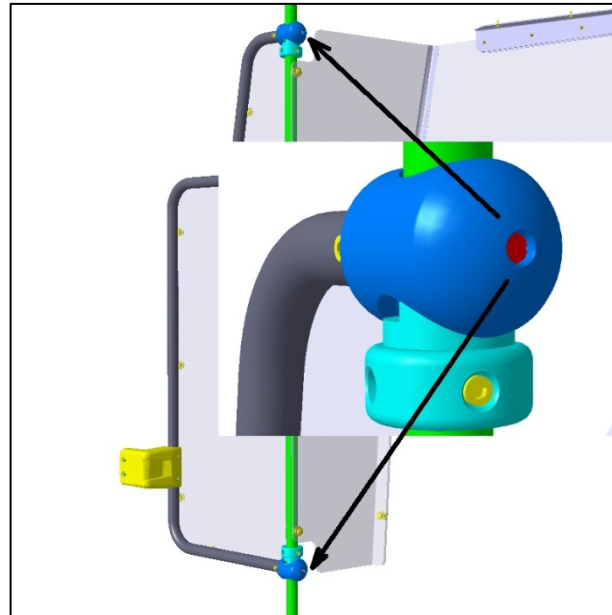

FIGURE 21

40. Catch assembly. Do not tighten yet!

**#406192** (1X) Catch support

**Female catch** (comes with door assembly)

**#500964** (4X) Washer 0.500 OD

**#500767** (2X) Nut 10-24

**#500387** (2X) Screw, 10-24 x 3/4

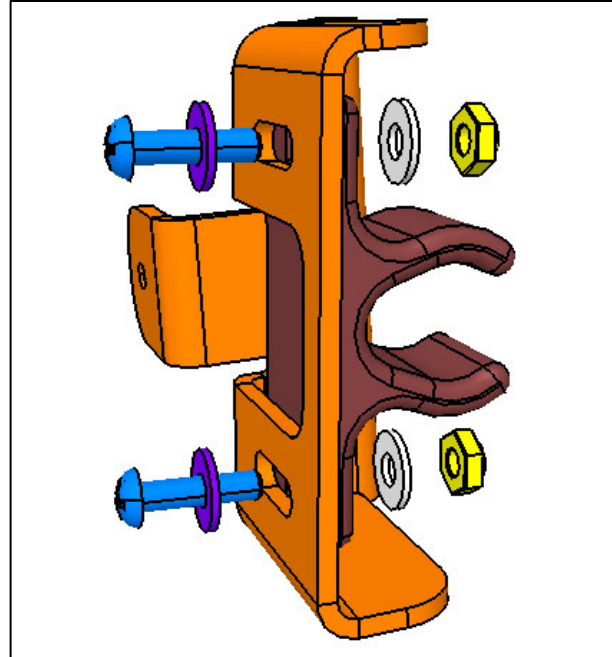

FIGURE 22

41. Close the door and align female catch.

42. Drill 1/8"

43. Assemble on handrail with following hardware:

**#504399** (3X) Snap cap washer

**#500855** (3X) Flat washer, 7/16" OD

**#500642** (3X) Screw, #8 x 3/4

**#504400** (3X) Cap, black

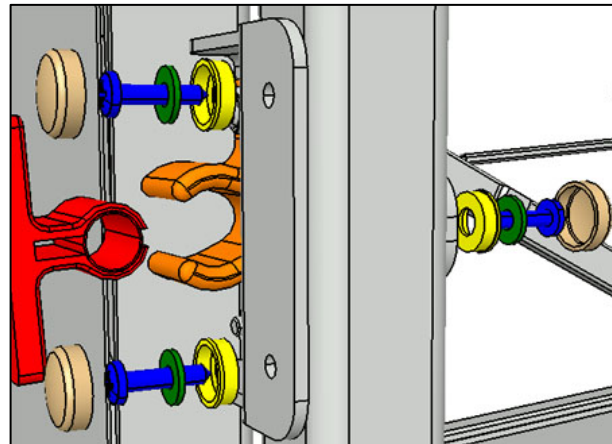

FIGURE 23

44. Close door.

45. Tighten the female catch assembly.

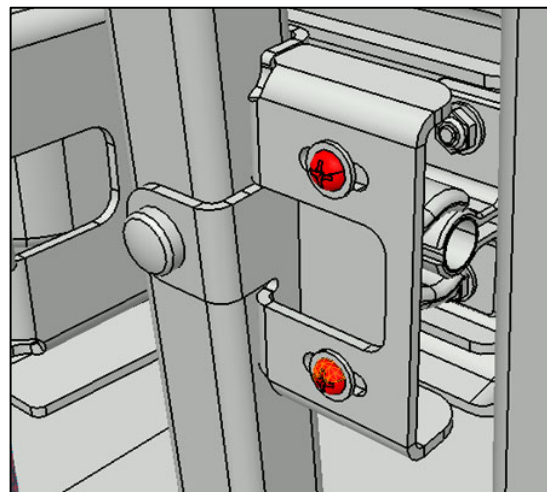

FIGURE 24

46. Using a fisher's scale (hanging scale)  
Door should open with a force of 40 to 45 pounds.
47. Turn adjusting screw accordingly.

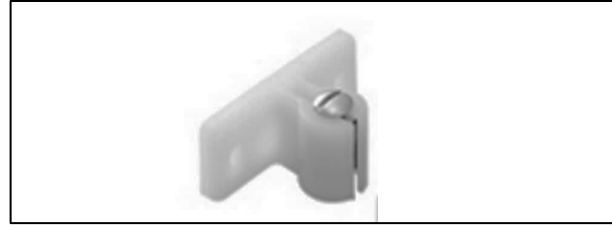

FIGURE 25

48. Install post as shown in figure. Adjust position to fit with door. Mark position.
49. Front holes: drill  $\text{Ø}7/32''$ .
50. Use two temporary self tapping screws #500625 to tap the holes.
51. Install provided screws. Rear holes drill  $\text{Ø}1/4''$
52. Install T-nut underneath.
53. Install provided screws.
54. Test door operation. Adjust accordingly.

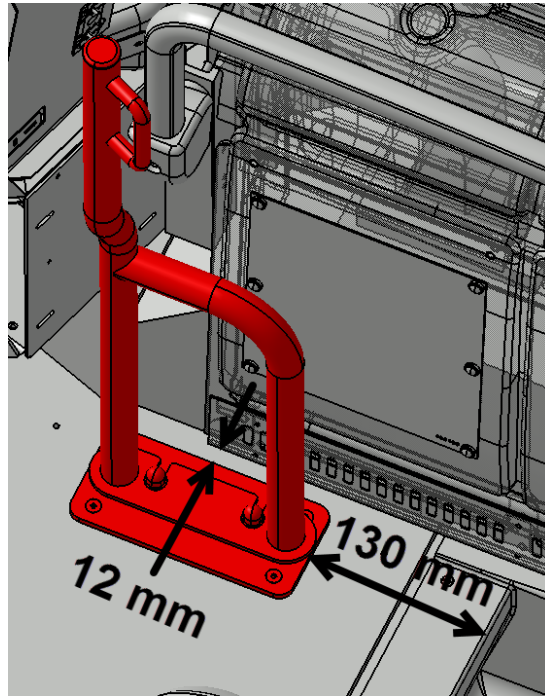
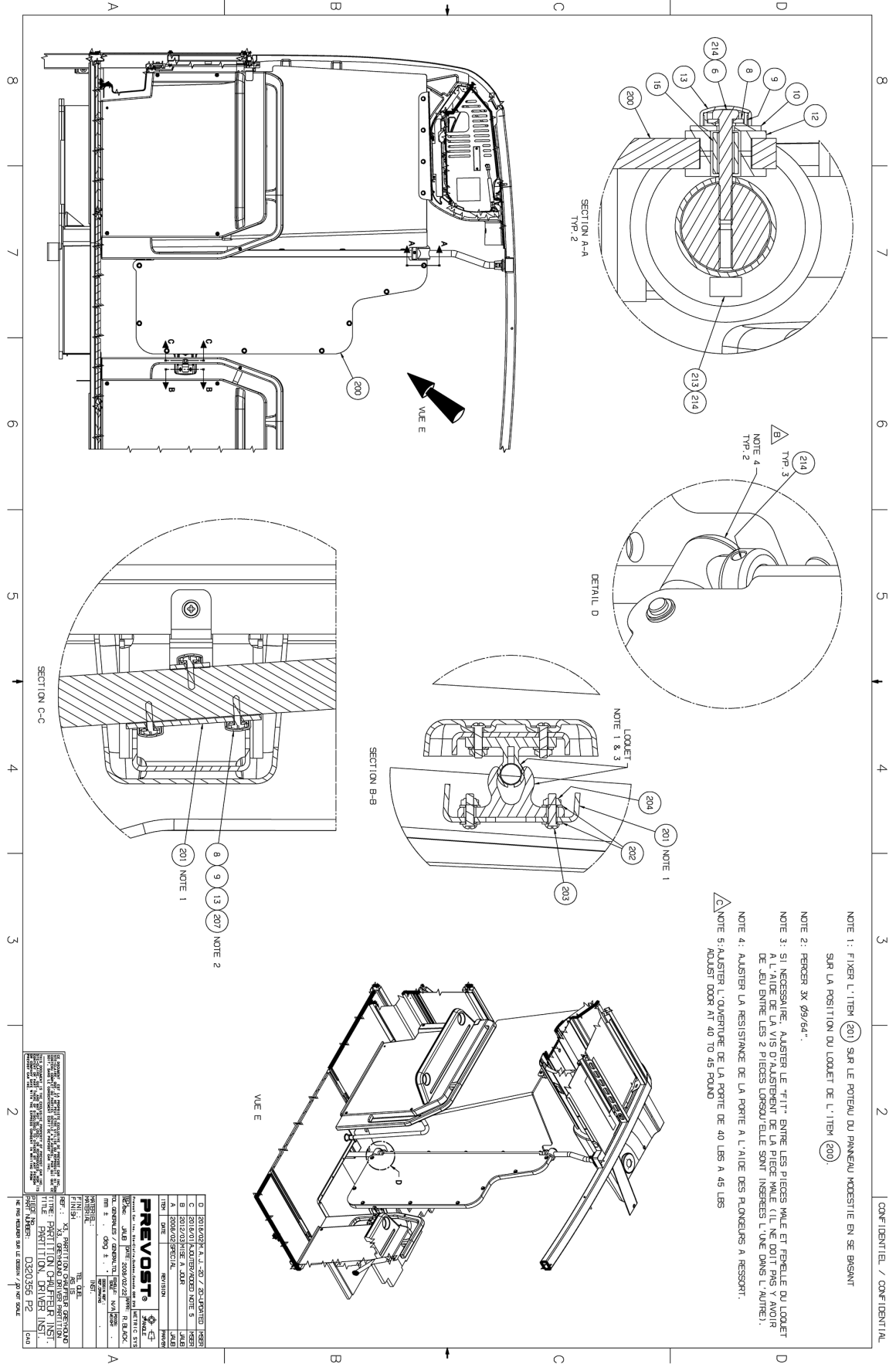

FIGURE 26

## PARTS / WASTE DISPOSAL

Discard waste according to applicable environmental regulations (Municipal/State[Prov.]/ Federal)





CONFIDENTIAL / CONFIDENTIAL

REV	DESCRIPTION	DATE	BY	CHK
C	REVISION 11.25.27 2012/01/27			
B	REVISION 11.25.27 2012/01/27			
A	REVISION 11.25.27 2012/01/27			

PREVOST®

Writer:

<QF7720959 rev 5>



