

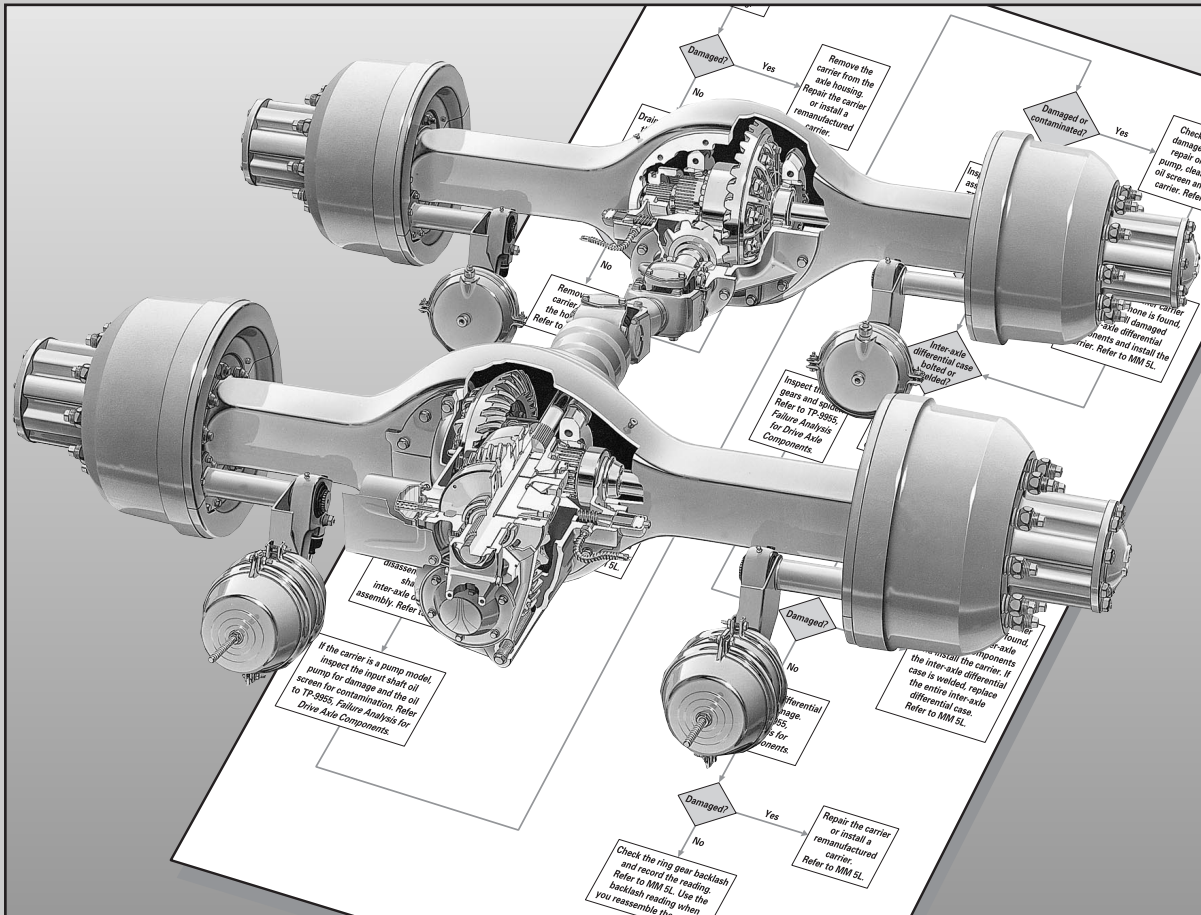

MERITOR™
A Heritage of Rockwell Technology

TECHNICAL BULLETIN

Forward and Rear Axle Carrier Diagnostic Flowcharts



Introduction

How to Use This Publication

Refer to the following diagnostic flowcharts to help you determine the source of axle differential carrier complaints.

Before you use the flowcharts, investigate the axle carrier complaint and confirm that the problem involves the carrier.

To locate the correct flowchart, refer to the following tables.

Forward Tandem Carrier

Flowchart	Page
Vehicle Will Not Move	2
Differential Making Noise	4
Oil Leak	6

Rear Tandem or Single Carrier

Flowchart	Page
Vehicle Will Not Move	7
Differential Making Noise	8
Oil Leak	9

All Rear Axles

Flowchart	Page
Contaminated Lubricant Found During Preventive Maintenance	10

Performing the Diagnostic Procedures in This Bulletin

Refer to the following publications when you perform the diagnostic procedures in this bulletin.

- *Lubrication*
Maintenance Manual No. 1
- *Single Reduction Differential Carriers*
Maintenance Manual No. 5
- *Single Reduction Rear Differential Carriers*
Maintenance Manual No. 5A
- *Tandem Axle Forward Carriers and Single Axle Carriers* — Maintenance Manual No. 5E
- *Single Reduction Forward Differential Carriers on Tandem Axles* — Maintenance Manual No. 5L
- *Failure Analysis for Drive Axle Components*
Manual No. TP-9955

To order copies of these publications or a CD version of the diagnostic flowcharts (TP-99113), call Meritor's Customer Service Center at 800-535-5560.

Forward Tandem Carrier

Vehicle Will Not Move

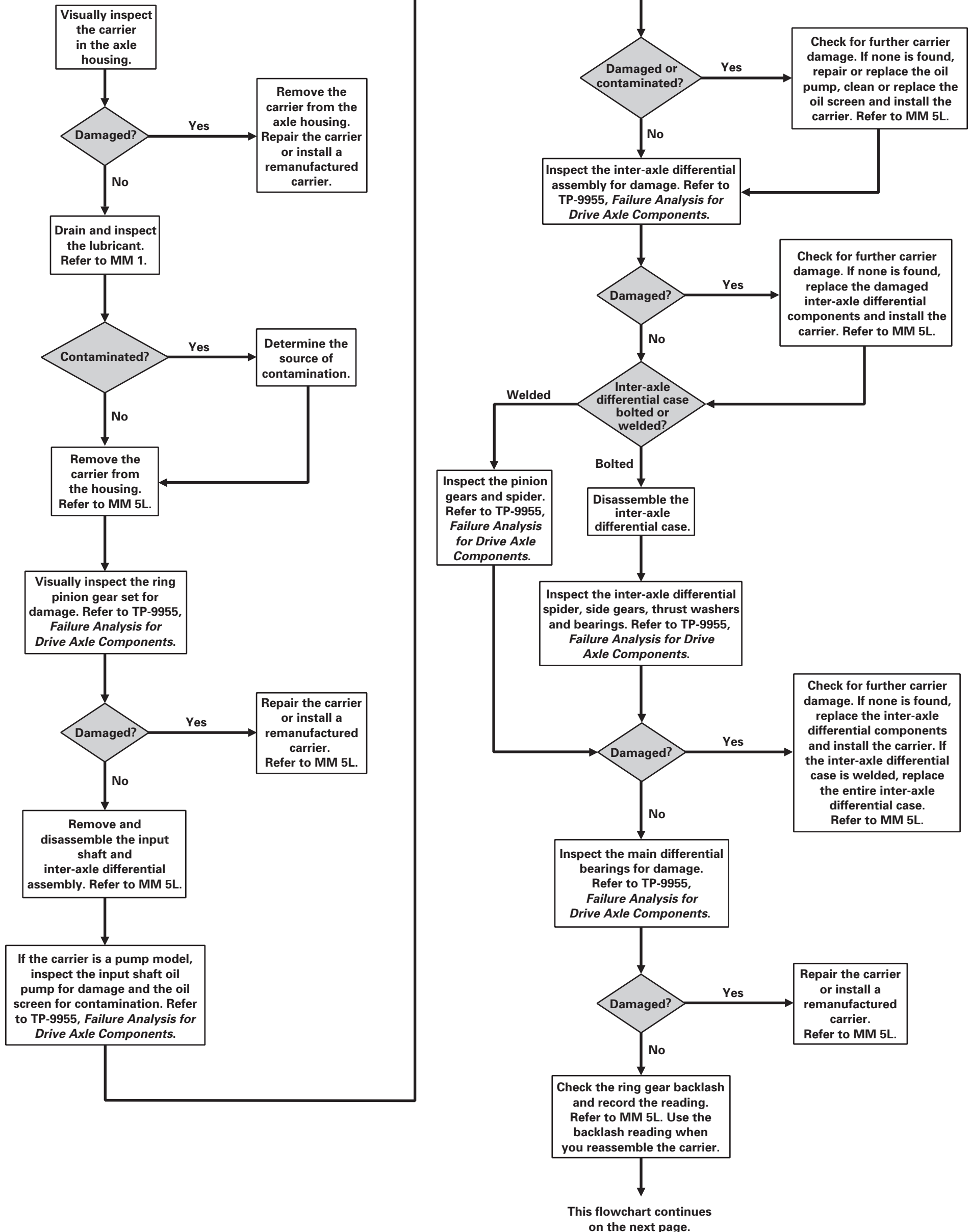

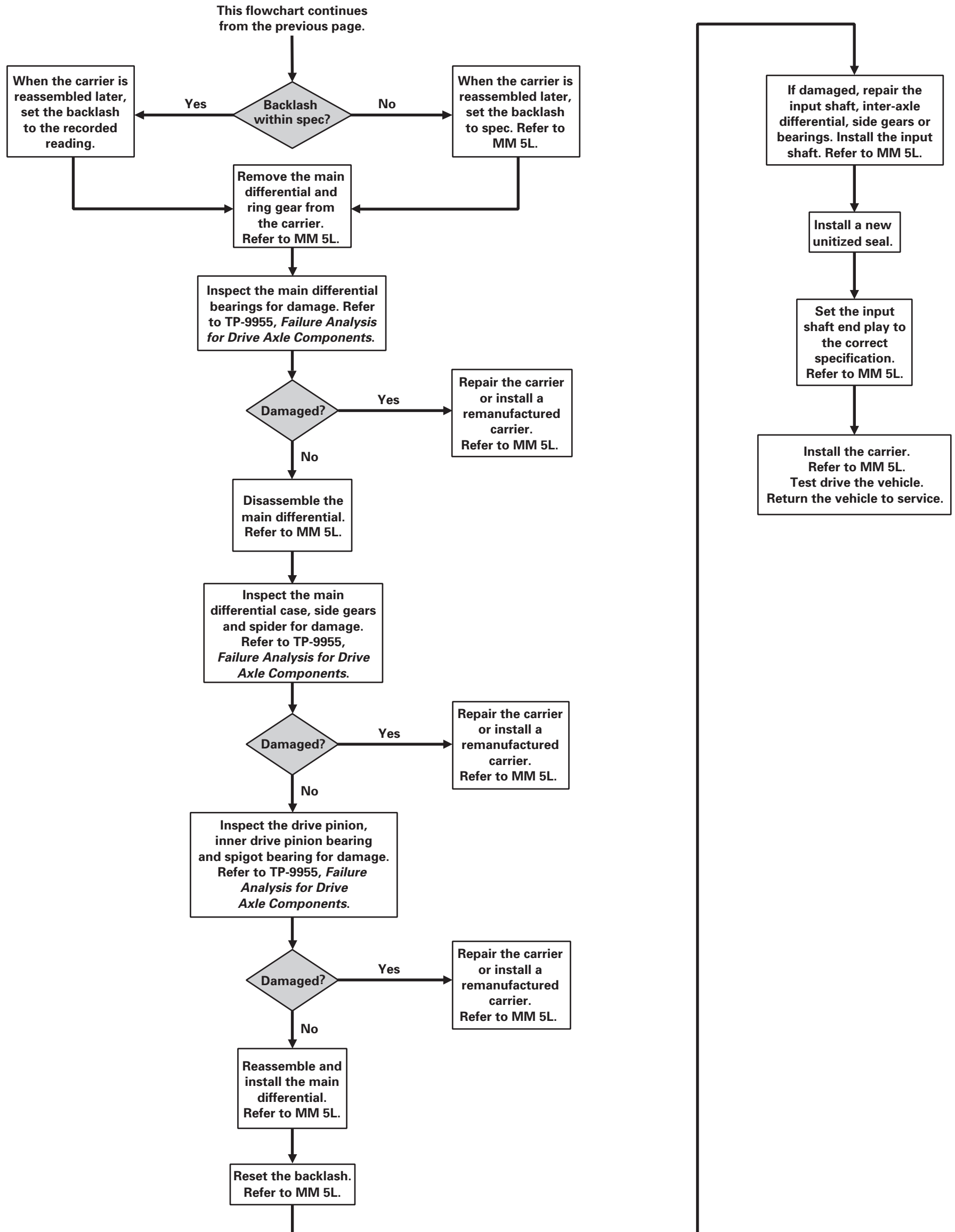

Forward Tandem Carrier

Differential Making Noise

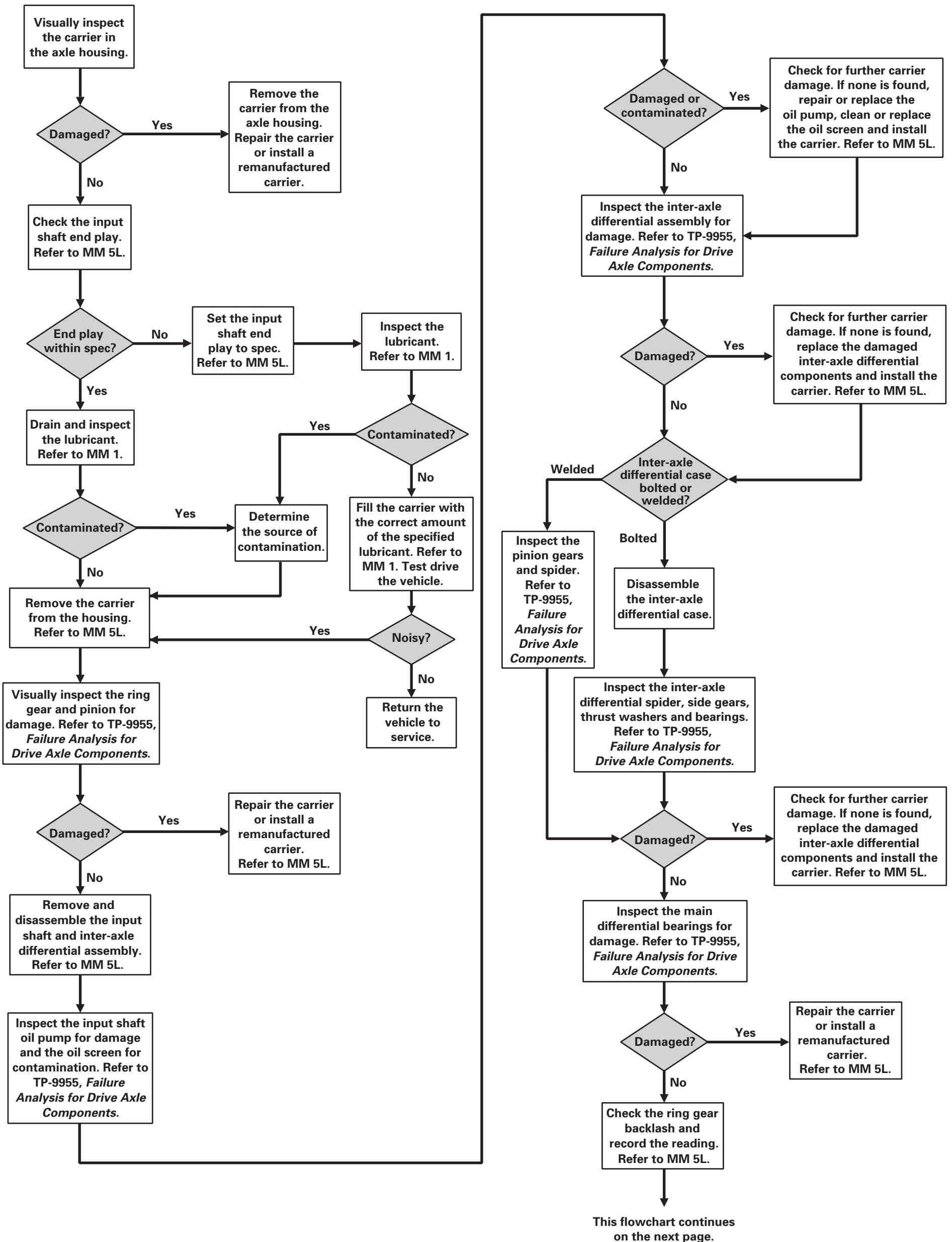

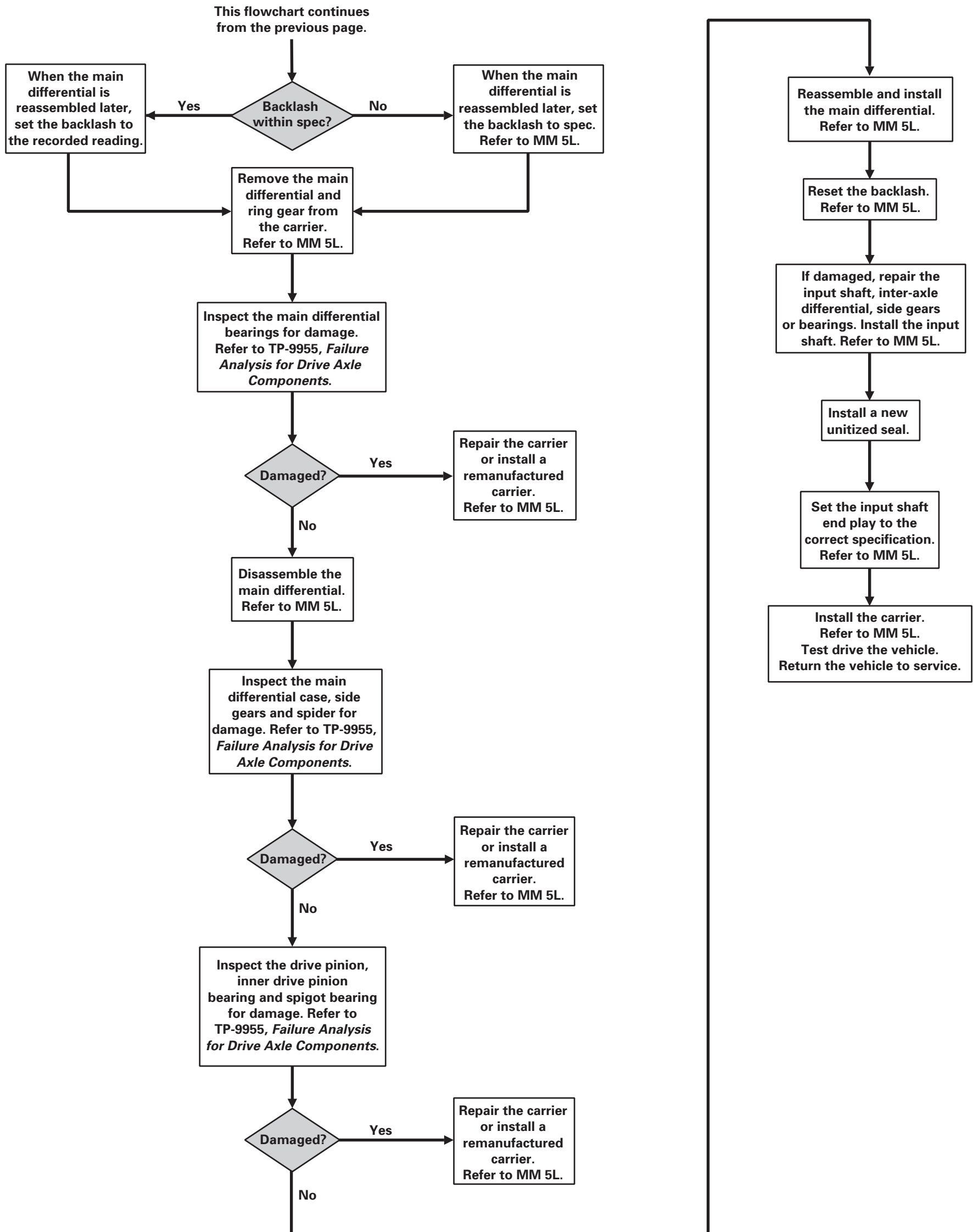

Forward Tandem Carrier Oil Leak

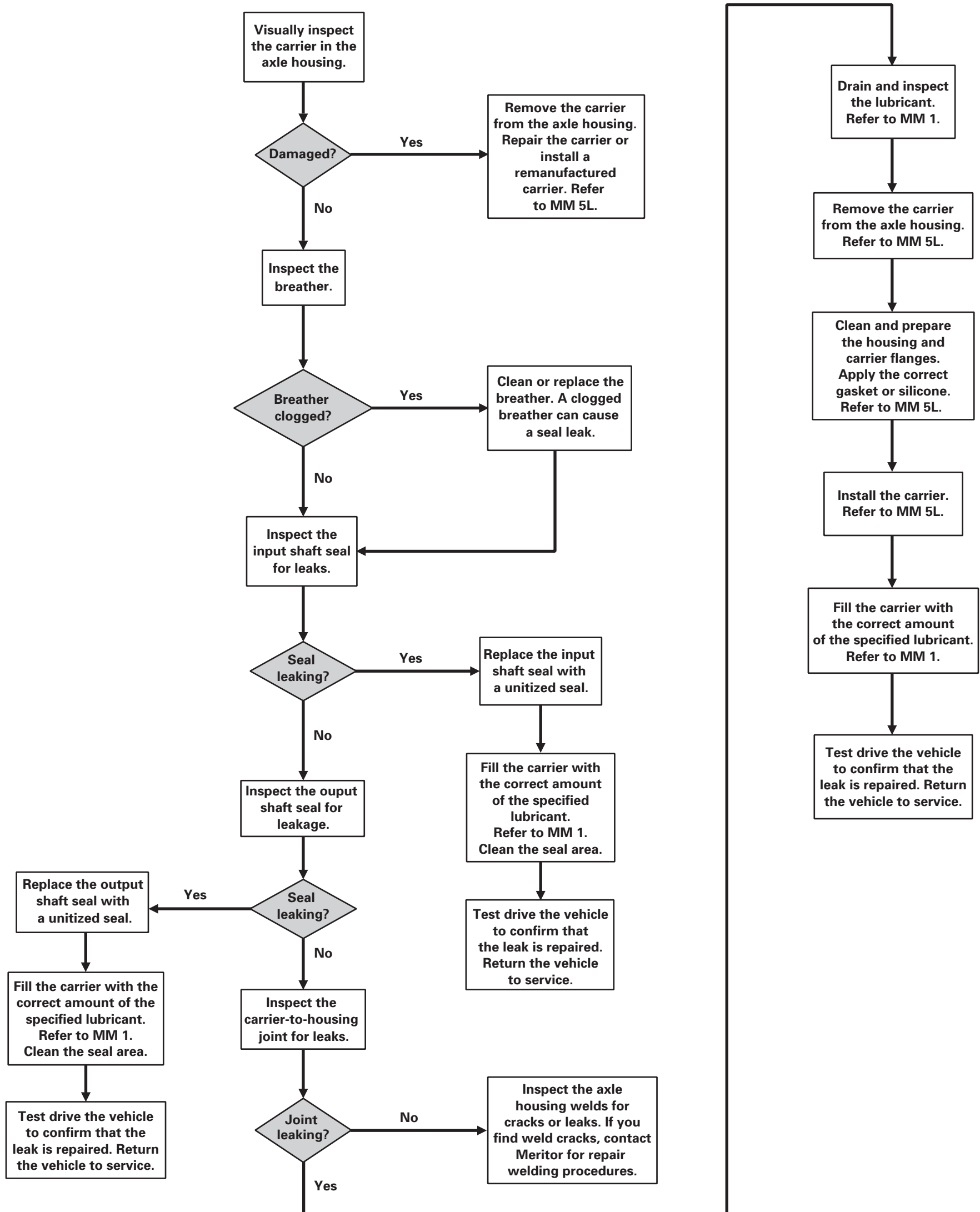

Rear Tandem or Single Carrier Vehicle Will Not Move

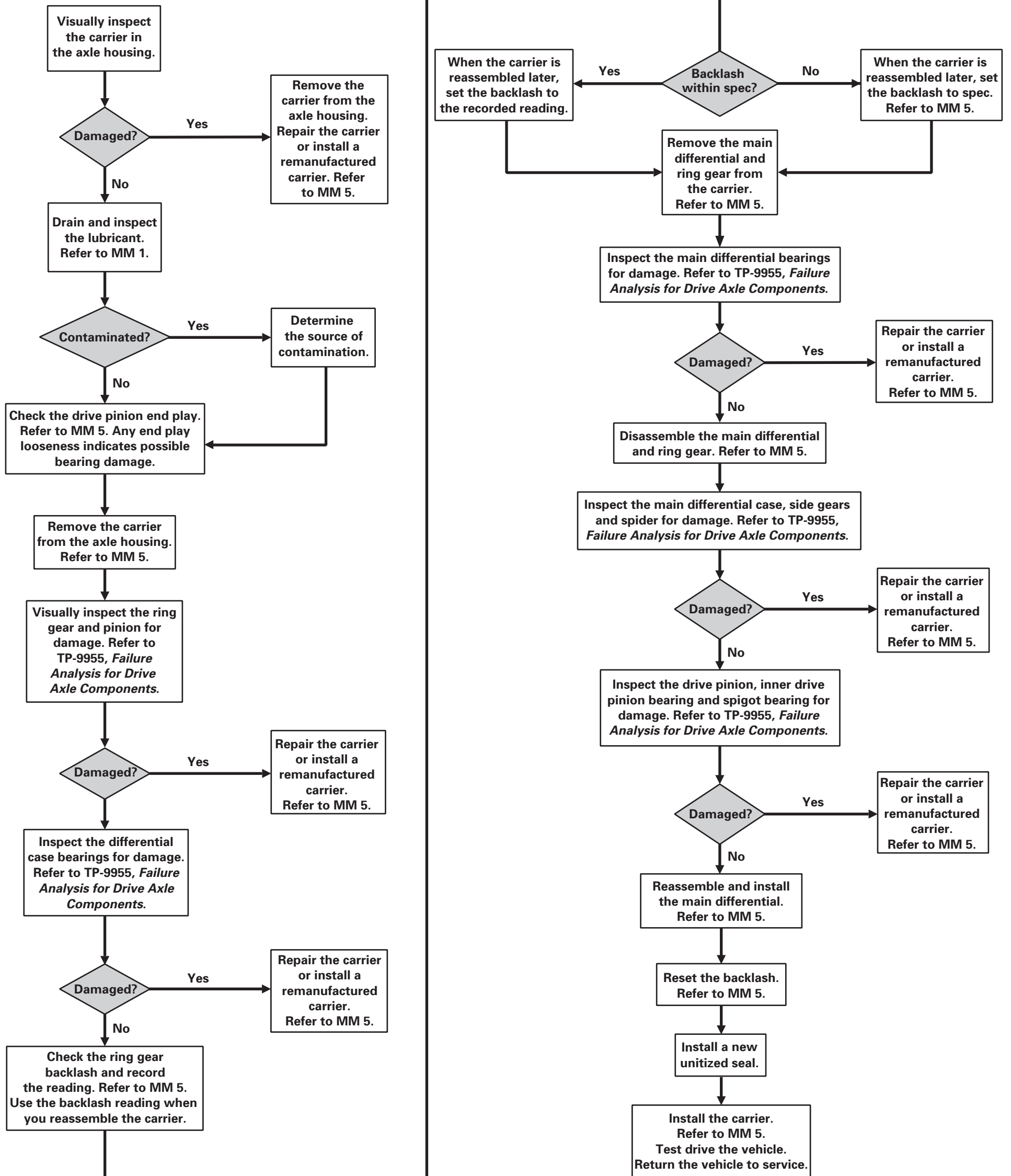

Rear Tandem or Single Carrier Differential Making Noise

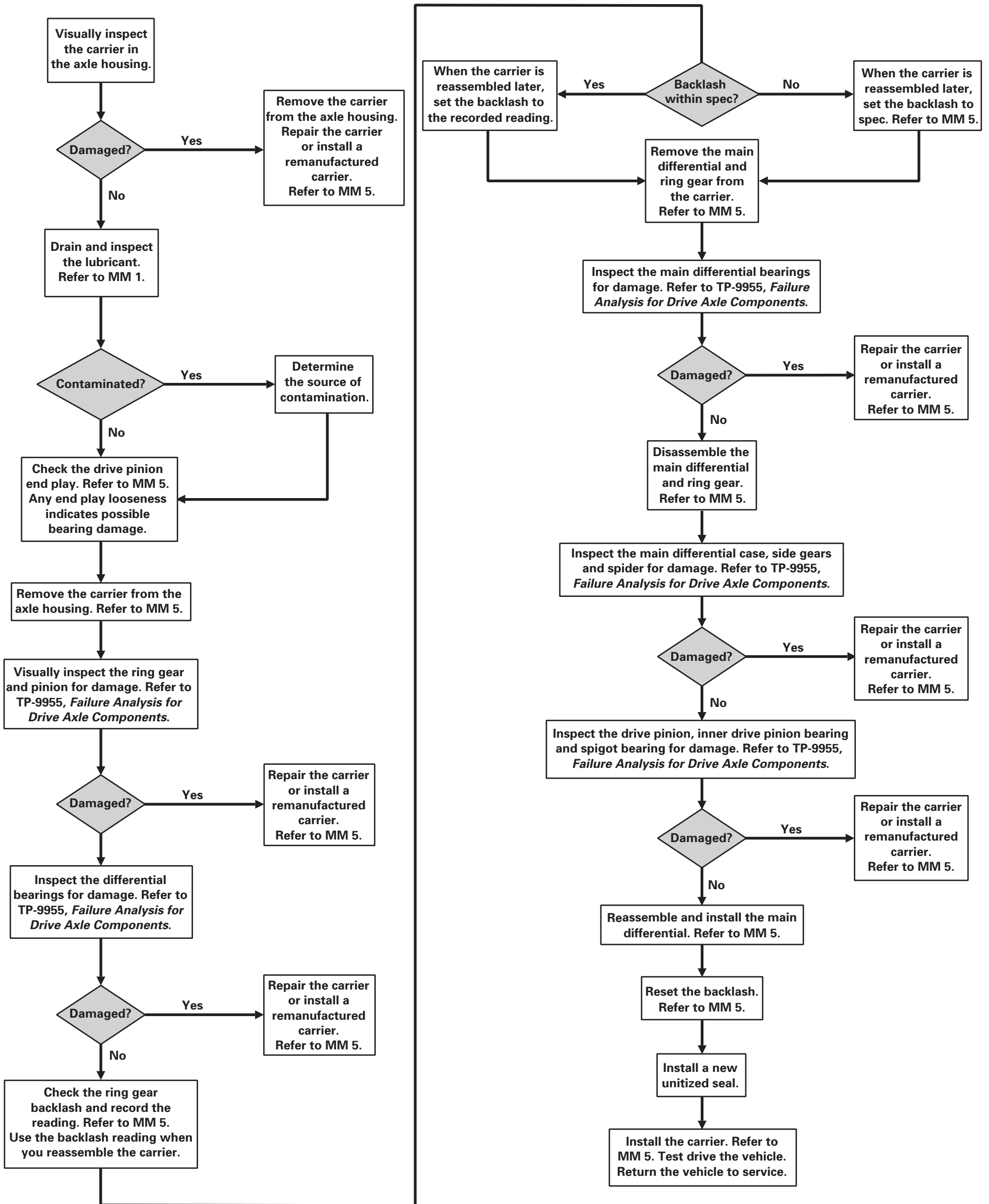

Rear Tandem or Single Carrier Oil Leak

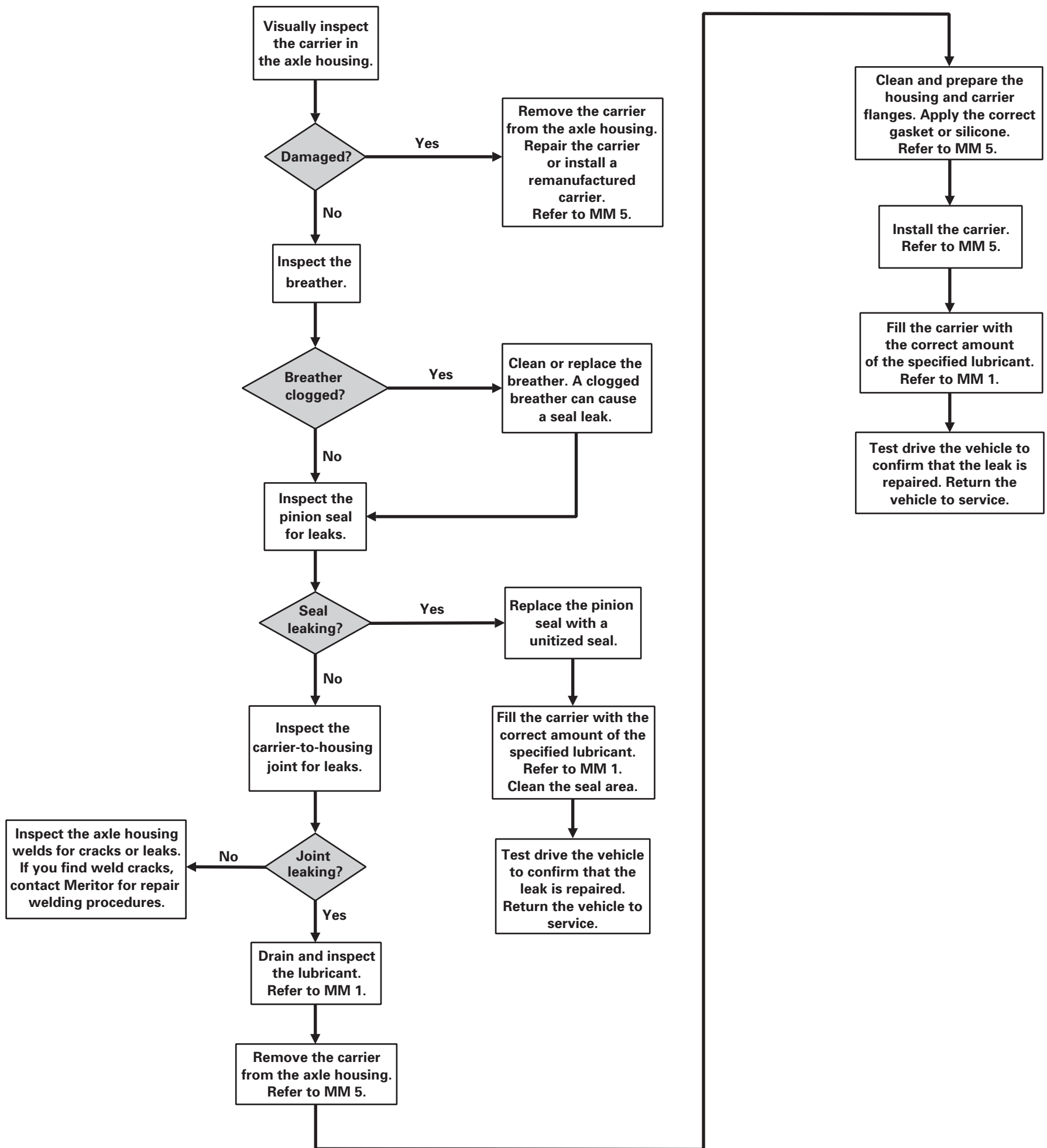

All Rear Axles

Contaminated Lubricant Found During Preventive Maintenance

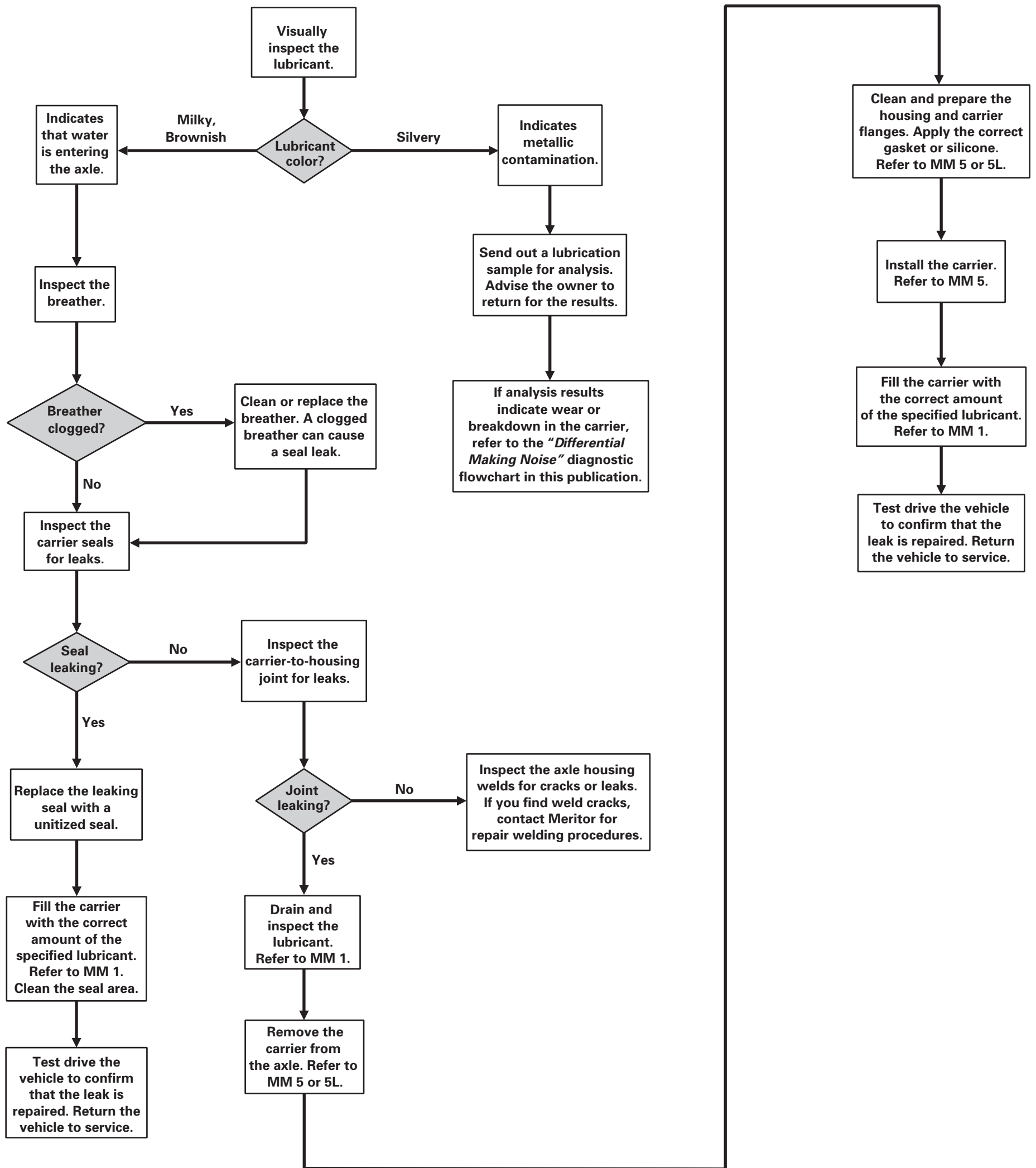



Meritor Heavy Vehicle Systems, LLC
2135 West Maple Road
Troy, MI 48084 USA
800-535-5560
www.meritorauto.com

Information contained in this publication was in effect at the time the publication was approved for printing and is subject to change without notice or liability. Meritor Heavy Vehicle Systems, LLC, reserves the right to revise the information presented or discontinue the production of parts described at any time.

© Copyright 1999
Meritor Automotive, Inc.
All Rights Reserved

Printed in the USA

TP-99125
Issued 12-99
16579/24240