

Bendix® DC-4® Double Check Valve

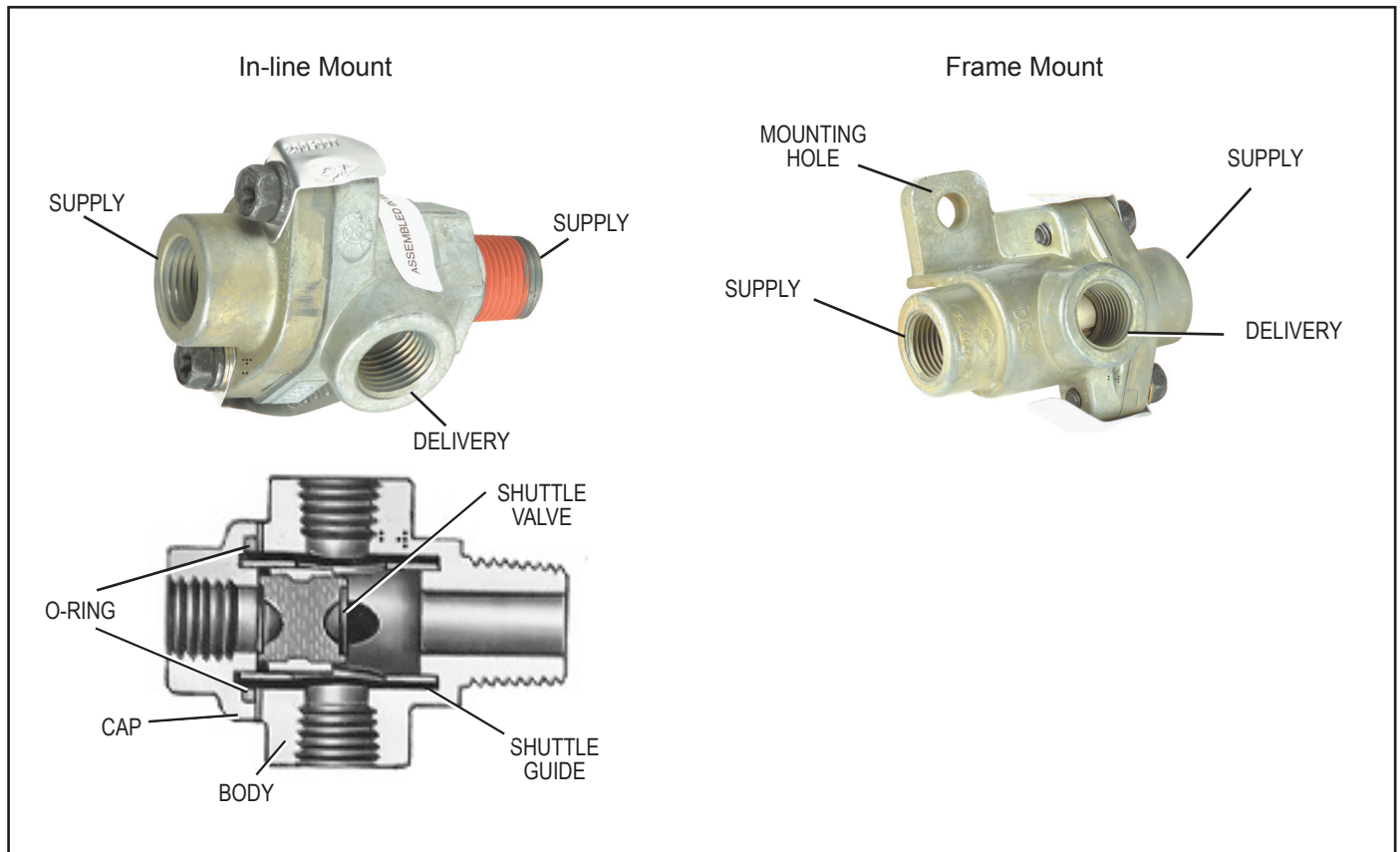

FIGURE 1 - BENDIX® DC-4® DOUBLE CHECK VALVE

DESCRIPTION

The Bendix® DC-4® double check valve is used in an air brake system to direct a flow of air into a common line from either of two sources, whichever is at the higher pressure. The valves may be used for directing air flow for specific functions or to select the higher pressure of either of two sources of air as a supply source.

Bendix manufactures two double check valves; one is mounted in the air line without being secured to the vehicle frame, and the other contains a mounting tab to secure it to the vehicle frame or chassis. Although the valves are somewhat different physically, the same function is performed by each type.

OPERATION

As air under pressure enters either end of the double check valve (inlet port), the moving shuttle responds to the pressure and seals the opposite port—assuming it is at a lower pressure level than the other. The air flow continues out the delivery port of the double check valve. The position of the shuttle will reverse if the pressure levels are reversed. Double check valves are designed so that the shuttle can never impede the backflow of air in the exhaust mode.

Figure 2 (see page 2) illustrates a typical double check valve used to control a given device—such as trailer brakes—from either of the two control sources.

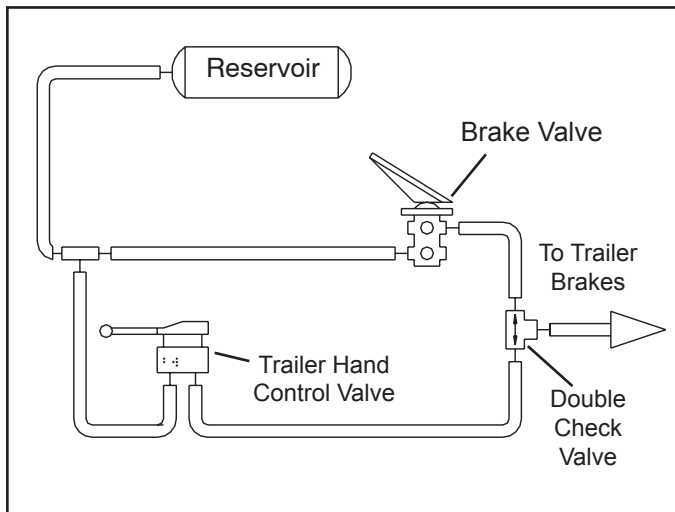

FIGURE 2 - DOUBLE CHECK VALVE: CONTROL OF SYSTEM FROM EITHER OF TWO CONTROL SOURCES

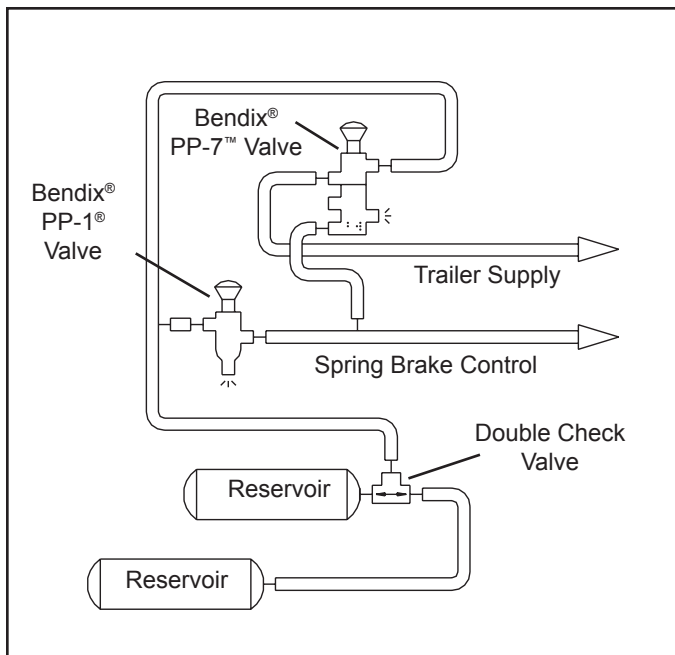

FIGURE 3 - DOUBLE CHECK VALVE: SYSTEM WITH TWO SUPPLY SOURCES

Figure 3 illustrates a typical double check valve used to supply air to a system (or systems) from either of two separate sources—whichever is at the greater pressure level. In this type of installation, the pressure differential to which the valve is subjected may—under certain conditions—be minimal. As a result, performance of the double check valve will be optimized if it is mounted in the horizontal position.

PREVENTIVE MAINTENANCE

Important: Review the Bendix Warranty Policy before performing any intrusive maintenance procedures. A warranty may be voided if intrusive maintenance is performed during the warranty period.

No two vehicles operate under identical conditions; as a result, maintenance intervals may vary. Experience is a valuable guide in determining the best maintenance interval for air brake system components. At a minimum, the Bendix® DC-4® double check valve should be inspected every 6 months or 1500 operating hours, whichever comes first, for proper operation. Should the DC-4 valve not meet the elements of the operational tests noted in this document, further investigation and service of the valve may be required.

SERVICE CHECKS

OPERATING AND LEAKAGE TEST

- A. When the double check valve is used in conjunction with a trailer control valve, the following operating and leakage test can be made:
1. Apply and release the foot brake valve and note that the brakes apply and release on both the tractor and the trailer.
 2. Apply and release the trailer control valve and note that only the trailer brakes apply and release. With the trailer control valve applied, check the exhaust port of the foot brake valve for leakage with a soap solution. Permissible leakage is a 1 inch bubble in 5 seconds (100 sccm).
 3. Apply and hold a full foot brake valve application. Check the exhaust port of the trailer control valve for leakage with a soap solution. Permissible leakage is a 1" bubble in 5 seconds (100 sccm). **Note:** On some vehicles, an exhaust line is connected to the exhaust port and piped outside the cab. In this case it may be necessary to disconnect this line to complete the leakage check.
- B. When checking the double check valve—either bench tested or tested on the vehicle—two separately controlled air supplies must be connected to the inlet ports.
1. Install an accurate test gauge in the outlet port or in a line from the outlet port.
 2. Apply and release air pressure to one inlet port and note that the gauge registers an application and release.
 3. Repeat by applying and releasing air to the other inlet port.

4. A leakage check should be performed at the inlet ports of the valve in the following manner:
 - a. Disconnect the air line from one inlet port.
 - b. Apply air to the other inlet port and coat the opposite inlet port with a soap solution. Permissible leakage is a 1" bubble in 5 seconds (100 sccm).
 - c. Repeat Step "b" applying air to the other inlet port while checking the opposite inlet port for leakage.

If the double check valve does not function as described, or if leakage is excessive, the valve should be repaired or replaced with genuine Bendix® parts. The following instructions should prove helpful:

DISASSEMBLY

1. Remove the end cap(s) from the valve.
2. Remove the grommets (if applicable).
3. Remove the shuttle and/or shuttle guide.

CLEANING AND INSPECTION

1. Clean all metal parts in mineral spirits and dry them completely.
2. Inspect all parts for excessive wear or deterioration. Inspect valve seats for nicks or burrs.
3. Inspect the bores of the valve housing for deep scuffing or gouges.

Replace all parts that were discarded, and any parts not found to be serviceable during inspection, using only genuine Bendix replacement parts.

ASSEMBLY

Before assembling the Bendix® DC-4® double check valve, lubricate all o-rings and o-ring grooves with silicone lubricant (Bendix piece number 291126 or equivalent).

NOTE: When using pipe thread sealant during assembly and installation, take particular care to prevent the sealant from entering the valve itself. Apply the sealant beginning with the second thread back from the end.

1. Install the shuttle and shuttle guide.
2. Coat all static seals such as o-rings, grommets, etc. with silicone lubricant (Bendix piece number 291126 or equivalent). It is not necessary to lubricate the shuttle.
3. Install the grommets.
4. Install the end cap(s).

TESTING OF REBUILT DOUBLE CHECK VALVE

Perform operating and leakage tests as described in "Service Checks" section.

GENERAL SAFETY GUIDELINES **WARNING! PLEASE READ AND FOLLOW THESE INSTRUCTIONS TO AVOID PERSONAL INJURY OR DEATH:**

When working on or around a vehicle, the following guidelines should be observed AT ALL TIMES:

- ▲ Park the vehicle on a level surface, apply the parking brakes and always block the wheels. Always wear personal protection equipment.
- ▲ Stop the engine and remove the ignition key when working under or around the vehicle. When working in the engine compartment, the engine should be shut off and the ignition key should be removed. Where circumstances require that the engine be in operation, **EXTREME CAUTION** should be used to prevent personal injury resulting from contact with moving, rotating, leaking, heated or electrically-charged components.
- ▲ Do not attempt to install, remove, disassemble or assemble a component until you have read, and thoroughly understand, the recommended procedures. Use only the proper tools and observe all precautions pertaining to use of those tools.
- ▲ If the work is being performed on the vehicle's air brake system, or any auxiliary pressurized air systems, make certain to drain the air pressure from all reservoirs before beginning ANY work on the vehicle. If the vehicle is equipped with a Bendix® AD-IS® air dryer system, a Bendix® DRM™ dryer reservoir module, or a Bendix® AD-9si™ air dryer, be sure to drain the purge reservoir.
- ▲ Following the vehicle manufacturer's recommended procedures, deactivate the electrical system in a manner that safely removes all electrical power from the vehicle.
- ▲ Never exceed manufacturer's recommended pressures.
- ▲ Never connect or disconnect a hose or line containing pressure; it may whip. Never remove a component or plug unless you are certain all system pressure has been depleted.
- ▲ Use only genuine Bendix® brand replacement parts, components and kits. Replacement hardware, tubing, hose, fittings, etc. must be of equivalent size, type and strength as original equipment and be designed specifically for such applications and systems.
- ▲ Components with stripped threads or damaged parts should be replaced rather than repaired. Do not attempt repairs requiring machining or welding unless specifically stated and approved by the vehicle and component manufacturer.
- ▲ Prior to returning the vehicle to service, make certain all components and systems are restored to their proper operating condition.
- ▲ For vehicles with Automatic Traction Control (ATC), the ATC function must be disabled (ATC indicator lamp should be ON) prior to performing any vehicle maintenance where one or more wheels on a drive axle are lifted off the ground and moving.
- ▲ The power **MUST** be temporarily disconnected from the radar sensor whenever any tests **USING A DYNAMOMETER** are conducted on a Bendix® Wingman® Advanced™-equipped vehicle.
- ▲ You should consult the vehicle manufacturer's operating and service manuals, and any related literature, in conjunction with the Guidelines above.

