

# INSTALLATION/SERVICE MANUAL

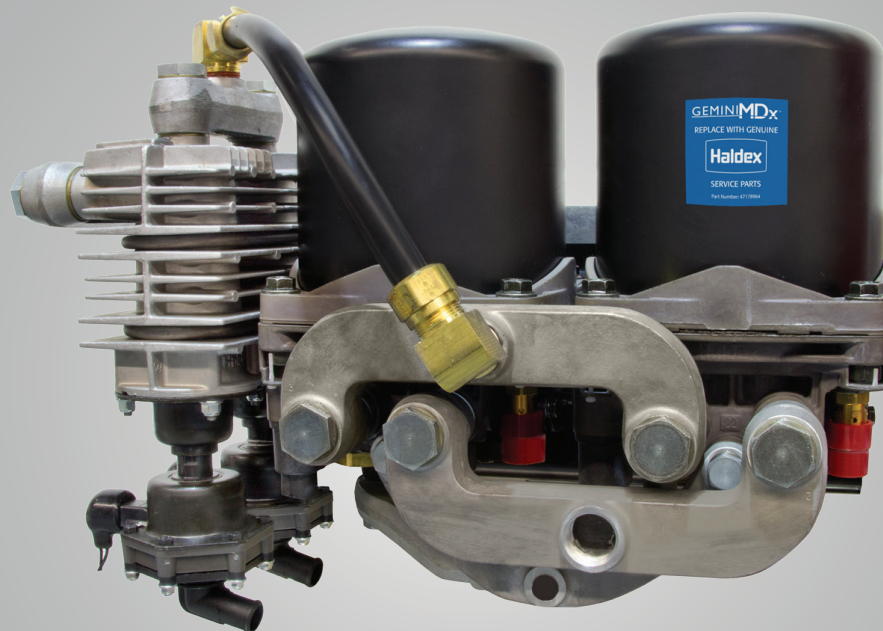

**GEMINI MDx<sup>®</sup>**

High Capacity Dual Dryer System





## Important Notices

### General

This manual has been designed to assist personnel in satisfactory installation, maintenance and troubleshooting of the Haldex GeminiMDx High Capacity Dual Air Dryer System. The intention has been to provide guidance on certain aspects of the product. It is expected that this manual will be in possession of the appropriate person throughout the install, maintenance and/or troubleshooting process.

### Safety and Important Precautions

- All company and vehicle manufacturer's safety procedures must be followed when installing the GeminiMDx Dryer.
- Always wear proper personal protective equipment, including approved eye glasses.
- Never work on or under a vehicle unless it is parked on a level surface and its wheels are blocked to prevent it from moving.
- Never work on a vehicle air brake system when the engine is running. Where circumstances require that the engine be in operation, extreme caution should be used to prevent personal injury resulting from contact with moving, rotating, leaking, heated or electrically charged components.
- Drain all air pressure from the air system before beginning any installation, service or repair.
- Never connect or disconnect a hose or line containing pressure. Never remove a component plug unless it is certain that all system pressure has been depleted.
- Never exceed recommended component or system pressures.
- Do not attempt to install, remove, disassemble or assemble a component until all recommended procedures have been read and are fully understood. Use only the proper tools and observe all precautions pertaining to the use of those tools.
- Components with stripped threads or damaged parts should be replaced rather than repaired. Repairs requiring machining or welding should not be attempted unless specifically approved and stated by the vehicle or component manufacturer.
- Prior to returning the vehicle to service, make certain all components and systems are restored to their proper operating condition.

### Mounting and Installation Precautions

- The GeminiMDx uses a 4-bolt mounting pattern. See "Dimensions and Port Identification" on Page 8.
- If the GeminiMDx is to be bolted directly to the frame or other support member, check the vehicle manufacturers recommendations.
- At a minimum use grade 5, 1/2" bolts and nuts.
- The GeminiMDx must not incline in any direction more than 15° from vertical.
- Mount in a space to avoid excessive heat sources (175°F maximum).
- Mount with the exhaust port oriented downward.
- Mount in an area where it is protected from wheel or road splash.

### Replacement Parts/Retrofit Components

Use appropriate spare parts documentation when obtaining spare parts. Only use Genuine Haldex replacement parts in the repair process. See a complete listing on Page 15.

### Questions?

If you have any questions on this product or any of the innovative products offered by Haldex, contact your local distributor for complete details. Technical Service or Troubleshooting help can be obtained by calling Haldex Technical Services Department at 800.643.2374, follow prompts.



## Table of Contents

Section	Page
<b>GeminiMDx Manifold Dual Dryer (high-capacity air drying system)</b>	
GeminiMDx Overview .....	2
GeminiMDx Anatomy.....	2
<b>Pre-Treatment</b>	
Consep (condenser/separator) Overview .....	3
Consep (condenser/separator) Anatomy/Function .....	3
Automatic Drain Valve (ADV) Function .....	3
<b>Drying</b>	
DRYest Air Dryer Overview .....	4
DRYest Air Dryer Anatomy.....	4
Cartridge Canister .....	4
Air Dryer Base .....	4
Valve Unit.....	4
Charging Phase.....	5
Unloading Phase.....	5
Regeneration Phase .....	5
Cut-In.....	5
<b>System Specifications</b> .....	6
<b>Torque Specifications</b> .....	6
<b>Plumbing Schematics</b>	
Pre-Treatment and Drying .....	7
Drying Only.....	7
<b>Dimensions and Port Identification</b> .....	8
<b>Electrical Diagrams</b>	
Dual Consep 12/24V Non-Heated Without Relay .....	11
Dual Consep 12/24V Heated With Electrical Relay or Timer Relay .....	11
Electrical Relay.....	11
Timer Relay .....	11
Air Dryer Heater .....	11
<b>Operational Check</b> .....	12
<b>Troubleshooting</b> .....	13
<b>Suggested Maintenance Schedule</b> .....	14
<b>GeminiMDx Part Number/Description Listing</b> .....	15
<b>Replacement Parts/Retrofit Components</b> .....	15
<b>Service Kit Components Identification</b> .....	16
<b>Service Kit Contents</b> .....	17
<b>Removal/Installation Instructions</b>	
GeminiMDx.....	18
Cartridge Canister .....	18
Valve Unit with Integrated Purge Valve .....	19
12/24 VDC Heater Assembly.....	20
Outlet Check Valve Assembly .....	21
Turbo-Protection Valve (TPV).....	21
Cyclone Insert .....	22
<b>Glossary</b> .....	23

The products described within this literature, including without limitation, product features, specifications, designs, availability and pricing are subject to change by Haldex and its subsidiaries at any time without notice. This document and other information from Haldex, its subsidiaries and authorized distributors provide product and/or system options for further investigation by users having technical expertise. It is important that you analyze all aspects of your application and review the information concerning the product or system, in the current literature or catalog. Due to the variety of operating conditions and applications for these products or systems, the user, through their own analysis and testing, is solely responsible for making the final selection of the products and systems and assuring that all performance, safety and warning requirements are met.

## GeminiMDx Manifold Dual Dryer

### GeminiMDx Overview

In its most basic form, the GeminiMDx dual dryer is the connection of two DRYest Air Dryers in parallel to treat the compressed air produced by high capacity air compressors. The GeminiMDx is a desiccant type dryer that removes moisture and contaminants from the compressed air before entering the air brake system.

A variant of the GeminiMDx includes a single or dual Consep (Condenser/Separator) to pre-treat the compressed air before entering the air dryers and extend the life of the air dryer's desiccant cartridge.

### GeminiMDx Anatomy

The GeminiMDx consists of the following major components: Dryest® air dryers, inlet/outlet manifolds, control/purge manifolds, banjo bolts, sealing washers and one or two Consep units (optional).

#### Dual Conseps [1]

The two Conseps are identical. They condense and separate contaminants from the compressed air. The Automatic Drain Valve (ADV), will drain the condensed liquid and separated contaminants.

#### Dual DRYest Air Dryers [2]

The two dryers are identical. They each contain a desiccant cartridge, turbo protection valve, purge valve, safety valve, outlet check valve and heater.

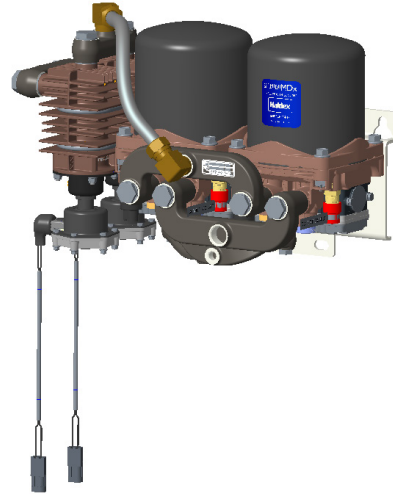

#### Cast Aluminum Manifolds [3,4,5]

The manifolds provide a single connection for inlet/outlet, control and purge air line connections and parallel flow to and from each Consep or air dryer.

#### Sealing Washers [6]

The sealing washers provide leak-free joints between the banjo bolts, manifolds and air dryers.

#### Banjo Bolts [7]

The banjo bolts secure the manifolds to the air dryers and are hollow with cross-drilled passages to allow air to flow to/from the manifolds to the air dryers.

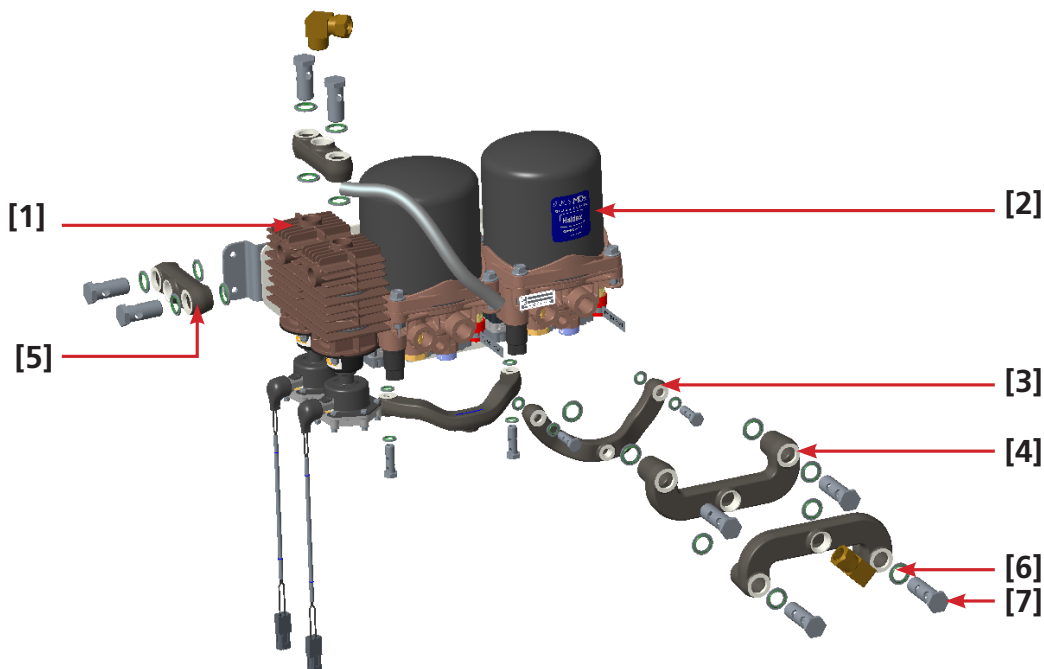

## Pre-Treatment

### Consep Overview

The Consep consists of a condenser/separator and a Automatic Drain Valve (ADV). The condenser/separator will condense and separate contaminants from the compressed air. The drain will expel condensed liquid and separated contaminants. When it is installed and adequately cooled, the Consep will extend the life of the desiccant cartridge.

### Consep Anatomy/Function

The compressed air is led into the Consep at the inlet port on the side of the **Aluminum Housing [1]**. The compressed air passes between the housing wall and the **Cyclone Insert [2]**. The shape of the cyclone forces the compressed air to rotate. The centrifugal effect which occurs when the air rotates around the cyclone forces the water and contaminants to the housing wall. At the base of the cyclone, the compressed air is directed upwards through the cyclone interior and out via the outlet port at the top of the housing. Water and contaminants which have been condensed and separated flow downwards through a **Filter [3]** and are collected in the sump of the **Automatic Drain Valve (ADV) [4]**. The liquid contaminants collected in the ADV are drained when the **Shuttle [5]** is lifted via electrical activation of the **Solenoid Coil [6]**.

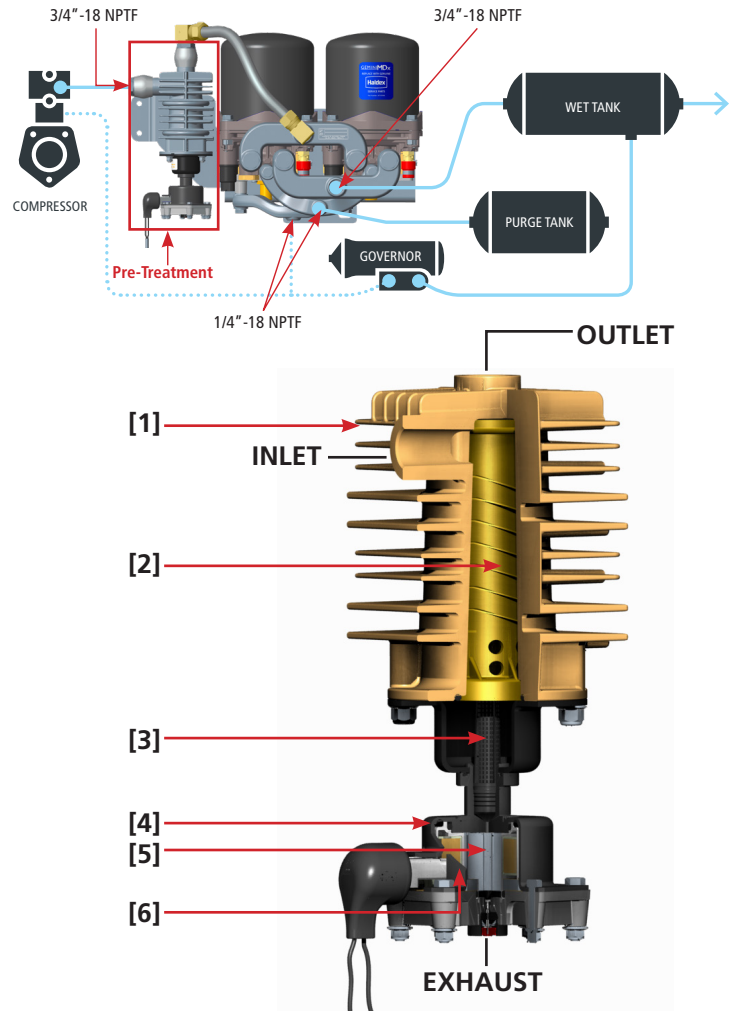

### Automatic Drain Valve (ADV) Function

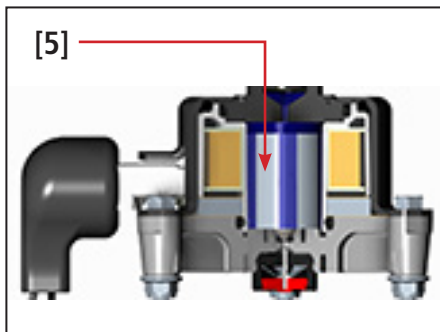

When air pressure is present and NO electrical power, the **Shuttle [5]** is forced against the lower seat. The entry to the sump is open to receive liquid contaminants.

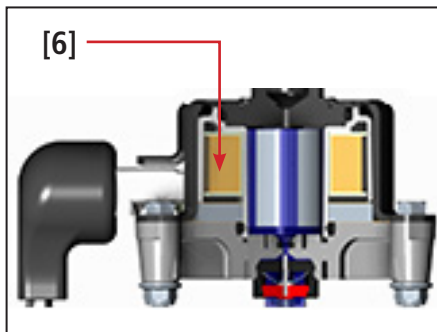

With electrical power, the **Solenoid Coil [6]** generates a magnetic field which pulls the shuttle against the upper seat. This closes the entry to the sump and drains liquid contaminants collected in the sump.

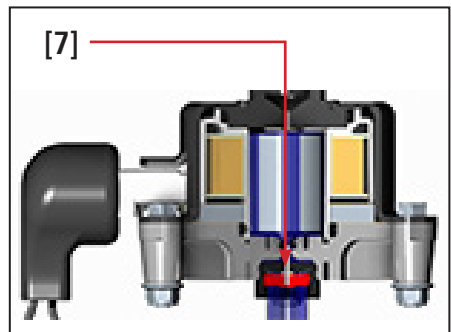

To manually drain the ADV, push the **Red Manual Drain Button [7]** to activate drainage. **This function only works if the ignition is off and the unit is pressurized.**

## Drying

### DRYest Air Dryer Overview

The Haldex DRYest is a desiccant type dryer that effectively collects and removes moisture, oil and contaminants before they enter the compressed air system. The DRYest provides filtered, moisture free air to the brake system which reduces freezing and corrosion of the components in the air system.

### Anatomy

The DRYest contains three major parts: **Cartridge Canister [1]** with five stages of drying, **Air Dryer Base [2]** and **Valve Unit [3]**.

### Cartridge Canister [1]

The **Cartridge Canister [1]** is where drying and contaminant removal occurs in the air dryer. The GeminiMDx Dual Dryer contains the Haldex patented MTC+ cartridge design which has five stages of drying. The desiccant cartridge is contained by the canister and affixed to the dryer base with an o-ring, mounting collar and four bolts.

### Air Dryer Base [2]

The **Air Dryer Base [2]** connects the **Cartridge Canister [1]** and the **Valve Unit [3]**. The base has connections for the inlet, outlet and purge reservoirs. The base also contains the following components:

- **Safety Valve [2.1]**
- **Outlet Check Valve [2.2]**
- **Turbo-Protection Valve (TPV) [2.3]**
- **Heater Element [2.4]**

### Valve Unit [3]

The **Valve Unit [3]** attaches to the **Air Dryer Base [2]** with six screws and contains the purge valve. The **Valve Unit [3]** has a control port for external air governor connection and includes a muffler style or drain tube style purge outlet.

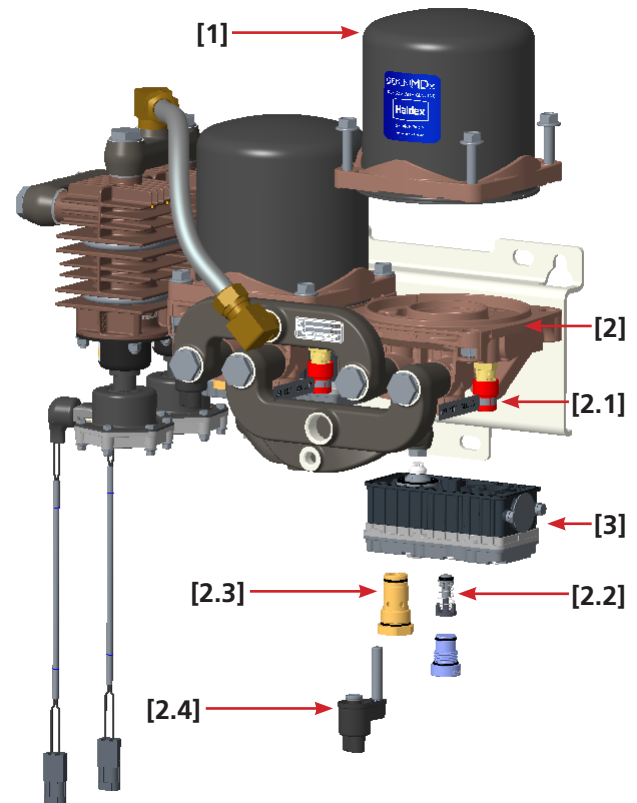
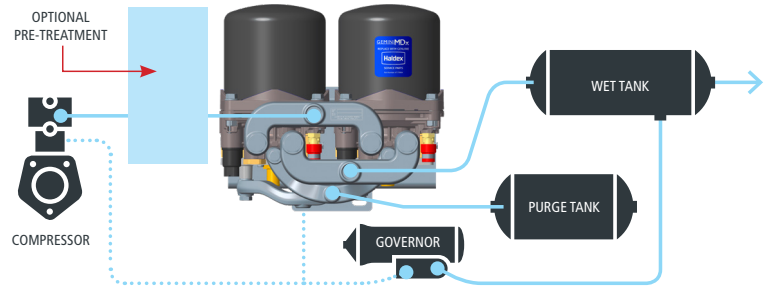

## Drying (cont'd)

### DRYest Function

#### Charging Phase

Air from the compressor or pre-treatment flows into the inlet manifold and divides to enter each air dryer. Once the inlet air pressure is greater than the **TPV [2.3]** opening pressure, the air enters each **Desiccant Cartridge [1]**. The air first passes through an aluminum **Inlet Filter [1.1]** in the cartridge, which traps droplets and solid particles.

The air continues traveling through several sections of **Desiccant [1.2] [1.3] [1.4]**, each section with increasing sizes of desiccant, to capture contaminants. Once the air passes through the cartridge the remaining water and oil molecules will be captured.

As the air exits the cartridge, it passes through an **Outlet Filter [1.5]**, through an **Outlet Check Valve [2.2]** and finally reaches the outlet manifold where it combines with the outlet air of the second dryer.

A small portion of air from the cartridge passes to the purge manifold where it combines with air from the other dryer and exits the purge manifold to fill an external purge reservoir.

#### Unloading Phase

When the air brake system pressure reaches the cut-out setting of the air governor, the output of the air governor passes to the air compressor unloader to stop the air compression and passes to the purge valve of each dryer via the control manifold. The purge valve opens to atmosphere and depressurizes the air dryer. The turbo protection valve (TPV) will close once the inlet air is below 35 psi. The regeneration cycle will begin. The outlet check valve will close, preventing the back flow from the system.

#### Regeneration Phase

During the unloading phase, a regeneration cycle (desorption) will remove the contaminants. Since the cartridge is depressurized, air from the external purge reservoir will flow back to the dryer, pass through the purge manifold to the desiccants, collect the captured contaminants and drain to the atmosphere via the purge valve and silencing unit. The regeneration cycle or purge cycle will continue until the purge reservoir air pressure depletes to 0 psi. This will last approximately 30 seconds. The purge valve will remain open until the brake system decreases to the air governor cut-in setting.

#### Cut-In

As air is consumed by the brake system, the air pressure decreases until the air governor cut-in pressure is achieved. At cut-in pressure the air governor closes, its output air exhausts to atmosphere, the unloader valves of the dryer close and the compressor begins to compress air. A new charging phase begins.

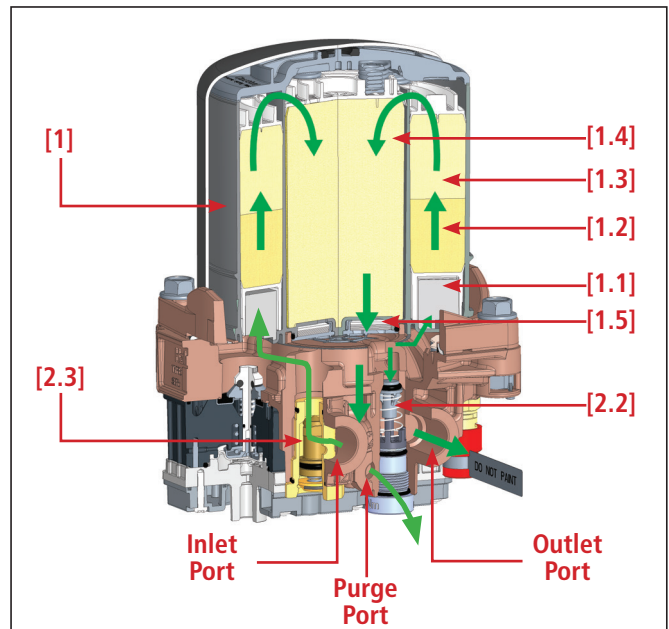

**Charging Phase**

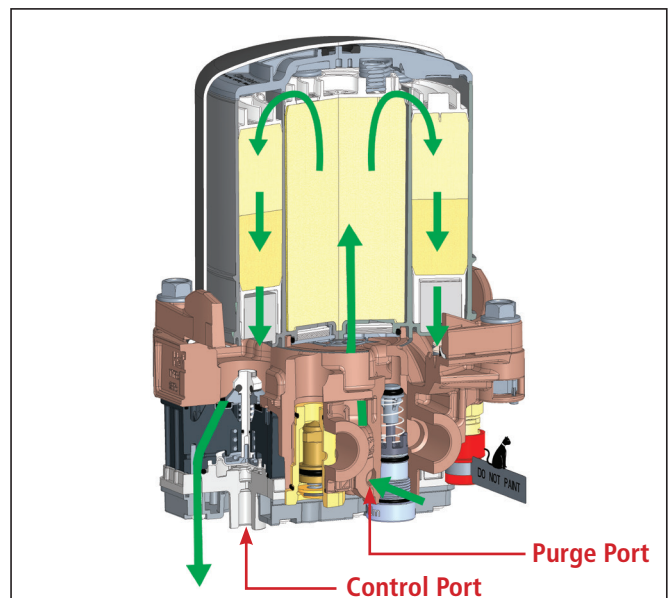

**Unloading Phase**



## System Specifications

	Dual Consep and Dual Dryer	Dual Consep Only	Dual Dryer Only
Weight	53 lbs. (with mounting bracket)	11 lbs.	40 lbs.
Envelope	20"W x 15"H x 12"D	6"W x 12"H x 8"D	14"W x 13"H x 10"D
Inlet/Outlet Ports	3/4" - 14 NPT	3/4" - 14 NPT	3/4" - 14 NPT
Control Port	1/4" - 18 NPT	n/a	1/4" - 18 NPT
Purge Port	1/4" - 18 NPT	n/a	1/4" - 18 NPT
Max. Working Pressure	150 PSIG	150 PSIG	150 PSIG
Safety Valve	160 PSIG	n/a	160 PSIG
Turbo Protection Inlet Required	35 PSI	n/a	35 PSI
Ambient Temperature	-40°F - +176°F	-40°F - +176°F	-40°F - +176°F
Maximum Inlet Air Temperature	+176°F	+176°F	+176°F
Recommended Inlet Air Temperature	+40°F - +150°F	+40°F - +150°	+40°F - +150°
Air Flow Capacity	70 SCFM	70 SCFM	70 SCFM
Minimum Purge Volume	600 in. <sup>3</sup>	n/a	600 in. <sup>3</sup>
Compressor Unloaded Time	30 seconds	n/a	30 seconds
Maximum Duty Cycle	25%	n/a	25%
Automatic Drain Valve	24VDC/1.0A 12VDC/2.0A	24VDC/1.0A 12VDC/2.0A	n/a
Heater Element	n/a	n/a	24VDC/4.0A 12VDC/8.0A
Heater Thermostat Operating Range	n/a	n/a	Closes 45° ± 7°F Opens 71° ± 6°F
Heater Element Resistance	n/a	n/a	12VDC: 1.4-1.8 Ω 24VDC: 5.9-6.9 Ω
Drain Capacity	n/a	1.3cc per ADV/Operation	n/a
Drain Options	n/a	Swivel Tube, Open	Muffler, Tube

## Torque Specifications

Consep Mounting Bolts to Bracket .....	6-11 ft-lbs (Tighten Bolts in Cross Pattern)
Dryer to Bracket: .....	35-50 ft-lbs
Consep Inlet and Outlet Manifold M22 Banjo Bolts .....	45-55 ft-lbs
Dryer Inlet and Outlet Manifold M22 Banjo Bolts .....	45-55 ft-lbs
Dryer Control and Purge Manifold M12 Banjo Bolts.....	130-150 in-lbs
ADV Mounting Nuts to Consep .....	80-98 in-lbs
Heater Retaining Screw.....	45-55 in-lbs
Turbo Protection Valve .....	45-55 ft-lbs
Check Valve Plug .....	84-94 in-lbs
Valve Unit Bolts .....	62-80 in-lbs
Cartridge Canister Bolts .....	32-35 ft-lbs



## Plumbing Schematics

### Pre-Treatment and Drying

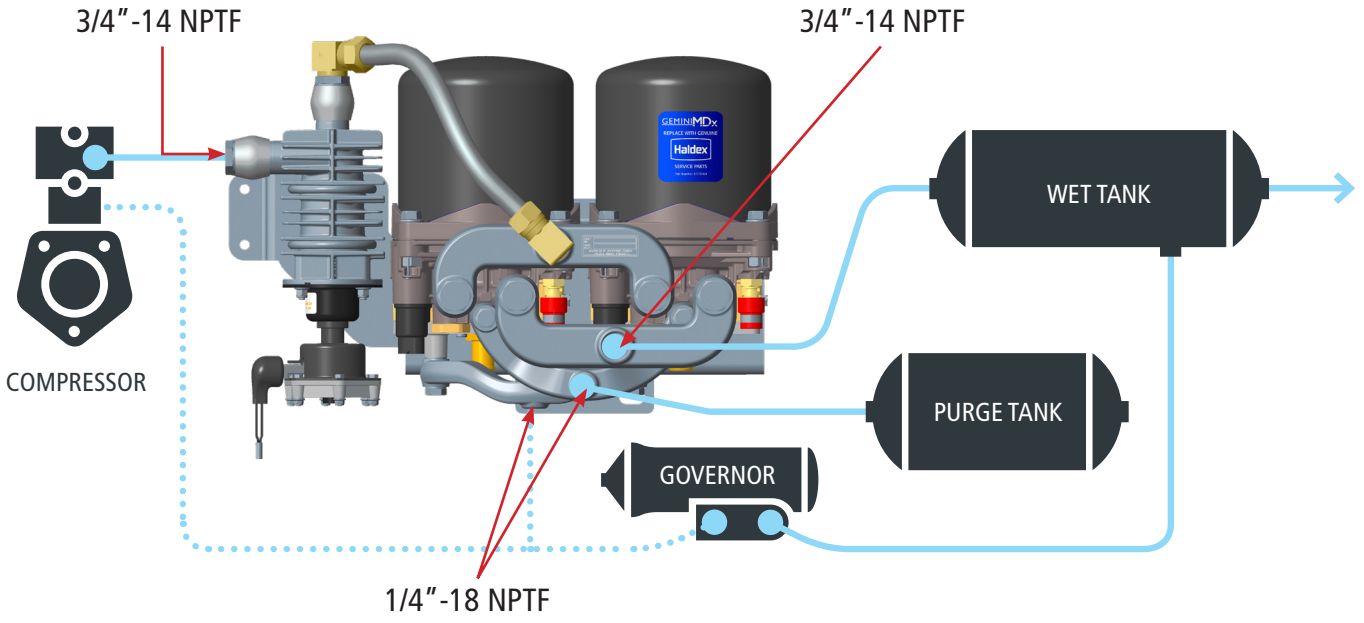

### Drying Only

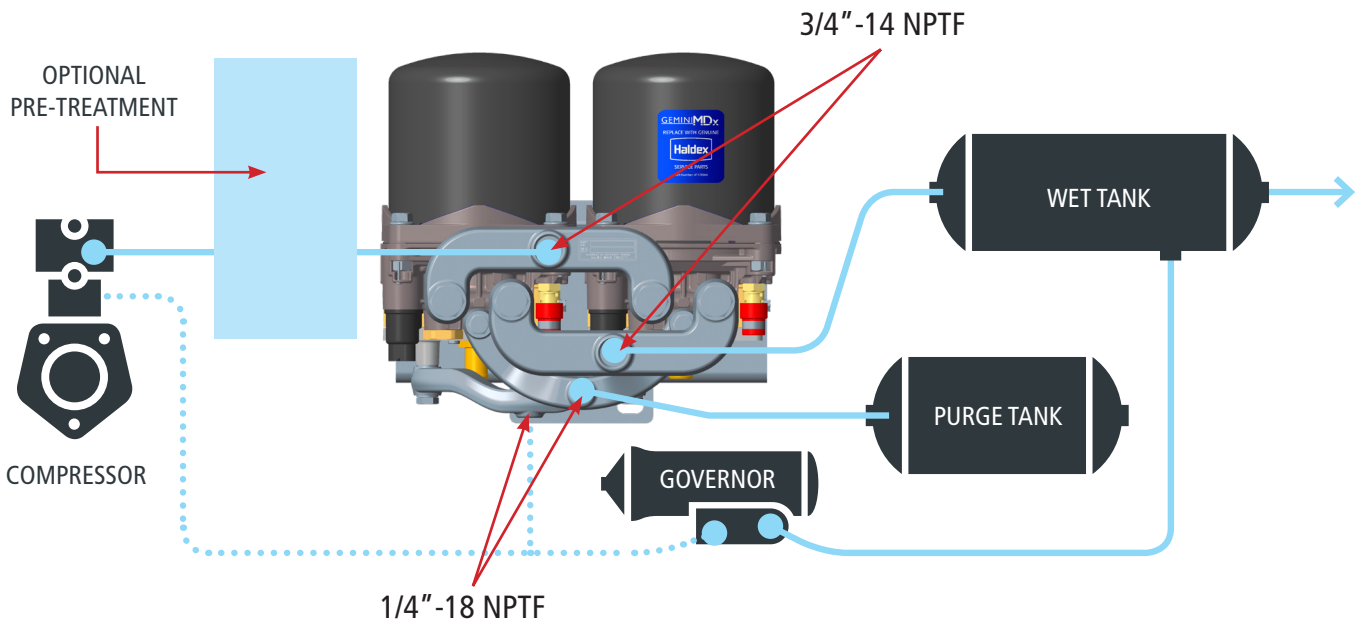

## Dimensions and Port Identification

### Dual Consep Assembly

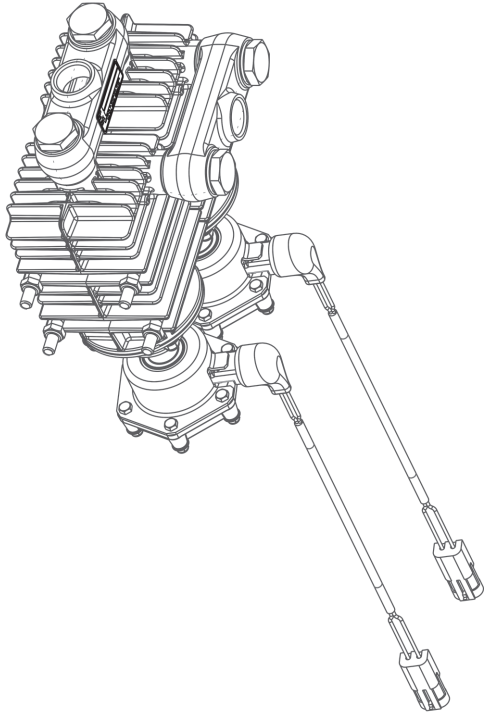

WIDE MOUNTING STYLE

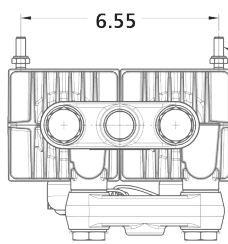

U-BOLTS

NARROW MOUNTING STYLE

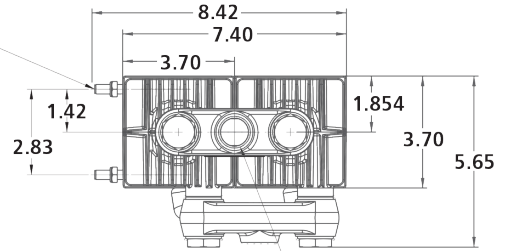

OUTLET PORT  
3/4-14 NPTF

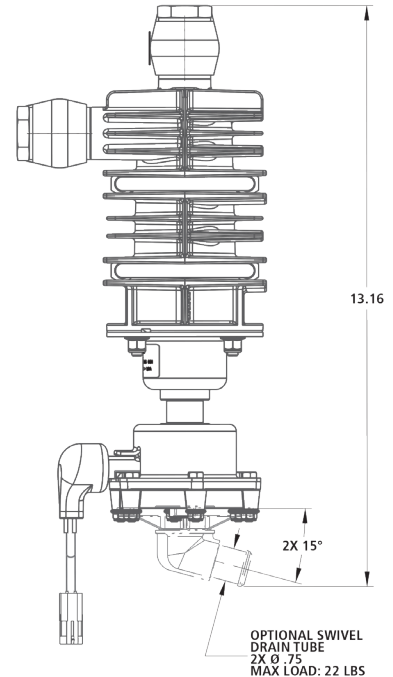
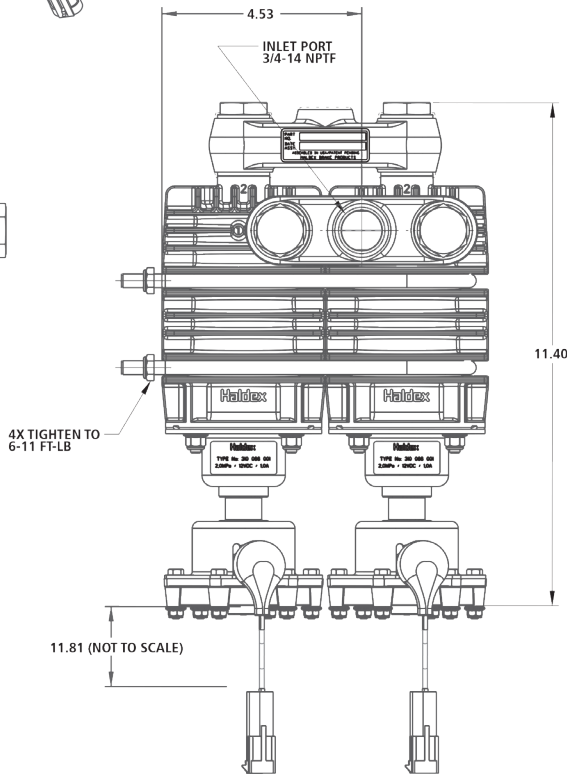
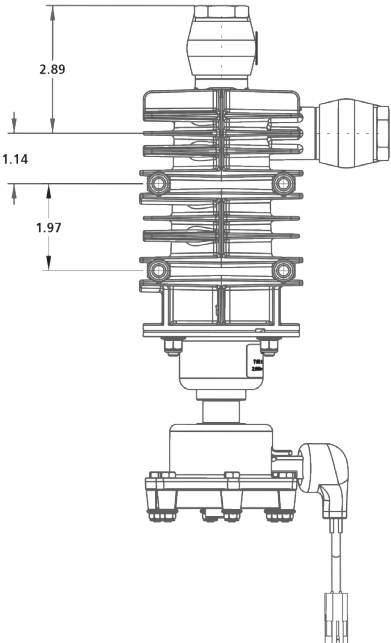

WEATHER PACK MALE  
MATES WITH DELPHI  
ELECTRICAL SYSTEMS  
P/N 12015792

## Dimensions and Port Identification

### Dual Dryer Assembly

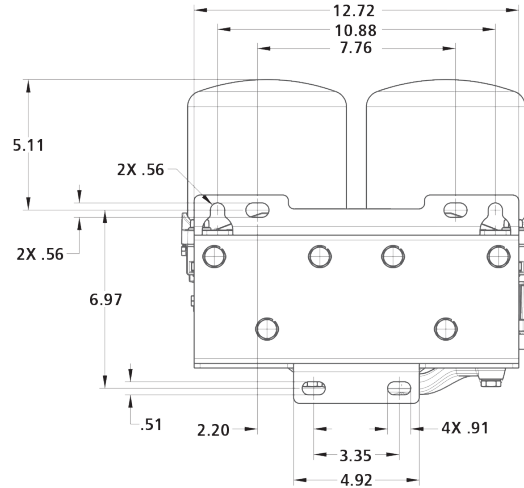
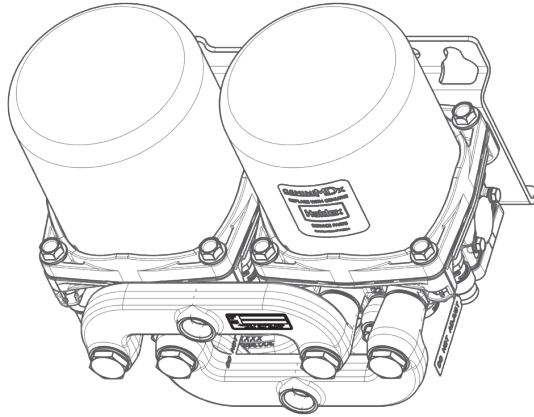

2.00 MINIMUM SPACE REQUIRED FOR CARTRIDGE CHANGE

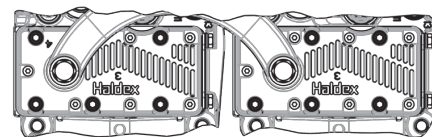
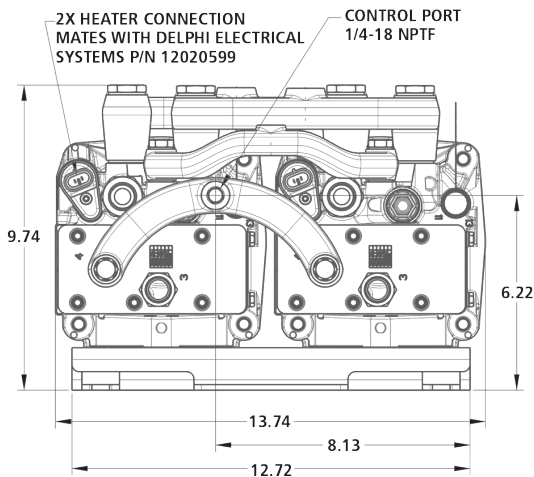
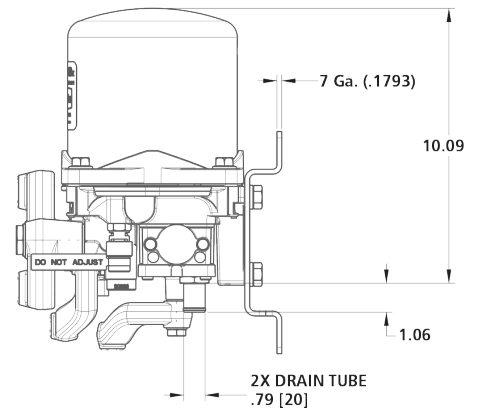
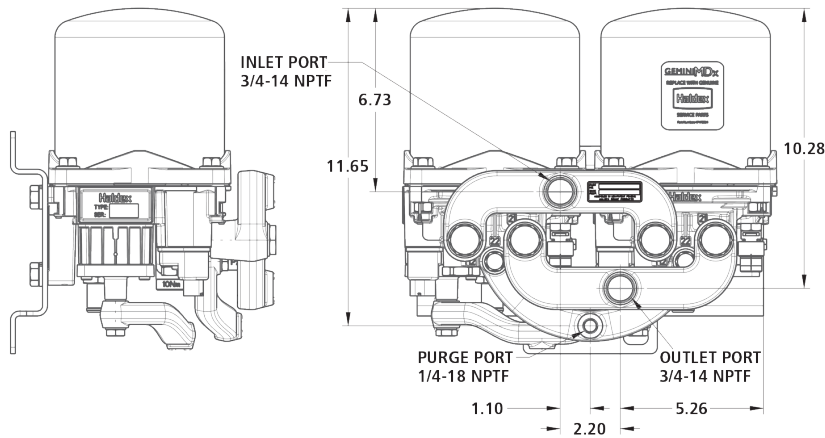

VIEW OF MUFFLER VERSION



## Dimensions and Port Identification

### Dual Consep/Dual Dryer Assembly

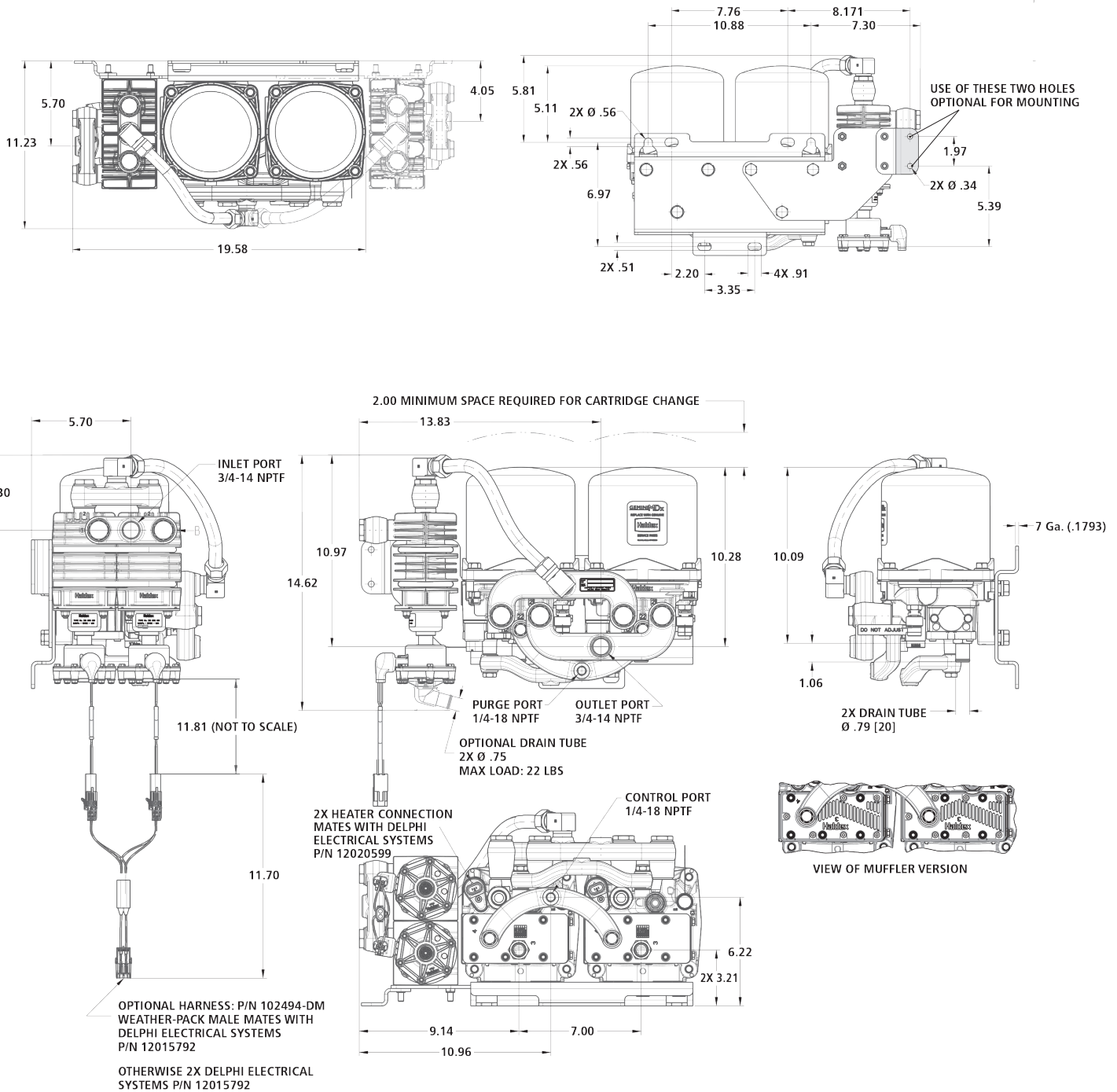

## Electrical Diagrams

### Dual Consep 12/24V Non-Heated Without Relay

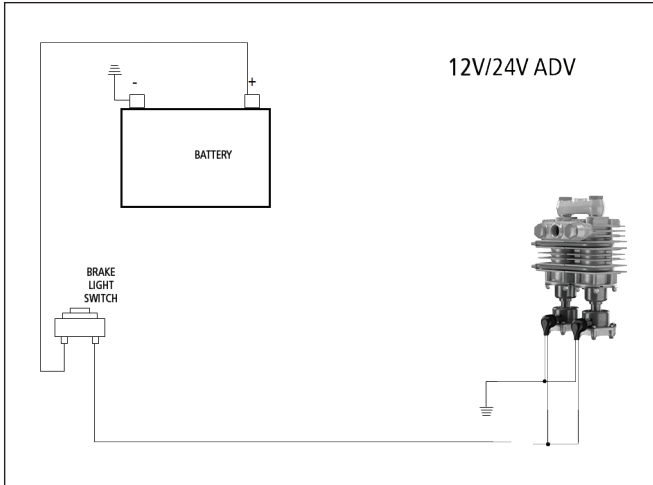

**Electrical Relay (not included)**

### Dual Consep 12/24V Heated with Electrical Relay or Timer Relay

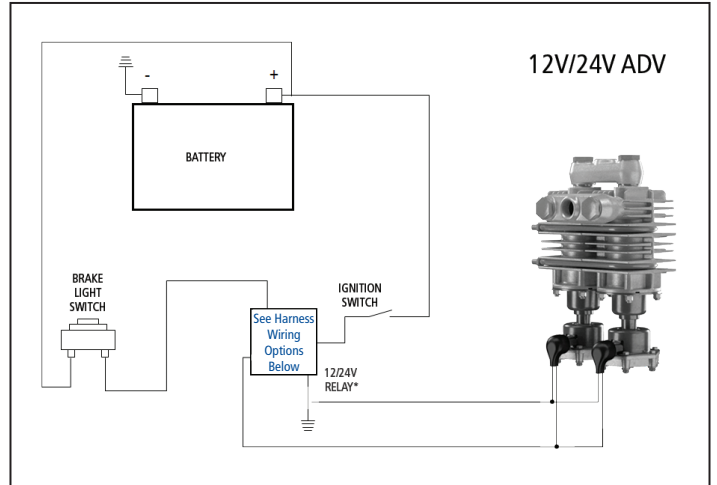

**Timer Relay (not included)**

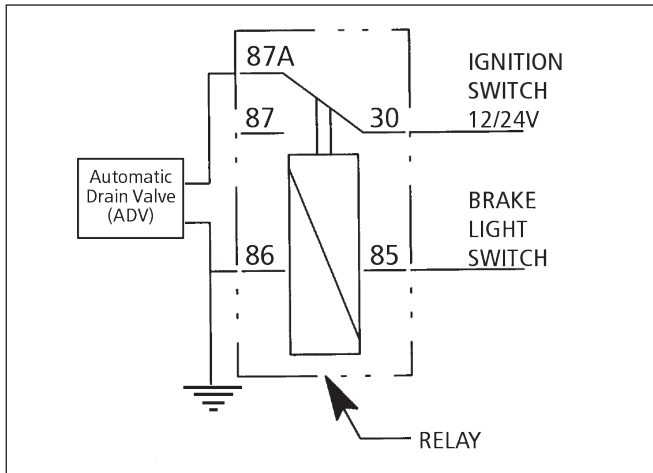

**Normal** - Connect to #87 (#87A not used)  
**Heated** - Connect to #87A as shown (#87 not used)

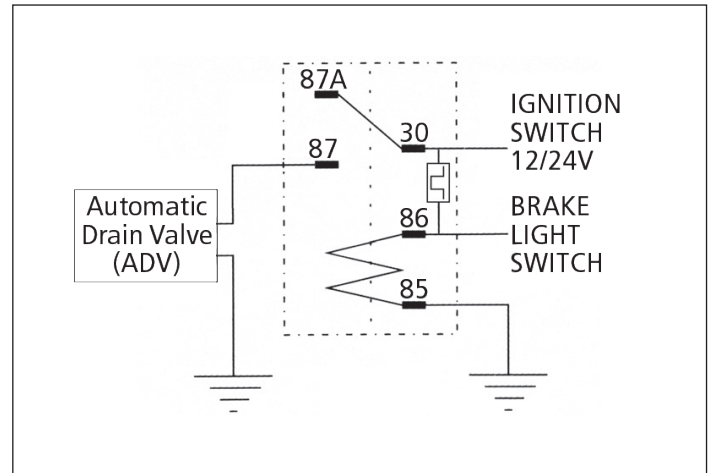

**Normal** - Connect to #87 as shown (#87A not used)  
 ON 3 Seconds/OFF 45 Seconds  
**Heated** - Connect to #87A (#87 not used)  
 ON 45 Seconds/OFF 3 Seconds

### Air Dryer Heater

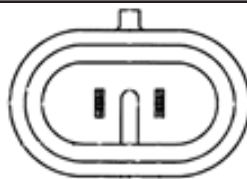
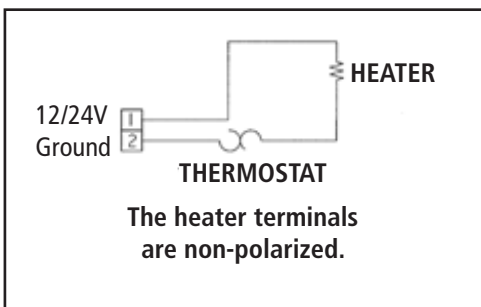

Connection per SAEJ2383.  
 Accepts Delphi Electrical  
 Systems P/N 12020599.

#### Thermostat Operation

**Closes** as temperature decreases to  $45^{\circ} \pm 7^{\circ} \text{ F}$   
**Opens** as temperature increases to  $71^{\circ} \pm 6^{\circ} \text{ F}$



## Operational Check

### Testing The GeminiMDx

Before placing the vehicle in service, perform the following tests:

1. Close all reservoir drain cocks.
2. Build up system air pressure to governor cut-out and note that the GeminiMDx dryer purges with an audible exhaust of air.
3. Check for air leaks by applying a soapy water solution around the dryer manifolds, banjo bolts, pipe fittings, and dryer base.
4. Actuate the service brakes to reduce system air pressure to governor "cut-in" pressure and ensure the compressor is in a loaded cycle. Note that the system once again builds to full pressure and is followed by a purge.
5. In order to check the Consep / ADV for proper operation the compressor must be in the compressor loaded cycle and the air governor must be between "cut-in" and "cut-out" pressure. This step can be performed concurrently with step 3.
  - a. Check the Consep for air leaks by applying a soapy water solution around the manifolds, banjo bolts, pipe fittings, and ADV mounting area and drain port.
  - b. Observe the ADV for an audible click, either during a brake application, timer function, or multiplexing signal. As the ADV clicks, and compressor loaded and governor between "cut-in" and "cut-out", the drain will expel a small "puff" of air. If contaminants are present, they will be expelled with the "puff".
  - c. Perform a manual drain test by depressing the red button on the bottom of the valve.
  - d. To check the ADV valve's heating element, turn on the vehicle's ignition. Wait ten minutes. The valve should be warm to the touch.
6. Operational check of air dryer heater:
  - a. The heater can be checked while in the air dryer housing.
  - b. The air dryer temperature must be below 45°F (thermostat closing temperature) to check the heater resistance.
  - c. Set volt-ohmmeter to ohms.
  - d. Disconnect the electrical plug.
  - e. Connect the continuity tester to the heater element terminals.
6. f. Measure the resistance
  - Acceptable 12VDC: 1.4-1.8  $\Omega$
  - Acceptable 24VDC: 5.9-6.9  $\Omega$
- g. Replace heater if 12VDC is <1.4  $\Omega$  or 24VDC is <5.9  $\Omega$ .
7. It is recommended that the vehicle be tested for leakage using the following procedure to assure the GeminiMDx will not cycle excessively.
  - a. Apply the parking brakes, build system pressure to governor cut-out and allow pressure to stabilize for at least one minute.
  - b. Observe the dash gauge pressures for two minutes and note any pressure drop. Pressure drop should not exceed 4 PSI with brakes released and 6 PSI with brakes applied. Any noticeable leakage must be repaired to avoid excessive dryer cycling.
9. **Charge Cycle Time:** During normal, daily operation the compressor should recover from governor cut-in to governor cut-out in 90 seconds or less at engine RPM's depending on vehicle vocation.
10. **Purge Cycle Time:** During normal, daily operation the compressor must remain unloaded for a minimum of 30 seconds between charge cycles. This minimum purge time is required to ensure complete regeneration of the desiccant.



## Troubleshooting

PROBLEM	CAUSE	REPAIR
Water in air system	Contaminants in desiccant	Change cartridge canister. Check compressor for excessive oil passage.
	Leaks in air system	Tighten air connections, soap connection and recheck for leaks.
Excessive compressor cycling	Excessive leaks in air system	Tighten air connections, soap connection and recheck for leaks.
	Defective dryer outlet check valve	Clean check valve seat and replace.
	Undersized compressor; duty cycle of compressor should not exceed 25%	Reduce air demand or install greater output compressor.
Safety valve is open	Cartridge canister is plugged	Excessive oil passage from compressor. Check for worn compressor, replace if necessary. Replace cartridge canister.
	Ice block in air dryer	Check heater function. Check electrical power to heater assembly. Refer to Operational Check Section Page 12. Replace heater assembly, if necessary.
	Excessive system pressure	Repair or replace air governor.
Poor drying efficiency	Air at inlet of dryer exceeds 170°F	Extend length of compressor discharge line. The 170°F dryer inlet temperature can usually be accomplished with 12' to 15' of compressor discharge line.
Short life of air dryer or cartridge canister	Air at inlet of dryer exceeds 170°F	Extend length of compressor discharge line. The 170°F dryer inlet temperature can usually be accomplished with 12' to 15' of compressor discharge line.
	Duty cycle of compressor does not allow for sufficient time for desiccant regeneration	During normal operation the compressor must remain unloaded for a minimum of 30 seconds to allow for sufficient purge. Lengthy loading times must be avoided. Air dryer must be "bypassed" in applications with high air use such as bulk unloading.
Water, oil or a mixture of both are present in air system	Desiccant contaminated with oil	Inspect, clean or replace cyclone insert in Consep. Replace cartridge canister. Drain all air tanks. Inspect compressor for correct operation.
Air pressure will not "build up"	Air leak from purge valve	Not a serviceable item. Refer to Valve Unit with Integrated Purge Valve Section on Page 19. Replace valve unit assembly.
	Governor not operating	Check operation of governor and replace if necessary.
	Ice block in air line, Consep or dryer	Check heater function. Check electrical power to heater assembly. Refer to Operational Check Section Page 12. Replace heater assembly, if necessary.



## Troubleshooting (cont'd)

PROBLEM	CAUSE	REPAIR
Heater element inoperable	Wrong voltage of element installed	Verify correct element or valve is being used. (12 VDC vs 24 VDC).
	Electrical power not present at heater element	Check for power and ground with ignition in "RUN" position.
	Heater element not functioning	Perform operation check. Replace heater element as needed.
Consep ADV inoperable	Electrical power not present at ADV	Check for power and ground with ignition in "RUN" position.
Consep ADV manual drain button inoperable	Debris collected around return spring	Flush with a non-residual cleaner and compressed air.

## Suggested Maintenance Schedule

Maintenance Interval	Maintenance Recommended
Daily	Ensure purge valve operation. Drain air system.
Weekly	Drain GeminiMDx purge tank and air tanks.
Monthly	Operational check of all GeminiMDx functions.
Every Two Years	Replace cartridge canisters.
Every Summer	Ensure discharge line temperature is <170°F
Every Winter	Check heater element operation. Refer to Operational Check Section Page 12.

The maintenance intervals are dependent on the operation conditions. The following is only a suggested service interval for general installations.

**One Year or 30,000 Miles, whichever comes first**

If the suggested interval is too long or too short for the particular application, adjust accordingly with the manufacturer's specifications.

During maintenance, the internal parts must be cleaned, inspected and/or replaced. Refer to Part Service Kit(s) on the following page.

The Consep must be inspected periodically for proper operation. The interval between inspections is determined by the type of service. High compressor duty cycles and high temperatures can cause a build-up of carbon in the condenser, drain valve and filter.





## GeminiMDx Part Number/Description Listing

	Aftermarket Part Number	Original Equipment Part Number	Dual Dryer Exhaust	Dual Dryer Heater, Volts	Consep, Quantity	Consep, Volts	Consep Tube Drain	Consep Orientation, Notes, Etc.	Dual Dryer Repair Kit	Consep Repair Kit	Combo (Both Dryer and Consep Together)
Pre-treatment and Dryer	DA37011	N4265AC	Silencer	24	1	12	N	Left side Consep bracket protruding	DQ6103	DQ6122	DQ6120
	DA37013	N4265AD	Silencer	24	1	12	N	Left side Consep bracket inverted	DQ6103	DQ6122	DQ6120
	DA37021	N4265AE	Silencer	24	1	24	N	Left side	DQ6103	DQ6107	DQ6127
	DA37061	N4265BC	Silencer	24	2	24	N	Left side	DQ6103	DQ6100	n/a
	DA37062	N4265BD	Silencer	24	2	24	N	Right side	DQ6103	DQ6100	n/a
	DA37181	N4265BR	Tube	24	2	24	Y	Left side	DQ6102	DQ6100	n/a
	DA37068	N4265BT	Silencer	24	2	24	N	Left side	DQ6103	DQ6100	n/a
	DA37251	N4265FB	Silencer	12	2	12	N	Right side	DQ6105	DQ6101	n/a
	DA37259	N4265FJ*	Silencer	12	2	12	N	Right side	DQ6105	DQ6101	n/a
Pre-treatment Only	DA39100	N4265CF	n/a	n/a	2	24	N	Wide mount	n/a	DQ6100	n/a
	DA39102	N4265CJ	n/a	n/a	2	24	N	Narrow mount	n/a	DQ6100	n/a
Dryer only	DA37000	N4265AA	Silencer	24	n/a	n/a	n/a	n/a	DQ6103	n/a	n/a
	DA37100	N4265AB	Tube	24	n/a	n/a	n/a	n/a	DQ6102	n/a	n/a
	DA37005	N4265DA**	Silencer	24	n/a	n/a	n/a	n/a	DQ6103	n/a	n/a
	DA37500	N4265EB	Tube	24	n/a	n/a	n/a	No Conseps; No TPVs [Nat. Asp. Appl.]	DQ6133	n/a	n/a

\*Consep connector is rotated 180 degrees under the dryer; \*\*SKF replacement

## Replacement Parts/Retrofit Components

Part Number	Description	Notes
102494DM	Y-Harness for Dual Consep	Two Weather-Pack Female Connectors to One Weather-Pack Male Connector
102494DN	Y-Harness for Dual Dryest	Two Metri-Pack 280 Female to Two Splice Connectors
41092749	Automatic Drain Valve (ADV) for 24V Consep	Complete Service Kit
41092750	Automatic Drain Valve (ADV) for 12V Consep	Complete Service Kit
41176281	Relay for 24V Automatic Drain Valve (ADV)	-
41176282	Relay for 12V Automatic Drain Valve (ADV)	-
41178240	Drain Tube Kit for Consep or Automatic Drain Valve	3/4" Side Outlet; Replaces Bottom Cover
41183400	Timer Relay for 24V Automatic Drain Valve (ADV)	-
41183401	Timer Relay for 12V Automatic Drain Valve (ADV)	-
47110020	Heater Repair Kit for 12V DRYest	12V Heater, Pigtail, Splice Connectors
47110021	Heater Repair Kit for 24V DRYest	24V Heater, Pigtail, Splice Connectors
DQ6121	Purge Tank Kit for GeminiMDx Dual Dryer System	600 cubic inch purge tank; fittings; 3/8" Air Line; Drain valve
DQR0001	GeminiMDx Retrofit Kit, 12 VDC	Includes: DA37259, 102494DM, 102494DN and DQ6121

### Service Kit Components

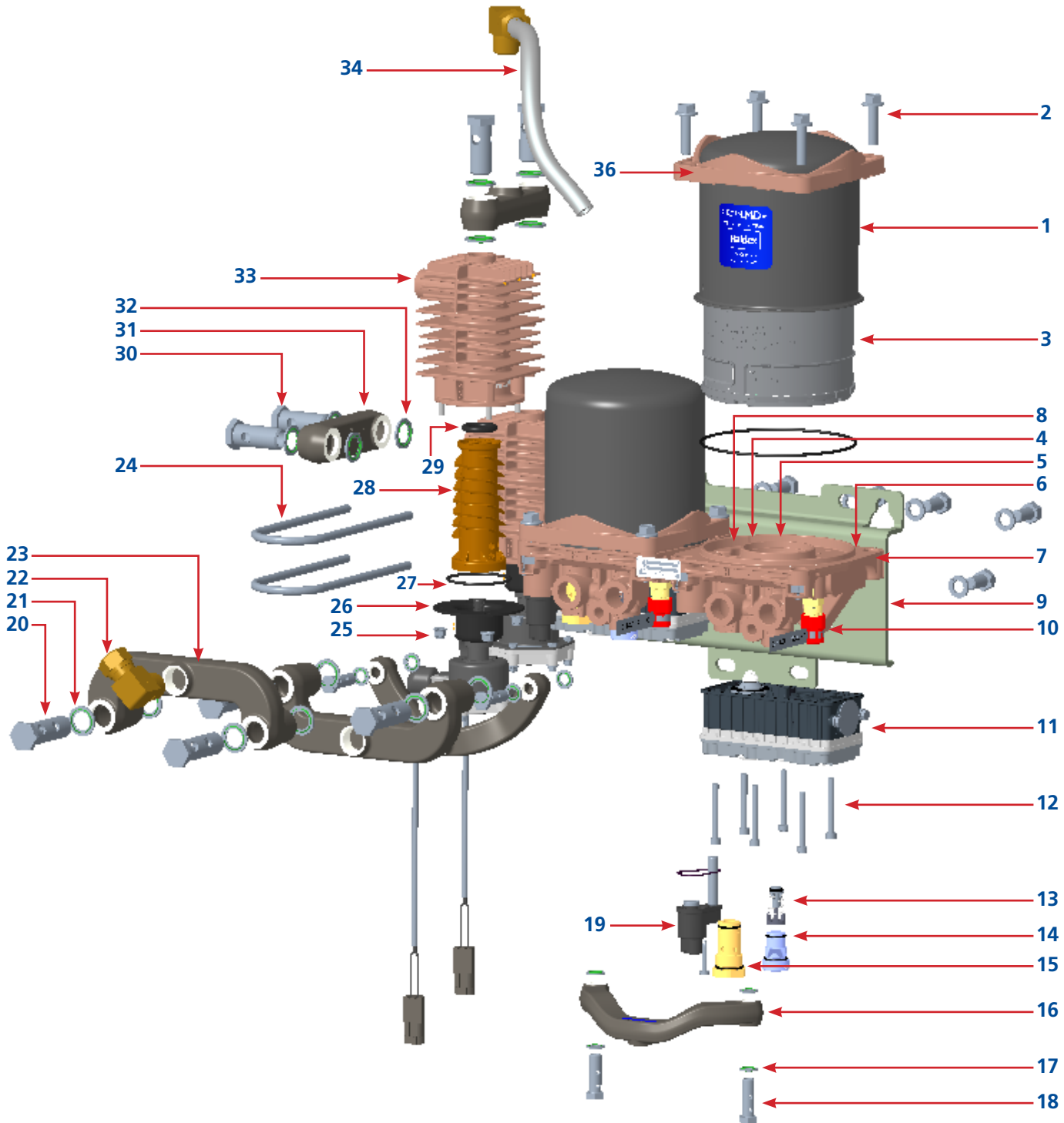



## Service Kit Contents

	Component Description	NSS	DUAL CONSEP KIT NUMBERS			DUAL DRYER KIT NUMBERS						SINGLE CONSEP DUAL DRYER KIT NUMBERS			SINGLE CONSEP KIT NUMBERS			INDIVIDUAL KITS TWO KITS REQUIRED PER DUAL DRYER								
			DQ6100	DQ6101	DQ6131	DQ6102	DQ6103	DQ6105	DQ6106	DQ6132	DQ6133	DQ6120	DQ6127	DQ6123	DQ6107	DQ6122	41277322	47178199	47178223	47189189	47110022	471-77484	47178964	47190361	47110024	47171868
1	CANISTER, CARTRIDGE	X																								
2	BOLT, HEX HEAD SHOULDER M10 X 40					8	8	8	8		8	8	8											4		
3	CARTRIDGE, DESICCANT					2	2	2	2		2	2	2										1			
4	PIN, LOCKING					2	2	2	2		2	2	2										1			
5	NUT, M10					8	8	8	8		8	8	8										4			
6	O-RING					2	2	2	2		2	2	2										1			
7	PIN, LOCKING					6	6	6	6		6	6	6										3			
8	CAP, VALVE																								1	
9	MOUNTING BRACKET, AIR DRYER	X																								
10	VALVE, SAFETY 160 PSI																							1		
11A	VALVE UNIT WITH SILENCER						2	2				2	2													
11B	VALVE UNIT WITH DRAIN TUBE					2					2															
12	BOLTS, VALVE UNIT					12	12	12	12		12	12	12													
13	VALVE, CHECK					2	2	2	2		2	2	2										1			
14	PLUG, OUTLET CHECK VALVE					2	2	2	2		2	2	2										1			
15	VALVE, TURBO PROTECTION					2	2	2	2			2	2										1			
16	MANIFOLD, CONTROL/PURGE	X																								
17	WASHER, M12 SEALING					8	8	8	8		8	8	8	8												
18	BOLT, M12 BANJO										4															
19A	HEATER, 24 VOLT					2	2				2	2	2										1			
19B	HEATER, 12 VOLT							2	2														1			
20	BOLT, M22 BANJO LONG										4															
21	WASHER, M22 SEALING		8	8	8	8	8	8	8		8	8	8													
22	MALE ELBOW, 90° 3/4" - 14 NPTF X 3/4" TUBE														1											
23	MANIFOLD, INLET/OUTLET	X																								
24	U-BOLT, NARROW	X																								
25	NUT, LOCKING M6		8	8								4	4									4	4			
26A	ADV FOR CONSEP, 24 VOLT		2										1									1				
26B	ADV FOR CONSEP, 12 VOLT			2								1										1				
27	O-RING, CYCLONE INSERT		2	2								1	1									1	1	1		
28	INSERT, CYCLONE		2	2								1	1									1	1	1		
29	O-RING, ADV		2	2								1	1									1	1	1		
30	BOLT, M22 BANJO SHORT					4																				
31	MANIFOLD, CONSEP	X																								
32	WASHER, M22 SEALING		8	8																						
33	HOUSING, CONSEP	X																								
34	TUBE, NYLON 3/4" DIA. X 14.25" LONG														1											
35	MALE ELBOW, 90° 1/2" - 14 NPTF X 3/4" TUBE (NOT SHOWN)														1											
36	COLLAR, CANISTER																									1

## Removal/Installation Instructions

### GeminiMDx

1. Ensure air pressure is at 0 PSI in air system.
2. Disconnect air lines from GeminiMDx manifolds and Consep inlet manifold.
3. Disconnect electrical connection from the Consep ADV.
4. Disconnect the electrical connection from both heating elements.
5. Remove the mounting bolts from the GeminiMDx bracket.
6. Remove the air dryer for inspection and maintenance.
7. Reinstall / install the unit to the mounting location using the mounting bolts. Tighten and torque the bolts to 35-50 ft-lbs
8. Connect electrical plugs to both heating elements.
9. Connect electrical plugs to the Consep ADV. Valve (ADV) electrical harness.
10. Reconnect air lines to the GeminiMDx manifolds and Consep inlet manifold.

Perform Operational Checks (Page 12).

**NOTE: Clean area above and around the GeminiMDx BEFORE removing the cartridge canister.**

### Cartridge Canister

1. Ensure air pressure is at 0 PSI in air system.
2. Clean and remove all debris around cartridge canister.
3. Remove four retaining bolts from retaining collar.

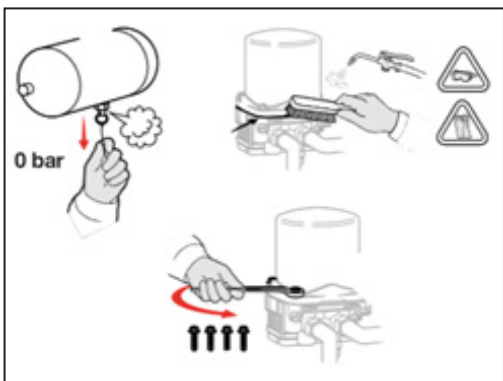

4. Lift cartridge canister away from dryer base.
5. Inspect and remove any debris from dryer base. Discard old o-rings and clean sealing surface.

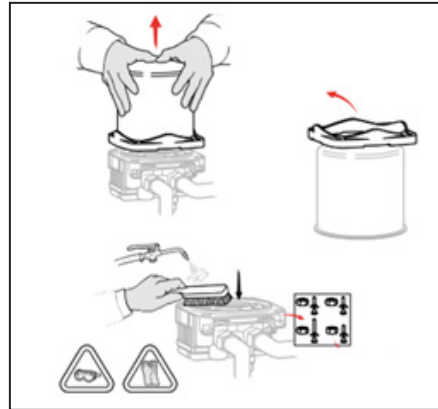

6. Ensure that protection cap for safety valve housing is not damaged. If cap is off, snap cap back into place.
7. Flip cartridge canister upside down. Rotate desiccant cartridge 45° and remove from canister.

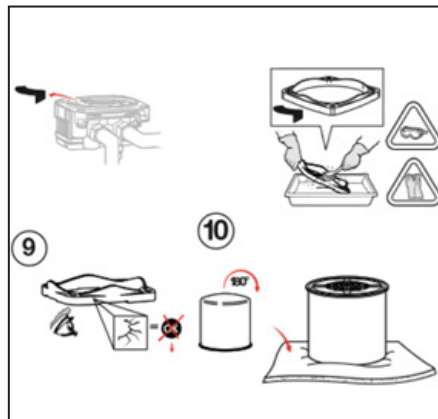

8. Install desiccant cartridge into canister and rotate 45° to secure the cartridge to the canister.

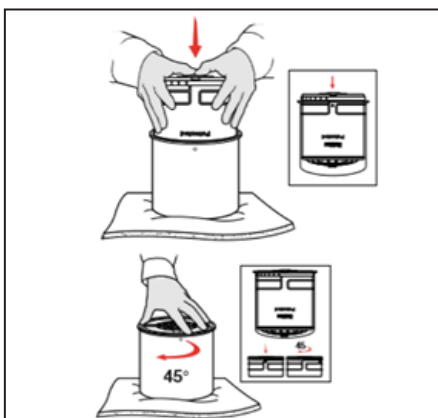

## Removal/Installation Instructions

### Cartridge Canister (cont'd)

9. Apply silicone-based grease to o-rings.
10. Install replacement nut and plastic locking pins.
11. Install cartridge canister with retaining collar on dryer base.

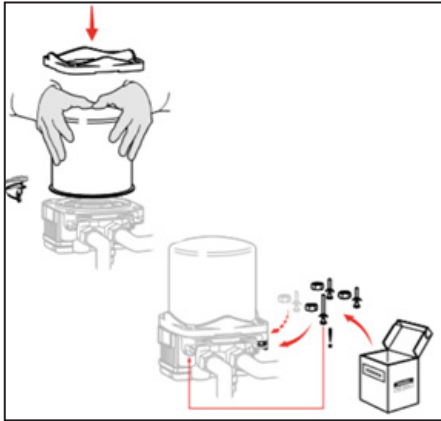

12. Using a cross pattern, tighten the four mounting bolts to 32-35 ft-lbs (43-47 Nm).

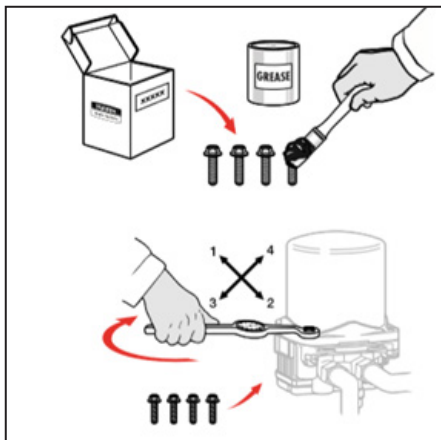

### Valve Unit with Integrated Purge Valve

**NOTE: Purge valve is not a serviceable item.**

1. Ensure air pressure is at 0 PSI in air system.
2. Remove control manifold for access to the valve unit.
3. Clean and remove all debris from around the valve unit.

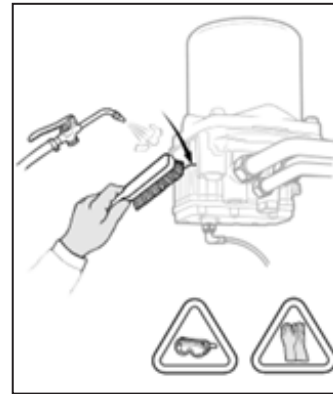

4. Remove six mounting bolts from valve unit.

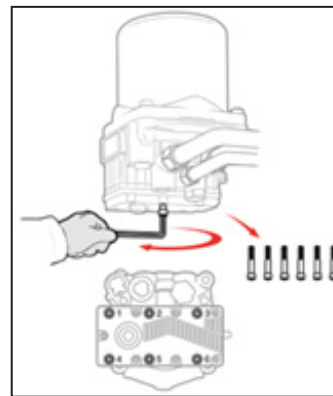

5. Clean mounting surfaces and apply grease to o-rings.

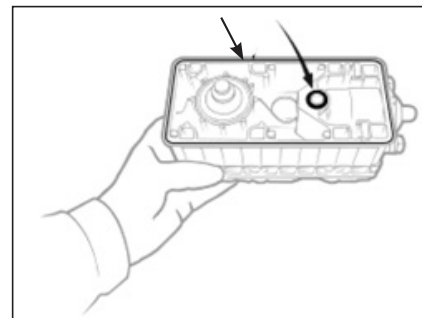

## Removal/Installation Instructions (cont'd)

### Valve Unit with Integrated Purge Valve (cont'd)

6. Install valve unit to dryer base.

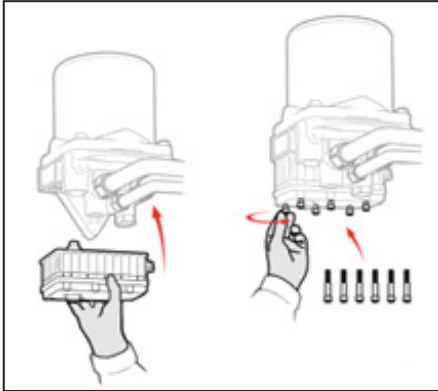

7. Tighten mounting bolts in star pattern to 62-80 in-lbs (7-9 Nm).

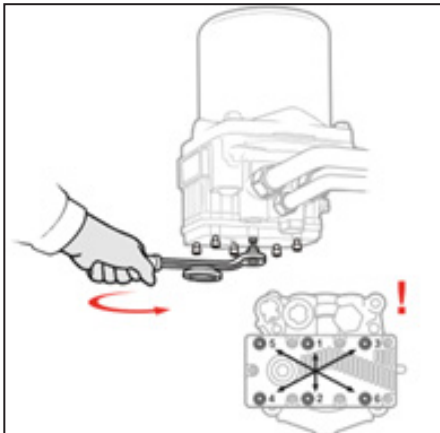

8. Reinstall control manifold. Apply a small amount of silicone compound to green part of the seal. Tighten M12 banjo bolt(s) to 130-150 in-lbs (15-17 Nm).

### 12/24 VDC Heater Assembly

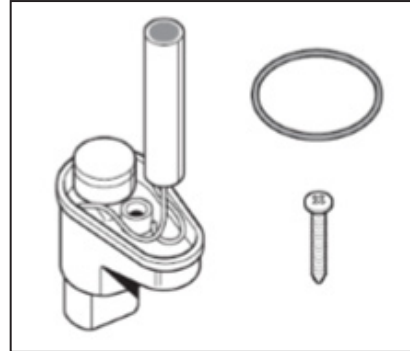

1. Disconnect electrical plug from heating assembly.
2. Remove the retaining screw (T25 Torx), heater assembly and o-ring from dryer base.
3. Install new heater element into dryer base.
4. Install retaining screw. Torque to 45-55 in-lbs (5-6 Nm).
5. Reconnect electrical plug to heating element.

## Removal/Installation Instructions (cont'd)

### Outlet Check Valve Assembly

1. Ensure air pressure is at 0 PSI in air system.
2. Remove control manifold to access outlet check valve plugs.
3. Clean and remove all debris from around the check valve.

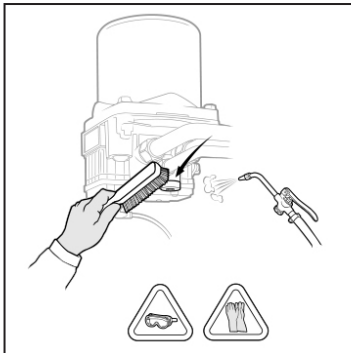

4. Remove check valve from dryer base.

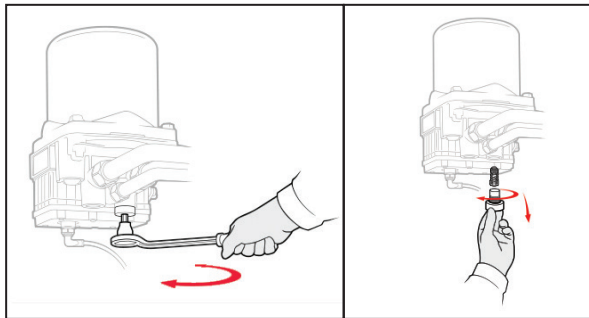

5. Inspect and clean check valve bore as necessary.
6. Retrieve new check valve and grease o-rings.
7. Install new check valve. Tighten to 84-94 in-lbs (9.5-10.5 Nm).

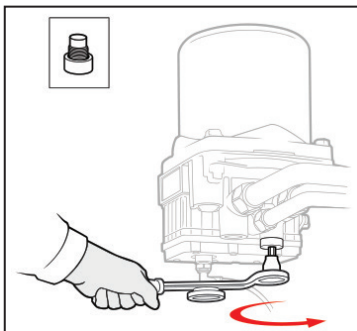

8. Reinstall control manifold. Apply a small amount of silicone grease to green part of banjo bolt seals. Tighten M12 banjo bolts to 130-150 in-lbs (15-17 Nm).

### Turbo-Protection Valve (TPV)

1. Disconnect air line from Consep manifold to dryer manifold.
2. Disconnect air line from GeminiMDx to system tanks.
3. Remove outlet manifold and control manifold for access to turbo-protection valve fitting.
4. Clean and remove all debris around fitting.

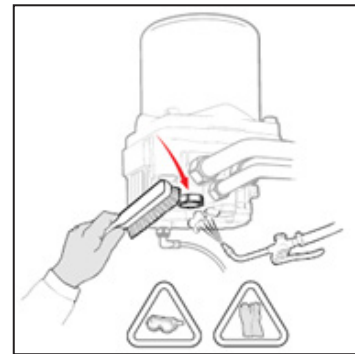

5. Loosen and remove fitting from dryer base.

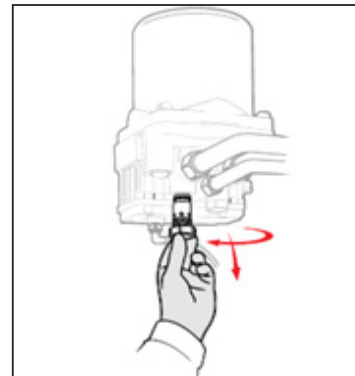

6. Ensure threads and fitting bore are free of debris.

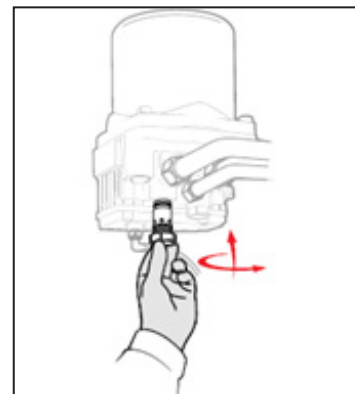

## Removal/Installation Instructions (cont'd)

### Turbo-Protection Valve (TPV) (cont'd)

7. Retrieve new TPV and grease o-ring.
8. Install TPV in dryer base and tighten to 45-55 ft-lbs (61-75 Nm).

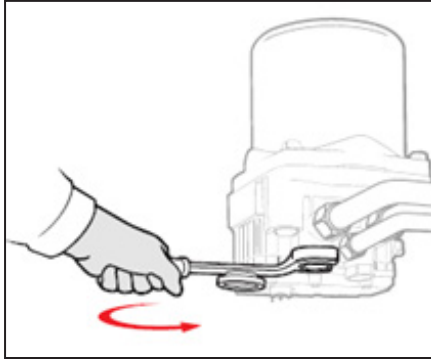

9. Reinstall control manifold and outlet manifold. Apply a small amount of silicone grease to green part of banjo bolts seals.

Tighten banjo bolt(s) to:

M22 45-55 ft-lbs (61-75 Nm)

M12 130-150 in-lbs (15-17 Nm)

10. Reconnect air line from system tanks to GeminiMDx.
11. Reconnect air line from dryer manifold to Consep manifold.

### Safety Valve

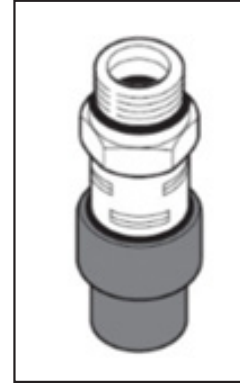

1. Ensure air pressure is at 0 PSI in air system.
2. Clean and remove all debris from around safety valve.
3. Remove safety valve from dryer base.
4. Inspect and clean safety valve bore as necessary.
5. Reinstall safety valve.



## Removal/Installation Instructions (cont'd)

### Cyclone/ADV for Consep

1. Ensure air pressure is at 0 PSI in air system.
2. Disconnect electrical connection.
3. Remove all four mounting nuts.

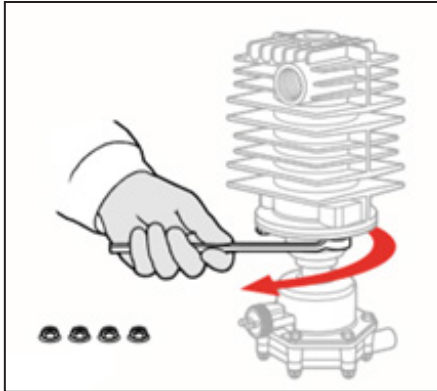

6. Install ADV for Consep. Tighten four mounting nuts to 80-98 in-lbs (9-11 Nm).

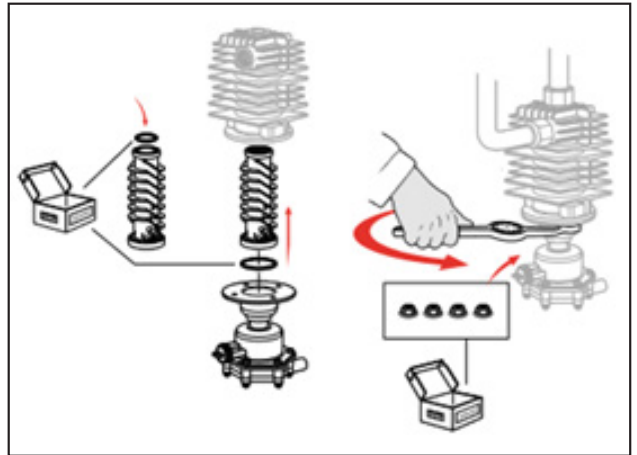

4. Remove cyclone and discard o-rings.

-OR-

If only replacing ADV for Consep, clean cyclone and o-rings.

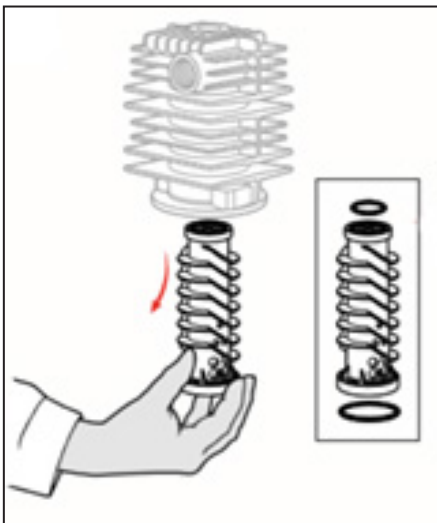

5. Apply grease to o-rings. Insert cyclone into Consep housing. Align notch of cyclone with Consep housing cutout.

## Glossary

**Adsorption:** Process by which water and oil molecules at high pressure are captured by the desiccant.

**Air Dryer:** A device that cools, filters and dries the air delivered by an air compressor.

**Compressor Load Cycle:** The time during which the air compressor is building air pressure in an air system.

**Compressor Unload Cycle:** The time during which the air compressor is not building air pressure in an air system.

**Desiccant:** A substance that adsorbs and desorbs moisture from air.

**Desorption:** Opposite to adsorption. When depressurized in the unloading phase, the air dryer desiccant will release the water and oil molecules. At the same time a back flow of dry air that collects the water and oil is led through the cartridge and exhausts it via the Purge Valve to atmosphere. The process is also called “regeneration”.

**Drying Cycle:** The time during which the air dryer cools, filters and removes moisture from the air.

**Duty Cycle:** Compressor loaded time divided by engine on time.

**Heater:** A heater helps prevent moisture collected within the air dryer from freezing. The integrated thermostat on the heater controls when the heater is energized.

**Outlet Check Valve:** A valve that prevents downstream air from flowing back through the air dryer.

**Purge Cycle:** The time during which the air dryer is undergoing decompression and regeneration.

**Purge Tank:** A dedicated external reservoir for which the air for desorption/regeneration comes from.

**Purge Valve:** A valve or valve unit that allows the collected moisture and contamination to be expelled from the air dryer during the purge cycle.

**Regeneration:** The controlled back flow of air through the desiccant to remove moisture and contaminants.

**Safety Valve:** A valve designed to relieve system pressure if it reaches a level higher than normal operating pressures. This protects other brake system components from high pressures that could cause system damage or failure.

**Turbo Protection Valve (TPV):** A valve that closes the dryer inlet during the compressor unload cycle to avoid engine turbocharge pressure loss.

inside back cover - blank



With more than 100 years of intensely focused innovation, Haldex holds unrivaled expertise in brake systems and air suspension systems for heavy trucks, trailers and buses. We live and breathe our business, delivering robust, technically superior solutions born from deep insight into our customers' reality.

By concentrating on our core competencies and following our strengths and passions, we combine both the operating speed and flexibility required by the market. Collaborative innovation is not only the essence of our products - it is also our philosophy. Our employees, spread on four continents, are constantly challenging the conventional and strive to ensure that the products we deliver create unique value for our customers and all end-users.

To learn more, contact your Haldex sales professional.

United States 816-891-2470  
Canada 519-621-6722  
Mexico 52-81-81569500

For additional contact information  
or to learn more about Haldex,  
please visit [Haldex.com](http://Haldex.com)

**L31279**  
US Rev. 11/19 (2)  
ART ONLY