

# Repair Instructions

A 132, A 132 II  
Buses



Copyright © ZF Friedrichshafen AG

This document is protected by copyright.

Complete or partial reproduction or distribution of this document is not permitted without the approval of ZF Friedrichshafen AG.

Infringements lead to civil and criminal prosecution.

This document is a translation of the German original.

---

<b>1</b>	<b>Preface</b> .....	<b>5</b>
1.1	Document overview .....	5
<b>2</b>	<b>Safety</b> .....	<b>6</b>
2.1	Signal words and symbols .....	6
2.2	General safety instructions .....	7
2.3	Product-specific safety instructions .....	9
2.3.1	Screw connection .....	9
<b>3</b>	<b>Notes on Repairs and Assembly</b> .....	<b>10</b>
3.1	General Notes .....	10
3.2	Cleaning the ZF product .....	10
3.3	Dismantling the ZF product .....	10
3.4	Assembling the ZF product .....	10
3.5	Cleaning parts .....	11
3.6	Reusing parts .....	11
3.7	Replacing parts .....	11
3.8	Reworking parts .....	12
<b>4</b>	<b>Technical Data</b> .....	<b>13</b>
4.1	Oil grade .....	13
4.2	Type plate .....	13
<b>5</b>	<b>Settings</b> .....	<b>14</b>
<b>6</b>	<b>Tightening Torques</b> .....	<b>15</b>
<b>7</b>	<b>Workshop Equipment</b> .....	<b>17</b>
7.1	Special tools .....	17
7.2	Standard tools and fixtures .....	27
7.3	Operating supplies and auxiliary materials .....	32
<b>8</b>	<b>Preparatory Activities</b> .....	<b>33</b>
8.1	Removing mounting parts .....	33
8.2	Clamping A 132/A 132 II .....	35
8.3	Draining oil .....	36
<b>9</b>	<b>Dismantling</b> .....	<b>37</b>
9.1	Removing the brake caliper .....	37
9.2	Removing and dismantling hub .....	39
9.2.1	Removing the hub .....	39
9.2.2	Dismantling hub .....	41
9.3	Removing tachometer and hub carrier .....	44
9.4	Removing breather .....	46
9.4.1	Removing breather (variant with ZF membrane breather) .....	46
9.4.2	Removing breather (variant with breather valve) .....	46

# Table of Contents

---

9.5	Removing axle insert .....	46
9.6	Disassembling axle insert .....	47
9.6.1	Fastening axle insert to the assembly truck .....	47
9.6.2	Removing crown wheel support .....	48
9.6.3	Disassembling differential .....	49
9.6.4	Dismantling differential .....	51
9.6.5	Removing the pinion .....	53
<b>10</b>	<b>Testing, Measuring, Adjusting .....</b>	<b>61</b>
10.1	Checking contact pattern (Gleason-gearing) .....	61
10.1.1	Contact pattern on crown wheel shifted towards the tip .....	62
10.1.2	Contact pattern on crown wheel shifted towards the root .....	62
<b>11</b>	<b>Assembly .....</b>	<b>63</b>
11.1	Assembling axle insert .....	63
11.1.1	Installing the pinion .....	63
11.1.2	Assembling differential .....	76
11.1.3	Installing the differential .....	79
11.1.4	Installing the crown wheel support .....	83
11.2	Installing axle insert .....	84
11.3	Mounting breather .....	86
11.3.1	Mounting breather (variant with ZF membrane breather) .....	86
11.3.2	Mounting breather (variant with breather valve) .....	86
11.4	Mounting hub carrier and tachometer .....	86
11.5	Assembling and installing hub .....	89
11.5.1	Assembling the hub .....	89
11.5.2	Mounting hub .....	93
11.6	Mounting brake caliper .....	96
11.7	Installing mounting parts .....	98
11.7.1	Mounting the spring carriers .....	98
11.7.2	Installing mounting parts .....	98
11.8	Filling with oil .....	100
<b>12</b>	<b>Annex .....</b>	<b>101</b>
12.1	Formulary and conversion tables .....	101
12.1.1	Conversion of length units .....	101
12.1.2	Conversion of mass units .....	101
12.1.3	Conversion of force units .....	102
12.1.4	Conversion of pressure units and units of stress .....	102
12.1.5	Conversion of torque units .....	103
12.1.6	Conversion of temperature units .....	104
12.2	Overview of revisions .....	104

# 1 Preface

In addition to the ZF documentation, observe the provisions of the vehicle manufacturer or the body manufacturer.

## 1.1 Document overview

The specifications listed in these documents must be observed, because they are a prerequisite for fault-free operation of the product and for the warranty granted by ZF Friedrichshafen AG. Please get in touch with your contact if you need binding documents.

Document no.	Designation	Technical information
4474.758.103	Operating Instructions	A 132, A 132 II

Tab. 1

## 2 Safety

### 2.1 Signal words and symbols

This document contains particularly highlighted safety instructions which are marked with one of the following signal words depending on the severity of the danger.

#### **DANGER**

##### **DANGER**

The signal word **DANGER** indicates a dangerous situation that, if not prevented, will lead to a severe injury or death.

⇒ Information as to how the danger can be prevented.

#### **WARNING**

##### **WARNING**

The signal word **WARNING** indicates a dangerous situation that, if not prevented, can lead to a severe injury or death.

⇒ Information as to how the danger can be prevented.

#### **CAUTION**

##### **CAUTION**

The signal word **CAUTION** indicates a dangerous situation that, if not prevented, can lead to a slight or moderate injury.

⇒ Information as to how the danger can be prevented.

#### **NOTICE**

The signal word **NOTICE** indicates a situation that, if not prevented, can lead to property damage.

⇒ Information as to how the property damage can be prevented.

The following symbols are additionally used:



This symbol refers to additional, safety-relevant information.



This symbol indicates information concerning special workflows, methods, application of aids, etc.

## 2.2 General safety instructions

Read all safety instructions and information. Failure to comply with safety instructions and information may lead to property damage, serious injuries or death.

### Intended use

The ZF product is exclusively intended for the application as defined in the contract and as agreed on the time of delivery. Any other or extended form of use does not comply with this definition of intended use. The intended use includes compliance with this documentation and other applicable documents, in order to avoid malfunctions and damage in operation.

The ZF product is designed and produced in line with state-of-the-art technology. The ZF product in its delivery status is safe to operate. However, the ZF product may pose dangers if improperly used by unauthorized, untrained and uninstructed staff or if not used according to its intended use.

Figures might deviate from the ZF product and are not drawn to scale. No conclusions can be drawn with regard to size and weight.

### Installation, commissioning, maintenance and repair

Perform assembly, commissioning, maintenance and repair work exclusively according to this documentation and other applicable documents.

Observe the following points:

- Employ authorized, trained and instructed staff.
- Observe technical provisions.
- Only use genuine ZF spare parts.
- Only use genuine ZF accessories.
- Only use genuine ZF special tools.
- Unauthorized changes and modifications lead to the expiry of the operator's license, warranty or guarantee.

In case of damage, contact ZF and have the following information on the product ready:

- Type
- Parts list [BoM] number
- Serial number
- Operating hours
- Description of damage

Observe safety instructions, valid safety regulations and legal conditions to prevent malfunctions and damage.

The country-specific safety regulations, accident prevention regulations and environmental protection provisions apply additionally.

Wear safety-relevant workwear for all work. Depending on the work, also wear personal protective equipment.

After completing the work, check correct function and functional security.

## Handling of ZF product

Unauthorized changes and modifications might impair functional security. Changes, modifications and applications are only permissible upon written approval by ZF Friedrichshafen AG.

Observe the following when working on the ZF product:

- Secure workspace.
- Only carry out work at the unit when in a voltage-free state.
- Protect unit against being started accidentally. Attach instruction plate where it is clearly visible.
- Perform work when engine is switched off.
- Protect engine against being started accidentally. Attach instruction plate where it is clearly visible.
- Do not stand beneath a suspended load.
- Do not work on a suspended load.
- Only use permitted means of transport and lifting devices with sufficient load-bearing capacity.
- Close open tubings and hoses and avoid damage.
- Observe tightening torques.
- Protect cables against mechanical damage.

## Noise

Noise might cause irreversible damage to hearing.

The perception of acoustic signals, warning calls or sounds warning of impending danger is impaired by noise.

Observe the following when working on the ZF product:

- Avoid noise.
- Wear ear protection.

## Operating supplies and aids

Operating supplies and aids might cause permanent damage to health and environmental damage.

Observe the following when selecting operating supplies and aids:

- Health risks
- Environmental compatibility
- Material safety data sheets

Observe the following when handling operating supplies and aids:

- Store operating supplies and aids in suitable and correctly labeled containers.
- Seek medical help in case of injuries due to hot, cold or caustic operating supplies or aids.

Observe the following to protect the environment:

- Collect leaking operating supplies and aids in sufficiently large containers.
- Observe disposal regulations.
- Observe material safety data sheets.



## 2.3 Product-specific safety instructions

### 2.3.1 Screw connection

The torque wrenches must be calibrated to DIN EN ISO 6789.

## 3 Notes on Repairs and Assembly

### 3.1 General Notes

- Please read this documentation prior to starting repair or assembly work.
- Prior to starting repair or assembly work, please find out whether ZF Service Information on the ZF product is available. ZF Service Information may contain tests or supplements to the product or to repair processes, which may not be included in this documentation. The ZF-Service Information is available at all ZF Services Partner or in the ZF-ServiceLine.
- In case of doubt, always contact the relevant expert departments of ZF Aftermarket.
- Please ensure that all work on the ZF product is performed expertly and under clean conditions.
- Use the specified special tools and equipment intended for the working procedures described.
- Please perform all work according to the working procedure described.
- Cover opened ZF products to prevent entry of foreign matter.
- Cover parts that have been removed and that are reusable and protect them against dirt and damage.
- After completion of work and inspections, specialized staff must ensure that the ZF product is again functioning perfectly and is safe to operate.

### 3.2 Cleaning the ZF product

Clean the ZF product with an appropriate cleaning agent prior to repair or assembly works.

#### **NOTICE**

**Possible damage to ZF product due to penetrating water.**

⇒ Be careful when using a pressure washer on the ZF product.

### 3.3 Dismantling the ZF product

- Reusable parts must be clearly assigned to the dismantled ZF-product and the assemblies defined in this documentation. The assignment makes sure that reusable parts (e.g. gear parts, spacers or shims, electronic components) are not mixed up.
- Assemblies which must not be disassembled or are only available as spare parts assemblies are described accordingly. Please refer to the spare parts catalog for the ZF product.
- Inspect the parts during disassembly in order to find a potential cause of damage.

### 3.4 Assembling the ZF product

Assemble the ZF product at a clean workplace. The order of work steps, configuration data, and tightening torques must be retained. Use the special tools specified in the work steps.

#### **Bearings**

The provisions for assembly of the bearings are described in the respective work step. Each bearing integrated must be lubricated with operating oil after assembly.

### Sealing compound

Sealing compound is only to be used when described as such in the work step (*refer to Section Operating supplies and auxiliary materials*). Please observe the manufacturer guidelines and processing instructions. Apply the sealing compound thinly and evenly. Keep oil ducts and oil bores free of sealing compound. When assembling the parts, no sealing compound must enter the oil ducts or oil bores.

### Retaining agents

Retaining agents are only to be used when described as such in the work step (*refer to Section Operating supplies and auxiliary materials*). Please observe the manufacturer guidelines and processing instructions.

### Oil

Fill the ZF product with oil before operation. For the procedure and approved oil grades, refer to the document valid for the ZF product, the type plate, and/or the latest List of Lubricants TE-ML. These documents are available at all ZF Services Partner and here [www.zf.com](http://www.zf.com).

## 3.5 Cleaning parts

- Clean all reusable parts.
- Clean lined clutch disks with a lint-free cloth only.
- Remove sealing compound residues on sealing faces or retaining agent residues, e.g., in tapped holes or on splines.
- Clean joining surfaces.
- Clean blind holes and blind hole threads.
- Lubricating bores, oil bores, oil ducts, bores for oil press fits and lubricating grooves must be free from dirt, preservatives and foreign matter. Check for free passage.
- Hose assemblies, tubes and joining elements must be free from dirt, oil and damage. Clean dirty or oily parts. Check for free passage. Replace damaged parts.
- Clean all cavities and reliefs.
- Remove preservatives from new parts.

## 3.6 Reusing parts

Authorized, specialized staff assess whether parts can be reused. Replace parts

- if they are damaged
- if they are worn, e. g. bearings, multidisks, thrust washers, etc.
- if they have a permanent deformation
- if they have been overheated during operation or during disassembly.

Only replace with original ZF parts or ZF-approved parts. Please refer to the spare parts catalog for the ZF product.

## 3.7 Replacing parts

The following parts must always be replaced:

- Bolts with reduced shank and seals

- Single-use parts
- Sealing rings
- Safety plates
- Shaft sealing rings

Only replace with original ZF parts or ZF-approved parts. Please refer to the spare parts catalog for the ZF product.

### **3.8 Reworking parts**

Specialized staff assess whether parts need to be reworked.

Minor damage on reusable components can be removed and reworked with suitable special tools if the component's function is not impaired.

Minor damage includes:

- Indentation marks on sealing faces
- Score marks or burrs caused by the disassembly of the ZF product
- Fretting corrosion
- Paint and corrosion damage

If rework is needed on spacer washers or shims because of clearance settings, ensure that the reworked surface is level with the starting face and has the same surface quality.

Debur all edges that can cause chip formation during the assembly process or represent a risk of injury for the specialized staff. Remove burrs or other similar instances of unevenness.

## 4 Technical Data

### 4.1 Oil grade

#### NOTICE

Damage to ZF product due to using incorrect oil is possible.

⇒ Only use oils listed in the valid ZF List of Lubricants.

 Observe the information on the type plate.

Approved oils and their material safety data sheets which are listed in the ZF List of Lubricants: **TE-ML 12** are binding.

The latest ZF List of Lubricants can be obtained from all ZF Service Centers and viewed at [www.zf.com](http://www.zf.com).

### 4.2 Type plate

The type plate contains the most important data.

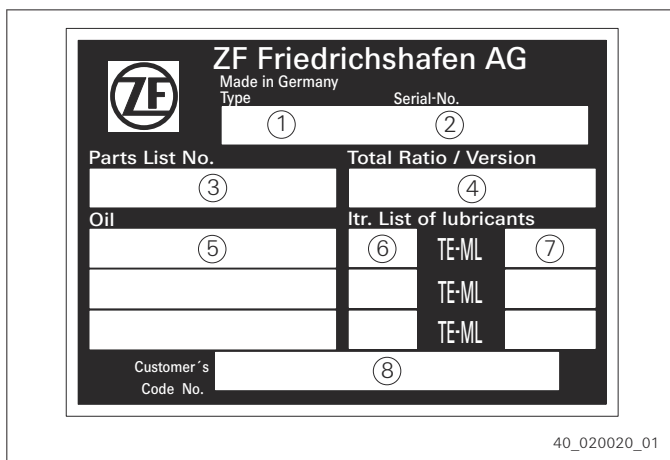

- 1 Product designation
- 2 Serial number
- 3 Parts list number
- 4 Transmission ratio
- 5 Oil specification
- 6 Approximate oil quantity for initial filling
- 7 No. of List of Lubricants
- 8 Customer spec. number, if known to ZF

The following data should be quoted when making inquiries or undertaking repairs: 1, 2, 3

Fig. 1 Type plate

## 5 Settings

Designation	Dimensions	Measuring instrument	Comment Chapter/Section
pinion bearing rolling torque	4.5 Nm to 10.5 Nm	Spring balance, thread	without shaft seal <ul style="list-style-type: none"> <li>Installing the pinion (variant with adjustable bearing), page 63</li> </ul>
pinion bearing rolling torque	4.5 Nm to 10.5 Nm	Torque wrench with scale dial gage	Tear-away torque <ul style="list-style-type: none"> <li>Installing the pinion (variant with adjustable bearing), page 63</li> </ul>
Backlash	0.27 mm to 0.33 mm	Dial gage with magnetic stand	<ul style="list-style-type: none"> <li>Installing the differential, page 79</li> </ul>
Bracket width	max. 387.95 mm $-0.2$ mm	Caliper gage	<ul style="list-style-type: none"> <li>Installing the differential, page 79</li> </ul>

## 6 Tightening Torques

Designation	Tightening torque	Measuring instrument	Comment Chapter/Section
Emergency loosening screw	<b>20 Nm (+5 Nm)</b> (maximum loosening torque)	Torque wrench	• Removing mounting parts, page 33
Hexagon screw M16 - 8.8	<b>195 Nm</b>	Torque wrench	• Installing the pinion (variant with adjustable bearing), page 63 • Installing pinion (variant with Pinion Pack), page 71
Double hexagon nut/slotted nut M50 x 1.5	<b>1,100 Nm</b>	Torque wrench and torque multiplier	• Installing the pinion (variant with adjustable bearing), page 63
Double hexagon nut/slotted nut M50 x 1.5	<b>1,100 Nm to 1,800 Nm</b>	Torque wrench and torque multiplier	• Installing the pinion (variant with adjustable bearing), page 63
Double hexagon nut/slotted nut M50 x 1.5	<b>1,500 Nm</b>	Torque wrench and torque multiplier	• Installing pinion (variant with Pinion Pack), page 71
Locking screw M16 x 1.5 - 12.9	<b>450 Nm</b>	Torque wrench	• Assembling differential, page 76 • Installing the differential, page 79
Hexagon screw M16 x 1.5 - 10.9	<b>300 Nm</b>	Torque wrench	• Assembling differential, page 76
Hexagon screw M24 - 10.9	<b>900 Nm</b>	Torque wrench	• Installing the differential, page 79
Hexagon nut M24 x 1.5	<b>150 Nm</b>	Torque wrench	• Installing the crown wheel support, page 83
Locking screws M16 x 1.5 - 12.9	<b>385 Nm</b>	Torque wrench	• Installing axle insert, page 84 • Mounting breather (variant with ZF membrane breather), page 86
Breather	<b>5.5 Nm</b>	Torque wrench	• Mounting breather (variant with breather valve), page 86
Torx screw M18 x 1.5 - 10.9	<b>440 Nm</b>	Torque wrench	• Mounting hub carrier and tachometer, page 86
Slotted nut M105 x 1.5	<b>100 Nm</b>	Torque wrench	• Mounting hub, page 93
Slotted nut M105 x 1.5	<b>850 Nm</b>	Torque wrench	• Mounting hub, page 93
Slotted nut M105 x 1.5	<b>1,200 Nm</b>	Torque wrench	• Mounting hub, page 93
Torx screw M16 x 1.5 - 10.9	<b>270 Nm</b>	Torque wrench	• Mounting hub, page 93
Cap screw/Hex screw/Torx screw M18 x 1.5 - 10.9	<b>440 Nm</b>	Torque wrench	• Mounting hub, page 93
Fit bolt M16 x 1.5 - 10.9	<b>270 Nm</b>	Torque wrench	• Mounting brake caliper, page 96
Hexagon screw M16 x 1.5 - 10.9	<b>270 Nm</b>	Torque wrench	• Mounting brake caliper, page 96
Cap screw M27 x 2 - 10.9	<b>1200 Nm</b>	Torque wrench	• Mounting spring carriers (variant with top spring carriers), page 98 • Mounting the spring carriers (variant with bottom spring carriers), page 98

## Tightening Torques

---

Designation	Tightening torque	Measuring instrument	Comment Chapter/Section
Locknut M16 x 1.5 - 10.9	<b>195 Nm (<math>\pm 15</math> Nm)</b>	Torque wrench	• Installing mounting parts, page 98
Emergency loosening screw	<b>20 Nm (+5 Nm)</b>	Torque wrench	• Installing mounting parts, page 98
Hexagon nut M18 x 1.5 - 10.9	<b>390 Nm</b>	Torque wrench	• Installing mounting parts, page 98
Hexagon screw M18 x 1.5 - 10.9	<b>390 Nm</b>	Torque wrench	• Installing mounting parts, page 98
Hexagon screw M18 x 1.5 - 8.8	<b>90 Nm</b>	Torque wrench	• Installing mounting parts, page 98
Hexagon nut	<b>70 Nm</b>	Torque wrench	• Installing mounting parts, page 98



## 7 Workshop Equipment

## 7.1 Special tools

The required quantity is listed. Please inquire as to packaging unit before ordering.

Figure	Order no. Designation Chapter/Section	Qty.	Comment
 <p>40_070221_01</p>	<b>5870.350.077</b>  <b>Supporting bracket</b>  <ul style="list-style-type: none"> <li>• Clamping A 132/A 132 II, page 35</li> </ul>	1	1 set = 2 units
 <p>40_070222_01</p>	<b>5870.350.075</b>  <b>Clamping fixture</b>  <ul style="list-style-type: none"> <li>• Clamping A 132/A 132 II, page 35</li> </ul>	2	1 set = 2 units
 <p>40_010032_01</p>	<b>5870.350.000</b>  <b>Assembly truck</b>  <ul style="list-style-type: none"> <li>• Clamping A 132/A 132 II, page 35</li> <li>• Fastening axle insert to the assembly truck, page 47</li> </ul>	1	
 <p>40_020185_01</p>	<b>5870.281.046</b>  <b>Load carrying fixture</b>  <ul style="list-style-type: none"> <li>• Removing the brake caliper, page 37</li> <li>• Mounting brake caliper, page 96</li> </ul>	1	

Figure	Order no. Designation Chapter/Section	Qty.	Comment
 <p>40_050029_01</p>	<p><b>AA01.137.137</b></p> <p><b>Eyebolt</b></p> <ul style="list-style-type: none"> <li>• Removing the brake caliper, page 37</li> <li>• Mounting brake caliper, page 96</li> </ul>	1	M16 x 35
 <p>40_040017_01</p>	<p><b>5870.345.036</b></p> <p><b>Pry bar</b></p> <ul style="list-style-type: none"> <li>• Removing the hub, page 39</li> <li>• Dismantling hub, page 41</li> <li>• Removing axle insert, page 46</li> </ul>	1	1 set = 2 units
 <p>40_020031_01</p>	<p><b>5870.401.146</b></p> <p><b>Slotted nut wrench</b></p> <ul style="list-style-type: none"> <li>• Removing the hub, page 39</li> <li>• Mounting hub, page 93</li> </ul>	1	
 <p>40_020033_01</p>	<p><b>AA01.395.095</b></p> <p><b>Load carrying fixture</b></p> <ul style="list-style-type: none"> <li>• Removing the hub, page 39</li> <li>• Mounting hub, page 93</li> </ul>	1	
 <p>40_020041_01</p>	<p><b>5870.100.069</b></p> <p><b>Assembly fixture</b></p> <ul style="list-style-type: none"> <li>• Dismantling hub, page 41</li> </ul>	1	





Figure	Order no. Designation Chapter/Section	Qty.	Comment
 <p>40_020289_01</p>	<p><b>5870.281.054</b></p> <p><b>Eye nut</b></p> <ul style="list-style-type: none"> <li>• Removing tachometer and hub carrier, page 44</li> <li>• Mounting hub carrier and tachometer, page 86</li> </ul>	1	M105 x 1.5
 <p>40_050723_01</p>	<p><b>AA02.045.674</b></p> <p><b>Eyebolt</b></p> <ul style="list-style-type: none"> <li>• Removing tachometer and hub carrier, page 44</li> <li>• Mounting hub carrier and tachometer, page 86</li> </ul>	2	M16 x 100
 <p>40_021400_01</p>	<p><b>5870.281.044</b></p> <p><b>Load-lifting equipment</b></p> <ul style="list-style-type: none"> <li>• Removing axle insert, page 46</li> <li>• Removing the pinion (variant with adjustable bearing), page 53</li> <li>• Removing pinion (variant with Pinion Pack), page 57</li> <li>• Installing the pinion (variant with adjustable bearing), page 63</li> <li>• Installing pinion (variant with Pinion Pack), page 71</li> <li>• Installing axle insert, page 84</li> </ul>	1	
 <p>40_020679_01</p>	<p><b>AA02.122.222</b></p> <p><b>Assembly fixture</b></p> <ul style="list-style-type: none"> <li>• Fastening axle insert to the assembly truck, page 47</li> </ul>	1	

Figure	Order no. Designation Chapter/Section	Qty.	Comment
 <p>40_021399_01</p>	<p><b>5870.656.048</b></p> <p><b>Socket wrench</b></p> <ul style="list-style-type: none"> <li>• Disassembling differential, page 49</li> <li>• Installing the differential, page 79</li> </ul>	1	
 <p>40_020198_01</p>	<p><b>5870.240.002</b></p> <p><b>Locking mechanism</b></p> <ul style="list-style-type: none"> <li>• Disassembling differential, page 49</li> <li>• Removing the pinion (variant with adjustable bearing), page 53</li> <li>• Removing pinion (variant with Pinion Pack), page 57</li> <li>• Installing the pinion (variant with adjustable bearing), page 63</li> <li>• Installing pinion (variant with Pinion Pack), page 71</li> <li>• Installing the differential, page 79</li> </ul>	1	
 <p>40_021397_01</p>	<p><b>5870.281.075</b></p> <p><b>Lifting device</b></p> <ul style="list-style-type: none"> <li>• Disassembling differential, page 49</li> <li>• Installing the differential, page 79</li> </ul>	1	
 <p>40_070218_01</p>	<p><b>5873.003.029</b></p> <p><b>Gripping device</b></p> <ul style="list-style-type: none"> <li>• Dismantling differential, page 51</li> </ul>	1	

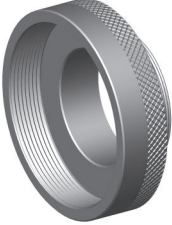
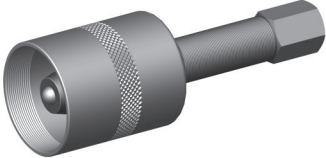
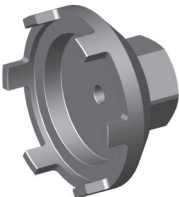

Figure	Order no. Designation Chapter/Section	Qty.	Comment
 <p>40_070219_01</p>	<p><b>5873.003.011</b></p> <p><b>Reduction</b></p> <ul style="list-style-type: none"> <li>• Dismantling differential, page 51</li> </ul>	1	
 <p>40_020058_01</p>	<p><b>5873.002.001</b></p> <p><b>Basic tool</b></p> <ul style="list-style-type: none"> <li>• Dismantling differential, page 51</li> <li>• Removing the pinion (variant with adjustable bearing), page 53</li> </ul>	1	<p>Use only in connection with gripping device.</p> <p>M95 x 2, length of sleeve 125 mm</p>
 <p>40_070215_01</p>	<p><b>5870.401.114</b></p> <p><b>Slotted nut wrench</b></p> <ul style="list-style-type: none"> <li>• Removing the pinion (variant with adjustable bearing), page 53</li> <li>• Removing pinion (variant with Pinion Pack), page 57</li> <li>• Installing the pinion (variant with adjustable bearing), page 63</li> <li>• Installing pinion (variant with Pinion Pack), page 71</li> </ul>	1	
 <p>40_040011_01</p>	<p><b>5870.400.001</b></p> <p><b>Offset screwdriver</b></p> <ul style="list-style-type: none"> <li>• Removing the pinion (variant with adjustable bearing), page 53</li> <li>• Removing pinion (variant with Pinion Pack), page 57</li> </ul>	2	

Figure	Order no. Designation Chapter/Section	Qty.	Comment
 <p style="text-align: right; font-size: small;">40_050065_01</p>	<p><b>5873.002.051</b></p> <p><b>Gripping device</b></p> <ul style="list-style-type: none"> <li>• Removing the pinion (variant with adjustable bearing), page 53</li> </ul>	1	M95 x 2
 <p style="text-align: right; font-size: small;">40_020056_01</p>	<p><b>5870.300.019</b></p> <p><b>Extracting device</b></p> <ul style="list-style-type: none"> <li>• Removing the pinion (variant with adjustable bearing), page 53</li> </ul>	1	Ø 56 mm to 110 mm
 <p style="text-align: right; font-size: small;">40_020094_01</p>	<p><b>5870.300.020</b></p> <p><b>Extracting device</b></p> <ul style="list-style-type: none"> <li>• Removing the pinion (variant with adjustable bearing), page 53</li> </ul>	1	
 <p style="text-align: right; font-size: small;">40_021398_01</p>	<p><b>5870.023.043</b></p> <p><b>Supporting ring</b></p> <ul style="list-style-type: none"> <li>• Removing pinion (variant with Pinion Pack), page 57</li> </ul>	1	
 <p style="text-align: right; font-size: small;">40_021401_01</p>	<p><b>AA02.380.643</b></p> <p><b>Driver tool</b></p> <ul style="list-style-type: none"> <li>• Installing the pinion (variant with adjustable bearing), page 63</li> </ul>	1	

Figure	Order no. Designation Chapter/Section	Qty.	Comment
 <p>40_020295_01</p>	<b>5870.260.004</b>  <b>Handle</b> <ul style="list-style-type: none"> <li>• Installing the pinion (variant with adjustable bearing), page 63</li> <li>• Assembling the hub, page 89</li> </ul>	1	Length 230 mm
 <p>40_020297_01</p>	<b>5870.058.081</b>  <b>Driver tool</b> <ul style="list-style-type: none"> <li>• Installing the pinion (variant with adjustable bearing), page 63</li> </ul>	1	
 <p>40_040056_01</p>	<b>5870.260.002</b>  <b>Handle</b> <ul style="list-style-type: none"> <li>• Installing the pinion (variant with adjustable bearing), page 63</li> <li>• Installing pinion (variant with Pinion Pack), page 71</li> </ul>	1	Length 160 mm
 <p>40_050224_01</p>	<b>5870.700.005</b>  <b>Load cell</b> <ul style="list-style-type: none"> <li>• Installing the pinion (variant with adjustable bearing), page 63</li> </ul>	1	Measuring range 1 to 25 kN
 <p>40_050638_01</p>	<b>5870.230.006</b>  <b>Spring balance</b> <ul style="list-style-type: none"> <li>• Installing the pinion (variant with adjustable bearing), page 63</li> </ul>	1	0 to 100 N

Figure	Order no. Designation Chapter/Section	Qty.	Comment
 <p style="text-align: right;">40_040159_01</p>	<p><b>5870.204.023</b></p> <p><b>Fixing pin</b></p> <ul style="list-style-type: none"> <li>• Installing the pinion (variant with adjustable bearing), page 63</li> <li>• Installing pinion (variant with Pinion Pack), page 71</li> </ul>	1	<p>1 set = 2 units</p> <p>M16 x 120</p>
 <p style="text-align: right;">40_080258_01</p>	<p><b>AA02.338.766</b></p> <p><b>Driver tool</b></p> <ul style="list-style-type: none"> <li>• Installing the pinion (variant with adjustable bearing), page 63</li> </ul>	1	
 <p style="text-align: right;">40_021497_01</p>	<p><b>5870.506.143</b></p> <p><b>Pressure bush</b></p> <ul style="list-style-type: none"> <li>• Installing pinion (variant with Pinion Pack), page 71</li> </ul>	1	
 <p style="text-align: right;">40_040157_01</p>	<p><b>5870.056.014</b></p> <p><b>Driver tool</b></p> <ul style="list-style-type: none"> <li>• Installing pinion (variant with Pinion Pack), page 71</li> </ul>	1	
 <p style="text-align: right;">40_080258_01</p>	<p><b>5870.048.238</b></p> <p><b>Driver tool</b></p> <ul style="list-style-type: none"> <li>• Installing pinion (variant with Pinion Pack), page 71</li> </ul>	1	



Figure	Order no. Designation Chapter/Section	Qty.	Comment
 <p>40_070223_01</p>	<p><b>5870.204.040</b></p> <p><b>Fixing pin</b></p> <ul style="list-style-type: none"> <li>• Assembling differential, page 76</li> <li>• Installing axle insert, page 84</li> </ul>	1	<p>1 set = 2 units</p> <p>M16 x 1.5 x 70</p>
 <p>40_021403_01</p>	<p><b>5870.200.058</b></p> <p><b>Caliper gauge</b></p> <ul style="list-style-type: none"> <li>• Installing the differential, page 79</li> </ul>	1	<p>Measuring length 500 mm, measuring jaw length 300 mm</p>
 <p>40_020145_01</p>	<p><b>AA00.387.830</b></p> <p><b>Pressing fixture</b></p> <ul style="list-style-type: none"> <li>• Mounting hub carrier and tachometer, page 86</li> </ul>	1	
 <p>40_020224_01</p>	<p><b>5870.610.010</b></p> <p><b>Assembly fixture</b></p> <ul style="list-style-type: none"> <li>• Assembling the hub, page 89</li> </ul>	1	<p>Use only in connection with insert.</p>
 <p>40_020225_01</p>	<p><b>5870.610.002</b></p> <p><b>Insert</b></p> <ul style="list-style-type: none"> <li>• Assembling the hub, page 89</li> </ul>	1	<p>Use only in connection with assembly device.</p> <p>M22 x 1.5</p>

Figure	Order no. Designation Chapter/Section	Qty.	Comment
 <p>40_021278_01</p>	<p><b>AA02.259.595</b></p> <p><b>Holding device</b></p> <ul style="list-style-type: none"> <li>Assembling the hub, page 89</li> </ul>	1	<p>To insert the hub when pressing in the wheel studs</p> <p>Pitch circle diameter 335 mm; for 10 wheel studs</p>
 <p>40_021279_01</p>	<p><b>AA02.259.716</b></p> <p><b>Holding device</b></p> <ul style="list-style-type: none"> <li>Assembling the hub, page 89</li> </ul>	1	<p>To insert the hub when pressing in the wheel studs</p> <p>Pitch circle diameter 286 mm; for 10 wheel studs</p>
 <p>40_020297_01</p>	<p><b>5870.050.007</b></p> <p><b>Driver tool</b></p> <ul style="list-style-type: none"> <li>Assembling the hub, page 89</li> </ul>	1	
 <p>40_020296_01</p>	<p><b>5870.345.121</b></p> <p><b>Support arbor</b></p> <ul style="list-style-type: none"> <li>Assembling the hub, page 89</li> </ul>	1	
 <p>40_020228_01</p>	<p><b>AA00.607.922</b></p> <p><b>Driver tool</b></p> <ul style="list-style-type: none"> <li>Assembling the hub, page 89</li> </ul>	1	

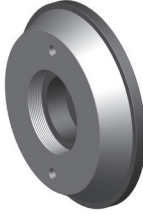
Figure	Order no. Designation Chapter/Section	Qty.	Comment
 40_020229_01	<b>5870.651.085</b>  <b>Assembly aid</b> <ul style="list-style-type: none"> <li>• Mounting hub, page 93</li> </ul>	1	
 40_040159_01	<b>5870.204.029</b>  <b>Fixing pin</b> <ul style="list-style-type: none"> <li>• Mounting hub, page 93</li> </ul>	1	1 set = 2 units M18 x 1.5 x 105

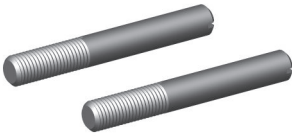
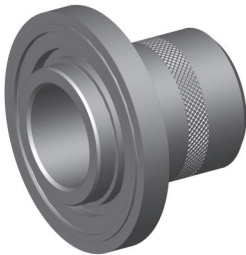
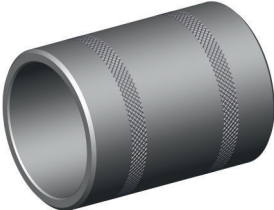
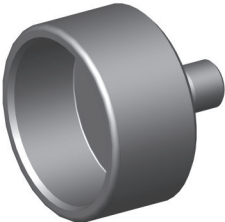
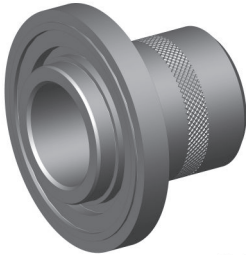
## 7.2 Standard tools and fixtures

To repair this ZF product use the following standard tools and fixtures.

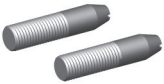
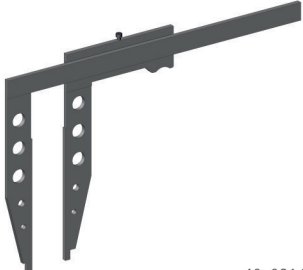
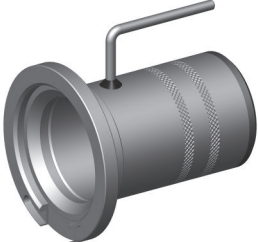
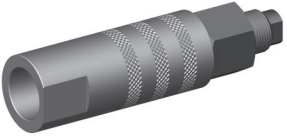
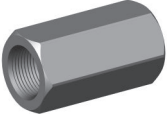
### Standard tools:

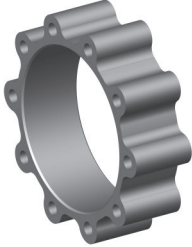
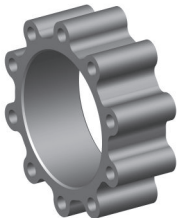
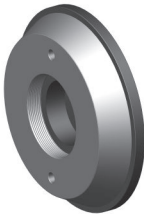
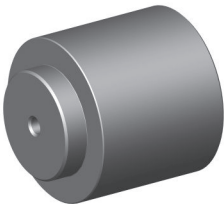
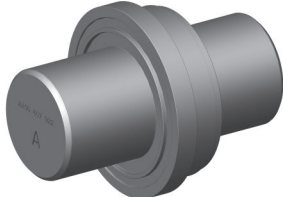
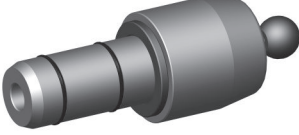
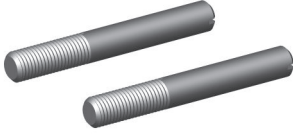
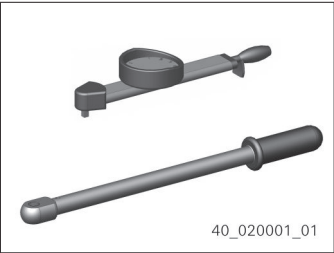
Figure	Order no. Designation	Comment
 40_020001_01 Fig. 2	5870.203.030 Torque wrench	0.6 Nm to 6.0 Nm
	5870.203.031 Torque wrench	1.0 Nm to 12 Nm
	5870.203.032 Torque wrench	3.0 Nm to 23 Nm
	5870.203.033 Torque wrench	5.0 Nm to 45 Nm
	5870.203.034 Torque wrench	10 Nm to 90 Nm
	5870.203.039 Torque wrench	80 Nm to 400 Nm
	5870.203.016 Torque wrench	140 Nm to 800 Nm
	5870.203.011 Torque wrench	750 Nm to 2,000 Nm
	5870.203.048 Torque wrench	1,500 Nm to 3,000 Nm

# Workshop Equipment

Figure	Order no. Designation	Comment
 <p>40_020016_01</p> <p>Fig. 3</p>	5870.900.013 Set of internal pliers	Contains the sizes: I1, I2, I3, I4
 <p>40_020017_01</p> <p>Fig. 4</p>	5870.900.014 Set of internal pliers	90° angled, contains the sizes: I11, I21, I31, I41
 <p>40_020002_01</p> <p>Fig. 5</p>	5870.900.015 Set of external pliers	Contains the sizes: A1, A2, A3, A4
 <p>40_020003_01</p> <p>Fig. 6</p>	5870.900.016 Set of external pliers	90° angled, contains the sizes: A11, A21, A31, A41
 <p>40_020004_01</p> <p>Fig. 7</p>	5870.970.001 Two-armed extractor	Span 80 mm Throat depth 100 mm
	5870.970.002 Two-armed extractor	Span 120 mm Throat depth 125 mm
	5870.970.003 Two-armed extractor	Span 170 mm Throat depth 125 mm
	5870.970.007 Two-armed extractor	Span 520 mm Throat depth 300 mm to 500 mm
	5870.970.026 Two-armed extractor	Span 250 mm Throat depth 200 mm
	5870.970.028 Two-armed extractor	Span 350 mm Throat depth 200 mm
	5870.970.027 Longer arms for two-armed extractor 5870.970.028	Throat depth 300 mm

Figure	Order no. Designation	Comment
 <p>40_020013_01</p> <p>Fig. 8</p>	5870.971.002 Three-armed extractor	Span 130 mm Throat depth 105 mm
	5870.971.004 Three-armed extractor	Span 295 mm Throat depth 235 mm
	5870.971.005 Three-armed extractor	Span 390 mm Throat depth 270 mm
	5870.971.006 Three-armed extractor	Span 640 mm Throat depth 300 mm
 <p>40_020018_01</p> <p>Fig. 9</p>	5870.281.026 Lifting strap	Load-bearing capacity 500 kg Effective length 4 m
 <p>40_020019_01</p> <p>Fig. 10</p>	AA02.000.695 Round sling	Load-bearing capacity 2,000 kg Effective length 2 m
 <p>40_020005_02</p> <p>Fig. 11</p>	5870.281.047 Lifting chain	
 <p>40_020012_01</p> <p>Fig. 12</p>	5870.221.500 Hot-air blower	230 V
	5870.221.501 Hot-air blower	115 V

# Workshop Equipment

Figure	Order no. Designation	Comment
 <p>40_020014_01</p> <p>Fig. 13</p>	<p>5870.345.071 Pry bar</p>	
 <p>40_020006_01</p> <p>Fig. 14</p>	<p>5870.280.004 Plastic hammer</p> <p>5870.280.006 Nylon insert</p>	<p>Spare part</p>
 <p>40_020015_01</p> <p>Fig. 15</p>	<p>5870.650.004 Striker</p>	
 <p>40_020007_01</p> <p>Fig. 16</p>	<p>5870.200.055 Magnetic holder</p>	
 <p>40_020008_01</p> <p>Fig. 17</p>	<p>5870.200.057 Dial gage</p>	

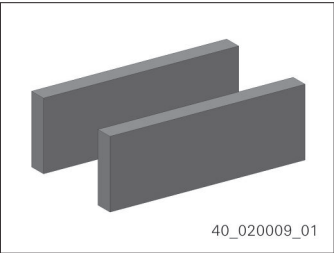
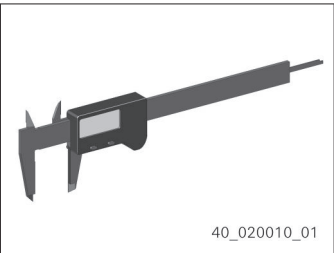
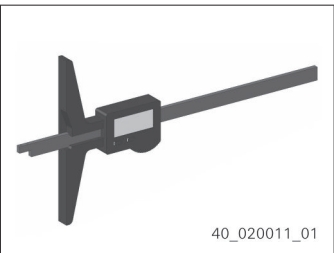
Figure	Order no. Designation	Comment
 <p>40_020009_01</p> <p>Fig. 18</p>	5870.200.066 Set of parallel gage blocks	Consisting of two pieces Height 70 mm
	5870.200.067 Set of parallel gage blocks	Consisting of two pieces Height 100 mm
 <p>40_020010_01</p> <p>Fig. 19</p>	5870.200.109 Digital caliper gage	Length 150 mm
 <p>40_020011_01</p> <p>Fig. 20</p>	5870.200.072 Digital depth gage	Length 200 mm
	5870.200.114 Digital depth gage	Length 300 mm

Tab. 2

Fixture	Comment	Requirement
Crane with precision hoist		Load-bearing capacity min. 1,500 kg
Arbor press	Manual operation	Press force max. 30 kN
Hydraulic press	Hydraulic actuation	

Tab. 3

Other Equipment	Comment	Requirement
Socket wrenches, open-end wrenches, box wrenches, hammers, screw drivers, pliers, front cutting pliers	Various sizes, respectively in a set	Commercial
Sand paper	In different grit sizes to clean surfaces	
Flat scraper	For removal of sealing compound	
Whetstone	For removal of minor damage and smoothing of plane faces	
Polishing cloth	For smoothing and cleaning of surfaces	
Foam roller	When applying sealing compound	

Tab. 4

## 7.3 Operating supplies and auxiliary materials

Order no. Designation	Manufacturer name	Comment Chapter/Section
0666.690.313 Jointing compound	LOCTITE 2701	<ul style="list-style-type: none"> <li>• Installing the pinion (variant with adjustable bearing), page 63</li> <li>• Installing pinion (variant with Pinion Pack), page 71</li> </ul>
0666.690.191 Spirit	PHÖNIX SPIRITUS	<ul style="list-style-type: none"> <li>• Installing the pinion (variant with adjustable bearing), page 63</li> <li>• Installing pinion (variant with Pinion Pack), page 71</li> </ul>
0666.790.033 Sealing compound	LOCTITE 574	<ul style="list-style-type: none"> <li>• Installing pinion (variant with Pinion Pack), page 71</li> <li>• Installing the crown wheel support, page 83</li> <li>• Installing axle insert, page 84</li> </ul>
0671.190.065 Silicone grease	UNIREX N 3	<ul style="list-style-type: none"> <li>• Mounting hub carrier and tachometer, page 86</li> </ul>
0671.190.180 Grease	RENOLIT LX-NHU 2	400 g <ul style="list-style-type: none"> <li>• Mounting hub, page 93</li> </ul>
0666.690.248 Jointing compound	LOCTITE 243	<ul style="list-style-type: none"> <li>• Installing mounting parts, page 98</li> </ul>



## 8 Preparatory Activities

### 8.1 Removing mounting parts

1. Place axle safely on a firm surface.

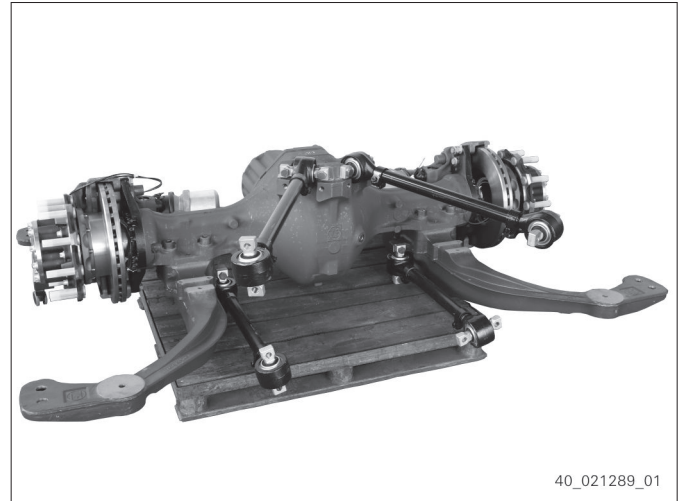

Fig. 21

2. Loosen hexagon screw on air spring (1).
3. Remove air spring (1).
4. Loosen hexagon nut on shock absorber (2).
5. Remove shock absorber (2).

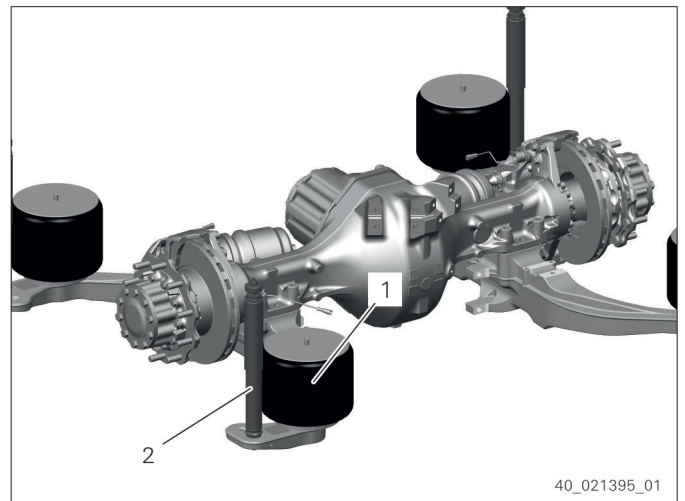

Fig. 22

6. Secure upper longitudinal control arm with crane.

#### 7. **NOTICE**

Damage due to the use of a driven power wrench.

⇒ Loosen screws manually.

Loosen hexagon screws and remove the upper longitudinal control arm.



Fig. 23

## Preparatory Activities

8. Remove second upper longitudinal control arm.
9. Secure lower longitudinal control arm with crane.

10. **NOTICE**

**Damage due to the use of a driven power wrench.**

⇒ Loosen screws manually.

Loosen hexagon nuts and remove the lower longitudinal control arm.

11. Remove the second lower longitudinal control arm.

12. **NOTICE**

**Damage due to the use of a driven power wrench.**

⇒ Loosen screws manually.

Loosen cap screws on both spring carriers.

13.  In the variant with spring carriers on top the axle remains in place and the spring carriers are removed by lifting upwards.

Place suitable wooden chocks (1) on the outside under the spring carriers.

14. Raise the axle slightly.

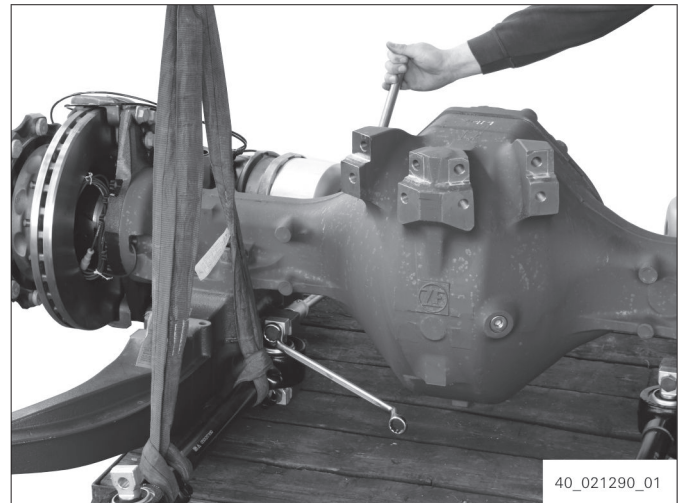

Fig. 24

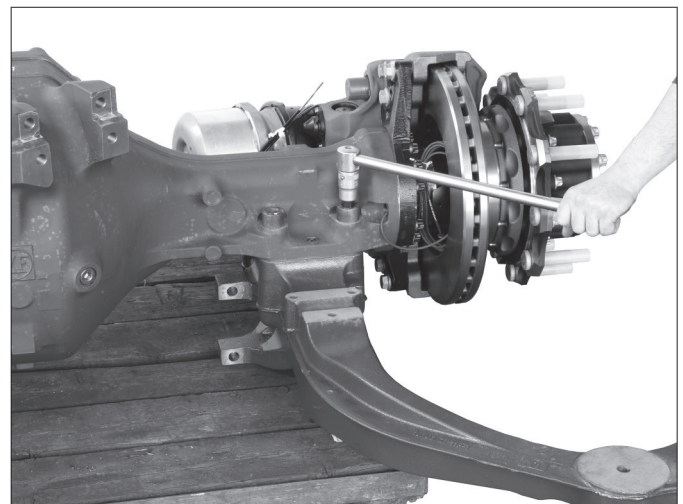

Fig. 25

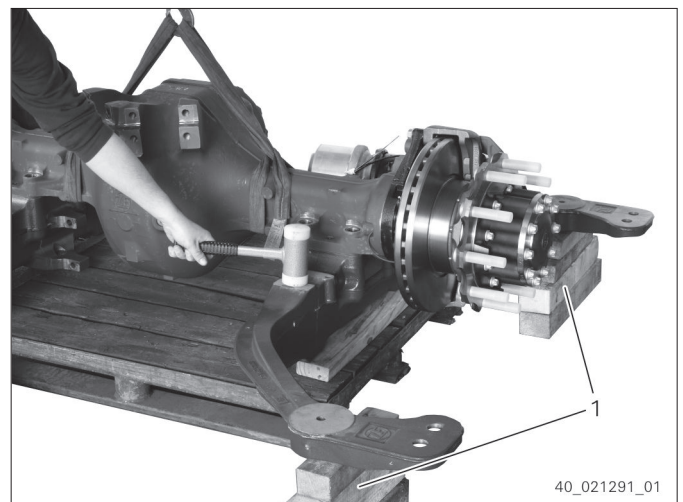

Fig. 26

15. **CAUTION**

**Risk of crushing due to moving load.  
Slight to moderate injury possible.**

- ⇒ Move load slowly and carefully.
- ⇒ Do not reach into danger area.

Move the spring carriers evenly downwards away from the axle.

## 16. Remove the axle.

17. **i** Observe the specifications of the brake manufacturer.

Unbolt emergency loosening screw on the brake cylinder.

Tightening torque: **20 Nm (+5 Nm)**  
(maximum loosening torque)

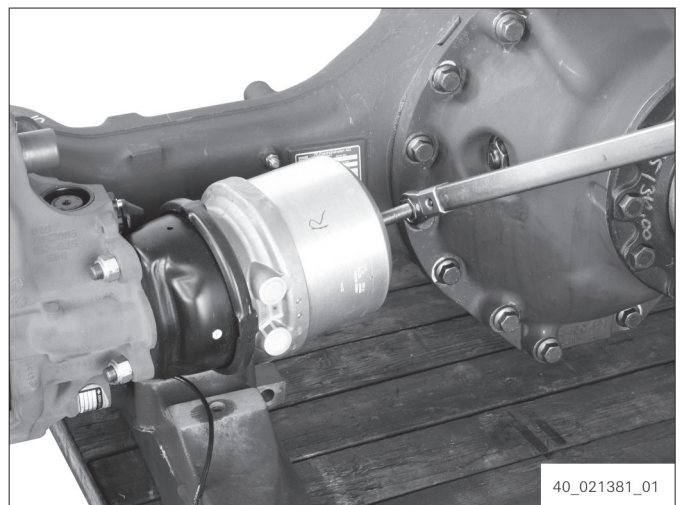

Fig. 27

## 18. Loosen locknuts and remove brake cylinder.

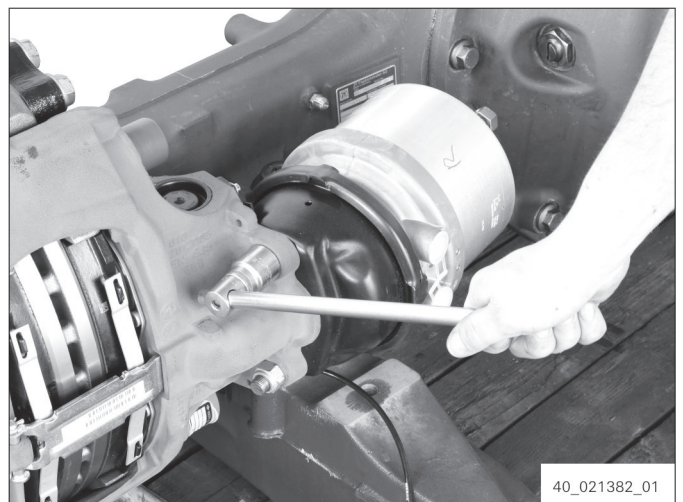

Fig. 28

## 8.2 Clamping A 132/A 132 II

Special tools:

- 5870.350.077 Supporting bracket

## Preparatory Activities

- 5870.350.075 Clamping fixture
  - 5870.350.000 Assembly truck
1. Use 5870.350.077 [Supporting bracket] and 5870.350.075 [Clamping fixture] to fix the axle on 5870.350.000 [Assembly truck] with the axle insert facing upwards.

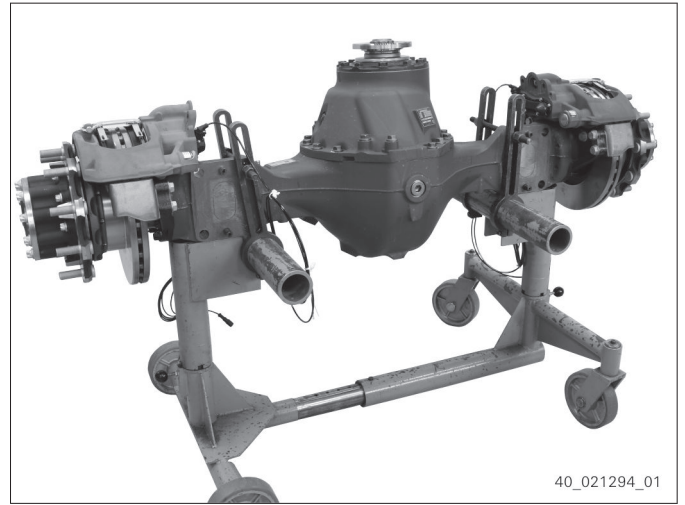



Fig. 29

### 8.3 Draining oil

 Observe the environmental regulations (*see General safety instructions*).

1. 

 <b>CAUTION</b>
<p><b>Risk of burn injuries due to contact with hot surfaces.</b>  <b>Slight or moderate injury possible.</b>                  ⇒ Wear protective gloves.</p>

Thoroughly clean all screw plugs.

2. Place suitable container under all the screw plugs.
3. Remove screw plug (1/2).  
 In case of the version with mounted breather, slight overpressure can build up in the axle.
4. Remove screw plug (3).
5. Completely drain oil into the containers.

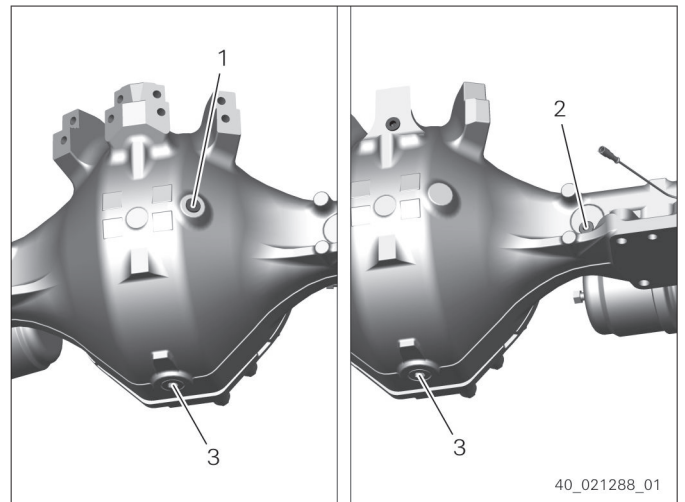

Fig. 30 Oil level check

- 1 Screw plug for oil level check
- 2 Screw plug for oil level check in case of variant with upper oil filling hole
- 3 Oil drain screw plug

## 9 Dismantling

### 9.1 Removing the brake caliper

Special tools:

- 5870.281.046 Load carrying fixture
- AA01.137.137 Eyebolt

 Observe the specifications of the brake manufacturer.

1. Loosen screws and pull out plug for brake wear indicator.

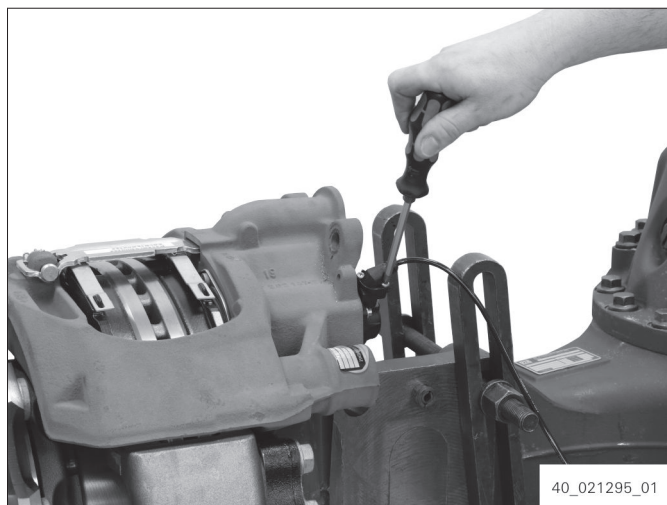

Fig. 31

2. Remove rubber cap.
3. Turn adjuster in counterclockwise direction manually until contact is obtained.

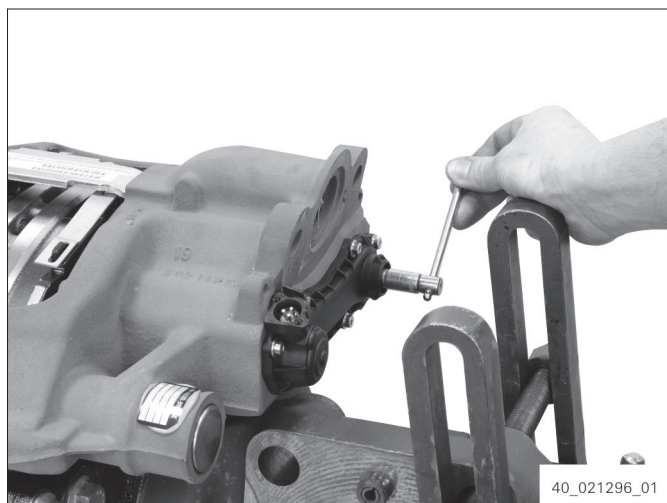

Fig. 32

## Dismantling

---

4. Remove spring split pin.
5. Remove washer (1) and pin (2).
6. Remove lining bracket (3).

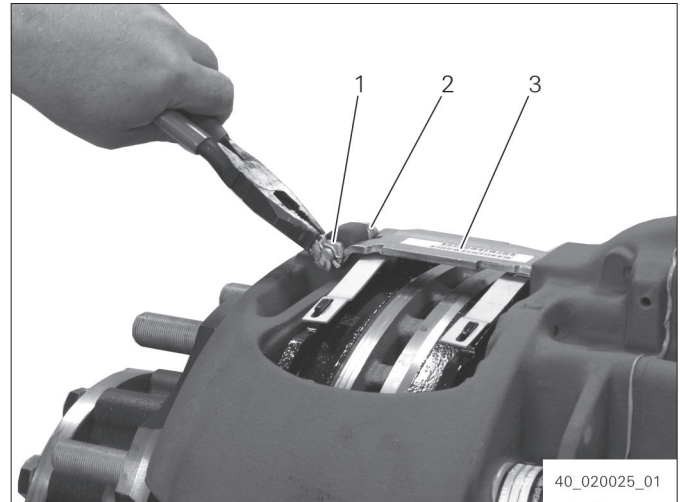

Fig. 33

7. Remove brake lining set.

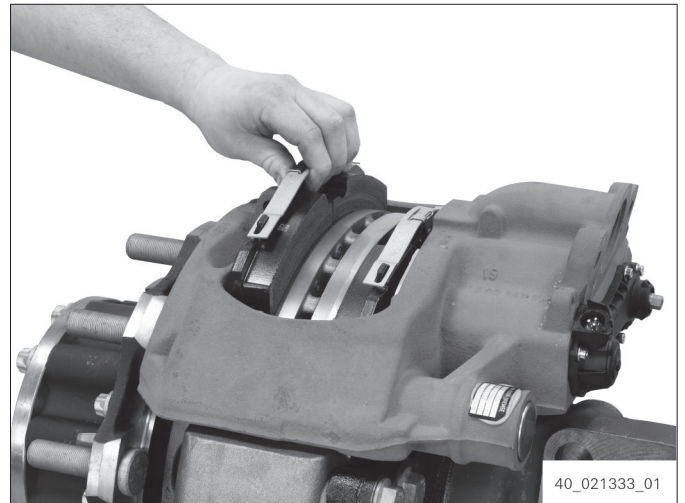

Fig. 34

8. Fix brake caliper with 5870.281.046 [Load carrying fixture], AA01.137.137 [Eyebolt], and crane.
9. Loosen hexagon screws and fit bolt on the brake caliper.
10. Remove brake caliper.

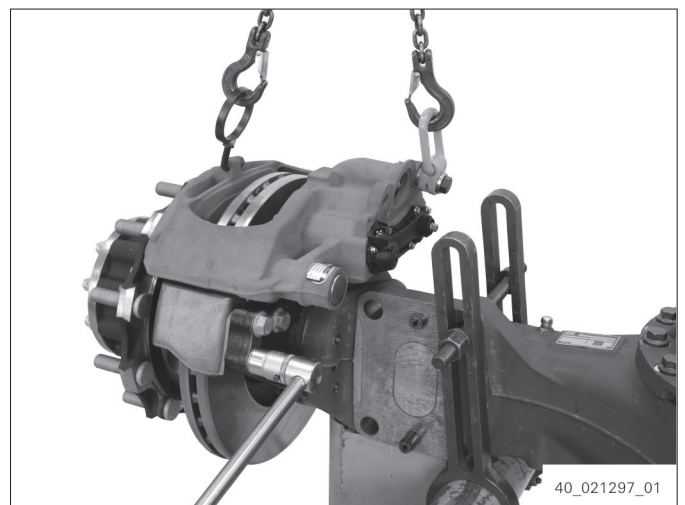

Fig. 35

## 9.2 Removing and dismantling hub

### 9.2.1 Removing the hub

Special tools:

- 5870.345.036 Pry bar
- 5870.401.146 Slotted nut wrench
- AA01.395.095 Load carrying fixture

1. Fix hub.
2. Loosen but do not remove bolted connection of the brake disk.  
  
→ The brake disk will be removed later.
3. Loosen bolted connection of the flange shaft.

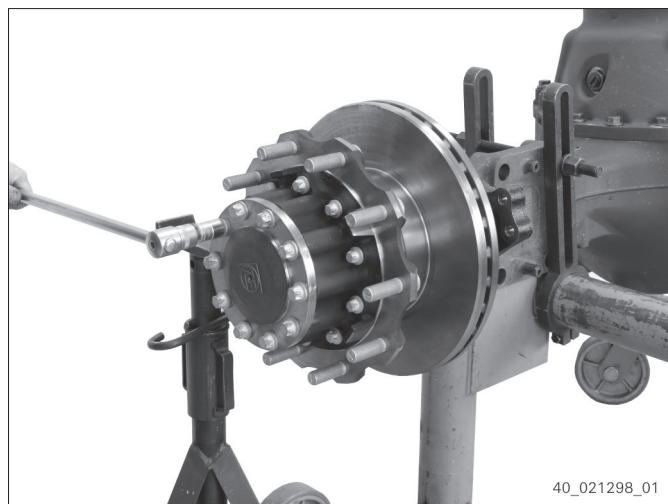

Fig. 36

4. Pull out flange shaft with 5870.345.036 [Pry bar] and remove it.

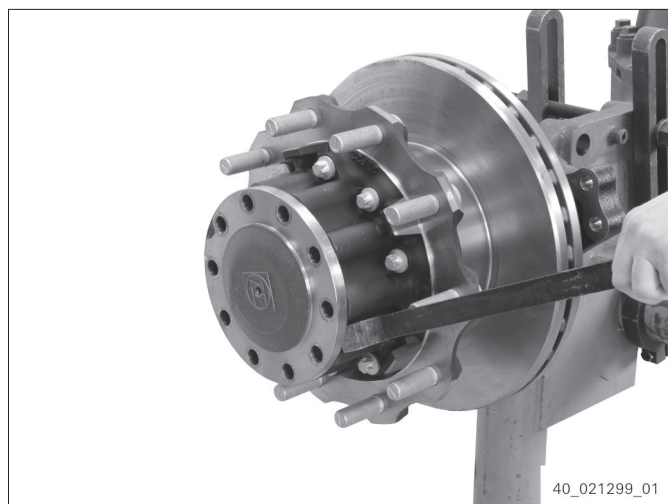

Fig. 37

## Dismantling

---

5. Remove O-ring (1) from flange shaft.

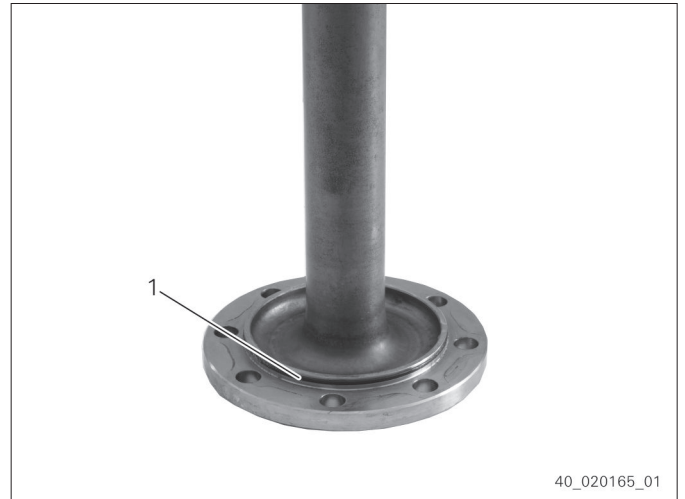

Fig. 38

6. Unlock slotted nut.
7. Loosen slotted nut with 5870.401.146 [Slotted nut wrench].
8. Remove locking plate.

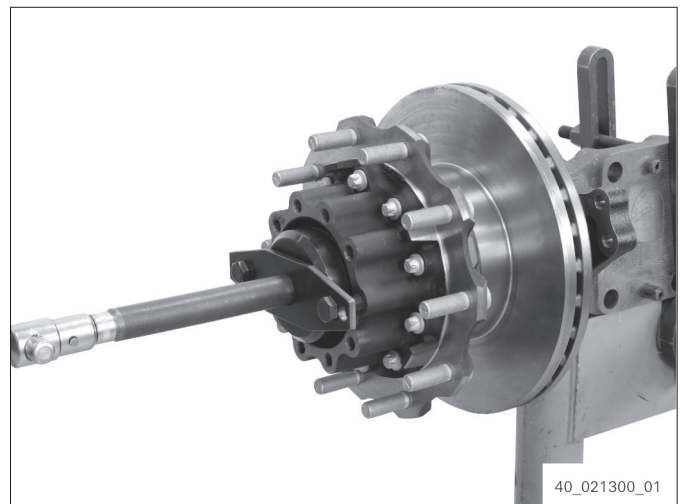

Fig. 39

9. Use AA01.395.095 [Load carrying fixture] to fix the hub to the crane.
10. Loosen slotted nut with 5870.401.146 [Slotted nut wrench].
11. Pull hub from the hub carrier.

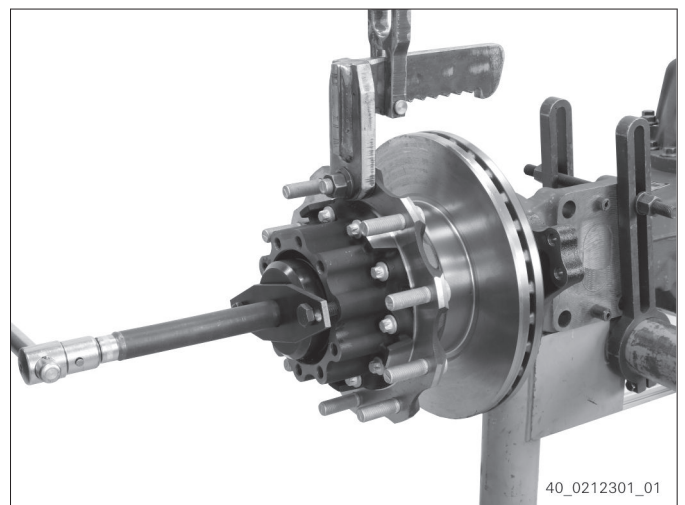

Fig. 40



12. To protect the thread from damage, bolt the slotted nut (1) flush onto the hub carrier.

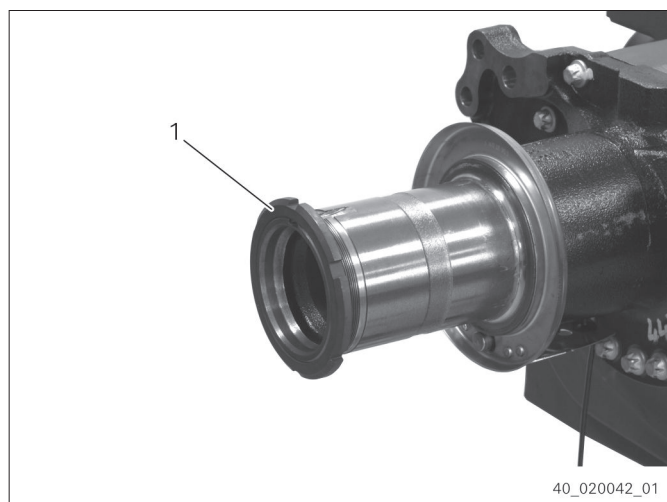

Fig. 41

### 9.2.2 Dismantling hub

Special tools:

- 5870.345.036 Pry bar
- 5870.100.069 Assembly fixture

1. Loosen Torx screws.
2. Remove hub.

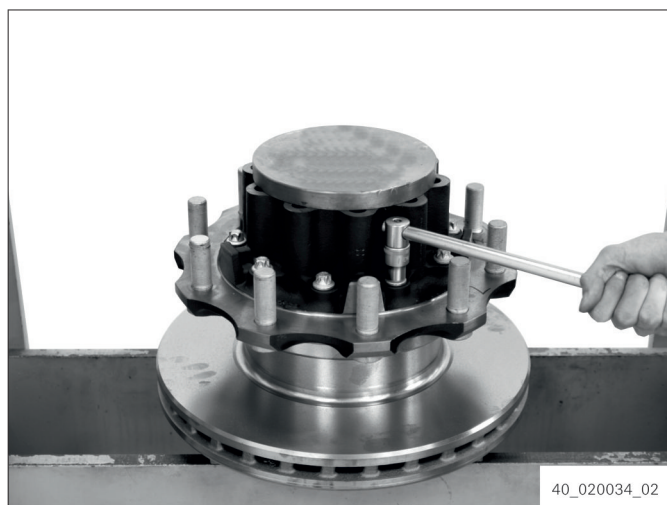

Fig. 42

## Dismantling

---

3. Remove O-ring.

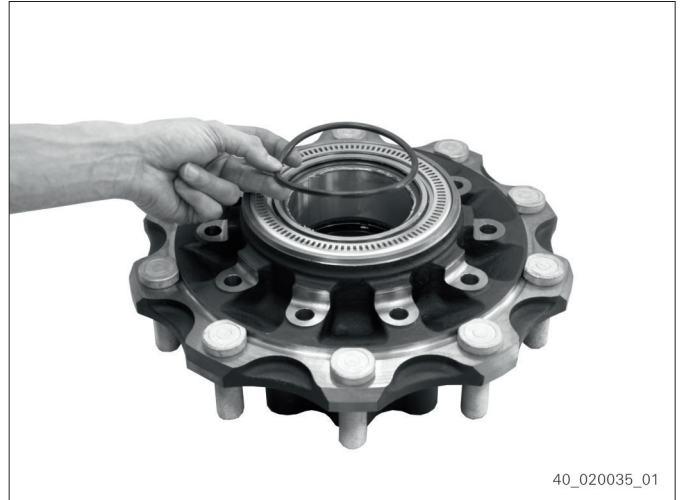

Fig. 43

4. Use 5870.345.036 [Pry bar] to pull ABS ring out of the hub and remove it.



Fig. 44

5. Remove securing ring (1).
6. Remove tapered roller bearing at the brake disk side from the hub.

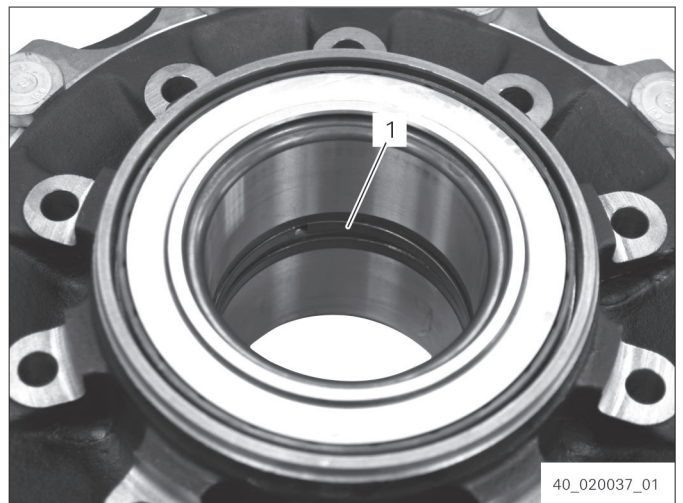

Fig. 45

7. Use 5870.100.069 [Assembly fixture] to press shaft seal from the tapered roller bearing.

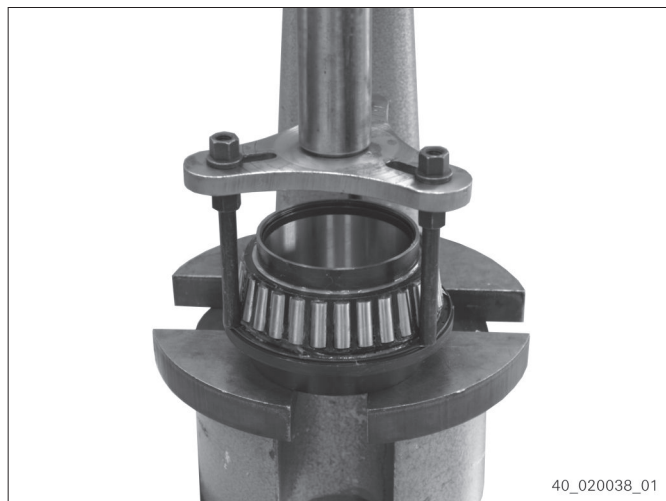

Fig. 46

8. Press tapered roller bearing and shaft seal out of the hub.

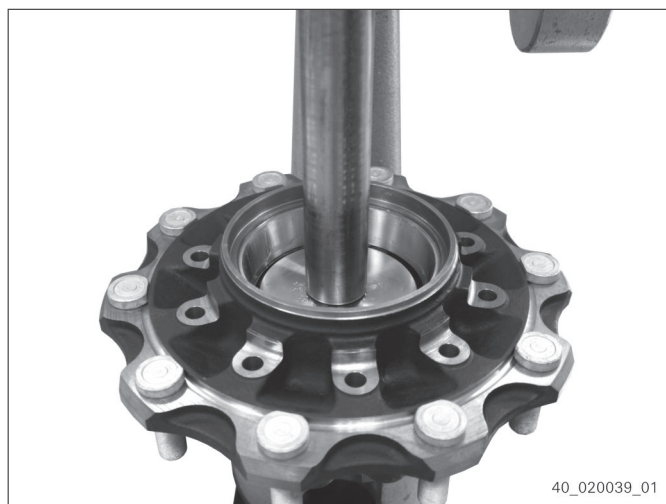



Fig. 47

9.  Do not mix up bearing outer rings. Use suitable appliances to tie together bearing outer ring and tapered roller bearing.

 **CAUTION**

Risk of injury due to parts flying away.  
Slight or moderate injury possible.  
⇒ Wear protective goggles.

Force out bearing outer rings.

10. Press wheel studs out of the hub.

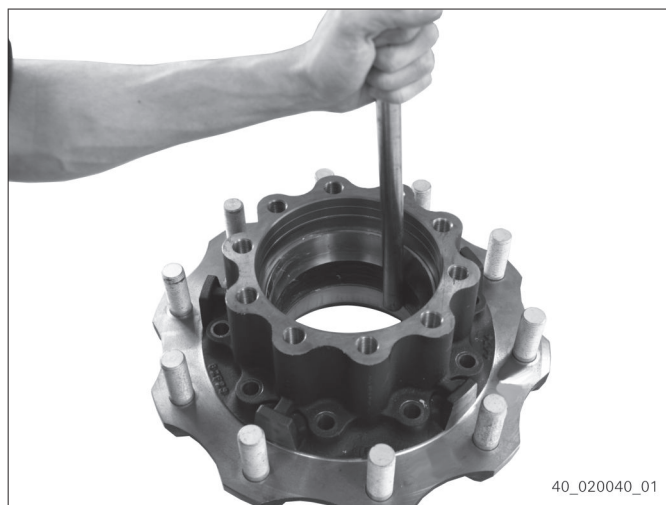

Fig. 48

## 9.3 Removing tachometer and hub carrier

Special tools:

- 5870.281.054 Eye nut
- AA02.045.674 Eyebolt

1. Push tachometer out of the hub carrier.

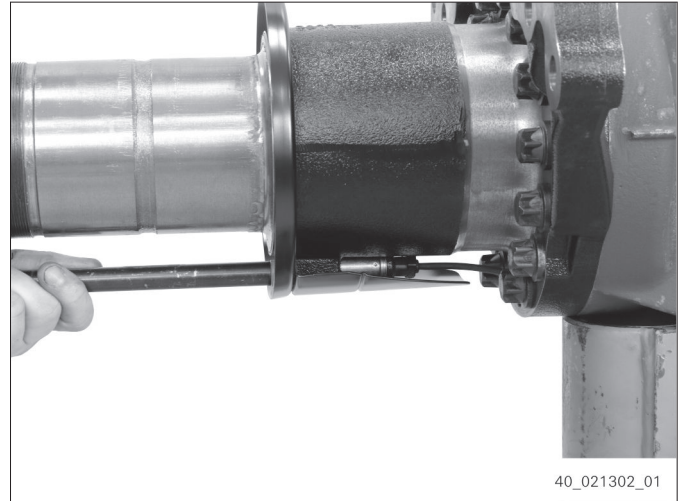

Fig. 49

2. Push bush out of the hub carrier.

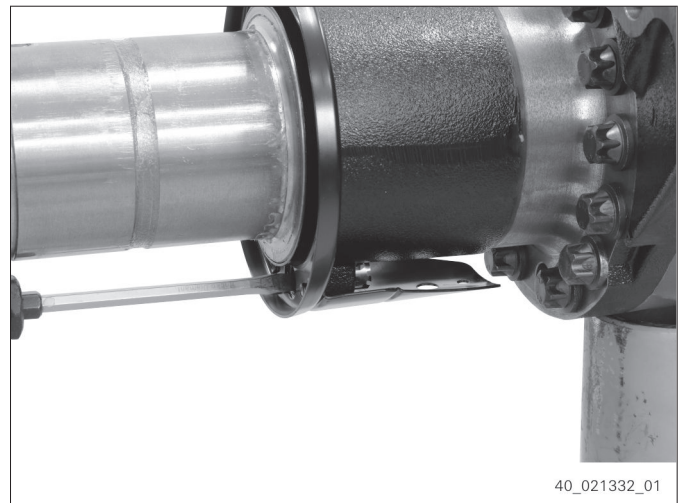

Fig. 50

3. Force the screen sheet off the hub carrier.

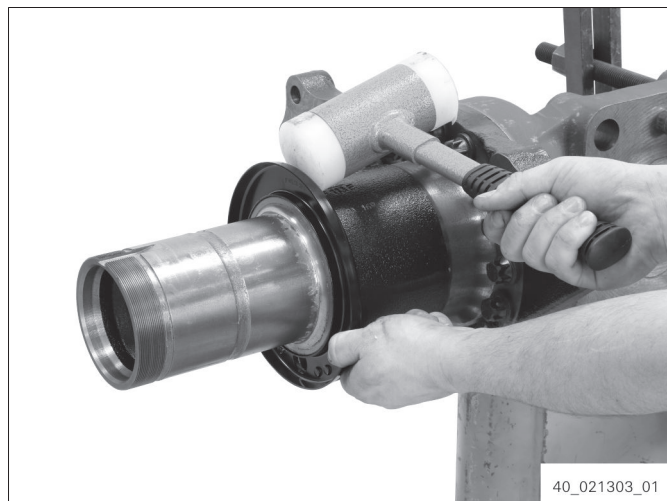

Fig. 51

4. Secure the hub carrier on the crane with 5870.281.054 [Eye nut] and two AA02.045.674 [Eyebolt].
5. Loosen Torx screws and remove the hub carrier.

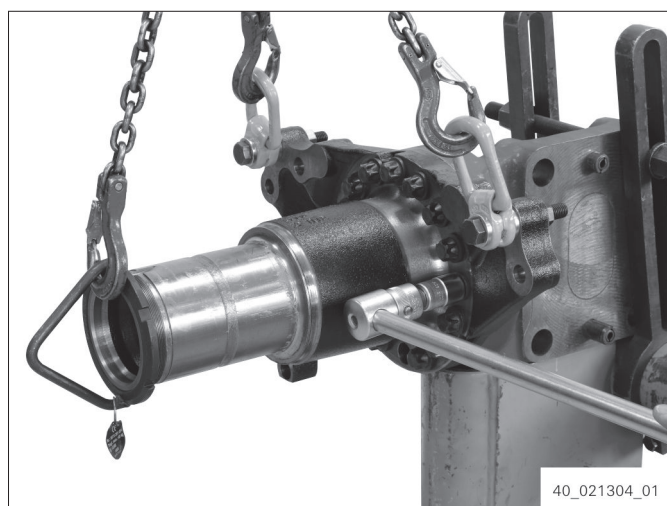

Fig. 52

6. Remove O-ring (1).

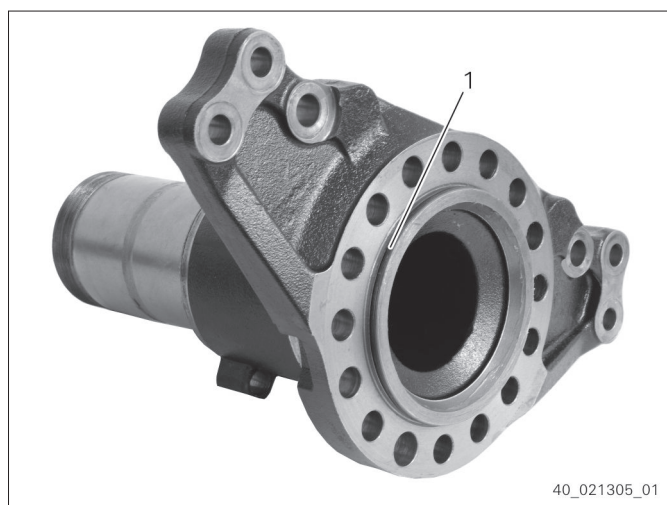

Fig. 53

## 9.4 Removing breather

### 9.4.1 Removing breather (variant with ZF membrane breather)

1. Open hose clamp (1).
2. Pull corrugated hose and hose (2) from the breather neck.
3. Unfasten screw connection (3) and remove breather.

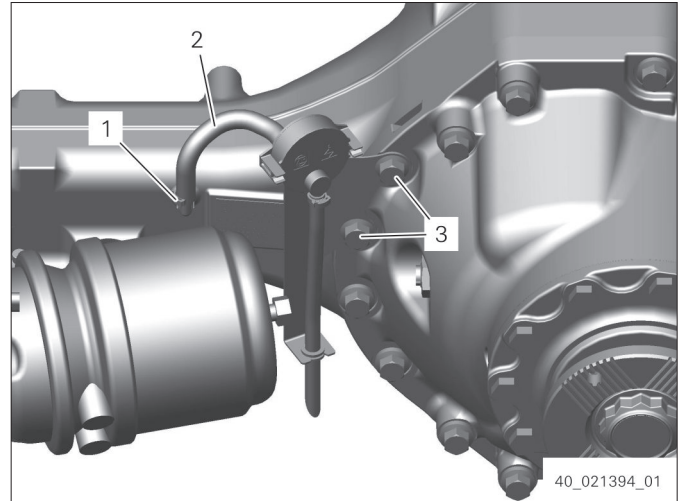

Fig. 54

### 9.4.2 Removing breather (variant with breather valve)

1. Loosen the breather.

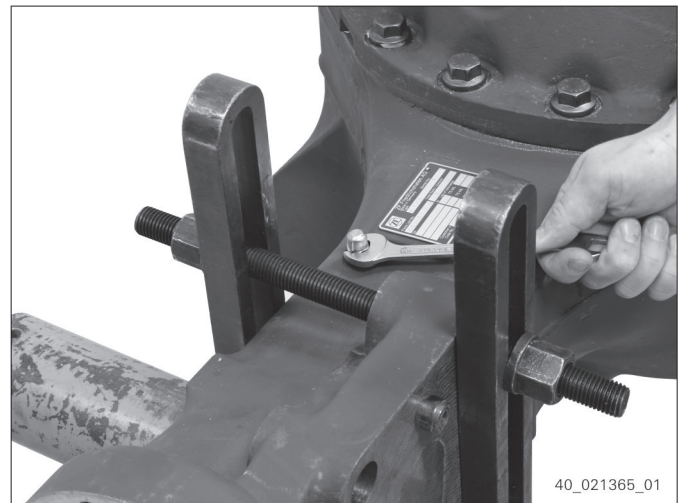

Fig. 55

## 9.5 Removing axle insert

Special tools:

- 5870.281.044 Load-lifting equipment
- 5870.345.036 Pry bar

1. Fasten axle insert to crane with 5870.281.044 [Load-lifting equipment].
2. Loosen bolted connection.

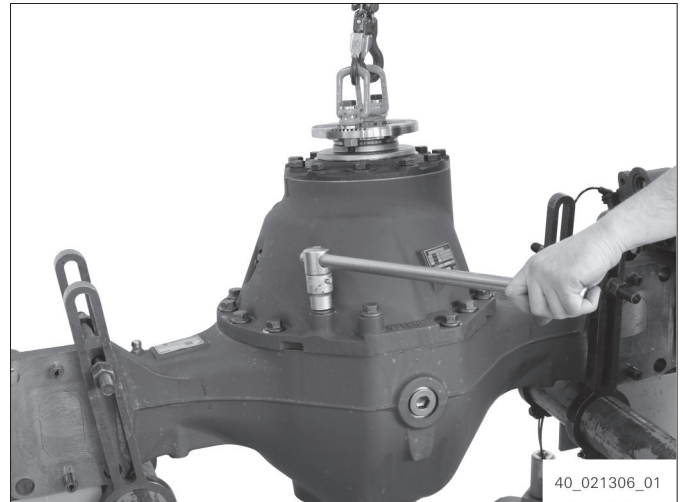

Fig. 56

3. Loosen axle insert with 5870.345.036 [Pry bar] and remove it from the axle housing.

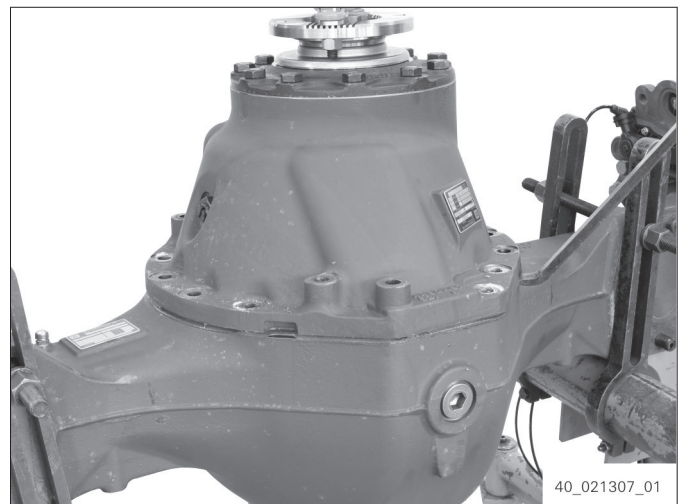

Fig. 57

## 9.6 Disassembling axle insert

### 9.6.1 Fastening axle insert to the assembly truck

Special tools:

- 5870.350.000 Assembly truck
- AA02.122.222 Assembly fixture

## Dismantling

1. Fasten axle insert to 5870.350.000 [Assembly truck] with AA02.122.222 [Assembly fixture].

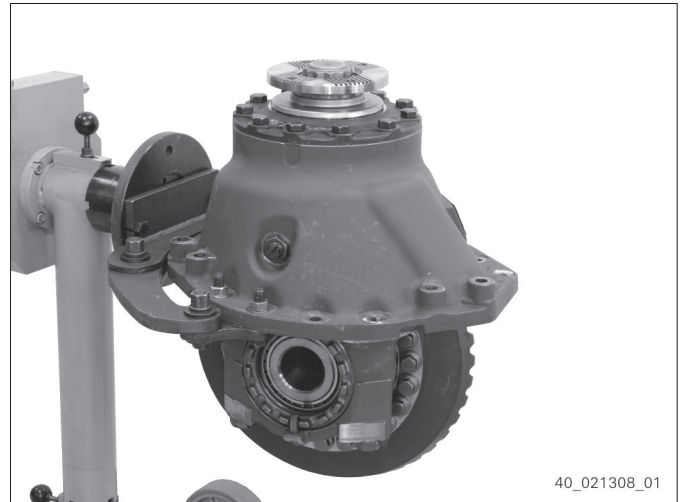

Fig. 58

### 9.6.2 Removing crown wheel support

1. Loosen hexagon nut.
2. Loosen adjusting screw.

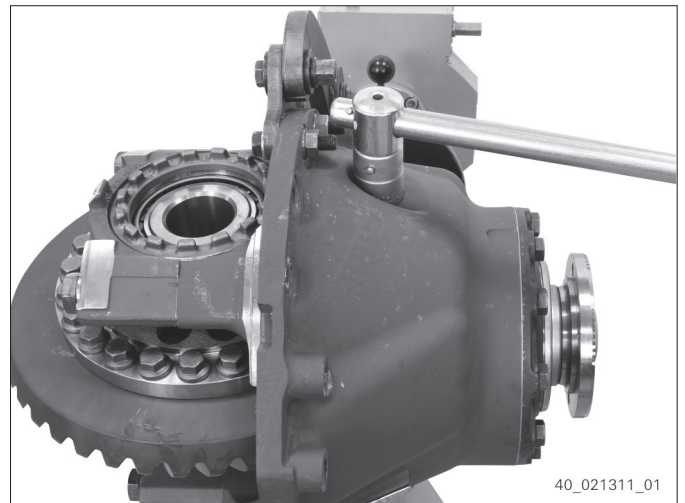

Fig. 59

3. Rotate input flange until the sliding pad (1) is visible.
4. Remove sliding pad (1).

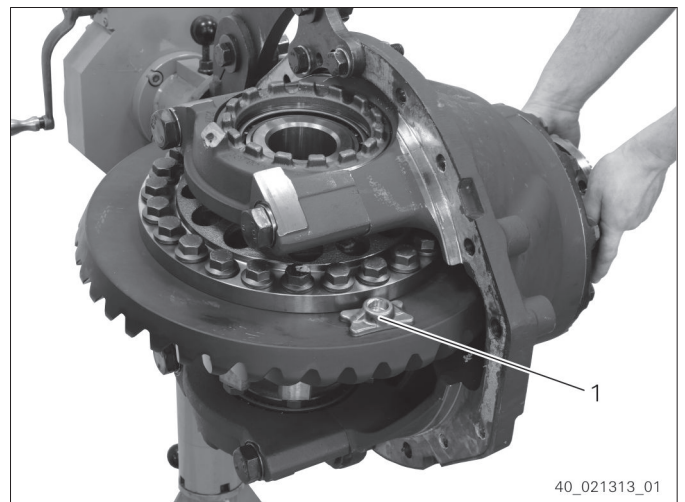

Fig. 60



### 9.6.3 Disassembling differential

Special tools:

- 5870.656.048 Socket wrench
- 5870.240.002 Locking mechanism
- 5870.281.075 Lifting device

1.

**⚠ CAUTION**

Risk of injury due to parts flying away.  
Slight or moderate injury possible.  
⇒ Wear protective goggles.

Force out slotted pins.

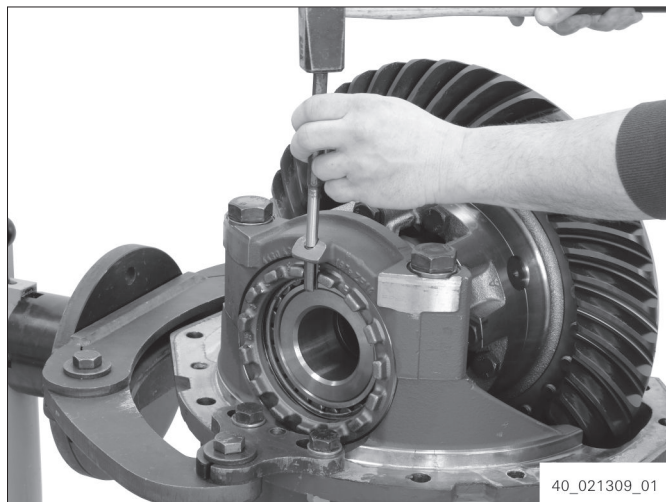

Fig. 61

2. Loosen adjusting nuts with 5870.656.048 [Socket wrench].

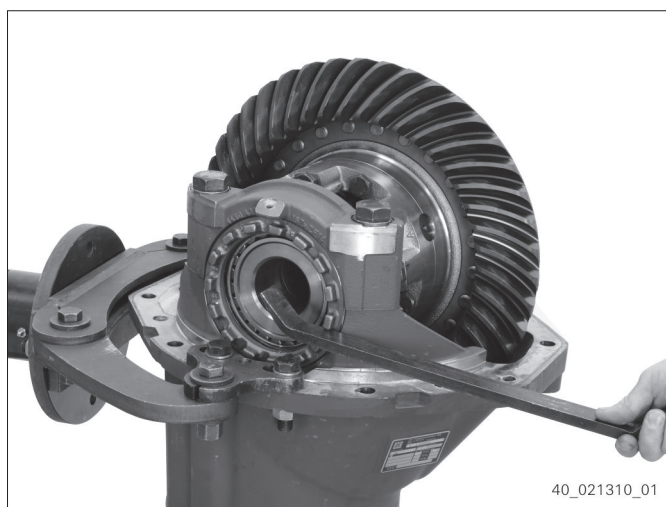

Fig. 62

## Dismantling

3. For variant with a ratio of  $i = 4.273$ ,  $i = 4.700$ ,  $i = 5.222$  and  $i = 5.875$ : fix 5870.240.002 [Locking mechanism] to input flange.

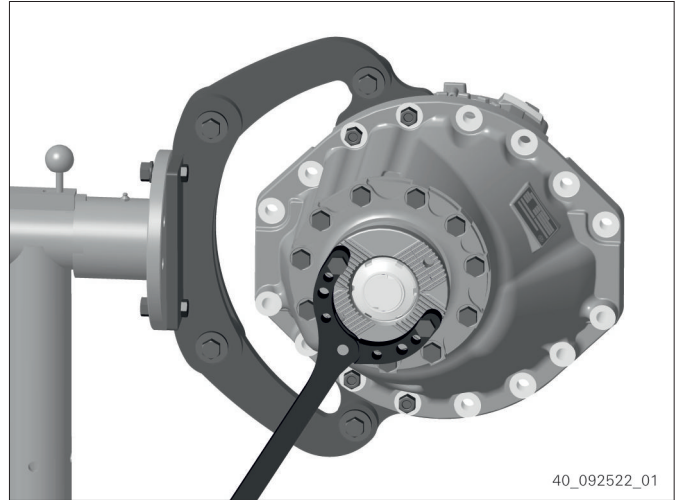

Fig. 63

4. For variant with a ratio of  $i = 4.273$ ,  $i = 4.700$ ,  $i = 5.222$  and  $i = 5.875$ : loosen eight locking screws.
5. Rotate differential until the missing screws are pointing towards the pinion.

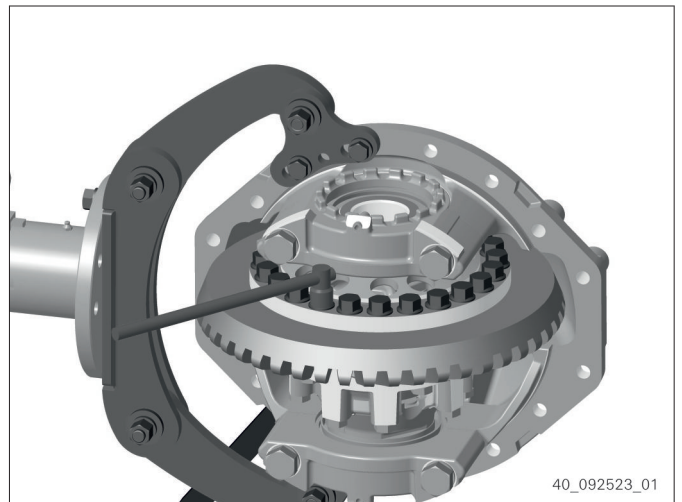

Fig. 64

6. Loosen but do not fully unscrew hexagon screws.

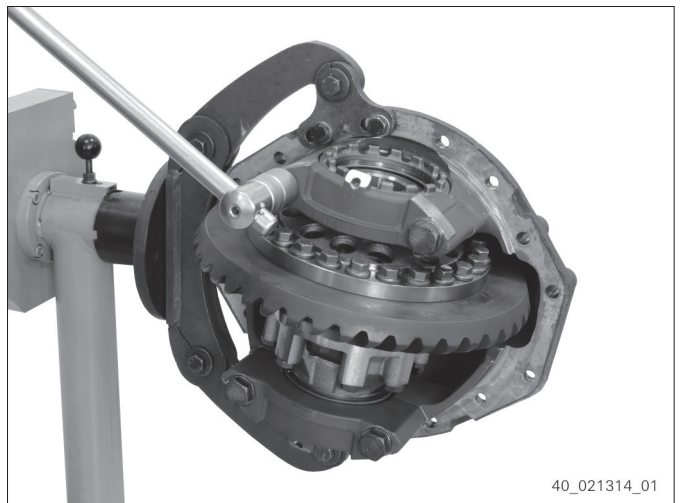

Fig. 65

7. Swivel axle insert upwards.
8. Mark installation position of the bearing brackets.
9. Loosen and remove hexagon screws.
10. Remove bearing brackets.
11. Lift differential using 5870.281.075 [Lifting device] and crane, and remove the releasing parts.

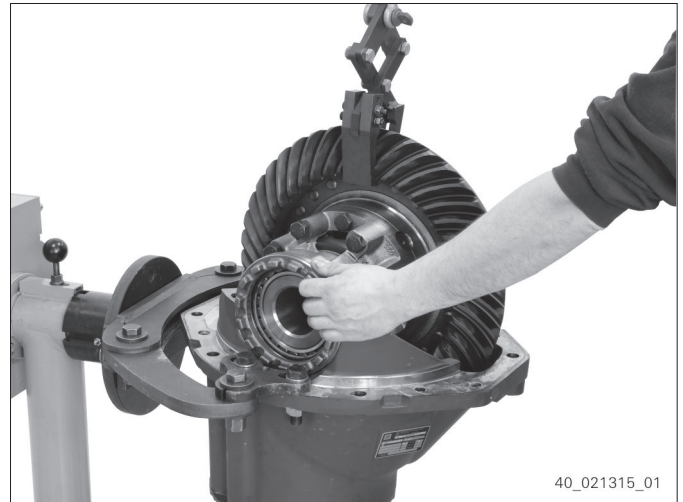

Fig. 66

#### 9.6.4 Dismantling differential

Special tools:

- 5873.003.029 Gripping device
  - 5873.003.011 Reduction
  - 5873.002.001 Basic tool
1. Pull off both tapered roller bearings with 5873.003.029 [Gripping device], 5873.003.011 [Reduction] and 5873.002.001 [Basic tool].



Fig. 67

## Dismantling

2. Mark mounting position of differential carrier half to differential carrier half.
3. Fix differential.
4. Loosen bolted connection.
5. Remove differential carrier half.

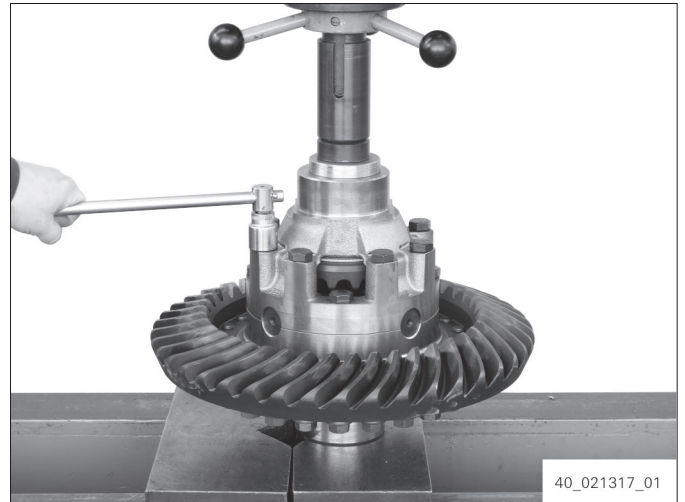

Fig. 68

6. Remove individual parts.

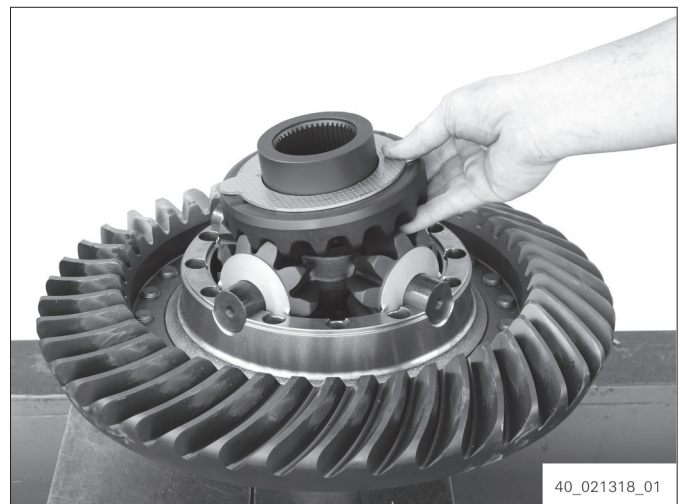

Fig. 69

7. Secure differential carrier half.
8. Loosen bolted connection.

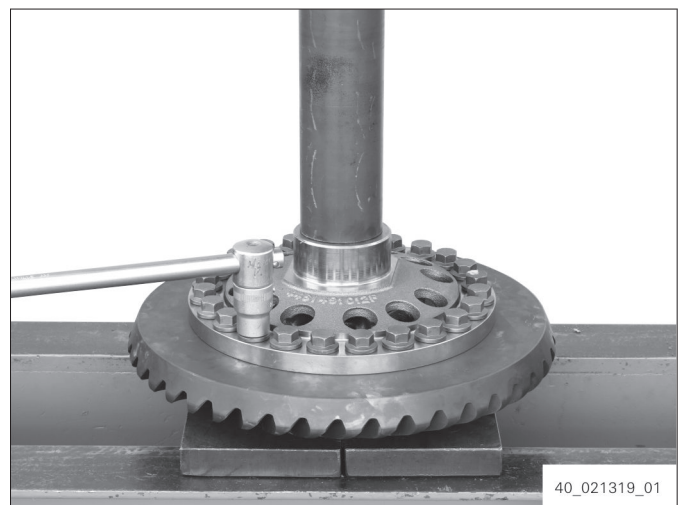

Fig. 70

9. Turn differential carrier half.
10. Support crown wheel from below.

11. Place a soft surface under the differential carrier half.

12. **⚠ CAUTION**

Risk of crushing due to hydraulic tool.  
Slight to moderate injury possible.  
⇒ Do not reach into danger area.

**⚠ CAUTION**

Risk of injury due to falling parts.  
Slight or moderate injury possible.  
⇒ Secure parts against falling down.

Press differential carrier half out of the crown wheel.

## 9.6.5 Removing the pinion

### 9.6.5.1 Removing the pinion (variant with adjustable bearing)

Special tools:

- 5870.240.002 Locking mechanism
- 5870.401.114 Slotted nut wrench
- 5870.400.001 Offset screwdriver
- 5870.281.044 Load-lifting equipment
- 5873.002.051 Gripping device
- 5873.002.001 Basic tool
- 5870.300.019 Extracting device
- 5870.300.020 Extracting device

1. Fasten input flange with 5870.240.002 [Locking mechanism].
2. Loosen double hex nut. On the variant with slotted nut, loosen slotted nut with 5870.401.114 [Slotted nut wrench].
3. Pull off input flange.
4. Remove screen sheet from input flange.

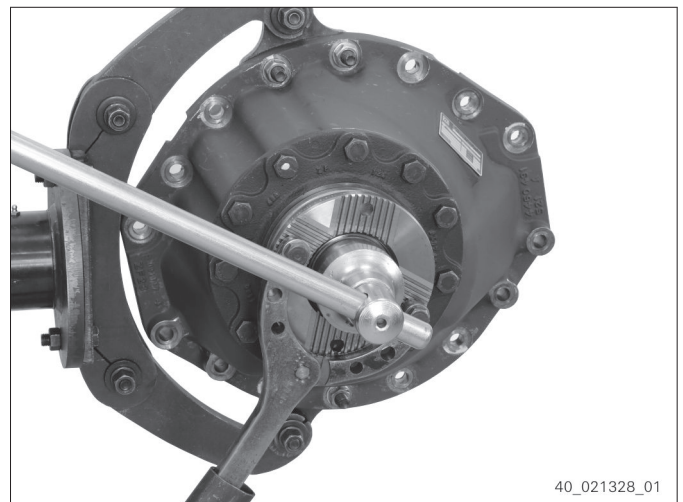

Fig. 71

## Dismantling

5. Remove shaft seal with 5870.400.001 [Offset screwdriver].



Fig. 72

6. Mark installation position of the bearing bush to the axle drive housing.
7. Loosen bolted connection.



Fig. 73

8. Slide on input flange.
9. Hand-tighten double hex nut.
10. Fasten bearing bush and pinion on the crane using 5870.281.044 [Load-lifting equipment].
11. Slowly raise the bearing bush with the crane and if necessary gently tap the axle drive housing.
12. Remove bearing bush from axle drive housing.
13. In variant with ring, remove the ring.
14. Disassemble input flange.



Fig. 74

15. In variant with O-ring, remove O-ring (1).



Fig. 75

16. Disengage retaining ring.



Fig. 76

17. Pull off the cylindrical roller bearing.



Fig. 77

## Dismantling

---

18. Screw double-hex nut onto pinion by hand.
19. Press drive pinion out of the bearing bush.

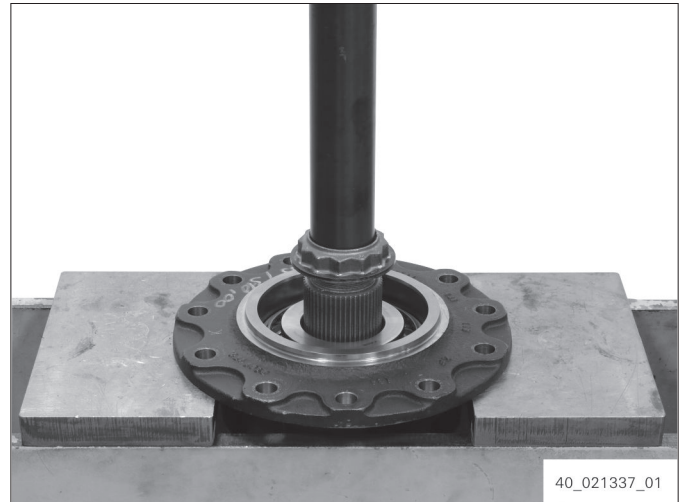

Fig. 78

20. Remove ring.

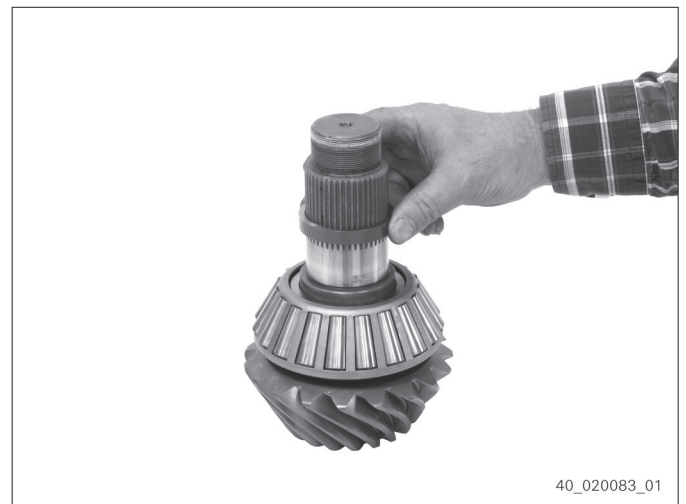

Fig. 79

21. Pull bearing inner ring off the drive pinion with 5873.002.051 [Gripping device] and 5873.002.001 [Basic tool].



Fig. 80



22. Use 5870.300.019 [Extracting device] and 5870.300.020 [Extracting device] to remove bearing inner rings from the bearing bush.

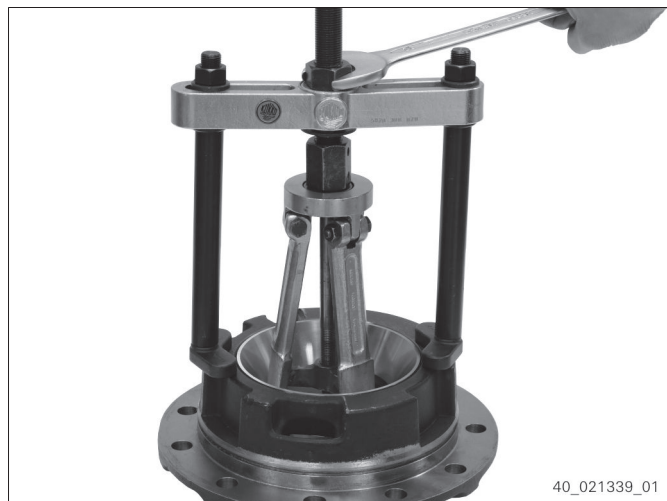

Fig. 81

### 9.6.5.2 Removing pinion (variant with Pinion Pack)

Special tools:

- 5870.240.002 Locking mechanism
- 5870.401.114 Slotted nut wrench
- 5870.400.001 Offset screwdriver
- 5870.281.044 Load-lifting equipment
- 5870.023.043 Supporting ring

**i** In this variant, the bearing bush is only available in assembled condition. Only the sealing element can be replaced.

1. **CAUTION**  
 Risk of injury due to parts flying away.  
 Slight or moderate injury possible.  
 ⇒ Wear protective goggles.

Unlock slotted nut.

2. Fasten input flange with 5870.240.002 [Locking mechanism].
3. On the variant with slotted nut, loosen slotted nut with 5870.401.114 [Slotted nut wrench].
4. Pull off input flange.
5. Remove screen sheet from input flange.

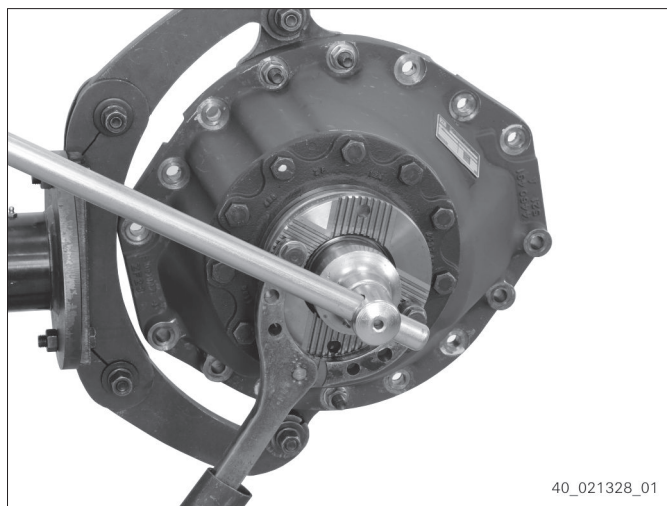

Fig. 82

## Dismantling

---

6. On variant with bearing race, remove bearing race.

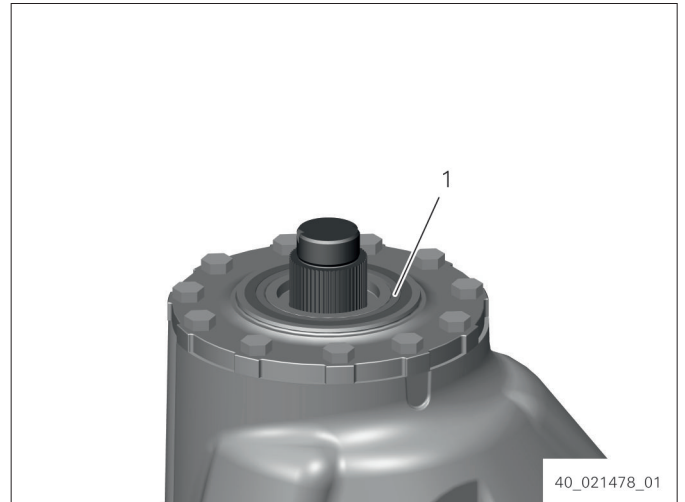

Fig. 83

7. Remove shaft seal with 5870.400.001 [Offset screwdriver].

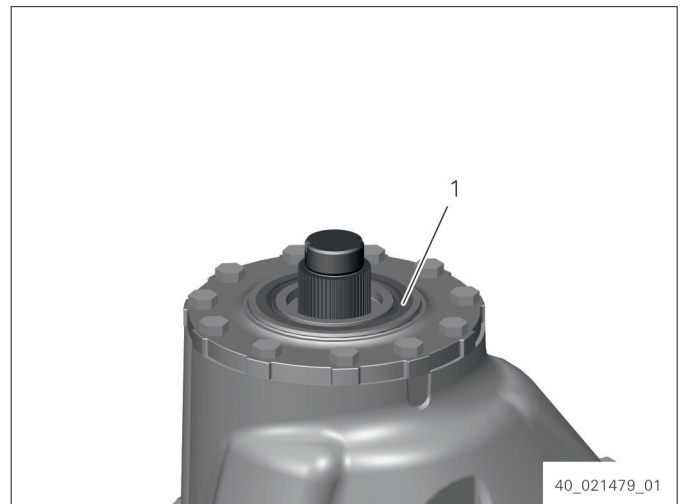

Fig. 84

8. Mark installation position of the bearing bush to the axle drive housing.
9. Loosen bolted connection.



Fig. 85

10. Slide on input flange.
11. Hand-tighten double hex nut.
12. Fasten bearing bush and pinion on the crane using 5870.281.044 [Load-lifting equipment].
13. Slowly raise the bearing bush with the crane and if necessary gently tap the axle drive housing.
14. Remove bearing bush from axle drive housing.
15. In variant with ring, remove the ring.
16. Disassemble input flange.
17. Disengage retaining ring.

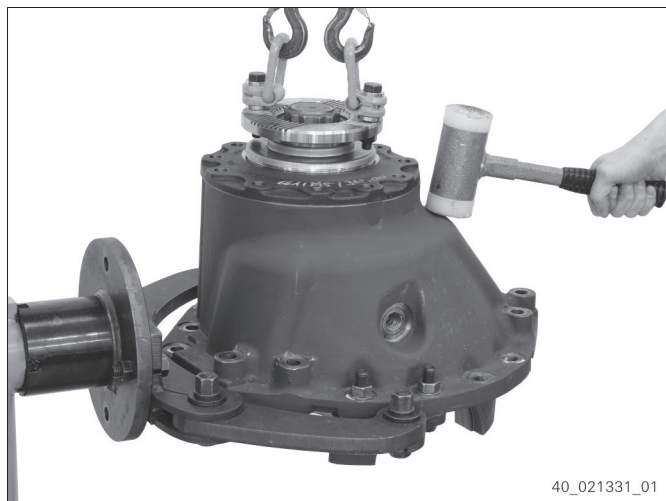

Fig. 86



Fig. 87

18. Pull off the cylindrical roller bearing.



Fig. 88

## Dismantling

---

19. Manually screw double hex nut/slotted nut onto the pinion.
20. Press drive pinion out of the bearing bush.
21. Slide 5870.023.043 [Supporting ring] under the tapered roller bearing on the drive pinion.
22. Place 5870.023.043 [Supporting ring] on the press plate.
23. Press drive pinion out of the tapered roller bearing and remove it.

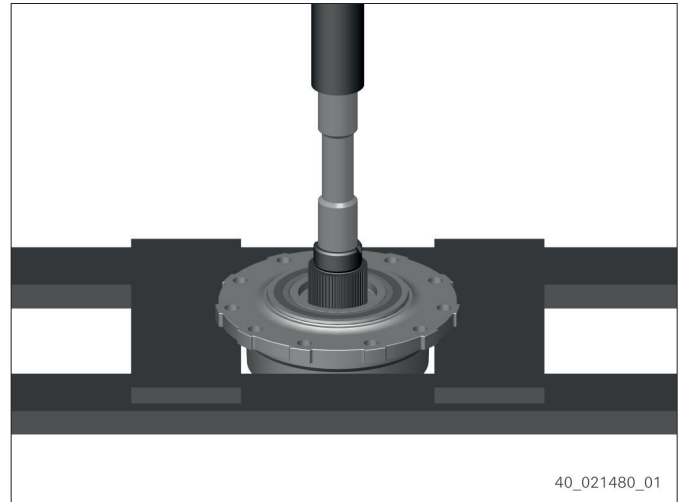
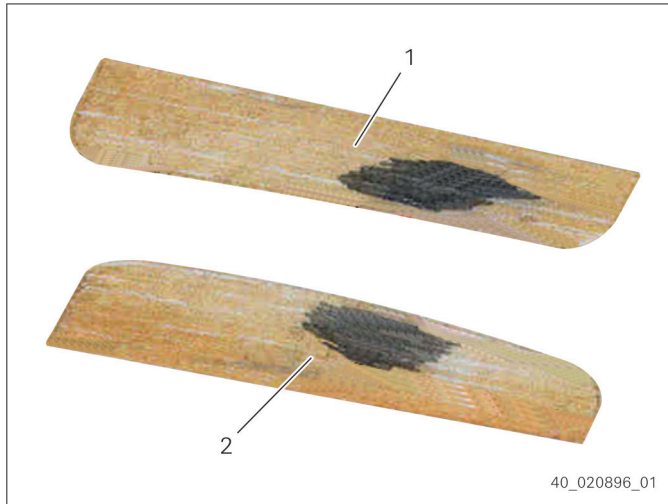

Fig. 89

10 Testing, Measuring, Adjusting

10.1 Checking contact pattern (Gleason-gearing)

Ideal contact pattern of the crown wheel.



- 1 Crown wheel convex (drive side)
- 2 Crown wheel concave (coast side)

Fig. 90 Ideal contact pattern

Indicators of an ideal contact pattern:

- It is tangent to the tooth centerline.
- Is tangent at least half as wide as the tooth is high.
- Is approximately in the center area between crown wheel inner side and crown wheel outer side.
- It looks similar on the convex and the concave side.

A visible line caused by the shot-peening process is allowed.

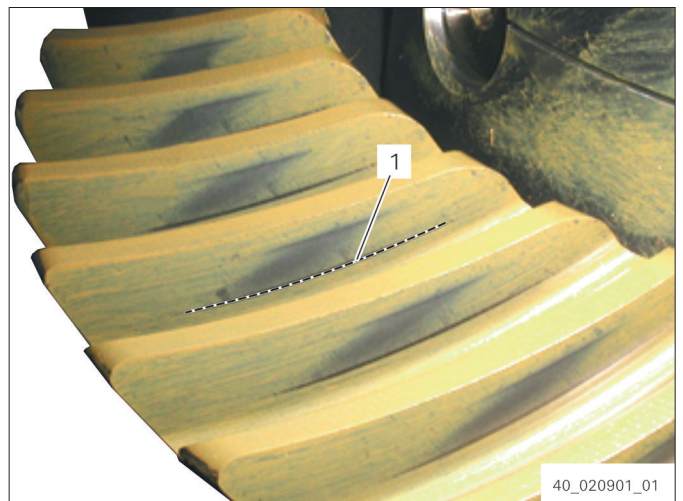

Fig. 91 Shot-peening edge

- 1 Shot-peening edge

The possible deviations and required correction measures are described in the following sections.

## 10.1.1 Contact pattern on crown wheel shifted towards the tip

- Contact pattern is shifted towards the tip.
- Contact pattern is too small.
- Contact pattern is not tangent to the tooth centerline.

1. Insert a **thinner** pinion distance disk on the **drive**.
2. Set backlash.
3. Check contact pattern.

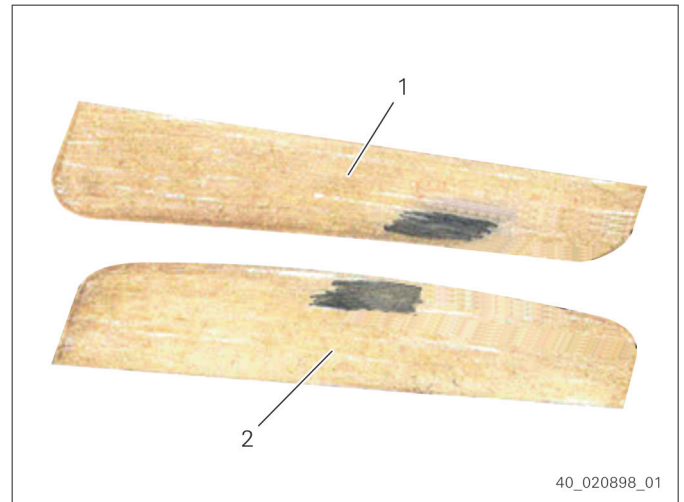

Fig. 92 Addendum tooth position

- 1 Crown wheel convex (drive side)
- 2 Crown wheel concave (coast side)

## 10.1.2 Contact pattern on crown wheel shifted towards the root

- Contact pattern is shifted towards the root.
- Contact pattern is tangent on the convex flank on the inner side of the crown wheel and on the concave flank on the outer side of the crown wheel.

1. Insert a **thicker** pinion distance disk on the **drive**.
2. Set backlash.
3. Check contact pattern.

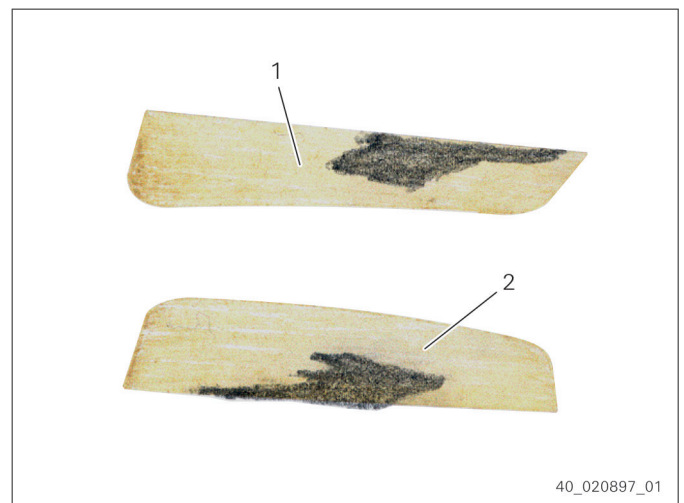

Fig. 93 Dedendum tooth position

- 1 Crown wheel convex (drive side)
- 2 Crown wheel concave (coast side)

## 11 Assembly

### 11.1 Assembling axle insert

#### 11.1.1 Installing the pinion

##### 11.1.1.1 Installing the pinion (variant with adjustable bearing)

Special tools:

- AA02.380.643 Driver tool
- 5870.260.004 Handle
- 5870.058.081 Driver tool
- 5870.260.002 Handle
- 5870.700.005 Load cell
- 5870.230.006 Spring balance
- 5870.204.023 Fixing pin
- 5870.281.044 Load-lifting equipment
- 5870.240.002 Locking mechanism
- 5870.401.114 Slotted nut wrench
- AA02.338.766 Driver tool

Operating supplies and auxiliary materials:

- 0666.690.313 LOCTITE 2701
  - 0666.690.191 PHÖNIX SPIRITUS
1. Press in the large bearing outer ring with AA02.380.643 [Driver tool] and 5870.260.004 [Handle].
  2. Press in the small bearing outer ring with 5870.058.081 [Driver tool] and 5870.260.002 [Handle].



Fig. 94

3. Compare mating number (1) e. g. "17" with mating number on the crown wheel. Both mating numbers must be identical.



Fig. 95

4. Press bearing inner ring onto pinion.

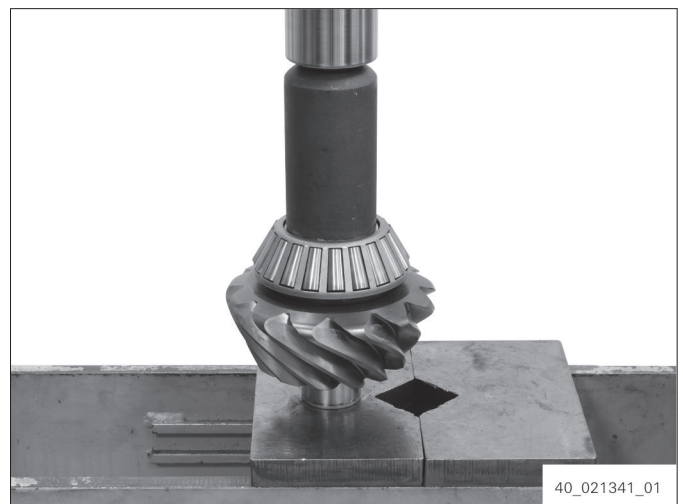

Fig. 96

5. Fit bearing bush on pinion.
6. Slide on spacer ring with  $s =$  e.g. 13.90 mm.

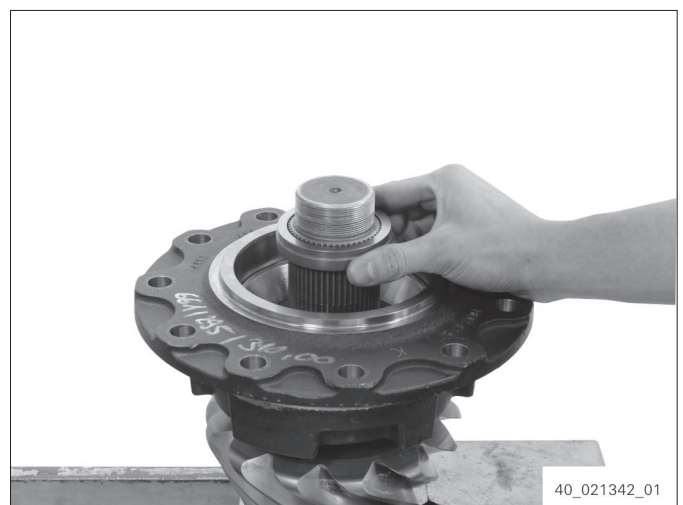

Fig. 97



7. Press on tapered roller bearing inner ring and rotate bearing bush several times in both directions.

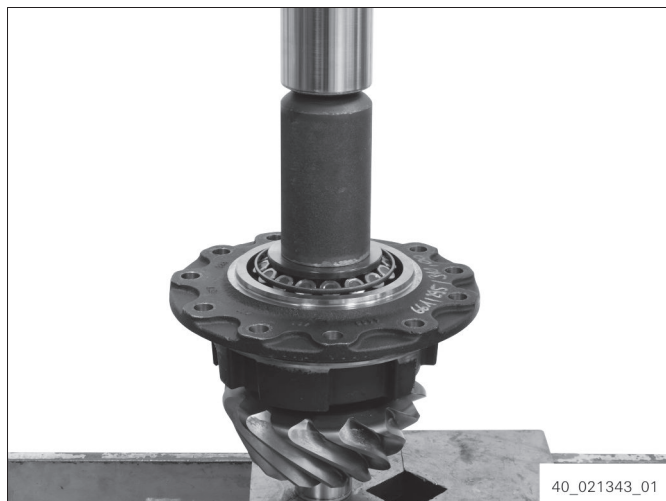

Fig. 98

8. Using a 5870.700.005 [Load cell] and press at 15 kN, press against the bearing inner ring.

9. Rotate bearing bush several times in both directions.

10. Wind thread onto the bearing bush.

11. Use 5870.230.006 [Spring balance] to determine force for unwinding the thread. Force  $F = \text{e.g. } 80 \text{ N}$

12. Calculate existing pinion bearing rolling torque and compare this with required pinion bearing rolling torque 4.5 Nm to 10.5 Nm.

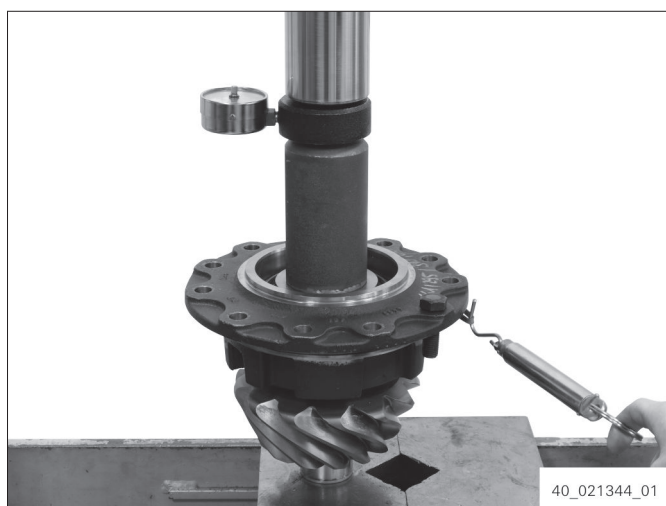

Fig. 99

Calculation example:

$$M = r \times F$$

$$M = 0.1075 \text{ m} \times 80 \text{ N}$$

$$M = 8.6 \text{ Nm}$$

In case of an insufficient rolling torque, install a thinner spacer ring.

In case of an excessive rolling torque, install a thicker spacer ring.

- 13. Slide on cylindrical roller bearing washer with the radius facing downwards.

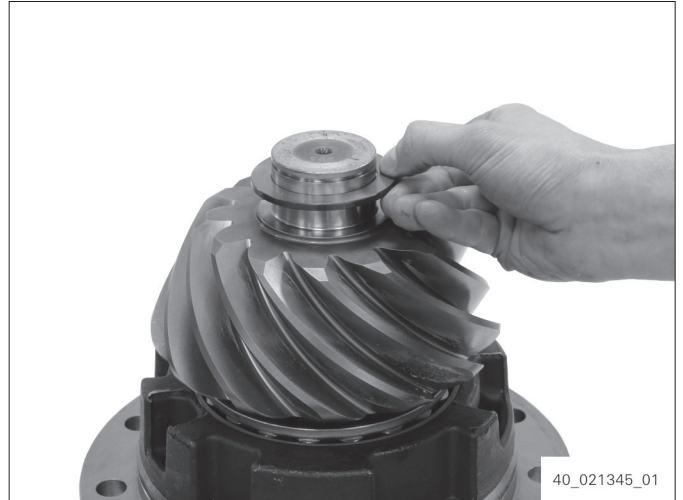



Fig. 100

- 14. 

 <b>CAUTION</b>
Risk of burn injuries due to contact with hot surfaces. Slight or moderate injury possible. ⇒ Wear protective gloves.

Warm the cylindrical roller bearing.

- 15. Slide on the cylindrical roller bearing.



Fig. 101

- 16. Insert retaining ring.



Fig. 102

17. Press screening plate on.

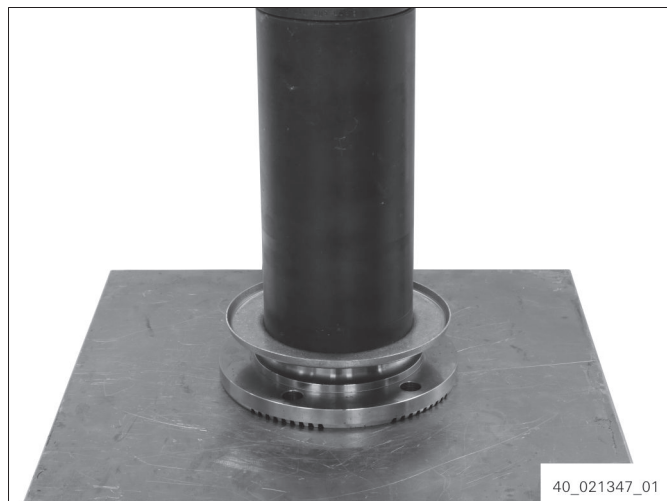

Fig. 103

18. Slide input flange onto pinion.
19. Screw old double hex nut or slotted nut on by hand.

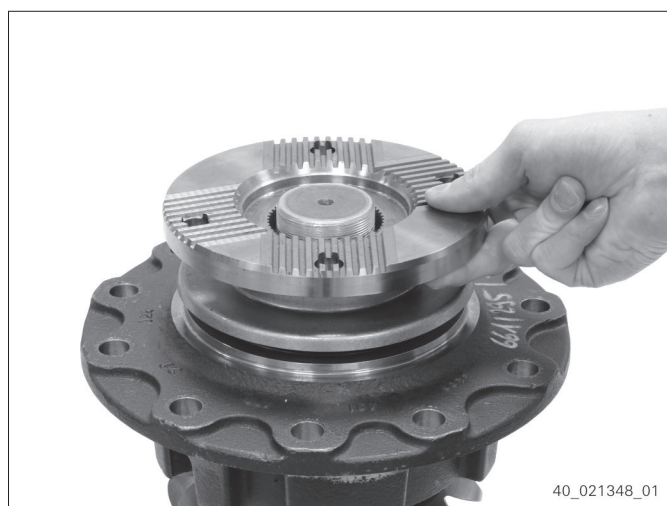

Fig. 104

20. Grease and insert O-ring (1).

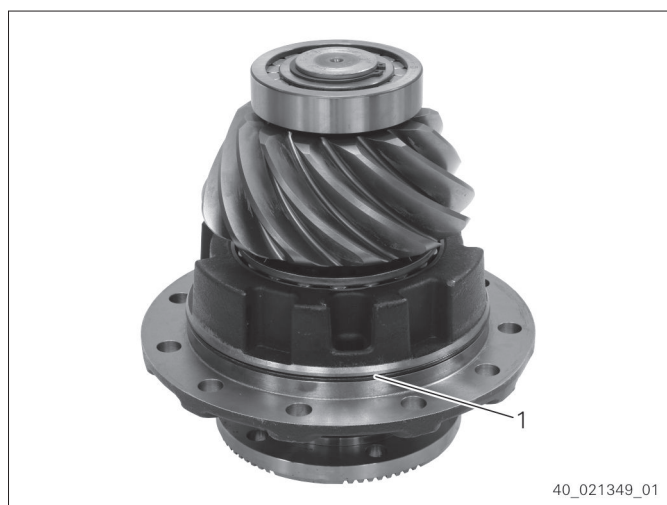

Fig. 105

## Assembly

21. Screw in two pieces 5870.204.023 [Fixing pin] (1).
22. In the variant with ring, slide on the ring.
23. Slide on adjustment plate (2) with  $s = \text{e.g. } 1.15 \text{ mm}$ .

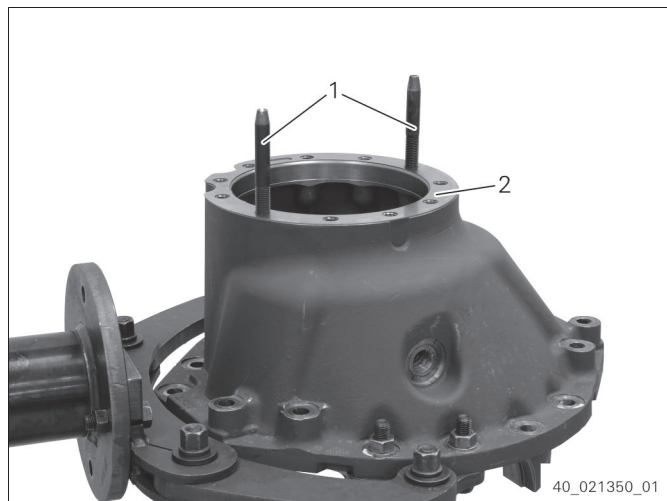

Fig. 106

24. Fasten bearing bush and pinion on the crane using 5870.281.044 [Load-lifting equipment].
25. Slide bearing bush into axle drive housing.

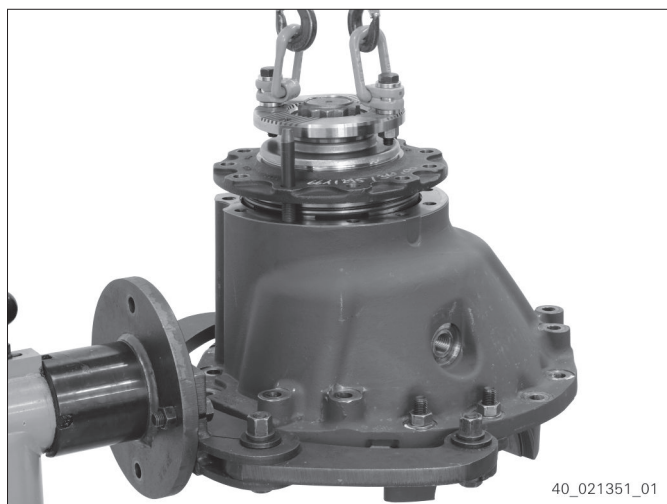

Fig. 107

26. Screw in and tighten hexagon screws. Tightening torque: **195 Nm**

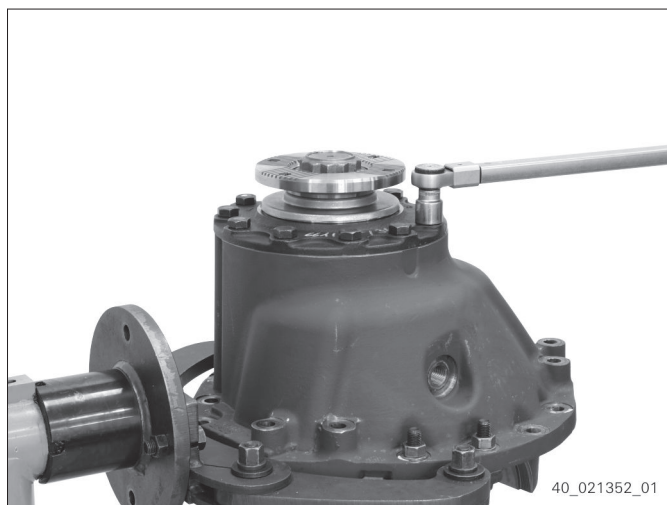

Fig. 108

27. Fasten input flange with 5870.240.002 [Locking mechanism].
28. Tighten double hex nut.  
In variant with slotted nut, tighten slotted nut with 5870.401.114 [Slotted nut wrench].  
Tightening torque: **1,100 Nm**



Fig. 109

29. Rotate pinion several times in both directions.
30. Turn the pinion slowly and check the required pinion bearing rolling torque 4.5 Nm to 10.5 Nm.
31. If the rolling torque is too small, retighten the double hex nut/slotted nut until the required rolling torque is reached.  
Tightening torque: **1,100 Nm to 1,800 Nm**  
In case of an insufficient rolling torque, install a thinner spacer ring.  
In case of an excessive rolling torque, install a thicker spacer ring.

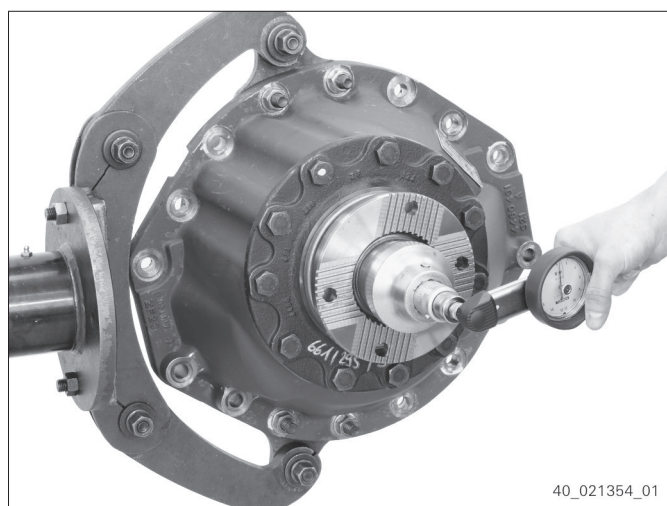

Fig. 110

32. Note down the applied tightening torque and adjusted rolling torque on pinion bearing.

→ Pinion bearing rolling torque is set.

When drive is finally installed, apply 0666.690.313 [LOCTITE 2701] to thread of double hex nut or use a new double-hex nut. In variant with slotted nut, force-fit the slotted nut after final installation.

## Assembly

33. Fasten input flange with 5870.240.002 [Locking mechanism].
34. Loosen double hex nut.  
On the variant with slotted nut, loosen slotted nut with 5870.401.114 [Slotted nut wrench].
35. Pull off input flange.

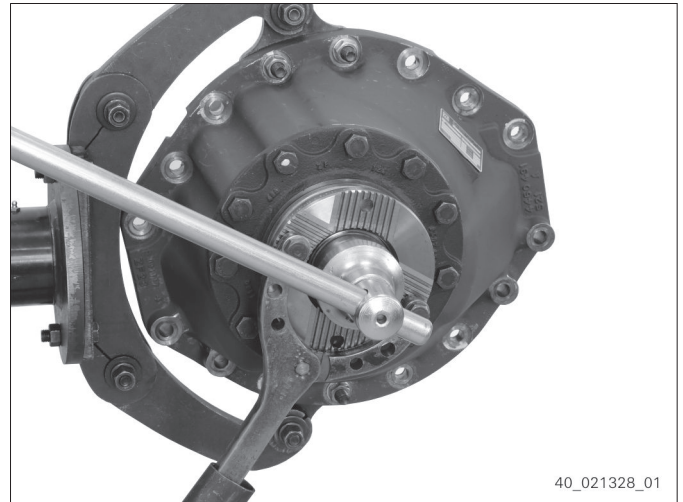

Fig. 111

36. Apply 0666.690.191 [PHÖNIX SPIRITUS] to outer diameter of shaft seal.
37. Insert shaft seal in the axle installation position with the mark for venting (1) in 12 o' clock position using AA02.338.766 [Driver tool].

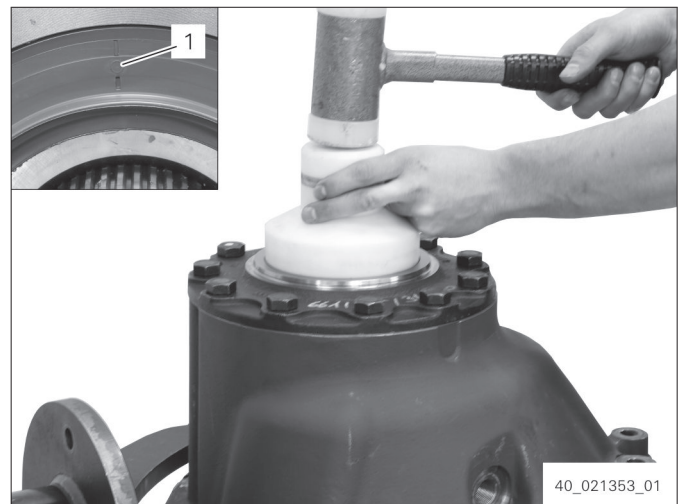



Fig. 112

38. Fasten input flange with 5870.240.002 [Locking mechanism].
39.  If the double hexagon nut was already bolted in, apply 0666.690.313 [LOCTITE 2701] onto the thread.

Alternatively, use a new double hex nut.

Screw the double hex nut on and tighten to the previously applied tightening torque.  
In variant with slotted nut, tighten slotted nut with 5870.401.114 [Slotted nut wrench].



Fig. 113

40.

**CAUTION**

Risk of injury due to parts flying away.  
Slight or moderate injury possible.  
⇒ Wear protective goggles.

In variant with slotted nut, force-fit slotted nut.

### 11.1.1.2 Installing pinion (variant with Pinion Pack)

Special tools:

- 5870.506.143 Pressure bush
- 5870.056.014 Driver tool
- 5870.260.002 Handle
- 5870.204.023 Fixing pin
- 5870.281.044 Load-lifting equipment
- 5870.048.238 Driver tool
- 5870.240.002 Locking mechanism
- 5870.401.114 Slotted nut wrench

Operating supplies and auxiliary materials:

- 0666.790.033 LOCTITE 574
- 0666.690.191 PHÖNIX SPIRITUS
- 0666.690.313 LOCTITE 2701

1.  In this variant, the bearing bush is only available in assembled condition. Only the sealing element can be replaced.

Fit bearing bush (1) on  
5870.506.143 [Pressure bush].

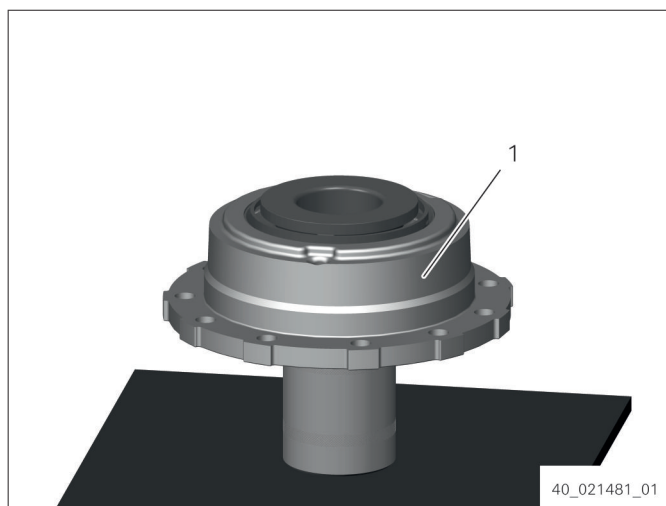

Fig. 114

2. Compare mating number (1) e. g. "17" with mating number on the crown wheel. Both mating numbers must be identical.



Fig. 115

3. Push pinion into bearing bush.
4. Rotate bearing bush and at the same time press in pinion until contact is obtained.

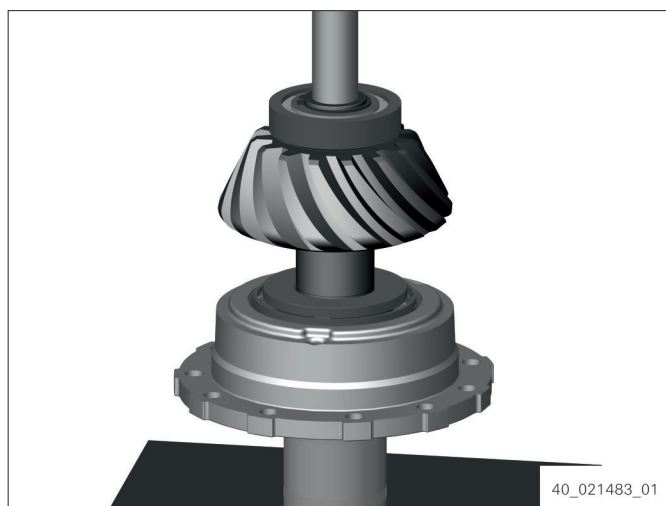

Fig. 116

5. Slide on cylindrical roller bearing washer with the radius facing downwards.



Fig. 117



6. **CAUTION**  
 Risk of burn injuries due to contact with hot surfaces.  
 Slight or moderate injury possible.  
 ⇒ Wear protective gloves.

Warm the cylindrical roller bearing.

7. Slide on the cylindrical roller bearing.



Fig. 118

8. Insert retaining ring.



Fig. 119

9. Use 5870.056.014 [Driver tool] and 5870.260.002 [Handle] to press on the screen sheet.

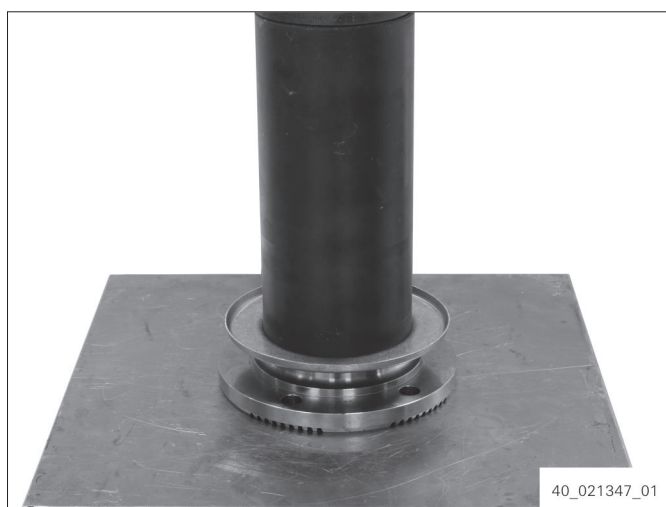

Fig. 120

## Assembly

10. Slide input flange onto pinion.
11. Screw old double hex nut or slotted nut on by hand.

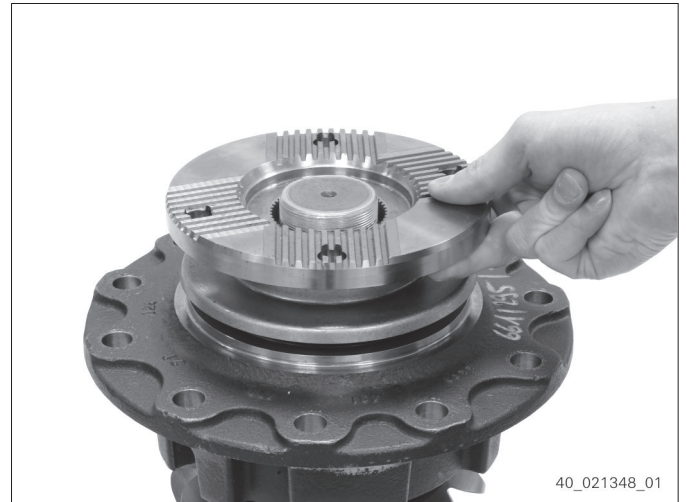

Fig. 121

12. Screw in two pieces 5870.204.023 [Fixing pin] (1).
13. Apply 0666.790.033 [LOCTITE 574] to the front face surfaces of the following parts.
14. In the variant with ring, slide on the ring.
15. Slide on adjustment plate (2) with  $s = \text{e.g. } 1.15 \text{ mm}$ .

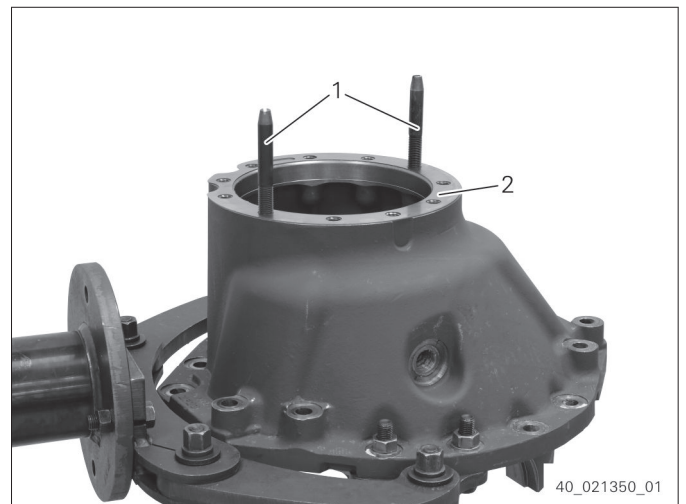

Fig. 122

16. Fasten bearing bush and pinion on the crane using 5870.281.044 [Load-lifting equipment].
17. Slide bearing bush into axle drive housing.

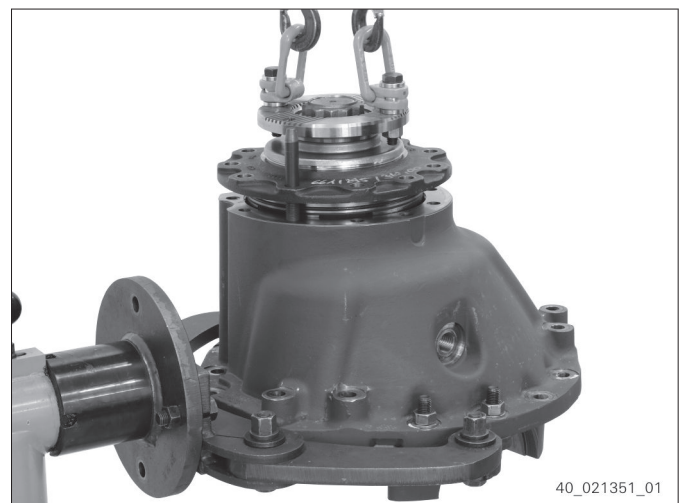

Fig. 123

18. Screw in and tighten hexagon screws.  
Tightening torque: **195 Nm**



Fig. 124

If removed, install the shaft seal

19. Remove double hex nut/slotted nut.
20. Pull off input flange.
21. Apply 0666.690.191 [PHÖNIX SPIRITUS] to outer diameter of shaft seal.
22. Insert shaft seal in the axle installation position with the mark for venting (1) in 12 o'clock position using 5870.048.238 [Driver tool].

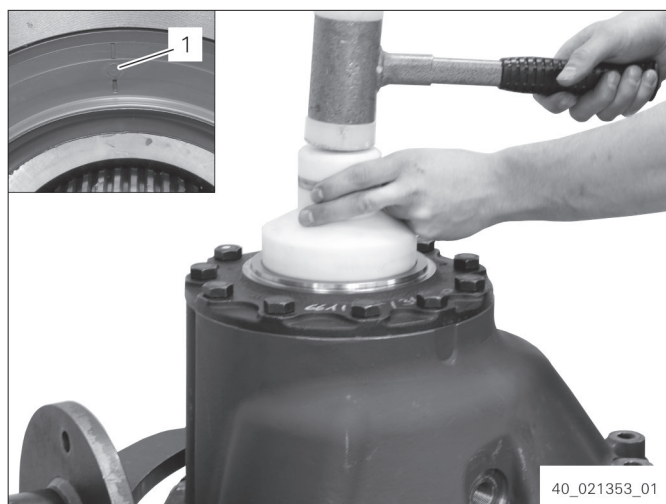



Fig. 125

23. Slide on input flange.
24. Fasten input flange with 5870.240.002 [Locking mechanism].
25.  If the double hexagon nut/slotted nut was already bolted in, apply 0666.690.313 [LOCTITE 2701] to the thread.

Alternatively, use a new double hex nut.

Tighten double hex nut.

In variant with slotted nut, tighten slotted nut with 5870.401.114 [Slotted nut wrench].

Tightening torque: **1,500 Nm**

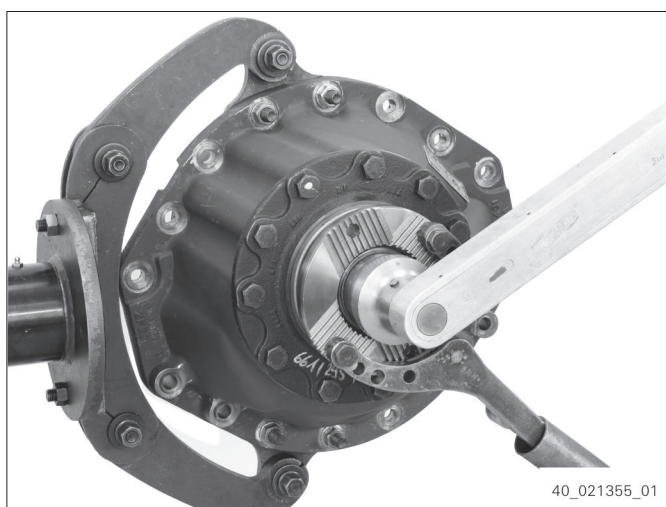

Fig. 126

26.

**⚠ CAUTION**

Risk of injury due to parts flying away.  
Slight or moderate injury possible.  
⇒ Wear protective goggles.

In variant with slotted nut, force-fit slotted nut.

## 11.1.2 Assembling differential

Special tools:

- 5870.204.040 Fixing pin

1. Compare mating number (1) e. g. "17" with mating number on the pinion. Both mating numbers must be identical.

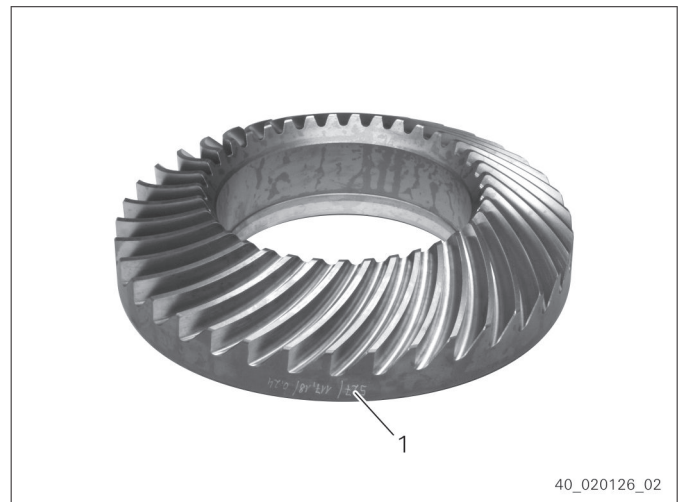

Fig. 127

2. Bolt two pieces 5870.204.040 [Fixing pin] onto the crown wheel.

3.

**⚠ CAUTION**

Risk of burn injuries due to contact with hot surfaces.  
Slight or moderate injury possible.  
⇒ Wear protective gloves.

Heat crown wheel.

4. Push crown wheel onto differential carrier half until contact is obtained.



Fig. 128

5.  Tighten screws, if the parts have max. 30 °C.

Fix differential.

6. Bolt in **new** locking screws and tighten crosswise.  
Tightening torque: **450 Nm**

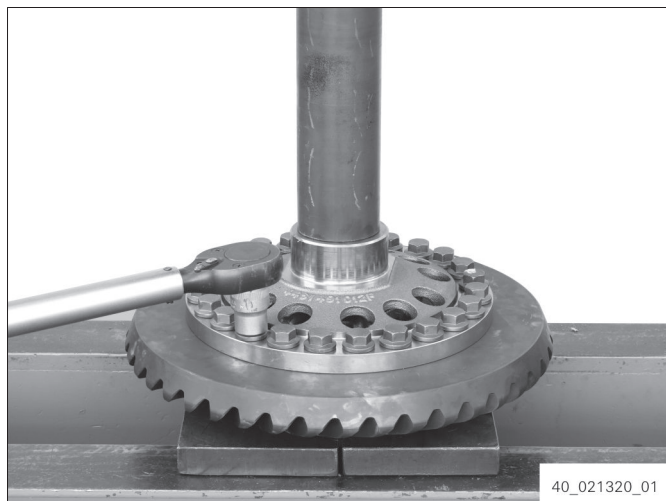

Fig. 129

7. For variant with a ratio of  $i = 4.273$ ,  $i = 4.700$ ,  $i = 5.222$  and  $i = 5.875$ : loosen eight locking screws as illustrated.

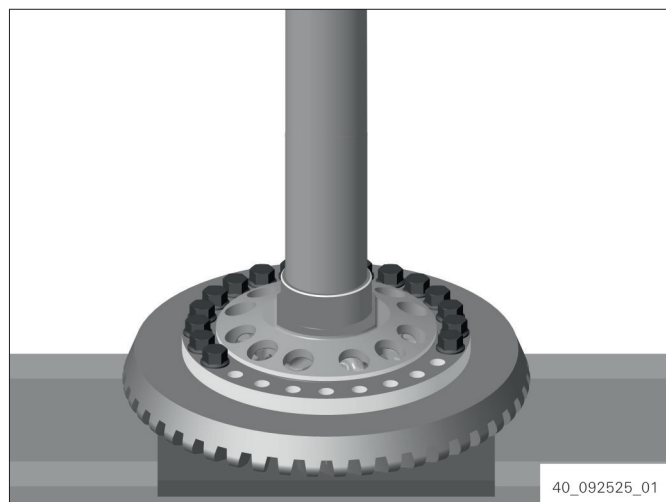

Fig. 130

8. Insert thrust washer.
9. Insert axle bevel gear.



Fig. 131

## Assembly

---

10. Fit differential bevel gears and thrust washers on differential spider.
11. Align the notches of the thrust washers horizontally.

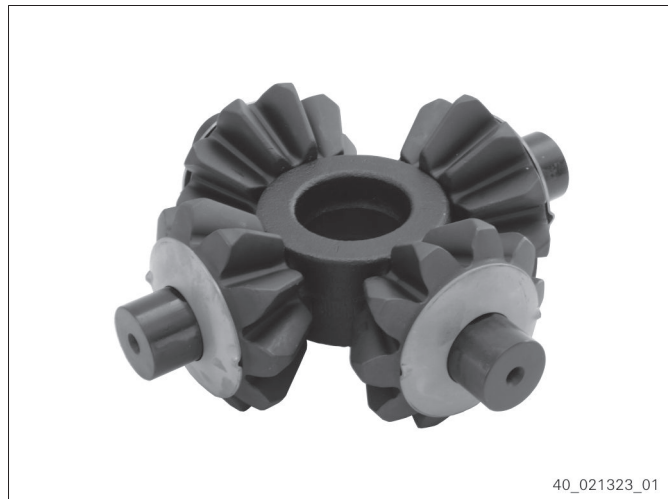

Fig. 132

12. Insert differential spider in differential carrier half.



Fig. 133

13. Glue thrust washer (1) with grease into differential carrier half.

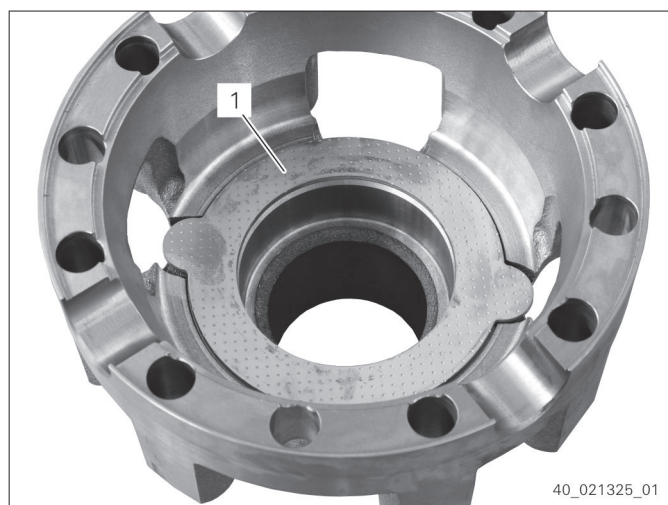

Fig. 134

14. Position differential carrier half according to marking.
15. Fix differential.
16. Bolt in hexagon screws and tighten crosswise.  
Tightening torque: **300 Nm**

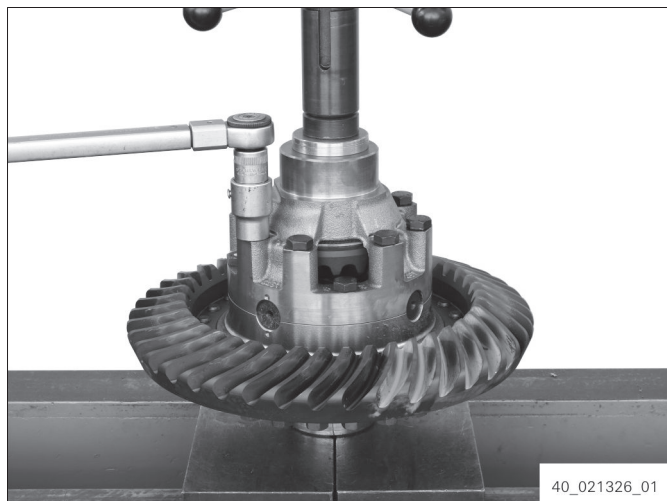

Fig. 135

17. Press bearing inner rings on until contact is obtained.



Fig. 136

### 11.1.3 Installing the differential

Special tools:

- 5870.281.075 Lifting device
- 5870.656.048 Socket wrench
- 5870.200.058 Caliper gauge
- 5870.240.002 Locking mechanism

## Assembly

1. Use 5870.281.075 [Lifting device] and crane to lift differential.
2. Slide bearing outer rings onto the differential and hold tight.

3. **⚠ CAUTION**

**Risk of crushing due to moving load.  
Slight to moderate injury possible.**

- ⇒ Move load slowly and carefully.
- ⇒ Do not reach into danger area.

Fit differential in the axle drive housing.  
For variant with a ratio of  $i = 4.273$ ,  $i = 4.700$ ,  
 $i = 5.222$  and  $i = 5.875$ : align differential with  
the eight missing locking screws facing  
downwards.

4. Insert both adjusting nuts into the thread halves.
5. Place both bearing brackets according to marked installation position on axle drive housing. Use hexagon screws as guide.
6. Check if adjusting nuts can be turned freely. If the adjusting nuts stick, check the position of the adjusting nuts and the bearing brackets.

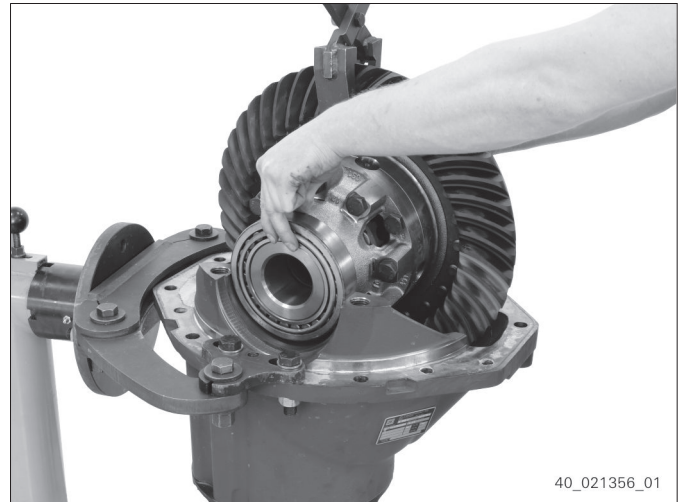

Fig. 137

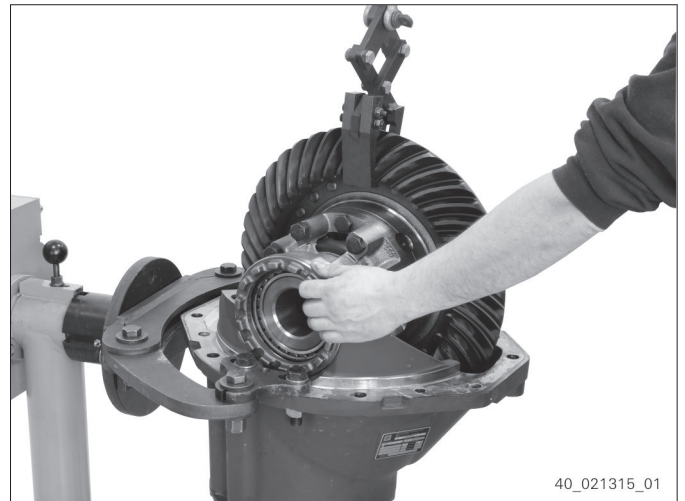

Fig. 138



7. Tighten hexagon screws.  
Tightening torque: **900 Nm**



Fig. 139

8. Manually screw in adjusting nuts until contact is obtained using 5870.656.048 [Socket wrench] but do not tighten.
9. Fully rotate differential several times in both directions.

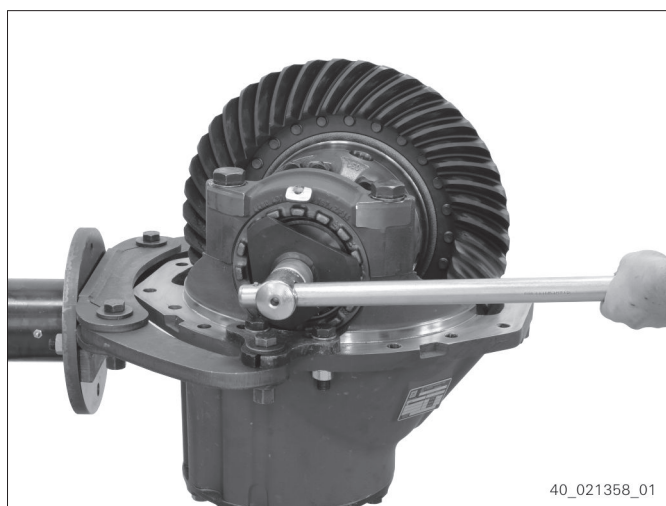

Fig. 140

10. Place dial gage with magnetic stand at right angles to the gearing of the crown wheel.
11. Check required Backlash 0.27 mm to 0.33 mm.
12. Rotate adjusting nuts until required backlash is obtained.
13. Tighten each adjusting nut by one notch using 5870.656.048 [Socket wrench].

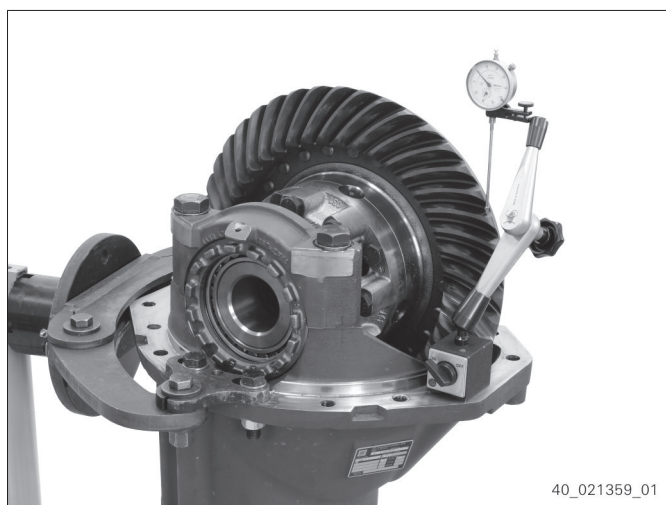

Fig. 141

## Assembly

14. Check Bracket width max.  
387.95 mm  $-0.2$  mm with  
5870.200.058 [Caliper gauge].  
Decrease preload on adjusting nuts if bracket  
width is exceeded.
15. Check backlash if preload has been changed.

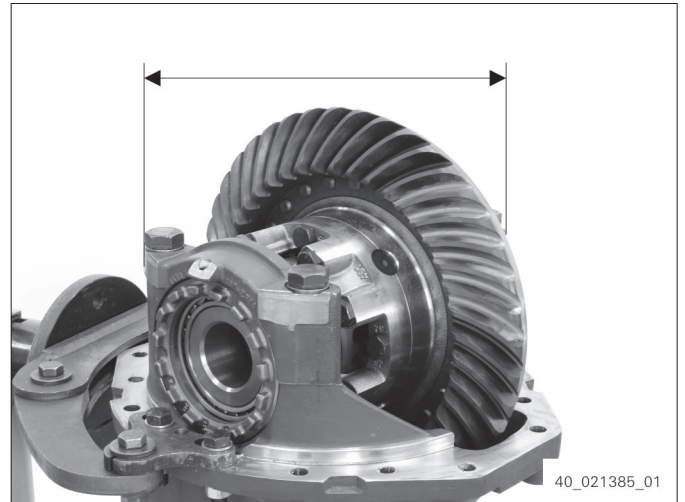

Fig. 142

16. For variant with a ratio of  $i = 4.273$ ,  $i = 4.700$ ,  
 $i = 5.222$  and  $i = 5.875$ : fix  
5870.240.002 [Locking mechanism] to input  
flange.

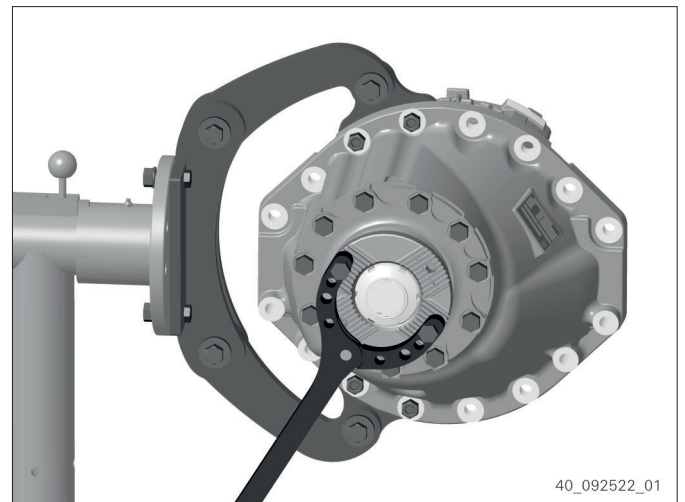

Fig. 143

17. For variant with a ratio of  $i = 4.273$ ,  $i = 4.700$ ,  
 $i = 5.222$  and  $i = 5.875$ : tighten **new** locking  
screws.  
Tightening torque: **450 Nm**
18. Remove 5870.240.002 [Locking mechanism].

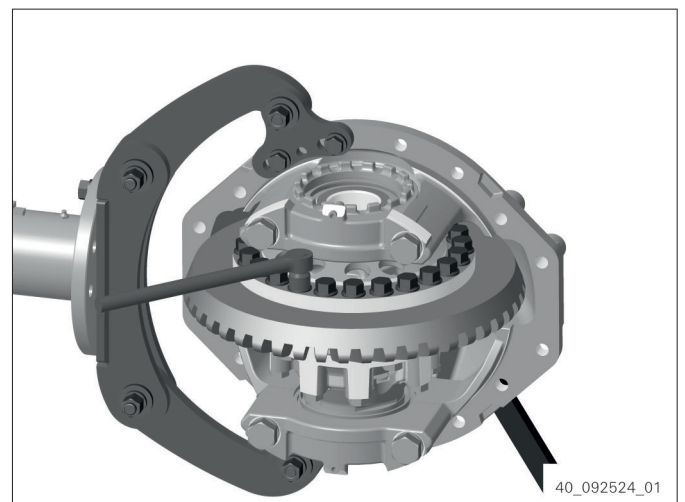

Fig. 144

19. Cover several drive and coast flanks on the crown wheel (1) with marking ink.
20. Rotate crown wheel several times in both directions.
21. Check contact pattern (refer to Section *Checking contact pattern (Gleason-gearing)*, page 61).

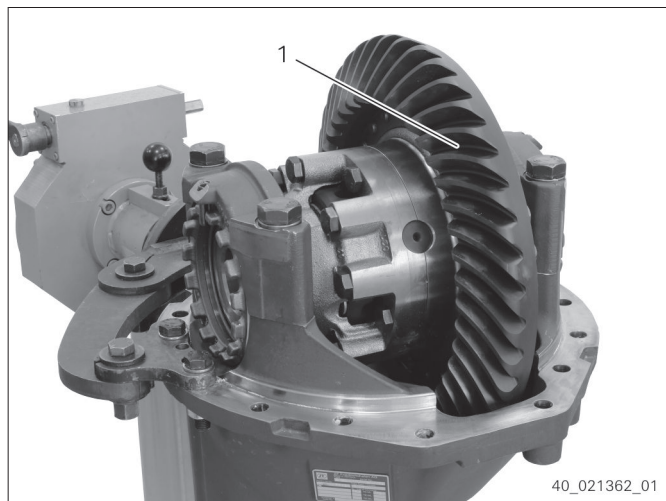



Fig. 145

22. 

 <b>CAUTION</b>
<p>Risk of injury due to parts flying away. Slight or moderate injury possible. ⇒ Wear protective goggles.</p>

Insert both slotted pins with the opening facing towards one direction of force until adjusting nut is secured.

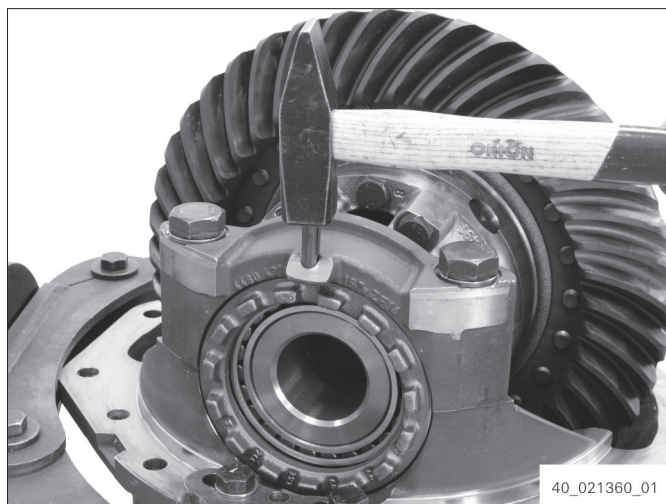

Fig. 146

#### 11.1.4 Installing the crown wheel support

Operating supplies and auxiliary materials:

- 0666.790.033 LOCTITE 574

## Assembly

1. Place sliding pad (1) onto crown wheel.
2. Rotate the input flange until the hole in the sliding pad aligns with the hole on the axle drive.

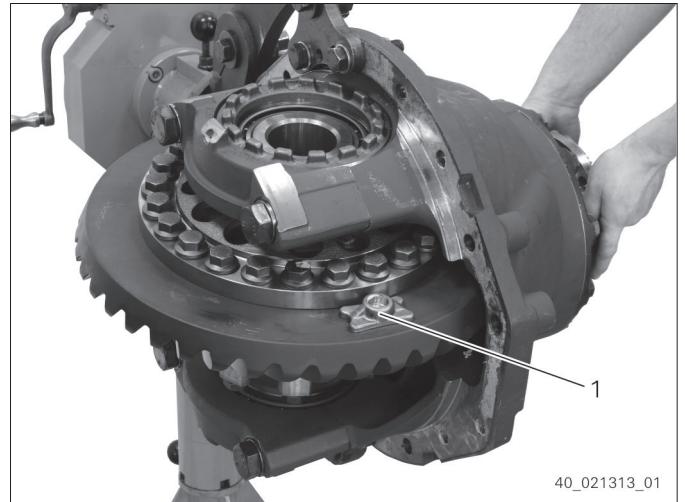

Fig. 147

3. Apply 0666.790.033 [LOCTITE 574] to the thread of the adjusting screw.
4. Screw in adjusting screw and tighten by hand.
5. Slowly unscrew the adjusting screw until the crown wheel can be turned.
6. Secure the adjusting screw in place and tighten hexagon nut.  
Tightening torque: **150 Nm**
7. Rotate crown wheel.  
If the crown wheel cannot be rotated, loosen the hex nut, unscrew the adjusting screw and retighten the hex nut.

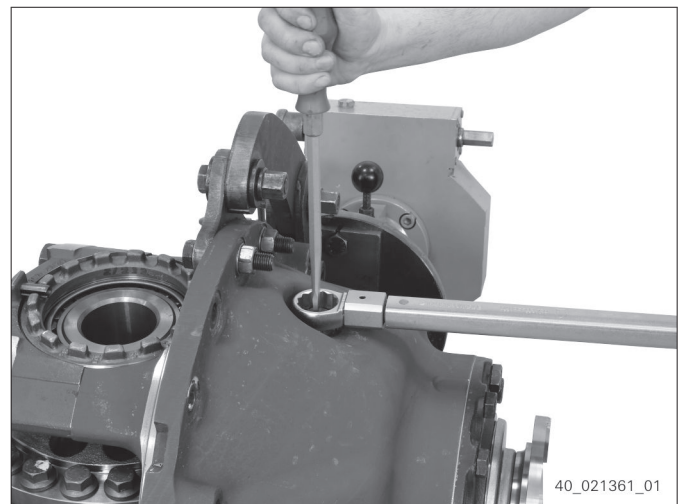

Fig. 148

### 11.2 Installing axle insert

Special tools:

- 5870.204.040 Fixing pin
- 5870.281.044 Load-lifting equipment

Operating supplies and auxiliary materials:

- 0666.790.033 LOCTITE 574

1. Apply 0666.790.033 [LOCTITE 574] to the mounting face of the axle housing.
2. Bolt two pieces 5870.204.040 [Fixing pin] (1) into axle housing.
3. Fasten axle insert to crane with 5870.281.044 [Load-lifting equipment].
4.  The axle insert can be installed on either side depending on the direction of rotation of the axle.

Insert the axle insert slowly in the axle housing.

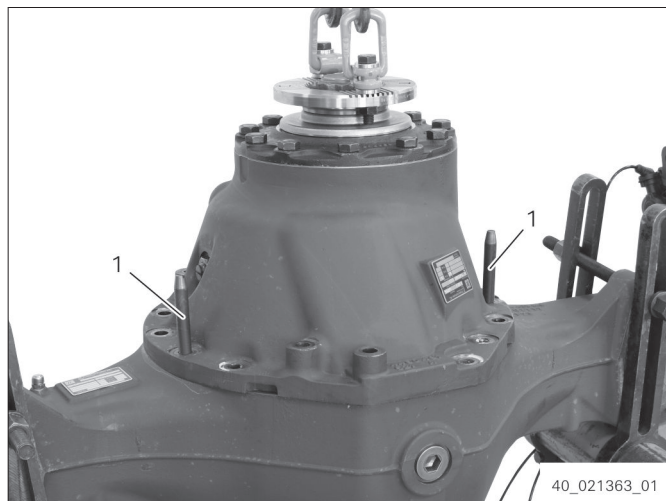

Fig. 149

5. Screw in **new** locking screws and tighten. Tightening torque: **385 Nm**



Fig. 150

6. If outputs have not been dismantled, install flange shafts.

## 11.3 Mounting breather

### 11.3.1 Mounting breather (variant with ZF membrane breather)

1. Fix the breather on the axle housing with locking screws (3).  
Tightening torque: **385 Nm**
2. Push the hose clamp (1) onto the hose.
3. Push the hose (2) onto the breather neck.
4. Secure hose (2) with hose clamp (1).

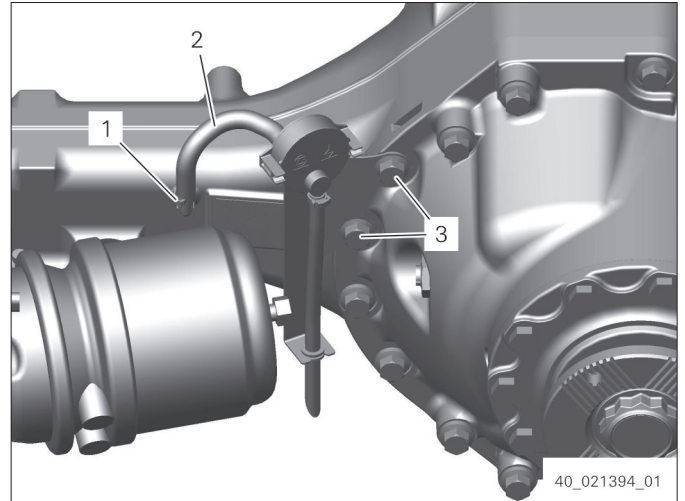

Fig. 151

### 11.3.2 Mounting breather (variant with breather valve)

1. Screw in breather and tighten.  
Tightening torque: **5.5 Nm**

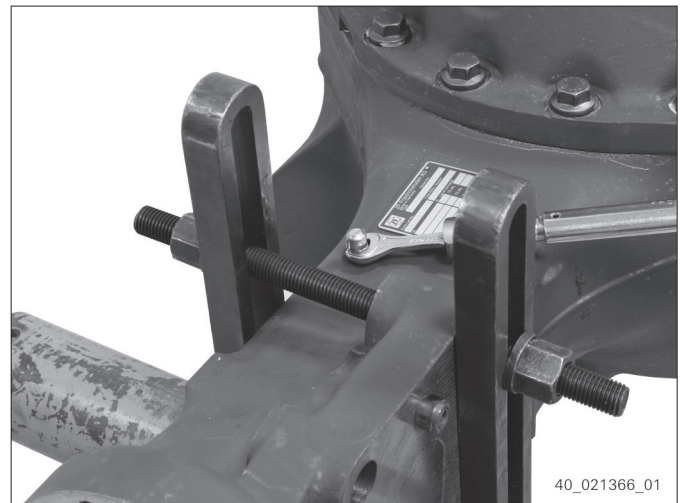

Fig. 152

## 11.4 Mounting hub carrier and tachometer

### Special tools:

- 5870.281.054 Eye nut
- AA02.045.674 Eyebolt
- AA00.387.830 Pressing fixture

### Operating supplies and auxiliary materials:

- 0671.190.065 UNIREX N 3

1. Fit O-ring (1).

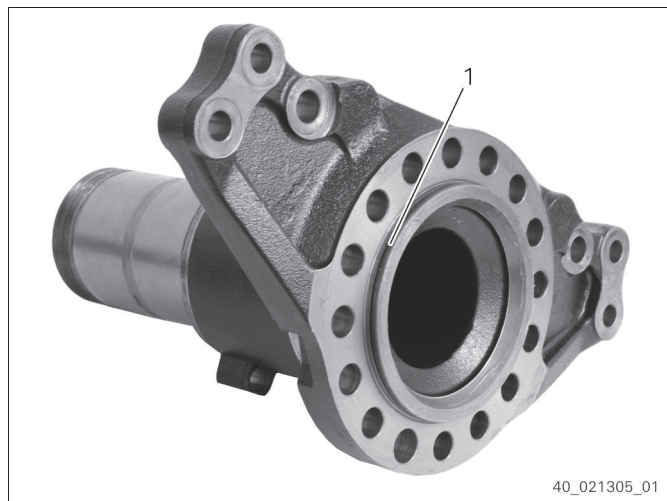

Fig. 153

2. Secure the hub carrier on the crane with 5870.281.054 [Eye nut] and two AA02.045.674 [Eyebolt].

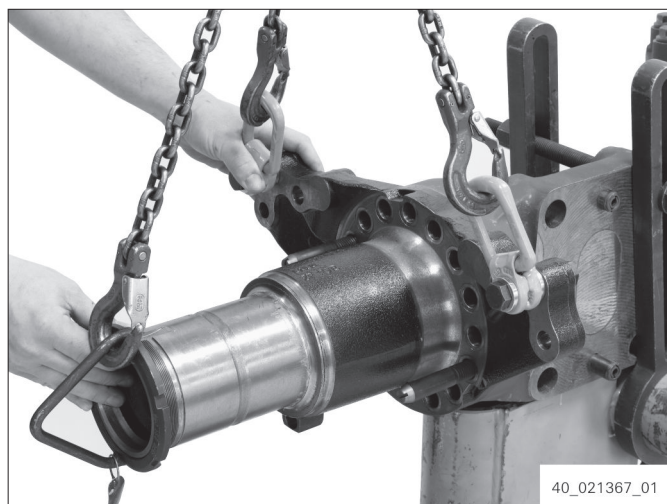

Fig. 154

3. Secure the hub carrier on the axle housing with Torx screws.  
Tightening torque: **440 Nm**

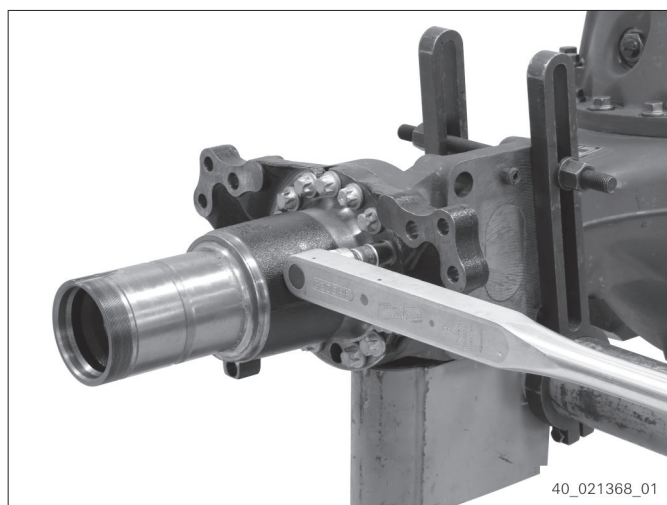

Fig. 155

## Assembly

4. Align the recess on the screen sheet with the boss on the hub carrier.
5. Align the recess on the AA00.387.830 [Pressing fixture] with the boss on the hub carrier.
6. Use AA00.387.830 [Pressing fixture] and plastic hammer to drive the screen sheet onto the hub carrier.

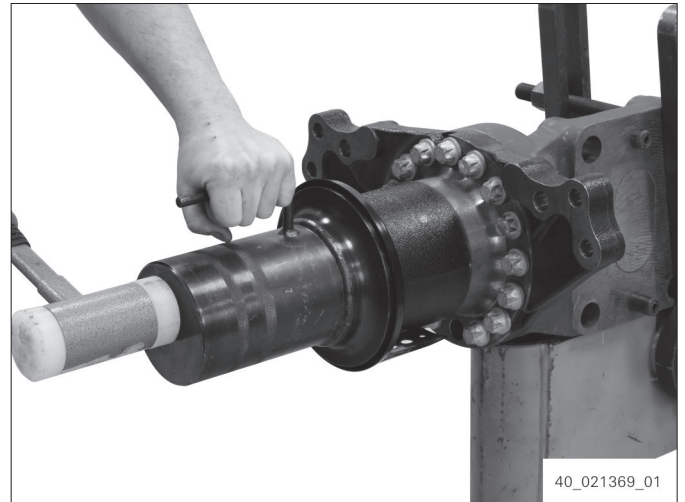

Fig. 156

7. Push bush (1) into the hub carrier.

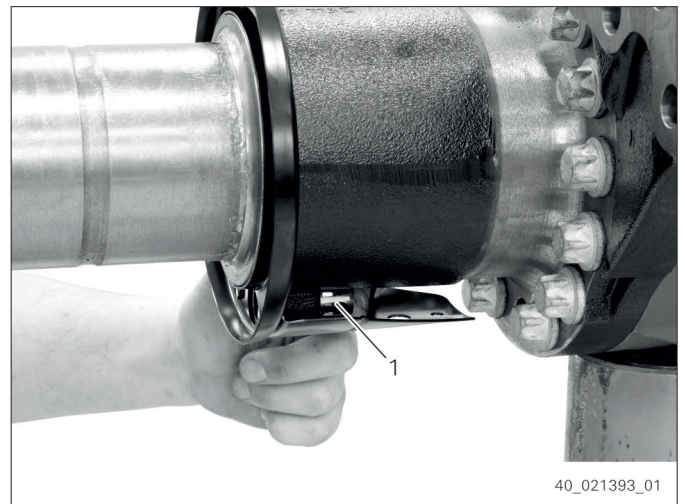



Fig. 157

8.  For the installation position refer to the current spare parts lists.

Apply a thin layer of 0671.190.065 [UNIREX N 3] to the outside of the tachometer.

9. Push the tachometer into the bush so that approx. 1 mm protrudes above the contact face of the compact bearing.

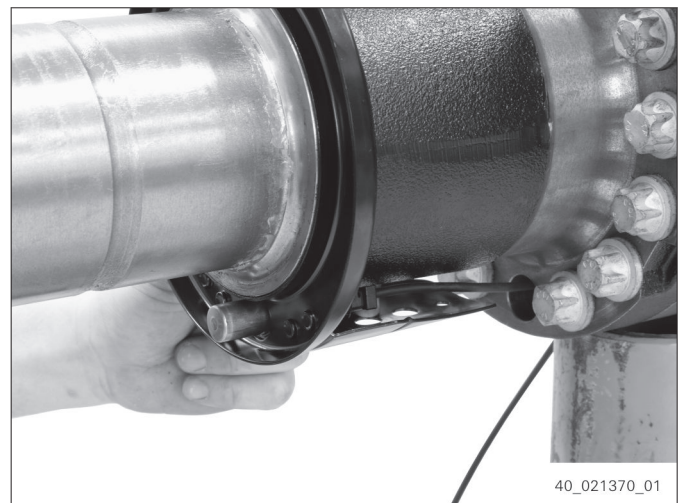

Fig. 158



10. Align the recess on the AA00.387.830 [Pressing fixture] with the boss on the hub carrier. Push AA00.387.830 [Pressing fixture] slowly until contact is reached with the hub carrier, then position the tachometer.

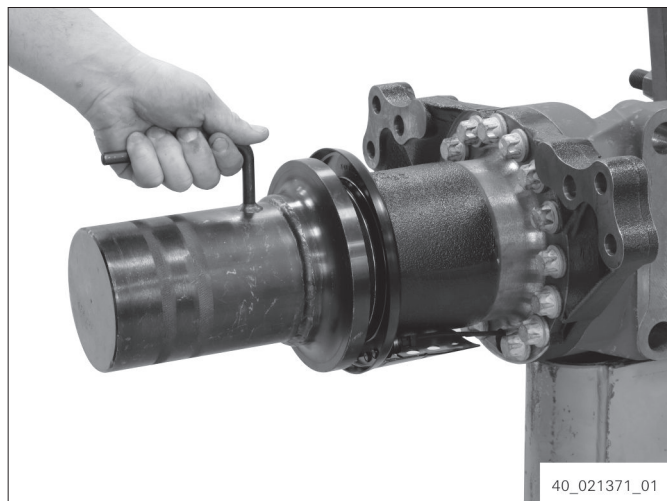



Fig. 159

## 11.5 Assembling and installing hub

### 11.5.1 Assembling the hub

Special tools:

- 5870.610.010 Assembly fixture
- 5870.610.002 Insert
- AA02.259.595 Holding device
- AA02.259.716 Holding device
- 5870.050.007 Driver tool
- 5870.260.004 Handle
- 5870.345.121 Support arbor
- AA00.607.922 Driver tool

1.  Only use 5870.610.010 [Assembly fixture] and 5870.610.002 [Insert] with hubs on which wheel studs have already been installed.

Use 5870.610.010 [Assembly fixture] and 5870.610.002 [Insert] to install the wheel studs.

Alternatively, place the hub on AA02.259.595 [Holding device] or AA02.259.716 [Holding device] and press the wheel studs in one after the other.

1.  Note the pitch circle diameter.

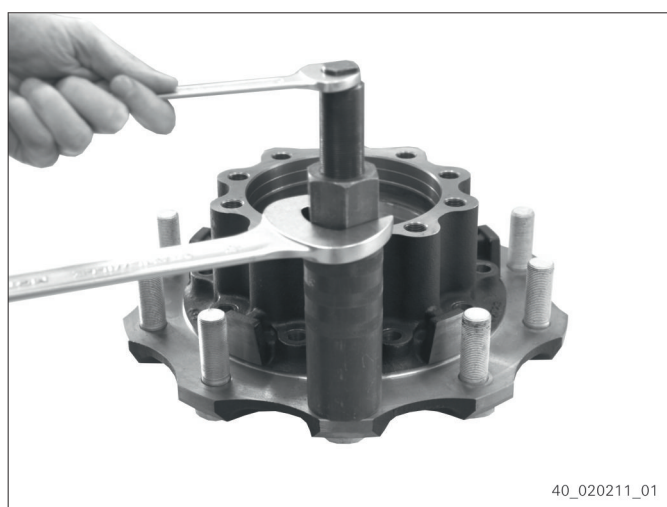



Fig. 160

2.  Do not mix up bearing cups.

Use 5870.050.007 [Driver tool] and 5870.260.004 [Handle] to press both bearing outer rings into the hub until contact is obtained.

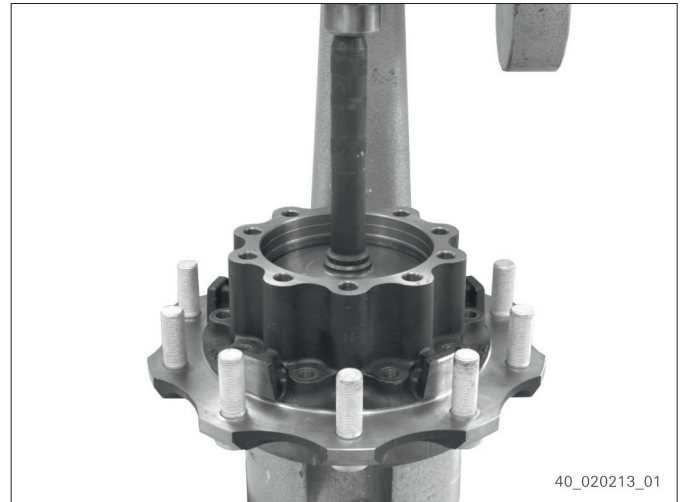

Fig. 161

3. Pack **125 – 150 g** grease (1) according to ZF List of Lubricants TE-ML 12 into the compact bearing (4). Press grease into the space between inner bearing ring and bearing cage from outside as well (arrows).

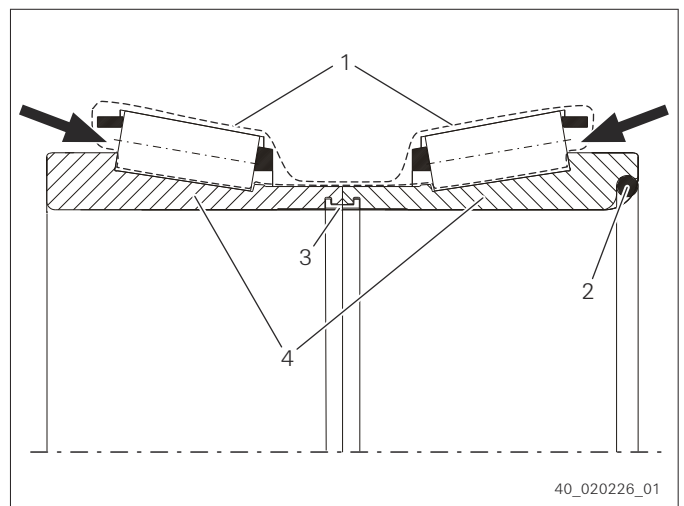

Fig. 162

- 1 Grease
- 2 O-ring
- 3 Retaining ring
- 4 Compact bearing (consisting of two individual tapered roller bearings)

4. Fit brake disk side bearing inner ring on the 5870.345.121 [Support arbor].
5. Insert the securing ring in the brake disk side bearing inner ring.

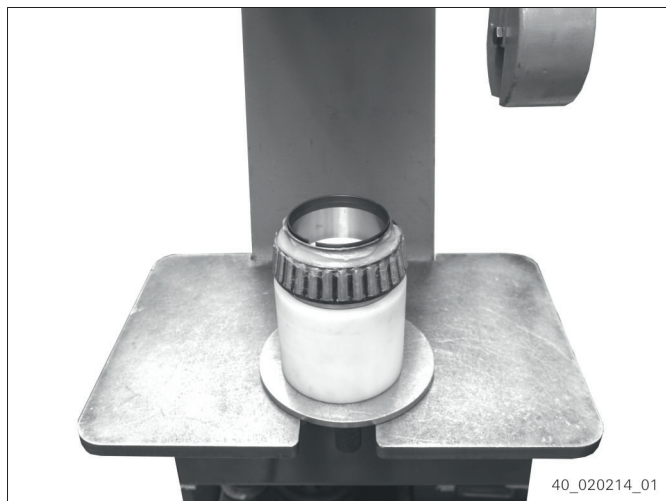

Fig. 163

6. Fit the hub on the brake disk side bearing inner ring.
7. Fit the outer bearing inner ring in the hub.

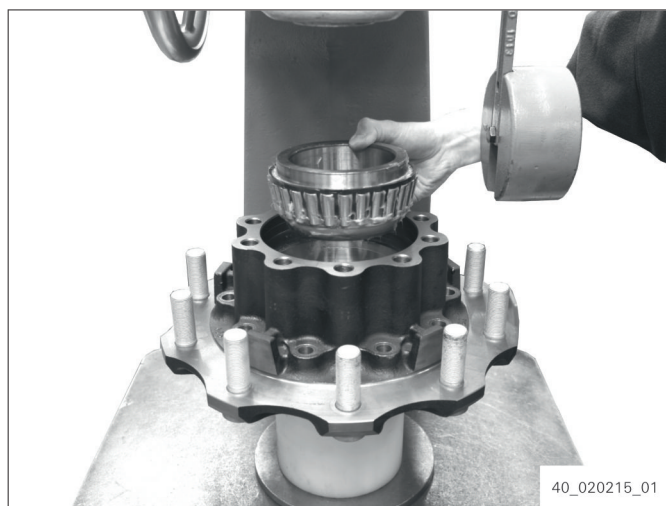

Fig. 164

8. Press the outer bearing inner ring slowly downwards until securing ring clicks audibly into place.
9. Rotate hub several times in both directions.

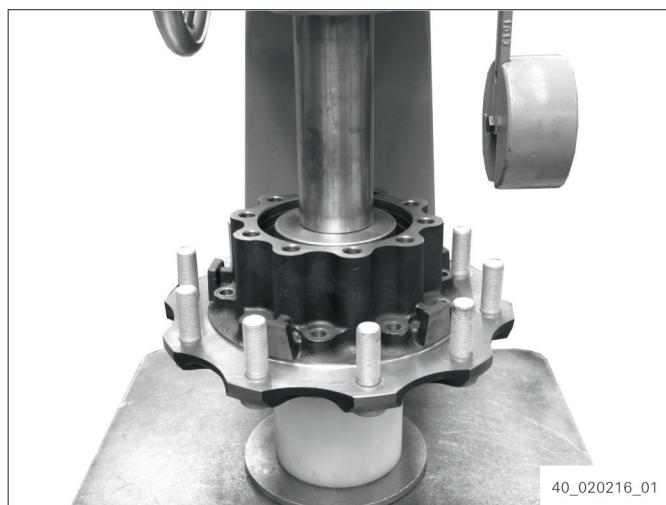

Fig. 165

10. Check whether the securing ring (1) is fully engaged.

→ When the securing ring (1) is fully engaged, the entire bearing is 140 mm – 0.3 mm high.

If the securing ring is not engaged, remove it and check grooves for dirt.

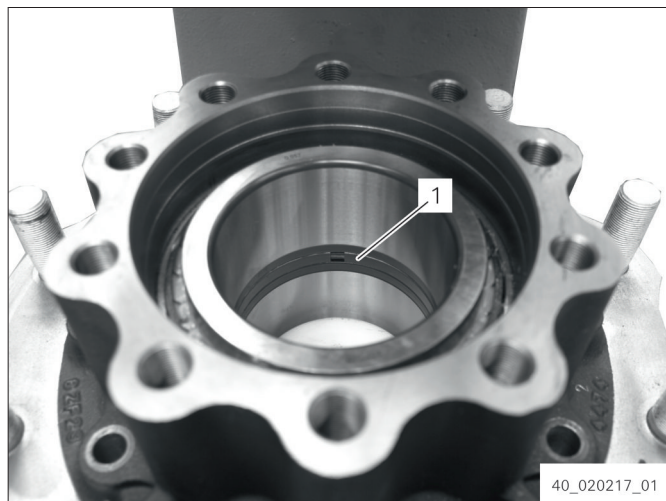

Fig. 166

11. Use AA00.607.922 [Driver tool] to insert the outer shaft sealing ring.

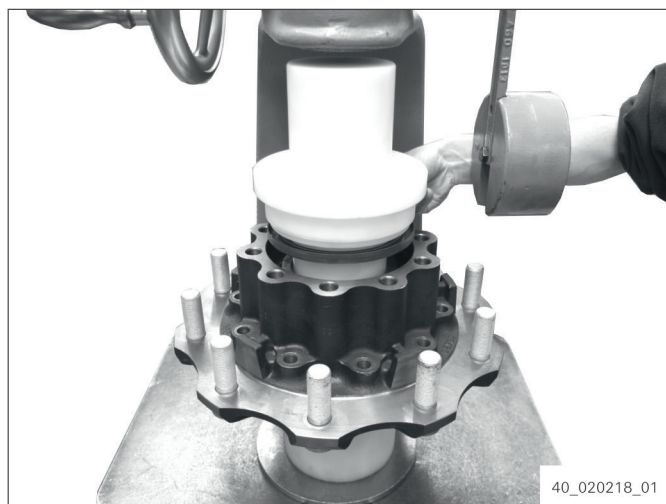

Fig. 167

12. Use AA00.607.922 [Driver tool] to insert the shaft sealing ring in the brake disk side.

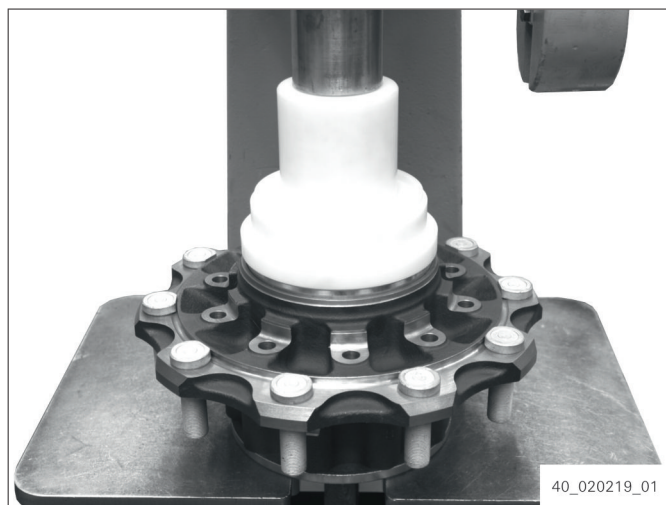

Fig. 168

13. Fit hub on brake disk.
14. Screw in Torx screws and tighten by hand.

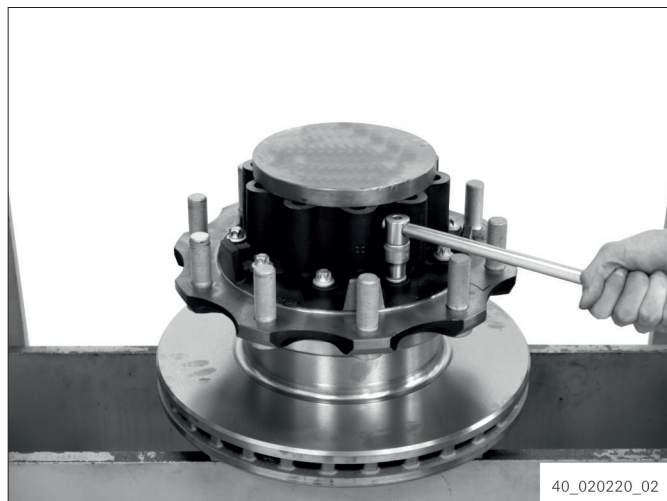

Fig. 169

15. Grease O-ring (1) and insert it in the radial groove on the compact bearing.

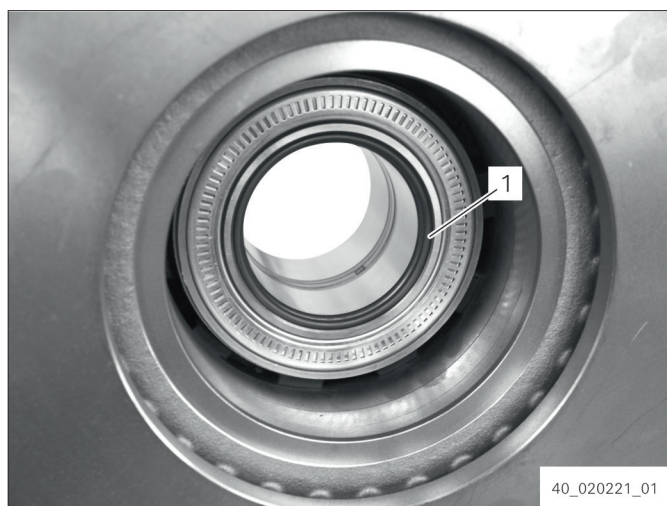

Fig. 170

### 11.5.2 Mounting hub

Special tools:

- 5870.651.085 Assembly aid
- AA01.395.095 Load carrying fixture
- 5870.401.146 Slotted nut wrench
- 5870.204.029 Fixing pin

Operating supplies and auxiliary materials:

- 0671.190.180 RENOLIT LX-NHU 2

## Assembly

1. Push 5870.651.085 [Assembly aid] (1) into the hub carrier.
2. Apply a thin, even layer of 0671.190.180 [RENOLIT LX-NHU 2] to both bearing seats (2).

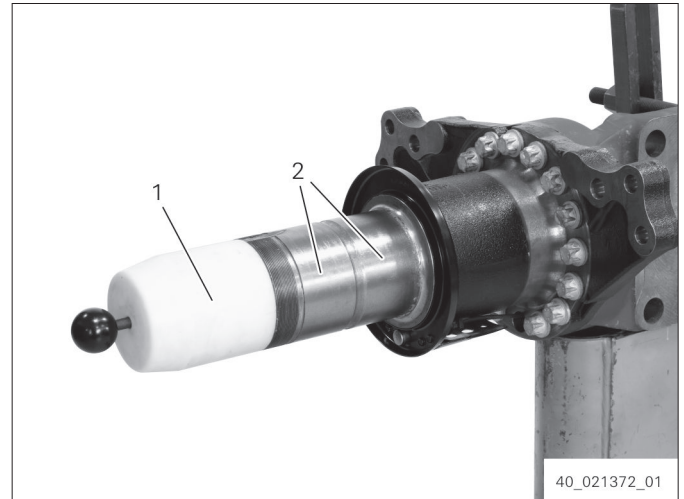

Fig. 171

3. Use AA01.395.095 [Load carrying fixture] to fix the hub to the crane.
4. Push hub carefully onto the hub carrier.
5. Screw on slotted nut with the chamfer facing outwards.

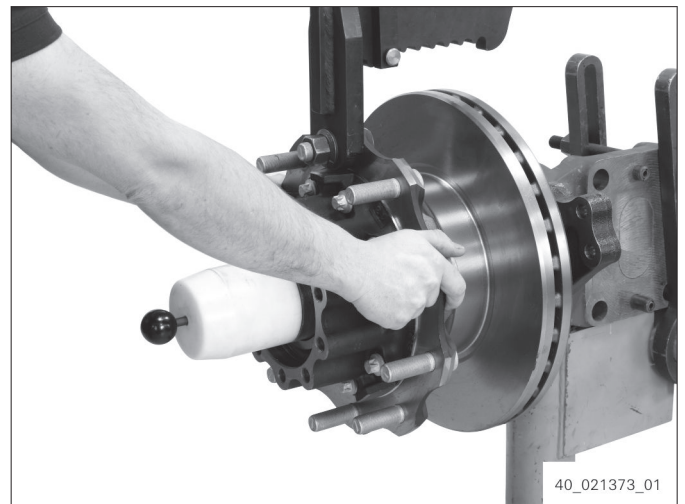

Fig. 172

6. Tighten slotted nut with 5870.401.146 [Slotted nut wrench]. Tightening torque: **100 Nm**
7. Rotate hub several times in both directions.
8. Tighten slotted nut with 5870.401.146 [Slotted nut wrench]. Tightening torque: **850 Nm**
9. Mount locking plate on the hub carrier with the tab facing inwards.

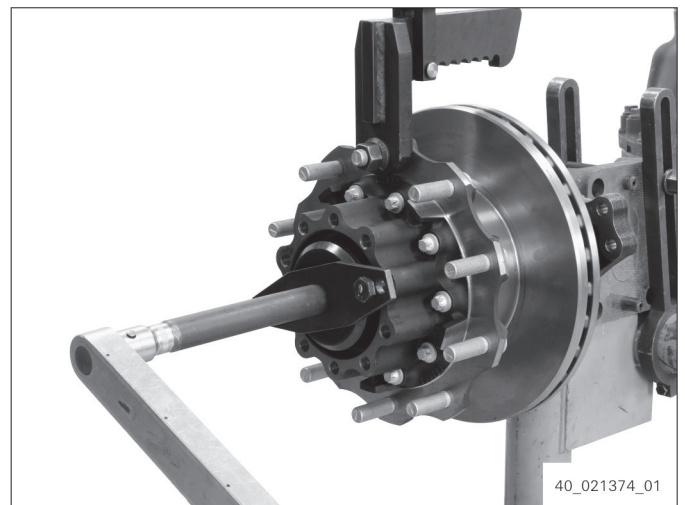

Fig. 173

10. Screw on slotted nut with the chamfer facing inwards.
11. Tighten slotted nut with 5870.401.146 [Slotted nut wrench]. Tightening torque: **1,200 Nm**
12. Tighten brake disk screw connection. Tightening torque: **270 Nm**

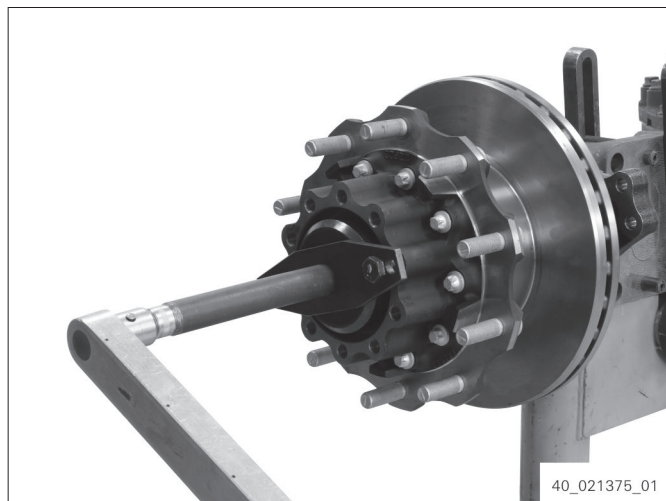

Fig. 174

13. Secure slotted nut with locking plate (1).

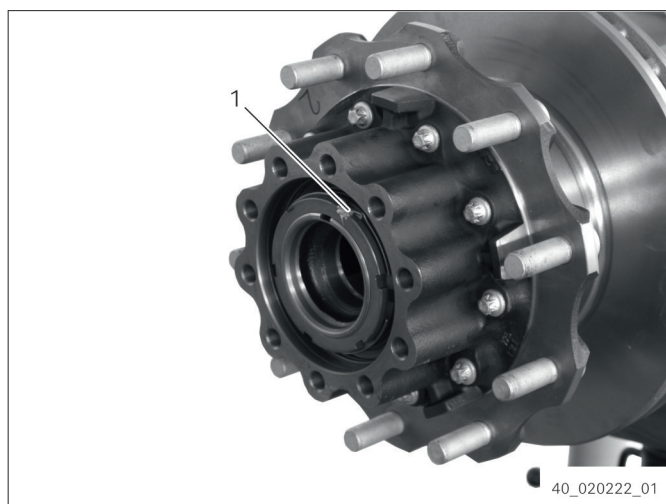

Fig. 175

14. Grease O-ring (1) and insert it in the annular groove on the flange shaft.



Fig. 176

## Assembly

15. Screw two pieces 5870.204.029 [Fixing pin] into the hub.
16. Push flange shaft into the hub carrier.

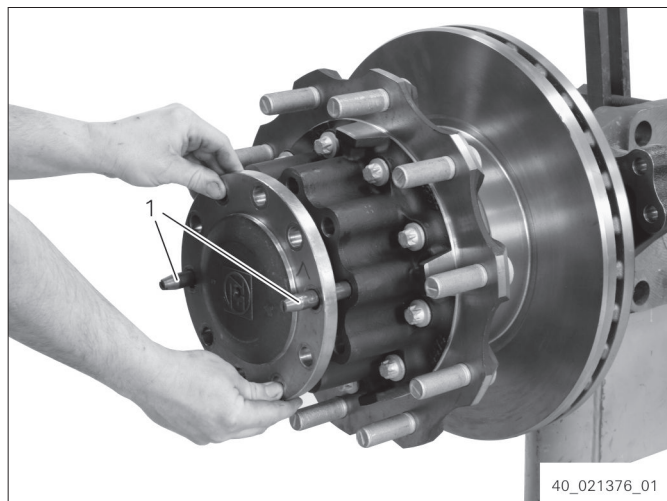



Fig. 177

17. Screw in and tighten screws.  
Tightening torque: **440 Nm**  
 Alternatively tighten screws with actuated brake.

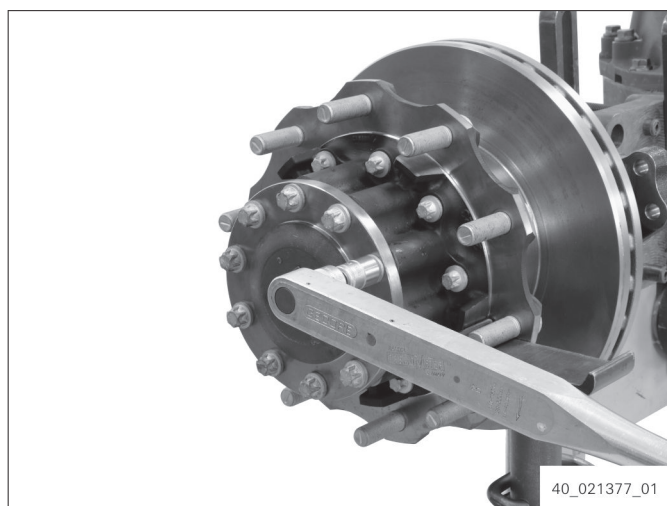



Fig. 178

### 11.6 Mounting brake caliper

Special tools:

- 5870.281.046 Load carrying fixture
- AA01.137.137 Eyebolt

 Observe the specifications of the brake manufacturer.



1. Use 5870.281.046 [Load carrying fixture] (1), AA01.137.137 [Eyebolt] (2) and crane to place the brake caliper on the hub carrier (brake carrier).
2. Screw in fit bolt at the front in driving direction and tighten.  
Tightening torque: **270 Nm**
3. Turn in and tighten hexagon screws.  
Tightening torque: **270 Nm**

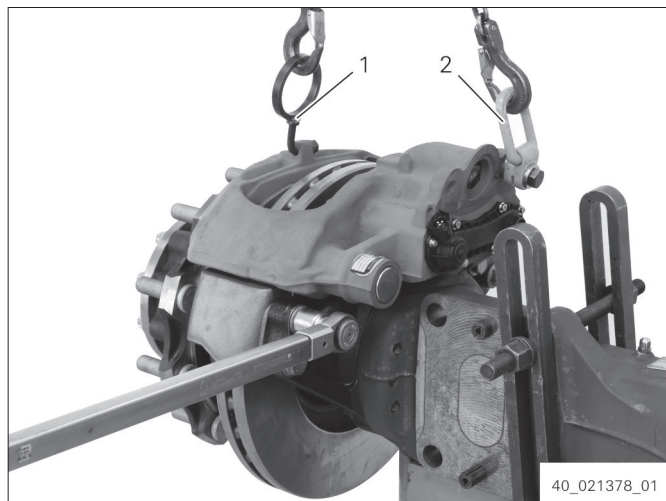

Fig. 179

4. Insert brake lining set in the brake caliper.

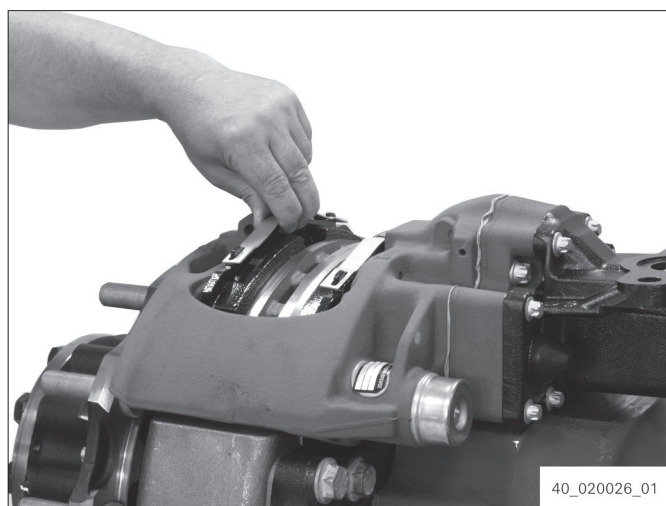

Fig. 180

5. Attach lining bracket (3) in the brake.
6. Press lining bracket (3) downwards and push pin (2) in the opposite direction to the driving direction into the hole on the brake caliper.
7. Push washer (1) onto pin (2).
8. Fix pin (2) with spring split pin.

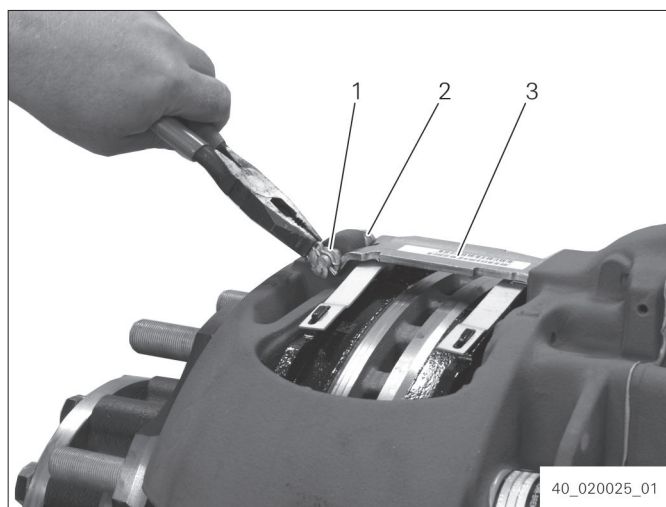

Fig. 181

## 11.7 Installing mounting parts

### 11.7.1 Mounting the spring carriers

#### 11.7.1.1 Mounting spring carriers (variant with top spring carriers)

1. Place the spring carrier (1) on the axle.
2. Screw in cap screws (2) by hand, do not tighten.
3. Drive in the large slotted pins from below.
4. Drive in the small slotted pins from below, offset by 180°.
5. Tighten cap screws.  
Tightening torque: **1200 Nm**
6. Mount second spring carrier.

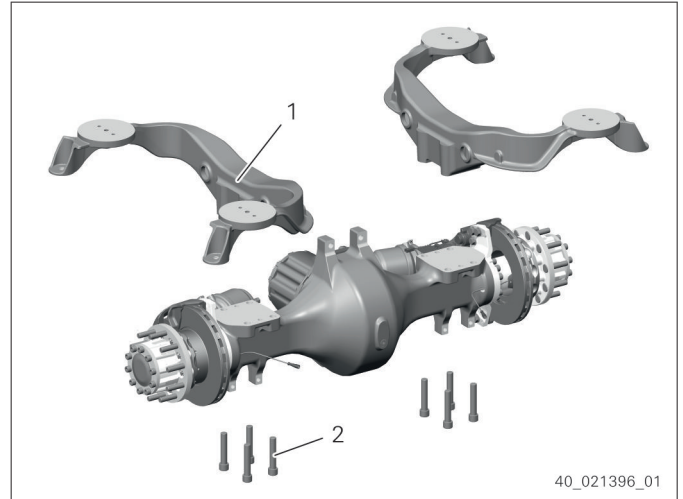

Fig. 182

#### 11.7.1.2 Mounting the spring carriers (variant with bottom spring carriers)

1. Use lifting device to place axle on the spring carrier.
2. Screw cap screws in by hand, do not tighten.
3. Drive in the large slotted pins from above.
4. Drive in the small slotted pins from above offset by 180°.
5. Tighten cap screws.  
Tightening torque: **1200 Nm**
6. Mount second spring carrier.

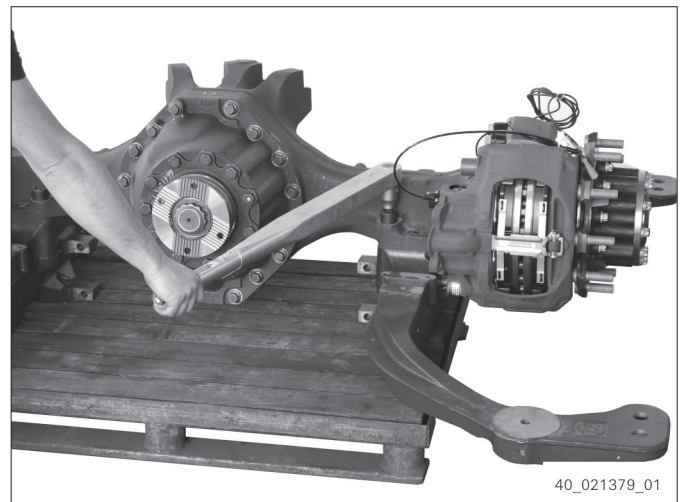

Fig. 183

## 11.7.2 Installing mounting parts

Operating supplies and auxiliary materials:

- 0666.690.248 LOCTITE 243

1. Fix brake cylinder with **new** locknuts.  
Tightening torque: **195 Nm ( $\pm 15$  Nm)**

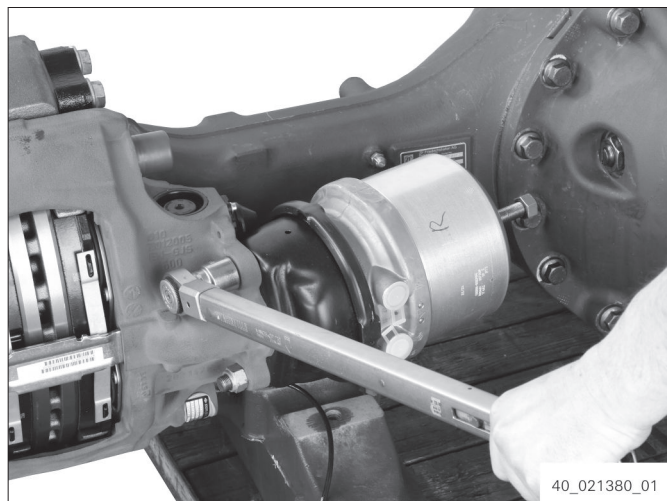

Fig. 184

2. Screw emergency loosening screw onto the brake cylinder.  
Tightening torque: **20 Nm (+5 Nm)**

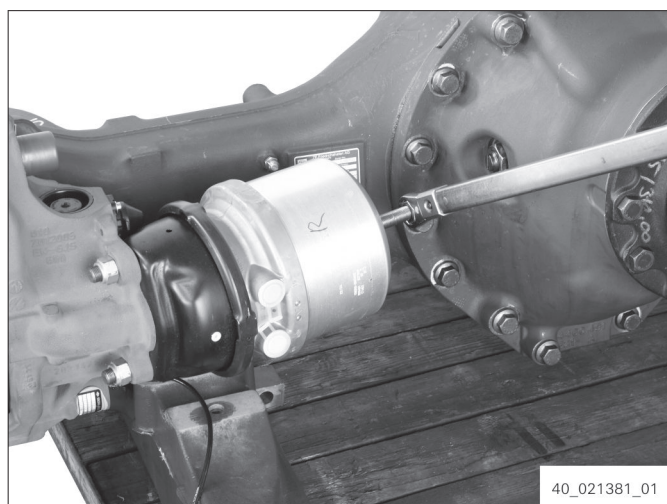

Fig. 185

3. Horizontally suspend the lower longitudinal control arm with the lifting tackle.
4. Mount lower longitudinal control arm using hex screws, washers (behind hex nuts) and hex nuts.  
Tightening torque: **390 Nm**
5. Mount second lower longitudinal control arm.

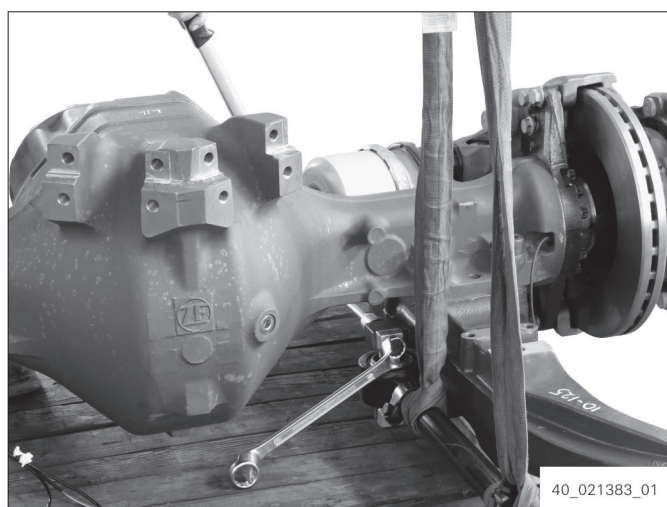

Fig. 186

## Assembly

6. Horizontally suspend the upper longitudinal control arm with the lifting tackle.
7. Turn in hexagon screws by hand.
8. Tighten hexagon screws.  
Tightening torque: **390 Nm**
9. Mount second top longitudinal control arm.

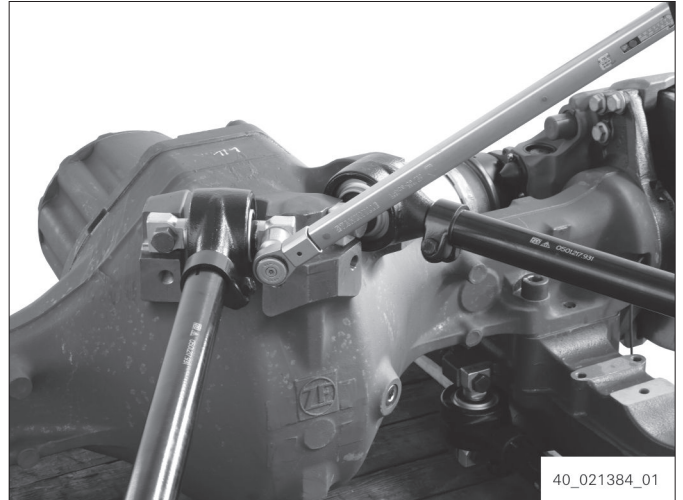

Fig. 187

10. Place air spring (1) on the spring carrier.
11. Apply 0666.690.248 [LOCTITE 243] to the thread of the hexagon screw.
12. Fix air spring (1) with hexagon screw.  
Tightening torque: **90 Nm**
13. Connect shock absorber (2) to the spring carrier.
14. Push disk, joint ring and disk on the shock absorber thread.
15. Fix shock absorber with hexagon nut.  
Tightening torque: **70 Nm**

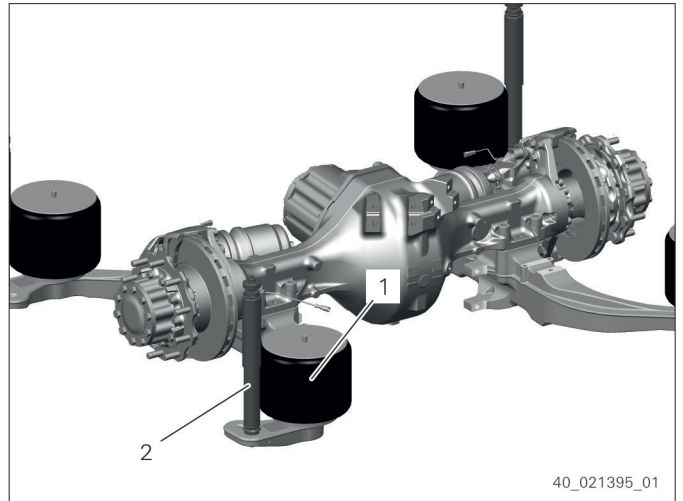

Fig. 188

### 11.8 Filling with oil



Observe the environmental regulations (*see General safety instructions*).

1.

#### **NOTICE**

The use of a non-approved lubricant can lead to property damage.

⇒ Only use lubricant from the currently valid ZF List of Lubricants.

Fill ZF product with oil (*refer to Section Document overview, page 5*).

## 12 Annex

## 12.1 Formulary and conversion tables

## 12.1.1 Conversion of length units

Unit	in	ft	yd	mile	n mile	mm	m	km
1 in	1	0.08333	0.02778	—	—	25.4	0.0254	—
1 ft	12	1	0.33333	—	—	304.8	0.3048	—
1 yd	36	3	1	—	—	914.4	0.9144	—
1 mile	63,360	5,280	1,760	1	0.86898	—	1,609.34	1.609
1 n mile	72,913	6,076.1	2,025.4	1.1508	1	—	1,852	1.852
1 mm	0.03937	$3.281 \cdot 10^{-3}$	$1.094 \cdot 10^{-3}$	—	—	1	0.001	$10^{-6}$
1 m	39.3701	3.2808	1.0936	—	—	1,000	1	0.001
1 km	39,370	3,280.8	1,093.6	0.62137	0.53996	$10^6$	1,000	1

Tab. 5 Length units

in inch

yd yard

n mile nautical mile

ft foot

mile statute mile

## further length units:

- 1 n mile = 1 sm = 1 international nautical mile = 1 arc minute of longitude
- In Great Britain: 1 n mile (UK) = 6,080 ft  $\approx$  1,853 m
- 1 Knoten = 1 n mile/h = 1.852 km/h

## 12.1.2 Conversion of mass units

Unit	gr	dram	oz	lb	long cwt	sh cwt	long tn	sh tn	g	kg	t
Avoirdupois system (in UK and US generally used commercial weight)											
1 gr	1	0.03657	0.00229	1/7,000	—	—	—	—	0.064799	—	—
1 dram	27.344	1	0.0625	0.00391	—	—	—	—	1.77184	—	—
1 oz	437.5	16	1	0.0625	—	—	—	—	28.3495	—	—
1 lb	7,000	256	16	1	0.00893	0.01	—	0.0005	453.592	0.45359	—
1 long cwt	—	—	—	112	1	1.12	0.05	—	—	50.8023	—
1 sh cwt	—	—	—	100	0.8929	1	0.04464	0.05	—	45.3592	—
1 long tn	—	—	—	2,240	20	22.4	1	1.12	—	1,016.05	1.01605
1 sh tn	—	—	—	2,000	17.857	20	0.8929	1	—	907.185	0.90718
SI units											
1 g	15.432	0.5644	0.03527	—	—	—	—	—	1	0.001	—
1 kg	—	—	35.274	2.2046	0.01968	0.02205	—	—	1,000	1	0.001
1 t	—	—	—	2,204.6	19.684	22.046	0.9842	1.1023	$10^6$	1,000	1

Tab. 6 Mass units

gr grain

lb pound

sh cwt short hundredweight

sh tn short ton

oz ounce

long cwt long hundredweight

long tn long ton

When cwt and tn are used without long or sh in front of it, this means long cwt and long tn in the UK, cwt and sh tn in the US.

## Further mass units:

- 1 slug = 14.5939 kg = mass which is accelerated by 1 ft/s<sup>2</sup> by a force of 1 lbf.
- 1 st (stone) = 14 lb = 6.35 kg (only UK)
- 1 qr (quarter) = 28 lb = 12.7006 kg (only UK, used rarely)
- 1 quintal = 100 lb = 1 sh cwt = 45.3592 kg
- 1 tdw (ton dead weight) = 1.016 t. tdw specifies the load capacity of cargo boats (load + ballast + fuel + food).

### 12.1.3 Conversion of force units

$$1 \text{ N} = 0.101972 \text{ kp} \approx 0.1 \text{ kp}$$

$$1 \text{ N} = 0.224809 \text{ lbf}$$

$$1 \text{ N} = 7.233011 \text{ pdl}$$

$$1 \text{ kp} = 9.80665 \text{ N} \approx 10 \text{ N}$$

$$1 \text{ lbf (pound-force)} = 4.44822 \text{ N}$$

$$1 \text{ pdl (poundal)} = 0.138255 \text{ N}^{1)}$$

$$1 \text{ sh (sthène)} = 10^3 \text{ N}$$

### 12.1.4 Conversion of pressure units and units of stress

Unit	N/m <sup>2</sup>	μbar	mbar	bar	N/mm <sup>2</sup>
Statutory pressure units and units of stress					
1 N/m <sup>2</sup> = 1 Pa	1	10	0.01	10 <sup>-5</sup>	10 <sup>-6</sup>
1 μbar	0.1	1	0.001	10 <sup>-6</sup>	10 <sup>-7</sup>
1 mbar	100	1,000	1	0.001	0.0001
1 bar	10 <sup>5</sup>	10 <sup>6</sup>	1,000	1	0.1
1 N/mm <sup>2</sup>	10 <sup>6</sup>	10 <sup>7</sup>	10,000	10	1
Pressure units and units of stress to be converted					
1 kp/mm <sup>2</sup>	—	—	98,066.5	98.0665	9.80665
1 at = 1 kp/cm <sup>2</sup>	98,066.5	—	980.665	0.98066	0.0981
1 kp/m <sup>2</sup> = 1 mmWS	9.80665	98.0665	0.0981	—	—
1 Torr = 1 mmHg	133.322	1,333.22	1.33322	—	—
1 atm	101,325	—	1,013.25	1.01325	—
Anglo-American pressure units and units of stress					

1) 1 pdl = Force required to accelerate a mass of 1 lb by 1 ft/s<sup>2</sup>.

Unit	N/m <sup>2</sup>	µbar	mbar	bar	N/mm <sup>2</sup>
1 lbf/in <sup>2</sup>	6,894.76	68,948	68.948	0.0689	0.00689
1 lbf/ft <sup>2</sup>	47.8803	478.8	0.4788	—	—
1 tonf/in <sup>2</sup>	—	—	—	154.443	15.4443

Tab. 7 Pressure units and units of stress

lbf/in<sup>2</sup> pound-force per square inch (psi)lbf/ft<sup>2</sup> pound-force per square foot (psf)tonf/in<sup>2</sup> (long) ton-force per square inch

Unit	kp/mm <sup>2</sup>	at	kp/m <sup>2</sup>	Torr	atm	lbf/in <sup>2</sup>	lbf/ft <sup>2</sup>	tonf/in <sup>2</sup>
Statutory pressure units and units of stress								
1 N/m <sup>2</sup> = 1 Pa	—	—	0.10197	0.0075	—	—	—	—
1 µbar	—	—	0.0102	—	—	—	—	—
1 mbar	—	—	10.197	0.7501	—	0.0145	2.0886	—
1 bar	0.0102	1.0197	10,197	750.06	0.9869	14.5037	2,088.6	—
1 N/mm <sup>2</sup>	0.10197	10.197	101,972	7,501	9.8692	145.037	20,886	0.06475
Pressure units and units of stress to be converted								
1 kp/mm <sup>2</sup>	1	100	10 <sup>6</sup>	73,556	96.784	1,422.33	—	0.63497
1 at = 1 kp/cm <sup>2</sup>	0.01	1	10,000	735.56	0.96784	14.2233	2,048.16	—
1 kp/m <sup>2</sup> = 1 mmWS	10 <sup>-6</sup>	10 <sup>-4</sup>	1	—	—	—	0.2048	—
1 Torr = 1 mmHg	—	0.00136	13.5951	1	0.00132	0.01934	2.7845	—
1 atm	—	1.03323	10,332.3	760	1	14.695	2,116.1	—
Anglo-American pressure units and units of stress								
1 lbf/in <sup>2</sup>	—	0.07031	703.07	51.715	0.06805	1	144	—
1 lbf/ft <sup>2</sup>	—	—	4.8824	0.35913	—	—	1	—
1 tonf/in <sup>2</sup>	1.57488	157.488	—	—	152.42	2,240	—	1

Tab. 8 Pressure units and units of stress

lbf/in<sup>2</sup> pound-force per square inch (psi)lbf/ft<sup>2</sup> pound-force per square foot (psf)tonf/in<sup>2</sup> (long) ton-force per square inch**Further pressure units and units of stress:**

- 1 pdl/ft<sup>2</sup> (pound per square foot) = 1.48816 N/m<sup>2</sup>
- 1 barye = 1 mbar
- 1 pz (pièce) = 1 sn/m<sup>2</sup> (sthène/m<sup>2</sup>) = 10<sup>3</sup>
- 1 dyn/cm = 1 µbar

**Standards:**

DIN 66034 Kilopond – Newton, Newton – Kilopond, conversion tables

DIN 66037 Kilopond/cm<sup>2</sup> – Bar, Bar – Kilopond/cm<sup>2</sup>, conversion tables

DIN 66038 Torr – Millibar, Millibar – Torr, conversion tables

**12.1.5 Conversion of torque units**

Unit	Nm	lb·ft
1 Nm	1	0.738
1 lb·ft	1.356	1

Tab. 9 Torque units

## 12.1.6 Conversion of temperature units

Unit	°C	°F	°R	K
1 °C	1	$^{\circ}\text{F} = \frac{9}{5}^{\circ}\text{C} + 32$	$^{\circ}\text{R} = \frac{9}{5}^{\circ}\text{C} + 491.7$	$\text{K} = 273 + ^{\circ}\text{C}$
1 °F	$^{\circ}\text{C} = \frac{5}{9} (^{\circ}\text{F} - 32)$	1	$^{\circ}\text{R} = ^{\circ}\text{F} + 459.7$	$\text{K} = (^{\circ}\text{F} - 32) \frac{9}{5} + 273$
1 °R	$^{\circ}\text{C} = \frac{5}{9} (^{\circ}\text{R} - 491.7)$	$^{\circ}\text{F} = ^{\circ}\text{R} - 459.7$	1	$\text{K} = \frac{9}{5} ^{\circ}\text{R}$
1 K	$^{\circ}\text{C} = \text{K} - 273$	$^{\circ}\text{F} = \frac{9}{5} (\text{K} - 273) + 32$	$^{\circ}\text{R} = \frac{9}{5} \text{K}$	1

10\_001790\_02\_en

Fig. 189

°C Degree Celsius  
°R Degree Rankine

°F Degree Fahrenheit  
K Kelvin

## 12.2 Overview of revisions

Index	Date of issue	Initiator
First Issue	2019-01	—
a	2022-07	—

Tab. 10 Edition

Changes to index a:

Chapter/Section				Comment
	Added	Changed	Removed	
Various		X		Editorially revised.
<i>(refer to Section Disassembling differential, page 49), (refer to Section Assembling differential, page 76), (refer to Section Installing the differential, page 79)</i>	X			Dismantling and assembling of the variants with the ratios of $i = 4.273$ , $i = 4.700$ , $i = 5.222$ and $i = 5.875$ added.

Tab. 11 Overview of revisions





ZF Friedrichshafen AG  
ZF Aftermarket  
Donaustraße 71  
94034 Passau  
Deutschland · Germany  
Telefon/Phone +49 851 494-0  
[www.zf.com/contact](http://www.zf.com/contact)