

## SECTION 9 TECHNICAL INFORMATION

<b>DIMENSIONS AND WEIGHTS</b> .....	<b>3</b>
<b>CAPACITIES</b> .....	<b>3</b>
<b>FUEL TYPE</b> .....	<b>3</b>
BIODIESEL FUELS .....	3
<b>WHEELS AND TIRES</b> .....	<b>4</b>
RECOMMENDED TIRE INFLATION PRESSURE AT MAXIMUM COLD LOAD .....	4
<b>BELTS</b> .....	<b>4</b>
<b>ENGINE</b> .....	<b>5</b>
VOLVO D13 .....	5
<b>ALLISON TRANSMISSION</b> .....	<b>5</b>
<b>PROPELLER SHAFT</b> .....	<b>5</b>
<b>BRAKES</b> .....	<b>5</b>
BRAKE CHAMBER EFFECTIVE AREA .....	5
<b>AIR SYSTEM</b> .....	<b>5</b>
<b>ANTILOCK BRAKING SYSTEM (ABS)</b> .....	<b>5</b>
TROUBLESHOOTING AND TESTING .....	5
<b>AUTOMATIC TRACTION CONTROL (ATC) – ELECTRONIC STABILITY CONTROL (ESC)</b> .....	<b>5</b>
<b>STEERING</b> .....	<b>6</b>
<b>ELECTRICAL SYSTEM</b> .....	<b>6</b>
<b>AXLES</b> .....	<b>6</b>
FRONT AXLE .....	6
DRIVE AXLE .....	6
AUXILIARY AXLE .....	6
<b>SUSPENSION</b> .....	<b>6</b>
INDEPENDENT FRONT SUSPENSION .....	7
DRIVE AXLE .....	7
AUXILIARY AXLE .....	7
<b>ALIGNMENT SPECIFICATIONS</b> .....	<b>7</b>
<b>COOLING SYSTEM</b> .....	<b>7</b>
<b>FUEL SYSTEM</b> .....	<b>7</b>
<b>EXHAUST SYSTEM</b> .....	<b>8</b>

## 9-2 TECHNICAL INFORMATION

---

<b>HEATING AND AIR CONDITIONING.....</b>	<b>8</b>
<b>OIL SPECIFICATIONS .....</b>	<b>8</b>
ENGINE .....	8
ALLISON TRANSMISSION .....	9
DIFFERENTIAL.....	9
COOLING FAN RIGHT ANGLE GEARBOX.....	9
POWER STEERING RESERVOIR.....	9
<b>PLATES AND CERTIFICATION.....</b>	<b>9</b>
SAFETY CERTIFICATION .....	9
DOT CERTIFICATION PLATE .....	10
VEHICLE IDENTIFICATION NUMBER (VIN).....	10
<b>COACH FINAL RECORD .....</b>	<b>10</b>

DIMENSIONS AND WEIGHTS		
Overall length (over bumpers)	45' 8" (13.9 m)	
Overall width	102" (2.59 m)	
Overall height (normal ride height)	149" (3.785 m)	
Wheelbase (center of front axle to center of drive axle)	316 ¼" (8.033 m)	
Floor height from ground	63" (1.6 m)	
Ground clearance	11" (280 mm)	
Step height from ground	14" (356 mm)	
Headroom	83" (1.956 m)	
Entrance door opening width	28" (711mm )	
Front overhang	76" (1,93 m)	
Rear overhang	108 ¼" (2.749 m)	
Front track	84.4" (2.145 m)	
Drive track	76.7" (1.949 m)	
Rear track (auxiliary axle)	83.6" (2.124 m)	
Turning circle radius	42' (12.8 m)	
Curb weight (before conversion)	31 990 lbs (14 540 Kg)	
Gross Vehicle Weight Rating (G.V.W.R.)	54,500 lbs (23 665 kg)	<i>Before VIN C-1910</i>
Gross Vehicle Weight Rating (G.V.W.R.)	55 500 lbs (25 174 kg)	<i>VIN C-1910 and up</i>
Front axle Gross Axle Weight Rating (G.A.W.R.)	18,000 lbs (7 500 kg)	<i>Before VIN C-1910</i>
Front axle Gross Axle Weight Rating (G.A.W.R.)	19 000 lbs (8 618 kg)	<i>VIN C-1910 and up</i>
Drive axle G.A.W.R.	22 500 lbs (10 230 kg)	
Auxiliary axle G.A.W.R.	14 000 lbs (6 365 kg)	

**NOTE**  
*Curb weight is given as an indication only and is subject to vary from coach to coach, mostly due to optional equipment.*

The Gross Vehicle Weight Rating (G.V.W.R.) and the Gross Axle Weight Rating (G.A.W.R.) for front, drive and auxiliary axles are listed on a certification plate located on the L.H. control panel in driver's section.

CAPACITIES	
Engine oil (in crankcase)	38 quarts 36 liters
Fuel tank (legal capacity equal to 95% of volume)	230 US gal. 870 liters
DEF tank	16 US gal. 60 liters
Cooling system	27.6 US gal. 104 liters
Allison transmission (does not include external circuit)	6 US gal. 23 liters
Differential oil	5 US gal. 19 liters
Power steering reservoir	4 US qts 3.7 liters
Carrier 05G A/C compressor oil	6.3 US pints (3 liters)
Windshield washer reservoir	5 US gal. (19 l)
Refrigerant	24.1 lbs (11 kg) 6 lbs (2.75 kg) small A/C

**FUEL TYPE**

Diesel engines for 2010 and later model year vehicles are designed to operate only with **Ultra Low Sulfur Diesel** (ULSD) fuel, which can contain no more than 15 ppm sulfur.

	<p><b>CAUTION</b></p>
<p>ULSD fuel is necessary to avoid fouling the engine's Aftertreatment Device (ATD). Use of fuel other than ULSD will reduce the efficiency and durability of the engine.</p>	

**BIODIESEL FUELS**

ULSD-B5 biodiesel may be used. B5 tells you the percentage of biodiesel mixed in with ULSD. B5 is 5% biodiesel and 95% ULSD.

Fuel used must meet engine manufacturer's specification for biodiesel fuel. Concerning the use of biodiesel with Volvo D13 engines, refer to Volvo's specifications.

## 9-4 TECHNICAL INFORMATION

Biodiesel fuels are alkyl esters of long chain fatty acids derived from renewable resources. Biodiesel fuels made from soybean or rapeseed oil through the proper transesterification reaction process are recommended. Other feedstock source of biodiesel fuels such as animal fat and used cooking oils are not recommended. Biodiesel fuels meeting ASTM D6751 specification and from BQ-9000 accredited producer, prior to blending can be mixed up to 5% maximum by volume in petroleum diesel fuel. The resulting mixture must meet the fuel properties of ASTM D975 specification. Failures attributed to the use of biodiesel fuel will not be covered by Volvo or Prevost product warranty. Also, any engine performance problem related to the use of biodiesel fuel would not be recognized nor considered as Volvo or Prevost's responsibility.

### WHEELS AND TIRES

Drive Axle Aluminum forged wheels... 9" X 22½"  
 Drive Axle Super Single Aluminum forged wheels ..... 14" X 22½"  
 Drive Axle Tires ..... 315/80 R 22½"  
 Drive Axle Super Single Tires .... 455/55 R 22½"  
 Auxiliary & Front Axle Aluminum forged Wheels ..... 10½" X 22½"  
 Auxiliary & Front Axle Tires ..... 365/70 R 22½"

### RECOMMENDED TIRE INFLATION PRESSURE AT MAXIMUM COLD LOAD

The recommended tire inflation pressures are given in the applicable documents supplied with the vehicle. In addition, cold tire inflation pressures are listed on the Department of Transport (DOT) certification plate, affixed on the wall behind the driver's seat.

**NOTE**  
 Bus Shells vehicles, before being converted, are not at their maximum weight and tire pressures are adjusted at lower level than the maximum allowed appearing on the DOT plate. Tires pressure must be re-adjusted once converted.

Vehicles equipped with TPMS: The TPMS target pressures are factory set to equal the prevailing tire pressure at delivery time. When tire pressures are increased to account for higher

vehicle weight, the TPMS set point need to be increased accordingly.

 **WARNING**  
 Special tire selection may lower maximum allowable speed limit, even below posted speed limit. For maximum safety, check with tire manufacturer.

 **CAUTION**  
 These tire pressures are established in accordance with the maximum allowable load on each axle. A lower pressure is recommended if the axle load is less than the above specifications. Weigh vehicle fully loaded and pressurize according to tire manufacturer's recommendations. For non standard tire and wheel specifications, see Prevost tire pressure tabulation in "Coach Final Record" or special specification chart affixed next to the DOT certification plate.

### BELTS

With Carrier 05G A/C compressor

Use	Model	Qty
Cooling fan drive	Poly-V 14PK2172	1
A/C system 05G compressor	BX-96	2
Water pump	10PK1512	1
Alternator Bosch HD10 2 x 24V-120A (mounted on engine)	Poly-V 8PK1587	1
Alternator, 1x "limp-home"	Poly-V 8PK1524	1
3 <sup>rd</sup> alternator (remote) Bosch 24V-120A or 12V-200A	8PK1080	1

With small A/C compressor

Use	Model	Qty
Cooling fan drive	Poly-V 14PK2172	1
Water pump	10PK1512	1
Small A/C compressor (on crankshaft pulley)	BX-92	2
Small A/C compressor	AX-32	2
Alternator Bosch HD10 2 x 24V-120A (mounted on engine)	Poly-V 8PK1587	1

Use	Model	Qty
Alternator, 1x "limp-home"	Poly-V 8PK1524	1
1 alternator (remote) Bosch 28V-120A or 12V-200A	8PK855	1
2 alternators (remote) Bosch 24V-120A	8PK1080	1

**NOTE**

*Belts specifications may vary. For proper belt selection, always consult your vehicle Coach Final Record.*

**ENGINE**

**VOLVO D13**

Type: 4 cycles / inline six cylinders  
 Displacement: 12.8 liters, SOHC, 4 valves per cylinder  
 Power ..... 500 HP  
 Torque ..... 1770 lbf-ft  
 Recom. cruise speed range.....1300-1500rpm  
 Full dress, dry weight..... 2519 lb

**ALLISON TRANSMISSION**

Allison MH4000 electronically controlled six speed automatic transmission.

**Gear Ratios**

1<sup>st</sup> ..... 3.510  
 2<sup>nd</sup> ..... 1.906  
 3<sup>rd</sup> ..... 1.429  
 4<sup>th</sup> ..... 1.000  
 5<sup>th</sup> ..... 0.737  
 6<sup>th</sup> ..... 0.639  
 Reverse ..... 4.801  
 Converter ..... 1.9

**PROPELLER SHAFT**

Dana SPL250

**BRAKES**

The features of the braking system include a dual system where the front and rear circuits are completely independent from each other. The brakes are Knorr SN7000 ventilated pneumatic disc brake type with ABS and automatic slack adjusters on front drive and auxiliary axles. Model 24/24 spring brakes on drive axle provide emergency and parking brakes. Emergency

brake application will be automatic if pressure drops below 40 psi. At 60 psi a warning light and buzzer will come on so the driver can bring the vehicle to a safe stop simply by a conventional application of the foot brake pedal.

**BRAKE CHAMBER EFFECTIVE AREA**

Front axle (IFS).....24 in<sup>2</sup>  
 Front axle (I-Beam).....24 in<sup>2</sup>  
 Drive axle ....24 in<sup>2</sup> service, 24 in<sup>2</sup> emerg/parking  
 Auxiliary axle..... 16 in<sup>2</sup> (service)

**AIR SYSTEM**

Compressed air is provided by a twin cylinder 31.8 cfm Wabco, gear-driven, water-cooled and engine oil lubricated air compressor.

**ANTILOCK BRAKING SYSTEM (ABS)**

The antilock braking system has one Electronic Control Unit (ECU) controlling a four channel system. A wheel slip sensor is mounted at each front axle and drive axle wheel. The a axle wheels are slave to the drive axle wheels.

The Electronic Control Module (ECM) is maintenance free. Its operating voltage is 24 ± 6 volts DC. The thermal operating range for the ECM is from -40 to 167°F (-40 to 75°C).

The solenoid control valves are maintenance free. Their operating voltage is 24 (+4.8, -2.4) volts DC. The rated current draw is 1.65 amps. The thermal operating range of the solenoid control valves is from -40 to 176°F (-40 to 80°C).

**TROUBLESHOOTING AND TESTING**

For troubleshooting and testing of the vehicle's anti-lock braking system, refer to Meritor-WABCO Maintenance Manual MM-0112 "Anti-Lock Braking System For Trucks, Tractors and Buses" or use menu "Diagnostics" of the DID (see "Driver information display menus" in *Other Features* chapter).

**AUTOMATIC TRACTION CONTROL (ATC) – ELECTRONIC STABILITY CONTROL (ESC)**

In addition to the ABS function, vehicle may be equipped with an advanced model of Bendix EC-60 controller to provide an **Automatic Traction Control (ATC)** feature. Bendix ATC can improve vehicle traction during acceleration,

## 9-6 TECHNICAL INFORMATION

---

and lateral stability while accelerating through curves. ATC utilizes **Engine Torque Limiting (ETL)** where the ECU communicates with the engine's controller and/or **Differential Braking (DB)** where individual wheel brake applications are used to improve vehicle traction.

The EC-60 advanced model controller also provides ABS-based stability features referred to as **ESC® Electronic Stability Control**.

Refer to Maintenance Manual, Section 12: Brake and Air System for more information on this system.

	<b>WARNING</b>
<p><b>ESC may reduce the vehicle speed automatically.</b></p> <p>ESC can make the vehicle <b>decelerate automatically</b>. ESC can slow the vehicle with or <b>without the operator applying the brake</b>, and <b>even when the throttle is being applied</b>.</p>	

	<b>CAUTION</b>
<p>Even with ESC-equipped vehicles, the driver remains responsible for ensuring vehicle stability during operation.</p>	

### STEERING

ZF 8098 integral steering gear model.

- Variable assistance in function of speed is optional.
- ZF servocomtronic integral steering gear model.
- ZF hydraulic pump gear driven from engine drive.
- Hydraulic reservoir and dipstick accessible from engine compartment.
- System pressure 2320 psi.
- Steering wheel diameter 17 3/4". Tilt and telescopic, pneumatically locked with foot operated switch for adjustment.
- Number of turns: 5¾.
- Outside turning radius: see Dimensions and Weight.

### ELECTRICAL SYSTEM

- 24 volt, negative ground;

- 12 volt exterior lighting;
- Four 12 volt, group 31 format maintenance-free batteries connected in series/parallel. Cold cranking capacity is 1900 amps with a reserve capacity of 195 minutes;
- Three manually operated circuit breakers located in the battery compartment can be tripped to cut low current direct loads and help preserving minimal charge when parked for a long period.
- 100 amp battery equalizer;

### AXLES

#### FRONT AXLE

- Prevost independent front suspension with recalibrated air springs for improved comfort.
- 18,000 lbs capacity (loading limit could be less depending on wheel and tire selection).
- Wide apart double A-arm design mounted on ball joints with torque link.
- Double sealed taper roller bearings bell crank and idler steering arm.
- Unitized wheel bearing (maintenance free bearing).
- Factory pre-adjusted caster.

#### DRIVE AXLE

- Meritor model RC23-165.
- Full floating banjo type.
- Induction hardened bearing journals for greater durability.
- Oil lubricated wheel bearing.
- Axle ratio 4.30 to 1 for optimized fuel economy at 65 mph (standard).
- Proposed ratios: 4.56 for performance.
- Differential ratios: Suggested standard 4.30. Option with Allison B500: 3.42, 4.10.

#### AUXILIARY AXLE

- Prevost hollow square beam.
- Unitized wheel bearings (maintenance free).
- Auxiliary axle may be lifted to provide better traction in snow and mud.

### SUSPENSION

Goodyear rolling lobe type air springs (bellows) are used throughout.

**INDEPENDENT FRONT SUSPENSION**

- 2 14-inch Bellows for a G.A.W.R. of 19,000 lb;
- 2 Shock absorbers;
- 2 Upper A-arms;
- 2 Lower A-arms;
- 1 Height control valve;
- 1 sway bar (1¾" diameter).

**DRIVE AXLE**

- 4 Bellows (11");
- 4 Shock absorbers;
- 3 Radius rods;
- 2 Height control valves;
- 1 Panhard rod
- 1 Anti-roll bar, 2" diameter

**AUXILIARY AXLE**

- 2 Bellows (12");
- 2 Shock absorbers;
- 3 Radius rods;
- 1 Panhard rod.

**ALIGNMENT SPECIFICATIONS**

Use wheel alignment systems which work with angle measurements only, such as Josam or Hunter systems. Alignment specifications are listed in the following tables:

FRONT AXLE (INDEPENDENT FRONT SUSPENSION)						
Load	Minimum value		Nominal value		Maximum value	
	Non-converted	Converted	Non-converted	Converted	Non-converted	Converted
Right camber	0.20°	-0.20°	0.30°	0°	0.55°	0.20°
Left camber	0.20°	-0.20°	0.30°	0°	0.50°	0.20°
Right caster	2.55°		2.8°		3.05°	
Left caster	2.55°		2.8°		3.05°	

Total toe-in	0.02°	0.04°	0.04°	0.06°	0.06°	0.08°
--------------	-------	-------	-------	-------	-------	-------

DRIVE AXLE			
	Minimum value	Nominal value	Maximum value
Thrust angle	-0.04°	0°	0.04°
Total toe	0.18° toe-in	0°	0.18° toe-out

AUXILIARY AXLE			
	Minimum value	Nominal value	Maximum value
Thrust angle *	-0.02°	0°	0.02°
Total toe	0.18° toe-in	0°	0.18° toe-out

(\* Use the drive axle as reference)

**COOLING SYSTEM**

- Extra capacity, copper fin radiator and aluminum charge air cooler.
- 3 speed fan clutch EECU controlled.
- Rubber insulated from the body.
- Expansion tank above radiator and remote mounted.
- System pressure 14 psi.
- One (1) 185° F thermostat.
- System capacity 27 US gal.
- Coolant filter.
- Radiator fan: 38 inches fan, belt and shaft driven.

**FUEL SYSTEM**

Polyethylene 230 us gallon/870 liters fuel tank located in middle of second baggage bay (heating and a/c section) includes:

- Anti-spill device.
- Two Safety filler cap, providing filling access on each side of the vehicle.
- Pressure relief valve.
- Electric fuel gage.
- Fuel cooler.
- Low level signal at 26 US gallon/98 liters.
- Primary filter 25 microns (standard).

## 9-8 TECHNICAL INFORMATION

- Fuel pro 382 filter available as an option as a primary filter.
- Secondary filter 3 to 5 microns.
- Shut-off valve on fuel supply line.

### EXHAUST SYSTEM

One all stainless steel exhaust system including:

- FleetGuard aftertreatment system made of a Diesel Particulate Filter (DPF), Diesel Oxidation Catalyst (DOC) and Selective Catalytic Reduction (SCR) unit. Noise, vibration and heat insulated. This ATD is mounted to the bus structure and is accessible through an exterior access door.
- Tail pipe diffuser and rain deviation device.
- Exhaust pipe with insulation and a flexible section.
- Exhaust to rear left hand top of rear cap.

### HEATING AND AIR CONDITIONING

Two air conditioning systems are available: the large capacity (central A/C) or the small capacity A/C (also known as driver's air). Vehicles equipped with the large capacity A/C benefit from a combination heating and cooling system that provides adequate capacity of conditioned and filtered air for all climatic conditions. Fresh air is drawn into the system from the left (driver's) side of the vehicle. Return air is taken from the middle of the vehicle. The driver's heater and defogger are controlled separately from the central unit. An air mixture selector enables air to be drawn into the system from outside the vehicle or recirculated. Driver's air provides cooling for the driver's area only, maximizing available baggage space for other uses. The small capacity A/C enables cooling the driver's area only.

SMALL HVAC SYSTEM	
Air conditioning capacity	2 tons
Refrigerant type	134a
Air flow	450 cfm (12,7 m <sup>3</sup> /min)

COMPRESSOR (for small HVAC system)	
Number of cylinders	7
Operating speed	700 to 6 000 rpm
Oil capacity	6.0 U.S. oz (0,18 l)

Approved oil	SP-20 (PAG)
--------------	-------------

CENTRAL HVAC SYSTEM	
Air conditioning capacity	7.5 tons
Refrigerant type	134a
Heating capacity	152 000 Btu/h
Air flow	2 600 cfm (73,6 m <sup>3</sup> /min)

COMPRESSOR (For Central HVAC System)	
Number of cylinders	6
Operating speed	400 to 2 200 rpm (1,750 rpm, nominal)
Minimum speed for lubrication	400 rpm
Oil capacity	4.5 U.S. qts (4,3 l)
Approved oil	Castrol SW-68 (POE)

#### NOTE

*The above oils are suitable for use with reciprocating compressors using refrigerant R-134a and with evaporator temperatures above -40°F (-40°C).*

### OIL SPECIFICATIONS

#### ENGINE

Use SAE 10W-30 meeting the following specification:

- Volvo VDS-4 or EO-O Premium plus
- API classification CJ-4.



#### CAUTION

CJ-4 contains less than 1% ash which is key to achieving maximum diesel particulate filter cleaning intervals. Use of high ash engine oils will reduce the cleaning interval on the Diesel Particulate Filter (DPF). DPF regenerates the combustible soot, but the ash (a product of the oil lubricant package) slowly accumulates in the channels of the DPF.



**ALLISON TRANSMISSION**

Allison Transmission recommends the following fluids:

- Castrol TranSynd™ or TES-295 specification equivalent fluid;
- Dexron-III® automatic transmission fluid;

**DIFFERENTIAL**

Multigrade gear oil meeting MIL-PRF-2105-E: 85W140 is recommended for use in drive axle. This lubricant performs well over a broad temperature range, providing good gear and bearing protection in a variety of climates. If temperature drops below 10°F (-12°C), 80W90 should be used, and below -15°F (-26°C), 75W90 should be used. In extreme conditions or for better performance, full synthetic gear oil should be used.

**COOLING FAN RIGHT ANGLE GEARBOX**

Use Synthetic Gear Lubricant SAE 75W-90.

**POWER STEERING RESERVOIR**

Use Dexron-IIE or Dexron-III automatic transmission fluid for this system.

**PLATES AND CERTIFICATION**

The main components of the vehicle, such as engine, transmission, axles and the chassis are identified by different serial numbers. It may be necessary to locate these numbers for warranty purposes.

In addition, option decals are located on the rocker cover (starter side). The engine serial and model number and a list of the optional engine equipment are written on these decals. Refer to this information when ordering replacement parts.

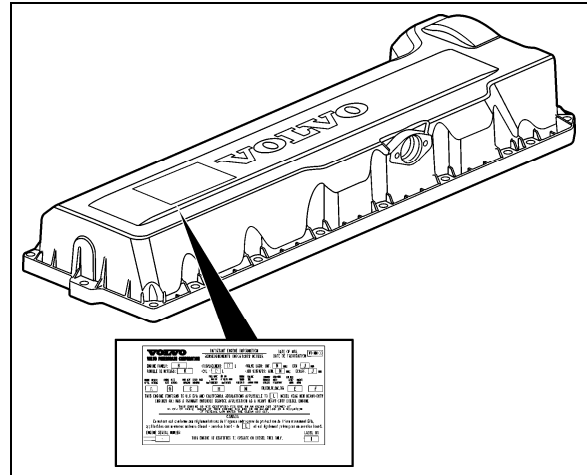

**VOLVO D13 ENGINE DATA PLATE**

00052

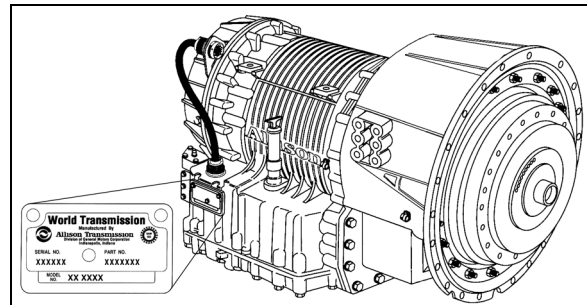

**TRANSMISSION DATA PLATE**

07076

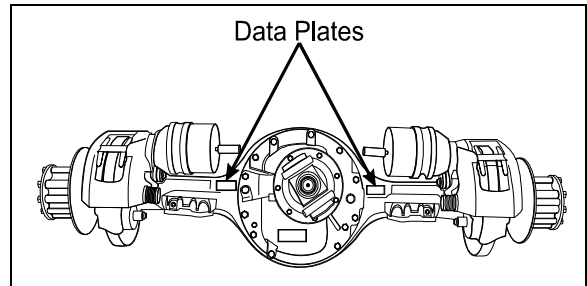

**DRIVE AXLE**

11019

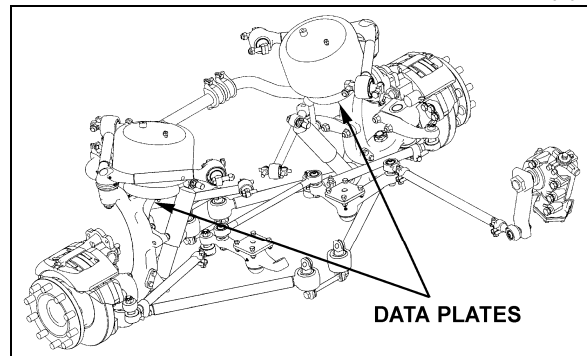

**IFS TYPICAL SERIAL & MODEL NUMBERS**

00025C

**SAFETY CERTIFICATION**

Vehicle components meet specifications and standards as follows:

## 9-10 TECHNICAL INFORMATION

- Material and parts conform to ASTM and/or SAE standards in effect at the time of manufacture.
- All factory-installed interior materials meet FMVSS 302 for fire resistance.
- Certified according to Provincial, State and Federal Safety standards (Canadian and US) BMCSS, FMVSS and CMVSS.

Other applicable certification labels are affixed to the applicable components.

### DOT CERTIFICATION PLATE

This certifies that vehicles manufactured by Prevost Car Inc. comply with all Federal Motor Vehicle Safety Standards at the time of manufacture. Information such as date of manufacture, model year, gross vehicle weight rating, tire types and inflation pressure is also etched on this plate. The DOT Certification plate is affixed to the panel behind the driver's seat.

		<b>PREVOST</b>		<input type="text"/>	
INCOMPLETE VEHICLE MANUFACTURED BY VEHICULE INCOMPLET FABRIQUE PAR		: PREVOST CAR INC. STE-CLAIRE, QUE.		<b>EC</b>	
DATE OF MFG. DATE DE FAB.		<input type="text"/>			
G.V.W.R. : P.N.B.V. :		24721 KG. (54500 LBS).			
AXLES/ ESSEUX	G.A.W.R./ P.N.B.E.	TIRES/ PNEUS	RIMS/ JANTES	COLD INFLATION PRESS. / FROID	SINGLE OR DUAL SIMPLE OU DOUBLE
	KG (LBS)			KPA (PSI)	
FRONT: AVANT :	8165 (18000)	365/70R22.5 (L)	22.5X10.5	724 (105)	S
INT. DIFF. :	10206 (22500)	315/80R22.5 (L)	22.5X9 (OUT) 22.5X8.25 (IN)	655 (95)	D
REAR: TANDEM:	6350 (14000)	365/70R22.5 (L)	22.5X10.5	552 (80)	S
THIS INCOMPLETE VEHICLE CONFORMS TO ALL APPLICABLE U.S. FEDERAL MOTOR VEHICLE SAFETY STANDARDS IN EFFECT ON THE DATE OF MANUFACTURE SHOWN ABOVE. IF COMPLETED IN ACCORDANCE WITH THE INSTRUCTIONS OF INCOMPLETE VEHICLE DOCUMENTS FURNISHED PURSUANT TO CFR PART 568, CONFORMITY TO THE OTHER SAFETY STANDARDS IS NOT SUBSTANTIALLY AFFECTED BY THE DESIGN OF THE INCOMPLETE VEHICLE.					
VEHICLE IDENTIFICATION NO. NO. IDENTIFICATION VEHICULE		<input type="text"/>			
		#405444			

### DOT CERTIFICATION PLATE

00016

### VEHICLE IDENTIFICATION NUMBER (VIN)

The Vehicle Identification Number is stamped on the DOT Certification plate behind the driver's seat, also on a plate located on the windshield frame pillar (driver's side). The VIN is visible from the outside of the vehicle. Make sure the correct vehicle identification number is given when ordering replacement parts. Using the VIN when ordering parts will facilitate processing.

#### NOTE

Record the VIN in the vehicle documentation and keep with company records. The VIN will normally be used for vehicle registration, service reference needs and for obtaining

vehicle insurance coverage.

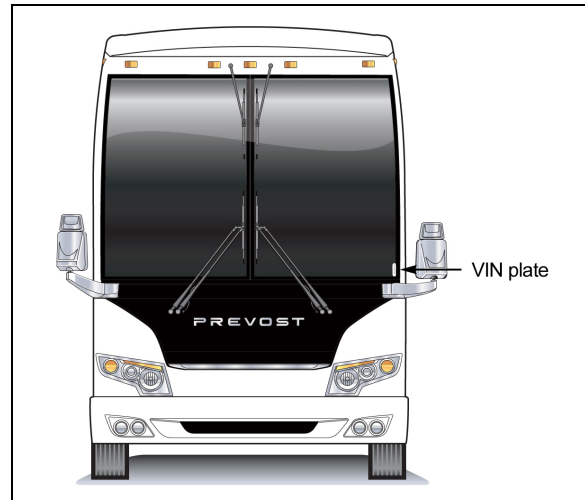

VEHICLE IDENTIFICATION NUMBER

18680

### COACH FINAL RECORD

The Coach Final Record is a record of all data pertaining to the assembly of the vehicle. This record is shipped to the new owner via a courier company. Retain this record in the company records office for reference and safe-keeping.