

PREVOST

WARRANTY BULLETIN

WB24-23A

DATE :	July 2024	SECTION:	06 ELECTRICAL
EXPIRATION:	July 2026		
SUBJECT:	CB5 BREAKER INSPECTION		

Revision: A

Part list change

11-01-2024





APPLICATION

NOTICE TO SERVICE CENTERS	
<i>Verify vehicle eligibility by checking warranty bulletin status with SAP or via ONLINE WARRANTY SYSTEM available on Service / Warranty tab of Prevost website.</i>	
Model	VIN 
X3-45 coaches Model Year: 2023 - 2024	From 2PCG33496 <u>PC736900</u> up to 2PCG33493 <u>RC736999</u> incl.
X3-45 VIP commercial use Model Year: 2023 - 2024	From 2PCCS3495 <u>PC736890</u> up to 2PCCS3496 <u>RC736996</u> incl.
X3-45 VIP motorhomes Model Year: 2023 - 2024	From 2PCBS3495 <u>PC736898</u> up to 2PCBS3490 <u>RC736990</u> incl.
H3-45 coaches Model Year: 2024	From 2PCH33496 <u>RC721496</u> up to 2PCH33497 <u>RC721782</u> incl.
H3-45 VIP motorhomes Model Year: 2023 - 2024	From 2PCVS3491 <u>PC721554</u> up to 2PCVS3491 <u>RC721783</u> incl.
This bulletin does not necessarily apply to all the above-mentioned vehicles, some vehicles may have been modified before delivery. The owners of the vehicles affected by this bulletin will be advised by a letter indicating the Vehicle Identification Number (VIN) of each vehicle concerned.	

DESCRIPTION

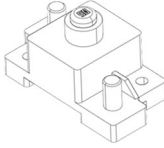
On the vehicles affected by this bulletin, inspect breaker CB5 and replace it if need it.

MATERIALOrder kit **WB24-23** which contains the following parts:

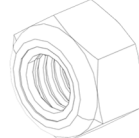
Part No	Description		Qty
563708	BREAKER 90A SENSATA		1
502681	NUT HEX NYRT NX500 M6-1.0 G8		2
5001936	NUT HEX NYRT NX500 3/8-16		2
5000025	NUT HEX NYRT NX500 3/8-16		4
5001787	NUT HEX NYRT SS M8-1.25X9.5		1
5001789	NUT HEX NYRT SS M8 X 1.25 X 8		1

Other parts that may be required. **Note that these parts are not covered by this bulletin:**

Part No.	Description	Qty
685353	YELLOW TORQUE SEAL, 1 OZ	AR

NOTE*Material can be obtained through regular channels.*

SAFETY PRECAUTIONS

- Eye protection should always be worn when working in a shop.
- Rules for Personal Protection Equipment should always be respected. Wear your PPE including but not limited to the following:



Safety First!



PROCEDURE



DANGER

Park vehicle safely, apply parking brake, stop the engine. Prior to working on the vehicle, set the ignition switch to the OFF position and trip the main circuit breakers equipped with a trip button. On the Commuter type vehicles, set the battery master switch (master cut-out) to the OFF position.

Lockout & Tag out (LOTO) must be performed during set-up, maintenance or repair activities. Refer to your local procedure for detailed information regarding the control of hazardous energy.

CB5 BREAKER INSPECTION X3 MODEL

1. Open compressor door.

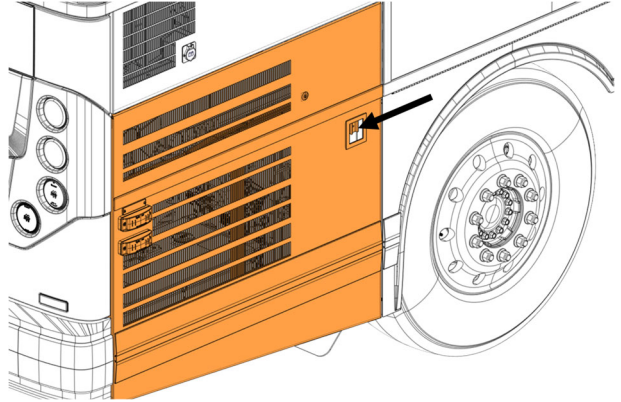

2. Open rear junction box.

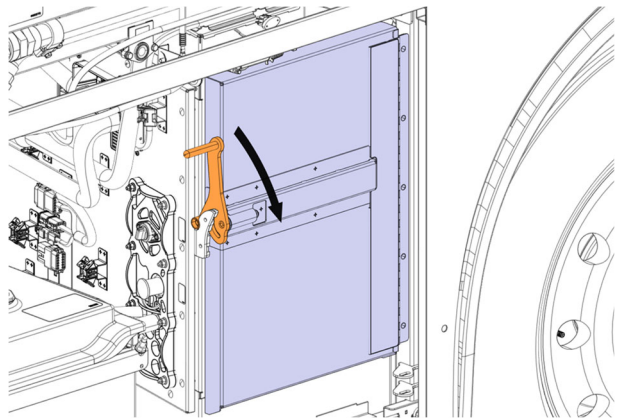

3. Locate CB5 breaker.

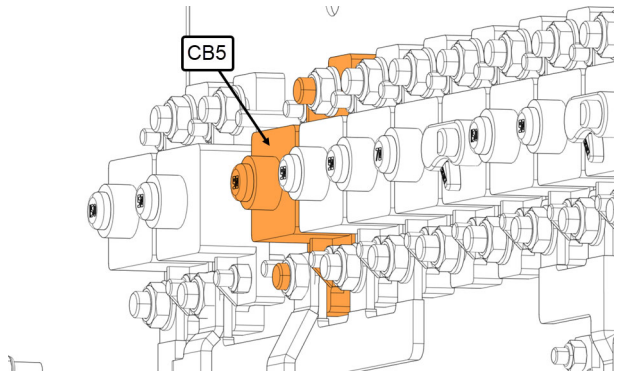

4. Verify if the breaker brand:

- If it is a **SENSATA** brand this ok, go to next step.
- If it is a **GLOSO** brand you need to replace it, go to breaker replacement section.

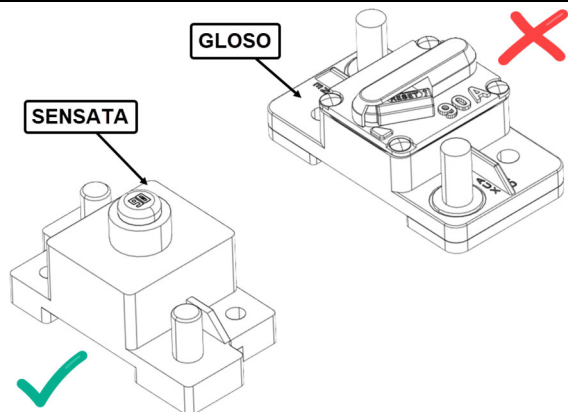

5. Close rear junction box door.

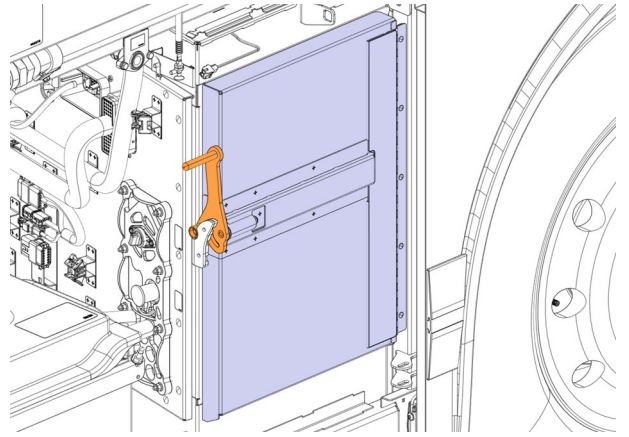

6. Close compressor door to complete the procedure.

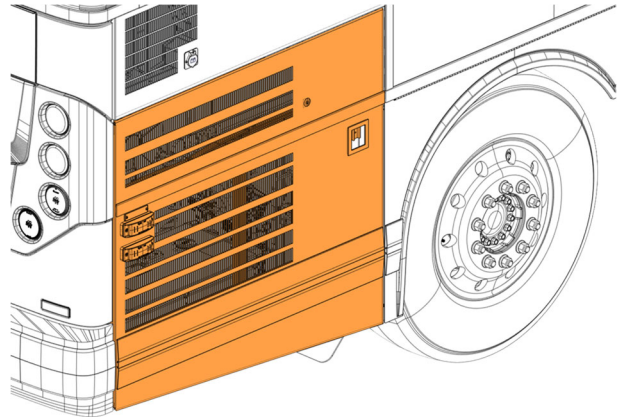

CB5 BREAKER INSPECTION H3 MODEL

1. Open rear service compartment door on curbside.

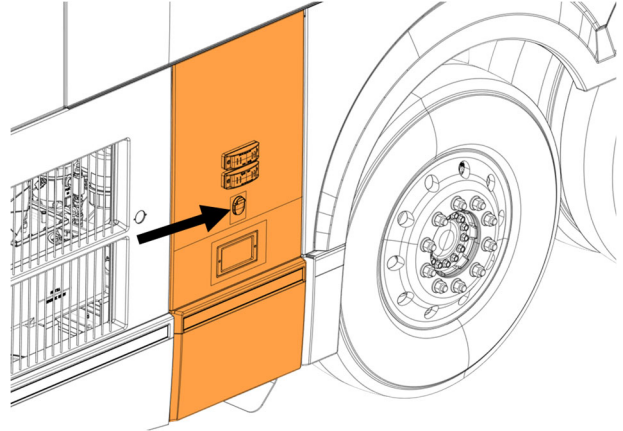

2. Locate CB5 breaker.

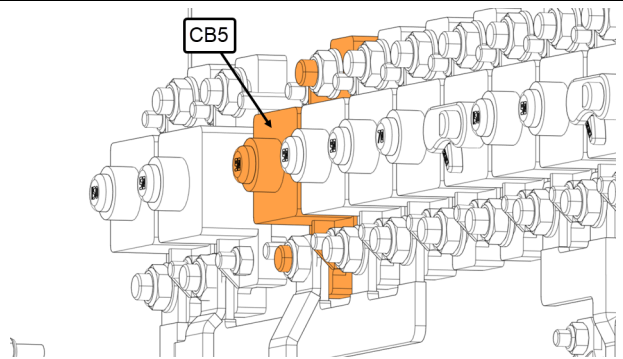

3. Verify if the breaker brand:

- If it is a **SENSATA** brand this ok, go to next step.
- If it is a **GLOSO** brand you need to replace it, go to breaker replacement section.

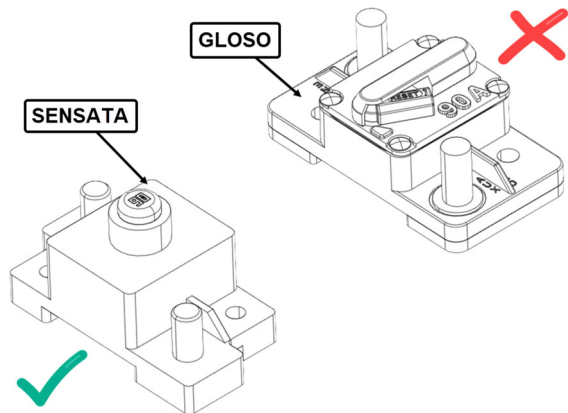

4. Close rear service compartment door on curbside to complete the procedure.

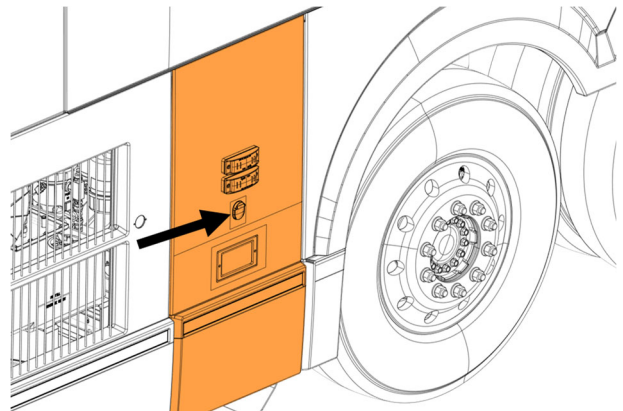

CB5 BREAKER REPLACEMENT X3 MODEL

1. Open compressor door.

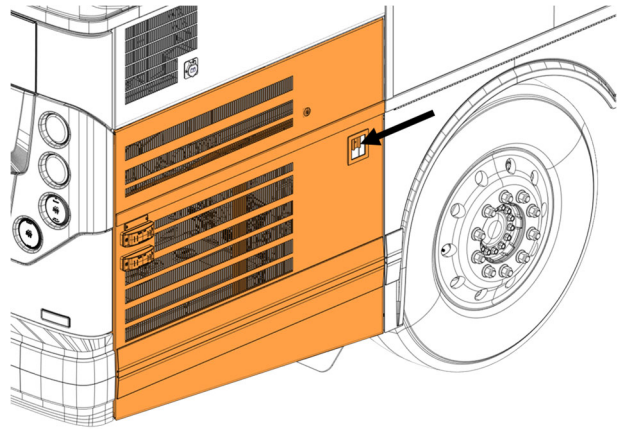

2. Turn off the switch of the main electrical.

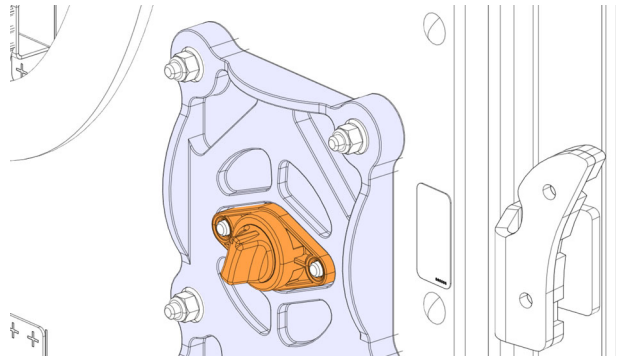

3. Remove battery cover.

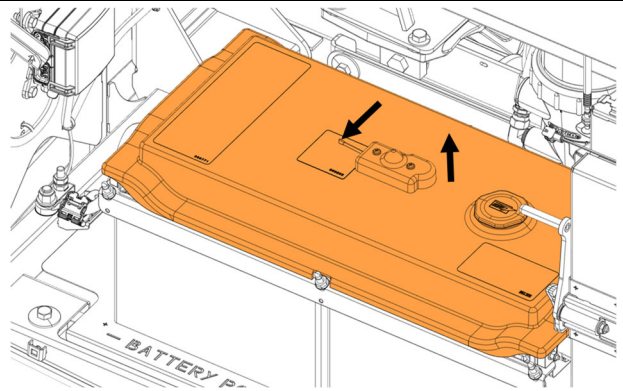

4. Disconnect battery ground.

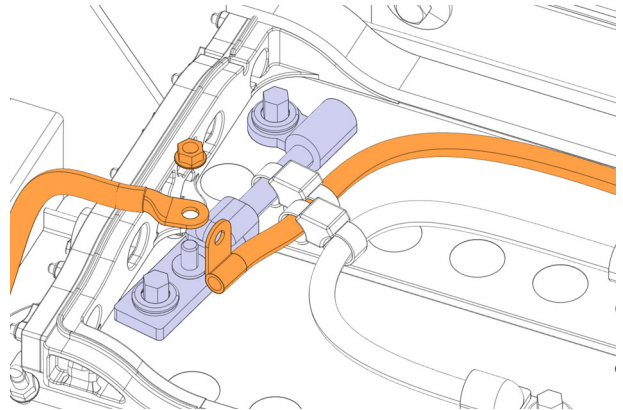

5. Open rear junction box.

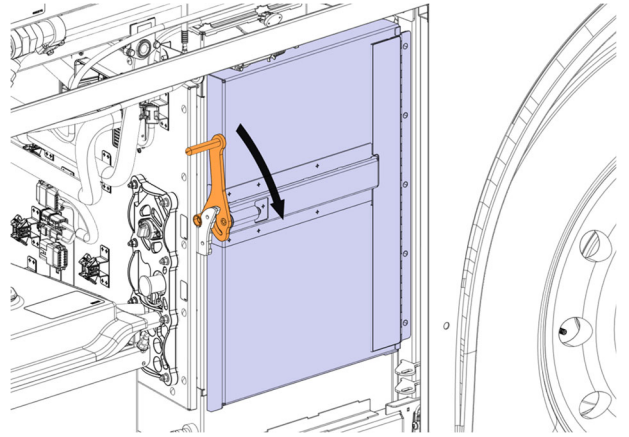

6. Locate CB5 breaker to replace.

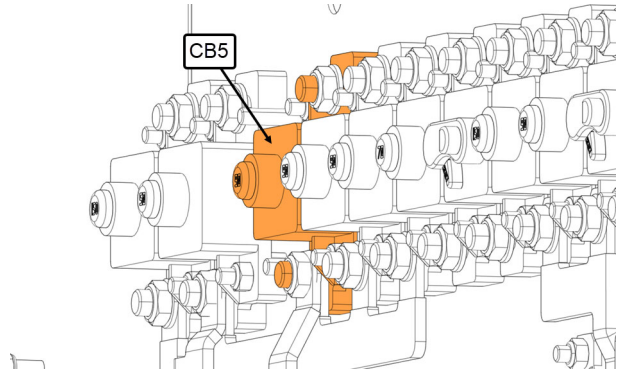

7. Open the fuse holder F101.

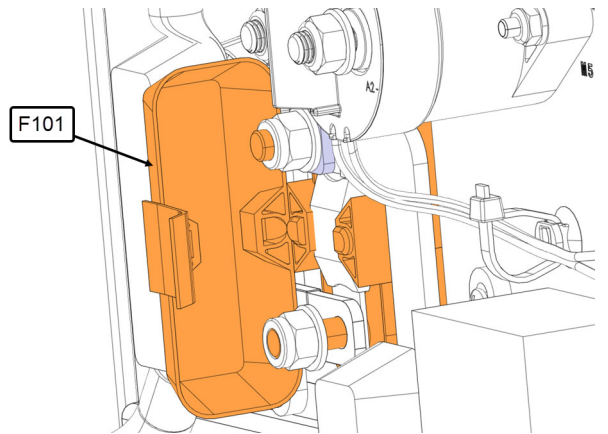

8. Remove the nuts (2x) and the washers (2x).
9. Discard the nuts (2x) and keep the washers (2x) for reuse.

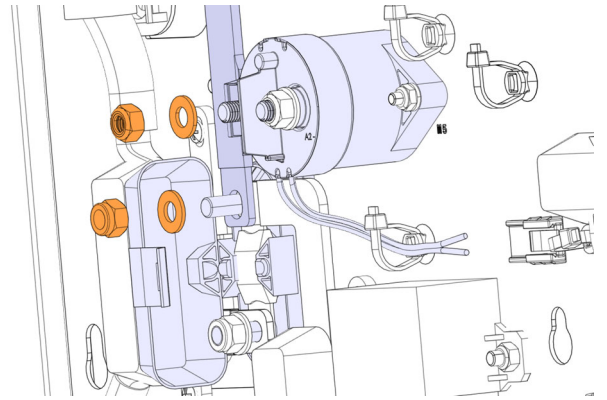

10. Remove the nuts (2x) and the washers (2x) and bus bar.

11. Discard the nuts (2x) and keep the washers (2x) and bus bar for reuse.

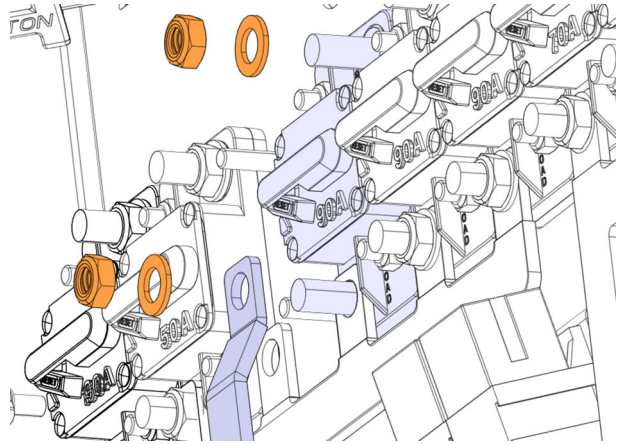

12. Remove the nuts (2x) and the washers (2x) and bus bar.

13. Discard the nuts (2x) and keep the washers (2x) and bus bar for reuse.

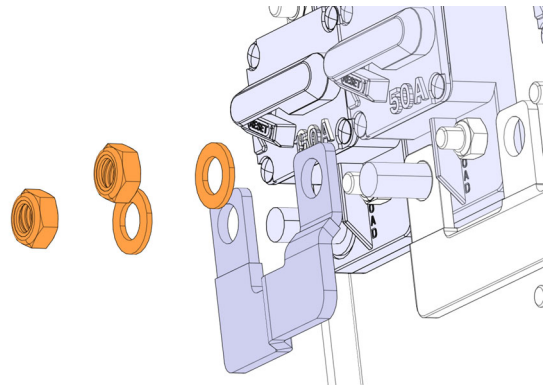

14. Remove the nuts (2x) and the washers (2x) and bus bar.

15. Discard the nuts (2x) and keep the washers (2x) and bus bar for reuse.

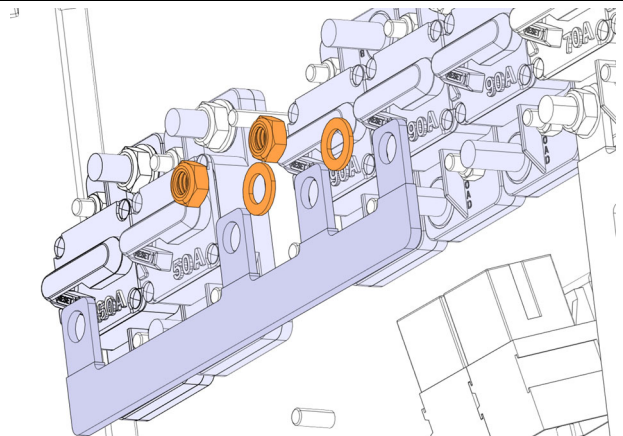

16. Remove the nuts (2x) and the breaker **CB5**.

17. Discard the nuts (2x) and the breaker **CB5**.

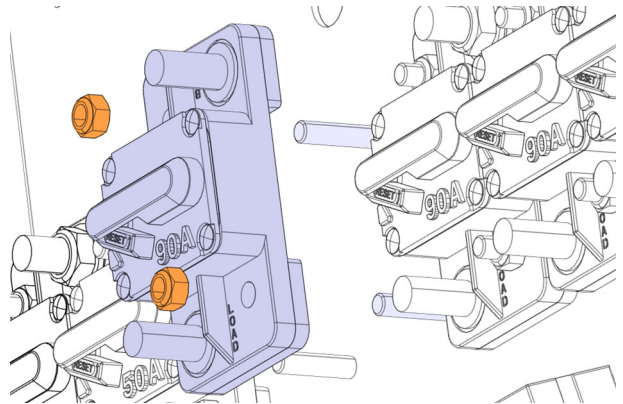

18. Install the new breaker CB5 563708 with new nuts 502681 (2x).

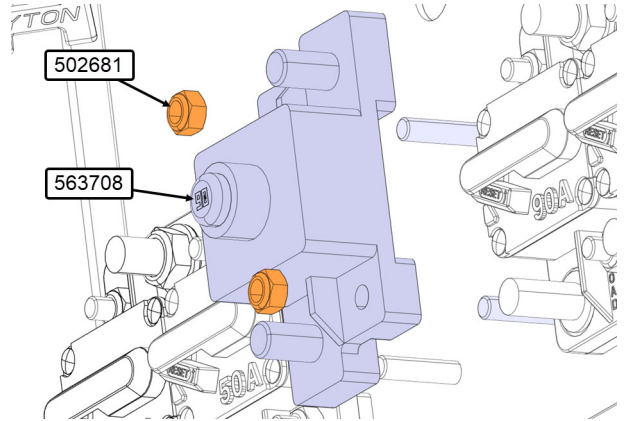

19. Tighten the nuts to **7 lb-ft** torque.

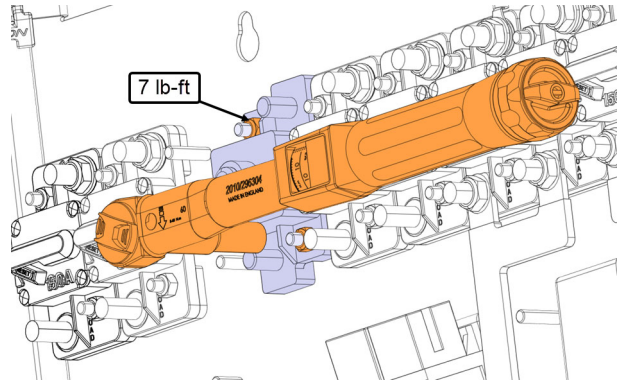

20. Reinstall bus bar with the new nuts 5000025 (2x) and the washers (2x).

Note: if you have difficulty installing the bus bar, loosen the nuts on the other circuit breakers.

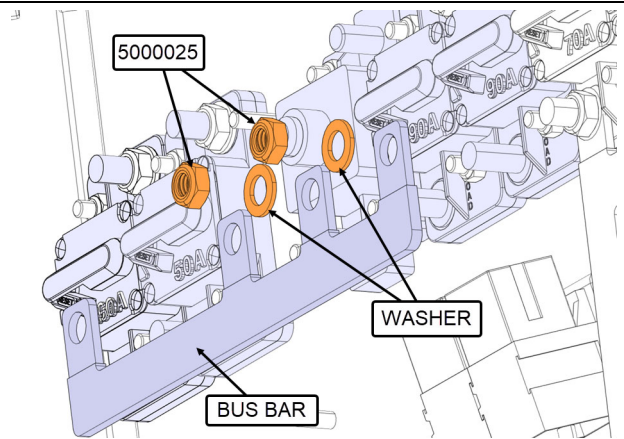

21. Tighten the nuts to **140 lb-in** torque.
22. Apply torque seal 685353 on the nut.

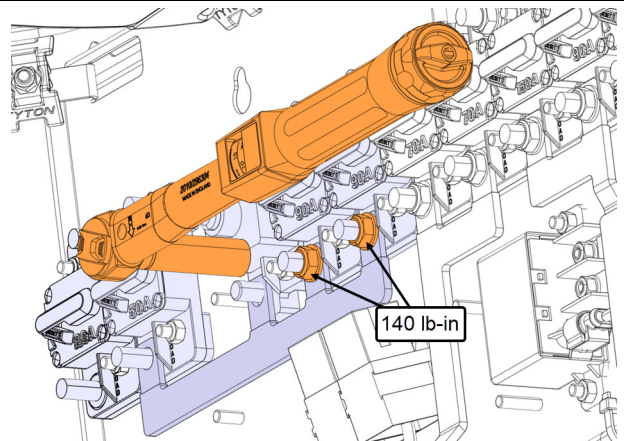

23. Reinstall bus bar with the new nuts 5000025 (2x) and the washers (2x).

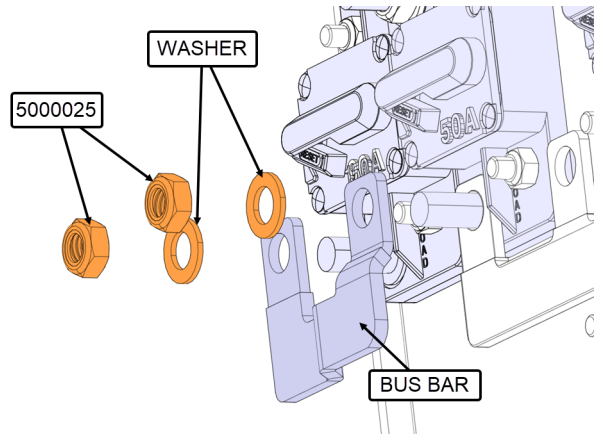

24. Tighten the nuts to **140 lb-in** torque.
25. Apply torque seal 685353 on the nut.

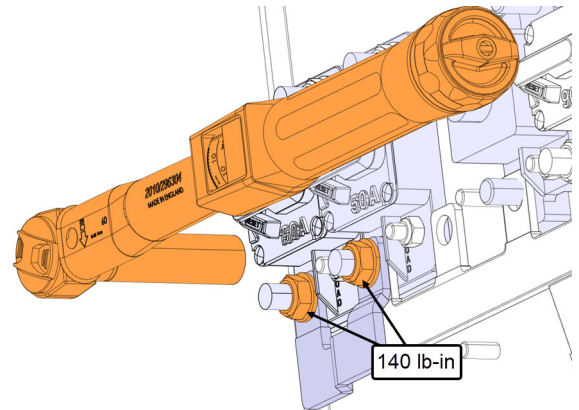

26. Reinstall bus bar with the new nuts 5001936 (2x) and the washers (2x).

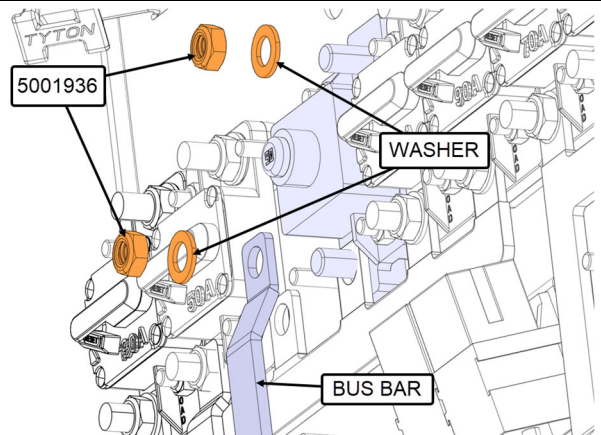

27. Tighten the nuts to **140 lb-in** torque.
28. Apply torque seal 685353 on the nut.

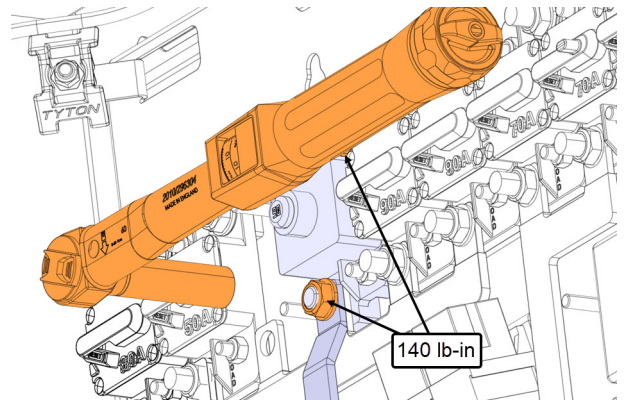

29. Secure bus bar on the batteries relay with the new nut 5001789 (1x) and the washer (1x).

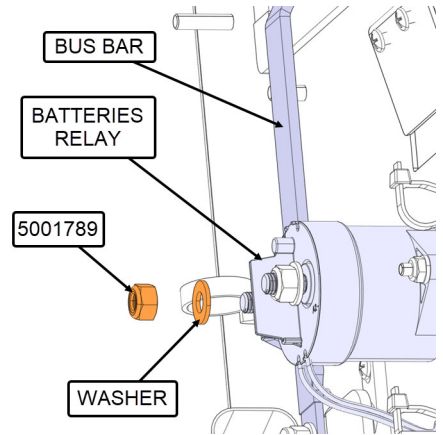

30. Tighten the nut to **100 lb-in** torque.
31. Apply torque seal 685353 on the nut.

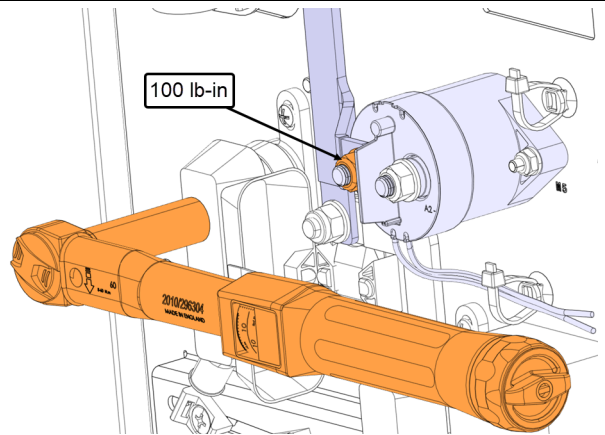

32. Secure bus bar on the fuse holder **F101** with the new nut 5001787 (1x) and the washer (1x).

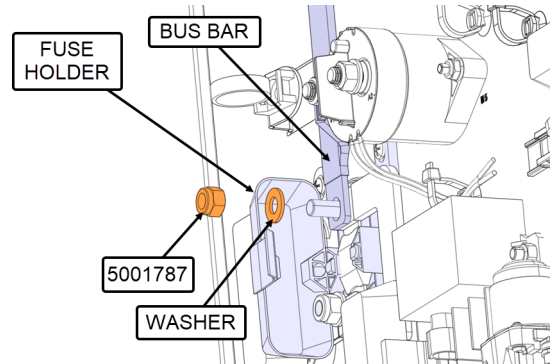

33. Tighten the nut to **125 lb-in** torque.
34. Apply torque seal 685353 on the nut.

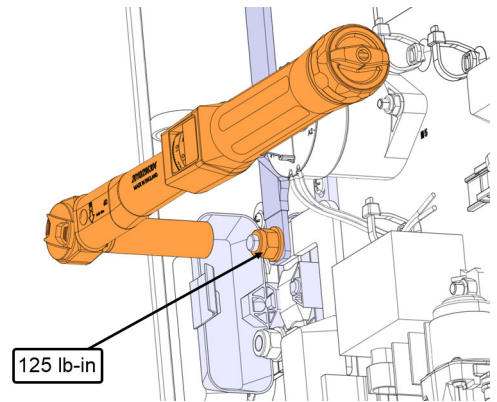

35. Close the fuse holder **F101**.



F101

The diagram shows a close-up of the fuse holder assembly. An orange fuse holder, labeled F101, is being pushed into a slot within a larger metal housing. The housing is light blue and has various electrical terminals and components visible.

36. Close rear junction box door.

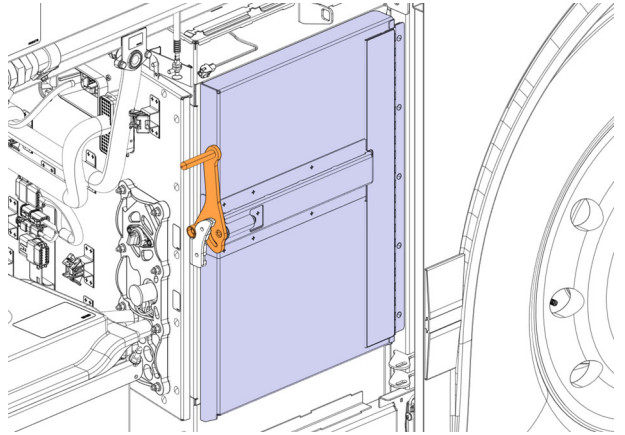

37. Reconnect battery ground.

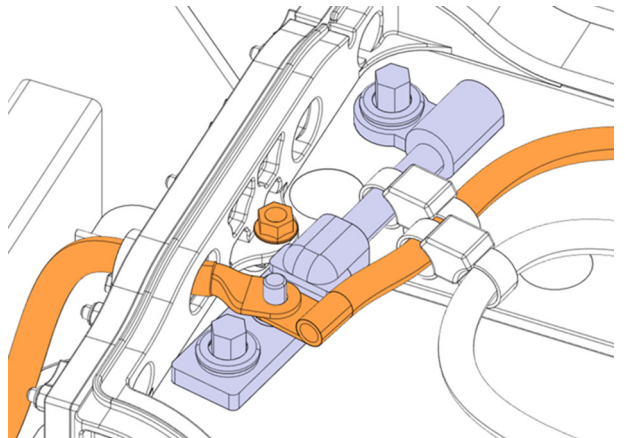

38. Tighten the nut to **170 lb-in** torque.



170 lb-in

The diagram shows a torque wrench being used to tighten a nut. The torque wrench is orange and has a label that reads "170 lb-in". The nut is located on a blue metal bracket. The bracket is attached to the chassis of the vehicle. The chassis is light blue and has various components visible.

39. Reinstall battery cover.

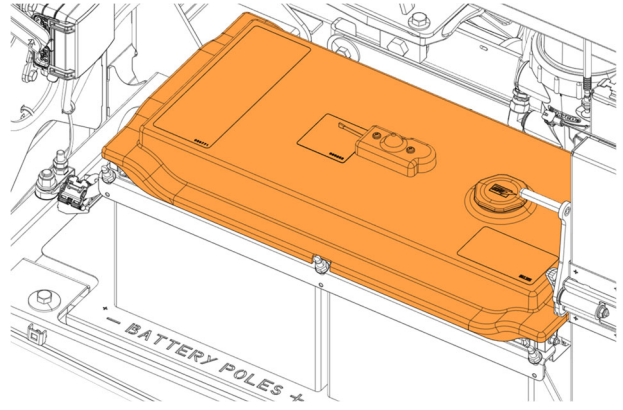

40. Turn on the switch of the main electrical.

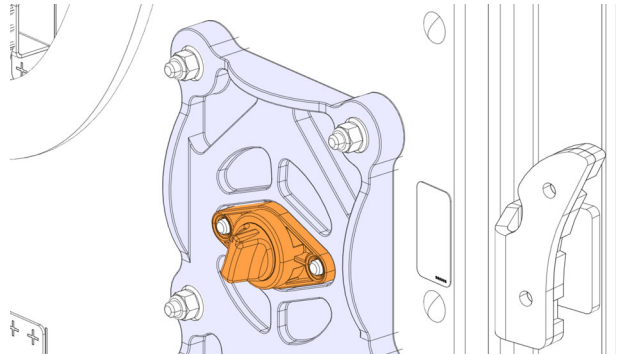

41. Close compressor door.

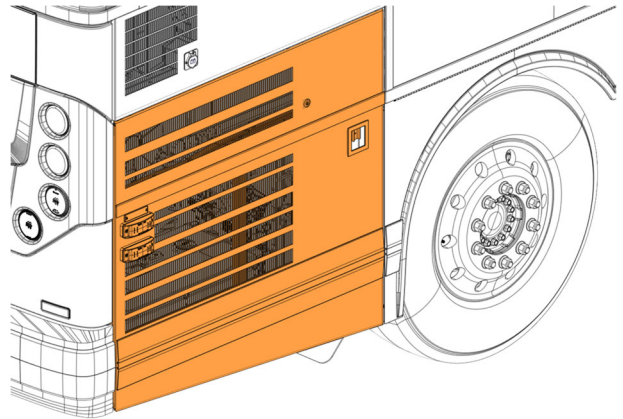

CB5 BREAKER REPLACEMENT H3 MODEL

1. Open compressor compartment door.

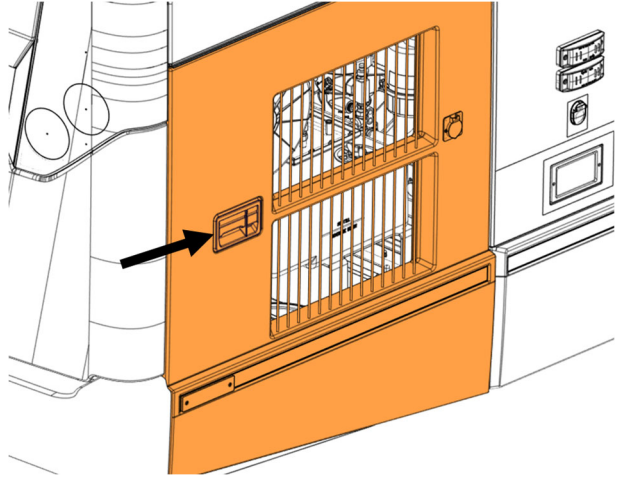

2. Turn off the switch of the main electrical.

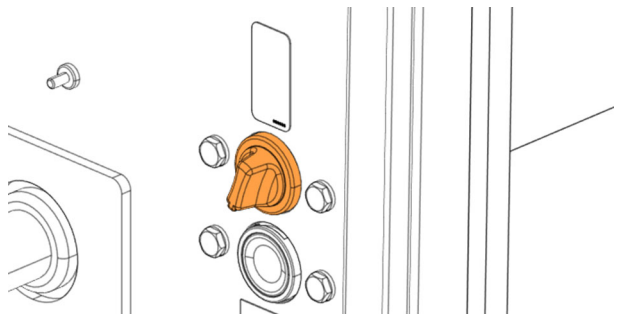

3. Open rear service compartment door on curbside.

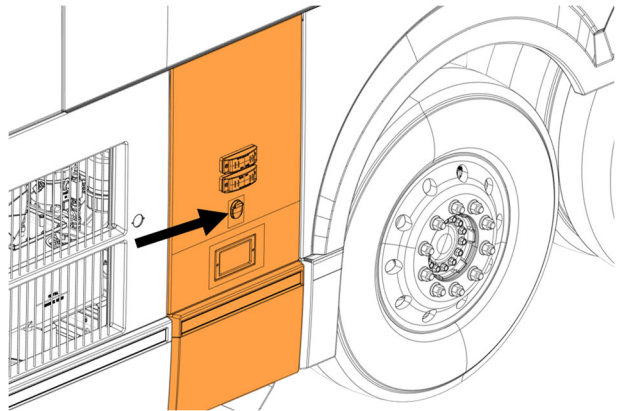

4. Remove battery cover.

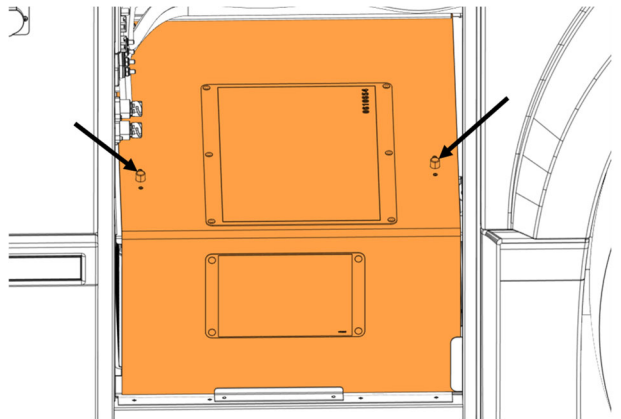

5. Disconnect battery ground.

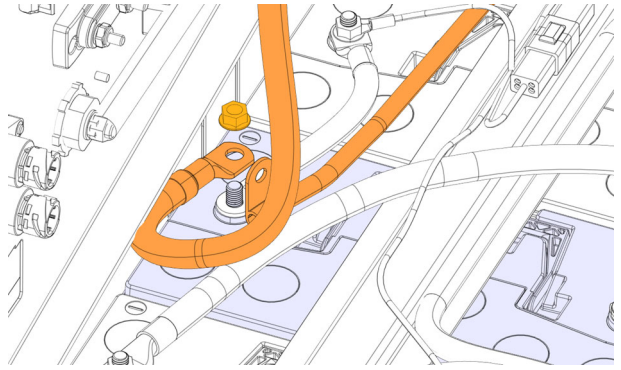

6. Locate CB5 breaker to replace.

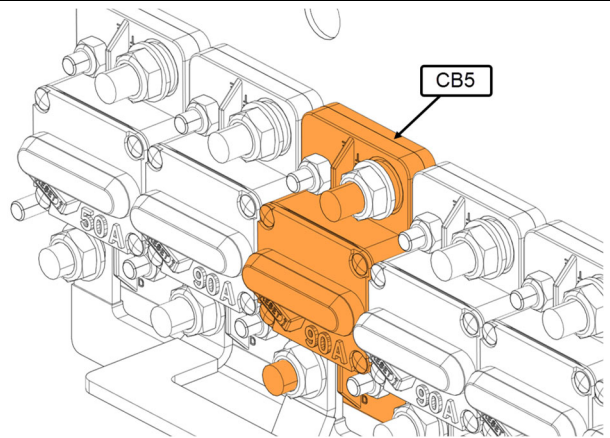

7. Open the fuse holder **F101**.

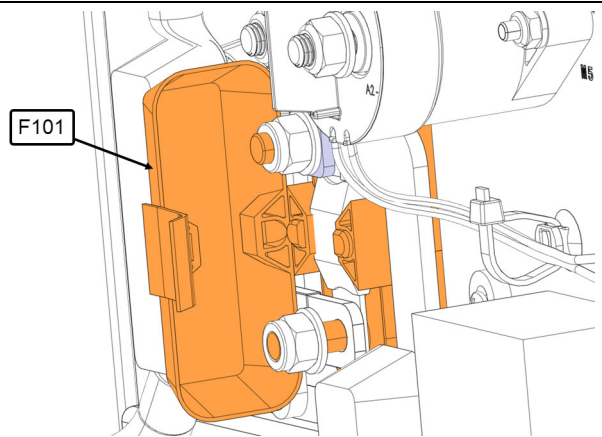

8. Remove the nuts (2x) and the washers (2x).
9. Discard the nuts (2x) and keep the washers (2x) for reuse.

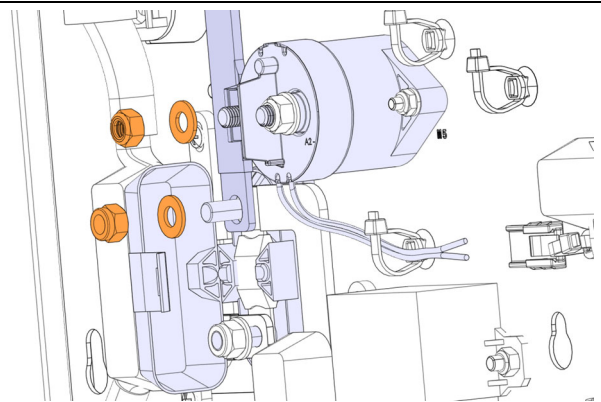

10. Remove the nuts (2x) and the washers (2x) and bus bar.

11. Discard the nuts (2x) and keep the washers (2x) and bus bar for reuse..

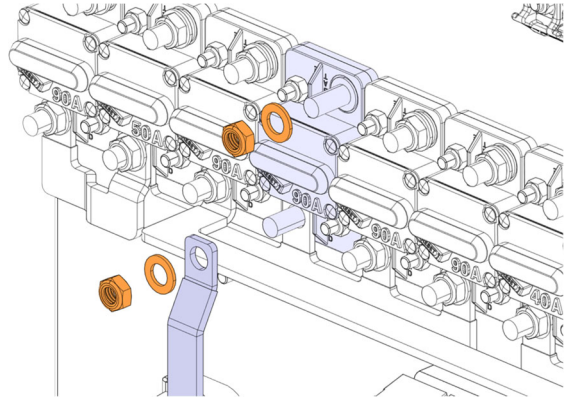

12. Remove the nuts (2x) and the washers (2x) and bus bar.

13. Discard the nuts (2x) and keep the washers (2x) and bus bar for reuse.

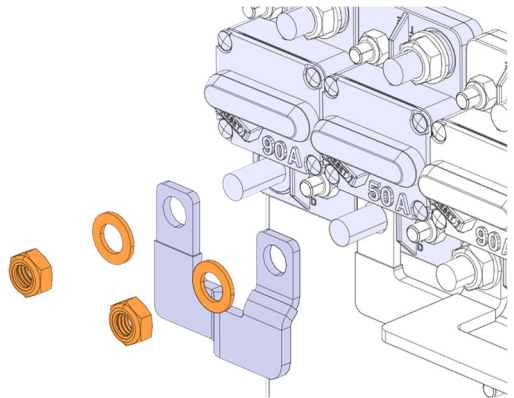

14. Remove the nuts (2x) and the washers (2x) and bus bar.

15. Discard the nuts (2x) and keep the washers (2x) and bus bar for reuse.

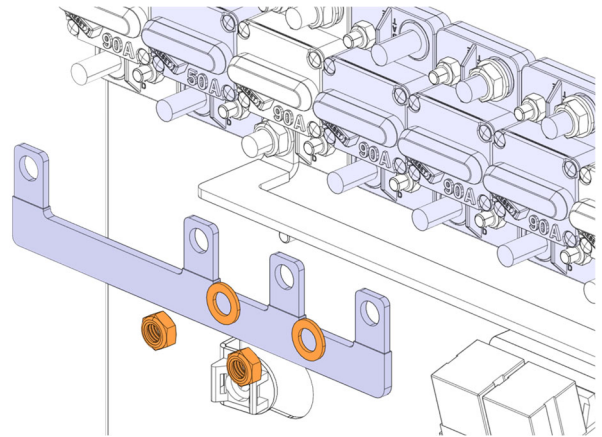

16. Remove the nuts (2x) and the breaker **CB5**.

17. Discard the nuts (2x) and the breaker **CB5**.

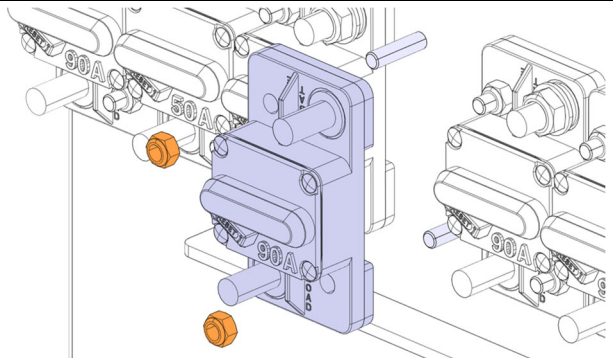

18. Install the new breaker CB5 563708 with new nuts 502681 (2x).

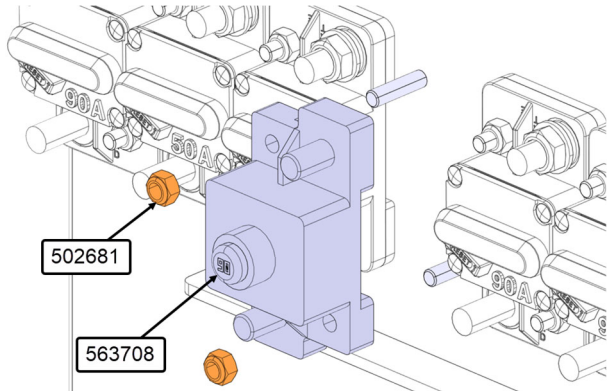

19. Tighten the nuts to **7 lb-ft** torque.

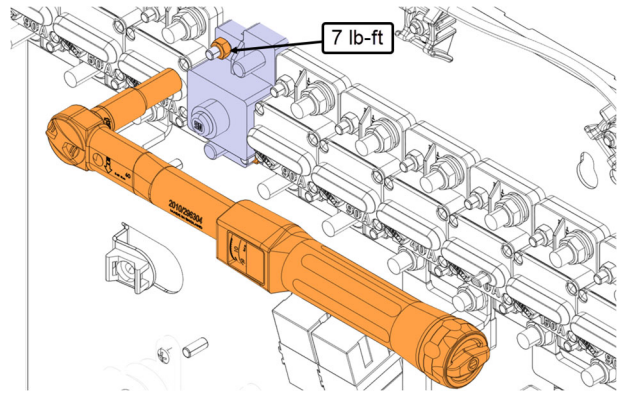

20. Reinstall bus bar with the new nuts 5000025 (2x) and the washers (2x).

Note: if you have difficulty installing the bus bar, loosen the nuts on the other circuit breakers.

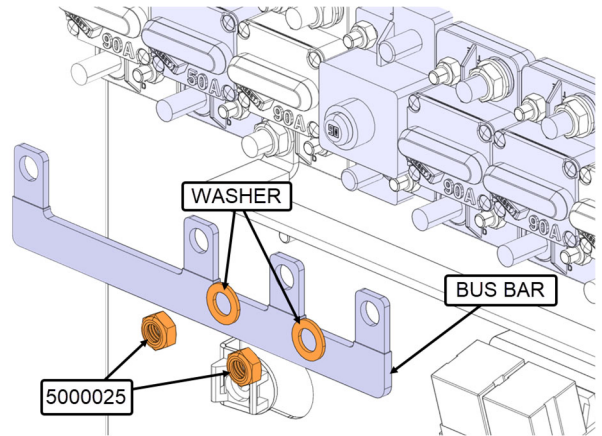

21. Tighten the nuts to **140 lb-in** torque.
22. Apply torque seal 685353 on the nut.

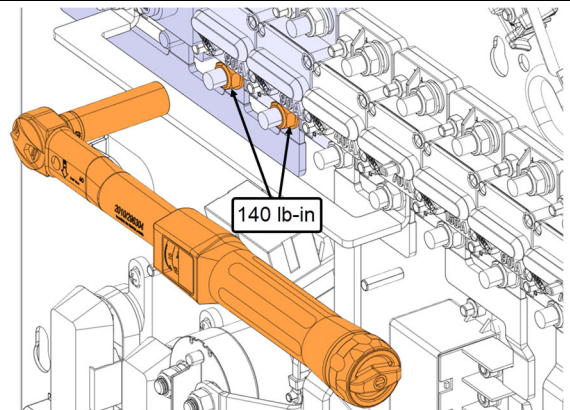

23. Reinstall bus bar with the new nuts 5000025 (2x) and the washers (2x).

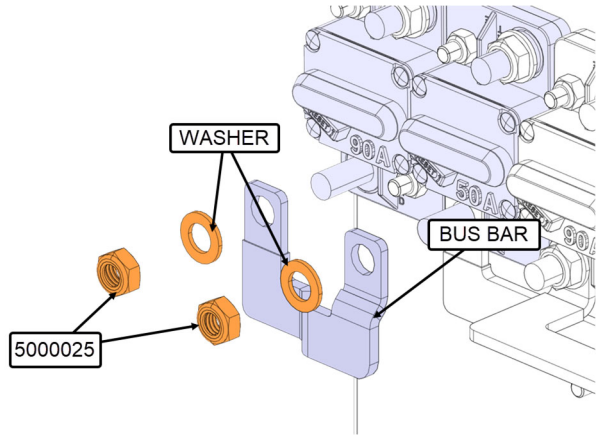

24. Tighten the nuts to **140 lb-in** torque.
25. Apply torque seal 685353 on the nut.

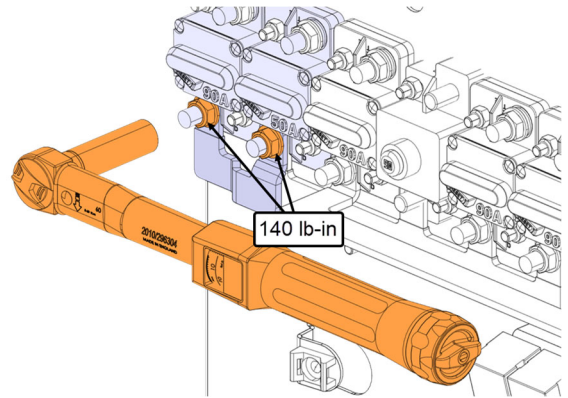

26. Reinstall bus bar with the new nuts 5001936 (2x) and the washers (2x).

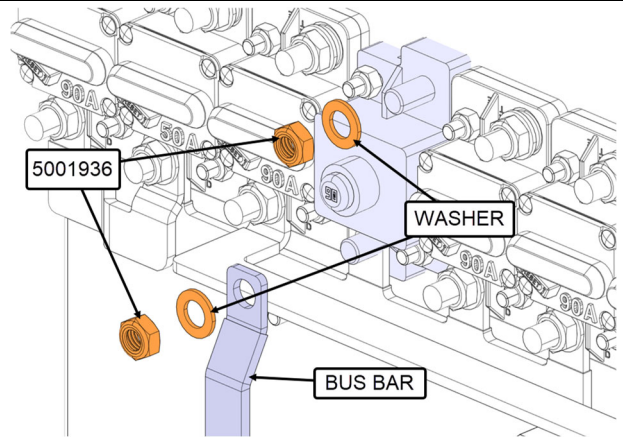

27. Tighten the nuts to **140 lb-in** torque.
28. Apply torque seal 685353 on the nut.

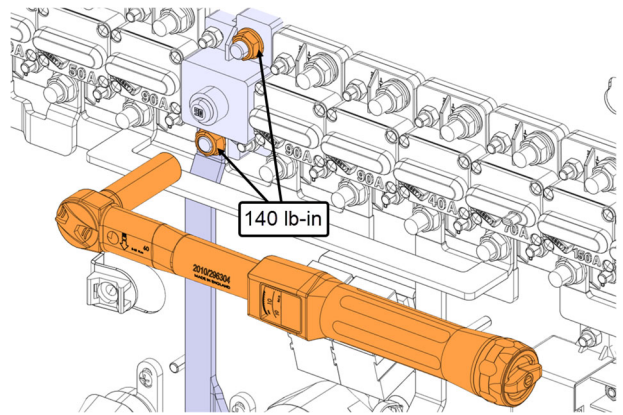

29. Secure bus bar on the batteries relay with the new nut 5001789 (1x) and the washer (1x).

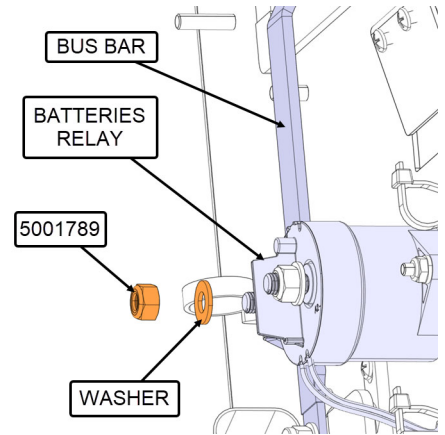

30. Tighten the nut to **100 lb-in** torque.
31. Apply torque seal 685353 on the nut.

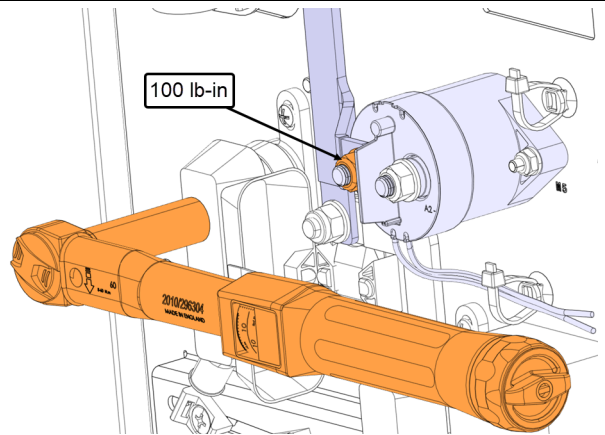

32. Secure bus bar on the fuse holder **F101** with the new nut 5001787 (1x) and the washer (1x).

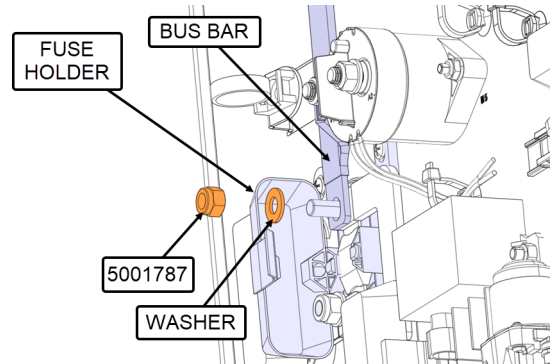

33. Tighten the nut to **125 lb-in** torque.
34. Apply torque seal 685353 on the nut.

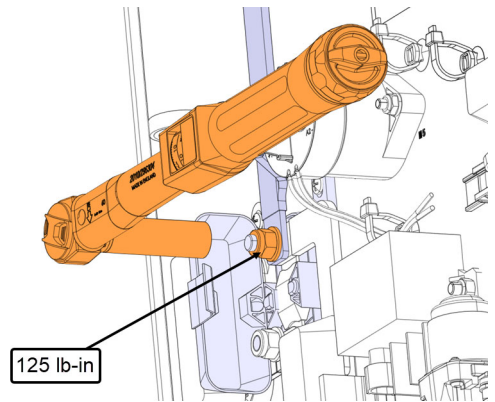

35. Close the fuse holder **F101**.



F101

The diagram shows a close-up of the fuse holder F101, which is highlighted in orange. It is a rectangular component with a hinged lid that is being closed. The surrounding area shows various electrical components and wiring.

36. Reconnect battery ground.

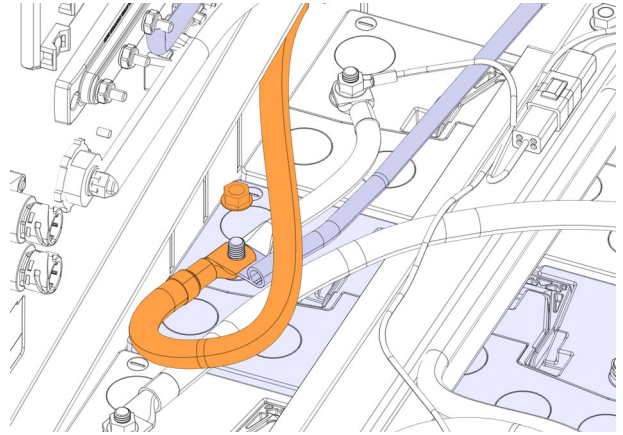

37. Tighten the nut to **170 lb-in** torque.

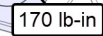

170 lb-in

The diagram shows a close-up of a nut being tightened. A torque wrench is being used to apply the correct torque. The torque wrench is highlighted in orange. The surrounding area shows various electrical components and wiring.

38. Reinstall battery cover.

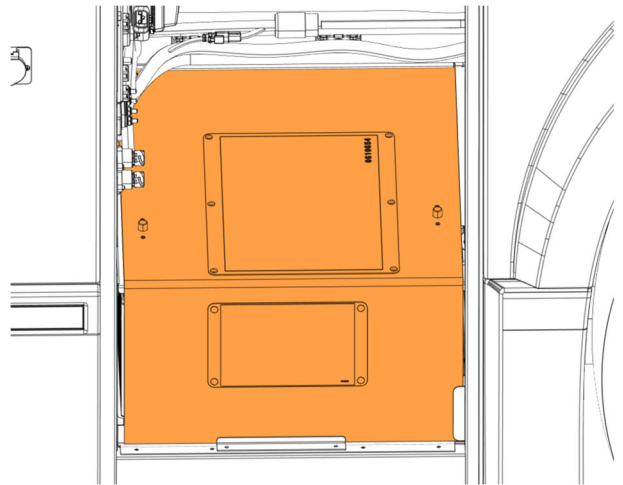

39. Close rear service compartment door.

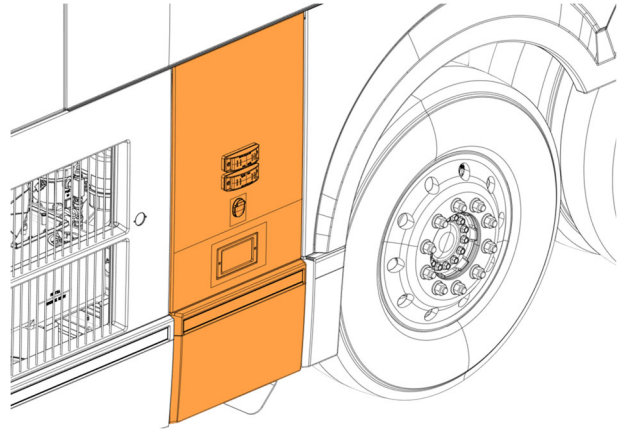

40. Turn on the switch of the main electrical.

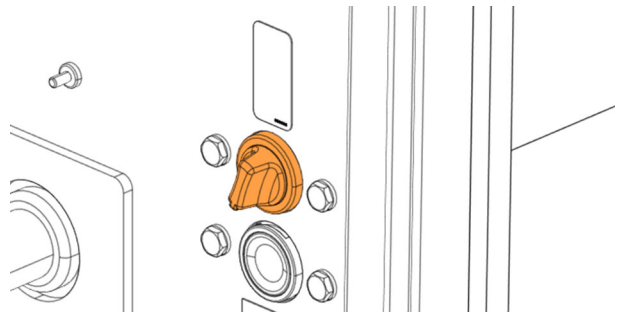

41. Close compressor compartment door.

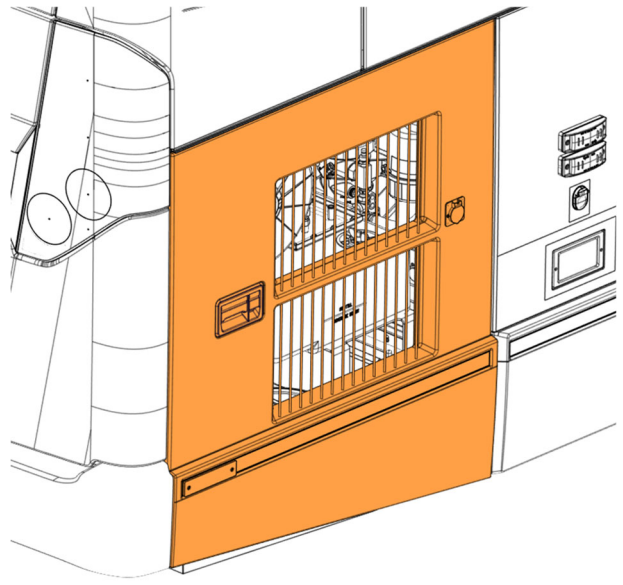

PARTS / WASTE DISPOSAL

DO NOT RETURN THE REPLACED PARTS. Discard waste according to applicable environmental regulations (Municipal/State[Prov.]/ Federal)

WARRANTY

This modification is covered by Prevost's normal warranty. We will reimburse you the parts and the part and labor as follows upon receipt of a warranty claim. Please submit claim via our Online Warranty System, available at www.prevostcar.com (under Service \ Warranty section).

- Use Claim Type: "Bulletin/Recall" and select "Warranty Bulletin WB24-23A".

Breaker inspection only

¼ hour (0.25) of labor

Breaker inspection and replacement

1 hour (1.0) of labor

OTHER

VBC Bulletin	N/A
Fail Code	06.16
Defect Code	09
Syst. Cond	B
Causal Part	564675

Access all our Service Bulletins on
<http://techpub.prevostcar.com/en/>
or scan the QR-Code with your smart phone.



Are you a Vehicle owner? E-mail us at
technicalpublications_prev@volvo.com and type "ADD" in the
subject to receive warranty bulletins applicable to your vehicle(s)
by e-mail.