

# PREVOST

## WARRANTY BULLETIN

**WB24-24**

DATE :	August 2024	SECTION:	06 ELECTRICAL
EXPIRATION:	August 2026		
SUBJECT:	<b>CB5 BREAKER REPLACEMENT</b>		

First Release

08-27-2024

### APPLICATION





<b>NOTICE TO SERVICE CENTERS</b> <i>Verify vehicle eligibility by checking warranty bulletin status with <b>SAP</b> or via <b>ONLINE WARRANTY SYSTEM</b> available on Service / Warranty tab of Prevost website.</i>	
Model	VIN 
X3-45 VIP commercial use Model Year: 2023 - 2024	2PCCS3498 <u>RC734005</u> / 2PCCS3497 <u>RC734013</u> 2PCCS3498 <u>RC734067</u> / 2PCCS3496 <u>RC734102</u>
X3-45 VIP motorhomes Model Year: 2024	2PCBS3499 <u>RC734011</u>
H3-45 coaches Model Year: 2024	2PCH33492 <u>RC721947</u>
<b>This bulletin does not necessarily apply to all the above-mentioned vehicles, some vehicles may have been modified before delivery. The owners of the vehicles affected by this bulletin will be advised by a letter indicating the Vehicle Identification Number (VIN) of each vehicle concerned.</b>	

### DESCRIPTION

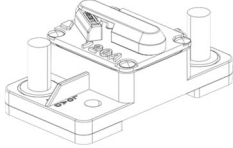

On the vehicles affected by this bulletin, replace the CB5 breaker 90 amp by 120 amp.

**MATERIAL**

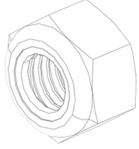
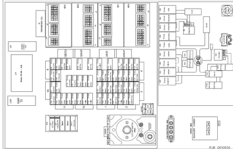
Order kit **WB24-24-1** which contains the following parts for **X3-45 VIP only**:

Part No	Description	Qty
564902	BREAKER 120A 	1
502681	NUT HEX NYRT NX500 M6-1.0 G8 	2
5000025	NUT HEX NYRT NX500 3/8-16 	4
5001787	NUT HEX NYRT SS M8-1.25X9.5 	1
5001789	NUT HEX NYRT SS M8 X 1.25 X 8 	1
0610656	DECAL REAR JUNCTION BOX COMPONENTS 	1

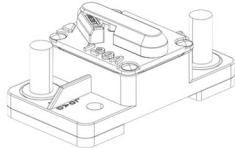
Order kit **WB24-24-2** which contains the following parts **for H3-45 only**:

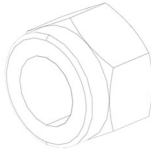
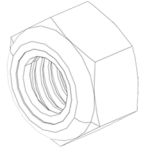
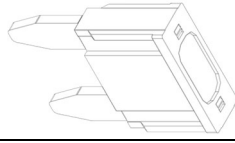
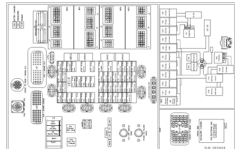
Part No	Description		Qty
564902	BREAKER 120A		1
502681	NUT HEX NYRT NX500 M6-1.0 G8		2
5000025	NUT HEX NYRT NX500 3/8-16		6
5001787	NUT HEX NYRT SS M8-1.25X9.5		1
5001789	NUT HEX NYRT SS M8 X 1.25 X 8		1
563153	FUSE ATM 25A		1
0610654	DECAL REAR JUNCTION BOX COMPONENTS		1

Other parts that may be required. **Note that these parts are not covered by this bulletin:**

Part No.	Description	Qty
685353	YELLOW TORQUE SEAL, 1 OZ	AR

**NOTE**

Material can be obtained through regular channels.

## SAFETY PRECAUTIONS

- Eye protection should always be worn when working in a shop.
- Rules for Personal Protection Equipment should always be respected. Wear your PPE including but not limited to the following:



# Safety First!



## PROCEDURE



### DANGER

Park vehicle safely, apply parking brake, stop the engine. Prior to working on the vehicle, set the ignition switch to the OFF position and trip the main circuit breakers equipped with a trip button. On the Commuter type vehicles, set the battery master switch (master cut-out) to the OFF position.

Lockout & Tag out (LOTO) must be performed during set-up, maintenance or repair activities. Refer to your local procedure for detailed information regarding the control of hazardous energy.

**CB5 BREAKER REPLACEMENT X3VIP MODEL**

1. Open compressor door.

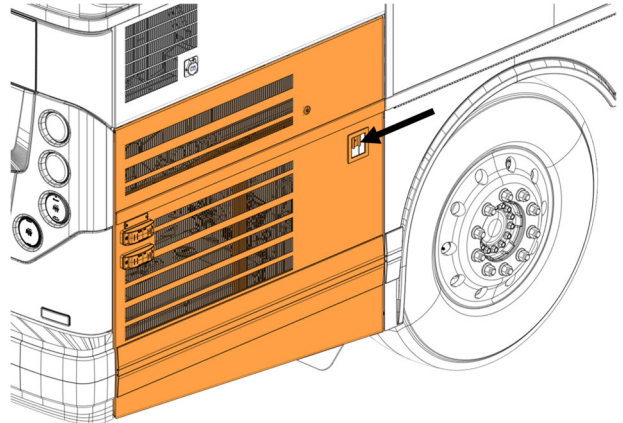

2. Turn off the switch of the main electrical.

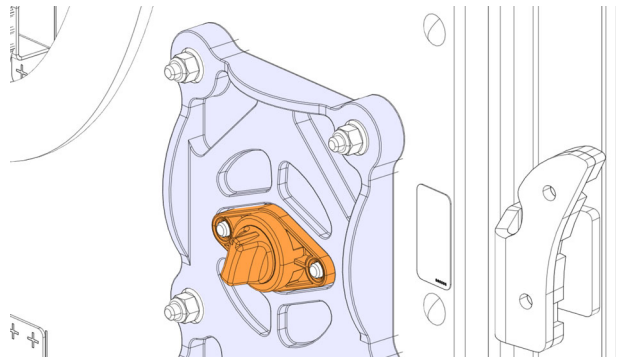

3. Remove battery cover.

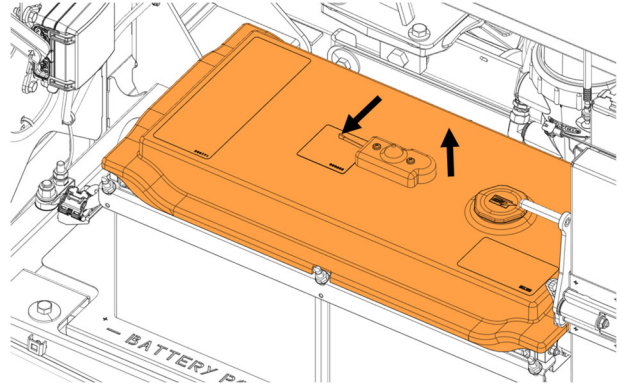

4. Disconnect battery ground.

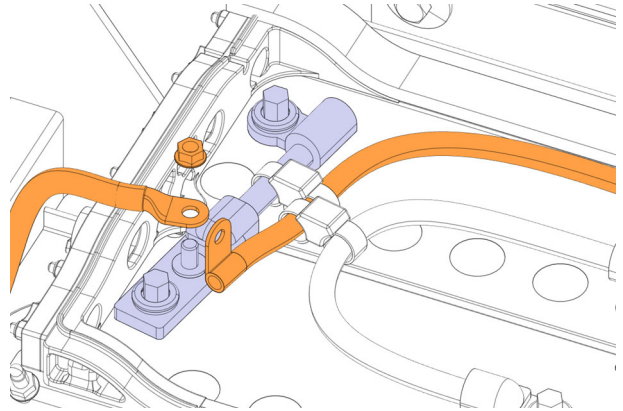

5. Open rear junction box.

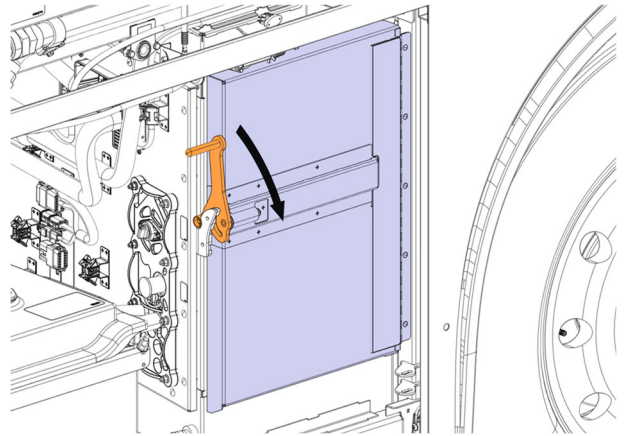

6. Locate the CB5 breaker to replace.

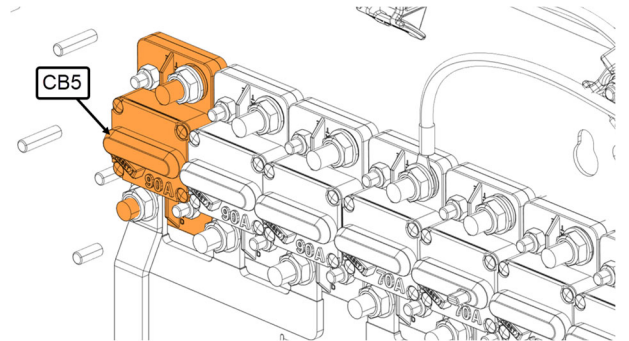

7. Open the fuse holder **F101**.

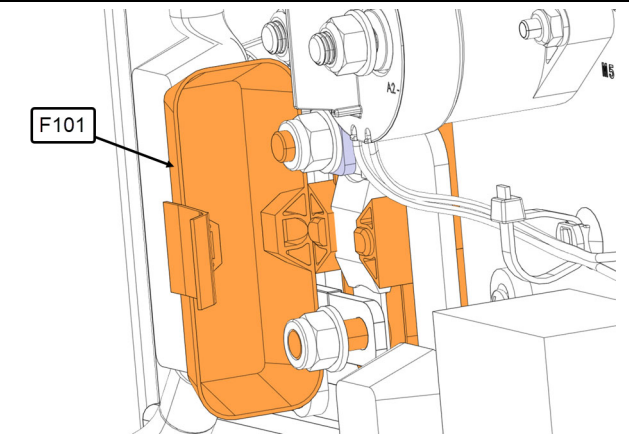

8. Remove the nuts (2x) and the washers (2x).  
9. Discard the nuts (2x) and keep the washers (2x) for reuse.

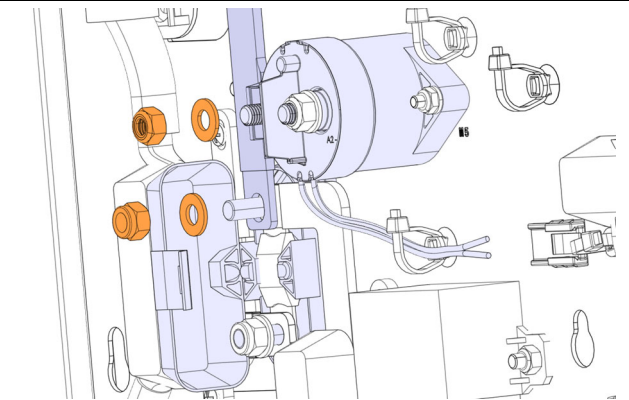

10. Remove the nuts (2x) and the washers (2x) and bus bar.

11. Discard the nuts (2x) and keep the washers (2x) and bus bar for reuse.

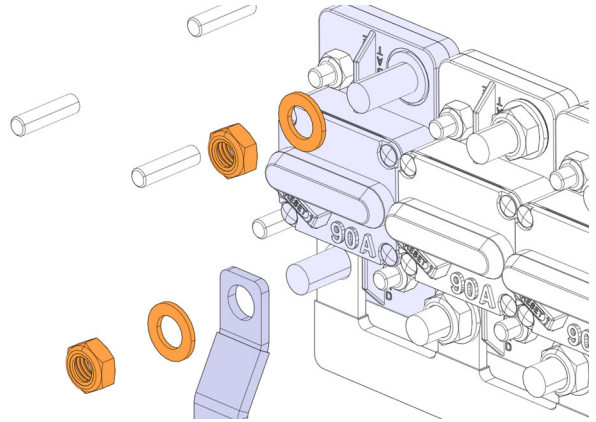

12. Remove the nuts (2x) and the washers (2x) and bus bar.

13. Discard the nuts (2x) and keep the washers (2x) and bus bar for reuse.

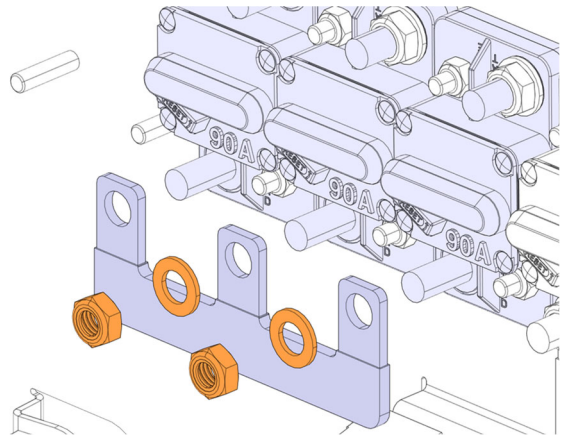

14. Remove the nuts (2x) and the breaker **CB5**.

15. Discard the nuts (2x) and the breaker **CB5**.

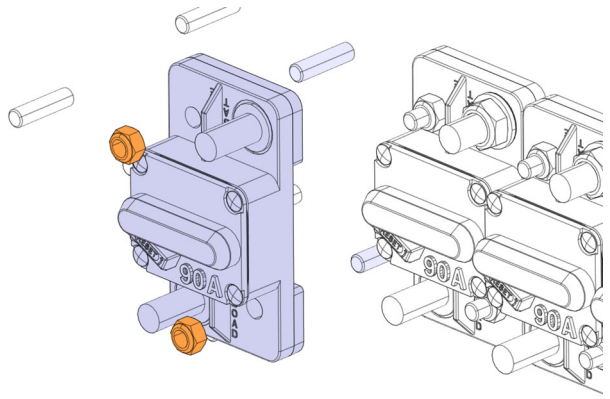

16. Install the new breaker CB5 564902 with the new nuts 502681 (2x).

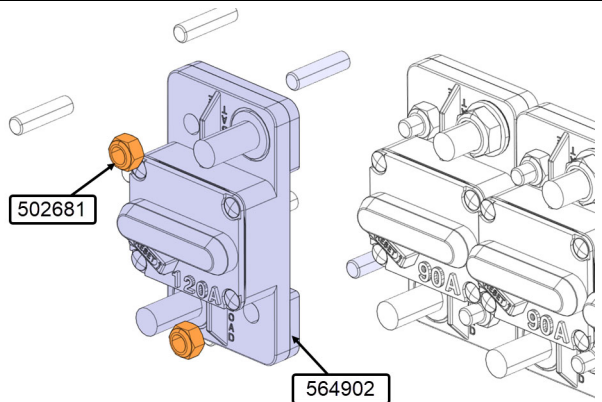

17. Tighten the nuts to **7 lb-ft** torque.

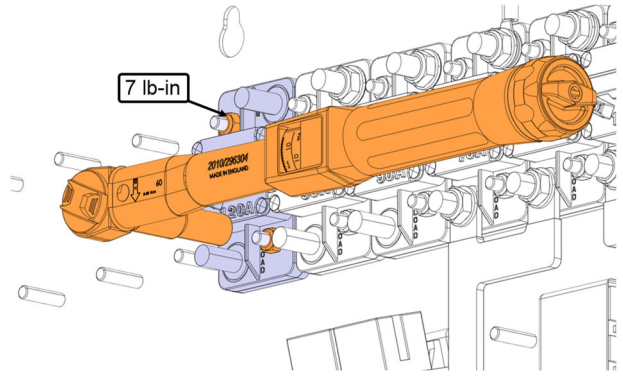

18. Reinstall the bus bar with the new nuts 5000025 (2x) and the washers (2x).

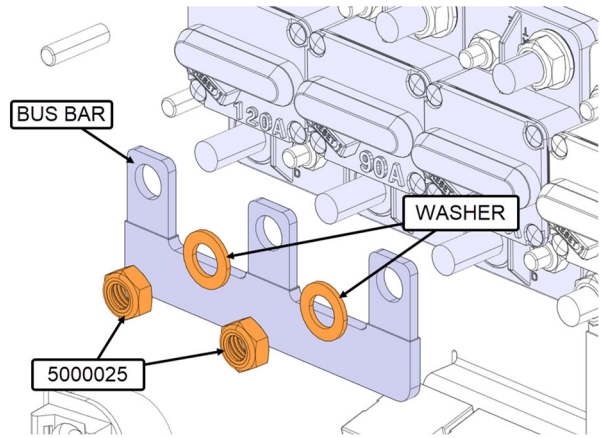

19. Tighten the nuts to **140 lb-in** torque.  
20. Apply torque seal 685353 on the nut.

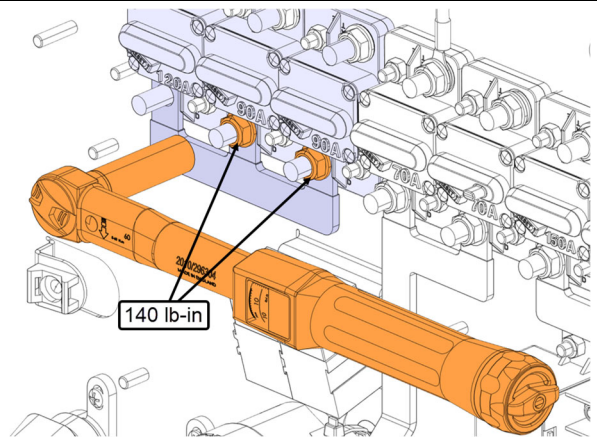

21. Reinstall the bus bar with the new nuts 5000025 (2x) and the washers (2x).

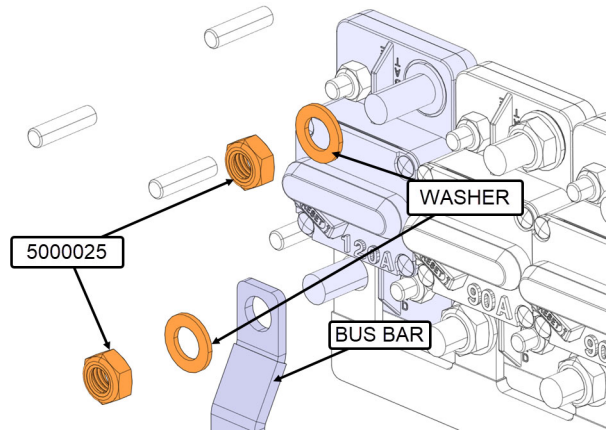



- 22. Tighten the nuts to **140 lb-in** torque.
- 23. Apply torque seal 685353 on the nut.

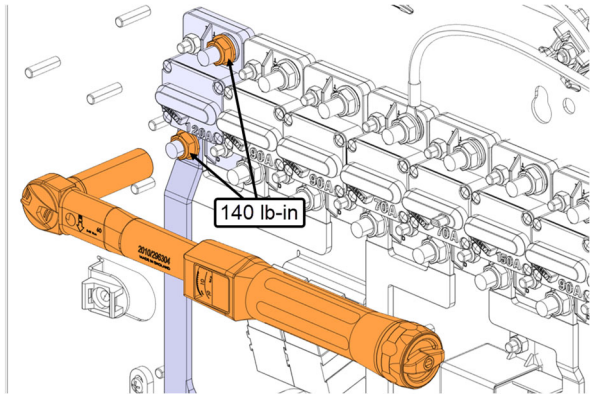

- 24. Secure the bus bar on the batteries relay with the new nut 5001789 (1x) and the washer (1x).

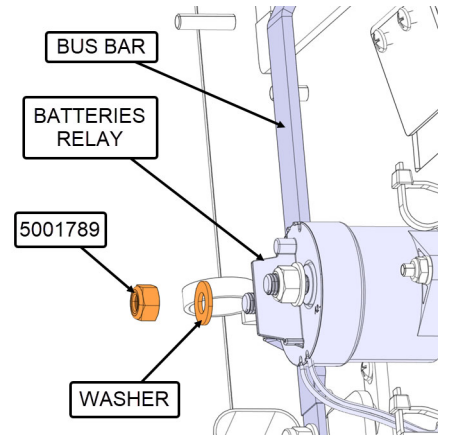

- 25. Tighten the nut to **100 lb-in** torque.
- 26. Apply torque seal 685353 on the nut.

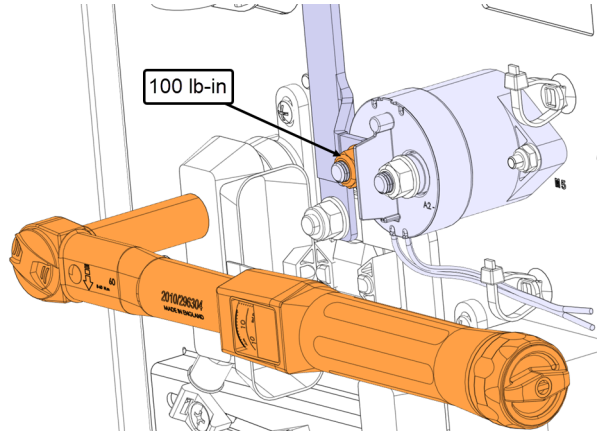

- 27. Secure the bus bar on the fuse holder **F101** with the new nut 5001787 (1x) and the washer (1x).

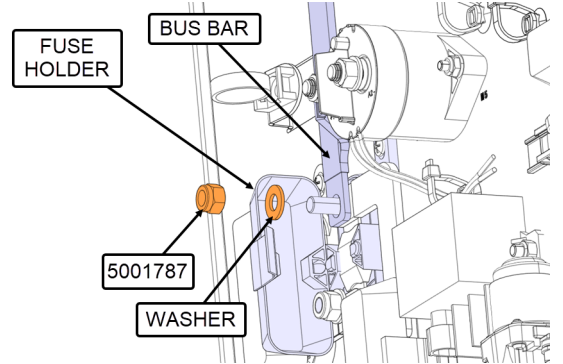

28. Tighten the nut to **125 lb-in** torque.  
29. Apply torque seal 685353 on the nut.

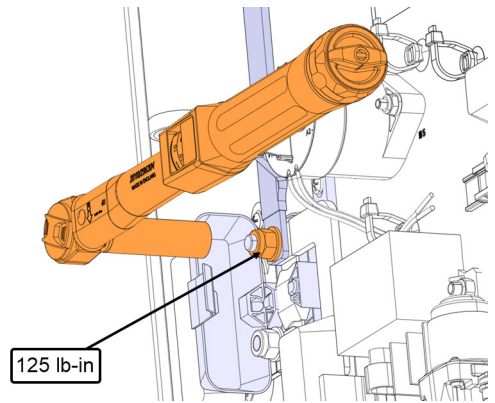

30. Close the fuse holder **F101**.

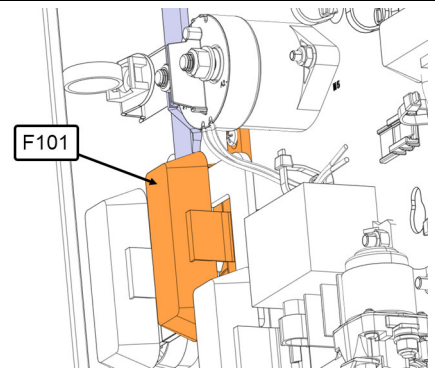

31. Remove the decal of the rear junction box components.

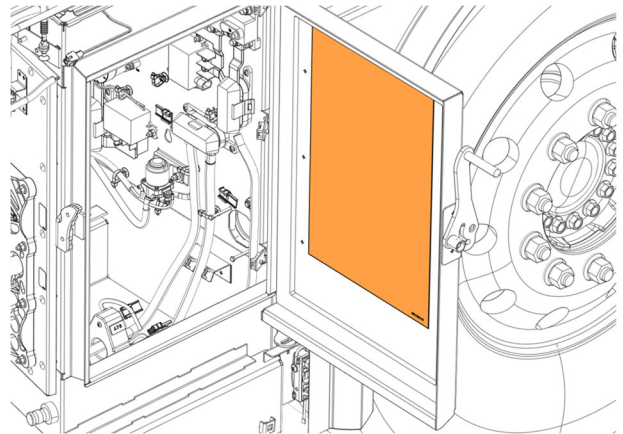

32. Install the new decal of the rear junction box components 0610656.

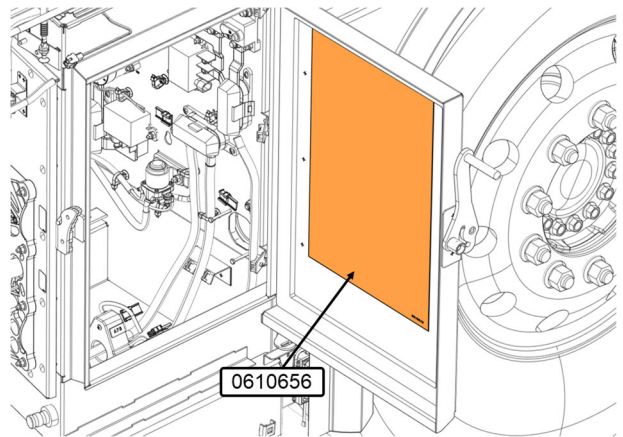

33. Close rear junction box door.

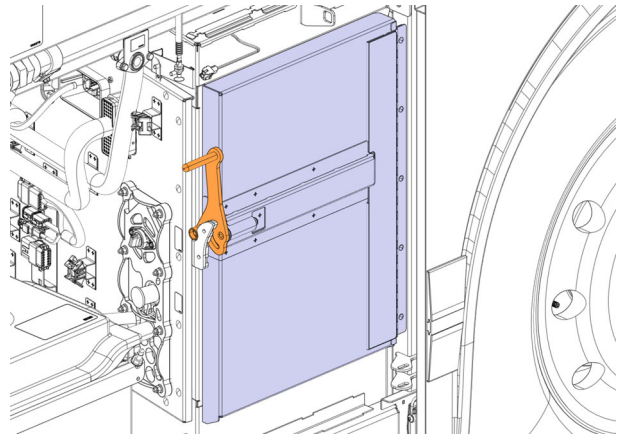

34. Reconnect battery ground.

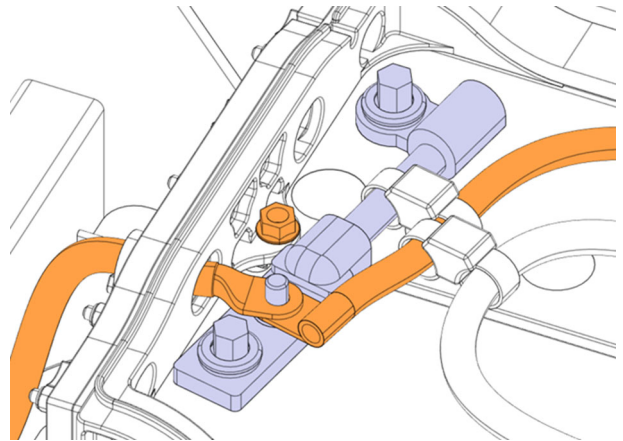

35. Tighten the nut to **170 lb-in** torque.

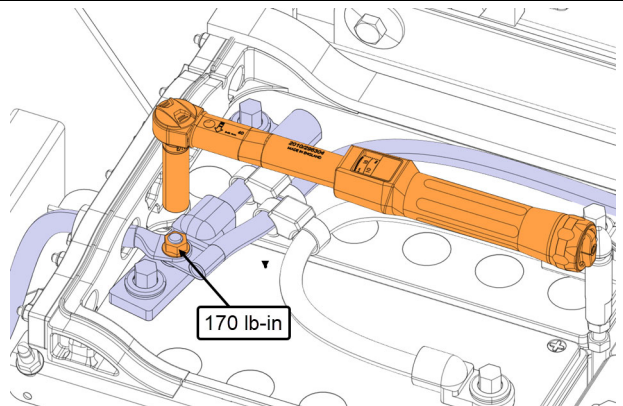

36. Reinstall battery cover.

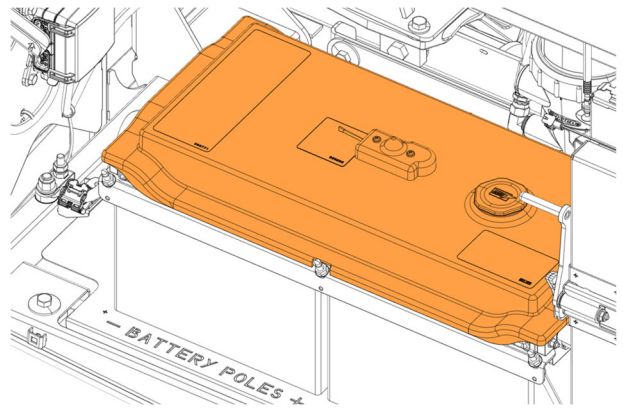

37. Turn on the switch of the main electrical.

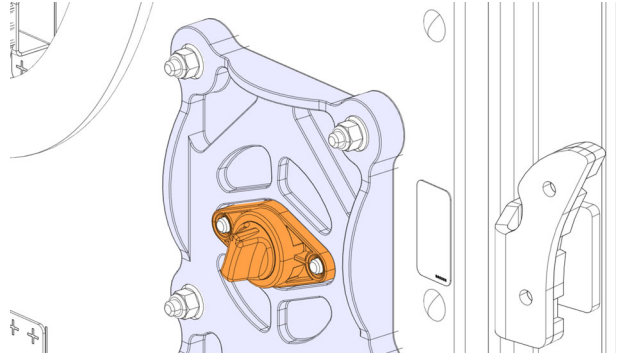

38. Close compressor door.

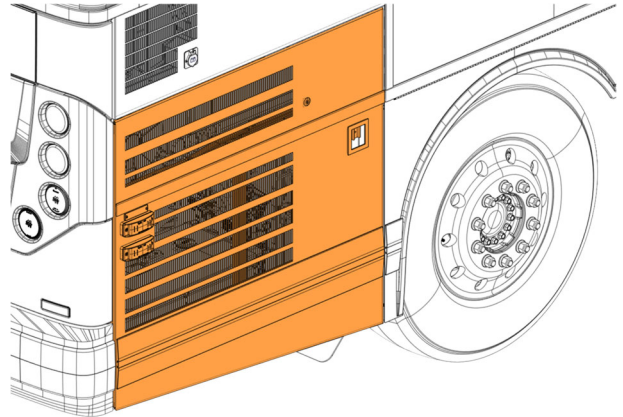

### CB5 BREAKER REPLACEMENT H3-45 MODEL

1. Open compressor compartment door.

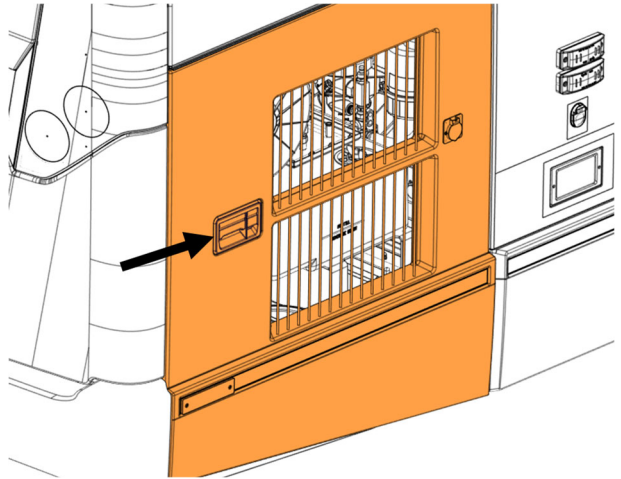

2. Turn off the switch of the main electrical.

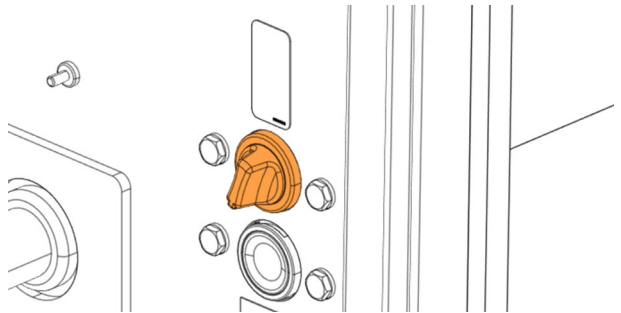

3. Open rear service compartment door on curbside.

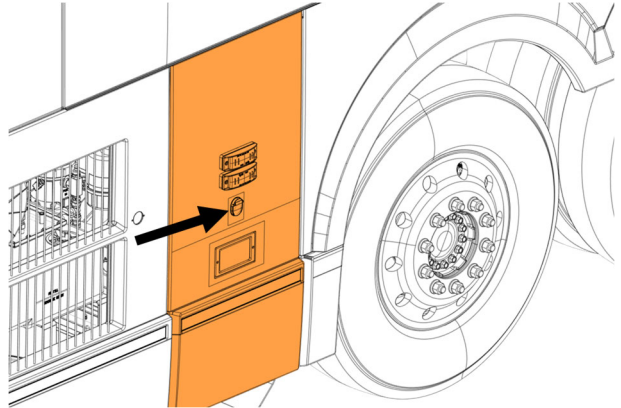

4. Remove battery cover.

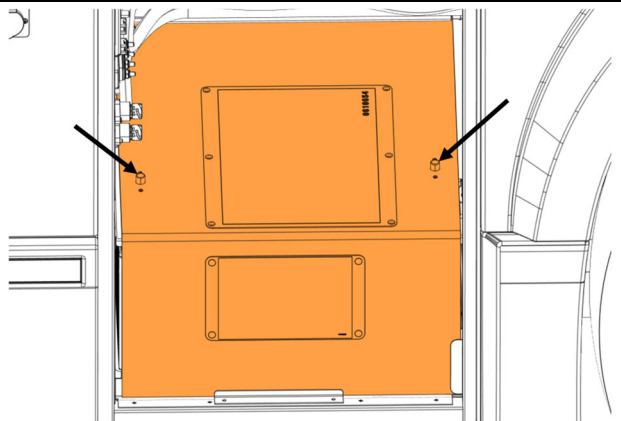

5. Disconnect battery ground.

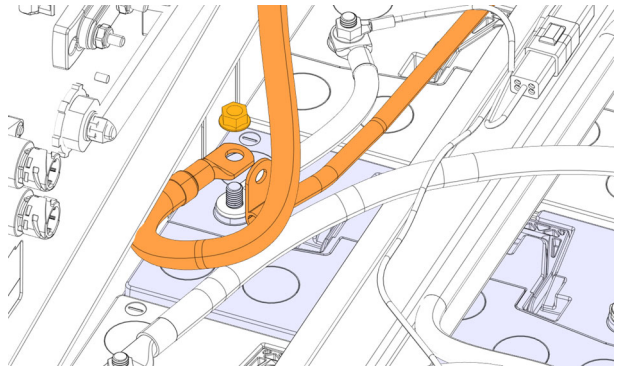

6. Locate the CB5 breaker to replace.

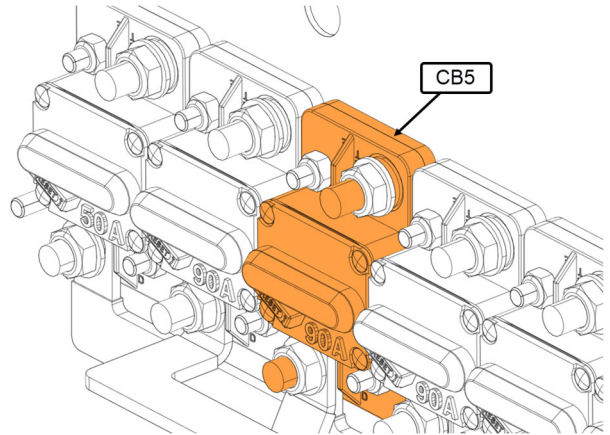

7. Open the fuse holder **F101**.

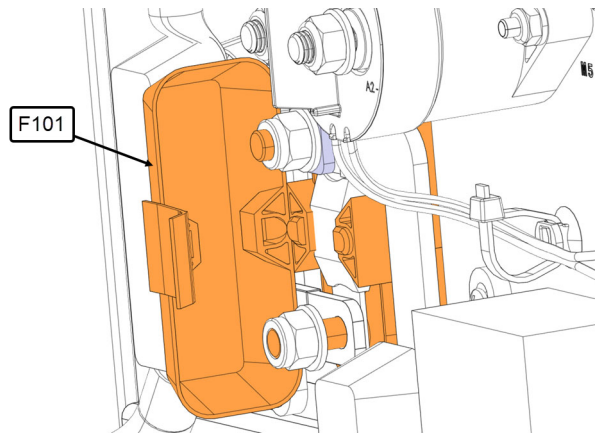

8. Remove the nuts (2x) and the washers (2x).  
9. Discard the nuts (2x) and keep the washers (2x) for reuse.

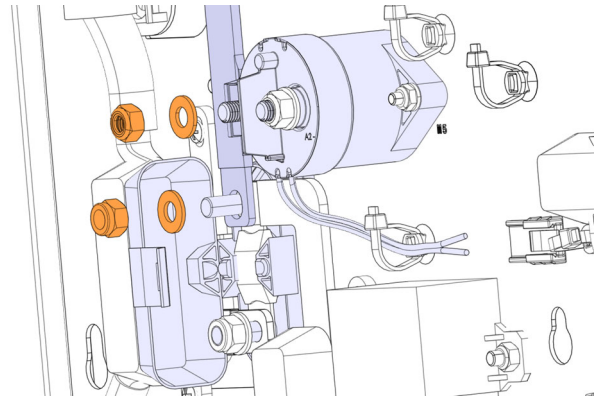

10. Remove the nuts (2x) and the washers (2x) and bus bar.
11. Discard the nuts (2x) and keep the washers (2x) and bus bar for reuse.

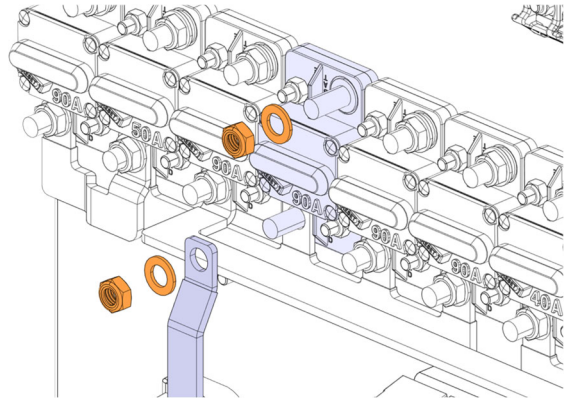

12. Remove the nuts (2x) and the washers (2x) and bus bar.
13. Discard the nuts (2x) and keep the washers (2x) and bus bar for reuse.

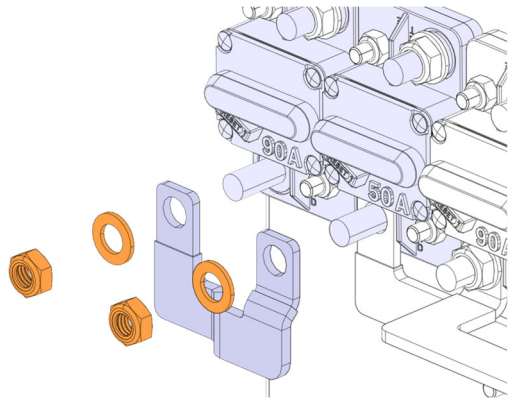

14. Remove the nuts (2x) and the washers (2x) and bus bar.
15. Discard the nuts (2x) and keep the washers (2x) and bus bar for reuse.

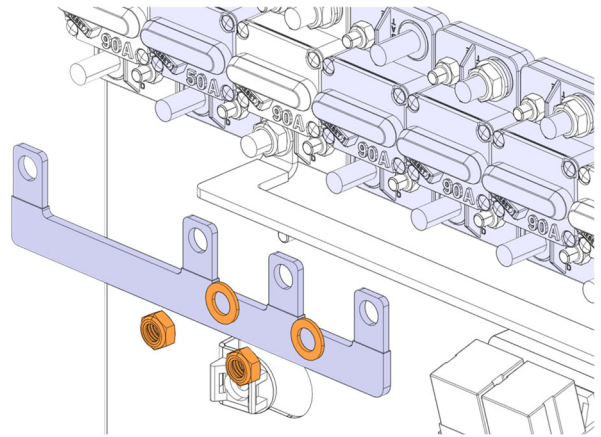

16. Remove the nuts (2x) and the breaker **CB5**.
17. Discard the nuts (2x) and the breaker **CB5**.

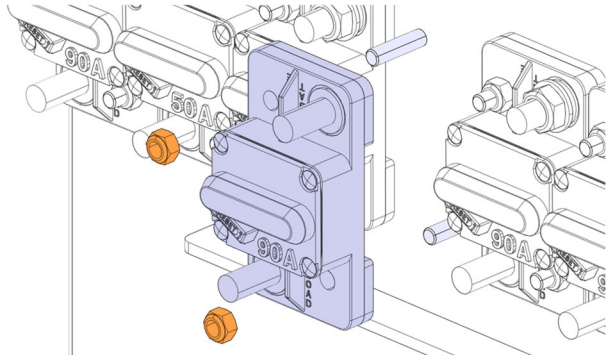

18. Install the new breaker CB5 564902 with the new nuts 502681 (2x).

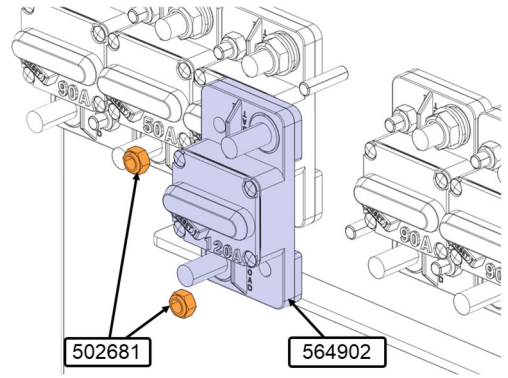

19. Tighten the nuts to **7 lb-ft** torque.

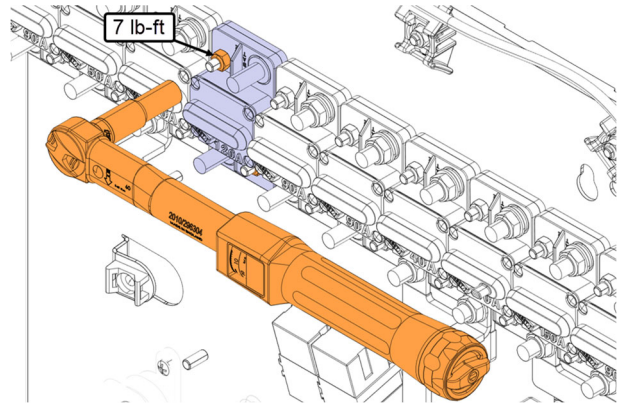

20. Reinstall the bus bar with the new nuts 5000025 (2x) and the washers (2x).

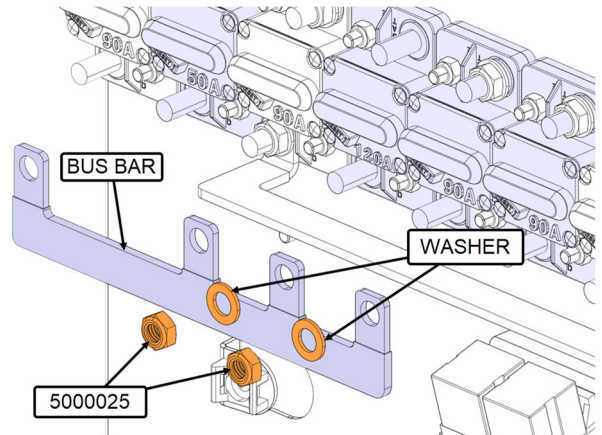

21. Tighten the nuts to **140 lb-in** torque.  
 22. Apply torque seal 685353 on the nut.

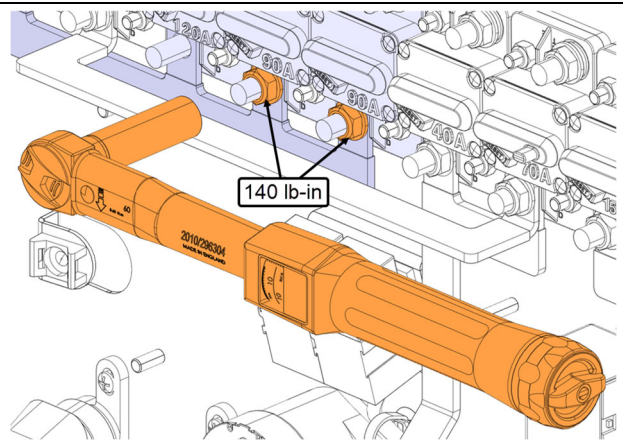



23. Reinstall the bus bar with the new nuts 5000025 (2x) and the washers (2x).

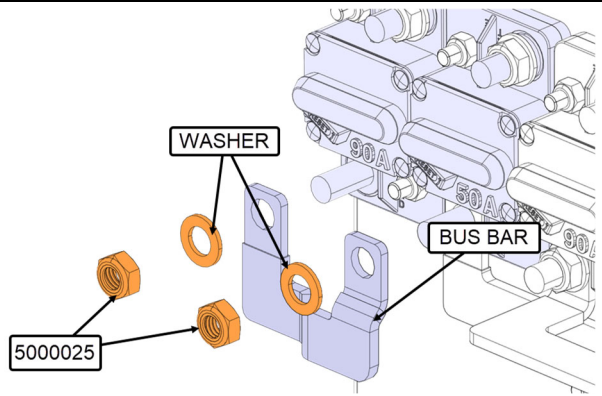

24. Tighten the nuts to **140 lb-in** torque.  
25. Apply torque seal 685353 on the nut.

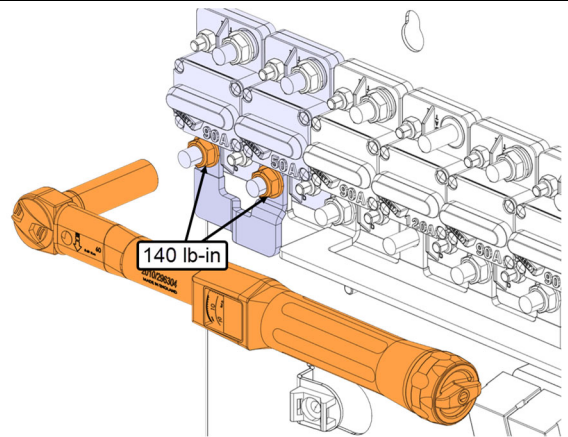

26. Reinstall the bus bar with the new nuts 5000025 (2x) and the washers (2x).

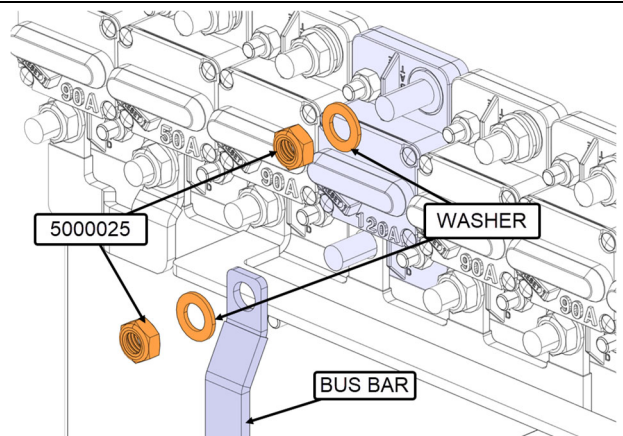

27. Tighten the nuts to **140 lb-in** torque.  
28. Apply torque seal 685353 on the nut.

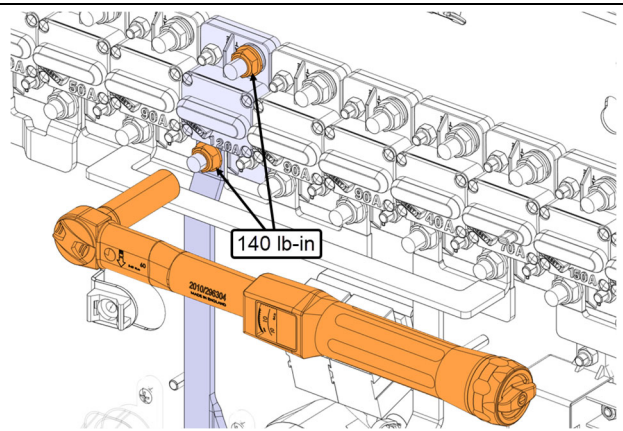

29. Secure the bus bar on the batteries relay with the new nut 5001789 (1x) and the washer (1x).

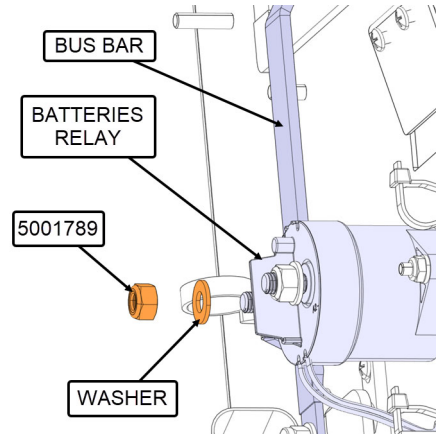

30. Tighten the nut to **100 lb-in** torque.  
31. Apply torque seal 685353 on the nut.

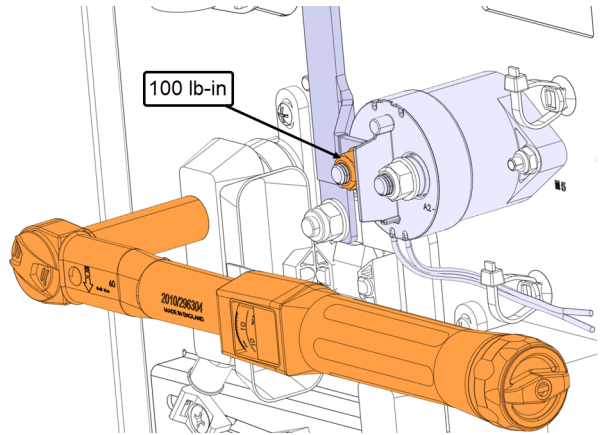

32. Secure the bus bar on the fuse holder **F101** with the new nut 5001787 (1x) and the washer (1x).

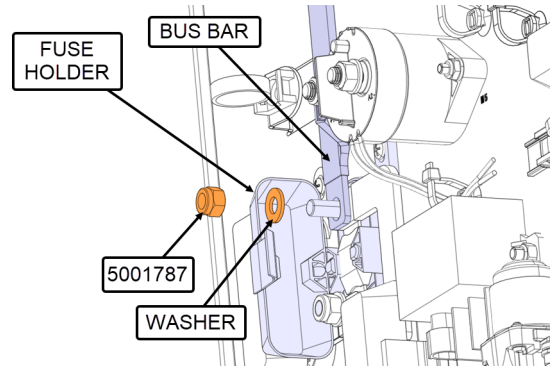

33. Tighten the nut to **125 lb-in** torque.  
34. Apply torque seal 685353 on the nut.

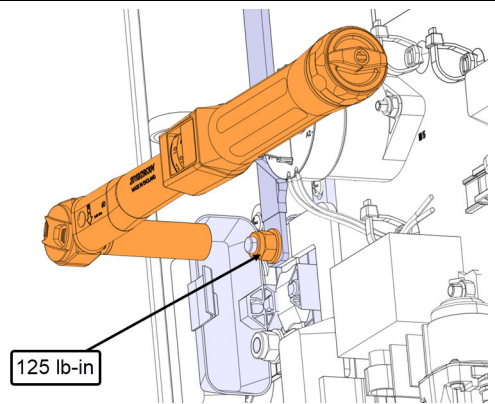

35. Close the fuse holder **F101**.

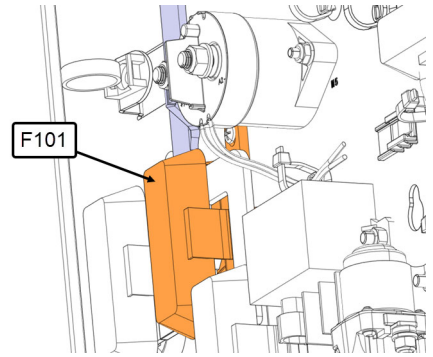

36. Locate the DVEC module.

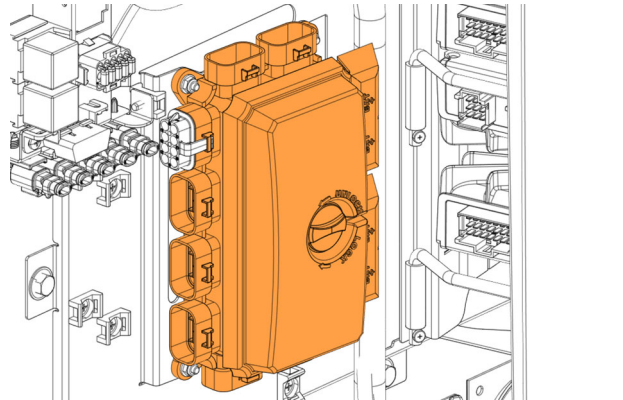

37. Remove the cover of the DVEC module.

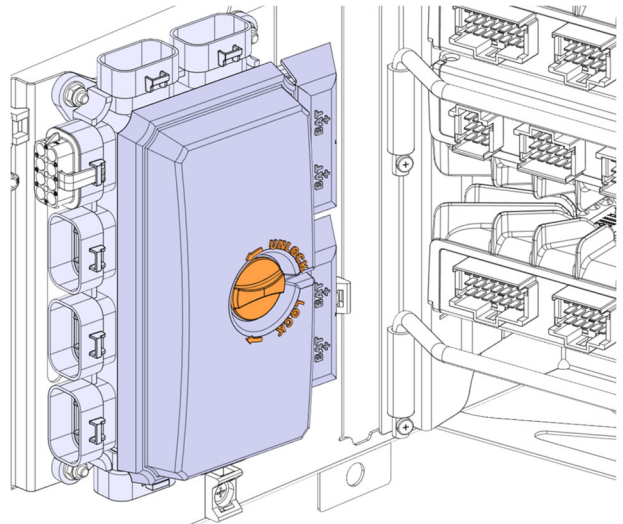

38. Replace the fuse **F130** with the new 563153.

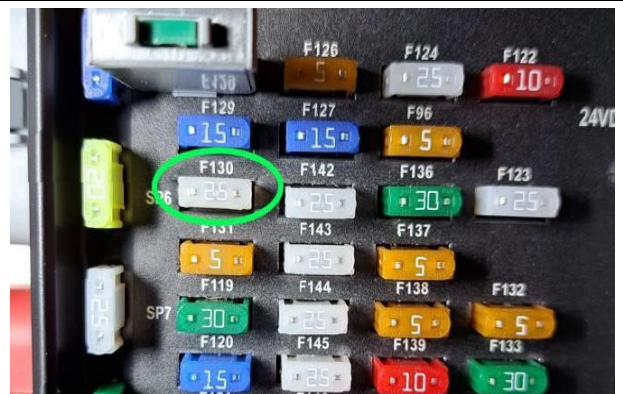

39. Reinstall the cover of the DVEC.

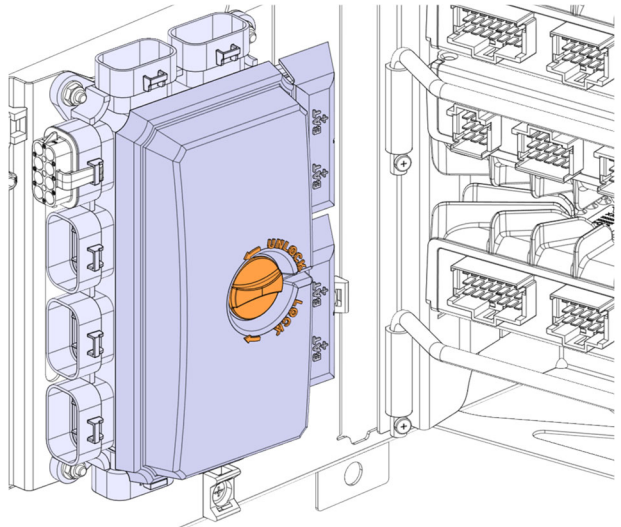

40. Disconnect the connectors **VECR1** (gray) and **VECR2** (red).

41. Remove the secondary lock of both connectors.

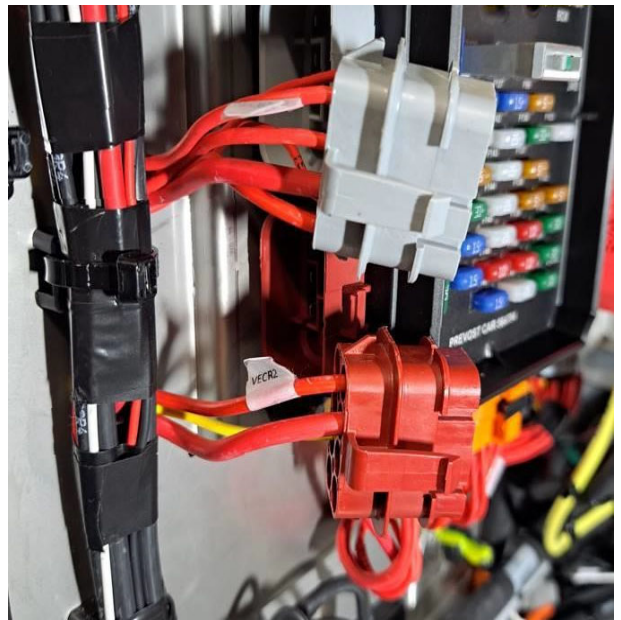

42. Extract the terminal from the position **C** of the connector **VECR2** (red).

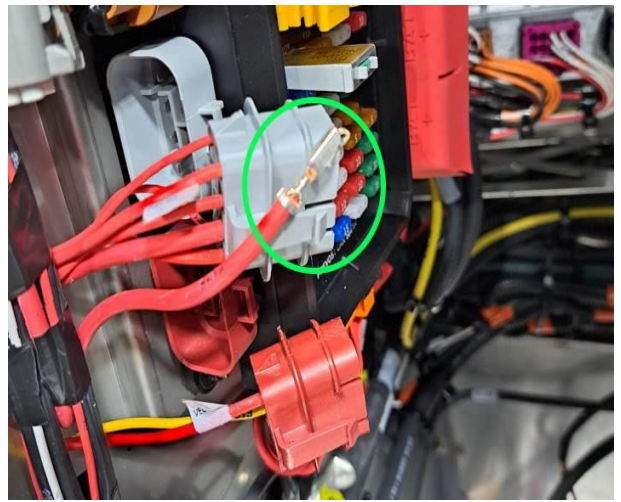

43. Insert the terminal at position **G** of the connector **VECR1** (gray)

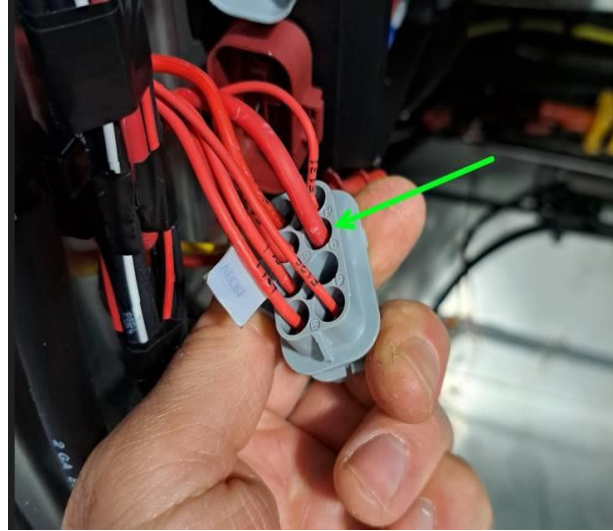

44. Reinstall the secondary lock of both connectors.

45. Identify the wire of terminal **F130**.

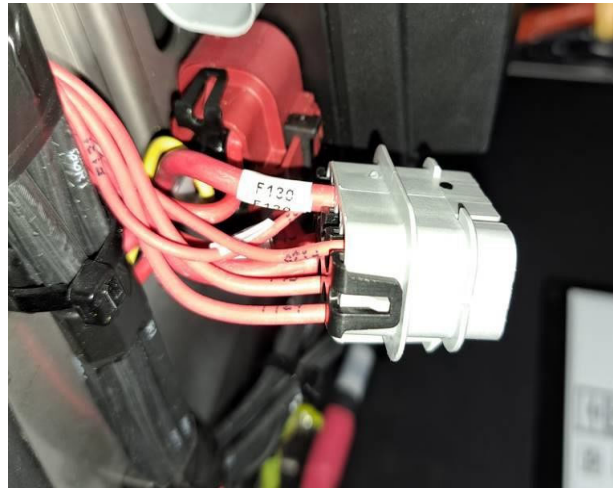

46. Reconnect the connectors **VECR1** (gray) and **VECR2** (red).



47. Reconnect battery ground.

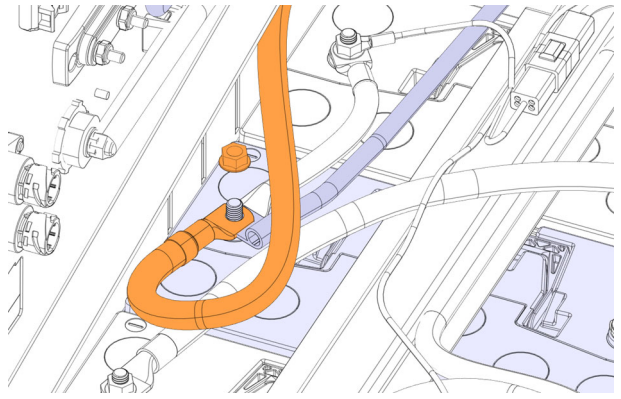

48. Tighten the nut to **170 lb-in** torque.

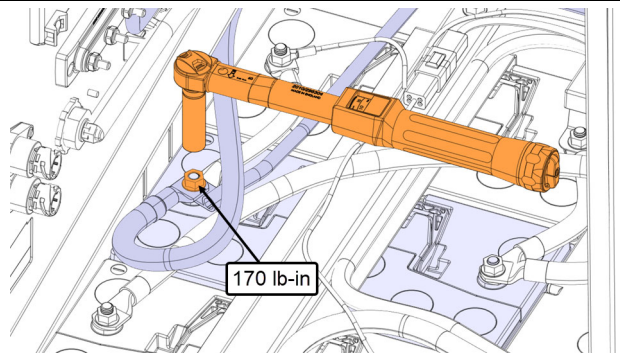

49. Remove the decal of the rear junction box components.

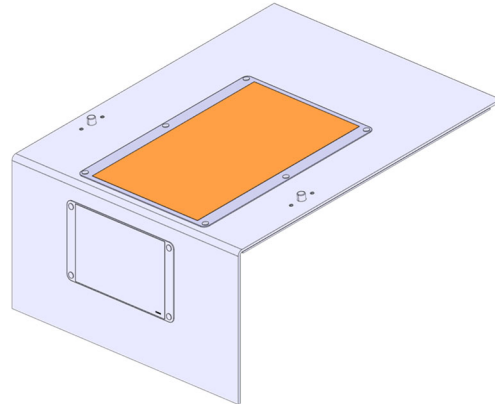

50. Install the new decal of the rear junction box components 0610654.

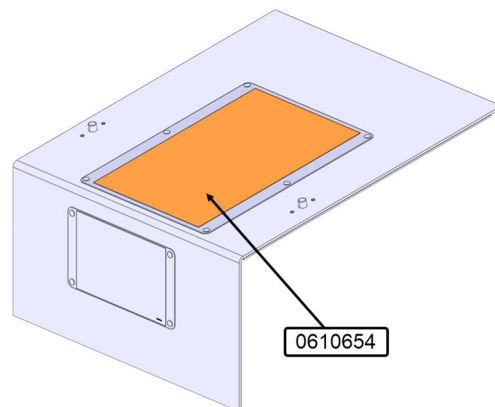

51. Reinstall battery cover.

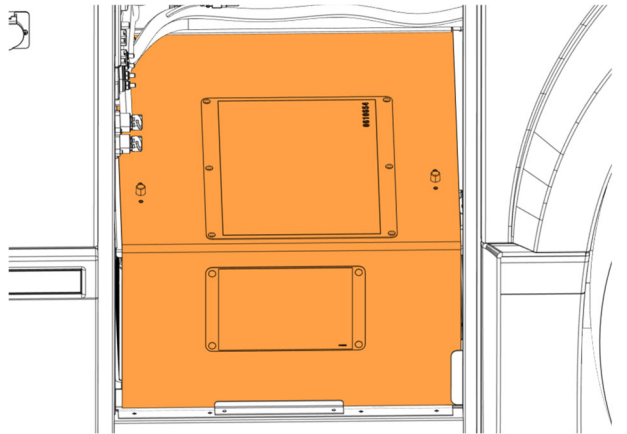

52. Close rear service compartment door.

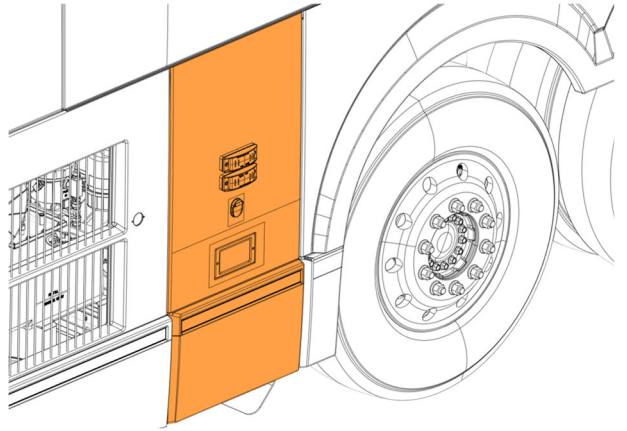

53. Turn on the switch of the main electrical.

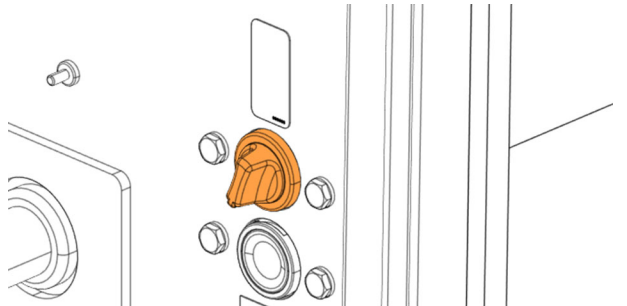

54. Close compressor compartment door.

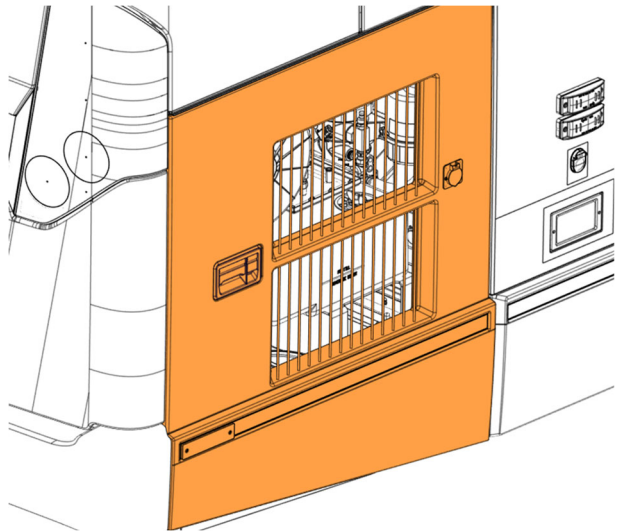

## PARTS / WASTE DISPOSAL

DO NOT RETURN THE REPLACED PARTS. Discard waste according to applicable environmental regulations (Municipal/State[Prov.]/ Federal)

## WARRANTY

This modification is covered by Prevo's normal warranty. We will reimburse you the parts and one hour (1.0) of labor upon receipt of a warranty claim. Please submit claim via our Online Warranty System, available at [www.prevo.com](http://www.prevo.com) (under Service \ Warranty section).

- Use Claim Type: "Bulletin/Recall" and select "Warranty Bulletin WB24-24".

## OTHER

VBC Bulletin	N/A
Fail Code	06.16
Defect Code	09
Syst. Cond	B
Causal Part	564675

Access all our Service Bulletins on  
<http://techpub.prevo.com/en/>  
or scan the QR-Code with your smart phone.



**Are you a Vehicle owner?** E-mail us at  
**[technicalpublications\\_prev@volvo.com](mailto:technicalpublications_prev@volvo.com)** and type "ADD" in the  
subject to receive warranty bulletins applicable to your vehicle(s)  
by e-mail.