

PREVOST

Instruction Sheet

IS-23053A

REPLACEMENT HEATER EBERSPACHER MODEL L-II BY MODEL L-III







Revision: A



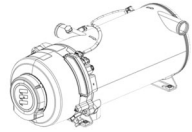

ADD MODEL X3-45

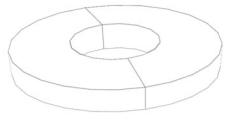
01-30-2025



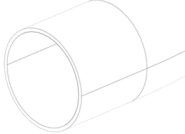

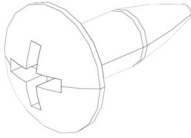



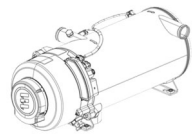

MATERIAL

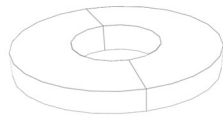

Kit #370597 includes the following parts: With H3-45 from K-0655 up to P-1452

Part No	Description		Qty
870289	WATER HEATER HYDRONIC L3 24KW		1
870252	TIMER EASYSTART		1
870253	COVER, EASYSTART TIMER		1
0610673	HARNESS CAN L3 FRONT/REAR		1
0610675	HARNESS TIMER EBERSPACHER		1
0600563	HARNESS EBERSPACHER HL3 ADAPTOR		1
504637	CABLE TIE, NYLON BLACK (STD)		20
5001848	WASHER BELL SS .331X.827X.098 (M8,5/16)		5
5001983	NUT HEX NYRT SS NSS M8X1.25		4
870295	AIR INTAKE		1

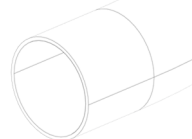



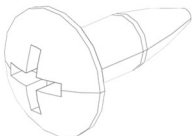

400632	FLANGE H3 ONLY		1
503031	PLAS TUBE 2 1/2"		100 inches
504024	CLAMP HOSE SS/CS 46-70		2
500124	SCREW TAPPINT TR PH SS #8X1/2		3
504750	CABLE TIE W/FIR TREE MOUNT		4
IS-23053	INSTRUCTION SHEET		1
FI-23053	FEUILLE D'INSTRUCTION		1



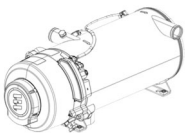

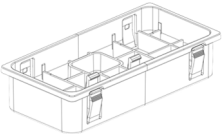
Kit #370697 includes the following parts: **Only with H3-45 from R-1453**

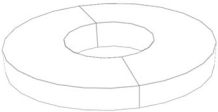
Part No	Description		Qty
870289	WATER HEATER HYDRONIC L3 24KW		1
870252	TIMER EASYSTART		1
870253	COVER, EASYSTART TIMER		1
0600216	AFSS/PREHEAT EBERSPACHER HARNESS		1
0610673	HARNESS CAN L3 FRONT/REAR		1
0600563	HARNESS EBERSPACHER HL3 ADAPTOR		1
504637	CABLE TIE, NYLON BLACK (STD)		20
5001848	WASHER BELL SS .331X.827X.098 (M8,5/16)		5
5001983	NUT HEX NYRT SS NSS M8X1.25		4
870295	AIR INTAKE		1
400632	FLANGE		1
503031	PLAS TUBE 2 1/2"		100 inches
504024	CLAMP HOSE SS/CS 46-70		2

500124	SCREW TAPPINT TR PH SS #8X1/2		3
504750	CABLE TIE W/FIR TREE MOUNT		4
IS-23053	INSTRUCTION SHEET		1
FI-23053	FEUILLE D'INSTRUCTION		1

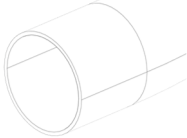
Kit #370939 includes the following parts: **With X3-45 from K-6453 and from K-7621**

Part No	Description		Qty
870289	WATER HEATER HYDRONIC L3 24KW		1
870252	TIMER EASYSTART		1
870253	COVER, EASYSTART TIMER		1
0610673	HARNESS CAN L3 FRONT/REAR		1
0610675	HARNESS TIMER EBERSPACHER		1
0600563	HARNESS EBERSPACHER HL3 ADAPTOR		1
504637	CABLE TIE, NYLON BLACK (STD)		20
5001848	WASHER BELL SS .331X.827X.098 (M8,5/16)		5
5001983	NUT HEX NYRT SS NSS M8X1.25		4
870295	AIR INTAKE		1

503031	PLAS TUBE 2 1/2"		108 inches
504024	CLAMP HOSE SS/CS 46-70		1
504751	DUAL SWIVEL SADDLE SPACER		3
504016	CABLE TIE, NYLON BLACK (LARGE)		6
IS-23053	INSTRUCTION SHEET		1
FI-23053	FEUILLE D'INSTRUCTION		1

<i>NOTE</i>
<i>Material can be obtained through regular channels.</i>

SAFETY PRECAUTIONS

- Eye protection should always be worn when working in a shop.
- Rules for Personal Protection Equipment should always be respected. Wear your PPE including but not limited to the following:



Safety First!



PROCEDURE



DANGER

Park vehicle safely, apply parking brake, stop the engine. Prior to working on the vehicle, set the ignition switch to the OFF position and trip the main circuit breakers equipped with a trip button. On Commuter type vehicles, set the battery master switch (master cut-out) to the OFF position.

Lock out & Tag out (LOTO) must be performed during set-up, maintenance or repair activities. Refer to your local procedure for detailed information regarding the control of hazardous energy.

HEATER REPLACEMENT H3-45 FROM K-0655 UP TO P-1452

1. Open the compressor door.

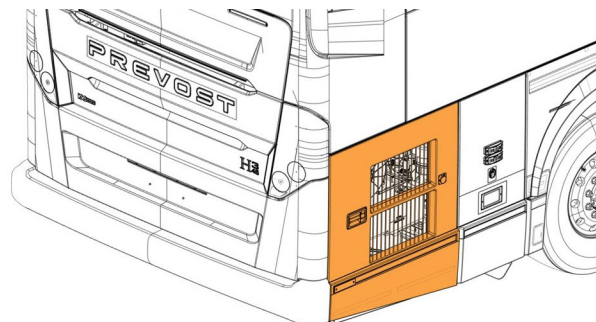

2. Lift the release lever to unlatch the engine compartment door.

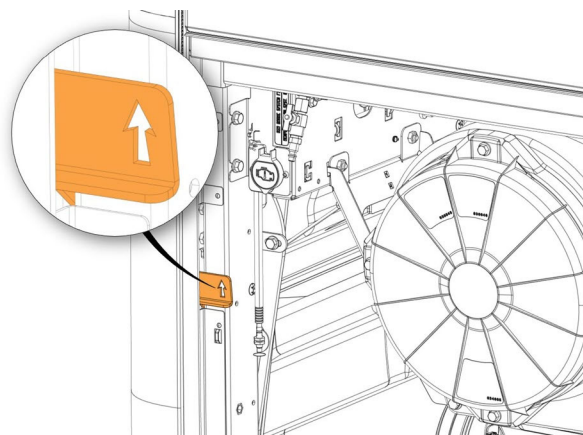

3. Pull the engine compartment door out and up to open.

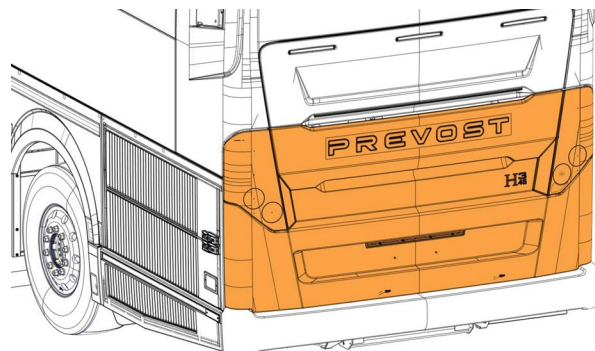

4. Press the release lever and push the DPF access hatch up until it locks in place.

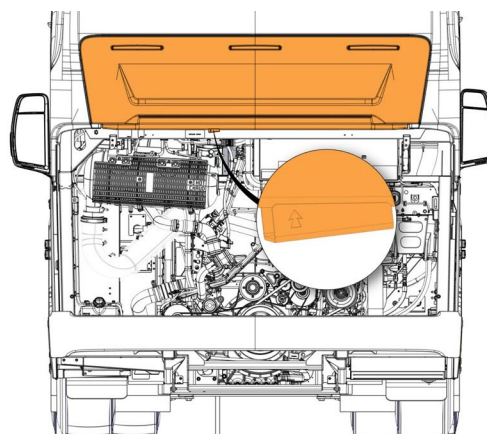

5. Open the pressure relief valve.
6. Remove the pressure cap.



CAUTION

Allow engine coolant to cool down before proceeding with the following steps.

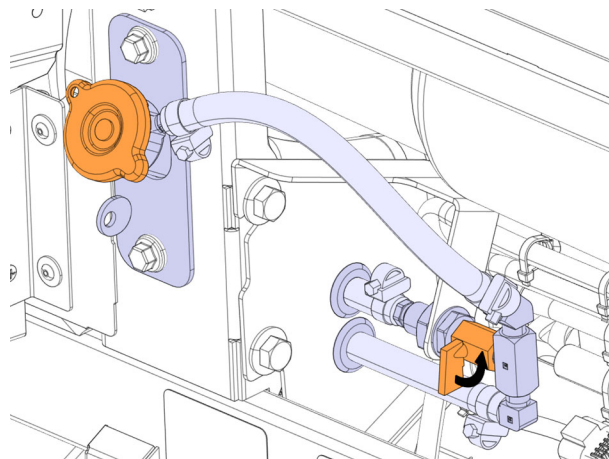

7. Locate the drain cock at the radiator water pipe.

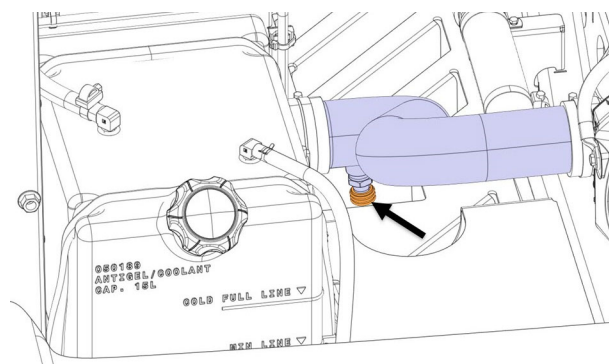

8. Remove the protection cap and connect the coolant extractor to the radiator drain cock.
9. Drain all the coolant.

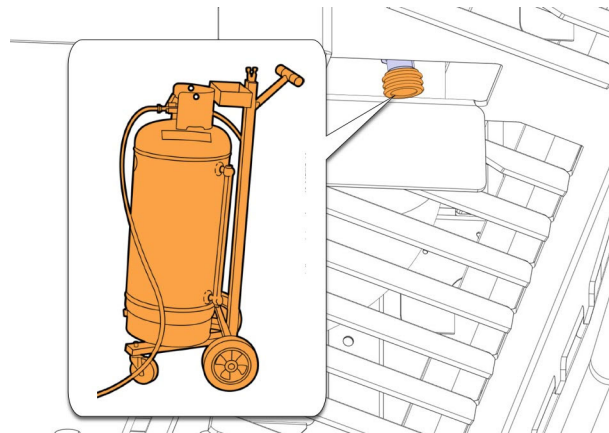

10. Unscrew the bottom of the heater exhaust keep the screw (1x) and discard the washer (1x).

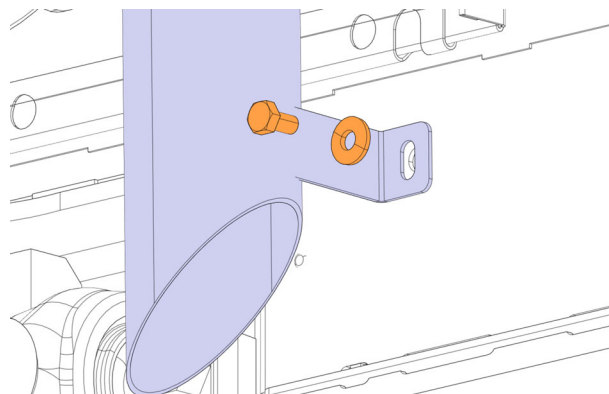

11. Unscrew the U-bolt clamp and remove the exhaust.

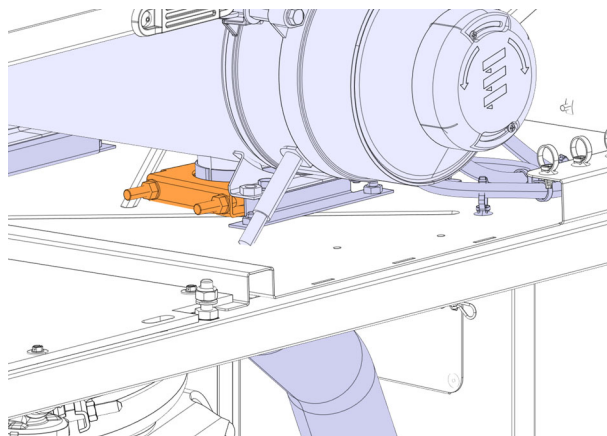

12. Cut the cable ties that secure the heater harness.

13. Disconnect the connectors **CSX1** & **CSX3** from the old heater harness.

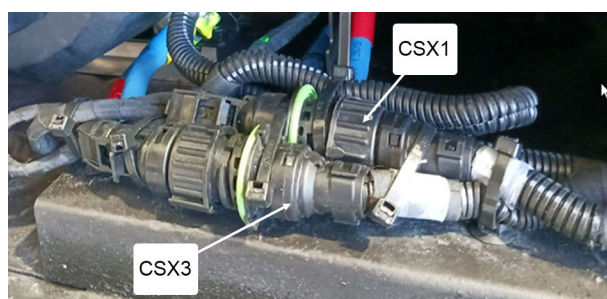

14. Disconnect the fuel hoses and discard the washers (4x) and the banjo bolt (2x).

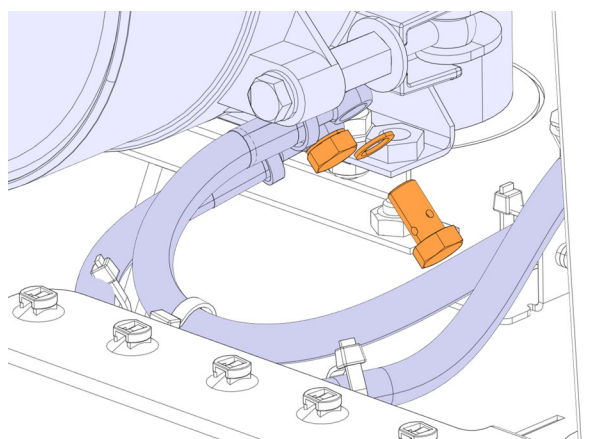

15. Unscrew the clamp and disconnect the inlet hose.

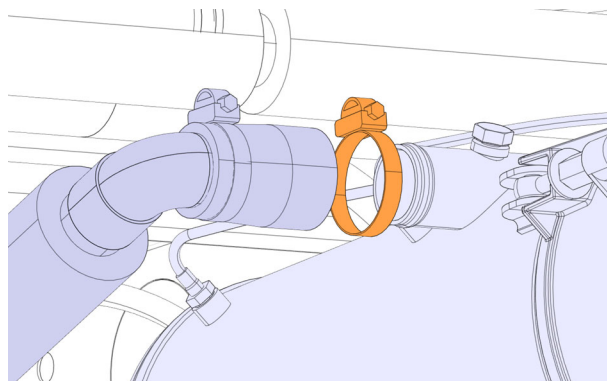

16. Unscrew the clamp and disconnect the outlet hose.

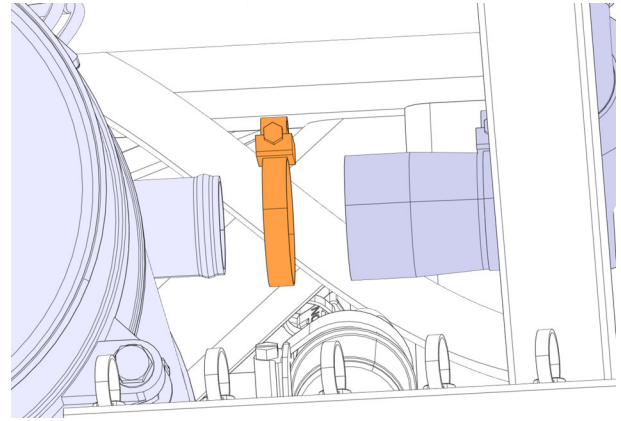

17. Unscrew the heater assembly, keep the screw (4x) and discard the washer (4x).

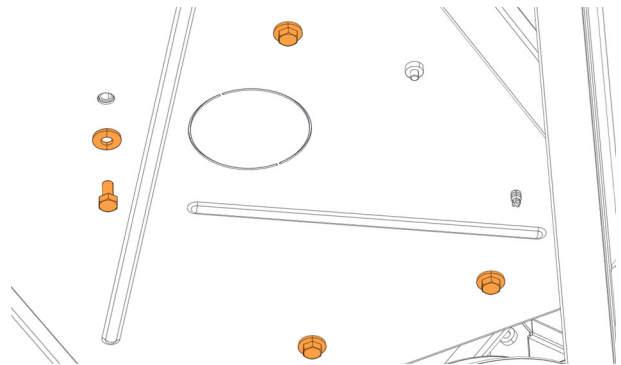

18. Remove the old heater assembly.

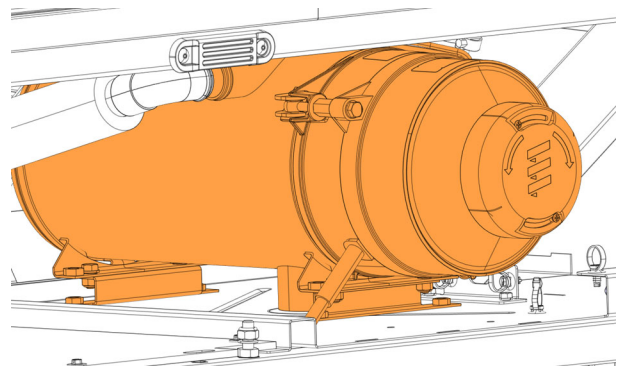

19. Unscrew the supports (2x) from the heater, keep the supports (2x), the screws (4x) and the washers (4x) and discard the nuts (4x).

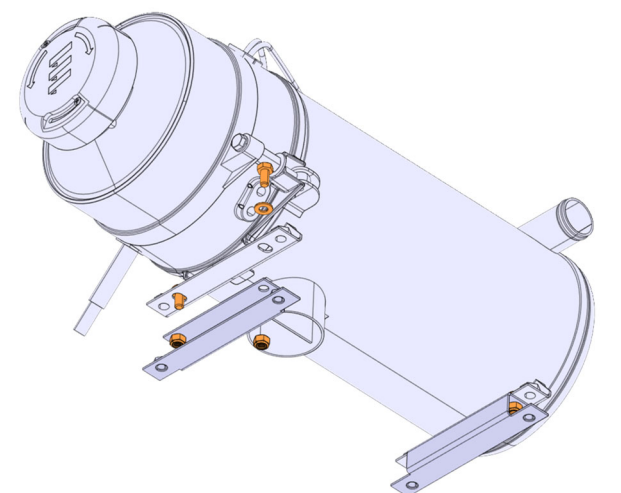

20. Remove the air intake of the new heater 870289.

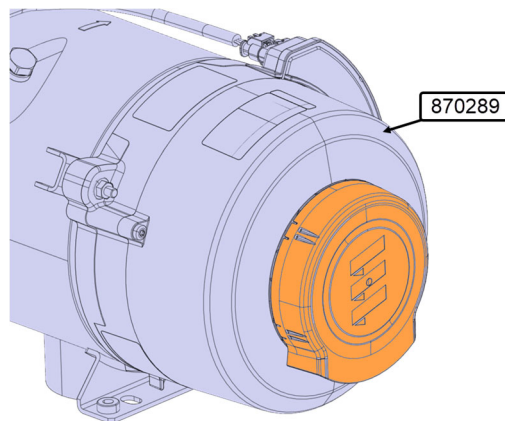

21. Install the new air intake 870295 on the new heater 870289.

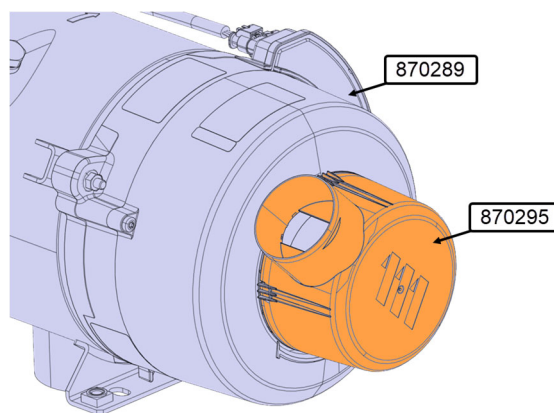

22. Install the supports (2X) on the new heater 870289 with the screws (4x), the washers (4x) and the new nuts 5001983 (4x).

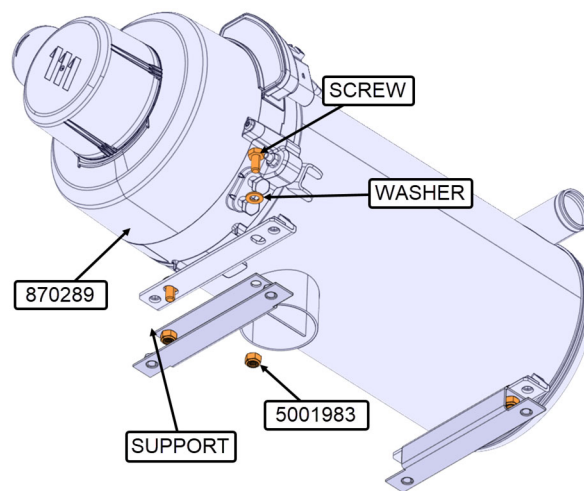

23. Install the new heater assembly.

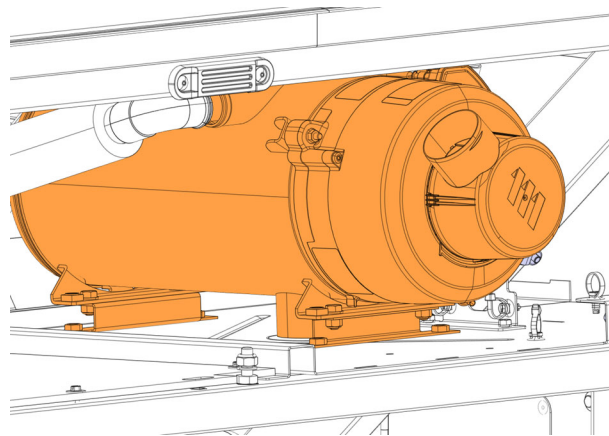

24. Secure the new heater assembly with the screws (4x) and the new washers 5001848 (4x) on the structure.

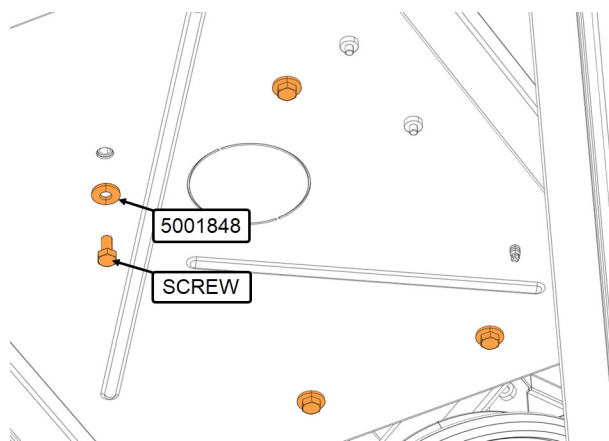

25. Connect the outlet hose with the clamp on the new heater.

26. Apply a torque of 30 lb-in to the clamp.

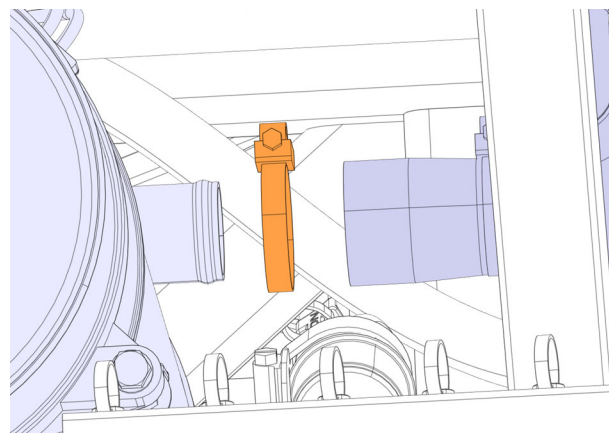

27. Connect the inlet hose with the clamp on the new heater.

28. Apply a torque of 30 lb-in to the clamp.

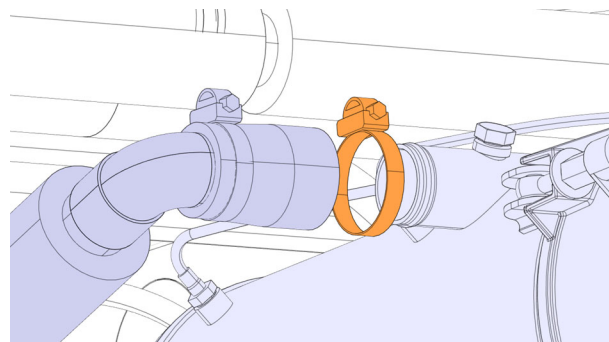

29. Reinstall the exhaust pipe with U-bolt clamp.

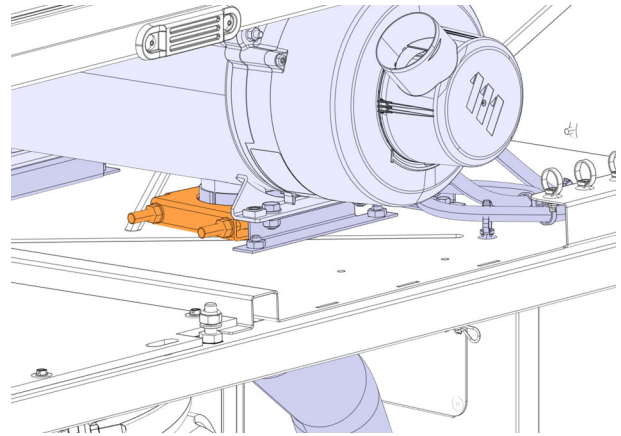

30. Secure the exhaust pipe bottom with the screw and the new washer 5001848.

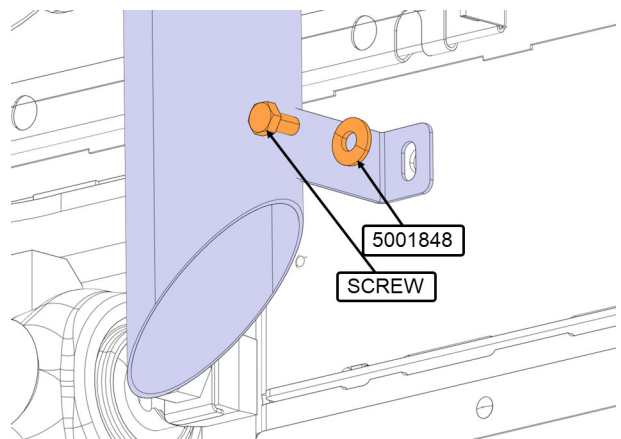

31. Reconnect the fuel hoses with the new washers (4x) and the banjo bolts (2x) (include with the heater).

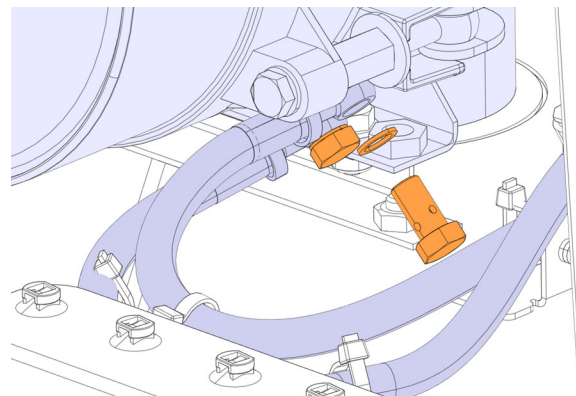

32. Open the last left baggage door.

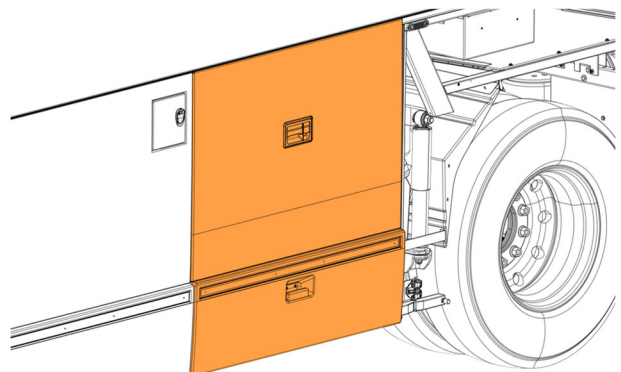

33. Drill a hole to $\text{\O} 3/8''$ in baggage panel.

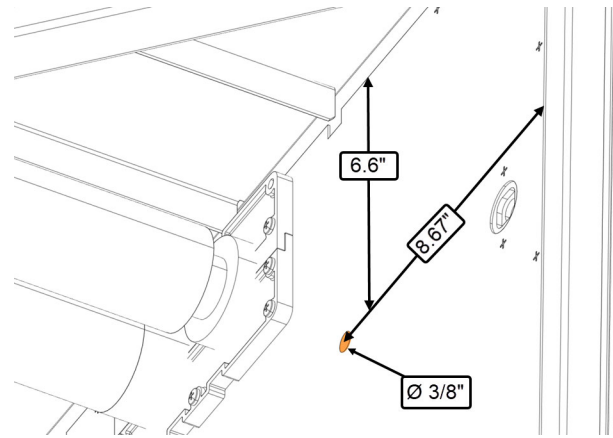

34. Drill a hole to $\text{\O} 2 1/4''$ in baggage panel.

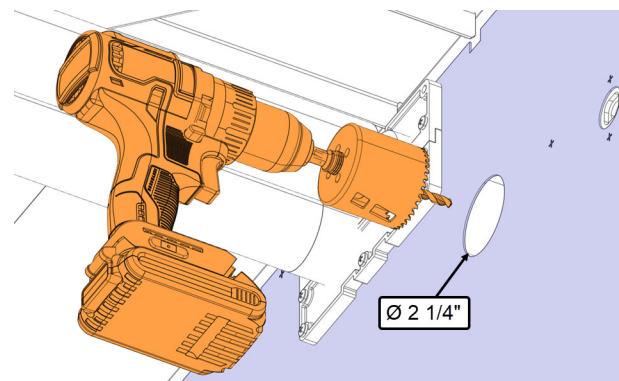

35. Install the flange 400632 with the screws 500124 (3x).

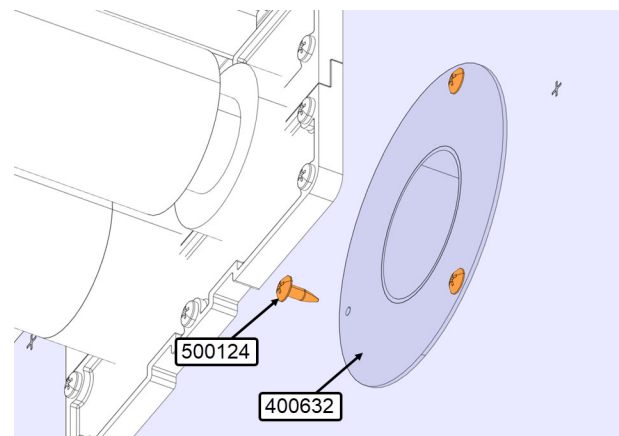

36. Drill four holes $\text{\O} 11/32''$ for the cable tie with fir tree mounts.

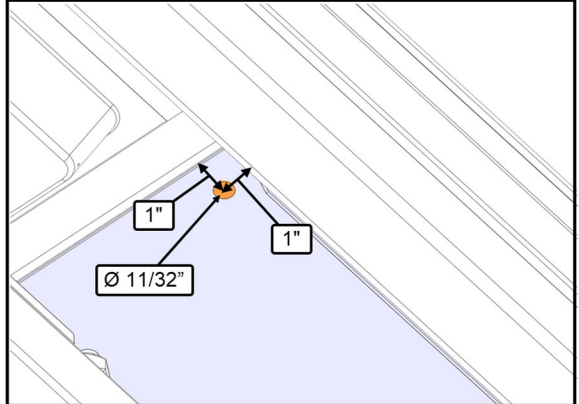
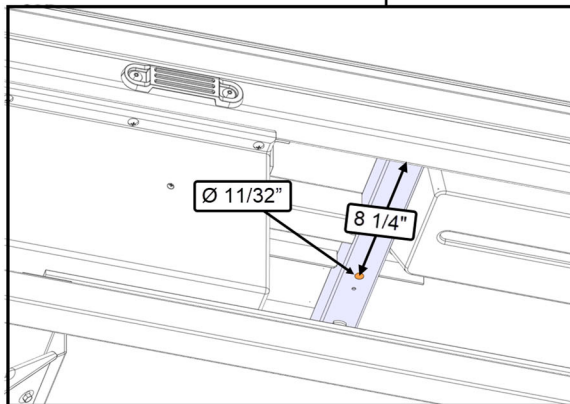
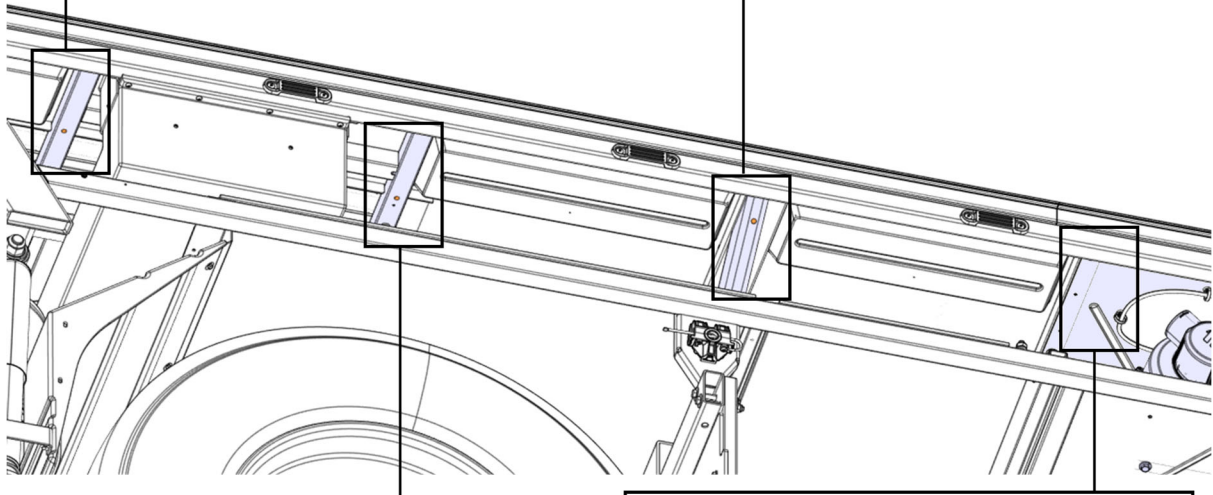
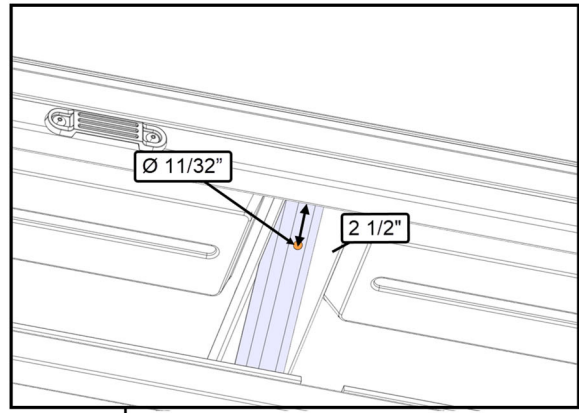

37. Connect the hose 503031 to the air intake 870295 of the heater with the clamp 504024.

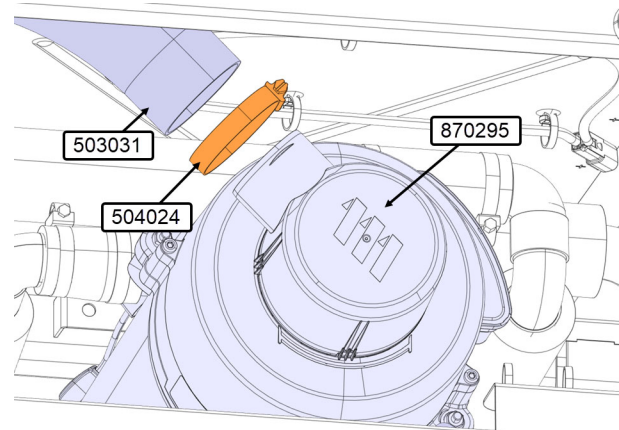

38. Run the hose 503031 above the air duct.

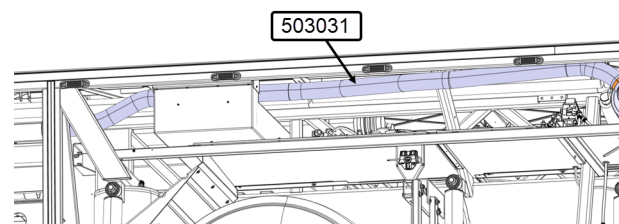

39. Connect the hose 503031 to the flange 400632 with the clamp 504024.

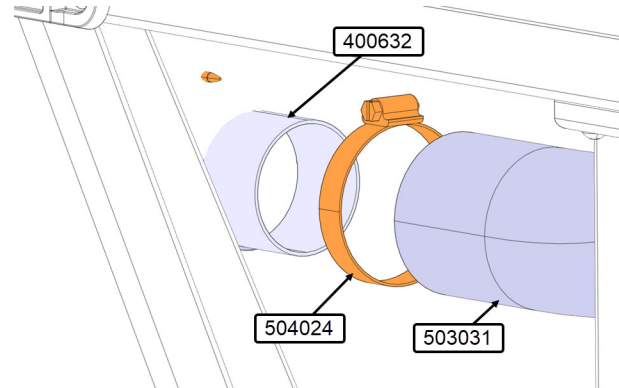

40. Secure the hose 503031 with the cable ties with fir tree mount 504750 (4x).

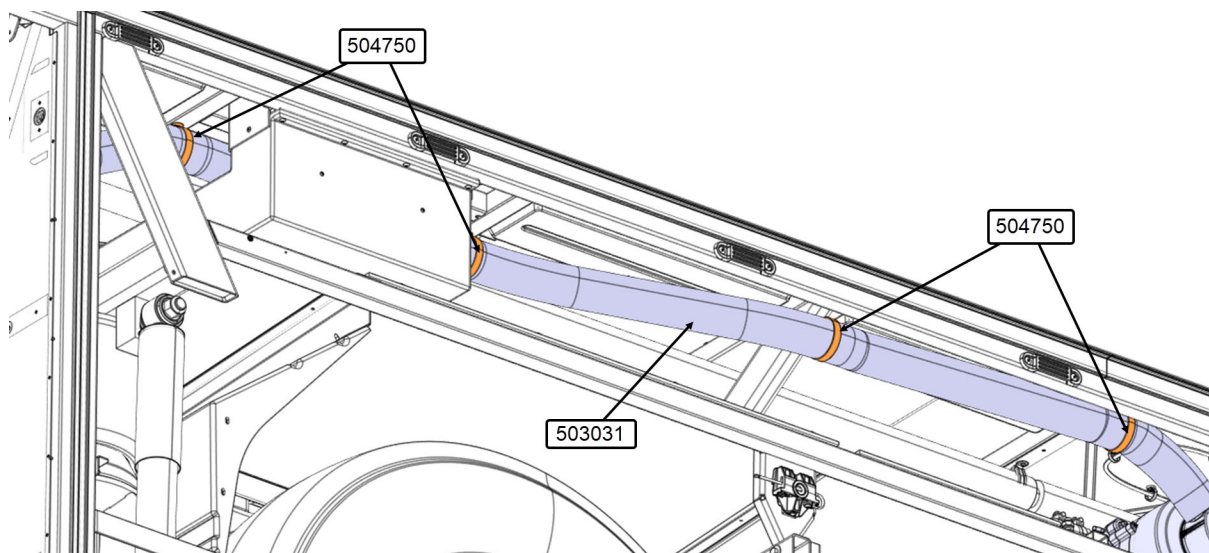

41. Connect harness 0600563 to position **3** & **4**.

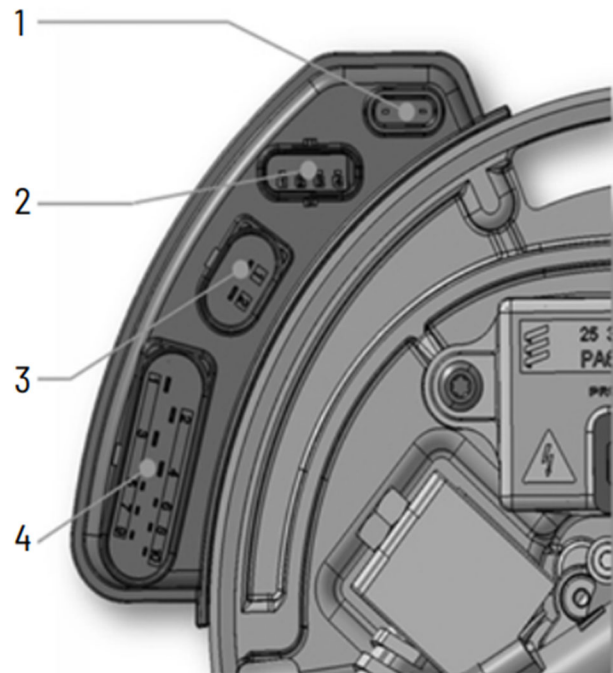

42. Connect the heater harness 0600563 to the connectors **CSX1** & **CSX3**.

43. Secure the harness with cable ties 504637(5X).

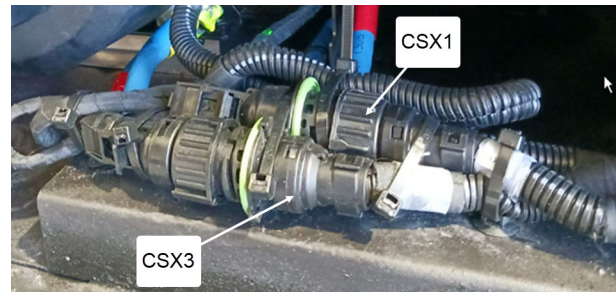

44. Install the heater to timer CAN harness 0610673 following the routing. You must start from the back of the vehicle to the front junction box.
45. Use a fish tool to reach the front of the vehicle using the existent PVC conduits.

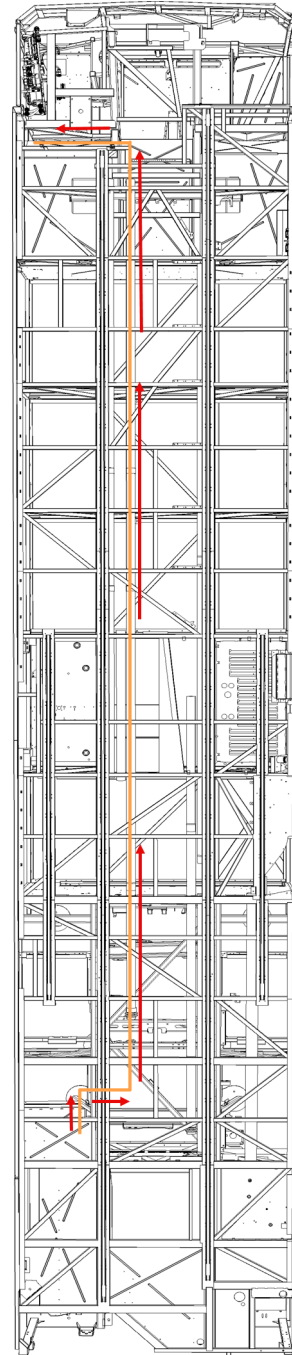

46. Connect the connector **A10.A3** of the heater to timer CAN harness 0610673 to heater position **2**.

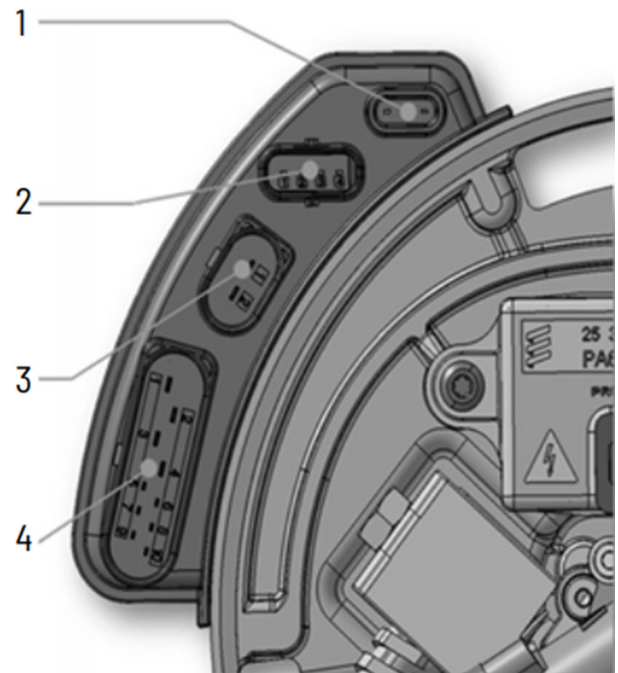

47. Disconnect the old timer connector **C430**.
48. Remove the old heater timer and discard.

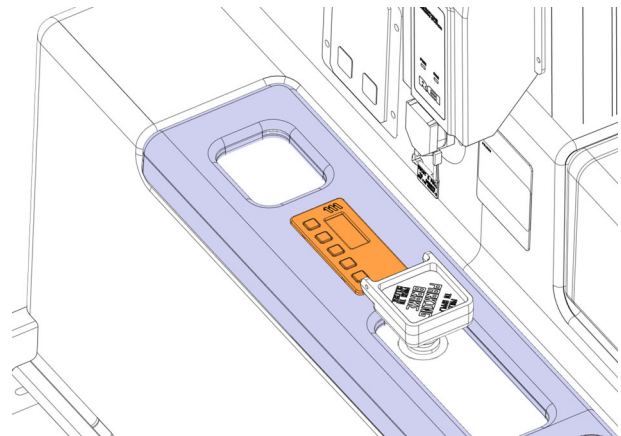

49. Open front service compartment door.
50. Remove the front junction box protector panel.

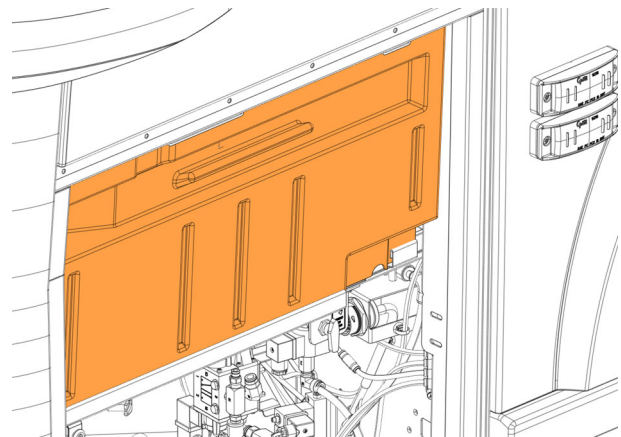

- 51. Remove the top panel.
- 52. Locate connector **C430** on left consol harness.

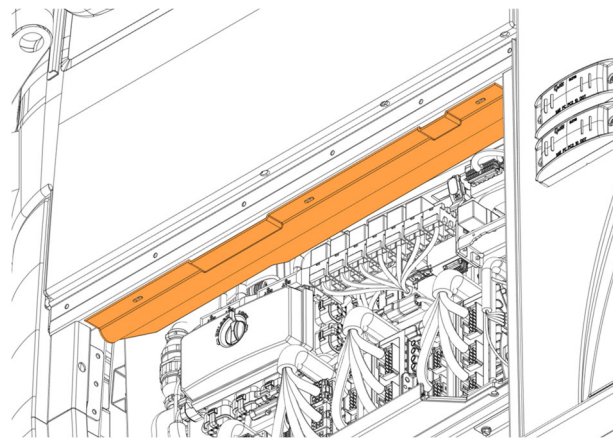

- 53. Connect the new timer harness 0610675 to connector **C430** of the left consol harness.

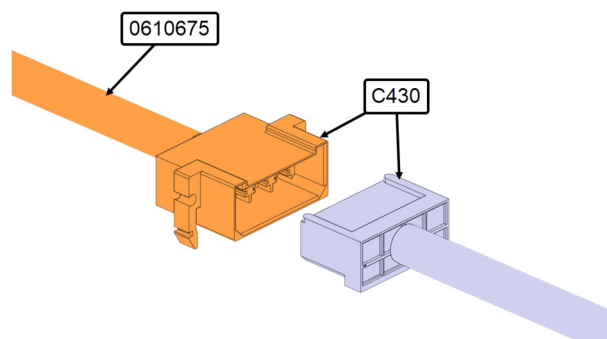

- 54. Connect the connector **C_A11B** of the heater to timer CAN harness 0610673 to connector **A11** of timer harness 0610675.

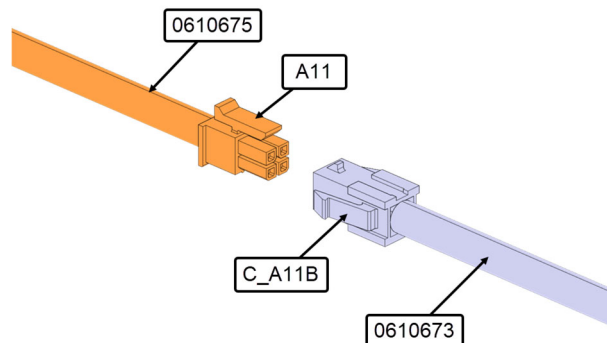

- 55. Install the new cover 870253 on the left consol in the hole for the heater timer.

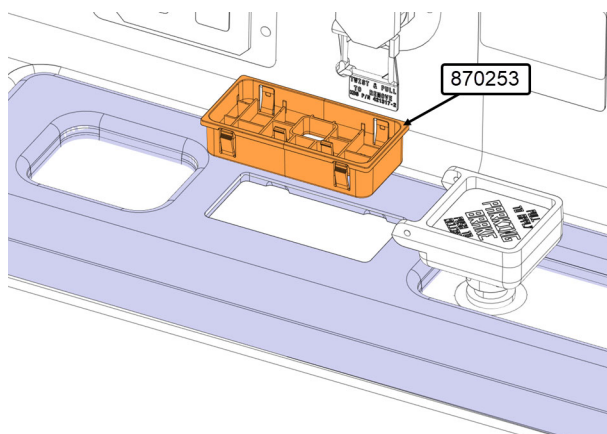

56. Install the new timer 870252 on the cover 870253 on the left consol.

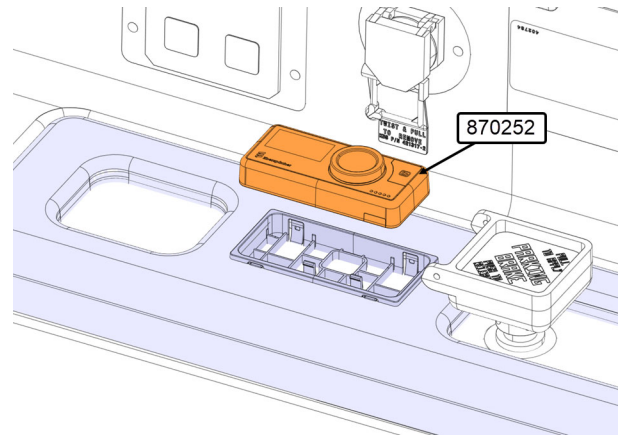

57. Connect the connector **C_A11A** of the heater to timer CAN harness 0610673 to timer 870252.

58. Secure all the harness 0610673 and 0610675 with cable ties 504637 (15x).

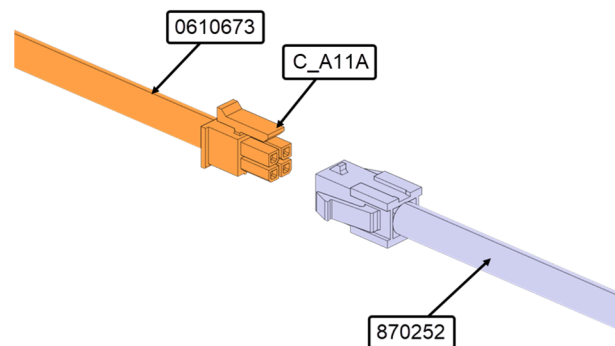

59. Refill the cooling system.

60. Disconnect the coolant extractor and reinstall the protection cap on the radiator drain cock.

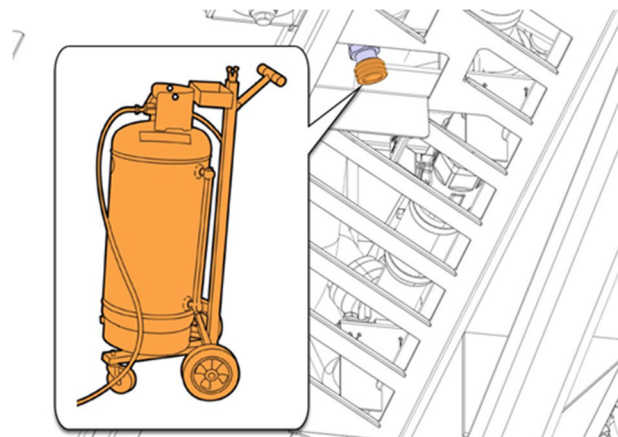

61. Close the surge tank pressure valve.

62. Reinstall the pressure cap.

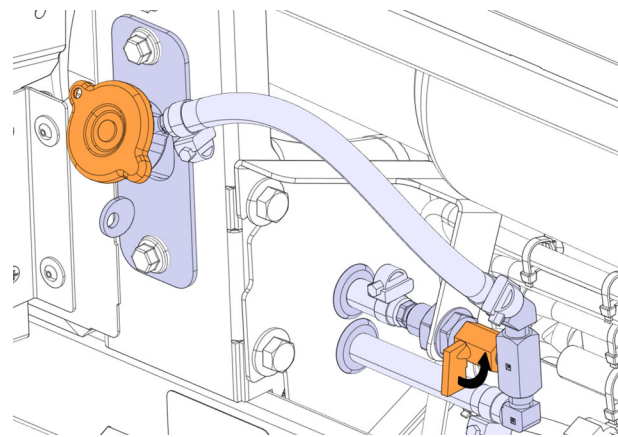

- 63. Start the engine and run at fast idle.
- 64. Check for leaks.
- 65. Stop the engine and allow cooling.

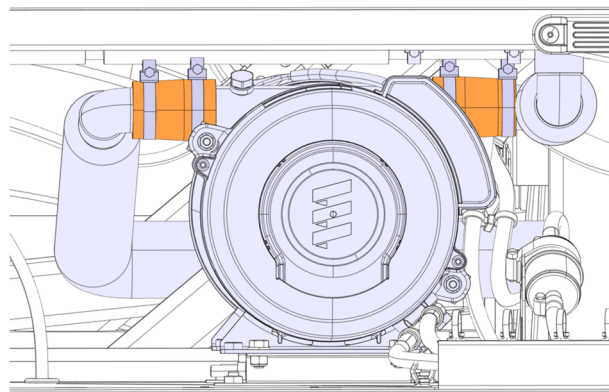

- 66. Check the coolant level through the recovery tank. Coolant level should be above the MIN LINE.
- 67. Remove the recovery tank filler cap to add coolant if required.

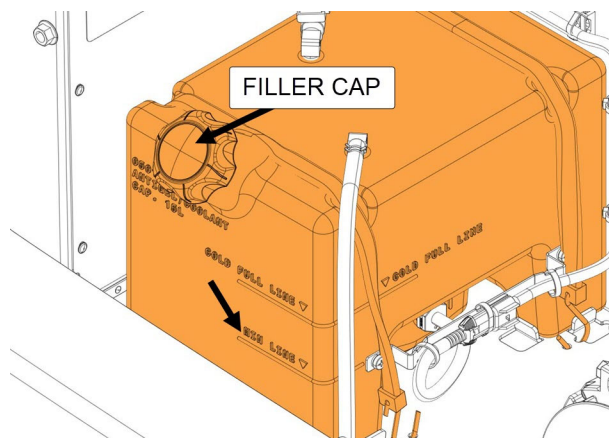

- 68. Close the DPF access hatch.

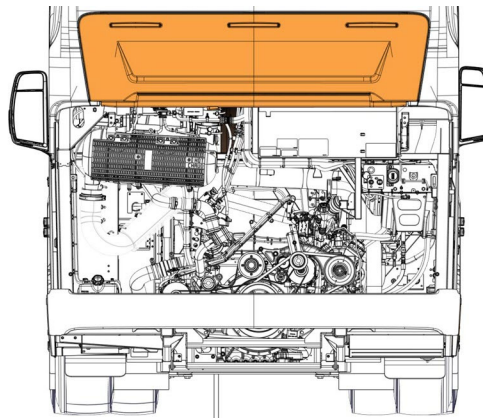

- 69. Close the engine compartment rear door.

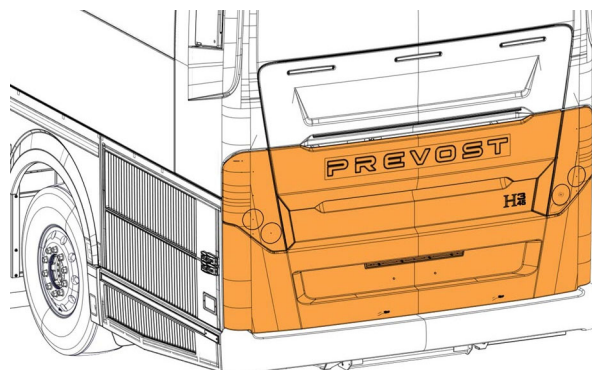

70. Close the compressor door. The procedure is complete, no further actions required.

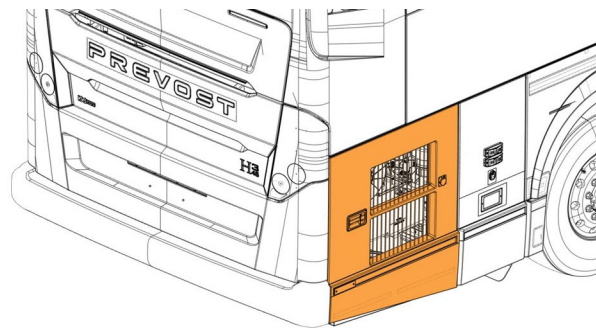

HEATER REPLACEMENT H3-45 FROM R-1453

1. Open the compressor door.

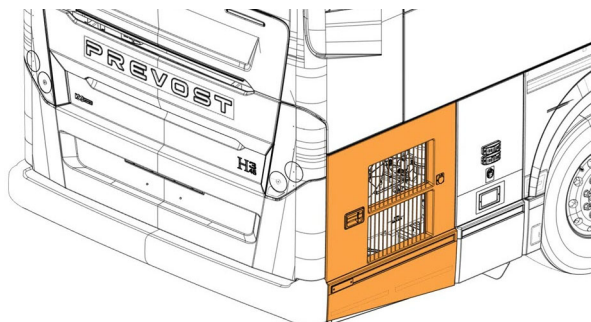

2. Lift the release lever to unlatch the engine compartment door.

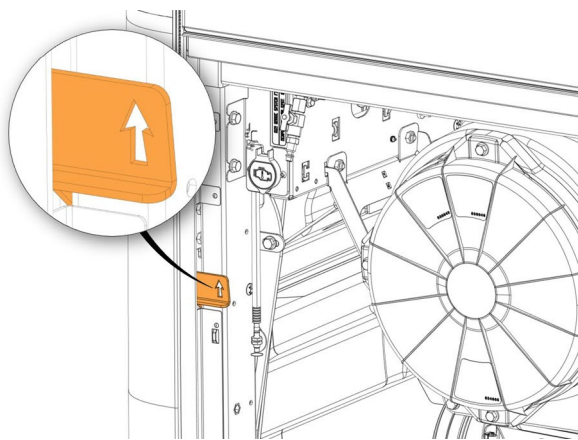

3. Pull the engine compartment door out and up to open.

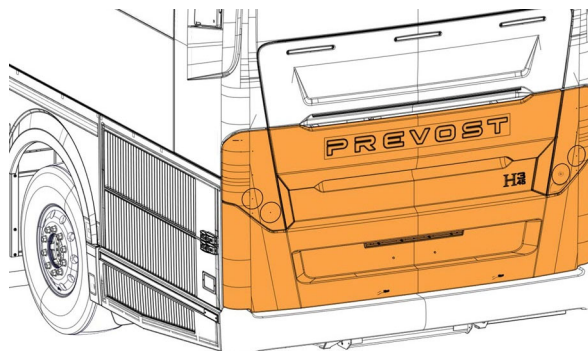

4. Press the release lever and push the DPF access hatch up until it locks in place.

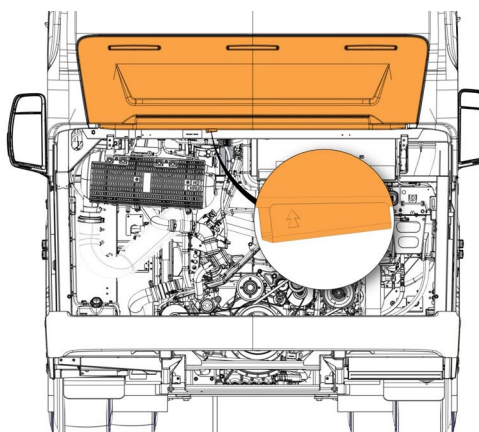

5. Open the pressure relief valve.
6. Remove the pressure cap.



CAUTION

Allow engine coolant to cool down before proceeding with the following steps.

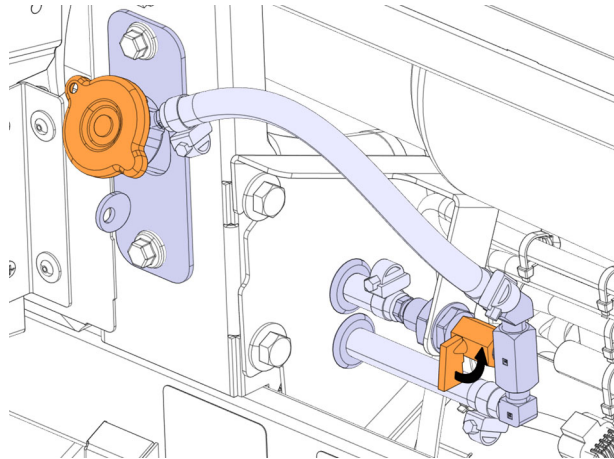

7. Locate the drain cock at the radiator water pipe.

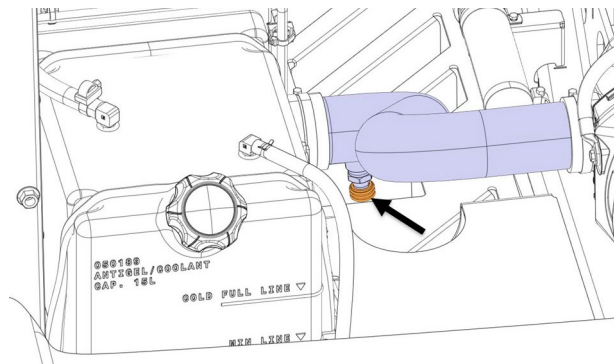

8. Remove the protection cap and connect the coolant extractor to the radiator drain cock.
9. Drain all the coolant.

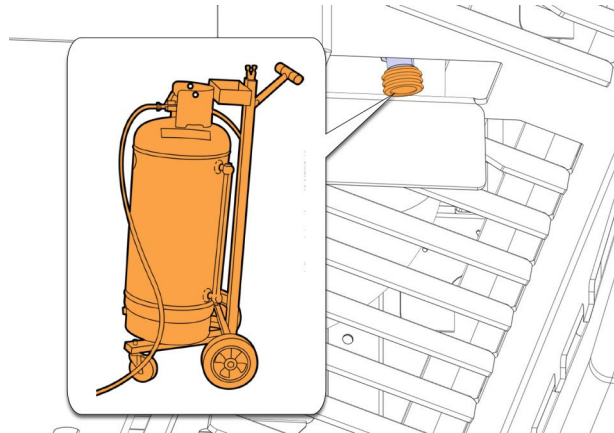

10. Unscrew the bottom of the heater exhaust keep the screw (1x) and discard the washer (1x).

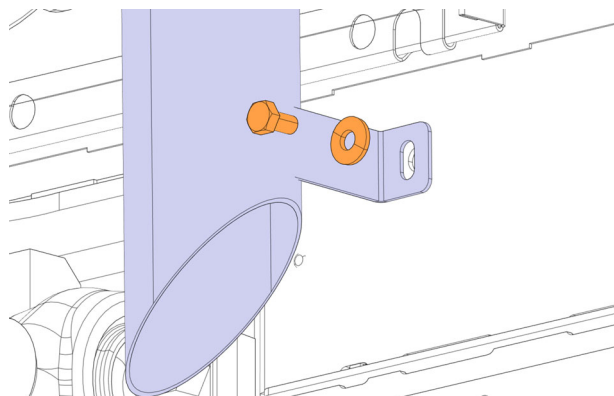

11. Unscrew the U-bolt clamp and remove the exhaust.

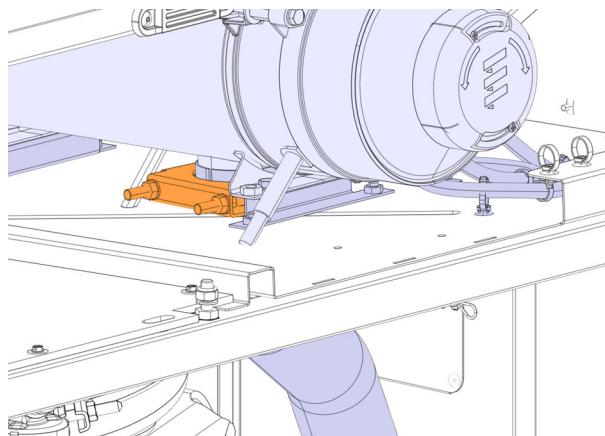

12. Cut the cable ties that secure the heater harness.
13. Disconnect the connectors **CSX1** & **CSX3** from the old heater harness.

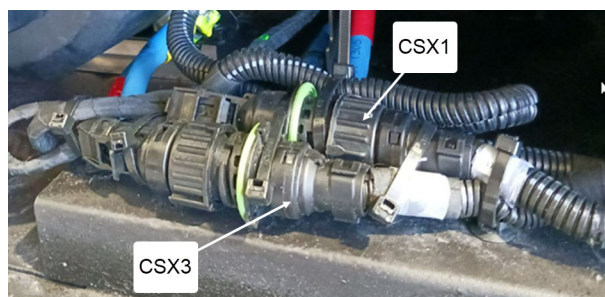

14. Disconnect the fuel hoses and discard the washers (4x) and the banjo bolt (2x).

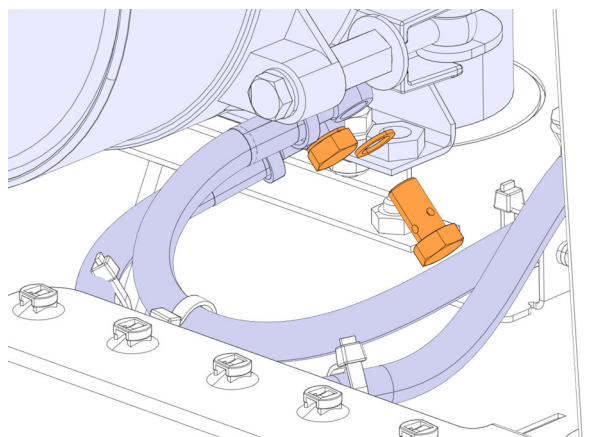

15. Unscrew the clamp and disconnect the inlet hose.

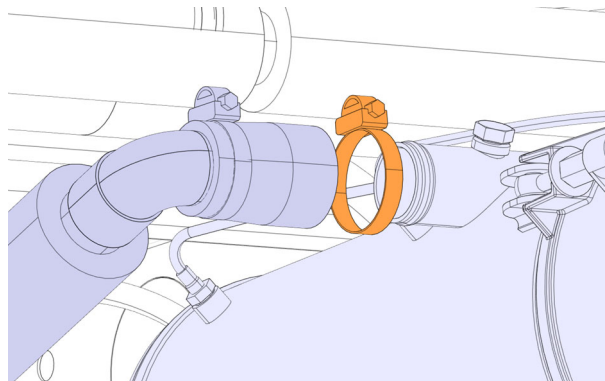

16. Unscrew the clamp and disconnect the outlet hose.

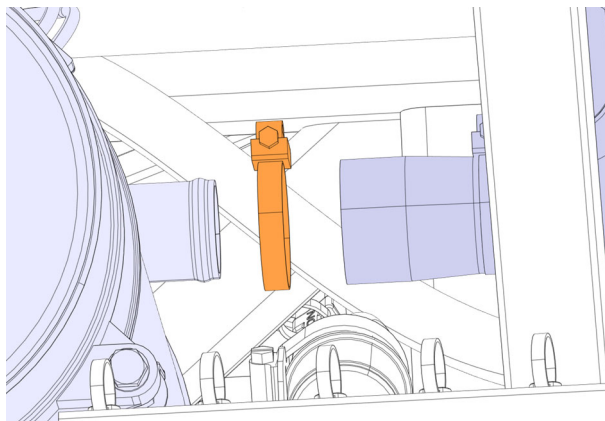

17. Unscrew the heater assembly, keep the screw (4x) and discard the washer (4x).

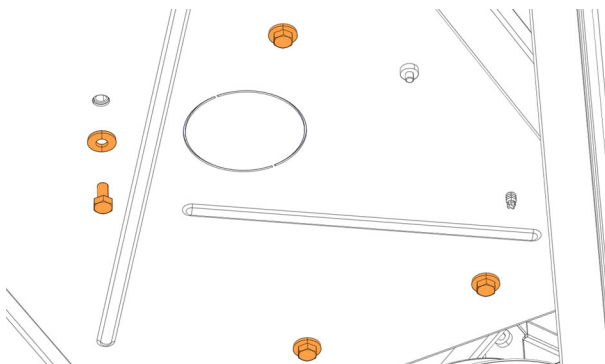

18. Remove the old heater assembly.

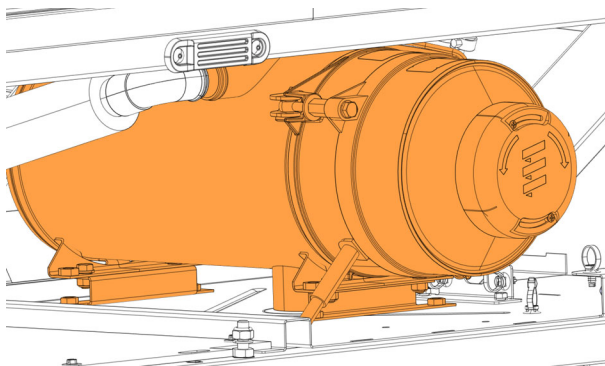

19. Unscrew the supports (2x) from the heater, keep the supports (2x), the screws (4x) and the washers (4x) and discard the nuts (4x).

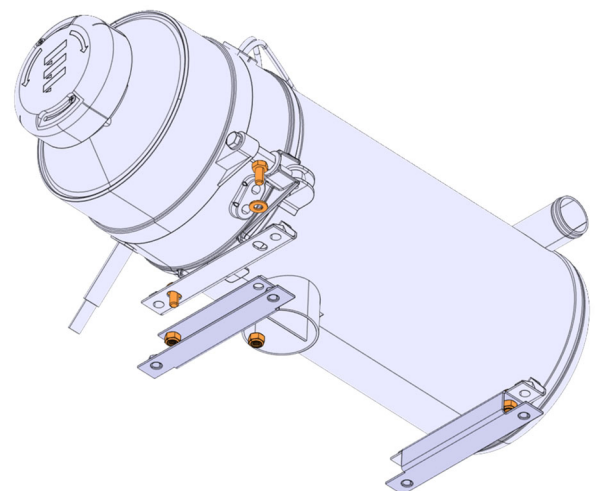

20. Remove the air intake of the new heater 870289.

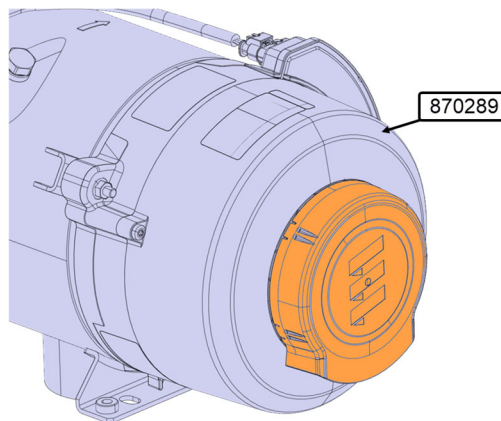

21. Install the new air intake 870295 on the new heater 870289.

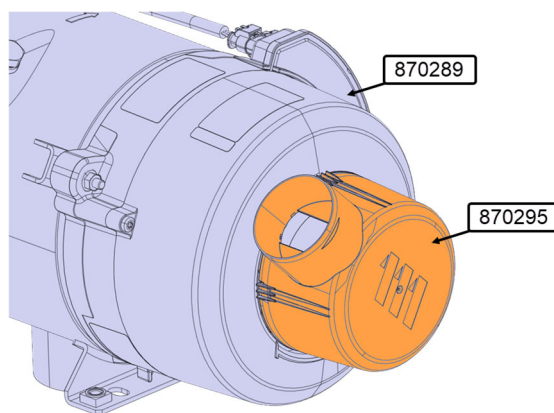

22. Install the supports (2X) on the new heater 870289 with the screws (4x), the washers (4x) and the new nuts 5001983 (4x).

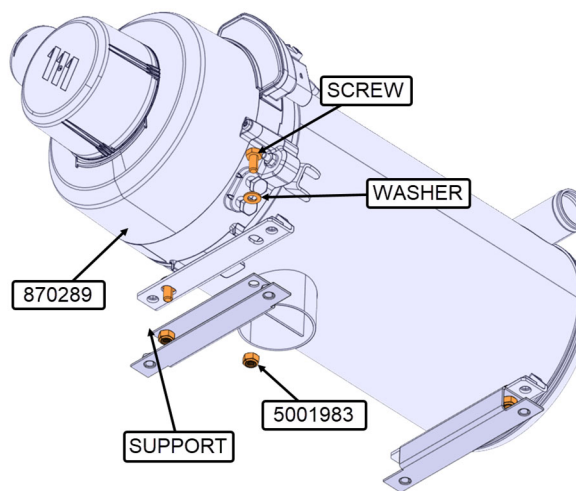

23. Install the new heater assembly.

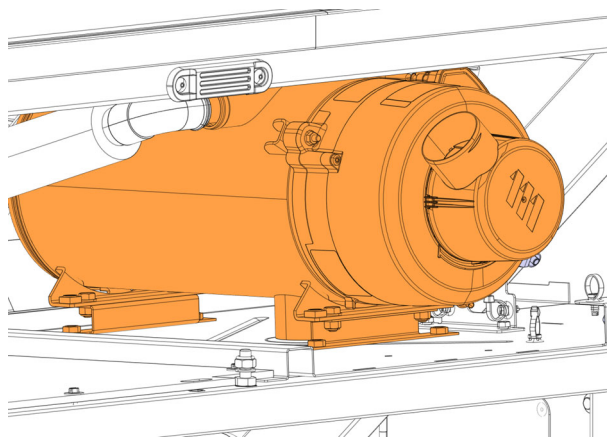

24. Secure the new heater assembly with the screws (4x) and the new washers 5001848 (4x) on the structure.

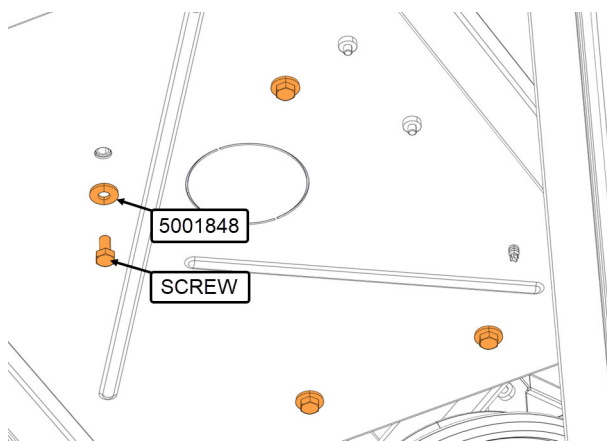

25. Connect the outlet hose with the clamp on the new heater.

26. Apply a torque of 30 lb-in to the clamp,

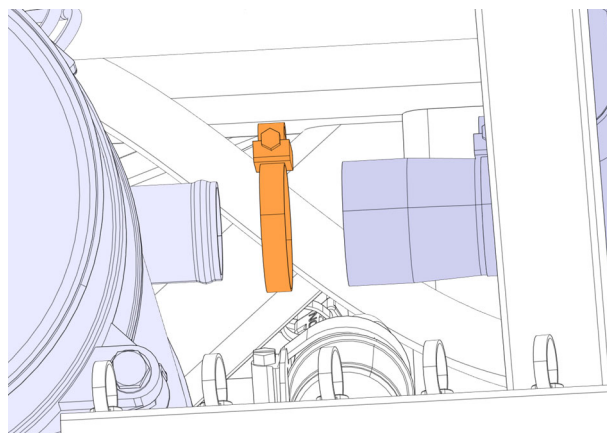

27. Connect the inlet hose with the clamp on the new heater.

28. Apply a torque of 30 lb-in to the clamp.

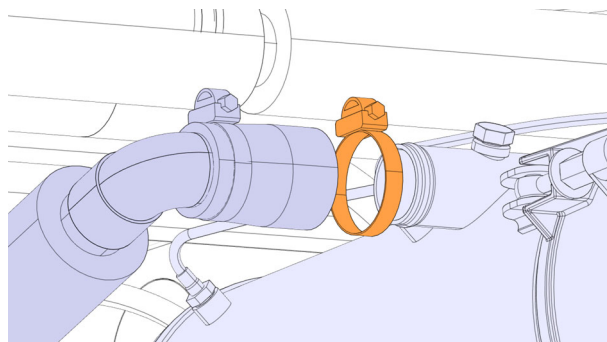

29. Reinstall the exhaust pipe with U-bolt clamp.

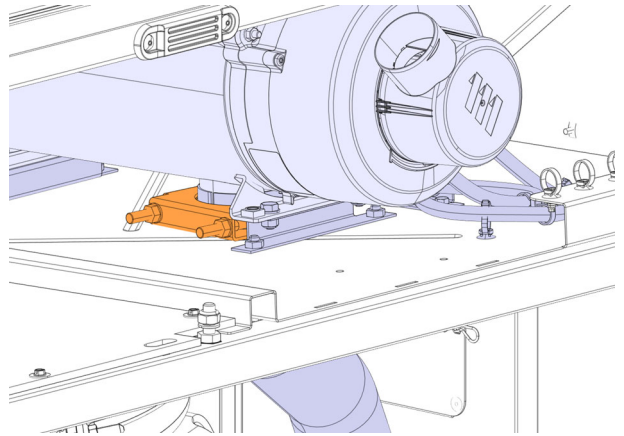

30. Secure the exhaust pipe bottom with the screw and the new washer 5001848.

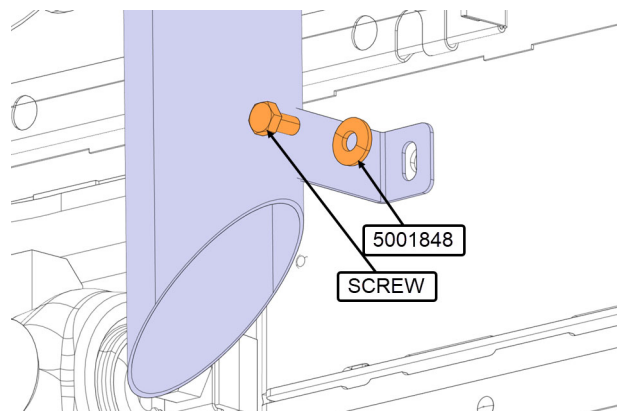

31. Reconnect the fuel hoses with the new washers 501123 (4x) and the banjo bolts (2x) (include with the heater).

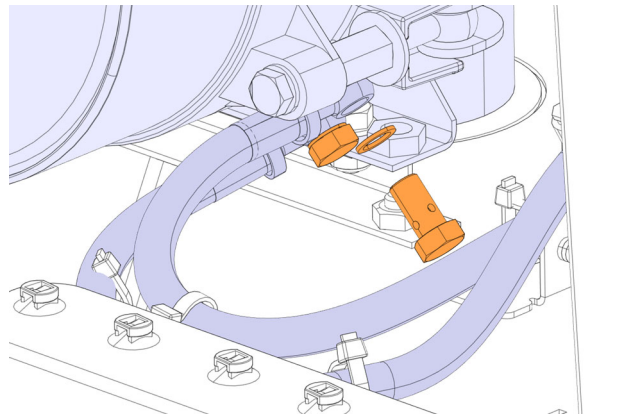

32. Open the last left baggage door.

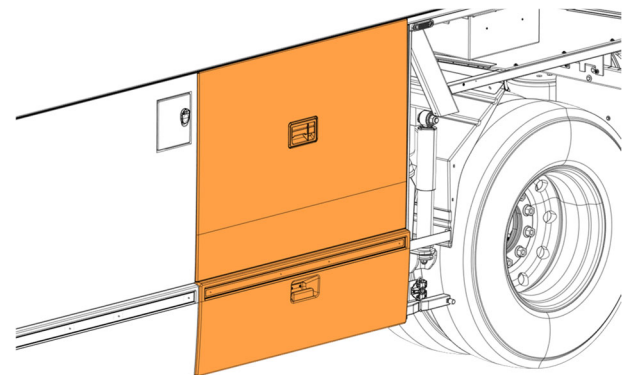

33. Drill a hole to $\varnothing 3/8"$ on baggage panel.

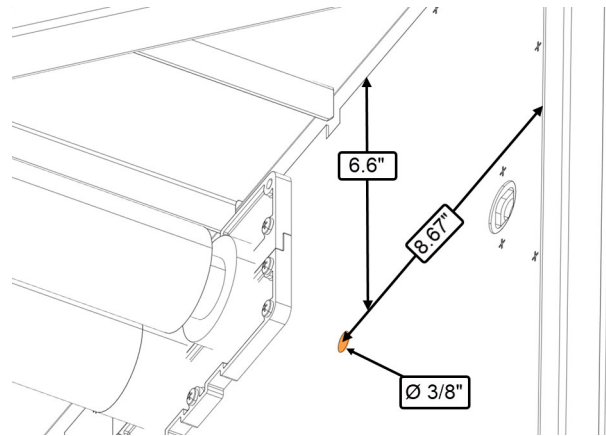

34. Drill a hole to $\varnothing 2 1/4"$ on baggage panel.

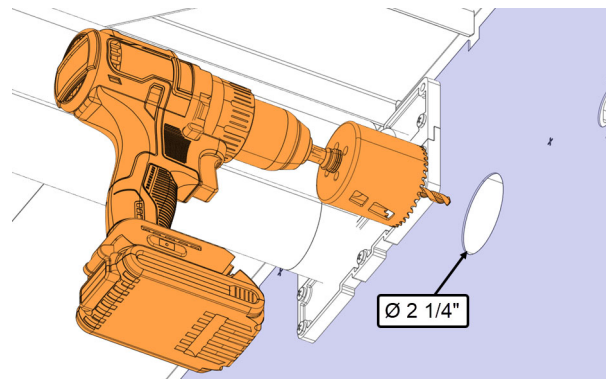

35. Install the flange 400632 with the screws 500124 (3x).

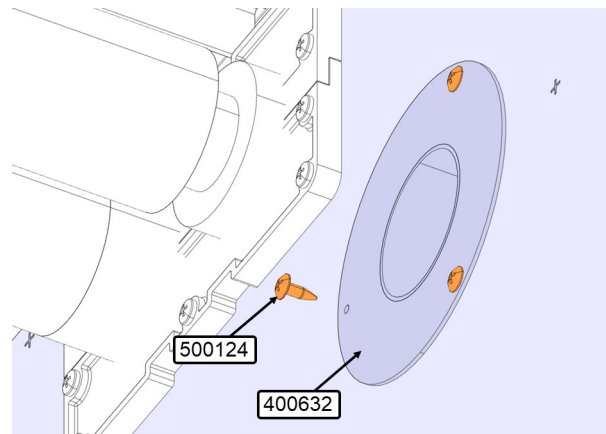

36. Drill four holes $\varnothing 11/32''$ for the cable tie with fir tree mounts.

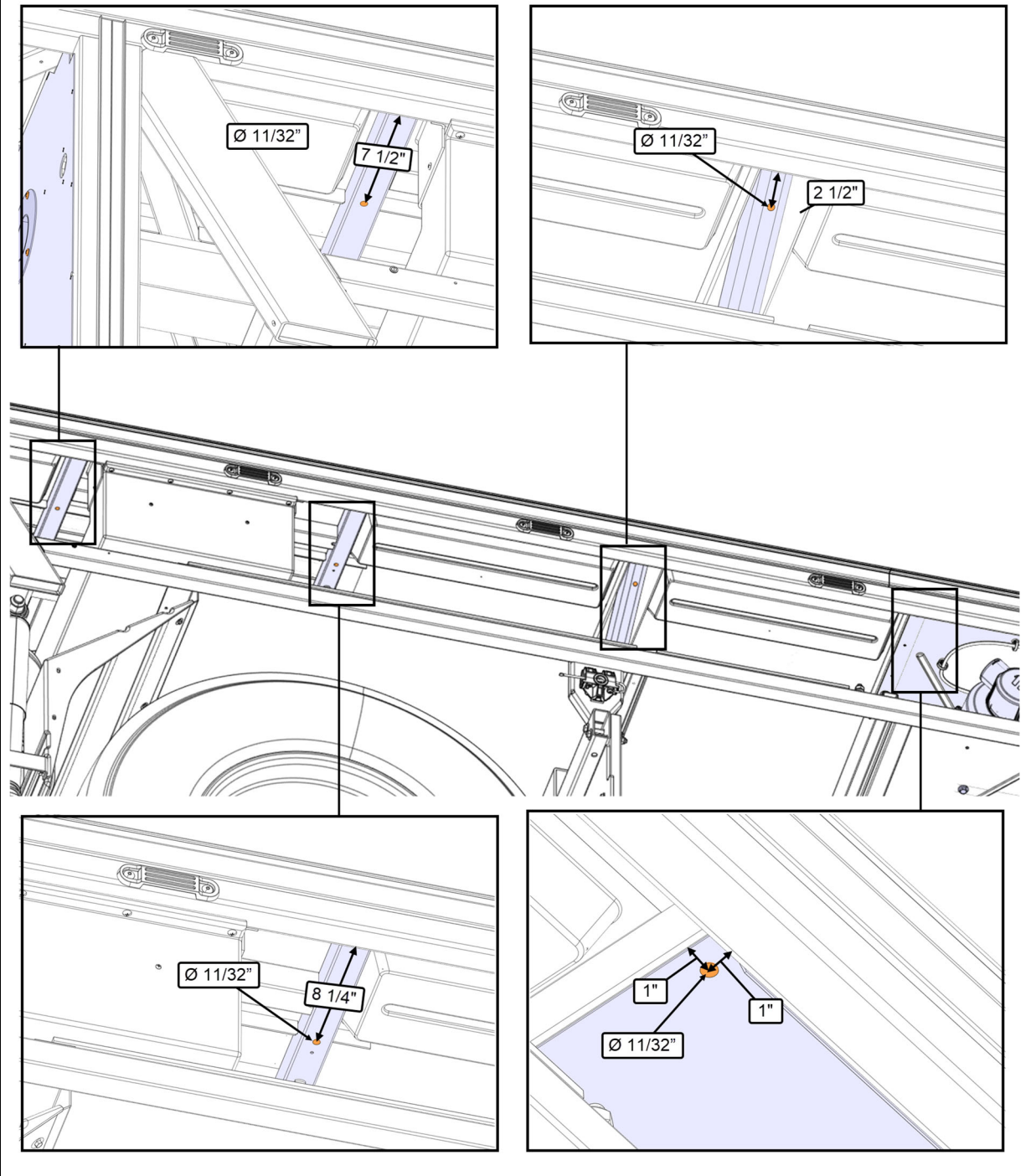

37. Connect the hose 503031 to the air intake 870295 of the heater with the clamp 504024.

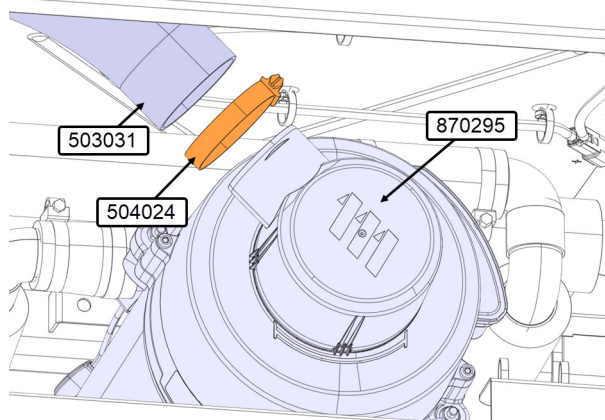

38. Run the hose 503031 above the air duct.

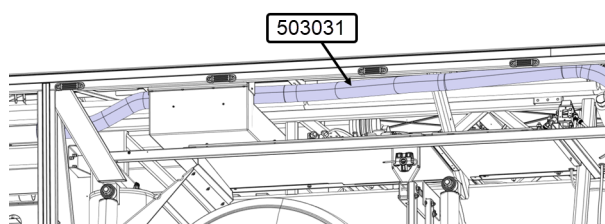

39. Connect the hose 503031 to the flange 400632 with the clamp 504024.

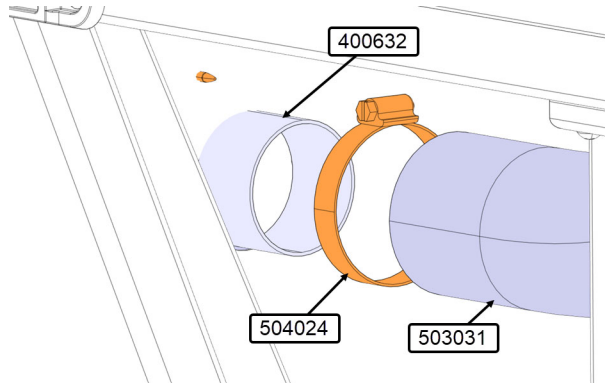

40. Secure the hose 503031 with the cable ties with fir tree mount 504750 (4x).

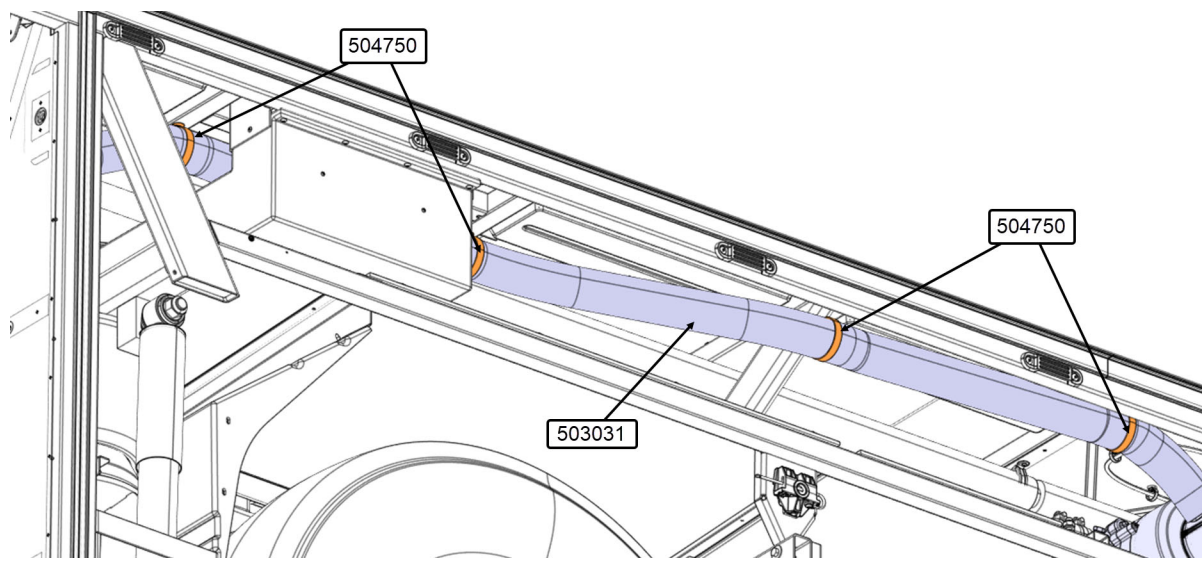

41. Connect harness 0600563 to position **3** & **4**.

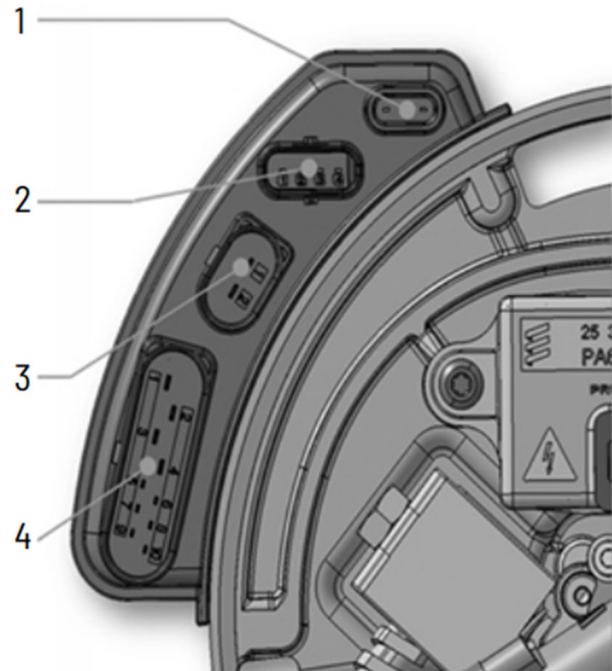

42. Connect the heater harness 0600563 to the connectors **CSX1** & **CSX3**.

43. Secure the harness with cable ties 504637(5X).

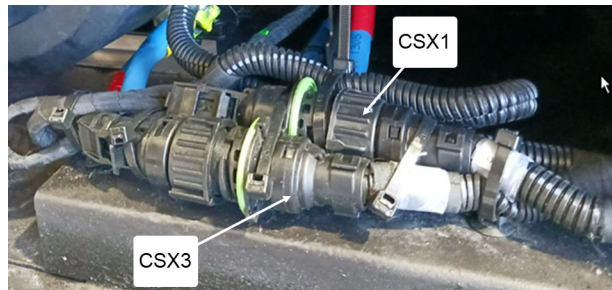

44. Install the heater to timer CAN harness 0610673 following the routing. You must start from the back of the vehicle to the front junction box.
45. Use a fish tool to reach the front of the vehicle using the existent PVC conduits.

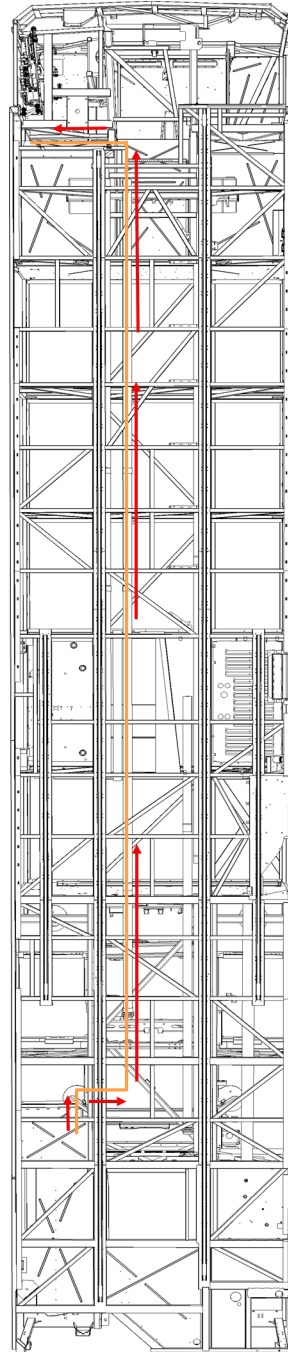

46. Connect the connector **A10.A3** of the heater to timer CAN harness 0610673 to heater position **2**.

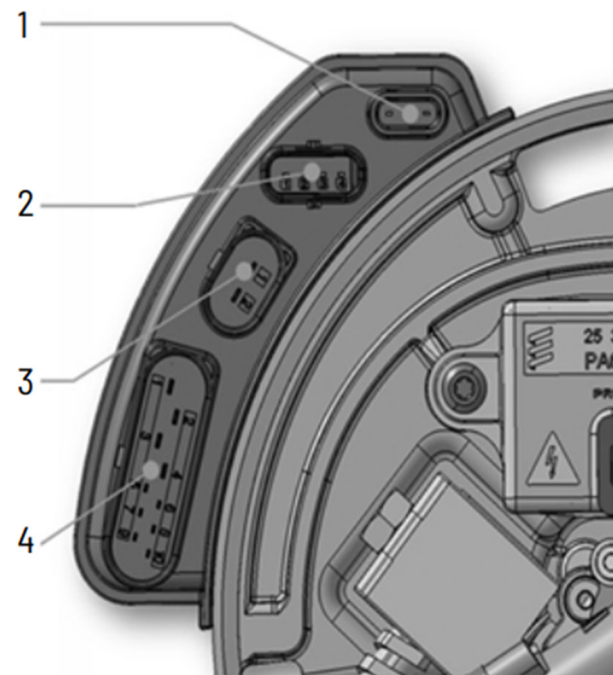

47. Remove the side consol.

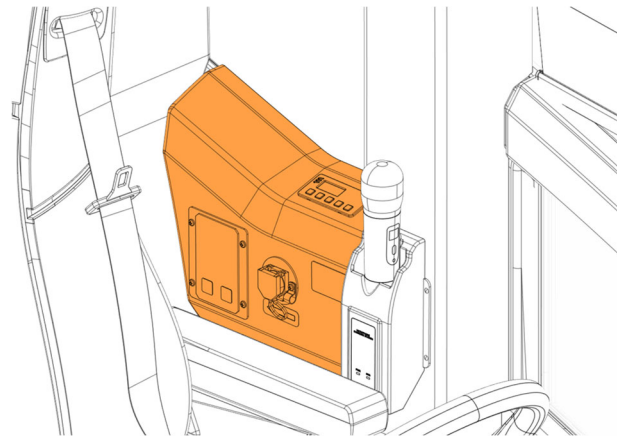

48. Disconnect connector **C430** of the consol harness from the front junction box main harness.

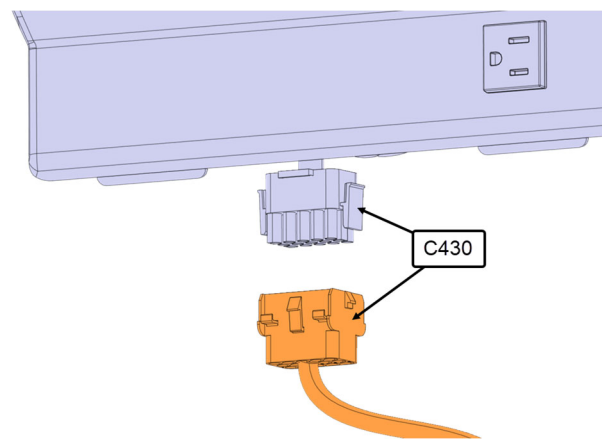

- 49. Disconnect the old timer connector **A11**.
- 50. Remove the old heater timer and discard.

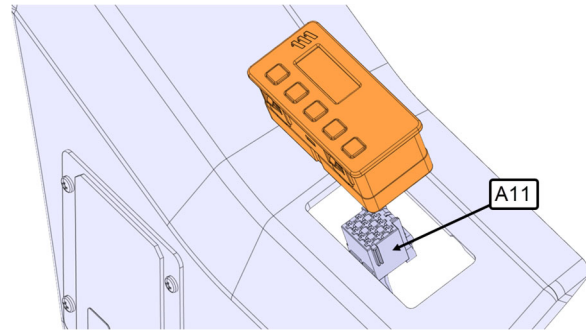

- 51. Cut cable ties(4x).

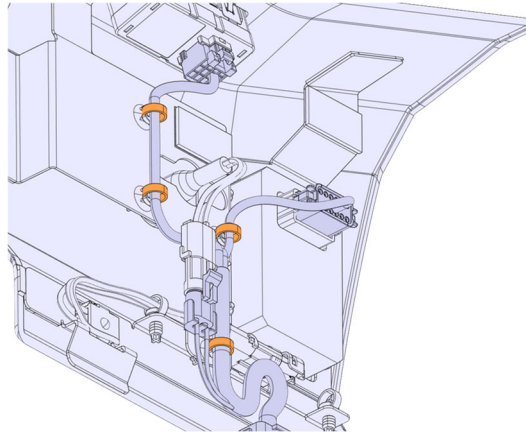

- 52. Disconnect the old consol harness and discard.

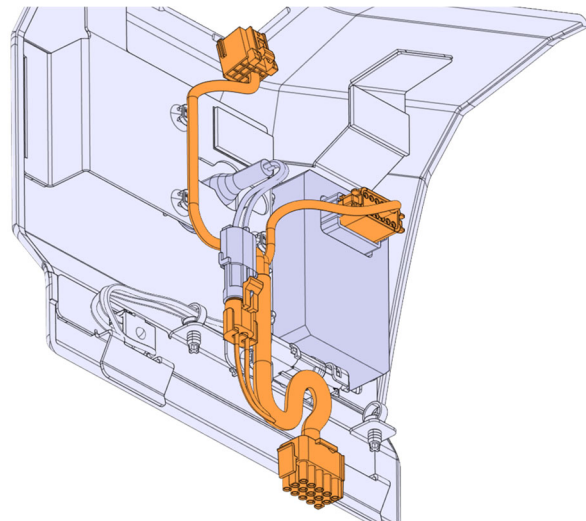

- 53. Install the new cover 870253 on the consol in the hole for the heater timer.

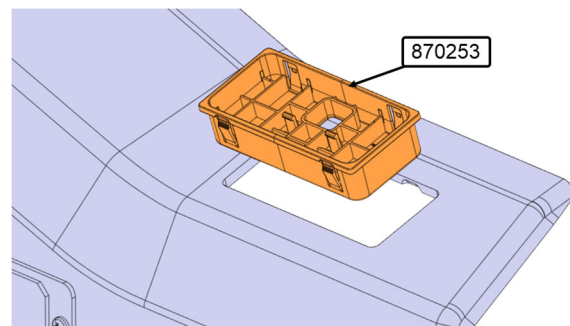

54. Install the new timer 870252 on the cover 870253 on the consol.

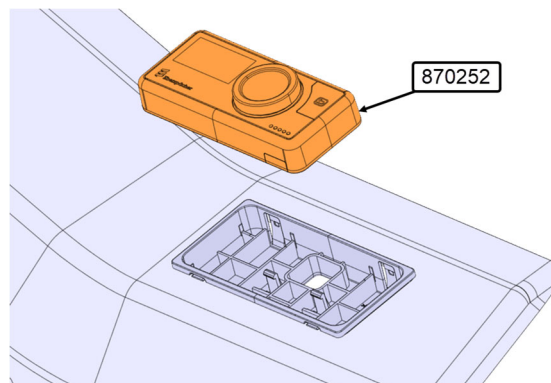

55. Install the new consol harness 0600216 with cable tie 504637 (4x).

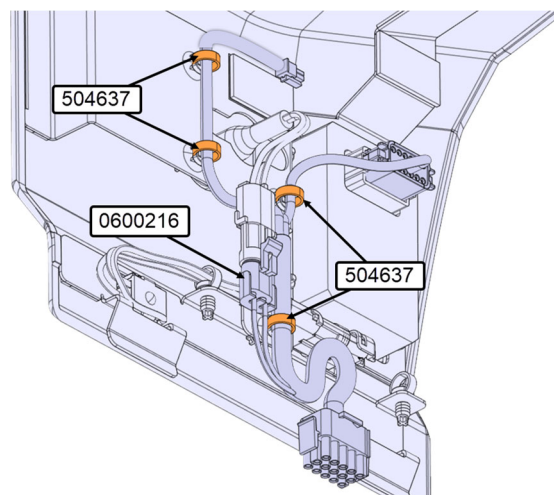

56. Open the front service door.

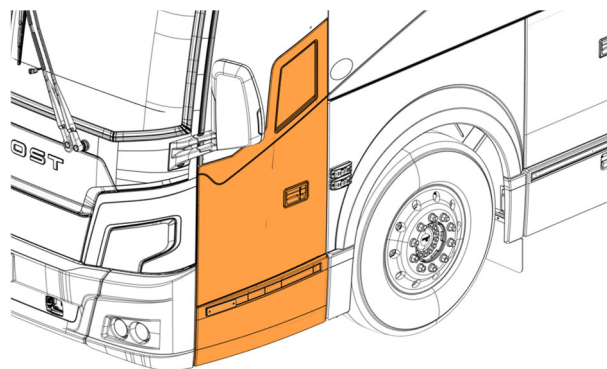

57. Open the front junction panel.

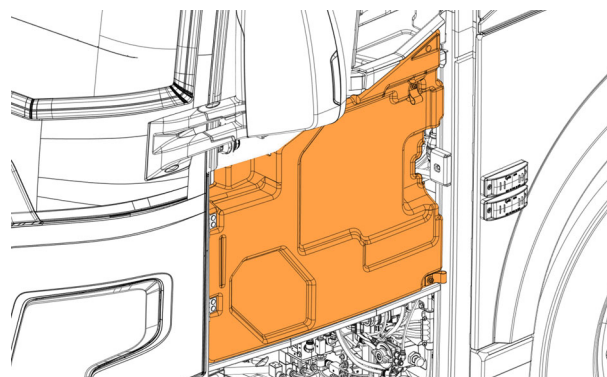

58. Run the harness 0610673 to reach the consol to connect the new timer.

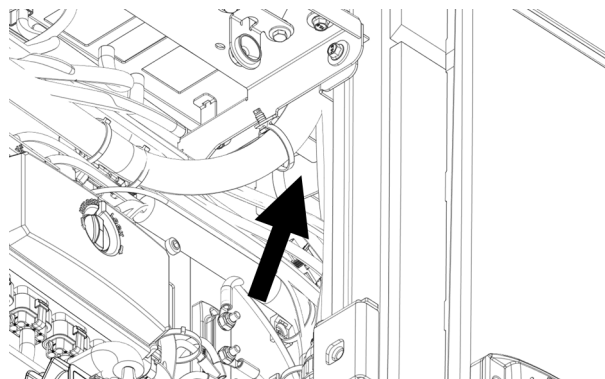

59. Connect the connector **C_A11B** of the heater to timer CAN harness 0610673 to connector **A11** of consol harness 0600216.

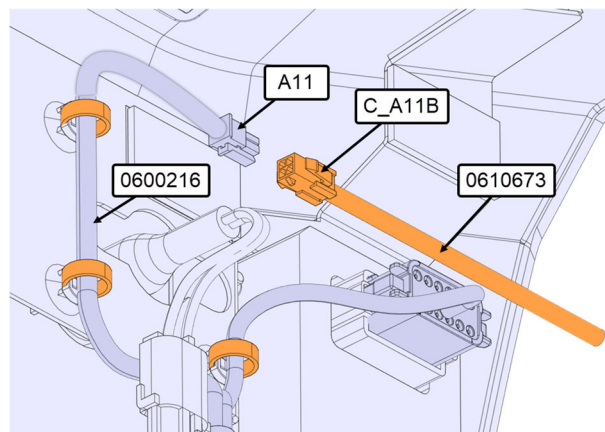

60. Connect the connector **C_A11A** of the heater to timer CAN harness 0610673 to timer 870252.

61. Secure all the harness 0610673 and 0610675 with cable ties 504637 (15x).

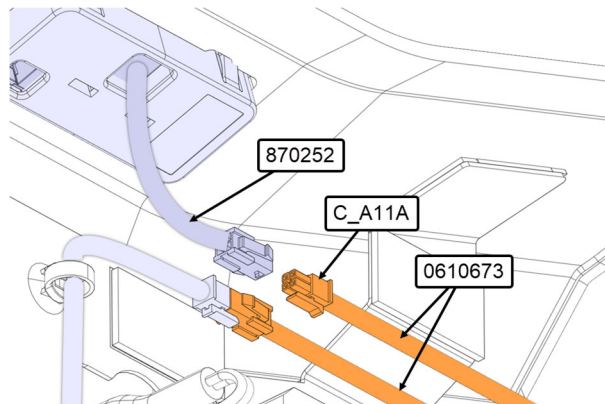

62. Refill the cooling system.

63. Disconnect the coolant extractor and reinstall the protection cap on the radiator drain cock.

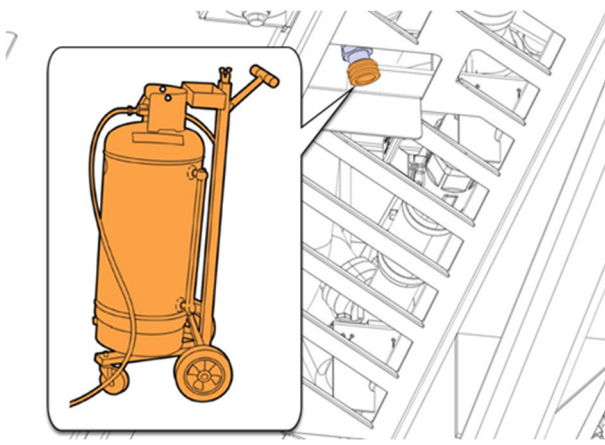

- 64. Close the surge tank pressure valve.
- 65. Reinstall the pressure cap.

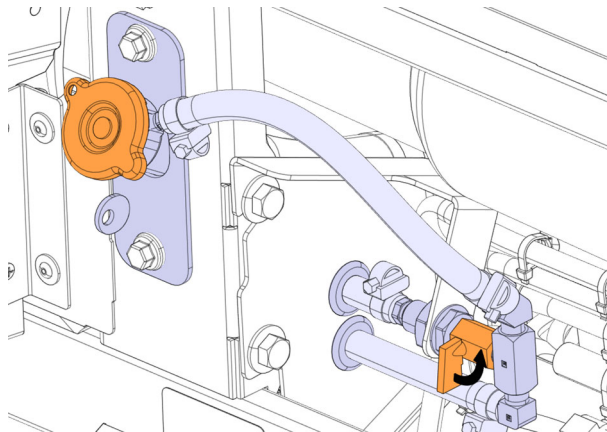

- 66. Start the engine and run at fast idle.
- 67. Check for leaks.
- 68. Stop the engine and allow cooling.

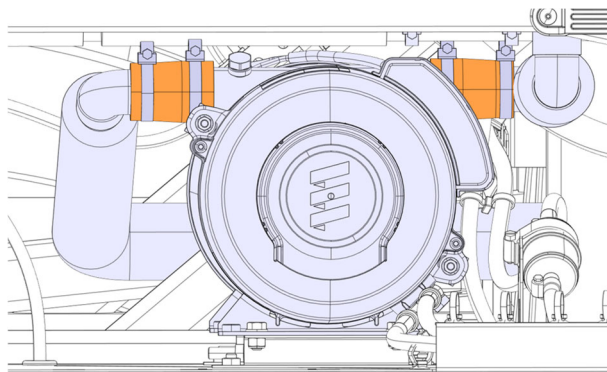

- 69. Check the coolant level through the recovery tank. Coolant level should be above the MIN LINE.
- 70. Remove the recovery tank filler cap to add coolant if required.

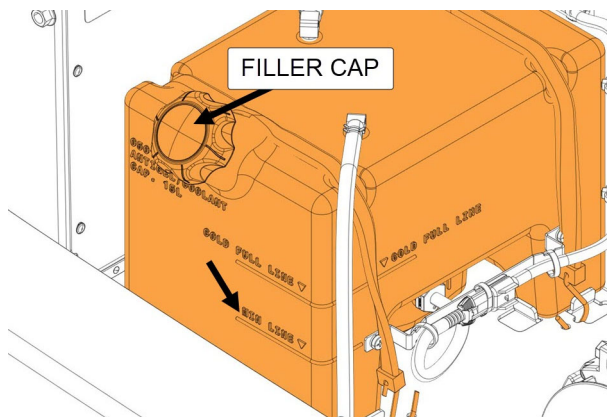

- 71. Close the DPF access hatch.

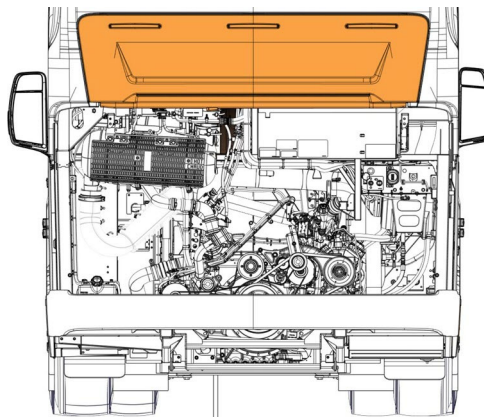

72. Close the engine compartment rear door.

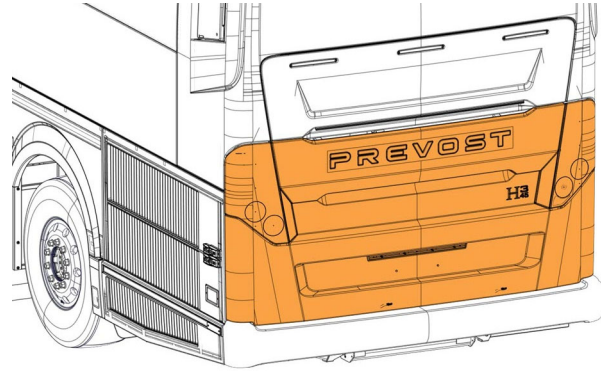

73. Close the compressor door. The procedure is complete, no further actions required.

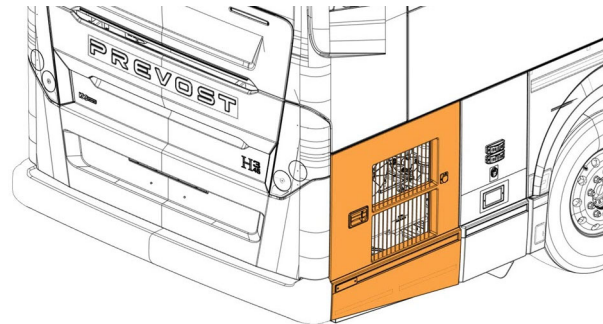

HEATER REPLACEMENT X3-45 FROM K-6453

1. Open the compressor door.

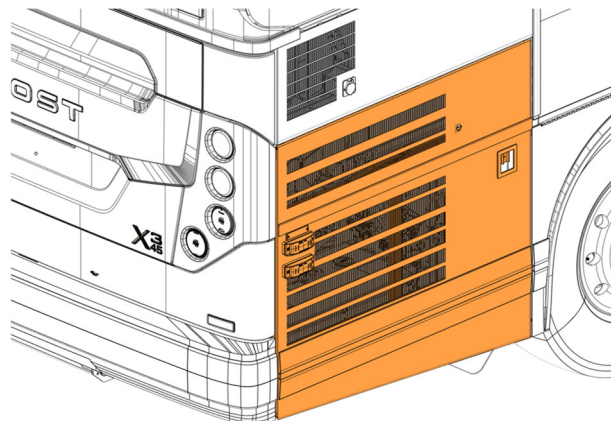

2. Lift the release lever to unlatch the engine compartment door.
3. Pull the engine compartment door out and up to open.

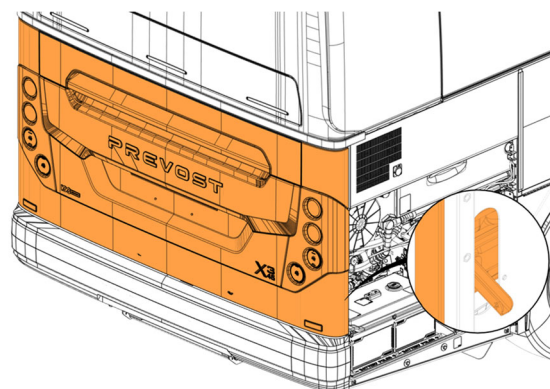

4. Open the pressure relief valve.
5. Remove the pressure cap.



CAUTION

Allow engine coolant to cool down before proceeding with the following steps.

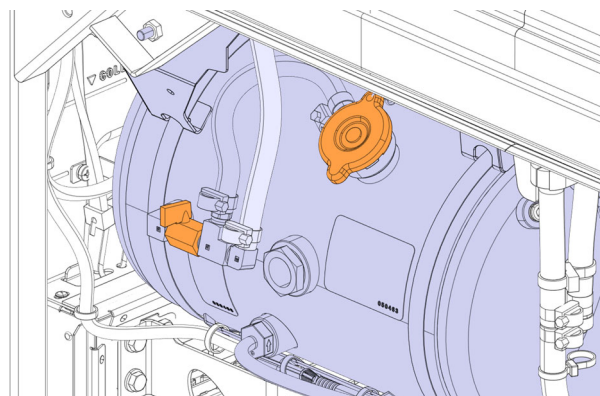

6. Locate coolant extractor fitting under the vehicle

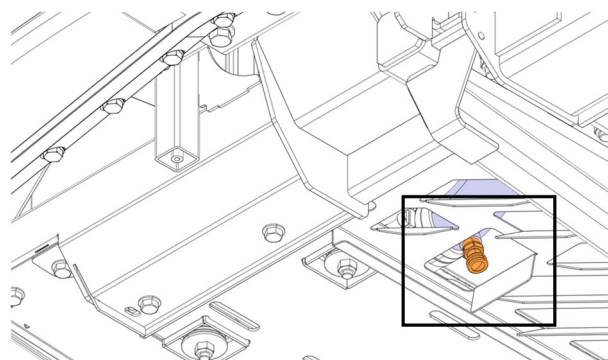

7. Remove protector cap.

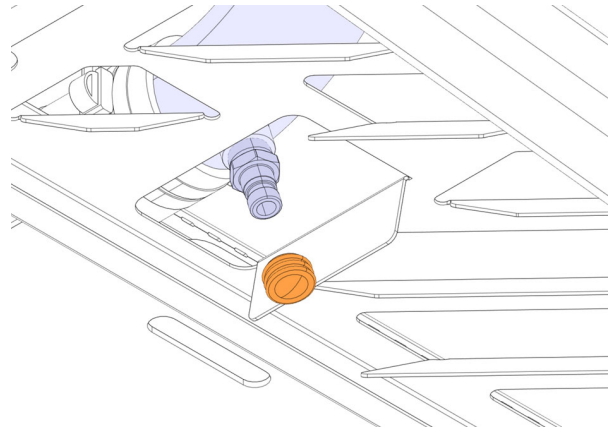

8. Plug the coolant recovery machine to the fitting.

9. Remove all the coolant.

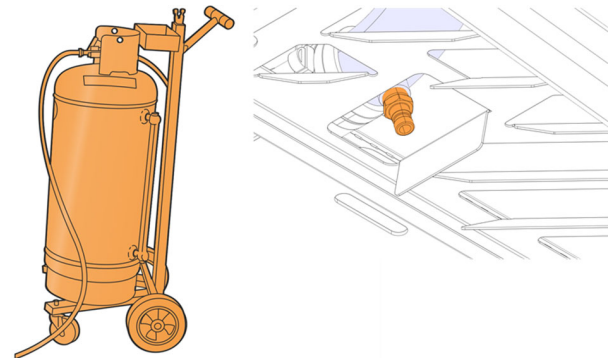

10. Unscrew the U-bolt clamp and remove the exhaust.

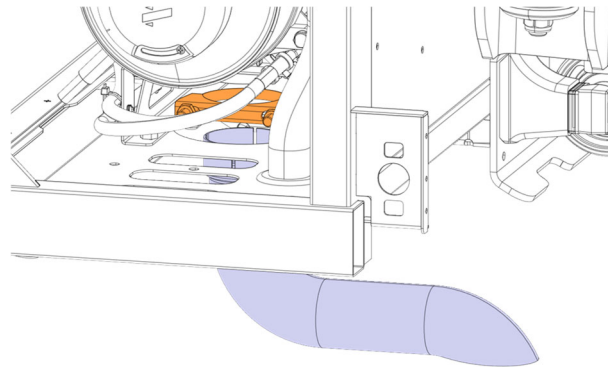

11. Cut the cable ties that secure the heater harness.

12. Disconnect the connectors **CSX1** & **CSX3** from the old heater harness.



13. Disconnect the fuel hoses and discard the washers (4x) and the banjo bolt (2x).

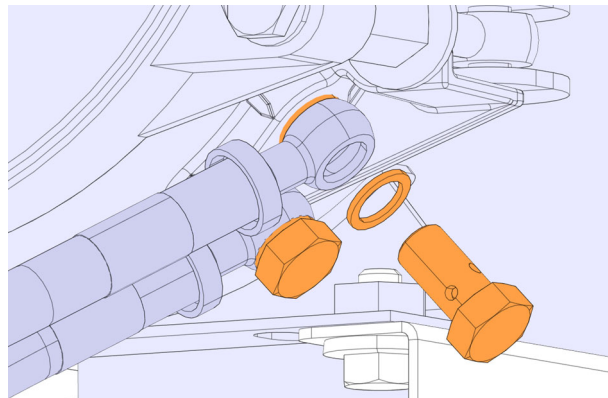

14. Unscrew the clamp and disconnect the inlet hose.

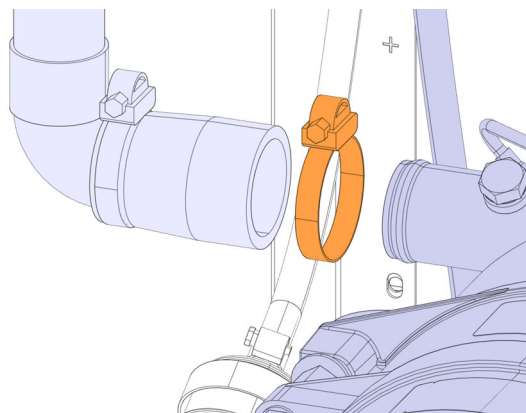

15. Unscrew the clamp and disconnect the outlet hose.

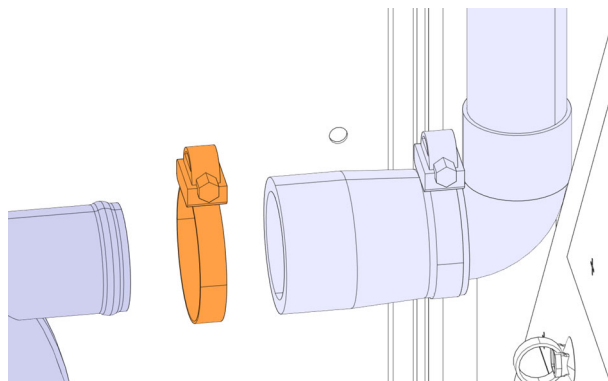

16. Unscrew the heater assembly, keep the screw (4x) and discard the washer (4x).

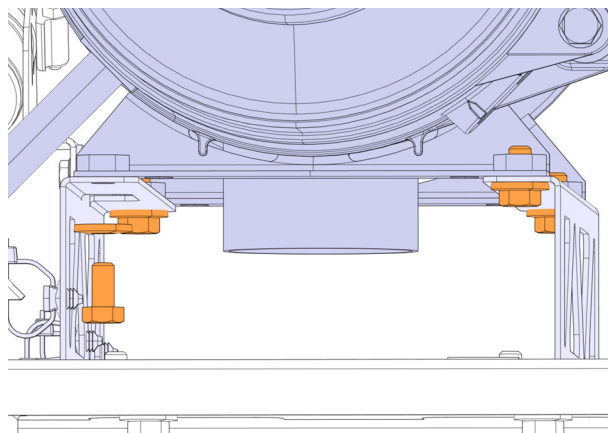

17. Remove the old heater.

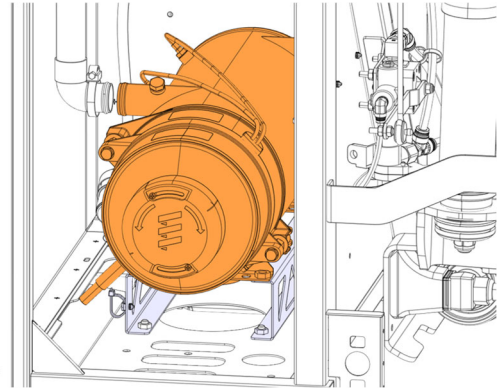

18. Remove the air intake of the new heater 870289.

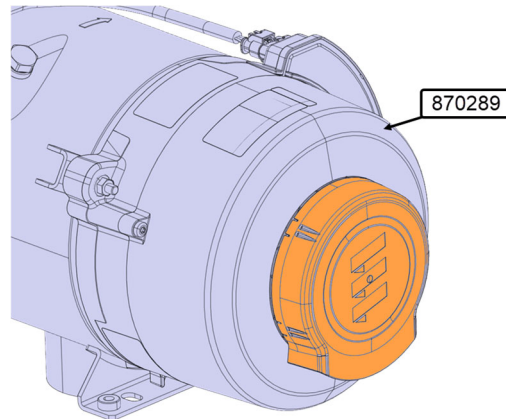

19. Install the new air intake 870295 on the new heater 870289.

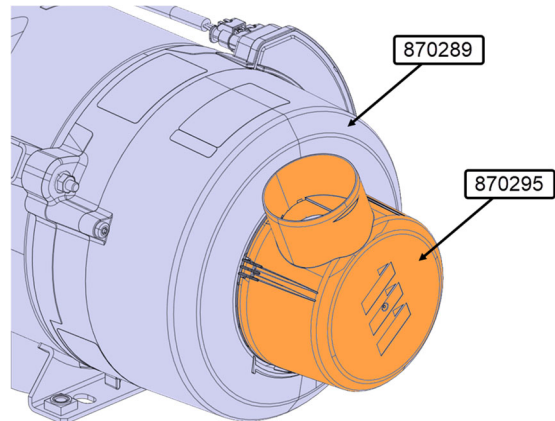

20. Install the new heater 870289.

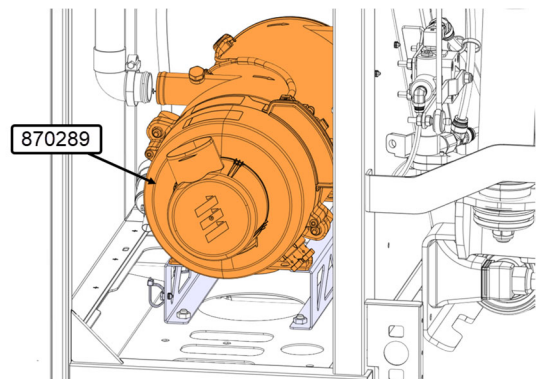

21. Secure the new heater 870289 with the screws (4x) and the new washers 5001848 (4x) on the support.

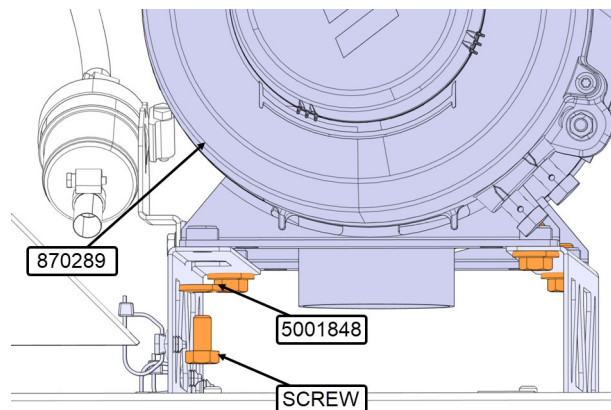

22. Connect the outlet hose with the clamp on the new heater.

23. Apply a torque of 30 lb-in to the clamp,

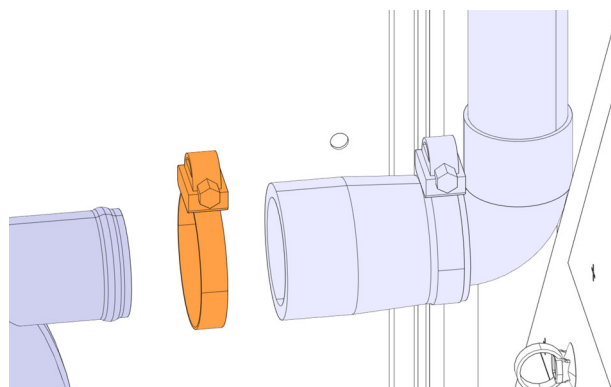

24. Connect the inlet hose with the clamp on the new heater.

25. Apply a torque of 30 lb-in to the clamp.

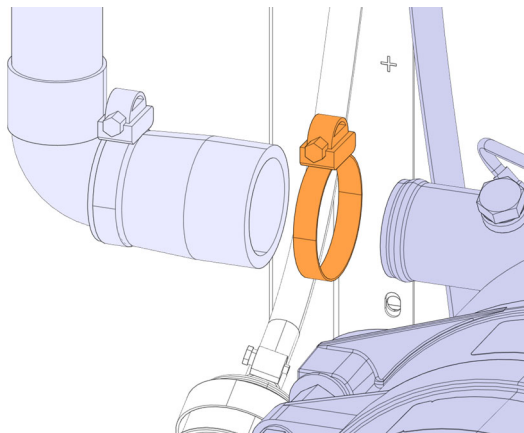

26. Reinstall the exhaust with U-bolt clamp.

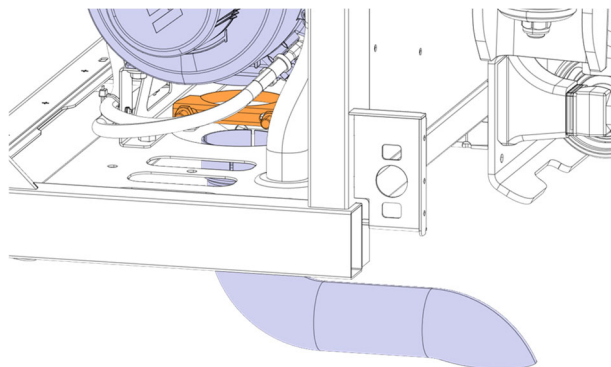

27. Reconnect the fuel hoses with the new washers 501123 (4x) and the banjo bolts (2x) (include with the heater).

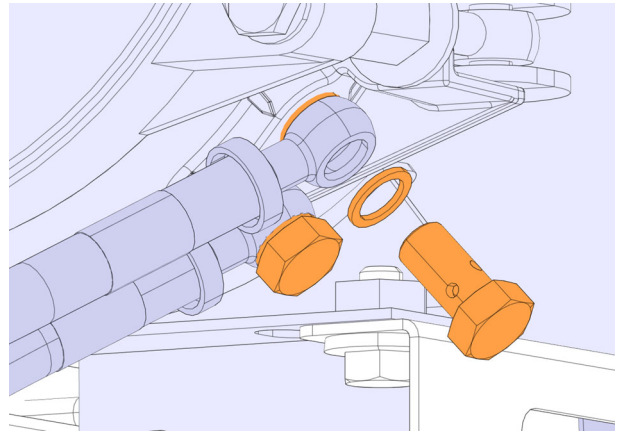

28. Open the last street side baggage door.

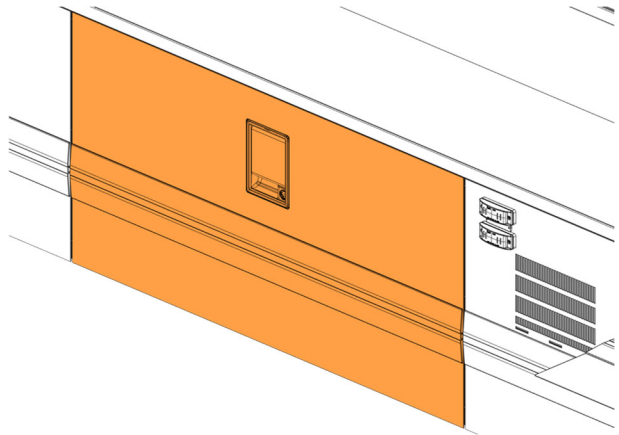

29. Knock out the hole pre-drill.

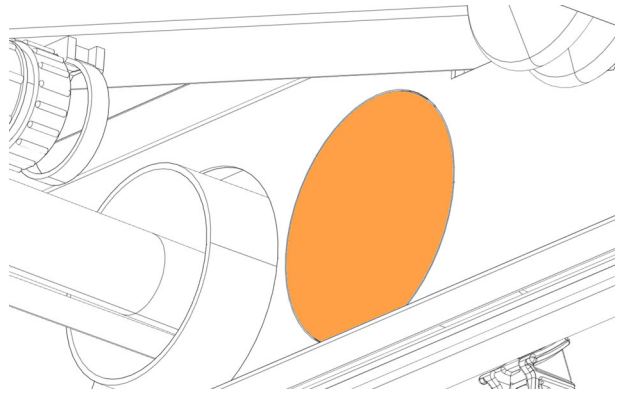

30. Run the hose 503031 through the hole and reach the preheater compartment.

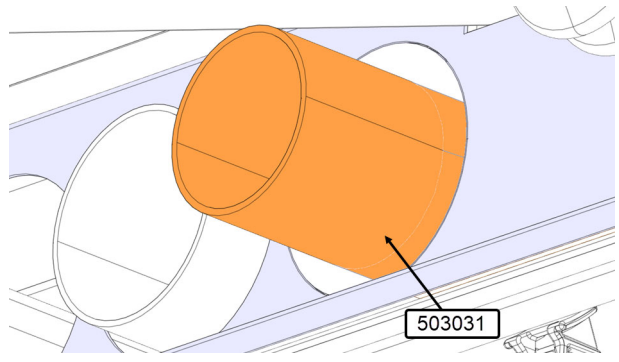

31. Leave the hose protruding by about 100mm and seal around the hose.



32. Connect the hose 503031 to the heater air intake with clamp 504024.

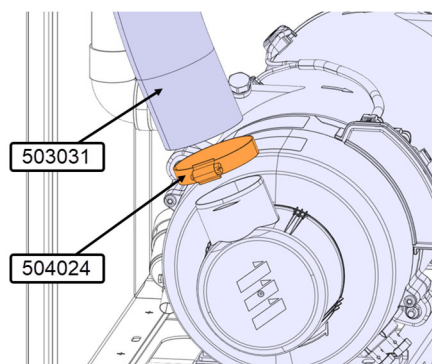

33. Secure the hose 503031 on existing hose with the dual swivel saddle spacers 504751 (3x) and the cable ties 504016 (6x).

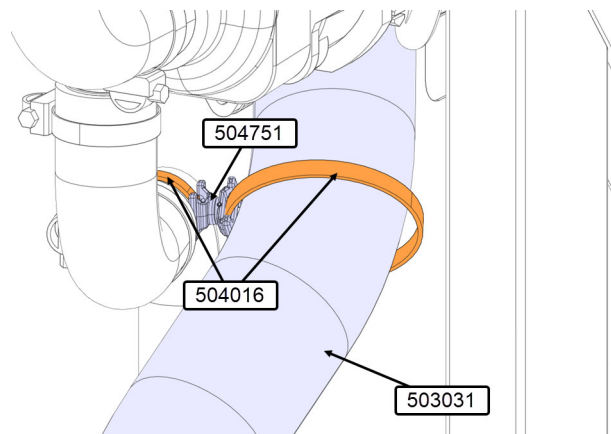

34. Connect heater harness 0600563 to position **3** & **4**.

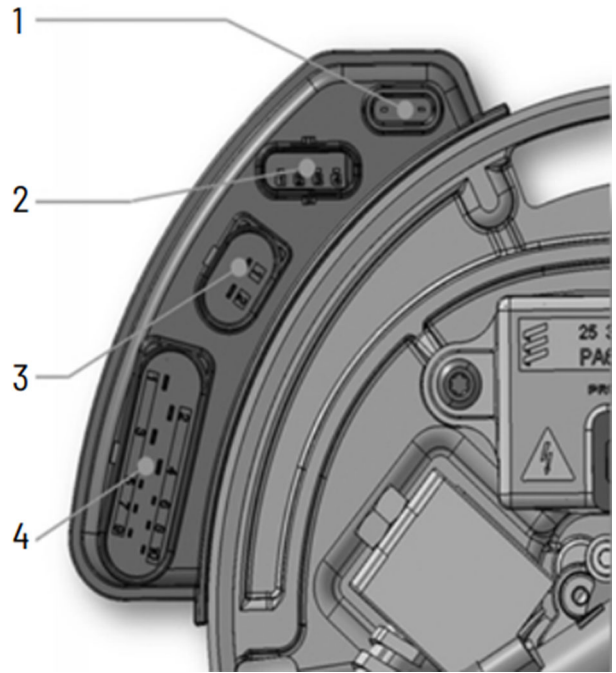

35. Connect the heater harness 0600563 to the connectors **CSX1** & **CSX3**.

36. Secure the harness with cable ties 504637(5X).

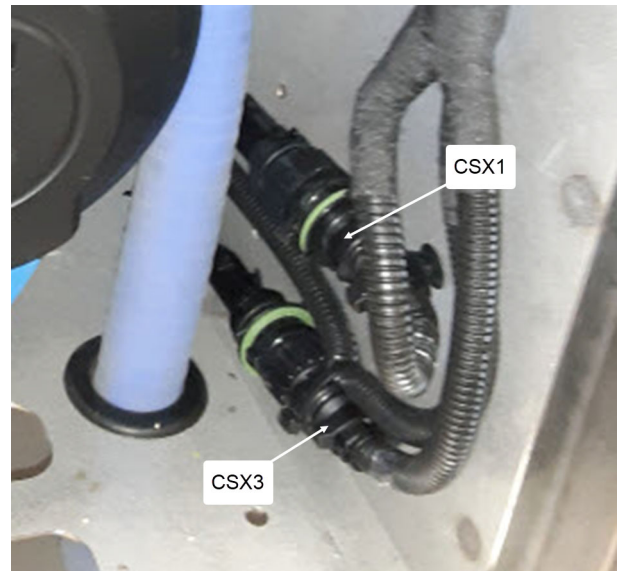

37. Install the heater to timer CAN harness 0610673 following the routing. You must start from the back of the vehicle to the front junction box.

38. Use a fish tool to reach the front of the vehicle using the existent PVC conduits.

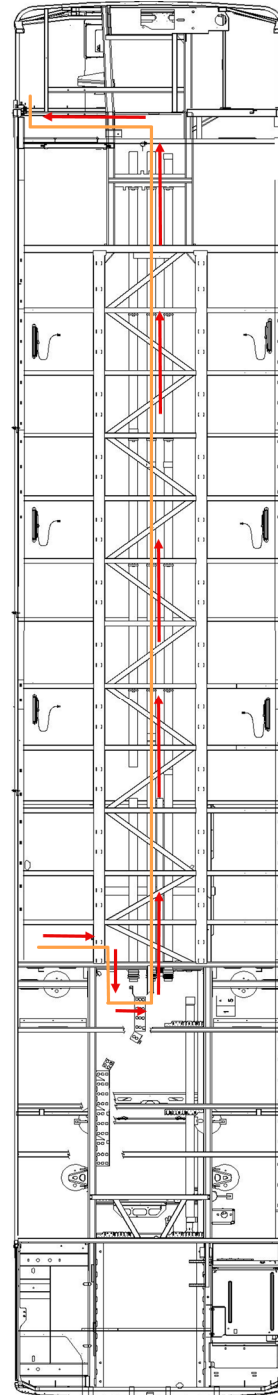

39. Connect the connector **A10.A3** of the heater to timer CAN harness 0610673 to heater position **2**.

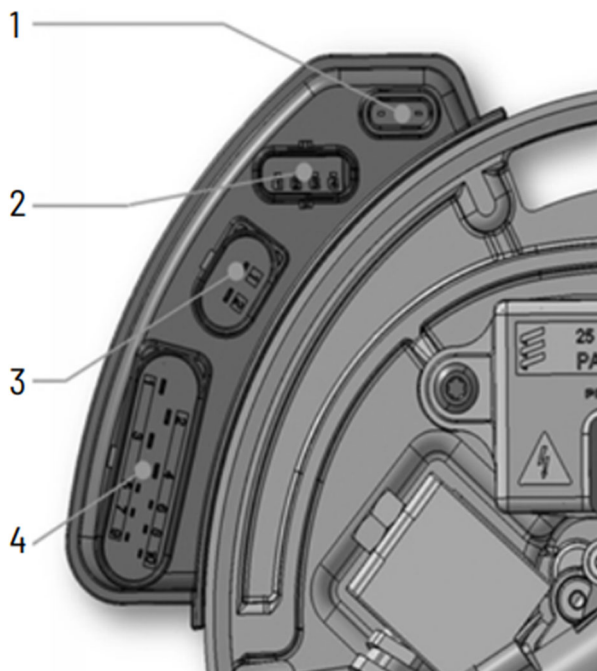

40. Disconnect the old timer connector **C430**.

41. Remove the old heater timer and discard.

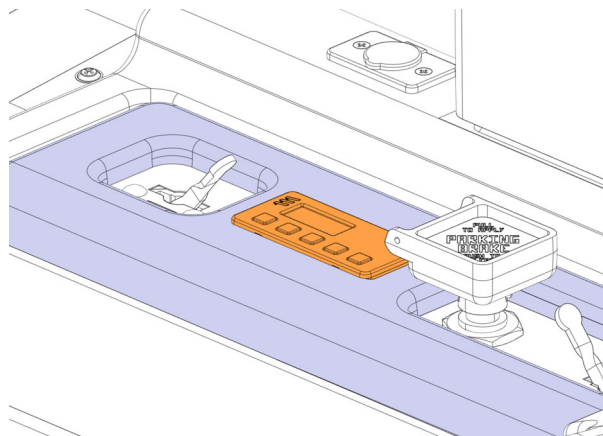

42. Open front service compartment door.

43. Open the front junction box protector door.

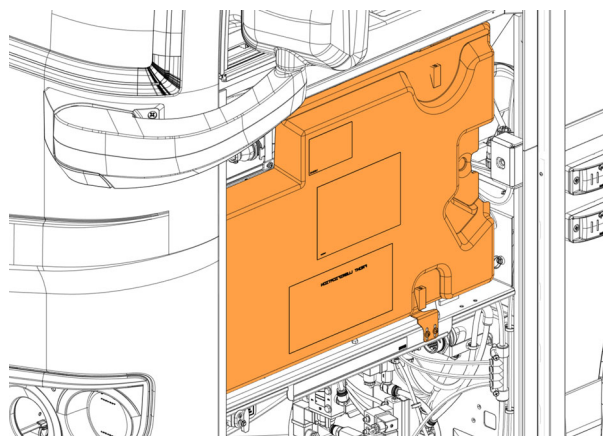

44. Locate connector **C430** on left consol harness.

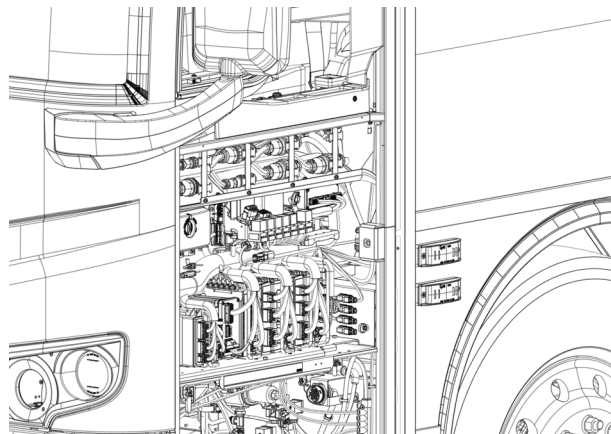

45. Connect the new timer harness 0610675 to connector **C430** of the left consol harness.

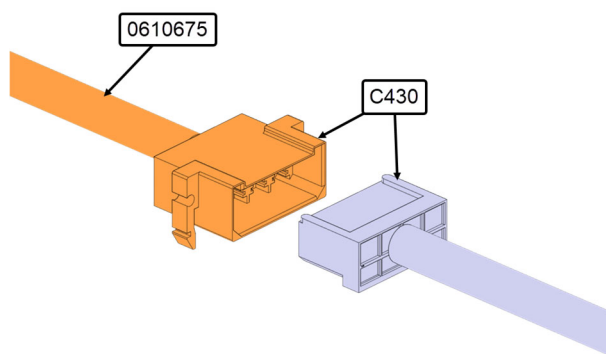

46. Connect the connector **C_A11B** of the heater to timer CAN harness 0610673 to connector **A11** of timer harness 0610675.

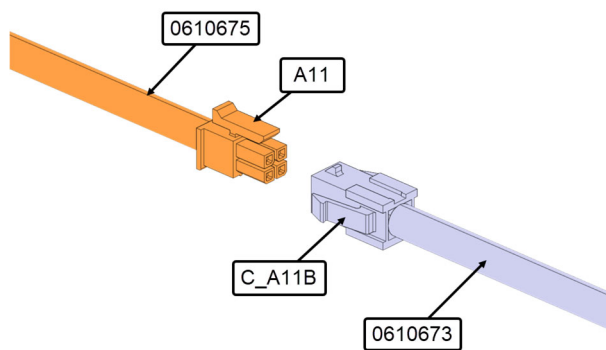

47. Install the new cover 870253 on the left consol in the hole for the heater timer.

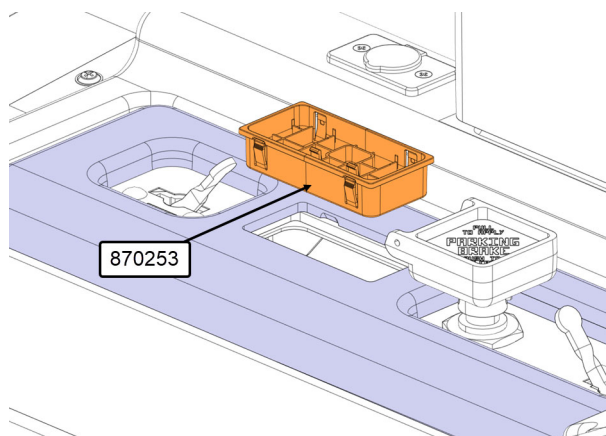

48. Install the new timer 870252 on the cover 870253 on the left consol.

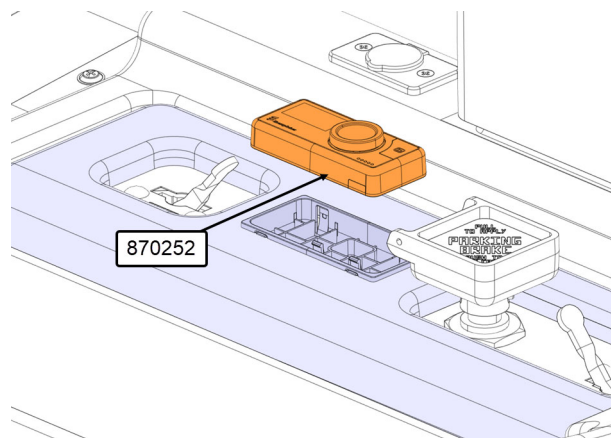

49. Connect the connector **C_A11A** of the heater to timer CAN harness 0610673 to timer 870252.

50. Secure all the harness 0610673 and 0610675 with cable ties 504637 (15x).

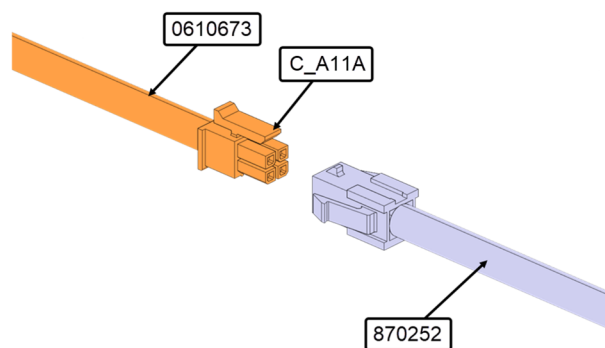

51. Close the pressure relief valve.

52. Reinstall the pressure cap.

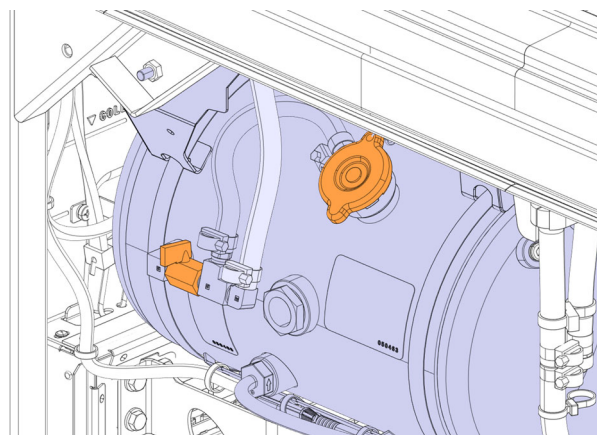

53. Plug the coolant recovery machine to the fitting.

54. Refill coolant.

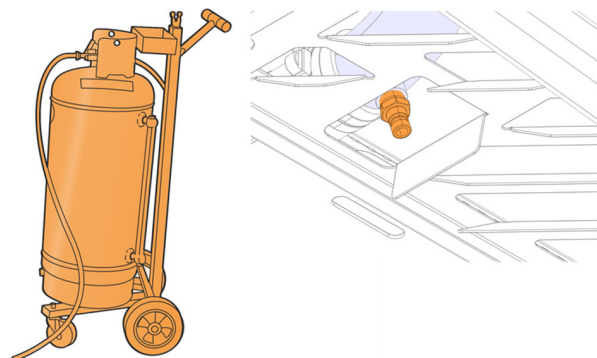

55. Disconnect the coolant extractor and reinstall the protection cap.

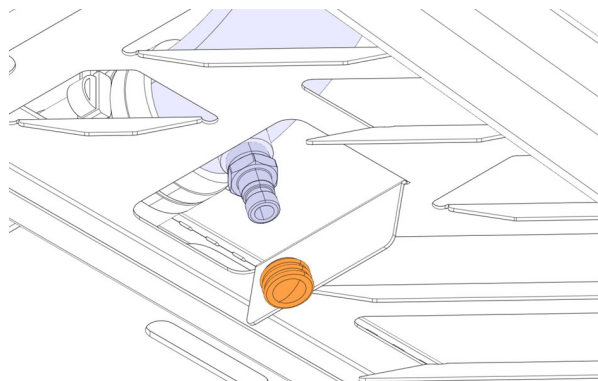

56. Start the engine and run at fast idle.
57. Check for leaks.
58. Stop the engine and allow cooling.

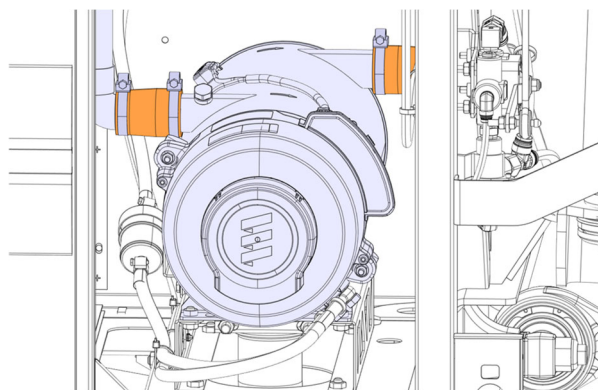

59. Check the coolant level through the recovery tank. Coolant level should be above the MIN LINE.
60. Use the recovery tank filler cap to add coolant if required.

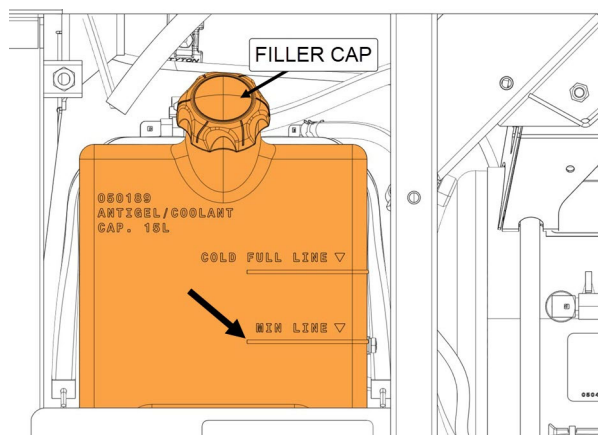

61. Close the engine compartment rear door.

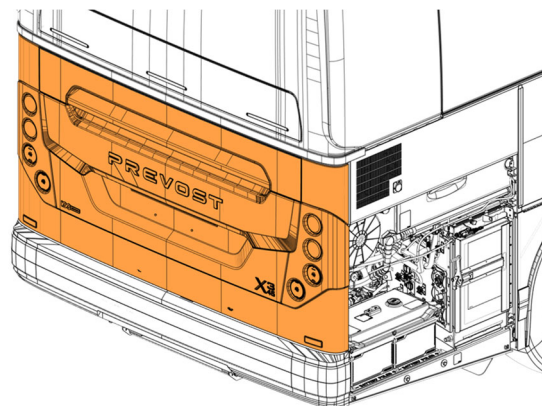

62. Close the compressor door. The procedure is complete, no further actions required.

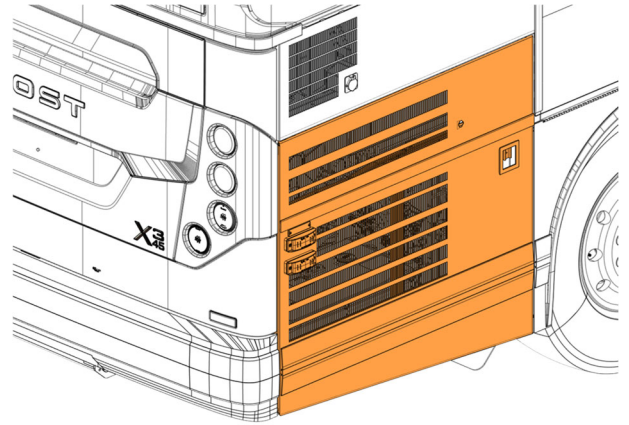

PARTS / WASTE DISPOSAL

Discard waste according to applicable environmental regulations (Municipal/State[Prov.]/ Federal)