

## CONTENTS

SECTION CHANGE LOG .....	4
<b>1. TORQUE TABLES .....</b>	<b>5</b>
<b>2. RICON WHEELCHAIR LIFT.....</b>	<b>7</b>
2.1 RICON WHEELCHAIR LIFT PERIODIC MAINTENANCE .....	7
2.2 RICON WHEELCHAIR LIFT CASSETTE REMOVAL & INSTALLATION .....	7
2.2.1 <i>Installation</i> .....	7
2.2.2 <i>Removal</i> .....	10
<b>3. AUDIO AND VIDEO SYSTEM DESCRIPTION – H3 SERIES .....</b>	<b>13</b>
3.1 TROUBLESHOOTING .....	16
<b>4. HOW TO RECEIVE SERVICE FOR YOUR REI AUDIO AND VIDEO PRODUCTS .....</b>	<b>17</b>
<b>5. DESCRIPTION OF AUDIO AND VIDEO SYSTEM INSTALLED ON X3-45 COACHES.....</b>	<b>18</b>
<b>6. DASHBOARD AM/FM RADIO .....</b>	<b>21</b>
6.1 REMOVAL/INSTALLATION .....	21
<b>7. VSS SOUND SELECTOR.....</b>	<b>21</b>
7.1 REMOVAL/INSTALLATION .....	21
<b>8. MULTICHANNEL POWER AMPLIFIER VA400.8 .....</b>	<b>21</b>
<b>9. 400W DSP POWER AMPLIFIER.....</b>	<b>22</b>
<b>10. BOOM-TYPE MICROPHONE .....</b>	<b>22</b>
10.1 REMOVAL.....	22
10.2 INSTALLATION .....	22
<b>11. HANDHELD PRIORITY MICROPHONE .....</b>	<b>23</b>
<b>12. WIRELESS MICROPHONE .....</b>	<b>23</b>
<b>13. MONITOR REMOVAL.....</b>	<b>23</b>
<b>14. SCENIC VIEWING SYSTEM.....</b>	<b>24</b>
<b>15. VD-404 MOBILE DVD PLAYER .....</b>	<b>24</b>
<b>16. ROOF ANTENNA INSTALLATION .....</b>	<b>24</b>
<b>17. BACK-UP CAMERA AND MONITOR .....</b>	<b>25</b>
<b>18. HUB ODOMETER.....</b>	<b>27</b>
18.1 DESCRIPTION .....	27
18.1.1 <i>Removal</i> .....	27
18.1.2 <i>Installation</i> .....	27
18.2 OPERATION .....	27

## SECTION 23: ACCESSORIES

<b>19.</b>	<b>ELECTRONIC DESTINATION SIGN (OPTIONAL)</b> .....	<b>28</b>
<b>20.</b>	<b>WINDSHIELD SUNSHADES</b> .....	<b>28</b>
20.1	END OF STROKE ADJUSTMENT .....	28
20.2	END OF STROKE ADJUSTMENT ON MOTORIZED SUNSHADES WITH CANTILEVER ARMS .....	29
<b>21.</b>	<b>PASSENGER SUNSHADES</b> .....	<b>29</b>
21.1	PRELOAD ADJUSTMENT .....	29
<b>22.</b>	<b>LAVATORY – H3 SERIES</b> .....	<b>29</b>
22.1	DESCRIPTION .....	30
22.2	MAINTENANCE.....	30
22.3	VENTILATION FAN .....	30
22.3.1	<i>Maintenance</i> .....	30
22.3.2	<i>Removal and Installation</i> .....	30
22.4	DOOR LOCK .....	31
22.5	LAVATORY LIGHT WITH MOTION SENSOR .....	31
22.5.1	<i>Removal and Installation</i> .....	31
22.5.2	<i>Dip Switch Settings</i> .....	31
22.6	EMERGENCY BUZZER .....	31
22.7	FRESH WATER TANK.....	31
22.7.1	<i>Fresh Water Tank Heater (Optional)</i> .....	32
22.7.2	<i>Fresh Water Tank Draining</i> .....	32
22.7.3	<i>Fresh Water Tank Filling</i> .....	32
22.8	LIQUID SOAP DISPENSER.....	32
22.9	FLUSH PUSH-BUTTON .....	33
22.9.1	<i>Pneumatic Timer Removal and Installation</i> .....	33
22.9.2	<i>Timer Adjustment</i> .....	33
22.10	FLUSH PUMP .....	34
22.10.1	<i>Flush Pump Pressure Adjustment</i> .....	34
22.11	SUMP TANK.....	34
22.11.1	<i>Sump Tank Draining</i> .....	34
22.11.2	<i>Sump Tank Filling</i> .....	34
22.12	CLEANING CABINET .....	34
<b>23.</b>	<b>LAVATORY INSTALLED ON X3-45 COACHES</b> .....	<b>35</b>
23.1	LAVATORY VENTILATION FAN .....	37
23.1.1	<i>Maintenance</i> .....	37
23.1.2	<i>Removal and Installation</i> .....	37
23.2	DOOR LOCK .....	37
23.3	LAVATORY LIGHT & NIGHT-LIGHT .....	38
23.4	EMERGENCY BUTTON .....	38
23.5	FLUSH PUSH BUTTON.....	38
23.5.1	<i>Flush push button removal and installation</i> .....	38
23.6	FLUSH PUMP .....	38
23.6.1	<i>Flush Pump Removal</i> .....	38
23.7	SUMP TANK.....	39
23.7.1	<i>Sump Tank Filling</i> .....	39
23.7.2	<i>Sump Tank Draining</i> .....	40
<b>24.</b>	<b>HORN INSTALLATION – X3 SERIES</b> .....	<b>40</b>
24.1	ELECTRIC OR AIR HORN MAINTENANCE.....	40

<b>25.</b>	<b>AIR HORN VALVE – H3 SERIES.....</b>	<b>41</b>
25.1	AIR HORN VALVE MAINTENANCE.....	41
<b>26.</b>	<b>WINDSHIELD WIPERS – H3 SERIES .....</b>	<b>42</b>
26.1	WIPER ECU MODULE A21 DIAGNOSTIC GUIDE H3 SERIES .....	42
<b>27.</b>	<b>WINDSHIELD WIPERS AND WASHERS – X3 SERIES.....</b>	<b>46</b>
27.1	GENERAL DESCRIPTION.....	46
27.2	WIPER ARM.....	46
27.2.1	<i>Wiper Arms Positioning</i> .....	46
27.3	WINDSHIELD WIPER MOTOR .....	47
27.3.1	<i>Windshield Wiper Motor Replacement</i> .....	47
27.4	TROUBLESHOOTING.....	48
<b>28.</b>	<b>AUTOMATIC FIRE SUPPRESSION SYSTEM (AFSS) (OPTIONAL).....</b>	<b>48</b>
28.1	STARTING THE VEHICLE AFTER TRIGGERING OF A FIRE ALARM.....	49
28.2	PERIODIC MAINTENANCE .....	49
<b>29.</b>	<b>TIRE PRESSURE MONITORING SYSTEM (TPMS SENSATA) – H3 SERIES.....</b>	<b>50</b>
29.1	TPMS DIAGNOSTIC TROUBLESHOOTING CODES – SENSATA SYSTEM .....	50
<b>30.</b>	<b>TIRE PRESSURE MONITORING SYSTEM (TPMS) – X3 SERIES.....</b>	<b>51</b>
<b>31.</b>	<b>ELECTRIC BRAKE CONTROL SYSTEM FOR TRAILER .....</b>	<b>51</b>
31.1	A40 CONNECTOR .....	51
31.2	7-BLADE RV/TRAILER CONNECTOR .....	51
31.3	VECT .....	52

**SECTION CHANGE LOG**

DESCRIPTION		DATE
1	Headlight cleaning system removed	Oct. 2023
2	Addition of Wiper ECU Module A21 – Diagnostic Guide	Jan. 2024
3	Addition of TMPS diagnostic troubleshooting codes table	Jan. 2024
4	Section 23 for H3 Series and X3 series merged into one section	June 2024
5	Addition of reference to Ricon wheelchair lift maintenance and service manual	June 2024
6		

1. TORQUE TABLES

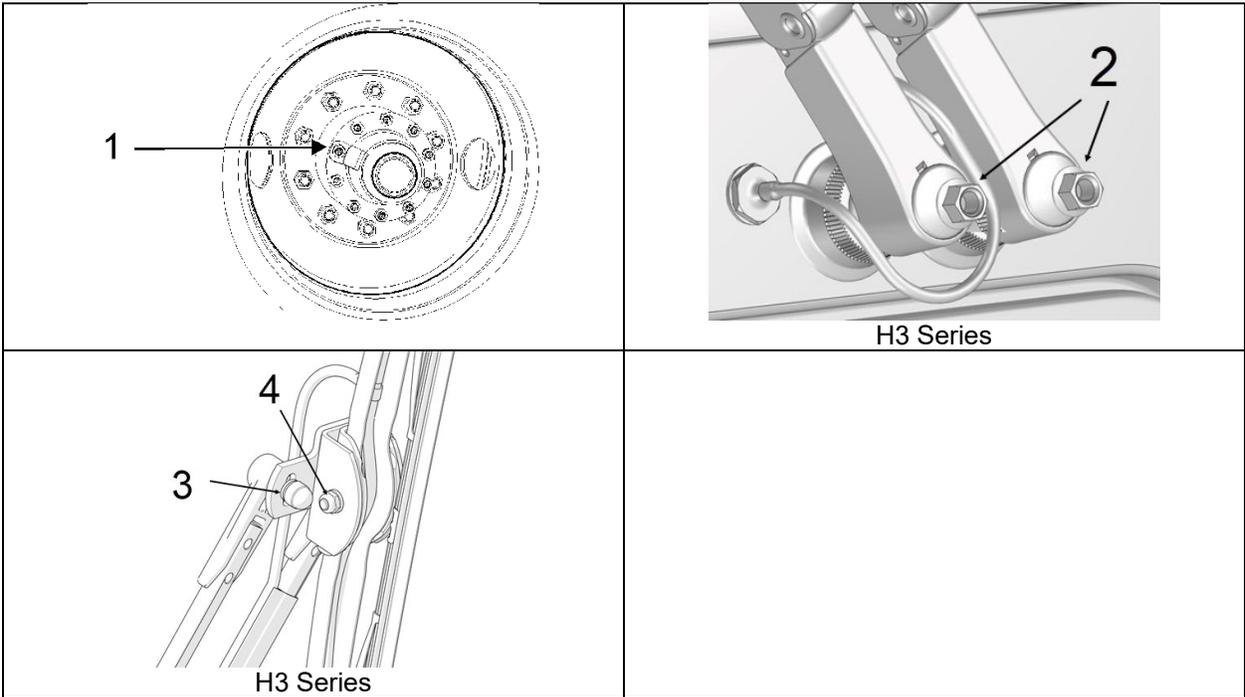

MISCELLANEOUS

No	DESCRIPTION	TORQUE
1	Hub odometer mounting bolts	<b>Erreur ! Liaison incorrecte.</b>
2	H3 Series wiper arm mounting nut	<b>Erreur ! Liaison incorrecte.</b>
3	H3 Series wiper blade adjustment nut	<b>Erreur ! Liaison incorrecte.</b>
4	H3 Series wiper blade mounting nut	<b>Erreur ! Liaison incorrecte.</b>

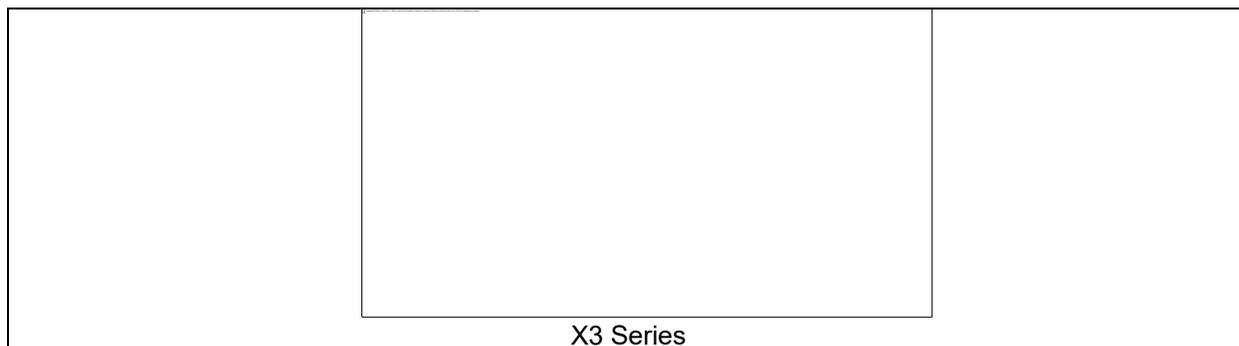

X3 Series

**MISCELLANEOUS**

No	DESCRIPTION	TORQUE
2	X3 Series wiper arm mounting bolts	first tightening <b>Erreur ! Liaison incorrecte.</b>
3	X3 Series wiper arm mounting bolts	second tightening <b>Erreur ! Liaison incorrecte.</b>

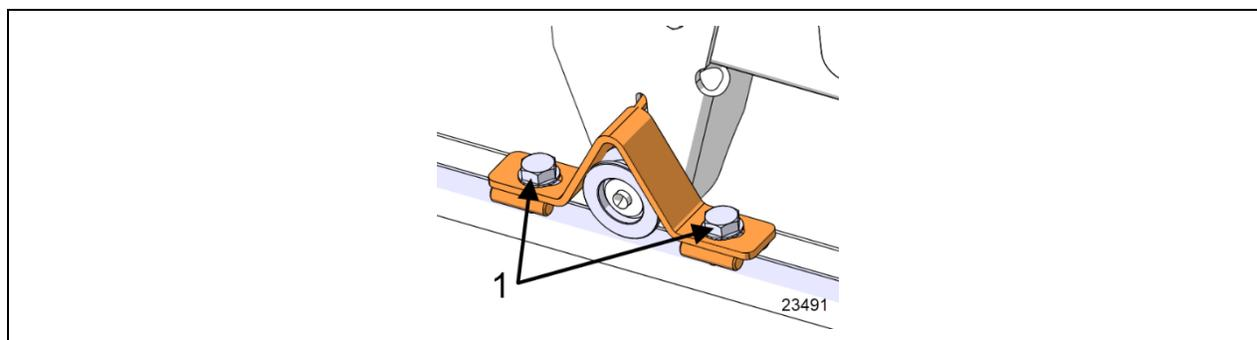

**WHEELCHAIR LIFT CASSETTE INSTALLATION**

No	DESCRIPTION	TORQUE
1	WCL cassette anchor bolts	<b>Erreur ! Liaison incorrecte.</b>

## 2. RICON WHEELCHAIR LIFT

### 2.1 RICON WHEELCHAIR LIFT PERIODIC MAINTENANCE

Regular maintenance of the Ricon Mirage F9TF/F9TH Public Use wheelchair lift will provide optimum performance and reduce the need for repairs.

Maintenance schedule and relevant information is available in the **Mirage F9TF/F9TH Public Use service manual**, part number **32DF9T16**.

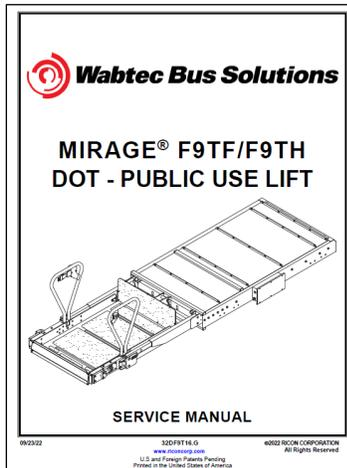

This manual is available at the Ricon website in PDF format. The website is located at [www.ricon-corp.com](http://www.ricon-corp.com). At the website, click on “Technical Documents”, “I agree”, and then “Service Manuals”.

You can also get this manual through **Prevost Technical Publications** site under *Supplier Publications* tab.

### 2.2 RICON WHEELCHAIR LIFT CASSETTE REMOVAL & INSTALLATION

**WARNING**

For better stability, keep the platform at minimum height when moving.

**WARNING**

Never deploy the platform from enclosure while standing on the telescopic legs.

**WARNING**

Telescopic legs were designed to support and move the platform only, do not use as a work table.

**WARNING**

Before moving platform, make sure that floor is level and free of obstacles.

#### 2.2.1 Installation

1. Install four lifting jacks on the wheelchair lift cassette.

**NOTE**

There are two telescopic legs for each platform side. The proper side is indicated onto the telescopic leg.

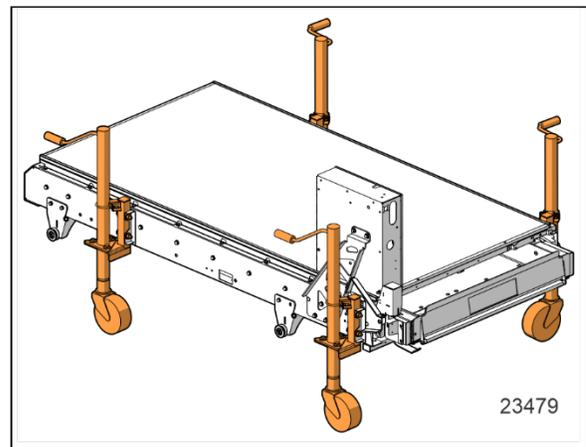

FIGURE 1: JACK INSTALLATION

2. **X3 SERIES ONLY:** Dismount partially the control box (4 screws) and tilt it slightly to allow the cassette to slide inside the compartment.

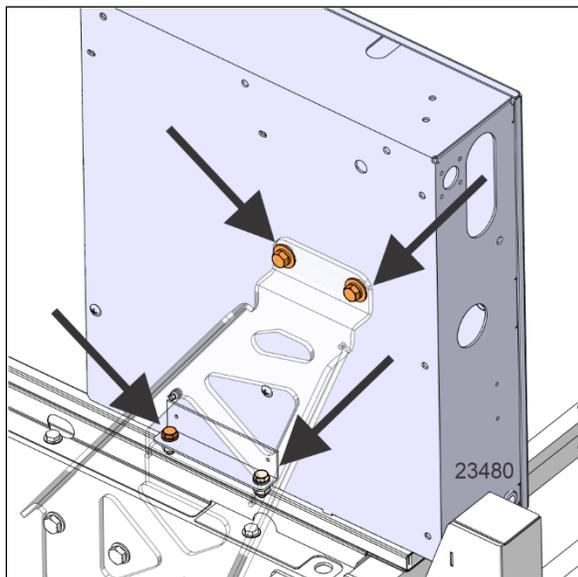

FIGURE 2: CONTROL BOX DISMOUNTING

- Slide the cassette into the compartment to get the rear rollers backward the rail front stopper.

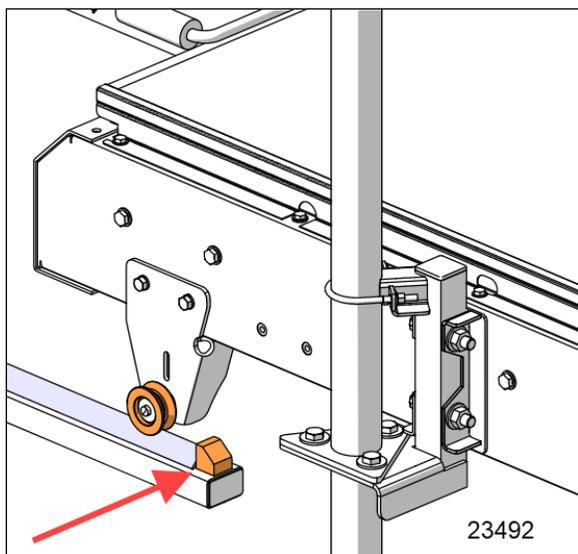

FIGURE 3: SLIDE CASSETTE OVER STOPPERS

- Drop down the rear side of the cassette until it gets contact with the rail and make sure the back rollers are aligned with the V-rail.
- Remove jacks (2) on the rear side.

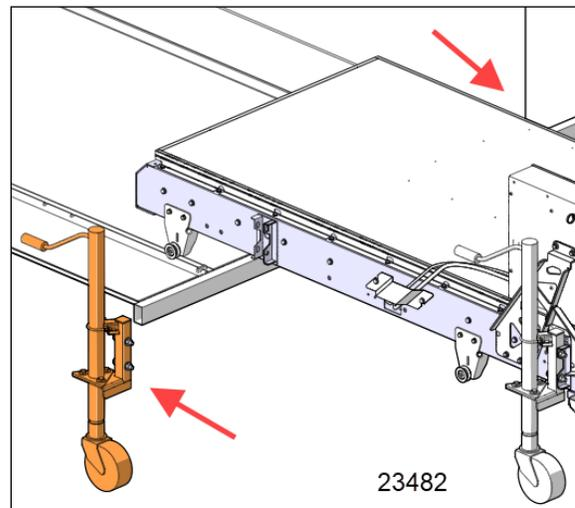

FIGURE 4: JACK REMOVAL ON REAR SIDE

- Reinstall the fasteners on the dismantled jacks.
- Keep sliding the cassette inside the compartment to get the front rollers backward of the stoppers.

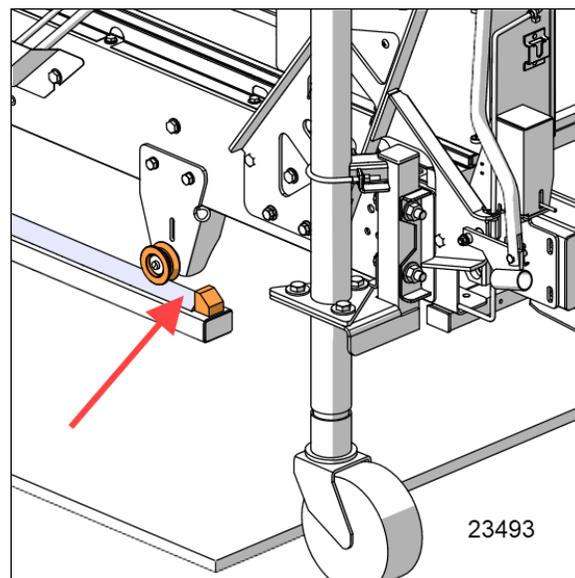

FIGURE 5: SLIDE THE CASSETTE INSIDE THE COMPARTMENT

- Drop down the front side of the cassette until it gets contact with the rail and make sure the rollers are aligned with the V-rail.
- Remove the jacks (2) on the front side of the cassette.



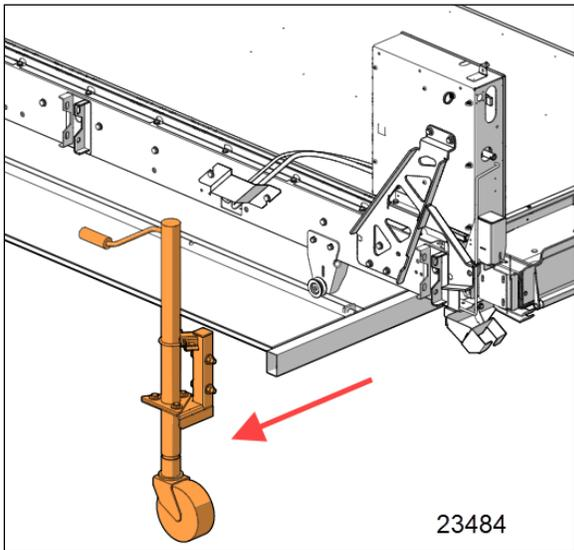

FIGURE 6: JACKS REMOVAL

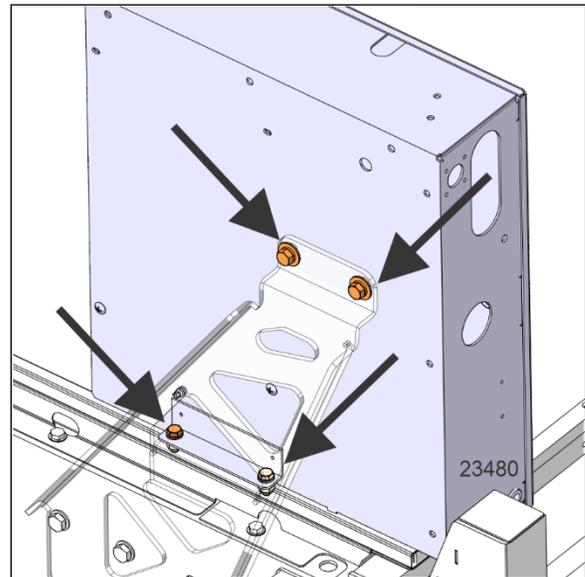

FIGURE 8: CONTROL BOX DISMOUNTING

10. Reinstall the fasteners on the dismantled jacks.

11. Install locks in four locations and tighten screws to prescribed torque.

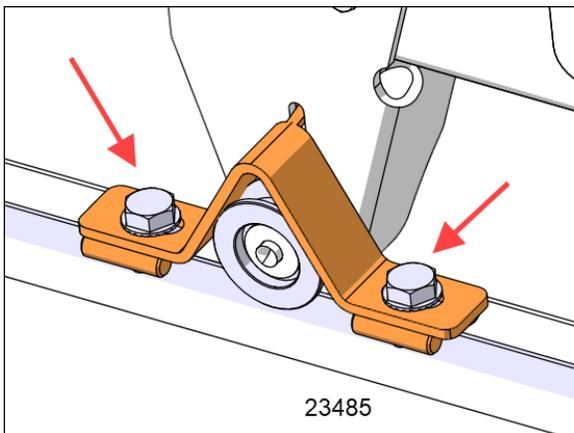

FIGURE 7: ANCHOR BOLTS INSTALLATION

12. **X3 SERIES ONLY:** Reinstall the control box with 4 screws.

**NOTE**

*HYDRAULIC MANUAL OVERRIDE LINKAGE*

*Due to interference with compartment door arm, when installing a WCL cassette built before 2020 on a X3 Series MY 2020 and later, the hydraulic manual override linkage must be replaced by hydraulic manual override linkage p/n 491693.*

HYDRAULIC MANUAL OVERRIDE LINKAGE

13. Plug the electrical connectors and lock it with the connector cover.

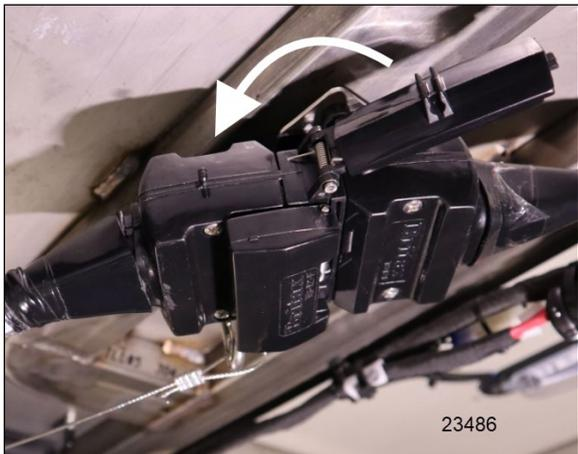

FIGURE 9: ELECTRICAL CONNECTION

14. Attach the protective wire.



FIGURE 10: PROTECTIVE WIRE INSTALLATION

### 2.2.2 Removal

1. Detach the protective wire. Unlock the connectors. Unplug the electrical connectors.

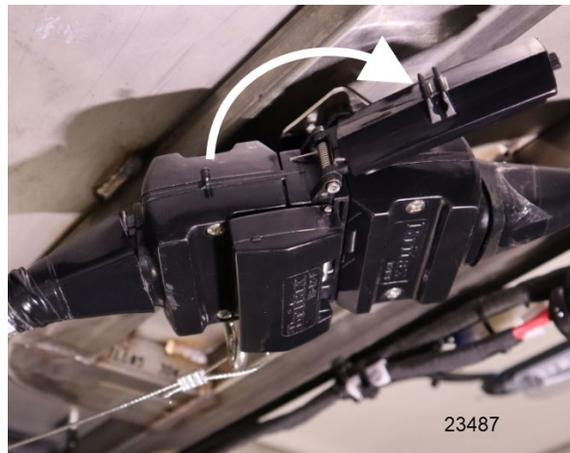

FIGURE 11: ELECTRICAL DISCONNECTION

2. Detach the protective wire.



FIGURE 12: PROTECTIVE WIRE INSTALLATION

3. **X3 SERIES ONLY:** Dismount partially the control box (4 screws) and tilt it slightly to allow the cassette to slide outside the compartment.

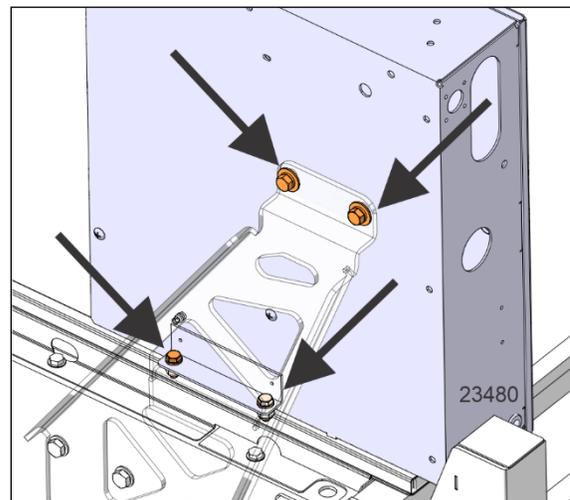

FIGURE 13: CONTROL BOX DISMOUNTING

- Remove locks in four locations and keep it with the removed cassette.

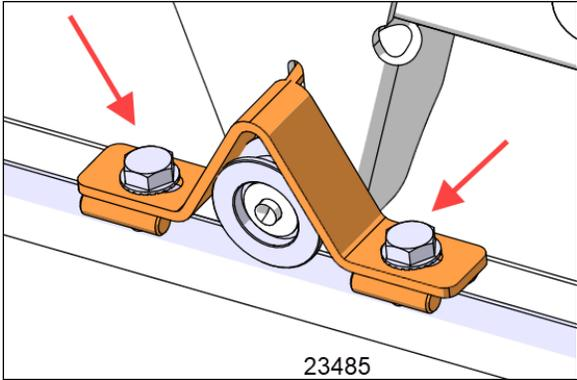

FIGURE 14: LOCKS REMOVAL

- Slide out the cassette until the front rollers get the stoppers. Install jacks on the front side of the cassette.
- Lift up the front side of the cassette until the front rollers clear the front stoppers.

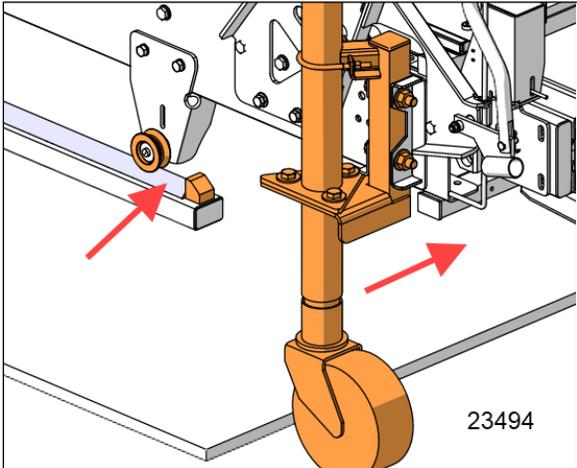

FIGURE 15: LIFT UP THE FRONT SIDE OF THE CASSETTE

- Keep sliding out the cassette until the rear rollers get to stoppers. Install jacks on the rear side of the cassette. Lift up the rear side until the rear rollers clear the stoppers.

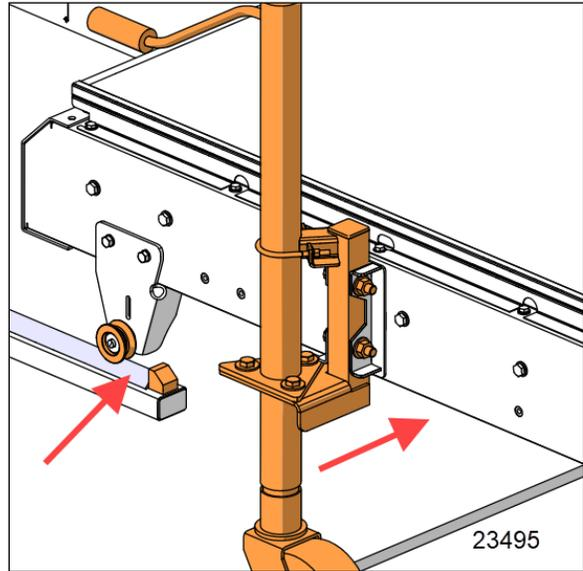

FIGURE 16: DROP THE REAR SIDE ON RAILS

- X3 SERIES ONLY:** Reinstall the control box with the screws (4).

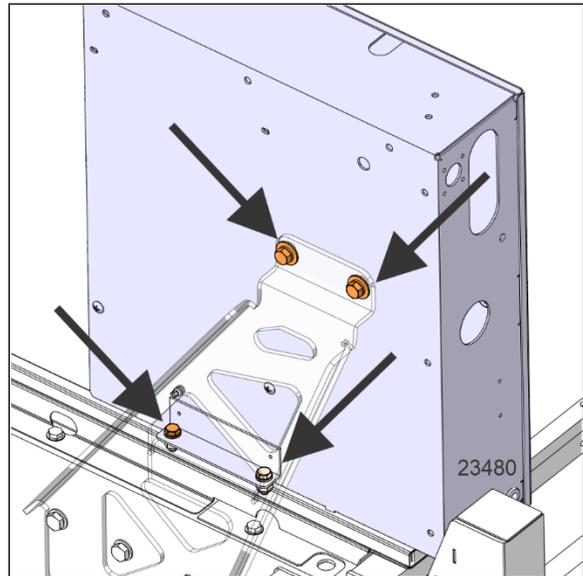

FIGURE 17: CONTROL BOX DISMOUNTING

- Slide out completely the wheelchair lift cassette.

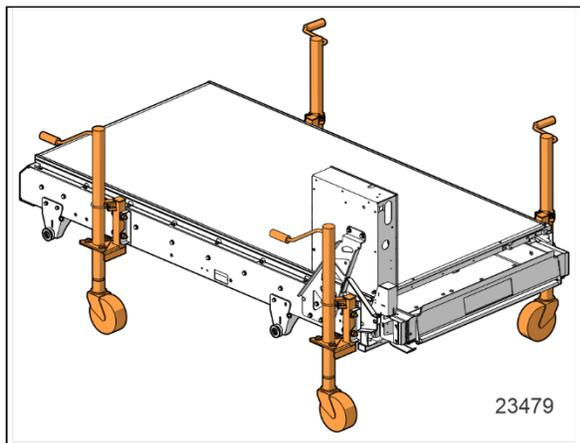

FIGURE 18: MOVE OUT THE CASSETTE

### 3. AUDIO AND VIDEO SYSTEM DESCRIPTION – H3 SERIES

The rack mounted components are gathered on the audio-video panel which is located in the first driver's side overhead compartment (Figure 19). In addition to the 400 watts power amplifier, an E-HDMI (automotive grade) switch provides options for systems such as TV, DVD, customer provided media player, scenic view and back-up cameras, GPS navigation system and wireless microphones. Options for AM/FM radio, satellite radio, karaoke, and other's entertainments systems may also be featured.

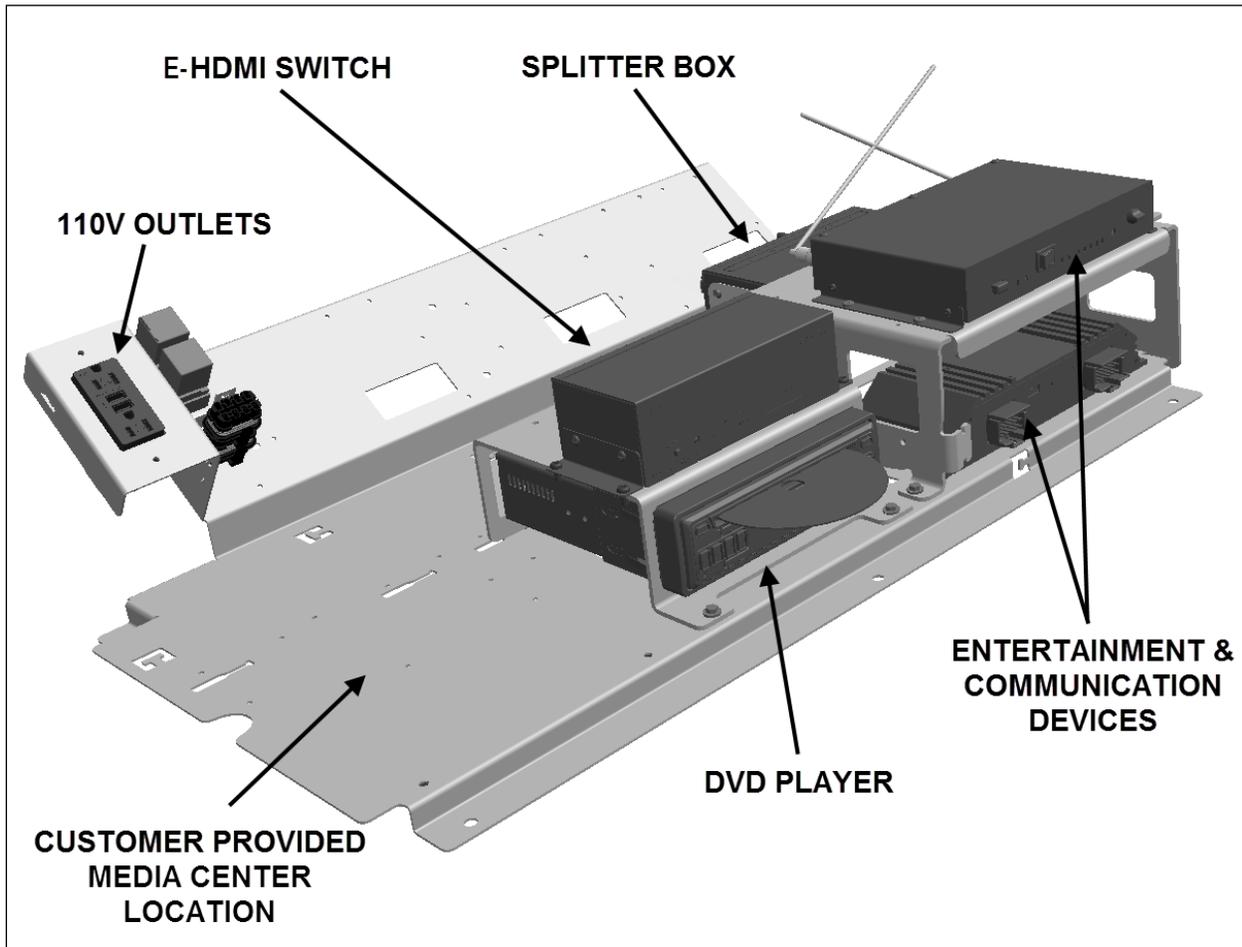

FIGURE 19: AUDIO-VIDEO PANEL IN OVERHEAD COMPARTMENT

A splitter box is also mounted on the audio/video panel and provides connection for four LCD screens. On some vehicles, a second splitter box mounted in the first curbside overhead compartment will allow the use of a total of six LCD screens.

Each passenger's overhead console mounted to the underside of the overhead compartments contains a 20-watt coaxial 10cm speaker. Powered by the amplifier, the speakers (28 in H3-45) are wired in stereo and arranged in a delta configuration.

A microphone outlet mounted in the driver's area is also provided as standard equipment.

<

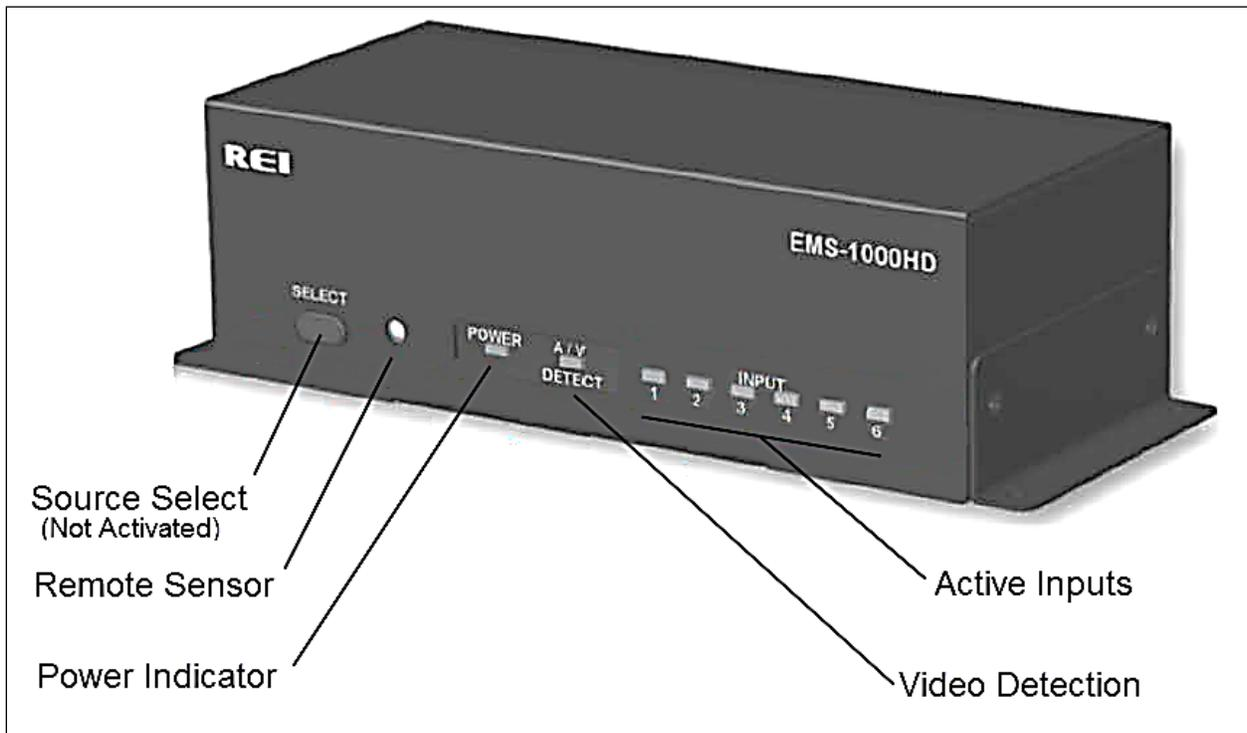

FIGURE 20: AUDIO-VIDEO CONTROLS AND INDICATORS ON THE FRONT FACE OF THE E-HDMI SWITCH

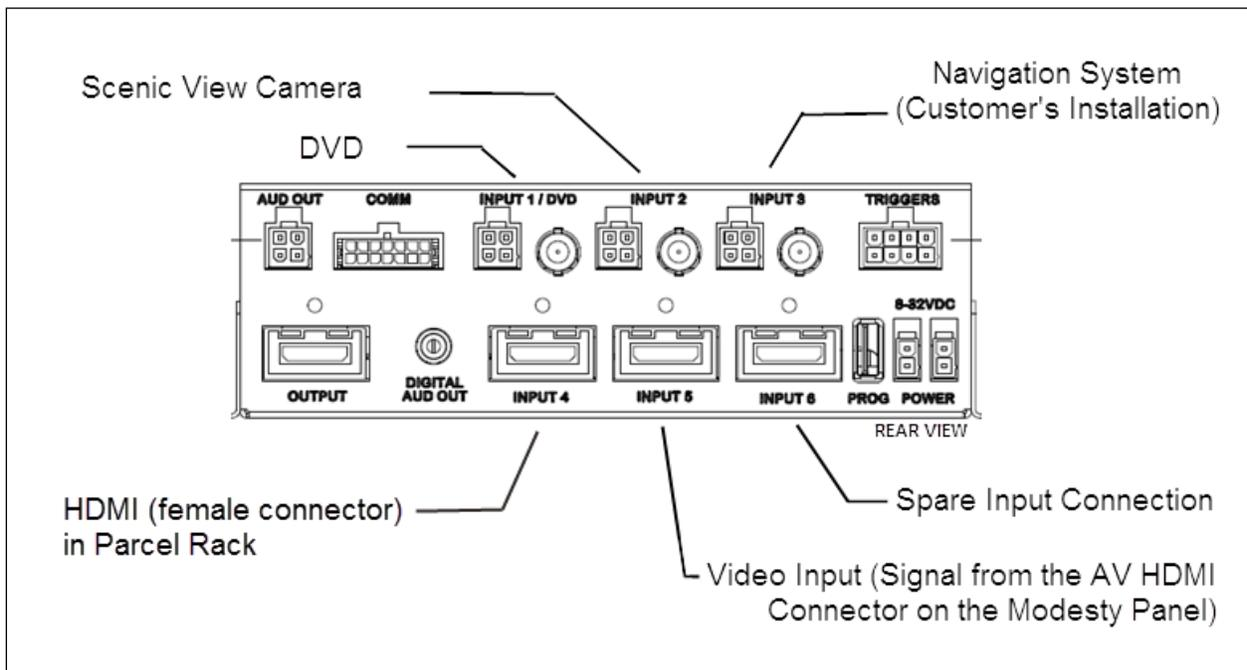

FIGURE 21: AUDIO-VIDEO CONNECTIONS AT THE BACK OF THE E-HDMI SWITCH

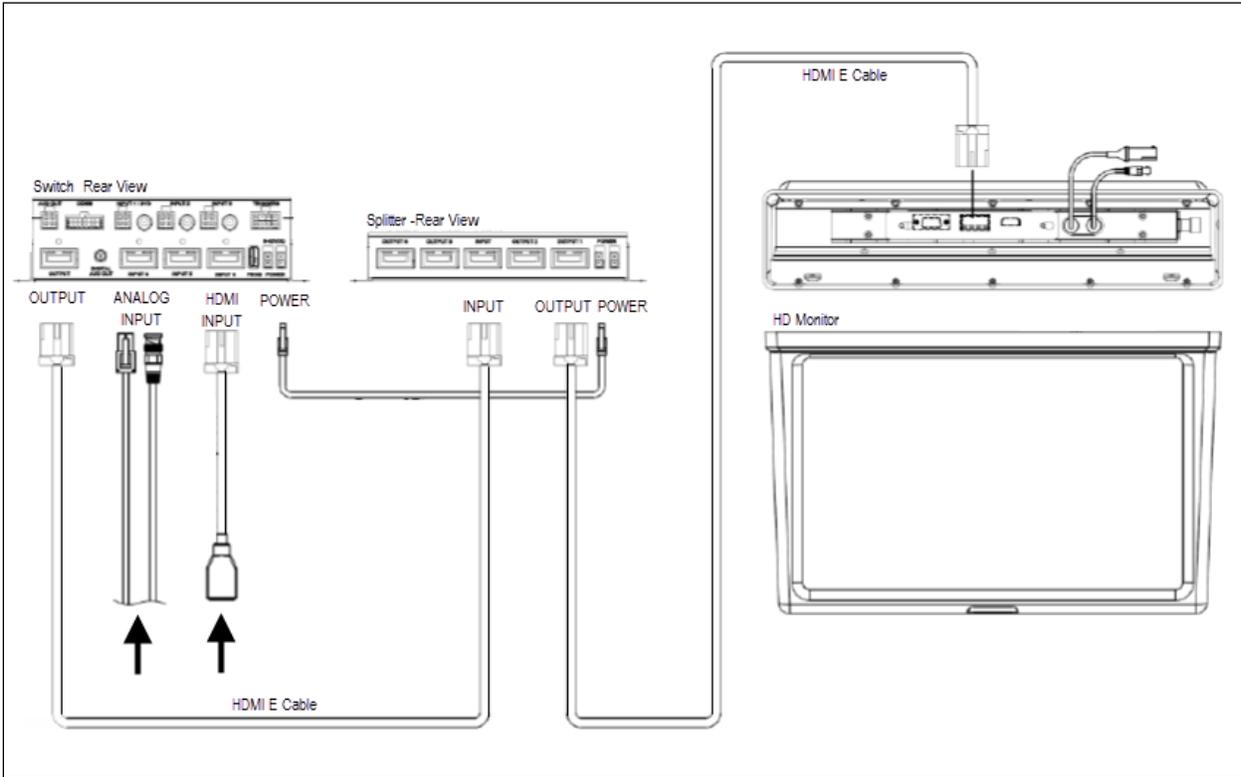

FIGURE 22: TYPICAL AUDIO-VIDEO CONNECTIONS USING FOUR OUTPUT SPLITTER BOX

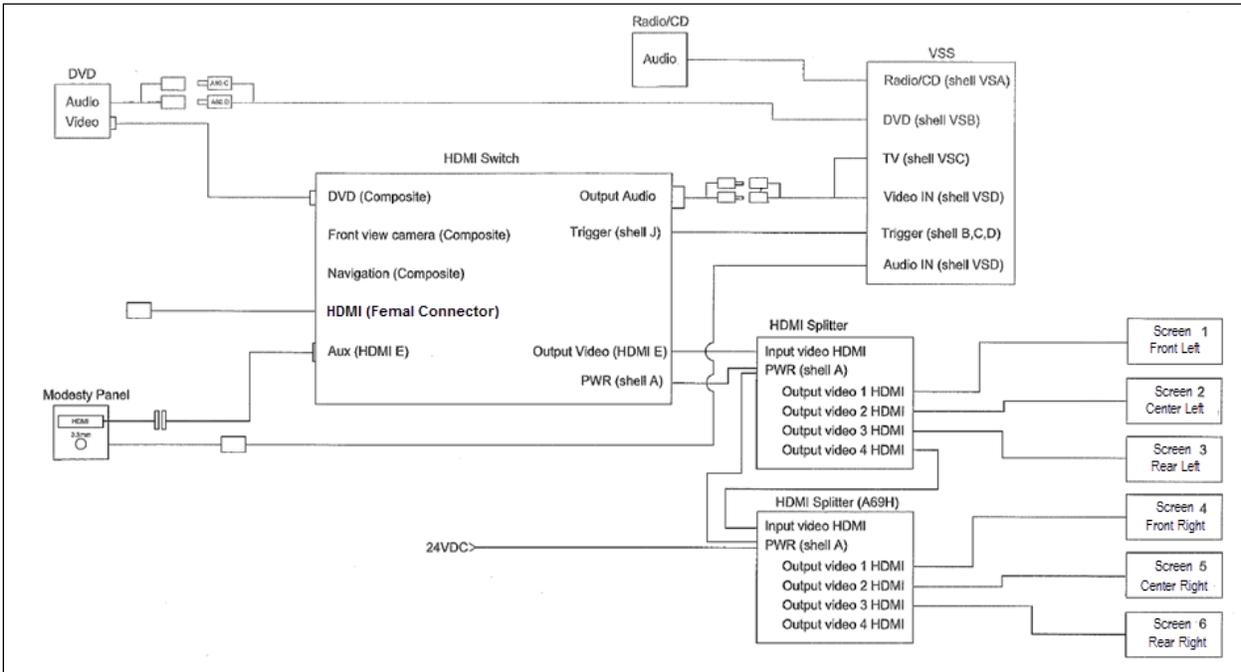

FIGURE 23: AUDIO-VIDEO CONNECTIONS USING TWO SPLITTER BOXES TO ALLOW THE USE OF SIX LCD MONITORS

## 3.1 TROUBLESHOOTING

Symptom	Possible Causes / Solutions
No picture, no sound	Check for proper voltage supply and correct cable connections. Ensure that the desired input is selected.
No picture	Check whether AV cable is properly connected. Check whether HDMI cables are properly connected. Verify that HDMI source is connected to "INPUT" connector and devices to "OUTPUT". Verify power connection and voltage.
No sound	Check for proper cable connections. Verify that the source volume level is properly set.
Remote control not working	Check that remote control is pointed toward device sensor. Verify remote batteries.



#### 4. HOW TO RECEIVE SERVICE FOR YOUR REI AUDIO AND VIDEO PRODUCTS

For assistance in obtaining service for REI products call toll free 877-726-4617 (Continental United States and Canada) between the hours of 7:00 A.M. - 5:00 P.M. CST Monday thru Friday (excluding Holidays).

Prior to calling REI, please have the part number, serial number, VIN number and detailed description of the problem ready to provide to the REI service representative. After providing information to REI, customers will be issued a return authorization number. When the REI service representative provides the return authorization number, they will also give instructions for returning the item. Any discrepancies in following this procedure may cause delays in the process.

**24/7** Tech Support

**CALL 1-877-726-4617**

E-Mail to [technicalsupport@radioeng.com](mailto:technicalsupport@radioeng.com)

##### REI Authorized Repair Facilities

REI  
6534 L Street  
Omaha, Nebraska 68117

REI  
1376 Bennett Drive, Unit 126  
Longwood, Florida 32750

REI products that may be installed in your coach:

MONITOR, COLOR BACK-UP CAMERA  
MONITOR, LCD 15.6"  
MONITOR, CENTRAL LCD 15.6"  
MONITOR, FLIP 19"  
MONITOR, 16:9 CENTRAL LCD 19"  
INDIVIDUAL ENTERTAINMENT SYSTEM  
AMPLIFIER, 8-CHANNEL  
DVD PLAYER

DVD REMOTE CONTROL  
CAMERA, COLOR BACK-UP  
CAMERA, COLOR PANORAMIC  
MICROPHONE, 10" CB TYPE  
MICROPHONE, WIRELESS  
RECEIVER, WIRELESS MIC 16-CHANNEL  
ENHANCED MEDIA SWITCH (E-HDMI)  
E-HDMI SPLITTER BOX

## 5. DESCRIPTION OF AUDIO AND VIDEO SYSTEM INSTALLED ON X3-45 COACHES

The rack mounted components are gathered on the audio-video panel which is located in the first driver's side overhead compartment (Figure 24). In addition to the power amplifier, options for AM/FM radio, satellite radio, karaoke, wireless microphone, DVD, scenic view and back-up camera system and GPS Navigation System module may be featured.

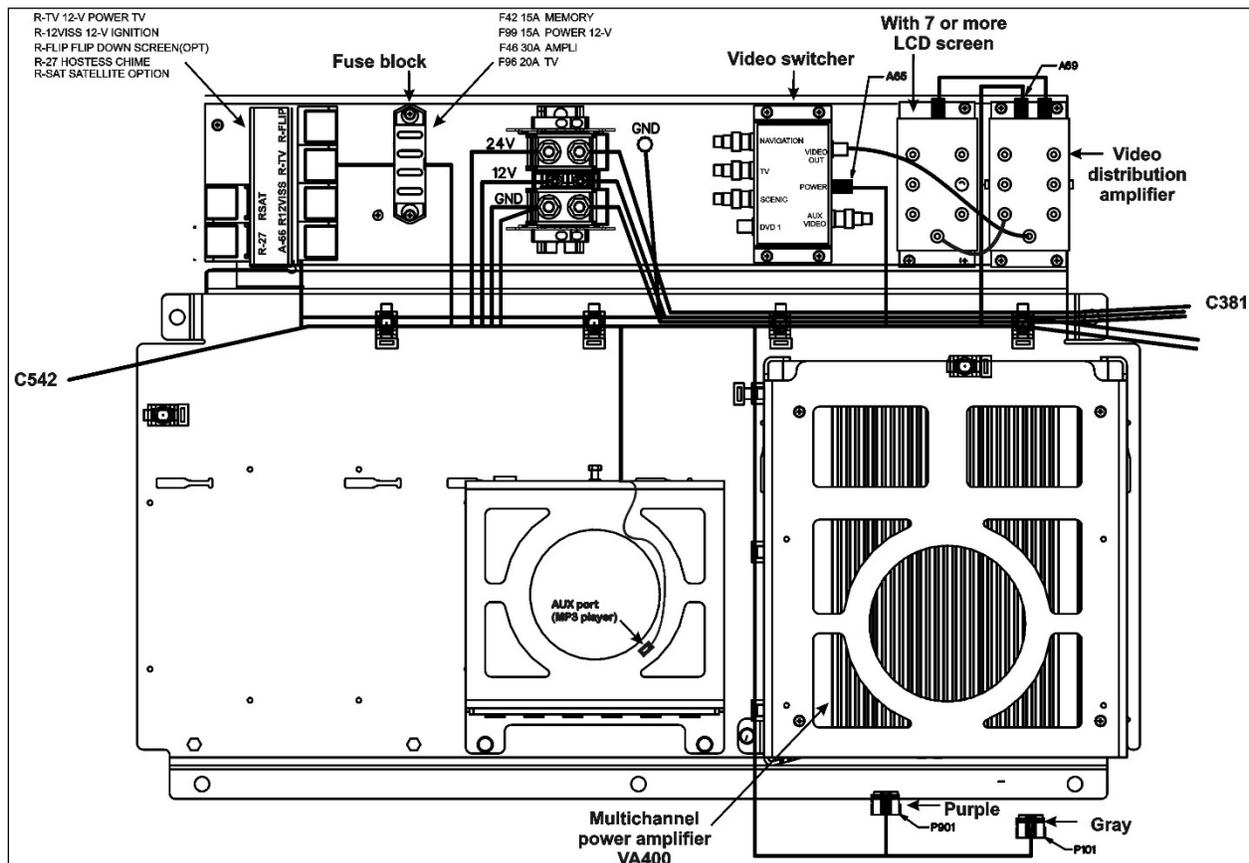

FIGURE 24 : AUDIO-VIDEO PANEL

Each service module mounted to the underside of the overhead compartments contains a 40-watt speaker. The speakers in the passenger section are wired in stereo and are powered by the amplifier. A microphone outlet mounted in the driver's area is provided as standard equipment.

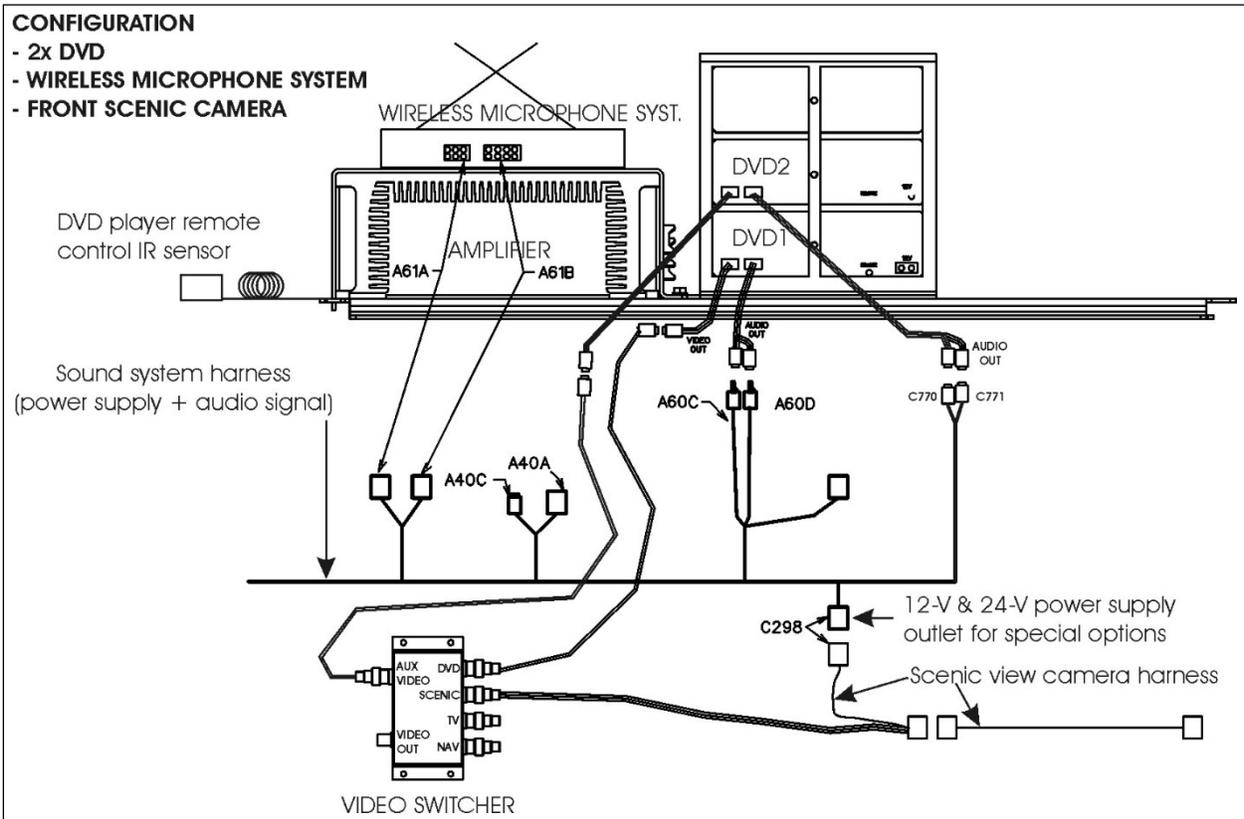

FIGURE 25

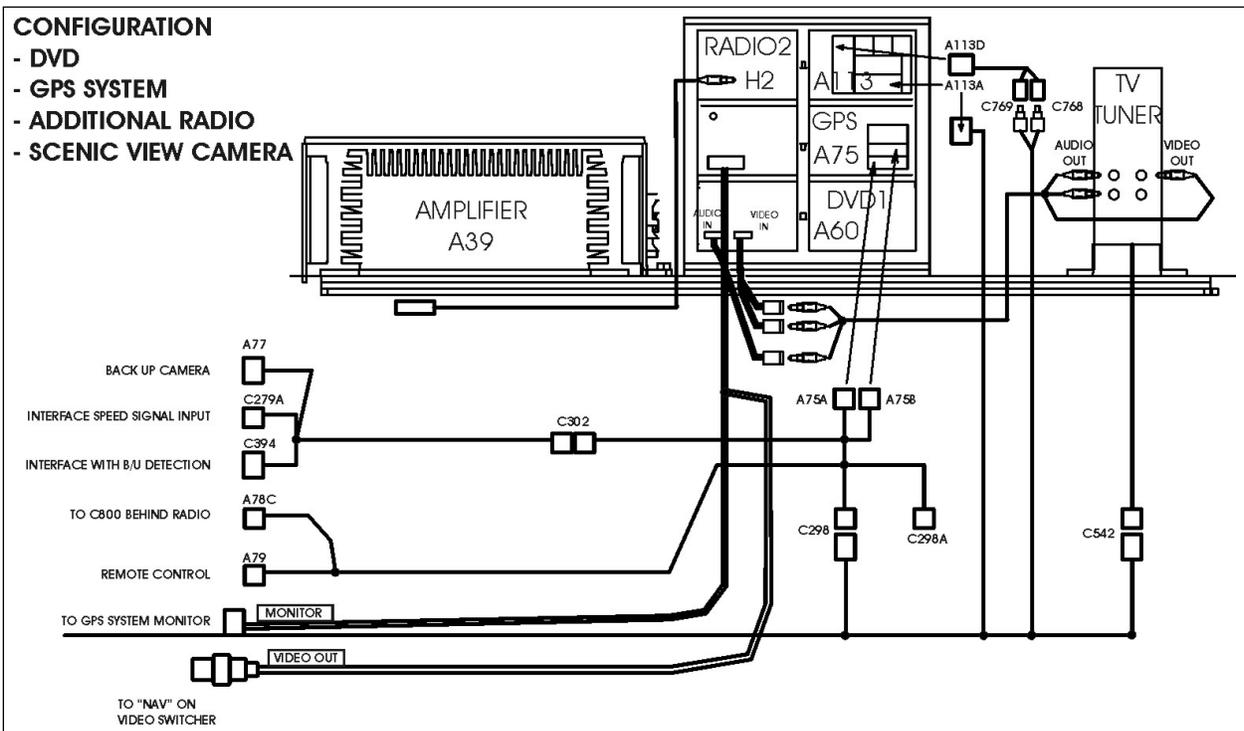

FIGURE 26: AUDIO & VIDEO CONNECTIONS

## SECTION 23: ACCESSORIES

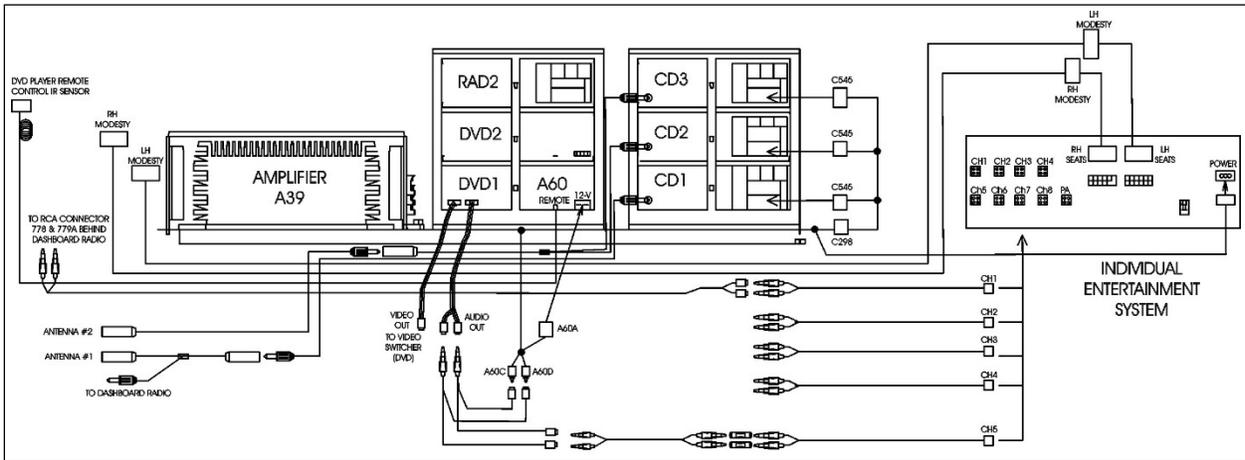

FIGURE 27: AUDIO-VIDEO CONNECTIONS

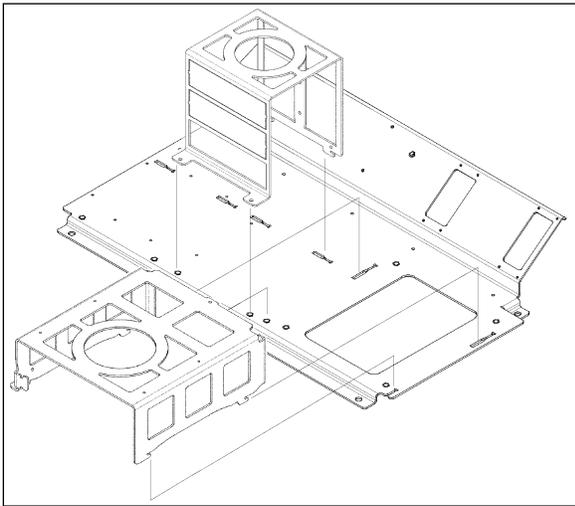

FIGURE 28: RACKS ON AUDIO-VIDEO PANEL 23059

## 6. DASHBOARD AM/FM RADIO



FIGURE 29: DASHBOARD AM/FM RADIO

### NOTE

*Before attempting to solve an electrical problem on the sound system, refer to the wiring diagrams.*

Refer to your vehicle Operator Manual for radio operating instructions.

### 6.1 REMOVAL/INSTALLATION

To remove the radio from its location, proceed as follows:

1. Place the ignition switch in the "OFF" position.
2. Remove the dashboard cover.
3. Disconnect the electrical cable connectors from radio and unfasten back plate securing nuts/screws.
4. To separate the radio from its support, insert the removal tool #20584494 in the holes found each side of the radio front panel.
5. Push the unit through the front dashboard panel.
6. Install a new unit by reversing the procedure.

## 7. VSS SOUND SELECTOR



FIGURE 30: VSS SOUND SELECTOR

### 7.1 REMOVAL/INSTALLATION

To remove the Sound Selector from its location, proceed as follows:

1. Place the ignition switch in the "OFF" position.
2. Remove the dashboard cover.
3. Unplug the connectors from the VSS and unfasten back plate securing nuts/screws.
4. On the front side of the unit, insert the removal tool #20584494 in the holes found each side in order to separate the unit from the support.
5. From behind, push the unit through the front dashboard panel.
6. Installation of a new unit is the same as removal but in reverse order.

The operating instructions are included in the Operator's Manual.

## 8. MULTICHANNEL POWER AMPLIFIER VA400.8

This 400-watt, 6-channels brings an added dimension to your stereo equipment and increases the total output of the system.

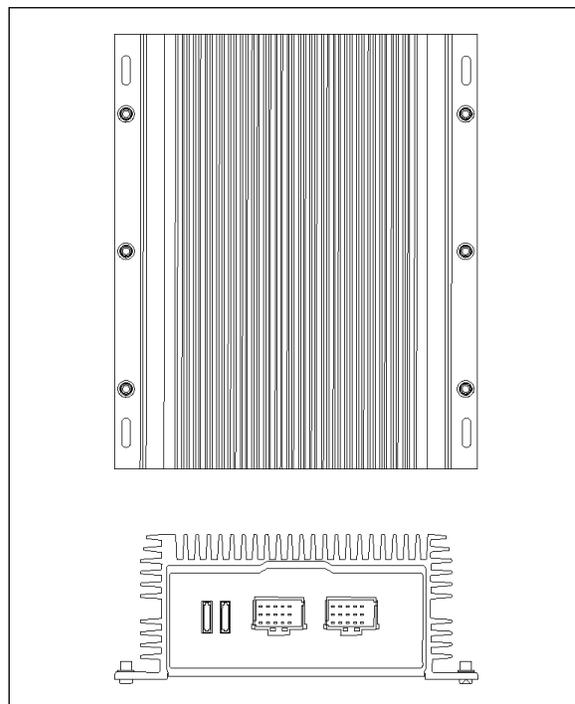

FIGURE 31: MULTICHANNEL POWER AMPLIFIER

For optimum sound quality, adjust the subwoofer crossover filter as shown on figure 9. This adjustment is necessary to balance the subwoofers volume in respect to the other

speakers and also to cut high frequencies for a better sound quality.

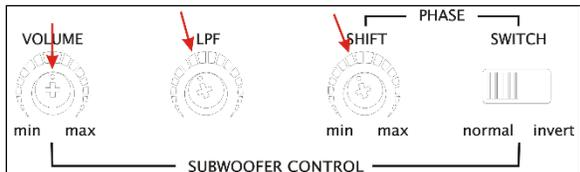

FIGURE 32: CROSSOVER ADJUSTMENT

### 9. 400W DSP POWER AMPLIFIER

This 400-watt, 8 channels digital amplifier brings an added dimension to your stereo equipment and increases the total output of the system.

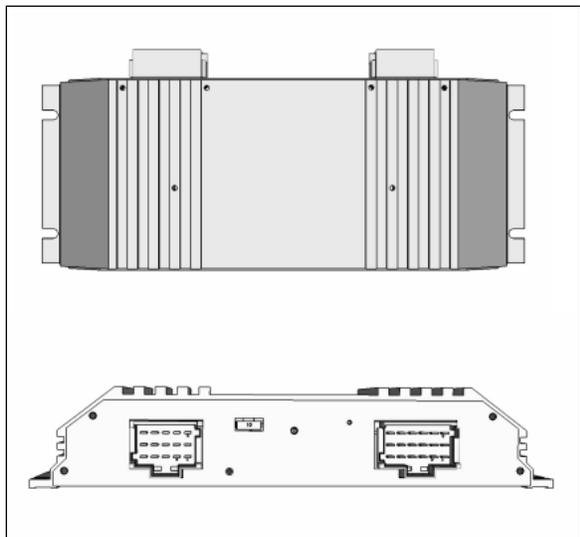

FIGURE 33: MULTICHANNEL 400W POWER AMPLIFIER

**CONNECTOR 9-966140-2 PINOUT**

Terminal	Function	Terminal	Function
1	R-DOOR (-)	9	L-DASH (-)
2	R-DASH (+)	10	GROUND
3	R-DASH (-)	11	GROUND
4	R-DOOR (+)	12	GROUND
5	L-DOOR (+)	13	+24V
6	L-DOOR (-)	14	+24V
7	REMOTE	15	+24V
8	L-DASH (+)	16	

**CONNECTOR 9-966140-1 PINOUT**

Terminal	Function	Terminal	Function
1	R-BUNK (-)	10	INPUT-RR (+)
2	WOOFER (1) (-)	11	INPUT-RR (-)
3	WOOFER (1) (+)	12	
4	R-BUNK (+)	13	INPUT-LR (-)
5	L-BUNK (-)	14	INPUT-LR (+)
6	L-BUNK (+)	15	INPUT-LF (+)
7		16	INPUT-RF (+)
8	WOOFER (2) (-)	17	INPUT-RF (-)
9	WOOFER (2) (+)	18	INPUT-LF (-)

Wiring diagrams for both connectors are shown to the right of the tables.

FIGURE 34: AMPLIFIER CONNECTORS PINOUT

### 10. BOOM-TYPE MICROPHONE

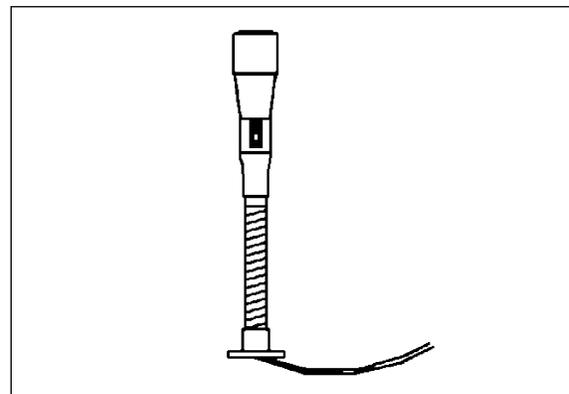

FIGURE 35: BOOM-TYPE MICROPHONE 23083

#### 10.1 REMOVAL

1. Place the ignition switch in the "OFF" position.
2. Remove the mounting screws at mounting flange.
3. Disconnect wiring.

#### 10.2 INSTALLATION

1. Reconnect wiring.

- Align mounting flange with holes and install screws.
- Remove spacer block mounting screws.
- Insert spacer block and install mounting screws.
- Place the battery master switch in the "ON" position.

## 11. HANDHELD PRIORITY MICROPHONE

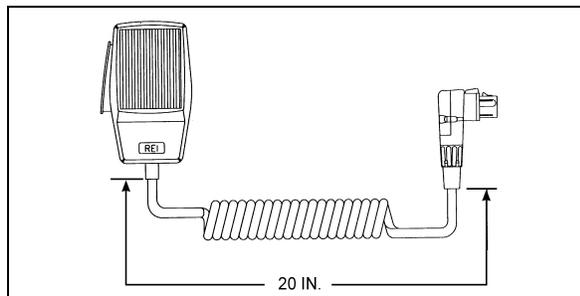

FIGURE 36: HANDHELD PRIORITY MICROPHONE 23216

## 12. WIRELESS MICROPHONE

The wireless microphone, receiver and charging cradle are custom designed units that allow for wireless communication from anywhere on the coach. The unit consists of a receiver mounted in the parcel area directly behind the driver, and a rechargeable hand-held microphone and charging unit. Instructions for proper use of the microphone are included in the "REI Operating Manual" which is provided in the technical publications box delivered with the vehicle.

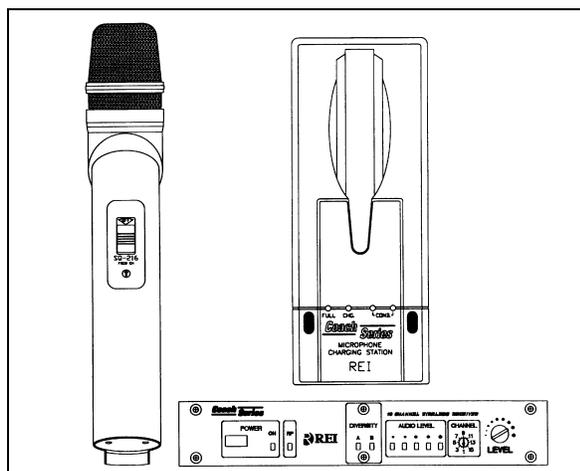

FIGURE 37: WIRELESS MICROPHONE

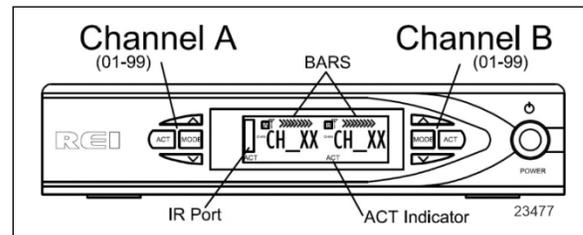

FIGURE 38: WIRELESS MIC RECEIVER

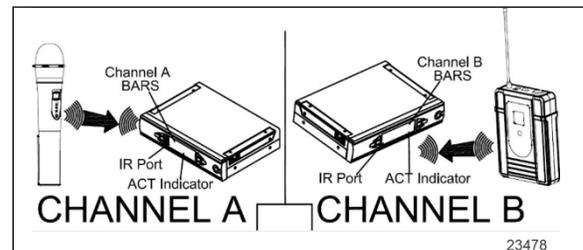

FIGURE 39: MIC DEVICES

Handheld mic always airs to channel A and belt pack mic always pairs to channel B.

To pair microphone to receiver:

- Press ACT button for appropriate channel. ACT indicator on receiver display will blink to show the receiver is searching for the device to be paired.
- Turn device on and face the IR ports towards the display on the receiver.
- When device has paired, there will be bars across the top edge of the receiver display for the appropriate channel.

## 13. MONITOR REMOVAL

- Place the ignition switch in the "OFF" position.
- Unfasten the retaining screw located on the monitor R.H. side.
- Slide the monitor to the right to release it from the mounting bracket.

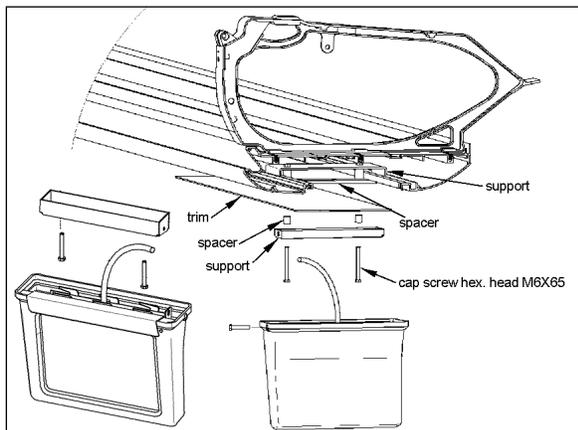

FIGURE 40: MONITOR MOUNTING

23221

## 14. SCENIC VIEWING SYSTEM

The scenic viewing system enables the passengers to view the road ahead of the vehicle. This system is composed of a camera, a dashboard mounted ON/OFF switch and the video switcher located on the audio-video panel.

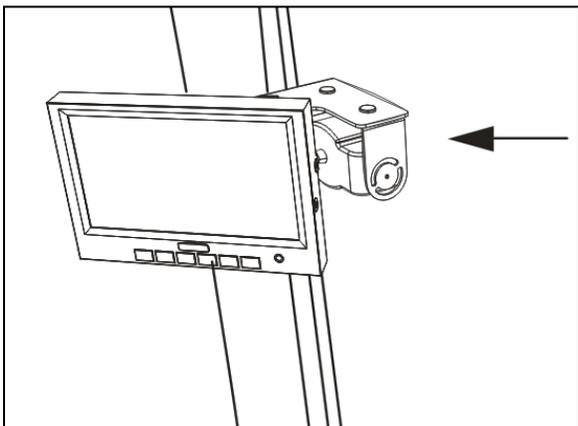

FIGURE 41: SCENIC VIEW CAMERA

## 15. VD-404 MOBILE DVD PLAYER



FIGURE 42: VD-404 MOBILE DVD PLAYER

The MOBILE DVD PLAYER is located in the first parcel compartment on the driver's side.

Instructions for proper use of this unit are found on your technical publications USB flash drive.

Features:

- POWER

Operating voltage: 12-volt DC

- COMPATIBILITY

This DVD player can play the following disc formats:  
DVD, CD, VCD, DVCD, MP3, CD-R, CD-RW

- SYSTEM FUNCTIONS

Video output system: system MULTI, NTSC or PAL switchable.

1 L/R audio output

1 L/R audio input

1 AUX video output

1 rear camera video input

3 video outputs with one dedicated self-switching rear view monitor

- ADDITIONAL VIDEO FEATURES

Multi-angle, multi-view, multi-audio function, multi-level forward and backward motion, play position memory, resume stop and repeat function.

## 16. ROOF ANTENNA INSTALLATION

1. Find the desire location and drill a hole according to specification.
2. To remove dirt and grease, wash hole edge with alcohol.
3. If so equipped, remove foam padding ring from antenna to free the metal surface (foam can produce air bulbs in new rubber seal).
4. With SIKA 205, wash the vehicle hole edge and the antenna base surface, wait at least two (2) minutes for chemical evaporation.
5. Apply new seal SIKA 221 on both, vehicle hole edge and antenna base.
6. Fix the antenna in place.
7. Remove excess seal and complete a finishing joint all around the antenna base.



### 17. BACK-UP CAMERA AND MONITOR

An optional back-up camera is available which provides the driver with visual assistance when backing-up. The camera is automatically activated when the transmission is put in reverse gear and the ignition switch is "ON".

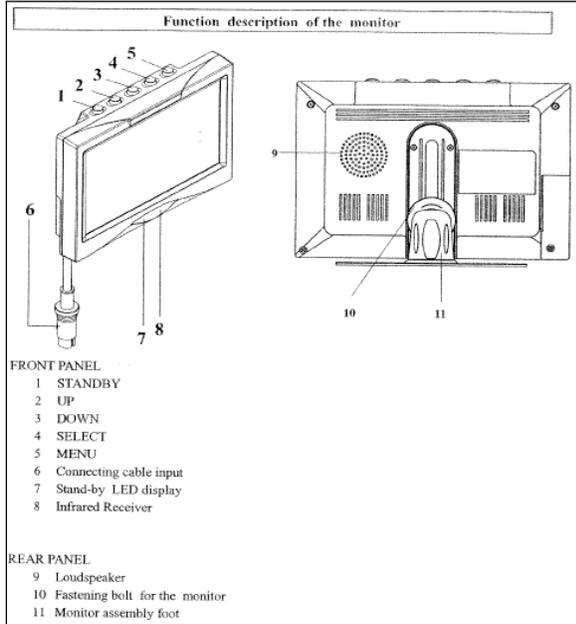

#### BUTTON DESCRIPTION

- 1) STANDBY** On/Off switch
- 2) UP** This key has 3 functions
  - Increase of the volume during normal operation;
  - Modification of the setting within a function e.g. contrast (after calling up the menu);
  - By pressing this key when putting in the reverse gear, the distance markings move upwards;
- 3) DOWN** This key has 3 functions
  - Decrease of the volume during normal operation;
  - Modification of the setting within a function e.g. contrast (after calling up the menu);
  - By pressing this key when putting in the reverse gear, the distance markings move downwards;
- 4) SELECT** This key has 3 functions

- Selection of the video sources (CA1 → CA2 → AV → CA1). Press less than 1.5 seconds;
- Selection of the functions e.g. picture setting (after calling up the menu);
- Deleting and calling OSD letters of title & time (press longer than 1.5 seconds) during normal operation;

- 5) MENU** This key has 2 functions
  - Activation of the dimmer function (press less than 1.5 seconds) during normal operation;
  - Calling up the menu (press longer than 1.5 seconds, four menus can be called up). Press the key once again to call up the individual menus;
    - a) PICTURE= Functions for the image setting;
    - b) USER= Selection of the system function;
    - c) TIME= Setting time and date;
    - d) INSTALL= Setting the camera function (e.g. mirror function);

#### 6) BUSH FOR THE MONITOR CABLE OF THE CONNECTION BOX

#### 7) STANDBY DISPLAY

#### 8) INFRARED RECEIVER

#### MONITOR MENU DISPLAY

The monitor (RV59 HD) is equipped with an On-Screen Display (OSD) function which displays date, camera, channel, mirror mode and distance markings. These functions can be selected on MENU. To calling up the menu, press longer than 1.5 seconds. Four menus can be called up. Press the key once again to call up the individual menus.

For calling up the menu PICTURE press the key **MENU** longer than 1.5 seconds. The menu PICTURE appears.

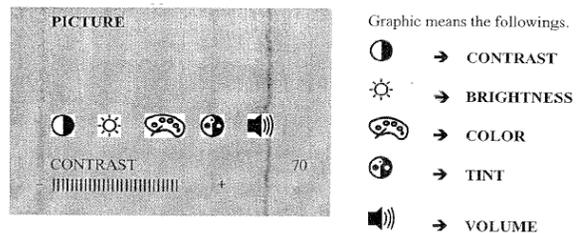

## SECTION 23: ACCESSORIES

Select the function (e.g. contrast) by pressing the key **SELECT** repeatedly. The setting within the function can be modified with the keys **UP** and **DOWN**.

For calling up the menu USER press the key **MENU** once again. The menu USER appears. Select the function (e.g. SELECTION) by pressing the key **SELECT** repeatedly as necessary. The setting within the function can be modified with the keys **UP** and **DOWN**.

USER		SETTINGS
LANGUE	ENG	ENGLISH/GERMAN (ENG/DEUT)
SCREEN WIDE		NOR 4:3, picture format 4:3 WIDE, picture format 16:9 FULL, picture format 16:9 middle enlarge
TITLE	ON	TITLE: CAMERA TITLE DISPLAY ON/OFF
TIME	ON	TIME: TIME DISPLAY ON/OFF

For calling up the menu TIME press the key **MENU** once again. The menu TIME appears. Select the function (e.g. DATE) by pressing the key **SELECT** repeatedly as necessary. The setting within the function can be modified with the keys **UP** and **DOWN**.

TIME	OPERATION
TIME 08:25	Hour-Month adjustable by UP BUTTON
DATE MAY01	Minute/Date adjustable by DOWN BUTTON
YEAR 2005	Year adjustable by UP/DOWN BUTTON

For calling up the menu INSTALL press the key **MENU** once again. The menu TIME appears. Select the function (e.g. SELECTION) by pressing the key **SELECT** repeatedly as necessary. The setting within the function can be modified with the keys **UP** and **DOWN**.

INSTALL	POSSIBLE SETTINGS:
REAR CAM1	Selection of priority camera (CAM1 or CAM2) which is triggered by rear gear.

CAM1	MIR	Selection of real picture or mirrored picture for camera 1.
CAM2	NOR	Selection of real picture or mirrored picture for camera 2.

### NOTE 1

The distance mark will appear on the picture of camera which set as MIR (mirrored).

### NOTE 2

Engaging the reverse gear, only distance mark will appear on the mirrored camera picture without any OSD. At the moment, no keys are available except UP/DOWN key for moving distance bar.

### BACK-UP CAMERA MODULE (Power box)

The connection line consists of 6 branch lines as below:

RED	Voltage supply 12-volt to 24-volt (max. 32-volt)
BLACK/BROWN	Earth cable
WHITE	Control wire for switching on the dimmer function (night operation)
YELLOW	Control wire for switching on the side camera. The connection is to be made at the INDICATOR
ORANGE	Control wire for switching on the reversing camera. The connection is to be made at the reversing light

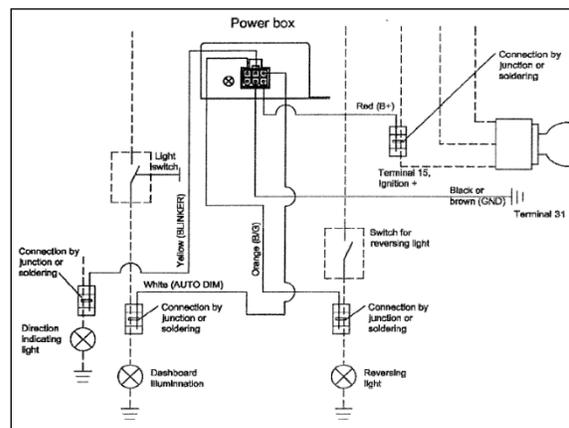

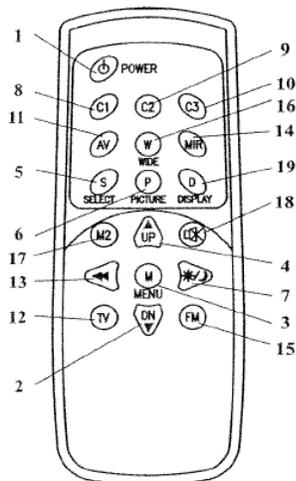

No	Key	Description
1	STANDBY	On/Off switch
2	DOWN ▼	This key has 3 functions. – Decrease of the volume during normal operation. – Modification of the setting within a function e. g. brightness (after calling up the menu). – By pressing this key when putting in the reverse gear the distance markings move downwards.
3	MENU	Calling up the menu on the screen. Three menus can be called up : a: PICTURE = Functions for the image setting b: USER = Selection of the system function c: TIME = Setting time and date d: INSTALL = Setting the camera function (e.g. mirror function)
4	UP ▲	This key has 3 functions. – Increase the volume during normal operation – Modification of the settings within a function e. g. contrast (after calling up the menu) – By pressing this key when putting in the reverse gear the distance markings move upwards.
5	SELECT	This key has 2 functions Selection of the video sources (CA1 → CA2 → AV) Selection of the functions e.g. picture setting (after calling up the menu)
6	PICTURER	Calls up the functions CONTRAST, BRIGHTNESS etc. directly for the picture setting. Carry out the setting with the key UP or DOWN.
7	DIMMER	Regulates the brightness to night operation temporarily
8	C1	Selection of the camera 1
9	C2	Selection of the camera 2
10	C3	Selection of the camera 3 (camera input 3 is not available))
11	AV	Selection of the video input (RCA)
12	TV	Not available
13	SEARCH	Not available
14	MIRROR	Reversing left and right of picture temporarily
15	FM	Not available
16	WIDE	Setting of the screen format NOR/NOR: 4:3, picture format 4:3 WIDE/WEIT, picture format 16:9 FULL/BREIT, picture format 16:9 middle enlarged
17	MONITOR2	Not available
18	MUTE	Switches off the tone temporarily
19	DISPLAY	This key has 2 functions – Deleting or calling OSD letters of Tile & Time temporarily – Leaving the menu

## 18. HUB ODOMETER

### 18.1 DESCRIPTION

An optional wheel hub odometer (Figure 43) may have been installed on the R.H. side of the drive axle. It indicates the total distance in miles or kilometers covered by the coach since it has left the factory, including road testing.

#### 18.1.1 Removal

To remove the unit, remove the two lock nuts and washers securing it to the wheel hub, and pull the unit off the studs.

#### 18.1.2 Installation

Place the hub odometer unit over the wheel hub studs. Replace the lock washers and nuts. Torque stud nuts.

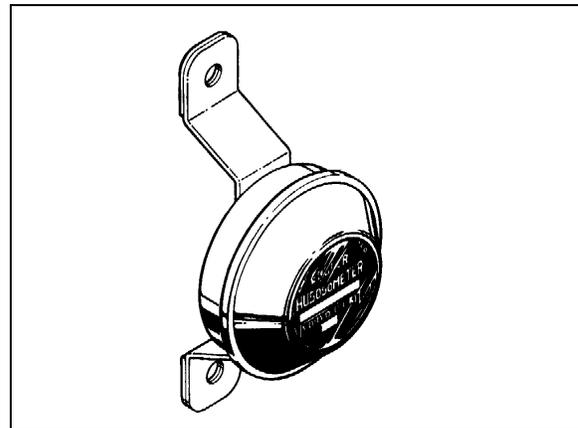

FIGURE 43: HUB ODOMETER

23027

### 18.2 OPERATION

The hub odometer is calibrated for a specific wheel size (diameter). Wheel rotation causes a mechanism inside the hub odometer to record distance after a predetermined number of rotations. The unit should be serviced at a competent speedometer repair facility.

#### NOTE

*Do not use paint, solvent or thinner on hub odometer face or on plastic hubcaps. Do not weld on hub odometer.*

## 19. ELECTRONIC DESTINATION SIGN (OPTIONAL)

The destination sign is located at upper front of the vehicle.

To change the destination, depress the selecting switches until the desired destination appears in the LCD display.

### NOTE

LCD display may be located at the back of the destination sign (series 600) or on the vehicle modesty panel (430 series). Refer to the corresponding supplier's [operating manual](#) for more information regarding operation and maintenance of the destination sign.

### NOTE

A data file must be loaded into the destination sign control unit before operating the system on the road. Insert the supplied USB key in the display USB port to automatically start the process.



FIGURE 44: DESTINATION SIGN LCD DISPLAY (SERIES 600 SHOWN) 23123-1

## 20. WINDSHIELD SUNSHADES

Two electrically operated sunshades are installed in the driver's area at the top of the windshields.

Control buttons are located on the steering wheel and the dashboard to operate sunshades individually. Refer to Operator's Manual: "Controls and Instruments" chapter for more information.



## CAUTION

*Pulling down manually on the sunshade may damage the mechanism.*

### 20.1 END OF STROKE ADJUSTMENT

The sunshades end positions are factory pre-adjusted. If an adjustment is required, proceed as follows:

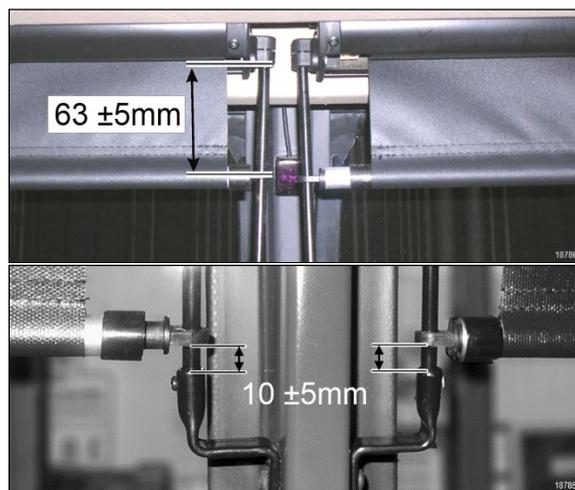

FIGURE 45: FACTORY ADJUSTMENT OF UPPER AND LOWER END POSITION

1. Place the ignition key to the ON position.
2. Move sunshade to within 10mm of the upper or lower end position.
3. On the sunshade roller end, there are two end of course setting buttons.
4. *White* button is for setting the *upper* end of course, *black* button is for *lower* end of course.

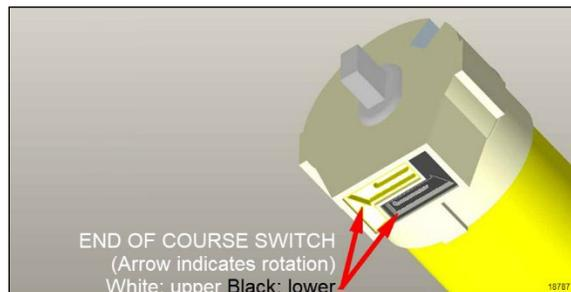

FIGURE 46: END OF COURSE SETTING SWITCHES

5. Insert a small screwdriver and depress the corresponding button. Release when you hear a click.

- Use the sunshade dash button to adjust to the desired position by small pulses. The dash buttons provide a finer control than the steering wheel button.

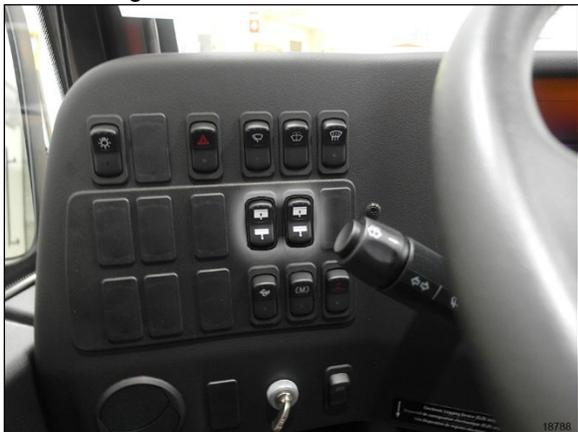

FIGURE 47: DASH SUNSHADE CONTROL BUTTONS

- When satisfied with the position, depress the end of course button on the sunshade. With a screwdriver. Release when you hear a click (Figure 46)
- Press twice on the control button to move the sunshade to the other end of stroke position.
- Proceed to fine adjustment of the other position by repeating steps above.

### 20.2 END OF STROKE ADJUSTMENT ON MOTORIZED SUNSHADES WITH CANTILEVER ARMS

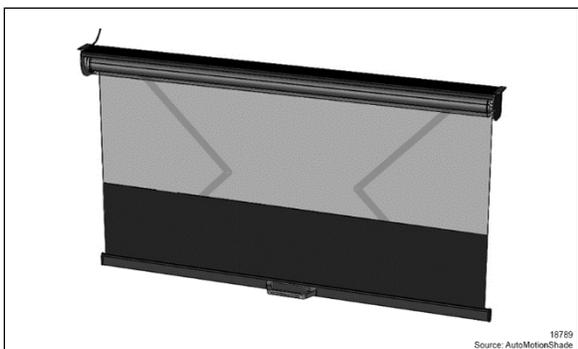

FIGURE 48: MOTORIZED SCISSOR TYPE SUNSHADE

Refer to AutoMotionShade [quick reference guide](#) provided on Prevest Technical Publications web site to adjust the motor limits.

## 21. PASSENGER SUNSHADES

Manually operated passenger sunshades are factory installed on some vehicles. The sunshades are pulled down and can be locked in the window side moldings at half or full close position.

To release, simply disengage the sunshade from the moldings and release. Spring tension will pull back the sunshade to the full open position.

Correct spring tension is set at the factory and should not need further adjustment.

However, if for any reason a sunshade has to be removed from the vehicle, preloading of the recoil mechanism will be required before re-installation to ensure that the sunshade returns to the full open position when released.

	<h3>CAUTION</h3>
<p><i>A special tool is required to remove the sunshade from the window support. Failure to use the special tool will result in permanent damage to the sunshade and/or window support.</i></p> <p><i>The special tool can be ordered from your Prevest part center under part # 685594</i></p>	

### 21.1 PRELOAD ADJUSTMENT

Using the chart below, preload the sunshade mechanism before installing the sunshade in the window support.

<p><b>NOTE</b></p>
<p><i>When installed, lower the sunshade 6po (15cm) and release. The sunshade should retract freely to the full open position. Re-adjust preload as needed.</i></p>

Sunshade Type	Req. Preload
Std Sunshade	10-12 turns
Rear Sunshade	10 turns
Small Rear Sunshade	8 turns
Large WCL Sunshade	12 turns
Small Trapezoidal Sunshade	8 turns

## 22. LAVATORY – H3 SERIES

## 22.1 DESCRIPTION

The lavatory is located in the rear R.H. corner of the coach. It is equipped with a chemical flush toilet, bathroom tissue dispenser, washbasin, towel dispenser, waste container, mirror and a cleaning cabinet. A liquid soap dispenser and moist towel dispenser are optional.

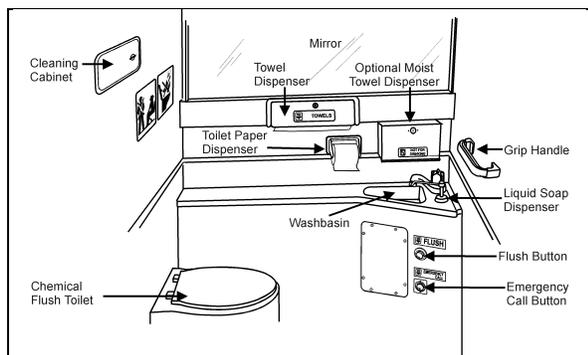

FIGURE 49: LAVATORY

Locking the lavatory door from the inside will illuminate a fluorescent light in the lavatory and two outside signs to indicate occupation. One sign is located on the outer wall of the lavatory and another sign is located over the windshield. An indicator light on the dashboard will illuminate to inform the driver when the lavatory is occupied. A night-light is permanently lit in the lavatory when the ignition switch is in the ON position.

## 22.2 MAINTENANCE

The servicing procedure for the lavatory is described in the "Operator's Manual" included in the technical publications box delivered with the vehicle.

## 22.3 VENTILATION FAN

The lavatory ventilation fan, mounted in engine compartment over the oil reserve tank (Figure 50), serves two purposes. It exhausts objectionable odors and provides a constant air circulation in the lavatory compartment by heating or cooling the lavatory with the vehicle ambient air. Air flows in the lavatory compartment through a vent grill located in the upper section of the lavatory door and exhausts through a grill located next to the toilet.

### NOTE

*This fan runs constantly when the ignition switch located on the dashboard is in the "ON" position.*

### 22.3.1 Maintenance

The frequency of preventive maintenance should be determined according to vehicle mileage and operating conditions. However, it is recommended to check this item every 50,000 miles (80 000 km) or once a year, whichever comes first.

Remove fan and motor assembly. Check for fan housing wheel and motor free operation. When defective motor occurs, new motor must be installed.

### 22.3.2 Removal and Installation

1. With the engine compartment rear door opened, remove hose clamp securing duct to ventilation fan inlet, and disconnect duct.
2. Disconnect the ventilation motor wiring connector.
3. Remove the two bolts retaining the ventilation fan housing support to the square tubing. Remove the ventilation fan assembly from its location.
4. The unit can now be disassembled and motor replaced.
5. Reverse previous steps to reinstall ventilation fan assembly on vehicle.

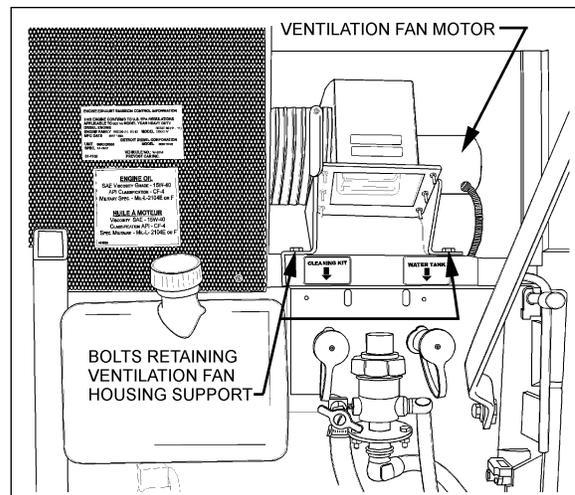

FIGURE 50: VENTILATION FAN INSTALLATION

## 22.4 DOOR LOCK

Lavatory door lock has inside and outside handles, as well as an inside latch to lock door from inside the compartment. If the lock fails to release, the door can be opened from the outside using a special key which is supplied to the driver. Lock assembly can be removed from the door, and then readily disassembled and parts replaced, if necessary. A thin coat of lubricant on all moving parts will ensure trouble-free operation.

## 22.5 LAVATORY LIGHT WITH MOTION SENSOR

The lavatory light, when dimmed, serves as a night-light and is illuminated as soon as the ignition switch is set to the "ON" position. A motion sensor will activate full light intensity whenever motion is detected in the lavatory compartment. The motion sensor will dim the light after a delay of 8 seconds when no additional motion is detected.

### NOTE

*The lavatory light motion sensor has a warm-up period of approximately 2 minutes after the ignition switch is set to the "ON". During that warm-up period, the motion sensor will not detect motion and will not activate the lavatory light to full intensity.*

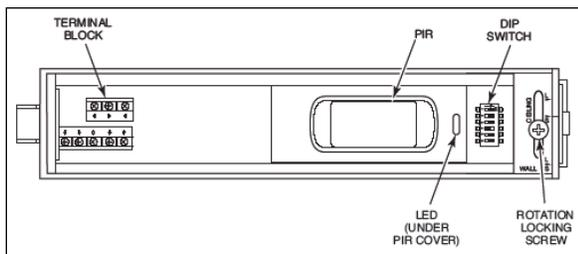

FIGURE 51: LAVATORY LIGHT MOTION SENSOR

### 22.5.1 Removal and Installation

- Open the sensor housing by pressing on the latch with a screwdriver. The latch is located on the side of the sensor nearest the lens. Pull the cover up away from the sensor's base.
- Loosen rotation locking screw two (2) turns (do not remove). Then, remove PCB assembly from the back plate of the sensor.
- Insert the wiring into one of the wire channels on the sensor's back plate.
- Securely affix the sensor's back plate to the wall using #6X3/4" screws.
- Reinstall the PCB assembly and then, tighten rotation locking screw.

### 22.5.2 Dip Switch Settings

Adjust DIP switches as follows:

1=off    2=off    3=off  
4=on    5=off    6=off

## 22.6 EMERGENCY BUZZER

The lavatory emergency buzzer is mounted on the alarm junction box in the front service compartment and sounds when the emergency call push-button switch in the lavatory compartment is activated. For specific wiring information, refer to wiring diagrams. To remove the emergency call push-button switch, proceed as follows:

- Remove both Phillips-head screws retaining pushbutton switch plate to wall.
- Remove steel plate located on L.H. side of pushbutton switch.
- Remove switch through this opening, taking care to disconnect electric wires.

## 22.7 FRESH WATER TANK

The fresh water tank located at rear of lavatory wall (over cleaning cabinet), supplies water to the washbasin by gravity. Two tubes are connected in the upper section of tank (Figure 54). One serves as overflow as well as vent tube and runs along the wall to the underside of the lavatory close to the engine air filter housing, while the other tube is connected to the fresh water fill valve which is mounted besides the engine oil reserve tank.

A third tube connected in the lower section of fresh water tank is provided with a T-connector and allows fresh water to flow to the washbasin faucet and to the low temperature water safety valve for automatic or manual draining. An

access panel, located at rear of last R.H. side row of seats and secured in place using 6 Phillips-head screws, allow access to the cleaning cabinet and fresh water tank tubing, fresh water tank heater and different wiring connectors.

### 22.7.1 Fresh Water Tank Heater (Optional)

75 watts, 110 volts AC immersion-type water heater may have been installed in the bottom of the fresh water tank. The heated portion of element must be immersed at all times to ensure proper heater life. The 110-120 volts in-station connector mounted on the engine compartment rear door provides the water heater power source.

### 22.7.2 Fresh Water Tank Draining

The fresh water tank can be drained by simply opening the fresh water drain cock (Figure 54). Don't forget to close cock when draining is done.



#### CAUTION

*If fresh water tank heater is inoperative or not installed on your vehicle, water should be drained from reservoir under cold weather conditions since it might freeze and damage both reservoir and connecting links.*

### 22.7.3 Fresh Water Tank Filling

Plug the fresh water supply hose to the fresh water tank fill connection (Figure 54); fill the tank until the overflow tube leaks, signaling that tank is full.



#### WARNING

*Never put antifreeze in fresh water tank; antifreeze is toxic.*



#### WARNING

*If tank has not been drained for an extended period of time, draining and filling operations must be repeated three (3) times in order to clean tank and eliminate contaminated water.*

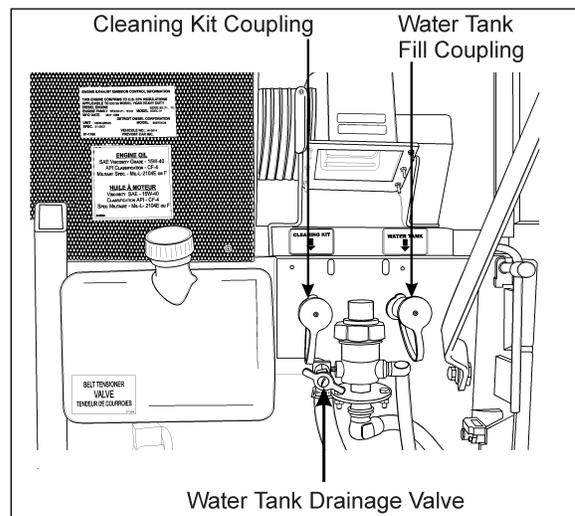

FIGURE 52: FRESH WATER TANK SERVICE VALVES

## 22.8 LIQUID SOAP DISPENSER

A liquid soap dispenser may have been installed as optional equipment. To refill dispenser, proceed as follows:

1. Turn cover slightly clockwise until it stops.
2. Insert projection at end of "BOBRICK" key into rectangular hole in cover (Figure 53). Push straight in. While holding "BOBRICK" key in, turn cover counterclockwise about 1/8 turn.



#### CAUTION

*Do not use "BOBRICK" key to turn cover.*

3. Lift out piston and spout, cover and supply tube.
4. Fill dispenser with soap. This model can dispense vegetable oil soaps, synthetic detergents, and lotion soaps.



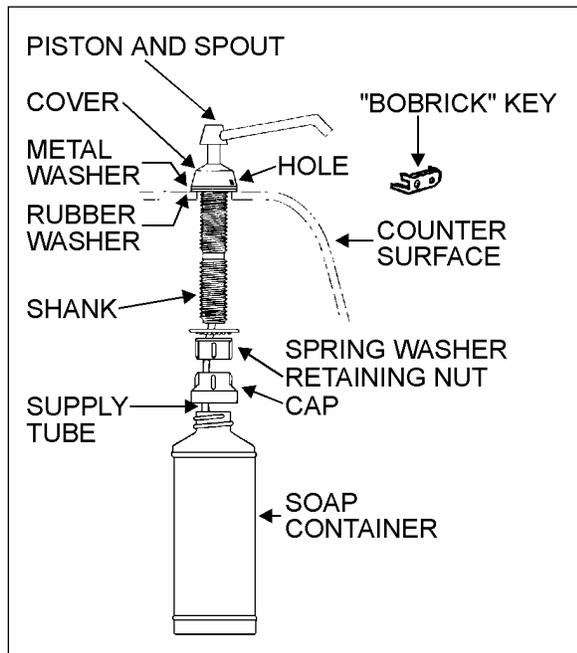

FIGURE 53: LIQUID SOAP DISPENSER 23039

**CAUTION**

*Never use abrasive cleaners.*

5. Replace supply tube, piston, and spout mechanism reversing the steps above.
6. Secure the cover by turning clockwise until lock snaps into position.

**NOTE**

*The dispenser requires priming when extremely viscous lotion soaps are used. Remove piston and spout, cover and supply tube assembly. Pump water into assembly, then replace into dispenser.*

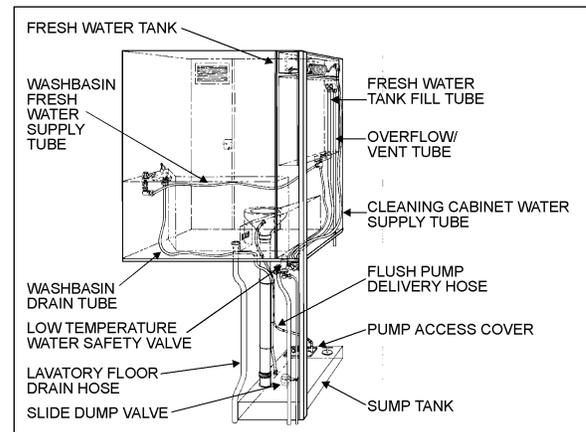

FIGURE 54: FUNCTIONING OF LAVATORY 23038

**22.9 FLUSH PUSH-BUTTON**

The green flush push-button is located near the toilet. Press on push-button to actuate a pneumatic timer located on the other side of wall. This timer allows an electric current flow during a preset time to a pump into the sump tank.

**22.9.1 Pneumatic Timer Removal and Installation**

1. Unscrew and remove the flush push-button locking ring.
2. Remove steel plate located on L.H. side of pushbutton switch.
3. Remove pneumatic timer through this opening, taking care to disconnect electric wires.

**NOTE**

*Care must be taken to avoid losing the spacers installed on the mounting sleeve.*

4. Reverse the above procedure to reinstall timer. Tighten lock nut:

**22.9.2 Timer Adjustment**

Timer can be adjusted from 0.2 second to 3 minutes by turning the time adjustment screw clockwise to increase time, and counterclockwise to decrease

time. To gain access to the time adjustment screw, repeat steps 1, 2 and 3 in the previous paragraph.

## 22.10 FLUSH PUMP

The submersible-type flush pump is mounted inside an enclosure in the sump tank (Figure 55). The enclosure is provided with a screened side which, serves as a strainer to prevent solid matters from entering the pump.

The pump requires no periodic maintenance other than cleaning of the strainer side using a water jet introduced through the circular cap opening, once the sump tank is completely drained. The pump can run dry periodically without damage. However, for maximum seal life, the run dry periods should be kept to a minimum.



### CAUTION

*If vehicle is stored for an extended period of time, make sure to clean the strainer as solid matter will tend to pack, and will necessitate replacement of strainer.*

### 22.10.1 Flush Pump Pressure Adjustment

The flush pump is provided with a manually-adjustable control valve mounted on the flush pump enclosure cover and serves to limit the flush pump output pressure. To adjust, ask an assistant to activate the flush pushbutton and check the liquid projection while you manually adjust the control valve

## 22.11 SUMP TANK

### 22.11.1 Sump Tank Draining

To drain sump tank, unscrew cap a few turns then turn drain valve handle CCW. Flush tank and pump cage with clean water. Close drain valve by turning handle CW.



### CAUTION

*The lavatory should be serviced by maintenance personnel after emergency draining. Lavatory tanks should be serviced only at suitably equipped stations.*

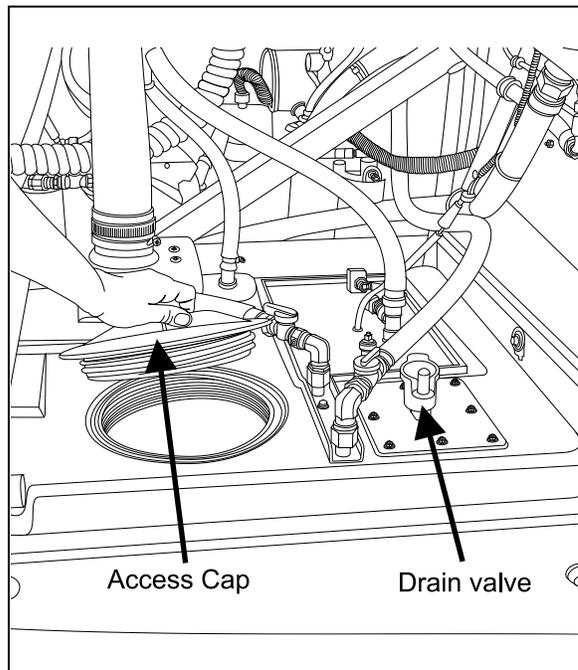

FIGURE 55: SUMP TANK

23294

### 22.11.2 Sump Tank Filling

Remove cap on sump tank. Fill Tank with 2 gallons (9 liters) of antifreeze and two gallons of water.



### CAUTION

*Do not overfill sump tank.*

### NOTE

*The antifreeze solution in the sump tank will be diluted by fresh water coming from the lavatory sink. Regular maintenance of the sump tank is required to prevent freezing.*

## 22.12 CLEANING CABINET

A coiled hose located in the cleaning cabinet above the toilet can be used during lavatory cleaning. To use, connect a fresh water supply to the "Hansen" quick-release coupling, identified as "Cleaning Kit", located besides the engine oil reserve tank (Figure 52). To prevent freezing during cold weather, drain the hose after every use. To drain the hose, uncoil and open the nozzle near the lavatory floor drain. Have an assistant push on

the spring ball of the quick-release coupling to allow air into the system.

### 23. LAVATORY INSTALLED ON X3-45 COACHES

The lavatory is located in the rear curb side corner of the coach. It is equipped with a chemical flush toilet, bathroom tissue dispenser, mirror and waste container access.

A movement detector will automatically illuminate a fluorescent light inside the lavatory and two outside occupied signs. One sign is located on the outer wall of the lavatory and another sign is located over the windshield. A telltale light on the dashboard will also illuminate to inform the driver when the lavatory is occupied.

If emergency assistance is required, the lavatory occupant can actuate a buzzer that will sound in driver's area. The buzzer push-button is located just below the toilet flush button.

The lavatory has its own ventilation system that operates only when ignition switch is in the "ON" position.

<b><i>NOTE</i></b>
This fan runs constantly when the ignition switch located on the dashboard is in the "ON" position.

Also, a drain hole located on lavatory floor drain water splashed on the floor to the engine compartment R.H. side.

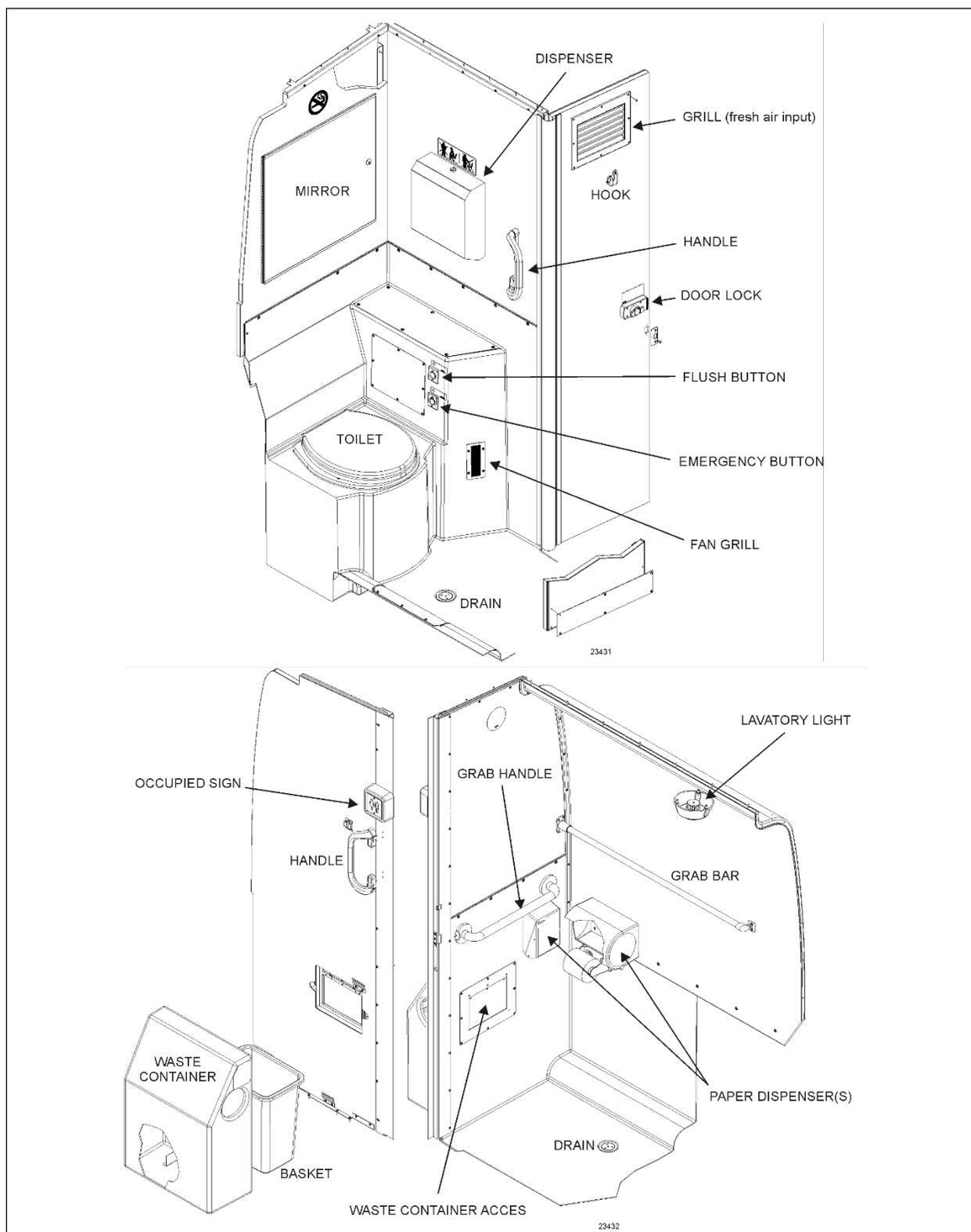

FIGURE 56: LAVATORY

### 23.1 LAVATORY VENTILATION FAN

The lavatory ventilation fan (Figure 57), mounted in engine compartment, serves two purposes. It exhausts objectionable odors and provides a constant air circulation in the lavatory compartment by heating or cooling the lavatory with the vehicle ambient air. Air flows in the lavatory compartment through a vent grill located on the lavatory door and exhausts through a grill located next to the toilet.

#### NOTE

*This fan runs constantly when the ignition switch located on the dashboard is in the "ON" position.*

#### 23.1.1 Maintenance

The frequency of preventive maintenance should be determined according to vehicle mileage and operating conditions. However, it is recommended to check this item every 50,000 miles (80 000 km) or once a year, whichever comes first.

Remove fan and motor assembly. Check for fan housing wheel and motor free operation. When defective motor occurs, new motor must be installed.

#### 23.1.2 Removal and Installation

1. Open SRC access door (*refer to Section 2 of the Operator's Manual under Exhaust Aftertreatment System Access Door*).
2. Locate fan assembly and disconnect the fan wiring connector.
3. Remove the fan shroud mounting screws and remove the ventilation fan assembly from its location.
4. The unit can now be disassembled and the motor and components replaced as necessary.
5. Reverse previous steps to reinstall fan assembly on vehicle.

#### NOTE

*Make sure fan shroud seal is in good condition prior to installation, replace as necessary*

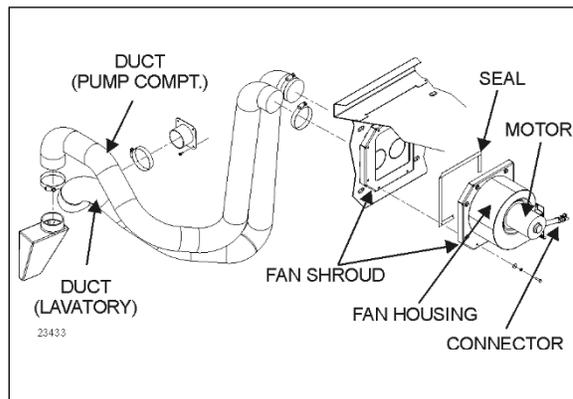

FIGURE 57: VENTILATION FAN INSTALLATION

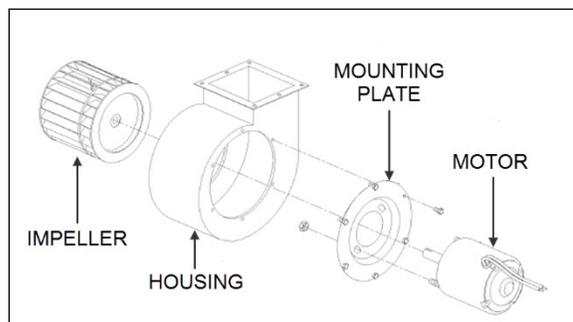

FIGURE 58: FAN ASSEMBLY COMPONENTS

### 23.2 DOOR LOCK

Lavatory door lock has inside and outside handles, as well as an inside latch to lock door from inside the compartment. If the lock fails to release, the door can be opened from the outside using a special key which is supplied to the driver. Lock assembly can be removed from the door; a thin coat of lubricant on all moving parts will ensure trouble-free operation.

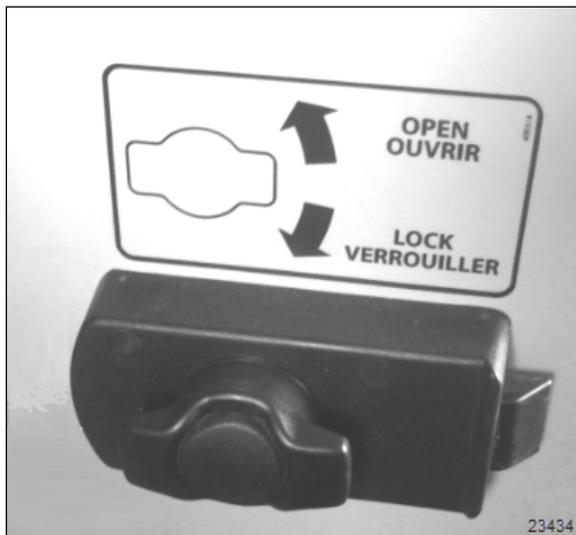

FIGURE 59: DOOR LOCK – FROM INSIDE LAVATORY

### 23.3 LAVATORY LIGHT & NIGHT-LIGHT

A lavatory LED light with built-in motion detector is installed on lavatory ceiling and will illuminate as soon as door (or occupant) movement is detected. At night, when the ignition switch is set to the ON position, the light will provide dimmed illumination inside the lavatory. The light & movement detector can be serviced as a complete assembly by removing the mounting screws holding the unit to the ceiling.

### 23.4 EMERGENCY BUTTON

The lavatory emergency buzzer is mounted on the inner curb side wall of lavatory and sounds when the emergency call push-button switch in the lavatory compartment is activated. For specific wiring information, refer to wiring diagrams. To remove the emergency call push-button switch, proceed as follows:

5. Remove both Phillips-head screws retaining pushbutton switch plate to wall.
6. Remove stainless steel plate located on L.H. side of pushbutton switch.
7. Remove switch through this opening, taking care to disconnect electric wires.

### 23.5 FLUSH PUSH BUTTON

The flush push-button is mounted on the inner curb side wall of lavatory just over the emergency

button. Press on push-button to actuate the pump located in the sump tank.

#### 23.5.1 Flush push button removal and installation

1. Remove both Phillips-head screws retaining pushbutton switch plate to wall.
2. Remove stainless steel plate located on L.H. side of pushbutton switch.
3. Remove pneumatic timer through this opening, taking care to disconnect electric wires.
8. Reverse the above procedure to reinstall timer.

### 23.6 FLUSH PUMP

The submersible-type flush pump is mounted inside an enclosure in the sump tank. The enclosure is provided with a screened side which, serves as a strainer to prevent solid matters from entering the pump.

The pump requires no periodic maintenance other than cleaning of the strainer side using a water jet introduced through the circular cap opening, once the sump tank is completely drained. The pump can run dry periodically without damage. However, for maximum seal life, the run dry periods should be kept to a minimum.



#### CAUTION

If vehicle is stored for an extended period of time, make sure to clean the strainer as solid matter will tend to pack, and will necessitate replacement of strainer.

#### 23.6.1 Flush Pump Removal

1. Drain tank.
2. Remove the toilet seat and cover.
3. Remove the toilet bowl flange.
4. Lift the toilet bowl, disconnect the water hose and remove the bowl & flap.
5. Remove the pump enclosure retaining screw and remove (lift-up) the complete assembly from the tank.

- Remove the enclosure cover to access and remove the pump.

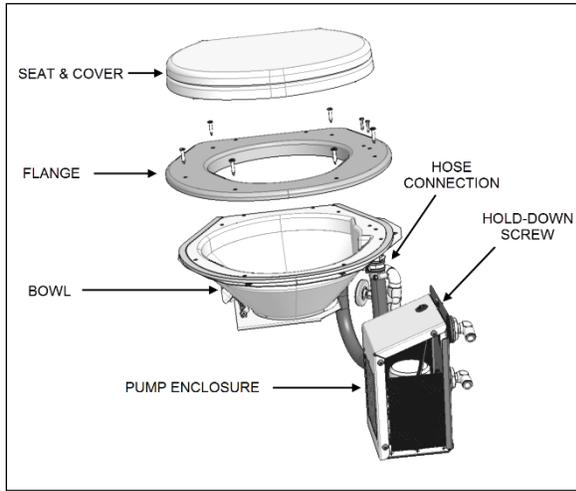

FIGURE 60: SUMP TANK PUMP ACCESS

## 23.7 SUMP TANK

### 23.7.1 Sump Tank Filling

Open the sump tank overflow valve (A) and connect a fresh water supply hose to the toilet sump tank fill connection (D). The sump tank is full when water starts flowing through the clear fill process overflow tube (start water level) (C). Close sump tank overflow valve (A) when the tank is full and drain fresh water fill tube using drain valve (B) to avoid ice damage during cold weather operation.

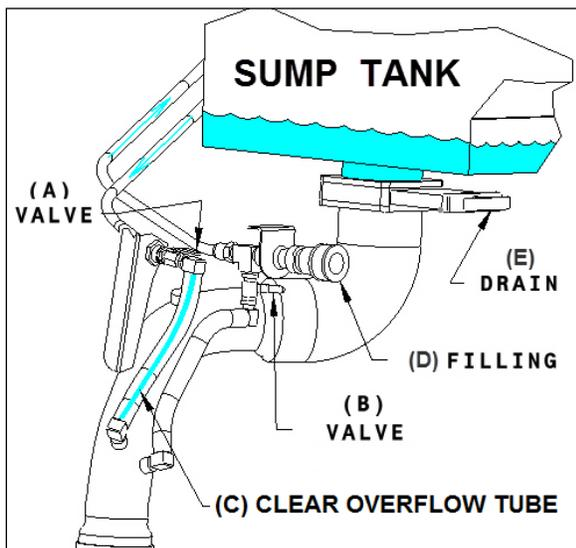
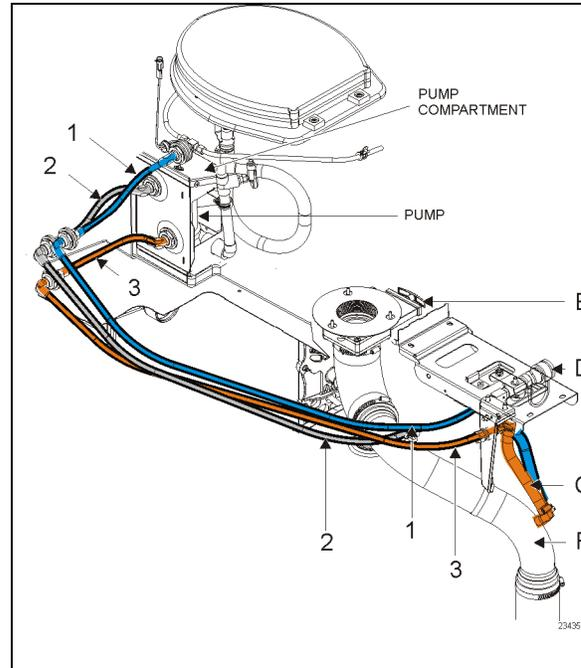

FIGURE 61: SUMP TANK SERVICE VALVES



- 1 – fresh water sump tank filler tube
- 2 – sump tank overflow
- 3 – fill process overflow tube
- C – clear fill overflow tube (“full” indicator)
- D – sump tank fill connection
- E – drain slide valve handle
- F – drain pipe

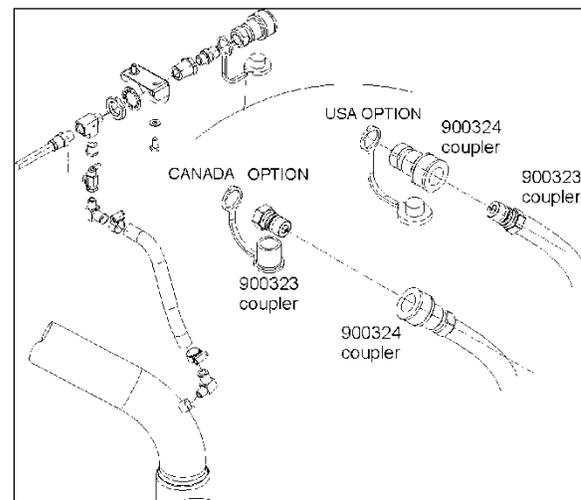

FIGURE 62: SUMP TANK FILL CONNECTION

## 23.7.2 Sump Tank Draining

When recirculating water in the toilet is soiled, drain sump tank. Pull the drain slide valve handle (E) and allow contents to drain. Remove the access cap and flush tank with clean water. To close, push the slide valve (E) back into closed position.

**CAUTION**

In cold weather, add 2 gallons (9 liters) of anti-freeze (e.g.: ethylene glycol) in the toilet before filling sump tank.

**CAUTION**

Lavatory tank should be serviced only at suitably equipped stations.

**NOTE**

*It is unlawful to dump sump tank contents in any location other than those designated as such.*

When a full draining is required, clean sump tank by repeating the draining and filling operations while leaving the drain cock opened. Close cocks and pour a pack of commercial toilet deodorant (Prevost part #900329) in toilet before adding the antifreeze and starting final filling of sump tank.

**WARNING**

The toilet deodorant contains products that can be very irritating to skin. Use rubber gloves when handling and then clean toilet seat.

**WARNING**

Antifreeze must comply with the effective environmental act.

**CAUTION**

When cold weather is expected and there is no antifreeze in the tank, sump tank must be drained.

**NOTE**

*If there is no antifreeze solution in the tank, there is less risk of freezing if engine is operating due to the heat it produces.*

**NOTE**

*New coaches are delivered with the sump and fresh water tanks empty. Fill with water before putting the coach in service.*

## 24. HORN INSTALLATION – X3 SERIES

The electric and air horns are located in a plastic box under the front step well and are accessible from the front body understructure. Refer to Operator's or Owner's Manual for operation.

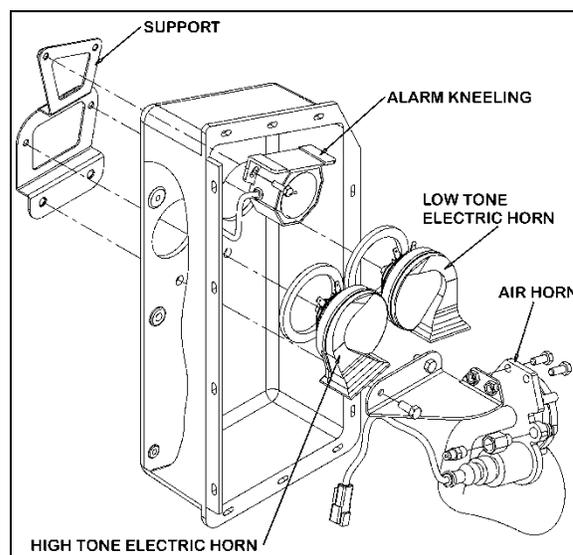

FIGURE 63: ELECTRIC &amp; AIR HORN INSTALLATION 23420

## 24.1 ELECTRIC OR AIR HORN MAINTENANCE

When needed, the electric or air horn can be serviced or replaced using the following procedure:

1. Raise vehicle by the jacking points;
2. Unplug the cable connector;
3. Disconnect the air tube if applicable;
4. Loosen the retaining bolts;
5. Service or replace the defective horn;
6. Reinstall by reversing procedure.



## 25. AIR HORN VALVE – H3 SERIES

The air horn valve is located in the front service compartment and the air horn valve button is on the steering wheel center.

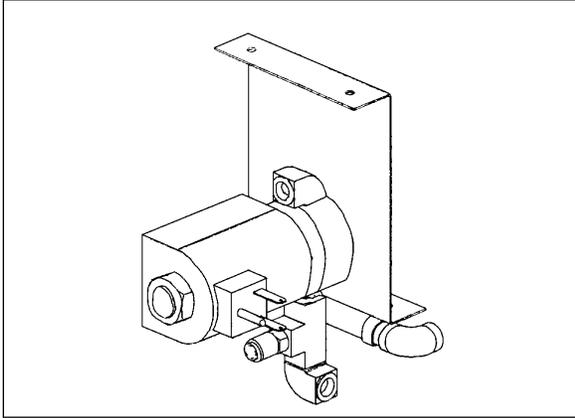

FIGURE 64: AIR HORN VALVE 23230

### 25.1 AIR HORN VALVE MAINTENANCE

When needed, the air horn valve can be serviced or replaced using the following procedure:

1. Unplug the cable connector;
2. Disconnect the air tubes;
3. Loosen the retaining bolts;
9. Service or replace the air horn valve;
10. Reinstall by reversing procedure.

## 26. WINDSHIELD WIPERS – H3 SERIES

Refer to Maintenance Information MI23-12 WIPER DRIVE MOTOR, LINKAGE AND PIVOT REPLACEMENT annexed after section 23B.

### 26.1 WIPER ECU MODULE A21 DIAGNOSTIC GUIDE H3 SERIES

WIPER ECU MODULE A21 (WWS2) DIAGNOSTIC GUIDE H3 SERIES					
Function in progress	No	Failure	Effects of failure on part/syst and driver	Fallback	Diagnostics
Wiper LOW (Normal), Intermittent and Single wipe	1.1	Wiper stalk-arm component failure (w/ error detection - Wiper Stalk Status =5, 6 or 7) occurs when the wiper is <u>A</u> ctive	No loss of operation - wiper Low mode is forced Active until key switch cycle	Force wiper Low	
	1.2	J1939 (D_BUS) between IC and MODULE A21 failure	No loss of operation - MODULE A21 shall detect J1939 (D_BUS) failure and then run on redundant functionality. Wiper Low shall be forced using "I_Speed-Low" digital input.	Uses redundant Digital Inputs.	
	1.3	FMI 3 or 4 is detected on digital input "I_SpeedLow"	No loss of operation - primary function on J1939 (D_BUS)	Continues to use primary J1939 (D_BUS)	MODULE A21 sends DM1, SPN 520711, No Lamp, FMI 12
	1.4	MODULE A21 component failure (Inoperable)	No wiper operation		
	1.5	Missing 24V Ignition input to MODULE A21	No wiper operation - MODULE A21 does not wake up		
	1.6	M1 motor error is detected: FMI3 -Voltage above normal or shorted high or FMI5-Current below normal or open circuit	No wiper Low operation – MODULE A21 will retry recovery at each second  *M2 motor remains operational		MODULE A21 sends DM1, SPN 520711, Amber Lamp, FMI 3 or 5 failure mode detected
	1.6.1	M1 motor error is detected: FMI6-Current above normal or grounded circuit	No wiper Low operation – MODULE A21 will retry recovery at each second for a limited number of shorts. After more than 5 HW over currents trips, motor is disabled until the next ignition cycle.  *M2 motor remains operational.		MODULE A21 sends DM1, SPN 520711, Amber Lamp, FMI4 or 6 depending of failure mode detected

	1.7	M2 motor error is detected: FMI3 -Voltage above normal or shorted high or FMI5-Current below normal or open circuit	No wiper Low operation – MODULE A21 will retry recovery at each second  *M1 motor remains operational		MODULE A21 sends DM1, SPN 520711, Amber Lamp, FMI 3 or 5 failure mode detected
	1.7.1	M1 motor error is detected: FMI6-Current above normal or grounded circuit	No wiper Low operation – MODULE A21 will retry recovery at each second for a limited number of shorts. After more than 5 HW over currents trips, motor is disabled until the next ignition cycle.  *M1 motor remains operational		MODULE A21 sends DM1, SPN 520711, Amber Lamp, FMI4 or 6 depending of failure mode detected
	1.8	'I_M1HomeSensor'' signal failure (no low to high transition on the wiper status input for 5 seconds)	Synchronization between both motors shall be cancelled. Motor 1 shall be forced to wipe continuously on low speed. (Prevost specific)	Motor 1 shall wipe continuously on low speed. (Prevost specific)	MODULE A21 sends DM1, SPN 520713, Amber Lamp, FMI 12
	1.9	'I_M2HomeSensor'' signal failure (no low to high transition on the wiper status input for 5 seconds)	Synchronization between both motors shall be cancelled. Motor 2 shall force to wipe continuously on low speed. (Prevost specific)	Motor 2 shall wipe continuously on low speed. (Prevost specific)	MODULE A21 sends DM1, SPN 520713, Amber Lamp, FMI 12
Wiper HIGH	2.1	Wiper stalk-arm component failure (with error detection -Wiper Stalk Status = 5,6 or 7) occurs when the wiper is Active	No loss of operation - wiper High (Fast) stays Active until key switch cycle	Continues wiper High	
	2.2	J1939 (D_BUS) between IC and MODULE A21 failure	No loss of operation - MODULE A21 shall detect J1939 failure then run on redundant functionality. Wiper High (Fast) shall be forced using "I_SpeedHigh" digital input.	Uses redundant Digital Inputs.	
	2.3	FMI 3 or 4 is detected on digital input "I_SpeedHigh"	No loss of operation - primary function on J1939 (D_BUS)	Continues to use primary J1939 (D_BUS)	MODULE A21 sends DM1, SPN 520711, No Lamp, FMI 12
	2.4	MODULE A21 component failure (Inoperable)	No wiper operation		
	2.5	Missing 24V Ignition input to MODULE A21	No wiper operation - MODULE A21 does not wake up		
	2.6	M1 motor error is detected: FMI3 -Voltage above normal or shorted high or FMI5-Current below normal or open circuit	No wiper High operation – MODULE A21 will retry recovery at each second  *M2 motor remain operational		MODULE A21 sends DM1, SPN 520711, Amber Lamp, FMI 3 or 5 failure mode detected
	2.6.1	M1 motor error is detected: FMI6-Current above normal or grounded circuit	No wiper Hi operation – MODULE A21 will retry recovery at each second for a limited number of shorts. After more than 5 HW over currents trips, motor is disabled until the next ignition cycle.  *M2 motor remains operational		MODULE A21 sends DM1, SPN 520711, Amber Lamp, FMI4 or 6 depending of failure mode detected

## SECTION 23: ACCESSORIES

	2.7	M2 motor error is detected: FMI3 -Voltage above normal or shorted high or FMI5-Current below normal or open circuit	No wiper High operation – MODULE A21 will retry recovery at each second.  *M1 motor remain operational		MODULE A21 sends DM1, SPN 520711, Amber Lamp, FMI 3 or 5 failure mode detected
	2.7.1	M2 motor error is detected: FMI6-Current above normal or grounded circuit	No wiper Hi operation – MODULE A21 will retry recovery at each second for a limited number of shorts. After more than 5 HW over currents trips, motor is disabled until the next ignition cycle.  *M2 motor remains operational		MODULE A21 sends DM1, SPN 520711, Amber Lamp, FMI4 or 6 depending of failure mode detected
	2.8	"I_M1HomeSensor" signal failure (no low to high transition on the wiper status input)	Synchronization between both motors shall be cancelled. Motor 1 shall wipe continuously. (Prevost specific)	Motor 2 shall wipe continuously on high speed. (Prevost specific)	MODULE A21 sends DM1, SPN 520713, No Lamp, FMI 12
	2.9	"I_M2HomeSensor" signal failure (no low to high transition on the wiper status input)	Synchronization between both motors shall be cancelled. Motor 2 shall wipe continuously. (Prevost specific)	Motor 2 shall wipe continuously on high speed. (Prevost specific)	MODULE A21 sends DM1, SPN 520713, No Lamp, FMI 12
Wiper Intermittent (Delay function)	3.1	Wiper stalk-arm component failure (w/ error detection - Wiper Adjust Status = 4,5,6 or 7 ) occurs when the wiper intermittent is <u>Active</u>	No loss of Intermittent operation - wiper intermittent stays Active using actual delay until key switch cycle	Continues wiper Intermittent using actual delay until key switch cycle	
	3.2	J1939 (D_BUS) between IC and MODULE A21 failure	No loss of operation - MODULE A21 shall detect J1939 (D_BUS) failure and then run on redundant functionality. Since Wiper Low is forced by using "I_Speed-Low" digital input, information on delay is not required.		
Windshield Washer Wiping	4.1	Wiper stalk-arm component failure (w/ error detection - Washing Status = 2 or 3) occurs when the wash is Active	Wash operates for 5 additional sec. before loss of wash operation		
	4.2	J1939 (D_BUS) between IC and MODULE A21 failure when the wash wiping is Active	MODULE A21 shall detect J1939 (D_BUS) failure and then operating wash wiping for 5 additional sec. before loss of wash wiping operation		
	4.3	MODULE A21 component failure (Inoperable)	No wash wiping operation		
	4.4	Missing 24V Ignition input to MODULE A21	No wash wiping operation - MODULE A21 does not wake up		
Wiper Off mode	5.1	Wiper stalk-arm component failure (with error detection -Wiper Stalk Status = 5,6 or 7) signals received by the MODULE A21 when wipers not active	No loss of operation - MODULE A21 shall use redundant digital inputs in case driver wants to operate wipers.	Uses redundant Digital Inputs.	

5.2	Wiper stalk-arm component failure (w/ error detection - Washing Status = 2 or 3) signals received by the MODULE A21 when wipers not active	No wash wiping operation available.		
5.3	M1 motor error is detected: FMI5-Current below normal or open circuit FMI6-Current above normal or grounded circuit	No wiper High operation - M1 motor output remains disabled until the next key ignition cycle.  *M2 motor remain available		MODULE A21 sends DM1, SPN 520711, Amber Lamp, FMI 5 or 6 depending of failure mode detected
5.4	M2 motor error is detected: FMI5-Current below normal or open circuit FMI6-Current above normal or grounded circuit	No wiper High operation - M2 motor output remains disabled until the next key ignition cycle.  *M1 motor remain available		MODULE A21 sends DM1, SPN 520711, Amber Lamp, FMI 5 or 6 depending of failure mode detected
5.5	Wiper motor 1 parked position (I_M1HomeSensor) signal failure. FMI3-Voltage above normal or shorted high FMI4-Voltage below normal or shorted low	Parked position cannot be determined. Wiper functions remain available for driver but without motors synchronization. (Prevost Specific)	Wiper functions remain available for driver but without motors synchronization. (Prevost Specific)	MODULE A21 sends DM1, SPN 520713, No lamp FMI 3 or 4 depending of failure mode
5.6	Wiper motor 2 parked position (I_M1HomeSensor) signal failure. FMI3-Voltage above normal or shorted high FMI4-Voltage below normal or shorted low	Parked position cannot be determined. Wiper functions remain available for driver but without motors synchronization. (Prevost Specific)	Wiper functions remain available for driver but without motors synchronization. (Prevost Specific)	MODULE A21 sends DM1, SPN 520713, No lamp FMI 3 or 4 depending of failure mode
5.7	FMI 3 or 4 is detected on digital input "I_SpeedLow"	No loss of operation - In case driver wants to operate wiper Low, primary function on J1939 (D_BUS) remain available	Use primary J1939 in case it's needed.	MODULE A21 sends DM1, SPN 520711, No Lamp, FMI 12
5.8	FMI 3 or 4 is detected on digital input "I_SpeedHigh"	No loss of operation - In case driver wants to operate wiper High, primary function on J1939 (D_BUS) remain available	Use primary J1939 in case it's needed.	MODULE A21 sends DM1, SPN 520711, No Lamp, FMI 12

## 27. WINDSHIELD WIPERS AND WASHERS – X3 SERIES

### 27.1 GENERAL DESCRIPTION

#### NOTE

When installing a wiper motor, arm or blade, follow recommended procedures to prevent misalignment, binding or malfunction. Check the windshield washer liquid hoses, fittings and connectors to be sure they are properly connected and seal with no restriction to the flow of washer liquid. Check that wiper arms have the proper sweep position and the washer nozzles are aimed so that spray is within the proper wiper pattern.

The windshield wipers are controlled by one electric wiper motor that is accessible for maintenance after removing the appropriate access panel beside the footwell (refer to Figure 67).

Turn the multifunction lever forward to activate windshield wipers (item 2, Figure 65). The first position operates the wipers at low speed and the second position operates the wipers at high speed. Turning the lever backwards will operate the wipers in the intermittent mode.

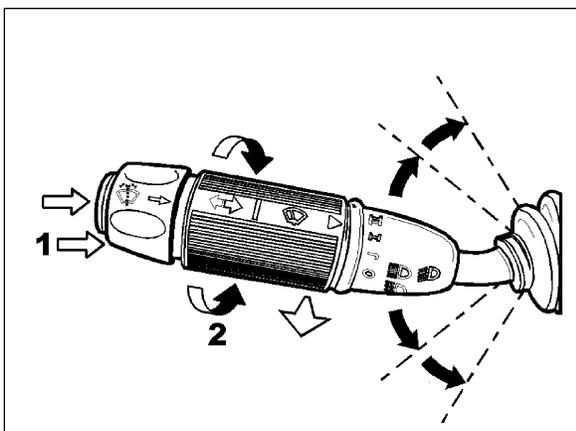

FIGURE 65: MULTIFUNCTION LEVER

23133

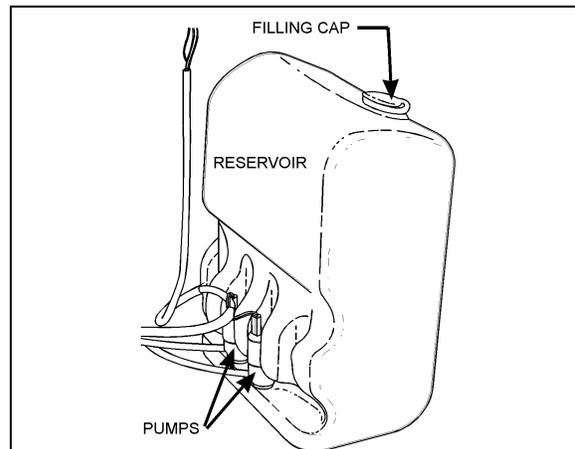

FIGURE 66: WINDSHIELD WASHER RESERVOIR

23220

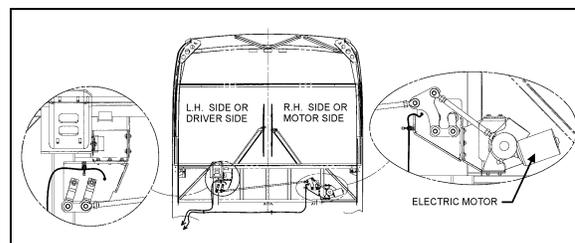

FIGURE 67: WINDSHIELD WIPER INSTALLATION

23287

The windshield washer pumps are electrically operated and are controlled by a washer control ring on the multifunction lever (item 1, Figure 65).

The windshield washer reservoir is located in the front service compartment (Figure 66). This unit pumps the washer liquid to the spray nozzles where it is dispersed across the windshield.

### 27.2 WIPER ARM

Check operation of the wipers for proper blade sweep and angle.

#### 27.2.1 Wiper Arms Positioning

1. Reinstall the wiper arms and position as shown in figure 40. Before positioning the wipers at their final position, tighten the nuts at first.

**TORQUE** Erreur ! Liaison incorrecte.

2. To find the final position of the wiper arms, lift then release the wiper arm so it falls back on the windshield.



**CAUTION**

Do not attempt to manually move the wiper arms to make wiper blade sweep adjustments as damage to the wiper linkage or motor may occur. If it is necessary to adjust the sweep of blades, remove the arms and make adjustment by positioning the arms using serration on the wiper arm pivot shafts.

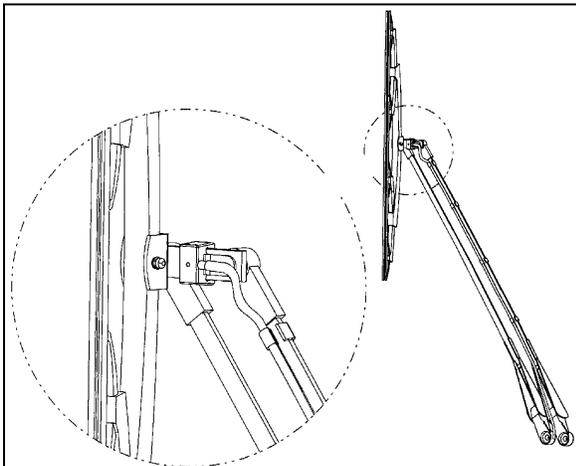

FIGURE 68: WINDSHIELD WIPER (MOTOR SIDE)

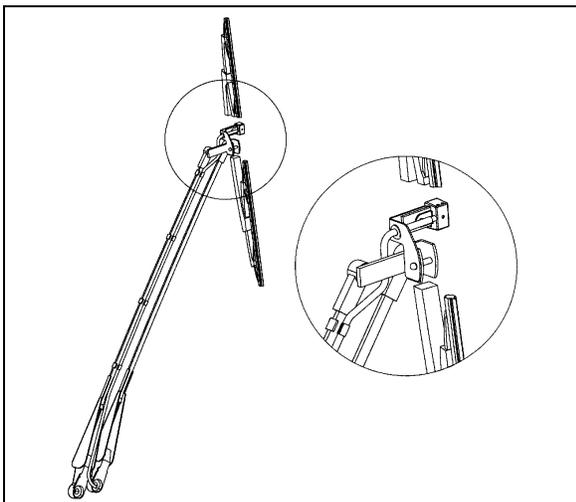

FIGURE 69: WINDSHIELD WIPER (DRIVER SIDE) 23328

3. When the final position is found, tighten wiper arm nuts. Wait 30 minutes and tighten again.

**TORQUE** Erreur ! Liaison incorrecte.

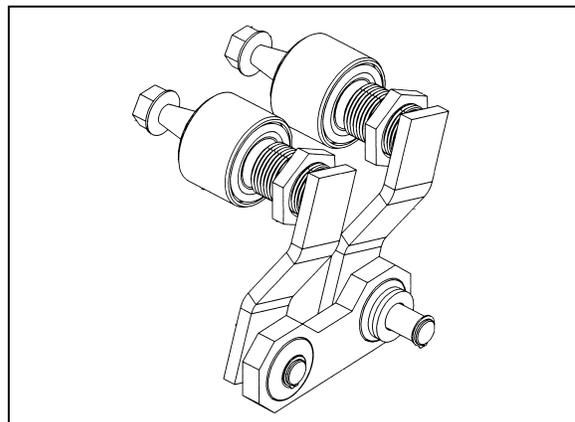

FIGURE 70: DRIVING MECHANISM (DRIVER SIDE) 23284

4. Lower the protective cover.
5. Connect the windshield washer tubing at the base of the wiper arm.
6. Check the adjustment on a wet windshield.

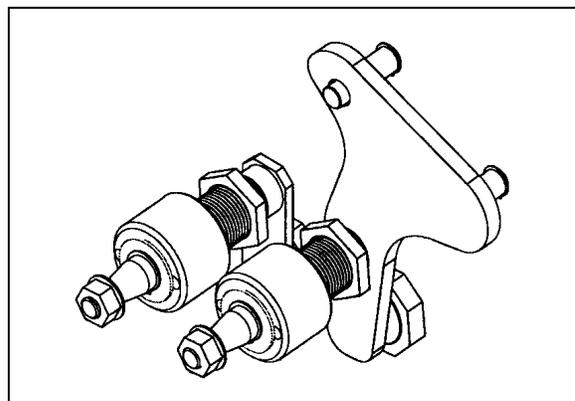

FIGURE 71: DRIVING MECHANISM (MOTOR SIDE) 23285

## 27.3 WINDSHIELD WIPER MOTOR

### 27.3.1 Windshield Wiper Motor Replacement

The windshield wiper motor is located at lower front of the vehicle, behind the defroster panel. Refer to Figure 67 for motor location.



**WARNING**

Park vehicle safely, apply parking brake, stop engine and set battery master switch to the "OFF" position prior to working on the vehicle.

1. Remove the Phillips-head screws retaining the defroster panels, and remove panels.
2. Disconnect wiring connector from the windshield wiper motor.
3. Loosen clamping screw retaining the lever at the end of the motor driving shaft.
4. Remove the three bolts holding the motor to the steel plate.

5. Remove the windshield wiper motor (Prevost #800328), reverse removal procedure to reinstall.

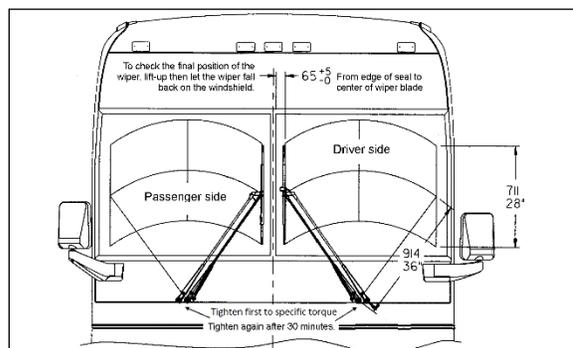

FIGURE 72: WIPER ARMS POSITIONING 23253

27.4 TROUBLESHOOTING

SYMPTOM	PROBABLE CAUSE	REMEDY
FAIL TO SPRAY WASHER FLUID	A. Reservoir empty. B. If below 32°F (0°C), improper washer fluid frozen. C. Contamination in tubing or nozzles. D. Tubing damage. E. Tubing bent (kinked) or off one or more connections.	A. Add proper fluid. B. Store coach or parts in heated area, then purge system with low-temperature solution. C. Remove with compressed air, if severely clogged, replace items. D. Replace section. E. Realign tubing and/or refit. Trim end to ensure proper fit or replace.
INADEQUATE SPRAYING	A. Tubing failure.	A. Replace tubing.
SLOW OPERATION	A. Improper solution. B. Jet stream improperly directed. C. Check if valve is stuck in the open position.	A. Replace with proper type solution. B. Reposition nozzles. C. Remove, clean or replace.

28. AUTOMATIC FIRE SUPPRESSION SYSTEM (AFSS) (OPTIONAL)

This optional system is used to shut down the engine and to extinguish a fire in the engine compartment or in the vicinity of the preheating system if so equipped.

The system operation is fully automatic and does not require assistance from the operator, however if required, the system can be manually activated by the operator at any time.

Refer to Prevost Operator's Manual or Owner's Manual for system operation and operational sequence (fire).



If more information is needed on the system, please refer to Kidde Dual Spectrum “Operation & Maintenance Manual”, found on your Technical Publications USB flash drive.

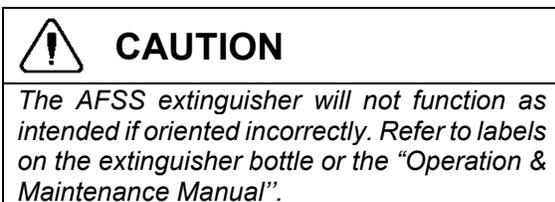

## 28.1 STARTING THE VEHICLE AFTER TRIGGERING OF A FIRE ALARM

The vehicle may be started after a fire alarm without resetting the system. Refer to ignition switch sequence below. This will not reset the system, rather it will instruct the vehicle’s multiplex system to ignore vehicle interface outputs from the protection panel. This feature is intended to be used only in emergency situations that require the vehicle to be restarted and moved a short distance prior to system reset. It should not be performed if the cause of the fire has not been clearly identified and corrected.

To start the vehicle, perform this ignition switch (key) sequence:

1. From the **ON** position;
2. Turn to **OFF**, return to **ON** and **START** vehicle within 2 seconds.

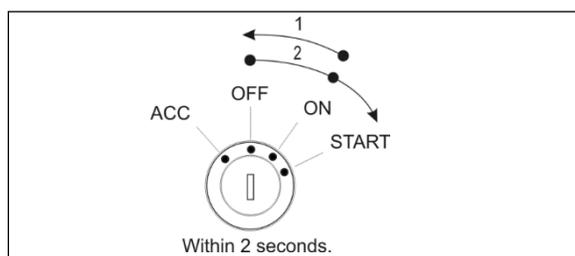

FIGURE 73: IGNITION SWITCH SEQUENCE

## 28.2 PERIODIC MAINTENANCE

### PRE-TRIP

- Verify that the Protection Panel “SYSTEM OK” lamp is on solid green.

**EVERY 3000 MILES OR MONTHLY** (whichever comes first)

### General

- Verify that neither the protected equipment nor the hazard has changed.
- Verify that no obvious physical damage or condition exists that might prevent system operation.

### Protection Panel

- Verify that all warning lamps and the audible alarm are operational by pressing the “TEST/RESET” button.

### Manual Activation Switch

- Verify that the tamper seal is intact and access to the switch is unobstructed.

### Fire Detectors

- Optical
  - Verify that the status lamp on the detector face is on solid green.
  - Verify that nothing is blocking the detector’s field of view.
  - Verify that the windows on the face of the detector are free of excess contamination (dirt, oil, grease, etc.) – if necessary, clean using a water soaked non-abrasive towel.
- Linear Thermal
  - Verify that there is no obvious physical damage and that the unit is free of excess contamination (dirt, oil, grease, etc.) – if necessary, clean using a water soaked non-abrasive towel.
  - Verify that mounting is secure and taught.

### Electrical Harness

- Verify that electrical connectors and electrical wiring have no visible damage and all connectors are securely seated.

### Extinguisher & Distribution System

- Verify that the extinguisher pressure gauge pointer is in the green arc at room temperature.
- Verify that distribution piping and nozzles are intact and unobstructed and that nozzle blow-off caps are in place.

**EVERY 18000 MILES OR SEMI-ANNUALLY** (whichever comes first)

- Perform a comprehensive fire system test using a Kidde Dual Spectrum System Test Set (Optical Test Kit P/N 420871-2).
- Service the extinguisher in accordance with KDS Document 160296, “KDS Pre-Engineered Fire Suppression System: Installation, Operation and Maintenance Manual”.



## MAINTENANCE

---

**EVERY SIX YEARS**

Have the fire extinguisher rebuilt by a qualified fire protection equipment company familiar with Kidde Dual Spectrum equipment and in accordance with KDS Document 160296, “KDS Pre-Engineered Fire Suppression System: Installation, Operation and Maintenance Manual”. Rebuilt shall include actuator, O-ring seals and dry chemical replacement.



## MAINTENANCE

---

**EVERY TWELVE YEARS**

Have the Extinguisher cylinder hydrostatically tested by a qualified fire protection equipment company familiar with Kidde Dual Spectrum equipment and in accordance with KDS Document 160296, “KDS Pre-Engineered Fire Suppression System: Installation, Operation and Maintenance Manual”.

### 29. TIRE PRESSURE MONITORING SYSTEM (TPMS SENSATA) – H3 SERIES

The optional active tire pressure and temperature monitoring system is a sensing device designed to identify and display tire operating data and activate an alert or warning when pressure or temperature irregularities are detected.

For more information on the operation of the system, refer to the Operator’s Manual, chapters “Controls and Instruments” and “Safety Features and Equipment”.

#### 29.1 TPMS DIAGNOSTIC TROUBLESHOOTING CODES – SENSATA SYSTEM

TPMS diagnostic troubleshooting codes – sensata system			
SPN	FMI	DESC	WU
168	3	TPMS ECU High voltage	
168	4	TPMS ECU low voltage	
171	9	AMB_Engine timeout	
241	10	Placard Pressure setting error	
639	9	Can bus communication error	
3509	18	LH front axle wheel sensor battery low	17
3510	18	RH axle front wheel sensor battery low	19
3511	18	LH outer drive axle wheel sensor battery low	26
3512	18	LH inner drive axle wheel sensor battery low	27
3513	18	RH inner drive axle wheel sensor battery low	29
3514	18	RH outer drive axle wheel sensor battery low	2A
5126	18	LH Tag axle wheel sensor battery Low	37
5127	18	RH tag axle wheel sensor battery low	39
518001	9	EEC1 message Time out	
518002	9	PropB_VehicleMode timeout	
518003	9	TCO1 message time out	
518004	9	TD message time out	
518005	11	eRX autoconfiguration error	
519001	4	eRX A supply short circuit front Antenna	
519001	9	eRX 18 missing Front Antenna	
519002	4	eRX B supply short circuit Rear LH Antenna	
519002	9	eRX 27 missing Rear LH Antenna	
519003	4	eRX C supply short circuit Rear RH Antenna	
519003	9	eRX 29 missing Rear RH antenna	
520001	9	LH front axle wheel sensor not responding	17
520002	9	RH axle front wheel sensor not responding	19
520003	9	LH outer drive axle wheel sensor not responding	26
520004	9	LH inner drive axle wheel sensor not responding	27
520005	9	RH inner drive axle wheel sensor not responding	29
520006	9	RH outer drive axle wheel sensor not responding	2A

520008	9	LH tag axle wheel sensor not responding	37
520009	9	RH tag axle wheel sensor not responding	39

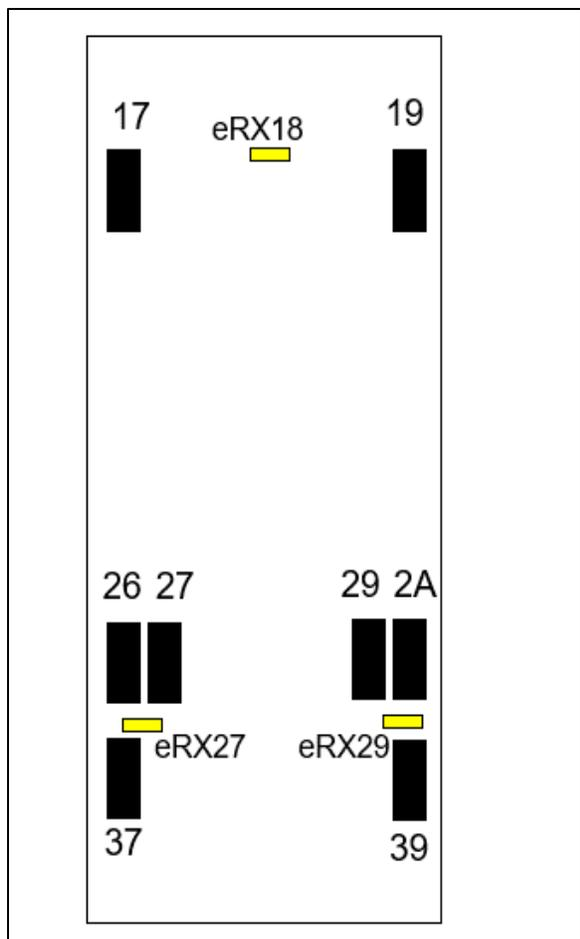

FIGURE 74: WHEEL SENSOR UNIT AND ERX ANTENNA

### 30. TIRE PRESSURE MONITORING SYSTEM (TPMS) – X3 SERIES

The optional active tire pressure and temperature monitoring system is a sensing device designed to identify and display tire operating data and activate an alert or warning when pressure or temperature irregularities are detected.

For more information on the operation and troubleshooting of the system, refer to Prevost X3-45 Coaches Operator's Manual, chapters "Controls and Instruments" and "Safety Features and Equipment" sections.

### 31. ELECTRIC BRAKE CONTROL SYSTEM FOR TRAILER

This optional feature is used to control the braking system of a trailer equipped with electric brakes. This system includes connector A40, a RV type trailer connector already installed on the trailer hitch, the VECT (Vehicle Electric Center Trailer) and the necessary harnesses.

On the vehicles equipped with this feature, the VECR fuses F117 & F119 are replaced by CB117 (20 Amp) & CB119 (30 Amp).

#### 31.1 A40 CONNECTOR

A40 connector is located in the front electrical and service compartment (aka front junction box). This connector is used to connect a brake controller.

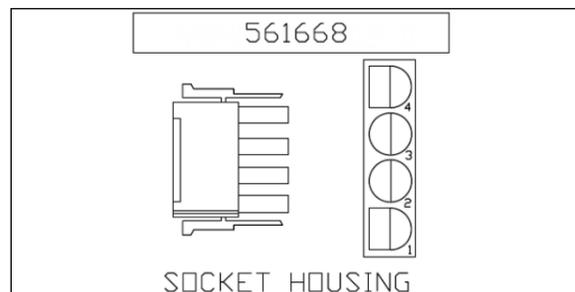

FIGURE 75: A40 CONNECTOR

Four circuits:

- 1) black 12V power (from ignition)
- 2) white ground
- 3) red input: 12V brake application signal from VECT (coach brake lights)
- 4) blue output: brake application signal to the trailer

#### 31.2 7-BLADE RV/TRAILER CONNECTOR

Seven circuits:

- 1) white ground
- 2) blue output: brake application signal to the trailer
- 3) brown taillights
- 4) black 12V supply for trailer accessories

## SECTION 23: ACCESSORIES

- 5) yellow left turn signal
- 6) green right turn signal
- 7) purple backup lights

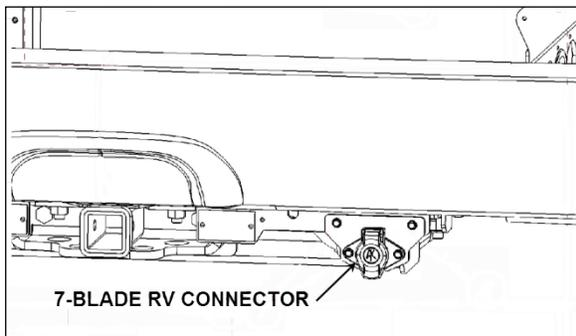

FIGURE 76: 7-BLADE TRAILER/RV CONNECTOR ON TRAILER HITCH

### 31.3 VECT

The VECT includes the following components:

Relays 51, 52, 53, 54 and 55

CB301, 20 Amp

Fuses (20A) 302, 303 and 304

Spare fuses: SP1-SP4

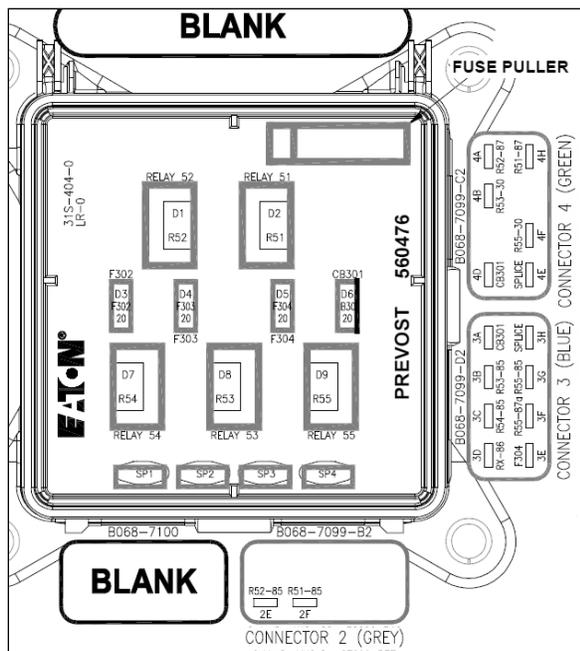

FIGURE 77: VECT

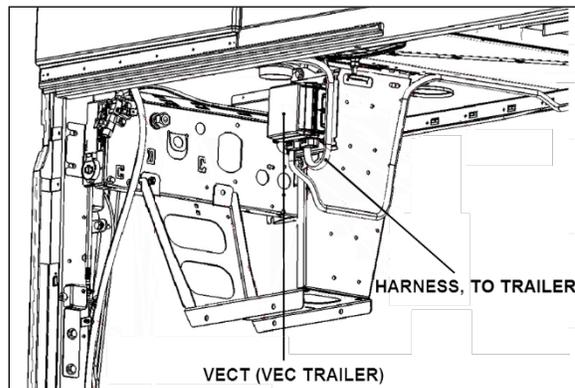

FIGURE 78: VECT (CURB SIDE) ON AIR FILTER BRACKET – H3 SERIES

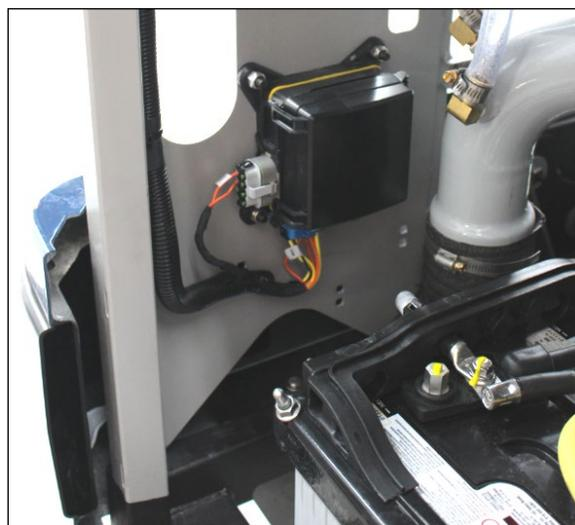

FIGURE 79: VECT (CURB SIDE) - X3 SERIES



## Table of contents

REQUIRED TOOLS .....	3
SAFETY MEASURES .....	4
PART 1 - DRIVE MOTOR REPLACEMENT .....	5
Drive Motor Bracket Removal .....	5
Linkage Disconnection from The Drive Motor Shaft .....	9
Drive Motor Removal and Replacement.....	9
Park Position Setting.....	11
Linkage Connection to The Drive Motor Shaft.....	12
Drive Motor Bracket Installation .....	13
PART 2 - WIPER PIVOT AND LINKAGE REPLACEMENT .....	15
Preparation .....	15
Wiper Arm and Pivot Hardware Removal.....	16
Wiper Pivot and Linkage Assembly Removal.....	19
Damaged Components Replacement .....	22
Pivot and Linkage Assembly Installation .....	22
Park Position Setting.....	23
Linkage Connection to The Drive Motor Shaft.....	23
Drive Motor Bracket Installation .....	23
Wiper Arm Installation.....	24
PARTS / WASTE DISPOSAL .....	26

# REQUIRED TOOLS

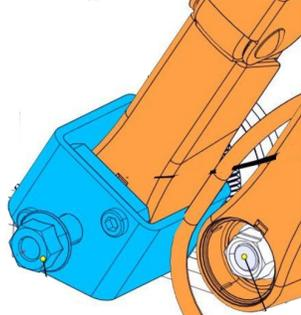
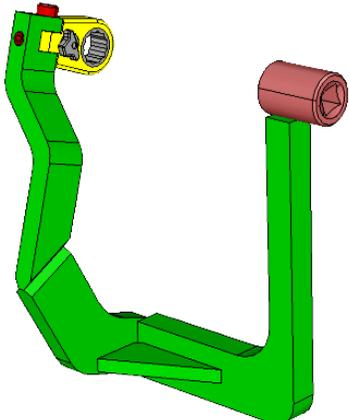
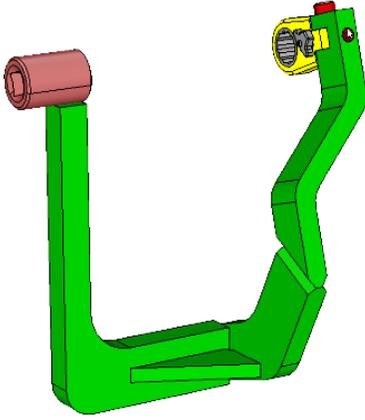
<p>RULER</p> 	<p>SMALL PRY BAR</p> 
<p>TORQUE WRENCH AND METRIC SOCKET SET</p> 	<p>RATCHET AND SOCKET SET – METRIC SET</p> 
<p>CAULKING GUN</p> 	<p>SMALL FLAT SCREWDRIVER</p> 
<p>MASKING TAPE</p> 	<p>WIPER ARM PULLER P/N G37807</p> 
<p>CURB SIDE MOTOR TORQUE TOOL P/N G37274</p> 	<p>STREET SIDE MOTOR TORQUE TOOL P/N G37605</p> 

## SAFETY MEASURES



**DANGER**

The wiper linkage can cut your fingers. Cut off the power supply before working on this system.

## SAFETY PRECAUTIONS

- Eye protection should always be worn when working in a shop.
- Rules for Personal Protection Equipment should always be respected. Wear your PPE including but not limited to the following:



**Safety  
First!**





## PART 1 - DRIVE MOTOR REPLACEMENT



### DANGER

Park vehicle safely, apply parking brake, stop engine. **Prior to working on the vehicle, set the ignition switch to the OFF position, set the battery master switch to the OFF position and trip the main circuit breakers equipped with a trip button.**

Lock out & Tag out (LOTO) must be performed during set-up, maintenance or repair activities. Refer to your local procedure for detailed information regarding the control of hazardous energy.



### DANGER

The wiper linkage can cut your fingers. Cut off the power supply before working on this system.

### Drive Motor Bracket Removal

1. Open the wiper mechanism access hatch.

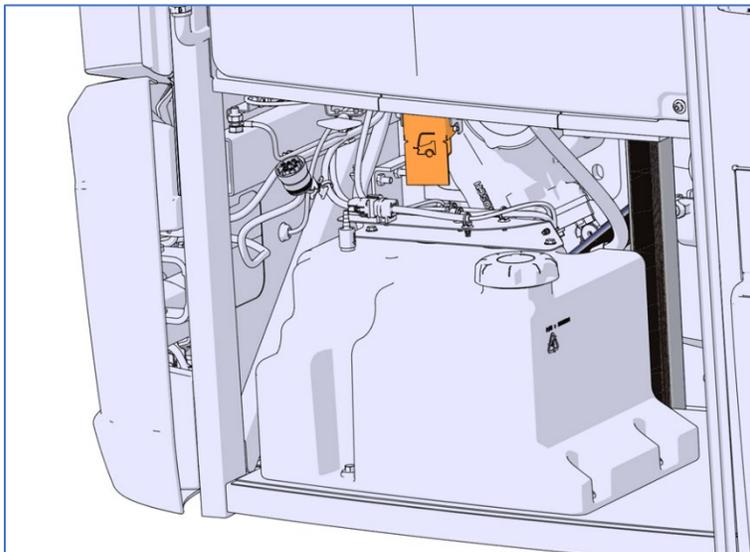

Figure 1

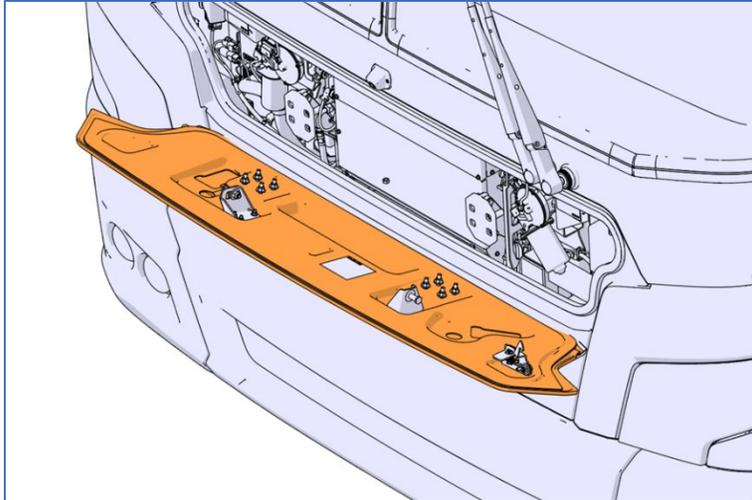

Figure 2

2. Cut the nylon tie securing the drive motor connector. Pry the yellow lock on the connector socket housing and then unplug the connector.

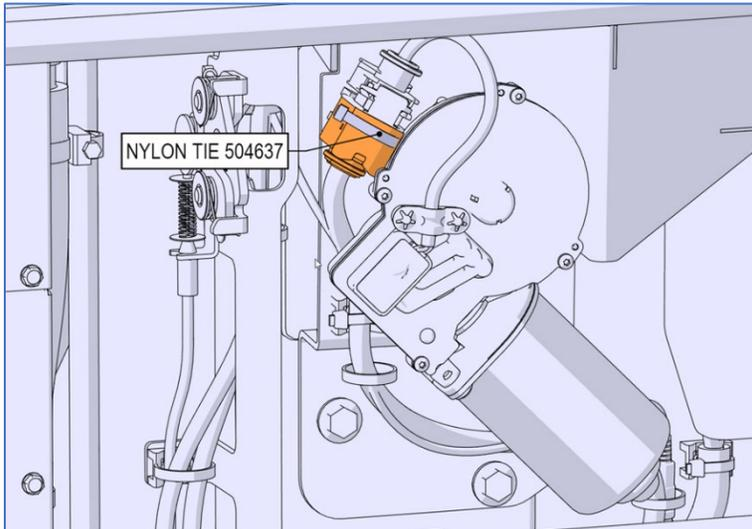

Figure 3: SREET SIDE DRIVE MOTOR SHOWN



Figure 4

3. Remove the four bolts that secure the drive motor bracket (use 13 mm socket).

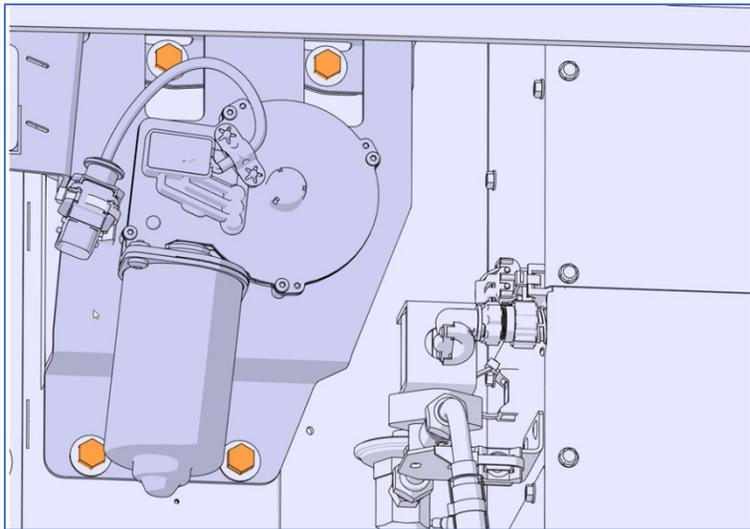

Figure 5: CURB SIDE DRIVE MOTOR

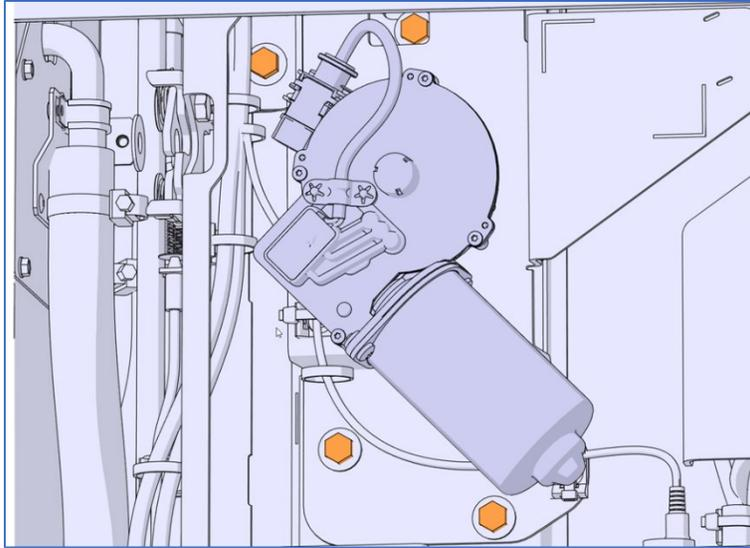

Figure 6 : STREET SIDE DRIVE MOTOR

4. At the back of the drive motor bracket, unscrew the drive motor shaft nut and remove the washer (use 17 mm socket).

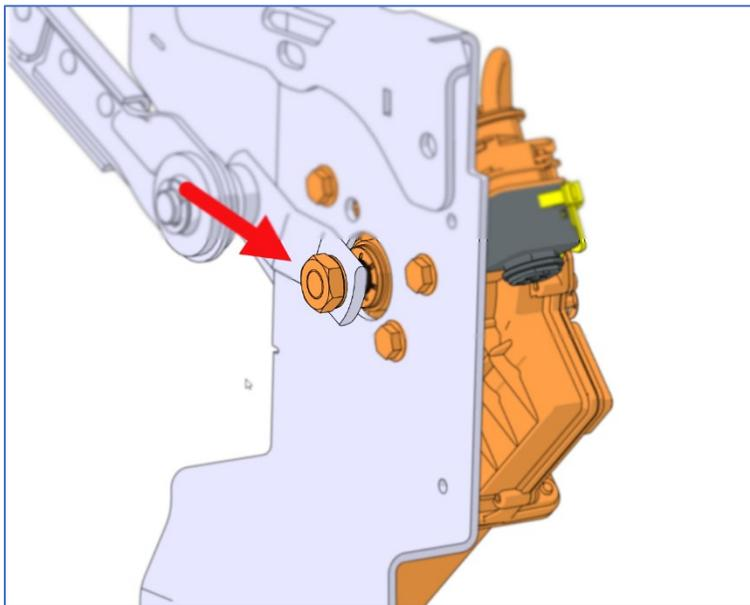

Figure 7

## Linkage Disconnection from The Drive Motor Shaft

5. Using a small pry bar, disconnect the linkage from the drive motor shaft.

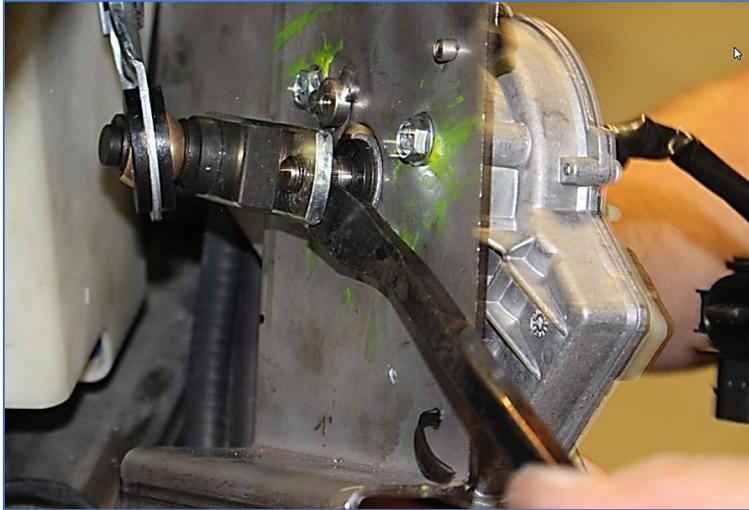

Figure 8

## Drive Motor Removal and Replacement

6. Dismount the drive motor from the bracket. To do so, unscrew the four mounting bolts.

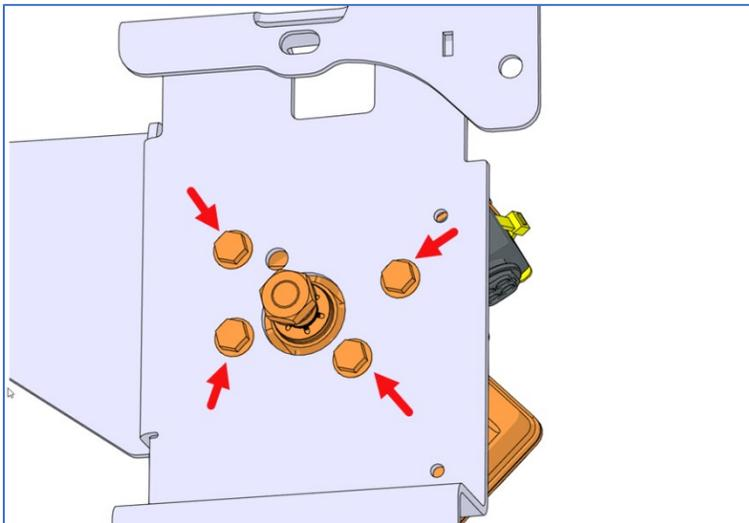

Figure 9

7. Install the new drive motor on the bracket oriented in relation with the bracket (8.5 Nm / 75 lb-in).

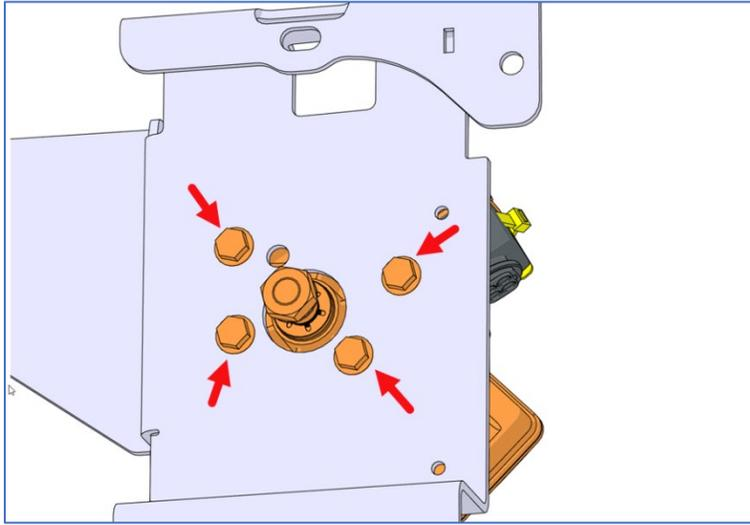

Figure 10

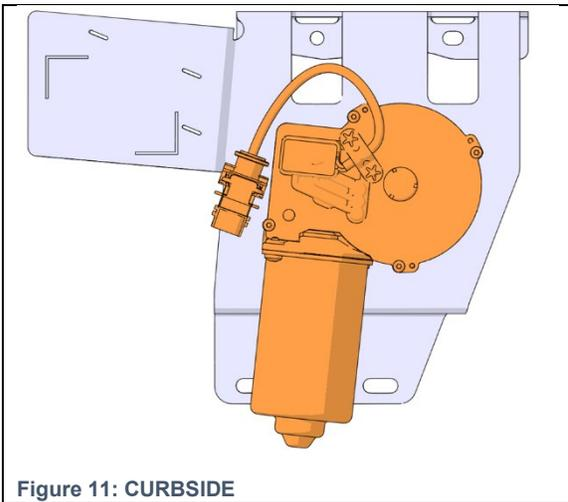

Figure 11: CURBSIDE

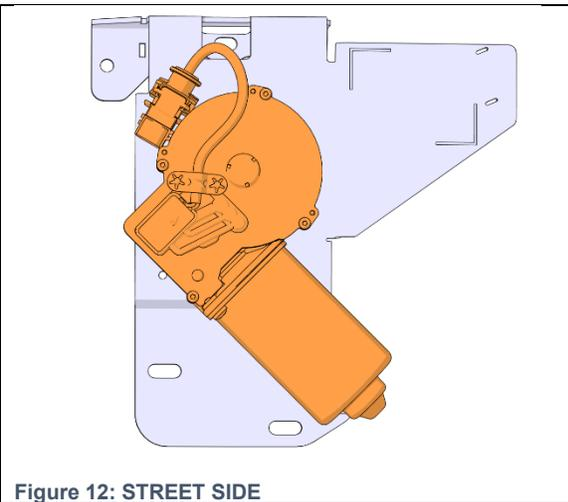

Figure 12: STREET SIDE

## Park Position Setting

NOTE: when setting the park position for the curb side drive motor, the street side drive motor connector must absolutely be connected.

8. **Momentarily**, plug the drive motor connector.
9. **Momentarily**, restore the power supply. Turn the wiper switch to ON then OFF so the new drive motor will be set to park position.



**DANGER**

The wiper linkage can cut your fingers. Cut off the power supply before working on this system.

10. Unplug the drive motor connector. Cut off the power supply.
11. Screw a M6-1.0x30 mm screw in the park position weldnut.
12. Connect the linkage to the drive motor shaft. **Make sure the link rests against the park position screw as shown.**

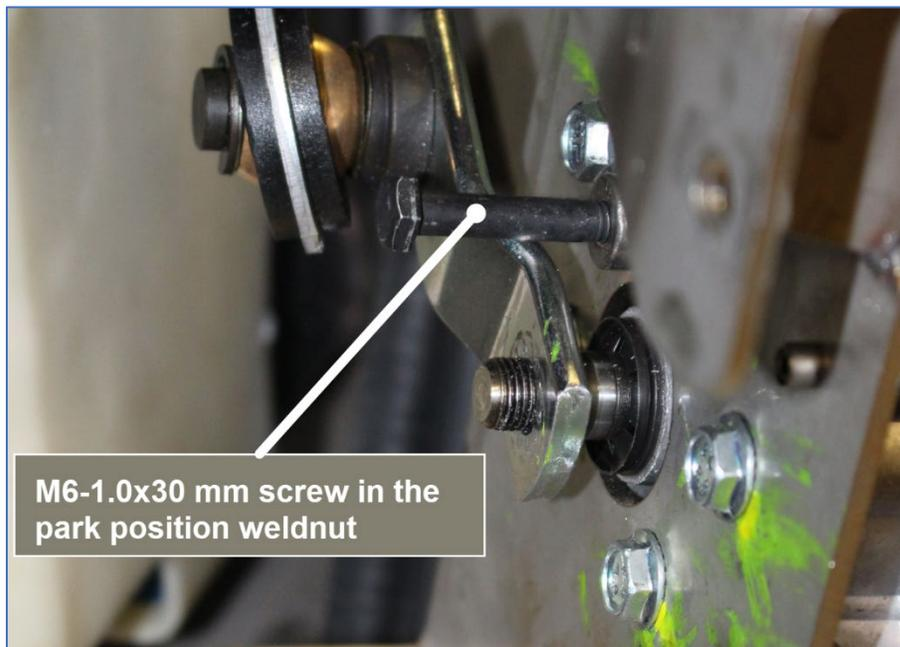

Figure 13

## Linkage Connection to The Drive Motor Shaft

13. Reinstall the washer then the shaft nut. Tighten to a torque of **35 Nm / 26 lb-ft**. Prescribed torque is mandatory. **Make sure the link rests against the park position screw during this operation.**

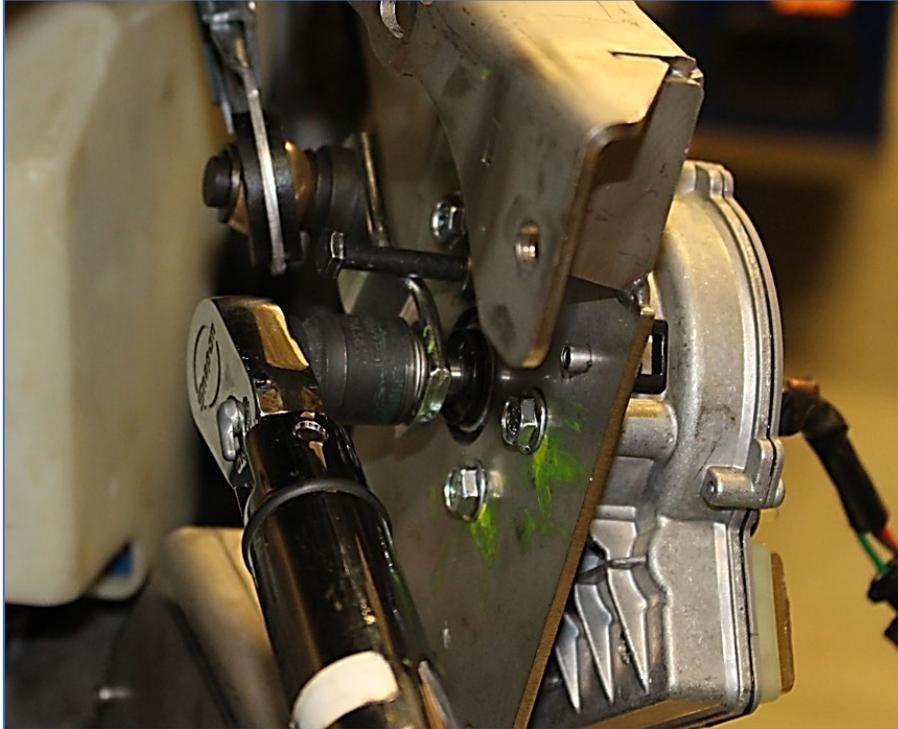

Figure 14



## Drive Motor Bracket Installation

14. Reinstall the drive motor bracket. Tighten bolts to **17 Nm / 13 lb-ft**. Prescribed torque is mandatory.

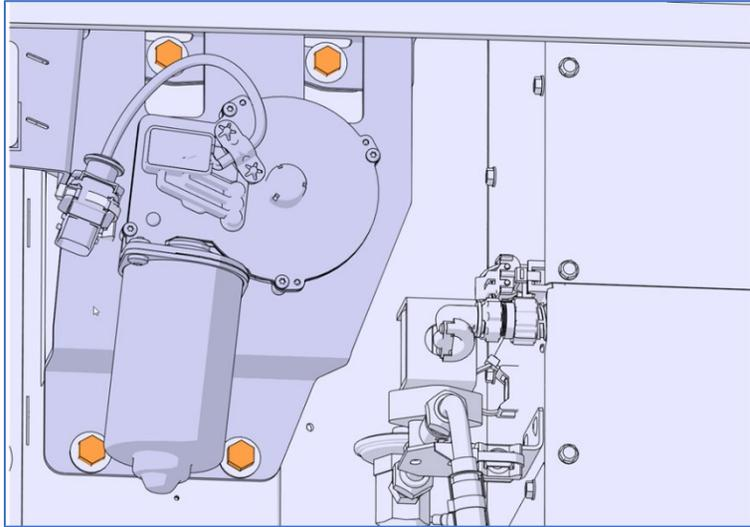

Figure 15: CURBSIDE DRIVE MOTOR

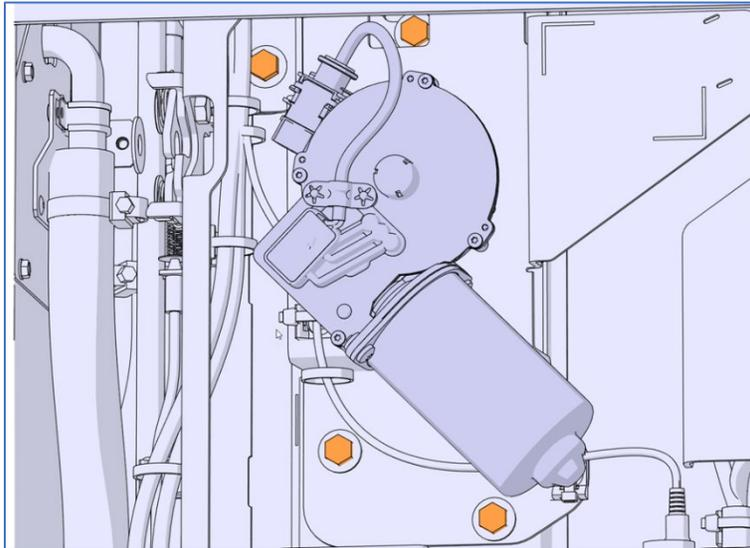

Figure 16 : STREET SIDE DRIVE MOTOR

15. Plug the drive motor connector and secure the connector using nylon tie p/n 504637.

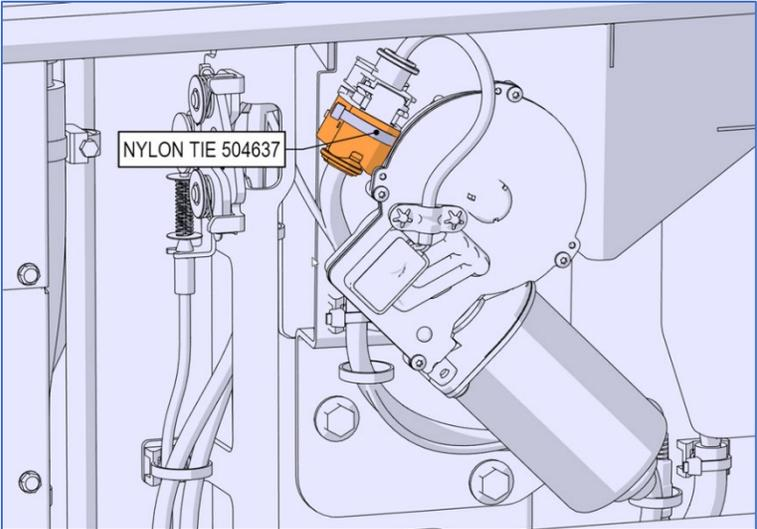

Figure 17

## PART 2 - WIPER PIVOT AND LINKAGE REPLACEMENT



**DANGER**

The wiper linkage can cut your fingers. Cut off the power supply before working on this system.

### Preparation

1. Make sure the wipers are in the park position as shown.
2. Mark wiper blades positions on the windshield.  
*Use masking tape or a pencil or marker that makes temporary markings when used on glass.*

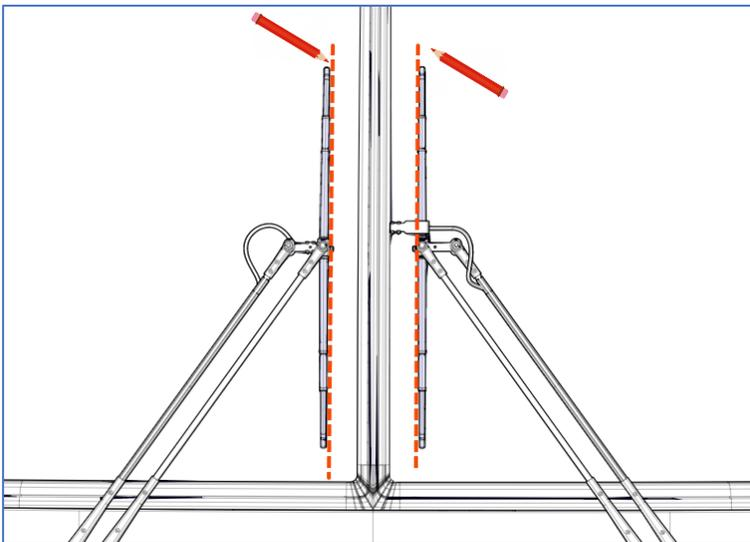

Figure 18

3. Perform Drive Motor Bracket Removal found in PART 1.
4. Perform Linkage Disconnection from The Drive Motor Shaft found in PART 1.

### Wiper Arm and Pivot Hardware Removal

5. Disconnect the windshield washer tube.

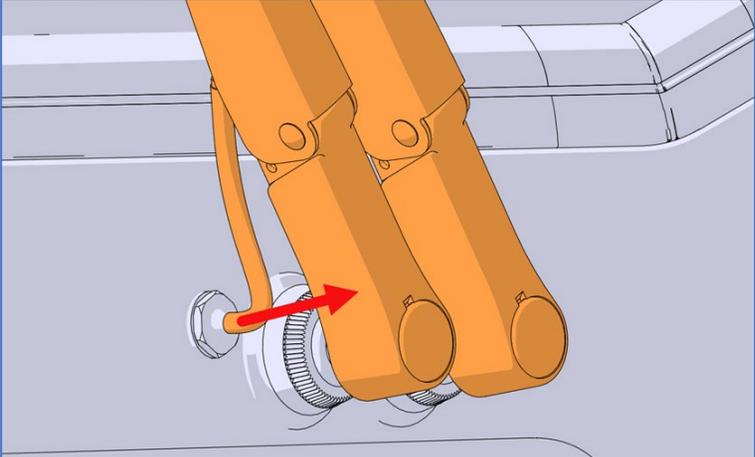

Figure 19

6. Remove the wiper arm nut caps.

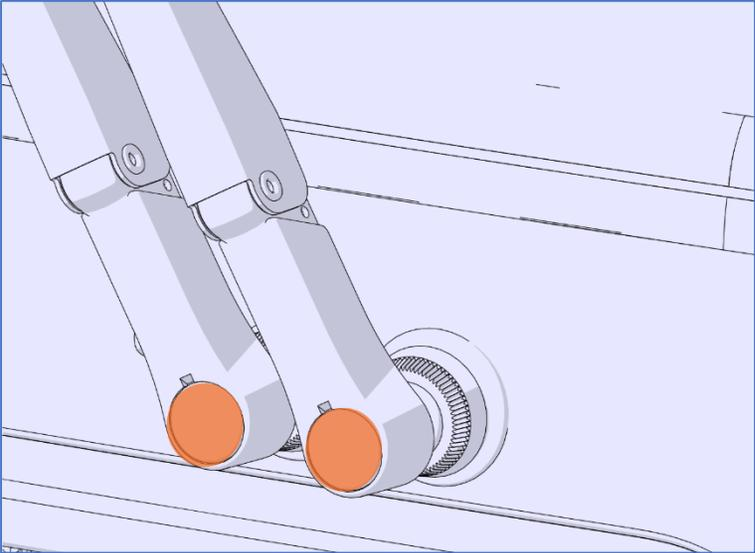

Figure 20

7. Unscrew the wiper arm nuts. Remove the wiper arms. Use of puller no. G37708 is recommended (use 15 mm socket).

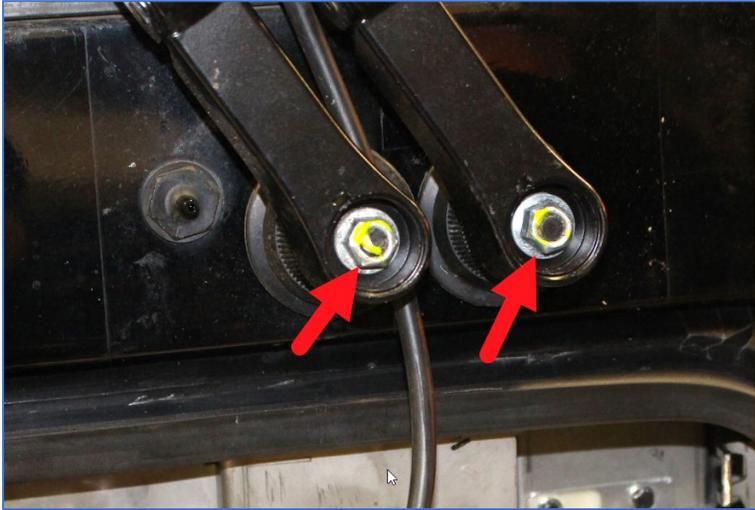

Figure 21

8. Remove the plastic nuts (item 1) and the rubber gaskets (item 2).

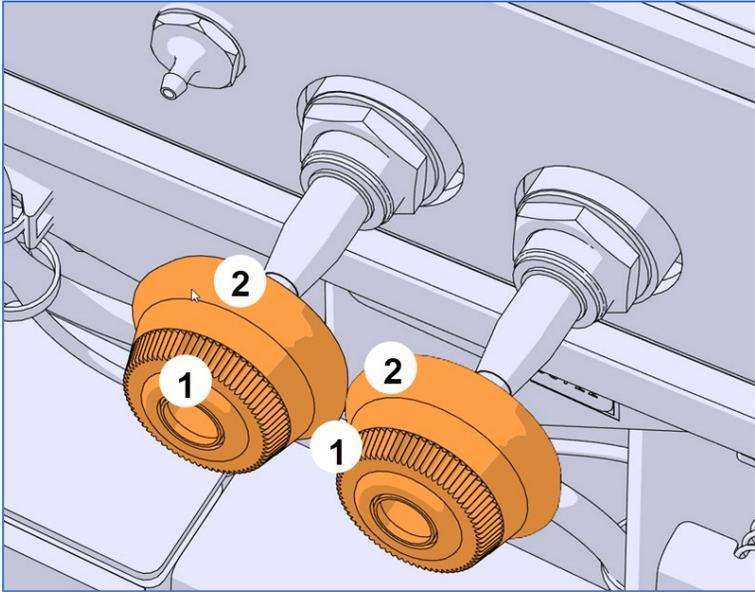

FIGURE 22

9. Remove the butyl sealant applied around the wiper pivots and the fiber panel.



Figure 23

10. Unscrew the two nuts shown on the image below (use 32 mm socket).

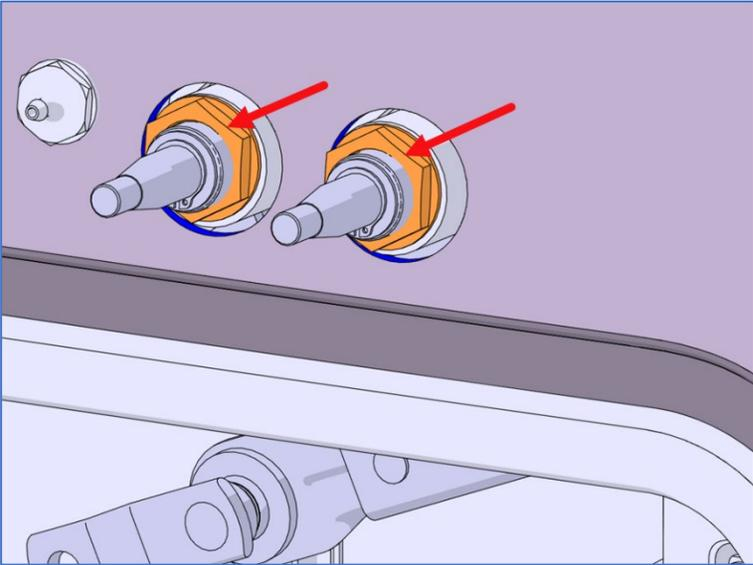

Figure 24

### Wiper Pivot and Linkage Assembly Removal

11. Loosen the four bolts identified on the image below.

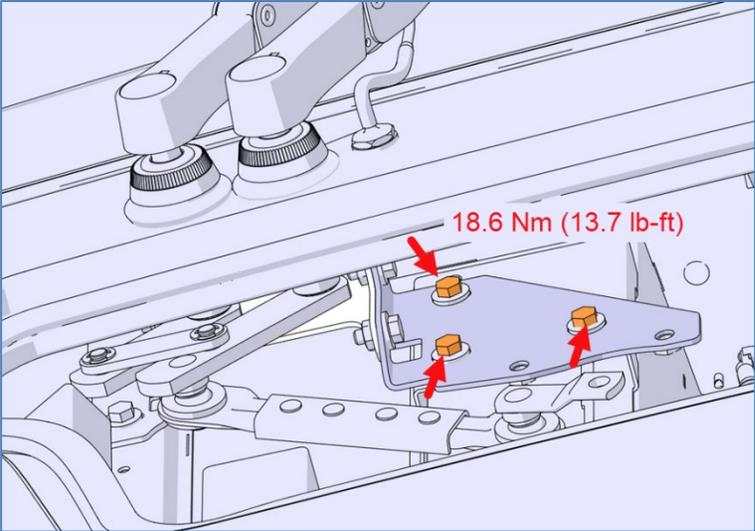

Figure 25: CURB SIDE

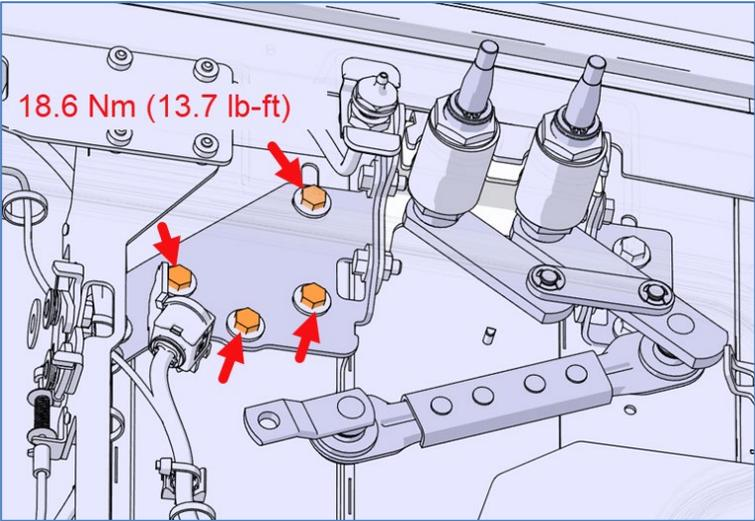

Figure 26 : STREET SIDE

12. Unscrew and remove the two bolts identified on the image below.

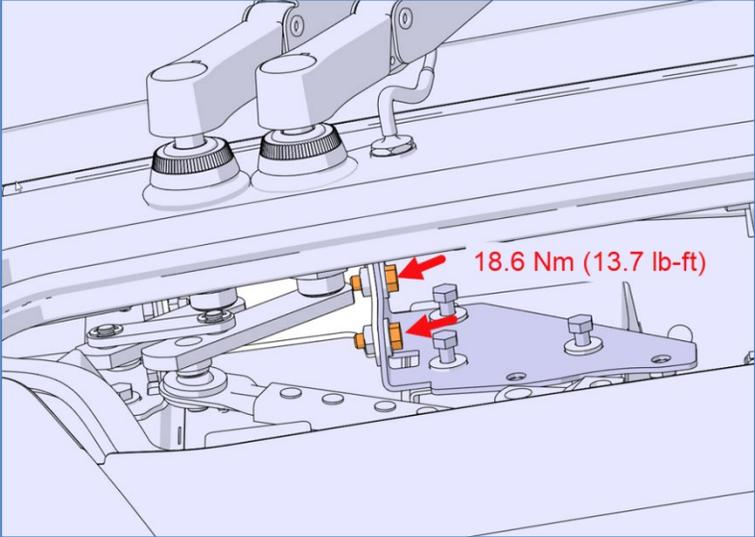

Figure 27: CURBSIDE

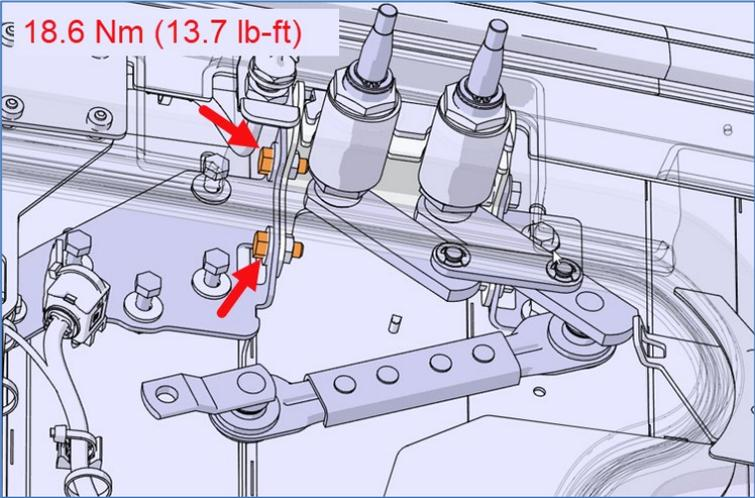

Figure 28 : STREET SIDE



13. Unscrew and remove the two bolts identified on the image below.

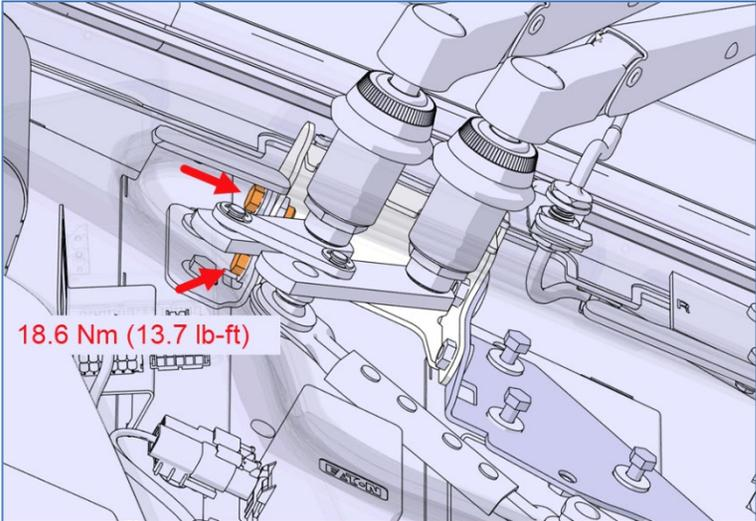
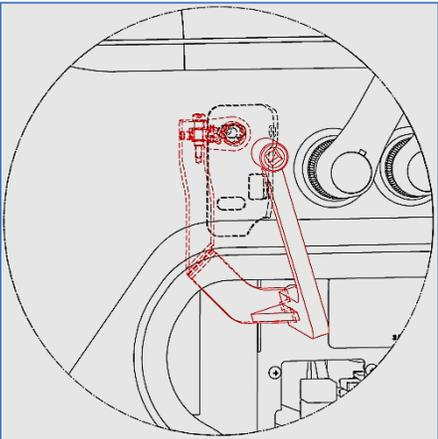

Figure 29: CURB SIDE



USE TORQUE TOOL G37274

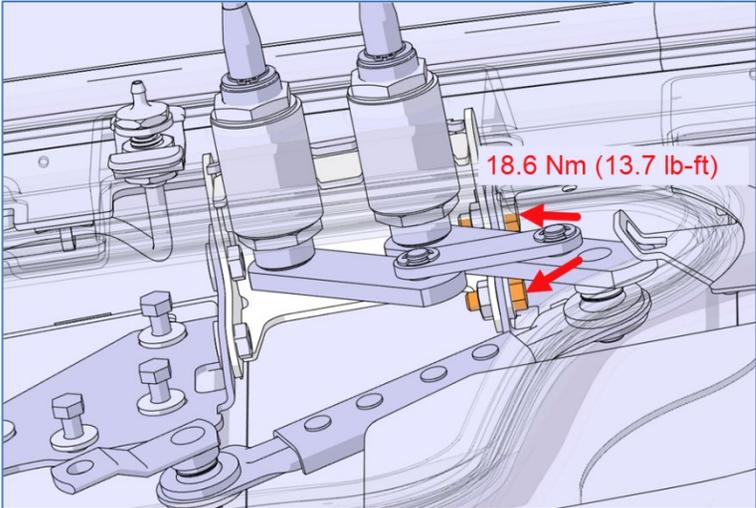
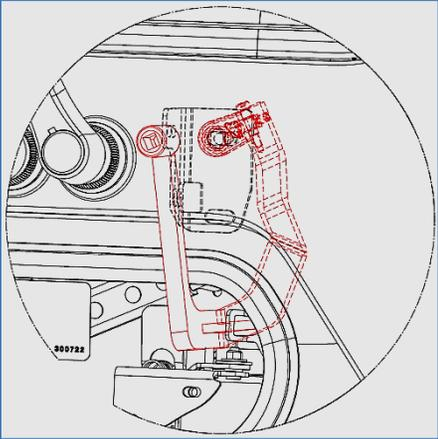

Figure 30 : STREET SIDE



USE TORQUE TOOL G37274

14. Remove the pivot and linkage assembly.

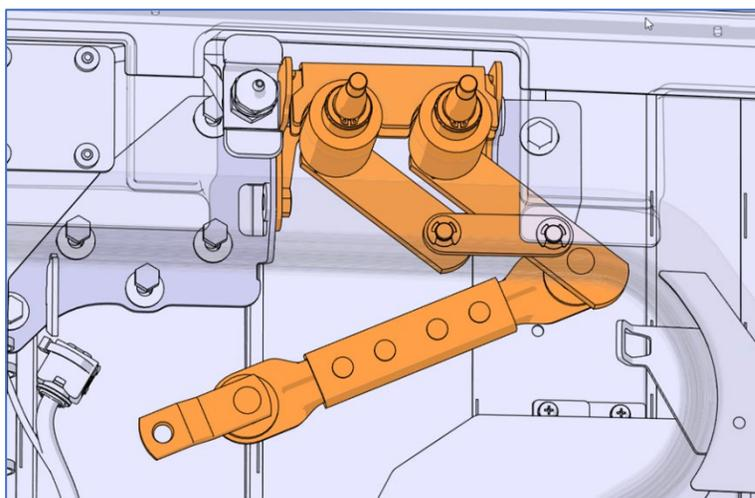

Figure 31

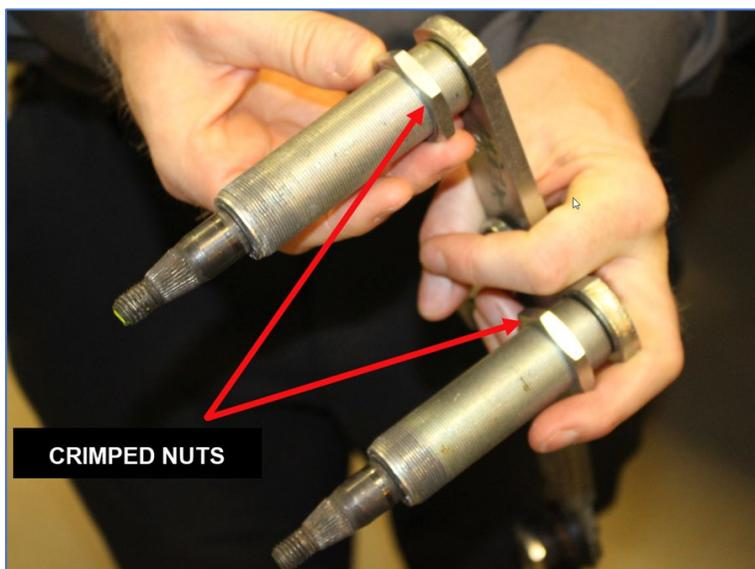

Figure 32

### Damaged Components Replacement

15. Replace the damaged components.

### Pivot and Linkage Assembly Installation

16. Reinstall the pivot and linkage assembly, reversing Wiper Pivot and Linkage Assembly Removal steps. Prescribed torque is mandatory. DO NOT install the wiper arms at this moment.

17. Tighten the pivot nuts.

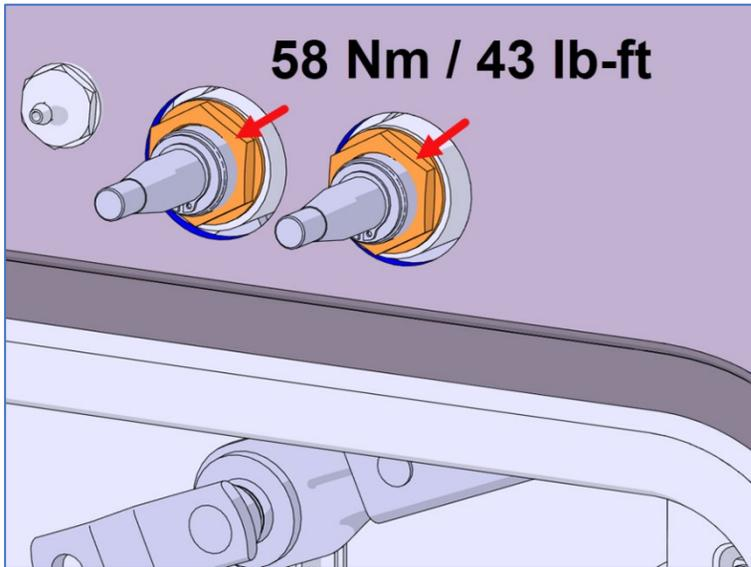

Figure 33

18. Apply butyl or Simson 70-03 sealant between the pivots and the fiber panel and smooth the joint. The sealant joint must be flush with surrounding surface.



Figure 34

### Park Position Setting

19. Perform Park Position Setting found in PART 1 DRIVE MOTOR REPLACEMENT.

### Linkage Connection to The Drive Motor Shaft

20. Perform Linkage Connection to The Drive Motor Shaft found in PART 1 DRIVE MOTOR REPLACEMENT.

### Drive Motor Bracket Installation

21. Perform Drive Motor Bracket Installation found in PART 1 DRIVE MOTOR REPLACEMENT.

## Wiper Arm Installation

22. Reinstall the rubber gaskets (item 2) and the plastic nuts (item 1).

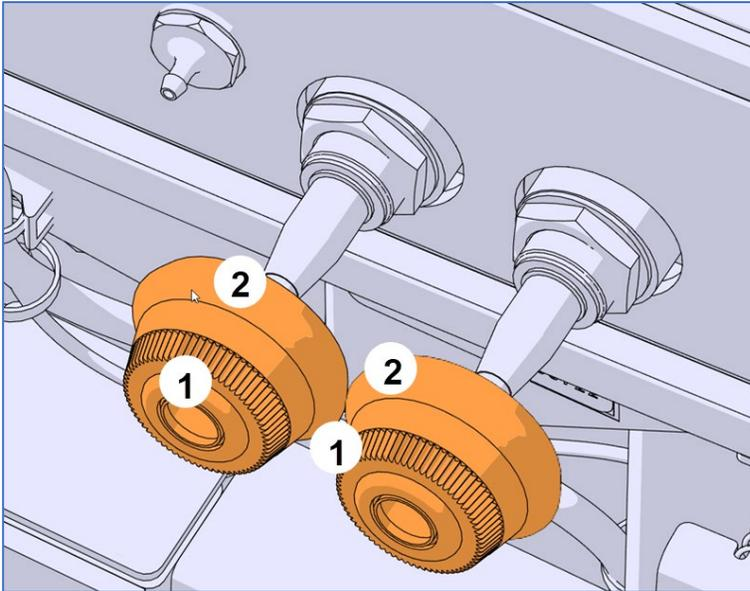

Figure 35

23. Reinstall the wiper arms, making sure the blades align with the marks made previously. Prescribed measurement is  $A=100$  mm (4 in) from the wiper blade to the center of the windshield extrusion.

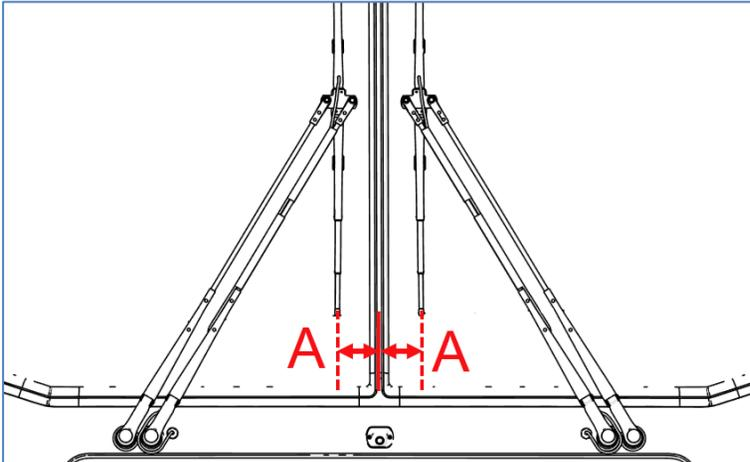

Figure 36

24. Tighten the wiper arms nut to 9 lb-ft. Pull the wiper arm and release. Make sure the blade returns at the proper position. Readjust if necessary.

25. Once proper position is achieved, tighten to 29 lb-ft.

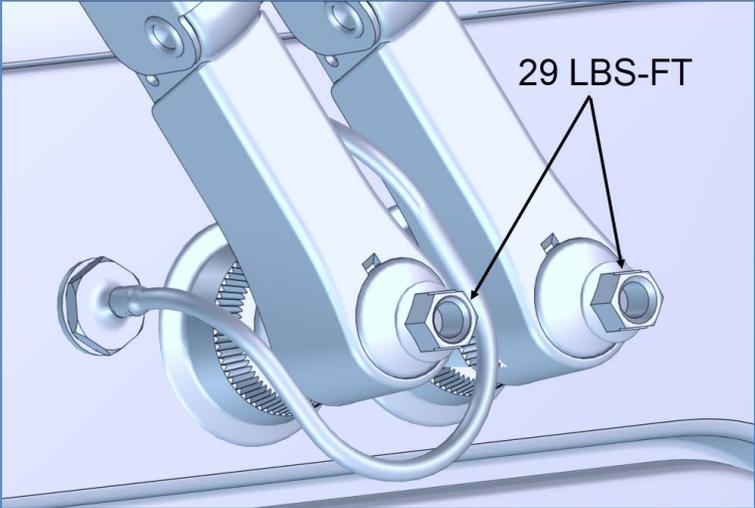

Figure 37

26. Reinstall the wiper arm nuts cap.

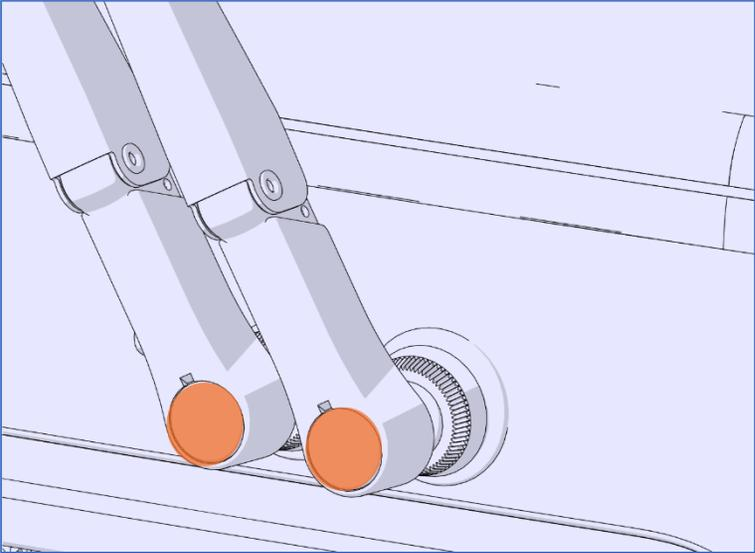

Figure 38

27. Connect the windshield washer tube.

## PARTS / WASTE DISPOSAL

Discard according to applicable environmental regulations (Municipal/State[Prov.]/ Federal)

Access all our Service Bulletins on <http://techpub.prevostcar.com/en/>  
Or scan the QR-Code with your smart phone

**Are you a Vehicle owner?**  
E-mail us at [technicalpublications\\_prev@volvo.com](mailto:technicalpublications_prev@volvo.com) and type "ADD" in the subject to  
receive warranty bulletins applicable to your vehicle(s) by e-mail.

